

Open File

Open File

UNITED STATES
DEPARTMENT OF THE INTERIOR
GEOLOGICAL SURVEY

Interpretation of Resistivity and Induced Polarization Profiles with
Severe Topographic Effects, Yucca Mountain Area, Nevada Test Site, Nevada

by

Christian Smith and Howard P. Ross

with an introduction

by

D. B. Hoover

Open-File Report 82-182

1982

This report is preliminary and has not been
reviewed for conformity with U.S. Geological
Survey editorial standards.

Prepared by the U.S. Geological Survey
for
Nevada Operations Office
U.S. Department of Energy
(Interagency Agreement DE-AI08-78ET44802)

Open File

Open File

UNITED STATES
DEPARTMENT OF THE INTERIOR
GEOLOGICAL SURVEY

Interpretation of Resistivity and Induced Polarization Profiles with
Severe Topographic Effects, Yucca Mountain Area, Nevada Test Site, Nevada

by

Christian Smith and Howard P. Ross

with an introduction

by

D. B. Hoover

Open-File Report 82-182

1982

This report is preliminary, and has not been
reviewed for conformity with U.S. Geological
Survey editorial standards.

Prepared by the U.S. Geological Survey
for
Nevada Operations Office
U.S. Department of Energy
(Interagency Agreement DE-AI08-78ET44802)

Introduction

The U.S. Geological Survey working under Interagency Agreement DE-AI08-78ET44802, with the Department of Energy is engaged in a broad program to assess and identify potential repositories for high level nuclear waste on the Nevada Test Site (NTS), figures no. 1 and 2. The U.S. Geological Survey's program consists of integrated geologic, hydrologic and geophysical studies that range in nature from regional to site specific. One site currently under intensive investigation is called the Yucca Mtn. site, located in the east-central part of Yucca Mountain Fig 2. The proposed emplacement medium is one or more welded tuff members of Tertiary age with an emplacement depth in the range of 1000 to 5000 ft. Inter-layered ash-fall tuffs or less welded units partially argillized and zeolitized (Spengler and others, 1979) are expected to provide good adsorptive properties so as to give multiple barriers to radio nuclide migration.

The Yucca Mtn. site under investigation covers about 6 square miles in the east central part of Yucca Mtn proper fig. 2 which is situated in the southwestern part of the NTS and the adjacent Nellis Air Force Range on the west. The general geological setting at the Yucca Mtn site is a thick sequence of ash-fall and ash-flow tuffs presumably relatively undisturbed in the site area, and dipping about 9° to the east or southeast. The estimated aggregate thickness of the tuffs is 7000 to 9000 ft. The generalized geologic map adapted from Lipman and McKay (1965), and Christiansen and Lipman (1965) is shown in plate A. The proposed site is bounded on the west by a well defined scissors fault and on the north by a major structural boundary along Yucca Wash, which is not clearly understood. The eastern boundary is less well defined but probably limited by north-trending basin and range faulting associated with the Fortymile Canyon Plate A. To the south increased faulting

in the volcanics identifies an approximate limit to the site.

A slingram survey in 1978 (V. Flanigan (personal commun., 1980) identified a number of conductive zones at shallow depth some of which were clearly identified with known faults. The slingram data also located a conductive zone in "Drill-Hole wash", plate A referred to as "The Wash" on plate 2 in the following Univ. of Utah work, and which was inferred to represent a zone of significant fracturing and faulting. As the Drill-Hole wash is a major northwest trending linear feature bisecting the potential repository the presence of a major fracture zone under the wash could have serious consequences for the acceptability of the site if it were open to fluid flow. To further assess the nature of faulting in the site area and particularly along Drill-Hole wash an expanded program of electrical studies was initiated. Electrical work within the site area has consisted of slingram, VLF, turam, Schlumberger vertical electrical soundings (VES), magnetotelluric (MT) soundings, E-field ratio telluric traverses (30 sec period), pole-dipole, dipole-dipole induced polarization IP traverses, and hole to surface surveys. The most extensive surface work has been with the dipole-dipole IP traverses using dipole spacings of from 200 to 1000 ft. Our primary emphasis was on the resistivity data as it was believed that this would best characterize the lithologies, contacts and fault zones present. Induced polarization data was acquired since it was hoped that it might assist in separating lithologies, particularly in differentiating zeolitized zones within the tuffs.

The generalized geologic section, fig. 3 section A-A' is adapted from Spengler and others (1979) and electric logs from drill hole UE25A1 are shown in fig. 4 from Hagstrum and others (1980). Hole UE25A1 is in the southwest part of drill-hole wash and was drilled prior to acquisition of the data

discussed in this report to a depth of 2500 ft principally for geologic information on subsurface lithologies within the proposed site.

Elevation changes within the site are about 1000 ft giving significant problems with both the acquisition and interpretation of electrical data. It was also because of this that heavy emphasis was placed on the dipole-dipole work for acquisition of data throughout the site. Dipole-dipole data can be acquired in rugged terrain and recent two-dimensional interpretive methods which include the effect of topography are better developed than for other electrical methods.

In this report C. Smith and H. Ross of the University of Utah Research Institute (UURI) discuss their 2-D modeling of all the dipole-dipole IP lines which were measured across Drill-Hole Wash. In order to make the report clearer to readers not familiar with the local geology figures 2, 3, and 4 and plate A have been included in the introduction to supplement the original report.

Geologic Setting

The Yucca Mountain area is located in the extreme southwest corner of the Nevada Test Site (NTS). The generalized geology is shown in plate A adapted from Lipman and McKay (1965) and Christiansen and Lipman (1965). The oldest rocks exposed in the mapped area are Miocene rhyolites and tuffs. Principal exposures in the survey area are various members of the Paintbrush tuff which attains thicknesses over 1000 ft (305 meters). Here the Paintbrush tuff consists of four principal ash-flow members; Tiva Canyon, Yucca mountain, Pah Canyon, and the lowermost Topopah Spring member separated by thin ash-fall tuff beds. The approximate geologic section is shown in fig. 3 taken in part from lithologies encountered in hole UE25A1 drilled to 2500 ft in Drill-Hole wash, Spengler and others (1979). The Tiva Canyon and Topopah Spring members

comprise the bulk of the Paintbrush tuff and are composed of thick compound cooling units. They contain zones of dense welding which persists laterally and vertically. The central part of the thick welded zones commonly contains a zone of lithophysal cavities unconnected or poorly connected and lined with secondary minerals. At the top of the Topopah Spring member is a vitric zone 13 ft (4 meters) thick which provides a sharp resistivity contrast with the overlying ashfall layers.

Below the Paintbrush are the tuffs of Calico Hills approximately 470 ft (143 meters) thick in this area composed of unwelded ash-flow and bedded and reworked ash-fall tuffs.

Underlying these units are the Crater flat tuffs. The upper unit is the Prow Pass member here about 490 ft (150 m) thick, composed of moderately welded to unwelded rhyolitic ash-flow tuffs moderately welded to unwelded. Below this is the Bullfrog member of similar composition. The Bullfrog is estimated at 500 ft thick (152 meters) in this area. Underlying lithologies are not yet well known below this member at the site. The principal lithologic unit being considered is a moderately to densely welded unit in or below the Crater Flat.

The principal structural features are north-south trending basin and range faults giving rise to a series of narrow north-trending hills in the eastern part of the region and an inferred graben along Fortymile Canyon. These narrow hills are all capped by the Tiva Canyon member. Yucca wash on the north is a major structural boundary evident in plate A whose nature is still in question. Yucca wash trends to the northwest and forms the northern boundary of the proposed site. This northwest trend is seen also in mapped faults in the northern part of the site area and by three prominent northwest trending valleys, the largest being Drill-Hole wash.

Alluvium and colluvium are thin in the valleys within the site area. Drill hole information at five holes in Drill-Hole wash gives the following result: UE-25 A1 30 ft (9.1 meters), UE-25 A4 30 ft (9.1 meters), UE-25 A5 90 ft (27 meters), UE-25 A6 20 ft (6 meters), UE-25 A-7 137 ft (42 meters) (Spengler and others, 1979). The alluvium is generally expected to increase towards the east to several hundred ft. At well J13 on the east side of Fortymile Canyon the alluvium is 425 ft thick (Winograd and Thordarson, 1975).

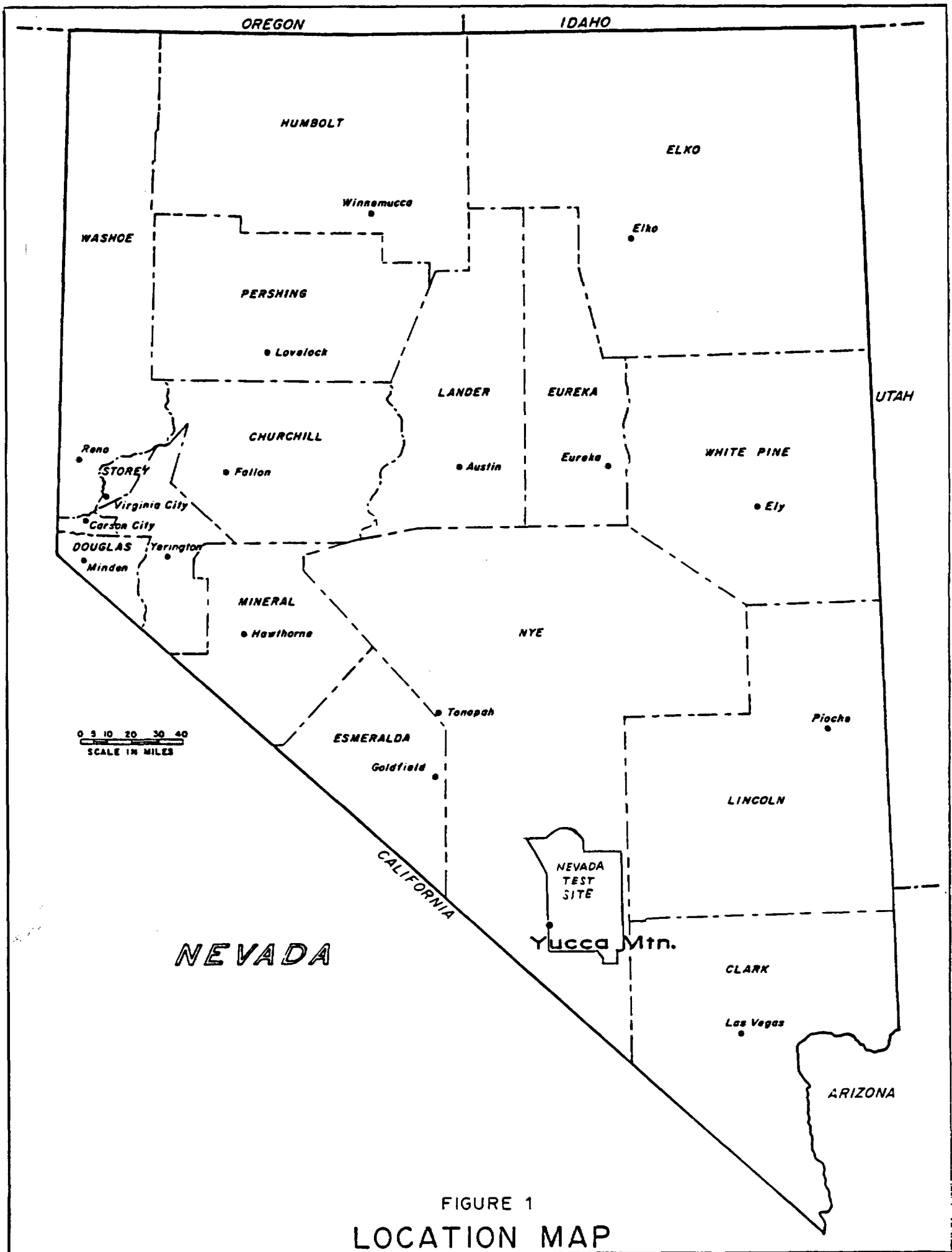

FIGURE 1
LOCATION MAP

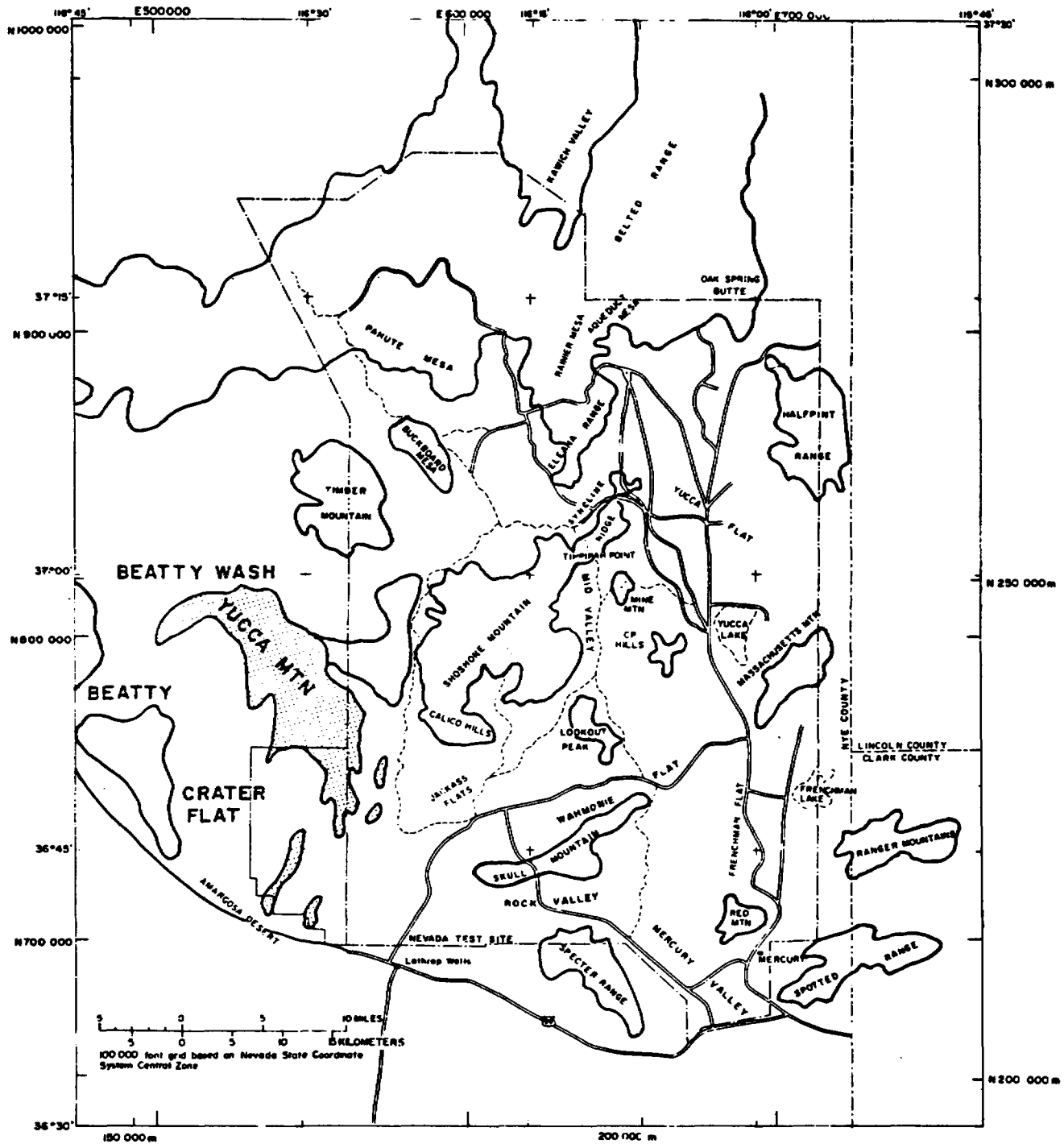

Figure 2.-- Index map of the Nevada Test Site and vicinity showing the location of Yucca Mountain

EXPLANATION

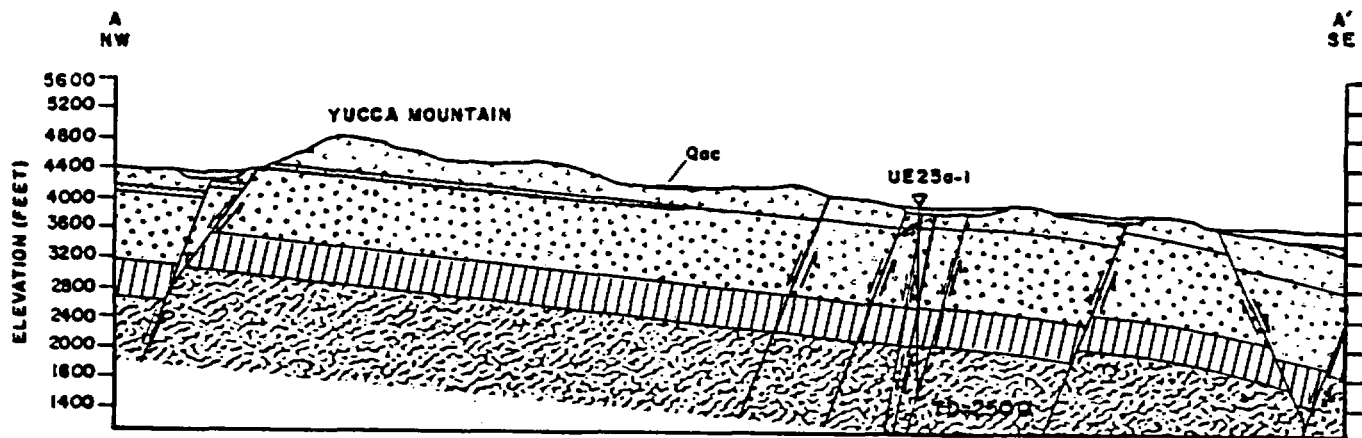
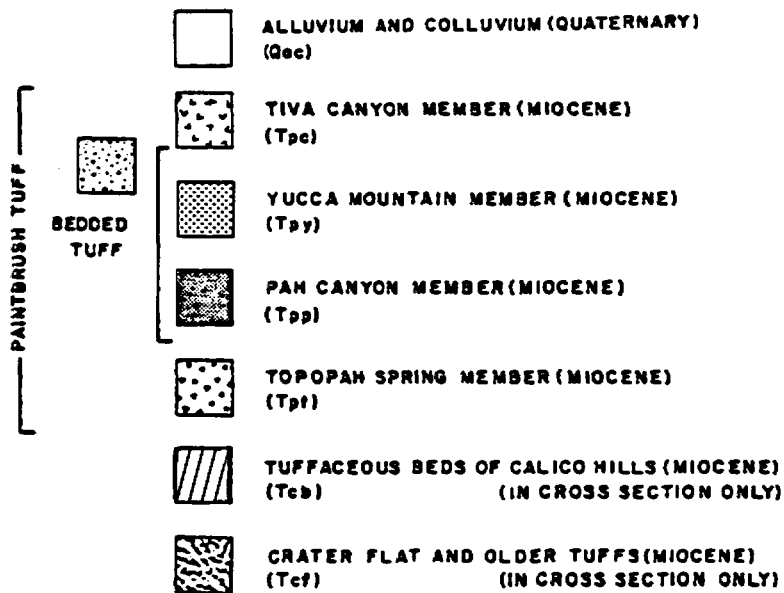

Figure 3. Generalized geologic section at Yucca Mountain from Spengler and others (1979)

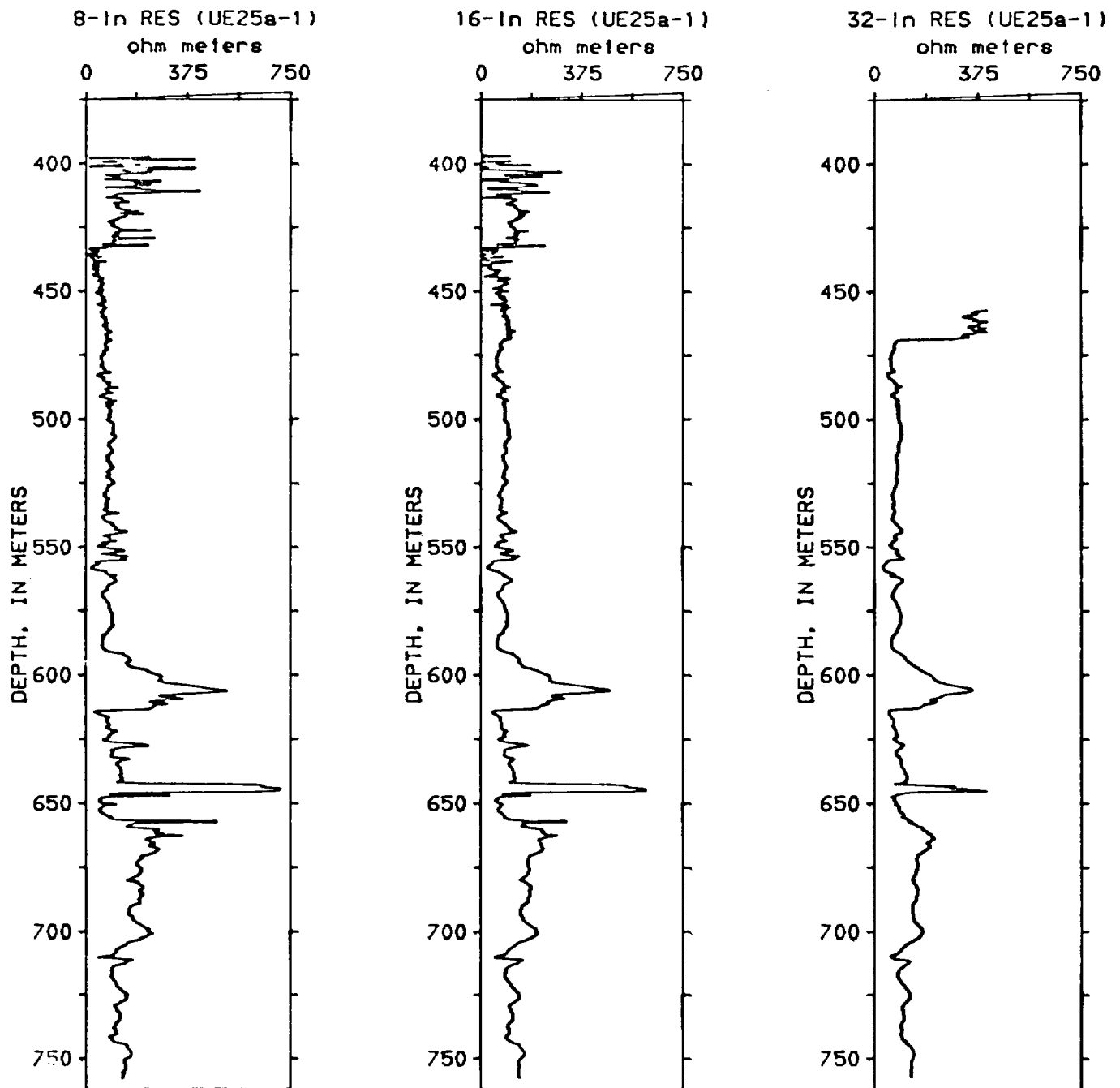

Figure 4. Electric logs from drill hole UE25a-1 at Yucca Mountain from Hagstrum and others (1980)

INTERPRETATION OF RESISTIVITY AND INDUCED POLARIZATION PROFILES WITH
SEVERE TOPOGRAPHIC EFFECTS, YUCCA MOUNTAIN AREA, NEVADA TEST SITE

by

Christian Smith

Howard P. Ross

EARTH SCIENCE LABORATORY
UNIVERSITY OF UTAH RESEARCH INSTITUTE
420 Chipeta Way, Suite 120
Salt Lake City, Utah 84108

October, 1979

Prepared for the
U.S. DEPARTMENT OF THE INTERIOR
GEOLOGICAL SURVEY

Under Purchase Order No. 83868

CONTENTS

	<u>Page</u>
ABSTRACT.....	1
INTRODUCTION.....	2
GEOLOGIC SETTING.....	3
INTERPRETATION.....	3
General.....	5
Lines A, B, and D - 200 foot dipoles.....	9
Lines C, D', and E - 500 foot dipoles.....	11
Lines B'- 1000 foot dipoles.....	14
DISCUSSION.....	15
REFERENCES.....	17
APPENDIX A TOPOGRAPHIC MODELS.....	A-1
APPENDIX B SENSITIVITY TESTS.....	
APPENDIX C NUMERICAL MODEL OUPUT.....	C-1

ILLUSTRATIONS

	<u>Page</u>
FIGURE 1 Index Map.....	6
FIGURE 2 Index Map of the Nevada Test Site.....	7
FIGURE 3 Yucca Mountain generalized geologic section.....	8
FIGURE 4 Electric logs from drill hole UE 25 Al Yucca Mountain.....	9
PLATE A Generalized geological map of part of Yucca Mountain, Nevada Test Site, Nevada.....	In pocket
PLATE I Line location map, Yucca Mountain, Nevada Test site.....	In pocket
PLATE II Interpreted resistivity/IP sections, Lines A, B, and D- 200 foot dipoles.....	In pocket
PLATE III Interpreted resistivity/IP sections, Lines C, D', and E - 500 foot dipoles	
PLATE IV Interpreted resistivity/IP section, Line B' - 1000 foot dipoles.....	In pocket
PLATE V Intrinsic resistivity/PFE distribution, depth interval 200-400 feet - 200 foot dipole lines.....	In pocket
PLATE VI Intrinsic resistivity/PFE distribution, depth interval 600-1000 feet - 500 and 1000 foot dipole lines.....	In pocket
PLATE VII Intrinsic resistivity/PFE distribution, depth interval 1500-2000 feet - 1000 foot dipole lines.....	In pocket
TABLE 1 Correlation of resistivity layers with mapped lithologies- Lines D' and E.....	7
TABLE 2 Inferred correlations between lithologies and electrical properties - 200 foot dipole lines.....	8
TABLE 3 Inferred correlations between lithologies and electrical properties - 500 foot dipole lines.....	9
TABLE 4 Summary of topographic effects.....	A-11
TABLE 5 Summary of interpretative models.....	C-1

ABSTRACT

A detailed numerical modeling and geologic interpretation has been completed for 9.5 line miles of dipole-dipole resistivity/IP data under U.S. Department of the Interior, Geological Survey, Purchase Order No. 83868. The data were recorded at the Yucca Mountain area on the Nevada Test Site, Nye County, Nevada.

A major fracture zone which trends N45°W is interpreted along the eastern flank of Yucca Mountain. This zone is indicated by low resistivities which continue to depth and from line to line. The low resistivities are thought to arise from the alteration of tuffs to clay minerals and zeolites as a result of the downward movement of ground water in the fracture zone.

A large area with uniformly high resistivity and few inferred faults occurs west of the inferred fracture zone, beneath the crest and eastern flank of Yucca Mountain. The area is only partially defined by the western portions of Lines B', C, D', and E. The relatively uniform high resistivities and moderate frequency effects (1.5 to 3.0 PFE) suggest that this is the most favorable location for a possible nuclear waste disposal site within the study area.

INTRODUCTION

The Earth Science Laboratory, University of Utah Research Institute (ESL-UURI) has responded to Purchase Order No. 83868 dated June 19, 1979 to provide an interpretation of resistivity/IP data for the U.S. Geological Survey. The purchase order called for state-of-the-art dipole-dipole resistivity/IP interpretation of several lines of data to be taken at the Yucca Mountain area on the Nevada Test Site (Figure 1 and 2) and additional lines as funds permitted.

An interim interpretation was submitted on August 6 and several tests of alternate models were submitted on September 13, 1979 (letter reports to Don Hoover by Christian Smith and Howard Ross). This report completes the deliverable requirements for the Yucca Mountain interpretations; a short report describing the interpretation of Wahmonie Line W-1 is submitted separately.

More than 9.5 line-miles of detailed dipole-dipole resistivity/IP data from the northeastern flank of Yucca Mountain, Nevada Test Site, have been interpreted through a computer modeling process. The seven dipole-dipole lines cross Yucca Mountain and a steep-sided wash which is its major drainage to the southeast (Plate I). Depending on the location and length of the dipoles (200, 500, or 1000 ft.), these topographic features create moderate to severe distortions in the data.

The centers of all the dipole-dipole lines (designated by 0 on the lines shown on Plate 1) are east of Yucca Mountain in a major wash that trends southeast toward Fortymile Canyon and western Jackass Flats. For simplicity in the following discussions this drainage is referred to as the 'wash'. The wash defines a line of local geographic demarcation: west of the wash, the ridges that project eastward from Yucca Mountain trend roughly east-west; east of the wash, the ridges trend southeast.

GEOLOGIC SETTING

The Yucca Mountain area is located in the extreme southwest corner of the Nevada Test Site. The oldest rocks exposed in the entire Topopah Spring SW quadrangle are Miocene (?) rhyolites and tuffs (Lipman and McKay, 1965). North-south trending basin and range faults give rise to a series of narrow north-trending hills capped by the Tiva Canyon Tuff, a member of the Miocene to Pliocene vitric, rhyolitic, welded to non-welded Paintbrush Tuff. The aggregate thickness of the numerous cooling units of the Paintbrush Tuff may exceed 2000 feet. Alluvium and colluvium generally thicken to the east and probably exceed several hundred feet on the eastern portion of resistivity lines (TR-3, TR-4) completed earlier (Ross and Lunbeck, 1978).

INTERPRETATION

The dipole-dipole resistivity/IP data have been interpreted through an interactive, iterative computer modeling process. A two-dimensional geometry is assumed (infinite strike length perpendicular to the survey line) and intrinsic resistivity/IP values are assigned for each body. The corresponding apparent resistivity/PFE values are computed by a finite-element program initially developed by Luiz Rijo (1977) and subsequently modified by the Earth Science Laboratory (Killpack and Hohmann, 1979). The program uses a fine mesh near the electrodes (i.e., near the surface) where the current density is large and potentials are rapidly changing. The mesh gradually becomes coarser with increased distance from the electrode positions, at depth. The dimensions of the mesh are scaled in units of 'a', the fundamental dipole length, and are indicated in the program output.

The apparent resistivity values are computed for dipole separations $n=1$ to 6, and then manually compared with the observed data to determine the goodness of fit and the model changes needed to achieve a better fit. The

interpretation rarely proceeds to a perfect match of observed and model data because of the time involved, the three-dimensional aspects of the field resistivity distributions, and the ambiguities of position, intrinsic resistivity and polarizability (PFE), and size of body that cannot be uniquely resolved.

The ESL finite-element program computes all the resistivity/PFE data values for a standard dipole-dipole spread of 7 transmitter electrodes. For observed profiles with larger spreads or multiple spreads, it is necessary to generate several overlapping model geometries to simulate the observed data. In the present study only Line E could be simulated by a single model.

After several model iterations (5 to 14 in the present study), the interpreter obtains a satisfactory approximation to the observed data and through a comparison of the last several iterations develops an awareness of the sensitivity of the model to small changes, probable non-two-dimensional aspects of the field data, questionable field data values, and the degree of ambiguity in the model. [Some adjustment of the overlapping model geometries and electrical properties is required to complete the inversion for long profiles.] The overlapping model geometries are adjusted to a single model which gives a satisfactory approximation to the observed data for each standard spread to complete the interpretation of long profiles.

For this study, the apparent resistivity was identified as the primary model property and a match between observed and model PFE values was given secondary importance. PFE distributions which cut across model resistivity boundaries or which disagree with observed data are qualitatively adjusted in an interpreted section for each profile.

After obtaining the simple physical-property model for each line, the models were compared in detail with geologic mapping (Lipman and McKay,

1965). Annotations of significant geologic data were then added to the interpretative section.

A final aspect of the interpretation was the selection of three key depth intervals, 200 to 400 feet, 600-1000 feet, and 1500 to 2000 feet, to present the interpretation in a plan format for use with geologic or topographic maps.

A detailed description of the interpretative results could be awkward and lengthy. Most of the detailed information regarding geometries and electrical properties is adequately presented in map or section form. A straightforward line-by-line description will bring out points of special interest.

Most of the Yucca Mountain observed resistivity data are affected by topography. The effects are most extreme for the diagonals of the pseudosection along a slope or across a change in slope. Fox et al. (1978) describe in detail the distortion of dipole-dipole data due to topography. All profiles which appeared to have a $\pm 10\%$ amplification in resistivity values due to topography have been modeled with a topographic surface. The topographic effect for all models is summarized in Table 1, and all topographic models are documented in Appendix A. Non-two-dimensional topography is not fully accounted for in this study.

General

Plates II, III, and IV contain the interpreted resistivity/IP models and the corresponding observed data for the 200, 500, and 1000 foot dipole lines, respectively. The resistivity values interpreted for most lines increase in a regular stepwise sequence, indicating gradational changes in the resistivity of the tuffs. Values of PFE often increase with increasing resistivity.

Lines D' and E cut geologic cross-section A-A' of Lipman and McKay (1965), and provide an opportunity to correlate the layers seen in the interpreted resistivity sections with mapped lithologies (Table 1). These

correlations are extrapolated to the other lines, Table 2 (200 foot dipole lines) and Table 3 (500 foot dipole lines).

The Tiva Canyon tuff is moderately to highly resistive. Lateral variations in its resistivity may indicate either faults or differential welding. Fractured zones, susceptible to zeolitization, have been inferred from areas of low resistivity within the Tiva Canyon tuff that extend to depth. The tuffs underlying the Tiva Canyon tuff display bimodal resistivity values: high below the ridges, low below the wash. This indicates that zeolitization and/or clay alteration takes place within structurally disturbed zones, i.e., mainly below the wash.

TABLE 1

CORRELATION OF RESISTIVITY LAYERS WITH MAPPED LITHOLOGIES - LINES D' AND E

Cross section A-A' (Lipman and McKay, 1965)		Resistivity section E (Plate III)		
Unit	Thickness (ft.)	Thickness (ft.)	Resistivity (ohm-m)	PFE(%)
Tpc-Tiva Canyon tuff	300	250	450	1.6
Tpy+Tmp	250	350	250	1.1
Tpp+Tpt	600	750±	150	1.2
Tt	---	---	600	1.2
Resistivity section D' (Plate III)				
Tpc-Tmp	450	450	450-1600	0.5-0.7
Tpp-Te	500	---	750	1.0

TABLE 2

INFERRED CORRELATION BETWEEN LITHOLOGIES AND ELECTRICAL PROPERTIES-200 FOOT DIPOLE LINES

Lithologic Unit	Thickness ft.			Resistivity (ohm-m)			PFE (%)		
	A	B	D	A	B	D	A	B	D
<u>Tpc</u>									
West of wash	200	200- 280	---	700- 2100	350- 1600	3200- 4000	0.8- 2.4	0.85- 2.05	1.5- 2.0
In wash	200- 320(?)	200+	200	300- 2100	350- 675	225- 800	1.2- 1.6	0.85- 1.5	0.9- 1.5
East of wash	200	320	400(?)	875- 2100	1200- 2400	1200- 2050	1.1- 1.2	1.3	1.9- 2.2
<u>Tpy-Tpt (upper)</u>									
West of wash	400*	400*	---	500*	550*	---	1.4*	1.5*	---
In wash	200	400	---	100- 210	65- 675	100- 800	0.3- 1.2	0.3- 1.5	0.9- 1.5
East of wash	<200	100- 200	---	700- 875	600- 925	225- 500+	0.8- 1.1	1.0- 1.2	1.4- 1.5
<u>Tpt (lower)+Tt(?)</u>									
West of wash	---	---	---	320- 700	900- 1600	---	0.8- 1.8	1.8- 2.05	---
In wash	---	---	---	100- 500	200- 1200	---	0.6- 1.2	0.6- 1.3	---
East of wash	---	---	---	210- 875(?)	200- 600	---	0.6- 1.1(?)	0.6- 1.0	---

*Excludes section in horst on flank of Yucca Mountain.

TABLE 3

INFERRED CORRELATION BETWEEN LITHOLOGIES AND ELECTRICAL PROPERTIES-500 FOOT DIPOLE LINES

Lithologic Unit	Thickness ft.			Resistivity (ohm-m)			PFE (%)		
	C	D'	E	C	D'	E	C	D'	E
<u>Upper Tpc-Tmp</u>									
West of wash	<500	650	750	175- 500	1000- 4000	150- 250	0.5- 1.2	0.5- 2.0	1.1- 1.2
In wash	<500	750?	650	175- 300	300- 600	450- 1500	0.3- 1.2	0.85- 1.2	1.1- 1.6
East of wash	300	700	---	1000- 2000	300- 1600	250- 1500	1.1- 2.0	0.5- 1.0	1.1- 1.6
<u>Middle Tpp+Tpt</u>									
West of wash	---	600?	750	500- 1300	100- 600	600- 900	1.0- 1.6	0.6- 1.2	0.6- 1.2
In wash	700	---	750?	500- 750	450- 600	250- 900	1.1- 2.0	0.7- 1.0	0.6- 1.2
East of wash	1050?	500?	750?	300- 1000-	200- 750	150- 600	0.5- 2.0	0.7- 1.3	1.2- 1.6
<u>Lower Tt(?)</u>									
West of wash	---	---	---	---	1000?- 4000?	600- 900	---	1.6?- 2.0?	1.1- 1.2
In wash	---	---	---	---		1500	---	---	1.1
East of wash	---	---	---	---	750	600	---	1.0	1.2

Lines A, B, and D - 200 Foot Dipoles

Plates II shows the interpreted sections along the three 200 foot dipole lines, Lines A, B, and D. Each line spans the wash and the adjacent ridges. Lines A and B trend N85°E down the dip slope of the Tiva Canyon tuff, are parallel, and are less than three dipole lengths apart (Plate I). Line D trends approximately N45°E, perpendicular to the local topography but approximately 45° to the structure.

The resistivity distribution along these lines suggest the correlations in Table 2. The sensitivity tests presented in Appendix B analyze the depth of resolution for four numerical models of Lines A and B. These tests indicate that the models are sensitive to resistivity changes at depths of three dipole units, 600 feet.

The salient feature common to all three 200 foot dipole lines is the decrease in the resistivities of the Tiva Canyon tuff in the vicinity of the wash. The abrupt lateral contrasts in resistivities rarely coincide with the tuff-alluvium boundary; the alluvium itself is not the low resistivity body.

The interpreted section for Line A provides an explanation for the lowered resistivity of the tuff in the wash. The numerous vertical and horizontal contrasts between adjacent resistive bodies suggest a broad zone of faulting, fracturing, or brecciation. The wash may have developed along a heterogeneous, structurally deformed zone.

Line A N85°E 200 Foot Dipoles

Lipman and McKay (1965) mapped two faults which are crossed by Lines A and B; both can be inferred from the interpreted sections, (Plate II). The contrasts in resistivity at stations 20W and 22W (700-1600 ohm-m, 200-500 ohm-m) suggest that the western mapped fault cuts Line A in this area. They (Lipman and McKay) also indicate that this fault has a pronounced dip to the

west. The eastern mapped fault is modeled as nearly vertical at station 18E.

A third fault cuts Line A near station 9W. It drops with similar resistivities down to the east. Together with the western mapped fault (between stations 20W and 22W), this fault bounds a horst on the east flank of Yucca Mountain.

The two ash-flow tuffs that underlie the Tiva Canyon tuff, the Yucca Mountain and Topopah Spring tuffs, thin and dip to the east. They combine to form a single electrical unit with bimodal resistivity/PFE values (Table 1). Below the ridges at the east and west ends of Line A the resistivity of the second layer is high (500-700 ohm-m) but within the horst block on the slope of Yucca Mountain and below the wash it is low (100-210 ohm-m).

Sensitivity tests (Appendix B) have shown that the third and deepest interpreted layer is well defined with high (700 ohm-m) resistivity on the west, below Yucca Mountain, and low (210 ohm-m) on the east. The lowered resistivity may be related to the east dip of the strata or to the deep circulation of ground water east towards Jackass Flats.

Line B N85°E 200 Foot Dipoles

Flat-earth models were used to model the nearly constant topographic slope of the western two-thirds of the line (Table 1). Agreement with observed data and between adjacent models is excellent, as shown below station 4E (Plate II and Appendix C).

Large contrasts in resistivity occur near stations 24W and 9W (Plate II). Lipman and McKay (1965) show a fault near station 24W but not near station 9W. The complex distribution and range of resistivities, and the inferred displacements on the faults suggest a structurally disturbed horst block on the east flank of Yucca Mountain.

The resistivity values drop to as low as 65 ohm-m within the inferred horst and below the Tiva Canyon tuff. Sensitivity tests (Appendix B) demonstrate that this low resistivity layer extends to depths of at least 3a (600 feet) and that the Topopah Spring tuff is not highly resistive along this part of Line B. A similar inference can be made about the area below the wash where low (65 ohm-m) resistivities are also observed.

East of the wash, resistivities increase dramatically. The units below the Tiva Canyon tuff thin to the east (Table 2).

Line D N45°E 200 Foot Dipoles

The topography along Line D creates severe distortion of the observed data (Appendix A), making accurate matches with model data difficult to achieve. The interpreted section (Plate II) has less detail than those for the two other 200 foot dipole lines.

Insufficient data were collected to justify detailed modeling of the western ridge crossed by Line D. The interpreted model indicates three possible faults near stations 9W, 9E, and 14E. The faults at stations 9W and 9E are buried by the alluvium of the wash and enclose an area with generally low (100-350 ohm-m) resistivities; this may be the northern extension of the fractured zones inferred along Lines A and B. The abrupt contrast in resistivities at station 14E suggests a normal fault with displacement down to the east.

Lines C, D' and E - 500 Foot Dipoles

Plate III shows the interpreted sections along the three 500 foot dipole lines. All three sections indicate the layering and eastward dip of the tuffs. The thicknesses of the resistivity layers and of the mapped lithologies agree well and suggest the correlations assigned in Table 1 and extrapolated in Table 3.

Several of the mapped faults can be seen in the resistivity sections; additional faults are suggested. At the scale seen with the 500 foot dipoles, only the area below the crest of Yucca Mountain has uniformly high resistivities and few inferred structural complications.

Line C S80°E 500 Foot Dipoles

Line C trends S80°E down the east flank of Yucca Mountain. The western half of Line C was modeled as a uniform slope to account for the average 10° dip to the topography (Table 4). Stations 10W to 30W lie in a narrow canyon (Plate 1) where minor lateral topographic effects are probably present for n=2 to 6 separation. The resistivity model indicates a general layering for much of this part of the line, with 300-500 ohm-m resistivities occurring 300-500 feet deep (Table 3). These in turn are underlain by higher (750-1300 ohm-m) resistivities to more than 1000 feet. Major vertical resistivity contrasts occur at stations 20W, 25W, and 35-38W. Most other lateral contrasts can reasonably be explained by thinning of units or differential welding. Frequency effects are rather uniform at depth, ranging from 1.0-1.6 PFE.

The ridge from station 10E to 35E appears as a highly resistive (2000 ohm-m) unit and must correspond to a densely welded portion of the Tiva Canyon tuff. Much of the line is underlain by 500 ohm-m resistivities with frequency effects varying from 1.1 to 2.0 PFE. Localized zones of lower resistivities occur at stations 17-20E and 30-40E. Major lateral resistivity contrasts which may indicate faulting are mapped at stations 5E, 15E, 17.5E, 20E, and 30E.

An area of low resistivity between station 10W and 10E corresponds to the intersection of two drainages. It seems likely that the drainages are structurally controlled, probably by fractured zones. The downward seepage of ground water may have altered the rocks to zeolites and clays which retain a

higher water content than adjacent unfractured rocks. At depths greater than 500 feet the rocks appear to be resistive (500-1000 ohm-m).

Line D' N45°E 500 Foot Dipoles

The west half of Line D' crosses both Yucca Mountain and a nearly perpendicular spur at approximately 45°. This rough terrain, near the head of a canyon, and the oblique orientation of the line violate the assumption of two-dimensionality inherent in the model. The topographic distortion evident in the west half of the line (Appendix A) may cause the disagreement among the interpreted models for Line D' and Lines C and TR-3 where they intersect (Plate VI).

The east half of Line D' is less affected by topography (Table 4). Near station 40E, Line D' cuts cross section A-A' of the geologic map (Lipman and McKay, 1965). The two layers present in the interpreted model can be related to the thickness of the volcanic strata in the cross section (Table 3).

The Tiva Canyon Tuff is generally resistive (1000-4000 ohm-m) in the ridges and on Yucca Mountain (Table 3). Four low resistivity bodies (200 ohm-m) at the surface may represent fractured zones. The thickness of the second layer is poorly defined, especially below the wash. Faulting inferred from resistivity contrasts appears to have dropped the area of the wash with respect to the ridges on either side.

Line E N45°E 500 Foot Dipoles

Line E cuts the geologic cross section A-A' of Lipman and McKay (1965). The thicknesses of the tuffs inferred from modeling of Line E corresponds well with those shown on the geologic section A-A' (Table 3). A resistive (600-1500 ohm-m) layer that crops out between stations 0 and 18E and east of station 35E may be densely welded portions of the Tiva Canyon tuff. Two areas with low (150-450 ohm-m) surface resistivities, west of station 0 and between

stations 18E and 35E, are probably more fractured, zeolitized, or altered than the resistive area they enclose.

The underlying layer is generally resistive (900 ohm-m), but between stations 20E and 33E it is conductive (150 ohm-m). The low resistivity body at depth (500-1000 feet) lies below a conductive area at the surface.

The deepest interpreted layer is resistive (Table 3). Faults are indicated by modeled resistivity contrasts at stations 0, 10E, 20E, and 35E. A small graben may be present between stations 0 and 10E.

Line B' N85°E 1000 Foot Dipoles

Two overlapping models simulate the topography traversed by Line B'. Topographic amplification is considerable, ranging from 63 to 128 percent along the line. The west half of the line crosses the crest of Yucca Mountain where the tuffs are resistive (800 ohm-m). Rather uniformly resistive rocks (400-800 ohm-m) are present at depths of 1000-2500 feet along the west half of the line. Important vertical resistivity contrasts indicative of faulting are present at stations 8W, 7W, 4.5W, 1W and 0.

A pronounced low resistivity (200 ohm-m) zone from 0 to 1E persists to depths greater than 1500 feet beneath the wash. Vertical discontinuities are modeled at stations 4E and, coincident with a postulated fault, at 6E. A thick alluvial fill is indicated east of 8E.

The line is nearly perpendicular to topography and structure with the exception of the wash between stations 1W and 1E. The fit to polarization data is excellent for the west half of the line where a range of 1.2 to 2.5 PFE is indicated. Higher intrinsic PFE's are indicated at depth between stations 3W and 4E, perhaps as large as 3.0 to 3.5 PFE.

Discussion

The 200 foot dipole lines resolve the lateral and vertical variations in resistivity in the wash and the adjacent ridges for limited depths. The 500 and 1000 foot dipole lines indicate the major structural and lithologic variations to much greater depths. The interpreted sections for all three dipole lengths possess an internal consistency. Faults and fracture zones apparent on the 200 foot dipole lines (Plate II) persist to the much greater depths seen in the 500 foot lines (Plate III) and the 1000 foot line (Plate IV). Zones that have been interpreted to be altered or zeolitized near the surface extend to depths greater than 1500 feet.

The north-northwest trend of the fractured zone inferred from the 200 foot dipole lines stands out in Plate V. This zone contains several anomalous low resistivity bodies that probably indicate areas where zeolitization or clay alteration have occurred within the Tiva Canyon tuff. This fractured zone may continue to the southeast down the wash, but it may also connect with the mapped faults shown in Plate V. On the east flank of Yucca Mountain the horst block crossed by Lines A and B may be a spur of the main fracture zone.

Plate VI presents the correlations in the interpreted resistivity sections for the 500 and 1000 foot dipole lines, including those analyzed by Ross and Lunbeck (1978), at the 600-1000 foot depth interval. With the exception of Line TR-3, all the lines are approximately perpendicular to the regional structural trend. Line TR-3 follows the wash, an inferred structural complexity and lower apparent resistivity.

The general north-northwest trend of structures in the Yucca Mountain area can clearly be seen in Plates VI and VII. The low resistivity zones that cut both Lines D' and E converge along Line TR-3 and may join the low resistivity zone seen along the wash. The low resistivity persists to depths

reater than 1500 feet (Plate IV), which argues against the wash as a site for nuclear waste disposal.

A large area with uniformly high resistivity and few inferred faults occurs along the western ends of the four northern dipole lines (Plates VI and VII). The 600-1000 ohm-m tuffs may be densely welded directly under the crest of Yucca Mountain; high resistivities at depth occur east of the crest. These relatively uniform high resistivities and the absence of inferred faults appear to offer the most favorable location for a possible nuclear waste disposal site within the study area.

References

- Blankennagel, R. K., and Weir, J. E., Jr., 1973, Geohydrology of the eastern part of Pahute Mesa, Nevada Test Site, Nye County, Nevada: U.S. Geol. Survey Prof. Paper 712-B, 35 p.
- Christiansen, R. L. and Lipman, P. W., 1965, Geologic map of the Topopah Spring NW quadrangle Nye County, Nevada: U.S. Geol. Survey Geol. Quad Map GQ-44.
- Ekren, E. B., 1968, Development of geologic knowledge at Nevada Test Site in Eckel, E. B., ed. Nevada Test Site: Geol. Soc. America Memo. 110, p. 5-19.
- Hagstrum, J. T., Daniels, J. J., and Scott, J. H., 1980, Interpretation of geophysical well-log measurements in drill hole UE25a-1, Nevada Test Site: U.S. Geol. Survey Open-file rept. 80-941.
- Hoover, D. L., 1968, Genesis of zeolites, Nevada Test Site, in Eckel, E. B., ed., Nevada Test Site: Geol. Soc. America Mem. 110, p. 275-284.
- Killpack, T. J., and Hohmann, G. W., 1979, Interactive dipole-dipole resistivity and IP modeling of arbitrary two-dimensional structures (IP2S users guide and documentation): ESL/UURI rept. 15.
- Lipman, P. W., and McKay, E. J., 1965, Geologic map of the Topopah Spring SW quadrangle, Nye County, Nevada: U.S. Geol. Survey Geol. Quad. Map GQ-439.
- Rijo, Luiz, 1977, Modeling of electric and electromagnetic data: unpub. Ph.D. thesis Dept. of Geol. and Geophy., Univ. Utah.
- Ross, H. P., and Lunbeck, J., 1978, Interpretation of resistivity and induced polarization profiles, Calico Hills and Yucca Mountain areas, Nevada Test Site: ESL/UURI rept. 8, 17 p.

Spengler R. W., Muller, D. C., and Livermore R. B., 1979, Preliminary report on the geology and geophysics of drill hole UE 25a-1 Yucca Mtn, Nevada Test Site: U.S. Geol. Survey Open-file rept. 79-1244.

Winograd, I. J., and Thordarson, W., 1975, Hydrogeologic and hydrochemical framework, South-central Great Basin, Nevada-California, with special reference to the Nevada Test Site: U.S. Survey Prof. Paper 712-C, 126 p.

APPENDIX A

TOPOGRAPHIC MODELS

Appendix A documents the models used to simulate the effects of topography and the computed effects for a homogeneous earth with an 100 ohm-m intrinsic resistivity. It is a copy of the figures from the deliverable dated August 6, 1979. Table 4 summarizes the topographic effects.

TABLE 4

SUMMARY OF TOPOGRAPHIC EFFECTS

MODEL	RANGE OF TOPOGRAPHIC EFFECT (%)	COMMENTS	APPENDIX PAGE
A West	56-152	simple	A-1
A Center	small	simple	A-2
A East	45-192	tractable	A-3
B West	small	uniform slope	
B Center	small	uniform slope	
B East	65-121	tractable	A-4
B' West	63-128	tractable	A-5
B' East	74-118	tractable	A-6
C West	small	uniform slope	
C East	59-141	tractable	A-7
D West	47-153	simple	A-8
D East	30-244	tractable	A-9
D' West	40-210	3 D area	A-10
D' East	31-192	tractable	A-11
E Center	39-206	complex	A-12

Note: The numerical model output for all lines is annotated to indicate correspondence of model geometry with observed data position. Layer thicknesses for the model are indicated in units of a , the dipole length. Intrinsic resistivities for the model bodies are read from left to right, corresponding to body 1, 2, 3, etc.

PROJECT NAME:
 NTS LINE A W/3
 MODEL NAME:
 TOPOGRAPHY

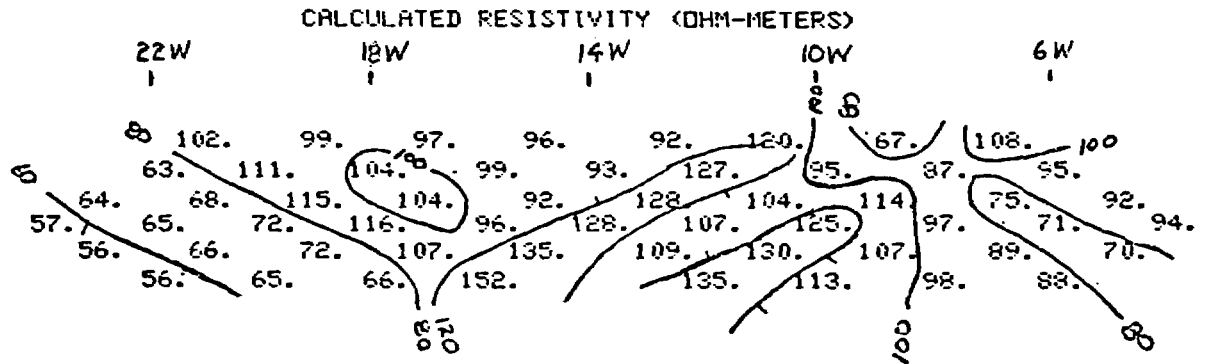
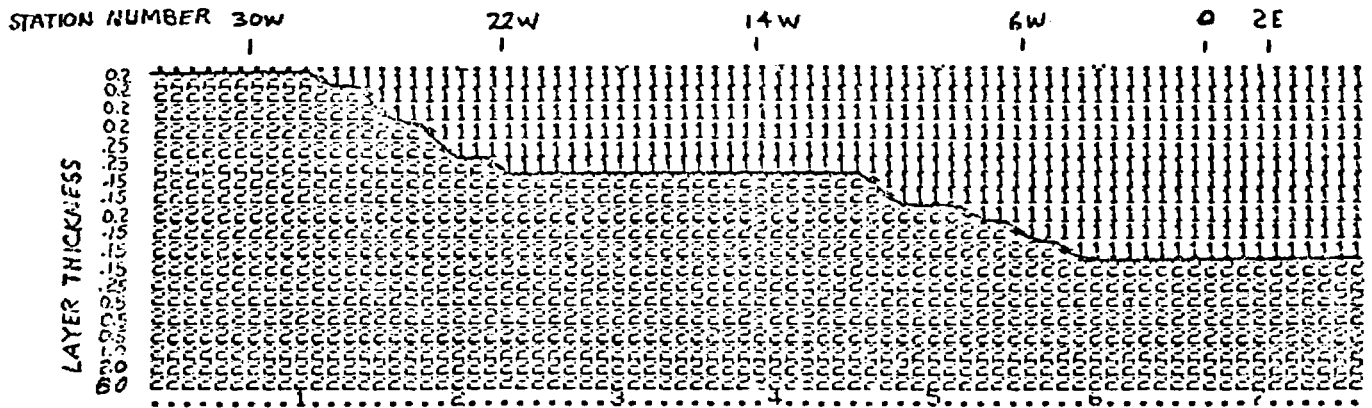

MEDIA RESISTIVITY (OHM-METERS)
 50000.00 100.00
 MEDIA PFE (%)
 .00 .00

Topographic amplification in percent for Yucca Mountain
 JP line A western third, 200 ft. dipoles
 Fig A-1

PROJECT NAME:
 NTS LINE A CENTER
 MODEL NAME:
 TOPOGRAPHY

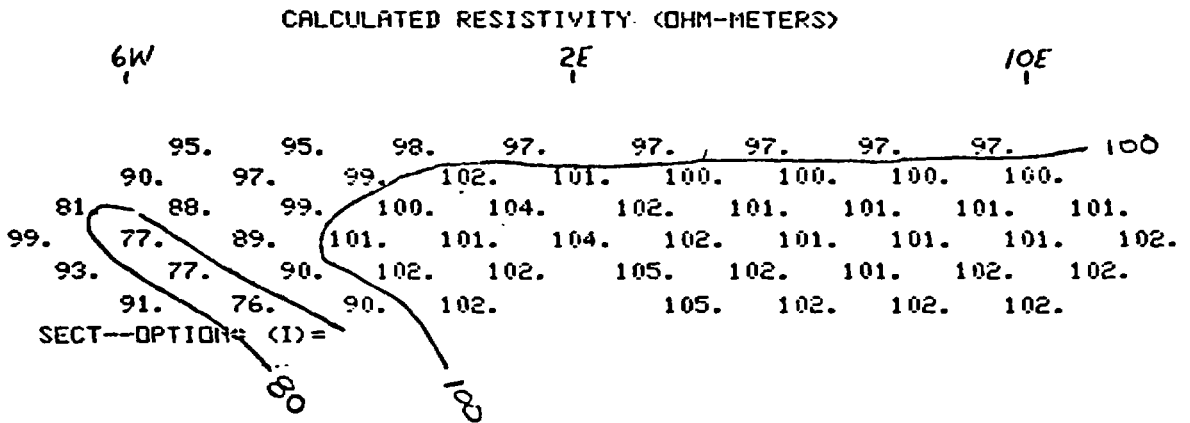
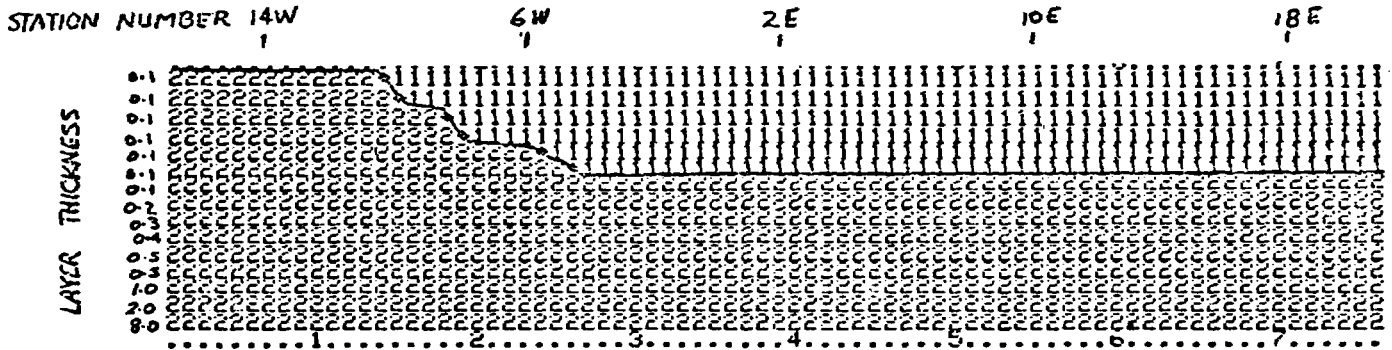

Topographic amplification in percent for Yucca Mountain
 IP line A center third, 200 ft. dipoles
 Fig A-2

PROJECT NAME:
 SITS: LINE A E/3
 MODEL NAME:
 TOPOGRAPHY

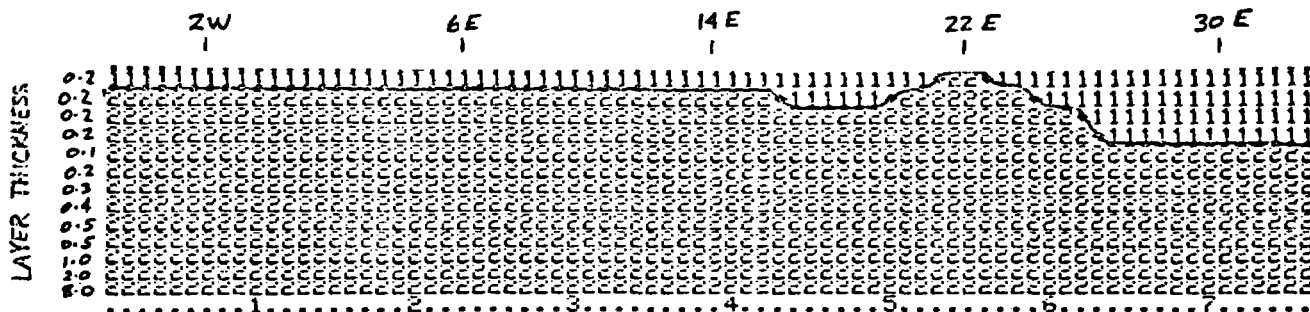

MEDIA RESISTIVITY (OHM-METERS)
 50000.00 100.00
 MEDIA PFE (%)
 .00 .00

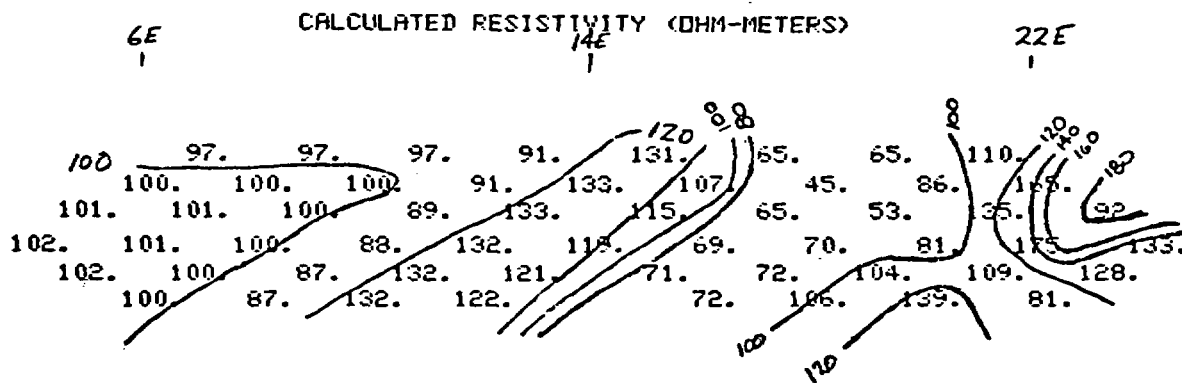

Topographic amplification in percent for Yucca Mountain
 line A eastern third 200 ft. dipoles
 Fig A-3

PROJECT NAME: B
 MODEL NAME: F
 E3 TOPOGRAPHY

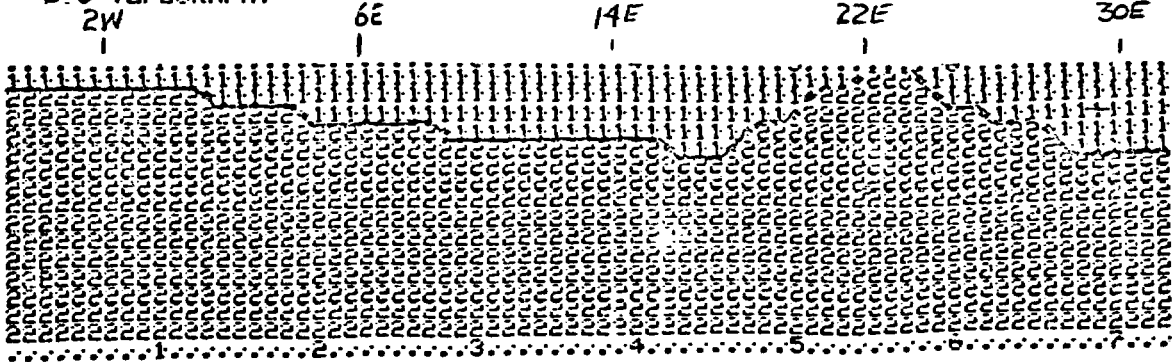

MEDIA RESISTIVITY (OHM-METERS)
 500000.00 100.00
 MEDIA AGE (KY)
 .00 .00

PROJECT NAME: B
 MODEL NAME: F
 E3 TOPOGRAPHY

APPARENT RESISTIVITY (CALCULATED)

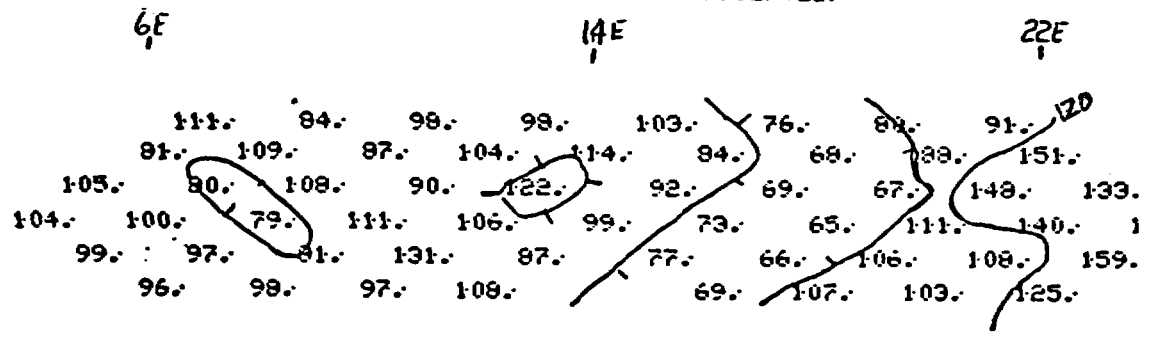

Topographic amplification in percent for Yucca Mountain
 line B eastern third 200 ft. dipoles
 Fig A-4

depths
a = 1000'
0.1a = 100'

PROJECT NAME:
NTS LINE B' E/2

MODEL NAME:
TOPO A = 1000'

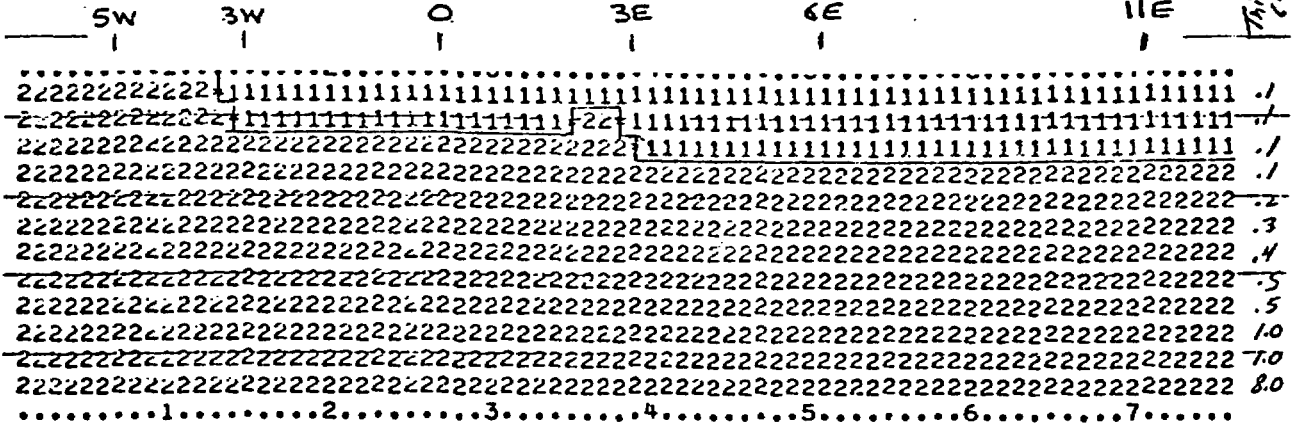

MEDIA RESISTIVITY (OHM-METERS)		Body	$\frac{\rho}{10000}$
AIR → 10000.00	100.00	Air 1	10000
MEDIA PFL (%)		ground 2	100
.00	.00		

APPARENT RESISTIVITY (CALCULATED)

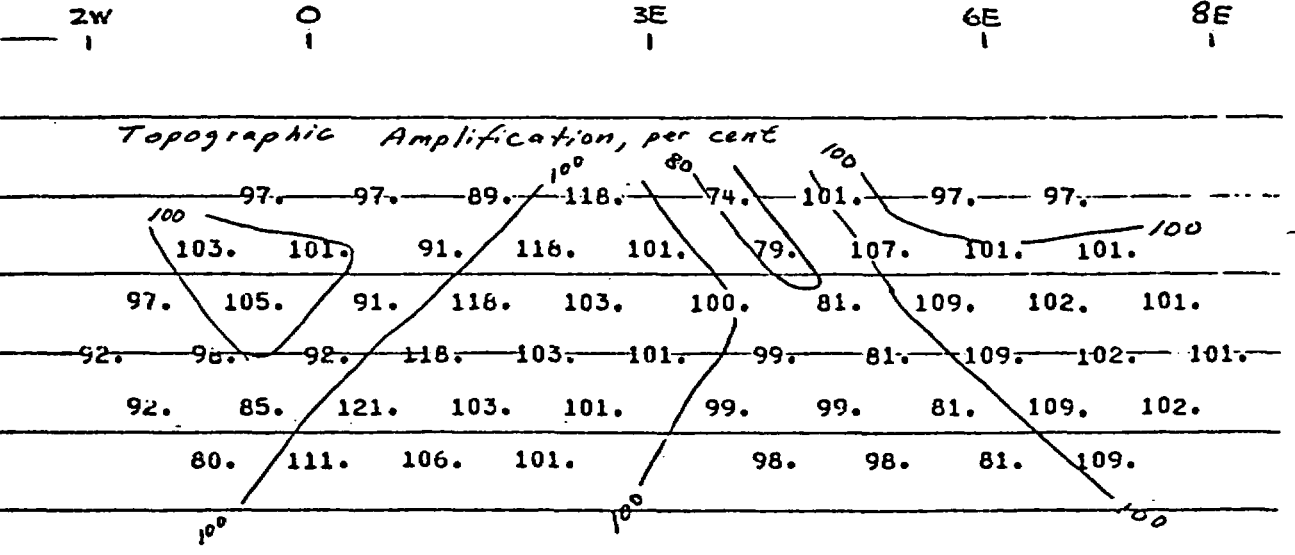

Topographic amplification in percent for Yucca Mountain line B eastern half 1000 ft. dipoles Fig A-5

PROJECT NAME:
 NTS LINE B' W/2
 MODEL NAME:
 TOPO MAP = 1000'

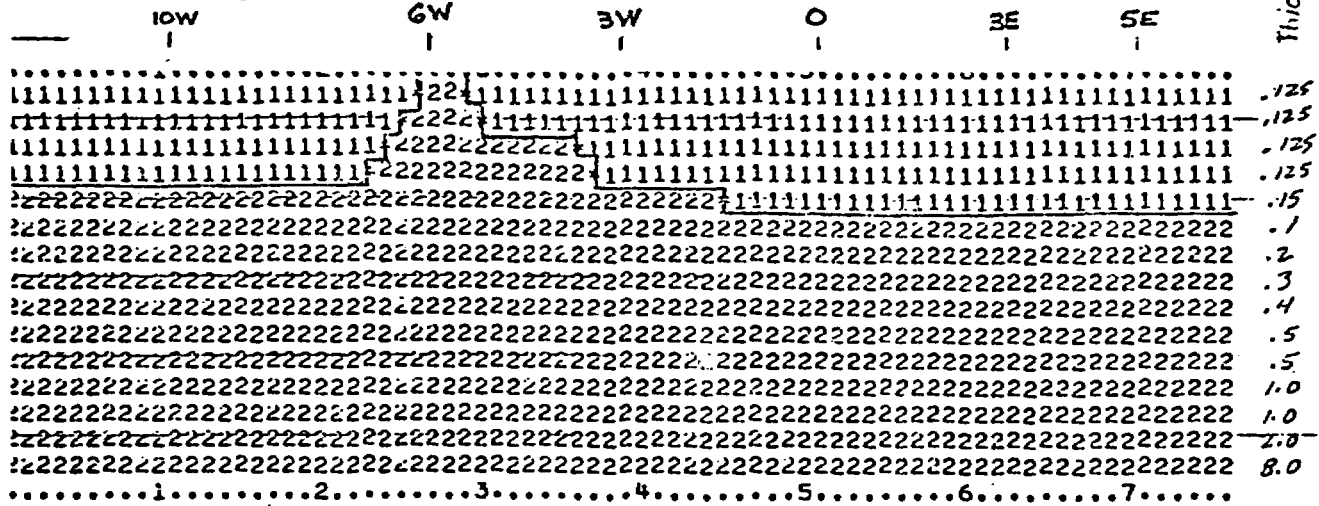

MEDIA RESISTIVITY (OHM-METERS)
 AIR → 10000.00 100.00
 MEDIA FFL (%)
 .00 .00

	Body	ρ
air	1	10000
ground	2	100

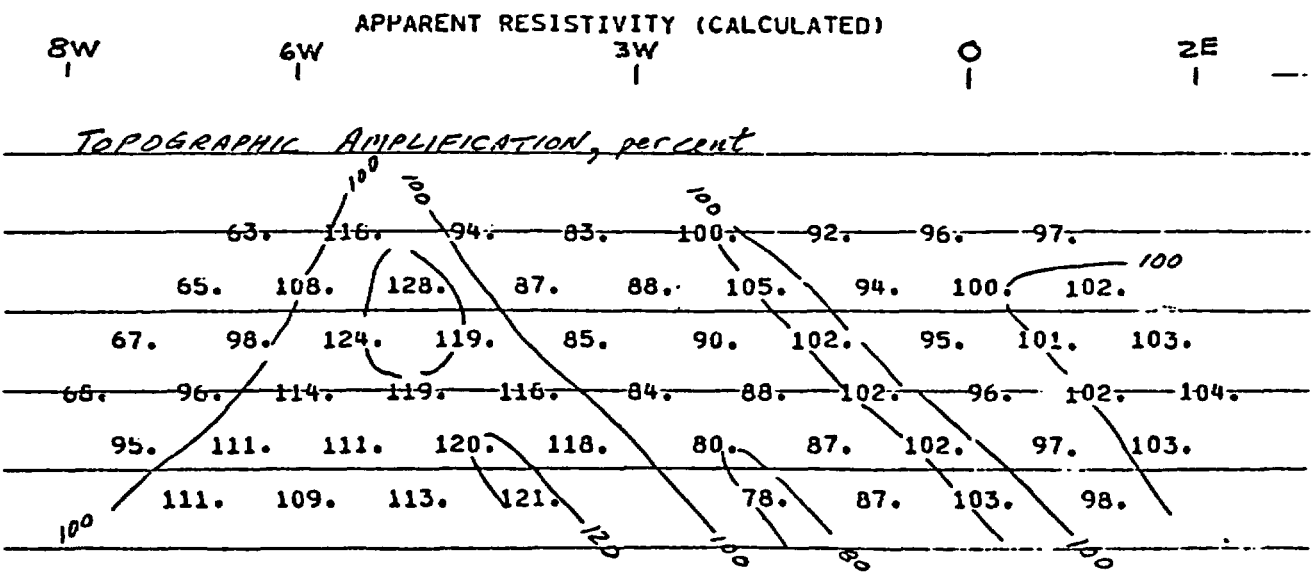

Topographic amplification in percent for Yucca Mountain
 line B western half 1000 ft. dipoles
 Fig A-6

PROJECT NAME:
 NTS LINE C E/2
 MODEL NAME:
 TOPOGRAPHY

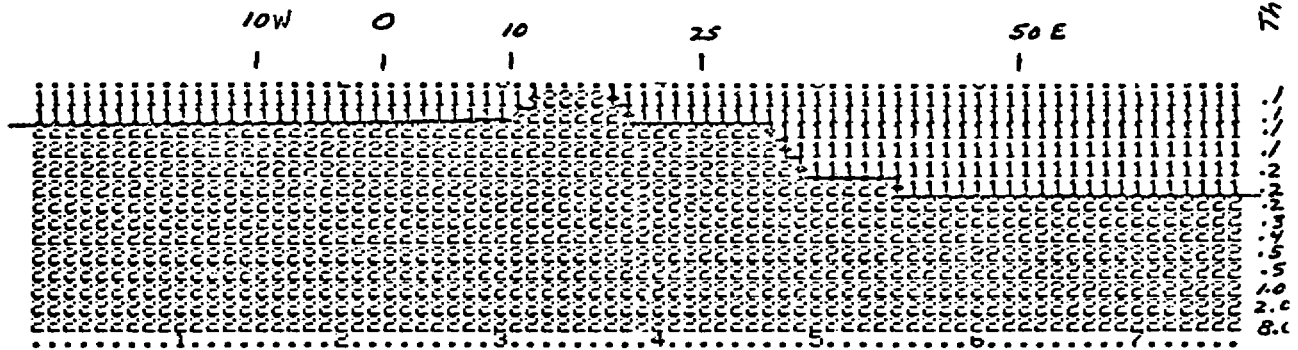

MEDIA RESISTIVITY (OHM-METERS)
 AIR → 50000.00 100.00
 MEDIA PFE (%) .00 .00

Body	P
AIR 1	50000
2	100

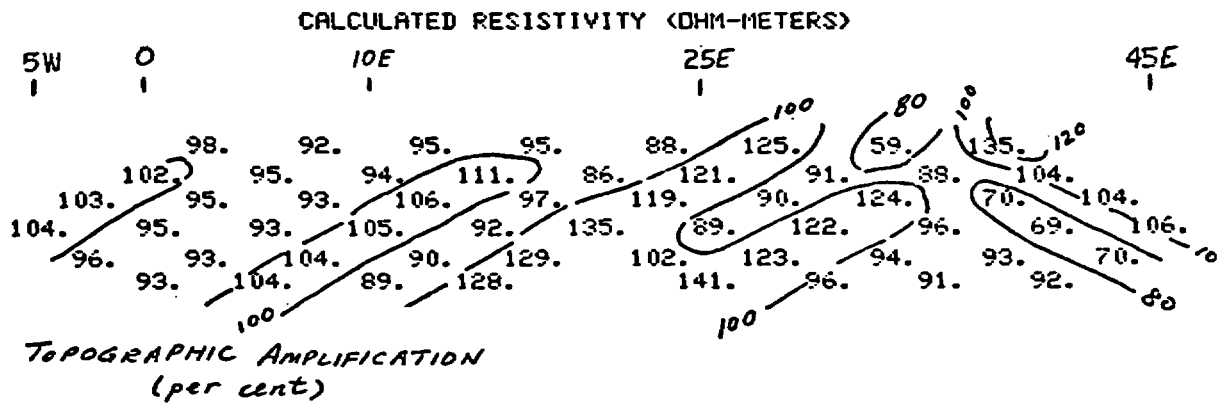

Topographic amplification in percent for Yucca Mountain
 line C eastern half 500 ft. dipoles
 Fig A-7

PROJECT NAME:
 NTS LINE D W/2
 MODEL NAME:
 SIMPLIFIED_TOPOGRAPHY

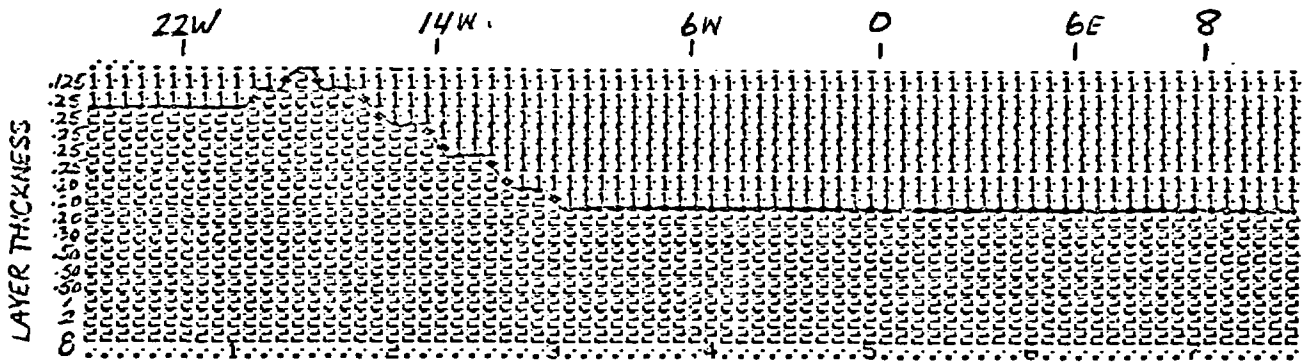

MEDIA RESISTIVITY (OHM-METERS)
 50000.00 100.00
 MEDIA PFE (%)
 .00 .00

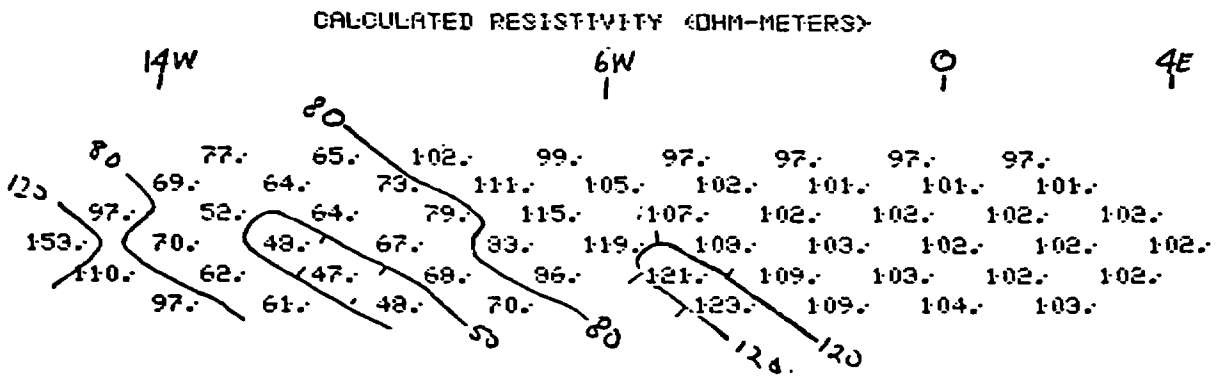

Topographic amplification in percent for Yucca Mountain
 line D western half 200 ft. dipoles
 Fig A-8

P NAME: LINE D E/2
 MODEL: SPT, HADP
 SIMPLIFIED TOPOGRAPHY
 LIST-OPTION# (I)=

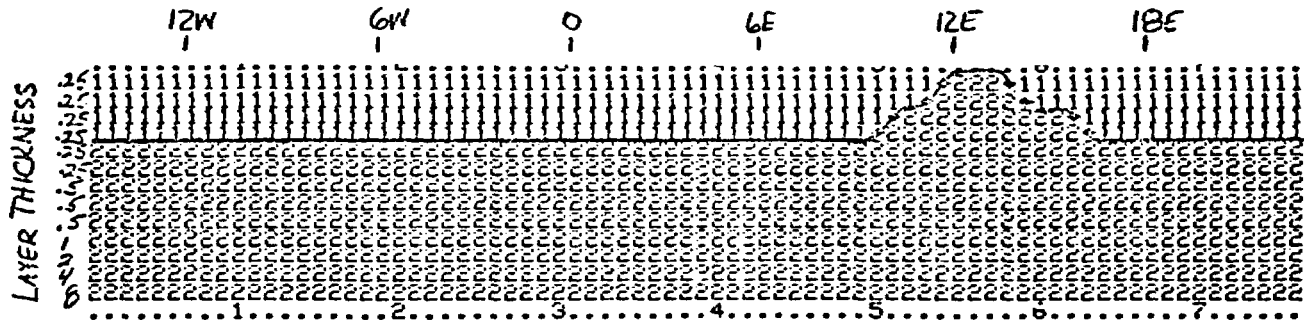

MEDIA RESISTIVITY (OHM-METERS)
 100.00
 MEDIA PFE (%)
 .00

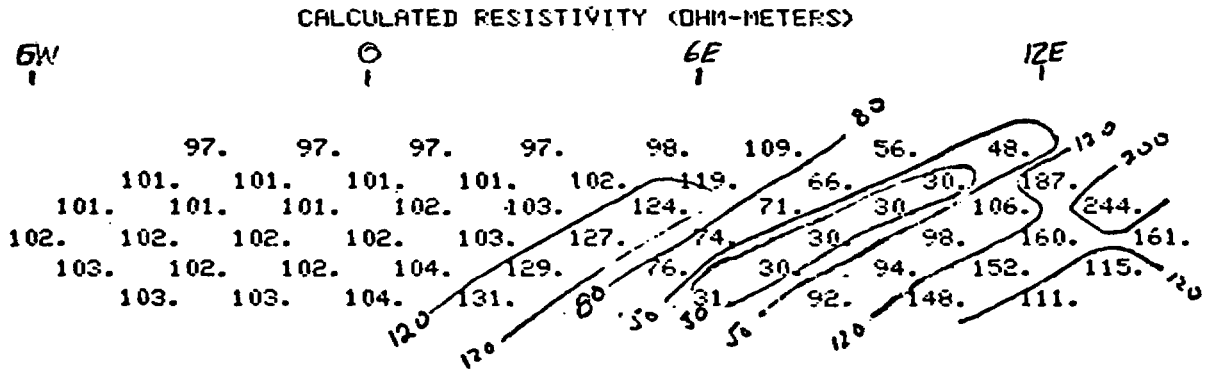

Topographic amplification in percent for Yucca Mountain
 line D eastern half 200 ft. dipoles
 Fig A-9

PROJECT NAME:
 MTS LINE D' W/2
 MODEL NAME:
 TOPOGRAPHY

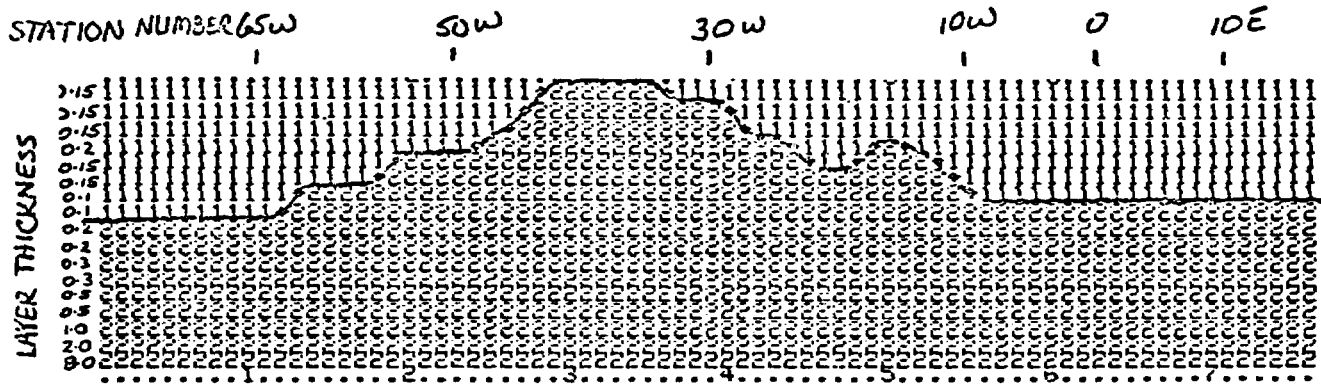

MEDIA RESISTIVITY (OHM-METERS)
 50000.00 100.00
 MEDIA PFE (%)
 .00 .00

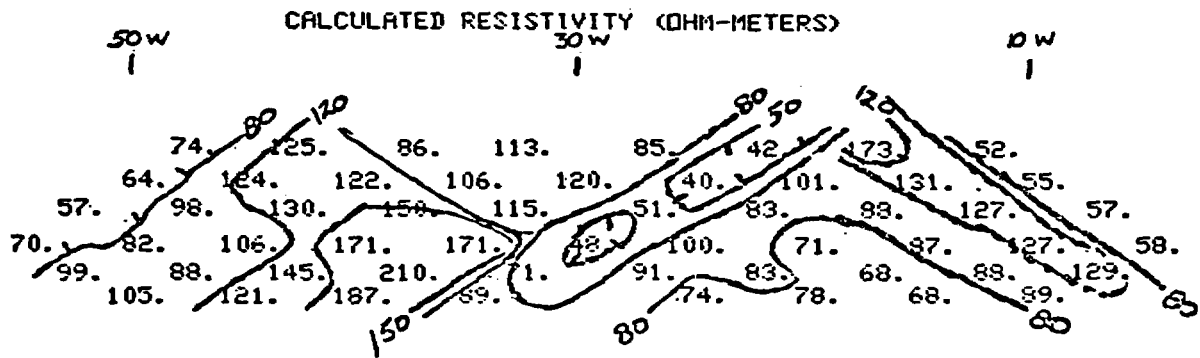

Topographic amplification in percent for Yucca Mountain
 line D western half 500 ft. dipoles
 Fig A-10

PROJECT NAME:
 HTS LINE D' E/2
 MODEL NAME:
 TOPOGRAPHY

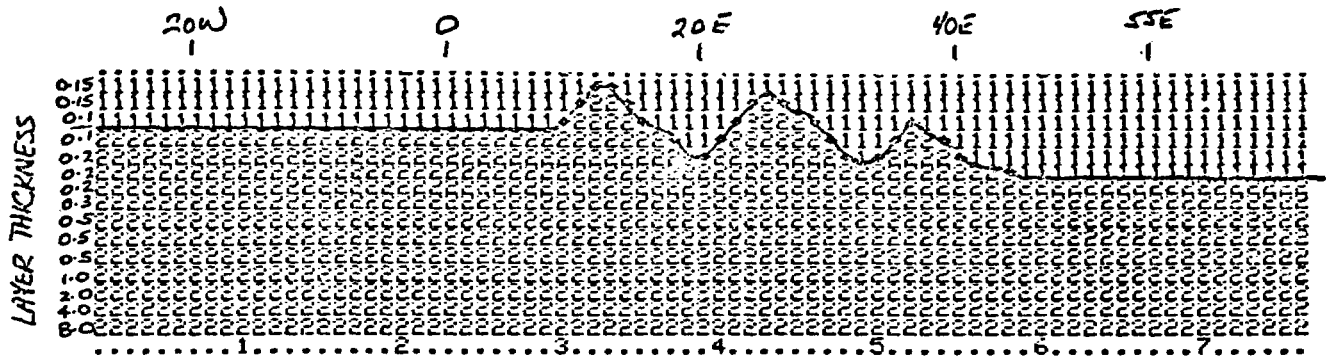

MEDIA RESISTIVITY (OHM-METERS)
 500000.00 100.00
 MEDIA PFE (%)
 .00 .00

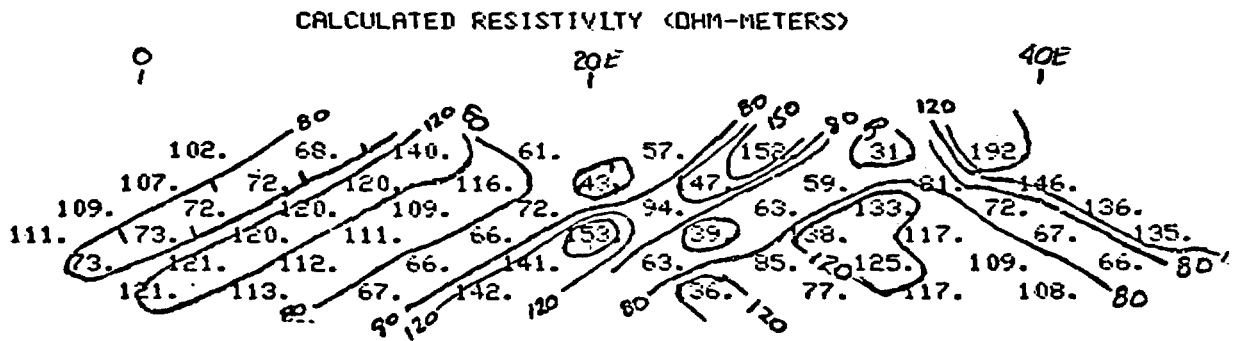

Topographic amplification in percent for Yucca Mountain
 line D eastern half 500 ft. dipoles
 Fig A-11

PROJECT NAME:
 NTS LINE E
 MODEL NAME:
 SIMPLIFIED TOPOGRAPHY

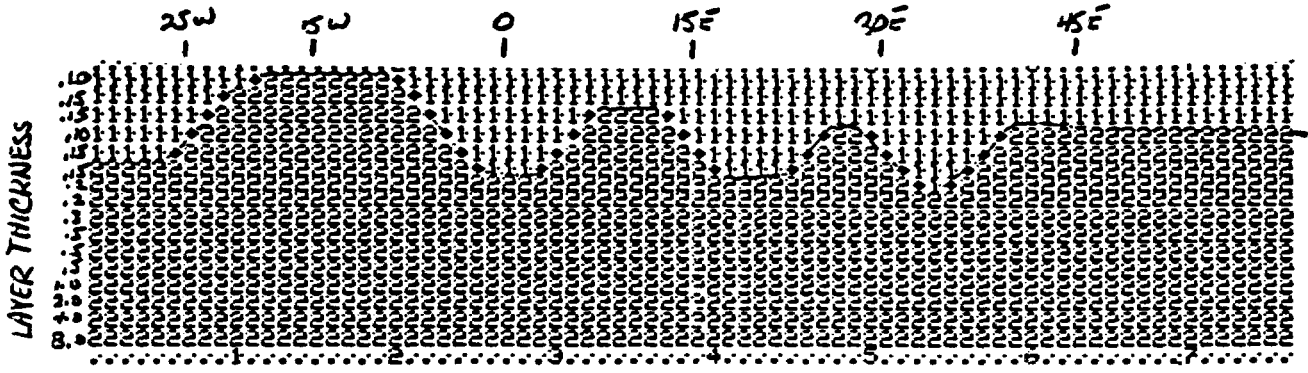

MEDIA RESISTIVITY (OHM-METERS)
 MEDIA RESISTIVITY (%)
 .00 100.00
 .00 .00

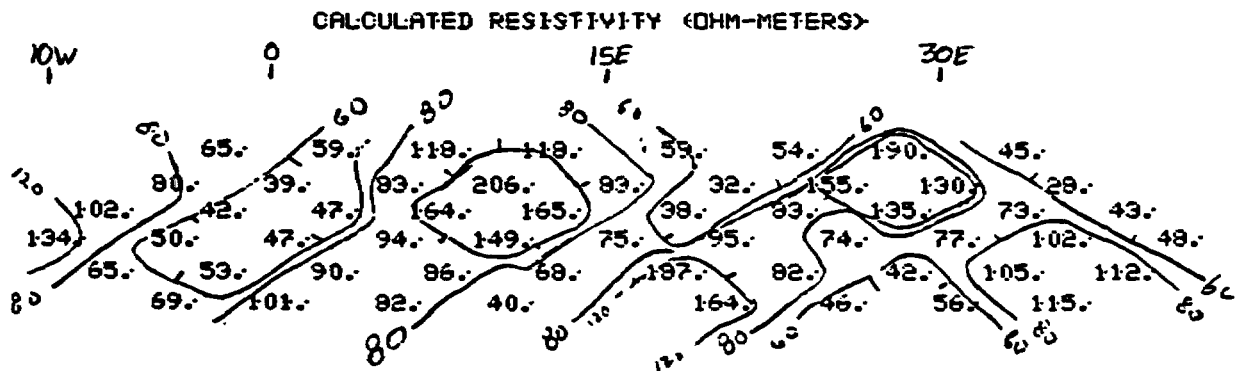

Topographic amplification in percent for Yucca Mountain
 line E 500 ft. dipoles
 Fig A-12

APPENDIX B

SENSITIVITY TESTS

Appendix B is a copy of the deliverable dated September 13, 1979 that documents the results of sensitivity tests performed on models for Lines A, B, and B'. Photocopier reduction has changed the scales of the figures so that they may be bound into the report.

Interpretation

The tests on Line B address the task of determining whether the Topopah Spring Member of the Paintbrush Tuff is resistive (500-1600 ohm-m) at a depth of 250 ft. (1.25a). Tests on Line A assess the response of our algorithm to changes in resistivities at depths greater than 2a (400 ft).

The tests on line B' examine the possibility that the resistive (2000 ohm-m) vitrophyre which crops out on the west side of Yucca Mountain dips east about 10°. A generally poor fit to most of the observed data argues against this, unless the resistivity of the unit decreases to 800-500 ohm-m.

The Topopah Spring tuff is not always resistive (\geq 500 ohm-m). On several places along Lines A and B the preferred models indicate that it has resistivities less than 300 ohm-m, occasionally as low as 65 ohm-m.

Our tests include cases where the algorithm is sensitive to changes in resistivities at depths greater than 3a.

Line A west/3 N85°E 200 foot dipoles

Preferred Model, #8 figure B-1: While several diagonals are well matched to n=6, some of the computed values are only 50% of the observed values at n=5,6. Because some of the model was improved by the higher values used in the first sensitivity test, a second test was conducted in an attempt to create a better match.

Sensitivity Test 1 figure B-2: At 1.15a (230 ft. depth), a 500 ohm-m body replaced the 300 ohm-m body of the preferred model east of station 6W. In this area, a slight improvement in the match between observed and computed resistivities occurred as shallow as n=3. This improvement suggests that an even higher resistivity at a greater depth may further enhance the match (see below). Replacing a 100 ohm-m body with a 500 ohm-m body at 2.2a (440 ft.) east of station 14W ruined the good match obtained in the

preferred model. West of station 14W, a slight improvement at n=3-6 resulted from substituting a 700 ohm-m body for a 200 ohm-m body at 2.2a (440 ft.). These changes indicate that the model is sensitive to resistivity values at depths greater than 2.2a.

Sensitivity Test 2 figure B3: A 1050 ohm-m body was inserted below a depth of 2.7a (540 ft.). Matches in the areas that showed some improvement in Test 1 were somewhat improved by Test 2. The areas where Test 1 ruined the match are again spoiled by the high resistivity at depth.

Results: The two sensitivity tests show that low resistivity (100-200 ohm-m) must extend to depths below 2.7a (540 ft.) in an area between stations 12 and 8W. Changing the resistivity at depths below 2.7a (540 ft.) from 500 to 1050 ohm-m has only a minor effect. The algorithm is much more sensitive to a five-fold increase in resistivity than it is to a two-fold increase at depths below 2.7a.

Line A East/3 N85°E 200 dipoles

Preferred Model, #7 figure B4: Agreement between observed and computed values are good at all n-spacings. Some diagonals are consistently high and others low, but computed values rarely differ by 20% from observed. Lack of agreement at n=6 is governed by the trends of the diagonals. The observed value of 198 ohm-m at n=6 below station 8E is the lowest along this part of Line A, is matched by the preferred model, and demands low resistivities at depth.

Sensitivity Test 1 figure B-5: The low resistivity bodies (100, 210 ohm-m) at depths greater than 2.1a were changed to 700 ohm-m. The 875 ohm-m body was allowed to remain. No significant changes occurred in the computed values at n=1&2. At n=3 some changes are evident, while at n=4-6 the computed values no longer match the observed values satisfactorily. The

198 ohm-m value at n=6 is not matched. This test demonstrates that the model is sensitive to resistivities below a depth equal to 2.1a (420 ft.). The strata at that depth are not uniformly resistive.

Sensitivity Test 2 figure B6: In this test, the low resistivity bodies (100, 210 ohm-m) were changed to 700 ohm-m at depths greater than 3.6a (720 ft.). Significant departures from the preferred model occur at n=5&6, but n=4 is unaffected. The algorithm is clearly sensitive to resistivity contrasts at 3.6a (720 ft.). The resistivity of the body at the surface west of station 22E was increased from 1400 ohm-m to 1600 ohm-m for this test. The match along the diagonal improved.

Results: The model in Line A East/3 is sensitive to changes in resistivity below 3.6a (720 ft.) This implies that the Topopah Spring Member of the Paintbrush Tuff has a low resistivity along the east half of Line A, except between stations 12E and 16E.

Line B west/3 N85°E200 foot dipoles

Preferred Model figure B-7: The preferred model produces a satisfactory match of computed to observed resistivities at all n spacings. The match is quite good at N=1-4. Some diagonals are generally low (70%) others are high (130%). The Topopah Spring Member of the Paintbrush Tuff is predicted to lie at a depth of 250 ft. (1.25a). This depth is marked by highly contrasting resistivities (100-1200 ohm-m). Resistive bodies (900-1600 ohm-m) appear at depths greater than 3a (600 ft.).

Sensitivity Test 1 figure B8: The assigned task is to determine whether the Topopah Springs Member can be modeled by a resistive layer at a depth of 250 ft. (1.25a). This test replaced all resistivities less than 550 ohm-m below depths greater than 1.5a (300 ft.) with high resistivities interpreted to be at greater depths.

Results: It is not possible to simulate the Topopah Springs tuff with a series of high resistivity bodies at depths greater than 1.5a (300 ft.). Severe distortion of the good match obtained in the preferred model occurs as shallow as n=2. The worst matches in the preferred model are supremely better than most of those in the sensitivity test. It must be inferred that the Topopah Springs tuff has a heterogeneous electrical response.

Line B East/3 N85°E 200 foot dipoles

Preferred Model figure B9: The match between the computed and the observed resistivities is satisfactory and shows that the volcanic strata can be successfully modeled with two layers of resistivity. Highly resistive and resistive (600-2400 ohm-m) strata overlie conductive (200-300 ohm-m) at depths between 1a and 1.5a (200-300 ft.). This pattern has a gentle eastward dip but is interrupted between stations 14E and 18E. The Topopah Springs tuff appears to be generally conductive along the east third of Line B.

Sensitivity Test 1 figure B10: A uniform 600 ohm-m layer replaces 200 and 300 ohm-m bodies at depths below 1.5 to 2.0a (300-400 ft.). Bodies with greater resistivities in the preferred model were allowed to remain.

Results: The Topopah Spring tuff is not a uniformly resistive slab at 250 ft. depth. The values computed for the sensitivity test deviate from the observed values at spacings as shallow as n=2. The only area where the computed values remain true to the observed at spacings as deep as n=4 is between stations 14E and 18E, where the preferred model shows resistive bodies (800-925 ohm-m) between 1.0a and 2.0a (200-400 ft.).

Line B' N85°B 1000 foot dipoles

B' W/2: The preferred model figure B11 shows a good overall fit to both resistivity and PFE for the west half of Line B'. This successful model shows a very resistive body (2000 ohm-m) cropping out just west of the ridge on Yucca Mountain and a fairly uniform (400-800 ohm-m), layered resistivity structure continuing to the east. The modeled resistivity contrasts between 800 and 550 ohm-m need not indicate a major structure, but perhaps a gradual change in volcanic units. Resistivity changes between 400, 800 and 2000 ohm-m are very significant and should be interpreted as high-angle structural discontinuities.

Sensitivity Test #1 fig B12: This alternate model tests the continuity of the very resistive (vitrophyre) layer and models it as a layer of 2000 ohm-m 0.75a (750 feet) to 1.5a (1500 feet) thick, dipping east at approximately 10°. The depth to this substituted layer varies from 0.1a to 2.0a, increasing to the east. This model results in a better fit to 12 data points and a poorer fit to 39 points, with two fits about the same. The improved area includes the extreme western diagonals, 7-8, 8-9, 9-10. The fit to the rest of the line is much poorer. Computed resistivity changes of 40% occur on the first separation, and up to 80% on n=5.

B'E/2: The dipping resistive body used as an alternate model for a sensitivity test of B' W/2, was extended beneath the east half of the line. The depth of the resistive layer varies here from 0.6a to 2.0a (2000 feet) near station 4E. One vertical conductive zone is apparent between stations 0 and 1E.

Sensitivity Test 1 fig 13, 14: Resistive units previously modeled as 400, 500, 600 and 800 ohm-m were replaced with 2000 ohm-m for a thickness which varies from 700 to 2000+ feet on the east (due to an input error between

stations 2W and 1E). Computed resistivity changes by 0-2% on n=1, up to 23% on n=2, and up to 87% on n=6. The fit is improved for 14 data points and is poorer for 27 values, with 6 remaining essentially unchanged.

Preferred Model
 Line A west 13
 Iter # 8 A/mch = 2.00

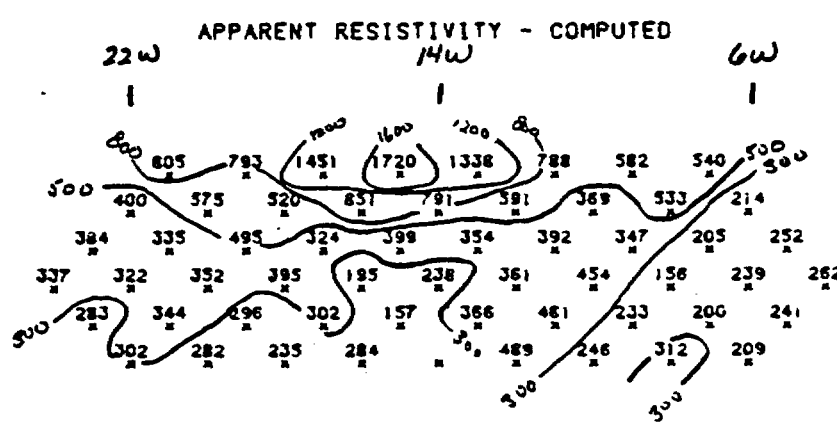
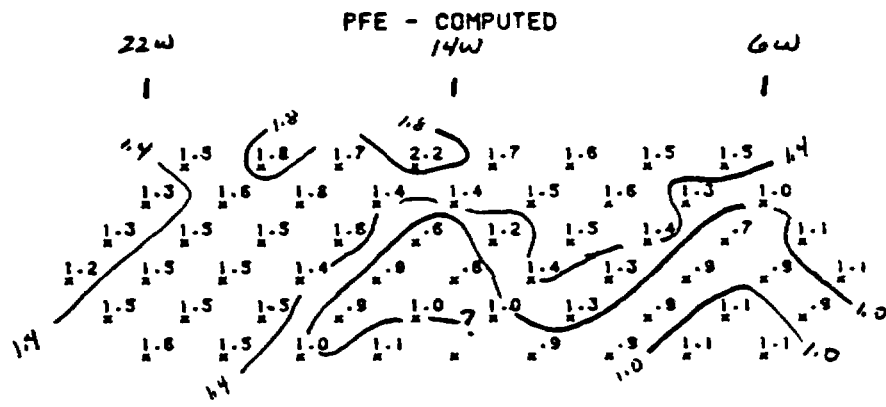
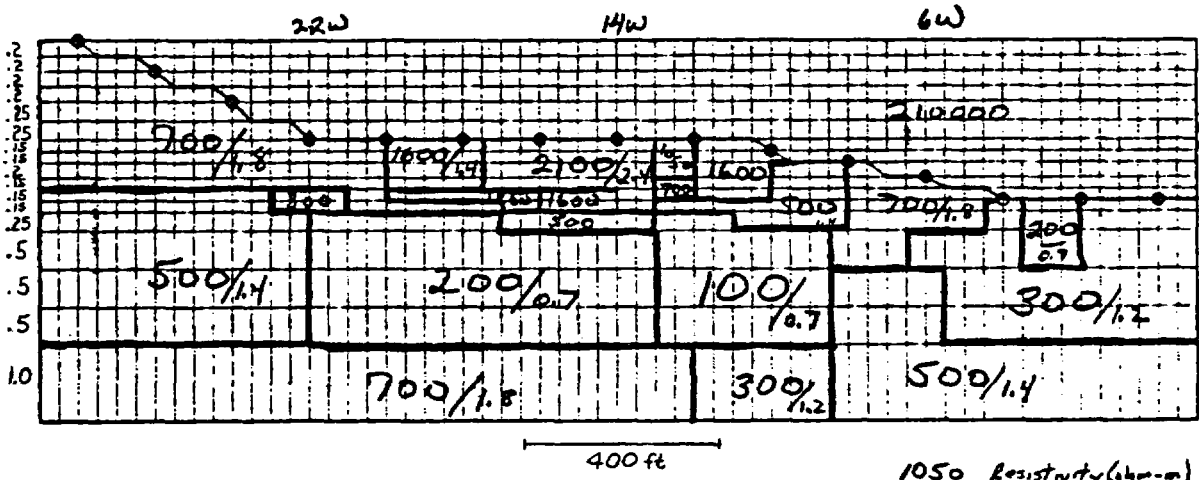

Fig. B1

PROJECT NAME:
 NTS LINE A WEST/3
 MODEL NAME:
 SENSITIVITY TRAIL #1

500, 700um substituted for
 100, 200, 300um below 1.15-2.2 A
 depending upon location

MEDIA RESISTIVITY (OHM-METERS)	210000.00	100.00	200.00	300.00	500.00
700.00	1050.00	1600.00	2100.00		
MEDIA PFE (%)	.00	.70	1.00	1.20	1.40
	1.80	1.80	1.40	2.40	

bracket indicates
 altered lines

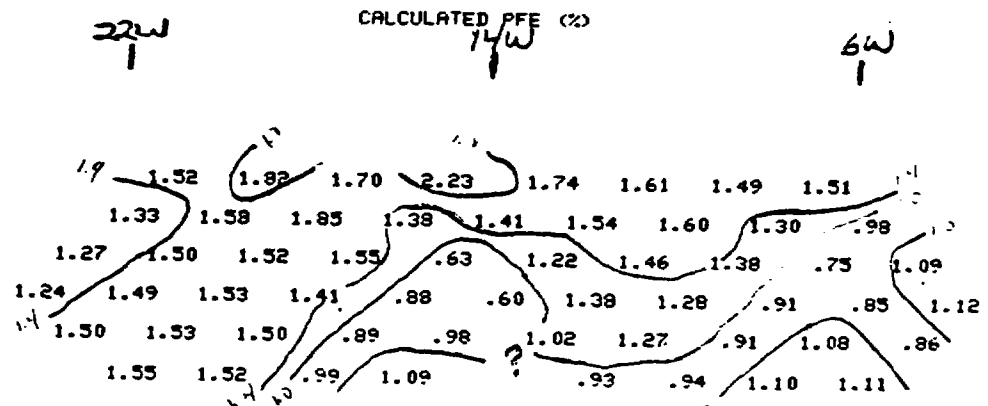
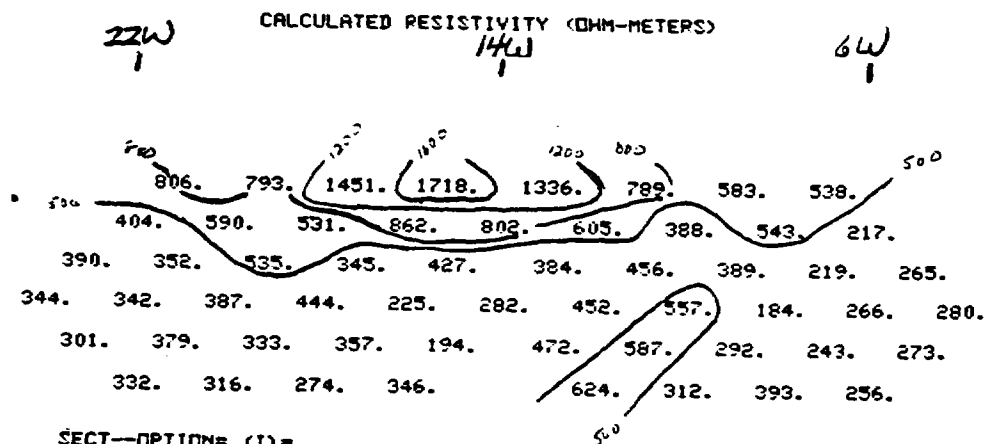
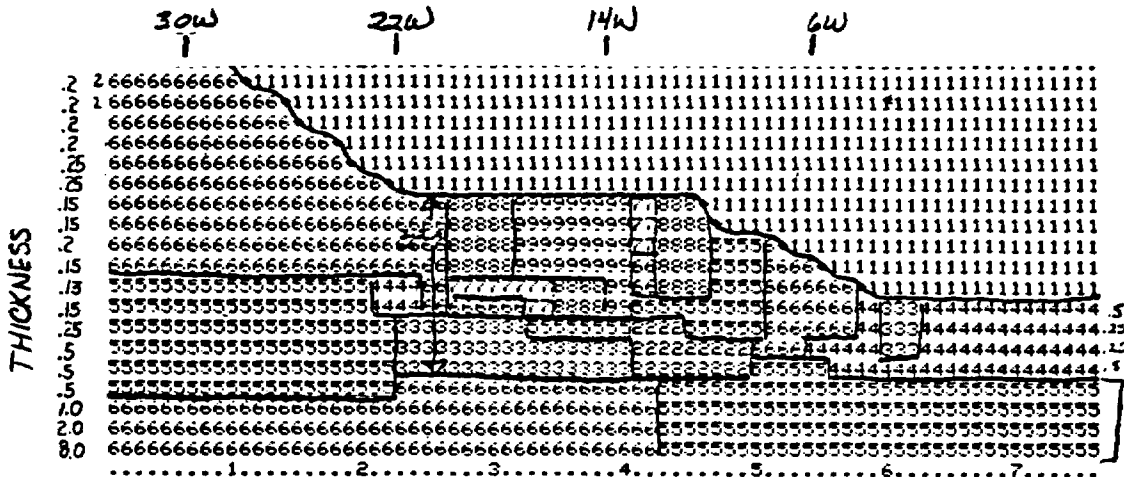

Fig. B2

PROJECT NAME:
NTS LANE A WEST/3
MODEL NAME:

1050 A M SUBSTITUTED FOR 100, 210 A M
at depths greater than
1.65-2.70 A

SENSITIVITY TRIAL #2
3w 14w 6w
lines altered

THICKNESS

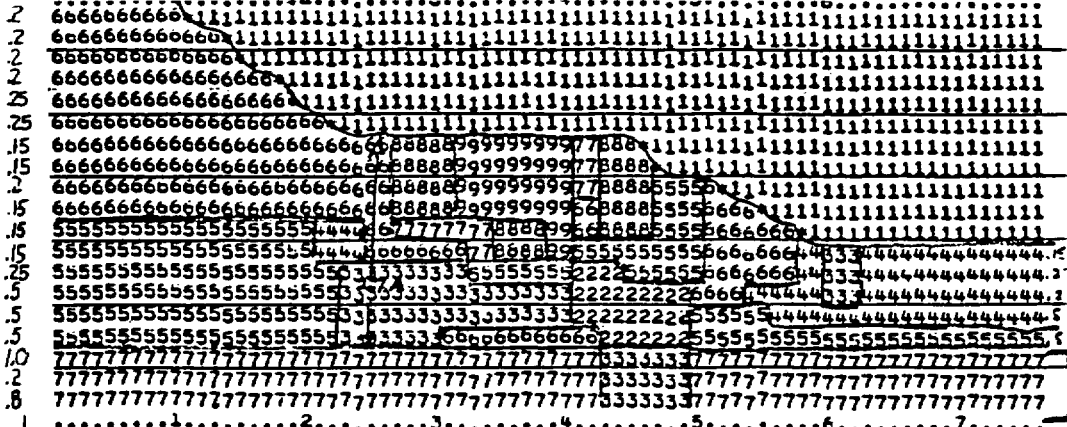

MEDIA RESISTIVITY (OHM-METERS)				
21000.00	100.00	200.00	300.00	500.00
700.00	1050.00	1000.00	2100.00	
MEDIA PFL (%)				
.00	.70	1.00	1.20	1.40
1.80	1.80	1.40	2.40	

APPARENT RESISTIVITY (CALCULATED)

22w 14w 6w

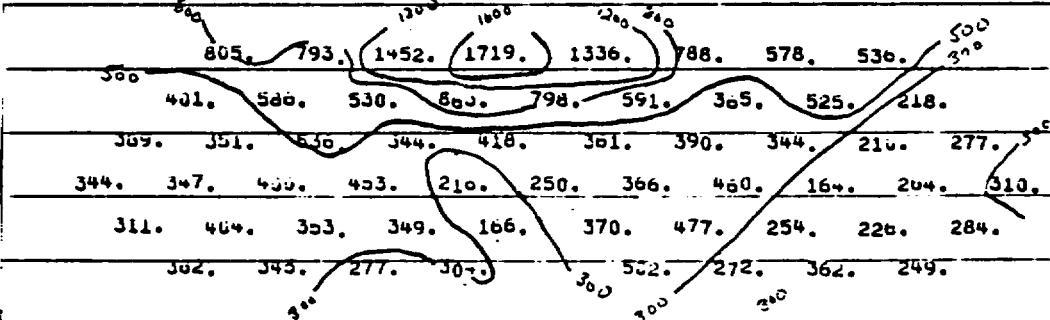

APPARENT PERCENT FREQUENCY EFFECT (CALCULATED)

22w 14w 6w

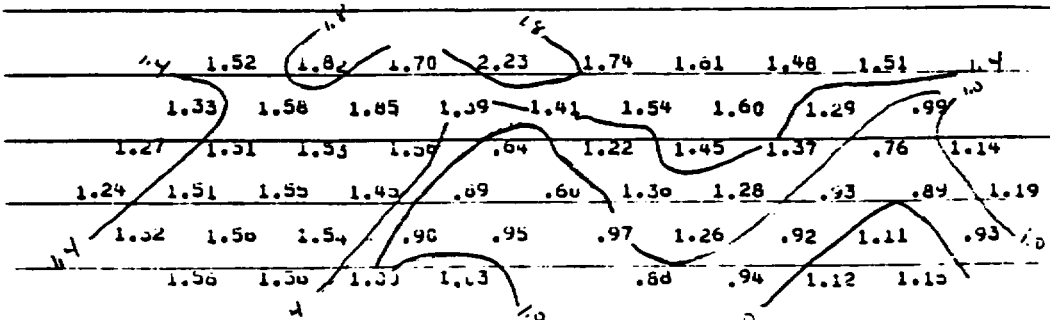

Fig. B3

Preferred Model

Line A East/3

Iter #7 A/inch=2.00

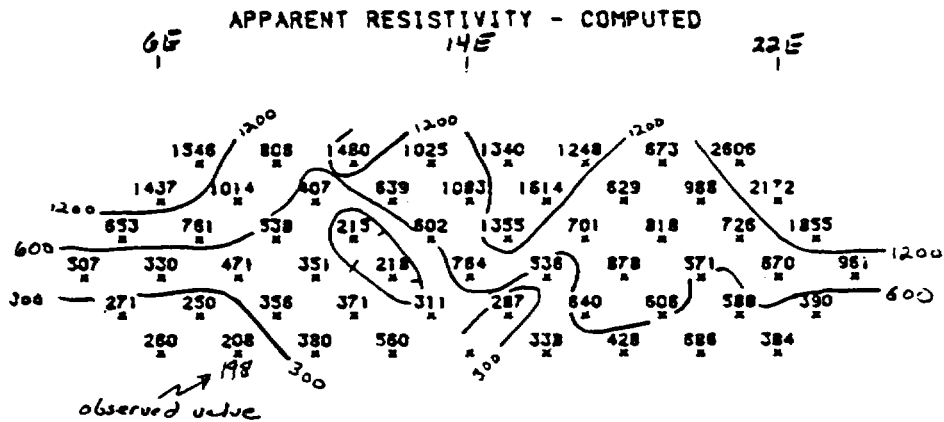
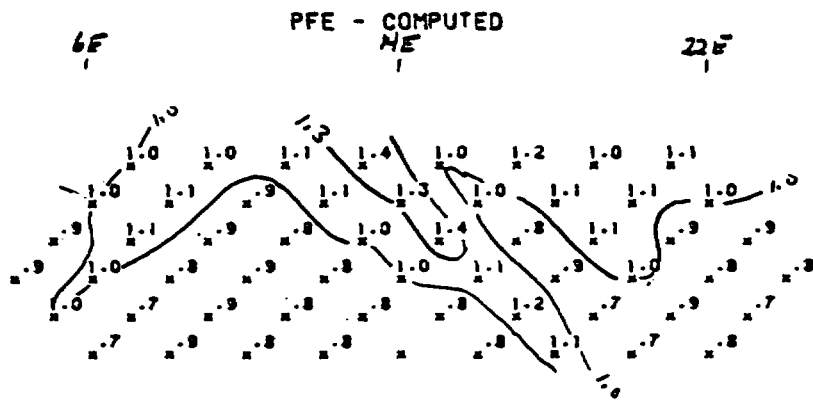
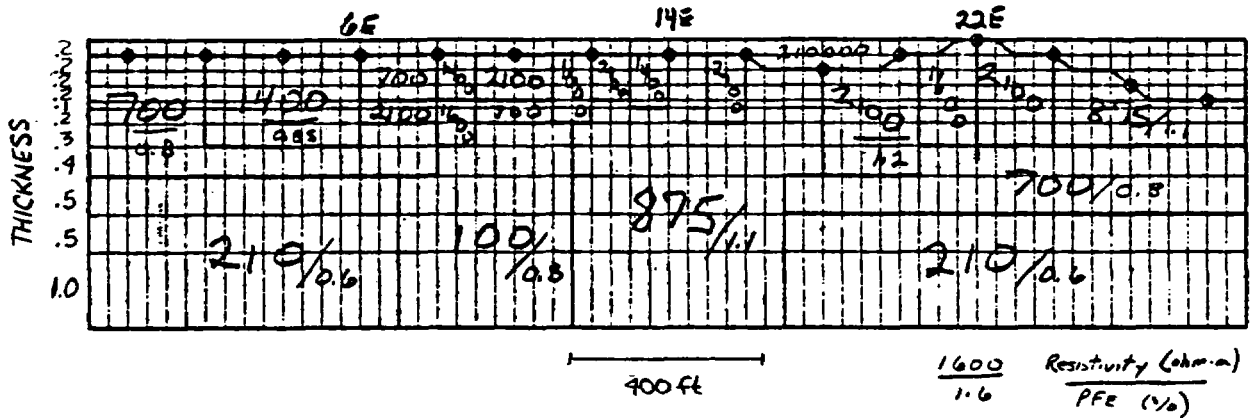

Fig. B4

PROJECT NAME:
 SENSITIVITY TRIAL #1
 MODEL NAME:
 NTS LINE A EAST/3

700.0m substituted for 100.0m
 at depths below 2.1 A \geq 400ft

875.0m body retained from
 preferred model

MEDIA RESISTIVITY (OHM-METERS)					
21000.00	100.00	210.00	700.00	875.00	
1400.00	1600.00	2100.00			
MEDIA PFE (%)					
.00	.80	.60	.80	1.10	
.85	1.60	1.20			

bracket indicates
 altered lines -

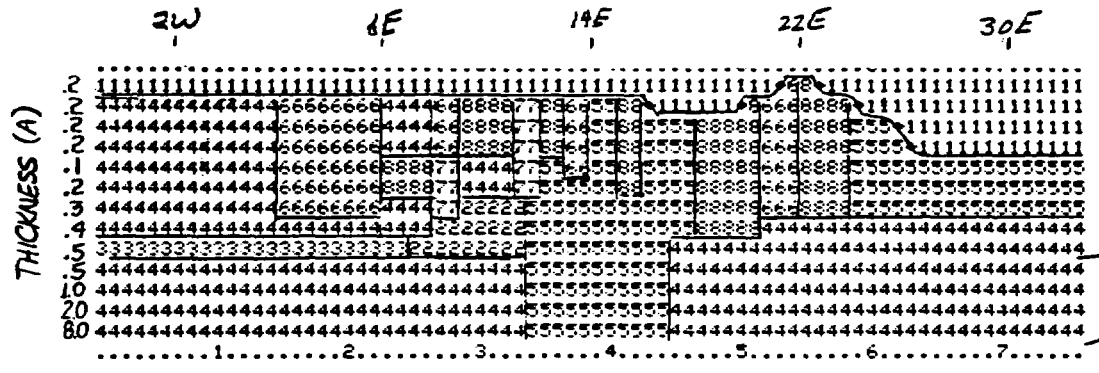

CALCULATED RESISTIVITY (OHM-METERS)

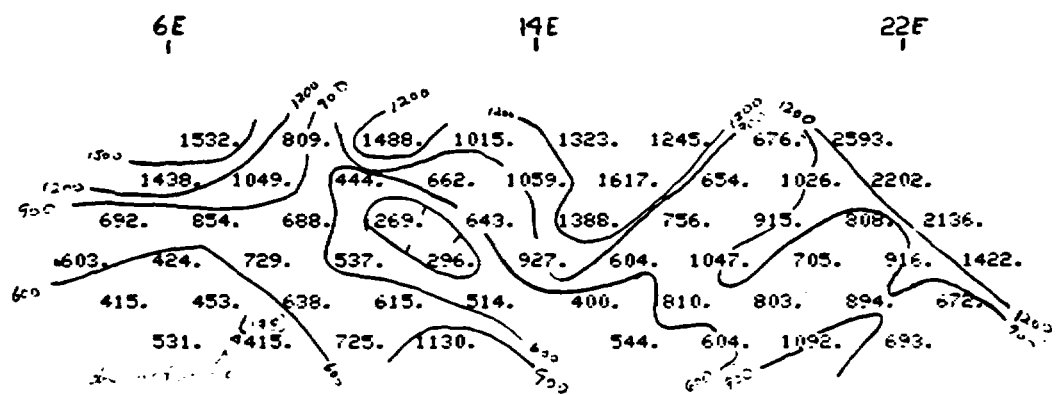

CALCULATED PFE (%)

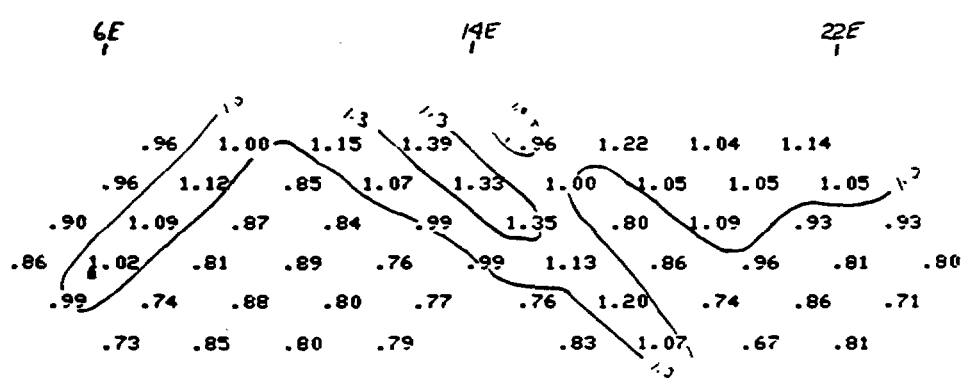

Fig. B5

700cm substituted for 100.210cm
at depths below 3.6 A=720%

PROJECT NAME:
NTS LINE A EAST/3

875cm retained from
preferred model

MODEL LABEL:
SENSITIVITY TRIAL #2

BRACKET INDICES
ALTERED IN THIS

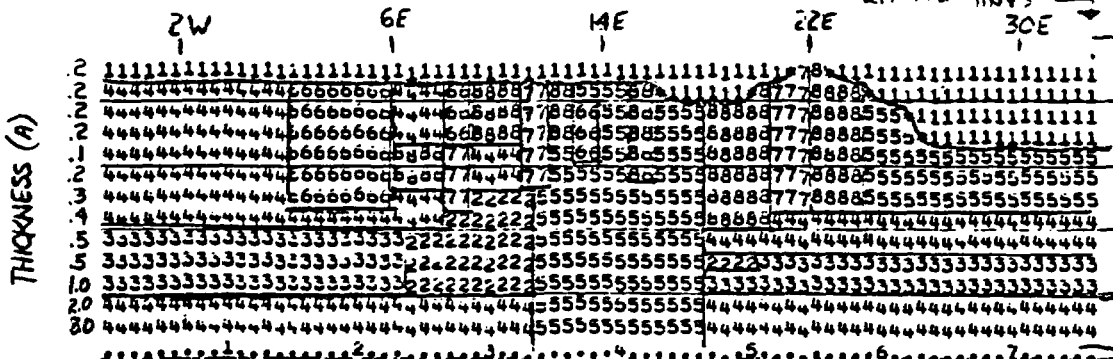

MEDIA RESISTIVITY (OHM-METERS)				
21000.00	160.00	210.00	700.00	875.00
1400.00	1600.00	2100.00		
MEDIA PFC (λ)				
.00	.60	.60	.00	1.10
.85	1.00	1.20		

APPARENT RESISTIVITY (CALCULATED)

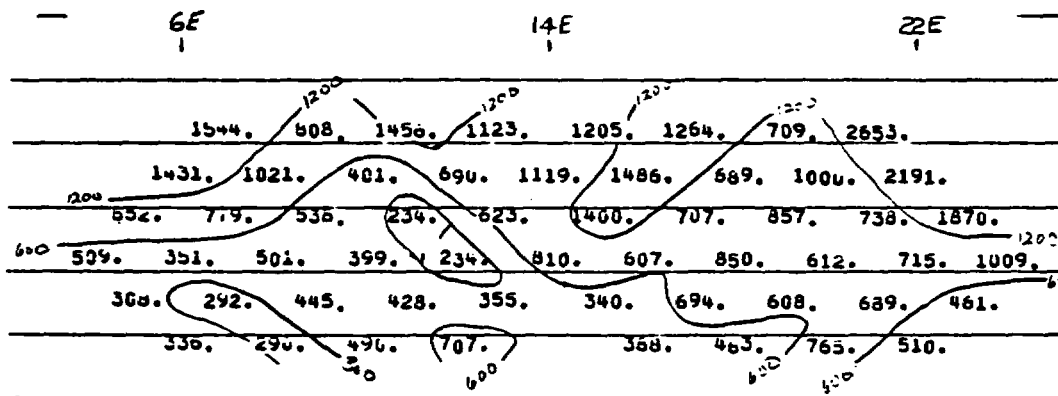

APPARENT PERCENT FREQUENCY EFFECT (CALCULATED)

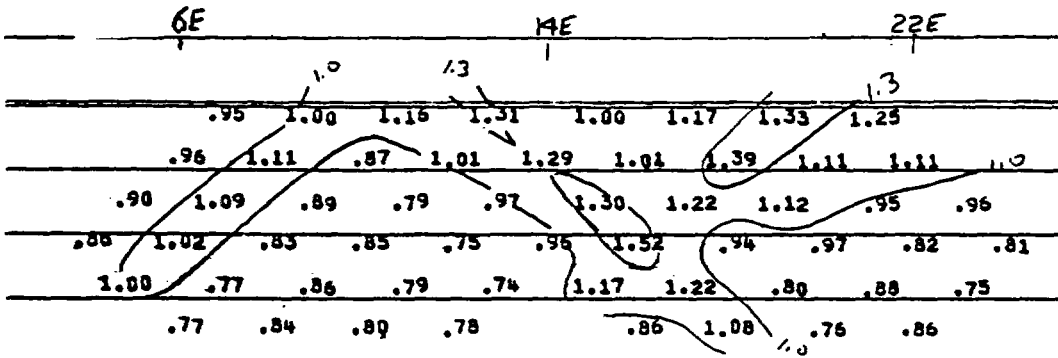
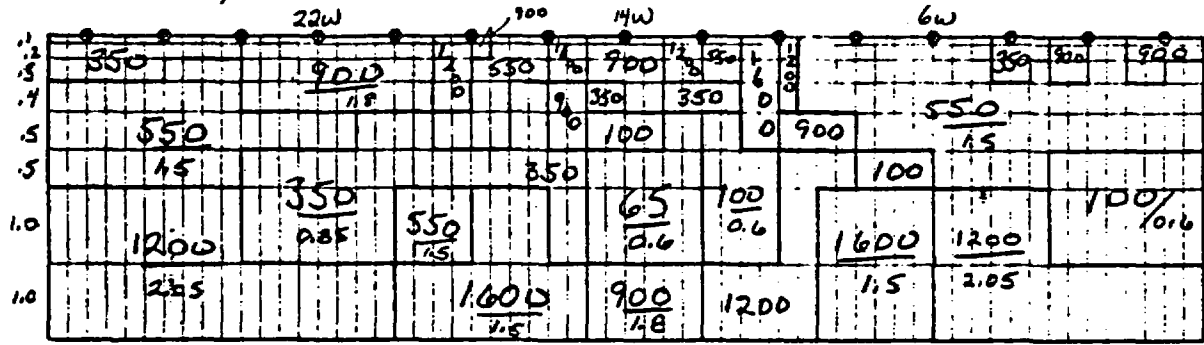

Fig. B6

Preferred Model
 Line B WAC/3
 Iter = 7 $A_{invc} = 2.00$



Thickness (A)

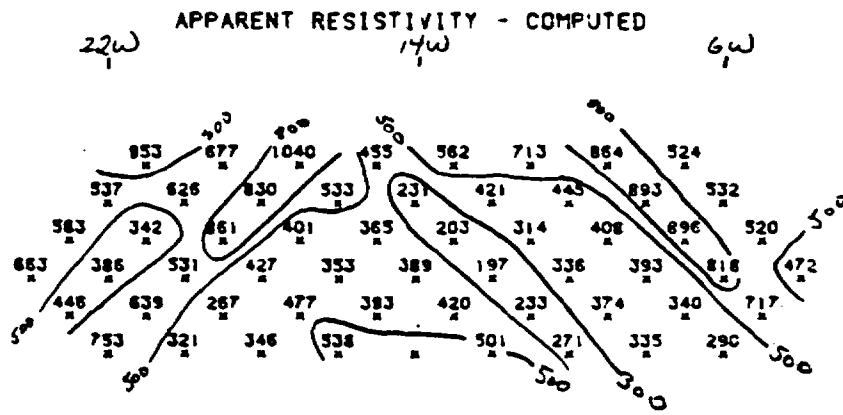
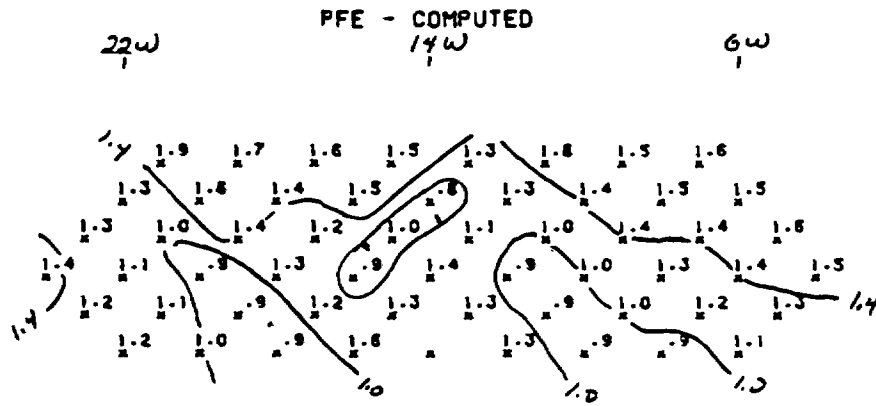
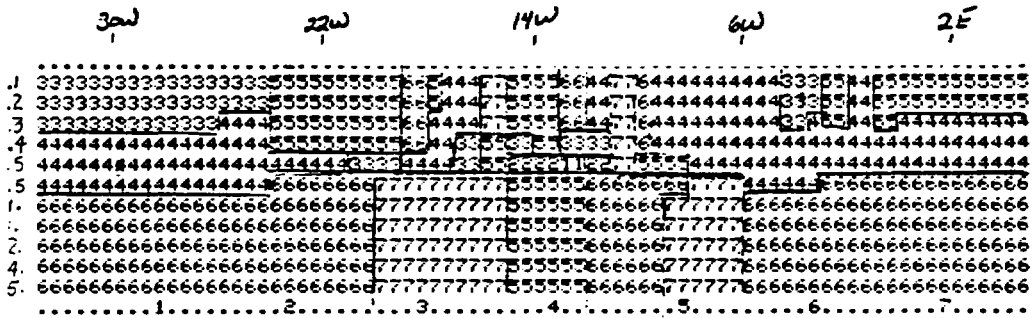

Fig. B7

PROJECT NAME:
 MTS LINE B WEST/3
 MODEL NAME:
 SENSITIVITY TRIAL = 1

MEDIA RESISTIVITY (OHM-METERS)					
65.00	100.00	350.00	550.00	900.00	
1200.00	1600.00				
MEDIA PFE (%)					
.60	.60	.85	1.50	1.80	
2.05	1.50				



Thickness (A)

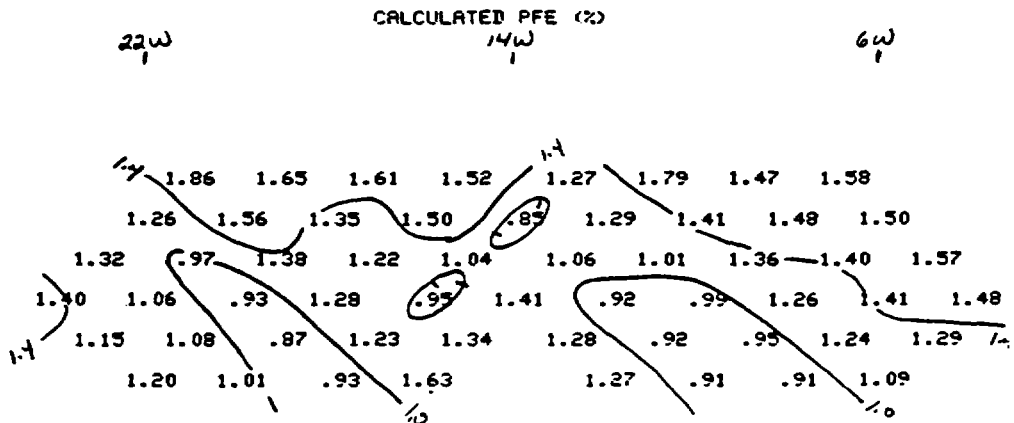
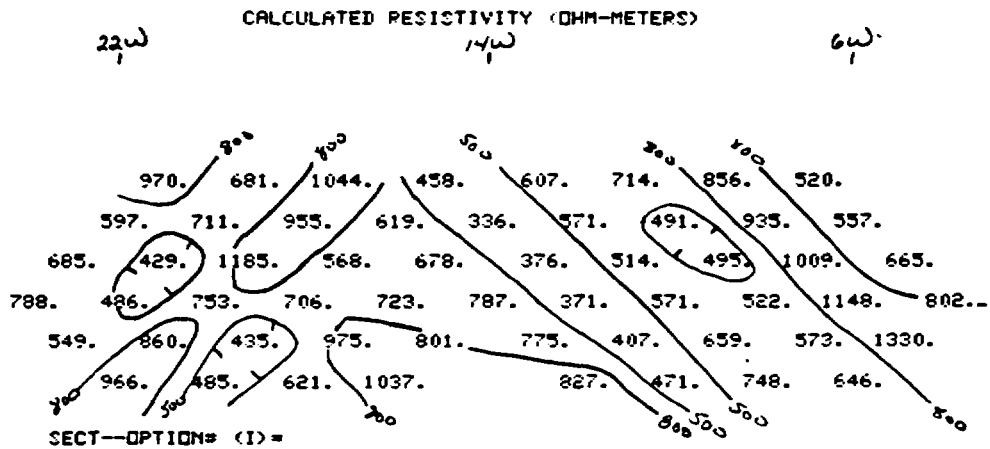
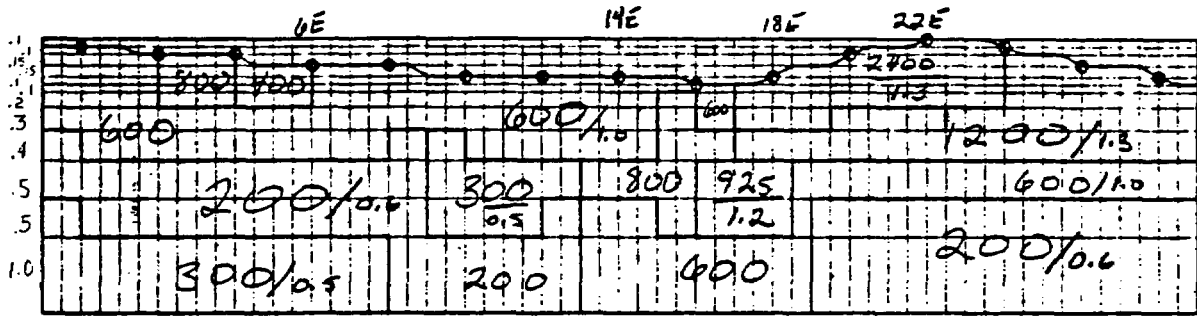

Fig. B8

Preferred Model
 Line B East 13
 Iter*6 A/inch = 2.00



800 Resistivity (ohm-in)
 1.2 PFE (%)

Thickness (A)

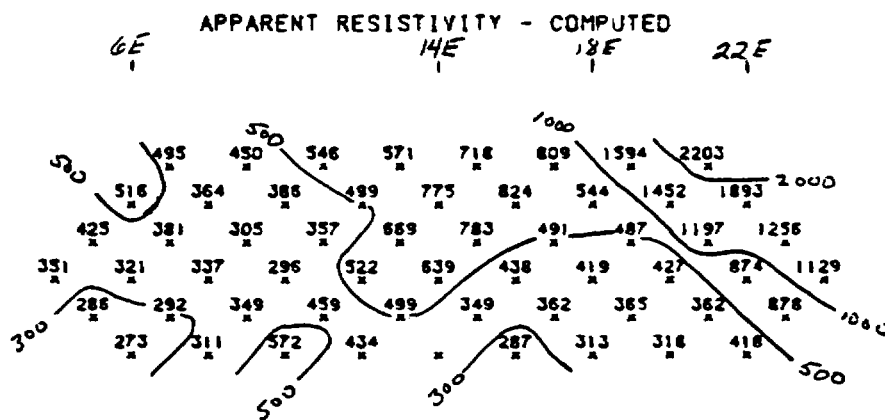
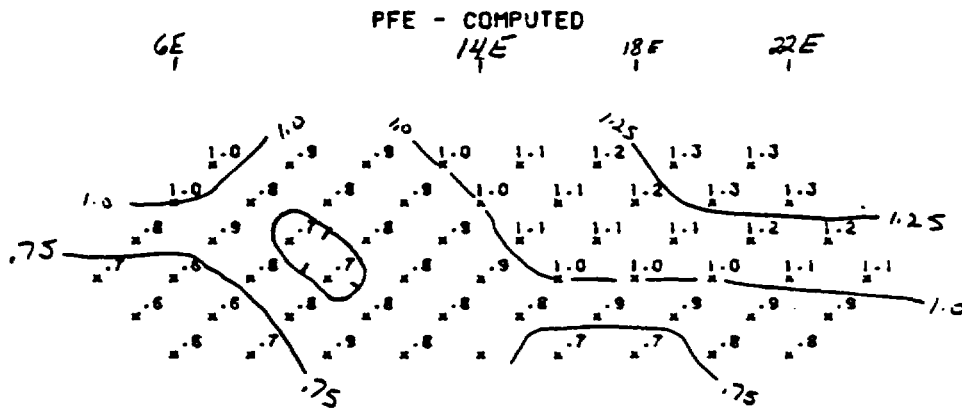

Fig. B9

PROJECT NAME:
 NTS LINE B EAST-3
 MODEL NAME:
 SENSITIVITY CHECK =1

MEDIA RESISTIVITY (OHM-METERS)	200.00	300.00	600.00	800.00
240000.00	200.00	300.00	600.00	800.00
1200.00	2400.00	925.00	400.00	
MEDIA PFE (%)	.60	.50	1.00	1.20
.00	.60	.50	1.00	1.20
1.30	1.30	1.20	1.00	

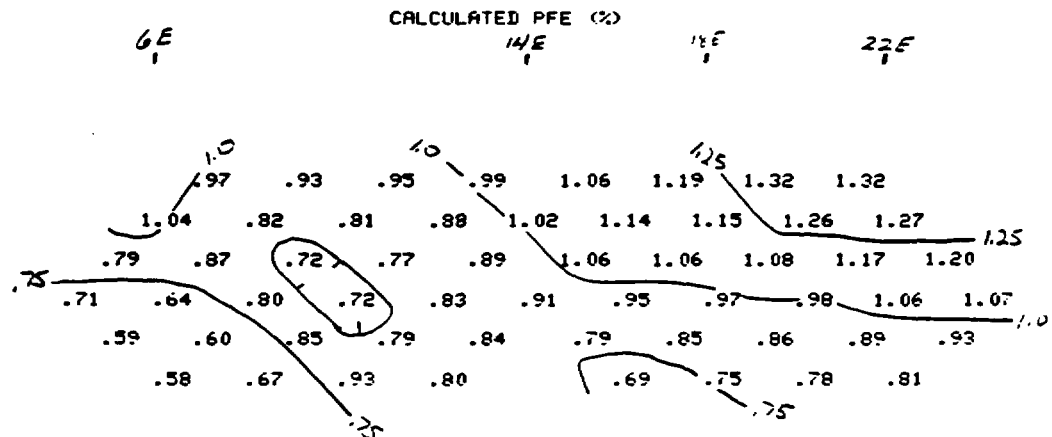
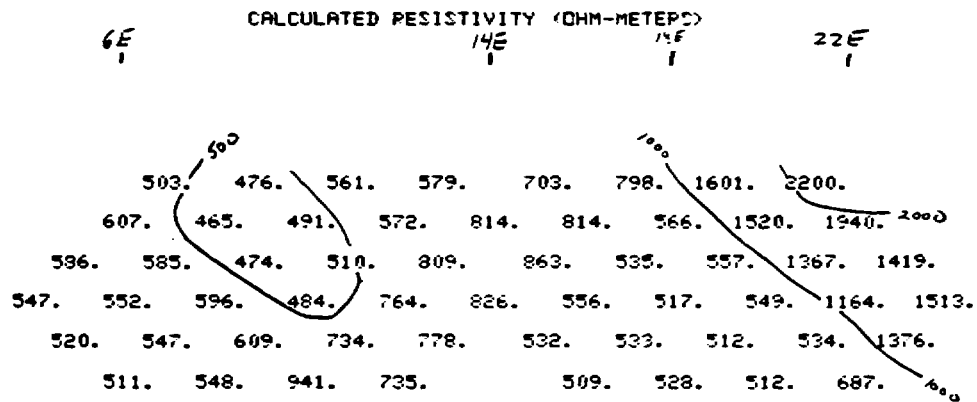
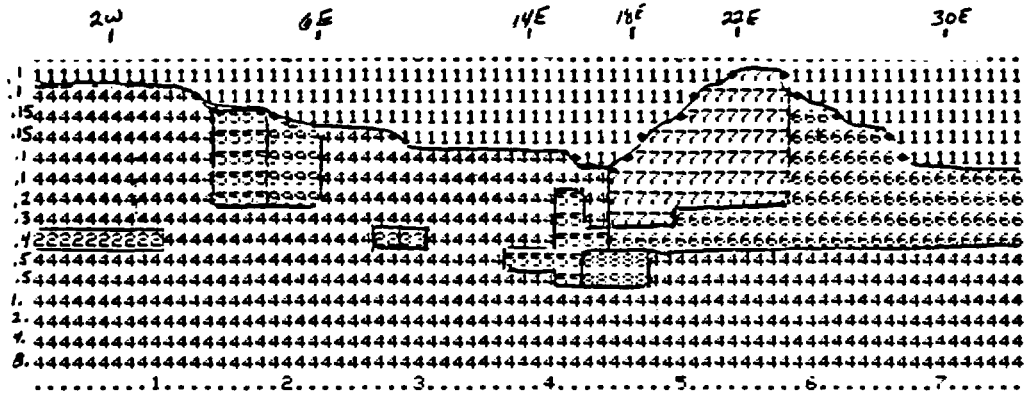

Fig. B10

Preferred Model
NTS Line B' West 1/2
Iter #6 A/INCN = 2.00

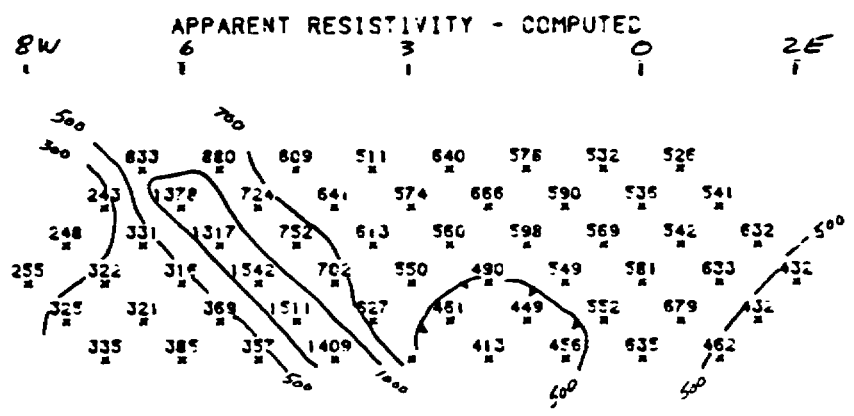
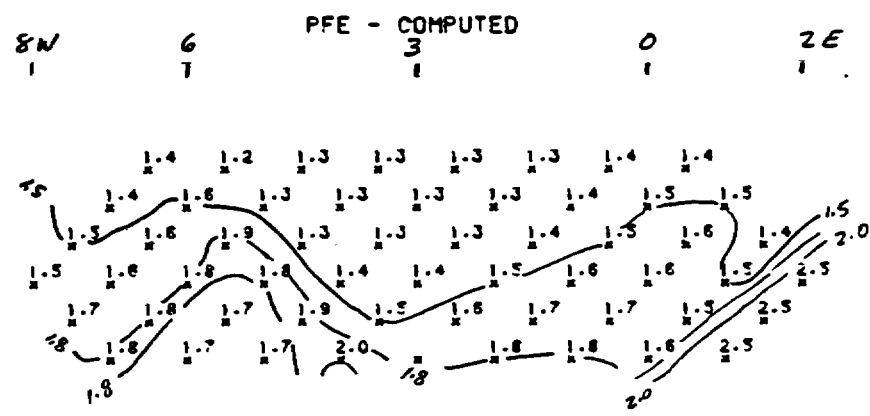
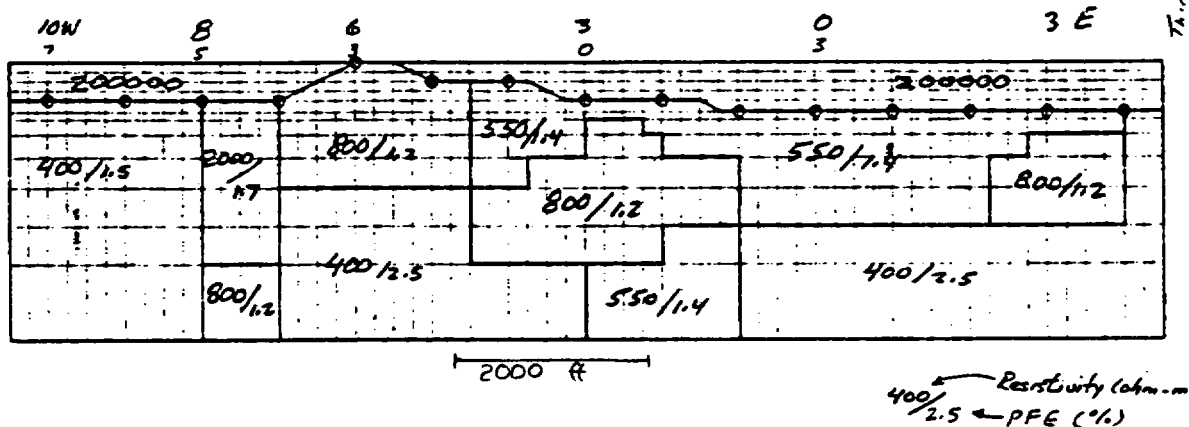

Fig. B11

PROJECT NAME:
 NTS LINE R WEST/2
 MODEL NAME:
 SENSITIVITY TRIAL #1

Body #6, 2000 ohm-m, substituted for 400, 550,
 and 800 ohm-m units at depths of
 0.1 m (=100 ft) to 2.0 m (=2000 ft).
 This simulates a 3° dip to East from
 resistive outcrop west of sta. 6W.

MEDIA RESISTIVITY (OHM-METERS)	400.00	400.00	550.00	800.00
200000.00				
2000.00				
MEDIA PFE (%)	1.50	2.50	1.40	1.20
.00				
1.70				

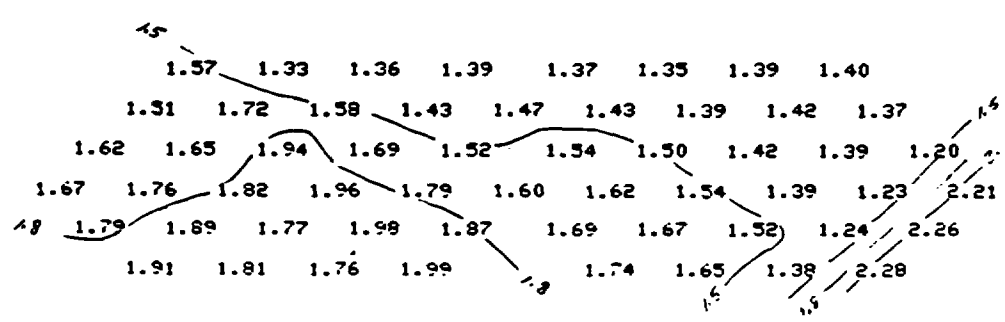
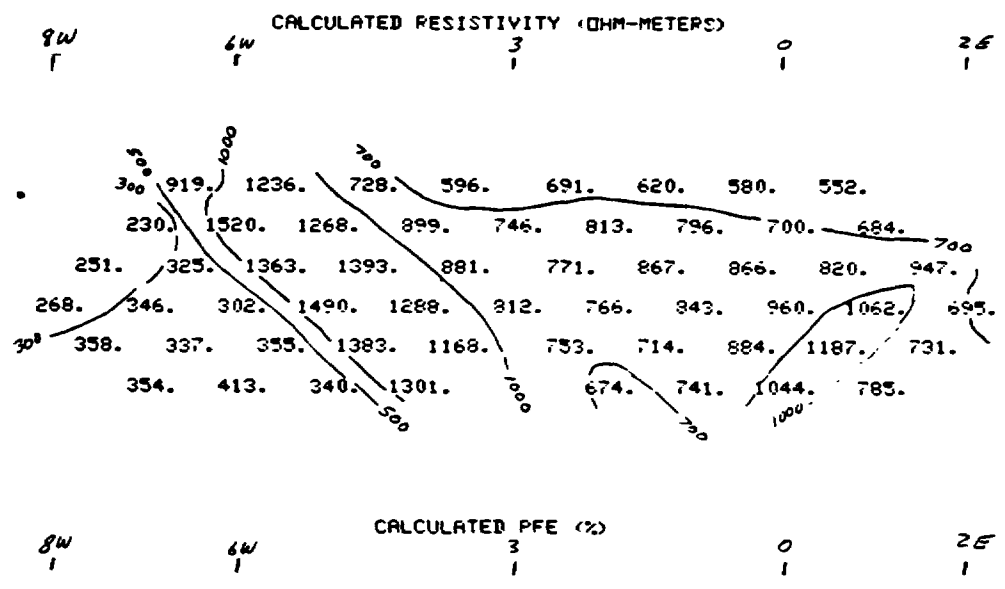
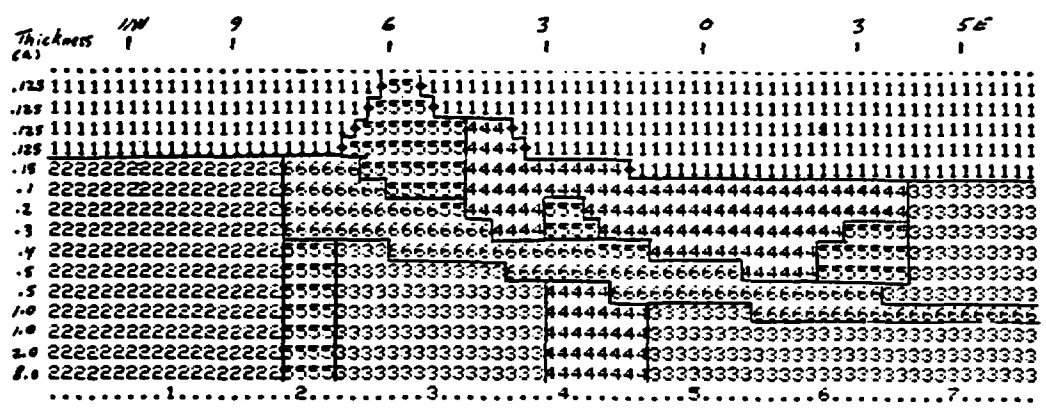

Fig. B12

Preferred Model
Line B' East/2
Iter #6 A/INCH=2.00

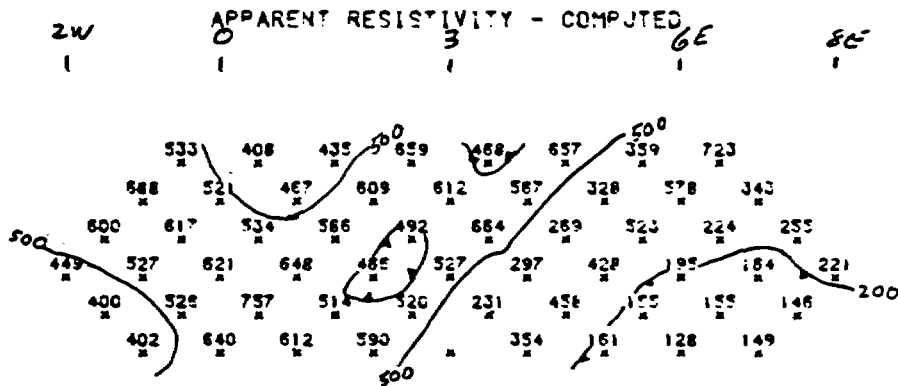
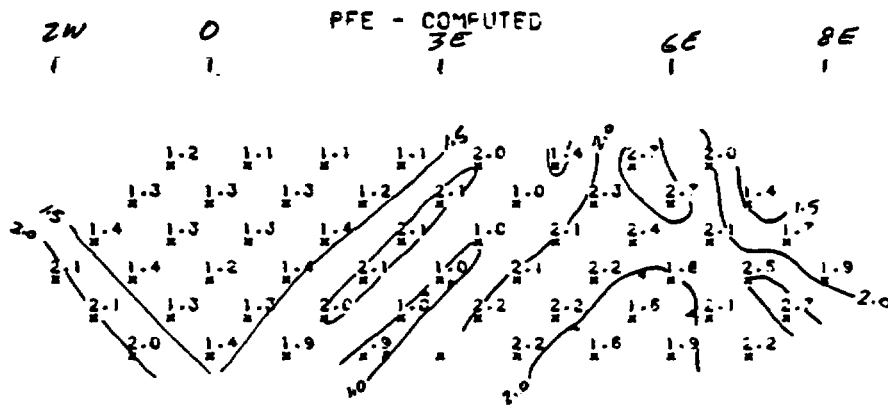
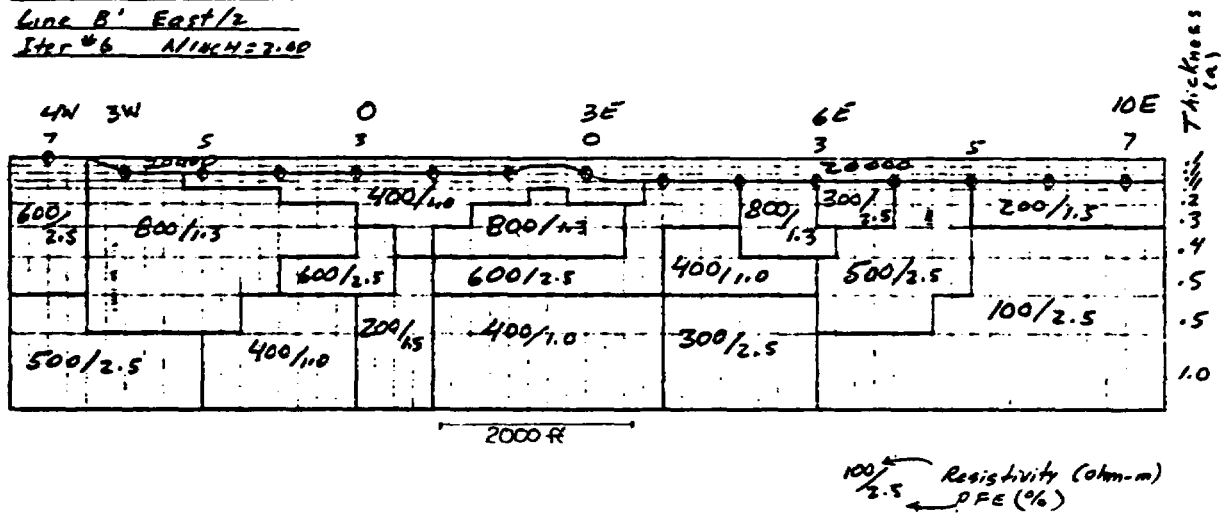
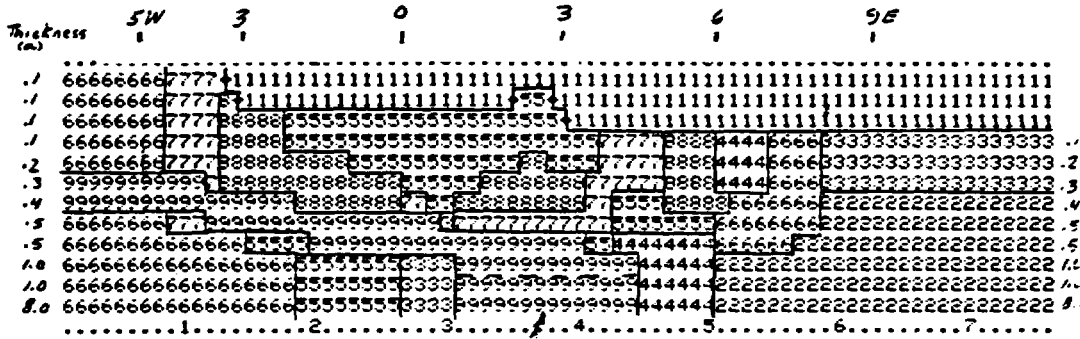

Fig. B13

PROJECT NAME:
 NTS LINE B' EAST/2
 MODEL NAME:
 SENSITIVITY TRIAL #1

Body #9, 2000 ohm-m substituted for 400, 500, 600 and 800 ohm-m at depths of 0.64 (=600 feet) to 2.0a (=2000 feet) Resistive layer is 0.7a thick on west to 1.5a thick at depth.

MEDIA RESISTIVITY (OHM-METERS)				
2000.00	100.00	200.00	300.00	400.00
300.00	600.00	800.00	<u>2000.00</u>	
MEDIA PFE (%)				
.00	2.50	1.50	2.50	1.00
2.50	2.50	1.30	<u>1.70</u>	



note: last two rows should not have been resistive effect should be small at depth = 3.0 to these rows.

2W 0 3 6 8E
 1 1 1 1 1

CALCULATED RESISTIVITY (OHM-METERS)

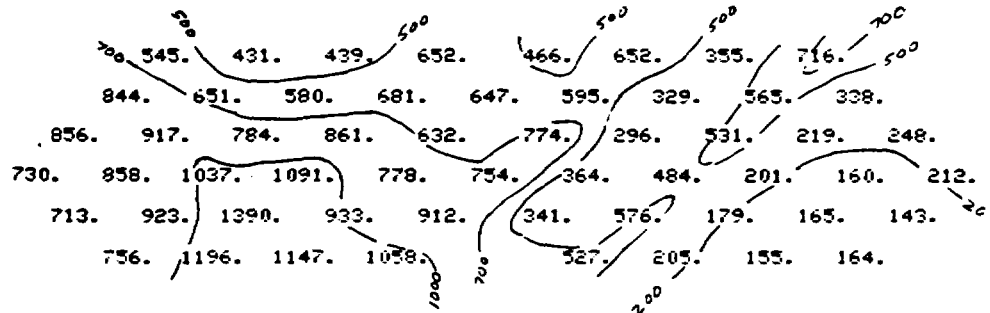

2W 0 3 6 8E
 1 1 1 1 1

CALCULATED PFE (%)

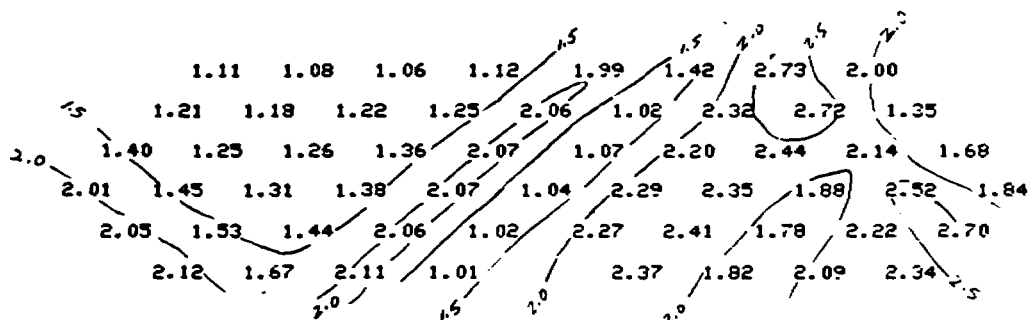

Fig. B14

APPENDIX C

NUMERICAL MODEL OUTPUT

Pages C1-15 document all final models. The body numbers, resistivities, and P.F.E.'s are indicated for each model. The body numbers used for the final models do not necessarily correspond to those in the interpreted sections, Plates II-IV. because of the merging of overlapping models.

TABLE 5

SUMMARY OF INTERPRETATIVE MODELS

Plate	Line	Dipole Length (feet)	Models	Iterations	Appendix Pages
2	A	200	W/3, center, E/3	8,7,7	1,2,3
2	B	200	W/3, center, E/3	7,7,6	4,5,6
4	B'	1000	W/2, E/2	6,5	7,8
3	C	500	W/2, E/2	8,8	9,10
2	D	200	W/2, E/2	10,8	11,12
3	D'	500	W/2, E/2	14,7	13,14
3	E	500	center	7	15

BODY NO.	RESISTIVITY (ohm-m)	P.F.E. %
1 (air)	210,000	0.0
2	100	0.7
3	200	1.0
4	300	1.2
5	500	1.4
6	700	1.8
7	1050	1.8
8	1600	1.4
9	2100	2.4

LINE A WEST/3 YUCCA MOUNTAIN AREA Nevada Test Site

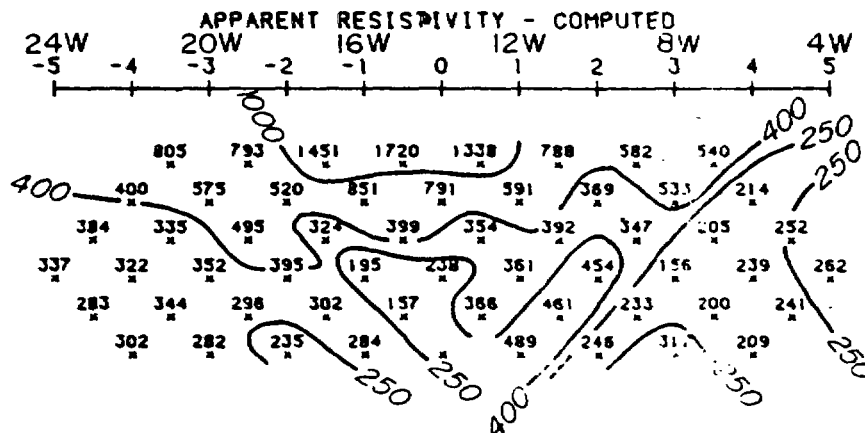
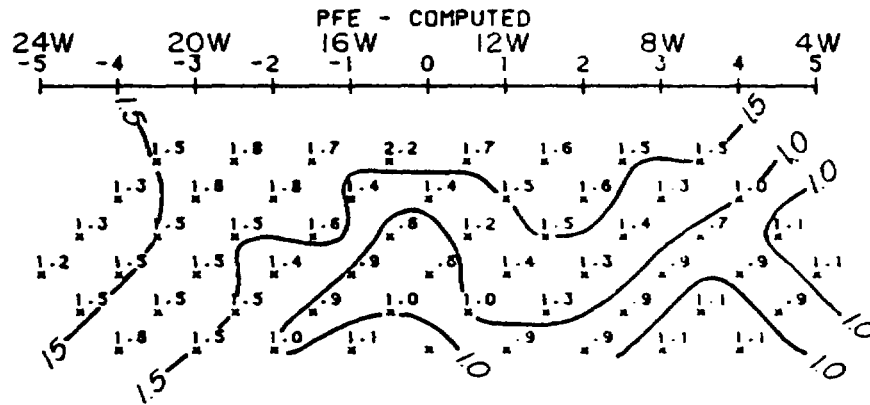
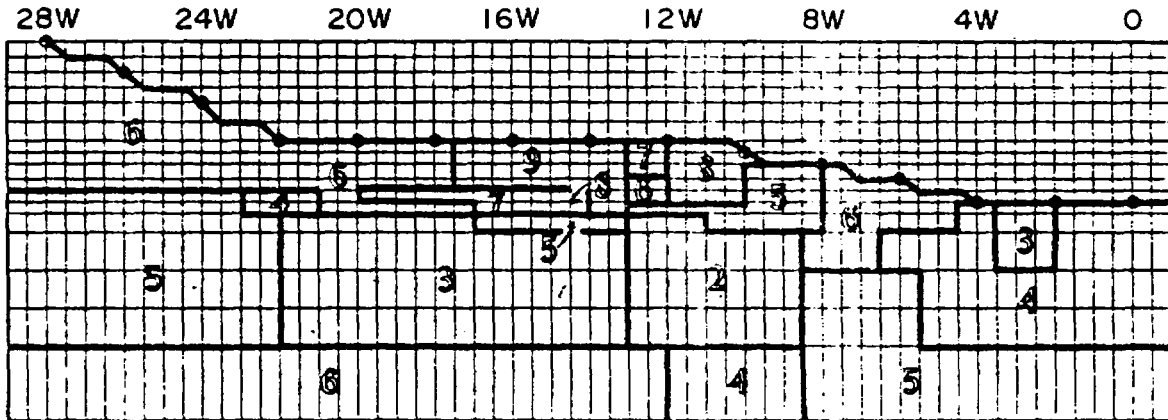

BODY RESISTIVITY NO.	P.F.E. (ohm-m)	%
1 (air)	150,000	0.0
2	100	0.3
3	320	1.5
4	500	1.2
5	700	0.75
6	900	0.8
7	1500	1.2
8	320	0.8

LINE A CENTER/3 YUCCA MOUNTAIN AREA Nevada Test Site

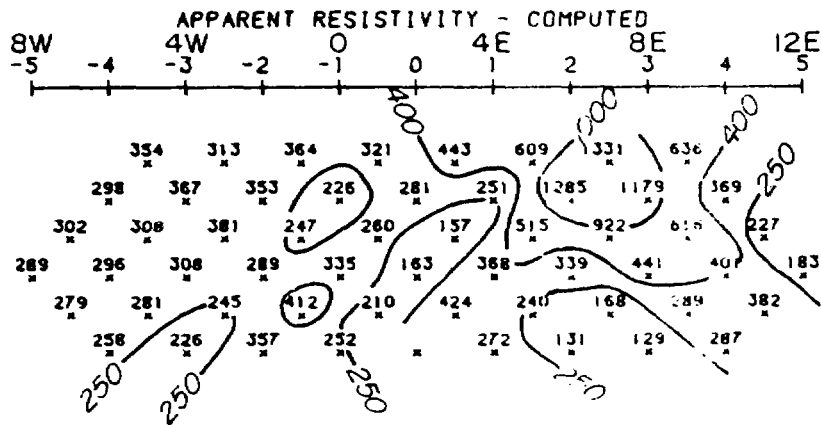
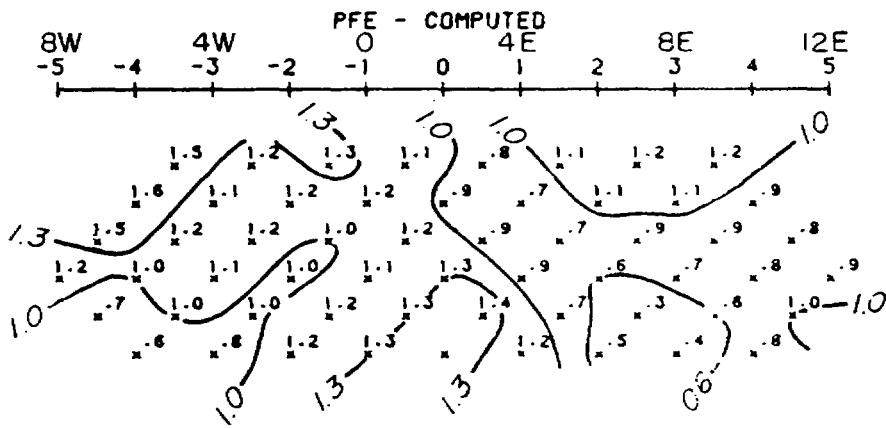
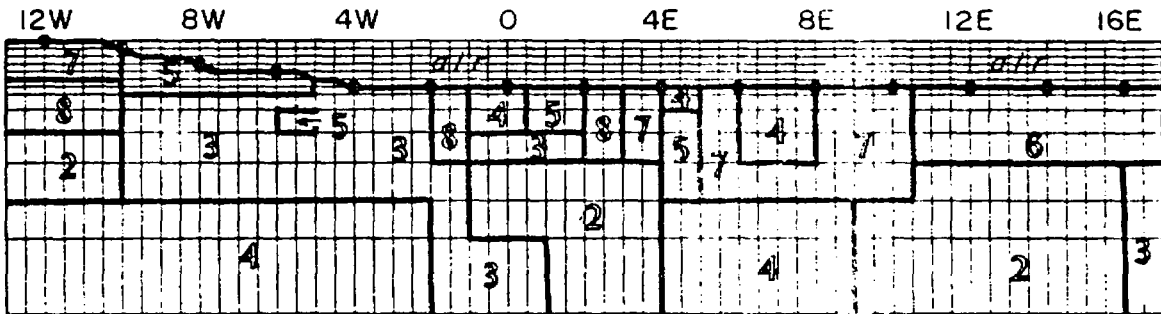

BODY NO.	RESISTIVITY (ohm-m)	P.F.E. %
1 (air)	210,000	0.0
2	100	0.8
3	210	0.6
4	700	0.8
5	875	1.1
6	1400	0.85
7	1600	1.6
8	2100	1.2

LINE A EAST/3 YUCCA MOUNTAIN AREA Nevada Test Site

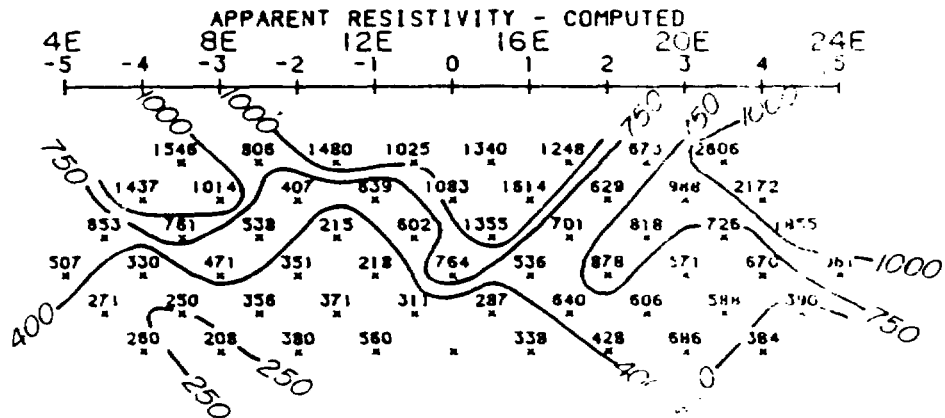
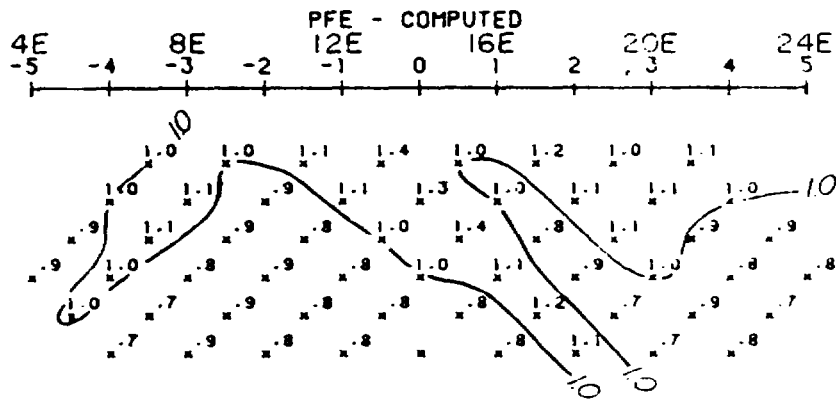
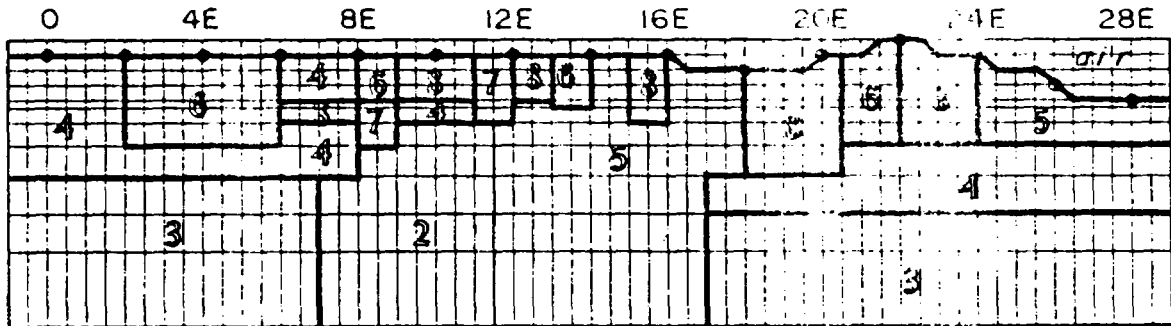

BODY RESISTIVITY NO.	P.F.E. (ohm-m)	%
1	65	0.6
2	100	0.6
3	350	0.85
4	550	1.5
5	900	1.8
6	1200	2.05
7	1600	1.5

LINE B WEST/3 YUCCA MOUNTAIN AREA Nevada Test Site

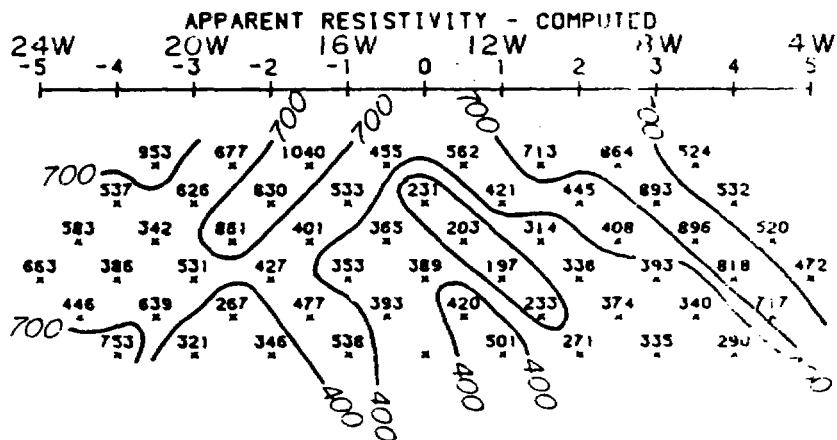
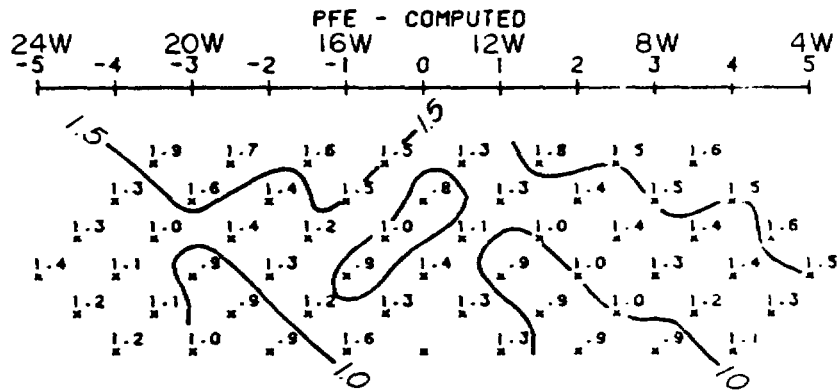
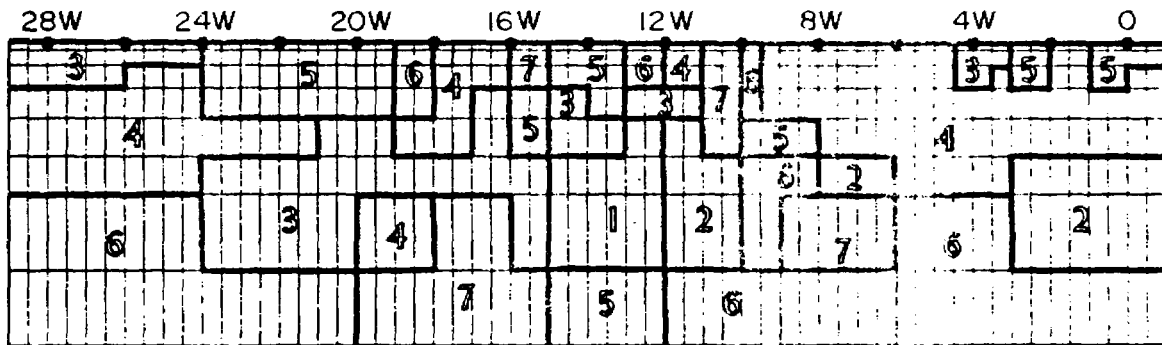

BODY NO.	RESISTIVITY (ohm-m)	P.F.E. %
1	65	0.6
2	150	0.6
3	250	0.6
4	350	1.25
5	550	1.5
6	675	1.5
7	900	1.1
8	65	0.3

LINE B CENTER/3 YUCCA MOUNTAIN AREA Nevada Test Site

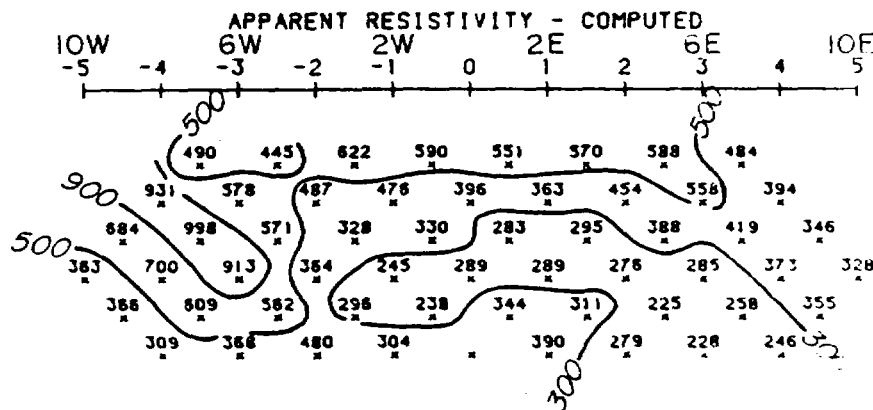
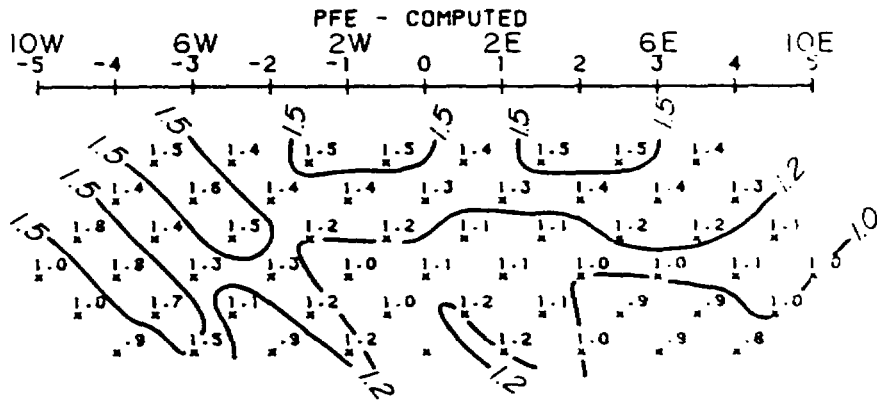
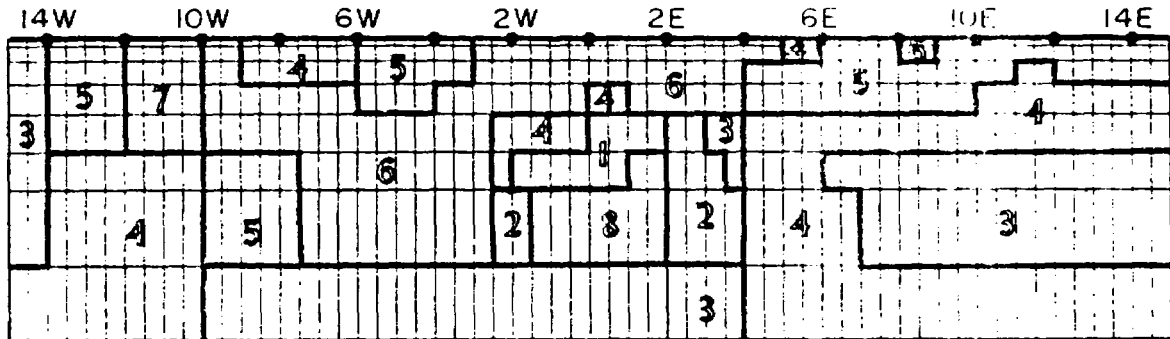

BODY RESISTIVITY P.F.E.		
NO.	(ohm-m)	%
1 (air)	240,000	0.0
2	200	0.6
3	300	0.5
4	600	1.0
5	800	1.2
6	1200	1.3
7	2400	1.3
8	925	1.2
9	400	1.0

LINE B EAST/3 YUCCA MOUNTAIN AREA Nevada Test Site

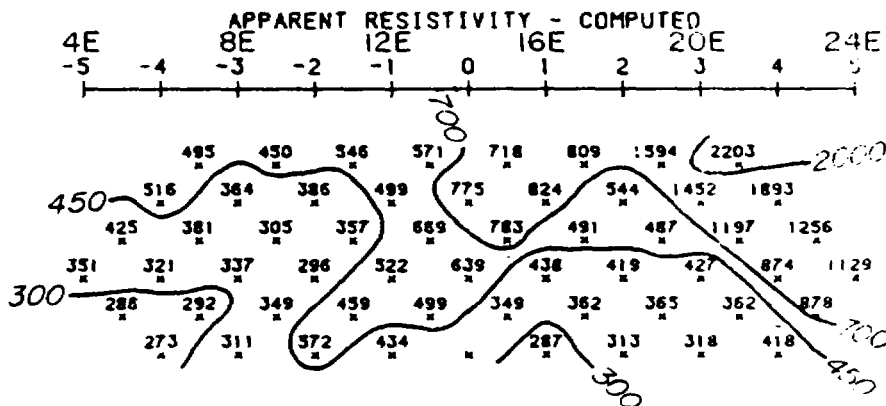
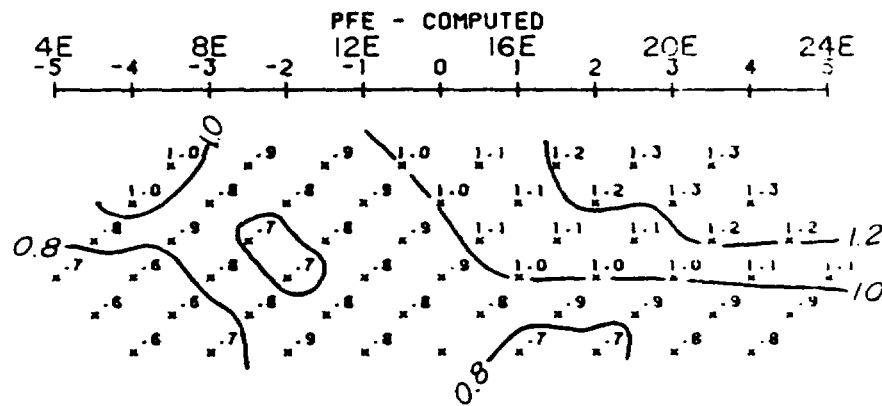
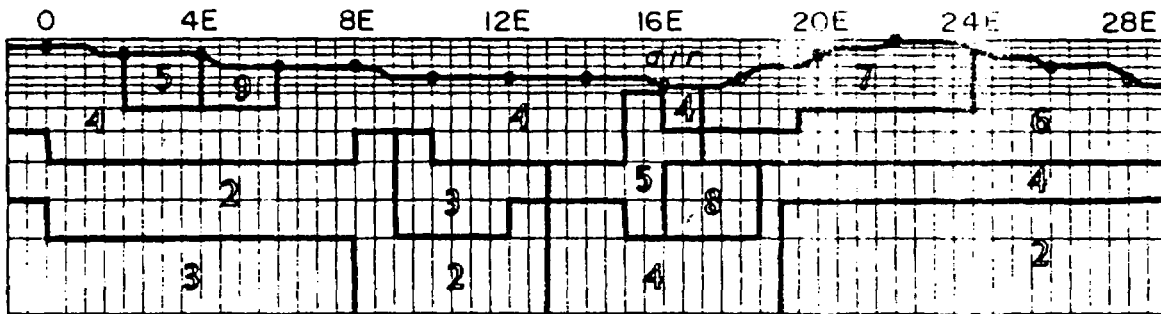

BODY NO.	RESISTIVITY (ohm-m)	P.F.E. %
1 (air)	20,000	00
2	400	15
3	400	25
4	550	14
5	800	1.2
6	2000	1.7

LINE B' WEST/2 YUCCA MOUNTAIN AREA Nevada Test Site

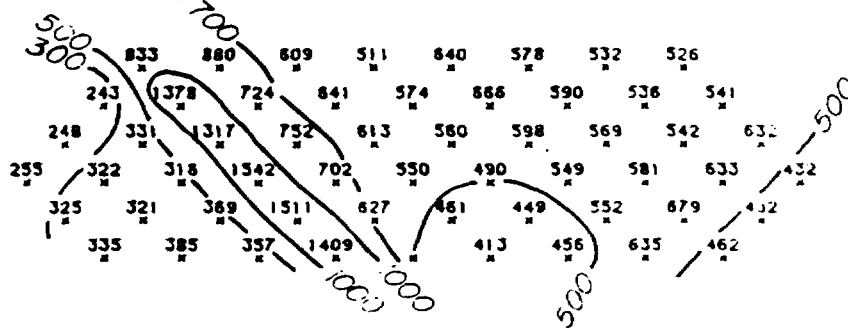
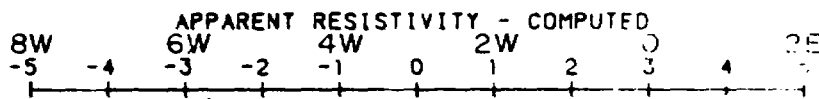
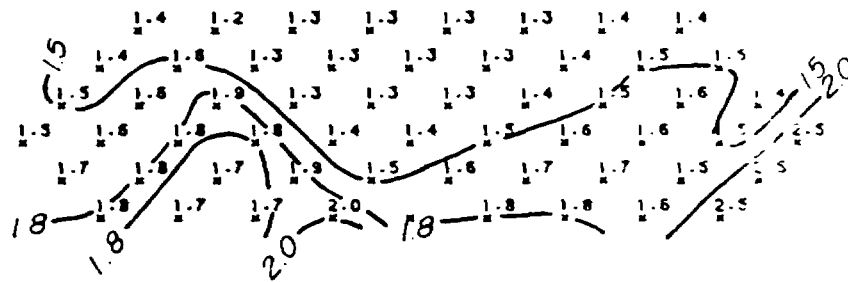
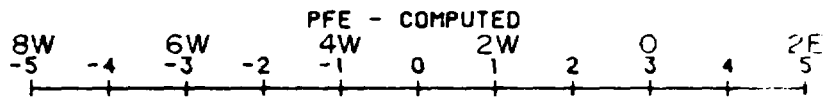
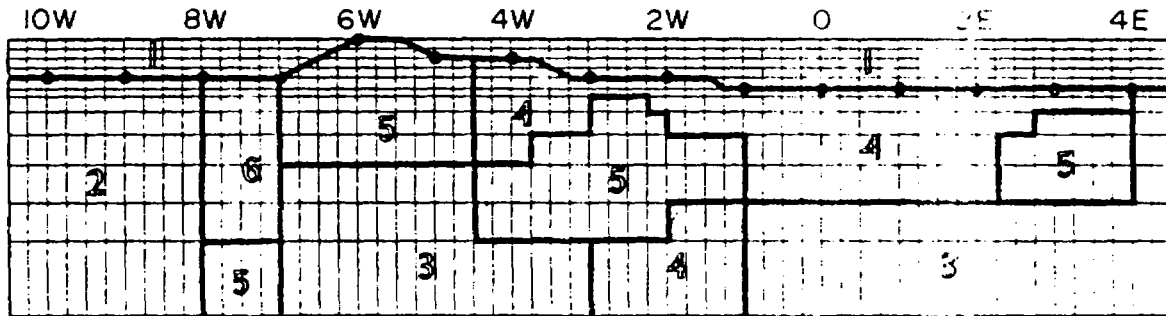

BODY NO.	RESISTIVITY (ohm-m)	P.F.E. (%)
1 (air)	20,000	0.0
2	100	2.5
3	200	1.5
4	300	2.5
5	400	1.0
6	500	2.5
7	600	2.5
8	800	1.3

LINE B' EAST/2 YUCCA MOUNTAIN AREA Nevada Test Site

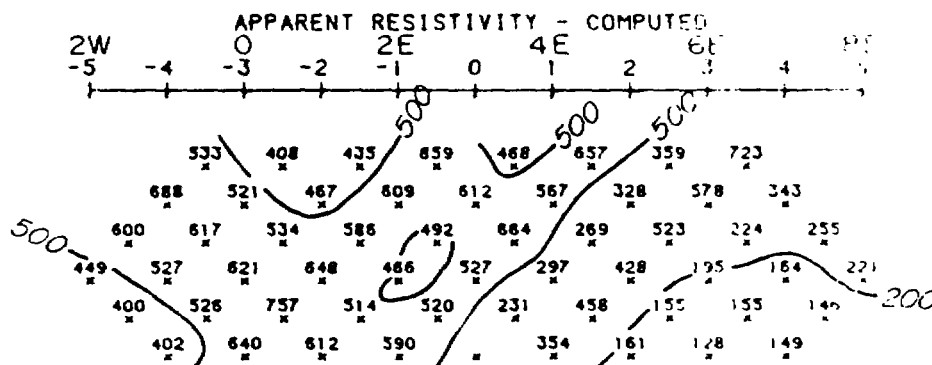
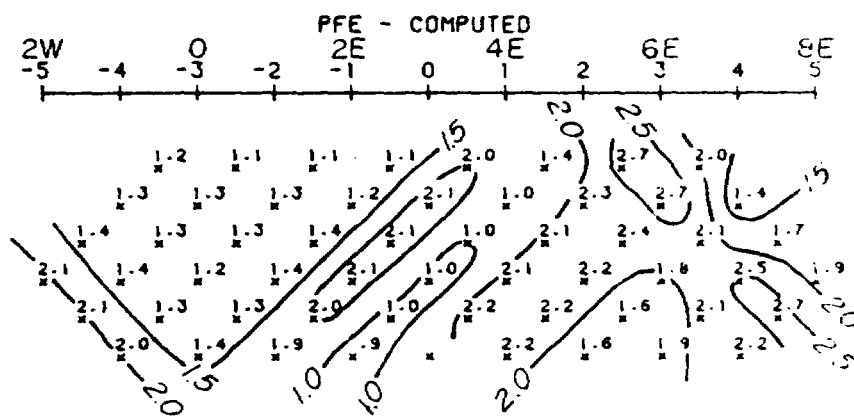
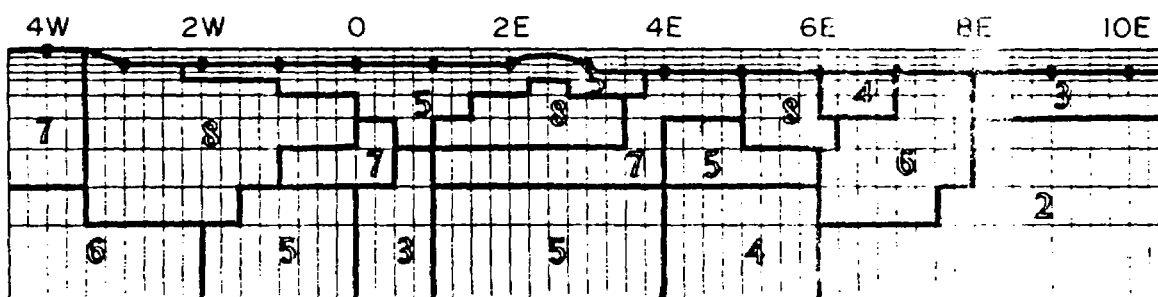

BODY NO.	RESISTIVITY (ohm-m)	P.F.E. %
1	175	0.5
2	250	0.5
3	300	1.2
4	500	1.1
5	750	1.2
6	1000	1.3
7	1300	1.6

LINE C WEST/2 YUCCA MOUNTAIN AREA Nevada Test Site

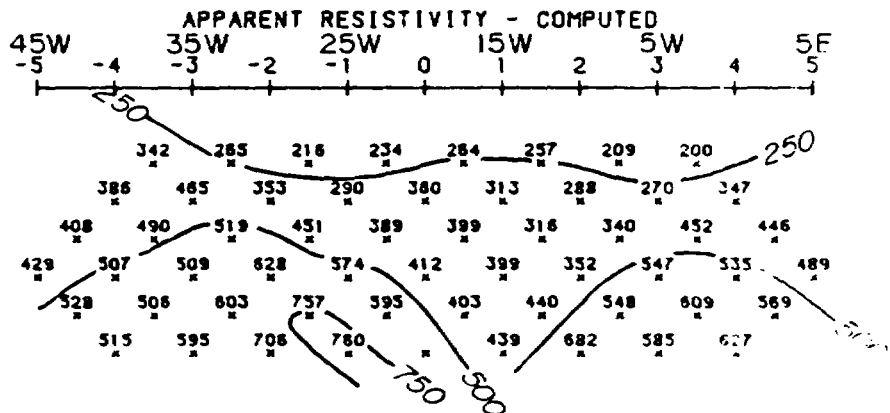
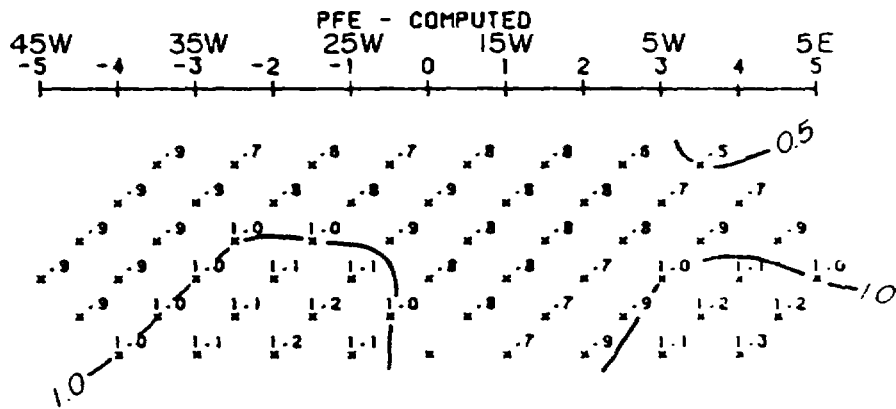
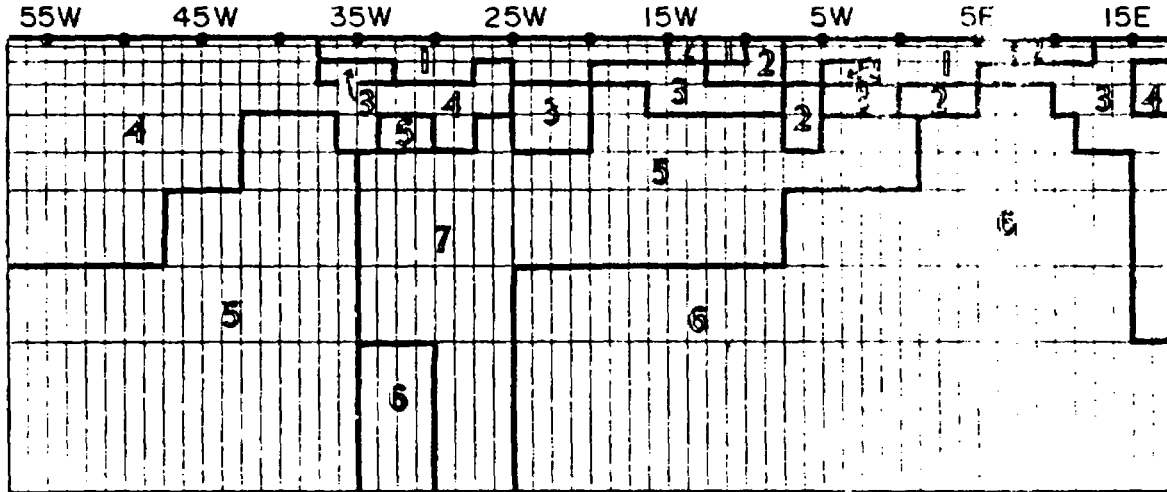

BODY NO.	RESISTIVITY (ohm-m)	PFE %
1 (air)	200,000	0.0
2	175	0.3
3	250	0.3
4	300	0.5
5	500	1.1
5	500	2.0
7	1000	1.5
8	2000	2.0
9	300	2.0

LINE C EAST/2 YUCCA MOUNTAIN AREA Nevada Test Site

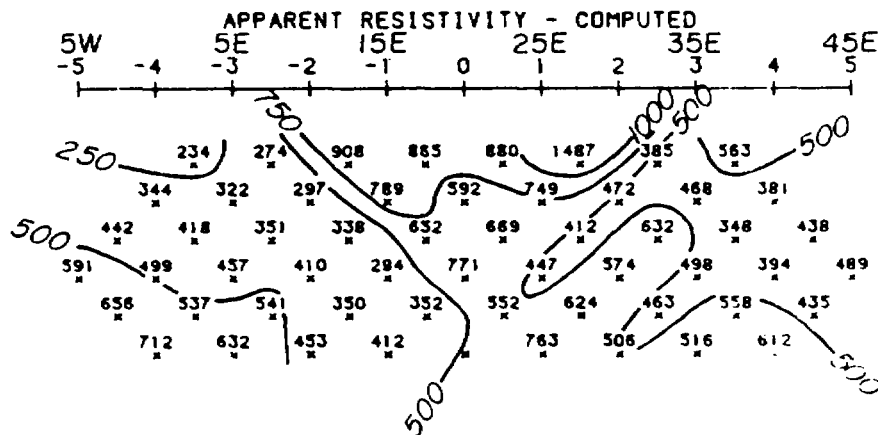
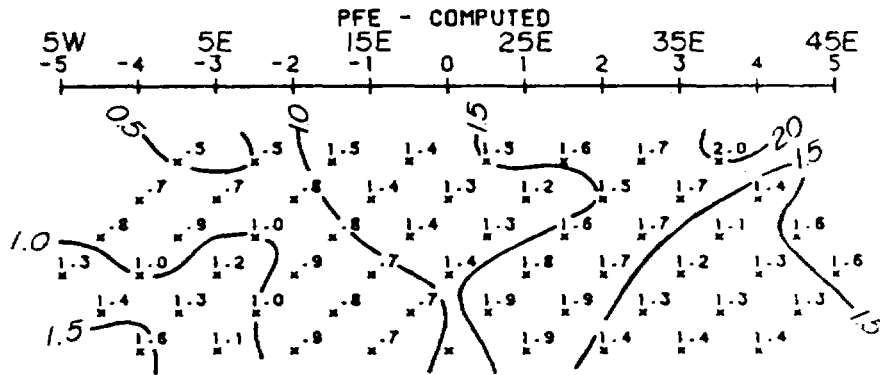
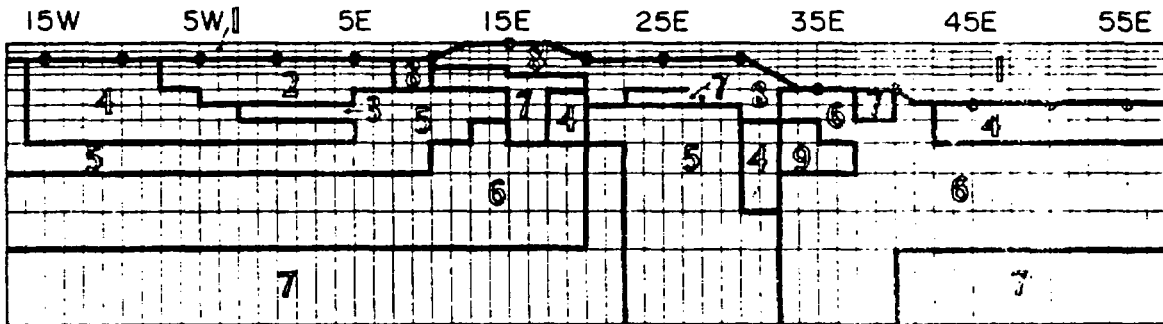

BODY NO.	RESISTIVITY (ohm-m)	P.F.E. %
1 (air)	400,000	0.0
2	100	1.5
3	225	1.5
4	300	1.5
5	500	1.5
6	800	1.5
7	3200	2.0
8	4000	1.5
9	225	0.9

LINE D WEST 1/2 YUCCA MOUNTAIN AREA Nevada Test Site

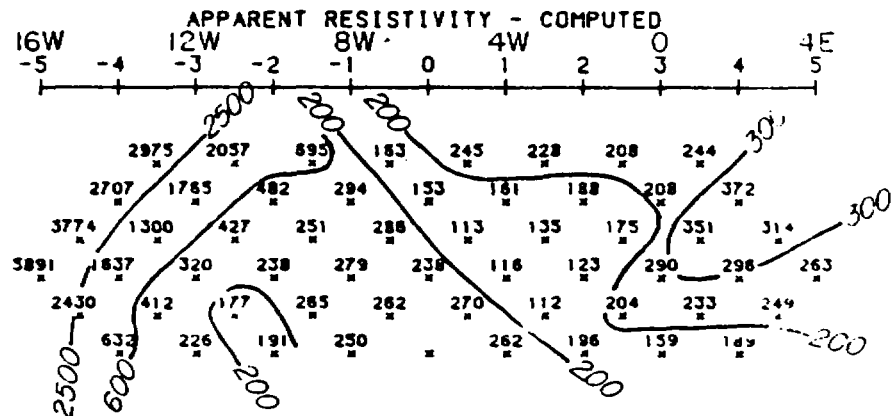
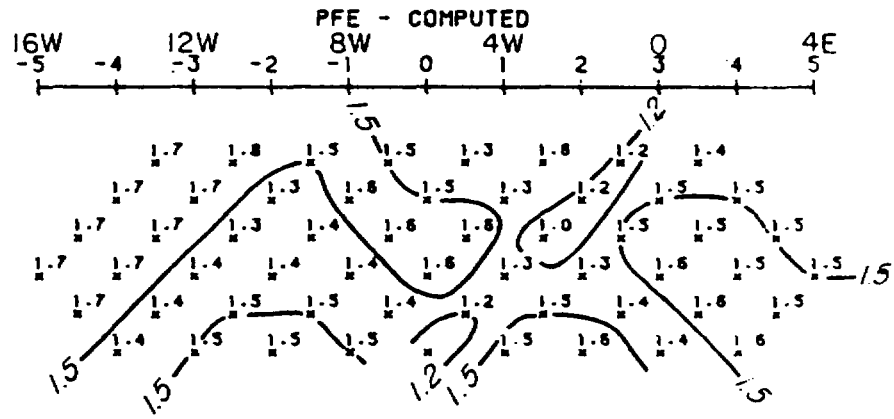
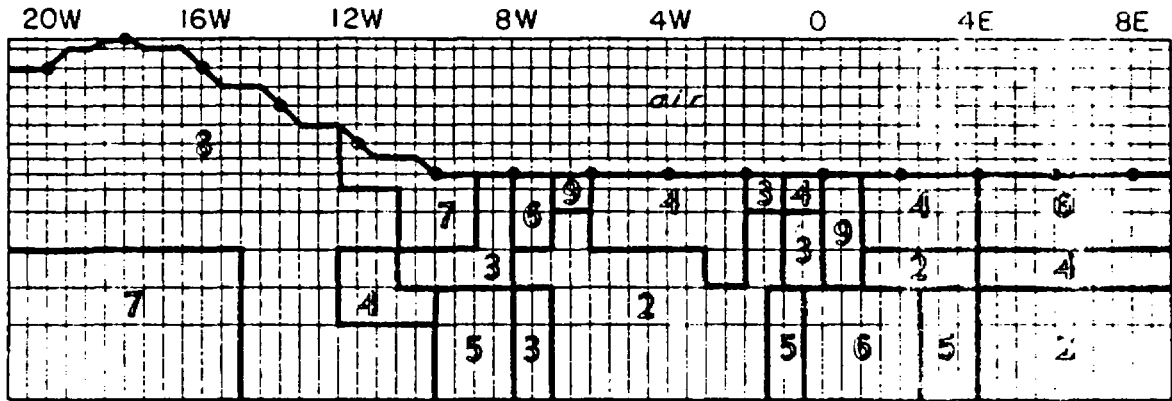

BODY NO.	RESISTIVITY (ohm-m)	P.F.E. (%)
1 (air)	200,000	0.0
2	100	0.9
3	225	1.4
4	350	1.1
5	425	1.4
6	800	2.2
7	1200	2.2
8	2050	1.9

LINE D EAST/2 YUCCA MOUNTAIN AREA Nevada Test Site

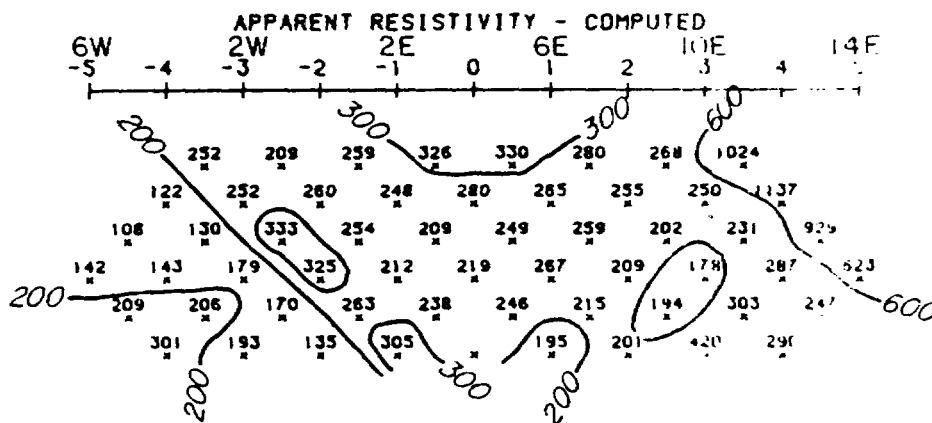
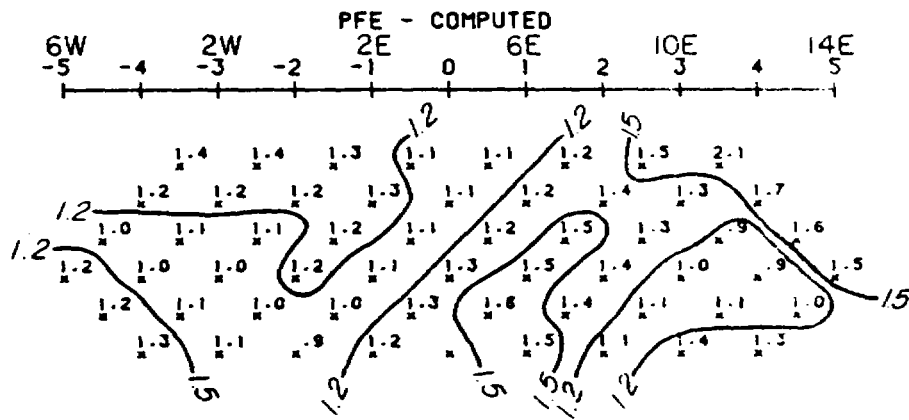
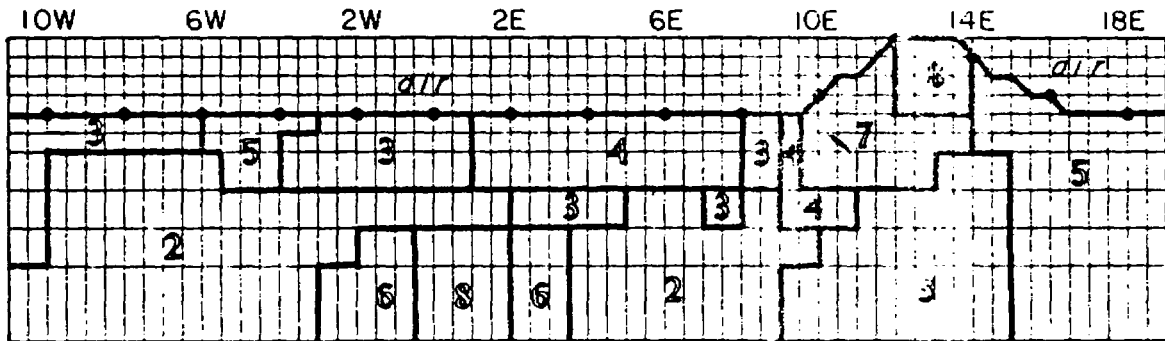

NO.	BODY RESISTIVITY (ohm-m)	P.F.E. %
1 (air)	400,000	0.0
2	100	0.6
3	200	1.0
4	400	0.6
5	600	1.2
6	1000	1.6
7	2000	1.2
8	4000	2.0

LINE D' WEST 1/2 YUCCA MOUNTAIN AREA Nevada Test Site

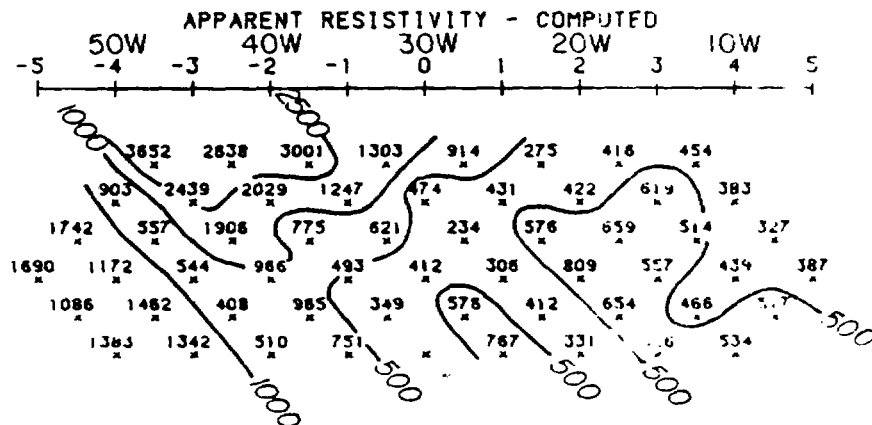
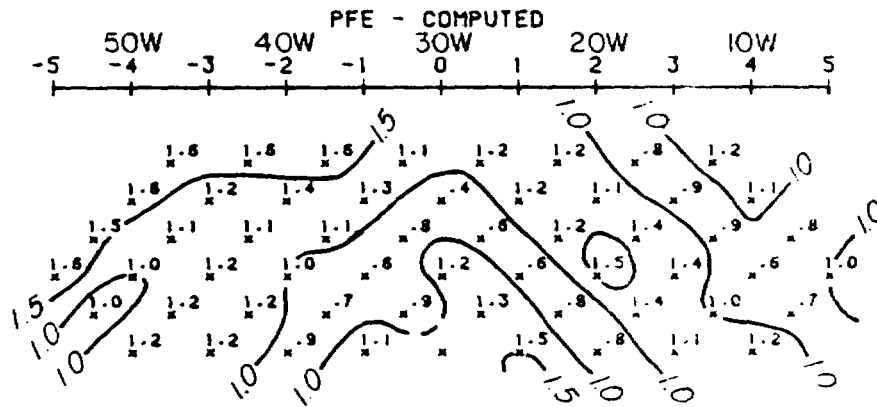
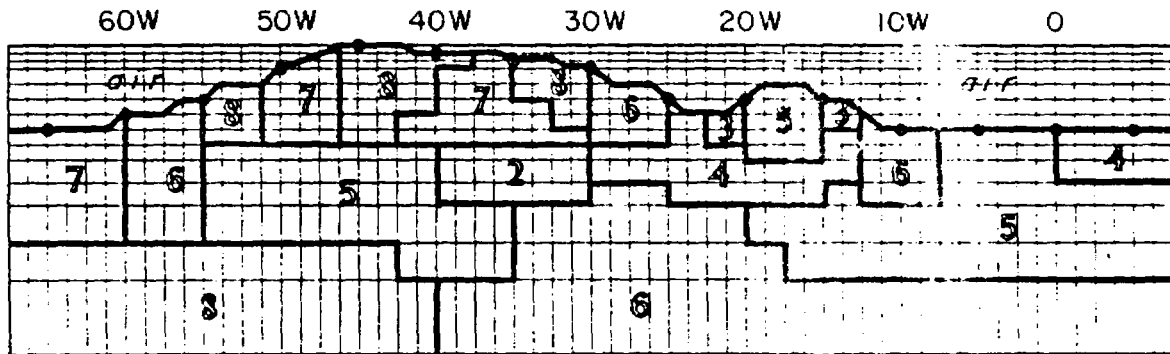

BODY NO	RESISTIVITY (ohm-m)	PFE %
1 (air)	160,000	0.0
2	200	1.3
3	300	3.5
4	450	0.7
5	600	1.0
6	750	1.4
7	1600	0.5

LINE D' EAST/2 YUCCA MOUNTAIN AREA Nevada Test Site

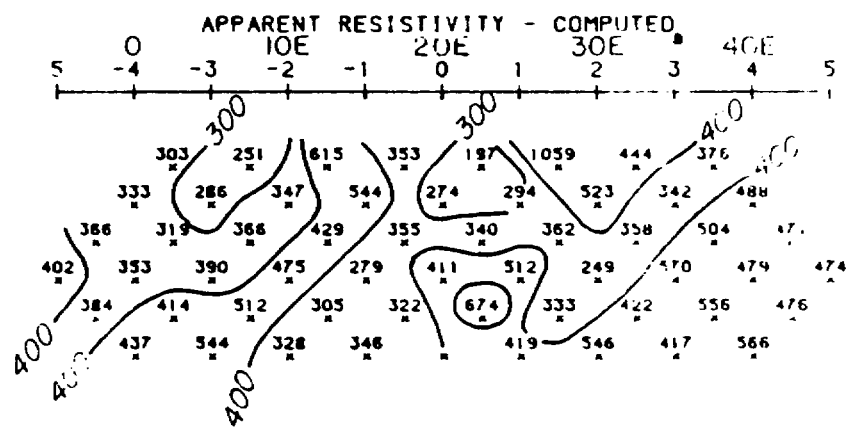
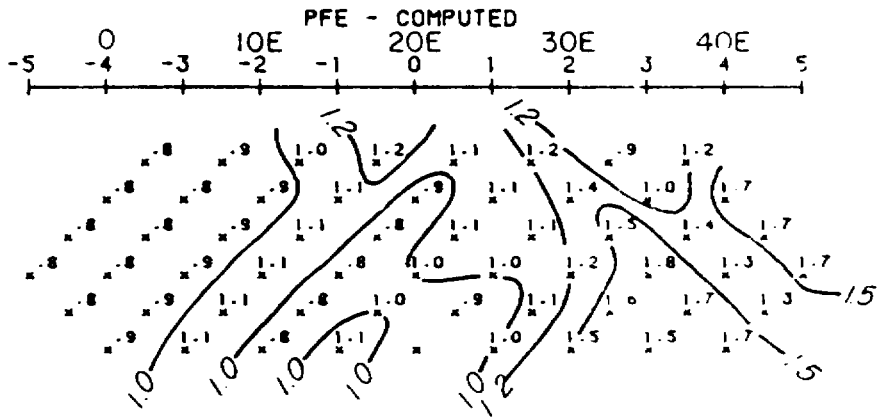
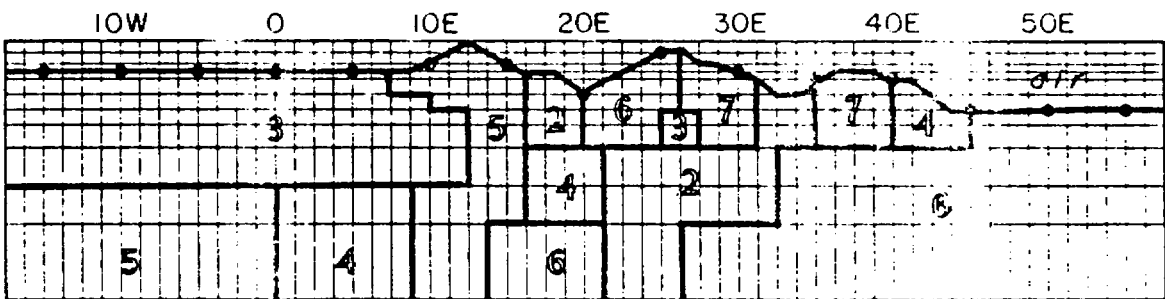

BODY RESISTIVITY P.F.E.		
NO.	(ohm-m)	%
1 (air)	150,000	0.0
2	150	1.2
3	250	1.1
4	900	1.2
5	450	1.6
6	600	1.2
7	1500	1.1
8	900	0.6

LINE E YUCCA MOUNTAIN AREA Nevada Test Site

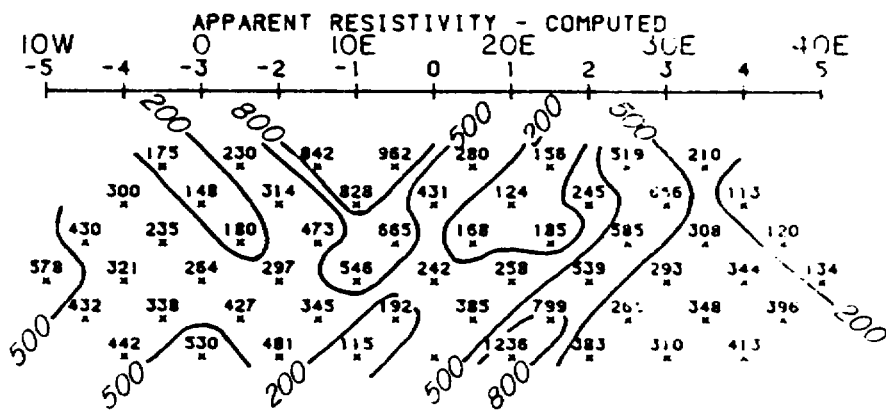
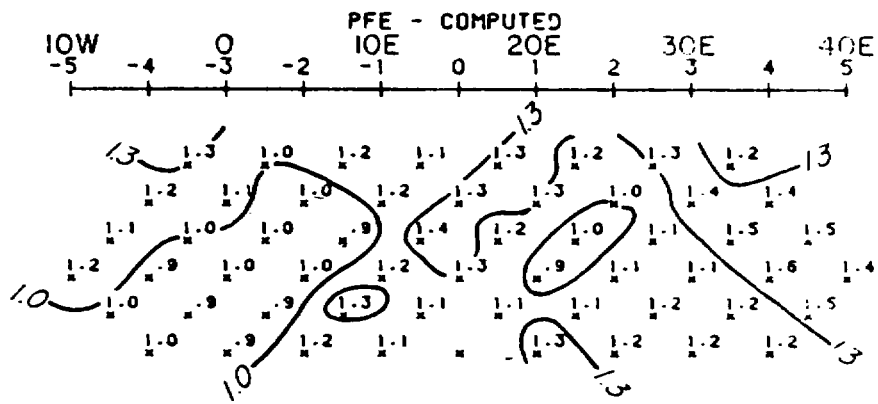
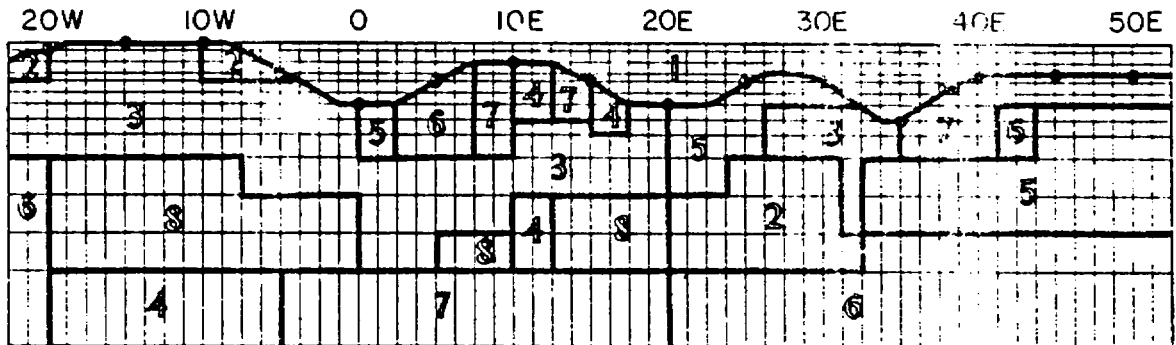

**THIS PAGE IS AN
OVERSIZED DRAWING OR
FIGURE,**

**THAT CAN BE VIEWED AT THE
RECORD TITLED:
PLATE VII
"INTERPRETED INTRINSIC
RESISTIVITY & P.F.E."**

WITHIN THIS PACKAGE.

D-01

**THIS PAGE IS AN
OVERSIZED DRAWING OR
FIGURE,**

**THAT CAN BE VIEWED AT THE
RECORD TITLED:
PLATE VI
"INTERPRETED INTRINSIC
RESISTIVITY & P.F.E."**

WITHIN THIS PACKAGE.

D-02

**THIS PAGE IS AN
OVERSIZED DRAWING OR
FIGURE,**

**THAT CAN BE VIEWED AT THE
RECORD TITLED:**

**PLATE V
"INTERPRETED INTRINSIC
RESISTIVITY & P.F.E."**

WITHIN THIS PACKAGE.

D-03

**THIS PAGE IS AN
OVERSIZED DRAWING OR
FIGURE,**

**THAT CAN BE VIEWED AT THE
RECORD TITLED:**

**PLATE IV
"INTERPRETED RESISTIVITY/ IP
SECTION LINE B' - 1000 FOOT
DIPOLES."**

WITHIN THIS PACKAGE.

D-04

**THIS PAGE IS AN
OVERSIZED DRAWING OR
FIGURE,**

**THAT CAN BE VIEWED AT THE
RECORD TITLED:**

**"PLATE A GENERALIZED GEOLOGIC
MAP OF PART OF YUCCA MOUNTAIN,
NEVADA TEST SITE, NEVADA."**

WITHIN THIS PACKAGE

D-05

**THIS PAGE IS AN
OVERSIZED DRAWING OR
FIGURE,**

**THAT CAN BE VIEWED AT THE
RECORD TITLED:**

**PLATE II INTERPRETED
RESISTIVITY/IP SECTIONS LINES A,B,
8 D - 200 FOOT DIPOLES.**

WITHIN THIS PACKAGE

D-06

**THIS PAGE IS AN
OVERSIZED DRAWING OR
FIGURE,**

**THAT CAN BE VIEWED AT THE
RECORD TITLED:**

**PLATE III INTERPRETED
RESISTIVITY/IP SECTIONS LINES C,D,
8 E - 500 FOOT DIPOLES.**

WITHIN THIS PACKAGE

D-07

**THIS PAGE IS AN
OVERSIZED DRAWING OR
FIGURE,**

**THAT CAN BE VIEWED AT THE
RECORD TITLED:**

**PLATE I
LINE LOCATION MAP YUCCA
MOUNTAIN AREA.**

WITHIN THIS PACKAGE

D-08