



UNITED STATES  
NUCLEAR REGULATORY COMMISSION  
REGION IV  
811 RYAN PLAZA DRIVE, SUITE 400  
ARLINGTON, TEXAS 76011-4005

November 5, 2003

Gregory M. Rueger, Senior Vice  
President, Generation and Chief Nuclear Officer  
Pacific Gas and Electric Company  
Diablo Canyon Power Plant  
P.O. Box 3  
Avila Beach, California 93424

SUBJECT: DIABLO CANYON POWER PLANT - SUMMARY OF THE EXIT MEETING WITH  
PACIFIC GAS AND ELECTRIC COMPANY TO DISCUSS THE RESULTS OF AN  
NRC SPECIAL INSPECTION (NRC INSPECTION REPORT 50-275/2003010  
AND 50-323/2003010)

Dear Mr. Rueger:

This refers to the public meeting conducted at the Pacific Gas and Electric Company's Community Center in San Luis Obispo, California, on October 28, 2003. The purpose of this meeting was to discuss the results of an NRC special inspection performed to better understand the circumstances surrounding the high number of battery charger failures. The meeting attendance list and a copy of the handout provided during the meeting are enclosed. The special inspection report will be available within 30 days from the date of this exit meeting on the NRC's document system.

In accordance with Section 2.790 of the NRC's "Rules of Practice," Part 2, Title 10, Code of Federal Regulations, a copy of this letter and its enclosure will be available electronically for public inspection in the NRC's Public Document Room or from the Publicly Available Records (PARS) component of NRC's document system (ADAMS). ADAMS is accessible from the NRC Web site at <http://www.nrc.gov/reading-rm/adams/index.html> (the Public Electronic Reading Room).

Should you have any questions concerning this matter, we will be pleased to discuss them with you.

Sincerely,

A handwritten signature in black ink that reads "William B. Jones".

William B. Jones, Chief  
Project Branch E  
Division of Reactor Projects

Dockets: 50-275  
50-323  
License : DPR-80  
DPR-82

Enclosures:

1. Attendance List
2. NRC Handout

cc w/enclosures:

David H. Oatley, Vice President  
and General Manager  
Diablo Canyon Power Plant  
P.O. Box 56  
Avila Beach, CA 93424

Lawrence F. Womack, Vice President, Power  
Generation & Nuclear Services  
Diablo Canyon Power Plant  
P.O. Box 56  
Avila Beach, CA 93424

James R. Becker, Vice President  
Diablo Canyon Operations and  
Station Director, Pacific Gas and  
Electric Company  
Diablo Canyon Power Plant  
P.O. Box 3  
Avila Beach, CA 93424

Pete Wagner  
Sierra Club California  
2650 Maple Avenue  
Morro Bay, CA 93442

Nancy Culver  
San Luis Obispo Mothers for Peace  
P.O. Box 164  
Pismo Beach, CA 93448

Chairman  
San Luis Obispo County Board of  
Supervisors  
Room 370  
County Government Center  
San Luis Obispo, CA 93408

Truman Burns\Mr. Robert Kinosian  
California Public Utilities Commission  
505 Van Ness, Rm. 4102  
San Francisco, CA 94102

Diablo Canyon Independent Safety Committee  
Robert R. Wellington, Esq.  
Legal Counsel  
857 Cass Street, Suite D  
Monterey, CA 93940

Ed Bailey, Radiation Control Program Director  
Radiologic Health Branch  
State Department of Health Services  
P.O. Box 942732 (MS 178)  
Sacramento, CA 94234-7320

Richard F. Locke, Esq.  
Pacific Gas and Electric Company  
P.O. Box 7442  
San Francisco, CA 94120

City Editor  
The Tribune  
3825 South Higuera Street  
P.O. Box 112  
San Luis Obispo, CA 93406-0112

James D. Boyd, Commissioner  
California Energy Commission  
1516 Ninth Street (MS 34)  
Sacramento, CA 95814

Electronic distribution by RIV:  
Regional Administrator (**BSM1**)  
DRP Director (**ATH**)  
DRS Director (**DDC**)  
Senior Resident Inspector (**DLP**)  
Branch Chief, DRP/E (**WBJ**)  
Senior Project Engineer, DRP/E (**VGG**)  
Staff Chief, DRP/TSS (**PHH**)  
RITS Coordinator (**NBH**)

ADAMS:  Yes     No    Initials: WBJ  
 Publicly Available     Non-Publicly Available     Sensitive     Non-Sensitive

R:\ DC\2003\DC10-15-03 MS.wpd

RIV/SPE/DRP/E	C/DRP/E			
VGGaddy,mjs	WBJones			
	<i>J</i>			
11/ /03	11/5/03			

OFFICIAL RECORD COPY

T=Telephone

E=E-mail

F=Fax

## ENCLOSURE 1

### MEETING ATTENDANCE

#### NRC

M. Satorius, Deputy Director, Division of Reactor Projects (DRP)  
W. Jones, Chief, Projects Branch E, DRP  
D. Proulx, Senior Resident Inspector, DRP  
N. O'Keefe, Senior Reactor Inspector, Division of Reactor Safety  
T. Jackson, Resident Inspector, DRP  
V. Dricks, Public Affairs Officer, RIV

#### LICENSEE

D. Oatley, Vice President and General Manager  
J. Becker, Vice President , Operations & Station Director  
L. Womack, Vice President, Nuclear Services  
S. Chesnut, Director, Engineering Services  
C. Belmont, Director, Nuclear Quality Analysis & Licensing  
R. Curb, Director, Outage Management

## MEETING ATTENDANCE

<b>LICENSEE/FACILITY</b>	Pacific Gas and Electric Company Diablo Canyon Power Plant
<b>DATE/TIME</b>	October 28, 2003; 1:00 p.m.
<b>LOCATION</b>	PG&E Community Center 6588 Ontario Rd San Luis Obispo, CA, 93405
<b>MEETING TYPE</b>	CATEGORY 1: The public is invited to observe this meeting and will have one or more opportunities to communicate with the NRC after the business portion, but before the meeting is adjourned.
<b>NAME (PLEASE PRINT)</b>	<b>ORGANIZATION</b>
STEVE CHESNUT	DCPP ENGINEERING SERVICES
Paul Roller	DCPP Operations Services Director
ROD CURB	DCPP OUTAGE MANAGEMENT
DAVID VOSBURG	DCPP STRATEGIC PROJECTS
David Taggant	DCPP NQAL - Quality Verification
John Martin	NSOC
Jacqueline Hinds	DCPP NQAL
Tom Jones	PG&E
Larry Parker	PG&E
John GRIFFIN	DCPP Reg. Svcs.
DON MALONE	PG&E - RS

Rochelle Becker

## MEETING ATTENDANCE

<b>LICENSEE/FACILITY</b>	Pacific Gas and Electric Company Diablo Canyon Power Plant
<b>DATE/TIME</b>	October 28, 2003; 1:00 p.m.
<b>LOCATION</b>	PG&E Community Center 6588 Ontario Rd San Luis Obispo, CA, 93405
<b>MEETING TYPE</b>	CATEGORY 1: The public is invited to observe this meeting and will have one or more opportunities to communicate with the NRC after the business portion, but before the meeting is adjourned.
<b>NAME (PLEASE PRINT)</b>	<b>ORGANIZATION</b>
JUDE A. FLEDERMAN	PG&E DCCP MAINTENANCE
STAN KETEUSEN	PG&E REGULATORY SERVICES
Rich Cheney	PG&E Problem Prevention & Resolution
Dave Miklisch	PG&E Strategic Projects
CAL GILLIES	PG&E PROBLEM PREVENTION & RESOLUTION
RUDY ORTEGA	PG&E ENGINEERING SERVICES
AMIR AFZALI	PG&E PRA GROUP

# SPECIAL INSPECTION EXIT TO DISCUSS DIABLO CANYON POWER PLANT BATTERY CHARGER FAILURES



The public is invited to observe this meeting and will have one or more opportunities to communicate with the NRC after the business portion, but before the meeting is adjourned.

October 28, 2003





UNITED STATES  
NUCLEAR REGULATORY COMMISSION  
REGION IV  
611 RYAN PLAZA DRIVE, SUITE 400  
ARLINGTON, TEXAS 76011-4005

August 7, 2003

MEMORANDUM TO: Neil O'Keefe, Senior Reactor Engineer, Division Reactor Safety

FROM: Arthur T. Howell III, Director, Division of Reactor Projects */RA/ by  
Gail Good*

SUBJECT: CHARTER FOR THE SPECIAL INSPECTION TEAM AT THE DIABLO  
CANYON POWER PLANT (DCPP)

In response to our initial evaluation of high failure rates of Unit 1 and 2 safety-related and backup battery chargers, during the period March 2002 through May 2003, a Special Inspection Team is being chartered. You are hereby designated as the Special Inspection Team leader.

A. Background

There are a total of three primary and two backup battery chargers for each unit. During a 15-month period, there were three battery charger failures on Unit 1 (two primary and a backup) and three failures (all primary) on Unit 2. DCPP has two safety trains spread over three 4160 V vital safety buses (F, G, and H). The safety-related 4160 V busses power the battery chargers through 4160/480 V step-down transformers that serve the smaller loads. The vital battery chargers are fed from the 480 V load distribution centers. These vital battery chargers supply 130 Vdc and 400 amperes to keep each of the three (F, G, and H) vital batteries charged and provide the normal power supply to the vital dc loads.

DCPP design has two installed backup battery chargers (nonsafety). Thus, a primary battery charger can be removed from service, but the batteries remain operable as long as the backup charger is in service. This lineup is permitted by TS 3.8.4 (dc sources) for 14 days.

The Unit 2 design is as follows (Unit 1 is similar):

- Bus F: Primary dedicated charger is Battery Charger 2-1
- Bus G: Primary dedicated charger is Battery Charger 2-2
- Bus H: Primary dedicated charger is Battery Charger 2-3-2
- Backup charger for Battery Charger 2-1 (F) is Battery Charger 2-2-1
- Backup charger for Battery Charger 2-2 (G) is also Battery Charger 2-2-1
- Backup charger for Battery Charger 2-3-2 (H) is Battery Charger 2-3-1

assessment. The senior reactor analyst determined that operator recovery actions would not be credited in the NRC's initial safety assessment based in part on the preliminary results from a simulator run where the licensee found that the loss of battery chargers was not readily recognized by the operators. The senior reactor analyst had telephone discussions with the licensee regarding their preliminary risk assessment and their assumptions used in modeling the battery charger failures. The analyst found that the licensee's and the NRC's initial safety assessments were generally within 1 order of magnitude of each other.

The NRC staff found that three of the special inspection deterministic criteria were met and that the safety significance was within the range of a special inspection and no additional inspection. Therefore, considering the deterministic criteria and the initial NRC safety assessment, Region IV has determined that a Special Inspection Team is appropriate and the team is being dispatched to gain a better understanding of the failures associated with the battery chargers and the licensee's common mode failure analysis as it relates to the root cause(s). The team will also determine the extent of the impact of the battery charger failures and the overall safety significance, and it will verify the licensee's actions leading up to and including the identification and resolution of the condition.

C. Scope

The team is expected to perform data gathering and fact-finding in order to address the following items:

1. Develop a complete sequence of events related to the subject battery chargers in the dc system and licensee actions taken in response to the failures.
2. Evaluate pertinent industry operating experience and potential precursors to the condition, including the effectiveness of any action taken in response to the operating experience.
3. Evaluate the adequacy of the licensee response to the battery charger failures (timeliness of evaluation, notifications, appropriate use of all relevant data, procedure usage, etc.).
4. Determine what evaluations were performed to assess operability of the battery chargers.
5. Review the licensee's root cause evaluation determination for independence, completeness, and accuracy, including the risk analysis of the event.
6. Review the licensee's justification for the established service life of the electrolytic capacitors in the battery chargers and other components.
7. Sample the licensee's preventive maintenance and aging management programs to independently assess the extent of condition in regard to other components.

# 125 Vdc Power System

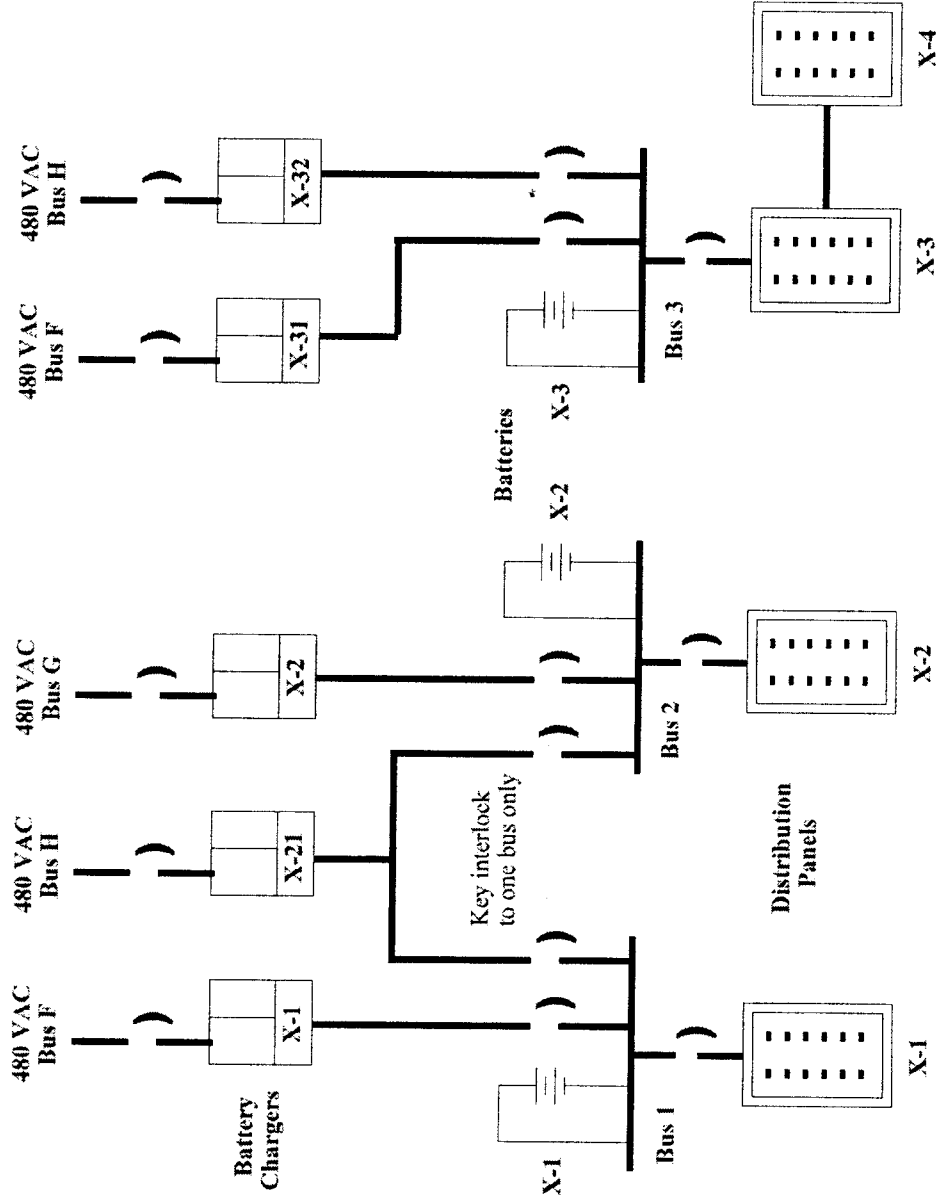

NOTE: 'X' denotes the unit, either '1' or '2'.

### 5-Year Battery Charger Failure History

<u>Charger 11</u>	<u>Charger 12</u>	<u>Charger 121</u> (spare)	<u>Charger 131</u> (spare)	<u>Charger 132</u>
<b>2/15/99</b>	<b>3/2/99</b>	5/8/02	None	3/22/02
	<b>12/15/00</b>			
	5/7/02			
<u>Charger 21</u>	<u>Charger 22</u>	<u>Charger 221</u> (spare)	<u>Charger 231</u> (spare)	<u>Charger 232</u>
<b>12/12/01</b>	<b>1/27/99</b>	None	None	2/22/03
5/27/03	<b>6/28/00</b>			
	<b>9/18/01</b>			
	2/19/03			

Dates in bold indicate failures which were not being considered in licensee's root cause analysis prior to the special inspection.

# Gate Filter Module

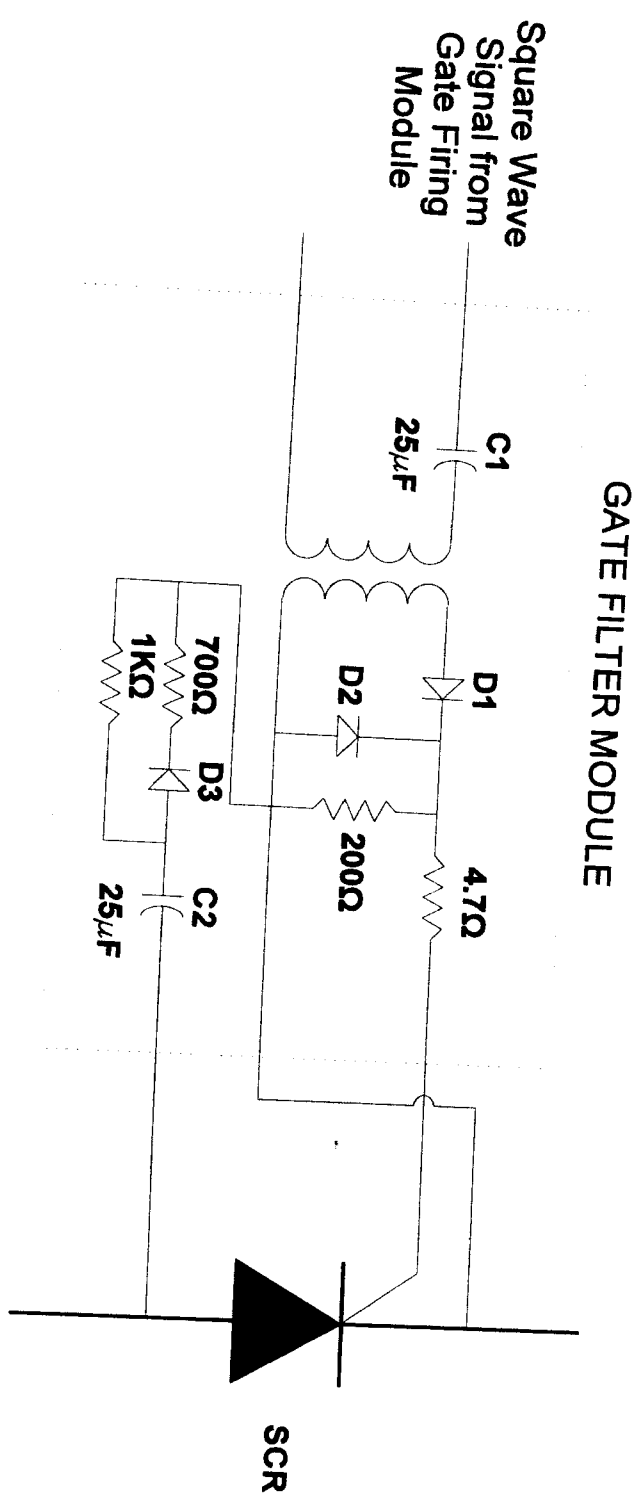

- 8. Review the licensee's restart process from planned and forced outages to assess deferred work activities. Sample the status of work deferred from the last Units 1 and 2 forced and refueling outage activities. Determine whether operability reviews were needed.
- 9. Review and assess the licensee's corrective actions and ensure that they have adequately evaluated and addressed the extent of condition. Include recommendations from the licensee's Maintenance Rule Panel.
- 10. Verify adequacy of postmaintenance testing activities for the battery chargers.
- 11. Evaluate and determine the common-cause failure aspects.
- 12. Review the condition for generic implications.

C. Guidance

Inspection Procedure 93812, "Special Inspection," dated July 7, 2003, provides additional guidance to be used by the Special Inspection Team.

This memorandum designates you as the Special Inspection Team leader. Your duties will be as described in Inspection Procedure 93812. The team composition will consist of yourself and Mr. Terry Jackson, Resident Inspector, DCCP. During performance of the Special Inspection, the designated team member is separated from normal duties and reports directly to you. The team is to emphasize fact-finding in its review of the circumstances surrounding the event, and it is not the responsibility of the team to examine the regulatory process. Safety concerns identified that are not directly related to the event should be reported to the Region IV office for appropriate action.

The Team will report to the site, conduct an entrance, and begin inspection on August 11, 2003. Tentatively, the inspection should be completed by the close of business on August 15, 2003. A formal exit will be scheduled following completion of the on-site inspection. A report documenting the results of the inspection will be issued within 30 days of the completion of the inspection. While the team is onsite, you will provide daily status briefings to Region IV management.

This Charter may be modified should the team develop significant new information that warrants review. Should you have any questions concerning this Charter, contact William B. Jones at (817) 860-8147.

cc via E-mail:  
T. Gwynn  
D. Chamberlain  
A. Howell  
G. Good  
A. Gody  
C. Marschall

Surveillance Test Procedure STP M-12B, "Battery Charger Performance Test," verifies a charger's capability to deliver greater than 130 Vdc at 400 amperes for at least 4 hours.

STP M-12A, "Vital Station Battery Modified Performance Test," verifies that the station vital batteries can power the dc loads for 2.5 hours at 400 amperes when disconnected from the battery chargers.

## B. Basis

On March 22, 2002, Primary Battery Charger 1-3-2 failed while in normal service. The licensee determined that the failure was due to an electrolytic capacitor failure. Subsequently, Primary Battery Charger 1-2 failed while recharging Battery 1-2, following completion of STP M-12A on May 7, and the following day Battery Charger 1-2-1 also failed while recharging Battery 1-2. The licensee determined that the battery charger failures were age-related failures of the electrolytic capacitors. The battery chargers were then placed in 10 CFR 50.65 a(1) of the maintenance rule. The maintenance rule panel determined that a common cause failure of Unit 1 battery chargers had occurred and that a prudent action would be to inspect/replace the electrolytic capacitors in the remaining battery chargers.

On February 19, 2003, during Refueling Outage 2RF11, Battery Charger 2-2 failed while recharging vital Battery 2-2 following completion of STP M-12A. Three days later Battery Charger 2-3-2 failed while recharging vital Battery 2-3 following completion of STP M-12A. On March 23 the Plant Safety Review Committee approved Unit 2 for restart and plant heatup to Mode 3 (Hot Standby). The following day Unit 2 entered Mode 2 and the outage ended with synchronization of the main generator to the grid. On May 22, 2003, the licensee attributed the Unit 2 battery charger failures to aged capacitors. On May 27 Battery Charger 2-1 failed a modified STP M-12B (1-hour load test). The licensee determined that the electrolytic capacitors failed.

The NRC staff considered both deterministic and safety significance criteria, established in NRC Management Directive 8.3, "NRC Incident Investigation Program," to determine whether a special inspection would be performed. In evaluating the battery charger failures for a special inspection, the NRC staff determined that three deterministic criteria were met. Specifically, the battery charger failures involved possible adverse generic implications, the failures were repetitive (common cause), and concerns were identified regarding the licensee's operational performance and the timeliness of corrective actions. In regard to the last item, the NRC staff noted that the licensee had delayed testing on Battery Charger 2-1 until after the completion of Refueling Outage (2RF11).

In regard to safety significance, an NRC senior reactor analyst performed a safety assessment. The senior reactor analyst assessed an incremental conditional core damage probability on the order of 6E-6 using the NRC's Standard Plant Analysis Risk (SPAR) model, Diablo Canyon, Revision 3QA, for the common cause failure of the three primary and two backup battery chargers. The senior reactor analyst and the licensee discussed the recovery action that should be considered in the safety

# **AGENDA**

**OPENING REMARKS:**

*Mark Satorius, Deputy Director, Division Reactor Projects, Region IV*

**INTRODUCTIONS:**

*Nuclear Regulatory Commission and Pacific Gas and Electric Company*

**SPECIAL INSPECTION:**

*William Jones, Chief, Project Branch E*

**INSPECTION RESULT:**

*Neil O'Keefe, Senior Reactor Engineer, Division Reactor Safety*

**LICENSEE COMMENTS:**

*David Oatley, Vice President and General Manager, Diablo Canyon*

**NRC COMMENTS :**

*Marks Satorius and William Jones*

**PUBLIC COMMENTS AND QUESTIONS**

**CLOSING REMARKS:**

*Nuclear Regulatory Commission and Pacific Gas and Electric*