

February 21, 2001

1280 APR 10 2001 RB W

**MEMORANDUM TO:** Christopher I. Grimes, Chief  
License Renewal and Standardization Branch  
Division of Regulatory Improvement Programs

**FROM:** Robert J. Prato, Project Manager *IRA*  
License Renewal and Standardization Branch  
Division of Regulatory Improvement Programs

**SUBJECT:** FORTHCOMING MEETING WITH ENTERGY OPERATIONS, INC.  
(ENTERGY), ON LICENSE RENEWAL FIRE PROTECTION SCOPING  
FOR ARKANSAS NUCLEAR ONE (ANO), UNIT 1

**DATE & TIME:** Wednesday, March 7, 2001  
9:30 a.m.

**LOCATION:** U.S. Nuclear Regulatory Commission  
One White Flint North  
11555 Rockville Pike  
Rockville, Maryland 20852  
Room O-10 B4

**PURPOSE:** To address the applicant's list of fire protection components required to meet 10 CFR 50.48.

**PARTICIPANTS\*:**

<u>NRC</u>	<u>Entergy</u>
J. Moore, OGC	D. James
J. Hannon, NRR	G. Young
C. Grimes, NRR	R. Lane
E. Weiss, NRR	R. Rispoli
T. Eaton	D. Williams
W. Burton, NRR	
R. Prato, NRR	

Docket No. 50-313 (Entergy))

cc: See next page

CONTACT: Robert J. Prato, NRR  
301-415-1147

\*Meetings between NRC technical staff and applicants or licensees are open for interested members of the public, interveners, or other parties to attend as observers pursuant to "Commission Policy Statement on Staff Meetings Open to the Public" 59 Federal Register 48340, 9/20/94.

Attachment 1

H/B W

03/08/01 MEETING

TITLE: Fire Protection, Public Meeting

Participant	Organization	Phone#
<u>Robert Prato</u>	<u>NRR/DRIP/RLSB</u>	<u>301-415-1147</u>
<u>Dale E. James</u>	<u>Energy - AAO</u>	<u>501-858-4619</u>
<u>Dan Williams</u>	<u>Energy - AAO</u>	<u>501-858-4628</u>
<u>Rick Lane</u>	<u>Energy - AAO</u>	<u>501-858-4400</u>
<u>Bon Rispoli</u>	<u>ENERGY - AAO</u>	<u>501-858-1915</u>
<u>Bill Beckley</u>	<u>NRC/NRR</u>	<u>301-415-1323</u>
<u>Tanya Eaton</u>	<u>NRC/NRR</u>	<u>301-415-3610</u>
<u>Ed Connell</u>	<u>NRC/NRR</u>	<u>301-415-3578</u>
<u>Dan Frumkin</u>	<u>NRC/NRR</u>	<u>501-415-2280</u>
<u>Chung-Yang Li</u>	<u>NRC/NRR</u>	<u>301-415-2830</u>
<u>Nancy St. Amant</u>	<u>NRC/OCC</u>	<u>301-415-1589</u>
<u>Chris Cimini</u>	<u>NRC/RLSB</u>	<u>301-415-1183</u>
<u>Grady</u>		

---

# ANO-1 License Renewal

Fire Protection Open Item

March 8, 2001



# Open Item

---

- ◆ Open Item 2.2.3.3.2.2-1 of ANO-1 SER requested Entergy Operations provide sufficient justification for the exclusion of certain fire protection components from the scope of license renewal



# Open Item

---

## ◆ Entergy Operations did not include

- ✦ Fire protection jockey pump
- ✦ Carbon dioxide systems
- ✦ Fire hydrants
- ✦ Fire water supply to the low level radwaste building
- ✦ Piping to the manual hose station



# Open Item Position

---

## ◆ Entergy Operations Position

- ✦ 10CFR50.48 focus is on safety-related equipment

- ✓ None of the SSC's discussed in the SER open item protect safety-related components or safe shutdown equipment



# Current Licensing Basis

## ◆ 10CFR50.48(a)(1)

- ✦ Requires each operating nuclear power plant have a fire protection plan that satisfies 10CFR Part 50, Appendix A, General Design Criterion (GDC) 3
- ✦ GDC 3 requires fire detection and fighting systems of appropriate capacity and capability shall be provided and designed to minimize the adverse effects of fires on structures, systems, and components (SSCs) important to safety



# Current Licensing Basis

## ◆ Per 10CFR50.48

- ✦ “the Plan shall also describe ....the means to limit fire damage to SSCs important to safety so that the capability to safely shut down the plant is ensured (Reference made to BTP APSCB 9.5-1)”





# Current Licensing Basis

## ◆ BTP APCS 9.5-1

- ✦ "Purpose of the Fire Protection Program.....is to maintain the ability to perform safe reactor plant shutdown functions and to minimize radioactive releases to the environment in the event of a fire."



# Current Licensing Basis

- ◆ Standard Review Plan “Review Procedures”
  - ✦ “APCSB reviews the analysis in the SAR of the fire potential in safety-related areas and the hazard of fires to these areas to determine that the proposed fire protection program is able to maintain the ability to perform safe shutdown functions and to minimize radioactive releases to the environment”



# Current Licensing Basis

## ◆ Standard Review Plan “Review Procedures”

- ✦ “APCSB reviews the FPS P&ID’s, plant layout drawings to verify that the facility arrangement, buildings, and structural and compartmentation features which effect the methods used for fire protection, fire control and control of hazards are acceptable for the protection of safety-related equipment.”



# Current Licensing Basis

## ◆ Standard Review Plan “Review Procedures”

- ✦ “APCSB determines that design criteria and basis for the detection and suppression systems for smoke, heat, flame control, are in accord[ance] with the BTP guidelines and provides adequate protection for safety-related equipment.”



# Current Licensing Basis

- ◆ Standard Review Plan “Review Procedures”
  - ✦ The reviewer will determine that the limiting conditions for operation and surveillance requirements of the Technical Specifications are in agreement with the requirements developed as a result of the staff's review.



# Current Licensing Basis

- ◆ Appendix R to 10CFR Part 50
  - ✦ Invoked by 10CFR50.48(b) to establish fire protection features required to satisfy GDC 3 with respect to certain generic issues for nuclear power plants licensed to operate before January 1, 1979
  - ✦ In Appendix R Introduction and Scope, "The phrases important to safety or safety-related will be used throughout this Appendix R as applying to all safety functions."



# Current Licensing Basis

## ◆ 1978 SER

- ✦ “We have reviewed the licensee’s analysis and have visited the plant to examine the relationship of safety-related components, systems, and structures with both combustibles and associated fire detection and suppression systems.”
- ✦ “Our review has been limited to the aspects of fire protection within the NRC’s jurisdiction, i.e., those aspects of fire protection related to the protection of public health and safety.”



# Jockey Pump

---

- ◆ Maintains fire main pressure when there is no demand on system
- ◆ Per BTP APSCB 9.5-1, "Details of fire pump installation should as a minimum conform to NFPA 20"
- ◆ Not a required component per NFPA 20 "Standard for the Installation of Stationary Pumps for Fire Protection"





# Jockey Pump

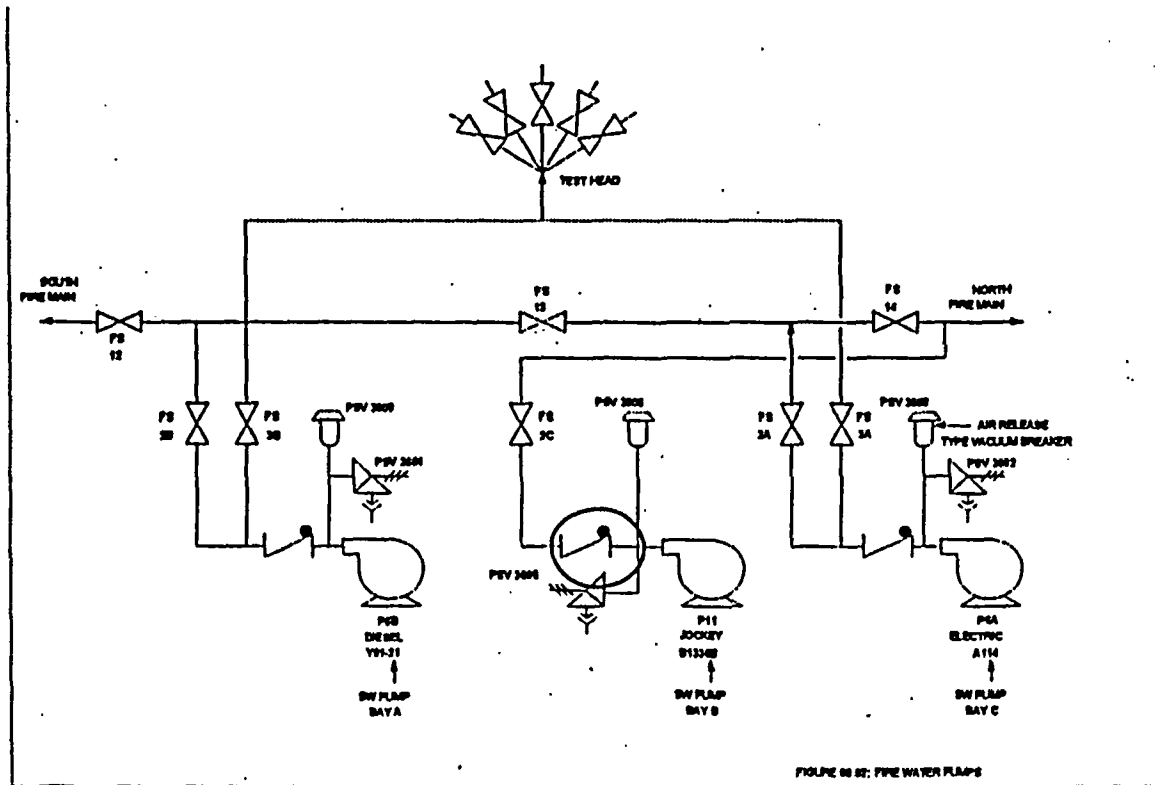

Entergy

Entergy

# Jockey Pump

---

- ◆ 1978 SER, Evaluation of plant features:
  - ✦ “Two vertical shaft centrifugal fire pumps are provided...”
  - ✦ “An automatic electric jockey pump maintains pressure on the fire piping system.”
- ◆ 1978 SER, Conclusion:
  - ✦ “We find that the fire pumps conform to the provisions of Appendix A to BTP 9.5-1 and are, therefore acceptable.”



# CO<sub>2</sub> & Hose Station

---

- ◆ Carbon dioxide

- ✦ System function is strictly to minimize damage to the main turbine and exciter in the event of a fire

- ◆ Hose station

- ✦ Located on the turbine building roof
- ✦ No safety-related equipment in the area



# CO<sub>2</sub> & Hose Station

## ◆ BTP 9.5-1

- ✦ No mention of protection schemes for turbine generator or exciter.



# CO<sub>2</sub> & Hose Station

## ◆ 1978 SER - Turbine Building

### ✦ Consequences if no fire suppression

- ✓ "The fire barriers separating safety-related areas from the turbine building assure that unmitigated turbine building fires have no adverse consequences on safety-related equipment located in adjacent areas"



# Fire Hydrants

---

## ◆ Fire Hydrants

- ✦ Not the primary source of fire protection needed to support safe shutdown in the event of a fire



# Fire Hydrants

---

- ◆ Fire hydrants referenced in several portions of 1978 SER
  - ✦ Intake structure
  - ✦ Fuel oil storage vault
  - ✦ Yard area



# Fire Hydrants

---

- ◆ 1978 SER yard area

- ✦ Consequences if no fire suppression

- ✓ "An unsuppressed fire in the transformers, auxiliary boiler, or storage tanks in the yard area would not present a significant fire exposure to safety-related systems because of intervening distance or barriers."





# Low Level Radwaste Building Piping

---

- ◆ The function of the piping to the new low level radwaste building is to minimize damage to plant property in the event of a fire.



# Low Level Radwaste Building Piping

---

## ✦ New construction 1986

- ✓ Building is constructed of reinforced concrete
- ✓ Minimal exposures
- ✓ No significant ignition sources
- ✓ Majority of materials stored in high integrity containers
- ✓ Limited building access
- ✓ No safe shutdown equipment

✦ These attributes minimize radioactive releases to the environment as a result of fire.



# 1978 SER Conclusions

---

## ◆ 1978 SER

### ✦ Conclusions

- ✓ "significant steps are being taken to assure that safe shutdown can be accomplished and the plant maintained in a safe condition during and following potential fire situations."
- ✓ "Fire detection and suppression systems will minimize, consistent with other safety requirements, the effects of fire on safety-related systems and will not in themselves significantly impair the capability of safety-related systems."
- ✓ "A fire in any fire zone will not damage safety-related structures such that they cannot perform their safety function."



# Conclusion

---

## ◆ Entergy Operations Position

- ✦ 10CFR50.48, BTP-9.5-1, SRP, Appendix R, and Technical Specifications focus on protection of safe shutdown equipment
- ✦ Conclusions contained in the 1978 fire protection SER support position that emphasis was on protection of safety-related equipment
- ✦ Open Item SSCs are not relied upon to protect safety-related equipment or mitigate fires that would challenge safe shutdown
- ✦ Open Item SSCs are not necessary in order to meet the requirements of 10CFR50.48

