

- NOTES:**
1. THE COMPONENT IS SHOWN TO ILLUSTRATE IT FUNCTIONALLY AND MAY NOT REFLECT THE EXACT CONFIGURATION.
  2. VALVE POSITIONS REFLECT AN ENGINE RUNNING CONDITION.
  3. SEE NOTE 5 ON SHEET 1 OF THIS DRAWING.
  4. CONTINUOUS AND INTERMITTENT PRELUDE DOES NOT FLOW THROUGH FILTERS 2F-7119A, 7119B, 7119C.
  5. SEE SHEET 1 OF THIS DRAWING FOR ALL REMAINING NOTES.

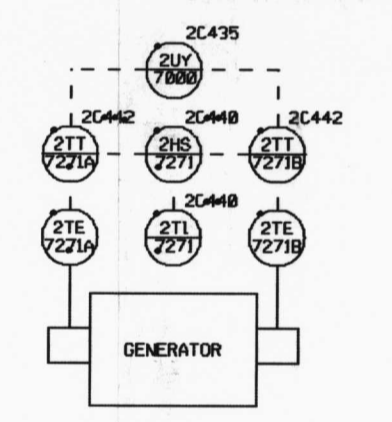

| LINE COLOR | LEGEND                                     |
|------------|--|
| (Symbol)   | SYSTEM/AMB REPORT                          |
| (Symbol)   | ALTERNATE AC DIESEL GENERATOR/82-R-2885-11 |
| (Symbol)   | LICENSE RENEWAL BOUNDARY                   |

ARKANSAS NUCLEAR ONE  
UNIT 2  
RUSSELLVILLE, ARKANSAS

| DRAWING NO | SHEET | REVISION |
|------------|-------|----------|
| LRA-M-2241 | 5     | B        |

| REV | DESCRIPTION             | DATE | BY | CHKD | APP'D |
|-----|-------------------------|------|----|------|-------|
| 1   | ISSUED FOR CONSTRUCTION |      |    |      |       |
| 2   | ISSUED FOR CONSTRUCTION |      |    |      |       |
| 3   | ISSUED FOR CONSTRUCTION |      |    |      |       |
| 4   | ISSUED FOR CONSTRUCTION |      |    |      |       |
| 5   | ISSUED FOR CONSTRUCTION |      |    |      |       |
| 6   | ISSUED FOR CONSTRUCTION |      |    |      |       |
| 7   | ISSUED FOR CONSTRUCTION |      |    |      |       |
| 8   | ISSUED FOR CONSTRUCTION |      |    |      |       |
| 9   | ISSUED FOR CONSTRUCTION |      |    |      |       |
| 10  | ISSUED FOR CONSTRUCTION |      |    |      |       |

2 BASED ON M-2241 SH 5 REV 3 1 RED X OF ORIGINAL

D-53