



Designated Original

Entergy Operations, Inc.
Waterloo Road
P.O. Box 756
Port Gibson, MS 39150
Tel 601 437 6470

Jerry C. Roberts
Director
Nuclear Safety Assurance

June 23, 2003

U.S. Nuclear Regulatory Commission
Washington, D.C. 20555

Attention: Document Control Desk

Subject: LER-2003-002-00 [Automatic Reactor Scram (#107) Due To
A Partial Loss of Offsite Power]

Grand Gulf Nuclear Station
Docket No. 50-416
License No. NPF-29

GNRO-2003/00038

Ladies & Gentlemen:

Attached is Licensee Event Report (LER) 2003-002-00 which is a final report. This letter does not contain any commitments.

Yours truly,

A handwritten signature in black ink, appearing to read "J. Roberts".

JCR/GWI:gwi

Attachment: LER 2003-002-00

cc: (See Next Page)

JE22

June 23, 2003
GNRO-2003/00038
Page 2 of 2

cc:

Hoeg	T. L.	(GGNS Senior Resident)	(w/a)
Levanway	D. E.	(Wise Carter)	(w/a)
Reynolds	N. S.		(w/a)
Smith	L. J.	(Wise Carter)	(w/a)
Thomas	H. L.		(w/o)

U.S. Nuclear Regulatory Commission
Mr. Thomas P. Gwynn (w/2)
Acting Regional Administrator, Region IV
611 Ryan Plaza Drive, Suite 400
Arlington, TX 76011

U.S. Nuclear Regulatory Commission
ATTN: Mr. Bhalchandra Vaidya, NRR/DLPM (w/2)
ATTN: FOR ADDRESSEE ONLY
ATTN: U.S. Postal Delivery Address Only
Mail Stop OWFN/7D-1
Washington, D.C. 20555-0001

NRC FORM 366 (7-2001)	U.S. NUCLEAR REGULATORY COMMISSION	APPROVED BY OMB NO. 3150-0104	EXPIRES 7-31-2004
LICENSEE EVENT REPORT (LER) (See reverse for required number of digits/characters for each block)		Estimated burden per response to comply with this mandatory information collection request: 50 hours. Reported lessons learned are incorporated into the licensing process and fed back to industry. Send comments regarding burden estimate to the Records Management Branch (T-8 E6), U.S. Nuclear Regulatory Commission, Washington, DC 20555-0001, or by internet e-mail to bjs1@nrc.gov, and to the Desk Officer, Office of Information and Regulatory Affairs, NEOB-10202 (3150-0104), Office of Management and Budget, Washington, DC 20503. If a means used to impose information collection does not display a currently valid OMB control number, the NRC may not conduct or sponsor, and a person is not required to respond to, the information collection.	

1. FACILITY NAME Grand Gulf Nuclear Station, Unit 1	2. DOCKET NUMBER 05000 416	3. PAGE 1 OF 7
---	--------------------------------------	--------------------------

4. Title: Reactor Scram Due to a Partial Loss of Offsite Power

5. EVENT DATE			6. LER NUMBER			7. REPORT DATE			8. OTHER FACILITIES INVOLVED	
MO	DAY	YEAR	YEAR	SEQUENTIAL NUMBER	REV NO	MO	DAY	YEAR	FACILITY NAME	DOCKET NUMBER
04	24	2003	2003	002	00	06	23	2003	N/A	05000
									FACILITY NAME	DOCKET NUMBER
									N/A	05000

9. OPERATING MODE	1	11. THIS REPORT IS SUBMITTED PURSUANT TO THE REQUIREMENTS OF 10 CFR §: (Check all that apply)									
10 POWER LEVEL	100	20.2201(b)		20.2203(a)(3)(ii)		50.73(a)(2)(ii)(B)		50.73(a)(2)(ix)(A)			
		20.2201(d)		20.2203(a)(4)		50.73(a)(2)(iii)		50.73(a)(2)(x)			
		20.2203(a)(1)		50.36(c)(1)(i)(A)		X	50.73(a)(2)(iv)(A)		73.71(a)(4)		
		20.2203(a)(2)(i)		50.36(b)(1)(ii)(A)			50.73(a)(2)(v)(A)		73.71(a)(5)		
		20.2203(a)(2)(ii)		50.36(c)(2)			50.73(a)(2)(v)(B)		X	OTHER Specify in Abstract below or in NRC Form 366A	
		20.2203(a)(2)(iii)		50.46(a)(3)(ii)			50.73(a)(2)(v)(C)				
		20.2203(a)(2)(iv)		50.73(a)(2)(i)(A)			50.73(a)(2)(v)(D)				
		20.2203(a)(2)(v)		50.73(a)(2)(i)(B)			50.73(a)(2)(vii)				
20.2203(a)(2)(vi)		X	50.73(a)(2)(i)(C)			50.73(a)(2)(viii)(A)					
20.2203(a)(3)(i)			50.73(a)(2)(ii)(A)			50.73(a)(2)(viii)(B)					

12. LICENSEE CONTACT FOR THIS LER

NAME: Gary W. Ingram Licensing Engineer	TELEPHONE NUMBER (Include Area Code) 601-437-6716
--	--

13. COMPLETE ONE LINE FOR EACH COMPONENT FAILURE DESCRIBED IN THIS REPORT

CAUSE	SYSTEM	COMPONENT	MANUFACTURER	REPORTABLE TO EPIX	CAUSE	SYSTEM	COMPONENT	MANUFACTURER	REPORTABLE TO EPIX
C	FK	MOD	A180	Y					

14. SUPPLEMENTAL REPORT EXPECTED				15. EXPECTED SUBMISSION DATE		MONTH	DAY	YEAR
YES (If yes, complete EXPECTED SUBMISSION DATE).				X	NO			

16. ABSTRACT (Limit to 1400 spaces, i.e., approximately 15 single-spaced typewritten lines)

GGNS automatically scrambled at approximately 0948 CDST on 4/24/2003 due to a partial loss of offsite power. At the time of the scram, there was a severe thunderstorm in the vicinity. High winds apparently resulted in closure of an open disconnect in the GGNS Switchyard which in turn led to the partial loss of offsite power.

During the event the Reactor Protection System (RPS) auto-actuated; High Pressure Core Spray (HPCS) and Reactor Core Isolation Cooling (RCIC) auto-initiated on Reactor (Rx) Water Level 2 and injected into the Rx to restore Rx water level; Division 2 and 3 Diesel Generators (DGs) started and energized the 16AB and 17AC Electrical Buses, respectively; the 15AA Electrical Bus lost power and was re-energized by the Division 1 DG shortly after the initial event; all Standby Service Water (SSW) divisions started; all main steam line isolation valves (MSIVs) isolated on loss of power; and containment isolation occurred.

Rx water level and pressure were restored and stabilized. Plant data was reviewed to confirm proper response of plant equipment. Switchyard inspections were conducted to assess damage and verify equipment condition prior to restoring tripped equipment. The NRC Resident Inspector was notified. NRC call-in per 10CFR50.72(b)(2)(iv) and 10CFR50.72(b)(3)(iv) was made at 1320 CDST.

LICENSEE EVENT REPORT (LER)

(See reverse for required number of
digits/characters for each block)

Estimated burden per response to comply with this mandatory information collection request: 50 hours. Reported lessons learned are incorporated into the licensing process and fed back to industry. Send comments regarding burden estimate to the Records Management Branch (T-6 E6), U.S. Nuclear Regulatory Commission, Washington, DC 20555-0001, or by internet e-mail to bjs1@nrc.gov, and to the Desk Officer, Office of Information and Regulatory Affairs, NEOB-10202 (3150-0104), Office of Management and Budget, Washington, DC 20503. If a means used to impose information collection does not display a currently valid OMB control number, the NRC may not conduct or sponsor, and a person is not required to respond to, the information collection.

1. FACILITY NAME

Grand Gulf Nuclear Station, Unit 1

2. DOCKET NUMBER

05000 416

3. PAGE

2 of 7

A. REPORTABLE OCCURRENCE

GGNS Reactor Scram 107 occurred at approximately 0948 CDST on 4/24/2003 due to a fault in the 500KV switchyard and a partial loss of offsite power. The partial loss of offsite power resulted from Disconnect J5205 closure sending 500KV to ground through the grounding straps installed for breaker maintenance. This caused the loss of the West 500KV Bus, Service Transformer 21 (ST21) [FK] lockout, and subsequent loss of both 500KV lines. A turbine trip on load reject occurred, resulting in a reactor scram on turbine control valve (TCV) [JI] fast closure.

All control rods [AA] fully inserted as expected. The reactor mode switch [JD] was taken to shutdown. Safety Relief Valves (SRVs) [JC] actuated on low-low set due to reactor pressure rise. The Division 2 air operated Auxiliary Building isolation valves [NF] closed due to loss of power, causing a loss of plant service water (PSW) [KG] and instrument air [LD] to the Auxiliary Building. Division 2 and Division 3 DGs [EK] started on bus under voltage and picked up Buses 16AB and 17AC, respectively, due to the ST21 lockout. About a minute later after the Main Generator tripped, Division 1 Bus 15AA experienced a bus under-voltage condition and was picked up by the Division 1 DG. Offsite power was automatically restored to the East 500 KV bus.

While all three DGs started and supplied their buses, this did not constitute a design bases Loss Of Offsite Power (LOOP) and an emergency declaration of an unusual event because the 115KV line to Engineered Safety Feature (ESF) Transformer 12 (ESF12) [FK] was available throughout the event. GGNS did experience a momentary interruption of electrical power for approximately 1.5 seconds in the 500KV Switchyard between the time the main generator breaker opened and the offsite breakers automatically closed.

At approximately 0956, HPCS [BG] and RCIC [BN] initiated and injected at Rx Water Level 2. Containment and Auxiliary Building valve isolations also occurred on Rx Water Level 2. The MSIVs [JC] closed on loss of power and the main condenser [SJ] was not available as a heat sink.

SRVs were used to control reactor pressure until reactor heat removal (RHR) [BO] was placed in service. RCIC was used for level control until the condensate and feedwater system [SD] was restored and placed in service. The reactor scram was reset at approximately 1803.

Licensee Event Report (LER) Reportable Events:

1. Operation or condition prohibited by technical specifications (TS) per 10CFR50.73(a)(2)(i).
2. Reactor Protection System (RPS) [JC] automatic actuation and automatic reactor scram per 10CFR50.73(a)(2)(iv).
3. Containment isolation per 10CFR50.73(a)(2)(iv).
4. MSIVs isolation per 10CFR50.73(a)(2)(iv).
5. HPCS automatic initiation and injection into the reactor to restore water level per 10CFR50.73(a)(2)(iv).
6. RCIC automatic initiation and injection into the reactor to restore water level per 10CFR50.73(a)(2)(iv).
7. Valid Division 1, 2, and 3 DG automatic starts on loss of power per 10CFR50.73(a)(2)(iv).

1212123 NRC FORM 366 (7-2001)	U.S. NUCLEAR REGULATORY COMMISSION LICENSEE EVENT REPORT (LER) (See reverse for required number of digits/characters for each block)	APPROVED BY OMB NO. 3150-0104 EXPIRES 7-31-2004 Estimated burden per response to comply with this mandatory information collection request: 50 hours. Reported lessons learned are incorporated into the licensing process and fed back to industry. Send comments regarding burden estimate to the Records Management Branch (T-6 E6), U.S. Nuclear Regulatory Commission, Washington, DC 20555-0001, or by internet e-mail to bj1@nrc.gov , and to the Desk Officer, Office of Information and Regulatory Affairs, NEOB-10202 (3150-0104), Office of Management and Budget, Washington, DC 20503. If a means used to impose information collection does not display a currently valid OMB control number, the NRC may not conduct or sponsor, and a person is not required to respond to, the information collection.
1. FACILITY NAME Grand Gulf Nuclear Station, Unit 1	2. DOCKET NUMBER 05000 416	3. PAGE 3 of 7

8. Standby Service Water (SSW) [BS] start per 10CFR50.73(a)(2)(iv).
 9. HPCS injection into the reactor vessel is reportable as a special report per Grand Gulf Technical Requirements Manual (TRM) section 7.7.2.1.

Events Not Reportable But Mentioned in This LER:

1. Loss of instrument air compressors [LD] and delayed recovery.

The partial loss of offsite power caused a loss of the Instrument Air (IA) System [LD]. The operating and back-up instrument and service air (SA) compressors [LF] lost power and the instrument air header depressurized before compressor operation was restored approximately 2 hours after the initiating event. The instrument air system restoration was complicated due to not having normal air header supply of control air and seal air for proper compressor start up and operation. This required a source of bottled gas to be used for seal air and control air in the restart of the compressor. The Unit 1 air compressor would not function properly. The Unit 2 instrument air compressor was started and provided air to the plant.

2. Exceeded 100 degree per hour heat up/cool down rate.

The 100 degree Fahrenheit (F)/hour heat-up and cool-down rates on various components were exceeded following the scram on 4/24/2003. The cool-down rate was exceeded on both reactor recirculation [AD] pump suctions, bottom head, and bottom head drains during the initial transient. Also, the heat up rate was exceeded on recirculation pump suctions, bottom head, and bottom head drains when Reactor Recirculation Pump "A" was started.

Engineering Calculation MC-Q1111-90207, Supplement 6, Revision 0, was performed utilizing the heat-up and cool-down rates from the plant scram on 04/24/2003. The calculated additional usage factors due to this event for Regions B and C are small in magnitude. The cumulative usage factors for all components to date are well within the ASME Section III Code allowable of 1.0, and therefore, the Reactor Coolant System (RCS) was acceptable for continued operation in accordance with TS 3.4.11.

3. All safety systems functioned as designed and responded properly. During this transient, no deviations were noted in any actuations.

B. INITIAL CONDITIONS

At the time of the event, the reactor was in OPERATIONAL MODE 1 with reactor power at approximately 100 percent and reactor pressure at approximately 1032 psig. Moderator temperature was approximately 540 degrees Fahrenheit and reactor level was approximately 36 inches.

C. DESCRIPTION OF OCCURRENCE

Switchyard owner Entergy Mississippi (MS) personnel had been working in the 500KV switchyard on Breaker J5204 [FK]. The breaker disconnects were locked open for the maintenance. A severe weather

<p>1212124 NRC FORM 366 (7-2001)</p> <p>LICENSEE EVENT REPORT (LER)</p> <p>(See reverse for required number of digits/characters for each block)</p>	<p>U.S. NUCLEAR REGULATORY COMMISSION</p>	<p>APPROVED BY OMB NO. 3150-0104 EXPIRES 7-31-2004</p> <p>Estimated burden per response to comply with this mandatory information collection request: 50 hours. Reported lessons learned are incorporated into the licensing process and fed back to industry. Send comments regarding burden estimate to the Records Management Branch (T-6 E6), U.S. Nuclear Regulatory Commission, Washington, DC 20555-0001, or by internet e-mail to bjr1@nrc.gov, and to the Desk Officer, Office of Information and Regulatory Affairs, NEOB-10202 (3150-0104), Office of Management and Budget, Washington, DC 20503. If a means used to impose information collection does not display a currently valid OMB control number, the NRC may not conduct or sponsor, and a person is not required to respond to, the information collection.</p>
<p>1. FACILITY NAME Grand Gulf Nuclear Station, Unit 1</p>	<p>2. DOCKET NUMBER 05000 416</p>	<p>3. PAGE 4 of 7</p>

front was passing through the area at the same time.

At approximately 0948 CDST GGNS automatically scrambled due to a partial loss of offsite power. The partial loss of offsite power resulted from Disconnect J5205 closure sending 500KV to ground through the grounding straps installed for breaker maintenance. This caused the loss of the West 500KV Bus, ST 21 lockout, and subsequent loss of both 500KV lines. A turbine trip on load reject occurred, resulting in a reactor scram on TCV fast closure.

All control rods fully inserted as expected. The reactor mode switch was taken to shutdown. SRVs actuated on low-low set due to reactor pressure rise. The Division 2 air operated Auxiliary Building isolation valves closed due to loss of power, causing a loss of PSW and instrument air to the Auxiliary Building. Division 2 and Division 3 DGs started on bus under voltage and picked up Buses 16AB and 17AC, respectively, due to the ST21 lockout. About a minute later after the Main Generator tripped, Division 1 Bus 15AA experienced a bus under-voltage condition, which dropped the remaining ESF bus, and was picked up by the Division I DG. Offsite power was automatically restored to the East 500 KV bus.

During the interval between the fault event and main generator output breaker trip, the generator experienced over and under frequency excursions. The over-frequency excursion was extremely brief and of negligible magnitude. The under-frequency deviation of larger magnitude and longer duration was evaluated and determined to have had no adverse impact on essential plant equipment.

At approximately 0956 reactor water level reached Level 2, causing HPCS and RCIC initiation and injection. Containment and Auxiliary Building valve isolations also occurred on Rx Water Level 2. Reactor level hovered at or near this level as demonstrated by the tripping and resetting of level 2 instruments. HPCS was secured shortly after initiation and reactor level was maintained by RCIC. Since the MSIVs had closed on loss of power, the main condenser was not available as a heat sink.

The surveillance requirement for TS 3.8.1.1 was not performed within the first hour. The surveillance consists of verifying correct breaker alignment and indicated power availability for each required offsite circuit. LCO 03-0402 was entered at approximately 0948 on 4/24/03 due to having less than 2 feeders. The first surveillance was completed at approximately 1117. The delay in performing the surveillance was due to response to plant needs following the scram.

A complication in the event was the loss of instrument air for approximately 2 hours. The air header pressure was completely lost and required a source of bottled gas for seal air and control air in the restart of the compressor. The Unit I instrument air compressor would not function properly. The Unit 2 instrument air compressor was started and provided air to the plant.

The reactor pressure control was maintained using SRVs until RHR shutdown cooling was placed in service. RCIC was used for level control until the condensate and feedwater system was restored and placed in service with the startup level control valve. The reactor scram was reset at approximately 1803.

LICENSEE EVENT REPORT (LER)

(See reverse for required number of
digits/characters for each block)

Estimated burden per response to comply with this mandatory information collection request: 50 hours. Reported lessons learned are incorporated into the licensing process and fed back to industry. Send comments regarding burden estimate to the Records Management Branch (T-6 E6), U.S. Nuclear Regulatory Commission, Washington, DC 20555-0001, or by internet e-mail to bjs1@nrc.gov, and to the Desk Officer, Office of Information and Regulatory Affairs, NEOB-10202 (3150-0104), Office of Management and Budget, Washington, DC 20503. If a means used to impose information collection does not display a currently valid OMB control number, the NRC may not conduct or sponsor, and a person is not required to respond to, the information collection.

1. FACILITY NAME

Grand Gulf Nuclear Station, Unit 1

2. DOCKET NUMBER

05000 416

3. PAGE

5 of 7

The post trip analysis investigation determined that all safety related equipment functioned properly. There were no safety system functional failures associated with this event.

The only plant condition/evolution in progress at the time of the scram that had an effect on the events leading to the scram or on the scram consequences was 500 KV Breaker J5204 being out of service for work, although there was no work going on because of bad weather at that time.

D. APPARENT CAUSE

1. It was concluded that high winds exceeding the counterbalance spring assembly limit and blowing in the "Close" direction overcame the force exerted by the counterbalance spring assembly, closing Disconnect J5205 and breaking the "Open" position locking bracket on the motor operator.
2. Coincident failure of the Baxter Wilson (BW) backup blocking carrier signal and the Franklin primary blocking carrier signal caused the loss of both 500KV offsite sources momentarily due to less than adequate pilot relay scheme/carrier preventive maintenance.

E. CORRECTIVE ACTIONS

Immediate Actions

Disconnects J5203 and J5205 were chained up. The carrier signals for the BW backup carrier and the Franklin primary carrier were disabled. Switchyard walk downs revealed no other obvious damage or deficiency on the air disconnects or other components potentially wind damaged that would preclude their continued use. The broken locking collar was replaced.

Interim Actions

Entergy MS issued a safety bulletin addressing this event and adjusted its switching orders to require additional restraints on appropriate switches.

The Franklin primary was returned to service but the Baxter Wilson backup carrier will remain out of service.

Long Term Actions

Condition Report CR-GGN-2003-1340 was written.

F. SAFETY ASSESSMENT

- As indicated by the Safety Significance Section of the root cause evaluation for CR-GGN-2003-1340, there is sufficient assurance that there was no damage to connected ESF Division I AC equipment due to generator over or under frequency conditions during the event. ESF Division II and III AC equipment was not affected because it segregated from the offsite source at the fault initiation

LICENSEE EVENT REPORT (LER)

(See reverse for required number of
digits/characters for each block)

Estimated burden per response to comply with this mandatory information collection request: 50 hours. Reported lessons learned are incorporated into the licensing process and fed back to industry. Send comments regarding burden estimate to the Records Management Branch (T-6 E6), U.S. Nuclear Regulatory Commission, Washington, DC 20555-0001, or by internet e-mail to bjs1@nrc.gov, and to the Desk Officer, Office of Information and Regulatory Affairs, NEOB-10202 (3150-0104), Office of Management and Budget, Washington, DC 20503. If a means used to impose information collection does not display a currently valid OMB control number, the NRC may not conduct or sponsor, and a person is not required to respond to, the information collection.

1. FACILITY NAME

Grand Gulf Nuclear Station, Unit 1

2. DOCKET NUMBER

05000 416

3. PAGE

6 of 7

time.

There were no noted concerns with voltage regulation during this event. Existing load shedding and sequencing (LSS) under-voltage set points are adequately designed to protect required equipment under degraded voltage conditions.

• This event was evaluated using the GGNS Revision 2a Equipment out of Service (EOOS) model. The initiating event was a loss of ST21 due to a high winds associated with severe weather that led to the closing of a 500KV disconnect switch to a grounded breaker (J5204). The J5204 breaker was undergoing maintenance at the time and had been grounded for personnel safety reasons. This led to the opening of Breakers J5208, J1652 (552-2105), J5216, J5228 and J5240. As a result, ST21 and the West bus were isolated. Since the Division 2 and 3 ESF Buses were connected to ST21, the Division 2 and 3 DGs started and connected to their respective buses. Subsequent to these actions, the Franklin and Baxter Wilson 500 KV lines were de-energized due to some failures in the control system. However, the generator output breaker (J5232) remained closed and the generator was the sole source of power for the East bus and powered ST11 and connected buses for a short period of time. Approximately 1 minute and 15 seconds from event initiation, J5232 opened and ST11 de-energized, which resulted in the loss of the Division 1 bus. Approximately 1.5 seconds after J5232 opened, the Franklin line was restored. The Baxter Wilson line was restored a short time later. The Div 1 DG started and connected to the Div 1 ESF bus due to the short loss of power from ST11.

There never was a complete loss of offsite power during this event since the Port Gibson line was available through out the duration. The Port Gibson (115KV) line provides power to the ESF 12 transformer. Any of the ESF buses could have been transferred to this source of power at any time during the event. Also, 500KV power to ST11 was restored almost immediately. Instrument air was lost initially, but was later restored (approximately 2 hours from event initiation). Based on these two considerations it is concluded that this event is best modeled as a T2, or Loss of PCS (Power Conversion System), initiator. A T2 initiator results in the loss of the power conversion systems (feedwater, condenser, and condensate) and the modeling of this event does allow for recovery of the power conversion systems. The modeling of the loss of instrument air initiator does not include recovery of instrument air so it is inappropriate for this event since instrument air was recovered (at approximately 2 hours).

The Revision 2a EOOS model was used for this evaluation. All initiators were set to zero except the T2 initiator, which was set to 1.0. In addition, 500KV equipment that was initially impacted was removed from service or the associated basic event was set to 1.0. This included the breakers which were discussed above, ST21, and the West bus. In addition, the system alignment for offsite power was changed so that ST11 was aligned to the East bus only.

The above configuration was quantified with an updated recovery rule file which included credit for long term recovery of the PCS, when possible, and which addressed combinations of human errors that had not previously been assessed. The quantification cutsets were reviewed and some additional changes were made. Since instrument air was not recovered until approximately 2 hours into the event, the failing to recover PCS within 40 minutes event was set to "true". The cutsets were also reviewed to identify any

LICENSEE EVENT REPORT (LER)

(See reverse for required number of
digits/characters for each block)

Estimated burden per response to comply with this mandatory information collection request: 50 hours. Reported lessons learned are incorporated into the licensing process and fed back to industry. Send comments regarding burden estimate to the Records Management Branch (T-6 E6), U.S. Nuclear Regulatory Commission, Washington, DC 20555-0001, or by Internet e-mail to bjr1@nrc.gov, and to the Desk Officer, Office of Information and Regulatory Affairs, NEOB-10202 (3150-0104), Office of Management and Budget, Washington, DC 20503. If a means used to impose information collection does not display a currently valid OMB control number, the NRC may not conduct or sponsor, and a person is not required to respond to, the information collection.

1. FACILITY NAME

Grand Gulf Nuclear Station, Unit 1

2. DOCKET NUMBER

05000 416

3. PAGE

7 of 7

additional potential for recovery. The resulting changes included the addition of the recovery of PCS in the four-hour-event to several cutsets where at least 4 hours would be available, adding a screening probability for failing to open the RCIC suction from suppression pool motor operated valve event, and the addition of a recovery event for cross tying SSW B to RHR for injection to the vessel to one cutset. The resulting conditional core damage probability (CCDP) is 8.50E-7. This value is not considered significant.

- Additionally, this event was the subject of a special inspection by the NRC. The inspection results are documented in Inspection Report 2003-007.

G. ADDITIONAL INFORMATION.

Due to difficulties with PDS computer points in the first 10 minutes of the event, HPCS injection information is not available. The circumstances resulting in the injection are described elsewhere in this report. This is the sixteenth cycle of the HPCS system experienced at GGNS at rated temperature and pressure. The current value of the nozzle usage factor is approximately 0.3, which is still within 0.70. Report of the ECCS injection is being submitted as part of this LER in accordance with the Special Reporting requirements of GGNS TRM Section 7.7.2.1.

Pursuant to 10CFR50.73(b)(5), the licensee considered this event to be an infrequent event. While similar events resulting in plant scrams have occurred, there has not been any occurrence of the same underlying concern in the past two years at GGNS.

Note:

Energy Industry Identification System (EIIIS) codes are identified in the text within brackets [].

Attachments:

1. Schematic of the GGNS 34.5KV Switchyard.
2. Schematic of the GGNS Distribution Switchyard.

Entergy Mississippi, Inc. Grand Gulf 34kV Switchyard

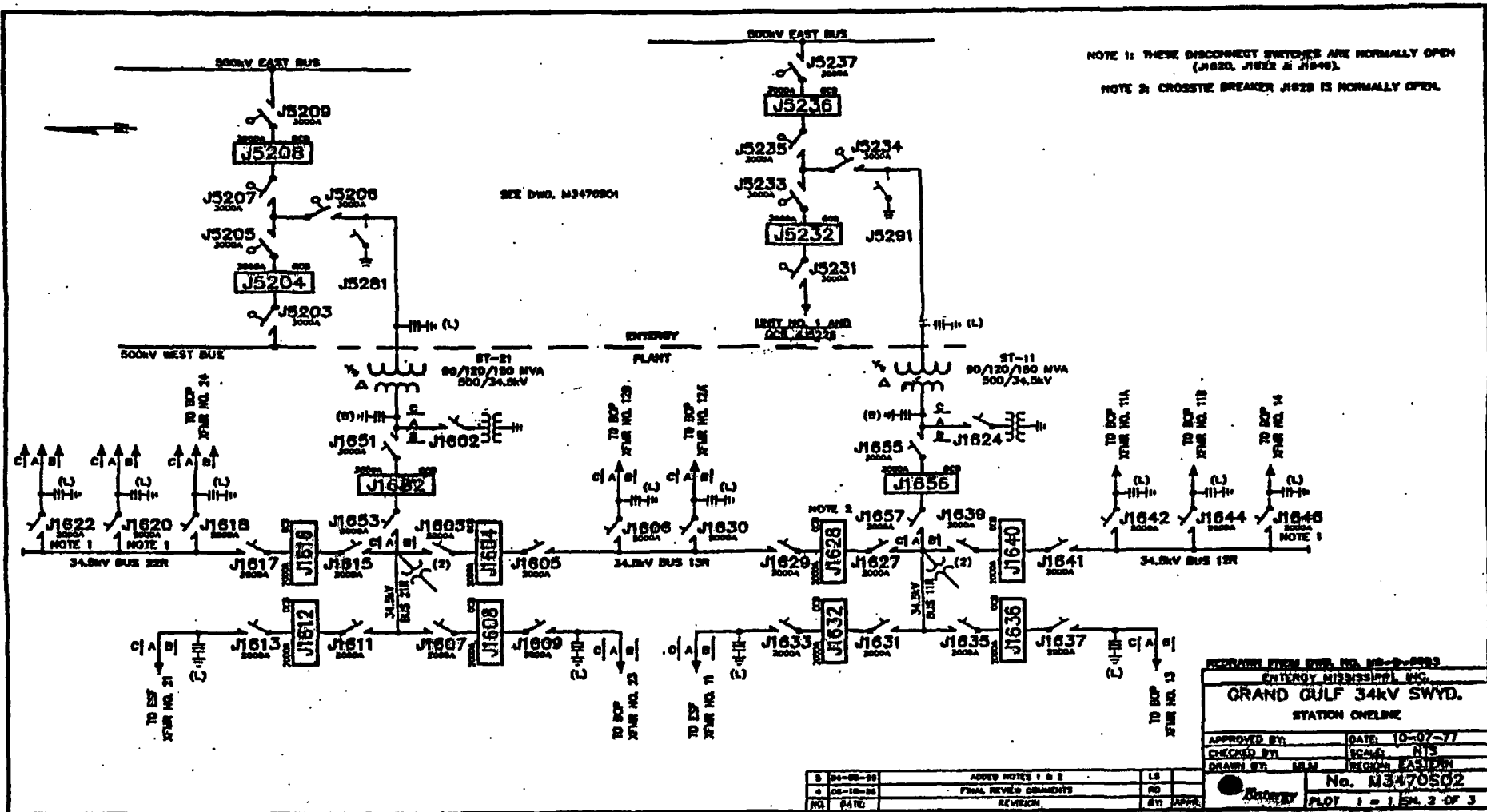

REVISION FROM DWG. NO. M3-3-2002 ENTERGY MISSISSIPPI, INC. GRAND GULF 34kV SWYD. STATION ONELINE	
APPROVED BY:	DATE: 10-07-97
CHECKED BY:	SCALE: NTS
DRAWN BY: MAM	REGION: EASTERN
No. M3470502	
PLOT 1 - 1, 2, 3 OF 3	

5	09-08-99	ADD NOTES 1 & 2	LS
4	08-16-95	FINAL REVIEW COMMENTS	RD
NO.	DATE	REVISION	BY

Grand Gulf Nuclear Station Distribution Switchyard

Switchyard

