



Institutt for energiteknikk  
OECD HALDEN REACTOR PROJECT

# HALDEN LOCA TEST SERIES TRIAL RUNS-IFA-650.1

*Erik Kolstad*

*Review meeting. Argonne. July, 2003*



## LOCA TRIAL RUNS – IFA-650.1

### Content

- **Background / Objectives**
- **Test facility / Instrumentation**
  - **Test rig / rod**
  - **Outer loop**
- **Pre-test code calculations**
- **Trial runs / results**
  - 800 °C – 2 runs**
  - 1100 °C – 4 runs**
- **Summary**



Institutt for energiteknikk  
OECD HALDEN REACTOR PROJECT

## Loss of Coolant Studies

The move to high burnup and the introduction of new cladding materials have generated a need to re-examine the safety criteria for loss-of-coolant accidents and to verify their continued validity. The integral in-pile tests in the Halden reactor will address LOCA issues using ex-LWR high burnup fuel segments. The Halden experiment will focus on effects that are different from those obtained in out-of-reactor tests.



## Some Halden Investigations in the Areas Thermal-Hydraulics, Critical Heat Transfer and LOCA

1963 - 68 Experiments on natural convection flow instabilities and dry-out limit

1965 - 72 Dry-out experiments in natural convection flow channels

1979 - 83 Safety-related tests: Blow-down, heatup & quench behaviour of nuclear rods and electric simulators. Thermal response studies

1982 - 85 Safety-related tests: Blow-down, heatup & quench behaviour of nuclear rods and electric simulators. Ballooning and rod-to-rod interaction studies

1996 - 98 Short-term dry-out test series



INSTITUTT FOR ENERGITEKNIKK  
HALDEN REACTOR PROJECT

## Halden LOCA Experiment (IFA-650)

(USNRC/EPRI/EDF/FRAMATOM-ANP/GNF /IRSN)

### Primary objectives

- 1) Measure the extent of fuel (fragment) relocation into the ballooned region and evaluate its possible effect on cladding temperature and oxidation
- 2) Investigate the extent (if any) of - "secondary transient hydriding" - on the inner side of the cladding above and below the burst region

# LOCA (1)

- **Loss Of Coolant Accident**
- **3 Phases:**
  - ◆ **Blowdown (fuel/core uncovered), decompression**
  - ◆ **Refill (ECCS systems start)**
  - ◆ **Reflood (water level above core top)**
- **Timing: uncover, quenching, long-term cooling**
- **Fuel temp. rises --> cladding oxidation and hydriding: embrittlement (melting) of cladding --> fragmentation**
- **Safety criteria:**
  - ◆ **Max. fuel temp. (PCT) not to exceed 2200 F (1204 C)**
  - ◆ **Oxidation of cladding not to exceed 17% of total clad thickness**
- **Rod swelling/ballooning may endanger core geometry / coolability**
- **Safety requirement: calculated geometry changes still warrant core cooling**

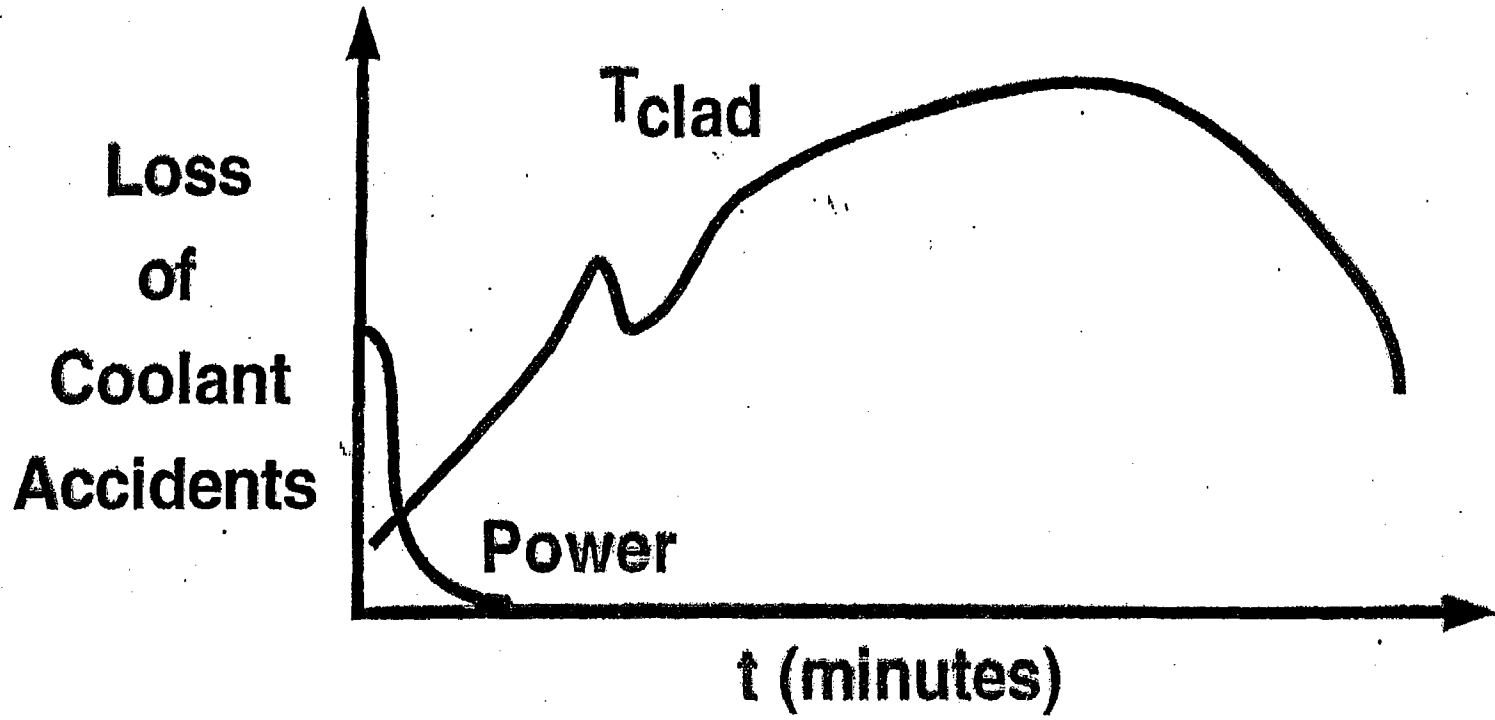

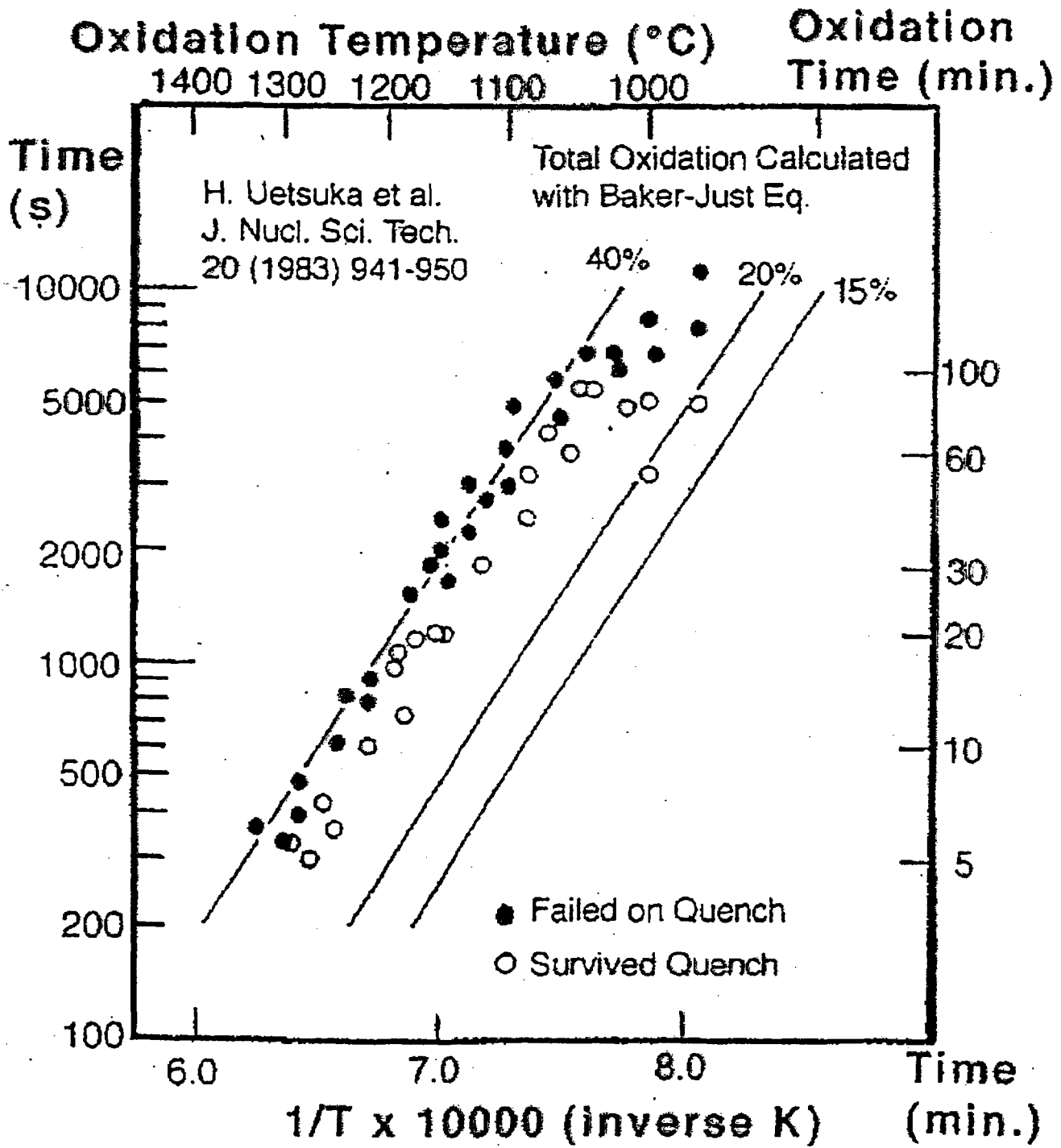

Figure X, Failure versus non-failure boundary for unconstrained :





## Conditions and Schedule

- Fresh rods for practicing
  - Low pressure for studying of required LHGR, flow and power control, spray, control of PCT, test termination etc.
  - Rod with overpressure to assess ballooning capabilities
  - More cladding TCs
  - Fuel TC
- Two high burnup PWR rods
  - Ca. 150 bar pressure at operating conditions
  - Possibly two temperature levels (800 / 1100)
- Two high burnup BWR rods
- One medium burnup BWR rod

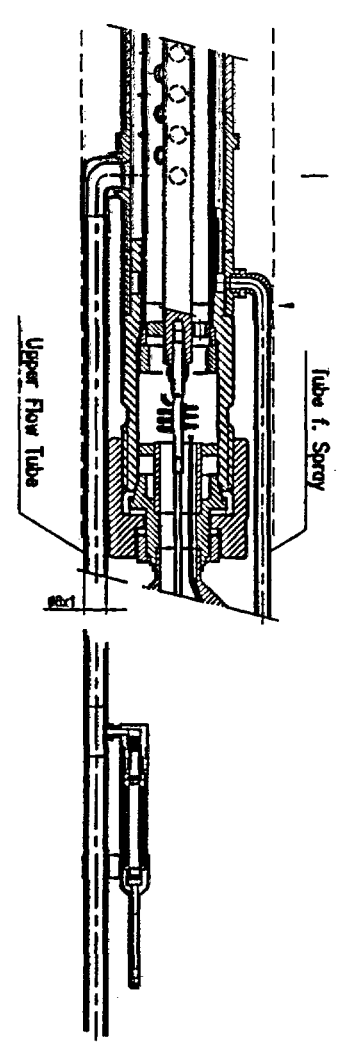
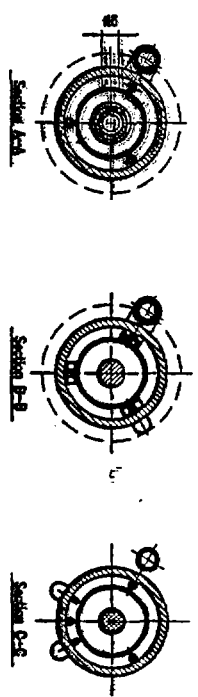
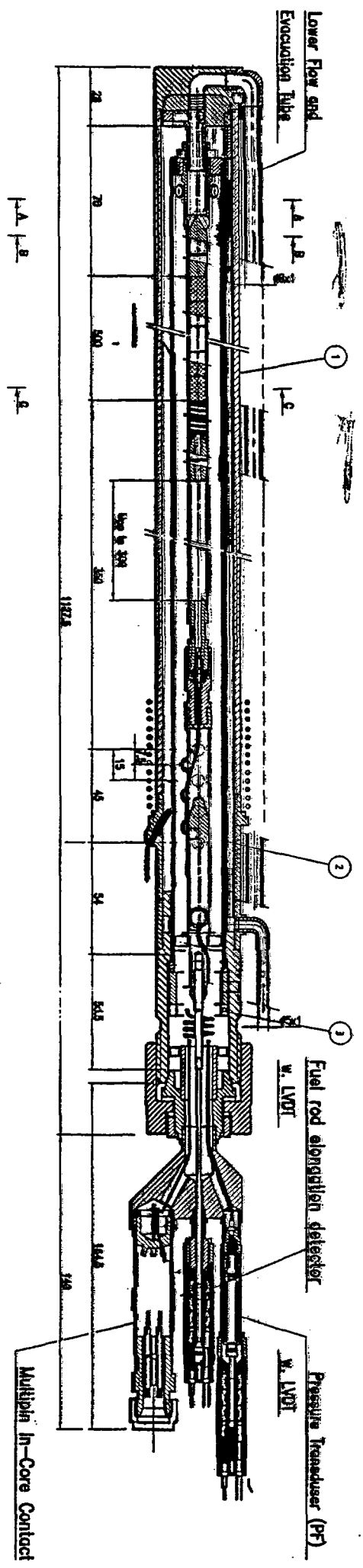

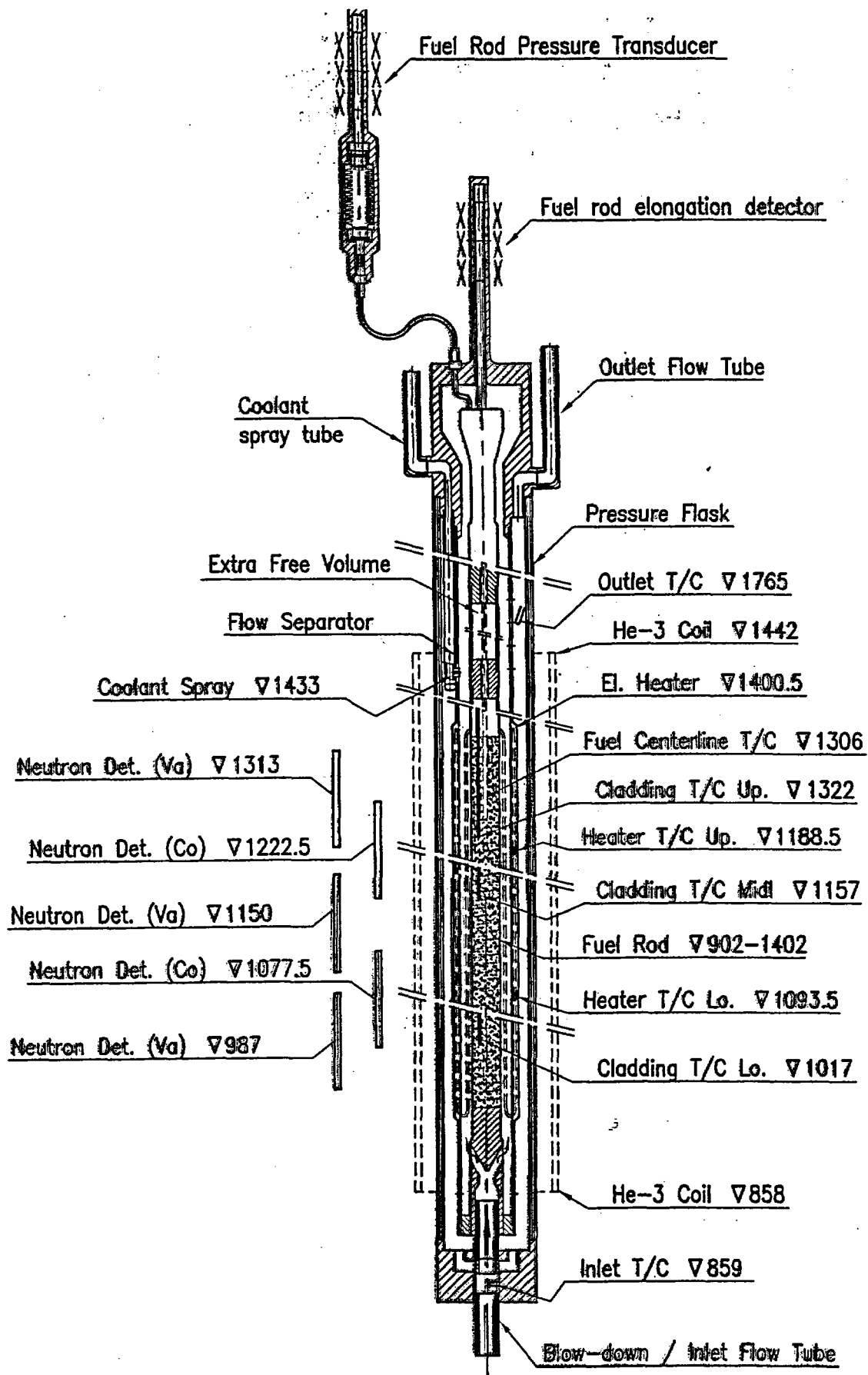

Schematic of LOCA Test Rig  
with Instrument levels



## LOCA Trial Runs - IFA-650.1

### Power calibrations (17 MW & 18 MW)

$$Q_A = KG \cdot ND \quad ND = (ND1+ND2+ND3)/3$$

$$KG = Q_A/ND \quad (\text{kW/nA})$$

$$LHGR = Q_A/LF \quad LF = \text{Fuel length} = 50 \text{ cm}$$

(Gamma heat ~5 - 6%)

$$KG (\text{no He}^3) = 0.90 \text{ KG} (40 \text{ bar He}^3)$$

Most runs without He<sup>3</sup>



## LOCA Trial Runs, IFA-650.1

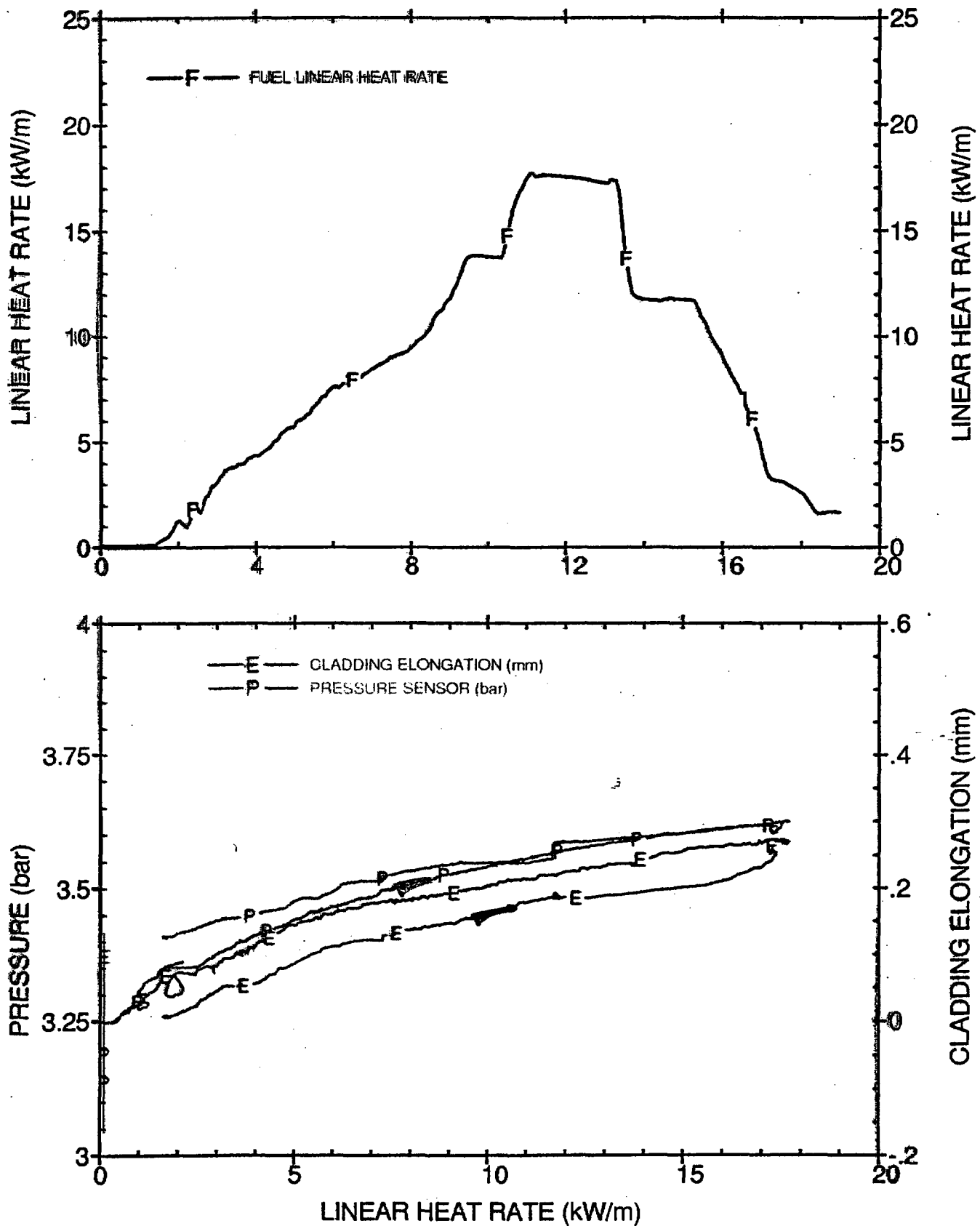



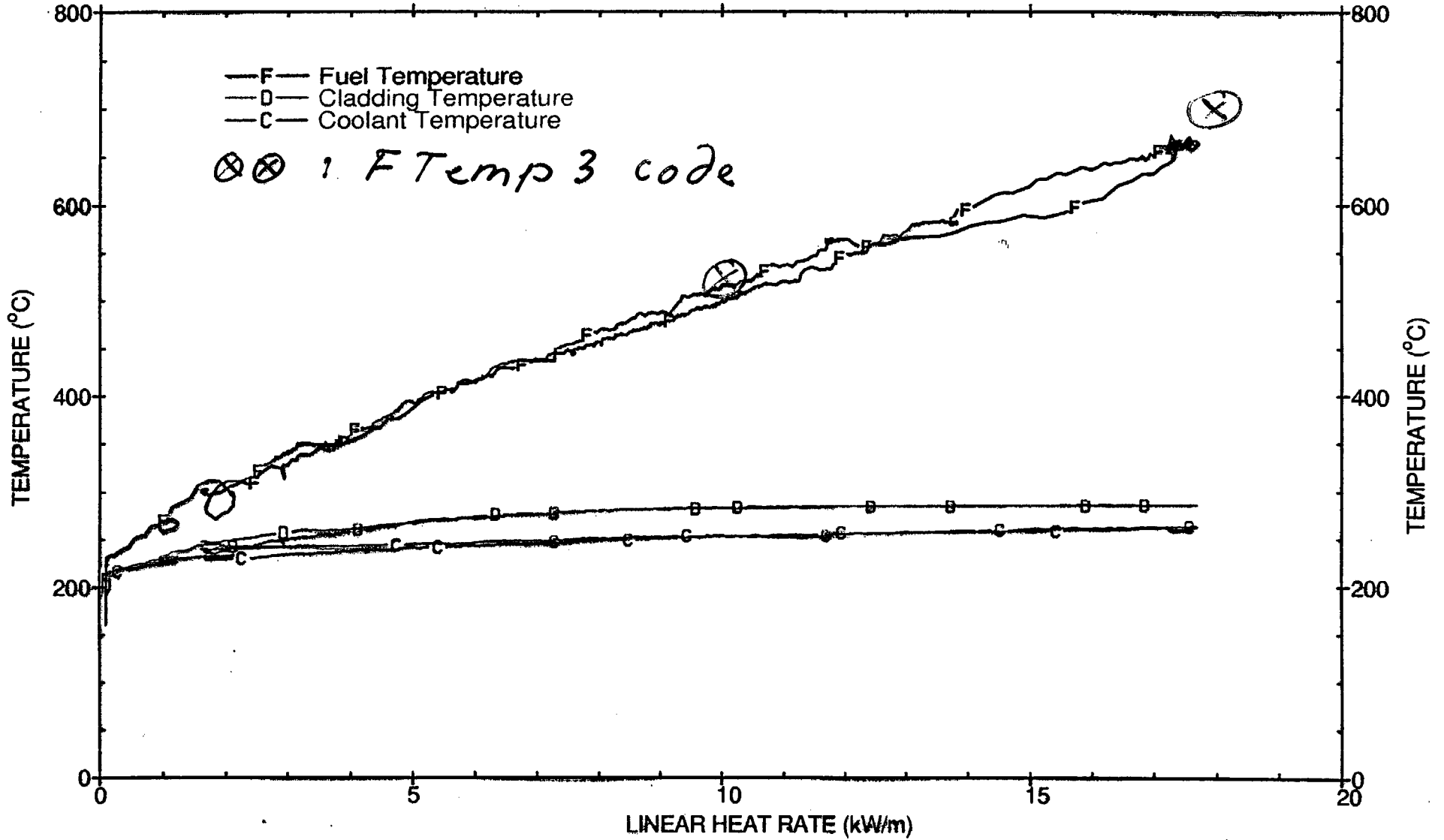

### LOCA Trial Runs, IFA-650.1,

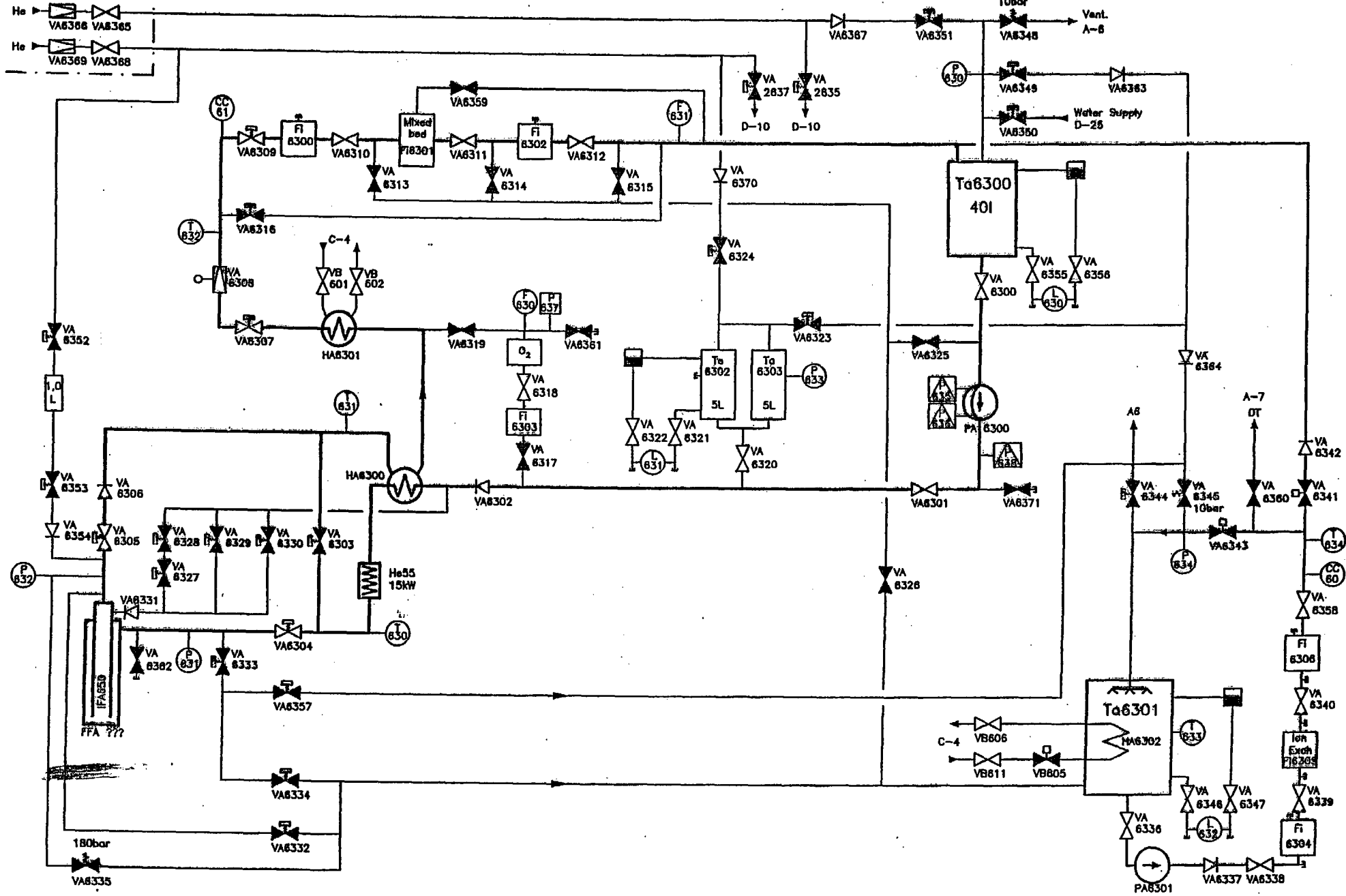

Gas Central 1



Drawn No.	Date : 010110	Approved	Changed, 021203 RSk	 INSTITUTT FOR ENERGITEKNIKK DECD HALDEN REACTOR PROJECT HALDEN NORWAY	Name: Loop13, Heavy Water High Press.	SS No.: D-20
Revised	Drawn : RSk	Checked Exp. Sup.	Changed 030131 RSk			
	Checked :		Changed			



INSTITUTT FOR ENERGITEKNIKK  
HALDEN REACTOR PROJECT

## LOCA Trial Runs - IFA-650.1

### Test rig instrumentation

- 3 neutron detector (Va)
- 2 Co-flux detectors
- 2 inlet TCs
- 2 outlet TCs
- 1 He<sup>3</sup> coil
- Heated flow separator (w/TCs)
- Flow meter (outer circuit)





## Design Features, cont.

- Instrumentation
  - cladding surface thermocouples
  - cladding extensometer
  - pressure sensor
  - fuel thermocouple (fresh fuel only)
  - fast response neutron detector
- Rod pressure will be close to the normal operating coolant pressure
- The free volume should be large, representative of the remaining volume in a full-scale fuel rod ( $\leq 15 \text{ cm}^3$ )
- No axial constraint will be provided, but the design may include a grid piece to assess the effect on cooling



## LOCA-TEST IFA-650.1

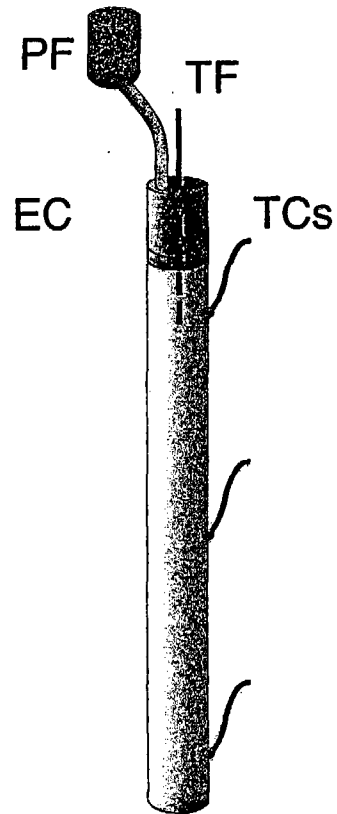

Axial power  
distribution

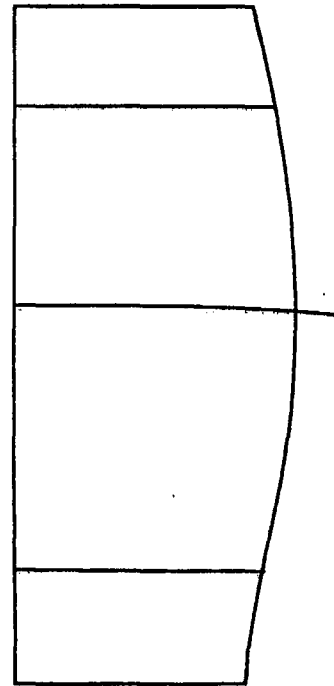

Rod  
instrumentation



INSTITUTT FOR ENERGITEKNIKK  
HALDEN REACTOR PROJECT

## LOCA Trial Runs - IFA-650.1

### Test rod/instrumentation

#### Rod (Zr-4)

Length: 500 mm  
O.D/I.D: 9.50/8.36 mm  
Gap size: 70 $\mu$ mm  
Enrichment: 4 w/o U-235  
Fill pressure: 2 bar He  
Free volume: 15 cc  
Dished pellets

#### Instrumentation

- 3 Clad TCs
- 1 Clad extensometer
- 1 Fuel thermocouple
- 1 Rod pressure sensor
- 2 Heater thermocouples



Institutt for energiteknikk  
OECD HALDEN REACTOR PROJECT

## LOCA TESTER-IFA-650.1 OG IFA-650.2

### Attachment of clad O.D. thermocouples

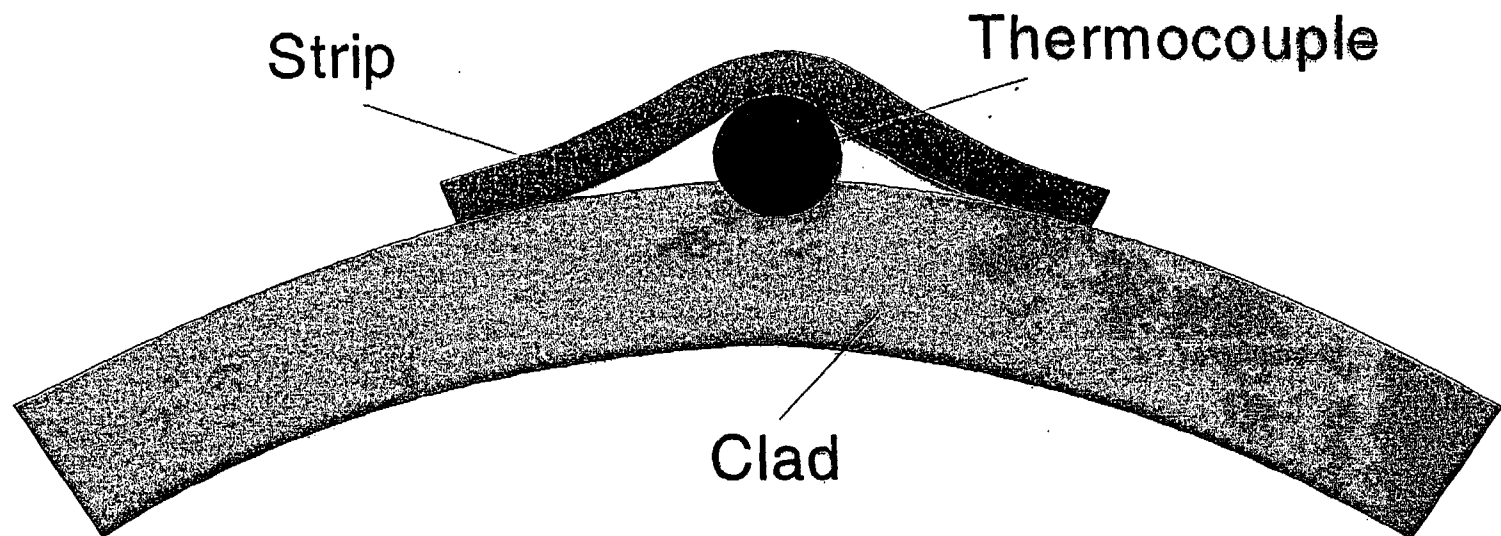

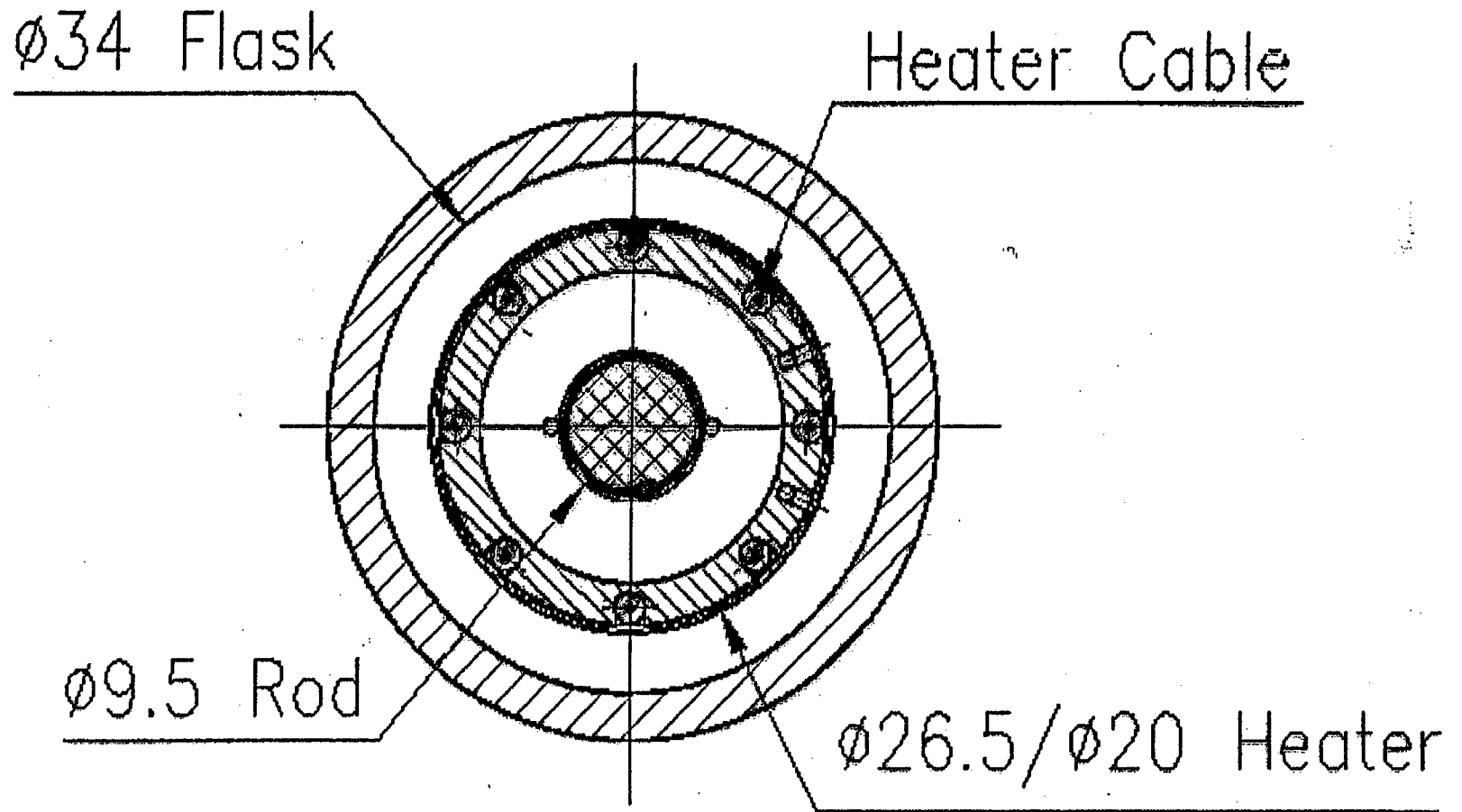
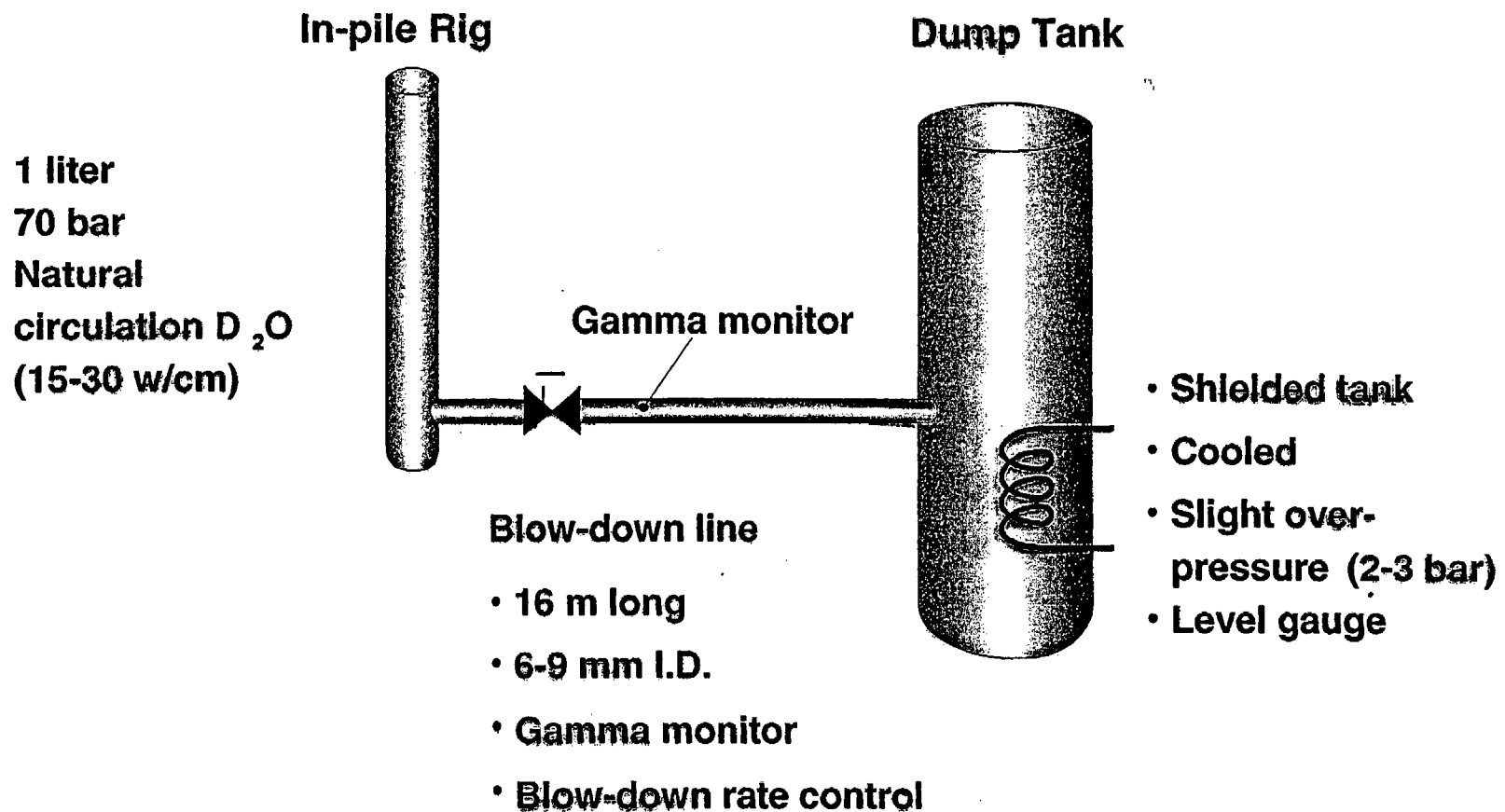

Figure 3. Cross sectional geometry of the fuel pin, flow separator and pressure tube.



## LOCA TRIAL RUNS – IFA-650.1





## LOCA Trial Runs - IFA-650.1

### Pre-test code calculations

- TRAC - BF1 code (PSI)
- FRAPTRAN - GENFLOW (VTT)
- SCTEMP and ALGOR (Halden)

# SCTEMP Code

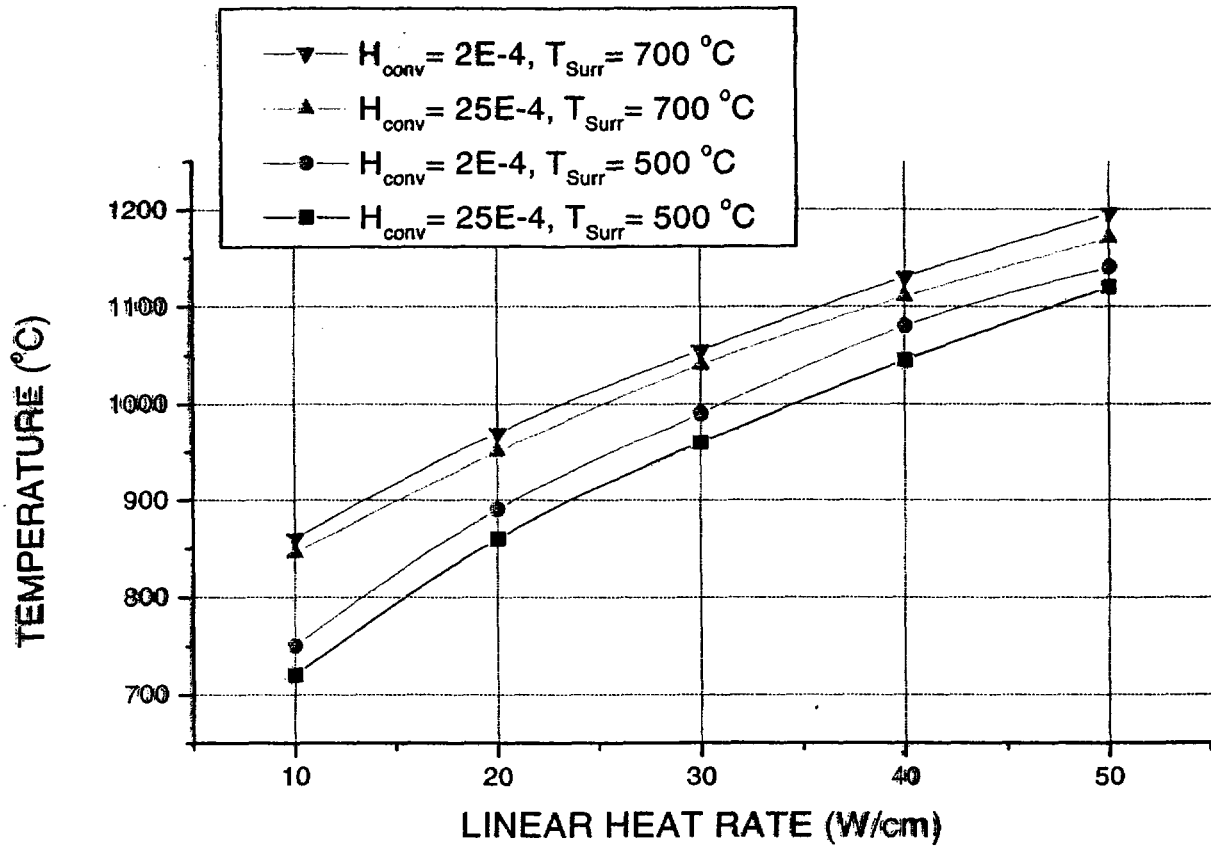

Figure 4. Maximum surface cladding temperature as a function of LHR using for different convective heat transfer coefficients and surroundings temperatures



## LOCA-Tests-IFA-650.1

Cladding temperature transient control by:

- Linear heat rate ( LHR) (10 -40 W/cm)
- Spray system
- Heated flow separator ( up to 20 W/cm)

# LOCA-Tests-IFA-650.1

Test scheme for the first rod.

- 1 - Steady-state operation (10-50 W/cm) with loop 13 connected
- 2 - Disconnection of loop 13. Natural convection flow
- 3 - Blow-down (< 30 secs) (to dump tank)
- 4 - Heat-up (< 2 mins)
- 5 - Peak clad temperatures (PCT) 800-1100 degr.C
- 6 - Quench by spray. Disconnect dump tank
- 7 - Re-establishment of state 2 (and 1)
- 8 - Repeat and re-run



# LOCA-TEST IFA-650.1

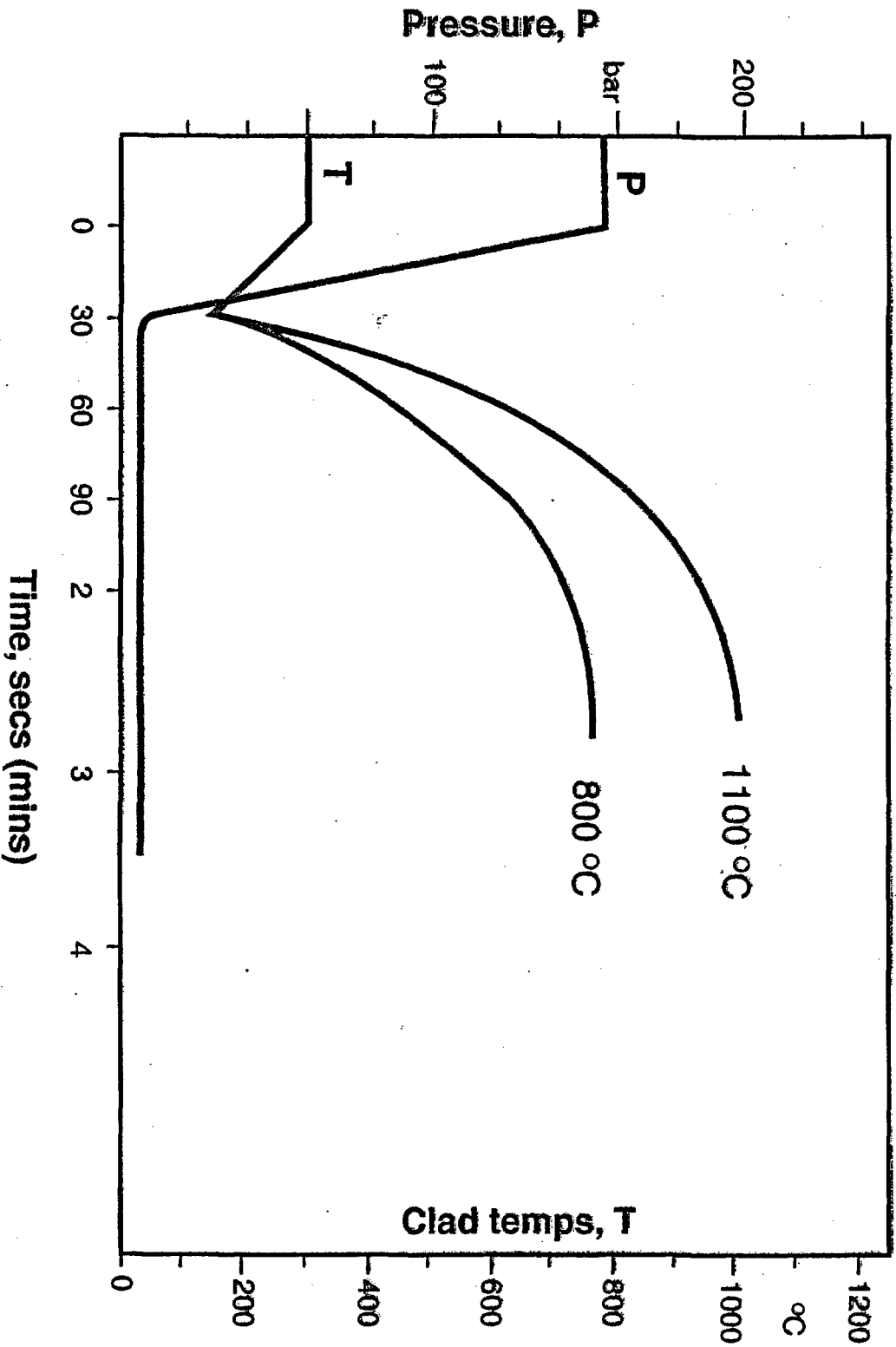



## LOCA TRIAL RUNS – IFA-650.1

- **Blow-down tests at zero power**
- **Power calibrations (~18 MW)**
- **Trial runs (5-6 MW)**

### 800 °C (2 runs)

- 14 W/cm (rod) + 6 W/cm (heater) (~ 830 °C)
- 14 W/cm + 6 W/cm (~ 830 °C)

### 1100 °C (4 runs)

- 20 W/cm + 12 W/cm (heater) (~ 900 °C)
- 25 W/cm + 6 W/cm (~ 930 °C)
- 25 W/cm + 18 W/cm (~ 1030 °C)
- 30 W/cm + 20 W/cm (~ 1120 °C)

Figure 5

Cladding temperature in IFA-650.1.

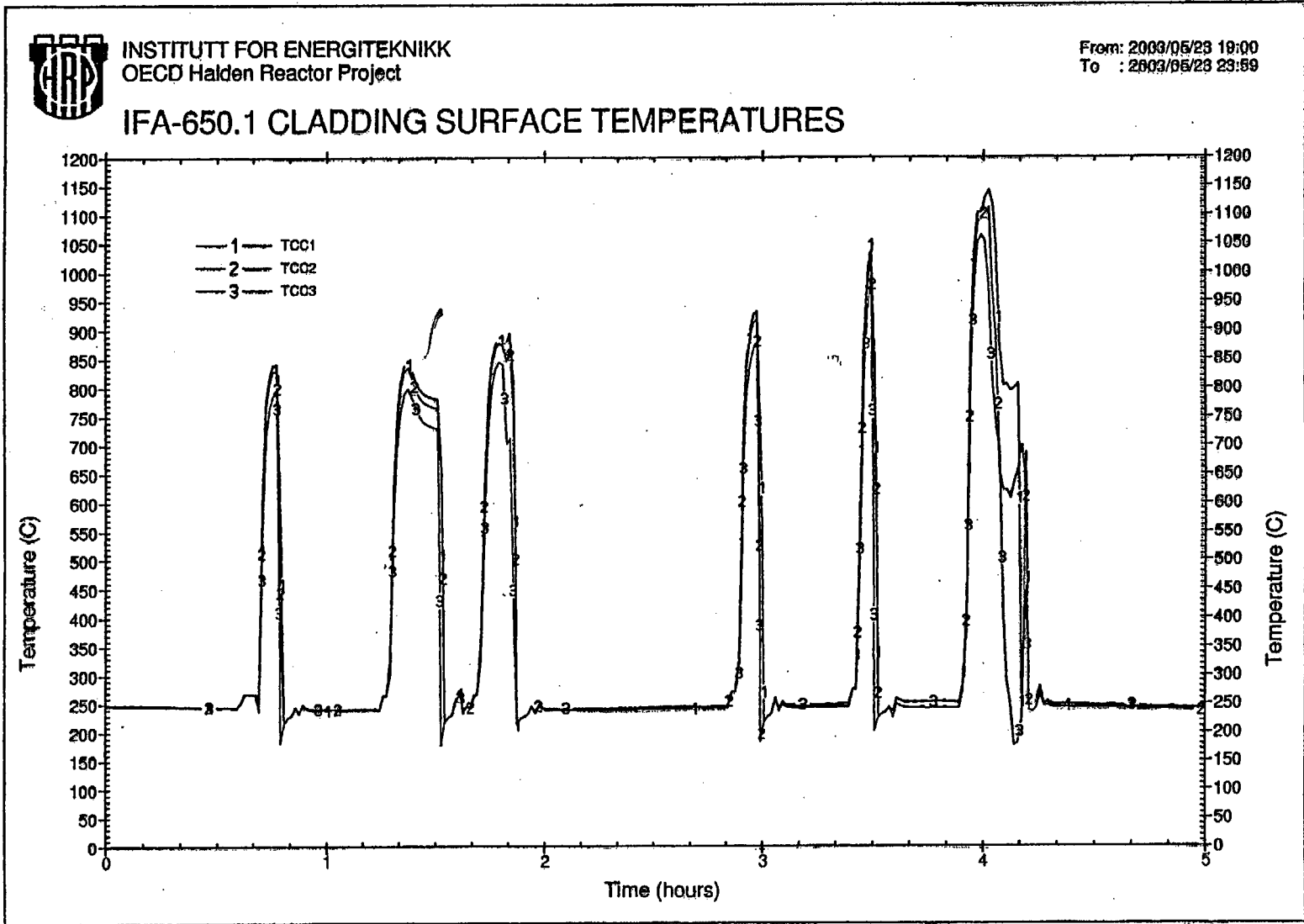



# LOCA Trial Runs, IFA-650.1

1st Run,  $Q_{rod} = 14 \text{ W/cm}$ ,  $Q_{heater} = 6 \text{ W/cm}$ ,  $TF_{max} = 850^\circ\text{C}$

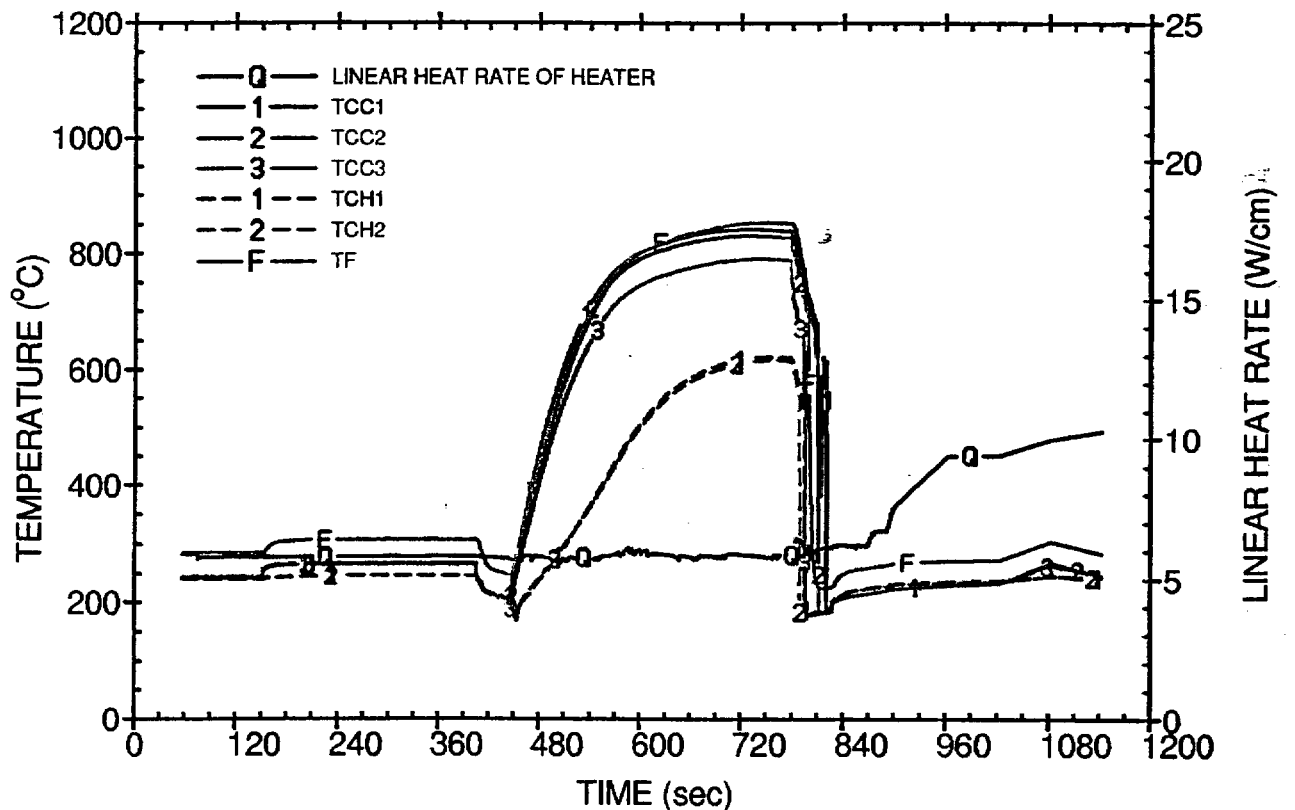
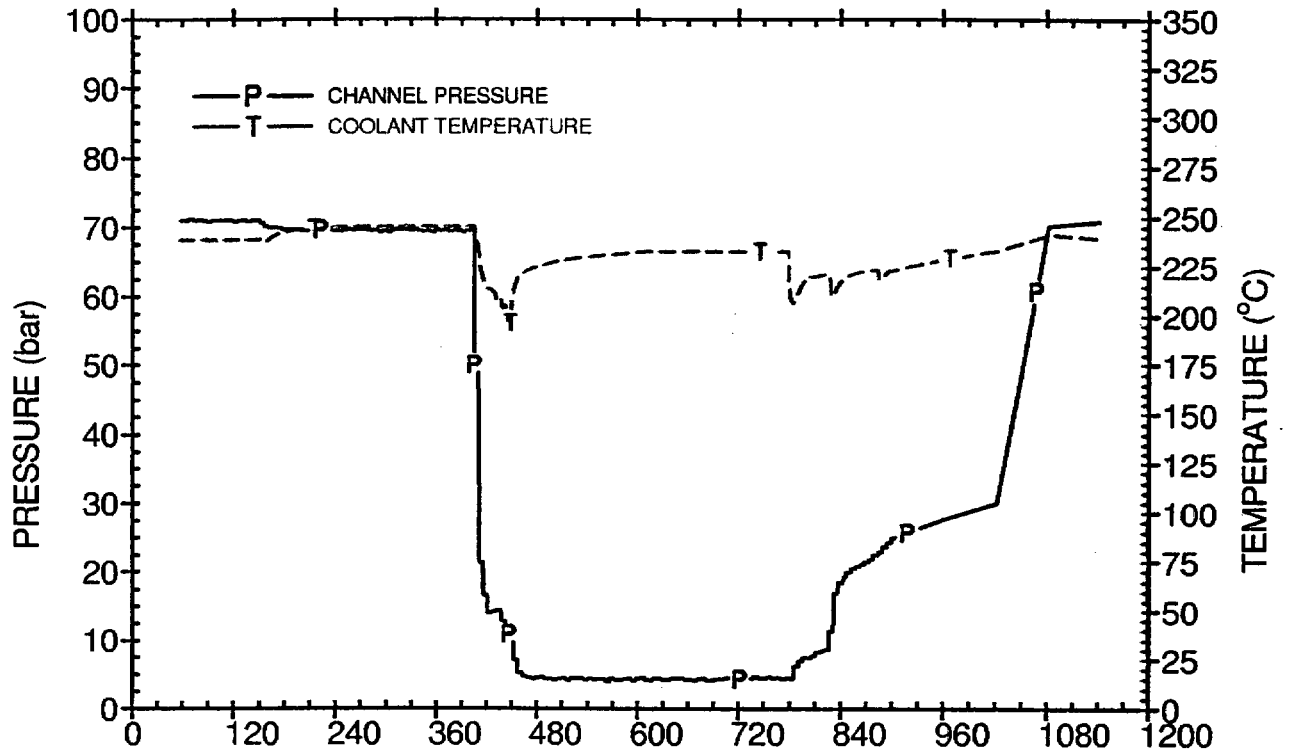



# LOCA Trial Runs, IFA-650.1

2nd Run,  $Q_{rod} = 14 \text{ W/cm}$ ,  $Q_{heater} = 6 \text{ W/cm}$ ,  $TF_{max} = 910^{\circ}\text{C}$

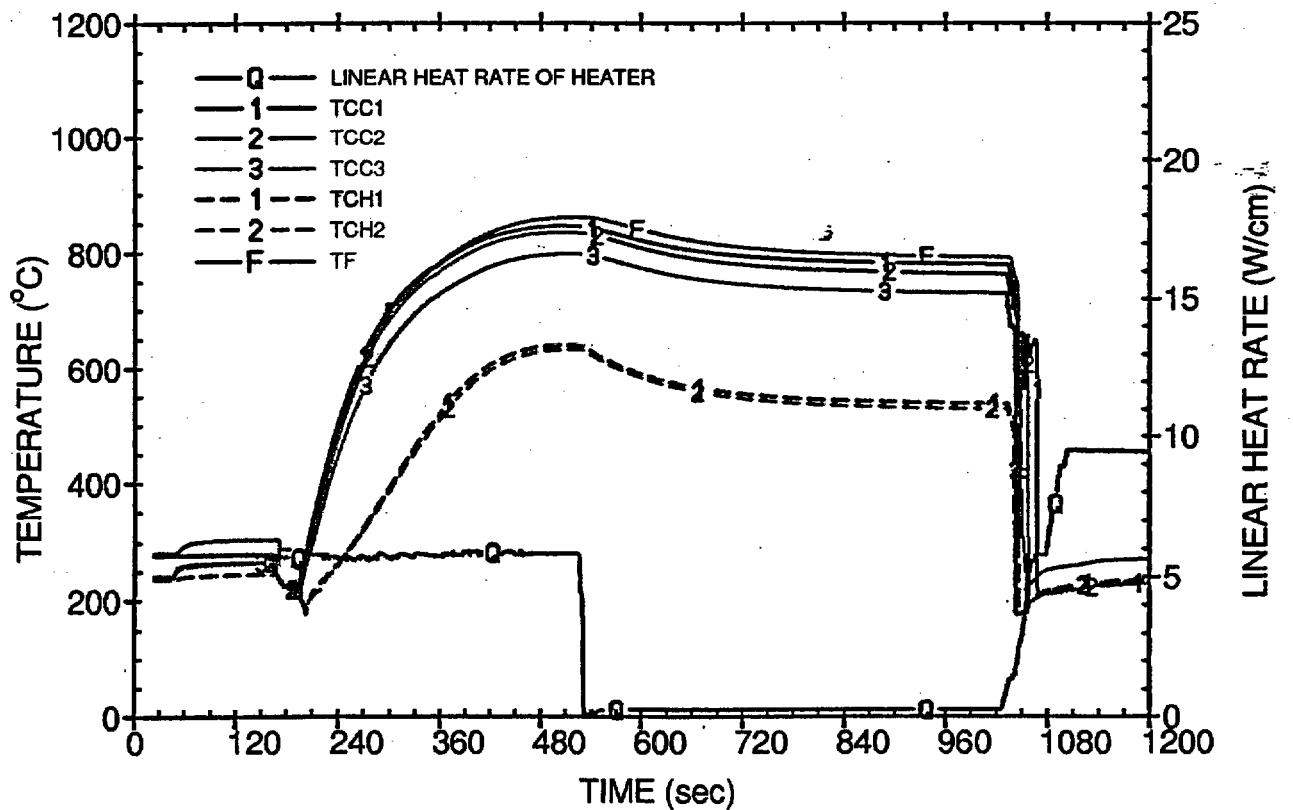
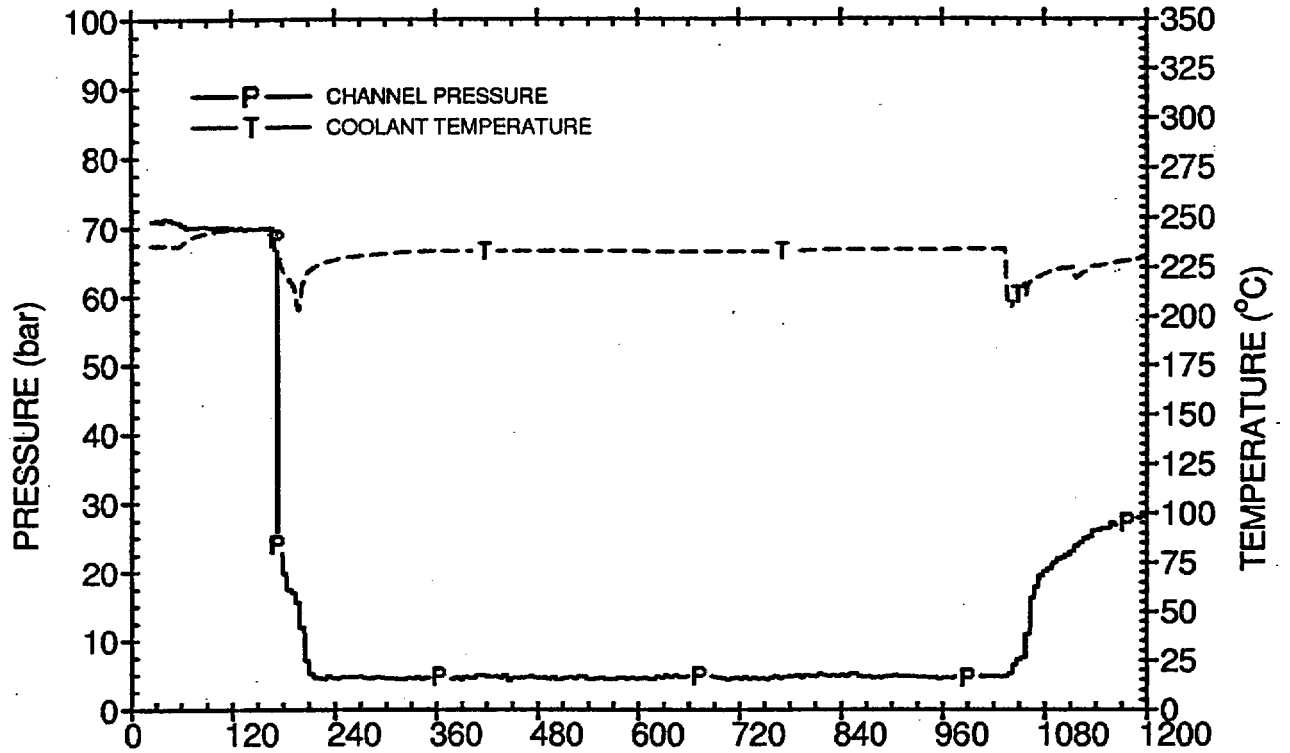



# LOCA Trial Runs, IFA-650.1

3rd Run,  $Q_{rod} = 20 \text{ W/cm}$ ,  $Q_{heater} = 12 \text{ W/cm}$ ,  $TF_{max} = 910^\circ\text{C}$

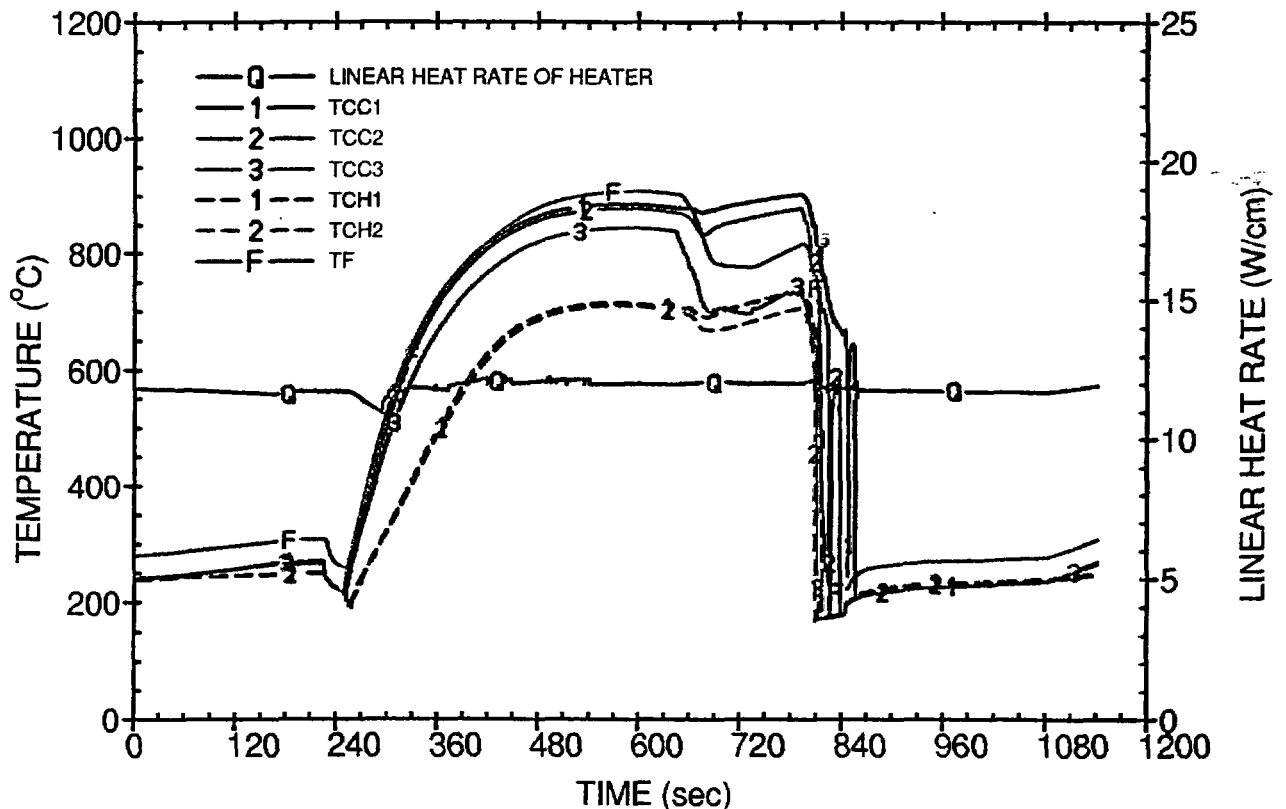
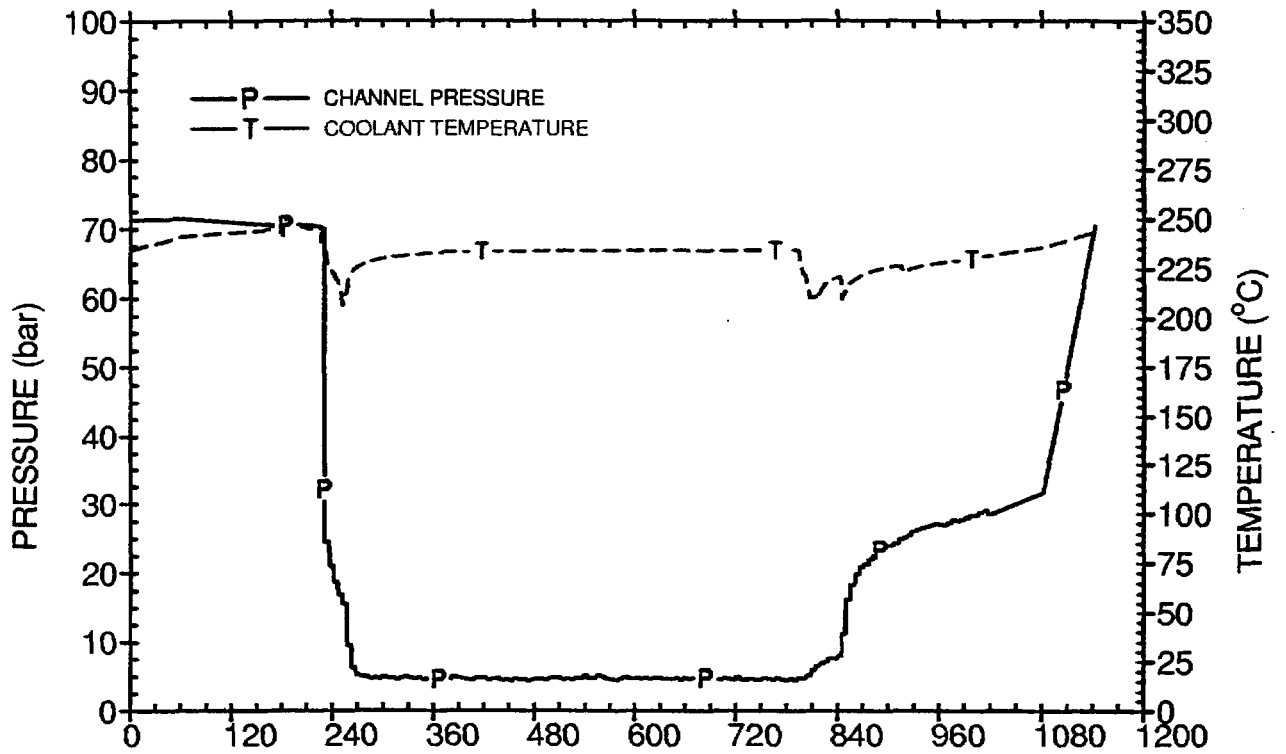





# LOCA Trial Runs, IFA-650.1

4th Run,  $Q_{rod} = 25 \text{ W/cm}$ ,  $Q_{heater} = 6 \text{ W/cm}$ ,  $TF_{max} = 960^\circ\text{C}$

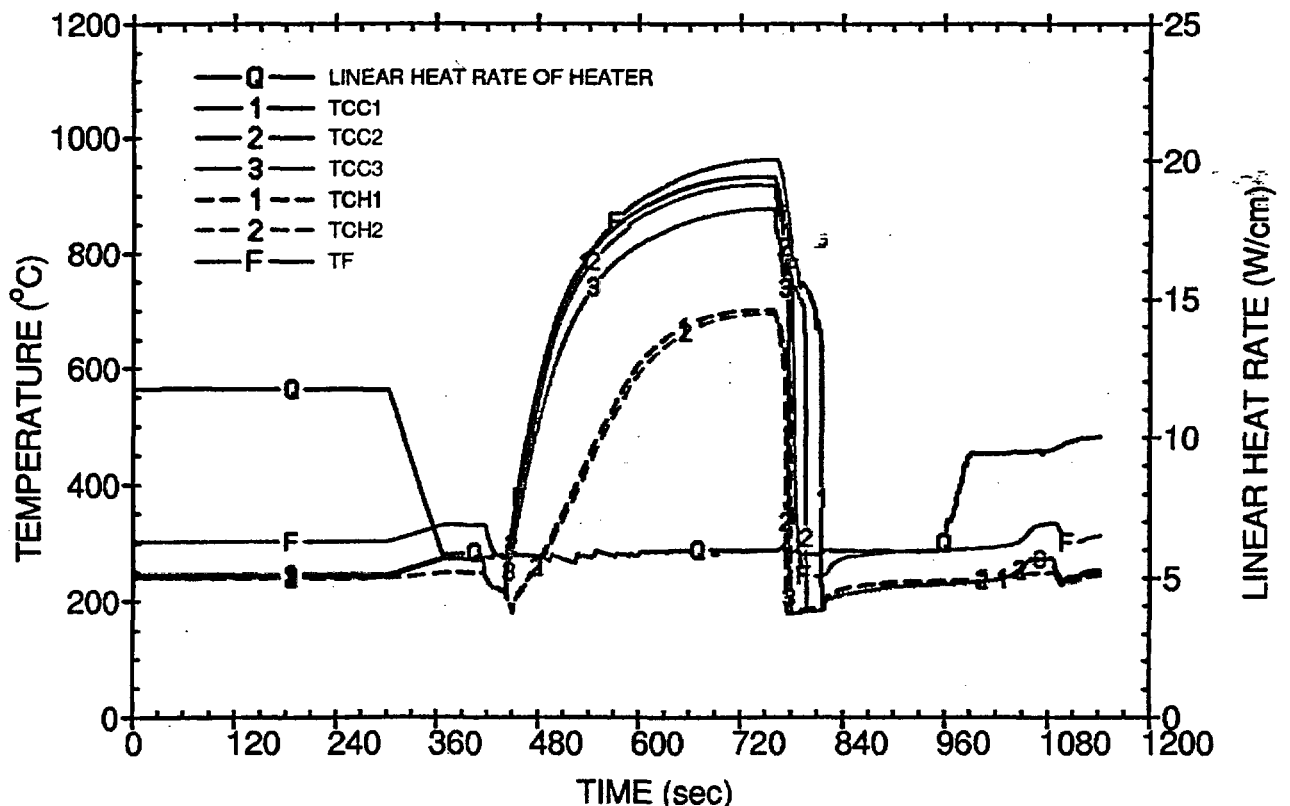
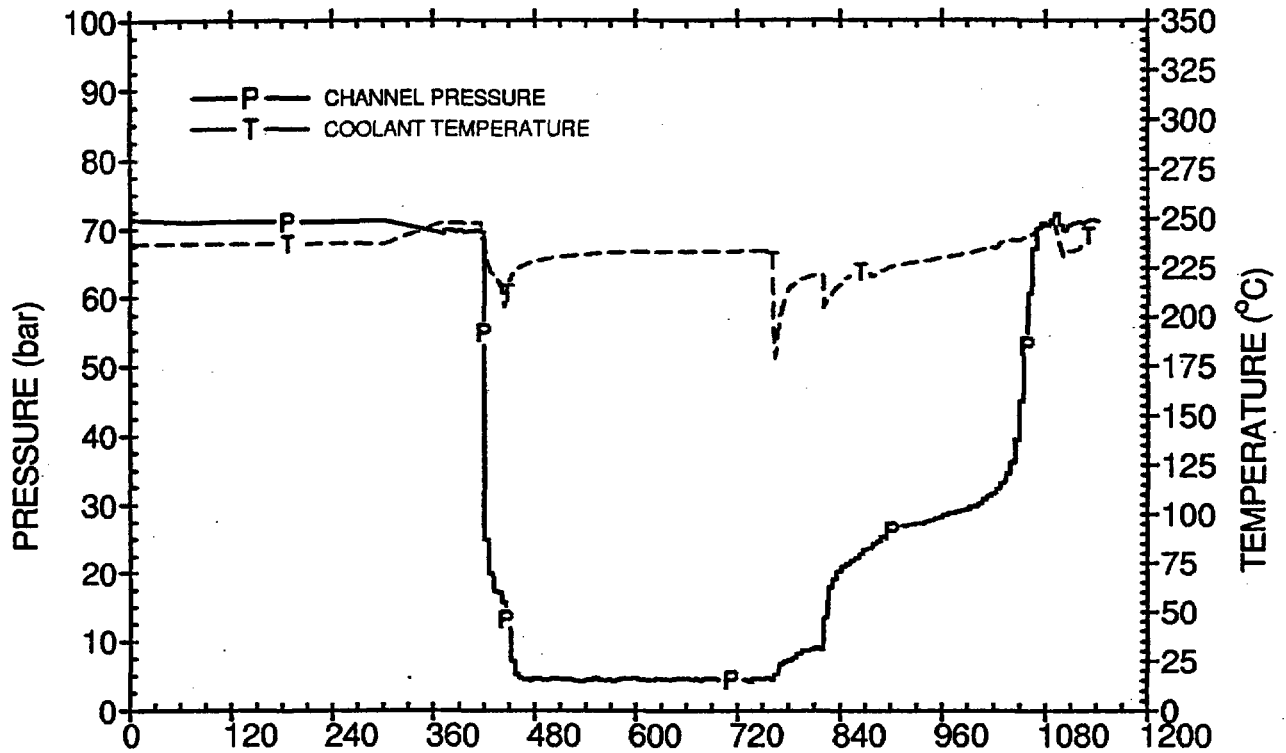



## LOCA Trial Runs, IFA-650.1

5th Run,  $Q_{rod} = 25 \text{ W/cm}$ ,  $Q_{heater} = 20 \text{ W/cm}$ ,  $TF_{max} = 1100^\circ\text{C}$

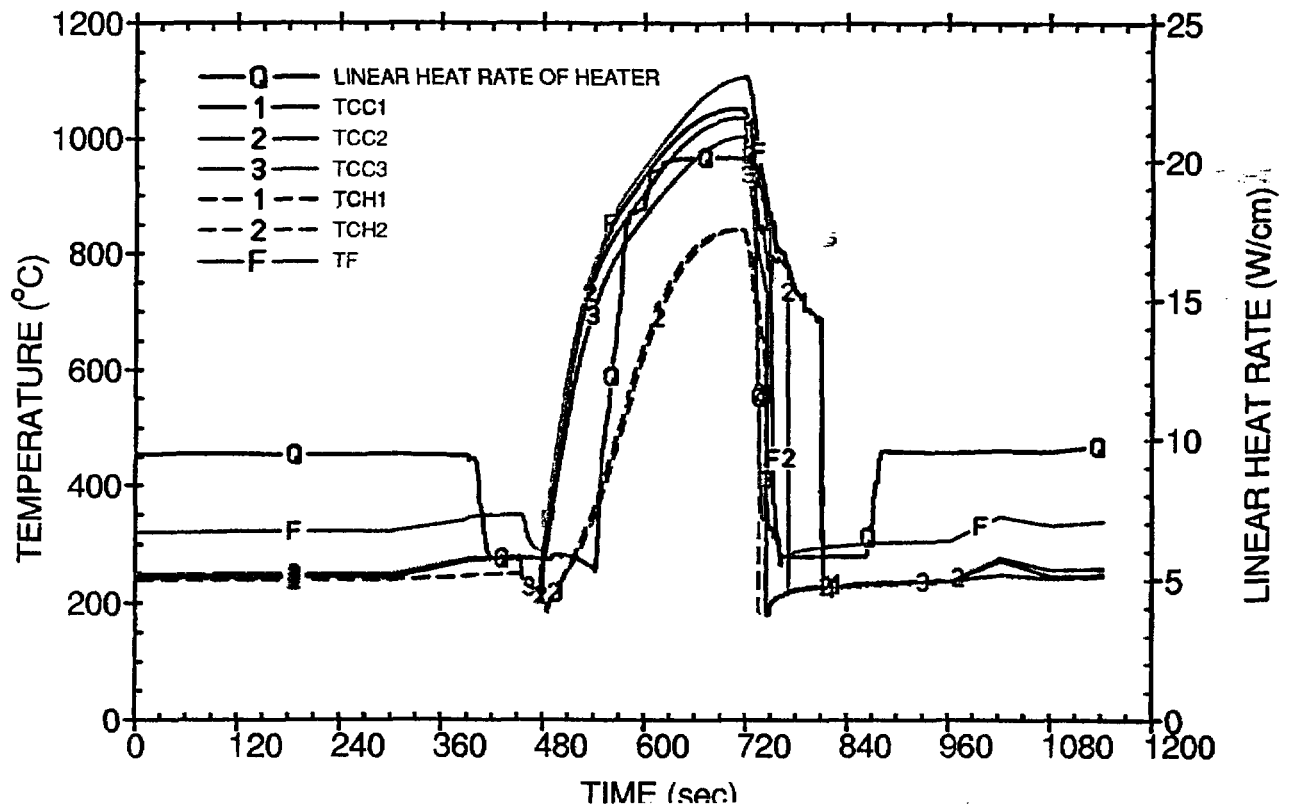
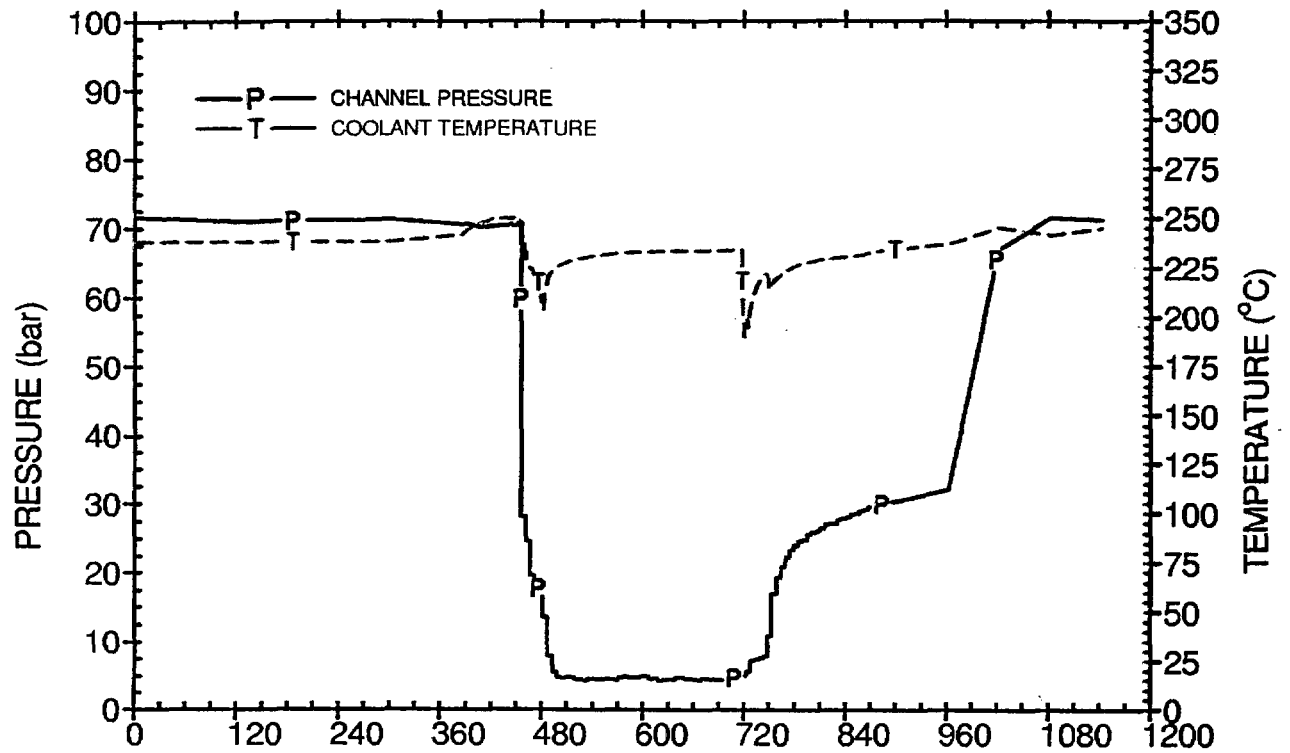



# LOCA Trial Runs, IFA-650.1

6th Run,  $Q_{rod} = 30 \text{ W/cm}$ ,  $Q_{heater} = 22 \text{ W/cm}$ ,  $TF_{max} = 1200^\circ\text{C}$

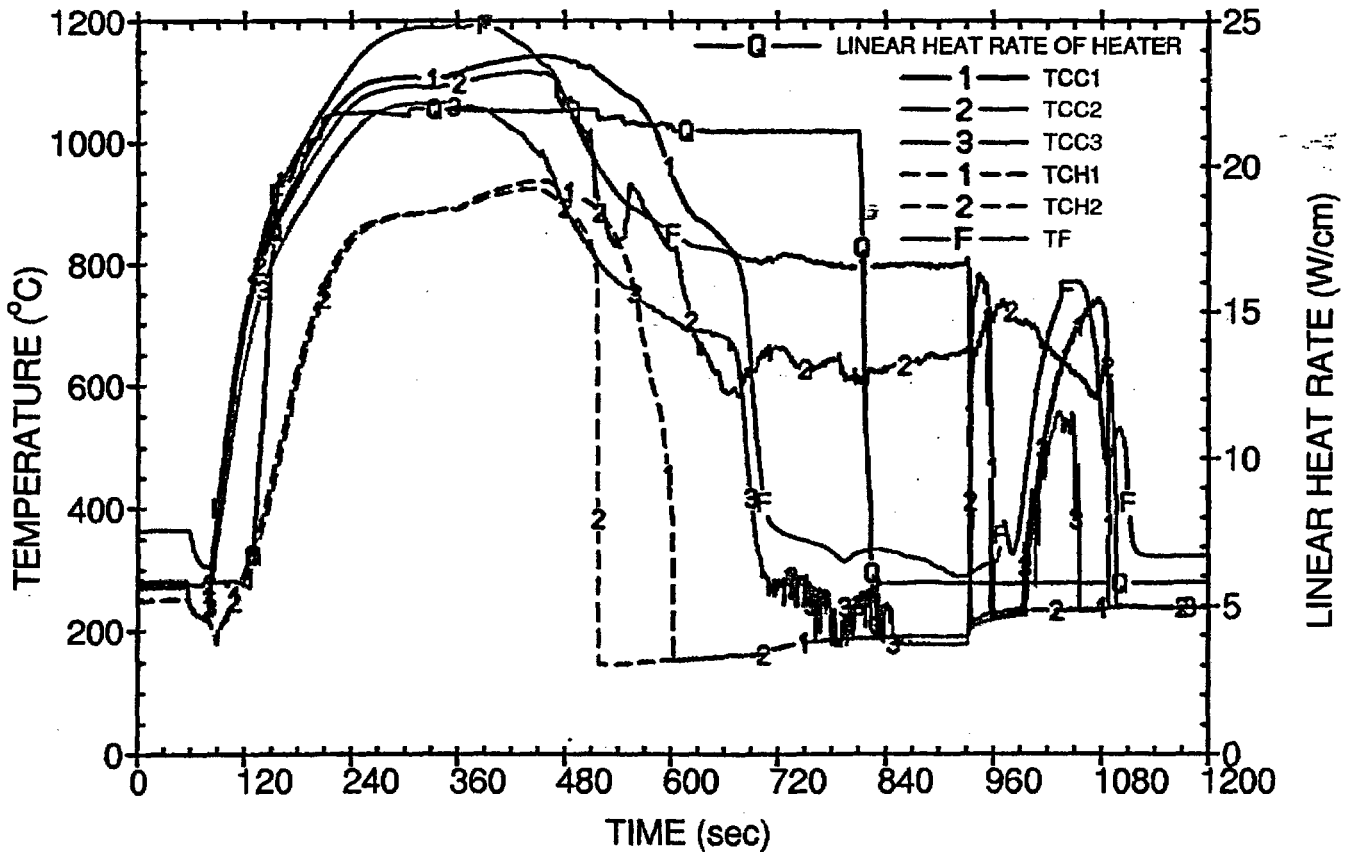
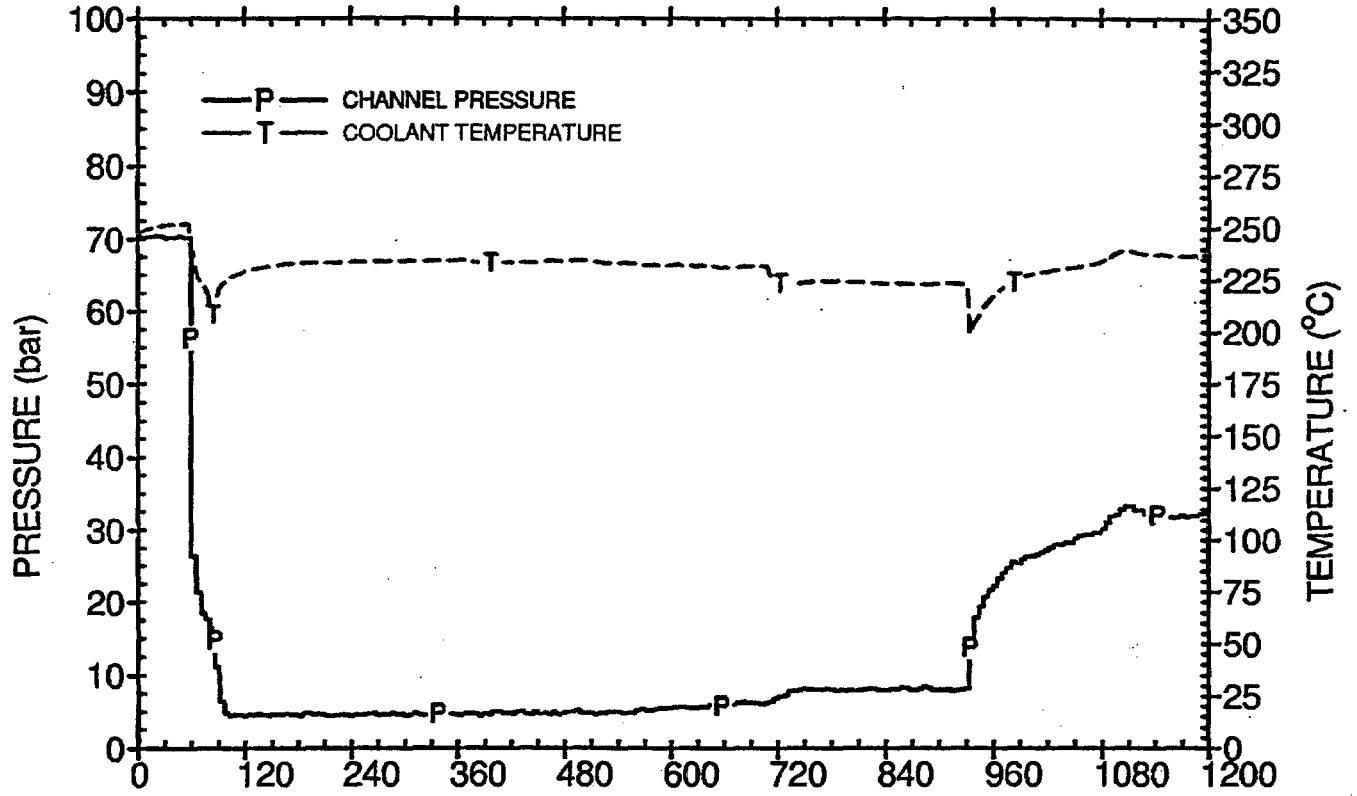



## LOCA Trial Runs, IFA-650.1

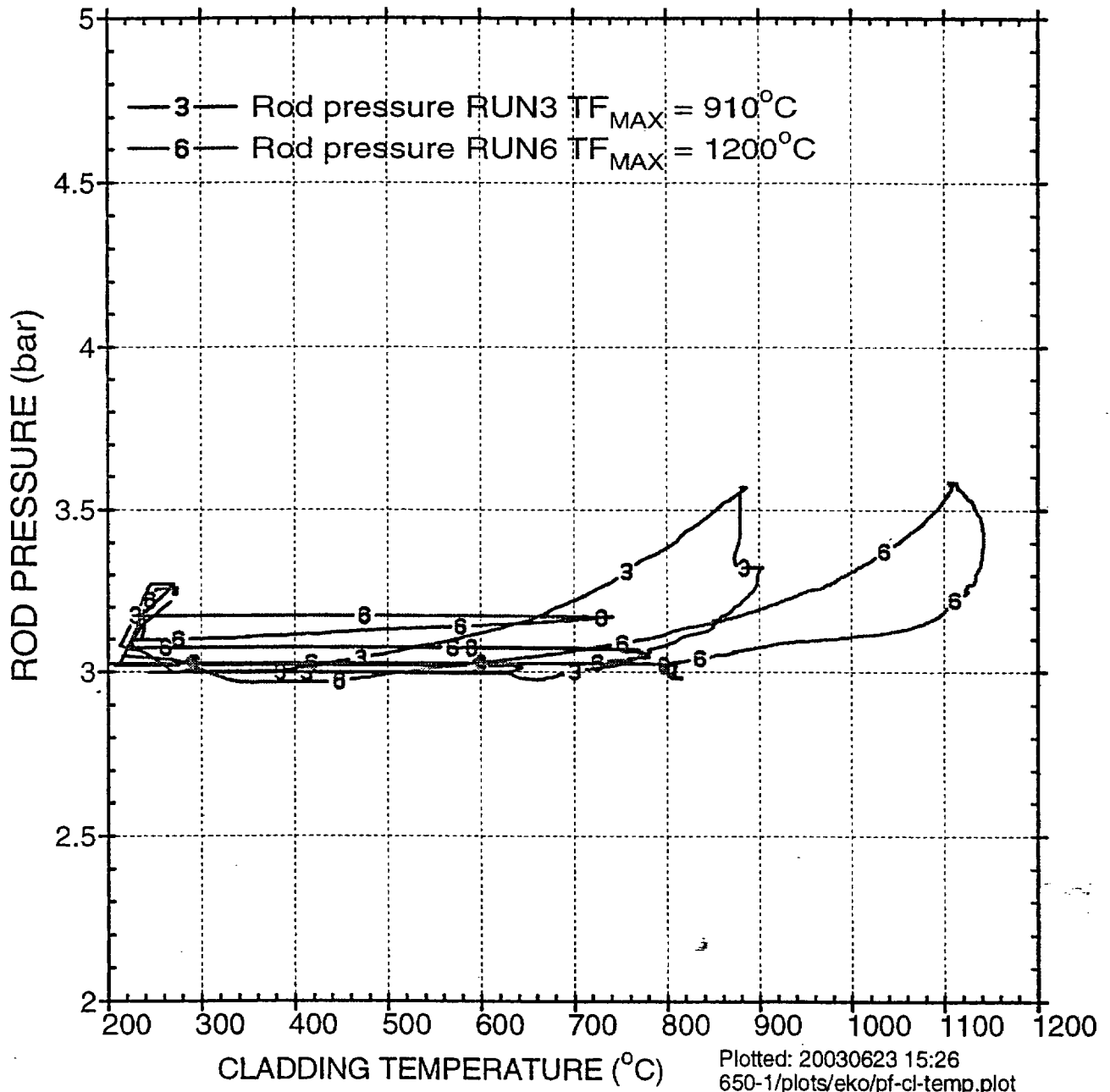



INSTITUTT FOR ENERGITEKNIKK  
OECD Halden Reactor Project

### LOCA Trial Runs, IFA-650.1,

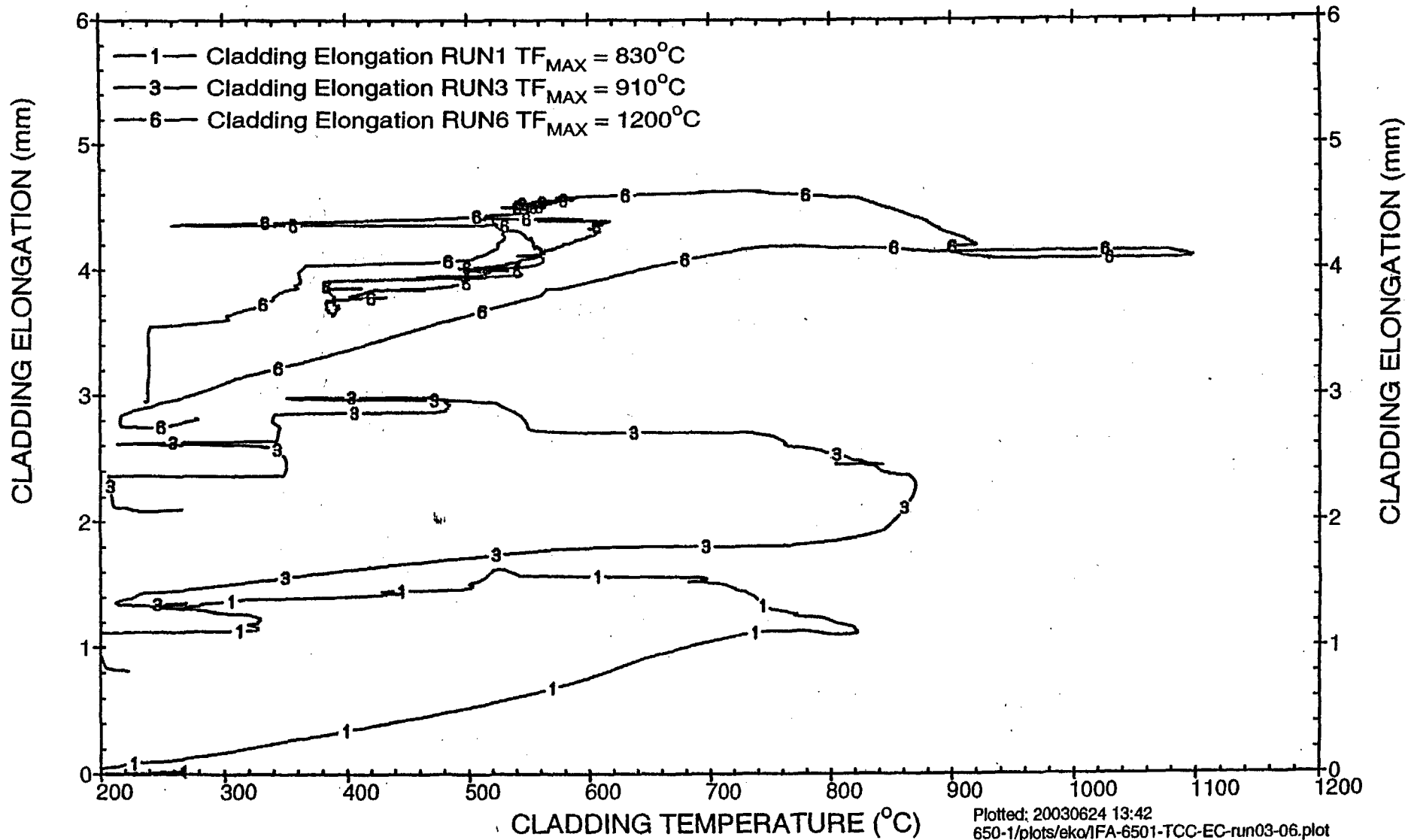



INSTITUTT FOR ENERGITEKNIKK  
HALDEN REACTOR PROJECT

## LOCA Trial Runs - IFA-650.1

### Summary:

- Trial runs on May 23<sup>rd</sup> (from 70 bar)
  - 2 runs to PCT = 800°C
  - 4 runs to PCT = 1100°C
- Loop and rig worked well
- Rod instrumentation worked well
- PCT reached by adjusting
  - LHGR (15 - 30 W/cm)
  - Heater (6 - 20 W/cm)
- Blowdown times ~30 secs
- Quench by spray system
- Check of axial power profile
- Next test in ~~September~~ *October*  
(pressurised PWR rod)



## Test Objects

- Pairs of rods (50 - 80 MWd/kg, 40 – 50 cm length) from commercial LWRs to be tested in PWR and BWR conditions, suitable to address possible effect of axial fuel fragment relocation
  - when does it occur (blow-down/heat-up, quenching)?
  - does bonding prevent the movement of fragments?
- Include medium burnup fuel (~40 MWd/kg, less or no bonding) to bridge the gap between low and high burnup
- VVER fuel envisaged for testing at a later stage



## LOCA FUEL BEHAVIOUR TESTS IFA-650 (PWR)

	Loading/Materials	2001	2002	2003	2004	2005
<b>P W R</b>	IFA - 650.1 (PWR) (Fresh rod)			■		
	IFA-650.2 (PWR)			■	<u>PIE</u>	
	IFA-650.3 (PWR)				■	<u>PIE</u>
<b>B W R</b>	IFA-650.4 (BWR) (Fresh rod)				■	
	IFA-650.5 (BWR)					■ <u>PIE</u>
	IFA-650.6 (BWR)					■
	IFA-650.7 (BWR)					■

Instrumentation: Cladding TCs, 1 PF & 1EC  
He3 coil, Flow control, spray system