

**TRANSMITTAL OF MEETING HANDOUT MATERIALS FOR
IMMEDIATE PLACEMENT IN THE PUBLIC DOMAIN**

*This form is to be filled out (typed or hand-printed) by the person who announced the meeting (i.e., the person who issued the meeting notice). The completed form, and the attached copy of meeting handout materials, will be sent to the Document Control Desk on the same day of the meeting; under no circumstances will this be done later than the working day after the meeting.
Do not include proprietary materials.*

DATE OF MEETING

06/10/2003

The attached document(s), which was/were handed out in this meeting, is/are to be placed in the public domain as soon as possible. The minutes of the meeting will be issued in the near future. Following are administrative details regarding this meeting:

Docket Number(s)	<u>50-259, 50-260, and 50-296</u>
Plant/Facility Name	<u>Browns Ferry Nuclear Plant, Units 1, 2, and 3</u>
TAC Number(s) (if available)	<u>MB5733, MB5734, and MB5735</u>
Reference Meeting Notice	<u>05/30/2003</u>
Purpose of Meeting (copy from meeting notice)	<u>To discuss the Alternative Source Term for Browns Ferry Plant including TVA's proposed exemption from GDC 41 for the standby liquid control system</u>

NAME OF PERSON WHO ISSUED MEETING NOTICE

Kahtan N. Jabbour

TITLE

Senior Project Manager

OFFICE

Office of Nuclear Reactor Regulation

DIVISION

Division of Licensing Project Management

BRANCH

Project Directorate II, Section 2

Distribution of this form and attachments:

Docket File/Central File

PUBLIC

DF01

Tennessee Valley Authority Browns Ferry Nuclear Plant Exemption Request for the Alternative Source Term Methodology

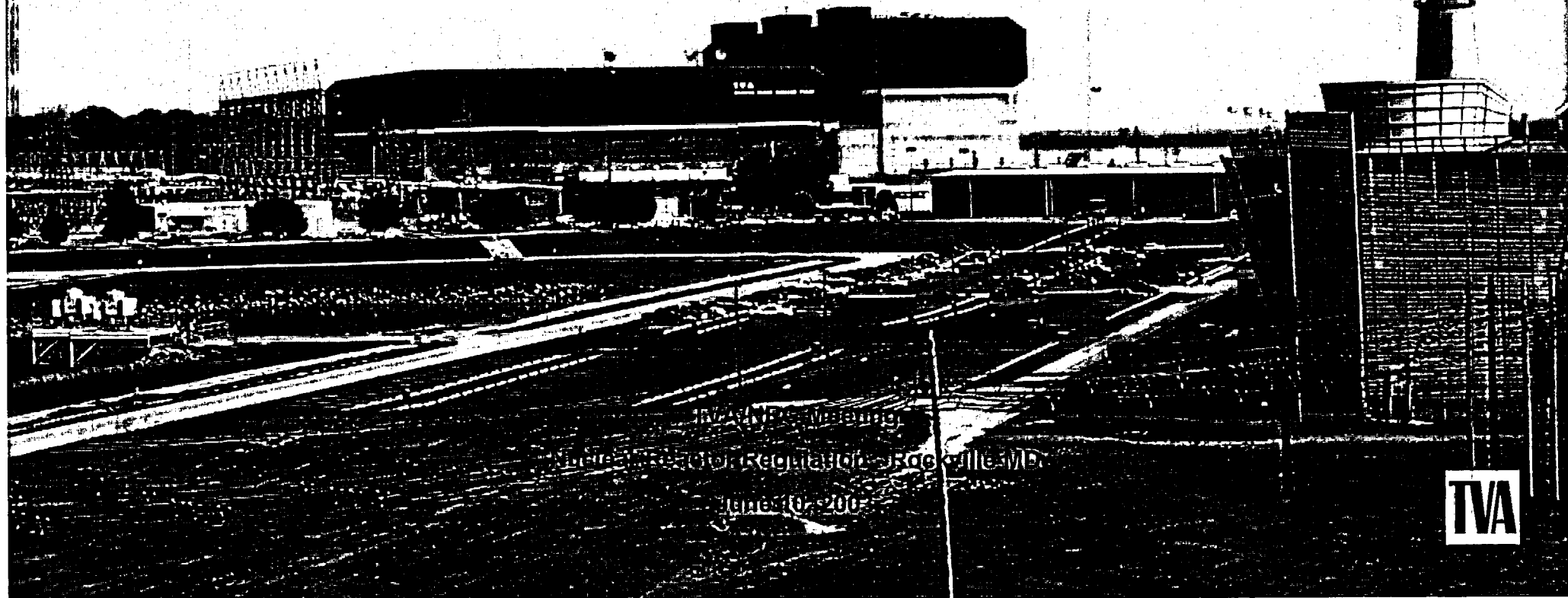
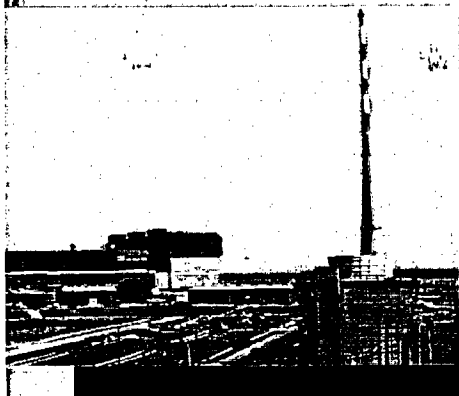

TVA/NRC Meeting

Nuclear Regulatory Commission, Rockville, MD

June 10, 2007



Agenda



-
- ◆ **Meeting Objectives**
 - ◆ **Background**
 - ◆ **Regulatory Criteria**
 - ◆ **Standby Liquid Control System Description**
 - ◆ **Exemption Request From 10 CFR 50 Appendix A
General Design Criteria 41**
 - ◆ **Content of Exemption Request**
 - ◆ **TVA Actions**
 - ◆ **Summary and Conclusion**

Introduction/Meeting Objectives



- ◆ **Meeting Objective**
 - **To reach a consensus on the content of TVA's proposed exemption request to 10 CFR 50 Appendix A - Criterion 41**



Background

- ◆ **TVA met with NRC Staff in January and July 2002, to describe the BFN implementation of the Alternative Source Term (AST) methodology (RG 1.183)**
- ◆ **TVA submitted the AST license amendment request (TS 405) to NRC on July 31, 2002.**
 - **Full Scope AST**
 - **Credited the Standby Liquid Control (SLC) system for suppression pool pH control consistent with precedent AST approvals**
 - **Requested elimination of charcoal adsorber filter testing requirements for the Standby Gas Treatment and Control Room Emergency Ventilation filter systems**



Background

- ◆ **Supplement (TS 405 S1) to license amendment was submitted to the staff in February 2003.**
- ◆ **Additional information concerning the BFN AST license amendment was submitted to the staff in December 2002, and March 2003.**
- ◆ **In February 2003, the NRC staff questioned the use of the Standby Liquid Control system, classified as a special safety system, for suppression pool pH control.**
- ◆ **TVA met with the NRC staff in April 2003 concerning the use of the SLC system for suppression pool pH control.**



Alternative Source Term Regulatory Criteria

- ◆ **Regulatory Guide 1.183 Section 5.1.2**
 - *“Credit may be taken for accident mitigation features that are classified as safety-related, are required to be operable by technical specifications, are powered by emergency power sources, and are either automatically actuated or, in limited cases, have actuation requirements explicitly addressed in emergency operating procedures. The single active component failure that results in the most limiting radiological consequences should be assumed. Assumptions regarding the occurrence and timing of a loss of offsite power should be selected with the objective of maximizing the postulated radiological consequences.”*



Alternative Source Term Regulatory criteria

◆ 10 CFR 50.2 - Definitions

- *Safety-related structures, systems and components means those structures, systems and components that are relied upon to remain functional during and following design basis events to assure:*
 - *(1) The integrity of the reactor coolant pressure boundary*
 - *(2) The capability to shut down the reactor and maintain it in a safe shutdown condition; or*
 - *(3) The capability to prevent or mitigate the consequences of accidents which could result in potential offsite exposures comparable to the applicable guideline exposures set forth in §50.34(a)(1) or §100.11 of this chapter, as applicable.*



Alternative Source Term Regulatory Criteria

- ◆ **10 CFR 50 Appendix A General Design Criterion 41 -
Containment Atmosphere Cleanup**
 - *“Systems to control fission products, hydrogen, oxygen, and other substances which may be released into the reactor containment shall be provided as necessary to reduce, consistent with the functioning of other associated systems, the concentration and quality of fission products released to the environment following postulated accidents, and to control the concentration of hydrogen or oxygen and other substances in the containment atmosphere following postulated accidents to assure that containment integrity is maintained.”*
 - *“Each system shall have suitable redundancy in components and features, and suitable interconnections, leak detection, isolation, and containment capabilities to assure that for onsite electric power system operation (assuming offsite power is not available) and for offsite electric power system operation (assuming onsite power is not available) its safety function can be accomplished, assuming a single failure.”*



Standby Liquid Control System Description

- ◆ **The SLC system is classified as a special safety system.**
 - **as defined in Section 1.2 of the BFN Updated Final Safety Analysis Report (UFSAR), a special safety system is a system the actions of which are essential to a safety action required in response to a special event.**
 - **system is subject to the augmented QA program.**
- ◆ **BFN technical specifications require periodic verification of component performance.**
- ◆ **System leak testing is performed in accordance with ASME section XI criteria.**
- ◆ **The SLC system is composed of redundant injection pumps and injection valves so that at least one pump and associated components assures system availability to perform the injection function.**



Standby Liquid Control System Description

- ◆ **Electrical power for the pumps and controls are supplied from different safety-related supplies. A loss of offsite power or a single power failure will not prevent system operation.**
- ◆ **Initiation of the SLC system is addressed by the emergency operating procedures.**
- ◆ **The system is manually actuated by one keylock switch located on the main control room console. Placing the switch in either "start A" or "start B" position starts the respective pump, opens both explosive valves, and closes the Reactor Water Cleanup system isolation valves.**
- ◆ **The system injection flow path is a single line through the containment and into the reactor vessel. The injection line has two containment isolation check valves in series.**

Standby Liquid Control System Description

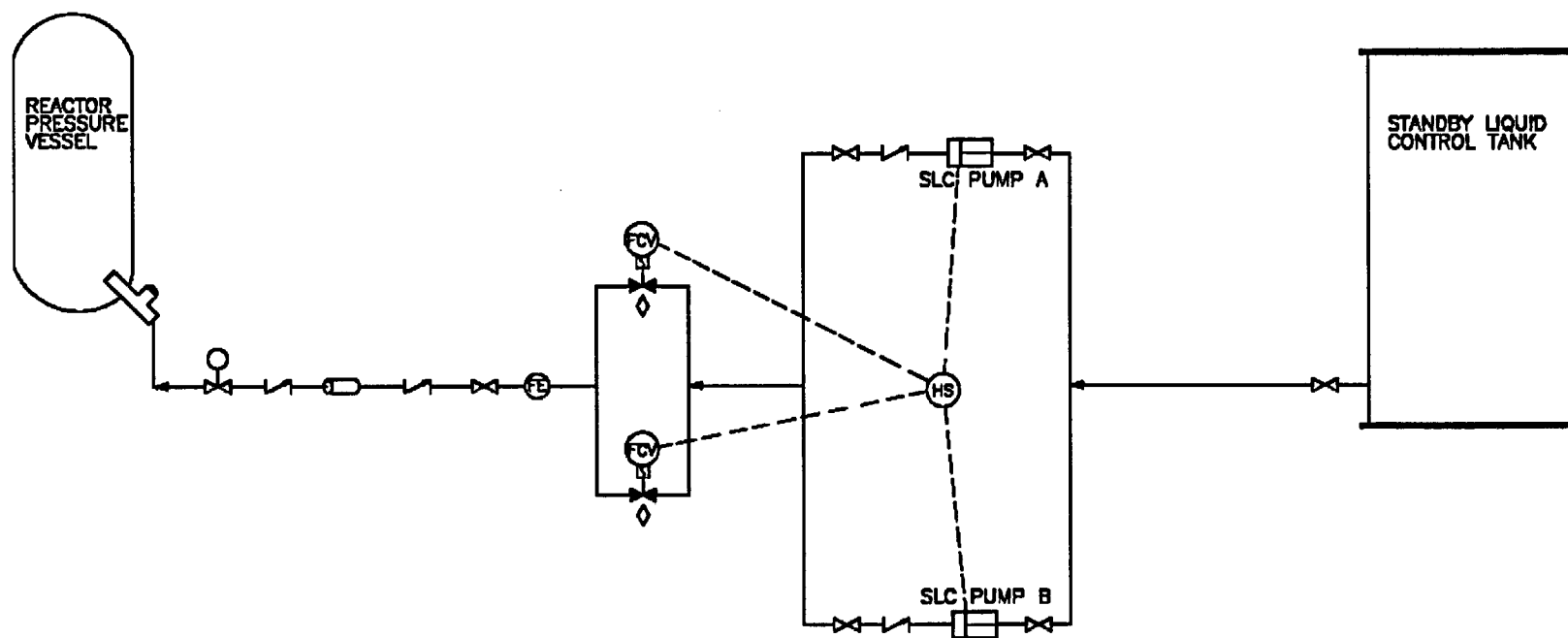



Proposed Exemption

- ◆ **10 CFR 50.12 authorizes the Commission to grant exemptions from the requirements of the regulations provided that:**
 - ◆ **The exemption is authorized by law;**
 - ◆ **The exemption does not present an undue risk to the public health and safety;**
 - ◆ **The requested exemption will not endanger the common defense and security;**
 - ◆ **Special circumstances are present as defined in 10 CFR 50.12 (a)(2).**



Proposed Exemption

- ◆ **TVA believes that special circumstances are present in this instance to warrant exemption from the requirements of 10 CFR 50 Appendix A GDC 41. Specifically, Section (ii), of 10 CFR 50.12(a)(2) states,**
 - **(ii)“Application of the regulation in the particular circumstances would not serve the underlying purpose of the rule or is not necessary to achieve the underlying purpose of the rule;....”**
- ◆ **The proposed exemption request from 10 CFR 50 Appendix A, Criterion 41 requirements to assume a single failure**
 - **Injection line containment isolation check valves.**
 - **Control circuitry**



Content of Proposed Exemption

- ◆ **System Description**
 - **Quality Assurance Program**
 - **SLC Single Failure Evaluation**
- ◆ **System Reliability**
 - **Maintenance Rule**
 - **Testing And Surveillance**
- ◆ **Dose Evaluation**
 - **Methodology**
 - **Results**
- ◆ **Risk Assessment**
 - **SLC System Availability Probability**
 - **System Initiation Probability**



TVA Actions

- ◆ **TVA to submit the exemption request by June 20, 2003**
- ◆ **Additionally, TVA will separately withdraw the changes to TS section 5.5.7 requested in the AST License amendment (TS 405) which TVA proposed deleting charcoal adsorber filter testing requirements in the Standby Gas Treatment and Control Room Emergency Ventilation filter systems**
 - **This will facilitate staff review of the license amendment**
 - **TVA will submit the revision to TS 405 by June 27, 2003**



Summary and Conclusion
