



May 4, 2003

L-2003-117
EA-03-009(IV)(F)(2)

U.S. Nuclear Regulatory Commission
Attn: Document Control Desk
Washington, DC 20555

Re: St. Lucie Unit 2
Docket No. 50-389
Order (EA-03-009)
Relaxation Request 1 - Supplement 3

On February 11, 2003, the NRC issued Order (EA-03-009) requiring specific inspections of the reactor pressure vessel head (RPVH) and associated penetration nozzles at pressurized water reactors. By FPL letter L-2003-086 on March 28, 2003, Florida Power & Light Company (FPL) requested relaxation from the requirements specified in Section IV, paragraph C.(1)(b)(i) for St. Lucie Unit 2 for the RPVH penetration nozzles for which ultrasonic testing (UT) requirements can not be completed as required. Relaxation Request 1 was supplemented by FPL letters L-2003-101 and L-2003-113 on April 18, 2003 and April 29, 2003, respectively.

On May 1, 2003, FPL discussed a proposed modification to the UT coverage requested for Relaxation Request 1. This letter provides a complete revision for Relaxation Request 1 based on UT results and actual penetration configurations identified during the UT inspection.

For any additional questions about these relaxation requests, please contact George Madden at (772) 467-7155.

Very truly yours,

A handwritten signature in black ink, appearing to read 'WJ', is written over the text 'Very truly yours,'.

William Jefferson, Jr.
Vice President
St. Lucie Plant

WJ/GRM

Attachment

A101

**ST. LUCIE UNIT 2 RELAXATION REQUEST NO. 1 Revision 1
FROM NRC Order EA-03-009**

**Hardship or Unusual Difficulty Without Compensating Increase in
Level of Quality or Safety**

1. ASME COMPONENTS AFFECTED

St. Lucie (PSL) Unit 2 has 102 ASME Class 1 reactor pressure vessel (RPV) head penetrations (including the vent). The scope of this relaxation is only applicable to the 91 RPV head penetrations with attached threaded guide funnels.

The St. Lucie Unit 2 Order Inspection Category in accordance with Section (IV.A.) is currently determined as "high" based on 14.0 EDY at this refueling outage¹ (RFO).

FPL Drawing No. 2998-3130, Rev. 3 (PSL-2)

2. APPLICABLE EXAMINATION REQUIREMENTS:

The NRC issued an Order² on February 11, 2003 establishing interim inspection requirements for reactor pressure vessel heads of pressurized water reactors. Section IV.C. of the Order states the following:

All Licensees shall perform inspections of the RPV head using the following techniques and frequencies:

(1) For those plants in the High category, RPV head and head penetration nozzle inspections shall be performed using the following techniques every refueling outage:

- (a) Bare metal visual examination of 100% of the RPV head surface (including 360° around each RPV head penetration nozzle), AND
- (b) Either:
 - (i) Ultrasonic testing of each RPV head penetration nozzle (i.e., nozzle base material) from two (2) inches above the J-groove weld to the bottom of the nozzle and an assessment to determine if leakage has occurred into the interference fit zone,

OR

¹ FPL letter L-2002-185, "St. Lucie Units 1 and 2, Docket Nos. 50-335, 50-389, Turkey Point Units 3 and 4, Docket Nos. 50-250 and 50-251, Response to NRC Bulletin 2002-02, Reactor Pressure Vessel Head Penetration Nozzle Inspection Programs," R. S. Kundalkar to NRC, September 11, 2002.

² US NRC Letter EA-03-009, "Issuance Of Order Establishing Interim Inspection Requirements For Reactor Pressure Vessel Heads At Pressurized Water Reactors," from Samuel J. Collins (NRC) to all Pressurized Water Reactor Licensees, dated February 11, 2003.

(ii) Eddy current testing or dye penetrant testing of the wetted surface of each J-Groove weld and RPV head penetration nozzle base material to at least two (2) inches above the J-groove weld.

Relaxation is requested from part IV.C.(1)(b)(i) of the Order to perform ultrasonic testing (UT) of the RPV head penetration inside the tube from 2 inches above the J-groove weld to the bottom of the penetration. Specifically, the relaxation is related to UT examination of the end of the RPV penetration nozzle.

3. REASON FOR REQUEST:

Pursuant to Order Section IV.F.(2) "Compliance with the Order for specific nozzles would result in hardship or unusual difficulty, without a compensating increase in the level of quality and safety," FPL is requesting this relaxation for St. Lucie Unit 2. There are 91 RPV head penetrations that contain areas of coverage less than that required by the NRC Order. The Order requires examination from 2 inches above the J-groove weld to the bottom of the RPV head penetration nozzle. The reduced coverage is caused by the nozzle configuration, the size of the fillet weld associated with the J-groove weld, and the limitations of probe design used for the Ultrasonic (UT) examination. Specifically, actual coverage below the weld, in the non-pressure boundary portion of the nozzle does not extend to the "bottom of the nozzle" as identified below:

- The bottom ID of the nozzle is internally threaded to accept a guide funnel. Available UT can not examine this area. Dye penetrant (PT) inspection, while not applicable to the ID threaded region, can be used for the OD surface, however, it is a high dose manual process.
- The distance between the bottom of the weld and the top of the threads is smaller than anticipated. The fillet weld associated with the partial penetration J-groove weld extends near the top of the threads. This condition may be caused by the combination of a longer fillet weld leg, and/or a shorter length of the penetration nozzle extending below the bottom head surface.

The configuration described above does not allow for inspection of a minimum of 1 inch below the weld, as proposed in rev. 0 of Relaxation Request #1^{3,4}. A typical example of the internally threaded nozzle, including the externally threaded guide funnel, at a high hillside angle is shown in Figure 1.

³ FPL letter L-2003-086, "St. Lucie Unit 2, Docket No. 50-389, Order (EA-03-009) Relaxation Requests 1 and 2, Examination Coverage of Reactor Pressure Vessel Head Penetration Nozzles, Supplemental Data," D. E. Jemigan to NRC, March 28, 2003.

⁴ FPL letter L-2003-101, "St. Lucie Unit 2, Docket No. 50-389, Order (EA-03-009) Relaxation Requests 1 and 2, Examination Coverage of Reactor Pressure Vessel Head Penetration Nozzles and Visual Inspection, Supplement," W. Jefferson to NRC, April 18, 2003.

The hardship is based on the following points:

- There is no available inspection method (including the available UT) that can inspect the threaded portion of the nozzle.
- The threaded funnels are permanently attached in place with a weld.
- Access to the OD of the nozzles is limited by the adjacent nozzles and attached funnels. The nozzles follow the curvature of the head as do the attached funnels. The 91 RPV nozzle penetration connected to control element drive mechanisms (CEDMs), are on 11.57 inches square pitch centers, with a 10.3 inches diameter funnel attached to the ends. This results in just over 1 inch of spacing between the funnels in the horizontal plane at the closest point.
- Methods for performing nozzle OD examinations are either dose intensive (PT), or not completely developed for field deployment by FPL's current vendor (ECT).

Accordingly, FPL is requesting a reduction of the examination coverage area based on a flaw tolerance analysis approach. As discussed below, this approach will provide an acceptable level of quality and safety with respect to reactor vessel structural integrity and leak integrity.

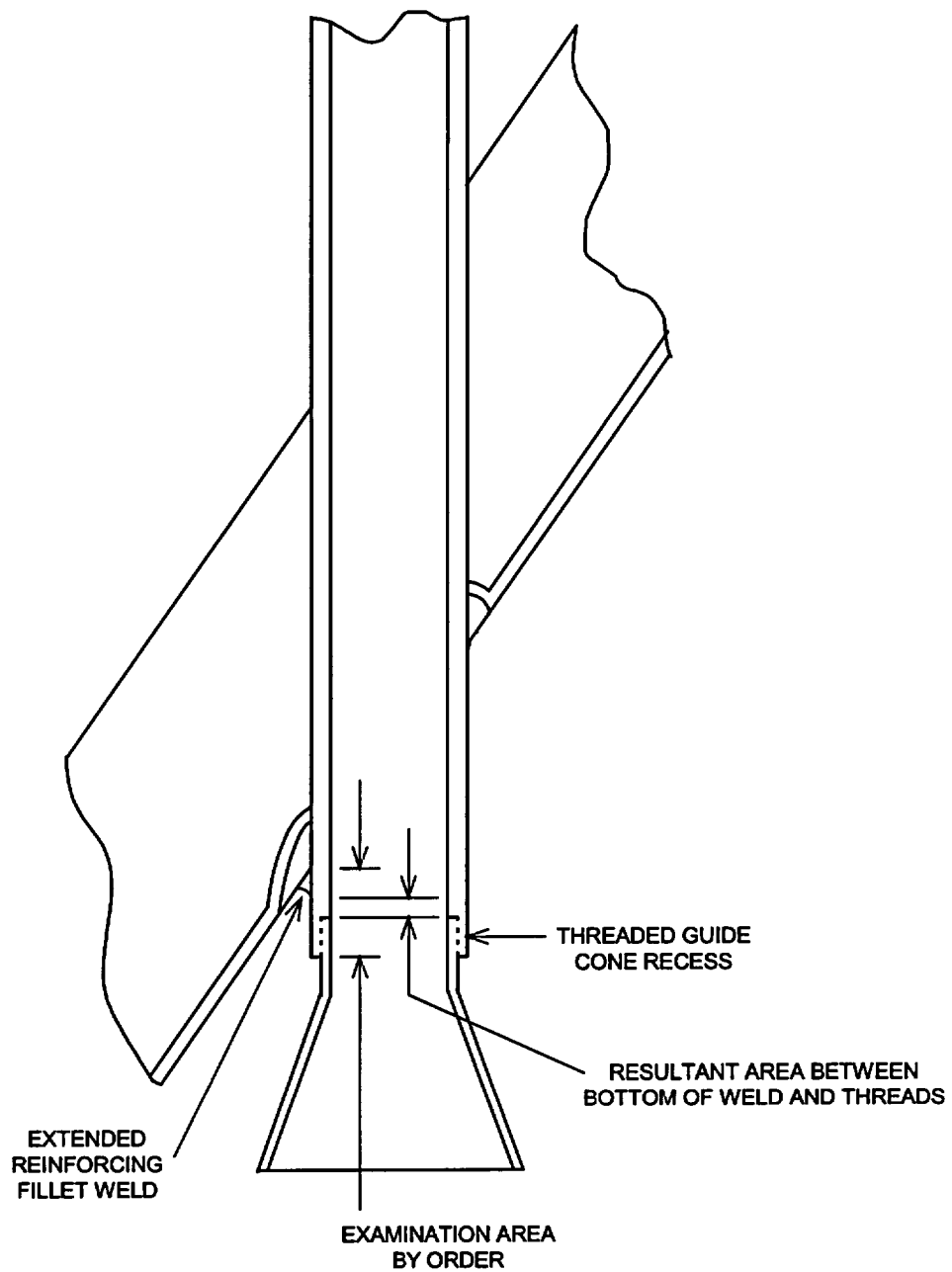

Figure 1
Typical St. Lucie Unit 2 CEDM Nozzle Configuration

4. PROPOSED ALTERNATIVE AND BASIS FOR USE:

The proposed alternative is to perform the UT examination to the extent practical. This is defined as follows:

- Perform UT examination to include the nozzle base material from 2 inches above the weld down to the bottom of the weld.
- Perform UT examination from the bottom of the weld to the maximum extent possible below the weld (≥ 0.30 inches below the weld).
- In the areas below the weld where the coverage is < 0.30 inches, the examination will be supplemented by an OD surface method. The surface examination will, as a minimum, extend from the end of the UT coverage to 0.50 inches below the weld.

Basis for the Relaxation:

Area From 2 Inches Above the Weld to the Bottom of the Weld:

The NRC Order required the area from 2 inches above the weld to the bottom of the weld to be examined 100% by UT. This includes 100% of the pressure-retaining portion of the nozzle base material, in which a safety significant circumferential flaw could result in ejection of a nozzle. This portion of the examination also includes the leak path assessment. No relaxation is requested in this area.

UT Examination of Area from the Bottom of the Weld to ≥ 0.30 Inches Below the Weld:

For the limiting nozzle location, a postulated axial through wall flaw a distance of 0.28 inches from the bottom of the weld, will take 18 months of operation to reach the weld. Therefore, the proposed ≥ 0.30 inches extent of UT inspection below the weld will support one 18-month period of operation (one refueling cycle) for St. Lucie Unit 2, as described below.

A flaw tolerance approach was developed to determine the minimum coverage distance below the weld required to assure that a postulated flaw would not grow into the weld in one 18-month period of operation. The basis for the approach is documented in WCAP-16038-P⁵ (previously transmitted to the NRC⁴) and shown in the WCAP Figures 6-12 through 6-18. These figures show, that for all nozzle intersection angles evaluated, if an axial through wall flaw were to exist 0.50 inches below the end of the weld, the predicted time for the flaw to grow to a point of contacting the weld would take greater than 5 years of operation. The center nozzle (Figure 6-12) is covered by this evaluation since the UT inspection distance exceeded 0.50 inches below the weld.

⁵ "Structural Integrity Evaluation of Reactor Vessel Upper Head Penetrations to Support Continued Operation: St. Lucie Unit 2," Westinghouse Electric Co. LLC, WCAP-16038-P Revision 0, March 2003.

To determine the limiting distance for a flaw to exist below the weld and not grow to contact the bottom of the weld within one 18-month period of operation (the minimum inspection area), the downhill side of the nozzle will be evaluated. Due to the horizontal plane of the threads, and the angle of the nozzle intersection with the RPV head, the extent of UT coverage is higher on the uphill side. The same calculation data used to produce figures 6-14, 6-16 and 6-18 in WCAP-16038-P was evaluated to determine the limiting nozzle location. At the limiting nozzle location, a postulated axial through wall flaw a distance of 0.28 inches from the bottom of the weld will take 18 months of operation to reach the lower portion of the weld. A summary of the results is given in Table 1.

Table 1: Minimum Inspection Coverage Distance Below the Weld to Support an Additional 18-Month Operation Period (Locations shown bound all others in between)

Nozzle Intersection Angle in Degrees	Upper Crack Tip (Distance in Inches from Bottom of Weld)
7.8° Downhill side of nozzle (Figure 6-14, WCAP-16038-P)	0.27
29.1° Downhill side of nozzle (Figure 6-16, WCAP-16038-P)	0.28
49.7° Downhill side of nozzle (Figure 6-18, WCAP-16038-P)	0.27

Figure 2 below provides a check of the determination in Table 1 above.

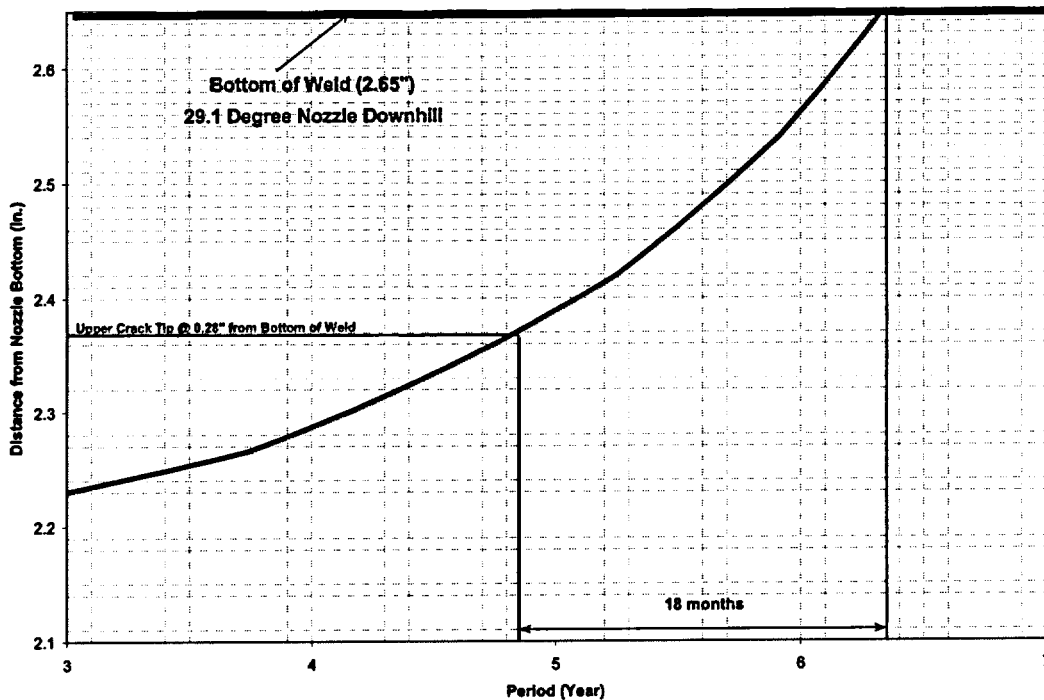

Figure 2: Graphical Determination of Minimum Inspection Coverage Distance Below the Weld to Support an Additional 18-Month Operation Period (Exploded section from Figure 6-16 of WCAP-16038-P).

An added conservatism is that no time is accounted for the postulated flaw to grow through the weld to the point of initiating a leak, or initiation of a circumferential flaw.

If the Extent of the UT Examination below the Bottom of the Weld is < 0.30 Inches, a Surface Examination is Proposed:

The surface examination minimum distance is selected based on the through wall flaw evaluation presented in WCAP-16038-P, Figures 6-14, 6-16 and 6-18, for an operational period of greater than 5 years. The surface examination is limited to the nozzle OD, since the hoop stresses are the highest on the nozzle OD directly adjacent to the weld, as shown in Figures E-1 through E-7 of WCAP-16038-P. The stress distributions for the nozzles are shown in Figures 5-4 through 5-7 of WCAP-16038-P. These figures show that the OD stress levels drop off quickly as the distance below the weld increases. This reduces the potential for cracking to exist in the uninspected area, greater than 0.50 inches below the weld, on the downhill side of the nozzle.

Interaction of Threaded Region with the Larger Fillet Weld Leg:

The penetration to head joint is a partial penetration J-groove weld with a corresponding fillet weld that acts to reduce the stress concentration at the sharp weld to nozzle corner, particularly at high hillside angles of intersection with the head. The depth of the partial penetration weld is fixed by the weld preparation detail drawing. However, the fillet weld leg size is specified as a smooth radius transition, as prescribed by ASME Section III, with no maximum on the leg size. The larger than expected fillet leg has resulted in a reduced area of nozzle base material below the weld on the downhill side of some nozzles. Revision 0 of this relaxation request⁶ cited a flaw tolerance approach, WCAP-16038-P, to address the unsuspectable region adjacent to the threaded funnel. In order to use the same report, Westinghouse was contacted to verify the continued validity of the report to the field identified condition. Westinghouse indicated that the residual stresses resulting from the weld fabrication process are due primarily to the shrinkage of the partial penetration J-groove weld and not the fillet weld leg, because the fillet weld cap is not as constrained as the J-groove weld. Assuming the fillet weld leg dimension were to increase, the stress distribution below the partial penetration J-groove weld would not be impacted beyond the calculation accuracy of the finite element analysis. Therefore, the flaw evaluation tables identified in the WCAP remain valid.

Preliminary Field Inspection Results for 60 CEDM Nozzles:

The UT coverage for a typical CEDM nozzle is shown in Figure 3. Since all of the 91 CEDM penetrations are unobstructed on the ID, 100% scan coverage can be obtained above the threaded area. This includes 100% of the area adjacent to the interference fit region between the nozzle and the head, for assessment of a potential "leak path." In the example below, the extent of UT coverage below the weld ranges from 0.79 inches at the downhill side to a maximum of 3.33 inches on the uphill side.

⁶ FPL letter L-2003-086, "St. Lucie Unit 2, Docket No. 50-389, Order (EA-03-009) Relaxation Requests 1 and 2, Examination Coverage of Reactor Pressure Vessel Head Penetration Nozzles, Supplemental Data," D. E. Jemigan to NRC, March 28, 2003

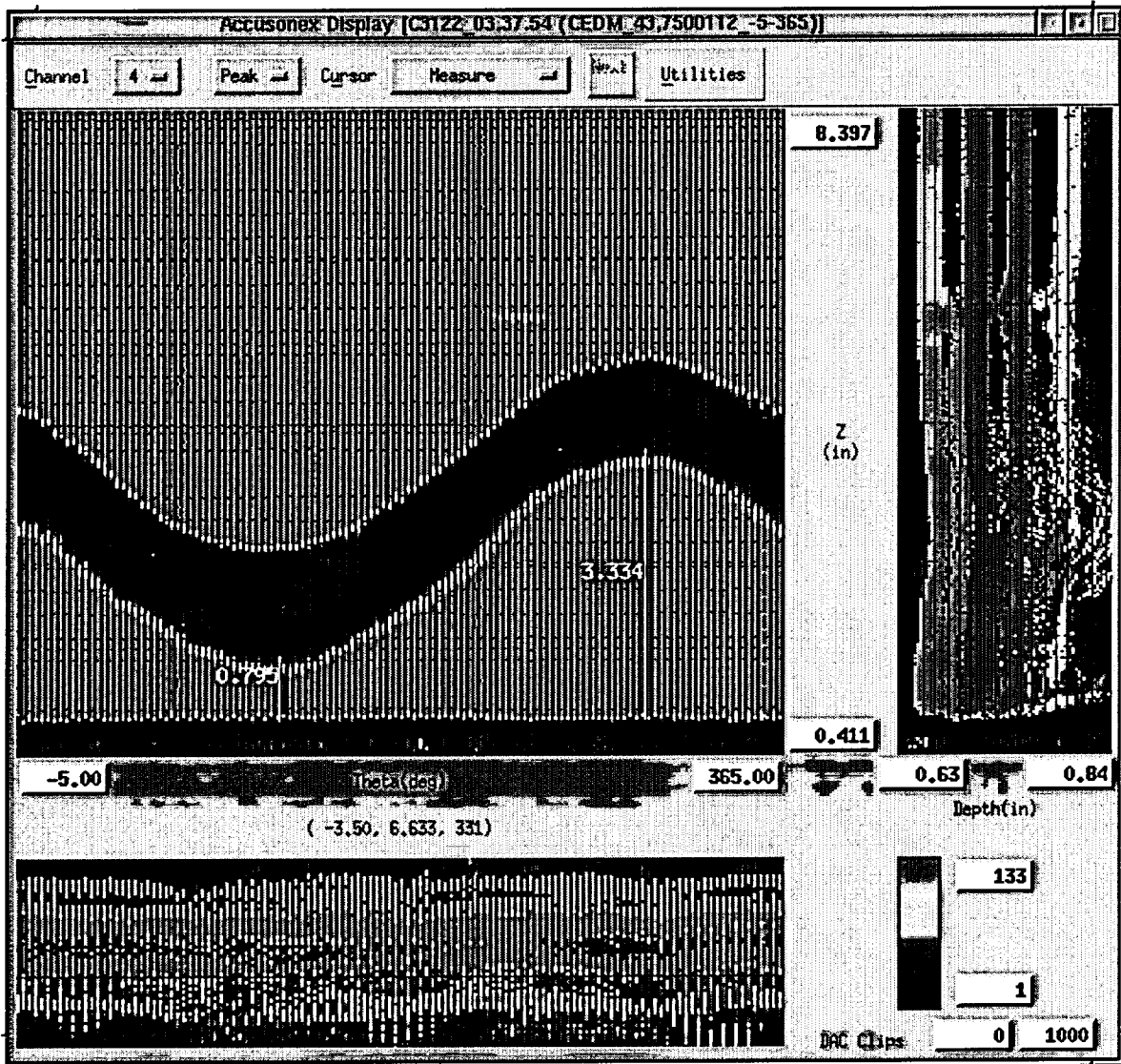

Figure 3: Typical UT "C" Scan of Nozzle 43 Showing Minimum and Maximum Coverage Area Below the Weld

Table 2 shows the UT coverage for the first 60 RVHP nozzles for which the UT data has been preliminarily evaluated. The extent of coverage on the downhill side is noted in the table. The corresponding uphill side for nozzle 43 is shown in Figure 3. The final list of all penetrations will be included in the 60-day post outage report required by the NRC Order².

Table 2: Preliminary Extent of UT Coverage in RVHP Nozzle Material, Sorted by Minimum Distance Below the Weld (St. Lucie 2-14 RFO)

Pen #	Min. Distance Above Weld Root on uphill side(Inches)	Coverage Above Weld Root (Theta)	Coverage @ Weld Root (Theta)	Weld Region Coverage (Theta)	Below Weld Coverage (Theta)	Min Distance Below Weld Toe on downhill side (Inches)	Theta range <0.30' of coverage on downhill side of weld	Theta range <1/2' of coverage on downhill side of weld
87	6.00	360	360	360	360	0.31	N/A	107
59	6.15	360	360	360	360	0.31	N/A	104
66	6.28	360	360	360	360	0.36	N/A	82
78	6.39	360	360	360	360	0.36	N/A	80
54	6.74	360	360	360	360	0.39	N/A	118
90	5.87	360	360	360	360	0.41	N/A	50
50	5.50	360	360	360	360	0.45	N/A	74
83	6.30	360	360	360	360	0.45	N/A	87
82	5.33	360	360	360	360	0.47	N/A	78
51	6.06	360	360	360	360	0.47	N/A	47
89	6.04	360	360	360	360	0.48	N/A	86
42	6.33	360	360	360	360	0.49	N/A	88
62	6.13	360	360	360	360	0.51	N/A	N/A
65	6.21	360	360	360	360	0.51	N/A	N/A
73	6.49	360	360	360	360	0.51	N/A	N/A
7	7.03	360	360	360	360	0.61	N/A	N/A
61	6.03	360	360	360	360	0.63	N/A	N/A
55	6.21	360	360	360	360	0.70	N/A	N/A
23	6.53	360	360	360	360	0.71	N/A	N/A
67	6.90	360	360	360	360	0.71	N/A	N/A
47	6.01	360	360	360	360	0.72	N/A	N/A
34	6.63	360	360	360	360	0.73	N/A	N/A
71	6.33	360	360	360	360	0.74	N/A	N/A
57	6.10	360	360	360	360	0.75	N/A	N/A
26	6.72	360	360	360	360	0.75	N/A	N/A
20	7.03	360	360	360	360	0.78	N/A	N/A
33	7.13	360	360	360	360	0.78	N/A	N/A
29	6.64	360	360	360	360	0.79	N/A	N/A
43	7.06	360	360	360	360	0.79	N/A	N/A
39	5.80	360	360	360	360	0.82	N/A	N/A
37	5.90	360	360	360	360	0.82	N/A	N/A
35	6.48	360	360	360	360	0.83	N/A	N/A
72	6.57	360	360	360	360	0.84	N/A	N/A
11	6.26	360	360	360	360	0.86	N/A	N/A
27	6.29	360	360	360	360	0.86	N/A	N/A
45	6.87	360	360	360	360	0.86	N/A	N/A
40	6.52	360	360	360	360	0.87	N/A	N/A
25	7.41	360	360	360	360	0.88	N/A	N/A
63	6.06	360	360	360	360	0.90	N/A	N/A
58	6.52	360	360	360	360	0.90	N/A	N/A
38	5.80	360	360	360	360	0.91	N/A	N/A
9	7.18	360	360	360	360	0.92	N/A	N/A
21	6.40	360	360	360	360	0.94	N/A	N/A
22	6.58	360	360	360	360	0.94	N/A	N/A
4	6.76	360	360	360	360	0.94	N/A	N/A
6	6.94	360	360	360	360	0.94	N/A	N/A
32	6.95	360	360	360	360	0.94	N/A	N/A
17	7.03	360	360	360	360	0.94	N/A	N/A
15	7.10	360	360	360	360	0.94	N/A	N/A
3	6.60	360	360	360	360	0.96	N/A	N/A
31	6.72	360	360	360	360	0.98	N/A	N/A
14	6.79	360	360	360	360	0.98	N/A	N/A

Table 2: Preliminary Extent of UT Coverage in RVHP Nozzle Material, Sorted by Minimum Distance Below the Weld (St. Lucie 2-14 RFO)								
Pen #	Min. Distance Above Weld Root on uphill side (Inches)	Coverage Above Weld Root (Theta)	Coverage @ Weld Root (Theta)	Weld Region Coverage (Theta)	Below Weld Coverage (Theta)	Min Distance Below Weld Toe on downhill side (Inches)	Theta range <0.30' of coverage on downhill side of weld	Theta range <1/2' of coverage on downhill side of weld
1	6.26	360	360	360	360	1.00	N/A	N/A
10	6.63	360	360	360	360	1.00	N/A	N/A
19	6.90	360	360	360	360	1.00	N/A	N/A
12	7.47	360	360	360	360	1.01	N/A	N/A
30	7.06	360	360	360	360	1.04	N/A	N/A
18	6.77	360	360	360	360	1.06	N/A	N/A
16	7.67	360	360	360	360	1.06	N/A	N/A
2	7.34	360	360	360	360	1.12	N/A	N/A

Conclusion:

Compliance with the requirement for UT coverage to the bottom of the nozzle is unnecessary to show structural integrity of the reactor vessel and RPV nozzle penetrations. Inspection to a point ≥ 0.30 inches below the weld will provide reasonable assurance of structural integrity and no pressure boundary leakage for an additional period of 18 months.

This conclusion is based on the following conditions:

- UT inspection of the most highly stressed pressure boundary portion of the nozzle (the area adjacent to the weld zone) is unaffected by the lack of coverage below the weld.
- UT of the interference fit zone above the weld (for leakage assessment) is unaffected by the lack of coverage below the weld.
- Cracks initiating in the unexamined bottom portion (nonpressure boundary area) of the nozzle would be of minimal safety significance with respect to pressure boundary leakage or nozzle ejection. This portion of the nozzle is below the pressure boundary and any cracks would have to grow through the examined portion of the tube to reach the pressure boundary.

Additional efforts to achieve the Order required examination area (below the weld) would result in a hardship due to unusual difficulty without a compensating increase in the level of quality and safety.

5. DURATION OF PROPOSED ALTERNATIVE:

This relaxation is applicable to the April/May 2003 refueling outage for PSL-2. After one operating cycle, the PSL-2 RPV head will be re-inspected per the Order.

6. PRECEDENTS:

- 1) Calvert Cliffs Nuclear Power Plant, Unit Nos. 1 and 2 – Relaxation of the Requirements of Order (EA-03-009), Regarding Reactor Pressure Vessel Head Inspections (TAC Nos. MB7752 and MB7753, dated April 18, 2003):

Calvert Cliffs used a flaw tolerance approach to address a postulated through wall flaw in the uninspected nonpressure boundary portion of the RPV head penetration which starts no less than 0.40 inches (specifically 0.376 inches) from the J-groove weld for an operational period of 2 years.

- 2) Turkey Point Unit 3 — Relaxation of the Requirements of Order (EA-03-009) Regarding Reactor Pressure Vessel Head Inspections (TAC No. MB7990, dated March 20, 2003):

Turkey Point 3 used a flaw tolerance approach to address a postulated through wall flaw in the uninspected nonpressure boundary portion of the RPV head penetration which starts no less than 1.00 inch from the J-groove weld for an operational period of 18 months for 9 nozzles.