

Attachment A
Effluent and Waste Disposal Semiannual Report
Quad Cities Nuclear Power Station, January – June 2002
SVP-03-052

ATTACHMENT 1
Effluent & Waste Disposable Annual Report
Page 1 of 7

GASEOUS EFFLUENTS – SUMMATION OF ALL RELEASES

Period: January – June 2002

A. FISSION & ACTIVATION GASES	UNIT	FIRST QUARTER	SECOND QUARTER	EST. TOTAL ERROR %
1. Total Release	Ci	7.98E+01	1.13E+02	12.4
2. Average release rate for the period	μCi/sec	1.03E+01	1.44E+01	
3. *Percent of ODCM limit Chimney & Stack	%	5.07E-03	5.78E-03	
		1.51E-03	1.90E-03	

B. IODINE				
1. Total Iodine – 131.	Ci	9.55E-04	7.87E-04	40.0
2. Average release rate for the period	μCi/sec	1.23E-04	1.00E-04	

C. PARTICULATES				
1. Particulates with half-lives > 8 days	Ci	4.01E-03	2.51E-03	30.1
2. Average release rate for the period	μCi/sec	5.15E-04	3.20E-04	
3. Gross alpha radioactivity	Ci	<LLD**	4.95E-06	

D. TRITIUM				
1. Total Release	Ci	3.51E+01	3.16E+01	8.1
2. Average release rate for the period	μCi/sec	4.51E00	4.02E00	

E. IODINE 131 & 133, TRITIUM & PARTICULATE				
1. Percent of ODCM limit Chimney & Stack	%	1.09E00	6.75E-01	

* % NOBLE GAS GAMMA/NOBLE GAS BETA DOSE LIMITS

** Gross Alpha LLD on page 6 of 7

ATTACHMENT 1
Effluent & Waste Disposable Annual Report
Page 2 of 7

MAIN CHIMNEY GASEOUS EFFLUENTS

NUCLIDES RELEASED	Unit	CONTINUOUS MODE		BATCH MODE	
		First Quarter	Second Quarter	First Quarter	Second Quarter
1. Fission gases					
Kr-85	Ci	<LLD*	<LLD*	NA	NA
Kr-85m	Ci	1.21E00	3.32E00	NA	NA
Kr-87	Ci	1.65E00	2.27E00	NA	NA
Kr-88	Ci	2.00E00	2.02E00	NA	NA
Xe-131m	Ci	8.79E-03	3.92E-01	NA	NA
Xe-133	Ci	2.79E+01	4.27E+01	NA	NA
Xe-133m	Ci	5.66E-02	1.38E-01	NA	NA
Xe-135	Ci	7.80E00	7.80E00	NA	NA
Xe-135m	Ci	8.96E00	1.36E+01	NA	NA
Xe-138	Ci	3.01E+01	3.28E+01	NA	NA
Ar-41	Ci	1.39E-01	1.97E-01	NA	NA
Total for Period	Ci	7.98E+01	1.13E+02	NA	NA
2. Iodines					
I-131	Ci	7.38E-04	7.87E-04	NA	NA
I-133	Ci	7.66E-04	9.41E-04	NA	NA
I-135	Ci	<LLD*	<LLD*	NA	NA
Total for Period	Ci	1.50E-03	1.73E-03	NA	NA
3. Particulates					
Sr-89	Ci	3.55E-04	3.49E-04	NA	NA
Sr-90	Ci	2.09E-06	3.15E-05	NA	NA
Cs-134	Ci	<LLD*	<LLD*	NA	NA
Cs-137	Ci	<LLD*	<LLD*	NA	NA
Ba-140	Ci	4.63E-04	8.96E-04	NA	NA
La-140	Ci	1.85E-04	4.34E-04	NA	NA
Cr-51	Ci	9.52E-05	<LLD*	NA	NA
Mn-54	Ci	2.56E-05	1.41E-05	NA	NA
Co-58	Ci	<LLD*	<LLD*	NA	NA
Co-60	Ci	3.57E-04	3.62E-04	NA	NA
Mo-99	Ci	<LLD*	<LLD*	NA	NA
Ag-110m	Ci	<LLD*	2.12E-05	NA	NA
Ce-141	Ci	<LLD*	<LLD*	NA	NA
Ce-144	Ci	<LLD*	<LLD*	NA	NA
Total for Period	Ci	1.48E-03	2.10E-03	NA	NA

*Actual gaseous LLD's reported on page 6 of 7 of this check list.

ATTACHMENT 1
Effluent & Waste Disposable Annual Report
Page 3 of 7

REACTOR VENTILATION GASEOUS EFFLUENTS

NUCLIDES RELEASED	Unit	CONTINUOUS MODE		BATCH MODE	
		First Quarter	Second Quarter	First Quarter	Second Quarter
1. Fission gases					
Kr-85	Ci	<LLD*	<LLD*	NA	NA
Kr-85m	Ci	<LLD*	<LLD*	NA	NA
Kr-87	Ci	<LLD*	<LLD*	NA	NA
Kr-88	Ci	<LLD*	<LLD*	NA	NA
Xe-133	Ci	<LLD*	<LLD*	NA	NA
Xe-135	Ci	<LLD*	<LLD*	NA	NA
Xe-135m	Ci	<LLD*	<LLD*	NA	NA
Xe-138	Ci	<LLD*	<LLD*	NA	NA
Ar-41	Ci	<LLD*	<LLD*	NA	NA
Total for Period	Ci	<LLD*	<LLD*	NA	NA
2. Iodines					
I-131	Ci	2.17E-04	<LLD*	NA	NA
I-133	Ci	1.46E-04	<LLD*	NA	NA
I-135	Ci	<LLD*	<LLD*	NA	NA
Total for Period	Ci	3.63E-04	<LLD*	NA	NA
3. Particulates					
Sr-89	Ci	<LLD*	<LLD*	NA	NA
Sr-90	Ci	<LLD*	<LLD*	NA	NA
Cs-134	Ci	<LLD*	<LLD*	NA	NA
Cs-137	Ci	4.95E-06	1.07E-05	NA	NA
Ba-140	Ci	<LLD*	<LLD*	NA	NA
La-140	Ci	<LLD*	<LLD*	NA	NA
Cr-51	Ci	<LLD*	<LLD*	NA	NA
Mn-54	Ci	7.64E-04	2.19E-05	NA	NA
Co-58	Ci	<LLD*	<LLD*	NA	NA
Fe-59	Ci	5.44E-06	<LLD*	NA	NA
Co-60	Ci	1.76E-03	3.74E-04	NA	NA
Mo-99	Ci	<LLD*	<LLD*	NA	NA
Ag-110m	Ci	<LLD*	<LLD*	NA	NA
Ce-141	Ci	<LLD*	<LLD*	NA	NA
Ce-144	Ci	<LLD*	<LLD*	NA	NA
Total for Period	Ci	2.53E-03	4.07E-04	NA	NA

*Actual gaseous LLD's reported on page 6 of 7.

ATTACHMENT 1
Effluent & Waste Disposable Annual Report
Page 4 of 7

LIQUID EFFLUENTS – SUMMATION OF ALL RELEASES

A. FISSION & ACTIVATION PRODUCTS	UNIT	FIRST QUARTER	SECOND QUARTER	EST TOTAL ERROR%
1. Total Release (not including tritium, gases & alpha)	Ci	4.24E-02	4.53E-03	5.6
2. Average diluted concentration during batch discharges for the period.	µCi/mL	7.10E-09	5.45E-10	
3. Percent of applicable limit*	%	1.19E-01	1.31E-02	
		6.33E-02	6.90E-03	
4. Maximum diluted concentration during batch discharges	µCi/mL	6.88E-09	6.35E-10	
B. TRITIUM				
1. Total Release	Ci	1.03E+01	6.22E00	4.1
2. Average diluted concentration during batch discharges for the period	µCi/mL	1.73E-06	7.48E-07	
3. Percent of applicable limit	%	5.40E-02	3.21E-02	
C. DISSOLVED & ENTRAINED GASES				
1. Total Release	Ci	<LLD	<LLD	5.6
2. Average diluted concentration during batch discharges for the period	µCi/mL	<LLD	<LLD	
3. Percent of applicable limit	%	NA	NA	
D. GROSS ALPHA ACTIVITY				
1. Total Release	Ci	<LLD**	<LLD**	14.8
2. Average diluted concentration during batch discharges for the period	µCi/mL	NA	NA	
E. VOLUME OF WASTE RELEASED (prior to dilution)	Liters	2.30E+06	1.24E+06	
F. VOLUME OF DILUTION WATER USED DURING BATCH DISCHARGES	Liters	5.97E+09	8.32E+09	
G. TOTAL VOLUME OF DILUTION WATER USED DURING PERIOD (quarter)	Liters	2.00E+11	4.48E+11	

* Whole Body/Organ (ODCM)

** Gross Alpha LLD on page 7 of 7

ATTACHMENT 1
Effluent & Waste Disposable Annual Report
Page 5 of 7

LIQUID EFFLUENTS

NUCLIDES RELEASED	Unit	CONTINUOUS MODE		BATCH MODE	
		First Quarter	Second Quarter	First Quarter	Second Quarter
Sr-89	Ci	<LLD*	<LLD*	<LLD*	<LLD*
Sr-90	Ci	<LLD*	<LLD*	<LLD*	<LLD*
Cs-134	Ci	<LLD*	<LLD*	<LLD*	<LLD*
Cs-137	Ci	1.47E-03	4.13E-05	2.25E-04	4.61E-05
I-131	Ci	9.19E-04	<LLD*	<LLD*	<LLD*
Co-58	Ci	7.58E-04	<LLD*	1.39E-04	<LLD*
Co-60	Ci	7.28E-03	4.38E-04	3.12E-03	4.59E-04
Fe-59	Ci	1.78E-04	<LLD*	<LLD*	<LLD*
Zn-65	Ci	8.97E-03	1.39E-03	6.46E-04	1.39E-04
Mn-54	Ci	2.05E-03	1.11E-04	1.06E-03	3.52E-05
Cr-51	Ci	1.88E-03	<LLD*	<LLD*	<LLD*
Zr-95	Ci	<LLD*	<LLD*	<LLD*	<LLD*
Nb-95	Ci	2.14E-04	<LLD*	<LLD*	<LLD*
Mo-99	Ci	4.38E-03	<LLD*	<LLD*	<LLD*
Tc-99m	Ci	2.99E-03	<LLD*	<LLD*	<LLD*
Ag-110m	Ci	<LLD*	<LLD*	6.13E-04	3.33E-05
Sb-122	Ci	1.37E-04	<LLD*	<LLD*	<LLD*
Sb-124	Ci	2.45E-04	<LLD*	2.47E-04	<LLD*
Ba-140	Ci	<LLD*	<LLD*	<LLD*	<LLD*
La-140	Ci	<LLD*	<LLD*	<LLD*	<LLD*
Fe-55	Ci	7.96E-05	<LLD*	4.74E-03	1.84E-03
Total for Period (above)	Ci	3.16E-02	1.98E-03	1.08E-02	2.55E-03
Xe-133	Ci	<LLD*	<LLD*	<LLD*	<LLD*
Xe-135	Ci	<LLD*	<LLD*	<LLD*	<LLD*

*Actual liquid LLD's reported on page 7.

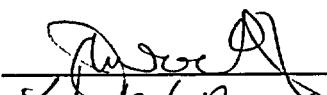
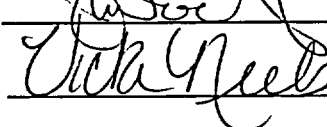
Prepared by:  Date: 04/18/03
 Approved by:  Date: 04-22-03

ATTACHMENT 1
Effluent & Waste Disposable Annual Report
Page 6 of 7
GASEOUS EFFLUENT LLD's (Most Restrictive)
CONTINUOUS MODE

NUCLIDE LOWER LIMITS OF DETECTION (LLD's)	UNIT	LLD Value	ODCM Required LLD
1. Fission gases			
Kr-85	uCi/cc	4.02E-06	None
Kr-85m	uCi/cc	1.67E-08	None
Kr-87	uCi/cc	3.35E-08	1E-04
Kr-88	uCi/cc	4.18E-08	1E-04
Xe-131m	uCi/cc	6.00E-07	None
Xe-133	uCi/cc	2.76E-08	1E-04
Xe-133m	uCi/cc	8.88E-08	1E-04
Xe-135	uCi/cc	1.16E-08	1E-04
Xe-135m	uCi/cc	1.58E-07	1E-04
Xe-138	uCi/cc	1.71E-07	1E-04
Ar-41	uCi/cc	7.19E-08	None
NUCLIDE LOWER LIMITS OF DETECTION (LLD's)			
2. Iodines			
I-131	uCi/cc	2.83E-13	1E-12
I-133	uCi/cc	3.56E-12	1E-10
I-135	uCi/cc	6.00E-09	None
NUCLIDE LOWER LIMITS OF DETECTION (LLD's)			
3. Particulates and Tritium			
H-3	uCi/cc	3.23E-11	1E-06
Sr-89	uCi/cc	2.30E-14	1E-11
Sr-90	uCi/cc	8.77E-15	1E-11
Cs-134	uCi/cc	1.47E-13	1E-11
Cs-137	uCi/cc	2.49E-13	1E-11
Ba-140	uCi/cc	4.25E-13	None
La-140	uCi/cc	6.22E-13	None
Mn-54	uCi/cc	1.86E-13	1E-11
Co-58	uCi/cc	2.06E-13	1E-11
Fe-59	uCi/cc	2.47E-13	1E-11
Co-60	uCi/cc	4.83E-13	1E-11
Zn-65	uCi/cc	4.31E-13	1E-11
Mo-99	uCi/cc	3.12E-12	1E-11
Ce-141	uCi/cc	2.92E-13	1E-11
Ce-144	uCi/cc	1.11E-12	1E-11
Gross Alpha ^A	uCi/cc	2.69E-14	1E-11

* ODCM RETS LLD's for weekly samples. These may be increased by a factor of 10 for daily samples.

^A Volume assumed to be 0.5 cfm for one week (1.43E+08 cc)

ATTACHMENT 1
Effluent & Waste Disposable Annual Report
Page 7 of 7

LIQUID EFFLUENT LLD's (Most Restrictive)
BATCH MODE

NUCLIDE LOWER LIMITS OF DETECTION (LLD's)	UNIT	LLD Value	ODCM Required LLD
3. Liquids			
H-3	uCi/cc	3.92E-06	1E-05
Sr-89	uCi/cc	8.12E-09	5E-08
Sr-90	uCi/cc	2.13E-09	5E-08
Fe-55	uCi/cc	1.23E-07	1E-06
Kr-85	uCi/cc	1.42E-05	None*
Kr-87	uCi/cc	1.50E-07	1E-05
Kr-88	uCi/cc	1.89E-07	1E-05
Xe-133	uCi/cc	1.50E-07	1E-05
Xe-133m	uCi/cc	3.90E-07	1E-05
Xe-135	uCi/cc	4.66E-08	1E-05
Xe-138	uCi/cc	6.45E-07	1E-05
Mn-54	uCi/cc	7.86E-08	5E-07
Co-58	uCi/cc	6.29E-08	5E-07
Co-60	uCi/cc	1.35E-07	5E-07
Zn-65	uCi/cc	1.32E-07	5E-07
Mo-99	uCi/cc	4.55E-07	5E-07
Ag-110m	uCi/cc	4.32E-08	None
Sb-124	uCi/cc	4.23E-08	None
I-131	uCi/cc	5.44E-08	1E-06
Cs-134	uCi/cc	5.46E-08	5E-07
Ba-140	uCi/cc	2.18E-07	None
La-140	uCi/cc	2.75E-08	None
Cs-137	uCi/cc	6.14E-08	5E-07
Ce-141	uCi/cc	1.01E-07	5E-07
Ce-144	uCi/cc	3.78E-07	5E-06
Gross Alpha	uCi/cc	9.03E-08	1E-07

* Kr-85 required by UFSAR section 9.1.3.3

Attachment B
Effluent and Waste Disposal Semiannual Report Supplemental Information
Quad Cities Nuclear Power Station, January – June 2002
SVP-03-052

**ATTACHMENT 3
Annual Effluent Report
Supplemental Information
Page 1 of 5**

Facility: Quad Cities Nuclear Power Station January – June 2002

Licensee: Exelon Generation Company

1. Regulatory Limits

a. For Noble Gases: (per unit)

Dose rate

1. Less than 500 mrem/year to the whole body
2. Less than 3000 mrem/year to the skin.

Dose Gamma Radiation

1. Less than or equal to 5 mrad/quarter.
2. Less than or equal to 10 mrad/year.

Beta Radiation

1. Less than or equal to 10 mrad/quarter.
2. Less than or equal to 20 mrad/year.

b,c. For Iodine-131, for Iodine-133, and for all radionuclides in particulate form with half-lives greater than 8 days.

Dose Rate

1. Less than 1500 mrem/year.

Dose

1. Less than or equal to 7.5 mrem/quarter.
2. Less than or equal to 15 mrem/year.

d. For Liquid: (per site)

Less than or equal to 3 mrem to the whole body during any calendar quarter.
Less than or equal to 10 mrem to any organ during any calendar quarter.
Less than or equal to 6 mrem to the whole body during any calendar year.
Less than or equal to 20 mrem to any organ during any calendar year.

**ATTACHMENT 3
Annual Effluent Report
Supplemental Information
Page 2 of 5**

2. Maximum Permissible Concentration

- a,b,c. For fission and activation gases, iodines, and particulates with half-lives greater than 8 days, allowable release limits are calculated by solving equations 10.1 and 10.2 from the Offsite Dose Calculation Manual. The alarm setpoint is conservatively set at approximately 10% of the 10CFR20 limit.
- d. For liquid effluents allowable release limits are calculated by solving equations 10.3 and 10.4 from the Offsite Dose Calculation Manual. The MPC values used for the monitors were as follows:

Radwaste discharge	7.17E-03 $\mu\text{Ci/ml}$
Service water	1.0E-05 $\mu\text{Ci/ml}$

3. Average Energy

The average gamma energy used to calculate the alarm setpoints for the noble gas monitors was 0.893 Mev for the First quarter, and 0.928 Mev for the Second quarter.

4. Measurements and Approximations of Total Radioactivity

- a. Fission and Activation Gases:
b. Iodines:
c. Particulates:

The main chimney and reactor building ventilation exhaust systems are continually monitored for iodines and particulates. These samples are pulled every 7 days and analyzed by gamma isotopic. The particulate papers are composited every 31 days and sent to a vendor for Sr89/90 and gross alpha analysis. Noble gas grab samples are pulled and analyzed by gamma isotopic weekly. Tritium samples are pulled and analyzed every month.

The Sr89/90 and gross alpha curies released values reported are actual. On a real time basis, the portion of the "percent of applicable limit" for these contributors is reported based on projections using the previous six (6) months available data. The actual results are obtained by editing the ODCM software inputs when the vendor results become available. Therefore, the "percent of applicable limits" in this report are actual.

ATTACHMENT 3
Annual Effluent Report
Supplemental Information
Page 3 of 5

The continuous strip chart recorders for the monitors on the release points are reviewed monthly for spikes and the activity released is calculated. An additional calculated activity for noble gases is added to the main chimney release each month. This calculation is done because most of the grab samples show less than the lower limit of detection due to the low amount of activity and the large dilution flow at the sample point. The calculation takes into account the normal offgas train and the gland steam contribution to the release.

The average flow at the release points is used to calculate the curies released.

d. Liquid Effluents

The river discharge tanks are analyzed before discharge by gamma isotopic. A composite representative portion of this sample is saved. This is composited with other discharges that occurred every 31 days and is analyzed for tritium and gross alpha. The monthly composites are composited quarterly and sent to a vendor for Sr89/90 and Fe 55. The discharge bay is sampled every 31 days and analyzed by gamma isotopic, for tritium and gross alpha. It is sampled quarterly and sent to a vendor for Sr89/90 and Fe 55 analysis. On a real time basis, the portion of the "percent of applicable limit" for these contributors is based on projections using scaling factors. The actual results are obtained by editing the ODCM software inputs when the vendor results become available. Therefore, the "percent of applicable limits" in this report are actual.

The tank volumes and activities are used to calculate the curies released for the River Discharge Tank. The total water released during the quarter and the activity is used to calculate the diluted activity released at the discharge bay, from batch discharges.

e. Estimated Total Error Percent

The estimated total error percents were calculated by taking the square root of the sum of the squares of errors for sampling and measurement parameters.

ATTACHMENT 3
Annual Effluent Report
Supplemental Information
Page 4 of 5

- f. Less than the lower limit of detection (<LLD*)

Samples are analyzed such that the Technical Specification LLD requirements are met. When a nuclide is not detected during the quarter, then <LLD is reported. The most conservative LLDs used for counting effluent samples are included in this report.

5. Batch Releases

a. Liquid

1.	Number of releases:	17
2.	Total time:	14,630 minutes
3.	Maximum time:	892 minutes
4.	Average time:	862 minutes
5.	Minimum time:	817 minutes
6.	Average stream flow:	63.9 gpm (discharge) 2.57E+05 gpm (dilution)

b. Gaseous – None.

6. Abnormal Releases

a. Liquid

1. In September 2001, a leak developed on the 1A RHR heat exchanger. While the RHR service water system is idle, leakage into the service water side of the heat exchanger can occur since the pressure is higher on the reactor (or suppression pool) side. The activity from this leak was included in the normal monthly liquid effluent releases and is reported under the “continuous” liquid section of this report. The leak was repaired in June 2002. There has continued to be a small amount of radioactivity identified in the service water side of this heat exchanger. Investigation continues to determine it’s source. At this time, the relatively small amount of radioactivity identified continues to be included in the normal monthly effluents and is also included in the “continuous” liquid section of this report.

**ATTACHMENT 3
Annual Effluent Report
Supplemental Information
Page 5 of 5**

b. Gaseous

1. On May 20, 2002, a fuel leak developed on U-1. The leak was determined to be a pin hole leak and was successfully suppressed on May 27, 2002. The increased noble gas activity, due to the fuel leak, resulted in a slight increase in the calculated effluent releases and was included in the normal monthly effluent releases for May 2002. The leaking fuel was replaced in November 2002 during a refuel outage (Q1R17).

Attachment C
Effluent and Waste Disposal Semiannual Report
Quad Cities Nuclear Power Station, July – December 2002
SVP-03-052

ATTACHMENT 1
Effluent & Waste Disposable Annual Report
Page 1 of 7

GASEOUS EFFLUENTS – SUMMATION OF ALL RELEASES

Period: July – December 2002

A. FISSION & ACTIVATION GASES	UNIT	THIRD QUARTER	FOURTH QUARTER	EST. TOTAL ERROR %
1. Total Release	Ci	9.24E+01	5.06E+01	12.4
2. Average release rate for the period	μCi/sec	1.16E+01	6.36E00	
3. *Percent of ODCM limit Chimney & Stack	%	8.88E-03	4.94E-03	
		2.34E-03	1.45E-03	

B. IODINE				
1. Total Iodine – 131.	Ci	1.42E-03	2.29E-03	40.0
2. Average release rate for the period	μCi/sec	1.79E-04	2.88E-04	

C. PARTICULATES				
1. Particulates with half-lives > 8 days	Ci	4.28E-03	1.88E-02	30.1
2. Average release rate for the period	μCi/sec	5.39E-04	2.36E-03	
3. Gross alpha radioactivity	Ci	8.53E-06	1.04E-05	

D. TRITIUM				
1. Total Release	Ci	6.01E+01	5.55E+01	8.1
2. Average release rate for the period	μCi/sec	7.56E00	6.98E00	

E. IODINE 131 & 133, TRITIUM & PARTICULATE				
1. Percent of ODCM limit Chimney & Stack	%	1.27E00	2.11E00	

* % NOBLE GAS GAMMA/NOBLE GAS BETA DOSE LIMITS

ATTACHMENT 1
Effluent & Waste Disposable Annual Report
Page 2 of 7

MAIN CHIMNEY GASEOUS EFFLUENTS

NUCLIDES RELEASED	Unit	CONTINUOUS MODE		BATCH MODE	
		Third Quarter	Fourth Quarter	Third Quarter	Fourth Quarter
1. Fission gases					
Kr-85	Ci	<LLD*	<LLD*	NA	NA
Kr-85m	Ci	1.10E00	6.14E-01	NA	NA
Kr-87	Ci	2.41E00	4.51E00	NA	NA
Kr-88	Ci	1.82E00	1.31E00	NA	NA
Xe-131m	Ci	1.84E-01	6.54E-02	NA	NA
Xe-133	Ci	7.99E00	3.94E00	NA	NA
Xe-135	Ci	3.70E00	1.49E00	NA	NA
Xe-135m	Ci	1.51E+01	7.62E00	NA	NA
Xe-138	Ci	5.99E+01	3.09E+01	NA	NA
Ar-41	Ci	1.75E-01	1.23E-01	NA	NA
Total for Period	Ci	9.24E+01	5.06E+01	NA	NA
2. Iodines					
I-131	Ci	1.39E-03	2.15E-03	NA	NA
I-133	Ci	2.16E-03	1.39E-03	NA	NA
I-135	Ci	<LLD*	<LLD*	NA	NA
Total for Period	Ci	3.55E-03	3.54E-03	NA	NA
3. Particulates					
Sr-89	Ci	7.27E-04	4.20E-04	NA	NA
Sr-90	Ci	4.57E-06	<LLD*	NA	NA
Cs-134	Ci	<LLD*	<LLD*	NA	NA
Cs-137	Ci	<LLD*	<LLD*	NA	NA
Ba-140	Ci	1.08E-03	4.98E-04	NA	NA
La-140	Ci	7.94E-04	5.06E-04	NA	NA
Cr-51	Ci	<LLD*	<LLD*	NA	NA
Mn-54	Ci	1.89E-05	1.45E-04	NA	NA
Co-58	Ci	<LLD*	1.55E-05	NA	NA
Co-60	Ci	5.13E-04	7.77E-04	NA	NA
Mo-99	Ci	<LLD*	5.26E-03	NA	NA
Ag-110m	Ci	1.65E-05	7.52E-05	NA	NA
Ce-141	Ci	<LLD*	<LLD*	NA	NA
Ce-144	Ci	<LLD*	<LLD*	NA	NA
Total for Period	Ci	3.15E-03	7.70E-03	NA	NA

*Actual gaseous LLD's reported on page 6 of 7 of this check list.

ATTACHMENT 1
Effluent & Waste Disposable Annual Report
Page 3 of 7

REACTOR VENTILATION GASEOUS EFFLUENTS

NUCLIDES RELEASED	Unit	CONTINUOUS MODE		BATCH MODE	
		Third Quarter	Fourth Quarter	Third Quarter	Fourth Quarter
1. Fission gases					
Kr-85	Ci	<LLD*	<LLD*	NA	NA
Kr-85m	Ci	<LLD*	<LLD*	NA	NA
Kr-87	Ci	<LLD*	<LLD*	NA	NA
Kr-88	Ci	<LLD*	<LLD*	NA	NA
Xe-133	Ci	<LLD*	<LLD*	NA	NA
Xe-135	Ci	<LLD*	4.26E-02	NA	NA
Xe-135m	Ci	<LLD*	<LLD*	NA	NA
Xe-138	Ci	<LLD*	<LLD*	NA	NA
Ar-41	Ci	<LLD*	<LLD*	NA	NA
Total for Period	Ci	<LLD	4.26E-02	NA	NA
2. Iodines					
I-131	Ci	3.50E-05	1.42E-04	NA	NA
I-133	Ci	<LLD*	<LLD*	NA	NA
I-135	Ci	<LLD*	<LLD*	NA	NA
Total for Period	Ci	3.50E-05	1.42E-04	NA	NA
3. Particulates					
Sr-89	Ci	3.21E-06	6.34E-06	NA	NA
Sr-90	Ci	<LLD*	<LLD*	NA	NA
Cs-134	Ci	<LLD*	<LLD*	NA	NA
Cs-137	Ci	<LLD*	<LLD*	NA	NA
Ba-140	Ci	<LLD*	<LLD*	NA	NA
La-140	Ci	<LLD*	<LLD*	NA	NA
Cr-51	Ci	<LLD*	9.23E-03	NA	NA
Mn-54	Ci	1.04E-04	1.97E-04	NA	NA
Co-58	Ci	<LLD*	<LLD*	NA	NA
Co-60	Ci	1.03E-03	1.60E-03	NA	NA
Zn-65	Ci	<LLD*	6.89E-05	NA	NA
Mo-99	Ci	<LLD*	<LLD*	NA	NA
Ag-110m	Ci	<LLD*	<LLD*	NA	NA
Ce-141	Ci	<LLD*	<LLD*	NA	NA
Ce-144	Ci	<LLD*	<LLD*	NA	NA
Total for Period	Ci	1.14E-03	1.11E-02	NA	NA

*Actual gaseous LLD's reported on page 6 of 7.

ATTACHMENT 1
Effluent & Waste Disposable Annual Report
Page 4 of 7

LIQUID EFFLUENTS – SUMMATION OF ALL RELEASES

A. FISSION & ACTIVATION PRODUCTS	UNIT	THIRD QUARTER	FOURTH QUARTER	EST TOTAL ERROR%
1. Total Release (not including tritium, gases & alpha)	Ci	2.71E-03	2.72E-02	5.6
2. Average diluted concentration during batch discharges for the period.	µCi/mL	1.90E-10	2.81E-09	
3. Percent of applicable limit*	%	2.16E-02	5.42E-02	
		1.03E-02	2.69E-02	
4. Maximum diluted concentration during batch discharges	µCi/mL	1.70E-10	6.83E-09	
B. TRITIUM				
1. Total Release	Ci	1.53E+01	1.24E+01	4.1
2. Average diluted concentration during batch discharges for the period	µCi/mL	1.08E-06	1.28E-06	
3. Percent of applicable limit	%	8.02E-02	6.40E-02	
C. DISSOLVED & ENTRAINED GASES				
1. Total Release	Ci	<LLD	5.84E-05	5.6
2. Average diluted concentration during batch discharges for the period	µCi/mL	<LLD	6.04E-12	
3. Percent of applicable limit	%	NA	3.02E-06	
D. GROSS ALPHA ACTIVITY				
1. Total Release	Ci	<LLD**	<LLD**	14.8
2. Average diluted concentration during batch discharges for the period	µCi/MI	NA	NA	
E. VOLUME OF WASTE RELEASED (prior to dilution)	Liters	1.81E+06	2.56E+06	
F. VOLUME OF DILUTION WATER USED DURING BATCH DISCHARGES	Liters	1.42E+10	9.67E+09	
G. TOTAL VOLUME OF DILUTION WATER USED DURING PERIOD (quarter)	Liters	4.86E+11	3.14E+11	

* Whole Body/Organ (ODCM)



** Gross Alpha LLD on page 7 of 7

ATTACHMENT 1
Effluent & Waste Disposable Annual Report
Page 5 of 7

LIQUID EFFLUENTS

NUCLIDES RELEASED	Unit	CONTINUOUS MODE		BATCH MODE	
		Third Quarter	Fourth Quarter	Third Quarter	Fourth Quarter
Sr-89	Ci	<LLD*	<LLD*	<LLD*	<LLD*
Sr-90	Ci	<LLD*	<LLD*	<LLD*	<LLD*
Cs-134	Ci	<LLD*	<LLD*	<LLD*	<LLD*
Cs-137	Ci	3.32E-05	5.00E-04	1.70E-04	3.70E-04
I-131	Ci	<LLD*	<LLD*	<LLD*	1.98E-05
Co-60	Ci	5.18E-04	6.12E-03	7.01E-04	3.20E-03
Co-58	Ci	<LLD*	2.29E-04	<LLD*	7.49E-05
Fe-59	Ci	<LLD*	<LLD*	<LLD*	<LLD*
Zn-65	Ci	8.18E-04	4.90E-03	4.28E-05	1.86E-04
Mn-54	Ci	1.98E-04	1.23E-03	3.82E-05	5.99E-04
Cr-51	Ci	<LLD*	<LLD*	1.01E-04	4.79E-04
Zr-95	Ci	<LLD*	<LLD*	<LLD*	<LLD*
Nb-95	Ci	<LLD*	<LLD*	<LLD*	<LLD*
Mo-99	Ci	<LLD*	<LLD*	<LLD*	<LLD*
Ag-110m	Ci	<LLD*	<LLD*	8.45E-05	1.82E-04
Ba-140	Ci	<LLD*	<LLD*	<LLD*	<LLD*
La-140	Ci	<LLD*	<LLD*	<LLD*	<LLD*
Fe-55	Ci	<LLD*	<LLD*	<LLD*	9.26E-03
Sb-124	Ci	<LLD*	<LLD*	<LLD*	3.04E-05
Total for Period (above)	Ci	1.57E-03	1.30E-02	1.14E-03	1.44E-02
Xe-133	Ci	<LLD*	<LLD*	<LLD*	5.84E-05
Xe-135	Ci	<LLD*	<LLD*	<LLD*	<LLD*

*Actual liquid LLD's reported on page 7.

Prepared by:  Date: 09-18-03
 Approved by:  Date: 04-22-03

ATTACHMENT 1
Effluent & Waste Disposable Annual Report

Page 6 of 7

GASEOUS EFFLUENT LLD's (Most Restrictive)
CONTINUOUS MODE

NUCLIDE LOWER LIMITS OF DETECTION (LLD's)	UNIT	LLD Value	ODCM Required LLD
1. Fission gases			
Kr-85	uCi/cc	4.02E-06	None
Kr-85m	uCi/cc	1.67E-08	None
Kr-87	uCi/cc	3.35E-08	1E-04
Kr-88	uCi/cc	4.18E-08	1E-04
Xe-131m	uCi/cc	6.00E-07	None
Xe-133	uCi/cc	2.76E-08	1E-04
Xe-133m	uCi/cc	8.88E-08	1E-04
Xe-135	uCi/cc	1.16E-08	1E-04
Xe-135m	uCi/cc	1.58E-07	1E-04
Xe-138	uCi/cc	1.71E-07	1E-04
Ar-41	uCi/cc	7.19E-08	None
NUCLIDE LOWER LIMITS OF DETECTION (LLD's)			
2. Iodines			
I-131	uCi/cc	2.83E-13	1E-12
I-133	uCi/cc	3.56E-12	1E-10
I-135	uCi/cc	6.00E-09	None
NUCLIDE LOWER LIMITS OF DETECTION (LLD's)			
3. Particulates and Tritium			
H-3	uCi/cc	3.23E-11	1E-06
Sr-89	uCi/cc	2.30E-14	1E-11
Sr-90	uCi/cc	8.77E-15	1E-11
Cs-134	uCi/cc	1.47E-13	1E-11
Cs-137	uCi/cc	2.49E-13	1E-11
Ba-140	uCi/cc	4.25E-13	None
La-140	uCi/cc	6.22E-13	None
Mn-54	uCi/cc	1.86E-13	1E-11
Co-58	uCi/cc	2.06E-13	1E-11
Fe-59	uCi/cc	2.47E-13	1E-11
Co-60	uCi/cc	4.83E-13	1E-11
Zn-65	uCi/cc	4.31E-13	1E-11
Mo-99	uCi/cc	3.12E-12	1E-11
Ce-141	uCi/cc	2.92E-13	1E-11
Ce-144	uCi/cc	1.11E-12	1E-11
Gross Alpha ^Δ	uCi/cc	2.69E-14	1E-11

* ODCM RETS LLD's for weekly samples. These may be increased by a factor of 10 for daily samples.

^Δ Volume assumed to be 0.5 cfm for one week (1.43E+08 cc)

ATTACHMENT 1
Effluent & Waste Disposable Annual Report
Page 7 of 7

LIQUID EFFLUENT LLD's (Most Restrictive)
BATCH MODE

NUCLIDE LOWER LIMITS OF DETECTION (LLD's)	UNIT	LLD Value	ODCM Required LLD
3. Liquids			
H-3	uCi/cc	3.92E-06	1E-05
Sr-89	uCi/cc	8.12E-09	5E-08
Sr-90	uCi/cc	2.13E-09	5E-08
Fe-55	uCi/cc	1.23E-07	1E-06
Kr-85	uCi/cc	1.42E-05	None*
Kr-87	uCi/cc	1.50E-07	1E-05
Kr-88	uCi/cc	1.89E-07	1E-05
Xe-133	uCi/cc	1.50E-07	1E-05
Xe-133m	uCi/cc	3.90E-07	1E-05
Xe-135	uCi/cc	4.66E-08	1E-05
Xe-138	uCi/cc	6.45E-07	1E-05
Mn-54	uCi/cc	7.86E-08	5E-07
Co-58	uCi/cc	6.29E-08	5E-07
Co-60	uCi/cc	1.35E-07	5E-07
Zn-65	uCi/cc	1.32E-07	5E-07
Mo-99	uCi/cc	4.55E-07	5E-07
Ag-110m	uCi/cc	4.32E-08	None
Sb-124	uCi/cc	4.23E-08	None
I-131	uCi/cc	5.44E-08	1E-06
Cs-134	uCi/cc	5.46E-08	5E-07
Ba-140	uCi/cc	2.18E-07	None
La-140	uCi/cc	2.75E-08	None
Cs-137	uCi/cc	6.14E-08	5E-07
Ce-141	uCi/cc	1.01E-07	5E-07
Ce-144	uCi/cc	3.78E-07	5E-06
Gross Alpha	uCi/cc	9.03E-08	1E-07

* Kr-85 required by UFSAR section 9.1.3.3.

Attachment D
Effluent and Waste Disposal Semiannual Report Supplemental Information
Quad Cities Nuclear Power Station, July - December 2002
SVP-03-052

ATTACHMENT 3
Annual Effluent Report
Supplemental Information
Page 1 of 4

Facility: Quad Cities Nuclear Power Station July – December 2002

Licensee: Exelon Generation Company

1. Regulatory Limits

a. For Noble Gases: (per unit)

Dose rate

1. Less than 500 mrem/year to the whole body
2. Less than 3000 mrem/year to the skin.

Dose Gamma Radiation

1. Less than or equal to 5 mrad/quarter.
2. Less than or equal to 10 mrad/year.

Beta Radiation

1. Less than or equal to 10 mrad/quarter.
2. Less than or equal to 20 mrad/year.

b,c. For Iodine-131, for Iodine-133, and for all radionuclides in particulate form with half-lives greater than 8 days.

Dose Rate

1. Less than 1500 mrem/year.

Dose

1. Less than or equal to 7.5 mrem/quarter.
2. Less than or equal to 15 mrem/year.

d. For Liquid: (per site)

Less than or equal to 3 mrem to the whole body during any calendar quarter.
Less than or equal to 10 mrem to any organ during any calendar quarter.
Less than or equal to 6 mrem to the whole body during any calendar year.
Less than or equal to 20 mrem to any organ during any calendar year.

ATTACHMENT 3
Annual Effluent Report
Supplemental Information
Page 2 of 4

2. Maximum Permissible Concentration

- a,b,c. For fission and activation gases, iodines, and particulates with half-lives greater than 8 days, allowable release limits are calculated by solving equations 10.1 and 10.2 from the Offsite Dose Calculation Manual. The alarm setpoint is conservatively set at approximately 10% of the 10CFR20 limit.
- d. For liquid effluents allowable release limits are calculated by solving equations 10.3 and 10.4 from the Offsite Dose Calculation Manual. The MPC values used for the monitors were as follows:

Radwaste discharge	7.17E-03 $\mu\text{Ci/ml}$
Service water	1.0E-05 $\mu\text{Ci/ml}$

3. Average Energy

The average gamma energy used to calculate the alarm setpoints for the noble gas monitors was 0.524 Mev for the third quarter, and 0.881 Mev for the fourth quarter.

4. Measurements and Approximations of Total Radioactivity

- a. Fission and Activation Gases:
b. Iodines:
c. Particulates:

The main chimney and reactor building ventilation exhaust systems are continually monitored for iodines and particulates. These samples are pulled every 7 days and analyzed by gamma isotopic. The particulate papers are composited every 31 days and sent to a vendor for Sr89/90 and gross alpha analysis. Noble gas grab samples are pulled and analyzed by gamma isotopic weekly. Tritium samples are pulled and analyzed every month.

The Sr89/90 and gross alpha curies released values reported are actual. On a real time basis, the portion of the "percent of applicable data. The actual results are obtained by editing the ODCM software inputs when the vendor results become available. Therefore, the "percent of applicable limits" in this report are actual.

ATTACHMENT 3
Annual Effluent Report
Supplemental Information
Page 3 of 4

The continuous strip chart recorders for the monitors on the release points are reviewed monthly for spikes and the activity released is calculated. An additional calculated activity for noble gases is added to the main chimney release each month. This calculation is done because most of the grab samples show less than the lower limit of detection due to the low amount of activity and the large dilution flow at the sample point. The calculation takes into account the normal offgas train and the gland steam contribution to the release.

The average flow at the release points is used to calculate the curies released.

d. Liquid Effluents

The river discharge tanks are analyzed before discharge by gamma isotopic. A composite representative portion of this sample is saved. This is composited with other discharges that occurred every 31 days and is analyzed for tritium and gross alpha. The monthly composites are composited quarterly and sent to a vendor for Sr89/90 and Fe 55. The discharge bay is sampled every 31 days and analyzed by gamma isotopic, for tritium and gross alpha. It is sampled quarterly and sent to a vendor for Sr89/90 and Fe 55 analysis. On a real time basis, the portion of the "percent of applicable limit" for these contributors is based on projections using scaling factors. The actual results are obtained by editing the ODCM software inputs when the vendor results become available. Therefore, the "percent of applicable limits" in this report are actual.

The tank volumes and activities are used to calculate the curies released for the River Discharge Tank. The total water released during the quarter and the activity is used to calculate the diluted activity released at the discharge bay, from batch discharges.

e. Estimated Total Error Percent

The estimated total error percents were calculated by taking the square root of the sum of the squares of errors for sampling and measurement parameters.

**ATTACHMENT 3
Annual Effluent Report
Supplemental Information
Page 4 of 4**

f. Less than the lower limit of detection (<LLD)

Samples are analyzed such that the Technical Specification LLD requirements are met. When a nuclide is not detected during the quarter, then <LLD is reported. The most conservative LLD's used for counting effluent samples are included in this report.

5. Batch Releases

a. Liquid

1.	Number of releases:	21
2.	Total time:	18,822 minutes
3.	Maximum time:	1,037 minutes
4.	Average time:	896 minutes
5.	Minimum time:	837 minutes
6.	Average stream flow:	61.3 gpm (discharge) 3.32E+05 gpm (dilution)

b. Gaseous

NONE.

6. Abnormal Releases

a. Liquid

1. In October 2002, a leak developed on the 2A RHR heat exchanger. While the RHR service water system is idle, the leakage into the service water side of the heat exchanger can occur since the pressure is higher on the reactor (or suppression pool) side. The activity from this leak was included in the normal monthly liquid effluent releases and is reported under the "continuous" liquid section of this report. The leak is scheduled to be repaired in September 2003.

b. Gaseous

NONE.

Attachment E
Quad Cities Station Meteorological Site Quarterly Joint-Frequency
Wind Rose Tables for 2002
SVP-03-052

Quad Cities Nuclear Station
33 ft. Wind Speed and Direction

January-March, 2002
196Ft-33Ft Delta-T (F)

SPEED CLASS	WIND DIRECTION CLASSES																	STABILITY CLASSES							
	N	NNE	NE	ENE	E	ESE	SE	SSE	S	SSW	SW	WSW	W	WNW	NW	NNW	TOTAL	EU	MU	SU	N	SS	MS	ES	TOTAL
EU	0.00	0.00	0.00	0.00	0.00	0.00	0.00	0.00	0.00	0.00	0.00	0.00	0.00	0.00	0.00	0.00	0.00	0.00	0.00	0.00	0.00	0.00	0.00	0.00	0.23
1 MU	0.00	0.00	0.00	0.00	0.00	0.00	0.00	0.00	0.00	0.00	0.00	0.00	0.00	0.00	0.00	0.00	0.00	0.00	0.00	0.00	0.00	0.00	0.00	0.00	0.00
9 SU	0.00	0.00	0.00	0.00	0.00	0.00	0.00	0.00	0.00	0.00	0.00	0.00	0.00	0.00	0.00	0.00	0.00	0.00	0.00	0.00	0.00	0.00	0.00	0.00	0.00
- N	0.00	0.00	0.00	0.00	0.00	0.00	0.00	0.00	0.00	0.00	0.00	0.00	0.23	0.00	0.00	0.00	0.00	0.00	0.00	0.00	0.00	0.00	0.00	0.00	0.23
2 SS	0.00	0.00	0.00	0.00	0.00	0.00	0.00	0.00	0.00	0.00	0.00	0.00	0.00	0.00	0.00	0.00	0.00	0.00	0.00	0.00	0.00	0.00	0.00	0.00	0.00
4 MS	0.00	0.00	0.00	0.00	0.00	0.00	0.00	0.00	0.00	0.00	0.00	0.00	0.00	0.00	0.00	0.00	0.00	0.00	0.00	0.00	0.00	0.00	0.00	0.00	0.00
ES	0.00	0.00	0.00	0.00	0.00	0.00	0.00	0.00	0.00	0.00	0.00	0.00	0.00	0.00	0.00	0.00	0.00	0.00	0.00	0.00	0.00	0.00	0.00	0.00	0.23
TOT	3.12	2.37	5.03	3.49	3.26	3.21	4.47	5.21	5.26	7.77	9.82	9.22	14.20	12.48	7.03	4.05	100.00	15.92	2.42	4.52	38.41	28.07	7.96	2.70	100.00

Wind Direction by Stability

N	NNE	NE	ENE	E	ESE	SE	SSE	S	SSW	SW	WSW	W	WNW	NW	NNW	TOTAL	-STABILITY CLASSES-
0.47	0.19	0.51	0.74	0.19	0.09	0.28	0.51	1.16	1.96	1.40	1.63	3.21	2.23	1.02	0.33	15.92	Extremely Unstable
0.05	0.05	0.09	0.14	0.14	0.00	0.05	0.00	0.05	0.14	0.23	0.33	0.70	0.19	0.14	0.14	2.42	Moderately Unstable
0.23	0.05	0.28	0.23	0.33	0.14	0.14	0.14	0.19	0.33	0.42	0.33	0.51	0.42	0.37	0.42	4.52	Slightly Unstable
1.86	1.30	3.91	1.44	1.07	0.56	0.88	0.88	1.07	0.88	2.65	2.89	5.49	6.89	4.10	2.51	38.41	Neutral
0.28	0.65	0.05	0.51	0.84	0.61	1.96	2.28	1.91	3.26	4.61	3.86	3.40	2.05	1.30	0.51	28.07	Slightly Stable
0.19	0.05	0.14	0.33	0.47	1.49	0.98	0.79	0.61	0.93	0.33	0.14	0.79	0.56	0.09	0.09	7.96	Moderately Stable
0.05	0.09	0.05	0.09	0.23	0.33	0.19	0.61	0.28	0.28	0.19	0.05	0.09	0.14	0.00	0.05	2.70	Extremely Stable

Wind Direction by Wind Speed

N	NNE	NE	ENE	E	ESE	SE	SSE	S	SSW	SW	WSW	W	WNW	NW	NNW	TOTAL	-WIND SPEED CLASSES-
0.00	0.00	0.00	0.00	0.00	0.00	0.00	0.00	0.00	0.00	0.00	0.00	0.00	0.00	0.00	0.00	0.00	C A L M
0.51	0.61	0.28	0.65	0.79	1.40	1.68	2.37	1.44	1.54	1.40	1.44	2.98	2.56	1.07	0.56	21.28	< 3.5 mph
1.49	1.44	2.56	1.30	1.58	1.44	2.70	2.09	2.65	5.21	6.80	6.42	4.98	3.49	3.54	2.28	50.00	3.6 - 7.5 mph
1.07	0.33	1.77	1.40	0.88	0.33	0.09	0.74	1.16	1.02	1.63	1.35	5.26	6.33	1.86	1.21	26.44	7.6 - 12.5 mph
0.05	0.00	0.42	0.14	0.00	0.05	0.00	0.00	0.00	0.00	0.00	0.00	0.74	0.09	0.56	0.00	2.05	12.6 - 18.5 mph
0.00	0.00	0.00	0.00	0.00	0.00	0.00	0.00	0.00	0.00	0.00	0.00	0.23	0.00	0.00	0.00	0.23	18.6 - 24.5 mph
0.00	0.00	0.00	0.00	0.00	0.00	0.00	0.00	0.00	0.00	0.00	0.00	0.00	0.00	0.00	0.00	0.00	> 24.5 mph

Quad Cities Nuclear Station
296 ft. Wind Speed and Direction

January-March, 2002
296Ft-33Ft Delta-T (F)

SPEED CLASS	WIND DIRECTION CLASSES																STABILITY CLASSES							TOTAL	
	N	NNE	NE	ENE	E	ESE	SE	SSE	S	SSW	SW	WSW	W	WNW	NW	NNW	TOTAL	EU	MU	SU	N	SS	MS		ES
EU	0.00	0.00	0.05	0.19	0.05	0.00	0.00	0.05	0.57	0.24	0.00	0.05	0.52	0.24	0.09	0.00	2.04	2.04							
1 MU	0.00	0.00	0.00	0.00	0.00	0.00	0.00	0.09	0.14	0.19	0.05	0.00	0.19	0.62	0.14	0.00	1.42	1.42							
9 SU	0.05	0.00	0.00	0.05	0.00	0.05	0.05	0.00	0.05	0.09	0.05	0.05	0.19	0.24	0.19	0.14	1.18		1.18						
- N	0.47	0.00	0.76	0.33	0.24	0.09	0.05	0.52	0.47	0.38	0.81	0.33	1.90	2.70	1.23	0.24	10.52		10.52						
2 SS	0.00	0.00	0.09	0.09	0.00	0.09	0.00	0.47	0.76	2.46	1.00	0.57	0.43	0.09	0.09	0.05	6.21			6.21					
4 MS	0.00	0.00	0.00	0.00	0.00	0.05	0.28	0.00	0.09	0.28	0.00	0.00	0.05	0.00	0.00	0.00	0.76					0.76			
ES	0.00	0.00	0.00	0.00	0.00	0.00	0.00	0.00	0.00	0.05	0.00	0.00	0.00	0.00	0.00	0.00	0.05						0.05		
																									22.18
EU	0.00	0.00	0.00	0.00	0.00	0.00	0.00	0.05	0.00	0.00	0.00	0.00	0.05	0.00	0.19	0.05	0.33	0.33							
G MU	0.00	0.00	0.00	0.00	0.00	0.00	0.00	0.05	0.00	0.00	0.00	0.00	0.05	0.05	0.09	0.00	0.24		0.24						
T SU	0.00	0.00	0.00	0.00	0.00	0.00	0.00	0.00	0.05	0.00	0.05	0.00	0.00	0.09	0.09	0.00	0.28			0.28					
N	0.00	0.00	0.28	0.14	0.00	0.05	0.00	0.05	0.14	0.05	0.14	0.09	1.04	0.62	0.28	0.05	2.94			2.94					
2 SS	0.00	0.00	0.00	0.00	0.00	0.00	0.00	0.19	0.33	0.24	0.05	0.00	0.05	0.00	0.00	0.00	0.85					0.85			
4 MS	0.00	0.00	0.00	0.00	0.00	0.00	0.00	0.00	0.05	0.05	0.00	0.00	0.00	0.00	0.00	0.00	0.09					0.09			
ES	0.00	0.00	0.00	0.00	0.00	0.00	0.00	0.00	0.00	0.00	0.00	0.00	0.00	0.00	0.00	0.00	0.00						0.00		
																									4.74
TOT	4.03	2.09	5.12	2.65	2.84	2.42	3.27	4.83	7.54	10.14	8.82	8.20	12.27	11.71	8.63	5.45	100.00	7.58	6.07	6.30	42.27	29.34	7.39	1.04	100.00

Wind Direction by Stability

N	NNE	NE	ENE	E	ESE	SE	SSE	S	SSW	SW	WSW	W	WNW	NW	NNW	TOTAL	-STABILITY CLASSES-
0.14	0.14	0.09	0.33	0.19	0.00	0.14	0.14	0.85	1.33	0.38	0.85	1.52	0.85	0.47	0.14	7.58	Extremely Unstable
0.24	0.05	0.14	0.24	0.00	0.05	0.05	0.14	0.33	0.47	0.57	0.76	1.18	1.18	0.43	0.24	6.07	Moderately Unstable
0.33	0.05	0.28	0.28	0.57	0.14	0.14	0.09	0.24	0.38	0.62	0.71	0.85	0.62	0.43	0.57	6.30	Slightly Unstable
2.32	1.37	4.12	1.52	1.71	0.66	0.95	1.23	1.85	1.37	2.89	2.04	5.64	6.68	4.64	3.27	42.27	Neutral
0.71	0.38	0.43	0.19	0.38	0.85	0.81	2.56	2.89	5.36	3.74	3.22	2.42	2.04	2.23	1.14	29.34	Slightly Stable
0.28	0.09	0.05	0.05	0.00	0.71	1.18	0.52	1.33	0.90	0.43	0.57	0.62	0.28	0.33	0.05	7.39	Moderately Stable
0.00	0.00	0.00	0.05	0.00	0.00	0.00	0.14	0.05	0.33	0.19	0.05	0.05	0.05	0.09	0.05	1.04	Extremely Stable

Wind Direction by Wind Speed

N	NNE	NE	ENE	E	ESE	SE	SSE	S	SSW	SW	WSW	W	WNW	NW	NNW	TOTAL	-WIND SPEED CLASSES-
0.00	0.00	0.00	0.00	0.00	0.00	0.00	0.00	0.00	0.00	0.00	0.00	0.00	0.00	0.00	0.00	0.00	C A L M
0.05	0.05	0.14	0.05	0.00	0.05	0.05	0.09	0.09	0.05	0.05	0.19	0.19	0.14	0.09	0.14	1.42	< 3.5 mph
0.43	0.38	0.14	0.14	0.24	0.24	0.38	0.24	0.52	0.38	0.66	0.66	0.90	0.57	1.23	0.66	7.77	3.6 - 7.5 mph
1.80	1.04	1.33	0.71	0.71	0.66	0.95	0.81	1.09	1.56	1.66	2.46	2.04	1.47	2.04	1.52	21.85	7.6 - 12.5 mph
1.23	0.62	2.32	0.95	1.61	1.14	1.52	2.23	3.18	4.12	4.31	3.79	4.69	4.88	2.84	2.61	42.04	12.6 - 18.5 mph
0.52	0.00	0.90	0.66	0.28	0.28	0.38	1.14	2.09	3.70	1.90	1.00	3.27	3.89	1.75	0.43	22.18	18.6 - 24.5 mph
0.00	0.00	0.28	0.14	0.00	0.05	0.00	0.33	0.57	0.33	0.24	0.09	1.18	0.76	0.66	0.09	4.74	> 24.5 mph

Quad Cities Nuclear Station
33 ft. Wind Speed and Direction

July-September, 2002
196Ft-33Ft Delta-T (F)

Number of Observations = 2068
Values are Percent Occurrence

SPEED CLASS	WIND DIRECTION CLASSES																STABILITY CLASSES							TOTAL	
	N	NNE	NE	ENE	E	ESE	SE	SSE	S	SSW	SW	WSW	W	WNW	NW	NNW	TOTAL	EU	MU	SU	N	SS	MS		ES
EU	0.00	0.00	0.00	0.00	0.00	0.00	0.00	0.00	0.00	0.00	0.00	0.00	0.00	0.00	0.00	0.00	0.00	0.00	0.00	0.00	0.00	0.00	0.00	0.00	0.00
MU	0.00	0.00	0.00	0.00	0.00	0.00	0.00	0.00	0.00	0.00	0.00	0.00	0.00	0.00	0.00	0.00	0.00	0.00	0.00	0.00	0.00	0.00	0.00	0.00	0.00
C SU	0.00	0.00	0.00	0.00	0.00	0.00	0.00	0.00	0.00	0.00	0.00	0.00	0.00	0.00	0.00	0.00	0.00	0.00	0.00	0.00	0.00	0.00	0.00	0.00	0.00
A N	0.00	0.00	0.00	0.00	0.00	0.00	0.00	0.00	0.00	0.00	0.00	0.00	0.00	0.00	0.00	0.00	0.00	0.00	0.00	0.00	0.00	0.00	0.00	0.00	0.00
L SS	0.00	0.00	0.00	0.00	0.00	0.00	0.00	0.00	0.00	0.00	0.00	0.00	0.00	0.00	0.00	0.00	0.00	0.00	0.00	0.00	0.00	0.00	0.00	0.00	0.00
M MS	0.00	0.00	0.00	0.00	0.00	0.00	0.00	0.00	0.00	0.00	0.00	0.00	0.00	0.00	0.00	0.00	0.00	0.00	0.00	0.00	0.00	0.00	0.00	0.00	0.00
ES	0.00	0.00	0.00	0.00	0.00	0.00	0.00	0.00	0.00	0.00	0.00	0.00	0.00	0.00	0.00	0.00	0.00	0.00	0.00	0.00	0.00	0.00	0.00	0.00	0.00
																									0.00
EU	0.00	0.05	0.05	0.10	0.00	0.05	0.19	0.00	0.00	0.05	0.05	0.15	0.34	0.05	0.15	0.05	1.26	1.26							
MU	0.00	0.00	0.00	0.05	0.00	0.00	0.00	0.00	0.05	0.00	0.10	0.15	0.00	0.05	0.05	0.00	0.44	0.44							
1 SU	0.00	0.00	0.00	0.05	0.05	0.00	0.00	0.05	0.10	0.15	0.05	0.10	0.05	0.10	0.05	0.00	0.73	0.73							
- N	0.10	0.15	0.19	0.19	0.19	0.34	0.29	0.19	0.24	0.15	0.24	0.34	0.29	0.34	0.19	0.05	3.48			3.48					
3 SS	0.29	0.44	0.77	0.73	1.06	1.02	0.63	0.48	0.68	0.68	0.53	1.06	0.87	1.06	0.92	0.19	11.41			11.41					
MS	0.58	0.77	1.11	0.73	1.26	0.92	0.97	0.97	0.97	0.77	0.82	0.53	0.53	0.44	0.29	0.48	12.14					12.14			
ES	0.63	0.87	0.73	0.63	2.03	3.19	0.87	0.24	0.19	0.29	0.19	0.05	0.53	0.53	0.05	0.24	11.27						11.27		40.72
EU	0.63	0.58	0.87	1.55	1.02	1.40	1.40	1.16	1.55	2.27	3.68	2.32	1.35	0.63	0.92	0.73	22.05	22.05							
MU	0.10	0.10	0.10	0.15	0.10	0.10	0.10	0.10	0.10	0.15	0.19	0.15	0.05	0.00	0.05	0.05	1.55	1.55							
4 SU	0.10	0.10	0.19	0.44	0.10	0.15	0.34	0.24	0.24	0.19	0.53	0.29	0.05	0.15	0.10	0.05	3.24			3.24					
- N	0.63	0.73	1.02	1.11	0.53	0.53	0.87	0.34	0.44	0.77	1.11	0.77	0.58	0.34	0.48	0.39	10.64			10.64					
7 SS	0.39	0.19	0.48	2.03	0.97	1.06	0.58	0.73	1.35	1.74	2.27	0.48	0.24	0.39	1.06	0.82	14.80					14.80			
MS	0.00	0.00	0.00	0.10	0.00	0.15	0.05	0.00	0.05	0.15	0.00	0.00	0.05	0.00	0.10	0.00	0.63					0.63			
ES	0.00	0.00	0.00	0.00	0.00	0.00	0.00	0.00	0.00	0.00	0.00	0.00	0.00	0.00	0.00	0.00	0.00						0.00		52.90
EU	0.24	0.15	0.05	0.48	0.53	0.44	0.00	0.10	0.00	0.53	0.34	0.05	0.19	0.34	0.00	0.10	3.53	3.53							
MU	0.00	0.00	0.00	0.05	0.00	0.00	0.05	0.00	0.00	0.00	0.00	0.00	0.00	0.00	0.00	0.00	0.10	0.10							
8 SU	0.00	0.00	0.00	0.00	0.05	0.00	0.00	0.00	0.10	0.05	0.10	0.00	0.00	0.00	0.05	0.00	0.34			0.34					
- N	0.24	0.00	0.15	0.19	0.15	0.00	0.05	0.00	0.10	0.10	0.10	0.05	0.00	0.10	0.15	0.05	1.40			1.40					
1 SS	0.10	0.00	0.00	0.10	0.15	0.00	0.05	0.00	0.00	0.19	0.19	0.00	0.00	0.05	0.15	0.05	1.02					1.02			
2 MS	0.00	0.00	0.00	0.00	0.00	0.00	0.00	0.00	0.00	0.00	0.00	0.00	0.00	0.00	0.00	0.00	0.00						0.00		
ES	0.00	0.00	0.00	0.00	0.00	0.00	0.00	0.00	0.00	0.00	0.00	0.00	0.00	0.00	0.00	0.00	0.00						0.00		6.38
EU	0.00	0.00	0.00	0.00	0.00	0.00	0.00	0.00	0.00	0.00	0.00	0.00	0.00	0.00	0.00	0.00	0.00	0.00							
1 MU	0.00	0.00	0.00	0.00	0.00	0.00	0.00	0.00	0.00	0.00	0.00	0.00	0.00	0.00	0.00	0.00	0.00			0.00					
3 SU	0.00	0.00	0.00	0.00	0.00	0.00	0.00	0.00	0.00	0.00	0.00	0.00	0.00	0.00	0.00	0.00	0.00			0.00					
- N	0.00	0.00	0.00	0.00	0.00	0.00	0.00	0.00	0.00	0.00	0.00	0.00	0.00	0.00	0.00	0.00	0.00					0.00			
1 SS	0.00	0.00	0.00	0.00	0.00	0.00	0.00	0.00	0.00	0.00	0.00	0.00	0.00	0.00	0.00	0.00	0.00					0.00			
8 MS	0.00	0.00	0.00	0.00	0.00	0.00	0.00	0.00	0.00	0.00	0.00	0.00	0.00	0.00	0.00	0.00	0.00						0.00		
ES	0.00	0.00	0.00	0.00	0.00	0.00	0.00	0.00	0.00	0.00	0.00	0.00	0.00	0.00	0.00	0.00	0.00						0.00		0.00

Quad Cities Nuclear Station
296 ft. Wind Speed and Direction

July-September, 2002
296Ft-33Ft Delta-T (F)

Number of Observations = 2189
Values are Percent Occurrence

SPEED CLASS	WIND DIRECTION CLASSES																STABILITY CLASSES								TOTAL
	N	NNE	NE	ENE	E	ESE	SE	SSE	S	SSW	SW	WSW	W	WNW	NW	NNW	TOTAL	EU	MU	SU	N	SS	MS	ES	
EU	0.00	0.00	0.00	0.00	0.00	0.00	0.00	0.00	0.00	0.00	0.00	0.00	0.00	0.00	0.00	0.00	0.00	0.00	0.00	0.00	0.00	0.00	0.00	0.00	0.00
MU	0.00	0.00	0.00	0.00	0.00	0.00	0.00	0.00	0.00	0.00	0.00	0.00	0.00	0.00	0.00	0.00	0.00	0.00	0.00	0.00	0.00	0.00	0.00	0.00	0.00
C SU	0.00	0.00	0.00	0.00	0.00	0.00	0.00	0.00	0.00	0.00	0.00	0.00	0.00	0.00	0.00	0.00	0.00	0.00	0.00	0.00	0.00	0.00	0.00	0.00	0.00
A N	0.00	0.00	0.00	0.00	0.00	0.00	0.00	0.00	0.00	0.00	0.00	0.00	0.00	0.00	0.00	0.00	0.00	0.00	0.00	0.00	0.00	0.00	0.00	0.00	0.00
L SS	0.00	0.00	0.00	0.00	0.00	0.00	0.00	0.00	0.00	0.00	0.00	0.00	0.00	0.00	0.00	0.00	0.00	0.00	0.00	0.00	0.00	0.00	0.00	0.00	0.00
M MS	0.00	0.00	0.00	0.00	0.00	0.00	0.00	0.00	0.00	0.00	0.00	0.00	0.00	0.00	0.00	0.00	0.00	0.00	0.00	0.00	0.00	0.00	0.00	0.00	0.00
ES	0.00	0.00	0.00	0.00	0.00	0.00	0.00	0.00	0.00	0.00	0.00	0.00	0.00	0.00	0.00	0.00	0.00	0.00	0.00	0.00	0.00	0.00	0.00	0.00	0.00
																									0.00
EU	0.00	0.00	0.00	0.00	0.00	0.05	0.00	0.00	0.00	0.00	0.00	0.00	0.00	0.05	0.05	0.00	0.14	0.14	0.00	0.00	0.00	0.00	0.00	0.00	0.00
MU	0.00	0.00	0.00	0.14	0.05	0.05	0.05	0.05	0.00	0.00	0.00	0.00	0.05	0.00	0.00	0.00	0.37	0.37	0.00	0.00	0.00	0.00	0.00	0.00	0.00
1 SU	0.00	0.00	0.00	0.00	0.05	0.00	0.00	0.00	0.00	0.00	0.00	0.05	0.00	0.05	0.00	0.00	0.14	0.14	0.14	0.00	0.00	0.00	0.00	0.00	0.00
- N	0.05	0.00	0.05	0.00	0.14	0.00	0.05	0.05	0.14	0.05	0.05	0.14	0.14	0.00	0.00	0.00	0.82	0.82	0.82	0.82	0.82	0.82	0.82	0.82	0.82
3 SS	0.00	0.05	0.00	0.09	0.14	0.00	0.00	0.05	0.00	0.00	0.00	0.00	0.00	0.00	0.00	0.05	0.37	0.37	0.37	0.37	0.37	0.37	0.37	0.37	0.37
MS	0.05	0.00	0.00	0.09	0.09	0.00	0.00	0.00	0.00	0.00	0.00	0.09	0.00	0.00	0.00	0.05	0.37	0.37	0.37	0.37	0.37	0.37	0.37	0.37	0.37
ES	0.00	0.05	0.00	0.00	0.05	0.00	0.00	0.09	0.00	0.09	0.05	0.00	0.05	0.14	0.00	0.00	0.50	0.50	0.50	0.50	0.50	0.50	0.50	0.50	0.50
																									2.70
EU	0.05	0.32	0.18	0.87	0.50	0.82	0.41	0.18	0.27	0.64	1.05	0.73	1.28	0.37	0.50	0.27	8.45	8.45	8.45	8.45	8.45	8.45	8.45	8.45	8.45
MU	0.14	0.09	0.14	0.32	0.41	0.27	0.14	0.09	0.14	0.27	0.18	0.14	0.09	0.05	0.09	0.14	2.70	2.70	2.70	2.70	2.70	2.70	2.70	2.70	2.70
4 SU	0.14	0.09	0.09	0.37	0.05	0.18	0.05	0.14	0.18	0.05	0.09	0.05	0.00	0.00	0.23	0.18	1.87	1.87	1.87	1.87	1.87	1.87	1.87	1.87	1.87
- N	0.27	0.18	0.32	0.37	0.27	0.27	0.37	0.14	0.14	0.23	0.27	0.18	0.23	0.14	0.23	0.05	3.65	3.65	3.65	3.65	3.65	3.65	3.65	3.65	3.65
7 SS	0.23	0.09	0.23	0.09	0.32	0.27	0.18	0.27	0.14	0.23	0.18	0.41	0.27	0.05	0.18	0.27	3.43	3.43	3.43	3.43	3.43	3.43	3.43	3.43	3.43
MS	0.09	0.05	0.14	0.18	0.41	0.14	0.05	0.18	0.14	0.23	0.27	0.23	0.18	0.09	0.32	0.23	2.92	2.92	2.92	2.92	2.92	2.92	2.92	2.92	2.92
ES	0.18	0.00	0.09	0.05	0.18	0.00	0.14	0.32	0.18	0.32	0.14	0.09	0.05	0.18	0.37	0.05	2.33	2.33	2.33	2.33	2.33	2.33	2.33	2.33	2.33
																									25.35
EU	0.41	0.32	0.32	0.32	0.59	0.46	0.73	0.64	0.78	1.10	0.78	0.87	0.37	0.14	0.27	0.41	8.50	8.50	8.50	8.50	8.50	8.50	8.50	8.50	8.50
MU	0.18	0.09	0.05	0.14	0.05	0.14	0.18	0.18	0.27	0.23	0.32	0.09	0.09	0.00	0.09	0.05	2.15	2.15	2.15	2.15	2.15	2.15	2.15	2.15	2.15
8 SU	0.05	0.09	0.14	0.27	0.18	0.05	0.27	0.05	0.05	0.14	0.23	0.05	0.09	0.05	0.09	0.00	1.78	1.78	1.78	1.78	1.78	1.78	1.78	1.78	1.78
- N	0.64	0.41	0.59	0.41	0.73	0.50	0.64	0.41	0.37	0.46	0.50	0.46	0.55	0.50	0.69	0.37	8.22	8.22	8.22	8.22	8.22	8.22	8.22	8.22	8.22
1 SS	0.09	0.27	0.37	1.23	1.37	0.73	0.64	0.50	0.32	0.46	0.27	0.64	0.55	0.37	0.78	0.50	9.09	9.09	9.09	9.09	9.09	9.09	9.09	9.09	9.09
2 MS	0.14	0.18	0.23	0.23	1.19	1.01	0.73	0.59	0.78	0.37	0.50	0.32	0.09	0.05	0.27	0.14	6.81	6.81	6.81	6.81	6.81	6.81	6.81	6.81	6.81
ES	0.05	0.09	0.05	0.23	0.14	0.18	0.37	0.91	0.96	0.59	0.41	0.09	0.00	0.18	0.27	0.09	4.61	4.61	4.61	4.61	4.61	4.61	4.61	4.61	4.61
																									41.16
EU	0.23	0.09	0.00	0.05	0.37	0.18	0.05	0.27	0.73	0.91	0.23	0.41	0.18	0.18	0.00	0.14	4.02	4.02	4.02	4.02	4.02	4.02	4.02	4.02	4.02
1 MU	0.00	0.00	0.00	0.05	0.00	0.05	0.00	0.09	0.05	0.23	0.05	0.09	0.09	0.09	0.05	0.00	0.82	0.82	0.82	0.82	0.82	0.82	0.82	0.82	0.82
3 SU	0.00	0.00	0.05	0.05	0.05	0.05	0.05	0.00	0.09	0.09	0.00	0.14	0.05	0.00	0.00	0.00	0.59	0.59	0.59	0.59	0.59	0.59	0.59	0.59	0.59
- N	0.14	0.27	0.09	0.41	0.55	0.23	0.32	0.32	0.46	0.78	0.64	0.32	0.14	0.18	0.23	0.37	5.44	5.44	5.44	5.44	5.44	5.44	5.44	5.44	5.44
1 SS	0.46	0.14	0.14	0.59	0.46	0.69	0.59	0.64	0.87	1.87	1.01	0.64	0.05	0.09	0.37	0.27	8.86	8.86	8.86	8.86	8.86	8.86	8.86	8.86	8.86
8 MS	0.00	0.14	0.09	0.09	0.18	0.59	0.46	0.64	0.73	0.64	0.09	0.09	0.09	0.09	0.05	0.05	4.02	4.02	4.02	4.02	4.02	4.02	4.02	4.02	4.02
ES	0.00	0.00	0.05	0.00	0.05	0.00	0.73	0.78	0.09	0.18	0.23	0.00	0.00	0.09	0.00	0.00	2.19	2.19	2.19	2.19	2.19	2.19	2.19	2.19	2.19
																									25.95

Quad Cities Nuclear Station
296 ft. Wind Speed and Direction

July-September, 2002
296Ft-33Ft Delta-T (F)

SPEED CLASS	WIND DIRECTION CLASSES																STABILITY CLASSES							TOTAL	
	N	NNE	NE	ENE	E	ESE	SE	SSE	S	SSW	SW	WSW	W	WNW	NW	NNW	TOTAL	EU	MU	SU	N	SS	MS		ES
EU	0.00	0.00	0.00	0.00	0.00	0.18	0.00	0.00	0.00	0.59	0.05	0.00	0.00	0.14	0.00	0.00	0.96	0.96							
1 MU	0.00	0.00	0.00	0.00	0.00	0.00	0.00	0.00	0.00	0.18	0.00	0.00	0.00	0.00	0.00	0.00	0.18	0.18							
9 SU	0.00	0.00	0.00	0.00	0.00	0.00	0.00	0.05	0.05	0.14	0.00	0.00	0.00	0.00	0.00	0.00	0.23		0.23						
- N	0.05	0.05	0.05	0.05	0.00	0.00	0.00	0.09	0.27	0.32	0.09	0.00	0.00	0.05	0.27	0.14	1.42			1.42					
2 SS	0.00	0.00	0.00	0.00	0.00	0.00	0.00	0.14	0.64	0.73	0.18	0.00	0.05	0.00	0.00	0.00	1.74				1.74				
4 MS	0.00	0.00	0.00	0.00	0.00	0.05	0.05	0.00	0.00	0.00	0.05	0.00	0.00	0.00	0.00	0.00	0.14					0.14			
ES	0.00	0.00	0.00	0.00	0.00	0.00	0.05	0.00	0.00	0.00	0.00	0.00	0.00	0.00	0.00	0.00	0.05						0.05		
																									4.71
EU	0.00	0.00	0.00	0.00	0.00	0.00	0.00	0.00	0.00	0.00	0.00	0.00	0.00	0.00	0.00	0.00	0.00	0.00	0.00						
G MU	0.00	0.00	0.00	0.00	0.00	0.00	0.00	0.00	0.00	0.00	0.00	0.00	0.00	0.00	0.00	0.00	0.00	0.00	0.00	0.00					
T SU	0.00	0.00	0.00	0.00	0.00	0.00	0.00	0.00	0.00	0.00	0.00	0.00	0.00	0.00	0.00	0.00	0.00	0.00	0.00	0.00					
N	0.00	0.00	0.00	0.00	0.00	0.00	0.05	0.00	0.00	0.00	0.00	0.00	0.00	0.00	0.00	0.00	0.05			0.05					
2 SS	0.00	0.00	0.00	0.00	0.00	0.00	0.00	0.00	0.00	0.09	0.00	0.00	0.00	0.00	0.00	0.00	0.09				0.09				
4 MS	0.00	0.00	0.00	0.00	0.00	0.00	0.00	0.00	0.00	0.00	0.00	0.00	0.00	0.00	0.00	0.00	0.00					0.00			
ES	0.00	0.00	0.00	0.00	0.00	0.00	0.00	0.00	0.00	0.00	0.00	0.00	0.00	0.00	0.00	0.00	0.00						0.00		
																									0.14
TOT	3.61	3.06	3.43	6.67	8.54	7.13	7.31	7.86	8.82	12.20	7.90	6.30	4.71	3.29	5.39	3.79	100.00	22.06	6.21	4.61	19.60	23.57	14.25	9.68	100.00

Wind Direction by Stability

N	NNE	NE	ENE	E	ESE	SE	SSE	S	SSW	SW	WSW	W	WNW	NW	NNW	TOTAL	-STABILITY CLASSES-
0.69	0.73	0.50	1.23	1.46	1.69	1.19	1.10	1.78	3.24	2.10	2.01	1.83	0.87	0.82	0.82	22.06	Extremely Unstable
0.32	0.18	0.18	0.64	0.50	0.50	0.37	0.41	0.46	0.91	0.55	0.32	0.32	0.14	0.23	0.18	6.21	Moderately Unstable
0.18	0.18	0.27	0.69	0.32	0.27	0.37	0.23	0.37	0.41	0.32	0.27	0.14	0.09	0.32	0.18	4.61	Slightly Unstable
1.14	0.91	1.10	1.23	1.69	1.01	1.42	1.01	1.37	1.83	1.55	1.10	1.05	0.87	1.42	0.91	19.60	Neutral
0.78	0.55	0.73	2.01	2.28	1.69	1.42	1.60	1.96	3.38	1.64	1.69	0.91	0.50	1.32	1.10	23.57	Slightly Stable
0.27	0.37	0.46	0.59	1.87	1.78	1.28	1.42	1.64	1.23	0.91	0.73	0.37	0.23	0.64	0.46	14.25	Moderately Stable
0.23	0.14	0.18	0.27	0.41	0.18	1.28	2.10	1.23	1.19	0.82	0.18	0.09	0.59	0.64	0.14	9.68	Extremely Stable

Wind Direction by Wind Speed

N	NNE	NE	ENE	E	ESE	SE	SSE	S	SSW	SW	WSW	W	WNW	NW	NNW	TOTAL	-WIND SPEED CLASSES-
0.00	0.00	0.00	0.00	0.00	0.00	0.00	0.00	0.00	0.00	0.00	0.00	0.00	0.00	0.00	0.00	0.00	CALM
0.09	0.09	0.05	0.32	0.50	0.09	0.09	0.23	0.14	0.14	0.09	0.27	0.23	0.23	0.05	0.09	2.70	< 3.5 mph
1.10	0.82	1.19	2.24	2.15	1.96	1.32	1.32	1.19	1.96	2.19	1.83	2.10	0.87	1.92	1.19	25.35	3.6 - 7.5 mph
1.55	1.46	1.74	2.83	4.25	3.06	3.56	3.29	3.52	3.33	3.02	2.51	1.74	1.28	2.47	1.55	41.16	7.6 - 12.5 mph
0.82	0.64	0.41	1.23	1.64	1.78	2.19	2.74	3.02	4.71	2.24	1.69	0.59	0.73	0.69	0.82	25.95	12.6 - 18.5 mph
0.05	0.05	0.05	0.05	0.00	0.23	0.09	0.27	0.96	1.96	0.37	0.00	0.05	0.18	0.27	0.14	4.71	18.6 - 24.5 mph
0.00	0.00	0.00	0.00	0.00	0.00	0.05	0.00	0.00	0.09	0.00	0.00	0.00	0.00	0.00	0.00	0.14	> 24.5 mph

Quad Cities Nuclear Station
296 ft. Wind Speed and Direction

October-December, 2002
296Ft-33Ft Delta-T (F)

Number of Observations = 2195
Values are Percent Occurrence

SPEED		WIND DIRECTION CLASSES															STABILITY CLASSES								
CLASS	N	NNE	NE	ENE	E	ESE	SE	SSE	S	SSW	SW	WSW	W	WNW	NW	NNW	TOTAL	EU	MU	SU	N	SS	MS	ES	TOTAL
EU	0.00	0.00	0.00	0.00	0.00	0.00	0.00	0.00	0.00	0.00	0.00	0.00	0.00	0.00	0.00	0.00	0.00	0.00	0.00						0.00
MU	0.00	0.00	0.00	0.00	0.00	0.00	0.00	0.00	0.00	0.00	0.00	0.00	0.00	0.00	0.00	0.00	0.00	0.00	0.00	0.00					0.00
C SU	0.00	0.00	0.00	0.00	0.00	0.00	0.00	0.00	0.00	0.00	0.00	0.00	0.00	0.00	0.00	0.00	0.00	0.00		0.00					
A N	0.00	0.00	0.00	0.00	0.00	0.00	0.00	0.00	0.00	0.00	0.00	0.00	0.00	0.00	0.00	0.00	0.00	0.00			0.00				
L SS	0.00	0.00	0.00	0.00	0.00	0.00	0.00	0.00	0.00	0.00	0.00	0.00	0.00	0.00	0.00	0.00	0.00	0.00				0.00			
M MS	0.00	0.00	0.00	0.00	0.00	0.00	0.00	0.00	0.00	0.00	0.00	0.00	0.00	0.00	0.00	0.00	0.00	0.00					0.00		
ES	0.00	0.00	0.00	0.00	0.00	0.00	0.00	0.00	0.00	0.00	0.00	0.00	0.00	0.00	0.00	0.00	0.00	0.00						0.00	0.00
																									0.00
EU	0.00	0.00	0.00	0.00	0.00	0.00	0.00	0.00	0.00	0.00	0.00	0.00	0.00	0.00	0.00	0.00	0.00	0.00	0.00	0.00					0.00
MU	0.00	0.00	0.00	0.00	0.00	0.00	0.00	0.00	0.00	0.00	0.00	0.00	0.00	0.00	0.00	0.00	0.00	0.00	0.00	0.00					0.00
1 SU	0.00	0.00	0.00	0.00	0.00	0.00	0.05	0.00	0.00	0.00	0.00	0.00	0.00	0.00	0.00	0.00	0.05			0.05					0.05
- N	0.09	0.00	0.05	0.05	0.05	0.05	0.00	0.05	0.00	0.00	0.14	0.09	0.05	0.05	0.00	0.00	0.64				0.64				0.64
3 SS	0.05	0.00	0.00	0.05	0.00	0.00	0.05	0.00	0.05	0.05	0.00	0.00	0.05	0.00	0.00	0.27					0.27				0.27
MS	0.00	0.05	0.00	0.05	0.00	0.00	0.00	0.00	0.00	0.00	0.05	0.00	0.05	0.00	0.00	0.18						0.18			0.18
ES	0.00	0.05	0.00	0.00	0.00	0.00	0.00	0.00	0.00	0.00	0.00	0.00	0.00	0.00	0.00	0.05							0.05	0.05	
																									0.18
																									1.18
EU	0.14	0.05	0.00	0.00	0.00	0.00	0.00	0.00	0.05	0.27	0.05	0.00	0.09	0.18	0.00	0.09	0.91	0.91							0.91
MU	0.05	0.14	0.09	0.05	0.09	0.00	0.05	0.00	0.14	0.18	0.09	0.09	0.09	0.14	0.09	0.14	1.41		1.41						1.41
4 SU	0.14	0.23	0.09	0.14	0.09	0.00	0.00	0.00	0.00	0.14	0.05	0.14	0.09	0.05	0.18	0.05	1.37			1.37					1.37
- N	0.36	0.59	0.46	0.14	0.50	0.18	0.18	0.05	0.00	0.09	0.09	0.14	0.18	0.32	0.36	0.27	3.92				3.92				3.92
7 SS	0.00	0.27	0.05	0.05	0.09	0.05	0.00	0.05	0.14	0.18	0.14	0.00	0.05	0.14	0.09	0.05	1.32				1.32				1.32
MS	0.00	0.09	0.05	0.09	0.27	0.05	0.14	0.09	0.05	0.00	0.14	0.18	0.00	0.14	0.05	0.00	1.32					1.32			1.32
ES	0.05	0.00	0.00	0.05	0.09	0.00	0.09	0.00	0.00	0.05	0.00	0.00	0.00	0.05	0.00	0.36							0.36	0.36	
																									10.62
EU	0.05	0.00	0.09	0.00	0.00	0.00	0.09	0.00	0.14	0.32	0.36	0.09	0.14	0.00	0.14	0.14	1.55	1.55							1.55
MU	0.18	0.05	0.09	0.05	0.00	0.00	0.05	0.00	0.14	0.23	0.18	0.09	0.09	0.05	0.14	0.18	1.50		1.50						1.50
8 SU	0.23	0.00	0.09	0.09	0.14	0.00	0.00	0.05	0.00	0.18	0.23	0.09	0.18	0.14	0.23	0.09	1.73			1.73					1.73
- N	1.96	1.23	1.09	1.37	1.00	0.68	0.14	0.09	0.14	0.64	0.59	0.91	1.00	1.87	1.64	1.09	15.44				15.44				15.44
1 SS	0.32	0.73	0.27	0.14	0.23	0.09	0.27	0.36	1.05	1.28	0.68	0.96	1.23	1.05	0.73	0.68	10.07				10.07				10.07
2 MS	0.14	0.09	0.14	0.05	0.55	0.09	0.64	0.27	0.14	0.36	0.32	0.09	0.09	0.14	0.18	0.36	3.64					3.64			3.64
ES	0.00	0.00	0.00	0.00	0.14	0.14	0.23	0.14	0.23	0.36	0.05	0.00	0.00	0.00	0.00	0.00	1.28						1.28	1.28	
																									35.22
EU	0.00	0.00	0.00	0.05	0.00	0.00	0.14	0.00	0.14	0.59	0.09	0.09	0.59	0.09	0.32	0.23	2.32	2.32							2.32
1 MU	0.05	0.00	0.05	0.00	0.00	0.09	0.00	0.00	0.09	0.23	0.23	0.23	0.50	0.18	0.09	0.05	1.78		1.78						1.78
3 SU	0.00	0.14	0.00	0.00	0.05	0.00	0.00	0.05	0.00	0.09	0.14	0.14	0.32	0.27	0.05	0.00	1.23			1.23					1.23
- N	0.73	0.73	1.05	1.14	0.68	0.68	0.09	0.23	0.55	0.59	0.73	1.05	2.82	1.78	2.10	1.05	15.99				15.99				15.99
1 SS	0.50	0.23	0.18	0.27	0.09	0.14	0.36	0.46	1.23	1.55	1.69	1.59	1.32	1.18	1.32	0.59	12.71				12.71				12.71
8 MS	0.05	0.00	0.05	0.00	0.09	0.05	0.46	0.23	0.73	0.55	0.00	0.09	0.05	0.05	0.27	0.09	2.73					2.73			2.73
ES	0.00	0.00	0.00	0.00	0.05	0.00	0.46	0.14	0.32	0.27	0.00	0.00	0.00	0.00	0.00	0.00	1.23						1.23	1.23	
																									38.00

Quad Cities Nuclear Station
296 ft. Wind Speed and Direction

October-December, 2002
296Ft-33Ft Delta-T (F)

SPEED CLASS	WIND DIRECTION CLASSES																STABILITY CLASSES								
	N	NNE	NE	ENE	E	ESE	SE	SSE	S	SSW	SW	WSW	W	WNW	NW	NNW	TOTAL	EU	MU	SU	N	SS	MS	ES	TOTAL
EU	0.00	0.00	0.00	0.00	0.00	0.00	0.00	0.05	0.18	0.14	0.00	0.14	0.14	0.05	0.00	0.00	0.68	0.68							
1 MU	0.00	0.00	0.00	0.00	0.00	0.00	0.05	0.00	0.05	0.18	0.18	0.05	0.05	0.05	0.00	0.00	0.59	0.59							
9 SU	0.00	0.00	0.00	0.00	0.05	0.14	0.00	0.00	0.00	0.05	0.00	0.05	0.05	0.00	0.00	0.00	0.32		0.32						
- N	0.09	0.09	0.14	0.00	0.64	0.41	0.00	0.18	0.18	0.32	0.50	0.32	2.55	1.09	0.59	0.18	7.29			7.29					
2 SS	0.00	0.00	0.00	0.09	0.00	0.23	0.00	0.05	0.87	0.96	0.68	0.23	0.32	0.00	0.05	0.00	3.46				3.46				
4 MS	0.00	0.00	0.00	0.00	0.00	0.05	0.00	0.00	0.00	0.05	0.00	0.00	0.00	0.00	0.00	0.00	0.09					0.09			
ES	0.00	0.00	0.00	0.00	0.00	0.00	0.00	0.00	0.05	0.00	0.00	0.00	0.00	0.00	0.00	0.00	0.05						0.05		
																									12.48
EU	0.00	0.00	0.00	0.00	0.00	0.00	0.00	0.00	0.00	0.00	0.00	0.00	0.00	0.00	0.00	0.00	0.00	0.00							
G MU	0.00	0.00	0.00	0.00	0.00	0.00	0.00	0.00	0.00	0.00	0.00	0.00	0.00	0.00	0.00	0.00	0.00	0.00	0.00						
T SU	0.00	0.00	0.00	0.00	0.00	0.00	0.00	0.00	0.00	0.00	0.00	0.00	0.05	0.05	0.00	0.00	0.09		0.09						
N	0.00	0.00	0.00	0.00	0.00	0.23	0.00	0.27	0.00	0.00	0.00	0.00	0.77	0.46	0.18	0.00	1.91			1.91					
2 SS	0.00	0.00	0.00	0.00	0.00	0.05	0.00	0.00	0.00	0.36	0.09	0.00	0.00	0.00	0.00	0.00	0.50				0.50				
4 MS	0.00	0.00	0.00	0.00	0.00	0.00	0.00	0.00	0.00	0.00	0.00	0.00	0.00	0.00	0.00	0.00	0.00					0.00			
ES	0.00	0.00	0.00	0.00	0.00	0.00	0.00	0.00	0.00	0.00	0.00	0.00	0.00	0.00	0.00	0.00	0.00						0.00		
																									2.51
TOT	5.15	4.74	4.01	3.87	4.87	3.37	3.51	2.78	6.61	10.25	7.47	6.83	12.89	9.48	8.84	5.33	100.00	5.47	5.28	4.78	45.19	28.34	7.97	2.96	100.00

Wind Direction by Stability

N	NNE	NE	ENE	E	ESE	SE	SSE	S	SSW	SW	WSW	W	WNW	NW	NNW	TOTAL	-STABILITY CLASSES-
0.18	0.05	0.09	0.05	0.00	0.00	0.23	0.05	0.50	1.32	0.50	0.32	0.96	0.32	0.46	0.46	5.47	Extremely Unstable
0.27	0.18	0.23	0.09	0.09	0.09	0.14	0.00	0.41	0.82	0.68	0.46	0.73	0.41	0.32	0.36	5.28	Moderately Unstable
0.36	0.36	0.18	0.23	0.32	0.14	0.05	0.09	0.00	0.46	0.41	0.41	0.68	0.50	0.46	0.14	4.78	Slightly Unstable
3.23	2.64	2.78	2.69	2.87	2.23	0.41	0.87	0.87	1.64	2.05	2.51	7.38	5.56	4.87	2.60	45.19	Neutral
0.87	1.23	0.50	0.59	0.41	0.55	0.68	0.91	3.33	4.37	3.28	2.78	2.96	2.37	2.19	1.32	28.34	Slightly Stable
0.18	0.23	0.23	0.18	0.91	0.23	1.23	0.59	0.91	0.96	0.50	0.36	0.18	0.32	0.50	0.46	7.97	Moderately Stable
0.05	0.05	0.00	0.05	0.27	0.14	0.77	0.27	0.59	0.68	0.05	0.00	0.00	0.00	0.05	0.00	2.96	Extremely Stable

Wind Direction by Wind Speed

N	NNE	NE	ENE	E	ESE	SE	SSE	S	SSW	SW	WSW	W	WNW	NW	NNW	TOTAL	-WIND SPEED CLASSES-
0.00	0.00	0.00	0.00	0.00	0.00	0.00	0.00	0.00	0.00	0.00	0.00	0.00	0.00	0.00	0.00	0.00	CALM
0.14	0.09	0.05	0.14	0.05	0.05	0.09	0.05	0.05	0.05	0.18	0.09	0.14	0.05	0.00	0.00	1.18	< 3.5 mph
0.73	1.37	0.73	0.50	1.14	0.27	0.46	0.18	0.36	0.91	0.55	0.55	0.50	0.96	0.82	0.59	10.62	3.6 - 7.5 mph
2.87	2.10	1.78	1.69	2.05	1.00	1.41	0.91	1.82	3.37	2.41	2.23	2.73	3.23	3.05	2.55	35.22	7.6 - 12.5 mph
1.32	1.09	1.32	1.46	0.96	0.96	1.50	1.09	3.05	3.87	2.87	3.19	5.60	3.55	4.15	2.00	38.00	12.6 - 18.5 mph
0.09	0.09	0.14	0.09	0.68	0.82	0.05	0.27	1.32	1.69	1.37	0.77	3.10	1.18	0.64	0.18	12.48	18.6 - 24.5 mph
0.00	0.00	0.00	0.00	0.00	0.27	0.00	0.27	0.00	0.36	0.09	0.00	0.82	0.50	0.18	0.00	2.51	> 24.5 mph

Quad Cities Nuclear Station
33 ft. Wind Speed and Direction

January-December, 2002
196Ft-33Ft Delta-T (F)

SPEED CLASS	WIND DIRECTION CLASSES																STABILITY CLASSES								
	N	NNE	NE	ENE	E	ESE	SE	SSE	S	SSW	SW	WSW	W	WNW	NW	NNW	TOTAL	EU	MU	SU	N	SS	MS	ES	TOTAL
EU	0.00	0.00	0.00	0.00	0.00	0.00	0.00	0.00	0.00	0.00	0.00	0.00	0.00	0.00	0.00	0.00	0.00	0.00	0.00	0.00	0.00	0.00	0.00	0.00	0.00
1 MU	0.00	0.00	0.00	0.00	0.00	0.00	0.00	0.00	0.00	0.00	0.00	0.00	0.00	0.00	0.00	0.00	0.00	0.00	0.00	0.00	0.00	0.00	0.00	0.00	0.00
9 SU	0.00	0.00	0.00	0.00	0.00	0.00	0.00	0.00	0.00	0.00	0.00	0.00	0.00	0.00	0.00	0.00	0.00	0.00	0.00	0.00	0.00	0.00	0.00	0.00	0.00
- N	0.00	0.00	0.00	0.00	0.00	0.00	0.00	0.00	0.00	0.00	0.00	0.00	0.00	0.00	0.00	0.00	0.00	0.00	0.00	0.00	0.00	0.00	0.00	0.00	0.00
2 SS	0.00	0.00	0.00	0.00	0.00	0.00	0.00	0.00	0.00	0.00	0.00	0.00	0.00	0.00	0.00	0.00	0.00	0.00	0.00	0.00	0.00	0.00	0.00	0.00	0.00
4 MS	0.00	0.00	0.00	0.00	0.00	0.00	0.00	0.00	0.00	0.00	0.00	0.00	0.00	0.00	0.00	0.00	0.00	0.00	0.00	0.00	0.00	0.00	0.00	0.00	0.00
ES	0.00	0.00	0.00	0.00	0.00	0.00	0.00	0.00	0.00	0.00	0.00	0.00	0.00	0.00	0.00	0.00	0.00	0.00	0.00	0.00	0.00	0.00	0.00	0.00	0.00
TOT	3.92	3.13	4.73	5.47	5.85	6.54	4.98	5.21	5.45	7.30	10.11	7.04	10.27	8.69	7.00	4.30	100.00	18.87	2.38	4.69	30.72	27.59	9.55	6.21	100.00

Wind Direction by Stability

N	NNE	NE	ENE	E	ESE	SE	SSE	S	SSW	SW	WSW	W	WNW	NW	NNW	TOTAL	-STABILITY CLASSES-
0.52	0.41	0.60	0.99	0.66	0.69	0.90	0.94	1.13	2.37	2.60	1.31	2.20	1.40	1.32	0.82	18.87	Extremely Unstable
0.07	0.12	0.09	0.16	0.11	0.07	0.09	0.06	0.07	0.18	0.29	0.25	0.33	0.16	0.18	0.14	2.38	Moderately Unstable
0.18	0.19	0.29	0.31	0.25	0.18	0.15	0.19	0.22	0.22	0.54	0.37	0.37	0.45	0.49	0.29	4.69	Slightly Unstable
2.12	1.20	2.40	1.77	1.93	1.46	0.77	0.71	0.78	0.99	1.92	1.99	3.95	4.11	2.86	1.77	30.72	Neutral
0.55	0.55	0.55	1.41	1.30	1.34	1.40	1.93	2.00	2.56	4.04	2.83	2.67	1.84	1.73	0.87	27.59	Slightly Stable
0.29	0.34	0.52	0.48	0.73	1.12	1.10	0.91	0.84	0.78	0.51	0.27	0.57	0.48	0.33	0.29	9.55	Moderately Stable
0.19	0.32	0.27	0.34	0.88	1.67	0.58	0.47	0.41	0.21	0.20	0.04	0.19	0.25	0.08	0.11	6.21	Extremely Stable

Wind Direction by Wind Speed

N	NNE	NE	ENE	E	ESE	SE	SSE	S	SSW	SW	WSW	W	WNW	NW	NNW	TOTAL	-WIND SPEED CLASSES-
0.00	0.00	0.00	0.00	0.00	0.00	0.00	0.00	0.00	0.00	0.00	0.00	0.00	0.00	0.01	0.00	0.01	CALM
0.86	1.12	1.28	1.34	2.30	3.18	2.31	2.12	2.05	1.67	1.70	1.65	2.29	2.12	1.27	0.78	28.03	< 3.5 mph
2.10	1.47	2.39	3.17	2.21	2.51	2.26	2.47	2.85	4.36	6.87	4.56	4.39	3.36	4.15	2.80	51.92	3.6 - 7.5 mph
0.92	0.54	0.93	0.88	1.28	0.75	0.41	0.61	0.55	1.27	1.51	0.80	3.12	3.06	1.35	0.71	18.72	7.6 - 12.5 mph
0.05	0.00	0.13	0.07	0.06	0.09	0.00	0.00	0.00	0.00	0.04	0.04	0.41	0.15	0.21	0.00	1.25	12.6 - 18.5 mph
0.00	0.00	0.00	0.00	0.00	0.00	0.00	0.00	0.00	0.00	0.00	0.00	0.06	0.00	0.00	0.00	0.06	18.6 - 24.5 mph
0.00	0.00	0.00	0.00	0.00	0.00	0.00	0.00	0.00	0.00	0.00	0.00	0.00	0.00	0.00	0.01	0.01	> 24.5 mph

Quad Cities Nuclear Station
296 ft. Wind Speed and Direction

January-December, 2002
296Ft-33Ft Delta-T (F)

SPEED CLASS	WIND DIRECTION CLASSES																STABILITY CLASSES							TOTAL	
	N	NNE	NE	ENE	E	ESE	SE	SSE	S	SSW	SW	WSW	W	WNW	NW	NNW	TOTAL	EU	MU	SU	N	SS	MS		ES
EU	0.00	0.00	0.02	0.05	0.01	0.05	0.06	0.12	0.36	0.43	0.01	0.06	0.17	0.15	0.08	0.01	1.57	1.57							
1 MU	0.00	0.00	0.00	0.01	0.00	0.00	0.02	0.02	0.06	0.18	0.06	0.01	0.06	0.21	0.03	0.02	0.69	0.69							
9 SU	0.01	0.00	0.00	0.01	0.01	0.05	0.01	0.01	0.06	0.09	0.01	0.03	0.07	0.08	0.06	0.05	0.55	0.55		0.55					
- N	0.20	0.05	0.32	0.16	0.38	0.42	0.13	0.31	0.39	0.39	0.44	0.18	1.15	1.23	0.60	0.18	6.54	6.54		6.54					
2 SS	0.00	0.00	0.05	0.05	0.01	0.09	0.03	0.37	0.82	1.27	0.55	0.23	0.22	0.02	0.03	0.01	3.76	3.76				3.76			
4 MS	0.00	0.00	0.00	0.00	0.00	0.06	0.09	0.01	0.02	0.08	0.02	0.00	0.01	0.00	0.00	0.00	0.30	0.30				0.30			
ES	0.00	0.00	0.00	0.00	0.00	0.00	0.01	0.00	0.01	0.01	0.00	0.00	0.00	0.00	0.00	0.00	0.03	0.03					0.03		
																									13.45
EU	0.00	0.00	0.00	0.00	0.00	0.00	0.00	0.06	0.02	0.09	0.00	0.00	0.05	0.08	0.05	0.01	0.36	0.36							
G MU	0.00	0.00	0.00	0.00	0.00	0.00	0.00	0.02	0.02	0.01	0.00	0.00	0.02	0.05	0.02	0.00	0.15	0.15		0.15					
T SU	0.00	0.00	0.00	0.00	0.00	0.00	0.00	0.00	0.01	0.02	0.01	0.00	0.01	0.05	0.02	0.01	0.14	0.14		0.14					
N	0.00	0.00	0.09	0.07	0.02	0.13	0.02	0.13	0.05	0.15	0.09	0.05	0.47	0.30	0.21	0.01	1.79	1.79			1.79				
2 SS	0.00	0.00	0.00	0.00	0.00	0.01	0.00	0.05	0.08	0.22	0.06	0.00	0.01	0.01	0.00	0.00	0.44	0.44				0.44			
4 MS	0.00	0.00	0.00	0.00	0.00	0.00	0.00	0.00	0.01	0.01	0.00	0.00	0.00	0.00	0.00	0.00	0.02	0.02				0.02			
ES	0.00	0.00	0.00	0.00	0.00	0.00	0.00	0.00	0.00	0.00	0.00	0.00	0.00	0.00	0.00	0.00	0.00	0.00					0.00		
																									2.90
TOT	4.05	2.96	4.04	4.43	5.51	4.50	4.79	5.81	8.46	11.45	8.48	6.03	8.58	8.10	7.66	5.14	100.00	12.75	6.33	5.41	34.92	26.38	10.02	4.19	100.00

Wind Direction by Stability

N	NNE	NE	ENE	E	ESE	SE	SSE	S	SSW	SW	WSW	W	WNW	NW	NNW	TOTAL	-STABILITY CLASSES-
0.28	0.29	0.24	0.44	0.48	0.52	0.68	0.65	1.28	2.36	1.10	0.88	1.29	0.96	0.83	0.47	12.75	Extremely Unstable
0.25	0.15	0.25	0.37	0.22	0.20	0.22	0.18	0.43	0.76	0.74	0.48	0.61	0.58	0.51	0.38	6.33	Moderately Unstable
0.28	0.18	0.28	0.45	0.38	0.15	0.17	0.18	0.24	0.44	0.47	0.37	0.47	0.40	0.52	0.42	5.41	Slightly Unstable
2.09	1.37	2.34	1.91	2.38	1.65	1.03	1.13	1.57	1.83	2.27	1.64	3.83	4.16	3.40	2.31	34.92	Neutral
0.77	0.62	0.59	0.85	1.05	1.14	1.03	2.00	2.75	4.13	2.81	2.13	1.97	1.58	1.76	1.19	26.38	Slightly Stable
0.29	0.30	0.28	0.30	0.82	0.75	1.13	0.96	1.55	1.13	0.69	0.46	0.36	0.24	0.44	0.33	10.02	Moderately Stable
0.09	0.05	0.06	0.10	0.18	0.09	0.53	0.72	0.65	0.80	0.39	0.07	0.05	0.17	0.20	0.05	4.19	Extremely Stable

Wind Direction by Wind Speed

N	NNE	NE	ENE	E	ESE	SE	SSE	S	SSW	SW	WSW	W	WNW	NW	NNW	TOTAL	-WIND SPEED CLASSES-
0.00	0.00	0.00	0.00	0.00	0.00	0.00	0.00	0.00	0.00	0.00	0.00	0.00	0.00	0.00	0.00	0.00	C A L M
0.10	0.07	0.06	0.15	0.15	0.07	0.08	0.14	0.12	0.09	0.10	0.17	0.16	0.10	0.06	0.08	1.71	< 3.5 mph
0.74	0.80	0.61	1.00	1.20	0.72	0.72	0.61	0.72	1.08	1.23	0.85	1.13	0.80	1.25	0.82	14.27	3.6 - 7.5 mph
1.91	1.30	1.51	1.72	2.30	1.57	1.86	1.71	2.21	3.14	2.63	2.13	1.89	2.06	2.61	1.95	32.51	7.6 - 12.5 mph
1.08	0.75	1.37	1.21	1.43	1.35	1.75	2.26	3.50	4.18	3.25	2.31	3.15	2.95	2.64	1.98	35.17	12.6 - 18.5 mph
0.21	0.05	0.39	0.28	0.42	0.66	0.36	0.84	1.72	2.46	1.10	0.52	1.68	1.70	0.81	0.28	13.45	18.6 - 24.5 mph
0.00	0.00	0.09	0.07	0.02	0.14	0.02	0.25	0.20	0.51	0.16	0.05	0.57	0.48	0.30	0.03	2.90	> 24.5 mph

(20) (20)

Attachment F
Solid Waste Disposition Summary
SVP-03-052

NRC REGULATORY GUIDE 1.21 REPORTS

Solid Waste Shipped Offsite for Disposal and Estimates of Major Nuclides by
Waste Class and Stream During Period from 01/01/2002 to 12/31/2002.

Waste Stream: Resins, Filters, and Evaporator Bottoms

Waste Class	Volume		Curies Shipped	% Error (Ci)
	Ft ³	M ³		
A	2.88E+03	8.16E+01	5.17E+02	+/- 12.3%
B	1.20E+02	3.41E+00	3.78E+01	+/- 12.3%
C	0.00E+00	0.00E+00	0.00E+00	+/- 12.3%
All	3.00E+03	8.50E+01	5.55E+02	+/- 12.3%

Waste Stream: Dry Active Waste

Waste Class	Volume		Curies Shipped	% Error (Ci)
	Ft ³	M ³		
A	7.84E+04	2.22E+02	2.19E+01	+/- 12.3%
B	0.00E+00	0.00E+00	0.00E+00	+/- 12.3%
C	0.00E+00	0.00E+00	0.00E+00	+/- 12.3%
All	7.84E+04	2.22E+03	2.19E+01	+/- 12.3%

Waste Stream: Irradiated Components

Waste Class	Volume		Curies Shipped	% Error (Ci)
	Ft ³	M ³		
A	0.00E+00	0.00E+00	0.00E+00	N/A
B	0.00E+00	0.00E+00	0.00E+00	N/A
C	0.00E+00	0.00E+00	0.00E+00	N/A
All	0.00E+00	0.00E+00	0.00E+00	N/A

Solid Waste Disposition

Number of Shipments	Mode of Transportation	Destination
41	Highway	Waste Processor
15	Highway	Disposal Site
5	Rail	Waste Processor

Attachment G
Offsite Dose Calculation Manual Revision 2002
SVP-03-052

ExelonSM

Nuclear

Offsite

Dose

Calculation

Manual

Docket Numbers:

Dresden	50-10, 50-237, 50-249
Quad Cities	50-254, 50-265
Zion	50-295, 50-304
LaSalle	50-373, 50-374
Byron	50-454, 50-455
Braidwood	50-456, 50-457

OFFSITE DOSE CALCULATION MANUAL

TABLE OF CONTENTS

Part 1: GENERIC SECTIONS

<u>TABLE OF CONTENTS</u>	<u>PAGE</u>
Chapter 1 Introduction	1
Chapter 2 Regulations and Guidelines	2
Chapter 3 Pathways	12
Chapter 4 Introduction to Methodology	15
Chapter 5 Measurement	28
Chapter 6 Implementation of Offsite Dose Assessment Program	30
Chapter 7 References	31
Chapter 8 Intentionally Left Blank	—
Chapter 9 Intentionally Left Blank	—
Appendix A Compliance Methodology	A-i
Appendix B Models and Parameters for Airborne and Liquid Effluent Calculations	B-i
Appendix C Generic Data	C-i
Appendix D Intentionally Left Blank	—
Appendix E Intentionally Left Blank	—
Part 2: SITE SPECIFIC SECTIONS	
Chapter 10 Radiological Effluent Treatment and Monitoring	
Chapter 11 Radiological Environmental Monitoring Program	
Chapter 12 Radiological Effluent Technical Standards	
Appendix F Station Specific Data	

OFFSITE DOSE CALCULATION MANUAL

TABLE OF CONTENTS (Continued)

CHAPTER 1	INTRODUCTION		
1.0	INTRODUCTION	<u>PAGE</u>	
1.1	STRUCTURE OF THIS MANUAL	1	
		1	
CHAPTER 2	REGULATIONS AND GUIDELINES		
2.0	INTRODUCTION	2	
2.1	CODE OF FEDERAL REGULATIONS	2	
	1. 10CFR20, Standards for Protection Against Radiation	2	
	2. Design Criteria (Appendix A of 10CFR50)	2	
	3. ALARA Provisions (Appendix I of 10CFR50)	2	
	4. 40CFR190, Environmental Radiation Protection Standards for Nuclear Power Operations	3	
	5. 40CFR141, National Primary Drinking Water Regulations	3	
2.2	RADIOLOGICAL EFFLUENT TECHNICAL SPECIFICATIONS/STANDARDS	3	
	1. Categories	4	
2.3	OFFSITE DOSE CALCULATION MANUAL	4	
2.4	OVERLAPPING REQUIREMENTS	5	
2.5	DOSE RECEIVER METHODOLOGY	5	
CHAPTER 3	EXPOSURE PATHWAYS		
3.0	INTRODUCTION	12	
3.1	AIRBORNE RELEASES	12	
3.2	LIQUID RELEASES	12	
3.3	RADIATION FROM CONTAINED SOURCES	13	

OFFSITE DOSE CALCULATION MANUAL

TABLE OF CONTENTS (Continued)

	<u>PAGE</u>
CHAPTER 4 METHODOLOGY	15
4.0 INTRODUCTION	15
4.1 IMPORTANT CONCEPTS AND PARAMETERS	15
1. Dose	15
2. Exposure Pathways	15
3. Categories of Radioactivity	16
4. Atmospheric Release Point Classifications	16
5. Historical Average Atmospheric Conditions	17
6. Relative Concentration Factor γ/Q and Gamma- γ/Q	18
7. Relative Deposition Factor D/Q	18
8. Dose Factors	19
4.2 AIRBORNE RELEASES	19
1. Gamma Air Dose	19
1. Finite Cloud Gamma Air Dose Factor	19
2. Semi-Infinite Cloud Gamma Air Dose Factor	20
2. Beta Air Dose	20
3. Total Body Dose and Dose Rate	20
4. Skin Dose and Dose Rate	21
5. Ground Radiation	21
6. Inhalation	22
7. Ingestion	22
4.3 LIQUID RELEASES	23
4.4 CONTAINED SOURCES OF RADIOACTIVITY	23
1. BWR Skyshine	23
2. Onsite Radwaste Storage Facilities	24
4.5 TOTAL DOSE REQUIREMENTS	24
1. Total Effective Dose Equivalent Limits of 10CFR20	24
2. Total Dose for Uranium Fuel Cycle	24
CHAPTER 5 MEASUREMENT	28
5.0 INTRODUCTION	28
5.1 EFFLUENT AND PROCESS MONITORING	28
5.2 METEOROLOGICAL MONITORING	28
5.3 RADIOLOGICAL ENVIRONMENTAL MONITORING PROGRAM	28
1. Interlaboratory Comparison Program	28

OFFSITE DOSE CALCULATION MANUAL

TABLE OF CONTENTS (Continued)

	<u>PAGE</u>
CHAPTER 6 IMPLEMENTATION OF OFFSITE DOSE ASSESSMENT	30
6.1 NUCLEAR POWER STATION	30
6.2 METEOROLOGICAL CONTRACTOR	30
6.3 REMP CONTRACTOR	30
CHAPTER 7 REFERENCES	31

OFFSITE DOSE CALCULATION MANUAL

LIST OF TABLES FOR THE ODCM GENERIC SECTIONS

<u>SECTION</u>	<u>TABLE NUMBER</u>	<u>TITLE</u>
Chapter 2	2-1	Regulatory Dose Limit Matrix
	2-2	Dose Assessment Receivers
	2-3	Dose Component/Regulation Matrix
Chapter 4	4-1	Radionuclide Types Considered For Airborne Effluent Exposure Pathways
	4-2	Radiation Dose Factors
Appendix A	A-0	Average Annual Concentrations Assumed to Produce a Total Body or Organ Dose of 4 mrem/yr
	A-1	Compliance Matrix
	A-2	Release Point Classifications
	A-3	Nearest Downstream Community Water Systems
	A-4	40CFR190 Compliance
Appendix B	B-0	Noble Gas Nuclide Fraction
	B-1	Portion of an Example Joint Frequency Distribution
Appendix C	C-1	Miscellaneous Dose Assessment Factors Environmental Parameters
	C-2	Miscellaneous Dose Assessment Factors - Consumption Rate Parameters
	C-3	Stable Element Transfer Data
	C-4	Atmospheric Stability Classes
	C-5	Vertical Dispersion Parameters
	C-6	Allowable Concentrations of Dissolved or Entrained Noble Gases Released from the Site to Unrestricted Areas in Liquid Waste
	C-7	Radiological Decay Constants (λ_i) in hr^{-1}
	C-8	Bio-accumulation Factors B, to be Used in the Absence of Site-Specific Data
	C-9	Dose Factors for Noble Gases
	C-10	External Dose Factors for Standing on Contaminated Ground
	C-11	Sector Code Definitions

OFFSITE DOSE CALCULATION MANUAL

LIST OF FIGURES FOR THE ODCM GENERIC SECTIONS

<u>SECTION</u>	<u>FIGURE NUMBER</u>	<u>TITLE</u>
Chapter 2	2-1	Simplified Flow Chart of Offsite Dose Calculations
Chapter 3	3-1	Radiation Exposure Pathways to Humans
Appendix B	B-1	Instantaneous View of a Plume
	B-2	A Gaussian Curve
	B-3	Effect of Observation Period on Plume Shape
	B-4	A Gaussian Plume

CHAPTER 1 INTRODUCTION

1.0 INTRODUCTION

The Offsite Dose Calculation Manual (ODCM) presents a discussion of the following:

- The basic concepts applied in calculating offsite doses from nuclear plant effluents.
- The regulations and requirements for the ODCM and related programs.
- The methodology and parameters for the offsite dose calculations used by the nuclear power stations to assess impact on the environment and compliance with regulations.

The methodology detailed in this manual is intended for the calculation of radiation doses during routine (i.e., non-accident) conditions. The calculations are normally performed using a computer program. Manual calculations may be performed in lieu of the computer program.

The dose effects of airborne radioactivity releases predominately depend on meteorological conditions (wind speed, wind direction, and atmospheric stability). For airborne effluents, the dose calculations prescribed in this manual are based on historical average atmospheric conditions. This methodology is appropriate for estimating annual average dose effects and is stipulated in the Bases Section of the Radiological Effluent Technical Standards (RETS) of all Exelon Nuclear nuclear power stations.

1.1 STRUCTURE OF THIS MANUAL

This manual is the ODCM for the following Exelon Nuclear power stations: Braidwood, Byron, Dresden, LaSalle, Quad Cities and Zion. It is divided into two parts. The material in the first part is generic (applicable to more than one station) and consists of Chapters 1 through 7 and Appendices A through C. The material in the second part is station (or site) specific. Therefore, there are six separate sets of station-specific sections each containing three chapters (chapters 10, 11, 12) and an appendix (App. F).

The chapters of the generic section provide a brief introduction to and overview of Exelon Nuclear's offsite dose calculation methodology and parameters. Appendices A and B provide detailed information on specific aspects of the methodology. Appendix C contains tables of values of the generic parameters used in offsite dose equations.

The station-specific section provides specific requirements for the treatment and monitoring of radioactive effluents, for the contents of the Radiological Environmental Monitoring Program (REMP) and the Radiological Effluent Technical Standards (RETS). These three programs are detailed in ODCM Chapters 10, 11 and 12, respectively. Appendix F contains tables of values for the station-specific parameters used in the offsite dose equations. References are provided as required in each station-specific chapter and appendix.

An ODCM Bases and Reference Document (see Reference 101) provides description of the bases for the methodology and parameters discussed in the generic section of the ODCM. This is a stand-alone document and is not considered to be a part of the ODCM.

CHAPTER 2

REGULATIONS AND GUIDELINES

2.0 INTRODUCTION

This chapter of the ODCM serves to illustrate the regulations and requirements that define and are applicable to the ODCM. Any information provided in the ODCM concerning specific regulations are not a substitute for the regulations as found in the Code of Federal Regulations (CFR) or Technical Specifications.

2.1 CODE OF FEDERAL REGULATIONS

Various sections of the Code of Federal Regulations (CFR) require nuclear power stations to be designed and operated in a manner that limits the radiation exposure to members of the public. These sections specify limits on offsite radiation doses and on effluent radioactivity concentrations and they also require releases of radioactivity to be "As Low As Reasonably Achievable". These requirements are contained in 10CFR20, 10CFR50 and 40CFR190. In addition, 40CFR141 imposes limits on the concentration of radioactivity in drinking water provided by the operators of public water systems.

2.1.1 10CFR20, Standards for Protection Against Radiation

This revision of the ODCM addresses the requirements of 10CFR20. The 10CFR20 dose limits are summarized in Table 2-1.

2.1.2 Design Criteria (Appendix A of 10CFR50)

Section 50.36 of 10CFR50 requires that an application for an operating license include proposed Technical Specifications. Final Technical Specifications for each station are developed through negotiation between the applicant and the NRC. The Technical Specifications are then issued as a part of the operating license, and the licensee is required to operate the facility in accordance with them.

Section 50.34 of 10CFR50 states that an application for a license must state the principal design criteria of the facility. Minimum requirements are contained in Appendix A of 10CFR50.

2.1.3 ALARA Provisions (Appendix I of 10CFR50)

Sections 50.34a and 50.36a of 10CFR50 require that the nuclear plant design and the station RETS have provisions to keep levels of radioactive materials in effluents to unrestricted areas "As Low As Reasonably Achievable" (ALARA). Although 10CFR50 does not impose specific limits on releases, Appendix I of 10CFR50 does provide numerical design objectives and suggested limiting conditions for operation. According to Section I of Appendix I of 10CFR50, design objectives and limiting conditions for operation, conforming to the guidelines of Appendix I "shall be deemed a conclusive showing of compliance with the "As Low As Reasonably Achievable" requirements of 10CFR50.34a and 50.36a."

An applicant must use calculations to demonstrate conformance with the design objective dose limits of Appendix I. The calculations are to be based on models and data such that the actual radiation exposure of an individual is "unlikely to be substantially underestimated" (see 10CFR50 Appendix I, Section III.A.1).

The guidelines in Appendix I call for an investigation, corrective action and a report to the NRC whenever the calculated dose due to the radioactivity released in a calendar quarter exceeds one-half of an annual design objective. The guidelines also require a surveillance program to monitor releases, monitor the environment and identify changes in land use.

2.1.4 40CFR190, Environmental Radiation Protection Standards for Nuclear Power Operations

Under an agreement between the NRC and the EPA, the NRC stipulated to its licensees in Generic Letter 79-041 that "Compliance with Radiological Effluent Technical Specifications (RETS), NUREG-0472 (Rev.2) for PWR's or NUREG-0473 (Rev.2) for BWR's, implements the LWR provisions to meet 40CFR190". (See Reference 103 and 49.)

The regulations of 40CFR190 limit radiation doses received by members of the public as a result of operations that are part of the uranium fuel cycle. Operations must be conducted in such a manner as to provide reasonable assurance that the annual dose equivalent to any member of the public due to radiation and to planned discharges of radioactive materials does not exceed the following limits:

- 25 mrem to the total body
- 75 mrem to the thyroid
- 25 mrem to any other organ

An important difference between the design objectives of 10CFR50 and the limits of 40CFR190 is that 10CFR50 addresses only doses due to radioactive effluents. 40CFR190 limits doses due to effluents and also to radiation sources maintained on site. See Section 2.4 for further discussion of the differences between the requirements of 10CFR50 Appendix I and 40CFR190.

2.1.5 40CFR141, National Primary Drinking Water Regulations

The following radioactivity limits for community water systems were established in the July, 1976 Edition of 40CFR141:

- Combined Ra-226 and Ra-228: ≤ 5 pCi/L.
- Gross alpha (particle activity including Ra-226 but excluding radon and uranium): ≤ 15 pCi/L.
- The average annual concentration of beta particle and photon radioactivity from man-made radionuclides in drinking water shall not produce an annual dose equivalent to the total body or any internal organ greater than 4 mrem/yr.

The regulations specify procedures for determining the values of annual average radionuclide concentration which produce an annual dose equivalent of 4 mrem. Radiochemical analysis methods are also specified. The responsibility for monitoring radioactivity in a community water system falls on the supplier of the water. However, some of the Exelon Nuclear stations have requirements related to 40CFR141 in their specific RETS. For calculation methodology, see Section A.6 of Appendix A.

2.2 RADIOLOGICAL EFFLUENT TECHNICAL STANDARDS

The Radiological Effluent Technical Standards (RETS) were formerly a subset of the Technical Specifications. They implement provisions of the Code of Federal Regulations aimed at limiting offsite radiation dose. The NRC published Standard Radiological Effluent Technical Specifications for PWRs (Reference 2) and for BWRs (Reference 3) as guidance to assist in the development of technical specifications. These documents have undergone frequent minor revisions to reflect changes in plant design and evolving regulatory concerns. The Radiological Effluent Technical Specifications have been removed from the Technical Specifications and placed in the ODCM as the Radiological Effluent Technical Standards (RETS) (see Reference 90). The RETS of each station are similar but not identical to the guidance of the Standard Radiological Effluent Technical Specifications.

2.2.1 Categories

The major categories found in the RETS are the following:

- **Definitions**
A glossary of terms (not limited to the ODCM).
- **Instrumentation**
This section states the Operability Requirements (OR) for instrumentation performance as well as the associated Surveillance Requirements. The conservative alarm/trip setpoints ensure regulatory compliance for both liquid and gaseous effluents. Surveillance requirements are listed to ensure ORs are met through testing, calibration, inspection and calculation. Also included are the bases for interpreting the requirements. The Operability Requirement (OR) is the ODCM equivalent of a Limiting Condition for Operation (LCO) as defined in both the NRC published Standard Radiological Effluent Technical Specifications and the stations' Technical Specifications.
- **Liquid Effluents**
This section addresses the limits, special reports and liquid waste treatment systems required to substantiate the dose due to liquid radioactivity concentrations to unrestricted areas. Surveillance Requirements and Bases are included for liquid effluents.
- **Gaseous Effluents**
This section addresses the limits, special reports and gaseous radwaste and ventilation exhaust treatment systems necessary for adequate documentation of the instantaneous offsite radiation dose rates and doses to a member of the public. Surveillance Requirements and Bases are included for gaseous effluents.
- **Radiological Environmental Monitoring Program**
This section details the Radiological Environmental Monitoring Program (REMP) involving sample collection and measurements to verify that the radiation levels released are minimal. This section describes the annual land use census and participation in an interlaboratory comparison program. Surveillance Requirements and Bases are included for environmental monitoring.
- **Reports and Records**
This section serves as an administrative guide to maintain an appropriate record tracking system. The management of procedures, record retention, review/audit and reporting are discussed.

2.3 OFFSITE DOSE CALCULATION MANUAL

The NRC in Generic Letter 89-01 defines the ODCM as follows (not verbatim) (see Reference 90):

The Offsite Dose Calculation Manual (ODCM) shall contain the methodology and parameters used in the calculation of offsite doses resulting from radioactive gaseous and liquid effluents, in the calculation of gaseous and liquid effluent monitoring Alarm/Trip Setpoints, and in the conduct of the Radiological Environmental Monitoring Program. The ODCM shall also contain (1) the Radioactive Effluent Controls and Radiological Environmental Monitoring Programs and (2) descriptions of the Information that should be included in the Annual Radiological Environmental Operating and Annual Radioactive Effluent Release Reports.

Additional requirements for the content of the ODCM are contained throughout the text of the RETS.

2.4 OVERLAPPING REQUIREMENTS

In 10CFR20, 10CFR50 and 40CFR190, there are overlapping requirements regarding offsite radiation dose and dose commitment to the total body. In 10CFR20.1301 the total effective dose equivalent (or TEDE) to a member of the public is limited to 100 mrem per calendar year. In addition, Appendix I to 10CFR50 establishes design objectives on annual total body dose or dose commitment of 3 mrem per reactor for liquid effluents and 5 mrem per reactor for gaseous effluents (see 10CFR50 Appendix I, Sections II.A and II.B.2(a)). Finally, 40CFR190 limits annual total body dose or dose commitment to a member of the public to 25 mrem due to all uranium fuel cycle operations.

While these dose limits/design objectives appear to overlap, they are different and each is addressed separately by the RETS. Calculations are made and reports are generated to demonstrate compliance to all regulations. Refer to Tables 2-1, 2-2 and 2-3 for additional information regarding instantaneous effluent limits, design objectives and regulatory compliance.

2.5 DOSE RECEIVER METHODOLOGY

Table 2-2 lists the location of the dose recipient and occupancy factors, if applicable. Dose is assessed at the location in the unrestricted area where the combination of existing pathways and receptor age groups indicates the maximum potential exposures. The dose calculation methodology is consistent with the methodology of Regulatory Guide 1.109 (Reference 6) and NUREG 0133 (Reference 14). Dose is therefore calculated to a maximum individual. The maximum individual is characterized as "maximum" with regard to food consumption, occupancy and other usage of the area in the vicinity of the plant site. Such a "maximum individual" represents reasonable deviation from the average for the population in general. In all physiological and metabolic respects the maximum individual is assumed to have those characteristics that represent averages for their corresponding age group. Thus, the dose calculated is very conservative compared to the "average" (or typical) dose recipient who does not go out of the way to maximize radioactivity uptakes and exposure.

Finally Table 2-3 relates the dose component (or pathway) to specific ODCM equations and the appropriate regulation.

Table 2-1
Regulatory Dose Limit Matrix

REGULATION	DOSE TYPE	DOSE LIMIT(s)		ODCM EQUATION	
		(quarterly)	(annual)		
Airborne Releases:					
10CFR50 App. I ¹	Gamma Dose to Air due to Noble Gas Radionuclides (per reactor unit)	5 mrad	10 mrad	A-1	
	Beta Dose to Air Due to Noble Gas Radionuclides (per reactor unit)	10 mrad	20 mrad	A-2	
	Organ Dose Due to Specified Non-Noble Gas Radionuclides (per reactor unit)	7.5 mrem	15 mrem	A-7	
	Total Body and Skin Dose (if air dose is exceeded)	Total Body	2.5 mrem	5 mrem	A-3
		Skin	7.5 mrem	15 mrem	A-4
Technical Specifications	Total Body Dose Rate Due to Noble Gas Radionuclides (instantaneous limit, per site)	500 mrem/yr		A-5	
	Skin Dose Rate Due to Noble Gas Radionuclides (instantaneous limit, per site)	3,000 mrem/yr		A-6	
	Organ Dose Rate Due to Specified Non-Noble Gas Radionuclides (instantaneous limit, per site)	1,500 mrem/yr		A-16	
Liquid Releases:					
10CFR50 App. I ¹	Whole (Total) Body Dose (per reactor unit)	1.5 mrem	3 mrem	A-17	
	Organ Dose (per reactor unit)	5 mrem	10 mrem	A-17	
Technical Specifications	The concentration of radioactivity in liquid effluents released to unrestricted areas	Ten (10) times the concentration values listed in 10CFR20 Appendix B; Table 2, Column 2, Table C-6 of ODCM Appendix C for Noble Gases		A-21	
Total Doses ¹:					
10 CFR 20.1301 (a)(1)	Total Effective Dose Equivalent ⁴	100 mrem/yr		A-25	
10CFR20.1301 (d) and 40CFR190	Total Body Dose	25 mrem/yr		A-25	
	Thyroid Dose	75 mrem/yr		A-25	
	Other Organ Dose	25 mrem/yr		A-25	
Other Limits ²:					
40CFR141	Total Body Dose Due to Drinking Water From Public Water Systems	4 mrem/yr		A-17	
	Organ Dose Due to Drinking Water From Public Water Systems	4 mrem/yr		A-17	

¹ These doses are calculated considering all sources of radiation and radioactivity in effluents.

- ² These limits are not directly applicable to nuclear power stations. They are applicable to the owners or operators of public water systems. However, the RETS of some of the Exelon Nuclear nuclear power stations require assessment of compliance with these limits. For additional information, see Section A.6 of Appendix A.
- ³ Note that 10CFR50 provides design objectives not limits.
- ⁴ Compliance with 10CFR20.1301(a)(1) is demonstrated by compliance with 40CFR190. Note that it may be necessary to address dose from on-site activity by members of the public as well.

TABLE 2-2
DOSE ASSESSMENT RECEIVERS

Dose Component or Pathway	Location; Occupancy if Different than 100%
"Instantaneous" dose rates from airborne radioactivity	Unrestricted area boundary location that results in the maximum dose rate
"Instantaneous" concentration limits in liquid effluents	Point where liquid effluents enter the unrestricted area
Annual average concentration limits for liquid effluents	Point where liquid effluents enter the unrestricted area
Direct dose from contained sources	Receiver spends part of this time in the controlled area and the remainder at his residence or fishing nearby; occupancy factor is considered and is site-specific. See Appendix F, Table F-8 for occupancy factors for N-16 skyshine.
Direct dose from airborne plume	Receiver is at the unrestricted area boundary location that results in the maximum dose.
Dose due to radioiodines, tritium and particulates with half-lives greater than 8 days for inhalation, ingestion of vegetation, milk and meat, and ground plane exposure pathways.	Receiver is at the location in the unrestricted area where the combination of existing pathways and receptor age groups indicates the highest potential exposures.
Ingestion dose from drinking water	The drinking water pathway is considered as an additive dose component in this assessment only if the public water supply serves the community immediately adjacent to the plant.
Ingestion dose from eating fish	The receiver eats fish from the receiving body of water (lake or river)
Total Organ Doses	Summation of ingestion/inhalation doses
Total Dose	Summation of above data (Note it may also be necessary to address dose from on-site activity by members of the public.)

TABLE 2-3
DOSE COMPONENT/REGULATION MATRIX

Dose Component or Pathway	Reference equation; Comments	Regulation in which dose component is utilized		
		10CFR20	40CFR190	10CFR50 App. I
"Instantaneous" dose rates from airborne radioactivity (RETS requirement only)	A-5: Total Body A-6: Skin A-16: Organ			
"Instantaneous" concentration limits in liquid effluents	A-21: Ten times the limits of Table 2, Col. 2, 10CFR20, Appendix B to §§20.1001 – 20.2402, Table C-6 of Appendix C for Noble Gases	X ⁽²⁾		
Annual average concentration limits for liquid effluents	10CFR20, Appendix B to §§20.1001 – 20.2402 ⁽²⁾	X ⁽³⁾		
Direct dose from contained sources	A-23 and Section A.3.2	X	X	
Direct dose from airborne plume	A-1: Gamma air dose A-2: Beta air dose A-3: Total body dose A-4: Skin dose	X	X	X X X X
Direct dose from radioactivity deposited on the ground	A-7 and A-8	X	X	X
Inhalation dose from airborne effluents	A-7 and A-9 ⁽¹⁾	X	X	X
Ingestion dose from vegetables	A-7, A10 and A-11 ⁽¹⁾	X	X	X
Ingestion dose from milk	A-7, A-12 and A-13 ⁽¹⁾	X	X	X
Ingestion dose from meat	A-7, A-14 and A-15 ⁽¹⁾	X	X	X
Ingestion dose from drinking water	A-17, A-18 and A-19 ⁽¹⁾	X	X	X
Ingestion dose from eating fish	A-17, A-18 and A-20 ⁽¹⁾	X	X	X
Total Organ Doses	A-25		X	X
Total Effective Dose Equivalent	A-25 ⁽⁴⁾	X		

1 Ingestion/inhalation dose assessment is evaluated for adult/teen/child and infant for 10CFR50 Appendix I compliance and for 10CFR20/40CFR190 compliance. Ingestion/inhalation dose factors are taken from Reg. Guide 1.109 (Reference 6).

2 Technical Specifications for most stations have been revised to allow 10 times the 10CFR20 value or specifically states the maximum instantaneous dose rate limit.

3 Optional for 10CFR20 compliance.

4 Compliance with the Total Effective Dose Equivalent limits of 10CFR20 is demonstrated by compliance with 40CFR190. It may also be necessary to address dose from on-site activity by members of the public.

Figure 2-1

Simplified Chart of Offsite Dose Calculations²

Category	Radionuclides	Pathway	Text Section	Receptor	Code and Limits	Frequency of Calculation ¹
Airborne	Releases:					
	Noble Gases:	Plume γ^a	A.1.3.1	Total Body	RETS: 500 mrem/yr Instantaneous	As Required by Station Procedure
	Noble Gases:	Plume γ^a and β^b	A.1.3.2	Skin	RETS: 3000 mrem/yr Instantaneous	
	Noble Gases:	Plume γ^a	A.1.2.1	Air ⁴	10CFR50 ³ : 5 mrad/qtr, 10 mrad/yr	Monthly
	Noble Gases:	Plume β^b	A.1.2.2		10CFR50 ³ : 10 mrad/qtr, 20 mrad/yr	
	Non-Noble Gases:	Inhalation ^b	A.1.5	Child (Any Organ)	RETS: 1500 mrem/yr Instantaneous	As required by Station Procedure
	Non-Noble Gases:	Ground Deposition ^c	A.1.4.1	Total body	10CFR50 ³ : 7.5 mrem/qtr, 15 mrem/yr	Monthly and Annually
Inhalation ^c		A.1.4.2	Four Age groups (All Organs)			
Vegetation ^d		A.1.4.3.1				
Milk ^d		A.1.4.3.2				
Meat ^d	A.1.4.3.3					
Liquid	Releases:					
	All	Water	A.2.2		RETS, 10 times 10CFR20 Appendix B; Table 2; Col. 2, Table C-6 of Appendix C for Noble Gases	As Required by Station Procedure
	Non-Noble Gases	Water ^e and Fish ^f	A.2.1	Total Body	10CFR50 ³ : 1.5 mrem/qtr 3 mrem/yr	Monthly
	Non-Noble Gases	Water ^e and Fish ^f	A.2.1	4 Age Groups (All Organs)	10CFR50 ³ : 5 mrem/qtr 10 mrem/yr	
Non-Noble Gases	Water ^e	A.6	Adult (Total Body and all Organs)	40CFR141: 4 mrem/yr	When Required by RETS	
Uranium Fuel Cycle:	All	All releases plus direct radiation from contained sources	A.4.2	Total Body	40CFR190: 25 mrem/yr	Annually
				Thyroid (Adult)	40CFR190: 75 mrem/yr	
				All Other Organs (Adult)	40CFR190: 25 mrem/yr	
TEDE:	All	External + Internal	A.5	Total Body + organs (Adult)	10CFR20: 100 mrem/yr	Annually

Figure 2-1 (Cont'd)

Notes for Figure 2-1:

1. Definition: Monthly means at least once per 31 days or once per month. See station RETS for exact requirements.
2. Additional Calculations: In addition to the calculations shown in this figure, monthly projections of doses due to radioactive materials are required for gaseous and liquid effluents from Exelon Nuclear nuclear power stations. See Sections A.1.6 and A.2.5 of Appendix A.

Also, projections of drinking water doses are required at least once per 92 days for Dresden and Quad Cities. See Section A.7 of Appendix A.
- 3 10 CFR 50 prescribes design objectives not limits
4. If the air dose is exceeded, doses to the total body and skin are calculated. Total body objectives are 2.5 mrem/qtr and 5.0 mrem/year; the skin dose objectives are 7.5 mrem/qtr and 15 mrem/year.
 - a Evaluated at the unrestricted area boundary.
 - b Evaluated at the location of maximum offsite X/Q.
 - c Ground plane and inhalation pathways are considered to be present at all offsite locations.
 - d Evaluated at the location in the unrestricted area where the combination of existing pathways and receptor age groups indicates the maximum potential exposures. If no real pathway exists then a hypothetical cow-milk producer is evaluated at 5 miles in the highest D/Q sector.
 - e Evaluated for the nearest downstream community water supply as specified in Table A-3 of Appendix A. The flow and dilution factors specified in Table F-1 of Appendix F are used.
 - f Evaluated for fish caught in the near-field region downstream of plant using the flow and dilution factors specified in Table F-1 of Appendix F.

CHAPTER 3

EXPOSURE PATHWAYS

3.0 INTRODUCTION

Figure 3-1 illustrates some of the potential radiation exposure pathways to humans due to routine operation of a nuclear power station. These exposure pathways may be grouped into three categories:

- **Airborne Releases**
Exposures resulting from radioactive materials released with gaseous effluents to the atmosphere.
- **Liquid Releases**
Exposures resulting from radioactive materials released with liquid discharges to bodies of water.
- **Radiation from Contained Sources**
Exposures to radiation from contained radioactive sources.

When performing radiation dose calculations, only exposure pathways that significantly contribute ($\geq 10\%$) to the total dose of interest need to be evaluated. The radiation dose from air and water exposure pathways are routinely evaluated. (see Regulatory Guide 1.109, Reference 6.)

3.1 AIRBORNE RELEASES

For airborne releases of radioactivity, the NRC considers the following pathways of radiation exposure of persons:

- External radiation from radioactivity airborne in the effluent plume.
- External radiation from radioactivity deposited by the plume on the ground.
- Ingestion of radioactivity on, or in, edible vegetation (from direct plume deposition).
- Ingestion of radioactivity that entered an animal food product (milk or meat) because the animal ingested contaminated feed, with the contamination due to direct deposition on foliage.
- Inhalation of radioactivity in the plume.

Dose for airborne releases is assessed at the location in the unrestricted area where the combination of existing pathways and receptor age groups indicates the maximum potential exposures.

3.2 LIQUID RELEASES

For liquid releases of radioactivity (Figure 3-1), the NRC considers the following pathways of radiation exposure of persons:

- Ingestion of aquatic food (e.g., fish or invertebrate) obtained from the body of water to which radioactive station effluents are discharged.
- Ingestion (drinking) of potable water contaminated by radioactive liquid effluents discharged from the station.

For the aquatic food pathway, only fish is considered since it is the only significant locally produced aquatic food consumed by humans.

The stations omit the pathways involving irrigation and animal consumption of contaminated water because these pathways were determined to be insignificant. The stations also omit the pathway of

radiation exposure from shoreline sediment because this pathway was also found to be insignificant (see ODCM Bases and Reference Document, Section O.3.2).

The stations have also verified that the dose contribution to people participating in water recreational activities (swimming and boating) is negligible. (See ODCM Bases and Reference Document, Reference 101, Tables O-3 and O-4) This pathway was not addressed explicitly in Regulatory Guide 1.109. Thus, the stations also omit dose assessments for the water recreational activities pathway.

Periodically the Illinois Army Corps of Engineers dredges silt and debris from the river beds near Exelon Nuclear nuclear stations. As a part of the land use census, Exelon Nuclear will determine if the Corps performed dredging within one mile of the discharge point. If so, Exelon Nuclear will obtain spoils samples, through it's REMP vendor, for analysis. The impact to the offsite dose will be evaluated on a case by case basis and added to the station annex of the ODCM when applicable.

In addition, to assure that doses due to radioactivity in liquid effluents will be ALARA, concentrations will be limited to ten times (10x) the values given in 10CFR20 Appendix B, Table 2; Column 2. Specific limitations for concentrations of entrained noble gases are contained in the stations' Radiological Effluent Technical Standards (RETS).

3.3 RADIATION FROM CONTAINED SOURCES

Radioactivity contained within tanks, pipes or other systems and contained radioactive material or waste stored on site can produce radiation at offsite locations. Annual offsite radiation doses near the stations due to such sources were judged to be negligible in comparison with applicable limits except for doses due to BWR turbine skyshine and potential doses due to radioactive waste storage facilities (excludes radioactive material storage). See ODCM Bases and Reference Document, Reference 101. Changes or modifications to the power station that may impact the offsite dose through increases to the direct radiation levels need to be evaluated on a case by case basis and added to Chapter 12 of the station annex to the ODCM when applicable (e.g.; the Old Steam Generator Storage Facilities).

Figure 3-1

Radiation Exposure Pathways to Humans

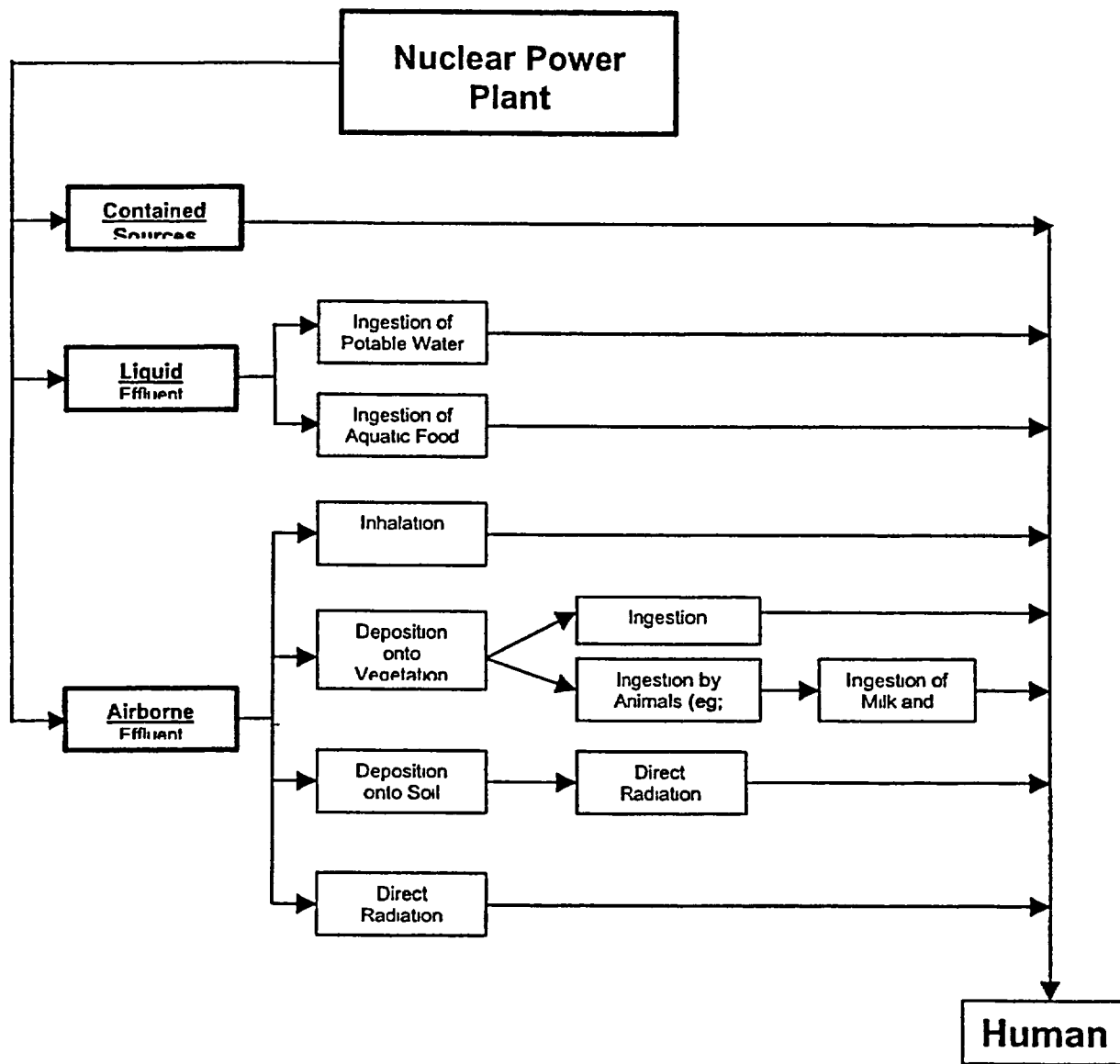

CHAPTER 4

METHODOLOGY

4.0 INTRODUCTION

This chapter provides an introduction to the methodology used by Exelon Nuclear to calculate offsite radiation doses resulting from the operation of nuclear power stations. Additional explanation and details of the methodology are provided in Appendices A and B. Appendix A discusses each dose limit in the RETS and provides the associated assessment equations. Appendix B describes methods used to determine values of parameters included in the equations.

4.1 IMPORTANT CONCEPTS AND PARAMETERS

4.1.1 Dose

The dose calculation equations contained in the ODCM are based on two types of exposure to radiation; external and internal exposure. The first type of exposure is that resulting from radioactive sources external to the body (including radiation emanating from an effluent plume, radiation emanating from radioactivity deposited on the ground and radiation emanating from contained sources (also referred to as direct radiation)). Exposure to radiation external to the body only occurs while the source of the radioactivity is present.

Internal exposure occurs when the source of radioactivity is inside the body. Radiation can enter the body by breathing air containing the radioactivity, or by consumption of food or drinking water containing radioactivity. Once radioactivity enters the body and becomes internal radiation, a person will continue to receive radiation dose until the radioactivity has decayed or is eliminated by biological processes. The dose from this type of exposure is also termed dose commitment, meaning that the person will continue to receive dose even-though the plume containing the radioactivity has passed by the individual, or even-though the individual is no longer drinking water containing radioactivity.

The regulations addressed by the ODCM may require assessment of either type of exposure to radiation or of both types in summation.

The term dose is used instead of the term "dose equivalent," as defined by the International Commission on Radiological Units and Measurements (ICRU). When applied to the evaluation of internal deposition of radioactivity, the term "dose," as used in the ODCM, includes the prospective dose component arising from retention in the body beyond the period of environmental exposure, i.e., the dose commitment. The dose commitment is evaluated over a period of 50 years.

4.1.2 Exposure Pathways

All of the exposure pathways are discussed in Chapter 3. This section presents the exposure pathways addressed by Exelon Nuclear nuclear stations in the ODCM and associated software.

For releases of radioactivity in airborne effluents the primary pathways are the following:

- Direct radiation from an effluent plume.
- Direct radiation from radioactivity deposited on the ground by a plume.
- Inhalation of radioactivity in a plume.
- Ingestion of radioactivity that entered the food chain from a plume that deposited radioactivity on vegetation.

For releases of radioactivity in liquid effluents, the exposure pathways considered are human consumption of water and fish.

When determining total doses, as required by 10CFR20 and 40CFR190, the BWR stations also consider direct radiation due to skyshine from nitrogen-16 (^{16}N) in turbines and associated piping. All nuclear power stations will consider exposure to radiation emanating from onsite radwaste storage facilities when they are put into operation.

4.1.3 Categories of Radioactivity

Radionuclide content of effluent releases from nuclear power stations can be categorized according to the characteristics of the radionuclides. In evaluating doses associated with a particular pathway, only those categories of radionuclides that significantly contribute to the dose need to be included in the dose calculations (See Section 3.0). The categories of radionuclides considered by the Exelon Nuclear nuclear power stations for each of the airborne pathways are summarized in Table 4-1. Selection of the significant airborne pathways was based on the following:

- The requirements in the RETS (see discussion in Appendix A)
- Applicable regulatory guidance (References 6 and 14), and
- A study of the potential radiological implications of nuclear facilities in the upper Mississippi River basin (Reference 20).

Calculations were used to determine which radionuclides were significant for a particular pathway. For example, in the case of direct radiation from a plume of airborne radioactivity, it was found that radiation from noble gases is significant and radiation from radioactive iodine was not. The dose rate per unit of airborne radioactivity concentration is about the same for noble gases and radioactive iodine since they emit comparable types and energies of radiation. However, the quantity of noble gas radioactivity released in routine nuclear plant operation typically exceeds the quantity of radioactive iodine by a factor of about 10,000.

As another example, consider the inhalation pathway. Here, the calculations showed that the dose commitment due to radioactive iodine was significant but the dose commitment due to radioactive noble gases was not significant and can be excluded from the compliance calculations for the inhalation pathway. This is true despite the fact that a much larger quantity of noble gas radioactivity is released. The reason for this is that the solubility of noble gas in body tissue is very low, whereas the inhaled radioactive iodine does concentrate in specific body organs such as the thyroid (see the discussion on Pages 228 and 231 to 234 of Reference 38).

4.1.4 Atmospheric Release Point Classifications

The dose impact from airborne release of radioactivity is determined by the height of the release of the effluent plume relative to the ground and by the location of the dose recipient.

The height an effluent plume maintains as it travels above the ground is related to the elevation of the release point and to the height of structures immediately adjacent as follows:

- If the elevation of the release point is sufficiently above the height of any adjacent structures, the plume will remain elevated for considerable distances.
- If the elevation of the release point is at or below the heights of adjacent structures, the plume is likely to be caught in the turbulence of the wakes created by wind passing over the buildings. The plume elevation would then drop to ground level.
- If the elevation of the release point is not significantly above the heights of adjacent structures, then the plume may be elevated or at ground level.

For the calculations of this manual, each established release point has been designated as belonging to one of three release point classifications:

- **Stack (or Elevated) Release Points** (denoted by the letter S or subscript s)
These are release points approximately twice the height of adjacent solid structures. Releases are treated as elevated releases unaffected by the presence of the adjacent structures.
- **Ground Level Release Points** (denoted by the letter G or subscript g)
These are release points at ground level or lower than adjacent solid structures. Releases are considered drawn into the downwind wake of these structures and are treated as ground level releases.
- **Vent (or Mixed Mode) Release Points** (denoted by the letter V or subscript v)
These are release points as high or higher than adjacent solid structures but lower than twice the structure's heights. These releases are treated as a mixture of elevated and ground level releases. The proportion of the release attributed to either elevated or ground level in a vent release is determined by the ratio of stack exit velocity to the wind speed (see Section B.1.2.4 of Appendix B).

The definitions of these classifications are based on Regulatory Guide 1.111 (Reference 7). A list of the classifications of specific airborne release points for each of the Exelon Nuclear nuclear power stations is contained in Table A-2 in Appendix A.

4.1.5 Historical Average Atmospheric Conditions

The dispersion characteristics of airborne effluents from a nuclear power station are dependent on weather conditions. Meteorological factors that directly affect the concentration of airborne radioactivity in a plume include the following:

- **Wind Direction**
The concentration of radioactivity is highest in the direction toward which the wind is blowing.
- **Wind Speed**
Greater wind speeds produce more dispersion and consequently lower concentrations of radioactivity.
- **Atmospheric Turbulence**
The greater the atmospheric turbulence, the more a plume spreads both vertically and horizontally. For calculations in this manual, the degree of turbulence is classified by use of seven atmospheric stability classes, designated A (extremely unstable) through G (extremely stable). The seven classes and some of their characteristics are listed in Table C-4 of Appendix C.

Meteorological conditions strongly impact the values of various parameters applied in the dose calculations of this manual. These include:

- The Relative Concentration Factors χ/Q and gamma- χ/Q (Section 4.1.6)
- The Relative Deposition Factor D/Q (Section 4.1.7)

The bases sections of the Standard Radiological Effluent Technical Specifications (guidance documents NUREGs 0472, 0473, 1301 and 1302) and the RETS specify that dose calculations be based on "historical average atmospheric conditions". Therefore, this manual provides values for the above

parameters that are based on station-specific historical average meteorological conditions. These values were obtained by averaging hourly values of the parameters over a long-term, several-year period of record. The averaging period was based on calendar years in order to avoid any bias from weather conditions associated with any one season. The period of record is identified in each of the tables providing the values (see Appendix F).

4.1.6 Relative Concentration Factors χ/Q and Gamma- χ/Q

A person immersed in a plume of airborne radioactivity is exposed to radiation from the plume and may also inhale some of the radioactivity from the plume. The concentration of radioactivity in air near the exposed person must be calculated to adequately evaluate doses resulting from any inhalation. The relative concentration factor χ/Q (referred to as "chi over Q") is used to simplify these calculations. χ/Q is the concentration of radioactivity in air, at a specified location, divided by the radioactivity release rate. χ/Q has the following units:

$$\text{Units of } \chi/Q = (\mu\text{Ci}/\text{m}^3) / (\mu\text{Ci}/\text{sec}) = \text{sec}/\text{m}^3$$

Station-specific values of χ/Q are provided for each nuclear power station in Table F-5 of Appendix F. These values are based on historical average atmospheric conditions (see Section 4.1.5). For each of the release point classifications (eg. stack, vent and ground level) and for the 16 compass-direction sectors (N, NNE, etc.), Table F-5 provides the maximum value of χ/Q for locations at or beyond the unrestricted area boundary.

The value of χ/Q for each sector reflects the fraction of time that the wind blew into that sector and the distribution of wind speeds and atmospheric stability classes during that time. Note that the value would be zero if the wind never blew into the sector.

The gamma- χ/Q provides a simplified method of calculating gamma air dose and dose rates for a finite and/or elevated plume. It is used in place of the semi-infinite plume model that tends to underestimate gamma air dose for elevated plumes. Use of the gamma- χ/Q also corrects for the tendency of the semi-infinite plume model to overestimate gamma air dose for mixed mode and ground level releases.

The methodologies for determining χ/Q and gamma- χ/Q are discussed in detail in Section B.3 of Appendix B.

4.1.7 Relative Deposition Factor D/Q

As a plume travels away from its release point, portions of the plume may touch the ground and deposit radioactivity on the ground and/or on vegetation. Occurrences of such deposition are important to model since any radioactivity deposited on the ground or on vegetation may directly expose people and/or may be absorbed into food products which can ultimately be ingested by people. The relative deposition factor is used to simplify the dose calculations for these pathways.

The relative deposition factor D/Q is the rate of deposition of radioactivity on the ground divided by the radioactivity release rate. Its value was determined for specific conditions. In this manual it has the following units:

$$\text{Units of } D/Q = [(\text{pCi}/\text{sec})/\text{m}^2] / (\text{pCi}/\text{sec}) = 1/\text{m}^2$$

The values of D/Q are affected by the same parameters that affect the values of χ/Q : release characteristics, meteorological conditions and location (see Section 4.1.6). Station-specific values of D/Q are provided for each Exelon Nuclear nuclear power station in Appendix F Tables F-5 and F-6. These values are based on historical average atmospheric conditions (see Section 4.1.5).

For each release point classification and for each of the 16 compass-direction sectors (N, NNE, etc.), Table F-5 provides the maximum value of D/Q for locations at or beyond the unrestricted area boundary.

In Table F-6, values of D/Q are given for the locations of the nearest milk and meat producers within 5 miles of the nuclear power station. The methodology for determining D/Q is discussed in Section B.4 of Appendix B.

4.1.8 Dose Factors

Various dose factors are used in this manual to simplify the calculation of radiation doses. These factors are listed in Table 4-2. Definitions of these factors are given in the remainder of this chapter. Methods of determining their values are addressed in Appendix B.

4.2 AIRBORNE RELEASES

4.2.1 Gamma Air Dose

The term 'gamma air dose' refers to the component of dose absorbed by air resulting from the absorption of energy from photons emitted during nuclear and atomic transformations, including gamma rays, x-rays, annihilation radiation, and Bremsstrahlung radiation (see footnote on page 1.109-19 of Regulatory Guide 1.109).

The noble gas dose factors of Reg. Guide 1.109, Table B-1 are based upon assumption of immersion in a semi-infinite cloud. For ground level and mixed mode releases this tends to over estimate the gamma air dose arising from a plume that is actually finite in nature.

For elevated releases, the Reg. Guide 1.109 noble gas dose factors will underestimate exposure as they consider only immersion and not that portion of exposure arising from sky shine. At distances close in to the point of elevated release, the ground level concentration as predicted by χ/Q will be essentially zero. In such a case, the sky shine component of the exposure becomes significant and must be considered.

The gamma- χ/Q provides a simplified method of calculating gamma air dose and dose rates for a finite and/or elevated plume. The methodology of Reg. Guide 1.109, Section C.2 and Appendix B provide the methodology for calculating finite cloud gamma air dose factors from which the gamma- χ/Q values can be derived. Section B.5 addresses the calculation of these dose factors.

Three gamma- χ/Q values are defined: $(\chi/Q)_s^Y$, $(\chi/Q)_v^Y$ and $(\chi/Q)_g^Y$ for stack, vent and ground level releases, respectively. Section B.3.5 addresses the calculation of the gamma- χ/Q values.

4.2.1.1 Finite Cloud Gamma Air Dose Factor

The finite cloud gamma air dose factor is determined by calculating the gamma dose rate to air (at a specific location and corresponding to a given release rate) and dividing that dose rate by the corresponding release rate:

$$\text{Finite Cloud Gamma Air Dose Factor} = \frac{(\text{mrad/yr})}{(\mu\text{Ci/sec})}$$

The methodology for this calculation is discussed in Section B.5 of Appendix B. The calculation is complex because the dose rate at any given point is affected by the radioactivity concentration and distance. Calculation of the finite cloud gamma air dose factor takes into consideration release characteristics, meteorological conditions and location (see Section 4.1.6). Additionally, the value is affected by radiological parameters: the distribution of energies and intensities for gamma emissions from each specific radionuclide and the photon attenuation characteristics of air.

In the ODCM, station-specific values of gamma dose factors are provided for each station in Appendix F, Table F-7. These values are based on historical average atmospheric conditions (see Section 4.1.5). For the release point classification and for each of the 16 compass-direction sectors, Table F-7 provides the maximum value of the gamma air dose factor for noble gas radionuclides at the unrestricted area

boundary. The value includes a correction for radioactive decay during transport of the radionuclide from the release point to the dose calculation location.

4.2.1.2 Semi-Infinite Cloud Gamma Air Dose Factor

The semi-infinite cloud gamma dose factor is the gamma air dose rate divided by the concentration of radioactivity in air at the dose calculation location. Values of these gamma dose factors are radionuclide specific and are provided in Appendix C, Table C-9.

The semi-infinite cloud gamma dose factor is used in conjunction with $\gamma\text{-}\chi/Q$ to calculate noble gas gamma air dose and dose rate for elevated and finite noble gas plumes. The $\gamma\text{-}\chi/Q$ is defined such that for a given finite cloud the semi-infinite cloud methodology will yield the same gamma air dose as the finite cloud methodology.

4.2.2 Beta Air Dose

The term 'beta air dose' refers to the component of dose absorbed by air resulting from the absorption of energy from emissions of beta particles, mono-energetic electrons and positrons during nuclear and atomic transformations (see the footnote on Page 1.109-20 of Regulatory Guide 1.109).

The Beta Air Dose Factor

The beta air dose factor is the beta air dose rate divided by the concentration of radioactivity in air at the dose calculation location. Values of the beta air dose factor are radionuclide specific and are provided in Appendix C Table C-9.

4.2.3 Total Body Dose and Dose Rate

Total Body Dose

Equation A-3 of Appendix A is used to calculate dose to the total body from noble gas radionuclides released in gaseous effluents. The total body dose equation is similar to that used to calculate gamma air dose (Equation A-1 of Appendix A).

Total Body Dose Rate

Equation A-5 of Appendix A is used to calculate dose rate to the total body. The assumptions used for this equation are the same as those used in the calculation of total body dose (Equation A-3 of Appendix A) except that any shielding benefit (dose attenuation) provided by residential structures is not applied. Since the calculation is for the maximum instantaneous dose rate, the dose recipient may be out of doors when exposed and would not be shielded from the exposure by any structural material.

The Total Body Dose Factor

The total body dose factor is the total body dose rate divided by the radioactive release rate. Values for the total body dose factor are site specific and are provided in Table C-9 of Appendix C.

4.2.4 Skin Dose and Dose Rate

Skin Dose

Equation A-4 of Appendix A is used to calculate dose to skin from noble gas radionuclides released in gaseous effluents. The skin dose is the summation of dose to the skin from beta and gamma radiation.

The equation for beta dose to skin is similar to that used to calculate beta dose to air (Equation A-2 of Appendix A) except that beta skin dose factors are used instead of beta air dose factors. The beta skin dose factor differs from the beta air dose factor by accounting for the attenuation of beta radiation by the dead layer of skin. The dead layer of skin is not susceptible to radiation damage and therefore is not of concern. The beta dose to the skin from non-noble gases is insignificant and is not calculated for the reason described in Section 4.1.3. When calculating the beta contribution to skin dose, no reduction is included in the calculations due to shielding provided by occupancy of residential structures.

The equation for gamma dose to skin is similar to that used to calculate gamma dose-to-air except for the following:

- Equation A-4 of Appendix A includes a units conversion factor 1.11 rem/rad to convert from units of gamma air dose (rad) to units of tissue dose equivalent (rem).
- Equation A-4 of Appendix A includes a dimensionless factor of 0.7 to account for the shielding due to occupancy of residential structures.

Equation A-4 of Appendix A uses gamma air dose factors not gamma total body dose factors. When calculating gamma dose to skin, no reduction is applied for the attenuation of radiation due to passage through body tissue (dead layer of skin).

Skin Dose Rate

Equation A-6 of Appendix A is used to calculate dose rate to skin. The assumptions are the same as those used in the calculation of skin dose (Equation A-4 of Appendix A) except that no credit is taken for shielding of gamma radiation by residential structures. The dose recipient may be outdoors when exposed and the maximum instantaneous dose rate is of concern.

The Skin Dose Factor

Values of the beta air dose factors and skin dose factors are nuclide specific and are provided in Table C-9 of Appendix C for 15 noble gas radionuclides.

4.2.5 Ground Radiation

Equations A-7 and A-8 of Appendix A are used to calculate the total body dose due to non-noble gas radionuclides released in gaseous effluents and deposited on the ground.

Comment

Note that if there is no release of radionuclide *i* during a given time period, then the deposition rate is zero, the ground plane concentration is zero and the resulting dose due to ground deposition is zero. If there is a release of radionuclide *i*, the ground concentration is computed as if that release had been occurring at a constant rate for the ground deposition time period.

The Ground Plane Dose Conversion Factor

The ground plane dose conversion factor is the dose rate to the total body per unit of radioactivity concentration on the ground. Values of the ground plane dose conversion factor that are calculated by

assuming constant concentration over an infinite plane are provided for various radionuclides in Table C-10 of Appendix C.

4.2.6 Inhalation

Dose

Radioactivity from airborne releases of radioactive iodine, particulate and tritium can enter the body through inhalation. Equations A-7 and A-9 of Appendix A are used to calculate dose commitment to the total body or organs due to inhalation of non-noble gas radionuclides released in gaseous effluents.

The Inhalation Dose Factor

Values for the inhalation dose commitment factor are nuclide specific and are taken from Reg. Guide 1.109 (Reference 6) Tables E-7, 8, 9 and 10. These tables include data for four age groups (adult, teenager, child and infant) and seven body organs.

Dose Rate

The inhalation dose rate is the rate at which dose is accrued by an individual breathing contaminated air. Equation A-16 of Appendix A is used to calculate dose commitment rate to an organ due to inhalation of non-noble gas radionuclides. The assumptions are the same as used in the calculation of inhalation dose. The dose rate is determined for the child age group in accordance with the guidance found in NUREGs 0472, 0473, 1301 and 1302 (References 2, 3, 105 and 106).

4.2.7 Ingestion

Airborne releases of radioactive iodine, particulate and tritium can enter the food chain through deposition on vegetation. The radioactivity can be ingested by humans who consume the vegetation or who consume products (e.g., milk or meat) of animals who have fed on the contaminated vegetation. Each Exelon Nuclear nuclear power station considers the following ingestion pathways:

- Vegetables
- Milk
- Meat.

Equations A-7 and A-10 through A-15 of Appendix A are used to calculate the dose due to ingestion of food containing non-noble gas radionuclides released in gaseous effluents. Dose is assessed at the location in the unrestricted area where the combination of existing pathways and receptor age groups indicates the maximum potential exposures.

Values of the ingestion dose commitment factor are the same for each Exelon Nuclear nuclear power station. The components of this factor are not impacted by station-specific parameters. The station-specific aspects of the calculation of ingestion dose only concern the quantity of radioactivity ingested. Values of the ingestion dose commitment factors are taken from Reg. Guide 1.109 Tables E-11, 12, 13 and 14. These tables include data for four age groups and seven organs.

The equations used for radioactivity concentration on vegetation and in milk, and meat are discussed in Appendix A.

4.3 LIQUID RELEASES

The evaluation of dose due to releases of radioactivity in liquid effluents is required to confirm compliance with the provisions of RETS related to 10CFR50 Appendix I. ODCM Section 3.2 and Figure 3-1 list some of the pathways by which radioactivity in liquid effluents can impact man. The pathways used by Exelon Nuclear to calculate dose from liquid effluents are ingestion by drinking water and by eating fish from the body of water receiving station liquid discharges. The nuclear power stations obtain the dose commitment due to radioactivity in liquid effluent releases by summing the dose commitments from the drinking water and fish pathways depending upon their presence.

Equations A-17 through A-20 of Appendix A are used to calculate dose for the member of the public due to consumption of drinking water and fish.

The radioactivity concentration in water is obtained by dividing the quantity of radioactivity released by the volume of water in which the release is diluted. The result can be modified by a factor to represent any additional dilution that might occur.

The radioactivity concentration in fish is the product of the radioactivity concentration in water and a bioaccumulation factor. The dilution factors for fish may be different from those for water. (The fish may be caught at a location different from where drinking water is drawn.)

The bioaccumulation factor accounts for the fact that the quantity of radioactivity in fish can build up with time to a higher value relative to the concentration of the radioactivity in the water they consume. The bioaccumulation factor is the equilibrium ratio of the concentration of radionuclide i in fish to its concentration in water. The same values are used for the bio-accumulation factor at each station. These values are provided in Appendix C, Table C-8.

4.4 CONTAINED SOURCES OF RADIOACTIVITY

In addition to the total body, skin and single organ dose assessments previously described, an additional assessment is required. The additional assessment addresses radiation dose due to radioactivity contained within the nuclear power station and its structures.

There are presently two types of contained sources of radioactivity which are of concern in offsite radiological dose assessments. The first is that due to gamma rays resulting from nitrogen-16 carry-over to the turbine in BWR steam (skyshine). The second is that due to gamma rays associated with radioactive material contained in onsite radwaste and radioactive material storage facilities.

4.4.1 BWR Skyshine

The most significant dose component to members of the public produced by "contained sources" is nitrogen-16 (^{16}N) within the turbine building of BWRs. Although primary side shielding is around the turbine and its piping, ^{16}N gamma rays scattered by air molecules in the overhead air space above the turbine and piping cause a measurable "skyshine" radiation dose in the local power plant environs.

Equation A-23 of Appendix A is used to evaluate skyshine dose. A complicating factor in the calculation is the practice at some stations of adding hydrogen to reactor coolant to improve coolant chemistry. The addition of hydrogen can increase the dose rate due to skyshine up to a factor of 10 times expected levels depending on injection rates and power levels (Reference 39). Increasing the hydrogen injection rate will increase the dose rates even further. (See Reference 102) The skyshine dose determined by Equation A-23 of Appendix A depends on the following factors:

- The distance of the dose recipient location from the turbine.
- The number of hours per year that the location is occupied by a dose recipient.
- The total energy [MWe-hr] generated by the nuclear power station with hydrogen addition.
- The total energy [MWe-hr] generated by the nuclear power station without hydrogen addition.

4.4.2 Onsite Radwaste and Rad Material Storage Facilities

Low-level radioactive waste may be stored at any Exelon Nuclear nuclear power station in the following types of storage facilities:

- Process Waste Storage Facilities
 - Interim Radwaste Storage Facility (IRSF) structure
 - Concrete vaults containing 48 radwaste liners (Also referred to as "48-pack");
- DAW Storage Facilities
 - Dry Active Waste (DAW) facilities (may include Butler buildings/warehouses)
- Replaced Steam Generator Storage Facilities

Rad Material may be stored in facilities on site

- Rad Material Storage Facilities
 - Contaminated tools and equipment in seavans and/or warehouses

Spent Fuel may be stored in facilities on site:

- ISFSI Facilities
 - Independent spent fuel storage installation facilities

Administrative controls are implemented by each station to ensure compliance to applicable regulations. The impact to the offsite dose will be evaluated on a case by case basis and added to the station annex of the ODCM when applicable. In addition, a 10CFR50.59 analysis may be required for radwaste storage facilities.

4.5 TOTAL DOSE REQUIREMENTS

4.5.1 Total Effective Dose Equivalent Limits; 10CFR20 and 40CFR190

10CFR20 requires compliance to dose limits expressed as "Total Effective Dose Equivalent" (TEDE). Although annual dose limits in 10CFR20 are now expressed in terms of TEDEs, 40CFR190 limits remain stated as organ dose. The NRC continues to require 10CFR50 Appendix I and 40CFR190 doses to be reported in terms of organ dose and not TEDE. Due to the fact that organ dose limits set forth in 40CFR190 are substantially lower than those of 10CFR20 (25 mrem/yr vs 100 mrem/yr), the NRC has stated that demonstration of compliance with the dose limits in 40CFR190 will be deemed as demonstration of compliance with the dose limits of 10CFR20 for most facilities (Reference 104). In addition to compliance with 40CFR190, it may be necessary for a nuclear power plant to address dose from on-site activity by members of the public.

4.5.2 Total Dose For Uranium Fuel Cycle

The nuclear power stations are required to determine the total dose to a member of the public due to all uranium fuel cycle sources in order to assess compliance with 40CFR190 as part of demonstrating compliance with 10CFR20.

The total dose for the uranium fuel cycle is the sum of doses due to radioactivity in airborne and liquid effluents and the doses due to direct radiation from contained sources at the nuclear power station. When evaluation of total dose is required for a station, the following contributions are summed:

- Doses due to airborne and liquid effluents from the station.

- Doses due to liquid effluents from nuclear power stations upstream.
- Doses due to nitrogen-16 (^{16}N) skyshine, if the station is a boiling water reactor.
- Doses due to any onsite radioactive waste storage facilities; if applicable.

Section A.5.2 of Appendix A discusses the details of evaluations.

Table 4-1

Radionuclide Types Considered For Airborne Effluent Exposure Pathways

<u>Category</u>	<u>External Radiation</u>		<u>Internal Radiation</u>	
	<u>Plume</u>	<u>Ground</u>	<u>Inhalation</u>	<u>Ingestion</u>
Noble Gases	X			
Tritium (H-3)			X	X
Iodine ^a		X	X	X
Particulate ^a		X	X	X

^a The nuclear power stations are not required to consider all iodine radionuclides. Only particulates with half-life greater than 8 days need be considered. For details, see Generic Letter 89-01 and the RETS.

Table 4-2
Radiation Dose Factors

<u>Name and Symbol</u>	<u>Units</u>	<u>Definition</u>	<u>Table</u>
Gamma Air Dose Factor M_i	mrad/yr per $\mu\text{Ci}/\text{m}^3$	Gamma air dose rate per unit of radioactivity concentration for radionuclide i.	RG 1.109 Table B-1, Column 4
Total Body Dose Factor: K_i	mrem/yr per $\mu\text{Ci}/\text{m}^3$	Total body dose rate per unit of radioactivity concentration for radionuclide i.	RG 1.109 Table B-1, Column 5
Beta Air Dose Factor N_i	mrad/yr per $\mu\text{Ci}/\text{m}^3$	Beta air dose rate per unit of radioactivity concentration for radionuclide i.	RG 1.109 Table B-1, Column 2
Beta Skin Dose Factor L_i	mrem/yr per $\mu\text{Ci}/\text{m}^3$	Beta skin dose rate per unit of radioactivity concentration for radionuclide i.	RG 1.109 Table B-1, Column 3
Ground Plane Dose Conversion Factor DFG_i	mrem/hr per pCi/m^2	Dose rate per unit of ground radioactivity concentration for radionuclide i.	RG 1.109 Table E-6, Column 2
Inhalation Dose Commitment Factor DFA_{ja}	mrem per pCi	Dose to organ j of age group a per unit of radioactivity inhaled for radionuclide i. (see Note 1)	RG 1.109 Tables: E-7, E-8, E-9, E-10
Ingestion Dose Commitment Factor DFI_{ja}	mrem per pCi	Dose to organ j of age group a per unit of radioactivity ingested for radionuclide i. (see Note 1)	RG 1.109 Tables: E-11, E-12, E-13, E-14

Note 1: Dose assessments for 10CFR20 and 40CFR 190 compliance are made for an adult only.

Dose assessments for 10CFR50 Appendix I are made using dose factors of Regulatory Guide 1.109 (Reference 6) for all age groups.

CHAPTER 5 MEASUREMENT

5.0 INTRODUCTION

Each nuclear station has three measurement programs associated with offsite dose assessment:

- Measurement of releases of radioactivity from the station.
- Measurement of meteorology at the station site.
- Measurement of levels of radiation and radioactivity in the environs surrounding the station.

5.1 EFFLUENT AND PROCESS MONITORING

Radioactivity in liquid and gaseous effluents is measured in order to provide data for calculating radiation doses and radioactivity concentrations in the environment of each nuclear power station. Measurement of effluent radioactivity is required by 10CFR20.1302 and 10CFR50. The RETS of each nuclear power station provide detailed requirements for instrumentation, sampling and analysis. Relevant Regulatory Guides are 1.21 (Reference 4) and 4.15 (Reference 13). Chapter 10 of the ODCM includes brief descriptions of effluent monitoring instruments at each nuclear power station. The RETS of each nuclear power station require submission to the NRC of reports of effluent radioactivity releases and environmental measurements.

5.2 METEOROLOGICAL MONITORING

Meteorological parameters are measured in the vicinity of each nuclear power station in order to provide data for calculating radiation doses due to airborne effluent radioactivity. Some nuclear power stations' Technical Specifications state applicable requirements (typically under the subheading, "Meteorological Instrumentation," in the instrumentation section). Regulatory guidance is given in Regulatory Guide 1.23 (Reference 5). Wind speed, wind direction and the temperature gradient are measured using instruments at two or more elevations on a meteorological tower at each Exelon Nuclear station. The elevations are chosen to provide meteorological data representative of the elevations of the airborne releases from the station. The Annual Radiological Environmental Operating Report includes a summary of meteorological data collected over the reporting year. These data are used to calculate optional isopleths of radiation dose and radioactivity concentration.

5.3 RADIOLOGICAL ENVIRONMENTAL MONITORING PROGRAM (REMP)

Each nuclear power station has a REMP that provides representative measurements of radiation and radioactive material in the environment. The program provides verification that measurable radiological impacts from the power station on the environment are within expectations derived from effluent measurements and calculations. The REMP is required by 10CFR50 (see Appendix I, Sections IV.B.2 and IV.B.3). General requirements of the program are prescribed in each station's RETS and more precise details (such as specific monitoring locations) are specified in ODCM Chapter 11.

5.3.1 Interlaboratory Comparison Program

The laboratory which performs the REMP analyses is required by the RETS to participate in an interlaboratory comparison program. The purpose is to provide an independent check on the laboratory's analytical procedures and to alert it to potential problems (e.g. accuracy). In order to assess the measurements of radioactivity in environmental media, an independent agency supplies participating laboratories with samples of environmental media containing unspecified amounts of radioactivity. The

laboratories measure the radioactivity concentrations and report the results to the agency. At a later time, the agency informs the participating laboratories of the actual concentrations and associated uncertainties. Any significant discrepancies are investigated by the participating laboratories. A similar process is used to assess measurements of environmental radiation by passive thermoluminescent dosimeters.

CHAPTER 6

IMPLEMENTATION OF OFFSITE DOSE ASSESSMENT PROGRAM

6.1 NUCLEAR POWER STATION

The nuclear power station staff is responsible for effluent monitoring. The staff determines effluent radioactivity concentration and flow rate. These data are used to determine the radioactivity release information required for the Radioactive Effluent Release Report and to perform monthly calculations and projections of offsite radiation dose.

The nuclear power station staff is also responsible for control of effluent radioactivity. Procedures are implemented for determining, calculating and implementing setpoints. Liquid and gaseous radwaste treatment systems and ventilation exhaust treatment systems are utilized when appropriate. The nuclear power station staff implements the Process Control Program (PCP) for solid radwaste and measures tank radioactivity and BWR off-gas radioactivity.

The nuclear power station staff maintains instrumentation associated with these activities and demonstrates operability of the instrumentation in accordance with the surveillance requirements of the RETS. In the event that any RETS requirements are violated, the nuclear power station staff is responsible for taking one of the actions allowed by the RETS and issuing any required reports to the NRC.

The nuclear power station staff assembles and distributes the Radioactive Effluent Release Report.

6.2 METEOROLOGICAL CONTRACTOR

The meteorological contractor operates and maintains the meteorological tower instrumentation at each nuclear power station. The contractor collects and analyzes the data and issues periodic reports. The contractor prepares the meteorological data summary required for the Annual Radiological Environmental Operating Report (AREOR) and also computes and plots isopleths included in the AREOR.

6.3 REMP CONTRACTOR

The radiological environmental contractor collects environmental samples and performs radiological analyses as specified in the nuclear power station's REMP (see ODCM Chapters 11 and 12). The contractor issues reports of results to appropriate points of contact and each nuclear station. The contractor participates in an interlaboratory comparison program and reports results in the Annual Radiological Environmental Operating Report. The contractor performs the annual land use census and assembles the Annual Radiological Environmental Operating Report.

CHAPTER 7

REFERENCES

1. Deleted
2. U.S. Nuclear Regulatory Commission, Standard Radiological Effluent Technical Specifications for Pressurized Water Reactors, NUREG-0472, Rev. 3, Draft, January 1983 (frequently revised).
3. U.S. Nuclear Regulatory Commission, Standard Radiological Effluent Technical Specifications for Boiling Water Reactors, NUREG-0473, Rev. 3, Draft, September 1982 (frequently revised).
4. U.S. Nuclear Regulatory Commission, Measuring, Evaluating, and Reporting Radioactivity in Solid Wastes and Releases of Radioactive Materials in Liquid and Gaseous Effluents from Light-Water-Cooled Nuclear Power Plants, Regulatory Guide 1.21. Revision 1, June 1974.
5. U.S. Nuclear Regulatory Commission, Onsite Meteorological Programs, Regulatory Guide 1.23, Safety Guide 23, February 17, 1972.
6. U.S. Nuclear Regulatory Commission, Calculation of Annual Doses to Man from Routine Releases of Reactor Effluents for the Purpose of Evaluating Compliance with 10 CFR Part 50 Appendix J, Regulatory Guide 1.109, Rev. 1, October 1977.
7. U.S. Nuclear Regulatory Commission, Methods for Estimating Atmospheric Transport and Dispersion of Gaseous Effluents in Routine Releases from Light-Water-Cooled Reactors, Regulatory Guide 1.111, Rev. 1, July 1977.
8. U.S. Nuclear Regulatory Commission, Calculation of Releases of Radioactive Materials in Gaseous and Liquid Effluents from Light-Water-Cooled Power Reactors, Regulatory Guide 1.112, Rev. 0-R, April 1976; reissued May 1977.
9. U.S. Nuclear Regulatory Commission, Estimating Aquatic Dispersion of Effluents from Accidental and Routine Reactor Releases for the Purpose of Implementing Appendix J, Regulatory Guide 1.113, Rev. 1, April 1977.
10. U.S. Nuclear Regulatory Commission, Programs for Monitoring Radioactivity in the Environs of Nuclear Power Plants, Regulatory Guide 4.1, Rev. 1, April 1975.
11. U.S. Nuclear Regulatory Commission, Preparation of Environmental Reports for Nuclear Power Stations, Regulatory Guide 4.2, Rev. 2, July 1976.
12. U.S. Nuclear Regulatory Commission, Environmental Technical Specifications for Nuclear Power Plants, Regulatory Guide 4.8, Rev. 1, December 1975. (See also the related Radiological Assessment Branch Technical Position, Rev. 1, November 1979.)
13. U.S. Nuclear Regulatory Commission, Quality Assurance for Radiological Monitoring Programs (Normal Operations)--Effluent Streams and the Environment, Regulatory Guide 4.15, Rev. 1, February 1979.
14. U.S. Nuclear Regulatory Commission, Preparation of Radiological Effluent Technical Specifications for Nuclear Power Plants, edited by J. S. Boegli et al. NUREG-0133, October 1978.

15. U.S. Nuclear Regulatory Commission, XOQDOQ: Computer Program for the Meteorological Evaluation of Routine Effluent Releases at Nuclear Power Stations, J. F. Sagendorf et al. NUREG/CR-2919, PNL-4380, September 1982.
16. U.S. Nuclear Regulatory Commission, Radiological Assessment, edited by J. E. Till and H. R. Meyer, NUREG/CR-3332, ORNL-5968, September 1983.
17. U.S. Nuclear Regulatory Commission, Standard Review Plan, NUREG-0800, July 1981.
18. U.S. Atomic Energy Commission, Meteorology and Atomic Energy 1968, edited by D. H. Slade, TID-21940, July 1968.
19. U.S. Atomic Energy Commission, Plume Rise, G. A. Briggs, TID-25075, 1969.
20. U.S. Atomic Energy Commission, The Potential Radiological Implications of Nuclear Facilities in the Upper Mississippi River Basin in the Year 2000, WASH 1209, January 1973.
21. U.S. Atomic Energy Commission, HASL Procedures Manual, Health and Safety Laboratory, HASL-300 (revised annually).
22. U.S. Department of Energy, Models and Parameters for Environmental Radiological Assessments, edited by C. W. Miller, DOE/TIC-11468, 1984.
23. U.S. Department of Energy, Atmospheric Science and Power Production, edited by D. Randerson, DOE/TIC-27601, 1984.
24. U.S. Environmental Protection Agency, Workbook of Atmospheric Dispersion Estimates, D. B. Turner, Office of Air Programs Publication No. AP-26, 1970.
25. U.S. Environmental Protection Agency, 40CFR190 Environmental Radiation Protection Requirements for Normal Operations of Activities in the Uranium Fuel Cycle, Final Environmental Statement, EPA 520/4-76-016, November 1, 1976.
26. U.S. Environmental Protection Agency, Environmental Analysis of the Uranium Fuel Cycle, EPA-520/9-73-003-C, November 1973.
27. American Society of Mechanical Engineers, Recommended Guide for the Prediction of the Dispersion of Airborne Effluents, 1973.
28. Eisenbud, M., Environmental Radioactivity, 3rd Edition, (Academic Press, Orlando, FL, 1987).
29. Glasstone, S., and Jordan, W. H., Nuclear Power and Its Environmental Effects (American Nuclear Society, LaGrange Park, IL, 1980).
30. International Atomic Energy Agency, Generic Models and Parameters for Assessing the Environmental Transfer of Radionuclides from Routine Releases, Safety Series, No. 57, 1982.
31. National Council on Radiation Protection and Measurements, Radiological Assessment: Predicting the Transport, Bioaccumulation, and Uptake by Man of Radionuclides Released to the Environment, NCRP Report No. 76, March 15, 1984.
32. American National Standards Institute, Guide to Sampling Airborne Radioactive Materials in Nuclear Facilities, ANSI N13.1-1969, February 19, 1969.

33. Institute of Electrical and Electronics Engineers, Specification and Performance of On-Site Instrumentation for Continuously Monitoring Radioactivity in Effluents, ANSI N13.10-1974, September 19, 1974.
34. American National Standards Institute, Testing and Procedural Specifications for Thermoluminescence Dosimetry (Environmental Applications), ANSI N545-1975, August 20, 1975.
35. American Nuclear Insurers, Effluent Monitoring, ANI/MAELU Engineering Inspection Criteria for Nuclear Liability Insurance, Section 5.1, Rev. 2, October 24, 1986.
36. American Nuclear Insurers, Environmental Monitoring, ANI/MAELU Engineering Inspection Criteria for Nuclear Liability Insurance, Section 5.2, Rev. 1, March 23, 1987.
37. American Nuclear Insurers, Environmental Monitoring Programs, ANI/MAELU Information Bulletin 86-1, June 9, 1986.
38. Cember, H., Introduction to Health Physics, 2nd Edition (Pergamon Press, Elmsford, NY 1983).
39. Electric Power Research Institute, Guidelines for Permanent BWR Hydrogen Water Chemistry Installations--1987 Revision, EPRI NP-5283-SR-A, Special Report, September 1987.
40. Commonwealth Edison Company, Information Relevant to Keeping Levels of Radioactivity in Effluents to Unrestricted Areas As Low As Reasonably Achievable, LaSalle County Station, Units 1 and 2, June 4, 1976.
41. U.S. Nuclear Regulatory Commission, Branch Technical Position, Radiological Assessment Branch, Revision 1, November 1979. (This is a branch position on Regulatory Guide 4.8.)
42. Deleted
43. U.S. Nuclear Regulatory Commission, Calculation of Releases of Radioactive Materials in Gaseous and Liquid Effluents from Pressurized Water Reactors (PWR-GALE Code), NUREG-0017, April 1976.
44. U.S. Nuclear Regulatory Commission, Calculation of Releases of Radioactive Materials in Gaseous and Liquid Effluents from Boiling Water Reactors (BWR-GALE Code), NUREG-0016, April 1976.
45. Sargent & Lundy, N-16 Skyshine from BWR Turbine Systems and Piping, NSLD Calculation No. D2-2-85, Rev. 0, 2/1/85.
46. Sargent & Lundy Calculation ATD-0138, Rev. 0, N-16 Skyshine Ground Level Dose from Dresden Turbine Systems and Piping, July 14, 1992.
47. Sargent & Lundy Calculation ATD-0139, Rev. 0, N-16 Skyshine Ground Level Dose from LaSalle Turbine Systems and Piping, July 28, 1992.
48. Sargent & Lundy Calculation ATD-0140, Rev. 0, N-16 Skyshine Ground Level Dose from Quad Cities Turbine Systems and Piping, July 28, 1992.
49. U.S. Nuclear Regulatory Commission, Methods for Demonstrating LWR Compliance with the EPA Uranium Fuel Cycle Standard (40 CFR Part 190), NUREG-0543, February 1980.

50. International Commission on Radiological Protection, Report of Committee Two on Permissible Dose for Internal Radiation, Recommendations of the International Commission on Radiological Protection, ICRP Publication 2, 1959.
51. U.S. Nuclear Regulatory Commission, Age-Specific Radiation Dose Commitment Factors for a One-Year Chronic Intake, Battelle Pacific Northwest Laboratories, NUREG-0172, 1977.
52. W. C. Ng, Transfer Coefficients for Prediction of the Dose to Man via the Forage-Cow-Milk Pathway from Radionuclides Released to the Biosphere, UCRL-51939.
53. E. C. Eimutis and M. G. Konicek, Derivations of Continuous Functions for the Lateral and Vertical Atmospheric Dispersion Coefficients, Atmospheric Environment 6, 859 (1972).
54. D. C. Kocher, Editor, Nuclear Decay Data for Radionuclides Occurring in Routine Releases from Nuclear Fuel Cycle Facilities, ORNL/NUREG/TM-102, August 1977.
55. R. L. Heath, Gamma-Ray Spectrum Catalog, Aerojet Nuclear Co., ANCR-1000-2, third or subsequent edition.
56. S. E. Thompson, Concentration Factors of Chemical Elements in Edible Aquatic Organisms, UCRL-50564, Rev. 1, 1972.
57. U.S. Nuclear Regulatory Commission, Instruction Concerning Risks from Occupational Radiation Exposure, Regulatory Guide 8.29, July 1981.
58. Dresden Nuclear Power Station, Radioactive Waste and Environmental Monitoring, Annual Report 1987, March 1988.
59. Reserved reference number
60. Sargent & Lundy Calculation ATD-0173, Rev. 0, 9/21/92, Annual Dose to Members of the Public Due to the LaSalle IRSE.
61. Sargent & Lundy Calculation ATD-0174, Rev. 0, 9/21/92, Annual Dose to Members of the Public Due to the Zion IRSE.
62. Sargent & Lundy Calculation ATD-0175, Rev. 0, 9/21/92, Annual Dose to Members of the Public Due to the Quad Cities IRSE.
63. Sargent & Lundy Calculation ATD-0176, Rev. 0, 9/21/92, Annual Dose to Members of the Public Due to the Dresden IRSE.
64. Reserved reference number
65. Sargent & Lundy Calculation ATD-0180, Rev. 0, 9/25/92, Dose Information Around Braidwood DAW Sea/Land Van Storage Area.
66. Sargent & Lundy Calculation ATD-0181, Rev. 0, 9/25/92, Dose Information Around Byron DAW Sea/Land Van Storage Area.
67. Sargent & Lundy Calculation ATD-0182, Rev. 0, 9/25/92, Dose Information Around Dresden DAW Sea/Land Van Storage Area.
68. Sargent & Lundy Calculation ATD-0183, Rev. 0, 9/25/92, Dose Information Around LaSalle DAW Sea/Land Van Storage Area.

69. Catalytic, Inc., Determination of Roof and Wall Shielding for Onsite and Offsite Radiation Protection from Skyshine, Calculation Index Number 70161-19, August 22, 1984 (applies to Dresden).
70. D. C. Kocher, Radioactivity Decay Data Tables, DOE/TIC-11026, 1981.
71. J. C. Courtney, A Handbook of Radiation Shielding Data, ANS/SD-76/14, July 1976.
72. Commonwealth Edison Company, Information Relevant to Keeping Levels of Radioactivity in Effluents to Unrestricted Areas As Low As Reasonably Achievable, Zion Station, Units 1 and 2, June 4, 1976.
73. Commonwealth Edison Company, Information Relevant to Keeping Levels of Radioactivity in Effluents to Unrestricted Areas As Low As Reasonably Achievable, Dresden Station, Units 2 and 3, June 4, 1976.
74. Commonwealth Edison Company, Information Relevant to Keeping Levels of Radioactivity in Effluents to Unrestricted Areas As Low As Reasonably Achievable, Quad Cities Station, Units 1 and 2, June 4, 1976.
75. Sargent & Lundy, METWRSUM, S&L Program Number 09.5.187-1.0.
76. Sargent & Lundy, Comments on CEC Co ODCM and List of S&L Calculations, Internal Office Memorandum, P. N. Derezotes to G. R. Davidson, November 23, 1988.
77. Sargent & Lundy, AZAP, A Computer Program to Calculate Annual Average Offsite Doses from Routine Releases of Radionuclides in Gaseous Effluents and Postaccident X/Q Values, S&L Program Number 09.8.054-1.7.
78. National Oceanic and Atmospheric Administration, A Program for Evaluating Atmospheric Dispersion from a Nuclear Power Station, J. F. Sagendorf, NOAA Technical Memorandum ERL ARL-42, Air Resources Laboratory, Idaho Falls, Idaho, May 1974.
79. G. P. Lahti, R. S. Hubner, and J. C. Golden, Assessment of Gamma-Ray Exposures Due to Finite Plumes, Health Physics 41, 319 (1981).
80. National Council of Radiation Protection and Measurements, Ionizing Radiation Exposure of the Population of the United States, NCRP Report No. 93, September 1, 1987.
81. Reserved reference number
82. W. R. Van Pelt (Environmental Analysts, Inc.), Letter to J. Golden (Exelon Nuclear) dated January 3, 1972.
83. Electric Power Research Institute, Radiological Effects of Hydrogen Water Chemistry, EPRI NP-4011, May 1985.
84. U.S. Nuclear Regulatory Commission, Draft Generic Environmental Impact Statement on Uranium Milling, NUREG-0511, April 1979.
85. U.S. Environmental Protection Agency, Environmental Analysis of the Uranium Fuel Cycle, Part I - Fuel Supply, EPA-520/9-73-003-B, October 1973.
86. U.S. Nuclear Regulatory Commission, Final Generic Environmental Statement on the Use of Recycle Plutonium in Mixed Oxide Fuel in Light Water Cooled Reactors, NUREG-0002, August 1976.

87. U.S. Nuclear Regulatory Commission, Demographic Statistics Pertaining to Nuclear Power Reactor Sites, NUREG-0348, Draft, December 1977.
88. Nuclear News 31, Number 10, Page 69 (August 1988).
89. General Electric Company, Irradiated Fuel Storage at Morris Operation, Operating Experience Report, January 1972 through December 1982, K. J. Eger, NEDO-20969B.
90. U.S. Nuclear Regulatory Commission, Generic Letter 89-01, "Guidance For The Implementation of Programmatic Controls For RETS In The Administrative Controls Section of Technical Specifications and the Relocation of Procedural Details of Current RETS to the Offsite Dose Calculation Manual or Process Control Program", January 1989.
91. "Assessment of the Impact of Liquid Radioactive Effluents from Braidwood Station on Proposed Public Water Intakes at Wilmington, Illinois", J.C. Golden, NSEP, January 1990
92. NRC Safety Evaluation Report (SER)/Idaho Notional Engineering Laboratory Technical Evaluation Report (TER) of the Commonwealth Edison Offsite Dose Calculation Manual (ODCM), Revision O.A, December 2, 1991.
93. Deleted
94. Deleted.
95. U.S. Nuclear Regulatory Commission, Standards for Protection Against Radiation (10CFR20).
96. U.S. Nuclear Regulatory Commission, Licensing of Production and Utilization Facilities (10CFR50).
97. Federal Register, Vol. 57, No. 169, Monday, August 31, 1992, page 39358.
98. Miller, Charles W., Models and Parameters for Environmental Radiological Assessments, U.S. Dept. of Energy, DE8102754, 1984, pages 32, 33, 48, and 49.
99. Kocher, D. C., "Dose-Rate Conversion Factors For External Exposure To Photons and Electrons", Health Physics Vol. 45, No. 3 (September), pp. 665-686, 1983.
100. U.S. Department of Health, Education and Welfare Public Health Service, Radiological Health Handbook, January 1970.
101. ODCM Bases and Reference Document, rev.0, November, 1998.
102. G. Moran, D. Goff, Quad Cities Nuclear Power Station; 1993 Hydrogen Water Chemistry Stress Corrosion Monitoring Test - Unit 2, 9/17-23/93.
103. U.S. Nuclear Regulatory Commission, Generic Letter 79-041, September 17, 1979.
104. Federal Register, Vol. 56, No. 98, Tuesday, May 21, 1991, page 23374, column 3.
105. U.S. Nuclear Regulatory Commission, Offsite Dose Calculation Manual Guidance: Standard Radiological Effluent Controls for Pressurized Water Reactors, NUREG-1301, April 1991.
106. U.S. Nuclear Regulatory Commission, Offsite Dose Calculation Manual Guidance: Standard Radiological Effluent Controls for Boiling Water Reactors, NUREG-1302, April 1991.

107. U.S. Nuclear Regulatory Commission, LADTAP II - Technical Reference and Users Guide, NUREG-4013, April 1986.

APPENDIX A
COMPLIANCE METHODOLOGY

TABLE OF CONTENTS

		<u>PAGE</u>
A.0	INTRODUCTION	A-1
A.1	AIRBORNE RELEASES	A-1
	1. Release Point Classifications	A-1
	2. Dose Due to Noble Gas Radionuclides	A-1
	1. Gamma Air Dose	A-1
	2. Beta Air Dose	A-3
	3. Total Body Dose	A-4
	4. Skin Dose	A-4
	3. Dose Rate Due to Noble Gas Radionuclides	A-5
	1. Total Body Dose Rate	A-5
	2. Skin Dose Rate	A-6
	4. Dose Due to Non-Noble Gas Radionuclides	A-7
	1. Ground Deposition	A-8
	2. Inhalation	A-9
	3. Food Ingestion Pathway Dose Factors	A-10
	- 1. Vegetation	A-10
	2. Milk	A-12
	3. Meat	A-13
	5. Dose Rate Due to Non-Noble Gas Radionuclides	A-14
	6. Operability and Use of Gaseous Effluent Treatment Systems	A-15
A.2	LIQUID RELEASES	A-16
	1. Dose	A-16
	1. Potable Water Pathway	A-17
	2. Fish Ingestion Pathway	A-18
	2. Liquid Effluent Concentrations Requirement	A-18
	3. Tank Discharges	A-19
	4. Tank Overflow	A-20
	5. Operability and Use of the Liquid Radwaste Treatment System	A-20
	6. Drinking Water	A-20
	7. Non-routine Liquid Release Pathways	A-21
A.3	DOSE DUE TO CONTAINED SOURCES	A-21
	1. BWR Skyshine	A-21
	2. Dose from Onsite Radwaste Storage Facilities	A-23
A.4	TOTAL DOSE LIMITS (10CFR20 and 40CFR190)	A-23
	1. Total External Total Body Dose	A-23
	2. Total Dose	A-24

APPENDIX A
TABLE OF CONTENTS (Cont'd)

	<u>PAGE</u>
A.5 COMPLIANCE TO TOTAL DOSE LIMITS	A-25
1. Total Dose Limit - 10CFR20 Compliance	A-25
1. Dose to a Member of the Public in the Unrestricted Area	A-25
2. Dose to a Member of the Public in the Restricted Area	A-25
2. Total Dose Due to the Uranium Fuel Cycle (40CFR190)	A-25
3. Summary of Compliance Methodology	A-26
A.6 DOSE DUE TO DRINKING WATER (40CFR141)	A-26
1. 40CFR141 Restrictions on Manmade Radionuclides	A-26
2. Application	A-27

LIST OF TABLES

<u>NUMBER</u>	<u>TITLE</u>	<u>PAGE</u>
A-0	Average Annual Concentrations Assumed to Produce a Total Body or Organ Dose of 4 mrem/yr.	A-27
A-1	Compliance Matrix	A-28
A-2	Release Point Classifications	A-29
A-3	Nearest Downstream Community Water Systems	A-30
A-4	40CFR190 Compliance	A-31

APPENDIX A

COMPLIANCE METHODOLOGY

A.0 INTRODUCTION

This appendix reviews the offsite radiological limits applicable to the nuclear power stations and presents in detail the equations and procedures used to assess compliance with these limits. An introduction to the calculational approach used here is given in Chapter 4. The approach incorporates simplifications such as the following:

- Use of pre-calculated atmospheric transport parameters based on historical average atmospheric conditions (see Section 4.1.5). These atmospheric dispersion and deposition factors are defined in Chapter 4.

The equations and parameters of this appendix are for use in calculating offsite radiation doses during routine operating conditions. They are not for use in calculating doses due to non-routine releases (e.g., accident releases).

This section of the ODCM provides the methodological details for demonstrating compliance with the 10CFR20, 10CFR50 Appendix I and 40CFR190 radiological limits for liquid and gaseous effluents.

An overview of the required compliance is given in Tables 2-1, 2-2, and 2-3. In Table 2-1, the dose components are itemized and referenced, and an indication of their regulatory application is noted. A more detailed compliance matrix is given in Table 2-3. Additionally, the locations of dose receivers for each dose component are given in Table 2-2.

The following sections detail the required radiological dose calculations.

A.1 AIRBORNE RELEASES

A.1.1 Release Point Classifications

The pattern of dispersion of airborne releases is dependent on the height of the release point relative to adjacent structures. For the equations of this appendix, each release point is classified as one of the following three height-dependent types, which are defined in Section 4.1.4:

- Stack (or Elevated) Release Point (denoted by the letter S or subscript s)
- Ground Level Release Point (denoted by the letter G or subscript g)
- Vent (or Mixed Mode) Release Point (denoted by the letter V or subscript v)

The release point classifications of routine release points at the nuclear power stations are stated in Table A-2.

A.1.2 Dose Due to Noble Gas Radionuclides

A.1.2.1 Gamma Air Dose

Requirement

RETS limit the gamma air dose due to noble gas effluents released from each reactor unit to areas at and beyond the unrestricted area boundary to the following:

- Less than or equal to 5 mrad per calendar quarter.
- Less than or equal to 10 mrad per calendar year.

Equation

The gamma air dose due to noble gases released in gaseous effluents is calculated by the following expression:

$$D_{\gamma} = (3.17E - 8) \sum_i M_i \{ (\chi/Q)_s^{\gamma} A_{is} + (\chi/Q)_v^{\gamma} A_{iv} + (\chi/Q)_g^{\gamma} A_{ig} \} \quad (A-1)$$

The summation is over noble gas radionuclides i.

D_{γ}	Gamma Air Dose	[mrad]
	Dose to air due to gamma radiation from noble gas radionuclides released in gaseous effluents.	
3.17E-8	Conversion Constant (seconds to years)	[yr/sec]
M_i	Gamma Air Dose Conversion Factor	[(mrad/yr)/(μCi/m ³)]
	Gamma air dose rate factor per unit of radioactivity release rate for radionuclide i. From Table C-9 of Appendix C.	
$(\chi/Q)_s^{\gamma}, (\chi/Q)_v^{\gamma}, (\chi/Q)_g^{\gamma}$	Gamma- χ /Q Factor	[sec/m ³]
	Radioactivity concentration based on finite cloud methodology at a specific location per unit of radioactivity release rate from a stack, vent or ground level release, respectively. See Section B.3.5 and Table F-5b of appendix F.	
A_{is}, A_{iv}, A_{ig}	Cumulative Radionuclide Release	[μCi]
	Measured cumulative release of radionuclide i over the time period of interest from a stack, vent, or ground level release point, respectively.	

Application

RETS require determination of cumulative and projected gamma air dose contributions due to noble gases for the current calendar quarter and the current calendar year at least once per 31 days (see Sections 12.4 of each station's RETS or Technical Specifications).

Gamma air dose is calculated for the sector with the highest offsite $(\chi/Q)^{\gamma}$ and is compared with the RETS limits on gamma air dose.

For a release attributable to a processing or effluent system shared by more than one reactor unit, the dose due to an individual unit is obtained by proportioning the effluents among the units sharing the system. The allocation procedure is specified in ODCM Chapter 10.

A.1.2.2 Beta Air Dose

Requirement

RETS limit the beta air dose due to noble gases in gaseous effluents released from each reactor unit to areas at and beyond the unrestricted area boundary to the following:

- Less than or equal to 10 mrad per calendar quarter.
- Less than or equal to 20 mrad per calendar year.

Equation

The beta air dose due to noble gases released in gaseous effluents is calculated by the following expression:

$$D_{\beta} = (3.17E - 8) \sum_i \left\{ N_i \left[(\chi/Q)_s A_{is} + (\chi/Q)_v A_{iv} + (\chi/Q)_g A_{ig} \right] \right\} \quad (A-2)$$

The summation is over noble gas radionuclides i .

D_{β}	Beta Dose	[mrad]
	Dose to air due to beta radiation from noble gas radionuclides released in gaseous effluents.	
3.17E-8	Conversion Constant (seconds to years)	[yr/sec]
N_i	Beta Air Dose Conversion Factor	[(mrad/yr)/(μ Ci/m ³)]
	Beta air dose rate per unit of radioactivity concentration for radionuclide i . Take from Table C-9 of Appendix C.	
$(\chi/Q)_s$ $(\chi/Q)_v$ $(\chi/Q)_g$	Relative Concentration Factor	[sec/m ³]
	Radioactivity concentration based on semi-infinite cloud methodology at a specified location per unit of radioactivity release rate for a stack, vent, or ground level release, respectively. See Section 4.1.6, Section B.3 of Appendix B, and Table F-5 of Appendix F.	
A_{is}, A_{iv}, A_{ig}	Cumulative Radionuclide Release	[μ Ci]
	Measured cumulative release of radionuclide i over the time period of interest from a stack, vent, or ground level release point, respectively.	

Application

RETS require determination of cumulative and projected beta air dose contributions due to noble gases for the current calendar quarter and the current calendar year at least once per 31 days (see Section 12.4 of each station's RETS or Technical Specification).

Beta air dose is calculated for the sector with the highest offsite (χ/Q) and is compared with the RETS limit on beta air dose.

For a release attributable to a processing or effluent system shared by more than one reactor unit, the dose due to an individual unit is obtained by proportioning the effluents among the units sharing the system. The allocation procedure is specified in ODCM Chapter 10.

A.1.2.3 Total Body Dose

Requirement

The total body dose, to any receiver is due, in part, to gamma radiation emitted from radioactivity in airborne effluents. This component is added to others to demonstrate compliance to the requirements of 40CFR190 and 10CFR20.

Equation

The total body dose component due to gamma radiation from noble gases released in gaseous effluents is calculated by the following expression:

$$D_{TB} = (3.17E - 8) \sum_i K_i \left\{ (\chi/Q)_s A_{is} + (\chi/Q)_v A_{iv} + (\chi/Q)_g A_{ig} \right\} \quad (A-3)$$

The summation is over noble gas radionuclides i.

D_{TB}	Total Body Dose	[mrem]
	Dose to the total body due to gamma radiation from noble gas radionuclides released in gaseous effluents.	
3.17E-8	Conversion Constant (seconds to years)	[yr/sec]
K_i	Gamma Total Body Dose Conversion Factor	[(mrem/yr)/(uCi/m3)]
	Gamma total body dose factor due to gamma emissions for noble gas radionuclide i released from a stack, vent or ground level release point, respectively. Taken from Table C-9 of Appendix C.	
A_{is}, A_{iv}, A_{ig}	Cumulative Radionuclide Release	[μCi]
	Measured cumulative release of radionuclide i over the time period of interest from a stack, vent, or ground level release point, respectively.	

Application

The total body dose is also calculated for the 40CFR190 and 10CFR20 compliance assessments. In some cases, the total body dose may be required in 10CFR50 Appendix I assessments (See Table 2-1).

A.1.2.4 Skin Dose

Requirement

There is no regulatory requirement to evaluate skin dose. However, this component is evaluated for reference as there is skin dose design objective contained in 10CFR50 Appendix I. Note that in the unlikely event that if beta air dose guideline is exceeded, then the skin dose will require evaluation.

Equation

The part of skin dose due to noble gases released in gaseous effluents is calculated by the following expression:

$$D_{SK} = (3.17E - 8) \sum_i \left\{ L_i \left[(\chi/Q)_s A_{Is} + (\chi/Q)_v A_{Iv} + (\chi/Q)_g A_{Ig} \right] + (1.11) M_i \left[(\chi/Q)_s^r A_{Is} + (\chi/Q)_v^r A_{Iv} + (\chi/Q)_g^r A_{Ig} \right] \right\} \quad (A-4)$$

The summation is over noble gas radionuclides i.

D_{SK}	Skin Dose	[mrem]
	Dose to the skin due to beta and gamma radiation from noble gas radionuclides released in gaseous effluents.	
L_i	Beta Skin Dose Conversion Factor	[(mrem/yr)/(μ Ci/m ³)]
	Beta skin dose rate per unit of radioactivity concentration for radionuclide i. Taken from Table C-9 of Appendix C.	
1.11	Conversion Constant (rads in air to rem in tissue)	[mrem/mrad]

All other terms have been previously defined.

Application

The skin dose is calculated for reference only.

A.1.3 Dose Rate Due to Noble Gas Radionuclides

A.1.3.1 Total Body Dose Rate

Requirement

RETS limit the total body dose rate due to noble gases in gaseous effluents released from a site to areas at and beyond the site boundary to less than or equal to 500 mrem/yr at all times. (see Section 12.4 of each station's RETS and Technical Specifications)

Equation

The total body dose rate due to noble gases released in gaseous effluents is calculated by the following expression:

$$\dot{D}_{TB} = \sum_i K_i \left\{ (\chi/Q)_s^r Q_{Is} + (\chi/Q)_v^r Q_{Iv} + (\chi/Q)_g^r Q_{Ig} \right\} \quad (A-5)$$

The summation is over noble gas radionuclides i.

\dot{D}_{TB}	Total Body Dose Rate	[mrem/yr]
	Dose rate to the total body due to gamma radiation from noble gas radionuclides released in gaseous effluents.	

Q_{is}, Q_{iv}, Q_{ig} Release Rate [μCi/sec]

Measured release rate of radionuclide i from a stack, vent or ground level release point, respectively. All other terms have been previously defined.

Application

RETS require the dose rate due to noble gases in gaseous effluents be determined to be within the above limit in accordance with methodology specified in the ODCM (see Section 12.4 of each station's RETS and Technical Specifications).

To comply with this specification, each station uses an effluent radiation monitor setpoint corresponding to an offsite total body dose rate at or below the limit (see Chapter 10). In addition, each station assesses compliance by calculating offsite total body dose rate on the basis of periodic samples obtained in accordance with station procedures.

A.1.3.2 Skin Dose Rate

Requirement

RETS limit the skin dose rate due to noble gases in gaseous effluents released from a site to areas at and beyond the site boundary to less than or equal to a dose rate of 3000 mrem/yr at all times. (See Section 12.4 of each station's RETS and/or Technical Specifications)

Equation

The skin dose rate due to noble gases released in gaseous effluents is calculated by the following expression:

$$\dot{D}_{SK} = \sum_i \left\{ L_i \left[(\chi/Q)_s Q_{is} + (\chi/Q)_v Q_{iv} + (\chi/Q)_g Q_{ig} \right] + (1.11) M_i \left[(\chi/Q)_s^{\gamma} Q_{is} + (\chi/Q)_v^{\gamma} Q_{iv} + (\chi/Q)_g^{\gamma} Q_{ig} \right] \right\} \tag{A-6}$$

The summation is over noble gas radionuclides i.

\dot{D}_{SK} Skin Dose Rate [mrem/yr]

Dose rate to skin due to beta and gamma radiation from noble gas radionuclides released in gaseous effluents.

Q_{is}, Q_{iv}, Q_{ig} Release Rate [μCi/sec]

Measured release rate of radionuclide i from a stack, vent or ground level release point, respectively.

All other terms been previously defined.

Application

RETS require the dose rate due to noble gases in gaseous effluents to be determined to be within the above limit in accordance with methodology specified in the ODCM. (See Section 12.4 of each station's RETS and Technical Specifications.)

To comply with this specification, each station uses an effluent radiation monitor setpoint corresponding to an offsite skin dose rate at or below the limit (see Chapter 10). In addition, each station assesses compliance by calculating offsite skin dose rate on the basis of samples obtained periodically in accordance with station procedures.

A.1.4 Dose Due to Non-Noble Gas Radionuclides

Requirement

RETS provide the following limits, based on 10CFR50 Appendix I, on the dose to a member of the public from specified non-noble gas radionuclides in gaseous effluents released from each reactor unit to areas at and beyond the unrestricted area boundary:

- Less than or equal to 7.5 mrem to any organ during any calendar quarter.
- Less than or equal to 15 mrem to any organ during any calendar year.

The individual dose components are also required as part of the 40CFR190 assessments and combined as part of the 10CFR20 assessment (See Section A.4). The dose due to radionuclides deposited on the ground is considered to be a component of the deep dose equivalent for 10CFR20 compliance and an organ (and total body) dose component for 10CFR50 Appendix I and 40CFR190 compliance.

In accordance with the definition of dose in Regulatory Guide 1.109, the term "dose" in this document when applied to individuals, is used instead of the more precise term "dose equivalent," as defined by the International Commission on Radiological Units and Measurements (ICRU). When applied to the evaluation of internal deposition of radioactivity, the term "dose" as used here, includes the prospective dose component arising from retention in the body beyond the period of environmental exposure, i.e., the dose commitment. The dose commitment is evaluated over a period of 50 years. Assessments for 10CFR50 Appendix I compliance are made for 4 age groups (adult/teenager/child/infant) using Regulatory Guide 1.109 (Reference 6) dose conversion factors.

Equation

The dose is calculated for releases in the time period under consideration.

Specifically, the dose is calculated as follows:

$$D_{aj}^{NNG} = (3.17E - 8) \sum_p \sum_i [W_s R_{s|p|j} A_{is} + W_v R_{v|p|j} A_{iv} + W_g R_{g|p|j} A_{ig}] \quad (A-7)$$

The summation is over pathways p and non-noble gas radionuclides i .

D_{aj}^{NNG}	Dose Due to Non-Noble Gas Radionuclides	[mrem]
	Dose due to non-noble gases (radioiodines, tritium and particulates) to age group a , and to organ j .	
3.17E-8	Conversion Constant (seconds to years)	[yr/sec]
W_s, W_v, W_g	Relative Concentration Factor	

Radioactive concentration at a specific location per unit of radioactivity release rate or concentration for stack, vent or ground level release, respectively.

$W_s, W_v, \text{ or } W_g = (\chi/Q)_s, (\chi/Q)_v, \text{ or } (\chi/Q)_g$ for immersion, inhalation and all tritium pathways.

$W_s, W_v, \text{ or } W_g = (D/Q)_s, (D/Q)_v, \text{ or } (D/Q)_g$ for ground plain and all ingestion pathways.

$(\chi/Q)_s, (\chi/Q)_v, (\chi/Q)_g$ Relative Concentration Factor [sec/m³]

Radioactivity concentration based on semi-infinite cloud model at a specified location per unit of radioactivity release rate for a stack, vent, or ground level release, respectively. See Section 4.1.6, Section B.3 of Appendix B, and Table F-5 of Appendix F.

$(D/Q)_s, (D/Q)_v, (D/Q)_g$ Relative Deposition Factor [1/m²]

Radioactivity concentration at a specified location per unit of radioactivity release concentration for a stack, vent, or ground level release, respectively. See Section 4.1.6, Section B.3 of Appendix B, and Table F-6 of Appendix F.

$R_{a|p|j}$ Site-Specific Dose Factor [(m² mrem/yr)/(μCi/sec)]
or [(mrem/yr)/(μCi/m³)]

Site-specific dose factor for age group a, nuclide i, pathway p and organ j. Pathway included are ground plane exposure, inhalation, vegetation ingestion, milk ingestion and meat ingestion. Values of $R_{a|p|j}$ are provided in Appendix F.

A_{is}, A_{iv}, A_{ig} Cumulative Radionuclide Release [μCi]

Measured cumulative release of radionuclide i over the time period of interest from a stack, vent, or ground level release point, respectively.

Application

RETS require cumulative and projected dose contributions for the current calendar quarter and the current calendar year for the specified non-noble gas radionuclides in airborne effluents to be determined at least once per 31 days (see Section 12.4 of each station's RETS and Technical Specifications).

To comply with this specification, each nuclear power station obtains and analyzes samples in accordance with the radioactive gaseous waste or gaseous effluent sampling and analysis program in its RETS. In accordance with NUREG 0133 (Reference 14), dose due to non-noble gases is assessed at the location in the unrestricted area where the combination of existing pathways and receptor age groups indicates the maximum potential exposure. The inhalation and ground plane exposure pathways are considered to exist at all locations. The food ingestion pathways at a specific location are considered based on their existence as determined by land use census. The values used for (χ/Q) and (D/Q) correspond to the applicable pathway location.

For a release attributable to a processing or effluent system shared by more than one reactor, the dose due to an individual unit is obtained by proportioning the effluents among the units sharing the system. The allocation procedure is specified in ODCM Chapter 10.

The dose evaluated is also included as part of the 10CFR20 and 40CFR190 assessment (See Section A.4).

A.1.4.1 Ground Deposition

The site-specific dose factor for ground deposition of radioactivity is considered to be a total body dose component and is calculated by the following expression:

$$R_{a|(GP)_j} [D/Q] = K' K'' (0.7) DFG_i \left[\frac{1 - e^{-\lambda_i t_b}}{\lambda_i} \right] \quad (A-8)$$

$R_{a|(GP)_j} [D/Q]$ Ground Plane Deposition Dose Factor [(m² mrem/yr)/(μCi/sec)]

Site-specific ground plane dose factor for age group a, nuclide i and organ j. The ground plane dose is calculated using (D/Q).

K' Conversion Constant (1E6 pCi per μCi) [pCi/μCi]

K'' Conversion Constant (8760 hr/yr) [hr/yr]
0.7 Shielding Factor; a factor which accounts for shielding due to occupancy of structures. dimensionless

DFG_i Ground Plane Dose Conversion Factor [(mrem/hr)/(pCi/m²)]

Dose rate to the total body per unit of surface radioactivity concentration due to standing on ground uniformly contaminated with radionuclide i. Taken from Table C-10 of Appendix C.

Note that ground plane dose factors are only given for the total body and no age group. Doses to other organs are assumed to be equal to the total body dose. All age groups are assumed to receive the same dose.

λ_i Radiological Decay Constant [hr⁻¹]

Radiological decay constant for radionuclide i. See Table C-7 of Appendix C.

t_b Time Period of Ground Deposition [hr]

Time period during which the radioactivity on the ground is assumed to have been deposited. See Table C-1 of Appendix C.

Application

The ground plane exposure pathway is considered to exist at all locations.

A.1.4.2 Inhalation

The site-specific dose factor for inhalation is calculated by the following expression:

$$R_{ai(\text{inhal})}[\chi/Q] = K'BR_aDFA_{aij} \quad (\text{A-9})$$

$R_{ai(\text{inhal})}[\chi/Q]$	Inhalation Pathway Dose Factor	$[(\text{mrem/yr})/(\mu\text{Ci}/\text{m}^3)]$
	Site-specific inhalation dose factor for age group <i>a</i> , nuclide <i>i</i> and organ <i>j</i> . The inhalation dose is calculated using (χ/Q) .	
K'	Conversion Constant (1E6 pCi per μCi)	$[\text{pCi}/\mu\text{Ci}]$
BR_a	Individual Air Inhalation Rate	$[\text{m}^3/\text{yr}]$
	The air intake rate for individuals in age group <i>a</i> . See Table C-2 of Appendix C.	
DFA_{aij}	Inhalation Dose Conversion Factor	$[\text{mrem}/\text{pCi}]$
	Dose commitment to an individual in age group <i>a</i> to organ <i>j</i> per unit of activity of radionuclide <i>i</i> inhaled. Taken from Tables E-7 through E-10 of Regulatory Guide 1.109. The values for H-3 and for Sr-90 are taken from NUREG 4013 (Reference 107).	

Application

The inhalation exposure pathway is considered to exist at all locations.

A.1.4.3 Food Ingestion Pathway Dose Factors

Application

Food ingestion pathway doses are calculated at locations indicated by the land use census survey. If no real pathway exists within 5 miles of the station, the cow-milk pathway is assumed to be located at 5 miles. Food pathway calculations are not made for sectors in which the offsite regions near the station are over bodies of water.

A.1.4.3.1 Vegetation Ingestion Pathway Dose Factor

The dose factor for consumption of vegetables is calculated by the following expression:

$$R_{ai(\text{veg})}[D/Q] = K' \left[\frac{(r)}{Y_v(\lambda_i + \lambda_w)} \right] (DFL_{aij}) [U_i^L f_L e^{-\lambda_i t_L} + U_i^S f_S e^{-\lambda_i t_S}] \quad (\text{A-10})$$

$R_{ai(\text{veg})}[D/Q]$	Vegetation Ingestion Pathway Dose Factor	$[(\text{m}^2 \text{ mrem/yr})/(\mu\text{Ci}/\text{sec})]$
	Site-specific vegetation ingestion dose factor for age group <i>a</i> , nuclide <i>i</i> and organ <i>j</i> . With the exception of H-3, the vegetation dose is calculated using (D/Q) .	
K'	Conversion Constant (1E6 pCi per μCi)	$[\text{pCi}/\mu\text{Ci}]$

r	Vegetation Retention Factor	dimensionless
Y_v	Agricultural Productivity Yield	[kg/ m ²]
λ_i	Radiological Decay Constant	[1/sec]
	Radiological decay constant for radionuclide i. See Table C-7 of Appendix C.	
λ_w	Weathering Decay Constant	[1/sec]
	Removal constant for physical loss of activity by weathering. See Table C-1 of Appendix C.	
$DFL_{a,ij}$	Ingestion Dose Conversion Factor	[mrem/pCi]
	Ingestion dose conversion factor for age group a, nuclide i and organ j. Converts pCi ingested to mrem. Taken from Tables E-11 through E-14 of Regulatory Guide 1.109. The values for H-3 and Sr-90 are taken from NUREG 4013 (Reference 107).	
U_a^L	Consumption Rate for Fresh Leafy Vegetation	[kg/yr]
	Consumption rate for fresh leafy vegetation for age group a.	
U_a^S	Consumption Rate for Stored Vegetation	[kg/yr]
	Consumption rate for stored vegetation for age group a.	
f_L	Local Leafy Vegetation Fraction	dimensionless
	Fraction of the annual intake of fresh leafy vegetation which is grown locally.	
f_g	Local Stored Vegetation Fraction	dimensionless
	Fraction of the annual intake of stored vegetation which is grown locally.	
t_L	Environmental Transport Time - Fresh Vegetation	[sec]
	Average time between harvest of leafy vegetation and its consumption.	
t_h	Environmental Transport Time - Stored Vegetation	[sec]
	Average time between harvest of stored vegetation and its consumption.	

The tritium dose from the vegetation pathway must be considered separately as the transport mechanism is based on airborne concentration rather than ground deposition. The dose factor for the tritium vegetation pathway is:

$$R_{a(H-3)(veg)} [X/Q] = K' K'' (U_a^L f_L + U_a^S f_g) DFL_{a(H-3)} [0.75(0.5/H)] \quad (A-11)$$

$R_{a(H-3)(veg)} [X/Q]$ Tritium Vegetation Ingestion Pathway Dose Factor [(mrem/yr)/(μCi/m³)]

	Site-specific tritium vegetation ingestion dose factor for age group <i>a</i> and organ <i>j</i> . The tritium vegetation dose is calculated using χ/Q .	
K'''	Conversion Constant (1E3 gm per Kg)	[gm/Kg]
H	Absolute Atmospheric Humidity	[gm/m ³]
0.75	Water Fraction	dimensionless
	The fraction of total vegetation that is water.	
0.5	Specific Activity Ratio	dimensionless

A.1.4.3.2 Milk Ingestion Pathway Dose Factor

The dose factor for consumption of milk is calculated by the following expressions:

$$R_{ai(\text{Milk})} [D/Q] = K' \frac{Q_F (U_{am})}{\lambda_i + \lambda_w} F_m(r) (DFL_{aj}) \left[\frac{f_p f_s}{Y_p} + \frac{(1 - f_p f_s) e^{-\lambda_i t_h}}{Y_s} \right] e^{-\lambda_i t_r} \quad (\text{A-12})$$

$R_{ai(\text{Milk})} [D/Q]$	Milk Ingestion Pathway Dose Factor	[(m ² mrem/yr)/(μ Ci/sec)]
	Site-specific milk ingestion dose factor for age group <i>a</i> , nuclide <i>i</i> and organ <i>j</i> . With the exception of H-3, the milk dose factor is calculated using (D/Q).	
K'	Conversion Constant (1E6 pCi per μ Ci)	[pCi/ μ Ci]
Q_F	Feed Consumption	[Kg/da]
	Amount of feed consumed by milk animal each day. See Table C-1 of Appendix C.	
U_{am}	Milk Consumption Rate	[l/yr]
	Milk consumption rate for age group <i>a</i> .	
F_m	Stable Element Transfer Coefficient for Milk	[da/l]
	Fraction of animal's daily intake of a particular chemical element which appears in each liter of milk (pCi/l in milk per pCi/da ingested by animal). See Table C-3 of Appendix C.	
f_p	Pasture Time Fraction	dimensionless
	Fraction of year that animal is on pasture.	

f_s	Pasture Grass Fraction	dimensionless
	Fraction of animal feed that is pasture grass while animal is on pasture.	
Y_p	Agricultural Productivity Yield - Pasture Grass	[kg/m ²]
	The agricultural productivity by unit area of pasture feed grass.	
Y_s	Agricultural Productivity Yield - Stored Feed	[kg/m ²]
	The agricultural productivity by unit area of stored feed.	
t_h	Environmental Transport Time - Stored Feed	[sec]
	Average time between harvest to consumption of stored feed by milk animal.	
t_t	Environmental Transport Time - Pasture to Consumption	[sec]
	Average time from pasture, to milk animal, to milk, to consumption.	

All other terms have been previously defined.

The tritium dose from the milk pathway must be considered separately as the transport mechanism is based on airborne concentration rather than ground deposition. The dose factor for the tritium milk pathway is:

$$R_{a(H-3)(Milk)}[\chi/Q] = K'K''F_m Q_F U_{am} DFL_{a(H-3)} [0.75(0.5/H)] \quad (A-13)$$

$R_{a(H-3)(Milk)}[\chi/Q]$	Tritium Milk Ingestion Pathway Dose Factor	[(mrem/yr)/(μCi/m ³)]
	Site-specific tritium milk ingestion dose factor for age group a and organ j. The tritium milk dose is calculated using χ/Q .	
K''	Conversion Constant (1E3 gm per Kg)	[gm/Kg]
H	Absolute Atmospheric Humidity	[gm/m ³]
0.75	Water Fraction	dimensionless
	The fraction of total vegetation that is water.	
0.5	Specific Activity Ratio	dimensionless

All other terms have been previously defined.

A.1.4.3.3 Meat

The dose factor for consumption of meat is calculated by the following expression:

$$R_{a(Meat)}[D/Q] = K' \frac{Q_F(U_{af})}{\lambda_l + \lambda_w} F_r(r) (DFL_{aj}) \left[\frac{f_p f_s}{Y_p} + \frac{(1 - f_p f_s) e^{-\lambda_l t_h}}{Y_s} \right] e^{-\lambda_l t_t} \quad (A-14)$$

$R_{ai(\text{Meat})} [D/Q]$	Meat Ingestion Pathway Dose Factor	$[(m^2 \text{ mrem/yr})/(\mu\text{Ci/sec})]$
	Site-specific meat ingestion dose factor for age group a, nuclide i and organ j. With the exception of H-3, the meat dose factor is calculated using (D/Q).	
U_{af}	Meat Consumption Rate	$[l/yr]$
	Meat consumption rate for age group a.	
F_f	Stable Element Transfer Coefficient for Meat	$[da/Kg]$
	Fraction of animal's daily intake of a particular chemical element which appears in each liter of meat (pCi/Kg in meat per pCi/da ingested by animal). See Table C-3 of Appendix C.	
t_h	Environmental Transport Time - Stored Feed	$[sec]$
	Average time between harvest to consumption of stored feed by meat animal.	
t_f	Environmental Transport Time - Pasture to Consumption	$[sec]$
	Average time from pasture, to meat animal, to meat, to consumption.	

All other terms have been previously defined.

The tritium dose from the meat pathway must be considered separately as the transport mechanism is based on airborne concentration rather than ground deposition. The dose factor for the tritium meat pathway is:

$$R_{a(H-3)(\text{Meat})} [\chi/Q] = K' K'' F_f Q_F U_{af} DFL_{a(H-3)} [0.75(0.5/H)] \quad (\text{A-15})$$

$R_{a(H-3)(\text{Meat})} [\chi/Q]$	Tritium Meat Ingestion Pathway Dose Factor	$[(\text{mrem/yr})/(\mu\text{Ci}/m^3)]$
	Site-specific tritium meat ingestion dose factor for age group a and organ j. The tritium meat dose is calculated using χ/Q .	
K''	Conversion Constant (1E3 gm per Kg)	$[gm/Kg]$
H	Absolute Atmospheric Humidity	$[gm/m^3]$
0.75	Water Fraction	dimensionless
	The fraction of total vegetation that is water.	
0.5	Specific Activity Ratio	dimensionless

All other terms have been previously defined.

A.1.5 Dose Rate Due to Non-Noble Gas Radionuclides

Requirement

RETS limit the dose rate to any organ, due to radioactive materials in gaseous effluents released from a site to areas at and beyond the site boundary, to less than or equal to a dose rate of 1500 mrem/yr (see Section 12.4 of each station's RETS and Technical Specifications).

Typically the child is considered to be the limiting receptor in calculating dose rate to organs due to inhalation of non-noble gas radionuclides in gaseous effluents.

Equation

The dose rate to any child organ due to inhalation is calculated by the following expression:

$$D_{(Child)(Inhal)j}^{NNG} = \sum_i R_{(Child)(Inhal)j} \left\{ (\chi/Q)_s Q_{is} + (\chi/Q)_v Q_{iv} + (\chi/Q)_g Q_{ig} \right\} \quad (A-16)$$

The summation is over non-noble gas radionuclides *i*.

$D_{(Child)(Inhal)j}^{NNG}$ Inhalation Dose Rate [mrem/yr]

Dose rate to the child age group from radionuclide *i*, via the inhalation pathway to organ *j* due to non-noble gas radionuclides.

$R_{(Child)(Inhal)j}$ Inhalation Dose Factor [(mrem/yr)/(μCi/m³)]

Inhalation dose factor for child age group for radionuclide *i*, and organ *j*. This dose factor is defined by Equation A-9.

Q_{is}, Q_{iv}, Q_{ig} Radionuclide Release Rate [μCi/sec]

Measured release rate of radionuclide *i* from a stack, vent, or ground level release point, respectively.

All other terms have been previously defined.

Application

RETS require the dose rate due to non-noble gas radioactive materials in airborne effluents be determined to be within the above limit in accordance with a sampling and analysis program specified in the RETS (see Section 12.4 of each station's RETS and Technical Specifications).

To comply with this specification, each station obtains and analyzes samples in accordance with the sampling and analysis program in its RETS. The child organ dose rate due to inhalation is calculated in each sector at the location of the highest offsite χ/Q . The result for the sector with the highest organ inhalation dose rate is compared to the limit.

A.1.6 Operability and Use of Gaseous Effluent Treatment Systems

Requirement

10CFR50 Appendix I and the station RETS require that the ventilation exhaust treatment system and the waste gas holdup system be used when projected offsite doses in 31 days, due to gaseous effluent releases, from each reactor unit, exceed any of the following limits:

- 0.2 mrad to air from gamma radiation.
- 0.4 mrad to air from beta radiation.
- 0.3 mrem to any organ of a member of the public.

The nuclear power stations are required to project doses due to gaseous releases from the site at least once per 31 days.

Equation

Offsite doses due to projected releases of radioactive materials in gaseous effluents are calculated using Equations A-1, A-2 and A-7. Projected cumulative radionuclide releases are used in place of measured cumulative releases A_{is} , A_{iv} and A_{ig} .

Application

For a release attributable to a processing or effluent system shared by more than one reactor unit, the dose due to an individual unit is obtained by proportioning the effluents among the units sharing the system. The allocation procedure is specified in Chapter 10 of this manual.

A.2 LIQUID RELEASES

A.2.1 Dose

Requirement

The design objectives of 10CFR50, Appendix I and RETS provide the following limits on the dose to a member of the public from radioactive materials in liquid effluents released from each reactor unit to restricted area boundaries:

- During any calendar quarter, less than or equal to 1.5 mrem to the total body and less than or equal to 5 mrem to any organ.
- During any calendar year, less than or equal to 3 mrem to the total body and less than or equal to 10 mrem to any organ.

The organ doses due to radioactivity in liquid effluents are also used as part of the 40CFR190 compliance and are included in the combination of doses to determine the total dose used to demonstrate 10CFR20 compliance. (See Section A.4)

Dose assessments for 10CFR50 Appendix I compliance are made for four age groups (adult/teenager/child/infant) using NUREG 0133 (Reference 14) methodology and Regulatory Guide 1.109 (Reference 6) dose conversion factors.

Equation

The dose from radioactive materials in liquid effluents considers the contributions for consumption of fish and potable water. All of these pathways are considered in the dose assessment unless demonstrated not to be present. While the adult is normally considered the maximum individual, the methodology provides for dose to be calculated for all four age groups. The dose to each organ (and to the total body) is calculated by the following expression:

$$D_{aj}^{Liq} = F \Delta t \sum_p \sum_i A_{a|p|j} C_i \quad (A-17)$$

The summation is over exposure pathways p and radionuclides i.

D_{aj}^{Liq} Organ and Total Body Dose Due to Liquid Effluents [mrem]

Dose to organ j (including total body) of age group a due to radioactivity in liquid effluents.

F Near Field Average Dilution Factor dimensionless

Dilution in the near field averaged over the period of interest. Defined as:

$$F = \frac{\text{Waste Flow}}{\text{Dilution Flow} \times Z} \quad (A-18)$$

Waste Flow Liquid Radioactive Waste Flow [gpm]

The average flow during disposal from the discharge structure release point into the receiving water body.

Dilution Flow Dilution Water Flow During Period of Interest [gpm]

Z Discharge Structure Mixing Factor dimensionless

Site-specific factor to account for the mixing effect of the discharge structure. The factor addresses the dilution which occurs in the near field between the discharge structure and the body of water containing the fish in the liquid ingestion pathway. From Table F-1, Appendix F.

Δt Duration of Release [hrs]

C_i Average Radionuclide Concentration [$\mu\text{Ci/ml}$]

Average concentration of radionuclide i, in the undiluted liquid effluent during time period Δt .

$A_{a|p|j}$ Site-Specific Liquid Dose Factor [(mrem/hr)/($\mu\text{Ci/ml}$)]

Site-specific dose factor for age group a, nuclide i, liquid pathway p and organ j. The pathways included are potable water and fish ingestion. $A_{a|p|j}$ is defined for these pathways in the following sections. Values for $A_{a|p|j}$ are provided in Appendix F.

A 2.1.1 Potable Water Pathway

The site-specific potable water pathway dose factor is calculated by the following expression:

$$A_{a|(PW)|j} = K_o \left\{ \frac{U_a^w}{D^w} \right\} DFL_{a|j} \quad (A-19)$$

Where:

$A_{a (PWj)}$	Site-Specific Dose Factor for Potable Water Pathway Site-specific potable water ingestion dose factor for age group a, nuclide i and organ j.	[(mrem/hr)/(μ Ci/ml)]
k_o	Conversion Constant (1.14E05) Units constant to convert years to hours, pCi to μ Ci and liters to ml.	[(yr-pCi/ml)/(hr- μ Ci-l)]
U_a^w	Potable Water Consumption Rate Potable water consumption rate for age group a. Taken from Table E-5 of Regulatory Guide 1.109.	[l/yr]
D^w	Potable Water Dilution Factor Dilution factor from the near field area within one-quarter mile of the release point to the potable water intake. From Table F-1, Appendix F.	dimensionless
$DFL_{a j}$	Ingestion Dose Conversion Factor Ingestion dose conversion factor for age group a, nuclide i and organ j. Converts pCi ingested to mrem. Taken from Tables E-11 through E-14 of Regulatory Guide 1.109. The values for H-3 and Sr-90 are taken from NUREG 4013 (Reference 107).	[mrem/pCi]

A.2.1.2 Fish Ingestion Pathway

The site-specific fish ingestion pathway dose factor is calculated by the following expression:

$$A_{a|(Fishj)} = k_o U_a^F B F_i D F L_{a|j} \quad (A-20)$$

Where:

$A_{a (Fishj)}$	Site-Specific Dose Factor for Potable Water Pathway Site-specific fish ingestion dose factor for age group a, nuclide i and organ j.	[(mrem/hr)/(μ Ci/ml)]
U_a^F	Fish Consumption Rate Fish consumption rate for age group a. Taken from Table E-5 of Regulatory Guide 1.109.	[kg/yr]
$B F_i$	Bioaccumulation Factor Bioaccumulation factor for nuclide i in fresh water fish. Taken from Table C-8 of Appendix C.	[(pCi/kg)/(pCi/l)]

All other terms have been previously defined.

Application

RETS require determination of cumulative and projected dose contributions from liquid effluents for the current calendar quarter and the current calendar year at least once per 31 days. (see Section 12.3 of each station's RETS and/or Technical Specifications).

For a release attributable to a processing or effluent system shared by more than one reactor unit, the dose due to an individual unit is obtained by proportioning the effluents among the units sharing the system. The allocation procedure is specified in ODCM Chapter 10.

A.2.2 Liquid Effluent Concentrations Requirement

Requirement

One method of demonstrating compliance to the requirements of 10CFR20.1301 is to demonstrate that the annual average concentrations of radioactive material released in gaseous and liquid effluents do not exceed the values specified in 10CFR20 Appendix B, Table 2, Column 2. (See 10CFR 20.1302(b)(2).) However, as noted in Section A.5.1, this mode of 10CFR20.1301 compliance has not been elected.

As a means of assuring that annual concentration limits will not be exceeded, and as a matter of policy assuring that doses by the liquid pathway will be ALARA; RETS provides the following restriction:

"The concentration of radioactive material released in liquid effluents to unrestricted areas shall be limited to ten times the concentration values in Appendix B, Table 2, Column 2 to 10CFR20.1001-20.2402."

This also meets the requirement of Station Technical Specifications and RETS.

Equation

According to the footnotes to 10CFR20 Appendix B, Table 2, Column 2, if a radionuclide mix of known composition is released, the concentrations must be such that

$$\sum_i \left(\frac{C_i}{10 ECL_i} \right) \leq 1 \tag{A-21}$$

where the summation is over radionuclide i.

C_i Radioactivity Concentration in Liquid Effluents to the Unrestricted Area [$\mu\text{Ci/ml}$]

Concentration of radionuclide i in liquid released to the unrestricted area.

ECL_i Effluent Concentration Limit in Liquid Effluents Released to the Unrestricted Area [$\mu\text{Ci/ml}$]

The allowable annual average concentration of radionuclide i in liquid effluents released to the unrestricted area. This concentration is specified in 10CFR20 Appendix B, Table 2; Column 2. Concentrations for noble gases are different and are specified in the stations' Technical Specifications/RETS.

10 Multiplier to meet the requirements of Technical Specifications.

If either the identity or concentration of any radionuclide in the mixture is not known, special rules apply. These are given in the footnotes in 10CFR20 Appendix B, Table 2, Column 2.

Application

The RETS and Technical Specifications require a specified sampling and analysis program to assure that liquid radioactivity concentrations at the point of release are maintained within the required limits.

To comply with this provision, each nuclear power station obtains and analyzes samples in accordance with the radioactive liquid waste (or effluent) sampling and analysis program in its RETS. Radioactivity concentrations in tank effluents are determined in accordance with Equation A-22 in the next section. Comparison with the Effluent Concentration Limit is made using Equation A-21.

A.2.3 Tank Discharges

When radioactivity is released to the unrestricted area with liquid discharge from a tank (e.g., a radwaste discharge tank), the concentration of a radionuclide in the effluent is calculated as follows:

$$C_i = C_i^t \frac{\text{Waste Flow}}{\text{Dilution Flow}} \quad (\text{A-22})$$

C_i	Concentration in Liquid effluent to the unrestricted area.	[$\mu\text{Ci/ml}$]
	Concentration of radionuclide i in liquid released to the unrestricted area.	
C_i^t	Concentration in the Discharge Tank	[$\mu\text{Ci/ml}$]
	Measured concentration of radionuclide i in the discharge tank.	

All other terms have been previously defined.

A.2.4 Tank Overflow

Requirement

To limit the consequences of tank overflow, the RETS/Technical Specifications may limit the quantity of radioactivity that may be stored in unprotected outdoor tanks. Unprotected tanks are tanks that are not surrounded by liners, dikes, or walls capable of holding the tank contents and that do not have tank overflows and surrounding area drains connected to the liquid radwaste treatment system. The specific objective is to provide assurance that in the event of an uncontrolled release of a tank's contents, the resulting radioactivity concentrations beyond the unrestricted area boundary, at the nearest potable water supply and at the nearest surface water supply, will be less than the limits of 10CFR20 Appendix B, Table 2; Column 2.

The Technical Specifications and RETS may contain a somewhat similar provision. For most nuclear power stations, specific numerical limits are specified on the number of curies allowed in affected tanks.

Application

Table F-1 of Appendix F provides information on the limits applicable to affected stations. The limits are as stated for some stations in the station Technical Specifications.

A.2.5 Operability and Use of the Liquid Radwaste Treatment System

Requirement

The design objectives of 10CFR50, Appendix I and RETS/Technical Specifications require that the liquid radwaste treatment system be operable and that appropriate portions be used to reduce releases of radioactivity when projected doses due to the liquid effluent from each reactor unit to restricted area boundaries exceed either of the following (see Section 12.3 of each station's RETS or Technical Specifications);

- 0.06 mrem to the total body in a 31 day period.
- 0.2 mrem to any organ in a 31 day period.

Equation

Offsite doses due to projected releases of radioactive materials in liquid effluents are calculated using Equation A-17. Projected radionuclide release concentrations are used in place of measured concentrations, C_r .

A.2.6 Drinking Water

Five nuclear power stations (Braidwood, Dresden, LaSalle, Quad Cities, and Zion) have requirements for calculation of drinking water dose that are related to 40CFR141, the Environmental Protection Agency National Primary Drinking Water Regulations. These are discussed in Section A.6.

A.2.7 Non-routine Liquid Release Pathways

Cases in which normally non-radioactive liquid streams (such as the Service Water) are found to contain radioactive material are non-routine will be treated on a case specific basis if and when this occurs. Since each station has sufficient capacity to delay a liquid release for reasonable periods of time, it is expected that planned releases will not take place under these circumstances. Therefore, the liquid release setpoint calculations need not and do not contain provisions for treating multiple simultaneous release pathways.

A.3 DOSE DUE TO CONTAINED SOURCES

There are presently two types of contained sources of radioactivity which are of concern in Exelon Nuclear offsite radiological dose assessments. The first source is that due to gamma rays from nitrogen-16 (^{16}N) carried over to the turbine in BWR (boiling water reactor) steam. The second source is that due to gamma rays associated with radioactive material resident in onsite radwaste storage facilities. Gamma radiation from these sources contributes to the total body dose.

A.3.1 BWR Skyshine

The contained onsite radioactivity source which results in the most significant offsite radiation levels at Exelon Nuclear nuclear power stations is skyshine resulting from ^{16}N decay inside turbines and steam piping at boiling water reactor (BWRs).

The ^{16}N that produces the skyshine effect is formulated through neutron activation of the oxygen atoms (oxygen-16, or ^{16}O) in reactor coolant as the coolant passes through the operating reactor core. The ^{16}N travels with the steam produced in the reactor to the steam driven turbine. While the ^{16}N is in transport, it radioactively decays with a half-life of about 7 seconds and produces 6 to 7 MeV gamma rays. Typically, offsite dose points are shielded from a direct view of components containing ^{16}N , but there can be skyshine radiation at offsite locations due to scattering of gamma rays off the mass of air above the steamlines and turbine.

The offsite dose rate due to skyshine has been found to have the following dependencies:

- The dose rate decreases as distance from the station increases.
- The dose rate increases non-linearly as the power production level increases.
- The dose rate increases when hydrogen is added to the reactor coolant, an action taken to improve reactor coolant chemistry characteristics (see Reference 39).

To calculate offsite dose due to skyshine in a given time period, a BWR must track the following parameters:

- The total gross energy E_h produced with hydrogen being added.
- The total gross energy E_o produced without hydrogen being added.

The turbines at BWR sites are sufficiently close to each other that energy generated by the two units at each site may be summed.

An initial estimate of BWR skyshine dose is calculated per the following equation:

$$D^{Sky} = (K)(E_o + M_h E_h) \sum_k \{ OF_k SF_k e^{-0.007R_k} \} \quad (A-23)$$

The summation is over all locations k occupied by a hypothetical maximally exposed member of the public characterized by the parameters specified in Table F-8 of Appendix F of the Dresden, LaSalle, and Quad Cities ODCMs. The parameters in Equation A-23 are defined as follows:

D^{Sky}	Dose Due to N-16 Skyshine	[mrem]
	External direct gamma dose due to BWR N-16 skyshine for the time period of interest.	
K	Empirical Constant	[mrem/(MWe-hr)]
	A constant determined by fitting data measured at each station.	
E_o	Electrical Energy Generated Without Hydrogen Addition	[MWe-hr]
	Total gross electrical energy generated without hydrogen addition in the time period of interest.	
E_h	Electrical Energy Generated with Hydrogen Addition	[MWe-hr]
	Total gross electrical energy generated with hydrogen addition in the period of interest.	
M_h	Multiplication Factor for Hydrogen Addition	dimensionless
	Factor applied to offsite dose rate when skyshine is present. Hydrogen addition increases main steam line radiation levels typically up to a factor of approximately 5 (see Page 8-1 of Reference 39). M_h is station specific and is given in Table F-8, Appendix F of Dresden, LaSalle and Quad Cities ODCMs.	
OF_k	Occupancy Factor	dimensionless
	The fraction of time that the dose recipient spends at location k during the period of interest. See Table F-8, Appendix F of Dresden, LaSalle and Quad Cities ODCMs.	
SF_k	Shielding Factor	dimensionless
	A dimensionless factor that accounts for shielding due to occupancy of structures.	

	$SF_k = 0.7$ if there is a structure at location k ;	
	$SF_k = 1.0$ otherwise. See Table F-8, Appendix F of Dresden, LaSalle and Quad Cities ODCMs.	
0.007	Empirical Constant	$[m^{-1}]$
	A constant determined by fitting data measured at the Dresden station (see Reference 45).	
R_k	Distance	$[m]$
	Distance from the turbine to location k . See Table F-8, Appendix F of Dresden, LaSalle and Quad Cities ODCMs.	

A.3.2 Dose from Onsite Radwaste Storage Facilities

Low-level radioactive waste may be stored at any, or all Exelon Nuclear nuclear power stations in the following types of storage facilities:

- Interim Radwaste Storage Facility (IRSF)
- Concrete vaults containing 48 radwaste liners (48-Pack)
- Dry Active Waste (DAW) facilities
- Butler buildings/warehouses
- Steam generator storage facilities
- Independent Spent Fuel Storage Installation (ISFSI) facilities

The "48-Pack" is a shielded concrete vault which is designed to hold three tiers of radwaste liners in a four by four array. The outer shell of the "48-Pack" is a three-foot thick concrete wall and a two and one-half foot thick concrete cover slab. The vault is placed on a poured concrete slab. The liners may have an average surface dose rate of fifteen (15) rem per hour (or up to 380 rem/hr if a 50.59 evaluation has been completed).

The DAW facility will contain low-level radioactive waste that would result in dose rates less than the 10CFR20 requirements.

The dose rates resulting from these radwaste and spent fuel storage facilities will be monitored frequently as they are being utilized, and if necessary, a dose calculation model similar to that of Equation A-23 will be developed and placed in the ODCM.

A.4 Total Dose Limits (10CFR20 and 40CFR190)

The regulatory requirements of 10CFR20 and 40CFR190 each limit total dose to individual members of the public without regard to specific pathways. The only significant exposure pathways for light water reactors included in 10CFR20 and 40CFR190 not addressed by 10CFR50 Appendix I are the direct radiation pathway and exposure from on-site activity by members of the public. Sections A.1 and A.2 considered organ doses from the gaseous and liquid effluent streams for purposes of compliance with 10CFR50 Appendix I. Section A.3 addresses the direct radiation component that must be considered for 10CFR20 and 40CFR190 compliance. The following sections will describe the methodology of assessing direct radiation dose and then the manner in which the various doses are combined to obtain the appropriate "total" for regulatory compliance purposes.

Although annual dose limits in 10CFR20 are now expressed in terms of Total Effective Dose Equivalent (TEDE) 40CFR190 limits are still stated as organ dose. The NRC continues to require 10CFR50 Appendix

1 and 40CFR190 doses to be reported in terms of organ dose. Due to the fact that organ dose limits set forth in 40CFR190 are substantially lower than those of 10CFR20 (25 mrem/yr vs 100 mrem/yr), the NRC has stated that demonstration of compliance with the dose limits in 40CFR190 will be deemed as demonstration of compliance with the dose limits of 10CFR20 for most facilities (Reference 104). In addition to compliance with 40CFR190 it may be necessary for a nuclear power plant to address dose from on-site activity by members of the public.

A.4.1 External Total Body Dose

The external total body dose is comprised of the following parts:

- 1) Total body dose due to noble gas radionuclides in gaseous effluents (Section A.1.2),
- 2) Dose due to N-16 skyshine and other contained sources (Sections A.3.1 and A.3.2) and
- 3) Total body dose due to radioactivity deposited on the ground (Section A.1.4.1).

The external total body dose due to radioactivity deposited on the ground is accounted for in the determination of the non-noble gas dose (See Equations A-7 and A-8) and is not considered here.

The total external total body dose, D^{Ex} , is given by:

$$D^{Ex} = D^{TB} + D^{Sky} + D^{OSF} \quad (A-24)$$

D^{Ex} Total External Total Body Dose [mrem]

Total external total body dose due to irradiation by external sources at the location of interest.

D^{TB} Noble Gas Total Body Dose [mrem]

External total body dose due to gamma radiation from noble gas radionuclides released in gaseous effluents at the location of interest. See Equation A-3.

D^{Sky} N-16 Skyshine Total Body Dose [mrem]

External total body dose due to N-16 skyshine for the period and location of interest. See Equation A-23.

D^{OSF} Dose From On-Site Storage Facilities [mrem]

External total body dose due to gamma radiation from on-site storage facilities at the location of interest. See Section A.3.2.

A.4.2 Total Dose

The total dose, D^{Tot} , in the unrestricted area to a member of the public due to plant operations is given by:

$$D^{Tot} = D^{Ex} + D_{aj}^{Liq} + D_{aj}^{NNG} \quad (A-25)$$

where:

D^{Tot} Total Dose To Member of Public [mrem]

Total off-site dose to a member of public due to plant operations.

D^{Ex} Total External Total Body Dose [mrem]

Total body dose due to external exposure to noble gases, N-16 skyshine and on-site storage facilities.

D_{aj}^{Liq} Liquid Effluent Dose [mrem]

Dose due to liquid effluents to age group *a* and organ *j*. The age group and organ with the highest dose from liquid effluents is used.

D_{aj}^{NNG} Non-Noble Gaseous Effluent Dose [mrem]

Dose due to non-noble gaseous effluents to age group *a* and organ *j*. The age group and organ with the highest dose from non-noble gas effluents is used.

A.5 COMPLIANCE TO TOTAL DOSE LIMITS

A.5.1 Total Effective Dose Equivalent Limit - 10CFR20 Compliance

Requirement

Each station's RETS limits the Total Effective Dose Equivalent (TEDE) to an annual limit of 100 mrem, as required by 10CFR20.1301 (a)(1). Demonstration of compliance with the limits of 40CFR190 (per Section 4.5.2) will be considered to demonstrate compliance with the 100 mrem/year limit.

A.5.1.1 Dose to a Member of the Public in the Unrestricted Area

The NRC has stated that demonstration of compliance with the limits of 40CFR190 or with the design objectives of Appendix I to 10CFR50 will be deemed to demonstrate compliance with the limits of 10CFR20.1301(a)(1). Power reactors that comply with Appendix I may also have to demonstrate that they are within the 25 mrem limit of 40CFR190 (See Reference 104).

A.5.1.2. Dose to a Member of the Public in the Restricted Area

In August of 1995, a revision to 10CFR20 was implemented that changed the definition of a member of the public. As a result, for each nuclear station, estimated doses were calculated for a member of the public who enters the site boundary, but is not authorized for unescorted access to the protected area of the site and does not enter any radiologically posted areas on the site. Realistic assumptions were made for occupancy times and locations visited while within the site boundary.

These evaluations indicate that the doses estimated for these members of the public are well within the 10CFR20 limits. These dose evaluations will be performed annually and if necessary, a model will be developed and included in the ODCM.

Application

Evaluation of the 40CFR190 dose is used to demonstrate compliance to 10CFR20 and satisfy station RETS and Technical Specifications (see Chapter 12).

A.5.2 Total Dose due to the Uranium Fuel Cycle (40CFR190)

Requirement

RETS and 40CFR190 limit the annual (calendar year) dose or dose commitment to any member of the public due to releases of radioactivity and to radiation from uranium fuel cycle sources to the following:

- Less than or equal to 25 mrem to the total body.
- Less than or equal to 25 mrem to any organ except the thyroid.
- Less than or equal to 75 mrem to the thyroid.

Total Dose Components

This requirement includes the total dose from operations at the nuclear power station. This includes doses due to radioactive effluents (airborne and liquid) and dose due to direct radiation from non-effluent sources (e.g., sources contained in systems on site). It also includes dose due to plants under consideration, neighboring plants and dose due to other facilities in the uranium fuel cycle.

The operations comprising the uranium fuel cycle are specified in 40CFR190.02(b). The following are included to the extent that they directly support the production of electrical power for public use utilizing nuclear energy:

- Milling of uranium ore.
- Chemical conversion of uranium.
- Isotopic enrichment of uranium.
- Fabrication of uranium fuel.
- Generation of electricity by a light-watered-cooled nuclear power plant using uranium fuel.
- Reprocessing of spent uranium fuel.

Excluded are:

- Mining operations.
- Operations at waste disposal sites.
- Transportation of any radioactive material in support of these operations.
- The re-use of recovered non-uranium special nuclear and by-product materials from the cycle.

When Compliance Assessment is Required

Compliance with the 40CFR190 regulations is now required as part of demonstration of compliance to 10CFR20 regulations per 10CFR20.1301(d).

Equation

The dose due to the uranium fuel cycle is determined by equation A-25.

A.5.3 Summary of Compliance Methodology

The required compliance is given in Tables 2-1, 2-2 and 2-3. In Table 2-1, the dose components are itemized and referenced, and an indication of their regulatory application is noted. A more detailed

compliance matrix is given in Table 2-3. The locations of dose receivers for each dose component are given in Table 2-2.

Further, Table 2-2 states the location of the receiver and occupancy factors, if applicable. In general, the receiver spends time in locations that result in maximum direct dose exposure and inhales and ingests radioactivity from sites that yield maximum pathway doses. Thus, the dose calculated is a very conservative one compared to the "average" receiver who does not go out of his way to maximize radioactivity uptakes. Finally, the connection between regulations, the ODCM equations and the station RETS and Technical Specifications is given in Table 12-0.

A.6 DOSE DUE TO DRINKING WATER (40CFR141)

The National Primary Drinking Water Regulations, 40CFR141, contain the requirements of the Environmental Protection Agency applicable to public water systems. Included are limits on radioactivity concentration. Although these regulations are directed at the owners and operators of public water systems, several stations have requirements in their Technical Specifications related to 40CFR141.

A.6.1 40CFR141 Restrictions on Manmade Radionuclides

Section 141.16 states the following (not verbatim):

- (a) The average annual concentration of beta particle and photon radioactivity from man-made radionuclides in drinking water shall not produce an annual dose equivalent to the total body or any internal organ greater than 4 millirem/year.
- (b) Except for the radionuclides listed in Table A-0, the concentration of man-made radionuclides causing 4 mrem total body or organ dose equivalents shall be calculated on the basis of drinking 2 liter of water per day. (Using the 168 hour data listed in "Maximum Permissible Body Burdens and Maximum Permissible Concentration of Radionuclides in Air or Water for Occupational Exposure," NBS Handbook 69 as amended August 1963, U.S. Department of Commerce.). If two or more radionuclides are present, the sum of their annual dose equivalents to the total body or any organ shall not exceed 4 millirem/year.

TABLE A-0
AVERAGE ANNUAL CONCENTRATIONS ASSUMED TO
PRODUCE A TOTAL BODY OR ORGAN DOSE OF 4 MREM/YR

Radionuclide	Critical Organ	pCi / liter
Tritium	Total body	20,000
Strontium-90	Bone marrow	8

A.6.2 Application

The projection or calculation of dose due to the drinking water pathway is made using Equations A-17 and A-19. Projections are made using projected radionuclide releases in place of measured releases A_r . Doses calculated using Equations A-17 and A-19 may differ from doses determined by the methodology prescribed in 40CFR141.16.

When required, a nuclear power station prepares a special report on radiological impact at the nearest community water system. This system is taken as the one listed in Table A-3 of this appendix. The report should include the following:

- The doses calculated by Equations A-17 and A-19.
- A statement identifying the dose calculation methodology (e.g., a reference to this manual).
- A statement that the doses calculated by the ODCM methodology are not necessarily the same as doses calculated by the methodology prescribed in 40CFR141.16.
- The data used to calculate the doses. This information includes the amounts of radioactivity released and the flow rate and dilution values used (see Table F-1). This information is provided to assist the operator of the community water system in performing its own dose assessment.

Table A-1

COMPLIANCE MATRIX

Regulation	Dose to be compared to limit
10CFR50 Appendix I	<ul style="list-style-type: none"> • Gamma air dose and beta air dose due to airborne radioactivity in effluent plume. • Total body and skin dose due to airborne radioactivity in effluent plume are reported only if certain gamma and beta air dose criteria are exceeded. • Dose for all organs and all four age groups due to iodine and particulate in effluent plume. Existing pathways are considered. • Dose for all organs and all four age groups due to radioactivity in liquid effluents.
10CFR20	<ul style="list-style-type: none"> • Adherence determined by compliance with dose limits of 40CFR190.
40CFR190 (now, by reference, also part of 10CFR20)	<ul style="list-style-type: none"> • Total body dose due to direct radiation, ground and plume exposure from all sources at a station. • Organ doses to an adult due to all pathways.
RETS/ODCM	<ul style="list-style-type: none"> • "Instantaneous" noble gas total body and skin dose rates and radioiodine, tritium and particulate inhalation dose rates to a child due to radioactivity in airborne effluents. • "Instantaneous" concentration limits for liquid effluents.

Table A-2

Release Point Classifications

<u>Station</u>	<u>Release Point</u>	<u>Release Point Classification^a</u>
Braidwood 1 & 2	Vent Stacks	Vent (Mixed Mode)
Byron 1 & 2	Vent Stacks	Vent (Mixed Mode)
Dresden 1	Plant Chimney Chemical Cleaning	Stack (Elevated) Vent (Mixed Mode)
Dresden 2 & 3	Chimney	Stack (Elevated)
	Reactor Building Ventilation Exhaust Stack	Vent (Mixed Mode)
LaSalle 1 & 2	Main Station Vent Stack	Stack (Elevated)
	Standby Gas Treatment Stack ^b	Stack (Elevated)
Quad Cities 1 & 2	Chimney	Stack (Elevated)
	Reactor Building Ventilation Exhaust Stack	Vent (Mixed Mode)
Zion 1 & 2	Vent Stacks	Ground Level

^aThe definitions of release point classifications (stack, vent and ground level) are given in Section 4.1.4.

^bThe LaSalle standby gas treatment stack is located inside the main station vent stack.

Table A-3

Nearest Downstream Community Water Systems

**Characteristics of Nearest
Affected Downstream Community
Water Supply**

<u>Station</u>	<u>Exelon Nuclear Facilities Upstream of Station</u>	<u>Location and Distance^a</u>	<u>Other Exelon Nuclear Stations Upstream of Water Supply</u>
Braidwood	None	Wilmington, 5 river miles	None
Byron	None	None within 115 river miles	NA ^b
Dresden	Braidwood	Peoria, 106 river miles	Braidwood LaSalle
LaSalle	Braidwood Dresden	Peoria, 97 river miles	Braidwood Dresden
Quad Cities	None	E. Moline, 16 river miles	None
Zion	None	Lake County Intake, 1.4 miles	None

^aODCM Bases and Reference Document (Reference 101) Table O-2 and O-6 provide the bases of the location and distance data.

^bNA = not applicable. For purposes of the calculations in the ODCM, there are no community water supplies affected by liquid effluents from Byron Station. This is based on the absence of community water supplies between the Byron Station liquid discharge to the Rock River and the confluence of the Rock and Mississippi Rivers, 115 miles downstream.

Table A-4
40CFR190 Compliance

40CFR190 Dose	Annual Limit (mrem)	ODCM Dose and Equation Number
Total Body	25	Total Body Dose; A-25 evaluated for total body
Thyroid	75	Thyroid Dose; A-25 evaluated for thyroid
Other Organs	25	Organ Dose; A-25 evaluated for all organs except thyroid

Notes:

1. The evaluation is made considering the following sources:
 - a. Radioactivity in contained sources within the station;
 - b. Radioactivity in station gaseous and liquid effluents;
 - c. Dose contributions from neighboring stations and other facilities in the nuclear fuel cycle.

APPENDIX B

MODELS AND PARAMETERS FOR AIRBORNE and LIQUID EFFLUENT CALCULATIONS

TABLE OF CONTENTS

	<u>PAGE</u>
SECTION 1: Models and Parameters for AIRBORNE Effluent Calculations	
B.0 INTRODUCTION	B-1
B.1 METEOROLOGICAL DATA AND PARAMETERS	B-1
1. Data	B-2
2. Joint Frequency Distribution	B-2
1. Downwind Direction Versus Upwind Direction	B-2
2. Stack JFD	B-3
3. Ground Level JFD	B-3
4. Vent JFDs	B-3
3. Average Wind Speed	B-4
1. Stack Release	B-5
2. Ground Level Release	B-5
3. Vent Release	B-5
B.2 GAUSSIAN PLUME MODELS	B-6
1. Mathematical Representation	B-6
2. Sector-Averaged Concentration	B-7
B.3 RELATIVE CONCENTRATION FACTOR γ/Q	B-7
1. Stack Release	B-8
1. Effective Release Height	B-9
1. Plume Rise	B-10
2. Terrain Effects	B-11
2. Ground Level Release	B-11
3. Vent Release	B-12
4. Removal Mechanisms	B-12
5. Gamma- γ/Q	B-13
B.4 RELATIVE DEPOSITION FACTOR D/Q	B-14
1. Stack Release	B-15
2. Ground Level Release	B-16
3. Vent Release	B-16
B.5 GAMMA AIR DOSE FACTORS (S_i, V_i, G_i)	B-17
1. Stack Release	B-17
2. Ground Level Release	B-19
3. Vent Release	B-19

APPENDIX B
Table of Contents (Cont'd)

	<u>PAGE</u>	
B.6	GAMMA TOTAL BODY DOSE CONVERSION FACTORS (K_i)	B-20
B.7	BETA AIR AND SKIN DOSE FACTORS (N_i, L_i)	B-20
B.8	GROUND PLANE DOSE CONVERSION FACTOR DFG_i	B-20
B.9	INHALATION DOSE COMMITMENT FACTOR $DFA_{ij,a}$	B-20
B.10	INGESTION DOSE COMMITMENT FACTOR $DFI_{ij,a}$	B-20
B.11	MEASURED RELEASE PARAMETERS	B-21
B.12	RADIOLOGICAL DECAY CONSTANTS	B-21
B.13	PRODUCTION/EXPOSURE PARAMETERS	B-21
SECTION 2: Models and Parameters for LIQUID Effluent Calculations:		
B.14	INTRODUCTION	B-22
B.15	DOSE	B-22
	1. Drinking Water	B-22
	2. Aquatic Foods (Fish)	B-22
	3. Parameters	B-23
	1. Flow and Dilution	B-23
	1. River Model	B-23
	2. Lake Michigan Model	B-23
	2. Dose Factors	B-23
	3. Measured Releases	B-23
	4. Consumption	B-24
B.16	CONCENTRATION IN TANK DISCHARGES	B-24

APPENDIX B

LIST OF TABLES

<u>NUMBER</u>	<u>TITLE</u>	<u>PAGE</u>
B-0	Noble Gas Nuclide Fraction	B-25
B-1	Portion of an Example Joint Frequency Distribution	B-26

LIST OF FIGURES

<u>NUMBER</u>	<u>TITLE</u>	<u>PAGE</u>
B-1	Instantaneous View of a Plume	B-27
B-2	A Gaussian Curve	B-28
B-3	Effect of Observation Period on Plume Shape	B-29
B-4	A Gaussian Plume	B-30

SECTION 1: MODELS AND PARAMETERS FOR AIRBORNE EFFLUENT CALCULATIONS

B.0 INTRODUCTION

The equations used for calculation of doses due to radioactive airborne effluents are given in Section A.1 of Appendix A. The equations involve the following types of parameters:

- **Meteorological Parameters**
These include χ/Q , gamma- χ/Q , D/Q and wind speed. Their values are based on historical average atmospheric conditions at a site for a selected multi-year historical period (see Section 4.1.5).
- **Dose Factors**
These parameters are used to provide a simple way to calculate doses and dose rates due to gamma and beta radiation. These parameters are independent of meteorological conditions and therefore generic (i.e., not station-specific).
- **Measured Release Parameters**
These are measured values of radioactivity releases and release rates.
- **Radiological Decay Constants**
These are used to account for the radioactive decay between the release of radioactivity to the environment and the exposure of persons to it.
- **Production/Exposure Parameters**
These are parameters characterizing agricultural production (e.g., length of growing season, transport times) and human exposure patterns (e.g., exposure period, breathing rate, food consumption rates). These parameters affect the quantities of radioactivity to which persons may be exposed.

This appendix discusses the methodology used to determine values of these parameters. Section B.1 addresses how the historical meteorology of a site is characterized by use of a function called the joint frequency distribution. Section B.1 and Sections B.3 through B.5 present equations that use the joint frequency distribution to obtain values for site-specific meteorological parameters. These equations involve a mathematical model of a plume known as the Gaussian plume model. This model is developed in Section B.2. Various generic dose factors are discussed in Sections B.6 through B.10. The other parameters are discussed in the remaining sections.

B.1 METEOROLOGICAL DATA AND PARAMETERS

Predicting where airborne effluent will travel requires information on the following:

- Wind speed
- Wind direction
- Atmospheric turbulence

The greater the atmospheric turbulence, the more an effluent plume will tend to broaden and the more dilute the concentration will be. Atmospheric turbulence is affected by the general condition of the atmosphere (e.g., the vertical temperature distribution) and by local features (e.g., objects that protrude into the wind stream). A commonly used classification scheme for the degree of atmospheric turbulence associated with the general condition of the atmosphere involves seven stability classes:

- A Extremely Unstable
- B Moderately Unstable
- C Slightly Unstable
- D Neutral

- E Slightly Stable
- F Moderately Stable
- G Extremely Stable

This classification scheme is based on Reference 5, Table 1. Each class is associated with a particular range of wind direction fluctuations and of vertical temperature gradients in the atmosphere. These are specified in Table C-4 of Appendix C.

B.1.1 Data

Historical atmospheric conditions at each nuclear power station were recorded by an instrumented meteorological tower that measured wind speed, wind direction, and temperature at various heights. Hourly average values of wind speed, wind direction, and stability class were determined. The difference in temperature between two heights was used to assign an atmospheric stability class based on the correlation between temperature gradient and stability class in Table C-4 of Appendix C.

In obtaining the data, quality assurance checks and corrections were made. Also, corrections were applied to compensate for the limitations of wind sensors at low speeds. A calm was said to exist if the wind speed was less than that of the threshold of either the anemometer (wind speed meter) or the wind direction vane. For calm conditions, a wind speed equal to one-half of the higher threshold was assigned. For each stability class, the wind directions during calm conditions were assumed to be distributed in proportion to the observed wind direction distribution of the lowest non-calm wind speed class.

B.1.2 Joint Frequency Distribution

The data for a particular historical period are summarized by developing a joint frequency distribution (JFD). Each such distribution specifies the fraction of time during the historical period that the following jointly occur:

- Wind speed within a particular range (wind speed class).
- Downwind direction in one of the 16 sectors corresponding to the 16 principal compass directions (N, NNE, etc.).
- Atmospheric conditions corresponding to one of the seven atmospheric stability classes discussed in Section B.1. Table B-1 of this appendix displays a portion of an example JFD.

Different JFDs are associated with the different release classifications defined in Section 4.1.4. One JFD is defined for stack releases, and another JFD is defined for ground level releases. Two JFDs are associated with vent (mixed mode) releases, one for the portion of the time the release is treated as elevated and the other for the portion of the time the release is treated as ground level.

B.1.2.1 Downwind Direction Versus Upwind Direction

Unless otherwise noted, any reference to wind direction in this document represents downwind direction, i.e., the direction in which the wind is blowing toward. This is because the parameters developed in this document are used to calculate radioactivity concentration and radiation dose downwind of a release point. In contrast, it is conventional for meteorologists to provide JFDs based on upwind direction, the direction from which the wind is blowing. For example, the JFDs presented in the annual operating reports of the nuclear power stations are obtained from a meteorological contractor and the directions specified in the reports are upwind directions. Users of JFDs should always be careful to ascertain whether the directions specified are upwind or downwind.

B.1.2.2 Stack JFD

For a stack release, the JFD is defined as follows:

$\Sigma f_s(n, \theta, c)$ Joint Frequency Distribution, Stack Release

The fraction of hours during a period of observation that all of the following hold:

- The average wind speed is within wind speed class n .
- The downwind direction is within the sector denoted by θ .
- The atmospheric stability class is c .

This function is defined for application to a stack release point (see Section 4.1.4). Its value is based on hourly average wind data obtained at a height representative of the release point height.

The stack JFD is normalized to 1:

$$\Sigma f_s(n, \theta, c) = 1 \quad \text{(B-1)}$$

The summation is over all wind speed classes n , all compass direction sectors θ , and all stability classes c .

B.1.2.3 Ground Level JFD

For a ground level release, the JFD $f_g(n, \theta, c)$ is defined in the same way as for a stack release except that the wind data are obtained at a height representative of a ground level release point. This height is taken as about 10 meters.

The ground level JFD is normalized to 1:

$$\Sigma f_g(n, \theta, c) = 1 \quad \text{(B-2)}$$

The summation is over all wind speed classes n , all compass direction sectors, and all stability classes c .

B.1.2.4 Vent JFDs

In accordance with the approach recommended in Regulatory Guide 1.111 (Reference 7), the plume from a vent release is treated as elevated part of the time and as ground level the rest of the time. Two JFDs are determined:

- $f_{v, elev}(n, \theta, c)$ characterizes the plume during the part of the time that it is considered elevated;
- $f_{v, gnd}(n, \theta, c)$ characterizes the plume during the part of the time that it is considered ground level.

Their definitions are as follows:

$f_{v, elev}(n, \theta, c)$ Joint Frequency Distribution, Elevated Portion of a Vent Release

The fraction of hours during a period of observation that the plume is considered elevated and that all of the following hold:

- The average wind speed is within wind speed class n .
- The downwind direction is within the sector denoted by θ .
- The atmospheric stability class is c .

$f_{v,gnd}(n,\theta,c)$ Joint Frequency Distribution,
Ground Level Portion of a Vent Release

The fraction of hours during a period of observation that the plume is considered ground level and that all of the following hold:

- The average wind speed is within wind speed class n .
- The downwind direction is within the sector denoted by θ .
- The atmospheric stability class is c .

The value of $f_{v,elev}(n, \theta, c)$ is based on hourly average wind data at a height representative of the vent release point. Where the measurement height differed considerably from the release height, wind speed data for the release height was obtained by extrapolation. The value of $f_{v,gnd}(n, \theta, c)$ is based on hourly average wind data obtained at a height representative of a ground level release point. This is taken as about 10 meters.

The sum of these two JFDs is normalized to 1:

$$\Sigma\{ f_{v,elev}(n, \theta, c) + f_{v,gnd}(n, \theta, c) \} = 1 \quad (B-3)$$

The summation is over all wind speed classes n , all compass direction sectors θ , and all stability classes c .

The prescription of Regulatory Guide 1.111 is used in determining the fraction of time that the plume is considered elevated and the fraction of time that it is considered ground level. The fractions are obtained from the ratio of stack exit velocity W_o to hourly average wind speed u at the height of the vent release point as follows:

•If $W_o/u > 5$, then the plume is considered elevated for the hour.

•If $W_o/u \leq 1$, then the plume is considered ground level for the hour.

•If $1 < W_o/u \leq 5$, the plume is considered to be a ground level release for a fraction G_t of the hour and an elevated release for a fraction $(1 - G_t)$ of the hour where G_t is defined as follows:

$$G_t = 2.58 - 1.58(W_o/u) \quad \text{for } 1.0 < W_o/u \leq 1.5 \quad (B-4)$$

$$G_t = 0.30 - 0.06(W_o/u) \quad \text{for } 1.5 < W_o/u \leq 5.0 \quad (B-5)$$

B.1.3 Average Wind Speed

Using the joint frequency distribution, average wind speeds are obtained for each station. Values are obtained for each downwind direction (N, NNE, etc.) and for various release point classifications (stack, vent, and ground level).

B.1.3.1 Stack Release

For a stack release, the following formula is used:

$$u_s(\theta) = \Sigma\{ f_s(n, \theta, c)u_n \} / \Sigma\{ f_s(n, \theta, c) \} \quad (B-6)$$

where the summations are over wind speed classes **n** and stability classes **c**.

$u_s(\theta)$ Average Wind Speed, Stack Release [m/sec]

The average wind speed in downwind direction θ for a stack release.

u_n Wind Speed for Class **n** [m/sec]

A wind speed representative of wind speed class **n**. For each wind speed class except the highest, u_n is the average of the upper and lower limits of the wind speed range for the class. For the highest wind speed class, u_n is the lower limit of the wind speed range for the class.

The parameter f_s is defined in Section B.1.2.2.

B.1.3.2 Ground Level Release

For a ground level release, the following formula is used:

$$u_g(\theta) = \Sigma\{ f_g(n, \theta, c)u_n \} / \Sigma\{ f_g(n, \theta, c) \} \quad (B-7)$$

where the summations are over wind speed classes **n** and stability classes **c**.

$u_g(\theta)$ Average Wind Speed, Ground Level Release [m/sec]

The average wind speed in downwind direction θ for a ground level release.

The parameter f_g is defined in Section B.1.2.3.

B.1.3.3 Vent Release

For a vent release, the following formula is used:

$$u_v(\theta) = \Sigma\{ [f_{v,elev}(n, \theta, c) + f_{v,gnd}(n, \theta, c)]u_n \} / \Sigma\{ f_{v,elev}(n, \theta, c) + f_{v,gnd}(n, \theta, c) \} \quad (B-8)$$

where the summations are over wind speed classes **n** and stability classes **c**.

$u_v(\theta)$ Average Wind Speed, Vent Release [m/sec]

The average wind speed in downwind direction θ for a vent release.

The parameters $f_{v,elev}$ and $f_{v,gnd}$ are defined in Section B.1.2.4.

B.2 GAUSSIAN PLUME MODELS

As a plume of airborne effluents moves away from an elevated release point, the plume both broadens and meanders. It has been found that the time-averaged distribution of material in an effluent plume can be well represented mathematically by a Gaussian function.

B.2.1 Mathematical Representation

In a widely used form of the Gaussian plume model, the distribution of radioactivity in a plume is represented mathematically by the equation below:

$$\chi(x,y,z) = [Q/(2\pi \sigma_y \sigma_z u)] \exp(-y^2/2\sigma_y^2) \times \{ \exp[-(z-h_e)^2/2\sigma_z^2] + \exp[-(z+h_e)^2/2\sigma_z^2] \} \quad (B-9)$$

$\chi(x,y,z)$ Radioactivity Concentration [$\mu\text{Ci}/\text{m}^3$]

The concentration of radioactivity at point (x,y,z) . The x , y , and z axis are defined as follows:

x Downwind Distance [m]
Distance from the stack along an axis parallel to the wind direction.

y Crosswind Distance [m]
Distance from the plume centerline along an axis parallel to the crosswind direction.

z Vertical Distance [m]
Distance from the ground (grade level at the stack) along an axis parallel to the vertical direction.

Q Release Rate [$\mu\text{Ci}/\text{sec}$]
Release rate of radioactivity.

σ_y, σ_z Horizontal and Vertical Dispersion Coefficients [m]
Standard deviations of the Gaussian distributions describing the plume cross-sections in the y and z directions, respectively. The values of σ_y and σ_z depend on several parameters:

- Downwind distance x .
Because a plume broadens and meanders as it travels away from its release point, the values of σ_y and σ_z increase as x increases.
- Atmospheric stability class.
The plume is broadest for extremely unstable atmospheric conditions (Class A) and narrowest for extremely stable conditions (Class G).
- Time period of averaging plume concentration.

The values of σ_y and σ_z increase as the averaging period increases.

u	Average Wind Speed	[m/sec]
	The average wind speed. The average speed of travel of the plume in the x direction.	
h_e	Effective Release Height	[m]
	The effective height of effluent release above grade elevation. This may be greater than the actual release height (see Section B.3.1.1.1).	

The two exponential functions of z in the curly brackets of Equation B-9 represent the emitted and reflected components of the plume. The reflected component (represented by the exponential with $(z + h_e)$ in its argument) arises from the assumption that all material in a portion of the plume that touches ground is reflected upward. This assumption is conservative if one is calculating airborne radioactivity concentration.

B.2.2 Sector-Averaged Concentration

Sometimes, it is desired to determine the average concentration of radioactivity in a sector due to release at a constant rate over an extended period of time (e.g., a year). For such a case, it is reasonable to assume that the wind blows with equal likelihood toward all directions within the sector. From Equation B-9, the following equation for ground level radioactivity concentration can be derived:

$$\chi_{\text{sector}} = [2.032 f Q / (\sigma_z u x)] \exp(-h^2_e / 2\sigma_z^2) \quad \text{(B-10)}$$

χ_{sector}	Sector-Averaged Ground Level Concentration	[$\mu\text{Ci}/\text{m}^3$]
	The time-averaged concentration of airborne radioactivity in a sector at ground level at a distance x from the release point.	
2.032	A dimensionless constant.	
f	Sector Fraction	
	The fraction of time that the wind blows into the sector.	
Q	Release rate of radioactivity.	[$\mu\text{Ci}/\text{sec}$]

The other parameter definitions are the same as for Equation B-9.

B.3 RELATIVE CONCENTRATION FACTOR χ/Q

The relative concentration factor χ/Q (called "chi over Q") provides a simplified method of calculating the radioactivity concentration at a given point in an effluent plume when the release rate is known:

$$\chi = Q (\chi/Q) \quad \text{(B-11)}$$

χ	Concentration of Radioactivity Concentration of radioactivity at point (x,y,z) in the atmosphere.	[$\mu\text{Ci}/\text{m}^3$]
--------------------------	--	-------------------------------

Q Release Rate [μCi/sec]

Release rate of radioactivity.

χ/Q Relative Concentration Factor [sec/m³]

Relative concentration factor for point (x,y,z). The airborne radioactivity concentration at (x,y,z) per unit release rate.

Expressions for χ/Q based on Gaussian plume models can be obtained from the equations for concentration χ in Section B.2 simply by dividing both sides of each equation by the release rate Q. For example, from Equation B-10, we obtain the following expression for the sector-averaged χ/Q:

$$(\chi_{\text{sector}}/Q) = [2.032 f/(\sigma_z u x)] \exp(-h_e^2/2\sigma_z^2) \quad \text{(B-12)}$$

The values of χ/Q used in ODCM calculations are both sector-averaged and time-averaged. The time averaging is based on the historical average atmospheric conditions of a specified multi-year time period (see Section 4.1.5) and is accomplished by use of the joint frequency distribution discussed in Section B.1.2. The formulas used to obtain the time- and sector-averaged χ/Q are based on Equation B-12, but vary depending on whether the release is a stack, ground level, or vent release. The three cases are discussed below.

B.3.1 Stack Release

For a stack release, the relative concentration factor is designated (χ/Q)_S. Its value is obtained by the following formula:

$$(\chi/Q)_S = (2.032/R) \sum \{ f_S(n,\theta,c) \times [\exp(-h_e^2/2\sigma_z^2)] / (u_n \sigma_z) \} \quad \text{(B-13)}$$

The summation is over wind speed classes n and atmospheric stability classes c.

(χ/Q)_S Relative Concentration Factor, Stack Release [sec/m³]

The time- and sector-averaged relative concentration factor due to a stack release for a point at ground level at distance R in downwind direction θ.

2.032 Constant

A dimensionless constant.

R Downwind Distance [m]

The downwind distance from the release point to the point of interest.

f_S(n,θ,c) Joint Frequency Distribution, Stack Release

This function is defined in Section B.1.2.2.

h_e Effective Release Height [m]

The effective height of an effluent release above grade elevation. For a stack release, h_e is obtained by correcting the actual height of the release point for plume rise, terrain effects, and downwash as described in Section B.3.1.1, below.

σ_z	Standard Vertical Dispersion Coefficient	[m]
	A coefficient characterizing vertical plume spread in the Gaussian model for stability class c at distance R (see Table C-5 of Appendix C).	
u_n	Wind Speed	[m/sec]
	A wind speed representative of wind speed class n . For each wind speed class except the highest, u_n is the average of the upper and lower limits of the wind speed range for the class. For the highest wind speed class, u_n is the lower limit of the wind speed range for the class.	

This expression is recommended by the NRC in Regulatory Guide 1.111 (Reference 7) and is based on a model designated there as the "constant mean wind direction model." In this model it is assumed that the mean wind speed, the mean wind direction, and the atmospheric stability class determined at the release point also apply at all points within the region in which airborne concentration is being evaluated.

B.3.1.1 Effective Release Height

For a stack release, the effective height of an effluent plume is the height of the release point corrected for plume rise and terrain effects:

If $(h_s + h_{pr} - h_t) < 100$ meters, then

$$h_e = h_s + h_{pr} - h_t \quad (B-14)$$

If $(h_s + h_{pr} - h_t) \geq 100$ meters, then;

$$h_e = 100 \text{ meters} \quad (B-15)$$

h_e	Effective Release Height	[m]
	The effective height of an effluent release above grade elevation.	
h_s	Actual Release Height	[m]
	The actual height of the release above grade elevation.	
h_{pr}	Plume Rise	[m]
	The rise of the plume due to its momentum and buoyancy. (See Section B.3.1.1.1.)	
h_t	Terrain Correction Parameter	[m]
	A parameter to account for the effect of terrain elevation on the effective height of a plume. Taken as zero (see Section B.3.1.1.2).	

B.3.1.1.1 Plume Rise

Because nuclear power stations generally have plumes that are not significantly warmer than room temperature, plume rise due to buoyancy is neglected. The formulas used to calculate plume rise due to momentum are given below.

Stability Classes A, B, C, and D

For these stability classes (corresponding to unstable and neutral conditions), h_{pr} is taken as the lesser of two quantities:

$$h_{pr} = \text{Minimum of } [(h_{pr})_1, (h_{pr})_2] \quad (B-16)$$

$$(h_{pr})_1 = (1.44)(W_o/u)^{2/3}(R/d)^{1/3}(d) - h_d \quad (B-17)$$

$$(h_{pr})_2 = (3)(W_o/u)(d) \quad (B-18)$$

W_o Stack Exit Velocity [m/sec]

The effluent stream velocity at the discharge point.

u Wind Speed [m/sec]

R Downwind Distance [m]

The downwind distance from the release point to the point of interest.

d Internal Stack Diameter [m]

The internal diameter of the stack from which the effluent is released.

h_d Downwash Correction [m]

A parameter to account for downwash at low exit velocities.

The parameter h_d is calculated by the following equations:

$$h_d = (3)(1.5 - W_o/u)(d) \text{ if } W_o < 1.5u \quad (B-19)$$

$$h_d = 0 \text{ if } W_o \geq 1.5u \quad (B-20)$$

Note that $(h_{pr})_1$ can increase without limit as R increases; thus, the effect of $(h_{pr})_2$ is to limit calculated plume rise at large distances from the nuclear power station.

Stability Classes E, F, and G

For these stability classes (corresponding to stable conditions), h_{pr} is taken as the minimum of four quantities:

$$h_{pr} = \text{Minimum of } [(h_{pr})_1, (h_{pr})_2, (h_{pr})_3, (h_{pr})_4] \quad (B-21)$$

$$(h_{pr})_3 = (4)(F/S)^{1/4} \quad (B-22)$$

$$(h_{pr})_4 = (1.5)(F/u)^{1/3}(S)^{-1/6} \quad (B-23)$$

F Momentum Flux Parameter [m⁴/sec²]

A parameter defined as:

$$F = W_o^2(d/2)^2 \quad (B-24)$$

S Stability Parameter [1/sec²]

A parameter defined as follows:

Stability Class	S
E	8.70E-4
F	1.75E-3
G	2.45E-3

The quantities $(h_{pr})_1$ and $(h_{pr})_2$ are as defined by Equations B-17 and B-18.

B.3.1.1.2 Terrain Effects

Due to general flatness of the terrain in the vicinity of the stations, the terrain correction parameter h_t was taken as zero in all calculations of meteorological dispersion and dose parameters for this Manual.

B.3.2 Ground Level Release

For a ground level release, the relative concentration factor is designated $(\chi/Q)_g$. Its value is obtained by the following formula:

$$(\chi/Q)_g = (2.032/R) \sum \{ f_g(n,\theta,c)/(u_n S_z) \} \quad (B-25)$$

The summation is over wind speed classes n and atmospheric stability classes c .

$(\chi/Q)_g$ Relative Concentration Factor, Ground Level Release [sec/m³]

The time- and sector-averaged relative concentration factor due to a ground level release for a point at ground level at distance R in downwind direction θ .

$f_g(n,\theta,c)$ Joint Frequency Distribution, Ground Level Release

This function is defined in Section B.1.2.3.

S_z Wake-Corrected Vertical Dispersion Coefficient [m]

The vertical dispersion coefficient corrected for building wake effects. The correction is made as described below.

The remaining parameters are defined in Section B.3.1.

Wake-Corrected Vertical Dispersion Coefficient

The wake-corrected vertical dispersion coefficient S_z in Equation B-25 is taken as the lesser of two quantities:

$$S_z = \text{Minimum of } [(S_z)_1, (S_z)_2] \quad \text{(B-26)}$$

$$(S_z)_1 = [\sigma_z^2 + D^2/(2\pi)]^{1/2} \quad \text{(B-27)}$$

$$(S_z)_2 = (\sigma_z)(3^{1/2}) \quad \text{(B-28)}$$

S_z Wake-Corrected Vertical Dispersion Coefficient [m]

The vertical dispersion coefficient corrected for building wake effects.

σ_z Standard Vertical Dispersion Coefficient [m]

The coefficient characterizing vertical plume spread in the Gaussian model for stability class *c* at distance *R* (see Table C-5 of Appendix C).

D Maximum Height of Neighboring Structure [m]

The maximum height of any neighboring structure causing building wake effects (see Table F-2 of Appendix F).

B.3.3 Vent Release

For a vent release, the relative concentration factor is designated $(\chi/Q)_v$. Its value is obtained by the following formula:

$$(\chi/Q)_v = (2.032/R) \sum \{ f_{v,elev}(n,\theta,c) \times [\exp(-h^2/2\sigma_z^2)]/(u_n \sigma_z) + f_{v,gnd}(n,\theta,c)/(u_n S_z) \} \quad \text{(B-29)}$$

The summation is over wind speed classes *n* and atmospheric stability classes *c*.

$(\chi/Q)_v$ Relative Concentration Factor, Vent Release [sec/m³]

The time and sector averaged relative concentration factor due to a vent release for a point at ground level at distance *R* in downwind direction θ .

The parameters $f_{v,elev}(n,\theta,c)$ and $f_{v,gnd}(n,\theta,c)$ are defined in Section B.1.2.4. The parameter S_z is defined in Section B.3.2. The remaining parameters are defined in Section B.3.1.

B.3.4 Removal Mechanisms

In Regulatory Guide 1.111, the NRC allows various removal mechanisms to be considered in evaluating the radiological impact of airborne effluents. These include radioactive decay, dry deposition, wet deposition, and deposition over water. For simplicity, these removal mechanisms cited by the NRC are not accounted for in the evaluation or use of χ/Q in this manual. This represents a conservative approximation as ignoring removal mechanisms increases the value of χ/Q .

B.3.5 Gamma- χ /Q

The noble gas dose factors of Reg. Guide 1.109, Table B-1 are based upon assumption of immersion in a semi-infinite cloud. For ground level and mixed mode releases this tends to overestimate the gamma air dose arising from a plume that is actually finite in nature.

For elevated releases, the Reg. Guide 1.109 noble gas dose factors will underestimate exposure as they consider only immersion and not that portion of exposure arising from sky shine. At distances close in to the point of elevated release, the ground level concentration as predicted by χ /Q will be essentially zero. In such a case, the sky shine component of the exposure becomes significant and must be considered.

The gamma- χ /Q provides a simplified method of calculating gamma air dose and dose rates for a finite and/or elevated plume. The methodology of Reg. Guide 1.109, Section C.2 and Appendix B provides the methodology for calculating finite cloud gamma air dose factors from which the gamma- χ /Q values can be derived. Section B.5 addresses the calculation of these dose factors.

The gamma- χ /Q is defined such that for a given finite cloud the semi-infinite cloud methodology will yield the same gamma air dose as the finite cloud methodology.

Three gamma- χ /Q values are defined: $(\chi/Q)_s^T$, $(\chi/Q)_v^T$ and $(\chi/Q)_g^T$ for stack, vent and ground level releases, respectively. These gamma- χ /Q values are calculated as follows:

For stack releases:

$$(\chi/Q)_s^T = \frac{\sum_i f_i S_i}{\sum_i f_i M_i} \quad (B-30)$$

The summation is over all noble gas radionuclides i .

$(\chi/Q)_s^T$	Gamma- γ /Q for Stack Releases	[sec/m3]
f_i	Noble Gas Nuclide Fraction	dimensionless
	Fraction of total noble gas release that is due to radionuclide i . Values for f_i are listed in Table B-0.	
S_i	Stack Release Gamma Air Dose Factor	[(mrad/yr)/(μ Ci/sec)]
	Gamma air dose factor for radionuclide i for stack releases as defined in Section B.5.1. Taken from Appendix F, Table 7.	
M_i	Semi-Infinite Cloud Dose Factor	[(mrad/yr)/(μ Ci/m ³)]
	Dose factor for immersion exposure to a semi-infinite cloud of noble gas. Taken from Reg. Guide 1.109, Table B-1, Col 4. (Note that the units in Reg. Guide 1.109 must be multiplied by 1E6 to convert pCi to μ Ci.)	

For vent releases:

$$(\chi/Q)_v^T = \frac{\sum_i f_i V_i}{\sum_i f_i M_i} \quad (B-31)$$

The summation is over all noble gas radionuclides i .

$(\chi/Q)_v^i$	Gamma- γ/Q for Vent Releases	[sec/m ³]
V_i	Vent Release Gamma Air Dose Factor	[(mrad/yr)/(μ Ci/sec)]
	Gamma air dose factor for radionuclide i for stack releases as defined in Section B.5.3. Taken from Appendix F, Table 7.	

All other terms have been previously defined.

For ground level releases:

$$(\chi/Q)_g^i = \frac{\sum_i f_i G_i}{\sum_i f_i M_i} \quad (\text{B-32})$$

The summation is over all noble gas radionuclides i .

$(\chi/Q)_g^i$	Gamma- γ/Q for Vent Releases	[sec/m ³]
G_i	Ground Level Release Gamma Air Dose Factor	[(mrad/yr)/(μ Ci/sec)]
	Gamma air dose factor for radionuclide i for ground level releases as defined in Section B.5.2. Taken from Appendix F, Table 7.	

All other terms have been previously defined.

The Noble Gas Nuclide Fraction, f_i is determined from historical release data and defined as:

$$f_i = \frac{A_i}{\sum_i A_i} \quad (\text{B-33})$$

The summation is over all noble gas radionuclides i .

A_i	Cumulative Radionuclide Release	units of activity
	Cumulative release of noble gas radionuclide i over a period of time.	

B.4 RELATIVE DEPOSITION FACTOR D/Q

The quantity D/Q (called "D over Q") is defined to provide the following simple way of calculating the rate of deposition of radioactivity at a given point on the ground when the release rate is known.

$$d = Q (D/Q) \quad (\text{B-34})$$

d	Deposition Rate	[(μ Ci/m ²)/sec]
	Rate of deposition of radioactivity at a specified point on the ground.	
Q	Release Rate of radioactivity.	[μ Ci/sec]

D/Q Relative Deposition Factor [1/m²]

Relative deposition factor for a specified point on the ground. The deposition rate per unit release rate.

The values of **D/Q** used in this manual are time-averaged. The time averaging is based on the historical average atmospheric conditions of a specified multi-year time period (see Section 4.1.5) and is accomplished by use of the joint frequency distribution described in Section B.1.2. The formulas used to obtain **D/Q** vary depending on whether the release is a stack, ground level, or vent release. The three cases are discussed below.

B.4.1 Stack Release

For a stack release, the relative deposition factor is designated $(D/Q)_S$. Its value is obtained by the following formula:

$$(D/Q)_S = [1/(2\pi R/16)] \sum \{ f_S(n, \theta, c) D_r(c, R, h_e) \} \quad (B-35)$$

The summation is over wind speed classes **n** and stability classes **c**.

(D/Q)_S Relative Deposition Factor, Stack Release [1/m²]

The time-averaged relative deposition factor due to a stack release for a point at distance **R** in the direction **θ**.

2π/16 Sector Width [radians]

The width of a sector over which the plume direction is assumed to be uniformly distributed (as in the model of Section B.2.2). Taken as 1/16 of a circle.

R Downwind Distance [m]

The downwind distance from the release point to the point of interest.

f_S(n, θ, c) Joint Frequency Distribution, Stack Release

This function is defined in Section B.1.2.2.

D_r(c, R, h_e) Relative Deposition Rate, Stack Release [m⁻¹]

The deposition rate per unit downwind distance [$\mu\text{Ci}/(\text{sec}\cdot\text{m})$] divided by the source strength [$\mu\text{Ci}/\text{sec}$] due to a stack release for stability class **c**, downwind distance **R**, and effective release height **h_e**.

The value is based on Figures 7 to 9 of Regulatory Guide 1.111, which apply, respectively, to release heights of 30, 60, and 100 m. Linear interpolation is used to obtain values at intermediate release heights. If the effective release height is greater than 100 meters, then the data for 100 meters are used.

h_e Effective Release Height [m]

The effective height of the release above grade elevation.
See Section B.3.1.1.

B.4.2 Ground Level Release

For ground level release, the relative deposition factor is designated $(D/Q)_g$. Its value is obtained by the following formula:

$$(D/Q)_g = [1/(2\pi R/16)] D_r(R) \Sigma\{ f_g(n,\theta,c) \} \quad (B-36)$$

The summation is over wind speed classes n and stability classes c .

$(D/Q)_g$ Relative Deposition Factor, Ground Level Release $[1/m^2]$

The time-averaged relative deposition factor due to a ground level release for a point at distance R in the direction θ .

$f_g(n,\theta,c)$ Joint Frequency Distribution, Ground Level Release

This function is defined in Section B.1.2.3.

$D_r(R)$ Relative Deposition Rate, Ground Level $[m^{-1}]$

The deposition rate per unit downwind distance $[\mu Ci/(sec-m)]$ divided by the source strength $[\mu Ci/sec]$ due to a ground level release for downwind distance R . The value is taken from Figure 6 of Regulatory Guide 1.111 and is the same for all atmospheric stability classes.

The remaining parameters are defined in Section B.4.1.

B.4.3 Vent Release

For a vent release, the relative deposition factor is designated $(D/Q)_v$. Its value is obtained by the following formula:

$$(D/Q)_v = [1/(2\pi R/16)] \times [\Sigma\{ f_{v,elev}(n,\theta,c) D_r(c,R,h_e) \} + D_r(R) \Sigma\{ f_{v,gnd}(n,\theta,c) \}] \quad (B-37)$$

The summation is over wind speed classes n and stability classes c .

$(D/Q)_v$ Relative Deposition Factor, Vent Release $[1/m^2]$

The time-averaged relative deposition factor due to a ground level release for a point at distance R in the direction θ .

The parameters $f_{v,elev}(n,\theta,c)$ and $f_{v,gnd}(n,\theta,c)$ are defined in Section B.1.2.4. The remaining parameters are defined in Sections B.4.1 and B.4.2.

B.5 GAMMA AIR DOSE FACTORS (S_i , V_i , G_i)

The gamma air dose factors provide a simple way of calculating doses and dose rates to air due to gamma radiation. For example, using a dose factor DF_i , gamma air dose rate may be calculated as follows:

$$\dot{D} = \sum \dot{D}_i \quad \text{(B-38)}$$

$$\dot{D}_i = \sum \{Q_i DF_i\} \quad \text{(B-39)}$$

The summations are over i radionuclides.

\dot{D}	Gamma Air Dose Rate	[mrad/yr]
	The gamma air dose rate due to all radionuclides released.	
\dot{D}_i	Gamma Air Dose Rate Due to Radionuclide i	[mrad/yr]
Q_i	Release Rate of Radionuclide i	[μ Ci/sec]
DF_i	Gamma Air Dose Factor for Radionuclide i	[(mrad/yr)/ (μ Ci/sec)]
	A factor used to calculate gamma air dose or dose rate due to release of radionuclide i . Gamma air dose rate at a particular location per unit release rate.	

Three gamma air dose factors are defined: S_i , V_i , and G_i . They are used for stack, vent, and ground level releases, respectively. These three release point classifications are defined in Section 4.1.4. The calculation of the three dose factors is discussed below.

B.5.1 Stack Release

For a stack release, the gamma air dose factor S_i is obtained by a model similar to that of Equation 6 of Regulatory Guide 1.109 (Reference 6). A sector-averaged Gaussian plume is assumed and the dose factor is evaluated on the basis of historical average atmospheric conditions. The value of S_i depends on distance R from the release point and on downwind sector θ .

The following equation is used:

$$S_i = [260/(2\pi R/16)] \times \sum \{f_s(n,\theta,c)[\exp(-\lambda_i R/3600u_n)] \times E_k \mu_a(E_k) A_{ki} I(h_e, u_n, c, \sigma_z, E_k)/u_n\} \quad \text{(B-40)}$$

The summation is over wind speed classes n , atmospheric stability classes c , and photon group indices k .

S_i	Gamma Air Dose Factor, Stack Release	[(mrad/yr)/ (μ Ci/sec)]
	The gamma air dose factor at ground level for a stack release for radionuclide i , downwind sector θ , downwind distance R from the release point, and the average atmospheric conditions of a specified historical time period.	

260	<p>Conversion factor [(mrad-radians-m³-disintegrations)/(sec-MeV-Ci)]</p> <p>Reconciles units of Equation B-36.</p>
2π/16	<p>Sector Width [radians]</p> <p>The width of a sector over which the plume direction is assumed to be uniformly distributed (as in the model of Section B.2.2). Taken as 1/16 of a circle.</p>
f_s(n,θ,c)	<p>Joint Frequency Distribution, Stack Release</p> <p>This function is defined in Section B.1.2.2.</p>
λ_i	<p>Radiological Decay Constant [hr⁻¹]</p> <p>Radiological Decay Constant for radionuclide i (see Table C-7 of Appendix C).</p>
3600	<p>Conversion Factor [sec/hr]</p> <p>The number of seconds per hour. Used to convert wind speed in meters/sec to meters/hr.</p>
E_k	<p>Photon Group Energy [MeV/photon]</p> <p>An energy representative of photon energy group k. The photons emitted by each radionuclide are grouped into energy groups in order to facilitate analysis. All photons with energy in energy group k are assumed to have energy E_k.</p>
μ_a(E_k)	<p>Air Energy Absorption Coefficient [m⁻¹]</p> <p>The linear energy absorption coefficient for air for photon energy group k. The fraction of energy absorbed in air per unit of distance traveled for a beam of photons of energy E_k. Distance is measured in units of linear thickness (meters).</p>
A_{ki}	<p>Effective Photon Yield [photons/disintegration]</p> <p>The effective number of photons emitted with energy in energy group k per decay of nuclide i. On the basis of Section B.1 of Regulatory Guide 1.109 (Reference 6), the parameter A_{ki} is calculated as follows:</p> $A_{ki} = [\sum \{A_m E_m \mu_a(E_m)\}] / [E_k \mu_a(E_k)] \quad \text{(B-41)}$ <p>The summation in the numerator is over the index m.</p>
A_m	<p>True Photon Yield [photons per disintegration]</p> <p>The actual number of photons emitted with energy E_m per decay of nuclide i.</p>

E_m [MeV/photon]	Photon Energy	
	The energy of the m^{th} photon within photon energy group k .	
$\mu_a(E_m)$	Air Energy Absorption Coefficient	[m^{-1}]
	The linear energy absorption coefficient for air for photon energy E_m .	
$I(\dots)$	I Function	
	A dimensionless parameter obtained by numerical evaluation of integrals that arise in the plume gamma dose problem. The value of I depends on the arguments (...) listed in Equation B-40. A specific definition for I is given by Equation F-13 of Regulatory Guide 1.109.	
	The integrals involved in calculating I arise from conceptually dividing up the radioactive plume into small elements of radioactivity and adding up the doses produced at the point of interest by all of the small elements. The distribution of radioactivity in the plume is represented by a sector-averaged Gaussian plume model like that discussed in Section B.2.2.	

The parameters R , h_e , u_n , and σ_z are defined in Section B.3.1.

B.5.2 Ground Level Release

The gamma air dose factor G_i for a ground level release is defined as follows:

G_i	Gamma Air Dose Factor, Ground Level Release	[(mrad/yr)/($\mu\text{Ci}/\text{sec}$)]
	The gamma air dose factor at ground level for a ground level release for radionuclide i , downwind sector θ , downwind distance R from the release point, and the average atmospheric conditions of a specified historical time period.	

The value of G_i is obtained by the same equation as used for a stack release, Equation B-36 of Section B.5.1, with the following modifications:

- The joint frequency distribution for a ground level release (f_g of Section B.1.2.3) is used in place of the one for a stack release (f_s).
- In evaluating the I function, the effective release height h_e is taken as zero.

This corresponds to use of a finite plume model.

B.5.3 Vent Release

For a vent release, the gamma air dose factor is calculated as follows:

$$V_i = [260/(2\pi R/16)] \times \sum \{ f_{v,\text{elev}}(n,\theta,c) [\exp(-\lambda_i R/3600u_n)] \times A_{ki} E_k \mu_a(E_k) I(h_e, u_n, c, \sigma_z, E_k)/u_n + f_{v,\text{gnd}}(n,\theta,c) [\exp(-\lambda_i R/3600u_n)] \times A_{ki} E_k \mu_a(E_k) I(0, u_n, c, \sigma_z, E_k)/u_n \} \quad (\text{B-42})$$

The summation is over wind speed classes n , atmospheric stability classes c , and photon group indices k .

V_i Gamma Air Dose Factor, Vent Release [(mrad/yr)/(μ Ci/sec)]

The gamma air dose factor at ground level for a vent release for radionuclide i , downwind sector θ , downwind distance R from the release point, and the average atmospheric conditions of a specified historical time period.

The parameters $f_{v,elev}(n,\theta,c)$ and $f_{v,ground}(n,\theta,c)$ are defined in Section B.1.2.4. The parameter σ_z is defined in Section B.3.2. The remaining parameters are discussed in Section B.5.1.

B.6 Gamma Total Body Dose Conversion Factor (K_i)

The gamma total body dose conversion factors (K_i) are used to calculate doses and dose rates due to gamma irradiation of the whole body. The gamma total body dose conversion factors are taken from Reg. Guide 1.109, Table B-1, Column 5. The gamma total body dose conversion factors in Table B-1 of Reg. Guide 1.109 are based upon the semi-infinite cloud model.

B.7 BETA AIR AND BETA SKIN DOSE CONVERSION FACTORS (N_i, L_i)

The beta air (N_i) and beta skin (L_i) dose conversion factors are used to calculate doses and dose rates due to noble gas beta exposure. The beta air dose conversion factors are taken from Reg. Guide 1.109, Table B-1, Column 2. The beta skin dose conversion factors are taken from Column 5 of that same table. The values are based on a semi-infinite cloud model.

B.8 GROUND PLANE DOSE CONVERSION FACTOR DFG_i

The ground plane dose conversion factor DFG_i is used to calculate dose due to standing on ground contaminated with radionuclide i (see Equation A-8 of Appendix A). The units of DFG_i are (mrem/hr) per (μ Ci/m²).

Values are provided (see Table C-10 of Appendix C) for dose to the whole body. The values are taken from Regulatory Guide 1.109 and are based on a model that assumes a uniformly contaminated ground plane.

B.9 INHALATION DOSE COMMITMENT FACTOR DFA_{ija}

The inhalation dose commitment factor DFA_{ija} is used to calculate dose and dose rate to organ j of an individual of age group a due to inhalation of radionuclide i (see Equations A-7 and A-9 of Appendix A).

Values of DFA_{ija} for 10CFR50 compliance are taken from Regulatory Guide 1.109 (Reference 6). The units of DFA_{ija} are mrem per pCi inhaled. Values are provided for seven organs, with the whole body considered as an organ (see Tables E-7, E-8, E-9 and E-10 in Reg. Guide 1.109).

B.10 INGESTION DOSE COMMITMENT FACTOR DFL_{ija}

The ingestion dose commitment factor DFL_{ija} is used to calculate dose to organ j of an individual of age group a due to ingestion of radionuclide i (see Equations A-7 and A10 through A20 of Appendix A).

Values of DFL_{ija} for 10CFR50 compliance are taken from Regulatory Guide 1.109 (Reference 6). The units of DFL_{ija} are mrem per pCi ingested. In Tables E-11, E-12, E-13 and E-14 of Reg. Guide 1.109, values are provided for seven organs, with the whole body considered as an organ.

B.11 MEASURED RELEASE PARAMETERS

Input parameters required for calculations of dose or dose rate due to airborne effluents include measured values of radioactivity release (A_{is} , A_{iv} , and A_{ig}) or release rate (Q_{is} , Q_{iv} , and Q_{ig}) (see Section A.1 of Appendix A). These are obtained per the nuclear power station procedures.

B.12 RADIOLOGICAL DECAY CONSTANTS

Values used for these are obtained from the literature and are specified in Table C-7 of Appendix C.

B.13 PRODUCTION/EXPOSURE PARAMETERS

These parameters characterize various aspects of agricultural production and human exposure. Values used for generic (site-independent) parameters are specified in Appendix C.

Values of site-specific parameters are given in Appendix F. Many of the values are based on Reg. Guide 1.109, while others are based on site-specific considerations.

SECTION 2:

MODELS AND PARAMETERS FOR LIQUID EFFLUENT CALCULATIONS

B.14 INTRODUCTION

Equations for radiation dose and radioactivity concentration due to liquid effluents are given in Section A.2 of Appendix A. The equations involve the following types of parameters:

- Flow and Dilution Parameters.
- Dose Factors.
- Measured Release Parameters.
- Transport/Consumption Parameters.

This section discusses the methodology used to determine these parameters. Section B.15 addresses dose calculations and Section B.16 addresses concentration calculations for tank discharges. For dose calculations, flow and dilution parameters are discussed for two different models; the River Model, which is used for all nuclear power stations except Zion, and the Lake Michigan Model, which is used for Zion.

B.15 DOSE

B.15.1 Drinking Water

The radiation dose due to consumption of drinking water containing released radioactivity is calculated by Equations A-17, A-18 and A-19 of Appendix A:

$$D_{aj}^{Liq} = F \Delta t \sum_p \sum_i A_{a|p|} C_i \quad (A-17)$$

$$F = \frac{\text{Waste Flow}}{\text{Dilution Flow} \times Z} \quad (A-18)$$

$$A_{a|(PW)|} = k_o \left\{ \frac{U_a^w}{D^w} \right\} DFL_{aj} \quad (A-19)$$

The summation is over index *i* (radionuclides) and *p* (pathways). The parameters are defined in Section A.2.1 of Appendix A.

This methodology addresses the following considerations:

- The duration of the release, Δt .
- The concentration of the activity released, C_i .
- The dilution that takes place in the environment is represented by the parameters **F** and **Z**.
- Receptor consumption rate, U_a^w .
- Dilution which occurs from the near field discharge area to potable water intake as represented by D^w .
- The dose commitment per unit of ingested radioactivity is DFL_{aj} .

B.15.2 Aquatic Foods (Fish)

Near the nuclear power stations, the only aquatic food of significance for human consumption is fish. The liquid dose due to consumption of fish containing released radioactivity is calculated by Equations A-17, A-18 and A-20 of Appendix A.

$$A_{ai(\text{Fish})j} = k_o U_a^f B F_i D F L_{-aj} \quad (\text{A-20})$$

The parameters are defined in Section A.2.1 of Appendix A.

This is similar to the methodology used for calculating the dose due to drinking water except for the addition of the bioaccumulation factor, $B F_i$. This factor is the equilibrium ratio of the concentration of radionuclide i in fish (pCi/kg) to its concentration in water (pCi/L). It accounts for the fact that radioactivity ingested by fish can accumulate in their bodies to a higher concentration than in the waters in which the fish live.

B.15.3 Parameters

B.15.3.1 Flow and Dilution

The values of dilution can differ for potable water and fish. The dilution for potable water will depend on where water is drawn, while that for fish will depend on where the fish are caught. Models used to determine these parameters are discussed below. The values used for each station are summarized in Table F-1 of Appendix F.

B.15.3.1.1 River Model

For the purpose of calculating the drinking water dose from liquid effluents discharged into a river, it is assumed that total dilution of the discharge in the river flow occurs prior to consumption. The measure of dilution for the potable water pathway is described by the parameter D^w . A value of $D^w = 1$ represents no dilution.

For the fish consumption pathway, the dilution in the near-field is described by the parameter Z . This is an estimate of the dilution of released radioactivity in the water consumed by fish caught near the station downstream of its discharge. No additional dilution is assumed to occur.

B.15.3.1.2 Lake Michigan Model

Only (Zion) discharges liquid effluents into Lake Michigan. For this nuclear power station, it is assumed that the dilution in the near-field (Z) is dictated by the initial entrainment dilution is a factor of 10. The potable water pathway dilution factor of 6 (D^w) is derived from the plume dilution (a factor of 3 over approximately 1 mile) and the current direction frequency (annual average factor of 2).

B.15.3.2 Dose Factors

Equations A-17 through A-20 of Appendix A determine dose due to ingested radioactivity using the same ingestion dose factor $D F L_{-ija}$ as used in the evaluation of airborne radioactivity which is ingested with foods. The units of $D F L_{-ija}$ are:

(mrem) per (pCi ingested)

For 10CFR50 Appendix I compliance, the data of Tables E-1, E-12, E-13 and E-14 of Reg. Guide 1.109, are used for four age groups and for seven organs, with the whole body considered as an organ.

B.15.3.3 Measured Releases

Calculations of dose due to liquid effluents require measured values of radioactivity concentration release (C_i) for input. These release values are obtained per the nuclear power station procedures.

B.15.3.4 Consumption

Equations A-19 and A-20 of Appendix A involve consumption rates for water and fish (U_a^w and U_a^f). The values used are specified for each nuclear power station in Table F-1 of Appendix F.

B.16 CONCENTRATION IN TANK DISCHARGES

The concentration of radioactivity in a release to the unrestricted area due to a tank discharge is calculated by Equation A-22 of Appendix A:

$$C_i = C_i^t \frac{\text{Waste Flow}}{\text{Dilution Flow}} \quad (\text{A-22})$$

The parameters are defined in Section A.2.3 of Appendix A.

The radioactivity concentration released from the tank (C_i^t at flow rate F^t) is diluted by mixing with the initial dilution stream (with flow rate F^d) to yield a lower concentration (C_i) in the combined streams.

Table B-0
Noble Gas Nuclide Fractions

Nuclide	Braidwood ¹	Byron ¹	Dresden ²	LaSalle ¹	QuadCities ³	Zion ¹
Ar-41	8.90E-01	8.90E-01	1.46E-02	0.00E+00	1.85E-02	0.00E+00
Kr-83m	0.00E+00	0.00E+00	0.00E+00	4.50E-03	0.00E+00	0.00E+00
Kr-85	2.49E+01	2.49E+01	3.50E-05	2.60E-05	3.11E-02	1.00E+00
Kr-85m	1.80E-01	1.80E-01	3.68E-02	8.00E-03	2.39E-02	0.00E+00
Kr-87	4.00E-02	4.00E-02	3.71E-02	2.60E-02	3.25E-02	0.00E+00
Kr-88	2.80E-01	2.80E-01	4.47E-02	2.60E-02	3.10E-02	0.00E+00
Kr-89	0.00E+00	0.00E+00	0.00E+00	1.70E-01	0.00E+00	0.00E+00
Kr-90	0.00E+00	0.00E+00	0.00E+00	3.70E-01	0.00E+00	0.00E+00
Xe-131m	1.40E+00	1.40E+00	0.00E+00	2.00E-05	1.15E-03	0.00E+00
Xe-133	7.11E+01	7.11E+01	4.88E-02	1.10E-02	6.34E-02	0.00E+00
Xe-133m	5.70E-01	5.70E-01	3.17E-04	3.80E-04	5.00E-05	0.00E+00
Xe-135	5.30E-01	5.30E-01	2.71E-01	2.90E-02	4.95E-02	0.00E+00
Xe-135m	0.00E+00	0.00E+00	1.10E-01	3.40E-02	1.77E-01	0.00E+00
Xe-137	0.00E+00	0.00E+00	0.00E+00	2.00E-01	0.00E+00	0.00E+00
Xe-138	4.00E-02	4.00E-02	4.37E-01	1.20E-01	5.72E-01	0.00E+00

Notes:

- (1) From Table 10-1.
- (2) From 1998 and 1999 Dresden Station Radiological Environmental Operating Reports.
- (3) From 1998 and 1999 Quad Cities Station Radiological Environmental Operating Reports.

Table B-1

Portion of an Example Joint Frequency Distribution

Summary Table of Percent by Direction and Class

Class	N	NNE	NE	ENE	E	ESE	SE	SSE	S
A	.289	.317	.301	.244	.249	.190	.198	.197	.336
B	.190	.187	.178	.158	.125	.065	.079	.130	.193
C	.269	.226	.252	.218	.190	.118	.152	.189	.302
D	3.298	2.327	2.338	2.684	1.992	1.334	1.365	2.172	3.012
E	1.466	1.198	.988	1.331	1.681	1.226	1.472	2.553	3.628
F	.804	.318	.185	.276	.899	.648	.803	1.293	1.732
G	.202	.091	.081	.099	.253	.250	.355	.400	.624
Total	6.217	4.663	4.304	5.011	5.169	3.830	4.424	6.933	9.826

Summary Table of Percent by Direction and Speed

Speed	N	NNE	NE	ENE	E	ESE	SE	SSE	S
.45	.098	.099	.078	.030	.009	.000	.014	.032	.046
1.05	.308	.154	.125	.137	.121	.093	.090	.090	.127
2.05	.939	.602	.458	.594	.843	.606	.598	.605	1.008
3.05	1.164	1.030	.779	.981	1.468	1.075	1.093	1.478	1.982
4.05	1.179	1.024	.878	.995	1.243	.831	1.027	1.727	2.110
5.05	.839	.631	.858	.798	.724	.474	.652	1.254	1.636
6.05	.612	.467	.496	.589	.417	.313	.418	.803	1.153
8.05	.755	.437	.612	.695	.310	.313	.405	.735	1.319
10.05	.253	.157	.183	.185	.032	.093	.103	.180	.374
13.05	.053	.081	.034	.027	.001	.031	.025	.028	.072
18.00	.016	.001	.004	.000	.000	.001	.001	.002	.000
99.00	.000	.000	.000	.000	.000	.000	.000	.000	.000
Total	6.217	4.663	4.304	5.011	5.169	3.830	4.424	6.933	9.826

Summary Table of Percent by Speed and Class

Class Speed	A	B	C	D	E	F	G
.45	.004	.001	.000	.095	.257	.275	.346
1.05	.018	.012	.027	.508	1.035	1.080	.780
2.05	.286	.171	.246	3.256	5.028	3.228	1.419
3.05	.744	.428	.616	6.258	7.173	3.272	.985
4.05	.992	.581	.781	8.185	6.404	1.902	.460
5.05	.909	.506	.808	7.302	4.357	.807	.077
6.05	.712	.388	.613	6.167	2.938	.164	.013
8.05	.819	.500	.755	7.616	2.734	.081	.011
10.05	.230	.150	.196	2.606	.667	.009	.000
13.05	.075	.032	.055	.785	.181	.001	.000
18.00	.004	.000	.018	.117	.012	.000	.000
99.00	.000	.000	.001	.001	.000	.000	.000

Figure B-1
Instantaneous View of Plume

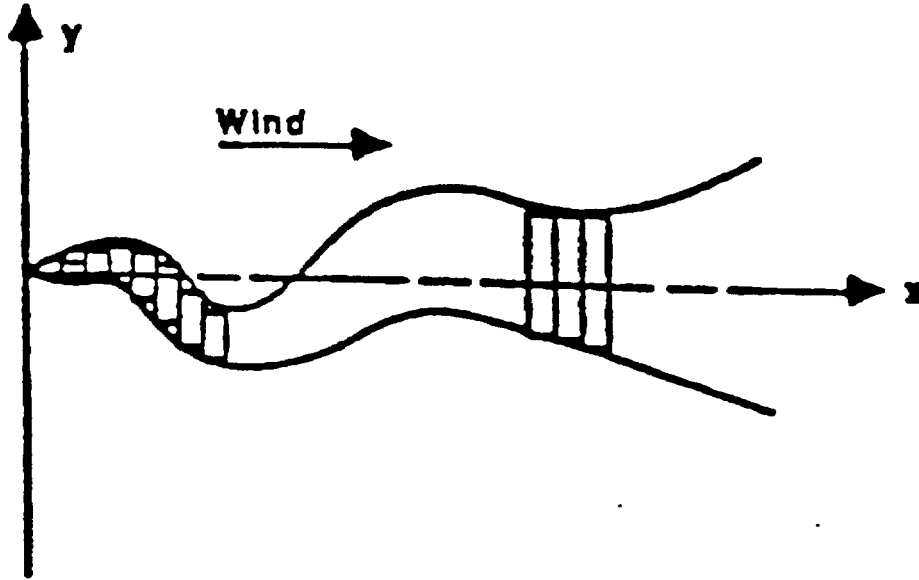

This figure represents a snapshot of a projection of a plume on the horizontal plane. As it moves downwind, the plume meanders about the average wind direction and broadens (adapted from Reference 18).

Figure B-2
A Gaussian Curve

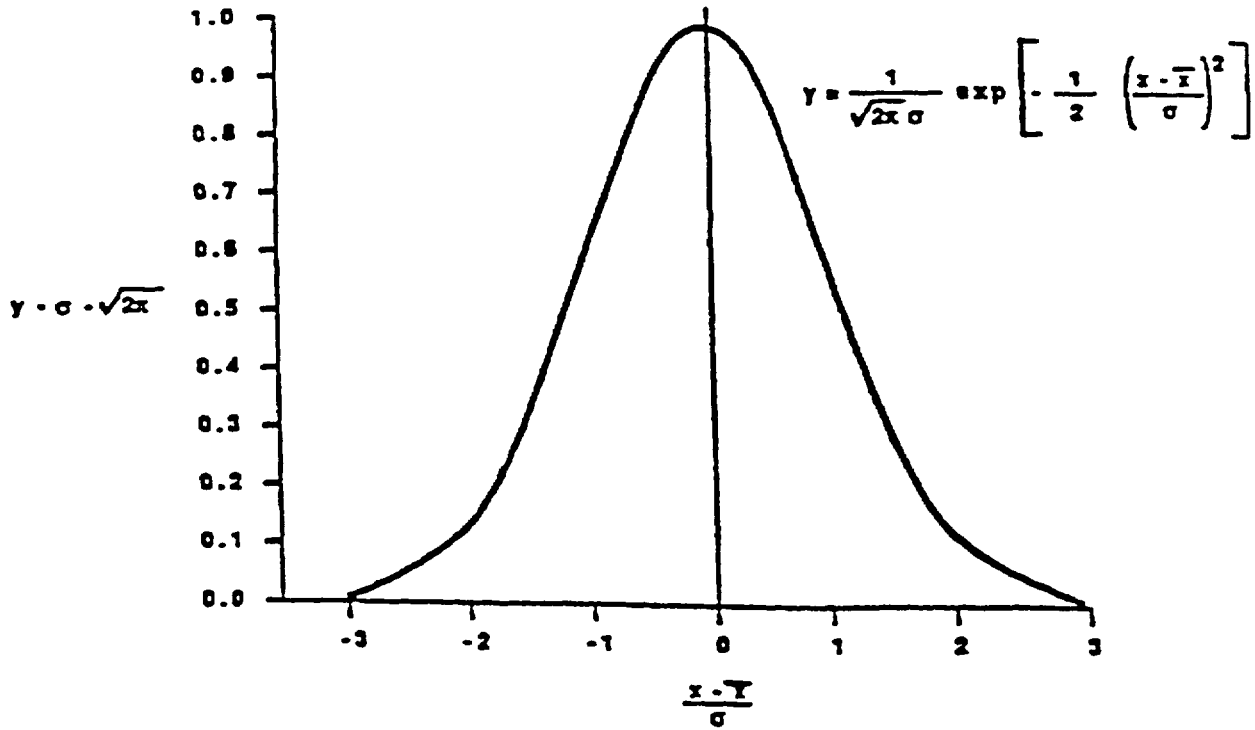

(Adapted from Reference 24 of Chapter 9, Page 61.)

Figure B-3

Effect of Observation Period on Plume Shape

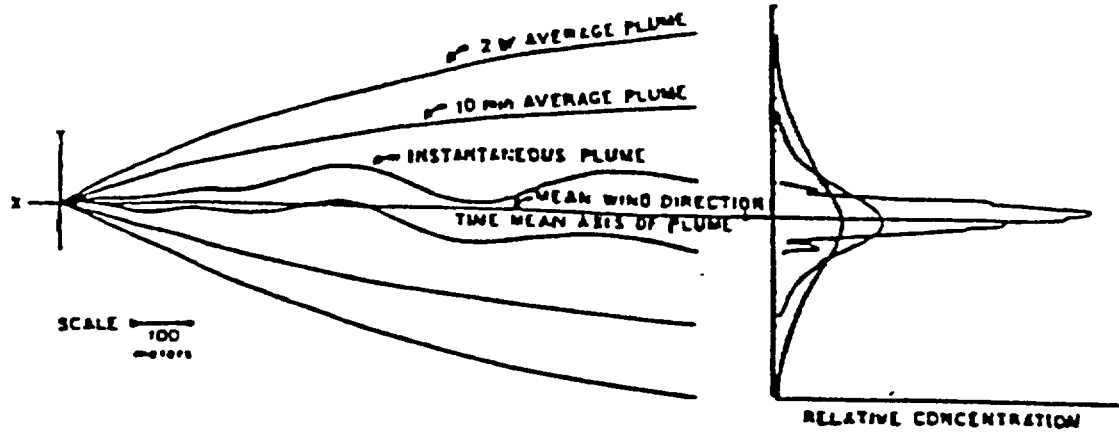

This sketch represents the approximate outlines of a smoke plume observed instantaneously and averaged over periods of 10 minutes and 2 hours. The diagram on the right shows the corresponding cross plume distribution patterns. The plume width increases as the period of observation increases (from Reference 18).

Figure B-4
A Gaussian Plume

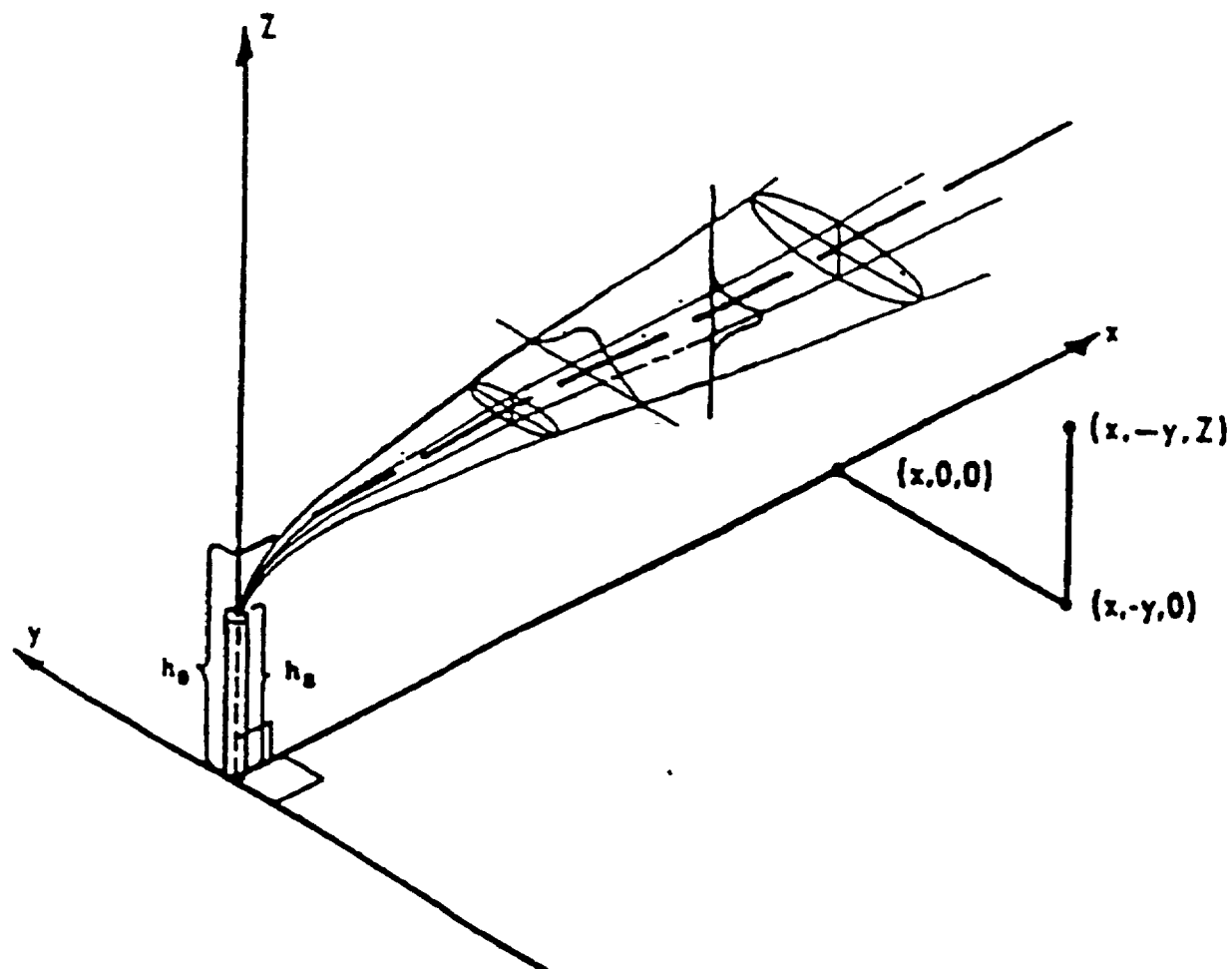

This sketch illustrates a plume characterized by Equation B-9. The plume is moving downwind in the x direction. Both the horizontal dispersion parameter σ_z increases as x increases. The reflected component has been omitted in this illustration (adapted from Reference 24).

APPENDIX C

GENERIC DATA

TABLE OF CONTENTS

	<u>PAGE</u>
C.1 INTRODUCTION	C-1
C.2 10CFR50 DOSE COMMITMENT FACTORS	C-1

LIST OF TABLES

<u>NUMBER</u>	<u>TITLE</u>	<u>PAGE</u>
C-1	Miscellaneous Dose Assessment Factors - Environmental Parameters	C-2
C-2	Miscellaneous Dose Assessment Factors - Consumption Rate Parameters	C-3
C-3	Stable Element Transfer Data	C-4
C-4	Atmospheric Stability Classes	C-6
C-5	Vertical Dispersion Parameters	C-7
C-6	Allowable Concentrations of Dissolved or Entrained Noble Gases Released from the Site to Unrestricted Areas in Liquid Waste	C-8
C-7	Radiological Decay Constants (λ_i) in hr^{-1}	C-9
C-8	Bioaccumulation Factors B_i to be Used in the Absence of Site-Specific Data	C-11
C-9	Dose Factors for Noble Gases	C-13
C-10	External Dose Factors for Standing on Contaminated Ground	C-14
C-11	Sector Code Definitions	C-17

**APPENDIX C
GENERIC DATA****C.1 INTRODUCTION**

This appendix contains generic (common to one or more of the stations) offsite dose calculation parameter factors, or values. Site specific factors are provided in the station annex Appendix F. The factors described in section C.2 are found in the prescribed references and are not repeated in this appendix.

C.2 10CFR50 DOSE COMMITMENT FACTORS

With the exception of H-3, the dose commitment factors for 10CFR50 related calculations are exactly those provided in Regulatory Guide 1.109 (Reference 6). The following table lists the parameters and the corresponding data tables in the RG 1.109:

<u>PATHWAY</u>	<u>ADULT</u>	<u>TEENAGER</u>	<u>CHILD</u>	<u>INFANT</u>
Inhalation	RG 1.109:Table E-7	RG 1.109:Table E-8	RG 1.109:Table E-9	RG 1.109:Table E-10
Ingestion	RG 1.109:Table E-11	RG 1.109:Table E-12	RG 1.109:Table E-13	RG 1.109:Table E-14

These tables are contained in Regulatory Guide 1.109 (Reference 6). Each table (E-7 through E-14) provides dose factors for seven organs for each of 73 radionuclides. For radionuclides not found in these tables, dose factors will be derived from ICRP 2 (Reference 50) or NUREG-0172 (Reference 51). The values for H-3 are taken from NUREG-4013 (Reference 107).

Table C-1
Miscellaneous Dose Assessment Factors -
Environmental Parameters

Parameter	Value	Comment	Equation	Basis ^a
f_g	0.76		A-10, A-11	A
f_l	1.0		A-10, A-11	A
f_p	1.0		A-12, A-14	A
f_s	1.0		A-12, A-14	A
t_b	9.46E8 sec	30 years	A-8	C
t_r	1.73E5 sec	Cow Milk Pathway (48 hours)	A-12	A
t_r	1.73E6 sec	Cow Meat Pathway (480 hours)	A-14	A
t_h	5.18E6 sec	60 days for produce - human consumption	A-10	A
t_h	7.78E6 sec	90 days for produce - animal consumption	A-12, A-14	A
t_l	8.64E4 sec	1 day for leafy vegetables	A-10	A
Q_F	50 Kg/da	Cow Consumption Rate	A-12, A-13, A-14, A-15	B
r	1.0	For Iodines	A-10, A-12, A-14	A
r	0.2	For Particulates	A-10, A-12, A-14	A
Y_p	0.7 Kg/m ²		A-12, A-14	A
Y_s	2.0 Kg/m ²		A-12, A-14	A
Y_v	2.0 Kg/m ²		A-10	A
λ_w	0.0021 hr ⁻¹		A-10, A-12, A-14	A
H	8 gm/m ³	Absolute Atmospheric Humidity	A-11, A-13, A-15	D

^aBasis key:

- A: Reference 6, Table E-15.
- B: Reference 6, Table E-3.
- C: The parameter t_b is taken as the midpoint of plant operating life (based upon an assumed 60 year plant operating lifetime).
- D: Reference 14, Section 5.3.1.3.

Table C-2
Miscellaneous Dose Assessment Factors -
Consumption Parameters

Type	Variable	Infant	Child	Teenager	Adult
Air	BR_a (m^3/yr)	1400	3700	8000	8000
Milk	U_{am} (L/yr)	330	330	400	310
Produce	U_a^S (Kg/yr)	0	520	630	520
Leafy Vegetables	U_a^L (Kg/yr)	0	26	42	64
Meat	U_{mf} (Kg/yr)	0	41	65	110
Water	U_a^W (L/yr)	330	510	510	730
Fish	U_a^F (Kg/yr)	0	6.9	16	21

From Regulatory Guide 1.109, Table E-5.

Table C-3
Stable Element Transfer Data

Element	F _I Meat (d/kg)	F _M (Cow) Milk (d/L)	Reference
H	1.2E-02	1.0E-02	6
Be	1.5E-03	3.2E-03	Footnote 1
C	3.1E-02	1.2E-02	6
F	2.9E-03	1.4E-02	Footnote 2
Na	3.0E-02	4.0E-02	6
Mg	1.5E-03	3.2E-03	Footnote 1
Al	1.5E-02	1.3E-03	Footnote 3
P	4.6E-02	2.5E-02	6
Cl	2.9E-03	1.4E-02	Footnote 2
Ar	NA	NA	NA
K	1.8E-02	7.2E-03	16
Ca	1.6E-03	1.1E-02	16
Sc	2.4E-03	7.5E-06	Footnote 4
Ti	3.4E-02	5.0E-06	Footnote 5
V	2.8E-01	1.3E-03	Footnote 6
Cr	2.4E-03	2.2E-03	6
Mn	8.0E-04	2.5E-04	6
Fe	4.0E-02	1.2E-03	6
Co	1.3E-02	1.0E-03	6
Ni	5.3E-02	6.7E-03	6
Cu	8.0E-03	1.4E-02	6
Zn	3.0E-02	3.9E-02	6
Ga	1.5E-02	1.3E-03	Footnote 3
Ge	9.1E-04	9.9E-05	Footnote 7
As	1.7E-02	5.0E-04	Footnote 8
Se	7.7E-02	1.0E-03	Footnote 9
Br	2.9E-03	2.2E-02	F _I Footnote 2; F _M from Ref. 16
Kr	NA	NA	NA
Rb	3.1E-02	3.0E-02	6
Sr	6.0E-04	8.0E-04	6
Y	4.6E-03	1.0E-05	6
Zr	3.4E-02	5.0E-06	6
Nb	2.8E-01	2.5E-03	6
Mo	8.0E-03	7.5E-03	6
Tc	4.0E-01	2.5E-02	6
Ru	4.0E-01	1.0E-06	6
Rh	1.5E-03	1.0E-02	6
Pd	5.3E-02	6.7E-03	Footnote 10
Cd	3.0E-02	2.0E-02	Footnote 11
In	1.5E-02	1.3E-03	Footnote 3
Sn	9.1E-04	9.9E-05	Footnote 7
Sb	5.0E-03	2.0E-05	98
Ag	1.7E-02	5.0E-02	6
Te	7.7E-02	1.0E-03	6
I	2.9E-03	6.0E-03	6
Xe	NA	NA	NA
Cs	4.0E-03	1.2E-02	6
Ba	3.2E-03	4.0E-04	6
La	2.0E-04	5.0E-06	6
Ce	1.2E-03	1.0E-04	6
Pr	4.7E-03	5.0E-06	6
Nd	3.3E-03	5.0E-06	6

Table C-3 (Cont'd)
Stable Element Transfer Data

Element	F _I Meat (d/kg)	F _M (Cow) Milk (d/L)	Reference
Pm	2.9E-04	2.0E-05	16
Sm	2.9E-04	2.0E-05	16
Eu	2.9E-04	2.0E-05	16
Gd	2.9E-04	2.0E-05	16
Dy	2.9E-04	2.0E-05	16
Er	2.9E-04	2.0E-05	16
Tm	2.9E-04	2.0E-05	16
Yb	2.9E-04	2.0E-05	16
Lu	2.9E-04	2.0E-05	16
Hf	3.4E-02	5.0E-06	Footnote 5
Ta	2.8E-01	1.3E-03	F _M - Ref.16; F _I -Footnote 6
W	1.3E-03	5.0E-04	6
Re	1.0E-01	1.3E-03	F _M - Ref.16; F _I -Footnote 12
Os	2.2E-01	6.0E-04	Footnote 13
Ir	7.3E-03	5.5E-03	Footnote 14
Pt	5.3E-02	6.7E-03	Footnote 10
Au	1.3E-02	3.2E-02	Footnote 15
Hg	3.0E-02	9.7E-06	F _M - Ref.16; F _I -Footnote 11
Tl	1.5E-02	1.3E-03	F _M - Ref.16; F _I -Footnote 3
Pb	9.1E-04	9.9E-05	98
Bi	1.7E-02	5.0E-04	98
Ra	5.5E-04	5.9E-04	98
Th	1.6E-06	5.0E-06	98
U	1.6E-06	1.2E-04	98
Np	2.0E-04	5.0E-06	6
Am	1.6E-06	2.0E-05	98

Notes:

1. NA = It is assumed that noble gases are not deposited on the ground.
2. Elements listed are those considered for 10CFR20 assessment and compliance.

Footnotes:

There are numerous F_I and F_M values that were not found in published literature. In these cases, the periodic table was used in conjunction with published values. The periodic table was used based on a general assumption that elements have similar characteristics when in the same column of the periodic table. The values of elements in the same column of the periodic table, excluding atomic numbers 58-71 and 90-103, were averaged then assigned to elements missing values located in the same column of the periodic table. This method was used for all columns where there were missing values except column 3A, where there was no data, hence, the average of column 2B and 4A were used.

1. Values obtained by averaging Reference 6 values of Ca, Sr, Ba and Ra.
2. F_I value obtained by assigning the Reference 6 value for I. F_M value obtained by averaging I(Ref. 6) and Br (Ref.16).
3. F_I values obtained by averaging Zn (Ref.6) and Pb (Ref. 98); there were no values for elements in the same column; an average is taken between values of columns 2B and 4A on the periodic table. F_M values obtained by using the value for Tl from Reference 16.
4. Values obtained by averaging Reference 6 values of Y and La
5. Values obtained by assigning the Reference 6 value for Zr.
6. F_I values obtained from Ref. 6 value for Nb. F_M values obtained by averaging values for Nb (Ref.6) and Ta (Ref. 16)
7. Values obtained from the Reference 6 values for Pb.
8. Values obtained from the Reference 6 values for Bi.
9. Values obtained from the Reference 6 values for Te.
10. Values obtained from the Reference 6 values for Ni.
11. F_I values obtained from Ref. 6 values for Zn F_M values obtained by averaging the Reference 6 values for Zn and Hg.
12. Values obtained by averaging Reference 6 values for Mn, Tc, Nd and Reference 98 value for U.
13. Values obtained by averaging Reference 6 values from Fe and Ru.
14. Values obtained by averaging Reference 6 values from Co and Rh.
15. Values obtained by averaging Reference 6 values from Cu and Ag.

Table C-4
Atmospheric Stability Classes

Description	Pasquill Stability Class	^a σ_{θ} (degrees)	Temperature Change with Height (°C/100 m)
Extremely Unstable	A	>22.5	<-1.9
Moderately Unstable	B	17.5 to 22.5	-1.9 to -1.7
Slightly Unstable	C	12.5 to 17.5	-1.7 to -1.5
Neutral	D	7.5 to 12.5	-1.5 to -0.5
Slightly Stable	E	3.8 to 7.5	-0.5 to 1.5
Moderately Stable	F	2.1 to 3.8	1.5 to 4.0
Extremely Stable	G	0 to 2.1	>4.0

^a σ_{θ} is the standard deviation of horizontal wind direction fluctuation over a period of 15 minutes to 1 hour.

From Regulatory Guide 1.21, Table 4B.

Table C-5
Vertical Dispersion Parameters

Section 1

Vertical Dispersion Parameters σ_z

σ_z (meters) = $aR^b + c$ with σ_z limited to a maximum of 1000 meters

R = downwind range (meters)

a, b and c have the values listed below:

Stability Class	100 < R < 1000			R > 1000		
	a	b	c	a	b	c
A	*	*	*	0.00024	2.094	-9.6
B	*	*	*	*	*	*
C	0.113	0.911	0.0	*	*	*
D	0.222	0.725	-1.7	1.26	0.516	-13.0
E	0.211	0.678	-1.3	6.73	0.305	-34.0
F	0.086	0.74	-0.35	18.05	0.18	-48.6
G	0.052	0.74	-0.21	10.83	0.18	-29.2

Basis: Reference 53, except for cases denoted by an asterisk. In these cases, the value of σ_z is obtained by a polynomial approximation to the data from Reference 53 (see Section 2 of this table). The functions given in Reference 50 are not used because they are discontinuous at 1000 meters.

Section 2

Polynomial Approximation for σ_z :

σ_z (meters) = $\exp [a_0 + a_1P + a_2P^2 + a_3P^3]$ with σ_z limited to a maximum of 1000 meters

P = $\log_e [R(\text{meters})]$

a_0 , a_1 , a_2 and a_3 have the values listed below:

Stability Class	Range	Coefficients
A	100 ≤ R ≤ 1000	$a_0 = -10.50$
		$a_1 = 6.879$
		$a_2 = -1.309$
		$a_3 = 0.0957$
B	100 ≤ R ≤ 1000	$a_0 = -0.449$
		$a_1 = 0.218$
		$a_2 = 0.112$
		$a_3 = -0.00517$
B	R > 1000	$a_0 = 319.148$
		$a_1 = -127.806$
		$a_2 = 17.093$
		$a_3 = -0.750$
C	R > 1000	$a_0 = 5.300$
		$a_1 = -1.866$
		$a_2 = 0.3509$
		$a_3 = -0.01514$

Table C-6
Allowable Concentration of Dissolved or Entrained Noble Gases
Released from the Site to Unrestricted Areas in Liquid Waste

<u>Nuclide</u>	Allowable Concentration ($\mu\text{Ci/mL}$) ^a	
	<u>Braidwood</u> <u>Byron</u>	<u>Dresden</u> <u>LaSalle</u> <u>Quad Cities</u> <u>Zion</u>
Kr 85m	2E-4	2E-4
Kr 85	2E-4	5E-4
Kr 87	2E-4	4E-5
Kr 88	2E-4	9E-5
Ar 41	2E-4	7E-5
Xe 131m	2E-4	7E-4
Xe 133m	2E-4	5E-4
Xe 133	2E-4	6E-4
Xe 135m	2E-4	2E-4
Xe 135	2E-4	2E-4

^aComputed from Equation 17 of ICRP Publication 2 (Reference 47) adjusted for infinite cloud submersion in water, and $R = 0.01 \text{ rem/week}$, $\rho_w = 1.0 \text{ gm/cm}^3$, and $P_w/P_1 = 1.0$.

Table C-7
Radiological Decay Constants (λ_j) in sec^{-1}

Isotope	Lambda	Isotope	Lambda	Isotope	Lambda
H-3	1.79E-09	As-73	1.00E-07	Tc-104	6.42E-04
Be-7	1.50E-07	As-74	4.50E-07	Ru-97	2.77E-06
C-14	3.83E-12	As-76	7.31E-06	Ru-103	2.04E-07
F-18	1.05E-04	As-77	4.97E-06	Ru-105	4.33E-05
Na-22	8.44E-09	Se-73	2.69E-05	Ru-106	2.18E-08
Na-24	1.28E-05	Se-75	6.69E-08	Rh-106	2.31E-02
Mg-27	1.22E-03	Br-77	3.36E-06	Pd-109	1.43E-05
Mg-28	9.19E-06	Br-80	6.61E-04	Cd-109	1.73E-08
Al-26	3.06E-14	Br-82	5.44E-06	In-111	2.83E-06
Al-28	5.14E-03	Br-83	8.06E-05	In-115M	4.42E-05
P-32	5.61E-07	Br-84	3.61E-04	In-116	2.13E-04
Cl-38	3.11E-04	Br-85	4.03E-03	Sn-113	6.97E-08
Ar-41	1.05E-04	Kr-79	5.50E-06	Sn-117M	5.89E-07
K-40	1.72E-17	Kr-81	1.05E-13	Sn-119M	2.74E-08
K-42	1.56E-05	Kr-83M	1.05E-04	Sb-117	6.89E-05
K-43	8.53E-06	Kr-85M	4.31E-05	Sb-122	2.97E-06
Ca-47	1.77E-06	Kr-85	2.05E-09	Sb-124	1.33E-07
Sc-44	4.89E-05	Kr-87	1.51E-04	Sb-125	7.94E-09
Sc-46M	3.69E-02	Kr-88	6.78E-05	Sb-126	6.47E-07
Sc-46	9.56E-08	Kr-90	2.14E-03	Ag-108M	1.73E-10
Sc-47	2.34E-06	Rb-84	2.44E-07	Ag-108	4.86E-03
Ti-44	4.64E-10	Rb-86	4.31E-07	Ag-110M	3.22E-08
V-48	5.03E-07	Rb-87	4.64E-19	Ag-111	1.08E-06
Cr-51	2.89E-07	Rb-88	6.47E-04	Te-121M	5.22E-08
Mn-52M	5.39E-04	Rb-89	7.47E-04	Te-121	4.78E-07
Mn-52	1.43E-06	Sr-85	1.24E-07	Te-123M	6.69E-08
Mn-54	2.56E-08	Sr-87M	6.86E-05	Te-125M	1.38E-07
Mn-56	7.47E-05	Sr-89	1.59E-07	Te-125	0.00E+00
Fe-52	2.33E-05	Sr-90	7.69E-10	Te-127M	7.36E-08
Fe-55	8.14E-09	Sr-91	2.03E-05	Te-127	2.06E-05
Fe-59	1.80E-07	Sr-92	7.11E-05	Te-129M	2.39E-07
Co-57	2.97E-08	Y-86	1.31E-05	Te-129	1.66E-04
Co-58	1.13E-07	Y-87	2.40E-06	Te-131M	6.42E-06
Co-60	4.17E-09	Y-88	7.53E-08	Te-131	4.61E-04
Ni-63	2.19E-10	Y-90	3.00E-06	Te-132	2.46E-06
Ni-65	7.64E-05	Y-91M	2.32E-04	Te-134	2.76E-04
Cu-64	1.52E-05	Y-91	1.37E-07	I-123	1.47E-05
Cu-67	1.30E-07	Y-92	5.44E-05	I-124	1.92E-06
Cu-68	2.31E-02	Y-93	1.91E-05	I-125	1.33E-07
Zn-65	3.28E-08	Zr-95	1.25E-07	I-130	1.56E-05
Zn-69M	1.40E-05	Zr-97	1.14E-05	I-131	9.97E-07
Zn-69	2.07E-04	Nb-94	1.08E-12	I-132	8.36E-05
Ga-66	2.05E-05	Nb-95	2.22E-06	I-133	9.25E-06
Ga-67	2.46E-06	Nb-97M	1.15E-02	I-134	2.19E-04
Ga-68	1.69E-04	Nb-97	1.60E-04	I-135	2.92E-05
Ga-72	1.36E-05	Mo-99	2.92E-06	Xe-127	2.20E-07
Ge-77	1.70E-05	Tc-99M	3.19E-05	Xe-129M	9.03E-07
As-72	7.42E-06	Tc-101	8.11E-04	Xe-131M	6.78E-07

Table C-7 (Cont'd)
Radiological Decay Constants (λ_i) in sec^{-1}

Isotope	Lambda	Isotope	Lambda
Xe-133M	3.67E-06	Yb-175	1.91E-06
Xe-133	1.53E-06	Lu-177	1.19E-06
Xe-135M	7.50E-04	Hf-181	1.89E-07
Xe-135	2.11E-05	Ta-182	7.00E-08
Xe-137	3.00E-03	Ta-183	1.61E-06
Xe-138	8.17E-04	W-187	8.08E-06
Cs-129	6.00E-06	Re-188	1.13E-05
Cs-132	1.24E-06	Os-191	5.22E-07
Cs-134	1.07E-08	Ir-194	1.01E-05
Cs-136	6.08E-07	Pt-195M	1.99E-06
Cs-137	7.28E-10	Pt-197	1.05E-05
Cs-138	3.58E-04	Au-195M	2.26E-02
Cs-139	1.23E-03	Au-195	4.39E-08
Ba-131	6.81E-07	Au-198	2.97E-06
Ba-133M	4.94E-06	Au-199	2.56E-06
Ba-133	2.09E-09	Hg-197	8.08E-06
Ba-135M	6.69E-06	Hg-203	1.72E-07
Ba-137M	4.53E-03	Tl-201	2.64E-06
Ba-137	0.00E+00	Tl-206	2.75E-03
Ba-139	1.39E-04	Tl-208	3.78E-03
Ba-140	6.28E-07	Pb-203	3.69E-06
Ba-141	6.31E-04	Pb-210	9.86E-10
Ba-142	1.08E-03	Pb-212	1.81E-05
La-140	4.78E-06	Pb-214	4.31E-04
La-142	1.21E-04	Bi-206	1.29E-06
Ce-139	5.83E-08	Bi-207	6.58E-10
Ce-141	2.47E-07	Bi-214	5.81E-04
Ce-143	5.83E-06	Ra-226	1.37E-11
Ce-144	2.83E-08	Th-232	1.56E-18
Pr-142	1.01E-05	U-238	4.92E-18
Pr-143	5.92E-07	Np-239	3.42E-06
Pr-144	6.67E-04	Am-241	5.08E-11
Nd-147	7.31E-07		
Nd-149	1.11E-04		
Pm-145	1.24E-09		
Pm-148M	1.94E-07		
Pm-148	1.49E-06		
Pm-149	3.64E-06		
Sm-153	4.11E-06		
Eu-152	1.62E-09		
Eu-154	2.50E-09		
Eu-155	4.42E-09		
Gd-153	3.33E-08		
Dy-157	2.39E-05		
Er-169	8.53E-07		
Er-171	2.56E-05		
Tm-170	6.25E-08		
Yb-169	2.51E-07		

(λ_i) = Radiological Decay Constant
= $0.693/T_1$

T_1 = Radiological Half-Life in hours
(from Reference 70).
Except for Cu-68, Tc-104, Ba-137, Ta-183, TL-206, Bi-206 which are from References 100.

Table C-8
Bioaccumulation Factors (BF_i) to be Used
in the Absence of Site-Specific Data

<u>Element</u>	<u>BF_i for Freshwater Fish (pCi/kg per pCi/L)</u>	<u>Reference</u>
H	9.0E-01	6
Be	2.8E+01	Footnote 2
C	4.6E+03	6
F	2.2E+02	Footnote 16
Na	1.0E+02	6
Mg	2.8E+01	Footnote 2
Al	2.2E+03	Footnote 13
P	1.0E+05	6
Cl	2.2E+02	Footnote 16
Ar	NA	NA
K	1.0E+03	Footnote 1
Ca	2.8E+01	Footnote 2
Sc	2.5E+01	Footnote 3
Ti	3.3E+00	Footnote 4
V	3.0E+04	Footnote 5
Cr	2.0E+02	6
Mn	4.0E+02	6
Fe	1.0E+02	6
Co	5.0E+01	6
Ni	1.0E+02	6
Cu	5.0E+01	6
Zn	2.0E+03	6
Ga	2.2E+03	Footnote 13
Ge	2.4E+03	Footnote 12
As	3.3E+04	Footnote 14
Se	4.0E+02	Footnote 15
Br	4.2E+02	6
Kr	NA	NA
Rb	2.0E+03	6
Sr	3.0E+01	6
Y	2.5E+01	6
Zr	3.3E+00	6
Nb	3.0E+04	6
Mo	1.0E+01	6
Tc	1.5E+01	6
Ru	1.0E+01	6
Rh	1.0E+01	6
Pd	1.0E+02	Footnote 9
Cd	2.0E+03	Footnote 11
In	2.2E+03	Footnote 13
Sn	2.4E+03	Footnote 12
Sb	1.0E+00	98
Ag	2.3E+00	56
Te	4.0E+02	6
I	1.5E+01	6
Xe	NA	NA
Cs	2.0E+03	6
Ba	4.0E+00	6
La	2.5E+01	6
Ce	1.0E+00	6
Pr	2.5E+01	6
Nd	2.5E+01	6
Pm	3.0E+01	98
Sm	3.0E+01	Footnote 3

Table C-8 (Cont'd)
Bioaccumulation Factors (BF_i) to be Used
in the Absence of Site-Specific Data

<u>Element</u>	<u>BF_i for Freshwater Fish (pCi/kg per pCi/L)</u>	<u>Reference</u>
Eu	1.0E+02	Footnote 3
Gd	2.6E+01	Footnote 3
Dy	2.2E+03	Footnote 3
Er	3.3E+04	Footnote 3
Tm	4.0E+02	Footnote 3
Yb	2.2E+02	Footnote 3
Lu	2.5E+01	Footnote 3
Hf	3.3E+00	Footnote 4
Ta	3.0E+04	Footnote 5
W	1.2E+03	6
Re	2.1E+02	Footnote 6
Os	5.5E+01	Footnote 7
Ir	3.0E+01	Footnote 8
Pt	1.0E+02	Footnote 9
Au	2.6E+01	Footnote 10
Hg	2.0E+03	Footnote 11
Tl	2.2E+03	Footnote 13
Pb	3.0E+02	98
Bi	2.0E+01	98
Ra	5.0E+01	98
Th	3.0E+01	98
U	1.0E+01	98
Np	1.0E+01	6
Am	3.0E+01	98

Footnotes:

NA = It is assumed that noble gases are not accumulated.

In Reference 6, see Table A-1.

A number of bioaccumulation factors could not be found in literature. In this case, the periodic table was used in conjunction with published element values. This method was used for periodic table columns except where there were no values for column 3A so the average of columns 2B and 4A was assigned.

1. Value is the average of Reference 6 values in literature for H, Na, Rb and Cs.
2. Value is the average of Ref. 6 values in literature for Sr, Ba and Ref. 98 values for Ra.
3. Value is the same as the Reference 6 value used for Y.
4. Value is the same as the Reference 6 value used for Zr.
5. Value is the same as the Reference 6 value used for Nb.
6. Value is the average of Reference 6 values in literature for Mn and Tc.
7. Value is the average of Reference 6 values in literature for Fe and Ru.
8. Value is the average of Reference 6 values in literature for Co and Rh.
9. Value is the same as the Reference 6 value used for Ni.
10. Value is the average of Reference 6 values in literature for Cu and Reference 56 value for Ag.
11. Value used is the same as the Reference 6 value used for Zn.
12. Value is the average of Reference 6 value in literature for C and Reference 98 value for Pb.
13. Value is the average of columns 2B and 4A, where column 2B is the "Reference 6 value for Zn" and column 4A is the average of "Reference 6 value for C and Reference 98 value for Pb".
14. Value is the average of Ref. 6 value found in literature for P and the Ref. 98 values for Bi and Sb.
15. Value is the same as the Reference 6 value used for Te.
16. Value is the average of Reference 6 values found in literature for Br and I.

Table C-9
Dose Factors for Noble Gases

Nuclide	Beta Air Dose Factor	Beta Skin Dose Factor	Gamma Air Dose Factor	Gamma Total Body Dose Factor
	N_i (mrad/yr per uCi/m ³)	L_i (mrem/yr per uCi/m ³)	M_i (mrad/yr per uCi/m ³)	K_i (mrem/yr per uCi/m ³)
Kr-83m	2.88E+02	---	1.93E+01	7.56E-02
Kr-85m	1.97E+03	1.46E+03	1.23E+03	1.17E+03
Kr-85	1.95E+03	1.34E+03	1.72E+01	1.61E+01
Kr-87	1.03E+04	9.73E+03	6.17E+03	5.92E+03
Kr-88	2.93E+03	2.37E+03	1.52E+04	1.47E+04
Kr-89	1.06E+04	1.01E+04	1.73E+04	1.66E+04
Kr-90	7.83E+03	7.29E+03	1.63E+04	1.56E+04
Xe-131m	1.11E+03	4.76E+02	1.56E+02	9.15E+01
Xe-133m	1.48E+03	9.94E+02	3.27E+02	2.51E+02
Xe-133	1.05E+03	3.06E+02	3.53E+02	2.94E+02
Xe-135m	7.39E+02	7.11E+02	3.36E+03	3.12E+03
Xe-135	2.46E+03	1.86E+03	1.92E+03	1.81E+03
Xe-137	1.27E+04	1.22E+04	1.51E+03	1.42E+03
Xe-138	4.75E+03	4.13E+03	9.21E+03	8.83E+03
Ar-41	3.28E+03	2.69E+03	9.30E+03	8.84E+03

Source: Table B-1 of Reference 6.

Table C-10
External Dose Factors for Standing on Contaminated Ground
DFG_{ij} (mrem/hr per pCi/ m²)

<u>Element</u>	<u>Whole Body Dose Factor</u>	<u>Reference</u>	<u>Element</u>	<u>Dose Factor</u>	<u>Reference</u>
H-3	0.00E+00	6	Be-7	5.95E-10	99
C-14	0.00E+00	6	F-18	1.19E-08	99
Na-22	2.42E-08	99	Na-24	2.50E-08	6
Mg-27	1.14E-08	99	Mg-28	1.48E-08	99
Al-26	2.95E-08	99	Al-28	2.00E-08	99
P-32	0.00E+00	6	Cl-38	1.70E-08	99
Ar-41	1.39E-08	99	K-40	2.22E-09	99
K-42	4.64E-09	99	K-43	1.19E-08	99
Ca-47	1.14E-08	99	Sc-44	2.50E-08	99
Sc-46m	1.21E-09	99	Sc-46	2.24E-08	99
Sc-47	1.46E-09	99	Ti-44	1.95E-09	99
V-48	3.21E-08	99	Cr-51	2.20E-10	6
Mn-52m	2.79E-08	99	Mn-52	3.80E-08	99
Mn-54	5.80E-09	6	Mn-56	1.10E-08	6
Fe-52	9.12E-09	99	Fe-55	0.00E+00	6
Fe-59	8.00E-09	6	Co-57	1.65E-09	99
Co-58	7.00E-09	6	Co-60	1.70E-08	6
Ni-63	0.00E+00	6	Ni-65	3.70E-09	6
Cu-64	1.50E-09	6	Cu-67	1.52E-09	99
Cu-68	8.60E-09 ¹	-	Zn-65	4.00E-09	6
Zn-69m	5.06E-09	99	Zn-69	0.00E+00	6
Ga-66	2.70E-08	99	Ga-67	1.89E-09	99
Ga-68	1.24E-08	99	Ga-72	3.00E-08	99
Ge-77	1.34E-08	99	As-72	2.23E-08	99
As-73	1.16E-10	99	As-74	9.41E-09	99
As-76	6.46E-09	99	As-77	1.79E-10	99
Se-73	1.38E-08	99	Se-75	4.98E-09	99
Br-77	3.84E-09	99	Br-80	2.01E-09	99
Br-82	3.00E-08	99	Br-83	6.40E-11	6
Br-84	1.20E-08	6	Br-85	0.00E+00	6
Kr-79	3.07E-09	99	Kr-81	1.59E-10	99
Kr-83m	1.42E-11	99	Kr-85m	2.24E-09	99
Kr-85	1.35E-10	99	Kr-87	1.03E-08	99
Kr-88	2.07E-08	99	Kr-90	1.56E-08	99
Rb-84	1.07E-08	99	Rb-86	6.30E-10	6
Rb-87	0.00E+00	99	Rb-88	3.50E-09	6
Rb-89	1.50E-08	6	Sr-85	6.16E-09	99
Sr-87m	3.92E-09	99	Sr-89	5.60E-13	6
Sr-90	1.84E-11	99	Sr-91	7.10E-09	6
Sr-92	9.00E-09	6	Y-86	4.00E-08	99
Y-87	5.53E-09	99	Y-88	2.88E-08	99
Y-90	2.20E-12	6	Y-91m	3.80E-09	6
Y-91	2.40E-11	6	Y-92	1.60E-09	6
Y-93	5.70E-10	6	Zr-95	5.00E-09	6
Zr-97	5.50E-09	6	Nb-94	1.84E-08	99
Nb-95	5.10E-09	6	Nb-97m	8.57E-09	99
Nb-97	8.48E-09	99	Mo-99	1.90E-09	6
Tc-99m	9.60E-10	6	Tc-101	2.70E-09	6
Tc-104	1.83E-08 ¹	-	Ru-97	2.99E-09	99
Ru-103	3.60E-09	6	Ru-105	4.50E-09	6
Ru/Rh-106	5.76E-09 ³	6, 99	Pc-109	3.80E-10	99
Cc-109	1.12E-10	99	In-111	5.11E-09	99
In-115m	2.01E-09	99	In-116	0.00E+00 ²	-
Sn-113	1.15E-09	99	Sn-117m	1.96E-08	99
Sn-119m	7.05E-11	99	Sb-117	0.00E+00 ²	-
Sb-122	2.71E-09 ¹	-	Sb-124	1.16E-08 ¹	-
Sb-125	4.56E-09	99	Sb-126	7.13E-10	99
Ag-108m	1.92E-08	99	Ag-108	1.14E-09	99
Ag-110m	1.80E-08	6	Ag-111	6.75E-10	99
Te-121m	2.65E-09	99	Te-121	6.75E-09	99
Te-123m	1.88E-09	99	Te-125m	3.50E-11	6
Te-125	0.00E+00 ²	-	Te-127m	1.10E-12	6
Te-127	1.00E-11	6	Te-129m	7.70E-10	6
Te-129	7.10E-10	6	Te-131m	8.40E-09	6

Table C-10 (cont.)
External Dose Factors for Standing on Contaminated Ground
 $DF_{H,1}$ (mrem/hr per pCi/ m²)

Element	Whole Body Dose Factor	Reference	Element	Dose Factor	Reference
Te-131	2.20E-09	6	Te-I-132	3.40E-09 ⁵	6
Te-134	1.05E-08	99	I-123	2.12E-09	99
I-124	1.23E-08	99	I-125	2.89E-10	99
I-130	1.40E-08	6	I-131	2.80E-09	6
I-133	3.70E-09	6	I-134	1.60E-08	6
I-135	1.20E-08	6	Xe-127	3.44E-09	99
Xe-129m	5.57E-10	99	Xe-131m	2.13E-10	99
Xe-133m	4.81E-10	99	Xe-133	5.91E-10	99
Xe-135m	5.23E-09	99	Xe-135	3.36E-09	99
Xe-137	4.26E-09	99	Xe-138	1.30E-08	99
Cs-129	3.39E-09	99	Cs-132	8.40E-09	99
Cs-134	1.20E-08	6	Cs-136	1.50E-08	6
Cs-137/Ba-137m	1.14E-08 ⁴	6, 99	Cs-138	2.10E-08	6
Cs-139	5.15E-09	99	Ba-131	5.74E-09	99
Ba-133m	8.10E-10	99	Ba-133	4.85E-09	99
Ba-135m	7.26E-10	99	Ba-137m	7.17E-09	99
Ba-137	0.00E+00 ²	-	Ba-139	2.40E-09	6
Ba-La-140	1.71E-08 ⁶	6	Ba-141	4.30E-09	6
Ba-142	7.90E-09	6	La-142	1.50E-08	6
Ce-139	2.04E-09	99	Ce-141	5.50E-10	6
Ce-143	2.20E-09	6	Ce-Pr-144	5.20E-10 ⁷	6
Pr-142	1.84E-09	99	Pr-143	0.00E+00	6
Nc-147	1.00E-09	6	Nc-149	5.32E-09	99
Pm-145	3.38E-10	99	Pm-148m	2.35E-08	99
Pm-148	7.22E-09	99	Pm-149	5.32E-10	99
Sm-153	8.95E-10	99	Eu-152	1.30E-08	99
Eu-154	1.41E-08	99	Eu-155	8.27E-10	99
Gc-153	1.46E-09	99	Dy-157	4.39E-09	99
Er-169	6.12E-14	99	Er-171	5.11E-09	99
Tm-170	3.41E-10	99	Yb-169	4.12E-09	99
Yb-175	4.94E-10	99	Lu-177	4.60E-10	99
Hf-181	6.67E-09	99	Ta-182	1.42E-08	99
Ta-183	2.93E-09 ¹	-	W-187	3.10E-09	6
Re-188	1.89E-09	99	Os-191	9.83E-10	99
Ir-194	2.31E-09	99	Pt-195m	9.79E-10	99
Pt-197	3.57E-10	99	Au-195m	2.54E-09	99
Au-195	1.14E-09	99	Au-198	5.19E-09	99
Au-199	1.18E-09	99	Hg-197	9.33E-10	99
Hg-203	2.89E-09	99	Tl-201	1.24E-09	99
Tl-206	0.00E+00 ²	-	Tl-208	3.58E-08	99
Pb-203	3.88E-09	99	Pb-210	3.57E-11	99
Pb-212	1.91E-09	99	Pb-214	3.18E-09	99
Bi-206	3.74E-08	99	Bi-207	1.77E-08	99
Bi-214	1.71E-08	99	Ra-226	8.78E-11	99
Th-232	8.14E-12	99	U-238	7.98E-12	99
Np-239	9.50E-10	6	Am-241	3.48E-10	99

- 1 Valued derived by comparing the percentage and MeV of the nuclide's gammas and then comparing to Cesium-137, as a value was not available in the literature.
- 2 0.0 due to low yield and short half life. A value was not available in the literature.
- 3 Value is the sum of Ru-106 (1.50E-9) and Rh-106 (4.26E-9). The Rh-106 value is from Reference 99 and the Ru-106 value is from Reference 6.
- 4 Value is the sum of Cs-137 (4.20E-9) and Ba-137m (7.17E-9) The values are from references 6 and 99, respectively.

- 5 Value is the sum of Te-132 (1.70E-9) and I-132 (1.70E-9).
- 6 Value is the sum of Ba-140 (2.10E-9) and La-140 (1.50E-8) from reference 6. In Reference 6, see Table E-6.
- 7 Value is the sum of Ce-144 (3.20E-10) and Pr-144 (2.00E-10) from reference 6.

Note: Dose assessments for 10CFR20 and 40CFR190 compliance are made for an adult only.

Dose assessments for 10CFR50 Appendix are made using dose factors of Regulatory Guide 1.109 (Reference 6) for all age groups.

Table C-11

Sector Code Definitions

<u>Sector Code</u>	<u>Sector Direction</u>	<u>Angle from North (Degrees)</u>
A	N	$348.75 < \theta \leq 11.25$
B	NNE	$11.25 < \theta \leq 33.75$
C	NE	$33.75 < \theta \leq 56.25$
D	ENE	$56.25 < \theta \leq 78.75$
E	E	$78.75 < \theta \leq 101.25$
F	ESE	$101.25 < \theta \leq 123.75$
G	SE	$123.75 < \theta \leq 146.25$
H	SSE	$146.25 < \theta \leq 168.75$
J	S	$168.75 < \theta \leq 191.25$
K	SSW	$191.25 < \theta \leq 213.75$
L	SW	$213.75 < \theta \leq 236.25$
M	WSW	$236.25 < \theta \leq 258.75$
N	W	$258.75 < \theta \leq 281.25$
P	WNW	$281.25 < \theta \leq 303.75$
Q	NW	$303.75 < \theta \leq 326.25$
R	NNW	$326.25 < \theta \leq 348.75$