

UNITED STATES
NUCLEAR REGULATORY COMMISSION
OFFICE OF NUCLEAR REACTOR REGULATION
WASHINGTON, D.C. 20555

December 17, 1993

NRC INFORMATION NOTICE 93-101: JET PUMP HOLD-DOWN BEAM FAILURE

Addressees

All holders of operating licenses or construction permits for boiling-water reactors (BWRs).

Purpose

The U.S. Nuclear Regulatory Commission (NRC) is issuing this information notice to alert addressees to a recent jet pump hold-down beam failure of a type not previously described by vendor guidance or by generic communications. It is expected that recipients will review the information for applicability to their facilities and consider actions, as appropriate, to avoid similar problems. However, suggestions contained in this information notice are not NRC requirements; therefore, no specific action or written response is required.

Background

On April 4, 1980, the NRC issued a bulletin, IEB 80-07, "BWR Jet Pump Assembly Failure," requesting that the owners of BWR-3 and BWR-4 plants perform visual and ultrasonic examinations of jet pump hold-down beams at the mid-length ligament sections bounding the beam bolt. This action resulted from a jet pump hold-down beam failure at Dresden Unit 3 and crack indications identified at other BWR-3 plants in early 1980. Observed cracks began at the bolt hole in the center of the jet pump hold-down beam. The bulletin also requested that licensees conduct jet pump operability surveillance on a daily basis and following unexpected changes in core flow indications, recirculation system flow indications, or an established power-core flow relationship. The nuclear steam supply system vendor, General Electric (GE), issued service information letters to owners of BWR plants on June 9, 1980, and in February 1981 providing guidance for recognizing jet pump problems using data gathered during plant operations. During implementation of the inspections prescribed in IEB 80-07, several other BWR-3 and BWR-4 plants reported discovery of beam cracking.

Description of Circumstances

On September 13, 1993, Grand Gulf power station (a BWR-6 plant) experienced an unplanned high-pressure core spray system initiation, due to a reactor low-water-level signal, that resulted in a reactor scram. Initially, the reasons for the water level anomalies detected in the "C" and "G" channels of the reactor water level instrumentation could not be determined. During restart from the reactor scram, the plant operations personnel discovered jet pump

9312160095

I&E

Notice 93-101

931217

DFD
111

flow differential pressure anomalies. During the investigation of the problem, the plant experienced oscillating water level indications and jet pump flow readings characteristic of a displaced jet pump mixer section. These indications occurred at high recirculation flows in the reactor core (77 percent core flow). Following reactor shutdown and disassembly, the licensee found the mixer assembly for jet pump 10 had separated from the diffuser and relocated between jet pump 8 and jet pump 9. The hold-down beam for jet pump 10 had cracked and failed.

Discussion

The jet pump hold-down beam failure at the Grand Gulf power station in September 1993 is unlike previous failures in that the hold-down beam for jet pump 10 failed in the transition area between the main body of the beam and the beam end as shown in Attachment 1. There have not been any previous reports of failures in this location. One beam end failed completely, causing the beam to come out of the transition piece, removing the restraint on the jet pump elbow and leading to the disassembly of jet pump 10. There is one hold-down beam for each jet pump assembly. Visual examination of the failed beam showed a crack face covering more than 270° of the cross-section of the intact beam end; the other beam end had cracked in the same location and was missing. The cracks began in an area where a radius machining cut had been made in the forging and led to failure in a location of the beam with a cross-section smaller than the areas that had been affected in previous cases. GE concluded that the probable cause of failure was an intergranular stress corrosion crack that propagated over 80 percent of the fracture surface. Fatigue striations covered the remaining 20 percent of the surface. GE stated that the loss of preload as a result of the intergranular stress corrosion may have induced the fatigue failure.

The licensee conducted ultrasonic examinations on the other inservice jet pump beams and found indications on jet pump 8 and jet pump 21 at the bolt hole area in the center of the hold-down beams. This cracking was consistent with that described in bulletin IEB 80-07. The licensee replaced all the jet pump beams with spare beams available on site.

In October 1993, ultrasonic test inspection of the hold-down beams at the Clinton power plant (a BWR-6 plant) revealed that one of the beams had crack indications around the center of the bolt hole region and the beam was replaced. On November 22, 1993, Pennsylvania Power and Light Company notified the NRC that it would be replacing all of the jet pump beams at Susquehanna Unit 1 before restarting from their refueling outage. This action was being taken as a precautionary measure given the new failure mode identified at the Grand Gulf station. GE has made a recommendation to licensees that they replace their jet pump hold-down beams as soon as practical if (1) they have beams of the same design as Grand Gulf and (2) the beams will have an accumulated service of more than eight years at the next refueling outage.

The water level anomalies that occurred at Grand Gulf on September 13 and September 28, 1993 were apparently caused by the turbulent flow conditions in the vicinity of jet pump 10. The potential for level anomalies was not discussed in bulletin IEB 80-07.

The disassembly of a jet pump could result in an increased flow area through the jet pump and a lower core flooding elevation. This could adversely affect the water level in the core during the reflood phase of a LOCA as well as the assumed blowdown flow during a LOCA. Although events to date have not resulted in damage which affected the operability of safety-related systems or equipment, a loose jet pump assembly could potentially cause such damage.

The NRC staff will continue to evaluate information concerning the beam end failure mechanism as it becomes available and will follow the progress of any new inspection techniques and corrective actions that may be developed. The NRC staff expects to meet with the BWR Owners Group and GE to discuss their action plans as a part of the ongoing safety evaluation to determine the need for further regulatory action. Areas of discussion will include evaluations of damage potential due to a displaced jet pump, effects of a failed jet pump on plant ATWS response, and the potential for LOCA loads to induce hold-down beam failures.

This information notice requires no specific action or written response. If you have any questions about the information in this notice, please contact the technical contacts listed below or the appropriate Office of Nuclear Reactor Regulation (NRR) Project Manager.

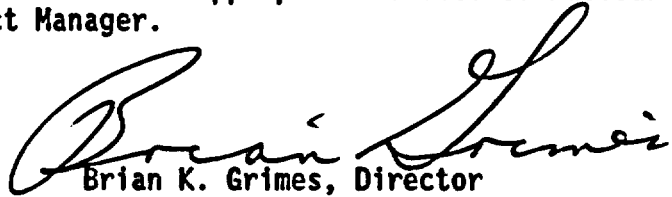
Brian K. Grimes, Director
Division of Operating Reactor Support
Office of Nuclear Reactor Regulation

Technical contacts: Rudolph H. Bernhard, RII
(601) 437-4620

James A. Davis, NRR
(301) 504-2713

Jonathan Witter, NRR
(301) 504-2978

Attachments:

1. Figure - Jet Pump Beam Failure Location
2. List of Recently Issued NRC Information Notices

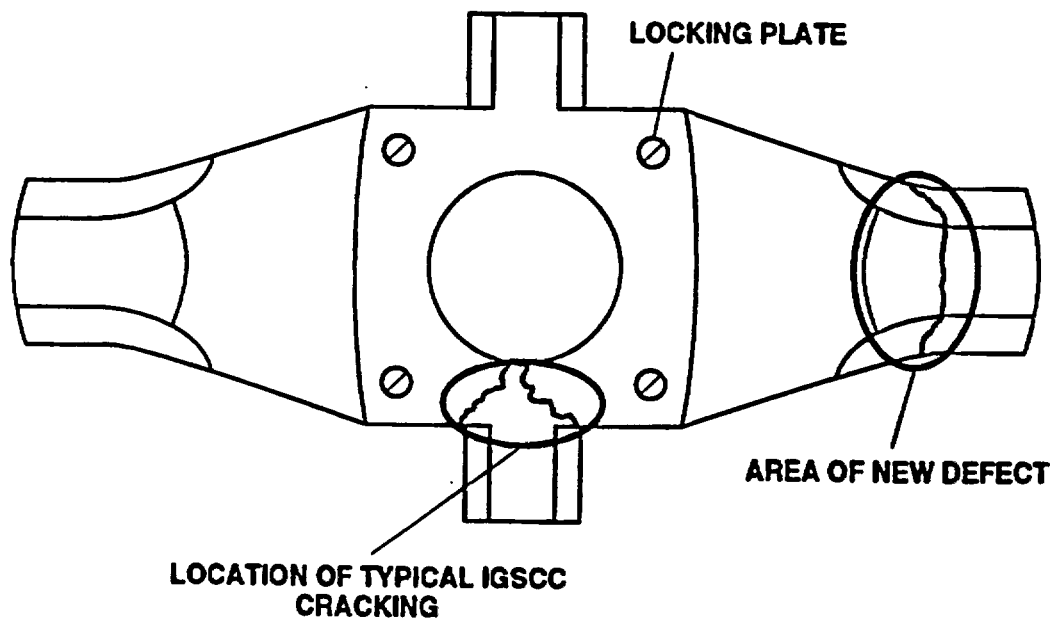
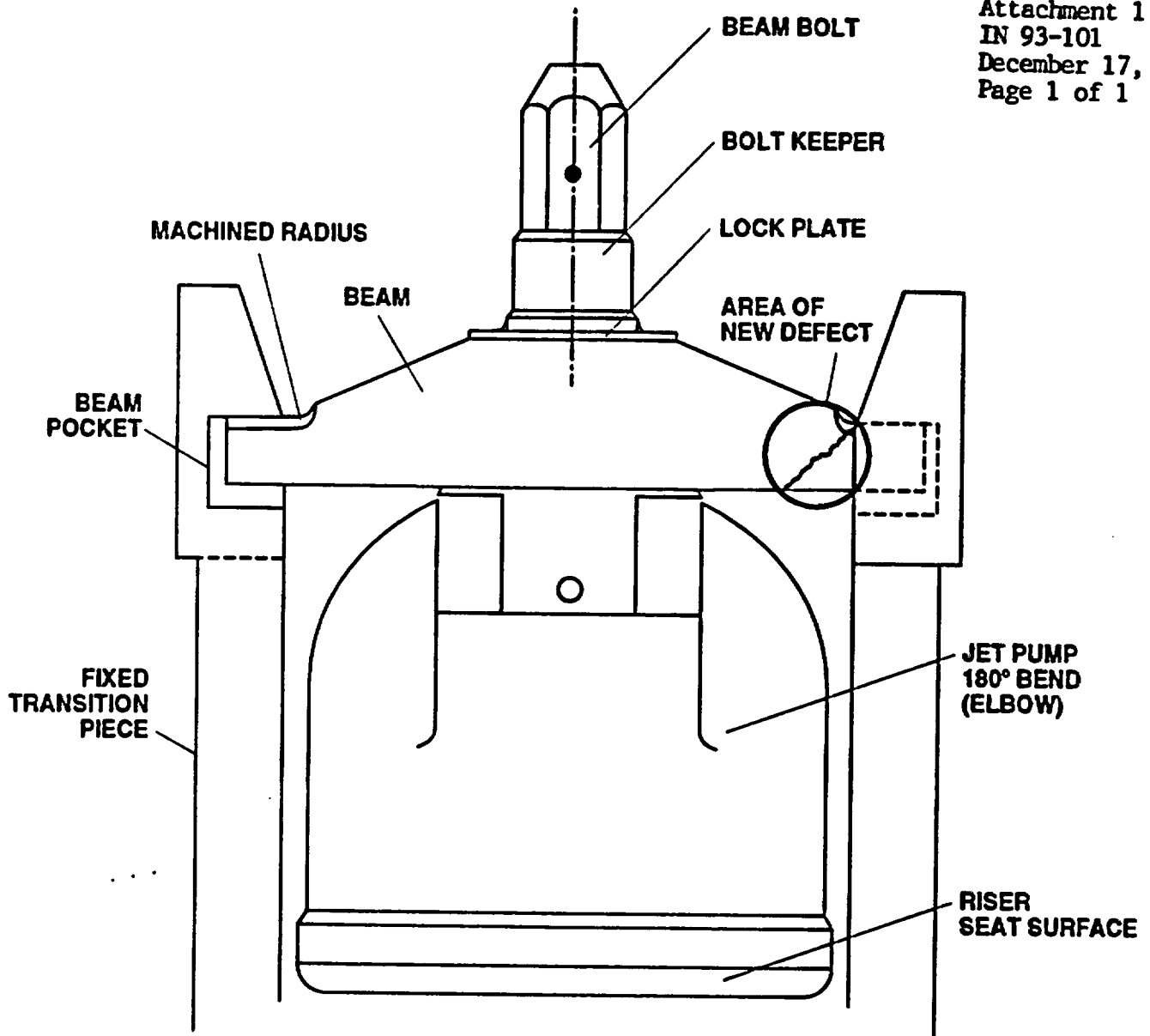

Jet Pump Beam Failure Location

LIST OF RECENTLY ISSUED
 NRC INFORMATION NOTICES

Information Notice No.	Subject	Date of Issuance	Issued to
93-100	Reporting Requirements for Bankruptcy	12/22/93	All U.S. Nuclear Regulatory Commission licensees.
91-29, Supp. 2	Potential Deficiencies Found During Electrical Distribution System Functional Inspections	12/22/93	All holders of OLs or CPs for nuclear power reactors.
93-99	Undervoltage Relay and Thermal Overload Setpoint Problems	12/21/93	All holders of OLs and CPs for nuclear power reactors.
93-98	Motor Brakes on Valve Actuator Motors	12/20/93	All holders of OLs and CPs for nuclear power reactors.
93-97	Failures of Yokes Installed on Walworth Gate and Globe Valves	12/17/93	All holders of OLs or CPs for nuclear power reactors.
93-96	Improper Reset Causes Emergency Diesel Generator Failures	12/14/93	All holders of OLs or CPs for nuclear power reactors.
93-95	Storm-Related Loss of Offsite Power Events due to Salt Buildup on Switchyard Insulators	12/13/93	All holders of OLs or CPs for nuclear power reactors located close to a large body of salt water.
93-94	Unauthorized Forced Entry into the Protected Area at Three Mile Island Unit 1 on February 7, 1993	12/09/93	All holders of OLs or CPs for nuclear power reactors.
93-93	Inadequate Control of Reactor Coolant System Conditions During Shutdown	12/08/93	All holders of OLs or CPs for nuclear power reactors.
93-92	Plant Improvements to Mitigate Common Dependencies in Component Cooling Water Systems	12/07/93	All holders of OLs or CPs for nuclear power reactors.

OL = Operating License
 CP = Construction Permit

The disassembly of a jet pump could result in an increased flow area through the jet pump and a lower core flooding elevation. This could adversely affect the water level in the core during the reflood phase of a LOCA as well as the assumed blowdown flow during a LOCA. Although events to date have not resulted in damage which affected the operability of safety-related systems or equipment, a loose jet pump assembly could potentially cause such damage.

The NRC staff will continue to evaluate information concerning the beam end failure mechanism as it becomes available and will follow the progress of any new inspection techniques and corrective actions that may be developed. The NRC staff expects to meet with the BWR Owners Group and GE to discuss their action plans as a part of the ongoing safety evaluation to determine the need for further regulatory action. Areas of discussion will include evaluations of damage potential due to a displaced jet pump, effects of a failed jet pump on plant ATWS response, and the potential for LOCA loads to induce hold-down beam failures.

This information notice requires no specific action or written response. If you have any questions about the information in this notice, please contact the technical contacts listed below or the appropriate Office of Nuclear Reactor Regulation (NRR) Project Manager.

Original signed by
 Brian K. Grimes

Brian K. Grimes, Director
 Division of Operating Reactor Support
 Office of Nuclear Reactor Regulation

Technical contacts: Rudolph H. Bernhard, RII
 (601) 437-4620

James A. Davis, NRR
 (301) 504-2713

Jonathan Witter, NRR
 (301) 504-2978

Attachments:

1. Figure - Jet Pump Beam Failure Location
2. List of Recently Issued NRC Information Notices

*See previous concurrences

OGCB: DORS*	EMCB:DE*	EMCB:DE*	EMCB:DE*	DE:D*	SRXB: DSSA*
TJKim	JDavis	RHermann	JStrosnider	JWiggins	JWitter
12/13/93	12/13/93	12/13/93	12/14/93	12/14/93	12/13/93
SRXB: DSSA*	SRXB: DSSA*	DSSA:D*	Tech Ed*	OGCB:DORS*	DORS:D
WLyons	RJones	AThadani	RSanders	GMarcus	BGrimes
12/13/93	12/13/93	12/15/93	12/10/93	12/16/93	12/16/93

The disassembly of a jet pump could result in an increased flow area through the jet pump and a lower core flooding elevation. This could adversely affect the water level in the core during the reflood phase of a LOCA as well as the assumed blowdown flow during a LOCA. Current Technical Specifications jet pump operability surveillances ensure that the operation of the reactor coolant recirculation system will be consistent with the assumptions used in the licensing basis analysis and require a plant shutdown if a failed jet pump is detected. In addition, although events to date have not resulted in damage which affected the operability of safety-related systems or equipment, a loose jet pump assembly could potentially cause such damage.

The NRC staff will continue to evaluate new information concerning the beam end failure mechanism as it becomes available and will follow the progress of any new inspection techniques and corrective actions that may be developed. The NRC plans to meet with the BWR Owners Group and GE to discuss their action plans as a part of the ongoing safety evaluation to determine the need for further regulatory action. These plans will include focusing on evaluations of damage potential due to a displaced jet pump, effects of a failed jet pump on plant ATWS response, and the potential for LOCA loads to induce hold-down beam failures.

This information notice requires no specific action or written response. If you have any questions about the information in this notice, please contact the technical contacts listed below or the appropriate Office of Nuclear Reactor Regulation (NRR) Project Manager.

Brian K. Grimes, Director
 Division of Operating Reactor Support
 Office of Nuclear Reactor Regulation

Technical contacts: Rudolph H. Bernhard, RII
 (601) 437-4620

James A. Davis, NRR
 (301) 504-2713

Jonathan Witter, NRR
 (301) 504-2978

Attachments:

1. Figure - Jet Pump Beam Failure Location
2. List of Recently Issued NRC Information Notices

*See previous concurrences

OGCB: DORS*	EMCB:DE*	EMCB:DE*	EMCB:DE*	DE:D*	SRXB: DSSA*
TJKim	JDavis	RHermann	JStrosnider	JWiggins	JWitter
12/13/93	12/13/93	12/13/93	12/14/93	12/14/93	12/13/93
SRXB: DSSA*	SRXB: DSSA*	DSSA:D*	Tech Ed*	OGCB:DORS	DORS:D
WLyons	RJones	ATHadani	RSanders	GMarcus <i>GMH</i>	BGrimes <i>gel</i>
12/13/93	12/13/93	12/15/93	12/10/93	12/16/93	12/ /93

The disassembly of a jet pump could result in an increased flow area through the jet pump and a lower core flooding elevation. This could adversely affect the water level in the core during the reflood phase of a LOCA as well as the assumed blowdown flow during a LOCA. Current Technical Specifications jet pump operability surveillances ensure that the operation of the reactor coolant recirculation system will be consistent with the assumptions used in the licensing basis analysis and require a plant shutdown if a failed jet pump is detected. In addition, although events to date have not resulted in damage which affected the operability of safety-related systems or equipment, a loose jet pump assembly could potentially cause such damage.

The NRC staff will continue to evaluate new information concerning the beam end failure mechanism as it becomes available and will follow the progress of any new inspection techniques and corrective actions that may be developed. The NRC plans to meet with the BWR Owners Group and GE to discuss their action plans as a part of the ongoing safety evaluation to determine the need for further regulatory action. These plans will include focusing on evaluations of damage potential due to a displaced jet pump, effects of a failed jet pump on plant ATWS response, and the potential for LOCA loads to induce hold-down beam failures.

This information notice requires no specific action or written response. If you have any questions about the information in this notice, please contact the technical contacts listed below or the appropriate Office of Nuclear Reactor Regulation (NRR) Project Manager.

Brian K. Grimes, Director
 Division of Operating Reactor Support
 Office of Nuclear Reactor Regulation

Technical contacts: Rudolph H. Bernhard, RII
 (601) 437-4620

James A. Davis, NRR
 (301) 504-2713

Jonathan Witter, NRR
 (301) 504-2978

Attachments:

1. Figure - Jet Pump Beam Failure Location
2. List of Recently Issued NRC Information Notices

*See previous concurrences

OGCB: DORS*	EMCB:DE*	EMCB:DE*	EMCB:DE	DE:D	SRXB: DSSA
TJKim	JDavis	RHermann	JStrosnider	JWiggins	JWitter
12/13/93	12/13/93	12/13/93	12/ /93	12/ /93	12/ /93
SRXB: DSSA	SRXB: DSSA	DSSA: <i>M</i>	Tech Ed*	OGCB:DORS	DORS:D
WLyons	RJones	ATHadani	RSanders	GMarcus	BGrimes
12/ /93	12/ /93	12//5/93	12/10/93	12/ /93	12/ /93

Although events to date have not resulted in damage which affected the operability of safety-related systems or equipment, a loose jet pump assembly could potentially cause such damage. In addition, the disassembly of a jet pump could potentially reduce the ability of the emergency core cooling systems to maintain core coverage following a postulated break in the reactor recirculation piping. The NRC plans to meet with the BWR Owners Group and GE to discuss their action plans as a part of the ongoing safety evaluation to determine the need for regulatory action to ensure safe operation of affected licensed facilities.

This information notice requires no specific action or written response. If you have any questions about the information in this notice, please contact the technical contacts listed below or the appropriate Office of Nuclear Reactor Regulation (NRR) Project Manager.

Brian K. Grimes, Director
 Division of Operating Reactor Support
 Office of Nuclear Reactor Regulation

Technical contacts: Rudolph H. Bernhard, RII
 (601) 437-4620

James A. Davis, NRR
 (301) 504-2713

Jonathan Witter, NRR
 (301) 504-2978

Attachments:

1. Figure - Jet Pump Beam Failure Location
2. List of Recently Issued NRC Information Notices

*See previous concurrences

OGCB: DORS <i>gav</i>	EMCB:DE	EMCB:DE	EMCB:DE	DE:D	SRXB: DSSA
TJKim <i>for</i>	JDavis	RHermann	JStrosnider	JWiggins	<i>Witter</i>
12/13/93	12/ /93	12/ /93	12/ /93	12/ /93	12/13/93
SRXB: DSSA	SRXB: DSSA	DSSA:D <i>gal</i>	Tech Ed*	OGCB:DORS	DORS:D
<i>Wiggins</i>	RJones	ATHadani	RSanders	GMarcus	BGrimes
12/13/93	12/17/93	12/ /93	12/10/93	12/ /93	12/ /93

Although events to date have not resulted in damage which affected the operability of safety-related systems or equipment, a loose jet pump assembly could potentially cause such damage. In addition, the disassembly of a jet pump could potentially reduce the ability of the emergency core cooling systems to maintain the core coverage assumed in the analyses following a postulated break in the reactor recirculation piping. The NRC staff will continue to evaluate new information concerning the beam end failure mechanism as it becomes available. The NRC plans to meet with the BWR Owners Group and GE to discuss their action plans as a part of the ongoing safety evaluation to determine the need for further regulatory action.

This information notice requires no specific action or written response. If you have any questions about the information in this notice, please contact the technical contacts listed below or the appropriate Office of Nuclear Reactor Regulation (NRR) Project Manager.

Brian K. Grimes, Director
 Division of Operating Reactor Support
 Office of Nuclear Reactor Regulation

Technical contacts: Rudolph H. Bernhard, RII
 (601) 437-4620

James A. Davis, NRR
 (301) 504-2713

Jonathan Witter, NRR
 (301) 504-2978

Attachments:

1. Figure - Jet Pump Beam Failure Location
2. List of Recently Issued NRC Information Notices

*See previous concurrences

OGCB: DORS*	EMCB:DE*	EMCB:DE*	EMCB:DE	DEVD	SRXB: DSSA
TJKim	JDavis	RHermann	JStrosnider	JWiggins	JWitter
12/13/93	12/13/93	12/13/93	12/14/93	12/14/93	12/ /93
SRXB: DSSA	SRXB: DSSA	DSSA:D	Tech Ed*	OGCB:DORS	DORS:D
WLyons	RJones	ATHadani	RSanders	GMarcus	BGrimes
12/ /93	12/ /93	12/ /93	12/10/93	12/ /93	12/ /93

OFFICIAL DOCUMENT NAME: GRANGULF.IN

Although events to date have not resulted in damage which affected the operability of safety-related systems or equipment, a loose jet pump assembly could potentially cause such damage. In addition, the disassembly of a jet pump could potentially reduce the ability of the emergency core cooling systems to maintain core coverage following a postulated break in the reactor recirculation piping. The NRC plans to meet with the BWR Owners Group and GE to discuss their action plans as a part of the ongoing safety evaluation to determine the need for regulatory action to ensure safe operation of affected licensed facilities.

This information notice requires no specific action or written response. If you have any questions about the information in this notice, please contact the technical contacts listed below or the appropriate Office of Nuclear Reactor Regulation (NRR) Project Manager.

Brian K. Grimes, Director
 Division of Operating Reactor Support
 Office of Nuclear Reactor Regulation

Technical contacts: Rudolph H. Bernhard, RII
 (601) 437-4620

James A. Davis, NRR
 (301) 504-2713

Jonathan Witter, NRR
 (301) 504-2978

Attachments:

1. Figure - Jet Pump Beam Failure Location
2. List of Recently Issued NRC Information Notices

*See previous concurrences

OGCB: DORS <i>JK</i>	EMCB:DE	EMCB:DE	EMCB:DE	DE:D	SRXB: DSSA
TJKim <i>JK</i>	JDavis <i>JK</i>	RHermann <i>JK</i>	JStrosnider	JWiggins	JWitter
12/13/93	12/13/93	12/13/93	12/ /93	12/ /93	12/ /93
SRXB: DSSA	SRXB: DSSA	DSSA:D	Tech Ed*	OGCB:DORS	DORS:D
WLyons	RJones	AThadani	RSanders	GMarcus	BGrimes
12/ /93	12/ /93	12/ /93	12/10/93	12/ /93	12/ /93