

**JOB PERFORMANCE MEASURE
NRC EXAM 2003-301-B1.A**

Job Position Nuclear Supervising Operator	No. NRC EXAM 2003-301-B1.a	Revision 1
JPM Title Feeding Reactor Vessel with SBFW during Reactor Vessel Low Level (Alternate Path)	Duration 15 Minutes	Page COVER SHEET

Examinee: _____ SRO / RO

Evaluator: _____

Evaluation Method: Perform / Simulator

Start Time _____

Stop Time _____

Total Time _____

PERFORMANCE EVALUATION							
Element	S	U	Comments	Element	S	U	Comments
1.							
2.							
* 3.							
* 4.							
* 5.							
6.							
7.							

_____ SATISFACTORY

_____ UNSATISFACTORY

ORAL EVALUATION (Not Required for ILO Exams)							
Question #	S	U	Comments	Question #	S	U	Comments

_____ SATISFACTORY

_____ UNSATISFACTORY

Evaluator Signature / Date: _____ / _____

JOB PERFORMANCE MEASURE

JPM Title Feeding Reactor Vessel with SBFW during Reactor Vessel Low Level (Alternate Path)	No.: NRC EXAM 2003-301-B1.a Revision: 1 Page 2
---	--

References: Required (R) / Available (A) SOP 23.107.01 Standby Feedwater System (R)
Tools and Equipment Required: None

Preferred Evaluation Method:

Perform	X	Walkthrough		Discuss	
Plant		Simulator	X	Classroom	

Evaluator Notes: ENSURE ALL INDUSTRIAL AND PERSONNEL SAFETY PRACTICES ARE USED AND ENFORCED. Start this JPM at the CRS Desk in the Simulator. K/A Reference : 2.1 Generic Knowledge and Abilities: 2.1.17 Ability to make accurate, clear, and concise verbal reports. 3.5 / 3.6 2.1.20 Ability to execute procedure steps. 4.3 / 4.2 2.1.21 Ability to obtain and verify controlled procedure copy. 3.1 / 3.2 2.1.23 Ability to perform specific procedures during all modes of operation. 3.3 / 3.5 2.1.30 Ability to locate and operate components including local controls. 3.4 / 3.5 2.1.28 Knowledge of purpose and function of major system components and controls 3.2 / 3.3 295031 Reactor Low Water Level EA1. Ability to operate and/or monitor the following as they apply to reactor low water level (CFR: 41.7 / 45.6): EA1.08 Alternate injection systems 3.8 / 3.9
Task Standard: It is realized that SBFW Pump A(B) is unable to inject to the vessel with the Keylock Mode Select Switch in the TEST position, reposition the Keylock Mode Select Switch and successfully inject to the RPV to restore RPV level to 173 to 214 inches.
Initial Conditions: The plant has experienced a Reactor Scram. HPCI, RCIC, and Feedwater are currently unavailable.
Initiating Cue(s): You are the Control Room NSO. The CRS has directed you to feed the RPV with Standby Feedwater and restore RPV level to 173 to 214 inches The system is in Standby, IAW 23.107.01 section 5.0.

JOB PERFORMANCE MEASURE

JPM Title Feeding Reactor Vessel with SBFW during Reactor Vessel Low Level (Alternate Path)	No.: NRC EXAM 2003-301-B1.a Revision: 1 Page 3
---	--

PERFORMANCE EVALUATION

Time Start _____

<u>Elements</u>	<u>Standards</u>
<p>NOTE: All controls and indications are located on H11-P601 unless otherwise specified.</p>	<p>NOTE: The operator may Recognize and report to CRS the Keylock Mode Select Switch in TEST and request CRS concurrence to place in NORMAL prior to start of the procedure.</p>
<p>PREREQUISITES: NONE</p>	<p>NOTE: The operator may perform feeding of the RPV with Standby Feedwater from memory in accordance with Operations Department Expectation (ODE) 10, Emergency Operating Procedure Expectations.</p>
6.2.1 Start N2103-C003A (B), West (East) Pump A (B) Aux Lube Oil Pump, if available.	6.2.1 Starts N2103-C003A (B), West (East) Pump A (B) Aux Lube Oil Pump, if available.
6.2.2 If Lube Oil Pump is running, dispatch an operator to verify lube oil pressure and flow as follows: <ol style="list-style-type: none"> 1. Lube oil pressure on N21-RA04 (RA03), SBFW Pump A (B) Lube Oil Supply Press Indicator, is greater than 15 psig. 2. There is oil flow through all four bull's eye flow indicators (two on pump and two on motor). <p>NOTE: If SBFW pumps are needed for vessel inventory and Aux Lube Oil Pump is running, Step 6.2.2 can be omitted without damage to the SBFW Pump</p> <p>CUE: IF ASKED</p> <p>6.2.2.1 Press>15psig</p> <p>6.2.2.2 Flow through all four bull's eyes</p>	<p>NOTE: This Step can be omitted.</p>
*6.2.3 Start N2103-C001 (2), West (East) Standby Feedwater Pump A (B).	*6.2.3 Starts N2103-C001 (2), West (East) Standby Feedwater Pump A (B).

JOB PERFORMANCE MEASURE

JPM Title Feeding Reactor Vessel with SBFW during Reactor Vessel Low Level (Alternate Path)	No.: NRC EXAM 2003-301-B1.a Revision: 1 Page 4
---	--

<u>Elements</u>	<u>Standards</u>
*6.2.4 Verify the following: <ol style="list-style-type: none"> 1. N2103-F001, SBFW Disch To RPV Iso Valve, automatically opens (first pump). 2. If running, N2103-C003A (B), West (East) Pump A (B) Aux Lube Oil Pump, automatically stops. 3. Lube oil pressure on N21-RA04 (RA03), SBFW Pump A (B) Lube Oil Supply Press Indicator, is greater than 15 psig. 4. There is oil flow through all four bull's eye flow indicators (two on pump and two on <p>CUE: IF ASKED:</p> <p>6.2.2.1 Press>15psig</p> <p>6.2.2.2 Flow through all four bull's eyes</p>	*6.2.4 Recognize and report to CRS, N2103-F001 did not Open. Place Keylock Mode Select Switch in NORMAL with CRS concurrence. Verify N2103-F001 Opens.
*6.2.5 Throttle N2103-F003, SBFW 4" Disch Flow Ctrl Vlv, to restore RPV level 173 to 214 inches.	6.2.5 RPV level restored to 173 to 214 inches
6.2.6 If more flow is desired, repeat Steps 6.2.1 through 6.2.5 for the second SBFW Pump.	6.2.6 If more flow is desired, repeat Steps 6.2.1 through 6.2.5 for the second SBFW Pump.
6.2.7 If more flow is necessary, throttle open N2103-F002, SBFW 6" Disch Flow Ctrl Vlv, to achieve desired flow.	6.2.7 If more flow is necessary, throttle open N2103-F002, SBFW 6" Disch Flow Ctrl Vlv, to achieve desired flow.

Time Stop _____

* Critical Steps

Terminating Cue(s):

After correcting position of the F001 Keylock Mode Select Switch, SBFW is injecting to the RPV, and RPV level is restored to 173 to 214 inches

JOB PERFORMANCE MEASURE

JPM Title Feeding Reactor Vessel with SBFW during Reactor Vessel Low Level (Alternate Path)	No.: NRC EXAM 2003-301-B1.a Revision: 1 Page 5
---	--

FOLLOW-UP DOCUMENTATION QUESTIONS

Reason for Followup question(s):

Question:

Reference:

Response:

Question:

Reference

Response:

JOB PERFORMANCE MEASURE

JPM Title Feeding Reactor Vessel with SBFW during Reactor Vessel Low Level (Alternate Path)	No.: NRC EXAM 2003-301-B1.a Revision: 1 Page 6
---	--

Simulator Setup

IC#:

Any shutdown IC with RPV level at approximately 150 inches

Malfunctions:

None

Remote Functions:

None

Override Functions:

None

Special Instructions:

1. Place Standby Feedwater Keylock Mode Switch in TEST
2. Trip HPCI, RCIC, and RFPs.

**JOB PERFORMANCE MEASURE
NRC EXAM 2003-301-B1.B**

JPM B1.a Cue Sheet

Initial Conditions:

The plant has experienced a Reactor Scram.

HPCI, RCIC, and Feedwater are currently unavailable to feed the RPV.

Initiating Cue(s):

You are the Control Room NSO.

The CRS has directed you to feed the RPV with Standby Feedwater and restore RPV level to 173 to 214 inches

The system is in Standby, IAW 23.107.01 section 5.0.

JOB PERFORMANCE MEASURE

JPM Title CCHVAC to Chlorine Mode	No.: NRC EXAM 2003-301-B1.b Revision: 1 Page 2
--------------------------------------	--

Job Position Nuclear Supervising Operator	No. NRC EXAM 2003-301-B1.b	Revision 1
JPM Title Open MSIVs Following an Isolation with Inboard MSIV(s) Failed Closed	Duration 20 Minutes	Page COVER SHEET

Examinee: _____ SRO / RO

Evaluator: _____

Evaluation Method: Perform / Simulator

Start Time _____

Stop Time _____

Total Time _____

PERFORMANCE EVALUATION							
Element	S	U	Comments	Element	S	U	Comments
*1.							
*2.							
*3.							
*4.							
*5.							
*6.							
*7.							
*8.							
*9.							
*10.							
*11.							

_____ SATISFACTORY

_____ UNSATISFACTORY

ORAL EVALUATION (Not Required for ILO Exams)							
Question #	S	U	Comments	Question #	S	U	Comments

_____ SATISFACTORY

_____ UNSATISFACTORY

JOB PERFORMANCE MEASURE

JPM Title CCHVAC to Chlorine Mode	No.: NRC EXAM 2003-301-B1.b Revision: 1 Page 3
--------------------------------------	--

Evaluator Signature / Date: _____ / _____

JOB PERFORMANCE MEASURE

JPM Title CCHVAC to Chlorine Mode	No.: NRC EXAM 2003-301-B1.b Revision: 1 Page 4
--------------------------------------	--

References: Required (R) / Available (A) 23.137, Nuclear Boiler System(R)
Tools and Equipment Required: None

Preferred Evaluation Method:

Perform	X	Walkthrough		Discuss	
Plant		Simulator	X	Classroom	

<p>Evaluator Notes:</p> <p>ENSURE ALL INDUSTRIAL AND PERSONNEL SAFETY PRACTICES ARE USED AND ENFORCED.</p> <p>This JPM may be performed in IC-18 with a Reactor Scram Start this JPM at the CRS Desk in the Simulator.</p> <p>K/A Reference :</p> <p>2.1 Generic Knowledge and Abilities:</p> <p>2.1.17 Ability to make accurate, clear, and concise verbal reports. 3.5 / 3.6</p> <p>2.1.20 Ability to execute procedure steps. 4.3 / 4.2</p> <p>2.1.21 Ability to obtain and verify controlled procedure copy. 3.1 / 3.2</p> <p>2.1.23 Ability to perform specific procedures during all modes of operation. 3.3 / 3.5</p> <p>2.1.30 Ability to locate and operate components including local controls. 3.4 / 3.5</p> <p>2.1.28 Knowledge of purpose and function of major system components and controls 3.2 / 3.3</p> <p>239001 – Main and Reheat Steam:</p> <p>K2 - Knowledge of electrical power supplies to the following: (CFR: 41.7)</p> <p>K2.01 - Main steam isolation valve solenoids 3.2 / 3.3</p> <p>A4 - Ability to manually operate and/or monitor in the control room: (CFR: 41.7 / 45.5 to 45.8)</p> <p>A4.01 – MSIVs 4.2 / 4.0</p>	
<p>Task Standard:</p> <p>MSIVs have been opened following an isolation</p>	
<p>Initial Conditions:</p> <p>The plant has experienced a Reactor Scram.</p> <p>The MSIVs have isolated due to a spurious isolation.</p>	
<p>Initiating Cue(s):</p> <p>You are the Control Room NSO.</p> <p>The CRS has directed you to open the MSIVs in accordance with 23.137</p> <p>Prerequisites have been met, and Step 7.1.2.1 and 7.1.2.2 are complete.</p>	

JOB PERFORMANCE MEASURE

JPM Title CCHVAC to Chlorine Mode	No.: NRC EXAM 2003-301-B1.b Revision: 1 Page 5
--------------------------------------	--

PERFORMANCE EVALUATION

Time Start _____

<u>Elements</u>	<u>Standards</u>
<p>NOTE: All controls and indications are located on COP H11-P601, H11-P602, and H11-P804 unless otherwise specified.</p> <p>NOTE: Per the Cue Sheet, all prerequisites have been met, and Step 7.1.2.1 and 7.1.2.2 are complete.</p> <p>*7.1.2.3. Equalize across Main Steam Isolation Valves by performing the following:</p> <p>a. Verify the following 3rd MSIVs are open:</p> <ul style="list-style-type: none"> • N1100-F607, 3rd MSIV Line C Iso Vlv • N1100-F608, 3rd MSIV Line D Iso Vlv • N1100-F609, 3rd MSIV Line A Iso Vlv • N1100-F610, 3rd MSIV Line B Iso Vlv 	<p>*7.1.2.3.</p> <p>a. Verifies the following 3rd MSIVs are open:</p> <ul style="list-style-type: none"> • N1100-F607, 3rd MSIV Line C Iso Vlv • N1100-F608, 3rd MSIV Line D Iso Vlv • N1100-F609, 3rd MSIV Line A Iso Vlv • N1100-F610, 3rd MSIV Line B Iso Vlv
<p>*b. Open the following Outboard MSIVs one at a time:</p> <ul style="list-style-type: none"> • B2103-F028A, Outboard MSIV Line A • B2103-F028B, Outboard MSIV Line B • B2103-F028C, Outboard MSIV Line C • B2103-F028D, Outboard MSIV Line D 	<p>*b. Opens the following Outboard MSIVs one at a time:</p> <ul style="list-style-type: none"> • B2103-F028A, Outboard MSIV Line A • B2103-F028B, Outboard MSIV Line B • B2103-F028C, Outboard MSIV Line C • B2103-F028D, Outboard MSIV Line D
<p>*c. Close or verify closed the following valves:</p> <ul style="list-style-type: none"> • P9500-F654, MS Line Drain to Cndr Iso Valve • B2100-F033, Main Steam Line Continuous Drain Isolation Valve. • B2103-F021, Main Steam Drain Line Orifice Bypass Valve. 	<p>*c. Closes or verifies closed</p> <ul style="list-style-type: none"> • P9500-F654, MS Line Drain to Cndr Iso Valve • B2100-F033, Main Steam Line Continuous Drain Isolation Valve. • B2103-F021, Main Steam Drain Line Orifice Bypass Valve.

JOB PERFORMANCE MEASURE

JPM Title CCHVAC to Chlorine Mode	No.: NRC EXAM 2003-301-B1.b Revision: 1 Page 6
--------------------------------------	--

<u>Elements</u>	<u>Standards</u>
<p>*d. Open the following Main Steam Line Outboard Drain Valves:</p> <ul style="list-style-type: none"> • B2100-F080A, Main Steam Line A Drain Valve • B2100-F080B, Main Steam Line B Drain Valve • B2100-F080C, Main Steam Line C Drain Valve • B2100-F080D, Main Steam Line D Drain Valve 	<p>*d. Opens</p> <ul style="list-style-type: none"> • B2100-F080A, Main Steam Line A Drain Valve • B2100-F080B, Main Steam Line B Drain Valve • B2100-F080C, Main Steam Line C Drain Valve • B2100-F080D, Main Steam Line D Drain Valve
<p>*e. To admit steam to Outboard Steam Line Area, open the following valves:</p> <ul style="list-style-type: none"> • B2103-F600, MS Line Otbd Drains Hdr Iso Vlv • B2103-F019, MS Line Otbd Drain Iso Valve • B2103-F016, MS Line Inbd Drain Iso Valve 	<p>*e. Opens the following valves:</p> <ul style="list-style-type: none"> • B2103-F600, MS Line Otbd Drains Hdr Iso Vlv • B2103-F019, MS Line Otbd Drain Iso Valve • B2103-F016, MS Line Inbd Drain Iso Valve
<p>*f. Close the following valves (COP H11-P804):</p> <ul style="list-style-type: none"> • P9500-F410, 52" Manifold East Drain Valve • P9500-F411, 52" Manifold West Drain Valve • N3039-F621, MS to Reheater Line Drain Valve 	<p>*f. Closes the following valves (COP H11-P804):</p> <ul style="list-style-type: none"> • P9500-F410, 52" Manifold East Drain Valve • P9500-F411, 52" Manifold West Drain Valve • N3039-F621, MS to Reheater Line Drain Valve
<p>*g. Close or verify closed N3013-F601, Gland Steam Inlet Hdr Iso Vlv.</p>	<p>*g. Closes or verifies closed N3013-F601, Gland Steam Inlet Hdr Iso Vlv.</p>
<p>*h. Determine differential pressure across Inboard MSIVs from the following pressure indicators:</p> <p>1) If less than 200 psig RPV Pressure, use the following:</p> <ul style="list-style-type: none"> • C32-R609, Reactor Pressure Recorder (COP H11-P603). • B21-R801 (R804), Div 1(2) MSIVLC Line Pressure Indicator (COP H11-P601/P602). <p>2) If greater than 200 psig RPV Pressure, use the following:</p> <ul style="list-style-type: none"> • C32-R609, Reactor Pressure Recorder (COP H11-P603). • N11-R800, Main Steam 52" Manifold Pressure Recorder (COP-H11-P804). 	<p>*h.</p> <p>1) If less than 200 psig RPV Pressure, uses the following:</p> <ul style="list-style-type: none"> • C32-R609, Reactor Pressure Recorder (COP H11-P603). • B21-R801 (R804), Div 1(2) MSIVLC Line Pressure Indicator (COP H11-P601/P602). <p>2) If greater than 200 psig RPV Pressure, uses the following:</p> <ul style="list-style-type: none"> • C32-R609, Reactor Pressure Recorder (COP H11-P603). • N11-R800, Main Steam 52" Manifold Pressure Recorder (COP-H11-P804).

JOB PERFORMANCE MEASURE

JPM Title CCHVAC to Chlorine Mode	No.: NRC EXAM 2003-301-B1.b Revision: 1 Page 7
--------------------------------------	--

<u>Elements</u>	<u>Standards</u>
<p>The maximum allowable differential pressure for opening Main Steam Isolation Valves (MSIVs) is 150 psid. Under all normal operating circumstances, MSIVs should not be opened with a differential pressure greater than 50 psid.</p>	
<p>*i. When the differential pressure across the Inboard MSIVs is less than or equal to 50 psid, open the following Inboard MSIVs, one at a time:</p> <ul style="list-style-type: none"> • B2103-F022A, Inboard MSIV Line A. • B2103-F022B, Inboard MSIV Line B. • B2103-F022C, Inboard MSIV Line C. • B2103-F022D, Inboard MSIV Line D. 	<p>*i. When the differential pressure across the Inboard MSIVs is less than or equal to 50 psid, opens the following Inboard MSIVs, one at a time:</p> <ul style="list-style-type: none"> • B2103-F022A, Inboard MSIV Line A. • B2103-F022B, Inboard MSIV Line B. • B2103-F022C, Inboard MSIV Line C. • B2103-F022D, Inboard MSIV Line D.
<p>*j. Open the following valves:</p> <ul style="list-style-type: none"> • B2100-F033, Main Steam Line Continuous Drain Isolation Valve. • P9500-F654, MS Line Drain to Cndr Iso Valve. • P9500-F410, 52" Manifold East Drain Valve. • P9500-F411, 52" Manifold West Drain Valve. • N3039-F621, MS to Reheater Line Drain Valve. 	<p>*j. Opens the following valves:</p> <ul style="list-style-type: none"> • B2100-F033, Main Steam Line Continuous Drain Isolation Valve. • P9500-F654, MS Line Drain to Cndr Iso Valve. • P9500-F410, 52" Manifold East Drain Valve. • P9500-F411, 52" Manifold West Drain Valve. • N3039-F621, MS to Reheater Line Drain Valve.
<p>*k. Close the following Main Steam Line Drain Valves:</p> <ul style="list-style-type: none"> • B2103-F016, MS Line Inbd Drain Iso Valve • B2103-F019, MS Line Otbd Drain Iso Valve 	<p>*k. Closes the following Main Steam Line Drain Valves:</p> <ul style="list-style-type: none"> • B2103-F016, MS Line Inbd Drain Iso Valve • B2103-F019, MS Line Otbd Drain Iso Valve

Time Stop _____

* Critical Steps

Terminating Cue(s):

MSIVs are open

JOB PERFORMANCE MEASURE

JPM Title CCHVAC to Chlorine Mode	No.: NRC EXAM 2003-301-B1.b Revision: 1 Page 8
--------------------------------------	--

FOLLOW-UP DOCUMENTATION QUESTIONS

Reason for Followup question(s):

Question:

Reference:

Response:

Question:

Reference

Response:

JOB PERFORMANCE MEASURE

JPM Title CCHVAC to Chlorine Mode	No.: NRC EXAM 2003-301-B1.b Revision: 1 Page 9
--------------------------------------	--

Simulator Setup

IC#:

IC 18 with Reactor Scram

Malfunctions:

None

Remote Functions:

Number	Title	Value
(B21) RF10	Condenser vacuum Isolation Logic Bypass Switch 34A	Bypass
(B21) RF10	Condenser vacuum Isolation Logic Bypass Switch 34B	Bypass
(B21) RF10	Condenser vacuum Isolation Logic Bypass Switch 34C	Bypass
(B21) RF10	Condenser vacuum Isolation Logic Bypass Switch 34D	Bypass

Override Functions:

None

Special Instructions:

Start the simulator in IC 18

Scram the Reactor

Close the MSIVs

Close N3013-F601, Gland Steam Inlet Hdr Iso Vlv.

Perform Step 7.1.2.1 of 23.137 - Insert Condenser Vacuum Isolation Logic Bypass Switchs 34A, 34B, 34C, and 34D.

Perform Step 7.1.2.2 of 23.137 – Reset MSIV Isolation Logic.

**JOB PERFORMANCE MEASURE
NRC EXAM 2003-301-B1.C**

JPM B1.b Cue Sheet

Initial Conditions:

The plant has experienced a Reactor Scram.

The MSIVs have isolated due to a spurious isolation.

Initiating Cue(s):

You are the Control Room NSO.

The CRS has directed you to open the MSIVs in accordance with 23.137

Prerequisites have been met, and Step 7.1.2.1 and 7.1.2.2 are complete.

JOB PERFORMANCE MEASURE

JPM Title Perform Manual Scram Functional Test	No.: NRC EXAM 2003-301-B1.c Revision: 1 Page 2
---	--

Job Position Nuclear Supervising Operator	No. NRC EXAM 2003-301-B1.c	Revision 1
JPM Title Perform Manual Scram Functional Test	Duration 20 Minutes	Page COVER SHEET

Examinee: _____ SRO / RO

Evaluator: _____

Evaluation Method: Perform / Simulator

Start Time _____

Stop Time _____

Total Time _____

PERFORMANCE EVALUATION							
Element	S	U	Comments	Element	S	U	Comments
*1.				*14.			
*2.				*15.			
*3.				*16.			
*4.				*17.			
*5.				*18.			
*6.				*19.			
*7.				*20.			
*8.				*21.			
*9.				22.			
*10.							
*11.							
*12.							
*13.							

_____ SATISFACTORY

_____ UNSATISFACTORY

ORAL EVALUATION (Not Required for ILO Exams)							
Question #	S	U	Comments	Question #	S	U	Comments

_____ SATISFACTORY

_____ UNSATISFACTORY

Evaluator Signature / Date: _____ / _____

JOB PERFORMANCE MEASURE

JPM Title Perform Manual Scram Functional Test	No.: NRC EXAM 2003-301-B1.c Revision: 1 Page 3
---	--

References: Required (R) / Available (A)
24.610.01, RPS - Manual Scram Functional Test (R)

Tools and Equipment Required:
None

Preferred Evaluation Method:

Perform	<u> X </u>	Walkthrough	<u> </u>	Discuss	<u> </u>
Plant	<u> </u>	Simulator	<u> X </u>	Classroom	<u> </u>

<p>Evaluator Notes:</p> <p>ENSURE ALL INDUSTRIAL AND PERSONNEL SAFETY PRACTICES ARE USED AND ENFORCED.</p> <p>This JPM may be performed in any IC. Start this JPM at the CRS Desk in the Simulator. K/A Reference : 212000 Reactor Protection System – K4. Knowledge of REACTOR PROTECTION SYSTEM design feature(s) and/or interlocks which provide for the following (CFR: 41.7):</p> <ul style="list-style-type: none"> K4.05 - Functional testing of the system while maintaining power operation 3.4 / 3.6 <p>A1. Ability to predict and/or monitor changes in parameters associated with operating the REACTOR PROTECTION SYSTEM controls including (CFR: 41.5 / 45.5):</p> <ul style="list-style-type: none"> A1.11 - System status lights and alarms 3.4 / 3.3; <p>A2. Ability to (a) predict the impacts of the following on the REACTOR PROTECTION SYSTEM ; and (b) based on those predictions, use procedures to correct, control, or mitigate the consequences of those abnormal conditions or operations (CFR: 41.5 / 45.6):</p> <ul style="list-style-type: none"> A2.03 - Surveillance testing 3.3 / 3.5 A2.19 - Partial system activation (half-SCRAM) 3.8 / 3.9 <p>A4. Ability to manually operate and/or monitor in the control room (CFR: 41.7 / 45.5 to 45.8):</p> <ul style="list-style-type: none"> A4.02 - Perform system functional test(s) 3.6 / 3.7 A4.07 - System status lights and alarms 4.0 / 3.9* A4.14 - Reset system following system activation 3.8 / 3.8
<p>Task Standard:</p> <p>Perform RPS Manual Scram Functional Test in accordance with 24.610.01</p>
<p>Initial Conditions:</p> <p>You are the Control Room Nuclear Supervising Operator. Plant conditions are as you see them.</p>
<p>Initiating Cue(s):</p> <p>The CRS directs you to perform RPS Manual Scram Functional Test in accordance with 24.610.01. A Licensed Operator is in the Relay Room standing by to assist.</p>

JOB PERFORMANCE MEASURE

JPM Title Perform Manual Scram Functional Test	No.: NRC EXAM 2003-301-B1.c Revision: 1 Page 4
---	--

PERFORMANCE EVALUATION

Time Start _____

Elements

Standards

NOTE: All controls and indications are located on COP H11-P603 unless otherwise noted.

<p>PREREQUISITES:</p> <p>4.3 Communications have been established between Control Room and an operator stationed at RPS Trip Logic Panel RR H11-P609 and RR H11-P611.</p> <p>NOTE: Simulator Booth Operator will act as the operator in Relay Room. The Booth Operator will be seated at the SOER terminal/printer and will function as both the Relay Room Operator and the SOER verifier.</p>	
<p>*5.1.1 Verify following annunciators clear:</p> <ol style="list-style-type: none"> 1. 3D73, TRIP ACTUATORS A1/A2 TRIPPED 2. 3D74, TRIP ACTUATORS B1/B2 TRIPPED 3. 3D77, MANUAL TRIP A SYS TRIP 4. 3D78, MANUAL TRIP B SYS TRIP 	<p>*5.1.1 Verifies annunciators clear:</p> <ol style="list-style-type: none"> 1. 3D73, TRIP ACTUATORS A1/A2 TRIPPED 2. 3D74, TRIP ACTUATORS B1/B2 TRIPPED 3. 3D77, MANUAL TRIP A SYS TRIP 4. 3D78, MANUAL TRIP B SYS TRIP
<p>*5.1.2 Verify following white scram Group 1, 2, 3, and 4 lights are ON:</p> <ol style="list-style-type: none"> 1. RPS "A" on RR H11-P609 2. RPS "B" on RR H11-P611 	<p>*5.1.2 Verifies white scram Group 1, 2, 3, and 4 lights are ON:</p> <ol style="list-style-type: none"> 1. RPS "A" on RR H11-P609 2. RPS "B" on RR H11-P611
<p>*5.1.3 Verify following blue scram GROUP 1, 2, 3, and 4 lights on COP H11-P603 are ON:</p> <ol style="list-style-type: none"> 1. Pilot Scram Valve Solenoids, Trip System A 2. Pilot Scram Valve Solenoids, Trip System B 	<p>*5.1.3 Verifies blue scram GROUP 1, 2, 3, and 4 lights on COP H11-P603 are ON:</p> <ol style="list-style-type: none"> 1. Pilot Scram Valve Solenoids, Trip System A 2. Pilot Scram Valve Solenoids, Trip System B

JOB PERFORMANCE MEASURE

JPM Title Perform Manual Scram Functional Test	No.: NRC EXAM 2003-301-B1.c Revision: 1 Page 5
---	--

<u>Elements</u>	<u>Standards</u>
<p>step will initiate a Half Scram.</p> <p>NOTE: Since the Manual Scram trip channel will auto-reset upon return of the A1 pushbutton to its normally closed position, Annunciator 3D77, with its associated SOER Alarm Point, will reset and the Scram Pushbutton Switch red backlight will go out when the operator releases the Manual Scram Pushbutton Switch.</p> <p>*5.1.4 Momentarily depress Manual Scram Trip A1 pushbutton on COP H11-P603 and verify:</p> <ol style="list-style-type: none"> 1. Annunciator 3D77, MANUAL TRIP A SYS TRIP, alarms. 2. Sequence of Events Recorder Point 013C71, alarms. 3. Red Manual Scram Trip A1 pushbutton light comes ON. 4. White scram Group 1, 2, 3, and 4 lights for RPS "A" on RR H11-P609 are OFF. 5. Blue scram GROUP 1, 2, 3, and 4 lights for Pilot Scram Valve Solenoids, Trip System A on COP H11-P603 are OFF. 	<p>*5.1.4 Depresses Manual Scram Trip A1 pushbutton on COP H11-P603 and verifies:</p> <ol style="list-style-type: none"> 1. Annunciator 3D77, MANUAL TRIP A SYS TRIP, alarms. 2. Sequence of Events Recorder Point 013C71, alarms. 3. Red Manual Scram Trip A1 pushbutton light comes ON. 4. White scram Group 1, 2, 3, and 4 lights for RPS "A" on RR H11-P609 are OFF. 5. Blue scram GROUP 1, 2, 3, and 4 lights for Pilot Scram Valve Solenoids, Trip System A on COP H11-P603 are OFF.
<p>*5.1.5 Place Scram Reset switch to GP1 and GP4 then GP2 and GP3 Position and release.</p>	<p>*5.1.5 Places Scram Reset switch to GP1 and GP4 then GP2 and GP3 Position and release.</p>
<p>*5.1.6 Verify the following:</p> <ol style="list-style-type: none"> 1. Red Manual Scram Trip A1, pushbutton light is OFF. 2. Annunciator 3D77, MANUAL TRIP A SYS TRIP, has cleared. 3. Sequence of Events Recorder Point 013C71, has reset. 4. White scram Group 1, 2, 3, and 4 lights for RPS A on RR H11-P609 are ON. 5. Blue scram GROUP 1, 2, 3, and 4 lights for Pilot Scram Valve Solenoids, Trip System A on COP H11-P603 are ON. 	<p>*5.1.6 Verifies the following:</p> <ol style="list-style-type: none"> 1. Red Manual Scram Trip A1, pushbutton light is OFF. 2. Annunciator 3D77, MANUAL TRIP A SYS TRIP, has cleared. 3. Sequence of Events Recorder Point 013C71, has reset. 4. White scram Group 1, 2, 3, and 4 lights for RPS A on RR H11-P609 are ON. 5. Blue scram GROUP 1, 2, 3, and 4 lights for Pilot Scram Valve Solenoids, Trip System A on COP H11-P603 are ON.

JOB PERFORMANCE MEASURE

JPM Title Perform Manual Scram Functional Test	No.: NRC EXAM 2003-301-B1.c Revision: 1 Page 6
---	--

<u>Elements</u>	<u>Standards</u>
<p>step will initiate a Half Scram.</p> <p>NOTE: Since the Manual Scram trip channel will auto-reset upon return of the A2 pushbutton to its normally closed position, Annunciator 3D77, with its associated SOER Alarm Point, will reset and the Scram Pushbutton Switch red backlight will go out when the operator releases the Manual Scram Pushbutton Switch.</p> <p>*5.1.7 Momentarily depress Manual Scram Trip A2 pushbutton on COP H11-P603 and verify:</p> <ol style="list-style-type: none"> 1. Annunciator 3D77, MANUAL TRIP A SYS TRIP, alarms. 2. Sequence of Events Recorder Point 011C71, alarms. 3. Red Manual Scram Trip A2 pushbutton light comes ON. 4. White scram Group 1, 2, 3, and 4 lights for RPS "A" on RR H11-P609 are OFF. 5. Blue scram GROUP 1, 2, 3, and 4 lights for Pilot Scram Valve Solenoids, Trip System A on COP H11-P603 are OFF. 	<p>*5.1.7 Momentarily depresses Manual Scram Trip A2 pushbutton on COP H11-P603 and verifies:</p> <ol style="list-style-type: none"> 1. Annunciator 3D77, MANUAL TRIP A SYS TRIP, alarms. 2. Sequence of Events Recorder Point 011C71, alarms. 3. Red Manual Scram Trip A2 pushbutton light comes ON. 4. White scram Group 1, 2, 3, and 4 lights for RPS "A" on RR H11-P609 are OFF. 5. Blue scram GROUP 1, 2, 3, and 4 lights for Pilot Scram Valve Solenoids, Trip System A on COP H11-P603 are OFF.
<p>*5.1.8 Place Scram Reset switch to GP1 and GP4 then GP2 and GP3 Position and release.</p>	<p>*5.1.8 Places Scram Reset switch to GP1 and GP4 then GP2 and GP3 Position and releases.</p>
<p>*5.1.9 Verify the following:</p> <ol style="list-style-type: none"> 1. Red Manual Scram Trip A2, pushbutton light is OFF. 2. Annunciator 3D77, MANUAL TRIP A SYS TRIP, has cleared. 3. Sequence of Events Recorder Point 011C71, has reset. 4. White scram Group 1, 2, 3, and 4 lights for RPS A on RR H11-P609 are ON. 5. Blue scram GROUP 1, 2, 3, and 4 lights for Pilot Scram Valve Solenoids, Trip System A on COP H11-P603 are ON. 	<p>*5.1.9 Verifies the following:</p> <ol style="list-style-type: none"> 1. Red Manual Scram Trip A2, pushbutton light is OFF. 2. Annunciator 3D77, MANUAL TRIP A SYS TRIP, has cleared. 3. Sequence of Events Recorder Point 011C71, has reset. 4. White scram Group 1, 2, 3, and 4 lights for RPS A on RR H11-P609 are ON. 5. Blue scram GROUP 1, 2, 3, and 4 lights for Pilot Scram Valve Solenoids, Trip System A on COP H11-P603 are ON.

JOB PERFORMANCE MEASURE

JPM Title Perform Manual Scram Functional Test	No.: NRC EXAM 2003-301-B1.c Revision: 1 Page 7
---	--

<u>Elements</u>	<u>Standards</u>
*5.1.10 Verify following annunciators clear: <ol style="list-style-type: none"> 1. 3D73, TRIP ACTUATORS A1/A2 TRIPPED 2. 3D74, TRIP ACTUATORS B1/B2 TRIPPED 3. 3D77, MANUAL TRIP A SYS TRIP 4. 3D78, MANUAL TRIP B SYS TRIP 	*5.1.10 Verifies following annunciators clear: <ol style="list-style-type: none"> 1. 3D73, TRIP ACTUATORS A1/A2 TRIPPED 2. 3D74, TRIP ACTUATORS B1/B2 TRIPPED 3. 3D77, MANUAL TRIP A SYS TRIP 4. 3D78, MANUAL TRIP B SYS TRIP
*5.1.11 Verify the following white scram Group 1, 2, 3, and 4 lights on: <ol style="list-style-type: none"> 1. RPS A on RR H11-P609 2. RPS B on RR H11-P611 	*5.1.11 Verifies the following white scram Group 1, 2, 3, and 4 lights on: <ol style="list-style-type: none"> 1. RPS A on RR H11-P609 2. RPS B on RR H11-P611
*5.1.12 Verify the following blue scram Group 1, 2, 3, and 4 lights on COP H11-P603 on: <ol style="list-style-type: none"> 1. Pilot Scram Valve Solenoids, Trip System A 2. Pilot Scram Valve Solenoids, Trip System B 	*5.1.12 Verifies the following blue scram Group 1, 2, 3, and 4 lights on COP H11-P603 on: <ol style="list-style-type: none"> 1. Pilot Scram Valve Solenoids, Trip System A 2. Pilot Scram Valve Solenoids, Trip System B
<p>NOTE: Since trip system B is tested in the same manner as trip system A, the Examiner may choose to terminate the JPM at this point. If terminating at this point, place "N/A" on the remaining steps on the JPM Cover Sheet.</p>	

JOB PERFORMANCE MEASURE

JPM Title Perform Manual Scram Functional Test	No.: NRC EXAM 2003-301-B1.c Revision: 1 Page 8
---	--

<u>Elements</u>	<u>Standards</u>
<p>step will initiate a Half Scram.</p> <p>NOTE: Since the Manual Scram trip channel will auto-reset upon return of the B1 pushbutton to its normally closed position, Annunciator 3D78, with its associated SOER Alarm Point, will reset and the Scram Pushbutton Switch red backlight will go out when the operator releases the Manual Scram Pushbutton Switch.</p> <p>*5.1.13 Momentarily depress Manual Scram Trip B1 pushbutton on COP H11-P603 and verify:</p> <ol style="list-style-type: none"> 1. Annunciator 3D78, MANUAL TRIP B SYS TRIP, alarms. 2. Sequence of Events Recorder Point 014C71, alarms. 3. Red Manual Scram Trip B1 pushbutton light on. 4. White scram Group 1, 2, 3, and 4 lights for RPS B on RR H11-P611 off. 5. Blue scram GROUP 1, 2, 3, and 4 lights for Pilot Scram Valve Solenoids, Trip System B on COP H11-P603 off. 	<p>*5.1.13 Momentarily depresses Manual Scram Trip B1 pushbutton on COP H11-P603 and verifies:</p> <ol style="list-style-type: none"> 1. Annunciator 3D78, MANUAL TRIP B SYS TRIP, alarms. 2. Sequence of Events Recorder Point 014C71, alarms. 3. Red Manual Scram Trip B1 pushbutton light on. 4. White scram Group 1, 2, 3, and 4 lights for RPS B on RR H11-P611 off. 5. Blue scram GROUP 1, 2, 3, and 4 lights for Pilot Scram Valve Solenoids, Trip System B on COP H11-P603 off.
<p>*5.1.14 Place Scram Reset switch to GP1 and GP4 then, GP2 and GP3 Position and release.</p>	<p>*5.1.14 Places Scram Reset switch to GP1 and GP4 then, GP2 and GP3 Position and releases.</p>
<p>*5.1.15 Verify the following:</p> <ol style="list-style-type: none"> 1. Red Manual Scram Trip B1, pushbutton light is off. 2. Annunciator 3D78, MANUAL TRIP B SYS TRIP, has cleared. 3. Sequence of Events Recorder Point 014C71, has reset. 4. White scram Group 1, 2, 3, and 4 lights for RPS B on RR H11-P611 on. 5. Blue scram GROUP 1, 2, 3, and 4 lights for Pilot Scram Valve Solenoids, Trip System B on COP H11-P603 on. 	<p>*5.1.15 Verifies the following:</p> <ol style="list-style-type: none"> 1. Red Manual Scram Trip B1, pushbutton light is off. 2. Annunciator 3D78, MANUAL TRIP B SYS TRIP, has cleared. 3. Sequence of Events Recorder Point 014C71, has reset. 4. White scram Group 1, 2, 3, and 4 lights for RPS B on RR H11-P611 on. 5. Blue scram GROUP 1, 2, 3, and 4 lights for Pilot Scram Valve Solenoids, Trip System B on COP H11-P603 on.

JOB PERFORMANCE MEASURE

JPM Title Perform Manual Scram Functional Test	No.: NRC EXAM 2003-301-B1.c Revision: 1 Page 9
---	--

<u>Elements</u>	<u>Standards</u>
<p>step will initiate a Half Scram.</p> <p>NOTE: Since the Manual Scram trip channel will auto-reset upon return of the B2 pushbutton to its normally closed position, Annunciator 3D78, with its associated SOER Alarm Point, will reset and the Scram Pushbutton Switch red backlight will go out when the operator releases the Manual Scram Pushbutton Switch.</p> <p>*5.1.16 Momentarily depress Manual Scram Trip B2 pushbutton on COP H11-P603 and verify:</p> <ol style="list-style-type: none"> 1. Annunciator 3D78, MANUAL TRIP B SYS TRIP, alarms. 2. Sequence of Events Recorder Point 012C71 alarms. 3. Red Manual Scram Trip B2 pushbutton light on. 4. White scram Group 1, 2, 3, and 4 lights for RPS B on RR H11-P611 off. 5. Blue scram GROUP 1, 2, 3, and 4 lights for Pilot Scram Valve Solenoids, Trip System B on COP H11-P603 off. 	<p>*5.1.16 Momentarily depress Manual Scram Trip B2 pushbutton on COP H11-P603 and verifies:</p> <ol style="list-style-type: none"> 1. Annunciator 3D78, MANUAL TRIP B SYS TRIP, alarms. 2. Sequence of Events Recorder Point 012C71 alarms. 3. Red Manual Scram Trip B2 pushbutton light on. 4. White scram Group 1, 2, 3, and 4 lights for RPS B on RR H11-P611 off. 5. Blue scram GROUP 1, 2, 3, and 4 lights for Pilot Scram Valve Solenoids, Trip System B on COP H11-P603 off.
<p>*5.1.17 Place Scram Reset switch to GP1 and GP4 then, GP2 and GP3 Position and release.</p>	<p>*5.1.17 Places Scram Reset switch to GP1 and GP4 then, GP2 and GP3 Position and releases.</p>
<p>*5.1.18 Verify the following:</p> <ol style="list-style-type: none"> 1. Red Manual Scram Trip B2, pushbutton light is off. 2. Annunciator 3D78, MANUAL TRIP B SYS TRIP, has cleared. 3. Sequence of Events Recorder Point 012C71, has reset. 4. White scram Group 1, 2, 3, and 4 lights for RPS B on RR H11-P611 on. 5. Blue scram GROUP 1, 2, 3, and 4 lights for Pilot Scram Valve Solenoids, Trip System B on COP H11-P603 on. 	<p>*5.1.18 Verifies the following:</p> <ol style="list-style-type: none"> 1. Red Manual Scram Trip B2, pushbutton light is off. 2. Annunciator 3D78, MANUAL TRIP B SYS TRIP, has cleared. 3. Sequence of Events Recorder Point 012C71, has reset. 4. White scram Group 1, 2, 3, and 4 lights for RPS B on RR H11-P611 on. 5. Blue scram GROUP 1, 2, 3, and 4 lights for Pilot Scram Valve Solenoids, Trip System B on COP H11-P603 on.

JOB PERFORMANCE MEASURE

JPM Title Perform Manual Scram Functional Test	No.: NRC EXAM 2003-301-B1.c Revision: 1 Page 10
---	---

<u>Elements</u>	<u>Standards</u>
*5.1.19 Verify following annunciators clear: 1. 3D73, TRIP ACTUATORS A1/A2 TRIPPED 2. 3D74, TRIP ACTUATORS B1/B2 TRIPPED 3. 3D77, MANUAL TRIP A SYS TRIP 4. 3D78, MANUAL TRIP B SYS TRIP	*5.1.19 Verifies following annunciators clear: 1. 3D73, TRIP ACTUATORS A1/A2 TRIPPED 2. 3D74, TRIP ACTUATORS B1/B2 TRIPPED 3. 3D77, MANUAL TRIP A SYS TRIP 4. 3D78, MANUAL TRIP B SYS TRIP
*5.1.20 Verify the following white scram Group 1, 2, 3, and 4 lights on: 1. RPS A on RR H11-P609. 2. RPS B on RR H11-P611.	*5.1.20 Verifies the following white scram Group 1, 2, 3, and 4 lights on: 1. RPS A on RR H11-P609. 2. RPS B on RR H11-P611.
*5.1.21 Verify the following blue scram Group 1, 2, 3, and 4 lights on COP H11-P603 on: 1. Pilot Scram Valve Solenoids, Trip System A 2. Pilot Scram Valve Solenoids, Trip System B	*5.1.21 Verifies the following blue scram Group 1, 2, 3, and 4 lights on COP H11-P603 on: 1. Pilot Scram Valve Solenoids, Trip System A 2. Pilot Scram Valve Solenoids, Trip System B
5.1.22 Record test personnel.	5.1.22 Records test personnel.
CUE: The CRS will assign an independent reviewer	

Time Stop _____

* Critical Steps

Terminating Cue(s):

24.610.01 complete or stopped at Step 5.1.12 per examiner discretion.

JOB PERFORMANCE MEASURE

JPM Title Perform Manual Scram Functional Test	No.: NRC EXAM 2003-301-B1.c Revision: 1 Page 11
---	---

FOLLOW-UP DOCUMENTATION QUESTIONS

Reason for Followup question(s):

Question:

Reference:

Response:

Question:

Reference

Response:

JOB PERFORMANCE MEASURE

JPM Title Perform Manual Scram Functional Test	No.: NRC EXAM 2003-301-B1.c Revision: 1 Page 12
---	---

Simulator Setup

IC#:

Any

Malfunctions:

None

Remote Functions:

Number	Title	Value
None		

Override Functions:

None

Special Instructions:

**JOB PERFORMANCE MEASURE
NRC EXAM 2003-301-B1.D**

JPM B1.c Cue Sheet

Initial Conditions:

Plant conditions are as you see them.

Initiating Cue(s):

You are the Control Room Nuclear Supervising Operator.

The CRS directs you to perform RPS Manual Scram Functional Test in accordance with 24.610.01

A Licensed Operator is in the Relay Room standing by to assist.

JOB PERFORMANCE MEASURE

JPM Title Drywell Vent in accordance with 29.ESP.07 (Alternate Path)	No.: NRC EXAM 2003-301-B1.d Revision: 1 Page 2
---	--

Job Position Nuclear Supervising Operator	No. NRC EXAM 2003-301-B1.d	Revision 1
JPM Title Drywell Vent in accordance with 29.ESP.07 (Alternate Path)	Duration 10 Minutes	Page COVER SHEET

Examinee: _____ SRO / RO

Evaluator: _____

Evaluation Method: Perform / Simulator

Start Time _____

Stop Time _____

Total Time _____

PERFORMANCE EVALUATION							
Element	S	U	Comments	Element	S	U	Comments
1.							
2.							
3.							
4.							
5.							
*6.							
*7.							
*8.							
*9.							

_____ SATISFACTORY

_____ UNSATISFACTORY

ORAL EVALUATION (Not Required for ILO Exams)							
Question #	S	U	Comments	Question #	S	U	Comments

_____ SATISFACTORY

_____ UNSATISFACTORY

JOB PERFORMANCE MEASURE

JPM Title Drywell Vent in accordance with 29.ESP.07 (Alternate Path)	No.: NRC EXAM 2003-301-B1.d Revision: 1 Page 3
---	--

Evaluator Signature / Date: _____ / _____

JOB PERFORMANCE MEASURE

JPM Title Drywell Vent in accordance with 29.ESP.07 (Alternate Path)	No.: NRC EXAM 2003-301-B1.d Revision: 1 Page 4
---	--

References: Required (R) / Available (A) 29.ESP.07, Primary Containment Venting
Tools and Equipment Required: None

Preferred Evaluation Method:

Perform	X	Walkthrough		Discuss	
Plant		Simulator	X	Classroom	

<p>Evaluator Notes:</p> <p>ENSURE ALL INDUSTRIAL AND PERSONNEL SAFETY PRACTICES ARE USED AND ENFORCED.</p> <p>This JPM may be performed in IC 18</p> <p>Start this JPM at the CRS Desk in the Simulator.</p> <p>K/A Reference :</p> <p>EPE: 295024 High Drywell Pressure</p> <p> EK3 - Knowledge of the reasons for the following responses as they apply to high drywell pressure (CFR: 41.5 / 45.6):</p> <p> EK3.07 Drywell venting 3.5 / 4.0</p> <p> EA1 - Ability to operate and/or monitor the following as they apply to high drywell pressure (CFR: 41.7 / 45.6):</p> <p> EA1.14 - Drywell ventilation system 3.4 / 3.5</p> <p> EA2 - Ability to determine and/or interpret the following as they apply to high drywell pressure (CFR: 41.10 / 43.5 / 45.13):</p> <p> EA2.01 Drywell pressure 4.2 / 4.4</p>
<p>Task Standard:</p> <p>Vent the Drywell to maintain pressure less than 1.68 psig.</p>
<p>Initial Conditions:</p> <p>Division II Drywell Cooling Fans have tripped for unknown reasons, Maintenance is investigating.</p> <p>The Crew has entered 29.100.01, SHEET 2, Primary Containment Control, due to high drywell temperature.</p>
<p>Initiating Cue(s):</p> <p>You are the Control Room Nuclear Supervising Operator.</p> <p>The CRS directs you to keep Dw pressure less than 1.68 psig in accordance with 29.ESP.07</p>

JOB PERFORMANCE MEASURE

JPM Title Drywell Vent in accordance with 29.ESP.07 (Alternate Path)	No.: NRC EXAM 2003-301-B1.d Revision: 1 Page 5
---	--

PERFORMANCE EVALUATION

Time Start _____

<u>Elements</u>	<u>Standards</u>
NOTE: All controls and indications are located on COP H11-P808 or COP-H11-P817 unless otherwise specified.	
PREREQUISITES: NONE	
venting the Drywell and Torus is prohibited.	
1.1 If venting the Torus, notify the SM and exit this section.	1.1 If venting the Torus, notify the SM and exit this section.
1.2 If conditions permit, verify RBHVAC is in operation.	1.2 If conditions permit, verify RBHVAC is in operation.
1.3 If RBHVAC is unavailable, start or verify running SGTS.	1.3 RBHVAC is running.
SGTS must be shutdown while venting to ensure that one charcoal bed is kept in reserve for later use.	
1.4 If venting through SGTS and both divisions of SGTS are operating, shutdown one division of SGTS.	1.4 RBHVAC will be running.
1.5 If PCRMS is alarming or inoperable: 1.5.1 Contact Chemistry to sample Primary Containment atmosphere for activity. 1.5.2 When Primary Containment atmosphere sample results are complete, continue at Step 1.6.	1.5 PCRMS is NOT alarming or inoperable:
Primary Containment may release radioactive gas/steam into the Reactor Building. CUE: If the candidate reports to the CRS that T4800-F455 is not opening and requests direction, tell the candidate (as the CRS) to follow the procedure.	

JOB PERFORMANCE MEASURE

JPM Title Drywell Vent in accordance with 29.ESP.07 (Alternate Path)	No.: NRC EXAM 2003-301-B1.d Revision: 1 Page 6
---	--

<u>Elements</u>	<u>Standards</u>
<p>*1.6 Vent from the Drywell as follows:</p> <p style="margin-left: 20px;">1.6.1 Close or verify closed T4800-F454, DW Press Ctrl N2 Supply Iso Vlv.</p> <p style="margin-left: 20px;">1.6.2 Open the following 1 Inch Pressure Control Valves:</p> <ol style="list-style-type: none"> T4800-F453, DW Press Ctrl Vent Iso Vlv. T4800-F455, DW Press Ctrl Inbd Iso Vlv. <p>NOTE (1): The Drywell Vent Path can be secured at any time (Step 1.6.8) to prevent Drywell Pressure from going below 5 inches wc.</p> <p>NOTE (2): Drywell Pressure may not be reduced immediately, plant conditions will have to be evaluated by the Shift Team to determine if the larger vent paths are required.</p>	<p>*1.6 Recognizes that T4800-F455 is not opening. Proceed to Step 1.6.4</p>
<p style="margin-left: 20px;">1.6.3 If Drywell Pressure is reduced to normal (5 to 19 inches wc), proceed to Step 1.6.8, otherwise continue.</p>	
<p>*1.6.4 If Drywell Pressure is not being reduced as fast as necessary, open the following 6" Vent Path Valves:</p> <ol style="list-style-type: none"> T4600-F411, DW 6" Purge Iso Vlv. T4803-F602, DW Exh Iso Vlv. 	<p>*1.6.4 Opens the following 6" Vent Path Valves:</p> <ol style="list-style-type: none"> T4600-F411, DW 6" Purge Iso Vlv. T4803-F602, DW Exh Iso Vlv.
<p>*1.6.5 If Drywell Pressure is reduced to normal (5 to 19 inches wc), proceed to Step 1.6.8, otherwise continue.</p>	<p>*1.6.5 Proceed to Step 1.6.8.</p>
<p>*1.6.8 Close or verify closed the following valves as necessary to maintain Drywell Pressure greater than 5 inches wc:</p> <ol style="list-style-type: none"> T4600-F402, DW 24" Purge Iso Vlv. T4803-F602, DW Exh Iso Vlv. T4600-F411, DW 6" Purge Iso Vlv. T4800-F455, DW Press Ctrl Inbd Iso Vlv. T4800-F453, DW Press Ctrl Vent Iso Vlv. 	<p>*1.6.8 Closes or verifies closed the following valves</p> <ol style="list-style-type: none"> T4600-F402, DW 24" Purge Iso Vlv. T4803-F602, DW Exh Iso Vlv. T4600-F411, DW 6" Purge Iso Vlv. T4800-F455, DW Press Ctrl Inbd Iso Vlv. T4800-F453, DW Press Ctrl Vent Iso Vlv.

Time Stop _____

* Critical Steps

JOB PERFORMANCE MEASURE

JPM Title Drywell Vent in accordance with 29.ESP.07 (Alternate Path)	No.: NRC EXAM 2003-301-B1.d Revision: 1 Page 7
---	--

Terminating Cue(s):

Drywell pressure between 5 and 19 in wc, with all valves closed.

JOB PERFORMANCE MEASURE

JPM Title Drywell Vent in accordance with 29.ESP.07 (Alternate Path)	No.: NRC EXAM 2003-301-B1.d Revision: 1 Page 8
---	--

FOLLOW-UP DOCUMENTATION QUESTIONS

Reason for Followup question(s):

Question:

Reference:

Response:

Question:

Reference

Response:

JOB PERFORMANCE MEASURE

JPM Title Drywell Vent in accordance with 29.ESP.07 (Alternate Path)	No.: NRC EXAM 2003-301-B1.d Revision: 1 Page 9
---	--

Simulator Setup

IC#:

IC 18 – Full Power

Malfunctions:

Number	Title	Value
None		

Remote Functions:

Number	Title	Value
None		

Override Functions:

None

Special Instructions:

To “Inactivate the Block” and prevent T4800-F455 from operating, go to the CETRAN window and type the following:

BP:T4800F455 <CR>

IA=

**JOB PERFORMANCE MEASURE
NRC EXAM 2003-301-B1.E**

JPM B1.d Cue Sheet

Initial Conditions:

Division II Drywell Cooling Fans have tripped for unknown reasons, Maintenance is investigating.

The Crew has entered 29.100.01, SHEET 2, Primary Containment Control, due to high drywell temperature.

Initiating Cue(s):

You are the Control Room Nuclear Supervising Operator.

The CRS directs you to keep Dw pressure less than 1.68 psig in accordance with 29.ESP.07

JOB PERFORMANCE MEASURE

JPM Title Start Individual CTG 11 from the Control Room	No.: NRC EXAM 2003-301-B1.e Revision 1 Page 2
--	---

Job Position Nuclear Supervising Operator	No. NRC EXAM 2003-301-B1.e	Revision 1
JPM Title Start Individual CTG 11 from the Control Room	Duration 25 Minutes	Page COVER SHEET

Examinee: _____ SRO / RO

Evaluator: _____

Evaluation Method: Perform / Simulator

Start Time _____

Stop Time _____

Total Time _____

PERFORMANCE EVALUATION							
Element	S	U	Comments	Element	S	U	Comments
1.							
*2.							
*3.							
*4.							
5.							
*6.							
*7.							
8.							
*9.							

_____ SATISFACTORY

_____ UNSATISFACTORY

ORAL EVALUATION (Not Required for ILO Exams)							
Question #	S	U	Comments	Question #	S	U	Comments

_____ SATISFACTORY

_____ UNSATISFACTORY

Evaluator Signature / Date: _____ / _____

JOB PERFORMANCE MEASURE

JPM Title Start Individual CTG 11 from the Control Room	No.: NRC EXAM 2003-301-B1.e Revision 1 Page 3
--	---

References: Required (R) / Available (A) 23.324, Supervisory Control - 120 KV Switchyard and CTG11 Generators
Tools and Equipment Required: None

Preferred Evaluation Method:

Perform	<u> X </u>	Walkthrough	<u> </u>	Discuss	<u> </u>
Plant	<u> </u>	Simulator	<u> X </u>	Classroom	<u> </u>

Evaluator Notes:	
ENSURE ALL INDUSTRIAL AND PERSONNEL SAFETY PRACTICES ARE USED AND ENFORCED.	
This JPM can be performed in in any IC.	
Start this JPM at the CRS Desk in the Simulator.	
K/A Reference :	
2.1	Generic Knowledge and Abilities:
2.1.17	Ability to make accurate, clear, and concise verbal reports. 3.5 / 3.6
2.1.20	Ability to execute procedure steps. 4.3 / 4.2
2.1.21	Ability to obtain and verify controlled procedure copy. 3.1 / 3.2
2.1.23	Ability to perform specific procedures during all modes of operation. 3.3 / 3.5
2.1.30	Ability to locate and operate components including local controls. 3.4 / 3.5
2.1.28	Knowledge of purpose and function of major system components and controls 3.2 / 3.3
2.4.2	Ability to recognize abnormal indications for system operating parameters which are entry into emergency/abnormal procedures. 4.0 / 4.3
2.4.11	Knowledge of abnormal condition procedures 3.4 / 3.6
262001 A.C. Electrical Distribution:	
K1.	Knowledge of the physical connections and/or cause-effect relationships for the following:
:	K1.01 EDG's 3.8 / 4.3
	K1.02 D.C. electrical distribution 3.3 / 3.6
	K1.03 Offsite power sources 3.4 / 3.8
	K1.06 Alternate shutdown system 3.6 / 3.9
K2.	Knowledge of electrical power supplies to the following:
	K2.01 Offsite sources of power 3.3 / 3.6
K3.	Knowledge of the effect that a loss or malfunction of will have on the following:
	K3.02 Emergency Generators 3.8 / 4.2
K4.	Knowledge of design feature(s) and/or interlocks which provide for:

JOB PERFORMANCE MEASURE

JPM Title Start Individual CTG 11 from the Control Room	No.: NRC EXAM 2003-301-B1.e Revision 1 Page 4
--	---

	K4.03 Interlocks between auto bus transfer and breakers	3.1 / 3.4
	K4.05 Paralleling AC sources (synchroscope)	3.4 / 3.6
K5.	Knowledge of operational implications of:	
	K5.01 Paralleling two AC sources	3.1 / 3.4
K6.	Knowledge of the effect that a loss or malfunction of will have on the following:	
	K6.02 Offsite power	3.6 / 3.9
A1.	Ability to predict and/or monitor changes in parameters associated with operating controls including:	
	A1.01 Effect on instrumentation and controls of switching power supplies	3.1 / 3.4
	A1.02 Effects of loads when energizing a bus	3.1 / 3.5
	A1.05 Breaker lineups	3.2 / 3.5
A2.	Ability to (a) predict the impacts of the following; and (b) based on those predictions, use procedures to correct, control, or mitigate the consequences of:	
	A2.03 Loss of Offsite power.	3.9 / 4.3
	A2.04 Loads that if deenergized would degrade/hinder plant ops	3.8 / 4.2
	A2.08 Opening a disconnect under load	3.3 / 3.6
	A2.09 Exceeding voltage limitations	3.1 / 3.4
	A2.11 Degraded system voltages	3.2 / 3.6
A3.	Ability to monitor auto operations of, including:	
	A3.01 Breaker tripping	3.1 / 3.2
A4.	Ability to manually operate and/or monitor in the Control room:	
	A4.01 All breakers and disconnects	3.4 / 3.7
	A4.02 Synchroscope, understanding running and incoming voltages	3.4 / 3.4
	A4.03 Local operation of breakers	3.2 / 3.4
	A4.04 Synchronizing and paralleling of different A.C. supplies	3.6 / 3.7
	A4.05 Voltage, current, power, and frequency on A.C. buses	3.3 / 3.3
264000 Emergency Generators (Diesel/Jet):		
K1.	Knowledge of the physical connections and/or cause-effect relationships for the following:	
	K1.01 A.C. electrical distribution	3.8 / 4.1
	K1.02 D.C. electrical distribution	3.3 / 3.4
	K1.04 Emergency generator C.W. system	3.2 / 3.3
	K1.05 Emergency generator F.O. system	3.2 / 3.3
	K1.06 Starting air system	3.2 / 3.2
	K1.07 ECCS systems	3.9 / 4.1
K3.	Knowledge of the effect that a loss or malfunction of will have on The following:	
	K3.01 ECCS systems	4.2 / 4.4
	K3.02 A.C. electrical distribution	3.9 / 4.2
	K3.03 Major loads fed from buses fed by emergency generators	4.1 / 4.2
K4.	Knowledge of design feature(s) and/or interlocks which provide for:	

JOB PERFORMANCE MEASURE

JPM Title Start Individual CTG 11 from the Control Room	No.: NRC EXAM 2003-301-B1.e Revision 1 Page 5
--	---

	K4.01	Emergency generator trips (normal)	3.5 / 3.7
	K4.02	Emergency generator trips (emergency/LOCA)	4.0 / 4.2
	K4.07	Local operation and control	3.3 / 3.4
	K4.08	Automatic startup	3.8 / 3.7
K5.		Knowledge of Knowledge of operational implications of:	
	K5.05	Paralleling A.C. sources	3.4 / 3.4
K6.		Knowledge of the effect that a loss or malfunction will have on the following:	
	K6.01	Starting air	3.8 / 3.9
	K6.02	F.O. pumps	3.6 / 3.6
	K6.03	L.O. pumps	3.5 / 3.7
	K6.07	C.W. system	3.8 / 3.9
	K6.08	A.C. power	3.6 / 3.7
	K6.09	D.C. power	3.3 / 3.5
A2.		Ability to (a) predict the impacts of the following; and (b) based on those predictions, use procedures to correct, control, or mitigate the consequences of:	
	A2.01	Parallel operation of emergency generator	3.5 / 3.6
	A2.02	Unloading prior to securing emergency generator	3.1 / 3.1
	A2.03	Operating under different loading conditions	3.4 / 3.4
	A2.05	Synch of emergency generator with electrical supplies	3.6 / 3.6
	A2.06	Opening normal and/or alternate power to emergency bus	3.4 / 3.4
	A2.08	Initiation of emergency generator fire protection system	3.3 / 3.7
	A2.09	Loss of A.C. power	3.7 / 4.1
	A2.10	LOCA	3.9 / 4.2
A4.		Ability to manually operate and/or monitor in the Control room:	
	A4.01	Adjustment of exciter voltage	3.3 / 3.4
	A4.02	Synchroscope	3.4 / 3.4
	A4.04	Man start, load, and stop of generator	3.7 / 3.7
	A4.05	Transfer of generator to grid	3.6 / 3.7

Task Standard:

Perform Startup and loading of individual CTG11-1 from the Control Room

Initial Conditions:

The Plant is Operating at full power.

Initiating Cue(s):

Central Systems Supervisor has requested that CTG11-1 be started and loaded to 13 MW for performance monitoring.

Prerequisites are complete.

JOB PERFORMANCE MEASURE

JPM Title Start Individual CTG 11 from the Control Room	No.: NRC EXAM 2003-301-B1.e Revision 1 Page 6
--	---

PERFORMANCE EVALUATION

Time Start _____	<u>Elements</u>	<u>Standards</u>
	<p>NOTE: Unless otherwise noted, all controls and indications for this section are located on COP H11-P811.</p>	
	<p>CUE: All prerequisites are complete:</p> <p>4.1.1 Prerequisites</p> <p>1. 120kV Circuit Breakers and CTG11 Units are in Standby Mode at the Fermi 2 Control Room, Fermi 1 Control Room, and CTG11 Control Center in accordance with the following sections of this procedure.</p> <p>a. Section 5.1, Standby Mode Of CTG11 Generators And 120kV Circuit Breakers At COP H11-P811</p> <p>b. Section 5.2, Standby Mode Of 120kV Circuit Breakers And CTG11 Generators At Fermi 1 Control Room Panel 2 And CTG11 Master Control Panel</p> <p>c. Section 5.3, Standby Mode Of CTG11 Generators At CTG11 Control Center</p>	<p>4.1.1 Prerequisites complete</p>
	<p>*2. If CTG11 Unit 1 is to be started, required data has been recorded on the CTG11 Unit 1 Start/Failure Log (Attachment 4).</p> <p>CUE: Provide candidate with copy of Attachment 4</p>	<p>*2. Records required data on the CTG11 Unit 1 Start/Failure Log (Attachment 4).</p>
	<p>TE (1): If operating CTG11 Units for any reason except to supply emergency power to the plant, with the concurrence of the CSS, CTG11 Units must be shutdown before CTG11 Fuel Oil Tank Level goes below 13 feet or CTG11 Unit 1 must be declared inoperable.</p> <p>TE (2): Enclosure F contains related alarm responses.</p> <p>*1. If a CTG11 Unit is loaded without any warmup period, complete Attachment 3 every 15 minutes for associated Units. Refer to Section 6.8, CTG11 Exhaust Temperature Thermocouple Operation.</p>	<p>*1. Directs operator to complete Attachment 3 every 15 minutes for CTG11-1. Refer to Section 6.8, CTG11 Exhaust Temperature Thermocouple Operation.</p>

JOB PERFORMANCE MEASURE

JPM Title Start Individual CTG 11 from the Control Room	No.: NRC EXAM 2003-301-B1.e Revision 1 Page 7
--	---

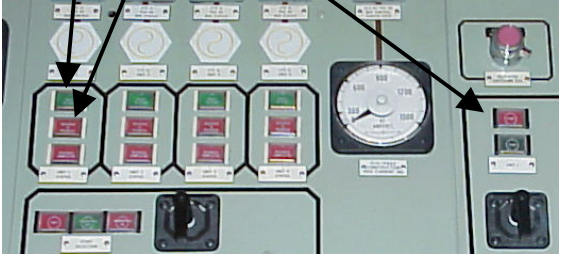
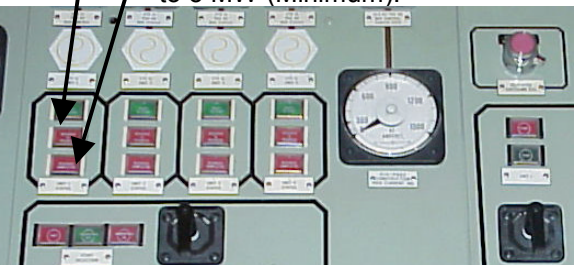
<u>Elements</u>	<u>Standards</u>
<p>CAUTION CTG11 Units 2, 3, and 4 must be started at approximately 1 minute intervals. This is necessary to prevent overload of Peaker Aux Power Transformer and excessive loading of Peaker Control Air Compressor.</p> <p>*2. Depress START pushbutton for the desired Unit (1, 2, 3 or 4) and verify following:</p> <ol style="list-style-type: none"> Red backlighted START pushbutton is ON. Green backlighted READY TO START indication goes OFF. Red backlighted SEQUENCE IN PROGRESS indication is ON. 	<p>*2. Depresses START pushbutton for the desired Unit 1 and verifies:</p> <ol style="list-style-type: none"> Red backlighted START pushbutton is ON. Green backlighted READY TO START indication goes OFF. Red backlighted SEQUENCE IN PROGRESS indication is ON. 
<p>NOTE: CTG11 Units 2, 3 and 4 will require approximately 8 to 10 minutes and CTG11 Unit 1, 12 minutes to reach synchronous speed and to automatically synchronize.</p> <p>3. When Unit Breaker closes as indicated by a red CLOSED light ON, verify:</p> <ol style="list-style-type: none"> Red backlighted SEQUENCE IN PROGRESS indication goes OFF. Red backlighted SEQUENCE COMPLETE indication is ON. Unit MW output increases up to 3 to 5 MW (Minimum). 	<p>3. When Unit Breaker closes as indicated by a red CLOSED light ON, verifies:</p> <ol style="list-style-type: none"> Red backlighted SEQUENCE IN PROGRESS indication goes OFF. Red backlighted SEQUENCE COMPLETE indication is ON. Unit MW output increases up to 3 to 5 MW (Minimum). 
<p>4. If ambient temperature is > 75°F., or it is anticipated that this temperature will be met during operation, CTG Auxiliary Cooling should be utilized to maintain optimum performance in accordance with Section 7.9.</p> <p>CUE: Ambient temperature is 55 °F</p>	<p>4. No Action</p>

JOB PERFORMANCE MEASURE

JPM Title Start Individual CTG 11 from the Control Room	No.: NRC EXAM 2003-301-B1.e Revision 1 Page 8
--	---

<u>Elements</u>	<u>Standards</u>
4.1.3 Detailed Procedure - Loading NOTE (1): There are two sets of controls available to adjust the MW output of CTG11 Units. NOTE (2): Raising load on CTG 11 Unit 1 to BASE LOAD (13-15MW) must be performed either in Manual Load Control per Step 4.1.3.1 below or by taking Local Control per Step 4.1.3.2.d and raising load per Section 4.2.4 or 4.2.5. 1. Manual Load Control NOTE: When operating Lower/Raise Control Switches for Unit Voltage and Governor Controls, be aware that command signal is present as long as switch is held in LOWER or RAISE. Anticipate time lag of controlled value after release of Control Switch. *a. Turn Governor to RAISE/LOWER and increase/decrease load to desired value.	1. Manual Load Control *a. Turns Governor to RAISE/LOWER and increase/decrease load to 13 MW .
b. If PEAK LOAD is desired, perform Section 6.1 (6.2), Increasing Load To Peak In Manual (Automatic). CUE: Peak Load not desired.	b. No Action
NOTE: Maintain Voltage and VARS within the capability curve (see Enclosure B). *c. Adjust VARS as indicated on the individual Megavar (MVAR) indicator using the Voltage Switch.	*c. Adjusts VARS as indicated on the individual Megavar (MVAR) indicator using the Voltage Switch to maintain within limits of Enclosure B.

Time Stop _____

* Critical Steps

Terminating Cue(s):

CTG11-1 is loaded to 13 MW

JOB PERFORMANCE MEASURE

JPM Title Start Individual CTG 11 from the Control Room	No.: NRC EXAM 2003-301-B1.e Revision 1 Page 9
--	---

FOLLOW-UP DOCUMENTATION QUESTIONS

Reason for Followup question(s):

Question:

Reference:

Response:

Question:

Reference

Response:

JOB PERFORMANCE MEASURE

JPM Title Start Individual CTG 11 from the Control Room	No.: NRC EXAM 2003-301-B1.e Revision 1 Page 10
--	--

Simulator Setup

IC#:

18

Malfunctions:

Number	Title	Value
None		

Remote Functions:

Number	Title	Value
None		

Override Functions:

None

Special Instructions:

**JOB PERFORMANCE MEASURE
NRC EXAM 2003-3001-B1.F**

JPM B1.e Cue Sheet

Initial Conditions:

The Plant is Operating at full power.

Initiating Cue(s):

Central Systems Supervisor has requested that CTG11-1 be started and loaded to 13 MW for performance monitoring.

Prerequisites are complete.

JOB PERFORMANCE MEASURE

JPM Title Switch Operating RBCCW Pumps	No.: NRC EXAM 2003-301-B1.f Revision: 1 Page 2
---	--

Job Position Nuclear Supervisory Operator	No. NRC EXAM 2003-3001-B1.f	Revision 1
JPM Title Switch Operating RBCCW Pumps	Duration 15 Minutes	Page COVER SHEET

Examinee: _____ SRO / RO

Evaluator: _____

Evaluation Method: Perform / Simulator

Start Time _____

Stop Time _____

Total Time _____

PERFORMANCE EVALUATION							
Element	S	U	Comments	Element	S	U	Comments
1.							
*2.							
*3.							
4.							
5.							

_____ SATISFACTORY

_____ UNSATISFACTORY

ORAL EVALUATION (Not Required for ILO Exams)							
Question #	S	U	Comments	Question #	S	U	Comments

_____ SATISFACTORY

_____ UNSATISFACTORY

JOB PERFORMANCE MEASURE

JPM Title Switch Operating RBCCW Pumps	No.: NRC EXAM 2003-301-B1.f Revision: 1 Page 3
---	--

Evaluator Signature / Date: _____ / _____

JOB PERFORMANCE MEASURE

JPM Title Switch Operating RBCCW Pumps	No.: NRC EXAM 2003-301-B1.f Revision: 1 Page 4
---	--

References: Required (R) / Available (A) 23.127, Reactor Building Closed Cooling Water/Emergency Equipment Cooling Water System (R)
Tools and Equipment Required: None

Preferred Evaluation Method:

Perform	_____X_____	Walkthrough	_____	Discuss	_____
Plant	_____	Simulator	_____X_____	Classroom	_____

Evaluator Notes: Start the JPM in the Simulator Control Room at the CRS desk. This JPM is performed in IC-18 at full power
Task Standard: Start standby RBCCW pump and place running RBCCW pump in standby.
Initial Conditions: The plant is operating at full power
Initiating Cue(s): You are the Control Nuclear Supervising Operator The CRS directs you to shift from North and Center pumps running to South and Center pumps running.

JOB PERFORMANCE MEASURE

JPM Title Switch Operating RBCCW Pumps	No.: NRC EXAM 2003-301-B1.f Revision: 1 Page 5
---	--

PERFORMANCE EVALUATION

Time Start _____

<u>Elements</u>	<u>Standards</u>
NOTE: Unless otherwise noted, all controls and indication are located on COP H11-P601 and P602.	
An EECW actuation may occur during pump shifts due to transients on system.	
6.1.2.1. To place standby RBCCW pump in service:	6.1.2.1 Plant announcement made that pump will be starting
NOTE: When standby RBCCW Pump is started P42-F403, RBCCW Differential Pressure Control Valve, will OPEN to compensate for the increased flow. *a. Start Standby RBCCW Pump.	*a. Start Standby RBCCW Pump.
*b. Stop RBCCW Pump to be removed from service.	*b. Stop RBCCW Pump to be removed from service.
*c. Verify P42-F403, RBCCW Differential Pressure Control Valve, is maintaining a proper differential pressure by verifying Annunciators, clear: <ul style="list-style-type: none"> • 2D100, RBCCW PUMPS RECIRC VLV OPEN • 2D104, RBCCW PUMPS RECIRC VLV CLOSED 	*c. Verify P42-F403, RBCCW Differential Pressure Control Valve, is maintaining a proper differential pressure by verifying Annunciators, clear: <ul style="list-style-type: none"> • 2D100, RBCCW PUMPS RECIRC VLV OPEN • 2D104, RBCCW PUMPS RECIRC VLV CLOSED
d. Periodically monitor temperatures and pressures in the system to ensure continued proper system operation using the following instruments: <ul style="list-style-type: none"> • P42-R802, RBCCW Press Ind • P42-R800, RBCCW Hx Outlet Temp Recorder 	d. Periodically monitor temperatures and pressures in the system to ensure continued proper system operation using the following instruments: <ul style="list-style-type: none"> • P42-R802, RBCCW Press Ind • P42-R800, RBCCW Hx Outlet Temp Recorder

Time Stop _____

* Critical Steps

Terminating Cue(s):

Standby pump is operating, operating pump is in standby

JOB PERFORMANCE MEASURE

JPM Title Switch Operating RBCCW Pumps	No.: NRC EXAM 2003-301-B1.f Revision: 1 Page 6
---	--

FOLLOW-UP DOCUMENTATION QUESTIONS

Reason for Followup question(s):

Question:

Reference:

Response:

Question:

Reference

Response:

JOB PERFORMANCE MEASURE

JPM Title Switch Operating RBCCW Pumps	No.: NRC EXAM 2003-301-B1.f Revision: 1 Page 7
---	--

Simulator Setup

IC#:

18

Malfunctions:

Number	Title	Value
None		

Remote Functions:

Number	Title	Value
None		

Override Functions:

None

Special Instructions:

**JOB PERFORMANCE MEASURE
NRC EXAM 2003-3001-B1.G**

JPM B1.f Cue Sheet

Initial Conditions:

The plant is operating at full power

Initiating Cue(s):

You are the Control Room Nuclear Supervising Operator

The CRS directs you to shift RBCCW pumps from North and Center pumps running to South and Center pumps running.

JOB PERFORMANCE MEASURE

JPM Title Shift Divisions of CCHVAC (Alternate Path)	No.: NRC EXAM 2003-301-B1.g Revision: 0 Page 2
---	--

Job Position Nuclear Supervising Operator	No. NRC EXAM 2003-301-B1.g	Revision 1
JPM Title Shift Divisions of CCHVAC (Alternate Path)	Duration 25 Minutes	Page COVER SHEET

Examinee: _____ SRO / RO

Evaluator: _____

Evaluation Method: Perform / Simulator

Start Time _____

Stop Time _____

Total Time _____

PERFORMANCE EVALUATION							
Element	S	U	Comments	Element	S	U	Comments
1.							
2.							
* 3.							
4.							
5.							
*6.							
*7.							
*8.							
*9.							
10.							
11.							
*12.							
*13.							

_____ SATISFACTORY

_____ UNSATISFACTORY

ORAL EVALUATION (Not Required for ILO Exams)							
Question #	S	U	Comments	Question #	S	U	Comments

_____ SATISFACTORY

_____ UNSATISFACTORY

Evaluator Signature / Date: _____ / _____

JOB PERFORMANCE MEASURE

JPM Title Shift Divisions of CCHVAC (Alternate Path)	No.: NRC EXAM 2003-301-B1.g Revision: 0 Page 3
---	--

References: Required (R) / Available (A)
 SOP 23.413 Control Center HVAC (R)
 ARP 17D27 (A)
 AOP 20.413.01 Control Center HVAC System Failure (A)

Tools and Equipment Required:
 None

Preferred Evaluation Method:

Perform	X	Walkthrough		Discuss	
Plant		Simulator	X	Classroom	

Evaluator Notes:
ENSURE ALL INDUSTRIAL AND PERSONNEL SAFETY PRACTICES ARE USED AND ENFORCED.
 This JPM may be performed in any IC.
 Start this JPM at the CRS Desk in the Simulator.
 K/A Reference :

2.1 Generic Knowledge and Abilities:

2.1.17	Ability to make accurate, clear, and concise verbal reports.	3.5 / 3.6
2.1.20	Ability to execute procedure steps.	4.3 / 4.2
2.1.21	Ability to obtain and verify controlled procedure copy.	3.1 / 3.2
2.1.23	Ability to perform specific procedures during all modes of operation.	3.3 / 3.5
2.1.30	Ability to locate and operate components including local controls.	3.4 / 3.5
2.1.28	Knowledge of purpose and function of major system components and controls	3.2 / 3.3
2.4.2	Ability to recognize abnormal indications for system operating parameters which are entry into emergency/abnormal procedures.	4.0 / 4.3
2.4.11	Knowledge of abnormal condition procedures	3.4 / 3.6

290003 Control Room HVAC:

K3.	Knowledge of effect that loss or malfunction will have on the following:	
K3.01	Control room habitability	3.5 / 3.8
K4.	Knowledge of design feature(s) and/or interlocks for the following:	
K4.01	System initiations/reconfigurations	3.1 / 3.2
A2.	Ability to predict the impact of the following:	
A2.01	Initiation/reconfiguration	3.1 / 3.2
A2.03	Initiation/reconfiguration failure	3.4 / 3.6
A3.	Ability to monitor automatic operation of:	
A3.01	Initiation/reconfiguration	3.3 / 3.5
A4.	Ability to manually operate and/or monitor in the control room:	

JOB PERFORMANCE MEASURE

JPM Title Shift Divisions of CCHVAC (Alternate Path)	No.: NRC EXAM 2003-301-B1.g Revision: 0 Page 4
---	--

A4.01 Initiate/reset the system	3.2 / 3.2
Task Standard: Shift Control Center HVAC operating trains in accordance with 23.413.	
Initial Conditions: The plant is operating at full power. Division 1 CCHVAC is operating.	
Initiating Cue(s): The CRS has directed that Division 2 CCHVAC placed in service and Division 1 CCHVAC be removed from service. A pre-job brief has been completed. All prerequisites are completed. Steps 6.1.2.1 and 6.1.2.2 are complete. An operator is in the field, standing by for direction. The CCHVAC Chiller unit will be automatically loaded.	

JOB PERFORMANCE MEASURE

JPM Title Shift Divisions of CCHVAC (Alternate Path)	No.: NRC EXAM 2003-301-B1.g Revision: 0 Page 5
---	--

PERFORMANCE EVALUATION

Time Start _____

<u>Elements</u>	<u>Standards</u>
NOTE: All controls and indications are located on COP H11-P808 (817) unless otherwise specified.	
PREREQUISITES: NONE	
<p>NOTE (1): Next step shall require an independent verifier.</p> <p>NOTE (2): Independent Verification and logging requirements only need to be done the first time if repetitive starts are to be made within a one hour time frame. Radiation monitors should be checked again if suspected changes to radiological conditions, electric power supplies, or alarms received dictate this conservative action.</p> <p>1. Perform operational checkout of D11-K809 (K813), Div 1 (2) CCHVAC Makeup Air Radiation Monitor, in accordance with 23.625, "Process Gaseous Radiation Monitoring."</p> <p>CUE: Operational check complete.</p>	1. No Action
<p>2. Document action taken and completion of independent verification in the Fermi 2 Unit Log.</p> <p>CUE: Documentation complete.</p>	2. No Action
NOTE: While both Divisions are operating, the damper lineup in Enclosures A, B, or C will not be correct.	
<p>*3. For the Division to be started verify:</p> <p>a. Div 1 (2) Mode Select switch is selected to the same mode as the running division.</p> <p>b. Div 1 (2) Emergency Air Intake Selector switch in AUTO.</p>	<p>*a. Verified Div 2 Mode Select switch is selected to the same mode as the running division.</p> <p>*b. Verified Div 2 Emergency Air Intake Selector switch in AUTO.</p>

JOB PERFORMANCE MEASURE

JPM Title Shift Divisions of CCHVAC (Alternate Path)	No.: NRC EXAM 2003-301-B1.g Revision: 0 Page 6
---	--

<u>Elements</u>	<u>Standards</u>
<p>4. For the Division to be started, verify or place Division 1 (2) switches for the following equipment in AUTO:</p> <ul style="list-style-type: none"> • T4100-B007 (B006), Div 1 (2) CCHVAC Supply Fan. • T4100-C041 (C040), Div 1 (2) CCHVAC Chilled Wtr Pump. • T4100-B028 (B027), Div 1 (2) CCHVAC Equip Room Cooler. • T4100-C031 (C030), Div 1 (2) CCHVAC Return Air Fan. • T4100-B009 (B008), Div 1 (2) CCHVAC Chiller. • T4100-C047 (C048), Div 1 (2) CCHVAC Emerg Makeup Fan. 	<p>4. Verified or placed Division 2 switches for the following equipment in AUTO:</p> <ul style="list-style-type: none"> • T4100-B007 (B006), Div 1 (2) CCHVAC Supply Fan. • T4100-C041 (C040), Div 1 (2) CCHVAC Chilled Wtr Pump. • T4100-B028 (B027), Div 1 (2) CCHVAC Equip Room Cooler. • T4100-C031 (C030), Div 1 (2) CCHVAC Return Air Fan. • T4100-B009 (B008), Div 1 (2) CCHVAC Chiller. • T4100-C047 (C048), Div 1 (2) CCHVAC Emerg Makeup Fan
<p>5 If selected T4100-B009 (B008), Div 1 (2) CCHVAC Chiller, is to be manually loaded, place Div 1 (2) Capacity Control Module AUTOMANUAL switch in MANUAL (H21-P285A (B), AB5-G13).</p> <p>CUE: As per initiating cues, the Chiller is to be automatically loaded</p>	<p>5 No action</p>
<p>*6. For division being placed in service, place Control Center HVAC Div 1 (2) Mode Select switch in ALL AUTO and verify:</p> <ul style="list-style-type: none"> • T4100-B007 (B006), Div 1 (2) CCHVAC Supply Fan, starts. • T4100-C041 (C040), Div 1 (2) CCHVAC Chilled Wtr Pump, starts. 	<p>*6. Places Control Center HVAC Div 2 Mode Select switch in ALL AUTO and verifies:</p> <ul style="list-style-type: none"> • T4100-B007 (B006), Div 1 (2) CCHVAC Supply Fan, starts. • T4100-C041 (C040), Div 1 (2) CCHVAC Chilled Wtr Pump, starts.
<p>*7. For division being removed from service, place Control Center Div 1 (2) switch in ALL STOP.</p> <p>CUE: Booth Operator - Activate (T41) MF 3575, "CCHVAC Div 2 Return Air Fan Trip" when ready to shift CCHVAC.</p> <p>CUE: As CRS, direct to return Div 1 CCHVAC to service.</p>	<p>*7. Places Control Center Div 1 switch in ALL STOP.</p> <ul style="list-style-type: none"> • Refers to ARP 17D27 • Reports to CRS that CCHVAC Return Air Fan is tripped • References AOP 20.413.01, Control Center HVAC System Failure • Recommends returning Div 1 CCHVAC to service to CRS
<p>*8 Returns to Step 6.1.2.3 of 23.413, Control Center HVAC</p>	<p>*8 Returns to Step 6.1.2.3 of 23.413, Control Center HVAC</p>

JOB PERFORMANCE MEASURE

JPM Title Shift Divisions of CCHVAC (Alternate Path)	No.: NRC EXAM 2003-301-B1.g Revision: 0 Page 7
---	--

<u>Elements</u>	<u>Standards</u>
*3. For the Division to be started verify: <ol style="list-style-type: none"> a. Div 1 (2) Mode Select switch is selected to the same mode as the running division. b. Div 1 (2) Emergency Air Intake Selector switch in AUTO. 	*3. Verifies: <ol style="list-style-type: none"> a. Div 1 Mode Select switch is selected to the same mode as the running division. b. Div 1 Emergency Air Intake Selector switch in AUTO.
4. For the Division to be started, verify or place Division 1 (2) switches for the following equipment in AUTO: <ul style="list-style-type: none"> • T4100-B007 (B006), Div 1 (2) CCHVAC Supply Fan. • T4100-C041 (C040), Div 1 (2) CCHVAC Chilled Wtr Pump. • T4100-B028 (B027), Div 1 (2) CCHVAC Equip Room Cooler. • T4100-C031 (C030), Div 1 (2) CCHVAC Return Air Fan. • T4100-B009 (B008), Div 1 (2) CCHVAC Chiller. • T4100-C047 (C048), Div 1 (2) CCHVAC Emerg Makeup Fan. 	4. Verifies or places Division 1 switches for the following equipment in AUTO: <ul style="list-style-type: none"> • T4100-B007 (B006), Div 1 CCHVAC Supply Fan. • T4100-C041 (C040), Div 1 CCHVAC Chilled Wtr Pump. • T4100-B028 (B027), Div 1 CCHVAC Equip Room Cooler. • T4100-C031 (C030), Div 1 CCHVAC Return Air Fan. • T4100-B009 (B008), Div 1 CCHVAC Chiller. • T4100-C047 (C048), Div 1 CCHVAC Emerg Makeup Fan.
5. If selected T4100-B009 (B008), Div 1 (2) CCHVAC Chiller, is to be manually loaded, place Div 1 (2) Capacity Control Module AUTOMANUAL switch in MANUAL (H21-P285A (B), AB5-G13).	5. No action
*6. For division being placed in service, place Control Center HVAC Div 1 (2) Mode Select switch in ALL AUTO and verify: <ul style="list-style-type: none"> • T4100-B007 (B006), Div 1 (2) CCHVAC Supply Fan, starts. • T4100-C041 (C040), Div 1 (2) CCHVAC Chilled Wtr Pump, starts. 	*6. Place Control Center HVAC Div 1 Mode Select switch in ALL AUTO and verify: <ul style="list-style-type: none"> • T4100-B007 (B006), Div 1 CCHVAC Supply Fan, starts. • T4100-C041 (C040), Div 1 CCHVAC Chilled Wtr Pump, starts.
*7. For division being removed from service, place Control Center Div 1 (2) switch in ALL STOP..	*7. Places Control Center Div 1 (2) switch in ALL STOP.

Time Stop _____

* Critical Steps

Terminating Cue(s):

Informs CRS Division 1 CCHVAC is operating in Normal Mode in accordance with 23.413

JOB PERFORMANCE MEASURE

JPM Title Shift Divisions of CCHVAC (Alternate Path)	No.: NRC EXAM 2003-301-B1.g Revision: 0 Page 8
---	--

FOLLOW-UP DOCUMENTATION QUESTIONS

Reason for Followup question(s):

Question:

Reference:

Response:

Question:

Reference

Response:

JOB PERFORMANCE MEASURE

JPM Title Shift Divisions of CCHVAC (Alternate Path)	No.: NRC EXAM 2003-301-B1.g Revision: 0 Page 9
---	--

Simulator Setup

IC#:

Any

Malfunctions:

Number	Title	Value
(T41) MF 3575	CCHVAC Div 2 Return Air Fan Trip	On

Remote Functions:

Number	Title	Value
None		

Override Functions:

None

Special Instructions:

**JOB PERFORMANCE MEASURE
NRC EXAM 2003-301-B2.A**

JPM B1.g Cue Sheet

Initial Conditions:

The plant is operating at full power.

Division 1 CCHVAC is operating.

Initiating Cue(s):

The CRS has directed that Division 2 CCHVAC placed in service and Division 1 CCHVAC be removed from service.

A pre-job brief has been completed.

All prerequisites are completed.

Steps 6.1.2.1 and 6.1.2.2 are complete.

An operator is in the field, standing by for direction.

The CCHVAC Chiller unit will be automatically loaded.

JOB PERFORMANCE MEASURE

JPM Title Switching Control Rod Drive Hydraulic FCV (Alternate Path)	No.: NRC EXAM 2003-301-B2.a Revision: 1 Page 2
---	--

Job Position Nuclear Supervising Operator	No. NRC EXAM 2003-301-B2.a	Revision 1
JPM Title Switching Control Rod Drive Hydraulic FCV (Alternate Path)	Duration 30 Minutes	Page COVER SHEET

Examinee: _____ SRO / RO

Evaluator: _____

Evaluation Method: Perform / Plant

Start Time _____

Stop Time _____

Total Time _____

PERFORMANCE EVALUATION							
Element	S	U	Comments	Element	S	U	Comments
1.				*14.			
2.				*15.			
3.				16.			
4.							
*5.							
*6.							
*7.							
8.							
9.							
*10.							
*11.							
*12.							
*13.							

_____ SATISFACTORY

_____ UNSATISFACTORY

ORAL EVALUATION (Not Required for ILO Exams)							
Question #	S	U	Comments	Question #	S	U	Comments

_____ SATISFACTORY

_____ UNSATISFACTORY

JOB PERFORMANCE MEASURE

JPM Title Switching Control Rod Drive Hydraulic FCV (Alternate Path)	No.: NRC EXAM 2003-301-B2.a Revision: 1 Page 3
---	--

Evaluator Signature / Date: _____ / _____

JOB PERFORMANCE MEASURE

JPM Title Switching Control Rod Drive Hydraulic FCV (Alternate Path)	No.: NRC EXAM 2003-301-B2.a Revision: 1 Page 4
---	--

References: Required (R) / Available (A) SOP 23.106, Control Rod Hydraulic System (R) AOP 20.206.03, CRD Flow Control Valve Failure (R)
Tools and Equipment Required: 15" Crescent Wrench

Preferred Evaluation Method:

Perform	<u> X </u>	Walkthrough	<u> </u>	Discuss	<u> </u>
Plant	<u> X </u>	Simulator	<u> </u>	Classroom	<u> </u>

<p>Evaluator Notes:</p> <p>ENSURE All industrial and personnel safety practices are used and enforced.</p> <p>This JPM should be performed in the plant. Do not operate any plant equipment. The evaluator should be prepared to simulate communications with the examinee as the Control Room and other plant operators as needed. Start this JPM at the A Flow Control Valve. K/A Reference: 201001 Control Rod Drive Hydraulic System</p> <table style="width: 100%; border-collapse: collapse;"> <tr> <td style="width: 5%; text-align: center;">K1</td> <td style="width: 80%;">Knowledge of the physical connections and/or cause effect relationships between control rod drive hydraulic system and the following (CFR: 41.2 to 41.9 / 45.7 to 45.8): K1.09, Plant air systems</td> <td style="width: 15%; text-align: right;">3.1 / 3.2</td> </tr> <tr> <td style="text-align: center;">A1</td> <td>Ability to predict and/or monitor changes in parameters associated with operating the control rod drive hydraulic SYSTEM controls including (CFR: 41.5 / 45.5): A1.09 - CRD drive water flow.</td> <td style="text-align: right;">2.9 / 2.8</td> </tr> <tr> <td style="text-align: center;">A2</td> <td>Ability to (a) predict the impacts of the following on the control rod drive hydraulic system ; and (b) based on those predictions, use procedures to correct, control, or mitigate the consequences of those abnormal conditions or operations (CFR: 41.5 / 45.6): A2.07, Flow control valve failure</td> <td style="text-align: right;">3.2 / 3.1</td> </tr> </table>	K1	Knowledge of the physical connections and/or cause effect relationships between control rod drive hydraulic system and the following (CFR: 41.2 to 41.9 / 45.7 to 45.8): K1.09, Plant air systems	3.1 / 3.2	A1	Ability to predict and/or monitor changes in parameters associated with operating the control rod drive hydraulic SYSTEM controls including (CFR: 41.5 / 45.5): A1.09 - CRD drive water flow.	2.9 / 2.8	A2	Ability to (a) predict the impacts of the following on the control rod drive hydraulic system ; and (b) based on those predictions, use procedures to correct, control, or mitigate the consequences of those abnormal conditions or operations (CFR: 41.5 / 45.6): A2.07, Flow control valve failure	3.2 / 3.1
K1	Knowledge of the physical connections and/or cause effect relationships between control rod drive hydraulic system and the following (CFR: 41.2 to 41.9 / 45.7 to 45.8): K1.09, Plant air systems	3.1 / 3.2							
A1	Ability to predict and/or monitor changes in parameters associated with operating the control rod drive hydraulic SYSTEM controls including (CFR: 41.5 / 45.5): A1.09 - CRD drive water flow.	2.9 / 2.8							
A2	Ability to (a) predict the impacts of the following on the control rod drive hydraulic system ; and (b) based on those predictions, use procedures to correct, control, or mitigate the consequences of those abnormal conditions or operations (CFR: 41.5 / 45.6): A2.07, Flow control valve failure	3.2 / 3.1							
<p>Task Standard:</p> <p>The CRD Flow Control Valves are shifted.</p>									
<p>Initial Conditions:</p> <p>You are the Shift Foreman Plant is operating normally at 100% power. "A" CRD Flow Control Valve is in service.</p>									
<p>Initiating Cue(s):</p> <p>The CRS directs Shift Foreman to shift CRD flow control valves, the in service FCV is responding poorly. All prerequisites are complete. Plant is operating normally at 100% power. "A" CRD Flow Control Valve is in service.</p>									

JOB PERFORMANCE MEASURE

JPM Title Switching Control Rod Drive Hydraulic FCV (Alternate Path)	No.: NRC EXAM 2003-301-B2.a Revision: 1 Page 5
---	--

PERFORMANCE EVALUATION

Time Start _____

<u>Elements</u>	<u>Standards</u>
<p>NOTE: Enters procedure 23.106, Control Rod Hydraulic Shift, beginning at Step 6.4.2.2</p> <p>CUE: Communication with the Control Room is established.</p> <p>1. Establish and maintain communication with the Control Room until the evolution is complete.</p>	<p>1. Communication with the Control Room is established.</p>
<p>CUE: Report as Control Room NSO:</p> <ul style="list-style-type: none"> • Control Rod Drive Hydraulic System Flow is 60 gpm. • Flow Controller is in AUTO. • Cooling Water Header to Reactor Differential Pressure is 11.5 psi. <p>2. Have the Control Room verify the Control Rod Drive Hydraulic System Flow is 37 to 63 gpm and the controller is in AUTO, maintaining Cooling Water Header to Reactor Differential Pressure 10 to 13 psi (H11-P603).</p>	<p>2. Control Room verified: The Control Rod Drive Hydraulic System Flow is 37 to 63 gpm. The Controller is in AUTO. The Cooling Water Header to Reactor Differential Pressure is 10 to 13 psi.</p>
<p>Note: The remaining steps are performed at the H21-P164 unless otherwise noted.</p> <p>CUE: The Drive Water Valve Selector Switch is in MANUAL and at minimum output.</p> <p>3. Verify the Drive Water Valve Selector Switch to be placed in service is in MANUAL and at minimum output.</p>	<p>3. The Drive Water Valve Selector Switch is in MANUAL and at minimum output.</p>
<p>CUE: The "A" Drive Water Flow Control Valve is in AUTO.</p> <p>4. Verify the "A" Drive Water Flow Control Valve is in AUTO.</p>	<p>4. The Drive Water Flow Control Valve is verified in AUTO.</p>
<p>CUE: The C11-F047B Flow Control Outlet Isolation Valve is open.</p> <p>* 5. Open or verify open the C11-F047A(B) Flow Control Outlet Isolation Valve for the valve being placed in service.</p>	<p>* 5. The C11-F047B Flow Control Outlet Isolation Valve is open.</p>

JOB PERFORMANCE MEASURE

JPM Title Switching Control Rod Drive Hydraulic FCV (Alternate Path)	No.: NRC EXAM 2003-301-B2.a Revision: 1 Page 6
---	--

<u>Elements</u>	<u>Standards</u>
<p>CUE: The C11-F046B Flow Control Inlet Isolation Valve is open.</p> <p>* 6. Open or verify open the C11-F046A(B) Flow Control Inlet Isolation Valve for the valve being placed in service.</p>	<p>* 6. The C11-F046B Flow Control Inlet Isolation Valve is open.</p>
<p>CUE: The "B" CRD Flow Controller demand is increased.</p> <p>* 7. Increase the demand on the Drive Water valve MANUAL / AUTO C11-D009A(B) Controller being placed in service.</p>	<p>* 7. The demand on the Drive Water Valve MANUAL / AUTO C11-D009B Controller has been increased.</p>
<p>CUE: The "A" Drive Water valve is closing.</p> <p>8. Verify the Drive Water Valve being taken out of service begins to close as the output controller for the Drive Water Flow Valve placed in service is increased.</p>	<p>8. The "A" Drive Water Valve closing is verified.</p>
<p>Note: The next step may require adjusting the Control Rod Drive Hydraulic System Flow Controller setpoint.</p> <p>CUE: C11-F002B, the "B" Drive Water Flow Control Valve is <u>NOT</u> opening.</p> <p>9. Verify the valve stem for the Drive Water Flow valve being placed in service is opening.</p>	<p>9. Verifies no response to flow control valve</p>
<p>CUE: No response from the flow control valve.</p> <p>CUE: Report as Control Room NSO:</p> <ul style="list-style-type: none"> • Crew has entered 20.106.03, CRD Flow Control Valve Failure • The FCV being removed from service had stopped responding. • Cooling Water Header to Reactor Differential Pressure is 11.5 psi. • Perform Step D of 20.106.03, CRD Flow Control Valve Failure – provide copy <p>*10. Adjust Control Rod Drive Hydraulic System Flow controller setpoint</p>	<p>*10. Reports no response from flow control valve</p>

JOB PERFORMANCE MEASURE

JPM Title Switching Control Rod Drive Hydraulic FCV (Alternate Path)	No.: NRC EXAM 2003-301-B2.a Revision: 1 Page 7
---	--

<u>Elements</u>	<u>Standards</u>
<p>NOTE: Begin at Step D.1 of 20.106.01, CRD Flow Control Valve Failure</p> <p>CUE: C11-K009A in Manual and Set to minimum</p> <p>*11. Verify C11-K009A in Manual and Set to minimum</p>	<p>*11 Verified C11-K009A in Manual and Set to minimum</p>
<p>CUE: C11-K009B in Manual and Set to minimum</p> <p>*12. Verify C11-K009B in Manual and Set to minimum</p>	<p>*12 Verified C11-K009B in Manual and Set to minimum</p>
<p>CUE: The C11-F047A Flow Control Outlet isolation Valve is open.</p> <p>CUE: The C11-F046A Flow Control Outlet isolation Valve is open.</p> <p>*13. For CRD FCV to be placed in service, verify C1100-F047A(B) open and C1100-F046A(B) open.</p>	<p>*13. Verified C1100-F047A open and C1100-F046A open.</p>
<p>CUE: The hand jack locking nut is loose.</p> <p>*14 Obtains crescent wrench from cart or tool bin and loosen hand jack locking nut on C11-F002A using a crescent wrench (15") (Enclosure A).</p>	<p>*14 Obtains crescent wrench from cart or tool bin and Loosen hand jack locking nut using a crescent wrench (15") (Enclosure A).</p>
<p>CUE: Flow is 60 gpm</p> <p>*15 For C11-F002A turn brass hand jack operator nut using a crescent wrench (15" or 12") to open (counterclockwise) or close (clockwise) CRD FCV, while observing flow. Establish a flow of 60 gpm locally (C11-R019).</p>	<p>*15 Establishes a flow of 60 gpm locally (C11-R019).</p>
<p>16. Notify the Control Room that the CRD Flow Control Valve is in local manual control</p>	<p>16. The Control Room is notified.</p>

Time Stop _____

* Critical Steps

Terminating Cue(s):

JOB PERFORMANCE MEASURE

JPM Title Switching Control Rod Drive Hydraulic FCV (Alternate Path)	No.: NRC EXAM 2003-301-B2.a Revision: 1 Page 8
---	--

Informs the Control Room that the Flow Control Valve A is in local manual control.

JOB PERFORMANCE MEASURE

JPM Title Switching Control Rod Drive Hydraulic FCV (Alternate Path)	No.: NRC EXAM 2003-301-B2.a Revision: 1 Page 9
---	--

FOLLOW-UP DOCUMENTATION QUESTIONS

Question: _____

Response: _____

Question: _____

Response: _____

JOB PERFORMANCE MEASURE

JPM Title Switching Control Rod Drive Hydraulic FCV (Alternate Path)	No.: NRC EXAM 2003-301-B2.a Revision: 1 Page 10
---	---

Plant Setup

Special Instructions:

1. Contact Control Room and inform CRS that this JPM is to be conducted.
2. Begin JPM.
3. Complete JPM
4. Inform Control Room JPM is complete.

**JOB PERFORMANCE MEASURE
NRC EXAM 2003-301-B2.B**

JPM B2.a Cue Sheet

Initial Conditions:

You are the Patrol NSO.

Plant is operating normally at 100% power.

“A” CRD Flow Control Valve is in service.

Initiating Cue(s):

The CRS directs the Patrol NSO to shift CRD flow control valves, the in service FCV is responding poorly.

All prerequisites are complete.

Plant is operating normally at 100% power.

“A” CRD Flow Control Valve is in service.

JOB PERFORMANCE MEASURE

JPM Title Defeat of RPS Automatic Logic Trips	No.: NRC EXAM 2003-301-B2.b Revision: 0 Page 2
--	--

Job Position Nuclear Supervising Operator	No. NRC Exam 2003-301-B2.b	Revision 0
JPM Title Defeat of RPS Automatic Logic Trips	Duration 25 Minutes	Page COVER SHEET

Examinee: _____ SRO / RO / NLO / SROC / STA

Evaluator: _____

Evaluation Method: Plant / Walkthrough Start Time _____

Stop Time _____

Total Time _____

PERFORMANCE EVALUATION							
Element	S	U	Comments	Element	S	U	Comments
*1.							
*2.							
*3.							
*4.							

_____ SATISFACTORY

_____ UNSATISFACTORY

ORAL EVALUATION (Not Required for ILO Exams)							
Question #	S	U	Comments	Question #	S	U	Comments

_____ SATISFACTORY

_____ UNSATISFACTORY

Evaluator Signature / Date: _____ / _____

JOB PERFORMANCE MEASURE

JPM Title Defeat of RPS Automatic Logic Trips	No.: NRC EXAM 2003-301-B2.b Revision: 0 Page 3
--	--

References: Required (R) / Available (A)

29.ESP.09, "Defeat of RPS Automatic Logic Trips"

Tools and Equipment Required:

- EOP Defeat Package for 29.ESP.09, "Defeat of RPS Automatic Logic Trips"
- Flashlight
- Low voltage electrical gloves

Preferred Evaluation Method:

Perform	X	Walkthrough		Discuss	
Plant	X	Simulator		Classroom	

Evaluator Notes:

ENSURE ALL INDUSTRIAL AND PERSONNEL SAFETY PRACTICES ARE USED AND ENFORCED.

Ensure SM informed of JPM walkthrough in relay room and cabinet doors opened for walkthrough of this task.

Stop the JPM if, at any time, this JPM interferes with plant operation.

K/A Reference :

2.1 Generic Knowledge and Abilities:

2.1.17	Ability to make accurate, clear, and concise verbal reports.	3.5 / 3.6
2.1.20	Ability to execute procedure steps.	4.3 / 4.2
2.1.21	Ability to obtain and verify controlled procedure copy.	3.1 / 3.2
2.1.23	Ability to perform specific procedures during all modes of operation.	3.3 / 3.5
2.1.30	Ability to locate and operate components including local controls.	3.4 / 3.5
2.1.28	Knowledge of purpose and function of major system components and controls	3.2 / 3.3

212000 Reactor protection System:

K3.	Knowledge of the effect that a loss or malfunction of RPS will have on the following:	
	K3.05 RPS Logic Channels	3.7 / 3.8
K4.	Knowledge of design feature(s) and/or interlocks which provide:	
	K4.12 Bypassing selected SCRAM signals(manual and auto)	3.9 / 4.1
K6.	Knowledge of the loss and/or malfunction of, will have an the following:	
	K6.05 RPS sensor inputs.	3.5 / 3.8
A3.	Ability to monitor automatics operation of:	
	A3.04 System status lights and alarms	3.9 / 3.8
A.4.	Ability to Manually operate and/or monitor in the Control Room:	
	A4.07 System status lights and alarms	4.0 / 3.9
	A4.16 Manually activate ATWS circuitry	4.4 / 4.4
	A4.17 Perform alternate reactivity/shutdown operations	4.1 / 4.1

JOB PERFORMANCE MEASURE

JPM Title Defeat of RPS Automatic Logic Trips	No.: NRC EXAM 2003-301-B2.b Revision: 0 Page 4
--	--

295015 Incomplete Scram:	
AK2. Knowledge of interrelationships for the following:	
AK2.04 RPS	4.0 / 4.1
AK2.08 Neutron monitoring system	3.6 / 3.7
AA1. Ability to operate and/or monitor the following:	
AA1.02 RPS	4.0 / 4.2
AA1.07 Neutron monitoring system	3.6 / 3.7
295037 Scram Condition and Reactor Power Above APRM Downscale:	
EK2. Knowledge of interrelations between the following:	
EK2.01 RPS	4.2 / 4.3
EK3. Knowledge of reasons for the following responses:	
EK3.07 Various alternate methods of control rod insertion	4.2 / 4.3
EA1. Ability to operate and monitor the following:	
EA1.01 RPS	4.6 / 4.6
Task Standard:	
RPS Automatic scram functions have been simulated defeated in accordance with 29.ESP.09.	
Initial Conditions:	
The plant has scrammed and power is NOT less than 3%.	
Initiating Cue(s):	
You are an extra operator assigned to the tagging center.	
CRS directs you to Defeat RPS Automatic Logic Trips per 29.ESP.09.	
Hand the candidate a copy of the procedure and the keys.	

JOB PERFORMANCE MEASURE

JPM Title Defeat of RPS Automatic Logic Trips	No.: NRC EXAM 2003-301-B2.b Revision: 0 Page 5
--	--

PERFORMANCE EVALUATION

Time Start _____

Elements

Standards

NOTE: All controls and indications are located

PREREQUISITES: NONE

*2.1	Install jumper Logic B2: H11-P611 Dev AX, Term 1 To Dev BL, Term 4.	Jumper H11-P611 Dev AX, Term 1 To Dev BL, Term 4 installed.
*2.2	Install jumper Logic B1: H11-P611 Dev DJ, Term 1 To Dev DW Term 4.	Jumper H11-P611 Dev DJ, Term 1 To Dev DW Term 4 installed.
*2.3	Install jumper Logic A2: H11-P609 Dev AX Term 1 To Dev BL Term 4.	Jumper H11-P609 Dev AX Term 1 To Dev BL Term 4 installed.
*2.4	Install jumper Logic A1: H11-P609 dev DJ Term 1 To Dev DW Term 4.	Jumper H11-P609 dev DJ Term 1 To Dev DW Term 4 installed.

Time Stop _____

* Critical Steps

Terminating Cue(s):

RPS Automatic Trips are defeated IAW 29.ESP.09

JOB PERFORMANCE MEASURE

JPM Title Defeat of RPS Automatic Logic Trips	No.: NRC EXAM 2003-301-B2.b Revision: 0 Page 6
--	--

FOLLOW-UP DOCUMENTATION QUESTIONS

Reason for Followup question(s):

Question:

Response:

Question:

Response:

JOB PERFORMANCE MEASURE

JPM Title Defeat of RPS Automatic Logic Trips	No.: NRC EXAM 2003-301-B2.b Revision: 0 Page 7
--	--

Plant Setup

Special Instructions:

5. Contact Control Room and inform CRS that this JPM is to be conducted.
6. Begin JPM.
7. Complete JPM
8. Inform Control Room JPM is complete.

**JOB PERFORMANCE MEASURE
NRC EXAM 2003-301-B2.B**

JPM B2.b Cue Sheet

Initial Conditions:

The plant has scrammed and power is NOT less than 3%.

Initiating Cue(s):

You are an extra operator assigned to the tagging center.

CRS directs you to Defeat RPS Automatic Logic Trips per 29.ESP.09.

JOB PERFORMANCE MEASURE

JPM Title Shutdown the Diesel Fire Pump	No.: NRC EXAM 2003-301-B2.c Revision: 0 Page 2
--	--

Job Position Nuclear Supervising Operator	No. NRC EXAM 2003-301-B2.c	Revision 0
JPM Title Shutdown the Diesel Fire Pump	Duration 15 Minutes	Page COVER SHEET

Examinee: _____ SRO / RO / NLO / SROC / STA

Evaluator: _____

Evaluation Method: Walkthrough / Plant Start Time _____
 Stop Time _____
 Total Time _____

PERFORMANCE EVALUATION							
Element	S	U	Comments	Element	S	U	Comments
1.				*14			
2.				15			
3.				16			
4.				17			
5.							
6.							
*7							
*8							
9							
10							
*11							
*12							
*13							

_____ SATISFACTORY

_____ UNSATISFACTORY

ORAL EVALUATION (Not Required for ILO Exams)							
Question #	S	U	Comments	Question #	S	U	Comments

_____ SATISFACTORY

_____ UNSATISFACTORY

Evaluator Signature / Date: _____ / _____

JOB PERFORMANCE MEASURE

JPM Title Shutdown the Diesel Fire Pump	No.: NRC EXAM 2003-301-B2.c Revision: 0 Page 3
--	--

References: Required (R) / Available (A) 28.504.02, Diesel Fire Pump Engine Weekly Operability Test (R)
Tools and Equipment Required: None

Preferred Evaluation Method:

Perform		Walkthrough	X	Discuss	
Plant	X	Simulator		Classroom	

Evaluator Notes: ENSURE ALL INDUSTRIAL AND PERSONNEL SAFETY PRACTICES ARE USED AND ENFORCED. This JPM should be performed in the plant. Start this JPM at the Protected Area parking lot K/A Reference : 286000 Fire Protection System																		
<table style="width: 100%; border-collapse: collapse;"> <tr> <td style="width: 5%; vertical-align: top;">K4.</td> <td style="width: 80%;">Knowledge of fire protection system design feature(s) and/or interlocks which provide for the following (CFR: 41.7) (CFR: 41.5 / 45.3) (CFR: 41.7 / 45.7) (CFR: 41.5 / 45.5) (CFR: 41.5 / 45.6) (CFR: 41.7 / 45.7) (CFR: 41.7 / 45.5 to 45.8)</td> <td style="width: 15%;"></td> </tr> <tr> <td></td> <td style="padding-left: 20px;">K4.05 Fire protection capability during loss of off-site power</td> <td style="text-align: right; vertical-align: bottom;">3.7 / 3.8</td> </tr> <tr> <td style="vertical-align: top;">K5</td> <td>Knowledge of the operational implications of the following concepts as they apply to fire protection system (CFR: 41.5 / 45.3):</td> <td></td> </tr> <tr> <td></td> <td style="padding-left: 20px;">K5.05 Diesel operations</td> <td style="text-align: right; vertical-align: bottom;">3.0 / 3.1</td> </tr> <tr> <td style="vertical-align: top;">A4</td> <td>Ability to manually operate and/or monitor in the control room (CFR: 41.7 / 45.5 to 45.8):</td> <td></td> </tr> <tr> <td></td> <td style="padding-left: 20px;">A4.06 Fire diesel</td> <td style="text-align: right; vertical-align: bottom;">3.4 / 3.4</td> </tr> </table>	K4.	Knowledge of fire protection system design feature(s) and/or interlocks which provide for the following (CFR: 41.7) (CFR: 41.5 / 45.3) (CFR: 41.7 / 45.7) (CFR: 41.5 / 45.5) (CFR: 41.5 / 45.6) (CFR: 41.7 / 45.7) (CFR: 41.7 / 45.5 to 45.8)			K4.05 Fire protection capability during loss of off-site power	3.7 / 3.8	K5	Knowledge of the operational implications of the following concepts as they apply to fire protection system (CFR: 41.5 / 45.3):			K5.05 Diesel operations	3.0 / 3.1	A4	Ability to manually operate and/or monitor in the control room (CFR: 41.7 / 45.5 to 45.8):			A4.06 Fire diesel	3.4 / 3.4
K4.	Knowledge of fire protection system design feature(s) and/or interlocks which provide for the following (CFR: 41.7) (CFR: 41.5 / 45.3) (CFR: 41.7 / 45.7) (CFR: 41.5 / 45.5) (CFR: 41.5 / 45.6) (CFR: 41.7 / 45.7) (CFR: 41.7 / 45.5 to 45.8)																	
	K4.05 Fire protection capability during loss of off-site power	3.7 / 3.8																
K5	Knowledge of the operational implications of the following concepts as they apply to fire protection system (CFR: 41.5 / 45.3):																	
	K5.05 Diesel operations	3.0 / 3.1																
A4	Ability to manually operate and/or monitor in the control room (CFR: 41.7 / 45.5 to 45.8):																	
	A4.06 Fire diesel	3.4 / 3.4																
Task Standard: Shutdown the Diesel Fire Pump																		
Initial Conditions: The plant is at full power 28.504.02, Diesel Fire Pump Engine Weekly Operability Test, is in progress.																		
Initiating Cue(s): The CRS directs you to relieve the person performing 28.504.02, Diesel Fire Pump Engine Weekly Operability Test. <i>The surveillance is on Step 5.1.18</i>																		

JOB PERFORMANCE MEASURE

JPM Title Shutdown the Diesel Fire Pump	No.: NRC EXAM 2003-301-B2.c Revision: 0 Page 4
--	--

PERFORMANCE EVALUATION

Time Start _____

<u>Elements</u>	<u>Standards</u>
PREREQUISITES: NONE	
NOTE: Begin at Step 5.1.18 of 28.504.02	
CUE: Give the candidate a copy of the completed surveillance up to Step 5.1.18 CUE: Speed is 1000 RPM CUE: Five minutes is up	
1. Adjust Engine Governor Control clockwise to idle speed (less than 1200 rpm) and run engine for approximately 5 minutes.	
CUE: Strobotac indicates 2250 RPM	
*2. Place Engine Governor Control to FULL SPEED (approximately 2300 rpm) position by turning counterclockwise to FULL OPEN and locking; then record engine speed below, from Strobotac:	*2. Places Engine Governor Control to FULL SPEED and records engine speed.
3. Open P8000-F154, Diesel Fire Pump Strainer Drain Valve.	3. Open P8000-F154, Diesel Fire Pump Strainer Drain Valve.
4. Turn each strainer handwheel 2 turns clockwise.	4. Turns each strainer handwheel 2 turns clockwise.
5. Close P8000-F154, Diesel Fire Pump Strainer Drain Valve.	5. Closes P8000-F154, Diesel Fire Pump Strainer Drain Valve.
6. Close and seal lock P8000-F010, Diesel Fire Pump Recirc Test Valve.	6. Closes and seal lock P8000-F010, Diesel Fire Pump Recirc Test Valve.
CUE: Discharge pressure is 170 psig	
*7. Record discharge pressure from X80-R401, Diesel Fire Pump Disch Press Indicator. Between 168 and 175 psig approximately.	*7. Records discharge pressure
CUE: CRNSO reports Diesel Fire Pump CMC Switch in OFF/RESET	
*8. Have place Diesel Fire Pump CMC Switch in OFF/RESET (COP H11-P807).	*8. Diesel Fire Pump CMC Switch in OFF/RESET (COP H11-P807).
9 Place Local Control Switch in OFF (Control Cabinet H21-P458).	9 Places Local Control Switch in OFF
CUE: CRNSO reports 7D2, DIESEL FIRE PUMP TROUBLE, alarms.	

JOB PERFORMANCE MEASURE

JPM Title Shutdown the Diesel Fire Pump	No.: NRC EXAM 2003-301-B2.c Revision: 0 Page 5
--	--

<u>Elements</u>	<u>Standards</u>
10. Verify Annunciator 7D2, DIESEL FIRE PUMP TROUBLE, alarms.	10. Verifies Annunciator 7D2, DIESEL FIRE PUMP TROUBLE, alarms.
CUE: CRNSO reports Diesel Fire Pump CMC Switch in AUTO.	
*11. Have CRNSO place Diesel Fire Pump CMC Switch in AUTO (COP H11-P807).	*11. Diesel Fire Pump CMC Switch in AUTO (COP H11-P807).
*12. Place Local Control Switch in AUTO (Control Cabinet H21-P458).	12. Places Local Control Switch in AUTO (Control Cabinet H21-P458).
13. Verify the following are clear: Annunciator 7D2, DIESEL FIRE PUMP TROUBLE. Annunciator 7D6, DIESEL FIRE PUMP AUTO START.	13. Verifies clear: Annunciator 7D2, DIESEL FIRE PUMP TROUBLE. Annunciator 7D6, DIESEL FIRE PUMP AUTO START.
CUE: Diesel Fire Pump Fuel Oil Tank Level is 35 inches	
NOTE: The Diesel Fire Pump Fuel Oil Tank Level is a TRM Section TR 3.12.2 limit. If the tank level is less than 28 inches on the level indicator or graduated dipstick, the SM must be notified immediately (see Enclosure A for Level Conversion Chart).	
*14. Perform the following: 1. Record Diesel Fire Pump Fuel Oil Tank Level: 2. Verify meets acceptable limits.	*14. Performs the following: 1. Record Diesel Fire Pump Fuel Oil Tank Level: 2. Verify meets acceptable limits
15. Inform Control Room to order fuel for Diesel Fire Pump if tank level is less than 32 inches (207 gallons).	15. No action
16. Notify the Control Room that the Diesel Fire Pump Weekly Test has been completed.	16. Notifies the Control Room that the Diesel Fire Pump Weekly Test has been completed.
17. Record test personnel.	17. Record test personnel.
CUE: CRS will assign an independent reviewer	

Time Stop _____

* Critical Steps

Terminating Cue(s):

JOB PERFORMANCE MEASURE

JPM Title Shutdown the Diesel Fire Pump	No.: NRC EXAM 2003-301-B2.c Revision: 0 Page 6
--	--

Records test personnel and is informed the CRS will assignan independent reviewer.

JOB PERFORMANCE MEASURE

JPM Title Sutdown the Diesel Fire Pump	No.: NRC EXAM 2003-301-B2.c Revision: 0 Page 7
---	--

FOLLOW-UP DOCUMENTATION QUESTIONS

Reason for Followup question(s):

Question:

Response:

Question:

Response:

JOB PERFORMANCE MEASURE

JPM Title Sutdown the Diesel Fire Pump	No.: NRC EXAM 2003-301-B2.c Revision: 0 Page 8
---	--

Plant Setup

Special Instructions:

9. Contact Control Room and inform CRS that this JPM is to be conducted.
10. Begin JPM.
11. Complete JPM
12. Inform Control Room JPM is complete.

**JOB PERFORMANCE MEASURE
NRC EXAM 2003-301-B1.A**

JPM B2.c Cue Sheet

Initial Conditions:

The plant is at full power

28.504.02, Diesel Fire Pump Engine Weekly Operability Test, is in progress.

Initiating Cue(s):

The CRS directs you to relieve the person performing 28.504.02, Diesel Fire Pump Engine Weekly Operability Test.

The surveillance is on Step 5.1.18