

Approved *[Signature]*

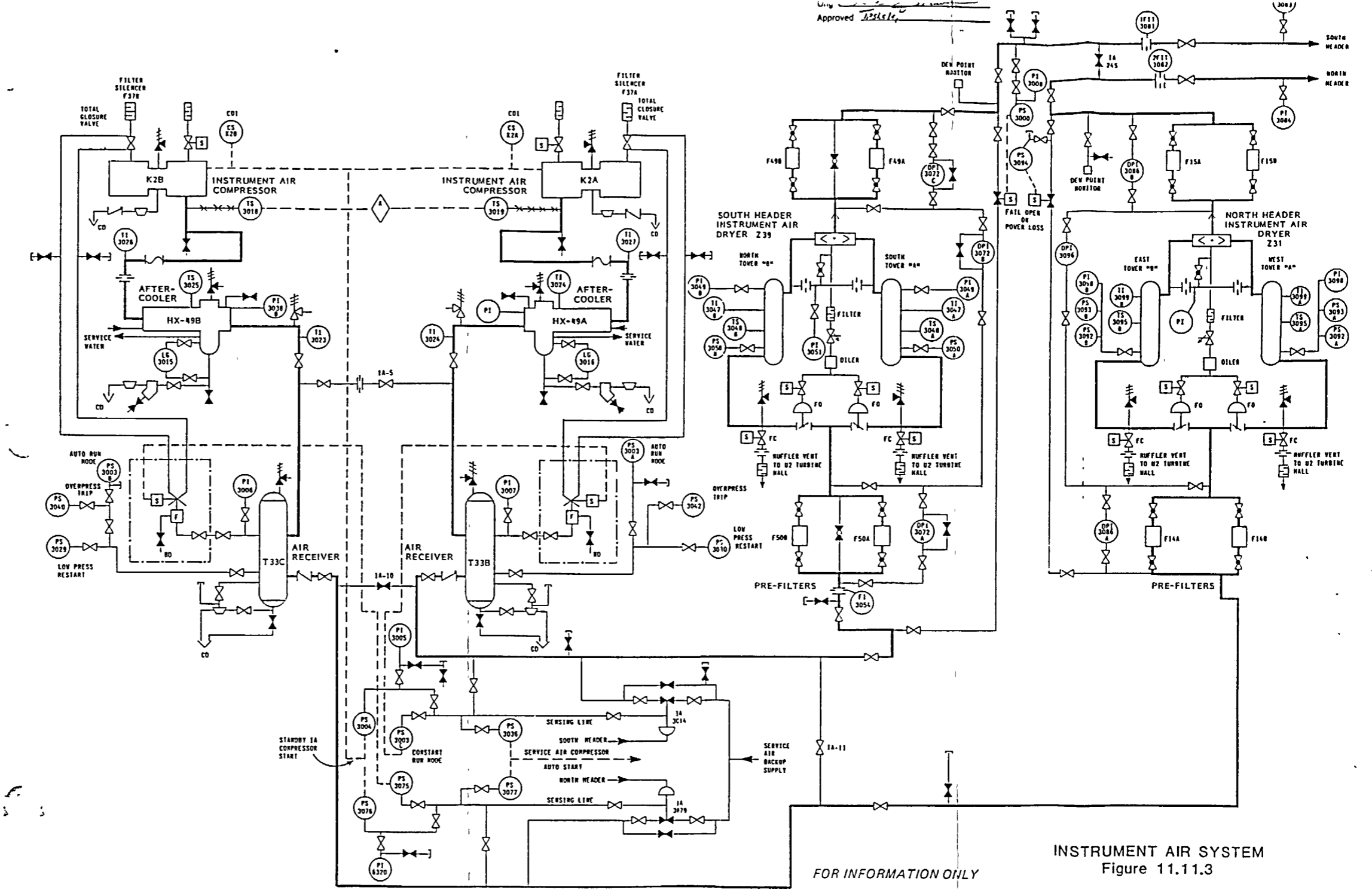

A149