



Florida Power
A Progress Energy Company

Crystal River Nuclear Plant
Docket No. 50-302
Operating License No. DPR-72

Ref.: 10 CFR 50.73

December 10, 2002
3F1202-02

U.S. Nuclear Regulatory Commission
Attn: Document Control Desk
Washington, DC 20555-0001

Subject: LICENSEE EVENT REPORT 50-302/02-002-00

Dear Sir:

Please find enclosed Licensee Event Report (LER) 50-302/02-002-00. The LER discusses a reactor trip from 100% Rated Thermal Power on November 7, 2002. This report is being submitted pursuant to 10CFR50.73(a)(2)(iv)(A).

If you have any questions regarding this submittal, please contact Mr. Sid Powell, Supervisor, Licensing & Regulatory Programs at (352) 563-4883.

Sincerely,

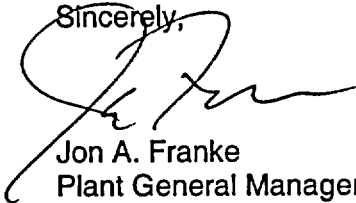

Jon A. Franke
Plant General Manager

JAF/dwh

Enclosure

xc: NRR Project Manager
Regional Administrator, Region II
Senior Resident Inspector

JE22

1. FACILITY NAME CRYSTAL RIVER UNIT 3	2. DOCKET NUMBER 05000 302	3. PAGE 1 OF 8
---	--------------------------------------	--------------------------

4. TITLE
Reactor Trip Due To Substation Generator Output Breaker Relay Mis-operation

5. EVENT DATE			6. LER NUMBER			7. REPORT DATE			8. OTHER FACILITIES INVOLVED	
MO	DAY	YEAR	YEAR	SEQUENTI AL NUMBER	REV NO	MO	DAY	YEAR	FACILITY NAME	DOCKET NUMBER
11	07	2002	02	- 002	- 00	12	10	2002		05000
									FACILITY NAME	DOCKET NUMBER
										05000

9. OPERATING MODE 1	11. THIS REPORT IS SUBMITTED PURSUANT TO THE REQUIREMENTS OF 10 CFR 50. (Check all that apply)									
10. POWER LEVEL 100%	20.2201(b)	20.2203(a)(3)(ii)	50.73(a)(2)(ii)(B)	50.73(a)(2)(ix)(A)						
	20.2201(d)	20.2203(a)(4)	50.73(a)(2)(iii)	50.73(a)(2)(x)						
	20.2203(a)(1)	50.36(c)(1)(i)(A)	X 50.73(a)(2)(iv)(A)	73.71(a)(4)						
	20.2203(a)(2)(i)	50.36(c)(1)(ii)(A)	50.73(a)(2)(v)(A)	73.71(a)(5)						
	20.2203(a)(2)(ii)	50.36(c)(2)	50.73(a)(2)(v)(B)	OTHER Specify in Abstract below or in NRC Form 366A						
	20.2203(a)(2)(iii)	50.46(a)(3)(ii)	50.73(a)(2)(v)(C)							
	20.2203(a)(2)(iv)	50.73(a)(2)(i)(A)	50.73(a)(2)(v)(D)							
	20.2203(a)(2)(v)	50.73(a)(2)(i)(B)	50.73(a)(2)(vii)							
	20.2203(a)(2)(vi)	50.73(a)(2)(i)(C)	50.73(a)(2)(viii)(A)							
	20.2203(a)(3)(i)	50.73(a)(2)(ii)(A)	50.73(a)(2)(viii)(B)							

12. LICENSEE CONTACT FOR THIS LER

NAME Dennis W. Herrin, Lead Engineer	TELEPHONE NUMBER (Include Area Code) (352) 563-4633
--	---

13. COMPLETE ONE LINE FOR EACH COMPONENT FAILURE DESCRIBED IN THIS REPORT

CAUSE	SYSTEM	COMPONENT	MANUFACTURER	REPORTABLE TO EPIX	CAUSE	SYSTEM	COMPONENT	MANUFACTURER	REPORTABLE TO EPIX
X	FK	21	C612	Y					

14. SUPPLEMENTAL REPORT EXPECTED	15. EXPECTED SUBMISSION DATE	MONTH	DAY	YEAR
YES (If yes, complete EXPECTED SUBMISSION DATE)	X NO			

16. ABSTRACT (Limit to 1400 spaces, i.e., approximately 15 single-spaced typewritten lines)

On November 7, 2002, Florida Power Corporation's (FPC's) Crystal River Unit 3 (CR-3) was in MODE 1 (POWER OPERATION) at 100 percent RATED THERMAL POWER (RTP). One of two 500 kilovolt (KV) substation generator output breakers (breaker 1662) was closed. The other 500KV substation generator output breaker (breaker 1661) was out of service for scheduled maintenance. At 14:39, a main turbine trip and subsequent anticipatory reactor trip occurred when breaker 1662 opened. The cause for opening of breaker 1662 was mis-operation of an Agastat 7024AC time delay relay contact used to remove power from phase-to-phase fault relay 39E and phase-to-ground fault relay 39F. Upon removal of the supply power to the Agastat relay, the relay contact created a voltage spike of the 39E relay power supply. Reactor Protection System actuation is reportable under 10CFR50.73(a)(2)(iv)(A). This condition does not represent a reduction in the public health and safety. The Agastat relay has been replaced by a multi-function programmable relay to block the trip signal from the 39E and 39F relays when applying or removing control power and prior to de-energizing the relays. No previous similar occurrences have been reported to the NRC by CR-3.

LICENSEE EVENT REPORT (LER)

1. FACILITY NAME	2. DOCKET	6. LER NUMBER			3. PAGE
CRYSTAL RIVER UNIT 3	05000302	YEAR	SEQUENTIAL NUMBER	REVISION NUMBER	2 OF 8
		02	- 002 -	00	

17. TEXT (If more space is required, use additional copies of NRC Form 366A)

EVENT DESCRIPTION

On November 7, 2002, Florida Power Corporation's (FPC's) Crystal River Unit 3 (CR-3) was in MODE 1 (POWER OPERATION) at 100 percent RATED THERMAL POWER (RTP). One of two 500 kilovolt (KV) substation generator output breakers (breaker 1662) [FK, BKR] was closed. The other 500KV substation generator output breaker (breaker 1661) was out of service for scheduled maintenance. At 14:39, an automatic reactor trip occurred when breaker 1662 opened. The breaker 1662 actuation resulted in a main turbine trip and subsequent anticipatory trip of the reactor.

Besides 500KV substation generator output breaker 1661 being out of service for scheduled maintenance, no structures, systems or components were inoperable at the start of the event that contributed to the event. Plant systems operated normally during the reactor trip with the following exceptions:

Control rod 4-3 [AA, ROD] initially dropped to approximately 10 percent withdrawn and stopped. The control rod then slowly drifted into the fully inserted position in approximately 10 minutes. Adequate shutdown margin existed during the event.

Main Steam Safety Valves MSV-34 and MSV-35 [SB, RV] did not reseal until Main Steam header pressure was lowered to approximately 980 pounds per square inch gauge (psig).

Auxiliary Steam System valve ASV-26 [SA, FCV] did not control auxiliary steam pressure in automatic and was placed in manual.

Condensate System pumps CDP-1A and CDP-1B [SD, P] tripped at the time of the reactor trip. CDP-1A was restarted.

Actuation of the Reactor Protection System is reportable to the NRC. At 16:58, on November 7, 2002, a non-emergency four-hour notification was made to the NRC Operations Center (Event Number 39354) in accordance with 10CFR50.72(b)(3)(iv)(A). This report is being submitted pursuant to 10CFR50.73(a)(2)(iv)(A).

SAFETY CONSEQUENCES

CR-3 connects to the 500KV substation through breakers 1661 and/or 1662 (see Drawing #1 - 500KV Substation Simplified Drawing). The 500KV substation [FK] also includes the incoming feeder from CR-5 (fossil generating plant), and outgoing transmission lines [FK, CBL] to Central Florida and Brookridge substations. Breakers 1661 and 1662 are designed to separate CR-3 from the grid under normal and abnormal conditions. Various relaying schemes associated with breakers 1661 and 1662 are designed to assure protection for the CR-3 main generator and 500KV substation from electrical faults.

LICENSEE EVENT REPORT (LER)

1. FACILITY NAME	2. DOCKET	6. LER NUMBER			3. PAGE
CRYSTAL RIVER UNIT 3	05000302	YEAR	SEQUENTIAL NUMBER	REVISION NUMBER	3 OF 8
		02	-- 002 --	00	

17. TEXT (If more space is required, use additional copies of NRC Form 366A)

CR-3 experienced a turbine trip and subsequent anticipatory reactor trip due to unexpected operation of breaker 1662 during system protective relay [FK, RLY] testing. Normal operating configuration would have required both 500KV generator output breakers 1661 and 1662 to open. However, breaker 1661 was out of service for maintenance and modification work. Post modification testing being performed was associated with relaying schemes for breaker 1661 and recent improvements made in the 500KV substation.

FPC concludes that opening of breaker 1662 with breaker 1661 out of service for scheduled maintenance did not represent a reduction in the public health and safety. Breaker 1662 operated as designed. Had both breaker 1661 and breaker 1662 been closed, the trip still would have occurred. The trip signal generated by the 39E and 39F relays go to both breakers 1661 and 1662.

In addition, both offsite power sources (Offsite Power Transformer and Back-up Engineered Safeguards (ES) Transformer) were available throughout the event to provide the normal source of power to the 4160V ES buses from the 230KV substation. No actuation of Emergency Feedwater System components, Engineered Safeguards components, Emergency Diesel Generators, Power Operated Relief Valves or pressurizer safety valves occurred or was required.

This event does not meet the Nuclear Energy Institute 99-02, Revision 2, definition of a Safety System Functional Failure.

CAUSE

The cause for opening of 500KV substation generator output breaker 1662 was mis-operation of an Agastat 7024AC time delay relay contact [FK, 21] used to remove power from the 39E phase-to-phase fault relay and 39F phase-to-ground fault relay. Upon removal of the supply power to the Agastat 7024AC time delay relay, the relay contact created a voltage spike of the 39E relay power supply.

The specific evolution in progress at the time of the event was the de-energization of test equipment used to complete one phase of the test involving the CR-3 related protective relaying associated with a Central Florida transmission line relay scheme modification. The CR-3 portion of the relay scheme was not altered, it was merely re-powered from a terminal block fed from potential transformers (PTs). The test instrument was connected to the PTs secondary with a test signal (voltage) to simulate a live Central Florida transmission line. This was done to verify power availability to the CR-3 portion of the circuit, as well as to test the new Central Florida transmission line relaying equipment. A CR-3 Agastat 7024AC time delay relay supervised the CR-3 input to the Central Florida transmission line via the PTs by monitoring that portion of the circuit between breakers 1661, breaker 1662, through the CR-3 step-up transformers, and back to the CR-3 generator. The design is such that if the relay observes an impedance condition consistent with a current flow towards the CR-3 generator at sufficient magnitude versus out of CR-3 to the Central Florida transmission line, the relay actuates trip functions necessary to separate CR-3 from the 500KV substation.

LICENSEE EVENT REPORT (LER)

1. FACILITY NAME	2. DOCKET	6. LER NUMBER			3. PAGE
CRYSTAL RIVER UNIT 3	05000302	YEAR	SEQUENTIAL NUMBER	REVISION NUMBER	4 OF 8
		02	-- 002 --	00	

17. TEXT (If more space is required, use additional copies of NRC Form 366A)

The associated logic includes a provision for automatically disabling this protection if the Central Florida transmission line is out of service. That provision is implemented using the Agastat 7024AC time delay relay to interrupt the power supply to the 39E and 39F relays. The relay is set to disable power to the 39E and 39F relays 1.5 seconds after the Central Florida transmission line is dead (zero volts).

CORRECTIVE ACTIONS

CR-3 Administrative Instruction AI-704, "Reactor Trip Review and Analysis," was performed.

The reactor trip is being addressed in the CR-3 Corrective Action Program as Nuclear Condition Report (NCR) 76622.

Control rod 4-3 initially dropped to approximately 10 percent withdrawn, then slowly inserting, is being addressed in NCR 76654.

Main Steam Safety Valves MSV-34 and MSV-35 not reseating until Main Steam header pressure was lowered to approximately 980 psig is being addressed in NCR 76658.

Auxiliary Steam System valve ASV-26 not controlling auxiliary steam pressure in automatic is being addressed in NCR 76721.

Condensate System pumps CDP-1A and CDP-1B tripping at the time of the reactor trip and CDP-1B losing its Deaerator Feed Tank level permit are being addressed in NCRs 76660 and 76682.

Engineering Change EC 50696, Revision 1, has been implemented. The way the 39E and 39F relays are disabled when the PT potential signal from the Central Florida transmission line is unavailable has been changed to prevent a repeat of the inadvertent trip of the CR-3 500KV substation generator output breakers. Previously, an Agastat 7024AC time delay relay removed the 125 volt direct current power from the 39E and 39F relays at 1.5 seconds after the loss of potential from the Central Florida transmission line potential transformers. The Agastat relay has been replaced by a multi-function programmable relay to block the trip signal from the 39E and 39F relays in addition to de-energizing input power to the relays. The new relay has an instantaneous pick-up set of contacts for energizing the power supplies and a 0.5 second delay for the trip signal when the relay is energized. When the new relay is de-energized, there is a 1.5 second delay for the trip signal and a 2 second delay for de-energizing the power supplies. The trip signal will effectively be blocked (0.5 seconds) both when applying control power and when removing control power from the two relays (39E and 39F). The 0.5 second blocking function will allow the 39E and 39F relay power supplies to energize (de-energize) without propagating a spurious trip of breakers 1661 and 1662.

LICENSEE EVENT REPORT (LER)

1. FACILITY NAME	2. DOCKET	6. LER NUMBER			3. PAGE
CRYSTAL RIVER UNIT 3	05000302	YEAR	SEQUENTIAL NUMBER	REVISION NUMBER	5 OF 8
		02	-- 002 --	00	

17. TEXT (If more space is required, use additional copies of NRC Form 366A)

EC 50696, Revision 1, documented the results of an evaluation focused on locating other relays that share potential or current signals with relays of the Central Florida or Brookridge transmission lines. No additional interdependencies were identified.

PREVIOUS SIMILAR EVENTS

No previous similar events involving inadvertent opening or either breaker 1661 or breaker 1662 have been reported to the NRC by CR-3.

DRAWING

Drawing #1 - 500KV Substation Simplified Drawing

ATTACHMENTS

Attachment 1 - Abbreviations, Definitions, and Acronyms

Attachment 2 - List of Commitments

LICENSEE EVENT REPORT (LER)

1. FACILITY NAME	2. DOCKET	6. LER NUMBER		3. PAGE
CRYSTAL RIVER UNIT 3	05000302	YEAR	SEQUENTIAL NUMBER	REVISION NUMBER
		02	- 002 -	00

17. TEXT (If more space is required, use additional copies of NRC Form 366A)

DRAWING #1

500KV SUBSTATION SIMPLIFIED DRAWING

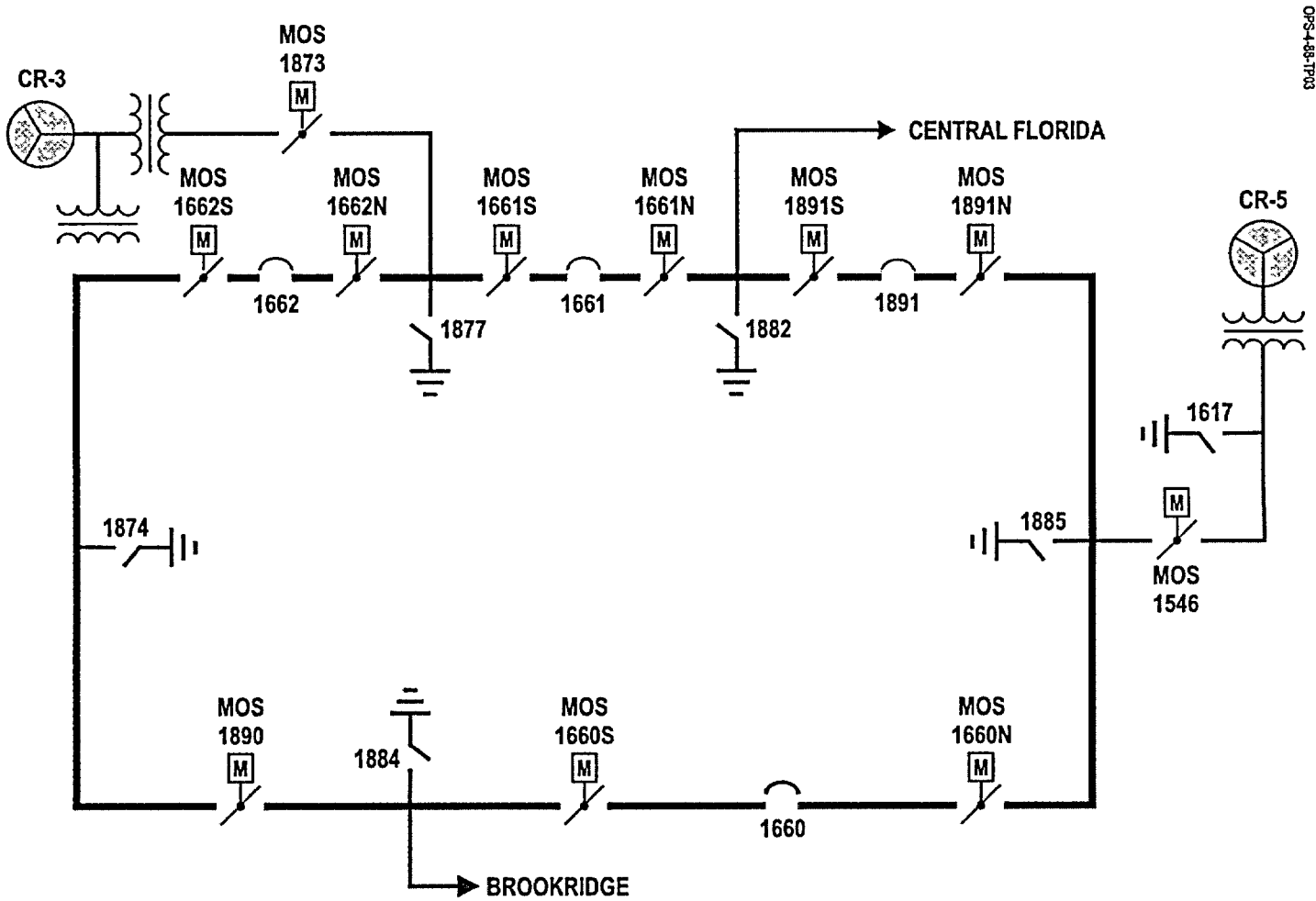

LICENSEE EVENT REPORT (LER)

1. FACILITY NAME	2. DOCKET	6. LER NUMBER			3. PAGE
CRYSTAL RIVER UNIT 3	05000302	YEAR	SEQUENTIAL NUMBER	REVISION NUMBER	7 OF 8
		02	- 002 -	00	

17. TEXT (If more space is required, use additional copies of NRC Form 366A)

ATTACHMENT 1

ABBREVIATIONS, DEFINITIONS AND ACRONYMS

AI	Administrative Instruction
ASV	Auxiliary Steam System Valve
CDP	Condensate System Valve
CFR	Code of Federal Regulations
CR-3	Crystal River Unit 3
CR-5	Crystal River Unit 5
FPC	Florida Power Corporation
EC	Engineering Change
ES	Engineered Safeguards
MSV	Main Steam System Valve
NCR	Nuclear Condition Report
KV	kilovolt
PT	Potential Transformer
RTP	Rated Thermal Power

NOTES: Improved Technical Specifications defined terms appear capitalized in LER text {e.g., MODE 1}

Defined terms/acronyms/abbreviations appear in parenthesis when first used {e.g., Reactor Building (RB)}.

EIIS codes appear in square brackets {e.g., reactor building penetration [NH, PEN]}.

LICENSEE EVENT REPORT (LER)

1. FACILITY NAME	2. DOCKET	6. LER NUMBER			3. PAGE
CRYSTAL RIVER UNIT 3	05000302	YEAR	SEQUENTIAL NUMBER	REVISION NUMBER	8 OF 8
		02	-- 002 --	00	

17. TEXT (If more space is required, use additional copies of NRC Form 366A)

ATTACHMENT 2

LIST OF COMMITMENTS

The following table identifies those actions committed to by Florida Power Corporation in this document. Any other actions discussed in the submittal represent intended or planned actions by Florida Power Corporation. They are described to the NRC for the NRC's information and are not regulatory commitments. Please notify the Supervisor, Licensing & Regulatory Programs of any questions regarding this document or any associated regulatory commitments.

RESPONSE SECTION	COMMITMENT	DUE DATE
	No regulatory commitments are being made in this submittal.	