



ACR Safety Systems Safety Support Systems Safety Assessment

**By Massimo Bonechi, Safety & Licensing Manager
ACR Development Project**

**Presented to US Nuclear Regulatory Commission
Office of Nuclear Reactor Regulation
September 25, 2002**





Presentation Outline

- **Safety Design Approach**
- **Inherent Safety Characteristics**
- **Safety Systems**
- **Safety Support Systems**
- **Severe Accident Resistance**
- **Scope of Safety Assessment**



Safety Design Approach

- **Defense in depth:**
 - **High-quality process systems to accommodate plant upsets and to minimize the likelihood of accidents**
 - **Reliable and fast-acting safety systems for reactor shutdown, emergency core cooling and containment**
 - **Reliable safety support systems to provide services to the safety systems and other mitigating systems**
 - **Backup heat sinks and secondary control area**
 - **Passive heat sinks to increase resistance against severe accidents**



Safety Design Approach

- **Seismic and environmental qualification of essential systems**
- **Separation and diversity of reactor shutdown systems and heat sinks**
- **Largely passive systems for reactor shutdown and emergency heat sinks**
- **Redundancy of divisions within safety systems and safety support systems**



Safety Design Approach

- **Design driven by Probabilistic Risk Assessment (PRA) building on the results of the studies performed on existing CANDU plants**
- **Large and separate volumes of water in and around the core to achieve a good balance between prevention and mitigation of severe core damage accidents**



Seismic Design

- **Design Basis Earthquake (DBE):** maximum earthquake postulated as initiating event. Equivalent in approach to the Safe Shutdown Earthquake in US NRC regulations.
- For the reference ACR design the DBE peak horizontal acceleration is 0.3g.



Inherent Safety Characteristics

- **ACR maintains the traditional CANDU inherent safety characteristics**
 - **Natural circulation capability in the reactor coolant system to cope with transients due to loss of forced flow**
 - **On-power fueling reduces excess reactivity holdup**
 - **Reactivity control devices are in the low pressure moderator so their mechanisms do not interfere with the reactor coolant pressure boundary**
 - **Moderator backup heat sink maintains core coolability for severe accidents**



Inherent Safety Characteristics

- **Additional inherent safety characteristics in ACR:**
 - **Negative power reactivity coefficient**
 - **Small negative full-core void reactivity offers a good balance of nuclear protection between loss-of-coolant accidents and fast cool-down accidents**
 - **Very flat and stable flux across the core reduces the number of reactivity control devices and minimizes the demand on the reactor control system**
 - **Larger safety and operating margins due to the use of ACR CANFLEX fuel with lower element rating and higher critical heat flux**



Safety Systems

- **Shutdown System 1**
- **Shutdown System 2**
- **Emergency Core Cooling**
- **Containment**



Shutdown Systems

- **Two fully capable, separate and diverse shutdown systems, each designed to cover the whole spectrum of design basis events**
- **Passive systems**
- **Seismically qualified**
- **Actuation of each system designed to meet minimum availability target of 0.999**

Reactor Assembly

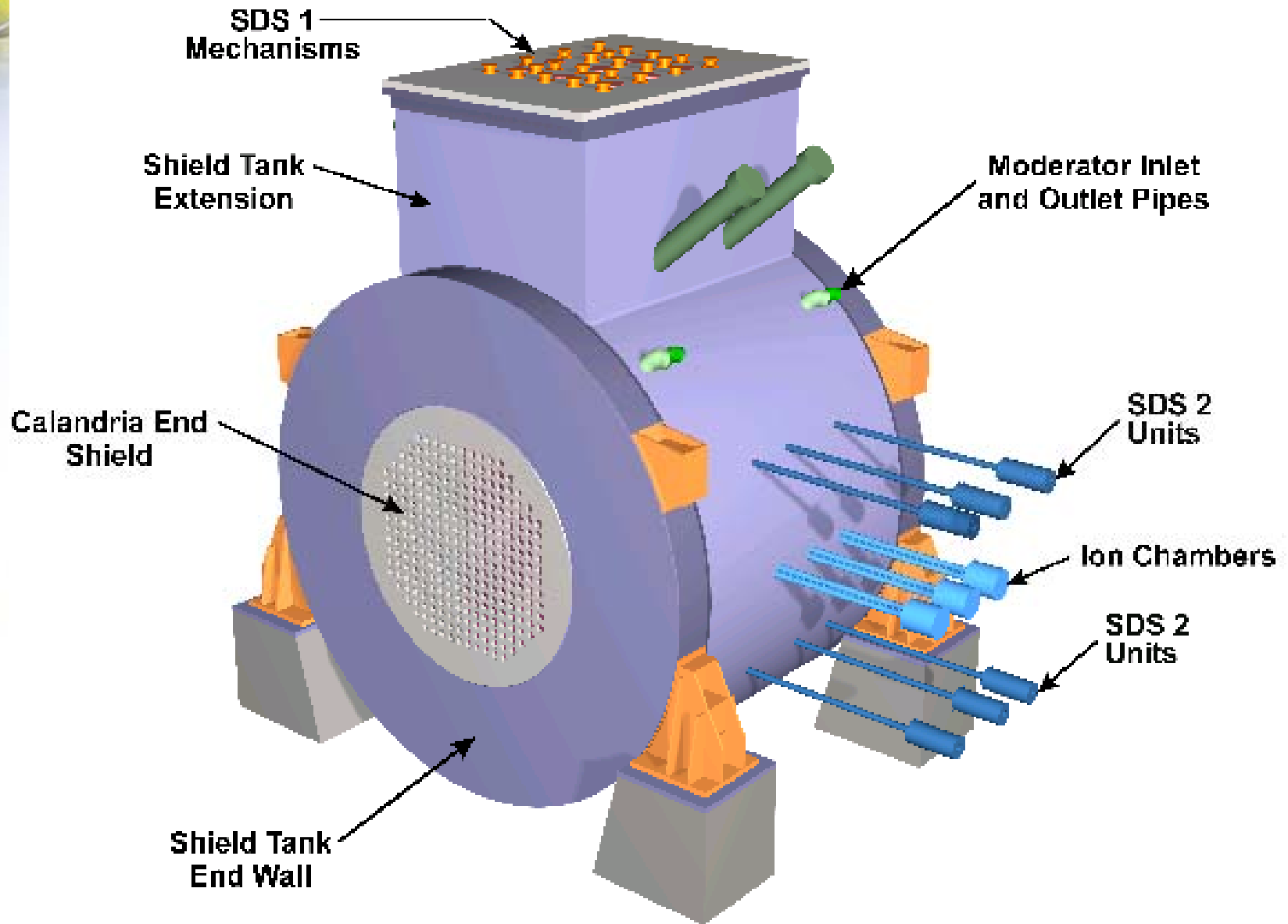



Shutdown System 1

- **Shutdown System 1 (SDS 1) consists of 20 mechanical shutoff rods that drop into the core by gravity upon reactor trip signal.**
- **The design of the shutoff units (rods + mechanisms) is based on the proven CANDU 6 design.**
- **SDS 1 is designed to insert -50 mk in less than 2 seconds after actuation.**



SDS 1 Shutoff Rod Unit

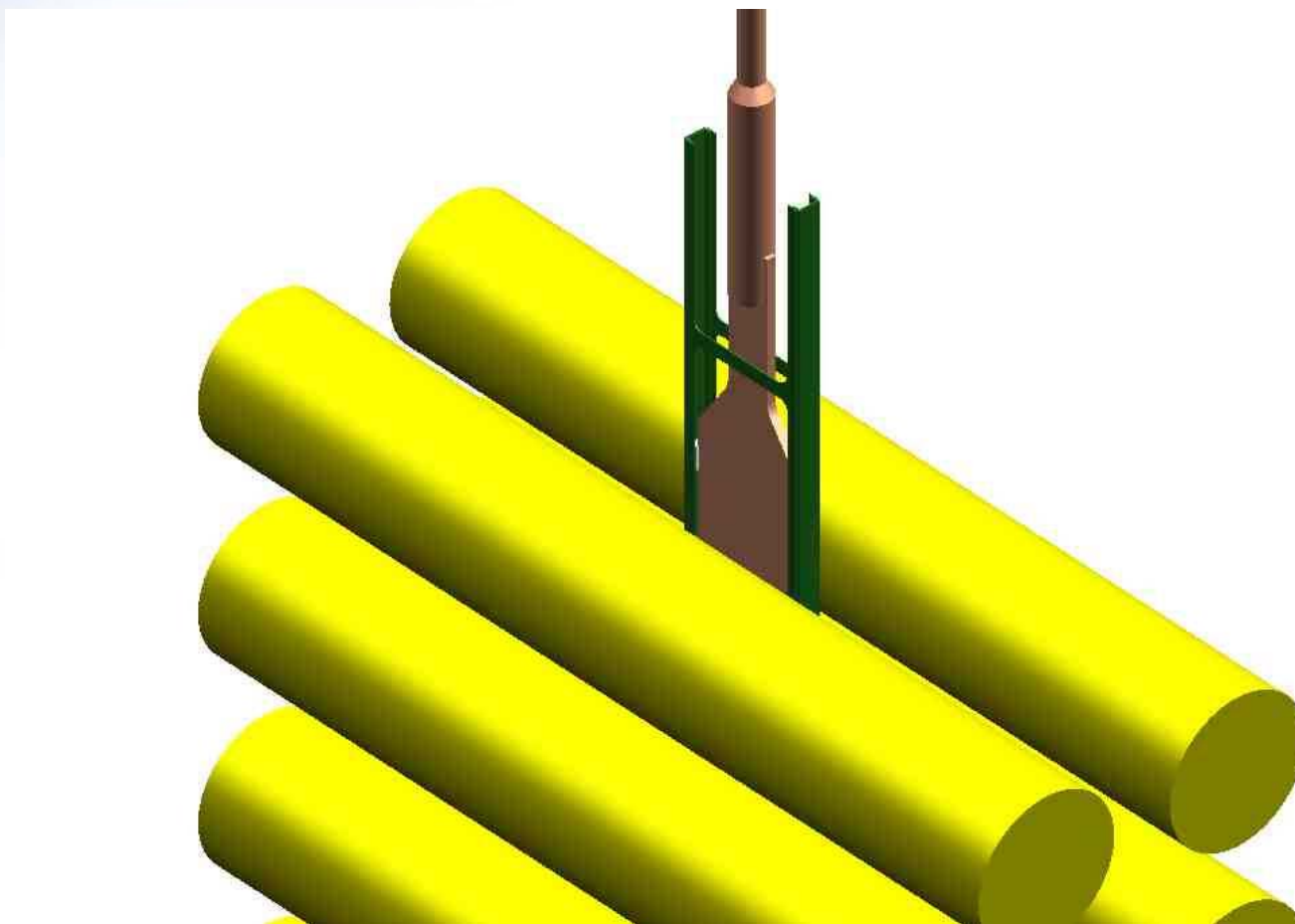



Shutdown System 2

- **Shutdown System 2 (SDS 2) injects concentrated gadolinium nitrate solution into the low pressure moderator to quickly render the core subcritical following postulated accidents.**
- **Injection is from pressurized tanks through nozzles traversing the calandria in the upper and lower reflector regions.**
- **SDS2 design is the same as in CANDU 6 except for location of injection nozzles.**
- **SDS 2 is designed to inject -50 mk of reactivity in less than two seconds.**
- **Contains enough gadolinium to inject -200 mk of reactivity, to keep the reactor shut down after an accident.**

Shutdown System 2

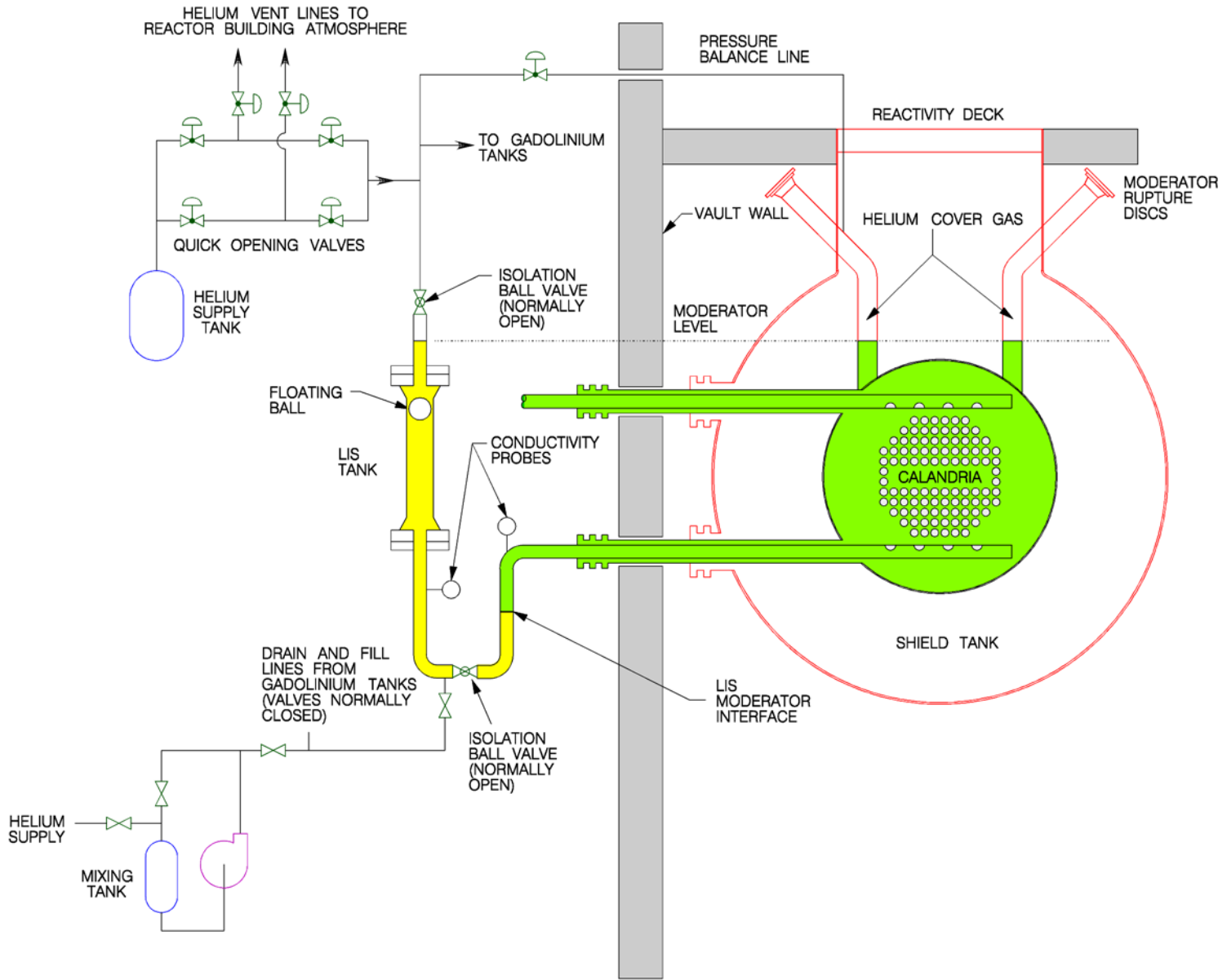



Emergency Core Cooling

- **The Emergency Core Cooling (ECC) function is carried out by two systems:**
 - **Emergency Coolant Injection (ECI) System for high-pressure coolant injection after a Loss-of-Coolant Accident (LOCA)**
 - **Long Term Cooling (LTC) System for recirculation after LOCA. The LTC system is also used for long term cooling of the reactor after shutdown following other accidents and transients.**



Emergency Coolant Injection System

- **Passive injection from pressurized tanks.**
- **The ECI system has been simplified to further enhance reliability and performance:**
 - **use of passive one-way rupture discs at the interface with the reactor coolant system (based on CANDU 9 design)**
 - **injection into reactor inlet headers only**
 - **large interconnect line between reactor outlet headers to assist in establishing an effective cooling flow path**
- **ECI actuation is designed to meet minimum availability target of 0.999.**

Emergency Coolant Injection System

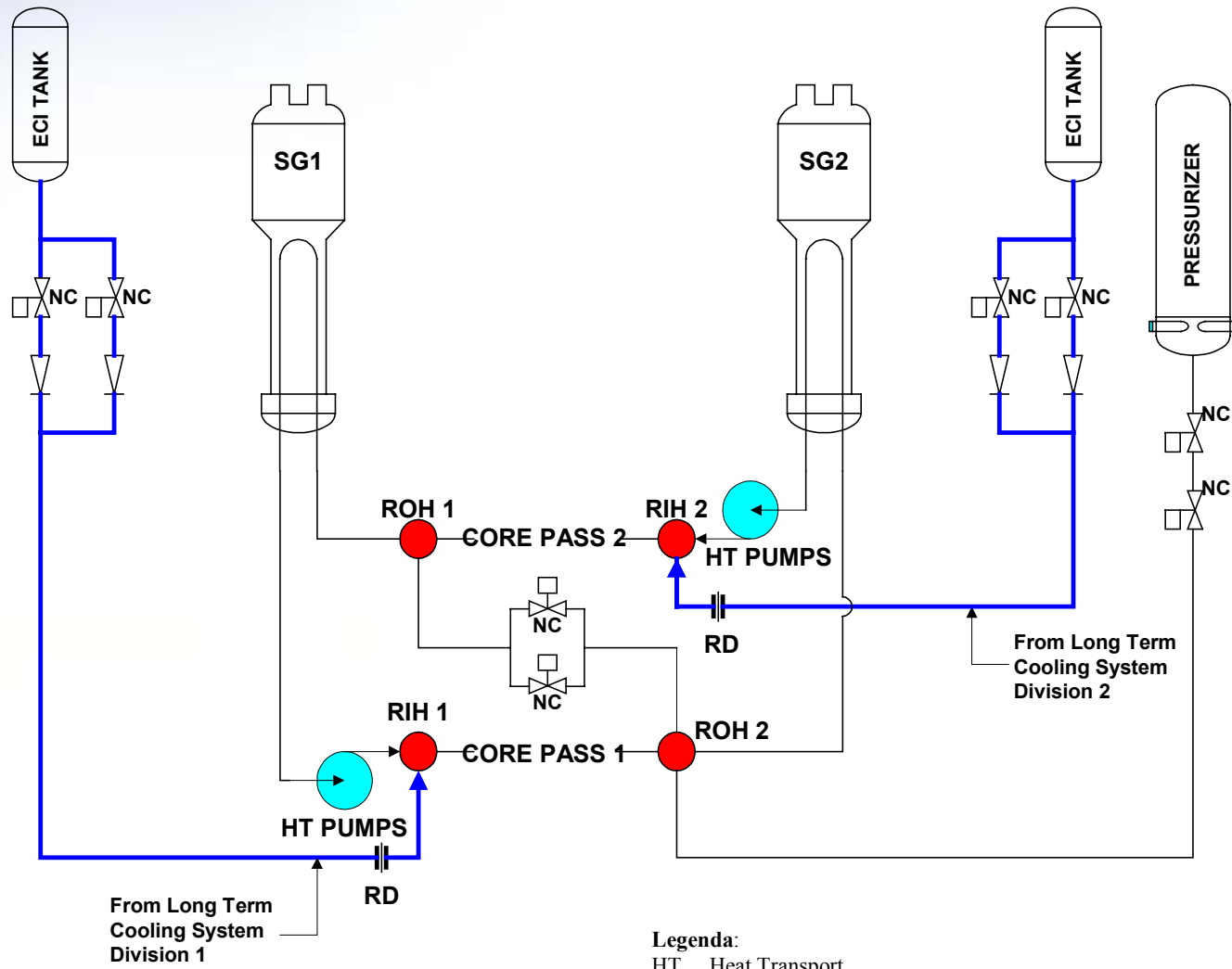

- Legenda:**
- HT Heat Transport
 - RD Rupture Disc
 - RIH Reactor Inlet Header
 - ROH Reactor Outlet Header



Long Term Cooling System

- **Long Term Cooling (LTC) system provides fuel cooling in the long term (recovery stage) of a LOCA and removes long term decay heat for all conditions with the reactor coolant pressure boundary intact.**
- **Comprised of two redundant divisions located in separate areas of the reactor auxiliary building. LTC pumps are supplied power by the Class III electrical system.**
- **The LTC system serves the function of shutdown cooling system for cool-down after a normal shutdown.**



LTC: Post-LOCA Recirculation

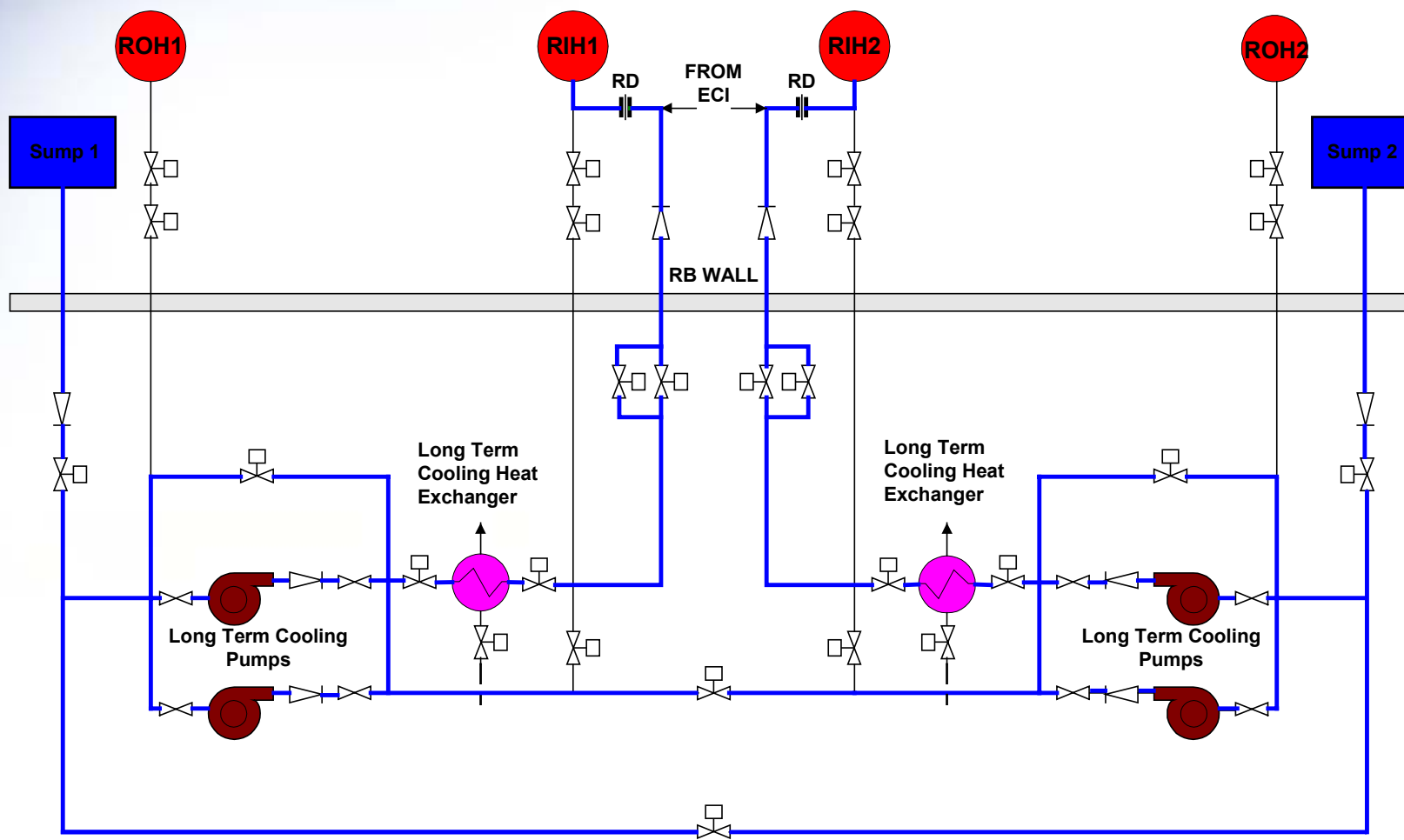



LTC: Cool-down

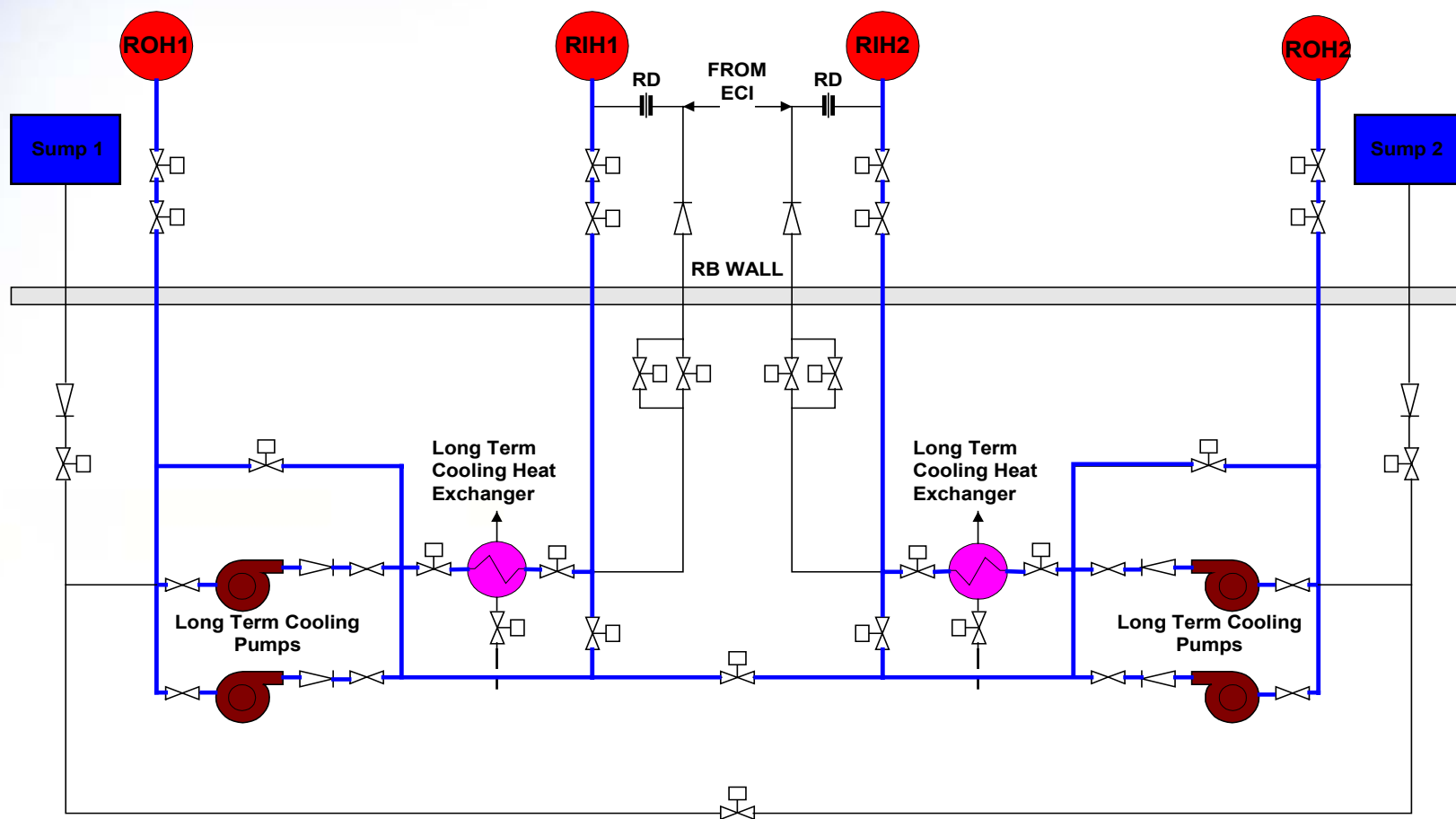



Containment

- **Steel-lined, pre-stressed concrete reactor building structure designed for a low leakage rate of 0.2% volume/day while providing a pressure retaining boundary for LOCA.**
- **Dry containment. Heat removal from the containment atmosphere after an accident is provided by the containment cooling system, comprised of local air coolers suitably distributed inside the reactor building.**
- **Containment isolation system automatically closes penetrations open to the reactor building atmosphere upon signals of high pressure or high radioactivity in the reactor building. The actuation system is designed for minimum availability target of 0.999.**
- **Hydrogen control following LOCA is provided by passive auto-catalytic recombiners.**

Containment

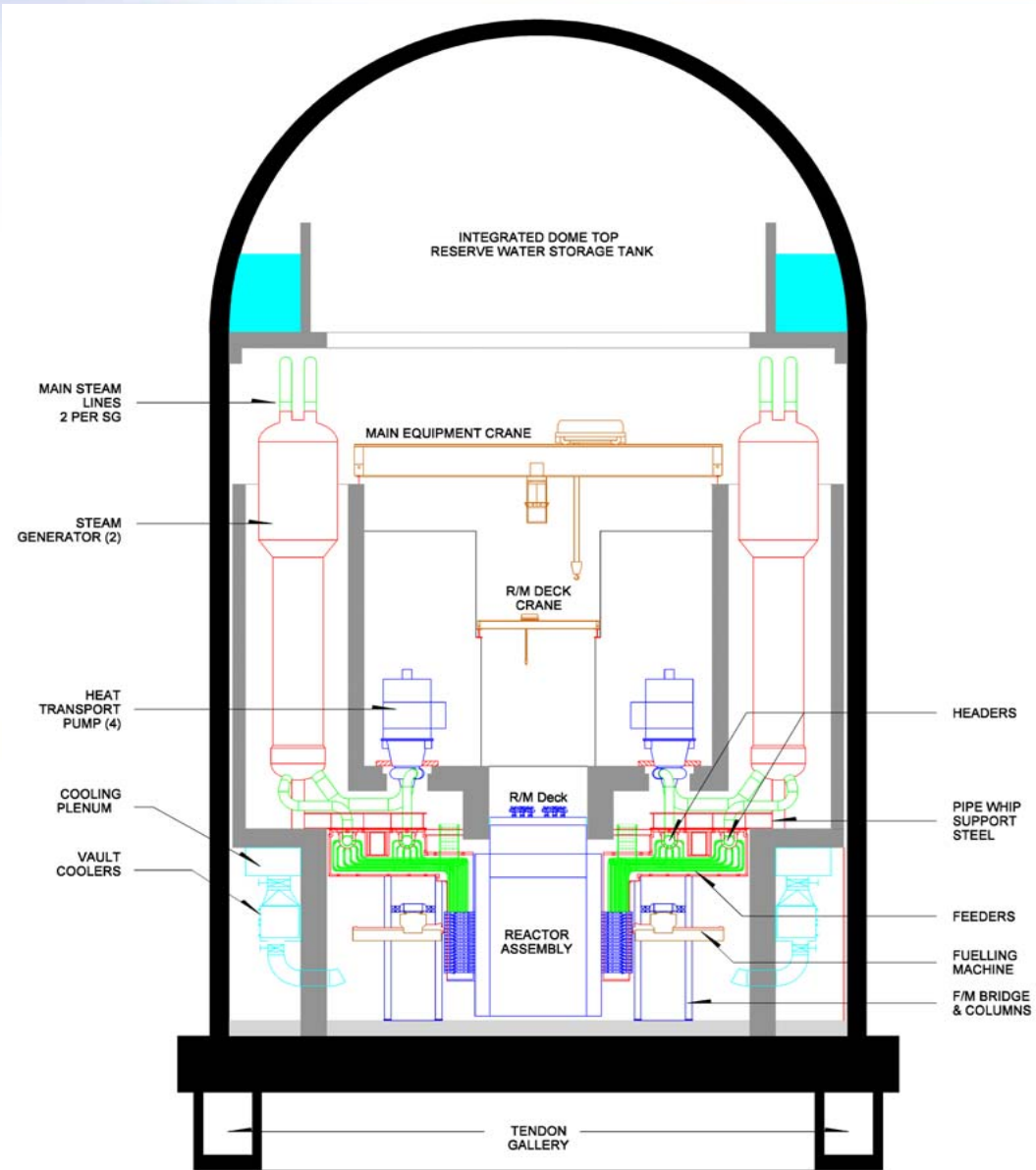



Safety Support Systems

- Reserve Water System
- Cooling Water Systems
- Electrical Power Systems
- Instrument Air Systems
- Secondary Control Area



Reserve Water System

- **Large water volume tank at high elevation in the reactor building**
- **Passive supply of water by gravity for**
 - **Containment sumps for NPSH of LTC pumps**
 - **Emergency feedwater to steam generators**
 - **Emergency make-up to the reactor coolant system**
 - **Make-up to moderator and shield tank for enhanced mitigation of severe accidents**

Reserve Water System

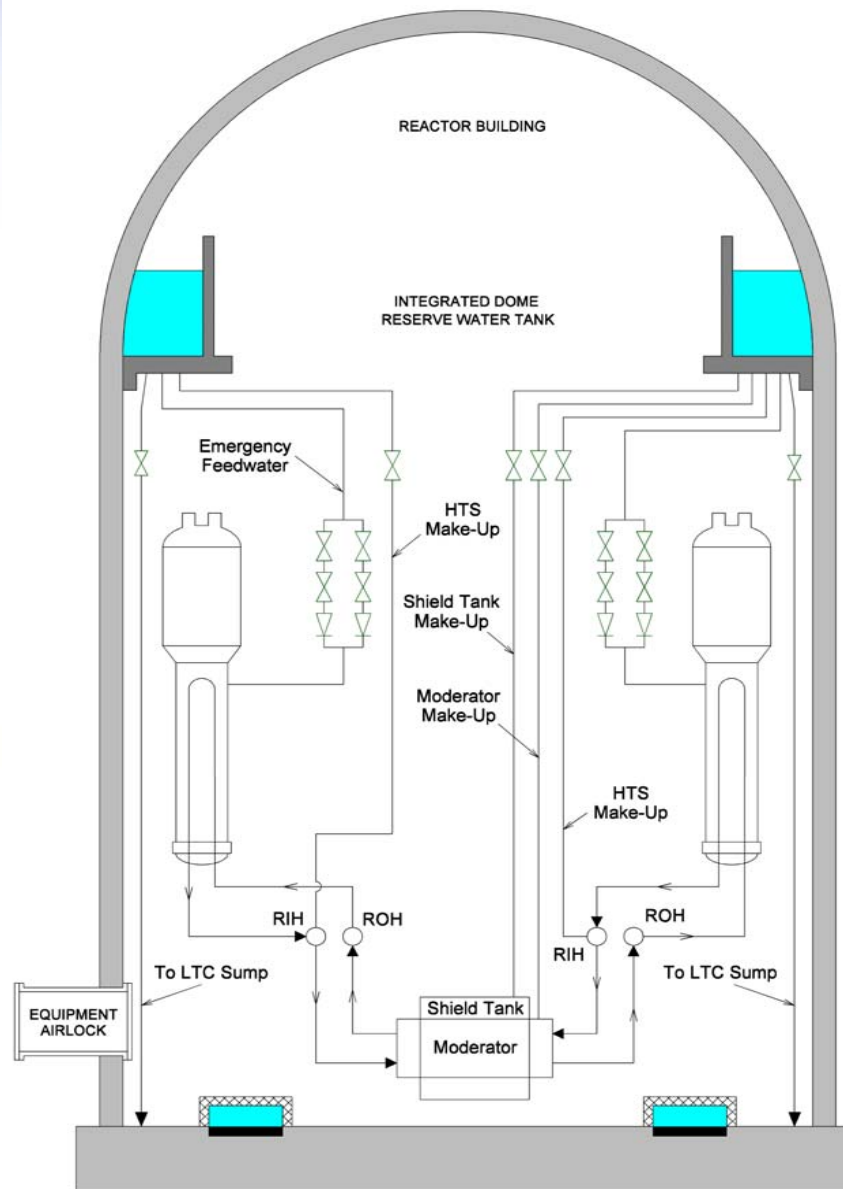



Service Water and Electrical Power Systems

- **The systems supply cooling water (raw service water and recirculated cooling water) and electrical power to safety related loads required for accident conditions**
- **Seismic qualification of service water and electrical power supplies**
- **Two redundant divisions of service water supplies for safe shutdown of each unit**
- **Two redundant divisions of Class I, II and III electrical power supplies in each unit**
- **Interconnection of service water and electrical power supplies between twin units to increase overall reliability and protection against common cause events in either unit**



Instrument Air Systems and Secondary Control Area

- **Instrument air is provided by compressed air supplies backed up by local air tanks**
- **Secondary control area completely separate from the main control room provides controls for safe shutdown, sufficient monitoring and cooling of either unit's reactor in case the main control room becomes uninhabitable**



Severe Accident Resistance

- Presence of large separate volumes of water in and around the core
- Moderator backup heat sink maintains core coolability under severe accident conditions
- If even moderator cooling is unavailable, the passive thermal capacities of moderator mass inside the calandria and light water in the shield tank slow down the progression of severe core damage
- Hence, a more benign (slower) challenge to the containment boundary with more time for recovery actions
- Further enhancements in ACR with the provision of passive water makeup to moderator and shield tank from the reserve water system to extend their passive thermal capacities



Heat Sinks for Severe Core Damage (SCD) Prevention and Mitigation

SCD Prevention
(no loss of core coolability)

Normal Heat Removal Systems

Emergency Heat Removal Systems

–Emergency Core Cooling

–Passive Emergency Feedwater from Reserve Water Tank

Backup moderator heat sink

SCD
Mitigation

Passive thermal capacity of moderator

Passive thermal capacity of shield water

Passive makeup to calandria vessel and shield tank from Reserve Water Tank

Severe Accident Management



Safety Assessment for the ACR Basic Engineering Program

- **Comprehensive safety assessment encompassing safety design, design basis accidents, severe accidents and PRA**
- **Assessment will be completed by March 2005**
- **Familiar with NRC RG 1.70 and Standard Review Plan**



Safety Assessment Process

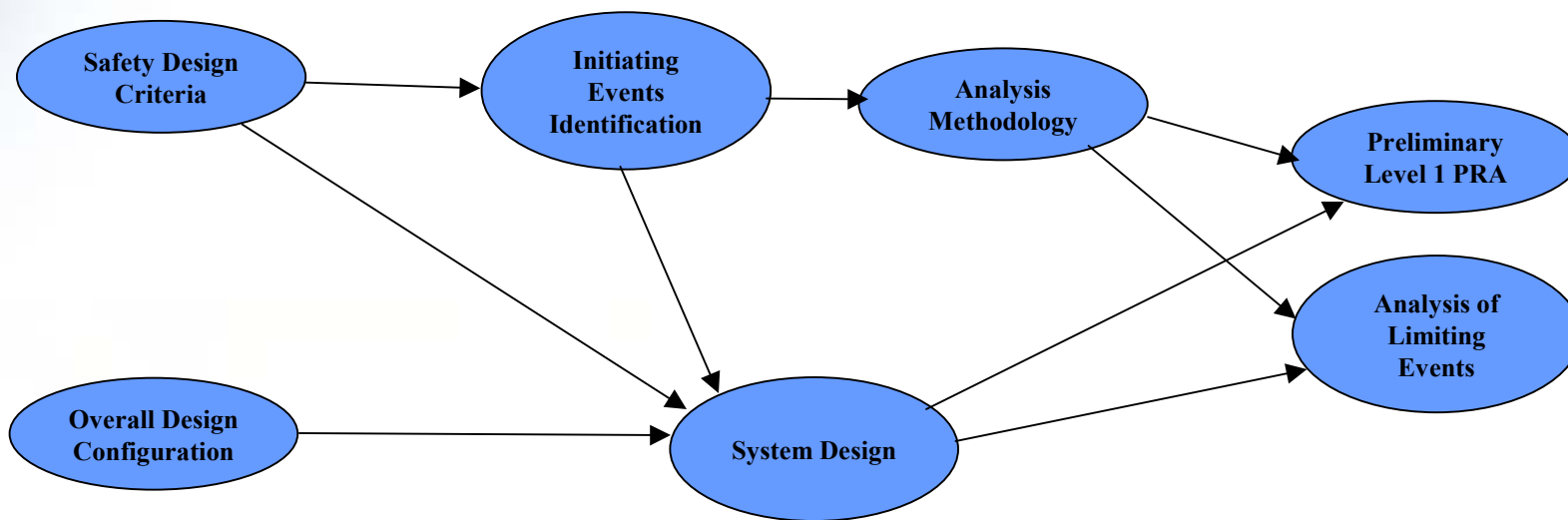



Scope of Safety Assessment

- **Safety Design Criteria, e.g.**
 - **Safety Related Systems**
 - **Shutdown Systems**
 - **Emergency Core Cooling**
 - **Containment**
 - **Seismic Requirements**
 - **Environmental Qualification**
 - **Separation of Systems and Components**
 - **Fire Protection**
 - **Radiation Protection**
 - **Overpressure Protection**



Scope of Safety Assessment

- **Safety Assessment Methodology**
 - **Design Basis Event Identification**
 - **Safety Analysis Initial Conditions, Assumptions and Acceptance Criteria**
 - **Safety Analysis Computer Codes**
 - **Probabilistic Risk Assessment Methodology and Scope**
 - **Severe Accidents: Design Objective and Program Plan**



Scope of Safety Assessment

- **Design Requirements of Safety Related Systems**
- **Design Descriptions of Safety Related Systems**
- **Compliance with Safety Design Criteria**
- **Design for Prevention and Mitigation of Severe Accidents**
- **Deterministic Analysis of Limiting Design Basis Events**
- **Preliminary Level 1 Probabilistic Risk Assessment**



Conclusion

- **Inherent safety characteristics for nuclear and thermal response of the reactor to transients and accidents**
- **Large number of passive safety features**
- **Strong safety design approach based on defense-in-depth and driven by PRA**
- **Redundancy and diversity of systems for reactor shutdown and heat sinks**
- **Comprehensive safety assessment as part of the ACR Basic Engineering Program**



 **AECL**
TECHNOLOGIES INC.