

✓ X

REGISTRY OF RADIOACTIVE SEALED SOURCES AND DEVICES
SAFETY EVALUATION OF DEVICE
(AMENDED IN ITS ENTIRETY)

NO.: CA471D105B

DATE: December 22, 1997

PAGE: 1 of 7

DEVICE TYPE: Basis Weight and Thickness Gauge

MODEL: 302

MANUFACTURER/DISTRIBUTOR: NDC Systems
5314 North Irwindale Avenue
Irwindale, CA 91706
(626) 960-3300 (voice)
(626) 939-3870 (fax)

SEALED SOURCE MODEL DESIGNATION: Amersham Model
KAC (X.1088 Capsule)
or Dupont Model NER 584 or NER 585

ISOTOPE: Krypton 85

MAXIMUM ACTIVITY: 200 millicuries (7.4 GBq)

LEAK TEST FREQUENCY: Not Required

PRINCIPAL USE: (E) Beta Gauge

CUSTOM SOURCE: _____ YES X NO

REGISTRY OF RADIOACTIVE SEALED SOURCES AND DEVICES
SAFETY EVALUATION OF DEVICE
(AMENDED IN ITS ENTIRETY)

NO.: CA471D105B

DATE: December 22, 1997

PAGE: 2 of 7

DEVICE TYPE: Basis Weight and Thickness Gauge

DESCRIPTION:

The Model 302 Beta Transmission Gauging System is specifically designed for thickness or mass measurement of thin plastic, paper or other essentially flat sheet material during the manufacture of that material, while the sensor housings are **either stationary or** traversed across the material by a motorized scanning frame.

The Model 302 is the Beta Transmission Sensor component of NDC Beta Transmission gauging systems. The Model 302 consists of two separate housings defining an air gap between them through which resides the sample to be measured (Attachment 1). The upper housing contains the radioactive source rigidly secured within a steel and tungsten composite holder utilizing a counterbored retaining well and a locked plate cover. A radiation shutter provided for powered useful beam control is composed of brass and tungsten and is of fail-safe design. These assemblies are contained by a steel framework subassembly that is securely fastened into a cast housing (Attachment 2). Additionally, a radiation shaping collimator aids in focusing the radiation towards the lower head. The lower head consists of a radiation detector and defines the measurement gap as nominally 2.0 cm.

The powered useful beam control system is incorporated such that if power fails, the source will remain in or return to, the OFF condition. This is accomplished by a spring return electrical or pneumatic actuator that must be electrically or pneumatically powered to maintain the source in the ON position (Attachments 2 and 3). Conspicuously visible signals which positively indicate when the system is in the ON condition (a red signal light) and when it is in the OFF condition (a green signal light) are located adjacent to the radiation source housing (Attachment 1). Multiple bulbs are used for each condition. **For both electrical and pneumatic actuator designs,** the powered useful beam control system was tested continuously in excess of 100,000 cycles without failure to return to the OFF condition upon removal of electrical power.

LABELING:

The device is labeled in accordance with Sections 30192.1 of the California Radiation Control Regulations (equivalent to 10 CFR 32.51), 10 CFR 20.1901, and 10 CFR 20.1904 (**Attachments 4 & 5**).

**REGISTRY OF RADIOACTIVE SEALED SOURCES AND DEVICES
SAFETY EVALUATION OF DEVICE
(AMENDED IN ITS ENTIRETY)**

NO.: CA471D105B

DATE: December 22, 1997

PAGE: 3 of 7

DEVICE TYPE: Basis Weight and Thickness Gauge

DIAGRAMS:

- | | |
|-----------------------------|---|
| Attachment 1 | Model 302 Sensor Probe on Traversing Scanner with On/Off Indicator Lights |
| Attachment 2 | Model 302 Source Holder/Solenoid/Shutter/Shielding Assembly (Electrical) |
| Attachment 3 | Model 302 Source Holder/Pneumatic actuator/Shutter/Shielding Assembly (Pneumatic) |
| Attachment 4 & 5 | Model 302 Labeling |
| Attachment 6 | Radiation Profile Model 302 Shutter Open & Closed (Electrical or pneumatic) |

CONDITIONS OF NORMAL USE:

The device is intended to measure the thickness or mass of essentially flat sheet material in industrial environments. The expected operating conditions are:

- | | |
|--------------|--|
| Temperature: | 15°C to 50°C |
| Humidity: | 0 to 100% |
| Pressure: | Atmospheric |
| Vibration: | Normal plant machinery vibration |
| Corrosion: | Corrosive liquids sometimes used - probe materials designed to be resistant. |

REGISTRY OF RADIOACTIVE SEALED SOURCES AND DEVICES
SAFETY EVALUATION OF DEVICE
(AMENDED IN ITS ENTIRETY)

NO.: CA471D105B

DATE: December 22, 1997

PAGE: 4 of 7

DEVICE TYPE: Basis Weight and Thickness Gauge

PROTOTYPE TESTING:

The **electrical actuator** units have been tested by the manufacturer for effects of severe vibration and at temperatures up to 100°C. Continuous vibration in accordance with the Class 4 test of ANSI, NBS Handbook No. 126 was carried out on a shake table. The unit was held at 60°C for several weeks. The shutter was operated in excess of 100,000 open-close cycles. **The manufacturer states that these vibration and temperature test results are also applicable to the pneumatic actuator units, as the design of the two devices is identical with the exception of the actuator.** The ANSI classification assigned by the manufacturer is 54-365-885-R2. This is based on tests in accordance with NBS 129, the ANSI classification of the Amersham source and materials of construction.

EXTERNAL RADIATION LEVELS:

The radiation profiles with the shutter open and closed were taken with a Lansverk R Meter (**Attachment 6**). With the source in the OFF position, the measured radiation is substantially less than 100 mrem/hr at 3.7cm. At 5cm it is substantially less than 5 mrem/hr.

QUALITY ASSURANCE AND CONTROL:

There is a quality inspection of all incoming components as well as those manufactured by NDC. An independent check is made by a quality assurance inspector who verifies proper construction of each device using specific tests prior to shipment.

LIMITATIONS AND/OR OTHER CONSIDERATIONS OF USE:

1. These devices shall be distributed to persons specifically or generally licensed by the NRC or Agreement States.
2. Initial first use training and all repairs shall be performed by NDC or by persons specifically licensed to do so by the NRC or Agreement States.
3. Relocation shall be performed by NDC or by persons specifically licensed to do so by the NRC or Agreement States.

REGISTRY OF RADIOACTIVE SEALED SOURCES AND DEVICES
SAFETY EVALUATION OF DEVICE
(AMENDED IN ITS ENTIRETY)

NO.: CA471D105B

DATE: December 22, 1997

PAGE: 5 of 7

DEVICE TYPE: Basis Weight and Thickness Gauge

4. Disposal or transfer shall be only to NDC or to persons specifically licensed by the NRC or Agreement States to dispose of or receive the device.
5. The device shall be tested for proper functioning of the on/off mechanism at intervals of not longer than six months.
6. General licensees are provided with instructions on calibration and shutter manipulation. The requirement of specific licensure for relocation, repair and disposal is emphasized within the "User manual."
7. Specific licensees of these devices are expected to seek authorization for shutter checks, and relocation. Such procedures are provided upon installation by NDC.
8. Generally licensed users are authorized to check the proper functioning of the shutter at intervals not to exceed six months, using instructions provided by the manufacturer. This check must be documented. Generally licensed users are also authorized to change the dust cover using instructions provided by the manufacturer.
9. This registration sheet and the information contained within the references shall not be changed without the written consent of the California Department of Health Services.

SAFETY ANALYSIS SUMMARY:

The distributor has submitted sufficient information to provide reasonable assurance that:

- The device can be safely operated by persons not having training in radiological protection.
- Under ordinary conditions of handling, storage and use of the device, the radioactive material contained in the device will not be released or inadvertently removed from the source housing, and it is unlikely that any person will receive in any period of one year a dose in excess of 10 percent of the limits specified in Section 20.1201(a), 10 CFR Part 20.
- Under accident conditions associated with handling, storage, and use of the source housing, it is unlikely that any person would receive an external radiation dose or dose commitment in excess of the dose to the appropriate organ as specified in the following chart:

REGISTRY OF RADIOACTIVE SEALED SOURCES AND DEVICES
SAFETY EVALUATION OF DEVICE
(AMENDED IN ITS ENTIRETY)

NO.: CA471D105B

DATE: December 22, 1997

PAGE: 6 of 7

DEVICE TYPE: Basis Weight and Thickness Gauge

PART OF BODY

DOSE

Whole body: head and trunk;
active blood-forming organs;
gonads; or lens of eye.

15 rem (0.15 Sv)

Hands and forearms; feet and
ankles; localized areas of skin
averaged over areas no larger
than 1 cm² (0.15 in²)

200 rem (2.0 Sv)

Other organs

50 rem (0.50 Sv)

Based on review of the Model 302 and the information and test data cited below, we continue to conclude that the device is acceptable for licensing purposes.

Furthermore, we continue to conclude that the device would be expected to maintain its containment integrity for normal conditions of use and accidental conditions which might occur during uses specified in this certificate.

REFERENCES:

The following supporting documents for the NDC Systems Model 302 gauge are hereby incorporated by reference and are made part of this registry document:

1. NDC Systems application dated July 28, 1993, with attached drawings and quality control procedures as modified by the letters with attachments dated December 3, 1993.
2. NDC Systems letters (with attachments), dated December 2, 1994 and March 17, 1995.
3. NDC Systems facsimile dated June 23, 1995 and the letters dated August 23, 1995 and December 13, 1996, with attachments thereto.

REGISTRY OF RADIOACTIVE SEALED SOURCES AND DEVICES
SAFETY EVALUATION OF DEVICE
(AMENDED IN ITS ENTIRETY)

NO.: CA471D105B

DATE: December 22, 1997

PAGE: 7 of 7

DEVICE TYPE: Basis Weight and Thickness Gauge

4. NDC Systems letter (with attachment), dated December 3, 1998.
5. NDC Systems facsimile dated December 22, 1998.

ISSUING AGENCY: California Department of Health Services

DATE: December 22, 1998

REVIEWED BY:

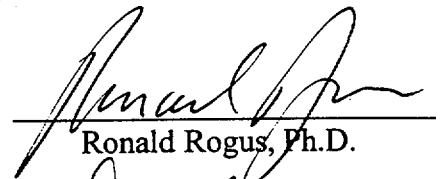
Ronald Rogus, Ph.D.

DATE: December 22, 1998

CONCURRED BY:

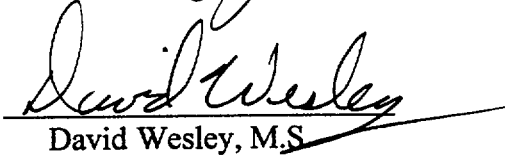
David Wesley, M.S.

REGISTRY OF RADIOACTIVE SEALED SOURCES AND DEVICES
SAFETY EVALUATION OF DEVICE
(AMENDED IN ITS ENTIRETY)

NO.: CA471D105B

DATE: December 22, 1998

ATTACHMENT: 1

DEVICE TYPE: Basis Weight and Thickness Gauge

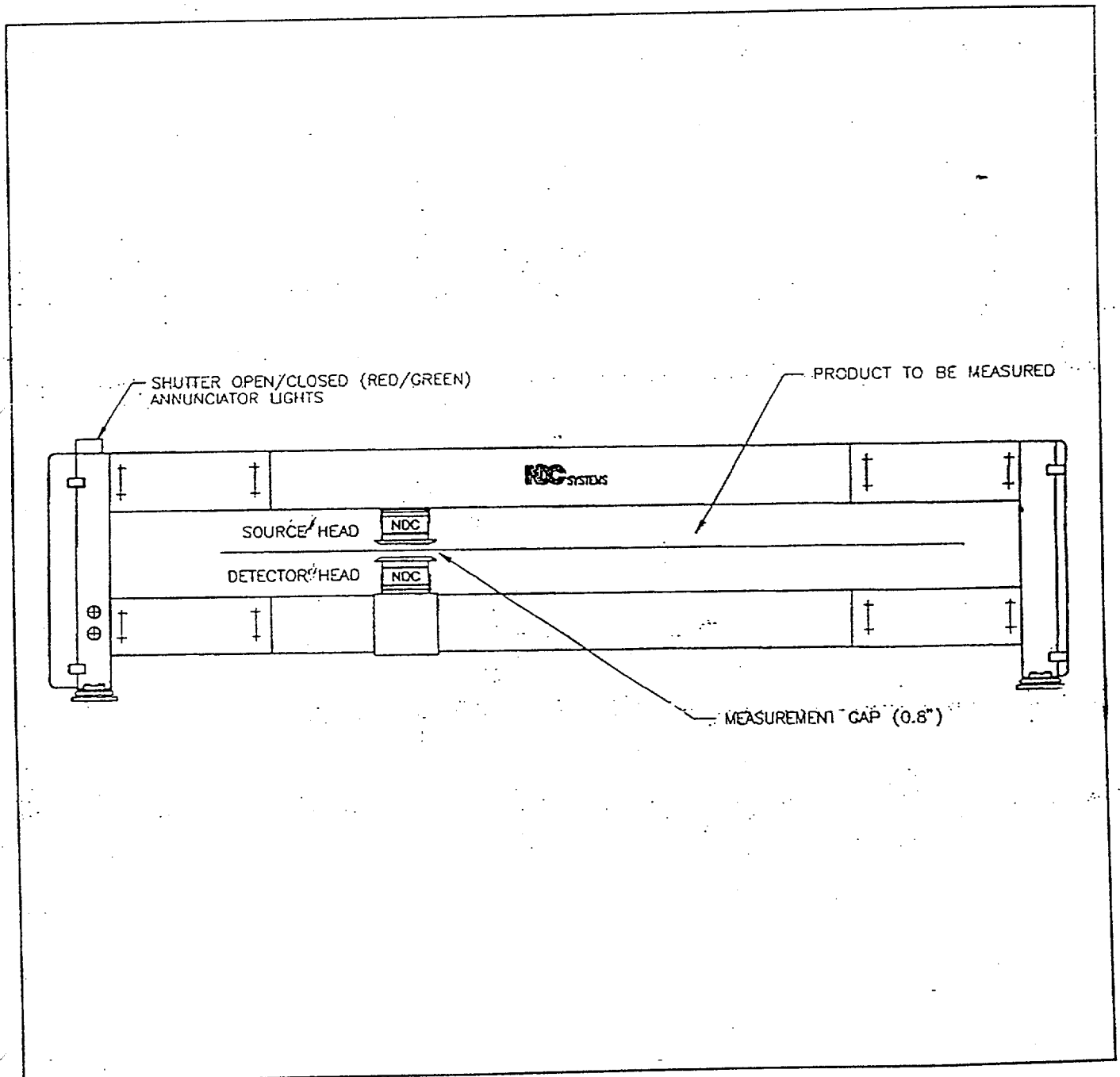

Model 302 Sensor Probe on Traversing Scanner

REGISTRY OF RADIOACTIVE SEALED SOURCES AND DEVICES
SAFETY EVALUATION OF DEVICE
(AMENDED IN ITS ENTIRETY)

NO.: CA471D105B

DATE: December 22, 1998

ATTACHMENT: 2

DEVICE TYPE: Basis Weight and Thickness Gauge

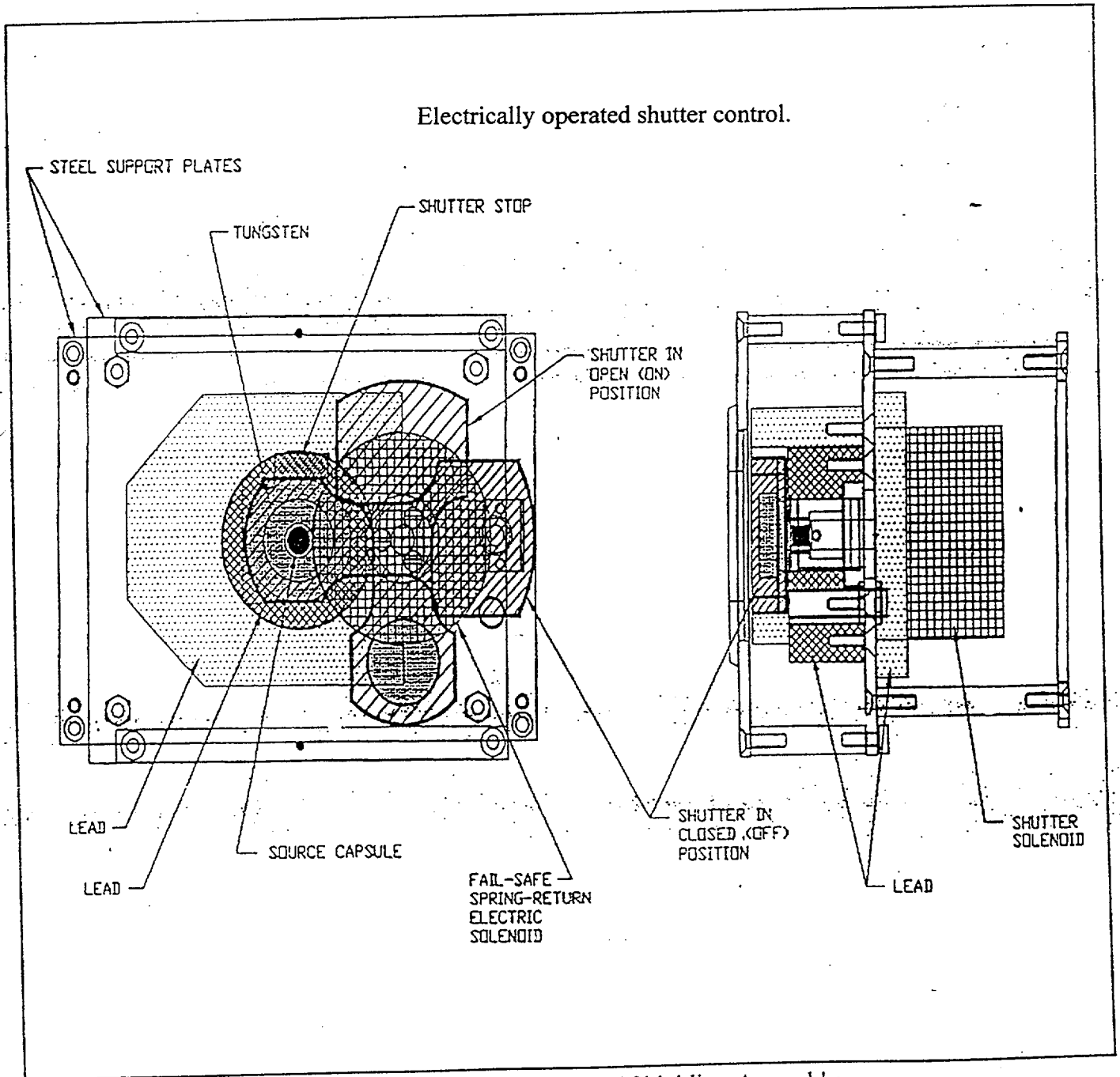

Model 302 Source Holder / Solenoid / Shutter / Shielding Assembly

REGISTRY OF RADIOACTIVE SEALED SOURCES AND DEVICES
SAFETY EVALUATION OF DEVICE
(AMENDED IN ITS ENTIRETY)

NO.: CA471D105B

DATE: December 22, 1998

ATTACHMENT: 3

DEVICE TYPE: Basis Weight and Thickness Gauge

Pneumatically operated shutter control.

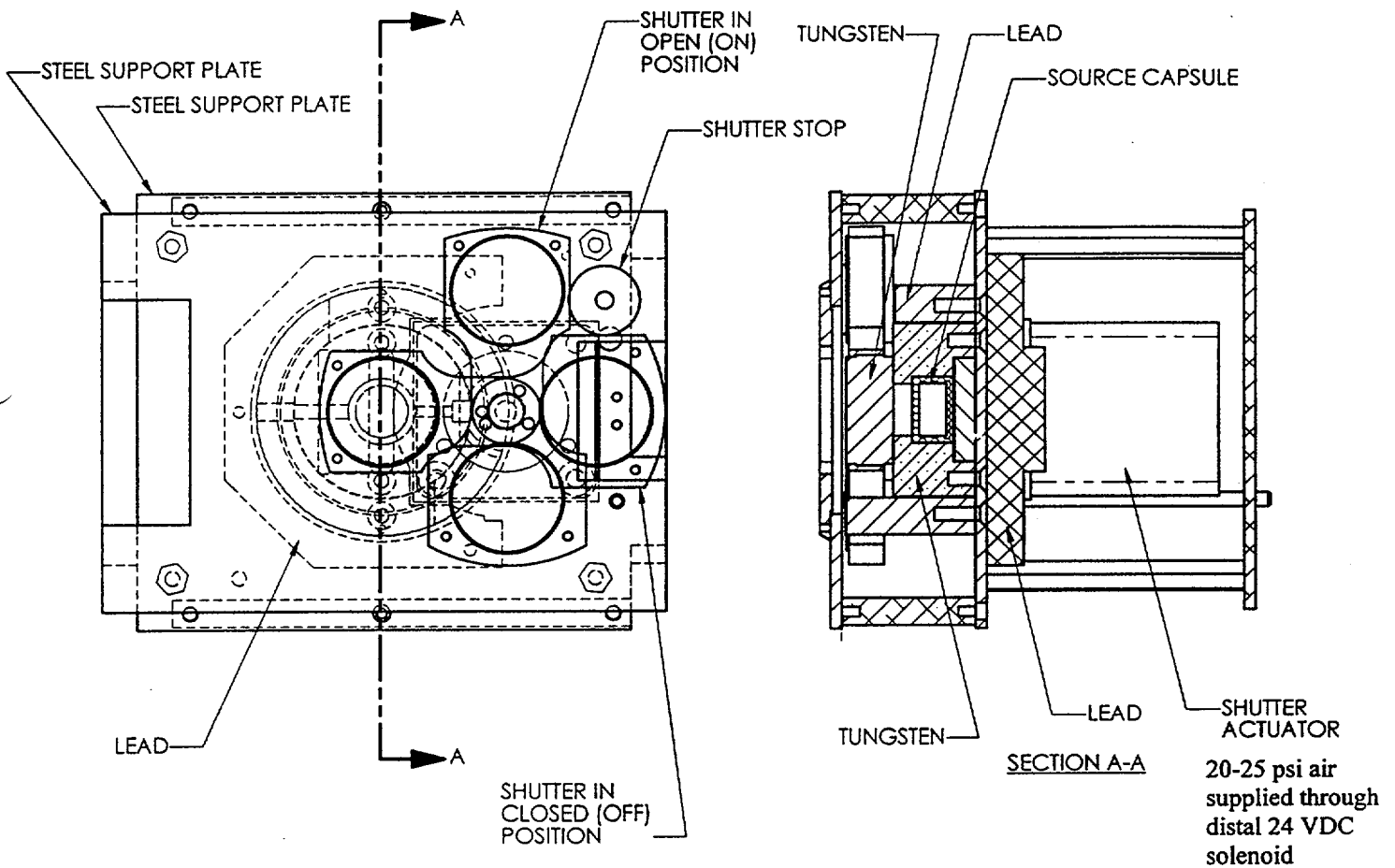

Model 302 Source Holder / Pneumatic actuator / Shutter / Shielding Assembly

**REGISTRY OF RADIOACTIVE SEALED SOURCES AND DEVICES
SAFETY EVALUATION OF DEVICE
(AMENDED IN ITS ENTIRETY)**

NO.: CA471D105B

DATE: December 22, 1998

ATTACHMENT: 4

DEVICE TYPE: Basis Weight and Thickness Gauge

TOP
VIEW

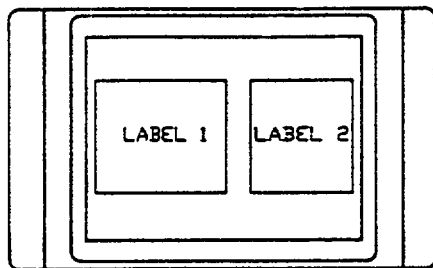

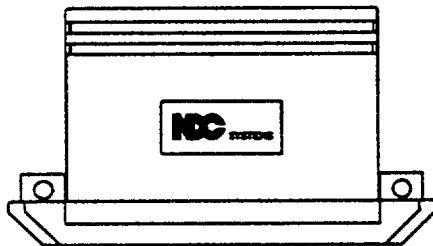

SEE FIGURE 3b
FOR DETAIL OF LABELS

SIDE
VIEW

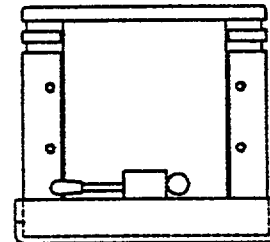

END VIEW



Title		MODEL 302 LABELING	
Author	Drawing No.	 324 S. EVANS AVE. EVANHLE, CALIFORNIA 92946	
Reference	Approved		
Date	Rev.		
	Rev.	REV. 02/98	

REGISTRY OF RADIOACTIVE SEALED SOURCES AND DEVICES
SAFETY EVALUATION OF DEVICE
(AMENDED IN ITS ENTIRETY)

NO.: CA471D105B

DATE: December 22, 1998

ATTACHMENT: 5

DEVICE TYPE: Basis Weight and Thickness Gauge

NDC SYSTEMS - IRWINDALE, CALIFORNIA 91706 - 818-960-3300 - Model 300 Series

The receipt, possession, use and transfer of this device are subject to a general license or equivalent and the regulations of the U.S. NRC or of a state with which the NRC has entered into an agreement for the exercise of regulatory authority.

Operation of this device shall be immediately suspended until any necessary repairs have been made, if there is any indication of possible failure of, or damage to the shielding or containment of radioactive material or to the shutter mechanism or indicator.

This device shall be tested for proper operation of the on-off mechanism and indicator at intervals not to exceed six months. Generally licensed users may perform the shutter check and change the dust cover using instructions provided by the manufacturer in the Radiation Safety Section of the Users Manual.

The sealed radioactive source (Promethium-147 or Strontium-90) contained in this device shall be tested at installation and every six months thereafter for leakage of radioactive material. Krypton-85 does not require this test. Generally licensed users may collect the sample using the instructions provided by the manufacturer in the Radiation Safety Section of the Users Manual. NDC or other specifically licensed persons must perform the test.

Maintenance, tests or other service involving the radioactive material, its shielding and containment shall be performed by persons holding a specific radioactive materials license to provide these services.

Installation, relocation, maintenance, repair and initial radiation survey of this device and leak testing, installation, replacement, and disposal of sealed sources containing radioactive material used in this device shall be performed only by persons holding a specific radioactive material license to provide these services.

This device shall not be transferred, abandoned or disposed of except by transfer to a person holding a specific radioactive material license to receive this device.

Removal of this label is prohibited.

SOLD UNDER CALIFORNIA
GENERAL LICENSE GL-1933-70

Made in USA

1 ARFI 1



CAUTION: RADIOACTIVE
MATERIAL

SOLD UNDER CALIF. GENERAL
LIC. GL-1933-70

NDC SYSTEMS MONROVIA, CA.

MODEL

S/N

SOURCE

STRENGTH

DATE

DO NOT REMOVE LABEL
MADE IN U.S.A.

LABEL 2

Model 302 Labeling

**REGISTRY OF RADIOACTIVE SEALED SOURCES AND DEVICES
SAFETY EVALUATION OF DEVICE
(AMENDED IN ITS ENTIRETY)**

NO.: CA471D105B

DATE: December 22, 1998

ATTACHMENT: 6

DEVICE TYPE: Basis Weight and Thickness Gauge

-1= Dose Rate
(7mg/cm²)
-2= Dose Rate
(300mg/cm²)

mrem

A-1=	.75
A-2=	.75
B-1=	.2
B-2=	.2
C-1=	.1
C-2=	.1
D-1=	71
D-2=	9.7
E-1=	1.8
E-2=	.3
F-1=	.13
F-2=	.1

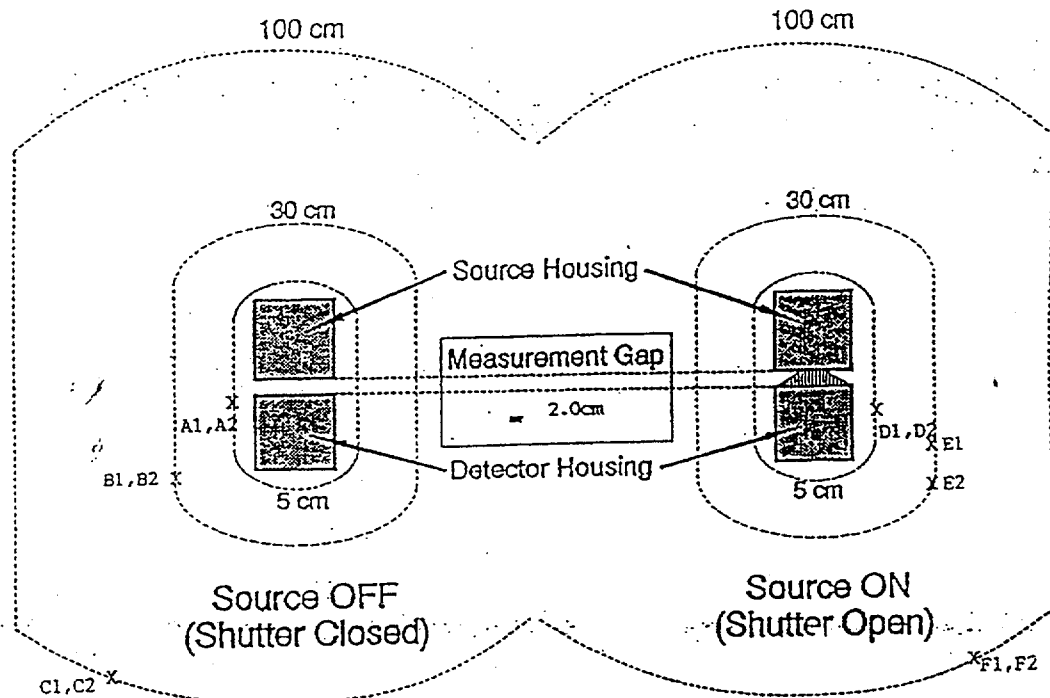

Model No. 302 Serial No. _____ Isotope Kr-85 Activity 200mCi

X = Position of maximum dose rate at specified distance

Radiation Profile Model 302 Shutter Open & Closed