

Document Distribution Manifest  
Controlled Documents - Current

Name: US NRC  
Title: ATTN: DOCUMENT CONTROL DESK  
Company: MONTI LICENSING  
Location: ATTN:DOUG NEVE  
MNGP-SAB/2ND FLOOR  
11 COPIES OF USAR

Manifest Number: 2002-411  
Distribution Type: M  
Holder Number: 195  
ID Number: YYYY09

Date Mailed: \_\_\_\_\_

Distribution Type: ENGINEERING WORK INSTRUCTIONS

Document Type	Document Number	Revision	Dist Cmt	Title
NOTE: Please insert the following issues in your manual, remove and destroy superceded material				
3005	EWI-09.04.01	8		INSERVICE TESTING PROGRAM

Receipt Acknowledgement

Note: All previous issues have been removed and replaced with issues received.

Received by: \_\_\_\_\_ Date: \_\_\_\_\_  
Signature *N/A*

RETURN WITHIN TWO WEEKS TO: DOCUMENT CONTROL, MONTICELLO SITE ADMINISTRATION BUILDING  
2807 West Co. Rd. 75, Monticello, MN 55362

Question? - call Candi Thilquist (763/295-1206)

A1047

**ENGINEERING WORK INSTRUCTION - TABLE OF CONTENTS**

<u>SECTION</u>		<u>PAGE</u>
1.0	INTRODUCTION .....	5
1.1	Relationship with Technical Specifications .....	5
1.2	Qualification of Test Personnel .....	5
1.3	IST Program Component Selection Criteria .....	5
1.4	Component Tables and Figures .....	6
2.0	PUMP INSERVICE TESTING PROGRAM .....	6
3.0	VALVE INSERVICE TESTING PROGRAM .....	7
3.1	Containment Isolation Valves .....	7
3.2	Pressure Isolation Valves .....	7
3.3	CRD Valves .....	7
3.4	Deferred Testing .....	7
3.5	Part-stroke Testing .....	8
3.6	Fail-Safe Actuators .....	8
3.7	Valve Position Indication Verification .....	8
3.8	Passive Valves .....	8
3.9	Stroke Times .....	9
3.10	Solenoid Valves Associated With Power Operated Valves .....	9
4.0	RELIEF REQUESTS .....	9
4.1	Pump Testing Relief Requests .....	9
4.1.1	PR-1 (TEST METHOD) .....	9
4.1.2	PR-3 (INSTRUMENT RANGE) .....	10
4.1.3	PR-6 (HPCI VIBRATION) .....	11
4.1.4	PR-8 (CALCULATING INLET PRESSURE) .....	12
4.1.5	PR-9 (INSTRUMENT RANGE) .....	13
4.2	Valve Testing Relief Requests .....	15
4.2.1	RBCW-1 (EXERCISE EACH REFUELING) .....	15
4.2.2	ESW-1 (TEST CHECK VALVES AS PAIRS) .....	15

REVIEW AND APPROVALS			
Prepared By: <i>[Signature]</i>	Reviewed By: <i>[Signature]</i>		
OC Review Req'd: YES	OC Meeting Number: 2317-DC	Date: 5/30/02	
Approved By: <i>[Signature]</i>	Date: 5/30/02		

FOR ADMINISTRATIVE USE ONLY			
3087 (DOCUMENT CHANGE, HOLD, AND COMMENT FORM) incorporated: 02-1395			
Resp Supv: MIR	Assoc Ref: 4 AWI-09.04.01	SR: Y	Freq: 2 yrs
ARMS: EWI-09.04.01	Doc Type: 3005	Admin Initials: <i>[Signature]</i>	Date: 10/11/05

<b>MONTICELLO NUCLEAR GENERATING PLANT</b>		<b>EWI-09.04.01</b>
<b>TITLE:</b>	<b>INSERVICE TESTING PROGRAM</b>	Revision 8
		Page 2 of 122

**ENGINEERING WORK INSTRUCTION - TABLE OF CONTENTS (CONT'D)**

<u>SECTION</u>		<u>PAGE</u>
4.2.3	SC-1 (DISASSEMBLY TEST OF CHECK VALVE GROUP) ...	16
4.2.4	NB-1 (SRV TESTING) .....	17
4.2.5	REC-1 (EXERCISE EACH REFUELING) .....	18
4.2.6	CRD-1 (TESTING DURING SCRAM TEST) .....	19
4.2.7	CRD-2 (TEST EACH REFUELING) .....	19
4.2.8	RHR-1 (DISASSEMBLY TEST OF CHECK VALVE GROUP) .	20
4.2.9	CS-1 (TEST CHECK VALVES AS PAIR) .....	20
4.2.10	SLC-1 (TEST EACH REFUELING) .....	21
4.2.11	RWCU-1 (TEST EACH REFUELING) .....	21
4.2.12	IA-2 (TEST EACH REFUELING) .....	22
4.2.13	SW-1 (TEST CHECK VALVES AS PAIRS) .....	22
4.2.14	ESW-2 (TEST CHECK VALVES AS PAIRS) .....	23
4.2.15	GR-2 (LRT INCREASED FREQUENCY) .....	23
4.2.16	GR-3 (LRT DURING APP J TEST) .....	24
4.2.17	GR-4 (STROKE TIME ACCEPTANCE BANDS) .....	24
4.2.18	GR-5 (COLD SHUTDOWN TESTING) .....	25
4.2.19	GR-7 (SP TEST LESS THAN 70 PSI) .....	26
4.2.20	RSW-1 (CONTROL VALVE TESTING) .....	27
5.0	DEFERRED TESTING JUSTIFICATIONS .....	29
5.1	Mechanical Vacuum Pump Isol Valves .....	29
5.2	RBCCW Isolation Valves .....	29
5.3	Feedwater Check Valves Backflow Test .....	30
5.4	MSIV Fail Safe Test .....	30
5.5	RECIRC Pump Discharge Valves .....	30
5.6	HPCI and RCIC Testable Check Valves .....	31
5.7	RHR Interlocks .....	32
5.8	HPCI Backflow Tests .....	32
5.9	RCIC Backflow Tests .....	32
5.10	Air to DW .....	33
5.11	PASS XFV Tests .....	33
5.12	Backfill Check Valves .....	34
5.13	XFV Tests .....	34
5.14	Air to DW II .....	34
5.15	Air to T-Ring Seals .....	35

**ENGINEERING WORK INSTRUCTION - TABLE OF CONTENTS (CONT'D)**

<u>SECTION</u>		<u>PAGE</u>
5.16	Air Supply Check Valves .....	35
5.17	RHR Testable Check Valves .....	35
5.18	Core Spray Testable Check Valves .....	36
5.19	Torus to Drywell Vacuum Breakers .....	37
5.20	HPCI-32 and RCIC-41 .....	38
5.21	HPCI-42 and RCIC-37 .....	39
5.22	CST-90 .....	40
6.0	REFERENCES .....	41
7.0	REQUIRED RECORDS .....	42
8.0	FIGURES .....	43
8.1	Main Steam .....	43
8.2	Feedwater .....	44
8.3	Reactor Recirculation .....	45
8.4	Core Spray .....	46
8.5	RHR Loop A .....	47
8.6	RHR Loop B .....	48
8.7	HPCI (Steam) .....	49
8.8	HPCI (Water) .....	50
8.9	RCIC (Steam) .....	51
8.10	RCIC (Water) .....	52
8.11	SBLC .....	53
8.12	Primary Containment Atmospheric Control .....	54
8.13	EDG - ESW .....	55
8.14	ESW .....	56
8.15	RHRSW .....	57
8.16	CRD - HCU .....	58
8.17	CRD-SDV .....	59
8.18	Compressed Air/FPCC .....	60
8.19	RBCCW/CST .....	61
8.20	Liquid Radwaste/RWCU .....	62
8.21	TIP .....	63
8.22	Excess Flow Check Valves .....	64
8.23	CGC, DIV I .....	65
8.24	CGC, DIV II .....	66

<b>MONTICELLO NUCLEAR GENERATING PLANT</b>		<b>EWI-09.04.01</b>
<b>TITLE:</b>	<b>INSERVICE TESTING PROGRAM</b>	Revision 8
		Page 4 of 122

**ENGINEERING WORK INSTRUCTION - TABLE OF CONTENTS (CONT'D)**

<u>SECTION</u>		<u>PAGE</u>
8.25	Primary Containment Sampling .....	67
8.26	Diesel Generator Auxiliaries .....	68
8.27	Mechanical Vac Pump/Recirc Seal Inj .....	69
8.28	Level Inst Backfill / Hard Pipe Vent .....	70
8.29	Safety Grade N2 .....	71
9.0	ATTACHMENTS .....	72
9.1	Pump Testing Table .....	72
9.2	Valve Table Symbols .....	73
9.3	Valve Testing Table .....	76
9.4	Technical Justifications .....	121

<b>MONTICELLO NUCLEAR GENERATING PLANT</b>		EWI-09:04.01
<b>TITLE:</b>	<b>INSERVICE TESTING PROGRAM</b>	Revision 8
		Page 5 of 122

## 1.0 INTRODUCTION

The program applies to the third Ten Year Inservice Inspection Interval beginning May 31, 1992. The program was originally scheduled to end May 31, 2002. Per the allowance granted by ASME Section XI Code and discussion by NUREG-1482, the ending date has been revised to March 8, 2003.

In lieu of Section XI, this program invokes certain ASME OM Code pump and valve testing requirements as allowed by Regulatory Guide 1.147 and 10CFR50.55a(f)(4)(iv). Hereafter in this document, the inservice testing requirements of ASME Section XI and ASME OM will be collectively referred to as "the Code" unless a more specific reference is necessary.

### 1.1 Relationship with Technical Specifications

Monticello will meet all requirements of both the Code and plant Technical Specifications unless there is a specific conflict between the two. In such cases, plant Technical Specifications will govern. Code requirements that cannot be met due to Technical Specification guidance will be identified in relief requests or Technical Specification changes will be prepared.

### 1.2 Qualification of Test Personnel

Personnel performing pump and valve testing per the Code will be qualified in accordance with the Monticello Nuclear Plant Quality Assurance Program. This is in keeping with the requirements of ASME Section XI, as clarified by ASME Code Interpretation XI-1-82-06R.

### 1.3 IST Program Component Selection Criteria

The components selected for this program are limited to Code Class 1, 2, or 3 pumps and valves as stated in 10CFR50.55a. The document that identifies Class 1, 2, and 3 components at Monticello is the Color Coded P&ID Q-List Extension. This document shows components that are Quality Groups A, B and C which correspond Code Classes 1, 2, and 3 respectively. These components are then judged as to whether they meet the Code scope criteria or if they are exempted from testing by the Code.

Component functions that mitigate the consequences of accidents that are beyond single failure criteria (i.e., beyond the design basis) are not included in this program. For example, valve positions that apply exclusively to Emergency Operating Procedure actions are not included as safety positions that must meet Code testing requirements.

<b>MONTICELLO NUCLEAR GENERATING PLANT</b>		EWI-09.04.01
<b>TITLE:</b>	<b>INSERVICE TESTING PROGRAM</b>	Revision 8
		Page 6 of 122

Subcomponents of safety related pumps or equipment are not identified as separate items and will be tested as an integral part of the inservice test. For example, the operational readiness of subcomponents of the HPCI pump, such as the auxiliary oil pump and the turbine driven oil pump, is verified by the satisfactory completion of the HPCI pump's inservice test. Similarly, subcomponents of the emergency diesel generator, such as the jacket water cooling pump and the engine fuel transfer pump, are not included in the IST program because they are considered to be an integral part of the emergency diesel generator and are verified by surveillance testing done on the diesel generator. In addition, such subcomponents are not designed to be individually tested in accordance with Code rules.

Pumps and valves judged important to safety but not considered Class 1, 2 or 3 components are also included in the program. These components are identified by the word "None" in the ASME class column of the pump and valve testing table. Testing of these non-code pumps and valves will be performed in accordance with the Code to the extent practical. Relief requests will not be submitted for non-code pumps and valves if Code requirements cannot be met.

In the NRC's Safety Evaluation dated September 24, 1992, the NRC stated that for the purpose of inspection and enforcement, they view the licensee submittal of the IST Program as a commitment for testing of all pumps and valves included in the program. In this Safety Evaluation, the NRC concurred that relief requests are not required for valves that are non-code class. However, the NRC stated that the licensee should document where Code requirements are impractical and further stated that a missed requirement for a component being tested under the IST Program, but outside the scope of 10CFR50.55a, would be a deviation from a commitment.

Therefore, all non-code components that are not tested in accordance with code requirements but are included in the IST Program should have a technical justification in this document if testing is not conducted in accordance with applicable code requirements.

#### **1.4 Component Tables and Figures**

The components selected for testing are listed in the Tables of Attachments 9.1 and 9.3. This program also provides system figures in Section 8.0 to be used as schematic aides in understanding the pump testing loop and active valve function. These figures are simplified and not controlled drawings, therefore, the P&ID referenced in the tables should be used in lieu of the figures when a detailed understanding of the system is desired.

## **2.0 PUMP INSERVICE TESTING PROGRAM**

The pump test program is conducted in accordance with Part 6 of ASME/ANSI OMa-1988 as allowed by ASME Code Case N-465, except for relief requested under the provisions of 10CFR50.55a. Attachment 9.1 identifies the pump inservice testing performed at Monticello. This table lists each pump required to be tested, each parameter to be measured, and applicable relief requests. These relief requests are included in Section 4.1 of this program.

<b>MONTICELLO NUCLEAR GENERATING PLANT</b>		EWI-09.04.01
<b>TITLE:</b>	<b>INSERVICE TESTING PROGRAM</b>	Revision 8
		Page 7 of 122

### 3.0 VALVE INSERVICE TESTING PROGRAM

The valve test program for Monticello is conducted in accordance with Subsection IWV of Section XI of the 1986 Edition of the ASME Boiler and Pressure Vessel Code, except for relief requested under the provisions of 10CFR50.55a and where all applicable portions of OMA-1988 Part 10 have been invoked. The NRC's Safety Evaluation Report dated September 9, 1994 stated, "... relief is not required for those inservice tests that are conducted in accordance with OM-6 and OM-10, or portions thereof, provided all related requirements are met." This section documents that OM-10 is being used in selected portions of the Monticello IST Program for valve inservice testing.

#### 3.1 **Containment Isolation Valves**

Containment isolation valves (CIV) falling within the scope of the Code are tested in accordance with the Section XI requirements of IWV-3400, Category A, with the exception of the seat leakage tests (IWV-3420). The seat leakage testing performed on these valves meets the intent of Section XI, but the actual test procedures will be conducted in accordance with the 10CFR50, Appendix J, Type C, CIV test program. See relief request GR-3 in Section 4.2.16.

All CIVs have been categorized as A-Active or A-Passive, and will, as a minimum, be leak tested per 10CFR50, Appendix J. Passive valves will in general have no other testing performed.

#### 3.2 **Pressure Isolation Valves**

The purpose of the plant Pressure Isolation Valves (PIVs) is to reduce the possibility of an inter-system LOCA which would occur by pressurizing low pressure systems to pressures exceeding their design limits. These Category A valves will be fully tested per IWV-3420, with the exception of relief requested under GR-2 (see Section 4.2.15).

#### 3.3 **CRD Valves**

The CRD valves included in this program are the scram discharge volume vent and drain valves, the scram inlet and outlet valves, the scram discharge header check valves, the charging water header check valves and the cooling water header check valves. These valves will be functionally tested during the individual rod scram time test required by Technical Specifications to be performed once each operating cycle. An additional test will be performed for the charging water header check valves each refueling.

The cooling water header check valve is also tested by normal control rod motion. Since each partially or fully withdrawn operable control rod is exercised one notch at least once a week in accordance with Technical Specifications, this valve will be tested at least quarterly.

#### 3.4 **Deferred Testing**

Valves that cannot be tested during power operation are identified by reference to a Deferred Testing Justification (DTJ) in Attachment 9.3. They are also generally identified by an FC or FR under "Tests Pfrmd". The deferred testing justifications are contained in Section 5.0 of this program.



<b>MONTICELLO NUCLEAR GENERATING PLANT</b>		EWI-09.04.01
<b>TITLE:</b>	<b>INSERVICE TESTING PROGRAM</b>	Revision 8
		Page 8 of 122

For those deferred to a Cold Shutdown frequency, the test planning should consider tests that were performed during the last Cold Shutdown. This will be accomplished by rotating through the Cold Shutdown tests in accordance with the guidance contained in NUREG 1482 on Cold Shutdown Testing.

### 3.5 Part-stroke Testing

The goal of this program is to perform full-stroke tests of all appropriate valves in order to assess the operational readiness of the valves via evaluation of valve degradation. With the exception of those valves for which specific relief has been requested, all valves will be full stroke tested.

Part-stroke testing of power-operated valves is often not possible, due to valve logic circuitry which only allows full-open or full-closed valve movement. Moreover, the intent of the Code is to assess valve operability through inservice testing; while a part-stroke exercise does provide some measure of confidence in valve operability, it does not provide assurance of valve safety-related function. In addition, a part-stroke of a power-operated valve has the possibility, through human or mechanical error, to cause adverse plant consequences (isolation of cooling water, plant transients, etc.) via an inadvertent full-stroke. Therefore, quarterly part stroke testing of the power-operated valves that are full stroke tested during Cold Shutdowns will not be performed.

Check valves whose safety function is to open will be full-stroked when possible. Since disk position is not always observable, the NRC staff has stated that "verification of the plant's safety analysis flow rate through the check valve would be an adequate demonstration of full-stroke requirement. Any flow rate less than design will be considered part-stroke exercising." Based on this position, check valves within the scope of this test program will be at least part-stroke exercised whenever any flow is passed through the valve. Check valves are full-stroke tested on at least the Code required frequency unless identified by relief request. Check valves for which a full-stroke exercise can not be confirmed, therefore, will be identified by an appropriate relief request.

### 3.6 Fail-Safe Actuators

No special tests will be performed for the valves with fail-safe actuators where normal cycling of the valve by the control switch removes the actuator power source. For these valves, the fail-safe function is tested by normal valve exercise testing. All other fail-safe valves will be tested in accordance with IWV-3415.

### 3.7 Valve Position Indication Verification

Verification of valve position indicator accuracy will be performed in accordance with Section XI IWV-3300 with the exception of those valves for which specific relief has been requested.

### 3.8 Passive Valves

These valves, which have no Code operability testing requirements, are valves in safety-related system which are not required to change position in order to accomplish their required safety-function. Monticello has categorized as

<b>MONTICELLO NUCLEAR GENERATING PLANT</b>		EWI-09.04.01
<b>TITLE:</b>	<b>INSERVICE TESTING PROGRAM</b>	Revision 8
		Page 9 of 122

B-Passive all non-containment isolation valves which are required by procedure to be maintained in their safety-related position. Any valves which are administratively locked-open or locked-closed in their safety-related position are also considered Category B-Passive. Due to the lack of testing requirements, these valves may be excluded from Attachment 9.3.

### 3.9 Stroke Times

Valves with extremely short stroke times (less than 2 seconds) have stroke times of such short duration that comparison of measurements with previous data for specified percentage increases is not indicative of degrading valve performance. With measurement of stroke times to the nearest second per IWV-3413(b), a very small increase in stroke time will result in an extremely large percentage change. Verification that valves meet a specified maximum stroke time of short duration provides adequate assurance of operability.

Also, the comparison of valve stroke times to the previous test results, without any evaluation of overall change in stroke time from initial test data, is not the optimum method of gauging valve performance. Therefore, relief has been obtained (GR-4) from comparing the current valve stroke time with previous stroke time data per IWV-3417 and as an alternative, the current valve stroke time data will be compared with a reference value stroke time taken when the valve is known to be in good condition.

### 3.10 Solenoid Valves Associated With Power Operated Valves

Solenoid valves associated with air or hydraulic operated valves are not identified individually in the IST Program. These solenoid valves are considered to demonstrate their performance as part of the operation of the valve assembly. Stroke time testing of the air or hydraulic operated valve demonstrates the acceptable performance of the associated solenoid valve.

## 4.0 RELIEF REQUESTS

### 4.1 Pump Testing Relief Requests

#### 4.1.1 PR-1 (TEST METHOD)

**System:** Standby Liquid Control (SBLC)

**P&ID:** M-127

**Pumps:** P-203A and P-203B

**Class:** 2

**Function:** To inject liquid poison into the reactor.

**Impractical Test Requirement:** OM-6-4.6.5; Flow Rate Measurement:  
OM-6-5.6; Duration of Tests

<b>MONTICELLO NUCLEAR GENERATING PLANT</b>		EWI-09.04.01
<b>TITLE:</b>	<b>INSERVICE TESTING PROGRAM</b>	Revision 8
		Page 10 of 122

**Basis for Relief:** The positive displacement SBLC pumps are designed to pump a constant flow rate regardless of system resistance. The SBLC system was not designed with a flow meter in the flow loop. The system was designed to be tested using a test tank where the change in level can be measured over time. This test methodology also limits the pump run time based on the size of the test tank. The cost associated with installing a flow meter would be impractical since changes in tank level over time is an accurate way to measure flow. The orifice used by flow meters could also result in an area where sodium pentaborate crystals accumulate and possibly restrict flow.

**Alternative Testing:** Determine pump flow rate by measuring changes in tank level over time. The pump will be started with suction from the condensate storage system and will discharge to the test tank. After approximately two minutes of operation the pump will be stopped and the change in level over the measured time will be converted to flow rate by the following formula:

$$Q(\text{GPM}) = 261.8 \times \Delta L (\text{In}) / \Delta t (\text{Sec})$$

where 261.8 includes tank dimensions and unit conversions

The vibration testing will be performed while recirculating an adequately filled test tank. Therefore, the duration of test code requirements for vibration testing will be met.

**Approval:** Relief granted in SER dated July 6, 1993.

#### 4.1.2 PR-3 (INSTRUMENT RANGE)

**System:** RHR and RHRSW

**P&ID:** M-120, M-121

**Instruments:** FT-10-111A, FT-10-111B, FT-10-97A and FT-10-97B

**Class:** 2 and 3

**Function:** Provides a flow signal to an indicating device.

**Impractical Test Requirement:** OM-6-4.6.1.2(a); Full scale range of each analog instrument **SHALL NOT** be greater than three times the reference value.

**Basis for Relief:** Flow transmitters FT-10-111A, FT-10-111B, FT-10-97A, and FT-10-97B are each designed to indicate flow while two parallel pumps are operating (RHR and RHRSW). During inservice testing, only one pump operates at a time. The resulting reference value of flow for one pump is less than one-third of the instrument's range. Replacing the flow transmitter to meet this requirement would not meet the design intent of providing a flow signal for two pump operation. Installing a second flow transmitter in parallel is impractical and a burden that does not increase the public's safety. These existing transmitters are very reliable. Past calibration records show the typical AS FOUND accuracy is 0.25% of full scale.

<b>MONTICELLO NUCLEAR GENERATING PLANT</b>		EWI-09.04.01
<b>TITLE:</b>	<b>INSERVICE TESTING PROGRAM</b>	Revision 8
		Page 11 of 122

**Alternative Testing:** Use the existing station instruments to measure pump inservice test parameters. Perform a loop check on the flow instrumentation for these systems that verifies the AS FOUND accuracy is within 2% of 3 times the reference value of any RHR or RHRSW pump. This will be done as part of the routine calibration schedule.

**Approval:** Relief granted in SER dated July 6, 1993.

#### 4.1.3 PR-6 (HPCI VIBRATION)

**System:** High Pressure Coolant Injection (HPCI)

**P&ID:** M-124

**Pump:** P-209

**Class:** 2

**Function:** Injects coolant into the reactor vessel independent of AC power.

**Code Test Requirement:** OM-6 Table 3a and paragraph 6.1; Vibration Alert limit of 0.325 in/Sec for the horizontal vibration data points and the resulting increased pump test frequency.

**Basis for Relief:** 10CFR Part 50, Section 50.55a(a) (3) states (in part):

“Proposed alternatives to the requirements of paragraphs (c), (d), (e), (f), and (h) of this section or portions thereof may be used when. . . (ii) Compliance with the specified requirements of this section would result in hardship or unusual difficulty without a compensating increase in the level of quality and safety.”

The HPCI pump consists of a centrifugal main pump, a separate centrifugal booster pump, a speed reducing gear for the booster pump, and a Terry turbine steam driver. All these components are mounted horizontally along the same drive train. Therefore, there are four independently balanced and aligned rotating assemblies that are coupled together. This configuration is significantly different than the typical single pump and electric motor that the OM-6 limits are based on. As a result, the normal (baseline) vibration readings in the horizontal direction on both the booster pump and main pump are approximately 0.325 in/Sec.

Application of a 0.325 in/Sec alert limit would require us to enter accelerated test frequency each time the pump was tested because one or more of these points measured would exceed this limit. Prior to the third ten year interval, the alert limit of 0.325 in/Sec was not a code requirement at Monticello. We have many years of in service test data showing that baseline vibrations at 0.325 in/Sec represent acceptable pump operation and that vibration levels have not trended up. We have also had these vibration levels analyzed by an Engineering Consultant that specializes in vibration analysis. Their analysis shows that this pump can operate at vibration levels up to 0.700 in/Sec.

NPRDS component history was reviewed for this type of pump. No failures attributed to extended hours of pump operation at vibration levels exceeding 0.325 in/Sec were found. The pump manufacturer, Byron-Jackson, also stated that these vibration levels did not require corrective action.

<b>MONTICELLO NUCLEAR GENERATING PLANT</b>		EWI-09.04.01
<b>TITLE:</b>	<b>INSERVICE TESTING PROGRAM</b>	Revision 8
		Page 12 of 122

Implementing the alert limit of 0.325 in/Sec would require us to constantly have the HPCI pump on accelerated test frequency. This would result in a monthly pump inservice test instead of quarterly. The intent of increased test frequency is to closely monitor a pump that is deteriorating from its baseline values. In this case, the pump would be operating at its normal vibration range and no change would be seen. The additional 8 tests a year would require a significant amount of time and resources and only create additional maintenance due to normal wear of the system. Modifications to try and reduce the vibration levels, such as installing new shafts and impellers, are extremely expensive and may not reduce the vibration levels. Therefore, requiring an alert limit of 0.325 in/Sec on the HPCI pump is an extreme hardship without a compensating increase in public safety.

An appropriate alert limit for these vibration data points is 0.500 in/Sec. This is based on previous test history, a review of industry data, the vibration analysis performed, and discussions held with the pump's manufacturer.

**Alternative Testing:** A vibration alert limit of 0.500 in/Sec will be used for the pump horizontal vibration data points. The OM-6 Code's required action limit of 0.700 in/Sec will be adhered to.

**Approval:** Relief granted in SER dated September 9, 1994.

#### 4.1.4 PR-8 (CALCULATING INLET PRESSURE)

**System:** Emergency Service Water, RHR Service Water

**P&ID:** M-811

**Pump:** P-111A-D and P-109A-D

**Class:** 3

**Function:** To provide cooling to safety related equipment; to provide decay heat removal.

**Impractical Test Requirement:** Measuring pump inlet pressure directly.

**Basis for Relief:** These pumps are vertical line shaft pumps submersed in the plant intake basin. By design, there is no inlet to the pump that can provide pressure measurement instrumentation.

**Alternative Testing:** Determine pump inlet pressure by converting the static head of water above the pump inlet to pressure with the following formula:

$$P \text{ (PSI)} = (H \text{ (FT)} - \text{PEL (FT)}) \times 0.433$$

where H is the basin level elevation, and PEL is the pump inlet elevation

The 0.433 factor is based on the density of water at 40°F. The same factor at the design basis temperature of 90°F is 0.431. The difference of 0.002 LB/in<sup>2</sup>-FT is considered negligible.

The basin level elevation will be measured from an instrument that is calibrated per OM-6 requirements.

<b>MONTICELLO NUCLEAR GENERATING PLANT</b>		EWI-09.04.01
<b>TITLE:</b>	<b>INSERVICE TESTING PROGRAM</b>	Revision 8
		Page 13 of 122

**Approval:** In a letter dated July 6, 1993, the NRC stated this relief request was not required. However, this relief request was written in response to a previous NRC SER, dated September 24, 1992, Action Item 5.9. Therefore, this relief request will remain in the program and be considered approved by NRC.

4.1.5 PR-9 (INSTRUMENT RANGE)

**System:** High Pressure Coolant Injection (HPCI) and Reactor Core Isolation Cooling (RCIC)

**P&ID:** M-124 HPCI and M-126 RCIC

**Pumps:** P-209 HPCI and P-207 RCIC

**Class:** 2

**Function:** To inject coolant into the reactor independent of AC power.

**Test Requirement from which Relief is Sought:** OMa-1988 Part 6 paragraph 4.6.1.2(a), analog instrument range **SHALL NOT** exceed 3 times the reference value.

**Basis for Relief:** 10CFR Part 50, Section 50.55a(a)(3) states (in part):

"Proposed alternatives to the requirements of paragraphs (c), (d), (e), (f), (g), and (h) of this section or portions thereof may be used when . . .

- (i) The proposed alternatives would provide an acceptable level of quality and safety, . . ."

Inservice pump testing is performed in accordance OMa-1988 Part 6. The differential pressure for the HPCI and RCIC pumps is determined by subtracting the indicated suction pressure from the indicated discharge pressure. The HPCI pump suction pressure is read in the Control Room from instrument PI-23-116, which is sent a 10 to 50 mAmp signal from local transmitter PT-23-100. The RCIC pump suction pressure is read locally from instrument PI-13-66. The relevant data for the instruments is as follows:

INSTRUMENT	PUMP	RANGE	REFERENCE VALUE	RATIO
PI-23-116	P-209	30" Hg Vacuum to 100 PSI	33.7 PSI	114.7/33.7 = 3.4 (See NOTE 1)
PT-23-100	P-209	10 to 50 mAmps	21.7 mAmps	40/11.7 = 3.4 (See NOTE 2)
PI-13-66	P-207	30" Hg Vacuum to 100 PSI	33.7 PSI	114.7/33.7 = 3.4 (See NOTE 1)

<b>MONTICELLO NUCLEAR GENERATING PLANT</b>		EWI-09.04.01
<b>TITLE:</b>	<b>INSERVICE TESTING PROGRAM</b>	Revision 8
		Page 14 of 122

**NOTE 1:** The vacuum range for the pressure indicators was converted to PSI for determining the ratio. 30" HG Vacuum = 14.7 PSI; thus the RANGE = 100 + 14.7 = 114.7 PSI. The same principle was applied to the reference value (REF VAL). With a reference value of 19 PSI indicated on the instrument, the reference value used for the ratio determination is 19 + 14.7 = 33.7 PSI.

**NOTE 2:** The pressure transmitter has a 10 to 50 mAmp range, or a span of 40 mAmps. The ratio for this instrument must be determined by reducing the reference value to its value on the 40 mAmp span (i.e., 21.7 mAmps equates to 11.7 mAmps on the 40 mAmp span).

The code requires the instrument range to be less than 3 times the test parameter reference value. The 2% code allowable instrument tolerance is then taken from this range requirement. The same instrument calibration tolerance can be applied to these instruments by simply calculating the code required tolerance from the code equivalent range as follows:

INSTRUMENT	REFERENCE VALUE	CODE EQUIVALENT RANGE	2% OF CODE EQUIVALENT RANGE
PI-23-116	33.7 PSI	3 x 33.7 = 101 PSI	± 2 PSI
PT-23-100	21.7 mAmps	3 x 11.7 = 35.1 mAmps	± 0.7 mAmps
PI-13-66	33.7 PSI	3 x 33.7 = 101 PSI	± 2 PSI

The existing instrument calibration tolerances are ± 2 PSI for the pressure indicators and ± 0.8 mAmps for the pressure transmitter. The calibration history for these instruments shows that they easily meet these existing tolerances. Recent calibration records show the instruments' AS FOUND accuracy of 1% or less of the code equivalent range.

Under the provisions of 10CFR50.55a(a)(3), this alternative to the Code requirement is proposed in that the alternative provides an equivalent level of quality and safety. The proposed alternative satisfies the code intent in that the accuracy of the instrumentation to assess the operational readiness of the HPCI and RCIC pumps will be maintained within Code requirements.

**Alternative Testing:** The instruments identified above will be calibrated to 2% of a code equivalent range. The code equivalent range will be calculated by multiplying the test parameter reference value by three. For pressure indicators PI-23-116 and PI-13-66 this will result in a allowable tolerance equal to ± 2 PSI on the output or ± 0.7 mAmps on the input (Note: PI-23-116 may be calibrated by determining the mAmps input signal required to establish a set PSI output).

Pressure transmitter PT-23-100 will be calibrated to ± 0.7 mAmps for the reasons discussed above.

**Approval:** Relief granted in SER dated December 8, 1994.

<b>MONTICELLO NUCLEAR GENERATING PLANT</b>		EWI-09.04.01
<b>TITLE:</b>	<b>INSERVICE TESTING PROGRAM</b>	Revision 8
		Page 15 of 122

## 4.2 Valve Testing Relief Requests

### 4.2.1 RBCW-1 (EXERCISE EACH REFUELING)

**System:** Reactor Building Cooling Water

**Valve:** RBCC-15

**Category:** A, C-1

**Class:** 2

**Function:** System check valve for system penetrating primary containment.

**Impractical Test Requirement:** IWV-3521; Test Frequency - exercise at least once every three months, quarterly.

**Basis for Relief:** This check valve is the inboard primary containment isolation valve for a system considered in service during plant operation. The normally open check valve requires an exercise in the reverse flow direction which can only be verified by leak testing. Primary containment leak testing performed each refueling, i.e., 10 CFR 50 Appendix J; constitutes proper valve exercising. Closing this valve during power operation would result in temperature transients in the equipment it supplies, including Recirc pump seals, possibly resulting in equipment damage. Also, this valve supplies drywell cooling during power operation and cold shutdown. Performing leak testing per Appendix J during Cold Shutdown would require de-inerting, entering containment, and shutdown of drywell cooling for an extended period, causing equipment damage and personnel hazard.

**Alternative Testing:** Exercise valve during refueling (at least once every two years) in conjunction with Appendix J leak testing.

**Approval:** Relief granted SER dated September 24, 1992.

### 4.2.2 ESW-1 (TEST CHECK VALVES AS PAIRS)

**System:** Emergency Service Water

**Valve:** SW-101, SW-102, SW-103, SW-104

**Category:** C-1

**Class:** 3

**Function:** To prevent diversion of ESW flow to non-safety related systems.

**Impractical Test Requirement:** Individual valve closure testing per IWV-3520.

**Basis for Relief:** Each pair of valves, SW-101/SW-102 and SW-103/SW-104, are in series with no test taps installed between them. Safety function is assured if either one of the pair of valves will provide safety function. This means that testing of the pair of valves will verify system safety function.



<b>MONTICELLO NUCLEAR GENERATING PLANT</b>		EWI-09.04.01
<b>TITLE:</b>	<b>INSERVICE TESTING PROGRAM</b>	Revision 8
		Page 16 of 122

**Alternative Testing:** Test each pair of valves, SW-101/SW-102 and SW-103/SW-104 quarterly by back flow testing each pair. If the pair fails a test, corrective action will be taken on both valves.

**Approval:** Relief granted in SER dated September 24, 1992.

4.2.3 SC-1 (DISASSEMBLY TEST OF CHECK VALVE GROUP)

**System:** Condensate Storage Transfer (a.k.a. Service Condensate)

**Valve:** CST-88, CST-92, CST-94

**Category:** C-1

**Class:** 2

**Function:** These are the boundary valves between the safety related RHR pumps discharge piping and the non-safety related service condensate keep fill system.

**Code Test Requirement:** IWV-3520; Full stroke exercise, frequency and method.

**Basis for Relief:** 10CFR50, Section 50.55a(f) (5) & (6) states (in part):

(5) (iii) If the licensee has determined that conformance with certain code requirements is impractical for its facility, the licensee **SHALL** notify the commission . . .

(6) (i) . . . The commission may grant relief and may impose alternative requirements . . . giving due consideration to the burden upon the licensee . . .

These valves have a closed safety position since they prevent diversion of RHR flow into the service condensate system. There are no test taps or instrumentation installed that would allow testing that proves by positive means that the disc moves to the seat on cessation or reversal of flow. Installation of test taps and isolation valves to reverse flow test these valves is a burden.

Generic Letter 89-04 position 2 allows grouping identical valves and testing them by disassembly and inspection on a refuel frequency.

**Alternative Testing:** These valves will be grouped and tested in accordance with Generic Letter 89-04 position 2 as follows:

Group: CST-88, CST-92, CST-94

All these check valves are the same size, type, and manufacturer. They all perform identical functions and have the same fluid through them. CST-92 and CST-94 interface with the A loop RHR discharge piping while CST-88 interfaces with B loop RHR discharge piping. Over the course of a refuel cycle, the valves experience the same service conditions through the same number of RHR system inservice tests and roughly the same RHR loop operating time in shutdown cooling. The valves are all in the same orientation. Therefore, they meet the design and service condition grouping criteria of Generic Letter 89-04, position 2.

<b>MONTICELLO NUCLEAR GENERATING PLANT</b>		EWI-09.04.01
<b>TITLE:</b>	<b>INSERVICE TESTING PROGRAM</b>	Revision 8
		Page 17 of 122

**Approval:** Relief granted in SER dated September 9, 1994.

4.2.4 NB-1 (SRV TESTING)

**System:** Nuclear Boiler/Main Steam

**Valve:** RV-2-71A, RV-2-71B, RV-2-71C, RV-2-71D, RV-2-71E, RV-2-71F, RV-2-71G, RV-2-71H

**Category:** B, C-1

**Class:** 1

**Function:** To provide automatic depressurization or overpressure protection for the reactor coolant pressure boundary.

**Code Test Requirement:** I WV-3410, Valve Exercising Test

**Basis for Relief:** 10CFR50, Section 50.55a(f) (5) & (6) states (in part):

(5) (iii) If the licensee has determined that conformance with certain code requirements is impractical for its facility, the licensee **SHALL** notify the commission . . .

(6) (i) . . . The commission may grant relief and may impose alternative requirements . . . giving due consideration to the burden upon the licensee . . .

In addition, 10CFR Part 50, Section 50.55a(a) (3) states (in part):

"Proposed alternatives to the requirements of paragraphs . . . may be used when . . .

(i) The proposed alternatives would provide an acceptable level of quality and safety, . . ."

These valves have an active, self actuation safety function to open and relieve an overpressurization condition in the reactor vessel. The valves also have an auxiliary actuating device (as defined in OM-1-1981) that acts to open the valves and depressurize the reactor vessel. This function allows low pressure emergency core cooling systems to inject during a LOCA (ADS) and also controls reactor pressure in certain design transients (low low set). The ADS automatic actuation provides for depressurizing the reactor vessel to permit low pressure ECCS system injection during a loss of coolant accident. The low low set automatic actuation provides control of the opening and closing setpoint following a scram during pressurization transients.

Although these valves have an auxiliary actuating device, they can not be treated and tested as category B, power operated valves. The requirements to stroke time them quarterly is not within the design capability of the valves or the plant. First of all, these valves have a passive safety function to remain closed and provide reactor coolant pressure boundary. Exercising them during power operation would cause a severe reactor power and pressure transient that could result in a reactor scram. It also increases the potential for second stage or pilot

<b>MONTICELLO NUCLEAR GENERATING PLANT</b>		<b>EWI-09.04.01</b>
<b>TITLE:</b>	<b>INSERVICE TESTING PROGRAM</b>	Revision 8
		Page 18 of 122

stage leakage due to seat wear or fouling. If this leakage is high enough, it can cause a spurious SRV lift and prevent reclosure of the valve. This condition is equivalent to an unisolable small break LOCA event. The NRC states in several documents that such challenges to the ADS function of the main steam safety/relief valves should be minimized. Therefore, justification to perform an exercise test on a once-per-cycle frequency is well established.

The reason the valves can not be stroke timed is that there is no direct indication of valve position. Their stroke time can only be measured by indirect means such as changes in turbine bypass valve position indication. This results in a high degree of variability in the measured stroke times due to other plant variables such as reactor pressure, turbine bypass valve position, measuring instrumentation response time, etc. This prohibits repeatable test conditions without a heavy burden on the licensee to fix these parameters each time. This burden is not offset by an increase in public safety since it is the consensus of the entire industry that stroke time testing is not a valuable indicator of margin to failure, for any valve.

**Alternative Testing:** These valves will be monitored for degradation by testing them in accordance with all applicable sections of OM-1-1981, including the requirements for auxiliary actuating devices. The valves will also be tested in accordance with Technical Specification 4.6.E which includes disassembly and inspection of at least two SRVs each refueling outage.

All SRVs will be exercised at reduced system pressure, in place, each operating cycle to verify the open and close capability of the valve.

**Approval:** Relief granted in SER dated August 25, 1995.

#### 4.2.5 REC-1 (EXERCISE EACH REFUELING)

**System:** Recirc Loops Pumps and Motors Nuclear Boiler System

**Valve:** XR-27-1, XR-27-2, XR-25-1, XR-25-2

**Category:** A, C-1

**Class:** 2

**Function:** Prevents reversal of flow from recirc seals to the CRD System.

**Impractical Test Requirement:** IWV-3521, Test Frequency - exercise at least once every three months, quarterly.

**Basis for Relief:** These valves are the inlet valves for the lower recirc pump seals. Exercising could result in loss of seal water to lower seals of the Reactor Coolant Recirculation pumps causing plant trip or equipment damage. The reactor coolant recirculation pumps are normally operated during all plant operating conditions except refueling. Testing during Cold Shutdown would require entering containment, de-inerting, and performing testing identical to 10CFR50 Appendix J testing, which contributes to an unnecessary burden on the Licensee with no corresponding increase in plant safety.

<b>MONTICELLO NUCLEAR GENERATING PLANT</b>		EWI-09.04.01
<b>TITLE:</b>	<b>INSERVICE TESTING PROGRAM</b>	Revision 8
		Page 19 of 122

**Alternative Testing:** Exercise the valves closed during refueling, in conjunction with Appendix J leak testing.

**Approval:** Relief granted in SER dated September 24, 1992.

#### 4.2.6 CRD-1 (TESTING DURING SCRAM TEST)

**System:** Control Rod Hydraulic System

**Valve:** CRD-114, CV-126, CV-127

**Category:** C-1, B-1, B-1

**Class:** 2

**Function:** CRD-114; Exhaust scram discharge flow from the CRD during a scram.

CV-126; Provide a scram accumulator pressure to the bottom of the control rod drive piston during a scram.

CV-127; Exhaust scram discharge water from the top of the control rod drive piston during a scram.

**Impractical Test Requirement:** IWV-3411, IWV-3521; Test Frequency - exercise at least once every three months, quarterly.

**Basis for Relief:** The above listed valves are located on each of the 121 hydraulic control units. There is no practical method of testing these valves in accordance with Section XI requirements. Testing these valves during power operation requires rapid insertion of each control rod. This introduces rapid reactivity transients and unreasonable wear of the control rod drive mechanism.

**Alternative Testing:** Proper operation of these valves will be verified by the individual control rod scram time test performed each refueling.

**Approval:** Relief granted in SER dated September 24, 1992.

#### 4.2.7 CRD-2 (TEST EACH REFUELING)

**System:** Control Rod Hydraulic System

**Valve:** CRD-115

**Category:** C-1

**Class:** 2

**Function:** Prevents depressurization of accumulator charges on cessation of flow.

**Impractical Test Requirement:** IWV-3521; Test Frequency - exercise at least once every three months, quarterly.

**Basis for Relief:** The above listed valve is located on each of the 121 hydraulic control units. These valves can be tested to verify proper seating only by doing a special test during cold shutdown/refueling.

<b>MONTICELLO NUCLEAR GENERATING PLANT</b>		<b>EWI-09.04.01</b>
<b>TITLE:</b>	<b>INSERVICE TESTING PROGRAM</b>	Revision 8
		Page 20 of 122

**Alternative Testing:** The test would involve depressurizing the accumulator charging water header and watching for accumulator low pressure alarms. Depressurizing the charging water header would cause a reversal of flow and the ball discs of the CRD-115 valves should move to their seats. If a ball disc did not move to its seat, the associated accumulator would rapidly depressurize and an alarm on low accumulator pressure would be received shortly thereafter. This test will be performed at least once each operating cycle, i.e., refueling.

**Approval:** Relief granted in SER dated September 24, 1992.

#### 4.2.8 RHR-1 (DISASSEMBLY TEST OF CHECK VALVE GROUP)

**System:** Residual Heat Removal

**Valve:** RHR-8-1, RHR-8-2

**Category:** C-1

**Class:** 2

**Function:** Provide minimum flow recirculation from the RHR pumps.

**Impractical Test Requirement:** Full flow test open quarterly per IWV-3520.

**Basis for Relief:** There is no means of measuring flowrate through this valve during quarterly pump testing. Operating the pump with only the minimum flow recirculation line available is not good operating practice, as recommended by the NRC for pump protection. This means there is no normal test method to examine these valves condition except disassembly.

**Alternative Testing:** These valves have been disassembled and manually exercised with no discernible degradation detected. Based on the results of these inspections, one valve will be inspected each refueling outage alternating between the valves. If degradation is detected, repairs will be made and the remaining valve **SHALL** also be inspected.

**Approval:** Relief granted in SER dated September 24, 1992.

#### 4.2.9 CS-1 (TEST CHECK VALVES AS PAIR)

**System:** Core Spray

**Valve:** CST-103-1, CST-104-1

**Category:** C-1

**Class:** 2

**Function:** To prevent diversion of core spray flow to condensate storage system.

**Impractical Test Requirement:** Individual valve closure testing per IWV-3520.

<b>MONTICELLO NUCLEAR GENERATING PLANT</b>		EWI-09.04.01
<b>TITLE:</b>	<b>INSERVICE TESTING PROGRAM</b>	Revision 8
		Page 21 of 122

**Basis for Relief:** Valves CST-103-1 and CST-104-1 are in series with no test taps installed between them. Safety function is assured if either one of the valves will provide safety function. This means that testing of the pair of valves will verify system safety function.

**Alternative Testing:** Test the pair of valves, CST-103-1 and CST-104-1, quarterly by back flow testing the pair. If the pair fails a test, corrective action will be taken on both valves.

**Approval:** Relief granted in SER dated September 24, 1992.

#### 4.2.10 SLC-1 (TEST EACH REFUELING)

**System:** Standby Liquid Control System

**Valve:** XP-6, XP-7

**Category:** A, C-1

**Class:** 1

**Function:** Standby Liquid Control Injection Check Valves

**Impractical Test Requirement:** IWV-3521; Test Frequency - exercise at least once every three months, quarterly.

**Basis for Relief:** To verify forward flow operability during normal operation would require firing a squib valve and injecting water into the reactor vessel using the SLC pumps. This is impractical due to the extensive maintenance and cost required to replace squib valves. The SLC system would also be inoperable while changing the squib valves.

**Alternative Testing:** Verify forward flow operability during refueling while performing the standby liquid control system injection test, which pumps demineralized water into the reactor vessel. Reverse flow testing will be performed during Appendix J leak rate testing.

**Approval:** Relief granted in SER dated September 24, 1992.

#### 4.2.11 RWCU-1 (TEST EACH REFUELING)

**System:** Reactor Water Cleanup

**Valve:** RC-6-1, RC-6-2

**Category:** C-1

**Class:** 2

**Function:** Prevent flow diversion from HPCI/RCIC injection.

**Impractical Test Requirement:** Full stroke quarterly per IWV-3520.

<b>MONTICELLO NUCLEAR GENERATING PLANT</b>		EWI-09.04.01
<b>TITLE:</b>	<b>INSERVICE TESTING PROGRAM</b>	Revision 8
		Page 22 of 122

**Basis for Relief:** Closure testing these valves requires testing identical to Local Leak Rate Testing. Closing these valves interrupts RWCU flow, which is required in all modes except refueling to maintain water chemistry and reduce radioactivity. Closure testing would require an extended period of inoperability of the primary feedwater system, as well as HPCI/RCIC during power operation. In Cold Shutdown, RWCU operates to reduce reactor coolant system contamination.

**Alternative Testing:** Verify closure at refueling by performance of back flow testing.

**Approval:** Relief granted in SER dated September 24, 1992.

#### 4.2.12 IA-2 (TEST EACH REFUELING)

**System:** Instrument Air - Reactor Building

**Valve:** AI-626-1 and AI-625

**Category:** A, C-1

**Class:** 2

**Function:** Prevent reversal of flow in TIP purge line.

**Impractical Test Requirement:** IWV-3521; Test Frequency - exercise at least once every three months, quarterly.

**Basis for Relief:** Check valves AI-626-1 and AI-625 are normally open check valves that are in service during all modes of operation. In addition, there is no practical means available to verify their discs travels promptly to the seat on cessation or reversal of flow.

**Alternative Testing:** Exercise valve by performance of 10CFR50 Appendix J leak testing during refueling.

**Approval:** Relief granted in SER dated September 24, 1992.

#### 4.2.13 SW-1 (TEST CHECK VALVES AS PAIRS)

**System:** RHR Service Water Systems and Makeup Intake Structure

**Valve:** SW-21-1, SW-22-1; SW-21-2, SW-22-2

**Category:** C-1

**Class:** 3

**Function:** Prevents reversal of RHRSW flow into the service water system.

**Impractical Test Requirement:** Individual valve closure testing per IWV-3520.

<b>MONTICELLO NUCLEAR GENERATING PLANT</b>		EWI-09:04.01
<b>TITLE:</b>	<b>INSERVICE TESTING PROGRAM</b>	Revision 8
		Page 23 of 122

**Basis for Relief:** Each pair of valves, SW-21-1/SW-22-1 and SW-21-2/SW-22-2, are in series with no test taps installed between them. Safety function is assured if either one of the pair of valves will provide safety function. This means that testing of the pair of valves will verify system safety function.

**Alternative Testing:** Test each pair of valves, SW-21-1/SW-22-1 and SW-21-2/SW-22-2, quarterly by back flow testing each pair. If the pair fails a test, corrective action will be taken on both valves.

**Approval:** Relief granted in SER dated September 24, 1992.

4.2.14 ESW-2 (TEST CHECK VALVES AS PAIRS)

- System:** Service Water Systems and Makeup Intake Structure
- Valve:** SW-15, SW-16; SW-17, SW-18; ESW-13, ESW-14; ESW-15, ESW-16
- Category:** C-1
- Class:** 3
- Function:** Prevents reversal of flow from emergency water system into the service water system.

**Impractical Test Requirement:** Individual valve closure testing per IWV-3520.

**Basis for Relief:** Each pair of valves are in series with no test taps installed between them. Safety function is assured if either one of the pair of valves will provide safety function. This means that testing of the pair of valves will verify system safety function.

**Alternative Testing:** Test each pair of valves quarterly by back flow testing each pair. If the pair fails a test, corrective action will be taken on both valves.

**Approval:** Relief granted in SER dated September 24, 1992.

4.2.15 GR-2 (LRT INCREASED FREQUENCY)

- System:** Various
- Valve:** Various
- Category:** A and AC pressure isolation valves (PIV)
- Class:** As applicable
- Function:** Various

**Impractical Test Requirement:** IWV-3427(b); Trending and Corrective action for leakage rates for valves 6 inch nominal pipe size and larger.



<b>MONTICELLO NUCLEAR GENERATING PLANT</b>		EWI-09.04.01
<b>TITLE:</b>	<b>INSERVICE TESTING PROGRAM</b>	Revision 8
		Page 24 of 122

**Basis for Relief:** These valves are located inside containment or inside radiation areas during operation and testing on an increased frequency would increase radiation exposure for testing personnel. Testing is now being performed during refueling to minimize exposure. With increased frequency, operational constraints would be placed upon the plant during cold shutdown. Monticello Nuclear Plant feels that the leakage rates for valves 6 in. and larger do not show enough consistency in the level of degradation prior to reaching the maximum leakage limit to justify maintaining these additional corrective action and trending requirements. This is in keeping with the NRC approved OM-10 code on Inservice Testing of Valves, which does not require trending of leakage rates.

**Alternative Testing:** Test in accordance with OMA-1988 part 10 paragraph 4.2.2.

**Approval:** Relief granted in SER dated September 24, 1992.

#### 4.2.16 GR-3 (LRT DURING APP J TEST)

**System:** Various

**Valve:** Various

**Category:** All those identified category A or A/C containment isolation valves in the valve testing tables.

**Class:** As Applicable

**Function:** Various

**Impractical Test Requirement:** IWV-3421 through 3425 regarding leak rate test methodology, and IWV-3427(b).

**Basis for Relief:** In keeping with NRC Staff position, all CIV testing **SHALL** be performed under 10CFR50 Appendix J in addition to IWV-3426 and IWV-3427(a) of Section XI. Testing per 10CFR50 Appendix J meets the intent of leak rate testing per Section XI, but will be controlled via the Local Leak Rate Testing Program.

**Alternative Testing:** Monticello **SHALL** test all CIVs under the requirements of 10CFR50 Appendix J, in addition to IWV-3426 and IWV-3427(a) of Section XI.

**Approval:** Relief granted in SER dated September 24, 1992.

#### 4.2.17 GR-4 (STROKE TIME ACCEPTANCE BANDS)

**System:** Various

**Valve:** Various

**Category:** A, B

**Class:** Various

**Function:** Various

**Impractical Test Requirement:** IWV-3413; Power Operated Valves, IWV-3417; Corrective Action

**Basis for Relief:** Generic Letter 89-04 Position 6 recognizes that measuring changes in stroke times from a reference value as opposed to measuring changes from the previous test is a better way to detect valve degradation. Generic Letter 89-04 Position 5 and OMa-1988, Part 10 provide NRC approved methodology for establishing a stroke time reference value, an acceptable stroke time band, and a limiting stroke time value. The alternative testing is in accordance with this methodology.

**Alternative Testing:** The power operated valve testing will be performed in accordance with OMa-1988, Part 10, paragraphs 4.2.1.4, 4.2.1.8, and 4.2.1.9. The acceptable band and Limiting Stroke Time (LST) will be determined as follows (RV time in Sec):

<u>Operator Type</u>	<u>Ref Value</u>	<u>Acc Band</u>	<u>LST</u>
Motor	RV > 10	0.85RV - 1.15RV	1.3RV
	$2 \leq RV \leq 10$	0.75RV - 1.25RV	1.5RV
Other	RV > 10	0.75RV - 1.25RV	1.5RV
	$2 \leq RV \leq 10$	0.50RV - 1.50RV	2.0RV
All	RV < 2	$\leq 2$	2

In addition, if a more restrictive value of stroke time exists in the Technical Specifications or the Updated Safety Analysis Report, it will be used as the LST instead of the value calculated above.

**Approval:** Relief granted in SER dated September 24, 1992.

#### 4.2.18 GR-5 (COLD SHUTDOWN TESTING)

**System:** See Valve Testing Table

**Valve:** See Valve Testing Table

**Category:** Various

**Class:** Various

**Function:** Various

**Impractical Test Requirement:** IWV-3412; Complete all cold shutdown frequency exercise testing prior to plant startup.

**Basis for Relief:** IWV-3412 has no allowance to startup the plant prior to completing the cold shutdown frequency exercise testing. The NRC approved OM-10 code on valve testing states that it is not the intent of the Code to keep the plant in cold shutdown in order to complete cold shutdown testing and it allows valve exercising to be deferred to refueling outages if quarterly and cold shutdown testing is not practical. Monticello has changed the frequency of many check valve exercise tests from refueling to cold shutdown in response to the Technical Evaluation Report comments in this program's SER dated September 24, 1992. This makes a large number of reverse

<b>MONTICELLO NUCLEAR GENERATING PLANT</b>		EWI-09.04.01
<b>TITLE:</b>	<b>INSERVICE TESTING PROGRAM</b>	Revision 8
		Page 26 of 122

flow check valve tests which are quite labor and time intensive required at cold shutdown. Requiring that all cold shutdown tests be completed prior to startup is impractical and a burden especially for unplanned and short outages.

**Alternative Testing:** Cold shutdown valve exercising for unplanned or forced outages, **SHALL** commence not later than 48 hours after cold shutdown is achieved. All valve testing does not have to be completed prior to subsequent plant startup. For extended outages, including refueling, where all required testing can be completed, exception to the above start time may be taken. However, during these extended outages, all cold shutdown frequency testing will be completed prior to plant startup.

In the event cold shutdown doesn't require specific de-inerting of containment, those valves requiring containment access for cold shutdown testing will be deferred until the next cold shutdown that provides containment access.

**Approval:** Relief granted in SER dated September 9, 1994.

#### 4.2.19 GR-7 (SP TEST LESS THAN 70 PSI)

**System:** Various

**Valve:** Various Relief Valves

**Category:** C

**Class:** Various

**Function:** To provide overpressure protection at 70 PSI or less.

**Impractical Test Requirement:** IWV-3512, Test Procedure and OM-1-1981 paragraphs 1.3.3.1.5(b) and 1.3.4.1.5(b), Valves Not Meeting Acceptance Criteria

**Basis for Relief:** OM-1-1981 requires that if a relief valve exceeds its stamped set pressure by 3% or greater, then the valve requires corrective action. This requirement is unnecessarily restrictive for valves with a set pressure of 70 PSI or less as it is smaller than the design and construction tolerances. The ASME Boiler and Pressure Vessel Code, Section III, specifies a tolerance of plus or minus 2 PSI for the design and operation of overpressure protection safety valves with a setpoint up to 70 PSI. Applying a 2 PSI tolerance for periodic testing of relief valves with a setpoint up to and including 70 PSI is within the requirements of Section III of the Code and is of no threat to the pressure boundary of power piping designed to nuclear quality standards.

**Alternative Testing:** For relief valves with a setpoint less than or equal to 70 PSI, the setpoint acceptance criteria will be  $\pm 2$  PSI. For relief valves with setpoints greater than 70 PSI, the setpoint acceptance criteria will not exceed 3% of the stamped set pressure. If a more restrictive acceptance band is required by the system design or license basis, then that criteria **SHALL** govern.

**Approval:** Relief granted in SER dated October 25, 1993.

<b>MONTICELLO NUCLEAR GENERATING PLANT</b>		EWI-09.04.01
<b>TITLE:</b>	<b>INSERVICE TESTING PROGRAM</b>	Revision 8
		Page 27 of 122

#### 4.2.20 RSW-1 (CONTROL VALVE TESTING)

**System:** Residual Heat Removal Service Water (RHRSW)

**Valve:** CV-1728 and CV-1729

**Category:** B-1

**Class:** 3

**Function:** To open, providing a flow path for RHRSW through the RHR heat exchanger.

#### **Test Requirement from which Relief is Sought:**

Section XI, paragraph IWV-3413,

- (a) The limiting value of Full-stroke time of each power operated valve **SHALL** be specified by the Owner. Full-stroke time is that time interval from initiation of the actuating signal to the end of the actuating cycle.
- (b) The stroke time of all power operated valves **SHALL** be measured to the nearest second. . . whenever such a valve is full-stroke tested.

Section XI, Paragraph IWV-3417,

- (a) If, for power operated valves, an increase in stroke time of 25% or more from the previous test, ... test frequency **SHALL** be increased to once each month until corrective action is taken....

#### **Basis for Relief:**

10CFR Part 50, Section 50.55a(f) (5) and (6) states, (in part):

(5)(iii) If the licensee has determined that conformance with certain code requirements is impractical for its facility, the licensee **SHALL** notify the commission....

(6)(i) ... The commission may grant relief and may impose alternative requirements ... giving due consideration to the burden upon the licensee....

In addition, 10CFR Part 50, Section 50.55a(a)(3) states (in part):

"Proposed alternatives to the requirements of paragraphs ... may be used when...

(i) The proposed alternatives would provide an acceptable level of quality and safety,..."

<b>MONTICELLO NUCLEAR GENERATING PLANT</b>		EWI-09.04.01
<b>TITLE:</b>	<b>INSERVICE TESTING PROGRAM</b>	Revision 8
		Page 28 of 122

IWV-3413 requires that a limiting value of full stroke time be established for a power operated valve and that the stroke time be measured whenever such a valve is full stroke tested. Performing full stroke time testing of these valves is impractical based on the control scheme design of the valves, adverse plant impact, and the functional requirements of the valves.

IWV-3413 states that full stroke time is that time interval from initiation of the actuating signal to the end of the actuating cycle. The control scheme design of these valves does not receive an actuation signal (neither by manual handswitch nor by automatic logic) to stroke to the position required to fulfill their safety function. RHRSW valves CV-1728 and CV-1729 are air operated control valves on the outlet line of the RHRSW side of the "A" and "B" RHR heat exchangers, respectively. These control valves maintain a differential pressure between the RHRSW process stream and the RHR process stream during RHRSW system operation. The valves are controlled by a positioner, controlled by a differential pressure indicating controller (DPIC). The DPIC senses pressure on the RHRSW discharge line and the RHR inlet line to the RHR heat exchanger. The desired differential pressure control point, and thus the desired valve position for system flow, is manually set by the operator by manual adjustment of the DPIC setpoint. The valve positioner positions the valve and modulates the valve position as necessary to maintain this control point. Stroke time testing of these valves on quarterly basis is not consistent with the design of the valve's control scheme and is not in the interest of plant safety.

These valves are interlocked to receive a closed signal when the Residual Heat Removal Service Water (RHRSW) pumps are de-energized. This interlock is provided to ensure that system water inventory is not lost during system shutdown. Stroke time testing of valves CV-1728 and CV-1729 when the Residual Heat Removal Service Water pumps are de-energized would result in the loss of liquid fill for a significant portion of the RHRSW system as well as require the bypassing of an interlock designed to minimize the potential for water hammer. Such testing increases the possibility of an adverse water hammer during startup of the RHRSW system as well as requires filling and venting of the system following the stroke time testing. In addition to the adverse impact on plant operation, such testing results in an undesirable burden on plant resources via the expenditure of person-hours and person-rem to perform system filling and venting.

Stroke time testing of the valves during RHRSW pump operation negates the loss of system fill concern; however, this testing would also have an adverse impact on plant safety and equipment integrity. Stroke time testing during pump operation would require the valve be initially in the closed position during pump operation. Establishing the initial test conditions of a closed valve during pump operation would result in an undesirable deadheading of the pump. Subsequent opening of the valve to perform stroke time testing will result in pump runout if a single RHRSW pump is in operation, an undesirable condition which adversely impacts pump integrity and performance. The pump runout concern can be addressed by stroke timing the valve open during operation of both RHRSW pumps; however, this exacerbates the pump deadheading concerns and would result in undesirable transients on the system.

<b>MONTICELLO NUCLEAR GENERATING PLANT</b>		EWI-09.04.01
<b>TITLE:</b>	<b>INSERVICE TESTING PROGRAM</b>	Revision 8
		Page 29 of 122

Proper stroke time testing would require the plant to modify the control logic of the valves. This hardship is not offset by an increase in public safety. In addition, the application of stroke time testing requirements to control valves has recently become an issue with the OM code committee and is subject to change and/or clarification. The proposed alternative testing is an effective means to ensure the valves perform their safety function and is consistent with other valve category test requirements, such as check valve exercising.

**Alternative Testing:**

IWV-3412 provides for demonstrating the necessary valve disk movement by observing indirect evidence (such as changes in system pressure, flow rate, level, or temperature), which reflect stem or disk position. The most representative test of the capability of valves CV-1728 and CV-1729 to perform their intended function is performed during inservice testing of the RHRSW pumps. Quarterly testing of the RHRSW pumps verifies the capability of the valves to operate properly to pass the maximum required accident flow as well as the valve position necessary to achieve required flow conditions. Testing of the valves in this manner demonstrates valve performance capability and provides a means to monitor for valve degradation.

**Approval:** Relief granted in SER dated August 25, 1995.

**5.0 DEFERRED TESTING JUSTIFICATIONS**

**5.1 Mechanical Vacuum Pump Isol Valves**

**System:** Steam Jet Air Ejectors

**P&ID:** M-104, SH-2

**Valves:** AO-1825A, AO-1825B

**Justification:** These valves are not required to be inservice tested by 10CFR50.55a. They are normally closed during power operation and have a closed safety position. To cycle and stroke time the valves, the mechanical vacuum pump must be started and stopped. Plant operating procedures prohibit operation of the mechanical vacuum pump above 5% power for safety reasons, therefore, the valves will be tested on a cold shutdown frequency.

**5.2 RBCCW Isolation Valves**

**System:** Reactor Building Cooling Water System

**P&ID:** M-111

**Valves:** MO-1426, MO-4229, MO-4230

**Justification:** These valves are normally open to supply cooling water to critical drywell components such as recirculation pump seals and the drywell coolers. They have a closed safety position as primary containment isolation valves. Full stroke testing these valves interrupts cooling flow to the Drywell and the system is non-redundant. Therefore, cycling these valves risks losing cooling to the Drywell

<b>MONTICELLO NUCLEAR GENERATING PLANT</b>		<b>EWI-09.04.01</b>
<b>TITLE:</b>	<b>INSERVICE TESTING PROGRAM</b>	Revision 8
		Page 30 of 122

which will result in equipment damage and plant shutdown due to high Drywell pressure or temperature. The valves will be tested on a cold shutdown frequency.

### 5.3 Feedwater Check Valves Backflow Test

**System:** Feedwater

**P&ID:** M-115

**Valves:** FW-91-1, FW-91-2, FW-94-1, FW-94-2, FW-97-1, FW-97-2

**Justification:** These valves are open during power operation as feedwater injection check valves. FW-97-1, 2 and FW-94-1, 2 have an open safety position because they are in the HPCI or RCIC injection flow path. They have a closed safety position as containment isolation valves. These valves are verified open quarterly as part of normal plant operation. The only method of cycling these valves closed is to perform a reverse flow test. That requires isolating and venting the system and installing temporary bypasses (hoses, gages, etc). This cannot be performed without shutting down the plant and entering the Drywell. Therefore, the closed position of these valves will be tested on a cold shutdown frequency.

FW-91-1, 2 have a closed safety position to prevent the diversion of HPCI or RCIC injection away from the vessel. The only method of cycling these valves closed is to perform a reverse flow test. That requires isolating and venting the system and installing temporary bypasses (hoses, gages, etc). This cannot be performed without shutting down the plant and entering the Drywell. Therefore, these valves will be tested on a cold shutdown frequency.

### 5.4 MSIV Fail Safe Test

**System:** Main Steam

**P&ID:** M-115

**Valves:** AO-2-80A through D

**Justification:** These valves have a closed safety position as primary containment isolation valves. They have a safety related air supply that acts to open and close them. The valves also have a spring to assist them closed. The safety related air supply and springs are taken credit for closing the valves in accident analyses. Since the fail safe function of the valve spring is not independently tested during the quarterly exercise test, a special test to vent the air supply and locally monitor valve stem movement is required. This test cannot be done during power operation since the valves are located inside the Drywell which is not accessible during power operations. The fail safe test of these valves will be performed on a cold shutdown frequency.

### 5.5 RECIRC Pump Discharge Valves

**System:** Recirc Loops Nuclear Boiler

**P&ID:** M-117-1

**Valves:** MO-2-53A, MO-2-53B

<b>MONTICELLO NUCLEAR GENERATING PLANT</b>		EWI-09.04.01
<b>TITLE:</b>	<b>INSERVICE TESTING PROGRAM</b>	Revision 8
		Page 31 of 122

**Justification:** These are the reactor recirculation pump discharge valves which are normally open during power operation to allow reactivity control using the recirculation pumps. Their safety position is closed to direct LPCI flow into the reactor. The valves cannot be cycled during power operation without securing the associated pump and severely interrupting core flow. This can cause equipment damage and also results in severe changes in power level which can cause plant shutdown. The valves will be tested on a cold shutdown frequency.

### 5.6 HPCI and RCIC Testable Check Valves

**System:** High Pressure Core Injection (HPCI) and Reactor Core Isolation Cooling (RCIC)

**P&ID:** M-124 (HPCI), M-126 (RCIC)

**Valves:** AO-23-18, HPCI Injection Testable Check Valve  
AO-13-22, RCIC Injection Testable Check Valve

**Category:** A/C-1

**Class:** 1

**Function:** The HPCI and RCIC check valves permit a high-pressure injection flow from either the Condensate Storage Tank or Suppression Chamber when the applicable pump discharge pressure is above reactor pressure.

**Code Test Requirement:** ASME Section XI, 1986 Edition, IWV 3522 and Part 10 (OM-10) of ASME/ANSI OMA-1988, paragraph 4.3.2.1, require these check valves be full stroke exercised on a quarterly basis. Using the requirements of OM-10, as permitted by Monticello Nuclear Generating Plant Safety Evaluation Report, TAC Nos. M88972 and M82638, dated September 9, 1994, full stroke exercising may be demonstrated either by using full flow, by use of a manual mechanical exerciser or by disassembly and inspection. OM-10 specifies acceptable alternatives by which the testing may be performed and the frequency for performing the full stroke exercise test if it cannot be performed quarterly. The test is intended to demonstrate that the valve obturator moves during exercising to its position required to fulfill its function. If full stroke exercising cannot be performed on a quarterly basis due to plant operation, system configuration or other similar impracticalities, then an Owner may defer testing to either a Cold Shutdown or a Refueling Outage frequency. Specific written relief is not required, rather the deferred testing justification becomes part of the IST Program available for review by the regulatory authorities.

**Alternate Test Method:** To satisfy the full flow exercising requirement and as permitted per OM-10, 4.3.2.4(d), the check valves will be disassembled and inspected on a Refueling Outage frequency.

**Justification:** The HPCI and RCIC pumps are turbine driven using reactor steam and thus can only be operated when the plant is hot with sufficient steam pressure. However, during plant operation it is impractical to full stroke exercise these check valves with flow due to the injection of cold water from the Condensate Storage Tanks and/or Suppression Chamber would produce reactivity excursions. This cold water could create a thermal shock to various Class 1 piping systems especially causing concerns at the weld joints. Providing there is inadequate thermal mixing in the reactor



<b>MONTICELLO NUCLEAR GENERATING PLANT</b>		EWI-09.04.01
<b>TITLE:</b>	<b>INSERVICE TESTING PROGRAM</b>	Revision 8
		Page 32 of 122

vessel, there is also a possibility that the cold water could reach the reactor vessel nozzles and reactor vessel internals. By minimizing the number of injections into the reactor vessel, the thermal cycling of weld joints and reactor components and the resulting piping stresses would be reduced.

### 5.7 RHR Interlocks

**System:** RHR

**P&ID:** M-121

**Valves:** MO-2026, MO-2027, MO-2029, MO-2030

**Justification:** These RHR valves are normally closed and have a closed safety position. They have interlocks in their open direction logic that prevents them from opening above a certain reactor pressure, approximately 75 PSIG. This interlock protects the low pressure piping of the RHR system from the high pressure reactor coolant on the other side of these valves. Since these valves are impractical to test during power operation, they will be tested on a cold shutdown frequency.

### 5.8 HPCI Backflow Tests

**System:** HPCI

**P&ID:** M-123, M-124

**Valves:** HPCI-9, HPCI-10, HPCI-14, HPCI-15, HPCI-31, HPCI-65, HPCI-71

**Justification:** The only way to test the closed safety position of these valves is by using a reverse flow test. Testing them at power requires isolating and venting the system which includes manual valve realignments, opening motor operated valve breakers, and defeating auto start logic which is a significant burden on plant resources. This total loss of system function dramatically reduces the level of safety during power operation. Therefore, the closed position of these valves will be verified by doing a reverse flow test on a cold shutdown frequency.

The open safety position of HPCI-9 and HPCI-10 will be verified during the quarterly inservice test of the HPCI system. The open safety position of HPCI-31 will be verified on a refuel outage frequency by disassembly and inspection as allowed by OM-10 and 10CFR50.55a (f) (4) (iv). A partial stroke of HPCI-31 will also be performed on a cold shutdown frequency with the same justification as stated in the preceding paragraph.

### 5.9 RCIC Backflow Tests

**System:** RCIC

**P&ID:** M-125, M-126

**Valves:** RCIC-9, RCIC-10, RCIC-16, RCIC-17, RCIC-31, RCIC-57, RCIC-59

**Justification:** The only way to test the closed safety position of these valves is by using a reverse flow test. Testing them at power requires isolating and venting the system which includes manual valve realignments, opening motor operated valve

<b>MONTICELLO NUCLEAR GENERATING PLANT</b>		EWI-09.04.01
<b>TITLE:</b>	<b>INSERVICE TESTING PROGRAM</b>	Revision 8
		Page 33 of 122

breakers, and defeating auto start logic which is a significant burden on plant resources. This total loss of system function dramatically reduces the level of safety during power operation. Therefore, the closed position of these valves will be verified by doing a reverse flow test on a cold shutdown frequency.

The open safety position of RCIC-9 and RCIC-10 will be verified during the quarterly inservice test of the RCIC system. The open safety position of RCIC-31 will be verified on a refuel outage frequency by disassembly and inspection as allowed by OM-10 and 10CFR50.55a (f) (4) (iv). A partial stroke of RCIC-31 will also be performed on a cold shutdown frequency with the same justification as stated in the preceding paragraph.

### 5.10 Air to DW

**System:** Safety Grade N<sub>2</sub> to DW

**P&ID:** M-131, SH-10

**Valves:** AI-598, AI-708, AI-713, AI-714, AI-730, SV-4235

**Justification:** These valves must be open to supply safety grade nitrogen for critical component functions inside the Drywell, among them holding the inboard MSIVs open. Since the inboard MSIVs fail closed, any interruption of the air supply to them during power operation risks a plant transient from the MSIVs drifting closed. All of these valves, except SV-4235, can only be exercised by isolating and venting the system, installing temporary bypasses (hoses, gages, etc.), and verifying full or no reverse flow across the check valve. Therefore, these valves will be tested on a cold shutdown frequency.

SV-4235 (among others) is not required to be inservice tested by 10CFR50.55a, however, it is included in this test program as good operating practice. Cold shutdown testing frequency is judged to be appropriate to adequately monitor the condition of this valve. Since there are administrative advantages to including SV-4235 in the same test procedure as the other valves in the system, it will be tested on a cold shutdown frequency.

### 5.11 PASS XFB Tests

**System:** PASS

**P&ID:** NF-96042

**Valves:** PAS-59-5, PAS-59-6

**Justification:** These valves are normally open and have a closed safety position to isolate the non-safety post accident sampling (PAS) system from the safety related RHR system. These valves are tested by isolating the system, installing temporary bypasses (hoses, gages, etc.) and performing steps similar to, but more extensive than, a check valve seat leakage test. Since this test is done in a high radiation area and it renders the non-redundant PAS system out of service, these valves will be tested on a cold shutdown frequency.

<b>MONTICELLO NUCLEAR GENERATING PLANT</b>		EWI-09.04.01
<b>TITLE:</b>	<b>INSERVICE TESTING PROGRAM</b>	Revision 8
		Page 34 of 122

### 5.12 Backfill Check Valves

**System:** CRD

**P&ID:** M-116

**Valves:** BF-12, BF-14, BF-24, BF-26, BF-35, BF-37, BF-46, BF-48

**Justification:** These valves are normally open and have a closed safety position to separate the non-safety control rod drive system from the safety related reactor coolant pressure boundary. The lines containing these valves tie into sensitive reactor vessel instrumentation that is important during both power operation and cold shutdown operation. These valves are verified closed by isolating and venting the system, installing temporary bypasses (hoses, gages, etc.), and performing a reverse flow, seat leakage test. Therefore, these valves will be verified closed on a refuel outage frequency as part of their seat leakage test. This frequency is allowed by OM-10 and 10CFR50.55a (f) (4) (iv).

### 5.13 XFV Tests

**System:** Various

**P&ID:** Various

**Valves:** XFV-1 thru 89

**Justification:** These valves are normally open and have a closed safety position as a primary containment barrier. The closed position of these valves is tested by installing temporary bypasses (hoses, gages, etc.) and performing steps similar to, but more extensive than, a check valve seat leakage test. The isolation of the lines containing these excess flow check valves takes instrumentation out of service that is important during both power operation and cold shutdown operation. These valves will be tested on a refuel outage frequency as allowed by OM-10 and 10CFR50.55a (f) (4) (iv).

This frequency is consistent with the Technical Specification requirement to verify proper operation of these valves once per cycle.

### 5.14 Air to DW II

**System:** Instrument Air

**P&ID:** M-131, SH-12

**Valves:** AI-571

**Justification:** This valve is normally open to supply instrument air to certain Drywell components, including the ADS and LLS function of two safety relief valves. It has a closed safety position as a primary containment isolation valve. Its closure test is performed by isolating and venting the system, installing temporary bypasses (hoses, gages, etc.) and performing a reverse flow, seat leakage test. Therefore, this valve will be tested on a cold shutdown frequency.

<b>MONTICELLO NUCLEAR GENERATING PLANT</b>		<b>EWI-09.04.01</b>
<b>TITLE:</b>	<b>INSERVICE TESTING PROGRAM</b>	Revision 8
		Page 35 of 122

### 5.15 Air to T-Ring Seals

**System:** Instrument Air - Reactor Building

**P&ID:** M-131, SH-14

**Valves:** AI-613 thru 613, AI-663, AI-666, AI-669, AI-672, AI-675, AI-678, AI-681, AI-683, AI-685, AI-694, AI-695

**Justification:** These check valves are not required to be inservice tested by 10CFR50.55a. They are included in the program as good operating practice. The valves either open or close to ensure safety grade nitrogen is directed to the primary containment atmospheric control valves. The check valves are tested by isolating and venting the system, installing temporary bypasses (hoses, gages, etc.), and verifying full or no reverse flow across them. Due to the burden of this testing, these valves will be tested on a refuel outage frequency. This is consistent with OM-10 and 10CFR50.55a(f)(4)(iv).

### 5.16 Air Supply Check Valves

**System:** Various

**P&ID:** Various

**Valves:** See Valve Testing Tables

**Justification:** These check valves are not required to be inservice tested by 10CFR50.55a. They are included in this program as good practice. Their closed position is important to safety by ensuring air is not rapidly lost after a postulated air line break. The check valves are tested by isolating and venting the system, installing temporary bypasses (hoses, gages, etc), and verifying no reverse flow across them. Due to the burden of this testing, these valves will be tested on a refuel outage frequency. This is consistent with OM-10 and 10CFR50.55a(f)(4)(iv).

### 5.17 RHR Testable Check Valves

**System:** Residual Heat Removal System (RHR)

**P&ID:** M-120, M-121

**Valves:** AO-10-46A, RHR Div 1 Low Pressure Core Injection (LPCI) Testable Check Valve  
AO-10-46B, RHR Div 2 Low Pressure Core Injection (LPCI) Testable Check Valve

**Category:** A/C-1

**Class:** 1

**Function:** These valves permit low pressure injection flow when the LPCI pump discharge pressure is above reactor pressure.

TITLE: INSERVICE TESTING PROGRAM

Revision 8

Page 36 of 122

**Code Test Requirement:** ASME Section XI, 1986 Edition, IWV 3522 and Part 10 (OM-10) of ASME/ANSI OMa-1988, paragraph 4.3.2.1, require these check valves be full stroke exercised on a quarterly basis. Using the requirements of OM-10, as permitted by Monticello Nuclear Generating Plant Safety Evaluation Report, TAC Nos. M88972 and M82638, dated September 9, 1994, full stroke exercising may be demonstrated either by using full flow, by use of a manual mechanical exerciser or by disassembly and inspection. OM-10 specifies acceptable alternatives by which the testing may be performed and the frequency for performing the full stroke exercise test if it cannot be performed quarterly. The test is intended to demonstrate that the valve obturator moves during exercising to its position required to fulfill its function. If full stroke exercising cannot be performed on a quarterly basis due to plant operation, system configuration or other similar impracticalities, then an Owner may defer testing to either a Cold Shutdown or a Refueling Outage frequency. Specific written relief is not required, rather the deferred testing justification becomes part of the IST Program available for review by the regulatory authorities.

**Alternate Test Method:** The valves will be full flow exercised during Cold Shutdown to the extent that the valve demonstrates the capability to perform its required function pursuant to applicable Code requirements.

**Justification:** During plant operation it is impractical to full stroke exercise these check valves with flow due to the fact RHR/LPCI Pumps do not supply sufficient discharge head to open these valves against full reactor pressure. These check valves also cannot be exercised during normal operation via a full flow test because the system injection motor operated valves can only be opened at reactor pressures less than 460 psig. In addition, injection of cold water from the Condensate Storage Tanks and/or Suppression Chamber would produce reactivity excursions. This cold water would create a thermal shock to various Class 1 piping systems especially causing concerns at the weld joints. Providing there is inadequate thermal mixing in the reactor vessel, there is a possibility that the cold water could reach the reactor vessel nozzles and reactor vessel internals. By minimizing the number of injections into the reactor vessel, the thermal cycling of weld joints and reactor components and the resulting piping stresses would be reduced.

### 5.18 Core Spray Testable Check Valves

**System:** Core Spray (CS)

**P&ID:** M-122

**Valves:** AO-14-13A, CS Injection Testable Check Valve  
AO-14-13B, CS Injection Testable Check Valve

**Category:** A/C-1

**Class:** 1

**Function:** The Core Spray system is an ECCS that is designed to provide reactor core cooling and thereby prevent fuel clad damage in conjunction with other ECCS during and following major transients and accidents. The check valves permit a high pressure injection flow from the Suppression Chamber when the applicable pump discharge pressure is above reactor pressure and also prevents reverse flow into the Core Spray from the

<b>MONTICELLO NUCLEAR GENERATING PLANT</b>		EWI-09.04.01
<b>TITLE:</b>	<b>INSERVICE TESTING PROGRAM</b>	Revision 8
		Page 37 of 122

reactor in the event that the motor operated injection isolation valves fail to close.

**Code Test Requirement:** ASME Section XI, 1986 Edition, IWV 3522 and Part 10 (OM-10) of ASME/ANSI OMa-1988, paragraph 4.3.2.1, require these check valves be full stroke exercised on a quarterly basis. Using the requirements of OM-10, as permitted by Monticello Nuclear Generating Plant Safety Evaluation Report, TAC Nos. M88972 and M82638, dated September 9, 1994, full stroke exercising may be demonstrated either by using full flow, by use of a manual mechanical exerciser or by disassembly and inspection. OM-10 specifies acceptable alternatives by which the testing may be performed and the frequency for performing the full stroke exercise test if it cannot be performed quarterly. The test is intended to demonstrate that the valve obturator moves during exercising to its position required to fulfill its function. If full stroke exercising cannot be performed on a quarterly basis due to plant operation, system configuration or other similar impracticalities, then an Owner may defer testing to either a Cold Shutdown or a Refueling Outage frequency. Specific written relief is not required, rather the deferred testing justification becomes part of the IST Program available for review by the regulatory authorities.

**Alternate Test Method:** The valves will be full flow exercised during cold shutdown to the extent that the valve demonstrates the capability to perform its required function pursuant to applicable code requirements.

**Justification:** These check valves cannot be exercised during normal plant operation via a full flow test because the CS system injection motor operated valves can only be opened when reactor pressures has decreased to 460 psig. Additionally, during plant operation it is impractical to full stroke exercise these check valves with flow due to the injection of cold water from the Suppression Chamber would produce reactivity excursions. This cold water could create a thermal shock to various Class 1 piping systems especially causing concerns at the weld joints. Providing there is inadequate thermal mixing in the reactor vessel, there is also a possibility that the cold water could reach the reactor vessel nozzles and reactor vessel internals. By minimizing the number of injections into the reactor vessel, the thermal cycling of weld joints and reactor components and the resulting piping stresses would be reduced.

### 5.19 Torus to Drywell Vacuum Breakers

**System:** Primary Containment

**P&ID:** M-143

**Valves:** AO-2382A, AO-2382B, AO-2382C, AO-2382E, AO-2382F, AO-2382G, AO-2382H, AO-2382K

**Category:** A/C-1

**Class:** 2

**Function:** These valves will open to permit gases to flow from the suppression chamber to the drywell. This prevents backflow of water and excessive water level variation in the downcomers submerged in the suppression pool water and prevents the primary containment from exceeding the external design pressure. Additionally, these valves close to prevent suppression pool bypass in the event of an SBA, an IBA or a DBA LOCA.

<b>MONTICELLO NUCLEAR GENERATING PLANT</b>		EWI-09.04.01
<b>TITLE:</b>	<b>INSERVICE TESTING PROGRAM</b>	Revision 8
		Page 38 of 122

**Code Test Requirement:** ASME Section XI, 1986 Edition, IWW-3522 and Part 10 (OM-10) of ASME/ANSI OMa-1988, paragraph 4.3.2.1, require these check valves be full stroke exercised on a quarterly basis. Using the requirements of OM-10, as permitted by Monticello Nuclear Generating Plant Safety Evaluation Report, TAC Nos. M88972 and M82638, dated September 9, 1994, full stroke exercising may be demonstrated either by using full flow, by use of a manual mechanical exerciser or by disassembly and inspection. For vacuum breakers, OM-10 allows for measuring the breakaway torque and comparing that value to a reference value established when the valve is known to be in good condition. If the measured breakaway torque does not vary from the reference value by more than 50%, then the exercising requirements are considered to be satisfied. If this test cannot be completed on a quarterly basis, OM-10 allows for the Owner to defer testing to a Cold Shutdown or Refueling Outage frequency. Specific written relief is not required, rather the deferred testing justification becomes part of the IST Program available for review by the regulatory authorities.

**Alternate Test Method:** These valves will be tested by measuring the breakaway torque and comparing this value to a reference value established when the valves were known to be in good condition. The return to closure will also be verified visually as the valve internals can be observed while moving the valve. This testing will be conducted on a Refueling Outage frequency.

**Justification:** This testing cannot be conducted quarterly due to the necessity to enter the suppression chamber to perform testing. The actuators on the valves do not meet code requirements for actuator size and therefore cannot be used to test quarterly without a plant modification. Cold Shutdown testing is also not practical due to the need to enter the suppression chamber, establish lighting, perform leak rate tests on hatches, and establish confined space control. Therefore, these valves will be tested on a Refueling Outage frequency when all of the conditions for testing are established.

## 5.20 HPCI-32 and RCIC-41

**System:** HPCI and RCIC

**P&ID:** M-124, M-126

**Valves:** HPCI-32 (CST SUCTION CHECK VALVE)  
RCIC-41 (CST SUCTION CHECK VALVE)

**Category:** C-1

**Class:** 2

**Function:** These valves both support the operation of HPCI and RCIC by allowing design flow to the pump suction from the CSTs. They also act as an isolation from backflow to the CSTs from the suction line.

**Code Test Requirement:** ASME Section XI, 1986 Edition, IWW 3522 and Part 10 (OM-10) of ASME/ANSI OMa-1988, paragraph 4.3.2.1, require these check valves be full stroke exercised on a quarterly basis. Using the requirements of OM-10, as permitted by Monticello Nuclear Generating Plant Safety Evaluation Report, TAC Nos. M88972 and M82638, dated September 9, 1994, full stroke exercising may be demonstrated either by using full flow, by use of a manual mechanical exerciser or by disassembly and inspection. OM-10 specifies acceptable alternatives by which the

<b>MONTICELLO NUCLEAR GENERATING PLANT</b>		EWI-09.04.01
<b>TITLE:</b>	<b>INSERVICE TESTING PROGRAM</b>	Revision 8
		Page 39 of 122

testing may be performed and the frequency for performing the full stroke exercise test if it cannot be performed quarterly. The test is intended to demonstrate that the valve obturator moves during exercising to its position required to fulfill its function. If full stroke exercising cannot be performed on a quarterly basis due to plant operation, system configuration or other similar impracticalities, then an Owner may defer testing to either a Cold Shutdown or a Refueling Outage frequency. Specific written relief is not required, rather the deferred testing justification becomes part of the IST Program available for review by the regulatory authorities.

**Alternate Test Method:** The valves will be exercised for a full closed stroke during Cold Shutdown to the extent that the valve demonstrates the capability to perform its required function pursuant to applicable Code requirements. A full or partial open stroke will still be verified during quarterly surveillance of the HPCI and RCIC system.

**Justification:** Testing the subject valves for closure during plant operation on a quarterly basis would be an undue burden due to the requirement to set up special instrumentation on the system. Setting up the instrumentation and realigning the system to test the closed function of these valves would extend HPCI and RCIC LCO times and affect plant operational readiness. Therefore, these valves will be close exercise tested in accordance with applicable code requirements on a Cold Shutdown frequency.

**5.21 HPCI-42 and RCIC-37**

**System:** HPCI and RCIC

**P&ID:** M-124, M-126

**Valves:** HPCI-42 (MIMINUM FLOW CHECK VALVE TO TORUS)  
RCIC-41 (MIMINUM FLOW CHECK VALVE TO TORUS)

**Category:** C-1

**Class:** 2

**Function:** These valves allow for pump minimum flow on both HPCI and RCIC.

**Code Test Requirement:** ASME Section XI, 1986 Edition, IWV-3522 and Part 10 (OM-10) of ASME/ANSI OMa-1988, paragraph 4.3.2.1, require these check valves be full stroke exercised on a quarterly basis. Using the requirements of OM-10, as permitted by Monticello Nuclear Generating Plant Safety Evaluation Report, TAC Nos. M88972 and M82638, dated September 9, 1994, full stroke exercising may be demonstrated either by using full flow, by use of a manual mechanical exerciser or by disassembly and inspection. OM-10 specifies acceptable alternatives by which the testing may be performed and the frequency for performing the full stroke exercise test if it cannot be performed quarterly. The test is intended to demonstrate that the valve obturator moves during exercising to its position required to fulfill its function. If full stroke exercising cannot be performed on a quarterly basis due to plant operation, system configuration or other similar impracticalities, then an Owner may defer testing to either a Cold Shutdown or a Refueling Outage frequency. Specific written relief is not required, rather the deferred testing justification becomes part of the IST Program available for review by the regulatory authorities.



<b>MONTICELLO NUCLEAR GENERATING PLANT</b>		<b>EWI-09.04.01</b>
<b>TITLE:</b>	<b>INSERVICE TESTING PROGRAM</b>	Revision 8
		Page 40 of 122

**Alternate Test Method:** These valves will be disassembled and inspected each refueling outage as allowed by OM-10, 4.3.2.4(c).

**Justification:** There is no means of measuring flow rate through these valves during quarterly pump testing. Operating the pump with only the minimum flow recirculation line available is not good operating practice, as recommended by the NRC for pump protection. Therefore, disassembly and inspection is the only alternative for verifying valve condition.

The disassembly and inspection of these valves was originally submitted as relief requests with the original Third 10 Year Interval (HPCI-5 and RCIC-5). The NRC provisionally approved these relief requests in their SER dated September 24, 1992. Subsequently, MNGP withdrew this relief request because it was not required per OM-10 guidelines. The NRC acknowledged the withdrawal of the relief request and the disassembly and inspection per OM-10 in their SER dated September 9, 1994.

## 5.22 CST-90

**System:** Service Condensate (Keep Fill)

**P&ID:** M-114-1

**Valves:** CST-90 (RHR CROSSTIE FILL LINE CHECK VALVE)

**Category:** C-1

**Class:** 2

**Function:** This Keep Fill discharge check valve prevents diversion of RHR water to non-safety related items.

**Code Test Requirement:** ASME Section XI, 1986 Edition, IWV-3522 and Part 10 (OM-10) of ASME/ANSI OMa-1988, paragraph 4.3.2.1, require these check valves be full stroke exercised on a quarterly basis. Using the requirements of OM-10 as permitted by Monticello Nuclear Generating Plant Safety Evaluation Report, TAC Nos. M88972 and M82638, dated September 9, 1994, full stroke exercising may be demonstrated either by using full flow, by use of a manual mechanical exerciser or by disassembly and inspection. OM-10 specifies acceptable alternatives by which the testing may be performed and the frequency for performing the full stroke exercise test if it cannot be performed quarterly. The test is intended to demonstrate that the valve obturator moves during exercising to its position required to fulfill its function. If full stroke exercising cannot be performed on a quarterly basis due to plant operation, system configuration or other similar impracticalities, then an Owner may defer testing to either a Cold Shutdown or a Refueling Outage frequency. Specific written relief is not required, rather the deferred testing justification becomes part of the IST Program available for review by the regulatory authorities.

**Alternate Test Method:** This valve will be disassembled and inspected each refueling outage as allowed by OM-10, 4.3.2.4(c).

<b>MONTICELLO NUCLEAR GENERATING PLANT</b>		EWI-09.04.01
<b>TITLE:</b>	<b>INSERVICE TESTING PROGRAM</b>	Revision 8
		Page 41 of 122

**Justification:** There is no means available to verify the disc in CST-90 travels promptly to the seat on cessation or reversal of flow.

The disassembly and inspection of this valve was originally submitted with relief request SC-1 in the original Third 10 Year Interval. The NRC provisionally approved this relief request in their SER dated September 24, 1992. Subsequently, MNGP withdrew CST-90 from the relief request and stated that it would be tested per OM-10 guidelines. The NRC acknowledged the withdrawal of CST-90 from the relief request and the disassembly and inspection per OM-10 in their SER dated September 9, 1994.

## 6.0 REFERENCES

- 6.1 10CFR50.55a(g); Inservice Inspection
- 6.2 1986 Edition ASME Boiler and Pressure Vessel Code - Section XI: Rules for Inservice Inspection of Nuclear Power Plant Components
- 6.3 Monticello Nuclear Plant; Piping and Instrument Diagrams
- 6.4 Monticello Nuclear Plant; Technical Specifications
- 6.5 Regulatory Guide 1.26
- 6.6 ANSI/ASME OM Standards
  - OM-1-1981 Relief Valve Inservice Testing
  - OM-6 Pump Inservice Testing
  - OM-10 Valve Inservice Testing
- 6.7 Monticello Updated Safety Analysis Report
  - Section 5, Containment Isolation
  - Section 6, Plant engineered Safeguards
  - Section 14, Plant Safety Analysis
- 6.8 Northern States Power Letter Dated August 12, 1982, from D.M. Musolf to Director NRR; Subject: Supplemental Information Concerning Inservice Testing Program
- 6.9 Northern States Power and NRC correspondence on Event V valves
- 6.10 NRC Generic Letter No. 89-04, "Guidance on Developing Acceptable Inservice Testing Programs"
- 6.11 4 AWI-01.03.03 (COLOR CODED P&ID Q-LIST EXTENSION)
- 6.12 Regulatory Guide 1.147
- 6.13 Monticello Nuclear Generating Plant Safety Evaluation Report for Third Ten-Year Inservice Testing Program (TAC M82638) - NRC, dated September 24, 1992
- 6.14 Monticello Nuclear Generating Plant Approval of Third Ten-Year Inservice Testing Program (TAC No. M82638) - NRC, dated July 6, 1993
- 6.15 Safety Evaluation of Relief Requests GR-7 And RCIC-6 - Monticello Nuclear Generating Plant Pump and Valve Inservice Testing Program (TAC No. M86939) - NRC, dated October 25, 1993

<b>MONTICELLO NUCLEAR GENERATING PLANT</b>		<b>EWI-09.04.01</b>
<b>TITLE:</b>	<b>INSERVICE TESTING PROGRAM</b>	Revision 8
		Page 42 of 122

- 6.16 Monticello Nuclear Generating Plant - Safety Evaluation (SE) of Relief Requests and Action Item Responses for the Pump and Valve Inservice Testing Program (TAC Nos. M88972 And M82638) - NRC, dated September 9, 1994
- 6.17 Monticello Nuclear Generating Plant - Safety Evaluation (SE) of Relief Request for the Pump and Valve Inservice Testing Program (TAC No. M90341) - NRC, dated December 8, 1994

**7.0 REQUIRED RECORDS**

7.1 Not Applicable

8.0 FIGURES

FIGURE  
 8.1 Main Steam

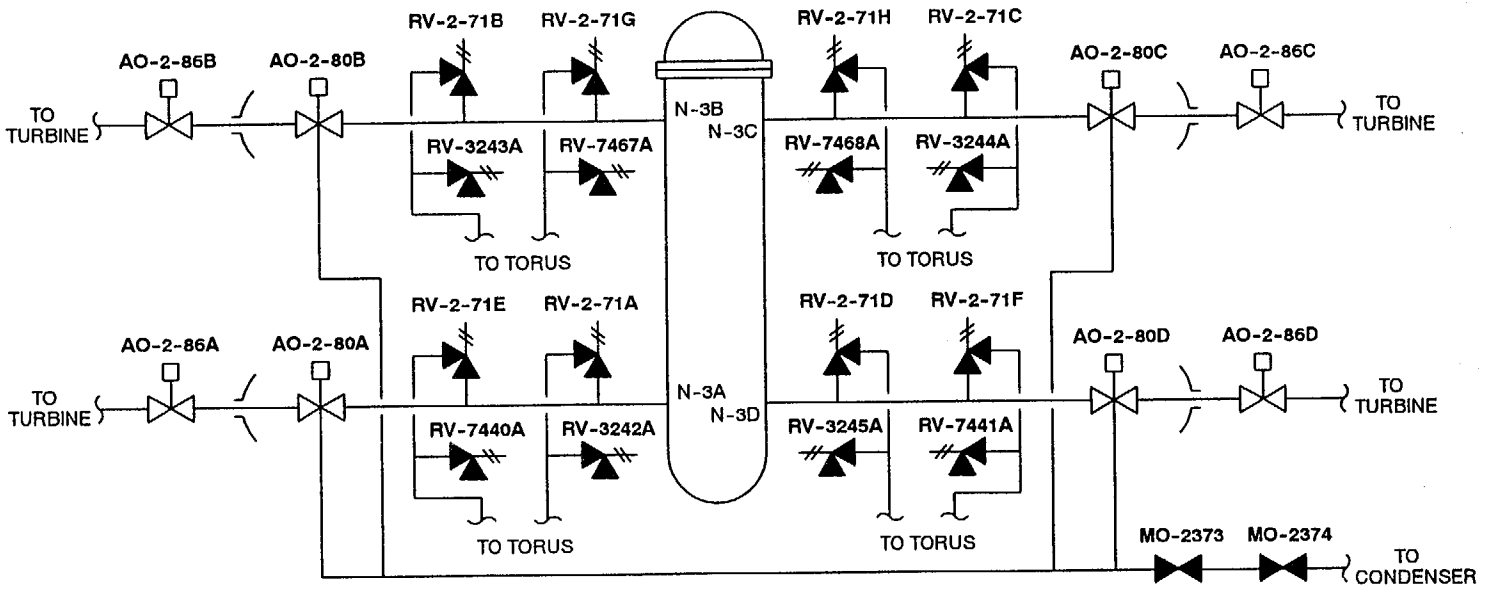

I/kab

<b>MONTICELLO NUCLEAR GENERATING PLANT</b>		<b>EWI-09.04.01</b>
<b>TITLE:</b>	<b>INSERVICE TESTING PROGRAM</b>	Revision 8
		Page 44 of 122

**FIGURE**

**8.2 Feedwater**

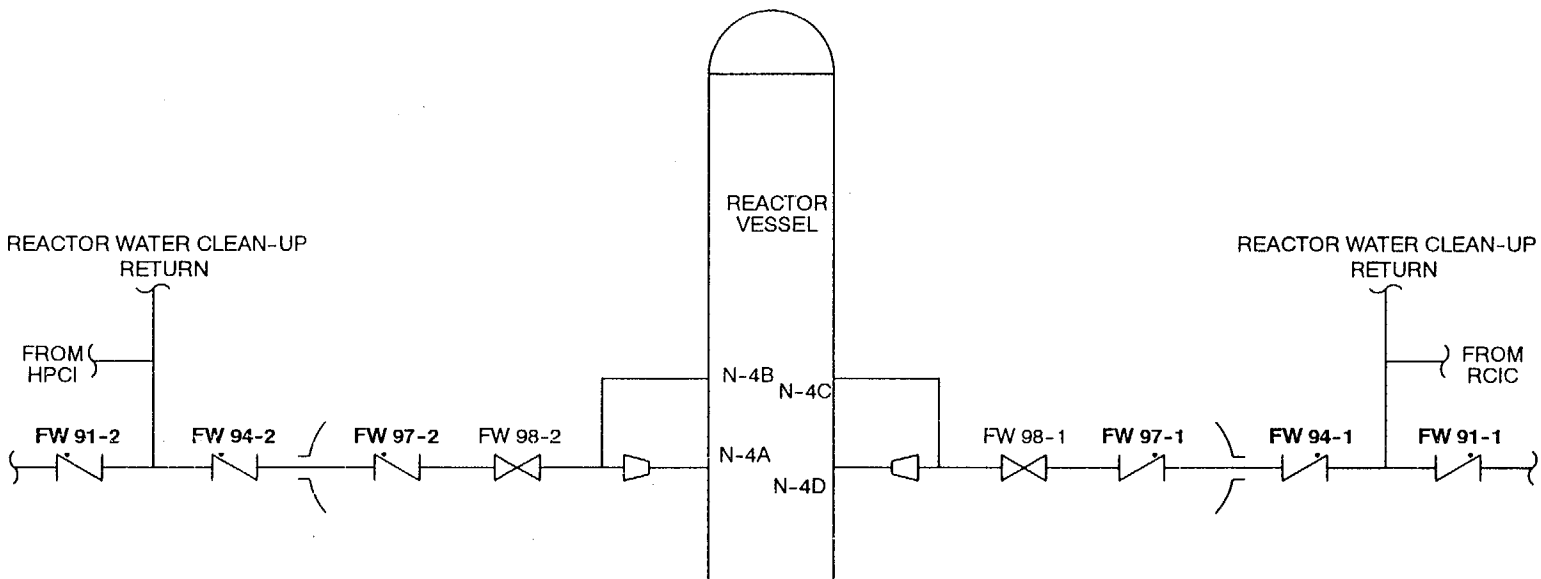

EWI-09.04.01-2  
113 DWG

I/kab

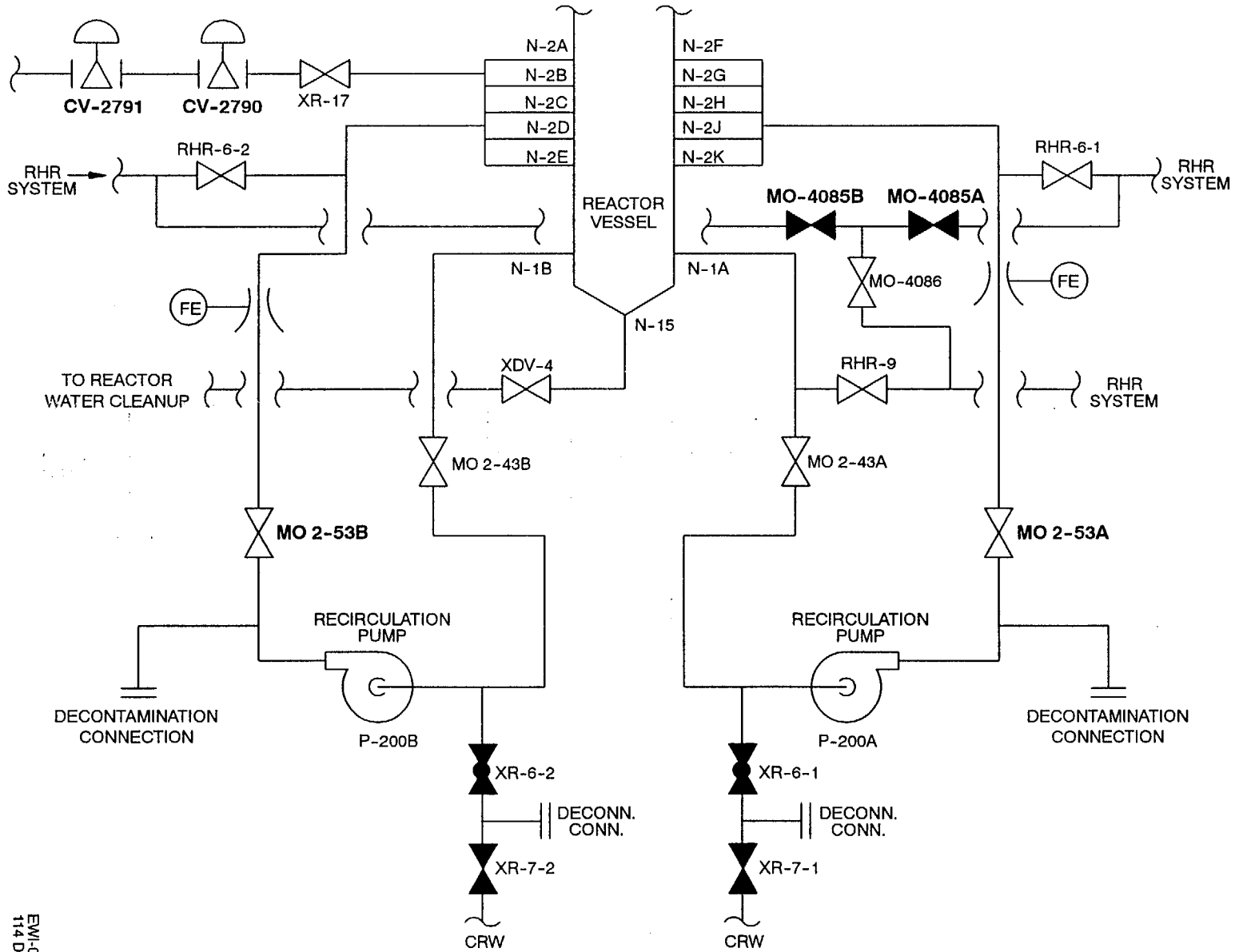

FIGURE

8.3 Reactor Recirculation

**MONTICELLO NUCLEAR GENERATING PLANT**  
**TITLE: INSERVICE TESTING PROGRAM**

Revision 8  
 Page 45 of 122  
 EWI-09.04.01

EWI-09.04.01-3  
 114 DWG

8.4 Core Spray

FIGURE

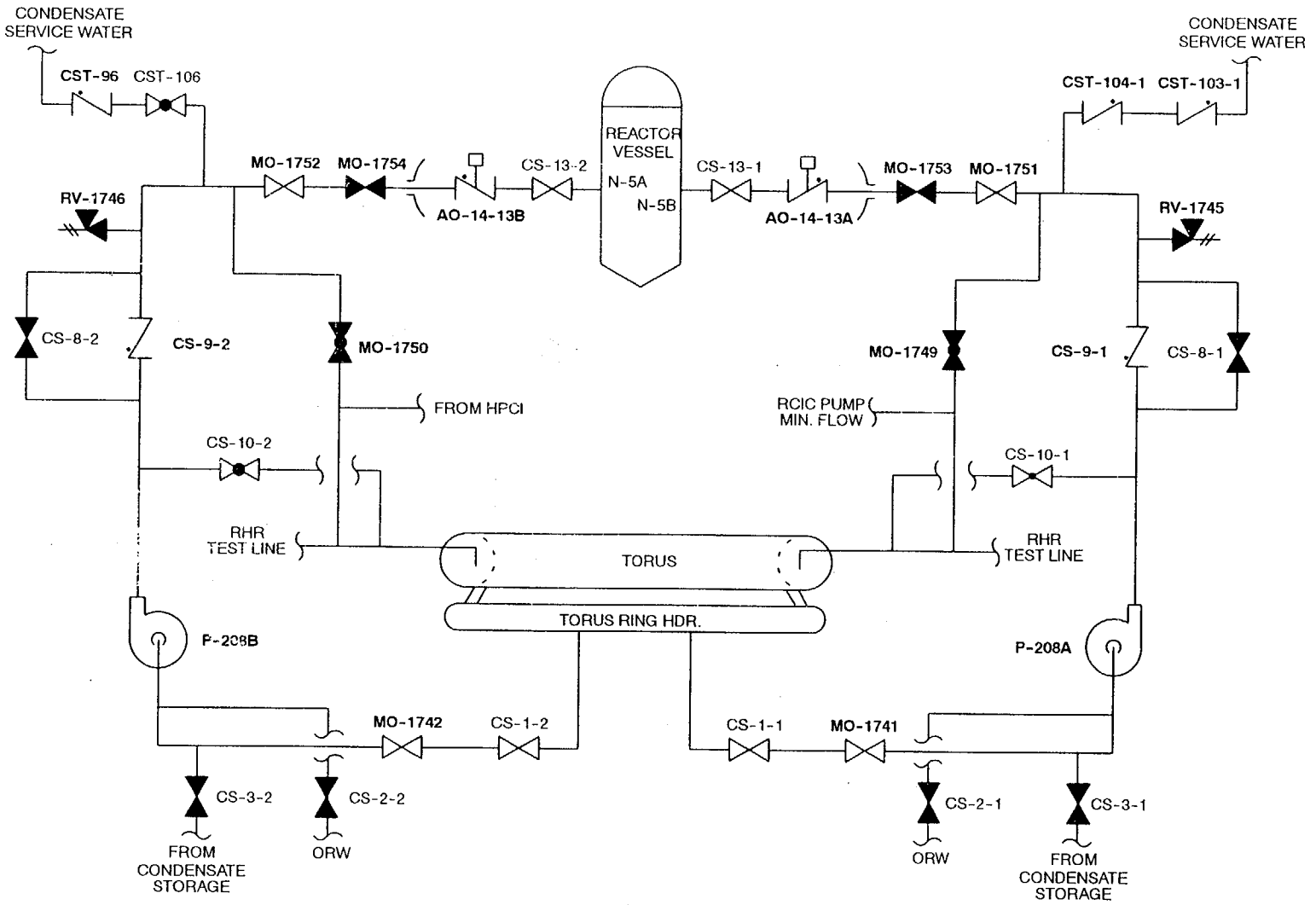

I/kab

I/kab

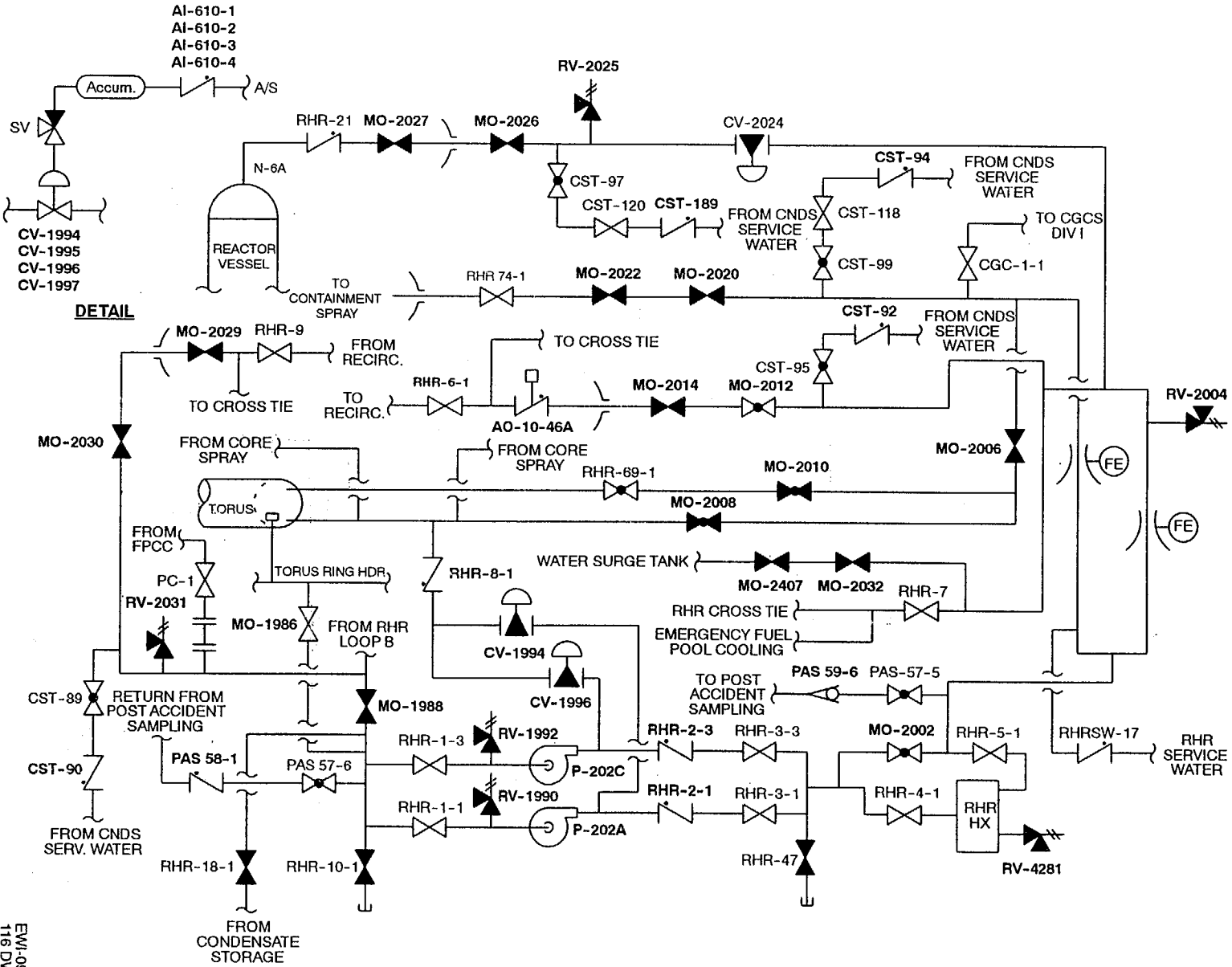

8.5 RHR Loop A

FIGURE

**MONTICELLO NUCLEAR GENERATING PLANT**  
**TITLE: INSERVICE TESTING PROGRAM**

Revision 8  
 Page 47 of 122  
 EWI-09.04.01

EWI-09.04.01-5  
116 DWG



I/kab

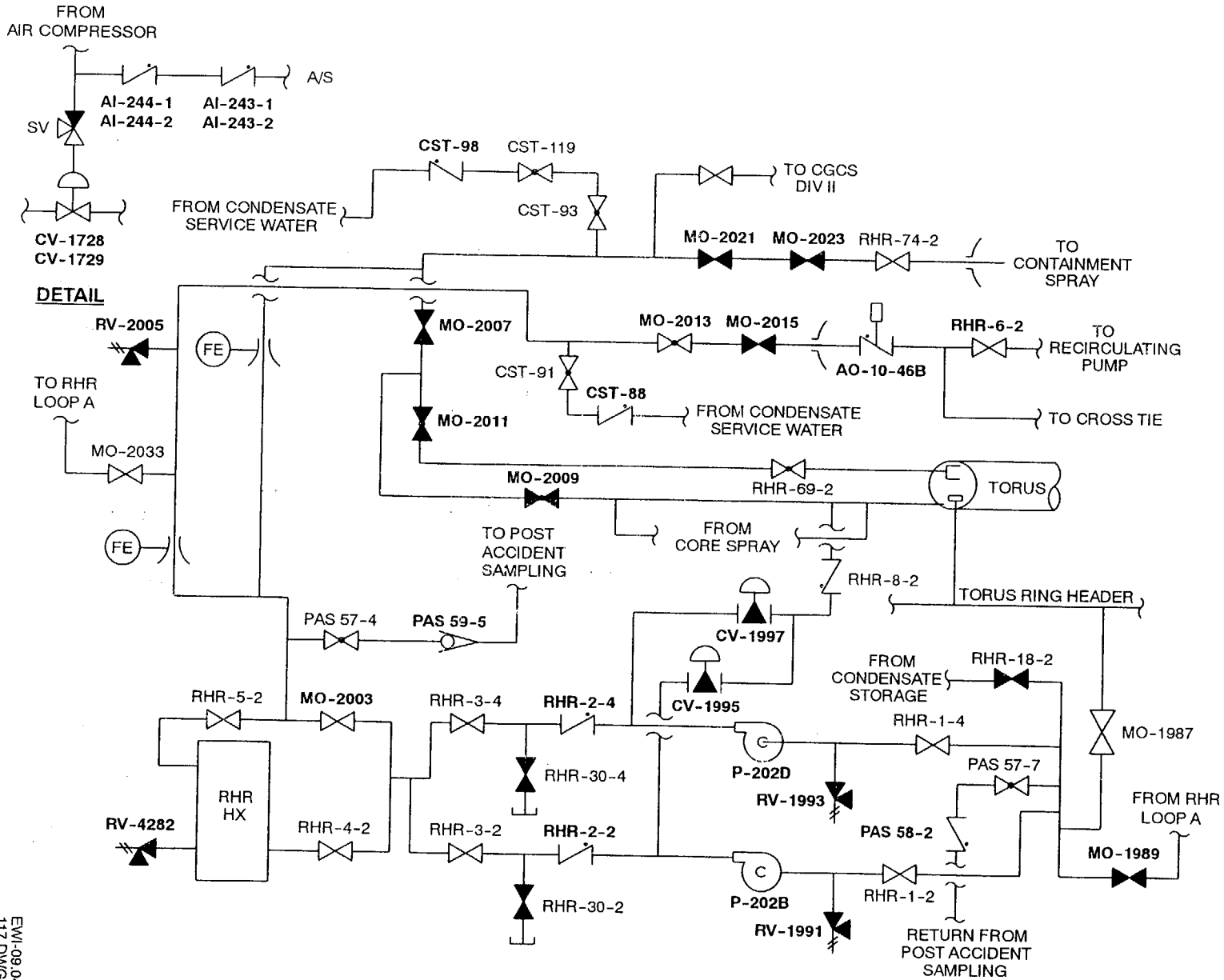

8.6 RHR Loop B

FIGURE

<b>MONTICELLO NUCLEAR GENERATING PLANT</b>	
<b>TITLE: INSERVICE TESTING PROGRAM</b>	
Revision 8	EWI-09.04.01
Page 48 of 122	

EWI-09.04.01-6  
117 DWG

I/kab

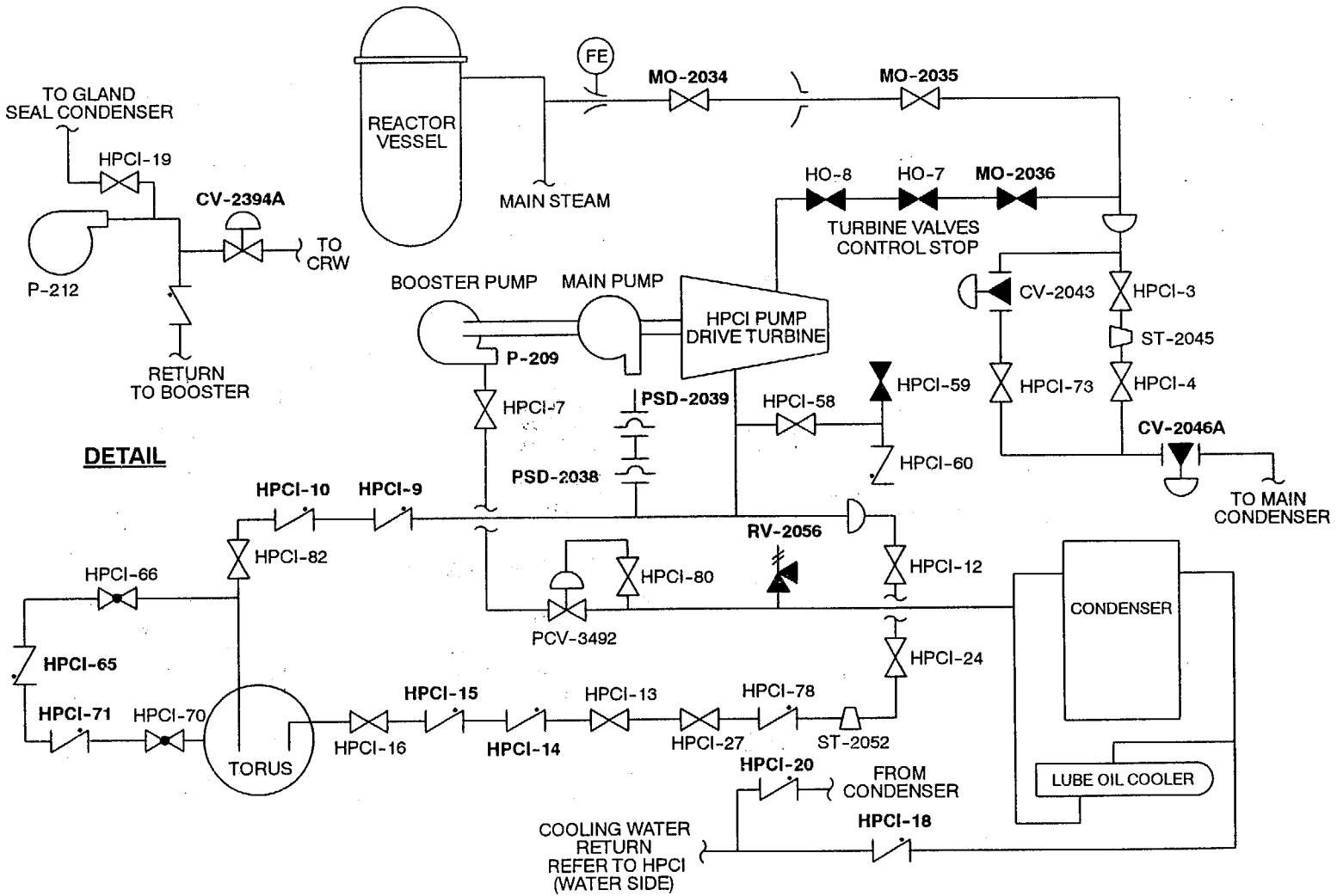

8.7 HPCI (Steam)

FIGURE

**MONTICELLO NUCLEAR GENERATING PLANT**  
**TITLE: INSERVICE TESTING PROGRAM**

EWI-09.04.01  
 Revision 8  
 Page 49 of 122

EWI-09.04.01-7  
 118 DWG

I/kab

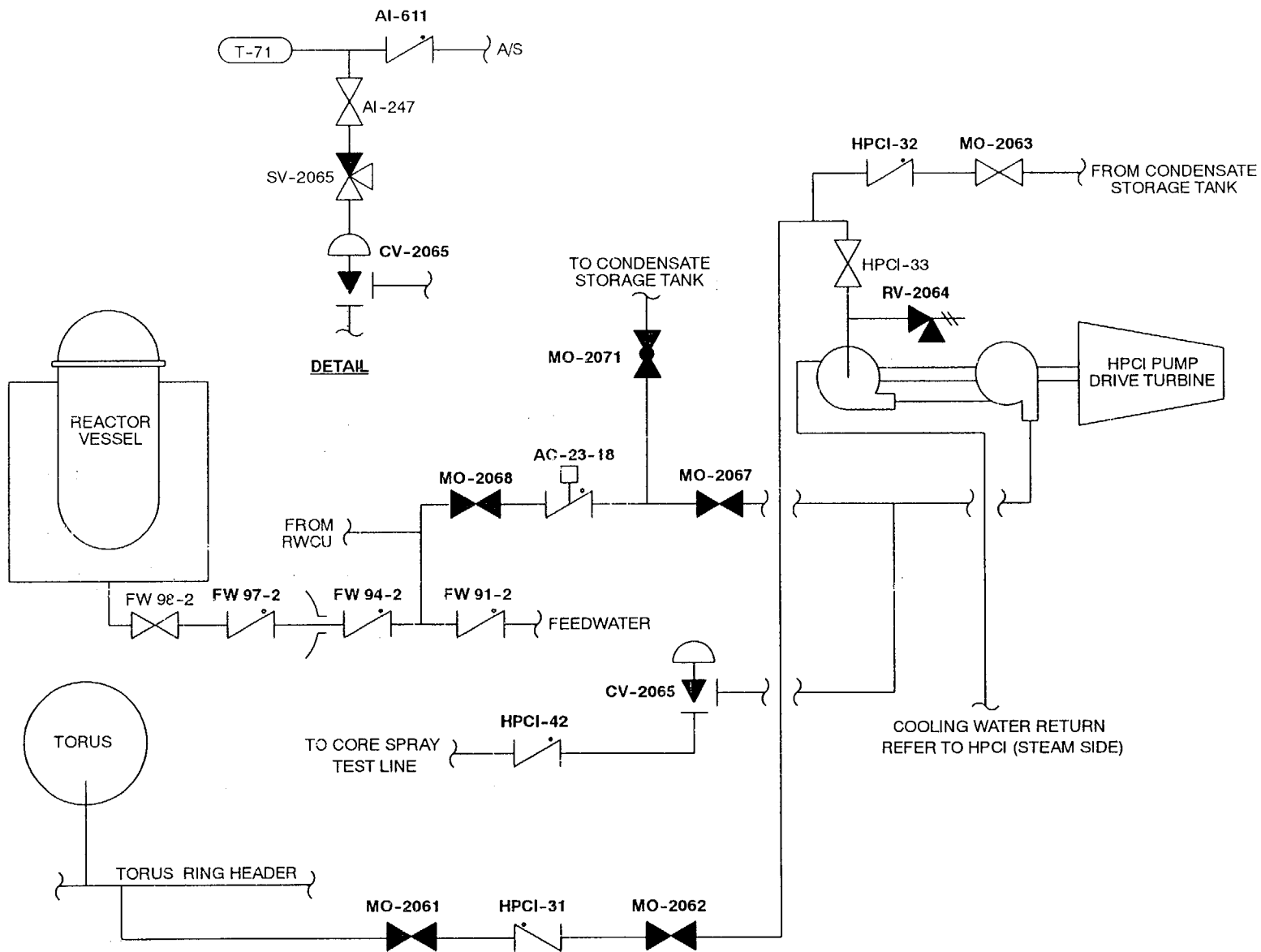

8.8 HPCI (Water)

FIGURE

**MONTICELLO NUCLEAR GENERATING PLANT**  
**TITLE: INSERVICE TESTING PROGRAM**

Revision 8  
 Page 50 of 122

EWI-09.04.01

EWI-09.04.01-8  
119 DWG

**FIGURE**

**8.9 RCIC (Steam)**

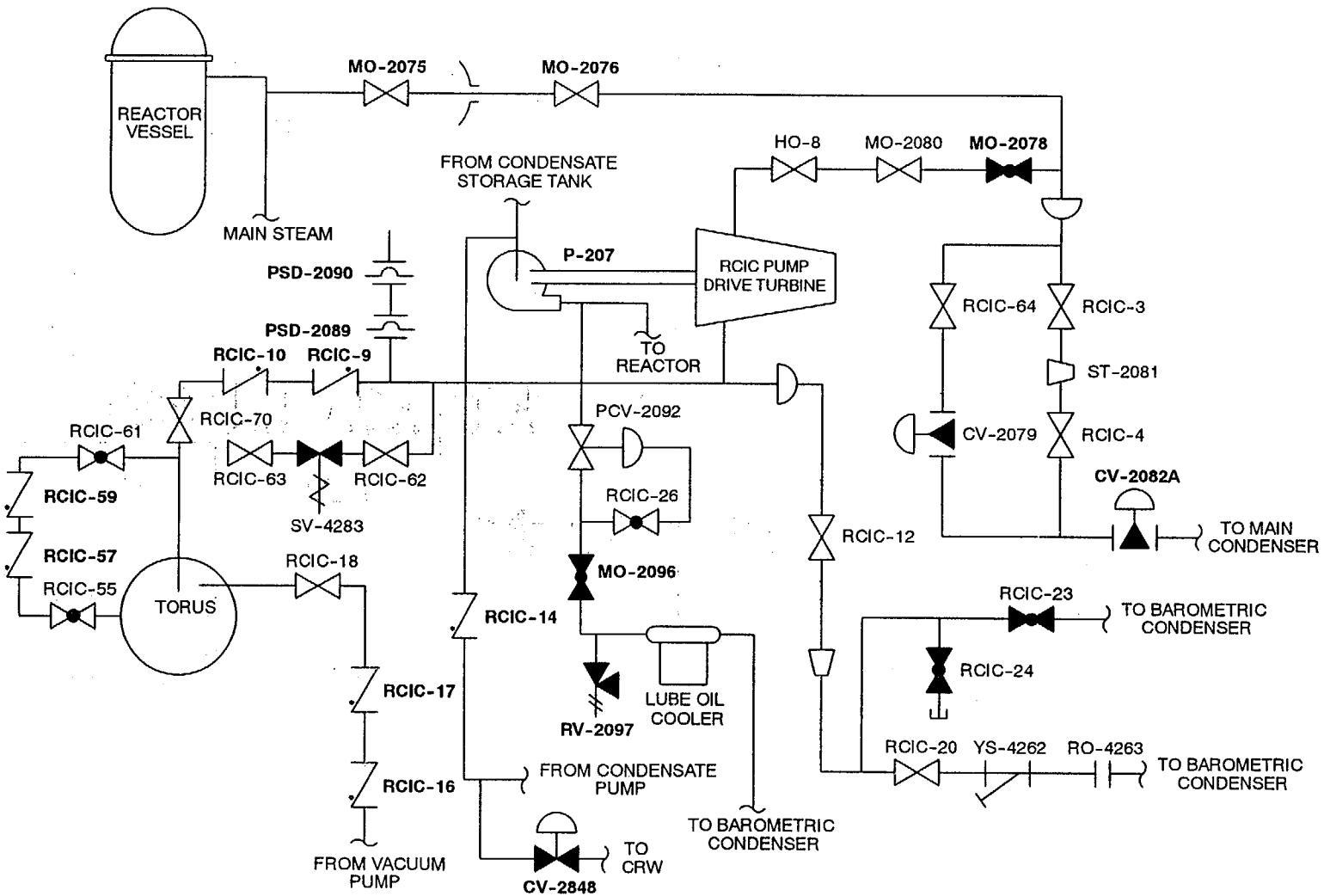

I/kab

I/kab

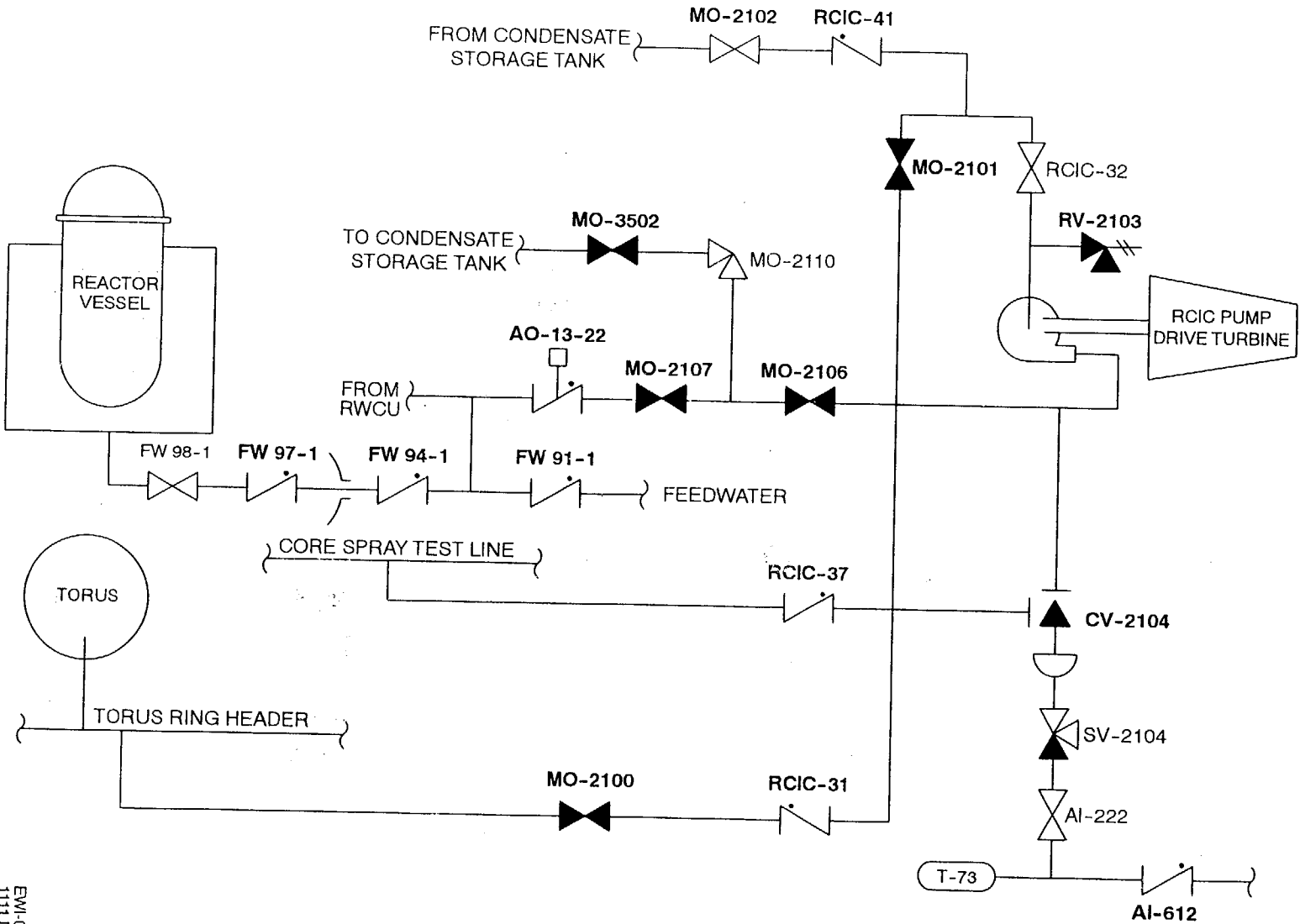

8.10 RCIC (Water)

FIGURE

**MONTICELLO NUCLEAR GENERATING PLANT**  
**TITLE: INSERVICE TESTING PROGRAM**

Revision 8  
 Page 52 of 122  
 EWI-09.04.01

I/kab

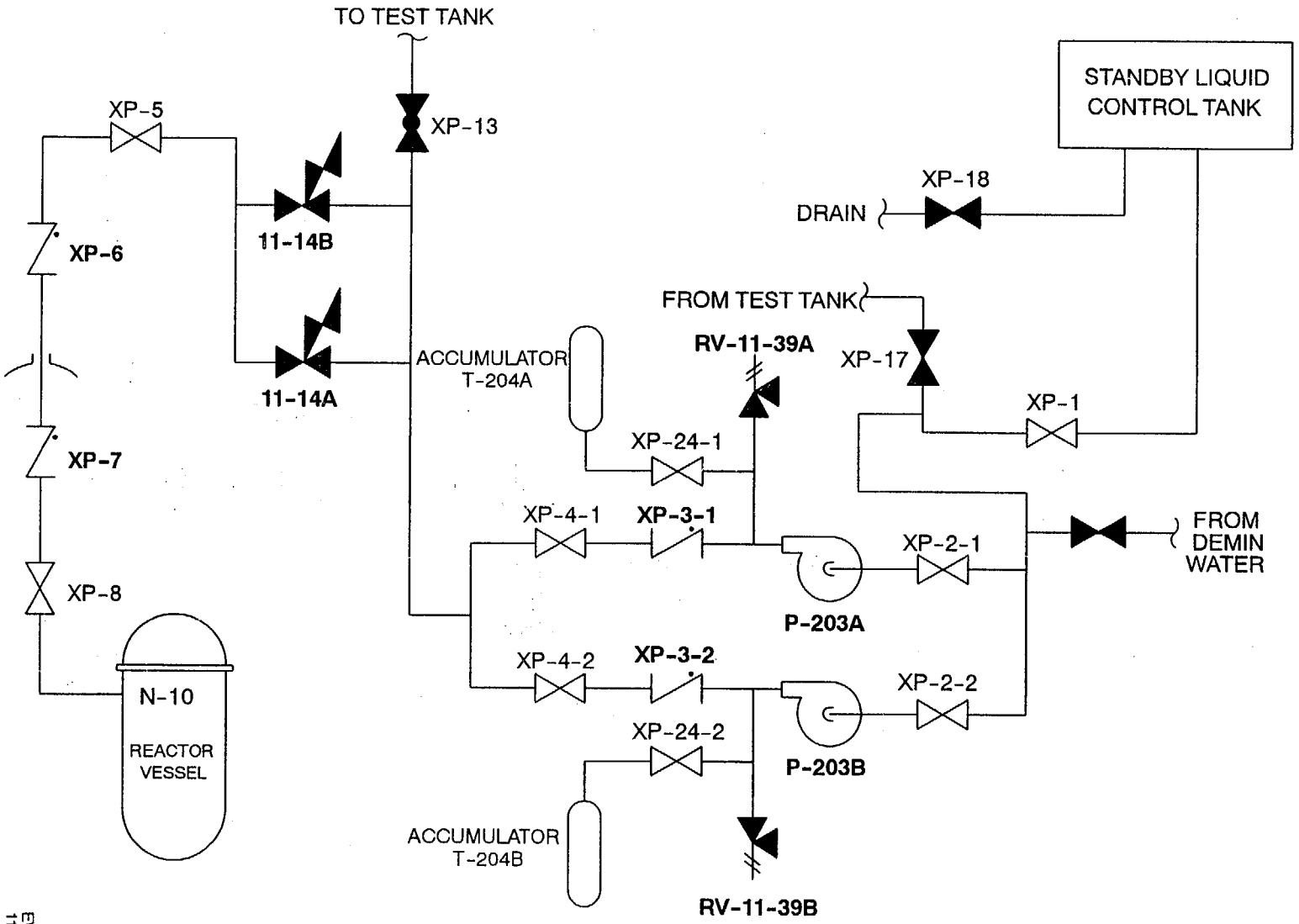

8.11 SBLC

FIGURE

<b>MONTICELLO NUCLEAR GENERATING PLANT</b>	
<b>TITLE: INSERVICE TESTING PROGRAM</b>	
Revision 8	EWI:09.04.01
Page 53 of 122	

EWI-09.04.01-11  
1112 DWG

8.12 Primary Containment Atmospheric Control

FIGURE

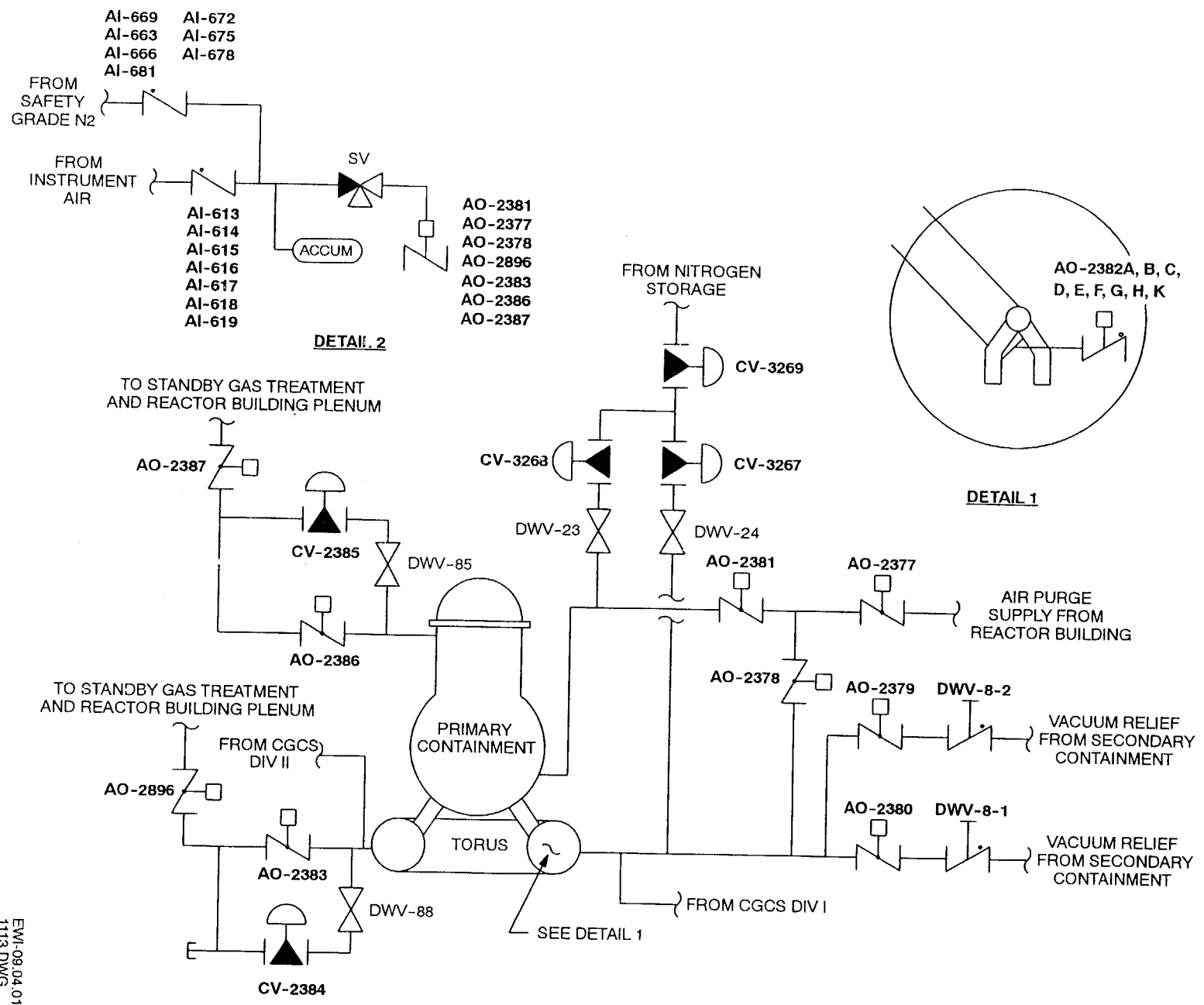

I/kab

EWI-09.04.01-12  
1113 DWG

I/kab

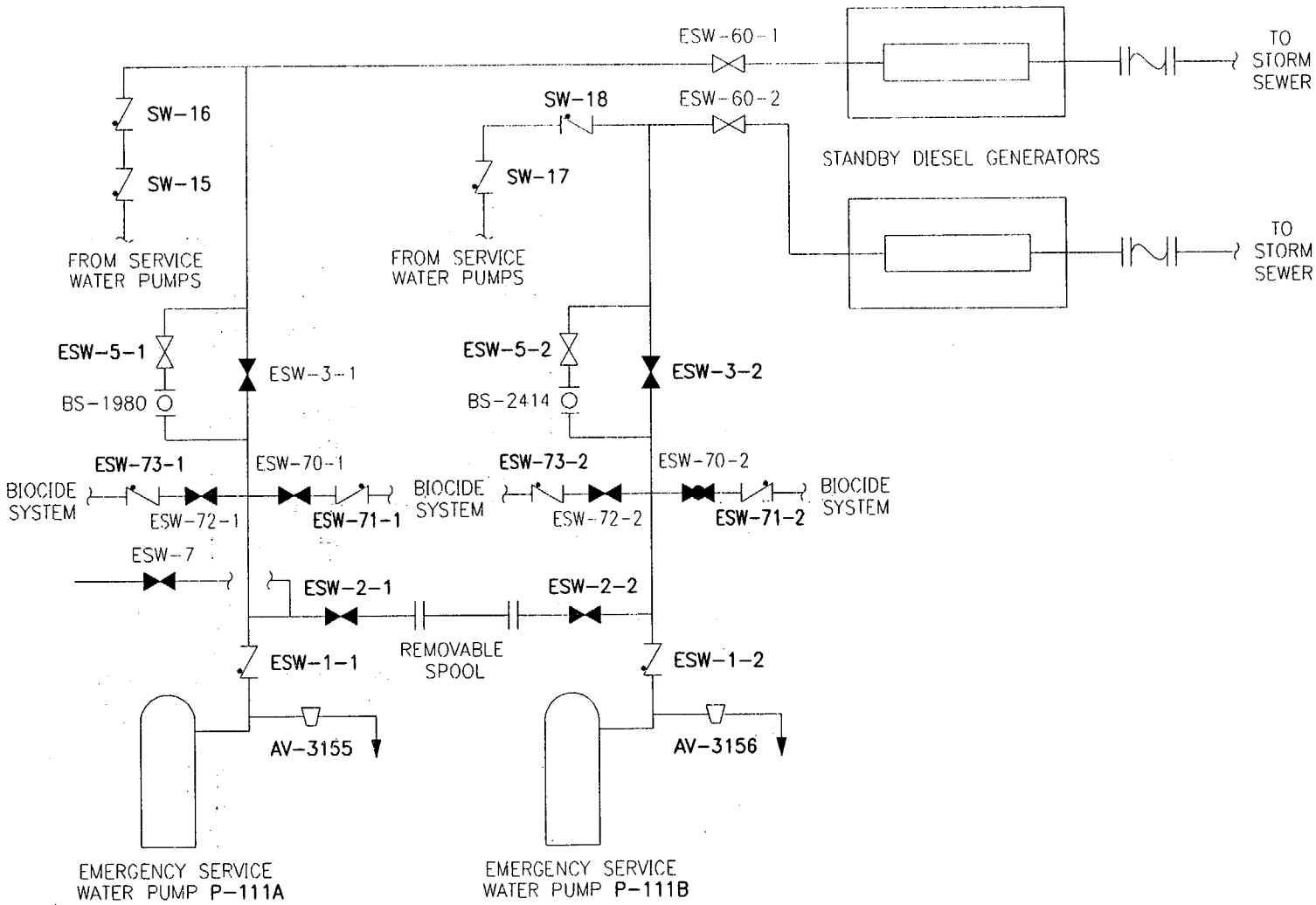

8.13 EDG - ESW

FIGURE

MONTICELLO NUCLEAR GENERATING PLANT		EWI-09.04.01
TITLE: INSERVICE TESTING PROGRAM		Revision 8
		Page 55 of 122



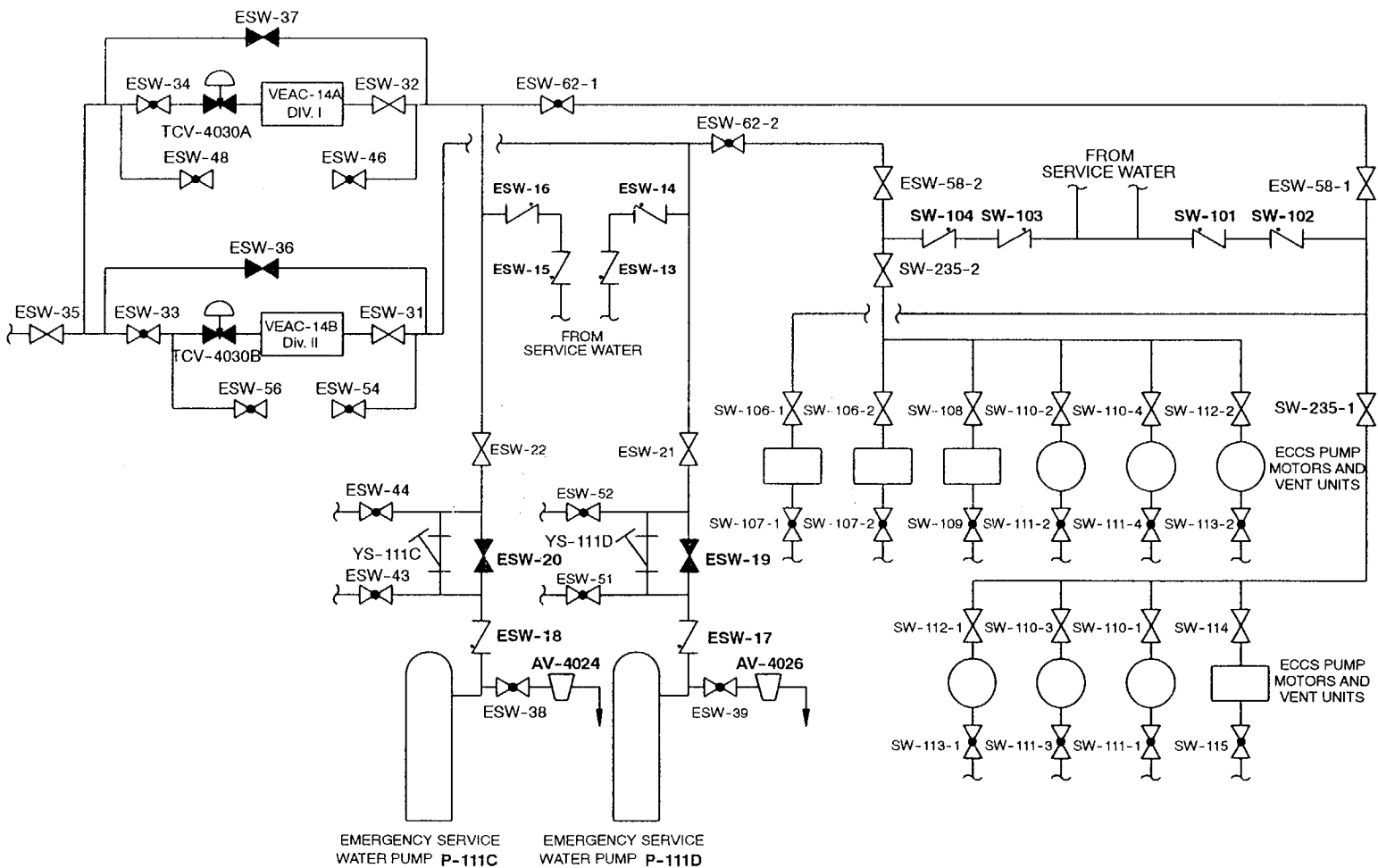

8.14 ESW

FIGURE

**MONTICELLO NUCLEAR GENERATING PLANT**  
**TITLE: INSERVICE TESTING PROGRAM**

Revision 8  
Page 56 of 122

EWI-09.04.01

**MONTICELLO NUCLEAR GENERATING PLANT**  
**TITLE: INSERVICE TESTING PROGRAM**

EWI-09.04.01  
 Revision 8  
 Page 57 of 122

**FIGURE**  
**8.15 RHRSW**

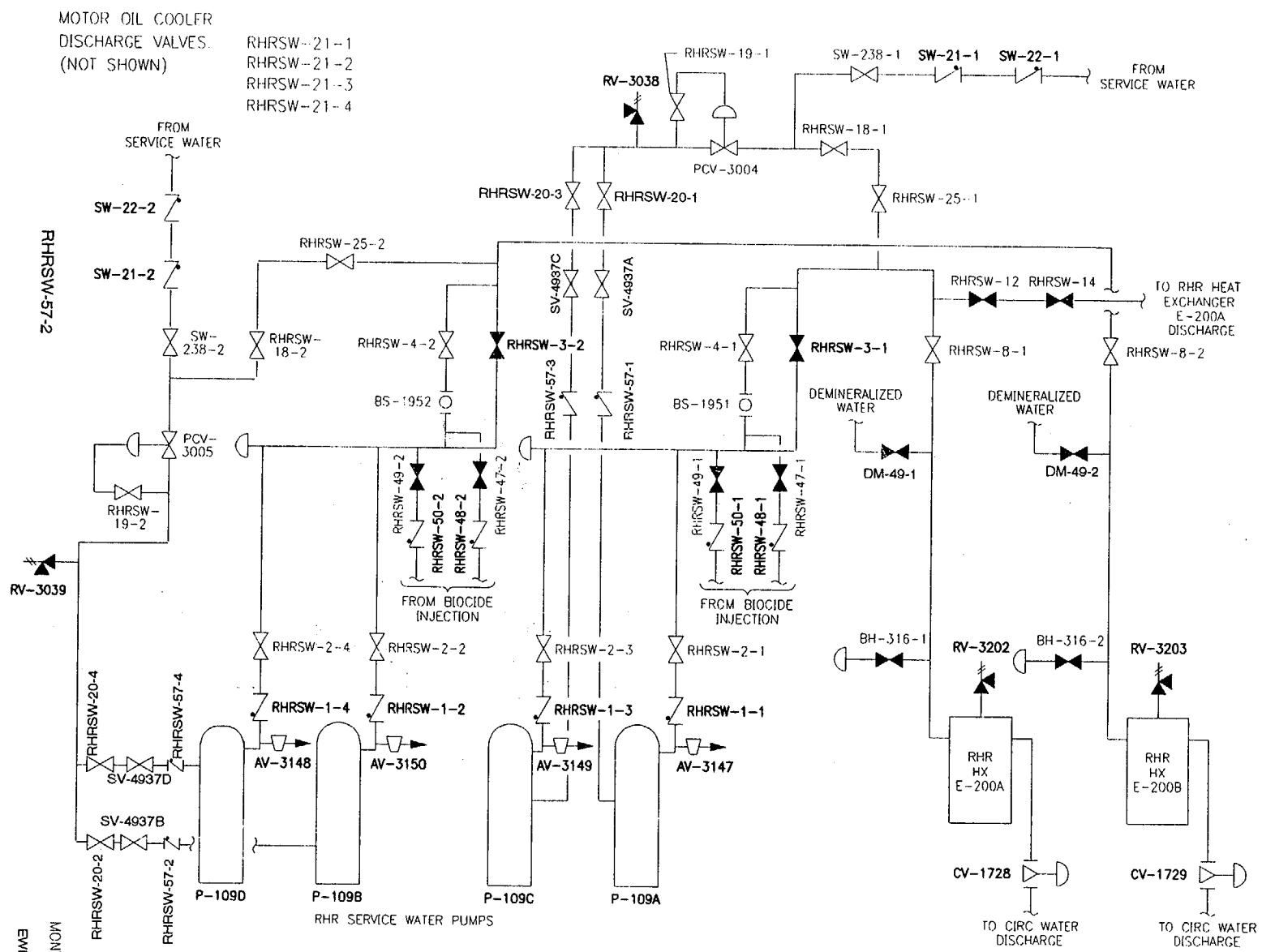

RHRSW-21-1  
 RHRSW-21-2  
 RHRSW-21-3  
 RHRSW-21-4

MOTOR OIL COOLER  
 DISCHARGE VALVES.  
 (NOT SHOWN)

/k/ab

MONTI CAD DWG  
 1116.DWG  
 EWI-09.04.01-15

<b>MONTICELLO NUCLEAR GENERATING PLANT</b>	
<b>TITLE: INSERVICE TESTING PROGRAM</b>	
Revision 8	EWI-09.04.01
Page 58 of 122	

FIGURE

8.16 CRD - HCU

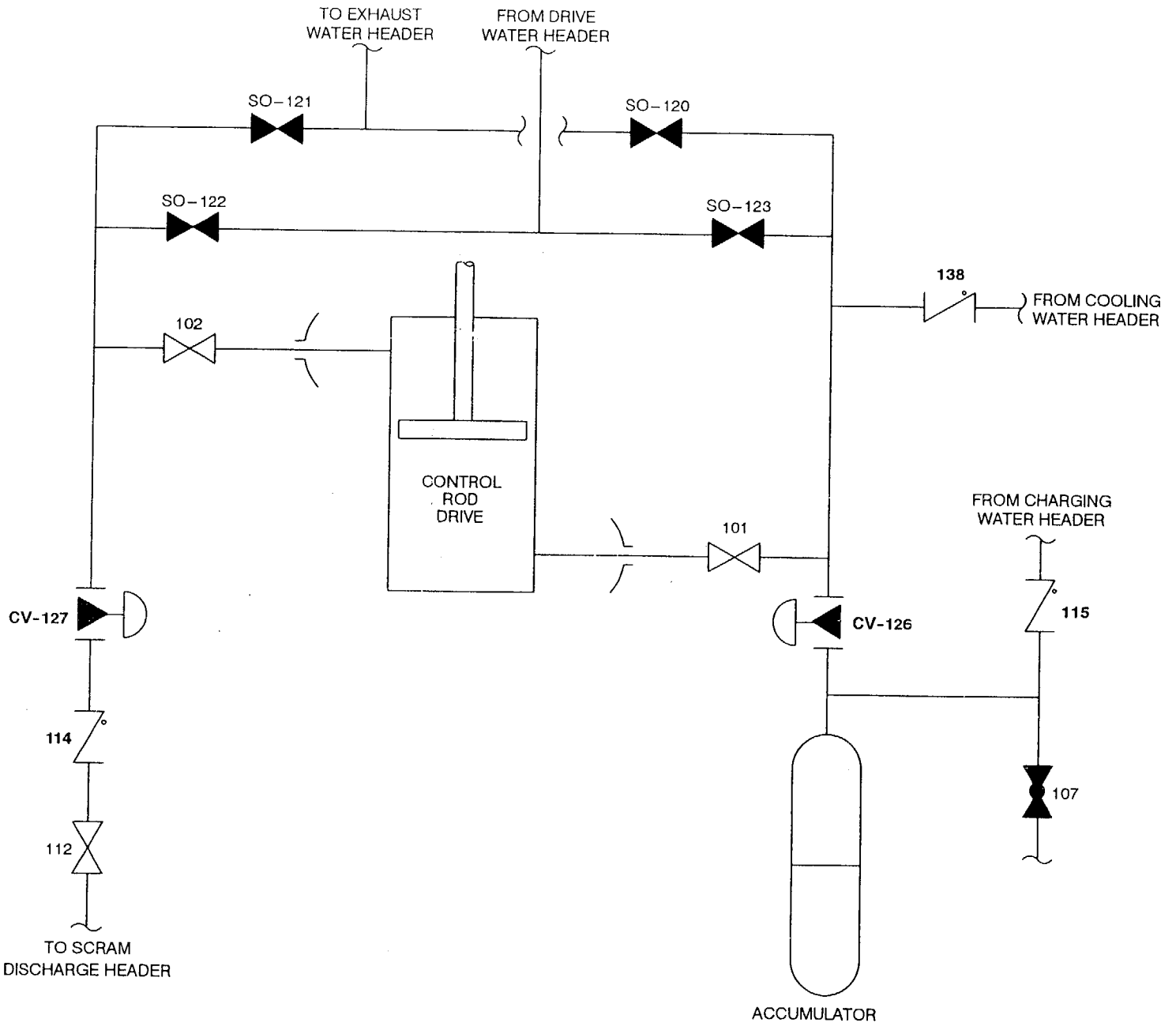

I/kab

<b>MONTICELLO NUCLEAR GENERATING PLANT</b>	
<b>TITLE:</b>	<b>INSERVICE TESTING PROGRAM</b>
Revision 8	EWI-09.04.01
Page 59 of 122	

FIGURE

8.17 CRD-SDV

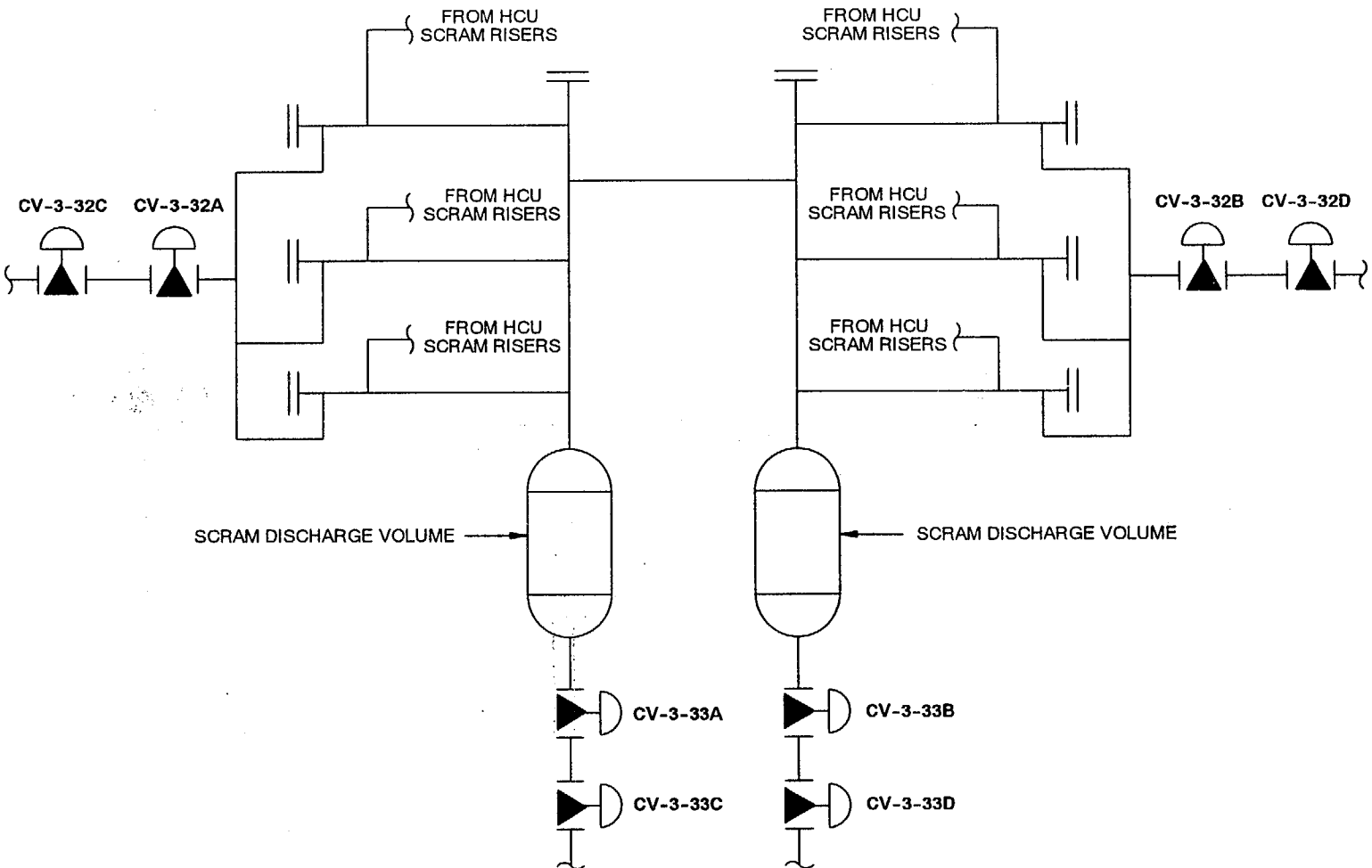

/k/ab

<b>MONTICELLO NUCLEAR GENERATING PLANT</b>	
<b>TITLE:</b>	<b>INSERVICE TESTING PROGRAM</b>
Revision 8	
Page 60 of 122	
EWI-09.04.01	

FIGURE

8.18 Compressed Air/FPCC

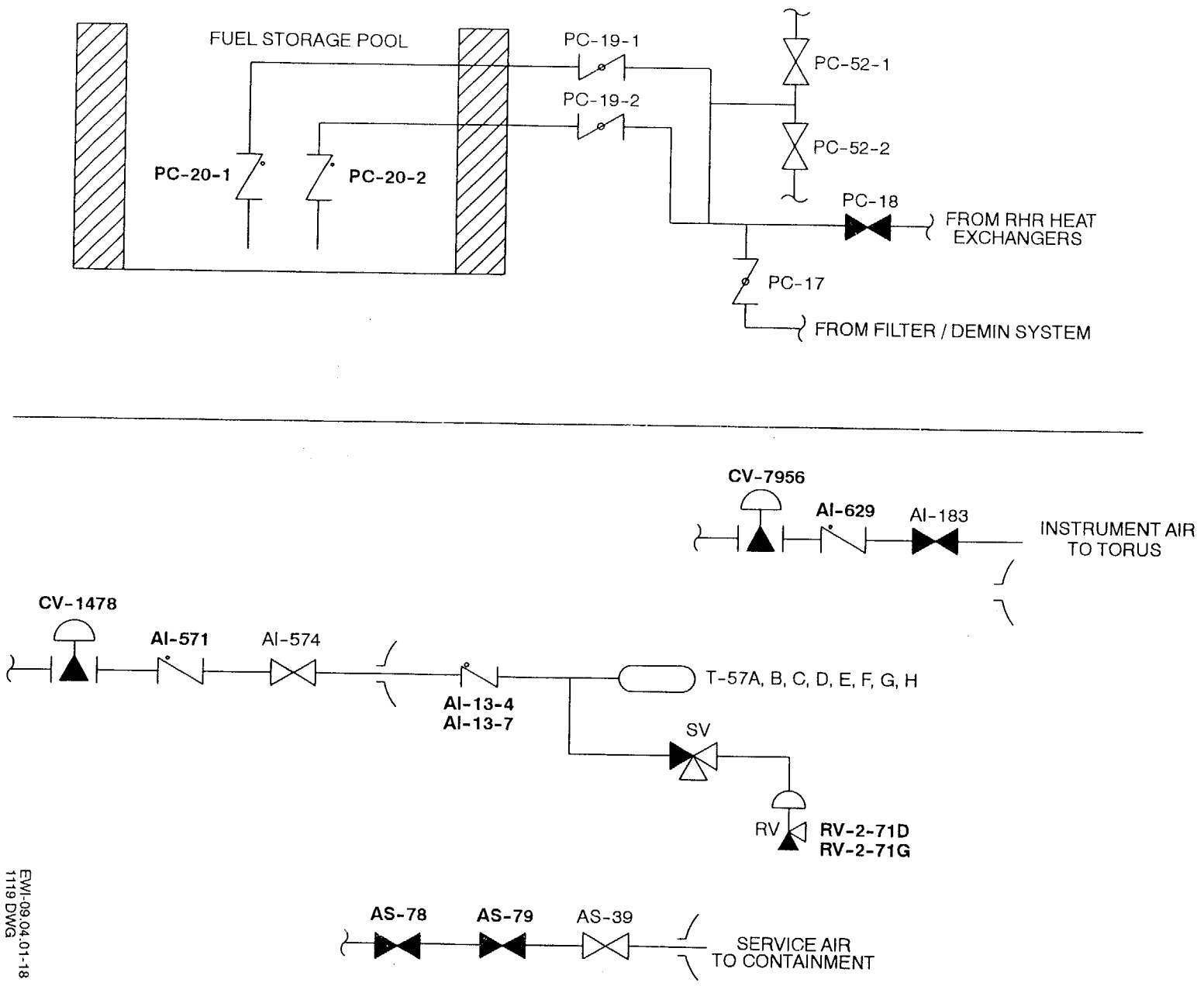

I/kab

EWI-09.04.01-18  
1119 DWG

<b>MONTICELLO NUCLEAR GENERATING PLANT</b>	
<b>TITLE:</b>	<b>INSERVICE TESTING PROGRAM</b>
EWI-09:04.01	
Revision 8	Page 61 of 122

FIGURE

8.19 RBCCW/CST

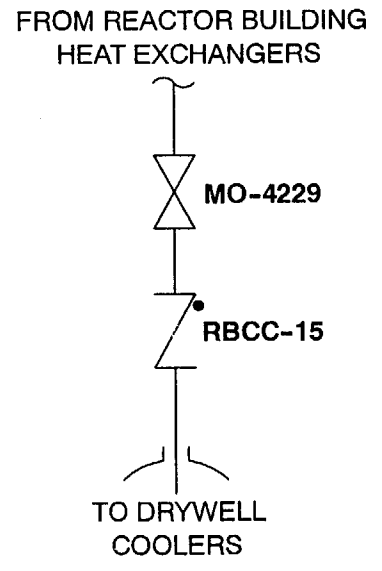
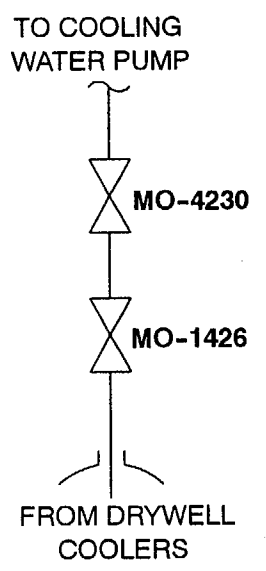
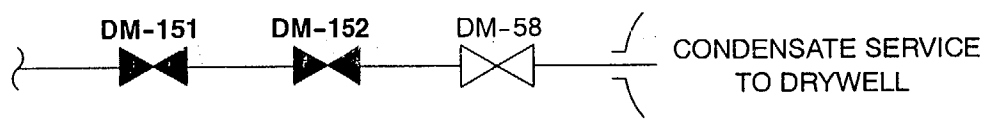

I/kab

<b>MONTICELLO NUCLEAR GENERATING PLANT</b>	
<b>TITLE:</b>	<b>INSERVICE TESTING PROGRAM</b>
Revision 8	
Page 62 of 122	
EWI-09.04.01	

8.20 Liquid Radwaste/RWCU

FIGURE

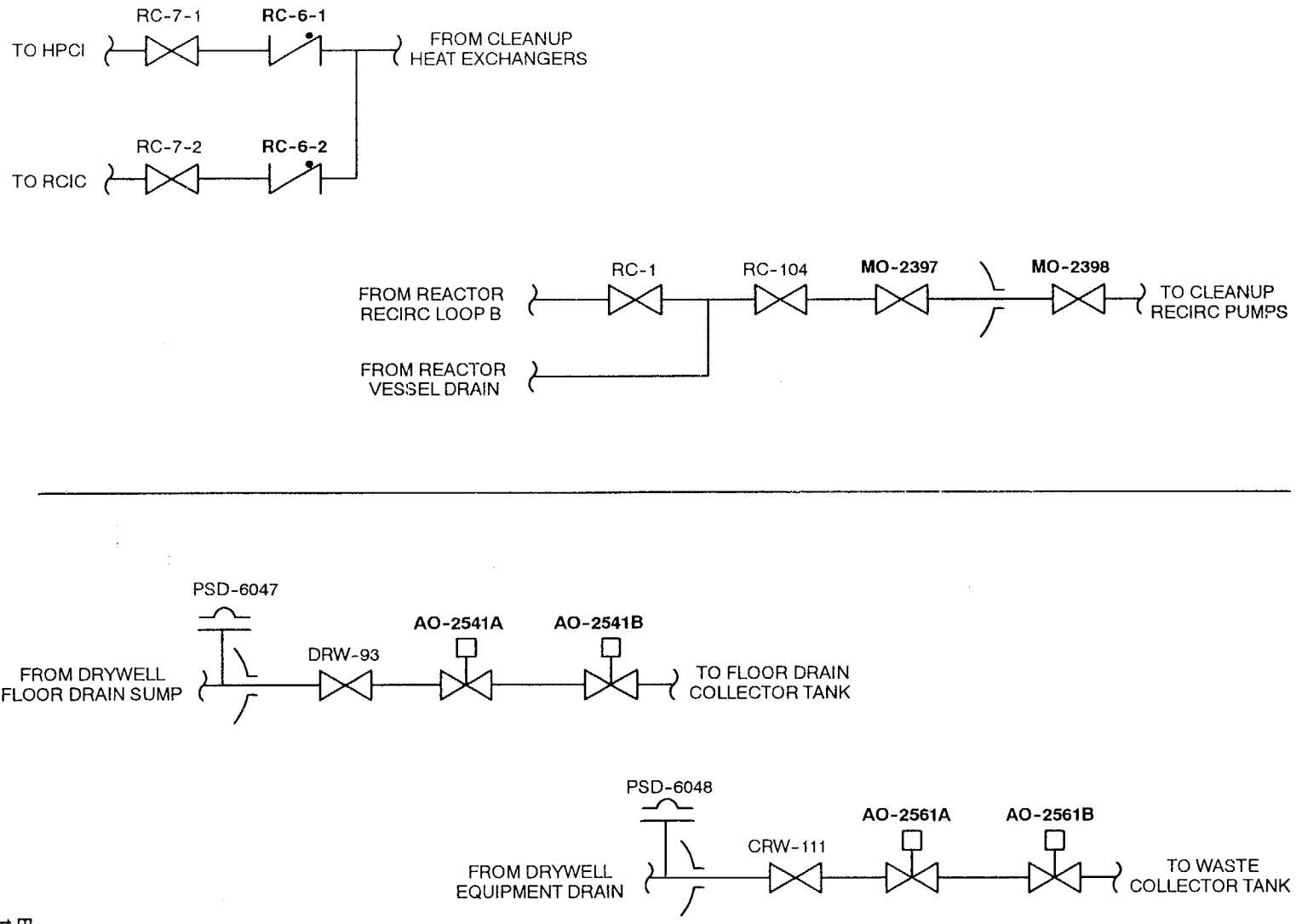

I/kab

EWI-09.04.01-20  
1121 DWG

FIGURE

8.21 TIP

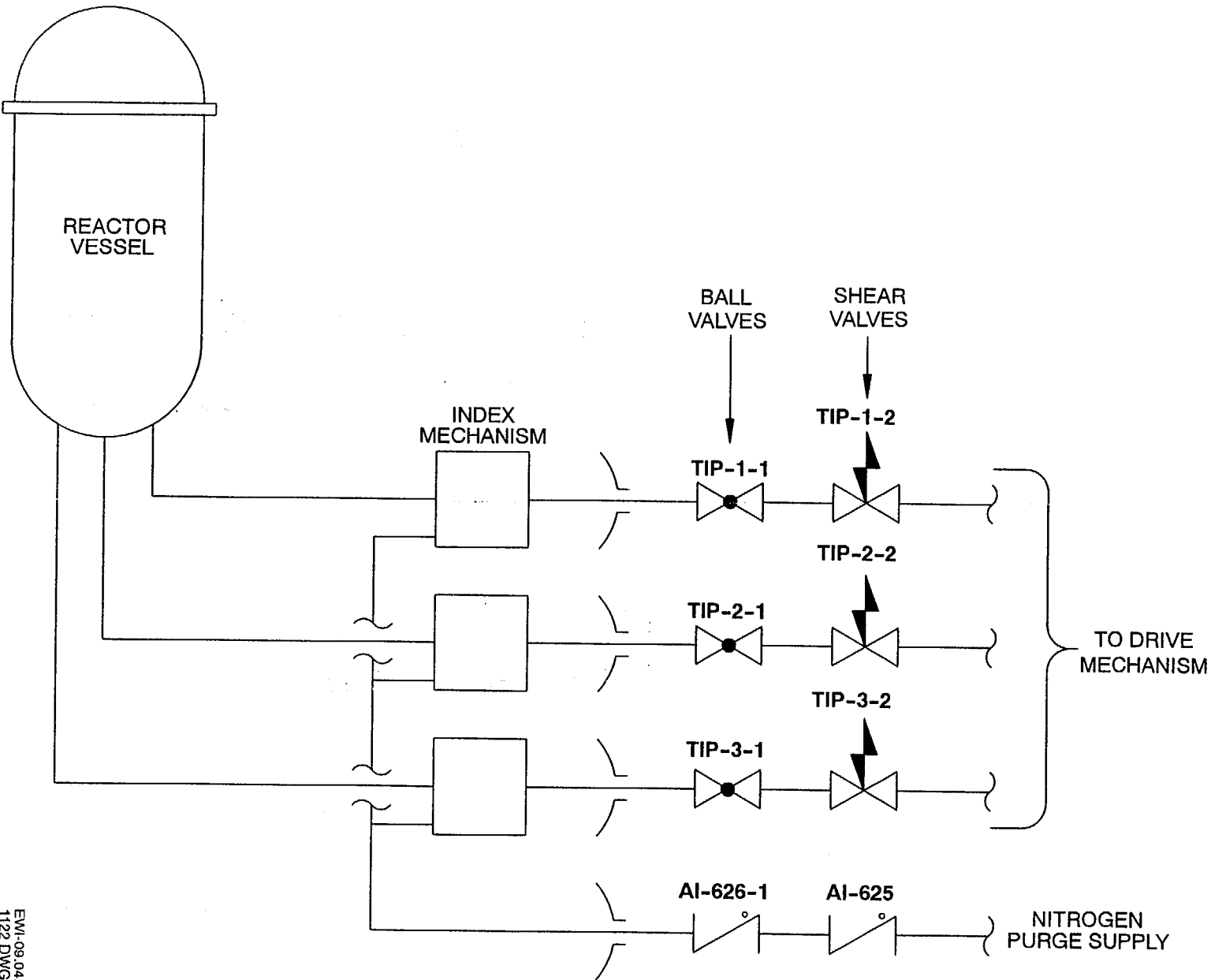

I/kab



<b>MONTICELLO NUCLEAR GENERATING PLANT</b>	
<b>TITLE:</b>	<b>INSERVICE TESTING PROGRAM</b>
Revision 8	
Page 64 of 122	
EWI-09.04.01	

FIGURE

8.22 Excess Flow Check Valves

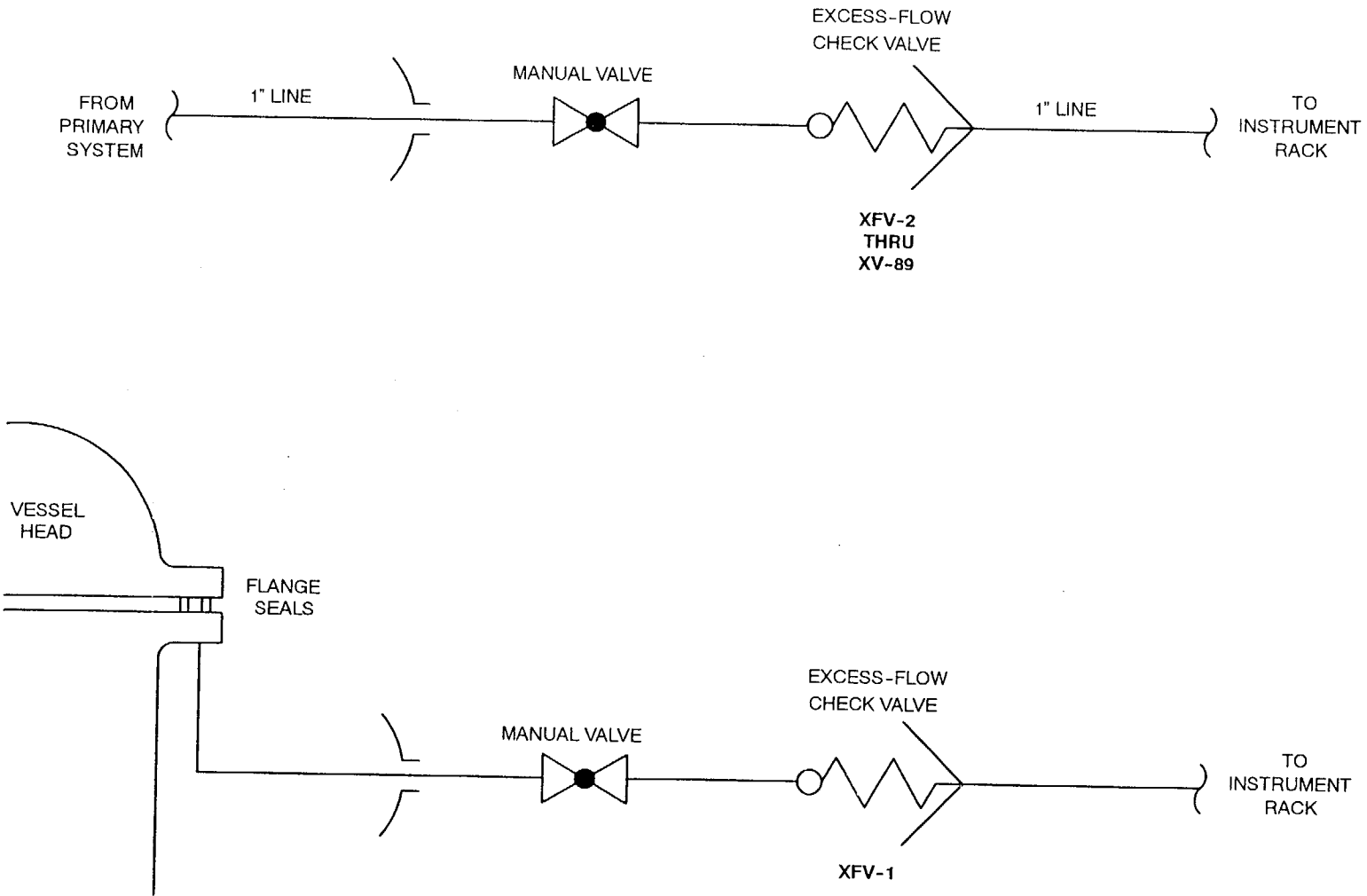

I/kab

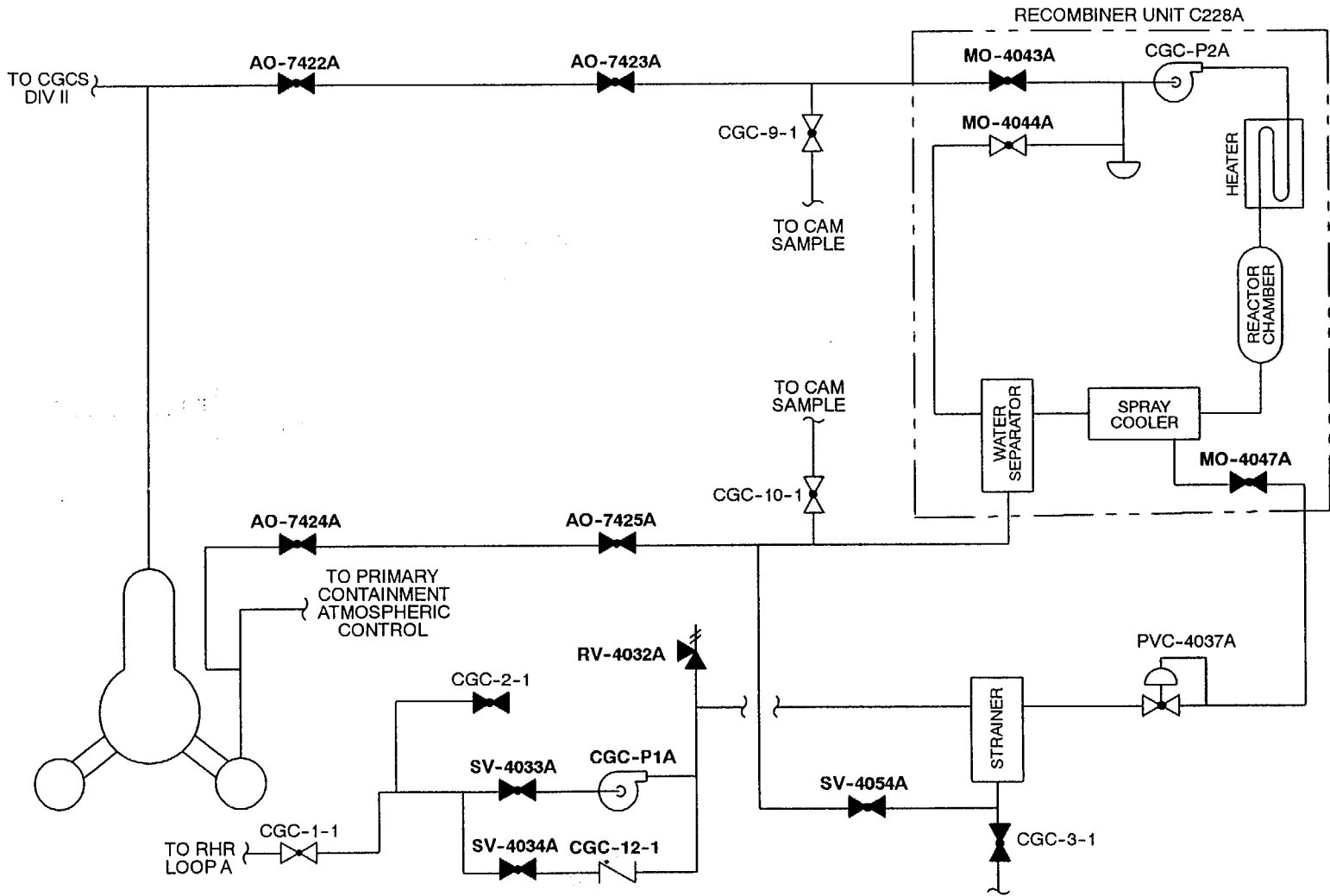

8.23 CGC, DIV I

FIGURE

**MONTICELLO NUCLEAR GENERATING PLANT**  
**TITLE: INSERVICE TESTING PROGRAM**

Revision 8  
Page 65 of 122  
EWI-09.04.01

<b>MONTICELLO NUCLEAR GENERATING PLANT</b>		<b>EWI-09 04.01</b>
<b>TITLE: INSERVICE TESTING PROGRAM</b>		<b>Revision 8</b>
		<b>Page 66 of 122</b>

**FIGURE**

**8.24 CGC, DIV II**

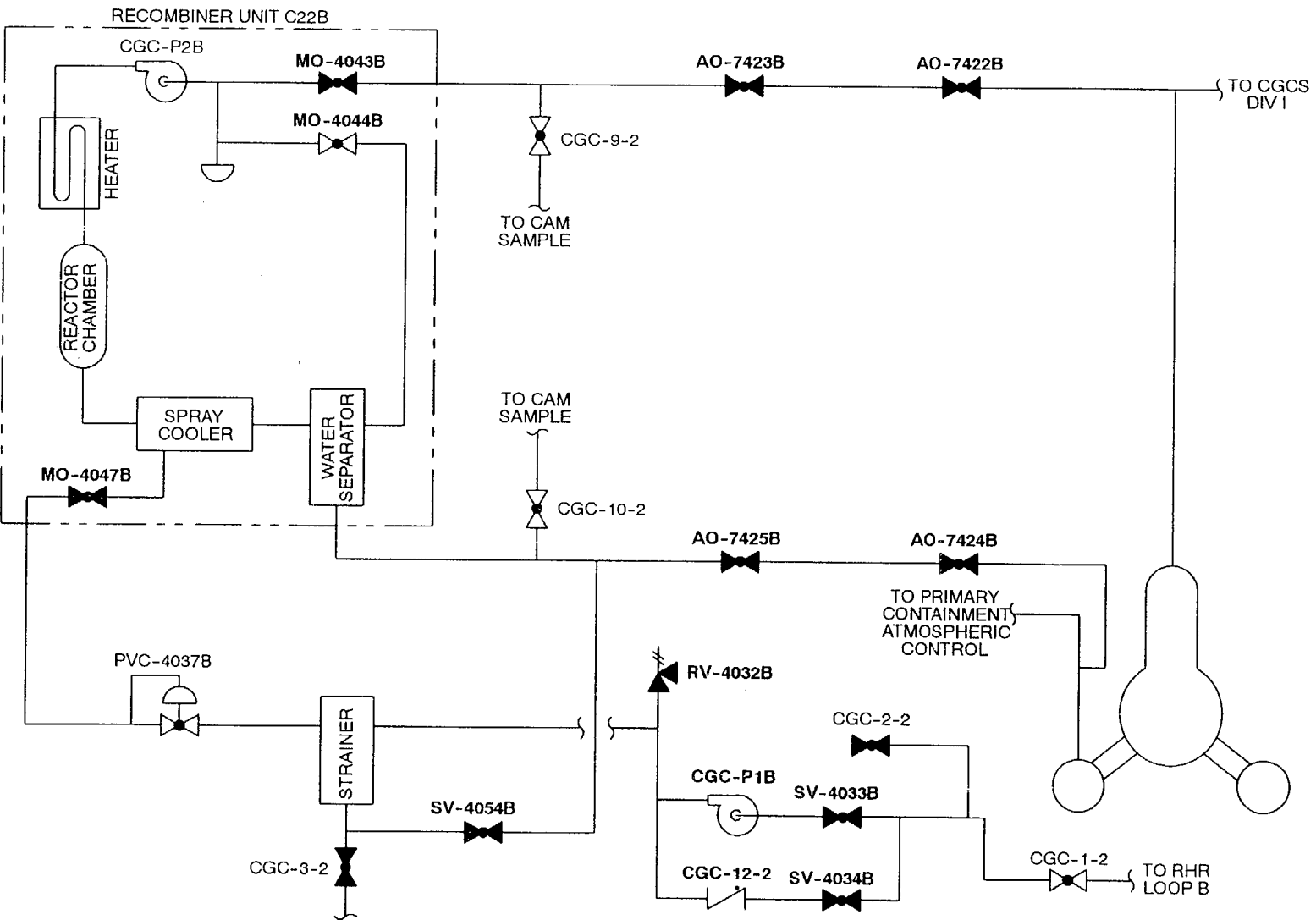

I/kab

EWI-09 04.01-24  
1125 DWG

FIGURE

8.25 Primary Containment Sampling

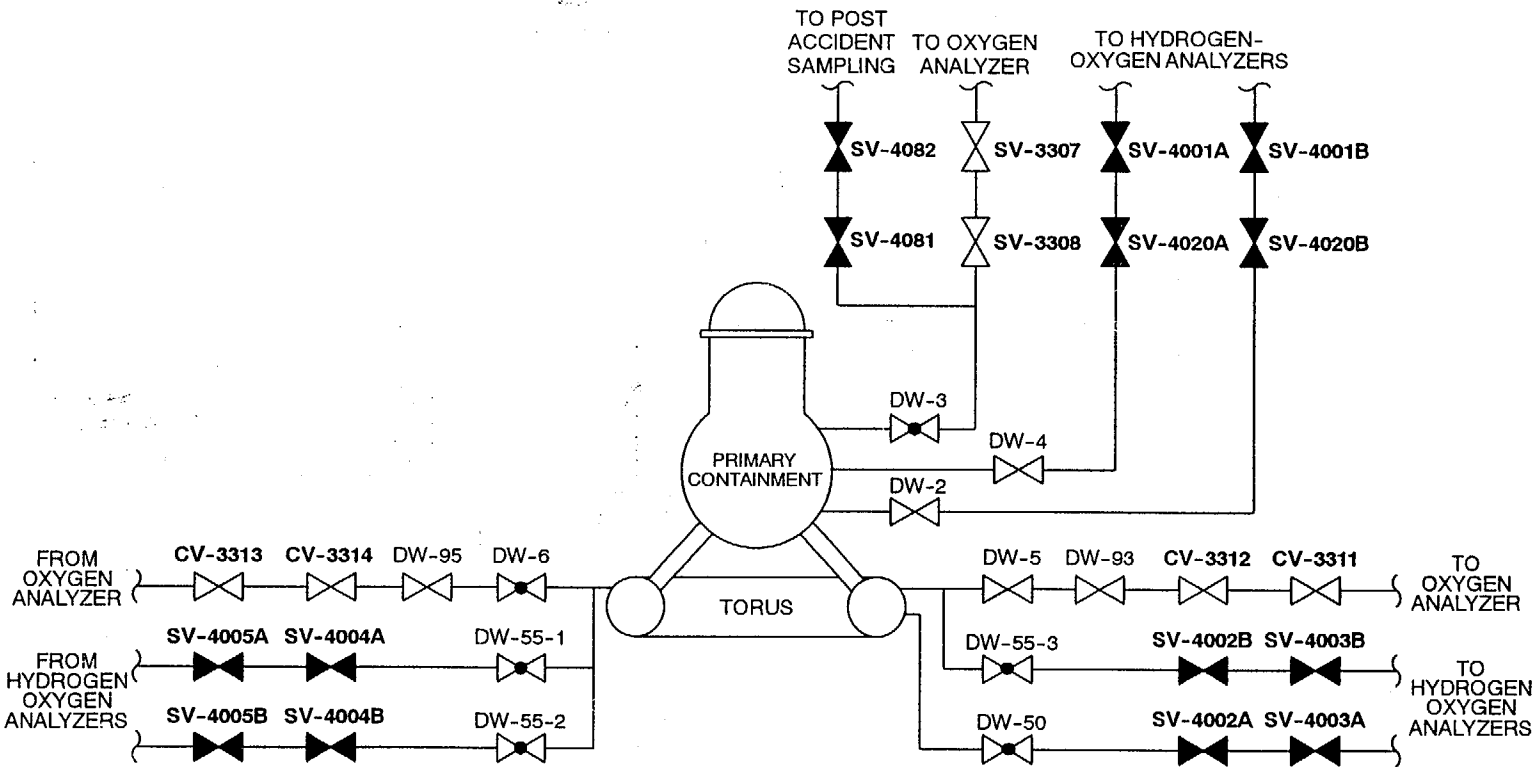

I/kab

**FIGURE**

**8.26 Diesel Generator Auxiliaries**

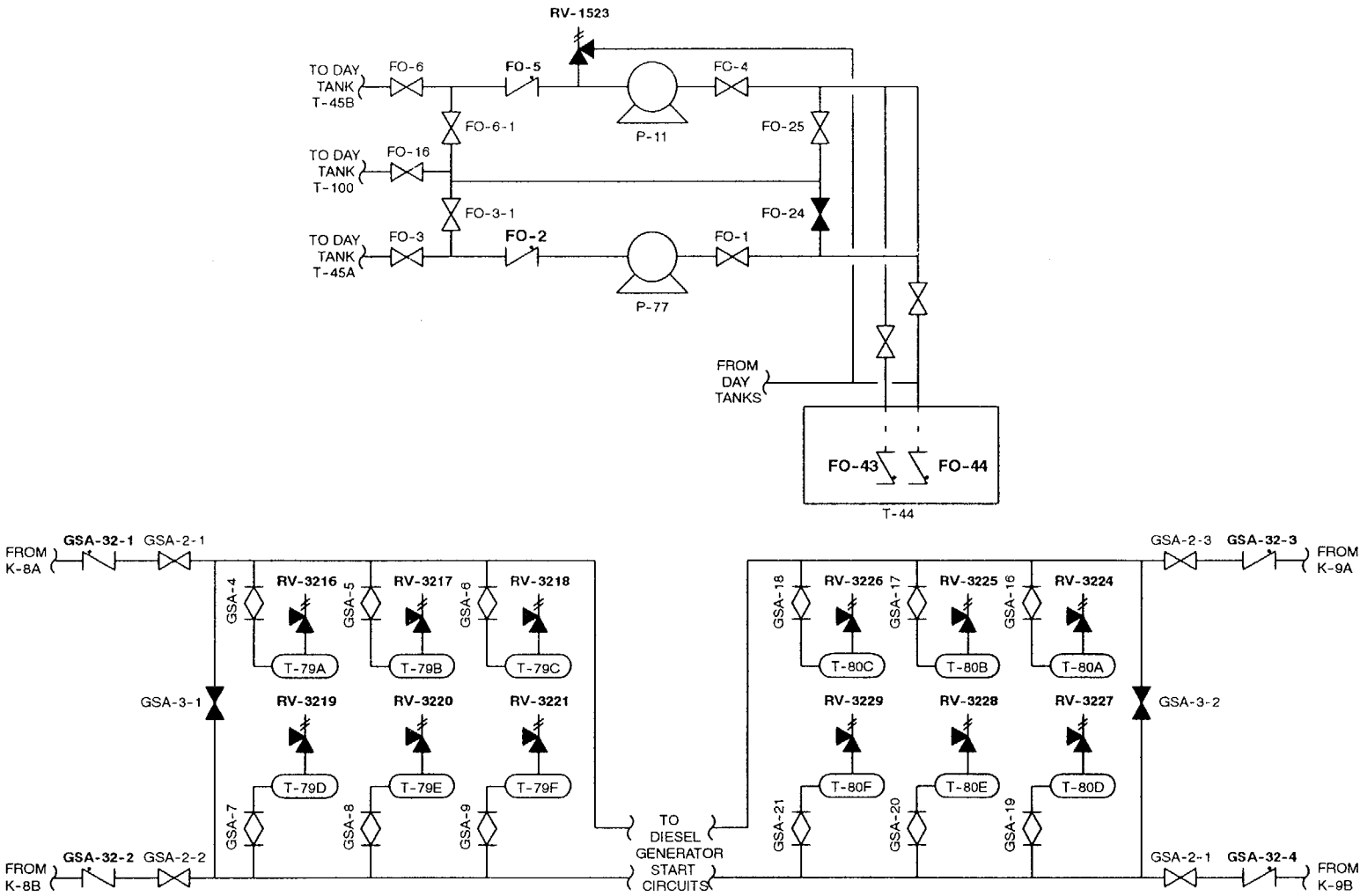

I/kab

FIGURE

8.27 Mechanical Vac Pump/Recirc Seal Inj

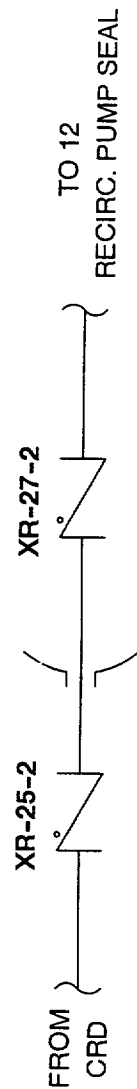
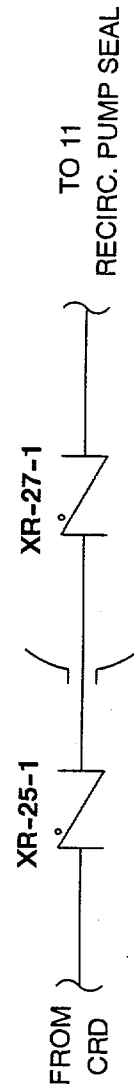
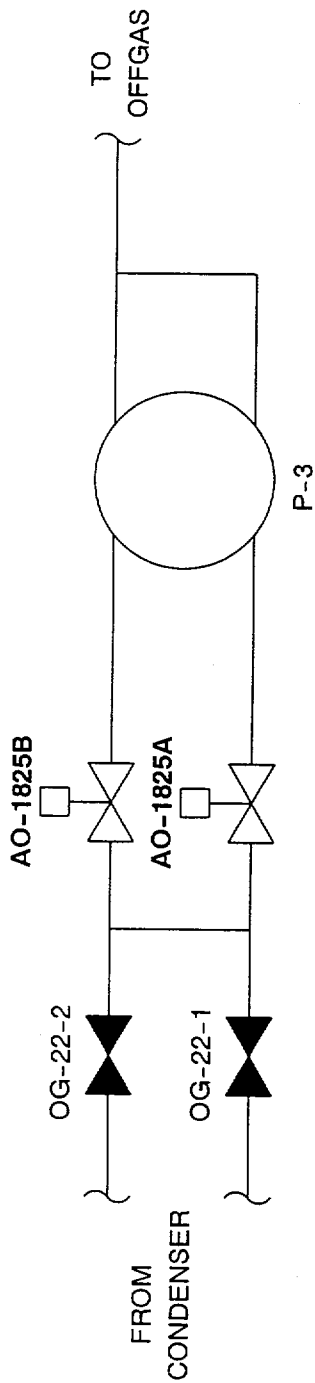

I/kab

**FIGURE**

**8.28 Level Inst Backfill / Hard Pipe Vent**

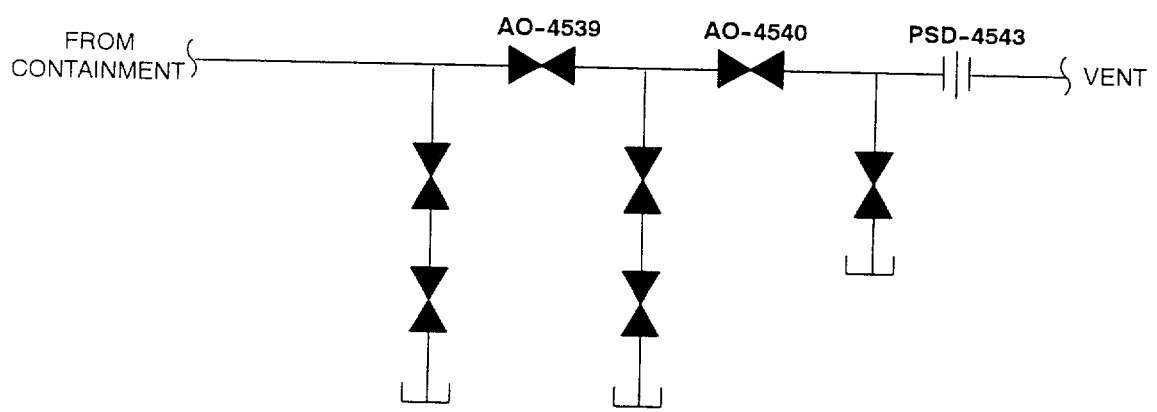
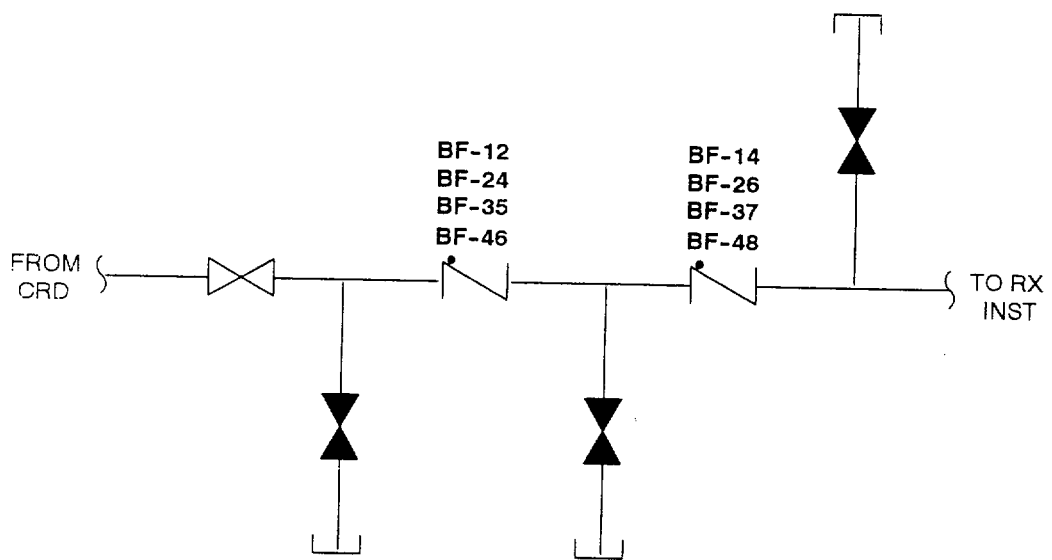

FIGURE

8.29 Safety Grade N2

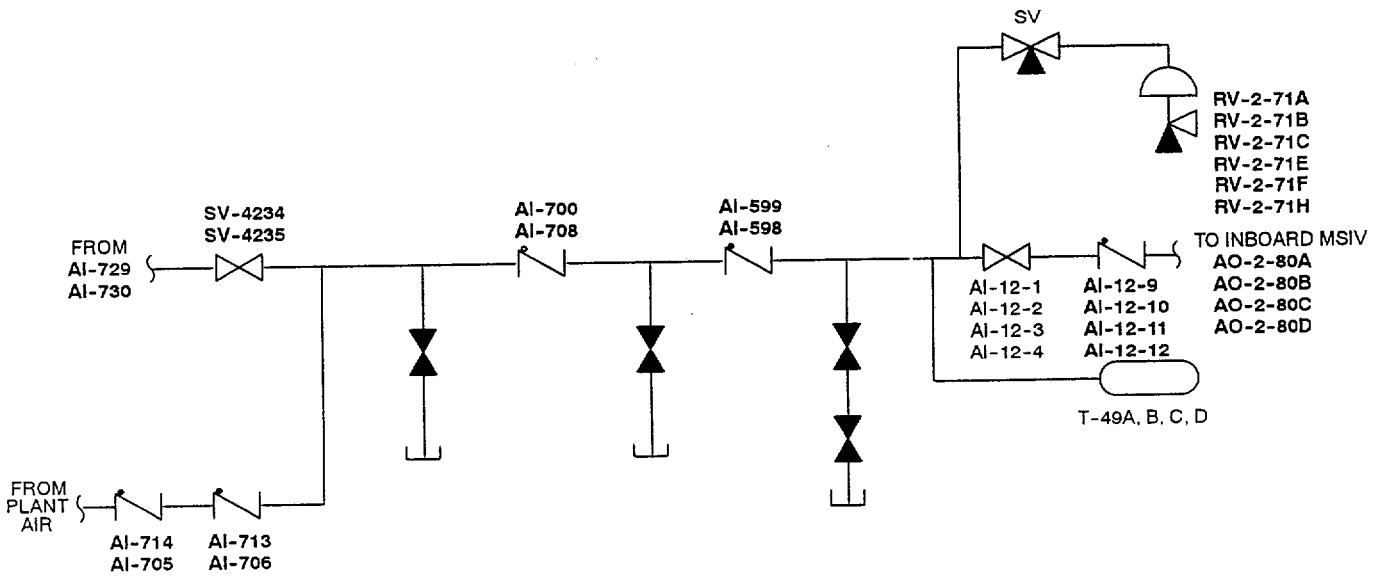



<b>MONTICELLO NUCLEAR GENERATING PLANT</b>		EWI-09.04.01
<b>TITLE:</b>	<b>INSERVICE TESTING PROGRAM</b>	Revision 8
		Page 72 of 122

**9.0 ATTACHMENTS**

ATTACHMENT

**9.1 Pump Testing Table**

Pump P&ID No.	Pump Number	Pump Name	ASME Class	Parameter to be Measured				Relief Req No.
				Speed <sup>1</sup>	Delta <sup>2</sup> Press	Vibration	Flow	
M-120	P-202B	RHR	2	NA	X	X	X	4.1.2
M-120	P-202D	RHR	2	NA	X	X	X	4.1.2
M-121	P-202A	RHR	2	NA	X	X	X	4.1.2
M-121	P-202C	RHR	2	NA	X	X	X	4.1.2
M-122	P-208A	Core Spray	2	NA	X	X	X	
M-122	P-208B	Core Spray	2	NA	X	X	X	
M-124	P-209	HPCI	2	X	X	X	X	4.1.3,4.1.5
M-126	P-207	RCIC	2	X	X	X	X	4.1.5
M-127	P-203A	SLC	2	NA	X	X	X	4.1.1
M-127	P-203B	SLC	2	NA	X	X	X	4.1.1
M-133	P-11	DOTP	NONE	NA	X	X	X	
M-811	P-109A	RHRSW	3	NA	X	X	X	4.1.2,4.1.4
M-811	P-109B	RHRSW	3	NA	X	X	X	4.1.2,4.1.4
M-811	P-109C	RHRSW	3	NA	X	X	X	4.1.2,4.1.4
M-811	P-109D	RHRSW	3	NA	X	X	X	4.1.2,4.1.4
M-811	P-111A	ESW	3	NA	X	X	X	4.1.4
M-811	P-111B	ESW	3	NA	X	X	X	4.1.4
M-811	P-111C	ESW	3	NA	X	X	X	4.1.4
M-811	P-111D	ESW	3	NA	X	X	X	4.1.4
NH-94896	CGCP-1A	CGC	3	NA	X	X	X	
NH-94897	CGCP-1B	CGC	3	NA	X	X	X	

**NOTE 1:** Not applicable to constant speed pumps.

**NOTE 2:** Discharge pressure is used for positive displacement pumps P-203A, P-203B and P-11.

ATTACHMENT9.2 Valve Table Symbols

## SYMBOLS USED TO DESIGNATE VALVE TYPE

<u>Symbol</u>	<u>Meaning</u>
CK	Check Valve
BF	Butterfly Valve
GT	Gate Valve
GL	Globe Valve
RV	Pressure Relief Valve
RD	Rupture Disk
AN	Angle Valve
PL	Plug Valve
SC	Stop Check
XP	Explosive Shear Valve
DI	Diaphragm
AR	Air Relief
BA	Ball Valve
FV	Excess Flow Check Valve

## SYMBOLS USED TO DESIGNATE VALVE ACTUATOR TYPE

<u>Symbol</u>	<u>Meaning</u>
MO	Motor
AO	Air
SO	Solenoid
MA	Manual
SA	Self Actuating

## SYMBOLS USED TO DESIGNATE VALVE POSITION

<u>Symbols</u>	<u>Meaning</u>
O	Open
C	Closed

**NOTE:** Monticello Nuclear Plant may revise, without notice, the identified positions listed in "Normal Position" and "Safety Position" based on changes in valves function/system configuration.

<b>MONTICELLO NUCLEAR GENERATING PLANT</b>		<b>EWI-09.04.01</b>
<b>TITLE:</b>	<b>INSERVICE TESTING PROGRAM</b>	Revision 8
		Page 74 of 122

ATTACHMENT

**9.2 Valve Table Symbols (Cont'd)**

SYMBOLS USED TO DESIGNATE TESTING REQUIREMENT

<u>Symbol</u>	<u>Meaning</u>
CE	Control valve exercise per IWV-3412, performed quarterly.
DI	Disassemble and inspect the valve each refueling outage as allowed by OM-10 and 10CFR50.55a(f)(4)(iv), unless otherwise noted.
EX	Explosive valve test per IWV-3610.
FC	Stroke Test per IWV-3400/3520, on a cold shutdown frequency (with stroke time measurement, as appropriate).
FE	Full stroke test on a quarterly frequency (with stroke time measurement as appropriate) per IWV-3400, or full stroke test of check valves per IWV-3520.
FR	Stroke test per IWV-3400, on a refueling frequency (with stroke time measurement, as appropriate), as allowed by OM-10 and 10CFR50.55a(f)(4)(iv), or a relief request.
FS	Fail safe test per IWV-3415.
LJ	Leak test per 10CFR50, App J, performed during refueling outages.
LK	Leak test per IWV-3420, performed during refueling outages.
PC	Partial stroke exercise test on a cold shutdown frequency as allowed by OM-10 and 10CFR50.55a(f)(4)(iv).
PE	Partial stroke exercise test on a quarterly frequency.
PI	Position indicator test per IWV-3300, performed during refueling outages.
RD	Rupture disk test per IWV-3620.
RR	See relief request for testing details.
SP	Periodic relief valve test per ASME/ANSI OM-1, 1981.

SYMBOLS USED TO DESIGNATE SECTION XI VALVE CATEGORY

<u>Symbol</u>	<u>Meaning</u>
A	Valves with specified maximum seat leakage rate.
B	Valves with no specified maximum seat leakage rate.
C	Self-actuating (check, relief valves).
D	Actuated by energy source capable of only one operation (rupture disks, explosive valves).

I/kab

ATTACHMENT**9.2 Valve Table Symbols (Cont'd)**

## SYMBOLS USED TO DESIGNATE ACTIVE AND PASSIVE VALVES

<u>Symbol</u>	<u>Meaning</u>
1	Active - valves which are required to change position to accomplish a specific function.
2	Passive - valves which are not required to change position to accomplish a specific function.

## MISCELLANEOUS SYMBOLS

<u>Symbol</u>	<u>Meaning</u>
DTJ	Deferred Testing Justification
TJ	Technical Justification

<b>MONTICELLO NUCLEAR GENERATING PLANT</b>		<b>EWI-09.04.01</b>
<b>TITLE:</b>	<b>INSERVICE TESTING PROGRAM</b>	Revision 8
		Page 76 of 122

ATTACHMENT

**9.3 Valve Testing Table**

<b>SYSTEM: Steam Jet Air Ejectors</b>									<b>P&amp;ID NO.: M-104-2</b>		
Valve No.	ASME Class	P&ID Coord	Sect XI Cat	Size (in.)	Vlv Type	Act Type	Norm Pos	Safety Pos	Req'd Tests	Rel Req, DTJ or TJ	Tests Pfrmd
AO-1825A	None	B-3	B-1	6	BF	AO	C	C	FE	5.1	FC
AO-1825B	None	B-3	B-1	6	BF	AO	C	C	FE	5.1	FC

<b>MONTICELLO NUCLEAR GENERATING PLANT</b>		<b>EWI-09.04.01</b>
<b>TITLE:</b>	<b>INSERVICE TESTING PROGRAM</b>	Revision 8
		Page 77 of 122

ATTACHMENT

**9.3 Valve Testing Table (Cont'd)**

<b>SYSTEM: Condensate &amp; Demineralized Water Storage System</b>									<b>P&amp;ID NO.: M-108</b>		
Valve No.	ASME Class	P&ID Coord	Sect XI Cat	Size (in.)	Vlv Type	Act Type	Norm Pos	Safety Pos	Req'd Tests	Rel Req, DTJ or TJ	Tests Pfrmd
DM-151	2	E-1	A-2	1	GT	MA	C	C	LJ		LJ
DM-152	2	E-1	A-2	1	GT	MA	C	C	LJ		LJ

<b>MONTICELLO NUCLEAR GENERATING PLANT</b>		EWI-09.04.01
<b>TITLE:</b>	<b>INSERVICE TESTING PROGRAM</b>	Revision 8
		Page 78 of 122

ATTACHMENT

**9.3 Valve Testing Table (Cont'd)**

SYSTEM: Reactor Building Cooling Water System									P&ID NO.: M-111		
Valve No.	ASME Class	P&ID Coord	Sect XI Cat	Size (in.)	Vlv Type	Act Type	Norm Pos	Safety Pos	Req'd Tests	Rel Req, DTJ or TJ	Tests Pfrmd
MO-1426	2	E-4	A-1	8	GT	MO	O	C	FE,LJ, PI	5.2	FC,LJ, PI
MO-4229	2	E-4	A-1	8	GT	MO	O	C	FE,LJ, PI	5.2	FC,LJ, PI
MO-4230	2	E-3	A-1	8	GT	MO	O	C	FE,LJ, PI	5.2	FC,LJ, PI
RBCC-15	2	E-3	A,C-1	8	CK	SA	O	C	FE,LJ	4.2.1	FR,LJ

<b>MONTICELLO NUCLEAR GENERATING PLANT</b>		<b>EWI-09.04.01</b>
<b>TITLE:</b>	<b>INSERVICE TESTING PROGRAM</b>	Revision 8
		Page 79 of 122

ATTACHMENT

**9.3 Valve Testing Table (Cont'd)**

<b>SYSTEM: RHR Service Water</b>									<b>P&amp;ID NO.: M-112</b>		
Valve No.	ASME Class	P&ID Coord	Sect XI Cat	Size (in.)	Vlv Type	Act Type	Norm Pos	Safety Pos	Req'd Tests	Rel Req, DTJ or TJ	Tests Pfrmd
RV-3202	3	C-5	C-1	2.5	RV	SA	C	O	SP		SP
RV-3203	3	C-4	C-1	2.5	RV	SA	C	O	SP		SP
CV-1728	3	A-5	B-1	12	GL	AO	C	O	CE	4.2.20	CE
CV-1729	3	A-4	B-1	12	GL	AO	C	O	CE	4.2.20	CE



<b>MONTICELLO NUCLEAR GENERATING PLANT</b>		<b>EWI-09.04.01</b>
<b>TITLE:</b>	<b>INSERVICE TESTING PROGRAM</b>	Revision 8
		Page 80 of 122

ATTACHMENT

**9.3 Valve Testing Table (Cont'd)**

SYSTEM: Emergency Service Water Systems									P&ID NO.: M-112		
Valve No.	ASME Class	P&ID Coord	Sect XI Cat	Size (in.)	Vlv Type	Act Type	Norm Pos	Safety Pos	Req'd Tests	Rel Req, DTJ or TJ	Tests Pfrmd
SW-101	None	E-1	C-1	3	CK	SA	O	C	FE	4.2.2	RR
SW-102	3	E-1	C-1	3	CK	SA	O	C	FE	4.2.2	RR
SW-103	None	E-3	C-1	3	CK	SA	O	C	FE	4.2.2	RR
SW-104	3	E-3	C-1	3	CK	SA	O	C	FE	4.2.2	RR

**ATTACHMENT****9.3 Valve Testing Table (Cont'd)**

SYSTEM: Service Condensate System									P&ID NO.: M-114-1		
Valve No.	ASME Class	P&ID Coord	Sect XI Cat	Size (in.)	Vlv Type	Act Type	Norm Pos	Safety Pos	Req'd Tests	Rel Req, DTJ or TJ	Tests Pfrmd
CST-88	2	B-5	C-1	2	CK	SA	O	C	FE	4.2.3	RR
CST-90	2	B-5	C-1	2	CK	SA	O	C	FE	5.22	DI
CST-92	2	B-5	C-1	2	CK	SA	O	C	FE	4.2.3	RR
CST-94	2	B-5	C-1	2	CK	SA	O	C	FE	4.2.3	RR
CST-96	2	B-6	C-1	2	CK	SA	O	C	FE		FE
CST-98	2	B-6	C-1	2	CK	SA	O	C	FE		FE
CST-189	2	B-6	C-1	1	CK	SA	O	C	FE		FE

ATTACHMENT

**9.3 Valve Testing Table (Cont'd)**

SYSTEM: Nuclear Boiler System Steam Supply									P&ID NO.: M-115		
Valve No.	ASME Class	P&ID Coord	Sect XI Cat	Size (in.)	Vlv Type	Act Type	Norm Pos	Safety Pos	Req'd Tests	Rel Req, DTJ or TJ	Tests Pfrmd
FW-91-1	2	A-3	C-1	14	CK	SA	O	C	FE	5.3	FC
FW-91-2	2	A-5	C-1	14	CK	SA	O	C	FE	5.3	FC
FW-94-1	1	A-3	A,C-1	14	CK	SA	O	O/C	FE,LJ	5.3	FE(O), FC(C), LJ
FW-94-2	1	A-4	A,C-1	14	CK	SA	O	O/C	FE,LJ	5.3	FE(O), FC(C), LJ
FW-97-1	1	A-3	A,C-1	14	CK	SA	O	O/C	FE,LJ	5.3	FE(O), FC(C), LJ
FW-97-2	1	A-4	A,C-1	14	CK	SA	O	O/C	FE,LJ	5.3	FE(O), FC(C), LJ
XFV-1	2	E-2	A,C-1	1	FV	SA	O	C	FE,LK	5.13	FR,LK
XFV-2	1	D-2	A,C-1	1	FV	SA	O	C	FE,LK	5.13	FR,LK
XFV-3	1	D-5	A,C-1	1	FV	SA	O	C	FE,LK	5.13	FR,LK
XFV-4	1	D-5	A,C-1	1	FV	SA	O	C	FE,LK	5.13	FR,LK
XFV-5	1	D-2	A,C-1	1	FV	SA	O	C	FE,LK	5.13	FR,LK
XFV-6	1	B-2	A,C-1	1	FV	SA	O	C	FE,LK	5.13	FR,LK
XFV-7	1	C-2	A,C-1	1	FV	SA	O	C	FE,LK	5.13	FR,LK
XFV-8	1	B-5	A,C-1	1	FV	SA	O	C	FE,LK	5.13	FR,LK
XFV-9	1	C-5	A,C-1	1	FV	SA	O	C	FE,LK	5.13	FR,LK

ATTACHMENT

**9.3 Valve Testing Table (Cont'd)**

SYSTEM: Nuclear Boiler System Steam Supply									P&ID NO.: M-115		
Valve No.	ASME Class	P&ID Coord	Sect XI Cat	Size (in.)	Vlv Type	Act Type	Norm Pos	Safety Pos	Req'd Tests	Rel Req, DTJ or TJ	Tests Pfrmd
AO-2-80A	1	C-5	A-1	18	GL	AO	O	C	FE,LJ,PI,FS	5.4	FE,LJ,PI,FS
AO-2-80B	1	E-5	A-1	18	GL	AO	O	C	FE,LJ,PI,FS	5.4	FE,LJ,PI,FS
AO-2-80C	1	E-2	A-1	18	GL	AO	O	C	FE,LJ,PI,FS	5.4	FE,LJ,PI,FS
AO-2-80D	1	C-2	A-1	18	GL	AO	O	C	FE,LJ,PI,FS	5.4	FE,LJ,PI,FS
AO-2-86A	1	C-5	A-1	18	GT	AO	O	C	FE,LJ,PI		FE,LJ,PI
AO-2-86B	1	E-5	A-1	18	GT	AO	O	C	FE,LJ,PI		FE,LJ,PI
AO-2-86C	1	E-2	A-1	18	GT	AO	O	C	FE,LJ,PI		FE,LJ,PI
AO-2-86D	1	C-2	A-1	18	GT	AO	O	C	FE,LJ,PI		FE,LJ,PI
MO-2373	1	B-5	A-1	3	GT	MO	C	C	FE,LJ,PI		FE,LJ,PI
MO-2374	1	B-6	A-1	3	GT	MO	C	C	FE,LJ,PI		FE,LJ,PI
RV-2-71A	1	B-4	B,C-1	6	RV	SA/AO	C	O	SP,FE	4.2.4	SP,FR,RR
RV-2-71B	1	D-4	B,C-1	6	RV	SA/AO	C	O	SP,FE	4.2.4	SP,FR,RR
RV-2-71C	1	D-3	B,C-1	6	RV	SA/AO	C	O	SP,FE	4.2.4	SP,FR,RR
RV-2-71D	1	B-3	B,C-1	6	RV	SA/AO	C	O	SP,FE	4.2.4	SP,FR,RR
RV-2-71E	1	B-4	B,C-1	6	RV	SA/AO	C	O	SP,FE	4.2.4	SP,FR,RR
RV-2-71F	1	B-3	B,C-1	6	RV	SA/AO	C	O	SP,FE	4.2.4	SP,FR,RR
RV-2-71G	1	D-4	B,C-1	6	RV	SA/AO	C	O	SP,FE	4.2.4	SP,FR,RR
RV-2-71H	1	D-3	B,C-1	6	RV	SA/AO	C	O	SP,FE	4.2.4	SP,FR,RR

ATTACHMENT

**9.3 Valve Testing Table (Cont'd)**

SYSTEM: Reactor Pressure Relief									P&ID NO.: M-115-1		
Valve No.	ASME Class	P&ID Coord	Sect XI Cat	Size (in.)	Vlv Type	Act Type	Norm Pos	Safety Pos	Req'd Tests	Rel Req, DTJ or TJ	Tests Pfrmd
RV-3242A	None	A-5	C-1	8	RV	SA	C	O/C	SP		SP
RV-3243A	None	C-6	C-1	8	RV	SA	C	O/C	SP		SP
RV-3244A	None	C-4	C-1	8	RV	SA	C	O/C	SP		SP
RV-3245A	None	A-4	C-1	8	RV	SA	C	O/C	SP		SP
RV-7440A	None	A-6	C-1	8	RV	SA	C	O/C	SP		SP
RV-7441A	None	A-4	C-1	8	RV	SA	C	O/C	SP		SP
RV-7467A	None	C-5	C-1	8	RV	SA	C	O/C	SP		SP
RV-7468A	None	C-4	C-1	8	RV	SA	C	O/C	SP		SP
XFV-10	2	C-7	A,C-1	1	FV	SA	O	C	FE,LK	5.13	FR,LK
XFV-11	2	C-7	A,C-1	1	FV	SA	O	C	FE,LK	5.13	FR,LK
XFV-12	2	A-7	A,C-1	1	FV	SA	O	C	FE,LK	5.13	FR,LK
XFV-13	2	A-7	A,C-1	1	FV	SA	O	C	FE,LK	5.13	FR,LK
XFV-14	2	C-3	A,C-1	1	FV	SA	O	C	FE,LK	5.13	FR,LK
XFV-15	2	C-3	A,C-1	1	FV	SA	O	C	FE,LK	5.13	FR,LK
XFV-16	2	A-3	A,C-1	1	FV	SA	O	C	FE,LK	5.13	FR,LK
XFV-17	2	A-3	A,C-1	1	FV	SA	O	C	FE,LK	5.13	FR,LK
XFV-18	2	A-3	A,C-1	1	FV	SA	O	C	FE,LK	5.13	FR,LK
XFV-19	2	C-3	A,C-1	1	FV	SA	O	C	FE,LK	5.13	FR,LK
XFV-20	2	A-7	A,C-1	1	FV	SA	O	C	FE,LK	5.13	FR,LK
XFV-21	2	C-7	A,C-1	1	FV	SA	O	C	FE,LK	5.13	FR,LK

ATTACHMENT

**9.3 Valve Testing Table (Cont'd)**

SYSTEM: Vessel Instrumentation Nuclear Boiler System									P&ID NO.: M-116		
Valve No.	ASME Class	P&ID Coord	Sect XI Cat	Size (in.)	Vlv Type	Act Type	Norm Pos	Safety Pos	Req'd Tests	Rel Req, DTJ or TJ	Tests Pfrmd
BF-12	2	B-3	A,C-1	0.37	CK	SA	O	C	FE,LK	5.12	FR,LK
BF-14	2	B-3	A,C-1	0.37	CK	SA	O	C	FE,LK	5.12	FR,LK
BF-24	2	B-3	A,C-1	0.37	CK	SA	O	C	FE,LK	5.12	FR,LK
BF-26	2	B-3	A,C-1	0.37	CK	SA	O	C	FE,LK	5.12	FR,LK
BF-35	2	A-3	A,C-1	0.37	CK	SA	O	C	FE,LK	5.12	FR,LK
BF-37	2	A-3	A,C-1	0.37	CK	SA	O	C	FE,LK	5.12	FR,LK
BF-46	2	A-3	A,C-1	0.37	CK	SA	O	C	FE,LK	5.12	FR,LK
BF-48	2	A-3	A,C-1	0.37	CK	SA	O	C	FE,LK	5.12	FR,LK
XFV-22	1	C-5	A,C-1	1	FV	SA	O	C	FE,LK	5.13	FR,LK
XFV-23	1	C-5	A,C-1	1	FV	SA	O	C	FE,LK	5.13	FR,LK
XFV-24	1	D-5	A,C-1	1	FV	SA	O	C	FE,LK	5.13	FR,LK
XFV-25	1	D-6	A,C-1	1	FV	SA	O	C	FE,LK	5.13	FR,LK
XFV-26	1	D-3	A,C-1	1	FV	SA	O	C	FE,LK	5.13	FR,LK
XFV-27	1	C-5	A,C-1	1	FV	SA	O	C	FE,LK	5.13	FR,LK
XFV-28	1	C-5	A,C-1	1	FV	SA	O	C	FE,LK	5.13	FR,LK
XFV-29	1	C-5	A,C-1	1	FV	SA	O	C	FE,LK	5.13	FR,LK
XFV-30	1	C-5	A,C-1	1	FV	SA	O	C	FE,LK	5.13	FR,LK
XFV-31	1	C-5	A,C-1	1	FV	SA	O	C	FE,LK	5.13	FR,LK
XFV-32	1	C-5	A,C-1	1	FV	SA	O	C	FE,LK	5.13	FR,LK
XFV-33	1	C-5	A,C-1	1	FV	SA	O	C	FE,LK	5.13	FR,LK
XFV-34	1	C-5	A,C-1	1	FV	SA	O	C	FE,LK	5.13	FR,LK
XFV-35	1	C-5	A,C-1	1	FV	SA	O	C	FE,LK	5.13	FR,LK
XFV-36	1	C-5	A,C-1	1	FV	SA	O	C	FE,LK	5.13	FR,LK
XFV-37	1	C-5	A,C-1	1	FV	SA	O	C	FE,LK	5.13	FR,LK
XFV-38	1	C-5	A,C-1	1	FV	SA	O	C	FE,LK	5.13	FR,LK
XFV-39	1	C-3	A,C-1	1	FV	SA	O	C	FE,LK	5.13	FR,LK
XFV-40	1	C-3	A,C-1	1	FV	SA	O	C	FE,LK	5.13	FR,LK
XFV-41	1	C-3	A,C-1	1	FV	SA	O	C	FE,LK	5.13	FR,LK

ATTACHMENT

**9.3 Valve Testing Table (Cont'd)**

SYSTEM: Vessel Instrumentation Nuclear Boiler System									P&ID No.: M-116 (cont'd)		
Valve No.	ASME Class	P&ID Coord	Sect XI Cat	Size (in.)	Vlv Type	Act Type	Norm Pos	Safety Pos	Req'd Tests	Rel Req, DTJ or TJ	Tests Pfrmd
XFV-42	1	C-3	A,C-1	1	FV	SA	O	C	FE,LK	5.13	FR,LK
XFV-43	1	C-3	A,C-1	1	FV	SA	O	C	FE,LK	5.13	FR,LK
XFV-44	1	C-3	A,C-1	1	FV	SA	O	C	FE,LK	5.13	FR,LK
XFV-45	1	C-3	A,C-1	1	FV	SA	O	C	FE,LK	5.13	FR,LK
XFV-46	1	C-3	A,C-1	1	FV	SA	O	C	FE,LK	5.13	FR,LK
XFV-47	1	C-3	A,C-1	1	FV	SA	O	C	FE,LK	5.13	FR,LK
XFV-48	1	C-3	A,C-1	1	FV	SA	O	C	FE,LK	5.13	FR,LK
XFV-49	1	C-3	A,C-1	1	FV	SA	O	C	FE,LK	5.13	FR,LK
XFV-50	1	C-3	A,C-1	1	FV	SA	O	C	FE,LK	5.13	FR,LK
XFV-51	1	C-3	A,C-1	1	FV	SA	O	C	FE,LK	5.13	FR,LK
XFV-52	1	D-5	A,C-1	1	FV	SA	O	C	FE,LK	5.13	FR,LK
XFV-53	1	D-3	A,C-1	1	FV	SA	O	C	FE,LK	5.13	FR,LK
XFV-54	1	D-5	A,C-1	1	FV	SA	O	C	FE,LK	5.13	FR,LK
XFV-55	1	D-3	A,C-1	1	FV	SA	O	C	FE,LK	5.13	FR,LK
XFV-56	1	D-5	A,C-1	1	FV	SA	O	C	FE,LK	5.13	FR,LK
XFV-57	1	D-3	A,C-1	1	FV	SA	O	C	FE,LK	5.13	FR,LK
XFV-88	1	D-5	A,C-1	1	FV	SA	O	C	FE,LK	5.13	FR,LK
XFV-89	1	D-3	A,C-1	1	FV	SA	O	C	FE,LK	5.13	FR,LK

ATTACHMENT

**9.3 Valve Testing Table (Cont'd)**

SYSTEM: Recirc Loops Nuclear Boiler System									P&ID NO.: M-117-1		
Valve No.	ASME Class	P&ID Coord	Sect XI Cat	Size (in.)	Vlv Type	Act Type	Norm Pos	Safety Pos	Req'd Tests	Rel Req, DTJ or TJ	Tests Pfrmd
CV-2790	2	D-5	A-1	0.75	GT	AO	O	C	FE,LJ,PI		FE,LJ,PI
CV-2791	2	D-6	A-1	0.75	GL	AO	O	C	FE,LJ,PI		FE,LJ,PI
MO-2-53A	1	B-2	B-1	28	GT	MO	O	C	FE,PI	5.5	FC,PI
MO-2-53B	1	B-6	B-1	28	GT	MO	O	C	FE,PI	5.5	FC,PI
XFV-58	1	B-2	A,C-1	1	FV	SA	O	C	FE,LK	5.13	FR,LK
XFV-59	1	B-2	A,C-1	1	FV	SA	O	C	FE,LK	5.13	FR,LK
XFV-60	1	A-3	A,C-1	1	FV	SA	O	C	FE,LK	5.13	FR,LK
XFV-61	1	B-6	A,C-1	1	FV	SA	O	C	FE,LK	5.13	FR,LK
XFV-62	1	B-6	A,C-1	1	FV	SA	O	C	FE,LK	5.13	FR,LK
XFV-63	1	A-5	A,C-1	1	FV	SA	O	C	FE,LK	5.13	FR,LK
XFV-64	1	D-5	A,C-1	1	FV	SA	O	C	FE,LK	5.13	FR,LK
XFV-65	1	D-5	A,C-1	1	FV	SA	O	C	FE,LK	5.13	FR,LK
XFV-66	1	E-2	A,C-1	1	FV	SA	O	C	FE,LK	5.13	FR,LK
XFV-67	1	C-5	A,C-1	1	FV	SA	O	C	FE,LK	5.13	FR,LK
XFV-68	1	C-5	A,C-1	1	FV	SA	O	C	FE,LK	5.13	FR,LK
XFV-69	1	E-6	A,C-1	1	FV	SA	O	C	FE,LK	5.13	FR,LK
XFV-70	1	E-6	A,C-1	1	FV	SA	O	C	FE,LK	5.13	FR,LK
XFV-71	1	E-2	A,C-1	1	FV	SA	O	C	FE,LK	5.13	FR,LK
XFV-72	1	E-6	A,C-1	1	FV	SA	O	C	FE,LK	5.13	FR,LK
XFV-73	1	E-6	A,C-1	1	FV	SA	O	C	FE,LK	5.13	FR,LK
XFV-74	1	E-2	A,C-1	1	FV	SA	O	C	FE,LK	5.13	FR,LK
XFV-75	1	E-2	A,C-1	1	FV	SA	O	C	FE,LK	5.13	FR,LK
XFV-76	1	D-2	A,C-1	1	FV	SA	O	C	FE,LK	5.13	FR,LK
XFV-77	1	D-2	A,C-1	1	FV	SA	O	C	FE,LK	5.13	FR,LK



<b>MONTICELLO NUCLEAR GENERATING PLANT</b>		<b>EWI-09.04.01</b>
<b>TITLE:</b>	<b>INSERVICE TESTING PROGRAM</b>	Revision 8
		Page 88 of 122

ATTACHMENT

**9.3 Valve Testing Table (Cont'd)**

<b>SYSTEM: Recirc Loops Pumps and Motors Nuclear Boiler System</b>									<b>P&amp;ID NO.: M-117-2</b>		
Valve No.	ASME Class	P&ID Coord	Sect XI Cat	Size (in.)	Vlv Type	Act Type	Norm Pos	Safety Pos	Req'd Tests	Rel Req, DTJ or TJ	Tests Pfrmd
XR-27-1	2	D-3	A,C-1	1	CK	SA	O	C	FE,LJ	4.2.5	FR,LJ
XR-27-2	2	D-5	A,C-1	1	CK	SA	O	C	FE,LJ	4.2.5	FR,LJ
XFV-78	1	C-3	A,C-1	1	FV	SA	O	C	FE,LK	5.13	FR,LK
XFV-79	1	C-3	A,C-1	1	FV	SA	O	C	FE,LK	5.13	FR,LK
XFV-80	1	C-4	A,C-1	1	FV	SA	O	C	FE,LK	5.13	FR,LK
XFV-81	1	C-4	A,C-1	1	FV	SA	O	C	FE,LK	5.13	FR,LK

ATTACHMENT

**9.3 Valve Testing Table (Cont'd)**

SYSTEM: Control Rod Hydraulic System (Recirc)									P&ID NO.: M-118		
Valve No.	ASME Class	P&ID Coord	Sect XI Cat	Size (in.)	Vlv Type	Act Type	Norm Pos	Safety Pos	Req'd Tests	Rel Req, DTJ or TJ	Tests Pfrmd
XR-25-1	2	A-4	A,C-1	1	CK	SA	O	C	FE,LJ	4.2.5	FR,LJ
XR-25-2	2	A-4	A,C-1	1	CK	SA	O	C	FE,LJ	4.2.5	FR,LJ

ATTACHMENT

**9.3 Valve Testing Table (Cont'd)**

SYSTEM: Control Rod Hydraulic System									P&ID NO.: M-119		
Valve No.	ASME Class	P&ID Coord	Sect XI Cat	Size (in.)	Vlv Type	Act Type	Norm Pos	Safety Pos	Req'd Tests	Rel Req, DTJ or TJ	Tests Pfrmd
CRD-114*	2	B-6	C-1	0.75	CK	SA	O/C	O	FE	4.2.6	FR
CRD-115*	2	B-4	C-1	0.50	CK	SA	O/C	C	FE	4.2.7	FR
CRD-138*	2	E-4	C-1	0.50	CK	SA	O/C	C	FE		FE
CV-126*	2	C-5	B-1	1	GL	AO	C	O	FE	4.2.6	FR
CV-127*	2	C-6	B-1	0.75	GL	AO	C	O	FE	4.2.6	FR
CV-3-32A	2	E-3	B-1	1	GL	AO	O	C	FE,PI		FE,PI
CV-3-32B	2	E-1	B-1	1	GL	AO	O	C	FE,PI		FE,PI
CV-3-32C	2	E-4	B-1	1	GL	AO	O	C	FE,PI		FE,PI
CV-3-32D	2	E-1	B-1	1	GL	AO	O	C	FE,PI		FE,PI
CV-3-33A	2	D-3	B-1	2	GL	AO	O	C	FE,PI		FE,PI
CV-3-33B	2	D-2	B-1	2	GL	AO	O	C	FE,PI		FE,PI
CV-3-33C	2	D-3	B-1	2	GL	AO	O	C	FE,PI		FE,PI
CV-3-33D	2	D-2	B-1	2	GL	AO	O	C	FE,PI		FE,PI

\* Typical of 121 control rod drive units

ATTACHMENT

**9.3 Valve Testing Table (Cont'd)**

SYSTEM: Residual Heat Removal System									P&ID NO.: M-120		
Valve No.	ASME Class	P&ID Coord	Sect XI Cat	Size (in.)	Vlv Type	Act Type	Norm Pos	Safety Pos	Req'd Tests	Rel Req, DTJ or TJ	Tests Pfrmd
AI-243-2	None	A-5	A,C-1	0.75	CK	SA	O	C	FE,LK	5.16 9.4.5	FR,LK
AI-244-2	None	A-5	A,C-1	0.75	CK	SA	O	C	FE,LK	5.16 9.4.5	FR,LK
AI-610-2	None	B-4	A,C-1	0.75	CK	SA	O	C	FE,LK	5.16	FR,LK
AI-610-4	None	C-4	A,C-1	0.75	CK	SA	O	C	FE,LK	5.16	FR,LK
AO-10-46B	1	D-2	A,C-1	16	CK	SA	C	O/C	FE,PI, LK	5.17	FC,PI, LK
CV-1995	2	B-4	B-1	2	GL	AO	C	O/C	FE,PI		FE,PI
CV-1997	2	C-4	B-1	2	GL	AO	C	O/C	FE,PI		FE,PI
MO-1987	2	C-3	B-1	20	GT	MO	O	O	FE,PI		FE,PI
MO-1989	2	A-2	B-1	18	GT	MO	C	C	FE,PI		FE,PI
MO-2003	2	C-5	B-1	14	GL	MO	O	O/C	FE,PI		FE,PI
MO-2007	2	D-6	B-1	12	GT	MO	C	O/C	FE,PI		FE,PI
MO-2009	2	D-6	B-1	10	GL	MO	C	O/C	FE,PI		FE,PI
MO-2011	2	D-5	A-1	4	GL	MO	C	O/C	FE,LJ, PI		FE,LJ, PI
MO-2013	2	D-3	A-1	16	GL	MO	O	O/C	FE,LJ, PI		FE,LJ, PI
MO-2015	1	D-3	A-1	16	GT	MO	C	O/C	FE,LJ, PI,LK		FE,LJ, PI,LK
MO-2021	2	E-3	A-1	10	GT	MO	C	O/C	FE,LJ, PI		FE,LJ, PI
MO-2023	2	E-2	A-1	10	GT	MO	C	O/C	FE,LJ, PI		FE,LJ, PI
MO-4085B	1	D-1	B-1	4	GT	MO	C	O/C	FE,PI		FE,PI
RHR-2-2	2	A-5	C-1	10	CK	SA	C	O/C	FE		FE
RHR-2-4	2	B-5	C-1	10	CK	SA	C	O/C	FE		FE
RHR-6-2	1	D-2	B-2	16	GT	MA	O	O	PI		PI
RHR-8-2	2	C-3	C-1	3	CK	SA	C	O	FE	4.2.8	RR

<b>MONTICELLO NUCLEAR GENERATING PLANT</b>		EWI-09.04.01
<b>TITLE:</b>	<b>INSERVICE TESTING PROGRAM</b>	Revision 8
		Page 92 of 122

ATTACHMENT

**9.3 Valve Testing Table (Cont'd)**

SYSTEM: Residual Heat Removal System									P&ID NO.: M-120 (cont'd)		
Valve No.	ASME Class	P&ID Coord	Sect XI Cat	Size (in.)	Vlv Type	Act Type	Norm Pos	Safety Pos	Req'd Tests	Rel Req, DTJ or TJ	Tests Pfrmd
RV-1991	2	B-3	C-1	1	RV	SA	C	O	SP		SP
RV-1993	2	C-3	C-1	1	RV	SA	C	O	SP		SP
RV-2005	2	E-6	C-1	1	RV	SA	C	O	SP		SP
RV-4282	2	B-6	C-1	2.50	RV	SA	C	O	SP		SP
RV-4908B	None	A-5	C-1	0.25	RV	SA	C	O	SP		SP

ATTACHMENT

**9.3 Valve Testing Table (Cont'd)**

SYSTEM: Residual Heat Removal System									P&ID NO.: M-121		
Valve No.	ASME Class	P&ID Coord	Sect XI Cat	Size (in.)	Vlv Type	Act Type	Norm Pos	Safety Pos	Req'd Tests	Rel Req, DTJ or TJ	Tests Pfrmd
AI-243-1	None	A-3	A,C-1	0.75	CK	SA	O	C	FE,LK	5.16 9.4.5	FR,LK
AI-244-1	None	A-3	A,C-1	0.75	CK	SA	O	C	FE,LK	5.16 9.4.5	FR,LK
AI-610-1	None	A-4	A,C-1	0.75	CK	SA	O	C	FE,LK	5.16	FR,LK
AI-610-3	None	C-6	A,C-1	0.75	CK	SA	O	C	FE,LK	5.16	FR,LK
AO-10-46A	1	D-5	A,C-1	16	CK	SA	C	O/C	FE,PI, LK	5.17	FC,PI, LK
CV-1994	2	B-4	B-1	2	GL	AO	C	O/C	FE,PI		FE,PI
CV-1996	2	C-5	B-1	2	GL	AO	C	O/C	FE,PI		FE,PI
MO-1986	2	B-6	B-1	20	GT	MO	O	O	FE,PI		FE,PI
MO-1988	2	B-6	B-1	18	GT	MO	C	C	FE,PI		FE,PI
MO-2002	2	B-3	B-1	14	GL	MO	O	O/C	FE,PI		FE,PI
MO-2006	2	D-3	B-1	12	GT	MO	C	O/C	FE,PI		FE,PI
MO-2008	2	C-3	B-1	10	GL	MO	C	O/C	FE,PI		FE,PI
MO-2010	2	C-3	A-1	4	GL	MO	C	O/C	FE,LJ, PI		FE,LJ, PI
MO-2012	2	D-5	A-1	16	GL	MO	O	O/C	FE,LJ, PI		FE,LJ, PI
MO-2014	1	D-5	A-1	16	GT	MO	C	O/C	FE,LJ, PI,LK		FE,LJ, PI,LK
MO-2020	2	E-5	A-1	10	GT	MO	C	O/C	FE,LJ, PI		FE,LJ, PI
MO-2022	2	E-5	A-1	10	GT	MO	C	O/C	FE,LJ, PI		FE,LJ, PI
MO-2026	1	E-6	A-1	4	GT	MO	C	C	FE,LJ, PI,LK	5.7	FC,LJ, PI,LK
MO-2027	1	E-6	A-1	4	GT	MO	C	C	FE,LJ, PI,LK	5.7	FC,LJ, PI,LK
MO-2029	1	D-6	A-1	18	GT	MO	C	C	FE,LJ, PI,LK	5.7	FC,LJ, PI,LK

<b>MONTICELLO NUCLEAR GENERATING PLANT</b>		EWI-09.04.01
<b>TITLE:</b>	<b>INSERVICE TESTING PROGRAM</b>	Revision 8
		Page 94 of 122

ATTACHMENT

**9.3 Valve Testing Table (Cont'd)**

SYSTEM: Residual Heat Removal System									P&ID NO.: M-121 (cont'd)		
Valve No.	ASME Class	P&ID Coord	Sect XI Cat	Size (in.)	Vlv Type	Act Type	Norm Pos	Safety Pos	Req'd Tests	Rel Req, DTJ or TJ	Tests Pfrmd
MO-2030	1	C-6	A-1	18	GT	MO	C	C	FE,LJ,PI,LK	5.7	FC,LJ,PI,LK
MO-2032	2	C-4	B-1	4	GT	MO	C	C	FE,PI		FE,PI
MO-2407	None	C-4	B-1	4	GT	MO	C	C	FE,PI		FE,PI
MO-4085A	1	C-6	B-1	4	GT	MO	C	O/C	FE,PI		FE,PI
RHR-2-1	2	A-4	C-1	10	CK	SA	C	O/C	FE		FE
RHR-2-3	2	B-4	C-1	10	CK	SA	C	O/C	FE		FE
RHR-6-1	1	D-6	B-2	16	GT	MA	O	O	PI		PI
RHR-8-1	2	C-5	C-1	3	CK	SA	O	O	FE	4.2.8	RR
RV-1990	2	B-5	C-1	1	RV	SA	C	O	SP		SP
RV-1992	2	C-5	C-1	1	RV	SA	C	O	SP		SP
RV-2004	2	D-2	C-1	1	RV	SA	C	O	SP		SP
RV-2025	2	E-4	C-1	1	RV	SA	C	O	SP		SP
RV-2031	2	B-6	C-1	1	RV	SA	C	O	SP		SP
RV-4281	2	B-2	C-1	2.50	RV	SA	C	O	SP		SP
RV-4908A	None	A-4	C-1	0.25	RV	SA	C	O	SP		SP

ATTACHMENT

**9.3 Valve Testing Table (Cont'd)**

SYSTEM: Core Spray System									P&ID NO.: M-122		
Valve No.	ASME Class	P&ID Coord	Sect XI Cat	Size (in.)	Vlv Type	Act Type	Norm Pos	Safety Pos	Req'd Tests	Rel Req, DTJ or TJ	Tests Pfrmd
AO-14-13A	1	E-3	A,C-1	8	CK	SA	C	O/C	FE,PI, LK	5.18	FC,PI, LK
AO-14-13B	1	E-4	A,C-1	8	CK	SA	C	O/C	FE,PI, LK	5.18	FC,PI, LK
CS-9-1	2	C-2	C-1	10	CK	SA	C	O/C	FE		FE
CS-9-2	2	C-5	C-1	10	CK	SA	C	O/C	FE		FE
CS-13-1	1	E-3	B-2	8	GT	MA	O	O	PI		PI
CS-13-2	1	E-4	B-2	8	GT	MA	O	O	PI		PI
CST-103-1	None	E-2	C-1	2	CK	SA	O	C	FE	4.2.9	RR
CST-104-1	2	E-2	C-1	2	CK	SA	O	C	FE	4.2.9	RR
MO-1741	2	A-3	B-1	12	GT	MO	O	O	FE,PI		FE,PI
MO-1742	2	A-4	B-1	12	GT	MO	O	O	FE,PI		FE,PI
MO-1749	2	D-2	B-1	6	GL	MO	C	C	FE,PI		FE,PI
MO-1750	2	D-5	B-1	6	GL	MO	C	C	FE,PI		FE,PI
MO-1751	2	E-3	A-1	8	GT	MO	O	O/C	FE,LJ, PI		FE,LJ, PI
MO-1752	2	E-5	A-1	8	GT	MO	O	O/C	FE,LJ, PI		FE,LJ, PI
MO-1753	1	E-3	A-1	8	GT	MO	C	O/C	FE,LJ, PI,LK		FE,LJ, PI,LK
MO-1754	1	E-5	A-1	8	GT	MO	C	O/C	FE,LJ, PI,LK		FE,LJ, PI,LK
RV-1745	2	E-2	C-1	2	RV	SA	C	O	SP		SP
RV-1746	2	E-6	C-1	2	RV	SA	C	O	SP		SP
XFV-82	1	C-3	A,C-1	1	FV	SA	O	C	FE,LK	5.13	FR,LK
XFV-83	1	D-4	A,C-1	1	FV	SA	O	C	FE,LK	5.13	FR,LK



ATTACHMENT

**9.3 Valve Testing Table (Cont'd)**

SYSTEM: High Pressure Coolant Injection System (Steam Side)									P&ID NO.: M-123		
Valve No.	ASME Class	P&ID Coord	Sect XI Cat	Size (in.)	Vlv Type	Act Type	Norm Pos	Safety Pos	Req'd Tests	Rel Req, DTJ or TJ	Tests Pfrmd
CV-2046A	2	C-1	B-1	1	GL	AO	O	C	FE,PI		FE,PI
CV-2394A	None	A-3	B-1	1	GL	AO	O/C	C	FE,PI		FE,PI
HPCI-9	2	C-5	A,C-1	16	CK	SA	C	O/C	FE,LJ	5.8	FE(O), FC(C), LJ
HPCI-10	2	C-5	A,C-1	16	CK	SA	C	O/C	FE,LJ	5.8	FE(O), FC(C), LJ
HPCI-14	2	B-4	C-1	2	CK	SA	C	C	FE	5.8	FC
HPCI-15	2	B-5	C-1	2	CK	SA	C	C	FE	5.8	FC
HPCI-18	2	A-2	C-1	2	CK	SA	C	O	FE		FE
HPCI-20	2	A-3	C-1	2	CK	SA	C	O/C	FE		FE
HPCI-65	2	B-6	C-1	2	CK	SA	C	C	FE	5.8/9.4.1	FC
HPCI-71	2	B-6	C-1	2	CK	SA	C	C	FE	5.8/9.4.1	FC
MO-2034	1	D-5	A-1	8	GT	MO	O	O/C	FE,LJ, PI		FE,LJ, PI
MO-2035	1	D-4	A-1	8	GT	MO	O	O/C	FE,LJ, PI		FE,LJ, PI
MO-2036	2	D-2	B-1	8	GT	MO	C	O	FE,PI		FE,PI
PSD-2038	2	C-5	D-1	16	RD	SA	O	O	RD		RD
PSD-2039	None	C-5	D-1	16	RD	SA	O	O	RD		RD
RV-2056	3	B-3	C-1	1.50	RV	SA	C	O	SP		SP
XFV-84	1	D-5	A,C-1	1	FV	SA	O	C	FE,LK	5.13	FR,LK
XFV-85	1	D-5	A,C-1	1	FV	SA	O	C	FE,LK	5.13	FR,LK

ATTACHMENT

**9.3 Valve Testing Table (Cont'd)**

SYSTEM: High Pressure Coolant Injection System (Water Side)									P&ID NO.: M-124		
Valve No.	ASME Class	P&ID Coord	Sect XI Cat	Size (in.)	Vlv Type	Act Type	Norm Pos	Safety Pos	Req'd Tests	Rel Req, DTJ or TJ	Tests Pfrmd
AI-611	None	C-4	A,C-1	0.75	CK	SA	O	C	FE,LK	5.16	FR,LK
AO-23-18	2	B-5	C-1	12	CK	SA	C	O/C	FE,PI	5.6	DI, PI
CV-2065	2	B-4	B-1	2	GL	AO	C	O/C	FE,PI		FE,PI
HPCI-31	2	A-4	C-1	14	CK	SA	C	O/C	FE	5.8	DI(O), FC(C), PC(O)
HPCI-32	2	E-4	C-1	14	CK	SA	C	O/C	FE	5.20	FE(O), FC(C)
HPCI-42	2	A-4	C-1	4	CK	SA	C	O	FE	5.21	DI
MO-2061	2	A-5	B-1	14	GT	MO	C	O/C	FE,PI		FE,PI
MO-2062	2	A-4	B-1	14	GT	MO	C	O/C	FE,PI		FE,PI
MO-2063	2	D-3	B-1	14	GT	MO	O	O/C	FE,PI		FE,PI
MO-2067	2	B-5	B-1	12	GT	MO	C	O	FE,PI		FE,PI
MO-2068	2	B-5	B-1	12	GT	MO	C	O	FE,PI		FE,PI
MO-2071	2	C-5	B-1	8	GL	MO	C	C	FE,PI		FE,PI
RV-2064	2	D-3	C-1	1	RV	SA	C	O	SP		SP

ATTACHMENT

**9.3 Valve Testing Table (Cont'd)**

SYSTEM: RCIC (Steam Side)									P&ID NO.: M-125		
Valve No.	ASME Class	P&ID Coord	Sect XI Cat	Size (in.)	Vlv Type	Act Type	Norm Pos	Safety Pos	Req'd Tests	Rel Req, DTJ or TJ	Tests Pfrmd
CV-2082A	2	C-1	B-1	1	GL	AO	O	C	FE,PI		FE,PI
CV-2848	None	A-4	B-1	1	GL	AO	O/C	C	FE,PI		FE,PI
MO-2075	1	D-5	A-1	3	GT	MO	O	O/C	FE,LJ,PI		FE,LJ,PI
MO-2076	1	D-4	A-1	3	GT	MO	O	O/C	FE,LJ,PI		FE,LJ,PI
MO-2078	2	D-2	B-1	3	GL	MO	C	O/C	FE,PI		FE,PI
MO-2096	2	A-3	B-1	2	GL	MO	C	O/C	FE,PI		FE,PI
RCIC-9	2	B-6	A,C-1	8	CK	SA	C	O/C	FE,LJ	5.9	FE(O),FC(C),LJ
RCIC-10	2	B-6	A,C-1	8	CK	SA	C	O/C	FE,LJ	5.9	FE(O),FC(C),LJ
RCIC-14	2	A-4	C-1	2	CK	SA	C	O/C	FE		FE
RCIC-16	2	A-5	C-1	2	CK	SA	C	C	FE	5.9	FC
RCIC-17	2	B-5	C-1	2	CK	SA	C	C	FE	5.9	FC
RCIC-57	2	B-6	C-1	1.50	CK	SA	C	C	FE	5.9/9.4.1	FC
RCIC-59	2	B-6	C-1	1.50	CK	SA	C	C	FE	5.9/9.4.1	FC
RV-2097	3	B-3	C-1	1	RV	SA	C	O	SP		SP
PSD-2089	2	C-5	D-1	8	RD	SA	O	O	RD		RD
PSD-2090	None	C-5	D-1	8	RD	SA	O	O	RD		RD
XFV-86	1	D-5	A,C-1	1	FV	SA	O	C	FE,LK	5.13	FR,LK
XFV-87	1	D-5	A,C-1	1	FV	SA	O	C	FE,LK	5.13	FR,LK

<b>MONTICELLO NUCLEAR GENERATING PLANT</b>		EWI-09.04.01
<b>TITLE:</b>	<b>INSERVICE TESTING PROGRAM</b>	Revision 8
		Page 99 of 122

ATTACHMENT

**9.3 Valve Testing Table (Cont'd)**

SYSTEM: RCIC (Water Side)									P&ID NO.: M-126		
Valve No.	ASME Class	P&ID Coord	Sect XI Cat	Size (in.)	Vlv Type	Act Type	Norm Pos	Safety Pos	Req'd Tests	Rel Req, DTJ or TJ	Tests Pfrmd
AI-612	None	C-5	A,C-1	0.75	CK	SA	O	C	FE,LK	5.16	FR,LK
AO-13-22	2	B-5	C-1	4	CK	SA	C	O/C	FE,PI	5.6	DI,PI
CV-2104	2	A-3	B-1	2	GL	AO	C	O/C	FE,PI		FE,PI
MO-2100	2	A-5	B-1	6	GT	MO	C	O	FE,PI		FE,PI
MO-2101	2	D-4	B-1	6	GT	MO	C	O	FE,PI		FE,PI
MO-2102	2	D-4	B-1	6	GT	MO	O	O/C	FE,PI		FE,PI
MO-2106	2	B-5	B-1	4	GT	MO	C	O	FE,PI		FE,PI
MO-2107	2	B-5	B-1	4	GT	MO	C	O	FE,PI		FE,PI
MO-3502	2	D-5	B-1	4	GT	MO	C	C	FE,PI		FE,PI
RCIC-31	2	A-4	C-1	6	CK	SA	C	O/C	FE	5.9	DI(O), FC(C), PC(O)
RCIC-37	2	A-4	C-1	2	CK	SA	C	O	FE	5.21	DI
RCIC-41	2	D-4	C-1	6	CK	SA	C	O/C	FE	5.20	FE(O), FC(C)
RV-2103	2	D-3	C-1	1	RV	SA	C	O	SP		SP

<b>MONTICELLO NUCLEAR GENERATING PLANT</b>		<b>EWI-09.04.01</b>
<b>TITLE:</b>	<b>INSERVICE TESTING PROGRAM</b>	Revision 8
		Page 100 of 122

ATTACHMENT

**9.3 Valve Testing Table (Cont'd)**

<b>SYSTEM: Standby Liquid Control System</b>									<b>P&amp;ID NO.: M-127</b>		
Valve No.	ASME Class	P&ID Coord	Sect XI Cat	Size (in.)	Vlv Type	Act Type	Norm Pos	Safety Pos	Req'd Tests	Rel Req, DTJ or TJ	Tests Pfrmd
XP-11-14A	2	D-5	D-1	1.50	XP	SA	C	O	EX		EX
XP-11-14B	2	E-5	D-1	1.50	XP	SA	C	O	EX		EX
RV-11-39A	2	C-4	C-1	1.50	RV	SA	C	O	SP		SP
RV-11-39B	2	B-4	C-1	1.50	RV	SA	C	O	SP		SP
XP-3-1	2	C-4	C-1	1.50	CK	SA	C	O	FE		FE
XP-3-2	2	B-4	C-1	1.50	CK	SA	C	O	FE		FE
XP-6	1	D-6	A,C-1	1.50	CK	SA	C	O/C	FE,LJ	4.2.10	FR,LJ
XP-7	1	C-6	A,C-1	1.50	CK	SA	C	O/C	FE,LJ	4.2.10	FR,LJ

ATTACHMENT

**9.3 Valve Testing Table (Cont'd)**

SYSTEM: Reactor Water Cleanup System									P&ID NO.: M-128		
Valve No.	ASME Class	P&ID Coord	Sect XI Cat	Size (in.)	Vlv Type	Act Type	Norm Pos	Safety Pos	Req'd Tests	Rel Req, DTJ or TJ	Tests Pfrmd
MO-2397	1	D-8	A-1	4	GT	MO	O	C	FE,LJ, PI		FE,LJ, PI
MO-2398	1	D-7	A-1	4	GT	MO	O	C	FE,LJ, PI		FE,LJ, PI
RC-6-1	2	D-6	A,C-1	1.5	CK	SA	O	C	FE,LK	4.2.11	FR,LK
RC-6-2	2	D-7	A,C-1	1.5	CK	SA	O	C	FE,LK	4.2.11	FR,LK

ATTACHMENT

**9.3 Valve Testing Table (Cont'd)**

SYSTEM: Primary Containment Nitrogen Control System									P&ID NO.: M-130		
Valve No.	ASME Class	P&ID Coord	Sect XI Cat	Size (in.)	Vlv Type	Act Type	Norm Pos	Safety Pos	Req'd Tests	Rel Req, DTJ or TJ	Tests Pfrmd
CV-3267	2	C-4	A-1	1	GL	AO	O	C	FE,LJ, PI		FE,LJ, PI
CV-3268	2	C-4	A-1	1	GL	AO	O	C	FE,LJ, PI		FE,LJ, PI
CV-3269	2	D-4	A-1	1	GL	AO	O	C	FE,LJ, PI		FE,LJ, PI
CV-3311	2	C-5	A-1	1	GL	AO	O	C	FE,LJ, PI		FE,LJ, PI
CV-3312	2	C-5	A-1	1	GL	AO	O	C	FE,LJ, PI		FE,LJ, PI
CV-3313	2	C-4	A-1	1	GL	AO	O	C	FE,LJ, PI		FE,LJ, PI
CV-3314	2	C-5	A-1	1	GL	AO	O	C	FE,LJ, PI		FE,LJ, PI
SV-3307	2	C-5	A-1	0.75	GL	SO	O	C	FE,LJ, PI		FE,LJ, PI
SV-3308	2	C-5	A-1	0.75	GL	SO	O	C	FE,LJ, PI		FE,LJ, PI

ATTACHMENT

**9.3 Valve Testing Table (Cont'd)**

SYSTEM: Containment Atmosphere Monitoring System									P&ID NO.: NH-91197		
Valve No.	ASME Class	P&ID Coord	Sect XI Cat	Size (in.)	Vlv Type	Act Type	Norm Pos	Safety Pos	Req'd Tests	Rel Req, DTJ or TJ	Tests Pfrmd
SV-4001A	2	B-6	A-1	0.75	GL	SO	C	C	FE,LJ,PI		FE,LJ,PI
SV-4001B	2	B-6	A-1	0.75	GL	SO	C	C	FE,LJ,PI		FE,LJ,PI
SV-4002A	2	A-5	A-1	0.75	GL	SO	C	C	FE,LJ,PI		FE,LJ,PI
SV-4002B	2	A-4	A-1	0.75	GL	SO	C	C	FE,LJ,PI		FE,LJ,PI
SV-4003A	2	A-5	A-1	0.75	GL	SO	C	C	FE,LJ,PI		FE,LJ,PI
SV-4003B	2	A-4	A-1	0.75	GL	SO	C	C	FE,LJ,PI		FE,LJ,PI
SV-4004A	2	A-4	A-1	0.75	GL	SO	C	C	FE,LJ,PI		FE,LJ,PI
SV-4004B	2	A-4	A-1	0.75	GL	SO	C	C	FE,LJ,PI		FE,LJ,PI
SV-4005A	2	B-4	A-1	0.75	GL	SO	C	C	FE,LJ,PI		FE,LJ,PI
SV-4005B	2	B-4	A-1	0.75	GL	SO	C	C	FE,LJ,PI		FE,LJ,PI
SV-4020A	2	A-6	A-1	0.75	GL	SO	C	C	FE,LJ,PI		FE,LJ,PI
SV-4020B	2	A-6	A-1	0.75	GL	SO	C	C	FE,LJ,PI		FE,LJ,PI



<b>MONTICELLO NUCLEAR GENERATING PLANT</b>		<b>EWI-09.04.01</b>
<b>TITLE:</b>	<b>INSERVICE TESTING PROGRAM</b>	Revision 8
		Page 104 of 122

ATTACHMENT

**9.3 Valve Testing Table (Cont'd)**

<b>SYSTEM: Post Accident Sampling</b>									<b>P&amp;ID NO.: NF-96042</b>		
Valve No.	ASME Class	P&ID Coord	Sect XI Cat	Size (in.)	Vlv Type	Act Type	Norm Pos	Safety Pos	Req'd Tests	Rel Req, DTJ or TJ	Tests Pfrmd
PAS-58-1	2	B-7	C-1	0.75	CK	SA	C	C	FE		FE
PAS-58-2	2	A-7	C-1	0.75	CK	SA	C	C	FE		FE
PAS-59-5	2	B-6	C-1	0.75	FV	SA	O	C	FE	5.11	FC
PAS-59-6	2	B-6	C-1	0.75	FV	SA	O	C	FE	5.11	FC
SV-4081	2	C-5	A-1	0.75	GL	SO	C	C	FE,LJ, PI		FE,LJ, PI
SV-4082	2	C-5	A-1	0.75	GL	SO	C	C	FE,LJ, PI		FE,LJ, PI

<b>MONTICELLO NUCLEAR GENERATING PLANT</b>		EWI-09.04.01
<b>TITLE:</b>	<b>INSERVICE TESTING PROGRAM</b>	Revision 8
		Page 105 of 122

ATTACHMENT

**9.3 Valve Testing Table (Cont'd)**

<b>SYSTEM: Service Air System</b>									<b>P&amp;ID NO.: M-131 SH4</b>		
Valve No.	ASME Class	P&ID Coord	Sect XI Cat	Size (in.)	Vlv Type	Act Type	Norm Pos	Safety Pos	Req'd Tests	Rel Req, DTJ or TJ	Tests Pfrmd
AS-78	2	D-8	A-2	1	GT	MA	C	C	LJ		LJ
AS-79	2	D-7	A-2	1	GT	MA	C	C	LJ		LJ

<b>MONTICELLO NUCLEAR GENERATING PLANT</b>		EWI-09.04.01
<b>TITLE:</b>	<b>INSERVICE TESTING PROGRAM</b>	Revision 8
		Page 106 of 122

ATTACHMENT

**9.3 Valve Testing Table (Cont'd)**

SYSTEM: MSIV/SRV Pneumatic Supply System									P&ID NO.: M-131 SH10		
Valve No.	ASME Class	P&ID Coord	Sect XI Cat	Size (in.)	Vlv Type	Act Type	Norm Pos	Safety Pos	Req'd Tests	Rel Req, DTJ or TJ	Tests Pfrmd
AI-12-9	2	A-3	C-1	1	CK	SA	O	O	FE		FE
AI-12-10	2	A-3	C-1	1	CK	SA	O	O	FE		FE
AI-12-11	2	B-3	C-1	1	CK	SA	O	O	FE		FE
AI-12-12	2	A-3	C-1	1	CK	SA	O	O	FE		FE
AI-598	2	B-5	A,C-1	1	CK	SA	O	O/C	FE,LJ	5.10	FC,LJ
AI-599	2	C-5	A,C-1	1	CK	SA	O	O/C	FE,LJ		FE,LJ
AI-700	2	C-5	A,C-1	1	CK	SA	O	O/C	FE,LJ		FE,LJ
AI-705	None	D-6	A,C-1	1	CK	SA	O	C	FE,LK		FE,LK
AI-706	None	D-6	A,C-1	1	CK	SA	O	C	FE,LK		FE,LK
AI-708	2	B-5	A,C-1	1	CK	SA	O	O/C	FE,LJ	5.10	FC,LJ
AI-713	None	B-6	A,C-1	1	CK	SA	O	C	FE,LK	5.10	FC,LK
AI-714	None	B-6	A,C-1	1	CK	SA	O	C	FE,LK	5.10	FC,LK
AI-729	None	C-7	A,C-1	0.75	CK	SA	C	O	FE		FE
AI-730	None	B-7	A,C-1	0.75	CK	SA	C	O	FE	5.10	FC
SV-4234	None	C-5	A-1	1	GL	SO	O	O/C	FE,PI, LK		FE,PI, LK
SV-4235	None	B-5	A-1	1	GL	SO	O	O/C	FE,PI, LK	5.10	FC,PI, LK

<b>MONTICELLO NUCLEAR GENERATING PLANT</b>		<b>EWI-09.04.01</b>
<b>TITLE:</b>	<b>INSERVICE TESTING PROGRAM</b>	Revision 8
		Page 107 of 122

ATTACHMENT

**9.3 Valve Testing Table (Cont'd)**

<b>SYSTEM: Instrument Air-Reactor Building</b>									<b>P&amp;ID NO.: M-131 SH12</b>		
Valve No.	ASME Class	P&ID Coord	Sect XI Cat	Size (in.)	Vlv Type	Act Type	Norm Pos	Safety Pos	Req'd Tests	Rel Req, DTJ or TJ	Tests Pfrmd
AI-13-4	None	D-3	A,C-1	0.75	CK	SA	C	C	FE,LK	5.16	FR,LK
AI-13-7	None	A-3	A,C-1	0.75	CK	SA	C	C	FE,LK	5.16	FR,LK
AI-571	2	C-5	A,C-1	2	CK	SA	O	C	FE,LJ	5.14	FC,LJ
CV-1478	2	C-5	A-1	2	GL	AO	O	C	FE,LJ, PI		FE,LJ, PI

ATTACHMENT

**9.3 Valve Testing Table (Cont'd)**

SYSTEM: Instrument Air-Reactor Building									P&ID NO.: M-131 SH14		
Valve No.	ASME Class	P&ID Coord	Sect XI Cat	Size (in.)	Vlv Type	Act Type	Norm Pos	Safety Pos	Req'd Tests	Rel Req, DTJ or TJ	Tests Pfrmd
AI-613	None	D-7	A,C-1	0.37	CK	SA	C	C	FE,LK	5.15	FR,LK
AI-614	None	C-7	A,C-1	0.37	CK	SA	C	C	FE,LK	5.15	FR,LK
AI-615	None	C-6	A,C-1	0.37	CK	SA	C	C	FE,LK	5.15	FR,LK
AI-616	None	C-6	A,C-1	0.37	CK	SA	C	C	FE,LK	5.15	FR,LK
AI-617	None	B-6	A,C-1	0.37	CK	SA	C	C	FE,LK	5.15	FR,LK
AI-618	None	B-1	A,C-1	0.37	CK	SA	C	C	FE,LK	5.15	FR,LK
AI-619	None	B-1	A,C-1	0.37	CK	SA	C	C	FE,LK	5.15	FR,LK
AI-625	2	C-4	A,C-1	0.37	CK	SA	O	C	FE,LJ	4.2.12	FR,LJ
AI-626-1	2	C-4	A,C-1	0.25	CK	SA	O	C	FE,LJ	4.2.12	FR,LJ
AI-629	2	B-6	A,C-1	0.37	CK	SA	C	C	FE,LJ		FE,LJ
AI-663	None	C-6	C-1	0.37	CK	SA	O	O	FE	5.15	FR
AI-666	None	C-5	C-1	0.37	CK	SA	O	O	FE	5.15	FR
AI-669	None	C-6	C-1	0.37	CK	SA	O	O	FE	5.15	FR
AI-672	None	A-6	C-1	0.37	CK	SA	O	O	FE	5.15	FR
AI-675	None	B-1	C-1	0.37	CK	SA	O	O	FE	5.15	FR
AI-678	None	B-1	C-1	0.37	CK	SA	O	O	FE	5.15	FR
AI-681	None	B-6	C-1	0.37	CK	SA	O	O	FE	5.15	FR
AI-683	None	B-5	A,C-1	0.37	CK	SA	C	C	FE,LK	5.15	FR,LK
AI-685	None	C-4	A,C-1	0.37	CK	SA	C	C	FE,LK	5.15	FR,LK
AI-694	None	B-5	C-1	0.37	CK	SA	O	O	FE		FE
AI-695	None	C-4	C-1	0.37	CK	SA	O	O	FE		FE
CV-7956	2	B-6	A-1	0.75	GL	AO	C	C	FE,LJ, PI		FE,LJ, PI

ATTACHMENT

**9.3 Valve Testing Table (Cont'd)**

SYSTEM: Diesel Oil									P&ID NO.: M-133		
Valve No.	ASME Class	P&ID Coord	Sect XI Cat	Size (in.)	Vlv Type	Act Type	Norm Pos	Safety Pos	Req'd Tests	Rel Req, DTJ or TJ	Tests Pfrmd
FO-2	None	C-3	C-1	1	CK	SA	O	C	FE		FE
FO-5	None	D-3	C-1	2	CK	SA	O/C	O	FE		FE
FO-43	None	B-2	C-1	1.5	CK	SA	O/C	O	FE		FE
FO-44	None	B-2	C-1	1.5	CK	SA	O	O	FE		FE
GSA-32-1	None	B-4	C-1	0.75	CK	SA	O/C	C	FE		FE
GSA-32-2	None	B-3	C-1	0.75	CK	SA	O/C	C	FE		FE
GSA-32-3	None	E-2	C-1	0.75	CK	SA	O/C	C	FE		FE
GSA-32-4	None	E-2	C-1	0.75	CK	SA	O/C	C	FE		FE
RV-1523	None	D-3	C-1	0.75	RV	SA	C	O	SP		SP
RV-3216	None	B-3	C-1	0.50	RV	SA	C	O	SP		SP
RV-3217	None	B-3	C-1	0.50	RV	SA	C	O	SP		SP
RV-3218	None	A-3	C-1	0.50	RV	SA	C	O	SP		SP
RV-3219	None	B-3	C-1	0.50	RV	SA	C	O	SP		SP
RV-3220	None	B-3	C-1	0.50	RV	SA	C	O	SP		SP
RV-3221	None	A-3	C-1	0.50	RV	SA	C	O	SP		SP
RV-3224	None	E-2	C-1	0.50	RV	SA	C	O	SP		SP
RV-3225	None	E-3	C-1	0.50	RV	SA	C	O	SP		SP
RV-3226	None	E-3	C-1	0.50	RV	SA	C	O	SP		SP
RV-3227	None	E-2	C-1	0.50	RV	SA	C	O	SP		SP
RV-3228	None	E-3	C-1	0.50	RV	SA	C	O	SP		SP
RV-3229	None	E-3	C-1	0.50	RV	SA	C	O	SP		SP

ATTACHMENT**9.3 Valve Testing Table (Cont'd)**

SYSTEM: Fuel Pool Cooling & Cleanup System									P&ID NO.: M-135		
Valve No.	ASME Class	P&ID Coord	Sect XI Cat	Size (in.)	Vlv Type	Act Type	Norm Pos	Safety Pos	Req'd Tests	Rel Req, DTJ or TJ	Tests Pfrmd
PC-20-1	None	E-3	C-1	6	CK	SA	O	C	FE		DI
PC-20-2	None	E-3	C-1	6	CK	SA	O	C	FE		DI

**NOTE:** These valves are not required to be tested by 10CFR50.55a and are included in the IST Program as good practice. Since the Code requirements for IST are not mandatory, these valves will be tested by grouping them together and performing a disassembly and inspection of one each refueling outage without including a relief request.

<b>MONTICELLO NUCLEAR GENERATING PLANT</b>		EWI-09.04.01
<b>TITLE:</b>	<b>INSERVICE TESTING PROGRAM</b>	Revision 8
		Page 111 of 122

ATTACHMENT

**9.3 Valve Testing Table (Cont'd)**

SYSTEM: Open (Dirty) Radwaste Sump System									P&ID NO.: M-137		
Valve No.	ASME Class	P&ID Coord	Sect XI Cat	Size (in.)	Vlv Type	Act Type	Norm Pos	Safety Pos	Req'd Tests	Rel Req, DTJ or TJ	Tests Pfrmd
AO-2541A	2	E-2	A-1	2	GT	AO	O	C	FE,LJ, PI		FE,LJ, PI
AO-2541B	2	E-1	A-1	2	GT	AO	O	C	FE,LJ, PI		FE,LJ, PI
PSD-6047	None	E-2	D-1	1/2	RD	SA	C	O	RD		RD



<b>MONTICELLO NUCLEAR GENERATING PLANT</b>		<b>EWI-09.04.01</b>
<b>TITLE:</b>	<b>INSERVICE TESTING PROGRAM</b>	Revision 8
		Page 112 of 122

ATTACHMENT

**9.3 Valve Testing Table (Cont'd)**

SYSTEM: Closed (Clean) Radwaste Sump System									P&ID NO.: M-138		
Valve No.	ASME Class	P&ID Coord	Sect XI Cat	Size (in.)	Vlv Type	Act Type	Norm Pos	Safety Pos	Req'd Tests	Rel Req, DTJ or TJ	Tests Pfrmd
AO-2561A	2	E-2	A-1	2	GT	AO	O	C	FE,LJ, PI		FE,LJ, PI
AO-2561B	2	E-1	A-1	2	GT	AO	O	C	FE,LJ, PI		FE,LJ, PI
PSD-6048	None	E-2	D-1	1/2	RD	SA	C	O	RD		RD

ATTACHMENT

**9.3 Valve Testing Table (Cont'd)**

SYSTEM: Primary Containment & Atmospheric Control System									P&ID NO.: M-143		
Valve No.	ASME Class	P&ID Coord	Sect XI Cat	Size (in.)	Vlv Type	Act Type	Norm Pos	Safety Pos	Req'd Tests	Rel Req, DTJ or TJ	Tests Pfrmd
AO-2377	2	C-2	A-1	18	BF	AO	C	C	FE,LJ,PI		FE,LJ,PI
AO-2378	2	B-3	A-1	18	BF	AO	C	C	FE,LJ,PI		FE,LJ,PI
AO-2379	2	C-2	A-1	20	BF	AO	C	O/C	FE,LJ,PI		FE,LJ,PI
AO-2380	2	B-2	A-1	20	BF	AO	C	O/C	FE,LJ,PI		FE,LJ,PI
AO-2381	2	C-3	A-1	18	BF	AO	C	C	FE,LJ,PI		FE,LJ,PI
AO-2382A	2	B-4	A,C-1	18	CK	SA	C	O/C	FE,LK,PI		FR,LK,PI
AO-2382B	2	B-4	A,C-1	18	CK	SA	C	O/C	FE,LK,PI		FR,LK,PI
AO-2382C	2	B-4	A,C-1	18	CK	SA	C	O/C	FE,LK,PI		FR,LK,PI
AO-2382E	2	B-4	A,C-1	18	CK	SA	C	O/C	FE,LK,PI		FR,LK,PI
AO-2382F	2	B-4	A,C-1	18	CK	SA	C	O/C	FE,LK,PI		FR,LK,PI
AO-2382G	2	B-4	A,C-1	18	CK	SA	C	O/C	FE,LK,PI		FR,LK,PI
AO-2382H	2	B-4	A,C-1	18	CK	SA	C	O/C	FE,LK,PI		FR,LK,PI
AO-2382K	2	B-4	A,C-1	18	CK	SA	C	O/C	FE,LK,PI		FR,LK,PI
AO-2383	2	B-6	A-1	18	BF	AO	C	C	FE,LJ,PI		FE,LJ,PI
AO-2386	2	D-6	A-1	18	BF	AO	C	C	FE,LJ,PI		FE,LJ,PI
AO-2387	2	D-6	A-1	18	BF	AO	C	C	FE,LJ,PI		FE,LJ,PI
AO-2896	2	C-6	A-1	18	BF	AO	C	C	FE,LJ,PI		FE,LJ,PI
CV-2384	2	A-6	A-1	2	GL	AO	C	C	FE,LJ,PI		FE,LJ,PI

<b>MONTICELLO NUCLEAR GENERATING PLANT</b>		<b>EWI-09.04.01</b>
<b>TITLE:</b>	<b>INSERVICE TESTING PROGRAM</b>	Revision 8
		Page 114 of 122

ATTACHMENT

**9.3 Valve Testing Table (Cont'd)**

<b>SYSTEM: Primary Containment &amp; Atmospheric Control System</b>									<b>P&amp;ID NO.: M-143 (cont'd)</b>		
Valve No.	ASME Class	P&ID Coord	Sect XI Cat	Size (in.)	Vlv Type	Act Type	Norm Pos	Safety Pos	Req'd Tests	Rel Req, DTJ or TJ	Tests Pfrmd
CV-2385	2	C-6	A-1	2	GL	AO	C	C	FE,LJ, PI		FE,LJ, PI
DWV-8-1	2	B-2	A,C-1	20	CK	SA	C	O/C	FE,LJ		FE,LJ
DWV-8-2	2	C-2	A,C-1	20	CK	SA	C	O/C	FE,LJ		FE,LJ

ATTACHMENT

**9.3 Valve Testing Table (Cont'd)**

SYSTEM: Service Water Systems and Makeup Intake Structure (RHRSW)									P&ID NO.: M-811		
Valve No.	ASME Class	P&ID Coord	Sect XI Cat	Size (in.)	Vlv Type	Act Type	Norm Pos	Safety Pos	Req'd Tests	Rel Req, DTJ or TJ	Tests Pfrmd
AV-3147	3	C-4	C-1	3	AR	SA	O	C	FE		FE
AV-3148	3	B-8	C-1	3	AR	SA	O	C	FE		FE
AV-3149	3	B-4	C-1	3	AR	SA	O	C	FE		FE
AV-3150	3	B-8	C-1	3	AR	SA	O	C	FE		FE
RHRSW-1-1	3	C-4	C-1	12	CK	SA	C	O/C	FE		FE
RHRSW-1-2	3	C-8	C-1	12	CK	SA	C	O/C	FE		FE
RHRSW-1-3	3	C-4	C-1	12	CK	SA	C	O/C	FE		FE
RHRSW-1-4	3	C-8	C-1	12	CK	SA	C	O/C	FE		FE
RHRSW-3-1	3	C-4	B-1	18	GT	MA	C	O	FE		FE
RHRSW-3-2	3	C-7	B-1	18	GT	MA	C	O	FE		FE
RHRSW-57-1	3	B-2	C-1	1.0	CK	SA	C	O	FE		FE
RHRSW-57-2	3	B-7	C-1	1.0	CK	SA	C	O	FE		FE
RHRSW-57-3	3	B-2	C-1	1.0	CK	SA	C	O	FE		FE
RHRSW-57-4	3	B-7	C-1	1.0	CK	SA	C	O	FE		FE
RV-3038	3	C-4	C-1	1	RV	SA	C	O	SP	4.2.19	SP
RV-3039	3	C-7	C-1	1	RV	SA	C	O	SP	4.2.19	SP
SW-21-1	3	C-3	C-1	1	CK	SA	O	C	FE	4.2.13	RR
SW-21-2	3	C-7	C-1	1	CK	SA	O	C	FE	4.2.13	RR
SW-22-1	None	C-3	C-1	1	CK	SA	O	C	FE	4.2.13	RR
SW-22-2	None	C-7	C-1	1	CK	SA	O	C	FE	4.2.13	RR
RHRSW-48-1	3	B-3		.5	CK	SA	C	C	FE		FE
RHRSW-48-2	3	B-7		.5	CK	SA	C	C	FE		FE
RHRSW-50-1	3	B-3		.5	CK	SA	C	C	FE		FE
RHRSW-50-2	3	B-7		.5	CK	SA	C	C	FE		FE
SV-4937A	3	B-2	B-1	1.0	GL	SO	C	O	FE		FE
SV-4937B	3	B-7	B-1	1.0	GL	SO	C	O	FE		FE
SV-4937C	3	B-2	B-1	1.0	GL	SO	C	O	FE		FE
SV-4937D	3	B-7	B-1	1.0	GL	SO	C	O	FE		FE

ATTACHMENT

**9.3 Valve Testing Table (Cont'd)**

SYSTEM: Service Water Systems and Makeup Intake Structure (ESW)									P&ID NO.: M-811		
Valve No.	ASME Class	P&ID Coord	Sect XI Cat	Size (in.)	Vlv Type	Act Type	Norm Pos	Safety Pos	Req'd Tests	Rel Req, DTJ or TJ	Tests Pfrmd
AV-3155	3	B-5	C-1	2	AR	SA	O	C	FE		FE
AV-3156	3	B-6	C-1	2	AR	SA	O	C	FE		FE
AV-4024	3	C-4	C-1	1	AR	SA	O	C	FE		FE
AV-4026	3	C-6	C-1	1	AR	SA	O	C	FE		FE
ESW-1-1	3	B-5	C-1	4	CK	SA	C	O	FE		FE
ESW-1-2	3	B-6	C-1	4	CK	SA	C	O	FE		FE
ESW-2-1	3	C-5	B-1	4	GT	MA	C	O/C	FE		FE
ESW-2-2	3	C-5	B-1	4	GT	MA	C	O/C	FE		FE
ESW-3-1	3	C-5	B-1	4	GT	MA	C	O	FE		FE
ESW-3-2	3	C-6	B-1	4	GT	MA	C	O	FE		FE
ESW-5-1	3	C-4	B-1	4	GT	MA	O	C	FE		FE
ESW-5-2	3	C-7	B-1	4	GT	MA	O	C	FE		FE
ESW-13	None	D-6	C-1	4	CK	SA	O	C	FE	4.2.14	RR
ESW-14	3	D-6	C-1	4	CK	SA	O	C	FE	4.2.14	RR
ESW-15	None	D-5	C-1	4	CK	SA	O	C	FE	4.2.14	RR
ESW-16	3	D-4	C-1	4	CK	SA	O	C	FE	4.2.14	RR
ESW-17	None	C-6	C-1	4	CK	SA	C	O	FE		FE
ESW-18	3	C-4	C-1	4	CK	SA	C	O	FE		FE
ESW-19	3	C-6	B-1	4	GT	MA	C	O	FE		FE
ESW-20	3	C-4	B-1	4	GT	MA	C	O	FE		FE
SW-15	None	D-7	C-1	4	CK	SA	C	C	FE	4.2.14	RR
SW-16	3	D-7	C-1	4	CK	SA	C	C	FE	4.2.14	RR
SW-17	None	D-7	C-1	4	CK	SA	C	C	FE	4.2.14	RR
SW-18	3	D-7	C-1	4	CK	SA	C	C	FE	4.2.14	RR
ESW-71-1	3	B-4		.5	CK	SA	C	C	FE		FE
ESW-73-1	3	B-4		.5	CK	SA	C	C	FE		FE
ESW-71-2	3	B-6		.5	CK	SA	C	C	FE		FE
ESW-73-2	3	B-6		.5	CK	SA	C	C	FE		FE

ATTACHMENT

**9.3 Valve Testing Table (Cont'd)**

SYSTEM: Combustible Gas Control System Div I (East)									P&ID NO.: NH-94896		
Valve No.	ASME Class	P&ID Coord	Sect XI Cat	Size (in.)	Vlv Type	Act Type	Norm Pos	Safety Pos	Req'd Tests	Rel Req, DTJ or TJ	Tests Pfrmd
AO-7422A	2	D-7	A-1	4	GL	AO	C	O/C	FE,LJ,PI,FS		FE,LJ,PI,FS
AO-7423A	2	D-7	A-1	4	GL	AO	C	O/C	FE,LJ,PI,FS		FE,LJ,PI,FS
AO-7424A	2	B-7	A-1	6	GL	AO	C	O/C	FE,LJ,PI,FS		FE,LJ,PI,FS
AO-7425A	2	B-7	A-1	6	GL	AO	C	O/C	FE,LJ,PI,FS		FE,LJ,PI,FS
CGC-12-1	3	A-5	C-1	1.50	CK	SA	C	O/C	FE		FE
MO-4043A	3	D-5	B-1	3	GL	MO	C	O	FE,PI		FE,PI
MO-4044A	3	C-5	B-1	3	GL	MO	C	O	FE,PI		FE,PI
MO-4047A	3	B-4	B-1	0.75	GL	MO	C	O	FE,PI		FE,PI
RV-4032A	3	B-5	C-1	1	RV	SA	C	O	SP		SP
SV-4033A	2	A-6	B-1	2	GL	SO	C	O	FE,PI		FE,PI
SV-4034A	2	A-6	B-1	2	GL	SO	C	O	FE,PI		FE,PI
SV-4054A	3	A-5	B-1	0.75	GL	SO	C	O	FE,PI		FE,PI

ATTACHMENT

**9.3 Valve Testing Table (Cont'd)**

SYSTEM: Combustible Gas Control System Div II (West)									P&ID NO.: NH-94897		
Valve No.	ASME Class	P&ID Coord	Sect XI Cat	Size (in.)	Vlv Type	Act Type	Norm Pos	Safety Pos	Req'd Tests	Rel Req, DTJ or TJ	Tests Pfrmd
AO-7422B	2	D-7	A-1	4	GL	AO	C	O/C	FE,LJ,PI,FS		FE,LJ,PI,FS
AO-7423B	2	D-7	A-1	4	GL	AO	C	O/C	FE,LJ,PI,FS		FE,LJ,PI,FS
AO-7424B	2	B-7	A-1	6	GL	AO	C	O/C	FE,LJ,PI,FS		FE,LJ,PI,FS
AO-7425B	2	B-7	A-1	6	GL	AO	C	O/C	FE,LJ,PI,FS		FE,LJ,PI,FS
CGC-12-2	3	A-5	C-1	1.50	CK	SA	C	O/C	FE		FE
MO-4043B	3	D-5	B-1	3	GL	MO	C	O	FE,PI		FE,PI
MO-4044B	3	C-5	B-1	3	GL	MO	C	O	FE,PI		FE,PI
MO-4047B	3	B-4	B-1	0.75	GL	MO	C	O	FE,PI		FE,PI
RV-4032B	3	B-5	C-1	1	RV	SA	C	O	SP		SP
SV-4033B	2	A-6	B-1	2	GL	SO	C	O	FE,PI		FE,PI
SV-4034B	2	A-6	B-1	2	GL	SO	C	O	FE,PI		FE,PI
SV-4054B	3	A-5	B-1	0.75	GL	SO	C	O	FE,PI		FE,PI

**ATTACHMENT**

**9.3 Valve Testing Table (Cont'd)**

<b>SYSTEM: Traversing Incore Probe System</b>									<b>P&amp;ID NO.: GE0719E520</b>		
<b>Valve No.</b>	<b>ASME Class</b>	<b>P&amp;ID Coord</b>	<b>Sect XI Cat</b>	<b>Size (in.)</b>	<b>Vlv Type</b>	<b>Act Type</b>	<b>Norm Pos</b>	<b>Safety Pos</b>	<b>Req'd Tests</b>	<b>Rel Req, DTJ or TJ</b>	<b>Tests Pfrmd</b>
TIP-1-1	2	D-5	A-1	0.25	BA	SO	C	C	FE,PI, LJ		FE,PI, LJ
TIP-2-1	2	D-5	A-1	0.25	BA	SO	C	C	FE,PI, LJ		FE,PI, LJ
TIP-3-1	2	D-5	A-1	0.25	BA	SO	C	C	FE,PI, LJ		FE,PI, LJ
TIP-1-2	2	D-5	D-1	0.25	XP	XP	O	C	EX		EX
TIP-2-2	2	D-5	D-1	0.25	XP	XP	O	C	EX		EX
TIP-3-2	2	D-5	D-1	0.25	XP	XP	O	C	EX		EX



<b>MONTICELLO NUCLEAR GENERATING PLANT</b>		<b>EWI-09.04.01</b>
<b>TITLE:</b>	<b>INSERVICE TESTING PROGRAM</b>	Revision 8
		Page 120 of 122

ATTACHMENT

**9.3 Valve Testing Table (Cont'd)**

SYSTEM: Hard Pipe Vent									P&ID NO.: NH-116629		
Valve No.	ASME Class	P&ID Coord	Sect XI Cat	Size (in.)	Vlv Type	Act Type	Norm Pcs	Safety Pos	Req'd Tests	Rel Req, DTJ or TJ	Tests Pfrmd
AO-4539	2	C-3	A-2	8	BF	AO	C	C	LJ		LJ
AO-4540	2	C-4	A-2	8	BF	AO	C	C	LJ		LJ
PSD-4543	None	B-6	D-2	10	RD	SA	C	C	RD		RD

<b>MONTICELLO NUCLEAR GENERATING PLANT</b>		<b>EWI-09.04.01</b>
<b>TITLE:</b>	<b>INSERVICE TESTING PROGRAM</b>	Revision 8
		Page 121 of 122

ATTACHMENT

**9.4 Technical Justifications**

9.4.1 HPCI-65, HPCI-71, RCIC-57 and RCIC-59 Safety Functions

The subject valves have a safety function in the closed direction and are tested for the closed direction. They do not have a safety function in the open direction. See Special Q-List Extension Subcommittee Meeting Minutes of March 9, 2001.

9.4.2 EDG Air Start Relief Valves and RHRSW Auxiliary Air Compressor Relief Valves

Components: RV-3216 through RV-3221 (EDG Air Tank Relief Valves)  
RV-3224 through RV-3229 (EDG Air Tank Relief Valves)  
RV-4908A/RV-4908B (K-10A/K-10B Relief Valves)

The above listed components are non-code class components as described in the EWI and the MNGP Q-list classification (color-coded P&ID). NRC relief from code requirements is not required by the NRC for these valves as described in the NRC Safety Evaluation to MNGP dated September 24, 1992. However, where testing is not in compliance with the code requirements due to impracticalities, the alternate testing will be documented in the IST Program. This technical justification serves the purpose of documenting our alternate testing of these valves.

OM-1 requires an accumulator with a minimum volume for air relief valve testing. These valves are tested for setpoint pressure only. An accumulator is not necessary for proper setpoint testing.

9.4.3 Check Valves With No Closed Safety Function Designation

Components: CRD-114, RHR-8-1/2, HPCI-18, HPCI-42, RCIC-37,  
XP-3-1/2  
AI-12-9, AI-12-10, AI-12-11, AI-12-12  
AI-729 and AI-730  
AI-663, AI-666, AI- 669, AI-672, AI-675, AI-678, AI-681,  
AI-694, AI-695  
FO-5, FO-34, FO-44  
ESW-1-1, ESW-1-2, ESW-17, ESW-18

The above components were reviewed by the Q-List Committee on March 10, 2001, to verify that no safety-related closed function existed for these check valves. This was verified by the committee. Specific details are contained in the Q-List Subcommittee Meeting Minutes dated March 12, 2001.

RHRSW-57-1, RHRSW-57-2, RHRSW-57-3, RHRSW-57-4 (See modification 00Q100)

<b>MONTICELLO NUCLEAR GENERATING PLANT</b>		EWI-09.04.01
<b>TITLE:</b>	<b>INSERVICE TESTING PROGRAM</b>	Revision 8
		Page 122 of 122

ATTACHMENT

**9.4 Technical Justifications (Cont'd)**

9.4.4 Requirement of an Accumulator for Relief Valve Testing with Compressible Fluids

OM-1 stipulates an accumulator with a minimum volume requirement in Sections 4.1.1.2 and 4.1.2.2. These sections would require this accumulator when testing both steam and gases respectively. The equations for the minimum volume are as follows:

$$\text{MINIMUM VOLUME} = (\text{VALVE CAPACITY} * \text{OPEN TIME}) / 10$$

The intent of this minimum requirement was for capacity testing of relief valves. OM-1 does not require capacity testing of relief valves. MNGP tests in accordance with OM-1 and performs a set pressure test. Subsequent versions of the code have removed the minimum volume requirement as a recognized error in the code.

MNGP does not require an accumulator with a minimum volume in relief valve testing. MNGP assumes that the open time for set pressure testing is 0 seconds due to the fact that an open time duration is not required to determine this parameter. If flow testing was being conducted, a required open time would be developed and would be utilized in this equation. Because 0 is assumed, the minimum volume would also be 0 cubic feet.

9.4.5 Testing of AI-243-1, AI-244-1 and AI-243-2, AI-244-2 in Series for Closed Position

AI-243-1 and AI-244-1 as well as AI-243-2 and AI-244-2 are tested in series as a pair. These valves cannot be tested individually due to the lack of test connections between the valves to verify individual operation. Testing these check valves individually would require a plant piping modification.

The subject valves are non-code class valves and therefore MNGP does not require a relief request for this code deviation (see Section 1.3 of this document). This technical justification serves as documentation of this deviance from code testing requirements. Documentation is required as described in Section 1.3 of this document.