

AMENDMENT OF SOLICITATION/MODIFICATION OF CONTRACT

1. CONTRACT ID CODE NRC-33-01-321 PAGE 1 OF PAGES

2. AMENDMENT/MODIFICATION NO. 003	3. EFFECTIVE DATE 4/15/2002	4. REQUISITION/PURCHASE REQ. NO. OCIO-01-321	ADMINISTRATIVE PROJECT NO. (if applicable) dated 3/19/2002
6. ISSUED BY U.S. Nuclear Regulatory Commission Division of Contracts and Property Mgt. Attn: Elinor Cunningham, M.S. T-7-I-2 IT Acquisition Management Branch Washington DC 20555		7. ADMINISTERED BY (if other than Item 6) CODE	

8. NAME AND ADDRESS OF CONTRACTOR (No., street, county, State and ZIP Code) ProBuilders Training & Consulting Services Inc. ATTN: Donald Johnson 9200 Basil Court Suite 105 Largo MD 20774	(X)	9A. AMENDMENT OF SOLICITATION NO. CIO-01-321
		9B. DATED (SEE ITEM 11)
		10A. MODIFICATION OF CONTRACT/ORDER NO. NRC-33-01-321
	X	10B. DATED (SEE ITEM 13) 04-01-2001

11. THIS ITEM ONLY APPLIES TO AMENDMENTS OF SOLICITATIONS

The above numbered solicitation is amended as set forth in Item 14. The hour and date specified for receipt of Offers is extended, is not extended. Offers must acknowledge receipt of this amendment prior to the hour and date specified in the solicitation or as amended, by one of the following methods: (a) By completing Items 8 and 15, and returning _____ copies of the amendment; (b) By acknowledging receipt of this amendment of each copy of the offer submitted; or (c) By separate letter or telegram which includes a reference to the solicitation and amendment numbers. FAILURE OF YOUR ACKNOWLEDGMENT TO BE RECEIVED AT THE PLACE DESIGNATED FOR THE RECEIPT OF OFFERS PRIOR TO THE HOUR AND DATE SPECIFIED MAY RESULT IN REJECTION OF YOUR OFFER. If by virtue of this amendment you desire to change an offer already submitted, such change may be made by telegram or letter, provided each telegram or letter makes reference to the solicitation and this amendment, and is received prior to the opening hour and date specified.

12. ACCOUNTING AND APPROPRIATION DATA (if required)
B&R: 210-15-524-346 JCN: D1930 BOC: 252A APPN:31X0200.210
OBLIGATION AMOUNT: \$237,666.71

13. THIS ITEM APPLIES ONLY TO MODIFICATIONS OF CONTRACTS/ORDERS, IT MODIFIES THE CONTRACT/ORDER NO. AS DESCRIBED IN ITEM 14.

(X) A. THIS CHANGE ORDER IS ISSUED PURSUANT TO: (Specify authority) THE CHANGES SET FORTH IN ITEM 14 ARE MADE IN THE CONTRACT ORDER NO. IN ITEM 10A.
X

B. THE ABOVE NUMBERED CONTRACT/ORDER IS MODIFIED TO REFLECT THE ADMINISTRATIVE CHANGES (such as changes in paying office, appropriation date, etc.) SET FORTH IN ITEM 14, PURSUANT TO THE AUTHORITY OF FAR 43.103(b).

C. THIS SUPPLEMENTAL AGREEMENT IS ENTERED INTO PURSUANT TO AUTHORITY OF: Mutual Agreement between two parties

D. OTHER (Specify type of modification and authority)
X

E. IMPORTANT: Contractor is not, is required to sign this document and return three copies to the issuing office.

14. DESCRIPTION OF AMENDMENT/MODIFICATION (Organized by UCF section headings, including solicitation/contract subject matter where feasible.)
See the attached continuation sheet.

Except as provided herein, all terms and conditions of the document referenced in Item 9A or 10A, as heretofore changed, remains unchanged and in full force and effect.

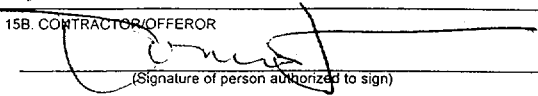
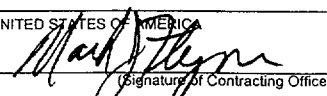
15A. NAME AND TITLE OF SIGNER (Type or print) Donald W. Johnson President	16A. NAME AND TITLE OF CONTRACTING OFFICER (Type or print) Mark J. Flynn Contracting Officer
15B. CONTRACTOR/OFFEROR  (Signature of person authorized to sign)	15C. DATE SIGNED 4/15/02
16B. UNITED STATES OF AMERICA BY  (Signature of Contracting Officer)	16C. DATE SIGNED 4/15/02

The purpose of this contract modification is to: (1) convert Section C for Option Years 1, 2, 3, and 4 to a Performance Based type Statement of Work; (2) revise Sections B.4.1 through B.4.4. of the contract ; (3) extend the period of performance of the contract to March 31, 2003; (4) change the NRC Project Officer; (5) add a NRC Technical Monitor; (6) incorporate the clause entitled " Appropriate Use of Government Furnished Information Technology (IT) Equipment and/or it Services/Access; and (7) obligate \$237,666.71. Accordingly, the contract is hereby modified as follows:

I. Under SECTION B - SUPPLIES OR SERVICES AND PRICE/COST, make the following changes:

1. Delete B.3 CONSIDERATION AND OBLIGATION-LABOR HOUR FOR REGULAR WORKING HOURS in its entirety and insert the following in lieu thereof:

"B.3 CONSIDERATION AND OBLIGATION -LABOR HOUR FOR REGULAR WORKING HOURS (Base Period - April 1, 2001 through April 14, 2002)"

a. The total ceiling amount of this contract is \$232,172.38. Payment will be made on a bi-monthly basis upon completion of all required services for that performance period.

b. The total obligated amount by the Government with respect to this contract is \$231,560.00. The Contractor shall not incur cost over the obligated amount unless a written contract modification is issued by the NRC Contracting Officer.

2. Add a new B.3.1 CONSIDERATION AND OBLIGATION - FIXED PRICE (OPTION YEARS)

"B.3.1 CONSIDERATION AND OBLIGATION - FIXED PRICE (OPTION YEARS)

The Firm Fixed Price amount of this contract for Option Year One is \$237,666.71. The total obligated amount under this contract is \$469,839.09."

3. Delete B.4.1 through B.4.2 PRICE SCHEDULE FOR WORK DURING REGULAR WORKING HOURS, in its entirety and replace with the following:

B.4.1 SCHEDULE OF ITEMS AND PRICES
 OPTION YEAR 1 - 4/15/2002 to 3/31/2003

ITEM NO.	SERVICE DESCRIPTION	QUANTITY	UNIT	UNIT PRICE	TOTAL
1.	GRAPHIC SERVICES				\$ 10,333.34
2.	GRAPHIC SERVICES				\$227,333.37
					\$237,666.71

B.4.2 SCHEDULE OF ITEMS AND PRICES
OPTION YEAR 2 - 4/1/2003 to 3/31/2004

ITEM NO.	SERVICE DESCRIPTION	QUANTITY	UNIT	UNIT PRICE	TOTAL
1.	GRAPHIC SERVICES				\$260,400.00

B.4.3 SCHEDULE OF ITEMS AND PRICES
OPTION YEAR 3 - 4/1/2004 - 3/31/2005

ITEM NO.	SERVICE DESCRIPTION	QUANTITY	UNIT	UNIT PRICE	TOTAL
1.	GRAPHIC SERVICES				\$273,419.66

B.4.4 SCHEDULE OF ITEMS AND PRICES
OPTION YEAR 4 - 4/1/2005 - 3/31/2006

ITEM NO.	SERVICE DESCRIPTION	QUANTITY	UNIT	UNIT PRICE	TOTAL
1.	GRAPHIC SERVICES				\$287,090.64

- II. Under Section C - DESCRIPTION/SPECIFICATIONS/STATEMENT OF WORK, delete the entire Section C.1 through C.8 and substitute the following in lieu thereof:

"SECTION C - DESCRIPTION/SPECIFICATIONS/WORK STATEMENT

C.1 BACKGROUND

The Graphics Section of the U.S. Nuclear Regulatory Commission (NRC) uses both computer software packages and traditional illustration techniques to generate a wide range of graphics products for NRC staff who are located mainly at its headquarters in Rockville, MD, as well as in its four regional offices. The Graphics Section supports a number of software packages for graphic applications that import and generate charts, graphs, technical illustrations, tables, and materials for a variety of visual media (view graphs, 35mm slides, color prints, etc). The Graphics Section also provides visual standards, consultation, visual enhancement, imaging and scanning for specific agency requirements.

In addition to daily work requirements of varying complexity, the trend towards dissemination of information to the public via the Internet has given rise to requests from some offices for design of Home Pages for the World Wide Web. With the rapid evolution of computer graphics into multimedia, the Graphics Section anticipates a growing demand for products using this technology.

C.2 CONTRACT OBJECTIVE

The Contractor shall provide graphic services to support the Graphics Section of the NRC. These products will be defined in work orders to be issued by the NRC Project Officer and/or technical monitor. The services will consist of tasks for graphics services, support for web design, support for quarterly newsletters, and support for annual and semi-annual publications. Delivery Dates for each product will be coordinated with the NRC Project Officer and/or technical monitor and may range from three (3) days to 3 weeks. All products shall conform to the requirements of the agency standards listed in this statement of work.

C.3 SCOPE OF WORK

The Contractor shall provide graphic services as required by the Graphics Section which includes: publication layout and design; design of brochures, pamphlets, posters, flyers, binders, exhibits, displays, presentation art, illustrations, charts, multimedia imaging and image scanning, and web design.

C.3.1 The Contractor shall ensure that all personnel assigned to work on this contract are qualified to perform the tasks outlined in this SOW. The Contractor's staff shall be properly trained to provide timely, accurate, complete, and courteous responses to all graphic requests.

C.3.1.1 The NRC Project Officer and/or technical monitor will provide individual work orders, with the appropriate technical direction, for the specific graphic services to be completed. The technical direction will include the type of work that is required (e.g., charts and graphs) a brief description of the project, an indication of how the final product will be used, and a specific deadline for completion.

C.3.1.2 All work completed by the Contractor shall be clean, neat, visually pleasing to the eye, accurate, and meet the deadline established by the NRC Project Officer or technical monitor. All completed projects shall require no more than two revisions by the NRC Project Officer and/or the technical monitor. These revisions will not be considered in Section C.3.10 related to unsatisfactory performance. Any revisions that exceed this amount will be considered as an unacceptable deliverable under that section.

C.3.1.3 If the Contractor cannot meet the deadline established by the NRC Project Officer and/or technical monitor, the contractor shall notify the Project Officer or the technical monitor, at least one (1) work day prior to the deadline.

C.3.1.4 The Contractor shall provide the following types of graphic services with associated delivery dates:

All days are business days.

Graphic Services:	Delivery Dates
• Technical Illustrations	within 10 days
• Charts and graphs	3 days
• Presentation templates	3 days
• Vugraphs and 35mm slides	3 days
• Masthead or logo design	within 10 days
• Exhibit designs	within 10 days
• Posters	within 10 days
• Framing and signage	within 10 days
• Reports	within 15 days
• Brochures - New	within 15 days
• Brochures - Revisions	5 days
• Newsletters	15 days
• Major conference materials	within 10 days
• Multimedia Imaging	within 10 days
• Name tags and tent cards	3 days
• Web Design	within 15 days

Samples of various graphic products are included in Attachment 1.

C.3.2 ESTIMATED QUANTITY BREAKDOWN FOR 12 MONTHS OF GRAPHIC SERVICES:

1. Complete an estimated 50 technical illustrations
2. Complete an estimated 150-200 graphs, charts and technical drawings for publications and presentations
3. Complete an estimated 40-50 publications and brochures (design and page makeup)
4. Complete an estimated 700-800 visuals for presentations
5. Complete an estimated 50-70 large poster designs
6. Complete an estimated 600-800 names tags and tent cards for meeting
7. Complete an estimated 300 multimedia request (web design)
8. Complete an estimated 4 Newsletters

C.3.3 SUPPORT FOR GRAPHIC SERVICES

The Contractor shall provide graphics support requested for major NRC-sponsored conferences such as the annual Nuclear Regulatory Information Conference. The following is a listing of products normally prepared for the conference:

1. Preliminary Agenda
2. Final Agenda
3. Registration form for industry
4. Layout and design of a 48"x66" photo organization chart of speakers
5. Layout and design of various maps for hotel and region

6. Pocket size conference agenda
7. Slides and viewgraph for NRC staff presentations
8. Conference Banner design if needed

C.3.3.1 The Contractor shall provide support for graphics services which includes various NRC publications such as the Accountability Report, the Information Digest, and the IG Semiannual Report. Each of these brochure publications require cover design and/or cover design modifications, typesetting, layout and design of interior pages, illustrations, charts (pie and bar) and graphs.

C.3.3.2 The Contractor shall provide graphics support services for posters and display art for various programs for the Office of Small Business and Civil Rights. These posters and display art includes Black History Month, Women's History Month Asian Pacific American Heritage Observance, Equality Day, Hispanic Heritage Month and the Native American Heritage Month.

C.3.3.3 The Contractor shall also be required to provide a wide variety of scientific and technical illustrations in support of NRC's health and safety issues such as 3D representations of containment buildings, detailed piping and electronic cabling drawings, BWR and PWR schematics showing basic plant components. Graphic materials needed include slides, view graphs, posters, exhibit, program brochure and signage.

C.3.4 SUPPORT FOR WEB DESIGN

The Contractor shall, as requested, provide input on redesign of the NRC's internal and external web sites. This input includes issues such as design elements, layout, web tools and various other web-related issues as needed. The Contractor shall perform research and provide reports on web tools, software, and other web design aspects as needed.

C.3.4.1 The Contractor shall assist with the creation of web pages which includes; designing web pages, assisting in the use of software to create pages, or designing various graphic elements, to be used on the web pages and provide graphic optimization and imaging management of electronic images for web placement.

C.3.5 QUARTERLY NEWSLETTER

The Contractor shall design and create a quarterly newsletter to provide supplemental information on using the NRC's Agency wide Documents Access and Management System (ADAMS) using information provided by the Project Officer or technical monitor to create the layout, design and graphics to enhance visual appeal, and create a better understanding of ADAMS.

C.3.6 ANNUAL OR SEMI -ANNUAL PUBLICATIONS

The Contractor shall design and create the annual or semi annual publications as listed below:

- Office of the Inspector General Semi Annual Report
- Information Digest
- NRC Editorial Style Guide
- The U.S. Nuclear Regulatory Commission and How it Works
- Accountability and Performance Report

C.3.7 WORK HOURS

The Contractor shall provide these services on Monday through Friday, from 7:30 a.m. to 4:15 p.m., Eastern time, excluding all Federal holidays.

C.3.8 METHOD OF SURVEILLANCE/QUALITY ASSURANCE

Quality Assurance Inspections performed by the NRC Project Officer/and or technical monitor, for all graphic products shall comply with standards specified in each individual work order and will include accuracy and timeliness. Further, the deliverables shall be clean, neat, and visually pleasing to the eye. Upon submission of each product, the NRC Project Officer and/or technical monitor will inspect the entire deliverable. Any corrections required by the contractor shall be made within 2 days of notification.

C.3.9 PERFORMANCE STANDARDS

The products delivered under this contract shall be of the highest quality, conform to the requirements stipulated in each work order, and be provided within the established delivery schedule. The Contractor shall meet these standards for all deliverables.

C.3.10 PAYMENT ADJUSTMENT FOR UNSATISFACTORY OR NONPERFORMANCE

If more than 10% of the total monthly deliverables are either late, unacceptable, or fail to conform to specifications reflected in the work orders, the NRC will deduct 5% of the fixed monthly amount due to the Contractor for that period.

C.3.11 ADJUSTMENT TO CONTRACT PRICE DUE TO VARIATION IN ESTIMATE QUANTITY

Over a period of one (1) year, if the estimate quantity (volume) for each of the eight (8) graphic services identified in C.3.2, vary, by more than ten percent (10%), an equitable downward/upward adjustment will be negotiated for that service. The Contractor shall be responsible to notify the Contracting Officer of the quantity adjustment in writing.

C.3.12 FACILITIES AND EQUIPMENT

NRC shall provide facilities located at 11545 Rockville Pike, Rockville, Maryland for Contractor staff with telephone, email and facsimile services. Computers, software and all other necessary supplies will also be provided by the NRC.

C.3.12.1 The NRC will provide the Contractor staff with both Mac/PC based computers using the following software:

- Adobe PageMaker
- Adobe In Design
- Adobe Acrobat
- Adobe Photoshop
- Adobe Illustrator
- WordPerfect
- Microsoft Word
- Quark XPress
- Microsoft PowerPoint
- Macromedia Freehand
- Macromedia Dream Weaver
- Microsoft Visual Source Safe

C.3.13 TRAINING

The NRC reserves the right to make changes to the software and hardware provided under this contract. The Contractor will be notified of such changes approximately 30 calendar days in advance of the change. The Contractor shall be responsible for providing personnel with the ability to utilize such software and hardware or obtain training for their current personnel in use of the hardware and software.

C.3.14 TECHNICAL MONITOR

Mr. Alvin Blunt is the technical monitor. The Technical Monitor may issue work and monitor performance under this contract.”

- III. Under Section F - Deliveries or Performance, delete F.2 DURATION OF CONTRACT PERIOD (MAR 1987) ALTERNATE 2 (MAR 1987) in its entirety and substitute the following in lieu thereof:

“F.2 DURATION OF CONTRACT PERIOD (MAR 1987)
ALTERNATE 2 (MAR 1987)

This contract shall commence on 04-01-2001 and will expire on 03-31-2003. The term of this contract may be extended at the option of the Government for an additional three one-year periods.”

- IV. Under Section G - CONTRACT ADMINISTRATION DATA, G.1, Project Officer Authority - Alternate 2, delete paragraph (a) in its entirety and substitute the following in lieu thereof:

"(a) The Contracting Officer's authorized representative, hereinafter referred to as the Project Officer, for this contract is:

Name: M. Linda McKenzie
Address: U.S. Nuclear Regulatory Commission
OCIO/IMD/PSB
Mail Stop T-4E16
Washington, DC 20555
Telephone Number: 301-415-6523"

- V. Under Section H - SPECIAL CONTRACT REQUIREMENTS, H.7, add the following clause:

"Appropriate Use of Government Furnished Information Technology (IT) Equipment and/or it Services/Access in full text (See Attachment 2)."

A summary of obligations for this contract from award date to the date of this action is shown below:

Total FY-01 Obligations:	\$231,560.00
Total FY-02 Obligations:	\$238,279.09
Cumulative Total of NRC Obligations	\$469,839.09

This modification obligates FY02 funds in the amount of \$237,666.71. All other terms and conditions remain unchanged.

Nuclear Power Plant (PWR)

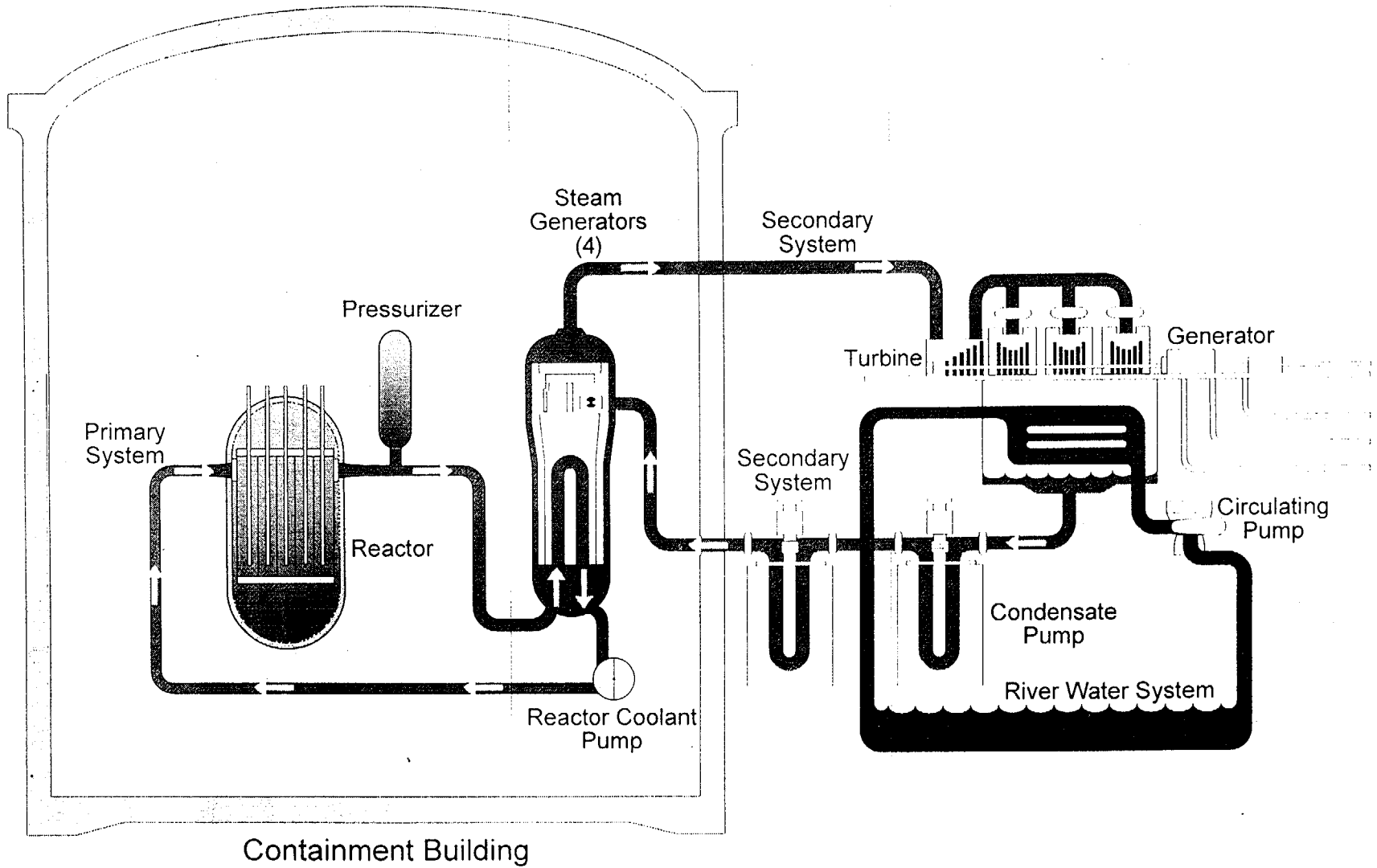

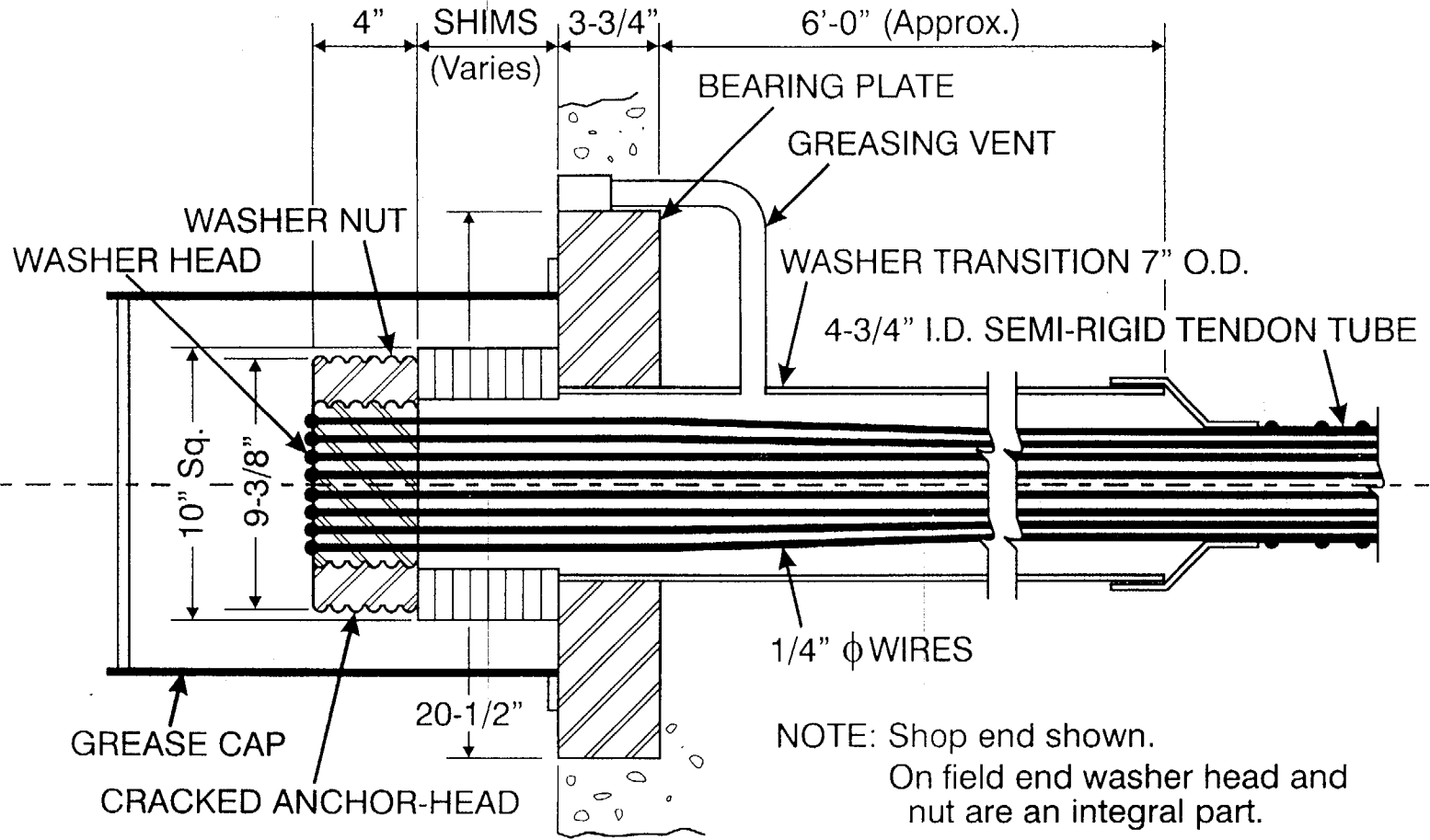

FIGURE 1 – FARLEY 170 WIRE PRESTRESS SYSTEM

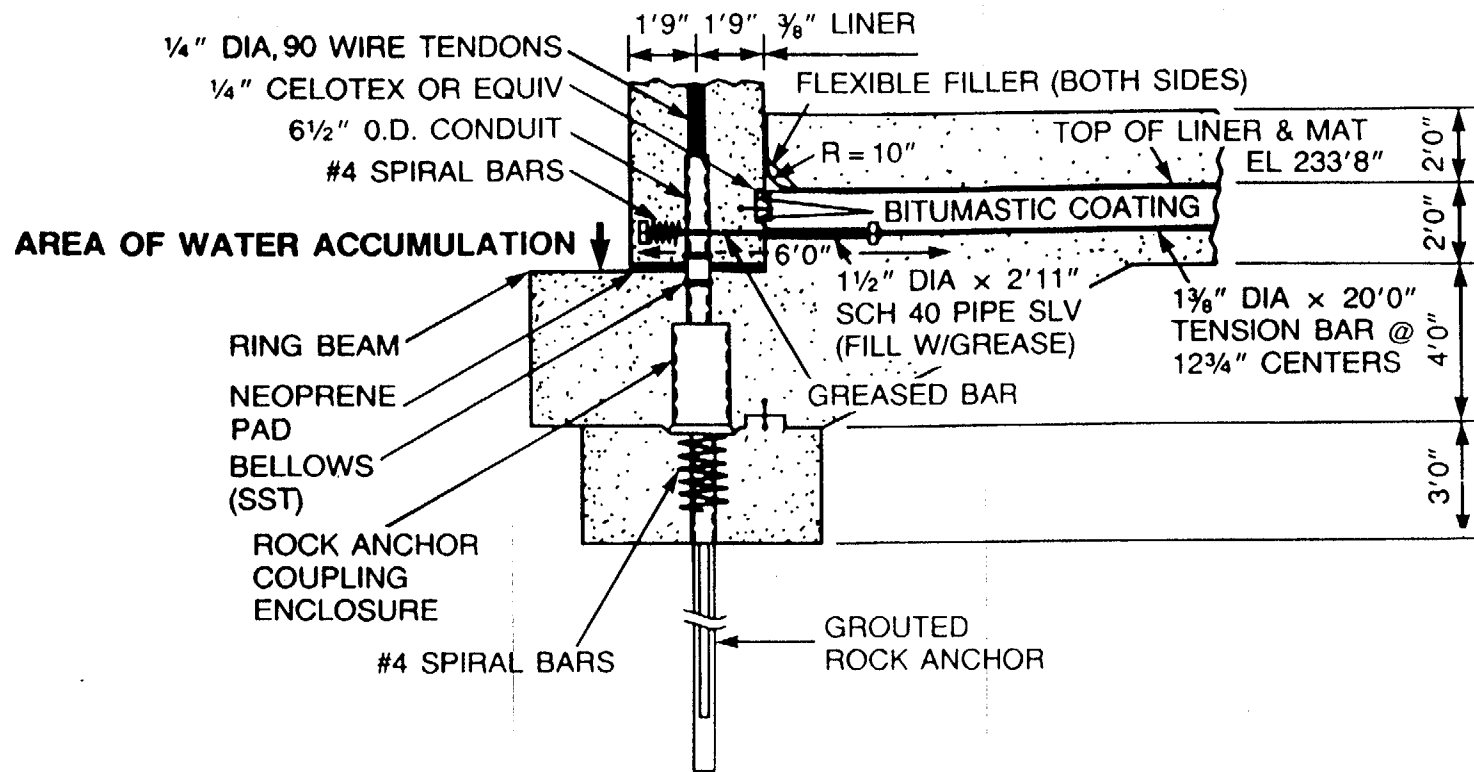

FIGURE 2 – CONTAINMENT BASE DETAILS AT GINNA

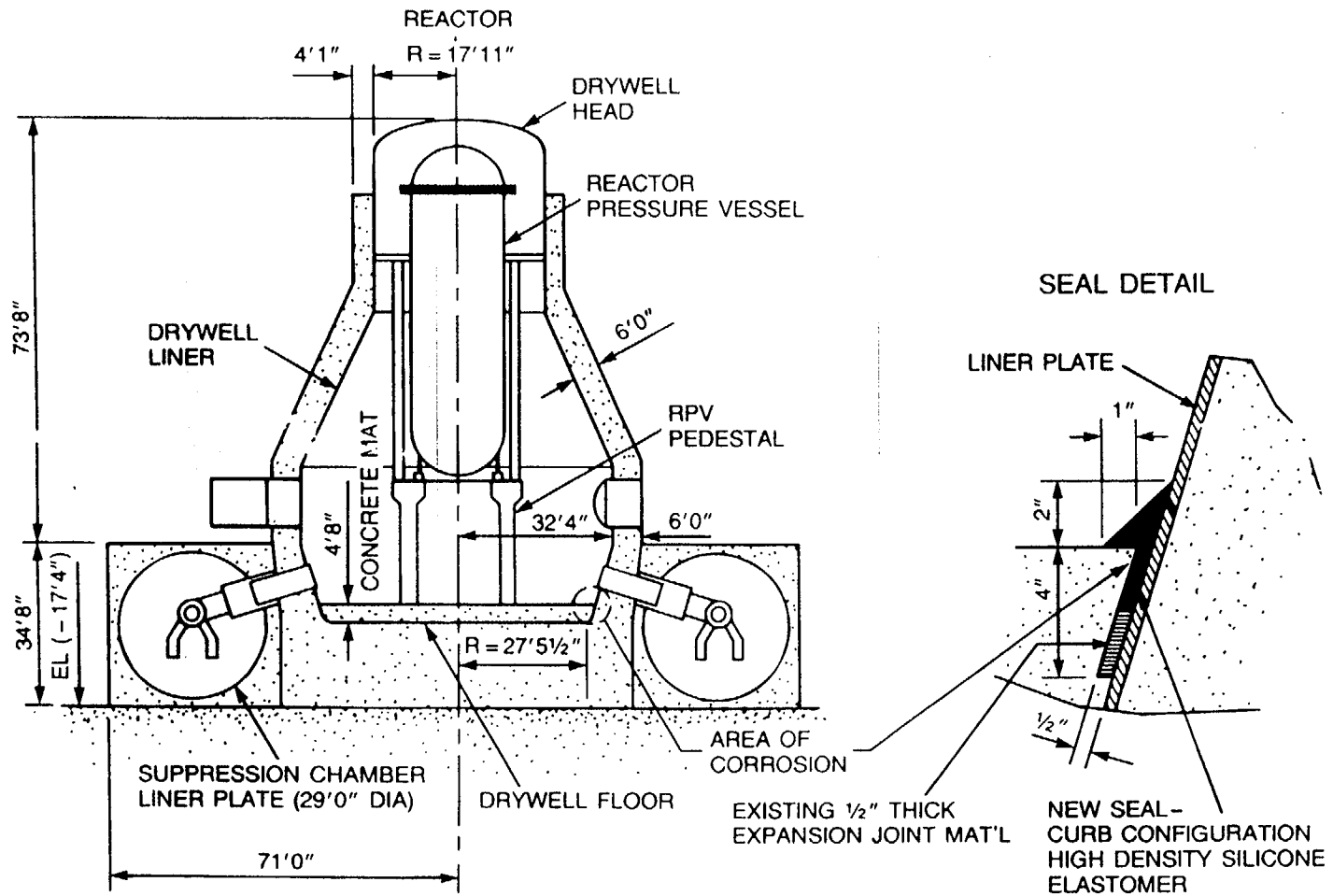

FIGURE 3 - DRYWELL LINER CORROSION AT BRUNSWICK

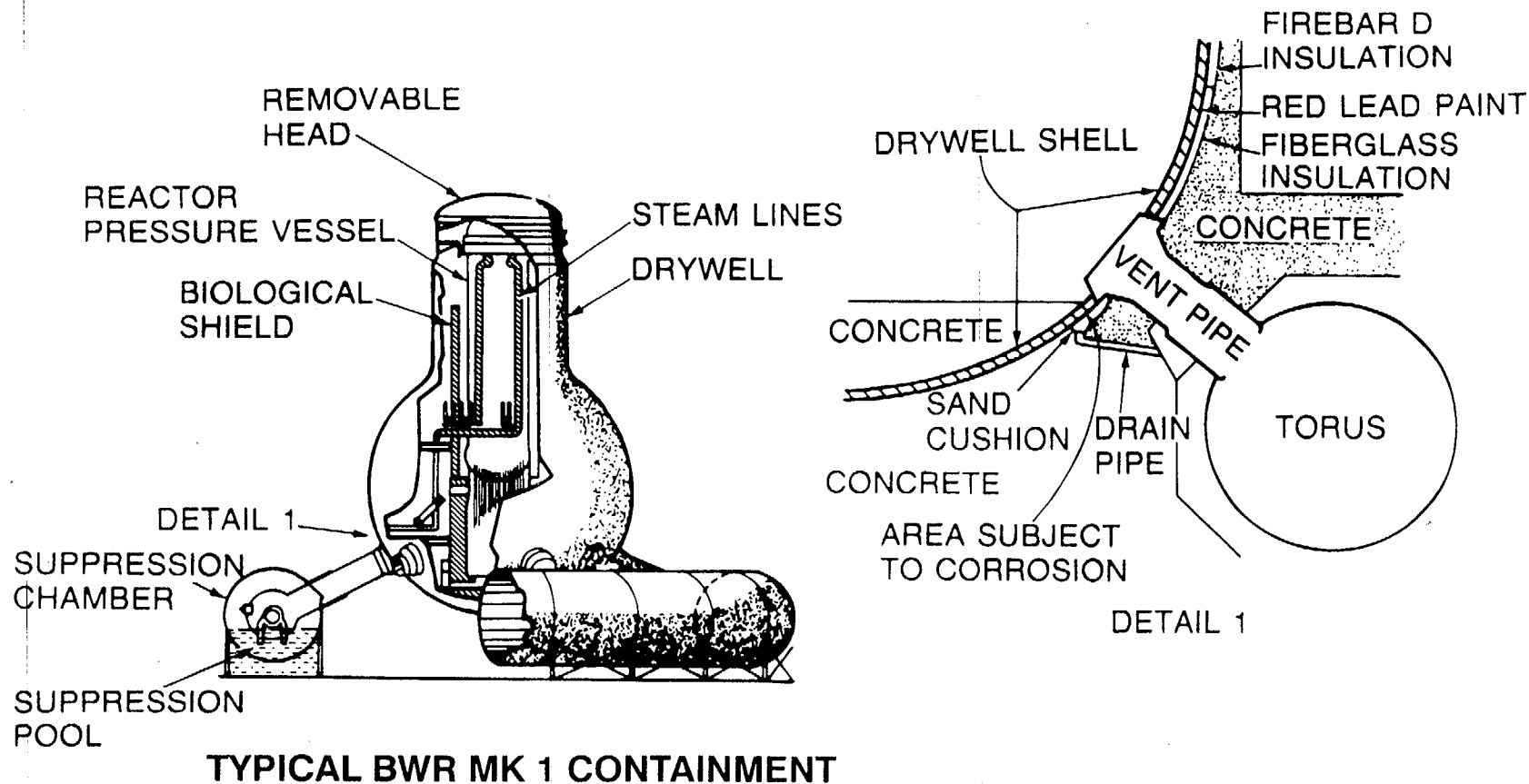

FIGURE 4 - OYSTER CREEK DRYWELL CORROSION

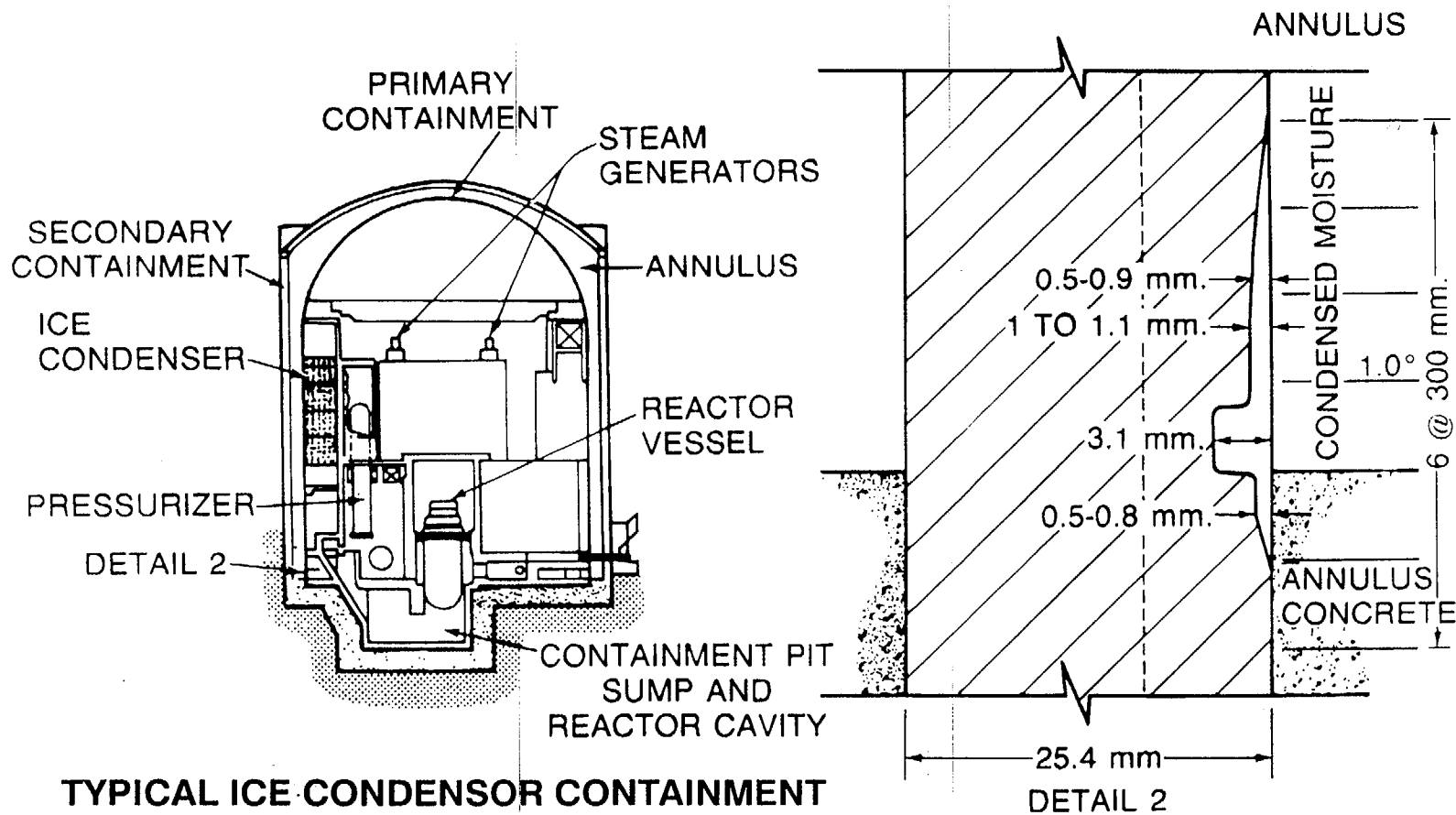
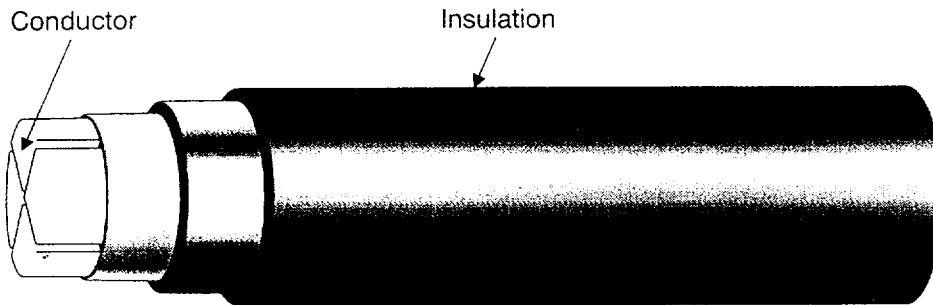
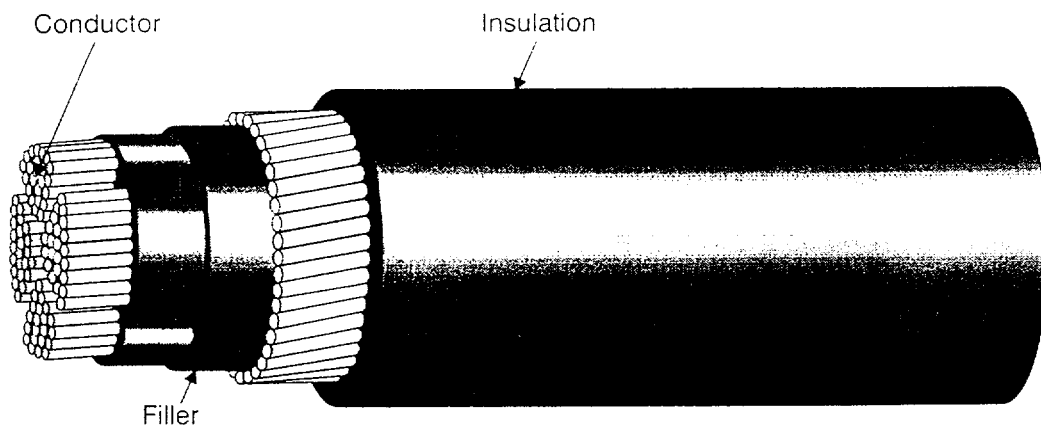

FIGURE 5 – CORROSION AT McQUIRE



Single-core, Sectoral Aluminum Conductor, PVC Insulated Cable



Four-core, Cooper Conductor, PVC Insulated Cable

Figure 2. Thermoplastic Insulated Cable Construction

MOX FUEL FABRICATION FACILITY Main One-Line Diagram

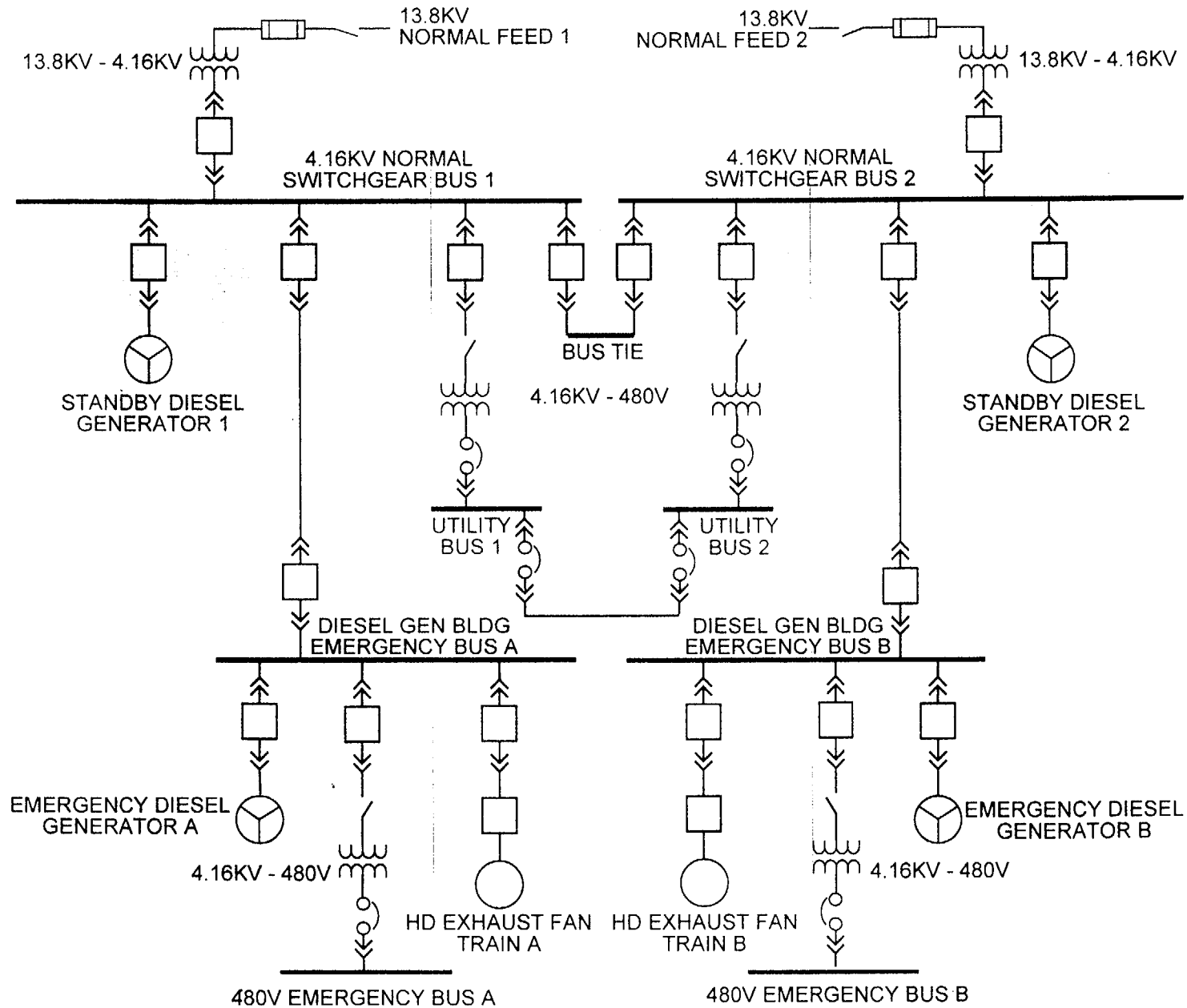

Enforcement Process

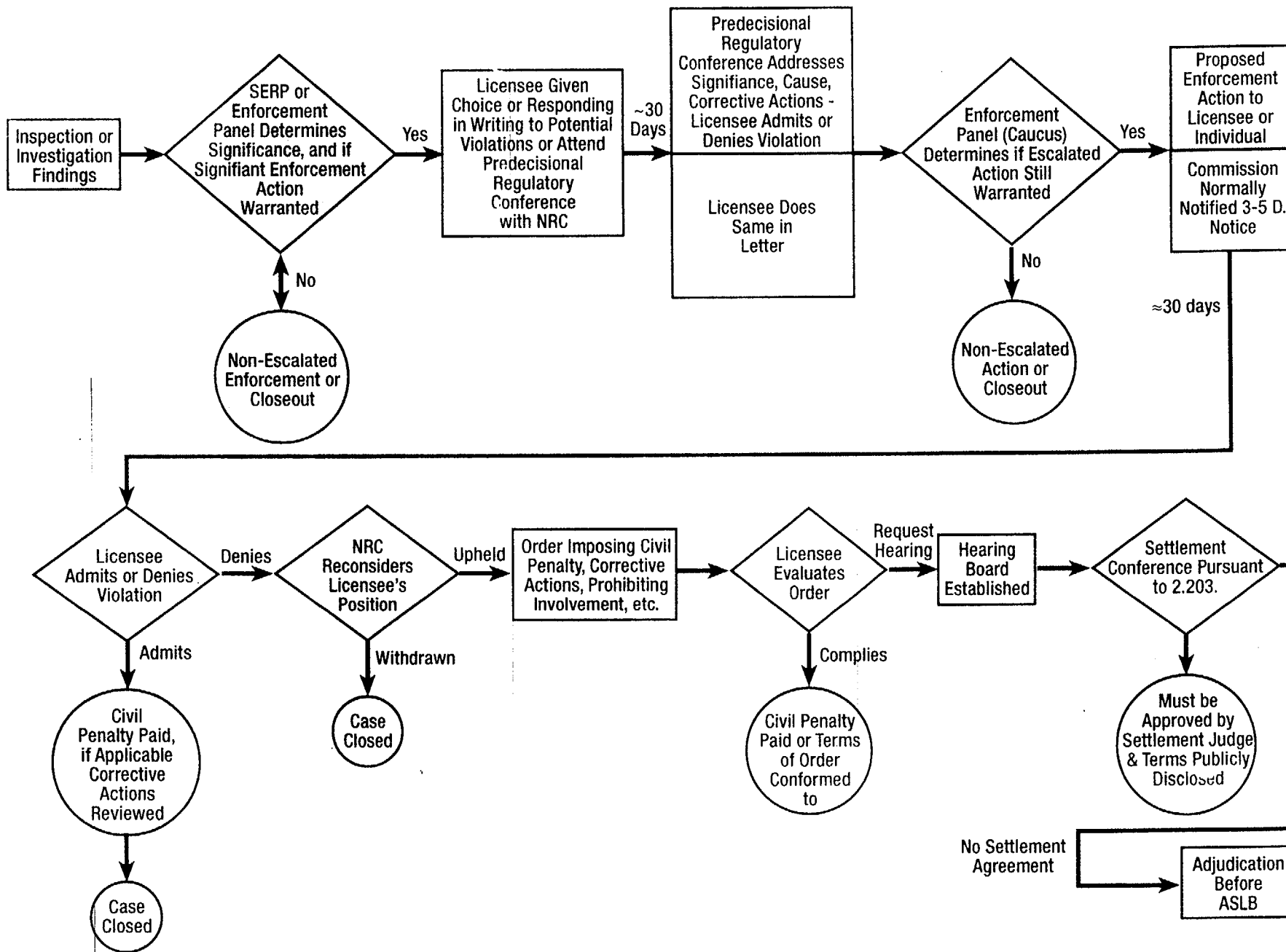

NRC and EPA Regions

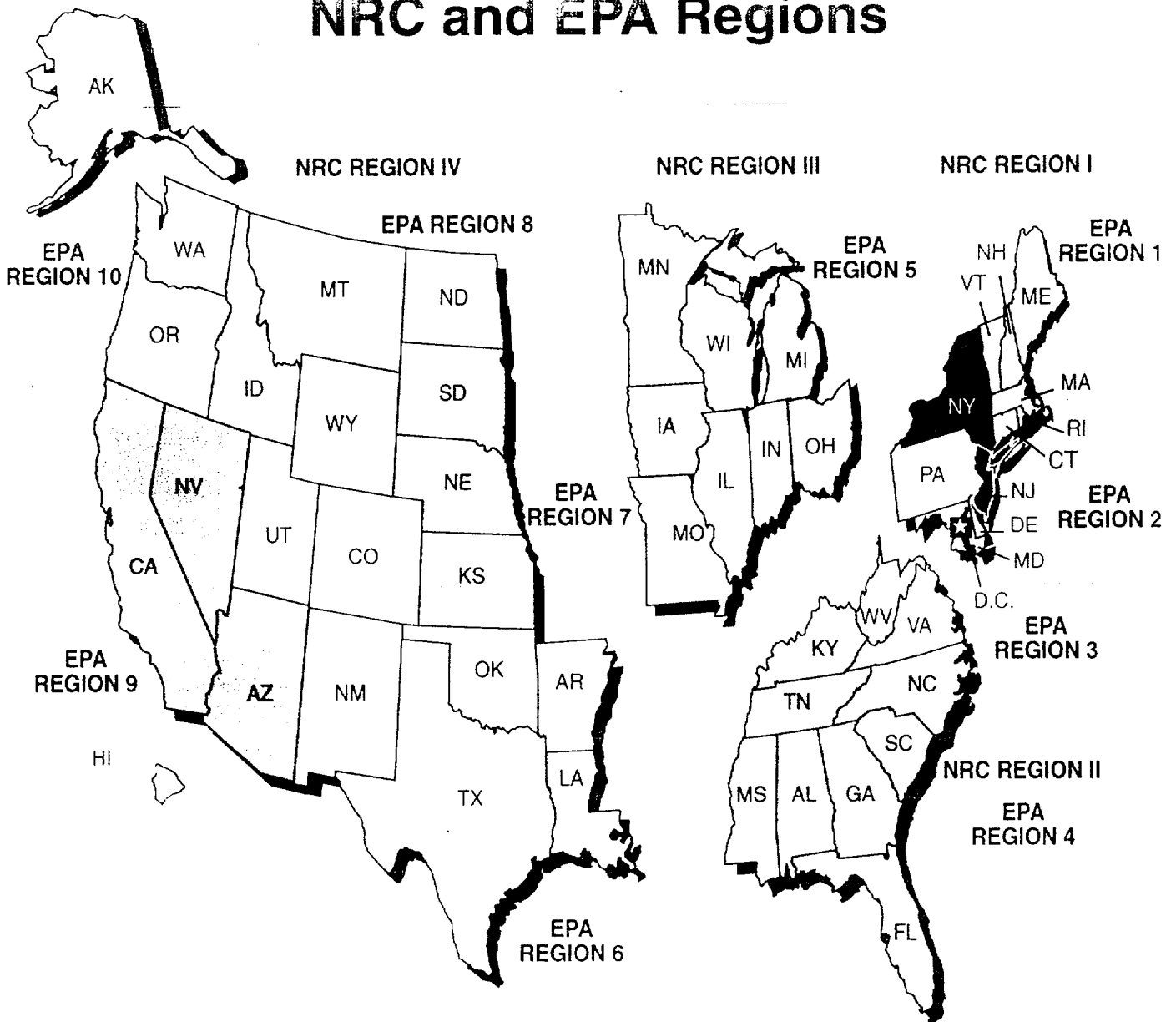

Note: • Included in NRC Region II and EPA Region 2 - Puerto Rico and U.S. Virgin Islands
 • Included in NRC Region IV - Alaska and Hawaii
 • Included in EPA Region 9 - Guam and American Samoa

PR 

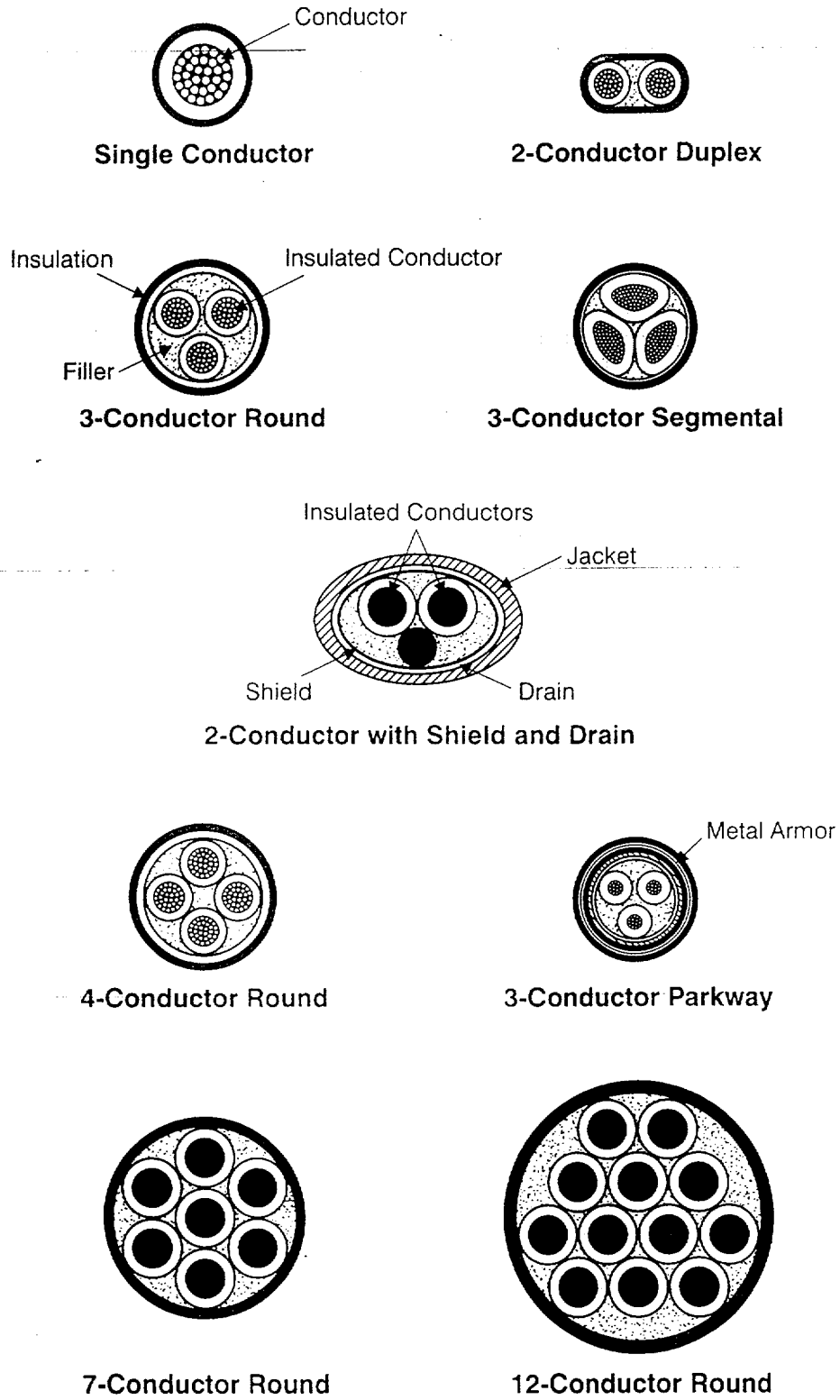

Figure 1. Basic Electrical Cable Construction - Common Single and Multi-conductor Cable Arrangements

ATTACHMENT 2

APPROPRIATE USE OF GOVERNMENT FURNISHED INFORMATION TECHNOLOGY (IT) EQUIPMENT AND/ OR IT SERVICES/ ACCESS (MARCH 2002)

As part of contract performance the NRC may provide the contractor with information technology (IT) equipment and IT services or IT access as identified in the solicitation or subsequently as identified in the contract or delivery order. Government furnished IT equipment, or IT services, or IT access may include but is not limited to computers, copiers, facsimile machines, printers, pagers, software, phones, Internet access and use, and email access and use. The contractor (including the contractor's employees, consultants and subcontractors) shall use the government furnished IT equipment, and / or IT provided services, and/ or IT access solely to perform the necessary efforts required under the contract. The contractor (including the contractor's employees, consultants and subcontractors) are prohibited from engaging or using the government IT equipment and government provided IT services or IT access for any personal use, misuse, abuses or any other unauthorized usage.

The contractor is responsible for monitoring its employees, consultants and subcontractors to ensure that government furnished IT equipment and/ or IT services, and/ or IT access are not being used for personal use, misused or abused. The government reserves the right to withdraw or suspend the use of its government furnished IT equipment, IT services and/ or IT access arising from contractor personal usage, or misuse or abuse; and/ or to disallow any payments associated with contractor (including the contractor's employees, consultants and subcontractors) personal usage, misuses or abuses of IT equipment, IT services and/ or IT access; and/ or to terminate for cause the contract or delivery order arising from violation of this provision.