



OG-02-019
May 23, 2002

WCAP-15315, Rev. 1
Project Number 694

Domestic Members

- AmerenUE
- Callaway
- American Electric Power Co.
D.C. Cook 1 & 2
- Carolina Power & Light Co.
H.B. Robinson 2
Shearon Harris
- Dominion Nuclear Connecticut
Millstone 3
- Dominion Virginia Power
North Anna 1 & 2
Surry 1 & 2
- Duke Power Company
Catawba 1 & 2
McGuire 1 & 2
- Entergy Nuclear Operations Inc.
Indian Point 2 & 3
- Exelon Generation Company LLC
Braidwood 1 & 2
Byron 1 & 2
- FirstEnergy Nuclear
Operating Co.
Beaver Valley 1 & 2
- Florida Power & Light Co.
Turkey Point 3 & 4
- Northeast Utilities
Seabrook
- Nuclear Management Co.
Point Beach 1 & 2
Prairie Island 1 & 2
Kewaunee
- Pacific Gas & Electric Co.
Diablo Canyon 1 & 2
- PSEG - Nuclear
Salem 1 & 2
- Rochester Gas & Electric Co.
R.E. Ginna
- South Carolina Electric
& Gas Co.
V.C. Summer
- STP Nuclear Operating Co.
South Texas Project 1 & 2
- Southern Nuclear
Operating Co.
J.M. Farley 1 & 2
A.W. Vogtle 1 & 2
- Tennessee Valley Authority
Sequoyah 1 & 2
Watts Bar 1
- TXU Electric
Commanche Peak 1 & 2
- Wolf Creek Nuclear
Operating Corp.
Wolf Creek

International Members

- Electrabel
Doel 1, 2, 4
Tihange 1, 3
- Electricite de France
Kansai Electric Power Co.
Mihama 1
Takahama 1
Ohi 1 & 2
- Korea Hydro & Nuclear Power Co.
Kori 1 - 4
Yonggwang 1 & 2
- British Energy plc
Sizewell B
- Krsko
Krsko
- Spanish Utilities
Asco 1 & 2
Vandellors 2
Almaraz 1 & 2
- Ringhals AB
Ringhals 2 - 4
- Taiwan Power Co.
Maanshan 1 & 2

Document Control Desk
U.S. Nuclear Regulatory Commission
Washington, DC 20555-0001

Attention: Chief, Information Management Branch,
Division of Inspection and Support Programs

Subject: Westinghouse Owners Group
**Transmittal of WCAP-15315, Rev. 1, "Reactor Vessel Closure
Head/Vessel Flange Requirements Evaluation for Operating PWR
and BWR Plants," (MUHP-3073)**

Reference: 1) Westinghouse Letter, H.A. Sepp to Rulemakings and Adjudications
Staff, "RE Petition for Rulemaking" NSBU-NRC-99-5954,
November 4, 1999.

2) Westinghouse Owners Group Letter, R. Bryan to Document
Control Desk, "Transmittal of WCAP-14040, Rev. 3,
'Methodology Used to Develop Cold Overpressure Mitigating
System Setpoints and RCS Heatup and Cooldown Limit Curves',"
OG-02-018, May 23, 2002.

This letter transmits five copies of WCAP-15315, Rev. 1, "Reactor Vessel Closure
Head/Vessel Flange Requirements Evaluation for Operating PWR and BWR
Plants," for review.

WCAP-15315, Rev. 0 and Westinghouse Electric Co. Petition for Rulemaking,
"Modification to Appendix G in 10 CFR 50," were submitted to the NRC in
November 1999 (Reference 1). WCAP-15315, Rev. 1 provides the technical
justification for eliminating the flange requirement of 10 CFR 50 Appendix G and
the additional technical information requested by the NRC during a meeting
between Westinghouse and the NRC on August 28, 2001. Specifically, Appendix
B was added to provide detailed stress distributions. In addition, Figure 4-1 was
revised to provide a more complete plot of the results, and Reference 2 was
corrected. None of these changes have any affect on the conclusion of reached in
this report.

*D048
1 Encl Rec'd*

OG-02-019
May 23, 2002

WCAP-14040-A, Rev. 3, "Methodology Used to Develop Cold Overpressure Mitigating System Setpoints and RCS Heatup and Cooldown Limit Curves," has also been submitted to the NRC for review (Reference 2). WCAP-14040, Rev. 3 contains an option to develop the Reactor Coolant System (RCS) Pressure-Temperature (P-T) limit curves without the flange requirement, currently required by 10CFR50 Appendix G. The option to develop P-T limit curves without the flange requirement would require NRC approval of an exemption request, or rulemaking to eliminate the requirement.

The report transmitted herewith bears a Westinghouse copyright notice. The NRC is permitted to make the number of copies of the information contained in these reports which are necessary for its internal use in connection with generic and plant-specific reviews and approvals as well as the issuance, denial, amendment, transfer, renewal, modification, suspension, revocation, or violation of a license, permit, order, or regulation subject to the requirements of 10 CFR 2.790 regarding restrictions on public disclosure to the extent such information has been identified as proprietary by Westinghouse, copyright protection notwithstanding. With respect to the non-proprietary versions of this report, the NRC is permitted to make the number of copies beyond those necessary for its internal use which are necessary in order to have one copy available for public viewing in the appropriate docket files in the public document rooms as may be required by NRC regulations if the number of copies submitted is insufficient for this purpose. Copies made by the NRC must include the copyright notice in all instances and the proprietary notice if the original was identified as proprietary.

If you require further information, please contact Mr. Ken Vavrek in the Westinghouse Owners Group Project Office at 412-374-4302.

Very truly yours,

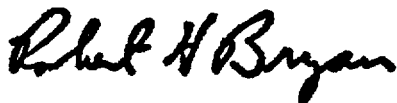

Robert H. Bryan, Chairman
Westinghouse Owners Group

enclosures

OG-02-019

May 23, 2002

cc: WOG Steering Committee (1L)
B. Barron, Duke Energy (1L)
WOG Primary Representatives (1L)
WOG Licensing Subcommittee Representatives (1L)
WOG Materials Subcommittee Representatives (1L)
G. Shukla, USNRC OWFN 07 E1 (1L, 3E)
A. L. Hiser Jr., USNRC OWFN 09 H6 (1L, 1E)
H.A. Sepp, Westinghouse, ECE 4-15 (1L)
G. Stevens, Structural Integrity Associates (1L)
S. Ranganath, General Electric Nuclear Power (1L)

Westinghouse Non-Proprietary Class 3



WCAP-15315
Revision 1

**Reactor Vessel Closure
Head/Vessel Flange
Requirements Evaluation
for Operating PWR and
BWR Plants**

Westinghouse Electric Company LLC



WCAP-15315
Revision 1

Reactor Vessel Closure Head/Vessel Flange Requirements Evaluation for Operating PWR and BWR Plants

April 2002

Warren Bamford
K. Robert Hsu
Joseph F. Petsche

Gary Stevens
Structural Integrity Associates

Sam Ranganath
General Electric Nuclear Power

Reviewer: 
E. Terek
Mechanical Systems Integration

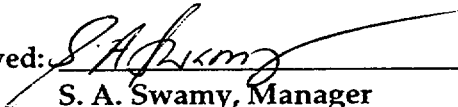
Approved: 
S. A. Swamy, Manager
Structural Mechanics Technology

Westinghouse Electric Company LLC
P.O. Box 355
Pittsburgh, PA 15230-0355

©2002 Westinghouse Electric Company LLC
All Rights Reserved

TABLE OF CONTENTS

| | | |
|-----|---|-----|
| 1.0 | Introduction..... | 1-1 |
| 2.0 | Technical Approach..... | 2-1 |
| 3.0 | Fracture Analysis Methods and Material Properties | 3-1 |
| 3.1 | Stress Intensity Factor Calculations | 3-1 |
| 3.2 | Fracture Toughness..... | 3-3 |
| 3.3 | Irradiation Effects..... | 3-3 |
| 4.0 | Flange Integrity | 4-1 |
| 5.0 | Are Flange Requirements Necessary? | 5-1 |
| 6.0 | Safety Implications of the Flange Requirement..... | 6-1 |
| 7.0 | References..... | 7-1 |
| | Appendix A – Stress Intensity Factor Curves for the Boltup Condition..... | A-1 |
| | Appendix B – Stress Distributions Used in the Evaluations | B-1 |

NOTICE

This report was prepared by Westinghouse as an account of work sponsored by the Westinghouse Owners Group (WOG). Neither the WOG, any member of the WOG, Westinghouse, nor any person acting on behalf of any of them:

- (a) Makes any warranty or representation whatsoever, express or implied, (I) with respect to the use of any information, apparatus, method, process, or similar item disclosed in this report, including merchantability and fitness for a particular purpose, (II) that such use does not infringe on or interfere with privately owned rights, including any party's intellectual property, or (III) that this report is suitable to any particular user's circumstance; or
- (b) Assumes responsibility for any damages or other liability whatsoever (including any consequential damages, even if the WOG or any WOG representative has been advised of the possibility of such damages) resulting from any selection or use of this report or any information apparatus, method, process, or similar item disclosed in this report.

Revision 1

This revision was created to provide some additional information requested by the NRC staff as a result of their review of the original report. Specifically, Appendix B was added to provide detailed stress distributions. In addition, Figure 4-1 was revised to provide a more complete plot of the results, and Reference 2 was corrected. None of these changes have any affect on the conclusions reached in this report.

COPYRIGHT NOTICE

This report has been prepared by Westinghouse Electric Company LLC, for the members of the Westinghouse Owners Group. Information in this report is the property of and contains copyright information owned by Westinghouse Electric Company LLC and/or its subcontractors and suppliers. It is transmitted to you in confidence and trust, and you agree to treat this document and the information contained therein in strict accordance with the terms and conditions of the agreement under which it was provided to you.

As a participating member of this Westinghouse Owners Group task, you are permitted to make the number of copies of the information contained in this report which are necessary for your internal use in connection with your implementation of the report results for your plant(s) in your normal conduct of business. Should implementation of this report involve a third party, you are permitted to make the number of copies of the information contained in this report which are necessary for the third party's use in supporting your implementation at your plant(s) in your normal conduct of business if you have received the prior, written consent of Westinghouse Electric Company LLC to transmit this information to a third party or parties. All copies made by you must include the copyright notice in all instances.

The NRC is permitted to make the number of copies beyond those necessary for its internal use that are necessary in order to have one copy available for public viewing in the appropriate docket files in the NRC public document room in Washington, DC if the number of copies submitted is insufficient for this purpose. Copies made by the NRC must include the copyright notice in all instances.

1.0 INTRODUCTION

10 CFR Part 50, Appendix G contains requirements for pressure-temperature limits for the primary system, and requirements for the metal temperature of the closure head flange and vessel flange regions. The pressure-temperature limits are to be determined using the methodology of ASME Section XI, Appendix G, but the flange temperature requirements are specified in 10CFR50 Appendix G. This rule states that the metal temperature of the closure flange regions must exceed the material unirradiated RT_{NDT} by at least 120°F for normal operation when the pressure exceeds 20 percent of the pre-service hydrostatic test pressure, which is 621 psig for a typical PWR, and 300 psig for a typical BWR.

This requirement was originally based on concerns about the fracture margin in the closure flange region. During the boltup process, outside surface stresses in this region typically reach over 70 percent of the steady state stress, without being at steady state temperature. The margin of 120°F and the pressure limitation of 20 percent of hydrotest pressure were developed using the K_{Ia} fracture toughness, in the mid 1970s, to ensure that appropriate margins would be maintained.

Improved knowledge of fracture toughness and other issues which affect the integrity of the reactor vessel have led to the recent change to allow the use of K_{Ic} in the development of pressure-temperature curves, as contained in ASME Code Case N640, "Alternative Reference Fracture Toughness for Development of P-T Limit Curves for Section XI, Division 1".

Figure 1-1 illustrates the problem created by the flange requirements for a typical PWR heatup curve. It is easy to see that the heatup curve using K_{Ic} provides for a much higher allowable pressure through the entire range of temperatures. For this plant, however, the benefit is negated at temperatures below $RT_{NDT} + 120^\circ\text{F}$ because of the flange requirement of 10 CFR Part 50, Appendix G. The flange requirement of 10 CFR 50 was originally developed using the K_{Ia} fracture toughness, and this report will show that use of the newly accepted K_{Ic} fracture toughness for flange considerations leads to the conclusion that the flange requirement can be eliminated.

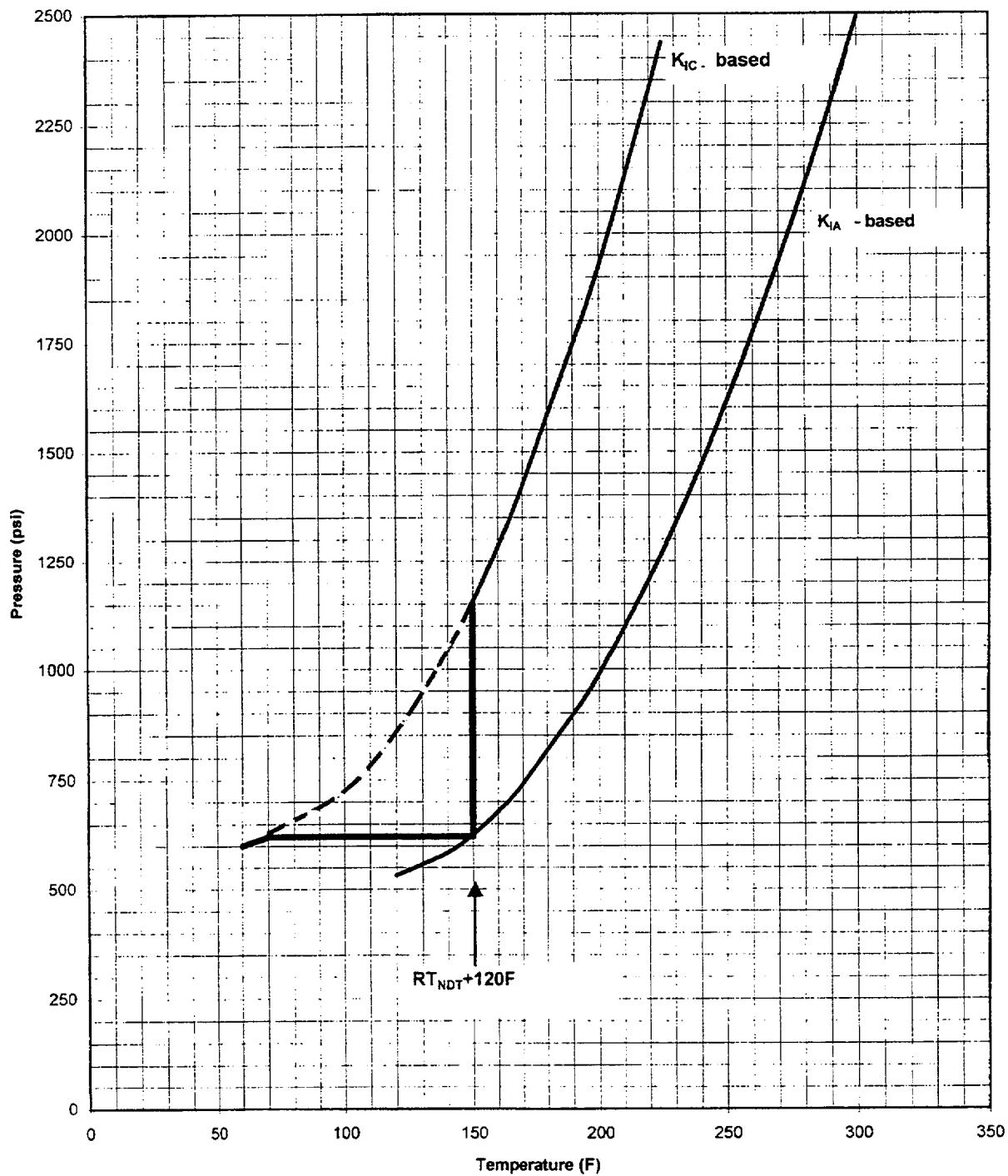

Figure 1-1 Illustration of the Impact of the Flange Requirement for a Typical PWR Plant

2.0 TECHNICAL APPROACH

The evaluation to be presented here is intended to cover all operating light water reactor vessels. Fracture evaluations have been performed on the range of geometries which exist, and results will be tabulated and discussed.

The geometry of the closure head region for all the vessels analyzed are shown in Figures 2-1 through 2-4. The geometries for the various PWR vessels are similar, and the same is true for the various BWR vessels. This is also reflected in the stresses, as will be discussed further in Section 4.

Stress analyses have been performed on all of these designs, and these stress results were used to perform fracture mechanics evaluations. The highest stress location in the closure head and vessel flange region is in the head, just above the bolting flange. This corresponds with the location of a weld in nearly all the designs. The highest stressed location is near the outside surface of the head in that region, and so the fracture evaluations have assumed a flaw at this location.

The goal of the evaluation is to compare the integrity of the closure head during the boltup process to the integrity during steady state operation. The question to be addressed is: With the higher K_{Ic} fracture toughness now known to be applicable, is there still a concern about the integrity of the closure head during boltup?

| Plant Type | Head Thickness | Vessel Diameter |
|------------------------|-----------------------|------------------------|
| Westinghouse 2 Loop | 5.66" | 132.4 |
| 3 Loop | 5.75 | 155.5 |
| 4 Loop | 7.0 | 178.9 |
| B&W | 6.63 | 168.4 |
| Combustion Engineering | 7.4 | 173.4 |
| GE Design 1 (CE) | 3.6 | 109.5 |
| Design 2 (B&W) | 4.0 | 122.4 |
| Design 3 (CBI) | 4.8 | 124.8 |

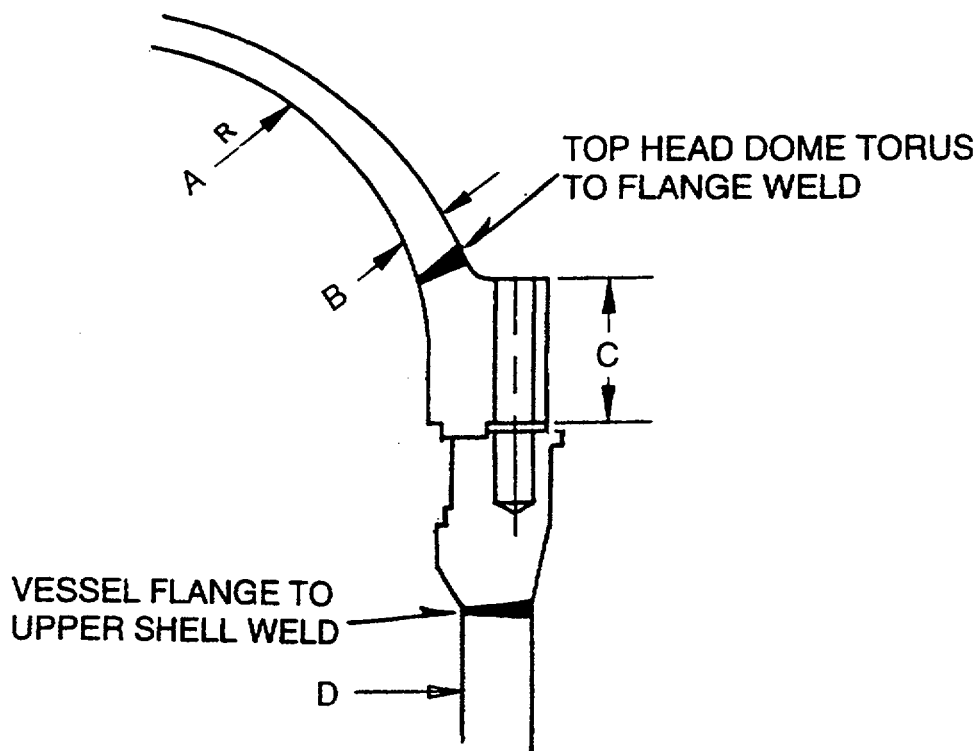

UPPER HEAD REGION

| | 2 LOOP | 3 LOOP | 4 LOOP |
|---|--------|--------|--------|
| A | 83.46 | 74.59 | 85.78 |
| B | 5.66 | 5.75 | 7.00 |
| C | 27.56 | 29.56 | 27.25 |
| D | 132.40 | 155.50 | 170.88 |

NOTE: ALL DIMENSIONS ARE IN INCHES

Figure 2-1 Geometry of the Upper Head/Flange Region of a Typical Westinghouse Reactor Vessel

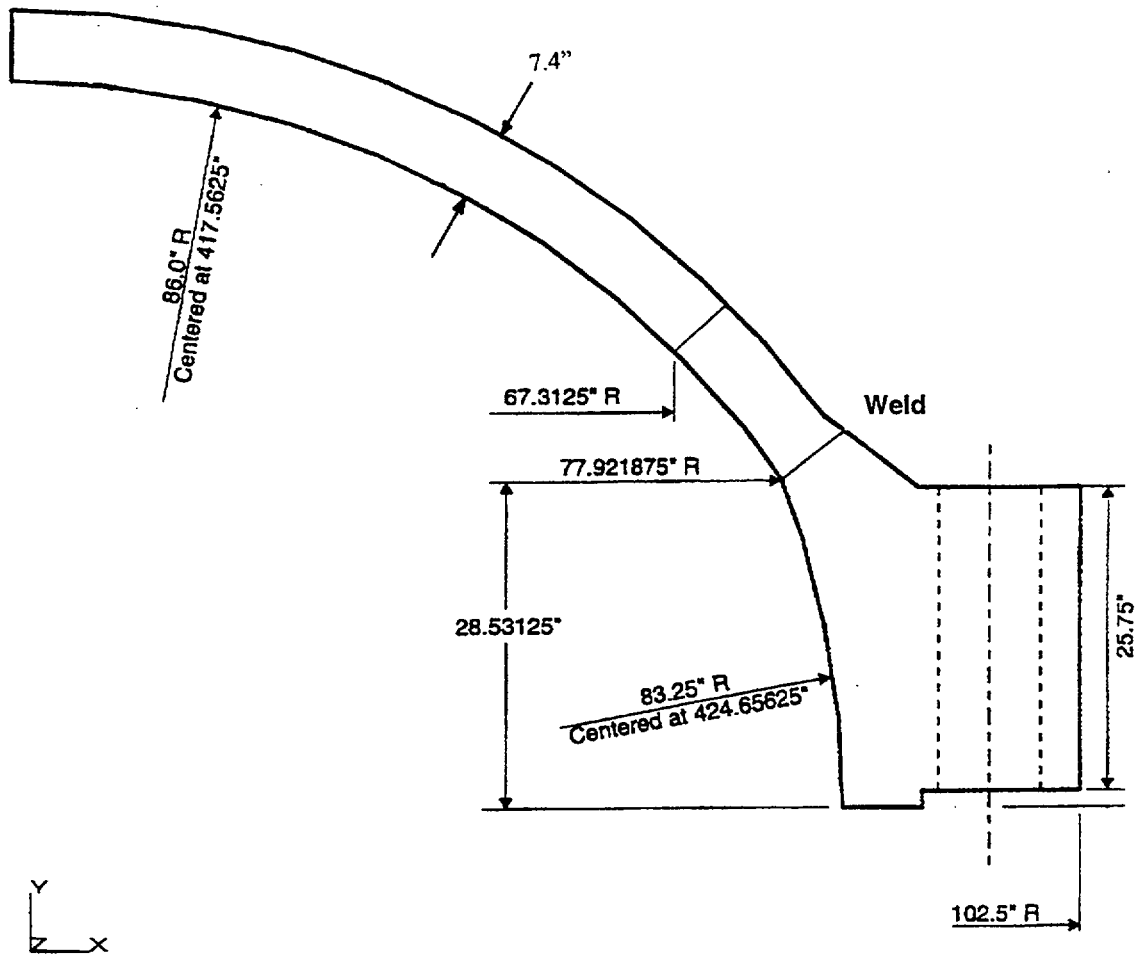
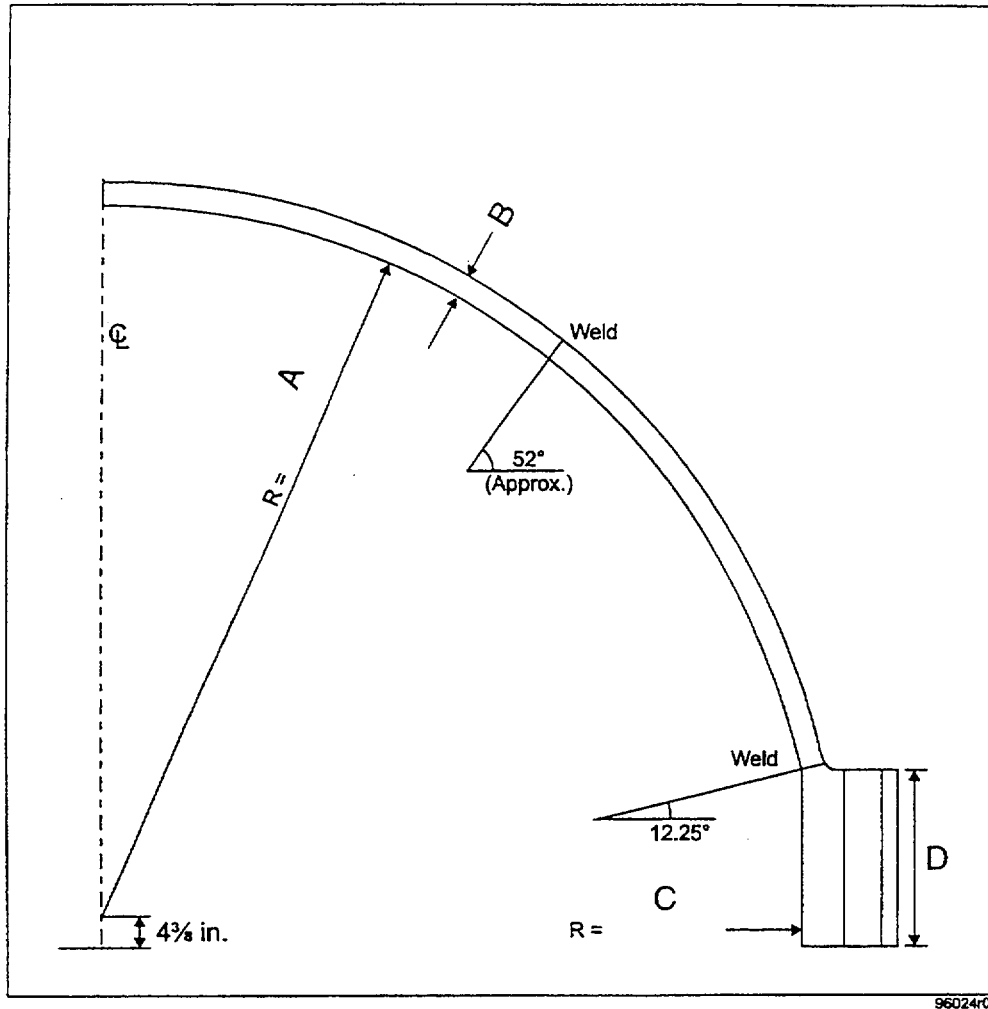

Figure 2-3 Geometry of Closure Head Region: Combustion Engineering Reactor Vessels



96024r0

| | CE | B&W | CB&I |
|---|-------|-------|-------|
| A | 109.5 | 125.6 | 124.8 |
| B | 3.6 | 4.0 | 4.8 |
| C | 109.5 | 122.4 | 124.8 |
| D | 24.4 | 31.0 | 28.2 |

NOTE: ALL DIMENSIONS ARE IN INCHES

Figure 2-4 Geometry of Closure Head Region: General Electric Reactor Vessels

3.0 FRACTURE ANALYSIS METHODS AND MATERIAL PROPERTIES

The fracture evaluation was carried out using the approach suggested by Section XI Appendix G (Ref. 1). A semi-elliptic surface flaw was postulated to exist in the highest stress region, which is at the outside surface of the closure flange. The flaw depth was assumed to encompass a range of depths into the wall thickness, and the shape was set at a length six times the depth.

3.1 STRESS INTENSITY FACTOR CALCULATIONS

One of the key elements of a fracture evaluation is the determination of the driving force or stress intensity factor (K_I). This was done using expressions available from the literature. In most cases, the stress intensity factor for the integrity calculations utilized a representation of the actual stress profile rather than a linearization. The stress profile was represented by a cubic polynomial:

$$\sigma(x) = A_0 + A_1 \frac{x}{t} + A_2 \left(\frac{x}{t} \right)^2 + A_3 \left(\frac{x}{t} \right)^3 \quad (3-1)$$

where

| | | |
|----------|---|---|
| x | = | is the coordinate distance into the wall, in. |
| t | = | wall thickness, in. |
| σ | = | stress perpendicular to the plane of the crack, ksi |
| A_i | = | coefficients of the cubic fit |

For the surface flaw with length six times its depth, the stress intensity factor expression of Raju and Newman (Ref. 2) was used when a complete stress distribution was available. The stress intensity factor $K_I(\phi)$ can be calculated anywhere along the crack front. The point of maximum crack depth is represented by $\phi = 0$, and this location was found to also be the point of maximum K_I for the cases considered here. The following expression is used for calculating $K_I(\phi)$, where ϕ is the angular location around the crack. The units of $K_I(\phi)$ are $\text{ksi}\sqrt{\text{in}}$.

$$K_I(\phi) = \left[\frac{\pi a}{Q} \right]^{0.5} \sum_{j=1}^4 G_j(a/c, a/t, t/R, \phi) A_j a^j \quad (3-2)$$

The magnification factors $G_1(\phi)$, $G_2(\phi)$, $G_3(\phi)$ and $G_4(\phi)$ are obtained by the procedure outlined in reference (2). The dimension "a" is the crack depth, and "c" is the crack length, while t is the wall thickness. In some cases only surface stress values were available, and in these cases the stresses were linearized through the thickness of the head, and the Raju-Newman expression was used.

3.2 FRACTURE TOUGHNESS

The other key element in a fracture evaluation is the fracture toughness of the material. The fracture toughness has been taken directly from the reference curves of Appendix A, Section XI. In the transition temperature region, these curves can be represented by the following equations:

$$K_{Ic} = 33.2 + 20.734 \exp. [0.02 (T - RT_{NDT})] \quad (3-4)$$

$$K_{Ia} = 26.8 + 12.445 \exp. [0.0145 (T - RT_{NDT})] \quad (3-5)$$

where K_{Ic} and K_{Ia} are in $\text{ksi}\sqrt{\text{in}}$.

The upper shelf temperature regime requires utilization of a shelf toughness which is not specified in the ASME Code. A value of $200 \text{ ksi}\sqrt{\text{in}}$ has been used here for all the regions except the nozzle inner radius regions, since the upper shelf Charpy energy exceeds 50 ft-lb, even after irradiation. This value is consistent with general practice in such evaluations, as shown for example in reference (3), which provides the background and technical basis of Appendix A of Section XI.

The other key element in the determination of the fracture toughness is the value of RT_{NDT} , which is a parameter determined from Charpy V-notch and drop-weight tests.

The value of RT_{NDT} for the closure flange region of operating PWR plants was surveyed for 82 PWR plants world wide, and the average value of RT_{NDT} was found to be 9°F . The results ranged from -50°F to $+60^\circ\text{F}$, with the 60°F cases representing the few cases where a test result was not available or the maximum allowed by the ordering requirement. For the head region of operating BWR plants, results ranged up to 40°F , which was the ordering requirement, while the average value of RT_{NDT} was found to be 10°F . Therefore, the value of 10°F was used for the illustrations to be discussed in Sections 4 and 5.

3.3 IRRADIATION EFFECTS

Neutron irradiation has been shown to produce embrittlement which reduces the toughness properties of reactor vessel steels. The decrease in the toughness properties can be assessed by determining the shift to higher temperatures of the reference nil-ductility transition temperature, RT_{NDT} .

The location of the closure flange region is such that the irradiation levels are very low and therefore the fracture toughness is not measurably affected.

4.0 FLANGE INTEGRITY

The first step in evaluation of the closure head/flange region is to examine the stresses. The stresses which are affected by the boltup event are the axial, or meridional stresses, which are perpendicular to the nominal plane of the closure head to flange weld. The stresses in this region during steady state operation are summarized in Table 4-1.

The boltup is the key condition to review here, in comparison with steady state operation, as these are the two key conditions of interest. No other transients result in stresses in this region at low temperatures. One might suggest that the cooldown might be of similar concern, but the boltup is governing for a number of reasons:

1. The heatup and cooldown transient is structured to ensure generous margins are maintained ($SF = 2$) for a large flaw in the irradiated beltline region. This is a more governing condition than the unirradiated flange region.
2. The cooldown transient has much higher temperatures in the head region than the boltup, and
3. The thermal stresses that are produced tend to counteract the boltup stresses; that is, they are tensile on the inside surface and compressive on the outside surface.

The table shows that the stresses in the various PWR designs are very similar during steady state operation, and stresses are not very high. The loadings are primarily membrane stress, and the bending stresses are somewhat lower. For the BWR designs, the membrane stress is very similar, as might be expected from use of the same design code. The bending stresses are higher for the BWR designs, due to the larger diameter and smaller thickness.

Table 4-2 provides a comparison of the stresses at boltup with those at steady state. It is easy to see that the stresses at boltup are mostly bending, with a very small membrane stress. As the vessel is pressurized, the membrane stresses increase.

The relative impact of these stresses can best be addressed through a fracture evaluation. A semi-elliptic surface flaw was postulated at the outer surface of the closure head flange, and the stress intensity factor, K , (or crack driving force) was calculated. The results are shown for the boltup condition in Figures 4-1 and 4-2. Figure 4-1 shows the results for the governing PWR design (B&W), while Figure 4-2 shows the results for the governing BWR design (B&W, 251 inches). In both cases it can be seen that the applied stress intensity factor at boltup reaches a maximum for a flaw about half way through the head thickness, and then decreases as the flaw extends into the lower stress region near the inside surface of the head. The maximum value of the stress intensity factor for each of the designs is tabulated in Table 4-3, and plots for each of the other design cases appear in the Appendix.

Also shown in Table 4-3 is the fracture toughness at boltup for typical PWR and BWR plants. The boltup temperature for a PWR is typically 60°F, while the boltup temperature for a BWR is typically 80°F. Since we know that the average value of RT_{NDT} is 10°F for all the plants, both the K_{Ic} and K_{Ia} values are easily calculated.

Study of Table 4-3 shows the difference in the integrity story using the two values of fracture toughness. Using the K_{Ia} toughness (which was the basis for the original flange requirements) it can be seen that the applied stress intensity factor exceeds the toughness for two cases, cases 2 and 6, for flaws about half way through the head thickness.

Using the K_{Ic} toughness, which has now been adopted by Section XI for P-T Curves, it can be seen that there is significant margin between the applied stress intensity factor and the fracture toughness at virtually all crack depths. Another objective of the requirements in Appendix G is to assure that fracture margins are maintained to protect against service induced cracking due to environmental effects. Since the governing flaw is on the outside surface (the inside is in compression) where there are no environmental effects, there is even greater assurance of fracture margin. Therefore it may be concluded that the integrity of the closure head/flange region is not a concern for any of the operating plants using the K_{Ic} toughness.

Furthermore, there are no known mechanisms of degradation for this region, other than fatigue. The calculated design fatigue usage for this region is less than 0.1, so it may be concluded that flaws are unlikely to initiate in this region.

**Table 4-1 Axial Stress Comparison Steady State Operation @ 2250 psi (PWR),
1000 psi (BWR)**

| Plant | OD Stress (ksi) | Membrane Stress (ksi) | Bending Stress (ksi) |
|-----------------------|--------------------|--------------------------|-------------------------|
| W 4 Loop | 22.8 | 10.0 | 12.8 |
| W 3 Loop | 20.9 | 11.6 | 9.3 |
| CE | 46.4 | 12.8 | 33.6 |
| B&W | 55.7 | 19.0 | 36.7 |
| GE BWR Design 1 (CE) | 49.6 | 18.0 | 31.6 |
| GE BWR Design 2 (B&W) | 53.0 | 15.5 | 37.5 |
| GE BWR Design 3 (CBI) | 52.5 | 14.3 | 38.2 |

Table 4-2 Stress Comparison Boltup vs. Steady State

| Plant | Boltup Membrane (ksi) | Boltup Bending (ksi) | SS Membrane (ksi) | SS Bending (ksi) |
|--------------------------|-----------------------------|-------------------------|----------------------|---------------------|
| W 4 Loop | 1.1 | 14.2 | 10.0 | 12.8 |
| W 3 Loop | 2.1 | 14.5 | 11.6 | 9.3 |
| CE | 0.8 | 22.8 | 12.8 | 33.6 |
| B&W | 4.3 | 27.6 | 19.0 | 36.7 |
| GE BWR Design 1 (CE) | 0.8 | 26.3 | 18.0 | 31.6 |
| GE BWR Design 2 (B&W) | 0.5 | 48.5 | 15.5 | 37.5 |
| GE BWR Design 3 (CBI) | 0.5 | 35.5 | 14.3 | 38.2 |

| Design | Maximum K, in $\text{ksi}\sqrt{\text{in}}$ (Flaw Depth/Thickness) | Fracture Toughness at Boltup* | |
|---------------------|--|--|--|
| | | K_{Ia} ($\text{ksi}\sqrt{\text{in}}$) | K_{Ic} ($\text{ksi}\sqrt{\text{in}}$) |
| 1. CE | 41 (.42) | 52.7 | 89.6 |
| 2. B&W | 56 (.60) | 52.7 | 89.6 |
| 3. W Four Loop | 31 (.44) | 52.7 | 89.6 |
| 4. W Three Loop | 32 (.44) | 52.7 | 89.6 |
| 5. GE BWR (CBI 251) | 56 (.42) | 61.4 | 117.3 |
| 6. GE BWR (B&W 251) | 69 (.40) | 61.4 | 117.3 |
| 7. GE BWR (CE 218) | 37 (.42) | 61.4 | 117.3 |

*Boltup is typically at 60°F for PWRs, and 80°F for BWRs.

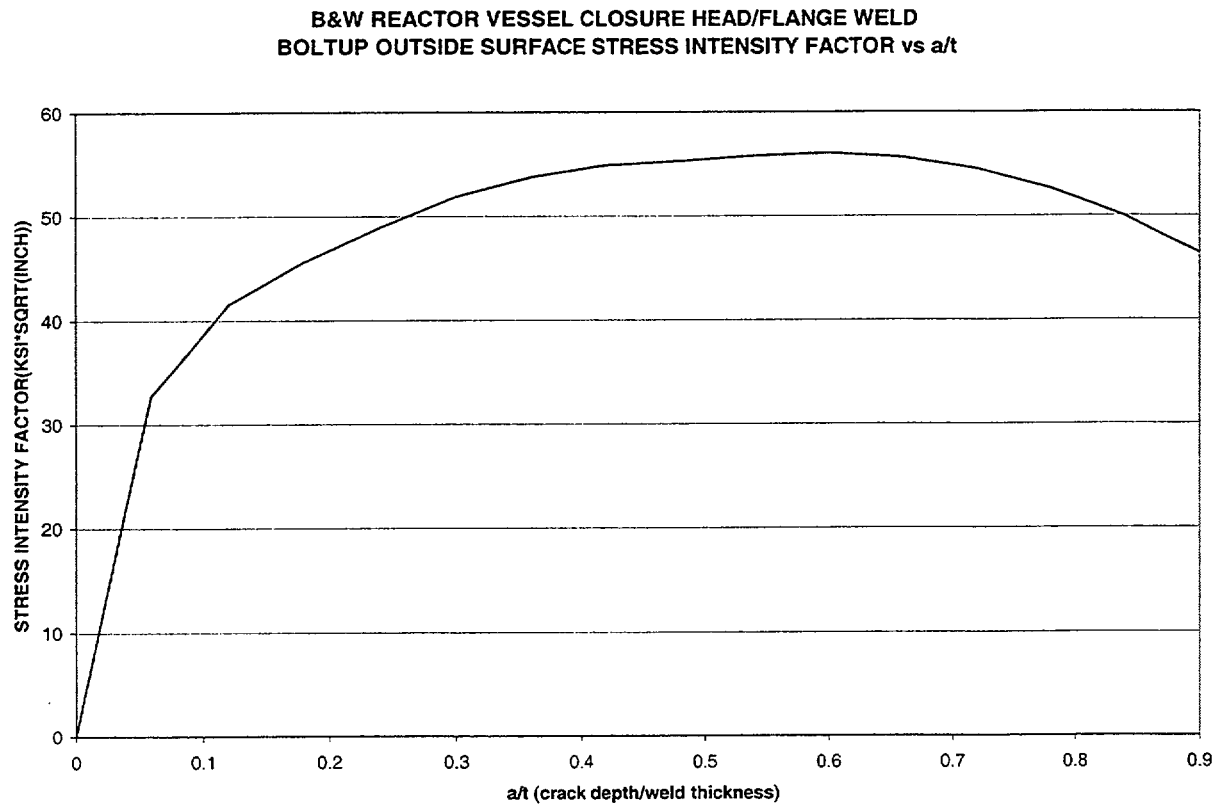

Figure 4-1 Crack Driving Force as a Function of Flaw Size: Outside Surface Flaw in the Closure Head to Flange Region Weld for the Governing PWR Design

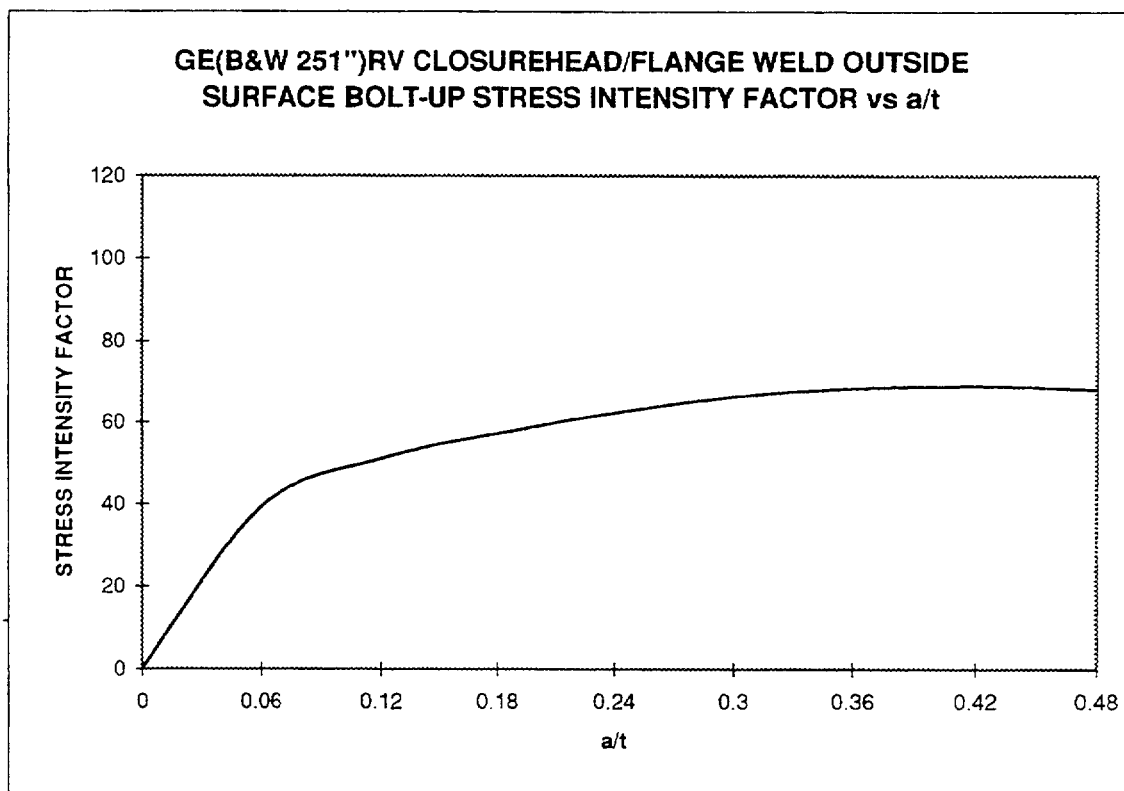

Figure 4-2 Crack Driving Force as a Function of Flaw Size: Outside Surface Flaw in the Closure Head to Flange Region Weld, for the Governing BWR Design (units of stress intensity factor are $\text{ksi}\sqrt{\text{in}}$)

5.0 ARE FLANGE REQUIREMENTS NECESSARY?

Using the K_{Ic} curve can support the elimination of the flange temperature requirement. This can be illustrated by examining the stress intensity factor change for a postulated flaw as the vessel is pressurized after boltup, progressing up to steady state operation.

The stresses at the region of interest are shown in Table 4-1, for steady state operation. Included here are the stresses at the outside surface, which is the highest stress location for this region, as well as the membrane and bending stresses. Table 4-2 shows a comparison of the boltup and steady state stresses for the same plant designs. The results are similar for the designs shown, which bracket all plants in service. No comparisons are available for two loop Westinghouse plants, but they are conservatively covered by the four loop Westinghouse plant results.

As the vessel is pressurized, the stresses in the closure flange region gradually change from mostly bending stresses to a combination of bending and membrane stresses. The stress intensity factor, or driving force, increases for a postulated flaw at the outside surface, as the vessel is pressurized.

As mentioned in Section 4, the boltup temperature for a PWR is nominally 60°F, while that for a BWR is nominally 80°F. From Section 3, the average value of RT_{NDT} for the closure head material is 10°F for all the designs, so boltup is typically at $RT_{NDT} + 50$ for PWRs, and $RT_{NDT} + 70$ °F for BWRs.

A direct comparison between the original basis for the boltup requirement and the new K_{Ic} approach is provided in Table 5-1. This table provides calculated boltup requirements for all the designs, using a safety factor of 2, and a reference flaw depth of $a/t = 0.10$, which was used by Randall as the basis for the original requirement (Ref. 4). The boltup requirements using K_{Ia} are shown in the right-most column, and the governing case would have a boltup requirement of $RT_{NDT} + 118$ °F, which closely matches the requirement of $RT_{NDT} + 120$ °F now in 10CFR50 Appendix G.

Now consider the equivalent result using K_{Ic} , which is just to the left of the column just discussed. The boltup requirement using the same margin now ranges from RT_{NDT} to $RT_{NDT} + 41$ F for PWR plants, and from RT_{NDT} to $RT_{NDT} + 56$ for BWR plants. Since the average value of RT_{NDT} is 10°F for all the plants, the boltup requirements can be easily translated into actual temperatures. For PWRs the requirement for boltup ranges from 10°F to 51°F, and the actual boltup temperature is 60°F. For BWRs the requirement ranges from 10°F to 66°F, and the actual boltup temperature is 80°F. It is therefore clear that no additional boltup requirements are necessary, and therefore the requirement can be eliminated from 10CFR50 Appendix G.

| Plant | K (a/t = .1) | K with SF = 2 | T - RT_{NTD} (°F) using K_{Ic} (a/t = .10) | T - RT_{NTD} (°F) using K_{Ia} (a/t = .10) |
|---------------|-------------------------|--------------------------|---|---|
| CE | 30.0 | 60.0 | 13 | 68 |
| B&W | 39.4 | 79.8 | 41 | 100 |
| W 4 Loop | 19.7 | 39.4 | 0 | 1 |
| W 3 Loop | 19.4 | 38.8 | 0 | 0 |
| GE (CBI 251") | 38.7 | 77.4 | 38 | 97 |
| GE (B&W 251") | 48.0 | 96.0 | 56 | 118 |
| GE (CE 218") | 25.1 | 50.2 | 0 | 43 |

*All units in ksi $\sqrt{\text{in}}$

6.0 SAFETY IMPLICATIONS OF THE FLANGE REQUIREMENT

There are important safety implications which are associated with the flange requirement, as illustrated by Figure 6-1. The safety concern is the narrow operating window at low temperatures forced by the flange requirement. The flange requirement sets a pressure limit of 621 psi for a PWR (20 percent of hydrotest pressure). Thus, no matter how good the toughness of the vessel, the P-T limit curve may be superceded by the flange requirement for temperatures below $RT_{NDT} + 120^{\circ}\text{F}$. This requirement was originally imposed to ensure the integrity of the flange region during boltup, but Section 4 has shown that this is no longer a concern.

The flange requirement can cause severe operational limitations when instrument uncertainties are added to the lower limit (621 psi), for the Low Temperature Overpressure Protection system of PWRs. The minimum pressure required to cool the seals of the main coolant pumps is 325 psi, so the operating window sometimes becomes very small, as shown schematically in Figure 6-1. If the operator allows the pressure to drop below the pump seal limit, the seals could fail, causing the equivalent of a small break LOCA, a significant safety problem. Elimination of the flange requirement will significantly widen the operating window for most PWRs.

An example will be provided to illustrate this situation for an operating PWR plant, Byron Unit 1. This is a forging-limited vessel at 12 EFPY, with a low leakage core, and low copper weld material in the core region. The vessel has excellent fracture toughness, which means that the flange notch is very prominent, as shown in the vessel heatup curve of Figure 6-2. As illustrated before in Figure 6-1, Byron has the LTOP setpoints significantly below the flange requirement of 621 psi, because of a relatively large instrument uncertainty. The setpoints of the two power operated relief valves are staggered by about 16 psi to prevent a simultaneous activation. The two PORVs have different instrument uncertainties, and for conservatism the higher uncertainty is used. A similar situation exists for cooldown, as shown in Figure 6-3.

Elimination of the flange requirement for Byron Unit 1 would mean that the PORV curve could become level at 604/587 psig, which are the leading/trailing setpoints to protect the PORV downstream piping, through the temperature range of the 350°F down to boltup at 60°F . The operating window between the leading PORV and the pump seal limit rises from 121 psig (446-325) to 262 psig (587-325). This change will make a significant improvement in plant safety by reducing the probability of a small LOCA, and easing the burden on the operators.

This is only one example of the impact of the flange requirement. Every operating PWR plant will have a different situation, but the operational safety level will certainly be generally improved by the elimination of this unnecessary requirement.

Elimination of the flange requirement has no impact on BWRs. The saturation temperature corresponding to the 300 psig operating pressure (20% of the pre-service hydrostatic test pressure) is 420°F . This is well in excess of the $RT_{ndt} + 120^{\circ}\text{F}$ requirement. Therefore the flange temperature requirements are satisfied regardless of whether they exist or not. Therefore, elimination of the flange temperature requirement has no impact on BWR flange integrity.

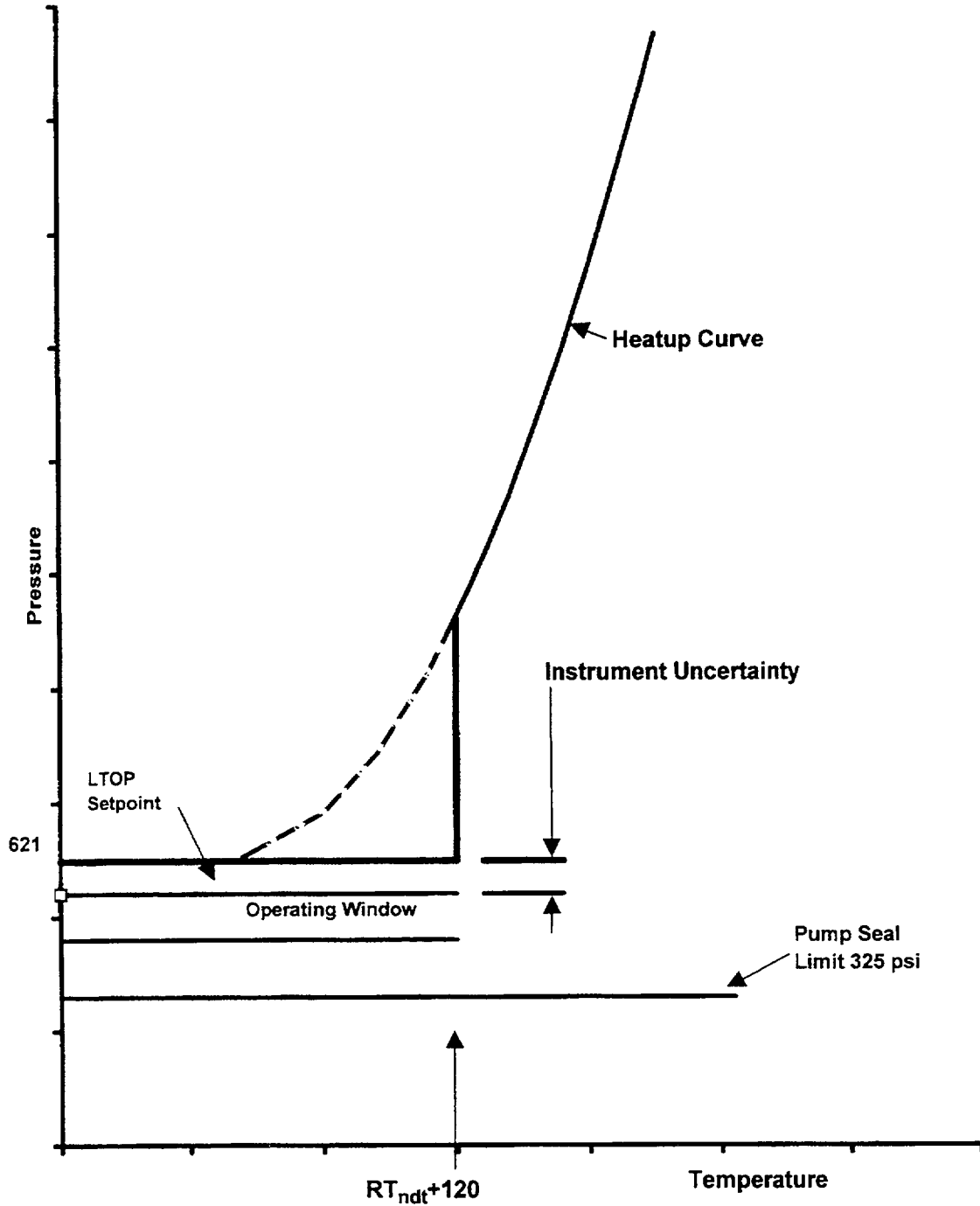

Figure 6-1 Illustration of the Flange Requirement and its Effect on the Operating Window for a Typical Heatup Curve

LIMITING MATERIAL: INTERMEDIATE SHELL FORGING 5P-5933 (using surv. capsule data)
 LIMITING ART VALUES AT 12 EFPY: 1/4T, 70°F
 3/4T, 60°F

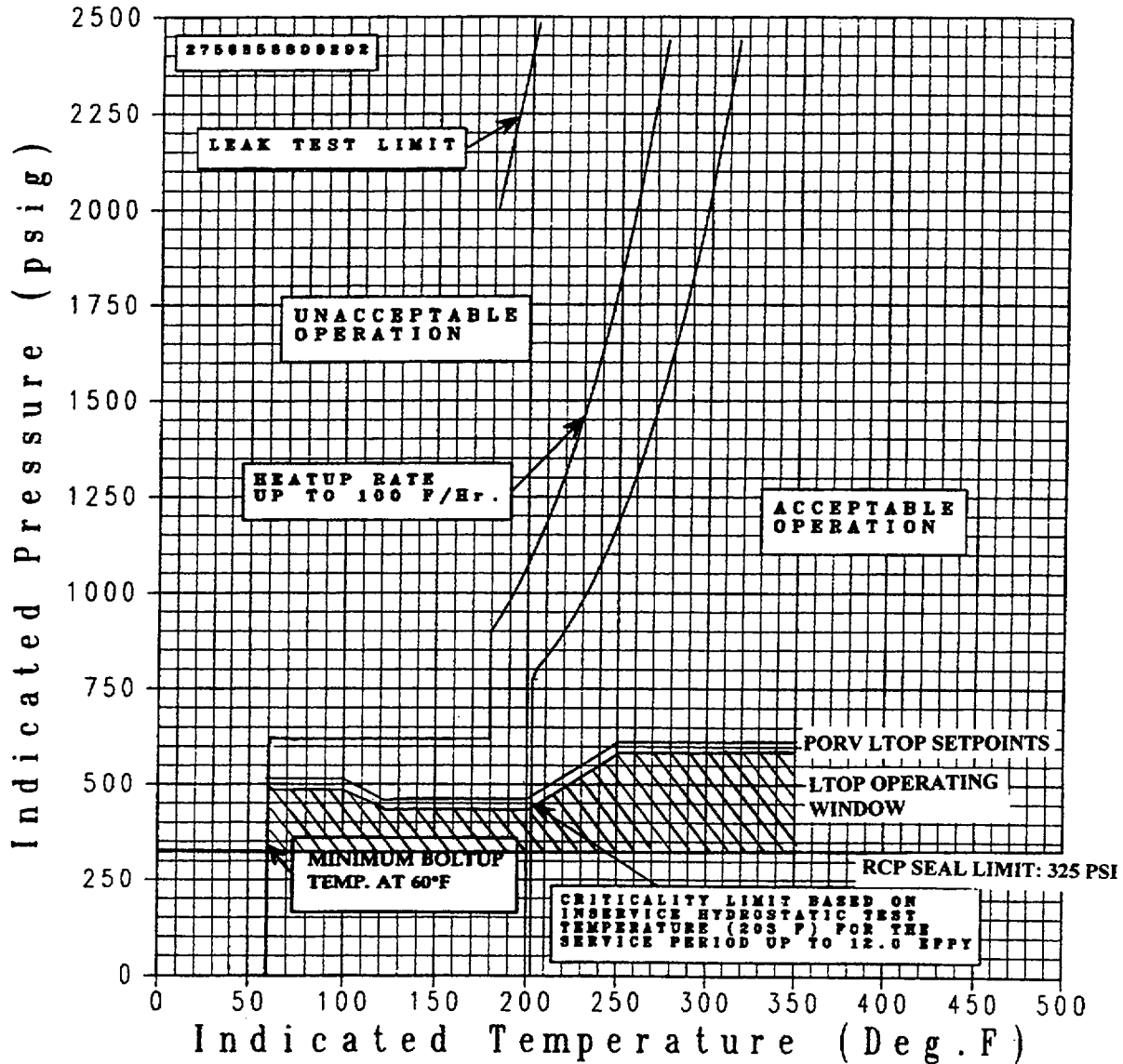

Figure 6-2 Illustration of the Actual Operating Window for Heatup of Byron Unit 1, a Low Copper Plant at 12 EFPY

LIMITING MATERIAL: INTERMEDIATE SHELL FORGING 5P-5933 (using surv. capsule data)
 LIMITING ART VALUES AT 12 EFPY: 1/4T, 70°F
 3/4T, 60°F

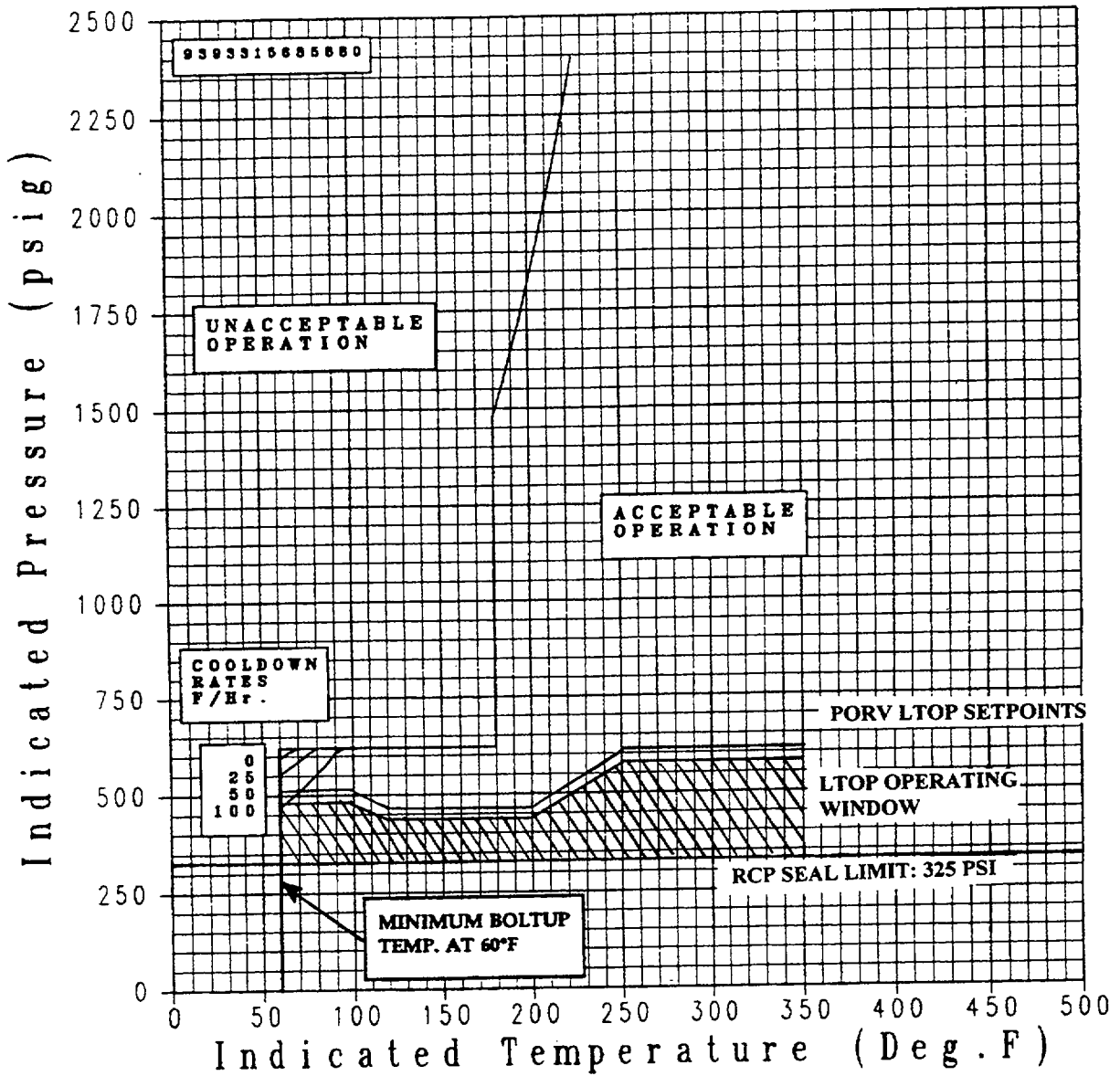

Figure 6-3 Illustration of the Actual Operating Window for Cooldown of Byron Unit 1, a Low Copper Plant at 12 EFPY

7.0 REFERENCES

1. ASME Boiler and Pressure Vessel Code, Section XI, Appendix G, 1996 Addenda, ASME, New York.
2. Raju, I. S. and Newman, J. C. Jr., "Stress Intensity Factor Influence Coefficients for Internal and External Surface Cracks in Cylindrical Vessels," Trans. ASME, Journal of Pressure Vessel Technology, Vol. 104, pp 293-98, 1982.
3. Marston, T. U., ed., "Flaw Evaluation Procedures: ASME Section XI," Electric Power Research Institute Report EPRI-NP-719 SR, August 1978.
4. Randall, N., Abstract of Comments and Staff Response to Proposed Revision to 10 CFR Part 50, Appendices G and H, Published for Comment in the Federal Register, November 14, 1980.

APPENDIX A

STRESS INTENSITY FACTOR CURVES FOR THE BOLTUP CONDITION

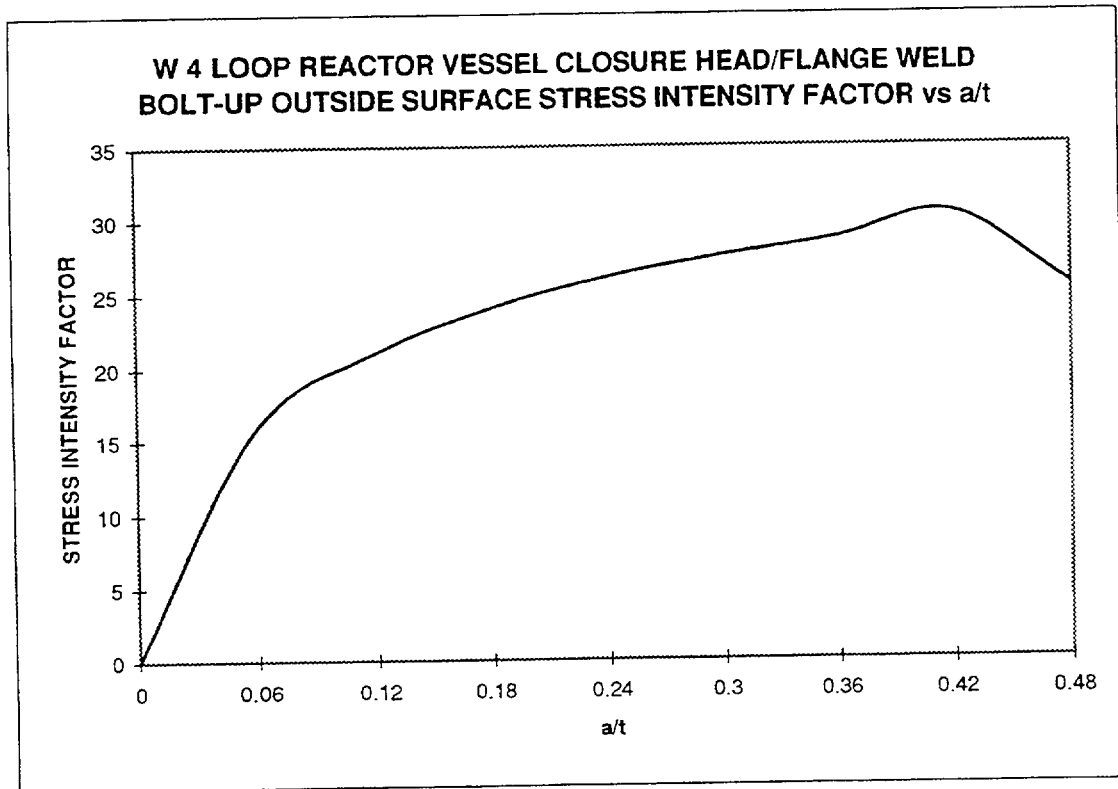

Figure A-1 Crack Driving Force as a Function of Flaw Size: Outside Surface Flaw in the Closure Head to Flange Region Weld for the Westinghouse Four Loop Plant Design (stress intensity factor units are $\text{ksi}\sqrt{\text{in}}$)

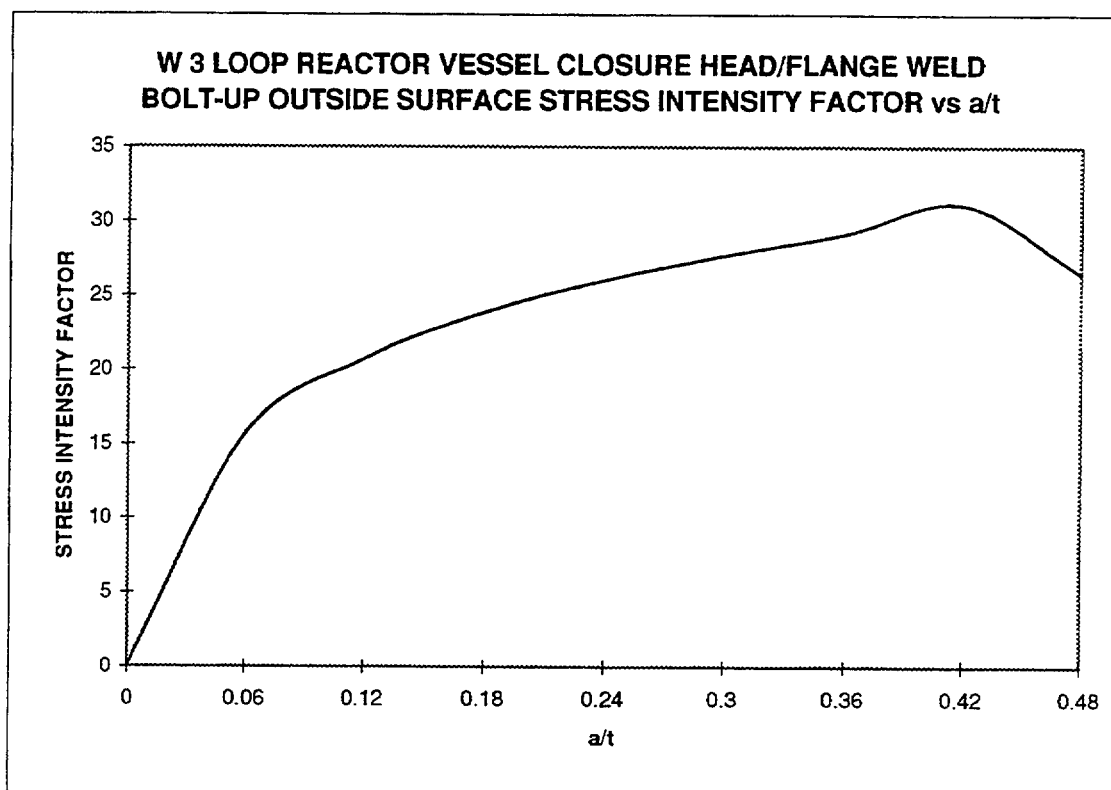

Figure A-2 Crack Driving Force as a Function of Flaw Size: Outside Surface Flaw in the Closure Head to Flange Region Weld for the Westinghouse Three Loop Plant Design (stress intensity factor units are $\text{ksi}\sqrt{\text{in}}$)

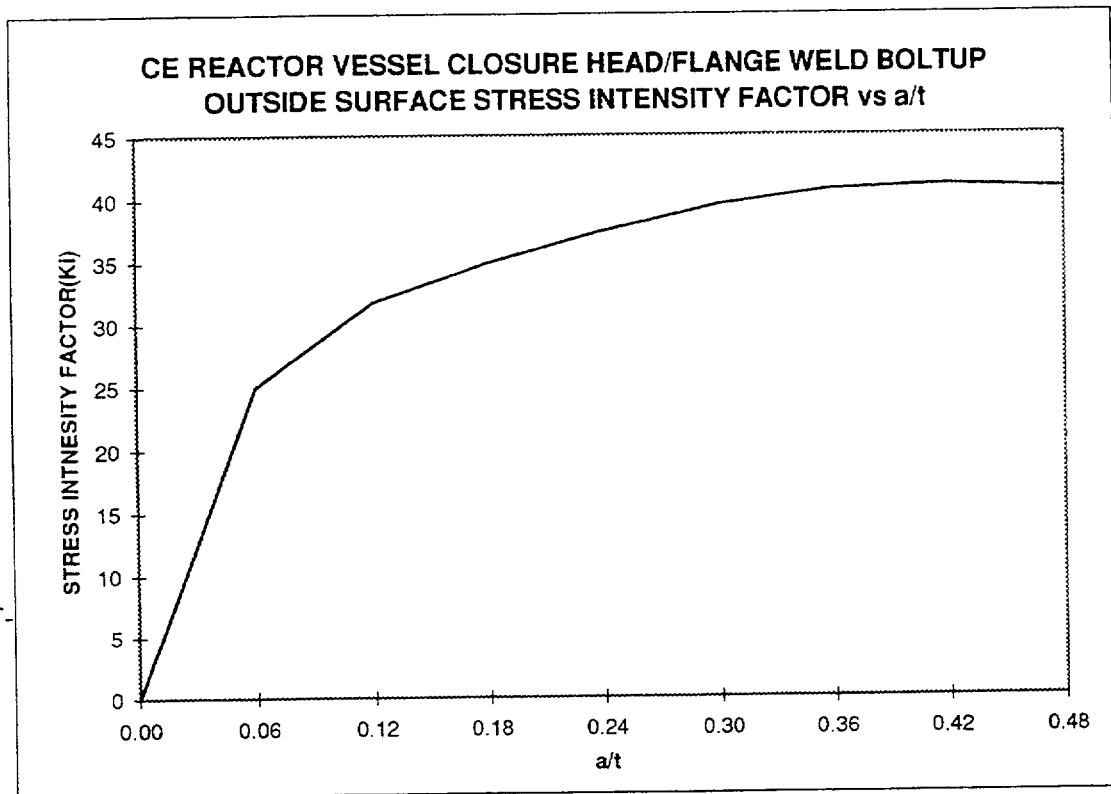

Figure A-3 Crack Driving Force as a Function of Flaw Size: Outside Surface Flaw in the Closure Head to Flange Region Weld for the Combustion Engineering Design (stress intensity factor units are $\text{ksi}\sqrt{\text{in}}$)

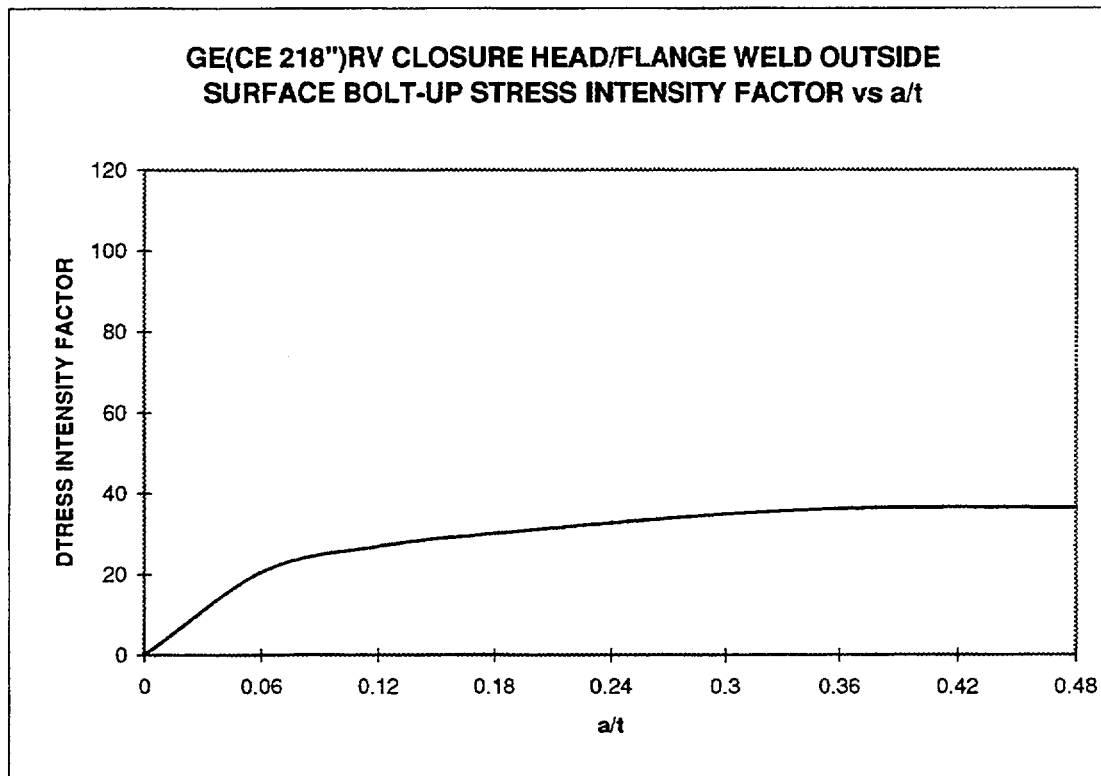

Figure A-4 Crack Driving Force as a Function of Flaw Size: Outside Surface Flaw in the Closure Head to Flange Region Weld for the General Electric – CE Fabricated Design (stress intensity factor units are $\text{ksi}\sqrt{\text{in}}$)

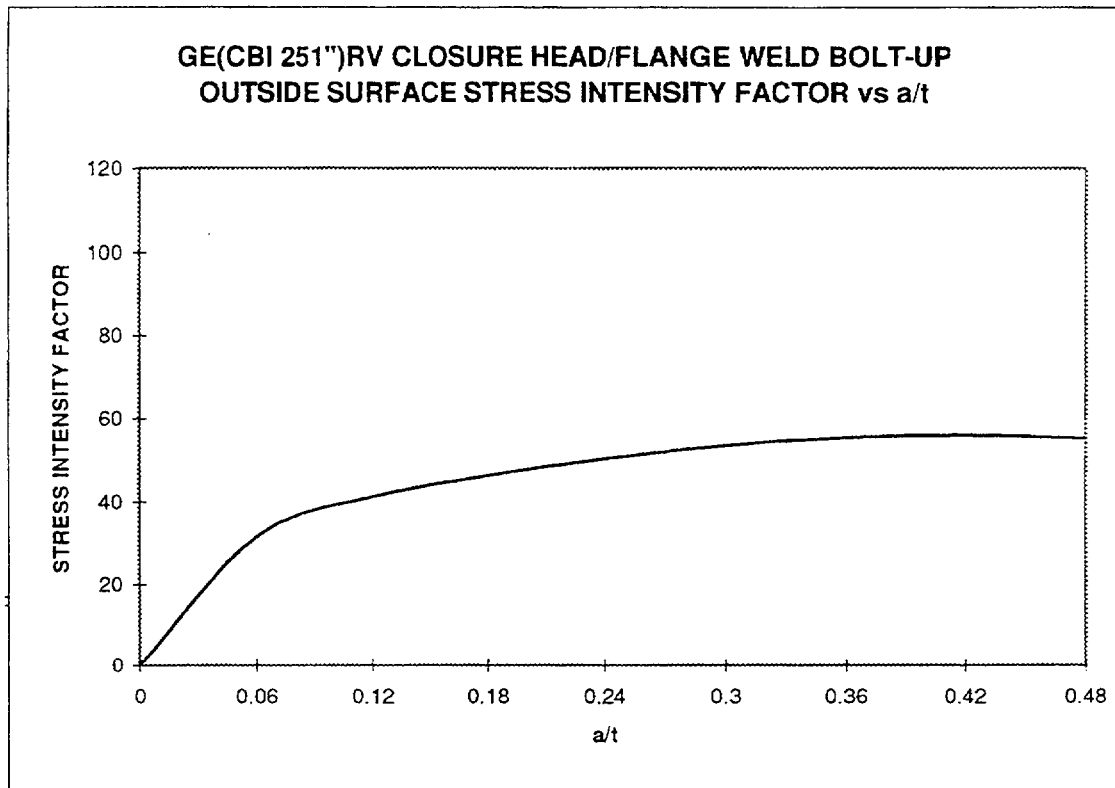

Figure A-5 Crack Driving Force as a Function of Flaw Size: Outside Surface Flaw in the Closure Head to Flange Region Weld for the General Electric – CBI Fabricated Design (stress intensity factor units are $\text{ksi}\sqrt{\text{in}}$)

APPENDIX B
STRESS DISTRIBUTIONS USED IN THE EVALUATIONS

| Table B-1 CE Plant | | |
|---------------------------|--------------------------------|------------------------------------|
| Distance (x/t) | Boltup Stress (ksi) | Boltup + 2250 psi (ksi) |
| 0 (ID) | -19.42 | -15.86 |
| 0.1 | -14.92 | -9.30 |
| 0.2 | -10.90 | -3.60 |
| 0.3 | -7.09 | 1.76 |
| 0.4 | -3.39 | 6.91 |
| 0.5 | 0.29 | 12.05 |
| 0.6 | 4.04 | 17.32 |
| 0.7 | 7.98 | 22.89 |
| 0.8 | 12.25 | 29.02 |
| 0.9 | 16.98 | 35.86 |
| 1.0 (OD) | 23.62 | 46.36 |

| Table B-2 B&W Plant | | |
|--------------------------------|--------------------------------|------------------------------------|
| Distance (x/t) | Boltup Stress (ksi) | Boltup + 2250 psi (ksi) |
| 0 (ID) | -15.08 | -6.35 |
| 0.1 | -11.83 | -1.92 |
| 0.188 | -8.52 | 2.53 |
| 0.281 | -5.2 | 6.95 |
| 0.380 | -1.89 | 11.33 |
| 0.472 | 1.42 | 15.73 |
| 0.582 | 5.33 | 20.73 |
| 0.708 | 10.13 | 25.99 |
| 0.775 | 16.50 | 33.67 |
| 0.872 | 21.98 | 41.22 |
| 1.0 (OD) | 31.90 | 55.70 |

Table B-3 Westinghouse 4 Loop

| Distance (x/t) | Boltup Stress (ksi) | Boltup + 2250 psi (ksi) |
|-------------------|------------------------|----------------------------|
| 0 (ID) | -14.38 | -6.58 |
| 0.1 | -10.77 | -2.87 |
| 0.2 | -7.83 | -2.43 |
| 0.3 | -5.14 | -0.04 |
| 0.4 | -2.66 | 2.94 |
| 0.5 | -0.26 | 6.44 |
| 0.6 | 2.16 | 9.96 |
| 0.7 | 4.72 | 14.52 |
| 0.8 | 7.54 | 23.34 |
| 0.9 | 11.24 | 31.54 |
| 1.0 (OD) | 19.70 | 42.51 |

Table B-4 Westinghouse 3 Loop

| Distance (x/t) | Boltup Stress (ksi) | Boltup + 2250 psi (ksi) |
|-------------------|------------------------|----------------------------|
| 0 (ID) | -15.45 | -10.55 |
| 0.125 | -10.90 | -4.00 |
| 0.250 | -7.01 | 1.39 |
| 0.375 | -3.37 | 6.43 |
| 0.5 | -2.41 | 8.89 |
| 0.625 | 4.27 | 16.47 |
| 0.75 | 8.88 | 23.08 |
| 0.875 | 14.59 | 31.39 |
| 1.0 | 27.72 | 48.62 |

| Table B-5 GE Reactor Vessels | | | |
|-------------------------------------|--------------------------|--------------------|----------------------|
| | B&W (251 in.) | CE (218 in) | CBI (251 in.) |
| Boltup | | | |
| ID Stress (ksi) | -48.0 | -25.5 | -35.0 |
| OD Stress (ksi) | 49.0 | 27.1 | 36.0 |
| Boltup & Steady State | | | |
| ID Stress (ksi) | -22.0 | -13.7 | -24.0 |
| OD Stress (ksi) | 53.0 | 49.6 | 52.5 |