

## APPENDIX C

### GENERIC DATA

#### TABLE OF CONTENTS

	<u>PAGE</u>
C.1 INTRODUCTION	C-1
C.2 10CFR50 DOSE COMMITMENT FACTORS	C-1
C.3 10CFR20 DOSE COMMITMENT FACTORS	C-1

#### LIST OF TABLES

<u>NUMBER</u>	<u>TITLE</u>	<u>PAGE</u>
C-1	Miscellaneous Dose Assessment Factors - Environmental Parameters	C-3
C-2	Miscellaneous Dose Assessment Factors - Consumption Rate Parameters	C-4
C-3	Stable Element Transfer Data	C-5
C-4	Atmospheric Stability Classes	C-7
C-5	Vertical Dispersion Parameters	C-8
C-6	Allowable Concentrations of Dissolved or Entrained Noble Gases Released from the Site to Unrestricted Areas in Liquid Waste	C-9
C-7	Radiological Decay Constants ( $\lambda_i$ ) in $\text{hr}^{-1}$	C-10
C-8	Bioaccumulation Factors $B_i$ to be Used in the Absence of Site-Specific Data	C-12
C-9	Beta Air and Skin Dose Factors for Noble Gases	C-14
C-10	External Dose Factors for Standing on Contaminated Ground	C-15
C-11	Sector Code Definitions	C-17

**APPENDIX C  
GENERIC DATA**

**C.1 INTRODUCTION**

This appendix contains generic (common to one or more of the stations) offsite dose calculation parameter factors, or values. Site specific factors are provided in the station annex Appendix F. The factors described in section C.2 and C.3 are found in the prescribed references and are not repeated in this appendix.

**C.2 10CFR50 DOSE COMMITMENT FACTORS**

The dose commitment factors for 10CFR50 related calculations are exactly those provided in Regulatory Guide 1.109 (Reference 6). The following table lists the parameters and the corresponding data tables in the RG 1.109:

<u>PATHWAY</u>	<u>ADULT</u>	<u>TEENAGER</u>	<u>CHILD</u>	<u>INFANT</u>
<b>Inhalation</b>	RG 1.109:Table E-7	RG 1.109:Table E-8	RG 1.109:Table E-9	RG 1.109:Table E-10
<b>Ingestion</b>	RG 1.109:Table E-11	RG 1.109:Table E-12	RG 1.109:Table E-13	RG 1.109:Table E-14

These tables are contained in Regulatory Guide 1.109 (Reference 6). Each table (E-7 through E-14) provides dose factors for seven organs for each of 73 radionuclides. For radionuclides not found in these tables, dose factors will be derived from ICRP 2 (Reference 50) or NUREG-0172 (Reference 51).

**C.3 10CFR20 DOSE COMMITMENT FACTORS**

Dose commitment factors for 10CFR20 related calculations are exactly those provided Federal Guidance Report Number 11 (Reference 93). The following table lists the parameters and the corresponding tables in the RG 1.109:

<u>PATHWAY</u>	<u>AVERAGE INDIVIDUAL</u>
<b>Inhalation</b>	FGR-11: Table 2.1
<b>Ingestion</b>	FGR-11: Table 2.2

The factors used in offsite dose calculations are for the seven organs (Gonad, Breast, Lung, R. Marrow, B. Surface, Thyroid and Remainder organs) but do not include the Effective (weighted) values. The factors in FGR#11 have units of Sieverts/Becquerel (Sv/Bq). To convert to traditional units of mrem/pCi multiply the factors by 3.7E+3.

**NOTE:** There are radionuclides listed in FGR-11 that have more than one clearance classification (day, week or year). For these nuclides, a conservative approach was used to pick the dose commitment factors for the dose calculations. For these nuclides, the highest (largest) value was picked for each organ no matter which clearance class it belonged to. As a result, for dose calculations involving these nuclides, the resulting calculated dose will be conservatively high when compared to a calculation that uses only the dose commitment factors for the clearance classification with the highest value for the Effective dose conversion factor. For example:

Assume that the radionuclide in question is Mg-28 and the pathway is inhalation. From Table 2.1 in FGR-11, the dose commitment values are:

<u>Nuclide</u>	<u>Class/f<sub>i</sub></u>	<u>Gonad</u>	<u>Breast</u>	<u>Lung</u>	<u>R. Marrow</u>	<u>B. Surface</u>	<u>Thyroid</u>	<u>Remainder</u>	<u>Effective</u>
Mg-28	D	2.91E-10	2.07E-10	2.96E-9	7.96E-10	1.42E-9	1.78E-10	1.04E-9	9.16E-10
	W	2.59E-10	1.46E-10	5.92E-9	4.03E-10	6.4E-10	1.07E-10	1.55E-9	1.33E-9

Mg-28 has two clearance classifications; D and W. The clearance class with the highest effective dose conversion factor (the column on the far right) is "W" clearance class. But the actual factors used in the

ODCM offsite dose calculations are picked from the highest value listed for each organ as shown in the bold text in the next table:

<u>Nuclide</u>	<u>Class/f<sub>i</sub></u>	<u>Gonad</u>	<u>Breast</u>	<u>Lung</u>	<u>R. Marrow</u>	<u>B. Surface</u>	<u>Thyroid</u>	<u>Remainder</u>	<u>Effective</u>
Mg-28	D	<b>2.91E-10</b>	<b>2.07E-10</b>	2.96E-9	<b>7.96E-10</b>	<b>1.42E-9</b>	<b>1.78E-10</b>	1.04E-9	9.16E-10
	W	2.59E-10	1.46E-10	<b>5.92E-9</b>	4.03E-10	6.4E-10	1.07E-10	<b>1.55E-9</b>	1.33E-9

Since some values are used from each of the classifications (the lung and remainder factors are class W and the gonad, breast, marrow, bone surface and thyroid are class D), the actual offsite dose calculation will result in a higher (more conservative) dose than if the organ dose conversion factors corresponding to the highest Effective dose conversion factor were used.

**Table C-1**  
**Miscellaneous Dose Assessment Factors -**  
**Environmental Parameters**

<u>Parameter and Value</u>	<u>Basis<sup>a</sup></u>
$f_p = 0.76$	A
$f_v = 1.0$	A
$t_h = 0$ for pasture grass (milk and meat pathways)	A
$t_h = 24$ hr (1 day for leafy vegetables)	A
$t_h = 1440$ hr (60 days for produce)	A
$t_h = 2160$ hr for stored feed (milk and meat pathways)	A
$t_e = 720$ hr (30 days for milk and meat)	A
$t_e = 1440$ hr (60 days for produce or leafy vegetables)	A
$f_r = 1.0$ May-October	B
$f_r = 0.0$ November-April	B
$f_g = 0.5$	B
$\lambda_w = 0.0021$ hr <sup>-1</sup>	A
$Y_v = 2.0$ kg/m <sup>2</sup> for leafy vegetables and produce pathways	A
$Y_v = 0.7$ kg/m <sup>2</sup> for milk and meat pathways	A
$t_s = 480$ hr (20 days)	A
$r = 1.0$ (iodines)	A
$r = 0.2$ (others)	A
$W_f = 50$ kg/day	C
$t_m = 48$ hr (2 days)	A
$t_b = 175,200$ hr (20 years)	D
$f_a = 1.0$ May-October	B
$f_a = 0.0$ November-April	B

**Miscellaneous Dose Assessment Factors - Environmental Parameters**

<sup>a</sup>Basis key:

- A: Reference 6, Table E-15.
- B: Typical for climate of Illinois and vicinity.
- C: Reference 6, Table E-3.
- D: The parameter  $t_b$  is taken as the midpoint of plant operating life (per Reference 6, Appendix C; Section 1).

**Table C-2**  
**Miscellaneous Dose Assessment Factors -**  
**Consumption Parameters**

Type	Variable	Infant	Child	Teenager	Adult
Air	$R_a$ ( $m^3/yr$ )	1400	3700	8000	8000
Milk	$U_a^M$ (L/yr)	330	330	400	310
Produce	$U_a^P$ (Kg/yr)	0	520	630	520
Leafy Vegetables	$U_a^V$ (Kg/yr)	0	26	42	64
Meat	$U_a^F$ (Kg/yr)	0	41	65	110
Water	$U_a^W$ (L/hr)	0.038	0.058	0.058	0.083
Fish	$U_a^r$ (Kg/hr)	0	7.9E-4	1.8E-3	2.4E-3

From Regulatory Guide 1.109, Table E-5.

**Table C-3**  
**Stable Element Transfer Data**

Element	$F_E$		Reference
	Meat (d/kg)	$F_M$ (Cow) Milk (d/L)	
H	1.2E-02	1.0E-02	6
Be	1.5E-03	3.2E-03	Footnote 1
C	3.1E-02	1.2E-02	6
F	2.9E-03	1.4E-02	Footnote 2
Na	3.0E-02	4.0E-02	6
Mg	1.5E-03	3.2E-03	Footnote 1
Al	1.5E-02	1.3E-03	Footnote 3
P	4.6E-02	2.5E-02	6
Cl	2.9E-03	1.4E-02	Footnote 2
Ar	NA	NA	NA
K	1.8E-02	7.2E-03	16
Ca	1.6E-03	1.1E-02	16
Sc	2.4E-03	7.5E-06	Footnote 4
Ti	3.4E-02	5.0E-06	Footnote 5
V	2.8E-01	1.3E-03	Footnote 6
Cr	2.4E-03	2.2E-03	6
Mn	8.0E-04	2.5E-04	6
Fe	4.0E-02	1.2E-03	6
Co	1.3E-02	1.0E-03	6
Ni	5.3E-02	6.7E-03	6
Cu	8.0E-03	1.4E-02	6
Zn	3.0E-02	3.9E-02	6
Ga	1.5E-02	1.3E-03	Footnote 3
Ge	9.1E-04	9.9E-05	Footnote 7
As	1.7E-02	5.0E-04	Footnote 8
Se	7.7E-02	1.0E-03	Footnote 9
Br	2.9E-03	2.2E-02	$F_E$ Footnote 2; $F_M$ from Ref. 16
Kr	NA	NA	NA
Rb	3.1E-02	3.0E-02	6
Sr	6.0E-04	8.0E-04	6
Y	4.6E-03	1.0E-05	6
Zr	3.4E-02	5.0E-06	6
Nb	2.8E-01	2.5E-03	6
Mo	8.0E-03	7.5E-03	6
Tc	4.0E-01	2.5E-02	6
Ru	4.0E-01	1.0E-06	6
Rh	1.5E-03	1.0E-02	6
Pd	5.3E-02	6.7E-03	Footnote 10
Cd	3.0E-02	2.0E-02	Footnote 11
In	1.5E-02	1.3E-03	Footnote 3
Sn	9.1E-04	9.9E-05	Footnote 7
Sb	5.0E-03	2.0E-05	98
Ag	1.7E-02	5.0E-02	6
Te	7.7E-02	1.0E-03	6
I	2.9E-03	6.0E-03	6
Xe	NA	NA	NA
Cs	4.0E-03	1.2E-02	6
Ba	3.2E-03	4.0E-04	6
La	2.0E-04	5.0E-06	6
Ce	1.2E-03	1.0E-04	6
Pr	4.7E-03	5.0E-06	6
Nd	3.3E-03	5.0E-06	6

**Table C-3 (Cont'd)**  
**Stable Element Transfer Data**

Element	F <sub>E</sub> Meat (d/kg)	F <sub>M</sub> (Cow) Milk (d/L)	Reference
Pm	2.9E-04	2.0E-05	16
Sm	2.9E-04	2.0E-05	16
Eu	2.9E-04	2.0E-05	16
Gd	2.9E-04	2.0E-05	16
Dy	2.9E-04	2.0E-05	16
Er	2.9E-04	2.0E-05	16
Tm	2.9E-04	2.0E-05	16
Yb	2.9E-04	2.0E-05	16
Lu	2.9E-04	2.0E-05	16
Hf	3.4E-02	5.0E-06	Footnote 5
Ta	2.8E-01	1.3E-03	F <sub>M</sub> - Ref.16; F <sub>E</sub> -Footnote 6
W	1.3E-03	5.0E-04	6
Re	1.0E-01	1.3E-03	F <sub>M</sub> - Ref.16; F <sub>E</sub> -Footnote 12
Os	2.2E-01	6.0E-04	Footnote 13
Ir	7.3E-03	5.5E-03	Footnote 14
Pt	5.3E-02	6.7E-03	Footnote 10
Au	1.3E-02	3.2E-02	Footnote 15
Hg	3.0E-02	9.7E-06	F <sub>M</sub> - Ref.16; F <sub>E</sub> -Footnote 11
Tl	1.5E-02	1.3E-03	F <sub>M</sub> - Ref.16; F <sub>E</sub> -Footnote 3
Pb	9.1E-04	9.9E-05	98
Bi	1.7E-02	5.0E-04	98
Ra	5.5E-04	5.9E-04	98
Th	1.6E-06	5.0E-06	98
U	1.6E-06	1.2E-04	98
Np	2.0E-04	5.0E-06	6
Am	1.6E-06	2.0E-05	98

Notes:

1. NA = It is assumed that noble gases are not deposited on the ground.
2. Elements listed are those considered for 10CFR20 assessment and compliance.

Footnotes:

- There are numerous F<sub>E</sub> and F<sub>M</sub> values that were not found in published literature. In these cases, the periodic table was used in conjunction with published values. The periodic table was used based on a general assumption that elements have similar characteristics when in the same column of the periodic table. The values of elements in the same column of the periodic table, excluding atomic numbers 58-71 and 90-103, were averaged then assigned to elements missing values located in the same column of the periodic table. This method was used for all columns where there were missing values except column 3A, where there was no data, hence, the average of column 2B and 4A were used.
1. Values obtained by averaging Reference 6 values of Ca, Sr, Ba and Ra.
  2. F<sub>E</sub> value obtained by assigning the Reference 6 value for I. F<sub>M</sub> value obtained by averaging I(Ref. 6) and Br (Ref.16).
  3. F<sub>E</sub> values obtained by averaging Zn (Ref.6) and Pb (Ref. 98); there were no values for elements in the same column; an average is taken between values of columns 2B and 4A on the periodic table. F<sub>M</sub> values obtained by using the value for Tl from Reference 16.
  4. Values obtained by averaging Reference 6 values of Y and La.
  5. Values obtained by assigning the Reference 6 value for Zr.
  6. F<sub>E</sub> values obtained from Ref. 6 value for Nb. F<sub>M</sub> values obtained by averaging values for Nb (Ref.6) and Ta (Ref. 16).
  7. Values obtained from the Reference 6 values for Pb.
  8. Values obtained from the Reference 6 values for Bi.
  9. Values obtained from the Reference 6 values for Te.
  10. Values obtained from the Reference 6 values for Ni.
  11. F<sub>E</sub> values obtained from Ref. 6 values for Zn. F<sub>M</sub> values obtained by averaging the Reference 6 values for Zn and Hg.
  12. Values obtained by averaging Reference 6 values for Mn, Tc, Nd and Reference 98 value for U.
  13. Values obtained by averaging Reference 6 values from Fe and Ru.
  14. Values obtained by averaging Reference 6 values from Co and Rh.
  15. Values obtained by averaging Reference 6 values from Cu and Ag.

**Table C-4**  
**Atmospheric Stability Classes**

Description	Pasquill Stability Class	<sup>a</sup> $\sigma_{\theta}$ (degrees)	Temperature Change with Height (°C/100 m)
Extremely Unstable	A	>22.5	<-1.9
Moderately Unstable	B	17.5 to 22.5	-1.9 to -1.7
Slightly Unstable	C	12.5 to 17.5	-1.7 to -1.5
Neutral	D	7.5 to 12.5	-1.5 to -0.5
Slightly Stable	E	3.8 to 7.5	-0.5 to 1.5
Moderately Stable	F	2.1 to 3.8	1.5 to 4.0
Extremely Stable	G	0 to 2.1	>4.0

<sup>a</sup> $\sigma_{\theta}$  is the standard deviation of horizontal wind direction fluctuation over a period of 15 minutes to 1 hour.

---

From Regulatory Guide 1.21, Table 4B.



**Table C-5**  
**Vertical Dispersion Parameters**

**Section 1**

Vertical Dispersion Parameters  $\sigma_z$

$\sigma_z$  (meters) =  $aR^b+c$  with  $\sigma_z$  limited to a maximum of 1000 meters

R = downwind range (meters)

a, b and c have the values listed below:

Stability Class	100 < R < 1000			R > 1000		
	a	b	c	a	b	c
A	*	*	*	0.00024	2.094	-9.6
B	*	*	*	*	*	*
C	0.113	0.911	0.0	*	*	*
D	0.222	0.725	-1.7	1.26	0.516	-13.0
E	0.211	0.678	-1.3	6.73	0.305	-34.0
F	0.086	0.74	-0.35	18.05	0.18	-48.6
G	0.052	0.74	-0.21	10.83	0.18	-29.2

Basis: Reference 53, except for cases denoted by an asterisk. In these cases, the value of  $\sigma_z$  is obtained by a polynomial approximation to the data from Reference 53 (see Section 2 of this table). The functions given in Reference 50 are not used because they are discontinuous at 1000 meters.

**Section 2**

Polynomial Approximation for  $\sigma_z$ :

$\sigma_z$  (meters) =  $\exp [a_0 + a_1P + a_2P^2 + a_3P^3]$  with  $\sigma_z$  limited to a maximum of 1000 meters

$P = \log_e [R(\text{meters})]$

$a_0, a_1, a_2$  and  $a_3$  have the values listed below:

Stability Class	Range	Coefficients
A	100 ≤ R ≤ 1000	$a_0 = -10.50$
		$a_1 = 6.879$
		$a_2 = -1.309$
		$a_3 = 0.0957$
B	100 ≤ R ≤ 1000	$a_0 = -0.449$
		$a_1 = 0.218$
		$a_2 = 0.112$
		$a_3 = -0.00517$
B	R > 1000	$a_0 = 319.148$
		$a_1 = -127.806$
		$a_2 = 17.093$
		$a_3 = -0.750$
C	R > 1000	$a_0 = 5.300$
		$a_1 = -1.866$
		$a_2 = 0.3509$
		$a_3 = -0.01514$

**Table C-6**  
**Allowable Concentration of Dissolved or Entrained Noble Gases**  
**Released from the Site to Unrestricted Areas in Liquid Waste**

<u>Nuclide</u>	Allowable Concentration ( $\mu\text{Ci/mL}$ ) <sup>a</sup>	
	Braidwood <u>Byron</u>	Dresden LaSalle Quad Cities <u>Zion</u>
Kr 85m	2E-4	2E-4
Kr 85	2E-4	5E-4
Kr 87	2E-4	4E-5
Kr 88	2E-4	9E-5
Ar 41	2E-4	7E-5
Xe 131m	2E-4	7E-4
Xe 133m	2E-4	5E-4
Xe 133	2E-4	6E-4
Xe 135m	2E-4	2E-4
Xe 135	2E-4	2E-4

<sup>a</sup>Computed from Equation 17 of ICRP Publication 2 (Reference 47) adjusted for infinite cloud submersion in water, and  $R = 0.01 \text{ rem/week}$ ,  $\rho_w = 1.0 \text{ gm/cm}^3$ , and  $P_w/P_t = 1.0$ .

Table C-7  
Radiological Decay Constants ( $\lambda_i$ ) in  $\text{hr}^{-1}$

Isotope	Lambda	Isotope	Lambda	Isotope	Lambda
H-3	6.44E-06	AS-73	3.6E-04	TC-104	2.31E+00
BE-7	5.4E-04	AS-74	1.62E-03	RU-97	9.96E-03
C-14	1.38E-08	AS-76	2.63E-02	RU-103	7.34E-04
F-18	3.78E-01	AS-77	1.79E-02	RU-105	1.56E-01
NA-22	3.04E-05	SE-73	9.69E-02	RU-106	7.84E-05
NA-24	4.62E-02	SE-75	2.41E-04	RH-106	8.33E+01
MG-27	4.39E+00	BR-77	1.21E-02	PD-109	5.15E-02
MG-28	3.31E-02	BR-80	2.38E+00	CD-109	6.22E-05
AL-26	1.10E-10	BR-82	1.96E-02	IN-111	1.02E-02
AL-28	1.85E+01	BR-83	2.90E-01	IN-115M	1.59E-01
P-32	2.02E-03	BR-84	1.30E+00	IN-116	7.66E-01
CL-38	1.12E+00	BR-85	1.45E+01	SN-113	2.51E-04
AR-41	3.79E-01	KR-79	1.98E-02	SN-117M	2.12E-03
K-40	6.19E-14	KR-81	3.77E-10	SN-119M	9.85E-05
K-42	5.61E-02	KR-83M	3.79E-01	SB-117	2.48E-01
K-43	3.07E-02	KR-85M	1.55E-01	SB-122	1.07E-02
CA-47	6.37E-03	KR-85	7.38E-06	SB-124	4.80E-04
SC-44	1.76E-01	KR-87	5.44E-01	SB-125	2.86E-05
SC-46M	1.33E+02	KR-88	2.44E-01	SB-126	2.33E-03
SC-46	3.44E-04	KR-90	7.71E+00	AG-108M	6.23E-07
SC-47	8.44E-03	RB-84	8.78E-04	AG-108	1.75E+01
TI-44	1.67E-06	RB-86	1.55E-03	AG-110M	1.16E-04
V-48	1.81E-03	RB-87	1.67E-15	AG-111	3.87E-03
CR-51	1.04E-03	RB-88	2.33E+00	TE-121M	1.88E-04
MN-52M	1.94E+00	RB-89	2.69E+00	TE-121	1.72E-03
MN-52	5.16E-03	SR-85	4.45E-04	TE-123M	2.41E-04
MN-54	9.23E-05	SR-87M	2.47E-01	TE-125M	4.98E-04
MN-56	2.69E-01	SR-89	5.71E-04	TE-125	0.00E+00
FE-52	8.37E-02	SR-90	2.77E-06	TE-127M	2.65E-04
FE-55	2.93E-05	SR-91	7.29E-02	TE-127	7.41E-02
FE-59	6.47E-04	SR-92	2.56E-01	TE-129M	8.59E-04
CO-57	1.07E-04	Y-86	4.70E-02	TE-129	5.96E-01
CO-58	4.08E-04	Y-87	8.63E-03	TE-131M	2.31E-02
CO-60	1.50E-05	Y-88	2.71E-04	TE-131	1.66E+00
NI-63	7.90E-07	Y-90	1.08E-02	TE-132	8.86E-03
NI-65	2.75E-01	Y-91M	8.35E-01	TE-134	9.93E-01
CU-64	5.46E-02	Y-91	4.94E-04	I-123	5.28E-02
CU-67	4.67E-04	Y-92	1.96E-01	I-124	6.91E-03
CU-68	8.31E+01	Y-93	6.86E-02	I-125	4.80E-04
ZN-65	1.18E-04	ZR-95	4.51E-04	I-130	5.61E-02
ZN-69M	5.04E-02	ZR-97	4.10E-02	I-131	3.59E-03
ZN-69	7.46E-01	NB-94	3.90E-09	I-132	3.01E-01
GA-66	7.37E-02	NB-95	8.00E-03	I-133	3.33E-02
GA-67	8.85E-03	NB-97M	4.15E+01	I-134	7.89E-01
GA-68	6.10E-01	NB-97	5.76E-01	I-135	1.05E-01
GA-72	4.91E-02	MO-99	1.05E-02	XE-127	7.93E-04
GE-77	6.13E-02	TC-99M	1.15E-01	XE-129M	3.25E-03
AS-72	2.67E-02	TC-101	2.92E+00	XE-131M	2.44E-03

Table C-7 (Cont'd)  
Radiological Decay Constants ( $\lambda_i$ ) in  $\text{hr}^{-1}$

Isotope	Lambda	Isotope	Lambda
XE-133M	1.32E-02	YB-175	6.89E-03
XE-133	5.51E-03	LU-177	4.30E-03
XE-135M	2.70E+00	HF-181	6.81E-04
XE-135	7.61E-02	TA-182	2.52E-04
XE-137	1.08E+01	TA-183	5.78E-03
XE-138	2.94E+00	W-187	2.91E-02
CS-129	2.16E-02	RE-188	4.08E-02
CS-132	4.46E-03	OS-191	1.88E-03
CS-134	3.84E-05	IR-194	3.62E-02
CS-136	2.19E-03	PT-195M	7.18E-03
CS-137	2.62E-06	PT-197	3.79E-02
CS-138	1.29E+00	AU-195M	8.15E+01
CS-139	4.41E+00	AU-195	1.58E-04
BA-131	2.45E-03	AU-198	1.07E-02
BA-133M	1.78E-02	AU-199	9.20E-03
BA-133	7.53E-06	HG-197	2.91E-02
BA-135M	2.41E-02	HG-203	6.20E-04
BA-137M	1.63E+01	TL-201	9.49E-03
BA-137	0.00E+00	TL-206	9.90E+00
BA-139	4.99E-01	TL-208	1.36E+01
BA-140	2.26E-03	PB-203	1.33E-02
BA-141	2.27E+00	PB-210	3.55E-06
BA-142	3.88E+00	PB-212	6.51E-02
LA-140	1.72E-02	PB-214	1.55E+00
LA-142	4.35E-01	BI-206	4.63E-03
CE-139	2.10E-04	BI-207	2.37E-06
CE-141	8.88E-04	BI-214	2.09E+00
CE-143	2.10E-02	RA-226	4.94E-08
CE-144	1.02E-04	TH-232	5.63E-15
PR-142	3.62E-02	U-238	1.77E-14
PR-143	2.13E-03	NP-239	1.23E-02
PR-144	2.40E+00	AM-241	1.83E-07
ND-147	2.63E-03		
ND-149	4.01E-01		
PM-145	4.47E-06		
PM-148M	6.99E-04		
PM-148	5.38E-03		
PM-149	1.31E-02		
SM-153	1.48E-02		
EU-152	5.82E-06		
EU-154	8.99E-06		
EU-155	1.59E-05		
GD-153	1.20E-04		
DY-157	8.60E-02		
ER-169	3.07E-03		
ER-171	9.22E-02		
TM-170	2.25E-04		
YB-169	9.03E-04		

$(\lambda_i)$  = Radiological Decay Constant  
=  $0.693/T_i$

$T_i$  = Radiological Half-Life in hours  
(from Reference 70).

Except for Cu-68, Tc-104, Ba-137, Ta-183, TL-206, Bi-206 which are from References 100.

**Table C-8**  
**Bioaccumulation Factors (B<sub>f</sub>) to be Used**  
**in the Absence of Site-Specific Data**

<u>Element</u>	<u>B<sub>f</sub> for</u> <u>Freshwater Fish</u> <u>(pCi/kg per pCi/L)</u>	<u>Reference</u>
H	9.0E-01	6
Be	2.8E+01	Footnote 2
C	4.6E+03	6
F	2.2E+02	Footnote 16
Na	1.0E+02	6
Mg	2.8E+01	Footnote 2
Al	2.2E+03	Footnote 13
P	1.0E+05	6
Cl	2.2E+02	Footnote 16
Ar	NA	NA
K	1.0E+03	Footnote 1
Ca	2.8E+01	Footnote 2
Sc	2.5E+01	Footnote 3
Ti	3.3E+00	Footnote 4
V	3.0E+04	Footnote 5
Cr	2.0E+02	6
Mn	4.0E+02	6
Fe	1.0E+02	6
Co	5.0E+01	6
Ni	1.0E+02	6
Cu	5.0E+01	6
Zn	2.0E+03	6
Ga	2.2E+03	Footnote 13
Ge	2.4E+03	Footnote 12
As	3.3E+04	Footnote 14
Se	4.0E+02	Footnote 15
Br	4.2E+02	6
Kr	NA	NA
Rb	2.0E+03	6
Sr	3.0E+01	6
Y	2.5E+01	6
Zr	3.3E+00	6
Nb	3.0E+04	6
Mo	1.0E+01	6
Tc	1.5E+01	6
Ru	1.0E+01	6
Rh	1.0E+01	6
Pd	1.0E+02	Footnote 9
Cd	2.0E+03	Footnote 11
In	2.2E+03	Footnote 13
Sn	2.4E+03	Footnote 12
Sb	1.0E+00	98
Ag	2.3E+00	56
Te	4.0E+02	6
I	1.5E+01	6
Xe	NA	NA
Cs	2.0E+03	6
Ba	4.0E+00	6
La	2.5E+01	6
Ce	1.0E+00	6
Pr	2.5E+01	6
Nd	2.5E+01	6
Pm	3.0E+01	98
Sm	3.0E+01	Footnote 3

**Table C-8 (Cont'd)**  
**Bioaccumulation Factors ( $B_i$ ) to be Used**  
**in the Absence of Site-Specific Data**

<u>Element</u>	<u><math>B_i</math> for Freshwater Fish (pCi/kg per pCi/L)</u>	<u>Reference</u>
Eu	1.0E+02	Footnote 3
Gd	2.6E+01	Footnote 3
Dy	2.2E+03	Footnote 3
Er	3.3E+04	Footnote 3
Tm	4.0E+02	Footnote 3
Yb	2.2E+02	Footnote 3
Lu	2.5E+01	Footnote 3
Hf	3.3E+00	Footnote 4
Ta	3.0E+04	Footnote 5
W	1.2E+03	6
Re	2.1E+02	Footnote 6
Os	5.5E+01	Footnote 7
Ir	3.0E+01	Footnote 8
Pt	1.0E+02	Footnote 9
Au	2.6E+01	Footnote 10
Hg	2.0E+03	Footnote 11
Tl	2.2E+03	Footnote 13
Pb	3.0E+02	98
Bi	2.0E+01	98
Ra	5.0E+01	98
Th	3.0E+01	98
U	1.0E+01	98
Np	1.0E+01	6
Am	3.0E+01	98

**Footnotes:**

NA = It is assumed that noble gases are not accumulated.

In Reference 6, see Table A-1.

A number of bioaccumulation factors could not be found in literature. In this case, the periodic table was used in conjunction with published element values. This method was used for periodic table columns except where there were no values for column 3A so the average of columns 2B and 4A was assigned.

1. Value is the average of Reference 6 values in literature for H, Na, Rb and Cs.
2. Value is the average of Ref. 6 values in literature for Sr, Ba and Ref. 98 values for Ra.
3. Value is the same as the Reference 6 value used for Y.
4. Value is the same as the Reference 6 value used for Zr.
5. Value is the same as the Reference 6 value used for Nb.
6. Value is the average of Reference 6 values in literature for Mn and Tc.
7. Value is the average of Reference 6 values in literature for Fe and Ru.
8. Value is the average of Reference 6 values in literature for Co and Rh.
9. Value is the same as the Reference 6 value used for Ni.
10. Value is the average of Reference 6 values in literature for Cu and Reference 56 value for Ag.
11. Value used is the same as the Reference 6 value used for Zn.
12. Value is the average of Reference 6 value in literature for C and Reference 98 value for Pb.
13. Value is the average of columns 2B and 4A, where column 2B is the "Reference 6 value for Zn" and column 4A is the average of "Reference 6 value for C and Reference 98 value for Pb".
14. Value is the average of Ref. 6 value found in literature for P and the Ref. 98 values for Bi and Sb.
15. Value is the same as the Reference 6 value used for Te.
16. Value is the average of Reference 6 values found in literature for Br and I.

**Table C-9**  
**Beta Air and Skin Dose Factors for Noble Gases**

<u>Nuclide</u>	Beta Air Dose Factor	Beta Skin Dose Factor
	$L_i$ (mrad/yr per $\mu\text{Ci}/\text{m}^3$ )	$\bar{L}_i$ (mrem/yr per $\mu\text{Ci}/\text{m}^3$ )
Kr-83m	2.88E+02	---
Kr-85m	1.97E+03	1.46E+03
Kr-85	1.95E+03	1.34E+03
Kr-87	1.03E+04	9.73E+03
Kr-88	2.93E+03	2.37E+03
Kr-89	1.06E+04	1.01E+04
Kr-90	7.83E+03	7.29E+03
Xe-131m	1.11E+03	4.76E+02
Xe-133m	1.48E+03	9.94E+02
Xe-133	1.05E+03	3.06E+02
Xe-135m	7.39E+02	7.11E+02
Xe-135	2.46E+03	1.86E+03
Xe-137	1.27E+04	1.22E+04
Xe-138	4.75E+03	4.13E+03
Ar-41	3.28E+03	2.69E+03

---

Source: Table B-1 of Reference 6.

**Table C-10**  
**External Dose Factors for Standing on Contaminated Ground**  
**DFG<sub>ij</sub> (mrem/hr per pCi/ m<sup>2</sup>)**

<u>Element</u>	<u>Whole Body Dose Factor</u>	<u>Reference</u>	<u>Element</u>	<u>Dose Factor</u>	<u>Reference</u>
H-3	0.00E+00	6	Be-7	5.95E-10	99
C-14	0.00E+00	6	F-18	1.19E-08	99
Na-22	2.42E-08	99	Na-24	2.50E-08	6
Mg-27	1.14E-08	99	Mg-28	1.48E-08	99
Al-26	2.95E-08	99	Al-28	2.00E-08	99
P-32	0.00E+00	6	Cl-38	1.70E-08	99
Ar-41	1.39E-08	99	K-40	2.22E-09	99
K-42	4.64E-09	99	K-43	1.19E-08	99
Ca-47	1.14E-08	99	Sc-44	2.50E-08	99
Sc-46m	1.21E-09	99	Sc-46	2.24E-08	99
Sc-47	1.46E-09	99	Ti-44	1.95E-09	99
V-48	3.21E-08	99	Cr-51	2.20E-10	6
Mn-52m	2.79E-08	99	Mn-52	3.80E-08	99
Mn-54	5.80E-09	6	Mn-56	1.10E-08	6
Fe-52	9.12E-09	99	Fe-55	0.00E+00	6
Fe-59	8.00E-09	6	Co-57	1.65E-09	99
Co-58	7.00E-09	6	Co-60	1.70E-08	6
Ni-63	0.00E+00	6	Ni-65	3.70E-09	6
Cu-64	1.50E-09	6	Cu-67	1.52E-09	99
Cu-68	8.60E-09 <sup>1</sup>	--	Zn-65	4.00E-09	6
Zn-69m	5.06E-09	99	Zn-69	0.00E+00	6
Ga-66	2.70E-08	99	Ga-67	1.89E-09	99
Ga-68	1.24E-08	99	Ga-72	3.00E-08	99
Ge-77	1.34E-08	99	As-72	2.23E-08	99
As-73	1.16E-10	99	As-74	9.41E-09	99
As-76	6.46E-09	99	As-77	1.79E-10	99
Se-73	1.38E-08	99	Se-75	4.98E-09	99
Br-77	3.84E-09	99	Br-80	2.01E-09	99
Br-82	3.00E-08	99	Br-83	6.40E-11	6
Br-84	1.20E-08	6	Br-85	0.00E+00	6
Kr-79	3.07E-09	99	Kr-81	1.59E-10	99
Kr-83m	1.42E-11	99	Kr-85m	2.24E-09	99
Kr-85	1.35E-10	99	Kr-87	1.03E-08	99
Kr-88	2.07E-08	99	Kr-90	1.56E-08	99
Rb-84	1.07E-08	99	Rb-86	6.30E-10	6
Rb-87	0.00E+00	99	Rb-88	3.50E-09	6
Rb-89	1.50E-08	6	Sr-85	6.16E-09	99
Sr-87m	3.92E-09	99	Sr-89	5.60E-13	6
Sr-90	1.84E-11	99	Sr-91	7.10E-09	6
Sr-92	9.00E-09	6	Y-86	4.00E-08	99
Y-87	5.53E-09	99	Y-88	2.88E-08	99
Y-90	2.20E-12	6	Y-91m	3.80E-09	6
Y-91	2.40E-11	6	Y-92	1.60E-09	6
Y-93	5.70E-10	6	Zr-95	5.00E-09	6
Zr-97	5.50E-09	6	Nb-94	1.84E-08	99
Nb-95	5.10E-09	6	Nb-97m	8.57E-09	99
Nb-97	8.48E-09	99	Mo-99	1.90E-09	6
Tc-99m	9.60E-10	6	Tc-101	2.70E-09	6
Tc-104	1.83E-08 <sup>1</sup>	--	Ru-97	2.99E-09	99
Ru-103	3.60E-09	6	Ru-105	4.50E-09	6
Ru/Rh-106	5.76E-09 <sup>3</sup>	6, 99	Pc-109	3.80E-10	99
Cc-109	1.12E-10	99	In-111	5.11E-09	99
In-115m	2.01E-09	99	In-116	0.00E+00 <sup>2</sup>	--
Sn-113	1.15E-09	99	Sn-117m	1.96E-08	99
Sn-119m	7.05E-11	99	Sb-117	0.00E+00 <sup>2</sup>	--
Sb-122	2.71E-09 <sup>1</sup>	--	Sb-124	1.16E-08 <sup>1</sup>	--
Sb-125	4.56E-09	99	Sb-126	7.13E-10	99
Ag-108m	1.92E-08	99	Ag-108	1.14E-09	99
Ag-110m	1.80E-08	6	Ag-111	6.75E-10	99
Te-121m	2.65E-09	99	Te-121	6.75E-09	99
Te-123m	1.88E-09	99	Te-125m	3.50E-11	6
Te-125	0.00E+00 <sup>2</sup>	--	Te-127m	1.10E-12	6
Te-127	1.00E-11	6	Te-129m	7.70E-10	6
Te-129	7.10E-10	6	Te-131m	8.40E-09	6
Te-131	2.20E-09	6	Te-I-132	3.40E-09 <sup>5</sup>	6
Te-134	1.05E-08	99	I-123	2.12E-09	99
I-124	1.23E-08	99	I-125	2.89E-10	99
I-130	1.40E-08	6	I-131	2.80E-09	6
I-133	3.70E-09	6	I-134	1.60E-08	6
I-135	1.20E-08	6	Xe-127	3.44E-09	99



**Table C-10 (cont.)**  
**External Dose Factors for Standing on Contaminated Ground**  
**DFG<sub>ij</sub> (mrem/hr per pCi/ m<sup>2</sup>)**

Element	Whole Body Dose Factor	Reference	Element	Dose Factor	Reference
Xe-129m	5.57E-10	99	Xe-131m	2.13E-10	99
Xe-133m	4.81E-10	99	Xe-133	5.91E-10	99
Xe-135m	5.23E-09	99	Xe-135	3.36E-09	99
Xe-137	4.26E-09	99	Xe-138	1.30E-08	99
Cs-129	3.39E-09	99	Cs-132	8.40E-09	99
Cs-134	1.20E-08	6	Cs-136	1.50E-08	6
Cs-137/Ba-137m	1.14E-08 <sup>4</sup>	6, 99	Cs-138	2.10E-08	6
Cs-139	5.15E-09	99	Ba-131	5.74E-09	99
Ba-133m	8.10E-10	99	Ba-133	4.85E-09	99
Ba-135m	7.26E-10	99	Ba-137m	7.17E-09	99
Ba-137	0.00E+00 <sup>2</sup>	--	Ba-139	2.40E-09	6
Ba-La-140	1.71E-08 <sup>6</sup>	6	Ba-141	4.30E-09	6
Ba-142	7.90E-09	6	La-142	1.50E-08	6
Ce-139	2.04E-09	99	Ce-141	5.50E-10	6
Ce-143	2.20E-09	6	Ce-Pr-144	5.20E-10 <sup>7</sup>	6
Pr-142	1.84E-09	99	Pr-143	0.00E+00	6
Nc-147	1.00E-09	6	Nc-149	5.32E-09	99
Pm-145	3.38E-10	99	Pm-148m	2.35E-08	99
Pm-148	7.22E-09	99	Pm-149	5.32E-10	99
Sm-153	8.95E-10	99	Eu-152	1.30E-08	99
Eu-154	1.41E-08	99	Eu-155	8.27E-10	99
Gc-153	1.46E-09	99	Dy-157	4.39E-09	99
Er-169	6.12E-14	99	Er-171	5.11E-09	99
Tm-170	3.41E-10	99	Yb-169	4.12E-09	99
Yb-175	4.94E-10	99	Lu-177	4.60E-10	99
Hf-181	6.67E-09	99	Ta-182	1.42E-08	99
Ta-183	2.93E-09 <sup>1</sup>	--	W-187	3.10E-09	6
Re-188	1.89E-09	99	Os-191	9.83E-10	99
Ir-194	2.31E-09	99	Pt-195m	9.79E-10	99
Pt-197	3.57E-10	99	Au-195m	2.54E-09	99
Au-195	1.14E-09	99	Au-198	5.19E-09	99
Au-199	1.18E-09	99	Hg-197	9.33E-10	99
Hg-203	2.89E-09	99	Tl-201	1.24E-09	99
Tl-206	0.00E+00 <sup>2</sup>	--	Tl-208	3.58E-08	99
Pb-203	3.88E-09	99	Pb-210	3.57E-11	99
Pb-212	1.91E-09	99	Pb-214	3.18E-09	99
Bi-206	3.74E-08	99	Bi-207	1.77E-08	99
Bi-214	1.71E-08	99	Ra-226	8.78E-11	99
Th-232	8.14E-12	99	U-238	7.98E-12	99
Np-239	9.50E-10	6	Am-241	3.48E-10	99

- 1 Valued derived by comparing the percentage and MeV of the nuclide's gammas and then comparing to Cesium-137, as a value was not available in the literature.
- 2 0.0 due to low yield and short half life. A value was not available in the literature.
- 3 Value is the sum of Ru-106 (1.50E-9) and Rh-106 (4.26E-9). The Rh-106 value is from Reference 99 and the Ru-106 value is from Reference 6.
- 4 Value is the sum of Cs-137 (4.20E-9) and Ba-137m (7.17E-9). The values are from references 6 and 99, respectively.
- 5 Value is the sum of Te-132 (1.70E-9) and I-132 (1.70E-9).
- 6 Value is the sum of Ba-140 (2.10E-9) and La-140 (1.50E-8) from reference 6. In Reference 6, see Table E-6.
- 7 Value is the sum of Ce-144 (3.20E-10) and Pr-144 (2.00E-10) from reference 6.

**Note:** Dose assessments for 10CFR20 and 40CFR190 compliance are made for an adult only using the dose commitment factors of Federal Guidance Report 11 (Reference 93). These are given in units of Sieverts per Becquerel. To convert these data to the conventional units of (mrem/pCi) the data must be multiplied by  $3.7 \times 10^3$ .

Dose assessments for 10CFR50 Appendix are made using dose factors of Regulatory Guide 1.109 (Reference 6) for all age groups.

Table C-11

Sector Code Definitions

<u>Sector Code</u>	<u>Sector Direction</u>	<u>Angle from North (Degrees)</u>
A	N	$348.75 < \theta \leq 11.25$
B	NNE	$11.25 < \theta \leq 33.75$
C	NE	$33.75 < \theta \leq 56.25$
D	ENE	$56.25 < \theta \leq 78.75$
E	E	$78.75 < \theta \leq 101.25$
F	ESE	$101.25 < \theta \leq 123.75$
G	SE	$123.75 < \theta \leq 146.25$
H	SSE	$146.25 < \theta \leq 168.75$
J	S	$168.75 < \theta \leq 191.25$
K	SSW	$191.25 < \theta \leq 213.75$
L	SW	$213.75 < \theta \leq 236.25$
M	WSW	$236.25 < \theta \leq 258.75$
N	W	$258.75 < \theta \leq 281.25$
P	WNW	$281.25 < \theta \leq 303.75$
Q	NW	$303.75 < \theta \leq 326.25$
R	NNW	$326.25 < \theta \leq 348.75$

**CHAPTER 10**

**BRAIDWOOD ANNEX INDEX**

Revision 4

**CHAPTER 10**

**RADIOACTIVE EFFLUENT TREATMENT AND MONITORING**

**TABLE OF CONTENTS**

<u>SECTION</u>	<u>PAGE</u>
<b>10.1 AIRBORNE RELEASES</b> .....	<b>1</b>
1. System Description .....	1
1. Waste Gas Holdup System.....	1
2. Ventilation Exhaust Treatment System.....	1
2. Radiation Monitors .....	1
1. Auxiliary Building Vent Effluent Monitors .....	1
2. Containment Purge Effluent Monitors.....	2
3. Waste Gas Decay Tank Monitors.....	2
4. Gland Steam and Condenser Air Ejector Monitors.....	2
5. Radwaste Building Ventilation Monitor .....	2
6. Component Cooling Water Monitor .....	2
7. Miscellaneous Ventilation Monitors .....	3
3. Alarm and Trip Setpoints.....	3
1. Setpoint Calculations .....	3
1. Auxiliary Building Vent Effluent Monitors .....	3
2. Containment Purge Effluent Monitors.....	3
3. Waste Gas Decay Tank Effluent Monitors.....	3
2. Release Limits .....	3
3. Release Mixture.....	5
4. Conversion Factors .....	5
5. HVAC Flow Rates.....	5
4. Allocation of Effluents from Common Release Points.....	5
5. Dose Projections for Batch Releases.....	5

**CHAPTER 10**

**RADIOACTIVE EFFLUENT TREATMENT AND MONITORING**

**TABLE OF CONTENTS**

<u>SECTION</u>	<u>PAGE</u>
<b>10.2 LIQUID RELEASES</b> .....	5
1. System Description .....	5
1. Release Tanks.....	5
2. Radiation Monitors .....	6
1. Liquid Radwaste Effluent Monitors .....	6
2. Station Blowdown Monitor .....	6
3. Reactor Containment Fan Cooler (RCFC) and Essential Service Water (ESSW) Outlet Line Monitors.....	6
4. Turbine Building Fire and Oil Sump Monitor.....	6
5. Condensate Polisher Sump Monitor.....	6
3. Alarm and Trip Setpoints.....	7
1. Setpoint Calculation.....	7
1. Station Blowdown Monitor .....	7
2. Liquid Radwaste Effluent Monitor .....	7
1. Release Tank Discharge Flow Rate .....	7
2. Release Limits .....	8
3. Release Mixture.....	8
4. Liquid Dilution Flow Rates .....	9
5. Projected Concentrations for Releases .....	9
3. Other Liquid Effluent Monitors .....	9
4. Conversion Factors .....	10
4. Allocation of Effluents from Common Release Points .....	10
<b>10.3 SOLIDIFICATION OF WASTE/PROCESS CONTROL PROGRAM</b> .....	10

**CHAPTER 10**

**LIST OF TABLES**

	<u>NUMBER</u>		<u>PAGE</u>
10-1	Assumed Composition of the Braidwood Station Noble Gas Effluent		10-11
10-2	Assumed Composition of the Braidwood Station Liquid Effluent		10-12

**CHAPTER 10**

## LIST OF FIGURES

	<u>NUMBER</u>	<u>PAGE</u>
10-1	Simplified HVAC and Gaseous Effluent Flow Diagram	10-13
10-2	Simplified Liquid Radwaste Processing Diagram	10-15
10-3	Simplified Liquid Effluent Flow Diagram	10-16
10-4	Simplified Solid Radwaste Process Diagram	10-17

**CHAPTER 10****RADIOACTIVE EFFLUENT TREATMENT AND MONITORING****10.1 AIRBORNE RELEASES****10.1.1 System Description**

A simplified HVAC and gaseous effluent flow diagram is provided in Figure 10-1. The principal release points for potentially radioactive airborne effluents are the two auxiliary building vent stacks (designated Unit 1 Vent Stack and Unit 2 Vent Stack in Figure 10-1). In the classification scheme of Section 4.1.4, each is classified as a vent release point (see Table A-1 of Appendix A).

**10.1.1.1 Waste Gas Holdup System**

The waste gas holdup system is designed and installed to reduce radioactive gaseous effluents by collecting reactor coolant system off-gases from the reactor coolant system and providing for delay or holdup to reduce the total radioactivity by radiodecay prior to release to the environment. The system is described in Chapter 11 of the Byron/Braidwood UFSAR.

**10.1.1.2 Ventilation Exhaust Treatment System**

Ventilation exhaust treatment systems are designed and installed to reduce gaseous radioiodine or radioactive material in particulate form in gaseous effluents by passing ventilation or vent exhaust gases through HEPA filters (and charcoal adsorbers when required to mitigate potential iodine releases) prior to release to the environment. Such a system is not considered to have any effect on noble gas effluents. The ventilation exhaust treatment systems are shown in Figure 10-1.

Engineered safety features atmospheric cleanup systems are not considered to be ventilation exhaust treatment system components.

**10.1.2 Radiation Monitors****10.1.2.1 Auxiliary Building Vent Effluent Monitors**

Monitors 1RE-PR028 (Unit 1) and 2RE-PR028 (Unit 2) continuously monitor the final effluent from the auxiliary building vent stacks.

Both vent stack monitors feature automatic isokinetic sampling, grab sampling, and tritium sampling.

No automatic isolation or control functions are performed by these monitors. Pertinent information on these monitors is provided in Byron/Braidwood UFSAR Table 11.5-1.



#### 10.1.2.2 Containment Purge Effluent Monitors

Monitors 1RE-PR001 (Unit 1) and 2RE-PR001 (Unit 2) continuously monitor the effluent from the Unit 1 and Unit 2 containments, respectively. When airborne radioactivity in the containment purge effluent stream exceeds a specified level, station personnel will follow established procedures to terminate the release by manually activating the containment purge valves. Additionally, the auxiliary building vent effluent monitors provide an independent, redundant means of monitoring the containment purge effluent.

No automatic isolation or control functions are performed by these monitors.

Pertinent information on these monitors is provided in Byron/Braidwood UFSAR Table 11.5-1.

Area Radiation Monitors 1(2) RE-AR011 and 1(2) RE-AR012 monitor the containment atmosphere. On high alarm during a containment purge, these monitors will automatically terminate the purge.

#### 10.1.2.3 Waste Gas Decay Tank Monitors

Monitors 0RE-PR002A/B continuously monitor the noble gas activity released from the gas decay tanks.

On high alarm, the monitors automatically initiate closure of the valve 0GW014 thus terminating the release.

Pertinent information on these monitors and associated control devices is provided in Byron/Braidwood UFSAR Table 11.5-1.

#### 10.1.2.4 Gland Steam and Condenser Air Ejector Monitors

Monitors 1RE-PR027 and 2RE-PR027 continuously monitor the condenser air ejector gas from Units 1 and 2, respectively. No control devices are initiated by these channels.

Pertinent information on these monitors is provided in Byron/Braidwood UFSAR Table 11.5-1.

#### 10.1.2.5 Radwaste Building Ventilation Monitor

Monitor 0RE-PR026 continuously monitors radioactivity in the radwaste building ventilation system. No control device is initiated by this channel.

Pertinent information on this monitor is provided in Byron/Braidwood UFSAR Table 11.5-1.

#### 10.1.2.6 Component Cooling Water Monitor

Monitor 0RE-PR009 (common), 1RE-PR009 (Unit 1), and 2RE-PR009 (Unit 2) continuously monitor the component cooling water heat exchanger outlets. On high alarm, 0RE-PR009 initiates closure of both component cooling water surge tank (CCWST) vents, 1RE-PR009 initiates closure of the Unit 1 CCWST vent, and 2RE-PR009 initiates closure of the Unit 2 CCWST vent.

10.1.2.7 Miscellaneous Ventilation Monitors

Monitor ORE-PR003 continuously monitors radioactivity in the ventilation exhaust from the laboratory fume hoods. No control device is initiated by this channel.

Pertinent information on this monitor and associated devices is provided in Byron/Braidwood UFSAR Table 11.5-1.

10.1.3 Alarm and Trip Setpoints

10.1.3.1 Setpoint Calculations

10.1.3.1.1 Auxiliary Building Vent Effluent Monitors

The High Alarm setpoint for the High Range Noble Gas Channel (1/2PR028D) is established at the maximum release rate for the station as calculated in 10.1.3.2. The Alert Alarm setpoint for the High Range Gas Channel is established at a fraction of the maximum release rate for the station.

The High Alarm setpoint for the Low Range Noble Gas Channel (1/2PR028B) is established at less than or equal to 50% of the maximum release rate for the station as calculated in 10.1.3.2. The Alert Alarm setpoint for the Low Range Gas Channel is established at a fraction of the High Alarm setpoint for the Low Range Noble Gas Channel.

10.1.3.1.2 Containment Purge Effluent Monitors

The setpoints are established at 1.50 times the analyzed containment noble gas activity during purge, plus the background reading of the monitor prior to purge.

10.1.3.1.3 Waste Gas Decay Tank Effluent Monitors

The setpoints are established at 1.50 times the analyzed waste gas tank activity during release.

10.1.3.2 Release Limits

Alarm and trip setpoints of gaseous effluent monitors are established to ensure that the release rate limits of RETS are not exceeded. The release limits are found by solving Equations 10-1 and 10-2 for the total allowed release rate of vent releases,  $Q_{tv}$ .

$$(1.11) Q_{tv} \sum \{V_i f_i\} \leq 500 \text{ mrem/yr} \quad (10-1)$$

$$Q_{tv} \sum \{(f_i) [L_i (X/Q)_v \exp (-\lambda_i R/3600 u_v)^* + 1.11V_i]\} < 3000 \text{ mrem/yr} \quad (10-2)$$

The summations are over noble gas radionuclides  $i$ .

- 1.11 Conversion Constant (mrem/mrad)
- $f_i$  Fractional Radionuclide Composition
- The release rate of noble gas radionuclide  $i$  divided by the total release rate of all noble gas radionuclides.
- $L_i$  Beta Skin Dose Factor (mrem/yr)/( $\mu\text{Ci}/\text{m}^3$ )
- Beta skin dose rate per unit of radioactivity concentration for radionuclide  $i$ . Attenuation of beta radiation during passage through 7 mg/cm<sup>2</sup> of dead skin is accounted for.
- $Q_{iv}$  Total Allowed Release Rate, Vent Release [ $\mu\text{Ci}/\text{sec}$ ]
- The total allowed release rate of all noble gas radionuclides released as vent releases.
- $\exp(-\lambda_i R/3600u_v)$  is set equal to 1.0 for setpoint calculations.
- $V_i$  Gamma Whole Body Dose Factor (mrad/yr)/( $\mu\text{Ci}/\text{sec}$ )
- Gamma whole body dose rate at a specified location per unit of radioactivity release rate for radionuclide  $i$  released from a vent. The attenuation of gamma radiation due to passage through 1 cm of body tissue of 1 g/cm<sup>3</sup> density is taken into account in calculating this quantity.
- $(X/Q)_v$  Relative Concentration Factor (sec/m<sup>3</sup>)
- Radioactivity concentration at a specified location per unit of radioactivity release rate for a vent release.

Equation 10-1 is based on Equation A-8 of Appendix A and the RETS restriction on whole body dose rate (500 mrem/yr) due to noble gases released in gaseous effluents (see Section A.1.3.1 of Appendix A). Equation 10-2 is based on Equation A-9 of Appendix A and the RETS restriction on skin dose rate (3000 mrem/yr) due to noble gases released in gaseous effluents (see Section A.1.3.2 of Appendix A).

Since the solution to Equation 10-2 is more conservative than the solution to Equation 10-1, the value of Equation 10-2 ( $7.02 \times 10^5 \mu\text{Ci}/\text{sec}$ ) is used as the limiting noble gas release rate. During evolutions involving releases from the containment or waste gas decay tanks, the release rate from each release path is procedurally limited to  $1 \times 10^5 \mu\text{Ci}/\text{sec}$ .

Calibration methods and surveillance frequency for the monitors will be conducted as specified in the RETS.

### 10.1.3.3 Release Mixture

In the determination of alarm and trip setpoints, the radioactivity mixture in exhaust air is assumed to have the radionuclide composition of Table 10-1.

### 10.1.3.4 Conversion Factors

The response curves used to determine the monitor count rates are based on the sensitivity to Xe-133 for conservatism.

### 10.1.3.5 HVAC Flow Rates

The plant vent stack flow rates are obtained from 1/2 PR28J. However, if the readout indicates "0" flow, the following minimum rated fan flow values are currently used:

Unit 1 -  $6.15 \times 10^6$  cc/sec

Unit 2 -  $4.55 \times 10^6$  cc/sec

### 10.1.4 Allocation of Effluents from Common Release Points

Radioactive gaseous effluents released from the auxiliary building, miscellaneous ventilation systems and the gas decay tanks are comprised of contributions from both units. Consequently, allocation is made evenly between units.

### 10.1.5 Dose Projections for Batch Releases

Dose projections are not made prior to release. Doses are calculated after purging the containment or venting the waste gas decay tanks. Per procedure, representative samples are obtained and analyzed, and the doses calculated on a monthly basis to verify compliance with 10CFR50.

## 10.2 LIQUID RELEASES

### 10.2.1 System Description

A simplified liquid effluent flow diagram is provided in Figure 10-3. A simplified liquid waste processing diagram is provided in Figure 10-2.

The liquid radwaste treatment system is designed and installed to reduce radioactive liquid effluents by collecting the liquids, providing for retention or holdup, and providing for treatment by demineralizer or a concentrator for the purpose of reducing the total radioactivity prior to release to the environment. The system is described in Chapter 11 of the Byron/Braidwood UFSAR.

#### 10.2.1.1 Release Tanks

There are two radwaste release tanks (0WX01T and 0WX26T) which receive liquid waste before discharge to the Kankakee river.

## 10.2.2 Radiation Monitors

### 10.2.2.1 Liquid Radwaste Effluent Monitors

Monitor 0RE-PR001 is used to monitor all releases from the release tanks. On high alarm, the monitor automatically initiates closure of valves 0WX-353 and 0WX-896 to terminate the release.

Pertinent information on the monitor and associated control devices is provided in Byron/Braidwood UFSAR Table 11.5-2.

### 10.2.2.2 Station Blowdown Monitor

Monitor 0RE-PR010 continuously monitors the circulating water blowdown. No control device is initiated by this channel.

Pertinent information on this monitor is provided in Byron/Braidwood UFSAR Table 11.5-2.

### 10.2.2.3 Reactor Containment Fan Cooler (RCFC) and Essential Service Water (ESSW) Outlet Line Monitors

Monitors 1RE-PR002, 2RE-PR002, 1RE-PR003, and 2RE-PR003 continuously monitor the RCFC and ESSW outlet lines.

No control device is initiated by these channels.

Pertinent information on these monitors is provided in Byron/Braidwood UFSAR Table 11.5-2.

### 10.2.2.4 Turbine Building Fire and Oil Sump Monitor

Monitor 0RE-PR005 continuously monitors the fire and oil sump discharge. On high alarm the monitor automatically initiates an interlock to trip the discharge pumps, close valve 0OD030, and terminate the release.

Pertinent information on this monitor is provided in Byron/Braidwood UFSAR Table 11.5-2.

### 10.2.2.5 Condensate Polisher Sump Monitor

Monitor 0RE-PR041 continuously monitors the condensate polisher sump discharge. On high alarm the monitor automatically initiates an interlock to trip the discharge pumps and terminate the release.

Pertinent information on this monitor is provided in Byron/Braidwood UFSAR Table 11.5-2.

10.2.3 Alarm and Trip Setpoints

10.2.3.1 Setpoint Calculations

Alarm and trip setpoints of liquid effluent monitors at the principal release points are established to ensure that the limits of RETS and 10CFR20 are not exceeded in the unrestricted area.

10.2.3.1.1 Station Blowdown Monitor

The monitor setpoint is found by solving equation 10-3.

$$P \leq C^{CW} + (1.25 \times C^T) \times [(F_{max}^r / (F^{CW} + F_{max}^r))] \quad (10-3)$$

**P** Release Setpoint [μCi/ml]

**1.25** Factor to account for minor fluctuations in count rate.

**$C^{CW}$**  Concentration of activity in the circulating water blowdown at the time of discharge. ("Background reading") [μCi/ml]

**$C^T$**  Analyzed activity in the release tank [μCi/ml]

**$F^{CW}$**  Circulating Water Blowdown Rate [gpm]

**$F_{max}^r$**  Maximum Release Tank Discharge Flow Rate [gpm]  
The flow rate from the radwaste discharge tank based on the more restrictive of the maximum chemistry permitted flow rate or the Maximum Radiological Permitted Discharge Flow Rate.

10.2.3.1.2 Liquid Radwaste Effluent Monitor

During release the setpoint is established at 1.5 times the analyzed tank activity plus the background reading.

10.2.3.1.2.1 Release Tank Discharge Flow Rate

Prior to each batch release, a grab sample is obtained.

The results of the analysis of the waste sample determine the discharge rate of each batch as follows:

$$F_{rad} = 0.5(F_{act}^d / \sum(C_i^T / 10 * DWC_i)) \quad (10-4)$$

The summation is over radionuclides i.

**0.5** Factor for conservatism

$F_{rad}$	Maximum Radiological Permitted Discharge Flow Rate The maximum permitted flow rate from the radwaste discharge tank based on radiological limits (not chemistry limits which may be more restrictive)	[gpm]
$F_{act}^d$	Circulating Water Blowdown Rate	[gpm]
$C_i^T$	Concentration of Radionuclide i in the Release Tank  The concentration of radioactivity in the radwaste discharge tank based on measurements of a sample drawn from the tank.	[ $\mu$ Ci/ml]
$DWC_i$	Derived Water Concentration of Radionuclide i  The concentration of radionuclide i given in Appendix B, Table 2, Column 2 to 10CFR20.1001-20.2402.	[ $\mu$ Ci/ml]
10	Multiplier	

#### 10.2.3.1.2.2 Release Limits

Release limits are determined from RETS. Discharge rates and setpoints are adjusted to ensure that 50% of applicable RETS are not exceeded. (See Section 10.2.3.1.2.1.)

In addition to the limits identified within the RETS, an administrative action level for tritium has been established for the Braidwood cooling pond. This limit, based on drinking water pathways, has been established as a control mechanism to ensure this pathway does not become a significant contributor to public dose. Because the public has access to the Braidwood cooling pond for fishing and/or boating, an administrative limit for discharges to the cooling pond is prudent to ensure dose to the public from this path remains well below limits.

The controls for this pathway will be established by limiting the quantity (Curies) discharged to the Braidwood cooling pond. The administrative action level will be established at 4 Ci/year. During times when tritium discharged to the cooling pond is in excess of the 4 Ci/year administrative action level, cooling pond tritium samples should be collected and analyzed (tritium LLD as defined in ODCM Chapter 12, Table 12.3-1) in order to assess actual tritium cooling pond tritium concentrations. Effluent pathways to the cooling pond are analyzed for tritium in accordance with ODCM Chapter 12, Table 12.3-1.

The administrative action level was chosen based on an equilibrium concentration of 200 pCi/l in the cooling pond water (1% of the public drinking water limit as specified in 40CFR141.) Information regarding calculation and assumptions can be found in Braidwood Health Physics Technical Document 98-001, "Cooling pond tritium issues".

#### 10.2.3.1.2.3 Release Mixture

For monitors 0RE-PR001 and 0RE-PR010 the release mixture used for the setpoint determination is the radionuclide mix identified in the grab sample isotopic analysis or the mix in Table 10-2.

10.2.3.1.2.4 Liquid Dilution Flow Rates

Dilution flow rates are obtained from circulating water blowdown transmitter loop OFT-CW032.

10.2.3.1.2.5 Projected Concentrations for Releases

After determining  $F_{max}^r$  from Equation 10-4, RETS compliance is verified using Equations 10-5 and 10-6.

$$C_i^a = C_i^T [F_{max}^r / (F_{max}^r + F_{act}^d)] \tag{10-5}$$

$$\sum \{ C_i^a / 10 * DWC_i \} \leq 0.5 \tag{10-6}$$

The summation is over radionuclides i.

$C_i^a$  Concentration of Radionuclide i in the Unrestricted Area [μCi/ml]

The calculated concentration of radionuclide i in the unrestricted area as determined by Equation 10-5.

$C_i^T$  Concentration of Radionuclide i in the Release Tank [μCi/ml]

The concentration of radioactivity in the radwaste discharge tank based on measurements of a sample drawn from the tank.

$DWC_i$  Derived Water Concentration of Radionuclide i of Radionuclide i [μCi/ml]

The concentration of radionuclide i given in Appendix B, Table 2, Column 2 to 10CFR20.1001-20.2402.

10 Multiplier

$F_{max}^r$  Maximum Release Tank Discharge a Flow Rate [gpm]

$F_{act}^d$  Circulating Water Blowdown Rate [gpm]

0.5 Factor for conservatism

10.2.3.1.3 Other Liquid Effluent Monitors

For all other liquid effluent monitors, including ORE-PR001 and ORE-PR010 when not batch releasing, setpoints are determined such that the concentration limits do not exceed 10 times the DWC value given in Appendix B, Table 2, Column 2 to 10CFR20.1001 - 20.2402 in the unrestricted area. Release mixtures are based on a representative isotopic mixture of the waste stream or inputs to the waste stream, or defaulted to the mix listed in Table 10-2.



#### 10.2.3.1.4 Conversion Factors

The readouts for the liquid effluent monitors are in  $\mu\text{Ci/ml}$ . The cpm to  $\mu\text{Ci/ml}$  conversion is determined for each monitor.

#### 10.2.4 Allocation of Effluents from Common Release Points

Radioactive liquid effluents released from either release tank (0WX01T or 0WX26T) are comprised of contributions from both units. Under normal operating conditions, it is difficult to apportion the radioactivity between the units. Consequently, allocation is made evenly between units.

### 10.3 **SOLIDIFICATION OF WASTE/PROCESS CONTROL PROGRAM**

The process control program (PCP) contains the sampling, analysis, and formulation determination by which solidification of radioactive wastes from liquid systems is ensured.

Figure 10-4 is a simplified diagram of solid radwaste processing system.

**Table 10-1**  
**Assumed Composition of the Braidwood Station**  
**Noble Gas Effluent**

Isotope	Percent of Total Annual Releases
Ar-41	00.89
Kr-85m	00.18
Kr-85	24.90
Kr-87	00.04
Kr-88	00.28
Xe-131m	01.40
Xe-133m	00.57
Xe-133	71.10
Xe-135	00.53
Xe-138	00.04

Table 10-2

## Assumed Composition of the Braidwood Station Liquid Effluent

Isotope	Concentration	Isotope	Concentration
	( $\mu\text{Ci/ml}$ )		( $\mu\text{Ci/ml}$ )
Mn-54	1.00E - 05	I-132	8.00E - 07
Co-58	9.00E - 06	I-133	1.00E - 07
Fe-59	5.00E - 06	Cs-134	9.00E - 07
Co-60	3.00E - 06	I-135	4.00E - 07
Rb-86	2.00E - 06	Cs-136	9.00E - 06
Nb-95	1.00E - 05	Cs-137	2.00E - 06
Zr-95	6.00E - 06	Ce-144	1.00E - 06
Mo-99	4.00E - 06	Np-239	1.00E - 05
Ru-103	8.00E - 06		
Ag-110m	3.00E - 06		
Te-127	2.00E - 05		
Te-129m	2.00E - 06		
I-130	3.00E - 07		
I-131	3.00E - 08		
Te-131m	4.00E - 06		
Te-132	2.00E - 06		

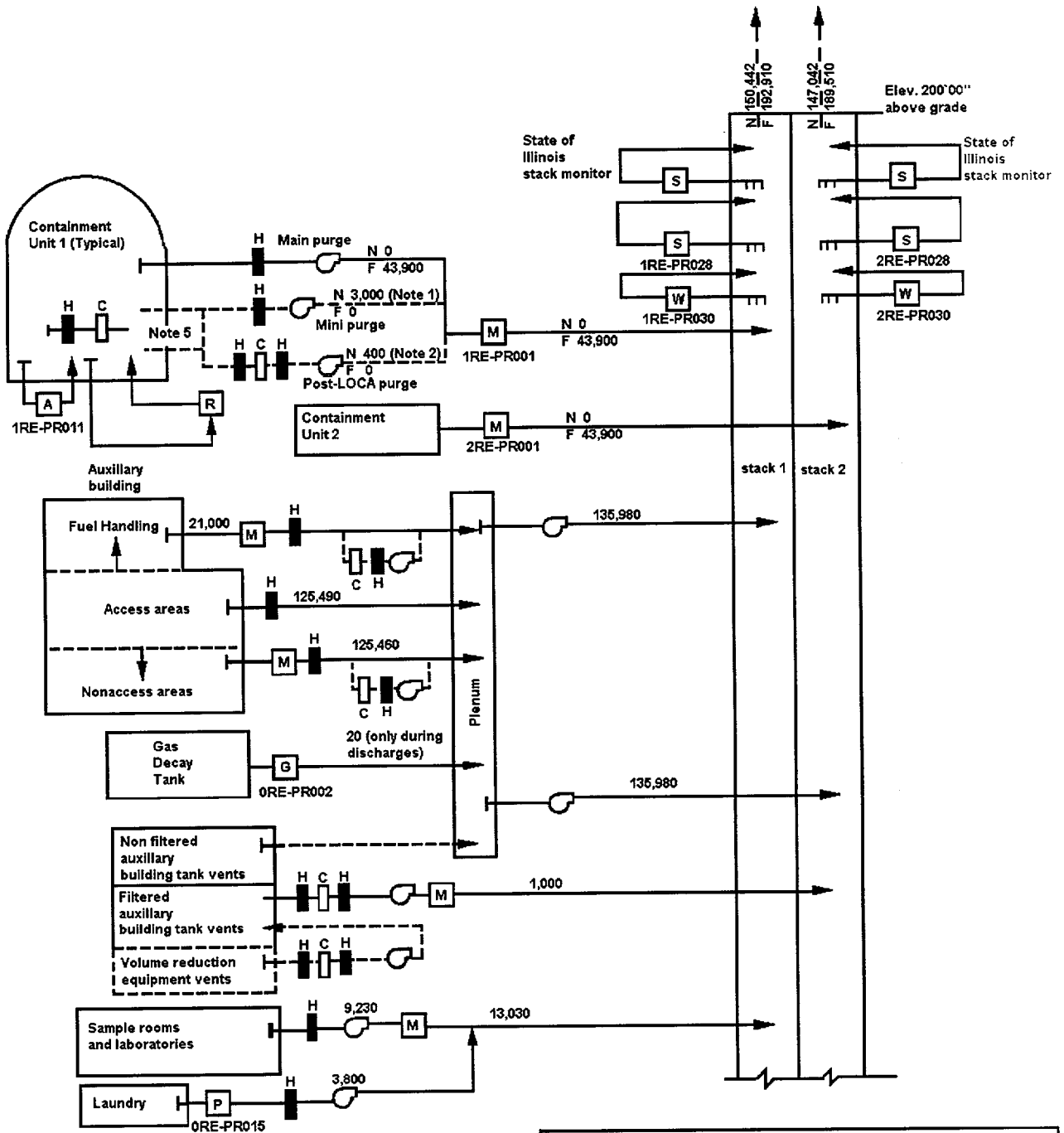

OFFSITE DOSE CALCULATION MANUAL  
BRAIDWOOD STATION

FIGURE 10-1  
SIMPLIFIED HVAC AND GASEOUS  
EFFLUENT FLOW DIAGRAM  
(SHEET 1 OF 2)

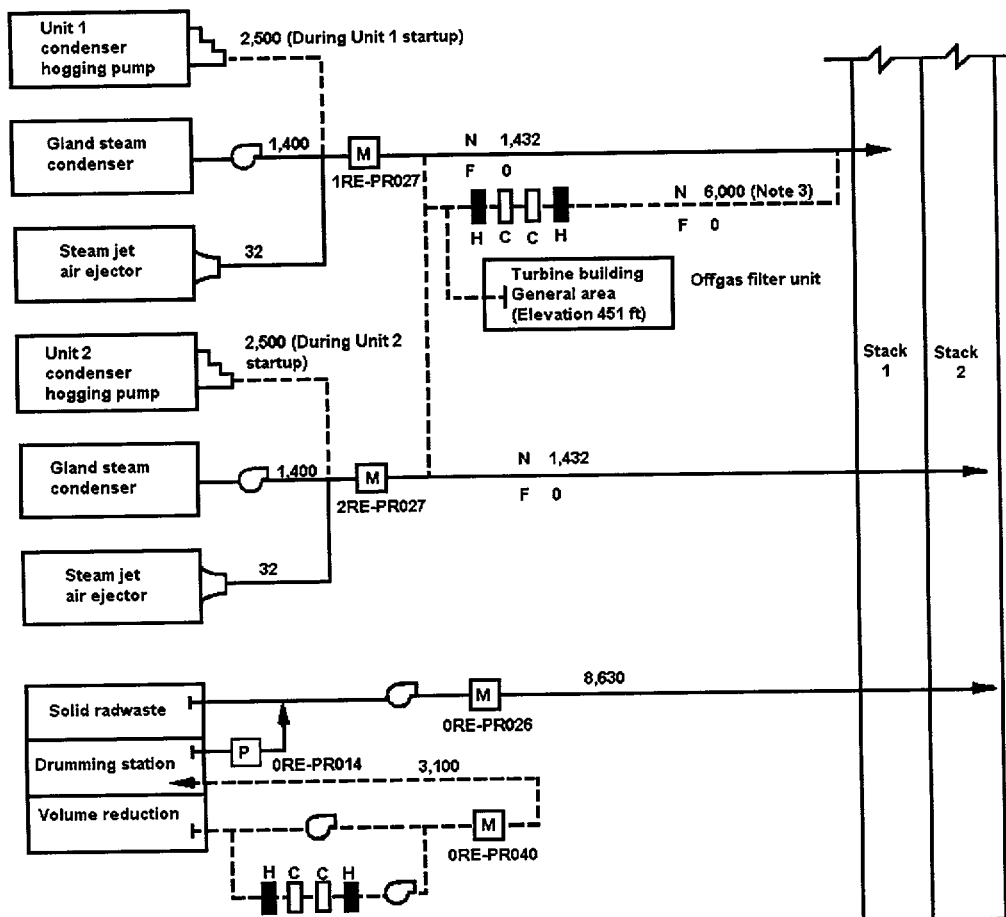

**LEGEND**

- Normal or frequent flow path
- Occasional flow path
- A Containment atmosphere radiation monitor
- C Charcoal filter
- F Refueling
- G Noble gas radiation monitor (offline)
- H HEPA filter
- M Three channel radiation monitor for particulate, iodine, and noble gas (offline)
- N Normal operation
- P Particulate monitor (offline)
- R Hydrogen recombiner
- S Normal range stack radiation monitor (particulate, iodine, and noble gas)
- W Wide-range stack noble gas radiation monitor

**NOTES**

1. Used intermittently to vent containment during normal operation.
2. Used only during postaccident operation.
3. Filter unit operates only when high radiation is detected in offgas system effluent. (Unit One only)
4. All flow rates are design flow rate in cubic feet per minute.
5. Intergrated Leak Rate Test (ILRT) pressure relief point (an alternate release point that is seldom used).

<b>OFFSITE DOSE CALCULATION MANUAL BRAIDWOOD STATION</b>
<b>FIGURE 10-1 SIMPLIFIED HVAC AND GASEOUS EFFLUENT FLOW DIAGRAM (SHEET 2 OF 2)</b>

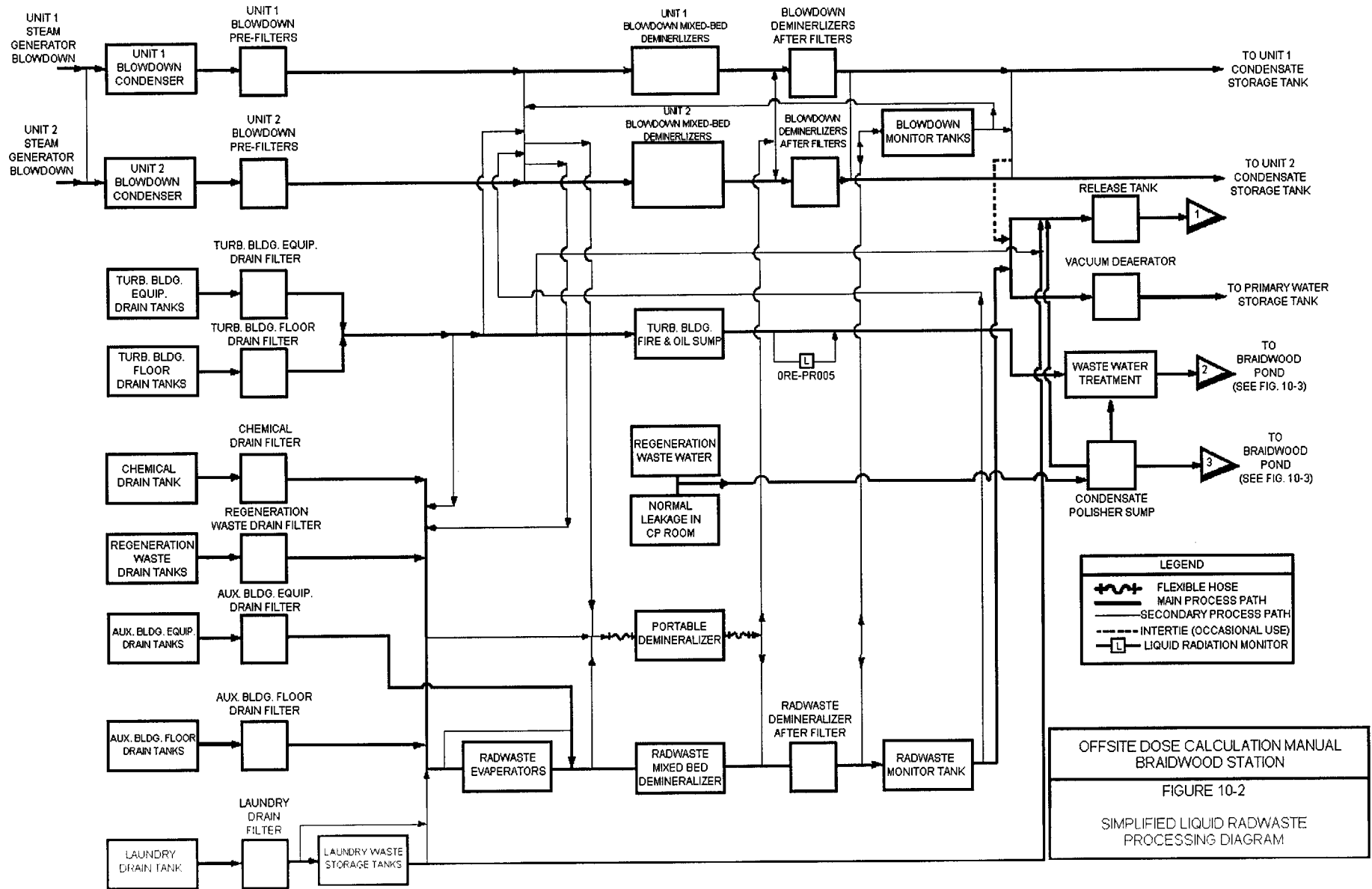

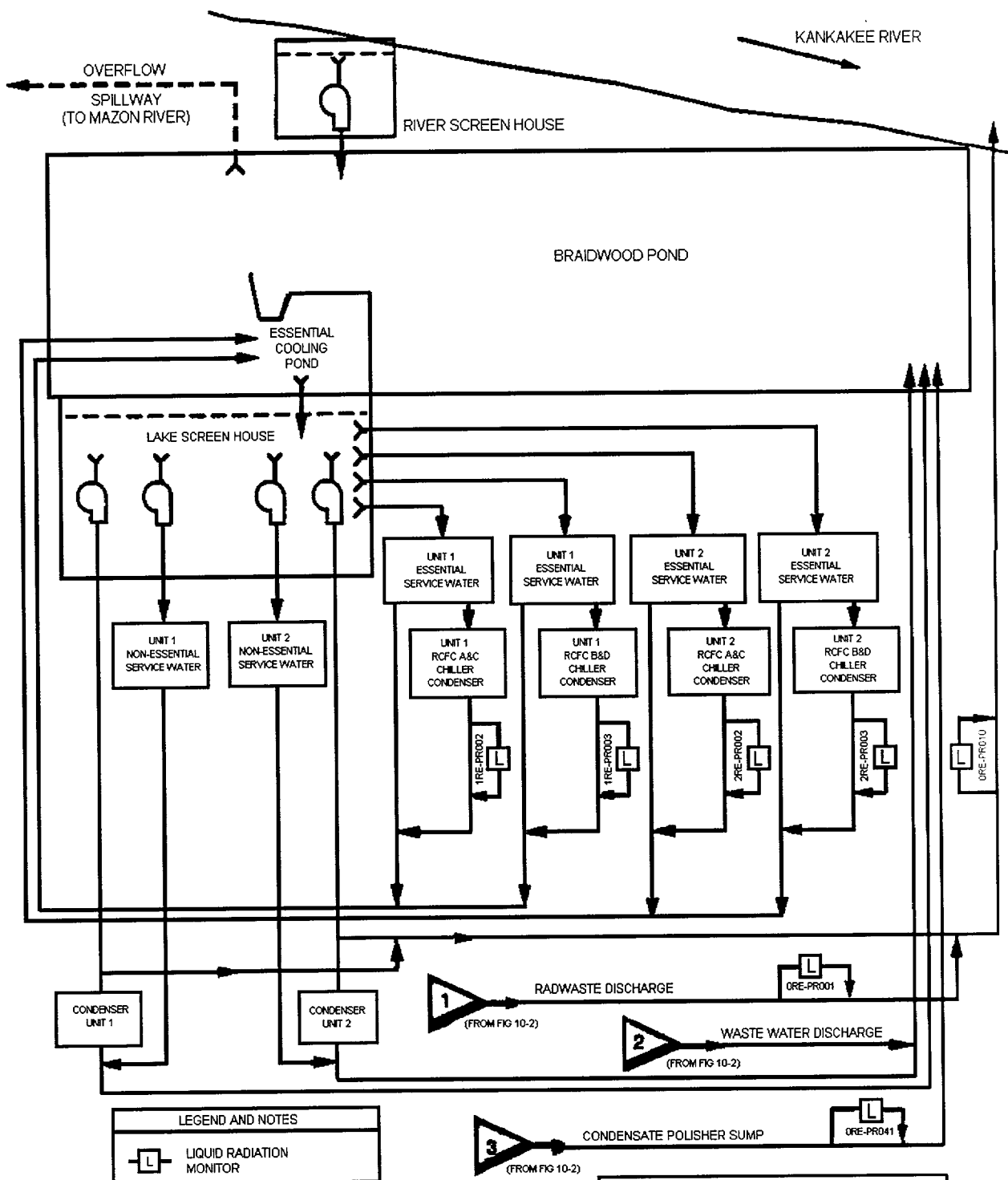

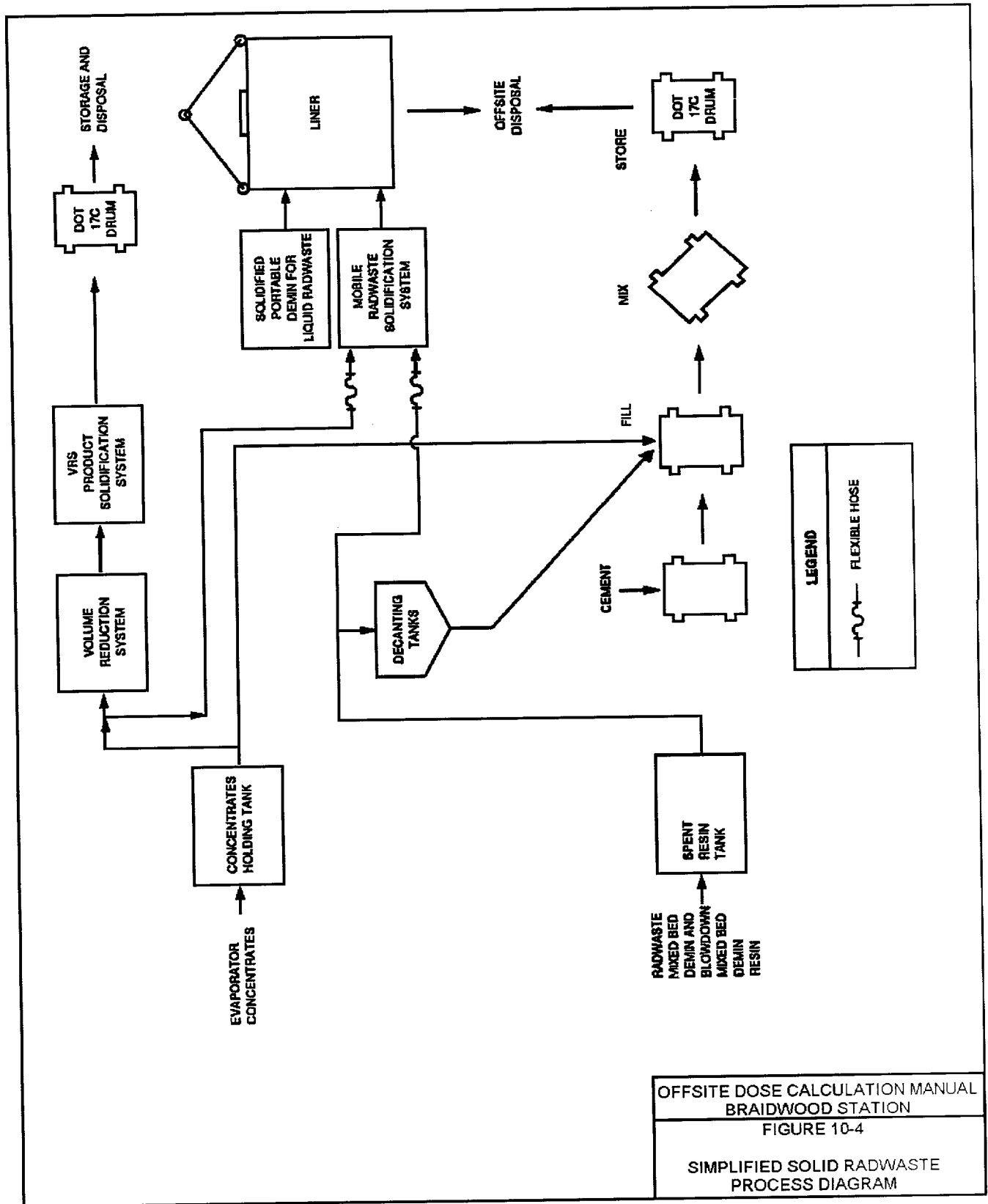

OFFSITE DOSE CALCULATION MANUAL  
BRAIDWOOD STATION  
FIGURE 10-4  
SIMPLIFIED SOLID RADWASTE  
PROCESS DIAGRAM



CHAPTER 11  
BRAIDWOOD ANNEX INDEX

Revision 2

|

CHAPTER 11  
RADIOLOGICAL ENVIRONMENTAL MONITORING PROGRAM  
Table of Contents

<u>CHAPTER</u>	<u>TITLE</u>	<u>PAGE</u>
11	RADIOLOGICAL ENVIRONMENTAL MONITORING PROGRAM	11-1

LIST OF TABLES

<u>NUMBER</u>	<u>TITLE</u>	<u>PAGE</u>
11-1	Radiological Environmental Monitoring Program	11-2

LIST OF FIGURES

<u>NUMBER</u>	<u>TITLE</u>	<u>PAGE</u>
11-1	Fixed Air Sampling Sites and Outer Ring TLD Locations	11-10
11-2	Inner Ring TLD Locations	11-11
11-3	Ingestion and Waterborne Exposure Pathway Sample Locations	11-12

CHAPTER 11  
RADIOLOGICAL ENVIRONMENTAL MONITORING PROGRAM

The radiological environmental monitoring program for the environs around Braidwood Station is given in Table 11-1.

Figures 11-1 through 11-3 show sampling and monitoring locations.

Table 11-1  
Radiological Environmental Monitoring Program

Exposure Pathway and/or Sample	Sample or Monitoring Locations	Sampling or Collection Frequency	Type and Frequency of Analysis
<p>1. <u>Airborne</u></p> <p>Radioactive and Particulates</p>	<p>a. <u>Indicators-Near Field</u></p> <p>BD-06, Godley, 0.5 mi WSW (0.8 km M)                      BD-19, Nearsite NW, 0.3 mi NW (0.5 km Q)                      BD-20, Nearsite N, 0.6 mi N (1.0 km A)                      BD-21, Nearsite NE, 0.5 mi NE (0.8 km C)</p> <p>b. <u>Indicators-Far Field</u></p> <p>BD-02, Custer Park, 5.0 mi E (8.0 km E)                      BD-04, Essex, 4.8 mi SSE (7.7 km H)                      BD-05, Gardner, 5.5 mi SW (8.8 km L)</p> <p>c. <u>Controls</u></p> <p>BD-03, County Line Road,                      6.2 mi ESE (10.0 km F)</p>	<p>Continuous sampler operation with particulate sample collection weekly, or more frequently if required by dust loading, and radioiodine canister collection biweekly.</p>	<p><u>Radioiodine Canisters:</u></p> <p>1-131 analysis biweekly on near field and control samples<sup>1</sup>.</p> <p><u>Particulate Sampler:</u></p> <p>Gross beta analysis following weekly filter change<sup>2</sup> and gamma isotopic analysis<sup>3</sup> quarterly on composite filters by location on near field and control samples<sup>1</sup>.</p>

Table 11-1 (Cont'd)  
Radiological Environmental Monitoring Program

Exposure Pathway and/or Sample	Sample or Monitoring Locations	Sampling or Collection Frequency	Type and Frequency of Analysis
2. <u>Direct Radiation</u>	a. <u>Indicators-Inner Ring</u>  BD-101-3, 0.5 mi N (0.8 km A) BD-101-4, 0.5 mi N (0.8 km A) BD-102-1, 1.1 mi NNE (1.8 km B) BD-102-2, 1.1 mi NNE (1.8 km B) BD-103-1, 1.0 mi NE (1.6 km C) BD-103-2, 1.0 mi NE (1.6 km C) BD-104-1, 0.7 mi ENE (1.1 km D) BD-104-2, 0.7 mi ENE (1.1 km D) BD-105-1, 2.2 mi E (3.5 km E) BD-105-2, 2.2 mi E (3.5 km E) BD-106-1, 2.5 mi ESE (4.0 km F) BD-106-2, 2.5 mi ESE (4.0 km F) BD-107-1, 3.2 mi SE (5.1 km G) BD-107-2, 3.2 mi SE (5.1 km G) BD-108-1, 3.2 mi SSE (5.1 km H) BD-108-2, 3.2 mi SSE (5.1 km H) BD-109-1, 3.8 mi S (6.1 km J) BD-109-2, 3.8 mi S (6.1 km J) BD-110-1, 2.8 mi SSW (4.5 km K) BD-110-2, 2.8 mi SSW (4.5 km K) BD-111a-1, 1.4 mi SW (2.2 km L) BD-111a-2, 1.4 mi SW (2.2 km L) BD-112-1, 0.7 mi WSW (1.1 km M) BD-112-2, 0.7 mi WSW (1.1 km M) BD-113a-1, 0.5 mi W (0.8 km N) BD-113a-2, 0.5 mi W (0.8 km N)	Quarterly	Gamma dose on each TLD quarterly.

Table 11-1 (Cont'd)  
Radiological Environmental Monitoring Program

Exposure Pathway and/or Sample	Sample or Monitoring Locations	Sampling or Collection Frequency	Type and Frequency of Analysis
<p>2. <u>Direct Radiation</u> (Cont'd)</p>	<p>a. <u>Indicators-Inner Ring</u> (Cont'd)</p> <p>BD-114-1, 0.4 mi WNW (0.6 km P)                      BD-114-2, 0.4 mi WNW (0.6 km P)                      BD-115-1, 0.3 mi NW (0.5 km Q)                      BD-115-2, 0.3 mi NW (0.5 km Q)                      BD-116-1, 0.4 mi NNW (0.6 km R)                      BD-116-2, 0.5 mi NNW (0.8 km R)</p> <p>b. <u>Indicators-Outer Ring</u></p> <p>BD-201-1, 4.2 mi N (6.8 km A)                      BD-201-2, 4.2 mi N (6.8 km A)                      BD-202-1, 4.8 mi NNE (7.7 km B)                      BD-202-2, 4.8 mi NNE (7.7 km B)                      BD-203-1, 4.9 mi NE (7.9 km C)                      BD-203-2, 4.9 mi NE (7.9 km C)                      BD-204-1, 4.3 mi ENE (6.9 km D)                      BD-204-2, 4.3 mi ENE (6.9 km D)                      BD-205-1, 4.0 mi E (6.4 km E)                      BD-205-2, 4.0 mi E (6.4 km E)                      BD-206-1, 4.5 mi ESE (7.2 km F)                      BD-206-2, 4.5 mi ESE (7.2 km F)                      BD-207-1, 4.5 mi SE (7.2 km G)                      BD-207-2, 4.5 mi SE (7.2 km G)                      BD-208-1, 4.5 mi SSE (7.2 km H)                      BD-208-2, 4.5 mi SSE (7.2 km H)                      BD-209-1, 4.8 mi S (7.7 km J)                      BD-209-2, 4.8 mi S (7.7 km J)</p>		

Table 11-1 (Cont'd)  
Radiological Environmental Monitoring Program

Exposure Pathway and/or Sample	Sample or Monitoring Locations	Sampling or Collection Frequency	Type and Frequency of Analysis
<p>2. <u>Direct Radiation</u> (Cont'd)</p>	<p>b. <u>Indicators-Outer Ring</u></p> <p>BD-210-1, 5.3 mi SSW (8.5 km K)                      BD-210-2, 5.3 mi SSW (8.5 km K)                      BD-211-1, 4.8 mi SW (7.7 km L)                      BD-211-2, 4.8 mi SW (7.7 km L)                      BD-212-3, 5.0 mi WSW (8.0 km M)                      BD-212-4, 5.0 mi WSW (8.0 km M)                      BD-213-3, 4.8 mi W (7.7 km N)                      BD-213-4, 4.8 mi W (7.7 km N)                      BD-214-1, 4.3 mi WNW (6.9 km P)                      BD-214-2, 4.3 mi WNW (6.9 km P)                      BD-215-1, 4.5 mi NW (7.2 km Q)                      BD-215-2, 4.5 mi NW (7.2 km Q)                      BD-216-1, 4.0 mi NNW (6.4 km R)                      BD-216-2, 4.0 mi NNW (6.4 km R)</p> <p>c. <u>Other</u></p> <p><u>Indicators</u></p> <p>One at each of the airborne location given in part 1.a and 1.b.</p>		

Table 11-1 (Cont'd)  
Radiological Environmental Monitoring Program

Exposure Pathway and/or Sample	Sample or Monitoring Locations	Sampling or Collection Frequency	Type and Frequency of Analysis
2. <u>Direct Radiation</u> (Cont'd)	c. <u>Controls</u>  One at each airborne control location given in part 1.c.		
3. <u>Waterborne</u>  a. <u>Ground/Well</u>	a. <u>Indicators</u>  BD-13, Braidwood City Hall Well, 1.7 mi NNE (2.7 km B) BD-34, Gibson Well, 4.7 mi E (7.6 km E) [22032 Rt. 113] BD-35, Joly Well, 4.7 mi E (7.6 km E) [22028 Rt. 113] BD-36, Hutton Well, 4.7 mi E (7.6 km E) [22040 Rt. 113] BD-37, Nurczyk Well, 4.7 mi E (7.6 km E) [22100 Davy Lane]	Quarterly	Gamma isotopic <sup>3</sup> and tritium analysis quarterly.
b. <u>Drinking Water</u>	a. <u>Indicator</u>  BD-22, Wilmington 6.0 mi NE (9.7 km C)	Weekly composite samples <sup>5</sup>	Gross beta and gamma isotopic analysis <sup>3</sup> on monthly composite; tritium analysis on quarterly composite.
c. <u>Surface Water</u>	a. <u>Indicator</u>  BD-10, Kankakee River downstream of discharge, 5.4 mi NE (8.7 km C)	Weekly grab samples	Gross beta and gamma isotopic analysis <sup>3</sup> on monthly composite; tritium analysis on quarterly composite.



Table 11-1 (Cont'd)  
Radiological Environmental Monitoring Program

Exposure Pathway and/or Sample	Sample or Monitoring Locations	Sampling or Collection Frequency	Type and Frequency of Analysis
3. <u>Waterborne</u> (Cont'd)			
d. <u>Control</u>	a. <u>Control</u>  BD-25, Kankakee River upstream of discharge, 9.6 mi E (15.4 km E)	Weekly grab samples	Gross beta and gamma isotopic analysis <sup>3</sup> on monthly composite; tritium analysis on quarterly composite.
e. <u>Sediments</u>	a. <u>Indicators</u>  BD-10, Kankakee River downstream of discharge, 5.4 mi E (8.7 km C)	Semiannually	Gamma isotopic analysis <sup>3</sup> semiannually.
4. <u>Ingestion</u>			
a. <u>Milk</u>	a. <u>Indicators</u>  BD-17, Halpin's Dairy, 5.5 mi SSW (8.8 km K) [8625 South Halpin Rd]  b. <u>Controls</u>  BD-18, Biros Farm, 8.7 mi W (14.0 km N) [1168 Reed Road]	Biweekly: May through October; monthly: November through April	Gamma isotopic <sup>3</sup> and I-131 analysis <sup>4</sup> on each sample.
b. <u>Fish</u>	a. <u>Indicator</u>  BD-28, Kankakee River in discharge area, 5.4 mi E (8.7 km E)  b. <u>Control</u>	Two times annually	Gamma isotopic analysis <sup>3</sup> on edible portions

	BD-25, Kankakee River upstream of discharge area, 9.6 mi E (15.4 km E)		
--	--	--	--

Table 11-1 (Cont'd)  
Radiological Environmental Monitoring Program

Exposure Pathway and/or Sample	Sample or Monitoring Locations	Sampling or Collection Frequency	Type and Frequency of Analysis
<p>4. <u>Ingestion</u> (Cont'd)</p> <p>c. <u>Food Products</u></p>	<p>a. <u>Indicators</u></p> <p>Two samples from each of the four major quadrants within 6.2 miles of the station, if available.</p> <p>Sample locations for food products may vary based on availability and therefore are not required to be identified here but shall be taken.</p> <p>b. <u>Controls</u></p> <p>Two samples within 9.3 to 18.6 miles of the Station, if available.</p>	<p>Annually</p>	<p>Gamma isotopic analysis<sup>3</sup> on each sample.</p>

- 
- 1 Far field samples are analyzed when near field results are inconsistent with previous measurements and the radioactivity is confirmed as having its origin in airborne effluents released from the station, or at the discretion of the Radiation Protection Director.
  - 2 Airborne particulate sample filters shall be analyzed for gross beta radioactivity 24 hours or more after sampling to allow for radon and thoron daughter decay. If gross beta activity in air particulate samples is greater than 10 times the yearly mean of control samples, gamma isotopic analysis shall be performed on the individual samples.
  - 3 Gamma isotopic analysis means the identification and quantification of gamma emitting radionuclides that may be attributable to the effluents from the station.
  - 4 I-131 analysis means the analytical separation and counting procedure are specific for this radionuclide.
  - 5 Grab sample(s) shall be taken at the time of collection if the compositor is not in service.

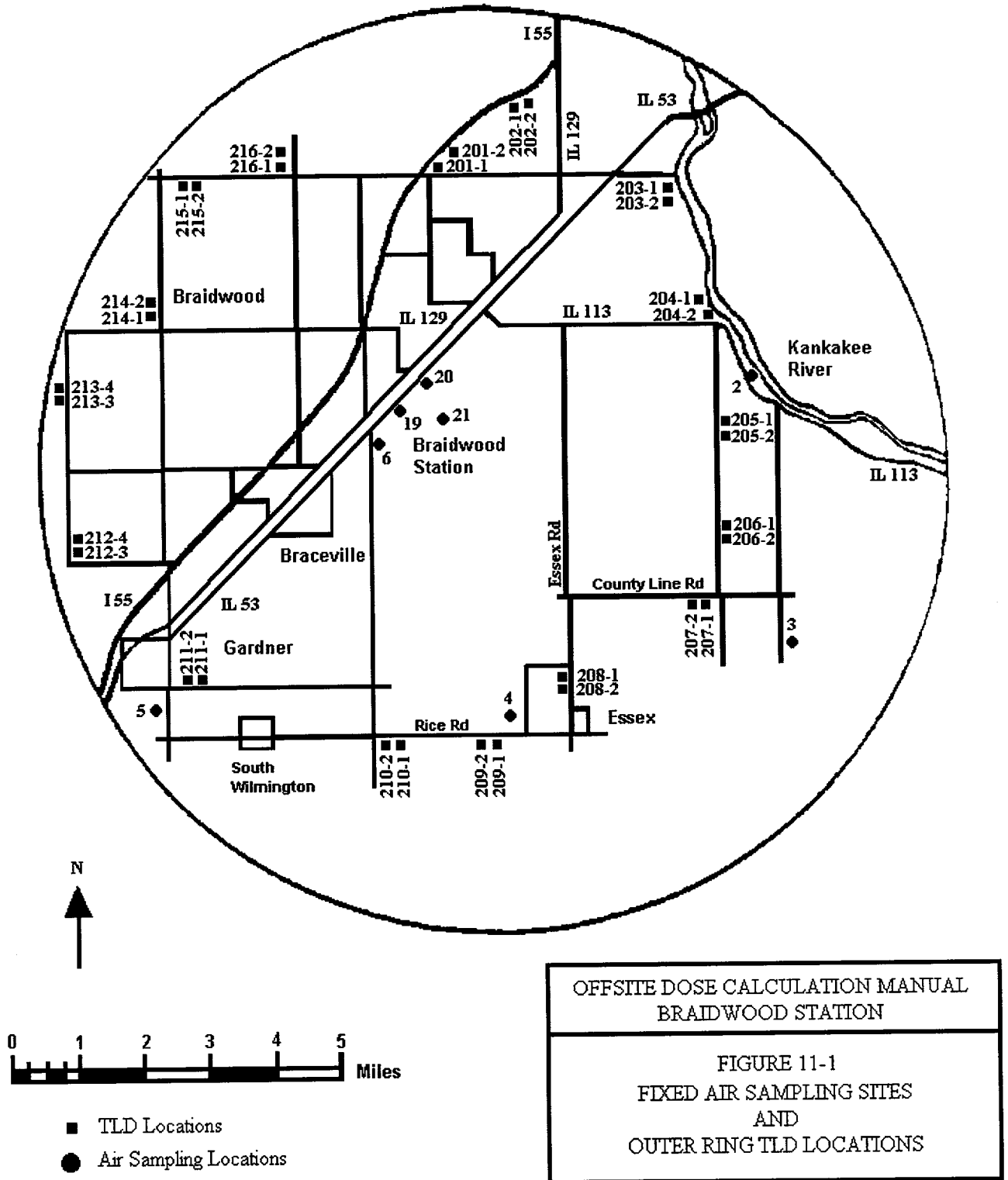

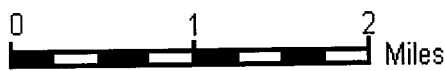
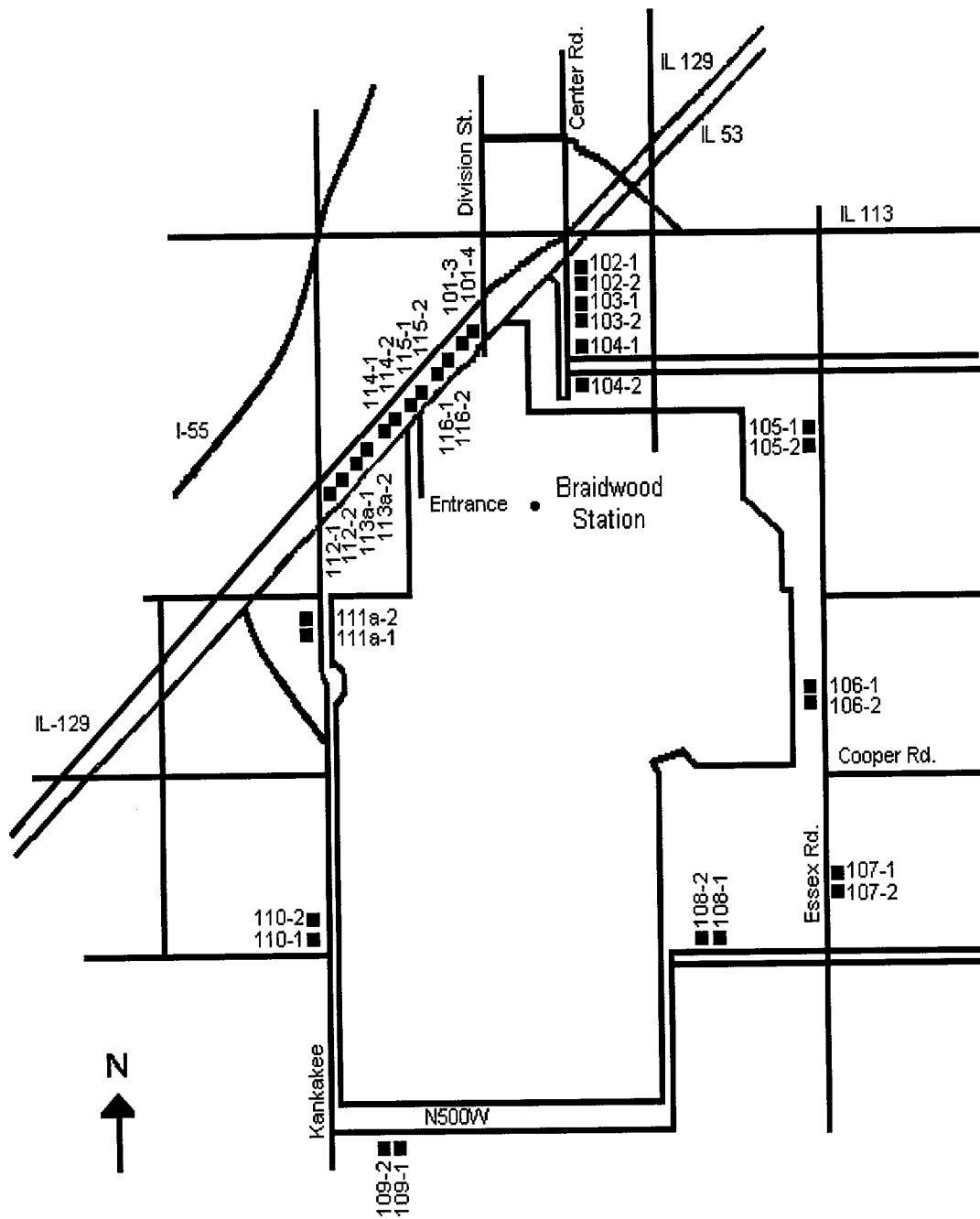

■ TLD Location

OFFSITE DOSE CALCULATION MANUAL  
BRAIDWOOD STATION

FIGURE 11-2

INNER RING TLD LOCATIONS

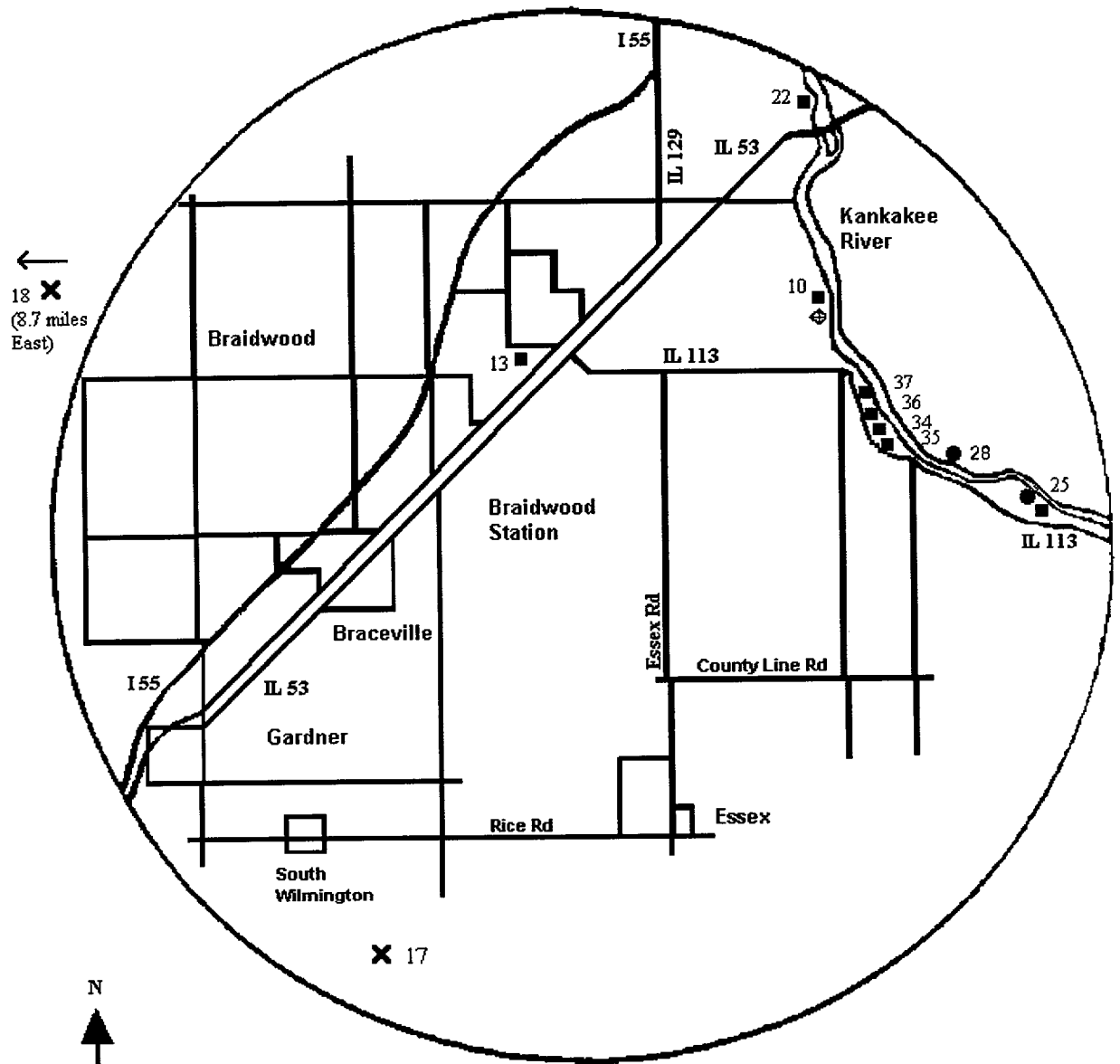

OFFSITE DOSE CALCULATION MANUAL  
BRAIDWOOD STATION

FIGURE 11-3  
INGESTION AND WATERBORNE EXPOSURE  
PATHWAY SAMPLE LOCATIONS

- Water    ◊ Sediment
- Fish    × Milk

**CHAPTER 12.0**

**SPECIAL NOTE**

The transfer of the Radiological Effluent Technical Specifications to the ODCM by Technical Specification, Amendment 35, dated April 13, 1992, was approved by the Nuclear Regulatory Commission.

Improved Technical Specifications (I.T.S.) sections are annotated following the CTS section and are only applicable after implementation of I.T.S.



**BRAIDWOOD**

Revision 5  
May 2001

**CHAPTER 12**

**ANNEX INDEX**

**Revision 5**

## CHAPTER 12

RADIOACTIVE EFFLUENT TECHNICAL STANDARDS  
(RETS)  
TABLE OF CONTENTS

	<u>PAGE</u>
12.0 RADIOLOGICAL EFFLUENT TECHNICAL STANDARDS	12-1
12.1 DEFINITIONS	12-4
12.2 INSTRUMENTATION	12-8
1. Radioactive Liquid Effluent Monitoring Instrumentation	12-8
2. Radioactive Gaseous Effluent Monitoring Instrumentation	12-13
12.3 LIQUID EFFLUENTS	12-20
1. Concentration	12-20
2. Dose	12-27
3. Liquid Radwaste Treatment System	12-29
12.4 GASEOUS EFFLUENTS	12-31
1. Dose Rate	12-31
2. Dose - Noble Gases	12-37
3. Dose - Iodine-131 and 133, Tritium, and Radioactive Material in Particulate Form	12-39
4. Gaseous Radwaste Treatment System	12-41
5. Total Dose	12-43
6. Dose Limits for Members of the Public	12-46
12.5 RADIOLOGICAL ENVIRONMENTAL MONITORING PROGRAM	12-47
1. Monitoring Program	12-47
2. Land Use Census	12-60
3. Interlaboratory Comparison Program	12-61
12.6 REPORTING REQUIREMENTS	12-62
1. Annual Radiological Environmental Operating Report	12-62
2. Annual Radioactive Effluent Release Report	12-64
3. Offsite Dose Calculation Manual (ODCM)	12-65
4. Major Changes to Liquid and Gaseous Radwaste Treatment Systems	12-66

## CHAPTER 12

RADIOACTIVE EFFLUENT TECHNICAL STANDARDS  
(RETS)  
LIST OF TABLES

	<u>PAGE</u>
12.0-1 Effluent Compliance Matrix	12-2
12.0-2 REMP Compliance Matrix	12-3
12.1-1 Frequency Notations	12-7
12.2-1 Radioactive Liquid Effluent Monitoring Instrumentation	12-9
12.2-2 Radioactive Liquid Effluent Monitoring Instrumentation Surveillance Requirements	12-11
12.2-3 Radioactive Gaseous Effluent Monitoring Instrumentation	12-14
12.2-4 Radioactive Gaseous Effluent Monitoring Instrumentation Surveillance Requirements	12-17
12.3-1 Radioactive Liquid Waste Sampling and Analysis Program	12-22
12.4-1 Radioactive Gaseous Waste Sampling and Analysis Program	12-33
12.5-1 Radiological Environmental Monitoring Program	12-50
12.5-2 Reporting Levels for Radioactivity Concentrations in Environmental Samples	12-56
12.5-3 Detection Capabilities for Environmental Sample Analysis	12-57

12.0 RADIOLOGICAL EFFLUENT TECHNICAL STANDARDS

Chapter 12 of the Braidwood Station ODCM is a compliance of the various regulatory requirements, surveillance and bases, commitments and/or components of the radiological effluent and environmental monitoring programs for Braidwood Station. To assist in the understanding of the relationship between effluent regulations, ODCM equations, RETS (Chapter 12 section) and related Technical Specification (I.T.S.) requirements, Table 12.0-1 is a matrix which relates these various components. The Radiological Environmental Monitoring Program fundamental requirements are contained within this chapter with Braidwood specific information in Chapter 11 and with a supplemental matrix in Table 12.0-2.

Table 12.0-1

EFFLUENT COMPLIANCE MATRIX

Regulation	Dose Component Limit	ODCM Equation	RETS	Technical Specification (ITS)
10CFR50 Appendix I	1. Gamma air dose and beta air dose due to airborne radioactivity in effluent plume.	A-1 A-2	12.4.2	6.8.4.e.8 (5.5.4.h)
	a. Whole body and skin dose due to airborne radioactivity in effluent plume are reported only if certain gamma and beta air dose criteria are exceeded.	A-6 A-7	N/A	N/A
	2. CDE for all organs and all four age groups due to iodines and particulates in effluent plume. All pathways are considered.	A-13	12.4.3	6.8.4.e.9 (5.5.4.i)
	3. CDE for all organs and all four age groups due to radioactivity in liquid effluents.	A-29	12.3.2	6.8.4.e.4 (5.5.4.d)
10CFR20	1. TEDE, totaling all deep dose equivalent components (direct, ground and plume shine) and committed effective dose equivalents (all pathways, both airborne and liquid-borne). CDE evaluation is made for adult only using FGR 11 data base.	A-38	12.4.6	6.8.4.e.3 (5.5.4.c)
40CFR190 (now by reference, also part of 10CFR20)	1. Whole body dose (DDE) due to direct dose, ground and plume shine from all sources at a station.	A-35	12.4.5	6.8.4.e.10 (5.5.4.j)
	2. Organ doses (CDE) to an adult due to all pathways.	A-13		
Technical Specifications (I.T.S.)	1. "Instantaneous" whole body (DDE), skin (SDE), and organ (CDE) dose rates to an adult due to radioactivity in airborne effluents. For the organ dose, only inhalation is considered.	A-8 A-9 A-28	12.4.1	6.8.4.e.7 (5.5.4.g)
	2. "Instantaneous" concentration limits for liquid effluents.	A-32	12.3.1	6.8.4.e.2 (5.5.4.b)
Technical Specifications (I.T.S.)	1. Radiological Effluent Release Report	NA	12.6.2	6.9.1.7 (5.6.3)

Table 12.0-2

REMP COMPLIANCE MATRIX

Regulation	Dose Component Limit	RETS	Technical Specification (ITS)
10CFR50 Appendix I Section IV.B.2	Implement environmental monitoring program.	12.5.1	6.8.4.f (TRM 5.2.C.1)
Technical Specification (I.T.S.)	Land Use Census	12.5.2	6.8.4.f.2 (TRM 5.2.C.2)
Technical Specifications (I.T.S.)	Interlaboratory Comparison Program	12.5.3	6.8.4.f.3 (TRM 5.2.C.3)
Technical Specifications (I.T.S.)	Radiological Environmental Operating Report	12.6.1	6.9.1.6 (5.6.2)

12.0 RADIOLOGICAL EFFLUENT TECHNICAL STANDARDS12.1 DEFINITIONS

- 12.1.1 Action shall be that which prescribes remedial measures required under designated conditions.
- 12.1.2 Analog Channel Operational Test shall be the injection of a simulated signal into the channel as close to the sensor as practicable to verify OPERABILITY of alarm, interlock and/or trip functions. The ANALOG CHANNEL OPERATIONAL TEST shall include adjustments, as necessary, of the alarm interlock and/or Trip Setpoints such that the Setpoints are within the required range and accuracy.
- 12.1.3 Channel Calibration shall be the adjustment, as necessary, of the channel such that it responds within the required range and accuracy to known values of input. The CHANNEL CALIBRATION shall encompass the entire channel including the sensors and alarm, interlock and/or trip functions and may be performed by any series of sequential, overlapping, or total channel steps such that the entire channel is calibrated.
- 12.1.4 Channel Check shall be the qualitative assessment of channel behavior during operation by observation. This determination shall include, where possible, comparison of the channel indication and/or status with other indications and/or status derived from independent instrument channels measuring the same parameter.
- 12.1.5 Continuous Sampling is uninterrupted sampling with the exception of sampling interruptions of short duration's, for routine activities (e.g. filter replacement)
- 12.1.6 Digital Channel Operational Test shall consist of exercising the digital computer hardware using data base manipulation and injecting simulated process data to verify OPERABILITY of alarm and/or trip functions.
- 12.1.7 Dose Equivalent I-131 shall be that concentration of I-131 (microcuries/gram) that alone would produce the same thyroid dose as the quantity and isotopic mixture of I-131, I-132, I-133, I-134, and I-135 actually present. The thyroid dose conversion factors used for this calculation shall be those listed in Table III of TID-14844, AEC, 1962, "Calculation of Distance Factors for Power and Test Reactor Sites", or those listed in Table E-7 of Regulatory Guide 1.109, Rev. 1, NRC, 1977, or ICRP 30, Supplement to Part 1, page 192-212, Table titled, "Committed Dose Equivalent in Target Organs or Tissues per Intake of Unit Activity".
- 12.1.8 Frequency - Table 12.1-1 provides the definitions of various frequencies for which surveillance's, sampling, etc. are performed unless defined otherwise. The 25% variance shall not be applied to Operability Action Statements. The bases to Technical Specification 4.0.2 (I.T.S. SR 3.0.2) sprovide clarifications to this requirement.
- 12.1.9 Member(s) of the Public means any individual except when that individual is receiving an occupational dose.
- 12.1.10 Occupational Dose means the dose received by an individual in the course of employment in which the individual's assigned duties involve exposure to radiation or to radioactive material from licensed and unlicensed sources of radiation, whether in the possession of the licensee or other person. Occupational dose does not include dose received from background radiation, from any medical administration the individual has received, from exposure to individuals administered radioactive material and released in accordance with 10CFR35.75, from voluntary participation in medical research programs, or as a member of the public.

12.0 RADIOLOGICAL EFFLUENT TECHNICAL STANDARDS (Cont.)

- 12.1.11 Operable/Operability a system, subsystem, train, component or device shall be OPERABLE or have OPERABILITY when it is capable of performing its specified function(s), and when all necessary attendant instrumentation, controls, electrical power, cooling or seal water, lubrication or other auxiliary equipment that are required for the system, subsystem, train, component, or device to perform its function(s) are also capable of performing their related support function(s).
- 12.1.12 Operational Mode (i.e. Mode) shall correspond to any one inclusive combination of core reactivity condition, power level, and average reactor coolant temperature specified in Table 1.2 of the Technical Specifications (I.T.S. Table 1.1-1).
- 12.1.13 Process Control Program (PCP) shall contain the current formulas, sampling, analyses, tests, and determinations to be made to ensure that processing and packaging of solid radioactive wastes based on demonstrated processing of actual or simulated wet solid wastes will be accomplished in such a way as to assure compliance with 10 CFR Parts 20, 61, 71 and State regulations, burial ground requirements, and other requirements governing the disposal of radioactive wastes.
- 12.1.14 Purge/Purging shall be any controlled process of discharging air or gas from a confinement to maintain temperature, pressure, humidity, concentration or other operating condition, in such a manner that replacement air or gas is required to purify the confinement.
- 12.1.15 Rated Thermal Power shall be a total reactor core heat transfer rate to the reactor coolant of 3586.6 MWt.
- 12.1.16 Site Boundary shall be that line beyond which the land is neither owned, nor leased, nor otherwise controlled by the licensee.
- 12.1.17 Solidification shall be the conversion of wet wastes into a form that meets shipping and burial ground requirements.
- 12.1.18 Source Check shall be the qualitative assessment of channel response when the channel sensor is exposed to a source of increased radioactivity.
- 12.1.19 Thermal Power shall be the total core heat transfer rate to the reactor coolant.
- 12.1.20 Unrestricted Area means an area, access to which is neither limited nor controlled by the licensee.
- 12.1.21 Ventilation Exhaust Treatment System shall be any system designed and installed to reduce gaseous radioiodine or radioactive material in particulate form in effluents by passing ventilation or vent exhaust gases through charcoal adsorbers and/or HEPA filters for the purpose of removing iodines or particulates from the gaseous exhaust stream prior to the release to the environment. Such a system is not considered to have any effect on noble gas effluents. Engineered Safety Features Atmospheric Cleanup Systems are not considered to be VENTILATION EXHAUST TREATMENT SYSTEM components.



12.0 RADIOLOGICAL EFFLUENT TECHNICAL STANDARDS (Cont.)

- 12.1.22 Venting shall be any controlled process of discharging air or gas from a confinement to maintain temperature, pressure, humidity, concentration or other operating condition, in such a manner that replacement air or gas is not provided or required during VENTING. Vent, used in system names, does not imply a VENTING process.
- 12.1.23 Waste Gas Holdup System shall be any system designed and installed to reduce radioactive gaseous effluents by collecting Reactor Coolant System off-gases from the Reactor Coolant System and providing for delay or holdup for the purpose of reducing the total radioactivity prior to release to the environment.
- 12.1.24 Definitions Peculiar to Estimating Dose to Members of the Public using the ODCM Computer Program.
- a. ACTUAL - ACTUAL refers to using known release data to project the dose to members of the public for the previous time period. This data is stored in the database and used to demonstrate compliance with the reporting requirements of Chapter 12.
  - b. PROJECTED - PROJECTED refers to using known release data from the previous time period or estimated release data to forecast a future dose to members of the public. This data is not incorporated into the database.

TABLE 12.1-1

FREQUENCY NOTATIONS\*

<u>NOTATION</u>	<u>FREQUENCY</u>
S - Shiftly	At least once per 12 hours.
D - Daily	At least once per 24 hours.
W - Weekly	At least once per 7 days.
M - Monthly	At least once per 31 days.
Q - Quarterly	At least once per 92 days.
SA - Semiannually	At least once per 184 days.
A - Annually	At least once per 366 days.
R - Refueling cycle	At least once per 18 months (550 days).
S/U - Startup	Prior to each reactor startup.
P - Prior	Prior to each radioactive release.
N.A.	Not applicable.

\* Each frequency requirement shall be performed within the specified time interval with the maximum allowable extension not to exceed 25% of the frequency interval. The 25% variance shall not be applied to Operability Action Statements. The bases to Technical Specification 4.0.2 (I.T.S. SR 3.0.2) provide clarifications to this requirement. These frequency notations do not apply to the Radiological Environmental Monitoring Program (REMP) as described in Section 12.5.

## 12.2 INSTRUMENTATION

### 12.2.1 Radioactive Liquid Effluent Monitoring Instrumentation

#### Operability Requirements

---

12.2.1.A The radioactive liquid effluent monitoring instrumentation channels shown in Table 12.2-1 shall be OPERABLE with their Alarm/Trip Setpoints set to ensure that the limits of 12.3.1.A are not exceeded. The Alarm/Trip Setpoints of these channels shall be determined and adjusted in accordance with the methodology and parameters in the ODCM.

Applicability: At all times

#### Action

1. With a radioactive liquid effluent monitoring instrumentation channel Alarm/Trip Setpoint less conservative than required by the above specification, immediately suspend the release of radioactive liquid effluents monitored by the affected channel, or declare the channel inoperable.
2. With less than the minimum number of radioactive liquid effluent monitoring instrumentation channels OPERABLE, take the ACTION shown in Table 12.2-1. Restore the inoperable instrumentation to OPERABLE status within the time specified in the ACTION, or explain in the next Radioactive Effluent Release Report pursuant to Section 12.6 why this inoperability was not corrected within the time specified.

#### Surveillance Requirements

---

12.2.1.B Each radioactive liquid effluent monitoring instrumentation channel shall be demonstrated OPERABLE by performance of the CHANNEL CHECK, SOURCE CHECK, CHANNEL CALIBRATION and DIGITAL and ANALOG CHANNEL OPERATIONAL TEST at the frequencies shown in Table 12.2-2.

#### Bases

---

12.2.1.C The radioactive liquid effluent instrumentation is provided to monitor and control, as applicable, the releases of radioactive materials in liquid effluents during actual or potential releases of liquid effluents. The Alarm/Trip Setpoints for these instruments shall be calculated and adjusted in accordance with the methodology and parameters in the ODCM to ensure that the alarm/trip will occur prior to exceeding the limits of RETS. The OPERABILITY and use of this instrumentation is consistent with the requirements of General Design Criteria 60, 63, and 64 of Appendix A to 10CFR50.

TABLE 12.2-1

RADIOACTIVE LIQUID EFFLUENT MONITORING INSTRUMENTATION

	<u>INSTRUMENT</u>	<u>MINIMUM CHANNELS OPERABLE</u>	<u>ACTION</u>
1.	Radioactivity Monitors Providing Alarm and Automatic Termination of Release		
a.	Liquid Radwaste Effluent Line (ORE-PR001)	1	31
b.	Fire and Oil Sump (ORE-PR005)	1	34
c.	Condensate Polisher Sump Discharge (ORE-PR041)	1	34
2.	Radioactivity Monitors Providing Alarm But Not Providing Automatic Termination of Release		
a.	Essential Service Water		
	1) Unit 1		
	a) RCFC 1A and 1C Outlet (1RE-PR002)	1	32
	b) RCFC 1B and 1D Outlet (1RE-PR003)	1	32
	2) Unit 2		
	a) RCFC 2A and 2C Outlet (2RE-PR002)	1	32
	b) RCFC 2B and 2D Outlet (2RE-PR003)	1	32
b.	Station Blowdown Line (ORE-PR010)	1	32
3.	Flow Rate Measurement Devices		
a.	Liquid Radwaste Effluent Line (Loop-WX001)	1	33
b.	Liquid Radwaste Effluent Low Flow Line (Loop-WX630)	1	33
c.	Station Blowdown Line (Loop-CW032)	1	33

TABLE 12.2-1 (Continued)RADIOACTIVE LIQUID EFFLUENT MONITORING INSTRUMENTATIONACTION STATEMENTS

- \*ACTION 31 - With the number of channels OPERABLE less than required by the Minimum Channels OPERABLE requirement, effluent releases via this pathway may continue for up to 14 days provided that prior to initiating a release:
- a. At least two independent samples are analyzed in accordance with Section 12.3 and
  - b. At least two technically qualified members of the facility staff independently verify the release rate calculations and discharge line valving.
- If a and b can not be met, suspend releases of radioactive effluents via this pathway.
- \*ACTION 32 - With the number of channels OPERABLE less than required by the Minimum Channels OPERABLE requirement, effluent releases via this pathway may continue for up to 30 days provided that, at least once per 12 hours, grab samples are collected and analyzed for principal gamma emitters and I-131 at a lower limit of detection as specified in Table 12.3-1.
- \*ACTION 33 - With the number of channels OPERABLE less than required by the Minimum Channels OPERABLE requirement, effluent releases via this pathway may continue for up to 30 days provided the flow rate is estimated at least once per 4 hours during actual releases. Pump performance curves generated in place may be used to estimate flow.
- \*ACTION 34 - With the number of channels OPERABLE less than required by the Minimum Channels OPERABLE requirement, effluent releases via this pathway may continue for up to 30 days provided grab samples are analyzed for principal gamma emitters and I-131 at a lower limit of detection as specified in Table 12.3-1:
- a. At least once per 12 hours when the specific activity of the secondary coolant is greater than 0.01 microCurie/gram DOSE EQUIVALENT I-131,
- OR
- b. At least once per 24 hours when the specific activity of the secondary coolant is less than or equal to 0.01 microCurie/gram DOSE EQUIVALENT I-131.

\* If effluent releases continue via this pathway beyond the time specified, continue to perform actions and explain in the next Radioactive Effluent Report why the time specified was exceeded.

TABLE 12.2-2  
RADIOACTIVE LIQUID EFFLUENT MONITORING INSTRUMENTATION SURVEILLANCE REQUIREMENTS

<u>INSTRUMENT</u>	<u>CHANNEL CHECK</u>	<u>SOURCE CHECK</u>	<u>CHANNEL CALIBRATION</u>	<u>DIGITAL CHANNEL OPERATIONAL TEST</u>	<u>ANALOG CHANNEL OPERATIONAL TEST</u>
1. Radioactivity Monitors Providing Alarm and Automatic Termination of Release					
a. Liquid Radwaste Effluent Line (0RE-PR001)	D	P	R(3)	Q(1)	N.A.
b. Fire and Oil Sump Discharge (0RE-PR005)	D	M	R(3)	Q(1)	N.A.
c. Condensate Polisher Sump Discharge (0RE-PR041)	D	M	R(3)	Q(1)*	N.A.
2. Radioactivity Monitors Providing Alarm But Not Providing Automatic Termination of Release					
a. Essential Service Water					
1) Unit 1					
a) RCFC 1A and 1C Outlet (1RE-PR002)	D	M	R(3)	Q(2)	N.A.
b) RCFC 1B and 1D Outlet (1RE-PR003)	D	M	R(3)	Q(2)	N.A.
2) Unit 2					
a) RCFC 2A and 2C Outlet (2RE-PR002)	D	M	R(3)	Q(2)	N.A.
b) RCFC 2B and 2D Outlet (2RE-PR003)	D	M	R(3)	Q(2)	N.A.
b. Station Blowdown Line (0RE-PR010)	D	M	R(3)	Q(2)	N.A.
3. Flow Rate Measurement Devices					
a. Liquid Radwaste Effluent Line (Loop-WX001)	D(4)	N.A.	R	N.A.	Q
b. Liquid Radwaste Effluent Low Flow Line (Loop-WX630)	D(4)	N.A.	R	N.A.	Q
c. Station Blowdown Line (Loop-CW032)	D(4)	N.A.	R	N.A.	Q

TABLE 12.2-2 (Continued)RADIOACTIVE LIQUID EFFLUENT MONITORING INSTRUMENTATION SURVEILLANCE  
REQUIREMENTSTABLE NOTATIONS

- (1) The DIGITAL CHANNEL OPERATIONAL TEST shall also demonstrate that automatic isolation of this pathway and control room alarm annunciation occur if any of the following conditions exists:
- a. Instrument indicates measured levels above the Alarm/Trip Setpoint, OR
  - b. Circuit failure (monitor loss of communications - alarm only, detector loss of counts, or monitor loss of power), OR
  - c. Detector check source test failure, OR
  - d. Detector channel out-of-service, OR
  - \* e. Monitor loss of sample flow. This is only applicable for ORE-PR001 and ORE-PR005. (Monitor ORE-PR041 will not trip on loss of sample flow).
- (2) The DIGITAL CHANNEL OPERATIONAL TEST shall also demonstrate that control room alarm annunciation occurs if any of the following conditions exists:
- a. Instrument indicates measured levels above the Alarm Setpoint, OR
  - b. Circuit failure (monitor loss of communications - alarm only, detector loss of counts, or monitor loss of power), OR
  - c. Detector check source test failure, OR
  - d. Detector channel out-of-service, OR
  - e. Monitor loss of sample flow.
- (3) The initial CHANNEL CALIBRATION shall be performed using one or more of the reference standards certified by the National Institute of Standards and Technology (NIST) or using standards that have been obtained from suppliers that participate in measurement assurance activities with NIST. These standards shall permit calibrating the system over its intended range of energy and measurement range. For subsequent CHANNEL CALIBRATION, sources that have been related to the initial calibration shall be used.
- (4) CHANNEL CHECK shall consist of verifying indication of flow during periods of release. CHANNEL CHECK shall be made at least once per 24 hours on days on which continuous, periodic, or batch releases are made.

## 12.2.2 Radioactive Gaseous Effluent Monitoring Instrumentation

### Operability Requirements

---

12.2.2.A The radioactive gaseous effluent monitoring instrumentation channels shown in Table 12.2-3 shall be OPERABLE with their Alarm/Trip Setpoints set to ensure that the limits of Section 12.4 are not exceeded. The Alarm/Trip Setpoints of these channels shall be determined and adjusted in accordance with the methodology and parameters in the ODCM.

Applicability: As shown in Table 12.2-3

Action:

1. With a radioactive gaseous effluent monitoring instrumentation channel Alarm/Trip Setpoint less conservative than required by the above section, immediately suspend the release of radioactive gaseous effluents monitored by the affected channel, or declare the channel inoperable.
2. With less than the minimum number of radioactive gaseous effluent monitoring instrumentation channels OPERABLE, take the ACTION shown in Table 12.2-3. Restore the inoperable instrumentation to OPERABLE status within the time specified in the ACTION, or explain in the next Annual Radioactive Effluent Release Report pursuant to Section 12.6 why this inoperability was not corrected within the time specified.

### Surveillance Requirements

---

12.2.2.B Each radioactive gaseous effluent monitoring instrumentation channel shall be demonstrated OPERABLE by performance of the CHANNEL CHECK, SOURCE CHECK, CHANNEL CALIBRATION and DIGITAL and CHANNEL OPERATIONAL TEST at the frequencies shown in Table 12.2-4.

### Bases

---

12.2.2.C The radioactive gaseous effluent instrumentation is provided to monitor and control, as applicable, the releases of radioactive materials in gaseous effluents during actual or potential releases of gaseous effluents. The Alarm/Trip Setpoints for these instruments shall be calculated and adjusted in accordance with the methodology and parameters in the ODCM to ensure that the alarm/trip will occur prior to exceeding the limits of RETS. The OPERABILITY and use of this instrumentation is consistent with the requirements of General Design Criteria 60, 63, and 64 of Appendix A to 10CFR50. The sensitivity of any noble gas activity monitor used to show compliance with the gaseous effluent release requirements of Section 12.4 shall be such that concentrations as low as  $1 \times 10^{-6}$  uCi/cc are measurable.



TABLE 12.2-3

RADIOACTIVE GASEOUS EFFLUENT MONITORING INSTRUMENTATION

<u>INSTRUMENT</u>	<u>MINIMUM CHANNELS OPERABLE</u>	<u>APPLICABILITY</u>	<u>ACTION</u>
1. Plant Vent Monitoring System - Unit 1			
a. Noble Gas Activity Monitor Providing Alarm			
1) High Range (1RE-PR028D)	1	*	39
2) Low Range (1RE-PR028B)	1	*	39
b. Iodine Sampler (1RE-PR028C)	1	*	40
c. Particulate Sampler (1RE-PR028A)	1	*	40
d. Effluent System Flow Rate Measuring Device (LOOP-VA019)	1	*	36
e. Sampler Flow Rate Measuring Device (1FT-PR165)	1	*	36
2. Plant Vent Monitoring System - Unit 2			
a. Noble Gas Activity Monitor Providing Alarm			
1) High Range (2RE-PR028D)	1	*	39
2) Low Range (2RE-PR028B)	1	*	39
b. Iodine Sampler (2RE-PR028C)	1	*	40
c. Particulate Sampler (2RE-PR028A)	1	*	40
d. Effluent System Flow Rate Measuring Device (LOOP-VA020)	1	*	36
e. Sampler Flow Rate Measuring Device (2FT-PR165)	1	*	36

TABLE 12.2-3 (Continued)

RADIOACTIVE GASEOUS EFFLUENT MONITORING INSTRUMENTATION

	<u>INSTRUMENT</u>	<u>MINIMUM CHANNELS OPERABLE</u>	<u>APPLICABILITY</u>	<u>ACTION</u>
3.	Not Used.			
4.	Gas Decay Tank System			
a.	Noble Gas Activity Monitor- Providing Alarm and Automatic Termination of Release (0RE-PR002A and 2B)	2	*	35
5.	Containment Purge System			
a.	Noble Gas Activity Monitor- Providing Alarm (RE-PR001B)	1	*	37
b.	Iodine Sampler (RE-PR001C)	1	*	40
c.	Particulate Sampler (RE-PR001A)	1	*	40
6.	Radioactivity Monitors Providing Alarm and Automatic Closure of Surge Tank Vent-Component Cooling Water Line (0RE-PR009 and RE-PR009)	2	*	41

TABLE 12.2-3 (Continued)RADIOACTIVE GASEOUS EFFLUENT MONITORING INSTRUMENTATIONTABLE NOTATIONS

\*At all times.

- \*\*ACTION 35 - With the number of channels OPERABLE less than required by the Minimum Channels OPERABLE requirement, the contents of the tank(s) may be released to the environment for up to 14 days provided that prior to initiating the release:
- a. At least two independent samples of the tank's contents are analyzed, and
  - b. At least two technically qualified members of the facility staff independently verify the release rate calculations and discharge valve lineup.
- If a and b can not be met, suspend releases of radioactive effluents via this pathway.
- \*\*ACTION 36 - With the number of channels OPERABLE less than required by the Minimum Channels OPERABLE requirement, effluent releases via this pathway may continue for up to 30 days provided the flow rate is estimated at least once per 4 hours.
- \*\*ACTION 37 - With the number of channels OPERABLE less than required by the Minimum Channels OPERABLE requirement, immediately suspend PURGING of radioactive effluents via this pathway. Releases may continue via this pathway for up to 7 days provided real time monitoring of radioactive effluents released via this pathway is established.
- \*\*ACTION 38 - Not used.
- \*\*ACTION 39 - With the number of channels OPERABLE less than required by the Minimum Channels OPERABLE requirement, effluent releases via this pathway may continue for up to 30 days provided grab samples are taken at least once per 12 hours and these samples are analyzed for principle gamma emitters at an LLD as specified in Table 12.4-1.
- \*\*ACTION 40 - With the number of channels OPERABLE less than required by the Minimum Channels OPERABLE requirement, effluent releases via the affected pathway may continue for up to 30 days provided samples are continuously collected with auxiliary sampling equipment as required in Table 12.4-1.
- \*\*ACTION 41 - With the number of channels OPERABLE less than required by the Minimum Channels OPERABLE requirement, effluent releases via this pathway may continue for up to 30 days provided that, at least once per 12 hours, liquid grab samples are collected and analyzed for radioactivity at a lower limit of detection as specified in Table 12.3-1.

---

\*\* If effluent releases continue via this pathway beyond the time specified, continue to perform actions and explain in the next Radioactive Effluent Report why the time specified was exceeded.

TABLE 12.2-4

RADIOACTIVE GASEOUS EFFLUENT MONITORING INSTRUMENTATION SURVEILLANCE REQUIREMENTS

<u>FUNCTIONAL UNIT</u>	<u>CHANNEL CHECK</u>	<u>SOURCE CHECK</u>	<u>CHANNEL CALIBRATION</u>	<u>DIGITAL CHANNEL OPERATIONAL TEST</u>	<u>MODES FOR WHICH SURVEILLANCE IS REQUIRED</u>
1. Plant Vent Monitoring System - Unit 1					
a. Noble Gas Activity Monitor-Providing Alarm					
1) High Range (1RE-PR028D)	D	M	R(3)	Q(2)	*
2) Low Range (1RE-PR028B)	D	M	R(3)	Q(2)	*
b. Iodine Sampler (1RE-PR028C)	D	M	R(3)	Q(2)	*
c. Particulate Sampler (1RE-PR028A)	D	M	R(3)	Q(2)	*
d. Effluent System Flow Rate Measuring Device (LOOP-VA019)	D	N.A.	R	Q	*
e. Sampler Flow Rate Measuring Device (1FT-PR165)	D	N.A.	R	Q	*
2. Plant Vent Monitoring System - Unit 2					
a. Noble Gas Activity Monitor-Providing Alarm					
1) High Range (2RE-PR028D)	D	M	R(3)	Q(2)	*
2) Low Range (2RE-PR028B)	D	M	R(3)	Q(2)	*
b. Iodine Sampler (2RE-PR028C)	D	M	R(3)	Q(2)	*

TABLE 12.2-4 (Continued)

RADIOACTIVE GASEOUS EFFLUENT MONITORING INSTRUMENTATION SURVEILLANCE REQUIREMENTS

<u>FUNCTIONAL UNIT</u>	<u>CHANNEL CHECK</u>	<u>SOURCE CHECK</u>	<u>CHANNEL CALIBRATION</u>	<u>DIGITAL CHANNEL OPERATIONAL TEST</u>	<u>MODES FOR WHICH SURVEILLANCE IS REQUIRED</u>
2. Plant Vent Monitoring System - Unit 2 (Continued)					
c. Particulate Sampler (2RE-PR028C)	D	M	R(3)	Q(2)	*
d. Effluent System Flow Rate Measuring Device (LOOP-VA020)	D	N.A.	R	Q	*
e. Sampler Flow Rate Measuring Device (2FT-PR165)	D	N.A.	R	Q	*
3. Not Used					
4. Gas Decay Tank System					
a. Noble Gas Activity Monitor Providing Alarm and Automatic Termination of Release (0RE-PR002A and 2B)	P	P	R(3)	Q(1)**	*
5. Containment Purge System					
a. Noble Gas Activity Monitor- Providing Alarm (RE-PR001B)	D	P	R(3)	Q(2)	*
b. Iodine Sampler (RE-PR001C)	P	P	R(3)	N.A.	*
c. Particulate Sampler (RE-PR001A)	P	P	R(3)	N.A.	*
6. Radioactivity Monitors Providing Alarm and Automatic Closure of Surge Tank Vent-Component Cooling Water Line (0RE-PR009 and RE-PR009)					
	D	M	R(3)	Q(1)	*

TABLE 12.2-4 (Continued)RADIOACTIVE GASEOUS EFFLUENT MONITORING INSTRUMENTATION  
SURVEILLANCE REQUIREMENTSTABLE NOTATIONS

- \* At all times.
- (1) The DIGITAL CHANNEL OPERATIONAL TEST shall also demonstrate that automatic isolation of this pathway and control room alarm annunciation occur if any of the following conditions exists:
- a. Instrument indicates measured levels above the Alarm/Trip Setpoint, OR
  - b. Circuit failure (monitor loss of communications - alarm only, detector loss of counts, or monitor loss of power), OR
  - c. Detector check source test failure, OR
  - d. Detector channel out-of-service, OR
  - \*\* e. Monitor loss of sample flow. Monitoring ORE-PR002A and 2B will not trip on loss of sample flow.
- (2) The DIGITAL CHANNEL OPERATIONAL TEST shall also demonstrate that control room alarm annunciation occurs if any of the following conditions exists:
- a. Instrument indicates measured levels above the Alarm Setpoint, OR
  - b. Circuit failure (monitor loss of communications - alarm only, detector loss of counts, or monitor loss of power), OR
  - c. Detector check source test failure, OR
  - d. Detector channel out-of-service, OR
  - e. Monitor loss of sample flow.
- (3) The initial CHANNEL CALIBRATION shall be performed using one or more of the reference standards certified by the National Institute of Standards and Technology (NIST) or using standards that have been obtained from suppliers that participate in measurement assurance activities with NIST. These standards shall permit calibrating the system over its intended range of energy and measurement range. For subsequent CHANNEL CALIBRATION, sources that have been related to the initial calibration shall be used.
- (4) CHANNEL CHECK shall consist of verifying indication of flow during periods of release. CHANNEL CHECK shall be made at least once per 24 hours on days on which continuous, periodic, or batch releases are made.

12.3 LIQUID EFFLUENTS12.3.1 ConcentrationOperability Requirements

---

- 12.3.1.A The concentration of radioactive material released in liquid effluents to UNRESTRICTED AREAS (see Braidwood Station ODCM Annex, Appendix F, Figure F-1) shall be limited to 10 times the concentration values in Appendix B, Table 2, Column 2 to 10CFR20.1001-20.2402, for radionuclides other than dissolved or entrained noble gases. For dissolved or entrained noble gases, the concentration shall be limited to  $2 \times 10^{-4}$  microCurie/ml total activity.

Applicability: At all times

Action:

1. With the concentration of radioactive material released in liquid effluents to UNRESTRICTED AREAS exceeding the above limits, immediately restore the concentration to within the above limits.

Surveillance Requirements

---

- 12.3.1.B.1 Radioactive liquid wastes shall be sampled and analyzed according to the sampling and analysis program of Table 12.3-1.
- 12.3.1.B.2 The results of the radioactivity analysis shall be used in accordance with the methodology and parameters in the ODCM to assure that the concentrations at the point of release are maintained within the limits of 12.3.1.A.

Bases

---

- 12.3.1.C This section is provided to ensure that the concentration of radioactive materials released in liquid waste effluents to UNRESTRICTED AREAS will be less than 10 times the concentration values in Appendix B, Table 2, Column 2 to 10CFR20.1001-20.2402. This limitation provides additional assurance that the levels of radioactive materials in bodies of water in UNRESTRICTED AREAS will result in exposures within: (1) the Section II.A design objectives of Appendix I, 10CFR50, to a MEMBER OF THE PUBLIC, and (2) the limits of 10CFR20.1301.

This section applies to the release of radioactive materials in liquid effluents from all units at the site.

12.3 LIQUID EFFLUENTS (Continued)Bases

---

The required detection capabilities for radioactive materials in liquid waste samples are tabulated in terms of the lower limits of detection (LLDs). Detailed discussion of the LLD, and other detection limits can be found in HASL Procedures Manual, HASL-300 (revised annually), Currie, L.A., "Limits for Qualitative Detection and Quantitative Determination - Application to Radiochemistry," Anal. Chem. 40, 586-93 (1968), and Hartwell, J.K., "Detection Limits for Radioanalytical Counting Techniques," Atlantic Richfield Hanford Company Report ARH-SA-215 (June 1975).



TABLE 12.3-1

RADIOACTIVE LIQUID WASTE SAMPLING AND ANALYSIS PROGRAM

LIQUID RELEASE TYPE	SAMPLING FREQUENCY	MINIMUM ANALYSIS FREQUENCY	TYPE OF ACTIVITY ANALYSIS	LOWER LIMIT OF DETECTION (LLD) <sup>(1)</sup> (μCi/ml)
1. Batch Release Tanks <sup>(2)</sup>	P Each Batch	P Each Batch	Principal Gamma Emitters <sup>(7)</sup>	5x10 <sup>-7</sup>
			I-131	1x10 <sup>-6</sup>
	P One Batch/M	M	Dissolved and Entrained Gases (Gamma Emitters) <sup>(7)</sup>	1x10 <sup>-5</sup>
	P Each Batch	M Composite <sup>(3)</sup>	H-3	1x10 <sup>-5</sup>
	P Each Batch	Q Composite <sup>(3)</sup>	Gross Alpha	1x10 <sup>-7</sup>
			Sr-89, Sr-90	5x10 <sup>-8</sup>
			Fe-55	1x10 <sup>-6</sup>
2. Continuous Releases <sup>(4)</sup>	Continuous <sup>(5)</sup>	W Composite <sup>(5)</sup>	Principal Gamma Emitters <sup>(7)</sup>	5x10 <sup>-7</sup>
			I-131	1x10 <sup>-6</sup>
a. Circulating Water Blowdown	M Grab Sample	M	Dissolved and Entrained Gases (Gamma Emitters) <sup>(7)</sup>	1x10 <sup>-5</sup>
b. Waste Water Treatment Discharge to Circulating Water Discharge	Continuous <sup>(5)</sup>	M Composite <sup>(5)</sup>	H-3	1x10 <sup>-5</sup>
			Gross Alpha	1x10 <sup>-7</sup>
c. Condensate Polisher Sump Discharge	Continuous <sup>(5)</sup>	Q Composite <sup>(5)</sup>	Sr-89, Sr-90	5x10 <sup>-8</sup>
			Fe-55	1x10 <sup>-6</sup>

TABLE 12.3-1 (Continued)

RADIOACTIVE LIQUID WASTE SAMPLING AND ANALYSIS PROGRAM

LIQUID RELEASE TYPE	SAMPLING FREQUENCY	MINIMUM ANALYSIS FREQUENCY	TYPE OF ACTIVITY ANALYSIS	LOWER LIMIT OF DETECTION (LLD) <sup>(1)</sup> ( $\mu$ Ci/ml)
3. Continuous Release <sup>(4)</sup> Essential Service Water Reactor Containment Fan Cooler (RCFC) Outlet Line	W <sup>(6)</sup> Grab Sample	W <sup>(6)</sup>	Principal Gamma Emitters <sup>(7)</sup>	5x10 <sup>-7</sup>
			I-131	1x10 <sup>-6</sup>
			H-3	1x10 <sup>-5</sup>
		M <sup>(6)</sup>	Dissolved and Entrained Gases (Gamma Emitters) <sup>(7)</sup>	1x10 <sup>-5</sup>
4. Continuous Surge Tank  Vent-Component Cooling Water Line <sup>(8)</sup>	None	None	Principal Gamma Emitters <sup>(7)</sup>	5x10 <sup>-7</sup>
			Dissolved and Entrained Gases (Gamma Emitters) <sup>(7)</sup>	1x10 <sup>-5</sup>
			I-131	1x10 <sup>-6</sup>

TABLE 12.3-1 (Continued)

RADIOACTIVE LIQUID WASTE SAMPLING AND ANALYSIS PROGRAM

TABLE NOTATIONS

- (1) The LLD is defined, for purposes of these sections, as the smallest concentration of radioactive material in a sample that will yield a net count, above system background, that will be detected with 95% probability with only 5% probability of falsely concluding that a blank observation represents a "real" signal.

For a particular measurement system, which may include radiochemical separations:

$$LLD = \frac{4.66s_b}{E \cdot V \cdot 2.22 \times 10^6 \cdot Y \cdot \exp(-\lambda\Delta t)}$$

Where:

LLD = the lower limit of detection (microCuries per unit mass or volume),

$s_b$  = the standard deviation of the background counting rate or of the counting rate of a blank sample as appropriate (counts per minute),

E = the counting efficiency (counts per disintegration),

V = the sample size (units of mass or volume),

$2.22 \times 10^6$  = the number of disintegrations per minute per microCurie,

Y = the fractional radiochemical yield, when applicable,

$\lambda$  = the radioactive decay constant for the particular radionuclide ( $\text{sec}^{-1}$ ), and

$\Delta t$  = the elapsed time between the midpoint of sample collection and the time of counting (sec).

Typical values of E, V, Y, and  $\Delta t$  should be used in the calculation.

Alternative LLD Methodology

An alternative methodology for LLD determination follows and is similar to the above LLD equation:

$$LLD = \frac{(2.71 + 4.65\sqrt{B}) \cdot \text{Decay}}{E \cdot V \cdot Y \cdot t \cdot (2.22 \times 10^6)}$$

TABLE 12.3-1 (Continued)

RADIOACTIVE LIQUID WASTE SAMPLING AND ANALYSIS PROGRAMTABLE NOTATIONS

Where:

B = background sum (counts)

E = counting efficiency, (counts detected/disintegration's)

q = sample quantity, (mass or volume)

b = abundance, (if applicable)

Y = fractional radiochemical yield or collection efficiency, (if applicable)

t = count time (minutes)

 $2.22 \times 10^6$  = number of disintegration's per minute per microCurie $2.71 + 4.65\sqrt{B} = k^2 + (2k \sqrt{2 \sqrt{B}})$ , and  $k = 1.645$ .

(k=value of the t statistic from the single-tailed t distribution at a significance level of 0.95 and infinite degrees of freedom. This means that the LLD result represents a 95% detection probability with a 5% probability of falsely concluding that the nuclide present when it is not or that the nuclide is not present when it is.)

Decay =  $e^{\lambda \Delta t} [\lambda RT / (1 - e^{-\lambda RT})] [\lambda T_d / (1 - e^{-\lambda T_d})]$ , (if applicable) $\lambda$  = radioactive decay constant, (units consistent with  $\Delta t$ , RT and  $T_d$ ) $\Delta t$  = "delta t", or the elapsed time between sample collection or the midpoint of sample collection and the time the count is started, depending on the type of sample, (units consistent with  $\lambda$ )RT= elapsed real time, or the duration of the sample count, (units consistent with  $\lambda$ ) $T_d$  = sample deposition time, or the duration of analyte collection onto the sample media, (units consistent with  $\lambda$ )

The LLD may be determined using installed radioanalytical software, if available. In addition to determining the correct number of channels over which to total the background sum, utilizing the software's ability to perform decay corrections (i.e. during sample collection, from sample collection to start of analysis and during counting), this alternate method will result in a more accurate determination of the LLD.

It should be recognized that the LLD is defined as a before the fact limit representing the capability of a measurement system and not as an after the fact limit for a particular measurement.

TABLE 12.3-1 (Continued)RADIOACTIVE LIQUID WASTE SAMPLING AND ANALYSIS PROGRAMTABLE NOTATIONS

- (2) A batch release is the discharge of liquid wastes of a discrete volume. Prior to sampling for analyses, each batch shall be isolated, and then thoroughly mixed to assure representative sampling.
- (3) A composite sample is one in which the quantity of liquid sampled is proportional to the quantity of liquid waste discharged and in which the method of sampling employed results in a specimen that is representative of the liquids released.
- (4) A continuous release is the discharge of liquid wastes of a nondiscrete volume, e.g., from a volume of a system that has an input flow during the continuous release.
- (5) To be representative of the quantities and concentrations of radioactive materials in liquid effluents, samples shall be collected continuously whenever the effluent stream is flowing. Prior to analyses, all samples taken for the composite shall be thoroughly mixed in order for the composite sample to be representative of the effluent release.
- (6) Not required unless the Essential Service Water RCFC Outlet Radiation Monitors RE-PR002 and RE-PR003 indicates measured levels greater than  $1 \times 10^{-6}$   $\mu\text{Ci/ml}$  above background at any time during the week.
- (7) The principal gamma emitters for which the LLD specification applies include the following radionuclides: Kr-87, Kr-88, Xe-133, Xe-133m, Xe-135, and Xe-138 for dissolved and entrained for principal gamma emitters. This list does not mean that only these nuclides are to be considered.

Other gamma peaks that are identifiable, together with those of the above nuclides, shall also be analyzed and reported in the Radioactive Effluent Release Report pursuant to Section 12.6.2, in the format outlined in Regulatory Guide 1.21, Appendix B, Revision 1, June 1974.

- (8) A continuous release is the discharge of dissolved and entrained gaseous waste from a nondiscrete liquid volume.

12.3.2 DoseOperability Requirements

---

12.3.2.A The dose or dose commitment to a MEMBER OF THE PUBLIC from radioactive materials in liquid effluents released, from each unit, to UNRESTRICTED AREAS (see Braidwood Station ODCM Annex, Appendix F, Figure F-1) shall be limited:

1. During any calendar quarter to less than or equal to 1.5 mrems to the whole body and to less than or equal to 5 mrems to any organ, and
2. During any calendar year to less than or equal to 3 mrems to the whole body and to less than or equal to 10 mrems to any organ.

Applicability: At all times.

Action:

1. With the calculated dose from the release of radioactive materials in liquid effluents exceeding any of the above limits, prepare and submit to the Commission within 30 days, pursuant to 10CFR50 Appendix I, Section IV.A, a Special Report that identifies the cause(s) for exceeding the limit(s) and defines the corrective actions that have been taken to reduce the releases and the proposed corrective actions to be taken to assure that subsequent releases will be in compliance with the above limits.

Surveillance Requirements

---

12.3.2.B Cumulative dose contributions from liquid effluents for the current calendar quarter and the current calendar year shall be determined in accordance with the methodology and parameters in the ODCM at least once per 31 days.

Bases

---

12.3.2.C This section is provided to implement the requirements of Sections II.A, III.A and IV.A of Appendix I, 10CFR50. The Operability Requirements implement the guides set forth in Section II.A of Appendix I. The ACTION statements provide the required operating flexibility and at the same time implement the guides set forth in Section IV.A of Appendix I to assure that the releases of radioactive material in liquid effluents to UNRESTRICTED AREAS will be kept "as low as is reasonably achievable." The dose calculation methodology and parameters in the ODCM implement the requirements in Section III.A of Appendix I that conformance with the guides of Appendix I be shown by calculational procedures based on models and data, such that the actual exposure of a MEMBER OF THE PUBLIC through appropriate pathways is unlikely to be substantially underestimated.

The equations specified in the ODCM for calculating the doses due to the actual release rates of radioactive materials in liquid effluents are consistent with the methodology provided in Regulatory Guide 1.109, "Calculation of Annual Doses to Man From Routine Releases of Reactor Effluents For the Purpose of Evaluating Compliance with 10CFR50, Appendix I" Revision 1, October 1977 and Regulatory Guide 1.113, "Estimating Aquatic Dispersion of Effluents from Accidental and Routine Reactor Releases for the Purpose of Implementing Appendix I," April 1977.

12.3.2 Dose (Continued)Bases

---

This section applies to the release of radioactive materials in liquid effluents from each reactor at the site. When shared Radwaste Treatment Systems are used by more than one unit on a site, the wastes from all units are mixed for shared treatment; by such mixing, the effluent releases cannot accurately be ascribed to a specific unit. An estimate should be made of the contributions from each unit based on input conditions, e.g., flow rates and radioactivity concentrations, or, if not practicable, the treated effluent releases may be allocated equally to each of the radioactive waste producing units sharing the Radwaste Treatment System. For determining conformance to Operability Requirements, these allocations from shared Radwaste Treatment Systems are to be added to the releases specifically attributed to each unit to obtain the total releases per unit.

### 12.3.3 Liquid Radwaste Treatment System

#### Operability Requirements

---

12.3.3.A The Liquid Radwaste Treatment System shall be OPERABLE and appropriate portions of the system shall be used to reduce releases of radioactivity when the projected doses due to the liquid effluent, from each unit, to UNRESTRICTED AREAS (see Braidwood Station ODCM Annex, Appendix F, Figure F-1) would exceed 0.06 mrem to the whole body or 0.2 mrem to any organ in a 31-day period.

Applicability: At all times.

Action:

1. With radioactive liquid waste being discharged without treatment and in excess of the above limits and any portion of the Liquid Radwaste Treatment System not in operation, prepare and submit to the Commission within 30 days, pursuant to 10CFR50 Appendix I, Section IV.A, a Special Report that includes the following information:
  - a. Explanation of why liquid radwaste was being discharged without treatment, identification of any inoperable equipment or subsystems, and the reason for the inoperability,
  - b. Action(s) taken to restore the inoperable equipment to OPERABLE status, and
  - c. Summary description of action(s) taken to prevent a recurrence.

#### Surveillance Requirements

---

12.3.3.B.1 Doses due to liquid releases from each unit to UNRESTRICTED AREAS shall be projected at least once per 31 days in accordance with the methodology and parameters in the ODCM when the Liquid Radwaste Treatment System is not being fully utilized.

12.3.3.B.2 The installed Liquid Radwaste Treatment System shall be considered OPERABLE by meeting Sections 12.3.1.A and 12.3.2.A.

#### Bases

---

12.3.3.C The OPERABILITY of the Liquid Radwaste Treatment System ensures that this system will be available for use whenever liquid effluents require treatment prior to release to the environment. The requirement that the appropriate portions of this system be used when specified provides assurance that the releases of radioactive materials in liquid effluents will be kept "as low as is reasonably achievable". This section implements the requirements of 10CFR50.36a, General Design Criterion 60 of Appendix A to 10CFR50 and the design objective given in Section II.D of Appendix I to 10CFR50.



12.3.3 Liquid Radwaste Treatment System (Continued)Bases

---

The specified limits governing the use of appropriate portions of the Liquid Radwaste Treatment System were specified as a suitable fraction of the dose design objectives set forth in Section II.A of Appendix I, 10CFR50, for liquid effluents.

This section applies to the release of radioactive materials in liquid effluents from each unit at the site. When shared Radwaste Treatment Systems are used by more than one unit on a site, the wastes from all units are mixed for shared treatment; by such mixing, the effluent releases cannot accurately be ascribed to a specific unit. An estimate should be made of the contributions from each unit based on input conditions, e.g., flow rates and radioactivity concentrations, or, if not practicable, the treated effluent releases may be allocated equally to each of the radioactive waste producing units sharing the Radwaste Treatment System. For determining conformance to Operability Requirements, these allocations from shared Radwaste Treatment Systems are to be added to the releases specifically attributed to each unit to obtain the total releases per unit.

12.4 GASEOUS EFFLUENTS12.4.1 Dose RateOperability Requirements

---

12.4.1.A The dose rate due to radioactive materials released in gaseous effluents from the site to areas at and beyond the SITE BOUNDARY (see Braidwood Station ODCM Annex, Appendix F, Figure F-1) shall be limited to the following:

1. For noble gases: less than or equal to a dose rate of 500 mrem/yr to the whole body and less than or equal to a dose rate of 3000 mrem/yr to the skin, and
2. For Iodine 131 and 133, for tritium, and for all radionuclides in particulate form with half-lives greater than 8 days: Less than or equal to 1500 mrem/yr to any organ.

Applicability: At all times.

Action:

1. With the dose rate(s) exceeding the above limits, immediately restore the release rate to within the above limit(s).

Surveillance Requirements

---

12.4.1.B.1 The dose rate due to noble gases in gaseous effluents shall be determined to be within the above limits in accordance with the methodology and parameters in the ODCM.

12.4.1.B.2 The dose rate due to Iodine 131 and 133, tritium, and all radionuclides in particulate form with half-lives greater than 8 days in gaseous effluents shall be determined to be within the above limits in accordance with the methodology and parameters in the ODCM by obtaining representative samples and performing analyses in accordance with the sampling and analysis program specified in Table 12.4-1.

Bases

---

12.4.1.C This section is provided to ensure that the dose at any time at and beyond the SITE BOUNDARY from gaseous effluents from all units on the site will be within the annual dose limits of 10CFR20. These limits provide reasonable assurance that radioactive material discharged in gaseous effluents will not result in the exposure of a MEMBER OF THE PUBLIC exceeding the limits specified in 10CFR20.1301.

12.4 GASEOUS EFFLUENTS (Continued)Bases

---

For MEMBERS OF THE PUBLIC who may at times be within the SITE BOUNDARY, the occupancy of that MEMBER OF THE PUBLIC will usually be sufficiently low to compensate for any increase in the atmospheric diffusion factor above that for the SITE BOUNDARY. Examples of calculations for such MEMBERS OF THE PUBLIC, with the appropriate occupancy factors, shall be given in the ODCM. The specified release rate limits restrict, at all times, the corresponding gamma and beta dose rates above background to a MEMBER OF THE PUBLIC at or beyond the SITE BOUNDARY to less than or equal to 500 mrem/year to the whole body or to less than or equal to 3000 mrem/year to the skin. These release rate limits also restrict, at all times the corresponding thyroid dose rate above background via the inhalation pathway to less than or equal to 1500 mrem/year.

This section applies to the release of radioactive materials in gaseous effluents from all units at the site.

The required detection capabilities for radioactive materials in liquid waste samples are tabulated in terms of the lower limits of detection (LLDs). Detailed discussion of the LLD, and other detection limits can be found in HASL Procedures Manual, HASL-300 (revised annually), Currie, L.A., "Limits for Qualitative Detection and Quantitative Determination - Application to Radiochemistry," Anal. Chem. **40**, 586-93 (1968), and Hartwell, J.K., "Detection Limits for Radioanalytical Counting Techniques," Atlantic Richfield Hanford Company Report ARH-SA-215 (June 1975).

TABLE 12.4-1

RADIOACTIVE GASEOUS WASTE SAMPLING AND ANALYSIS PROGRAM

GASEOUS RELEASE TYPE	SAMPLING FREQUENCY	MINIMUM ANALYSIS FREQUENCY	TYPE OF ACTIVITY ANALYSIS	LOWER LIMIT OF DETECTION (LLD) <sup>(1)</sup> (μCi/cc)
1. Waste Gas Decay Tank	P Each Tank Grab Sample	P Each Tank	Principal Gamma Emitters <sup>(2)</sup>	1x10 <sup>-4</sup>
2. Containment Purge	P Each Purge <sup>(3)</sup> Grab Sample	P Each Purge <sup>(3)</sup>	Principal Gamma Emitters <sup>(2)</sup>	1x10 <sup>-4</sup>
			H-3	1x10 <sup>-7</sup>
3. Auxiliary Bldg. Vent Stack (Unit 1 and 2)	M <sup>(4)(5)</sup> Grab Sample	M	Principal Gamma Emitters <sup>(2)</sup>	1x10 <sup>-4</sup>
			H-3	1x10 <sup>-7</sup>
	Continuous <sup>(6)</sup>	W <sup>(7)</sup> Charcoal Sample	I-131	1x10 <sup>-12</sup>
			I-133	1x10 <sup>-10</sup>
	Continuous <sup>(6)</sup>	W <sup>(7)</sup> Particulate Sample	Principal Gamma Emitters <sup>(2)</sup>	1x10 <sup>-11</sup>
	Continuous <sup>(6)</sup>	Q Composite Particulate Sample	Gross Alpha	1x10 <sup>-11</sup>
	Continuous <sup>(6)</sup>	Q Composite Particulate Sample	Sr-89, Sr-90	1x10 <sup>-11</sup>
Continuous	N.A. Noble Gas Monitor	Noble Gases, Gross Beta or Gamma	1x10 <sup>-6</sup>	

TABLE 12.4-1 (Continued)

RADIOACTIVE GASEOUS WASTE SAMPLING AND ANALYSIS PROGRAM

TABLE NOTATIONS

- (1) The LLD is defined, for purposes of these specifications, as the smallest concentration of radioactive material in a sample that will yield a net count, above system background, that will be detected with 95% probability with only 5% probability of falsely concluding that a blank observation represents a "real" signal.

For a particular measurement system, which may include radiochemical separation:

$$LLD = \frac{4.66S_b}{E \cdot V \cdot 2.22 \times 10^6 \cdot Y \cdot \exp(-\lambda \Delta t)}$$

Where:

LLD = the lower limit of detection (microCuries per unit mass or volume),

$s_b$  = the standard deviation of the background counting rate or of the counting rate of a blank sample as appropriate (counts per minute),

E = the counting efficiency (counts per disintegration),

V = the sample size (units of mass or volume),

$2.22 \times 10^6$  = the number of disintegrations per minute per microCurie,

Y = the fractional radiochemical yield, when applicable,

$\lambda$  = the radioactive decay constant for the particular radionuclide ( $\text{sec}^{-1}$ ), and

$\Delta t$  = the elapsed time between the midpoint of sample collection and the time of counting (sec).

Typical values of E, V, Y, and  $\Delta t$  should be used in the calculation.

Alternate LLD Methodology

An alternate methodology for LLD determination follows and is similar to the above LLD equation:

$$LLD = \frac{(2.71 + 4.65\sqrt{B}) \cdot \text{Decay}}{E \cdot V \cdot Y \cdot t \cdot (2.22 \times 10^6)}$$

TABLE 12.4-1 (Continued)

RADIOACTIVE GASEOUS WASTE SAMPLING AND ANALYSIS PROGRAMTABLE NOTATIONS

Where:

B = background sum (counts)

E = counting efficiency, (counts detected/disintegrations)

q = sample quantity, (mass or volume)

b = abundance, (if applicable)

Y = fractional radiochemical yield or collection efficiency, (if applicable)

t = count time (minutes)

2.22 X10<sup>6</sup> = number of disintegrations per minute per microCurie(2.71 + 4.65√B) = k<sup>2</sup> + (2k √ 2 √ B), and k = 1.645.

(k=value of the t statistic from the single-tailed t distribution at a significance level of 0.95 and infinite degrees of freedom. This means that the LLD result represents a 95% detection probability with a 5% probability of falsely concluding that the nuclide present when it is not or that the nuclide is not present when it is.)

Decay = e<sup>-λΔt</sup> [λRT/(1-e<sup>-λRT</sup>)] [λT<sub>d</sub>/(1-e<sup>-λT<sub>d</sub></sup>)], (if applicable)λ = radioactive decay constant, (units consistent with Δt, RT and T<sub>d</sub>)

Δt = "delta t", or the elapsed time between sample collection or the midpoint of sample collection and the time the count is started, depending on the type of sample, (units consistent with λ)

RT = elapsed real time, or the duration of the sample count, (units consistent with λ)

T<sub>d</sub> = sample deposition time, or the duration of analyte collection onto the sample media, (unit consistent with λ)

The LLD may be determined using installed radioanalytical software, if available. In addition to determining the correct number of channels over which to total the background sum, utilizing the software's ability to perform decay corrections (i.e. during sample collection, from sample collection to start of analysis and during counting), this alternate method will result in a more accurate determination of the LLD.

It should be recognized that the LLD is defined as a before the fact limit and not as an after the fact limit for a particular measurement.

TABLE 12.4-1 (Continued)RADIOACTIVE GASEOUS WASTE SAMPLING AND ANALYSIS PROGRAMTABLE NOTATIONS

- (2) The principal gamma emitters for which the LLD specification applies include the following radionuclides: Kr-87, Kr-88, Xe-133, Xe-133m, Xe-135, and Xe-138 in noble gas releases and Mn-54, Fe-59, Co-58, Co-60, Zn-65, Mo-99, I-131, Cs-134, Cs-137, Ce-141, and Ce-144 in particulate releases. This list does not mean that only these nuclides are to be considered.
- Other gamma peaks that are identifiable, together with those of the above nuclides, shall also be analyzed and reported in the Radioactive Effluent Release Report pursuant to Section 12.6.2, in the format outlined in Regulatory Guide 1.21, Appendix B, Revision 1, June 1974.
- (3) Sampling and analysis shall also be performed following shutdown, startup, or a THERMAL POWER change exceeding 15% of RATED THERMAL POWER within a 1-hour period.
- (4) Tritium grab samples shall be taken at least once per 24 hours when the refueling canal is flooded.
- (5) Tritium grab samples shall be taken at least once per 7 days from the spent fuel pool area, whenever spent fuel is in the spent fuel pool.
- (6) The ratio of the sample flow rate to the sampled stream flow rate shall be known for the time period covered by each dose or dose rate calculation made in accordance with Sections 12.4.1.A, 12.4.2.A and 12.4.3.A.
- (7) Samples shall be changed at least once per 7 days and analyses shall be completed within a timeframe necessary to meet the applicable lower limits of detection, but not to exceed 48 hours. Sampling shall also be performed at least once per 24 hours for at least 7 days following each shutdown, startup or THERMAL POWER change exceeding 15% of RATED THERMAL POWER within a 1-hour period and analyses shall be completed within a timeframe necessary to meet the applicable lower limits of detection, but not to exceed 48 hours. When samples collected for 24 hours are analyzed, the corresponding LLDs may be increased by a factor of 10. This requirement does not apply if: (1) analysis shows that the DOSE EQUIVALENT I-131 concentration in the reactor coolant has not increased more than a factor of 3, and (2) the noble gas monitor shows that effluent activity has not increased more than a factor of 3.

12.4.2 Dose - Noble GasesOperability Requirements

---

12.4.2.A The air dose due to noble gases released in gaseous effluents, from each unit, to areas at and beyond the SITE BOUNDARY (see Braidwood Station ODCM Annex, Appendix F, Figure F-1) shall be limited to the following:

1. During any calendar quarter: Less than or equal to 5 mrad for gamma radiation and less than or equal to 10 mrad for beta radiation, and
2. During any calendar year: Less than or equal to 10 mrad for gamma radiation and less than or equal to 20 mrad for beta radiation.

Applicability: At all times.

Action:

1. With the calculated air dose from radioactive noble gases in gaseous effluents exceeding any of the above limits, prepare and submit to the Commission within 30 days, pursuant to 10CFR50 Appendix I, Section IV.A, a Special Report that identifies the cause(s) for exceeding the limit(s) and defines the corrective actions that have been taken to reduce the releases and the proposed corrective actions to be taken to assure that subsequent releases will be in compliance with the above limits.

Surveillance Requirements

---

12.4.2.B Cumulative dose contributions for the current calendar quarter and the current calendar year for noble gases shall be determined in accordance with the methodology and parameters in the ODCM at least once per 31 days.

Bases

---

12.4.2.C This section is provided to implement the requirements of Sections II.B, III.A and IV.A of Appendix I, 10CFR50. The Operability Requirements implement the guides set forth in Section II.B of Appendix I. The ACTION statements provide the required operating flexibility and at the same time implement the guides set forth in Section IV.A of Appendix I to assure that the releases of radioactive material in gaseous effluents to area at or beyond the SITE BOUNDARY will be kept "as low as is reasonable achievable." The Surveillance Requirements implement the requirements in Section III.A of Appendix I that conformance with the guides of Appendix I be shown by calculational procedures based on models and data such that the actual exposure of a MEMBER OF THE PUBLIC through appropriate pathways is unlikely to be substantially underestimated.



12.4.2 Dose - Noble Gases (Continued)Bases

---

The dose calculation methodology and parameters established in the ODCM for calculating the doses due to the actual release rates of radioactive materials in gaseous effluents are consistent with the methodology provided in Regulatory Guide 1.109, "Calculation of Annual Doses to Man From Routine Releases of Reactor Effluents For the Purpose of Evaluating Compliance with 10CFR50, Appendix I" Revision 1, October 1977 and Regulatory Guide 1.111, "Methods for Estimating Atmospheric Transport and Dispersion of Gaseous Effluents in Routine Releases from Light-Water Cooled Reactors, Revision 1," July 1977. The ODCM equations provided for determining the air doses at and beyond the SITE BOUNDARY are based upon the historical average atmospheric conditions.

This section applies to the release of radioactive materials in gaseous effluents from each unit at the site. When shared Radwaste Treatment Systems are used by more than one unit on a site, the wastes from all units are mixed for shared treatment; by such mixing, the effluent releases cannot accurately be ascribed to a specific unit. An estimate should be made of the contributions from each unit based on input conditions, e.g., flow rates and radioactivity concentrations, or, if not practicable, the treated effluent releases may be allocated equally to each of the radioactive waste producing units sharing the Radwaste Treatment System. For determining conformance to Operability Requirements, these allocations from shared Radwaste Treatment Systems are to be added to the releases specifically attributed to each unit to obtain the total releases per unit.

### 12.4.3 Dose - Iodine I-131 and 133, Tritium, and Radioactive Material in Particulate Form

#### Operability Requirements

---

12.4.3.A The dose to a MEMBER OF THE PUBLIC from Iodine-131 and 133, tritium, and all radionuclides in particulate form with half-lives greater than 8 days in gaseous effluents released, from each unit, to areas at and beyond the SITE BOUNDARY (see Braidwood Station ODCM Annex, Appendix F, Figure F-1) shall be limited to the following:

1. During any calendar quarter: Less than or equal to 7.5 mrems to any organ, and
2. During any calendar year: Less than or equal to 15 mrems to any organ.

Applicability: At all times.

Action:

1. With the calculated dose from the release of Iodine-131 and 133, tritium, and radionuclides in particulate form with half-lives greater than 8 days, in gaseous effluents exceeding any of the above limits, prepare and submit to the Commission within 30 days, pursuant to 10CFR50 Appendix I, Section IV.A, a Special Report that identifies the cause(s) for exceeding the limit(s) and defines the corrective actions that have been taken to reduce the releases and the proposed corrective actions to be taken to assure that subsequent releases will be in compliance with the above limits.

#### Surveillance Requirements

---

12.4.3.B Cumulative dose contributions for the current calendar quarter and the current calendar year for Iodine-131 and 133, tritium, and radionuclides in particulate form with half-lives greater than 8 days shall be determined in accordance with the methodology and parameters in the ODCM at least once per 31 days.

#### Bases

---

12.4.3.C This section is provided to implement the requirements of Sections II.C, III.A and IV.A of Appendix I, 10CFR50. The Operability Requirements are the guides set forth in Section II.C of Appendix I. The ACTION statements provide the required operating flexibility and at the same time implement the guides set forth in Section IV.A of Appendix I to assure that the releases of radioactive material in gaseous effluents to areas at or beyond the SITE BOUNDARY will be kept "as low as is reasonable achievable." The ODCM calculational methods specified in the Surveillance Requirements implement the requirements in Section III.A of Appendix I that conformance with the guides of Appendix I be shown by calculational procedures based on models and data, such that the actual exposure of a MEMBER OF THE PUBLIC through appropriate pathways is unlikely to be substantially underestimated.

12.4.3 Dose (Continued)Bases

---

The ODCM calculational methodology and parameters for calculating the doses due to the actual release rates of the subject materials are consistent with the methodology provided in Regulatory Guide 1.109, "Calculation of Annual Doses to Man From Routine Releases of Reactor Effluents For the Purpose of Evaluating Compliance with 10CFR50, Appendix I" Revision 1, October 1977 and Regulatory Guide 1.111, "Methods for Estimating Atmospheric Transport and Dispersion of Gaseous Effluents in Routine Releases from Light-Water-Cooled Reactors," Revision 1, July 1977. These equations also provide for determining the actual doses based upon the historical average atmospheric conditions. The release rate specifications for Iodine-131 and 133, tritium, and radionuclides in particulate form with half-lives greater than 8 days are dependent upon the existing radionuclide pathways to man, in the areas at and beyond the SITE BOUNDARY. The pathways that were examined in the development of these calculations were: (1) individual inhalation of airborne radionuclides, (2) deposition of radionuclides onto green leafy vegetation with subsequent consumption by man, (3) deposition onto grassy areas where milk animals and meat producing animal's graze with consumption of the milk and meat by man, and (4) deposition on the ground with subsequent exposure to man.

This section applies to the release of radioactive materials in gaseous effluents from each unit at the site. When shared Radwaste Treatment Systems are used by more than one unit on a site, the wastes from all units are mixed for shared treatment; by such mixing, the effluent releases cannot accurately be ascribed to a specific unit. An estimate should be made of the contributions from each unit based on input conditions, e.g., flow rates and radioactivity concentrations, or, if not practicable, the treated effluent releases may be allocated equally to each of the radioactive waste producing units sharing the Radwaste Treatment System. For determining conformance to Operability Requirements, these allocations from shared Radwaste Treatment Systems are to be added to the releases specifically attributed to each unit to obtain the total releases per unit.

#### 12.4.4 Gaseous Radwaste Treatment System

##### Operability Requirements

---

12.4.4.A The VENTILATION EXHAUST TREATMENT SYSTEM and the WASTE GAS HOLDUP SYSTEM shall be OPERABLE and appropriate portions of these systems shall be used to reduce releases of radioactivity when the projected doses in 31 days due to gaseous effluent releases, from each unit, to areas at and beyond the SITE BOUNDARY (see Braidwood Station ODCM Annex, Appendix F, Figure F-1) would exceed:

1. 0.2 mrad to air from gamma radiation, or
2. 0.4 mrad to air from beta radiation, or
3. 0.3 mrem to any organ of a MEMBER OF THE PUBLIC.

Applicability: At all times.

Action:

1. With radioactive gaseous waste being discharged without treatment and in excess of the above limits, prepare and submit to the Commission within 30 days, pursuant to 10CFR50 Appendix I, Section IV.A, a Special Report that includes the following information:
  - a. Identification of any inoperable equipment or subsystems, and the reason for the inoperability,
  - b. Action(s) taken to restore the inoperable equipment to OPERABLE status, and
  - c. Summary description of action(s) taken to prevent a recurrence.

##### Surveillance Requirements

---

12.4.4.B.1 Doses due to gaseous releases from each unit to areas at and beyond the SITE BOUNDARY shall be projected at least once per 31 days in accordance with the methodology and parameters in the ODCM when Gaseous Radwaste Treatment Systems are not being fully utilized.

12.4.4.B.2 The installed VENTILATION EXHAUST TREATMENT SYSTEM and WASTE GAS HOLDUP SYSTEM shall be considered OPERABLE by meeting Section 12.4.1 or 12.4.2 and 12.4.3.

##### Bases

---

12.4.4.C The OPERABILITY of the WASTE GAS HOLDUP SYSTEM and the VENTILATION EXHAUST TREATMENT SYSTEM ensures that the system will be available for use whenever gaseous effluents require treatment prior to release to the environment.

12.4.4 Gaseous Radwaste Treatment System (Continued)Bases

---

The requirement that the appropriate portions of this system be used when specified provides reasonable assurance that the releases of radioactive materials in gaseous effluents will be kept "as low as is reasonably achievable". This section implements the requirements of 10CFR50.36a, General Design Criterion 60 of Appendix A to 10CFR50 and the design objective given in Section II.D of Appendix I to 10CFR50. The specified limits governing the use of appropriate portions of the Gaseous Radwaste Treatment System were specified as a 2% fraction of the dose design objectives set forth in Section II.B and II.C of Appendix I, 10CFR50, for gaseous effluents.

This section applies to the release of radioactive materials in gaseous effluents from each unit at the site. When shared Radwaste Treatment Systems are used by more than one unit on a site, the wastes from all units are mixed for shared treatment; by such mixing, the effluent releases cannot accurately be ascribed to a specific unit. An estimate should be made of the contributions from each unit based on input conditions, e.g., flow rates and radioactivity concentrations, or, if not practicable, the treated effluent releases may be allocated equally to each of the radioactive waste producing units sharing the Radwaste Treatment System. For determining conformance to Operability Requirements, these allocations from shared Radwaste Treatment Systems are to be added to the releases specifically attributed to each unit to obtain the total releases per unit.

12.4.5 Total DoseOperability Requirements

---

- 12.4.5.A The annual (calendar year) dose or dose commitment to any MEMBER OF THE PUBLIC due to releases of radioactivity and to radiation from uranium fuel cycle sources shall be limited to less than or equal to 25 mrem to the whole body or any organ, except the thyroid, which shall be limited to less than or equal to 75 mrem.

Applicability: At all times.

Action:

1. With the calculated doses from the release of radioactive materials in liquid or gaseous effluents exceeding twice the limits of Sections 12.3.2, 12.4.2, or 12.4.3, calculations should be made including direct radiation contributions from the units and from outside storage tanks to determine whether the above limits of Section 12.4.5.A have been exceeded. If such is the case, prepare and submit to the Commission within 30 days, a Special Report that defines the corrective action to be taken to reduce subsequent releases to prevent recurrence of exceeding the above limits and includes the schedule for achieving conformance with the above limits. This Special Report, as defined in 10CFR20.2203, shall include an analysis that estimates the radiation exposure (dose) to a MEMBER OF THE PUBLIC from uranium fuel cycle sources, including all effluent pathways and direct radiation, for the calendar year that includes the release(s) covered by this report. It shall also describe levels of radiation and concentration of radioactive material involved, and the cause of the exposure levels or concentrations. If the estimated dose(s) exceeds the above limits, and if the release condition resulting in violation of 40CFR190 has not already been corrected, the Special Report shall include a request for a variance in accordance with the provisions of 40CFR190. Submittal of the report is considered a timely request, and a variance is granted until staff action on the request is complete.

Surveillance Requirements

---

- 12.4.5.B.1 Cumulative dose contributions from liquid and gaseous effluents shall be determined in accordance with Sections 12.3.2, 12.4.2, and 12.4.3, and in accordance with the methodology and parameters in the ODCM.
- 12.4.5.B.2 Cumulative dose contributions from direct radiation from the units and from radwaste storage tanks shall be determined in accordance with the methodology and parameters in the ODCM. This requirement is applicable only under conditions set forth in ACTION 1 of Section 12.4.5.A.
- 12.4.5.B.3 Initial estimates of expected dose rates at the Old Steam Generator Storage Facility (OSGSF) are provided through calculations. After the old steam generators are placed in the facility and the equipment opening is sealed, a radiation survey of the walls and roof will be performed. The measured dose rates will be used for comparison to the calculated dose rates and to confirm or adjust the initial estimates for use in 10CFR20, 10CFR50 Appendix I, and 40CFR190 compliance determinations.

12.4.5 Total Dose (Continued)Surveillance Requirements

Environmental TLDs are located near the OSGSF. The TLDs are processed quarterly to determine the dose at the locations for use in compliance determinations.

Quarterly monitoring of the sump for indications of liquid is performed and, if liquid is present and seepage appears to have occurred, a sample will be taken and analyzed.

Bases

12.4.5.C.1 This section is provided to meet the dose limitations of 40CFR190 that have been incorporated into 10CFR20 by 46FR18525. The section requires the preparation and submittal of a Special Report whenever the calculated doses due to releases of radioactivity and to radiation from uranium fuel cycle sources exceed 25 mrems to the whole body or any organ, except the thyroid, which shall be limited to less than or equal to 75 mrems. For sites containing up to four reactors, it is highly unlikely that the resultant dose to a MEMBER OF THE PUBLIC will exceed the dose limits of 40CFR190 if the individual reactors remain within twice the dose design objectives of Appendix I, and if direct radiation doses from the reactor units and outside storage tanks are kept small. The Special Report will describe a course of action that should result in the limitation of the annual dose to a MEMBER OF THE PUBLIC to within the 40CFR190 limits. For the purposes of the Special Report, it may be assumed that the dose commitment to the MEMBER OF THE PUBLIC from other uranium fuel cycle sources is negligible, with the exception that dose contributions from other nuclear fuel cycle facilities at the same site or within a radius of 8 km must be considered. If the dose to any MEMBER OF THE PUBLIC is estimated to exceed the requirements of 40CFR190, the Special Report with a request for a variance (provided the release conditions resulting in violation of 40CFR190 have not already been corrected), in accordance with the provisions of 40CFR190.11 and 10CFR20.2203, is considered to be a timely request and fulfills the requirements of 40CFR190 until NRC staff action is completed. The variance only relates to the limits of 40CFR190, and does not apply in any way to the other requirements for dose limitation of 10CFR20, as addressed in Sections 12.3.1 and 12.4.1. An individual is not considered a MEMBER OF THE PUBLIC during any period in which he/she is engaged in carrying out any operation that is part of the nuclear fuel cycle.

12.4.5.C.2 The OSGSF was constructed to provide long-term storage of the four old steam generators removed from Braidwood Station Unit 1 during the Steam Generator Replacement Outage. The facility is designed to ensure that the dose rates at the wall and roof meet the limits of 10CFR20 (UFSAR Zone 1-A for the walls and Zone 1-B for the roof). The facility is also designed to ensure that the dose rates at the site boundary and to the nearest resident meet the limits of 10CFR20 and 40CFR190.

The OSGSF design includes 2'-6" thick concrete walls and 1'-6" inch thick concrete roof. Personnel access is through a labyrinth-style vestibule with a locked exterior door and a lockable sliding door for access beyond the vestibule to the interior of the facility. A water collection sump is provided with access from the vestibule for sampling water if liquid is present. The opening used for placement of the steam generators inside the facility will be sealed with concrete panels. The panels have a tongue and groove design to preclude radiation "shine" after installation.

12.4.5 Total Dose (Continued)Bases

---

The potential for radiological release from the OSGSF is also minimized by sealing openings in the steam generators caused by removed piping with welded structural cover plates or seal plugs. Trunnions installed during removal of the old steam generators from the containment and existing opening covers remain attached to the steam generators to ensure the penetrations are leaktight. External exposed surfaces of the steam generators are coated to seal and fix surface contamination to the steam generators.



## 12.4.6 Dose Limits for Members of the Public

### Operability Requirements

---

12.4.6.A The licensee shall conduct operations such that the TEDE to individual MEMBERS OF THE PUBLIC does not exceed 100 mrem in a year. In addition, the dose in any unrestricted area from external sources does not exceed 2 mrem in any one hour. The Effluents Program shall implement monitoring, sampling and analysis of radioactive liquid and gaseous effluents in accordance with 10CFR20.1302 and with the methodology and parameters in the ODCM.

Applicability: At all times.

Action:

1. If the calculated dose from the release or exposure of radiation meets or exceeds the 100 mrem/year limit for the MEMBER OF THE PUBLIC, prepare and submit a report the Commission in accordance with 10CFR20.2203.
2. If the dose in any unrestricted area from external sources of radiation meets or exceeds the 2 mrem in any one hour limit for the MEMBER OF THE PUBLIC, prepare and submit a report to the Commission in accordance with 10CFR20.2203.

### Surveillance Requirements

---

12.4.6.B Calculate the TEDE to individual MEMBERS OF THE PUBLIC annually to determine compliance with the 100 mrem/year limit in accordance with the ODCM. In addition, evaluate and/or determine if direct radiation exposures exceed 2 mrem in any hour in unrestricted areas.

### Bases

---

12.4.6.C This section applies to direct exposure of radioactive materials as well as radioactive materials released in gaseous and liquid effluents. 10CFR20.1301 sets forth the 100 mrem/year dose limit to members of the public; 2 mrem in any one hour limit in the unrestricted area; and reiterates that the licensee is also required to meet the 40CFR190 standards. 10CFR20.1302 provides options to determine compliance to 10CFR20.1301. Compliance to the above operability requirement is based on 10CFR20 and 40CFR190.

12.5 RADIOLOGICAL ENVIRONMENTAL MONITORING PROGRAM

12.5.1 Monitoring Program

Operability Requirements

---

12.5.1.A The Radiological Environmental Monitoring Program shall be conducted as specified in Table 12.5-1.

Applicability: At all times.

Action:

1. With the Radiological Environmental Monitoring Program not being conducted as specified in Table 12.5-1, prepare and submit to the Commission, in the Annual Radiological Environmental Operating Report required by Section 12.6.1, a description of the reasons for not conducting the program as required and the plans for preventing a recurrence.

Deviations are permitted from the required sampling schedule if specimens are unobtainable due to hazardous conditions, seasonal unavailability, malfunction of sampling equipment, if a person/business who participates in this program goes out of business or no longer can provide sample, or contractor omission which is corrected as soon as discovered. If the equipment malfunctions, corrective actions shall be completed as soon as practical. If a person/business supplying samples goes out of business, a replacement supplier shall be found as soon as possible. All deviations from the sampling schedule will be described in the Annual Radiological Environmental Operating Report.

2. With the level of radioactivity as the result of plant effluents in an environmental sampling medium at a specified location exceeding the reporting levels of Table 12.5-2 when averaged over any calendar quarter, prepare and submit to the Commission within 30 days, pursuant to 10CFR50 Appendix I, Section IV.A, a Special Report that identifies the cause(s) for exceeding the limit(s) and defines the corrective actions to be taken to reduce radioactive effluents so that the potential annual dose\* to a MEMBER OF THE PUBLIC is less than the calendar year limits of Section 12.3.2, 12.4.2, or 12.4.3. When more than one of the radionuclides in Table 12.5.2 are detected in the sampling medium, this report shall be submitted if:

$$\frac{\text{concentration (1)}}{\text{reporting level (1)}} + \frac{\text{concentration (2)}}{\text{reporting level (2)}} + \dots \geq 1.0$$

When radionuclides other than those in Table 12.5-2 are detected and are the result of plant effluents, this report shall be submitted if the potential annual dose\* to A MEMBER OF THE PUBLIC from all radionuclides is equal to or greater than the calendar year limits of Section 12.3.2, 12.4.2, or 12.4.3. This report is not required if the measured level of radioactivity was not the result of plant effluents; however, in such an event, the condition shall be reported and described in the Annual Radiological Environmental Operating Report required by Section 12.6.1.

---

\*The methodology and parameters used to estimate the potential annual dose to a MEMBER OF THE PUBLIC shall be indicated in this report.

12.5 RADIOLOGICAL ENVIRONMENTAL MONITORING PROGRAM (Continued)

3. If the sample type or sampling location(s) as required by Table 12.5-1 become(s) permanently unavailable, identify suitable alternative sampling media for the pathway of interest and/or specific sampling locations for obtaining replacement samples and add them to the Radiological Environmental Monitoring Program as soon as practicable. The specific locations from which samples were unavailable may then be deleted from the monitoring program.

Prepare and submit a controlled version of the ODCM within 180 days including a revised figure(s) and table reflecting the new location(s) with supporting information identifying the cause of the unavailability of samples and justifying the selection of new location(s) for obtaining samples.

Surveillance Requirements

- 12.5.1.B The radiological environmental monitoring program samples shall be collected pursuant to Table 12.5-1 from the specific locations given in the table and figure(s) in the ODCM, and shall be analyzed pursuant to the requirements of Table 12.5-1 and the detection capabilities required by Table 12.5-3.

Bases

- 12.5.1.C The Radiological Environmental Monitoring Program required by this section provides representative measurements of radiation and of radioactive materials in those exposure pathways and for those radionuclides that lead to the highest potential radiation exposures of MEMBERS OF THE PUBLIC resulting from the station operation. This monitoring program implements Section IV.B.2 of Appendix I to 10CFR50 and thereby supplements the radiological effluent monitoring program by verifying that the measurable concentrations of radioactive materials and levels of radiation are not higher than expected on the basis of the effluent measurements and the modeling of the environmental exposure pathways. Guidance for this monitoring program is provided by the Radiological Assessment Branch Technical Position on Environmental Monitoring. The initially specified monitoring program will be effective for at least the first 3 years of commercial operation. Following this period, program changes may be initiated based on operational experience.

The required detection capabilities for environmental sample analyses are tabulated in terms of the lower limits of detection (LLDs). The LLDs required by Table 12.5-3 are considered optimum for routine environmental measurements in industrial laboratories. It should be recognized that the LLD is defined as a before the fact limit representing the capability of a measurement system and not as an after the fact limit for a particular measurement.

Detailed discussion of the LLD, and other detection limits, can be found in HASL Procedures Manual, HASL-300 (revised annually), Currie, LA., "Limits for Qualitative Detection and Quantitative Determination - Application to Radiochemistry," Anal. Chem. 40, 586-93 (1968), and Hartwell, J.K., "Detection Limits for Radioanalytical Counting Techniques," Atlantic Richfield Hanford Company Report ARH-SA-215 (June 1975).s

12.5 RADIOLOGICAL ENVIRONMENTAL MONITORING PROGRAM (Continued)

Interpretations

---

12.5.1.D Table 12.5-1 requires "one sample of each community drinking water supply downstream of the plant within 10 kilometers." Drinking water supply is defined as water taken from rivers, lakes, or reservoirs (not well water) which is used for drinking.

TABLE 12.5-1

RADIOLOGICAL ENVIRONMENTAL MONITORING PROGRAM

EXPOSURE PATHWAY AND/ OR SAMPLE	NUMBER OF REPRESENTATIVE SAMPLES AND SAMPLE LOCATIONS <sup>(1)</sup>	SAMPLING AND COLLECTION FREQUENCY	TYPE AND FREQUENCY OF ANALYSIS
<p>1. Airborne Radioiodine and Particulates</p>	<p>Samples from a total of eight locations:</p> <p>a. Indicator- Near Field</p> <p>Four samples from locations within 4 km (2.5 mi) in different sectors.</p> <p>b. Indicator- Far Field</p> <p>Three additional locations within 4 to 10 km (2.5 to 6.2 mi) in different sectors.</p> <p>c. Control</p> <p>One sample from a control location within 10 to 30 km (6.2 to 18.6 mi).</p>	<p>Continuous sampler operation with particulate sample collection weekly (or more frequently if required due to dust loading), and radioiodine canister collection biweekly.</p>	<p><u>Radioiodine Canister:</u> I-131 analysis biweekly on near field samples and control.<sup>(2)</sup></p> <p><u>Particulate Sampler:</u> Gross beta analysis following weekly filter change<sup>(3)</sup> and gamma isotopic analysis<sup>(4)</sup> quarterly on composite filters by location on near field samples and control.<sup>(2)</sup></p>

TABLE 12.5-1 (Continued)

RADIOLOGICAL ENVIRONMENTAL MONITORING PROGRAM

EXPOSURE PATHWAY AND/ OR SAMPLE	NUMBER OF REPRESENTATIVE SAMPLES AND SAMPLE LOCATIONS <sup>(1)</sup>	SAMPLING AND COLLECTION FREQUENCY	TYPE AND FREQUENCY OF ANALYSIS
<p>2. Direct Radiation<sup>(5)</sup></p>	<p>Forty routine monitoring stations either with a thermoluminescent dosimeter (TLD) or with one instrument for measuring dose rate continuously, placed as follows:</p> <p>a. Indicator- Inner Ring (100 Series TLD) One in each meteorological sector, in the general area of the SITE BOUNDARY (0.1 to 3.8 miles);</p> <p>b. Indicator- Outer Ring (200 Series TLD) One in each meteorological sector, within 6.1 to 10 km (3.8 to 6.2 mi); and</p> <p>c. Other</p> <p>One at each Airborne location given in part 1.a. and 1.b.</p> <p>The balance of the TLDs to be placed at special interest locations beyond the Restricted Area where either a MEMBER OF THE PUBLIC or Commonwealth Edison employees have routine access. (300 Series TLD)</p>	<p>Quarterly</p>	<p>Gamma dose on each TLD quarterly.</p>

TABLE 12.5-1 (Continued)

RADIOLOGICAL ENVIRONMENTAL MONITORING PROGRAM

EXPOSURE PATHWAY AND/ OR SAMPLE	NUMBER OF REPRESENTATIVE SAMPLES AND SAMPLE LOCATIONS <sup>(1)</sup>	SAMPLING AND COLLECTION FREQUENCY	TYPE AND FREQUENCY OF ANALYSIS
2. Direct Radiation <sup>(5)</sup> (Cont'd)	d. Control  One at each Airborne control location given in part 1.c	Quarterly	Gamma dose on each TLD quarterly.
3. Waterborne a. Ground/ Well  b. Drinking <sup>(7)</sup>  c. Surface Water <sup>(7)</sup>  d. Control Sample <sup>(7)</sup>	a. Indicator  Samples from two sources only if likely to be affected. <sup>(6)</sup>  a. Indicator  One Sample from each community drinking water supply that could be affected by the station discharge within 10 km (6.2 mi) downstream of discharge.  If no community water supply (Drinking Water) exists within 10 km downstream of discharge then surface water sampling shall be performed.  a. Indicator  One sample downstream  a. Control  One surface sample upstream of discharge.	Quarterly   Weekly grab samples.   Weekly grab samples.   Weekly grab samples.	Gamma isotopic <sup>(4)</sup> and tritium analysis quarterly.   Gross beta and gamma isotopic analyses <sup>(4)</sup> on monthly composite; tritium analysis on quarterly composite.   Gross beta and gamma isotopic analyses <sup>(4)</sup> on monthly composite; tritium analysis on quarterly composite.   Gross beta and gamma isotopic analyses <sup>(4)</sup> on monthly composite; tritium analysis on quarterly composite.

TABLE 12.5-1 (Continued)

RADIOLOGICAL ENVIRONMENTAL MONITORING PROGRAM

EXPOSURE PATHWAY AND/ OR SAMPLE	NUMBER OF REPRESENTATIVE SAMPLES AND SAMPLE LOCATIONS <sup>(1)</sup>	SAMPLING AND COLLECTION FREQUENCY	TYPE AND FREQUENCY OF ANALYSIS
e. Sediment	a. Indicator  At least one sample from downstream <sup>(7)</sup> area within 10 km (6.2 mi).	Semiannually.	Gamma isotopic analysis <sup>(4)</sup> semiannually.
4. Ingestion  a. Milk <sup>(8)</sup>	a. Indicator  Samples from milking animals from a maximum of three locations within 10 km (6.2 mi) distance.  b. Control  One sample from milking animals at a control location within 10 to 30 km (6.2 to 18.6 mi).	Biweekly <sup>(9)</sup> when animals are on pasture (May through October), monthly at other times (November through April).	Gamma isotopic <sup>(4)</sup> and I-131 <sup>(10)</sup> analysis on each sample.
b. Fish	a. Indicator  Representative samples of commercially and recreationally important species in discharge area.  b. Control  Representative samples of commercially and recreationally important species in control locations upstream of discharge.	Two times annually.	Gamma isotopic analysis <sup>(4)</sup> on edible portions



TABLE 12.5-1 (Continued)

RADIOLOGICAL ENVIRONMENTAL MONITORING PROGRAM

EXPOSURE PATHWAY AND/ OR SAMPLE	NUMBER OF REPRESENTATIVE SAMPLES AND SAMPLE LOCATIONS <sup>(1)</sup>	SAMPLING AND COLLECTION FREQUENCY	TYPE AND FREQUENCY OF ANALYSIS
c. Food Products	<p>a. Indicator</p> <p>Two representative samples from the principal food pathways grown in each of four major quadrants within 10 km (6.2 mi):</p> <p>At least one root vegetable sample<sup>(11)</sup></p> <p>At least one broad leaf vegetable (or vegetation)<sup>(11)</sup></p> <p>b. Control</p> <p>Two representative samples similar to indicator samples grown within 15 to 30 km (9.3 to 18.6 mi).</p>	Annually	Gamma isotopic <sup>(4)</sup> analysis on each sample.

TABLE 12.5-1 (Continued)  
RADIOLOGICAL ENVIRONMENTAL MONITORING PROGRAM  
TABLE NOTATIONS

- (1) Specific parameters of distance and direction from the centerline of the midpoint of the two units and additional description where pertinent, shall be provided for each and every sample location in Table 12.5-1 of the ODCM Station Annexes. Refer to NUREG-0133, "Preparation of Radiological Effluent Technical Specifications for Nuclear Power Plants," October 1978, and to Radiological Assessment Branch Technical Position, Revision 1, November 1979.
- (2) Far field samples are analyzed when the respective near field sample results are inconsistent with previous measurements and radioactivity is confirmed as having its origin in airborne effluents from the station, or at the discretion of the Radiation Protection Director.
- (3) Airborne particulate sample filters shall be analyzed for gross beta radioactivity 24 hours or more after sampling to allow for radon and thoron daughter decay. If gross beta activity in air particulate samples is greater than 10 times the yearly mean of control samples, gamma isotopic analysis shall be performed on the individual samples.
- (4) Gamma isotopic analysis means the identification and quantification of gamma emitting radionuclides that may be attributable to the effluents from the station.
- (5) One or more instruments, such as a pressurized ion chamber, for measuring and recording dose rate continuously may be used in place of, or in addition to, integrating dosimeters. Film badges shall not be used as dosimeters for measuring direct radiation. The 40 locations is not an absolute number. The number of direct radiation monitoring stations may be reduced according to geographical limitations; e.g., If a station is adjacent to a lake, some sectors may be over water thereby reducing the number of dosimeters which could be placed at the indicated distances. The frequency of analysis or readout for TLD systems will depend upon the characteristics of the specific system used and should be selected to obtain optimum dose information with minimal fading.
- (6) Groundwater samples shall be taken when this source is tapped for drinking or irrigation purposes in areas where the hydraulic gradient or recharge properties are suitable for contamination.
- (7) The "downstream" sample shall be taken in an area beyond but near the mixing zone. The "upstream sample" shall be taken at a distance beyond significant influence of the discharge. Upstream samples in an estuary must be taken far enough upstream to be beyond the station influence.
- (8) If milking animals are not found in the designated indicator locations, or if the owners decline to participate in the REMP, all milk sampling may be discontinued.
- (9) Biweekly refers to every two weeks.
- (10) I-131 analysis means the analytical separation and counting procedure are specific for this radionuclide.
- (11) One sample shall consist of a volume/weight of sample large enough to fill contractor specified container.

TABLE 12.5-2

REPORTING LEVELS FOR RADIOACTIVITY CONCENTRATIONS IN ENVIRONMENTAL SAMPLES  
REPORTING LEVELS

ANALYSIS	WATER (pCi/l)	AIRBORNE PARTICULATE OR GASES (pCi/m <sup>3</sup> )	FISH (pCi/kg, wet)	MILK (pCi/l)	FOOD PRODUCTS (pCi/kg, wet)
H-3	20,000 <sup>(1)</sup>				
Mn-54	1,000		30,000		
Fe-59	400		10,000		
Co-58	1,000		30,000		
Co-60	300		10,000		
Zn-65	300		20,000		
Zr-Nb-95	400				
I-131	2 <sup>(2)</sup>	0.9		3	100
Cs-134	30	10	1,000	60	1,000
Cs-137	50	20	2,000	70	2,000
Ba-La-140	200			300	

(1) For drinking water samples. This is 40 CFR Part 141 value. If no drinking water pathway exists, a value of 30,000 pCi/l may be used.  
 (2) If no drinking water pathway exists, a value of 20 pCi/l may be used.

TABLE 12.5-3

DETECTION CAPABILITIES FOR ENVIRONMENTAL SAMPLE ANALYSIS<sup>(1)</sup>

LOWER LIMIT OF DETECTION (LLD)<sup>(2)(3)</sup>

ANALYSIS	WATER (pCi/l)	AIRBORNE PARTICULATE OR GASES (pCi/m <sup>3</sup> )	FISH (pCi/kg, wet)	MILK (pCi/l)	FOOD PRODUCTS (pCi/kg, wet)	SEDIMENT (pCi/kg, dry)
Gross Beta	4	0.01	1000			
H-3	2000 <sup>(7)</sup>					
Mn-54	15		130			
Fe-59	30		260			
Co-58,60	15		130			
Zn-65	30		260			
Zr-Nb-95	15					
I-131 <sup>(6)</sup>	1/15 <sup>(4)</sup>	0.07	100	0.5/5 <sup>(5)</sup>	60	
Cs-134	15	0.01	100	15	60	150
Cs-137	18	0.01	100	18	80	180
Ba-La-140	15			15		

**TABLE 12.5-3 (Continued)**  
**DETECTION CAPABILITIES FOR ENVIRONMENTAL SAMPLE ANALYSIS**  
**TABLE NOTATIONS**

- (1) The nuclides on this list are not the only nuclides intended to be considered. Other peaks that are identifiable, together with those of the above nuclides, shall also be analyzed and reported in the Annual Radiological Environmental Operating Report.
- (2) Required detection capabilities for thermoluminescent dosimeters used for environmental measurements shall be in accordance with the recommendations of Regulatory Guide 4.13.
- (3) The Lower Limit of Detection (LLD) is defined, for purposes of these specifications, as the smallest concentration of radioactive material in a sample that will yield a net count, above system background, that will be detected with 95% probability with only 5% probability of falsely concluding that a blank observation represents a "real" signal.

For a particular measurement system, which may include radiochemical separation, the LLD is defined as follows:

$$LLD = \frac{4.66 S_b + 3/t_b}{(E) (V) (2.22) (Y) (\exp (-\lambda\Delta t))}$$

$$LLD \sim \frac{4.66 S_b}{(E) (V) (2.22) (Y) (\exp (-\lambda\Delta t))}$$

Where:  $4.66 S_b \gg 3/t_b$

LLD = the "a priori" Minimum Detectable Concentration (picoCuries per unit mass or volume),

$s_b$  = the standard deviation of the background counting rate or of the counting rate of a blank sample, as appropriate (counts per minute),

$$= \frac{\sqrt{Total\ Counts}}{t_b}$$

E = the counting efficiency(counts per disintegration),

V = the sample size (units of mass or volume),

2.22 = the number of disintegrations per minute per picoCurie,

Y = the fractional radiochemical yield, when applicable,

$\lambda$  = the radioactive decay constant for the particular radionuclide ( $sec^{-1}$ ),

**TABLE 12.5-3 (Continued)**  
**DETECTION CAPABILITIES FOR ENVIRONMENTAL SAMPLE ANALYSIS**  
**TABLE NOTATIONS**

$t_b$  = counting time of the background or blank (minutes), and

$\Delta t$  = the elapsed time between sample collection, or end of the sample collection period, and the time of counting (sec).

Typical values of E, V, Y, and  $\Delta t$  should be used in the calculation.

It should be recognized that the LLD is defined as a before the fact limit representing the capability of a measurement system and not as an after the fact limit for a particular measurement.

Analyses shall be performed in such a manner that the stated LLDs will be achieved under routine conditions. Occasionally, background fluctuations, unavoidable small sample sizes, the presence of interfering nuclides, or other uncontrollable circumstances may render these LLDs unachievable. In such cases, the contributing factors shall be identified and described in the Annual Radiological Environmental Operating Report.

- (4) If no drinking water pathway exists, the value of 15 pCi/l may be used.
- (5) A value of 0.5 pCi/l shall be used when the animals are on pasture (May through October) and a value of 5 pCi/l shall be used at all other times (November through April).
- (6) This LLD applies only when the analytical separation and counting procedure are specific for this radionuclide
- (7) This LLD is the minimum allowable, however, vendors performing environmental sample analyses off-site will be required to meet an LLD of 200 pCi/l.

12.5.2 Land Use CensusOperability Requirements

---

- 12.5.2.A. A Land Use Census shall be conducted and shall identify within a distance of 10 km (6.2 miles) the location in each of the 16 meteorological sectors\* of the nearest milk animal, the nearest residence\*\*, and an enumeration of livestock. For dose calculation, a garden will be assumed at the nearest residence.

Applicability: At all times.

Action:

1. With a Land Use Census identifying a location(s) that yields a calculated dose or dose commitment, via the same exposure pathway 20% greater than at a location from which samples are currently being obtained in accordance with Section 12.5.1, add the new location(s) within 30 days to the Radiological Environmental Monitoring Program given in Chapter 11. The sampling location(s), excluding the control location, having the lowest calculated dose or dose commitment(s), via the same exposure pathway, may be deleted from this monitoring program after October 31 of the year in which this Land Use Census was conducted. Submit in the next Annual Radiological Environmental Operating Report documentation for a change in the ODCM including a revised figure(s) and table(s) for the ODCM reflecting the new location(s) with information supporting the change in sampling locations.

\*This requirement may be reduced according to geographical limitations; e.g. at a lake site where some sector's will be over water.

\*\*The nearest industrial facility shall also be documented if closer than the nearest residence.

Surveillance Requirements

---

- 12.5.2.B The Land Use Census shall be conducted during the growing season, between June 1 and October 1, at least once per 12 months using that information that will provide the best results, such as by a door-to-door survey, aerial survey, or by consulting local agriculture authorities. The results of the Land Use Census shall be included in the Annual Radiological Environmental Operating Report.

Bases

---

- 12.5.2.C This specification is provided to ensure that changes in the use of areas at and beyond the SITE BOUNDARY are identified and that modifications to the Radiological Environmental Monitoring Program given in the ODCM are made if required by the results of this census.

This census satisfies the requirements of Section IV.B.3 of Appendix I to 10CFR50. An annual garden census will not be required since the licensee will assume that there is a garden at the nearest residence in each sector for dose calculations.

12.5.3 Interlaboratory Comparison Program

Operability Requirements

---

12.5.3.A Analyses shall be performed on radioactive materials supplied as part of an Interlaboratory Comparison Program that correspond to samples required by Table 12.5-1.

Applicability: At all times.

Action:

1. With analyses not being performed as required above, report the corrective actions taken to prevent a recurrence to the Commission in the Annual Radiological Environmental Operating Report.

Surveillance Requirements

---

12.5.3.B A summary of the results obtained as part of the above required Interlaboratory Comparison Program shall be included in the Annual Radiological Environmental Operating Report.

Bases

---

12.5.3.C The requirement for participation in an Interlaboratory Comparison Program is provided to ensure that independent checks on the precision and accuracy of the measurements of radioactive material in environmental samples matrices are performed as part of the quality assurance program for environmental monitoring in order to demonstrate that the results are valid for the purposes of Section IV.B.2 of Appendix I to 10CFR50.



12.6 REPORTING REQUIREMENTS12.6.1 Annual Radiological Environmental Operating Report\*

Routine Annual Radiological Environmental Operating Report covering the operation of the Unit(s) during the previous calendar year shall be submitted prior to May 1 (I.T.S. May 15) of each year.

The Annual Radiological Environmental Operating Report shall include summaries, interpretations, and an analysis of trends of the results of the radiological environmental surveillance activities for the report period, including a comparison with preoperational studies, with operational controls as appropriate, and with previous environmental surveillance reports, and an assessment of the observed impacts of the plant operation on the environment.

The Annual Radiological Environmental Operating Report shall include the results of all radiological environmental samples and of all environmental radiation measurements taken during the period pursuant to the locations specified in the tables and figures in Chapter 11 of the ODCM, as well as summarized and tabulated results of these analyses and measurements in the format of the table in the Radiological Assessment Branch Technical Position, Revision 1, November 1979. In the event that some individual results are not available for inclusion with the report, the report shall be submitted noting and explaining the reasons for the missing results. The missing data shall be submitted as soon as possible in a supplementary report.

The reports shall also include the following: a summary description of the Radiological Environmental Monitoring Program; legible maps covering all sampling locations keyed to a table giving distances and directions from the midpoint between the two units; reasons for not conducting the Radiological Environmental Monitoring Program as required by Section 12.5.1, a Table of Missed Samples and a Table of Sample Anomalies for all deviations from the sampling schedule of Table 11.1-1; discussion of environmental sample measurements that exceed the reporting levels of Table 12.5-2 but are not the result of plant effluents, discussion of all analyses in which the LLD required by Table 12.5-3 was not achievable; result of the Land Use Census required by Section 12.5.2; and the results of the licensee participation in an Interlaboratory Comparison Program and the corrective actions being taken if the specified program is not being performed as required by Section 12.5.3.

---

\*A single submittal may be made for a multiple unit station.

12.6 REPORTING REQUIREMENTS (Cont'd)12.6.1 Annual Radiological Environmental Operating Report (Cont'd)

The Annual Radiological Environmental Operating Report shall also include an annual summary of hourly meteorological data collected over the applicable year. This annual summary may be either in the form of an hour-by-hour listing on magnetic tape of wind speed, wind direction, atmospheric stability, and precipitation (if measured), or in the form of joint frequency distributions of wind speed, wind direction, and atmospheric stability. In lieu of submission with the Annual Radiological Environmental Operating Report, the licensee has the option of retaining this summary of required meteorological data on site in a file that shall be provided to the NRC upon request.

The Annual Radiological Environmental Operating Report shall also include an assessment of the radiation doses due to the radioactive liquid and gaseous effluents released from the Unit or Station during the previous calendar year. This report shall also include an assessment of the radiation doses to the most likely exposed MEMBER OF THE PUBLIC from reactor releases and other near-by uranium fuel cycle sources including doses from primary effluent pathways and direct radiation, for the previous calendar year. The assessment of radiation doses shall be performed in accordance with the methodology and parameters in the ODCM, and in compliance with 10CFR20 and 40CFR190, "Environmental Radiation Protection Standards for Nuclear Power Operation."

12.6 REPORTING REQUIREMENTS (Continued)12.6.2 Annual Radioactive Effluent Release Report\*\*

Routine Annual Radioactive Effluent Release Reports covering the operation of the unit during the previous calendar year operation shall be submitted prior to May 1 of the following year.

The Annual Radioactive Effluent Release Reports shall include a summary of the quantities of radioactive liquid and gaseous effluents and solid waste released from the unit as outlined in Regulatory Guide 1.21, "Measuring Evaluating, and Reporting Radioactivity in Solid Wastes and Releases of Radioactive Materials in Liquid and Gaseous Effluents from Light-Water-Cooled Nuclear Power Plants," Revision 1, June 1974, with data summarized on a quarterly basis following the format of Appendix B thereof.

For solid wastes, the format for Table 3 in Appendix B shall be supplemented with three additional categories: class of solid wastes (as defined by 10CFR61), type of container (e.g., LSA, Type A, Type B, Large Quantity), and SOLIDIFICATION agent or absorbent (e.g., cement, urea formaldehyde).

The Annual Radioactive Effluent Release Reports shall include a list and description of unplanned releases from the site to areas beyond the site boundary of radioactive materials in gaseous and liquid effluents made during the reporting period.

The Annual Radioactive Effluent Release Reports shall include any changes made during the reporting period to the PCP, as well as any major changes to Liquid, Gaseous or Solid Radwaste Treatment Systems, pursuant to Section 12.6.3.

The Annual Radioactive Effluent Release Reports shall also include the following: an explanation as to why the inoperability of liquid or gaseous effluent monitoring instrumentation was not corrected within the time specified in Section 12.2.1 or 12.2.2, respectively; and description of the events leading to liquid holdup tanks or gas storage tanks exceeding the limits of Technical Specification 3.11.1.4 or 3.11.2.6 (I.T.S. 5.5.12), respectively.

---

\*\*A single submittal may be made for a multiple unit station. The submittal should combine those sections that are common to all units at the station; however, for units with separate radwaste systems, the submittal shall specify the releases of radioactive material from each unit.

12.6 REPORTING REQUIREMENTS (Continued)12.6.3 Offsite Dose Calculation Manual (ODCM)

12.6.3.1 The ODCM shall be approved by the Commission prior to initial implementation.

12.6.3.2 Licensee-initiated changes to the ODCM:

- a. Shall be documented and records of reviews performed shall be retained as required by Specification 6.10.2 (UFSAR Chapter 17). This documentation shall contain:
  1. Sufficient information to support the change together with the appropriate analyses or evaluations justifying the change(s); and
  2. A determination that the change will maintain the level of radioactive effluent control required by 10CFR20, 40CFR190, 10CFR50.36a, and Appendix I to 10CFR50 and not adversely impact the accuracy or reliability of effluent, dose, or setpoint calculations.
- b. Shall become effective after review and acceptance by the Onsite Review and Investigative Function and the approval of the Plant Manager on the date specified by the Onsite Review and Investigative Function.
- c. Shall be submitted to the Commission in the form of a complete legible copy of the entire ODCM or updated pages if the Commission retains a controlled copy. If an entire copy of the ODCM is submitted, it shall be submitted as part of or concurrent with the Annual Radioactive Effluent Release Report for the period of the report in which any change to the ODCM was made effective. Each change shall be identified by markings in the margin of the affected pages, clearly indicating the area of the page that was changed, and shall indicate the date (e.g., month/year) the change was implemented.

12.6 REPORTING REQUIREMENTS (Continued)12.6.4 Major Changes to Liquid and Gaseous Radwaste Treatment Systems\*

Licensee-initiated major changes to the Radwaste Treatment Systems (liquid and gaseous):

- a. Shall be reported to the Commission in the Annual Radioactive Effluent Release Report for the period in which the evaluation was reviewed by the Onsite Review and Investigative Function. The discussion of each change shall contain:
  - 1) A summary of the evaluation that led to the determination that the change could be made in accordance with 10CFR50.59;
  - 2) Sufficient detailed information to totally support the reason for the change without benefit of additional and supplemental information;
  - 3) A detailed description of the equipment, components, and processes involved and the interfaces with other plant systems;
  - 4) An evaluation of the change which shows the predicted releases of radioactive materials in liquid and gaseous effluents and/or quantity of solid waste that differ from those previously predicted in the License application and amendments thereto;
  - 5) An evaluation of the change, which shows the expected maximum exposures to a MEMBER OF THE PUBLIC and to the general population that differ from those previously estimated in the License application and amendments thereto;
  - 6) A comparison of the predicted releases of radioactive materials, in liquid and gaseous effluents and in solid waste, to the actual releases for the period prior to when the changes are to be made;
  - 7) An estimate of the exposure to plant operating personnel as a result of the change; and
  - 8) Documentation of the fact that the change was reviewed and found acceptable by the Onsite Review and Investigative Function.
- b. Shall become effective upon review and acceptance by the Onsite Review and Investigative Function.

---

\*Licensees may choose to submit the information called for in this section as part of the annual FSAR update.

BRAIDWOOD

Revision 4  
August 1999

APPENDIX F  
BRAIDWOOD ANNEX INDEX  
REVISION 4

APPENDIX F  
STATION-SPECIFIC DATA FOR BRAIDWOOD  
UNITS 1 AND 2  
TABLE OF CONTENTS

		<u>PAGE</u>
F.1	INTRODUCTION	F-1
F.2	REFERENCES	F-1

APPENDIX F  
LIST OF TABLES

<u>NUMBER</u>	<u>TITLE</u>	<u>PAGE</u>
F-1	Aquatic Environmental Dose Parameters	F-2
F-2	Station Characteristics	F-3
F-3	Critical Ranges	F-4
F-4	Average Wind Speeds	F-5
F-5	X/Q and D/Q Maxima At or Beyond the Unrestricted Area Boundary	F-6
F-5a	X/Q and D/Q Maxima At or Beyond the Restricted Area Boundary	F-7
F-6	D/Q at the Nearest Milk Cow and Meat Animal Locations Within 5 Miles	F-8
F-7	Maximum Offsite Finite Plume Gamma Dose Factors Based on 1 cm Depth at the Unrestricted Area Boundary for Selected Nuclides	F-9
F-7a	Maximum Offsite Finite Plume Gamma Dose Factors Based on 1 cm Depth at the Restricted Area Boundary for Selected Nuclides	F-24
<b>Supplemental Tables</b>		
A	Mixed Mode Joint Frequency Distribution Table Summaries - 203 and 34 Foot Elevation Data	F-39
	-Summary Table of Percent by Direction and Class -Summary Table of Percent by Direction and Speed -Summary Table of Percent by Speed and Class	
B	Ground Level Joint Frequency Distribution Table Summaries	F-44
	-Summary Table of Percent by Direction and Class -Summary Table of Percent by Direction and Speed -Summary Table of Percent by Speed and Class	



APPENDIX F  
LIST OF FIGURES

<u>NUMBER</u>	<u>TITLE</u>	<u>PAGE</u>
F-1	Unrestricted Area Boundary	F-46
F-2	Restricted Area Boundary	F-47

APPENDIX F  
STATION-SPECIFIC DATA FOR BRAIDWOOD  
UNITS 1 AND 2

## F.1 INTRODUCTION

This appendix contains data relevant to the Braidwood site. Included is a figure showing the unrestricted area boundary and values of parameters used in offsite dose assessment.

## F.2 REFERENCES

1. Sargent & Lundy, Nuclear Analysis and Technology Division Braidwood Calculation No. ATD-0149, Revisions 0, 1, 2, and 3, 3/30/95 for Braidwood.
2. "Assessment of the Impact of Liquid Radioactive Effluents from Braidwood Station on Proposed Public Water Intakes at Wilmington, Illinois", J.C. Golden NSEP, January 1990.
3. "Verification of Environmental Parameters Used for Commonwealth Edison Company's Offsite Dose Calculations," NUS Corporation, 1988.
4. "Verification of Environmental Parameters Used for Commonwealth Edison Company's Offsite Dose Calculations," NUTECH Engineers Group, 1992.

Table F-1  
Aquatic Environmental Dose Parameters

General Information

There is no irrigation occurring on the Kankakee River downstream of the station.

Recreation includes one or more of the following: boating, waterskiing, swimming, and sport fishing.

Downstream dams are within 50 miles of the station. One is located on the Kankakee. The other is the Illinois River at Dresden Island, Marseilles and Starved Rock. The Kankakee River flows into the Illinois River about 12 river miles downstream of the station.

This is based on information in Figure 2.1-13 of the Braidwood Environmental Report and in Section 2.4.1.1 and Figure 2.4-2 of the LaSalle Environmental Report.

Water and Fish Ingestion Parameters

<u>Parameter<sup>a</sup></u>	<u>Value</u>
U <sup>w</sup> , water usage, L/hr	0.042
U <sup>f</sup> , fish consumption, kg/hr	2.4E-3
1/M <sup>w</sup> , 1/M <sup>f</sup>	0.25, 1.0
F <sup>w</sup> , cfs	3950
F <sup>f</sup> , cfs	3950
t <sup>f</sup> , hr <sup>b</sup>	24.0
t <sup>w</sup> , hr <sup>c</sup>	3.0

Limits on Radioactivity in Unprotected Outdoor Tanks<sup>d</sup>

Outside Temporary Tank  $\leq 10$  Ci<sup>e</sup>

per Technical Specification 5.5.12

<sup>a</sup> The parameters are defined in Section A.2.1 of Appendix A.

<sup>b</sup> t<sup>f</sup> (hr) = 24 hr (all stations) for the fish ingestion pathway

<sup>c</sup> t<sup>w</sup> (hr) = 3 hr (distance nearest potable water intake, to Wilmington, is 4 river miles downstream; a flow rate of 1.4 mph is assumed)

<sup>d</sup> See Section A.2.4 of Appendix A.

<sup>e</sup> Tritium and dissolved or entrained noble gases are excluded from this limit.

Table F-2  
Station Characteristics

STATION: Braidwood

LOCATION: Braceville, Illinois

CHARACTERISTICS OF ELEVATED RELEASE POINT: Not Applicable (NA)

- |                                     |   |
|-------------------------------------|---|
| 1) Release Height = ___m            | 2) Diameter = ___m                      |
| 3) Exit Speed = ___ms <sup>-1</sup> | 4) Heat Content ___Kcal s <sup>-1</sup> |

CHARACTERISTICS OF VENT STACK RELEASE POINT

- |   |                             |
|---|-----------------------------|
| 1) Release Height = <u>60.66</u> m <sup>a</sup> | 2) Diameter = <u>2.80</u> m |
| 3) Exit Speed = <u>11.0</u> ms <sup>-1a</sup>   |                             |

CHARACTERISTICS OF GROUND LEVEL RELEASE

- |   |
|---|
| 1) Release Height = 0 m                             |
| 2) Building Factor (D) = <u>60.6</u> m <sup>a</sup> |

METEOROLOGICAL DATA

A 320 ft Tower is Located 573 m NE of vent stack release point

Tower Data Used in Calculations

Release Point	Wind Speed and Direction	Differential Temperature
<u>Elevated</u>	<u>(NA)</u>	<u>(NA)</u>
<u>Vent</u>	<u>203 ft</u>	<u>199-30 ft</u>
<u>Ground</u>	<u>34 ft</u>	<u>199-30 ft</u>

<sup>a</sup> Used in calculating the meteorological and dose factors in Tables F-5, F-6, and F-7. See Sections B.3 through B.6 of Appendix B.

Table F-3  
Critical Ranges

Direction	Unrestricted Area Boundary <sup>a</sup> (m)	Restricted Area Boundary (m)	Nearest Resident Within 6.2 miles (m)	Nearest Dairy Farm within 6.2 Miles <sup>c</sup> (m)
N	610	305	800	None
NNE	914	265	2800	None
NE	792	299	1100	None
ENE	701	361	1200	None
E	1036	355	1200	None
ESE	2713	425	3500	None
SE	3414	448	4300	None
SSE	3444	540	None	None
S	4633	530	6700	None
SSW	975	540	2000	None
SW	632	632	600	None
WSW	555	555	800	None
W	518	500	600	None
WNW	503	434	600	None
NW	495	428	600	None
NNW	510	442	600	None

<sup>a</sup> See Updated Final Safety Analysis Report Table 2.1-1a and Environmental Report. Used in calculating the meteorological and dose factors in Tables F-5 and F-7. See Sections B.3 through B.6 of Appendix B.

<sup>b</sup> 1998 annual survey by Teledyne Isotopes Midwest Laboratories. The distances are rounded to the nearest conservative 100 meters.

<sup>c</sup> 1998 annual milch animal census, by Teledyne Isotopes Midwest Laboratories. Used in calculating the D/Q values in Table F-6. The distances are rounded to the nearest conservative 100 meters.

Table F-4  
Average Wind Speeds

Downwind Direction	Average Wind Speed (m/sec) <sup>a</sup>		
	<u>Elevated</u> <sup>b</sup>	<u>Mixed Mode</u>	<u>Ground Level</u> <sup>c</sup>
N	7.6	6.0	4.7
NNE	7.5	5.8	4.4
NE	6.1	5.3	3.9
ENE	6.2	5.2	3.7
E	6.6	5.4	4.0
ESE	6.8	5.6	4.3
SE	6.2	5.3	3.9
SSE	5.8	5.2	4.1
S	5.5	4.9	3.6
SSW	5.5	5.0	3.7
SW	5.3	4.8	3.3
WSW	4.7	4.2	2.4
W	5.4	4.4	2.2
WNW	6.0	4.6	2.4
NW	6.0	4.8	3.1
NNW	6.8	5.4	3.9

<sup>a</sup> Based on Braidwood site meteorological data, January 1978 through December 1987. Calculated in Reference 1 of Section F.2, using formulas in Section B.1.3 of Appendix B.

<sup>b</sup> The elevated and ground level values are provided for reference purposes only. Routine dose calculations are performed using the mixed mode values.

Table F-5  
X/Q and D/Q Maxima at or Beyond the Unrestricted Area Boundary

Downwind Direction	Mixed Mode (Vent) Release				Ground Level Release		
	Radius (meters)	X/Q (sec/m**3)	Radius (meters)	D/Q (1/m**2)	Radius (meters)	X/Q (sec/m**3)	D/Q (1/m**2)
N	610.	1.161E-06	610.	1.643E-08	610.	4.646E-06	3.355E-08
NNE	914.	5.076E-07	914.	7.023E-09	914.	1.783E-06	1.382E-08
NE	792.	2.990E-07	792.	4.274E-09	792.	1.738E-06	1.092E-08
ENE	701.	4.281E-07	701.	4.903E-09	701.	2.174E-06	1.310E-08
E	1036.	3.104E-07	1036.	3.780E-09	1036.	1.505E-06	8.551E-09
ESE	2713.	1.065E-07	2713.	1.164E-09	2713.	3.990E-07	1.949E-09
SE	3414.	7.575E-08	3414.	7.225E-10	3414.	2.757E-07	1.088E-09
SSE	3444.	6.028E-08	3444.	6.345E-10	3444.	2.165E-07	1.015E-09
S	4633.	4.068E-08	4633.	2.644E-10	4633.	1.749E-07	4.520E-10
SSW	975.	1.925E-07	975.	2.843E-09	975.	1.333E-06	6.781E-09
SW	632.	5.153E-07	632.	5.408E-09	632.	3.485E-06	1.494E-08
WSW	555.	7.821E-07	555.	4.558E-09	555.	5.471E-06	1.853E-08
W	518.	8.901E-07	518.	5.064E-09	518.	5.902E-06	1.830E-08
WNW	503.	1.077E-06	503.	6.100E-09	503.	6.472E-06	1.913E-08
NW	495.	1.081E-06	495.	8.650E-09	495.	5.501E-06	2.537E-08
NNW	510.	1.098E-06	510.	1.185E-08	510.	5.421E-06	3.023E-08

Braidwood Site Meteorological Data 1/78 - 12/87

Note: Based on Reference 1 of Section F.2 and the formulas in Sections B.3 and B.4 of Appendix B.

X/Q is used for beta skin, and inhalation dose pathways. See Sections A.1.2, A.1.3, and A.1.4.2 of Appendix A.

D/Q is used for produce and leafy vegetable pathways. Section A.1.4 of Appendix A.

The ground level release data are provided for reference purposes only. Routine dose calculations are performed using mixed mode data.

Radius is the approximate distance from the midpoint between gaseous effluent release points to the location of highest X/Q or D/Q at or beyond the unrestricted area boundary (UAB).

Table F-5a

## X/Q and D/Q Maxima at or Beyond the Restricted Area Boundary

Downwind Direction	Mixed Mode (Vent) Release				Ground Level Release		
	Radius (meters)	X/Q (sec/m**3)	Radius (meters)	D/Q (1/m**2)	Radius (meters)	X/Q (sec/m**3)	D/Q (1/m**2)
N	305.	3.766E-06	305.	4.266E-08	305.	1.551E-05	9.627E-08
NNE	265.	3.841E-06	265.	3.855E-08	265.	1.445E-05	9.318E-08
NE	299.	1.412E-06	299.	1.473E-08	299.	8.827E-06	4.892E-08
ENE	361.	1.265E-06	361.	1.138E-08	361.	6.706E-06	3.652E-08
E	355.	1.669E-06	355.	1.590E-08	355.	8.978E-06	4.611E-08
ESE	425.	1.264E-06	425.	1.678E-08	425.	7.012E-06	4.132E-08
SE	448.	1.056E-06	448.	1.266E-08	448.	6.269E-06	3.177E-08
SSE	540.	5.596E-07	540.	8.639E-09	540.	3.673E-06	2.258E-08
S	530.	6.166E-07	530.	5.425E-09	530.	4.576E-06	1.745E-08
SSW	540.	4.441E-07	540.	6.000E-09	540.	3.423E-06	1.748E-08
SW	632.	5.153E-07	632.	5.408E-09	632.	3.485E-06	1.494E-08
WSW	555.	7.821E-07	555.	4.558E-09	555.	5.471E-06	1.853E-08
W	500.	9.431E-07	500.	5.289E-09	500.	6.265E-06	1.932E-08
WNW	434.	1.384E-06	434.	7.394E-09	434.	8.361E-06	2.399E-08
NW	428.	1.381E-06	428.	1.050E-08	428.	7.070E-06	3.170E-08
NNW	442.	1.388E-06	442.	1.444E-08	442.	6.878E-06	3.766E-08

Braidwood Site Meteorological Data 1/78 - 12/87

Note: Based on Reference 1 of Section F.2 and the formulas in Sections B.3 and B.4 of Appendix B.

The ground level release data are provided for reference purposes only. Routine dose calculations are performed using mixed mode data.

Radius is the approximate distance from the midpoint between gaseous effluent release points to the location of highest X/Q or D/Q at or beyond the restricted area boundary (RAB).



Table F-6

D/Q at the Nearest Milk Cow and Meat Animal Locations within 5 miles

Downwind Direction	Nearest Milk Cow D/Q (1/m**2)			Nearest Meat Animal D/Q (1/m**2)		
	Radius (meters)	Mixed Release	Ground Release	Radius (meters)	Mixed Release	Ground Release
N	8000	2.694E-10	4.083E-10	4100	8.404E-10	1.347E-09
NNE	8000	2.158E-10	3.221E-10	8000	2.158E-10	3.221E-10
NE	8000	1.333E-10	2.015E-10	1400	1.999E-09	4.252E-09
ENE	8000	1.305E-10	1.987E-10	5300	2.604E-10	4.153E-10
E	8000	1.614E-10	2.447E-10	3700	5.792E-10	9.701E-10
ESE	8000	1.962E-10	2.874E-10	3700	7.121E-10	1.134E-09
SE	8000	1.779E-10	2.395E-10	4300	4.998E-10	7.250E-10
SSE	8000	1.591E-10	2.270E-10	6600	2.218E-10	3.226E-10
S	8000	1.074E-10	1.704E-10	8000	1.074E-10	1.704E-10
SSW	8000	1.172E-10	1.757E-10	8000	1.172E-10	1.757E-10
SW	8000	1.417E-10	1.921E-10	1900	1.341E-09	2.425E-09
WSW	8000	1.143E-10	1.943E-10	6100	1.800E-10	3.169E-10
W	8000	9.700E-11	1.724E-10	2500	6.142E-10	1.350E-09
WNW	8000	9.286E-11	1.723E-10	8000	9.286E-11	1.723E-10
NW	8000	1.255E-10	2.228E-10	8000	1.255E-10	2.228E-10
NNW	8000	1.639E-10	2.781E-10	8000	1.639E-10	2.781E-10

Braidwood Site Meteorological Data 1/78 - 12/87

Table F-7

Maximum Offsite Finite Plume Gamma Dose Factors Based on 1 cm Depth at the Unrestricted Area Boundary for Kr-83m

Downwind Direction	Unrestricted Area Bound (meters)	Mixed Mode (Vent) Release		Ground Level Release			
		Radius (meters)	V (mrad/yr)/(uCi/sec)	VBAR	Radius (meters)	G (mrad/yr)/(uCi/sec)	GBAR
N	610.	610.	1.455E-04	1.097E-04	610.	5.333E-04	4.021E-04
NNE	914.	914.	6.375E-05	4.807E-05	914.	2.125E-04	1.602E-04
NE	792.	792.	3.828E-05	2.886E-05	792.	2.007E-04	1.513E-04
ENE	701.	701.	5.294E-05	3.992E-05	701.	2.575E-04	1.941E-04
E	1036.	1036.	3.703E-05	2.792E-05	1036.	1.718E-04	1.295E-04
ESE	2713.	2713.	1.129E-05	8.514E-06	2713.	3.792E-05	2.859E-05
SE	3414.	3414.	7.089E-06	5.345E-06	3414.	2.141E-05	1.614E-05
SSE	3444.	3444.	6.047E-06	4.559E-06	3444.	1.798E-05	1.356E-05
S	4633.	4633.	3.224E-06	2.431E-06	4633.	9.268E-06	6.988E-06
SSW	975.	975.	2.363E-05	1.782E-05	975.	1.444E-04	1.088E-04
SW	632.	632.	5.930E-05	4.472E-05	632.	3.694E-04	2.786E-04
WSW	555.	555.	8.469E-05	6.386E-05	555.	5.942E-04	4.480E-04
W	518.	518.	9.909E-05	7.471E-05	518.	6.292E-04	4.744E-04
WNW	503.	503.	1.205E-04	9.082E-05	503.	6.653E-04	5.016E-04
NW	495.	495.	1.242E-04	9.366E-05	495.	6.066E-04	4.574E-04
NNW	510.	510.	1.322E-04	9.969E-05	510.	6.144E-04	4.633E-04

Braidwood Site Meteorological Data 1/78 - 12/87

Note: Based on Reference 1 of Section F.2 and the formulas in Sections B.5 and B.6 of Appendix B.

Routine dose calculations are performed using mixed mode (vent) release data.

Table F-7 (Continued)

Maximum Offsite Finite Plume Gamma Dose Factors Based on 1 cm Depth at the Unrestricted Area Boundary for Kr-85m

Downwind Direction	Unrestricted Area Bound (meters)	Mixed Mode (Vent) Release			Ground Level Release		
		Radius (meters)	V (mrad/yr)/(uCi/sec)	VBAR	Radius (meters)	G (mrad/yr)/(uCi/sec)	GBAR
N	610.	610.	9.989E-04	9.590E-04	610.	2.731E-03	2.164E-03
NNE	914.	914.	4.979E-04	4.785E-04	914.	1.222E-03	1.171E-03
NE	792.	792.	3.618E-04	3.481E-04	792.	1.173E-03	1.124E-03
ENE	701.	701.	4.452E-04	4.280E-04	701.	1.363E-03	1.305E-03
E	1036.	1036.	3.452E-04	3.320E-04	1036.	1.023E-03	9.809E-03
ESE	2713.	2713.	1.220E-04	1.174E-04	2713.	3.051E-04	2.930E-04
SE	3414.	3414.	8.179E-05	7.874E-05	3414.	1.970E-04	1.893E-04
SSE	3444.	3444.	6.958E-05	6.700E-05	3444.	1.634E-04	1.570E-04
S	4633.	4633.	4.000E-05	3.851E-05	4633.	1.051E-04	1.010E-04
SSW	975.	975.	2.413E-04	2.323E-04	975.	9.063E-04	8.688E-04
SW	632.	632.	5.199E-04	4.999E-04	632.	1.989E-03	1.905E-03
WSW	555.	555.	6.707E-04	6.444E-04	555.	3.061E-03	2.929E-03
W	518.	518.	6.908E-04	6.632E-04	518.	3.081E-03	2.947E-03
WNW	503.	503.	7.511E-04	7.204E-04	503.	3.126E-03	2.988E-03
NW	495.	495.	8.396E-04	8.059E-04	495.	2.915E-03	2.788E-03
NNW	510.	510.	9.023E-04	8.662E-04	510.	3.091E-03	2.958E-03

Braidwood Site Meteorological Data 1/78 - 12/87

Table F-7 (Continued)

Maximum Offsite Finite Plume Gamma Dose Factors Based on 1 cm Depth at the Unrestricted Area Boundary for Kr-85

Downwind Direction	Unrestricted Area Bound (meters)	Mixed Mode (Vent) Release			Ground Level Release		
		Radius (meters)	V (mrad/yr)/(uCi/sec)	VBAR	Radius (meters)	G (mrad/yr)/(uCi/sec)	GBAR
N	610.	610.	1.125E-05	1.088E-05	610.	2.986E-05	2.888E-05
NNE	914.	914.	5.661E-06	5.474E-06	914.	1.344E-05	1.300E-05
NE	792.	792.	4.192E-06	4.053E-06	792.	1.311E-05	1.268E-05
ENE	701.	701.	5.150E-06	4.980E-06	701.	1.486E-05	1.437E-05
E	1036.	1036.	4.044E-06	3.911E-06	1036.	1.145E-05	1.107E-05
ESE	2713.	2713.	1.468E-06	1.420E-06	2713.	3.702E-06	3.579E-06
SE	3414.	3414.	1.025E-06	9.911E-07	3414.	2.620E-06	2.534E-06
SSE	3444.	3444.	8.593E-07	8.310E-07	3444.	2.101E-06	2.032E-06
S	4633.	4633.	5.432E-07	5.253E-07	4633.	1.699E-06	1.643E-06
SSW	975.	975.	2.853E-06	2.759E-06	975.	1.042E-05	1.008E-05
SW	632.	632.	6.098E-06	5.897E-06	632.	2.227E-05	2.154E-05
WSW	555.	555.	7.858E-06	7.599E-06	555.	3.400E-05	3.288E-05
W	518.	518.	7.924E-06	7.663E-06	518.	3.388E-05	3.276E-05
WNW	503.	503.	8.499E-06	8.219E-06	503.	3.430E-05	3.317E-05
NW	495.	495.	9.567E-06	9.251E-06	495.	3.174E-05	3.069E-05
NNW	510.	510.	1.025E-05	9.909E-06	510.	3.393E-05	3.281E-05

Braidwood Site Meteorological Data 1/78 - 12/87

Table F-7 (Continued)

Maximum Offsite Finite Plume Gamma Dose Factors Based on 1 cm Depth at the Unrestricted Area Boundary for Kr-87

Downwind Direction	Unrestricted Area Bound (meters)	Mixed Mode (Vent) Release			Ground Level Release		
		Radius (meters)	V (mrad/yr)/(uCi/sec)	VBAR	Radius (meters)	G (mrad/yr)/(uCi/sec)	GBAR
N	610.	610.	3.313E-03	3.217E-03	610.	8.088E-03	7.853E-03
NNE	914.	914.	1.650E-03	1.602E-03	914.	3.649E-03	3.543E-03
NE	792.	792.	1.249E-03	1.213E-03	792.	3.373E-03	3.275E-03
ENE	701.	701.	1.516E-03	1.472E-03	701.	4.077E-03	3.958E-03
E	1036.	1036.	1.150E-04	1.117E-03	1036.	2.954E-03	2.868E-03
ESE	2713.	2713.	3.948E-04	3.834E-04	2713.	8.084E-04	7.849E-04
SE	3414.	3414.	2.559E-04	2.486E-04	3414.	4.691E-04	4.555E-04
SSE	3444.	3444.	2.231E-04	2.167E-04	3444.	4.098E-04	3.979E-04
S	4633.	4633.	1.162E-04	1.129E-04	4633.	2.055E-04	1.996E-04
SSW	975.	975.	8.253E-04	8.015E-04	975.	2.477E-03	2.405E-03
SW	632.	632.	1.758E-03	1.707E-03	632.	5.625E-03	5.462E-03
WSW	555.	555.	2.229E-03	2.165E-03	555.	8.703E-03	8.450E-03
W	518.	518.	2.276E-03	2.210E-03	518.	8.931E-03	8.671E-03
WNW	503.	503.	2.431E-03	2.360E-03	503.	9.052E-03	8.789E-03
NW	495.	495.	2.792E-03	2.711E-03	495.	8.646E-03	8.395E-03
NNW	510.	510.	2.982E-03	2.896E-03	510.	9.023E-03	8.761E-03

Braidwood Site Meteorological Data 1/78 - 12/87

Table F-7 (Continued)

Maximum Offsite Finite Plume Gamma Dose Factors Based on 1 cm Depth at the Unrestricted Area Boundary for Kr-88

Downwind Direction	Unrestricted Area Bound (meters)	Mixed Mode (Vent) Release			Ground Level Release		
		Radius (meters)	V (mrad/yr)/(uCi/sec)	VBAR	Radius (meters)	G (mrad/yr)/(uCi/sec)	GBAR
N	610.	610.	7.997E-03	7.772E-03	610.	1.968E-02	1.911E-02
NNE	914.	914.	4.019E-03	3.906E-03	914.	8.899E-03	8.644E-03
NE	792.	792.	3.059E-03	2.974E-03	792.	8.441E-03	8.199E-03
ENE	701.	701.	3.725E-03	3.621E-03	701.	9.870E-03	9.586E-03
E	1036.	1036.	2.878E-03	2.798E-03	1036.	7.394E-03	7.182E-03
ESE	2713.	2713.	1.022E-03	9.941E-04	2713.	2.215E-03	2.152E-03
SE	3414.	3414.	6.859E-04	6.670E-04	3414.	1.396E-03	1.357E-03
SSE	3444.	3444.	5.929E-04	5.766E-04	3444.	1.185E-03	1.151E-03
S	4633.	4633.	3.301E-04	3.210E-04	4633.	6.987E-04	6.792E-04
SSW	975.	975.	2.066E-03	2.009E-03	975.	6.466E-03	6.281E-03
SW	632.	632.	4.389E-03	4.267E-03	632.	1.422E-02	1.381E-02
WSW	555.	555.	5.589E-03	5.433E-03	555.	2.182E-02	2.119E-02
W	518.	518.	5.607E-03	5.449E-03	518.	2.205E-02	2.141E-02
WNW	503.	503.	5.947E-03	5.779E-03	503.	2.232E-02	2.167E-02
NW	495.	495.	6.814E-03	6.622E-03	495.	2.097E-02	2.036E-02
NNW	510.	510.	7.265E-03	7.060E-03	510.	2.215E-02	2.151E-02

Braidwood Site Meteorological Data 1/78 - 12/87

BRAIDWOOD

Revision 4  
August 1999

Table F-7 (Continued)

Maximum Offsite Finite Plume Gamma Dose Factors Based on 1 cm Depth at the Unrestricted Area Boundary for Kr-89

Downwind Direction	Unrestricted Area Bound (meters)	Mixed Mode (Vent) Release		Ground Level Release			
		Radius (meters)	V (mrad/yr)/(uCi/sec)	VBAR	Radius (meters)	G (mrad/yr)/(uCi/sec)	GBAR
N	610.	610.	4.323E-03	4.199E-03	610.	7.655E-03	7.435E-03
NNE	914.	914.	1.692E-03	1.643E-03	914.	2.645E-03	2.569E-03
NE	792.	792.	1.305E-03	1.268E-03	792.	2.219E-03	2.155E-03
ENE	701.	701.	1.577E-03	1.532E-03	701.	3.016E-03	2.929E-03
E	1036.	1036.	9.092E-04	8.833E-04	1036.	1.387E-03	1.347E-03
ESE	2713.	2713.	1.140E-04	1.108E-04	2713.	9.720E-05	9.442E-05
SE	3414.	3414.	4.392E-05	4.266E-05	3414.	2.983E-05	2.897E-05
SSE	3444.	3444.	3.822E-05	3.712E-05	3444.	3.079E-05	2.990E-05
S	4633.	4633.	9.027E-06	8.769E-06	4633.	6.198E-06	6.021E-06
SSW	975.	975.	6.764E-04	6.571E-04	975.	1.066E-03	1.036E-03
SW	632.	632.	1.750E-03	1.700E-03	632.	3.181E-03	3.089E-03
WSW	555.	555.	2.009E-03	1.951E-03	555.	4.608E-03	4.475E-03
W	518.	518.	2.170E-03	2.108E-03	518.	4.949E-03	4.807E-03
WNW	503.	503.	2.410E-03	2.341E-03	503.	5.589E-03	5.428E-03
NW	495.	495.	3.227E-03	3.134E-03	495.	7.228E-03	7.020E-03
NNW	510.	510.	3.714E-03	3.608E-03	510.	7.735E-03	7.512E-03

Braidwood Site Meteorological Data 1/78 - 12/87

Table F-7 (Continued)

Maximum Offsite Finite Plume Gamma Dose Factors Based on 1 cm Depth at the Unrestricted Area Boundary for Kr-90

Downwind Direction	Unrestricted Area Bound (meters)	Mixed Mode (Vent) Release		Ground Level Release			
		Radius (meters)	V (mrad/yr)/(uCi/sec)	VBAR	Radius (meters)	G (mrad/yr)/(uCi/sec)	GBAR
N	610.	610.	8.576E-04	8.317E-04	610.	9.142E-04	8.863E-04
NNE	914.	914.	1.453E-04	1.409E-04	914.	1.212E-04	1.175E-04
NE	792.	792.	1.302E-04	1.263E-04	792.	1.132E-04	1.098E-04
ENE	701.	701.	1.874E-04	1.817E-04	701.	1.634E-04	1.584E-04
E	1036.	1036.	5.480E-05	5.316E-05	1036.	3.996E-05	3.875E-05
ESE	2713.	2713.	2.691E-07	2.610E-07	2713.	1.795E-07	1.741E-07
SE	3414.	3414.	1.662E-08	1.612E-08	3414.	6.748E-09	6.546E-09
SSE	3444.	3444.	2.647E-08	2.568E-08	3444.	2.033E-08	1.972E-08
S	4633.	4633.	5.354E-10	5.193E-10	4633.	3.704E-10	3.592E-10
SSW	975.	975.	4.411E-05	4.278E-05	975.	3.803E-05	3.688E-05
SW	632.	632.	2.254E-04	2.186E-04	632.	1.980E-04	1.920E-04
WSW	555.	555.	2.280E-04	2.212E-04	555.	1.855E-04	1.799E-04
W	518.	518.	2.822E-04	2.738E-04	518.	1.673E-04	1.622E-04
WNW	503.	503.	3.444E-04	3.341E-04	503.	2.412E-04	2.339E-04
NW	495.	495.	5.611E-04	5.442E-04	495.	5.535E-04	5.366E-04
NNW	510.	510.	8.014E-04	7.772E-04	510.	9.221E-04	8.940E-04

Braidwood Site Meteorological Data 1/78 - 12/87



Table F-7 (Continued)

Maximum Offsite Finite Plume Gamma Dose Factors Based on 1 cm Depth at the Unrestricted Area Boundary for Xe-131m

Downwind Direction	Unrestricted Area Bound (meters)	Mixed Mode (Vent) Release		Ground Level Release			
		Radius (meters)	V (mrad/yr)/(uCi/sec)	VBAR	Radius (meters)	G (mrad/yr)/(Uci/sec)	GBAR
N	610.	610.	1.355E-04	1.065E-04	610.	4.922E-04	3.831E-04
NNE	914.	914.	6.125E-05	4.839E-05	914.	1.988E-04	1.553E-04
NE	792.	792.	3.806E-05	3.031E-05	792.	1.946E-04	1.520E-04
ENE	701.	701.	5.153E-05	4.083E-05	701.	2.358E-04	1.838E-04
E	1036.	1036.	3.805E-05	3.024E-05	1036.	1.677E-04	1.310E-04
ESE	2713.	2713.	1.232E-05	9.849E-06	2713.	4.412E-05	3.474E-05
SE	3414.	3414.	8.612E-06	6.883E-06	3414.	3.046E-05	2.401E-05
SSE	3444.	3444.	6.862E-06	5.499E-06	3444.	2.387E-05	1.883E-05
S	4633.	4633.	4.603E-06	3.676E-06	4633.	1.914E-05	1.510E-05
SSW	975.	975.	2.441E-05	1.949E-05	975.	1.504E-04	1.176E-04
SW	632.	632.	6.073E-05	4.813E-05	632.	3.620E-04	2.819E-04
WSW	555.	555.	8.569E-05	6.762E-05	555.	5.701E-04	4.435E-04
W	518.	518.	9.576E-05	7.527E-05	518.	5.874E-04	4.565E-04
WNW	503.	503.	1.132E-04	8.870E-05	503.	6.171E-04	4.790E-04
NW	495.	495.	1.167E-04	9.171E-05	495.	5.515E-04	4.285E-04
NNW	510.	510.	1.244E-04	9.777E-05	510.	5.698E-04	4.432E-04

Braidwood Site Meteorological Data 1/78 - 12/87

Table F-7 (Continued)

Maximum Offsite Finite Plume Gamma Dose Factors Based on 1 cm Depth at the Unrestricted Area Boundary for Xe-133m

Downwind Direction	Unrestricted Area Bound (meters)	Mixed Mode (Vent) Release		Ground Level Release			
		Radius (meters)	V (mrad/yr)/(uCi/sec)	VBAR	Radius (meters)	G (mrad/yr)/(uCi/sec)	GBAR
N	610.	610.	2.561E-04	2.223E-04	610.	8.256E-04	7.023E-04
NNE	914.	914.	1.216E-04	1.063E-04	914.	3.481E-04	2.984E-04
NE	792.	792.	8.185E-05	7.244E-05	792.	3.399E-04	2.912E-04
ENE	701.	701.	1.055E-04	9.274E-05	701.	4.017E-04	3.426E-04
E	1036.	1036.	8.032E-05	7.091E-05	1036.	2.943E-04	2.524E-04
ESE	2713.	2713.	2.749E-05	2.446E-05	2713.	8.394E-05	7.303E-05
SE	3414.	3414.	1.908E-05	1.697E-05	3414.	5.806E-05	5.060E-05
SSE	3444.	3444.	1.562E-05	1.394E-05	3444.	4.609E-05	4.022E-05
S	4633.	4633.	1.005E-05	8.929E-06	4633.	3.632E-05	3.171E-05
SSW	975.	975.	5.390E-05	4.788E-05	975.	2.651E-04	2.276E-04
SW	632.	632.	1.243E-04	1.092E-04	632.	6.091E-04	5.186E-04
WSW	555.	555.	1.679E-04	1.466E-04	555.	9.488E-04	8.060E-04
W	518.	518.	1.799E-04	1.560E-04	518.	9.658E-04	8.185E-04
WNW	503.	503.	2.046E-04	1.763E-04	503.	1.001E-03	8.459E-04
NW	495.	495.	2.185E-04	1.894E-04	495.	9.067E-04	7.683E-04
NNW	510.	510.	2.337E-04	2.027E-04	510.	9.487E-04	8.059E-04

Braidwood Site Meteorological Data 1/78 - 12/87

Table F-7 (Continued)

Maximum Offsite Finite Plume Gamma Dose Factors Based on 1 cm Depth at the Unrestricted Area Boundary for Xe-133

Downwind Direction	Unrestricted Area Bound (meters)	Mixed Mode (Vent) Release			Ground Level Release		
		Radius (meters)	V (mrad/yr)/(uCi/sec)	VBAR	Radius (meters)	G (mrad/yr)/(uCi/sec)	GBAR
N	610.	610.	2.824E-04	2.536E-04	610.	9.100E-04	8.050E-04
NNE	914.	914.	1.355E-04	1.224E-04	914.	3.891E-04	3.466E-04
NE	792.	792.	9.079E-05	8.273E-05	792.	3.804E-04	3.389E-04
ENE	701.	701.	1.161E-04	1.052E-04	701.	4.450E-04	3.946E-04
E	1036.	1036.	8.914E-05	8.108E-05	1036.	3.295E-04	2.937E-04
ESE	2713.	2713.	3.072E-05	2.812E-05	2713.	9.583E-05	8.640E-05
SE	3414.	3414.	2.135E-05	1.953E-05	3414.	6.660E-05	6.011E-05
SSE	3444.	3444.	1.740E-05	1.596E-05	3444.	5.275E-05	4.767E-05
S	4633.	4633.	1.130E-05	1.033E-05	4633.	4.215E-05	3.809E-05
SSW	975.	975.	5.975E-05	5.460E-05	975.	2.978E-04	2.657E-04
SW	632.	632.	1.367E-04	1.238E-04	632.	6.726E-04	5.954E-04
WSW	555.	555.	1.830E-04	1.649E-04	555.	1.044E-03	9.224E-04
W	518.	518.	1.965E-04	1.762E-04	518.	1.056E-03	9.311E-04
WNW	503.	503.	2.231E-04	1.990E-04	503.	1.088E-03	9.570E-04
NW	495.	495.	2.383E-04	2.135E-04	495.	9.911E-04	8.736E-04
NNW	510.	510.	2.563E-04	2.299E-04	510.	1.044E-03	9.221E-04

Braidwood Site Meteorological Data 1/78 - 12/87

Table F-7 (Continued)

Maximum Offsite Finite Plume Gamma Dose Factors Based on 1 cm Depth at the Unrestricted Area Boundary for Xe-135m

Downwind Direction	Unrestricted Area Bound (meters)	Mixed Mode (Vent) Release			Ground Level Release		
		Radius (meters)	V (mrad/yr)/(uCi/sec)	VBAR	Radius (meters)	G (mrad/yr)/(uCi/sec)	GBAR
N	610.	610.	1.924E-03	1.856E-03	610.	4.403E-03	4.240E-03
NNE	914.	914.	9.071E-04	8.750E-04	914.	1.913E-03	1.843E-03
NE	792.	792.	6.745E-04	6.509E-04	792.	1.628E-03	1.568E-03
ENE	701.	701.	8.149E-04	7.862E-04	701.	2.191E-03	2.110E-03
E	1036.	1036.	5.710E-04	5.510E-04	1036.	1.368E-03	1.319E-03
ESE	2713.	2713.	1.557E-04	1.503E-04	2713.	2.479E-04	2.391E-04
SE	3414.	3414.	8.843E-05	8.536E-05	3414.	1.163E-04	1.122E-04
SSE	3444.	3444.	7.741E-05	7.472E-05	3444.	1.062E-04	1.025E-04
S	4633.	4633.	3.277E-05	3.163E-05	4633.	4.020E-05	3.879E-05
SSW	975.	975.	4.100E-04	3.957E-04	975.	1.011E-03	9.747E-04
SW	632.	632.	8.898E-04	8.587E-04	632.	2.532E-03	2.439E-03
WSW	555.	555.	1.092E-03	1.054E-03	555.	3.989E-03	3.842E-03
W	518.	518.	1.187E-03	1.145E-03	518.	4.362E-03	4.200E-03
WNW	503.	503.	1.304E-03	1.258E-03	503.	4.495E-03	4.327E-03
NW	495.	495.	1.546E-03	1.490E-03	495.	4.695E-03	4.521E-03
NNW	510.	510.	1.673E-03	1.613E-03	510.	4.688E-03	4.514E-03

Braidwood Site Meteorological Data 1/78 - 12/87

BRAIDWOOD

Revision 4  
August 1999

Table F-7 (Continued)

Maximum Offsite Finite Plume Gamma Dose Factors Based on 1 cm Depth at the Unrestricted Area Boundary for Xe-135

Downwind Direction	Unrestricted Area Bound (meters)	Mixed Mode (Vent) Release		Ground Level Release			
		Radius (meters)	V (mrad/yr)/(uCi/sec)	VBAR	Radius (meters)	G (mrad/yr)/(uCi/sec)	GBAR
N	610.	610.	1.353E-03	1.307E-03	610.	3.674E-03	3.548E-03
NNE	914.	914.	6.781E-04	6.554E-04	914.	1.652E-03	1.596E-03
NE	792.	792.	4.952E-04	4.788E-04	792.	1.599E-03	1.545E-03
ENE	701.	701.	6.084E-04	5.880E-04	701.	1.833E-03	1.770E-03
E	1036.	1036.	4.753E-04	4.595E-04	1036.	1.395E-03	1.348E-03
ESE	2713.	2713.	1.700E-04	1.644E-04	2713.	4.326E-04	4.181E-04
SE	3414.	3414.	1.160E-04	1.121E-04	3414.	2.914E-04	2.816E-04
SSE	3444.	3444.	9.782E-05	9.459E-05	3444.	2.377E-04	2.297E-04
S	4633.	4633.	5.868E-05	5.674E-05	4633.	1.698E-04	1.641E-04
SSW	975.	975.	3.328E-04	3.217E-04	975.	1.253E-03	1.211E-03
SW	632.	632.	7.144E-04	6.906E-04	632.	2.708E-03	2.615E-03
WSW	555.	555.	9.205E-04	8.896E-04	555.	4.150E-03	4.007E-03
W	518.	518.	9.408E-04	9.091E-04	518.	4.151E-03	4.008E-03
WNW	503.	503.	1.018E-03	9.833E-04	503.	4.203E-03	4.058E-03
NW	495.	495.	1.139E-03	1.101E-03	495.	3.908E-03	3.773E-03
NNW	510.	510.	1.225E-03	1.183E-03	510.	4.166E-03	4.022E-03

Braidwood Site Meteorological Data 1/78 - 12/87

Table F-7 (Continued)

Maximum Offsite Finite Plume Gamma Dose Factors Based on 1 cm Depth at the Unrestricted Area Boundary for Xe-137

Downwind Direction	Unrestricted Area Bound (meters)	Mixed Mode (Vent) Release		Ground Level Release			
		Radius (meters)	V (mrad/yr)/(uCi/sec)	VBAR (mrad/yr)/(uCi/sec)	Radius (meters)	G (mrad/yr)/(uCi/sec)	GBAR (mrad/yr)/(uCi/sec)
N	610.	610.	6.360E-04	6.154E-04	610.	1.202E-03	1.164E-03
NNE	914.	914.	2.578E-04	2.494E-04	914.	4.345E-04	4.205E-04
NE	792.	792.	1.950E-04	1.887E-04	792.	3.640E-04	3.522E-04
ENE	701.	701.	2.355E-04	2.279E-04	701.	4.977E-04	4.816E-04
E	1036.	1036.	1.407E-04	1.361E-04	1036.	2.400E-04	2.322E-04
ESE	2713.	2713.	2.042E-05	1.976E-05	2713.	1.931E-05	1.868E-05
SE	3414.	3414.	8.468E-06	8.195E-06	3414.	6.393E-06	6.186E-06
SSE	3444.	3444.	7.384E-06	7.146E-06	3444.	6.474E-06	6.265E-06
S	4633.	4633.	1.951E-06	1.888E-06	4633.	1.457E-06	1.410E-06
SSW	975.	975.	1.038E-04	1.004E-04	975.	1.812E-04	1.753E-04
SW	632.	632.	2.577E-04	2.493E-04	632.	5.246E-04	5.076E-04
WSW	555.	555.	2.977E-04	2.881E-04	555.	7.771E-04	7.519E-04
W	518.	518.	3.247E-04	3.143E-04	518.	8.444E-04	8.170E-04
WNW	503.	503.	3.635E-04	3.517E-04	503.	9.371E-04	9.067E-04
NW	495.	495.	4.769E-04	4.615E-04	495.	1.167E-03	1.129E-03
NNW	510.	510.	5.441E-04	5.265E-04	510.	1.222E-03	1.182E-03

Braidwood Site Meteorological Data 1/78 - 12/87

Table F-7 (Continued)

Maximum Offsite Finite Plume Gamma Dose Factors Based on 1 cm Depth at the Unrestricted Area Boundary for Xe-138

Downwind Direction	Unrestricted Area Bound (meters)	Mixed Mode (Vent) Release			Ground Level Release		
		Radius (meters)	V (mrad/yr)/(uCi/sec)	VBAR	Radius (meters)	G (mrad/yr)/(uCi/sec)	GBAR
N	610.	610.	4.201E-03	4.079E-03	610.	9.169E-03	8.898E-03
NNE	914.	914.	1.982E-03	1.925E-03	914.	3.986E-03	3.869E-03
NE	792.	792.	1.504E-03	1.460E-03	792.	3.379E-03	3.280E-03
ENE	701.	701.	1.805E-03	1.753E-03	701.	4.549E-03	4.415E-03
E	1036.	1036.	1.262E-03	1.225E-03	1036.	2.830E-03	2.747E-03
ESE	2713.	2713.	3.395E-04	3.297E-04	2713.	5.079E-04	4.931E-04
SE	3414.	3414.	1.926E-04	1.871E-04	3414.	2.381E-04	2.312E-04
SSE	3444.	3444.	1.685E-04	1.636E-04	3444.	2.185E-04	2.121E-04
S	4633.	4633.	7.045E-05	6.842E-05	4633.	8.174E-05	7.937E-05
SSW	975.	975.	9.144E-04	8.880E-04	975.	2.091E-03	2.030E-03
SW	632.	632.	1.991E-03	1.934E-03	632.	5.266E-03	5.072E-03
WSW	555.	555.	2.429E-03	2.359E-03	555.	8.199E-03	7.957E-03
W	518.	518.	2.609E-03	2.534E-03	518.	8.973E-03	8.708E-03
WNW	503.	503.	2.834E-03	2.751E-03	503.	9.247E-03	8.973E-03
NW	495.	495.	3.387E-03	3.288E-03	495.	9.733E-03	9.445E-03
NNW	510.	510.	3.657E-03	3.551E-03	510.	9.712E-03	9.425E-03

Braidwood Site Meteorological Data 1/78 - 12/87

Table F-7 (Continued)

Maximum Offsite Finite Plume Gamma Dose Factors Based on 1 cm Depth at the Unrestricted Area Boundary for Ar-41

Downwind Direction	Unrestricted Area Bound (meters)	Mixed Mode (Vent) Release		Ground Level Release			
		Radius (meters)	V (mrad/yr)/(uCi/sec)	VBAR	Radius (meters)	G (mrad/yr)/(uCi/sec)	GBAR
N	610.	610.	5.141E-03	4.977E-03	610.	1.283E-02	1.242E-02
NNE	914.	914.	2.568E-03	2.485E-03	914.	5.780E-03	5.595E-03
NE	792.	792.	1.935E-03	1.873E-03	792.	5.421E-03	5.248E-03
ENE	701.	701.	2.357E-03	2.282E-03	701.	6.445E-03	6.239E-03
E	1036.	1036.	1.803E-03	1.746E-03	1036.	4.745E-03	4.593E-03
ESE	2713.	2713.	6.281E-04	6.080E-04	2713.	1.352E-03	1.309E-03
SE	3414.	3414.	4.128E-04	3.996E-04	3414.	8.140E-04	7.880E-04
SSE	3444.	3444.	3.580E-04	3.466E-04	3444.	7.007E-04	6.783E-04
S	4633.	4633.	1.924E-04	1.862E-04	4633.	3.770E-04	3.650E-04
SSW	975.	975.	1.289E-03	1.247E-03	975.	4.067E-03	3.937E-03
SW	632.	632.	1.991E-03	1.934E-03	632.	9.104E-03	8.813E-03
WSW	555.	555.	2.429E-03	2.359E-03	555.	1.404E-02	1.359E-02
W	518.	518.	3.562E-03	3.448E-03	518.	1.430E-02	1.384E-02
WNW	503.	503.	3.806E-03	3.685E-03	503.	1.449E-02	1.403E-02
NW	495.	495.	4.350E-03	4.211E-03	495.	1.371E-02	1.327E-02
NNW	510.	510.	4.647E-03	4.498E-03	510.	1.439E-02	1.393E-02

Braidwood Site Meteorological Data 1/78 - 12/87



Table F-7a

Maximum Offsite Finite Plume Gamma Dose Factors Based on 1 cm Depth at the Restricted Area Boundary for Kr-83m

Downwind Direction	Restricted Area Bound (meters)	Mixed Mode (Vent) Release		Ground Level Release			
		Radius (meters)	V (mrad/yr)/(uCi/sec)	VBAR	Radius (meters)	G (mrad/yr)/(uCi/sec)	GBAR
N	305.	305.	3.994E-04	3.012E-04	305.	1.521E-03	1.147E-03
NNE	265.	265.	3.883E-04	2.928E-04	265.	1.406E-03	1.060E-03
NE	299.	299.	1.555E-04	1.173E-04	299.	9.211E-04	6.945E-04
ENE	361.	361.	1.372E-04	1.034E-04	361.	7.062E-04	5.325E-04
E	355.	355.	1.785E-04	1.346E-04	355.	9.139E-04	6.891E-04
ESE	425.	425.	1.505E-04	1.135E-04	425.	7.634E-04	5.756E-04
SE	448.	448.	1.196E-04	9.017E-05	448.	6.583E-04	4.964E-04
SSE	540.	540.	6.996E-05	5.275E-05	540.	4.053E-04	3.056E-04
S	530.	530.	6.499E-05	4.900E-05	530.	4.639E-04	3.498E-04
SSW	540.	540.	5.532E-05	4.171E-05	540.	3.829E-04	2.887E-04
SW	632.	632.	5.930E-05	4.472E-05	632.	3.694E-04	2.786E-04
WSW	555.	555.	8.469E-05	6.386E-05	555.	5.942E-04	4.480E-04
W	500.	500.	1.045E-04	7.876E-05	500.	6.646E-04	5.011E-04
WNW	434.	434.	1.497E-04	1.129E-04	434.	8.320E-04	6.273E-04
NW	428.	428.	1.537E-04	1.159E-04	428.	7.562E-04	5.702E-04
NNW	442.	442.	1.633E-04	1.231E-04	442.	7.667E-04	5.781E-04

Braidwood Site Meteorological Data 1/78 - 12/87

---

Note: Based on Reference 1 of Section F.2 and the formulas in Sections B.5 and B.6 of Appendix B.

Routine dose calculations are performed using mixed mode release data.

Table F-7a (Continued)

Maximum Offsite Finite Plume Gamma Dose Factors Based on 1 cm Depth at the Restricted Area Boundary for Kr-85m

Downwind Direction	Restricted Area Bound (meters)	Mixed Mode (Vent) Release		Ground Level Release			
		Radius (meters)	V (mrad/yr)/(uCi/sec)	VBAR	Radius (meters)	G (mrad/yr)/(uCi/sec)	GBAR
N	305.	305.	2.263E-03	2.169E-03	305.	6.552E-03	6.259E-03
NNE	265.	265.	2.146E-03	2.056E-03	265.	5.928E-03	5.662E-03
NE	299.	299.	1.094E-03	1.050E-03	299.	4.111E-03	3.928E-03
ENE	361.	361.	9.475E-04	9.097E-04	361.	3.165E-03	3.025E-03
E	355.	355.	1.197E-03	1.149E-03	355.	4.072E-03	3.891E-03
ESE	425.	425.	1.073E-03	1.031E-03	425.	3.584E-03	3.427E-03
SE	448.	448.	9.074E-04	8.718E-04	448.	3.167E-03	3.029E-03
SSE	540.	540.	6.068E-04	5.836E-04	540.	2.086E-03	1.997E-03
S	530.	530.	5.227E-04	5.023E-04	530.	2.351E-03	2.249E-03
SSW	540.	540.	4.797E-04	4.613E-04	540.	1.999E-03	1.913E-03
SW	632.	632.	5.199E-04	4.999E-04	632.	1.989E-03	1.905E-03
WSW	555.	555.	6.707E-04	6.444E-04	555.	3.061E-03	2.929E-03
W	500.	500.	7.204E-04	6.915E-04	500.	3.224E-03	3.083E-03
WNW	434.	434.	8.947E-04	8.578E-04	434.	3.764E-03	3.597E-03
NW	428.	428.	9.954E-04	9.552E-04	428.	3.505E-03	3.351E-03
NNW	442.	442.	1.068E-03	1.025E-03	442.	3.712E-03	3.551E-03

Braidwood Site Meteorological Data 1/78 - 12/87

BRAIDWOOD

Revision 4  
August 1999

Table F-7a (Continued)

Maximum Offsite Finite Plume Gamma Dose Factors Based on 1 cm Depth at the Restricted Area Boundary for Kr-85

Downwind Direction	Restricted Area Bound (meters)	Mixed Mode (Vent) Release		Ground Level Release			
		Radius (meters)	V (mrad/yr)/(uCi/sec)	VBAR	Radius (meters)	G (mrad/yr)/(uCi/sec)	GBAR
N	305.	305.	2.521E-05	2.437E-05	305.	7.053E-05	6.820E-05
NNE	265.	265.	2.389E-05	2.310E-05	265.	6.351E-05	6.141E-05
NE	299.	299.	1.248E-05	1.207E-05	299.	4.443E-05	4.296E-05
ENE	361.	361.	1.083E-05	1.047E-05	361.	3.404E-05	3.292E-05
E	355.	355.	1.366E-05	1.320E-05	355.	4.396E-05	4.251E-05
ESE	425.	425.	1.220E-05	1.180E-05	425.	3.889E-05	3.760E-05
SE	448.	448.	1.042E-05	1.008E-05	448.	3.470E-05	3.355E-05
SSE	540.	540.	7.029E-06	6.797E-06	540.	2.290E-05	2.215E-05
S	530.	530.	6.111E-06	5.909E-06	530.	2.632E-05	2.545E-05
SSW	540.	540.	5.594E-06	5.409E-06	540.	2.217E-05	2.144E-05
SW	632.	632.	6.098E-06	5.897E-06	632.	2.227E-05	2.154E-05
WSW	555.	555.	7.858E-06	7.599E-06	555.	3.400E-05	3.288E-05
W	500.	500.	8.255E-06	7.983E-06	500.	3.541E-05	3.424E-05
WNW	434.	434.	1.009E-05	9.757E-06	434.	4.111E-05	3.976E-05
NW	428.	428.	1.131E-05	1.093E-05	428.	3.802E-05	3.677E-05
NNW	442.	442.	1.209E-05	1.169E-05	442.	4.056E-05	3.922E-05

Braidwood Site Meteorological Data 1/78 - 12/87

Table F-7a (Continued)

Maximum Offsite Finite Plume Gamma Dose Factors Based on 1 cm Depth at the Restricted Area Boundary for Kr-87

Downwind Direction	Restricted Area Bound (meters)	Mixed Mode (Vent) Release			Ground Level Release		
		Radius (meters)	V (mrad/yr)/(uCi/sec)	VBAR	Radius (meters)	G (mrad/yr)/(uCi/sec)	GBAR
N	305.	305.	7.480E-03	7.264E-03	305.	1.972E-02	1.915E-02
NNE	265.	265.	7.100E-03	6.895E-03	265.	1.802E-02	1.749E-02
NE	299.	299.	3.780E-03	3.671E-03	299.	1.225E-02	1.189E-02
ENE	361.	361.	3.246E-03	3.152E-03	361.	9.572E-03	9.294E-03
E	355.	355.	4.060E-03	3.943E-03	355.	1.220E-02	1.185E-02
ESE	425.	425.	3.644E-03	3.539E-03	425.	1.068E-02	1.037E-02
SE	448.	448.	3.081E-03	2.992E-03	448.	9.262E-03	8.992E-03
SSE	540.	540.	2.111E-03	2.050E-03	540.	6.149E-03	5.971E-03
S	530.	530.	1.762E-03	1.711E-03	530.	6.549E-03	6.359E-03
SSW	540.	540.	1.664E-03	1.616E-03	540.	5.727E-03	5.561E-03
SW	632.	632.	1.758E-03	1.707E-03	632.	5.625E-03	5.462E-03
WSW	555.	555.	2.229E-03	2.165E-03	555.	8.703E-03	8.450E-03
W	500.	500.	2.375E-03	2.306E-03	500.	9.363E-03	9.090E-03
WNW	434.	434.	2.903E-03	2.818E-03	434.	1.098E-02	1.066E-02
NW	428.	428.	3.315E-03	3.219E-03	428.	1.044E-02	1.014E-02
NNW	442.	442.	3.533E-03	3.431E-03	442.	1.090E-02	1.058E-02

Braidwood Site Meteorological Data 1/78 - 12/87

Table F-7a (Continued)

Maximum Offsite Finite Plume Gamma Dose Factors Based on 1 cm Depth at the Restricted Area Boundary for Kr-88

Downwind Direction	Restricted Area Bound (meters)	Mixed Mode (Vent) Release		Ground Level Release			
		Radius (meters)	V (mrad/yr)/(uCi/sec)	VBAR	Radius (meters)	G (mrad/yr)/(uCi/sec)	GBAR
N	305.	305.	1.790E-02	1.739E-02	305.	4.712E-02	4.574E-02
NNE	265.	265.	1.698E-02	1.650E-02	265.	4.272E-02	4.146E-02
NE	299.	299.	9.121E-03	8.865E-03	299.	2.947E-02	2.861E-02
ENE	361.	361.	7.868E-03	7.647E-03	361.	2.281E-02	2.214E-02
E	355.	355.	9.873E-03	9.595E-03	355.	2.928E-02	2.842E-02
ESE	425.	425.	8.818E-03	8.571E-03	425.	2.578E-02	2.503E-02
SE	448.	448.	7.516E-03	7.306E-03	448.	2.271E-02	2.205E-02
SSE	540.	540.	5.155E-03	5.012E-03	540.	1.505E-02	1.462E-02
S	530.	530.	4.382E-03	4.260E-03	530.	1.666E-02	1.618E-02
SSW	540.	540.	4.092E-03	3.978E-03	540.	1.429E-02	1.388E-02
SW	632.	632.	4.389E-03	4.267E-03	632.	1.422E-02	1.381E-02
WSW	555.	555.	5.589E-03	5.433E-03	555.	2.182E-02	2.119E-02
W	500.	500.	5.844E-03	5.680E-03	500.	2.308E-02	2.241E-02
WNW	434.	434.	7.074E-03	6.873E-03	434.	2.690E-02	2.612E-02
NW	428.	428.	8.064E-03	7.837E-03	428.	2.520E-02	2.447E-02
NNW	442.	442.	8.580E-03	8.338E-03	442.	2.660E-02	2.583E-02

Braidwood Site Meteorological Data 1/78 - 12/87

Table F-7a (Continued)

Maximum Offsite Finite Plume Gamma Dose Factors Based on 1 cm Depth at the Restricted Area Boundary for Kr-89

Downwind Direction	Restricted Area Bound (meters)	Mixed Mode (Vent) Release		Ground Level Release			
		Radius (meters)	V (mrad/yr)/(uCi/sec)	VBAR	Radius (meters)	G (mrad/yr)/(uCi/sec)	GBAR
N	305.	305.	1.243E-02	1.208E-02	305.	2.613E-02	2.538E-02
NNE	265.	265.	1.213E-02	1.178E-02	265.	2.655E-02	2.579E-02
NE	299.	299.	6.070E-03	5.896E-03	299.	1.438E-02	1.397E-02
ENE	361.	361.	4.638E-03	4.506E-03	361.	1.132E-02	1.099E-02
E	355.	355.	5.715E-03	5.551E-03	355.	1.360E-02	1.321E-02
ESE	425.	425.	5.133E-03	4.986E-03	425.	1.084E-02	1.053E-02
SE	448.	448.	4.043E-03	3.927E-03	448.	8.014E-03	7.784E-03
SSE	540.	540.	2.636E-03	2.561E-03	540.	5.137E-03	4.990E-03
S	530.	530.	1.936E-03	1.880E-03	530.	4.055E-03	3.938E-03
SSW	540.	540.	1.970E-03	1.914E-03	540.	4.039E-03	3.922E-03
SW	632.	632.	1.750E-03	1.700E-03	632.	3.181E-03	3.089E-03
WSW	555.	555.	2.009E-03	1.951E-03	555.	4.608E-03	4.475E-03
W	500.	500.	2.313E-03	2.247E-03	500.	5.385E-03	5.230E-03
WNW	434.	434.	3.129E-03	3.040E-03	434.	7.749E-03	7.526E-03
NW	428.	428.	4.110E-03	3.993E-03	428.	9.703E-03	9.424E-03
NNW	442.	442.	4.671E-03	4.537E-03	442.	1.017E-02	9.878E-03

Braidwood Site Meteorological Data 1/78 - 12/87

Table F-7a (Continued)

Maximum Offsite Finite Plume Gamma Dose Factors Based on 1 cm Depth at the Restricted Area Boundary for Kr-90

Downwind Direction	Restricted Area Bound (meters)	Mixed Mode (Vent) Release			Ground Level Release		
		Radius (meters)	V (mrad/yr)/(uCi/sec)	VBAR	Radius (meters)	G (mrad/yr)/(uCi/sec)	GBAR
N	305.	305.	5.688E-03	5.515E-03	305.	8.218E-03	7.966E-03
NNE	265.	265.	6.051E-03	5.868E-03	265.	9.375E-03	9.087E-03
NE	299.	299.	2.447E-03	2.374E-03	299.	3.836E-03	3.719E-03
ENE	361.	361.	1.410E-03	1.367E-03	361.	1.941E-03	1.882E-03
E	355.	355.	1.896E-03	1.839E-03	355.	2.575E-03	2.496E-03
ESE	425.	425.	1.516E-03	1.470E-03	425.	1.818E-03	1.762E-03
SE	448.	448.	1.032E-03	1.001E-03	448.	1.147E-03	1.112E-03
SSE	540.	540.	5.186E-04	5.030E-04	540.	6.013E-04	5.830E-04
S	530.	530.	3.564E-04	3.457E-04	530.	4.307E-04	4.176E-04
SSW	540.	540.	3.743E-04	3.630E-04	540.	4.345E-04	4.213E-04
SW	632.	632.	2.254E-04	2.186E-04	632.	1.980E-04	1.920E-04
WSW	555.	555.	2.280E-04	2.212E-04	555.	1.855E-04	1.799E-04
W	500.	500.	3.175E-04	3.080E-04	500.	1.971E-04	1.911E-04
WNW	434.	434.	5.483E-04	5.319E-04	434.	4.559E-04	4.420E-04
NW	428.	428.	8.796E-04	8.532E-04	428.	9.766E-04	9.468E-04
NNW	442.	442.	1.222E-03	1.185E-03	442.	1.523E-03	1.477E-03

Braidwood Site Meteorological Data 1/78 - 12/87

Table F-7a (Continued)

Maximum Offsite Finite Plume Gamma Dose Factors Based on 1 cm Depth at the Restricted Area Boundary for Xe-131m

Downwind Direction	Restricted Area Bound (meters)	Mixed Mode (Vent) Release			Ground Level Release		
		Radius (meters)	V (mrad/yr)/(uCi/sec)	VBAR	Radius (meters)	G (mrad/yr)/(uCi/sec)	GBAR
N	305.	305.	3.585E-04	2.801E-04	305.	1.342E-03	1.040E-03
NNE	265.	265.	3.471E-04	2.710E-04	265.	1.225E-03	9.489E-04
NE	299.	299.	1.442E-04	1.135E-04	299.	8.221E-04	6.377E-04
ENE	361.	361.	1.274E-04	1.002E-04	361.	6.227E-04	4.832E-04
E	355.	355.	1.664E-04	1.307E-04	355.	8.136E-04	6.311E-04
ESE	425.	425.	1.406E-04	1.108E-04	425.	6.887E-04	5.349E-04
SE	448.	448.	1.152E-04	9.088E-05	448.	6.093E-04	4.733E-04
SSE	540.	540.	6.798E-05	5.395E-05	540.	3.772E-04	2.936E-04
S	530.	530.	6.550E-05	5.172E-05	530.	4.533E-04	3.523E-04
SSW	540.	540.	5.419E-05	4.299E-05	540.	3.656E-04	2.846E-04
SW	632.	632.	6.073E-05	4.813E-05	632.	3.620E-04	2.819E-04
WSW	555.	555.	8.569E-05	6.762E-05	555.	5.701E-04	4.435E-04
W	500.	500.	1.006E-04	7.904E-05	500.	6.184E-04	4.805E-04
WNW	434.	434.	1.391E-04	1.088E-04	434.	7.616E-04	5.907E-04
NW	428.	428.	1.429E-04	1.121E-04	428.	6.807E-04	5.285E-04
NNW	442.	442.	1.521E-04	1.194E-04	442.	7.027E-04	5.461E-04

Braidwood Site Meteorological Data 1/78 - 12/87



Table F-7a (Continued)

Maximum Offsite Finite Plume Gamma Dose Factors Based on 1 cm Depth at the Restricted Area Boundary for Xe-133m

Downwind Direction	Restricted Area Bound (meters)	Mixed Mode (Vent) Release			Ground Level Release		
		Radius (meters)	V (mrad/yr)/(uCi/sec)	VBAR	Radius (meters)	G (mrad/yr)/(uCi/sec)	GBAR
N	305.	305.	6.308E-04	5.411E-04	305.	2.135E-03	1.798E-03
NNE	265.	265.	6.053E-04	5.184E-04	265.	1.940E-03	1.632E-03
NE	299.	299.	2.759E-04	2.399E-04	299.	1.321E-03	1.115E-03
ENE	361.	361.	2.417E-04	2.099E-04	361.	1.005E-03	8.488E-04
E	355.	355.	3.110E-04	2.695E-04	355.	1.307E-03	1.103E-03
ESE	425.	425.	2.701E-04	2.350E-04	425.	1.125E-03	9.516E-04
SE	448.	448.	2.251E-04	1.964E-04	448.	9.971E-04	8.442E-04
SSE	540.	540.	1.413E-04	1.245E-04	540.	6.325E-04	5.379E-04
S	530.	530.	1.293E-04	1.131E-04	530.	7.461E-04	6.326E-04
SSW	540.	540.	1.123E-04	9.889E-05	540.	6.124E-04	5.209E-04
SW	632.	632.	1.243E-04	1.092E-04	632.	6.091E-04	5.186E-04
WSW	555.	555.	1.679E-04	1.466E-04	555.	9.488E-04	8.060E-04
W	500.	500.	1.883E-04	1.632E-04	500.	1.014E-03	8.589E-04
WNW	434.	434.	2.477E-04	2.129E-04	434.	1.222E-03	1.031E-03
NW	428.	428.	2.634E-04	2.277E-04	428.	1.107E-03	9.360E-04
NNW	442.	442.	2.813E-04	2.434E-04	442.	1.157E-03	9.803E-04

Braidwood Site Meteorological Data 1/78 - 12/87

Table F-7a (Continued)

Maximum Offsite Finite Plume Gamma Dose Factors Based on 1 cm Depth at the Restricted Area Boundary for Xe-133

Downwind Direction	Restricted Area Bound (meters)	Mixed Mode (Vent) Release		Ground Level Release			
		Radius (meters)	V (mrad/yr)/(uCi/sec)	VBAR	Radius (meters)	G (mrad/yr)/(uCi/sec)	GBAR
N	305.	305.	6.810E-04	6.050E-04	305.	2.299E-03	2.013E-03
NNE	265.	265.	6.509E-04	5.774E-04	265.	2.084E-03	1.823E-03
NE	299.	299.	2.984E-04	2.679E-04	299.	1.431E-03	1.256E-03
ENE	361.	361.	2.612E-04	2.343E-04	361.	1.090E-03	9.571E-04
E	355.	355.	3.363E-04	3.011E-04	355.	1.414E-03	1.241E-03
ESE	425.	425.	2.954E-04	2.656E-04	425.	1.226E-03	1.079E-03
SE	448.	448.	2.460E-04	2.216E-04	448.	1.088E-03	9.581E-04
SSE	540.	540.	1.555E-04	1.411E-04	540.	6.963E-04	6.158E-04
S	530.	530.	1.408E-04	1.270E-04	530.	8.174E-04	7.209E-04
SSW	540.	540.	1.231E-04	1.117E-04	540.	6.754E-04	5.974E-04
SW	632.	632.	1.367E-04	1.238E-04	632.	6.726E-04	5.954E-04
WSW	555.	555.	1.830E-04	1.649E-04	555.	1.044E-03	9.224E-04
W	500.	500.	2.055E-04	1.842E-04	500.	1.108E-03	9.759E-04
WNW	434.	434.	2.689E-04	2.394E-04	434.	1.323E-03	1.160E-03
NW	428.	428.	2.860E-04	2.557E-04	428.	1.204E-03	1.059E-03
NNW	442.	442.	3.071E-04	2.749E-04	442.	1.266E-03	1.116E-03

Braidwood Site Meteorological Data 1/78 - 12/87

Table F-7a (Continued)

Maximum Offsite Finite Plume Gamma Dose Factors Based on 1 cm Depth at the Restricted Area Boundary for Xe-135m

Downwind Direction	Restricted Area Bound (meters)	Mixed Mode (Vent) Release		Ground Level Release			
		Radius (meters)	V (mrad/yr)/(uCi/sec)	VBAR	Radius (meters)	G (mrad/yr)/(uCi/sec)	GBAR
N	305.	305.	4.596E-03	4.429E-03	305.	1.180E-02	1.135E-02
NNE	265.	265.	4.387E-03	4.227E-03	265.	1.125E-02	1.082E-02
NE	299.	299.	2.254E-03	2.174E-03	299.	7.028E-03	6.764E-03
ENE	361.	361.	1.883E-03	1.816E-03	361.	5.738E-03	5.523E-03
E	355.	355.	2.326E-03	2.242E-03	355.	7.076E-03	6.811E-03
ESE	425.	425.	2.121E-03	2.046E-03	425.	6.001E-03	5.778E-03
SE	448.	448.	1.723E-03	1.662E-03	448.	4.819E-03	4.640E-03
SSE	540.	540.	1.178E-03	1.137E-03	540.	3.220E-03	3.101E-03
S	530.	530.	9.052E-04	8.734E-04	530.	2.852E-03	2.747E-03
SSW	540.	540.	9.038E-04	8.720E-04	540.	2.739E-03	2.638E-03
SW	632.	632.	8.898E-04	8.587E-04	632.	2.532E-03	2.439E-03
WSW	555.	555.	1.092E-03	1.054E-03	555.	3.989E-03	3.842E-03
W	500.	500.	1.246E-03	1.202E-03	500.	4.617E-03	4.446E-03
WNW	434.	434.	1.593E-03	1.536E-03	434.	5.652E-03	5.441E-03
NW	428.	428.	1.869E-03	1.802E-03	428.	5.820E-03	5.603E-03
NNW	442.	442.	2.013E-03	1.940E-03	442.	5.812E-03	5.596E-03

Braidwood Site Meteorological Data 1/78 - 12/87

Table F-7a (Continued)

Maximum Offsite Finite Plume Gamma Dose Factors Based on 1 cm Depth at the Restricted Area Boundary for Xe-135

Downwind Direction	Restricted Area Bound (meters)	Mixed Mode (Vent) Release			Ground Level Release		
		Radius (meters)	V (mrad/yr)/(uCi/sec)	VBAR	Radius (meters)	G (mrad/yr)/(uCi/sec)	GBAR
N	305.	305.	3.039E-03	2.936E-03	305.	8.709E-03	8.406E-03
NNE	265.	265.	2.880E-03	2.781E-03	265.	7.856E-03	7.583E-03
NE	299.	299.	1.481E-03	1.431E-03	299.	5.482E-03	5.292E-03
ENE	361.	361.	1.284E-03	1.241E-03	361.	4.211E-03	4.065E-03
E	355.	355.	1.621E-03	1.567E-03	355.	5.425E-03	5.237E-03
ESE	425.	425.	1.455E-03	1.406E-03	425.	4.794E-03	4.629E-03
SE	448.	448.	1.235E-03	1.194E-03	448.	4.257E-03	4.110E-03
SSE	540.	540.	8.285E-04	8.008E-04	540.	2.811E-03	2.714E-03
S	530.	530.	7.163E-04	6.923E-04	530.	3.197E-03	3.087E-03
SSW	540.	540.	6.561E-04	6.342E-04	540.	2.709E-03	2.615E-03
SW	632.	632.	7.144E-04	6.906E-04	632.	2.708E-03	2.615E-03
WSW	555.	555.	9.205E-04	8.896E-04	555.	4.150E-03	4.007E-03
W	500.	500.	9.804E-04	9.473E-04	500.	4.340E-03	4.190E-03
WNW	434.	434.	1.210E-03	1.168E-03	434.	5.044E-03	4.869E-03
NW	428.	428.	1.348E-03	1.302E-03	428.	4.686E-03	4.524E-03
NNW	442.	442.	1.446E-03	1.397E-03	442.	4.987E-03	4.815E-03

Braidwood Site Meteorological Data 1/78 - 12/87

Table F-7a (Continued)

Maximum Offsite Finite Plume Gamma Dose Factors Based on 1 cm Depth at the Restricted Area Boundary for Xe-137

Downwind Direction	Restricted Area Bound (meters)	Mixed Mode (Vent) Release			Ground Level Release		
		Radius (meters)	V (mrad/yr)/(uCi/sec)	VBAR	Radius (meters)	G (mrad/yr)/(uCi/sec)	GBAR
N	305.	305.	1.764E-03	1.707E-03	305.	3.915E-03	3.788E-03
NNE	265.	265.	1.712E-03	1.657E-03	265.	3.949E-03	3.821E-03
NE	299.	299.	8.519E-04	8.244E-04	299.	2.178E-03	2.108E-03
ENE	361.	361.	6.624E-04	6.410E-04	361.	1.748E-03	1.692E-03
E	355.	355.	8.157E-04	7.893E-04	355.	2.100E-03	2.032E-03
ESE	425.	425.	7.381E-04	7.142E-04	425.	1.690E-03	1.636E-03
SE	448.	448.	5.802E-04	5.615E-04	448.	1.259E-03	1.219E-03
SSE	540.	540.	3.822E-04	3.699E-04	540.	8.154E-04	7.890E-04
S	530.	530.	2.803E-04	2.713E-04	530.	6.471E-04	6.261E-04
SSW	540.	540.	2.864E-04	2.772E-04	540.	6.459E-04	6.250E-04
SW	632.	632.	2.577E-04	2.493E-04	632.	5.246E-04	5.076E-04
WSW	555.	555.	2.977E-04	2.881E-04	555.	7.771E-04	7.519E-04
W	500.	500.	3.453E-04	3.341E-04	500.	9.141E-04	8.844E-04
WNW	434.	434.	4.671E-04	4.520E-04	434.	1.275E-03	1.234E-03
NW	428.	428.	6.017E-04	5.823E-04	428.	1.543E-03	1.493E-03
NNW	442.	442.	6.784E-04	6.565E-04	442.	1.588E-03	1.537E-03

Braidwood Site Meteorological Data 1/78 - 12/87

Table F-7a (Continued)

Maximum Offsite Finite Plume Gamma Dose Factors Based on 1 cm Depth at the Restricted Area Boundary for Xe-138

Downwind Direction	Restricted Area Bound (meters)	Mixed Mode (Vent) Release			Ground Level Release		
		Radius (meters)	V (mrad/yr)/(uCi/sec)	VBAR	Radius (meters)	G (mrad/yr)/(uCi/sec)	GBAR
N	305.	305.	1.001E-02	9.714E-03	305.	2.457E-02	2.384E-02
NNE	265.	265.	9.553E-03	9.273E-03	265.	2.347E-02	2.278E-02
NE	299.	299.	5.016E-03	4.870E-03	299.	1.459E-02	1.416E-02
ENE	361.	361.	4.169E-03	4.048E-03	361.	1.195E-02	1.160E-02
E	355.	355.	5.137E-03	4.988E-03	355.	1.471E-02	1.427E-02
ESE	425.	425.	4.679E-03	4.543E-03	425.	1.247E-02	1.210E-02
SE	448.	448.	3.827E-03	3.716E-03	448.	9.982E-03	9.687E-03
SSE	540.	540.	2.630E-03	2.554E-03	540.	6.694E-03	6.497E-03
S	530.	530.	2.023E-03	1.964E-03	530.	5.857E-03	5.684E-03
SSW	540.	540.	2.021E-03	1.962E-03	540.	5.661E-03	5.495E-03
SW	632.	632.	1.991E-03	1.934E-03	632.	5.226E-03	5.072E-03
WSW	555.	555.	2.429E-03	2.359E-03	555.	8.199E-03	7.957E-03
W	500.	500.	2.739E-03	2.659E-03	500.	9.502E-03	9.221E-03
WNW	434.	434.	3.459E-03	3.358E-03	434.	1.164E-02	1.130E-02
NW	428.	428.	4.093E-03	3.974E-03	428.	1.207E-02	1.172E-02
NNW	442.	442.	4.399E-03	4.271E-03	442.	1.204E-02	1.169E-02

Braidwood Site Meteorological Data 1/78 - 12/87

Table F-7a (Continued)

Maximum Offsite Finite Plume Gamma Dose Factors Based on 1 cm Depth at the Restricted Area Boundary for Ar-41

Downwind Direction	Restricted Area Bound (meters)	Mixed Mode (Vent) Release		Ground Level Release			
		Radius (meters)	V (mrad/yr)/(uCi/sec)	VBAR	Radius (meters)	G (mrad/yr)/(uCi/sec)	GBAR
N	305.	305.	1.160E-02	1.122E-02	305.	3.106E-02	3.006E-02
NNE	265.	265.	1.101E-02	1.065E-02	265.	2.826E-02	2.736E-02
NE	299.	299.	5.833E-03	5.646E-03	299.	1.936E-02	1.874E-02
ENE	361.	361.	5.023E-03	4.863E-03	361.	1.505E-02	1.456E-02
E	355.	355.	6.295E-03	6.094E-03	355.	1.925E-02	1.864E-02
ESE	425.	425.	5.640E-03	5.459E-03	425.	1.689E-02	1.635E-02
SE	448.	448.	4.783E-03	4.630E-03	448.	1.477E-02	1.430E-02
SSE	540.	540.	3.262E-03	3.157E-03	540.	9.781E-03	9.468E-03
S	530.	530.	2.756E-03	2.667E-03	530.	1.066E-02	1.032E-03
SSW	540.	540.	2.580E-03	2.497E-03	540.	9.211E-03	8.917E-03
SW	632.	632.	2.748E-03	2.660E-03	632.	9.104E-03	8.813E-03
WSW	555.	555.	3.504E-03	3.392E-03	555.	1.404E-02	1.359E-02
W	500.	500.	3.715E-03	3.596E-03	500.	1.498E-02	1.450E-02
WNW	434.	434.	4.539E-03	4.393E-03	434.	1.753E-02	1.697E-02
NW	428.	428.	5.159E-03	4.994E-03	428.	1.652E-02	1.599E-02
NNW	442.	442.	5.499E-03	5.323E-03	442.	1.734E-02	1.679E-02

Braidwood Site Meteorological Data 1/78 - 12/87

Supplemental Table A  
Mixed Mode Joint Frequency Distribution Table Summaries

203 Foot Elevation Data

Summary Table of Percent by Direction and Class

Class	N	NNE	NE	ENE	E	ESE	SE	SSE	S	SSW	SW	WSW	W	WNW	NW	NNW	Total
A	.280	.321	.441	.315	.303	.256	.282	.266	.474	.369	.202	.197	.191	.274	.463	.421	5 076
B	.197	.241	.284	.208	.205	.167	.196	.220	.352	.288	.180	.192	.206	.225	.327	.335	3 833
C	.321	.302	.421	.293	.201	.203	.277	.312	.437	.404	.322	.342	.373	.399	.457	.409	5 474
D	1.523	1.590	2.149	1.974	1.372	1.014	1.324	1.529	2.031	1.900	1.899	1.846	2.109	2.248	2.191	2.014	28 713
E	.679	.612	.764	.976	.986	.870	1.136	1.439	2.079	1.501	1.065	.921	.993	1.133	.922	.790	16 866
F	.344	.278	.260	.298	.387	.496	.530	.438	.559	.526	.386	.397	.589	.688	.556	.417	7 148
G	.166	.095	.098	.078	.156	.174	.270	.213	.186	.199	.258	.210	.253	.266	.184	.159	2 966
Total	3.520	3.439	4.418	4.143	3.611	3.180	4.025	4.418	6.118	5.187	4.322	4.104	4.714	5.231	5.100	4.545	70 076

Summary Table of Percent by Direction and Speed

Speed	N	NNE	NE	ENE	E	ESE	SE	SSE	S	SSW	SW	WSW	W	WNW	NW	NNW	Total
.45	.008	.016	.027	.025	.001	.000	.017	.017	.001	.001	.002	.016	.037	.026	.001	.026	222
1.05	.044	.032	.042	.045	.026	.025	.036	.031	.032	.023	.033	.025	.037	.035	.040	.026	.532
2.05	.224	.266	.281	.260	.239	.213	.243	.225	.237	.220	.208	.208	.262	.244	.244	.243	3 819
3.05	.405	.426	.540	.610	.459	.334	.467	.438	.596	.383	.393	.384	.447	.437	.507	.487	7 313
4.05	.669	.622	.756	.973	.670	.453	.614	.663	.695	.543	.596	.663	.678	.702	.749	.782	10 829
5.05	.824	.519	.875	.926	.681	.482	.669	.639	.769	.677	.711	.681	.738	.782	.889	.808	11 470
6.05	.670	.607	.761	.675	.674	.587	.657	.729	.944	.825	.833	.766	.788	.975	.909	.876	12 279
8.05	.732	.789	.956	.534	.726	.919	1.073	1.227	2.070	1.858	1.268	1.131	1.378	1.598	1.381	1.041	18 680
10.05	.137	.154	.174	.094	.127	.158	.235	.423	.727	.621	.265	.216	.331	.404	.359	.245	4 667
13.05	.007	.008	.005	.002	.008	.010	.014	.026	.047	.037	.012	.012	.017	.028	.020	.012	.265
18.00	.000	.000	.000	.000	.000	.000	.000	.000	.000	.000	.000	.000	.000	.000	.000	.000	.000
99.00	.000	.000	.000	.000	.000	.000	.000	.000	.000	.000	.000	.000	.000	.000	.000	.000	.000
Total	3.520	3.439	4.418	4.143	3.611	3.180	4.025	4.418	6.118	5.187	4.322	4.104	4.714	5.231	5.100	4.545	70.076

NOTE: Wind directions in tables are presented in "wind from" and not "wind to" direction.



BRAIDWOOD

Revision 4  
August 1999

In order to determine the final mixed mode values, 70.076% of the elevated value (presented in the 250 FT Mixed Mode table) and 29.924% of the ground level value (presented in the 30 FT Mixed Mode table) are used to calculate the final values.

BRAIDWOOD

Revision 4  
August 1999

Supplemental Table A - Continued  
Mixed Mode Joint Frequency Distribution Table Summaries

203 Foot Elevation Data

Summary Table of Percent by Speed and Class

Class Speed	A	B	C	D	E	F	G
.45	.006	.005	.006	.075	.052	.048	.030
1.05	.014	.025	.027	.200	.108	.071	.088
2.05	.175	.197	.378	1.756	.659	.372	.283
3.05	.500	.593	.836	3.100	1.206	.683	.393
4.05	.803	.697	1.005	4.441	2.225	1.083	.575
5.05	.880	.674	.921	4.456	2.845	1.230	.464
6.05	.885	.588	.806	4.760	3.357	1.417	.466
8.05	1.469	.854	1.160	7.631	5.000	1.976	.591
10.05	.325	.190	.320	2.165	1.332	.259	.076
13.05	.018	.011	.015	.129	.081	.009	.002
18.00	.000	.000	.000	.000	.000	.000	.000
99.00	.000	.000	.000	.000	.000	.000	.000

Supplemental Table A - Continued  
Mixed Mode Joint Frequency Distribution Table Summaries

34 Foot Elevation Data

Summary Table of Percent by Direction and Class

Class	N	NNE	NE	ENE	E	ESE	SE	SSE	S	SSW	SW	WSW	W	WNW	NW	NNW	Total
A	.068	.071	.077	.054	.100	.075	.110	.135	.278	.215	.062	.050	.127	.270	.257	.176	2.125
B	.054	.044	.059	.031	.035	.049	.061	.083	.172	.123	.058	.045	.121	.178	.150	.096	1.357
C	.067	.056	.098	.059	.044	.049	.091	.124	.212	.133	.121	.082	.212	.276	.219	.164	2.005
D	.453	.551	.613	.453	.420	.423	.641	.928	1.487	1.230	.697	.717	1.084	1.498	1.044	.889	13.125
E	.304	.387	.249	.180	.230	.368	.580	1.093	1.991	1.311	.435	.346	.299	.343	.227	.317	8.659
F	.044	.063	.050	.059	.086	.160	.161	.137	.339	.306	.077	.133	.144	.130	.074	.050	2.014
G	.022	.006	.013	.025	.035	.059	.061	.037	.102	.079	.024	.058	.039	.038	.026	.017	.641
Total	1.012	1.177	1.159	.860	.950	1.181	1.705	2.535	4.580	3.397	1.475	1.430	2.027	2.729	1.997	1.709	29.924

Summary Table of Percent by Direction and Speed

Speed	N	NNE	NE	ENE	E	ESE	SE	SSE	S	SSW	SW	WSW	W	WNW	NW	NNW	Total
.45	.014	.002	.014	.018	.010	.009	.004	.008	.001	.001	.000	.000	.005	.000	.008	.000	.096
1.05	.014	.016	.027	.048	.065	.061	.030	.025	.013	.010	.010	.016	.019	.018	.018	.017	.408
2.05	.051	.052	.093	.181	.248	.259	.165	.099	.072	.055	.051	.087	.119	.138	.103	.077	1.849
3.05	.121	.145	.172	.202	.189	.251	.309	.248	.269	.222	.166	.260	.234	.213	.174	.151	3.325
4.05	.158	.155	.187	.158	.173	.215	.319	.364	.490	.509	.246	.222	.241	.243	.237	.220	4.139
5.05	.130	.134	.156	.123	.152	.191	.296	.385	.600	.521	.236	.148	.233	.287	.270	.214	4.075
6.05	.141	.152	.186	.089	.098	.128	.310	.435	.718	.639	.216	.167	.244	.388	.340	.247	4.499
8.05	.250	.325	.268	.038	.017	.065	.236	.667	1.498	1.032	.420	.321	.544	.922	.648	.498	7.748
10.05	.111	.168	.050	.001	.000	.001	.032	.214	.679	.302	.102	.117	.269	.371	.183	.199	2.799
13.05	.023	.029	.006	.000	.000	.000	.005	.076	.214	.102	.024	.082	.107	.131	.015	.076	.891
18.00	.000	.000	.000	.000	.000	.000	.000	.014	.027	.002	.004	.012	.011	.017	.000	.010	.096
99.00	.000	.000	.000	.000	.000	.000	.000	.000	.000	.000	.000	.000	.000	.000	.000	.000	.000
Total	1.012	1.177	1.159	.860	.950	1.181	1.705	2.535	4.580	3.397	1.475	1.430	2.027	2.729	1.997	1.709	29.924

NOTE: Wind directions in tables are presented in "wind from" and not "wind to" direction.

Supplemental Table A - Continued  
Mixed Mode Joint Frequency Distribution Table Summaries

34 Foot Elevation Data

Summary Table of Percent by Speed and Class

Class Speed	A	B	C	D	E	F	G
.45	.000	.000	.000	.008	.015	.031	.044
1.05	.001	.001	.003	.049	.126	.151	.076
2.05	.017	.020	.029	.335	.690	.531	.226
3.05	.127	.103	.157	1.118	1.175	.491	.155
4.05	.277	.192	.291	1.686	1.211	.383	.098
5.05	.332	.209	.274	1.870	1.179	.176	.035
6.05	.381	.219	.358	2.236	1.223	.076	.005
8.05	.735	.445	.632	3.993	1.844	.098	.001
10.05	.214	.126	.211	1.358	.837	.053	.000
13.05	.038	.040	.044	.424	.320	.024	.000
18.00	.001	.002	.004	.049	.040	.000	.000
99.00	.000	.000	.000	.000	.000	.000	.000

Supplemental Table B  
Ground Level Joint Frequency Distribution Table Summaries

Summary Table of Percent by Direction and Class

Class	N	NNE	NE	ENE	E	ESE	SE	SSE	S	SSW	SW	WSW	W	WNW	NW	NNW	Total
A	.379	.415	.470	.394	.420	.291	.417	.418	.728	.637	.246	.229	.358	.572	.648	.609	7.230
B	.280	.286	.336	.241	.229	.206	.285	.332	.539	.411	.256	.206	.340	.407	.441	.431	5.203
C	.385	.373	.501	.358	.246	.226	.388	.471	.665	.521	.462	.380	.598	.688	.624	.619	7.504
D	2.098	2.216	2.532	2.483	1.766	1.392	2.034	2.692	3.611	3.198	2.674	2.392	3.065	3.678	3.063	2.925	41.820
E	.968	1.029	.914	1.221	1.210	1.387	1.849	2.754	4.116	2.772	1.298	1.258	1.197	1.411	1.052	1.068	25.502
F	.339	.347	.302	.382	.552	.788	.729	.605	.949	.850	.366	.630	.795	.765	.441	.313	9.153
G	.147	.074	.128	.163	.228	.358	.330	.229	.404	.300	.133	.268	.248	.233	.191	.157	3.588
Total	4.595	4.740	5.183	5.242	4.650	4.647	6.012	7.502	11.013	8.687	5.435	5.359	6.600	7.753	6.460	6.122	100.000

Summary Table of Percent by Direction and Speed

Speed	N	NNE	NE	ENE	E	ESE	SE	SSE	S	SSW	SW	WSW	W	WNW	NW	NNW	Total
.45	.194	.111	.128	.160	.078	.087	.042	.126	.063	.013	.078	.004	.037	.051	.101	.054	1.328
1.05	.219	.263	.364	.579	.686	.517	.311	.267	.218	.181	.174	.196	.257	.264	.275	.269	5.038
2.05	.630	.645	.996	1.658	1.833	1.698	1.367	.962	.771	.631	.561	.842	1.076	1.169	.952	.780	16.571
3.05	.949	1.045	1.179	1.382	1.085	1.218	1.744	1.581	1.820	1.435	1.128	1.533	1.442	1.369	1.174	1.070	21.156
4.05	.915	.902	1.015	.839	.577	.624	1.228	1.593	2.123	2.039	1.256	1.084	1.167	1.180	1.189	1.215	18.947
5.05	.650	.641	.667	.416	.260	.292	.641	1.126	1.881	1.520	.937	.609	.884	1.104	.995	.959	13.582
6.05	.495	.462	.432	.159	.113	.143	.395	.758	1.435	1.236	.598	.445	.644	.936	.770	.751	9.771
8.05	.408	.472	.346	.046	.018	.067	.247	.785	1.782	1.226	.573	.436	.706	1.160	.806	.738	9.815
10.05	.113	.170	.050	.001	.000	.001	.032	.214	.679	.302	.102	.116	.269	.372	.183	.201	2.805
13.05	.023	.029	.006	.000	.000	.000	.005	.076	.214	.102	.024	.082	.107	.131	.015	.076	.889
18.00	.000	.000	.000	.000	.000	.000	.000	.014	.027	.002	.004	.012	.011	.017	.000	.010	.096
99.00	.000	.000	.000	.000	.000	.000	.000	.000	.000	.000	.000	.000	.000	.000	.000	.000	.000
Total	4.595	4.740	5.183	5.242	4.650	4.647	6.012	7.502	11.013	8.687	5.435	5.359	6.600	7.753	6.460	6.122	100.000

NOTE: Wind directions in tables are presented in "wind from" and not "wind to" direction.

Supplemental Table B -Continued  
Ground Level Joint Frequency Distribution Table Summaries

Summary Table of Percent by Speed and Class

Class Speed	A	B	C	D	E	F	G
.45	.027	.018	.021	.197	.339	.388	.338
1.05	.102	.093	.145	1.038	1.463	1.379	.818
2.05	.426	.498	.798	4.865	5.159	3.380	1.448
3.05	1.147	1.009	1.493	8.268	6.225	2.342	.872
4.05	1.618	1.158	1.699	8.574	4.596	1.059	.244
5.05	1.448	.969	1.213	6.908	2.689	.304	.055
6.05	1.155	.661	1.007	5.053	1.763	.118	.014
8.05	1.054	.629	.870	5.084	2.068	.107	.002
10.05	.215	.126	.212	1.360	.839	.053	.000
13.05	.038	.040	.044	.423	.320	.024	.000
18.00	.001	.002	.004	.049	.040	.000	.000
99.00	.000	.000	.000	.000	.000	.000	.000

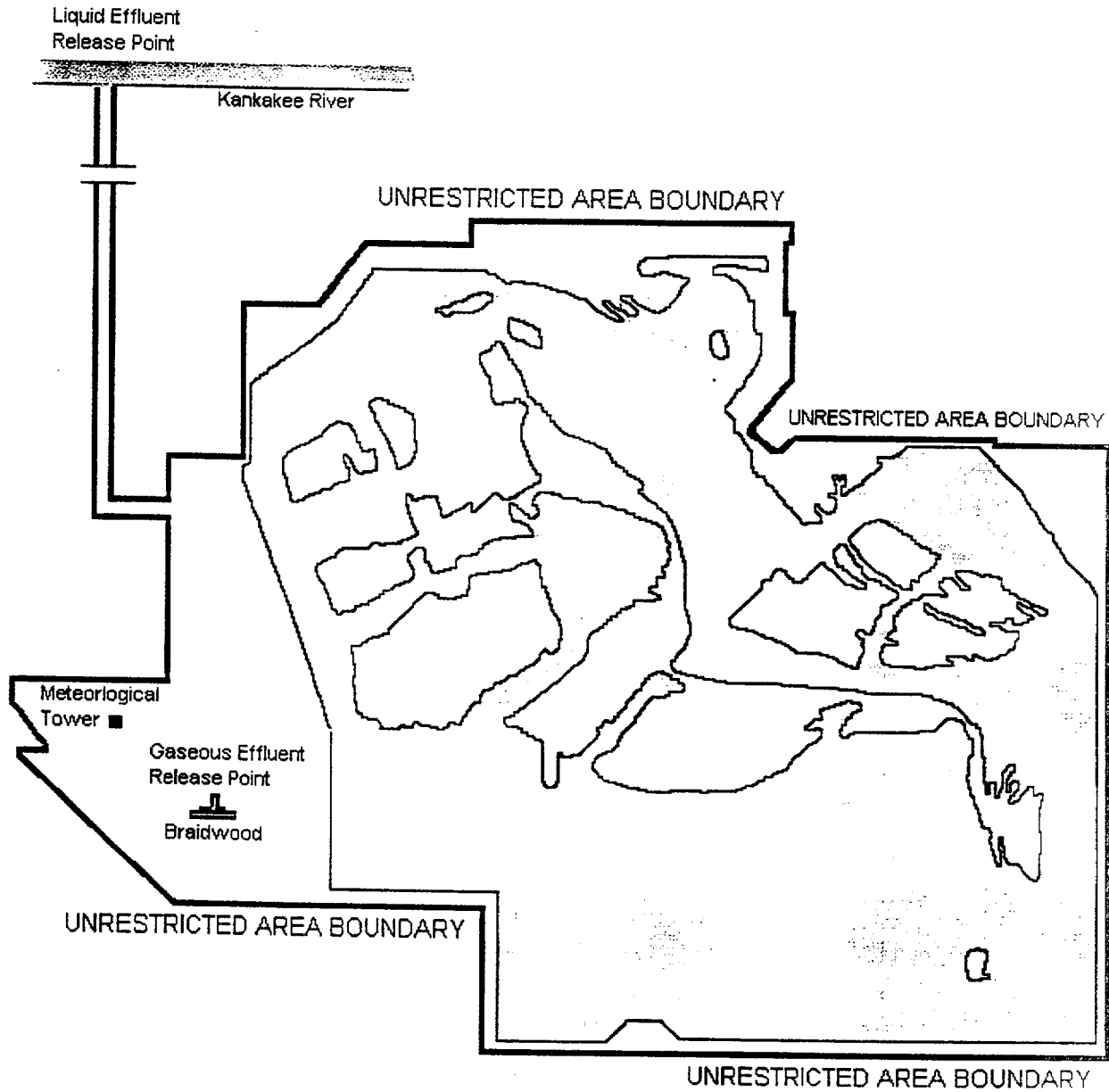

OFFSITE DOSE CALCULATION  
MANUAL BRAIDWOOD STATION  
FIGURE F-1  
UNRESTRICTED AREA BOUNDARY

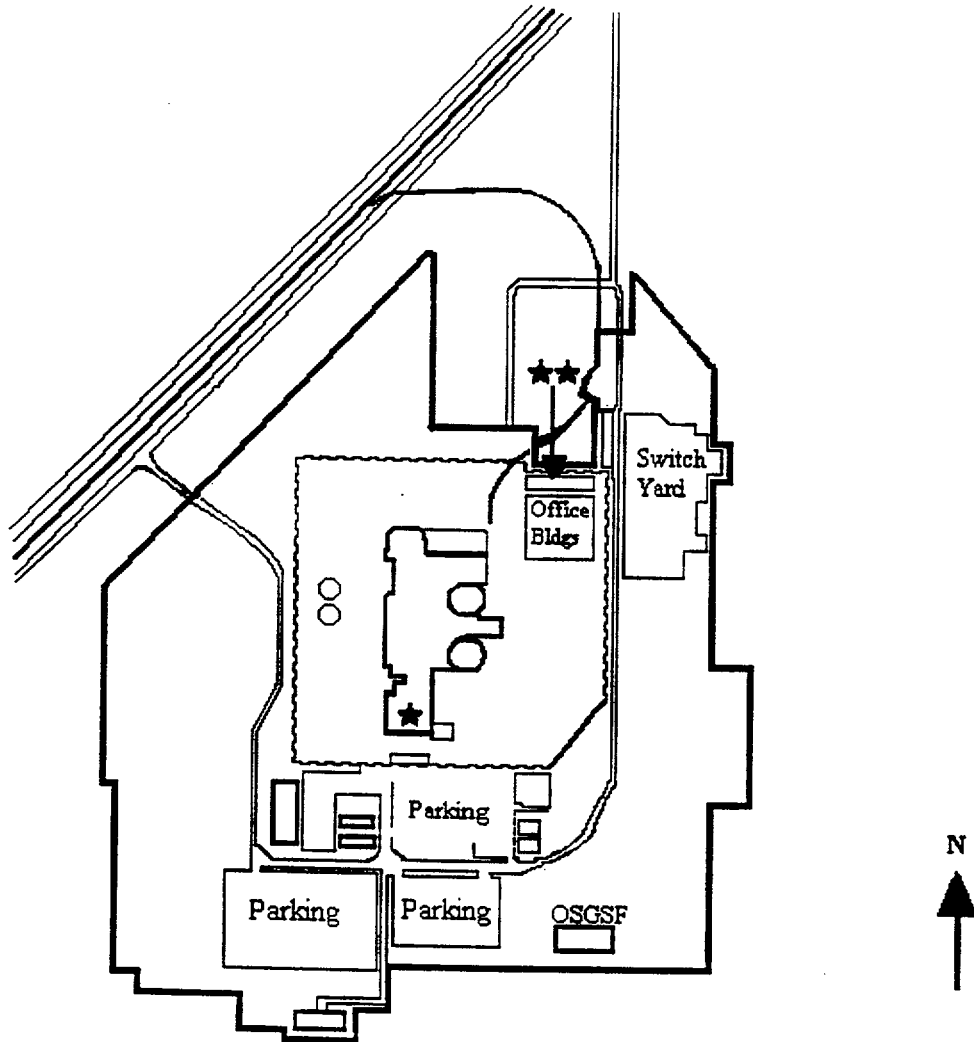

- ★ Low Level Radwaste Storage Building  
(in Service Building Truck Bay)
- ★★ DAW Storage Area
- Restricted Area Boundary
- OSGSF Old Steam Generator Storage Facility

OFFSITE DOSE CALCULATION MANUAL BRAIDWOOD STATION
FIGURE F-2 RESTRICTED AREA BOUNDARY