

SECTION ON C-C

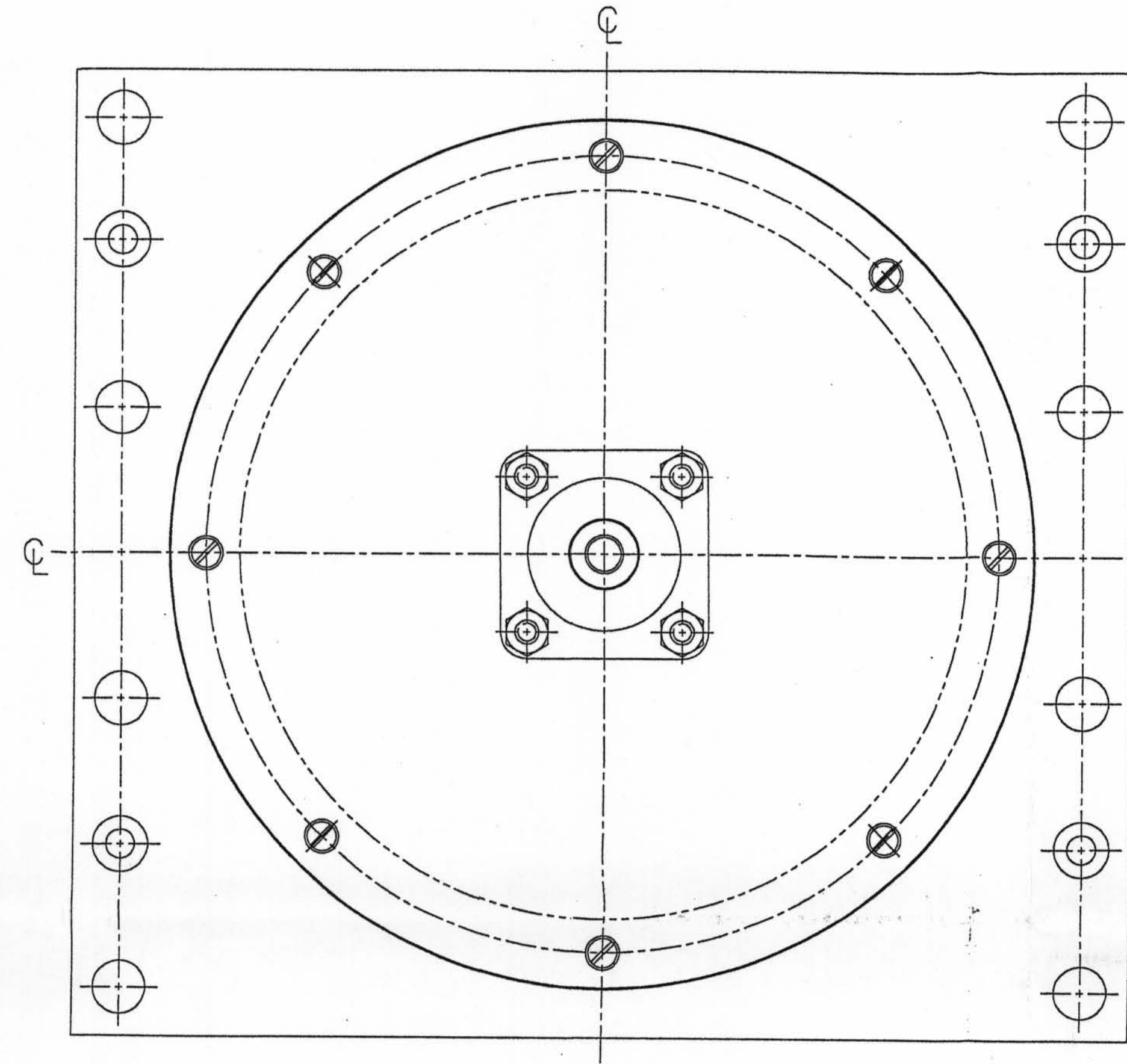

FRONT VIEW

- NOTE:
- 1) PIN DISK (ITEM 12) TO SHAFT (ITEM 10) BEFORE SCREWING SHUTTER (ITEM 11) TO DISK.
 - 2) ALLOW MINIMUM CLEARANCE BETWEEN DISK AND HOUSING ENSURING DISK IS FREE TO ROTATE.

ITEM LIST				
ITEM	PART NUMBER	QTY.	U/M	DESCRIPTION
1	0227-00-0069	4	EA	SCREW, SOCKET HD. CAP, BLK., M6 x 80
2	0231-00-0056	8	EA	SCREW, SOCKET FLAT HD., Z/P, M6 x 12
3	0231-00-0114	4	EA	SCREW, SOCKET FLAT HD., Z/P, M10 x 30
4	0250-00-0009	8	EA	NUT, HEX, Z/P, M10
5	0252-00-0026	4	EA	WASHER, Z/P, 1/4 x 1 x #16
6	0252-00-0046	8	EA	WASHER, SPRING, Z/P, 10mm
7	0254-00-0180	2	EA	ROLL PIN, CAD PL., M5 x 26
8	5010-00-0134	1	EA	PLATE, ROTARY SHUTTER SHIELDING
9	5208-00-0005	2	EA	BEARING, FLANGE UNIT, 5/8" DIA. SHAFT
10	5415-00-0004	1	EA	SHAFT, SHUTTER CONTROL
11	6625-00-0005	1	EA	SHUTTER, ROTARY
12	7255-00-0007	1	EA	DISC, SHUTTER CONTROL
13	8020-00-0036	1	EA	HOUSING, ROTARY SHUTTER SHIELDING

D-7

<p>SHUTTER ASSEMBLY ROTARY</p> <p>MCI MINERAL CONTROL INSTRUMENTATION PTY LIMITED PO BOX 84 UNLEY SOUTH AUSTRALIA 5061</p>		USED ON	CM100	DRAWING No.	6625-90-0001	REV No.	0		
		DRAWN	D.O.	DATE	9/1/98	SCALE:	1:2	SHEET 1 OF 1	
		CHECKED		GENERAL TOLERANCE	±0.5 LINEAR	±0.25 ANGULAR	±0.25 HOLE CRS.	DIMENSIONS IN MILLIMETRES UNLESS OTHERWISE STATED	
		CHANGE	REV No.	DATE	CHANGE NOTICE No.				

D-7