



REGULATORY DOCKET FILE COPY
UNITED STATES
NUCLEAR REGULATORY COMMISSION
WASHINGTON, D. C. 20555

October 28, 1980

CR/1

Dockets Nos. 50-321
and 50-366

Mr. William Widner
Vice President - Engineering
Georgia Power Company
P. O. Box 4545
Atlanta, Georgia 30302

Dear Mr. Widner:

The Commission has issued the enclosed Amendments Nos. 79 and 18 to Facility Operating Licenses Nos. DPR-57 and NPF-5 for the Edwin I. Hatch Nuclear Plant, Units Nos. 1 and 2. The amendments consist of changes to the Technical Specifications in response to your application dated September 15, 1980.

These changes to the Technical Specifications involve incorporation of certain of the TMI-2 Lessons Learned Category "A" requirements. These requirements concern 1) Emergency Power Supply/Inadequate Core Cooling, 2) Valve Position Indication, 3) Containment Isolation, 4) Shift Technical Advisor Augmentation, 5) Integrity of Systems Outside Containment, and 6) Iodine Monitoring.

Copies of the Safety Evaluation and a related Notice of Issuance are also enclosed.

Sincerely,

Robert W. Reid, Chief
Operating Reactors Branch #4
Division of Licensing

Enclosures:

1. Amendment No. 79 to DPR-57
2. Amendment No. 18 to NPF-5
3. Safety Evaluation
4. Notice

cc w/enclosures:
See next page

60

8011140264

Hatch 1/2
Georgia Power Company

50-321/366

cc w/enclosure(s):

G. F. Trowbridge, Esq.
Shaw, Pittman, Potts and Trowbridge
1800 M Street, N.W.
Washington, D. C. 20036

Ruble A. Thomas
Vice President
P. O. Box 2625
Southern Services, Inc.
Birmingham, Alabama 35202

Ozen Batum
P. O. Box 2625
Southern Services, Inc.
Birmingham, Alabama 35202

Mr. H. B. Lee, Chairman
Appling County Commissioners
County Courthouse
Baxley, Georgia 31513

Mr. L. T. Gucwa
Georgia Power Company
Engineering Department
P. O. Box 4545
Atlanta, Georgia 30302

Mr. Max Manry
Georgia Power Company
Edwin I. Hatch Plant
P. O. Box 442
Baxley, Georgia 31513

U. S. Environmental Protection Agency
Region IV Office
ATTN: EIS COORDINATOR
345 Courtland Street, N.E.
Atlanta, Georgia 30308

Appling County Public Library
Parker Street
Baxley, Georgia 31513

Mr. R. F. Rodgers
U.S. Nuclear Regulatory Commission
Route 1, P. O. Box 279
Baxley, Georgia 31513

Director, Technical Assessment
Division
Office of Radiation Programs
(AW-459)
U. S. Environmental Protection Agency
Crystal Mall #2
Arlington, Virginia 20460

cc w/enclosure(s) & incoming dtd.:
9/15/80

Charles H. Badger
Office of Planning and Budget
Room 610
270 Washington Street, S.W.
Atlanta, Georgia 30334



UNITED STATES
NUCLEAR REGULATORY COMMISSION
WASHINGTON, D. C. 20555

GEORGIA POWER COMPANY
OGLETHORPE POWER CORPORATION
MUNICIPAL ELECTRIC AUTHORITY OF GEORGIA
CITY OF DALTON, GEORGIA

DOCKET NO. 50-321

EDWIN I. HATCH NUCLEAR PLANT, UNIT NO. 1

AMENDMENT TO FACILITY OPERATING LICENSE

Amendment No. 79
License No. DPR-57

1. The Nuclear Regulatory Commission (the Commission) has found that:
 - A. The application for amendment by Georgia Power Company, et al., (the licensee) dated September 15, 1980, complies with the standards and requirements of the Atomic Energy Act of 1954, as amended (the Act) and the Commission's rules and regulations set forth in 10 CFR Chapter I;
 - B. The facility will operate in conformity with the application, the provisions of the Act, and the rules and regulations of the Commission;
 - C. There is reasonable assurance (i) that the activities authorized by this amendment can be conducted without endangering the health and safety of the public, and (ii) that such activities will be conducted in compliance with the Commission's regulations;
 - D. The issuance of this amendment will not be inimical to the common defense and security or to the health and safety of the public; and
 - E. The issuance of this amendment is in accordance with 10 CFR Part 51 of the Commission's regulations and all applicable requirements have been satisfied.
2. Accordingly, the license is amended by changes to the Technical Specifications as indicated in the attachment to this license amendment and paragraph 2.C.(2) of Facility Operating License No. DPR-57 is hereby amended to read as follows:

The Technical Specifications contained in Appendices A and B, as revised through Amendment No. 79, are hereby incorporated in the license. The licensee shall operate the facility in accordance with the Technical Specifications.

3. This amendment is effective as of the date of issuance.

FOR THE NUCLEAR REGULATORY COMMISSION

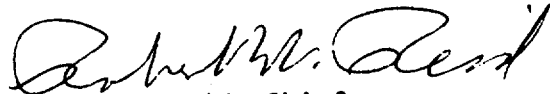

Robert W. Reid, Chief
Operating Reactors Branch #4
Division of Licensing

Attachment:
Changes to the Technical
Specifications

Date of Issuance: October 28, 1980

ATTACHMENT TO LICENSE AMENDMENT NO. 79

FACILITY OPERATING LICENSE NO. DPR-57

DOCKET NO. 50-321

Replace the following pages of the Appendix "A" Technical Specifications with the enclosed pages. The revised pages are identified by Amendment number and contain vertical lines indicating the area of change.

Remove

vi
3.2-22
3.2-23
3.2-48
6-4
6-6
6-21

Insert

vi
3.2-22
3.2-23
3.2-48
6-4
6-6
6-21

<u>Section</u>	<u>Section</u>	<u>Page</u>
	LIMITING CONDITIONS FOR OPERATION	
	SURVEILLANCE REQUIREMENTS	
5.0	MAJOR DESIGN FEATURES	5.0-1
	A. Site	5.0-1
	B. Reactor Core	5.0-1
	C. Reactor Vessel	5.0-1
	D. Containment	5.0-1
	E. Fuel Storage	5.0-1
	F. Seismic Design	5.0-2
6.0	ADMINISTRATIVE CONTROLS	6-1
	6.1 Responsibility	6-1
	6.2 Organization	6-1
	6.3 Unit Staff Qualifications	6-6
	6.4 Training	6-6
	6.5 Review and Audit	6-6
	6.6 Reportable Occurrence Action	6-12
	6.7 Safety Limit Violation	6-12
	6.8 Procedures	6-13
	6.9 Reporting Requirements	6-14
	6.10 Record Retention	6-18
	6.11 Radiation Protection Program	6-20
	6.12 High Radiation Area	6-20
	6.13 Integrity of Systems Outside Containment	6-21
	6.14 Iodine Monitoring	6-21
	6.15 Environmental Qualification	6-22

Table 3.2-11

INSTRUMENTATION WHICH PROVIDES SURVEILLANCE INFORMATION

Ref. No. (a)	Instrument (b)	Required Operable Instrument Channels	Type and Range	Action	Remarks
1	Reactor Water Level (GE/MAC)	1	Recorder	(c)	(d)
		2	Indicator 0 to 60"	(c)	(d)
2	Shroud Water Level	1	Recorder	(c)	(d)
		1	Indicator +200" to +500"	(c)	(d)
3	Reactor Pressure	1	Recorder	(c)	(d)
		2	Indicator 0 to 1200 psig	(c)	(d)
4.	Drywell Pressure	2	Recorder -5 to +80 psig	(c)	(d)
5	Drywell Temperature	2	Recorder 0 to 500°F	(c)	(d)
6	Suppression Chamber Air Temperature	2	Recorder 0 to 500°F	(c)	(d)
7	Suppression Chamber Water Temperature	2	Recorder 0 to 250°F	(c)	(d)
8	Suppression Chamber Water Level	2	Indicator 0 to 300"	(c)	(d)
		2	Recorder 0 to 30"	(c)(e)	(d)
9	Suppression Chamber Pressure	2	Recorder -5 to +80 psig	(c)	(d)
10	Rod Position Information System (RPIS)	1	28 Volt Indicating Lights	(c)	(d)
11	Hydrogen and Oxygen Analyzer	1	Recorder 0 to 52	(c)	(d)
12	Post LOCA Radiation Monitoring System	1	Recorder	(c)	(d)
			Indicator 1 to 10 ⁶ R/hr	(c)	(d)
13	Drywell/Suppression Chamber Differential Pressure	2	Recorder -0.5 to +2.5 psid	(c)(e)	(d)
14	a) Safety/Relief Valve Position Primary Indicator	1	Pressure Switch 4-100 psig	(f)	
	b) Safety/Relief Valve Position Secondary Indicator	1	Temperature element 0-600°F	(f)	

PLANT HATCH UNIT 1
 Amendment No. 42, 46, 58, 79

3.2-22

NOTES FOR TABLE 3.2-11

- a. The column entitled "Ref. No." is only for convenience so that a one-to-one relationship can be established between items in Table 3.2-11 and items in Table 4.2-11.
- b. Limiting Conditions for Operation for the Neutron Monitoring System are listed in Table 3.2-7.
- c. From and after the date that one of these parameters is reduced to one indication, continued operation is permissible during the succeeding thirty days unless such instrumentation is sooner made operable.

Continued operation is permissible for seven days from and after the date that one of these parameters is not indicated in the control room. Surveillance of local panels will be substituted for indication in the control room during the seven days.

- d. Drywell and Suppression Chamber Pressure are each recorded on the same recorders. Each output channel has its own recorder.

Drywell and Suppression Chamber air temperature and suppression chamber water temperature are all recorded on the same recorders. Each output channel has its own recorder. Each recorder takes input from several temperature elements.

Hydrogen and Oxygen are indicated on one recorder. The recorder has two pens, one pen for each parameter.

Each channel of the post LOCA radiation monitoring system includes two detectors; one located in the drywell and the other in the suppression chamber. Each detector feeds a signal to a separate log count rate meter. The meter output goes to a two pen recorder. One high radiation level alarm is provided per channel and annunciation of alarm is provided in the control room.

- e. In the event that all indications of this parameter is disabled and such indication cannot be restored in six (6) hours, an orderly shutdown shall be initiated and the reactor shall be in a Hot Shutdown condition in six (6) hours and a Cold Shutdown condition in the following eighteen (18) hours.
- f. If either the primary or secondary indication is inoperable, the torus temperature will be monitored at least once per shift to observe any unexplained temperature increase which might be indicative of an open SRV. With both the primary and secondary monitoring channels of two or more SRVs inoperable either restore sufficient inoperable channels such that no more than one SRV has both primary and secondary channels inoperable within 7 days or be in at least hot shutdown within the next 12 hours.

Table 4.2-11

Check and Calibration Minimum Frequency for Instrumentation
Which Provides Surveillance Information

Ref. No. (a)	Instrument	Instrument Check Minimum Frequency (b)	Instrument Calibration Minimum Frequency (c)
1	Reactor Water Level (GE/MAC)	Each shift	Every 6 months
2	Shroud Water Level	Each shift	Every 6 months
3	Reactor Pressure	Each shift	Every 6 months
4	Drywell Pressure	Each shift	Every 6 months
5	Drywell Temperature	Each shift	Every 6 months
6	Suppression Chamber Air Temperature	Each shift	Every 6 months
7	Suppression Chamber Water Temperature	Each shift	Every 6 months
8	Suppression Chamber Water Level	Each shift	Every 6 months
9	Suppression Chamber Pressure	Each shift	Every 6 months
10	Rod Position Information System (RPIS)	Each shift	N/A
11	Hydrogen and Oxygen Analyzer	Each shift	Every 6 months
12	Post LOCA Radiation	Each shift	Every 6 months
13	Drywell/Suppression Chamber Differential Pressure	Each shift	Every 6 months
14	a) Safety/Relief Valve Position Pri- mary Indicator	Monthly	Every 18 months
	b) Safety/Relief Valve Position Secondary Indicator	Monthly	Every 18 months

PLANT HATCH UNIT 1
Amendment No. 42, 55, 79

3.2-48

TABLE 6.2.2-1

MINIMUM SHIFT CREW COMPOSITION#

Condition of Unit 1 - Unit 2 in Reactor Power Operation,
Hot Standby or Hot Shutdown Condition

LICENSE CATEGORY	APPLICABLE OPERATIONAL CONDITIONS	
	1, 2, 3	4 & 5
SOL**	2	2*
OL**	3	2
Non-Licensed	3	3
Shift Technical Advisor	1	1

Condition of Unit 1 - Unit 2 in Cold Shutdown Condition
or Refuel Mode

LICENSE CATEGORY	APPLICABLE OPERATIONAL CONDITIONS	
	1, 2, 3	4 & 5
SOL**	2	1*
OL**	2	2
Non-Licensed	3	3
Shift Technical Advisor	1	None

Condition of Unit 1 - No Fuel in Unit 2

LICENSE CATEGORY	APPLICABLE OPERATIONAL CONDITIONS	
	1, 2, 3	4 & 5
SOL	1	1*
OL	2	1
Non-Licensed	2	1
Shift Technical Advisor	1	None

*Does not include the Licensed Senior Reactor Operator or Senior Reactor Operator Limited to Fuel Handling, supervising CORE ALTERATIONS.

**Assumes each individual is licensed on both units.

#Shift crew composition, including an individual qualified in radiation protection procedures, may be less than the minimum requirements for a period of time not to exceed 2 hours in order to accommodate unexpected absence of on duty shift crew members provided immediate action is taken to restore the shift crew composition to within the minimum requirements of Table 6.2.2-1.

6.3 UNIT STAFF QUALIFICATIONS

6.3.1 Each member of the unit staff shall meet or exceed the minimum qualifications of ANSI N18.1-1971 for comparable positions, except for the Health Physicist-Radiochemist who shall meet or exceed the qualifications of Regulatory Guide 1.8, September 1975, and the Shift Technical Advisor* who shall have a bachelor's degree or equivalent in a scientific or engineering discipline with specific training in plant design, and response and analysis of the plant for transients and accidents.

6.4 TRAINING

6.4.1 A retraining and replacement training program for the unit staff shall be maintained under the direction of the Senior Methods and Training Specialist and shall meet or exceed the requirements and recommendations of Section 5.5 of ANSI N18.1-1971 and Appendix "A" of 10 CFR Part 55.

6.4.2 A training program for fire protection shall be maintained under the direction of the Senior Regulatory Specialist and shall meet or exceed the requirements of Section 27 of the NFPA Code-1975, except for fire protection training sessions which shall be held at least once per 92 days.

6.5 REVIEW AND AUDIT

6.5.1 PLANT REVIEW BOARD (PRB)

FUNCTION

6.5.1.1 The PRB shall function to advise the Plant Manager on all matters related to nuclear safety.

COMPOSITION

6.5.1.2 The Plant Review Board shall be composed of the:

Chairman:	Plant Manager
Vice Chairman:	Assistant Plant Manager
Member:	Operations Superintendent
Member:	Superintendent Plant Engineer Services
Member:	Maintenance Superintendent
Member:	Senior Quality Control Specialist
Member:	Health Physicist-Radiochemist

ALTERNATES

6.5.1.3 All alternate members shall be appointed in writing by the PRB Chairman to serve on a temporary basis; however, no more than two alternates shall participate as voting members in PRB activities at any one time.

* The qualifications for the Shift Technical Advisor apply after January 1, 1981.

ADMINISTRATIVE CONTROL

to enter such areas shall be provided with or accompanied by one or more of the following:

- a. A radiation monitoring device which continuously indicates the radiation dose rate in the area.
- b. A radiation monitoring device which continuously integrates the radiation dose rate in the area and alarms when a preset integrated dose is received. Entry into such areas with this monitoring device may be made after the dose rate level in the area has been established and personnel have been made knowledgeable of them.
- c. An individual qualified in radiation protection procedures who is equipped with a radiation dose rate monitoring device. This individual shall be responsible for providing positive control over the activities within the area and shall perform periodic radiation surveillance at the frequency specified by the facility Health Physicist in the Radiation Work Permit.

6.12.2 The requirements of 6.12.1, above, shall also apply to each high radiation area in which the intensity of radiation is greater than 1000 mrem/hr. In addition, locked doors shall be provided to prevent unauthorized entry into such areas and the keys shall be maintained under the administrative control of the Shift Foreman on duty and/or the Plant Health Physicist.

6.13 INTEGRITY OF SYSTEMS OUTSIDE CONTAINMENT

The licensee shall implement a program to reduce leakage from systems outside containment that would or could contain highly radioactive fluids during a serious transient or accident to as low as practical levels. This program shall include the following:

- 1) Provisions establishing preventive maintenance and periodic visual inspection requirements, and
- 2) System leak test requirements, to the extent permitted by system design and radiological conditions, for each system at a frequency not to exceed refueling cycle intervals. The systems subject to this testing are (1) Residual Heat Removal, (2) Core Spray, (3) Reactor Water Cleanup, (4) HPCI, and (5) RCIC.

6.14 IODINE MONITORING

The licensee shall implement a program which will ensure the capability to accurately determine the airborne iodine concentration in vital areas* under accident conditions. This program shall include the following:

- 1) Training of personnel,
- 2) Procedures for monitoring, and
- 3) Provisions for maintenance of sampling and analysis equipment.

* Areas requiring personnel access for establishing hot shutdown condition.



UNITED STATES
NUCLEAR REGULATORY COMMISSION
WASHINGTON, D. C. 20555

GEORGIA POWER COMPANY
OGLETHORPE POWER CORPORATION
MUNICIPAL ELECTRIC AUTHORITY OF GEORGIA
CITY OF DALTON, GEORGIA

DOCKET NO. 50-366

EDWIN I. HATCH NUCLEAR PLANT, UNIT NO. 2

AMENDMENT TO FACILITY OPERATING LICENSE

Amendment No. 18
License No. NPF-5

1. The Nuclear Regulatory Commission (the Commission) has found that:
 - A. The application for amendment by Georgia Power Company, et al., (the licensee) dated September 15, 1980, complies with the standards and requirements of the Atomic Energy Act of 1954, as amended (the Act) and the Commission's rules and regulations set forth in 10 CFR Chapter I;
 - B. The facility will operate in conformity with the application, the provisions of the Act, and the rules and regulations of the Commission;
 - C. There is reasonable assurance (i) that the activities authorized by this amendment can be conducted without endangering the health and safety of the public, and (ii) that such activities will be conducted in compliance with the Commission's regulations;
 - D. The issuance of this amendment will not be inimical to the common defense and security or to the health and safety of the public; and
 - E. The issuance of this amendment is in accordance with 10 CFR Part 51 of the Commission's regulations and all applicable requirements have been satisfied.
2. Accordingly, the license is amended by changes to the Technical Specifications as indicated in the attachment to this license amendment and paragraph 2.C.(2) of Facility Operating License No. NPF-5 is hereby amended to read as follows:

The Technical Specifications contained in Appendices A and B, as revised through Amendment No. 18, are hereby incorporated in the license. The licensee shall operate the facility in accordance with the Technical Specifications.

3. This amendment is effective as of the date of issuance.

FOR THE NUCLEAR REGULATORY COMMISSION

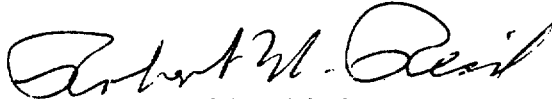

Robert W. Reid, Chief
Operating Reactors Branch #4
Division of Licensing

Attachment:
Changes to the Technical
Specifications

Date of Issuance: October 28, 1980

ATTACHMENT TO LICENSE AMENDMENT NO. 18

FACILITY OPERATING LICENSE NO. NPF-5

DOCKET NO. 50-366

Replace the following pages of the Appendix "A" Technical Specifications with the enclosed pages. The revised pages are identified by Amendment number and contain vertical lines indicating the area of change. Over-leaf pages are included.

Remove

--

3/4 3-54

3/4 3-55

6-4

6-5

6-19

--

Insert

XVII (added)

3/4 3-54

3/4 3-55

6-4

6-5

6-19

6-20 (added)

INDEX

ADMINISTRATIVE CONTROLS

<u>SECTION</u>	<u>PAGE</u>
6.13 INTEGRITY OF SYSTEMS OUTSIDE CONTAINMENT.....	6-19
6.14 IODINE MONITORING.....	6-20
6.15 ENVIRONMENTAL QUALIFICATION.....	6-21

INSTRUMENTATION

POST-ACCIDENT MONITORING INSTRUMENTATION

LIMITING CONDITION FOR OPERATION

3.3.6.4 The post-accident monitoring instrumentation channels shown in Table 3.3.6.4-1 shall be OPERABLE.

APPLICABILITY: CONDITIONS 1 and 2.

ACTION:

- a. With one or more of the above required post-accident monitoring channels inoperable, either restore the inoperable channel(s) to OPERABLE status within 30 days or be in at least HOT SHUTDOWN within the next 12 hours.
- b. The provisions of Specification 3.0.4 are not applicable.

SURVEILLANCE REQUIREMENTS

4.3.6.4 Each of the above required post-accident monitoring instrumentation channels shall be demonstrated OPERABLE by performance of the CHANNEL CHECK and CHANNEL CALIBRATION operations at the frequencies shown in Table 4.3.6.4-1.

TABLE 3.3.6.4-1

POST-ACCIDENT MONITORING INSTRUMENTATION

<u>INSTRUMENT</u>	<u>MINIMUM CHANNELS OPERABLE</u>
1. Reactor Vessel Pressure (2C32-R605 A, B, C)	2
2. Reactor Vessel Water Level (2B21-R610, 2B21-R615)	2
3. Suppression Chamber Water Level (2T48-R622 A, B)	2
4. Suppression Chamber Water Temperature (2T47-R626, 2T47-R627)	2
5. Suppression Chamber Pressure (2T48-R608, 2T48-R609)	2
6. Drywell Pressure (2T48-R608, 2T48-R609)	2
7. Drywell Temperature (2T47-R626, 2T47-R627)	2
8. Post-LOCA Gamma Radiation (2D11-K622 A, B, C, D)	2
9. Drywell H ₂ -O ₂ Analyzer (2P33-R601 A, B)	2
10. a) Safety/Relief Valve Position Primary Indicator (2B21-N301 A-H and K-M)	*
b) Safety/Relief Valve Position Secondary Indicator (2B21-N004 A-H and K-M)	*

*If either the primary or secondary indication is inoperable, the torus temperature will be monitored at least once per shift to observe any unexplained temperature increases which might be indicative of an open SRV. With both the primary and secondary monitoring channels of two or more SRVs inoperable either restore sufficient inoperable channels such that no more than one SRV has both primary and secondary channels inoperable within 7 days or be in at least hot shutdown within the next 12 hours.

PLANT HATCH UNIT 2

3/4 3-54

Amendment No. 18

TABLE 4.3.6.4-1

POST-ACCIDENT MONITORING INSTRUMENTATION SURVEILLANCE REQUIREMENTS

<u>INSTRUMENT</u>	<u>CHANNEL CHECK</u>	<u>CHANNEL CALIBRATION</u>
1. Reactor Vessel Pressure	M	Q
2. Reactor Vessel Water Level	M	Q
3. Suppression Chamber Water Level	M	R
4. Suppression Chamber Water Temperature	M	R
5. Suppression Chamber Pressure	M	R
6. Drywell Pressure	M	Q
7. Drywell Temperature	M	R
8. Post-LOCA Gamma Radiation	M	R
9. Drywell H ₂ -O ₂ Analyzer	M	Q
10. a) Safety/Relief Valve Position Primary Indication	M*	R
b) Safety/Relief Valve Position Secondary Indication	M*	R

*See 4.4.2.a

PLANT HATCH UNIT 2

3/4 3-55

Amendment No. 18

INSTRUMENTATION

SOURCE RANGE MONITORS

LIMITING CONDITION FOR OPERATION

3.3.6.5 Three source range monitors shall be OPERABLE.

APPLICABILITY: CONDITIONS 2*, 3 and 4.

ACTION:

- a. In CONDITION 2* with one of the above required source range monitors inoperable, restore 3 source range monitors to OPERABLE status within 4 hours or be in at least HOT SHUTDOWN within the next 6 hours.
- b. In CONDITION 3 or 4, with two or more of the above required source range monitors inoperable, verify all control rods to be fully inserted in the core and lock the reactor mode switch in the Shutdown position within one hour.

SURVEILLANCE REQUIREMENTS

4.3.6.5 Each of the above required source range monitors shall be demonstrated OPERABLE by:

- a. Performance of a:
 1. CHANNEL CHECK at least once per:
 - (a) 12 hours in CONDITION 2*, and
 - (b) 24 hours in CONDITION 3 or 4.
 2. CHANNEL CALIBRATION** at least once per 18 months.
- b. Performance of a CHANNEL FUNCTIONAL TEST:
 1. Within 24 hours prior to moving the reactor mode switch from the Shutdown position if not performed within the previous 7 days, and
 2. At least once per 31 days.
- c. Verifying, prior to withdrawal of control rods, that the SRM count rate is at least 3 cps with the detector fully inserted.

* With IRMs on range 2 or below.

** May exclude neutron detectors.

HATCH - UNIT 2

6-3

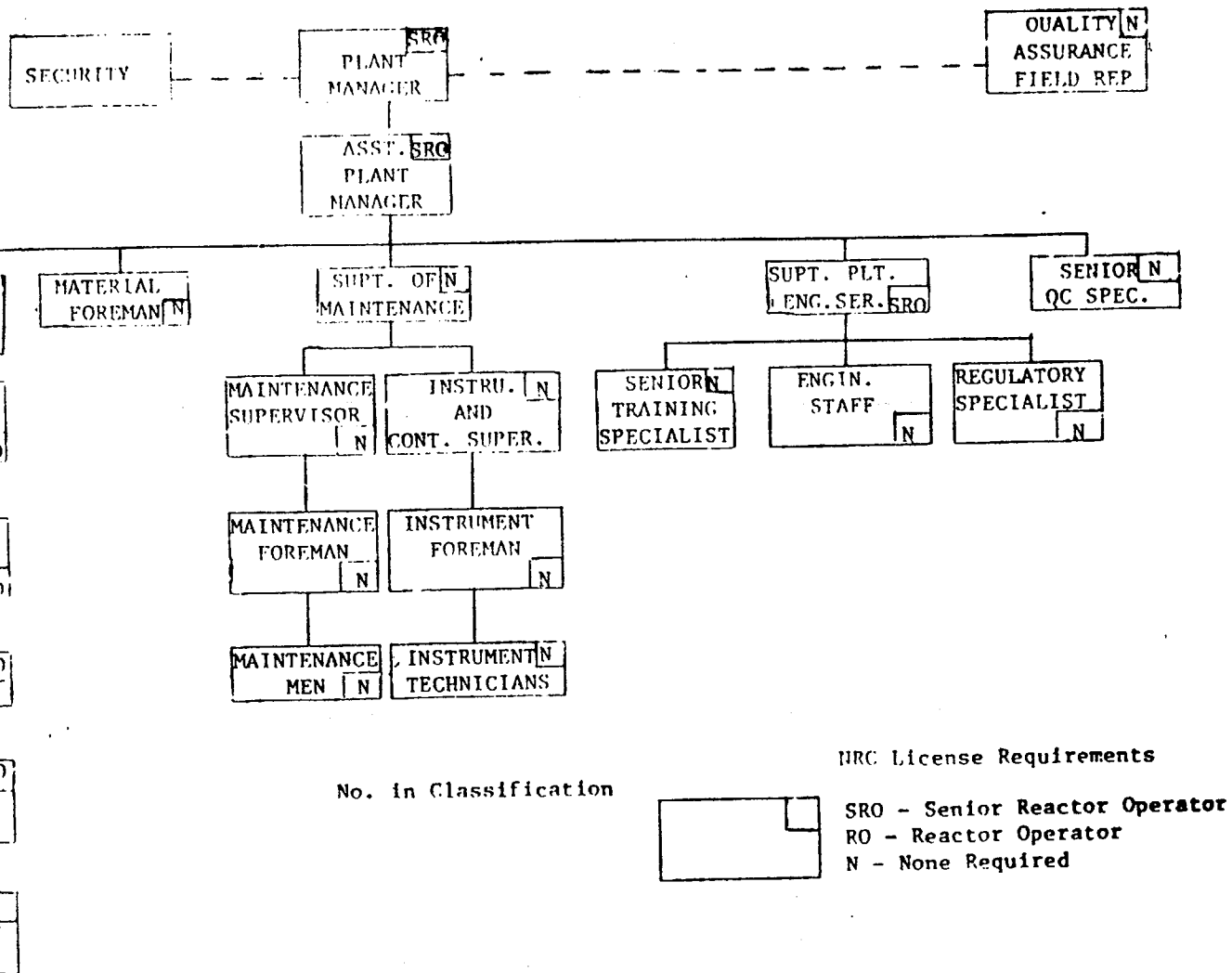

————— Lines of Responsibility

----- Lines of Communication

Either the Plant Manager or Assistant Plant Manager will obtain a Senior Reactor Operator's License.

Figure 6.2.2-1

UNIT ORGANIZATION

TABLE 6.2.2-1

MINIMUM SHIFT CREW COMPOSITION#Condition of Unit 2 - Unit 1 in Reactor Power Operation,
Hot Standby or Hot Shutdown Condition

LICENSE CATEGORY	APPLICABLE OPERATIONAL CONDITIONS	
	1, 2, 3	4 & 5
SOL**	2	2*
OL**	3	2
Non-Licensed	3	3
Shift Technical Advisor	1	1

Condition of Unit 2 - Unit 1 in Cold Shutdown Condition
or Refuel Mode

LICENSE CATEGORY	APPLICABLE OPERATIONAL CONDITIONS	
	1, 2, 3	4 & 5
SOL**	2	1*
OL**	2	2
Non-Licensed	3	3
Shift Technical Advisor	1	None

Condition of Unit 2 - No Fuel in Unit 1

LICENSE CATEGORY	APPLICABLE OPERATIONAL CONDITIONS	
	1, 2, 3	4 & 5
SOL	1	1*
OL	2	1
Non-Licensed	2	1
Shift Technical Advisor	1	None

*Does not include the Licensed Senior Reactor Operator or Senior Reactor Operator Limited to Fuel Handling, supervising CORE ALTERATIONS.

**Assumes each individual is licensed on both units.

#Shift crew composition, including an individual qualified in radiation protection procedures, may be less than the minimum requirements for a period of time not to exceed 2 hours in order to accommodate unexpected absence of on duty shift crew members provided immediate action is taken to restore the shift crew composition to within the minimum requirements of Table 6.2.2-1.

6.3 UNIT STAFF QUALIFICATIONS

6.3.1 Each member of the unit staff shall meet or exceed the minimum qualifications of ANSI N18.1-1971 for comparable positions, except for the Health Physicist-Radiochemist who shall meet or exceed the qualifications of Regulatory Guide 1.8, September 1975, and the Shift Technical Advisor* who shall have a bachelor's degree or equivalent in a scientific or engineering discipline with specific training in plant design, and response and analysis of the plant for transients and accidents.

6.4 TRAINING

6.4.1 A retraining and replacement training program for the unit staff shall be maintained under the direction of the Senior Methods and Training Specialist and shall meet or exceed the requirements and recommendations of Section 5.5 of ANSI N18.1-1971 and Appendix "A" of 10 CFR Part 55.

6.4.2 A training program for fire protection shall be maintained under the direction of the Senior Regulatory Specialist and shall meet or exceed the requirements of Section 27 of the NFPA Code-1975, except for fire protection training sessions which shall be held at least once per 92 days.

6.5 REVIEW AND AUDIT

6.5.1 PLANT REVIEW BOARD (PRB)

FUNCTION

6.5.1.1 The PRB shall function to advise the Plant Manager on all matters related to nuclear safety.

COMPOSITION

6.5.1.2 The Plant Review Board shall be composed of the:

Chairman:	Plant Manager
Vice Chairman:	Assistant Plant Manager
Member:	Operations Superintendent
Member:	Superintendent Plant Engineer Services
Member:	Maintenance Superintendent
Member:	Senior Quality Control Specialist
Member:	Health Physicist-Radiochemist

ALTERNATES

6.5.1.3 All alternate members shall be appointed in writing by the PRB Chairman to serve on a temporary basis; however, no more than two alternates shall participate as voting members in PRB activities at any one time.

* The qualifications for the Shift Technical Advisor apply after January 1, 1981.

ADMINISTRATIVE CONTROLS

MEETING FREQUENCY

6.5.1.4 The PRB shall meet at least once per calendar month and as convened by the PRB Chairman or his designated alternate.

QUORUM

6.5.1.5 The minimum quorum of the PRB necessary for the performance of the PRB responsibility and authority provisions of these Technical Specifications shall consist of the Chairman or Vice Chairman and three members including alternates.

RESPONSIBILITIES

6.5.1.6 The Plant Review Board shall be responsible for:

- a. Review of (1) all procedures required by Specification 6.8 and changes thereto, (2) any other proposed procedures or changes thereto as determined by the Plant Manager to affect nuclear safety.
- b. Review of all proposed tests and experiments that affect nuclear safety.
- c. Review of all proposed changes to Appendix "A" Technical Specifications.
- d. Review of all proposed changes or modifications to unit systems or equipment that affect nuclear safety.
- e. Investigation of all violations of the Technical Specifications including the preparation and forwarding of reports covering evaluation and recommendations to prevent recurrence to the Manager of Production and to the Safety Review Board (SRB).
- f. Review of events requiring 24 hour written notification to the Commission.
- g. Review of unit operations to detect potential nuclear safety hazards.
- h. Performance of special reviews, investigations or analyses and reports thereon as requested by the Plant Manager or the SRB.

ADMINISTRATIVE CONTROL

to enter such areas shall be provided with or accompanied by one or more of the following:

- a. A radiation monitoring device which continuously indicates the radiation dose rate in the area.
- b. A radiation monitoring device which continuously integrates the radiation dose rate in the area and alarms when a preset integrated dose is received. Entry into such areas with this monitoring device may be made after the dose rate level in the area has been established and personnel have been made knowledgeable of them.
- c. An individual qualified in radiation protection procedures who is equipped with a radiation dose rate monitoring device. This individual shall be responsible for providing positive control over the activities within the area and shall perform periodic radiation surveillance at the frequency specified by the facility Health Physicist in the Radiation Work Permit.

6.12.2 The requirements of 6.12.1, above, shall also apply to each high radiation area in which the intensity of radiation is greater than 1000 mrem/hr. In addition, locked doors shall be provided to prevent unauthorized entry into such areas and the keys shall be maintained under the administrative control of the Shift Foreman on duty and/or the Plant Health Physicist.

6.13 INTEGRITY OF SYSTEMS OUTSIDE CONTAINMENT

The licensee shall implement a program to reduce leakage from systems outside containment that would or could contain highly radioactive fluids during a serious transient or accident to as low as practical levels. This program shall include the following:

- 1) Provisions establishing preventive maintenance and periodic visual inspection requirements, and
- 2) System leak test requirements, to the extent permitted by system design and radiological conditions, for each system at a frequency not to exceed refueling cycle intervals. The systems subject to this testing are (1) Residual Heat Removal, (2) Core Spray, (3) Reactor Water Cleanup, (4) HPCI, and (5) RCIC.

ADMINISTRATIVE CONTROL

6.14 IODINE MONITORING

The licensee shall implement a program which will ensure the capability to accurately determine the airborne iodine concentration in vital areas* under accident conditions. This program shall include the following:

- 1) Training of personnel,
- 2) Procedures for monitoring, and
- 3) Provisions for maintenance of sampling and analysis equipment.

* Areas requiring personnel access for establishing hot shutdown condition.



UNITED STATES
NUCLEAR REGULATORY COMMISSION
WASHINGTON, D. C. 20666

SAFETY EVALUATION BY THE OFFICE OF NUCLEAR REACTOR REGULATION
SUPPORTING AMENDMENT NO. 79 TO FACILITY OPERATING LICENSE NO. DPR-57
AND AMENDMENT NO. 18 TO FACILITY OPERATING LICENSE NO. NPF-5

GEORGIA POWER COMPANY

OGLETHORPE POWER CORPORATION

MUNICIPAL ELECTRIC AUTHORITY OF GEORGIA

CITY OF DALTON, GEORGIA

EDWIN I. HATCH NUCLEAR PLANT, UNITS NOS. 1 AND 2

DOCKETS NOS. 50-321 AND 50-366

I. INTRODUCTION

By letter dated September 15, 1980, the Georgia Power Company (the licensee) proposed changes to the Technical Specifications (TSs) appended to Facility Operating Licenses Nos. DPR-57 and NPF-5 for the Edwin I. Hatch Nuclear Plant, Units Nos. 1 and 2. The changes involve the incorporation of certain of the TMI-2 Lessons Learned Category "A" requirements. The licensee's request is in direct response to the NRC staff's letter dated July 2, 1980.

II. BACKGROUND INFORMATION

By our letter dated September 13, 1979, we issued to all operating nuclear power plants requirements established as a result of our review of the Three Mile Island Unit 2 accident. Certain of these requirements, designated Lessons Learned Category "A" requirements, were to have been completed by the licensee prior to any operation subsequent to January 1, 1980. Our evaluation of the licensee's compliance with these Category "A" items was attached to our letter to Georgia Power Company dated February 26, 1980.

In order to provide reasonable assurance that operating reactor facilities are maintained within the limits determined acceptable following the implementation of the TMI-2 Lessons Learned Category "A" items, we requested that licensees amend their TSs to incorporate additional Limiting Conditions of Operation and Surveillance Requirements, as appropriate. This request was transmitted to all licensees on July 2, 1980. Included therein were model specifications that we had determined to be acceptable. The licensee's application is in direct response to our request. Each of the issues identified by the NRC staff and the licensee's response is discussed in the Evaluation below.

III. EVALUATION

1. Emergency Power Supply/Inadequate Core Cooling

As applicable to Boiling Water Reactors (BWRs), we indicated that water level

instrumentation is important to post-accident monitoring and that surveillance of this instrumentation should be performed. The licensee's response to this request stated that the current surveillance requirements for the reactor water level instrumentation at Hatch meet or exceed our guidance.

We have reviewed the current specifications (Tables 3.2-11 and 4.2-11 for Hatch 1 and Tables 3.3.6.4-1 and 4.3.6.4-1 for Hatch 2) and determined that water level instrumentation is included. The specifications provide ACTION statements for inoperable instrument channels. Surveillance requirements for instrument checks and calibration are also included. The frequency of surveillance meets or exceeds our guidelines. Based on this review, we conclude that no changes are required to satisfy our request.

2. Valve Position Indication

Our requirements for installation of a reliable position indicating system for relief and safety valves was based on the need to provide the operator with a diagnostic aid to reduce the ambiguity between indications that might indicate either an open relief/safety valve or a small line break. Such a system did not need to be safety grade provided that backup methods of determining valve position are available.

The licensee's request would add both the primary indicating system (tail-pipe pressure switches) and the secondary indicating system (downstream temperature detectors) to the specifications. Actions have been specified for the condition of an inoperable channel and for inoperability of both primary and backup detector channels. Additionally, surveillance requirements have been included. Based on our review, we find the licensee's recommended changes satisfy our guidelines and are acceptable.

3. Containment Isolation

Our request indicated that the specifications should include a Table of Containment Isolation Valves which reflect the diverse isolation signal requirement of this Lessons Learned issue.

The licensee's request stated that the current specifications include a requirement for diverse isolation signals and that no changes are required.

We have reviewed the current specifications (Tables 3.2-1, 3.2-8, 3.7-1, 4.2-1 and 4.2-8 for Hatch 1 and Tables 3.3.2-1, 3.3.2-2, 3.3.2-3, 4.3.2-1 and 3.6.3-1 for Hatch 2). These tables include a listing of valves, actuation signals and surveillance requirements. Based on this review, we have determined that the current specifications satisfy our request and that no changes are necessary.

4. Shift Technical Advisor (STA)

Our request indicated that the TSS related to minimum shift manning should be revised to reflect the augmentation of an STA. The STA function includes both accident and operating experience assessment.

The licensee proposed the addition of an STA to the minimum shift crew composition and the specific qualifications of this individual.

These qualifications state that the STA shall have a bachelor's degree or equivalent in a scientific or engineering discipline with specific training in plant design, and response and analysis of the plant for transients and accidents. Since our position does not require degreed STAs until January 31, 1981, the licensee requested that the effective date for the STA requirement be delayed until that time.

Our evaluation of the adequacy of the licensee's actions to provide STAs, including the interim period from January 1, 1980, to January 1, 1981, was contained in our letter dated February 26, 1980. That evaluation concluded that it was acceptable for the interim period to use, as STAs, Senior Reactor Operators with added training.

In view of the above, we have determined that the requirement to augment shift manning with an STA even during the interim period should be implemented; deferral to January 1, 1981, of the requirements for a degreed individual is acceptable. We've discussed this with the licensee and he agreed. Therefore, the licensee's request as modified by the NRC staff satisfies our request and is acceptable.

5. Integrity of Systems Outside Containment

Our letter dated July 2, 1980, indicated that the license should be amended by adding a license condition related to a Systems Integrity Measurements Program. Such a condition would require the licensee to effect an appropriate program to eliminate or prevent the release of significant amounts of radioactivity to the environment via leakage from engineered safety systems and auxiliary systems, which are located outside reactor containment.

The licensee's application did not address this issue. Discussions between members of our staffs indicated that (1) the licensee has implemented a leakage reduction program, as reported in our evaluation dated February 26, 1980, and (2) the application did not address this issue since TSs are not involved.

The licensee's representatives indicated that they did not object to including such provisions. They suggested that they be incorporated into the Administrative Controls Section of the specifications. Accordingly, we have included the requirements and determined that our request has been satisfied.

6. Iodine Monitoring

Our letter dated July 2, 1980, indicated that the license should be amended by adding a license condition related to iodine monitoring. Such a condition would require the licensee to effect a program which would ensure the capability to determine the airborne iodine concentration in areas requiring personnel access under accident conditions.

The licensee's application did not address this issue. Discussions between members of our staffs indicated that (1) the licensee has implemented a program to satisfy this issue, as reported in our evaluation dated February 26, 1980. This program includes the training of personnel, procedures for monitoring, and provisions for maintenance of sampling and analysis equipment; (2) the licensee's application did not address this issue since TSs are not involved.

The licensee's representatives indicated that they did not object to including such provisions as part of the Administrative Controls Section of the TSs. Accordingly, we have included the requirement and determined that our request has been satisfied.

IV. ENVIRONMENTAL CONSIDERATIONS

We have determined that the amendments do not involve a change in effluent types or total amounts nor an increase in power level and will not result in any significant environmental impact. Having made this determination, we have further concluded that the amendments involve an action which is insignificant from the standpoint of environmental impact and pursuant to 10 CFR Section 51.5(d)(4) that an environmental impact statement or negative declaration and environmental impact appraisal need not be prepared in connection with the issuance of these amendments.

V. CONCLUSIONS

We have concluded, based on the considerations discussed above, that: (1) because the amendments do not involve a significant increase in the probability or consequences of accidents previously considered and do not involve a significant decrease in a safety margin, the amendments do not involve a significant hazards consideration, (2) there is reasonable assurance that the health and safety of the public will not be endangered by operation in the proposed manner, and (3) such activities will be conducted in compliance with the Commission's regulations and the issuance of these amendments will not be inimical to the common defense and security or to the health and safety of the public.

Dated: October 28, 1980

UNITED STATES NUCLEAR REGULATORY COMMISSION
DOCKETS NOS. 50-321 AND 50-366
GEORGIA POWER COMPANY, ET AL.
NOTICE OF ISSUANCE OF AMENDMENTS TO FACILITY
OPERATING LICENSES

The U. S. Nuclear Regulatory Commission (the Commission) has issued Amendments Nos. 79 and 18 to Facility Operating Licenses Nos. DPR-57 and NPF-5, issued to Georgia Power Company, Oglethorpe Power Corporation, Municipal Electric Authority of Georgia, and City of Dalton, Georgia, which revised Technical Specifications for operation of the Edwin I. Hatch Nuclear Plant, Units Nos. 1 and 2 (the facility) located in Appling County, Georgia. The amendments are effective as of the date of issuance.

These changes to the Technical Specifications involve incorporation of certain of the TMI-2 Lessons Learned Category "A" requirements. These requirements concern 1) Emergency Power Supply/Inadequate Core Cooling, 2) Valve Position Indication, 3) Containment Isolation, 4) Shift Technical Advisor Augmentation, 5) Integrity of Systems Outside Containment and 6) Iodine Monitoring.

The application for the amendments complies with the standards and requirements of the Atomic Energy Act of 1954, as amended (the Act), and the Commission's rules and regulations. The Commission has made appropriate findings as required by the Act and the Commission's rules and regulations in 10 CFR Chapter I, which are set forth in the license amendments. Prior public notice of these amendments was not required since the amendments do not involve a significant hazards consideration.

The Commission has determined that the issuance of these amendments will not result in any significant environmental impact and that pursuant to 10 CFR §51.5(d)(4) an environmental impact statement or negative declaration and environmental impact appraisal need not be prepared in connection with the issuance of these amendments.

For further details with respect to this action, see (1) the application for amendments dated September 15, 1980, (2) Amendments Nos. 79 and 18 to Licenses Nos. DPR-57 and NPF-5, and (3) the Commission's related Safety Evaluation. All of these items are available for public inspection at the Commission's Public Document Room, 1717 H Street, N. W., Washington, D. C. and at the Appling County Public Library, Parker Street, Baxley, Georgia 31513. A copy of items (2) and (3) may be obtained upon request addressed to the U. S. Nuclear Regulatory Commission, Washington, D. C. 20555, Attention: Director, Division of Licensing.

Dated at Bethesda, Maryland, this 28th day of October 1980.

FOR THE NUCLEAR REGULATORY COMMISSION

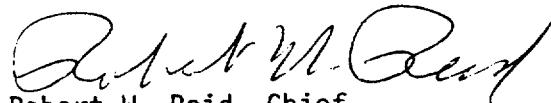

Robert W. Reid, Chief
Operating Reactors Branch #4
Division of Licensing