

INDIAN POINT UNIT 2 NRC PUBLIC MEETING

JUNE 19, 2000



6/19/00

AGENDA

- **INTRODUCTION**
- **CONGRESSIONAL REMARKS**
- **DESCRIPTION OF NRC REVIEW PROCESS AND STATUS**
- **PUBLIC QUESTIONS AND COMMENTS**
- **CLOSING**

ISSUES

- **STEAM GENERATOR INTEGRITY**

- ▶ **STARTUP ISSUE**
- ▶ **“10 CFR 2.206 PETITION”**

- **IP-2 PERFORMANCE WEAKNESSES**

- ▶ **LONGER TERM ISSUE**
- ▶ **“AGENCY FOCUS” PLANT**

NRC OVERSIGHT ACTIVITIES

- **INSPECTIONS**
 - ▶ **RESIDENT INSPECTORS**
 - ▶ **AUGMENTED INSPECTIONS -- AITs**

- **“AGENCY FOCUS” DESIGNATION**

- **PLANNED MEETING ON PERFORMANCE IMPROVEMENTS**
 - ▶ **WITHIN NEXT TWO MONTHS**

- **FOLLOW-UP, HEIGHTENED INSPECTION AND OVERSIGHT**

STEAM GENERATOR REVIEW PROCESS

- **JACK STRONSNIDER, DIRECTOR
DIVISION OF ENGINEERING, NRR**

CONDITIONS THAT MUST BE SATISFIED TO OPERATE STEAM GENERATORS

- **CON ED MUST DETERMINE THE CAUSE OF THE FAILURE AND TAKE CORRECTIVE ACTION**
- **CON ED MUST INSPECT THE STEAM GENERATORS AND REPAIR DEFECTIVE TUBES**
- **CON ED MUST PERFORM AN ENGINEERING ANALYSIS DEMONSTRATING THE STEAM GENERATORS MEET NRC REQUIREMENTS**
- **NRC APPROVAL IS REQUIRED IN A SAFETY EVALUATION REPORT**

CAUSE OF THE TUBE FAILURE AND CORRECTIVE ACTION

- ▣ **CON ED SUBMITTED ITS EVALUATION OF THE CAUSE OF THE FAILURE TO NRC ON APRIL 14, 2000**
 - ▶ **“PRINCIPAL CAUSE OF THE LEAKAGE WAS THE INABILITY TO DETECT THE INDICATION IN 1997 INSPECTION DUE TO NOISE IN THE SIGNAL”**
- **NRC AGREES THAT DEFICIENCIES IN CON ED STEAM GENERATOR INSPECTION LED TO THE TUBE FAILURE**
- **CON ED CORRECTIVE ACTIONS INCLUDED USE OF IMPROVED INSPECTION METHODS**

CON ED STEAM GENERATOR INSPECTIONS AND REPAIR

- **CON ED CONDUCTED TUBE INSPECTIONS FOLLOWING THE TUBE FAILURE**
 - ▶ **IMPROVED INSPECTION METHODS WERE USED**
 - ▶ **ALL TUBES WITH INDICATIONS OF CRACKING WERE REMOVED FROM SERVICE**
 - ▶ **ALL TUBES IN THE ROW WITH THE FAILED TUBE WERE REMOVED FROM SERVICE**

NRC OVERSIGHT OF LICENSEE INSPECTION ACTIVITIES

- **REGIONAL AND HEADQUARTERS STAFF ON SITE DURING CON ED'S STEAM GENERATOR INSPECTIONS**

- **INTERNATIONALLY RENOWNED EDDY CURRENT EXPERT AND EXPERTS FROM ARGONNE NATIONAL LABORATORY ASSISTED NRC STAFF**

CON ED ENGINEERING ANALYSIS

- **CON ED SUBMITTED ITS ANALYSIS (OPERATIONAL ASSESSMENT) TO NRC ON JUNE 2, 2000**

- **PROVIDES CON ED'S BASES FOR:**
 - ▶ **RETURNING STEAM GENERATORS TO OPERATION**

 - ▶ **ACCEPTABLE PERIOD OF OPERATION**

- **REQUIRES NRC REVIEW AND APPROVAL IN A SAFETY EVALUATION REPORT**

NRC SAFETY EVALUATION REPORT

- **KEY ISSUES THAT MUST BE SATISFACTORILY ADDRESSED**
 - ▶ **ADEQUACY OF ENHANCED INSPECTION METHODS**
 - ▶ **ASSUMED RATES OF DEGRADATION DURING OPERATION**
 - ▶ **CONFIDENCE THAT TUBES WILL MEET REGULATORY REQUIREMENTS THROUGHOUT THE PROPOSED PERIOD OF OPERATION**

- **SCHEDULE FOR NRC REVIEW AND SAFETY EVALUATION REPORT**
 - ▶ **DEPENDS ON ISSUES THAT ARISE DURING REVIEW AND LICENSEE'S ABILITY TO RESPOND TO THEM**
 - ▶ **NRC WILL TAKE THE TIME NECESSARY TO COMPLETE A THOROUGH REVIEW**

NRC'S IP-2 LESSONS LEARNED TASK GROUP

- **CHARTER:** *To conduct, based on the February 15, 2000, steam generator tube failure at Indian Point 2 (IP-2), an evaluation of the technical and regulatory processes related to assuring steam generator tube integrity in order to identify lessons learned and recommend any areas for improvement.*
- **TASK GROUP MEMBERSHIP IS INTEROFFICE AND MULTI-DISCIPLINED**
- **FINAL REPORT WITH TASK GROUP REPORT WILL BE ISSUED TWO MONTHS FOLLOWING ISSUANCE OF THE STAFF'S SAFETY EVALUATION REPORT ON CON ED'S OPERATIONAL ASSESSMENT**
- **STAFF'S SAFETY EVALUATION REPORT ON CON ED'S OPERATIONAL ASSESSMENT WILL BE PROVIDED TO THE TASK GROUP BEFORE IT IS ISSUED**



Indian Point Unit 2 Event ¶

[[Indian Point 2 Event](#) | [Nuclear Reactors](#) | [NRC Home Page](#)] ¶

Workers at Indian Point Nuclear Power Plant, Unit 2, manually shut down the reactor in Buchanan, N.Y., at 7:29 p.m. on Tuesday, February 15, 2000 following indications of a steam generator tube failure in one of the plant's four steam generators. The plant is operated by Consolidated Edison Company of New York. The steam generators are components that transfer heat from the reactor systems to the power-generating portion of a nuclear power plant. Plant safety systems performed as designed during the shutdown.

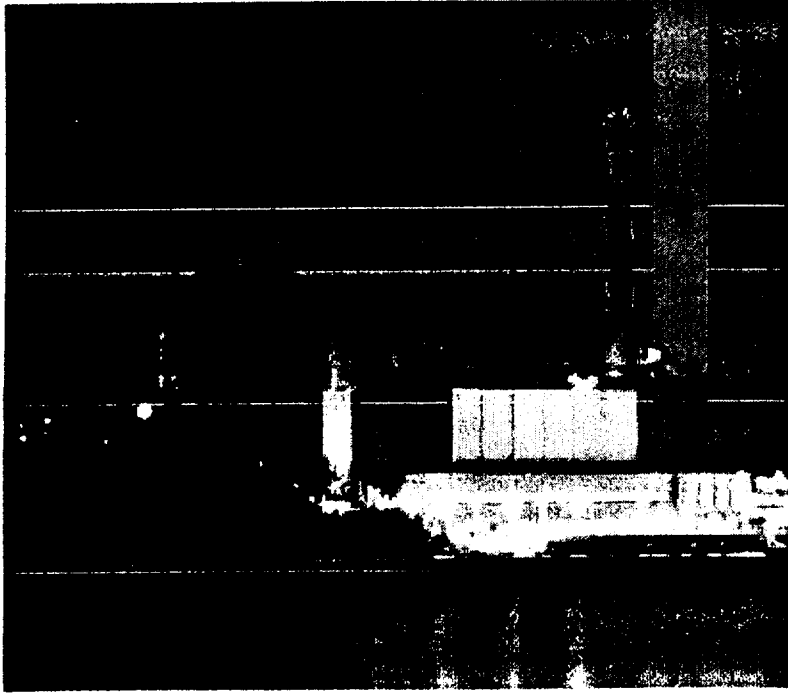

To learn more about the major systems and components associated with a Pressurized Water Reactor (PWR) as found at the Indian Point 2 Nuclear Power Plant, see [PWR Systems](#) ¶

 [Cutaway view of a Westinghouse PWR steam generator design](#) ¶

 [Indian Point 2 Plant Information Book](#)
Please let us know how user friendly you find Web site by e-mail to lx1@nrc.gov. This site is under development and will be periodically updated. In particular, we are interested in m

PWR SYSTEM

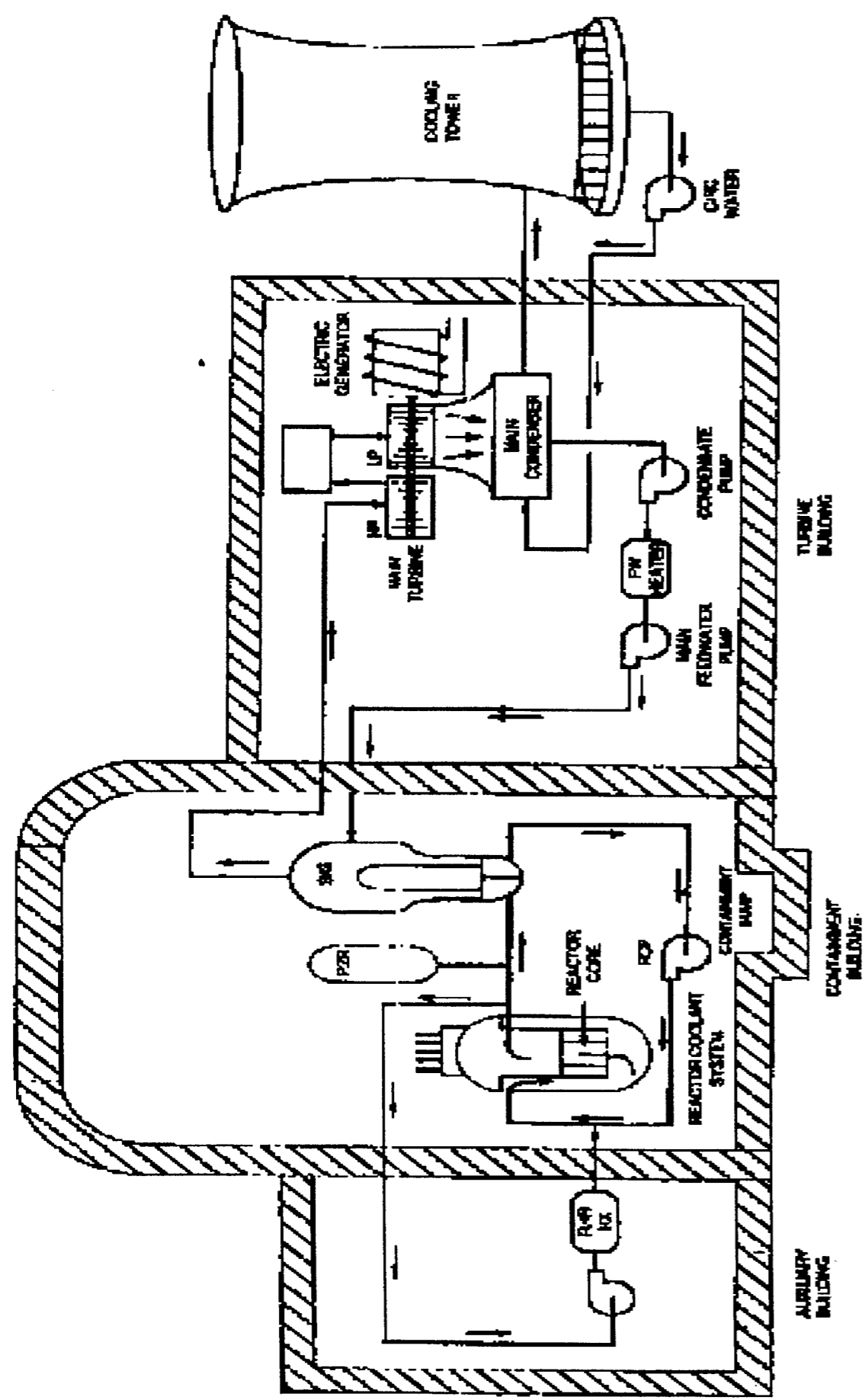

WESTINGHOUSE STEAM GENERATOR

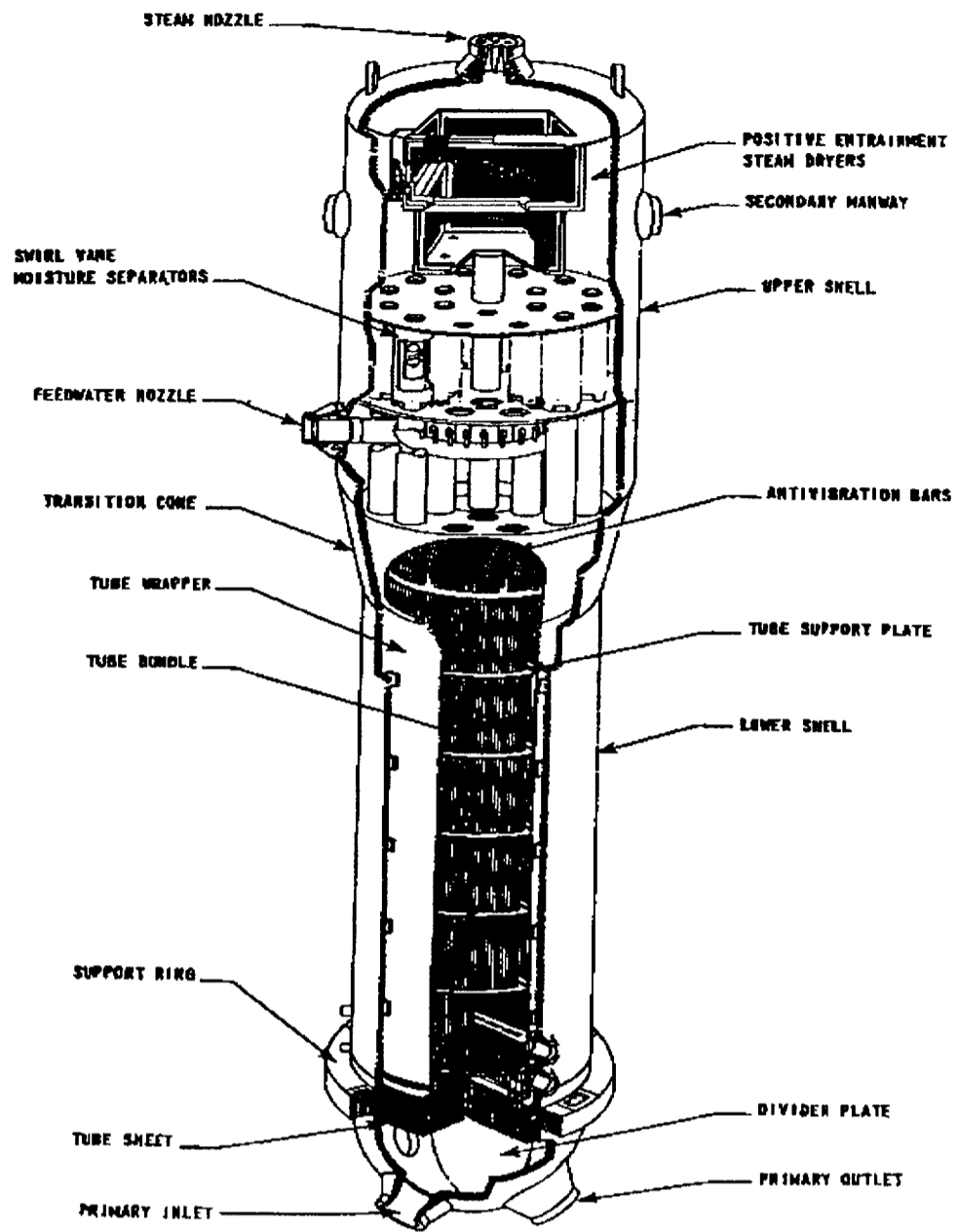

10 CFR 2.206 PETITION PROCESS

- **SUZANNE BLACK, DEPUTY DIRECTOR
DIVISION OF LICENSING PROJECT
MANAGEMENT, NRR**

10 CFR 2.206 PROCESS

- **REGULATION PROVIDING ANY PERSON AN OPPORTUNITY TO REQUEST ENFORCEMENT ACTION**
- **AGENCY PROCESS TO IMPLEMENT THIS REGULATION (MANAGEMENT DIRECTIVE 8.11)**
 - ▶ **PETITION REVIEW BOARD DETERMINES IF REQUESTS MEET THE CRITERIA**
 - ▶ **ACKNOWLEDGMENT LETTER SENT TO PETITIONER**
 - ▶ **PETITION REVIEWED AND DIRECTOR'S DECISION ISSUED**
- **COMMISSION REVIEW IS AT THEIR DISCRETION**

CURRENT 2.206 PETITION

- **PETITION SUBMITTED BY UCS MARCH 14, 2000**
- **PETITIONED NRC TO DELAY RESTART PENDING**
 - ▶ **REPLACEMENT OF ALL FOUR SGs**
 - ▶ **RESOLUTION OF SG TUBE INTEGRITY CONCERNS RAISED IN A DPO**
 - ▶ **DISTRIBUTION OR STOCKPILING OF POTASSIUM IODIDE TABLETS TO PERSONS WITHIN THE 10-MILE EPZ**
- **CONSIDERABLE COMMUNICATION SINCE THEN INCLUDING AN ACKNOWLEDGMENT LETTER, A PUBLIC MEETING, AND SUPPLEMENTS TO THE ORIGINAL PETITION**
- **SECOND ACKNOWLEDGMENT LETTER WILL ADDRESS SUPPLEMENTAL INFORMATION PROVIDED ON POTASSIUM IODIDE ISSUE AND RESOLUTION OF SG TUBE INTEGRITY CONCERNS**
- **DECISION ON THE ISSUES REVIEWED UNDER 2.206 WILL BE MADE PRIOR TO IP2 RESTART. ADMINISTRATIVE PROCESSING OF DIRECTOR'S DECISION MAY BE AFTER RESTART**
- **PETITIONERS WILL BE INFORMED OF DECISION PRIOR TO RESTART**

RECENT CORRESPONDENCE

- **RECENT REQUEST RELATED TO ADEQUACY OF IP2 EMERGENCY PLANNING IS BEING HANDLED USING OUR 2.206 PROCESS**