

THERMAL HYDRAULICS OF SPENT FUEL POOL FOR DECOMMISSIONING PLANTS

presentation at

**NRC / NEI / PUBLIC WORKSHOP
Gaithersburg, MD**

July 15 - 16, 1999

by

Kalyan K. Niyogi, Ph.D., P.E



**HOLTEC
INTERNATIONAL**

5/1/75

- **INTRODUCTION**
- **SCENARIOS**
- **METHODOLOGY**
- **EVALUATION**
- **CONCLUSIONS**

SCENARIOS

Spent Fuel Pool Heatup with No SFP Cooling

- Normal Ventilation System Operating
- Natural Circulation Cooling w/o Forced Ventilation

Loss of Cooling Water

METHODOLOGY

Spent Fuel Pool Heatup with No SFP Cooling

Calculation of Decay Heat - ORIGEN

Pool Evaporation Model

Steady State SFP and Fuel Building Temperature

Normal Ventilation System Operating

Natural Circulation Cooling w/o Forced Ventilation

METHODOLOGY

Loss of Cooling Water

CFD Model for Natural Circulation of Air

**Heat Transfer between Storage Racks and
Surrounding Building Structure**

Heat Transfer inside Racks and Fuel Assemblies

COMPLETE POOL DRAINDOWN

CFD Model (FLUENT) in 2-D and 3-D

Convective Heat Transfer

Porous Media Assupmtion

EVALUATION

Maximum Local Temperature

Maximum Fuel Cladding Temperature

Effect of

Thermal Radiation

2-D / 3-D

Fuel Shuffling

Rack Design

CONCLUSIONS

- CFD techniques provide acceptable predictions of results
- Plant specific analysis is necessary to factor in Burnup, Fuels, Rack Design Details, etc.
- Fuel shuffling may provide significant advantage

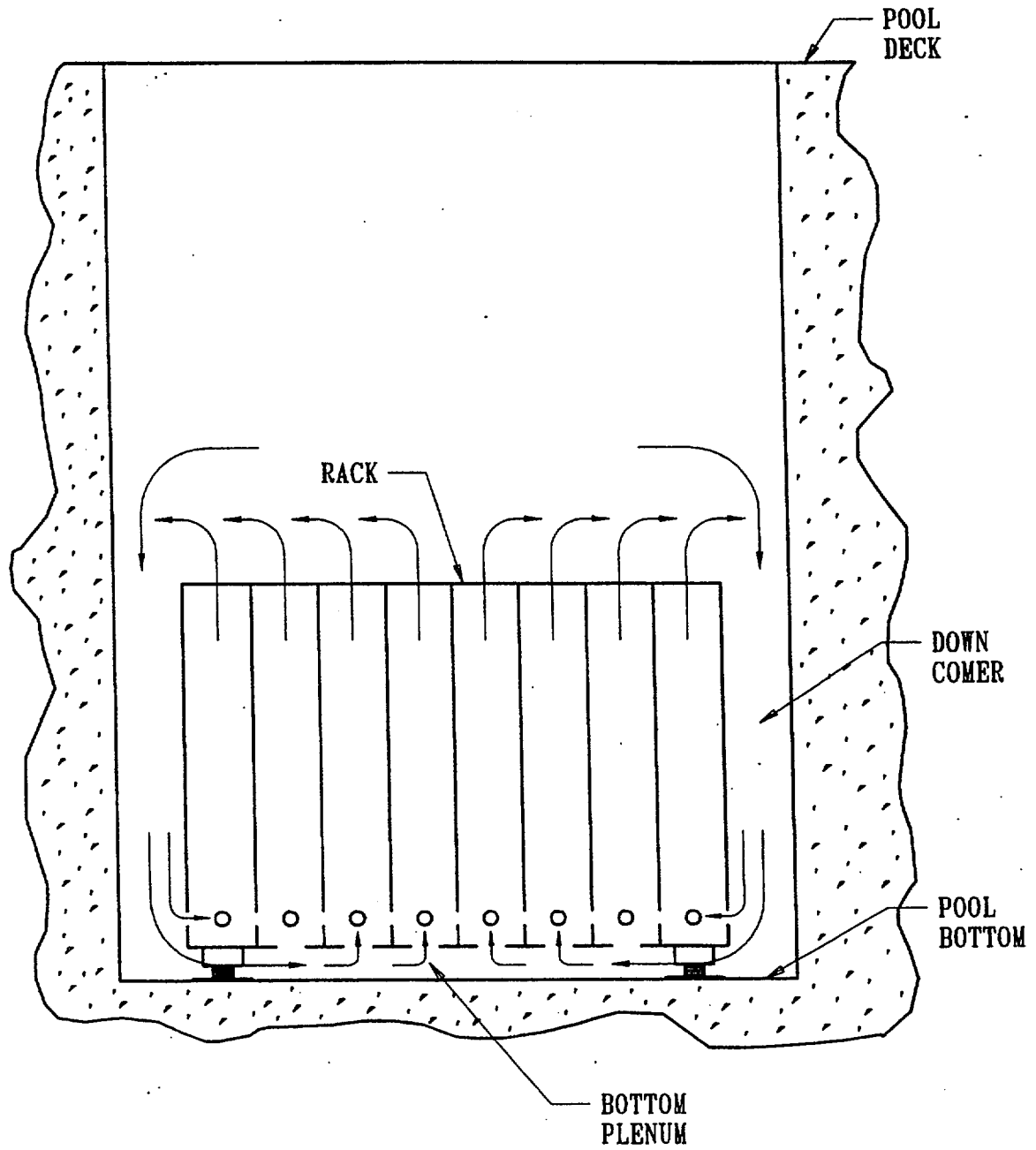

Figure 1: Air Convection Currents in the empty Pool

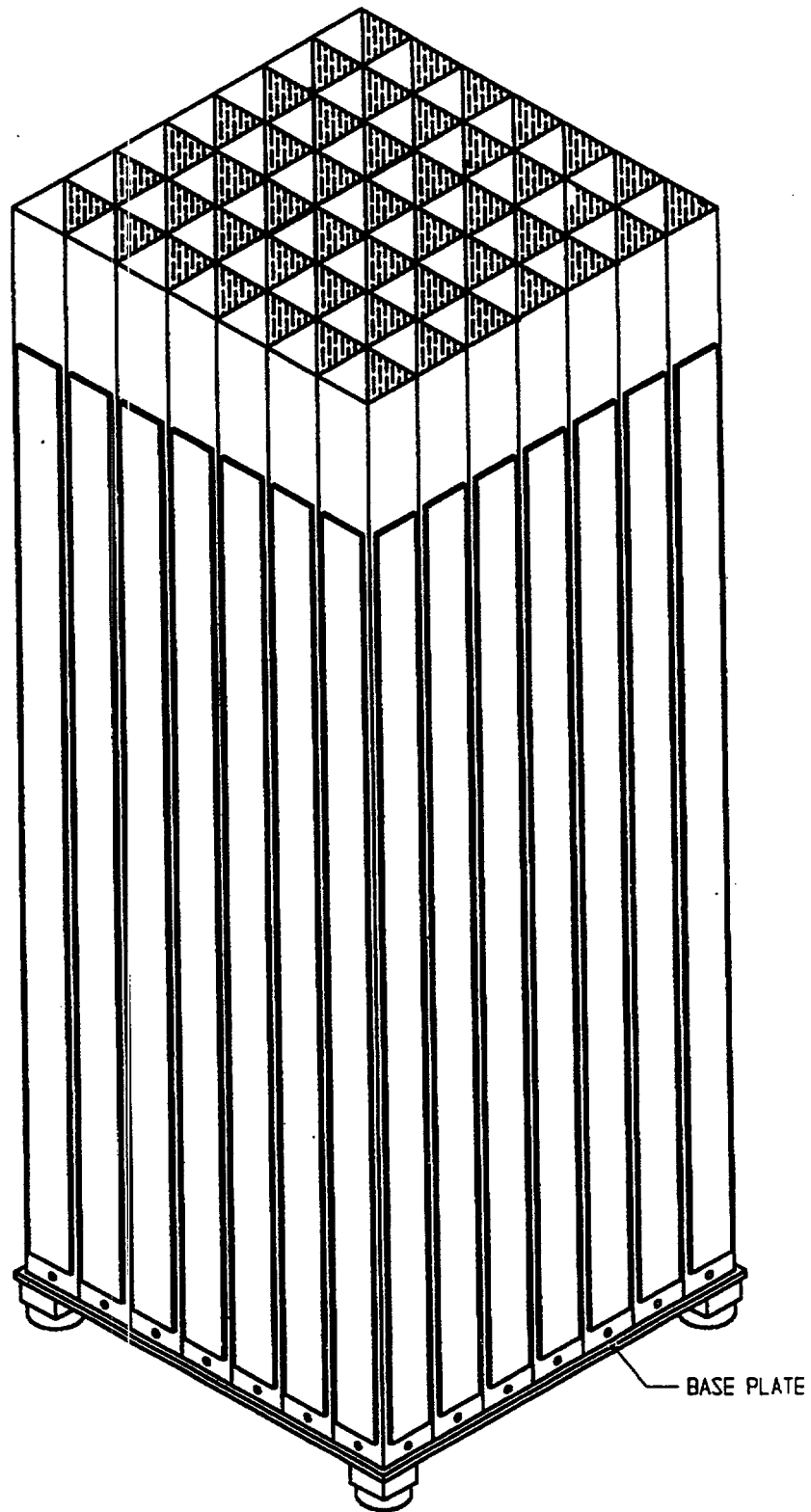

Figure 2: Pictorial View of Rack with Side Holes

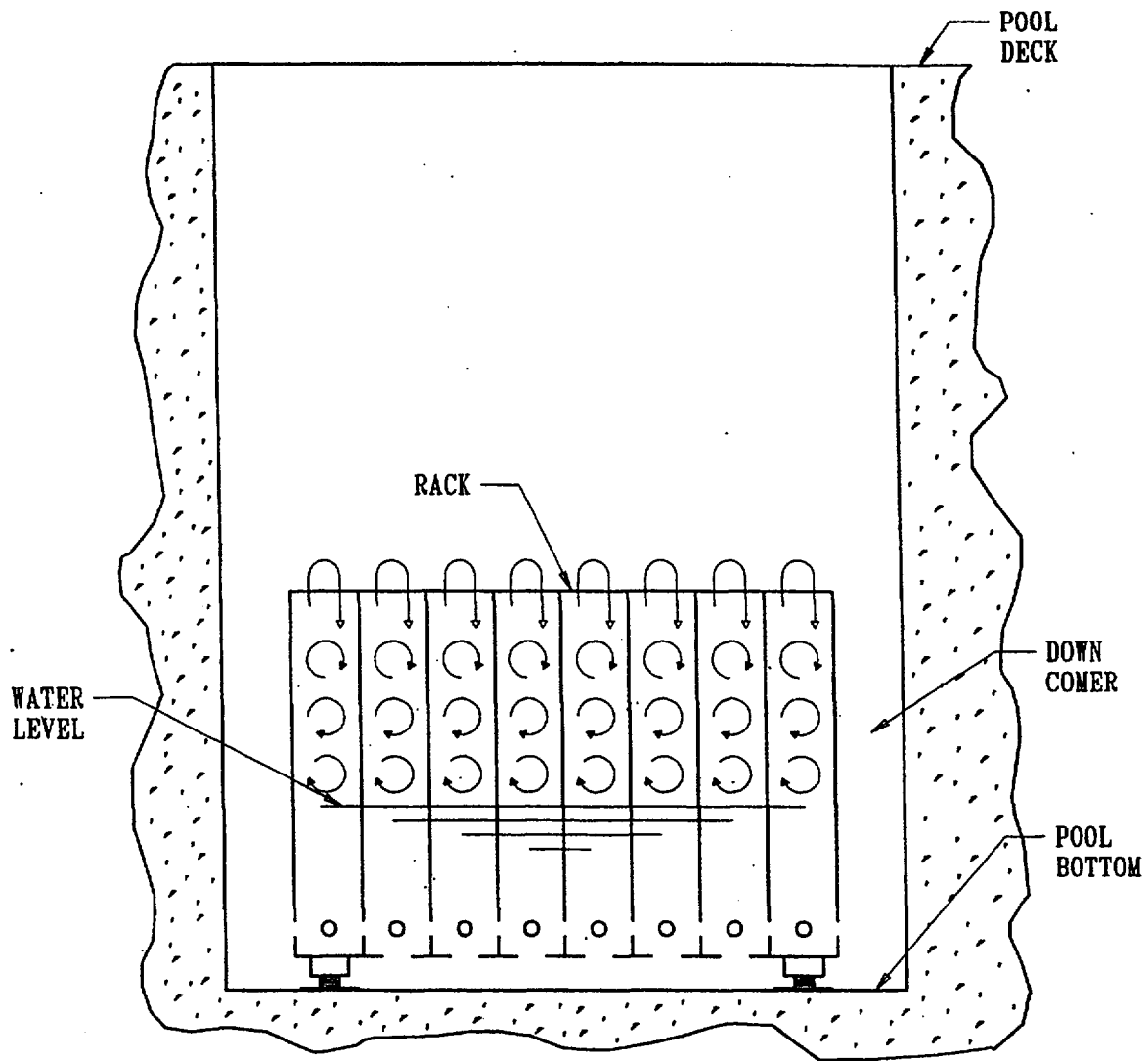

Figure 3: Air Convection Current in the Pool (Pool partially empty)

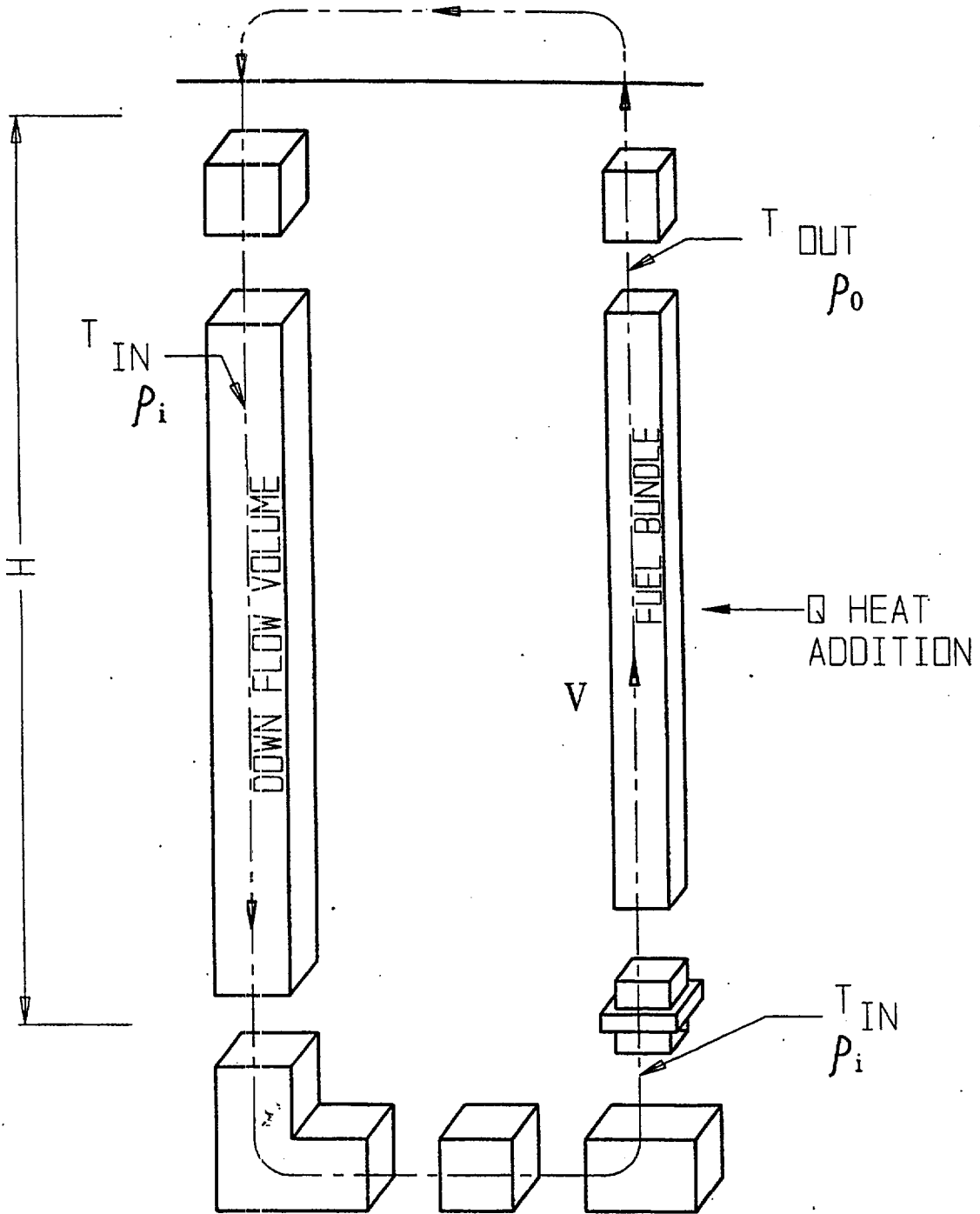

Figure 7: Thermal Chimney Flow Model

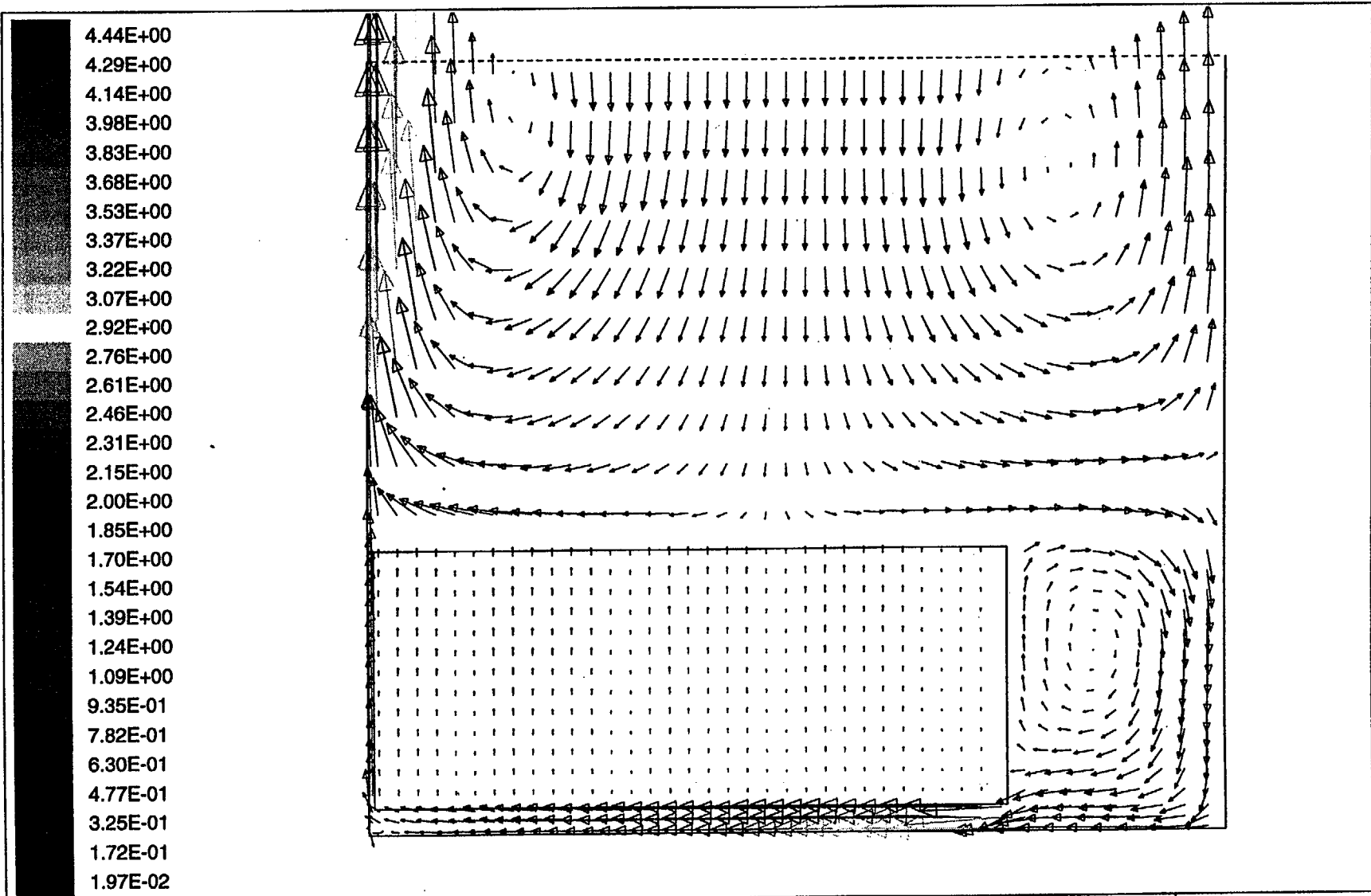

FIGURE 3: VELOCITY VECTORS PLOT (SCENARIO - A)
 Velocity Vectors (M/S)
 Max = 4.442E+00 Min = 1.974E-02

May 15 1997
 Fluent 4.32
 Fluent Inc.

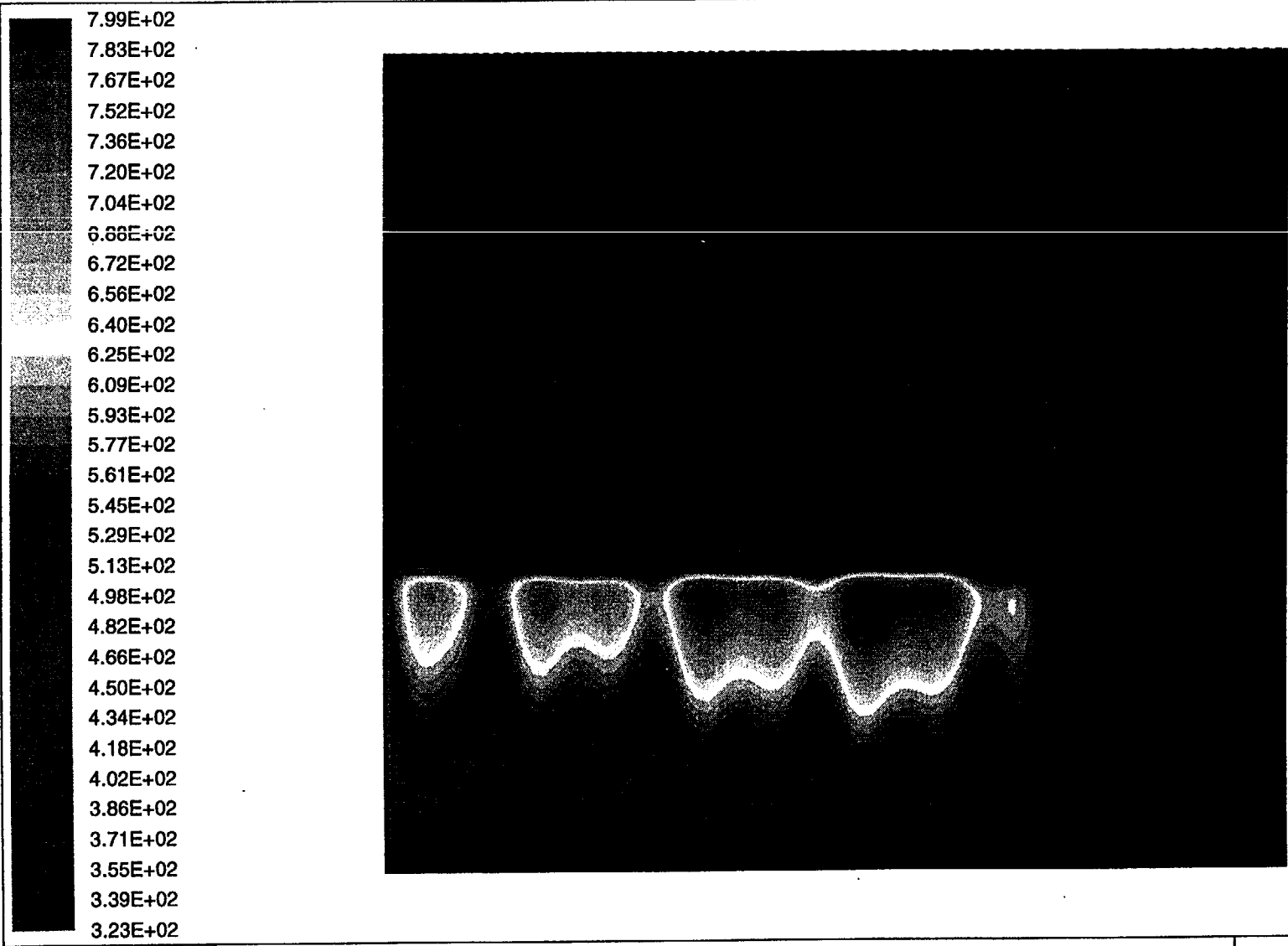

FIGURE 4: TEMPERATURE CONTOURS PLOT (SCENARIO - A)
 Temperature (Degrees Kelvin)
 Max = 7.992E+02 Min = 3.230E+02

May 15 1997
 Fluent 4.32
 Fluent Inc.

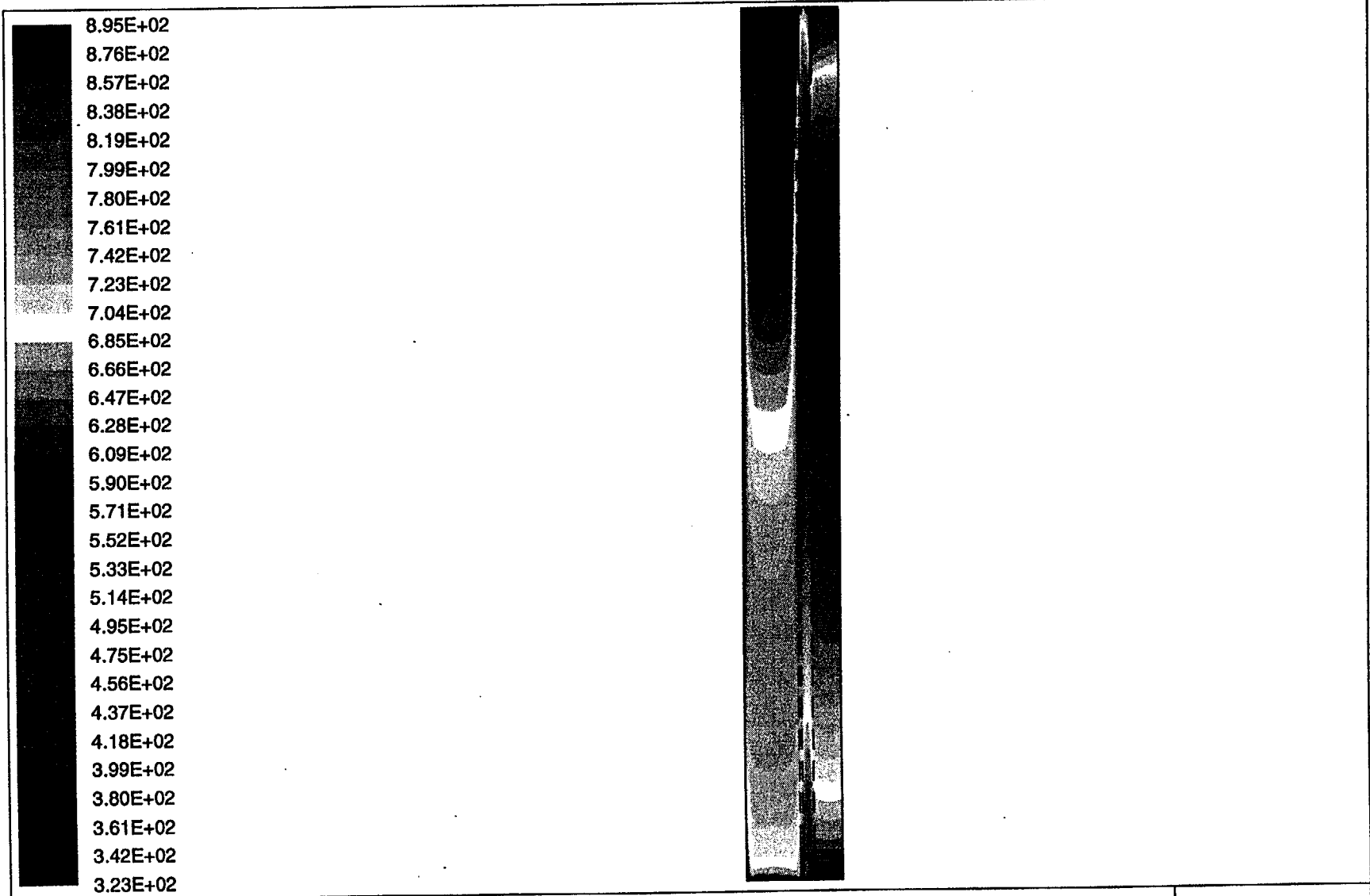

FIGURE 5: TEMPERATURE CONTOURS PLOT (SCENARIO - B)
 Temperature (Degrees Kelvin)
 Max = 8.948E+02 Min = 3.230E+02

May 15 1997
 Fluent 4.32
 Fluent Inc.

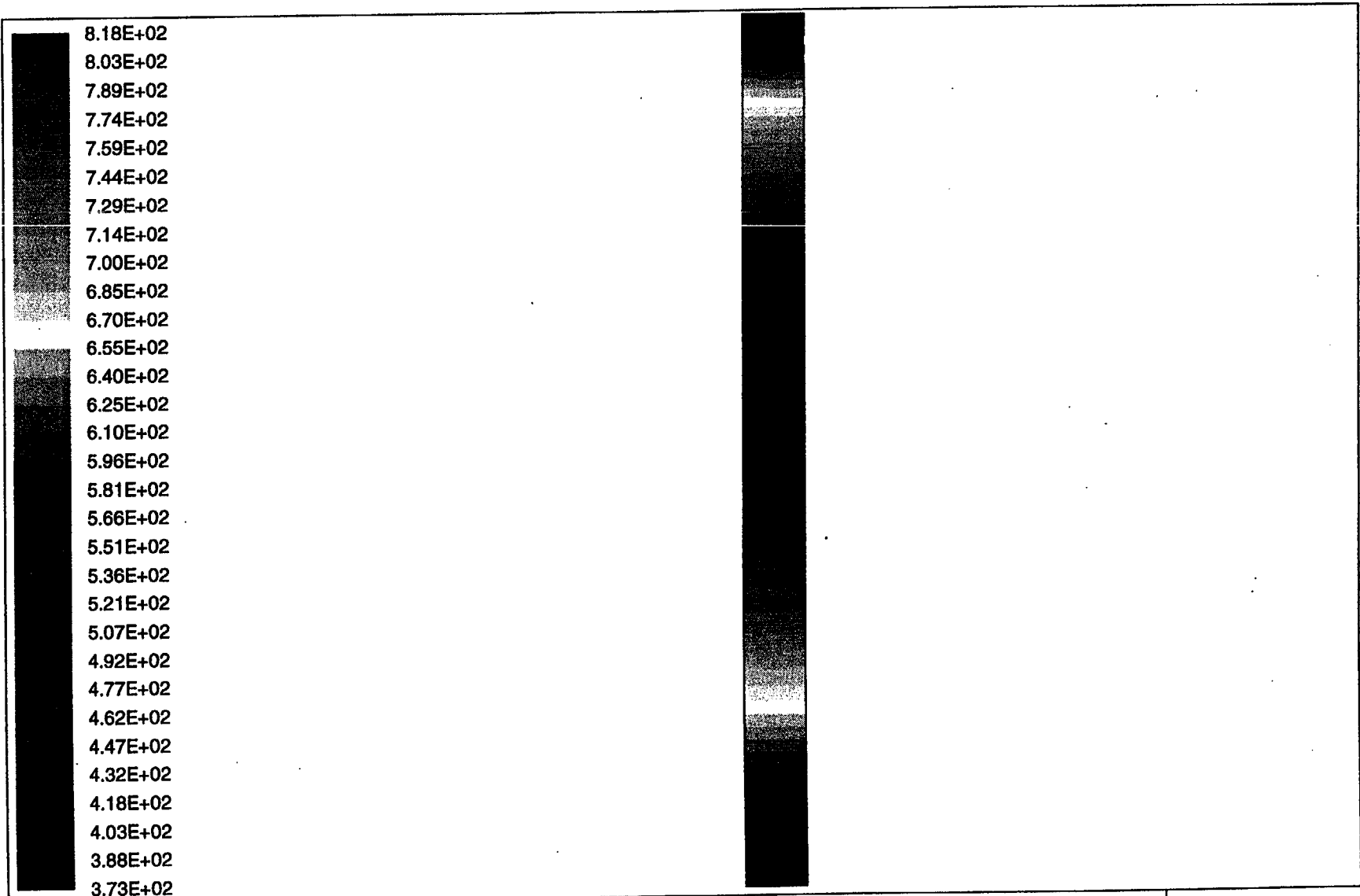
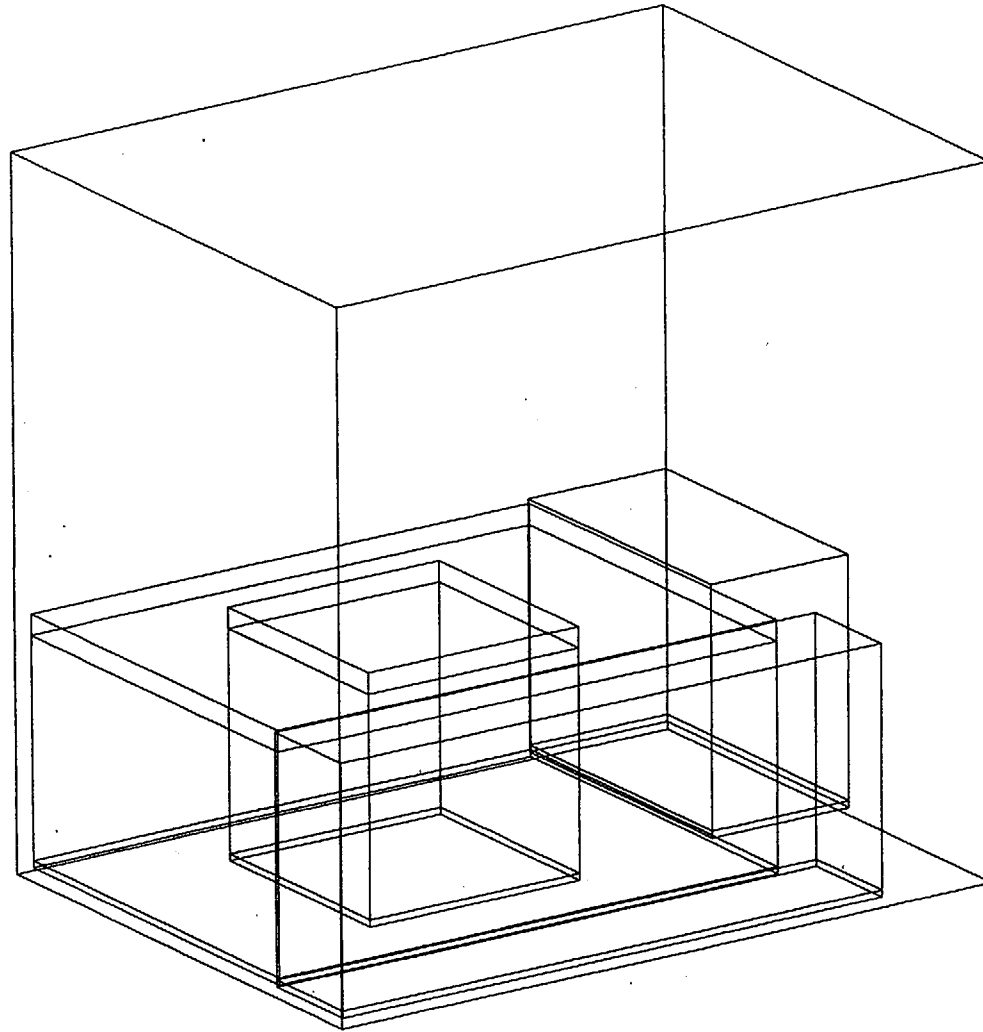

FIGURE 6: Region III Racks Cell Temperature Contours
 Temperature (Degrees Kelvin)
 Max = 8.183E+02 Min = 3.730E+02

Aug 06 1997
 Fluent 4.32
 Fluent Inc.



Grid

Fluent/UNS 4.2 (3d, ke)
Thu Jul 15 1999
Fluent Inc.

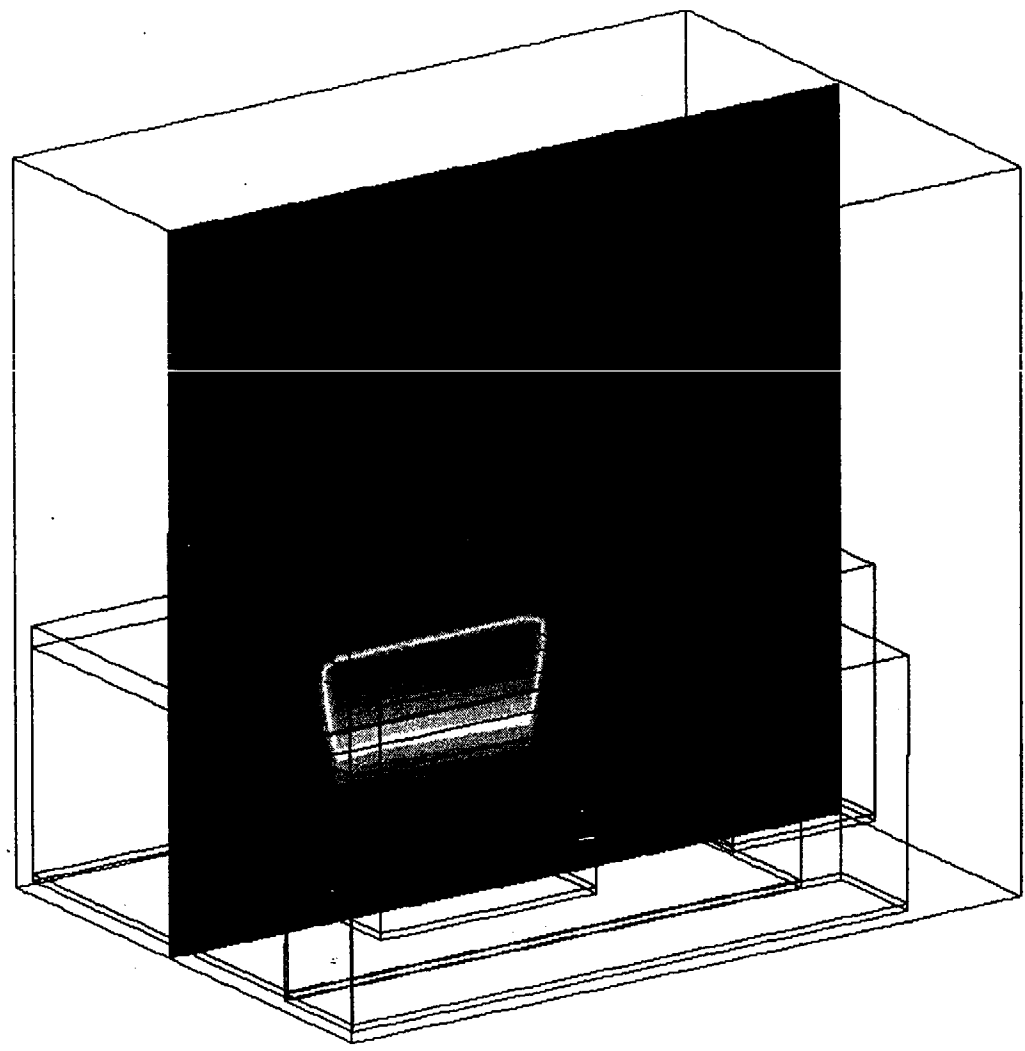
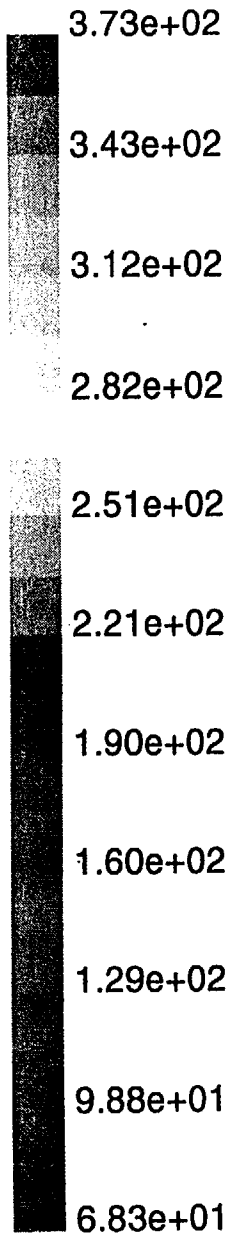

Contours of Static Temperature (c)

Fluent/UNS 4.2 (3d, ke)
Thu Jul 15 1999
Fluent Inc.

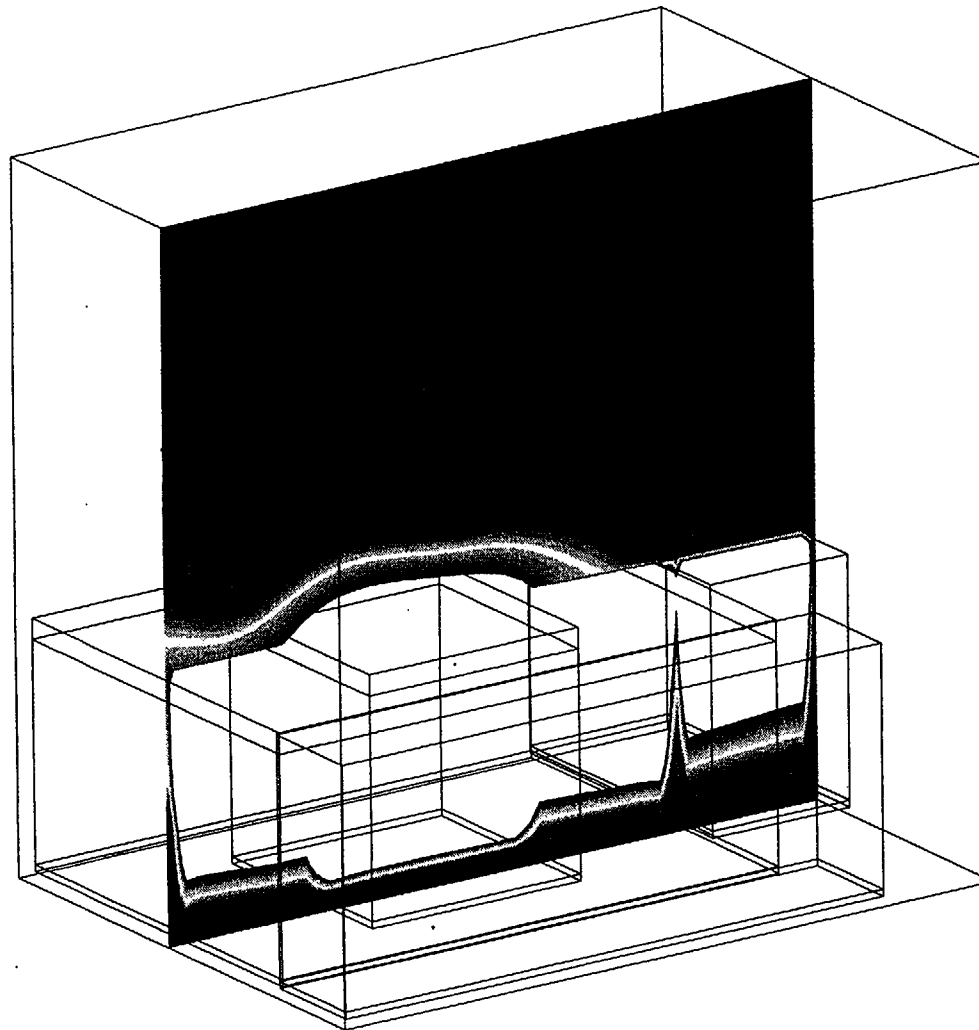
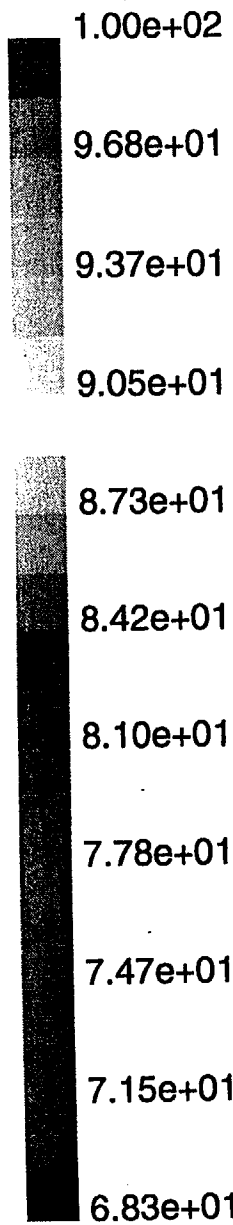

Contours of Static Temperature (c)

Fluent/UNS 4.2 (3d, ke)
Thu Jul 15 1999
Fluent Inc.

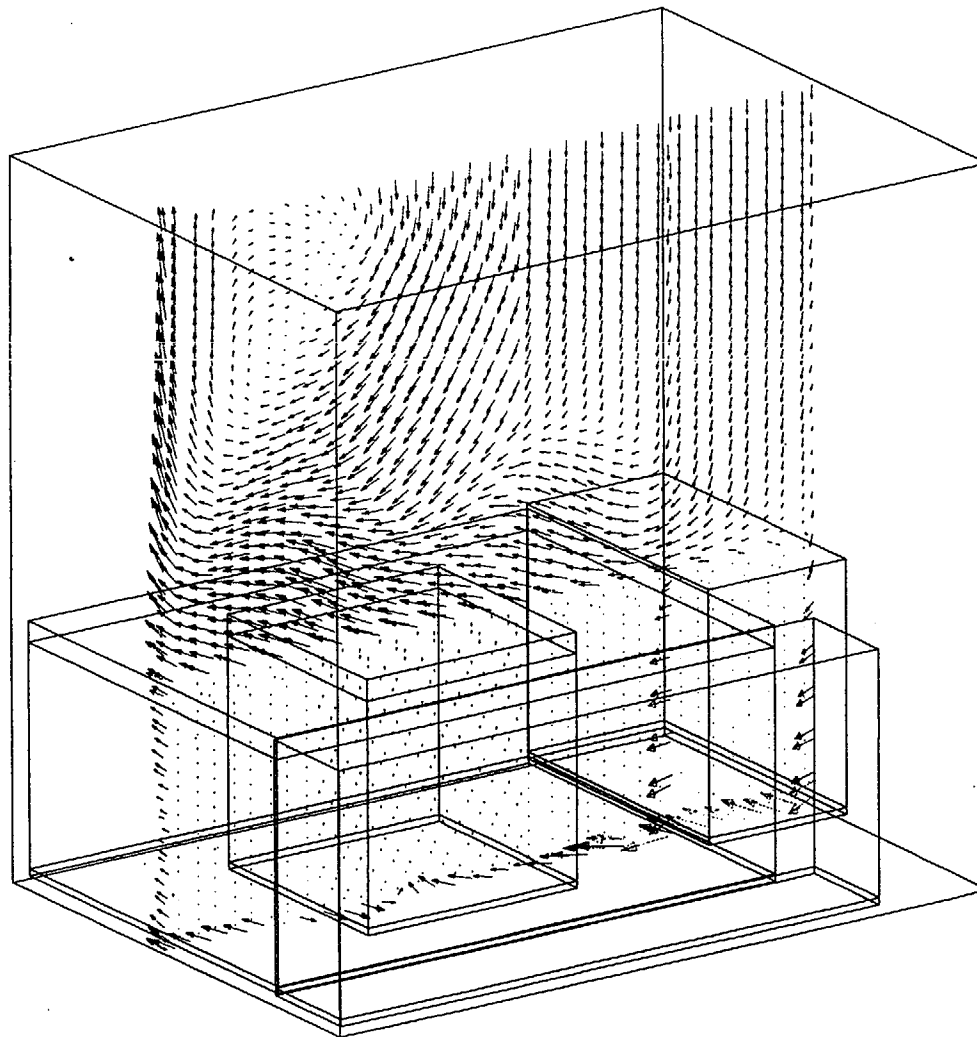
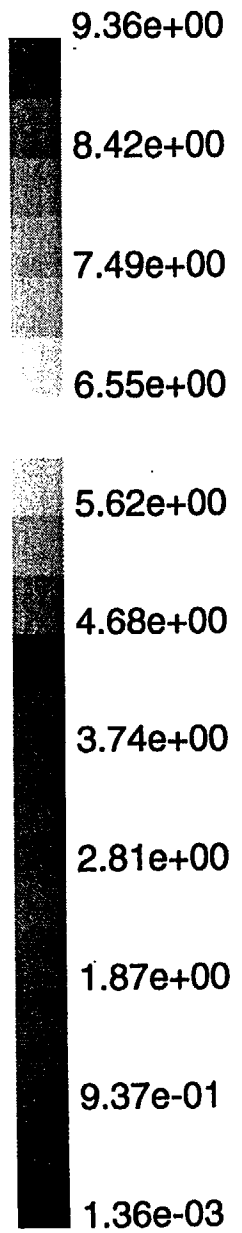

Velocity Vectors Colored By Velocity Magnitude (ft/s)

Fluent/UNS 4.2 (3d, ke)
Thu Jul 15 1999
Fluent Inc.

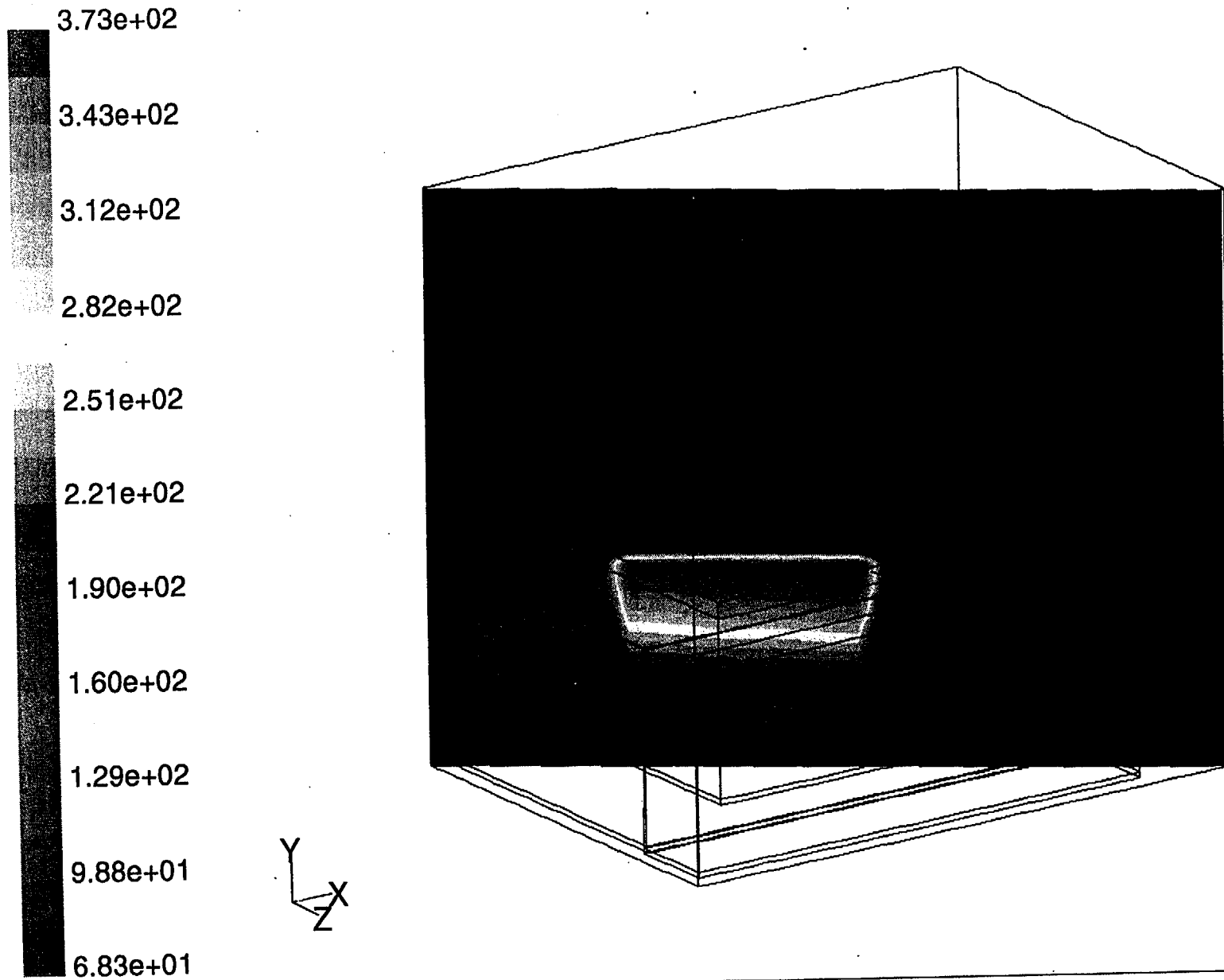

Contours of Static Temperature (c)

Fluent/UNS 4.2 (3d, ke)
Thu Jul 15 1999
Fluent Inc.

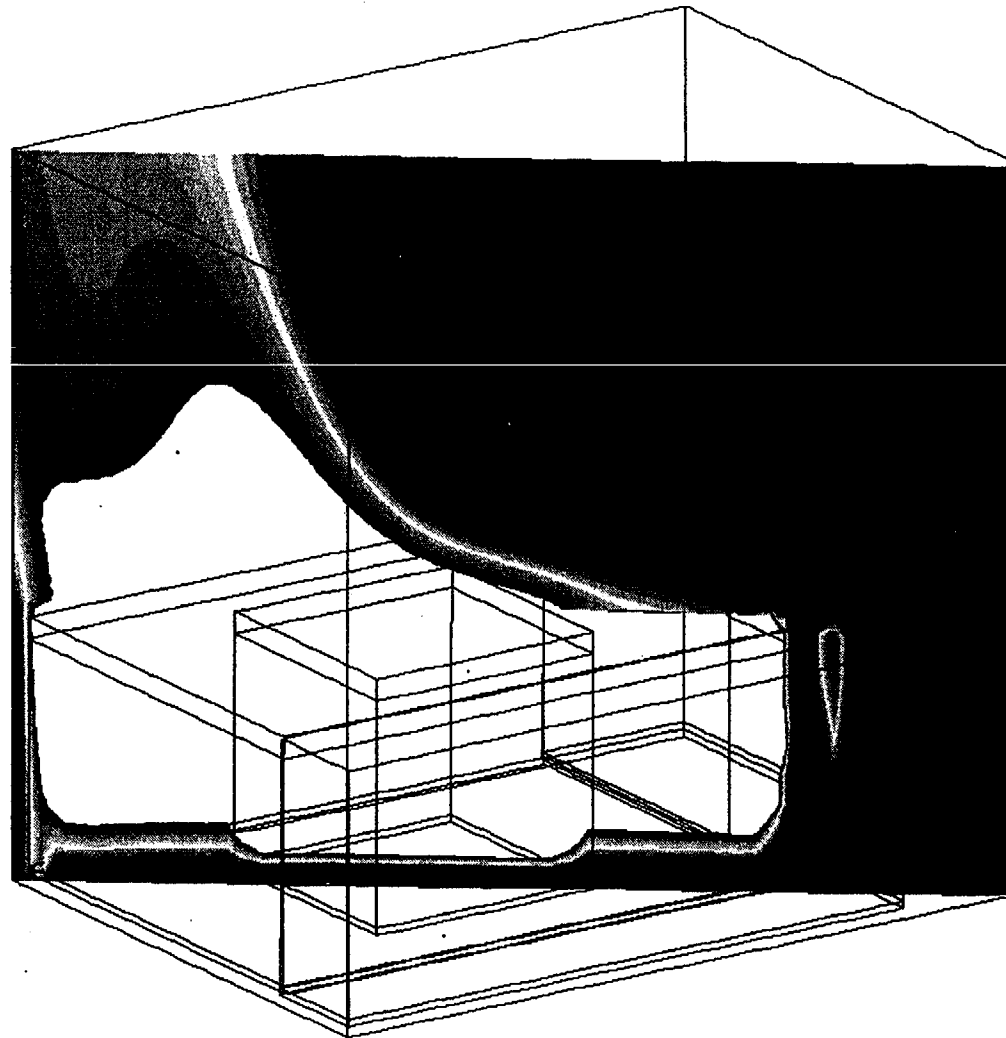
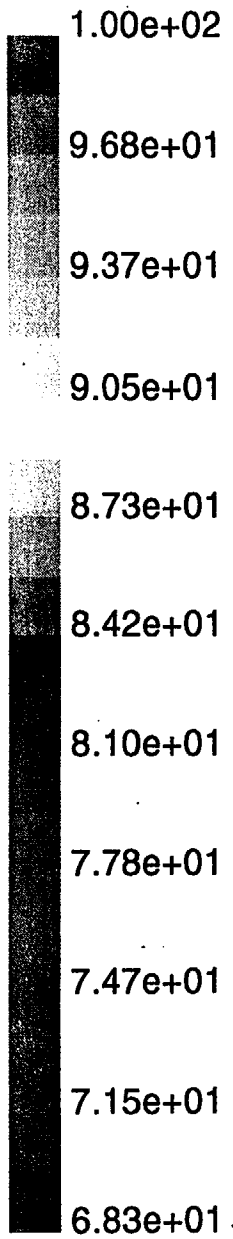

Contours of Static Temperature (c)

Fluent/UNS 4.2 (3d, ke)
Thu Jul 15 1999
Fluent Inc.

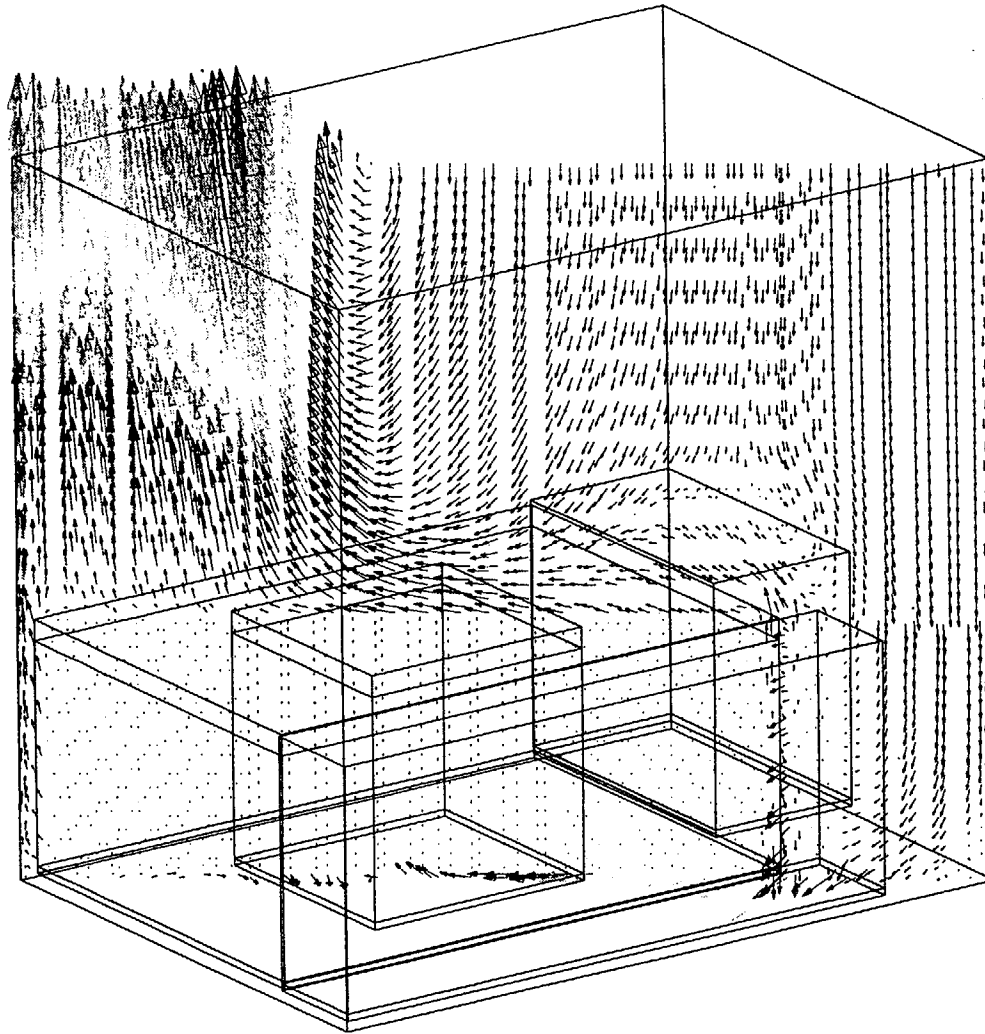
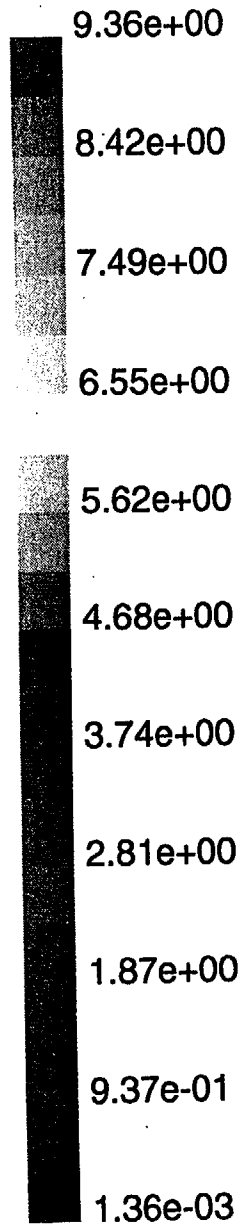

Velocity Vectors Colored By Velocity Magnitude (ft/s)

Fluent/UNS 4.2 (3d, ke)
Thu Jul 15 1999
Fluent Inc.

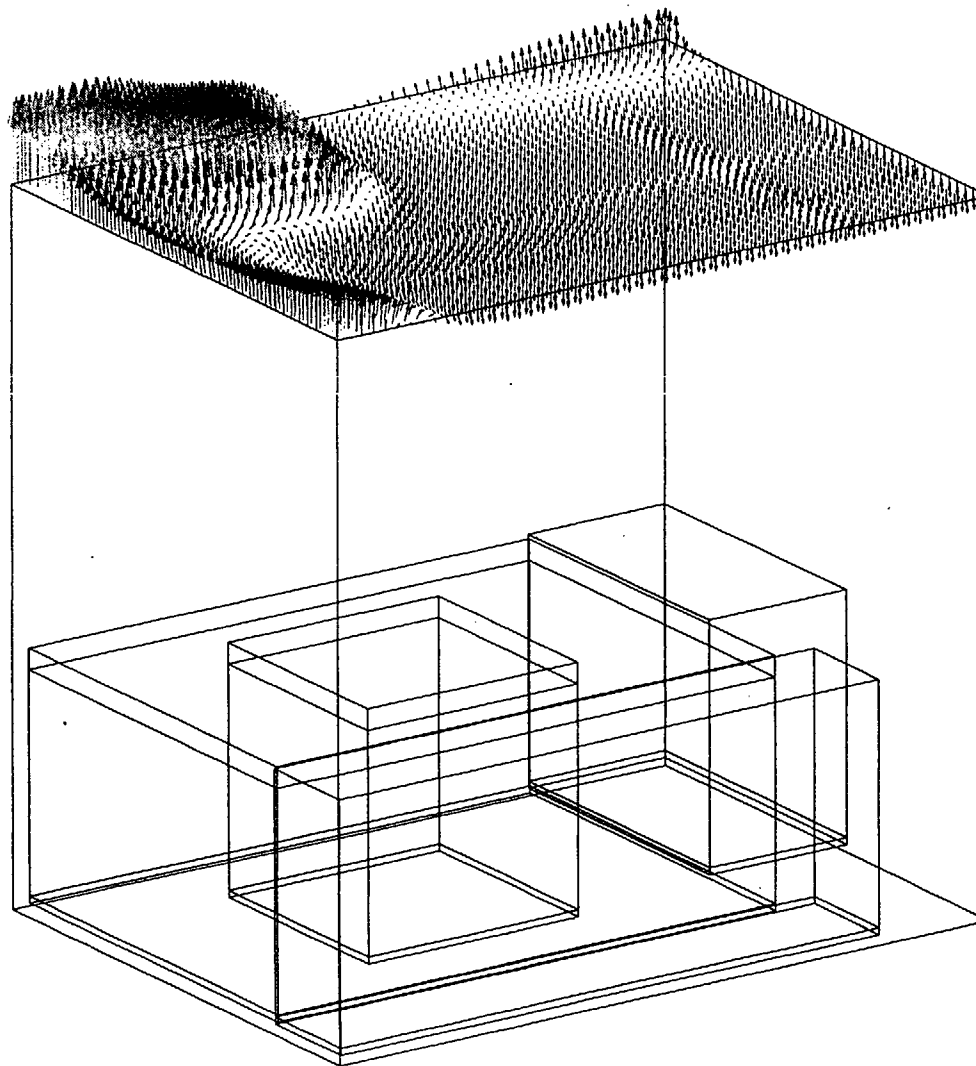
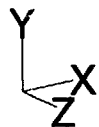
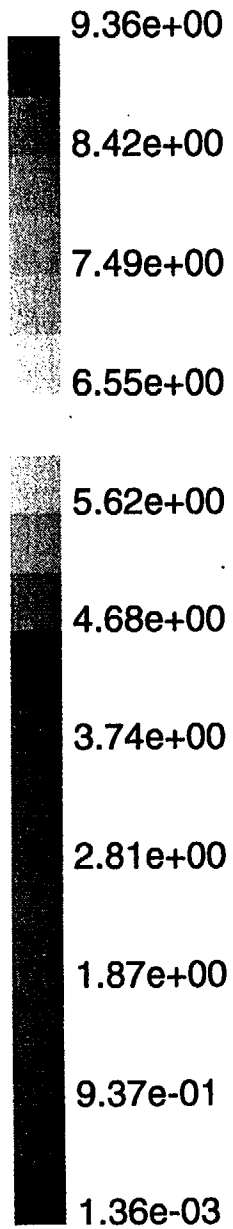

Velocity Vectors Colored By Velocity Magnitude (ft/s)

Fluent/UNS 4.2 (3d, ke)
Thu Jul 15 1999
Fluent Inc.

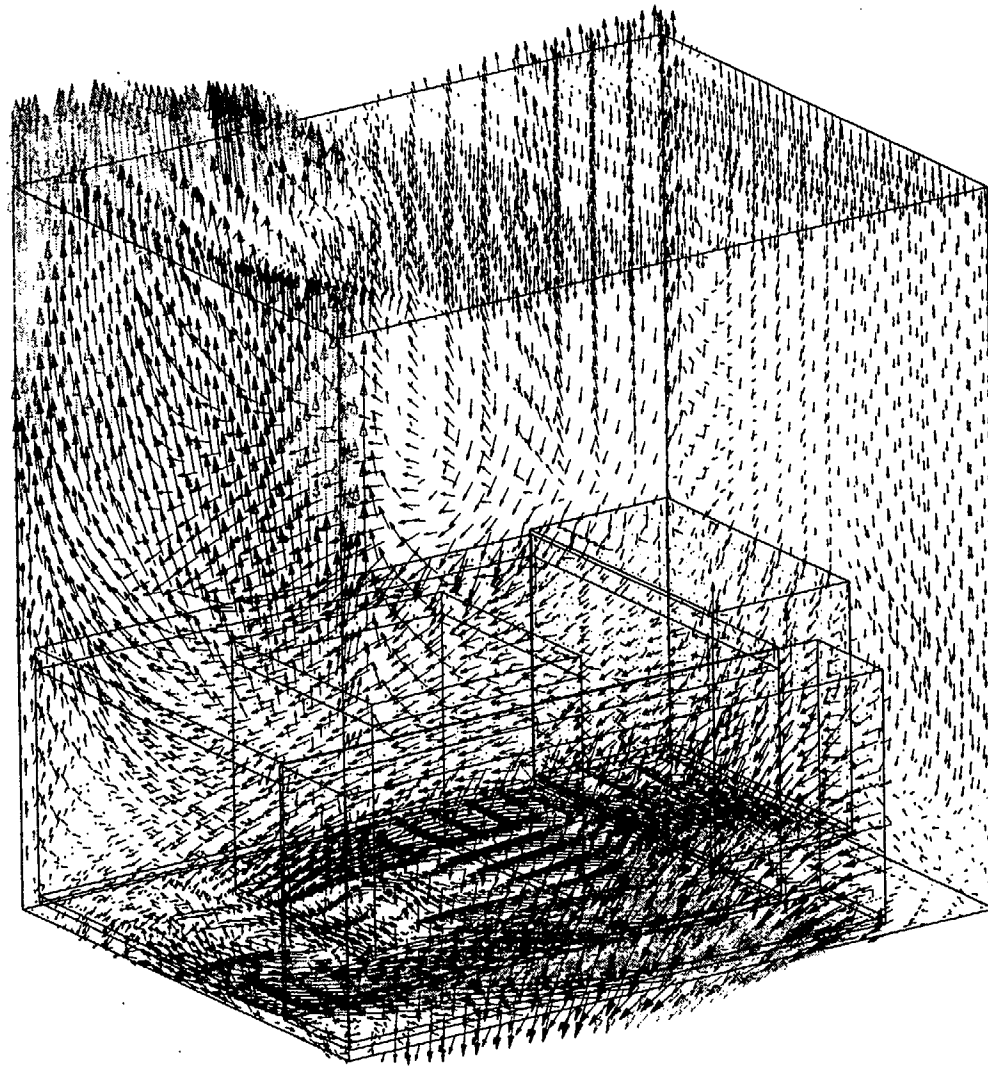
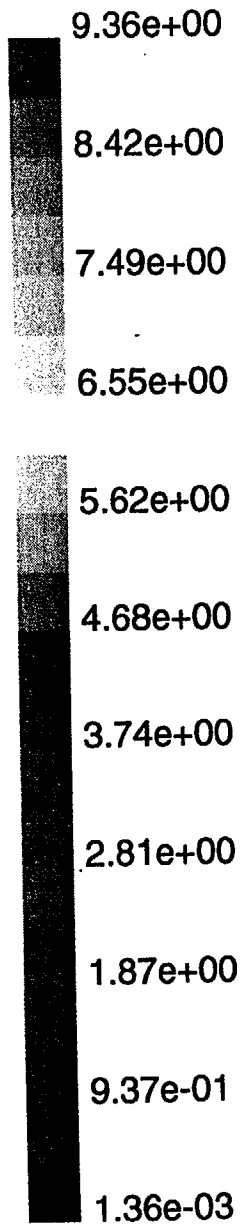

Velocity Vectors Colored By Velocity Magnitude (ft/s)

Fluent/UNS 4.2 (3d, ke)
Thu Jul 15 1999
Fluent Inc.