

April 30, 2001

Docket Number 50-346
License Number NPF-3
Serial Number 2708

United States Nuclear Regulatory Commission
Document Control Desk
Washington, D.C. 20555

Subject: Combined Annual Radiological Environmental Operating Report and Radiological Effluent Release Report

Ladies and Gentlemen:

Provided under this cover is the combined 2000 Annual Radiological Environmental Operating Report (AREOR) and the January through December 2000 Radiological Effluent Release Report (RERR) for the Davis-Besse Nuclear Power Station (DBNPS). The AREOR and the RERR are submitted by April 30 of each year to satisfy the requirements of the DBNPS Technical Specifications 6.9.1.10 and 6.9.1.11. For your reference, the enclosed Table 1 provides a listing of the specific requirements detailed in the DBNPS Offsite Dose Calculation Manual (ODCM) and the portion of the AREOR which was prepared to meet each requirement.

Additional information is also provided under this cover to the Document Control Desk only. This information includes:

- ODCM Revision 13 (dated January 14, 2000)
- RERR Meteorological Data (on 3 ½ inch microdisk)
- Environmental, Inc. Midwest Laboratory, Final Monthly Progress Report for January through December 2000 (which contains the 2000 Radiological Environmental Monitoring Program Sample Analysis Results)

Should you have any questions or require additional information, please contact Mr. Bruce L. Geddes, Supervisor – Nuclear Chemical Services, at (419) 321-7388.

Very truly yours,

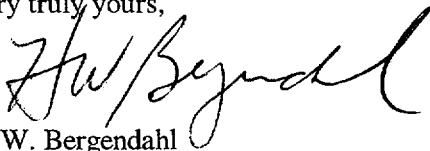

H. W. Bergendahl
Davis-Besse Plant Manager

AMPs

Enclosures

cc: J. E. Dyer, Region III Administrator
K. S. Zellers, DB-1 Senior Resident Inspector
S. P. Sands, NRC Project Manager
Utility Radiological Safety Board of Ohio

ADDG
JEHB

Docket Number 50-346
License Number NPF-3
Serial Number 2708
Enclosure 1

Table 1: AREOR Sections Prepared to Meet Requirements of ODCM 7.1

Description of Requirement

- Summaries, interpretations, and analyses of trends of the radiological environmental surveillance activities, and an assessment of the observed impacts of the plant (pages 35 through 78 and Appendix D)
- Results of the Land Use Census (pages 109 through 114)
- Results of the analysis of radiological environmental samples and of environmental radiation measurements (Environmental, Inc. Midwest Laboratory, Final Monthly Progress Report for January through December 2000)
- Summary description of the radiological environmental monitoring program (pages 26 through 81)
- At least two legible maps, covering sampling locations keyed to a table giving distances and directions from the centerline of one reactor (pages 42 through 77)
- The results of licensee participation in the Interlaboratory Comparison Program (Appendix A)
- Discussion of cases in which specimens were unobtainable due to hazardous conditions, seasonal unavailability, malfunction of automatic sampling equipment and other legitimate reasons (pages 38 through 39)

Docket Number 50-346
License Number NPF-3
Serial Number 2708
Enclosure 2

COMMITMENT LIST

The following list identifies those actions committed to by the Davis-Besse Nuclear Power Station in this document. Any other actions discussed in the submittal represent intended or planned actions by Davis-Besse. They are described only as information and are not regulatory commitments. Please notify the Manager – Regulatory Affairs (419-321-8450) at Davis-Besse of any questions regarding this document or associated regulatory commitments.

COMMITMENTS

DUE DATE

None

N/A

2000 Annual Radiological Environmental Operating Report

including the
Radiological Effluent
Release Report

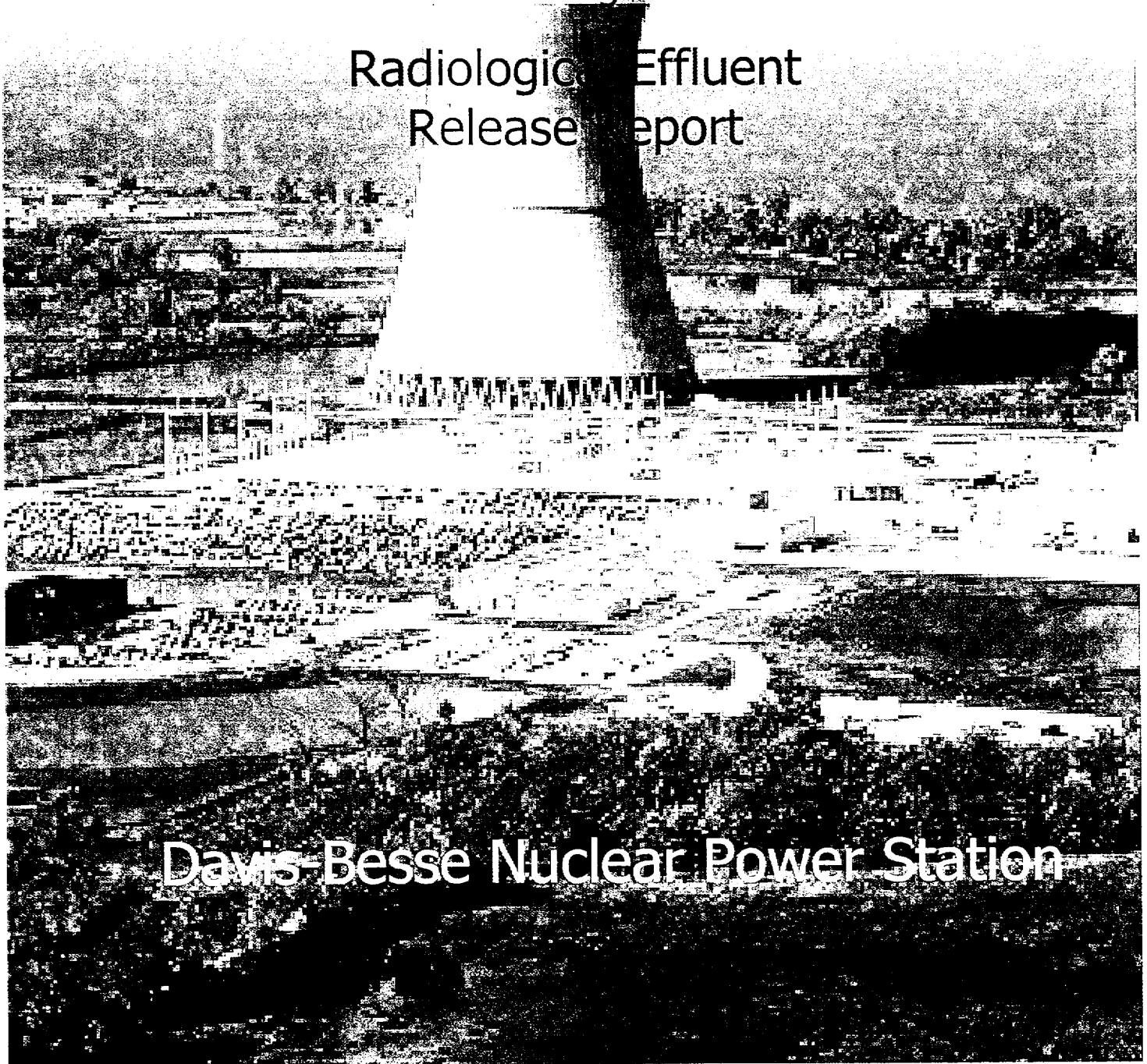

Davis-Besse Nuclear Power Station

ANNUAL RADIOLOGICAL
ENVIRONMENTAL OPERATING
REPORT

Davis-Besse Nuclear Power Station
January 1, 2000 through December 31, 2000

Prepared by: Bruce J. Pedollet Date: 4/25/01
Supervisor - Nuclear Chemistry Services

Approved by: Robert B. Cook Date: 4/25/01
Manager - Chemistry

Davis-Besse Nuclear Power Station

April 2001

TABLE OF CONTENTS

<u>Title</u>	<u>Page</u>
List of Tables	iv
List of Figures	vi
Executive Summary	viii
INTRODUCTION	
Fundamentals	1
Radiation and Radioactivity	2
Interaction with Matter	3
Quantities and Units of Measurement	5
Sources of Radiation	7
Health Effects of Radiation	9
Health Risks	10
Benefits of Nuclear Power	11
Nuclear Power Production	11
Station Systems	16
Reactor Safety and Summary	19
Radioactive Waste	19
Description of the Davis-Besse Site	22
References	24
RADIOLOGICAL ENVIRONMENTAL MONITORING PROGRAM	
Introduction	26
Preoperational Surveillance Program	26
Operational Surveillance Program Objectives	27
Quality Assurance	27
Program Description	28
Sample Analysis	32
Sample History Comparison	35

<u>Title</u>	<u>Page</u>
RADIOLOGICAL ENVIRONMENTAL MONITORING PROGRAM (continued)	
2000 Program Deviations	38
Atmospheric Monitoring	39
Terrestrial Monitoring	45
Aquatic Monitoring	57
Direct Radiation Monitoring	68
Conclusion	78
References	79
RADIOACTIVE EFFLUENT RELEASE REPORT	
Protection Standards	82
Sources of Radioactivity Released	82
Processing and Monitoring	83
Exposure Pathways	84
Dose Assessment	85
Results	86
Regulatory Limits	87
Effluent Concentration Limits	88
Average Energy	88
Measurements of Total Activity	88
Batch Releases	89
Sources of Input Data	90
Doses to Public Due to Activities Inside the Site Boundary	90
Inoperable Radioactive Effluent Monitoring Equipment	91
Changes to The ODCM and PCP	91
Borated Water Storage Tank Radionuclide Concentration	91
LAND USE CENSUS	
Program Design	109
Methodology	109
Results	110

<u>Title</u>	<u>Page</u>
NON-RADIOLOGICAL ENVIRONMENTAL PROGRAMS	
Meteorological Monitoring	115
Land and Wetlands Management	140
Water Treatment Plant Operation	141
Chemical Waste Management	146
Waste Minimization and Recycling	149
APPENDICES	
Appendix A: Interlaboratory Comparison Program Results	151
Appendix B: Data Reporting Conventions	175
Appendix C: Effluent Concentration Limit of Radioactivity in Air and Water Above Background in Unrestricted Areas	177
Appendix D: REMP Sampling Summary	179

List of Tables

<u>Title</u>	<u>Table Number</u>	<u>Page Number</u>
Risk Factors: Estimated Decrease in Average Life Expectancy	1	10
Sample Codes and Collection Frequencies	2	30
Sample Collection Summary	3	31
Radiochemical Analyses Performed on REMP Samples	4	33
Air Monitoring Locations	5	41
Milk Monitoring Location	6	46
Groundwater Monitoring Locations	7	48
Broadleaf Vegetation and Fruit Locations	8	49
Animal/Wildlife Feed Locations	9	50
Wild and Domestic Meat Locations	10	51
Soil Locations	11	53
Treated Surface Water Locations	12	58
Untreated Surface Water Locations	13	61
Shoreline Sediment Locations	14	62
Fish Locations	15	64
Thermoluminescent Dosimeter Locations	16	70
Gaseous Effluents - Summation of All Releases	17	92
Gaseous Effluents - Ground Level Releases - Batch Mode	18	93
Gaseous Effluents - Ground Level Releases - Continuous Mode	18	94
Gaseous Effluents - Mixed Mode Releases - Batch Mode	19	96
Gaseous Effluents - Mixed Mode Releases - Continuous Mode	19	97
Liquid Effluents - Summation of All Releases	20	99
Liquid Effluents - Nuclides Released - Batch Releases	21	100
Liquid Effluents - Nuclides Released - Continuous Releases	21	102
Solid Waste and Irradiated Fuel Shipments	22	104
Doses Due to Gaseous Releases for January through December 2000	23	106
Doses Due to Liquid Releases for January through December 2000	24	107
Annual Dose to The Most Exposed Member of The Public 2000	25	108
Closest Exposure Pathways Present in 2000	26	112
Pathway Locations and Corresponding Atmospheric Dispersion (X/Q) and Deposition (D/Q) Parameters	27	114

<u>Title</u>	<u>Table Number</u>	<u>Page Number</u>
Summary of Meteorological Data Recovery for 2000	28	120
Summary of Meteorological Data Measured for 2000	29	121
Joint Frequency Distribution by Stability Class	30	135

List of Figures

<u>Description</u>	<u>Figure Number</u>	<u>Page Number</u>
The Atom	1	1
Principal Decay Scheme of the Uranium Series	2	3
Range and Shielding of Radiation	3	4
Sources of Exposure to the Public	4	8
Fission Diagram	5	12
Fuel Rod, Fuel Assembly, Reactor Vessel	6	13
Station Systems	7	15
Dry Fuel Storage Module Arrangement	8	21
Map of Area Surrounding Davis-Besse	9	22
2000 Airborne Particulate Gross Beta	10	40
Air Sample Site Map	11	42
Air Sample 5-mile Radius Map	12	43
Air Sample 25-mile Radius Map	13	44
Gross Beta Groundwater 1982-2000	14	47
Cs-137 in Soil 1972-2000	15	52
Terrestrial Site Map	16	54
Terrestrial 5-mile Radius Map	17	55
Terrestrial 25-mile Radius Map	18	56
Gross Beta in Treated Surface Water 1972-2000	19	58
Gross Beta Concentration in Untreated Surface Water 1972-2000	20	60
Gross Beta Fish 1972-2000	21	63
Aquatic Site Map	22	65
Aquatic 5-mile Map	23	66
Aquatic 25-mile Map	24	67
Gamma Dose for Environmental TLDs 1973 – 2000	25	69
TLD Site Map	27	75
TLD 5-mile Map	28	76
TLD 25-mile Map	29	77
Exposure Pathways	30	85

<u>Description</u>	<u>Figure Number</u>	<u>Page Number</u>
Land Use Census Map	31	111
Wind Rose Annual Average 100M	32	123
Wind Rose Annual Average 75M	33	124
Wind Rose Annual Average 10M	34	125
Wind Rose Monthly Average 100M	35	126
Wind Rose Monthly Average 75M	36	129
Wind Rose Monthly Average 10M	37	132
Water Treatment Plant Schematic	38	142

Executive Summary

The Annual Radiological Environmental Operating Report (AREOR) is a detailed report on the Environmental Monitoring Programs conducted at the Davis-Besse Nuclear Power Station from January 1 through December 31, 2000. This report meets all of the requirements in Regulatory Guide 4.8, Davis-Besse Technical Specifications 6.9.1.10, and Davis-Besse Offsite Dose Calculation Manual (ODCM) Section 7.1. Reports included are the Radiological Environmental Monitoring Program, Land Use Census, and the Non-Radiological Environmental Programs, which consist of Meteorological Monitoring, Land and Wetland Management, Water Treatment, Chemical Waste Management, and Waste Minimization and Recycling. This report also includes the Radiological Effluent Release Report for the reporting period of January 1 through December 31, 2000.

Radiological Environmental Monitoring Program

The Radiological Environmental Monitoring Program (REMP) is established to monitor the radiological condition of the environment around Davis-Besse. The REMP is conducted in accordance with Regulatory Guide 4.8, Davis-Besse Technical Specification 6.8.4.d and the Davis-Besse ODCM Section 6.0. This program includes the sampling and analysis of environmental samples and evaluating the effects of releases of radioactivity on the environment.

Radiation levels and radioactivity have been monitored within a 25-mile radius around Davis-Besse since 1972. The REMP was established at Davis-Besse about five years before the Station became operational. This pre-operational sampling and analysis program provided data on radiation and radioactivity normally present in the area as natural background. Davis-Besse has continued to monitor the environment by sampling air, groundwater, milk, edible meat, fruit and vegetables, animal feed, soil, drinking water, surface water, fish, shoreline sediment, and by measuring radiation directly.

Samples are collected from indicator and control locations. Indicator locations are within approximately 5 miles of the site and are expected to show naturally occurring radioactivity plus any increases of radioactivity that might occur due to the operation of Davis-Besse. Control locations are farther away from the Station and are expected to indicate the presence of only naturally occurring radioactivity. The results obtained from the samples collected from indicator locations are compared with the results from those collected from control locations and with the concentrations present in the environment before Davis-Besse became operational. This allows for the assessment of any impact the operation of Davis-Besse might have had on the surrounding environment.

Approximately 2000 radiological environmental samples were collected and analyzed in 2000. An explanation for the sample program deviations for this reporting period is provided on page 38.

The results of the REMP indicate that Davis-Besse continues to be operated safely in accordance with applicable federal regulations. No measurable increase above background radiation or radioactivity is attributed to the operation of Davis-Besse.

The sampling results are divided into four sections: atmospheric monitoring, terrestrial monitoring, aquatic monitoring and direct radiation monitoring:

- Air is continuously being filtered at 10 locations, onsite and up to 25 miles away, and the filters are collected to monitor the atmosphere. The 2000 results are similar to those observed in preoperational and previous operational programs. Only background and fallout radioactivity normally present in the environment was detected and only at concentrations normal to the area.
- Terrestrial monitoring includes analysis of milk, ground water, meat, fruits, vegetables, animal feed and soil samples. Samples are collected onsite and up to 25 miles away depending on the type of sample. The results of the analyses of the terrestrial samples indicate concentrations of radioactivity similar to previous years and indicates no build-up of radioactivity due to the operation of Davis-Besse.
- Aquatic monitoring includes the collection and analysis of drinking water, untreated surface water, fish and shoreline sediments from onsite and the vicinity of Lake Erie. The 2000 results of analysis for fish, untreated surface water, drinking water and shoreline sediment indicate normal background concentration of radionuclides and show no increase or build-up of radioactivity due to the operation of Davis-Besse.
- Direct radiation averaged 13.9 mrem/91days at indicator locations and 15.0 mrem/91 days at control locations. This is similar to results of previous years.

The operation of Davis-Besse in 2000 caused no significant increase in the concentrations of radionuclides in the environment and no adverse effect on the quality of the environment. Radioactivity released in the Station's effluents was well below the applicable federal regulatory limits. The estimated radiation dose to the general public due to the operation of Davis-Besse in 2000 was well below all applicable regulatory limits.

In order to estimate radiation dose to the public, the pathways through which public exposure can occur must be known. To identify these exposure pathways, an Annual Land Use Census is performed as part of the REMP. During the census, Davis-Besse personnel travel every public road within a five mile radius of the Station to locate the radiological exposure pathways (e.g., residences, vegetable gardens, milk cows/goats, etc.). The one pathway of particular interest is the pathway that, for a specific radionuclide, provides the greatest dose to a sector of the population. This is called the critical pathway. The critical pathway for 2000 is a garden in the West sector, 1610 meters from Davis-Besse.

Radiological Effluent Release Report

The Radiological Effluent Release Report (RERR) is a detailed listing of radioactivity released from the Davis-Besse Nuclear Power Station during the period January 1, 2000 through December 31, 2000. The doses due to radioactivity released during this period were estimated to be:

Liquid Effluents:

Maximum Individual Whole Body Dose	5.54E-02 mrem (0.0554 mrem)
Maximum Individual Significant Organ Dose	6.25E-02 mrem (0.0625 mrem)
Total Integrated Population Dose	5.33E-01 person-rem (0.533 person-rem)
Average Dose to the Individual	2.44E-04 mrem (0.000238 mrem)

Gaseous Effluents:

Maximum Individual Whole Body Dose due to I-131, H-3 and Particulates with half-lives greater than 8 days	1.36E-03 mrem (0.00136 mrem)
Maximum Significant Organ Dose due to I-131, H-3 and Particulates with half-lives greater than 8 days	1.98E-02 mrem (0.0198 mrem)
Total Integrated Population Dose due to I-131, H-3 and Particulates with half-lives greater than 8 days	7.15E-03 person-rem (0.00715 person-rem)
Average Dose to an individual in the population due to I-131, H-3 and Particulates with half-lives greater than 8 days	3.27E-06 mrem (0.00000327 mrem)
Maximum Individual Skin Dose due to noble gases	2.50E-03 mrad (0.00250 mrad)
Maximum Individual Whole Body Dose due to noble gases	8.97E-04 mrad (0.000897 mrad)
Total Integrated Population Dose due to noble gases	1.24E-03 person-rem (0.00124 person-rem)
Average Dose to individual in population due to noble gases	5.68E-07 mrem (0.000000568 mrem)

The Total Body doses to an individual and population in an unrestricted area due to direct radiation from Davis-Besse is not distinguishable from background. These doses represent an extremely small fraction of the limits set by the NRC or the limits set in the ODCM.

The abnormal gaseous releases during this reporting period are listed on page 89.

There were no changes to the Process Control Program (PCP) and one change to the ODCM during this reporting period.

Non-Radiological Environmental Programs

Meteorological Monitoring

The Meteorological Monitoring Program at Davis-Besse is part of a program for evaluating the radiological effects of the routine operation of Davis-Besse on the surrounding environment. Meteorological monitoring began in October, 1968.

Meteorological data recorded at Davis-Besse include wind speed, wind direction, sigma theta (standard deviation of wind direction), ambient temperature, differential temperature, dew point and precipitation. Two instrument-equipped meteorological towers are used to collect data. Data recovery for the five instruments that are operationally required by Davis-Besse Technical Requirement Manual was 99.8 %.

Marsh Management

The FirstEnergy Company owns the Navarre Marsh. It is leased to the U.S. Fish and Wildlife Service, who manage it as part of the Ottawa National Wildlife Refuge.

Special projects conducted in 2000 with the cooperation of Ohio Department of Natural Resources included Canada goose banding and a Volunteer Eagle Watcher Workshop. Davis-Besse hosted the sixth annual Federal Junior Duck Stamp Art Contest for the State of Ohio in cooperation with the Ottawa National Wildlife Refuge.

A pair of American Bald Eagles built a new nest and fledged a healthy pair of eaglets.

Water Treatment

Davis-Besse uses Lake Erie as a source of water for its Water Treatment Plant. The water is treated onsite to produce high purity water for use in the Station's cooling systems.

Since December 1, 1998, domestic water at the site has been provided by the Carroll Township Water Treatment Plant.

Sewage is treated onsite at the Davis-Besse Wastewater Treatment Plant (WWTP). The sewage is processed and then pumped to a basin where further reduction in solid content takes place. Following a settling period, the water is discharged, along with other station wastewater, back to Lake Erie.

Chemical Waste Management

The Chemical Waste Management Program at Davis-Besse was developed to ensure that the off-site disposal of non-radioactive hazardous and nonhazardous chemical wastes is performed in accordance with all applicable state and federal regulations. Chemical waste disposal vendors contracted by Davis-Besse use advanced technology for offsite disposal of chemical wastes in order to protect human health and the environment.

In 2000, the Davis-Besse Nuclear Power Station qualified as a large quantity generator due to a one-time waste generated in September from an on-site sodium hypochlorite tank leak that resulted in the generation of 50,166 pounds of hazardous waste.

As required by Superfund Amendment and Reauthorization Act (SARA), Davis-Besse reported hazardous products and chemicals to local fire departments and local and state planning commissions. As part of the program to remove PCB fluid from Davis-Besse, all electrical transformers have been retrofilled and reclassified as non-PCB transformers.

Waste Minimization and Recycling

The Waste Minimization and Recycling Program at Davis-Besse began in 1991 with the collection and recycling of paper. This program was expanded and reinforced during 1993 to include the recycling of paper, aluminum cans, cardboard, and metal. Paper and cardboard recycling typically exceeds 50 tons annually. The scrap metal collected onsite is sold to scrap companies.

Appendices

Appendix A contains results from the Interlaboratory Comparison Program required by Davis-Besse Technical Specifications. Samples with known concentrations of radioisotopes are prepared by the Environmental Protection Agency (EPA), and then sent (with information on sample type and date of collection only) to the laboratory contracted by the Davis-Besse Nuclear Power Station to analyze its REMP samples. Results are checked by the EPA against known values. The results from both the contracted laboratory and the EPA are provided in Appendix A.

Appendix B contains data reporting conversions used in the REMP at Davis-Besse. The appendix provides an explanation of the format and computational methods used in reporting REMP data. Information on counting uncertainties and the calculations of averages and standard deviations is also provided.

Appendix C lists the effluent concentration limits for alpha and beta emitting radioisotopes and for certain other radioisotopes in air and water samples. These concentrations are taken directly from the Code of Federal Regulations, and provide comparison values for actual REMP sampling results for 2000.

Appendix D provides a REMP sampling summary from 2000. The appendix provides a listing of the following for each sample type:

- the number and types of analyses performed,
- the lower limit of detection for each analysis,
- the mean and range of results for control and indicator locations,
- the mean, range, and location description for the location with the highest annual mean,
- the number of non-routine results.

For detailed studies, Appendix D provides more specific information than that listed in Chapter 2 of this report. The information presented in Appendices A through D was provided by Teledyne Isotopes Midwest Laboratories in their Final Progress Report to Toledo Edison (February, 2001).



Introduction

Introduction

Coal, oil, natural gas and hydropower are used to run this nation's electric generating stations; however, each method has its drawbacks. Coal-fired power can affect the environment through mining, acid rain and air pollution. Oil and natural gas are in limited supply and are therefore costly, and hydropower is limited due to the environmental impact of damming our waterways and the scarcity of suitable sites in our country.

Nuclear energy provides an alternate source of energy, which is readily available. The operation of nuclear power stations has a very small impact on the environment. In fact, the Davis-Besse Nuclear Power Station is surrounded by hundreds of acres of marshland, which make up part of the Ottawa National Wildlife Refuge, the only national refuge in Ohio. In order to provide better understanding of this unique source of energy, background information on basic radiation characteristics, risk assessment, reactor operation and effluent control is provided in this section.

Fundamentals

The Atom

All matter consists of **atoms**. Simply described, atoms are made up of positively and negatively charged particles, and particles which are neutral. These particles are called **protons, electrons, and neutrons**, respectively (Figure 1). The relatively large protons and neutrons are packed tightly together in a cluster at the center of the atom called the **nucleus**. Orbiting around this nucleus are one or more smaller electrons. In an electrically neutral atom the negative charges of the electrons are balanced by the positive charges of the protons. Due to their dissimilar charges, the protons and electrons have a strong attraction for each other, which helps hold the atom together. Other attractive forces between the protons and neutrons keep the densely packed protons from repelling each other, preventing the nucleus from breaking apart.

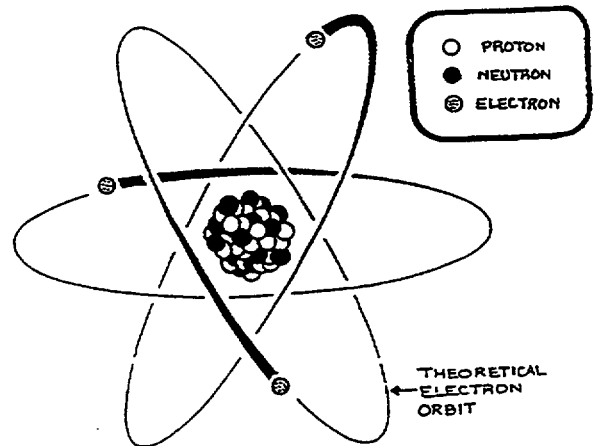

Figure 1: An atom consists of two parts: a nucleus containing positively charged protons and electrically neutral neutrons and one or more negatively charged electrons orbiting the nucleus. Protons and neutrons are nearly identical in size and weight, while each is about 2000 times heavier than an electron.

Radiation and Radioactivity

Isotopes and Radionuclides

A group of identical atoms, containing the same number of protons, make up an **element**. In fact, the number of protons an atom contains determines its chemical identity. For instance, all atoms with one proton are hydrogen atoms and all atoms with eight protons are oxygen atoms. However, the number of neutrons in the nucleus of an element may vary. Atoms with the same number of protons, but different numbers of neutrons are called **isotopes**. Different isotopes of the same element have the same chemical properties and many are stable or nonradioactive. An unstable or radioactive isotope of an element is called a **radioisotope, radioactive atom, or radionuclide**. Radionuclides usually contain an excess amount of energy in the nucleus. The excess energy is usually due to a surplus or deficit in the number of neutrons in the nucleus. Radionuclides can be naturally occurring such as uranium-238, beryllium-7 and potassium-40, or man-made, such as iodine-131, cesium-137, and cobalt-60.

Radiation

Radiation is simply the conveyance of energy through space. For instance, heat emanating from a stove is a form of radiation, as are light rays, microwaves, and radio waves. **Ionizing radiation** is another type of radiation and has similar properties to those of the examples listed above. Ionizing radiation consists of both **electromagnetic radiation** and **particulate radiation**. Electromagnetic radiation is energy with no measurable mass that travels with a wave-like motion through space. Included in this category are **gamma rays** and **X-rays**. Particulate radiation consists of tiny, fast moving particles which, if unhindered, travel in a straight line through space. The three types of particulate radiation of concern to us are **alpha particles**, made up of 2 protons and 2 neutrons; **beta particles**, which are essentially free electrons (electrons not attached to an atom); and **neutrons**. The properties of these types of radiation will be described more fully in the Range and Shielding section.

Radioactive Decay

Radioactive atoms attempt to reach a stable, non-radioactive state through a process known as **radioactive decay**. Radioactive decay is the release of energy from an atom through the emission of ionizing radiation. Radioactive atoms may decay directly to a stable state or may go through a series of decay stages, called a **radioactive decay series**, and produce several **daughter products** that eventually result in a stable atom. The loss of energy and/or matter through radioactive decay may transform the atom into a chemically different element. For example, when uranium-238 decays, it emits an alpha particle and, as a result, the atom loses 2 protons and 2 neutrons. As discussed previously, the number of protons in the nucleus of an atom determines its chemical identity. Therefore, when the uranium-238 atom loses the 2 protons and 2 neutrons, it is transformed into an atom of thorium-234. Thorium-234 is one of the 14 successive daughter products of uranium-238. Radon is another daughter product, and the series ends with stable lead-206.

This example is part of a known radioactive decay series, called the uranium series, which begins with uranium-238 and ends with lead-206 (Figure 2).

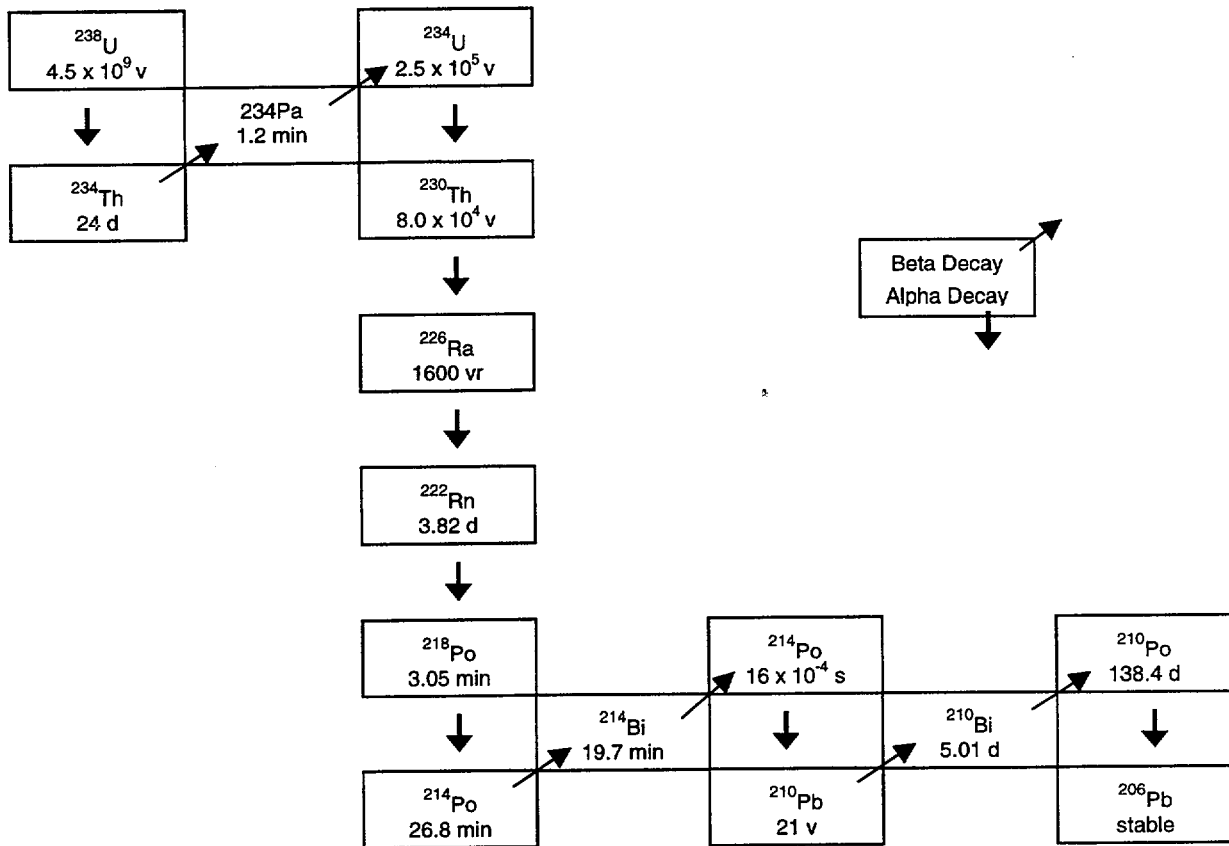

Figure 2: Principal Decay Scheme of the Uranium Series.

Half-life

Most radionuclides vary greatly in the frequency with which their atoms release radiation. Some radioactive materials, in which there are only infrequent emissions, tend to have a very long half-lives. Those radioactive materials that are very active, emitting radiation more frequently, tend to have comparably shorter half-lives. The length of time an atom remains radioactive is defined in terms of **half-lives**. Half-life is the amount of time required for a radioactive substance to lose half of its activity through the process of radioactive decay. Half-lives vary from millionths of a second to millions of years.

Interaction with Matter

Ionization

Through interactions with atoms, alpha, beta, and gamma radiation lose their energy. When these forms of radiation interact with any form of material, the energy they impart may cause

atoms in that material to become **ions**, or charged particles. Normally, an atom has the same number of protons as electrons. Thus, the number of positive and negative charges cancel, and the atom is electrically neutral. When one or more electrons are removed an ion is formed. Ionization is one of the processes that may result in damage to biological systems.

Range and Shielding

Particulate and electromagnetic radiation each travel through matter differently because of their different properties. Alpha particles contain 2 protons and 2 neutrons, are relatively large, and carry an electrical charge of +2. Alpha particles are ejected from the nucleus of a radioactive atom at speeds ranging from 2,000 to 20,000 miles per second. However, due to its comparatively large size, an alpha particle usually does not travel very far before it loses most of its energy through collisions and other interactions with atoms. As a result, a sheet of paper or a few centimeters of air can easily stop alpha particles (Figure 3).

Beta particles are very small, and comparatively fast particles, traveling at speeds near the speed of light (186,000 miles per second). Beta particles have an electrical charge of either +1 or -1. Because they are so small and have a low charge, they do not collide and interact as often as alpha particles, so they can travel farther. Beta particles can usually travel through several meters of air, but may be stopped by a thin piece of metal or wood.

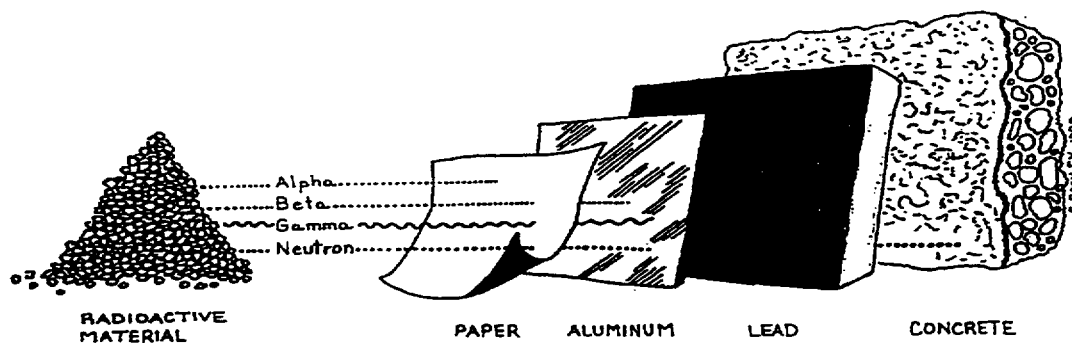

Figure 3: As radiation travels, it collides and interacts with other atoms and loses energy. Alpha particles can be stopped by a sheet of paper, and beta particles by a thin sheet of aluminum. Gamma radiation is shielded by highly dense materials such as lead, while hydrogenous materials (those containing hydrogen atoms), such as water and concrete, are used to stop neutrons.

Gamma rays are pure energy and travel at the speed of light. They have no measurable charge or mass, and generally travel much farther than alpha or beta particles before being absorbed. After repeated interactions, the gamma ray finally loses all of its energy and vanishes. The range of a gamma ray in air varies, depending on the ray's energy and interactions. Very high energy gamma radiation can travel a considerable distance, whereas low energy gamma radiation may travel only a few feet in air. Lead is used as shielding material for gamma radiation because of its density. Several inches of lead or concrete may be needed to effectively shield gamma rays.

Neutrons come from several sources, including the interactions of cosmic radiation with the earth's atmosphere and nuclear reactions within operating nuclear power reactors. However, neutrons are not of environmental concern since the neutron source at nuclear power stations is sealed within the containment building.

Because neutrons have no charge, they are able to pass very close to the nuclei of the material through which they are traveling. As a result, neutrons may be captured by one of these nuclei or they may be deflected. When deflected, the neutron loses some of its energy. After a series of these deflections, the neutron has lost most of its energy. At this point, the neutron moves about as slowly as the atoms of the material through which it is traveling, and is called a **thermal neutron**. In comparison, fast neutrons are much more energetic than thermal neutrons and have greater potential for causing damage to the material through which they travel. Fast neutrons can have from 200 thousand to 200 million times the energy of thermal neutrons.

Neutron shielding is designed to slow fast neutrons and absorb thermal neutrons. Neutron shielding materials commonly used to slow neutrons down are water or polyethylene. The shield is then completed with a material such as cadmium, to absorb the now thermal neutrons. At Davis-Besse, concrete is used to form an effective neutron shield because it contains water molecules and can be easily molded around odd shapes.

Quantities and Units of Measurement

There are several quantities and units of measurement used to describe radioactivity and its effects. Three terms of particular usefulness are **activity**, **absorbed dose**, and **dose equivalent**.

Activity: Curie

Activity is the number of atoms in a sample that disintegrate (decay) per unit of time. Each time an atom disintegrates, radiation is emitted. The **curie (Ci)** is the unit used to describe the activity of a material and indicates the rate at which the atoms of a radioactive substance are decaying. One curie indicates the disintegration of 37 billion atoms per second.

A curie is a unit of activity, not a quantity of material. Thus, the amount of material required to produce one curie varies. For example, one gram (1/28th of an ounce) of radium-226 is the equivalent of one curie of activity, but it would take 9,170,000 grams (about 10 tons) of thorium-232 to equal one curie.

Smaller units of the curie are often used, especially when discussing the low concentrations of radioactivity detected in environmental samples. For instance, the microcurie (uCi) is equal to one millionth of a curie, while the picocurie (pCi) represents one trillionth of a curie.

Absorbed Dose: Rad

Absorbed dose is a term used to describe the radiation energy absorbed by any material exposed to ionizing radiation, and can be used for both particulate and electromagnetic radiation. The

Rad (radiation absorbed dose) is the unit used to measure the absorbed dose. It is defined as the energy of ionizing radiation deposited per gram of absorbing material (1 Rad = 100 erg/gm). The rate of absorbed dose is usually given in Rad/hr.

If the biological effect of radiation is directly proportional to the energy deposited by radiation in an organism, the Rad would be a suitable measurement of the biological effect. However, biological effects depend not only on the total energy deposited per gram of tissue, but on how this energy is distributed along its path. Experiments have shown that certain types of radiation are more damaging per unit path of travel than are others. Thus, another unit is needed to quantify the biological damage caused by ionizing radiation.

Dose Equivalent: Rem

Biological damage due to alpha, beta, gamma and neutron radiation may result from the ionization caused by this radiation. Some types of radiation, especially alpha particles which cause dense local ionization, can result in up to 20 times the amount of biological damage for the same energy imparted as do gamma or X-rays. Therefore, a **quality factor** must be applied to account for the different ionizing capabilities of various types of ionizing radiation. When the quality factor is multiplied by the absorbed dose, the result is the **dose equivalent**, which is an estimate of the possible biological damage resulting from exposure to a particular type of ionizing radiation. The dose equivalent is measured in **rem (radiation equivalent man)**.

An example of this conversion from absorbed dose to dose equivalent uses the quality factor for alpha radiation, which is equal to 20. Thus, 1 Rad of alpha radiation is approximately equal to 20 rem. Beta and gamma radiation each have a quality factor of 1, therefore one Rad of either beta or gamma radiation is approximately equal to one rem. Neutrons have a quality factor ranging from 2 to 10. One rem produces the same amount of biological damage, regardless of the source. In terms of radiation, the rem is a relatively large unit. Therefore, a smaller unit, the **millirem**, is often used. One millirem (mrem) is equal to 1/1000 of a rem.

Deep Dose Equivalent (DDE)

Deep dose equivalent is the measurement of dose within the body, from sources of radiation that are external to the body. It is what is measured and recorded on thermoluminescent dosimeters (TLDs), film badges or other dosimeters. For example, at Davis-Besse or at any hospital that has x-ray equipment, you will see people wearing these devices. These instruments are worn to measure DDE.

Committed Effective Dose Equivalent (CEDE)

Committed effective dose equivalent is a measure of the dose received from any radioactive material taken into the body. It is calculated from the sum of the products of the committed dose equivalent to the organ or tissue multiplied by the organ or tissue-weighting factor. CEDE accounts for all the dose delivered during the entire time the radioactive material is in the body.

Total Effective Dose Equivalent (TEDE)

Total effective dose equivalent means the sum of the deep dose equivalent (for dose from sources external to the body) and the committed effective dose equivalent (for internal dose). As these are both doses to the body, they are not tracked separately. The NRC limits occupational dose to a radiation worker to five rem (5000 mrem) TEDE per year.

Sources of Radiation

Background Radiation

Radiation is not a new creation of the nuclear power industry; it is a natural occurrence on the earth. It is probably the most "natural" thing in nature. Mankind has always lived with radiation and always will. In fact, during every second of life, over 7,000 atoms undergo radioactive decay "naturally" in the body of the average adult. In addition, radioactive decay also occurs naturally in soil, water, air, and space. All these common sources of radiation contribute to the natural background radiation to which everyone is exposed.

The earth is constantly showered by a steady stream of high-energy gamma rays and particulate radiation that come from space, known as cosmic radiation. The atmosphere shields us from most of this radiation, but everyone still receives about 20 to 50 mrem each year from this source. The thinner air at higher altitudes provides less protection against cosmic radiation. So people living at higher altitudes or flying in an airplane are exposed to more cosmic radiation. Radionuclides commonly found in the atmosphere as a result of cosmic ray interactions include beryllium-7, carbon-14, tritium (H-3), and sodium-22.

Another common naturally occurring radionuclide is potassium-40. About one-third of the external and internal dose from naturally occurring background radiation is attributed to this radioactive isotope of potassium.

The major source of background radiation is radon, a colorless, odorless, radioactive gas that results from the decay of radium-226, a member of the uranium-238 decay series. Since uranium occurs naturally in all soils and rocks, everyone is continuously exposed to radon and its daughter products. Radon would not be considered to pose a health hazard unless it is concentrated in a confined area, such as buildings, basements or underground mines. Radon-related health concerns stem from the exposure of the lungs to this radioactive gas. Radon emits alpha radiation when it decays, this could cause damage to internal tissues when inhaled. As a result, exposure to the lungs is of concern, as the only recognized health effect associated with exposure to radon is an increased risk of lung cancer. This effect has been seen when the radon is present at levels common in uranium mines. According to the National Council on Radiation Protection and Measurement (NCRP), over half of the radiation dose the average American receives is attributed to radon.

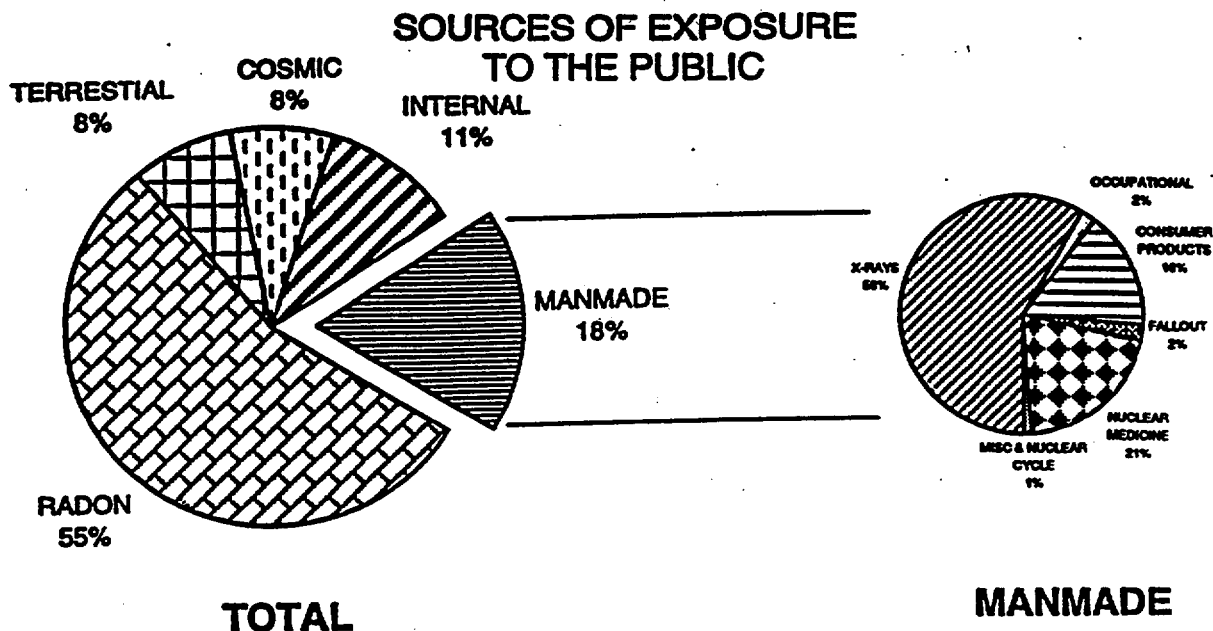

Figure 4: The most significant annual dose received by an individual of the public is that received from naturally occurring radon. A very small annual dose to the public results from producing electricity by nuclear power.

Further information on radon, its measurement, and actions to reduce the radon concentration in buildings can be obtained by contacting the state radon program office at the following address:

Radiological Health Program
 Ohio Department of Health
 P.O. Box 118
 Columbus, Ohio 43216-0118
 (614) 481-5800
 (800) 523-4439 (in Ohio Only)

The approximate average background radiation in this area (see Figure 4) is 300 mrem/year.

Man-Made Radiation

In addition to naturally occurring cosmic radiation and radiation from naturally occurring radioactivity, people are also exposed to man-made radiation. The largest sources of exposure include medical x-rays and radioactive pharmaceuticals. Small doses are also received from consumer products such as televisions, smoke detectors, and fertilizers. Fallout from nuclear weapons tests is another source of man-made exposure. Fallout radionuclides include strontium-90, cesium-137, and tritium. Less than one percent of the annual dose a member of the public receives is a result of having electricity generated by nuclear power.

Health Effects of Radiation

The effects of ionizing radiation on human health have been under study for more than 80 years. Scientists have obtained valuable knowledge through the study of laboratory animals that were exposed to radiation under extremely controlled conditions. However, it has been difficult to relate the biological effects of irradiated laboratory animals to the potential health effects on humans.

The effects of radiation on humans can be divided into two categories, somatic and genetic. Somatic effects are those which develop in the directly exposed individual, including a developing fetus. Genetic effects are those which are observed in the offspring of the exposed individual.

Somatic effects can be divided further into acute and chronic effects. Acute effects develop shortly after exposure to large amount of radiation. Much study has been done with human populations that were exposed to ionizing radiation under various circumstances. These groups include the survivors of the atomic bomb, persons undergoing medical radiation treatment, and early radiologists, who accumulated large doses of radiation, unaware of the potential hazards.

Chronic effects are a result of exposure to radiation over an extended period of time. Examples of such groups are clock dial painters, who ingested large amounts of radium by "tipping" the paint brushes with their lips, and uranium miners, who inhaled large amounts of radioactive dust while mining pitchblende (uranium ore). The studies performed on these groups have increased our knowledge of the health effects from comparatively very large doses of radiation received over long periods of time.

Continuous exposure to low levels of radiation may produce somatic changes over an extended period of time. For example, someone may develop cancer from man-made radiation, background radiation, or some other source not related to radiation. Because all illnesses caused by low level radiation can also be caused by other factors, it is virtually impossible to determine individual health effects of low level radiation. Even though no effects have been observed at doses less than 50 rem, to be conservative, we assume the health effects resulting from low doses of radiation occur proportionally to those observed following large doses of radiation. Most radiation scientists agree that this assumption over-estimates the risks associated with a low-level radiation exposure. The effects predicted in this manner have never been actually observed in any individuals exposed to low level radiation. Therefore, the most likely somatic effect of low level radiation is believed to be a small increased risk of cancer.

Genetic effects could occur as a result of ionizing radiation interacting with the genes in the human cells. Radiation (as well as common chemicals) can cause physical changes or mutations in the genes. Chromosome fibers can break and rearrange, causing interference with the normal cell division of the chromosome by affecting their number and structure. A cell is able to rejoin the ends of a broken chromosome, but if there are two breaks close enough together in space and time, the broken ends from one break could join incorrectly with those from another. This could cause translocations, inversions, rings, and other types of structural rearrangements. When this

happens, new mutated genes are created. Radiation is not the only mechanism by which such changes can occur. Spontaneous mutations and chemically induced mutations also have been observed. These mutated genes may be passed from parent to offspring. Viable mutations due to low level, low dose radiation have not been observed in humans.

Health Risks

While people may accept the risks inherent in their personal activities, such as smoking and driving to work each day, they are less inclined to accept the risk inherent in producing electricity. As with any industrial environment, it is not possible to guarantee a risk free environment. Thus, attention should be focused on taking steps to safeguard the public, on developing a realistic assessment of the risks, and on placing these risks in perspective. The perceptions of risk associated with exposure to radiation may have the greatest misunderstanding. Because people may not understand ionizing radiation and its associated risks, they may fear it. This fear is compounded by the fact that we cannot hear, smell, taste or feel ionizing radiation.

However, we do not fear other potentially hazardous things for which we have the same lack of sensory perception, such as radio waves, carbon monoxide, and small concentrations of numerous cancer-causing substances. These risks are larger and measurable compared to those presumed to be associated with exposure to low level, low dose radiation. Most of these risks are with us throughout our lives, and can be added up over a lifetime to obtain a total effect. Table 1 shows a number of different factors that decrease the average life expectancy of individuals in the United States.

Table 1: Risk Factors: Estimated Decrease in Average Life Expectancy

Overweight by 30%:		3.6 years
Cigarette smoking:	1 pack/day	7.0 years
	2 packs/day	10.0 years
Heart Disease:		5.8 years
Cancer:		2.7 years
City Living (not rural):		5.0 years
All operating commercial nuclear power plants totaled:		less than 12 minutes

Benefits of Nuclear Power

Nuclear power plays an important part in meeting today's electricity needs, and will continue to serve as an important source of electric energy well into the future. Today more than twenty percent of the electricity produced in the United States is from nuclear powered electrical generating stations.

Nuclear power offers several advantages over alternative sources of electric energy:

- nuclear power has an excellent safety record dating back to 1957 when the first commercial nuclear power station began operating,
- uranium, the fuel for nuclear power stations, is a relatively inexpensive fuel that is readily available in the United States,
- Nuclear power is the cleanest energy source for power stations that use steam to produce electricity. There are no greenhouse gases or acid gases produced when using nuclear fuel.

The following sections provide information on the fundamentals of how Davis-Besse uses nuclear fuel and the fission process to produce electricity.

Nuclear Power Production

Electricity is produced in a nuclear power station in the same way as in a fossil-fueled station with the exception of the source of heat. Heat changes water to steam that turns a turbine. In a fossil-fueled station, the fuel is burned in a furnace, which is also a boiler. Inside the boiler, water is turned into steam. In a nuclear station, a reactor that contains a core of nuclear fuel, primarily uranium, replaces the furnace. Heat is produced when the atoms of uranium are split, or fissioned, inside the reactor.

What is Fission?

A special force called the binding force holds the protons and neutrons together in the nucleus of the atom. The strength of this binding force varies from atom to atom. If the bond is weak enough, the nucleus can be split when bombarded by a free neutron (Figure 5). This causes the entire atom to split, producing smaller atoms, more free neutrons, and heat. In a nuclear reactor, a chain reaction of fission events provides the heat necessary to boil the water to produce steam.

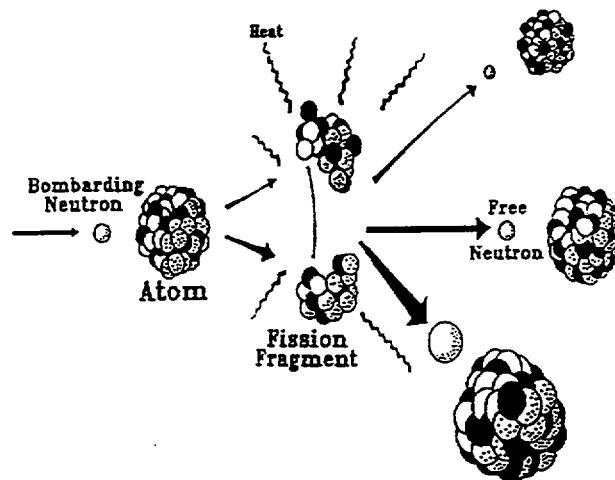

Figure 5: When a heavy atom, such as uranium-235 is split or fissioned, heat, free neutrons, and fission fragments result. The free neutrons can then strike neighboring atoms causing them to fission also. In the proper environment, this process can continue indefinitely in a chain reaction.

Nuclear Fuel

The fissioning of one uranium atom releases approximately 50 million times more energy than the combustion of a single carbon atom common to all fossil fuels. Since a single small reactor fuel pellet contains trillions of atoms, each pellet can release an extremely large amount of energy. The amount of electricity that can be generated from three small fuel pellets would require about 3.5 tons of coal or 12 barrels of oil to generate.

Nuclear fission occurs spontaneously in nature, but these natural occurrences cannot sustain themselves because the freed neutrons either are absorbed by non-fissionable atoms or quickly **decay**. In contrast, a nuclear reactor minimizes neutron losses, thus sustaining the fission process by several means:

- using fuel that is free of impurities that might absorb the free neutrons,
- enriching the concentration of the rarer fissionable isotope of uranium (U-235) relative to the concentration of U-238, a more common isotope that does not fission easily,
- slowing down neutron by providing a "moderator" such as water to increase the probability of fission.

Natural uranium contains less than one percent U-235 compared to the more abundant U-238 when it's mined. Before it can be economically used in a reactor, it is enriched to three to five percent U-235, in contrast to nuclear material used in nuclear weapons which is enriched to over 97 percent. Because of the low levels of U-235 in nuclear fuel, a nuclear power station **cannot** explode like a bomb.

After the uranium ore is separated from the earth and rock, it is concentrated in a milling process. After milling the ore to a granular form and dissolving out the uranium with acid, the uranium is converted to **uranium hexafluoride (UF₆)**. UF₆ is a chemical form of uranium that exists as a gas at temperatures slightly above room temperature. The UF₆ is then highly purified and shipped to an enrichment facility where **gaseous diffusion converters** increase the concentration of U-235. The enriched gaseous UF₆ is then converted into powdered **uranium dioxide (UO₂)**, a highly stable ceramic material. The UO₂ powder is put under high pressure to form **fuel pellets**, each about 5/8 inch long and 3/8 inch in diameter. Approximately five pounds of these pellets are placed into a 12-foot long metal tube made of zirconium alloy. The tubes constitute the **fuel cladding**. The fuel cladding is highly resistant to heat, radiation, and corrosion. When the tubes are filled with fuel pellets, they are called **fuel rods**.

The Reactor Core

Two hundred eight fuel rods comprise a single **fuel assembly**. The **reactor core** at Davis-Besse contains 177 of these fuel assemblies, each approximately 14 feet tall and 2,000 pounds in weight. In addition to the fuel rods, the fuel assembly also contains 16 vacant holes for the insertion of **control rods**, and one vacant hole for an **incore-monitoring probe**. This probe monitors temperature and neutron levels in the fuel assembly. The Davis-Besse reactor vessel, which contains all the fuel assemblies, weighs 838,000 pounds, has a diameter of 14 feet, is 39 feet high, and has steel walls that are 8 1/2 inch thick.

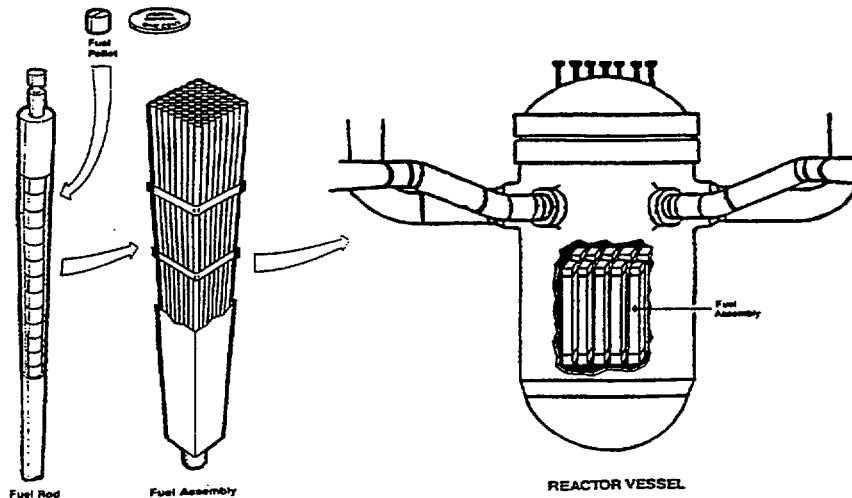

Figure 6: The reactor core at Davis-Besse contains 177 fuel assemblies. Each assembly contains 208 fuel rods. Each fuel rod is filled with approximately five pounds of fuel pellets, each pellet is approximately 3/8 inch in diameter and 5/8 inch long.

Fission Control

The fission rate inside the reactor core is controlled by raising or lowering **control rod assemblies** into the reactor core. Each assembly consists of "fingers" containing silver, indium, and cadmium metals that absorb free neutrons, thus disrupting the fission chain reaction. When control rod assemblies are slowly withdrawn from the core, fissioning begins and heat is produced. If the control rod assemblies are inserted rapidly into the reactor core, as during a plant "trip", the chain reaction ceases. A slower acting (but more evenly distributed) method of fission control is achieved by the addition of a **neutron poison** to the reactor coolant water. At Davis-Besse, high purity boric acid is concentrated or diluted in the coolant to achieve the desired level of fission. Boron-10 readily absorbs free neutrons, forming boron-11, removing the absorbed neutrons from the chain reaction.

Reactor Types

Virtually all of the commercial reactors in this country are either **boiling water reactors (BWRs)** or **pressurized water reactors (PWRs)**. Both types are also called **light water reactors (LWRs)** because their coolant, or medium to transfer heat, is ordinary water, which contains the light isotope of hydrogen. Some reactors use the heavy isotope of hydrogen (deuterium) in the reactor coolant. Such reactors are called **heavy water reactors (HWRs)**.

In BWRs, water passes through the core and boils into steam. The steam passes through separators which remove water droplets. The steam then travels to dryers before entering the turbine. After passing through the turbine the steam is condensed back into water and returns to the core to repeat the cycle.

In PWRs, the reactor water or coolant is pressurized to prevent it from boiling. The reactor water is then pumped to a **steam generator** (heat exchanger) where its heat is transferred to a secondary water supply. The secondary water inside the generator boils into steam, which is then used to turn the turbine. This steam is then condensed back into water and returned to the steam generator. Davis-Besse uses a PWR design.

The following paragraphs describe the various systems illustrated in Figure 7. Major systems in the Davis-Besse Station are assigned a different color in the figure.

Davis-Besse Nuclear Power Station Unit No. 1

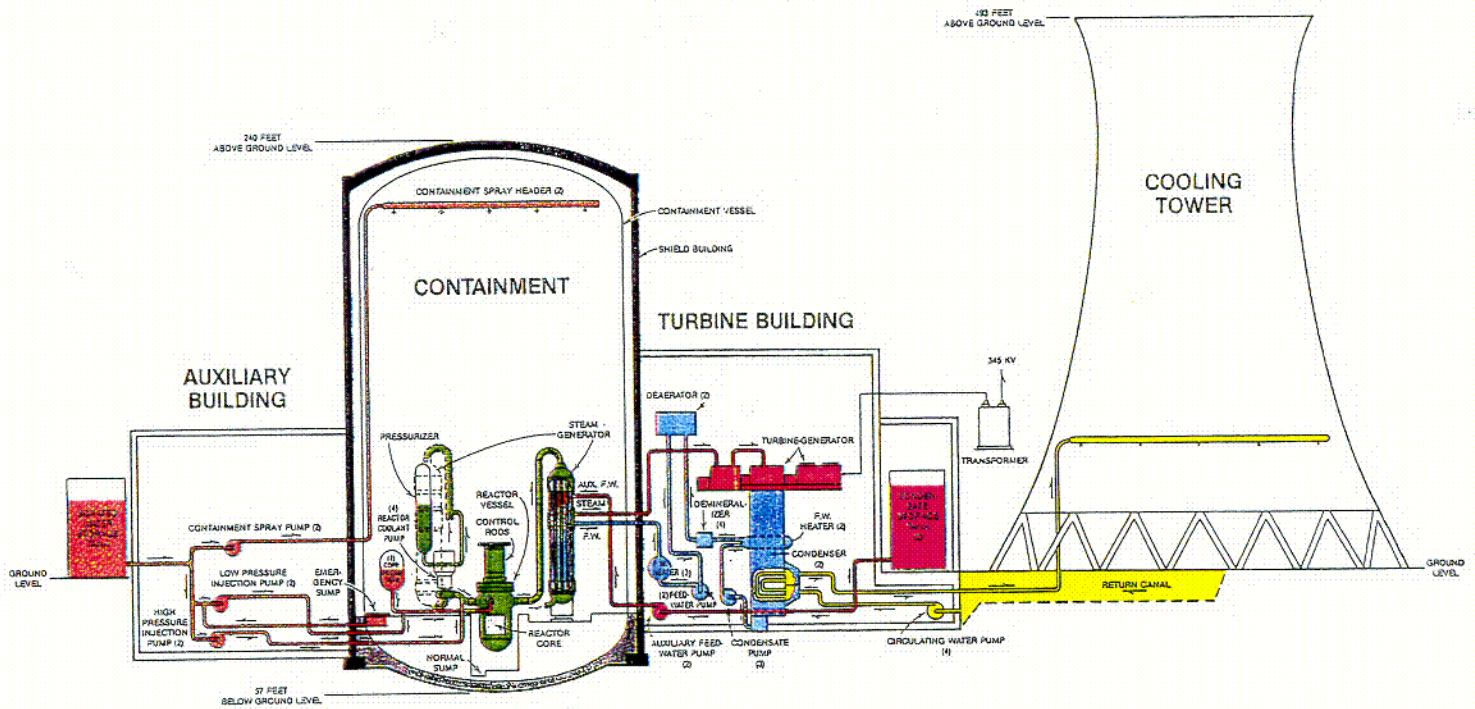

Figure 7: Station Systems

Station Systems

Containment Building and Fission Product Release Barriers

The **containment building** houses the reactor vessel, the pressurizer, two steam generators, the reactor coolant pumps and reactor coolant system piping. The building is constructed of an inner 1 -1/2 inch thick steel liner or **containment vessel**, and the **shield building** with steel reinforced concrete walls 2 feet thick. The shield building protects the containment vessel from a variety of environmental factors and provides an area for a **negative pressure boundary** around the steel containment vessel. In the event that the integrity of the containment vessel is compromised (e.g., a crack develops), this negative pressure boundary ensures that any airborne radioactive contamination present in the containment vessel is prevented from leaking out into the environment. This is accomplished by maintaining the pressure inside the shield building lower than that outdoors, thus forcing clean outside air to leak in, while making it impossible for the contaminated air between the containment vessel and the shield building to leak out. The containment vessel is the third in a **series of barriers** that prevent the release of fission products in the unlikely event of an accident. The first barrier to the release of fission products is the fuel cladding itself. The second barrier is the walls of the primary system, i.e. the reactor vessel, steam generator and associated piping.

The Steam Generators

The **steam generators** perform the same function as a boiler at a fossil-fueled power station. The steam generator uses the heat of the primary coolant inside the steam generator tubes to boil the secondary side **feedwater** (secondary coolant). Fission heat from the reactor core is transferred to the steam generator in order to provide the steam necessary to drive the turbine. However, heat must also be removed from the core even after reactor shutdown in order to prevent damage to the fuel cladding. Therefore, pumps maintain a continuous flow of coolant through the reactor and steam generator. **Primary loop water** (green in Figure 7) exits the reactor at approximately 606°F, passes through the steam generator, transferring some of its heat energy to the **secondary loop water** (blue in Figure 7) without actually coming in contact with it. Primary coolant water exits the steam generator at approximately 558°F to be circulated back into the reactor where it is again heated to 606°F as it passes up through the fuel assemblies. Under ordinary conditions, water inside the primary system would boil long before it reached such temperatures. However, it is kept under a pressure of approximately 2,200 pounds-per-square-inch (psi) at all times. This prevents the water from boiling and is the reason the reactor at Davis-Besse is called a Pressurized Water Reactor. Secondary loop water enters the base of the steam generator at approximately 450°F and under 1,100 psi pressure. At this pressure, the water can easily boil into steam as it passes over the tubes containing the primary coolant water.

Both the primary and the secondary coolant water are considered **closed loop systems**. This means that they are designed not to come in physical contact with one another. Rather, the cooling water in each loop transfers heat energy by **convection**. Convection is a method of **heat transfer** that can occur between two fluid media. It is the same process by which radiators are used to heat homes. The water circulating inside the radiator is separated from the air (a "fluid" medium) by the metal piping.

The Turbine - Generator

The turbine, main generator, and the condenser are all housed in what is commonly referred to as the **Turbine Building**. The purpose of the **turbine** is to convert the **thermal energy** of the steam produced in the steam generator (referred to as **main steam**, red in Figure 7) to **rotational energy** of the turbine generator shaft. The turbine at Davis-Besse is actually composed of one six-stage high-pressure turbine and two seven-stage low-pressure turbines aligned on a common shaft. A **turbine stage** refers to a set of blades. Steam enters at the center of each turbine and moves outward along the shaft in opposite directions through each successive stage of blading. As the steam passes over the turbine blades, it loses pressure. Thus, the blades must be proportionally larger in successive stages to extract enough energy from the steam to rotate the shaft at the correct speed.

The purpose of the **main generator** is to convert the rotational energy of the shaft to **electrical energy** for commercial usage and support of station systems. The main generator is composed of two parts, a stationary **stator** that contains coils of copper conductors, and a **rotor** that supplies a rotating magnetic field within the coils of the stator. Electrical current is generated in the stator portion of the main generator. From this point, the electric current passes through a series of **transformers** for transmission and use throughout northern Ohio.

The Condenser

After the spent steam in the secondary loop (blue in Figure 7) passes through the high and low pressure turbines, it is collected in a cavernous **condenser** several stories tall and containing more than 70,000 small tubes. **Circulating water** (yellow in Figure 7) goes to the **cooling tower** after passing through the tubes inside the condenser. As the steam from the low-pressure turbines passes over these tubes, it is cooled and condensed. The condensed water is then purified and reheated before being circulated back into the steam generator again in a closed loop system. Circulating water forms the third (or **tertiary**) and final loop of cooling water used at the Davis-Besse Station.

Similar to the primary to secondary interface, the secondary to tertiary interface is based on a closed loop design. The circulating water is able to cool the steam in the condenser, without ever actually coming in contact with it, by the process of convection. Even in the event of a primary to secondary leak, the water vapor exiting the Davis-Besse cooling tower would remain non-radioactive. Closed loops are an integral part of the design of any nuclear facility. This design feature greatly reduces the chance of environmental impact from station operation.

The Cooling Tower

The Cooling Tower at Davis-Besse is easily the most noticeable feature of the plant. The tower stands 493 feet high and the diameter of the base is 411 feet. Two nine-foot diameter pipes circulate 480,000 gallons of water per minute to the tower. Its purpose is to recycle water from the condenser by cooling and returning it.

After passing through the condenser, the Circulating Water has warmed to approximately 100°F. In order to cool the water back down to around 70°F, the Circulating Water enters the Cooling Tower about 40 feet above the ground. The water is sprayed evenly over a series of baffles called **fillsheets**, which are suspended vertically in the base of the tower. A natural draft of air blowing upward through these baffles cools the water by the process of **evaporation**. The evaporated water exits the top of the Cooling Tower as **water vapor**.

As much as 10,000 gallons of water per minute are lost to the atmosphere via the Cooling Tower. Even so, approximately 98 percent of the water drawn from Lake Erie for station operation can be recycled through the Cooling Tower for reuse. A small portion of the Circulating Water is discharged back to Lake Erie at essentially the same temperature it was withdrawn earlier. The slightly warmer water has no adverse environmental impact on the area of lake surrounding the discharge point.

Miscellaneous Station Safety Systems

The orange system in Figure 7 is part of the **Emergency Core Cooling System (ECCS)** housed in the **Auxiliary Building** of the station. The ECCS consists of three overlapping means of keeping the reactor core covered with water, in the unlikely event of a Loss of Coolant Accident (LOCA), thereby protecting the fuel cladding barrier against high temperature failure. Depending upon the severity of the loss of pressure inside the primary system, the ECCS will automatically channel borated water into the reactor by using **high-pressure injection pumps**, a **core flood tank**, or **low-pressure injection pumps**. Borated water can also be sprayed from the ceiling of the containment vessel to cool and condense any steam that escapes the primary system.

The violet system illustrated in Figure 7 is responsible for maintaining the primary coolant water in a liquid state. It accomplishes this by adjusting the pressure inside the primary system. Heaters inside the **Pressurizer** turn water into steam. This steam takes up more space inside the Pressurizer, thereby increasing the overall pressure inside the primary system. The Pressurizer is equipped with spray heads that shower cool water over the steam in the unit. In this case, the steam condenses and the overall pressure inside the primary system drops. The **Quench Tank** pictured in Figure 8 is simply where excess steam is directed and condensed for storage.

The scarlet system in Figure 7 is part of the **Auxiliary Feedwater System**, a key safety system in event the main feedwater supply (blue in Figure 7) to the Steam Generator is lost. Following a reactor shutdown, the Auxiliary Feedwater System can supply water to the Steam Generators from the **Condensate Storage Tanks**. The Auxiliary Feedwater System is housed in the Turbine Building along with the Turbine, Main Generator, and the Condenser.

Reactor Safety and Summary

Nuclear power plants are inherently safe, not only by the laws of physics, but by design. Nuclear power plants cannot explode like a bomb because the concentration of fissionable material is far less than is necessary for such a nuclear explosion. Also, many safety features are equipped with several backup systems to ensure that any possible accident would be prevented from causing a serious health or safety threat to the public, or serious impact on the local environment. Davis-Besse, like all U.S. nuclear units, has many overlapping, or redundant safety features. If one system should fail, there are still back-up systems to assure the safe operation of the Station. During normal operation, the **Reactor Control System** regulates the power output by adjusting the position of the control rods. The reactor can be automatically shut down by a separate **Reactor Protection System** that causes all the control rod assemblies to be quickly and completely inserted into the reactor core, stopping the chain reaction. To guard against the possibility of a Loss of Coolant Accident, the Emergency Core Cooling System is designed to pump reserve water into the reactor automatically if the reactor coolant pressure drops below a predetermined level.

The Davis-Besse Nuclear Power Station was designed, constructed, and operates to produce a reliable, safe, and environmentally sound source of electricity.

Radioactive Waste

Many of the activities we depend on in our everyday lives produce radioactive waste by-products. Nuclear energy, industrial processes, and medical treatments are some of these activities. These by-products are managed and disposed of under strict requirements set by the federal government. With the exception of used nuclear fuel assemblies, these by-products produced at commercial power plants are referred to as low level radioactive waste.

Low Level Radioactive Waste

Low level radioactive waste consists mainly of ordinary trash and other items that have become contaminated with radioactive materials. It includes plastic gloves and other protective clothing, machine parts and tools, medical and laboratory equipment, filters, resins, and general scrap.

The radioactive material in low level radioactive waste emits the same types of radiation that naturally occurring radioactive materials tend to emit. Most low level radioactive waste "decays" to background levels of radioactivity in months or years. Nearly all of it diminishes to stable materials in less than 300 years.

Davis-Besse presently ships low level radioactive waste to a South Carolina disposal facility located at Barnwell, South Carolina. This facility was closed to out-of-compact generators from July 1, 1994 to July 1, 1996. It was reopened to all generators on July 1, 1996. At this time, Davis-Besse resumed shipping of low-level radioactive waste to the facility. Davis-Besse has the capacity to store low-level waste produced on site in the Low Level Radioactive Waste Storage Facility (LLRWSF) for several years, should the Barnwell facility close again.

High Level Nuclear Waste

Like any industrial or scientific process, nuclear energy does produce waste. The most radioactive is defined as "high-level" waste (because it has high levels of radioactivity). Ninety-nine percent of high-level waste from nuclear plants is used nuclear fuel. The fuel undergoes certain changes during fission. Most of the fragments of fission, pieces that are left over after the atom is split, are radioactive. After a period of time, the fission fragments trapped in the fuel assemblies reduce the efficiency of the chain reaction. Every 18 to 24 months, the oldest fuel assemblies are removed from the reactor and replaced with fresh fuel.

High-level nuclear waste volumes are small. Davis-Besse produces about 30 tons of used fuel every 24 months. All the used fuel produced by all America's nuclear energy plants since the first plant started operating over 30 years ago would cover an area the size of a football field about five yards deep. All of America's nuclear plants combined produce only 3,000 tons of used fuel each year. By contrast, the U.S. produces about 300 million tons of chemical waste annually. Also, nuclear waste slowly loses its radioactivity, but some chemical waste remains hazardous indefinitely.

Davis-Besse presently stores most of its used fuel in a steel-lined water-filled concrete vault inside the plant. The Department of Energy is charged with constructing a permanent high-level waste repository for all of the nation's nuclear plants. By law, the Department of Energy was supposed to accept fuel from utilities by the end of 1998. Currently, Yucca Mountain, Nevada, is being considered as a possible site. Until the permanent DOE site is developed, nuclear plants will be responsible for the continued safe storage of high-level waste. At Davis-Besse, the fuel pool reached its capacity in 1996. At the end of 1996, Davis-Besse began the process of moving the older fuel assemblies that no longer require water cooling to air-cooled concrete shielded canisters. These will remain onsite until the Department of Energy facilities are ready to receive them. Dry fuel storage is already used in many countries, including Canada, and in the U.S. at nuclear plants in Arkansas, Colorado, Maryland, Michigan, Minnesota, Virginia, Wisconsin and South Carolina. Figure 8 illustrates the Dry Fuel Storage module arrangement at Davis-Besse.

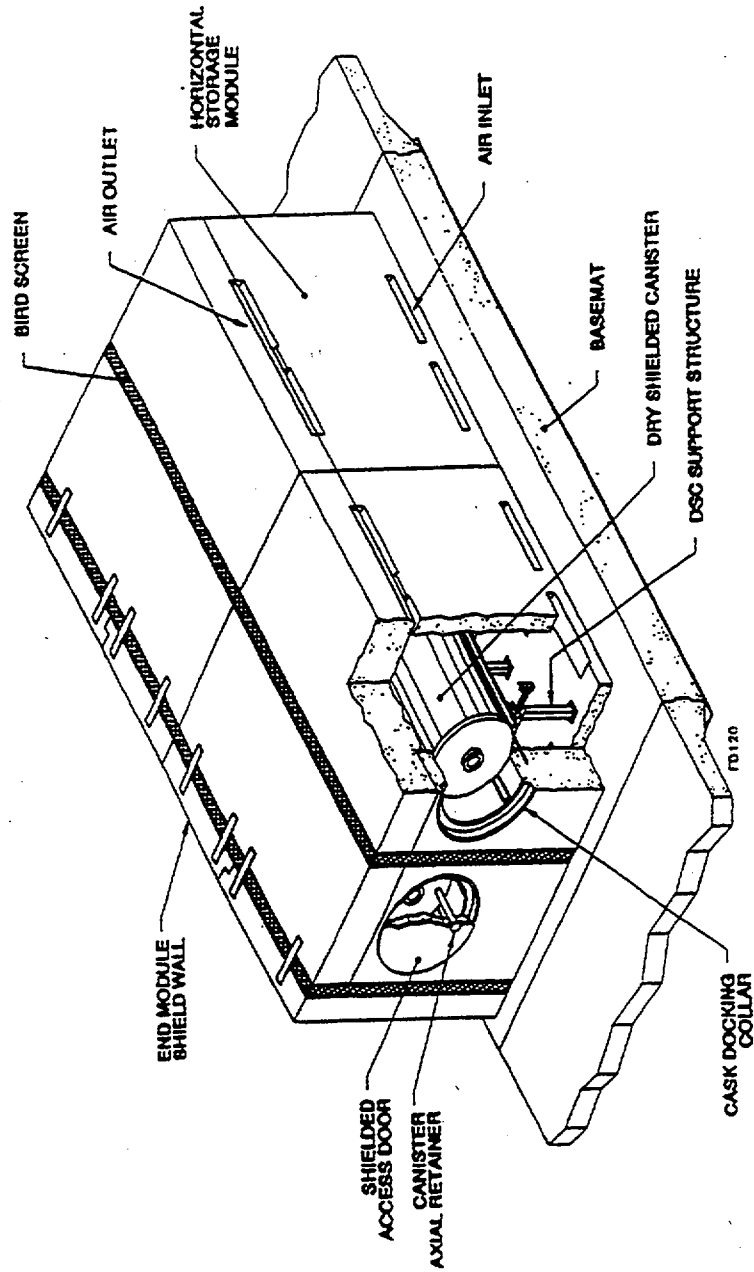

Figure 8: Dry Fuel Storage Module Arrangement

Description of the Davis-Besse Site

The Davis-Besse site is located in Carroll Township of Ottawa County, Ohio. It is on the southwestern shore of Lake Erie, just north of the Toussaint River. The site lies north and east of Ohio State Route 2, approximately 10 miles northwest of Port Clinton, 7 miles north of Oak Harbor, and 25 miles east of Toledo, Ohio (Figure 9).

This section of Ohio is flat and marshy, with maximum elevations of only a few feet above the level of Lake Erie. The area originally consisted of swamp forest and marshland, rich in wildlife but unsuitable for settlement and farming. During the nineteenth century, the land was cleared and drained, and has been farmed successfully since. Today, the terrain consists of farmland with marshes extending in some places for up to two miles inland from the Sandusky Lake Shore Ridge.

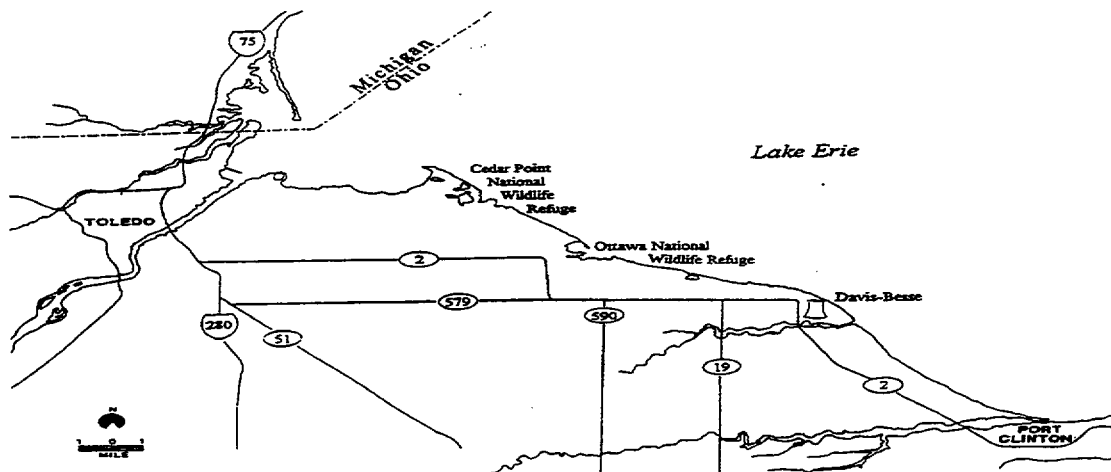

Figure 9: Davis-Besse is near Oak Harbor, Port Clinton, and the Ottawa National Wildlife Refuge.

The Davis-Besse site is mainly comprised of marshland, with a small portion consisting of farmland. The marshes are part of a valuable ecological resource, providing a breeding ground for a variety of wildlife, and a refuge for migratory birds. The site includes a tract known as Navarre Marsh, which was acquired from the U.S. Bureau of Sport Fisheries and Wildlife, Department of the Interior. In 1971, Toledo Edison purchased the 188-acre Toussaint River Marsh. The Toussaint River Marsh is contiguous with the 610-acre Navarre Marsh section of the Ottawa National Wildlife Refuge.

The immediate area near Davis-Besse is sparsely populated. Ottawa County had a population of 40,985 according to the 2000 Census. The incorporated communities nearest to Davis-Besse are:

- Port Clinton - 10 miles southeast, population 6,391
- Oak Harbor - 7 miles south, population 2,841
- Rocky Ridge - 7 miles west southwest, population 389
- Toledo (nearest major city) - 25 miles west, population 313,619

There are some residences along the lakeshore used mainly as summer homes. However, the major resort area of the county is farther east, around Port Clinton, Lakeside, and the Bass Islands.

The majority of non-marsh areas around the Davis-Besse site are used for farming. The major crops include soybeans, corn, wheat, oats, hay, fruits and vegetables. Meat and dairy animals are not major sources of income in the area. The main industries within five miles of the site are located in Erie Industrial Park, about four miles southeast of the station.

Most of the remaining marshes in the area have been maintained by private hunting clubs, the U.S. Fish and Wildlife Service, and the Ohio Department of Natural Resources, Division of Wildlife. The State of Ohio Department of Natural Resources operates many wildlife and recreational areas within 10 miles of the Station. These include Magee Marsh, Turtle Creek, Crane Creek State Park, and the Ottawa National Wildlife Refuge. Magee Marsh and Turtle Creek lie between three and six miles WNW of the Station. Magee Marsh is a wildlife preserve that allows public fishing, nature study, and a controlled hunting season. Turtle Creek, a wooded area at the southern end of Magee Marsh, offers boating and fishing. Crane Creek State Park is adjacent to Magee Marsh and is a popular picnicking, swimming, and fishing area. The Ottawa National Wildlife Refuge lies four to nine miles WNW of the Site, immediately west of Magee Marsh.

References

1. "Basic Radiation Protection Criteria," Report No. 39, National Council on Radiation Protection and Measurement, Washington, D.C. (January 1971).
2. "Cesium-137 from the Environment to Man: Metabolism and Dose," Report No. 52, National Council on Radiation Protection and Measurements, Washington, D.C. (January 1977).
3. Deutch, R., "Nuclear Power, A Rational Approach," Fourth edition, GP Courseware, Inc., Columbia, MD. (1987).
4. Eisenbud, M., "Environmental Radioactivity," Academic Press, Inc., Orlando, FL. (1987).
5. "Environmental Radiation Measurements," Report No. 50, National Council on Radiation Protection and Measurements, Washington, D.C. (December 1976).
6. "Exposure of the Population in the United States and Canada from Natural Background Radiation," Report No. 94, National Council on Radiation Protection and Measurements, Washington, D.C. (December 1987).
7. "Health Effects of Exposure to Low Levels of Ionizing Radiation: BEIR V," Committee on the Biological Effects of Ionizing Radiations, Board on Radiation Effects Research Commission on Life Sciences, National Research Council, National Academy Press, Washington, D.C. (1990).
8. Hendee, William R., and Doege, Theodore C., "Origin and Health Risks of Indoor Radon," Seminars in Nuclear Medicine, Vol. XVIII, No. 1, American Medical Association, Chicago, IL. (January 1987).
9. Hurley, P., "Living with Nuclear Radiation," University of Michigan Press, Ann Arbor, MI. (1982).
10. "Indoor Air Quality Environmental Information Handbook: Radon," prepared for the United States Department of Energy, Assistant Secretary for Environment, Safety and Health, by Mueller Associated, Inc., Baltimore, MD. (January 1986).
11. Introduction to Davis-Besse Nuclear Power Station Plant Technology, July 1992, Rev. 4, Pg.2-9.
12. "Ionizing Radiation Exposure of the Population of the United States," Report No. 93, National Council on Radiation Protection and Measurements, Washington, D.C. (September 1987).
13. "Natural Background Radiation in the United States," Report No. 45, National Council on Radiation Protection and Measurements, Washington, D.C. (November 1975).

14. "Nuclear Energy Emerges from 1980's Poised for New Growth," U.S. Council for Energy Awareness, Washington, D.C. (1989).
15. "Nuclear Power: Answers to Your Questions," Edison Electric Institute, Washington, D.C. (1987).
16. "Public Radiation Exposure from Nuclear Power Generation in the United States," Report No. 92, National Council on Radiation Protection and Measurement, Washington, D.C. (December 1987).
17. "Radiation Protection Standards," Department of Environmental Sciences and Physiology and the Office of Continuing Education, Harvard School Of Public Health, Boston, MA. (July 1989).
18. Radiological Environmental Monitoring Report for Three Mile Island Station," GPU Nuclear Corporation, Middletown, PA. (1985).
19. "Sources, Effects and Risk of Ionizing Radiation," United Nations Scientific Committee on the Effects of Atomic Radiation, 1988 Report to the General Assembly, United Nations, New York (1988).
20. "Standards for Protection Against Radiation," Title 10, Part 20, Code of Federal Regulation, Washington, D.C. (1988).
21. "Domestic Licensing of Production and Utilization Facilities," Title 10, Part 50, Code of Federal Regulations, Washington, D.C. (1988).
22. "Environmental Radiation Protection Standard for Nuclear Power Operations," Title 40, Part 190, Code of Federal Regulations, Washington, D.C. (1988).
23. "Tritium in the Environment," Report No. 62, National Council on Radiation Protection and Measurement, Washington, D.C. (March 1979).
24. Site Environmental Report, Fernald Environmental Management Project, United States Department of Energy (June 1993).
25. " Exposure from the Uranium Series with Emphasis on Radon and it's daughters" Report No. 77, National Council on Radiation Protection and Measurements, Washington, D.C. (1984).
26. "Evaluation of Occupational and Environmental Exposures to Radon and Radon daughter in the United States," Report No. 78, National Council on Radiation Protection and Measurements, Washington, D.C. (1984).



Radiological Environmental Monitoring Program

Radiological Environmental Monitoring Program

Introduction

The **Radiological Environmental Monitoring Program (REMP)** was established at Davis-Besse for several reasons: to provide a supplementary check on the adequacy of containment and effluent controls, to assess the radiological impact of the Station's operation on the surrounding area, and to determine compliance with applicable radiation protection guides and standards. The REMP was established in 1972, five years before the Station became operational. This **preoperational surveillance program** was established to describe and quantify the radioactivity, and its variability, in the area prior to the operation of Davis-Besse. After Davis-Besse became operational in 1977, the **operational surveillance program** continued to measure radiation and radioactivity in the surrounding areas.

A variety of environmental samples are collected as part of the REMP at Davis-Besse. The selection of sample types is based on the established critical pathways for the transfer of radionuclides through the environment to humans. The selection of sampling locations is based on sample availability, local meteorological and hydrological characteristics, local population characteristics, and land usage in the area of interest. The selection of sampling frequencies for the various environmental media is based on the radionuclides of interest, their respective half-lives, and their behavior in both the biological and physical environment.

A description of the REMP at Davis-Besse is provided in the following section. In addition, a brief history of analytical results for each sample type collected since 1972, and a more detailed summary of the analyses performed during this reporting period, is also provided.

Preoperational Surveillance Program

The federal government requires nuclear facilities to conduct radiological environmental monitoring prior to constructing the facility. This preoperational surveillance program is aimed at collecting the data needed to identify critical pathways, including selection of the radioisotope and sample media combinations to be included in the surveillance program conducted after facility operation begins. Radiochemical analyses performed on the environmental samples should include not only those nuclides expected to be released during facility operation, but should also include typical fallout radionuclides and natural background radioactivity. All environmental media with a potential to be affected by facility operation, as well as those media directly in the critical pathways, should be sampled on at least an annual basis during the preoperational phase of the environmental surveillance program.

The preoperational surveillance design, including nuclide/media combinations, sampling frequencies and locations, collection techniques, and radioanalyses performed, should be carefully considered and incorporated in the design of the operational surveillance program. In this manner, data can be compared in a variety of ways (for example: from year to year, location to location, etc.) in order to detect any radiological impact the facility has on the surrounding environment. Data collection during the preoperational phase should be planned to provide a comprehensive database for evaluating any future changes in the environment surrounding the nuclear facility.

Davis-Besse began its preoperational environmental surveillance program five years before the Station began producing power for commercial use in 1977. Data accumulated during those early years provide an extensive database from which Station personnel are able to identify trends in the radiological characteristics of the local environment. The environmental surveillance program at Davis-Besse will continue after the Station has reached the end of its economically useful life and decommissioning has begun.

Operational Surveillance Program Objectives

The operational phase of the environmental surveillance program at Davis-Besse was designed with the following objectives in mind:

- to fulfill the obligations of the radiological surveillance sections of the Station's Technical Specifications and Offsite Dose Calculation Manual;
- to determine whether any significant increase occurs in the concentration of radionuclides in critical pathways;
- to identify and evaluate the buildup, if any, of radionuclides in the local environment, or any changes in normal background radiation levels; and
- to verify the adequacy of Station controls for the release of radioactive materials.

Quality Assurance

An important part of the environmental monitoring program at Davis-Besse is the **Quality Assurance (QA) Program**. It is conducted in accordance with the guidelines specified in NRC Regulatory Guide 4.15, "Quality Assurance for Radiological Monitoring Programs." The QA Program is designed to identify possible deficiencies in the REMP so that corrective actions can be initiated promptly. Davis-Besse's Quality Assurance program also provides confidence in the results of the REMP through:

- performing regular audits (investigations) of the REMP, including a careful examination of sample collection techniques and record keeping;
- performing audits of contractor laboratories which analyze the environmental samples;
- requiring analytical contractor laboratories to participate in the United States Environmental Protection Agency Cross-Check Program;

- requiring analytical contractor laboratories to split samples for separate analysis followed by a comparison of results;
- splitting samples prior to analysis by independent laboratories, and then comparing the results for agreement, and, finally;
- requiring analytical contractor laboratories to perform in-house spiked sample analyses.

Quality Assessment audits and inspections of the Davis-Besse REMP are performed by the FirstEnergy Nuclear Operating Company QA Department and the NRC. In addition, the NRC and the Ohio Department of Health (ODH) also perform independent environmental monitoring in the vicinity of Davis-Besse. The types of samples collected and the sampling locations used by the NRC and ODH were incorporated in Davis-Besse's REMP. Hence, the analytical results from the different programs can be compared. This practice of comparing results from identical samples, collected and analyzed by different parties, provides a valuable tool to verify the quality of the laboratories analytical procedures and the data generated.

In 1987, environmental sampling personnel at Davis-Besse incorporated their own QA program into the REMP. Duplicate samples, called quality control samples, were collected at several locations. These duplicate samples were assigned different identification numbers than the numbers assigned to the routine samples. This ensured that the analytical laboratory would not know the samples were identical. The laboratory results from analysis of the quality control samples and the routine samples could then be compared for agreement. Quality control sampling has been integrated into the program and has become an important part of the REMP since 1987. Quality control sampling locations are changed frequently in order to duplicate as many sampling locations as possible, and to ensure the contractor laboratory has no way of correctly pairing a quality control sample with its routine sample counterpart.

Program Description

Overview

The Radiological Environmental Monitoring Program (REMP) at Davis-Besse is conducted in accordance with Title 10, Code of Federal Regulations, Part 50; Regulatory Guide 4.8; the Davis-Besse Nuclear Power Station Operating License, Appendix A (Technical Specifications); the Davis-Besse Offsite Dose Calculation Manual (ODCM) and Station Operating Procedures. Samples are collected weekly, monthly, quarterly, semiannually, or annually, depending upon the sample type and nature of the radionuclides of interest. Environmental samples collected by Davis-Besse personnel are divided into four general types:

- **atmospheric** -- including samples of airborne particulates and airborne radio-iodine
- **terrestrial** -- including samples of milk, groundwater, broad leaf vegetation, fruits, animal/wildlife feed, soil, and wild and domestic meat
- **aquatic** -- including samples of treated and untreated surface water, fish, and shoreline sediments
- **direct radiation** -- measured by thermoluminescent dosimeters

All environmental samples are labeled using a sampling code. Table 2 provides the sample codes and collection frequency for each sample type.

REMP samples are collected onsite and offsite up to 25 miles away from the Station. Sampling locations may be divided into two general categories: indicator and control. Indicator locations are those which would be most likely to display the effects caused by the operation of Davis-Besse. Generally, they are located within five miles of the station. Control locations are those which should be unaffected by Station operations. Typically, these are more than five miles away from the Station. Data obtained from the indicator locations are compared with data from the control locations. This comparison allows REMP personnel to take into account naturally-occurring background radiation or fallout from weapons testing in evaluating any radiological impact Davis-Besse has on the surrounding environment. Data from indicator and control locations are also compared with preoperational data to determine whether significant variations or trends exist.

Since 1987, the REMP has been reviewed and modified to develop a comprehensive sampling program adjusted to the current needs of the utility. Modifications have included additions of sampling locations above the minimum amount required in the ODCM and increasing the number of analyses performed on each sample. Besides adding new locations, duplicate or Quality Control (QC) sample collection was initiated to verify the accuracy of the lab analyzing the environmental samples. These additional samples are referred to as the REMP Enhancement Samples. Approximately 2000 samples were collected and over 2300 analyses were performed during 2000. In addition, 15% of the sampling locations were quality control sampling locations. Table 3 shows the number of the sampling location and number collected for each type.

Table 2: Sample Codes and Collection Frequencies

Sample Type	Sample Code	Collection Frequency
Airborne Particulate	AP	Weekly
Airborne Iodine	AI	Weekly
Thermoluminescent Dosimeter	TLD	Quarterly, Annually
Milk	MIL	Monthly (semi-monthly during grazing season)
Groundwater	WW	Quarterly
Broadleaf Vegetation	BLV	Monthly (when available)
Surface Water - Treated	SWT	Weekly
Surface Water - Untreated	SWU	Weekly (lake water – monthly in summer)
Fish	FIS	Annually
Shoreline Sediment	SED	Semiannually
Soil	SOI	Semiannually
Animal/Wildlife Feed	DFE/WFE	Annually
Meat-Domestic	DME	Annually
Meat-Wild	WME	Annually
Fruit	FRU	Annually

Table 3: Sample Collection Summary

Sample Type (Remarks)	Collection Type*/ Frequency**	Number of Locations	Number of Samples Collected	Number of Samples Missed
Atmospheric				
Airborne Particulates	C/W	10	530	0
Airborne Radioiodine	C/W	10	530	0
Terrestrial				
Milk (Jan.-Dec.)	G/M	1	12	0
Groundwater	G/Q***	1	5	0
Domestic Meat	G/A	2	2	0
Broadleaf				
Vegetation / Fruit	G/M	6	13	0
Soil	G/SA	10	20	0
Animal/Wildlife Feed	G/A	5	5	0
Aquatic				
Treated	Comp/WM	2	106	0
Surface Water	G/WM***	3	159	0
Untreated	G/WM***	3	156	3****
Surface Water	Comp/WM	3	159	0
	G/M	5	35	0
Fish (3 species)	G/A	2	6	0
Shoreline Sediments	G/SA	5	10	0
Direct Radiation				
Thermoluminescent	C/Q***	75	295	5
Dosimeters (TLD)	C/A***	75	75	0

* Type of Collection: C = Continuous; G = Grab; Comp = Composite

** Frequency of Collection: WM = Weekly composite Monthly; W = Weekly

*** Includes quality control location, SWU and SWT QC included in weekly grab sample/composited monthly

**** Hazardous weather conditions prevented sample collection

SM = Semimonthly; M = Monthly; Q = Quarterly; SA = Semiannually; A = Annually

Sample Analysis

When environmental samples are analyzed, several types of measurements may be performed to provide information about the radionuclides present. The major analyses that are performed on environmental samples collected for the Davis-Besse REMP include:

Gross beta analysis measures the total amount of beta emitting radioactive material present in a sample. Beta radiation may be released by many different radionuclides. Since beta decay gives a continuous energy spectrum rather than the discrete lines or "peaks" associated with gamma radiation, identification of specific beta emitting nuclides is much more difficult. Therefore, gross beta analysis only indicates whether the sample contains normal or abnormal concentrations of beta emitting radionuclides; it does not identify specific radionuclides. Gross beta analysis merely acts as a tool to identify samples that may require further analysis.

Gamma spectral analysis provides more specific information than does gross beta analysis. Gamma spectral analysis identifies each gamma emitting radionuclide present in the sample, and the amount of each nuclide present. Each radionuclide has a very specific "fingerprint" that allows for swift and accurate identification. For example, gamma spectral analysis can be used to identify the presence and amount of iodine-131 in a sample. Iodine-131 is a man-made radioactive isotope of iodine that may be present in the environment as a result of fallout from nuclear weapons testing, routine medical uses in diagnostic tests, and routine releases from nuclear power stations.

Tritium analysis indicates whether a sample contains the radionuclide tritium (H-3) and the amount present. As discussed in the Introduction Section, tritium is an isotope of hydrogen that emits low energy beta particles.

Strontium analysis identifies the presence and amount of strontium-89 and strontium-90 in a sample. These man-made radionuclides are found in the environment as a result of fallout from nuclear weapons testing. Strontium is usually incorporated into the calcium pool of the biosphere. In other words, strontium tends to replace calcium in living organisms and becomes incorporated in bone tissue. The principal strontium exposure pathway is via milk produced by cattle grazed on pastures exposed to deposition from airborne releases.

Gamma Doses measured by thermoluminescent dosimeters while in the field are determined by a special laboratory procedure. Table 4 provides a list of the analyses performed on environmental samples collected for the Davis-Besse REMP.

Often samples will contain little radioactivity, and may be below the lower limit of detection for the particular type of analysis used. The lower limit of detection (LLD) is the smallest amount of sample activity that can be detected with a reasonable degree of confidence, at a predetermined level. When a measurement of radioactivity is reported as less than LLD (<LLD), it means that the radioactivity is so low that it cannot be accurately measured with any degree of confidence by that particular method for an individual analysis.

Table 4: Radiochemical Analyses Performed on REMP Samples

Sample Type	Analyses Performed
Atmospheric Monitoring	
Airborne Particulate	Gross Beta Gamma Spectral Strontium-89 Strontium-90
Airborne Radioiodine	Iodine-131
Terrestrial Monitoring	
Milk	Gamma Spectral Iodine-131 Strontium-89 Strontium-90 Stable Calcium Stable Potassium
Groundwater	Gross Beta Gamma Spectral Tritium Strontium-89 Strontium-90
Broadleaf Vegetation and Fruits	Gamma Spectral Iodine-131 Strontium-89 Strontium-90
Animal/Wildlife Feed	Gamma Spectral
Soil	Gamma Spectral
Wild and Domestic Meat	Gamma Spectral

Table 4: Radiochemical Analyses Performed on REMP Samples
(continued)

Sample Type	Analyses Performed
Aquatic monitoring	
Untreated Surface Water	Gross Beta Gamma Spectral Tritium Strontium-89 Strontium-90
Treated Surface Water	Gross Beta Gamma Spectral Tritium Strontium-89 Strontium-90 Iodine-131
Fish	Gross Beta Gamma Spectral
Shoreline Sediment	Gamma Spectral
Direct Radiation Monitoring	
Thermoluminescent Dosimeters	Gamma Dose

Sample History Comparison

The measurement of radioactive materials present in the environment will depend on factors such as weather or variations in sample collection techniques or sample analysis. This is one reason why the results of sample analyses are compared with results from other locations and from earlier years. Generally, the results of sample analyses are compared with preoperational and operational data. Additionally, the results of indicator and control locations are also compared. This allows REMP personnel to track and trend the radionuclides present in the environment, to assess whether a buildup of radionuclides is occurring and to determine the effects, if any, the operation of Davis-Besse is having on the environment. If any unusual activity is detected, it is investigated to determine whether it is attributable to the operation of Davis-Besse, or to some other source such as nuclear weapons testing. A summary of the REMP sample analyses performed from 1972 through the current reporting period is provided in the following section.

Atmospheric Monitoring

- **Airborne Particulates:** No radioactive particulates have been detected as a result of Davis-Besse's operation. Only natural and fallout radioactivity from nuclear weapons testing and the 1986 nuclear accident at Chernobyl have been detected.
- **Airborne Radioiodine:** Radioactive iodine-131 fallout was detected in 1976, 1977, and 1978 from nuclear weapons testing, and in 1986 (0.12 to 1.2 picocuries per cubic meter) from the nuclear accident at Chernobyl.

Terrestrial Monitoring:

- **Groundwater:** Only naturally occurring radioactive material has been detected in groundwater.
- **Milk:** Iodine-131 from nuclear weapons testing fallout was detected in 1976 and 1977 at concentrations of 1.36 and 23.9 picocuries/liter respectively. In 1986, concentrations of 8.5 picocuries/liter were detected from the nuclear accident at Chernobyl. No iodine-131 detected has been attributable to the operation of Davis-Besse.
- **Domestic and Wild Meat:** Only naturally occurring potassium-40 and very low cesium-137 from fallout activity has been detected in meat samples. Potassium-40 has ranged from 1.1 to 4.6 picocuries/gram weight (wet). Cesium-137 was detected in 1974, 1975, and 1981 due to fallout from nuclear weapons testing.
- **Broadleaf Vegetation and Fruits:** Only naturally occurring radioactive material and material from nuclear weapons testing has been detected.
- **Soil:** Only natural background and material from nuclear weapons testing and the 1986 nuclear accident at Chernobyl has been detected.
- **Animal/Wildlife Feed:** Only natural background and material from weapons testing has been detected.

Aquatic Monitoring

- **Surface Water (Treated and Untreated):** In 1979 and 1980, the tritium concentrations at location T-7 were above normal background. Location T-7 is a beach well fed directly by Lake Erie. The fourth quarter sample in 1979 read 590 picocuries per liter, and the first quarter sample in 1980 had a concentration of 960 picocuries per liter. A follow-up sample was collected in Lake Erie between T-7 and the Davis-Besse liquid discharge point. This sample contained tritium at a concentration of 2737 picocuries per liter. These concentrations could be attributed to the operation of Davis-Besse. Even so, these results at T-7 were more than 39 times lower than the annual average concentration allowed by the EPA National Interim Primary Drinking Water Regulations (40CFR141), and were only 0.032% of the Maximum Permissible Concentration (MPC of 3,000,000 picocuries per liter) for tritium in unrestricted areas. The follow-up sample was less than 0.1% of the MPC. None of the subsequent samples indicated any significant difference between the background tritium concentration and the concentration at T-7.

In 1991, the tritium concentration in the untreated surface water at T-130 was above normal background levels. T-130 is located in Lake Erie approximately 300 yards from the mouth of the Toussaint River. The August composite was 884 picocuries per liter. Follow up samples were less than the LLD of 330 picocuries per liter. Although this concentration may be attributed to the operation of Davis-Besse, it was only 0.029% of the maximum permissible concentration for tritium in an unrestricted area. This did not have any significant adverse effect on the environment and the population near the station.

The December 1992 composite for tritium at T-3 (mouth of Toussaint River) showed trace amounts of activity, which may be attributed to the normal operation of the station. The tritium concentration for the composite was 950 pCi/l. This is only 0.032 percent of the maximum permissible concentration of 3,000,000 pCi/l for tritium in an unrestricted area, as stated in 10 CFR 20, Appendix B, Table 2. Subsequent samples collected during January 1993 showed that the tritium had returned to below the LLD of 330 pCi/l.

In the fourth quarter of 1994, tritium was detected at 336 ± 94 pCi/l, slightly above the lower limit of detection for tritium, at one of the treated water sampling locations. Tritium was also detected at several of the untreated water sampling locations at an average concentration of 470 pCi/l during the 3rd and 4th quarters of 1994. Samples taken in January 1995 indicated that the tritium concentration in untreated water was less than the lower limit of detection for tritium in water. For comparison purposes, tritium concentrations in Lake Erie untreated surface water, determined during the preoperational sampling period of July 1972 through June 1974, ranged from 180 pCi/l to 590 pCi/l with an average concentration of less than 300 pCi/l.

In 1995, trace amounts of tritium were detected in six untreated water samples collected in May and one sample collected in October. The tritium detected ranged between 330 to 1234 pCi/l with an average concentration of 681 pCi/l. This is well below the allowable effluent concentration limit of 20,000 pCi/l for tritium in an unrestricted area, as stated in 40 CFR 141. Subsequent samples taken showed the tritium activity to be <330 pCi/l.

During 1996, tritium was detected ranged between 330 and 589 pCi/l with an average concentration of 340.3 pCi/l in 8 untreated surface water samples. Tritium in the remaining untreated surface water samples was <330 pCi/l.

During 1997, the tritium detected in 4 untreated surface water samples ranged between 340 and 575 pCi/l, and had an average concentration of 430 pCi/l. Even though these may be attributed to the operation of Davis-Besse, this average concentration is much less than the maximum permissible concentration allowed for tritium in unrestricted areas.

During 1999, tritium was detected in 11 untreated surface water samples. Ten samples ranged between 337 and 550 pCi/l. The eleventh, a control sample located 5.8 miles WNW of the station, measured 5288 pCi/l. The tritium in this sample is not thought to be from the operation of Davis-Besse for the following reasons: a) this control sample point is upstream of Davis-Besse, b) two indicator samples collected between this location and the plant showed no detectable tritium activity and, c) tritium was not detected in a subsequent sample taken at this location.

Seven untreated surface water samples showed detectable tritium levels in 2000, ranging from 342 pCi/l to 1013 pCi/l. The tritium may have been due to the operation of Davis-Besse, but these concentrations are well below the allowable limits in unrestricted areas.

- **Fish:** Only natural background radioactive material and material from nuclear testing has been detected.
- **Shoreline Sediments:** Only natural background, material from nuclear testing and from the 1986 nuclear accident at Chernobyl has been detected.

Direct Radiation Monitoring:

- **Thermoluminescent Dosimeters (TLDs):** The annual average gamma dose rates for the current reporting period recorded by TLDs have ranged from 24.5 to 80.7 millirem per year at control locations and between 20.9 and 91.8 millirem per year at indicator locations. No increase above natural background radiation attributable to the operation of Davis-Besse has been observed.

2000 Program Deviations

Provided below is a description and explanation of 2000 environmental sample collection deviations:

- Broadleaf vegetation was not collected during January, February, March, April, May, June, November and December because of seasonal unavailability.
- On 3/7/00, air sampler T-7 pump would not re-start. Sample pump was replaced.
- On 4/4/00, air sample pump T-11 was short 5 hours for the previous sample period. Investigation found that power was off in that area of Port Clinton for a construction project.
- First Quarter and annual TLDs missing at T-151 on 4/12/00. Road construction removed the utility pole on which the TLD was mounted. Replacement TLDs mounted on nearby pole.
- Air samplers T1, T-2, and T-3 lost 40 minutes of run time due to loss of all offsite power on 4/23/00. Power re-established after 40 minutes.
- Two days run time lost on air sampler T-9 in Oak Harbor discovered on 5/9/00 due to a maintenance outage on substation. Power supplied with extension cord for the remainder of the outage.
- 3 or 4 days of Untreated Service Water composite sample lost at T-12 due to short in power cord on 5/9/00. Cord replaced and composite sample collected, although not completely representative of the previous week.
- On 5/31/00, T-8 air sampler was not running at time of sample collection. A blown fuse was replaced, which fixed the problem.
- On 6/7/00, T-9 air sampler was 1.7 hours short of actual time. A short power outage occurred during the previous week.
- A power outage and thunderstorms caused air samplers T-1, T-2, T-4 and T-8 to show a difference of greater than 1.7 hours between timer readings and actual time difference on 6/21/00. Blown fuses on T-4 and T-8 were replaced.
- On 7/20/00, run times on air samplers T-4, T-8 and T-27 showed greater than 1.7 hours difference between elapsed time and timer readings. T-8 and T-27 restarted without problems. T-4 had to have transformer fuse replaced by line crew.
- Particulate filter on air sampler T-2 found with tiny holes in it on 7/20/00. Filter replaced and inspected closely after vacuum check. Sample T-4 provided backup for the required site perimeter air samplers..
- On 7/20/00, Untreated Surface Water compositor at T-22 found with line plugged with algae. Grab sample was taken after the tubing was replaced.
- Vandalism suspected when four annual/quarterly TLDs were missing on 7/21/00. Replacement TLDs were installed 8-10 feet above the ground at locations T-19, T-150, T-155 and T-204.
- TLDs at T-67 were found in cage on ground on 7/21/00. Replacement TLDs were installed at the proper level.
- On 8/23/00, T-11 air sampler could not achieve proper flow on restart. Pump replaced.

- On 8/23/00, T-3 air sampler had faulty timer, which was replaced.
- T-3 air sampler was found not running on 9/27/00, but had power. Pump replaced.
- On 10/4/00, Air sampler at T-2 showed greater than 1.7 hours difference between timer and elapsed time. Pump changed; defective timer replaced.
- Maintenance on intake at Port Clinton (T-11, Untreated Surface Water) caused loss of composite sample on 10/10/00. A grab sample was obtained from opposite intake wetwell, and compositor relocated to that side.
- On 10/10/00, Air sampler T-4 showed difference of greater than 1.7 hours between timer and elapsed time. Storms may have caused short power outage. Pump restarted and verified operating 26 hours later.
- Collection of wild meat samples was attempted for both muskrat and deer. No muskrats were trapped, and deer samples collected by the Ottawa National Wildlife Refuge were not sufficient for analysis.

Atmospheric Monitoring

Air Samples

Environmental air sampling is conducted to detect any increase in the concentration of airborne radionuclides that may be inhaled by humans or serve as an external radiation source. Inhaled radionuclides may be absorbed from the lungs, gastrointestinal tract, or from the skin. Air samples collected by the Davis-Besse REMP include both **airborne particulates** and **airborne radioiodine**.

Samples are collected weekly with low volume vacuum pumps which draw a continuous sample through a glass fiber filter and charcoal cartridge at a rate of approximately one cubic foot per minute. Airborne particulate samples are collected on 47 mm diameter filters. Charcoal cartridges are installed downstream of the particulate filters to sample for the airborne radioiodine.

The airborne samples are sent to an offsite contractor laboratory for analysis. At the laboratory, the airborne particulate filters are stored for 72 hours before they are analyzed to allow for the decay of naturally occurring short-lived radionuclides. However, due to the short half-life of iodine-131 (approximately eight days), the airborne radioiodine cartridges are analyzed upon receipt by the contractor laboratory.

Airborne Particulates

Davis-Besse continuously samples air for airborne radionuclides at ten locations. There are six indicator locations including four around the site boundary (T-1, T-2, T-3, and T-4), one at Sand Beach (T-7), and another at a local farm (T-8). There are four control locations, Oak Harbor (T-9), Port Clinton (T-11), Toledo (T-12) and Crane Creek (T-27). Gross beta analysis is performed on each of the weekly samples. Each quarter, the filters from each location are combined (composite) and analyzed for gamma emitting radionuclides, strontium-89 and strontium-90. Beta-emitting radionuclides were detected at the indicator and control locations at average concentration of 0.024 pCi/m³ and 0.025 pCi/m³, respectively. Beryllium-7 was the only gamma emitting radionuclide detected by the gamma spectroscopic analysis of the quarterly composites.

Beryllium-7 is a naturally occurring radionuclide produced in the upper atmosphere by cosmic radiation. No other gamma emitting radionuclides were detected above their respective LLDs. Strontium-89 (Sr-89) and Strontium-90 (Sr-90) were not detected above their LLDs. These results show no adverse change in radioactivity in air samples due to operation of the Davis-Besse Nuclear Power Station in 2000.

Airborne Iodine-131

Airborne iodine-131 samples are collected at the same ten locations as the airborne particulate samples. Charcoal cartridges are placed downstream of the particulate filters. These cartridges are collected weekly, sealed in separate collection bags and sent to the laboratory for gamma spectral analysis. In all of the samples collected in 2000, there was no detectable iodine-131 above the LLD of 0.07 pCi/m³.

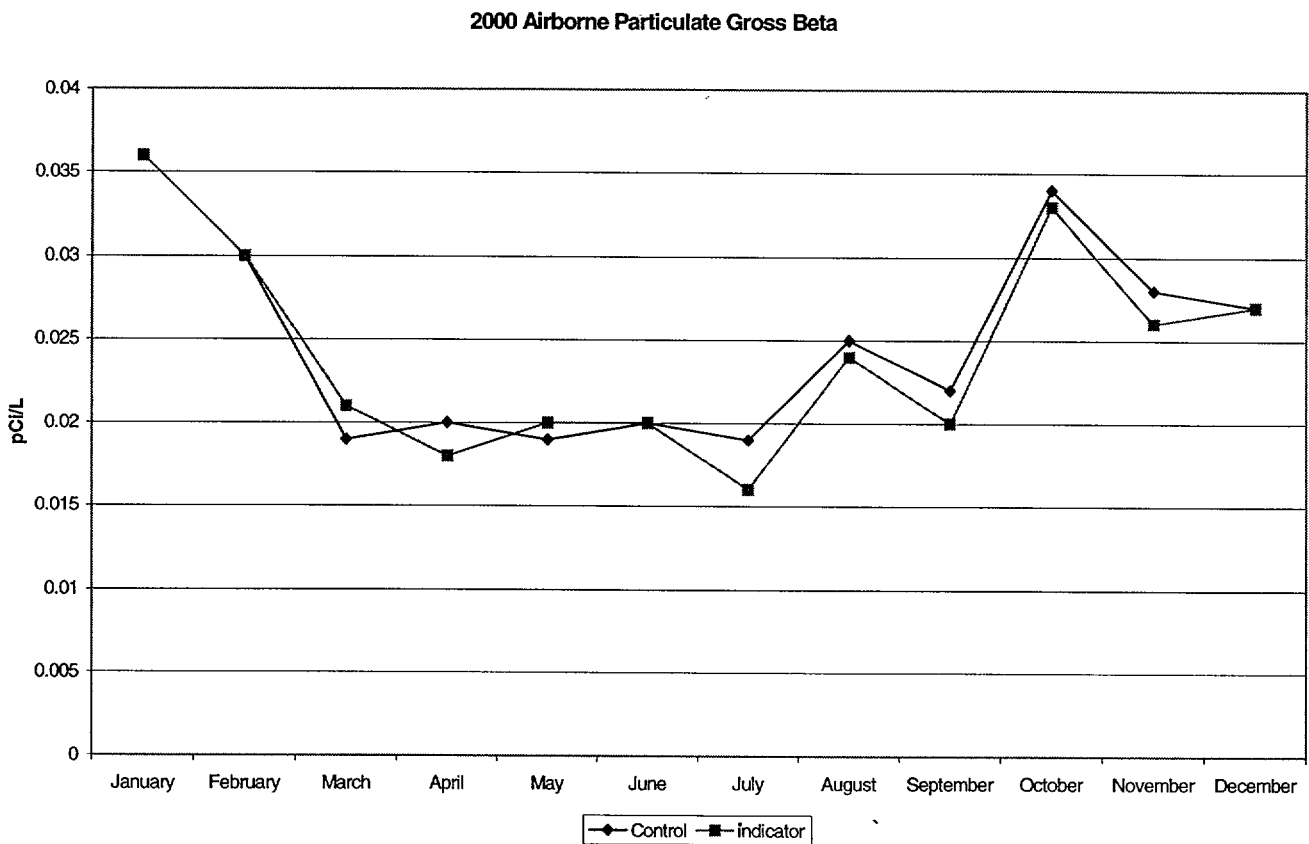

Figure 10: Concentrations of beta-emitting radionuclides in airborne particulate samples were nearly identical at indicator and control locations.

Table 5: Air Monitoring Locations

Sample Location Number	Type of Location	Location Description
T-1	I	Site boundary, 0.6 miles ENE of Station
T-2	I	Site boundary, 0.9 miles E of Station
T-3	I	Site boundary, 1.4 miles ESE of Station
T-4	I	Site boundary, 0.8 miles S of Station
T-7	I	Sand Beach, main entrance, 0.9 miles NW of Station
T-8	I	Earl Moore Farm, 2.7 miles WSW of Station
T-9	C	Oak Harbor Substation, 6.8 miles SW of Station
T-11	C	Port Clinton Water Treatment Plant, 9.5 miles SE of Station
T-12	C	Toledo Water Treatment Plant, 23.5 miles WNW of Station
T-27	C	Crane Creek State Park, 5.3 miles WNW of Station

I = Indicator C = Control

DAVIS-BESSE NUCLEAR POWER STATION RADIOLOGICAL ENVIRONMENTAL MONITORING PROGRAM

AIR SAMPLES: SITE

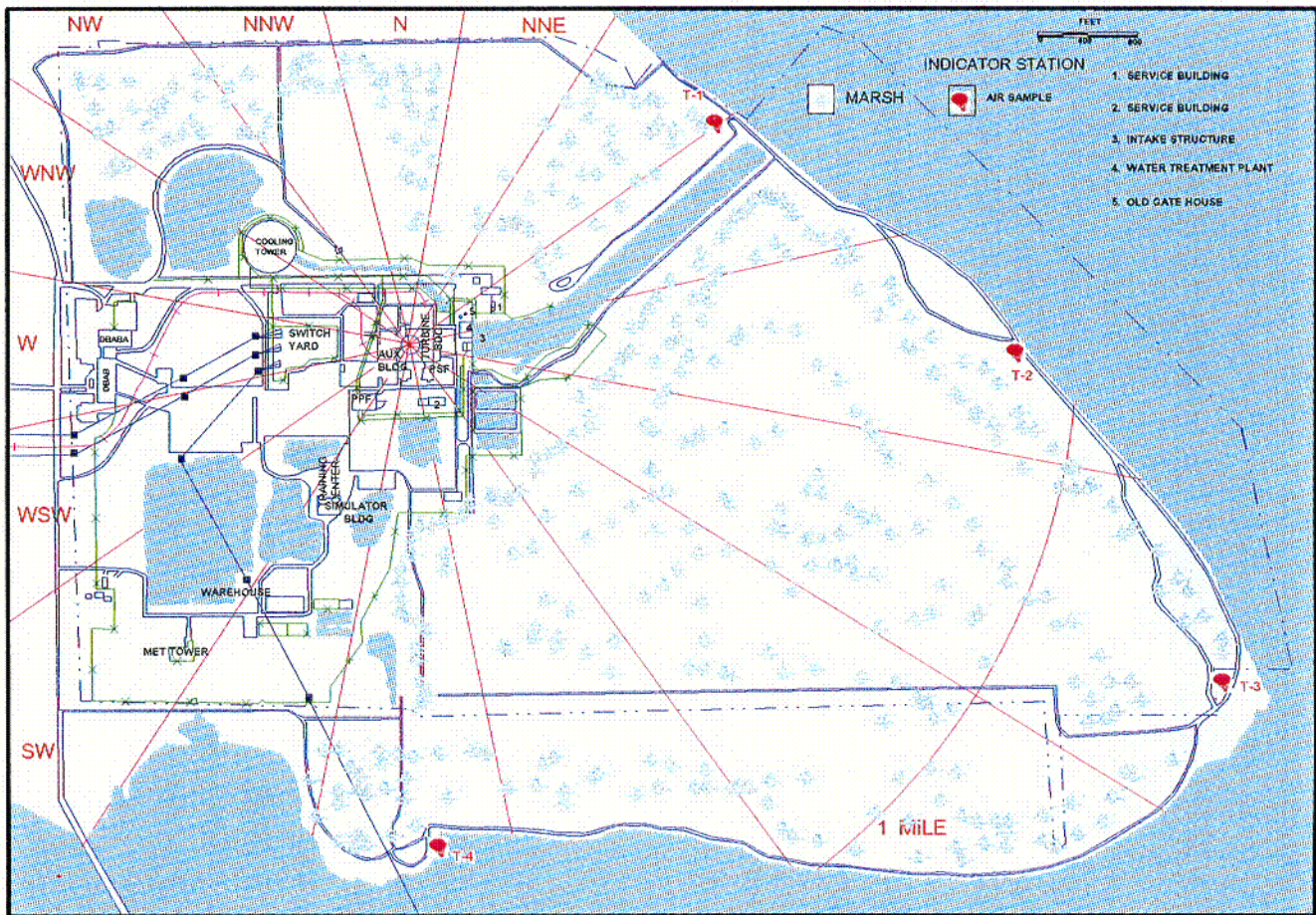

ENVIRONMENTAL MONITORING

Figure 11: Air Sample Site Map

**DAVIS-BESSE NUCLEAR POWER STATION
RADIOLOGICAL ENVIRONMENTAL MONITORING PROGRAM
AIR SAMPLES: 5 MILES RADIUS**

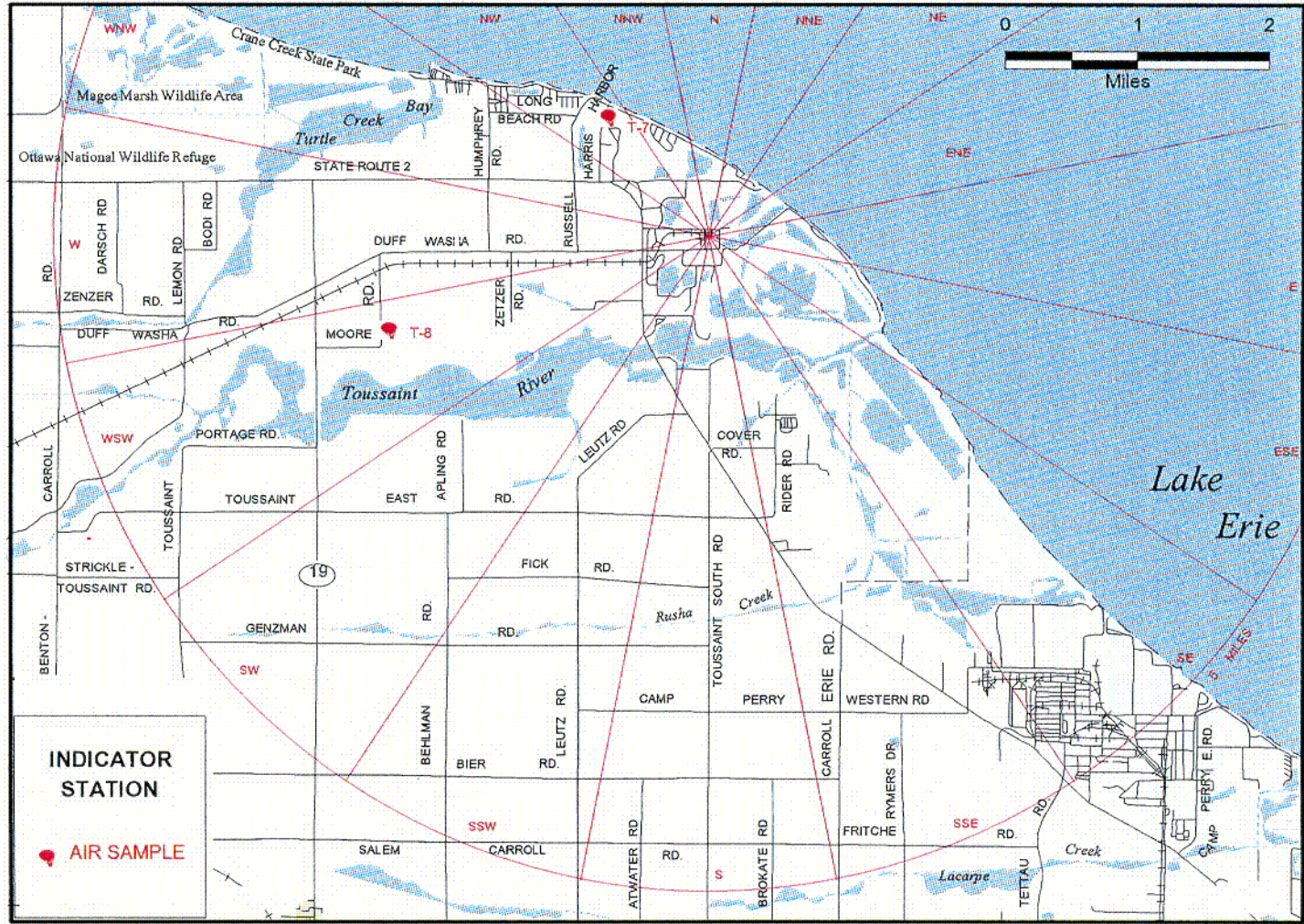

ENVIRONMENTAL MONITORING

Figure 12: Air Sample 5-mile Map

**DAVIS-BESSE NUCLEAR POWER STATION
RADIOLOGICAL ENVIRONMENTAL MONITORING PROGRAM
AIR SAMPLES: 5-25 MILE RADIUS**

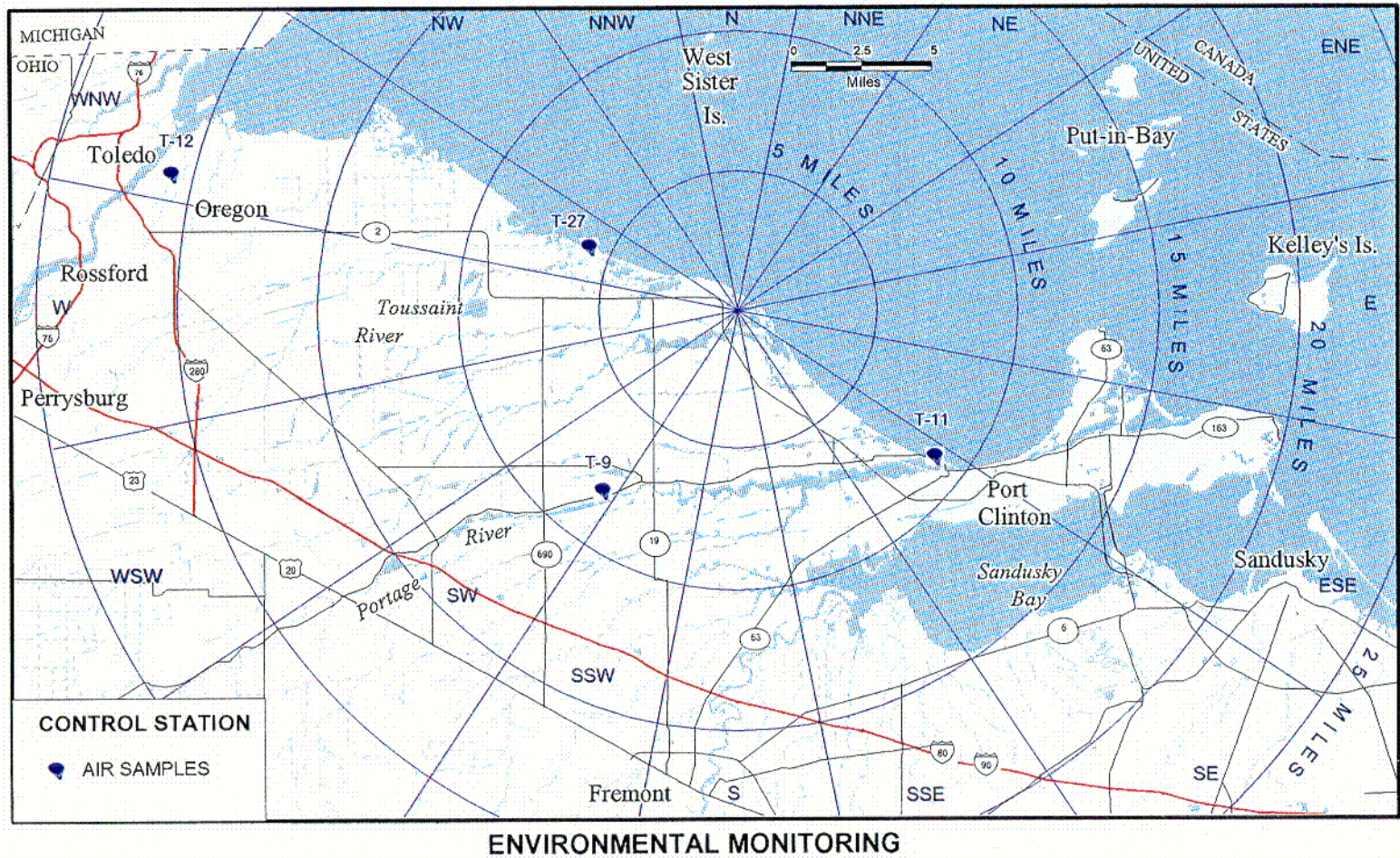

Figure 13: Air Sample 25-mile Map

CO4

Terrestrial Monitoring

The collection and analysis of groundwater, milk, meat, fruits and broad leaf vegetation provides data to assess the buildup of radionuclides that may be ingested by humans. Animal and wildlife feed samples provide additional information on radionuclides that may be present in the food chain. The data from soil sampling provides information on the deposition of radionuclides from the atmosphere.

Many radionuclides are present in the environment due to sources such as cosmic radiation and fallout from nuclear weapons testing. Some of the radionuclides present are:

- **tritium**, present as a result of the interaction of cosmic radiation with the upper atmosphere and as a result of routine release from nuclear facilities
- **beryllium-7**, present as a result of the interaction of cosmic radiation with the upper atmosphere
- **cesium-137**, a man-made radionuclide which has been deposited in the environment, (for example, in surface soils) as a result of fallout from nuclear weapons testing and routine releases from nuclear facilities
- **potassium-40**, a naturally occurring radionuclide normally found throughout the environment (including humans)
- **fallout radionuclides** from nuclear weapons testing, including strontium-89, strontium-90, cesium-137, cerium-141, cerium-144, and ruthenium-106. These radionuclides may also be released in minute amounts from nuclear facilities

The radionuclides listed above are expected to be present in many of the environmental samples collected in the vicinity of the Davis-Besse Station. The contribution of radionuclides from the operation of Davis-Besse is assessed by comparing sample results with preoperational data, operational data from previous years, control location data, and the types and amounts of radioactivity normally released from the Station in liquid and gaseous effluents.

Milk Samples

Milk sampling is a valuable tool in environmental surveillance because it provides a direct basis for assessing the build up of radionuclides in the environment that may be ingested by humans. Milk is collected and analyzed because it is one of the few foods commonly consumed soon after production. The milk pathway involves the deposition of radionuclides from atmospheric releases onto forage consumed by cows. The radionuclides present in the forage-eating cow become incorporated into the milk, which is then consumed by humans.

When available, milk samples are collected at indicator and control locations once a month from November through April, and twice a month between May and October. Sampling is increased in the summer when the herds are usually outside on pasture and not on

stored feed. In December of 1993, indicator location T-8 was eliminated from the sampling program. The family at this location sold the herd, and no other indicator milk site has existed since that time. The control location will continue to be sampled monthly in order to gather additional baseline data. If any dairy animals are discovered within five miles of the station, efforts will be made to include them in the milk-sampling program as indicator sites.

The 2000 milk samples were analyzed for strontium-89, strontium-90, iodine-131 and other gamma emitting radionuclides, stable calcium and potassium. A total of 12 milk samples were collected in 2000. Strontium-89 was not detected above its LLD. Strontium-90 was detected in all but one sample collected. The annual average concentration of strontium-90 was 0.84 pCi/l. For all sample sites, the annual average concentration was similar to those measured in the previous years.

Iodine-131 was not detected in any of the milk samples above the LLD of 0.38 pCi/l. The concentrations of barium-140 and cesium-137 were below their respective LLDs in all samples collected.

Since the chemistries of calcium and strontium are similar, as are potassium and cesium, organisms tend to deposit cesium radioisotopes in muscle tissue and strontium radioisotopes in bones. In order to detect the potential environmental accumulation of these radionuclides, the ratios of the strontium radioisotopes radioactivity (pCi/l) to the concentration of calcium (g/l), and cesium radioisotopes radioactivity (pCi/l) to the concentration of potassium (g/l) were monitored in milk. These ratios are compared to standard values to determine if build up is occurring. No statistically significant variations in the ratios were observed.

Table 6: Milk Monitoring Location

Sample Location Number	Type of Location	Location Description
T-24	C	Toft Dairy, Sandusky, 21.0 miles SE of Station

C = Control

Groundwater Samples

Soil acts as a filter and an ion exchange medium for most radionuclides. However, tritium and other radionuclides such as ruthenium-106 have a potential to seep through the soil and could reach groundwater. Davis-Besse does not discharge its liquid effluents directly to the ground. In the past, REMP personnel sampled local wells on a quarterly basis to ensure early detection of any adverse impact on the local groundwater supplies due to Station operation. In addition, a quality control sample was collected at one of the wells each quarter. The groundwater samples were analyzed for beta emitting radionuclides, tritium, strontium-89, strontium-90 and gamma emitting radionuclides.

During the fall of 1998, the Carroll Township Water Plant was placed into operation, and offered residents a reliable source of high-quality, inexpensive drinking water. This facility has replaced all of the wells within five miles of Davis-Besse, as verified by the Ottawa County Health Department. The last indicator location sample was taken during the first quarter of 1999. One Control location is still sampled quarterly at T-27, and it averaged <2.7 pCi/l for the year 2000. There were no tritium, Strontium-89, Strontium-90 or gamma-emitting radionuclides above their respective detection limits in any of the samples collected.

Gross Beta Ground Water 1982-2000

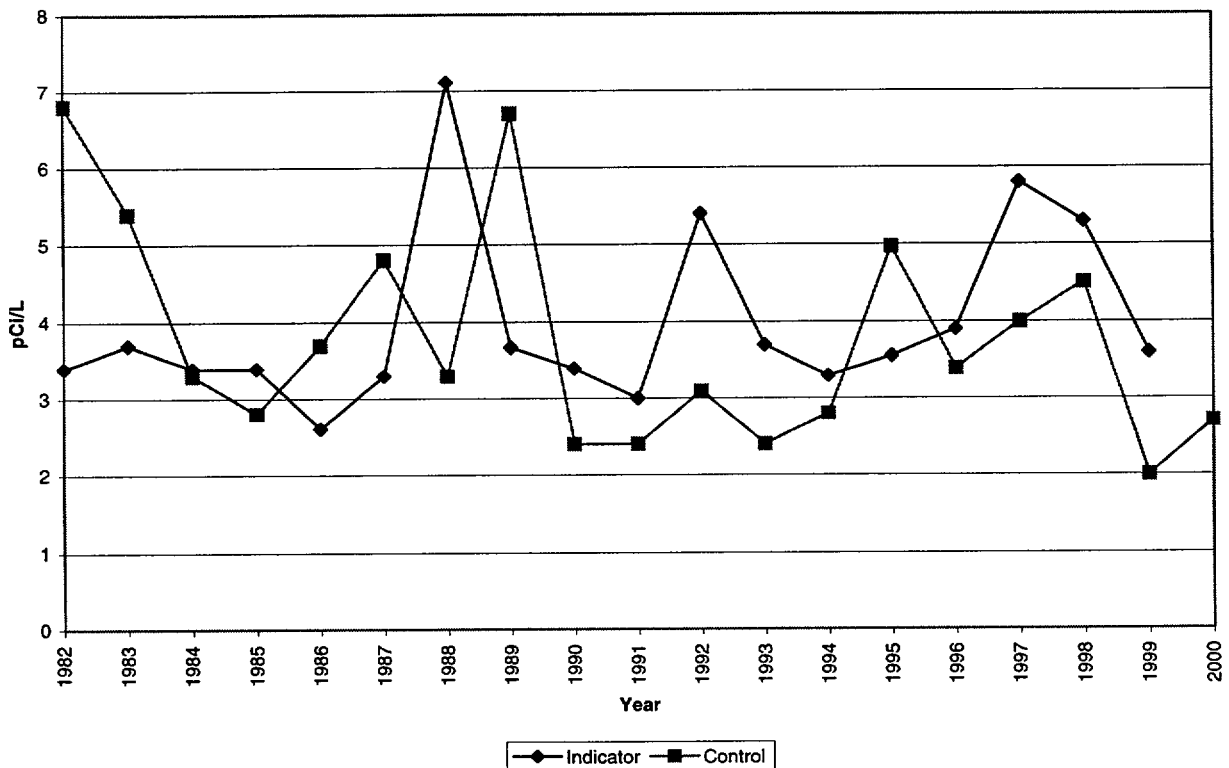

Figure 14: Shown above are the annual averages for gross beta in groundwater from 1982 - 2000.

Table 7: Groundwater Monitoring Locations

Sample Location Number	Type of Location	Location Description
T-27	C	Crane Creek State Park, 5.3 miles WNW of Station

C = control

Broadleaf Vegetation and Fruit Samples

Fruits and broadleaf vegetation also represent a direct pathway to humans. Fruits and broadleaf vegetation may become contaminated by deposition of airborne radioactivity (nuclear weapons fallout or airborne releases from nuclear facilities) or from irrigation water drawn from lake water receiving liquid effluents (hospitals, nuclear facilities, etc.). Radionuclides from the soil may be absorbed by the roots of the plants and become incorporated into the edible portions. During the growing season, edible broadleaf vegetation, such as kale and cabbage, and fruit, such as apples, are collected from farms in the vicinity of Davis-Besse.

In 2000, broadleaf vegetation samples were collected at two indicator locations (T-17 and T-19) and one control location (T-37). Fruit samples were collected at two indicator locations (T-8 and T-25) and one control location (T-209). Broadleaf vegetation was collected once per month during the growing season. Broadleaf vegetation consisted of cabbage. The fruit collected was apples. All samples were analyzed for gamma emitting radionuclides, strontium-89, strontium-90, and iodine-131.

Iodine-131 was not detected above the LLD of 0.011 pCi/g (wet) in any broadleaf vegetation nor above the LLD of 0.015 pCi/g (wet) in fruit samples. The only gamma-emitting radionuclide detected in the fruit and broadleaf vegetation samples was potassium-40, which is naturally occurring. In broadleaf vegetation, strontium-90 (Sr-90) was detected at average concentrations of 0.005 pCi/g (wet) for indicator locations and below the LLD of 0.005 pCi/g (wet) for control locations. In the fruit samples, Sr-90 was detected at 0.002 and 0.001 pCi/g (wet) at indicator sites T-8 and T-25, and was not detected at control site T-209. Results of broadleaf vegetation and fruit samples were similar to results observed in previous years. The operation of Davis-Besse had no observable adverse radiological effect on the surrounding environment in 2000.

Table 8: Broadleaf Vegetation and Fruit Locations

Sample Location Number	Type of Location	Location Description
T-8	I	Moore Farm, 2.7 miles WSW of Station
T-17	I	J. Sobieralski , 1.8 miles SSE of Station
T-19	I	B. Skinner, 1.0 mile W of Station
T-25	I	Witt Farm, 1.6 miles south of Station
T-37	C	Bench Farm, 13.0 miles SW of Station
T-209	C	Roving Control Location

I = indicator, C = control

Animal/Wildlife Feed Samples

As with broadleaf vegetation and fruit samples, samples of domestic animal feed, as well as vegetation consumed by wildlife, provide an indication of airborne radionuclides deposited in the vicinity of the Station. Analyses of animal/wildlife feed samples also provide data for determining radionuclide concentration in the food chain. Domestic animals feed samples are collected at two domestic meat-sampling locations. Wildlife feed samples are collected from the Navarre Marsh and from a local marsh within five miles of the Station. As in all terrestrial samples, naturally occurring potassium-40, cosmic ray-produced radionuclides such as beryllium-7, and fallout radionuclides from nuclear weapons testing may be present in the feed samples.

There is one indicator location (T-197) and one control location (T-34). The feed collected was chicken feed. All samples were analyzed for gamma-emitting radionuclides.

Wildlife feed was collected annually at three locations (T-31, T-32 and T-198). The samples consisted of the edible portions of cattails and smartweed. Samples were analyzed for gamma-emitting radionuclides.

In both the animal and wildlife feed, naturally occurring potassium-40 was detected. Beryllium-7 was detected at T-31 and T-32. All other radionuclides were below their respective LLDs. The operation of Davis-Besse had no adverse effect on the surrounding environment.

Table 9: Animal/Wildlife Feed Locations

Sample Location Number	Type of Location	Location Description
T-31	I	Davis-Besse, onsite roving location
T-32	C	Metzer Marsh, 10.0 miles WNW of the Station
T-34	C	Hemminger residence, 9 miles W of the Station
T-197	I	Lochotzki residence 4.0 miles W of the Station Lemon Road
T-198	I	Toussaint Creek Wildlife Area 4.0 miles WSW of the Station

I = indicator C = control

Wild and Domestic Meat Samples

Sampling of domestic and wild meat provides information on environmental radionuclide concentrations that humans may be exposed to through an ingestion pathway. The principle pathways for radionuclide contamination of meat animals include deposition of airborne radioactivity in their food and drinking water and contamination of their drinking water from radionuclides released in liquid effluents.

The REMP generally collects wild meat and domestic meat (chicken) on an annual basis. Wild animals commonly consumed by residents in the vicinity of Davis-Besse include waterfowl, deer, rabbits and muskrats. Analyses from these animals provide general information on radionuclide concentration in the food chain. When evaluating the results from analyses performed on meat animals, it is important to consider the age, diet and mobility of the animal before drawing conclusions on radionuclides concentration in the local environment or in a species as a whole.

Meat samples were taken in 2000 as follows:

- Domestic Meat: Chickens were collected at one indicator location (T-197) and one control location (T-34). The samples were analyzed for gamma emitting nuclides. Only naturally-occurring radionuclides were detected in the edible portion of the chicken.
- Wild Meat: Collection of wild meat samples was attempted (muskrat), but proved unsuccessful due to low population density of these animals on site. Venison samples were collected from deer during a controlled hunt both here (indicator) and at the Ottawa National Wildlife refuge, but the sample size was insufficient for analysis.

Table 10: Wild and Domestic Meat Locations

Sample Location Number	Type of Location	Location Description
T-31	I	Onsite roving location
T-34	C	Hemminger residence, Wallbridge Rd, 9 miles W of the Station
T-197	I	Lochotzki residence, 4.0 miles W of the Station Lemon Road
T-210	C	Roving offsite location

I = indicator C = control

Soil Samples

Soil samples are generally collected twice a year at the sites that are equipped with air samplers. Only the top layer of soil is sampled in an effort to identify possible trends in the local environmental nuclide concentration caused by atmospheric deposition of fallout and station-released radionuclides. Generally, the sites are relatively undisturbed, so that the sample will be representative of the actual deposition in the area. Ideally, there should be little or no vegetation present, because the vegetation could affect the results of analyses. Approximately five pounds of soil are taken from the top two inches at each site. Many naturally occurring radionuclides such as beryllium-7 (Be-7), potassium-40 (K-40) and fallout radionuclides from nuclear weapons testing are detected. Fallout radionuclides that are often detected include strontium-90 (Sr-90), cesium-137 (Cs-137), cerium-141 (Ce-141) and ruthenium-106 (Ru-106).

During 2000, soil was collected at ten sites in April and October. The indicator locations included T-1, T-2, T-3, T-4, T-7, and T-8. The control locations were T-9, T-11, T-12, and T-27. All soil samples were analyzed for gamma emitting radionuclides. The results show that the only gamma emitter detected in addition to naturally occurring Be-7 and K-40 was Cs-137. Cs-137 was found in both indicator and control locations at average concentrations of 0.11 pCi/g dry and 0.22 pCi/g dry, respectively. The concentrations were similar to that observed in previous years (Figure15).

Cs-137 in Soil 1972-2000

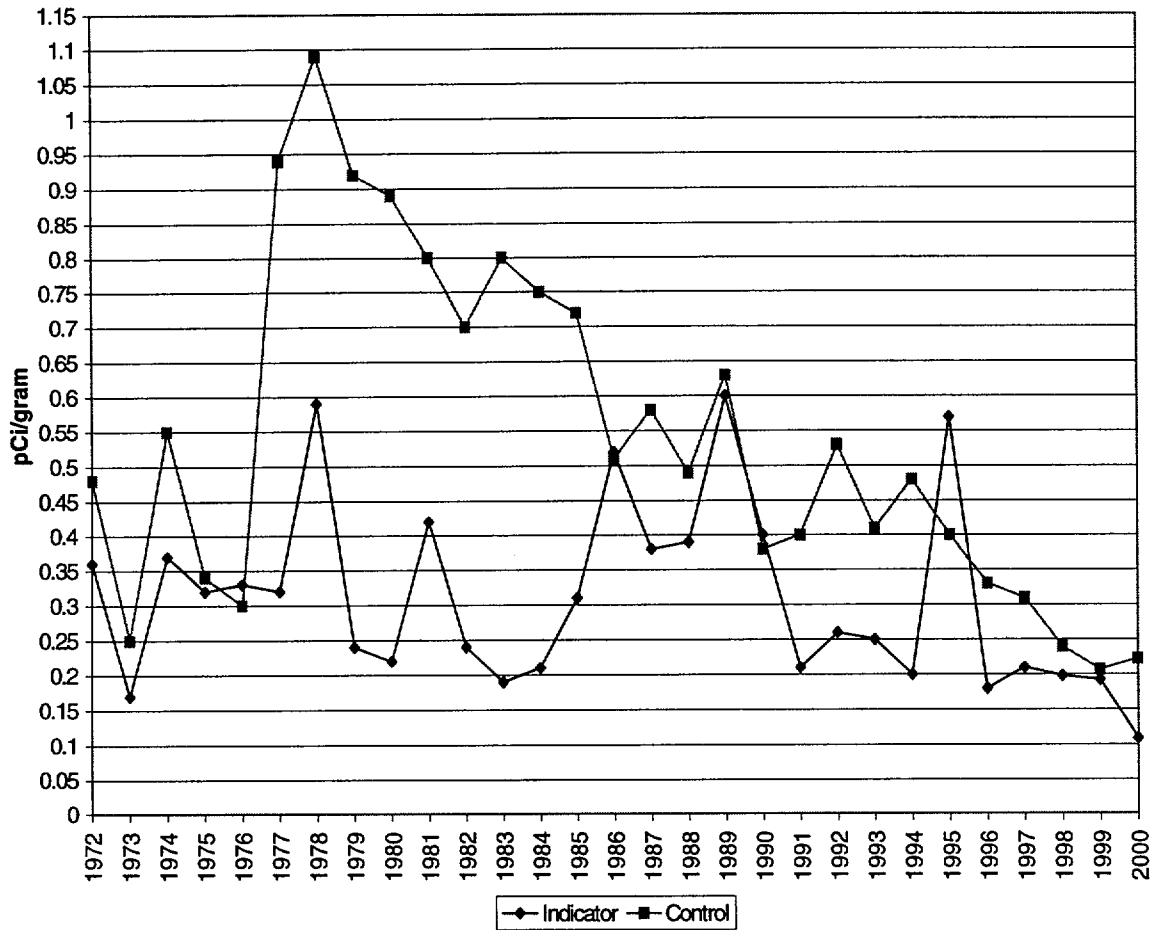

Figure 15: The concentration of cesium-137 in soil has remained fairly constant over the years REMP has been conducted. The peak seen in 1978 was due to fallout from nuclear weapons testing.

Table 11: Soil Locations

Sample Location Number	Type of Location	Location Description
T-1	I	Site boundary, 0.6 miles ENE of Station
T-2	I	Site boundary, 0.9 miles E of Station
T-3	I	Site boundary 1.4 miles ESE of Station
T-4	I	Site boundary 0.8 miles S of Station
T-7	I	Sand Beach, main entrance, 0.9 miles NW of Station
T-8	I	Moore Farm, 2.7 miles WSW of Station
T-9	C	Oak Harbor Substation, 6.8 miles SW of Station
T-11	C	Port Clinton Water Treatment Plant, 9.5 miles SE of Station
T-12	C	Toledo Water Treatment Plant, 23.5 miles WNW of Station
T-27	C	Crane Creek State Park, 5.3 miles WNW of Station

I = indicator C = control

DAVIS-BESSE NUCLEAR POWER STATION RADIOLOGICAL ENVIRONMENTAL MONITORING PROGRAM TERRESTRIAL SAMPLES: SITE

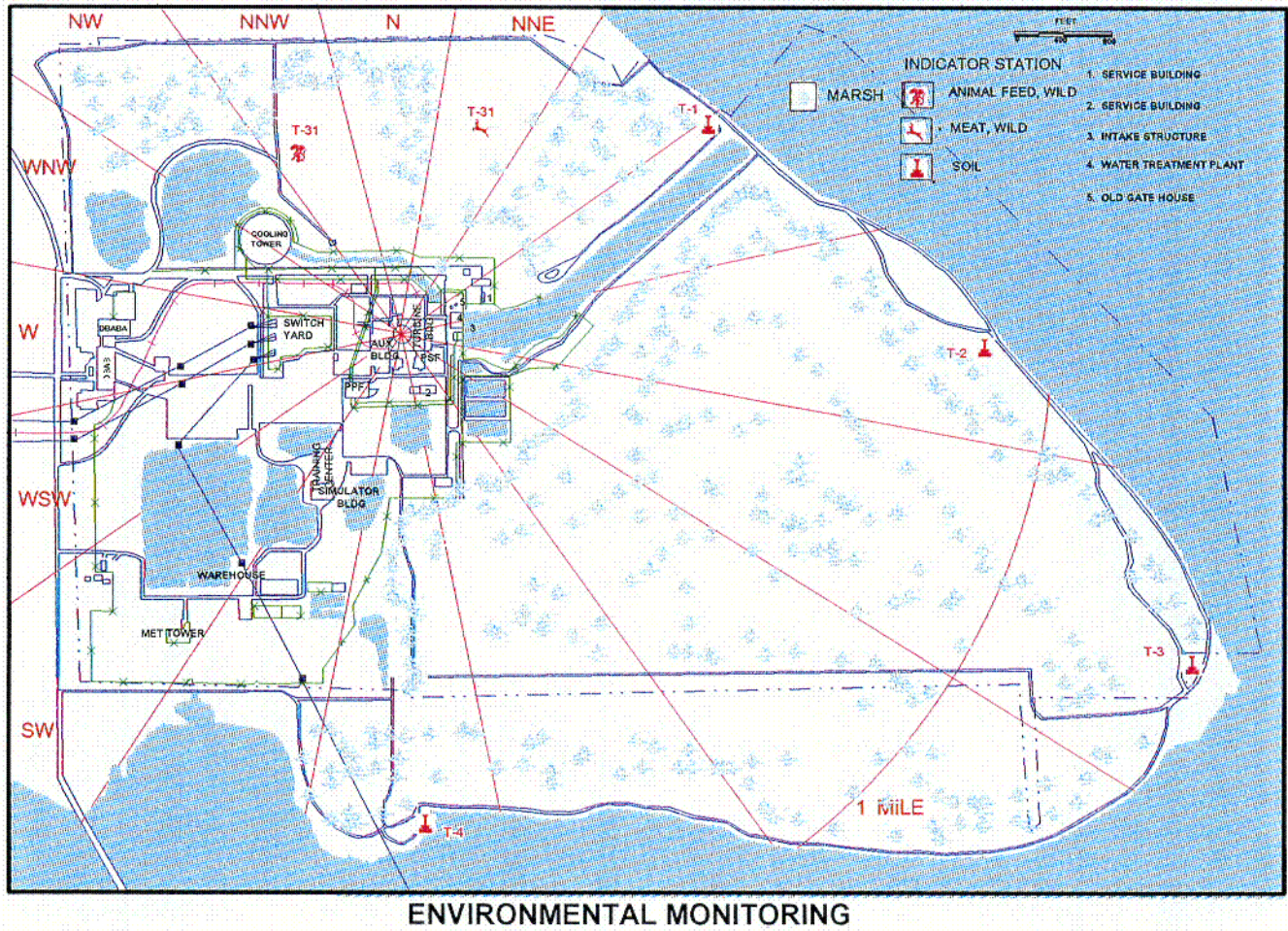
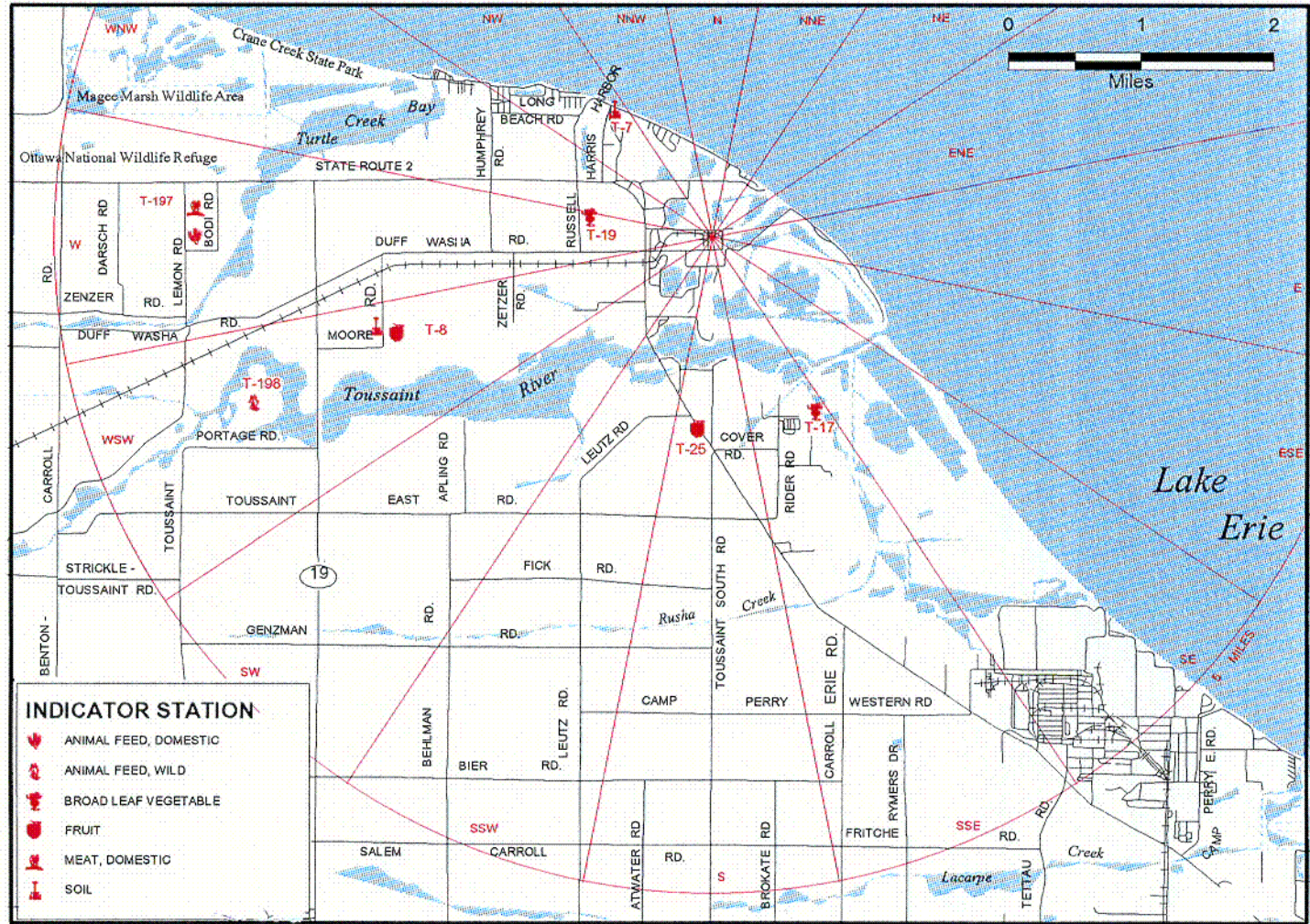

Figure 16: Terrestrial Site Map

**DAVIS-BESSE NUCLEAR POWER STATION
RADIOLOGICAL ENVIRONMENTAL MONITORING PROGRAM
TERRESTRIAL SAMPLES: 5 MILE RADIUS**



ENVIRONMENTAL MONITORING

Figure 17: Terrestrial 5-mile Map

DAVIS-BESSE NUCLEAR POWER STATION RADIOLOGICAL ENVIRONMENTAL MONITORING PROGRAM

TERRESTRIAL SAMPLES: 5-25 MILE RADIUS

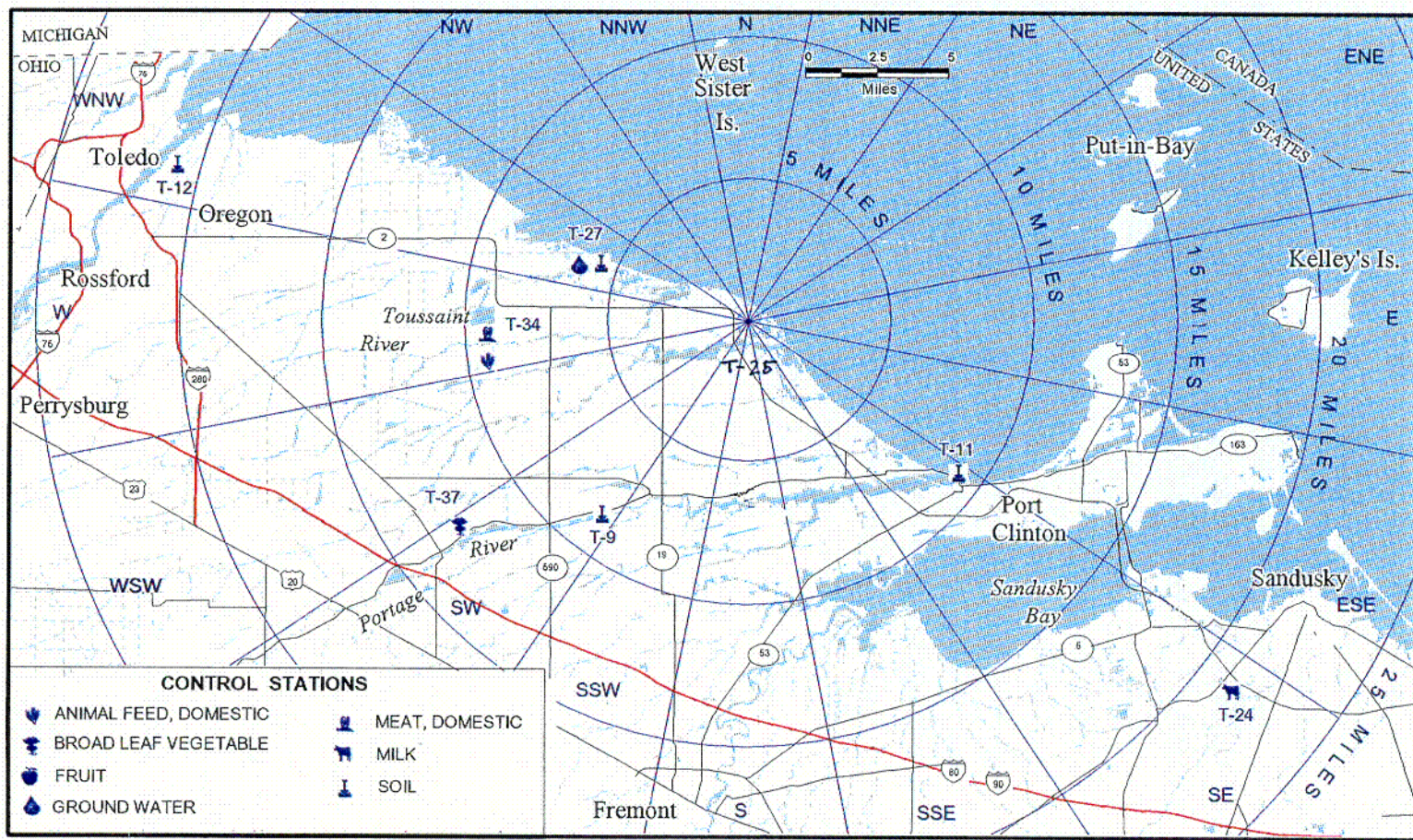

ENVIRONMENTAL MONITORING

Figure 18: Terrestrial 25-mile Map

Aquatic Monitoring

Radionuclides may be present in Lake Erie from many sources including atmospheric deposition, run-off/soil erosion, and releases of radioactive material in liquid effluents from hospitals or nuclear facilities. These sources provide two forms of potential exposure to radiation, external and internal. External exposure can occur from the surface of the water, shoreline sediments and from immersion (swimming) in the water. Internal exposure can occur from ingestion of radionuclides, either directly from drinking water, or as a result of the transfer of radionuclides through the aquatic food chain with eventual consumption of aquatic organisms, such as fish. To monitor these pathways, Davis-Besse samples treated surface water (drinking water), untreated surface water (lake or river water), fish, and shoreline sediments.

Treated Surface Water

Treated surface water is water from Lake Erie, which has been processed for human consumption. Radiochemical analysis of this processed water provides a direct basis for assessing the dose to humans from ingestion of drinking water.

Samples of treated surface water were collected from two indicators (T-22B and T-50) and two control locations (T-11 and T-12A). These locations include the water treatment facilities for Carroll Township, Erie Industrial Park, Port Clinton and Toledo. Samples were collected weekly and composited monthly. The monthly composites were analyzed for beta emitting radionuclides. The samples were also composited in a quarterly sample and analyzed for strontium-89, strontium-90, gamma emitting radionuclides, and tritium. One QC sample was collected from a routine location, which was changed each month.

The annual average of beta-emitting radionuclides for indicator and control locations was 2.45 pCi/l and 2.30 pCi/l, respectively. These results are similar to previous years as shown in Figure 19. Tritium was detected above the LLD of 330 pCi/l at one location during January, at T-22. The concentration at T-22 was 378 pCi/l. Strontium-89 was not detected above the LLD 1.3 pCi/l. Strontium-90 activity was not detected above its LLD of 1.0 pCi/l. These results are similar to those of previous years and indicate no adverse impact on the environment resulting from the operation of Davis-Besse in 2000.

Each month, weekly quality control samples were collected at different locations. The results of the analyses from the quality control samples were consistent with the routine samples. The average concentration of beta emitting radionuclides detected at the QC location was 2.4 pCi/l. There was good agreement between the routine and QC locations.

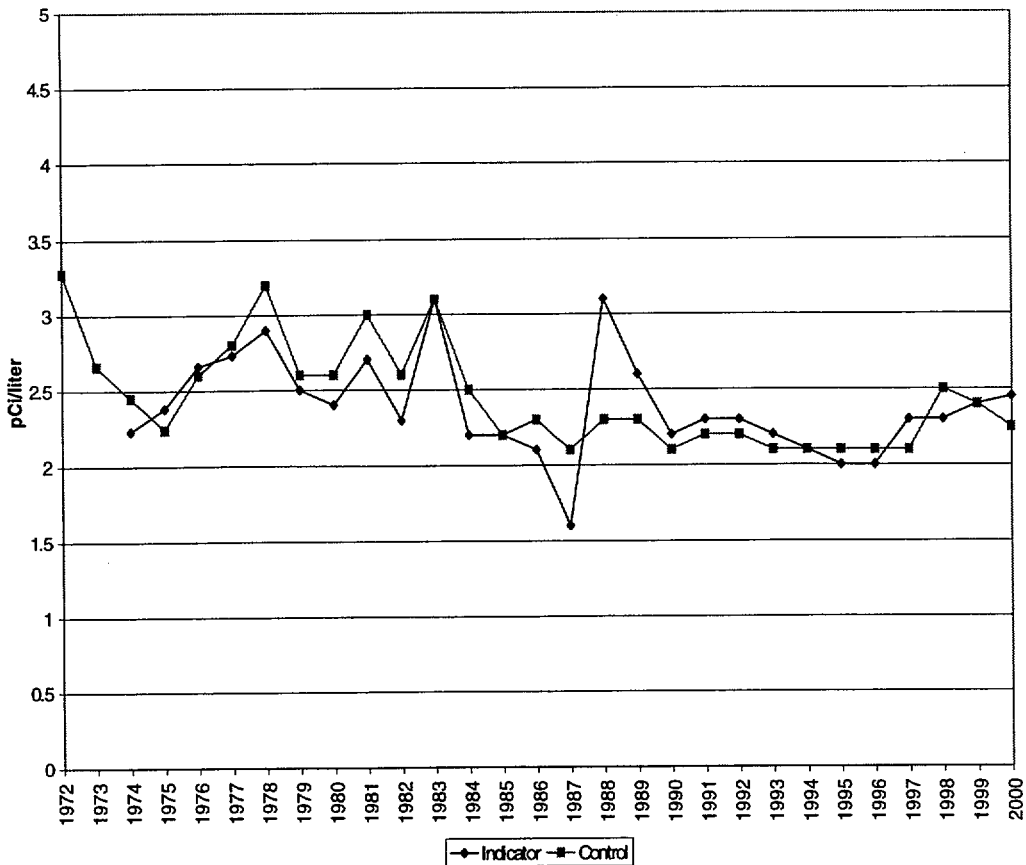

Figure 19: Since 1974, the annual concentrations of beta emitting radionuclides in treated surface water samples collected from indicator locations have been consistent with those from control locations. Davis-Besse has had no measurable radiological impact on surface water used to make drinking water.

Table 12: Treated Surface Water Locations

Sample Location Number	Type of Location	Location Description
T-11	C	Port Clinton Water Treatment Plant 9.5 miles SE of Station
T-12	C	Toledo Water Treatment Plant 23.5 miles WNW of Station
T-22B	I	Carroll Township water sampled at Davis-Besse
T-50	I	Erie Industrial Park, Port Clinton, 4.5 miles SE of Station
T-143	QC	Quality Control Site

I = indicator, C = control, QC = quality control

Untreated Surface Water

Sampling and analysis of untreated surface water provides a method of assessing the dose to humans from external exposure from the lake surface as well as immersion in the water. It also provides information on the radionuclides present which may affect drinking water, fish, and irrigated crops.

Routine Program

The routine program is the basic sampling program that is performed year round. Untreated water samples are collected from water intakes used by nearby water treatment plants. Routine samples are collected at Port Clinton, Toledo, Carroll Township Intake and Erie Industrial Park. A sample is also collected from Lake Erie at the mouth of the Toussaint River. These samples are collected weekly and composited monthly. The monthly composite is analyzed for beta emitting radionuclides, tritium, and gamma emitting radionuclides. The samples are composited further quarterly and analyzed for strontium-89 and strontium-90. A QC sample is also collected weekly. It is at a different location each month.

Summer Program

The summer program is designed to supplement the routine untreated water sampling program in order to provide a more comprehensive study during the months of high lake recreational activity, such as boating, fishing, and swimming. These samples are obtained in areas along the shoreline of Lake Erie. The samples are collected monthly and analyzed for beta emitting radioactivity, tritium, strontium-89, strontium-90 and gamma emitting radionuclides.

For the routine samples composited weekly, the beta emitting radionuclides had an average concentration of 3.18 pCi/l at indicator and 2.48 pCi/l at control locations, respectively. The average concentration of beta emitting radionuclides in lake water samples 3.62 pCi/indicator and 3.37 pCi/l at control locations.

During 2000, tritium was detected in 7 untreated surface water, ranging from 342 pCi/liter to 1078 pCi/liter. Six samples were indicator locations and one was a control location.

Cesium-137 was not detectable in samples of untreated water above the LLD of 9 pCi/l.

Gross Beta Concentration in Untreated Surface Water 1977-2000

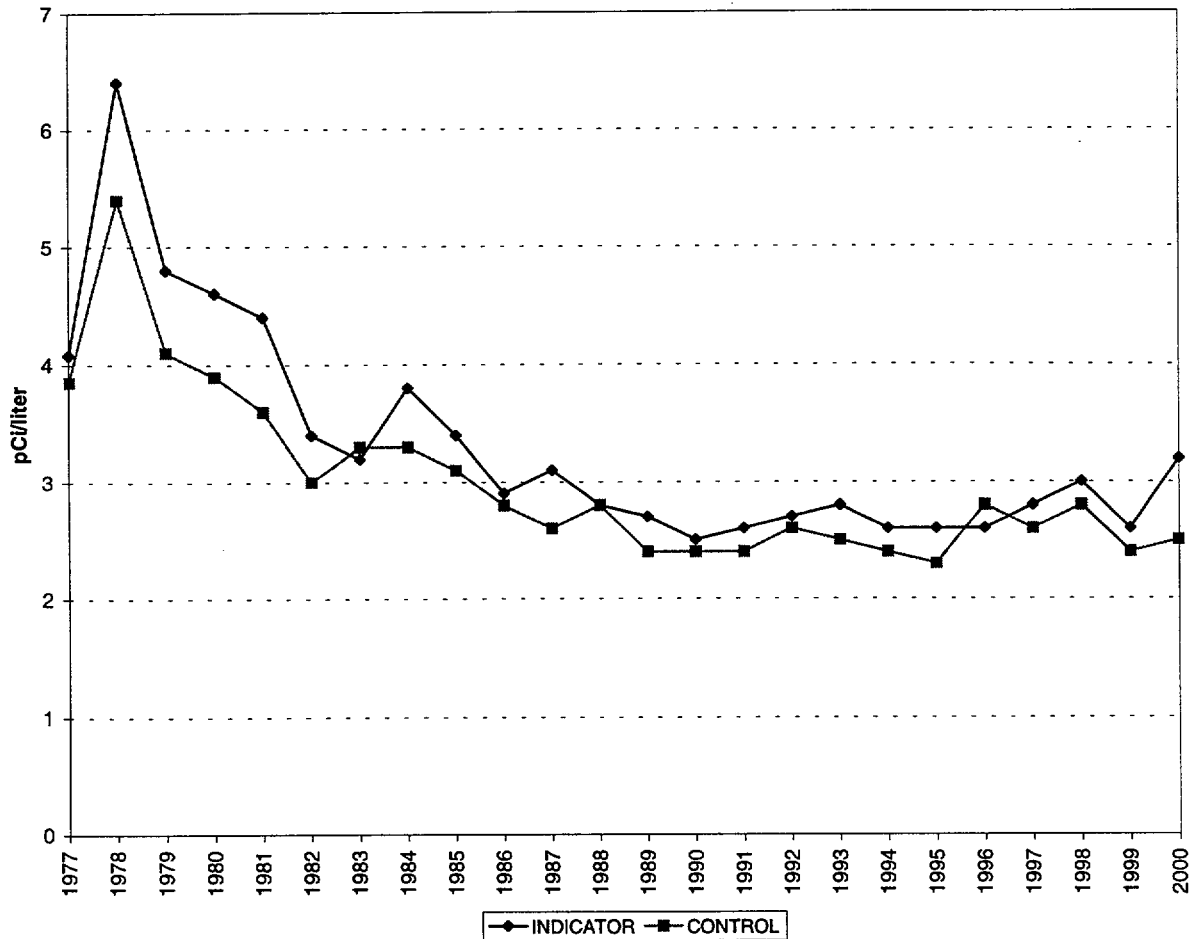

Figure 20: The average concentration of beta emitting radionuclides in untreated water was similar between control and indicator locations. This demonstrates that Davis-Besse had no radiological impact on the surrounding environment.

Each month, weekly quality control samples were collected at different locations. The results of the analyses from the quality control samples were consistent with the routine samples. The average concentration of beta emitting radionuclides detected at the QC location was 2.88 pCi/l and 2.90 pCi/l at routine locations. Tritium was detected in one sample at just above the LLD. Cesium-137 was not detected in any sample above its LLD. There was good agreement between the routine and QC locations.

Table 13: Untreated Surface Water Locations

Sample Location Number	Type of Location	Location Description
T-3	I	Site boundary, 1.4 miles ESE of Station
T-11	C	Port Clinton Water Treatment Plant, 9.5 miles SE of Station
T-12	C	Toledo Water Treatment Plant, sample taken from intake crib, 11.25 miles NW of Station
T-22A	I	Carroll Township Water Intake, Humphrey Rd., 3.0 miles NW of Station
T-50	I	Erie Industrial Park, Port Clinton, 4.5 miles SE of Station
T-132	I	Lake Erie, 1.0 miles E of Station
T-133	I	Lake Erie, 0.8 miles N of Station
T-137	C	Lake Erie, 5.8 miles WNW of Station
T-145	QC	Roving Quality Control Site
T-158	C	Lake Erie, 10.0 miles WNW of Station
T-162	C	Lake Erie, 5.4 miles SE of Station

I = indicator, C = control

Shoreline Sediment

The sampling of shoreline sediments can provide an indication of the accumulation of undissolved radionuclides which may lead to internal exposure to humans through the ingestion of fish, through resuspension into drinking water supplies, or as an external radiation source from shoreline exposure to fishermen and swimmers.

Samples of deposited sediments in water along the shore were collected at various times from three indicator sites (T-3, T-4, and T-132) and one control location (T-27). Shoreline sediment was collected with a shovel. All samples were analyzed for gamma emitting radionuclides. Naturally occurring potassium-40 was detected at both control and indicator locations. Cs-137 was not detected at any locations. These results are similar to previous years.

Table 14: Shoreline Sediment Locations

Sample Location Number	Type of Location	Location Description
T-3	I	Site boundary, 1.4 miles ESE of Station
T-4	I	Site boundary, 0.8 miles S of Station
T-27	C	Crane Creek State Park, 5.3 miles WNW of Station
T-132	I	Lake Erie, 1.0 miles E of Station

I = indicator C = control

Fish Sample

Fish are analyzed primarily to quantify the dietary radionuclide intake by humans, and secondarily to serve as indicators of radioactivity in the aquatic ecosystem. The principal nuclides which may be detected in fish include naturally occurring potassium-40, as well as cesium-137, and strontium-90. Depending upon the feeding habit of the species (e.g., bottom-feeder versus predator), results from sample analyses may vary.

With the aid of a local commercial fisherman, Davis-Besse routinely collects three species of fish (walleye, white perch or white bass and carp) once a year from sampling locations near the Station's liquid discharge point and more than ten miles away from the Station where fish populations would not be expected to be impacted by the Station operation. Walleye are collected because they are a popular sport fish and white perch or white bass are collected because they are an important commercial fish. Carp are collected because they are bottom feeders where contaminants may settle.

The average concentration of beta emitting radionuclides in fish was similar for indicator and control locations (2.74 pCi/g and 2.64 pCi/g wet weight, respectively). Cesium-137 was not detected above the LLD of <0.016 pCi/g for indicator and control locations. No other gamma emitters were detected above their respective LLDs.

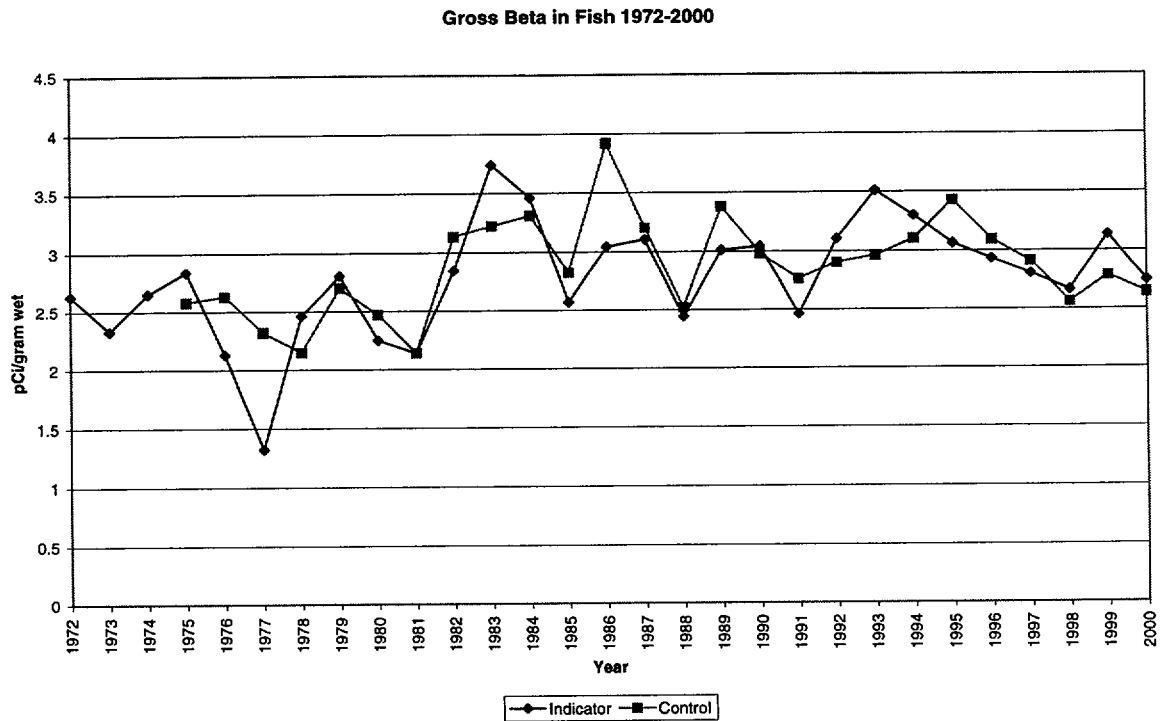

Figure 21: Average concentrations of beta emitting radionuclides in fish samples were similar at indicator and control locations and were within the range of results of previous years.

Table 15: Fish Locations

Sample Location Number	Type of Location	Location Description
T-33	I	Lake Erie, within 5 miles radius of Station
T-35	C	Lake Erie, greater than 10 mile radius of Station

I = indicator C= control

DAVIS-BESSE NUCLEAR POWER STATION RADIOLOGICAL ENVIRONMENTAL MONITORING PROGRAM AQUATIC SAMPLES: SITE

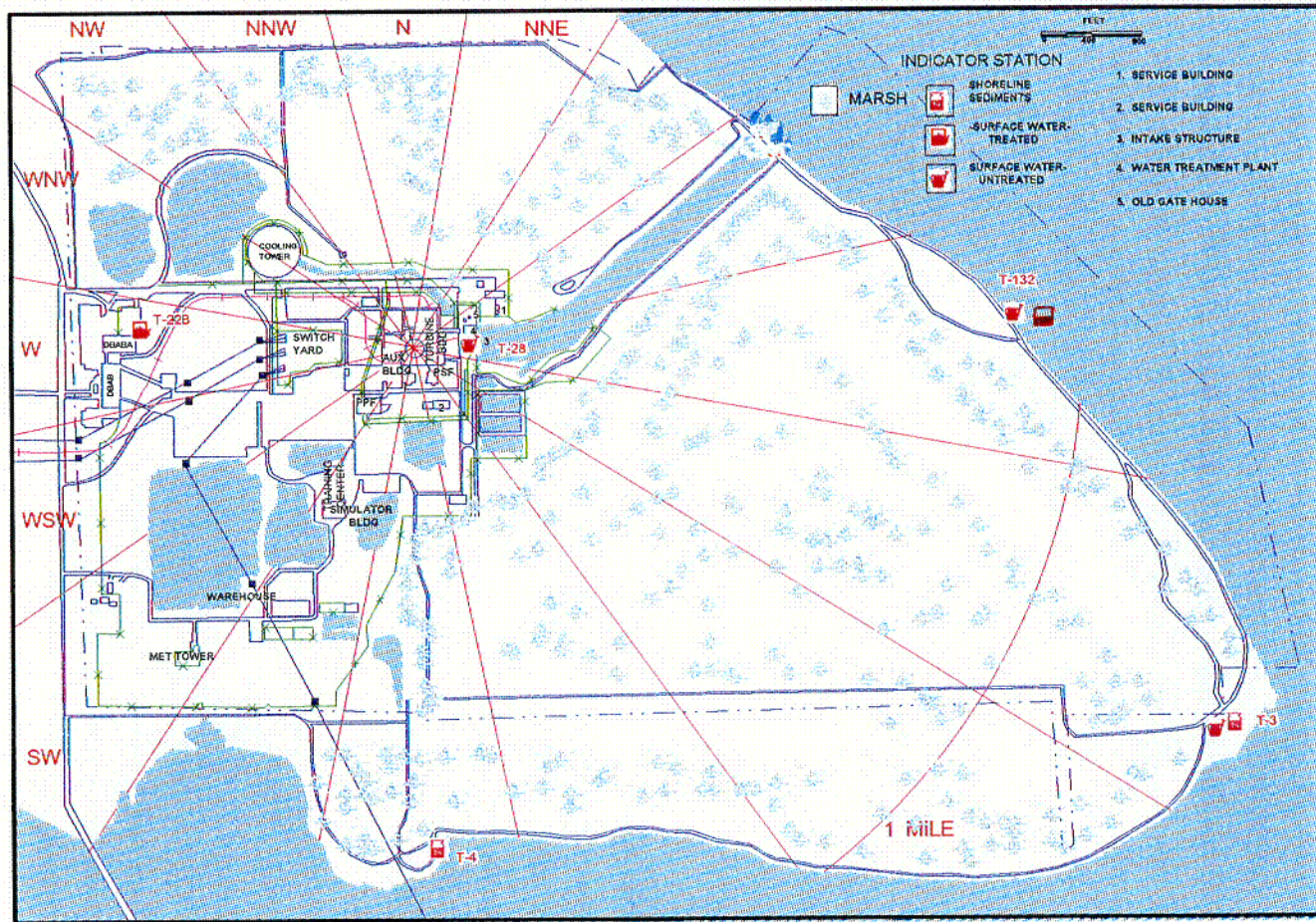
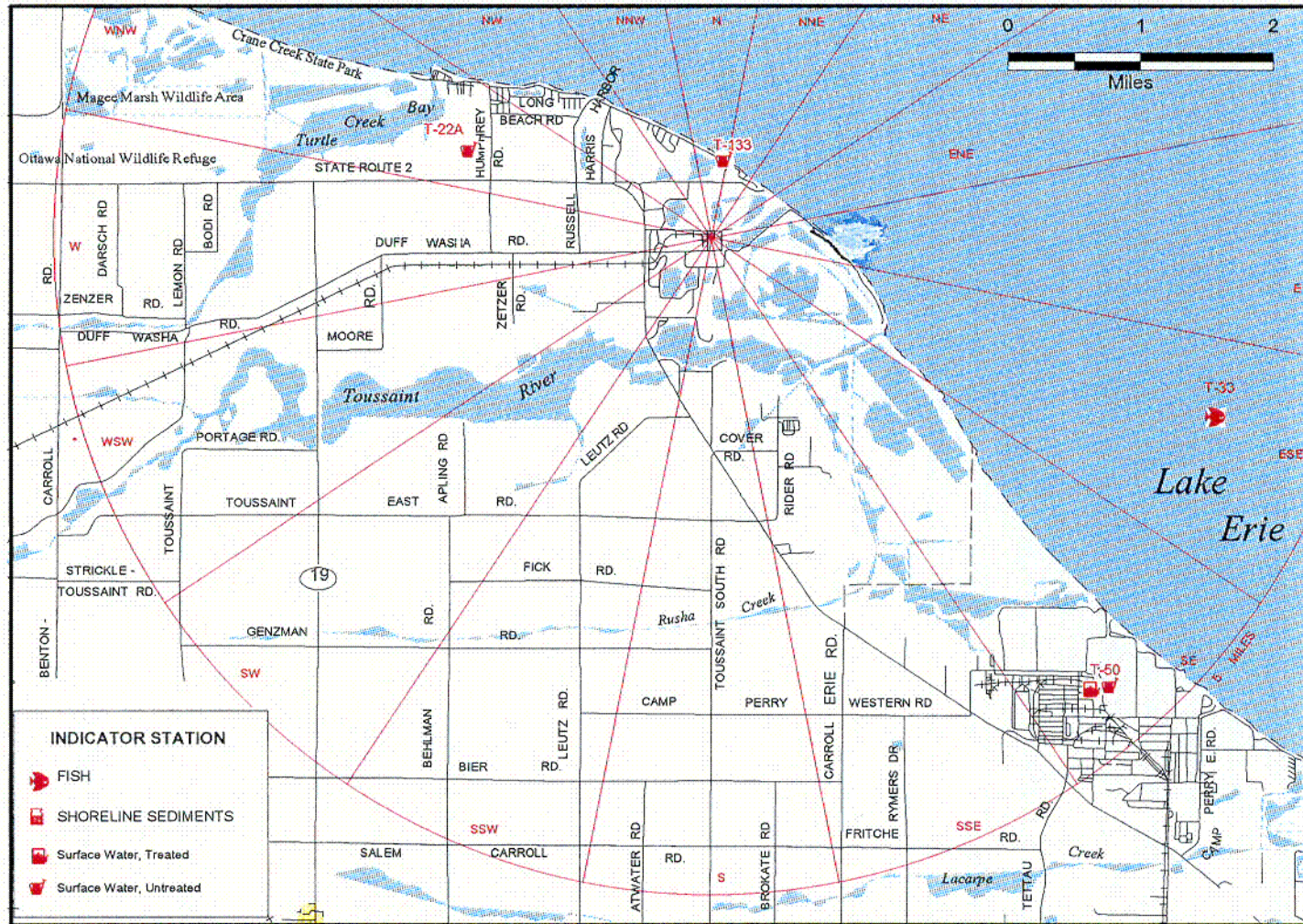

Figure 22: Aquatic Site Map

**DAVIS-BESSE NUCLEAR POWER STATION
RADIOLOGICAL ENVIRONMENTAL MONITORING PROGRAM
AQUATIC SAMPLES: 5 MILE RADIUS**



ENVIRONMENTAL MONITORING

Figure 23: Aquatic 5-mile Map

**DAVIS-BESSE NUCLEAR POWER STATION
RADIOLOGICAL ENVIRONMENTAL MONITORING PROGRAM
AQUATIC SAMPLES: 5-25 MILE RADIUS**

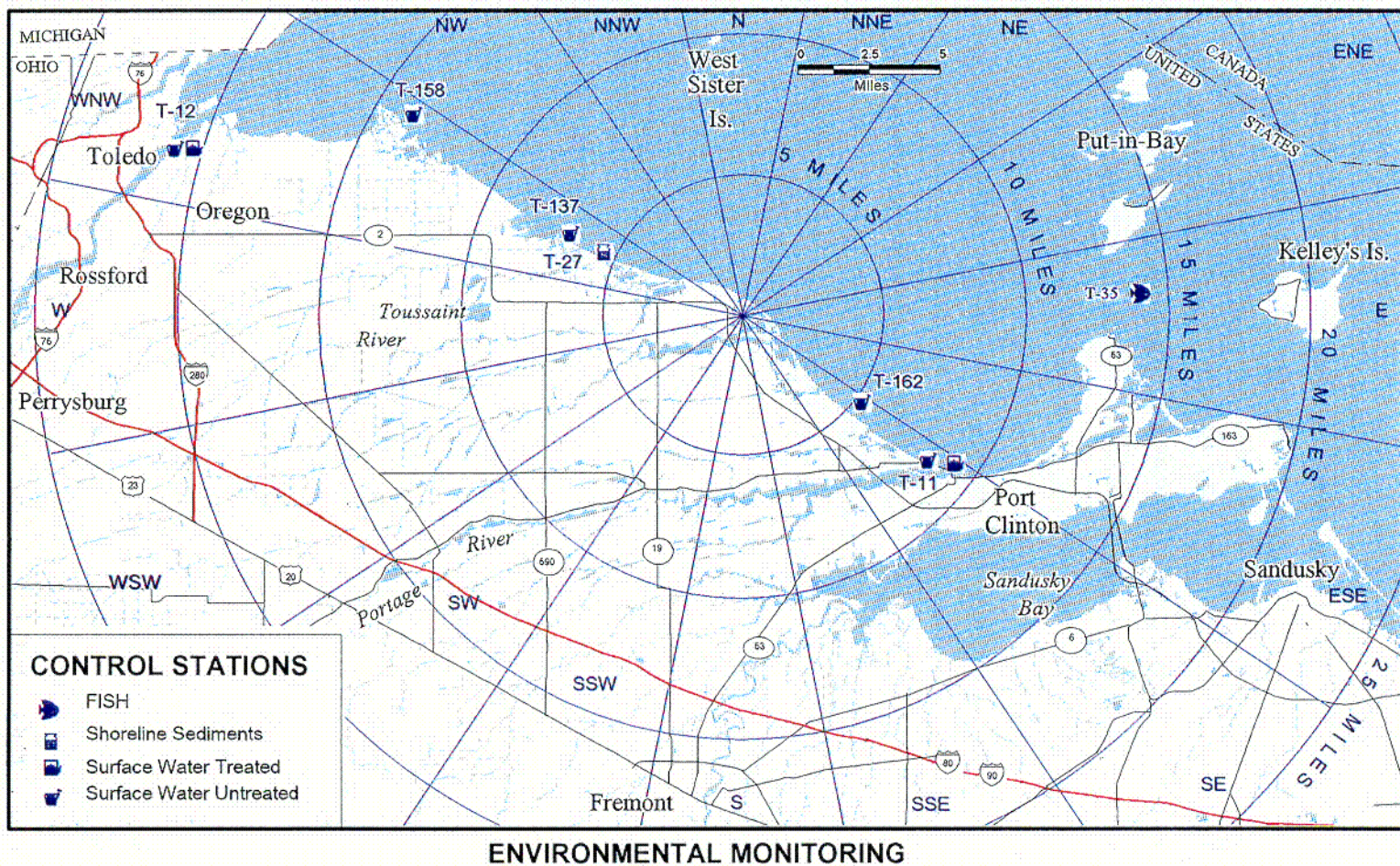

Figure 24: Aquatic 25-mile Map

Direct Radiation Monitoring

Thermoluminescent Dosimeters

Radionuclides present in the air and deposited on the ground may directly irradiate individuals. Direct radiation levels at and around Davis-Besse are constantly monitored by thermoluminescent dosimeters (TLDs). TLDs are small devices which store radiation dose information. The TLDs used at Davis-Besse contain a calcium sulfate: dysprosium ($\text{CaSO}_4:\text{Dy}$) card with four main readout areas. Multiple readout areas are used to ensure the precision of the measurements.

Thermoluminescence is a process in which ionizing radiation interacts with phosphor, which is the sensitive material in the TLD. Energy is trapped in the TLD material and can be stored for several months or years. This provides an excellent method to measure the dose received over long periods of time. The energy that was stored in the TLD as a result of interaction with radiation is released and measured by a controlled heating process in a calibrated reading system. As the TLD is heated, the phosphor releases the stored energy in the form of light. The amount of light detected is directly proportional to the amount of radiation to which the TLD was exposed. The reading process re-zeroes the TLD and prepares it for reuse.

TLD Collection

Davis-Besse has 75 TLD locations (64 indicator and 11 control) which are collected and replaced on a quarterly and annual basis. Eighteen QC TLDs are also collected on a quarterly and annual basis. There are a total of 186 TLDs in the environment surrounding Davis-Besse at any given time. By collecting TLDs on a quarterly and annual basis from a single site, each measurement serves as a quality control check on the other. Over 98% of the quarterly TLDs placed in the field and 99% of the annual TLDs placed in the field were retrieved and evaluated during the current reporting period.

In 2000, the average dose equivalent for quarterly TLDs at all indicator locations was 13.9 mrem/91 days, and for all control locations was 15.0 mrem/91 days. The average dose equivalent for annual TLDs in 2000 was 56.1 mrem/365 days at indicator locations and 60.2 mrem/365 days for control locations.

Quality Control TLDs

Duplicate TLDs have been placed at 18 sites. These TLDs were placed in the field at the same time and at the same location as some of the routine TLDs, but were assigned quality control site numbers. This allows us to take several measurements at the location without the laboratory being aware that they are the same. A comparison of the quality control and routine results provides a method to check the accuracy of the measurements. The average dose equivalent at the routine TLDs averaged 13.7 mrem/91 days while the quality control TLDs yielded an average dose equivalent of 13.6 mrem/91 days. All the quality control and routine sample results were similar, demonstrating the accuracy of both the TLDs and the laboratory's measurements.

Gamma Dose for Environmental TLDs 1973-2000

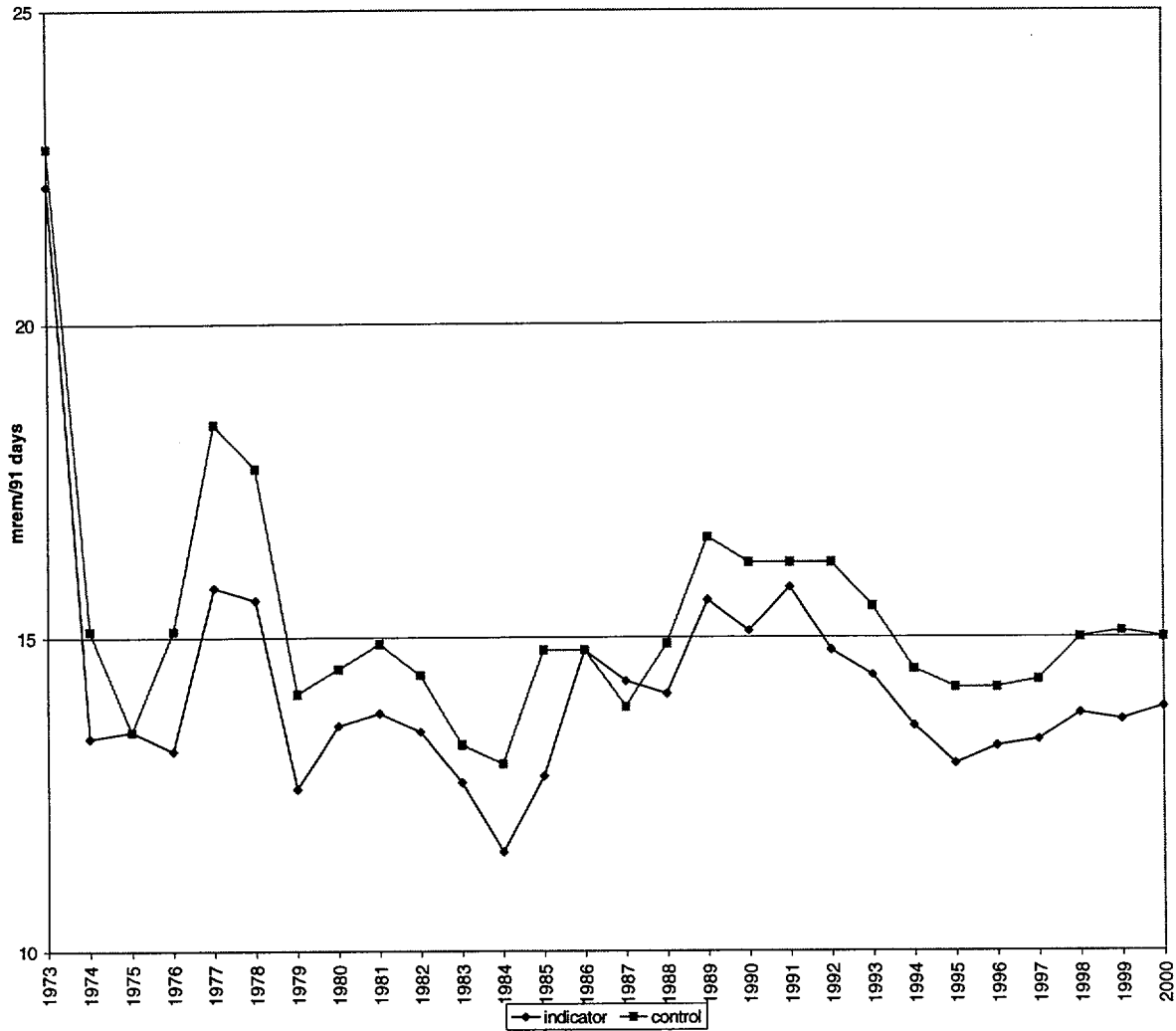

Figure 25: The similarity between indicator and control results demonstrated that the operation of Davis-Besse has not caused any abnormal gamma dose.

Table 16: Thermoluminescent Dosimeter Locations

Sample Location Number	Type of Location	Location Description
T-1	I	Site boundary, 0.6 miles ENE of Station
T-2	I	Site boundary, 0.9 miles E of Station
T-3	I	Site boundary, 1.4 miles ESE of Station
T-4	I	Site boundary, 0.8 miles S of Station
T-5	I	Site boundary, 0.5 miles W of Station
T-6	I	Site boundary, 0.5 miles NNE of Station
T-7	I	Sand Beach, main entrance, 0.9 miles NW of Station
T-8	I	Earl Moore Farm, 2.7 miles WSW of Station
T-9	C	Oak Harbor Substation, 6.8 miles SW of Station
T-10	I	Site boundary, 0.5 miles SSW of Station near warehouse
T-11	C	Port Clinton Water Treatment Plant, 9.5 miles SE of Station
T-12	C	Toledo Water Treatment Plant, 23.5 miles WNW of Station
T-24	C	Sandusky, 21.0 miles SE of Station
T-27	C	Crane Creek State Park, 5.3 miles WNW of Station
T-38	I	Site boundary, 0.6 miles ENE of Station
T-39	I	Site boundary 1.2 miles ENE of Station
T-40	I	Site boundary, 0.7 miles SE of Station
T-41	I	Site boundary, 0.6 miles SSE of Station
T-42	I	Site boundary, 0.8 miles SW of Station

Table 16: Thermoluminescent Dosimeter Locations (continued)

Sample Location Number	Type of Location	Location Description
T-43	I	Site boundary, 0.5 miles SW of Station
T-44	I	Site boundary, 0.5 miles WSW of Station
T-45	I	Site boundary, 0.5 miles WNW of Station
T-46	I	Site boundary, 0.5 miles NW of Station
T-47	I	Site boundary, 0.5 miles N of Station
T-48	I	Site boundary, 0.5 miles NE of Station
T-49	I	Site boundary, 0.5 miles NE of Station
T-50	I	Erie Industrial Park, Port Clinton, 4.5 miles SE of Station
T-51	C	on Siren Pole, 5.5 miles SSE of Station
T-52	I	Miller Farm, 3.7 miles S of Station
T-53	I	Nixon Farm, 4.5 miles S of Station
T-54	I	Weis Farm, 4.8 miles SW of Station
T-55	I	King Farm, 4.5 miles W of Station
T-60	I	Site boundary, 0.3 miles S of Station
T-62	I	Site boundary, 1.0 mile SE of Station
T-65	I	Site boundary, 0.3 miles E of Station
T-66	I	Site boundary, 0.3 miles ENE of Station
T-67	I	Site boundary, 0.3 miles NNW of Station
T-68	I	Site boundary, 0.5 miles WNW of Station
T-69	I	Site boundary, 0.4 miles W of Station

Table 16: Thermoluminescent Dosimeter Locations (continued)

Sample Location Number	Type of Location	Location Description
T-71	I	Site boundary, 0.1 mile NNW of Station
T-73	I	Site boundary, 0.1 mile WSW of Station
T-74	I	Site boundary, 0.1 mile SSW of Station
T-75	I	Site boundary, 0.2 mile SSE of Station
T-76	I	Site boundary, 0.1 mile SE of Station
T-80	QC	Quality Control Site
T-81	QC	Quality Control Site
T-82	QC	Quality Control Site
T-83	QC	Quality Control Site
T-84	QC	Quality Control Site
T-85	QC	Quality Control Site
T-86	QC	Quality Control Site
T-88	QC	Quality Control Site
T-87	QC	Quality Control currently located in lead pig, DBAB annex
T-89	QC	Quality Control Site
T-91	I	State Route 2 and Rankie Road, 2.5 miles SSE of Station
T-92	I	Locust Point Road, 2.7 miles WNW of Station
T-93	I	Twelfth Street, Sand Beach, 0.6 miles NNE of Station
T-94	I	State Route 2, 1.8 miles WNW of Station
T-95	C	State Route 579, 9.3 miles W of Station

Table 16: Thermoluminescent Dosimeter Locations (continued)

Sample Location Number	Type of Location	Location Description
T-100	C	Ottawa County Highway Garage, Oak Harbor, 6.0 miles S of Station
T-111	C	Toussaint North Road, 8.3 miles WSW of Station
T-112	I	Thompson Road, 1.5 miles SSW of Station
T-113	QC	Quality Control Site
T-114	QC	Quality Control Site
T-115	QC	Quality Control Site
T-116	QC	Quality Control Site
T-117	QC	Quality Control Site
T-118	QC	Quality Control Site
T-119	QC	Quality Control Site
T-120	QC	Quality Control Site
T-121	I	State Route 19, 2.0 miles W of Station
T-122	I	Duff Washa and Humphrey Road, 1.7 miles W of Station
T-123	I	Zetzer Road, 1.6 miles WSW of Station
T-124	C	Church and Walnut Street, Oak Harbor, 6.5 miles SSW of Station
T-125	I	Behlman and Bier Roads, 4.4 miles SSW of Station
T-126	I	Camp Perry Western and Toussaint South Road, 3.7 miles S of Station
T-127	I	Camp Perry Western and Rymers Road, 4.0 miles SSE of Station

Table 16: Thermoluminescent Dosimeter Locations (continued)

Sample Location Number	Type of Location	Location Description
T-128	I	Erie Industrial Park, Port Clinton Road, 4.0 miles SE of Station
T-142	I	Site Boundary, 0.8 miles SSE of Station
T-150	I	Humphrey and Hollywood Road, 2.1 miles NW of Station
T-151	I	State Route 2 and Humphrey Road, 1.8 miles WNW of Station
T-153	I	Leutz Road, 1.4 miles SSW of Station
T-154	I	State Route 2, 0.7 miles SW of Station
T-155	C	Fourth and Madison Streets, Port Clinton, 9.5 miles SE of Station
T-200	QC	Quality Control Site
T-201	I	Sand Beach, 1.1 miles NNW of Station
T-202	I	Sand Beach 0.8 miles NNW of Station
T-203	I	Sand Beach, 0.7 miles N of Station
T-204	I	Sand Beach, 0.7 miles N of Station
T-205	I	Sand Beach, 0.5 miles NNE of Station
T-206	I	Site Boundary, 0.6 miles NW of Station
T-207	I	Site Boundary, 0.5 miles N of Station
T-208	I	Site Boundary, 0.5 miles NNE of Station.

I = indicator, C = control, QC = quality control

DAVIS-BESSE NUCLEAR POWER STATION RADIOLOGICAL ENVIRONMENTAL MONITORING PROGRAM

TLD SAMPLES: SITE

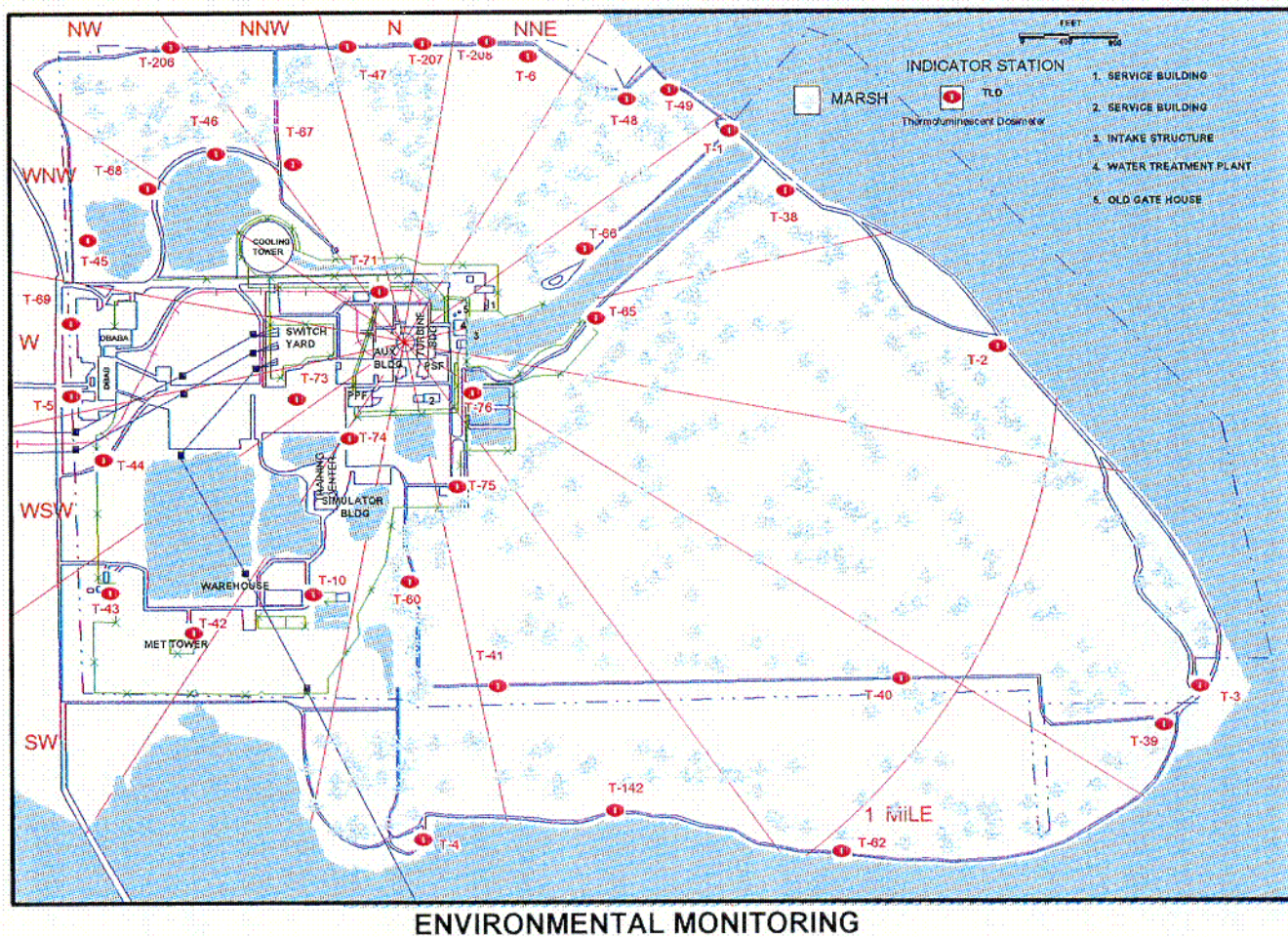
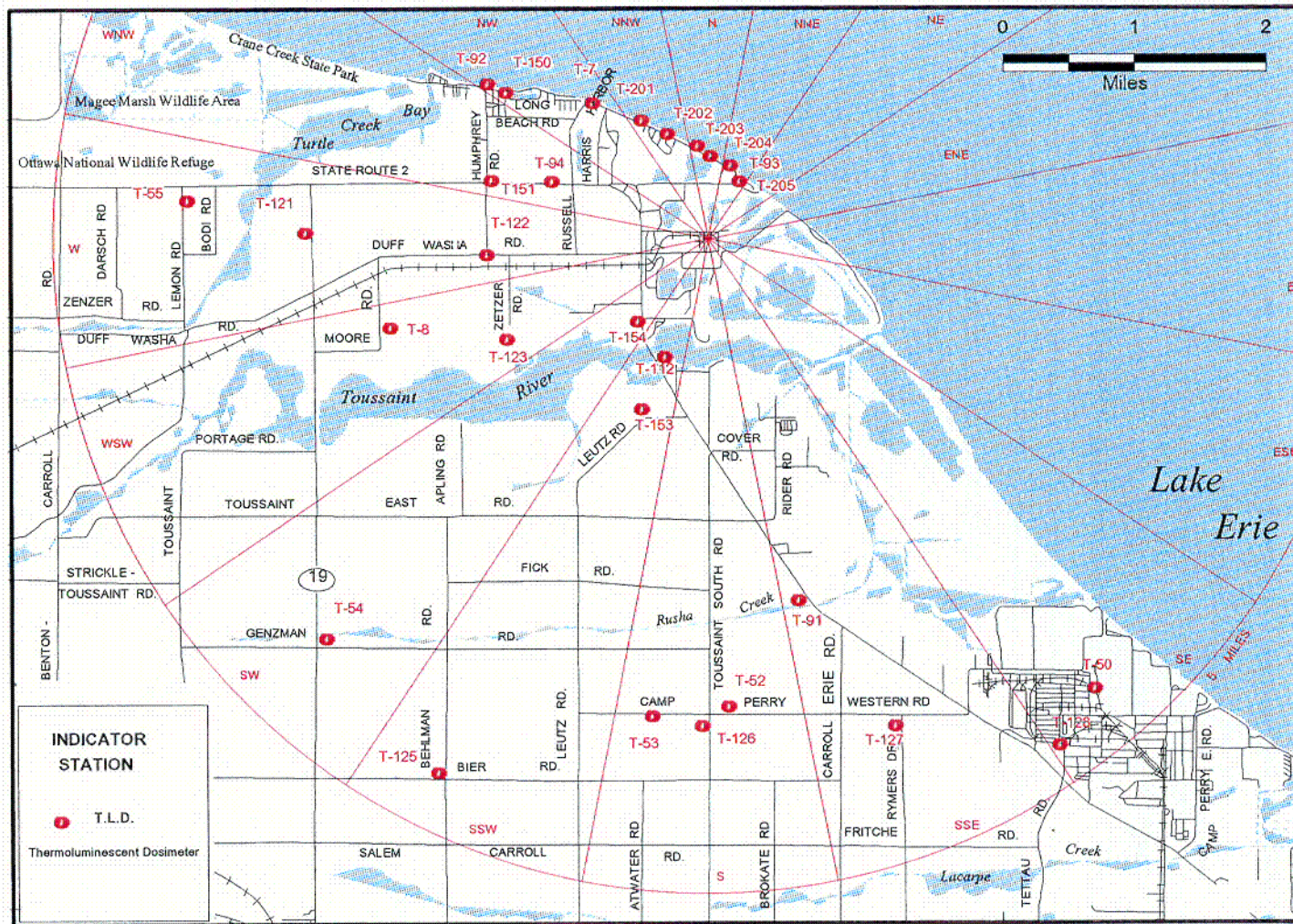

Figure 27: TLD Site Map

**DAVIS-BESSE NUCLEAR POWER STATION
 RADIOLOGICAL ENVIRONMENTAL MONITORING PROGRAM
 TLD SAMPLES: 5 MILE RADIUS**



ENVIRONMENTAL MONITORING

Figure 28: TLD 5-mile Map

**DAVIS-BESSE NUCLEAR POWER STATION
RADIOLOGICAL ENVIRONMENTAL MONITORING PROGRAM
TLD SAMPLES: 5-25 MILE RADIUS**

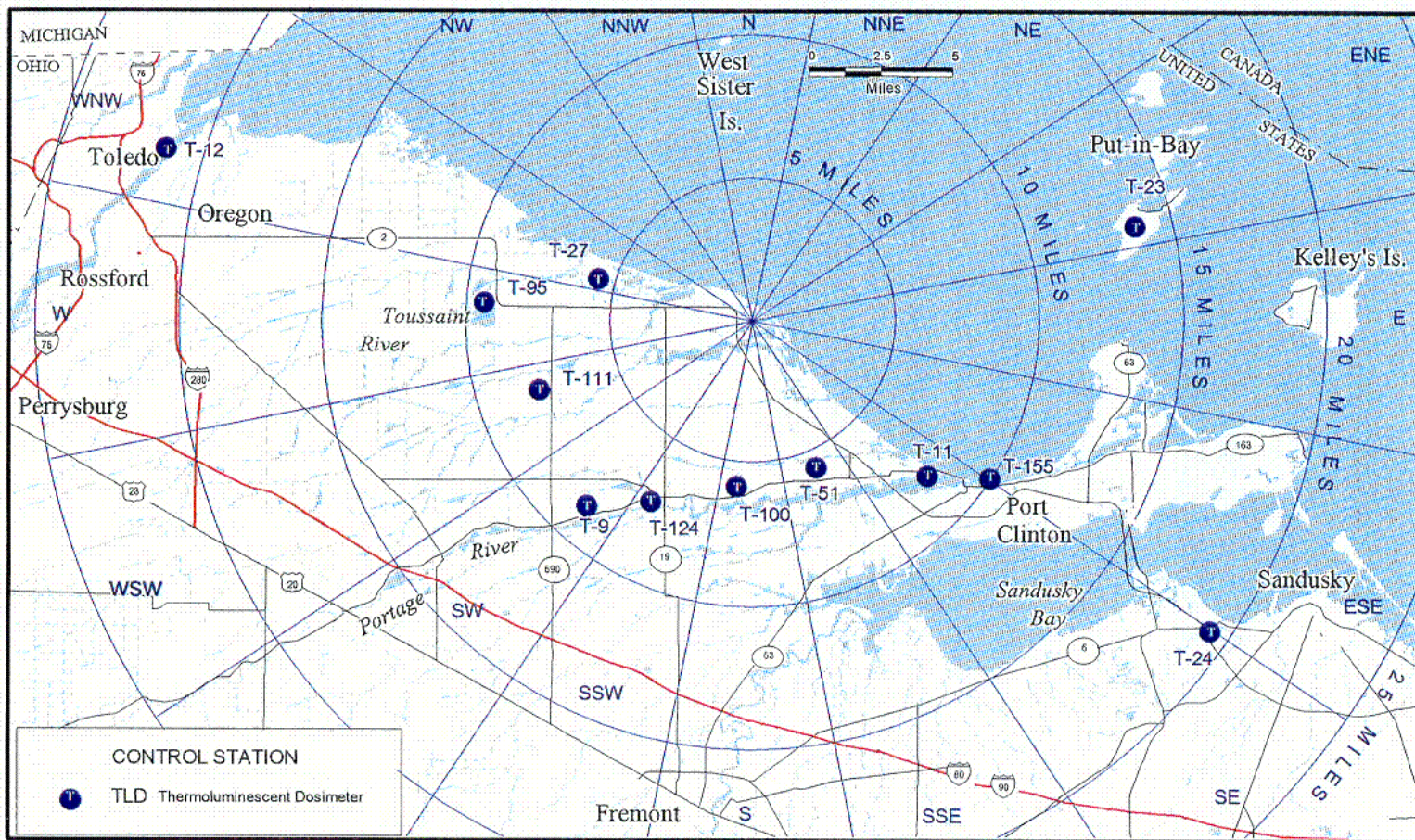

ENVIRONMENTAL MONITORING

Figure 29: TLD 25-mile Map

77

Conclusion

The Radiological Environmental Monitoring Program at Davis-Besse is conducted to determine the radiological impact of the Station's operation on the environment. Radionuclide concentrations measured at indicator locations were compared with concentrations measured at control locations in previous operational studies and in the preoperational surveillance program. These comparisons indicate normal concentrations of radioactivity in all environmental samples collected in 2000. Davis-Besse's operation in 2000 indicated no observable adverse radiological impact on the residents and environment surrounding the station. The results of the sample analyses performed during the period of January through December 2000 are summarized in Appendix D of this report.

References

1. "Cesium-137 from the Environment to Man: Metabolism and Dose," Report No.52, National Council on Radiation Protection and Measurement, Washington, D.C. (January 1977).
2. "Environmental Radiation Measurements," Report No.50, National Council on Radiation Protection and Measurement, Washington, D.C. (December 1976).
3. "Exposure of the Population in the United States and Canada from Natural Background Radiation," Report No.94, National Council on Radiation Protection and Measurement, Washington, D.C. (December 1987).
4. "A Guide for Environmental Radiological Surveillance at U.S. Department of Energy Installations," DOE/EP-0023, Department of Energy, Washington, D.C. (July 1981).
5. "Ionizing Radiation Exposure of the Population of the United States," Report No.93, National Council on Radiation Protection and Measurement, Washington, D.C. (September 1987).
6. "Natural Background Radiation in the United States," Report No.45, National Council on Radiation Protection and Measurement, Washington, D.C. (November 1975).
7. "Numerical Guides for Design Objectives and Limiting Conditions for Operation to meet the Criterion 'As Low As Reasonably Achievable' for Radioactive Material in Light Water Cooled Nuclear Power Reactor Effluents," Code of Federal Regulations, Title 10 Energy, Part 50 "Domestic Licensing of Production and Utilization Facilities," Appendix I (1988).
8. "Performance, Testing and Procedural Specifications for Thermoluminescent Dosimetry," American National Standards Institute, Inc., ANSI-N45-1975, New York, New York (1975).
9. "Public Radiation Exposure from Nuclear Power Generation in the United States," Report No.92, National Council on Radiation Protection and Measurement, Washington, D.C. (December 1987).
10. "Radiological Assessment: Predicting the Transport, Bioaccumulation and Uptake by Man of Radionuclides Released to the Environment," Report No.76, National Council on Radiation Protection and Measurement, Washington, D.C. (March 1984).
11. Regulatory Guide 4.1, "Programs for Monitoring Radioactivity in the Environs of Nuclear Power Plants," US NRC (April 1975).
12. Regulatory Guide 4.13, "Performance, Testing, and Procedural Specifications for Thermoluminescent Dosimetry: Environmental Applications," US NRC (July 1977).
13. Regulatory Guide 4.15, "Quality Assurance for Radiological Monitoring Programs (Normal Operations) - Effluent Streams and the Environment," US NRC (February 1979).

14. Regulatory Guide 0475, "Radiological Environmental Monitoring by NRC Licensees for Routine Operations of Nuclear Facilities," US NRC (September 1978).
15. "Standards for Protection Against Radiation," Code of Federal Regulations, Title 10, Energy, Part 20 (1993).
16. Teledyne Isotopes Midwest Laboratory, "Operational Radiological Monitoring for the Davis-Besse Nuclear Power Station Unit No.1, Oak Harbor, OH," Annual Report, Parts I and II (1977 through 1990).
17. Teledyne Isotopes Midwest Laboratory, "Final Monthly Progress Report to Toledo Edison Company", (1991-1999).
18. Environmental, Inc. Midwest Laboratory, "Final Report to FirstEnergy Corporation", (2000)
19. Teledyne Isotopes Midwest Laboratory, "Preoperational Environmental Radiological Monitoring for the Davis-Besse Power Station Unit No. 1", Oak Harbor, OH (1972-1977).
20. Toledo Edison Company, "Davis-Besse: Nuclear Energy for Northern Ohio."
21. Toledo Edison Company, "Davis-Besse Nuclear Power Station, Unit No. 1, Radiological Effluent Technical Specifications", Volume 1, Appendix A to License No. NPF-3.
22. Toledo Edison Company, "Final Environmental Statement -Related to the Construction of Davis-Besse Nuclear Power Station," Docket #50-346 (1987).
23. Toledo Edison Company, "Performance Specifications for Radiological Environmental Monitoring Program," S-72N.
24. Toledo Edison Company, "Radiological Environmental Monitoring Program," DB-HP-00015.
25. Toledo Edison Company, "Radiological Environmental Monitoring Quarterly, Semiannual, and Annual Sampling", DB-HP-03004.
26. Toledo Edison Company, "Radiological Monitoring Weekly, Semimonthly, and Monthly Sampling," DB-HP-03005.
27. Toledo Edison Company, "REMP Enhancement Sampling", DB-HP-10101.
28. Toledo Edison Company, "Updated Safety Analysis for the Offsite Radiological Monitoring Program", USAR 11.6, Revision 14, (1992).
29. Toledo Edison Company, "Annual Radiological Environmental Operating Report Preparation and Submittal", DB-HP-00014.

30. Toledo Edison Company, Davis-Besse Nuclear Power Station, Offsite Dose Calculation Manual
31. "Tritium in the Environment", Report No. 62, National Council on Radiation Protection and Measurements, Washington, D.C. (March 1979).

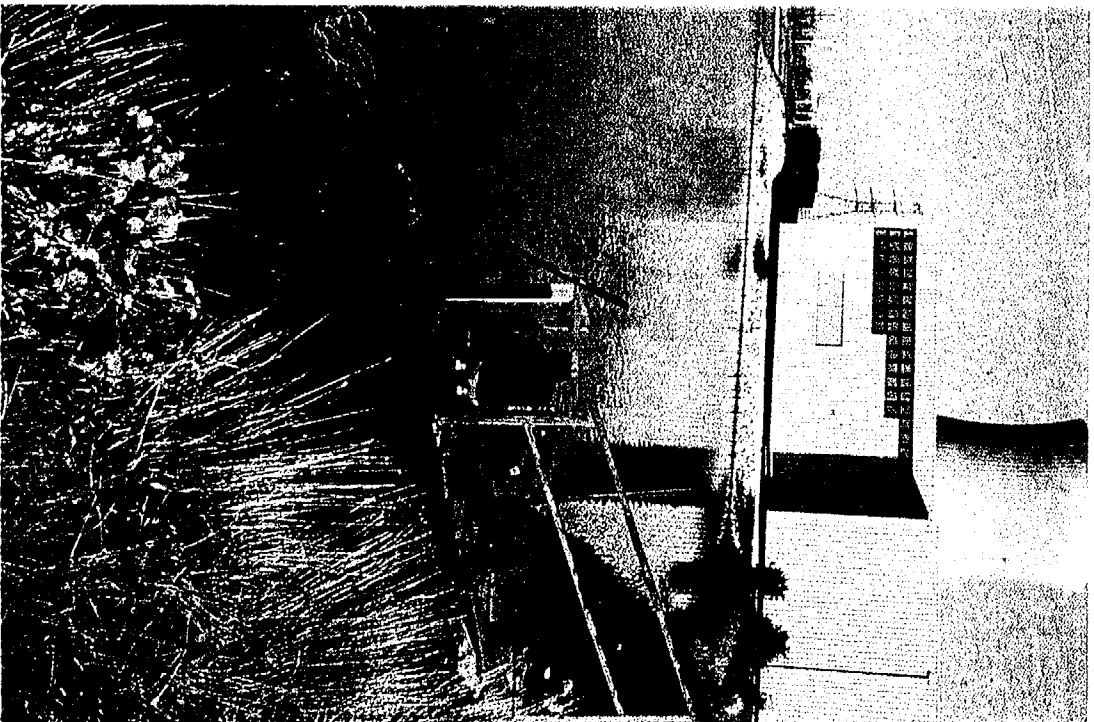

Radioactive Effluent Release Report

Radioactive Effluent Release Report

January 1 through December 31, 2000

Protection Standards

Soon after the discovery of x-rays in 1895 by Wilhelm Roentgen, the potential hazards of ionizing radiation were recognized and efforts were made to establish radiation protection standards. The primary source of recommendations for radiation protection standards within the United States is the National Council on Radiation Protection and Measurement (NCRP). Many of these recommendations have been given legislative authority through publication in the Code of Federal Regulations (CFR) by the Nuclear Regulatory Commission (NRC).

The main objective in the control of radiation is to ensure that any dose is kept not only within regulatory limits, but As Low As Reasonably Achievable (ALARA). The ALARA principle applies to reducing radiation dose both to the individual working at Davis-Besse and to the general public. "Reasonably achievable" means that exposure reduction is based on sound economic decisions and operating practices. By practicing ALARA, Davis-Besse minimizes health risk and environmental detriment and ensures that doses are maintained well below regulatory limits.

Sources of Radioactivity Released

During the normal operation of a nuclear power station, most of the fission products are retained within the fuel and fuel cladding. However, small amounts of radioactive fission products and trace amounts of the component and structure surfaces which have been activated are present in the primary coolant water. The three types of radioactive material released are noble gases, iodine and particulates, and tritium.

The noble gas fission products in the primary coolant are given off as a gas when the coolant is depressurized. These gases are then collected by a system designed for gas collection and stored for radioactive decay prior to release.

Small releases of radioactivity in liquids may occur from valves, piping or equipment associated with the primary coolant system. These liquids are collected through a series of floor and equipment drains and sumps. All liquids of this nature are monitored and processed, if necessary, prior to release.

Noble Gas

Some of the fission products released in airborne effluents are radioactive isotopes of noble gases, such as xenon and krypton. Noble gases are biologically and chemically nonreactive.

They do not concentrate in humans or other organisms. They contribute to human radiation dose by being an external source of radiation exposure to the body. Xenon-133 and xenon-135, with half-lives of approximately five days and nine hours, respectively, are the major radioactive noble gases released. They are readily dispersed in the atmosphere.

Iodine and Particulates

Annual releases of radioisotopes of iodine, and those particulates with half-lives greater than 8 days, in gaseous and liquid effluents are small. Factors such as their high chemical reactivity and solubility in water, combined with the high efficiency of gaseous and liquid processing systems, minimize their discharge. The predominant radioiodine released is iodine-131 with a half-life of approximately eight days. The main contribution of radioactive iodine to human dose is to the thyroid gland, where the body concentrates iodine.

The principal radioactive particulates released are fission products (e.g., cesium-134 and cesium-137) and activation products (e.g., cobalt-58 and cobalt-60). Radioactive cesium and cobalt contribute to internal radiation exposure of tissues such as the muscle, liver, and intestines. These particulates are also a source of external radiation exposure if deposited on the ground.

Tritium

Tritium, a radioactive isotope of hydrogen, is the predominant radionuclide in liquid effluents. It is also present in gaseous effluents. Tritium is produced in the reactor coolant as a result of neutron interaction with deuterium (also a hydrogen isotope) present in the water and with the boron in the primary coolant. When tritium, in the form of water or water vapor, is ingested or inhaled it is dispersed throughout the body until eliminated.

Processing and Monitoring

Effluents are strictly controlled to ensure radioactivity released to the environment is minimal and does not exceed regulatory limits. Effluent control includes the operation of monitoring systems, in-plant and environmental sampling and analyses programs, quality assurance programs for effluent and environmental programs, and procedures covering all aspects of effluent and environmental monitoring.

The radioactive waste treatment systems at Davis-Besse are designed to collect and process the liquid and gaseous wastes which contain radioactivity. For example, the Waste Gas Decay Tanks are holding tanks which allow radioactivity in gases to decay prior to release via the station vent.

Radioactivity monitoring systems are used to ensure that all releases are below regulatory limits. These instruments provide a continuous indication of the radioactivity present. Each instrument is equipped with alarms and indicators in the control room. The alarm setpoints are low enough to ensure the limits will not be exceeded. If a monitor alarms, a release from a tank is automatically stopped.

All wastes are sampled prior to release and analyzed in a laboratory to identify the specific concentrations of radionuclides being released. Sampling and analysis provide a more sensitive and precise method of determining effluent composition than with monitoring instruments alone.

A meteorological tower is located in the southwest sector of the Station. It is linked to computers which record the meteorological data. Coupled with the effluent release data, the meteorological data are used to calculate the dose to the public.

Beyond the plant, devices maintained in conjunction with the Radiological Environmental Monitoring Program constantly sample the air in the surrounding environment. Frequent samples of other environmental media, such as water and vegetation, are also taken to determine if buildup of deposited radioactive material has occurred in the area.

Exposure Pathways

Radiological exposure pathways define the methods by which people may become exposed to radioactive material. The major pathways of concern are those which could cause the highest calculated radiation dose. These projected pathways are determined from the type and amount of radioactive material released, the environmental transport mechanism, and the use of the environment. The environmental transport mechanism includes consideration of physical factors, such as the hydrological (water) and meteorological (weather) characteristics of the area. An Annual average on the water flow, wind speed, and wind direction are used to evaluate how the radionuclides will be distributed in an area for gaseous or liquid releases. An important factor in evaluating the exposure pathways is the use of the environment. Many factors are considered such as dietary intake of residents, recreational use of the area, and the locations of homes and farms in the area.

The external and internal exposure pathways considered are shown in Figure 30. The release of radioactive gaseous effluents involves pathways such as external whole body exposure, deposition of radioactive material on plants, deposition on soil, inhalation by animals destined for human consumption, and inhalation by humans. The release of radioactive material in liquid effluents involves pathways such as drinking water, fish consumption, and direct exposure from the lake at the shoreline while swimming.

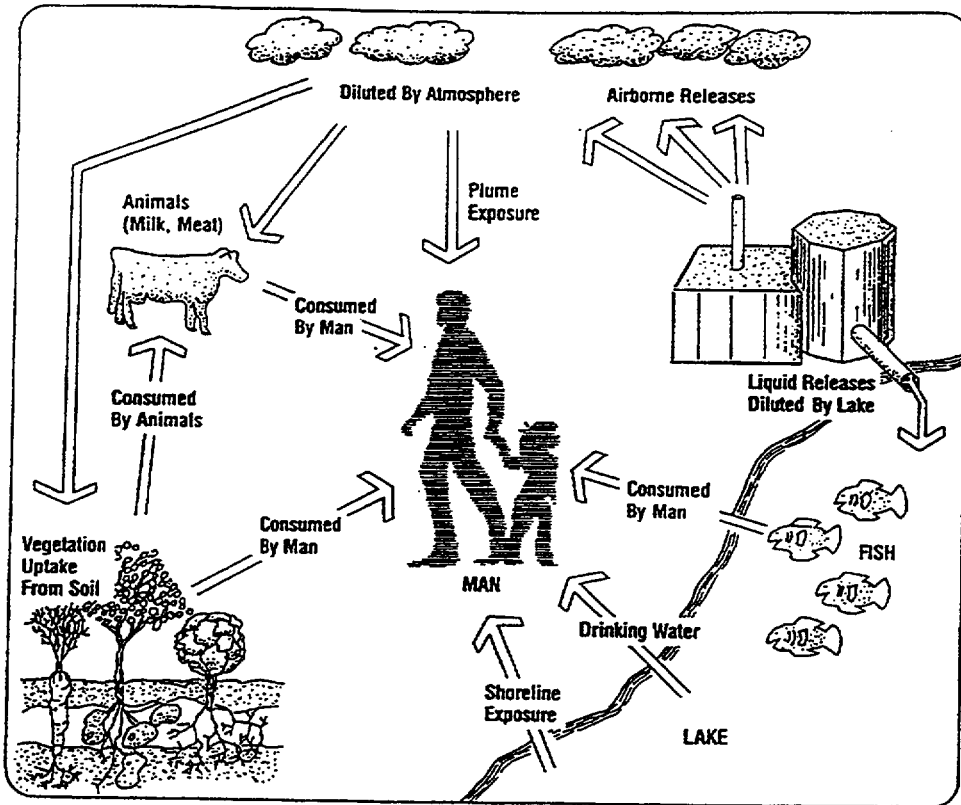

Figure 30: The exposure pathways shown here, are monitored through the Radiological Environmental Monitoring Program (REMP), and are considered when calculating doses to the public.

Although radionuclides can reach humans by many different pathways, some result in more dose than others. The critical pathway is the exposure pathway which will provide, for a specific radionuclide, the greatest dose to a population, or to a specific group of the population, called the critical group. The critical group may vary depending on the radionuclides involved, the age and diet of the group, or other cultural factors. The dose may be delivered to the whole body or to a specific organ. The organ receiving the greatest fraction of the dose is called the critical organ.

Dose Assessment

Dose is the energy deposited by radiation in an exposed individual. Whole body exposure to radiation involves the exposure of all organs. Most background exposures are of this form. Both non-radioactive and radioactive elements can enter the body through inhalation or ingestion. When they do, they are usually not distributed evenly. For example, iodine concentrates in the thyroid gland, cesium collects in muscle and liver tissue, and strontium collects in bone tissue.

The total dose to organs from a given radionuclide depends on the amount of radioactive material present in the organ and the amount of time that the radionuclide remains in the organ. Some radionuclides remain for very short times due to their rapid radioactive decay and/or elimination rate from the body, while other radionuclides may remain in the body for longer periods of time.

The dose to the general public in the area surrounding Davis-Besse is calculated for each liquid or gaseous release. The dose due to radioactive material released in gaseous effluents is calcu-

lated using factors such as the amount of radioactive material released, the concentration beyond the site boundary, the average weather conditions at the time of the release, the locations of exposure pathways (cow milk, goat milk, vegetable gardens and residences), and usage factors (inhalation, food consumption). The dose due to radioactive material released in liquid effluents is calculated using factors such as the total volume of liquid, the total volume of dilution water, near field dilution, and usage factors (water and fish consumption, shoreline and swimming factors). These calculations produce a conservative estimation of the dose.

Results

The Radioactive Effluent Release Report is a detailed listing of radioactivity released from the Davis-Besse Nuclear Power Station during the period from January 1, 2000 through December 31, 2000.

- Summation of the quantities of radioactive material released in gaseous and liquid effluents (Tables 17-21)
- Summation of the quantities of radioactive material contained in solid waste packaged and shipped for offsite disposal at federally approved sites (Table 22)
- A listing of all radioactive effluent monitoring instrumentation required by the Offsite Dose Calculation Manual, but which were inoperable for more than 30 days

During this reporting period, the estimated maximum individual offsite dose due to radioactivity released in effluent was:

Liquid Effluents:

- 5.54E-02 mrem, whole body
- 6.25E-02 mrem, thyroid

Gaseous Effluents:

Noble Gas:

- 8.97E-04 mrad, whole body
- 2.50E-03 mrad, skin

Iodine - 131, Tritium, and Particulates with Half-lives greater than 8 Days:

- 1.36E-03 mrem, whole body
- 1.98E-02 mrem, thyroid

These doses are an extremely small fraction of the limits set by the NRC in the Davis-Besse ODCM.

Additional normal release pathways from the secondary system exist. For gaseous effluents, these pathways include the auxiliary feed pump turbine exhausts, the main steam safety valve system and the atmospheric vent valve system, steam packing exhaust and main feed water. For liquid effluents, the additional pathways include the Turbine Building drains via the settling basins. Releases via these pathways are included in the normal release tables in this report.

Regulatory Limits

Gaseous Effluents

In accordance with Offsite Dose Calculation Manual, dose rates due to radioactivity released in gaseous effluents from the site to areas at and beyond the site boundary shall be limited to the following:

Noble gases:

- Released at a rate equal to or less than 500 mrem TEDE per year. (Note: the total dose due to these releases is also limited to 50 mrem in any calendar year.)
- Released at a rate such that the total dose to the skin will be less than or equal to 3000 mrem in a year.

Iodine-131, tritium, and all radionuclides in particulate form with half-lives greater than 8 days:

- Released at a rate such that the total dose to any organ will be less than or equal to 1500 mrem in a year.

In accordance with 10CFR50, Appendix I, Sec. IIB. 1, air dose due to radioactivity released in gaseous effluents to areas at and beyond the site boundary shall be limited to the following:

- Less than or equal to 10 mrad total for gamma radiation and less than or equal to 20 mrad total for beta radiation in any calendar year.

In accordance with 10CFR50, Appendix I, Sec. IIC, dose to a member of the public from Iodine-131, tritium, and all radionuclides in particulate form with half-lives greater than 8 days in gaseous effluents released to areas at and beyond the site boundary shall be limited to the following:

- Less than or equal to 15 total mrem to any organ in any calendar year.

Liquid Effluents

In accordance with 10CFR50, Appendix I, Sec IIA, the dose or dose commitment to a member of the public from radioactivity in liquid effluents released to unrestricted areas shall be limited to accumulated doses of:

- Less than or equal to 3 mrem to the total body and less than or equal to 10 mrem to any organ in any calendar year.

Effluent Concentration Limits

The Effluent Concentration Limits (ECs) for liquid and gaseous effluents at and beyond the site boundary are listed in 10CFR20, Appendix B, Table II, Column 2, with the most restrictive EC being used in all cases. For dissolved and entrained gases the EC of 2.0E-04 uCi/ml is applied. This EC is based on the Xe-135 DAC of 1E-05 uCi/ml of air (submersion dose) converted to an equivalent concentration in water as discussed in the International Commission on Radiological Protection (ICRP), Publication 2.

Average Energy

The Davis-Besse ODCM limits the dose equivalent rates due to the release of fission and activation products to less than or equal to 500 mrem per year to the total body and less than or equal to 3000 mrem per year to the skin. Therefore, the average beta and gamma energies (\bar{E}) for gaseous effluents as described in Regulatory Guide 1.21, "Measuring, Evaluating, and Reporting Radioactivity in Solid Wastes and Releases of Radioactive Materials in Liquid and Gaseous Effluents from Light-Water-Cooled Nuclear Power Plants" are not applicable.

Measurements of Total Activity

Fission and Activation Gases:

These gases, excluding tritium, are collected in a marinelli beaker specially modified for gas sampling, steel flasks, or glass vials and are counted on a germanium detector for principal gamma emitters. Radionuclides that are detected are quantified via gamma spectroscopy.

Tritium gas is collected using a bubbler apparatus and counted by liquid scintillation.

Iodine

Iodine is collected on a charcoal cartridge filter and counted on a germanium detector. Specific quantification of each iodine radionuclide is via gamma spectroscopy.

Particulates

Particulates are collected on filter paper and counted on a germanium detector. Specific quantification of each radionuclide present on the filter paper is via gamma spectroscopy.

Liquid Effluents

Liquid effluents are collected in a marinelli beaker and counted on a germanium detector. Quantification of each gamma-emitting radionuclide present in liquid samples is via gamma spectroscopy. Tritium in the liquid effluent is quantified by counting an aliquot of a composite sample in a liquid scintillation counting system.

Batch Releases

Liquid from 1/1/00 through 12/31/00

1. Number of batch releases:	70
2. Total time period for the batch releases:	109.0 hours
3. Maximum time period for a batch release:	188 minutes
4. Minimum time period for a batch release:	56 minutes
5. Average time period for a batch release:	93.43 minutes

Gaseous from 1/1/00 through 12/31/00

1. Number of batch releases:	13
2. Total time period for the batch releases:	214.8 hours
3. Maximum time period for a batch release:	7165 minutes
4. Minimum time period for a batch release:	23 minutes
5. Average time period for batch release:	991.4 minutes

Abnormal Releases

<u>System</u>	<u>Month</u>	<u>Time(Sec.)</u>	<u>Tritium Release</u>	<u>Exposure Dose</u>
Aux 50#	January	35	1.40E-05 Ci	1.42E-07
Aux 50#	March	300	9.92E-05 Ci	1.23E-08
Aux 235#	April	65	3.24E-05 Ci	4.02E-09

Total activity due to Abnormal Releases is 1.46E-04 Curies of Tritium.

Total Dose due to Abnormal Releases is 1.58E-07 mrem

Percent of ODCM Release Limits

The following table presents the ODCM annual dose limits and the associated offsite dose to the public, in percent of limits, for January 1, 2000 through December 31, 2000.

	SPECIFICATION	ANNUAL DOSE	LIMIT	PERCENT OF LIMIT
Report Period: January 1, 2000- December 31, 2000 (gaseous)				
	Noble gases (gamma)	8.97E-04 mrad	10 mrad	8.97E-03
	Noble gases (beta)	2.50E-03 mrad	20 mrad	1.25E-02
	I-131, tritium and particulates	1.36E-03 mrem	15 mrem	9.07E-03
Report Period: January 1, 2000 - December 31, 2000 (liquid)				
	Total body	5.54E-02 mrem	3 mrem	1.85E+00
	Organ	6.25E-02 mrem	10 mrem	6.25E-01

Sources of Input Data

- Water Usage: Survey of Water Treatment Plants (DSR-95-00347)
- 0-50 mile meat, milk, vegetable production, and population data was taken from 1982 Annual Environmental Operating Report entitled, "Evaluation of Compliance with Appendix I to 10CFR50: Updated Population, Agricultural, Meat - Animal, and Milk Production Data Tables for 1982". This evaluation was based on the 1980 Census, the Agricultural Ministry of Ontario 1980 report entitled "Agricultural Statistics and Livestock Marketing Account", the Agricultural Ministry of Ontario report entitled "Agricultural Statistics for Ontario, 1980 Publication 21, 1980", the Michigan Department of Agriculture report entitled "Michigan Agricultural Statistics, 1981", and the Ohio Crop Reporting Service report entitled "Ohio Agricultural Statistics, 1981".
- Gaseous and liquid source terms: Tables 17 through 21 of this report.
- Location of the nearest individuals and pathways by sector within 5 miles, see Land Use Census Section of the report.
- Population of the 50-mile Radius of Davis-Besse (DSR-95-00398).

Dose to Public Due to Activities Inside the Site Boundary

In accordance with ODCM Section 7.2, the Radioactive Effluent Release Report includes an assessment of radiation doses from radioactivity released in liquid and gaseous effluents to members of the public due to activities inside the site boundary.

In special instances, members of the public are permitted access to the Radiologically Restricted Area within the Davis-Besse Station. Tours for the public are conducted with the assurance that no individual will receive any appreciable dose due to radioactivity released in gaseous or liquid effluents (i.e., not more than a small fraction of the 40 CFR 190 standards.)

The Wellness Center, Pavilion, Training Center pond and the forebay/canal area located inside DBNPS Owner Controlled Area are accessible to members of the public. The Pavilion is accessible to the public for social activities. The Training Center pond, forebay/canal area allows the member of the public to fish on site under a "catch-an-release" program; therefore the fish pathway is not considered applicable. Considering the frequency and duration of the visits, the resultant dose would be a small fraction of the calculated maximum site boundary dose. For purposes of assessing the dose to members of the public in accordance with ODCM Section 7.2, the following exposure assumptions are used:

- Exposure time for maximally-exposed visitors is 250 hours (1 hr/day, 5 day/ week, 50 wk/yr)
- Annual average meteorological dispersion (conservative, default use of maximum site boundary dispersion).
- For direct "shine" from the Independent Spent Fuel Storage Installation (ISFSI), default use of the maximum dose rate for a completed (full) ISFSI, and a distance of 950 feet.

The equations in the ODCM may be used for calculating the potential dose to a member of the public for activities inside the site boundary. Based on these assumptions, this dose would be at least a factor of 35 less than the maximum site boundary air dose, as calculated in the ODCM. Nowhere onsite are areas accessible to the public where exposure to liquid effluents could occur. Therefore, the modeling of the ODCM conservatively estimates the maximum potential dose to members of the public.

Inoperable Radioactive Effluent Monitoring Equipment

There was no radioactive effluent monitoring equipment required to be operable that was inoperable for greater than 30 days during the reporting period.

Changes to the ODCM and PCP

There was one alteration to the ODCM, Revision 13.0. Appendix D was added and the Land Use Census sections were updated. The Process Control Program (PCP) had no changes in the reporting period.

Borated Water Storage Tank Radionuclide Concentration

During the Reporting Period of 2000, the BWST tank concentration did not exceed the ODCM specification of Section 2.2.4. The sum of the limiting fraction of nuclides, a unitless number between 0 and 1, did not exceed the limit of 1. Of the three samples taken, the highest sum of the limiting fraction of nuclides reported was 0.774 on 5/10/00.

Table 17
Gaseous Effluents - Summation of All Releases

Type	Unit	1st Qtr 2000	2nd Qtr 2000	3rd Qtr 2000	4th Qtr 2000	Est. Total % Error
Fission and Activation Gases						
Total Release	Ci	1.25E+01	5.08E+01	0.00E+00	5.74E-01	2.5E+01
Average Release Rate for Period ^a	μCi/sec	1.59E+00	6.44E+00	0.00E+00	7.32E-02	
Percent of ODCM Limits	See Supplemental Information in ODCM Release Limits Section 3.3, Gaseous Effluent Monitor Setpoint Determination					
Iodines						
Total Iodines	Ci	5.90E-05	2.36E-03	1.71E-05	8.32E-07	2.5E+01
Average Release Rate for Period ^a	μCi/sec	7.48E-06	2.99E-04	2.17E-06	1.05E-07	
Percent of ODCM Limits	See Supplemental Information in ODCM Release Limits Section 3.3, Gaseous Effluent Monitor Setpoint Determination					
Particulates						
Particulates with half-lives greater than 8 days	Ci	1.79E-06	2.13E-06	1.25E-06	0.00E+00	2.5E+01
Average Release Rate for Period ^a	μCi/sec	2.27E-07	2.70E-07	1.59E-07	0.00E+00	
Percent of ODCM Limits	See Supplemental Information in ODCM Release Limits Section 3.3, Gaseous Effluent Monitor Setpoint Determination					
Tritium						
Total Release	Ci	4.24E+00	2.01E+01	1.40E+01	1.19E+01	2.5E+01
Average Release Rate for Period ^a	μCi/sec	5.38E-01	2.55E+00	1.78E+00	1.51E+00	
Percent of ODCM Limits	See Supplemental Information in ODCM Release Limits Section 3.3, Gaseous Effluent Monitor Setpoint Determination					

^a The average release rate is taken over the entire quarter. It is NOT averaged over the time period of the releases.

Table 18
Gaseous Effluents - Ground Level Releases
Batch Mode^a

Nuclide	Unit	1st Qtr 2000	2nd Qtr 2000	3rd Qtr 2000	4th Qtr 2000
Fission Gases					
	Ci				
Kr-85		LLD ^b	LLD ^b	LLD ^b	LLD ^b
Kr-85m		LLD	LLD	LLD	LLD
Kr-87		LLD	LLD	LLD	LLD
Kr-88		LLD	LLD	LLD	LLD
Xe-133		LLD	5.32E-02	LLD	LLD
Xe-135		LLD	LLD	LLD	LLD
Xe-135m		LLD	LLD	LLD	LLD
Xe-138		<u>LLD</u>	<u>LLD</u>	<u>LLD</u>	<u>LLD</u>
Total for Period:		N/A	5.32E-02	N/A	N/A
Iodines					
	Ci				
I-131		LLD	1.70E-05	LLD	LLD
I-132		LLD	LLD	LLD	LLD
I-133		LLD	LLD	LLD	LLD
I-135		<u>LLD</u>	<u>LLD</u>	<u>LLD</u>	<u>LLD</u>
Total for Period:		N/A	1.70E-05	N/A	N/A
Particulates and Tritium					
	Ci				
H-3		2.66E-03	9.76E-03	LLD	7.58E-03
Sr-89		LLD	LLD	LLD	LLD
Sr-90		LLD	LLD	LLD	LLD
Cs-134		LLD	LLD	LLD	LLD
Cs-137		LLD	LLD	LLD	LLD
Ba-140		LLD	LLD	LLD	LLD
Co-58		LLD	LLD	LLD	LLD
Total for Period:		2.66E-03	9.76E-03	N/A	7.58E-03

Table 18 (Continued)
Gaseous Effluents - Ground Level Releases
Continuous Mode^c

Nuclide	Unit	1st Qtr 2000	2nd Qtr 2000	3rd Qtr 2000	4th Qtr 2000
Fission Gases					
	Ci				
Kr-85		LLD ^b	LLD ^b	LLD ^b	LLD
Kr-85m		LLD	LLD	LLD	LLD
Kr-87		LLD	LLD	LLD	LLD
Kr-88		LLD	LLD	LLD	LLD
Xe-133		LLD	LLD	LLD	LLD
Xe-135		LLD	LLD	LLD	LLD
Xe-135m		LLD	LLD	LLD	LLD
Xe-138		<u>LLD</u>	<u>LLD</u>	<u>LLD</u>	<u>LLD</u>
Total for Period:		N/A	N/A	N/A	N/A
Iodines					
	Ci				
I-131		LLD	LLD	LLD	LLD
I-133		LLD	LLD	LLD	LLD
I-135		<u>LLD</u>	<u>LLD</u>	<u>LLD</u>	<u>LLD</u>
Total for Period:		N/A	N/A	N/A	N/A
Particulates and Tritium					
	Ci				
H-3		2.27 E-02	2.17E-03	1.43E-02	2.71E-02
Sr-89		LLD	LLD	LLD	LLD
Sr-90		LLD	LLD	LLD	LLD
Cs-134		LLD	LLD	LLD	LLD
Cs-137		LLD	LLD	LLD	LLD
Ba-140		<u>LLD</u>	<u>LLD</u>	<u>LLD</u>	<u>LLD</u>
Total for Period:		2.27E-02	2.17E-03	1.43E-02	2.71E-02

Table 18 (Continued)
Gaseous Effluents - Ground Level Releases
Continuous and Batch Mode

Ar-41:	<2.2E-08	μCi/ml
Kr-85:	<6.2E-06	μCi/ml
Kr-85m:	<2.0E-08	μCi/ml
Kr-87:	<3.4E-08	μCi/ml
Kr-88:	<4.0E-08	μCi/ml
Xe-131m:	<9.0E-08	μCi/ml
Xe-133:	<4.6E-08	μCi/ml
Xe-133m:	<1.6E-07	μCi/ml
Xe-135:	<1.9E-08	μCi/ml
Xe-135m:	<4.0E-07	μCi/ml
Xe-138:	<2.5E-07	μCi/ml
I-131:	<1.0E-07	μCi/ml
I-133:	<2.1E-08	μCi/ml
I-135:	<2.1E-08	μCi/ml
Mn-54	<2.0E-08	μCi/ml
Fe-59:	<4.0E-08	μCi/ml
Co-58:	<3.0E-08	μCi/ml
Co-60:	<2.0E-08	μCi/ml
Zn-65:	<4.0E-08	μCi/ml
Mo-99:	<2.0E-07	μCi/ml
Cs-134:	<2.1E-08	μCi/ml
Cs-137:	<3.0E-08	μCi/ml
Ce-141:	<3.0E-08	μCi/ml
Ce-144:	<1.2E-07	μCi/ml
Ba-140:	<7.0E-08	μCi/ml
La-140:	<3.0E-08	μCi/ml
Sr-89:	<5.0E-08	μCi/ml
Sr-90:	<6.0E-09	μCi/ml

- a Auxiliary Feed Pump Turbine Exhaust, Main Steam Safety Valves, and Auxiliary Boiler Outage Release are listed as batch releases.
- b These radionuclides were not identified in concentrations above the lower limit of detection (LLD).
- c Atmospheric Vent Valve weepage and Steam Packing Exhaust are continuous releases.

Table 19
Gaseous Effluents - Mixed Mode Releases
Batch Mode

Nuclide	Unit	1st Qtr 2000	2nd Qtr 2000	3rd Qtr 2000	4th Qtr 2000
Fission Gases					
Ar-41	Ci	7.97E-03	6.70E-03	LLD	LLD
Kr-85	Ci	6.26E-01	4.25E+00	LLD	LLD
Kr-85m	Ci	5.97E-04	2.22E-04	LLD	5.14E-05
Kr-87	Ci	1.83E-04	LLD	LLD	LLD
Kr-88	Ci	LLD	LLD	LLD	LLD
Xe-133	Ci	2.66E+00	1.51E+01	LLD	LLD
Xe-133m	Ci	1.40E-02	9.55E-02	LLD	LLD
Xe-135	Ci	1.17E-02	7.11E-02	LLD	LLD
Xe-135m	Ci	LLD	LLD	LLD	LLD
Xe-138	Ci	LLD	LLD	LLD	LLD
Xe-131m	Ci	<u>7.81E-02</u>	<u>5.54E-01</u>	<u>LLD</u>	<u>LLD</u>
Total for Period:		3.40E+00	1.95E+01	LLD	5.14E-05
*Iodines					
I-131	Ci	LLD	LLD	LLD	LLD
I-132	Ci	LLD	LLD	LLD	LLD
I-133	Ci	LLD	LLD	LLD	LLD
I-135	Ci	LLD	LLD	LLD	LLD
Total for Period:	Ci	LLD	LLD	LLD	LLD
*Particulates					
H-3	Ci	<u>2.96E-02</u>	<u>1.80E-01</u>	<u>LLD</u>	<u>2.10E-04</u>
Total for Period:	Ci	2.96E-02	1.80E-01	LLD	2.10E-04

* Release of iodines and particulates are quantified in Mixed Mode Releases, Continuous Mode (Unit Station Vent)

Table 19 (Continued)
Gaseous Effluents - Mixed Mode Releases
Continuous Mode

Nuclide	Unit	1st Qtr 2000	2nd Qtr 2000	3rd Qtr 2000	4th Qtr 2000
Fission Gases					
Ar-41	Ci	LLD	LLD	LLD	LLD
Kr-85	Ci	LLD	LLD	LLD	LLD
Kr-85m	Ci	LLD	LLD	LLD	LLD
Kr-87	Ci	1.67E+00	LLD	LLD	LLD
Kr-88	Ci	LLD	LLD	LLD	LLD
Xe-133	Ci	7.48E+00	3.05E+01	LLD	5.74E-01
Xe-133m	Ci	LLD	LLD	LLD	LLD
Xe-135	Ci	LLD	1.37E-01	LLD	LLD
Xe-135m	Ci	LLD	LLD	LLD	LLD
Xe-138	Ci	<u>LLD</u>	<u>LLD</u>	<u>LLD</u>	<u>LLD</u>
Total for Period:		9.15E+00	3.06+01	LLD	5.74E-01
Iodines					
I-131	Ci	5.90E-05	2.46E-03	1.71E-5	8.32E-07
I-133	Ci	5.15E-06	3.55E-04	LLD	LLD
I-135	Ci	LLD	LLD	LLD	LLD
I-132	Ci	<u>LLD</u>	<u>LLD</u>	<u>LLD</u>	<u>LLD</u>
Total for Period:		6.42E-5	2.82E-03	1.71E-05	8.32E-07
Particulates and Tritium					
H-3	Ci	4.19E+00	1.99E+01	1.40E+01	1.19E+01
Sr-89 ^{b,c}	Ci	LLD	LLD	LLD	LLD
Sr-90 ^{b,c}	Ci	LLD	LLD	LLD	LLD
Cs-134	Ci	LLD	LLD	LLD	LLD
Cs-137	Ci	LLD	LLD	LLD	LLD
Ba-140	Ci	LLD	LLD	LLD	LLD
Co-58	Ci	LLD	2.13E-06	LLD	LLD
La-140	Ci	LLD	LLD	LLD	LLD
Co-60	Ci	<u>LLD</u>	<u>LLD</u>	<u>1.25E-06</u>	<u>LLD</u>
Total for Period:		4.19E+00	1.99E+01	1.4E+01	1.19E+01

Table 19 (Continued)

Gaseous Effluents - Mixed Mode Releases

Continuous Mode ^a			Batch Mode ^a		
Ar-41	<2.9E-08	μCi/ml	Kr-87	<4.5E-06	μCi/ml
Kr-85	<3.3E-06	μCi/ml	Kr-88	<6.6E-06	μCi/ml
Kr-85m	<1.3E-08	μCi/ml	Xe-135	<1.4E-05	μCi/ml
Kr-87	<6.0E-08	μCi/ml	Xe-135m	<2.1E-06	μCi/ml
Kr-88	<6.0E-08	μCi/ml	Xe-138	<2.8E-05	μCi/ml
Xe-131m	<4.4E-07	μCi/ml	Ar-41	<1.8E-06	μCi/ml
Xe-133m	<7.2E-08	μCi/ml	Kr-85	<1.2E-06	μCi/ml
Xe-135	<1.1E-08	μCi/ml	Xe-133	<2.4E-06	μCi/ml
Xe-135m	<5.9E-06	μCi/ml	Xe-133m	<1.0E-05	μCi/ml
Xe-138	<2.0E-05	μCi/ml			
I-135 ^c	<3.9E-10	μCi/ml			
Mn-54 ^c	<2.6E-14	μCi/ml			
Fe-59 ^c	<3.0E-14	μCi/ml			
Co-58 ^c	<3.0E-14	μCi/ml			
Co-60 ^c	<2.5E-14	μCi/ml			
Zn-65 ^c	<1.0E-13	μCi/ml			
Mo-99 ^c	<1.8E-14	μCi/ml			
Cs-134 ^c	<1.6E-14	μCi/ml			
Cs-137 ^c	<1.3E-14	μCi/ml			
Ce-141 ^c	<1.2E-13	μCi/ml			
Ce-144 ^c	<1.2E-14	μCi/ml			
Ba-140 ^c	<4.0E-14	μCi/ml			
La-140 ^c	<1.0E-14	μCi/ml			
Sr-89 ^{b,c}	<9.3E-16	μCi/ml			
Sr-90 ^{b,c}	<3.1E-16	μCi/ml			

a These radionuclides were not identified in every quarter in concentrations above the lower limit of detection (LLD). The largest LLD value is listed.

b Quarterly composite sample for continuous mode.

c Analysis not required for batch release.

Table 20
Liquid Effluents - Summation of All Releases

Type	Unit	1st Qtr 2000	2nd Qtr 2000	3rd Qtr 2000	4th Qtr 2000	Est. Total % Error
Fission and Activation Products						
Total Release (without Tritium, Gases, Alpha)	Ci	2.09E-03	3.12E-02	7.01E-03	1.78E-02	2.0E+01
Average Diluted Concentration During Period ^a	μCi/ml	2.23E-10	3.57E-09	5.80E-10	1.81E-09	
Percent of ODCM Limits	%	See Supplement information in ODCM Release Limits Section				
Percent of 10CFR20 Limit	%	3.98E-03	3.79E-02	5.90E-03	1.23E-02	
Tritium						
Total Release	Ci	1.43E+02	3.79E+01	7.9E+01	1.07E+02	2.0E+01
Average Diluted Concentration During Period ^a	μCi/ml	1.54E-05	4.33E-06	6.52E-06	1.09E-05	
Percent of 10CFR20 Limit	%	1.54E+00	4.33E-01	6.52E-01	1.09E+0	
Dissolved and Entrained Gases						
Total Release	Ci	2.61E-01	1.99E-03	3.58E-05	0.00E-00	2.0E+01
Average Diluted Concentration During Period ^a	μCi/ml	2.79E-08	2.27E-10	2.95E-12	0.00E-00	
Percent of 10CFR20 Limit	%	1.39E-02	1.14E-04	1.47E-06	0.00E-00	
Gross Alpha						
Total Release	Ci	1.26E-04	3.00E-03	LLD	2.03E-03	2.0E+01
Volume of Waste Released (prior to dilution)						
Batch	liter	6.78E+05	5.90E+05	4.03E+05	3.72E+05	2.0E+01
Continuous	liter	1.13E+08	1.38E+08	1.02E+08	9.73E+07	2.0E+01
Volume of Dilution Water						
Batch	liter	1.59E+08	1.42E+08	1.31E+08	1.05E+08	2.0E+01
Continuous	liter	9.08E+09	8.46E+09	1.19E+10	9.63E+09	2.0E+01
Total Volume of Water Released	liter	9.35E+09	8.75E+09	1.21E+10	9.83E+09	

^a Tritium and alpha are found in both continuous and batch releases. Average diluted concentrations are based on total volume of water released during the quarter. Fission and Activation products and Dissolved and Entrained Gases are normally only detected in batch releases.

Table 21
Liquid Effluents - Nuclides Released
Batch Releases

Nuclide	Unit	1st Qtr 2000	2 nd Qtr 2000	3rd Qtr 2000	4th Qtr 2000
Fission and Activation Products					
Co-58	Ci	1.96E-04	1.23E-02	2.79E-03	8.69E-03
Co-60	Ci	1.96E-04	5.16E-04	2.33E-04	1.39E-03
Ag-110m	Ci	3.56E-04	7.72E-03	2.84E-03	2.12E-04
Sb-125	Ci	4.39E-04	4.73E-03	2.63E-04	7.13E-03
Cs-134	Ci	LLD	LLD	LLD	LLD
Cs-137	Ci	1.02E-05	9.19E-06	LLD	1.61E-05
Sr-89 ^{a, b}	Ci	LLD	LLD	LLD	LLD
Sr-90 ^{a, b}	Ci	8.79E-05	LLD	LLD	LLD
Fe-55	Ci	7.44E-04	2.48E-03	7.06E-04	LLD
Cr-51	Ci	7.05E-06	7.11E-04	1.06E-04	7.01E-05
I-131	Ci	2.77E-05	8.40E-04	8.89E-07	LLD
I-132	Ci	LLD	2.00E-04	LLD	LLD
I-133	Ci	LLD	6.90E-06	LLD	LLD
Te-132	Ci	LLD	4.97E-05	LLD	LLD
Tc-99m	Ci	1.12E-06	7.46E-05	LLD	LLD
Sb-124	Ci	5.65E-07	9.33E-04	8.14E-06	1.65E-04
Sn-113	Ci	LLD	1.08E-04	9.31E-06	2.07E-05
Ru-103	Ci	LLD	3.30E-06	2.48E-06	LLD
Mn-54	Ci	LLD	LLD	LLD	1.84E-05
Np-239	Ci	LLD	LLD	LLD	LLD
Co-57	Ci	1.39E-06	2.32E-05	1.08E-05	1.18E-04
Nb-95	Ci	LLD	1.72E-05	LLD	LLD
Zr-95	Ci	1.29E-06	8.54E-05	LLD	LLD
Se-75	Ci	LLD	LLD	LLD	LLD
Fe-59	Ci	LLD	1.70E-05	LLD	LLD
Zn-65	Ci	LLD	LLD	LLD	LLD
Ce-144	Ci	LLD	LLD	LLD	LLD
Na-24	Ci	LLD	LLD	LLD	LLD
Zr-97	Ci	9.20E-06	2.54E-04	4.49E-05	LLD
Ce-141	Ci	LLD	LLD	LLD	LLD
Nb-97	Ci	LLD	LLD	LLD	LLD
La-140	Ci	1.39E-06	3.70E-05	LLD	LLD
Ba-140	Ci	LLD	LLD	LLD	LLD
Ru-106	Ci	LLD	6.10E-05	LLD	LLD
Ba-139	Ci	LLD	LLD	LLD	LLD
Mo-99	Ci	<u>LLD</u>	<u>2.32E-05</u>	<u>LLD</u>	<u>LLD</u>
Total for Period:	Ci	2.09E-03	3.12E-02	7.01E-03	1.78E-02

Table 21 (continued)
Liquid Effluents - Nuclides Released
Batch Releases

Nuclide	Unit	1st Qtr 2000	2nd Qtr 2000	3rd Qtr 2000	4th Qtr 2000
Tritium	Ci	1.43E+02	3.75E+01	7.90E+01	1.07E+2
Dissolved and Entrained Gases					
Kr-85m	Ci	LLD ^a	LLD ^a	LLD ^a	LLD ^a
Kr-85	Ci	9.49E-03	LLD	LLD	LLD
Xe-131m	Ci	7.81E-03	2.42E-04	LLD	LLD
Xe-133	Ci	2.43E-01	1.74E-03	3.58E-05	LLD
Xe-135	Ci	1.24E-05	1.73E-06	LLD	LLD
Xe-133m	Ci	4.59E-04	LLD	LLD	LLD
I-135	Ci	7.86E-06	LLD	LLD	LLD
Total for Period:	Ci	2.61E-01	1.99E-03	3.58E-05	N/A

Table 21 (continued)
Liquid Effluents - Nuclides Released
Continuous Releases

Nuclide	Unit	1st Qtr 2000	2nd Qtr 2000	3rd Qtr 2000	4th Qtr 2000
Fission and Activation Products					
Cr-51	Ci	LLD ^a	LLD ^a	LLD ^a	LLD ^a
Fe-59	Ci	LLD	LLD	LLD	LLD
Co-58	Ci	LLD	LLD	LLD	LLD
Co-60	Ci	LLD	LLD	LLD	LLD
Zn-65	Ci	LLD	LLD	LLD	LLD
Sr-89 ^{a,b}	Ci	LLD	LLD	LLD	LLD
Sr-90 ^{a,b}	Ci	LLD	LLD	LLD	LLD
Nb-95	Ci	LLD	LLD	LLD	LLD
Zr-95	Ci	LLD	LLD	LLD	LLD
Mo-99	Ci	LLD	LLD	LLD	LLD
Tc-99m	Ci	LLD	LLD	LLD	LLD
I-131	Ci	LLD	LLD	LLD	LLD
Cs-134	Ci	LLD	LLD	LLD	LLD
Cs-137	Ci	LLD	LLD	LLD	LLD
Ba-140/La-140	Ci	LLD	LLD	LLD	LLD
Ce-141	Ci	<u>LLD</u>	<u>LLD</u>	<u>LLD</u>	<u>LLD</u>
Total for Period:		N/A	N/A	N/A	N/A
Tritium	Ci	5.97E-01	3.80E-01	0.00E-00	2.56E-01
Dissolved and Entrained Gases					
Kr-85	Ci	LLD	LLD	LLD	LLD
Xe-131m	Ci	LLD	LLD	LLD	LLD
Xe-133	Ci	LLD	LLD	LLD	LLD
Xe-133m	Ci	LLD	LLD	LLD	LLD
Xe-135	Ci	LLD	LLD	LLD	LLD
Total for Period:	Ci	<u>N/A</u>	<u>N/A</u>	<u>N/A</u>	<u>N/A</u>

Table 21 (continued)

Liquid Effluents - Nuclides Released^a

Na-24	<2.0E-08	μCi/ml	Sb-124	<1.0E-08	μCi/ml
Cr-51	<1.7E-07	μCi/ml	Sb-125	<1.7E-08	μCi/ml
Mn-54	<2.1E-08	μCi/ml	Te-132	<1.8E-08	μCi/ml
Fe-55 ^b	<7.0E-07	μCi/ml	Ce-141	<3.0E-08	μCi/ml
Fe-59	<4.2E-08	μCi/ml	Ce-144	<1.7E-07	μCi/ml
Co-57	<1.6E-08	μCi/ml	Cs-134	<2.1E-08	μCi/ml
Co-58	<1.9E-08	μCi/ml	Ce-136	<2.8E-08	μCi/ml
Co-60	<2.5E-08	μCi/ml	Cs-137	<2.7E-08	μCi/ml
Zn-65	<5.2E-08	μCi/ml	Ba-140	<7.0E-08	μCi/ml
Se-75	<2.4E-08	μCi/ml	La-140	<3.0E-08	μCi/ml
Sr-89 ^b	<3.0E-08	μCi/ml	Np-239	<1.2E-07	μCi/ml
Sr-90 ^b	<8.0E-09	μCi/ml	I-131	<2.5E-08	μCi/ml
Zr-95	<4.0E-08	μCi/ml	I-132	<1.0E-08	μCi/ml
Zr-97	<2.5E-08	μCi/ml	I-133	<2.1E-08	μCi/ml
Nb-95	<2.1E-08	μCi/ml	I-135	<1.7E-07	μCi/ml
Mo-99	<1.6E-07	μCi/ml	Kr-85	<6.2E-06	μCi/ml
Tc-99m	<1.8E-08	μCi/ml	Xe-131	<7.7E-07	μCi/ml
Ru-103	<2.2E-08	μCi/ml	Xe-133	<4.6E-08	μCi/ml
Ag-110m	<2.5E-08	μCi/ml	Xe-133m	<1.6E-07	μCi/ml
Sn-113	<2.8E-08	μCi/ml	Xe-135	<1.9E-08	μCi/ml

^a These radionuclides were not identified every quarter in concentrations above the lower limit of detection (LLD). The largest LLD value is used for each radionuclide. LLDs are applicable to both batch and continuous modes due to identical sample and analysis methods.

^b Quarterly composite sample

Table 22

Solid Waste and Irradiated Fuel Shipments

A. SOLID WASTE SHIPPED OFFSITE FOR BURIAL OR DISPOSAL (Not irradiated fuel)

1. Type of Waste		Unit	12-month Period	Est. Total Error, %
a.	Spent resins, filter sludges, evaporator bottoms, etc.	m ³	2.44E+01	2.5E+01
		Ci	1.78E+00	2.5E+01
b.	Dry compressible waste, contaminated equip., etc.	m ³	1.67E+01	2.5E+01
		Ci	7.60E+00	2.5E+01
c.	Irradiated components, control rods, etc.	m ³	N/A	N/A
		Ci		
d.	Others: dewatered primary system cartridge filters	m ³	1.27E-01	2.5E+01
		Ci	1.41E-01	2.5E+01

2. Estimate of major nuclide composition (by type of waste)

	Type	Percent (%)	Est. Total Error, %
a. Spent Resins	Fe ⁵⁵	3.21E+01	2.50E+01
	Co ⁵⁸	1.98E+01	2.50E+01
	Co ⁶⁰	7.36E+00	2.50E+01
	Ni ⁶³	2.27E+01	2.50E+01
	Sb ¹²⁵	3.56E+00	2.50E+01
	Mn ⁵⁴	1.63E+00	2.50E+01
	Cs ¹³⁷	2.58E+00	2.50E+01
	C ¹⁴	1.55E+00	2.50E+01
	H ³	6.46E+00	2.50E+01
b. Dry compressible waste, contaminated equipment, etc.	Fe ⁵⁵	6.87E+01	2.50E+01
	Co ⁶⁰	1.00E+00	2.50E+01
	C ¹⁴	2.00E+00	2.50E+01
	Cs ¹³⁴	2.40E+00	2.50E+01
	Cs ¹³⁷	2.30E+01	2.50E+01
	Co ⁵⁸	1.50E+00	2.50E+01
c. None			
d. Cartridge filters	Fe ⁵⁵	3.45E+01	2.50E+01
	Co ⁵⁸	3.20E+01	2.50E+01
	Ni ⁶³	1.64E+01	2.50E+01
	Zn ⁶⁵	1.47E+01	2.50E+01
	Cs ¹³⁷	1.99E+00	2.50E+01
	Co ⁶⁰	2.27E+01	2.50E+01
	C ¹⁴	1.29E+00	2.50E+01

Table 22 (continued)

Solid Waste and Irradiated Fuel Shipments

3. Solid Waste Disposition

Number of Shipments:	1
Mode of Transportation:	Truck
Destination:	Barnwell, SC
Type of Container (Container Volume):	1 resin/filter media HIC (5.72 m ³) buried
Number of Shipments:	5
Mode of Transportation:	Truck
Destination:	GTS Duratek, Oak Ridge, TN for processing then disposal at Envirocare of Utah or Barnwell S.C.
Type of Container (Container Volume):	Metal boxes (36.3 m ³)
Volume shipped for processing	300.97m ³
Volume disposed	15.86m ³
Number of Shipments:	5
Mode of Transportation:	Truck
Destination:	ATG Inc. Richland Washington for processing then disposal at Envirocare of Utah or Barnwell S.C.
Type of Container (Container Volume):	Steel tank (15.2 m ³), HIC (1.4m ³) Metal boxes (2.6 m ³)
Volume shipped for processing	72.88m ³
Volume disposed	7.45m ³
Number of Shipments:	1
Mode of Transportation:	Truck
Destination:	AERC, Oak Ridge Tenn. for processing then disposal at Envirocare of Utah
Type of Container (Container Volume):	Metal liners (4.82m ³)
Volume shipped for processing	14.45m ³
Volume disposed	13.03m ³

B. IRRADIATED FUEL SHIPMENTS

There were no shipments of irradiated fuel.

Table 23

Doses Due to Gaseous Releases
For January through December 2000

Maximum Individual Dose Due to I-131, H-3 and Particulates with Half-Lives Greater than 8 days.

Whole Body Dose	1.36E-03 mrem
Significant Organ Dose	1.98E-02 mrem

Maximum Individual Dose Due to Noble Gas

Whole Body Dose	8.97E-04 mrad
Skin Dose	2.50E-03 mrad

Population Dose Due to I-131, H-3 and Particulates with Half-Lives Greater than 8 days.

Total Integrated Population Dose	7.15E-03 person-rem
Average Dose to Individual in Population	3.27E-06 mrem

Population Dose Due to Noble Gas

Total Integrated Population Dose	1.24E-03 person-rem
Average Dose to Individual in Population	5.68E-07 mrem

Table 24
Doses Due to Liquid Releases
for January through December 2000

Maximum Individual Whole Body Dose	5.54E-02 mrem
Maximum Individual Significant Organ Dose	6.25E-02 mrem
Population Dose	
Total Integrated Population Dose	5.33E-01 person-rem
Average Dose to Individual	2.44E-04 mrem

Table 25

Annual Dose to The Most Exposed (from all pathways) Member of the Public 2000

	ANNUAL DOSE (mrem)	40CFR190 LIMIT (mrem)	PERCENT OF LIMIT
Whole Body Dose*			
Noble Gas	8.97E-04		
Iodine, Tritium, Particulates Liquid	1.36E-03 5.54E-02		
Total Whole Body Dose	5.76E-02	25	2.31E-01
Thyroid Dose			
Iodine, Tritium, Particulates	8.18E-02	75	1.09E-01
Skin Dose			
Noble Gas	3.74E-03	25	1.50E-02
Significant Organ Dose (Thyroid)	8.18E-02	25	3.27E-01

Meteorological Data

Meteorological data on 3½ inch microdisk for January through December 31, 2000, has been submitted with this document to the U. S. Nuclear Regulatory Commission, Document Control Desk, Washington, D.C. 20555.

*Direct radiation from the facility is not distinguishable from natural background and is, therefore, not included in this compilation.



Land Use Census

Land Use Census

Program Design

Each year a Land Use Census is conducted by Davis-Besse in order to update information necessary to estimate radiation dose to the general public and to determine if any modifications are necessary to the Radiological Environmental Monitoring Program (REMP). The Land Use Census is required by Title 10 of the Code of Federal Regulations, Part 50, Appendix I and Davis-Besse Nuclear Power Station Offsite Dose Calculation Manual, Section 5, Assessment of Land Use Census Data. The Land Use Census identifies gaseous pathways by which radioactive material may reach the general population around Davis-Besse. The information gathered during the Land Use Census for dose assessment and input into the REMP ensure these programs are as current as possible. The pathways of concern are listed below:

- **Inhalation Pathway** - Internal exposure as a result of breathing radionuclides carried in the air.
- **Ground Exposure Pathway** - External exposure from radionuclides deposited on the ground
- **Plume Exposure Pathway** - External exposure directly from a plume or cloud of radioactive material.
- **Vegetation Pathway** - Internal exposure as a result of eating vegetables, fruit, etc. which have a build up of deposited radioactive material or which have absorbed radionuclides through the soil.
- **Milk Pathway** - Internal exposure as a result of drinking milk, which may contain radioactive material as a result of a cow or goat grazing on a pasture contaminated by radionuclides.

Methodology

The Land Use Census consists of recording and mapping the locations of the closest residences, dairy cattle and goats, and broad leaf vegetable gardens (greater than 500 square feet) in each meteorological sector within a five mile radius of Davis-Besse.

The surveillance portion of the 2000 Land Use Census was performed during the month of July. In order to gather as much information as possible, the locations of residences, dairy cows, dairy goats, and vegetable gardens were recorded. The residences, vegetable gardens, and milk animals are used in the dose assessment program. The vegetable gardens must be at least 500 square feet in size, with at least 20% of the vegetables being green leafy plants (such as lettuce, cabbage, and kale).

Each residence is tabulated as being an inhalation pathway, as well as ground and plume exposure pathways. Each garden is tabulated as a vegetation pathway.

All of the locations identified are plotted on a map (based on the U.S. Geological Survey 7.5 minute series of the relevant quadrangles) which has been divided into 16 equal sectors corresponding to the 16 cardinal compass points (Figure 31). The closest residence, milk animal, and vegetable garden in each sector are determined by measuring the distance from each to the station vent at Davis-Besse.

Results

The following changes in the pathways were recorded in the 2000 census:

- **S Sector** – A garden at 4960 meters replaced a garden at 3360 meters
- **SW Sector** - The garden at 5330 meters was replaced by a garden at 5400 meters.
- **WSW Sector** – A garden was added at 4270 meters
- **WNW Sector** – The garden at 2900 meters was removed and a residence was added at 1750 meters.

The critical receptor identified by the 2000 Land Use Census is a garden in the **W** sector at 1610 meters from Davis-Besse.

The detailed list in Table 26 was used to update the database of the effluent dispersion model used in dose calculations. Table 26 is divided by sectors and lists the distance (in meters) of the closest pathway in each meteorological sector.

Table 27 provided information on pathways, critical age group, atmospheric dispersion (X/Q) and deposition (D/Q) parameters for each sector. This information is used to update the Offsite Dose Calculation Manual (ODCM). The ODCM describes the methodology and parameters used in calculating offsite doses from radioactivity released in liquid and gaseous effluents and in calculating liquid and gaseous effluent monitoring instrumentation alarm/trip setpoints.

DAVIS-BESSE NUCLEAR POWER STATION
 RADIOLOGICAL ENVIRONMENTAL MONITORING PROGRAM
 PRIMARY PATHWAYS WITHIN 5 MILES RADIUS

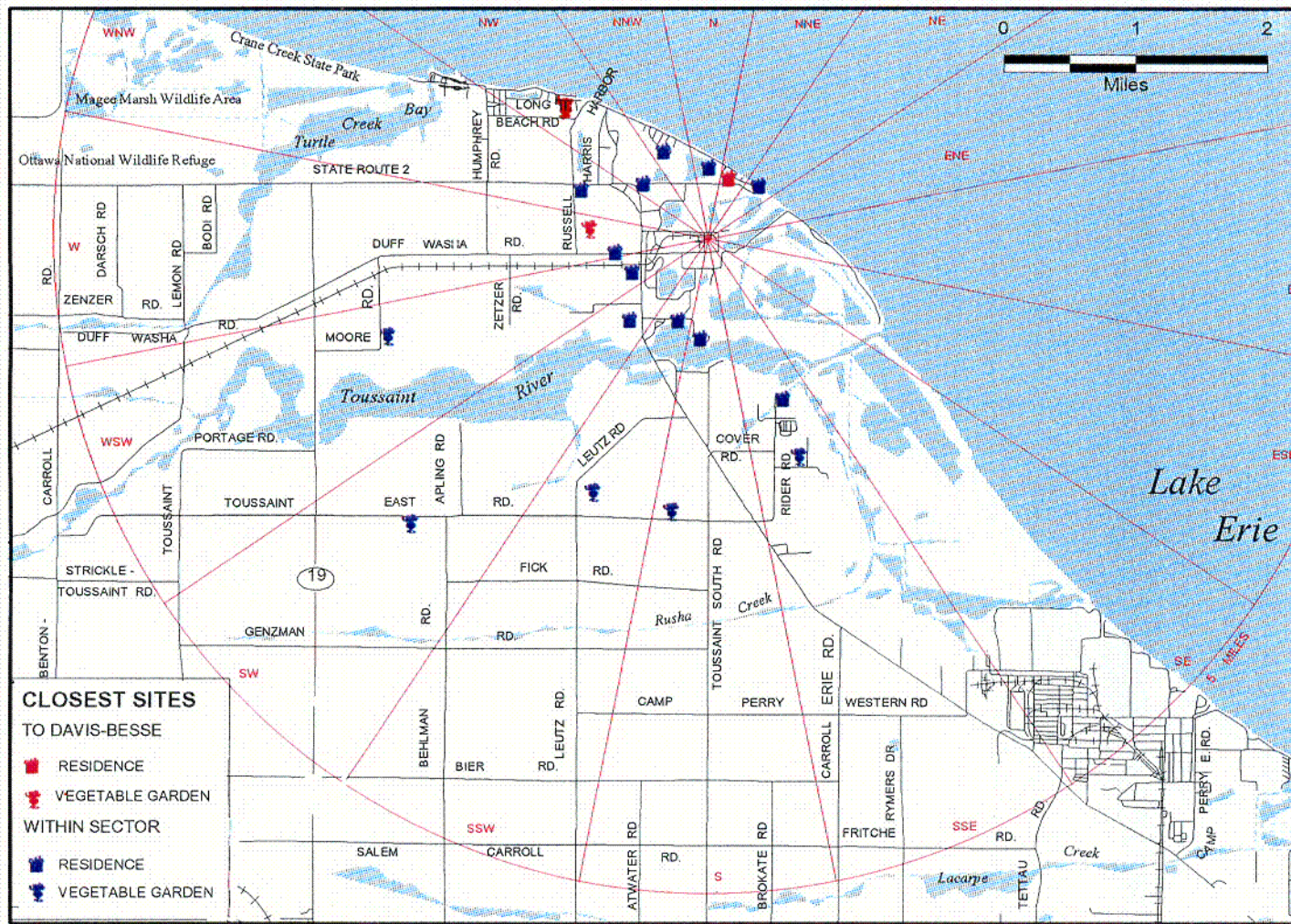

ENVIRONMENTAL MONITORING

Figure 31: Land Use Census Map

Table 26
Closest Exposure Pathways Present in 2000

<u>Sector</u>	<u>Distance from Station (meters)</u>	<u>Closest Pathways</u>
N	880	Inhalation Ground Exposure Plume Exposure
NNE	880	Inhalation Ground Exposure Plume Exposure
NE	900	Inhalation Ground Exposure Plume Exposure
ENE, E, ESE, SE	N/A	Located over Lake Erie
SSE	2860	Vegetation
SSE**	1970	Inhalation Ground Exposure Plume Exposure
S**	4960	Vegetation
S**	1030	Inhalation Ground Exposure Plume Exposure
SSW	2350	Vegetation
SSW	980	Inhalation Ground Exposure Plume Exposure
SW**	5400	Vegetation
SW	1040	Inhalation Ground Exposure Plume Exposure

** Changes since 1999

Table 26 (continued)
Closest Exposure Pathways Present in 2000

<u>Sector</u>	<u>Distance from Station (meters)</u>	<u>Closest Pathways</u>
WSW**	1540	Inhalation Ground Exposure Plume Exposure
WSW**	4270	Vegetation
W	980	Inhalation Ground Exposure Plume Exposure
W	1610	Vegetation
WNW**	1750	Inhalation Ground Exposure Plume Exposure
NW	1490	Inhalation Ground Exposure Plume Exposure
NW	2300	Vegetation
NNW	1270	Inhalation Ground Exposure Plume Exposure

** Changes since 1999

Table 27
Pathway Locations and Corresponding
Atmospheric Dispersion (X/Q) and Deposition (D/Q)
Parameters

SECTOR	METERS	CRITICAL PATHWAY	AGE GROUP	X/Q (SEC/M³)	D/Q (M⁻²)
N	880	Inhalation	Child	9.15E-07	8.40E-09
NNE	880	Inhalation	Child	1.24E-06	1.44E-08
NE	900	Inhalation	Child	1.26E-06	1.58E-08
ENE*	---	---	---	---	---
E*	---	---	---	---	---
ESE*	---	---	---	---	---
SE*	---	---	---	---	---
SSE	2860	Vegetation	Child	6.91E-08	8.13E-10
S**	4960	Vegetation	Child	3.28E-08	2.29E-10
SSW	2350	Vegetation	Child	5.90E-08	1.03E-09
SW**	5400	Vegetation	Child	3.71E-08	3.13E-10
WSW**	4270	Vegetation	Child	5.71E-08	5.31E-10
W	1610	Vegetation	Child	2.77E-07	4.37E-09
WNW**	1750	Inhalation	Child	1.46E-07	1.72E-09
NW	2300	Vegetation	Child	6.98 E-08	5.79E-10
NNW	1270	Inhalation	Child	2.41E-07	1.73E-09

* Since these sectors are located over marsh areas and Lake Erie, no ingestion pathways are present.

** Changes since 1999