

REVISIONS							
LTR	DESCRIPTION	DATE	BY	CHK	ENG	APPD	APPD
A	GENERAL REVISION	8-17-98	DHD				
B	GENERAL REVISION	9-16-98	JLF	FEL	JLF	FEL	LLA
C	PER CUST COMMENTS & DESIGN CHANGES	11-16-98	JLF	SPC	JLF	PAJ	YH

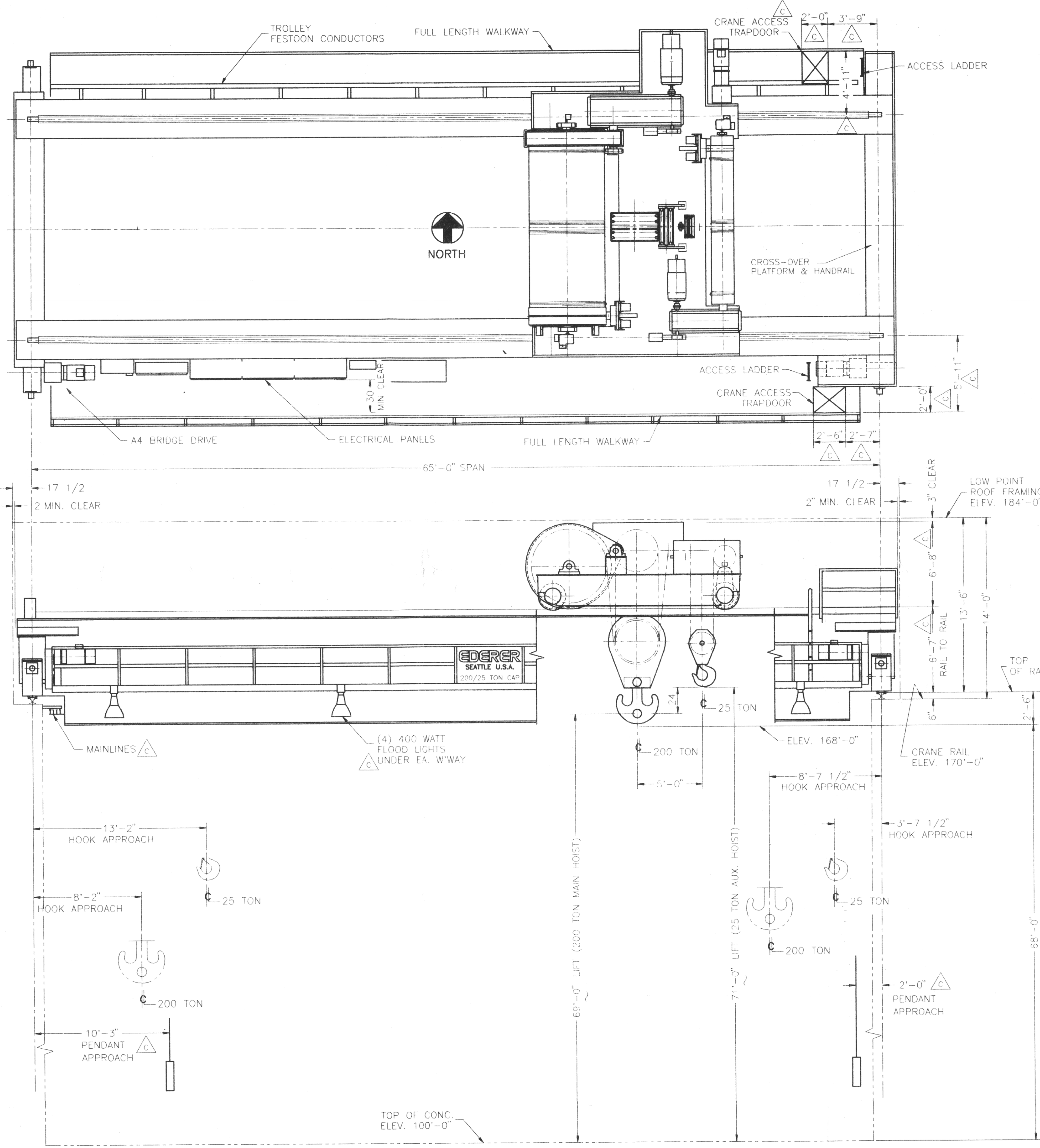

CRANE DATA:	
POWER:	480-3-60
BRIDGE WHEEL:	(8) 30" DIA.
MAXIMUM STATIC WHEEL LOAD:	147,000 LBS.
RUNWAY RAIL:	171 LBS./YARD
SERVICE:	INDOOR
DUTY:	NOG 1 TYPE 1
CONTROL:	RADIO REMOTE & PENDANT BACKUP

WEIGHTS	
GIRDER W/ CONTROL PANELS & W'WAY	68 K
GIRDER W/ TR. FESTOON & W'WAY	58 K
TROLLEY	111.5 K
MAIN HOIST LOWER BLOCK	15 K
AUX HOIST LOWER BLOCK	3.5 K
EQUALIZING SILLS (EACH)	6 K
END TRUCKS, DRIVER (EACH)	8 K
END TRUCKS, IDLER (EACH)	6.7 K
TOTAL CRANE WEIGHT	310 K

SPEEDS (+/- 10%) fpm			
	NO LOAD	RATED LOAD	
BRIDGE	-	40	
TROLLEY	-	25	
MAIN HOIST	5.7	3.8	
AUX HOIST	21	14	

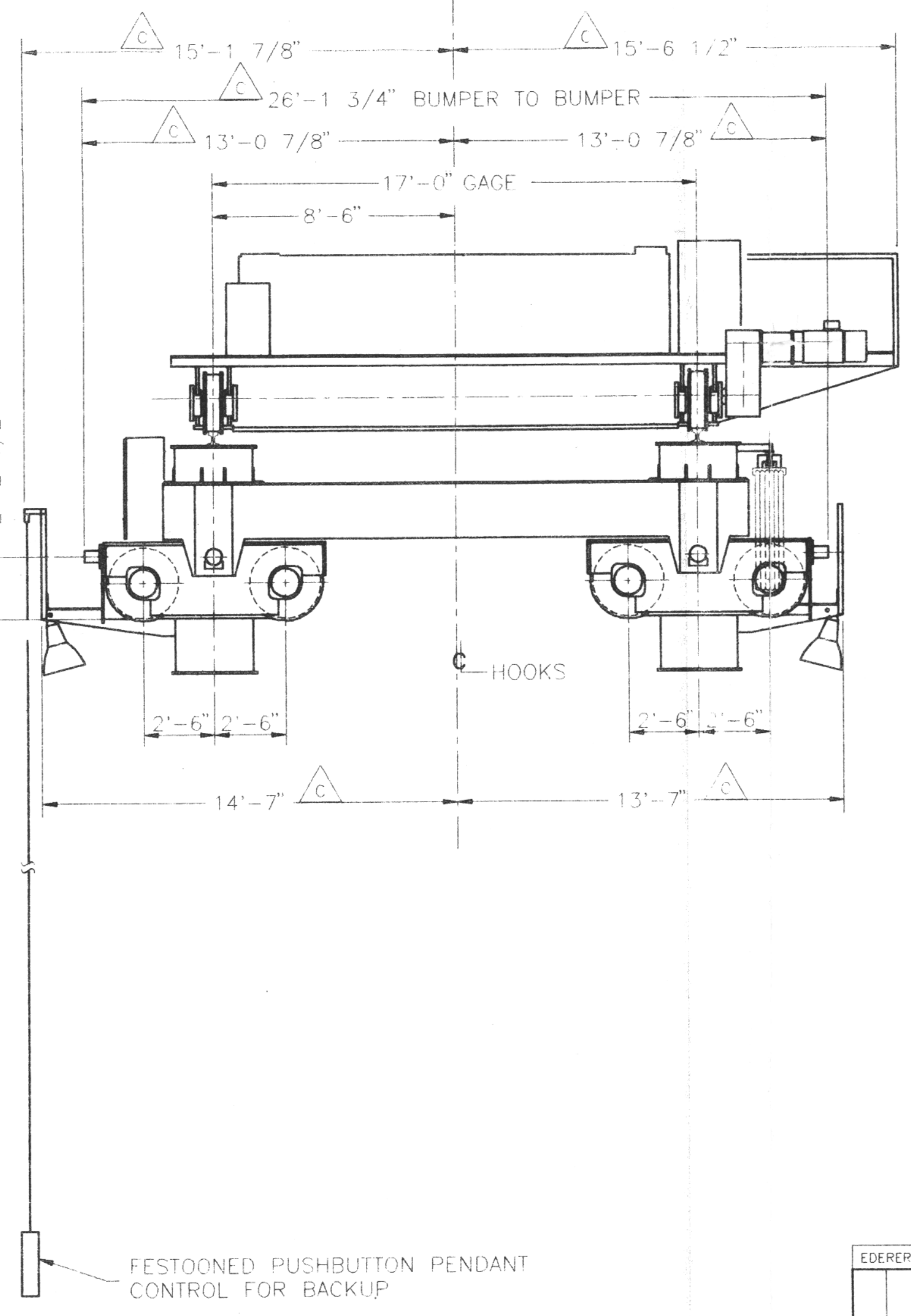

APERTURE CARD
99030 20151

P.O. NO. 0599602-023

THIS DOCUMENT AND THE CONTENTS THEREOF ARE THE PROPRIETARY TECHNOLOGY OF EDERER INCORPORATED AND MAY NOT BE USED OR DISCLOSED TO OTHERS WITHOUT WRITTEN PERMISSION OF EDERER INCORPORATED.

EDERER INCORPORATED, 2925 FIRST AVE SO. SEATTLE, WA 98124 TEL: 206-622-4421 FAX: 206-623-8583								
ITEM NO	DESCRIPTION	QTY.	MATERIAL	WEIGHT				
LIST OF MATERIALS								
ITEMS WITH SPECIAL QUALITY REQUIREMENTS		0	SCALE 1/4" = 1 FT	TOTAL WT. - LBS				
ADVANCE ORDERED ITEMS		COST ITEM NO						
DRAWN	DHD	7-23-98						
CHECK	JLF	9/16/98						
ENG.	JLF	9/16/98						
APPD.	FEL	10/14/98						
APPD.	L.L. ANDERSON	10/14/98						
<table border="0"> <tr> <td>EDERER INCORPORATED</td> <td>WASHINGTON STAR CRANES</td> </tr> <tr> <td>E EDERER U WASHINGTON S STAR C CRANES</td> <td></td> </tr> </table>					EDERER INCORPORATED	WASHINGTON STAR CRANES	E EDERER U WASHINGTON S STAR C CRANES	
EDERER INCORPORATED	WASHINGTON STAR CRANES							
E EDERER U WASHINGTON S STAR C CRANES								
CLEARANCE DRAWING								
200/25 TON CAPACITY BRIDGE CRANE								
PRIVATE FUEL STORAGE FACILITY								
SKULL VALLEY, UTAH								
PA-2189				REV C				

78-22
9903020151
2/11/99