

CATAWBA

FINAL SUBMITTAL

**CATAWBA
INITIAL LICENSE EXAMINATION
JOB PERFORMANCE MEASURE**

JPM 1R/ADMIN

Evaluate QPTR Calculation and Determine Required
Technical Specification Actions

CANDIDATE

EXAMINER

**CATAWBA
INITIAL LICENSE EXAMINATION
JOB PERFORMANCE MEASURE**

Task:

Evaluate N-41 failure and QPTR calculation and determine required Technical Specification actions.

Alternate Path:

N/A

Facility JPM #:

NEW

K/A Rating(s):

GKA 2.1.7 (3.7/4.4)

Task Standard:

Determine that QPTR is not within allowable Technical Specification values and determine required actions..

Preferred Evaluation Location:

Simulator In-Plant

Preferred Evaluation Method:

Perform Simulate

References:

PT/1/A/4600/009 Enclosure 13.1
PT/0/A/4600/002A
Technical Specification 3.2.4
Technical Specification 3.3.1

Validation Time: _____ **Time Critical:** No

Candidate: _____
NAME

Time Start : _____
Time Finish: _____

Performance Rating: SAT _____ UNSAT _____ Performance Time _____

Examiner: _____ / _____
NAME SIGNATURE DATE

=====

COMMENTS

Tools/Equipment/Procedures Needed:

CNS Tech Specs
PT/0/A/4600/008B Enclosure 13.3

READ TO OPERATOR

DIRECTION TO TRAINEE:

I will explain the initial conditions, and state the task to be performed. All control room steps shall be performed for this JPM, including any required communications. I will provide initiating cues and reports on other actions when directed by you. Ensure you indicate to me when you understand your assigned task. To indicate that you have completed your assigned task return the handout sheet I provided you.

INITIAL CONDITIONS:

You are the OATC
The following events have occurred on Unit 1:

Power is being reduced from 100% RTP to repair and oil leak on 1A Feed Pump

0000 The OAC failed and is not operating

0400 Power Range Channel N-41 failed low

0500 Power reduction is stopped at 63% RTP

1200 QPTR calculation is due

1230 Results of the QPTR calculation are brought to the control room

INITIATING CUE:

What actions are/were required based on the information given above?

JPM OVERALL STANDARD:

Determine QPTR is not within the limits of Tech Spec 3.2.4 and determine the actions required by Tech Spec 3.2.4. Determine that N-41 is inoperable per Tech Spec 3.3.1 and determine the actions required by Tech Spec 3.3.1.

K/A 2.1.7 (3.7/4.4)

<p>Examiner Note: If the candidate requests a copy of PT/1/A/4600/009 (Loss of Operator Aid Computer), inform him that the BOP will perform this PT.</p> <p>STEP 1: Operator obtains a copy of Tech Spec 3.3.1 and determines that the following bistables associated with N-41 must be tripped by 1000</p> <p>Overpower delta T Overtemperature delta T P/R hi flux low setpoint P/R high flux high setpoint P/R high flux rate</p> <p>STANDARD: Operator determines that N-41 is inoperable and goes to Tech Spec 3.3.1 and determines that Conditions D and E apply</p> <p>COMMENTS:</p>	<p>CRITICAL STEP</p> <p>___SAT</p> <p>___UNSAT</p>
<p>STEP 2: Operator determines that a quadrant is >1.02 at 1200 and recommends performing the required actions of Technical Specification 3.2.4 Condition A.</p> <p>STANDARD: Operator determines that a quadrant is > 1.02 and goes to Technical specification 3.2.4 for actions required. Determines that Required Actions A.1; A.2; A.3; A.4; A.5; A.6 and A.7 all apply.</p> <p>Examiner Note: Required actions A.2 and A.4 are critical. Required Action A.1 is in progress and so is not critical. Required Actions A.3; A.5; A.6 and A.7 are performed by other station groups and so are not critical</p> <p>COMMENTS:</p>	<p>CRITICAL STEP</p> <p>___SAT</p> <p>___UNSAT</p>

TIME STOP: _____

CANDIDATE CUE SHEET
(TO BE RETURNED TO EXAMINER UPON COMPLETION OF TASK)

INITIAL CONDITIONS:

The following events have occurred on Unit 1:

Power is being reduced from 100% RTP to repair and oil leak on 1A Feed Pump

0000 The OAC failed and is not operating

0400 Power Range Channel N-41 failed low

0500 Power reduction is stopped at 63% RTP

1200 QPTR calculation is due

1230 Results of the QPTR calculation are brought to the control room

INITIATING CUE:

What actions are/were required based on the information given above?

CANDIDATE CUE SHEET
(TO BE RETURNED TO EXAMINER UPON COMPLETION OF TASK)

INITIAL CONDITIONS:

The following events have occurred on Unit 1:

Power is being reduced from 100% RTP to repair and oil leak on 1A Feed Pump

0000 The OAC failed and is not operating

0400 Power Range Channel N-41 failed low

0500 Power reduction is stopped at 63% RTP

1200 QPTR calculation is due

1230 Results of the QPTR calculation are brought to the control room

INITIATING CUE:

What actions are/were required based on the information given above?

ENCLOSURE 13.3
QUADRANT TILT CALCULATIONS

Detector (Upper)	Meas. Current	Calibration Current	Relative Flux RF (Meas. Current ÷ Calibration Current)	Average Relative Flux (Upper) (Avg. of All Detector Currents)	Tilt (Upper) (Relative Flux ÷ Average Flux)
N-41	0	0	0		0
N-42	255	237.1	.988		1.004
N-43	251	253.9	.989		1.005
N-44	198	203.2	.974		.9902
				.9836	

Detector (Lower)	Meas. Current	Calibration Current	Relative Flux (Meas. Current ÷ Calibration Current)	Average Relative Flux (Lower) (Avg. of All Detector Currents)	Tilt (Lower) (Relative Flux ÷ Average Flux)
N-41	0	0	0		0
N-42	271	261.2	1.044		1.029
N-43	264	264.9	1.004		.9998
N-44	220	222.1	.995		.9809
				1.0143	

DVM S/N: 1234777 Cal. Due Date: 9/30/99

Date/Time of Current Measurements: 9/21/99 1 1130

Recorded By Jed Fox Date: 9/21/99

Calculation Verified By Mark Hawley Date: 9/21/99

Duke Power Company Catawba Nuclear Station	Procedure No. PT/1/A/4600/009
	Revision No. 061
	Electronic Reference No. CN005GA4

Loss of Operator Aid Computer

Continuous Use

Loss of Operator Aid Computer

1. Purpose

To document Technical Specifications requirements normally performed by the Operator Aid Computer in the event that the unit Operator Aid Computer is out of service.

2. Reference

- 2.1 OP/1/A/6700/003 (Operation with the Operator Aid Computer Out of Service)
- 2.2 Catawba TS and SLC Requirements:
 - 2.2.1 TS 3.1.4
 - 2.2.2 TS 3.1.6
 - 2.2.3 TS 3.2.3
 - 2.2.4 TS 3.2.4
 - 2.2.5 TS 3.4.2
 - 2.2.6 TS 3.7.5
 - 2.2.7 TS 3.4.13
 - 2.2.8 TS 3.4.15
 - 2.2.9 SR 3.1.4.1
 - 2.2.10 SR 3.1.6.2
 - 2.2.11 SR 3.2.3.1
 - 2.2.12 SR 3.2.4.1
 - 2.2.13 SR3.4.2.1
 - 2.2.14 SLC 16.5-7

3. Time Required

- 3.1 Manpower - One Operator
- 3.2 Time - Until the Operator Aid Computer is restored to service.

3.3 Frequency - When the Operator Aid Computer is out of service.

4. Prerequisite Tests

None

5. Test Equipment

None

6. Limits and Precautions

6.1 IF an acceptance criteria is NOT met, the Operations Shift Manager and the Operator at the Controls should be notified immediately.

6.2 IF the unit status OR system condition prevents the performance of a surveillance item, the item should be noted on the affected data sheet with an explanation and the Operations Shift Manager and the Operator at the Controls should be notified immediately.

7. Required Unit Status

None

8. Prerequisite System Condition

— Verify the Operator Aid Computer is out of service.

9. Test Method

A visual inspection of various system instrumentation will be made until the computer is returned to service.

10. Data Required

Complete Enclosures as required.

11. Acceptance Criteria

11.1 No data taken shall exceed limits listed on the Enclosures.

11.2 Any discrepancy noted during the performance of this test which does NOT keep the test from meeting the acceptance criteria shall be given to the Operations Shift Manager for evaluation.

- 11.3 Any discrepancy which keeps the test from meeting the acceptance criteria will be listed on a Procedure Discrepancy Process Record showing corrective action taken.
- 11.4 IF the acceptance criteria is NOT met, the Compliance Engineer shall be notified immediately for determination of reportability.

12. Procedure

- 12.1 IF a Safety Injection has occurred, immediately dispatch an NLO to monitor ND/NS Sump at Aux Waste Panel 1ELCC0013, (AB-543, MM-53-54, Rm 200) per Enclosure 13.1 (ND/NS Sump Monitoring).
- 12.2 IF in Modes 5 OR 6, EVERY 15 MINUTES document the critical core parameters listed on Enclosure 13.2 (Critical Core Parameters Sheet) (Reference OEP).
- 12.3 IF Start Up Of ND System During Plant Cooldown (OP/1/A/6200/004) is in progress AND KCHX Maximized Cooling Temperature Monitoring is being performed, within 15 minutes and every 15 minutes thereafter record parameters on Enclosure 13.3.
- 12.4 EVERY 15 MINUTES record on Enclosure 13.4 (Auxiliary Building Ventilation Supply Unit Status) the status of the Auxiliary Building Ventilation System supply units.
- 12.5 IF in Modes 1-4, within 30 minutes of Loss of OAC and once per hour thereafter, verify and record on Enclosure 13.5 (Ventilation Unit Condensate Drain Tank Input Rate Determination) that the rate of increase in VUCDT level is < 1% per hour.
- 12.6 IF in Modes 1-4, within 30 minutes of Loss of OAC, begin performing Enclosure 13.6 (Containment Floor and Equipment Sumps Input Rate Determination) to verify input to the Containment Floor and Equipment Sump is less than 1 gpm.
- 12.7 IF in Modes 1-4, within 30 minutes of Loss of OAC and once per hour thereafter, verify and record on Enclosure 13.7 (1EMF-38 Delta Count Rate Determination) that the change in count rate on 1EMF-38 is < 750 cpm in one hour.
- 12.8 IF in Modes 1-4, within 30 minutes of Loss of OAC and once per hour thereafter, verify and record on Enclosure 13.8 (1EMF-39 Delta Count Rate Determination) that the change in count rate on 1EMF-39 is < 6700 cpm in one hour.
- 12.9 IF ALL the following conditions exist (Reference SR 3.4.2.1):
- Reactor Critical
 - $T_{AVG} < 561^{\circ}F$
 - $T_{REF} - T_{AUCT} - Hi/Lo$ Alarm Present, Annunciator 1AD2 A/4

EVERY 30 MINUTES verify Reactor Coolant loops $T_{AVG} \geq 551^{\circ}F$ by completing Enclosure 13.9 (T_{AVG} Data Sheet).

- 12.10 IF both trains of the plasma display monitor are inoperable in Modes 1-6, EVERY 60 MINUTES OR after 10% change in power, complete Enclosure 13.10 (Subcooling Data Sheet) to monitor subcooling margin.

NOTE: To calculate the initial change in MWH, the previous hour reading may be obtained from the Unit 2 switchboard log.

- 12.11 IF Unit 1 net generation can NOT be obtained from the Unit 1 operator aid computer, EVERY HOUR on the HOUR complete Enclosure 13.11 (Electrical Data Sheet).

NOTE:

1. IF pressure (primary and secondary) are verified < 200 psig, then temperatures are NOT required to be taken nor recorded.
2. Use a calibrated pyrometer to obtain S/G shell temperatures.

- 12.12 IF NC T_C is > 80°F AND a NC pump is operating, then the secondary side temperature is > 80°F AND documentation of shell temps is NOT necessary. IF in Modes 5, 6 OR No Mode, EVERY 60 MINUTES complete Enclosure 13.12 (Steam Generator Data Sheet) (Reference SLC 16.5-7).
- 12.13 IF in Mode 1 AND less than 50% rated power, prior to exceeding 50% rated power AND every 1 hour thereafter, with the AFD monitor alarm inoperable, monitor and log the indicated Axial Flux Difference for each operable excore channel on Enclosure 13.13 (Axial Flux Difference (% Δ Flux) Following Loss of AFD Monitor Alarm). (Reference SR 3.2.3.1 and TS 3.2.3).
- 12.14 IF in Mode 1 AND $\geq 50\%$ rated power, once within 1 hour AND every 1 hour thereafter with the AFD monitor alarm inoperable, monitor and log the indicated Axial Flux Difference for each operable excore channel on Enclosure 13.13 (Axial Flux Difference (% Δ Flux) Following Loss of AFD Monitor Alarm). (Reference SR 3.2.3.1 and TS 3.2.3).
- 12.15 IF in Modes 1 OR 2, EVERY 4 HOURS verify by signing off on Enclosure 13.14 (Rod Verification Checklist) that the Digital Rod Position indication for all rods are within ± 12 steps of their group step counter demand position and operable (Reference SR 3.1.4.1).
- 12.16 IF in Mode 1 OR 2 AND $K_{EFF} \geq 1.0$, EVERY 4 HOURS verify and record on Enclosure 13.15 (Rod Insertion Limit Checksheet) that each control bank of rods is above the rod insertion limit (Reference SR 3.1.6.2).

- 12.17 IF in Modes 1,2, 3, OR Mode 4, when steam generators are being used for heat removal, EVERY 4 HOURS record CA suction source temperatures measured locally using a calibrated Keithley 872 digital thermometer, Type J or its equivalent per Enclosure 13.16 (CA Suction Source Temperature Monitoring Data.)
- 12.18 IF in Modes 1-4, EVERY 6 HOURS, document data needed for primary to secondary leakage calculation on Enclosure 13.17 (Primary to Secondary Leakage Calculation Data) and provide data to Chemistry. Notify Secondary Chemistry to perform CP/O/B/8800/014 (Chemistry Procedure for the Determination Of Steam Generator Tube Leak Rate).
- 12.19 IF Auxiliary Spray is being used for pressurizer pressure control, EVERY 12 HOURS complete Enclosure 13.18 (Pressurizer Spray ΔT Data Sheet).
- 12.20 IF in Mode 1 AND above 50% rated power, once within 12 hours and every 12 hours thereafter, document Quadrant Power Tilt Ratio, as calculated by PT/0/A/4600/08B (Man. Cal. of Quad. Tilt), in Enclosure 13.1 of PT/1/A/4600/002A (Mode 1 Periodic Surveillance Items). (Reference SR 3.2.4.1)
- 12.21 IF in Modes 1-3, within 12 HOURS of the Loss of OAC and every 12 hours thereafter, monitor the CA piping surface temperatures. Perform OP/1/A/6250/002, Enclosure 4.12 (Checking Pipe Surface Temperatures).
- 12.22 IF in Modes 1-2, within 12 HOURS of the Loss of OAC and every 12 hours thereafter, monitor the Overtemperature Delta T parameters and record on Enclosure 13.19 (Overtemperature Delta T Setpoint Channel Check).
- 12.23 IF in Modes 1-4, EVERY 24 HOURS perform a manual leakage calculation of the NC System in accordance with PT/1/A/4150/001I (NC Manual Leakage Calculation). (Reference TS 3.4.15, Required Action A.1).
- 12.24 Update Enclosure 13.20 (Chemistry Data Sheet) as information becomes available from Chemistry.
- 12.25 WHEN the OAC is returned to service, notify Shift Work Manager to coordinate with Local IT and Reactor Group Duty Engineer to ensure OAC is updating properly.
- 12.26 Verify the acceptance criteria specified in Section 11 is met.
- 12.27 Test is completed with:
- No discrepancies
 - Discrepancy Sheet attached
- 12.28 Submit PT/1/A/4600/009 (Loss of Operator Aid Computer) to the Shift Supervisor.

13. Enclosures

- 13.1 ND/NS Sump Monitoring
- 13.2 Critical Core Parameters Sheet
- 13.3 KCHX Maximized Cooling Temperature Monitoring
- 13.4 Auxiliary Building Ventilation Supply Unit Status
- 13.5 Ventilation Unit Condensate Drain Tank Input Rate Determination
- 13.6 Containment Floor and Equipment Sumps Input Rate Determination
- 13.7 IEMF-38 Delta Count Rate Determination
- 13.8 IEMF-39 Delta Count Rate Determination
- 13.9 T_{AVG} Data Sheet
- 13.10 Subcooling Data Sheet
- 13.11 Electrical Data Sheet
- 13.12 Steam Generator Data Sheet
- 13.13 Axial Flux Difference (% Δ Flux) Following Loss of AFD Monitor Alarm
- 13.14 Rod Verification Checklist
- 13.15 Rod Insertion Limit Checksheet
- 13.16 CA Suction Source Temperature Monitoring Data
- 13.17 Primary to Secondary Leakage Calculation Data
- 13.18 Pressurizer Spray ΔT Data Sheet
- 13.19 Overtemperature Delta T Setpoint Channel Check
- 13.20 Chemistry Data Sheet

1. Procedure

1.1 On Panel 1ELCC0013, (AB-543, MM-53-54, Rm 200) monitor Annunciator A/6 (Units 1 & 2 ND & NS Sump Level Hi-Hi) to verify it is dark.

1.1.1 IF Annunciator A/6 (Units 1 & 2 ND & NS Sump Level Hi-Hi) is in alarm, OR comes into alarm, notify the Control Room.

1.1.2 Time of alarm _____.

1.1.3 Person notified _____.

NOTE: Additional copies may be made for multiple turnovers as needed.

1.2 Person responsible for monitoring panel. _____

1.2.1 Turnover to _____

Turnover to _____

Turnover to _____

Turnover to _____

Turnover to _____

Turnover to _____

Turnover to _____

Containment Floor and Equipment Sumps
Input Rate Determination

1. Procedure

NOTE: If any containment floor and equipment sump pump starts during the 10 minute test period the test results will **NOT** be valid. The test should be repeated until valid results are obtained. (i.e. no pump start during test period)

1.1 Stop the following sump pumps and place in "Manual":

- "PUMP 1A1 CONT FLOOR & EQUIP SUMP"
- "PUMP 1A2 CONT FLOOR & EQUIP SUMP"
- "PUMP 1B1 CONT FLOOR & EQUIP SUMP"
- "PUMP 1B2 CONT FLOOR & EQUIP SUMP"

NOTE: The Containment Floor and Equipment Sumps may be pumped down as necessary, however, a new initial sump level reading should be recorded after the pumps are returned to the "Manual" position.

1.2 IF at any time during the performance of this test the sump level reaches $\geq 15"$, perform the following:

1.2.1 Place the following sump pumps in "AUTO":

- "PUMP 1A1 CONT FLOOR & EQUIP SUMP"
- "PUMP 1A2 CONT FLOOR & EQUIP SUMP"
- "PUMP 1B1 CONT FLOOR & EQUIP SUMP"
- "PUMP 1B2 CONT FLOOR & EQUIP SUMP"

NOTE: A level less than 4" is below the calibration range of the Containment Floor and Equipment Sump level instrumentation, therefore the Leakage Detection Systems must be declared inoperable at sump level less than 4". {PIP 95-0878}

1.2.2 Verify the affected sump level is lowered to 10" as indicated on 1WLP5740 (Cont Floor and Equipment Sump A Level) or 1WLP5750 (Cont Floor and Equipment Sump B Level):

1.2.3 Return the following sump pumps to "Manual" and stopped:

- "PUMP 1A1 CONT FLOOR & EQUIP SUMP"
- "PUMP 1A2 CONT FLOOR & EQUIP SUMP"
- "PUMP 1B1 CONT FLOOR & EQUIP SUMP"
- "PUMP 1B2 CONT FLOOR & EQUIP SUMP"

**Containment Floor and Equipment Sumps
Input Rate Determination**

- _____ 1.3 Record initial sump readings on the "Containment Floor and Equipment Sump Inleakage Rate Log Sheet".
- 1.4 Once per hour, record sump level readings on the "Containment Floor and Equipment Sump Inleakage Rate Log Sheet".
- 1.5 Calculate the leakage rate using the "Sump Volume vs. Level Indication Table".
- 1.6 Verify leakage is < 1 gpm.
- 1.7 **IF** the input to the Containment Floor and Equipment Sumps is > 1 gpm, perform the following:
- Refer to TS 3.4.13.
 - Determine if NC System leakage is > 1 gpm.
- _____ 1.8 **WHEN** the OAC is returned to service, place the following sump pumps in "AUTO":
- "PUMP 1A1 CONT FLOOR & EQUIP SUMP"
 - "PUMP 1A2 CONT FLOOR & EQUIP SUMP"
 - "PUMP 1B1 CONT FLOOR & EQUIP SUMP"
 - "PUMP 1B2 CONT FLOOR & EQUIP SUMP"

**Containment Floor and Equipment Sumps
Input Rate Determination**

SUMP VOLUME VS. LEVEL INDICATION TABLE

Level Indication	Water Volume		Level Indication	Water Volume		Level Indication	Water Volume
4.0	126.5		9.0	383.2		14.0	510.3
4.1	131.9		9.1	386.5		14.1	512.5
4.2	137.3		9.2	389.7		14.2	514.8
4.3	142.6		9.3	393.0		14.3	517.0
4.4	148.0		9.4	396.2		14.4	519.3
4.5	153.4		9.5	399.5		14.5	521.5
4.6	158.8		9.6	402.7		14.6	523.7
4.7	164.2		9.7	406.0		14.7	526.0
4.8	169.5		9.8	409.2		14.8	528.2
4.9	174.9		9.9	412.5		14.9	530.5
5.0	180.3		10.0	415.1		15.0	532.7
5.1	185.6		10.1	417.8		15.1	534.9
5.2	190.8		10.2	420.6		15.2	537.2
5.3	196.1		10.3	423.3		15.3	539.4
5.4	201.3		10.4	426.0		15.4	541.7
5.5	206.6		10.5	428.7		15.5	543.9
5.6	211.8		10.6	431.4		15.6	546.1
5.7	217.1		10.7	434.2		15.7	548.4
5.8	222.3		10.8	436.9		15.8	550.6
5.9	227.6		10.9	439.6		15.9	552.9
6.0	232.8		11.0	442.3		16.0	555.1
6.1	238.1		11.1	444.6		16.1	557.4
6.2	243.3		11.2	446.9		16.2	559.6
6.3	248.6		11.3	449.2		16.3	561.8
6.4	253.8		11.4	451.5		16.4	564.1
6.5	259.1		11.5	453.8		16.5	566.3
6.6	264.4		11.6	456.1		16.6	568.6
6.7	269.6		11.7	458.4		16.7	570.8
6.8	274.9		11.8	460.7		16.8	573.1
6.9	280.1		11.9	463.0		16.9	575.3
7.0	285.4		12.0	465.3		17.0	577.6
7.1	290.7		12.1	467.6		17.1	579.8
7.2	296.0		12.2	469.8		17.2	582.0
7.3	301.3		12.3	472.1		17.3	584.3
7.4	306.6		12.4	474.3		17.4	586.5
7.5	311.9		12.5	476.6		17.5	588.8
7.6	317.1		12.6	478.8		17.6	591.0
7.7	322.4		12.7	481.1		17.7	593.3
7.8	327.7		12.8	483.3		17.8	595.5
7.9	333.0		12.9	485.6		17.9	597.8
8.0	338.3		13.0	487.8		18.0	600.0
8.1	342.8		13.1	490.1			
8.2	347.3		13.2	492.3			
8.3	351.8		13.3	494.6			
8.4	356.3		13.4	496.8			
8.5	360.8		13.5	499.1			
8.6	365.2		13.6	501.3			
8.7	369.7		13.7	503.6			
8.8	374.2		13.8	505.8			
8.9	378.7		13.9	508.1			

To calculate the Rate of volume increase in the Sump, perform the following calculation:

$$\frac{(\text{Sump A Gals.}(T2) - \text{Sump A Gals.}(T1)) + (\text{Sump B Gals.}(T2) - \text{Sump B Gals.}(T1))}{(\text{Time at } T2 - \text{Time at } T1)}$$

- NOTE:**
1. T1 is the data from the previous reading.
 2. T2 is the data from the current reading.

Enclosure 13.11
Electrical Data Sheet

PT/1/A/4600/009
Page 2 of 2

Date/ Time	DG1A MWH	Δ DG1A MWH	DG1B MWH	Δ DG1B MWH	AEB A MWH	Δ AEB A MWH	U2 CT from U1 MWH	Δ U2 CT from U1 MWH	SSF DG MWH NOTE 2	Δ SSF DG MWH NOTE 2	U1 CT from U2 MWH	Δ U1 CT from U2 MWH	Unit 1 Aux	Unit 1 Net	Initials

Perform the following calculations:
 Unit 1 Aux = (1ATE + 1T1A + 1T1B + 1T2A + 1T2B + 1ETA + 1ETB + SSFD + U1CTU2-U2CTU1-BLR A)
 UNIT 1 NET GEN = (GROSS MWH - Unit 1 Aux)

NOTE: 1. Δ = the change in MWH from the previous hour.
 2. Obtain SSF KWH from the SSF DG control panel and convert to MWH.
IF SSF DG has NOT been run in the previous hour, use previous hour reading.

CA Suction Source Temperature Monitoring
Data**1. Procedure**

- 1.1 Every 4 hours, measure the following temperatures by using a Calibrated Kiethly 872 Digital Thermometer, Model "J" or equivalent and record on table of this enclosure.
- UST 1A at 1CSTX5860 (TB-639, 1D-33)
 - UST 1B at 1CSTX5890 (TB-639, 1D-27)
 - CST at 1CSTX5020 (TB-573, 1C-33)
 - Hotwell Pump Discharge at 1CMTX5070 (TB-575, 1M-25)
- 1.2 IF UST temperature is ≥ 120 °F,
- 1.2.1 Notify CRSRO
- 1.2.2 Verify 1CM-127 (CM-CF Cleanup Flow Ctrl) is:
- A. Isolated
- OR
- B. IF in Modes 3 or 4 AND 1CM-127 is open, immediately close 1CM-127.
- 1.2.3 Ensure Aux Steam is isolated to the UST by verifying the following valves closed:
- 1AS-15 (AS to UST HTR Isol) (TB 609, 1C-29)
 - 1AS-22 (AS to 1A UST HTR Ctrl Inlet) (TB-640, 1C-30)
 - 1AS-25 (AS to 1A UST HTR Ctrl BYP) (TB-640, 1C-30)
 - 1AS-28 (AS to 1B UST HTR Ctrl Inlet) (TB-640, 1C-29)
 - 1AS-31 (AS to 1B UST HTR Ctrl BYP) (TB-640, 1C-29)
- 1.2.4 Verify 1CM-33 (Hotwell High Level Control) (TB-581, 1L-25) is isolated and NOT leaking past seat by checking downstream pipe temperature ≤ 120 °F.
- 1.2.5 Notify MSE.
- 1.2.6 IF temperature of 1A OR 1B UST is ≥ 130 °F, declare CA System inoperable per TS 3.7.5.

CA Suction Source Temperature Monitoring
Data

- 1.3 IF CST is ≥ 120 °F
- 1.3.1 Notify CRSRO
- 1.3.2 IF UST is overflowing, as determined by UST level $\geq 130\%$; measure overflow pipe temperature (TB-594, 1C/1D-29) using Calibrated Kiethly 872 Digital Thermometer, Model "J" or equivalent and record on table of this enclosure.
- 1.3.3 IF overflow pipe temperature ≥ 120 °F, refer to step 1.2.
- 1.3.4 Verify Manual Loader for Condensate Storage Tank (1ASML0170, CST Temp Ctrl) (TB 573, 1E-32) is set per OP/0/B/6250/007A (Auxiliary Steam System Alignment).
- 1.3.5 IF Aux Steam Manual Loader for CST is malfunctioning, then:
- Ensure 1AS-16 (AS to CST HTR Ctrl Inlet) (TB-582, 1E-33) is closed.
 - Notify MSE.
- 1.3.6 IF temperature of CST is ≥ 130 °F, secure both CST pumps AND:
- A. IF UST is overflowing to the CST as indicated by UST level $\geq 130\%$, measure temp on UST overflow line (TB-594, 1C/1D-29).
- B. IF temp is ≥ 130 °F, declare CA System inoperable.
- C. IF the UST is NOT overflowing to the CST as indicated by UST level $\leq 130\%$, measure UST temp directly on A UST or B UST as high up as possible. IF temp is ≥ 130 °F, declare CA system inoperable.
- 1.4 IF Hotwell pump discharge temperature reaches ≥ 130 °F, then:
- 1.4.1 IF 1CM-33 is isolated in accordance with compensatory action for CM-33 (PIP 0-C-98-2437 compensatory actions), then no further action is required.
- 1.4.2 IF Unit 1 S/Gs are not relied upon for heat removal, then no further action is required.
- 1.4.3 IF Unit 1 is in modes 1,2,3, or 4 with CA required operable and 1CM-33 is not isolated in accordance with compensatory action for CM-33, then isolate 1CM-33 per compensatory action.

CA Suction Source Temperature Monitoring
Data

- 1.5 IF Hotwell pump discharge temperature reaches $\geq 132^{\circ}\text{F}$, then:
- 1.5.1 IF 1CM-33 is isolated in accordance with compensatory action for CM-33 (PIP 0-C-98-2437 compensatory actions), then no further action is required.
 - 1.5.2 IF Unit 1 S/Gs are not relied upon for heat removal, then no further action is required.
 - 1.5.3 IF Unit 1 is in modes 1,2,3, or 4 with CA required operable and 1CM-33 is not isolated in accordance with compensatory action for CM-33, then declare auxiliary feedwater system inoperable and apply Tech Spec 3.7.5.

CA Suction Source Temperature Monitoring Data

Date Time/Initial	1A UST Temp 1CSTX5860 (TB-639,1D-33)	1B UST Temp 1CSTX5890 (TB-639, 1D-27)	Htwl Pump Disch Temp 1CMTX5070 (TB-575, 1M-25)	CST Temp 1CSTX5020 (TB-573, 1C-33) (1)	UST Overflow Line Temp (TB-594, 1C/1D-29) (2)	Pyrometer #	Cal Due Date

- (1) IF temp is ≥ 130 °F, Step 1.3.6 actions apply.
- (2) IF temp is ≥ 130 °F, Step 1.2.6 actions apply.

Pressurizer Spray ΔT Data Sheet

Date/Time	Pressurizer Steam Temperature	Spray Line Temperature	ΔT	Initial

ACCEPTANCE CRITERIA - Differential temperature between the pressurizer and auxiliary spray water must be $< 260^{\circ}\text{F}$.

NOTE: WHEN using Residual Heat Removal Pump 1A (ND Pump 1A), use Residual Heat Removal Heat Exchanger "A" Inlet Temperature on 1MC7. WHEN using Residual Heat Removal Pump 1B (ND Pump 1B), use Residual Heat Removal Heat Exchanger "B" Inlet temperature on 1MC7. WHEN using Chemical Volume and Control System, use Regenerative Heat Exchanger charging temperature on 1MC5.

Enclosure 13.20
Chemistry Data Sheet

PT/1/A/4600/009
Page 1 of 4

Analysis	CONC		DATE/TIME
NC Boron		PPM	
		PPM	
		PPM	
PZR Boron		PPM	
		PPM	
		PPM	
BAT Boron		PPM	
		PPM	
		PPM	
FWST Boron		PPM	
		PPM	
		PPM	
KF Pool Boron		PPM	
		PPM	
		PPM	
ACCUM A Boron		PPM	
		PPM	
		PPM	
ACCUM B Boron		PPM	
		PPM	
		PPM	
ACCUM C Boron		PPM	
		PPM	
		PPM	
ACCUM D Boron		PPM	
		PPM	
		PPM	
NC Oxygen		PPB	
		PPB	
		PPB	

Enclosure 13.20
Chemistry Data Sheet

PT/1/A/4600/009
Page 2 of 4

Analysis	CONC		DATE/TIME
NC Chloride		PPB	
		PPB	
		PPB	
NC Fluoride		PPB	
		PPB	
		PPB	
NC Dose Equiv I-131		$\mu\text{Ci/ML}$	
		$\mu\text{Ci/ML}$	
		$\mu\text{Ci/ML}$	
NC Gross Activity		$\mu\text{Ci/ML}$	
		$\mu\text{Ci/ML}$	
		$\mu\text{Ci/ML}$	
NC Activity Max.		$\mu\text{Ci/ML}$	
		$\mu\text{Ci/ML}$	
		$\mu\text{Ci/ML}$	
CF Oxygen		PPB	
		PPB	
		PPB	

Enclosure 13.20
Chemistry Data Sheet

PT/1/A/4600/009
Page 3 of 4

Analysis	CONC		DATE/TIME
CF Cation		μMHO	
		μMHO	
		μMHO	
BB Sodium		PPB	
		PPB	
		PPB	
BB Cation		μMHO	
		μMHO	
		μMHO	
CF Gross Activity		μCi/ML	
		μCi/ML	
		μCi/ML	
Boiler A (Conductivity)		μMHO	
		μMHO	
		μMHO	
Boiler A (Solids)		PPB	
		PPB	
		PPB	
Boiler A (Hydrazine)		PPB	
		PPB	
		PPB	
Boiler A (pH)			
Boiler B (Conductivity)		μMHO	
		μMHO	
		μMHO	
Boiler B (Solids)		PPB	
		PPB	
		PPB	

Enclosure 13.20
Chemistry Data Sheet

PT/1/A/4600/009
Page 4 of 4

Analysis	CONC		DATE/TIME
Boiler B (Hydrazine)		PPB	
		PPB	
		PPB	
Boiler B (pH)			

Analysis	Status	Date/Time
Seal Inj. Filter 1A		
Seal Inj. Filter 1B		
NC Filter 1A		
NC Filter 1B		
NV Mixed Bed Demin. 1A		
NV Mixed Bed Demin. 1B		
NV Cation Bed Demin.		

Comments: _____

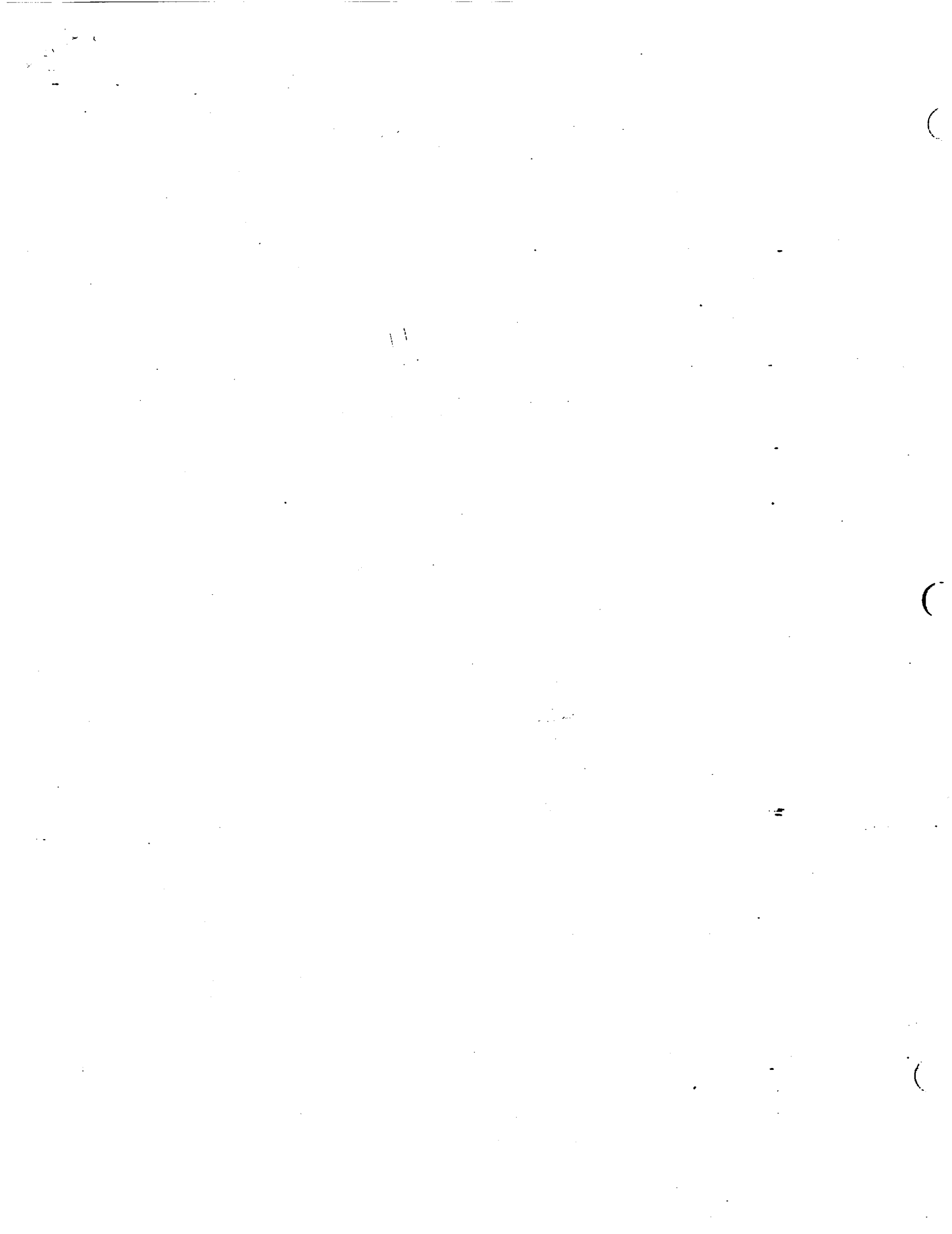

Duke Power Company
PROCEDURE PROCESS RECORD

(1) ID No. PT/1/A/4600/009
Revision No. 61

PREPARATION

(2) Station CATAWBA NUCLEAR STATION

(3) Procedure Title LOSS OF OPERATOR AID COMPUTER

(4) Prepared By [Signature] Date 07/15/99

(5) Requires 10CFR50.59 evaluation?
 Yes (New procedure or revision with major changes)
 No (Revision with minor changes)
 No (To incorporate previously approved changes)

(6) Reviewed By [Signature] (QR) Date 7-21-99

Cross-Disciplinary Review By _____ (QR) NA RF Date _____

Reactivity Mgmt. Review By _____ (QR) NA RF Date _____

(7) Additional Reviews

Reviewed By _____ Date _____

Reviewed By _____ Date _____

(8) Temporary Approval (if necessary)

By _____ (SRO/QR) Date _____

By _____ (QR) Date _____

(9) Approved By [Signature] Date 7/22/99

PERFORMANCE (Compare with control copy every 14 calendar days while work is being performed.)

(10) Compared with Control Copy _____ Date _____

Compared with Control Copy _____ Date _____

Compared with Control Copy _____ Date _____

(11) Date(s) Performed _____

Work Order Number (WO#) _____

COMPLETION

(12) Procedure Completion Verification

Yes N/A Check lists and/or blanks properly initialed, signed, dated, or filled in N/A, as appropriate?

Yes N/A Listed enclosures attached?

Yes N/A Data sheets attached, completed, dated, and signed?

Yes N/A Charts, graphs, etc. attached, dated, identified, and marked?

Yes N/A Procedure requirements met?

Verified By _____ Date _____

(13) Procedure Completion Approved _____ Date _____

(14) Remarks (attach additional pages, if necessary)

T
INFORMATION ONLY

Duke Power Company PROCEDURE PROCESS RECORD

(1) ID No. PT/1/A/4600/002A
Revision No. 167

PREPARATION

(2) Station CATAWBA NUCLEAR STATION

(3) Procedure Title MODE 1 PERIODIC SURVEILLANCE ITEMS

(4) Prepared By [Signature] Date 07/13/99

(5) Requires 10CFR50.59 evaluation?
 Yes (New procedure or revision with major changes)
 No (Revision with minor changes)
 No (To incorporate previously approved changes)

(6) Reviewed By [Signature] (QR) Date 07-14-99
Cross-Disciplinary Review By _____ (QR) NA [Signature] Date _____
Reactivity Mgmt. Review By _____ (QR) NA [Signature] Date _____

(7) Additional Reviews
Reviewed By _____ Date _____
Reviewed By _____ Date _____

(8) Temporary Approval (if necessary)
By _____ (SRO/QR) Date _____
By _____ (QR) Date _____

(9) Approved By [Signature] Date 7/14/99

PERFORMANCE (Compare with control copy every 14 calendar days while work is being performed.)

(10) Compared with Control Copy _____ Date _____
Compared with Control Copy _____ Date _____
Compared with Control Copy _____ Date _____

(11) Date(s) Performed _____
Work Order Number (WO#) _____

COMPLETION

(12) Procedure Completion Verification
 Yes N/A Check lists and/or blanks properly initialed, signed, dated, or filled in N/A, as appropriate?
 Yes N/A Listed enclosures attached?
 Yes N/A Data sheets attached, completed, dated, and signed?
 Yes N/A Charts, graphs, etc. attached, dated, identified, and marked?
 Yes N/A Procedure requirements met?
Verified By _____ Date _____

(13) Procedure Completion Approved _____ Date _____

(14) Remarks (attach additional pages, if necessary)
Change 167A - 7/14/99 - Encl 13.1

†
INFORMATION ONLY

**Duke Power Company
Catawba Nuclear Station**

Mode 1 Periodic Surveillance Items

Continuous Use

Procedure No.

PT/1/A/4600/002A

Revision No.

167

Electronic Reference No.

CN005G9I

Mode 1 Periodic Surveillance Items

1. Purpose

- 1.1 To verify compliance with technical specification surveillance items which have a frequency of verification from once per twelve hours (semi-daily) to once per seven days (weekly).
- 1.2 To give guidance for the proper operation of various instruments and/or systems.

2. References

- 2.1 Technical Specifications
- 2.2 FSAR Chapter 16 Selected Licensee Commitments

3. Time Required

- 3.1 Manpower - One NCO
- 3.2 Frequency - Time
 - 3.2.1 Semi-daily, daily - One hour thirty minutes
[Day shift (0700-1000)]
[Night shift (1900-2200)]
 - 3.2.2 Weekly - Two hours[Day shift,
Sunday (0700-1000)]

4. Prerequisite Tests

None

5. Test Equipment

None

6. Limits and Precautions

None

7. Required Unit Status

___ Mode 1

8. Prerequisite System Condition

None

9. Test Method

- 9.1 A visual inspection shall be made to verify various systems' instrumentation is operating properly and/or indicating acceptable values or system status.
- 9.2 The OAC shall be used for various required calculations, when operable. When inoperable, manual calculations will be performed per PT/1/A/4600/009 (Loss of Operator Aid Computer).
- 9.3 Performance of this PT will include all the applicable surveillance items based on the frequency of the surveillance.

10. Data Required

- 10.1 Enclosure 13.1 (Periodic Surveillance Items Data)
- 10.2 Enclosure 13.2 (Loose Parts Monitor Data) as required

11. Acceptance Criteria

- 11.1 Enclosures 13.1 (Periodic Surveillance Items Data) and 13.2 (Loose Parts Monitor Data) contain acceptance criteria for individual surveillance items.
- 11.2 Channel checks meet the acceptance criteria when the redundant channels are within the tolerances listed in Enclosure 13.1 (Periodic Surveillance Items Data). Redundant channels may be checked on either the OAC, control room or local gauges. The acceptance criteria shall **NOT** be met by checking the same channel on two redundant indications such as a control room gauge and the OAC.
- 11.3 Discrepancies on instrument channel checks due to transient conditions may be evaluated to determine instrument operability. Where other independent means can be used to verify instrument operability, the intent of the channel check is met.
- 11.4 Any discrepancy noted during the performance of this test which does **NOT** keep the test from meeting the acceptance criteria shall be given to the Unit/WCC SRO for evaluation.
- 11.5 Any discrepancy which keeps the test from meeting the acceptance criteria will be listed on a Procedure Discrepancy Process Record showing the corrective action taken.
- 11.6 **IF** the acceptance criteria is **NOT** met, all applicable sections shall be logged in TSAIL.

12. Procedure

- NOTE:**
1. **IF** the Operator Aid Computer (OAC) becomes inoperable, perform the applicable steps requiring the Operator Aid Computer per PT/1/A/4600/009 (Loss of Operator Aid Computer).
 2. **IF** an Operator Aid Computer Point is inoperable, perform the applicable surveillance item using the available control room or local indication.

- 12.1 Complete Enclosure 13.1 (Periodic Surveillance Items Data) for the applicable surveillance items as described in the following steps:
 - 12.1.1 Perform the surveillance items in Enclosure 13.1 (Periodic Surveillance Items Data) based on frequency (semi-daily, daily and weekly).
 - 12.1.2 Frequency Requirements:
 - 12.1.2.1 Day shift and night shift will perform the semi-daily surveillance items.
 - 12.1.2.2 The daily surveillance items will be performed along with the semi-daily items of the shift specified.
 - 12.1.2.3 Day shift will perform weekly surveillance items along with the performance of the semi-daily items on Sunday or the day specified. These items are identified by a (W) or (day of week) in the SHIFT INITIALS column.
 - 12.1.2.4 The non-shaded blocks under the SHIFT INITIALS column are for the operators to sign off in for the performed surveillance items that meet their acceptance criteria.
 - 12.1.3 Numbers in parenthesis refer to notes and qualifying conditions specific to the surveillance requirement. These conditions are explained at the bottom of that page.
 - 12.1.4 N/A all sign offs **NOT** required based on the frequency of the surveillance.
 - 12.1.5 **IF** a surveillance item exists with a qualifying condition, **AND** plant conditions are such that the qualifying condition is **NOT** met, the item may be N/A'd and initialed.

- ____ 12.2 Verify the acceptance criteria specified in Section 11 is met.
- ____ 12.3 Test is completed with:
- No discrepancies
 - Discrepancy Sheet attached
- ____ 12.4 This test was completed to satisfy the following requirement(s):
- Semi-daily
 - Daily
 - Weekly
- ____ 12.5 Submit PT/1/A/4600/002A (Mode 1 Periodic Surveillance Items) to the Unit/WCC SRO.

13. Enclosures

- 13.1 Periodic Surveillance Items Data
- 13.2 Loose Parts Monitor Data

Enclosure 13.1

Periodic Surveillance Items Data

#	SURVEILLANCE ITEM (Tech Spec Reference)	ACCEPTANCE CRITERIA	QUALIFYING CONDITIONS	COMPUTER POINT ID	DAY SHIFT INITIALS	NIGHT SHIFT INITIALS
1	Turbine Impulse Pressure Channel Check	Each indication is within 32 psig of the other channel.		C1A0737 - C1A0851		
2	Shutdown and Control Rod Position Indication System (SR 3.1.4.1)	A. OAC demand for all shutdown and control rod banks agree within ± 1 step of its control board indication.	(1)	Shutdown Banks A-E Demand C1P1546 - C1P1550 Control Rod Banks A-D Demand C1P1390 - C1P1393		
		B. Each shutdown and control rod OAC DRPI indication agrees within ± 1 step of each shutdown and control rod indication on DRPI.	(2)			
		C. Rod position indication system and demand position indication system shall agree on rod position within ± 12 steps.	(2)(3)	C1P1551 - C1P1559		

- (1) Contact the Shift Work Manager if the acceptance criteria is **NOT** met. Assistance from Rod Control System Engineer may be needed.
- (2) Digital Rod Position Indication for individual rods may be obtained from the OAC Control Rod Position Information, RODS.
- (3) Required every 4 hours when the rod position deviation monitor (OAC Points C1P1551 through C1P1559) is inoperable, as indicated by points C1L4406 or C1L4407 in alarm, the acceptance criteria of Surveillance Item 2A **OR** 2B **NOT** met, **OR** points with NCAL quality code **AND/OR** magenta quality color. Record data on PT/1/A/4600/009 (Loss of Operator Aid Computer).

Enclosure 13.1

Periodic Surveillance Items Data

PT/1/A/4600/002A

Page 2 of 34

#	SURVEILLANCE ITEM (Tech Spec Reference)	ACCEPTANCE CRITERIA	QUALIFYING CONDITIONS	COMPUTER POINT ID	DAY SHIFT INITIALS	NIGHT SHIFT INITIALS
3	Shutdown and Control Rod Position (SR 3.1.4.1)	Each rod's indicated position shall be within ± 12 steps of its group step demand position.	(4)(5)	C1P1546 - C1P1550 C1P1390 - C1P1393		
4	Shutdown Rod Position (SR 3.1.5.1)	All shutdown banks shall be within the limits specified in the COLR as indicated by DRPI indication (± 4 steps)	(4)(6)			
5	Power Range Monitor Channel Check (SR 3.3.1.1, Table 3.3.1-1 Item 2a & 2b)	Each indication is within 2% of the average of all power range channels.		C1P0738		

-
- (4) Digital Rod Position Indication for individual rods may be obtained from the OAC Control Rod Position Information, RODS.
- (5) Required every 4 hours when the rod position deviation monitor (OAC Points C1P1551 through C1P1559) is inoperable, as indicated by points C1L4406 or C1L4407 in alarm, the acceptance criteria of Surveillance Item 2A OR 2B NOT met, OR points with NCAL quality code AND/OR magenta quality color. Record data on PT/1/A/4600/009 (Loss of Operator Aid Computer).
- (6) DRPI system accuracy of ± 4 steps is applicable for this surveillance.

Enclosure 13.1

Periodic Surveillance Items Data

PT/1/A/4600/002A
Page 3 of 34

#	SURVEILLANCE ITEM (Tech Spec Reference)	ACCEPTANCE CRITERIA	QUALIFYING CONDITIONS	COMPUTER POINT ID	DAY SHIFT INITIALS	NIGHT SHIFT INITIALS
6	Power Range/ Calorimetric Comparison (SR 3.3.1.2, Table 3.3.1-1 Item 2a)	Each Power Range Channel agrees within $\pm 2\%$ of C1P1385 (Reactor Thermal Power, Best) Calculate below: BETP _____ % Channel I _____ % Difference _____ % BETP _____ % Channel II _____ % Difference _____ % BETP _____ % Channel III _____ % Difference _____ % BETP _____ % Channel IV _____ % Difference _____ %	(7)(8)(9)	C1P1385		

- (7) Steady state conditions should be established for 30 minutes prior to performing the surveillance. IF the difference exceeds $\pm 2\%$, contact IAE to calibrate NIs and refer to the TS 3.3.1 Bases.
- (8) NOT required to be performed until 12 hours after Thermal Power $\geq 15\%$ RTP.
- (9) IF OAC point C1P1385 is unavailable, contact RXG Duty Engineer to complete PT/0/4220/001 (Manual Calculation of Thermal Power and NC Flow) to determine the Best Estimate Thermal Power (BETP) and compare the channels.

Periodic Surveillance Items Data

#	SURVEILLANCE ITEM (Tech Spec Reference)	ACCEPTANCE CRITERIA	QUALIFYING CONDITIONS	COMPUTER POINT ID	DAY SHIFT INITIALS	NIGHT SHIFT INITIALS
7	Axial Flux Difference (SR 3.2.3.1)	Verify AFD within limits for each OPERABLE excore channel as specified in the COLR. Record actual AFD below. N-41 _____ N-42 _____ N-43 _____ N-44 _____	(10)	C1P1522, 1523, 1524 and 1525	(W)	
8	Intermediate Range Monitor Channel Check (SR 3.3.1.1, Table 3.3.1-1 Item 4)	Each indication is within ½ decade of the other channel.	(11)	C1A0766 C1A0767		

(10) In Mode 1 \geq 50% rated thermal power.

(11) Below P-10 Setpoint.

Enclosure 13.1

Periodic Surveillance Items Data

PT/1/A/4600/002A
Page 5 of 34

#	SURVEILLANCE ITEM (Tech Spec Reference)	ACCEPTANCE CRITERIA	QUALIFYING CONDITIONS	COMPUTER POINT ID	DAY SHIFT INITIALS	NIGHT SHIFT INITIALS
9	Control Rod Insertion Limit (SR 3.1.6.2)	All control rods shall be above their insertion limits.	(12)	1AD-2 A/9 Alarm Dark 1AD-2 B/9 Alarm Dark C1L4409 NOT in alarm		
10	Control Bank Sequence and Overlap (SR 3.1.6.3)	Sequence and overlap limits specified in the COLR are met for control banks NOT fully withdrawn from the core.				
11	Quadrant Power Tilt Ratio (SR 3.2.4.1)	Ratio ≤ 1.02 . IF OAC is out of service, record QPTR value, obtained from PT/0/A/4600/08B QPTR value _____	(13)	Excore Power Distribution Monitor, AFD	(W)	

(12) Required every 4 hours when rod insertion limit monitor is inoperable. Reference 1AD-2 A/9 or 1AD2 B/9 or C1L4464, C1L4406 or C1L4407, or Pt C1L4409. Record data on PT/1/A/4600/009 (Loss of Operator Aid Computer).

(13) **NOT** required to be performed until 12 hours after exceeding 50% RTP.

Enclosure 13.1

Periodic Surveillance Items Data

#	SURVEILLANCE ITEM (Tech Spec Reference)	ACCEPTANCE CRITERIA	QUALIFYING CONDITIONS	COMPUTER POINT ID	DAY SHIFT INITIALS	NIGHT SHIFT INITIALS
12	NC System Leakage (Sump Inventory) (TS LCO 3.4.15)	1. C1L4554 in service 2. Quality - GOOD 3. Cont Floor & Equip Sump A and B levels > 4 inches.	(14) (15) (16)	C1L4554		
13	Primary Containment Upper Compartment Average Air Temp. (SR 3.6.5.1)	Temp: 75 - 100°F Record temperature: _____°F	(17)	C1P1500		
14	Primary Containment Lower Compartment Average Air Temp. (SR 3.6.5.2)	Temp: 100 - 120°F Record temperature: _____°F	(17)	C1P1501		

(14) Refer to TS 3.4.15, Condition A and perform applicable actions.

(15) IF OAC point C1L4554, OR its inputs (WLLT6880, WLLT6870) are inoperable, perform the applicable section in PT/1/A/4600/009 (Loss of Operator Aid Computer). (Reg. Guide 1.45)

(16) IF Cont Floor & Equip Sump A OR B, level < 4 ½ inches, then add water to the affected sump to increase sump level to a range of 10 - 14 inches.

(17) IF OAC is out of service, notify IAE to perform IP/1/B/3172/006 (Procedure For VV System Temperature Measurements Upon Loss of OAC) to determine computer point readings.

Enclosure 13.1

Periodic Surveillance Items Data

#	SURVEILLANCE ITEM (Tech Spec Reference)	ACCEPTANCE CRITERIA	QUALIFYING CONDITIONS	COMPUTER POINT ID	DAY SHIFT INITIALS	NIGHT SHIFT INITIALS
15	Containment Pressure Monitor Channel Check (SR 3.3.2.1, Table 3.3.2-1 Items 1c, 2c, 3b3, & 4c)	Press. Differential between highest and lowest channels ≤ 0.3 psig. Calculate below: High Channel _____ psig Low Channel _____ psig Differential _____ psig		1NSP5040, 1NSP5050, 1NSP5060, 1NSP5070 (located on 1MC11)		
16	CPCS Monitor Channel Check (SR 3.3.2.1, Table 3.3.2-1 Items 9a & 9b)	Pressure differential between highest and lowest Train Related Channels ≤ 0.3 psig. Calculate below: TRAIN A High Channel _____ psig Low Channel _____ psig Differential _____ psig TRAIN B High Channel _____ psig Low Channel _____ psig Differential _____ psig		C1A1492 C1A1498 C1A1504 C1A1510 C1A1516 C1A1522 C1A1528 C1A1534		
17	Primary Containment Internal Pressure. (SR 3.6.4.1)	Pressure: -0.1 psig to +0.3 psig		C1A1492 C1A1498 C1A1504 C1A1510 C1A1516 C1A1522 C1A1528 C1A1534 and Control Room Indication (1MC11) 1NSP5040 1NSP5050 1NSP5060 1NSP5070		

Enclosure 13.1

Periodic Surveillance Items Data

PT/1/A/4600/002A

Page 8 of 34

#	SURVEILLANCE ITEM (Tech Spec Reference)	ACCEPTANCE CRITERIA	QUALIFYING CONDITIONS	COMPUTER POINT ID	DAY SHIFT INITIALS	NIGHT SHIFT INITIALS
18	S/G Water Level Monitor Channel Check (SR 3.3.1.1, Table 3.3.1-1 Item 13) & (SR 3.3.2.1, Table 3.3.2-1 Item 5b & 6b)	Level differential between highest and lowest channels $\leq 4\%$. Calculate below: S/G A High Channel _____ % Low Channel _____ % Differential _____ % S/G B High Channel _____ % Low Channel _____ % Differential _____ % S/G C High Channel _____ % Low Channel _____ % Differential _____ % S/G D High Channel _____ % Low Channel _____ % Differential _____ %		C1A0731 C1A0845 C1A0911 C1A0531 C1A0626 C1A0632 C1A0537 C1A0638 C1A0644 C1A0627 C1A0633 C1A0543 C1A0639 C1A0645 C1A0628 C1A0549		

Enclosure 13.1

Periodic Surveillance Items Data

PT/1/A/4600/002A

Page 9 of 34

#	SURVEILLANCE ITEM (Tech Spec Reference)	ACCEPTANCE CRITERIA	QUALIFYING CONDITIONS	COMPUTER POINT ID	DAY SHIFT INITIALS	NIGHT SHIFT INITIALS
19	S/G Steam Line Pressure Monitor Channel Check (SR 3.3.2.1, Table 3.3.2-1 Item 4d(1) & 4d(2))	<p>Pressure differential between highest and lowest channels ≤ 52 psig. Calculate below:</p> <p><u>S/G A</u> High Channel _____ psig Low Channel _____ psig Differential _____ psig</p> <p><u>S/G B</u> High Channel _____ psig Low Channel _____ psig Differential _____ psig</p> <p><u>S/G C</u> High Channel _____ psig Low Channel _____ psig Differential _____ psig</p> <p><u>S/G D</u> High Channel _____ psig Low Channel _____ psig Differential _____ psig</p>		<p>C1A0723 C1A1274 C1A1280</p> <p>C1A0729 C1A1286 C1A1292</p> <p>C1A0735 C1A1298 C1A1304</p> <p>C1A0741 C1A1310 C1A1316</p>		

#	SURVEILLANCE ITEM (Tech Spec Reference)	ACCEPTANCE CRITERIA	QUALIFYING CONDITIONS	COMPUTER POINT ID	DAY SHIFT INITIALS	NIGHT SHIFT INITIALS
20	Steam Generator PORV Nitrogen Supply (SR 3.7.4.1) & (SLC 16.10-1)	<p>Absence of Alarm 1AD-3 C/1</p> <p>S/G A PORV N₂ Press <u>NOT</u> Lo-C1D3584 or 1MIPG 6630 _____ psig 1MIPG 6631 _____ psig</p> <p>S/G B PORV N₂ Press <u>NOT</u> Lo-C1D3585 or 1MIPG 6620 _____ psig 1MIPG 6621 _____ psig</p> <p>S/G C PORV N₂ Press <u>NOT</u> Lo-C1D3586 or 1MIPG 6610 _____ psig 1MIPG 6611 _____ psig</p> <p>S/G D PORV N₂ Press <u>NOT</u> Lo-C1D3587 or 1MIPG 6600 _____ psig 1MIPG 6601 _____ psig</p>	(18)	C1D3584 C1D3585 C1D3586 C1D3587		

(18) IF annunciator is in alarm, verify both of the nitrogen bottles associated with each PORV has a pressure \geq 2100 psig. IF any nitrogen bottle has a pressure $<$ 2100 psig, the associated S/G PORV is inoperable and refer to TS 3.7.4. (PIP 99-2893)

Enclosure 13.1

Periodic Surveillance Items Data

#	SURVEILLANCE ITEM (Tech Spec Reference)	ACCEPTANCE CRITERIA	QUALIFYING CONDITIONS	COMPUTER POINT ID	DAY SHIFT INITIALS	NIGHT SHIFT INITIALS
21	PZR Water Level Monitor Channel Check (SR 3.3.1.1, Table 3.3.1-1 Item 9)	Level differential between highest and lowest channels $\leq 3.5\%$. Calculate below: High Channel _____ % Low Channel _____ % Differential _____ %		C1A0707 C1A0867 C1A0873		
22	PZR Total Water Volume (SR 3.4.9.1)	PZR Level: $\leq 92\%$ N/R		C1A0707 C1A0867 C1A0873		
23	PZR Pressure Monitor Channel Check (SR 3.3.1.1, Table 3.3.1-1 Item 8a & 8b) & (SR 3.3.2.1, Table 3.3.2-1 Item 1d))	Press. differential between highest and lowest channels ≤ 28 psig. Calculate below: High Channel _____ psig Low Channel _____ psig Differential _____ psig		C1A0713 C1A0868 C1A0874 C1A0880		

Enclosure 13.1

Periodic Surveillance Items Data

PT/1/A/4600/002A

Page 12 of 34

#	SURVEILLANCE ITEM (Tech Spec Reference)	ACCEPTANCE CRITERIA	QUALIFYING CONDITIONS	COMPUTER POINT ID	DAY SHIFT INITIALS	NIGHT SHIFT INITIALS
24	PZR Pressure (SR 3-1.1)	<p>COMPUTER AVERAGE With 4 channels operable ≥ 2222 psig With 3 channels operable ≥ 2224 psig</p> <p>OR</p> <p>METER AVERAGE With 4 channels operable ≥ 2227 psig With 3 channels operable ≥ 2230 psig</p> <p>circle one COMPUTER or METER</p> <p>_____ psig Channel I _____ psig Channel II _____ psig Channel III _____ psig Channel IV (Total Press) _____ psig (# Oper Channels) \div _____ (Average) = _____ psig</p>		CIA0713 CIA0868 CIA0874 CIA0880		

Enclosure 13.1

Periodic Surveillance Items Data

#	SURVEILLANCE ITEM (Tech Spec Reference)	ACCEPTANCE CRITERIA	QUALIFYING CONDITIONS	COMPUTER POINT ID	DAY SHIFT INITIALS	NIGHT SHIFT INITIALS
25	Boron Injection Flow Path (BAT to NCS) (SLC 16.9-8)	The temperature of the heated portion of the flow path is $\geq 65^{\circ}\text{F}$. (Heat trace temperature monitor points 103-106, 108.)	(19)		(W)	

(19) Temperature may be obtained locally.

SMU Point 103	Junction Box 1(P) NV1-03	(AB-556, HH-JJ, 54, Rm 234)
SMU Point 104	Junction Box 1(P) NV1-04	(AB-550, HH-JJ, 53-54, Rm 234)
SMU Point 105	Junction Box 1(P) NV1-05	(AB-566, LL-MM, 52-53, Rm 315)
SMU Point 106	Junction Box 1(P) NV1-06	(AB-567, MM, 52-53, Rm 310)
SMU Point 108	Junction Box 1(P) NV1-08	(AB-569, NN-58, Rm 300)

Refer to CNM-1354.05-0118 and CNM-1354.05-0119 for point location if required.

Enclosure 13.1
Periodic Surveillance Items Data

#	SURVEILLANCE ITEM (Tech Spec Reference)	ACCEPTANCE CRITERIA	QUALIFYING CONDITIONS	COMPUTER POINT ID	DAY SHIFT INITIALS	NIGHT SHIFT INITIALS
26	NC System Flow Monitor Channel Check (SR 3.3.1.1, Table 3.3.1-1 Item 10a & 10b)	Flow differential between the highest and lowest channels $\leq 5\%$. Calculate below: <u>Loop A</u> High Channel _____ % Low Channel _____ % Differential _____ % <u>Loop B</u> High Channel _____ % Low Channel _____ % Differential _____ % <u>Loop C</u> High Channel _____ % Low Channel _____ % Differential _____ % <u>Loop D</u> High Channel _____ % Low Channel _____ % Differential _____ %		1NCP5000/5010/ 5020 1NCP5030/5040/ 5050 1NCP5060/5070 5080 1NCP5090/5100/ 5110		
27	NC System Total Flow (SR 3.4.1.3) & (SR 3.4.1.1)	Flow $\geq 100\%$.	(20)	C1P0859		

(20) IF OAC point C1P0859 is unavailable, Contact RXG Duty Engineer to complete PT/0/4220/001 (Manual Calculation of Thermal Power and NC Flow) to determine NC Flow and compare the channels.

Enclosure 13.1

Periodic Surveillance Items Data

#	SURVEILLANCE ITEM (Tech Spec Reference)	ACCEPTANCE CRITERIA	QUALIFYING CONDITIONS	COMPUTER POINT ID	DAY SHIFT INITIALS	NIGHT SHIFT INITIALS
28	Overtemperature AT Setpoint Channel Check (SR 3.3.1.1, Table 3.3.1-1 Item 6)	OAC Points <u>NOT</u> in alarm	(21)(22)(23)	C1P0943 C1P0944 C1P0945 C1P0946		
29	Overpower AT Setpoint Channel Check (SR 3.3.1.1, Table 3.3.1-1 Item 7)	Difference between the highest and lowest indication $\leq 4\%$. Calculate below: High Channel _____ % Low Channel _____ % Differential _____ %	(24)	C1A0656 C1A0657 C1A0658 C1A0659		

- (21) At lower power levels (< ~ 65%), the instrumentation will be overranged (> 150%). If overranged, the value of the OAC points for the indicated vs. calculated difference will display in blue and have a SUS quality code. The calculation's input should be checked for validity (e.g. GOOD quality, no inserted values) using the command SHOW_ININSOPOT.
- (22) If OAC Point(s) in alarm, contact the Reactor Group Duty Engineer to evaluate.
- (23) If OAC Point(s) fail, refer to PT/1/A/4600/009 (Loss of Operator Aid Computer) to complete this Surveillance.
- (24) If difference is greater than allowable, notify Reactor Group Duty Engineer to perform a qualitative assessment of channels to determine operability. (PIP 96-2701)

Enclosure 13.1
Periodic Surveillance Items Data

PT/1/A/4600/002A
Page 16 of 34

#	SURVEILLANCE ITEM (Tech Spec Reference)	ACCEPTANCE CRITERIA	QUALIFYING CONDITIONS	COMPUTER POINT ID	DAY SHIFT INITIALS	NIGHT SHIFT INITIALS
30	NC System AT Monitor Channel Check (SR 3.3.1.1, Table 3.3.1-1)	Difference between the highest and lowest indication $\leq 4\%$. Calculate below: High Channel _____ % Low Channel _____ % Differential _____ %	(25)	C1A0675 C1A0681 C1A0687 C1A0693		
31	Boric Acid Storage Tank Solution Temp. (SIC 16.9-12)	Temp: $\geq 65^{\circ}\text{F}$			(W)	
32	Boric Acid Storage Tank Level (SIC 16.9-12)	Contained volume \geq minimum value as specified in the COLR		C1A1406	(W)	
33	Cold Leg Accumulators Operable (SR 3.5.1.2) & (SR 3.5.1.3)	Absence of all alarms: 1AD9 D/1-4 1AD9 E/1-4				
34	Cold Leg Recirc FWST To Cont Sump Swap Enable Trn A/B Lamp Test	Each Trns ENABLED light illuminates when depressing LAMP TEST pushbutton.				

(25) If difference is greater than allowable, notify Reactor Group Duty Engineer to perform a qualitative assessment of channels to determine operability. (PIP 96-2701)

Enclosure 13.1

Periodic Surveillance Items Data

#	SURVEILLANCE ITEM (Tech Spec Reference)	ACCEPTANCE CRITERIA	QUALIFYING CONDITIONS	COMPUTER POINT ID	DAY SHIFT INITIALS	NIGHT SHIFT INITIALS
35	NC System Tave (SR 3.1.1.2)	<p>COMPUTER AVERAGE With 3 or 4 channels operable ≤ 593°F</p> <p>OR</p> <p>METER AVERAGE With 3 or 4 channels operable ≤ 592°F</p> <p>circle one COMPUTER OR METER</p> <p>_____ °F A Loop _____ °F B Loop _____ °F C Loop _____ °F D Loop</p> <p>(Total Temp) _____ °F # Oper Channels + _____ (Average) = _____ °F</p>		C1A0860 C1A0861 C1A0862 C1A0863		
36	Tave Low (P-4) Interlock Channel Check (SR 3.3.2.1, Table 3.3.2-1 Item 5d)	<p>Channel A shall be within ± 2.5°F of the average of all operable channels.</p> <p>Channel B shall be within ± 3.5°F of the average of all operable channels.</p> <p>Channel C shall be within ± 2.0°F of the average of all operable channels.</p> <p>Channel D shall be within ± 3.0°F of the average of all operable channels.</p>		C1A0860 C1A0861 C1A0862 C1A0863		

Enclosure 13.1

Periodic Surveillance Items Data

#	SURVEILLANCE ITEM (Tech Spec Reference)	ACCEPTANCE CRITERIA	QUALIFYING CONDITIONS	COMPUTER POINT ID	DAY SHIFT INITIALS	NIGHT SHIFT INITIALS										
37	Cold Leg A. cumulator Discharge Isolation Valves (SR 3.5.1.1)	Following valves shall be open as determined by the monitor light NOT lit: <table border="0"> <tr> <td><u>Valve #</u></td> <td><u>IMD-1</u></td> </tr> <tr> <td>INI-54A</td> <td>A-10</td> </tr> <tr> <td>INI-65B</td> <td>A-2</td> </tr> <tr> <td>INI-76A</td> <td>B-11</td> </tr> <tr> <td>INI-88B</td> <td>B-3</td> </tr> </table>	<u>Valve #</u>	<u>IMD-1</u>	INI-54A	A-10	INI-65B	A-2	INI-76A	B-11	INI-88B	B-3				
<u>Valve #</u>	<u>IMD-1</u>															
INI-54A	A-10															
INI-65B	A-2															
INI-76A	B-11															
INI-88B	B-3															
38	ECCS Valve Status (SR 3.5.2.1)	Valve position/power disconnect switch position as indicated below:														
	IFW 27A	Open														
	IFW 55B	Open														
	INI-162A	Open / DISCON														
	INI-121	Closed / DISCON														
	INI-152B	Closed / DISCON														
	INI-173A	Open / DISCON														
	INI-183B	Closed / DISCON														
	INI-178B	Open / DISCON														
	INI-100B	Open / DISCON														
	INI-147B	Open / DISCON														

Periodic Surveillance Items Data

#	SURVEILLANCE ITEM (Tech Spec Reference)	ACCEPTANCE CRITERIA	QUALIFYING CONDITIONS	COMPUTER POINT ID	DAY SHIFT INITIALS	NIGHT SHIFT INITIALS
39	Standby Nuclear Service Water Pond Temp. (SR 3.7.9.2)	Temp: $\leq 90.4^{\circ}\text{F}$ $\leq 90.4^{\circ}\text{F}$ (ORNP8130)	(26)(27)	CIA1346		
40	Standby Nuclear Service Water Pond Level (SR 3.7.9.1)	Level: ≥ 571.5 ft. ≥ 571.5 ft. (ORNP7350) ≥ 571 ft. (local)		CIA1013		
41	Lake Wylie Water Temperature (SLC 16.9-14)	Water temperature of Lake Wylie \leq 92°F when aligned to the Nuclear Service Water System, as measured in the discharge of an operating RN pump Record below and in the RO Logbook _____°F	(28)	1(2) RNP 5000 1(2) RNP 5010		
42	FWST Level Monitor Channel Check (SR 3.3.2.1, Table 3.3.2-1 Item 7b)	Level differential between highest and lowest channels $\leq 3\%$. Calculate below: High Channel _____ % Low Channel _____ % Differential _____ %		CIA1262 CIA1268 CIA1250 CIA1256		

(26) Only required from 0000 hrs. June 30 to 2400 hrs. September 30, N/A all other times.

(27) If OAC point CIA1346 AND Gauge ORNP8130 are inoperable OR OAC point CIA1346 is inoperable, the temperature reading may be obtained per PT/0/A/4400/024 (SNSWP Temperature Monitoring).

(28) Only required from 0000 hrs. June 30 to 2400 hrs. September 30, when RN suction is aligned to Lake Wylie. N/A all other times.

Periodic Surveillance Items Data

#	SURVEILLANCE ITEM (Tech Spec Reference)	ACCEPTANCE CRITERIA	QUALIFYING CONDITIONS	COMPUTER POINT ID	DAY SHIFT INITIALS	NIGHT SHIFT INITIALS
43	FWST Borated Water Volume (SR 3.5.4.2) & (SLC 16.9-12)	A minimum contained water volume as presented in the COLR or SR 3.5.4.2, whichever is larger.		CIA1262/CIA1268 CIA1250/CIA1256	(W)	
44	FWST Solution Temp (SR 3.5.4.1) & (SLC 16.9-12)	Min. 70°F Max. 100°F		CIA1154/CIA1160 CIA0545		
45	Groundwater Level (WZ) (SLC 16.7-8)	Monitor Well Levels ≤ the top of the adjacent floor slab as verified by: 1. Absence of Alarm Annunciator 1AD13 D/1, D/2 and D/3 <u>AND</u> 2. Locally on 0ELMC0001 as follows: Monitor Well #2 Level ≤ 550 ft.-0" Monitor Well #4 Level ≤ 558 ft.-6" Monitor Well #5 Level ≤ 558 ft.- 6" Monitor Well #7 Level ≤ 550 ft. -0" Monitor Well #10 Level ≤ 560 ft. -0" Monitor Well #11 Level ≤ 560 ft. -0"	(29)		(W)	
46	Ice Condenser Inlet Door Position Monitoring System (SLC 16.6-3)	Successful annunciator panel test for annunciator window 1AD13 A/7 Absence of Alarm Annunciator 1AD13 A/7				

(29) Local levels from 0ELMC0001 are obtained by the Aux Bldg Rounds person.

Enclosure 13.1

Periodic Surveillance Items Data

PT/1/A/4600/002A

Page 21 of 34

#	SURVEILLANCE ITEM (Tech Spec Reference)	ACCEPTANCE CRITERIA	QUALIFYING CONDITIONS	COMPUTER POINT ID	DAY SHIFT INITIALS	NIGHT SHIFT INITIALS
47	Ice Bed Temp. Monitor Channel Check (SLC 16.6-2)	At least 2 channels in the ice bed at each of the three basic elevations (< 11', 30' 9", and 55' above the floor of the ice condenser) for each one-third of the ice condensers are indicating within 5°F of each other.	(30)			
48	Ice Bed Temperature (SR 3.6.12.1)	All operable channel temps. ≤ 27°F				
49	Spent Fuel Pool Water Level (SR 3.7.14.1) & (SLC 16.9-21)	Level: ≥ 37.6 ft. (≥ 23 ft. above fuel assemblies)			(W)	
50	Control Room Air Temp. (SR 3.7.11.1)	All Thermometers are ≤ 90°F	(31)			
51	Chlorine Detector Channel Check (SLC 16.6-4)	Absence of alarm Annunciator IAD18 B/8 & E/8 (Unit 1 Intake Hi Chlorine) (Unit 2 Intake Hi Chlorine)				

(30) IF NF Chart Recorder is NOT inking, ensure a priority E work request has been submitted.

(31) Thermometers located on columns CC-55, CC-57 and CC-59.

Enclosure 13.1
Periodic Surveillance Items Data

#	SURVEILLANCE ITEM (Tech Spec Reference)	ACCEPTANCE CRITERIA	QUALIFYING CONDITIONS	COMPUTER POINT ID	DAY SHIFT INITIALS	NIGHT SHIFT INITIALS
52	Wind Speed Monitor Channel Check (SLC 16.7-3)	Lower wind speed has power and is indicating on scale.	(32)(33)			
		Upper wind speed has power and is indicating on scale.	(32)(33)			
53	Wind Direction Monitor Channel Check (SLC 16.7-3)	Lower wind direction has power and is indicating on scale.	(32)(33)			
		Upper wind direction has power and is indicating on scale.	(32)(33)			
54	Outside Air Temp ΔT Channel Check (SLC 16.7-3)	Instrument has power and is indicating on scale.	(32)(33)			
55	Loose Parts Monitor Channel Check (SLC 16.7-4)	System operable per Enclosure 13.2.				

- (32) Initiate work request (R005) for IAE to inspect the Meteorological Instrument System for any failures or abnormalities.
- (33) Traces should be variable for wind speeds, wind directions, delta temperature and ambient temperature. **IF** any channel is drawing a straight line, it should be evaluated for operability.

Periodic Surveillance Items Data

#	SURVEILLANCE ITEM (Tech Spec Reference)	ACCEPTANCE CRITERIA	QUALIFYING CONDITIONS	COMPUTER POINT ID	DAY SHIFT INITIALS	NIGHT SHIFT INITIALS
56	IEMF15 Channel Check (SLC 16.7-10)	1. Power light on 2. Meter is reading $\geq \frac{1}{2}$ of background from setpoint logbook	(34)			
57	IEMF31 Channel Check (SLC 16.11-2)	1. Power light on 2. No "LOSS OF SAMPLE FLOW" alarm 3. Meter is reading $\geq \frac{1}{2}$ of background from setpoint logbook	(34)			
58	IEMF33 Channel Check (SLC 16.11-7)	1. Power light on 2. No "LOSS OF SAMPLE FLOW" alarm 3. Meter is reading $\geq \frac{1}{2}$ of background from setpoint logbook	(34)			
59	IEMF35 Channel Check (SLC 16.11-7) 35L	1. Power light on 2. No "LOSS OF SAMPLE FLOW" alarm 3. Meter is reading $\geq \frac{1}{2}$ of background from setpoint logbook	(34)		(W)	

(34) If meter reading is NOT $\geq \frac{1}{2}$ of background from setpoint logbook, contact Radiation Protection for operability determination

Enclosure 13.1

Periodic Surveillance Items Data

#	SURVEILLANCE ITEM (Tech Spec Reference)	ACCEPTANCE CRITERIA	QUALIFYING CONDITIONS	COMPUTER POINT ID	DAY SHIFT INITIALS	NIGHT SHIFT INITIALS
60	HEMF36 Channel Check (SLC 16.11-7) 36 Low	1. Power light on 2. No "LOSS OF SAMPLE FLOW" alarm 3. Meter is reading \geq 1/2 of background from setpoint logbook	(35)			
61	HEMF37 Channel Check (SLC 16.11-7)	1. Power light on 2. No "LOSS OF SAMPLE FLOW" alarm 3. Meter is reading \geq 1/2 of background from setpoint logbook	(35)		(W)	
62	HEMF 38, 39, 40 Cont Isolation Valve Position	IMI-5230 Open				
		IMI-5231 Open				
		IMI-5232 Open				
		IMI-5233 Open				
63	HEMF38 Channel Check (SR 3.4.15.1) 38L	1. Power light on 2. No "LOSS OF SAMPLE FLOW" alarm 3. Meter is reading \geq 1/2 of background from setpoint logbook	(35)	C1E0147		

(35) If meter reading is NOT \geq 1/2 of background from setpoint logbook, contact Radiation Protection for operability determination.

Periodic Surveillance Items Data

#	SURVEILLANCE ITEM (Tech Spec Reference)	ACCEPTANCE CRITERIA	QUALIFYING CONDITIONS	COMPUTER POINT ID	DAY SHIFT INITIALS	NIGHT SHIFT INITIALS
64	IEMF39 Channel Check (SR 3.4.15.1) & (SLCs 16.7-10, 16.11-7) 39L	1. Power light on 2. No "LOSS OF SAMPLE FLOW" alarm 3. Meter is reading $\geq \frac{1}{2}$ of background from setpoint logbook	(36)	C1E0155		
65	IEMF39 Channel Check (SLC 16.11-7) 39L	Verify EMF39 Trip 2 setpoint is set at ≤ 3 times containment activity.	(37)(38)			
66	EMF41 Channel Check (SLC 16.7-10)	1. Power light on 2. No "LOSS OF SAMPLE FLOW" alarm 3. Meter is reading $\geq \frac{1}{2}$ of background from setpoint logbook 4. The scanner scan/stop switch positioned to "SCAN".	(36)			

(36) IF meter reading is NOT $\geq \frac{1}{2}$ of background from setpoint logbook, contact Radiation Protection for operability determination.

(37) N/A if VQ release in progress.

(38) EMF Setpoint Log should be used to determine current Trip 2 setpoint value as necessary.

Enclosure 13.1

Periodic Surveillance Items Data

PT/1/A/4600/002A
Page 26 of 34

#	SURVEILLANCE ITEM (Tech Spec Reference)	ACCEPTANCE CRITERIA	QUALIFYING CONDITIONS	COMPUTER POINT ID	DAY SHIFT INITIALS	NIGHT SHIFT INITIALS
67	HEMF42 Channel Check (SLC 16.7-10)	1. Power light on 2. No "LOSS OF SAMPLE FLOW" alarm 3. Meter is reading $\geq \frac{1}{2}$ of background from setpoint logbook	(39)	C1E0214		
68	EMF43 Channel Check (SLC 16.7-10) 43A	1. Power light on 2. No "LOSS OF SAMPLE FLOW" alarm 3. Meter is reading $\geq \frac{1}{2}$ of background from setpoint logbook	(39)	C1E0218		
69	EMF43 Channel Check (SLC 16.7-10) 43B	1. Power light on 2. No "LOSS OF SAMPLE FLOW" alarm 3. Meter is reading $\geq \frac{1}{2}$ of background from setpoint logbook	(39)	C1E0222		

(39) If meter reading is NOT $\geq \frac{1}{2}$ of background from setpoint logbook, contact Radiation Protection for operability determination.

Periodic Surveillance Items Data

#	SURVEILLANCE ITEM (Tech Spec Reference)	ACCEPTANCE CRITERIA	QUALIFYING CONDITIONS	COMPUTER POINT ID	DAY SHIFT INITIALS	NIGHT SHIFT INITIALS
70	1EMI46 Channel Check (SLC 16.7-10) 46A	1. Power light on 2. <u>IF</u> a train related KC pump is on, verify no "LOSS OF SAMPLE FLOW" alarm 3. Meter is reading $\geq \frac{1}{2}$ of background from setpoint logbook	(40)			
71	1EMI46 Channel Check (SLC 16.7-10) 46B	1. Power light on 2. <u>IF</u> a train related KC pump is on, verify no "LOSS OF SAMPLE FLOW" alarm 3. Meter is reading $\geq \frac{1}{2}$ of background from setpoint logbook	(40)			
72	EMI49 Channel Check (SLC 16.11-2) 49L	1. Power light on 2. No "LOSS OF SAMPLE FLOW" alarm 3. Meter is reading $\geq \frac{1}{2}$ of background from setpoint logbook	(40)	C1E0263		

(40) IF meter reading is NOT $\geq \frac{1}{2}$ of background from setpoint logbook, contact Radiation Protection for operability determination.

Enclosure 13.1

Periodic Surveillance Items Data

PT/1/A/4600/002A
Page 28 of 34

#	SURVEILLANCE ITEM (Tech Spec Reference)	ACCEPTANCE CRITERIA	QUALIFYING CONDITIONS	COMPUTER POINT ID	DAY SHIFT INITIALS	NIGHT SHIFT INITIALS
73	EMI-50 Channel Check (SLC 16.11-7) 50L	1. Power light on 2. No "LOSS OF SAMPLE FLOW" alarm 3. Meter is reading $\geq \frac{1}{2}$ of background from setpoint logbook	(41)	C1E0271		
74	Fuel Building Ventilation (SR 3.7.13.1)	VF operable with flow being discharged through HEPA filter 1A1/1A2 or 1B1/1B2 and Charcoal filters.	(42)			
75	Doghhouse Water Level Channel Check	Verify annunciators operable and no alarms on: 1AD8; D/7, D/8, E/7, E/8				

(41) IF meter reading is NOT $\geq \frac{1}{2}$ of background from setpoint logbook, contact Radiation Protection for operability determination

(42) During movement of irradiated fuel assemblies in the fuel building.

Periodic Surveillance Items Data

#	SURVEILLANCE ITEM (Tech Spec Reference)	ACCEPTANCE CRITERIA	QUALIFYING CONDITIONS	COMPUTER POINT ID	DAY SHIFT INITIALS	NIGHT SHIFT INITIALS
76	RL Minimum Flow Interlock Channel (SLC 16.11-2)	Annunciator IAD12 F/3 dark if RL Disch Flow on ORLP5080, above RL Disch Lo Flow Setpoint (MC9) or opposite combination.	(43)			
77	RL Discharge Flow Channel Check	OAC points C1P0903 <u>OR</u> Unit 2 P0903 <u>AND</u> C1P0904 <u>OR</u> Unit 2 P0904 are in service <u>AND NOT</u> overranged.	(43)	C1P0903/C1P0904 Unit 2 C2P0903/C2P0904		
78	RL Intake Temp Channel Check	C1P1521 or Unit 2 P1521 in service and on scale	(43)	C1P1521 Unit 2 C2P1521		
79	RL Discharge Temp Channel Check	C1P1376 or Unit 2 P1376 in service and on scale	(43)	C1P1376 Unit 2 C2P1376		
		C1P1377 or Unit 2 P1377 in service and on scale	(43)	C1P1377 Unit 2 C2P1377		

(43) IF RL instruments inoperable, refer to PT/0/A/4250/011 (RL Temperature and Discharge Flow Determinations).

Enclosure 13.1
 Periodic Surveillance Items Data

#	SURVEILLANCE ITEM (Tech Spec Reference)	ACCEPTANCE CRITERIA	QUALIFYING CONDITIONS	COMPUTER POINT ID	DAY SHIFT INITIALS	NIGHT SHIFT INITIALS
80	Unit Vent Flow Rate Monitor Channel Check (SIC 16.11-7)	Instrument in service with > 0 SCFM indicated with any systems exhausting to the unit vent. Circle method used to determine flow rate Local/Computer (%) x 195,000 cfm = _____ cfm	(44)(45)	C1A1104		

(-4) IF Unit Vent Flow Monitor is inoperable, refer to PT/1/A/4450/017 (Unit Vent flow Manual Calculation).

(-15) IF C1A1104 is NOT in service, determine unit vent flow rate by multiplying 195,000 cfm by reading on local meter 1VAP8300 (AB-594, III-52) and record in space provided above.

#	SURVEILLANCE ITEM (Tech Spec Reference)	ACCEPTANCE CRITERIA	QUALIFYING CONDITIONS	COMPUTER POINT ID.	DAY SHIFT INITIALS	NIGHT SHIFT INITIALS
81	RN Pit Level Channel Check (SR 3.3.2.1; Table 3.3.2-1 Item 10)	Level Differential between the highest and lowest level is ≤ 1.5 ft. Calculate below: RN Pit A 1RNP7400 (1MC9) _____ 2RNP7400 (2MC9) _____ OAC point CIA1453 _____ Difference _____ Manual Measurement _____ RN Pit B 1RNP7370 (1MC9) _____ 2RNP7370 (2MC9) _____ OAC point CIA1459 _____ Difference _____ Manual Measurement _____	(46)(47)	CIA1453 CIA1459		

(46) IF the A TRN and/or B TRN RN Pit Level Instruments are out by > 1.5 ft., a manual measurement of water level in the pit can be made. Each instrument in the pit shall be within 1.5 ft. of the measured value. The top of the grating on the platform in the pit below the RN pump motors is at 580' - 0".

(47) OAC points CIA1453 (C2A1453) and CIA1459 (C2A1459) may be obtained from the Unit 1 (Unit 2) OAC. IF OAC point is unavailable to determine pit level, issue Model Work Orders #94085162 (ORNLT7390, RN Pit A) and #94085173 (ORNLT7360, RN Pit B) as necessary for level determination.

Enclosure 13.1
Periodic Surveillance Items Data

#	SURVEILLANCE ITEM (Tech Spec Reference)	ACCEPTANCE CRITERIA	QUALIFYING CONDITIONS	COMPUTER POINT ID	DAY SHIFT INITIALS	NIGHT SHIFT INITIALS
82	Transfer Canal Weir Gate	Weir Gate Seal Pressure 30 psig \pm 5 and no visible leakage past seal.	(48)			
83	SSF Stby Makeup Pump Suction Source (SLC 16.7-9)	Spent Fuel Pool Level \geq 37 Feet with weir gate removed.			(W)	
84	D/G 1A Prelube Oil Filter AP	\leq 20 psid	(49)(50)		(W)	
85	D/G 1B Prelube Oil Filter AP	\leq 20 psid	(49)(50)		(W)	
86	HEMI-38 Leakage Detection System (SR 3.4.15.1)	1. C1P0590 in service 2. Quality - GOOD	(51)	C1P0590		
87	HEMI-39 Leakage Detection System (SR 3.4.15.1)	1. C1P0591 in service 2. Quality - GOOD	(51)	C1P0591		

(48) N/A if weir gate removed.

(49) Obtained by Aux Bldg Rounds person, when engine aligned for Stby Readiness.

(50) If differential pressure > 20 psid, the acceptance criteria is met if a high priority work request is written to investigate the cause of the excessive pressure.

(51) If OAC point is unavailable, perform applicable section of PT/1/A/4600/009 (Loss of Operator Aid Computer). (Reg Guide 1.45)

Periodic Surveillance Items Data

#	SURVEILLANCE ITEM (Tech Spec Reference)	ACCEPTANCE CRITERIA	QUALIFYING CONDITIONS	COMPUTER POINT ID	DAY SHIFT INITIALS	NIGHT SHIFT INITIALS
88	Condensate Storage System (SR 3.7.6.1)	225,000 gallons contained water volume. Calculate below: <u>UST</u> <ul style="list-style-type: none"> • ICSCR5840 _____ % • Revised Data Book Figure 22 (Upper Surge Tank Volume vs Level) or Locally from ICSLG5970 _____ Gals. <u>Hotwell</u> <ul style="list-style-type: none"> • ICSCR5840 _____ ft. • Revised Data Book Figure 11 (Hotwell Volume vs Level) _____ Gals. TOTAL _____ Gals				

Enclosure 13.1

Periodic Surveillance Items Data

#	SURVEILLANCE ITEM (Tech Spec Reference)	ACCEPTANCE CRITERIA	QUALIFYING CONDITIONS	COMPUTER POINT ID	DAY SHIFT INITIALS	NIGHT SHIFT INITIALS
89	CA Pumps Flow Control Accumulator Tanks Air Pressure	Air pressure in all 8 Accumulator air tanks \geq 80 psig	(52)(53)		(W)	

(52) IF the pressure in any of the Accumulator Air Tanks is less than 80 psig, generate a PIP to have Engineering to re-evaluate the DEI limits.
WHEN the PIP is generated, acceptance criteria shall be considered to be satisfied.

(53) Obtained by the Aux Bldg Rounds person.

NOTE: IF any alarm monitor unit or control unit alarm indication LED fails, the acceptance criteria is met if a work request is written to investigate and repair LED.

1. Procedure

1.1 Perform the following for the Alarm Rack Verifications:

1.1.1 On the "ALARM MONITOR UNIT", verify the following:

- The LEDs numbered 1 through 22 are dark.
- The "SELECT" keyswitch is in the "PRIMARY" position.
- The "PRIMARY" LED is illuminated.

1.1.2 On the "CONTROL UNIT", verify the following:

- The "OUTPUTS" keyswitch is in the "ENABLE" position.
- The "EVENT ALARM" LED is dark.
- The "SYSTEM FAILURE" LED is dark.
- The Normal/Inhibit keyswitch is in the "NORMAL" position.

1.1.3 Press the "POWER" button on the "TAPE RECORDER CONSOLE".

1.1.4 Verify the "OFF" light illuminates on the "POWER" button.

NOTE: Annunciator 1AD-4, window A/8 "LOOSE PARTS PANEL TROUBLE" should alarm when performing the next step.

1.1.5 Press the Event Alarm "TEST" button.

1.1.6 Verify the following:

- The "EVENT ALARM" LED on the "CONTROL UNIT" is illuminated.
- Annunciator 1AD-4, A/8 "LOOSE PARTS PANEL TROUBLE" is illuminated.

1.1.7 Press the Event Alarm "RESET" button.

Loose Parts Monitor Data

- 1.1.8 Verify the following:
- The "EVENT ALARM" LED on the "CONTROL UNIT" is dark.
 - Annunciator 1AD-4, A/8 "LOOSE PARTS PANEL TROUBLE" is dark.

NOTE: Annunciator 1AD-4, window A/8 "LOOSE PARTS PANEL TROUBLE" should alarm when performing the next step.

- 1.1.9 Press the System Failure "TEST" button.
- 1.1.10 Verify the following:
 - The "SYSTEM FAILURE" LED on the "CONTROL UNIT" is illuminated.
 - Annunciator 1AD-4, A/8 "LOOSE PARTS PANEL TROUBLE" is illuminated.
- 1.1.11 Press the System Failure "RESET" button.
- 1.1.12 Verify the following:
 - The "SYSTEM FAILURE" LED on the "CONTROL UNIT" is dark.
 - Annunciator 1AD-4, A/8 "LOOSE PARTS PANEL TROUBLE" is dark.
- 1.1.13 Press the "POWER" button on the "TAPE RECORDER CONSOLE".
- 1.1.14 Verify the "ON" light illuminates on the "POWER" button.

Loose Parts Monitor Data

1.2 Perform the following for the Audio Monitor Verifications:

- NOTE:**
1. The left or right filter may be used to perform the Audio Monitor Verifications.
 2. The cutoff frequencies in the following step may be varied if desired to improve clarity of the sound.

1.2.1 Adjust the cutoff frequencies on the audio monitor as follows:

"LOW" cutoff = 01.0 kHz

"HIGH" cutoff = 15.0 kHz

- 1.2.2 Using the "LINE" and "CHANNEL" selector switches, listen to each channel long enough to gain a familiarity with current background noise. {PIP 96-0025}

_____ 1	_____ 9	_____ 17
_____ 2	_____ 10	_____ 18
_____ 3	_____ 11	_____ 19
_____ 4	_____ 12	_____ 20
_____ 5	_____ 13	_____ 21
_____ 6	_____ 14	_____ 22
_____ 7	_____ 15	
_____ 8	_____ 16	

- _____ 1.2.3 IF abnormal noise is present (abnormal noises can be knocks, pings, bangs, etc.), record as a discrepancy and notify the Reactor Engineering Duty Engineer. {PIP 96-0025}

_____ 1.3 Perform the following for the Analog Tape Recorder Verifications.

1.3.1 Power "ON" LED is illuminated.

1.3.2 Tape cassette is in place.

1.3.3 Tape cassette is rewound.

- _____ 1.4 Verify no voltage alarm LEDs are illuminated on channels 1-22 on the signal modules of the Signal Processor unit. {PIP 96-0025}

- _____ 1.5 Sign off Surveillance Item 55, Loose Parts Monitor System operable, if Steps 1.1 through 1.4 of this enclosure are signed off as complete and attach to Enclosure 13.1 (Periodic Surveillance Items Data).

Loose Parts Monitor Data

- 1.6 - Notify the Reactor Engineering Duty Engineer of any discrepancies associated with the completion of this enclosure that have NOT been previously identified and a work request initiated to correct. (PIP 96-0025)

3.2 POWER DISTRIBUTION LIMITS

3.2.4 QUADRANT POWER TILT RATIO (QPTR)

LCO 3.2.4 The QPTR shall be ≤ 1.02 .

APPLICABILITY: MODE 1 with THERMAL POWER > 50% RTP.

-----NOTE-----

Not applicable until calibration of the excore detectors is completed subsequent to refueling.

ACTIONS

CONDITION	REQUIRED ACTION	COMPLETION TIME
<p>A. QPTR not within limit.</p>	<p>A.1 Reduce THERMAL POWER $\geq 3\%$ from RTP for each 1% of QPTR > 1.02.</p>	<p>2 hours</p>
	<p><u>AND</u></p>	
	<p>A.2 Perform SR 3.2.4.1 and reduce THERMAL POWER $\geq 3\%$ from RTP for each 1% of QPTR > 1.02.</p>	<p>Once per 12 hours</p>
	<p><u>AND</u></p>	
	<p>A.3 Perform SR 3.2.1.1 and SR 3.2.2.1.</p>	<p>24 hours</p>
	<p><u>AND</u></p>	<p><u>AND</u></p> <p>Once per 7 days thereafter</p> <p>(continued)</p>

ACTIONS

CONDITION	REQUIRED ACTION	COMPLETION TIME
<p>A. (continued)</p>	<p>A.4 Reduce Power Range Neutron Flux - High Trip Setpoint $\geq 3\%$ for each 1% of QPTR > 1.02.</p> <p><u>AND</u></p> <p>A.5 Reevaluate safety analyses and confirm results remain valid for duration of operation under this condition.</p> <p><u>AND</u></p> <p>A.6 -----NOTE----- Perform Required Action A.6 only after Required Action A.5 is completed.</p> <p>-----</p> <p>Calibrate excore detectors to show zero QPT.</p> <p><u>AND</u></p>	<p>72 hours</p> <p>Prior to increasing THERMAL POWER above the more restrictive limit of Required Action A.1 or A.2</p> <p>Prior to increasing THERMAL POWER above the more restrictive limit of Required Action A.1 or A.2</p> <p>(continued)</p>

ACTIONS

CONDITION	REQUIRED ACTION	COMPLETION TIME
<p>A. (continued)</p>	<p>A.7 -----NOTE----- Required Action A.7 must be completed when Required Action A.6 is completed. ----- Perform SR 3.2.1.1 and SR 3.2.2.1.</p>	<p>Within 24 hours after reaching RTP <u>OR</u> Within 48 hours after increasing THERMAL POWER above the more restrictive limit of Required Action A.1 or A.2</p>
<p>B. Required Action and associated Completion Time not met.</p>	<p>B.1 Reduce THERMAL POWER to \leq 50% RTP.</p>	<p>4 hours</p>

SURVEILLANCE REQUIREMENTS

SURVEILLANCE	FREQUENCY
<p>SR 3.2.4.1 -----NOTES-----</p> <ol style="list-style-type: none"> 1. With input from one Power Range Neutron Flux channel inoperable and THERMAL POWER <75% RTP, the remaining three power range channels can be used for calculating QPTR. 2. SR 3.2.4.2 may be performed in lieu of this Surveillance. 3. This SR is not required to be performed until 12 hours after exceeding 50% RTP. <p>-----</p> <p>Verify QPTR is within limit by calculation.</p>	<p>7 days</p> <p><u>AND</u></p> <p>Once within 12 hours and every 12 hours thereafter with the QPTR alarm inoperable</p>
<p>SR 3.2.4.2 -----NOTES-----</p> <p>Only required to be performed if input from one or more Power Range Neutron Flux channels are inoperable with THERMAL POWER \geq 75% RTP.</p> <p>-----</p> <p>Verify QPTR is within limit using the movable incore detectors.</p>	<p>12 hours</p>

BASES

ACTIONS (continued)

of 2 hours allows sufficient time to identify the cause and correct the tilt. Note that the power reduction itself may cause a change in the tilted condition.

A.2

After completion of Required Action A.1, the QPTR alarm may still be in its alarmed state. As such, any additional changes in the QPTR are detected by requiring a check of the QPTR once per 12 hours thereafter. If the QPTR continues to increase, THERMAL POWER has to be reduced accordingly. A 12 hour Completion Time is sufficient because any additional change in QPTR would be relatively slow.

A.3

The peaking factors $F_{\Delta H}(X,Y)$ and $F_Q(X,Y,Z)$ are of primary importance in ensuring that the power distribution remains consistent with the initial conditions used in the safety analyses. Performing SRs on $F_{\Delta H}(X,Y)$ and $F_Q(X,Y,Z)$ within the Completion Time of 24 hours ensures that these primary indicators of power distribution are within their respective limits. A Completion Time of 24 hours takes into consideration the rate at which peaking factors are likely to change, and the time required to stabilize the plant and perform a flux map. If these peaking factors are not within their limits, the Required Actions of these Surveillances provide an appropriate response for the abnormal condition. If the QPTR remains above its specified limit, the peaking factor surveillances are required each 7 days thereafter to evaluate $F_{\Delta H}(X,Y)$ and $F_Q(X,Y,Z)$ with changes in power distribution. Relatively small changes are expected due to either burnup and xenon redistribution or correction of the cause for exceeding the QPTR limit.

A.4

If QPTR exceeds a value of 1.02, the Power Range Neutron Flux-High trip setpoint is reduced by 3% for each 1% QPTR exceeds 1.02. Lowering this setpoint maintains the same margin to trip by limiting the transient response of the core. The 72 hour Completion Time is sufficient for this activity to be performed and is acceptable based on the low probability of a transient occurring in this time frame.

BASES

ACTIONS (continued)

A.5

Although $F_{\Delta H}(X,Y)$ and $F_Q(X,Y,Z)$ are of primary importance as initial conditions in the safety analyses, other changes in the power distribution may occur as the QPTR limit is exceeded and may have an impact on the validity of the safety analysis. A change in the power distribution can affect such reactor parameters as bank worths and peaking factors for rod malfunction accidents. When the QPTR exceeds its limit, it does not necessarily mean a safety concern exists. It does mean that there is an indication of a change in the gross radial power distribution that requires an investigation and evaluation that is accomplished by examining the incore power distribution. Specifically, the core peaking factors and the quadrant tilt must be evaluated because they are the factors that best characterize the core power distribution. This re-evaluation is required to ensure that, before increasing THERMAL POWER to above the more restrictive limit of Required Action A.1 or A.2, the reactor core conditions are consistent with the assumptions in the safety analyses.

A.6

If the QPTR has exceeded the 1.02 limit and a re-evaluation of the safety analysis is completed and shows that safety requirements are met, the excore detectors are recalibrated to show a zero QPT prior to increasing THERMAL POWER to above the more restrictive limit of Required Action A.1 or A.2. This is done to detect any subsequent significant changes in QPTR.

Required Action A.6 is modified by a Note that states that the QPT is not zeroed out until after the re-evaluation of the safety analysis has determined that core conditions at RTP are within the safety analysis assumptions (i.e., Required Action A.5). This Note is intended to prevent any ambiguity about the required sequence of actions.

A.7

Once the flux tilt is zeroed out (i.e., Required Action A.6 is performed), it is acceptable to return to full power operation. However, as an added check that the core power distribution at RTP is consistent with the safety analysis assumptions, Required Action A.7 requires verification that $F_Q(X,Y,Z)$ and $F_{\Delta H}(X,Y)$ are within their specified limits within 24 hours of

BASES

ACTIONS (continued)

reaching RTP. As an added precaution, if the core power does not reach RTP within 24 hours, but is increased slowly, then the peaking factor surveillances must be performed within 48 hours of the time when the more restrictive of the power level limit determined by Required Action A.1 or A.2 is exceeded. These Completion Times are intended to allow adequate time to increase THERMAL POWER to above the more restrictive limit of Required Action A.1 or A.2, while not permitting the core to remain with unconfirmed power distributions for extended periods of time.

Required Action A.7 is modified by a Note that states that the peaking factor surveillances must be done after the excore detectors have been calibrated to show zero tilt (i.e., Required Action A.6). The intent of this Note is to have the peaking factor surveillances performed at operating power levels, which can only be accomplished after the excore detectors are calibrated to show zero tilt and the core returned to power.

B.1

If Required Actions A.1 through A.7 are not completed within their associated Completion Times, the unit must be brought to a MODE or condition in which the requirements do not apply. To achieve this status, THERMAL POWER must be reduced to $\leq 50\%$ RTP within 4 hours. The allowed Completion Time of 4 hours is reasonable, based on operating experience regarding the amount of time required to reach the reduced power level without challenging plant systems.

SURVEILLANCE REQUIREMENTS

SR 3.2.4.1

SR 3.2.4.1 is modified by three Notes. Note 1 allows QPTR to be calculated with three power range channels if THERMAL POWER is $< 75\%$ RTP and the input from one Power Range Neutron Flux channel is inoperable. Note 2 allows performance of SR 3.2.4.2 in lieu of SR 3.2.4.1. Note 3 states that the SR is not required to be performed until 12 hours after exceeding 50% RTP. This is necessary to establish core conditions necessary to provide meaningful calculation.

This Surveillance verifies that the QPTR, as indicated by the Nuclear Instrumentation System (NIS) excore channels, is within its limits. The

BASES

SURVEILLANCE REQUIREMENTS (continued)

Frequency of 7 days when the QPTR alarm is OPERABLE is acceptable because of the low probability that this alarm can remain inoperable without detection.

When the QPTR alarm is inoperable, the Frequency is increased to 12 hours. This Frequency is adequate to detect any relatively slow changes in QPTR, because for those causes of QPT that occur quickly (e.g., a dropped rod), there typically are other indications of abnormality that prompt a verification of core power tilt.

SR 3.2.4.2

This Surveillance is modified by a Note, which states that it is required only when the input from one or more Power Range Neutron Flux channels are inoperable and the THERMAL POWER is $\geq 75\%$ RTP.

With an NIS power range channel inoperable, tilt monitoring for a portion of the reactor core becomes degraded. Large tilts are likely detected with the remaining channels, but the capability for detection of small power tilts in some quadrants is decreased. Performing SR 3.2.4.2 at a Frequency of 12 hours provides an accurate alternative means for ensuring that any tilt remains within its limits.

For purposes of monitoring the QPTR when one power range channel is inoperable, the moveable incore detectors are used to confirm that the normalized symmetric power distribution is consistent with the indicated QPTR and any previous data indicating a tilt. The incore detector monitoring is performed with a full incore flux map or two sets of four thimble locations with quarter core symmetry. The two sets of four symmetric thimbles is a set of eight unique detector locations. These locations are C-8, E-5, E-11, H-3, H-13, L-5, L-11, and N-8.

The symmetric thimble flux map can be used to generate symmetric thimble "tilt." This can be compared to a reference symmetric thimble tilt, from the most recent full core flux map, to generate an incore tilt. Therefore, incore tilt can be used to confirm that QPTR is within limits.

With one or more NIS channel inputs to QPTR inoperable, the indicated tilt may be changed from the value indicated with all four channels OPERABLE. To confirm that no change in tilt has actually occurred, which might cause the QPTR limit to be exceeded, the incore result may be compared against previous flux maps either using the symmetric

BASES

SURVEILLANCE REQUIREMENTS (continued)

thimbles as described above or a complete flux map. Nominally, quadrant tilt from the Surveillance should be within 2% of the tilt shown by the most recent flux map data.

REFERENCES

1. 10 CFR 50.46.
2. UFSAR Section 15.4.8.
3. 10 CFR 50, Appendix A, GDC 26.
4. 10 CFR 50.36, Technical Specifications, (c)(2)(ii).

B 3.2 POWER DISTRIBUTION LIMITS

B 3.2.4 QUADRANT POWER TILT RATIO (QPTR)

BASES

BACKGROUND

The QPTR limit ensures that the gross radial power distribution remains consistent with the design values used in the safety analyses. Precise radial power distribution measurements are made during startup testing, after refueling, and periodically during power operation.

The power density at any point in the core must be limited so that the fuel design criteria are maintained. Together, LCO 3.2.3, "AXIAL FLUX DIFFERENCE (AFD)," LCO 3.2.4, and LCO 3.1.6, "Control Rod Insertion Limits," provide limits on process variables that characterize and control the three dimensional power distribution of the reactor core. Control of these variables ensures that the core operates within the fuel design criteria and that the power distribution remains within the bounds used in the safety analyses.

APPLICABLE SAFETY ANALYSES

This LCO precludes core power distributions that violate the following fuel design criteria:

- a. During a large break loss of coolant accident, the peak cladding temperature must not exceed 2200°F (Ref. 1);
- b. The DNBR calculated for the hottest fuel rod in the core must be above the approved DNBR limit. (The LCO alone is not sufficient to preclude DNB criteria violations for certain accidents, i.e., accidents in which the event itself changes the core power distribution. For these events, additional checks are made in the core reload design process against the permissible statepoint power distributions.);
- c. During an ejected rod accident, the energy deposition to the fuel must not exceed 280 cal/gm (Ref. 2); and
- d. The control rods must be capable of shutting down the reactor with a minimum required SDM with the highest worth control rod stuck fully withdrawn (Ref. 3).

The LCO limits on the AFD, the QPTR, the Heat Flux Hot Channel Factor ($F_Q(X,Y,Z)$), the Nuclear Enthalpy Rise Hot Channel Factor ($F_{\Delta H}(X,Y)$), and control bank insertion are established to preclude core power distributions that exceed the safety analyses limits.

BASES

APPLICABLE SAFETY ANALYSES (continued)

The QPTR limits ensure that $F_{\Delta H}(X,Y)$ and $F_Q(X,Y,Z)$ remain below their limiting values by preventing an undetected change in the gross radial power distribution.

In MODE 1, the $F_{\Delta H}(X,Y)$ and $F_Q(X,Y,Z)$ limits must be maintained to preclude core power distributions from exceeding design limits assumed in the safety analyses.

The QPTR satisfies Criterion 2 of 10 CFR 50.36 (Ref. 4).

LCO

The QPTR limit of 1.02, at which corrective action is required, provides a margin of protection for both the DNB ratio and linear heat generation rate contributing to excessive power peaks resulting from X-Y plane power tilts. A limiting QPTR of 1.02 can be tolerated before the margin for uncertainty in $F_Q(X,Y,Z)$ and $F_{\Delta H}(X,Y)$, or safety analysis peaking assumptions are possibly challenged.

APPLICABILITY

The QPTR limit must be maintained in MODE 1 with THERMAL POWER > 50% RTP to prevent core power distributions from exceeding the design limits.

Applicability in MODE 1 \leq 50% RTP and in other MODES is not required because there is either insufficient stored energy in the fuel or insufficient energy being transferred to the reactor coolant to require the implementation of a QPTR limit on the distribution of core power. The QPTR limit in these conditions is, therefore, not important. Note that the $F_{\Delta H}(X,Y)$ and $F_Q(X,Y,Z)$ LCOs still apply, but allow progressively higher peaking factors at 50% RTP or lower.

The Applicability is modified by a Note which states that the LCO is not applicable until the excore nuclear instrumentation is calibrated subsequent to a refueling. This refers to the final excore nuclear instrumentation calibration performed at \geq 75% RTP and not any interim calibrations.

ACTIONS

A.1

With the QPTR exceeding its limit, a power level reduction of 3% from RTP for each 1% by which the QPTR exceeds 1.02 is a conservative tradeoff of total core power with peak linear power. The Completion Time

3.2 POWER DISTRIBUTION LIMITS

3.2.1 Heat Flux Hot Channel Factor (F_o(X,Y,Z))

LCO 3.2.1 F_o^M(X,Y,Z) shall be within the limits specified in the COLR.

APPLICABILITY: MODE 1.

ACTIONS

CONDITION	REQUIRED ACTION	COMPLETION TIME
<p>A. F_o^M(X,Y,Z) not within steady state limit.</p>	<p>A.1 Reduce THERMAL POWER ≥ 1% RTP for each 1% F_o^M(X,Y,Z) exceeds limit.</p>	<p>15 minutes</p>
	<p><u>AND</u></p>	
	<p>A.2 Reduce Power Range Neutron Flux— High trip setpoints ≥ 1% for each 1% F_o^M(X,Y,Z) exceeds limit.</p>	<p>72 hours</p>
	<p><u>AND</u></p>	
	<p>A.3 Reduce Overpower ΔT trip setpoints ≥ 1% for each 1% F_o^M(X,Y,Z) exceeds limit.</p>	<p>72 hours</p>
	<p><u>AND</u></p>	
	<p>A.4 Perform SR 3.2.1.1, SR 3.2.1.2, and SR 3.2.1.3.</p>	<p>Prior to increasing THERMAL POWER above the limit of Required Action A.1</p>

(continued)

SURVEILLANCE REQUIREMENTS

NOTE

During power escalation at the beginning of each cycle, THERMAL POWER may be increased until an equilibrium power level has been achieved, at which a power distribution map is obtained.

SURVEILLANCE	FREQUENCY
SR 3.2.1.1 Verify F _Q ^M (X,Y,Z) is within steady state limit.	Once within 12 hours after achieving equilibrium conditions after exceeding, by ≥ 10% RTP, the THERMAL POWER at which F _Q ^M (X,Y,Z) was last verified <u>AND</u> 31 EFPD thereafter

(continued)

SURVEILLANCE REQUIREMENTS (continued)

SURVEILLANCE	FREQUENCY
<p>SR 3.2.1.3 -----NOTES-----</p> <p>1. Extrapolate $F_{\alpha}^M(X,Y,Z)$ using at least two measurements to 31 EFPD beyond the most recent measurement. If $F_{\alpha}^M(X,Y,Z)$ is within limits and the 31 EFPD extrapolation indicates:</p> $F_{\alpha}^M(X,Y,Z)_{\text{EXTRAPOLATED}} \geq F_{\alpha}^L(X,Y,Z)_{\text{RPS EXTRAPOLATED}},$ <p>and</p> $\frac{F_{\alpha}^M(X,Y,Z)_{\text{EXTRAPOLATED}}}{F_{\alpha}^L(X,Y,Z)_{\text{RPS EXTRAPOLATED}}} > \frac{F_{\alpha}^M(X,Y,Z)}{F_{\alpha}^L(X,Y,Z)_{\text{RPS}}}$ <p>then:</p> <p>a. Increase $F_{\alpha}^M(X,Y,Z)$ by a factor of 1.02 and reverify $F_{\alpha}^M(X,Y,Z) \leq F_{\alpha}^L(X,Y,Z)_{\text{RPS}}$; or</p> <p>b. Repeat SR 3.2.1.3 prior to the time at which $F_{\alpha}^M(X,Y,Z) \leq F_{\alpha}^L(X,Y,Z)_{\text{RPS}}$ is extrapolated to not be met.</p> <p>2. Extrapolation of $F_{\alpha}^M(X,Y,Z)$ is not required for the initial flux map taken after reaching equilibrium conditions.</p> <p>-----</p> <p>Verify $F_{\alpha}^M(X,Y,Z) \leq F_{\alpha}^L(X,Y,Z)_{\text{RPS}}$.</p>	<p>Once within 12 hours after achieving equilibrium conditions after exceeding, by \geq 10% RTP, the THERMAL POWER at which $F_{\alpha}^M(X,Y,Z)$ was last verified</p> <p><u>AND</u></p> <p>31 EFPD thereafter</p>

B 3.2 POWER DISTRIBUTION LIMITS

B 3.2.1 Heat Flux Hot Channel Factor (F_Q(X,Y,Z))

BASES

BACKGROUND

The purpose of the limits on the values of F_Q(X,Y,Z) is to limit the local (i.e., pellet) peak power density. The value of F_Q(X,Y,Z) varies axially (Z) and radially (X,Y) in the core.

F_Q(X,Y,Z) is defined as the maximum local fuel rod linear power density divided by the average fuel rod linear power density, assuming nominal fuel pellet and fuel rod dimensions. Therefore, F_Q(X,Y,Z) is a measure of the peak fuel pellet power within the reactor core.

During power operation, the global power distribution is limited by LCO 3.2.3, "AXIAL FLUX DIFFERENCE (AFD)," and LCO 3.2.4, "QUADRANT TILT POWER RATIO (QPTR)," which are directly and continuously measured process variables. These LCOs, along with LCO 3.1.6, "Control Bank Insertion Limits," maintain the core limits on power distributions on a continuous basis.

F_Q(X,Y,Z) varies with fuel loading patterns, control bank insertion, fuel burnup, and changes in axial power distribution and to a lesser extent, with boron concentration and moderator temperature.

F_Q(X,Y,Z) is measured periodically using the incore detector system. These measurements are generally taken with the core at, or near steady state conditions.

Using the measured three dimensional power distributions, it is possible to derive a measured value for F_Q(X,Y,Z). However, because this value represents a steady state condition, it does not include the variations in the value of F_Q(X,Y,Z) that are present during nonequilibrium situations.

To account for these possible variations, the F_Q(X,Y,Z) limit is reduced by precalculated factors to account for perturbations from steady state conditions to the operating limits.

Core monitoring and control under nonsteady state conditions are accomplished by operating the core within the limits of the appropriate LCOs, including the limits on AFD, QPTR, and control rod insertion.

BASES

LCO (continued)

where: F_{0}^{RTP} is the $F_{0}(X,Y,Z)$ limit at RTP provided in the COLR, and is reduced by measurement uncertainty, $K(BU)$, and manufacturing tolerances provided in the COLR,

$K(Z)$ is the normalized $F_{0}(X,Y,Z)$ as a function of core height provided in the COLR, and

$$P = \frac{\text{THERMAL POWER}}{\text{RTP}}$$

The actual values of F_{0}^{RTP} , $K(BU)$, and $K(Z)$ are given in the COLR; however, F_{0}^{RTP} , without adjustments for manufacturing tolerances and measurement uncertainty, is normally a number on the order of 2.32, and $K(Z)$ and $K(BU)$ are functions that are represented by figures in the COLR.

For relaxed AFD limit operation, $F_{0}^{M}(X,Y,Z)$ (measured $F_{0}(X,Y,Z)$) is compared against three limits:

- Steady state limit, $(F_{0}^{RTP}/P) * K(Z)$,
- Transient operational limit, $F_{0}^{L}(X,Y,Z)^{OP}$, and
- Transient RPS limit, $F_{0}^{L}(X,Y,Z)^{RPS}$.

A steady state evaluation requires obtaining an incore flux map in MODE 1. From the incore flux map results we obtain the measured value $F_{0}^{M}(X,Y,Z)$ of $F_{0}(X,Y,Z)$. Then, $F_{0}^{M}(X,Y,Z)$ is adjusted by a radial local peaking factor and compared to F_{0}^{RTP} which has been reduced by manufacturing tolerances, $K(BU)$, and flux map measurement uncertainty.

$K(BU)$ is the normalized $F_{0}^{L}(X,Y,Z)$ as a function of burnup and is provided in the COLR.

$F_{0}^{L}(X,Y,Z)^{OP}$ and $F_{0}^{L}(X,Y,Z)^{RPS}$ are cycle dependent design limits to ensure the $F_{0}(X,Y,Z)$ is met during transients. The expression for $F_{0}^{L}(X,Y,Z)^{OP}$ is:

$$F_{0}^{L}(X,Y,Z)^{OP} = F_{0}^{D}(X,Y,Z) * M_{0}(X,Y,Z) / UMT * MT * TILT$$

BASES

LCO (continued)

The F_Q(X,Y,Z) limits typically define limiting values for core power peaking that precludes peak cladding temperatures above 2200°F during either a large or small break LOCA.

This LCO requires operation within the bounds assumed in the safety analyses. Calculations are performed in the core design process to confirm that the core can be controlled in such a manner during operation that it can stay within the F_Q(X,Y,Z) limits. If F_Q(X,Y,Z) cannot be maintained within the steady state LOCA limits, reduction of the core power is required.

Violating the steady state LOCA limits for F_Q(X,Y,Z) produces unacceptable consequences if a design basis event occurs while F_Q(X,Y,Z) is outside its specified limits.

APPLICABILITY

The F_Q(X,Y,Z) limits must be maintained in MODE 1 to prevent core power distributions from exceeding the limits assumed in the safety analyses. Applicability in other MODES is not required because there is either insufficient stored energy in the fuel or insufficient energy being transferred to the reactor coolant to require a limit on the distribution of core power. The exception to this is the steam line break event, which is assumed for analysis purposes to occur from very low power levels. At these low power levels, measurements of F_Q(X,Y,Z) are not sufficiently reliable. Operation within analysis limits at these conditions is inferred from startup physics testing verification of design predictions of core parameters in general.

ACTIONS

A.1

Reducing THERMAL POWER by ≥ 1% RTP for each 1% by which F^M_Q(X,Y,Z) exceeds its steady state limit, maintains an acceptable absolute power density. F^M_Q(X,Y,Z) is the measured value of F_Q(X,Y,Z) and the steady state limit includes factors accounting for measurement uncertainty and manufacturing tolerances. The Completion Time of 15 minutes provides an acceptable time to reduce power in an orderly manner and without allowing the plant to remain in an unacceptable condition for an extended period of time.

BASES

ACTIONS (continued)

$$\% \text{ Operational Margin} = \left(1 - \frac{F_o^M(X,Y,Z)}{F_o^L(X,Y,Z)^{OP}} \right) * 100\%$$

If the operational margin is less than zero, then F_o^M(X,Y,Z) is greater than F_o^L(X,Y,Z)^{OP} and there exists a potential for exceeding the peak local power assumed in the core in a LOCA or in the loss of flow accidents. Reducing the AFD by ≥ 1% from the COLR limit for each 1% by which F_o^M(X,Y,Z) exceeds the operational limit within the allowed Completion Time of 4 hours restricts the axial flux distribution such that even if a transient occurred, core peaking factors are not exceeded. Adjusting the transient operational limit by the equivalent change in AFD limits establishes the appropriate revised surveillance limits.

C.1 and C.2

The margin contained within the reactor protection system (RPS) Overtemperature ΔT setpoints during transient operations is based on the relationship between F_o^M(X,Y,Z) and the RPS limit, F_o^L(X,Y,Z)^{RPS}, as follows:

$$\% \text{ RPS Margin} = \left(1 - \frac{F_o^M(X,Y,Z)}{F_o^L(X,Y,Z)^{RPS}} \right) * 100\%$$

If the RPS margin is less than zero, then F_o^M(X,Y,Z) is greater than F_o^L(X,Y,Z)^{RPS} and there exists a potential for F_o^M(X,Y,Z) to exceed peak clad temperature limits during certain Condition 2 transients. The Overtemperature ΔT K1 value is required to be reduced as follows:

$$K1_{ADJUSTED} = K1 - |KSLOPE * \% \text{ RPS Margin}|$$

Where K1_{ADJUSTED} is the reduced Overtemperature ΔT K1 value

KSLOPE is a penalty factor used to reduce K1 and is defined in the COLR

% RPS Margin is the most negative margin determined above.

BASES

SURVEILLANCE REQUIREMENTS (continued)

verification. It only requires verification after a power level is achieved for extended operation that is 10% higher than that power at which F_Q was last measured.

SR 3.2.1.1

Verification that $F^M_Q(X,Y,Z)$ is within its specified steady state limits involves either increasing $F^M_Q(X,Y,Z)$ to allow for manufacturing tolerance, $K(BU)$, and measurement uncertainties for the case where these factors are not included in the F_Q limit. For the case where these factors are included, a direct comparison of $F^M_Q(X,Y,Z)$ to the F_Q limit can be performed. Specifically, $F^M_Q(X,Y,Z)$ is the measured value of $F_Q(X,Y,Z)$ obtained from incore flux map results. Values for the manufacturing tolerance, $K(BU)$, and measurement uncertainty are specified in the COLR.

The limit with which $F^M_Q(X,Y,Z)$ is compared varies inversely with power above 50% RTP and directly with functions called $K(Z)$ and $K(BU)$ provided in the COLR.

If THERMAL POWER has been increased by $\geq 10\%$ RTP since the last determination of $F^M_Q(X,Y,Z)$, another evaluation of this factor is required 12 hours after achieving equilibrium conditions at this higher power level (to ensure that $F^M_Q(X,Y,Z)$ values have decreased sufficiently with power increase to stay within the LCO limits).

The Frequency of 31 EFPD is adequate to monitor the change of power distribution with core burnup because such changes are slow and well controlled when the plant is operated in accordance with the Technical Specifications (TS).

SR 3.2.1.2 and 3.2.1.3

The nuclear design process includes calculations performed to determine that the core can be operated within the $F_Q(X,Y,Z)$ limits. Because flux maps are taken in steady state conditions, the variations in power distribution resulting from normal operational maneuvers are not present in the flux map data. These variations are, however, conservatively calculated by considering a wide range of unit maneuvers in normal operation. The maximum peaking factor increase over steady state values, is determined by a maneuvering analysis (Ref. 5).

BASES

SURVEILLANCE REQUIREMENTS (continued)

than the measured factor is of the current limit, additional actions must be taken. These actions are to meet the $F_Q(X,Y,Z)$ limit with the last $F^M_Q(X,Y,Z)$ increased by a factor of 1.02, or to evaluate $F_Q(X,Y,Z)$ prior to the projected point in time when the extrapolated values are expected to exceed the extrapolated limits. These alternative requirements attempt to prevent $F_Q(X,Y,Z)$ from exceeding its limit for any significant period of time without detection using the best available data. $F^M_Q(X,Y,Z)$ is not required to be extrapolated for the initial flux map taken after reaching equilibrium conditions since the initial flux map establishes the baseline measurement for future trending. Also, extrapolation of $F^M_Q(X,Y,Z)$ limits are not valid for core locations that were previously rodged, or for core locations that were previously within $\pm 2\%$ of the core height about the demand position of the rod tip.

$F_Q(X,Y,Z)$ is verified at power levels $\geq 10\%$ RTP above the THERMAL POWER of its last verification, 12 hours after achieving equilibrium conditions to ensure that $F_Q(X,Y,Z)$ is within its limit at higher power levels.

The Surveillance Frequency of 31 EFPD is adequate to monitor the change of power distribution with core burnup. The Surveillance may be done more frequently if required by the results of $F_Q(X,Y,Z)$ evaluations.

The Frequency of 31 EFPD is adequate to monitor the change of power distribution because such a change is sufficiently slow, when the plant is operated in accordance with the TS, to preclude adverse peaking factors between 31 day surveillances.

REFERENCES

1. 10 CFR 50.46, 1974.
2. UFSAR Section 15.4.8.
3. 10 CFR 50, Appendix A, GDC 26.
4. 10 CFR 50.36, Technical Specifications, (c)(2)(ii).
5. DPC-NE-2011PA "Duke Power Company Nuclear Design Methodology for Core Operating Limits of Westinghouse Reactors", March 1990.

SURVEILLANCE REQUIREMENTS

NOTE

During power escalation at the beginning of each cycle, THERMAL POWER may be increased until an equilibrium power level has been achieved, at which a power distribution map is obtained.

SURVEILLANCE	FREQUENCY
SR 3.2.2.1 Verify F _{ΔH} ^M (X,Y) is within steady state limit.	Once within 12 hours after achieving equilibrium conditions after exceeding, by ≥ 10% RTP, the THERMAL POWER at which F _{ΔH} ^M (X,Y) was last verified <u>AND</u> 31 EFPD thereafter

(continued)

B 3.2 POWER DISTRIBUTION LIMITS

B 3.2.2 Nuclear Enthalpy Rise Hot Channel Factor ($F_{\Delta H}(X,Y)$)

BASES

BACKGROUND

The purpose of this LCO is to establish limits on the power density at any point in the core so that the fuel design criteria are not exceeded and the accident analysis assumptions remain valid. The design limits on local (pellet) and integrated fuel rod peak power density are expressed in terms of hot channel factors. Control of the core power distribution with respect to these factors ensures that local conditions in the fuel rods and coolant channels do not challenge core integrity at any location during either normal operation or a postulated accident analyzed in the safety analyses.

$F_{\Delta H}(X,Y)$ is defined as the ratio of the integral of the linear power along the fuel rod with the highest integrated power to the average integrated fuel rod power. Therefore, $F_{\Delta H}(X,Y)$ is a measure of the maximum total power produced in a fuel rod.

$F_{\Delta H}(X,Y)$ is sensitive to fuel loading patterns, bank insertion, and fuel burnup. $F_{\Delta H}(X,Y)$ typically increases with control bank insertion and typically decreases with fuel burnup.

$F_{\Delta H}(X,Y)$ is not directly measurable but is inferred from a power distribution map obtained with the movable incore detector system. Specifically, the results of the three dimensional power distribution map are analyzed by a computer to determine $F_{\Delta H}(X,Y)$. This factor is calculated at least every 31 EFPD. However, during power operation, the global power distribution is monitored by LCO 3.2.3, "AXIAL FLUX DIFFERENCE (AFD)," and LCO 3.2.4, "QUADRANT POWER TILT RATIO (QPTR)," which address directly and continuously measured process variables.

The COLR provides peaking factor limits that ensure that the design basis value of the departure from nucleate boiling (DNB) is met for normal operation, operational transients, and any transient condition arising from events of moderate frequency. The DNB design basis for operational transients and transients of moderate frequency preclude DNB and is met by limiting the minimum local DNB heat flux ratio to the design limit value using an NRC approved critical heat flux (CHF) correlation. All DNB limited transient events are assumed to begin with an $F_{\Delta H}(X,Y)$ value that satisfies the LCO requirements.

BASES

APPLICABLE SAFETY ANALYSES (continued)

factors are inserted directly into the LOCA safety analyses that verify the acceptability of the resulting peak cladding temperature (Ref. 3).

The fuel is protected in part by Technical Specifications, which ensure that the initial conditions assumed in the safety and accident analyses remain valid. The following LCOs ensure this: LCO 3.2.3, "AXIAL FLUX DIFFERENCE (AFD)," LCO 3.2.4, "QUADRANT POWER TILT RATIO (QPTR)," LCO 3.1.6, "Control Bank Insertion Limits," LCO 3.2.2, "Nuclear Enthalpy Rise Hot Channel Factor (F_{ΔH})," and LCO 3.2.1, "Heat Flux Hot Channel Factor (F_Q(X,Y,Z))."

F_{ΔH}(X,Y) and F_Q(X,Y,Z) are measured periodically using the movable incore detector system. Measurements are generally taken with the core at, or near, steady state conditions. Core monitoring and control under transient conditions (Condition 1 events) are accomplished by operating the core within the limits of the LCOs on AFD, QPTR, and Control Bank Insertion Limits.

F_{ΔH}(X,Y) satisfies Criterion 2 of 10 CFR 50.36 (Ref. 4).

LCO

F_{ΔH}(X,Y) shall be limited by the following relationship:

$$F_{\Delta H}^M(X,Y) \leq F_{\Delta H}^L(X,Y)^{LCO}$$

where: F_{ΔH}^M(X,Y) is defined as the measured radial peak, and

F_{ΔH}^L(X,Y)^{LCO} is defined as the steady state maximum allowable radial peak defined in the COLR.

The F_{ΔH}^L(X,Y)^{LCO} limit identifies the coolant flow channel with the maximum enthalpy rise. This channel has the least heat removal capability and thus the highest probability for DNB.

F_{ΔH}^L(X,Y)^{LCO} limits are maximum allowable radial peak (MARP) limits which are developed in accordance with the methodology outlined in Reference 5. MARP limits are constant DNBR limits which are a function of both the magnitude and location of the axial peak F(Z), therefore, justifying the X,Y dependence of the F_{ΔH}^L(X,Y)^{LCO} limit.

The limiting value, F_{ΔH}^L(X,Y)^{LCO}, is also power dependent and can be described by the following relationship:

BASES

ACTIONS

A.1

If $F_{\Delta H}^M(X,Y)$ is not within limit, THERMAL POWER must be reduced at least RRH% from RTP for each 1% $F_{\Delta H}(X,Y)$ exceeds the limit. Reducing power increases the DNBR margin and does not likely cause the DNBR limit to be violated in steady state operation. The Completion Time of 2 hours provides an acceptable time to reach the required power level without allowing the plant to remain in an unacceptable condition for an extended period of time.

Condition A is modified by a Note that requires that Required Actions A.3.2.2 and A.4 must be completed whenever Condition A is entered. Thus, if compliance with the LCO is restored, Required Action A.3.2.2 and A.4 nevertheless requires another measurement and calculation of $F_{\Delta H}(X,Y)$ in accordance with SR 3.2.2.1.

A.2.1 and A.2.2

Upon completion of the power reduction in Required Action A.1, the unit is allowed an additional 6 hours to restore $F_{\Delta H}(X,Y)$ to within its RTP limits. This restoration may, for example, involve realigning any misaligned rods enough to bring $F_{\Delta H}(X,Y)$ within its limit. When the $F_{\Delta H}(X,Y)$ limit is exceeded, the DNBR limit is not likely violated in steady state operation, because events that could significantly perturb the $F_{\Delta H}(X,Y)$ value (e.g., static control rod misalignment) are considered in the safety analyses. However, the DNBR limit may be violated if a DNBR limiting event occurs. Thus, the allowed Completion Time of 8 hours provides an acceptable time to restore $F_{\Delta H}(X,Y)$ to within its RTP limits without allowing the plant to remain in an unacceptable condition for an extended period of time.

If the value of $F_{\Delta H}(X,Y)$ is not restored to within its specified RTP limit, the alternative option is to reduce the Power Range Neutron Flux—High Trip Setpoint \geq RRH% for each 1% $F_{\Delta H}^M(X,Y)$ exceeds the limit in accordance with Required Action A.2.2. The reduction in trip setpoints ensures that continuing operation remains at an acceptable low power level with adequate DNBR margin and limits the consequences of a transient by limiting the transient power level which can be achieved during a postulated event.

BASES

ACTIONS (continued)

This Required Action is modified by a Note that states that THERMAL POWER does not have to be reduced prior to performing this Action.

B.1

When Required Actions A.1 through A.4 cannot be completed within their required Completion Times, the plant must be placed in a mode in which the LCO requirements are not applicable. This is done by placing the plant in at least MODE 2 within 6 hours. The allowed Completion Time of 6 hours is reasonable, based on operating experience regarding the time required to reach MODE 2 from full power conditions in an orderly manner and without challenging plant systems.

**SURVEILLANCE
REQUIREMENTS**

SR 3.2.2.1 and SR 3.2.2.2 are modified by a Note. The Note applies during the first power ascension after a refueling. It states that THERMAL POWER may be increased until an equilibrium power level has been achieved at which a power distribution map can be obtained. This allowance is modified, however, by one of the Frequency conditions that requires verification that $F_{\Delta H}^M(X,Y)$ is within the specified limits after a power rise of more than 10% RTP over the THERMAL POWER at which it was last verified to be within specified limits. Because $F_{\Delta H}^M(X,Y)$ could not have previously been measured in this reload core, power may be increased to RTP prior to an equilibrium verification of $F_{\Delta H}(X,Y)$ provided nonequilibrium measurements of $F_{\Delta H}(X,Y)$ are performed at various power levels during startup physics testing. This ensures that some determination of $F_{\Delta H}(X,Y)$ is made at a lower power level at which adequate margin is available before going to 100% RTP. The Frequency condition is not intended to require verification of the parameter after every 10% increase in power level above the last verification. It only requires verification after a power level is achieved for extended operation that is 10% higher than that power at which $F_{\Delta H}(X,Y)$ was last measured.

SR 3.2.2.1

The value of $F_{\Delta H}^M(X,Y)$ is determined by using the movable incore detector system to obtain a flux distribution map at any THERMAL POWER greater than 5% RTP. A computer program is used to process the measured 3-D power distribution to calculate the steady state $F_{\Delta H}^L(X,Y)^{LCO}$ limit which is compared against $F_{\Delta H}^M(X,Y)$.

BASES

SURVEILLANCE REQUIREMENTS (continued)

channel factor to the surveillance limit is likely to decrease below the value of that ratio when the measurement was taken.

Each of these extrapolations is applied separately to the enthalpy rise hot channel factor surveillance limit. If both of the extrapolations are unfavorable, i.e., if the extrapolated factor is expected to exceed the extrapolated limit and the extrapolated factor is expected to become a larger fraction of the extrapolated limit than the measured factor is of the current limit, additional actions must be taken. These actions are to meet the F^M_{ΔH}(X,Y) limit with the last F^M_{ΔH}(X,Y) increased by a factor of 1.02, or to evaluate F^M_{ΔH}(X,Y) prior to the point in time when the extrapolated values are expected to exceed the extrapolated limits. These alternative requirements attempt to prevent F^M_{ΔH}(X,Y) from exceeding its limit for any significant period of time without detection using the best available data. F^M_{ΔH}(X,Y) is not required to be extrapolated for the initial flux map taken after reaching equilibrium conditions since the initial flux map establishes the baseline measurement for future trending.

F^M_{ΔH}(X,Y) is verified at power levels 10% RTP above the THERMAL POWER of its last verification, 12 hours after achieving equilibrium conditions to ensure that F^M_{ΔH}(X,Y) is within its limit at high power levels.

The Surveillance Frequency of 31 EFPD is adequate to monitor the change of power distribution with core burnup. The Surveillance may be done more frequently if required by the results of F^M_{ΔH}(X,Y) evaluations.

The Frequency of 31 EFPD is adequate to monitor the change of power distribution because such a change is sufficiently slow, when the plant is operated in accordance with the TS, to preclude adverse peaking factors between 31 day surveillances.

REFERENCES

1. UFSAR Section 15.4.8
2. 10 CFR 50, Appendix A, GDC 26.
3. 10 CFR 50.46.
4. 10 CFR 50.36, Technical Specifications, (c)(2)(ii).
5. DPC-NE-2005P, "Duke Power Company Thermal Hydraulic Statistical Core Design Methodology", September 1992.

**CATAWBA
INITIAL LICENSE EXAMINATION
JOB PERFORMANCE MEASURE**

JPM 1S/ADMIN

Complete Technical Specification Evaluation and TSAIL
Entry

CANDIDATE

EXAMINER

**CATAWBA
INITIAL LICENSE EXAMINATION
JOB PERFORMANCE MEASURE**

Task:

Complete Technical Specification Evaluation and TSAIL Entry.

Alternate Path:

N/A

Facility JPM #:

NEW

K/A Rating(s):

GKA 2.1.12 (2.9/4.0)

Task Standard:

Complete Technical Specification Evaluation and TSAIL Entry

Preferred Evaluation Location:

Simulator In-Plant

Preferred Evaluation Method:

Perform Simulate

References:

Validation Time: _____ **Time Critical:** No

Candidate: _____
NAME

Time Start : _____
Time Finish: _____

Performance Rating: SAT _____ UNSAT _____ Performance Time _____

Examiner: _____
NAME

SIGNATURE

DATE

=====

COMMENTS

Tools/Equipment/Procedures Needed:

Computer with TSAIL software loaded
CNS Tech Specs
VX System Design Basis Document

READ TO OPERATOR

DIRECTION TO TRAINEE:

I will explain the initial conditions, and state the task to be performed. All control room steps shall be performed for this JPM, including any required communications. I will provide initiating cues and reports on other actions when directed by you. Ensure you indicate to me when you understand your assigned task. To indicate that you have completed your assigned task return the handout sheet I provided you.

INITIAL CONDITIONS:

Unit 1 is in Mode 1. You are the Control Room SRO. You were informed 15 minutes ago that during surveillance testing of the 1B Containment Air Return Fan that the fan started 7 minutes and 33 seconds following receipt of the start signal.

The auxiliary building rounds NLO now reports that CPCS transmitter 1NSPT-5160 (CPCS Channel 1) on the Train A CPCS Control Cabinet is failed low. IAE has verified that the channel is inoperable.

INITIATING CUE:

Evaluate plant status in accordance with Technical Specifications, based upon the data provided.

JPM OVERALL STANDARD:

Candidate determines that the unit meets the conditions for entry into Technical Specification 3.0.3.

KA 2.1.12 (2.9/4.0)

<p>STEP 1: Determine that Containment Air Return Fan 1B is inoperable.</p> <p>STANDARD: Declares Containment Air Return Fan 1B inoperable per Technical Specification 3.6.11 due to Surveillance Requirement 3.6.11.1 not being met</p> <p>COMMENTS:</p>	<p>CRITICAL STEP</p> <p><input type="checkbox"/> SAT</p> <p><input type="checkbox"/> UNSAT</p>
<p>STEP 2 Determine that failure of Train A Channel 1 CPCS transmitter (NSPT-5160 from Design Basis Document) renders Containment Air Return Fan 1A inoperable</p> <p>STANDARD: Declares Containment Air Return Fan 1A inoperable per Technical Specification 3.3.2 Function 9.</p> <p>COMMENTS:</p>	<p>CRITICAL STEP</p> <p><input type="checkbox"/> SAT</p> <p><input type="checkbox"/> UNSAT</p>
<p>STEP 3 Determine required action for both Containment Air Return Fans being inoperable.</p> <p>STANDARD: Candidate determines that Technical Specification 3.0.3 is applicable.</p> <p>COMMENTS:</p>	<p>CRITICAL STEP</p> <p><input type="checkbox"/> SAT</p> <p><input type="checkbox"/> UNSAT</p>

TIME STOP: _____

**CANDIDATE CUE SHEET
(TO BE RETURNED TO EXAMINER UPON COMPLETION OF TASK)**

INITIAL CONDITIONS:

Unit 1 is in Mode 1. You are the Control Room SRO. You were informed 15 minutes ago that during surveillance testing of the 1B Containment Air Return Fan that the fan started 7 minutes and 33 seconds following receipt of the start signal.

The auxiliary building rounds NLO now reports that CPCS transmitter 1NSPT-5160 (CPCS Channel 1) on the Train A CPCS Control Cabinet is failed low. IAE has verified that the channel is inoperable.

INITIATING CUE:

Evaluate plant status in accordance with Technical Specifications, based upon the data provided.

3.6 CONTAINMENT SYSTEMS

3.6.11 Air Return System (ARS)

LCO 3.6.11 Two ARS trains shall be **OPERABLE**.

APPLICABILITY: MODES 1, 2, 3, and 4.

ACTIONS

CONDITION	REQUIRED ACTION	COMPLETION TIME
A. One ARS train inoperable.	A.1 Restore ARS train to OPERABLE status.	72 hours
B. Required Action and associated Completion Time not met.	B.1 Be in MODE 3 .	6 hours
	<u>AND</u> B.2 Be in MODE 5 .	36 hours

SURVEILLANCE REQUIREMENTS

SURVEILLANCE	FREQUENCY
SR 3.6.11.1 Verify each ARS fan starts on an actual or simulated actuation signal, after a delay of ≥ 8.0 minutes and ≤ 10.0 minutes, and operates for ≥ 15 minutes.	92 days

(continued)

B 3.6 CONTAINMENT SYSTEMS

B 3.6.11 Air Return System (ARS)

BASES

BACKGROUND

The ARS is designed to assure the rapid return of air from the upper to the lower containment compartment after the initial blowdown following a Design Basis Accident (DBA). The return of this air to the lower compartment and subsequent recirculation back up through the ice condenser assists in cooling the containment atmosphere and limiting post accident pressure and temperature in containment to less than design values. Limiting pressure and temperature reduces the release of fission product radioactivity from containment to the environment in the event of a DBA.

The ARS also promotes hydrogen dilution by mixing the hydrogen with containment atmosphere and distributing throughout the containment.

The ARS consists of two separate trains of equal capacity, each capable of meeting the design bases. Each train includes a 100% capacity air return fan, and associated motor operated damper in the fan discharge line to the containment lower compartment. The damper acts as a barrier between the upper and lower compartments to prevent reverse flow which would bypass the ice condenser. The damper is normally closed and remains closed throughout the initial blowdown following a postulated high energy line break. The damper motor is actuated several seconds after the Containment High-High pressure setpoint is reached and a start permissive from the Containment Pressure Control System is present. A backdraft damper is also provided at the discharge of each fan to serve as a check valve. Each train is powered from a separate Engineered Safety Features (ESF) bus.

The ARS fans are automatically started by the containment pressure High-High signal 9 ± 1 minutes after the containment pressure reaches the pressure setpoint and a start permissive from the Containment Pressure Control System is present. The time delay ensures that no energy released during the initial phase of a DBA will bypass the ice bed through the ARS fans.

BASES

APPLICABLE SAFETY ANALYSES (continued)

For certain aspects of transient accident analyses, maximizing the calculated containment pressure is not conservative. In particular, the cooling effectiveness of the Emergency Core Cooling System during the core reflood phase of a LOCA analysis increases with increasing containment backpressure. For these calculations, the containment backpressure is calculated in a manner designed to conservatively minimize, rather than maximize, the calculated transient containment pressures, in accordance with 10 CFR 50, Appendix K (Ref. 2).

The analysis for minimum internal containment pressure (i.e., maximum external differential containment pressure) assumes inadvertent simultaneous actuation of both the ARS and the Containment Spray System.

The modeled ARS actuation from the containment analysis is based upon a response time associated with exceeding the containment pressure High-High signal setpoint to achieving full ARS air flow. A delayed response time initiation provides conservative analyses of peak calculated containment temperature and pressure responses. The ARS total response time of 600 seconds includes signal delays.

The ARS satisfies Criterion 3 of 10 CFR 50.36 (Ref. 3).

LCO

In the event of a DBA, one train of the ARS is required to provide the minimum air recirculation for heat removal assumed in the safety analyses. To ensure this requirement is met, two trains of the ARS must be OPERABLE. This will ensure that at least one train will operate, assuming the worst case single failure occurs, which is in the ESF power supply.

APPLICABILITY

In MODES 1, 2, 3, and 4, a DBA could cause an increase in containment pressure and temperature requiring the operation of the ARS. Therefore, the LCO is applicable in MODES 1, 2, 3, and 4.

In MODES 5 and 6, the probability and consequences of these events are reduced due to the pressure and temperature limitations of these MODES. Therefore, the ARS is not required to be OPERABLE in these MODES.

BASES

SURVEILLANCE REQUIREMENTS (continued)

and the two train redundancy available.

SR 3.6.11.3

Verifying the OPERABILITY of the return air damper provides assurance that the proper flow path will exist when the fan is started. This Surveillance also tests the circuitry, including time delays to ensure the system operates properly. The Frequency of 92 days was developed considering the importance of the dampers, their location, physical environment, and probability of failure. Operating experience has also shown this Frequency to be acceptable.

SR 3.6.11.4 and SR 3.6.11.5

Verifying the OPERABILITY of the check damper in the air return fan discharge line to the containment lower compartment provides assurance that the proper flow path will exist when the fan is started and that reverse flow can not occur when the fan is not operating. The Frequency of 92 days was developed considering the importance of the dampers, their location, physical environment, and probability of failure. Operating experience has also shown this Frequency to be acceptable.

SR 3.6.11.6 and SR 3.6.11.7

These SRs require verification that each ARS motor operated damper is allowed to open or is prevented from opening and each ARS fan is allowed to start or is de-energized or prevented from starting based on the presence or absence of Containment Pressure Control System start permissive and terminate signals. The CPCS is described in the Bases for LCO 3.3.2, "ESFAS." The 18 month Frequency is based on operating experience which has shown it to be acceptable.

-
- | | |
|-------------------|---|
| REFERENCES | <ol style="list-style-type: none">1. UFSAR, Section 6.2.2. 10 CFR 50, Appendix K.3. 10 CFR 50.36, Technical Specifications, (c)(2)(ii). |
|-------------------|---|

Table 3.3.2-1 (page 5 of 5)
Engineered Safety Feature Actuation System Instrumentation

FUNCTION	APPLICABLE MODES OR OTHER SPECIFIED CONDITIONS	REQUIRED CHANNELS	CONDITIONS	SURVEILLANCE REQUIREMENTS	ALLOWABLE VALUE	TRIP SETPOINT
8. ESFAS Interlocks						
a. Reactor Trip, P-4	1,2,3	1 per train, 2 trains	F	SR 3.3.2.8	NA	NA
b. Pressurizer Pressure, P-11	1,2,3	3	O	SR 3.3.2.5 SR 3.3.2.9	≥ 1944 and ≤ 1966 psig	1955 psig
c. T _{avg} - Low Low, P-12	1,2,3	1 per loop	O	SR 3.3.2.5 SR 3.3.2.9	≥ 550°F	≥ 553°F
9. Containment Pressure Control System						
a. Start Permissive	1,2,3,4	4 per train	P	SR 3.3.2.1 SR 3.3.2.7 SR 3.3.2.9	≤ 0.45 psid	≤ 0.4 psid
b. Termination	1,2,3,4	4 per train	P	SR 3.3.2.1 SR 3.3.2.7 SR 3.3.2.9	≥ 0.25 psid	≥ 0.3 psid
10. Nuclear Service Water Suction Transfer - Low Pit Level						
	1,2,3,4	3 per pit	Q,R	SR 3.3.2.1 SR 3.3.2.9 SR 3.3.2.11	≥ El. 555.4 ft	≥ El. 557.5 ft

ACTIONS (continued)

CONDITION	REQUIRED ACTION	COMPLETION TIME
O. One channel inoperable.	<p>O.1 Verify interlock is in required state for existing unit condition.</p> <p><u>OR</u></p> <p>O.2.1 Be in MODE 3.</p> <p><u>AND</u></p> <p>O.2.2 Be in MODE 4.</p>	<p>1 hour</p> <p>7 hours</p> <p>13 hours</p>
P. One or more Containment Pressure Control System channel(s) inoperable.	<p>P.1 Declare affected supported system inoperable.</p>	<p>Immediately</p>
Q. One Nuclear Service Water Suction Transfer-Low Pit Level channel in one or more pits inoperable.	<p>Q.1 -----NOTE----- The inoperable channel may be bypassed for up to 2 hours for surveillance testing of other channels. ----- Place channel in trip.</p> <p><u>OR</u></p> <p>Q.2.1 Be in MODE 3.</p> <p><u>AND</u></p> <p>Q.2.2 Be in MODE 5.</p>	<p>4 hours</p> <p>10 hours</p> <p>40 hours</p>

(continued)

Editorial Minor Modification

() **Outage Related** **Unit** 5 **QA Condition:** 1 **PIP#** 0-C98-2400 **Project Number** ENGE-9665

Work Orders: _____ **Systems Affected:** IPE _____ **Component/Structure:** _____ **Startup Requirements:** _____

Approvals:

CDI _____	Date: _____	Originator <i>D.A. Smith</i>	Date: <i>4/6/99</i>
CDI _____	Date: _____	Checked <i>[Signature]</i>	Date: <i>4/6/99</i>
CDI _____	Date: _____	Tech. Approval <i>J.M. Blackley</i>	Date: <i>4/13/99</i>
CDI _____	Date: _____	Imple. Approval _____	Date: _____

Attached to Minor Mod:

- Sketches 242 Attached
- Other (Minor Mod Notes - 2 pages)

Cleared Stage

- No Exceptions
- Technical exception - PIP # _____
- Corrections to document list PIP# _____ Describe exceptions/corrections
- Other editorial exceptions _____

Contact Originator (if exception taken): _____

Cleared: _____ Date: _____

Approved: _____ Date: _____

Problem Description

While developing the TN for NSM CN-11377/00, editorial errors were discovered in numerous drawings related to the Solid State Protection System. Additionally, there are no Electrical Elementaries for several relays contained in the Auxiliary Safeguards Cabinets.

Modification Description

Revise SSPS, ESF, and AUXSFGA drawings to correct editorial errors. Additionally, develop Electrical Elementaries for the Auxiliary Safeguards Cabinet relays which do not currently have a EE. Refer to the attached mod notes for further information.

Document List	VTO	Rev	Rev
CN-1711-01.02		39	
CN-1711-03.01		13	
CN-1757-01.02		10	
CN-1757-01.04		11	
CN-1757-01.05		10	
CN-1757-01.07		13	
CN-1783-03.01		29	
CN-1783-03.02		26	
CN-1783-03.04		6	
CN-1783-03.05		15	
CN-1783-03.06		33	
CN-1783-03.07		32	

DATE: _____

REVISED BY: _____

Editorial Minor Modification

() Outage Related

Unit 5

QA Condition: 1

PIP#
0-C98-2400

Project Number
CNGE-2865

CNEE-0270-05.04	X	1		
CNEE-0270-05.05	X	1		
CNEE-0270-05.06	X	1		
CNEE-0270-05.07	X	1		
CNEE-0270-05.08	X	1		
CNEE-0270-05.09	X	2		
CNEE-0274-01.07	X	21		
CNEE-0274-01.09	X	10		
CNEE-0274-01.13	X	2		
CNEE-0274-01.28	X	NEW		
CNEE-0274-01.29	X	NEW		
CNEE-0274-01.30	X	NEW		
CNEE-0274-01.31	X	NEW		
CNEE-0274-01.32	X	NEW		
CNLT-1765-01.01		21		
CNM 1399.08-0014 024		6		
CNM 1399.08-0014 039		D5		
CNM 1399.08-0047 017		DJ		
CNM 1399.08-0047 020		DE		
CNM 1399.08-0047 027		L		
CNM 1399.08-0047 029		DJ		
CNM 2399.08-0012 039		D5		
CNM 2399.08-0013 029		DK		
CNS-1557.VX-00-0001		4		
CNWT-1711-02.026 <i>log 4-14-99</i>		5		
CNWT-1717-01.06		98		
CNWT-1717-01.07		15		
CNWT-2711-02.026 <i>log 4-14-99</i>		65		
CNWT-2717-01.06		79		
CNWT-2717-01.07		1		

31.3.2.3 Containment Air Return Fan Bypass Test Dampers

Dampers IARF-D-5, IARF-D-6, and IARF-D-7 are provided to allow testing of Containment Air Return Fan ARF-1A while IARF-D-8, IARF-D-9, and IARF-D-10 allow testing of Containment Air Return Fan ARF-1B. These dampers are controlled by a single solenoid valve, 1VXBP1 and 1VXBP2 for Train A and B, respectively. The solenoid valves are energized during performance testing only. Originally designed to be operated in conjunction with the VX Test Panel (IRB-ECP-2) the solenoid valves and corresponding bypass test dampers are presently operated by placing electrical jumpers in the appropriate termination cabinets.

31.3.2.4 Hydrogen Skimmer Fans

Hydrogen Skimmer Fans HS-1A and HS-1B use automatic control as the primary mode of operation with manual control provided as a backup. Each fan is operated by a three position (RUN-OFF-AUTO) key-lock selector switch located on main control board IMC4. The selector switch is normally placed in automatic with the key removed to lock the switch in position. The operational status of the fans are provided by status lights located directly above the key-lock selector switch on the main control board. Refer to Figure 4 for the following discussion of the hydrogen skimmer fan controls and interlock logic.

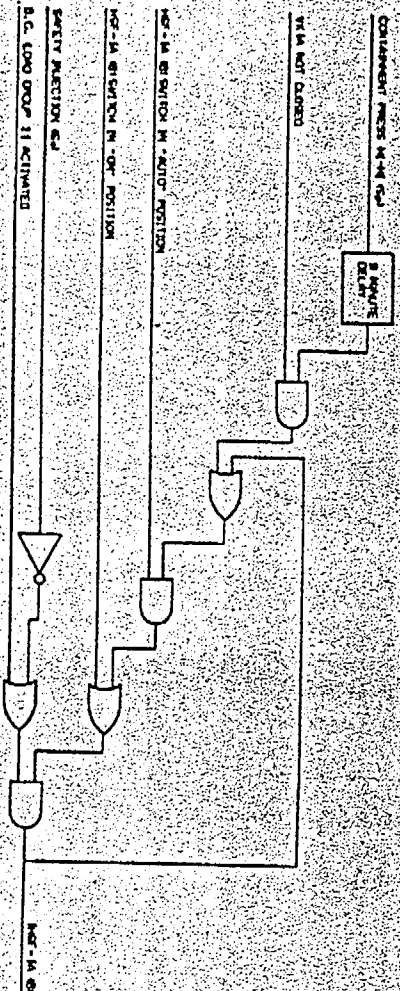

NOTE: TEST SWITCH CONTACTS NOT SHOWN.

Figure 4.

"INTERIM-AS-BUILT"

MINOR MOD # CNCE-9665 P₂ 241 74 242
 DRAWING # CNS-1557-VX-00-0001 REV# 4
 PREPARED BY RJK/MS DATE 7/3/93

32.3.2.3 Containment Air Return Fan Bypass Test Dampers

Dampers 2ARF-D-5, 2ARF-D-6, and 2ARF-D-7 are provided to allow testing of Containment Air Return Fan ARF-2A while 2ARF-D-8, 2ARF-D-9, and 2ARF-D-10 allow testing of Containment Air Return Fan ARF-2B. These dampers are controlled by a single solenoid valve, 2VXEPI and 2VXEP2 for Train A and B, respectively. The solenoid valves are energized during performance testing only. Originally designed to be operated in conjunction with the VX Test Panel (2RB-ECP-2) the solenoid valves and corresponding bypass test dampers are presently operated by placing electrical jumpers in the appropriate termination cabinets.

32.3.2.4 Hydrogen Skimmer Fans

Hydrogen Skimmer Fans HS-2A and HS-2B use automatic control as the primary mode of operation with manual control provided as a backup. Each fan is operated by a three position (RUN-OFF-AUTO) key-lock selector switch located on main control board 2MC4. The selector switch is normally in automatic with the key removed to lock the switch in position. The operational status of the fans are provided by status lights located directly above the key-lock selector switch on the main control board. Refer to Figure 10 for the following discussion of the hydrogen skimmer fan controls and interlock logic.

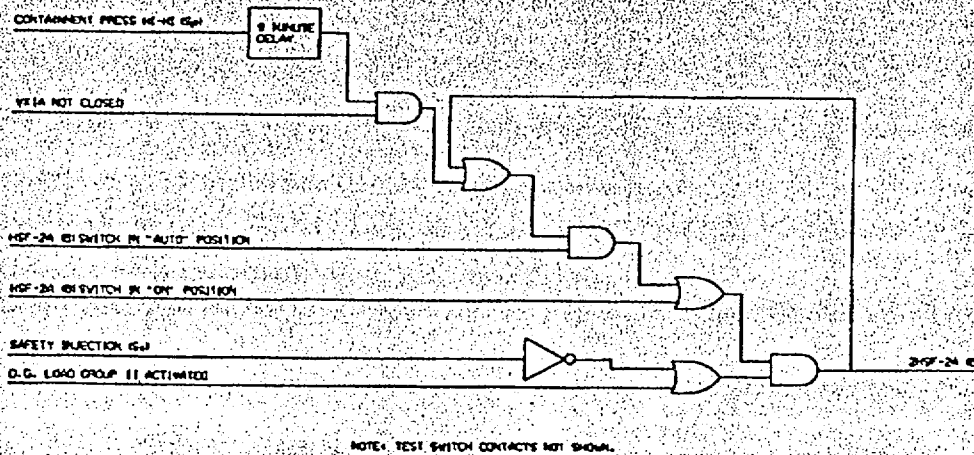

"INTERIM-AS-BUILT"

Figure 10.

The hydrogen skimmer fans are assigned to Diesel Load Sequencer Group 11. As such, each fan is interlocked with the Diesel Generator Load Sequencer such that upon receipt of a safety injection signal (Ss), the fan is load shed and operation is inhibited until Load Group 11 is sequenced on the Diesel Generator. This interlock will take precedence over both manual and automatic operation and cannot be defeated.

Manual operation is subject only to the above interlock and is continuous once selected. Automatic operation is initiated by an Sp signal (Hi-Hi Containment Pressure or Manual Spray Actuation) through a 9 +/- 1 minute time delay and is interlocked with the respect that the inlet valve must be open before an automatic start after the time delay expires and the respective inlet valve is scaled-in. Once generated, the automatic start signal can be moved to the OFF position.

P, 242 of 242

MINOR MOD # CNCE-9665
 DRAWING # CNS-1557.VX-00-0001 REV# 4
 PREPARED BY R. J. Jones DATE 7/7/98

ORIGINAL

Corrective Minor Modification w/o Field Work

() Outage Related

Unit: 5

QA Condition: 1

PIP#
0-C99-0578

Project Number
CNCE-10338

Work Orders: _____ Systems Affected: VX Component/Structure: VX HSS Suction Valves Startup Requirements: _____

Approvals:

CDI <u>NA</u>	Date: <u>4/29/99</u>	Originator: <u>Jeffery Hays</u>	Date: <u>4/22/99</u>
CDI _____	Date: _____	Checked: <u>[Signature]</u>	Date: <u>4/29/99</u>
CDI _____	Date: _____	Tech. Approval: <u>[Signature]</u>	Date: <u>4/29/99</u>
CDI _____	Date: _____	Imple. Approval: _____	Date: _____

Attached to Minor Mod:	Other Forms (placed in Mod file)	Other Items Considered
<input checked="" type="checkbox"/> 50.59 (72.48 ONS only) Evaluation	<input type="checkbox"/> Documentation of Design Inputs Required for QA-1	Operating Experience <input type="checkbox"/> Yes <input checked="" type="checkbox"/> N/A
<input checked="" type="checkbox"/> SAR Revision	<input type="checkbox"/> Other ()	Affects on PM W/O's <input type="checkbox"/> Yes <input checked="" type="checkbox"/> N/A
<input checked="" type="checkbox"/> Sketches <u>9</u> Attached		Materials Concerns (includes spare parts) <input type="checkbox"/> Yes <input checked="" type="checkbox"/> N/A
<input type="checkbox"/> Engineering Instructions Attached		Y2K Concerns (NSD301 Appendix B) <input type="checkbox"/> Yes <input checked="" type="checkbox"/> N/A
<input checked="" type="checkbox"/> Other ()		

Cleared Stage

No Exceptions Corrections to document list PIP# _____ Describe exceptions/corrections

Technical exception - PIP # _____ Other editorial exceptions _____

Contact Originator (if exception taken): _____	DATE: _____
Cleared: _____ Date: _____	REVISED BY: _____
Approved: _____ Date: _____	

Problem Description

The ESF Response Time for the Hydrogen Skimmer System (HSS) suction valves 1(2)VX-1A and 1(2)VX-2B as stated in the test procedure, PT/1(2)/A/4200/09, are greater than the allowable time as listed in UFSAR Table 7-15. The allowable time from UFSAR Table 7-15 is 600 seconds for the Containment Air Return and Hydrogen Skimmer (VX) System Operation. Based upon review of the Catawba licensing basis documents, the HSS suction valves are only required to start opening within 8 - 10 minutes after an Containment High High Pressure (Sp) Signal. In order to clarify the design basis function of the HSS suction valves, the VX System DBD, UFSAR Table 7-15, and the Bases for Technical Specification will be revised. UFSAR Table 7-15 will be revised in accordance with NSD 220. The Bases for Technical Specification 3.6.8 will be revised in accordance with NSD 221. CNCE-10338 will revise the VX System DBD. Calculation CNC-1552.08-00-0194, Rev. 3, "Reanalysis of the Catawba Hydrogen Skimmer System Flow Requirements", was revised to support the above design basis document changes.

Modification Description

Revise the VX Hydrogen Skimmer System (HSS) Design Basis Document (DBD) to Reflect Changes to UFSAR Table 7-15, "ESF Response Times", and the Bases for Technical Specification 3.6.8, "Hydrogen Skimmer System". These changes are necessary to clarify the design basis function of the HSS suction valves.

Editorial Minor Modification

<p>Work Orders: VX</p> <p>Systems Affected:</p> <p>Component/Structure</p> <p>Startup Requirements:</p>	<p>QA Condition: 1</p> <p>Unit: 5</p> <p><input type="checkbox"/> Outage Related</p>	<p>Project Number CNCE-10202 PIP # 0-C98-1774</p>																		
<p>Distribution (number of copies)</p> <table border="1" style="width: 100%; border-collapse: collapse;"> <tr><td>Minor Mod Controller</td><td>NSRB</td></tr> <tr><td>Work Control</td><td>Training</td></tr> <tr><td>Regulatory Compliance</td><td>Operations</td></tr> <tr><td>Quality Assurance</td><td>Materials(C & F)</td></tr> <tr><td>Mech. Systems</td><td>Chemistry</td></tr> <tr><td>Mech/Civil Equipment</td><td>Security</td></tr> <tr><td>I & E Equip. Systems</td><td>Doc; Management</td></tr> <tr><td>Modification Engr.</td><td>RP</td></tr> <tr><td>Maintenance Procedures</td><td>Originator</td></tr> </table>			Minor Mod Controller	NSRB	Work Control	Training	Regulatory Compliance	Operations	Quality Assurance	Materials(C & F)	Mech. Systems	Chemistry	Mech/Civil Equipment	Security	I & E Equip. Systems	Doc; Management	Modification Engr.	RP	Maintenance Procedures	Originator
Minor Mod Controller	NSRB																			
Work Control	Training																			
Regulatory Compliance	Operations																			
Quality Assurance	Materials(C & F)																			
Mech. Systems	Chemistry																			
Mech/Civil Equipment	Security																			
I & E Equip. Systems	Doc; Management																			
Modification Engr.	RP																			
Maintenance Procedures	Originator																			
<p>Problem Description PIP 98-1774 stated that UFSAR Figure 6-103 (VX flow diagram) should have been revised as part of CNCE-8849 to show the correct Containment Air Return Fan starting time. While researching this issue, some other editorial errors were discovered in the VX DBD. Also, the VX DBD has references to the old Technical Specification sections which have changed due to implementation of the Improved Tech Specs.</p>																				
<p>Modification Description To resolve the issue raised in PIP 0-C98-1774 for CNCE-8849, Note 1 on VX flow diagrams CN-1(2)557-1.0 will be revised to show a Containment Air Return Fan start time of 9 +/- 1 min. as stated in the UFSAR, DBD, and Tech Spec information. This will more accurately state the fan starting requirements even though the current 10 min. value in the Note is not necessarily wrong. The VX DBD will also be revised to correct a PIP number referenced in Sections 31 and 32 and also update the Technical Specification sections referenced since these have changed with the implementation of the Improved Tech Specs.</p>																				
<div style="border: 1px solid black; padding: 10px; width: fit-content; margin: auto;"> <p>DATE: _____</p> <p>REVISED BY: _____</p> </div>																				
<p>Originator: <u>Donally D Davis</u> Date: <u>2/25/99</u></p> <p>Checked: <u>R J Dorley</u> Date: <u>3/31/99</u></p> <p>Cross Discipline Insp.: <u>NA</u> Date: <u>3/31/99</u></p> <p>Cross Discipline Insp.: <u>NA</u> Date: <u>3/31/99</u></p> <p>Cross Discipline Insp.: <u>NA</u> Date: <u>3/31/99</u></p> <p>Tech. Approval: <u>[Signature]</u> Date: <u>4/1/99</u></p> <p>Imple. Approval: <u>N/A</u> Date: _____</p>																				
<p>Attached:</p> <p><input type="checkbox"/> TN/Engineering Instructions <input type="checkbox"/> Other _____</p> <p><input checked="" type="checkbox"/> Sketches 7 Attached <input type="checkbox"/> Documentation of Design Inputs</p> <p><input type="checkbox"/> Mod Test Plan</p> <p><input type="checkbox"/> 50.59 (72.48ONS) Evaluation</p> <p><input type="checkbox"/> Appendix R(MNS/ONS Only)</p> <p><input type="checkbox"/> SAR Revision</p>																				
<p>Document List</p> <table border="1" style="width: 100%; border-collapse: collapse;"> <thead> <tr> <th>Document List</th> <th>VTO</th> <th>Rev</th> <th>Rev</th> </tr> </thead> <tbody> <tr> <td>CN-1557-1.0 <u>As built</u></td> <td>X</td> <td>9</td> <td></td> </tr> <tr> <td>CN-2557-1.0 <u>As-built</u></td> <td>X</td> <td>9</td> <td></td> </tr> <tr> <td>CNS-1557-VX-00-0001</td> <td></td> <td>4</td> <td></td> </tr> </tbody> </table>	Document List	VTO	Rev	Rev	CN-1557-1.0 <u>As built</u>	X	9		CN-2557-1.0 <u>As-built</u>	X	9		CNS-1557-VX-00-0001		4		<p>Cleared Stage</p> <p><input type="checkbox"/> No Exceptions</p> <p><input type="checkbox"/> Technical exception - PIP # _____ (call originator)</p> <p><input type="checkbox"/> Corrections to document list - PIP # _____</p> <p><input type="checkbox"/> Other editorial exception</p> <p>Describe exceptions/corrections</p> <p>_____</p> <p>_____</p> <p>_____</p> <p>_____</p> <p>_____</p> <p>Originator Called: _____ Date: _____</p> <p>Cleared: _____ Date: _____</p> <p>Approved: _____ Date: _____</p>			
Document List	VTO	Rev	Rev																	
CN-1557-1.0 <u>As built</u>	X	9																		
CN-2557-1.0 <u>As-built</u>	X	9																		
CNS-1557-VX-00-0001		4																		

20.1.3 NORMAL OPERATION

During normal power operation, this system is in a standby mode and does not perform any function. The Containment Air Return & Hydrogen Skimmer System (VX) shall be operable and capable of performing its nuclear safety related function in plant modes 1, 2, 3 and 4 (Power Operation, Startup, Hot Standby and Hot Shutdown, respectively).

20.1.4 DESIGN BASIS EVENTS

20.1.4.1 Containment Air Return System

The function of the Containment Air Return System is to mitigate the consequences of a HELB. This function shall be performed during injection and recirculation (if recirculation is necessary). The system shall be capable of performing this function with only on-site power available during and following the event.

The Containment Air Return Fans shall be utilized following a HELB to return air from upper Containment to lower Containment after peak containment pressure has been reached to provide mixing of containment atmosphere during the long term pressure peak. After the initial containment pressure peak has been reduced, the ice condenser and NS System are capable of maintaining containment pressure below the containment design pressure with the assumption of steam generation by residual energy until the ice bed is melted. If steam generation is assumed after ice melt, the NS System maintains the pressure below the containment design pressure with the Containment Air Return Fans circulating air in Containment.

One 40,000 cfm Containment Air Return Fan is assumed operable following a HELB per assumptions made in References 20.6.1.7.9, "Catawba FSAR Section 6.2.1.1.3.1, Loss of Coolant Accident," 20.6.1.7.18, "Catawba FSAR Section 15.4.8.4, Spectrum of Rod Control Assembly Ejection Accidents," and 20.6.1.7.19, "Catawba FSAR Section 15.6.5.3, LOCA - Radiological Consequences." One 40,000 cfm Containment Air Return Fan is assumed operable following a MSLB for heat removal per assumptions made in reference 20.6.1.7.10, "Catawba FSAR Section 6.2.1.1.3.3, Steam Line Break." Both Containment Air Return Fans (80,000 cfm total) are assumed operating per assumptions made in reference 20.6.1.7.11, "Catawba FSAR Section 6.2.1.5, Minimum Containment Pressure Pressure Analysis for Performance Capability Studies of Emergency Core Cooling System."

The Containment Air Return Fans start after a 9 +/-1 minute time delay provided several permissives have been satisfied. The first permissive is received from the Containment Pressure Control System (CPCS) when containment pressure is greater than 0.4 psig. The Diesel Generator (D/G) sequencer load group 11 permissive must also be present for a fan start. The fan will continue to run until containment pressure is less than or equal to 0.25 psig. 0.4 psig and 0.25 psig will be used as fan on and off respectively. Per Reference 20.6.2.1.1, "Catawba Technical Specification Section ~~20.6.2.1.1~~, Engineered Safety Features Actuation System Instrumentation, Table ~~3.3.2.1~~ (Item 1)," the CPCS start permissive setpoint is 0.4 psig and the termination setpoint is 0.3 psig. 0.3 psig is used for reset to insure the fan is off before the 0.25 psig setpoint is reached.

CE-10202

The normally closed Containment Air Return Fan isolation damper will open following a 10 second delay after receipt of the Sp (Containment High- High pressure) signal. Several permissives must also be present to allow the damper to reposition. The first permissive is a signal from the CPCS that containment pressure is greater than 0.4 psig. The second is a signal from a differential pressure switch which verifies the differential pressure across the damper is less than 0.5 psig. The D/G load sequencer load group 1 permissive must also be present for the damper to open.

"INTERIM - AS - BUILT"

Each electric recombiner is capable of processing a maximum of 100 scfm of Containment atmosphere. Flow through recombiners is due to natural circulation and is limited by flow orifices internal to the device. There are two recombiners per unit and each recombiner has a 100% capacity. Units are controlled manually following a LOCA to control hydrogen concentration. Power and controls for the hydrogen recombiners are located outside of containment.

Reference 20.6.2.1, ³ "Catawba Technical Specification Section ^{3.6.7} ~~20.6.2.1~~, Electric Hydrogen Recombiners, ~~Surveillance Requirements~~" requires the recombiners to be demonstrated operable ~~at least once every 6~~ 18 months. This is done by measuring the internal heater sheath temperature after 90 minutes and insuring the temperature is greater than or equal to 700°F. After reaching 900°F, the power setting is increased to maximum. After 2 minutes the power meter should read greater than or equal to 60 kilowatts.

CE-10202

The hydrogen recombiners are not part of the VX System. Their operation is independent of the operation of the VX System but have been included here due to their parallel function of hydrogen control. Also, since the recombiners do not have a system designation, the VX System design basis is a convenient and logical place to define their design parameters.

20.2 SYSTEM GENERIC DESIGN CRITERIA

20.2.1 Single Failure

The guidelines for the application of the single failure criterion are documented in Reference 20.6.3.1.1, "CNS-1465.00-00-0001, Plant Design Basis Specification for Systems Single Failure." The VX System shall be designed against the consequences of any single active or passive failure without loss of capability of the system to perform its intended safety functions in mitigating the consequences of a design basis initiating event.

Active components shall be designated per the definition presented in Reference 20.6.3.1.1, "CNS-1465.00-00-0001, Plant Design Basis Specification for Systems Single Failure."

20.2.2 System Class

The Containment Air Return & Hydrogen Skimmer System (VX) is a QA 1 Engineered Safeguards System. The guidelines for the selection of dampers and ductwork are documented in Reference 20.6.3.1.18, "CNS-1211.00-00-0005, Supplement No. 6, Heating, Ventilating and Air Conditioning; Reactor Building." Guidelines for selection of fans are documented in Reference 20.6.3.1.20, "CNS-1211.00-00-0006, Vane Axial Fan Motor Systems Related to Nuclear Safety."

The VX System is classified as a Safety Class 2 system. Imbedded piping is non-safety. Exposed piping and valves in lower containment compartments where the the HSF take suction is class 'F', seismic. This will insure the piping and valves remain in place following a seismic event. These valves are not missile protected in that a missile strike to a small number of these valves will not compromise the ability of the system to perform its design function.

20.2.3 Containment Penetrations

The VX System has no containment penetrations.

MINOR MOD# CNCE-10202

DWG# CNS-1557.VX-00-0001 REV# 4

PREPARED BY Danell Davis DATE 2/25/99

PAGE 4 OF 7

20.6.1.7.16 Catawba FSAR Section 7.6.10, Instrumentation & Controls for Containment Air Return, Hydrogen Skimmer and Hydrogen Recombiner System

20.6.1.7.17 Catawba FSAR Section 8.3.1.4, AC Power Systems - Independence of Redundant Systems

20.6.1.7.18 Catawba FSAR Section 15.4.8.4, Spectrum of Rod Control Assembly Ejection Accidents

20.6.1.7.19 Catawba FSAR Section 15.6.5.3, LOCA - Radiological Consequences

20.6.2 CATAWBA TECHNICAL SPECIFICATION

20.6.2.1.1 Catawba Technical Specification Section ^{3.6.11} ~~14.6.8.3~~ ^{System (ARS)} Containment Air Return and Hydrogen Skimmer System, Table 3.6.8-1

20.6.2.1.2 Catawba Technical Specification Section ^{3.6.8} ~~14.6.8.4~~ Containment Air Return and Hydrogen Skimmer System, Surveillance Requirements (HSS)

20.6.2.1.3 Catawba Technical Specification Section ~~14.6.8.5~~ Containment Air Return and Hydrogen Skimmer System, Surveillance Requirements

20.6.2.1.4 Catawba Technical Specification Section ³ ~~14.6.8.6~~ Electric Hydrogen Recombiners, Surveillance Requirements 3.6.7

20.6.2.1.5 Catawba Technical Specification Section ⁴ ~~14.6.8.7~~ Engineered Safety Features Actuation System Instrumentation, Table ~~3.3.2-1~~ 3.3.2 (ESFAS) 3.3.2-1 (Item 9)

20.6.3 ENGINEERING DOCUMENTS

20.6.3.1 Design Basis Specifications and Manuals

CE-10202

20.6.3.1.1 CNS-1465.00-00-0001, Plant Design Basis Specification for Systems Single Failure

20.6.3.1.2 CNS-1465.00-00-0002, Plant Design Basis Specification for System Class

20.6.3.1.3 CNS-1465.00-00-0004, Plant Design Basis Specification for Loss of Instrument Air

20.6.3.1.4 CNS-1465.00-00-0005, Plant Design Basis Specification for Design Basis Events

20.6.3.1.5 CNS-1465.00-00-0006, Plant Design Basis Specification for Fire Protection

20.6.3.1.6 CNS-1465.00-00-0011, Plant Design Basis Specification for Flooding From External Sources

20.6.3.1.7 CNS-1465.00-00-0007, Plant Design Basis Specification for Selsmic Design

20.6.3.1.8 CNS-1465.00-00-0008, Plant Design Basis Specification for Tomado/Wind

20.6.3.1.9 CNS-1435.00-00-0002, Design Basis Specification for Post Fire Safe Shutdown

20.6.3.1.10 CNS-1563.NS-00-0001, Design Basis Specification for the Containment Spray (NS) System

20.6.3.1.11 CNS-1559.VY-00-0001, Design Basis Specification for the Containment Hydrogen Sample and Purge System

20.6.3.1.12 CNS-112.01-EPE-0001, Design Basis Specification for the EPE System

INTERIM-AS-BUILT

fans. The interlock originates from the same channel as the damper interlock. It is physically located in the primary contactor circuit and is separated from the other CPCS interlock located in the secondary contactor according to the separation criteria defined in Reference 20.6.3.1.10, "CNS-1563.NS-00-0001, Design Basis Specification for the Containment Spray (NS) System." The CPCS interlocks may be bypassed for testing purposes via test switches on the CPCS cabinets. See Reference 20.6.3.1.10, "CNS-1563.NS-00-0001, Design Basis Specification for the Containment Spray (NS) System," for a detailed description of the CPCS including special requirements for the CPCS circuitry and cables.

The containment air return fans are assigned to Diesel Load Sequencer Group 11. As such, each fan is interlocked with the Diesel Generator Load Sequencer such that upon receipt of a safety injection signal (Ss), the fan is load shed and operation is inhibited until Load Group 11 is sequenced on the Diesel Generator. This interlock will take precedence over both manual and automatic operation and cannot be defeated.

Manual and automatic control is selected via the key-lock selector switch. Both are subject to the above interlocks. Manual operation of the fans is continuous once selected. Automatic operation is initiated by an Sp signal and is processed through a 9 +/- 1 minute time delay. If the signal is still active after the time delay, an automatic start signal is generated and sealed-in. Once sealed-in, the automatic start signal can only be reset by positioning the selector switch to the OFF position. The CPCS interlock can defeat both the automatic and manual signal and thus allows the CPCS to cycle the Containment Air Return Fans as required to maintain containment pressure below 0.45 psig.

(PIP 0-C91-0305) - CE-10202
PIR 0-C91-0090 identified a problem of potential cycling of the Containment Air Return Fans around the CPCS permissive setpoints. The Containment air Return Fans were declared OPERABLE since they would have not performed their intended safety function by the time containment pressure decreased to the CPCS setpoints. Engineering determined that rapid cycling of the fans around the CPCS setpoints was not a credible concern because the heat sources necessary to cause cycling of the fans are not present in the long term stages of any transient after containment pressure is reduced below 0.3 psig (Reference PIP 0-C97-1027).

Control room annunciator alarms are provided to alert the operator of high fan vibration, Containment Air Return Fan running with the corresponding isolation damper closed, Hydrogen Skimmer Fan running with the corresponding suction valve closed, and control circuit power failure. Digital computer points are provided to indicate the status of the CPCS interlock for the fans.

31.3.2.2 Containment Air Return Fan Isolation Dampers

Containment air return fan dampers IARF-D-2 and IARF-D-4 use automatic control as the primary mode of operation with manual control provided as a backup. The dampers are operated via momentary pushbutton operators (OPEN-CLOSE) located on main control board IMC4. The position of each damper is indicated by position indicating lights integral to the pushbutton operator.

The control logic for opening the dampers in both automatic and manual modes is interlocked with the following signals in a logical OR function: 1) an ECCS Sp signal, 2) the train-related Containment Air Return Fan control switch in the ON position, or 3) the train related Hydrogen Skimmer Fan control switch in the ON position. Manual opening of the dampers is dependent only upon satisfying one of the above interlocks. The automatic control logic incorporates a 10 second time delay, after which, the interlock signal is sealed-in. Once sealed-in, two additional interlocks must be satisfied for automatic opening: 1) the permissive from the CPCS must be present (containment pressure greater than .45 psig), and 2) the differential pressure across the damper must be less than 0.5 psig. Refer to Figure 2 for a logic diagram of the damper M/O logic circuit.

INTERIM-AS-BUILT

the fan is load shed and operation is inhibited until Load Group 11 is sequenced on the Diesel Generator. This interlock will take precedence over both manual and automatic operation and cannot be defeated.

Manual and automatic control is selected via the key-lock selector switch. Both are subject to the above interlocks. Manual operation of the fans is continuous once selected. Automatic operation is initiated by an Sp signal and is processed through a 9 +/- 1 minute time delay. If the signal is still active after the time delay, an automatic start signal is generated and sealed-in. Once sealed-in, the automatic start signal can only be reset by positioning the selector switch to the OFF position. The CPCS interlock can defeat both the automatic and manual signal and thus allows the CPCS to cycle the Containment Air Return Fans as required to maintain containment pressure above 0.45 psig.

R (PIP 0-C91-0305) CE-10202
PIP 0-C91-0090 identified a problem of potential cycling of the Containment Air Return Fans around the CPCS permissive setpoints. The Containment Air Return fans were declared OPERABLE since they would have already performed their intended safety function by the time containment pressure decreased to the CPCS setpoints. Engineering determined that rapid cycling of the fans around the CPCS setpoints was not a credible concern because the heat sources necessary to cause cycling of the fans are not present in the long term stages of any transient after containment pressure is reduced below 0.3 psig (Reference PIP 0-C97-1027).

Control room annunciator alarms are provided to alert the operator of high fan vibration, Containment Air Return Fan running with the corresponding isolation damper closed, Hydrogen Skimmer Fan running with the corresponding suction valve closed, and control circuit power failure. Digital computer points are provided to indicate the status of the CPCS interlock for the fans.

32.3.2.2 Containment Air Return Fan Isolation Dampers

Containment Air Return Fan dampers 2ARF-D-2 and 2ARF-D-4 use automatic control as the primary mode of operation with manual control provided as a backup. The dampers are operated via momentary pushbutton operators (OPEN-CLOSE) located on main control board 2MC4. The position of each damper is indicated by position indicating lights integral to the pushbutton operator.

The control logic for opening the dampers in both automatic and manual modes is interlocked with the following signals in a logical OR function: 1) an ECCS Sp signal, 2) the train-related Containment Air Return Fan control switch in the ON position, or 3) the train related Hydrogen Skimmer Fan control switch in the ON position. Manual opening of the dampers is dependent only upon satisfying one of the above interlocks. The automatic control logic incorporates a 10 second time delay, after which, the interlock signal is sealed-in. Once sealed-in, two additional interlocks must be satisfied for automatic opening: 1) the permissive from the CPCS must be present (containment pressure greater than .45 psig), and 2) the differential pressure across the damper must be less than 0.5 psig. Refer to Figure 8 for a logic diagram of the damper M/O logic circuit.

MINOR MOD# CNCE-10202

DWG# CNS-1557.VX-00-0001 REV# 4

PREPARED BY Danell Davis DATE 2/25/99

PAGE 7 OF 7

"INTERIM-AS-BUILT"

✓
~~MOD IN PROGRESS/SEE INTERIM AS-BUILT~~
FOR MOD. CE-10202 REV. _____
VN'S _____

5/5/99

~~MOD IN PROGRESS/SEE INTERIM AS-BUILT~~
FOR MOD. CE-9669 REV. _____
VN'S _____

5/5/99

**Containment Air Return & Hydrogen Skimmer System (VX) Design
Basis Specification
Spec. CNS-1557.VX-00-0001
Rev. 5**

~~MOD IN PROGRESS/SEE INTERIM AS-BUILT~~
FOR MOD. CE-10338 REV. _____
VN'S _____

5/5/99

May 25, 1994

Duke Power Company
Catawba Nuclear Station
Units 1 and 2

Revision Log

- Revision 1 8/25/94
- Revision 2 2/21/95
- Revision 3 8/19/97
- Revision 4 3/18/98
- Revision 5 3-23-99
- Revision 6 _____

VERIFICATION OF SPECIFICATION

Station and Unit Number: Catawba Nuclear Station, Units 1 and 2
Title of Specification: Containment Air Return & Hydrogen Skimmer System (VX)
Design Basis Specification
Specification Number: CNS-1557.VX-00-0001
Revision: 5

This document specifies items related to **QA CONDITION 1**. In accordance with established procedures, its quality has been assured. Signatures certify that the above specification was originated, checked, approved and inspected (or waived) as noted.

Signature also certifies that a review for determining potential impact to work performed per previous revisions was conducted for this revision.

Previous Work Impacted by this revision: Yes, See Attachment No

Prepared By: *Jeffrey Page* Date: 4/26/99
Checked By: *A.R. Lindgren* Date: 4/28/99
Approved By: *TV Moore* Date: 5/17/99

Inspection Waived by Sponsor and Other Teams

Inspection Waived By: *TV Moore* Date: 5/17/99

For

Location/Team	<u><i>CNS/MSE</i></u>	Location/Team	_____
Location/Team	<u><i>CNS/CEN</i></u>	Location/Team	_____
Location/Team	<u><i>NGO/ELECT.</i></u>	Location/Team	_____
Location/Team	_____	Location/Team	_____
Location/Team	_____	Location/Team	_____

Inspected by Other Teams:

Location/Team	<u>CNS/MOD ENGR. ELECT.</u>	Inspected By/Date	<u>Raymond Sambucetti / 5-3-99</u>
Location/Team	<u>G.O./NED Safety Analyst</u>	Inspected By/Date	<u>A.A. Lindelhardt / 5/11/99</u>
Location/Team	_____	Inspected By/Date	_____
Location/Team	_____	Inspected By/Date	_____
Location/Team	_____	Inspected By/Date	_____
Location/Team	_____	Inspected By/Date	_____
Location/Team	_____	Inspected By/Date	_____
Location/Team	_____	Inspected By/Date	_____
Location/Team	_____	Inspected By/Date	_____
Location/Team	_____	Inspected By/Date	_____

(FOR ASME CODE ITEMS)

Group: _____ Date: _____
Engineering

This is to certify that the above specification has been reviewed by me, the undersigned, and is correct, complete, and in compliance with _____ Edition including the _____ Addendum of ASME Code, Section III, Paragraph _____.

(SEAL)
Signature: _____
Name: _____
Professional Engineer
No. & State: _____

Document Revision Description

Form 170.1 Rev.1

REVISION NO.	PAGES or SECTIONS REVISED AND DESCRIPTION
0	Initial Issue
1	Revised Section 20.5.1.1 per NSM CN-21321/00 to reflect additional CPCS interlock on Containment Air Return Fans. Revised Section 32.3.2.1 per NSM CN-21321/00 to reflect additional CPCS interlock on Containment Air Return Fans and to remove Open Item concerning PIR 0-C91-0117.
2	Revised section 20.5.1.1 per NSM CN-11321/00 to reflect additional CPCS interlock on Containment Air Return Fans. Revised Section 31.3.2.1 per NSM CN-11321/00 to reflect additional CPCS interlock on Containment Air Return Fans and to remove Open Item concerning PIR 0-C91-0117.
3	Revised Sections 20.1.4.1, 20.1.4.2, 31.1.3.2, 31.3.2.1, 32.1.3.2, and 32.3.2.1 per Minor Mod CE-8849.
4	Revised Section 20.4.2.2 per Minor Mod CE-9170.
5	Revised Section 20.1.4.1 per Minor Mod CE-10195.



Contents

10. INTRODUCTION	1
10.1 SYSTEM BOUNDARY AND SCOPE	1
10.2 SYSTEM PURPOSE	1
10.2.1 GENERAL	1
10.2.2 VX SYSTEM ROLE IN PLANT OPERATIONS	1
10.3 SPECIFICATION FORMAT AND USE	2
20. DESIGN BASIS AND CRITERIA	3
20.1 SYSTEM FUNCTIONAL DESIGN BASIS	3
20.1.1 CONTAINMENT AIR RETURN SYSTEM	3
20.1.2 HYDROGEN SKIMMER SYSTEM	3
20.1.3 NORMAL OPERATION	4
20.1.4 DESIGN BASIS EVENTS	4
20.1.4.1 Containment Air Return System	4
20.1.4.2 Hydrogen Skimmer System	5
20.1.4.3 Electric Hydrogen Recombiners	6
20.2 SYSTEM GENERIC DESIGN CRITERIA	6
20.2.1 Single Failure	6
20.2.2 System Class	7
20.2.3 Containment Penetrations	7
20.2.4 Seismic	7
20.2.5 Tornado/Wind	7
20.2.6 Missiles	8
20.2.7 Pipe Rupture	8
20.2.8 Equipment Qualification	8
20.2.9 Electrical Separation	9
20.2.10 Flood	9
20.2.11 Loss of Instrument Air	9
20.2.12 Radiation Protection	9
20.2.13 Fire Protection	9
20.2.14 Loss Of Control Room	9
20.3 SYSTEM SPECIFIC DESIGN CRITERIA	10
20.3.1 STANDARD REVIEW PLAN	10
20.3.2 SYSTEM FLOW REQUIREMENTS	11
20.3.2.1 Containment Air Return System	11
20.3.2.2 Hydrogen Skimmer System	11
20.3.2.3 Electric Hydrogen Recombiners	12
20.4 EQUIPMENT DESIGN BASES	12
20.4.1 MECHANICAL EQUIPMENT	12
20.4.1.1 Containment Air Return Fans 1/2A and 1/2B	12
20.4.1.2 Hydrogen Skimmer Fans 1/2A and 1/2B	13
20.4.1.3 Electric Hydrogen Recombiners	13
20.4.2 DUCTWORK AND DAMPERS	13
20.4.2.1 Ductwork	13
20.4.2.2 Dampers	13
20.5 INSTRUMENTATION AND CONTROLS	14
20.5.1.1 Containment Air Return Fans and Isolation Dampers	14
20.5.1.2 Hydrogen Skimmer Fans and Inlet Isolation Valves	15
20.5.1.3 Electric Hydrogen Recombiners	15

20.5.1.4 Bypass and Inoperable Status Indication	15
20.6 DESIGN BASIS REFERENCES	17
20.6.1 LICENSING	17
20.6.1.1 Title 10, Code of Federal Regulations, Part 50, "Domestic Licensing of Production and Utilization Facilities, "NRC, through current update	17
20.6.1.2 Regulatory Guides	17
20.6.1.3 NUREG'S	18
20.6.1.4 Branch Technical Positions	18
20.6.1.5 Codes and Standards	18
20.6.1.6 Miscellaneous	18
20.6.1.7 Catawba FSAR	18
20.6.2 CATAWBA TECHNICAL SPECIFICATION	19
20.6.3 ENGINEERING DOCUMENTS	19
20.6.3.1 Design Basis Specifications and Manuals	19
20.6.3.2 Calculations	20
20.6.3.3 Vendor Documents	20
20.6.3.4 Correspondence	20
20.6.3.5 Other	21
30. SYSTEM DESIGN FEATURES	23
30.1 SYSTEM GENERIC DESIGN FEATURES	23
30.2 SYSTEM SPECIFIC DESIGN FEATURES	23
30.3 EQUIPMENT DESIGN FEATURES	23
30.3.1 MECHANICAL EQUIPMENT DESIGN FEATURES	24
30.3.1.1 Containment Air Return System Fans	24
30.3.1.2 Hydrogen Skimmer System Fans	24
30.3.1.3 Electric Hydrogen Recombiners	24
30.3.2 DUCTWORK AND DAMPERS	25
30.3.2.1 Ductwork	25
30.3.2.2 Dampers (and valves used as dampers)	25
31. UNIT 1 SYSTEM AND EQUIPMENT DESCRIPTION	27
31.1 SYSTEM DESCRIPTION AND FUNCTION	27
31.1.1 FUNCTIONAL DESCRIPTION	27
31.1.1.1 Containment Air Return System	27
31.1.1.2 Hydrogen Skimmer System	27
31.1.1.3 Electric Hydrogen Recombiners	28
31.1.2 SYSTEM OPERATION	28
31.1.2.1 HELB OPERATION	28
31.1.2.2 POST-HELB OPERATION	29
31.1.2.3 OPERATING INDICATIONS	29
31.1.2.4 PERIODIC TESTING	29
31.1.2.5 MAINTENANCE ACTIVITIES	30
31.1.3 SYSTEM LIMITS AND PRECAUTIONS	30
31.1.3.1 Containment Air Return Fans	30
31.1.3.2 Isolation Damper	30
31.2 UNIT 1 EQUIPMENT DESCRIPTION	30
31.2.1 Fans (ARF-1A and 1B)	30
31.2.2 Fans (HSF-1A and 1B)	30
31.2.3 Electric Hydrogen Recombiners	30
31.2.4 Motor Operated Dampers (and valves used as dampers)	30
31.2.4.1 Containment Air Return Fan Isolation Dampers (1ARF-D-2,4)	31
31.2.4.2 Hydrogen Skimmer Fan Inlet Valves (1VX1A, 2B)	31

31.2.5	Containment Air Return Fan Check Dampers (1ARF-D-1, 3)	31
31.2.6	Containment Air Return Fan Bypass Dampers (1ARF-D-5 through 10)	31
31.2.7	Hydrogen Skimmer Fan Throttle Valves (1VX3 through 28)	31
31.3	INSTRUMENTATION AND CONTROLS	31
31.3.1	INSTRUMENTATION	31
31.3.1.1	Containment Air Return Fan Isolation Damper Differential Pressure	32
31.3.1.2	Hydrogen Skimmer Fan Temperature and Suction Pressure	32
31.3.1.3	Containment Air Return Fan Discharge Pressure	32
31.3.1.4	Hydrogen Recombiner Heater Temperature Monitor Panels	32
31.3.2	CONTROLS	32
31.3.2.1	Containment Air Return Fans	33
31.3.2.2	Containment Air Return Fan Isolation Dampers	34
31.3.2.3	Containment Air Return Fan Bypass Test Dampers	36
31.3.2.4	Hydrogen Skimmer Fans	36
31.3.2.5	Hydrogen Skimmer Fan Inlet Valves (1VX1A, 2B)	37
31.3.2.6	VX and VP Test Panel (1RB-ECP-2)	38
31.3.2.7	Electric Hydrogen Recombiner System	38
31.3.3	INDICATORS	39
31.3.4	RECORDERS	39
31.3.5	STATUS INDICATION	39
31.3.5.1	Status Lights	39
31.3.5.2	Monitor Lights	39
31.3.5.3	1.47 Panel Bypass Lights	40
31.3.6	SYSTEM ALARMS	40
31.3.6.1	Annunciators	40
31.3.6.2	Computer Inputs	40
31.4	POWER SOURCES	41
31.5	DESIGN DOCUMENT CROSS REFERENCE	41
31.5.1	DUKE DRAWINGS	41
31.5.2	VENDOR DRAWINGS	42
32.	UNIT 2 SYSTEM AND EQUIPMENT DESCRIPTION	43
32.1	SYSTEM DESCRIPTION AND FUNCTION	43
32.1.1	FUNCTIONAL DESCRIPTION	43
32.1.1.1	Containment Air Return System	43
32.1.1.2	Hydrogen Skimmer System	43
32.1.1.3	Electric Hydrogen Recombiners	44
32.1.2	SYSTEM OPERATION	44
32.1.2.1	HELB OPERATION	44
32.1.2.2	POST-HELB OPERATION	45
32.1.2.3	OPERATING INDICATIONS	45
32.1.2.4	PERIODIC TESTING	45
32.1.2.5	MAINTENANCE ACTIVITIES	45
32.1.3	SYSTEM LIMITS AND PRECAUTIONS	46
32.1.3.1	Containment Air Return Fans	46
32.1.3.2	Isolation Damper	46
32.2	UNIT 2 EQUIPMENT DESCRIPTION	46
32.2.1	Fans (2ARF-1A and 1B)	46
32.2.2	Fans (2HSF-1A and 1B)	46
32.2.3	Electric Hydrogen Recombiners	46
32.2.4	Motor Operated Dampers (and valves used as dampers)	46
32.2.4.1	Containment Air Return Fan Isolation Dampers (2ARF-D-2,4)	46
32.2.4.2	Hydrogen Skimmer Fan Inlet Valves (2VX1A, 2B)	47

32.2.5	Containment Air Return Fan Check Dampers (2ARF-D-1, 3)	47
32.2.6	Containment Air Return Fan Bypass Dampers (2ARF-D-5 through 10)	47
32.2.7	Hydrogen Skimmer Fan Throttle Valves (2VX3 through 28)	47
32.3	INSTRUMENTATION AND CONTROLS	47
32.3.1	INSTRUMENTATION	47
32.3.1.1	Containment Air Return Fan Isolation Damper Differential Pressure	47
32.3.1.2	Hydrogen Skimmer Fan Temperature and Suction Pressure	48
32.3.1.3	Containment Air Return Fan Discharge Pressure	48
32.3.1.4	Hydrogen Recombiner Heater Temperature Monitor Panels	48
32.3.2	CONTROLS	48
32.3.2.1	Containment Air Return Fans	48
32.3.2.2	Containment Air Return Fan Isolation Dampers	50
32.3.2.3	Containment Air Return Fan Bypass Test Dampers	52
32.3.2.4	Hydrogen Skimmer Fans	52
32.3.2.5	Hydrogen Skimmer Fan Inlet Valves (2VX1A, 2B)	53
32.3.2.6	VX and VP Test Panel (2RB-ECP-2)	54
32.3.2.7	Electric Hydrogen Recombiner System	54
32.3.3	INDICATORS	55
32.3.4	RECORDERS	55
32.3.5	STATUS INDICATION	55
32.3.5.1	Status Lights	55
32.3.5.2	Monitor Lights	55
32.3.5.3	1.47 Panel Bypass Lights	56
32.3.6	SYSTEM ALARMS	56
32.3.6.1	Annunciators	56
32.3.6.2	Computer Inputs	56
32.4	POWER SOURCES	57
32.5	DESIGN DOCUMENT CROSS REFERENCE	57
32.5.1	DUKE DRAWINGS	57
32.5.2	VENDOR DRAWINGS	58

10. INTRODUCTION

10.1 SYSTEM BOUNDARY AND SCOPE

This specification documents the system and equipment design bases for the Containment Air Return & Hydrogen Skimmer System (VX). The major components of the VX System are fans, ductwork, dampers and controls. The arrangement of these components is depicted on flow diagrams CN-1557-1.0 (Unit 1) and CN-2557-1.0 (Unit 2). It should be noted that each of the two reactor units at Catawba Nuclear Station has a separately functioning VX System and that both are monitored from a single control room. A VX System designation is assigned to the equipment and components covered by this specification.

The VX System interfaces with:

- Diesel Load Sequencing System (EQB)
- Containment Pressure Control System (CPCS)
- 600 VAC Essential Auxiliary Power (EPE)
- 120 VAC Essential Power System (EPY)
- 208/120 VAC Blackout Auxiliary Power (ETE)
- 240/120 VAC Auxiliary Control Power System (EPF)
- 120/ VAC Vital Instrumentation and Control Power (EPG)
- 208/120 VAC Station Normal Auxiliary Power (ETA)
- Instrument Air System (VI)

This document will consider the interfaces only as they directly act on the VX System. For example, the EQB System interface will be considered only after a signal has been received by VX. How the signal is generated is covered in other documents.

10.2 SYSTEM PURPOSE

10.2.1 GENERAL

The Containment Air Return & Hydrogen Skimmer System (VX) consist of two sub-systems, the Containment Air Return sub-system and the Hydrogen Skimmer sub-system.

The purpose of the Containment Air Return sub-system is to assure a rapid return of air from upper containment to lower containment following a Loss Of Coolant Accident (LOCA) or a Main Steam Line Break (MSLB). This system also provides post-accident recirculation of air through the ice condenser.

The purpose of the Hydrogen Skimmer sub-system is to insure adequate mixing of the containment atmosphere to prevent excessive hydrogen build-up in isolated pockets and dead-ended spaces following a LOCA.

10.2.2 VX SYSTEM ROLE IN PLANT OPERATIONS

This system does not provide any normal ventilation function and operates only during accident conditions. This system is required to be in an OPERABLE condition during plant Modes 1, 2, 3 and 4 (Power Operation, Startup, Hot Standby and Hot Shutdown respectively).

10.3 SPECIFICATION FORMAT AND USE

This specification serves as the basis for development of all future VX System design documents. Any time an evaluation determines that a condition exists which violates a requirement set forth in this specification, a problem resolution process shall be invoked.

Throughout this specification, the terms "shall" and "should" are used to denote requirements and recommendations, respectively.

Section 20, "DESIGN BASIS AND CRITERIA" on page 3 states system and equipment design basis. Section 30, "SYSTEM DESIGN FEATURES" on page 23 states those additional features that have been provided to meet various codes, standards, or good engineering practices but are not required for the systems design basis. Sections 31, "UNIT 1 SYSTEM AND EQUIPMENT DESCRIPTION" on page 27 and 32, "UNIT 2 SYSTEM AND EQUIPMENT DESCRIPTION" on page 43 are Unit 1 and Unit 2 System Descriptions, respectively. The description sections document how the system functions in general in meeting the requirements of Section 20, "DESIGN BASIS AND CRITERIA" on page 3.

20. DESIGN BASIS AND CRITERIA

System functional design basis is addressed in Section 20.1, "SYSTEM FUNCTIONAL DESIGN BASIS." System generic design criteria are addressed in Section 20.2, "SYSTEM GENERIC DESIGN CRITERIA" on page 6. System specific design criteria are addressed in Section 20.3, "SYSTEM SPECIFIC DESIGN CRITERIA" on page 10. System and equipment design basis are addressed in Section 20.4, "EQUIPMENT DESIGN BASES" on page 12. Design basis references are listed in Section 20.6, "DESIGN BASIS REFERENCES" on page 17.

20.1 SYSTEM FUNCTIONAL DESIGN BASIS

The design basis function of the Containment Air Return & Hydrogen Skimmer System (VX) is to:

1. provide sufficient circulation of air and steam to allow the ice condenser to maintain containment pressures less than the design pressure of 15 psig, and
2. provide sufficient mixing of hydrogen from isolated pockets and dead-ended spaces to allow the Hydrogen Recombiners to reduce the concentration of hydrogen to less than 4% volume

Containment pressures are reduced by rapidly moving air from upper containment to lower containment upon receipt of the required permissives (Containment Air Return System). Hydrogen concentrations are reduced by pulling air from dead-ended spaces in lower containment and discharging near the Hydrogen Recombiners.

20.1.1 CONTAINMENT AIR RETURN SYSTEM

Following a High Energy Line Break (HELB) in Containment, the Containment Air Return Fans will provide for a return of air from upper Containment to lower Containment. The recirculation of Containment air shall enhance the ice condenser and Containment Spray System (NS) removal of heat (for HELB) and removal of fission products (LOCA only) per references 20.6.1.7.9, "Catawba FSAR Section 6.2.1.1.3.1, Loss of Coolant Accident" and 20.6.1.7.10, "Catawba FSAR Section 6.2.1.1.3.3, Steam Line Break."

20.1.2 HYDROGEN SKIMMER SYSTEM

Systems to control fission products, hydrogen, oxygen and other substances which may be released into Containment shall be provided as necessary to reduce (consistent with the functioning of other associated systems), the concentration and quantity of fission products released to the environment following postulated accidents, and to control the concentration of hydrogen or oxygen or other substances in the containment atmosphere following postulated accidents to assure that containment integrity is maintained (Reference 20.6.1.1.7, "10CFR50, Appendix A, General Design Criterion 41, Containment Atmosphere Cleanup").

Consistent with that requirement, hydrogen pocketing in Containment is prevented through use of the VX System.

20.1.3 NORMAL OPERATION

During normal power operation, this system is in a standby mode and does not perform any function. The Containment Air Return & Hydrogen Skimmer System (VX) shall be operable and capable of performing its nuclear safety related function in plant modes 1, 2, 3 and 4 (Power Operation, Startup, Hot Standby and Hot Shutdown, respectively).

20.1.4 DESIGN BASIS EVENTS

20.1.4.1 Containment Air Return System

The function of the Containment Air Return System is to mitigate the consequences of a HELB. This function shall be performed during injection and recirculation (if recirculation is necessary). The system shall be capable of performing this function with only on-site power available during and following the event.

The Containment Air Return Fans shall be utilized following a HELB to return air from upper Containment to lower Containment after peak containment pressure has been reached to provide mixing of containment atmosphere during the long term pressure peak. After the initial containment pressure peak has been reduced, the ice condenser and NS System are capable of maintaining containment pressure below the containment design pressure with the assumption of steam generation by residual energy until the ice bed is melted. If steam generation is assumed after ice melt, the NS System maintains the pressure below the containment design pressure with the Containment Air Return Fans circulating air in Containment.

One 40,000 cfm Containment Air Return Fan is assumed operable following a HELB per assumptions made in References 20.6.1.7.9, "Catawba FSAR Section 6.2.1.1.3.1, Loss of Coolant Accident," 20.6.1.7.18, "Catawba FSAR Section 15.4.8.4, Spectrum of Rod Control Assembly Ejection Accidents," and 20.6.1.7.19, "Catawba FSAR Section 15.6.5.3, LOCA - Radiological Consequences." One 40,000 cfm Containment Air Return Fan is assumed operable following a MSLB for heat removal per assumptions made in reference 20.6.1.7.10, "Catawba FSAR Section 6.2.1.1.3.3, Steam Line Break." Both Containment Air Return Fans (80,000 cfm total) are assumed operating per assumptions made in reference 20.6.1.7.11, "Catawba FSAR Section 6.2.1.5, Minimum Containment Pressure Pressure Analysis for Performance Capability Studies of Emergency Core Cooling System."

The Containment Air Return Fans start after a 9 +/- 1 minute time delay provided several permissives have been satisfied. The first permissive is received from the Containment Pressure Control System (CPCS) when containment pressure is greater than 0.4 psig. The Diesel Generator (D/G) sequencer load group 11 permissive must also be present for a fan start. The fans will continue to run until containment pressure is less than or equal to 0.25 psig. 0.4 psig and 0.25 psig will be used as fan on and off respectively. Per Reference 20.6.2.1.5, "Catawba Technical Specification Section 3/4.3.2, Engineered Safety Features Actuation System Instrumentation, Table 3.3-4 (Item 7)," the CPCS start permissive setpoint is 0.4 psig and the termination setpoint is 0.3 psig. 0.3 psig is used for reset to insure the fan is off before the 0.25 psig Technical Specification allowable value is reached. 0.4 psig is used to insure the fan starts up prior to reaching the 0.45 psig Technical Specification allowable value. The extra margin between the Tech. Spec. trip setpoints and the allowable values are provided to compensate for instrument drift between successive calibrations.

The normally closed Containment Air Return Fan isolation damper will open following a 10 second time delay after receipt of the Sp (Containment High- High pressure) signal. Several permissives must also be present to allow the damper to reposition. The first permissive is a signal from the CPCS that containment pressure is greater than 0.4 psig. 0.4 psig is used to insure the damper opens prior to reaching the 0.45 psig Technical Specification allowable value. The second is a signal from a differential pressure switch which

verifies the differential pressure across the damper is less than 0.5 psig. The D/G load sequencer load group 1 permissive must also be present for the damper to open. After the 10 second time delay and these permissives are present, the Containment Air Return Fan isolation damper starts to open. The Containment Air Return Fan isolation damper does not automatically close when the pressure decreases to the 0.30 psig CPCS setpoint. The isolation damper must be manually closed from the control room.

The containment Pressure Control System (CPCS) is described in Reference 20.6.3.1.10, "CNS-1563.NS-00-0001, Design Basis Specification for the Containment Spray (NS) System." The following VX System equipment is INOPERABLE if the loop is removed from service:

<u>INSTRUMENT LOOP</u>	<u>EQUIPMENT</u>
NSLP5160	VX Air Return Fan A
NSLP5170	VX Air Return Fan A and Air Return Fan A Motor Operated Isolation Damper
NSLP5240	VX Air Return Fan B
NSLP5250	VX Air Return Fan B and Air Return Fan B Motor Operated Isolation Damper

The Containment Air Return Fans start time delay is referenced in DPC-1552.08-00-0160, Rev 0, "McGuire/Catawba GOTHIC Ice Condenser Containment Base Model", which is used in Catawba's nuclear safety analyses calculations. Initially during a design basis accident LOCA or HELB, natural circulation forces steam and air flow from lower containment through the ice condenser to upper containment. Hydrogen accumulation is not a major concern, and adequate mixing of the containment atmosphere occurs (Reference 20.6.3.2.5). Therefore, the Containment Air Return Fans are not required until approximately 10 minutes after the design basis accident. The fan start time delay allows the upper and lower containment pressure to equalize and minimize the differential pressure.

The basis for opening the Containment Air Return Fan isolation damper this early in the event comes from the NSSS vendor accident analysis. This analysis indicates that a pressure reversal between the upper and lower containments, with upper positive with respect to lower containment, will occur as early as 16 seconds into the event for some accident scenarios. The pressure reversal is caused by the volume of air removed from lower containment through the ice condenser to upper containment. Opening the isolation damper provides an assured flow path for pressure equalization between the upper and lower containments during this period of the initial blow down.

In letter Duke-3100, N.J. Lipuralo and C.G. Tinkler (Westinghouse) to S.K. Blackley (Duke), Westinghouse requested the fan isolation damper be open 15 seconds after receipt of a Containment Hi-Hi pressure signal in response to the Reverse Pressure Differential Analysis. The decision was made within Duke Power to open the damper in 10 seconds +/- 1 second to insure compliance with Westinghouse request. Figure 6-16 of the FSAR is a graphical representation of the Peak Reverse Differential Pressure Transient.

20.1.4.2 Hydrogen Skimmer System

The function of the Hydrogen Skimmer System is to mitigate the consequences of a LOCA. This function shall be performed during injection and recirculation (if recirculation is necessary). The system shall be capable of performing this function with only on-site power available during and following the event.

Hydrogen production in Containment can be the product of several sources. The possible sources of hydrogen are the zirconium-water reaction, evolution of dissolved hydrogen in the Reactor coolant, corrosion of plant materials, and the radiolysis of core and sump water. Reference 20.6.1.1.11, "10CFR50, Section 50.44, Standards for Combustible Gas Control Systems in Light Water Cooled Power Reactors"

requires the capability to provide mixing of the containment environment and controlling combustible gas concentrations in containment following a LOCA to insure minimal hydrogen pocketing.

The hydrogen skimmer fans will start after 9 +/-1 minutes have elapsed from the receipt of the Sp signal provided several permissives have been satisfied. The diesel generator load sequencer load group 11 permissive must be present and the isolation damper 'open' permissive must be present.

The Hydrogen Skimmer Fans start time delay is referenced in CNC-1552.08-00-0194, "Reanalysis of the Catawba Hydrogen Skimmer System Flow Requirements." Based on safety analysis calculations, hydrogen accumulation is not a major concern, and the LOCA blowdown will provide adequate mixing of the containment atmosphere in the first ten minutes.

20.1.4.3 Electric Hydrogen Recombiners

The function of the recombiners is to mitigate the consequences of a LOCA. These are safety related devices and shall be capable of functioning with only on-site power following the event. The electric hydrogen recombiners also remove hydrogen from the containment atmosphere. They are designed to process a capacity such that the containment hydrogen concentration does not exceed 4% by volume.

Each electric recombiner is capable of processing a maximum of 100 scfm of Containment atmosphere. Flow through recombiners is due to natural circulation and is limited by flow orifices internal to the device. There are two recombiners per unit and each recombiner has a 100% capacity. Units are controlled manually following a LOCA to control hydrogen concentration. Power and controls for the hydrogen recombiners are located outside of containment.

Reference 20.6.2.1.4, "Catawba Technical Specification Section 3/4.6.4.2, Electric Hydrogen Recombiners, Surveillance Requirements" requires the recombiners to be demonstrated operable at least once every 6 months. This is done by measuring the internal heater sheath temperature after 90 minutes and insuring the temperature is greater than or equal to 700°F. After reaching 700°F, the power setting is increased to maximum. After 2 minutes the power meter should read greater than or equal to 60 kilowatts.

The hydrogen recombiners are not part of the VX System. Their operation is independent of the operation of the VX System but have been included here due to their parallel function of hydrogen control. Also, since the recombiners do not have a system designation, the VX System design basis is a convenient and logical place to define their design parameters.

20.2 SYSTEM GENERIC DESIGN CRITERIA

20.2.1 Single Failure

The guidelines for the application of the single failure criterion are documented in Reference 20.6.3.1.1, "CNS-1465.00-00-0001, Plant Design Basis Specification for Systems Single Failure." The VX System shall be designed against the consequences of any single active or passive failure without loss of capability of the system to perform its intended safety functions in mitigating the consequences of a design basis initiating event.

Active components shall be designated per the definition presented in Reference 20.6.3.1.1, "CNS-1465.00-00-0001, Plant Design Basis Specification for Systems Single Failure."

20.2.2 System Class

The Containment Air Return & Hydrogen Skimmer System (VX) is a QA 1 Engineered Safeguards System. The guidelines for the selection of dampers and ductwork are documented in Reference 20.6.3.1.18, "CNS-1211.00-00-0005, Supplement No. 6, Heating, Ventilating and Air Conditioning; Reactor Building." Guidelines for selection of fans are documented in Reference 20.6.3.1.20, "CNS-1211.00-00-0006, Vane Axial Fan Motor Systems Related to Nuclear Safety."

The VX System is classified as a Safety Class 2 system. Imbedded piping is non-safety. Exposed piping and valves in lower containment compartments where the the HSF take suction is class 'F', seismic. This will insure the piping and valves remain in place following a seismic event. These valves are not missile protected in that a missile strike to a small number of these valves will not compromise the ability of the system to perform its design function.

20.2.3 Containment Penetrations

The VX System has no containment penetrations.

20.2.4 Seismic

Per Reference 20.6.1.1.1, "10CFR50, Appendix A, General Design Criterion 2, Design Bases for Protection Against Natural Phenomena," safety related systems, structures, and components are required to be protected from the effects of earthquakes. Compliance with this requirement is documented in Reference 20.6.1.7.1, "Catawba FSAR Section 3.2, Classification of Structures, Systems, and Components."

For information pertaining to seismic design criteria see Reference 20.6.3.1.7, "CNS-1465.00-00-0007, Plant Design Basis Specification for Seismic Design."

The VX System and the structures which house this system (Reactor Building) are designed to withstand the effects of a Seismic Event without loss of capability of the system to perform its safety function.

Nuclear safety related (QA 1) mechanical equipment shall be qualified in accordance with the guideline set forth in Reference 20.6.1.7.5, "Catawba FSAR Section 3.9.2.2, Seismic Qualification of Safety Related Mechanical Equipment." Nuclear safety related instrumentation and electrical equipment shall be seismically qualified in accordance with the guidelines set forth in Reference 20.6.1.7.6, "Catawba FSAR Section 3.10, Seismic Qualification of Seismic Category I Instrumentation and Electrical Equipment."

20.2.5 Tornado/Wind

Per Reference 20.6.1.1.1, "10CFR50, Appendix A, General Design Criterion 2, Design Bases for Protection Against Natural Phenomena," safety related systems, components, and structures are required to be protected from the effects of a tornado. Compliance with this requirement is documented in Reference 20.6.1.7.2, "Catawba FSAR Section 3.3, Wind and Tornado Loadings." Tornado/Wind analysis is also addressed in Reference 20.6.3.1.15, "CNS-1108.02-00-0001, Catawba Structural Design Specification." For information pertaining to Tornado/Wind design criteria see Reference 20.6.3.1.8, "CNS-1465.00-00-0008, Plant Design Basis Specification for Tornado/Wind."

All Category I structures, except those structures not exposed to wind, are designed to withstand the effects of wind and tornado loadings, without loss of capability of the structure to perform its safety function. The

nuclear safety related portions of the VX System are housed entirely within the Reactor Building, which is a Category I structure, and therefore, the VX System is protected from the effects of tornado/wind.

20.2.6 Missiles

Per Reference 20.6.1.1.2, "10CFR50, Appendix A, General Design Criterion 4, Environmental and Dynamic Effects Design Bases," safety related systems, components, and structures are required to be protected from the effects of tornado generated missiles and other selected missiles (i.e., turbine blade). Compliance with this requirement is documented in Reference 20.6.1.7.4, "Catawba FSAR Section 3.5, Missile Protection." Missile protection is also discussed in Reference 20.6.3.1.15, "CNS-1108.02-00-0001, Catawba Structural Design Specification."

Per reference 20.6.3.3.2, "CNM-1211.00-2326, Missile Penetration Calculations - Joy Technologies Fans, Inc.," neither the Containment Air Return nor the Hydrogen Skimmer Fans will produce a missile capable of penetrating the fan housing in the event of a rotor failure.

The structures which contain the VX System (Reactor Buildings) are designed to withstand the effects of tornado generated missiles and internally generated missiles.

20.2.7 Pipe Rupture

The VX System is required to mitigate the consequences of a pipe rupture (HELB) and the subsequent containment pressurization.

In accordance with Reference 20.6.3.1.19, "Environmental Qualification Criteria Manual (EQCM)," all safety related VX Equipment is located within the Reactor Building which is protected against postulated effects from flooding.

Reactor Building floor curbs (4" high) direct water that falls on the operating floor, away from the Containment Air Return Fan pits and is designed to limit flooding of the fan pits from internal sources (pipe rupture and/or NS System actuation) per Reference 20.6.3.1.14, "CNS-1144.00-00-0010, Design Basis Specification for The Reactor Building Structures" Section 30.2.3.9.1.. Six inch angle iron dams have also been provided around the VX fan pits to assist in minimizing fan pit flooding.

20.2.8 Equipment Qualification

All VX System safety related equipment shall be reviewed to determine if it is located in a harsh environment. Any equipment identified as being in such an environment shall be evaluated to determine its environmental qualification requirements and be qualified in accordance with Reference 20.6.1.1.12, "10CFR50, Section 50.49, Environmental Qualification of Electric Equipment Important to Safety For Nuclear Power Plants."

Compliance with this requirement is documented in Reference 20.6.1.7.7, "Catawba FSAR Section 3.11, Environmental Design of Mechanical and Electrical Equipment" and Reference 20.6.1.6.1, "Duke Power Company - Catawba Nuclear Station - Response to NUREG 0588 (H. B. Tucker letter to H. R. Denton, dated February 8, 1984)." The requirements to maintain the environmental qualification of nuclear safety related equipment are identified in Reference 20.6.3.1.16, "CNLT-1780-03.01, Environmental Qualification Master List (EQML)" and Reference 20.6.3.1.17, "EQMM-1393.01, Environmental Qualification Maintenance Manual (EQMM)." The environmental conditions used to qualify equipment are identified in Reference 20.6.3.1.19, "Environmental Qualification Criteria Manual (EQCM)."

20.2.9 Electrical Separation

The VX System design shall incorporate complete physical and electrical separation between redundant trains of safety related wiring and equipment and between either train and non-safety related wiring and equipment, per References 20.6.1.7.13, "Catawba FSAR Section 7.1.2.2, Instrumentation & Controls - Independence of Redundant Controls," 20.6.1.7.17, "Catawba FSAR Section 8.3.1.4, AC Power Systems - Independence of Redundant Systems," and 20.6.3.5.1, "Electrical Design Manual."

20.2.10 Flood

Per Reference 20.6.1.1.1, "10CFR50, Appendix A, General Design Criterion 2, Design Bases for Protection Against Natural Phenomena," safety related systems, components, and structures shall be protected from the effects of a flood. Compliance with this requirement is documented in Reference 20.6.1.7.3, "Catawba FSAR Section 3.4, Water Level (Flood) Design."

For information pertaining to flood design criteria see Reference 20.6.3.1.6, "CNS-1465.00-00-0011, Plant Design Basis Specification for Flooding From External Sources."

20.2.11 Loss of Instrument Air

The guidelines for incorporating Loss of Instrument Air in the Catawba design are outlined in Reference 20.6.3.1.3, "CNS-1465.00-00-0004. Plant Design Basis Specification for Loss of Instrument Air."

Bypass dampers used for air return fan testing use instrument air, however, components required for accident mitigation do not use the Instrument Air System and are not affected by this criteria.

20.2.12 Radiation Protection

The VX System is not a source of Design Basis Radiation.

20.2.13 Fire Protection

Mechanical systems shall be designed in accordance with fire protection requirements established in References 20.6.1.3.1, "NUREG 0800, Standard Review Plan, July 1981," 20.6.3.1.5, "CNS-1465.00-00-0006, Plant Design Basis Specification for Fire Protection," and 20.6.3.1.9, "CNS-1435.00-00-0002, Design Basis Specification for Post Fire Safe Shutdown."

The VX System is not designed to mitigate the consequences of a fire. All fire protection criteria related to this system are considered to be design features and are described in Section 30, "SYSTEM DESIGN FEATURES" on page 23.

In some cases, equipment for both trains is located in the same fire area. Unit shutdown is assured for a fire in those areas per Reference 20.6.3.1.9, "CNS-1435.00-00-0002, Design Basis Specification for Post Fire Safe Shutdown."

20.2.14 Loss Of Control Room

The VX System is not required to bring the station to a prompt hot shutdown and subsequent cold shutdown condition during this event.

20.3 SYSTEM SPECIFIC DESIGN CRITERIA

20.3.1 STANDARD REVIEW PLAN

The design of the Containment Air Return & Hydrogen Skimmer System (VX) shall conform to the General Design Criteria as described in Section 3.2.1 Seismic Classification, 3.2.2 System Quality Group Classification, 6.2.1 Containment Functional Design, 6.2.5 Combustible Gas Control in Containment, 6.5.1 ESF Atmospheric Cleanup Systems, 7.1 Instrumentation and Controls of the Standard Review Plan, and Reference 20.6.1.3.2, "NUREG 0954, Safety Evaluation Report related to the operation of Catawba Nuclear Station, Units 1 and 2."

1. Reference 20.6.1.1.1, "10CFR50, Appendix A, General Design Criterion 2, Design Bases for Protection Against Natural Phenomena," as it applies to systems and components being designed to withstand the effects of natural phenomena such as earthquakes, tornadoes, etc.

Response

This requirement and compliance references are addressed in Sections 20.2.4, "Seismic" and 20.2.5, "Tornado/Wind."

2. Reference 20.6.1.1.2, "10CFR50, Appendix A, General Design Criterion 4, Environmental and Dynamic Effects Design Bases," with respect to structures housing the system being capable of withstanding the effects of external missiles and internally generated missiles, pipe whip, and jet impingement forces associated with pipe breaks.

Response

This requirement and compliance references are addressed in Sections 20.2.6, "Missiles" and 20.2.7, "Pipe Rupture."

3. Reference 20.6.1.1.3, "10CFR50, Appendix A, General Design Criterion 16, Containment Design," as it relates to systems being provided to establish barriers against the uncontrolled release of radioactivity to the environment.

Response

This criterion requires in part, that systems be provided to assure that containment design conditions important to safety are not exceeded. The VX System, in conjunction with other supporting systems (CPCS, NS), is capable of rapidly reducing containment pressure following a LOCA, and maintaining them at acceptable levels.

4. Reference 20.6.1.1.4, "10CFR50, Appendix A, General Design Criterion 38, Containment Heat Removal Systems," as it applies to systems being provided to remove heat and control pressure and temperature following a LOCA.

Response

This requirement and compliance references are addressed in Section 20.1.4, "DESIGN BASIS EVENTS." Inadvertent operation of the Containment Air Return Fans and opening of the Containment Air Return Fan Isolation Dampers could result in a pressure reduction which could possibly exceed the containment lower design limit of -1.5 psig.

5. Reference 20.6.1.1.7, "10CFR50, Appendix A, General Design Criterion 41, Containment Atmosphere Cleanup," as it applies to controlling fission products within containment and released to the environment.

6. Reference 20.6.1.1.8, "10CFR50, Appendix A, General Design Criterion 42, Inspection of Containment Atmosphere Cleanup Systems," for permitting appropriate periodic inspection of atmospheric cleanup systems.
7. Reference 20.6.1.1.9, "10CFR50, Appendix A, General Design Criterion 43, Testing of Containment Atmosphere Cleanup Systems," for permitting appropriate testing of atmospheric systems.

Response

In meeting GDC 41, 42, and 43 requirements, the following provisions are made:

- Hydrogen Control - The VX System is designed such that hydrogen concentrations will be maintained below 4%. The Hydrogen Skimmer System draws from the dead-ended spaces in lower containment and discharges near the Hydrogen Recombiners. The ARFs provide for hydrogen dilution by mixing the hydrogen with containment atmosphere and distributing throughout containment. The Electric Hydrogen Recombiners function to reduce hydrogen concentrations in containment. They are manually started following a LOCA.
 - Testing - VX system components are tested to insure proper function. Such tests include verification of fan performance, verification of fan start on receipt of proper signal, and proper damper/valve positioning. Each test is also required by CNS Technical Specification.
 - Technical Specification - Technical Specifications specify appropriate limiting conditions for operation, tests, and inspections to insure systems are capable of performing its design function when required.
8. Reference 20.6.1.1.10, "10CFR50, Appendix A, General Design Criterion 50, Containment Design Basis" as it relates to systems being provided to insure the containment and its internal structures can accommodate the pressure and temperature conditions resulting from a LOCA.

Response

This requirement and compliance references are addressed in Section 20.1.4, "DESIGN BASIS EVENTS"

20.3.2 SYSTEM FLOW REQUIREMENTS

20.3.2.1 Containment Air Return System

Upon actuation by an Engineered Safety Feature (ESF) signal, receipt of a Diesel Generator Load Sequencer (EQB) signal, and satisfied permissives, the Containment Air Return Fans start. Each train has a 100% capacity fan with a nominal design flow of 40,000 cfm (which includes approximately 10% margin).

20.3.2.2 Hydrogen Skimmer System

Upon actuation by an Engineered Safety Feature (ESF) signal, receipt of a Diesel Generator Load Sequencer (EQB) signal, and satisfied permissives, the Hydrogen Skimmer Fans start. Each train has a 100% capacity fan with a nominal design flow of 4260 cfm.

Reference 20.6.3.2.5, "CNC-1552.08-00-0194, Reanalysis of the Catawba Hydrogen Skimmer System Flow Requirements" documents the required flowrates from the dead ended spaces to maintain hydrogen concentrations below 4%. The flowrates are as follows:

<u>Compartment</u>	<u>Flowrate</u>
Rx Vessel Compartment	99 cfm
In-Core Instrument Room	8 cfm
S/G Enclosure(4)	1 cfm (each S/G)
Accumulator A Compartment	6 cfm
Accumulator B Compartment	6 cfm
Pressurizer Enclosure	165 cfm

20.3.2.3 Electric Hydrogen Recombiners

The electric hydrogen recombiners are actuated manually. Upon actuation, each train functions by natural circulation and is limited to a maximum flow of 100 scfm.

20.4 EQUIPMENT DESIGN BASES

The VX System equipment design bases are described in this section. The system consists of two sub-systems, the Containment Air Return Fan and the Hydrogen Skimmer Fan sub-systems. Each sub-system consists of two (2) 100% redundant, independent, and separately located trains. Associated with each Containment Air Return Fan train is one 100% capacity fan, three bypass test dampers, one isolation damper and one backdraft damper. Associated with each Hydrogen Skimmer Fan train is one 100% capacity fan, one isolation damper, and 13 flow control valves.

Test Acceptance Criteria (TAC) sheets have been developed for components requiring Design Engineering initiated test acceptance criteria. A Unit 2 TAC sheet exists for each of the Unit 1 TACs listed. The following table provides guidance for locating system test acceptance criteria:

<u>Drawing</u>	<u>Title</u>
CNTC-1557-VX.M001-01	Hydrogen Skimmer Fans
CNTC-1557-VX.M002-01	Containment Air Return Fans
CNTC-1557-VX.M003-01	Containment Air Return Fan Isolation Dampers
CNTC-1557-VX.M004-01	Containment Air Return Fan Check Dampers
CNTC-1557-VX.M005-01	Hydrogen Skimmer Fan Isolation Dampers
CNTC-1557-VX.M006-01	Electric Hydrogen Recombiners

20.4.1 MECHANICAL EQUIPMENT

20.4.1.1 Containment Air Return Fans 1/2A and 1/2B

Active:	Yes	1E Power:	Yes
ESF:	Yes	ESF Response Time:	9 +/- 1 minute

Each fan's design capacity is 40,000 CFM. Both fans of the same unit start following receipt of the necessary permissives (ie. Sp signal following HELB blowdown, differential pressure permissive, etc.). The Containment Air Return Fans have sufficient head to overcome the divider barrier differential pressure (per Reference 20.6.1.7.8, "Catawba FSAR Section 6.2.1, Containment Functional Design") resulting from steam flow and fan air flow entering the ice condenser through the lower inlet doors.

20.4.1.2 Hydrogen Skimmer Fans 1/2A and 1/2B

Active:	Yes	IE Power:	Yes
ESF:	Yes	ESF Response Time:	9+/-1 minute

Each fan's design capacity is 4260 CFM. Both fans of the same unit start following receipt of the necessary permissives (ie. Sp signal following HELB blowdown, suction valve open, etc.).

20.4.1.3 Electric Hydrogen Recombiners

Active:	Yes	IE Power:	Yes
ESF:	No	ESF Response Time:	N/A

The hydrogen recombiners are limited to 100 scfm air flow. There are two recombiners per unit, each with a 100% capacity. The units are started manually following a HELB.

20.4.2 DUCTWORK AND DAMPERS

20.4.2.1 Ductwork

The ductwork for the Containment Air Return sub-system is redundant (i.e., each train of the Containment air return sub-system has its own independent supply header) and is configured in separated headers. Ductwork is considered a passive, safety-related component.

Ductwork for the hydrogen skimmer system is actually piping. Piping is used instead of ductwork to eliminate a possible rupture of the ductwork which would provide a leak path from upper containment to lower containment. Embedded portions of the hydrogen skimmer piping is class 'H', non-safety related. Piping inside rooms where this system takes suction is class 'F'. Piping from the crane wall to the inlet connection to each fan is class 'B'.

20.4.2.2 Dampers

All dampers shall be QA Condition I, Seismically Qualified. In addition actuators for the dampers are required to be QA Condition I, Seismically qualified.

1. Containment Air Return Fan Isolation Dampers (1/2ARF-D-2,4)

The isolation dampers shall be Low Leakage Design (Category I) as defined in ANSI N509-1976 and shall fail as-is.

2. Containment Air Return Fan Check (Backdraft) Dampers (1/2ARF-D-1,3)

The check dampers prevent back flow from lower containment to upper containment through the ARF's when the isolation dampers are open.

3. Containment Air Return Fan Bypass Test Dampers (1/2ARF-D-5 through 10)

The bypass test dampers are Low Leakage Design (Category III) as defined by ANSI N509-1976 and shall fail in the closed position. These dampers are used only during testing of the Containment Air Return Fans.

4. Hydrogen Skimmer Fan Isolation Dampers (1/2VX1A, 2B)

The isolation dampers (valves used as dampers) shall be ASME Section III, class 2 and shall fail as-is. These provide isolation between upper and lower containment. These are IWV Category B, active valves.

20.5 INSTRUMENTATION AND CONTROLS

Safety related instrumentation requirements are addressed in this section. The system description portion of this specification provides a complete listing of the instrumentation and controls provided to meet the requirements set forth in this section. This section does not provide a complete list of all system instrumentation.

20.5.1.1 Containment Air Return Fans and Isolation Dampers

Specific requirements for the Containment Air Return Fan system are listed in Reference 20.6.1.3.1, "NUREG 0800, Standard Review Plan, July 1981." As required by item II.1 in Section 6.2.2 of the subject reference, each completely redundant train of the Containment Air Return Fan system is provided with safety-related controls, powered from Class 1E power sources, thus assuring the capability to withstand a single failure without loss of function of the entire Containment Air Return System. As required by Item II.8 of Section 6.2.2 of the subject reference, safety-related indication of the status of the fans and dampers is provided on the main control board in order to determine the operational status of the system. As required by item II.7 of Section 6.2.2 and item II.4 of Section 6.2.1.1.B of the subject reference, the controls for the Containment Air Return Fans and isolation dampers have been designed to facilitate testing of the system. A test panel has been installed which allows testing of the Containment Air Return Fans, isolation dampers, hydrogen skimmer fans, and isolation valves. Although designed to permit testing by exclusive use of this panel, current procedures use a combination of electrical jumpers and the test circuitry associated with this panel. For a description of the test panel operating procedures, see Sections 31.3.2.6, "VX and VP Test Panel (1RB-ECP-2)" on page 38 and 32.3.2.6, "VX and VP Test Panel (2RB-ECP-2)" on page 54. Provisions for testing the Containment Pressure Control System permissives are discussed below.

In accordance with Reference 20.6.1.3.1, "NUREG 0800, Standard Review Plan, July 1981," Item II.5, each Containment Air Return Fan and Isolation Damper is interlocked with the Containment Pressure Control System (CPCS) in order to prevent any inadvertent actuation of the VX System which may cause the containment structure to exceed the negative design limits. The CPCS permissives inhibit operation of the air return fans and isolation dampers below 0.25 psig. Specifically, the CPCS consists of two train related cabinets, CPCC1 and CPCC2, for Train A and B, respectively. Each cabinet accepts inputs from four separate pressure transmitters. Two of these transmitters are used to generate permissives for the air return fan and isolation damper. The circuitry for each of these permissives is separated inside the CPCS cabinets using the same criteria for separation between two safety trains. Additionally, the cables from the sensors to the cabinets and from the cabinets to the fan and damper circuits are also separated according to standard separation criteria. By separating the permissive circuits, a single failure cannot affect both permissives simultaneously. One permissive is dedicated solely to the air return fan while the other permissive operates both the damper and fan. Providing two permissives on the fan is necessary due to the damper permissive not possessing the capability to automatically close the damper. Without damper closure, design against inadvertent actuation per the above reference requires two independent permissives be available to stop the fans. With this design, no single failure can allow the containment air return system (fans and dampers) to operate concurrently to depressurize containment. Details of the implementation of these interlocks within the fan and damper control circuits is discussed in Sections 31.3.2.1, "Containment Air Return Fans," 31.3.2.2, "Containment Air Return Fan Isolation Dampers," 32.3.2.1, "Containment Air Return Fans," and 32.3.2.2, "Containment Air Return Fan Isolation Dampers." The Containment Pressure Control System

and its associated separation requirements is discussed in Reference 20.6.3.1.10, "CNS-1563.NS-00-0001, Design Basis Specification for the Containment Spray (NS) System."

20.5.1.2 Hydrogen Skimmer Fans and Inlet Isolation Valves

In order to meet the requirements of Reference 20.6.1.3.1, "NUREG 0800, Standard Review Plan, July 1981" items II.c and II.6 of Section 6.2.5, each completely redundant train of hydrogen skimmer fans and isolation valves is provided with safety-related controls and powered from Class 1E power sources, thus assuring the capability to withstand a single failure without loss of function. As required by Items II.11 and III.5 of the subject reference, indication of the operational status of the fans and the position of the isolation valves is provided via safety-grade indicating lights on the main control board. The required redundancy and alarm capability is provided by either monitor light alarms or Operator Aid Computer digital alarms, both of which provide indication and alarms in the control room.

As required by Item II.10 of the subject reference, the controls for the skimmer fans and isolation valves have been designed to facilitate testing of the system. Test Panel RB-ECP-2 allows testing of the skimmer fans and isolation valves. Although designed to permit testing by exclusive use of this panel, current procedures use a combination of electrical jumpers and the test circuitry associated with this panel. For a description of the test panel operating procedures, see Sections 31.3.2.6, "VX and VP Test Panel (1RB-ECP-2)" on page 38 and 32.3.2.6, "VX and VP Test Panel (2RB-ECP-2)" on page 54.

20.5.1.3 Electric Hydrogen Recombiners

In order to meet the requirements of Reference 20.6.1.3.1, "NUREG 0800, Standard Review Plan, July 1981" items II.c and II.6 of Section 6.2.5, each completely redundant train of hydrogen recombiners is provided with safety-related controls, powered from Class 1E power sources, thus assuring the capability to withstand a single failure without loss of function. The requirements of Items II.11 and III.5 are complied with by indicating lights on the Hydrogen Recombiner Control Panel and by the temperature indication provided by the Hydrogen Recombiner Heater Temperature Monitor Panel. Additionally, Item II.10 of the subject reference is complied with by utilizing the Hydrogen Recombiner Heater Temperature Monitor Panel to verify proper recombiner temperature are achieved when started for testing.

20.5.1.4 Bypass and Inoperable Status Indication

As required by Reference 20.6.1.2.1, "Regulatory Guide 1.47, Bypassed and Inoperable Status Indication for Nuclear Power Plant Safety Systems," status lights are provided on a train related basis to indicate a condition in which the safety function of the VX system is either bypassed or inoperable. The logic for each light is as follows:

"VX Train A Bypassed"

VX CPCS Train A Circuit Loss of Power

OR

VX CPCS Train A Circuit in Test Mode

OR

VX Test Switch Train A in Test Mode

OR

Isolation Damper ARF-D-2 Loss of Power

OR

Hydrogen Skimmer Fan HSF-1(2)A Loss of Power

OR

Containment Air Return Fan ARF-1(2)A Loss of Power

OR

Inlet Isolation Valve VX1A Closed or Intermediate Position Concurrent with Loss of Power

OR

Control Logic Circuitry Loss of Power

OR

Diesel Generator A or Sequencer A Bypassed

OR

Selector Switch for ARF-1(2)A in OFF Position

OR

Selector Switch for HSF-1(2)A in OFF Position

OR

1.47 Panel Master Test Actuation

"VX Train B Bypassed"

VX CPCS Train B Circuit Loss of Power

OR

VX CPCS Train B Circuit in Test Mode

OR

VX Test Switch Train B in Test Mode

OR

Isolation Damper ARF-D-4 Loss of Power

OR

Hydrogen Skimmer Fan HSF-1(2)B Loss of Power

OR

Containment Air Return Fan ARF-1(2)B Loss of Power

OR

Inlet Isolation Valve VX2B Closed or Intermediate Position Concurrent with Loss of Power

OR

Control Logic Circuitry Loss of Power

OR

Diesel Generator B or Sequencer A Bypassed

OR

Selector Switch for ARF-1(2)B in OFF Position

OR

Selector Switch for HSF-1(2)B in OFF Position

OR

1.47 Panel Master Test Actuation

20.6 DESIGN BASIS REFERENCES

20.6.1 LICENSING

20.6.1.1 Title 10, Code of Federal Regulations, Part 50, "Domestic Licensing of Production and Utilization Facilities," NRC, through current update

20.6.1.1.1 10CFR50, Appendix A, General Design Criterion 2, Design Bases for Protection Against Natural Phenomena

20.6.1.1.2 10CFR50, Appendix A, General Design Criterion 4, Environmental and Dynamic Effects Design Bases

20.6.1.1.3 10CFR50, Appendix A, General Design Criterion 16, Containment Design

20.6.1.1.4 10CFR50, Appendix A, General Design Criterion 38, Containment Heat Removal Systems

20.6.1.1.5 10CFR50, Appendix A, General Design Criterion 39, Inspection of Containment Heat Removal Systems

20.6.1.1.6 10CFR50, Appendix A, General Design Criterion 40, Testing of Containment Heat Removal Systems

20.6.1.1.7 10CFR50, Appendix A, General Design Criterion 41, Containment Atmosphere Cleanup

20.6.1.1.8 10CFR50, Appendix A, General Design Criterion 42, Inspection of Containment Atmosphere Cleanup Systems

20.6.1.1.9 10CFR50, Appendix A, General Design Criterion 43, Testing of Containment Atmosphere Cleanup Systems

20.6.1.1.10 10CFR50, Appendix A, General Design Criterion 50, Containment Design Basis

20.6.1.1.11 10CFR50, Section 50.44, Standards for Combustible Gas Control Systems in Light Water Cooled Power Reactors

20.6.1.1.12 10CFR50, Section 50.49, Environmental Qualification of Electric Equipment Important to Safety For Nuclear Power Plants

20.6.1.1.13 10CFR50, Appendix R, Fire Protection Program for Nuclear Power Facilities

20.6.1.2 Regulatory Guides

20.6.1.2.1 Regulatory Guide 1.47, Bypassed and Inoperable Status Indication for Nuclear Power Plant Safety Systems

20.6.1.3 NUREG'S

20.6.1.3.1 NUREG 0800, Standard Review Plan, July 1981

20.6.1.3.2 NUREG 0954, Safety Evaluation Report related to the operation of Catawba Nuclear Station, Units 1 and 2

20.6.1.4 Branch Technical Positions

N/A

20.6.1.5 Codes and Standards

20.6.1.5.1 ANSI N509. Nuclear Power Plant Air Cleaning Units and Components, 1980

20.6.1.5.2 SMACNA High Velocity Duct Construction Standards, 1969

20.6.1.5.3 ASME Section IX, Article IWV

20.6.1.6 Miscellaneous

20.6.1.6.1 Duke Power Company - Catawba Nuclear Station - Response to NUREG 0588 (H. B. Tucker letter to H. R. Denton, dated February 8, 1984)

20.6.1.6.2 CNSD-0010-10, Electrical System Description for the 240/120 VAC Auxiliary Control Power System

20.6.1.6.3 CNSD-0010-12, Electrical System Description for the 208/120 VAC Normal Auxiliary Power System

20.6.1.6.4 Design Study CNDS-107, VX Controls/Test Circuitry Review

20.6.1.7 Catawba FSAR

20.6.1.7.1 Catawba FSAR Section 3.2, Classification of Structures, Systems, and Components

20.6.1.7.2 Catawba FSAR Section 3.3, Wind and Tornado Loadings

20.6.1.7.3 Catawba FSAR Section 3.4, Water Level (Flood) Design

20.6.1.7.4 Catawba FSAR Section 3.5, Missile Protection

20.6.1.7.5 Catawba FSAR Section 3.9.2.2, Seismic Qualification of Safety Related Mechanical Equipment

20.6.1.7.6 Catawba FSAR Section 3.10, Seismic Qualification of Seismic Category I Instrumentation and Electrical Equipment

20.6.1.7.7 Catawba FSAR Section 3.11, Environmental Design of Mechanical and Electrical Equipment

20.6.1.7.8 Catawba FSAR Section 6.2.1, Containment Functional Design

20.6.1.7.9 Catawba FSAR Section 6.2.1.1.3.1, Loss of Coolant Accident

20.6.1.7.10 Catawba FSAR Section 6.2.1.1.3.3, Steam Line Break

20.6.1.7.11 Catawba FSAR Section 6.2.1.5, Minimum Containment Pressure Pressure Analysis for Performance Capability Studies of Emergency Core Cooling System

20.6.1.7.12 Catawba FSAR Section 6.2.5, Combustible Gas Control in Containment

20.6.1.7.13 Catawba FSAR Section 7.1.2.2, Instrumentation & Controls - Independence of Redundant Controls

20.6.1.7.14 Catawba FSAR Section 7.3, Instrumentation & Controls for ESF Actuation System

20.6.1.7.15 Catawba FSAR Section 7.6.4, Instrumentation & Controls for Containment Pressure Control System

20.6.1.7.16 Catawba FSAR Section 7.6.10, Instrumentation & Controls for Containment Air Return, Hydrogen Skimmer and Hydrogen Recombiner System

20.6.1.7.17 Catawba FSAR Section 8.3.1.4, AC Power Systems - Independence of Redundant Systems

20.6.1.7.18 Catawba FSAR Section 15.4.8.4, Spectrum of Rod Control Assembly Ejection Accidents

20.6.1.7.19 Catawba FSAR Section 15.6.5.3, LOCA - Radiological Consequences

20.6.2 CATAWBA TECHNICAL SPECIFICATION

20.6.2.1.1 Catawba Technical Specification Section 3/4.6.5.6, Containment Air Return and Hydrogen Skimmer Systems, LCO

20.6.2.1.2 Catawba Technical Specification Section 3/4.6.5.6.1, Containment Air Return and Hydrogen Skimmer Systems, Surveillance Requirements

20.6.2.1.3 Catawba Technical Specification Section 3/4.6.5.6.2, Containment Air Return and Hydrogen Skimmer Systems, Surveillance Requirements

20.6.2.1.4 Catawba Technical Specification Section 3/4.6.4.2, Electric Hydrogen Recombiners, Surveillance Requirements

20.6.2.1.5 Catawba Technical Specification Section 3/4.3.2, Engineered Safety Features Actuation System Instrumentation, Table 3.3-4 (Item 7)

20.6.3 ENGINEERING DOCUMENTS

20.6.3.1 Design Basis Specifications and Manuals

20.6.3.1.1 CNS-1465.00-00-0001, Plant Design Basis Specification for Systems Single Failure

20.6.3.1.2 CNS-1465.00-00-0002, Plant Design Basis Specification for System Class

20.6.3.1.3 CNS-1465.00-00-0004, Plant Design Basis Specification for Loss of Instrument Air

20.6.3.1.4 CNS-1465.00-00-0005, Plant Design Basis Specification for Design Basis Events

- 20.6.3.1.5 CNS-1465.00-00-0006, Plant Design Basis Specification for Fire Protection
- 20.6.3.1.6 CNS-1465.00-00-0011, Plant Design Basis Specification for Flooding From External Sources
- 20.6.3.1.7 CNS-1465.00-00-0007, Plant Design Basis Specification for Seismic Design
- 20.6.3.1.8 CNS-1465.00-00-0008, Plant Design Basis Specification for Tornado/Wind
- 20.6.3.1.9 CNS-1435.00-00-0002, Design Basis Specification for Post Fire Safe Shutdown
- 20.6.3.1.10 CNS-1563.NS-00-0001, Design Basis Specification for the Containment Spray (NS) System
- 20.6.3.1.11 CNS-1559.VY-00-0001, Design Basis Specification for the Containment Hydrogen Sample and Purge System
- 20.6.3.1.12 CNS-112.01-EPE-0001, Design Basis Specification for the EPE System
- 20.6.3.1.13 CNS-106.01-EPY-0001, Design Basis Specification for the EPY System
- 20.6.3.1.14 CNS-1144.00-00-0010, Design Basis Specification for The Reactor Building Structures
- 20.6.3.1.15 CNS-1108.02-00-0001, Catawba Structural Design Specification
- 20.6.3.1.16 CNLT-1780-03.01, Environmental Qualification Master List (EQML)
- 20.6.3.1.17 EQMM-1393.01, Environmental Qualification Maintenance Manual (EQMM)
- 20.6.3.1.18 CNS-1211.00-00-0005, Supplement No. 6, Heating, Ventilating and Air Conditioning; Reactor Building
- 20.6.3.1.19 Environmental Qualification Criteria Manual (EQCM)
- 20.6.3.1.20 CNS-1211.00-00-0006, Vane Axial Fan Motor Systems Related to Nuclear Safety
- 20.6.3.2 Calculations**
 - 20.6.3.2.1 CNC-1211.00-00-0015, Air Return Fans Static and Total Pressure Calculation
 - 20.6.3.2.2 CNC-1211.00-00-0030, Hydrogen Skimmer System Static Pressure and Fan Selection
 - 20.6.3.2.3 CNC-1211.00-00-0057, Hydrogen Skimmer Fan Seismic Verification
 - 20.6.3.2.4 CNC-1211.00-00-0058, Seismic Qualification of the Hydrogen Recombiner
 - 20.6.3.2.5 CNC-1552.08-00-0194, Reanalysis of the Catawba Hydrogen Skimmer System Flow Requirements
- 20.6.3.3 Vendor Documents**
 - 20.6.3.3.1 CNM-1211.00-0446, System VX Controls
 - 20.6.3.3.2 CNM-1211.00-2326, Missile Penetration Calculations - Joy Technologies Fans, Inc.
- 20.6.3.4 Correspondence**

20.6.3.4.1 Letter from Hal B. Tucker to Harold R. Denton of the USNRC dated April 14, 1983

20.6.3.5 Other

20.6.3.5.1 Electrical Design Manual

30. SYSTEM DESIGN FEATURES

This section contains a description of the Containment Air Return & Hydrogen Skimmer System design features. These are aspects of the systems design and construction that are provided to satisfy various codes, standards, or good engineering practices but are not required by the systems design basis requirements.

30.1 SYSTEM GENERIC DESIGN FEATURES

The Containment Air Return Fans are designed for the following general parameters:

PARAMETER	MINIMUM	MAXIMUM
Containment Air Return Fan Flow	40,000 cfm	N/A
Power Supply Voltage ¹	80%	113%
Power Supply Frequency	98%	102%
Control Power Voltage	90%	110%
Control Power Frequency	95%	105%
Radiation	0	1 x 10 ⁹

The Hydrogen Skimmer Fans are designed for the following general parameters:

PARAMETER	MINIMUM	MAXIMUM
Hydrogen Skimmer Fan Flow	4260 cfm	N/A
Power Supply Voltage ¹	80%	113%
Power Supply Frequency	98%	102%
Control Power Voltage	90%	110%
Control Power Frequency	95%	105%
Radiation	0	1 x 10 ⁹

30.2 SYSTEM SPECIFIC DESIGN FEATURES

None

30.3 EQUIPMENT DESIGN FEATURES

¹ Equipment is specified to start at 80% of nameplate voltage. However steady state operation parameters are 90%.

30.3.1 MECHANICAL EQUIPMENT DESIGN FEATURES

30.3.1.1 Containment Air Return System Fans

The Containment Air Return fans are direct drive, vane-axial fans, supplied by Joy Technologies Inc. with a design flow rate of 40,000 cfm developing a total pressure of 6.42 inwg at design air density of 0.11 lbm/cu.ft. The fans are driven by 60 hp electric motors with nominal voltage requirements of 575 VAC/3ph/60hz.

PARAMETER	MINIMUM	MAXIMUM
Influent Temperature	50°F	250°F
Influent Flow	N/A	N/A
Influent Humidity	N/A	100% R.H.
Power Supply Voltage	540 VAC	675 VAC
Power Supply Frequency	58.8 hz	61.2 hz

30.3.1.2 Hydrogen Skimmer System Fans

The Hydrogen Skimmer fans are direct drive, centrifugal blower fans supplied by Joy Manufacturing Company with a design flow rate of 4260 cfm developing a fan static pressure of 55.72 inwg at design air density of 0.11 lbm/cu.ft. The fans are driven by 75 hp electric motors with nominal voltage requirements of 575 VAC/3ph/60 hz.

PARAMETER	MINIMUM	MAXIMUM
Influent Temperature	50°F	250°F
Influent Flow	N/A	N/A
Influent Humidity	0% R.H.	100% R.H.
Power Supply Voltage	540 VAC	675 VAC
Power Supply Frequency	58.8 hz	61.2 hz

30.3.1.3 Electric Hydrogen Recombiners

The recombiners are static devices relying on natural convection to circulate containment atmosphere through these devices. They are supplied by Westinghouse. Flow is limited to 100 scfm by an internal flow limiting orifice.

PARAMETER	MINIMUM	MAXIMUM
Influent Temperature	50°F	250°F
Influent Flow	0	100 scfm
Influent Humidity	0% R.H.	100% R.H.
Power Supply Voltage	540 VAC	575 VAC
Power Supply Frequency	58.8 hz	61.2 hz

30.3.2 DUCTWORK AND DAMPERS

30.3.2.1 Ductwork

Ductwork is constructed in accordance with SMACNA guidelines from 16 gauge 304 stainless steel. Reference Construction Specification CNS-1211.00-00-0005, Supplement No. 6 for details.

30.3.2.2 Dampers (and valves used as dampers)

Isolation Dampers

The Containment Air Return fan isolation dampers (1/2 ARF-D-2,D-4) are single blade dampers with fail as-is electric motor actuators.

The hydrogen skimmer fan isolation dampers (1/2 VX1A,2B) are butterfly valves with fail as-is electric motor actuators.

Check Dampers

The Containment Air Return fan check dampers (1/2 ARF-D-1,3) are two bladed counterbalanced, backdraft type. counterbalanced, backdraft type.

Bypass Test Dampers

The Containment Air Return fan bypass test dampers (1/2 ARF-D-5 through 10) are parallel blade, low leakage design with fail closed pneumatic actuators.

Throttle Valves

Hydrogen Skimmer Fan throttle valves (1/2VX3 through 28) are manually operated butterfly valves positioned for flow balance and locked in position.

31. UNIT 1 SYSTEM AND EQUIPMENT DESCRIPTION

This section contains a description of the Unit 1 VX System and documents how the system functions to meet the requirements set forth in Section 20, "DESIGN BASIS AND CRITERIA" on page 3. Where Train related information is given, Train A information such as tag numbers will be shown with Train B information in parentheses.

31.1 SYSTEM DESCRIPTION AND FUNCTION

31.1.1 FUNCTIONAL DESCRIPTION

The Containment Air Return & Hydrogen Skimmer System (VX) consists of two sub-systems, the Containment Air Return System and Hydrogen Skimmer System. The purpose of the Containment Air Return System is to assure rapid return of air from upper to lower containment after initial HELB blowdown. The Hydrogen Skimmer System assures adequate mixing of containment atmosphere to prevent excessive hydrogen build-up from occurring in isolated pockets and dead-ended spaces in lower containment. This system does not operate to provide any normal ventilation requirements.

31.1.1.1 Containment Air Return System

The Unit 1 Containment Air Return System consist of two 100% capacity independent ventilation trains. Each ventilation train consists of a fan, ductwork, dampers and instrumentation. Following a Unit 1 HELB, each train functions to enhance ice condenser removal of heat and fission products by maintaining forced convection flow through the ice condenser.

The Containment Air Return System function is accomplished by returning air which was displaced from lower containment by the high energy line break through the ice condenser into upper containment back to lower containment. Fan flow is discharged to lower containment through ports in the fan room crane wall. These ports provide for equalization of pressure between the lower containment and dead ended spaces. After discharge into lower containment, air flows together with steam leaving the break through the lower inlet doors into the ice condenser compartment where the steam portion is condensed. The air flow returns to upper containment through the intermediate and upper doors of the ice condenser. The fan runs continuously after actuation, circulating air through the containment volume, provided that containment pressure is above the CPCS (Containment Pressure Control System) termination permissive. The fans are cycled on and off as needed to maintain containment pressure by CPCS.

The Containment Air Return Fans also have sufficient head to overcome the divider barrier differential pressure resulting from steam flow and fan air flow entering the ice condenser through the lower inlet doors.

31.1.1.2 Hydrogen Skimmer System

The Hydrogen Skimmer System consists of two 100% capacity independent ventilation trains. Valves are used instead of dampers and stainless steel piping is used instead of ductwork. Piping is utilized to eliminate a possible rupture of the ductwork that could provide a path bypassing the ice condenser during high energy line breaks. Following a Unit 1 LOCA, each train functions to remove hydrogen concentrations from dead-ended spaces in lower containment. The Hydrogen Skimmer System takes suction in dead-ended lower containment areas and discharges near the Hydrogen Recombiners. The Containment Air Return Fans provide mixing which dilutes the hydrogen concentration below acceptable limits. This dilution is only a

temporary solution to the hydrogen concentration problem. The Hydrogen Recombiners are required for long term hydrogen concentration reduction. To insure proper flows from each dead-ended space, flow control valves (butterfly valves) in the suction header located in these spaces were positioned for flow balance and locked in position. The flow balance insures adequate atmosphere turnover in these spaces to maintain hydrogen concentrations below 4 %. The Containment Air Return Fans provide mixing which dilutes the hydrogen concentration below acceptable limits. Required flowrates from dead ended spaces to maintain hydrogen concentrations below 4% are documented in Reference 20.6.3.2.5, "CNC-1552.08-00-0194, Reanalysis of the Catawba Hydrogen Skimmer System Flow Requirements."

In the event of a LOCA the VX System will start automatically upon initiation by Sp (Containment High-High Pressure) signal provided two permissive signals are received (CPCS and EQB-Diesel Generator Load Sequencing System). The VX System can also be activated manually from the Control Room by turning the RUN-OFF-AUTO key lock selector switch located on MC4 to the RUN position.

31.1.1.3 Electric Hydrogen Recombiners

Following a LOCA, the recombiners are manually started to reduce the hydrogen concentration. The hydrogen recombiners use electric resistance heaters to heat the air entering the recombiner to the hydrogen-oxygen reaction temperatures. There are two recombiners per unit provided with diesel backed power. Each recombiner has a maximum process capacity of 100 scfm. Operation of the recombiners insures containment atmosphere remains below 4% hydrogen. The recombiners are not used with atmospheres above 6% hydrogen concentration. Station Management must be consulted for recommendations on how to reduce hydrogen concentration when above 6% due to the potential for significant pressure rise if a hydrogen burn results.

The control/power panel for the recombiners is located in the Auxiliary Building which remains accessible after a LOCA. The system is interlocked such that operation is possible if an Sp signal is not present and Load Group 11 has been loaded by the sequencer.

31.1.2 SYSTEM OPERATION

31.1.2.1 HELB OPERATION

Upon receipt of the Sp (Containment High-High Pressure) signal from the Solid State Protection System (SSPS), a 10 second time delay is actuated for the Containment Air Return Fan isolation damper. The damper will open if two permissives have been satisfied. The first permissive is received from the CPCS when containment pressure is 0.4 psig or greater. This is to prevent an inadvertent signal from opening the damper. The second permissive comes from a differential pressure switch which requires the pressure differential between upper and lower containment to be less than 0.5 psig, with the lower containment pressure positive with respect to upper containment. This prevents an overload of the isolation damper actuator. The opening of the damper provides a path for pressure relief when a reversal of containment pressure occurs between upper and lower containment.

Upon receipt of the Sp signal from the SSPS, a 9 +/-1 minute time delay is energized allowing the Containment Air Return Fan to start provided two additional permissives are received. One permissive is from the EQB System. The other permissive signal is received from CPCS when pressure inside containment is 0.4 psig. When pressure inside containment falls below 0.25 psig, the pressure permissive signal is de-energized and the Containment Air Return Fan is de-energized. The isolation damper remains open. The fans will automatically restart on a CPCS signal of 0.4 psig.

Upon receipt of the Sp signal from the SSPS, a 9+/-1 minute time delay is energized for each Hydrogen Skimmer Fan isolation valve (used as a damper). The valve(s) will open after the time delay.

Upon receipt of the Sp signal from the SSPS, a 9+/-1 minute time delay is energized for each Hydrogen Skimmer Fan. The fan(s) will start after the time delay provided two additional permissives are received. The first permissive is from EQB Load Group 11. The second permissive is from the isolation valve (valve not closed signal) switch pack.

The electric hydrogen recombiners are started manually from a control panel located in the Auxiliary Building. They are typically started within 24 hours of a LOCA and remain in operation until manually terminated. Air is drawn into the recombiner by natural convection and passes into the preheater section. Preheating is accomplished by convection heating from the heater section. The warmed air is passed through an orifice plate which limits flow to 100 scfm and into the heater section. The air is heated to approximately 1100-1400°F which precipitates the hydrogen-oxygen recombination. Water vapor is the product.

For information on indications and alarms see Sections 31.3.3, "INDICATORS" on page 39 and 31.3.6, "SYSTEM ALARMS" on page 40 respectively.

31.1.2.2 POST-HELB OPERATION

During Post HELB operations, the VX system will continue to run provided the 0.25 psig containment permissive is still present.

31.1.2.3 OPERATING INDICATIONS

31.1.2.4 PERIODIC TESTING

In accordance with Catawba Technical Specifications, the Containment Air Return & Hydrogen Skimmer System is periodically tested to verify system performance and availability. Operation of the system in Modes 1-4 requires that testing activities not affect system performance without appropriate entrance into the Technical Specification LCO or implementation of compensatory measures.

Surveillance tests are conducted to ensure that:

1. Containment Air Return & Hydrogen Skimmer Fans start automatically on a Containment High-High pressure test signal.
2. Proper Containment Air Return Fan operation with the isolation damper closed and bypass dampers open.
3. Proper Hydrogen Skimmer Fan operation with the motor operated inlet valve closed.
4. Motor operated Containment Air Return Fan isolation damper opens on a Containment High-High Pressure test signal with the Air Return Fan off.
5. The Containment Air Return Fan check damper opens with the Air Return Fan operating.
6. The Containment Air Return Fan check damper is closed when the Containment Air Return Fan is off.
7. That the motor operated Hydrogen Skimmer Fan inlet valve opens automatically and the Hydrogen Skimmer Fans receive a start permissive signal.

31.1.2.5 MAINTENANCE ACTIVITIES

****LATER****

31.1.3 SYSTEM LIMITS AND PRECAUTIONS

31.1.3.1 Containment Air Return Fans

Containment Air return fans shall not be operated with the isolation dampers (1ARF-D-2,1ARF-D-4) open.

31.1.3.2 Isolation Damper

Isolation damper (1ARF-D-2,1ARF-D-4) actuator add-on switch pack is periodically verified to be in proper working order after refueling outages.

31.2 UNIT 1 EQUIPMENT DESCRIPTION

Design information for significant equipment, valves (used as dampers), fans and dampers is specified in this section. Safety-related equipment functions are described in Section 20.4, "EQUIPMENT DESIGN BASES" on page 12.

31.2.1 Fans (ARF-1A and 1B)

The Containment Air Return Fans consist of the following:

Type: Vane-Axial Drive: Direct
Manufacturer: Joy Manufacturing Co.

31.2.2 Fans (HSF-1A and 1B)

The Hydrogen Skimmer Fans consist of the following:

Type: Centrifugal Blower Drive: Direct
Manufacturer: Joy Manufacturing Co.

31.2.3 Electric Hydrogen Recombiners

Manufacturer: Westinghouse
Type: Electric
Quantity: 2 per unit

31.2.4 Motor Operated Dampers (and valves used as dampers)

31.2.4.1 Containment Air Return Fan Isolation Dampers (1ARF-D-2,4)

The isolation dampers consist of the following:

Single blade construction w/ Rotork Operator
Fail As-is

31.2.4.2 Hydrogen Skimmer Fan Inlet Valves (1VX1A, 2B)

The suction inlet valves consist of the following:

Fisher Butterfly Valves w/ Limitorque Operator
Fail As-is

31.2.5 Containment Air Return Fan Check Dampers (1ARF-D-1, 3)

The check dampers consist of the following:

Two Blade Counterbalanced

31.2.6 Containment Air Return Fan Bypass Dampers (1ARF-D-5 through 10)

The bypass dampers consist of the following:

Parallel blade, Low leakage w/ Pneumatic Actuator
Spring closed, Fail closed

31.2.7 Hydrogen Skimmer Fan Throttle Valves (1VX3 through 28)

The throttle valves consist of the following:

BIF butterfly valves w/ manual operators
locked in position

31.3 INSTRUMENTATION AND CONTROLS

This section documents system Instrumentation and Controls. The information presented in this section should be used in conjunction with the I&C List, I&C Details, Electrical Elementaries, etc., for a complete understanding of system Instrumentation and Controls operations.

31.3.1 INSTRUMENTATION

31.3.1.1 Containment Air Return Fan Isolation Damper Differential Pressure

Differential pressure switches 1VXPS5100 (Train A) and 1VXPS5110 (Train B) measure the differential pressure across the pressure boundary between upper and lower containments. Contact output from the switches are used to provide interlocks for preventing dampers 1ARF-D-2 (Train A) and 1ARF-D-4 (Train B) from opening against high differential pressure across the dampers, thus preventing possible overloading to the damper actuator. Additionally, a high differential pressure condition may be simulated via test switches located on the VX Test Panel (1RB-ECP-2). The test switches energize solenoid valves 1VXEP3 or 1VXEP4, for 1ARF-D-2 and 1ARF-D-4, respectively, which in turn admits instrument air at system pressure to the high pressure port of the switch. This was intended to be used to ensure the dampers remained closed during testing of the fans; however, it is not currently used. Instead, the damper breaker is opened to prevent inadvertent damper actuation during testing.

31.3.1.2 Hydrogen Skimmer Fan Temperature and Suction Pressure

The stator temperature of each Hydrogen Skimmer Fan is monitored by individual thermocouples which provide analog inputs to the Operator Aid Computer (OAC). The suction pressure of each fan is monitored between the fan inlet isolation valve (1VX1A, 1VX2B) and the fan suction and is available as analog inputs on the OAC for response time testing.

31.3.1.3 Containment Air Return Fan Discharge Pressure

The discharge pressure of each Containment Air Return Fan is measured between the discharge of the fan and the check damper (1ARF-D-1, 1ARF-D-3) and is available as analog inputs on the OAC for response time testing.

31.3.1.4 Hydrogen Recombiner Heater Temperature Monitor Panels

As described in Section 31.3.2.7, "Electric Hydrogen Recombiner System" on page 38, each hydrogen recombinder has three chromel-alumel thermocouples imbedded in heater bank #3. The Hydrogen Recombiner Control Panel was originally supplied with instrumentation for monitoring these thermocouples. However, at the time this equipment was installed, there were no chromel-alumel electrical penetrations available. Consequently, a heated reference junction termination box was added inside containment. The reference junction box converts the chromel and alumel thermocouple leads to copper leads at a controlled reference junction temperature. By controlling the reference junction temperature, the need for active compensation of the thermocouple readings is eliminated. An RTD is also provided for external monitoring of the reference junction temperature. The three thermocouple readings and the reference junction temperature reading are then sent via copper wire to the train-related Hydrogen Recombiner Heater Temperature Monitor Panels located in the Electrical Penetration Rooms. A digital temperature indicator and selector switch is provided on the monitor panel for displaying any one of the three thermocouple readings. The indicator is calibrated for chromel-alumel thermocouple at a fixed reference junction temperature corresponding to the controlled temperature of the reference junction box. Indication of the actual reference junction temperature is also provided for detecting actual deviations from the controlled reference junction temperature which would affect calibration of the thermocouples.

31.3.2 CONTROLS

31.3.2.1 Containment Air Return Fans

Containment Air Return Fans ARF-1A and ARF-1B use automatic control as the primary mode of operation with manual control provided as a backup. Each fan is operated by a three position (RUN-OFF-AUTO) key-lock selector switch located on main control board IMC4. The selector switch is normally placed in automatic with the key removed to lock the switch in position. The operational status of the fans are provided by status lights located directly above the key-lock selector switch on the main control board. Refer to Figure 1 for the following discussion of the air return fan controls and interlock logic.

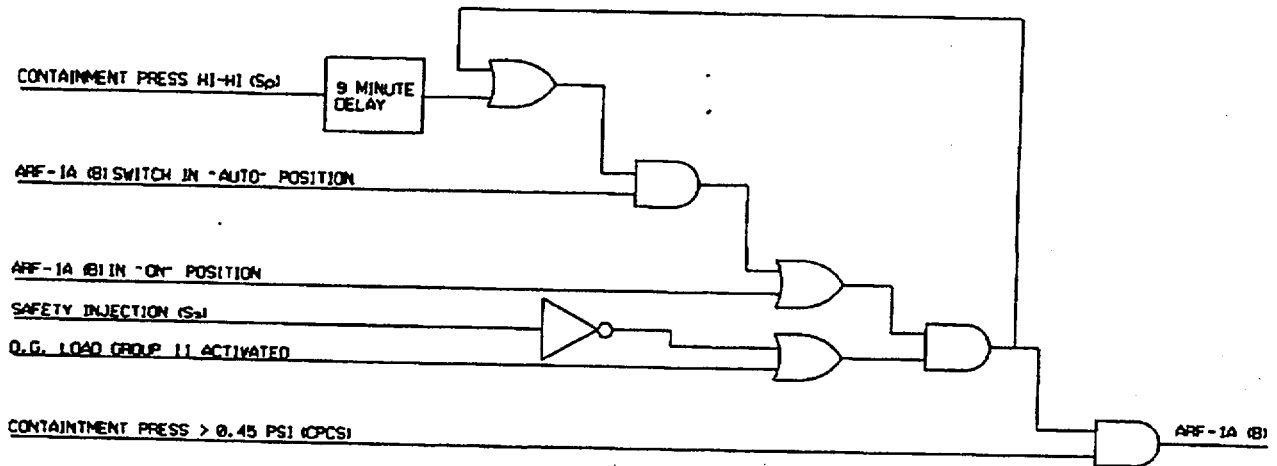

NOTE: TEST SWITCH CONTACTS NOT SHOWN.

Figure 1.

Each fan is interlocked with the CPCS to prevent operation below a containment pressure of 0.25 psig. Inadvertent operation of the air return system could pressurize lower containment with respect to upper containment, resulting in the ice condenser doors opening to equalize pressure. The circulation of air through the ice condenser and subsequent ice melt could result in a pressure reduction which could possibly exceed the lower design limit. Unlike the Containment Spray Pumps, however, each Air Return Fan utilizes two channels of CPCS interlocks. The fans were originally designed to use one channel dedicated to the fans. However, due to difficulties in maintaining separation requirements of Reference 20.6.3.1.10, "CNS-1563.NS-00-0001, Design Basis Specification for the Containment Spray (NS) System," the CPCS interlocks for the air return fans were not placed directly in the fan control circuit but were implemented by using the CPCS permissive to control a second contactor for the fans. This secondary contactor is electrically located between the primary fan contactor and the fan motor and therefore overrides any and all fan controls and interlocks discussed below. When energized, the secondary contactor simply allows the primary contactor and control circuit to function as normal. This configuration provided one CPCS channel to control the fans while a separate channel controlled the dampers. However, the damper logic was later modified to remove the CPCS interlock with the M/C circuit such that the damper will not automatically close upon receiving the appropriate CPCS signal. Since the air return dampers are not automatically closed by the CPCS upon reaching 0.25 psig decreasing, termination of the air return system became totally dependent upon the CPCS permissive for the air return fan. Assuming a single failure which prohibits the CPCS from terminating fan operation at 0.25 psig, the fans could continue to operate with the dampers open. Thus, in order to meet the single failure criteria for the CPCS, a second interlock was added to the

fans. The interlock originates from the same channel as the damper interlock. It is physically located in the primary contactor circuit and is separated from the other CPCS interlock located in the secondary contactor according to the separation criteria defined in Reference 20.6.3.1.10, "CNS-1563.NS-00-0001, Design Basis Specification for the Containment Spray (NS) System." The CPCS interlocks may be bypassed for testing purposes via test switches on the CPCS cabinets. See Reference 20.6.3.1.10, "CNS-1563.NS-00-0001, Design Basis Specification for the Containment Spray (NS) System," for a detailed description of the CPCS including special requirements for the CPCS circuitry and cables.

The containment air return fans are assigned to Diesel Load Sequencer Group 11. As such, each fan is interlocked with the Diesel Generator Load Sequencer such that upon receipt of a safety injection signal (Ss), the fan is load shed and operation is inhibited until Load Group 11 is sequenced on the Diesel Generator. This interlock will take precedence over both manual and automatic operation and cannot be defeated.

Manual and automatic control is selected via the key-lock selector switch. Both are subject to the above interlocks. Manual operation of the fans is continuous once selected. Automatic operation is initiated by an Sp signal and is processed through a 9 +/- 1 minute time delay. If the signal is still active after the time delay, an automatic start signal is generated and sealed-in. Once sealed-in, the automatic start signal can only be reset by positioning the selector switch to the OFF position. The CPCS interlock can defeat both the automatic and manual signal, and thus allows the CPCS to cycle the Containment Air Return Fans as required to maintain containment pressure below 0.45 psig.

PIP 0-C91-0090 identified a problem of potential cycling of the Containment Air Return Fans around the CPCS permissive setpoints. The Containment air Return Fans were declared OPERABLE since they would have already performed their intended safety function by the time containment pressure decreased to the CPCS setpoints. Engineering determined that rapid cycling of the fans around the CPCS setpoints was not a credible concern because the heat sources necessary to cause cycling of the fans are not present in the long term stages of any transient after containment pressure is reduced below 0.3 psig (Reference PIP 0-C97-1027).

Control room annunciator alarms are provided to alert the operator of high fan vibration, Containment Air Return Fan running with the corresponding isolation damper closed, Hydrogen Skimmer Fan running with the corresponding suction valve closed, and control circuit power failure. Digital computer points are provided to indicate the status of the CPCS interlock for the fans.

31.3.2.2 Containment Air Return Fan Isolation Dampers

Containment air return fan dampers 1ARF-D-2 and 1ARF-D-4 use automatic control as the primary mode of operation with manual control provided as a backup. The dampers are operated via momentary pushbutton operators (OPEN-CLOSE) located on main control board 1MC4. The position of each damper is indicated by position indicating lights integral to the pushbutton operator.

The control logic for opening the dampers in both automatic and manual modes is interlocked with the following signals in a logical OR function: 1) an ECCS Sp signal, 2) the train-related Containment Air Return Fan control switch in the ON position, or 3) the train related Hydrogen Skimmer Fan control switch in the ON position. Manual opening of the dampers is dependent only upon satisfying one of the above interlocks. The automatic control logic incorporates a 10 second time delay, after which, the interlock signal is sealed-in. Once sealed-in, two additional interlocks must be satisfied for automatic opening: 1) the permissive from the CPCS must be present (containment pressure greater than .45 psig), and 2) the differential pressure across the damper must be less than 0.5 psig. Refer to Figure 2 for a logic diagram of the damper M/O logic circuit.

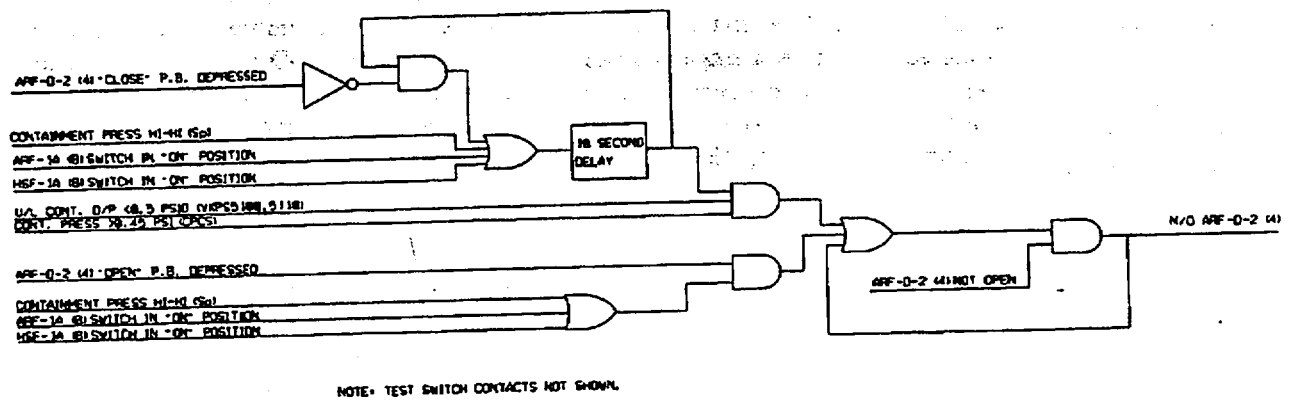

Figure 2.

The control logic for closing the dampers in manual mode is direct, with no intervening interlocks. However, once closed, if the control logic discussed above for automatic opening of the dampers is satisfied, the damper will immediately reopen. There is no automatic control for closing the dampers due to the limitation of the environmental qualification of pressure switches 1VXPS5100 and 1VXPS5110. These switches prevent the damper from opening against a high differential pressure across the damper and thus protect the damper actuator from possible overload. However, they are only qualified to operate 5 minutes under accident conditions, after which the mechanical integrity of the switches may become degraded. This requires the switches to be electrically isolated from the class 1E control circuit once the dampers open and remain isolated indefinitely. This is accomplished by wiring the switches in series with damper limit switches. Since closing the damper would close the limit switches and reconnect the pressure switches to the control circuit, automatic closure of the damper is not provided. Refer to Figure 3 for a logic diagram of the damper M/C logic circuit.

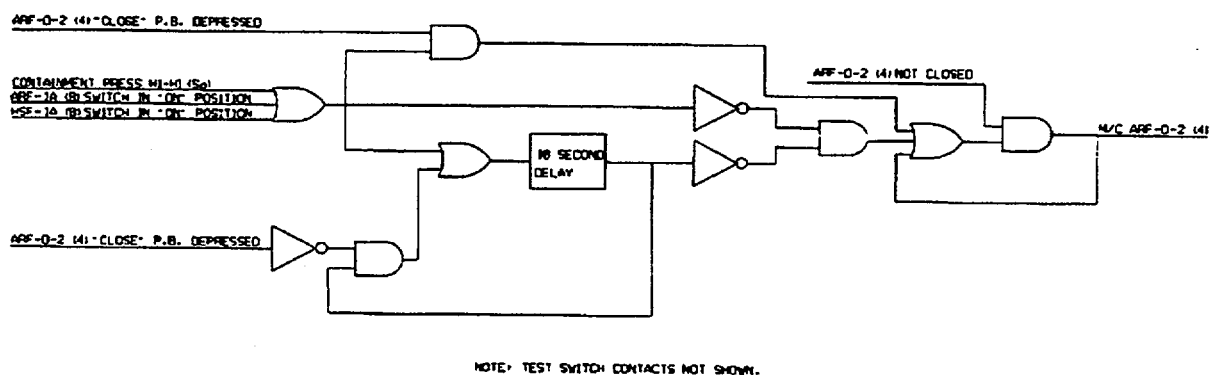

Figure 3.

31.3.2.3 Containment Air Return Fan Bypass Test Dampers

Dampers 1ARF-D-5, 1ARF-D-6, and 1ARF-D-7 are provided to allow testing of Containment Air Return Fan ARF-1A while 1ARF-D-8, 1ARF-D-9, and 1ARF-D-10 allow testing of Containment Air Return Fan ARF-1B. These dampers are controlled by a single solenoid valve, 1VXEP1 and 1VXEP3 for Train A and B, respectively. The solenoid valves are energized during performance testing only. Originally designed to be operated in conjunction with the VX Test Panel (1RB-ECP-2) the solenoid valves and corresponding bypass test dampers are presently operated by placing electrical jumpers in the appropriate termination cabinets.

31.3.2.4 Hydrogen Skimmer Fans

Hydrogen Skimmer Fans HS-1A and HS-1B use automatic control as the primary mode of operation with manual control provided as a backup. Each fan is operated by a three position (RUN-OFF-AUTO) key-lock selector switch located on main control board 1MC4. The selector switch is normally placed in automatic with the key removed to lock the switch in position. The operational status of the fans are provided by status lights located directly above the key-lock selector switch on the main control board. Refer to Figure 4 for the following discussion of the hydrogen skimmer fan controls and interlock logic.

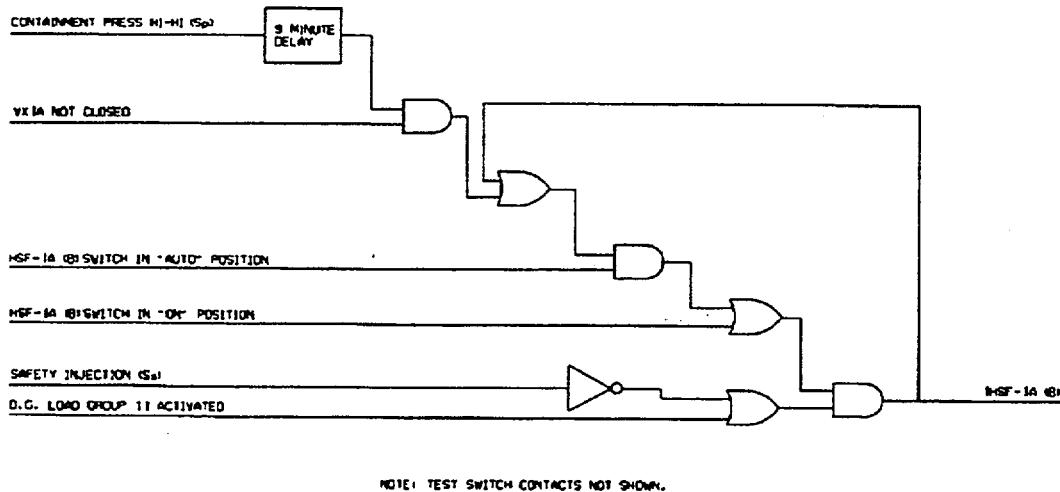

Figure 4.

The hydrogen skimmer fans are assigned to Diesel Load Sequencer Group 11. As such, each fan is interlocked with the Diesel Generator Load Sequencer such that upon receipt of a safety injection signal (Ss), the fan is load shed and operation is inhibited until Load Group 11 is sequenced on the Diesel Generator. This interlock will take precedence over both manual and automatic operation and cannot be defeated.

Manual operation is subject only to the above interlock and is continuous once selected. Automatic operation is initiated by an Sp signal (Hi-Hi Containment Pressure or Manual Spray Actuation) through a 9 +/- 1 minute time delay and is interlocked with the respective inlet isolation valve (1VX1A, 1VX2B) such that the inlet valve must be open before an automatic start signal is generated. If the Sp signal is still present after the time delay expires and the respective inlet valve is open, an automatic start signal is generated and sealed-in. Once generated, the automatic start signal can only be reset by moving the selector switch to the OFF position.

Train related control room annunciator alarms are provided to alert the operator if the Hydrogen Skimmer Fan is being operated with the corresponding inlet valve closed.

31.3.2.5 Hydrogen Skimmer Fan Inlet Valves (1VX1A, 2B)

Hydrogen Skimmer Fan Inlet Valves 1VX1A and 1VX2B use automatic control as the primary method of operation with manual control provided as a backup. The valves are operated via momentary pushbutton operators (OPEN-CLOSE) located on main control board 1MC4. The position of each valve is indicated by position indicating lights integral to the pushbutton operator.

The control logic for opening the inlet valves in both automatic and manual modes is interlocked with the following signals in a logical OR function: 1) an ECCS Sp signal, 2) the train-related Containment Air Return Fan control switch in the ON position, or 3) the train-related Hydrogen Skimmer Fan control switch in the ON position. Manual opening of the inlet valves is dependent only upon satisfying one of the above interlocks. The automatic control logic incorporates a 9 +/- 1 minute time delay, after which, the interlock signal is sealed-in and the valves open. Refer to Figure 5 for a logic diagram of the valve M/O logic circuit.

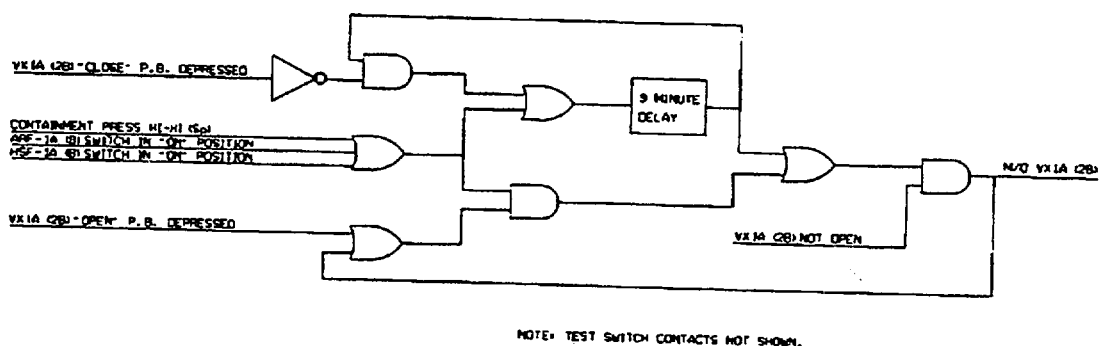

Figure 5.

The control logic for closing the inlet valves in manual mode is direct, with no intervening interlocks. However, once closed, if the control logic discussed above for automatic opening of the inlet valves is satisfied, the valve will immediately reopen. There is no automatic control for closing the valves. Refer to Figure 6 for a logic diagram of the valve M/C logic circuit.

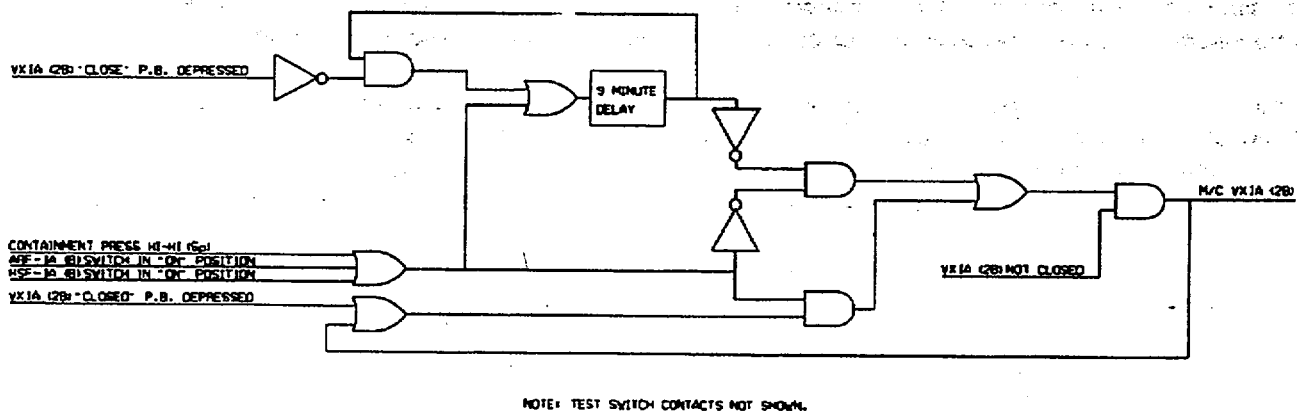

Figure 6.

31.3.2.6 VX and VP Test Panel (1RB-ECP-2)

Test Panel 1RB-ECP-2 provides a means to test the Containment Air Return Fans, isolation dampers, hydrogen skimmer fans, and inlet isolation valves and verify the time-delay logic associated with each. The test panel is not currently used; however, individual parts of the circuitry associated with the panel are used in conjunction with external electrical jumpers for testing. A detailed description of the test panel operating procedures can be found in Reference 20.6.1.6.4, "Design Study CNDS-107, VX Controls/Test Circuitry Review," Attachment 3. For actual testing, refer to the appropriate performance test procedures.

31.3.2.7 Electric Hydrogen Recombiner System

The Electric Hydrogen Recombiner System (EHRS) is a natural convection flameless, thermal reactor-type hydrogen/oxygen recombinder. In its basic operation, it heats a continuous stream of air/hydrogen mixture to a temperature sufficient for spontaneous recombination of the hydrogen with the oxygen in the air to form water vapor. The system consists of two independent recombination units, each of which contains the electric heater banks, a power supply panel that contains the equipment for powering the heaters, and a power control panel to the heaters.

The recombination units are located inside containment in the vicinity of the discharge of the Hydrogen Skimmer Fans. It consists of an inlet preheater section, a heater-recombination section, and a mixing chamber. The heater-recombination section contains four banks of heaters. Each bank contains 60 individual, U-type heating elements connected in series-parallel arrangements as required to obtain the power rating for each bank. Heater bank #3 in each recombination unit has three chromel-alumel thermocouples mechanically fastened and welded to the heater sheaths. These thermocouples are provided to verify heater operation and to indicate plate temperature for performance testing.

The power supply panel is located in the Auxiliary Building and contains all the necessary electrical equipment to provide the power required by the heaters in the recombination unit. It is a self-supporting, floor-mounted cabinet.

The control panel is located in the Auxiliary Building next to the power supply panel and contains all the control and monitoring equipment required for operating the recombination unit. It contains a master ON-OFF switch, a control potentiometer for adjusting the amount of power supplied to the recombination

units, and a wattmeter for indication of the power supplied. The system as purchased also provided a display for monitoring any one of the three thermocouples imbedded in heater bank #3 and a selector switch for selecting between the three. However, due to lack of chromel-alumel electrical penetrations at the time of equipment installation, a different method of monitoring the thermocouples has been provided via the Hydrogen Recombiner Heater Temperature Monitor Panel described in Section 31.3.1.4, "Hydrogen Recombiner Heater Temperature Monitor Panels" on page 32. The display and controls on the Hydrogen Recombiner Control Panel have been abandoned in place.

The master control switch on the control panel is interlocked such that the system can be operated only if an Ss signal is not present or after Diesel Load Sequencer Load Group 11 has been cycled onto the bus. This interlock essentially prevents operation of the Hydrogen Recombiner between the initial receipt of a Ss and when Load Group 11 is activated. This is also the same interlock as is used on the Containment Air Return Fans described in Section 31.3.2.1, "Containment Air Return Fans" on page 33, and the Hydrogen Skimmer Fans described in Section 31.3.2.4, "Hydrogen Skimmer Fans" on page 36.

31.3.3 INDICATORS

None.

31.3.4 RECORDERS

None.

31.3.5 STATUS INDICATION

31.3.5.1 Status Lights

The following status lights provide information concerning the VX System but are actually part of the Containment Spray (NS) System. For additional information, refer to reference 20.6.3.1.10, "CNS-1563.NS-00-0001, Design Basis Specification for the Containment Spray (NS) System."

VX SYS CPCS TRAIN A INHIBIT
VX SYS CPCS TRAIN B INHIBIT

31.3.5.2 Monitor Lights

Group I
AIR RETURN FAN ARF-A RUNNING
AIR RETURN FAN ARF-B RUNNING
HYDROGEN SKIMMER FAN HSF-A RUNNING
HYDROGEN SKIMMER FAN HSF-B RUNNING
ARF ISOL DAMPER ARF-D-2 OPEN
ARF ISOL DAMPER ARF-D-4 OPEN
HSF INLET ISOLATION VLV VX1 OPEN
HSF INLET ISOLATION VLV VX2 OPEN

31.3.5.3 1.47 Panel Bypass Lights

See Section 20.5.1.4, "Bypass and Inoperable Status Indication" on page 15 for a list of 1.47 Bypass Lights.

31.3.6 SYSTEM ALARMS

31.3.6.1 Annunciators

VX TRAIN A TROUBLE

VX TRAIN B TROUBLE

31.3.6.2 Computer Inputs

31.3.6.2.1 Analog Inputs

HSF A MTR STATOR TEMP

HSF B MTR STATOR TEMP

31.3.6.2.2 Digital Inputs

HYDROGEN SKIMMER FAN A SUCT PRESS	LO, NOT LO
HYDROGEN SKIMMER FAN B SUCT PRESS	LO, NOT LO
CONTAINMENT AIR RETURN FAN A DISCH PRESS	LO, NOT LO
CONTAINMENT AIR RETURN FAN B DISCH PRESS	LO, NOT LO
VLV VX1A HYDROGEN SKIMMER FAN A ISOL	OPEN, NOT OPEN
VLV VX1A HYDROGEN SKIMMER FAN A ISOL	CLOSED, NOT CLOSED
VLV VX2B HYDROGEN SKIMMER FAN B ISOL	OPEN, NOT OPEN
VLV VX2B HYDROGEN SKIMMER FAN B ISOL	CLOSED, NOT CLOSED
DAMPER ARF-D-2 CONT AIR RETURN FAN A ISOL	OPEN, NOT OPEN
DAMPER ARF-D-2 CONT AIR RETURN FAN A ISOL	CLOSED, NOT CLOSED
DAMPER ARF-D-4 CONT AIR RETURN FAN B ISOL	OPEN, NOT OPEN
DAMPER ARF-D-4 CONT AIR RETURN FAN B ISOL	CLOSED, NOT CLOSED
CPCS BLOCK OF VX CONT AIR RET FAN A OPR	ENGAGED, NOT ENGAGED
CPCS BLOCK OF VX CONT AIR RET FAN B OPR	ENGAGED, NOT ENGAGED

31.4 POWER SOURCES

The following equipment is supplied with essential 600 VAC, 3 phase, 60 Hz. power. For the design basis and a detailed description of the system providing this power, see Reference 20.6.3.1.12, "CNS-112.01-EPE-0001, Design Basis Specification for the EPE System."

Equipment	MCC (600 VAC)	Compt./Bkr.
Containment Air Return Fan ARF-1A	1EMXX	F11A
Power Lockout Contactor ARF-1A	1EMXM	F01A
Containment Air Return Fan ARF-1B	1EMXL	F11A
Power Lockout Contactor ARF-1B	1EMX	F01A
Hydrogen Skimmer Fan 1HSF-1A	1EMXX	F11B
Hydrogen Skimmer Fan 1HSF-1B	1EMXL	F11B
Containment Air Return Fan Damper 1ARF-D-2	1EMXX	F10A
Containment Air Return Fan Damper 1ARF-D-4	1EMXL	F10A
Hydrogen Skimmer Fan Inlet Isol. Valve 1VX001A	1EMXX	F06A
Hydrogen Skimmer Fan Inlet Isol. Valve 1VX002B	1EMXL	F06A
Hydrogen Recombiner Panel 1A	1EMXX	F07C
Hydrogen Recombiner Panel 1B	1EMXL	F07C

Low voltage instrumentation and control circuits are powered from various systems. Design basis information and system description information for the safety-related systems and system description information for the non-safety systems can be found in the following references.

1. Reference 20.6.3.1.13, "CNS-106.01-EPY-0001, Design Basis Specification for the EPY System"
2. Reference 20.6.1.6.2, "CNSD-0010-10, Electrical System Description for the 240/120 VAC Auxiliary Control Power System"
3. Reference 20.6.1.6.3, "CNSD-0010-12, Electrical System Description for the 208/120 VAC Normal Auxiliary Power System"

31.5 DESIGN DOCUMENT CROSS REFERENCE

31.5.1 DUKE DRAWINGS

Flow Diagram:	CN-1557-1.0
Summary Flow Diagram:	CNSF-1557-VX.01
Instrument Details:	CN-1499-VX Series
Electrical Elementaries:	CNEE-0165-01 Series
Connection and Outline Diagrams:	CN-1735-01 Series
Piping Isometrics:	CN-1491-VX Series
Test Acceptance Criteria:	CNTC-1557-VX Series

31.5.2 VENDOR DRAWINGS

For information on VX System Equipment, use DPCo. Equipment and Valve Data Base Files.

32. UNIT 2 SYSTEM AND EQUIPMENT DESCRIPTION

This section contains a description of the Unit 2 VX System and documents how the system functions to meet the requirements set forth in Section 20, "DESIGN BASIS AND CRITERIA" on page 3. Where Train related information is given, Train A information such as tag numbers will be shown with Train B information in parentheses.

32.1 SYSTEM DESCRIPTION AND FUNCTION

32.1.1 FUNCTIONAL DESCRIPTION

The Containment Air Return & Hydrogen Skimmer System (VX) consists of two sub-systems, the Containment Air Return System and Hydrogen Skimmer System. The purpose of the Containment Air Return System is to assure rapid return of air from upper to lower containment after initial HELB blowdown. The Hydrogen Skimmer System assures adequate mixing of containment atmosphere to prevent excessive hydrogen build-up from occurring in isolated pockets and dead-ended spaces in lower containment. This system does not operate to provide any normal ventilation requirements.

32.1.1.1 Containment Air Return System

The Unit 2 Containment Air Return System consist of two 100% capacity independent ventilation trains. Each ventilation train consists of a fan, ductwork, dampers and instrumentation. Following a Unit 2 HELB, each train functions to enhance ice condenser removal of heat and fission products by maintaining forced convection flow through the ice condenser.

The Containment Air Return System function is accomplished by returning air which was displaced from lower containment by the high energy line break through the ice condenser into upper containment back to lower containment. Fan flow is discharged to lower containment through ports in the fan room crane wall. These ports provide for equalization of pressure between the lower containment and dead ended spaces. After discharge into lower containment, air flows together with steam leaving the break through the lower inlet doors into the ice condenser compartment where the steam portion is condensed. The air flow returns to upper containment through the intermediate and upper doors of the ice condenser. The fan runs continuously after actuation, circulating air through the containment volume, provided that containment pressure is above the CPCS (Containment Pressure Control System) termination permissive. The fans are cycled on and off as needed to maintain containment pressure by CPCS.

The Containment Air Return Fans also have sufficient head to overcome the divider barrier differential pressure resulting from steam flow and fan air flow entering the ice condenser through the lower inlet doors.

32.1.1.2 Hydrogen Skimmer System

The Hydrogen Skimmer System consists of two 100% capacity independent ventilation trains. Valves are used instead of dampers and stainless steel piping is used instead of ductwork. Piping is utilized to eliminate a possible rupture of the ductwork that could provide a path bypassing the ice condenser during high energy line breaks. Following a Unit 2 LOCA, each train functions to remove hydrogen concentrations from dead-ended spaces in lower containment. The Hydrogen Skimmer System takes suction in dead-ended lower containment areas and discharges near the inlet of the Containment Air Return Fans. The Containment Air Return Fans provide mixing which dilutes the hydrogen concentration below acceptable limits. This dilution

is only a temporary solution to the hydrogen concentration problem. The Hydrogen Recombiners are required for long term hydrogen concentration reduction. To insure proper flows dead-ended space, flow control valves (butterfly valves) in the suction header located in these spaces were positioned for flow balance and locked in position. The flow balance insures adequate atmosphere turnover in these spaces to maintain hydrogen concentrations below 4 %. The Containment Air Return Fans provide mixing which dilutes the hydrogen concentration below acceptable limits. Required flowrates from dead ended spaces to maintain hydrogen concentrations below 4% are documented in Reference 20.6.3.2.5, "CNC-1552.08-00-0194, Reanalysis of the Catawba Hydrogen Skimmer System Flow Requirements."

In the event of a HELB the VX System will start automatically upon initiation by Sp (Containment High-High Pressure) signal provided two permissive signals are received (CPCS and EQB-Diesel Generator Load Sequencing System). The VX System can also be activated manually from the Control Room by turning the RUN-OFF-AUTO key lock selector switch located on MC4 to the RUN position.

32.1.1.3 Electric Hydrogen Recombiners

Following a LOCA, the recombiners are manually started to reduce the hydrogen concentration. The hydrogen recombiners use electric resistance heaters to heat the air entering the recombiner to the hydrogen-oxygen reaction temperatures. There are two recombiners per unit provided with diesel backed power. Each recombiner has a maximum process capacity of 100 scfm. Operation of the recombiners insures containment atmosphere remains below 4% hydrogen. The recombiners are not used with atmospheres above 6% hydrogen concentration. Station Management must be consulted for recommendations on how to reduce hydrogen concentration when above 6% due to the potential for significant pressure rise if a hydrogen burn results.

The control/power panel for the recombiners is located in the Auxiliary Building which remains accessible after a LOCA. The system is interlocked such that operation is possible if an Sp signal is not present and Load Group 11 has been loaded by the sequencer.

32.1.2 SYSTEM OPERATION

32.1.2.1 HELB OPERATION

Upon receipt of the Sp signal from the Solid State Protection System (SSPS), a 10 second time delay is actuated for the Containment Air Return Fan isolation damper. The damper will open if two permissives have been satisfied. The first permissive is received from the CPCS when containment pressure is 0.4 psig or greater. This is to prevent an inadvertent signal from opening the damper. The second permissive comes from a differential pressure switch which requires the pressure differential between upper and lower containment to be less than 0.5 psig with the lower containment positive with respect to upper containment. This prevents an overload of the isolation damper actuator. The opening of the damper provides a path for pressure relief when a reversal of containment pressure occurs.

Upon receipt of the Sp signal from the SSPS, a 9 +/-1 minute time delay is energized allowing the Containment Air Return Fan to start provided two additional permissives are received. One permissive is from the EQB System. The other permissive signal is received from CPCS when pressure inside containment is 0.4 psig. When pressure inside containment falls below 0.25 psig, the pressure permissive signal is de-energized and the Containment Air Return Fan is de-energized. The isolation damper remains open. The fans will automatically restart on a CPCS signal of 0.4 psig.

Upon receipt of the Sp signal from the SSPS, a 9 +/-1 minute time delay is energized for each Hydrogen Skimmer Fan isolation valve (used as damper). The valve(s) will open after the time delay.

Upon receipt of the Sp signal from the SSPS, a 9 +/- 1 minute time delay is energized for each Hydrogen Skimmer Fan. The fan(s) will start after the time delay provided two additional permissives are received. The first permissive is from EQB Load Group 11. The second permissive is from the isolation valve (valve not closed signal) switch pack.

The electric hydrogen recombiners are started manually from a control panel located in the Auxiliary building. They are typically started within 24 hours of a LOCA and remain in operation until manually terminated. Air is drawn into the recombiner by natural convection and passes into the preheater section. Preheating is accomplished by convection heating from the heater section. The warmed air is passed through an orifice plate which limits flow to 100 scfm and into the heater section. The air is heated to approximately 1100-1400°F which precipitates the hydrogen-oxygen recombination. Water vapor is the product.

For information on indications and alarms see Sections 32.3.3, "INDICATORS" on page 55 and 32.3.6, "SYSTEM ALARMS" on page 56 respectively.

32.1.2.2 POST-HELB OPERATION

During Post HELB operations, the VX system will continue to run provided the 0.25 psig containment permissive is still present.

32.1.2.3 OPERATING INDICATIONS

32.1.2.4 PERIODIC TESTING

In accordance with Catawba Technical Specifications, the Containment Air Return & Hydrogen Skimmer System is periodically tested to verify system performance and availability. Operation of the system in Modes 1-4 requires that testing activities not affect system performance without appropriate entrance into the Technical Specification LCO or implementation of compensatory measures.

Surveillance tests are conducted to ensure that:

1. Containment Air Return & Hydrogen Skimmer Fans start automatically on a Containment High-High pressure test signal.
2. Proper Containment Air Return Fan operation with the isolation damper closed and bypass dampers open.
3. Proper Hydrogen Skimmer Fan operation with the motor operated inlet valve closed.
4. Motor operated Containment Air Return Fan isolation damper opens on a Containment High-High Pressure test signal with the Containment Air Return Fan off.
5. The Containment Air Return Fan check damper opens with the Containment Air Return Fan operating.
6. The Containment Air Return Fan check damper is closed when the Containment Air Return Fan is off.
7. That the motor operated Hydrogen Skimmer Fan inlet valve opens automatically and the Hydrogen Skimmer Fans receive a start permissive signal.

32.1.2.5 MAINTENANCE ACTIVITIES

****LATER****

32.1.3 SYSTEM LIMITS AND PRECAUTIONS

32.1.3.1 Containment Air Return Fans

Containment Air return fans shall not be operated with the isolation dampers (2ARF-D-2,2ARF-D-4) open.

32.1.3.2 Isolation Damper

Isolation damper (2ARF-D-2,2ARF-D-4) actuator add-on switch pack is periodically verified to be in proper working order after refueling outages.

32.2 UNIT 2 EQUIPMENT DESCRIPTION

Design information for significant equipment, valves (used as dampers), fans and dampers is specified in this section. Safety-related equipment functions are described in Section 20.4, "EQUIPMENT DESIGN BASES" on page 12.

32.2.1 Fans (2ARF-1A and 1B)

The Containment Air Return Fans consist of the following:

Type: Vane-Axial Drive: Direct
Manufacturer: Joy Manufacturing Co.

32.2.2 Fans (2HSF-1A and 1B)

The Hydrogen Skimmer Fans consist of the following:

Type: Centrifugal Blower Drive: Direct
Manufacturer: Joy Manufacturing Co.

32.2.3 Electric Hydrogen Recombiners

Manufacturer: Westinghouse
Type: Electric
Quantity: 2 per unit

32.2.4 Motor Operated Dampers (and valves used as dampers)

32.2.4.1 Containment Air Return Fan Isolation Dampers (2ARF-D-2,4)

The isolation dampers consist of the following:

Single blade construction w/ Limitorque Operator
Fail As-is

32.2.4.2 Hydrogen Skimmer Fan Inlet Valves (2VX1A, 2B)

The suction inlet valves consist of the following:

Fisher Butterfly Valves w/ Rotork Operator
Fail As-is

32.2.5 Containment Air Return Fan Check Dampers (2ARF-D-1, 3)

The check dampers consist of the following:

Two Blade Counterbalanced

32.2.6 Containment Air Return Fan Bypass Dampers (2ARF-D-5 through 10)

The bypass dampers consist of the following:

Parallel blade, Low leakage w/ Pneumatic Actuator
Spring closed, Fail closed

32.2.7 Hydrogen Skimmer Fan Throttle Valves (2VX3 through 28)

The throttle valves consist of the following:

BIF butterfly valves w/ manual operators
locked in position

32.3 INSTRUMENTATION AND CONTROLS

This section documents system Instrumentation and Controls. The information presented in this section should be used in conjunction with the I&C List, I&C Details, Electrical Elementaries, etc., for a complete understanding of system Instrumentation and Controls operations.

32.3.1 INSTRUMENTATION

32.3.1.1 Containment Air Return Fan Isolation Damper Differential Pressure

Differential pressure switches 2VXPS5100 (Train A) and 2VXPS5110 (Train B) measure the differential pressure across the pressure boundary between upper and lower containment. Contact outputs from the switches are used to provide interlocks for preventing dampers 2ARF-D-2 (Train A) and 2ARF-D-4 (Train B) from opening against high differential pressure across the dampers, thus preventing possible overloading to the damper actuator. Additionally, a high differential pressure condition may be simulated via test switches located on the VX Test Panel (2RB-ECP-2). The test switches energize solenoid valves 2VXEP3 or 2VXEP4, for 2ARF-D-2 and 2ARF-D-4, respectively, which in turn admits instrument air at system pressure to the high pressure port of the switch. This was intended to be used to ensure the dampers remained closed during testing of the fans; however, it is not currently used. Instead, the damper breaker is opened to prevent inadvertent damper actuation during testing.

32.3.1.2 Hydrogen Skimmer Fan Temperature and Suction Pressure

The stator temperature of each Hydrogen Skimmer Fan is monitored by individual thermocouples which provide analog inputs to the Operator Aid Computer (OAC). The suction pressure of each fan is monitored between the fan inlet isolation valve (2VX1A, 2VX2B) and the fan inlet and is available as an analog input on the OAC for response time testing.

32.3.1.3 Containment Air Return Fan Discharge Pressure

The discharge pressure of each Containment Air Return Fan is measured between the discharge of the fan and the check damper (2ARF-D-1, 2ARF-D-3) and is available as analog inputs on the OAC for response time testing.

32.3.1.4 Hydrogen Recombiner Heater Temperature Monitor Panels

As described in Section 32.3.2.7, "Electric Hydrogen Recombiner System" on page 54, each hydrogen recombinder has three chromel-alumel thermocouples imbedded in heater bank #3. The Hydrogen Recombiner Control Panel was originally supplied with instrumentation for monitoring these thermocouples. However, at the time this equipment was installed, there were no chromel-alumel electrical penetrations available. Consequently, a heated reference junction termination box was added inside containment. The reference junction box converts the chromel and alumel thermocouple leads to copper leads at a controlled reference junction temperature. By controlling the reference junction temperature, the need for active compensation of the thermocouple readings is eliminated. An RTD is also provided for external monitoring of the reference junction temperature. The three thermocouple readings and the reference junction temperature reading are then sent via copper wire to the train-related Hydrogen Recombiner Heater Temperature Monitor Panels located in the Electrical Penetration Rooms. A digital temperature indicator and selector switch is provided on the monitor panel for displaying any one of the three thermocouple readings. The indicator is calibrated for chromel-alumel thermocouple at a fixed reference junction temperature corresponding to the controlled temperature of the reference junction box. Indication of the actual reference junction temperature is also provided for detecting actual deviations from the controlled reference junction temperature which would affect calibration of the thermocouples.

32.3.2 CONTROLS

32.3.2.1 Containment Air Return Fans

Containment Air Return Fans ARF-2A and ARF-2B use automatic control as the primary mode of operation with manual control provided as a backup. Each fan is operated by a three position (RUN-OFF-AUTO) key-lock selector switch located on main control board 2MC4. The selector switch is normally placed in automatic with the key removed to lock the switch in position. The operational status of the fans are provided by status lights located directly above the key-lock selector switch on the main control board. Refer to Figure 7 for the following discussion of the Containment Air Return Fan controls and interlock logic.

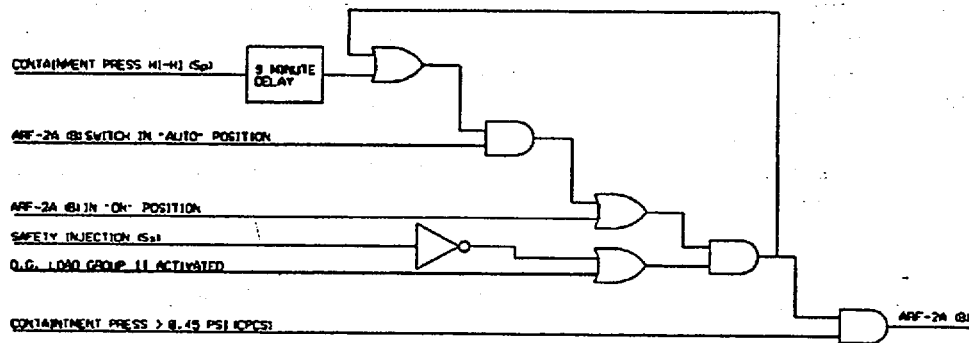

NOTE: TEST SWITCH CONTACTS NOT SHOWN.

Figure 7.

Each fan is interlocked with the Containment Pressure Control System (CPCS) to prevent operation below a containment pressure of 0.25 psig. Inadvertent operation of the air return system could pressurize lower containment with respect to upper containment, resulting in the ice condenser doors opening to equalize pressure. The circulation of air through the ice condenser and subsequent ice melt could result in a pressure reduction which could possibly exceed the lower design limit. Unlike the Containment Spray Pumps, however, each Air Return Fan utilizes two channels of CPCS interlocks. The fans were originally designed to use one channel dedicated to the fans. However, due to difficulties in maintaining the separation requirements of 20.6.3.1.10, "CNS-1563.NS-00-0001, Design Basis Specification for the Containment Spray (NS) System," the CPCS interlocks for the air return fans were not placed directly in the fan control circuit but were implemented by using the CPCS permissive to control a second contactor for the fans. This secondary contactor is electrically located between the primary fan contactor and the fan motor and therefore overrides any and all fan controls and interlocks discussed below. When energized, the secondary contactor simply allows the primary contactor and control circuit to function as normal. This configuration provided one CPCS channel to control the fans while a separate channel controlled the dampers. However, the damper logic was later modified to remove the CPCS interlock with the M/C circuit such that the damper will not automatically close upon receiving the appropriate CPCS signal. Since the air return dampers are not automatically closed by the CPCS upon reaching 0.25 psig decreasing, termination of the air return system became totally dependent upon the single CPCS permissive for the air return fan. Assuming a single failure which prohibits the CPCS permissive from terminating fan operating at 0.25 psig, the fans could continue to operate with the dampers open. Thus, in order to meet the single failure criteria for the CPCS, a second interlock was added to the fans. This interlock originates from the same channel as the damper interlock. It is physically located in the primary contactor circuit and is separated from the other CPCS interlock located in the secondary contactor according to the separation criteria defined in Reference 20.6.3.1.10, "CNS-1563.NS-00-0001, Design Basis Specification for the Containment Spray (NS) System." The CPCS interlocks may be bypassed for testing purposes via test switches on the CPCS cabinets. See Reference 20.6.3.1.10, "CNS-1563.NS-00-0001, Design Basis Specification for the Containment Spray (NS) System" for a detailed description of the CPCS including special separation requirements for the CPCS circuitry and cables.

The Containment Air Return Fans are assigned to Diesel Load Sequencer Group 11. As such, each fan is interlocked with the Diesel Generator Load Sequencer such that upon receipt of a safety injection signal (Ss),

the fan is load shed and operation is inhibited until Load Group 11 is sequenced on the Diesel Generator. This interlock will take precedence over both manual and automatic operation and cannot be defeated.

Manual and automatic control is selected via the key-lock selector switch. Both are subject to the above interlocks. Manual operation of the fans is continuous once selected. Automatic operation is initiated by an Sp signal and is processed through a 9 +/- 1 minute time delay. If the signal is still active after the time delay, an automatic start signal is generated and sealed-in. Once sealed-in, the automatic start signal can only be reset by positioning the selector switch to the OFF position. The CPCS interlock can defeat both the automatic and manual signal, and thus allows the CPCS to cycle the Containment Air Return Fans as required to maintain containment pressure below 0.45 psig.

PIP 0-C91-0090 identified a problem of potential cycling of the Containment Air Return Fans around the CPCS permissive setpoints. The Containment Air Return fans were declared OPERABLE since they would have already performed their intended safety function by the time containment pressure decreased to the CPCS setpoints. Engineering determined that rapid cycling of the fans around the CPCS setpoints was not a credible concern because the heat sources necessary to cause cycling of the fans are not present in the long term stages of any transient after containment pressure is reduced below 0.3 psig (Reference PIP 0-C97-1027).

Control room annunciator alarms are provided to alert the operator of high fan vibration, Containment Air Return Fan running with the corresponding isolation damper closed, Hydrogen Skimmer Fan running with the corresponding suction valve closed, and control circuit power failure. Digital computer points are provided to indicate the status of the CPCS interlock for the fans.

32.3.2.2 Containment Air Return Fan Isolation Dampers

Containment Air Return Fan dampers 2ARF-D-2 and 2ARF-D-4 use automatic control as the primary mode of operation with manual control provided as a backup. The dampers are operated via momentary pushbutton operators (OPEN-CLOSE) located on main control board 2MC4. The position of each damper is indicated by position indicating lights integral to the pushbutton operator.

The control logic for opening the dampers in both automatic and manual modes is interlocked with the following signals in a logical OR function: 1) an ECCS Sp signal, 2) the train-related Containment Air Return Fan control switch in the ON position, or 3) the train related Hydrogen Skimmer Fan control switch in the ON position. Manual opening of the dampers is dependent only upon satisfying one of the above interlocks. The automatic control logic incorporates a 10 second time delay, after which, the interlock signal is sealed-in. Once sealed-in, two additional interlocks must be satisfied for automatic opening: 1) the permissive from the CPCS must be present (containment pressure greater than .45 psig), and 2) the differential pressure across the damper must be less than 0.5 psig. Refer to Figure 8 for a logic diagram of the damper M/O logic circuit.

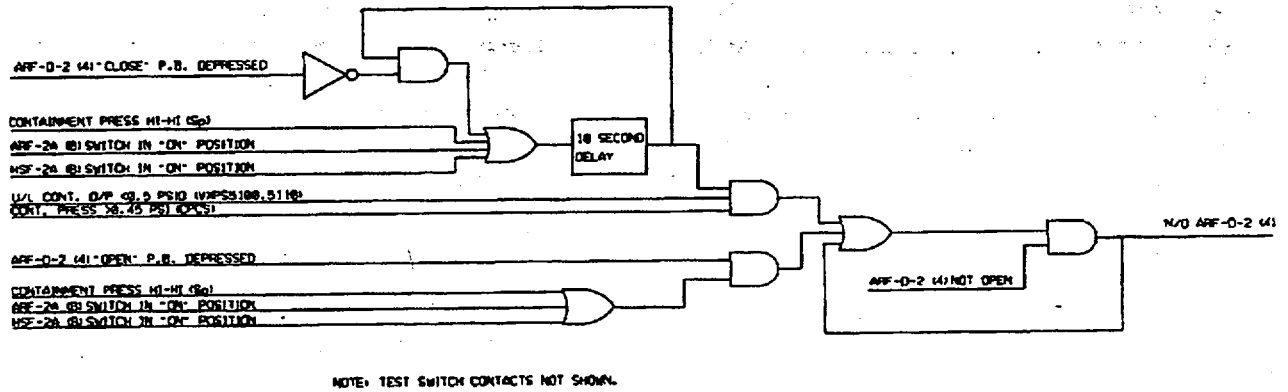

Figure 8.

The control logic for closing the dampers in manual mode is direct, with no intervening interlocks. However, once closed, if the control logic discussed above for automatic opening of the dampers is satisfied, the damper will immediately reopen. There is no automatic control for closing the dampers due to the limitation of the environmental qualification of pressure switches 2VXPS5100 and 2VXPS5110. These switches prevent the damper from opening against a high differential pressure across the damper and thus protect the damper actuator from possible overload. However, they are only qualified to operate 5 minutes under accident conditions, after which the mechanical integrity of the switches may become degraded. This requires the switches to be electrically isolated from the class 1E control circuit once the dampers open and remain isolated indefinitely. This is accomplished by wiring the switches in series with damper limit switches. Since closing the damper would close the limit switches and reconnect the pressure switches to the control circuit, automatic closure of the damper is not provided. Refer to Figure 9 for a logic diagram of the damper M/C logic circuit.

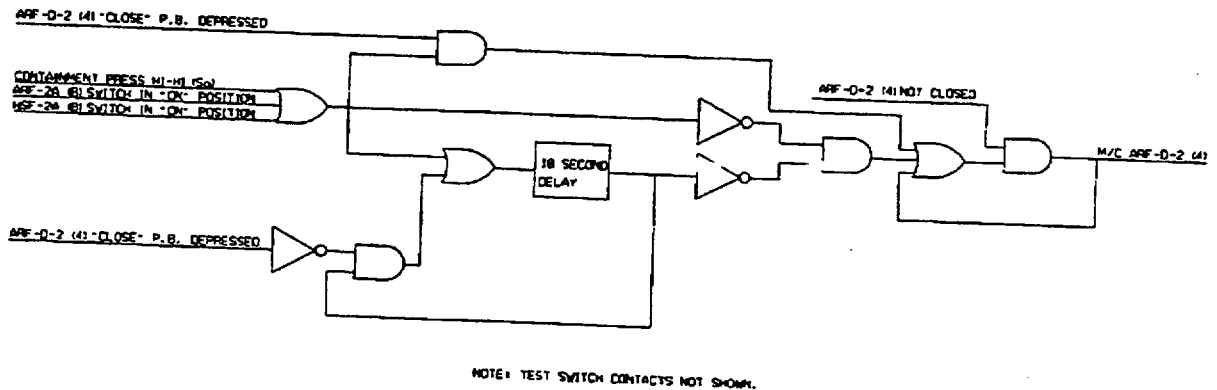

Figure 9.

32.3.2.3 Containment Air Return Fan Bypass Test Dampers

Dampers 2ARF-D-5, 2ARF-D-6, and 2ARF-D-7 are provided to allow testing of Containment Air Return Fan ARF-2A while 2ARF-D-8, 2ARF-D-9, and 2ARF-D-10 allow testing of Containment Air Return Fan ARF-2B. These dampers are controlled by a single solenoid valve, 2VXEP1 and 2VXEP3 for Train A and B, respectively. The solenoid valves are energized during performance testing only. Originally designed to be operated in conjunction with the VX Test Panel (2RB-ECP-2) the solenoid valves and corresponding bypass test dampers are presently operated by placing electrical jumpers in the appropriate termination cabinets.

32.3.2.4 Hydrogen Skimmer Fans

Hydrogen Skimmer Fans HS-2A and HS-2B use automatic control as the primary mode of operation with manual control provided as a backup. Each fan is operated by a three position (RUN-OFF-AUTO) key-lock selector switch located on main control board 2MC4. The selector switch is normally in automatic with the key removed to lock the switch in position. The operational status of the fans are provided by status lights located directly above the key-lock selector switch on the main control board. Refer to Figure 10 for the following discussion of the hydrogen skimmer fan controls and interlock logic.

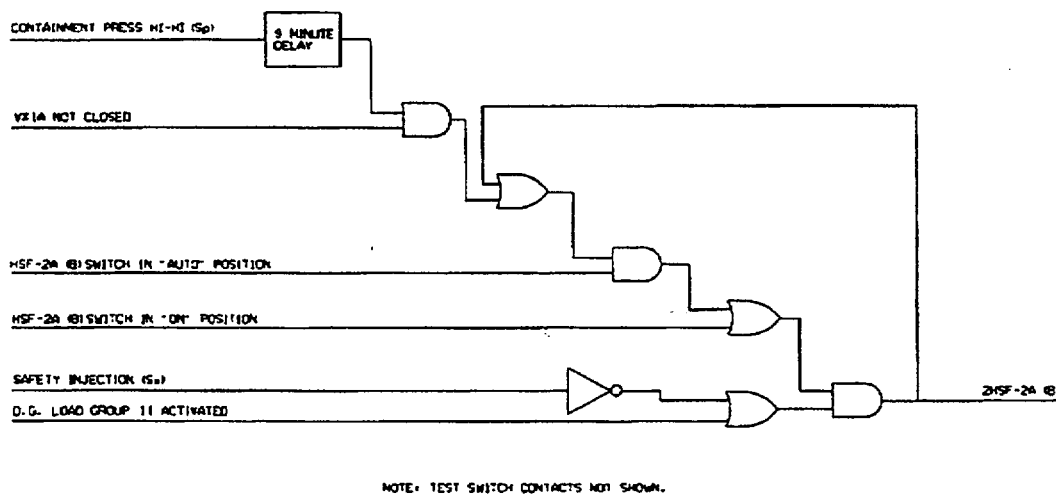

Figure 10.

The hydrogen skimmer fans are assigned to Diesel Load Sequencer Group 11. As such, each fan is interlocked with the Diesel Generator Load Sequencer such that upon receipt of a safety injection signal (Ss), the fan is load shed and operation is inhibited until Load Group 11 is sequenced on the Diesel Generator. This interlock will take precedence over both manual and automatic operation and cannot be defeated.

Manual operation is subject only to the above interlock and is continuous once selected. Automatic operation is initiated by an Sp signal (Hi-Hi Containment Pressure or Manual Spray Actuation) through a 9 +/- 1 minute time delay and is interlocked with the respective inlet isolation valve (2VX1A, 2VX2B) such that the inlet valve must be open before an automatic start signal is generated. If the Sp signal is still present after the time delay expires and the respective inlet valve is open, an automatic start signal is generated and sealed-in. Once generated, the automatic start signal can only be reset by moving the selector switch to the OFF position.

Train related control room annunciator alarms are provided to alert the operator if the Hydrogen Skimmer Fan is being operated with the corresponding inlet valve closed.

32.3.2.5 Hydrogen Skimmer Fan Inlet Valves (2VX1A, 2B)

Hydrogen Skimmer Fan Inlet Valves 2VX1A and 2VX2B use automatic control as the primary method of operation with manual control provided as a backup. The valves are operated via momentary pushbutton operators (OPEN-CLOSE) located on main control board 2MC4. The position of each valve is indicated by position indicating lights integral to the pushbutton operator.

The control logic for opening the inlet valves in both automatic and manual modes is interlocked with the following signals in a logical OR function: 1) an ECCS Sp signal, 2) the train-related Containment Air Return Fan control switch in the ON position, or 3) the train-related Hydrogen Skimmer Fan control switch in the ON position. Manual opening of the inlet valves is dependent only upon satisfying one of the above interlocks. The automatic control logic incorporates a 9+/-1 minute time delay, after which, the interlock signal is sealed-in and the valves open. Refer to Figure 11 for a logic diagram of the valve M/O logic circuit.

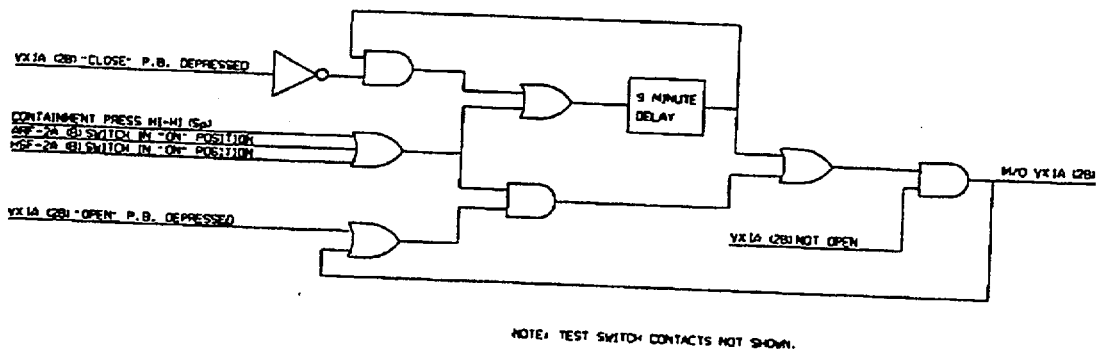

Figure 11.

The control logic for closing the inlet valves in manual mode is direct, with no intervening interlocks. However, once closed, if the control logic discussed above for automatic opening of the inlet valves is satisfied, the valve will immediately reopen. There is no automatic control for closing the valves. Refer to Figure 12 for a logic diagram of the valve M/C logic circuit.

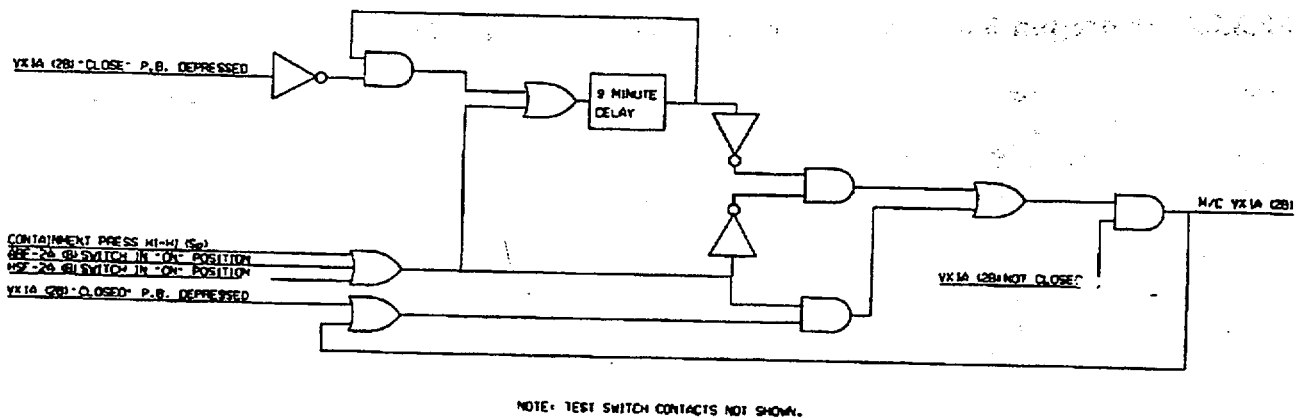

Figure 12.

32.3.2.6 VX and VP Test Panel (2RB-ECP-2)

Test Panel 2RB-ECP-2 provides a means to test the Containment Air Return Fans, isolation dampers, hydrogen skimmer fans, and inlet isolation valves and verify the time-delay logic associated with each. The test panel is not currently used; however, individual parts of the circuitry associated with the panel are used in conjunction with external electrical jumpers for testing. A detailed description of the test panel operating procedures can be found in Reference 20.6.1.6.4, "Design Study CNDS-107, VX Controls/Test Circuitry Review," Attachment 3. For actual testing, refer to the appropriate performance test procedures.

32.3.2.7 Electric Hydrogen Recombiner System

The Electric Hydrogen Recombiner System (EHRS) is a natural convection flameless, thermal reactor-type hydrogen/oxygen recombinder. In its basic operation, it heats a continuous stream of air/hydrogen mixture to a temperature sufficient for spontaneous recombination of the hydrogen with the oxygen in the air to form water vapor. The system consists of two independent recombination units, each of which contains the electric heater banks, a power supply panel that contains the equipment for powering the heaters, and a power control panel to the heaters.

The recombination units are located inside containment in the vicinity of the discharge of the Hydrogen Skimmer Fans. It consists of an inlet preheater section, a heater-recombination section, and a mixing chamber. The heater-recombination section contains four banks of heaters. Each bank contains 60 individual, U-type heating elements connected in series-parallel arrangements as required to obtain the power rating for each bank. Heater bank #3 in each recombination unit has three chromel-alumel thermocouples mechanically fastened and welded to the heater sheaths. These thermocouples are provided to verify heater operation and to indicate plate temperature for performance testing.

The power supply panel is located in the Auxiliary Building and contains all the necessary electrical equipment to provide the power required by the heaters in the recombination unit. It is a self-supporting, floor-mounted cabinet.

The control panel is located in the Auxiliary Building next to the power supply panel and contains all the control and monitoring equipment required for operating the recombination unit. It contains a master

ON-OFF switch, a control potentiometer for adjusting the amount of power supplied to the recombination units, and a wattmeter for indication of the power supplied. The system as purchased also provided a display for monitoring any one of the three thermocouples imbedded in heater bank #3 and a selector switch for selecting between the three. However, due to lack of chromel-alumel electrical penetrations at the time of equipment installation, a different method of monitoring the thermocouples has been provided via the Hydrogen Recombiner Heater Temperature Monitor Panel described in Section 32.3.1.4, "Hydrogen Recombiner Heater Temperature Monitor Panels" on page 48. The display and controls on the Hydrogen Recombiner Control Panel have been abandoned in place.

The master control switch on the control panel is interlocked such that the system can be operated only if an Ss signal is not present or after Diesel Load Sequencer Load Group 11 has been cycled onto the bus. This interlock essentially prevents operation of the Hydrogen Recombiner between the initial receipt of a Ss and when Load Group 11 is activated. This is also the same interlock as is used on the Containment Air Return Fans described in Section 32.3.2.1, "Containment Air Return Fans" on page 48, and the Hydrogen Skimmer Fans described in Section 32.3.2.4, "Hydrogen Skimmer Fans" on page 52.

32.3.3 INDICATORS

None.

32.3.4 RECORDERS

None.

32.3.5 STATUS INDICATION

32.3.5.1 Status Lights

The following status lights provide information concerning the VX System but are actually part of the Containment Spray (NS) System. For additional information, refer to reference 20.6.3.1.10, "CNS-1563.NS-00-0001, Design Basis Specification for the Containment Spray (NS) System."

VX SYS CPCS TRAIN A INHIBIT

VX SYS CPCS TRAIN B INHIBIT

32.3.5.2 Monitor Lights

Group I

AIR RETURN FAN ARF-A RUNNING

AIR RETURN FAN ARF-B RUNNING

HYDROGEN SKIMMER FAN HSF-A RUNNING

HYDROGEN SKIMMER FAN HSF-B RUNNING

ARF ISOL DAMPER ARF-D-2 OPEN

ARF ISOL DAMPER ARF-D-4 OPEN

HSF INLET ISOLATION VLV VX1 OPEN

HSF INLET ISOLATION VLV VX2 OPEN

32.3.5.3 1.47 Panel Bypass Lights

See Section 20.5.1.4, "Bypass and Inoperable Status Indication" on page 15 for a list of 1.47 Bypass Lights.

32.3.6 SYSTEM ALARMS

32.3.6.1 Annunciators

VX TRAIN A TROUBLE

VX TRAIN B TROUBLE

32.3.6.2 Computer Inputs

32.3.6.2.1 Analog Inputs

HSF A MTR STATOR TEMP

HSF B MTR STATOR TEMP

32.3.6.2.2 Digital Inputs

HYDROGEN SKIMMER FAN A SUCT PRESS	LO, NOT LO
HYDROGEN SKIMMER FAN B SUCT PRESS	LO, NOT LO
CONTAINMENT AIR RETURN FAN A DISCH PRESS	LO, NOT LO
CONTAINMENT AIR RETURN FAN B DISCH PRESS	LO, NOT LO
VLV VX1A HYDROGEN SKIMMER FAN A ISOL	OPEN, NOT OPEN
VLV VX1A HYDROGEN SKIMMER FAN A ISOL	CLOSED, NOT CLOSED
VLV VX2B HYDROGEN SKIMMER FAN B ISOL	OPEN, NOT OPEN
VLV VX2B HYDROGEN SKIMMER FAN B ISOL	CLOSED, NOT CLOSED
DAMPER ARF-D-2 CONT AIR RETURN FAN A ISOL	OPEN, NOT OPEN
DAMPER ARF-D-2 CONT AIR RETURN FAN A ISOL	CLOSED, NOT CLOSED
DAMPER ARF-D-4 CONT AIR RETURN FAN B ISOL	OPEN, NOT OPEN
DAMPER ARF-D-4 CONT AIR RETURN FAN B ISOL	CLOSED, NOT CLOSED
CPCS BLOCK OF VX CONT AIR RET FAN A OPR	ENGAGED, NOT
CPCS BLOCK OF VX CONT AIR RET FAN B OPR	ENGAGED ENGAGED, NOT ENGAGED

32.4 POWER SOURCES

The following equipment is supplied with essential 600 VAC, 3 phase, 60 Hz. power. For the design basis and a detailed description of the system providing this power, see Reference 20.6.3.1.12, "CNS-112.01-EPE-0001, Design Basis Specification for the EPE System."

Equipment	MCC (600 VAC)	Compt./Bkr.
Containment Air Return Fan ARF-2A	2EMXK	F11A
Power Lockout Contactor ARF-2A	2EMXM	F01A
Containment Air Return Fan ARF-2B	2EMXL	F11A
Power Lockout Contactor ARF-2B	2EMX	F01A
Hydrogen Skimmer Fan 1HSF-2A	2EMXK	F11B
Hydrogen Skimmer Fan 1HSF-2B	2EMXL	F11B
Containment Air Return Fan Damper 2ARF-D-2	2EMXK	F10A
Containment Air Return Fan Damper 2ARF-D-4	2EMXL	F10A
Hydrogen Skimmer Fan Inlet Isol. Valve 2VX001A	2EMXK	F06A
Hydrogen Skimmer Fan Inlet Isol. Valve 2VX002B	2EMXL	F06A
Hydrogen Recombiner Panel 2A	2EMXK	F07C
Hydrogen Recombiner Panel 2B	2EMXL	F07C

Low voltage instrumentation and control circuits are powered from various systems. Design basis information and system description information for the safety-related systems and system description information for the non-safety systems can be found in the following references.

1. Reference 20.6.3.1.13, "CNS-106.01-EPY-0001, Design Basis Specification for the EPY System"
2. Reference 20.6.1.6.2, "CNSD-0010-10, Electrical System Description for the 240/120 VAC Auxiliary Control Power System"
3. Reference 20.6.1.6.3, "CNSD-0010-12, Electrical System Description for the 208/120 VAC Normal Auxiliary Power System"

32.5 DESIGN DOCUMENT CROSS REFERENCE

32.5.1 DUKE DRAWINGS

Flow Diagram:	CN-2557-1.0
Summary Flow Diagram:	CNSF-2557-VX.01
Instrument Details:	CN-2499-VX Series
Electrical Elementaries:	CNEE-0265-01 Series
Connection and Outline Diagrams:	CN-2735-01 Series
Piping Isometrics:	CN-2491-VX Series
Test Acceptance Criteria:	CNTC-2557-VX Series

32.5.2 VENDOR DRAWINGS

For information on VX System Equipment, use DPCo. Equipment and Valve Data Base Files.

**CATAWBA
INITIAL LICENSE EXAMINATION
JOB PERFORMANCE MEASURE**

JPM 2/ADMIN

Perform a Manual Shutdown Margin Calculation
(Unit at Power)

CANDIDATE

EXAMINER

**CATAWBA
INITIAL LICENSE EXAMINATION
JOB PERFORMANCE MEASURE**

Task:

Perform a manual shutdown margin calculation (Unit at Power)

Alternate Path:

N/A

Facility JPM #:

OP-CN-ADM 3.A1 (Modified)

K/A Rating(s):

GKA 2.1.25 (2.8/3.1)

Task Standard:

Determine if adequate shutdown margin exists per Technical Specifications.

Preferred Evaluation Location:

Simulator In-Plant

Preferred Evaluation Method:

Perform Simulate

References:

Validation Time: _____ **Time Critical:** No

Candidate: _____
NAME

Time Start : _____
Time Finish: _____

Performance Rating: SAT _____ UNSAT _____ Performance Time _____

Examiner: _____
NAME

SIGNATURE / DATE

COMMENTS

Simulator Setup

Reset Simulator to IC-3.

READ TO OPERATOR

DIRECTION TO TRAINEE:

I will explain the initial conditions, and state the task to be performed. All control room steps shall be performed for this JPM, including any required communications. I will provide initiating cues and reports on other actions when directed by you. Ensure you indicate to me when you understand your assigned task. To indicate that you have completed your assigned task, return the handout sheet I provided you.

INITIAL CONDITIONS:

You are the Unit 1 OATC. The Reactivity Computer (RACTBAL) is out-of-service. You have just been informed by the Control Room SRO that the following rods are untriappable:

- M-4
- H-8
- D-12

Current boron concentration is 34 ppm.

INITIATING CUE:

Perform a Shutdown Margin Calculation per OP/0/A/6100/006 (Reactivity Balance Calculation) and determine if adequate shutdown margin exists.

JPM OVERALL STANDARD:

Candidate determines that shutdown margin is less than required.

K/A 2.1.25 (2.8/3.1)

<p>STEP 1: Performs Section 2.3 and N/A's Section 2.2.</p> <p>STANDARD: Step 2.2 marked N/A.</p> <p>COMMENTS:</p>	<p>___SAT</p> <p>___UNSAT</p>
<p>STEP 2: Record data required in step 2.3.</p> <p>STANDARD: Operator determines the following using the simulator and the initial conditions.;</p> <p>Unit: <u>1</u></p> <p>Date/Time: <u>Present Date/Time</u></p> <p>Present Thermal Power, Best Estimate: <u>99%</u></p> <p>Present Cycle Burnup: <u>420EFPD</u></p> <p>Present Control Bank Position: <u>198 SWD</u>, Control Bank <u>D</u></p> <p>Number of untrippable RCCA(s): <u>3</u></p> <p>Untrippable RCCA(s) core location(s): <u>M-4; H-8; D-12</u></p> <p>COMMENTS:</p>	<p>___SAT</p> <p>___UNSAT</p>
<p>STEP 3: Determine total applicable rod worth.</p> <p>STANDARD: Determine total available rod worth to be 4521 pcm per section 5.7 of R.O.D. Manual.</p> <p>COMMENTS:</p>	<p>CRITICAL STEP</p> <p>___SAT</p> <p>___UNSAT</p>

<p>STEP 4: Determine there are multiple untrippable RCCA's.</p> <p>STANDARD: N/A steps 2.4.3 and 2.4.4.</p> <p>COMMENTS:</p>	<p>CRITICAL STEP</p> <p><input type="checkbox"/> SAT</p> <p><input type="checkbox"/> UNSAT</p>
<p>STEP 5: Determine location of highest reactivity worth RCCA and its reactivity worth penalty.</p> <p>STANDARD: Determines RCCA <u>H-8</u> in highest worth. Rod worth is <u>411 pcm</u> per section 5.8 of the R.O.D. Manual.</p> <p>COMMENTS:</p>	<p>CRITICAL STEP</p> <p><input type="checkbox"/> SAT</p> <p><input type="checkbox"/> UNSAT</p>
<p>STEP 6: Determine maximum stuck rod worth during cycle.</p> <p>STANDARD: Determines maximum rodstuck worth during cycle is <u>835 pcm</u> per section 5.7 of the R.O.D. Manual.</p> <p>COMMENTS:</p>	<p>CRITICAL STEP</p> <p><input type="checkbox"/> SAT</p> <p><input type="checkbox"/> UNSAT</p>
<p>STEP 7: Calculate total untrippable RCCA reactivity worth penalty.</p> <p>STANDARD: Calculates a penalty at <u>2081 pcm</u>.</p> <p>COMMENTS:</p>	<p>CRITICAL STEP</p> <p><input type="checkbox"/> SAT</p> <p><input type="checkbox"/> UNSAT</p>

<p>STEP 8: Calculate inserted reactivity worth of rods.</p> <p>STANDARD: Determines: Reactivity worth of HZP, NoXenon to be <u>126 pcm</u> Reactivity worth at HZP Peak Xenon to be <u>163 pcm</u>. Calculates an inserted reactivity worth of <u>144.5 pcm</u>.</p> <p>COMMENTS:</p>	<p>CRITICAL STEP</p> <p>___ SAT</p> <p>___ UNSAT</p>
<p>STEP 9: Calculate available reactivity worth of trippable rods.</p> <p>STANDARD: Determines: Total available rod worth <u>4521 pcm</u> Untrippable RCCA penalty <u>2081 pcm</u> <u>Inserted Rod Worth 144.5 pcm</u> <u>Calculates 2259.5 pcm available worth of trippable RCCA's</u></p> <p>COMMENTS:</p>	<p>CRITICAL STEP</p> <p>___ SAT</p> <p>___ UNSAT</p>
<p>STEP 10: Determine worst case power. defect for present conditions.</p> <p>STANDARD: Determine: Power defect of <u>2440 pcm</u> per section 5.9 of R.O.D. Manual Transient Flux Redistribution Allowance of <u>265 pcm</u> per Section 5.7 of the R.O.D. Manual. Calculates worst case power defect of <u>2705 pcm</u>.</p> <p>COMMENTS:</p>	<p>CRITICAL STEP</p> <p>___ SAT</p> <p>___ UNSAT</p>

<p>STEP 11: Calculate SDM for present conditions.</p> <p>STANDARD: Determines available worth of trippable RCA's <u>2295.5 pcm</u> Worst Case Power Defect <u>2705 pcm</u> Calculates present SDM of (-)<u>409.5 pcm</u></p> <p>COMMENTS:</p>	<p>CRITICAL STEP</p> <p><input type="checkbox"/> SAT</p> <p><input type="checkbox"/> UNSAT</p>
<p>STEP 12: Determines that SDM is not adequate.</p> <p>STANDARD: Determine present SDM is less than <u>1300 pcm</u>.</p> <p>COMMENTS:</p>	<p>CRITICAL STEP</p> <p><input type="checkbox"/> SAT</p> <p><input type="checkbox"/> UNSAT</p>

TIME STOP: _____

CANDIDATE CUE SHEET
(TO BE RETURNED TO EXAMINER UPON COMPLETION OF TASK)

INITIAL CONDITIONS:

You are the Unit 1 OATC. The Reactivity Computer (RACTBAL) is out of-service. You have just been informed by the Control Room SRO that the following rods are untriappable:

- M-4
- H-8
- D-12

Current boron concentration is 34 ppm.

INITIATING CUE:

Perform a Shutdown Margin Calculation per OP/0/A/6100/006 (Reactivity Balance Calculation) and determine if adequate shutdown margin exists.

Key

REACTIVITY BALANCE CALCULATION
OP/0/A/6100/06
SHUTDOWN MARGIN - UNTRIPPABLE RCCA(S) - MODES 1 & 2
ENCLOSURE 4.3

1.0 INITIAL CONDITIONS

1.1 Limits and Precautions have been reviewed.

2.0 PROCEDURE

NOTES: 1) In Modes 1 or 2 with all RCCAs trippable, shutdown margin is satisfied provided control banks are positioned above the Control Rod Insertion limits in Section 2.2 of the R.O.D. manual (and if Unit shutdown occurs, T-COLD remains above the Allowable Moderator Temperature limit of Section 2.6 of the R.O.D. manual.)

2) Assume all values are positive unless otherwise indicated by parentheses. If parentheses precede the value [i.e. () _____ pcm], record the sign provided with data. The calculations account for these sign conventions.

2.1 If performing a MANUAL calculation, N/A Step 2.2 (including all substeps).

N/A

2.2 Perform the following steps if using the REACTBAL program to complete the calculation:

- 2.2.1 Access Reactivity Balance Program per Enclosure 4.7.
- 2.2.2 Select program option 3 (Shutdown Margin Modes 1 & 2 With Untrippable RCCA(s)).
- 2.2.3 Enter appropriate values as prompted.
- 2.2.4 Print program results, label appropriately, and attach to this enclosure.
- 2.2.5 Ensure that a separate, independent calculation has been performed per steps 2.2.1 through 2.2.4.
- 2.2.6 Verify that both attachments to this enclosure yield the same results.
- 2.2.7 N/A the rest of this enclosure (steps 2.3 through 2.7).

Performed By: _____ Date/Time: ____/____/____

Verified By: _____ Date/Time: ____/____/____

2.3 Determine the following information:

Step	Description	Reference	Value
2.3.1	Unit	N/A	1
2.3.2	Date/Time	N/A	Now
2.3.3	Present Thermal Power, Best Estimate	P1385	100 %
2.3.4	Present cycle burnup	P1457 or Reactor Group Duty Engineer	420 EFPD
2.3.5	Present control bank position	N/A	198 SWD on Control Bank D
2.3.6	Number of untrippable RCCA(s)	N/A	3
2.3.7	Untrippable RCCA(s) core locations(s).	N/A	M4, H8, D12

REACTIVITY BALANCE CALCULATION
OP/0/A/6100/06
SHUTDOWN MARGIN - UNTRIPPABLE RCCA(S) - MODES 1 & 2
ENCLOSURE 4.3

- 2.4 Determine available reactivity worth of trippable RCCAs for present conditions:
- 2.4.1 Determine Total Available Rod Worth (Section 5.7 of R.O.D. manual) 4521 pcm
- 2.4.2 If there are multiple untrippable RCCAs, N/A steps 2.4.3 and 2.4.4
- ~~N/A~~ Determine reactivity worth penalty for untrippable RCCA core location of Step 2.3.7 (Section 5.8 of R.O.D. manual). N/A pcm
- ~~N/A~~ N/A steps 2.4.5 through 2.4.8.
- 2.4.5 Determine untrippable RCCA of Step 2.3.7 with the highest reactivity worth penalty (Section 5.8 of ROD Manual). Core Location A-8
- 2.4.6 Record reactivity worth of the untrippable RCCA of Step 2.4.5 (Section 5.8 of ROD Manual). 411 pcm
- 2.4.7 Determine maximum stuck rod worth during cycle (Section 5.7 of the R.O.D. manual). 835 pcm
- 2.4.8 Calculate total untrippable RCCA reactivity worth penalty for multiple untrippable RCCAs per the table below.

Description	Reference	Value
A. Number of Untrippable RCCAs	Step 2.3.6	<u>3</u>
B. Additional Penalty (Max Stuck Rod)	Step 2.4.7	<u>835</u> pcm
C. Highest Penalty	Step 2.4.6	<u>411</u> pcm
Total untrippable RCCA Worth Penalty for Multiple RCCAs	{ [(A) - 1] X (B) } + (C)	<u>2081</u> pcm

- 2.4.9 Record Total Untrippable RCCA Penalty from Step 2.4.3 or Step 2.4.8, whichever is applicable. 2081 pcm

NOTE:

Interpolation is not required in step 2.4.10. Reactivity worth may be determined by choosing the highest reactivity worth from Section 5.6 of the R.O.D Manual associated with rod positions that bound the present rod position.

- 2.4.10 Use present control bank position of Step 2.3.5 to look up specified data from Section 5.6 of ROD Manual and calculate inserted reactivity worth as follows:

$$\left(\frac{124}{\text{(HZP, No Xenon)}} \text{ pcm} + \frac{163}{\text{(HZP, Peak Xenon)}} \text{ pcm} \right) \times 0.5 = \underline{144.5} \text{ pcm}$$

REACTIVITY BALANCE CALCULATION
OP/0/A/6100/06
SHUTDOWN MARGIN - UNTRIPPABLE RCCA(S) - MODES 1 & 2
ENCLOSURE 4.3

2.4.11 Calculate available reactivity worth of trippable RCCAs:

Description	Reference	Value
A. Total Available Rod Worth	Step 2.4.1	4521 pcm
B. Untrippable RCCAs Penalty	Step 2.4.9	2081 pcm
C. Inserted Worth of Present Position	Step 2.4.10	144.5 pcm
Available Worth of Trippable RCCAs	(A) - (B) - (C)	2295.5 pcm

NOTE: Interpolation of Power Defect is not required for step 2.5. Bounding burnups and power levels may be used to select the highest Power Defect from section 5.9 of the R.O.D. manual.

2.5 Determine worst case power defect for present conditions:

Description	Reference	Value
A. Total Power Defect at present thermal power (Step 2.3.3) and cycle burnup (Step 2.3.4)	Section 5.9 of R.O.D. manual	2440 pcm
B. Transient Flux Redistribution Allowance	Section 5.7 of R.O.D. manual	265 pcm
Worst case power defect for present conditions:	(A) + (B)	2705 pcm

CAUTION

SDM shall be within the limits specified by the COLR per Tech Spec 3.1.1.

2.6 Calculate SDM for present conditions:

Description	Reference	Value
A. Available worth of Trippable RCCAs	Step 2.4.11	2295.5 pcm
B. Worst Case Power Defect	Step 2.5	2705 pcm
Present SDM	(A) - (B)	(-) 409.5 pcm

NOTE: Separate, independent calculation must be performed by the verifier.

2.7 Sign the appropriate space below. N/A the unsigned space.

Performed By: _____ Date/Time: ____/____/____

Verified By: _____ Date/Time: ____/____/____

Source: CNEI-0400-26
Prepared By: MW Hawes
Revision: 251
Date: 5/18/99

UNIT ONE REACTOR OPERATING DATA MANUAL
SECTION 5.1

HZP Critical Boron Concentration vs Burnup
(ARO, No Xe, Eq Sm)

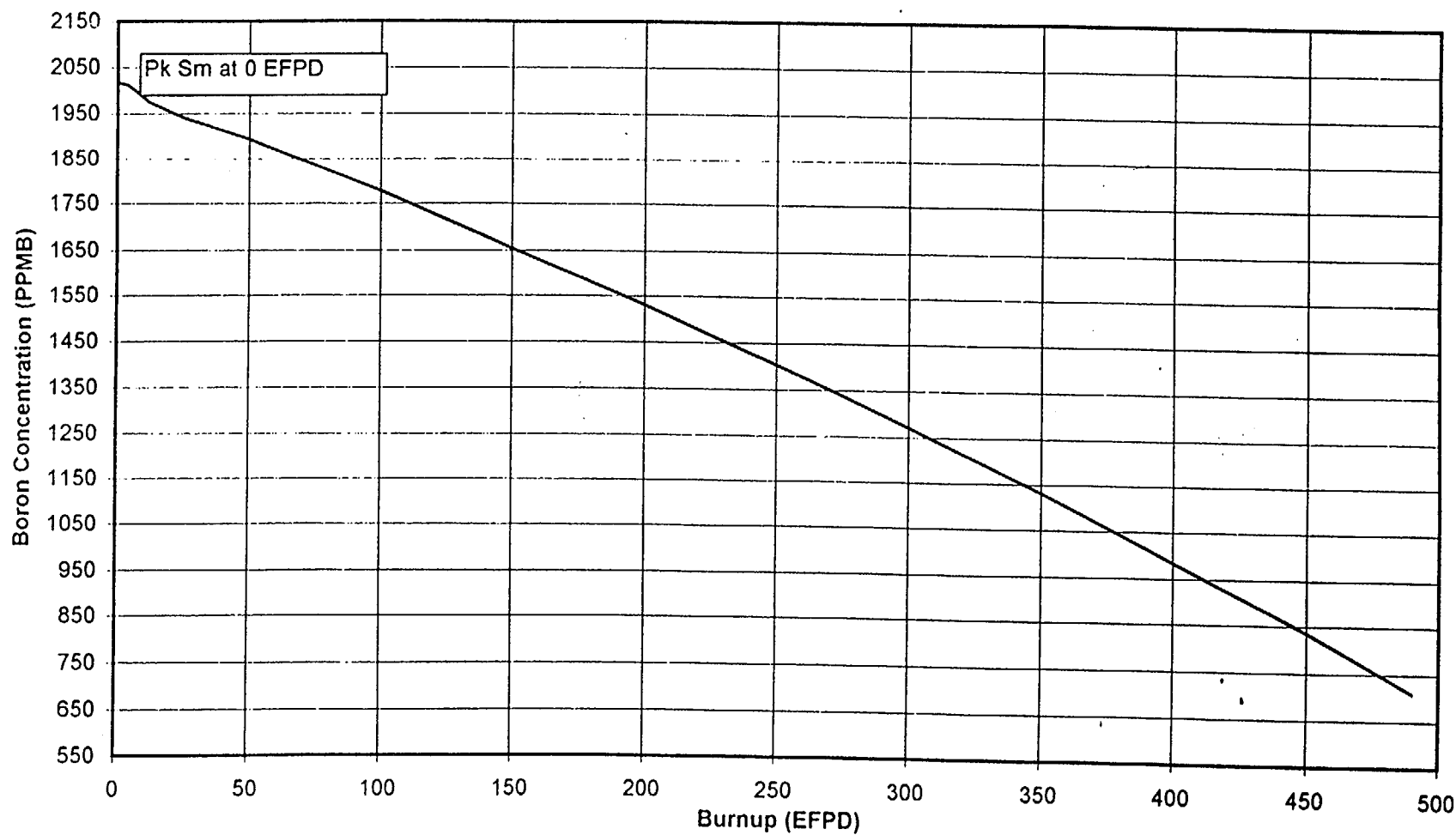

(Note: See data in section 5.4)

UNIT ONE
REACTOR OPERATING DATA
SECTION 5.2
HFP CRITICAL BORON CONCENTRATION
(ARO, EQ XE, EQ SM)

Source: CNEI-0400-26
Prepared by: JR Fox
Revision Number: 262
Date: 7/22/99

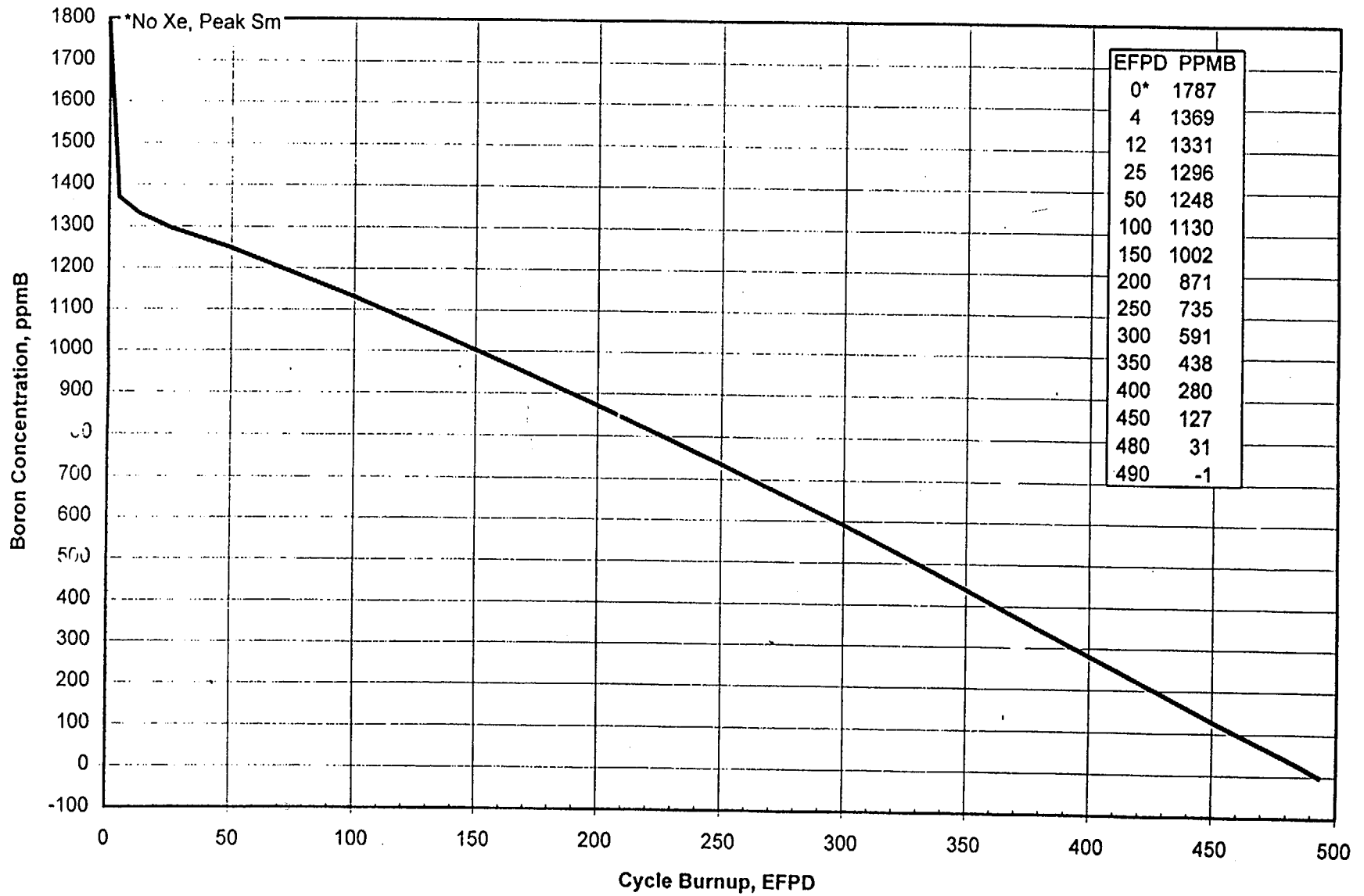

UNIT ONE
 REACTOR OPERATING DATA
 SECTION 5.3
 ARI DIFFERENTIAL BORON WORTH

Source: CNEI-0400-26
 Prepared By: M.W. Hawes
 Revision Number: 251
 Date: 5/18/99

BURNUP (EFPD)	TEMPERATURE															
	68	100	150	200	250	300	350	400	450	500	510	520	530	540	550	557
0	-8.61	-8.56	-8.46	-8.32	-8.12	-7.92	-7.69	-7.47	-7.18	-6.89	-6.82	-6.74	-6.67	-6.60	-6.52	-6.47
20	8.63	-8.58	-8.48	-8.34	-8.13	-7.93	-7.70	-7.48	-7.19	-6.89	-6.82	-6.74	-6.66	-6.59	-6.51	-6.46
40	-8.65	-8.60	-8.50	-8.36	-8.15	-7.94	-7.71	-7.48	-7.19	-6.90	-6.82	-6.74	-6.66	-6.58	-6.50	-6.44
60	-8.68	-8.63	-8.52	-8.37	-8.16	-7.95	-7.72	-7.49	-7.19	-6.90	-6.82	-6.74	-6.65	-6.57	-6.49	-6.43
80	-8.70	-8.65	-8.53	-8.39	-8.18	-7.96	-7.73	-7.49	-7.20	-6.91	-6.82	-6.73	-6.65	-6.56	-6.47	-6.41
100	-8.72	-8.67	-8.55	-8.41	-8.19	-7.97	-7.74	-7.50	-7.21	-6.91	-6.82	-6.73	-6.64	-6.55	-6.46	-6.40
120	-8.78	-8.73	-8.61	-8.46	-8.24	-8.02	-7.77	-7.53	-7.23	-6.93	-6.84	-6.76	-6.67	-6.58	-6.50	-6.44
140	-8.84	-8.79	-8.67	-8.52	-8.29	-8.07	-7.81	-7.56	-7.25	-6.95	-6.87	-6.78	-6.70	-6.62	-6.53	-6.47
160	-8.90	-8.85	-8.73	-8.57	-8.34	-8.11	-7.85	-7.58	-7.28	-6.98	-6.89	-6.81	-6.73	-6.65	-6.57	-6.51
180	-8.96	-8.91	-8.79	-8.63	-8.39	-8.16	-7.89	-7.61	-7.30	-7.00	-6.92	-6.84	-6.76	-6.68	-6.60	-6.54
200	9.02	-8.97	-8.84	-8.68	-8.44	-8.21	-7.93	-7.64	-7.33	-7.02	-6.94	-6.87	-6.79	-6.71	-6.63	-6.58
220	-9.10	-9.05	-8.91	-8.72	-8.53	-8.34	-8.02	-7.70	-7.39	-7.08	-7.00	-6.92	-6.84	-6.76	-6.68	-6.63
240	-9.17	-9.12	-8.97	-8.77	-8.62	-8.47	-8.12	-7.77	-7.45	-7.13	-7.05	-6.97	-6.89	-6.81	-6.73	-6.68
260	-9.24	-9.19	-9.04	-8.83	-8.68	-8.53	-8.18	-7.84	-7.52	-7.19	-7.11	-7.03	-6.95	-6.87	-6.79	-6.73
280	-9.30	-9.25	-9.10	-8.92	-8.72	-8.52	-8.21	-7.91	-7.59	-7.26	-7.18	-7.10	-7.02	-6.94	-6.86	-6.80
300	9.36	-9.31	-9.17	-9.01	-8.75	-8.50	-8.24	-7.99	-7.66	-7.33	-7.25	-7.17	-7.09	-7.01	-6.93	-6.87
320	9.47	-9.42	-9.27	-9.11	-8.85	-8.60	-8.34	-8.08	-7.75	-7.42	-7.34	-7.26	-7.17	-7.09	-7.01	-6.95
340	-9.58	-9.52	-9.38	-9.21	-8.95	-8.69	-8.43	-8.17	-7.84	-7.51	-7.42	-7.34	-7.26	-7.18	-7.10	-7.04
360	-9.68	-9.63	-9.49	-9.32	-9.05	-8.79	-8.52	-8.26	-7.93	-7.59	-7.51	-7.43	-7.35	-7.26	-7.18	-7.12
380	-9.79	-9.73	-9.59	-9.42	-9.15	-8.88	-8.62	-8.35	-8.02	-7.68	-7.60	-7.51	-7.43	-7.35	-7.26	-7.21
400	-9.90	-9.84	-9.70	-9.52	-9.25	-8.98	-8.71	-8.44	-8.11	-7.77	-7.69	-7.60	-7.52	-7.43	-7.35	-7.29
420	-10.03	-9.97	-9.83	-9.65	-9.37	-9.10	-8.83	-8.56	-8.22	-7.88	-7.79	-7.71	-7.62	-7.53	-7.45	-7.39
440	-10.16	-10.10	-9.96	-9.77	-9.50	-9.22	-8.95	-8.67	-8.33	-7.99	-7.90	-7.81	-7.72	-7.63	-7.54	-7.48
460	-10.29	-10.23	-10.09	-9.90	-9.62	-9.34	-9.06	-8.79	-8.44	-8.10	-8.01	-7.91	-7.82	-7.73	-7.64	-7.58
480	-10.42	-10.36	-10.22	-10.03	-9.74	-9.46	-9.18	-8.90	-8.55	-8.21	-8.11	-8.02	-7.92	-7.83	-7.74	-7.67
490	-10.49	-10.43	-10.28	-10.09	-9.81	-9.52	-9.24	-8.96	-8.61	-8.26	-8.17	-8.07	-7.98	-7.88	-7.79	-7.72

Note: Calculated at the ARI critical boron concentration for each temperature and burnup.

Source: CNEI-0400-26, C1C12 SOR
Prepared by: MW Hawes
Revision Number: 251
Date: 5/18/99

UNIT ONE
REACTOR OPERATING DATA
SECTION 5.4
HZP DIFFERENTIAL BORON WORTH

Cycle Burnup (EFPD)	Critical Boron Concentration (PPMB)	Differential Boron Worth (PCM/PPMB)
0*	2017	-6.27
4	2011	-6.27
12	1974	-6.26
25	1940	-6.26
50	1892	-6.26
100	1777	-6.31
150	1653	-6.39
200	1529	-6.50
250	1402	-6.63
300	1270	-6.77
350	1131	-6.94
400	983	-7.12
450	834	-7.33
480	742	-7.46
490	710	-7.51

*Peak Samarium

Source: CNEI-0400-26, C1C12 SOR
Prepared By: JR. Fox
Revision Number 262
Date: 7/22/99

UNIT ONE
REACTOR OPERATING DATA
SECTION 5.5
HFP DIFFERENTIAL BORON WORTH

(HFP, ARO, Eq Xe, Eq Sm)

Cycle Burnup (EFPD)	Critical Boron Concentration (PPMB)	Differential Boron Worth (PCM/PPMB)	ITC (PCM/°F)
0*	1787	-6.05	-11.80
4	1369	-6.05	-15.07
12	1331	-6.05	-15.49
25	1296	-6.05	-15.91
50	1248	-6.06	-16.66
100	1130	-6.12	-18.59
150	1002	-6.21	-20.64
200	871	-6.33	-22.69
250	735	-6.47	-24.84
300	591	-6.58	-27.17
350	438	-6.79	-29.70
400	280	-7.03	-32.50
450	127	-7.30	-35.44
480	31	-7.49	-37.52
490	-1	-7.53	-37.74

* No Xenon, Peak Samarium

UNIT ONE
 REACTOR OPERATING DATA
 SECTION 5.6
 INTEGRAL ROD WORTH IN OVERLAP

HZP, No Xenon

Control Bank Position Steps Withdrawn				50 EFPD	100 EFPD	200 EFPD	300 EFPD	400 EFPD
Bk A	Bk B	Bk C	Bk D	0 - 75 EFPD IRW (PCM)	76 - 150 EFPD IRW (PCM)	151 - 250 EFPD IRW (PCM)	251 - 350 EFPD IRW (PCM)	351 - 490 EFPD IRW (PCM)
226	226	226	226	0	0	0	0	0
226	226	226	225	1	1	1	2	3
226	226	226	220	4	5	7	10	15
226	226	226	215	7	9	14	19	28
226	226	226	210	10	13	20	27	41
226	226	226	205	20	26	38	50	70
226	226	226	200	30	40	56	73	98
226	226	226	195	40	53	75	96	126
226	226	226	190	50	66	93	119	155
226	226	226	185	65	84	115	144	183
226	226	226	180	80	102	137	169	212
226	226	226	175	95	120	159	195	241
226	226	226	170	110	138	182	220	270
226	226	226	165	126	156	202	241	292
226	226	226	160	142	174	222	262	313
226	226	226	155	157	192	242	284	335
226	226	226	150	173	210	263	305	357
226	226	226	145	189	226	280	323	374
226	226	226	140	205	243	298	341	391
226	226	226	135	221	260	316	358	408
226	226	226	130	236	277	333	376	425
226	226	226	125	252	293	349	391	437
226	226	226	120	267	308	364	405	449
226	226	226	116	279	321	376	416	459
226	226	226	110	298	339	394	433	473
226	226	221	105	315	357	414	454	497
226	226	216	100	332	375	433	475	521
226	226	211	95	356	402	466	514	570
226	226	206	90	380	429	498	552	619
226	226	201	85	404	456	531	591	667

UNIT ONE
 REACTOR OPERATING DATA
 SECTION 5.6
 INTEGRAL ROD WORTH IN OVERLAP

HZP, No Xenon

Control Bank Position Steps Withdrawn				50 EFPD	100 EFPD	200 EFPD	300 EFPD	400 EFPD
				0 - 75 EFPD	76 - 150 EFPD	151 - 250 EFPD	251 - 350 EFPD	351 - 490 EFPD
Bk A	Bk B	Bk C	Bk D	IRW (PCM)	IRW (PCM)	IRW (PCM)	IRW (PCM)	IRW (PCM)
226	226	196	80	428	483	563	630	716
226	226	191	75	457	515	602	674	770
226	226	186	70	486	548	640	718	824
226	226	181	65	516	580	679	763	877
226	226	176	60	545	612	717	807	931
226	226	171	55	577	647	754	848	975
226	226	166	50	609	681	791	888	1020
226	226	161	45	641	715	828	929	1064
226	226	156	40	673	750	865	969	1109
226	226	151	35	705	784	902	1007	1147
226	226	146	30	738	818	938	1045	1186
226	226	141	25	771	852	975	1083	1224
226	226	136	20	804	886	1011	1121	1263
226	226	131	15	838	921	1047	1157	1296
226	226	126	10	872	955	1082	1193	1330
226	226	121	5	906	990	1117	1228	1363
226	226	116	0	939	1024	1152	1264	1396
226	226	110	0	960	1045	1174	1286	1416
226	221	105	0	984	1070	1202	1315	1445
226	216	100	0	1008	1096	1230	1344	1474
226	211	95	0	1039	1127	1264	1382	1515
226	206	90	0	1070	1159	1299	1419	1556
226	201	85	0	1101	1191	1333	1457	1597
226	196	80	0	1132	1223	1368	1494	1638
226	191	75	0	1170	1261	1408	1535	1680
226	186	70	0	1207	1300	1448	1576	1722
226	181	65	0	1245	1338	1488	1617	1764
226	176	60	0	1283	1377	1528	1658	1806
226	171	55	0	1327	1420	1570	1698	1842
226	166	50	0	1372	1464	1613	1738	1878

Source: CNEI-0400-26, C1C12 SOR
 Prepared by: MW Hawes
 Revision Number: 251
 Date: 5/18/99

UNIT ONE
 REACTOR OPERATING DATA
 SECTION 5.6
 INTEGRAL ROD WORTH IN OVERLAP

HZP, No Xenon

Control Bank Position Steps Withdrawn				50 EFPD	100 EFPD	200 EFPD	300 EFPD	400 EFPD
Bk A	Bk B	Bk C	Bk D	0 - 75 EFPD IRW (PCM)	76 - 150 EFPD IRW (PCM)	151 - 250 EFPD IRW (PCM)	251 - 350 EFPD IRW (PCM)	351 - 490 EFPD IRW (PCM)
226	161	45	0	1416	1508	1655	1778	1915
226	156	40	0	1461	1552	1698	1818	1951
226	151	35	0	1507	1597	1738	1852	1977
226	146	30	0	1553	1642	1779	1886	2004
226	141	25	0	1600	1687	1820	1920	2030
226	136	20	0	1646	1732	1860	1954	2056
226	131	15	0	1684	1768	1891	1979	2074
226	126	10	0	1722	1804	1922	2003	2092
226	121	5	0	1760	1840	1953	2028	2111
226	116	0	0	1798	1876	1984	2053	2129
226	110	0	0	1821	1898	2003	2068	2140
221	105	0	0	1844	1921	2024	2088	2161
216	100	0	0	1867	1943	2045	2109	2183
211	95	0	0	1894	1970	2072	2138	2219
206	90	0	0	1921	1996	2099	2167	2256
201	85	0	0	1948	2023	2125	2197	2292
196	80	0	0	1974	2049	2152	2226	2328
191	75	0	0	2006	2080	2183	2260	2368
186	70	0	0	2038	2111	2215	2293	2407
181	65	0	0	2069	2142	2246	2327	2447
176	60	0	0	2101	2173	2277	2361	2487
171	55	0	0	2137	2206	2309	2393	2520
166	50	0	0	2172	2240	2341	2425	2553
161	45	0	0	2208	2274	2373	2457	2585
156	40	0	0	2244	2307	2405	2489	2618
151	35	0	0	2278	2339	2434	2518	2644
146	30	0	0	2312	2371	2463	2546	2670
141	25	0	0	2346	2403	2492	2574	2695
136	20	0	0	2380	2435	2522	2602	2721
131	15	0	0	2404	2458	2544	2624	2739

Source: CNEI-0400-26, C1C12 SOR
 Prepared by: MW Hawes
 Revision Number: 251
 Date: 5/18/99

UNIT ONE
 REACTOR OPERATING DATA
 SECTION 5.6
 INTEGRAL ROD WORTH IN OVERLAP

HZP, No Xenon

Control Bank Position Steps Withdrawn				50 EFPD	100 EFPD	200 EFPD	300 EFPD	400 EFPD
Bk A	Bk B	Bk C	Bk D	0 - 75 EFPD IRW (PCM)	76 - 150 EFPD IRW (PCM)	151 - 250 EFPD IRW (PCM)	251 - 350 EFPD IRW (PCM)	351 - 490 EFPD IRW (PCM)
126	10	0	0	2428	2482	2567	2646	2758
121	5	0	0	2452	2506	2590	2667	2776
116	0	0	0	2476	2529	2612	2689	2794
110	0	0	0	2491	2543	2626	2702	2805
105	0	0	0	2504	2557	2640	2716	2815
100	0	0	0	2518	2571	2654	2729	2825
95	0	0	0	2532	2585	2666	2740	2831
90	0	0	0	2546	2599	2679	2750	2837
85	0	0	0	2560	2612	2691	2760	2843
80	0	0	0	2574	2626	2703	2770	2850
75	0	0	0	2588	2638	2713	2777	2853
70	0	0	0	2603	2651	2723	2784	2857
65	0	0	0	2617	2663	2732	2791	2861
60	0	0	0	2631	2676	2742	2798	2865
55	0	0	0	2644	2686	2748	2802	2866
50	0	0	0	2658	2697	2755	2806	2868
45	0	0	0	2671	2707	2761	2810	2869
40	0	0	0	2684	2717	2767	2814	2870
35	0	0	0	2693	2723	2771	2816	2871
30	0	0	0	2702	2730	2775	2818	2872
25	0	0	0	2711	2736	2778	2820	2873
20	0	0	0	2720	2742	2782	2821	2874
15	0	0	0	2724	2745	2783	2822	2874
10	0	0	0	2728	2748	2785	2822	2874
5	0	0	0	2732	2751	2787	2823	2874
0	0	0	0	2736	2754	2788	2823	2874

Source: CNEI-0400-26, C1C12 SOR
 Prepared by: MW Hawes
 Revision Number: 251
 Date: 5/18/99

UNIT ONE
 REACTOR OPERATING DATA
 SECTION 5.6
 INTEGRAL ROD WORTH IN OVERLAP

HZP, No Xenon

Control Bank Position	Shutdown Bank Position Steps Withdrawn					50 EFPD	100 EFPD	200 EFPD	300 EFPD	400 EFPD
	SD E	SD D	SD C	SD B	SD A	0 - 75 EFPD IRW (PCM)	76 - 150 EFPD IRW (PCM)	151 - 250 EFPD IRW (PCM)	251 - 350 EFPD IRW (PCM)	351 - 490 EFPD IRW (PCM)
226	226	226	226	226	226	0	0	0	0	0
0	226	226	226	226	226	2736	2754	2788	2823	2874
0	0	226	226	226	226	3399	3428	3495	3575	3658
0	0	0	226	226	226	4078	4107	4161	4218	4297
0	0	0	0	226	226	4877	4905	4935	4959	5028
0	0	0	0	0	226	5594	5629	5672	5710	5806
0	0	0	0	0	0	5820	5857	5889	5907	5996

Source: CNEI-0400-26, C1C12 SOR
 Prepared by: MW Hawes
 Revision Number: 251
 Date: 5/18/99

UNIT ONE
 REACTOR OPERATING DATA
 SECTION 5.6
 INTEGRAL ROD WORTH IN OVERLAP

HZP, Peak Xenon

Control Bank Position Steps Withdrawn				50 EFPD	100 EFPD	200 EFPD	300 EFPD-	400 EFPD
				0 - 75 EFPD	76 - 150 EFPD	151 - 250 EFPD	251 - 350 EFPD	351 - 490 EFPD
Bk A	Bk B	Bk C	Bk D	IRW (PCM)	IRW (PCM)	IRW (PCM)	IRW (PCM)	IRW (PCM)
226	226	226	226	0	0	0	0	0
226	226	226	225	1	2	2	3	4
226	226	226	220	8	10	13	17	22
226	226	226	215	15	18	24	31	40
226	226	226	210	22	26	35	46	58
226	226	226	205	41	49	61	76	93
226	226	226	200	61	71	88	107	128
226	226	226	195	81	93	115	138	163
226	226	226	190	100	115	141	168	198
226	226	226	185	124	141	169	198	228
226	226	226	180	148	166	197	228	259
226	226	226	175	171	191	224	257	289
226	226	226	170	195	217	252	287	320
226	226	226	165	215	237	273	308	341
226	226	226	160	234	258	295	330	363
226	226	226	155	254	278	316	352	384
226	226	226	150	274	299	337	373	405
226	226	226	145	291	316	355	390	421
226	226	226	140	308	333	372	406	437
226	226	226	135	324	350	389	423	452
226	226	226	130	341	367	406	439	468
226	226	226	125	355	380	419	451	478
226	226	226	120	369	394	431	462	488
226	226	226	116	380	404	441	471	496
226	226	226	110	396	421	457	485	508
226	226	221	105	415	440	478	509	537
226	226	216	100	433	459	500	533	565
226	226	211	95	468	498	545	585	624
226	226	206	90	503	536	590	636	683
226	226	201	85	538	574	635	688	743

Source: CNEI-0400-26, C1C12 SOR
 Prepared by: MW Hawes
 Revision Number: 251
 Date: 5/18/99

UNIT ONE
 REACTOR OPERATING DATA
 SECTION 5.6
 INTEGRAL ROD WORTH IN OVERLAP

HZP, Peak Xenon

Control Bank Position Steps Withdrawn				50 EFPD	100 EFPD	200 EFPD	300 EFPD	400 EFPD
Bk A	Bk B	Bk C	Bk D	0 - 75 EFPD IRW (PCM)	76 - 150 EFPD IRW (PCM)	151 - 250 EFPD IRW (PCM)	251 - 350 EFPD IRW (PCM)	351 - 490 EFPD IRW (PCM)
226	226	196	80	573	613	680	739	802
226	226	191	75	614	657	730	794	861
226	226	186	70	655	702	779	849	920
226	226	181	65	696	746	829	904	979
226	226	176	60	737	790	879	959	1038
226	226	171	55	775	829	920	1003	1082
226	226	166	50	813	868	962	1046	1126
226	226	161	45	850	907	1003	1090	1170
226	226	156	40	888	946	1045	1134	1215
226	226	151	35	923	982	1081	1170	1250
226	226	146	30	959	1017	1118	1206	1286
226	226	141	25	994	1053	1154	1243	1321
226	226	136	20	1030	1089	1191	1279	1357
226	226	131	15	1063	1122	1222	1309	1383
226	226	126	10	1097	1155	1254	1338	1409
226	226	121	5	1130	1188	1285	1367	1436
226	226	116	0	1164	1221	1317	1396	1462
226	226	110	0	1184	1241	1335	1414	1478
226	221	105	0	1210	1268	1364	1444	1510
226	216	100	0	1237	1294	1392	1474	1542
226	211	95	0	1271	1331	1435	1520	1593
226	206	90	0	1306	1369	1477	1567	1644
226	201	85	0	1341	1406	1519	1614	1696
226	196	80	0	1376	1443	1562	1660	1747
226	191	75	0	1416	1485	1606	1708	1796
226	186	70	0	1456	1526	1651	1755	1845
226	181	65	0	1497	1568	1696	1803	1895
226	176	60	0	1537	1609	1741	1850	1944
226	171	55	0	1582	1654	1784	1890	1981
226	166	50	0	1628	1699	1827	1930	2019

Source: CNEI-0400-26, C1C12 SOR
 Prepared by: MW Hawes
 Revision Number: 251
 Date: 5/18/99

UNIT ONE
 REACTOR OPERATING DATA
 SECTION 5.6
 INTEGRAL ROD WORTH IN OVERLAP

HZP, Peak Xenon

Control Bank Position Steps Withdrawn				50 EFPD	100 EFPD	200 EFPD	300 EFPD	400 EFPD
Bk A	Bk B	Bk C	Bk D	0 - 75 EFPD IRW (PCM)	76 - 150 EFPD IRW (PCM)	151 - 250 EFPD IRW (PCM)	251 - 350 EFPD IRW (PCM)	351 - 490 EFPD IRW (PCM)
226	161	45	0	1673	1743	1870	1970	2057
226	156	40	0	1718	1788	1912	2010	2094
226	151	35	0	1764	1831	1949	2040	2120
226	146	30	0	1809	1874	1985	2070	2146
226	141	25	0	1855	1917	2022	2099	2172
226	136	20	0	1900	1960	2058	2129	2198
226	131	15	0	1936	1994	2085	2150	2215
226	126	10	0	1972	2027	2112	2172	2233
226	121	5	0	2008	2060	2139	2193	2250
226	116	0	0	2044	2093	2165	2214	2267
226	110	0	0	2065	2113	2181	2227	2278
221	105	0	0	2088	2136	2204	2249	2302
216	100	0	0	2111	2158	2226	2272	2326
211	95	0	0	2139	2187	2257	2307	2367
206	90	0	0	2166	2215	2289	2342	2407
201	85	0	0	2194	2243	2320	2378	2447
196	80	0	0	2221	2272	2351	2413	2487
191	75	0	0	2254	2304	2385	2449	2526
186	70	0	0	2286	2337	2419	2486	2565
181	65	0	0	2319	2370	2453	2522	2603
176	60	0	0	2352	2402	2487	2559	2642
171	55	0	0	2386	2435	2518	2588	2671
166	50	0	0	2420	2467	2548	2617	2699
161	45	0	0	2454	2499	2579	2647	2727
156	40	0	0	2489	2531	2609	2676	2756
151	35	0	0	2518	2558	2632	2697	2775
146	30	0	0	2547	2585	2654	2717	2793
141	25	0	0	2577	2612	2677	2738	2812
136	20	0	0	2606	2639	2699	2759	2831
131	15	0	0	2625	2657	2715	2773	2843

UNIT ONE
 REACTOR OPERATING DATA
 SECTION 5.6
 INTEGRAL ROD WORTH IN OVERLAP

HZP, Peak Xenon

Control Bank Position Steps Withdrawn				50 EFPD	100 EFPD	200 EFPD	300 EFPD	400 EFPD
Bk A	Bk B	Bk C	Bk D	0 - 75 EFPD IRW (PCM)	76 - 150 EFPD IRW (PCM)	151 - 250 EFPD IRW (PCM)	251 - 350 EFPD IRW (PCM)	351 - 490 EFPD IRW (PCM)
126	10	0	0	2645	2676	2731	2787	2856
121	5	0	0	2665	2694	2747	2801	2868
116	0	0	0	2685	2713	2763	2815	2880
110	0	0	0	2697	2724	2773	2824	2888
105	0	0	0	2707	2733	2781	2831	2894
100	0	0	0	2717	2743	2790	2838	2900
95	0	0	0	2726	2750	2796	2843	2903
90	0	0	0	2734	2758	2802	2848	2907
85	0	0	0	2743	2766	2808	2853	2910
80	0	0	0	2752	2773	2814	2859	2914
75	0	0	0	2758	2778	2818	2861	2915
70	0	0	0	2765	2784	2822	2864	2916
65	0	0	0	2772	2789	2825	2866	2918
60	0	0	0	2778	2794	2829	2869	2919
55	0	0	0	2783	2798	2831	2870	2920
50	0	0	0	2788	2802	2833	2871	2922
45	0	0	0	2793	2805	2835	2871	2923
40	0	0	0	2797	2809	2837	2872	2924
35	0	0	0	2800	2811	2838	2873	2924
30	0	0	0	2803	2812	2839	2874	2924
25	0	0	0	2806	2814	2840	2875	2924
20	0	0	0	2809	2816	2841	2876	2924
15	0	0	0	2810	2817	2842	2876	2924
10	0	0	0	2811	2818	2842	2876	2924
5	0	0	0	2813	2819	2843	2876	2924
0	0	0	0	2814	2820	2843	2876	2924

Source: CNEI-0400-26, C1C12 SOR
 Prepared by: MW Hawes
 Revision Number: 251
 Date: 5/18/99

UNIT ONE
 REACTOR OPERATING DATA
 SECTION 5.6
 INTEGRAL ROD WORTH IN OVERLAP

HZP, Peak Xenon

Control Bank Position	Shutdown Bank Position Steps Withdrawn					50 EFPD	100 EFPD	200 EFPD	300 EFPD	400 EFPD
	SD E	SD D	SD C	SD B	SD A	0 - 75 EFPD IRW (PCM)	76 - 150 EFPD IRW (PCM)	151 - 250 EFPD IRW (PCM)	251 - 350 EFPD IRW (PCM)	351 - 490 EFPD IRW (PCM)
226	226	226	226	226	226	0	0	0	0	0
0	226	226	226	226	226	2814	2820	2843	2876	2924
0	0	226	226	226	226	3471	3480	3518	3575	3643
0	0	0	226	226	226	4179	4190	4224	4272	4341
0	0	0	0	226	226	5034	5043	5067	5100	5170
0	0	0	0	0	226	5797	5810	5846	5896	5992
0	0	0	0	0	0	6074	6094	6130	6171	6272

UNIT ONE
 REACTOR OPERATING DATA
 SECTION 5.6
 INTEGRAL ROD WORTH IN OVERLAP

HFP, Equilibrium Xenon

Control Bank Position Steps Withdrawn				50 EFPD	100 EFPD	200 EFPD	300 EFPD	400 EFPD
Bk A	Bk B	Bk C	Bk D	0 - 75 EFPD IRW (PCM)	76 - 150 EFPD IRW (PCM)	151 - 250 EFPD IRW (PCM)	251 - 350 EFPD IRW (PCM)	351 - 490 EFPD IRW (PCM)
226	226	226	226	0	0	0	0	0
226	226	226	225	1	1	1	2	2
226	226	226	220	5	6	8	10	13
226	226	226	215	9	11	14	17	23
226	226	226	210	13	16	21	25	33
226	226	226	205	23	27	34	41	53
226	226	226	200	33	38	47	57	72
226	226	226	195	43	49	60	73	91
226	226	226	190	54	60	73	89	110
226	226	226	185	66	74	89	107	131
226	226	226	180	78	88	105	125	152
226	226	226	175	90	103	122	144	173
226	226	226	170	103	117	138	162	194
226	226	226	165	117	132	154	179	213
226	226	226	160	131	146	170	197	231
226	226	226	155	145	161	186	214	250
226	226	226	150	158	176	202	232	269
226	226	226	145	173	191	219	249	288
226	226	226	140	188	207	235	266	306
226	226	226	135	203	222	252	284	324
226	226	226	130	218	237	268	301	342
226	226	226	125	233	253	284	318	360
226	226	226	120	249	269	301	335	377
226	226	226	116	261	281	314	348	390
226	226	226	110	279	300	334	369	411
226	226	221	105	299	320	355	392	437
226	226	216	100	318	340	377	416	464
226	226	211	95	345	369	410	452	504
226	226	206	90	372	398	442	488	544
226	226	201	85	399	427	475	524	584

UNIT ONE
 REACTOR OPERATING DATA
 SECTION 5.6
 INTEGRAL ROD WORTH IN OVERLAP

HFP, Equilibrium Xenon

Control Bank Position Steps Withdrawn				50 EFPD	100 EFPD	200 EFPD	300 EFPD	400 EFPD
Bk A	Bk B	Bk C	Bk D	0 - 75 EFPD IRW (PCM)	76 - 150 EFPD IRW (PCM)	151 - 250 EFPD IRW (PCM)	251 - 350 EFPD IRW (PCM)	351 - 490 EFPD IRW (PCM)
226	226	196	80	427	455	508	560	624
226	226	191	75	461	491	545	600	669
226	226	186	70	495	526	582	641	713
226	226	181	65	529	562	619	682	758
226	226	176	60	563	597	657	722	803
226	226	171	55	599	637	697	764	846
226	226	166	50	636	676	738	805	888
226	226	161	45	673	716	779	847	931
226	226	156	40	710	756	820	889	973
226	226	151	35	750	795	860	930	1016
226	226	146	30	791	834	900	971	1059
226	226	141	25	832	873	940	1012	1102
226	226	136	20	872	911	980	1053	1145
226	226	131	15	911	950	1019	1093	1186
226	226	126	10	949	988	1058	1133	1226
226	226	121	5	987	1027	1097	1173	1267
226	226	116	0	1025	1065	1136	1213	1307
226	226	110	0	1048	1088	1159	1237	1332
226	221	105	0	1078	1118	1191	1270	1367
226	216	100	0	1108	1148	1222	1304	1402
226	211	95	0	1147	1188	1263	1347	1449
226	206	90	0	1186	1227	1305	1391	1495
226	201	85	0	1225	1267	1346	1434	1541
226	196	80	0	1264	1307	1387	1478	1587
226	191	75	0	1310	1353	1434	1526	1636
226	186	70	0	1356	1399	1481	1574	1685
226	181	65	0	1402	1446	1528	1622	1734
226	176	60	0	1448	1492	1575	1669	1783
226	171	55	0	1495	1538	1622	1717	1830
226	166	50	0	1541	1585	1668	1764	1876

UNIT ONE
 REACTOR OPERATING DATA
 SECTION 5.6
 INTEGRAL ROD WORTH IN OVERLAP

HFP, Equilibrium Xenon

Control Bank Position Steps Withdrawn				50 EFPD	100 EFPD	200 EFPD	300 EFPD	400 EFPD
Bk A	Bk B	Bk C	Bk D	0 - 75 EFPD IRW (PCM)	76 - 150 EFPD IRW (PCM)	151 - 250 EFPD IRW (PCM)	251 - 350 EFPD IRW (PCM)	351 - 490 EFPD IRW (PCM)
226	161	45	0	1588	1631	1714	1812	1922
226	156	40	0	1635	1678	1761	1859	1969
226	151	35	0	1685	1728	1809	1905	2015
226	146	30	0	1736	1778	1858	1951	2062
226	141	25	0	1787	1828	1907	1997	2109
226	136	20	0	1838	1878	1956	2043	2156
226	131	15	0	1882	1921	1998	2085	2196
226	126	10	0	1926	1964	2041	2126	2237
226	121	5	0	1970	2007	2084	2167	2278
226	116	0	0	2014	2049	2126	2209	2319
226	110	0	0	2041	2075	2152	2233	2344
221	105	0	0	2071	2105	2177	2260	2372
216	100	0	0	2101	2134	2203	2286	2400
211	95	0	0	2134	2168	2238	2322	2437
206	90	0	0	2166	2203	2272	2358	2475
201	85	0	0	2199	2237	2307	2394	2513
196	80	0	0	2232	2271	2341	2429	2551
191	75	0	0	2272	2307	2378	2468	2592
186	70	0	0	2312	2343	2415	2506	2634
181	65	0	0	2352	2379	2452	2544	2676
176	60	0	0	2392	2415	2489	2582	2718
171	55	0	0	2431	2456	2529	2622	2758
166	50	0	0	2470	2496	2569	2663	2799
161	45	0	0	2510	2537	2609	2703	2839
156	40	0	0	2549	2578	2649	2744	2880
151	35	0	0	2590	2618	2689	2783	2920
146	30	0	0	2630	2658	2728	2823	2960
141	25	0	0	2671	2698	2767	2863	3000
136	20	0	0	2712	2738	2807	2903	3041
131	15	0	0	2742	2768	2838	2934	3072

UNIT ONE
 REACTOR OPERATING DATA
 SECTION 5.6
 INTEGRAL ROD WORTH IN OVERLAP

HFP, Equilibrium Xenon

Control Bank Position Steps Withdrawn				50 EFPD	100 EFPD	200 EFPD	300 EFPD	400 EFPD
Bk A	Bk B	Bk C	Bk D	0 - 75 EFPD IRW (PCM)	76 - 150 EFPD IRW (PCM)	151 - 250 EFPD IRW (PCM)	251 - 350 EFPD IRW (PCM)	351 - 490 EFPD IRW (PCM)
126	10	0	0	2772	2799	2868	2965	3103
121	5	0	0	2802	2829	2899	2996	3134
116	0	0	0	2832	2859	2930	3027	3165
110	0	0	0	2850	2877	2948	3046	3183
105	0	0	0	2865	2892	2964	3062	3199
100	0	0	0	2879	2907	2979	3078	3215
95	0	0	0	2895	2922	2995	3094	3230
90	0	0	0	2910	2938	3011	3109	3245
85	0	0	0	2925	2953	3026	3125	3260
80	0	0	0	2941	2968	3042	3141	3275
75	0	0	0	2955	2982	3057	3155	3288
70	0	0	0	2969	2997	3071	3170	3302
65	0	0	0	2984	3011	3086	3184	3315
60	0	0	0	2998	3026	3101	3198	3328
55	0	0	0	3012	3040	3115	3213	3342
50	0	0	0	3026	3055	3129	3227	3356
45	0	0	0	3041	3069	3143	3242	3370
40	0	0	0	3055	3083	3158	3256	3384
35	0	0	0	3069	3097	3170	3266	3392
30	0	0	0	3082	3110	3183	3276	3400
25	0	0	0	3096	3123	3195	3287	3407
20	0	0	0	3109	3137	3208	3297	3415
15	0	0	0	3118	3145	3216	3303	3421
10	0	0	0	3127	3153	3223	3310	3427
5	0	0	0	3135	3161	3231	3317	3433
0	0	0	0	3144	3169	3238	3324	3438

Source: CNEI-0400-26
Prepared by: M.W. Hawes
Revision Number: 251
Date: 5/18/99

UNIT ONE
REACTOR OPERATING DATA
SECTION 5.7
TOTAL AVAILABLE ROD WORTH

Total Available RCCA Worth
(HZP, Eq Xe, Eq Sm)

The minimum total rod worth available during cycle	5858 PCM
Maximum stuck rod worth during cycle (ppmb)	111 PPM
Maximum stuck rod worth during cycle (pcm)	835 PCM
Total rod worth less max stuck rod worth	5023 PCM
Less 10% uncertainty	-502 PCM
Total available rod worth	4521 PCM
Transient Flux Redistribution Allowance	265 PCM

UNIT ONE
 REACTOR OPERATING DATA
 SECTION 5.8
 INOPERABLE RCCA WORTHS

<u>CRDM NUMBER</u>	<u>CRDM LOCATION</u>	<u>WORTH (PCM)</u>	<u>CRDM NUMBER</u>	<u>CRDM LOCATION</u>	<u>WORTH (PCM)</u>
SA2-1	B-4	36	CA1-2	H-10	677
CB2-1	B-6	90	SE1-3	H-12	431
CC1-2	B-8	33	CC1-3	H-14	33
CB1-2	B-10	90	SB2-4	J-3	202
SA1-2	B-12	36	SB1-3	J-13	202
SD1-1	C-5	326	CB2-4	K-2	90
SB2-1	C-7	202	CC2-4	K-6	677
SB1-2	C-9	202	CA2-2	K-8	677
SC1-2	C-11	326	CC2-3	K-10	677
SA1-1	D-2	36	CB1-3	K-14	90
CD1-1	D-4	397	SD1-4	L-3	326
SE1-2	D-8	431	SC1-3	L-13	326
CD2-1	D-12	397	SA2-4	M-2	36
SA2-2	D-14	36	CD2-2	M-4	397
SC1-1	E-3	326	SE1-4	M-8	431
SD1-2	E-13	326	CD1-2	M-12	397
CB1-1	F-2	90	SA1-3	M-14	36
CC2-1	F-6	677	SC1-4	N-5	326
CA2-1	F-8	677	SB1-4	N-7	202
CC2-2	F-10	677	SB2-3	N-9	202
CB2-2	F-14	90	SD1-3	N-11	326
SB1-1	G-3	202	SA1-4	P-4	36
SB2-2	G-13	202	CB1-4	P-6	90
CC1-1	H-2	33	CC1-4	P-8	33
SE1-1	H-4	431	CB2-3	P-10	90
CA1-1	H-6	677	SA2-3	P-12	36
CD2-3	H-8	411			

NOTE: If more than 1 inoperable rod is known to exist then use the worth of the highest worth inoperable rod from the table above and add 835 pcm for each additional known inoperable rod.

Total Power Defect (PCM) as a Function of Power and Cycle Burnup
from 0 - 100% FP

BURNUP (EFPD)	POWER (%FP)										
	0	5	10	15	20	25	30	35	40	45	50
0	0	80	160	240	320	400	477	554	631	707	784
20	0	82	165	247	330	412	490	569	648	726	805
40	0	84	168	252	336	420	499	579	659	738	818
60	0	85	170	256	341	426	507	587	668	749	829
80	0	86	173	259	346	432	514	596	677	759	840
100	0	88	176	263	351	439	521	604	686	769	851
120	0	90	179	269	358	448	532	616	699	783	867
140	0	91	183	274	365	457	542	627	712	798	883
160	0	93	186	279	373	466	552	639	725	812	899
180	0	95	190	285	380	475	563	650	738	826	914
200	0	97	193	290	387	484	573	662	751	841	930
220	0	99	198	297	396	495	586	677	768	860	951
240	0	101	202	303	404	506	599	692	785	879	972
260	0	103	207	310	413	516	612	707	802	898	993
280	0	105	211	316	422	527	625	722	819	917	1014
300	0	108	215	323	431	538	638	737	836	936	1035
320	0	111	221	332	442	553	655	757	859	960	1062
340	0	114	227	341	454	568	672	776	881	985	1090
360	0	116	233	349	466	582	689	796	903	1010	1117
380	0	119	239	358	477	597	706	816	925	1035	1144
400	0	122	245	367	489	611	723	835	948	1060	1172
420	0	125	250	376	501	626	741	856	971	1086	1201
440	0	128	256	384	513	641	758	876	994	1112	1229
460	0	131	262	393	524	655	776	896	1017	1138	1258
480	0	134	268	402	536	670	793	917	1040	1164	1287
490	0	135	271	406	542	677	802	927	1052	1177	1301

UNIT ONE
REACTOR OPERATING DATA
SECTION 5.9
POWER DEFECT

Source: CNEI-0400-26
Prepared By: MW Hawes
Revision 251
Date: 5/18/99
Page 1 of 2

Total Power Defect (PCM) as a Function of Power and Cycle Burnup
from 0 - 100% FP

BURNUP (EFPD)	POWER (%FP)									
	55	60	65	70	75	80	85	90	95	100
0	863	941	1020	1098	1176	1256	1335	1415	1494	1574
20	884	964	1043	1123	1202	1284	1365	1447	1528	1609
40	898	979	1059	1140	1220	1303	1386	1469	1552	1635
60	910	992	1073	1154	1236	1320	1405	1489	1574	1658
80	922	1005	1087	1169	1251	1337	1423	1509	1595	1681
100	934	1018	1101	1184	1267	1354	1442	1529	1616	1704
120	952	1037	1122	1206	1291	1381	1470	1560	1649	1738
140	969	1056	1142	1229	1316	1407	1499	1590	1682	1773
160	987	1075	1163	1252	1340	1434	1527	1621	1715	1808
180	1004	1094	1184	1274	1364	1460	1556	1652	1748	1843
200	1022	1114	1205	1297	1389	1487	1585	1682	1780	1878
220	1045	1138	1232	1326	1420	1520	1621	1721	1822	1922
240	1068	1163	1259	1355	1451	1554	1657	1760	1863	1967
260	1091	1188	1286	1384	1482	1588	1693	1799	1905	2011
280	1114	1213	1313	1413	1513	1621	1730	1838	1946	2055
300	1137	1238	1340	1442	1544	1655	1766	1877	1988	2099
320	1167	1271	1375	1479	1584	1698	1812	1927	2041	2155
340	1196	1303	1410	1517	1624	1741	1859	1976	2094	2211
360	1226	1336	1445	1554	1664	1784	1905	2026	2147	2268
380	1256	1368	1480	1592	1704	1828	1952	2076	2200	2324
400	1286	1400	1515	1629	1743	1871	1998	2125	2253	2380
420	1318	1435	1552	1669	1786	1917	2048	2178	2309	2440
440	1349	1469	1589	1709	1829	1963	2097	2231	2365	2500
460	1381	1503	1626	1749	1871	2009	2146	2284	2422	2559
480	1412	1538	1663	1788	1914	2055	2196	2337	2478	2619
490	1428	1555	1682	1808	1935	2078	2221	2364	2506	2649

UNIT ONE
REACTOR OPERATING DATA
SECTION 5.9
POWER DEFECT

Source: CNEI-0400-26
Prepared By: MW Hawes
Revision 251
Date: 5/18/99
Page 2 of 2

UNIT ONE
 REACTOR OPERATING DATA
 SECTION 5.10
 MODERATOR AND ISOTHERMAL TEMPERATURE COEFFICIENTS

Source: CNEI-0400-26
 Prepared By: M W Hawes
 Revision Number: 251
 Date: 5/18/99

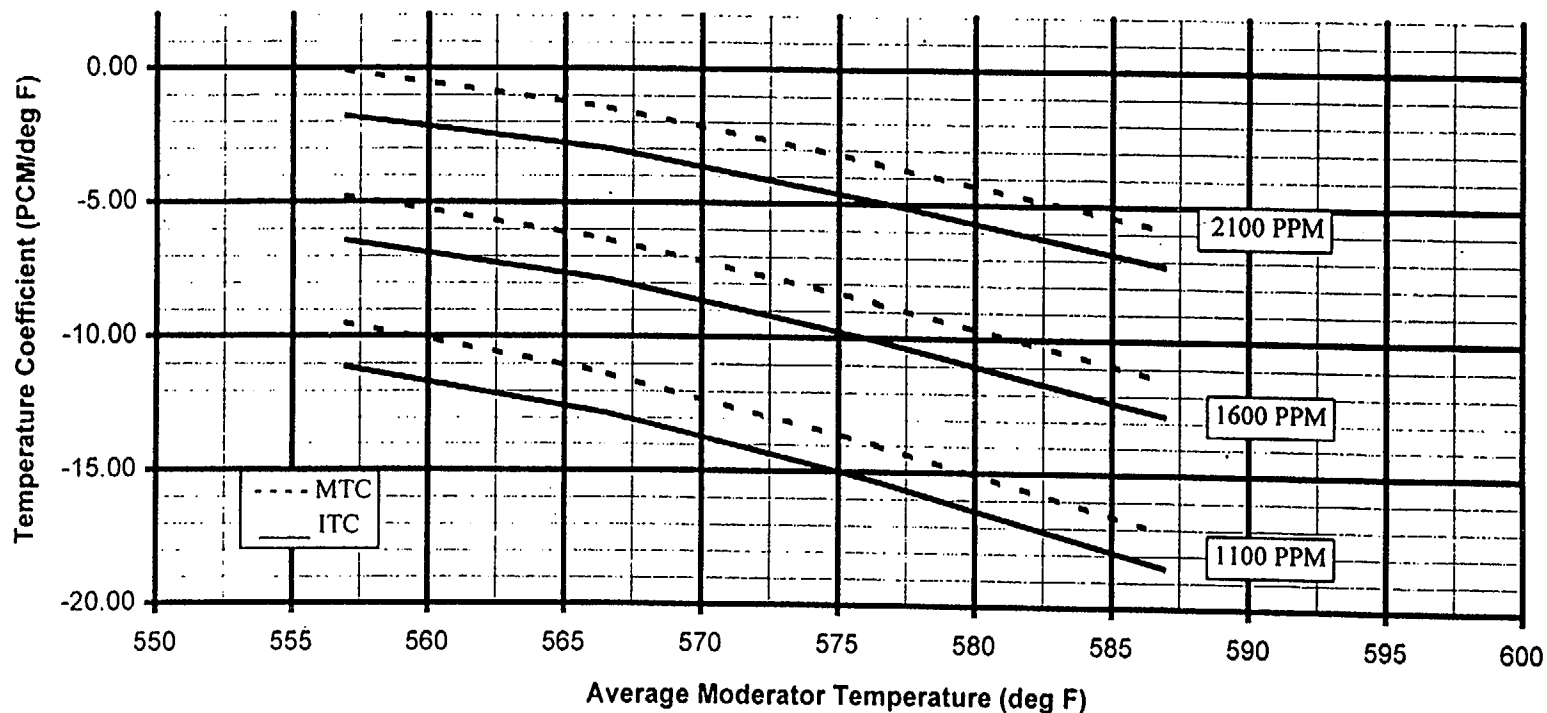

Temp.	1100 PPM ITC	1600 PPM ITC	2100 PPM ITC	1100 PPM MTC	1600 PPM MTC	2100 PPM MTC
557	-11.14	-6.44	-1.81	-9.52	-4.78	-0.10
566.6	-12.85	-7.88	-3.00	-11.38	-6.38	-1.46
576.4	-15.37	-10.10	-4.91	-14.00	-8.69	-3.48
586.9	-18.45	-12.76	-7.20	-17.15	-11.42	-5.84

UNIT ONE
 REACTOR OPERATING DATA
 SECTION 5.11
 MINIMUM SHUTDOWN MARGIN BORON
 Required Boron Concentration for 1.0% Shutdown Margin
 as a Function of Temperature and Burnup

CORE AVERAGE TEMPERATURE (°F)

BURNUP (EFPD)	33	68	70	80	90	100	110	120	130	140	150	160	170	180	190	200
0	1885	1876	1876	1873	1871	1869	1867	1865	1863	1861	1859	1857	1855	1853	1850	1848
20	1849	1840	1839	1837	1835	1833	1831	1829	1827	1825	1823	1821	1819	1817	1815	1812
40	1813	1804	1803	1801	1799	1797	1795	1793	1791	1789	1787	1785	1783	1781	1779	1776
60	1777	1768	1767	1765	1763	1761	1759	1757	1755	1753	1751	1749	1747	1745	1743	1740
80	1741	1732	1732	1729	1727	1725	1723	1721	1719	1717	1715	1713	1711	1709	1707	1704
100	1705	1696	1696	1693	1691	1689	1687	1685	1683	1681	1679	1677	1675	1673	1670	1668
120	1669	1660	1659	1657	1655	1653	1651	1649	1647	1645	1643	1641	1638	1636	1634	1632
140	1633	1624	1623	1621	1619	1616	1614	1612	1610	1608	1606	1604	1602	1600	1597	1595
160	1596	1587	1587	1584	1582	1580	1578	1576	1573	1571	1569	1567	1565	1563	1561	1558
180	1559	1550	1550	1547	1545	1543	1541	1539	1537	1534	1532	1530	1528	1526	1524	1521
200	1521	1513	1513	1510	1508	1506	1504	1502	1500	1497	1495	1493	1491	1489	1486	1484
220	1481	1475	1475	1473	1471	1469	1467	1465	1463	1460	1458	1456	1454	1451	1449	1447
240	1443	1437	1437	1435	1433	1431	1429	1427	1425	1423	1420	1418	1416	1414	1411	1409
260	1404	1398	1398	1396	1394	1392	1390	1388	1386	1384	1382	1379	1377	1375	1373	1370
280	1365	1359	1358	1356	1354	1352	1350	1348	1346	1344	1341	1339	1337	1335	1332	1330
300	1326	1318	1318	1315	1313	1311	1309	1307	1305	1302	1300	1298	1296	1294	1291	1289
320	1285	1276	1275	1273	1271	1268	1266	1264	1262	1260	1258	1255	1253	1251	1248	1246
340	1241	1233	1232	1230	1227	1225	1223	1221	1219	1216	1214	1212	1210	1207	1205	1202
360	1199	1189	1188	1186	1183	1181	1179	1177	1174	1172	1170	1168	1165	1163	1160	1157
380	1155	1145	1144	1141	1139	1137	1134	1132	1130	1128	1125	1123	1120	1118	1115	1112
400	1111	1100	1099	1097	1094	1092	1090	1087	1085	1083	1081	1078	1075	1072	1069	1066
420	1067	1055	1055	1052	1050	1047	1045	1043	1040	1038	1036	1033	1030	1027	1024	1020
440	1022	1011	1011	1008	1006	1003	1001	998	996	994	991	988	985	982	979	975
460	978	967	967	964	962	959	957	954	952	949	947	944	941	938	935	931
480	934	924	924	921	919	916	914	911	909	906	903	900	897	894	891	887
490	912	903	902	900	897	895	892	890	887	885	882	879	876	873	870	866

NOTE: 1) Tech Spec Refueling boron concentration is 2750 ppmb (per C1C12 COLR)

2) Fill and Vent Boron concentration is 1971 ppmb.

UNIT ONE
REACTOR OPERATING DATA
SECTION 5.11
MINIMUM SHUTDOWN MARGIN BORON

Required Boron Concentration for 1.3% Shutdown Margin
as a Function of Temperature and Burnup

CORE AVERAGE TEMPERATURE (°F)

BURNUP (EFPD)	200	225	250	275	300	325	350	375	400	425	450	475	500	525	550	557
0	1863	1857	1851	1845	1838	1830	1821	1809	1796	1782	1765	1742	1712	1674	1627	1612
20	1827	1821	1814	1808	1800	1792	1782	1771	1757	1743	1724	1701	1670	1632	1584	1569
40	1791	1784	1778	1771	1763	1755	1745	1733	1718	1704	1685	1660	1629	1590	1541	1525
60	1755	1748	1741	1734	1727	1718	1708	1695	1680	1665	1645	1620	1588	1547	1497	1481
80	1718	1712	1705	1698	1690	1681	1671	1658	1643	1627	1606	1580	1547	1505	1454	1437
100	1682	1675	1669	1662	1654	1645	1634	1621	1605	1588	1567	1540	1506	1463	1410	1393
120	1645	1639	1632	1626	1618	1608	1597	1584	1567	1550	1528	1501	1465	1421	1366	1348
140	1609	1602	1596	1589	1581	1572	1560	1546	1530	1512	1489	1461	1424	1378	1322	1304
160	1572	1565	1559	1552	1544	1535	1523	1509	1492	1473	1450	1421	1383	1335	1277	1259
180	1534	1528	1522	1515	1507	1497	1485	1471	1453	1434	1411	1380	1341	1292	1232	1213
200	1497	1491	1484	1477	1469	1459	1447	1432	1414	1395	1370	1339	1299	1249	1188	1168
220	1460	1453	1446	1439	1430	1420	1408	1393	1374	1355	1330	1297	1257	1206	1143	1123
240	1421	1414	1407	1400	1391	1381	1368	1353	1334	1314	1288	1255	1213	1161	1098	1077
260	1382	1375	1368	1360	1351	1340	1327	1311	1292	1271	1244	1211	1168	1115	1050	1030
280	1342	1335	1328	1321	1311	1300	1286	1268	1248	1226	1199	1165	1121	1067	1001	980
300	1300	1295	1288	1280	1270	1258	1243	1225	1203	1181	1153	1117	1073	1018	950	929
320	1257	1252	1245	1237	1227	1214	1198	1179	1157	1134	1105	1069	1023	967	898	876
340	1212	1208	1201	1193	1182	1168	1152	1132	1109	1085	1056	1019	972	915	844	822
360	1167	1162	1156	1147	1136	1122	1105	1085	1061	1036	1006	968	921	862	790	767
380	1122	1117	1110	1101	1089	1075	1057	1036	1011	987	956	917	868	808	734	711
400	1076	1071	1063	1054	1042	1027	1009	987	962	936	905	865	815	753	678	654
420	1030	1024	1017	1007	995	979	961	938	912	886	853	812	761	698	621	597
440	985	978	970	960	947	931	912	889	863	835	802	760	708	643	565	540
460	940	933	924	913	900	884	864	841	813	785	751	708	654	588	508	483
480	896	888	878	867	853	836	816	792	764	735	700	655	601	533	452	426
490	874	866	856	844	830	813	793	768	740	710	674	629	574	506	424	398

NOTE: 1) Tech Spec Refueling boron concentration is 2750 ppmb (per C1C12 COLR)

2) Fill and Vent Boron concentration is 1971 ppmb.

Boron Concentration (PPMB) for K-eff = 0.99 as a function of
Temperature and Burnup with *Control Banks Only Inserted*

Bounds ARI cases with Highest Worth Bank Withdrawn

NC SYSTEM AVERAGE TEMPERATURE (°F)

BURNUP (EFPD)	325	350	375	400	425	450	475	500	525	550	557
0	1974	1969	1966	1958	1948	1936	1927	1907	1883	1849	1838
20	1921	1916	1912	1903	1893	1880	1870	1849	1824	1789	1777
40	1875	1870	1365	1856	1845	1832	1821	1799	1772	1736	1724
60	1837	1831	1826	1817	1805	1791	1779	1756	1728	1690	1678
80	1818	1812	1806	1796	1784	1769	1757	1733	1705	1665	1652
100	1783	1776	1770	1759	1746	1731	1718	1693	1663	1622	1609
120	1746	1738	1732	1720	1707	1691	1677	1651	1620	1578	1564
140	1707	1700	1692	1680	1666	1649	1634	1608	1576	1532	1517
160	1664	1656	1648	1635	1620	1602	1587	1559	1526	1481	1466
180	1624	1615	1607	1593	1578	1559	1543	1514	1480	1432	1417
200	1583	1574	1565	1551	1534	1515	1498	1468	1433	1384	1368
220	1542	1532	1523	1508	1491	1471	1453	1422	1385	1335	1319
240	1500	1491	1480	1465	1447	1426	1408	1376	1338	1286	1269
260	1457	1447	1436	1420	1402	1380	1361	1328	1288	1235	1218
280	1412	1402	1391	1374	1355	1332	1312	1278	1237	1183	1166
300	1367	1356	1344	1327	1307	1283	1263	1227	1185	1130	1112
320	1320	1309	1296	1279	1258	1233	1212	1175	1132	1075	1057
340	1273	1261	1248	1229	1208	1182	1160	1122	1077	1018	1000
360	1222	1209	1195	1176	1153	1127	1104	1065	1018	957	937
380	1174	1160	1146	1126	1102	1075	1051	1010	962	899	879
400	1125	1111	1096	1075	1050	1022	997	955	906	841	820
420	1077	1062	1046	1024	999	970	943	900	849	783	761
440	1028	1012	996	973	947	917	889	844	793	724	702
460	979	963	946	923	895	864	835	789	736	666	643
480	930	913	896	872	843	811	780	733	679	607	584
490	906	888	871	846	817	784	753	705	650	578	554

UNIT ONE REACTOR OPERATING DATA
SECTION 5.12
MODE 3 BORON CONCENTRATION

SOURCE CNEI-0400-26
PREPARED BY M.W.Hawes
REVISION 251
DATE 5/18/99

Boron Concentration (PPMB) for K-eff = 0.99 as a function of
Temperature and Burnup with *Control Banks Only Inserted*

Bounds ARI cases with Highest Worth Bank Withdrawn

NC SYSTEM AVERAGE TEMPERATURE (°F)

BURNUP (EFPD)	68	75	100	125	150	175	200	225	250	275	300
0	2000	1999	1996	1993	1990	1988	1986	1984	1982	1981	1978
20	1949	1948	1944	1941	1939	1936	1934	1932	1929	1928	1925
40	1904	1903	1899	1896	1894	1892	1889	1886	1884	1883	1880
60	1867	1866	1861	1858	1857	1854	1851	1849	1846	1845	1842
80	1848	1847	1843	1840	1837	1835	1832	1830	1828	1827	1823
100	1813	1812	1808	1805	1802	1799	1797	1795	1792	1792	1788
120	1777	1776	1772	1769	1766	1763	1761	1758	1756	1756	1751
140	1740	1738	1735	1731	1728	1725	1723	1720	1718	1718	1713
160	1699	1697	1694	1690	1687	1684	1681	1679	1676	1675	1670
180	1660	1658	1655	1651	1648	1645	1642	1639	1636	1636	1630
200	1620	1619	1615	1611	1608	1605	1602	1599	1596	1596	1590
220	1580	1579	1575	1571	1568	1565	1562	1558	1555	1555	1549
240	1540	1539	1535	1531	1527	1524	1521	1518	1515	1514	1508
260	1498	1497	1493	1489	1485	1482	1479	1475	1472	1472	1465
280	1455	1454	1450	1446	1442	1439	1435	1432	1428	1428	1421
300	1412	1411	1406	1402	1398	1395	1391	1387	1383	1383	1376
320	1368	1366	1362	1357	1354	1350	1346	1342	1338	1337	1330
340	1323	1322	1317	1312	1309	1305	1301	1296	1292	1291	1283
360	1275	1274	1269	1265	1260	1256	1253	1248	1243	1241	1233
380	1229	1228	1223	1219	1215	1210	1206	1202	1197	1194	1185
400	1184	1183	1178	1173	1169	1164	1160	1155	1149	1146	1137
420	1139	1137	1133	1128	1123	1118	1114	1108	1102	1099	1089
440	1094	1092	1087	1082	1077	1072	1067	1061	1055	1051	1041
460	1048	1047	1042	1037	1032	1026	1021	1015	1008	1004	993
480	1003	1002	997	991	986	980	974	968	960	956	944
490	981	979	974	969	963	957	951	944	937	932	920

UNIT ONE REACTOR OPERATING DATA
SECTION 5.12
MODE 3 BORON CONCENTRATION

SOURCE CNEI-0400-26
PREPARED BY M.W.Hawes
REVISION 251
DATE 5/18/99

SOURCE CNEI-0400-26
 PREPARED BY M.W.Hawes
 REVISION 251
 DATE 5/18/99

UNIT ONE REACTOR OPERATING DATA
 SECTION 5.13
 SHUTDOWN FISSION PRODUCT CORRECTION

Time (hours)	Time (days)	Correction (ppm)	Time (hours)	Time (days)	Correction (ppm)	Time (hours)	Time (days)	Correction (ppm)
0	0.00	0.0	240	10.00	49.0	1056	44.00	55.3
6	0.25	2.7	246	10.25	49.0	1080	45.00	55.4
12	0.50	5.5	252	10.50	49.1	1104	46.00	55.6
18	0.75	9.3	258	10.75	49.2	1128	47.00	55.7
24	1.00	13.0	264	11.00	49.2	1152	48.00	55.8
30	1.25	15.7	270	11.25	49.3	1176	49.00	55.9
36	1.50	18.4	276	11.50	49.3	1200	50.00	56.1
42	1.75	21.1	282	11.75	49.4	1224	51.00	56.2
48	2.00	23.7	288	12.00	49.4	1248	52.00	56.3
54	2.25	26.3	312	13.00	49.7	1272	53.00	56.5
60	2.50	28.9	336	14.00	49.9	1296	54.00	56.6
66	2.75	31.6	360	15.00	50.1	1320	55.00	56.7
72	3.00	34.2	384	16.00	50.3	1344	56.00	56.8
78	3.25	35.1	408	17.00	50.6	1368	57.00	57.0
84	3.50	36.1	432	18.00	50.8	1392	58.00	57.1
90	3.75	37.1	456	19.00	51.0	1416	59.00	57.2
96	4.00	38.0	480	20.00	51.2	1440	60.00	57.4
102	4.25	39.0	504	21.00	51.5	1464	61.00	57.3
108	4.50	39.9	528	22.00	51.7	1488	62.00	57.3
114	4.75	40.8	552	23.00	51.9	1512	63.00	57.2
120	5.00	41.7	576	24.00	52.2	1536	64.00	57.2
126	5.25	42.1	600	25.00	52.4	1560	65.00	57.2
132	5.50	42.5	624	26.00	52.6	1680	70.00	57.0
138	5.75	42.8	648	27.00	52.8	1800	75.00	56.8
144	6.00	43.2	672	28.00	53.1	1920	80.00	56.7
150	6.25	43.6	696	29.00	53.3	2040	85.00	56.5
156	6.50	43.9	720	30.00	53.5	2160	90.00	56.3
162	6.75	44.3	744	31.00	53.6	2280	95.00	56.2
168	7.00	44.6	768	32.00	53.8	2400	100.00	56.0
174	7.25	45.0	792	33.00	53.9	2520	105.00	55.8
180	7.50	45.4	816	34.00	54.0	2640	110.00	55.6
186	7.75	45.7	840	35.00	54.2	2760	115.00	55.5
192	8.00	46.1	864	36.00	54.3	2880	120.00	55.3
198	8.25	46.5	888	37.00	54.4	3000	125.00	55.1
204	8.50	46.8	912	38.00	54.5	3120	130.00	54.9
210	8.75	47.2	936	39.00	54.7	3240	135.00	54.7
216	9.00	47.5	960	40.00	54.8	3360	140.00	54.5
222	9.25	47.9	984	41.00	54.9	3480	145.00	54.3
228	9.50	48.3	1008	42.00	55.0	3600	50.00	54.1
234	9.75	48.6	1032	43.00	55.2			

Duke Power Company PROCEDURE PROCESS RECORD

2 MJ
(1) ID No. OP/O/A/6100/06
Revision 58

PREPARATION

(2) Station CATAWBA NUCLEAR STATION

(3) Procedure Title Reactivity Balance Calculation

(4) Prepared By [Signature] Date 6/9/99

Additional Changes Included. Yes No Update Audit Review Date Yes No

(5) Requires 10CFR50.59 evaluation?
 Yes (New procedure or revision with major changes)
 No (Revision with minor changes)
 No (To incorporate previously approved changes)

(6) Reviewed By [Signature] (QR) Date 6/9/99
Cross-Disciplinary Review By [Signature] (QR) NA Date 6-10-99
Reactivity Mgmt. Review By [Signature] (QR) NA Date 6-10-99

(7) Additional Reviews

Reviewed By _____ Date _____
Reviewed By _____ Date _____

(8) Temporary Approval (if necessary)

By _____ (SRO/QR) Date _____
By _____ (QR) Date _____

(9) APPROVED BY [Signature] Date 6/10/99

PERFORMANCE (Compare with control copy at least once every 14 calendar days while work is being performed)

(10) Compared with Control Copy _____ Date _____
Compared with Control Copy _____ Date _____
Compared with Control Copy _____ Date _____

(11) Dates(s) Performed _____
Work Order Number (W/O #) _____

COMPLETION

(12) Procedure Completion Verification

- Yes N/A Check lists and/or blanks properly initialed, signed, dated, or filled in NA, as appropriate?
- Yes N/A Listed enclosures attached?
- Yes N/A Data sheets attached, completed, dated and signed?
- Yes N/A Charts, graphs, etc. attached and properly dated, identified and marked?
- Yes N/A Procedure requirements met?

Verified By _____ Date _____

(13) Procedure Completion Approved _____ Date _____

(14) Remarks (attach additional pages, if necessary)

INFORMATION ONLY

DUKE POWER COMPANY
CATAWBA NUCLEAR STATION
REACTIVITY BALANCE CALCULATION
OP/0/A/6100/06

1.0 PURPOSE

- 1.1 To estimate critical NC System boron concentration before criticality based on other assumed core reactivity conditions.
- 1.2 To estimate critical control bank position before criticality based on other assumed core reactivity conditions.
- 1.3 To calculate shutdown margin in Modes 1 and 2 with UNTRIPPABLE RCCAs.
- 1.4 To calculate the NC System boron concentration at which shutdown margin will NOT be met in Modes 2 (with K-eff < 1.0), 3, 4, and 5.
- 1.5 To verify K-eff < 0.99 with shutdown banks withdrawn.
- 1.6 To calculate the NC System boron concentration at which refueling boron concentration will NOT be met in Mode 6.

2.0 LIMITS AND PRECAUTIONS

NOTE: All curves/tables used in this procedure are found in Unit One (Two) Reactor Operating Data (R.O.D.) manual.

- 2.1 Ensure all data used by this procedure are for the correct unit.
- 2.2 NC System T-AVG should be maintained within ± 1 °F of T-REF in Modes 1 and 2 to reduce uncertainties in calculations.
- 2.3 Shutdown margin (SDM) shall be ≥ 1000 pcm in Mode 5. (Tech Spec 3.1.1 and Enclosure 4.4)
- 2.4 SDM shall be ≥ 1300 pcm in Modes 1, 2, 3, and 4. (Tech Spec 3.1.1 and Enclosure 4.3, or 4.4)
- 2.5 Required refueling boron concentration is obtained from Tech Spec 3.9.1 and Enclosure 4.6.
- 2.6 If T-AVG is < 500 °F, credit for only 50% of xenon worth can be taken for verifying SDM.
- 2.7 NC System boron concentration shall be \geq required boron concentration for SDM at a new NC System T-AVG before beginning NC System T-AVG change in Modes 3, 4, and 5.
- 2.8 Criticality shall NOT be obtained outside the maximum window (± 750 pcm) of estimated critical control bank position.
- 2.9 Desired critical control bank position shall NOT be below the control bank insertion limits OR above any temporary control bank withdrawal limits.
- 2.10 Verification of K-eff < 0.99 with shutdown banks withdrawn shall only be performed above 200 °F.

3.0 PROCEDURE

- 3.1 For estimated critical NC System boron concentration (ECB), refer to Enclosure 4.1.
- 3.2 For estimated critical control bank position (ECP) refer to Enclosure 4.2.
- 3.3 For SDM calculation with untrippable RCCAs, refer to Enclosure 4.3.
- 3.4 For SDM verification in Modes 5, 4, 3, or 2 (with $K_{\text{eff}} < 1.0$), (with or without xenon credit), refer to Enclosure 4.4.
- 3.5 For Verification of $K_{\text{eff}} < 0.99$ with shutdown banks withdrawn, refer to Enclosure 4.5.
- 3.6 For refueling boron concentration verification in Mode 6, refer to Enclosure 4.6.
- 3.7 For instructions on running REACTBAL computer program, refer to Enclosure 4.7.
- 3.8 For Shutdown Fission Product Correction Factor, refer to Enclosure 4.8.

4.0 ENCLOSURES

- 4.1 Estimated Critical Boron Concentration (ECB).
- 4.2 Estimated Critical Control Bank Position (ECP).
- 4.3 Shutdown Margin - Modes 1 and 2 - Untrippable RCCA(s).
- 4.4 Shutdown Margin - (With or Without Xenon Credit).
- 4.5 Verification of $K_{\text{eff}} < 0.99$ with Shutdown Banks Withdrawn
- 4.6 Shutdown Boron Concentration - Mode 6.
- 4.7 REACTBAL Computer Program Directions.
- 4.8 Shutdown Fission Product Correction Factor

REACTIVITY BALANCE CALCULATION
OP/0/A/6100/06
ESTIMATED CRITICAL BORON CONCENTRATION (ECB)
ENCLOSURE 4.1

1.0 INITIAL CONDITIONS

1.1 Limits and Precautions have been reviewed.

2.0 PROCEDURE

NOTES: 1) Assume all values are positive unless otherwise indicated by parentheses. If parentheses precede the value [i.e. () _____ pcm], enter the sign provided with data. The calculations account for these sign conventions.

2) All ECB calculations must be performed independently by a Qualified Reactor Engineer and a Licensed Operator.

2.1 Access Reactivity Balance Program per Enclosure 4.7.

2.2 Select program option 1 (Estimated Critical Boron (ECB) Calculation).

NOTES: 1) Sign must be provided with Difference from Equilibrium Samarium [i.e., () _____ pcm].

2) If cycle burnup is ≤ 12 EFPD, 0 pcm should be used for Difference from Equilibrium Samarium.

2.3 Enter appropriate values as prompted.

2.4 Enter a desired critical rod position at least 1000 pcm above HZP Rod Insertion Limit of Control Bank C at 48 steps withdrawn (Section 5.8 of ROD Manual).

2.5 Print program results, label appropriately, and attach to this enclosure.

2.6 Ensure that separate, independent calculation has been performed per steps 2.1 through 2.5.

2.7 Verify that both attachments to this enclosure yield the same result.

NOTE: Separate performance of Enclosure 4.8 and verification of calculation in step 2.9 meets independent verification requirements for step 2.9.

2.8 If cycle burnup is > 12 EFPD, perform Enclosure 4.8 to determine Shutdown Fission Product Correction Factor.

2.9 Complete the following:

Description	Reference	Value
A. Calculated ECB	Attachment	ppm
B. Shutdown Fission Product Penalty (enter 0 if Encl. 4.8 not completed)	Encl. 4.8 (if applicable)	ppm
Corrected Estimated Critical Boron Concentration	(A) + (B)	ppm

Licensed Operator: _____ Date/Time: ____/____/____

Reactor Engineer: _____ Date/Time: ____/____/____

REACTIVITY BALANCE CALCULATION
OP/0/A/6100/06
ESTIMATED CRITICAL CONTROL BANK POSITION (ECP)
ENCLOSURE 4.2

1.0 INITIAL CONDITIONS

1.1 Limits and Precautions have been reviewed.

2.0 PROCEDURE

NOTES: 1) Assume all values are positive unless otherwise indicated by parentheses. If parentheses precede the value [i.e. () _____ pcm], enter the sign provided with data. The calculations account for these sign conventions.

2) All ECP calculations must be performed independently by a Qualified Reactor Engineer and a Licensed Operator.

2.1 If cycle burnup is > 12 EFPD, complete Enclosure 4.8.

2.2 Complete the following:

Description	Reference	Value
A. Current Measured Boron Conc	Chemistry Sample	ppm
B. Shutdown Fission Product Penalty (enter 0 if Encl 4.8 not completed)	Encl 4.8 (if applicable)	ppm
Corrected Boron Concentration for Input into REACTBAL	(A) - (B)	ppm

2.3 Access Reactivity Balance Program per Enclosure 4.7.

2.4 Select program option 2 (Estimated Critical Control Bank Position (ECP) Calculation).

NOTES: 1) Sign must be provided with Difference from Equilibrium Samarium [i.e., () _____ pcm].

2) If cycle burnup is \leq 12 EFPD, 0 pcm should be used for Difference from Equilibrium Samarium.

2.5 Enter appropriate values as prompted - use value from step 2.2 for Current Boron Concentration.

2.6 Verify that Rod Insertion Limits and (if applicable) Rod Withdrawal Limits will NOT be violated based on ECP results.

2.7 Print program results, label appropriately, and attach to this enclosure.

NOTE: Separate performance of Enclosure 4.8 and verification of calculation in step 2.2 meets independent verification requirements for step 2.2.

2.8 Ensure that separate, independent calculation has been performed per steps 2.1 through 2.7.

2.9 Verify that both attachments to this enclosure yield the same results.

Licensed Operator: _____ Date/Time: ____/____/____

Reactor Engineer: _____ Date/Time: ____/____/____

REACTIVITY BALANCE CALCULATION
OP/0/A/6100/06
SHUTDOWN MARGIN - UNTRIPPABLE RCCA(S) - MODES 1 & 2
ENCLOSURE 4.3

1.0 INITIAL CONDITIONS

1.1 Limits and Precautions have been reviewed.

2.0 PROCEDURE

NOTES: 1) In Modes 1 or 2 with all RCCAs trippable, shutdown margin is satisfied provided control banks are positioned above the Control Rod Insertion limits in Section 2.2 of the R.O.D. manual (and if Unit shutdown occurs, T-COLD remains above the Allowable Moderator Temperature limit of Section 2.6 of the R.O.D. manual.)

2) Assume all values are positive unless otherwise indicated by parentheses. If parentheses precede the value [i.e. () _____ pcm], record the sign provided with data. The calculations account for these sign conventions.

2.1 If performing a MANUAL calculation, N/A Step 2.2 (including all substeps).

2.2 Perform the following steps if using the REACTBAL program to complete the calculation:

2.2.1 Access Reactivity Balance Program per Enclosure 4.7.

2.2.2 Select program option 3 (Shutdown Margin Modes 1 & 2 With Untrippable RCCA(s)).

2.2.3 Enter appropriate values as prompted.

2.2.4 Print program results, label appropriately, and attach to this enclosure.

2.2.5 Ensure that a separate, independent calculation has been performed per steps 2.2.1 through 2.2.4.

2.2.6 Verify that both attachments to this enclosure yield the same results.

2.2.7 N/A the rest of this enclosure (steps 2.3 through 2.7).

Performed By: _____ Date/Time: _____ / _____

Verified By: _____ Date/Time: _____ / _____

2.3 Determine the following information:

Step	Description	Reference	Value
2.3.1	Unit	N/A	
2.3.2	Date/Time	N/A	
2.3.3	Present Thermal Power, Best Estimate	P1385	%
2.3.4	Present cycle burnup	P1457 or Reactor Group Duty Engineer	EFPD
2.3.5	Present control bank position	N/A	_____ SWD on Control Bank _____
2.3.6	Number of untrippable RCCA(s)	N/A	
2.3.7	Untrippable RCCA(s) core locations(s).	N/A	

REACTIVITY BALANCE CALCULATION
OP/0/A/6100/06
SHUTDOWN MARGIN - UNTRIPPABLE RCCA(S) - MODES 1 & 2
ENCLOSURE 4.3

- 2.4 Determine available reactivity worth of trippable RCCAs for present conditions:
- 2.4.1 Determine Total Available Rod Worth (Section 5.7 of R.O.D. manual) _____ pcm
 - 2.4.2 If there are multiple untrippable RCCAs, N/A steps 2.4.3 and 2.4.4
 - 2.4.3 Determine reactivity worth penalty for untrippable RCCA core location of Step 2.3.7 (Section 5.8 of R.O.D. manual). _____ pcm
 - 2.4.4 N/A steps 2.4.5 through 2.4.8.
 - 2.4.5 Determine untrippable RCCA of Step 2.3.7 with the highest reactivity worth penalty (Section 5.8 of ROD Manual). Core Location _____
 - 2.4.6 Record reactivity worth of the untrippable RCCA of Step 2.4.5 (Section 5.8 of ROD Manual). _____ pcm
 - 2.4.7 Determine maximum stuck rod worth during cycle (Section 5.7 of the R.O.D. manual). _____ pcm
 - 2.4.8 Calculate total untrippable RCCA reactivity worth penalty for multiple untrippable RCCAs per the table below.

Description	Reference	Value
A. Number of Untrippable RCCAs	Step 2.3.6	
B. Additional Penalty (Max Stuck Rod)	Step 2.4.7	pcm
C. Highest Penalty	Step 2.4.6	= pcm
Total untrippable RCCA Worth Penalty for Multiple RCCAs	{ [(A) - 1] X (B) } + (C)	pcm

- 2.4.9 Record Total Untrippable RCCA Penalty from Step 2.4.3 or Step 2.4.8, whichever is applicable. _____ pcm

NOTE:

Interpolation is not required in step 2.4.10. Reactivity worth may be determined by choosing the highest reactivity worth from Section 5.6 of the R.O.D Manual associated with rod positions that bound the present rod position.

- 2.4.10 Use present control bank position of Step 2.3.5 to look up specified data from Section 5.6 of ROD Manual and calculate inserted reactivity worth as follows:

$$\left(\frac{\text{_____ pcm}}{\text{(HZP, No Xenon)}} + \frac{\text{_____ pcm}}{\text{(HZP, Peak Xenon)}} \right) \times 0.5 = \text{_____ pcm}$$

REACTIVITY BALANCE CALCULATION
OP/0/A/6100/06
SHUTDOWN MARGIN - UNTRIPPABLE RCCA(S) - MODES 1 & 2
ENCLOSURE 4.3

2.4.11 Calculate available reactivity worth of trippable RCCAs:

Description	Reference	Value
A. Total Available Rod Worth	Step 2.4.1	pcm
B. Untrippable RCCAs Penalty	Step 2.4.9	pcm
C. Inserted Worth of Present Position	Step 2.4.10	pcm
Available Worth of Trippable RCCAs	(A) - (B) - (C)	pcm

NOTE: Interpolation of Power Defect is not required for step 2.5. Bounding burnups and power levels may be used to select the highest Power Defect from section 5.9 of the R.O.D. manual.

2.5 Determine worst case power defect for present conditions:

Description	Reference	Value
A. Total Power Defect at present thermal power (Step 2.3.3) and cycle burnup (Step 2.3.4)	Section 5.9 of R.O.D. manual	pcm
B. Transient Flux Redistribution Allowance	Section 5.7 of R.O.D. manual	pcm
Worst case power defect for present conditions:	(A) + (B)	pcm

CAUTION

SDM shall be within the limits specified by the COLR per Tech Spec 3.1.1.

2.6 Calculate SDM for present conditions:

Description	Reference	Value
A. Available worth of Trippable RCCAs	Step 2.4.11	pcm
B. Worst Case Power Defect	Step 2.5	pcm
Present SDM	(A) - (B)	() pcm

NOTE: Separate, independent calculation must be performed by the verifier.

2.7 Sign the appropriate space below. N/A the unsigned space.

Performed By: _____ Date/Time: ____/____/____

Verified By: _____ Date/Time: ____/____/____

REACTIVITY BALANCE CALCULATION
OP/0/A/6100/06
SHUTDOWN MARGIN - (WITH OR WITHOUT XENON CREDIT)
ENCLOSURE 4.4

1.0 INITIAL CONDITIONS

1.1 Limits and Precautions have been reviewed.

2.0 PROCEDURE

2.1 If performing a MANUAL calculation, N/A Step 2.2 (including all substeps).

2.2 Perform the following steps if using the REACTBAL program to complete the calculation:

2.2.1 Access Reactivity Balance Program per Enclosure 4.7.

NOTE: Program option 4 also applies to Mode 2 with K-eff < 1.0.

2.2.2 Select program option 4 (Shutdown Margin Modes 5, 4, or 3 (With and Without Xenon)).

NOTES: 1) Sign must be provided with Difference from Equilibrium Samarium [i.e., () _____ pcm].

2) If cycle burnup is ≤ 12 EFPD, 0 pcm should be used for Difference from Equilibrium Samarium.

2.2.3 Enter appropriate values as prompted.

2.2.4 Print program results, label appropriately, and attach to this enclosure.

2.2.5 Ensure that a separate, independent calculation has been performed per steps 2.2.1 through 2.2.4.

2.2.6 Verify that both attachments to this enclosure yield the same results.

2.2.7 N/A the rest of this enclosure (steps 2.3 through 2.9).

Performed By: _____ Date/Time: _____/_____/_____
 Verified By: _____ Date/Time: _____/_____/_____

NOTE: Assume all values are positive unless otherwise indicated by parentheses. If parentheses precede the value [i.e. () _____ pcm], record the sign provided with data. The calculations account for these sign conventions.

2.3 Determine the following information:

	Description	Reference	Value
2.3.1	Unit	N/A	
2.3.2	Date/Time	N/A	
2.3.3	Present NC System Boron Conc	N/A	ppm
2.3.4	Present NC System T-AVG	N/A	° F
2.3.5	Desired NC System T-AVG	N/A	° F
2.3.6	Present cycle burnup	P1457 or Reactor Group Duty Engineer	EFPD
2.3.7	Present Difference from Equilibrium Samarium Worth (use 0 pcm if burnup is ≤ 12 EFPD)	P1475 or Reactor Group Duty Engineer	() pcm
2.3.8	Date and time of latest valid Iodine and Xenon concentrations. N/A if xenon free.	Reactor Group Duty Engineer or current time if using OAC	_____/_____/_____

REACTIVITY BALANCE CALCULATION
OP/0/A/6100/06
SHUTDOWN MARGIN - (WITH OR WITHOUT XENON CREDIT)
ENCLOSURE 4.4

	Description	Reference	Value
2.3.9	Iodine concentration at time listed in step 2.3.8; 0 if xenon free.	P0124 or Reactor Group Duty Engineer	atm/cc
2.3.10	Xenon concentration at time listed in step 2.3.8; 0 if xenon free.	P0125 or Reactor Group Duty Engineer	atm/cc

NOTE: Interpolation is not required for step 2.4. Bounding temperatures and burnups may be used to select the highest boron concentration in Section 5.11 of R.O.D manual.

2.4 Determine the maximum required boron concentration _____ ppm for 1.0 or 1.3% SDM for the range of T-AVG of steps 2.3.4 and 2.3.5 at current cycle burnup (Step 2.3.6), from Section 5.11 of the R.O.D manual:

2.5 Calculate additional boron concentration penalties:

2.5.1 Calculate untrippable RCCA penalty:

Description	Reference	Value
A. Number of Untrippable RCCA(s) not fully inserted	N/A	
B. Boron Penalty per Untrippable rod	N/A	160 ppm
Untrippable RCCA Penalty	(A) X (B)	ppm

2.5.2 Enter Zero Power Physics Testing penalty; 100 ppm _____ ppm if physics testing is not complete, otherwise, enter 0 ppm.

2.5.3 Calculate total additional boron concentration penalty:

Description	Reference	Value
A. Untrippable RCCA Penalty	Step 2.5.1	ppm
B. Additional Boron Conc Penalty for ZPPT	Step 2.5.2	ppm
Total Boron Penalty	(A) + (B)	ppm

2.6 Calculate total required boron concentration for SDM:

Description	Reference	Value
A. Required SDM Boron	Step 2.4	ppm
B. Total Boron Penalty	Step 2.5.3	ppm
Total Required Boron Concentration for SDM (Xenon Free)	(A) + (B)	ppm

REACTIVITY BALANCE CALCULATION
OP/0/A/6100/06
SHUTDOWN MARGIN - (WITH OR WITHOUT XENON CREDIT)
ENCLOSURE 4.4

- 2.7 Determine the Boron Difference between Required Boron Concentration for SDM and current NC System boron concentration.

Description	Reference	Value
A. Total Required Boron Concentration for SDM	Step 2.6	ppm
B. Present NC System Boron Concentration	Step 2.3.3	ppm
Boron Difference	(A) - (B)	ppm

NOTE: A negative boron difference in Step 2.7 implies that SDM is maintained for Xenon free conditions.

- 2.7.1 If Boron Difference (Step 2.7) is negative, N/A Step 2.8.

- 2.8 Determine the Xenon Credit as follows:

NOTE: Interpolation is not required for step 2.8.1. Bounding NC System T-AVG and cycle burnup may be used to select the highest Differential Boron Worth from Section 5.3 of R.O.D manual.

- 2.8.1 Determine the ARI, Differential Boron Worth at _____ pcm/ppm lower T-AVG of Step 2.3.4 or 2.3.5 and cycle burnup of step 2.3.6 from Section 5.3 of the R.O.D. manual:

- 2.8.2 Calculate the reactivity worth of the boron difference:

Description	Reference	Value
A. Boron Difference	Step 2.7	ppm
B. ARI Differential Boron Worth	Step 2.8.1	pcm/ppm
Reactivity Worth of Boron Difference	(A) X (B)	pcm

- 2.8.3 Calculate the xenon worth that is required to ensure SDM at the present NC System boron.

- 2.8.3.1 If T-AVG is ≥ 500 ° F, calculate the Xenon Worth as follows:

Description	Reference	Value
A. Reactivity Worth	Step 2.8.2	pcm
B. Difference from Eq Sm Worth	Step 2.3.7	() pcm
Xenon Worth	{{(A) - (B)} / 0.85}	pcm

REACTIVITY BALANCE CALCULATION
OP/0/A/6100/06
SHUTDOWN MARGIN - (WITH OR WITHOUT XENON CREDIT)
ENCLOSURE 4.4

2.8.3.2 If T-AVG is < 500 ° F, calculate the Xenon Worth as follows:

Description	Reference	Value
A. Reactivity Worth	Step 2.8.2	pcm
B. Difference from Eq \$m Worth	Step 2.3.7	() pcm
Xenon Worth	{{(A) - (B)} X 2	pcm

2.8.4 Predict Xenon for approximately two days into the future using OAC Xenon Predict Program or Offline RPEXENPR program and data from 2.3.1 through 2.3.10.

Note: SDM is ensured between the Dates/Times of step 2.8.5 at the present NC System boron or higher. After the Date/Time of xenon decay of step 2.8.5, NC System boration will be required to maintain SDM.

2.8.5 Interpolate the Dates/Times from the xenon predict of step 2.8.4 that equal the xenon worth of step 2.8.3.

xenon build-in _____/_____/_____

xenon decay _____/_____/_____

NOTE: Separate, independent calculation must be performed by the verifier.

2.9 Sign the appropriate space below. N/A the unsigned space.

Performed By: _____ Date/Time: _____/_____/_____

Verified By: _____ Date/Time: _____/_____/_____

REACTIVITY BALANCE CALCULATION
OP/0/A/6100/06
VERIFICATION OF K-EFF < 0.99 WITH SHUTDOWN BANKS WITHDRAWN
ENCLOSURE 4.5

1.0 INITIAL CONDITIONS

1.1 Limits and Precautions have been reviewed.

2.0 PROCEDURE

NOTE: Assume all values are positive unless otherwise indicated by parentheses. If parentheses precede the value [i.e. () _____ pcm], enter the sign provided with data. The calculations account for these sign conventions.

2.1 If cycle burnup is > 12 EFPD, complete Enclosure 4.8. Label and attach.

2.2 Complete the following:

Description	Reference	Value
A. Current Measured Boron Conc	Chemistry Sample	ppm
B. Shutdown Fission Product Penalty (enter 0 if Encl 4.8 not completed)	Encl 4.8 (if applicable)	ppm
Corrected Boron Concentration for Input into REACTBAL	(A) - (B)	ppm

2.3 Access Reactivity Balance Program per Enclosure 4.7.

2.4 Select program option 5 (Verification of K-eff < 0.99 with Shutdown Banks Withdrawn).

NOTES: 1) Sign must be provided with Difference from Equilibrium Samarium [i.e., () _____ pcm].

2) If cycle burnup is \leq 12 EFPD, 0 pcm should be used for Difference from Equilibrium Samarium.

2.5 Enter appropriate values as prompted - use value from step 2.2 for Current Boron Concentration.

2.6 Print program results, label appropriately, and attach to this enclosure.

NOTE: Separate performance of Enclosure 4.8 and verification of calculation in step 2.2 meets independent verification requirements for step 2.2.

2.7 Ensure that separate, independent calculation has been performed per steps 2.1 through 2.6.

2.8 Verify that attachments to this enclosure yield the same result.

Performed By: _____ Date/Time: _____ / _____

Verified By: _____ Date/Time: _____ / _____

REACTIVITY BALANCE CALCULATION
OP/0/A/6100/06
SHUTDOWN BORON CONCENTRATION - MODE 6
ENCLOSURE 4.6

1.0 INITIAL CONDITIONS

1.1 Limits and Precautions have been reviewed.

2.0 PROCEDURE

- 2.1 Determine present boron concentration of the operating ND train. _____ ppm
- 2.2 Record Tech Spec Refueling Boron Concentration from bottom of page of Section 5.11 of the R.O.D. manual. _____ ppm
- 2.3 Verify present boron concentration of Step 2.1 is greater than refueling boron concentration of Step 2.2.

NOTE: Separate, independent calculation must be performed by the verifier.

2.6 Sign the appropriate space below. N/A the unsigned space.

Performed By: _____ Date/Time: ____/____/____

Verified By: _____ Date/Time: ____/____/____

REACTIVITY BALANCE CALCULATION
OP/0/A/6100/06
REACTBAL COMPUTER PROGRAM INSTRUCTIONS
ENCLOSURE 4.7

1.0 INITIAL CONDITIONS

1.1 Limits and Precautions have been reviewed.

2.0 PROCEDURE

NOTE: The following steps assume the use of the BOP PC located in the control room horseshoe.

2.1 Select (Double-Click) the Reactivity Balance icon on the desktop.

CAUTION

**Check all inputs for each screen carefully and correct as needed before proceeding to the next screen.
Ensure the correct Unit is specified.**

- 2.2 Select an option as directed by the procedure. Input data appropriately when prompted. Hit the enter key to move from one item to the next. If an error is made, there is an opportunity to re-enter data when the bottom of the screen is reached.
- 2.3 For Xenon predict calculations, Xenon and Iodine concentrations at a specific time while the Unit was at zero power are requested. This information can be obtained from the OAC (and related databases) or Reactor Engineering. The OAC point id's for these concentrations are C1(2)P0125 and C1(2)P0124.
- 2.4 Once the input screen is completed, results will be displayed. The program output will be printed in the Red Tag Room.
- 2.5 When finished using program, select option 8 to quit.

REACTIVITY BALANCE CALCULATION
OP/0/A/6100/06
SHUTDOWN FISSION PRODUCT CORRECTION FACTOR
ENCLOSURE 4.8

1.0 INITIAL CONDITIONS

1.1 Limits and Precautions have been reviewed.

2.0 PROCEDURE

2.1 If no previous Unit Trip/Shutdown has occurred in the last 3 EFPD, determine the Shutdown Fission Product Correction Factor as follows:

Description	Reference	Value
A. Date/Time of Unit Trip or Shutdown:	Control Room Log Books	____/____
B. Date/Time of anticipated Unit Startup:	N/A	____/____
C. Duration of Shutdown	(B) - (A)	hours
D. Shutdown Fission Product Correction Factor (using duration from C)	ROD Manual (Sec 5.13)	ppm

2.2 N/A Steps 2.3 through 2.5.

2.3 If previous Unit Trip/Shutdown has occurred in the last 1 EFPD, perform the following:

Description	Reference	Value
A. Date/Time of previous Unit Trip or Shutdown:	Control Room Log Books	____/____
B. Date/Time of anticipated Unit Startup:	Step 2.1(B)	____/____
C. Duration of Shutdown	(B) - (A)	hours
D. Shutdown Fission Product Correction Factor (using duration from C)	ROD Manual (Sec 5.13)	ppm

2.4 N/A Step 2.5.

REACTIVITY BALANCE CALCULATION
OP/0/A/6100/06
SHUTDOWN FISSION PRODUCT CORRECTION FACTOR
ENCLOSURE 4.8

2.5 If there has been 1 to 3 EFPD of burnup between present Unit Trip/Shutdown and previous Unit Trip/Shutdown, perform the following:

Description	Reference	Value
A. Date/Time of Unit Trip or Shutdown:	Control Room Log Books	____/____/____
B. Date/Time of anticipated Unit Startup:	N/A	____/____/____
C. Duration of Shutdown	(B) - (A)	_____ hours
D. Shutdown Fission Product Correction Factor - Present Shutdown (using duration from 2.5.C)	ROD Manual (Sec 5.13)	_____ ppm

2.5.1 If duration of shutdown from 2.5.C is > 72 hours Shutdown Fission Product Correction Factor is as shown in Step 2.5.D.

2.5.2 N/A Step 2.5.3.

2.5.3 If duration from 2.5.C is < 72 hours perform the following:

Description	Reference	Value
A. Date/Time of previous Unit Trip or Shutdown:	Control Room Log Books	____/____/____
B. Date/Time of previous Unit Startup:	Control Room Log Books	____/____/____
C. Duration of Previous Shutdown	(B) - (A)	_____ hours
D. Shutdown Fission Product Correction Factor - Previous Shutdown (using duration from 2.5.3.C)	ROD Manual (Sec 5.13)	_____ ppm
E. Shutdown Fission Product Correction Factor	(2.5.3.D) * 0.5 + (2.5.D)	_____ ppm

2.6 Ensure that separate, independent calculation has been performed and yields the same result.

Performed By: _____ Date/Time: ____/____/____

Verified By: _____ Date/Time: ____/____/____

**CATAWBA
INITIAL LICENSE EXAMINATION
JOB PERFORMANCE MEASURE**

JPM 3/ADMIN

Review and Sequence a Tagout

CANDIDATE

EXAMINER

Tools/Equipment/Procedures Needed:

Flow Diagram CN-1573-1.0
Flow Diagram CN-1574-2.5

READ TO OPERATOR

DIRECTION TO TRAINEE:

I will explain the initial conditions, and state the task to be performed. All control room steps shall be performed for this JPM, including any required communications. I will provide initiating cues and reports on other actions when directed by you. Ensure you indicate to me when you understand your assigned task. To indicate that you have completed your assigned task return the handout sheet I provided you.

INITIAL CONDITIONS:

Unit 1 is at 100% power. An NLO has completed an R&R to isolate 1B KC Heat Exchanger due to a tube leak per W/O 1234. The NLO requests you to sequence and evaluate the tagout. OP/0/A/6100/006C, Enclosure 4.18 (RN System Alignment for Train B KC Hx Cleaning) and OP/1/A/6400/005, Enclosure 4.8 (KC Train 1A Alignment for KC Hx 1B Cleaning) have been performed.

INITIATING CUE:

Review and sequence R&R.

JPM OVERALL STANDARD:

Candidate correctly evaluates the R&R to isolate 1B KC Hx using the provided R&R and flow diagrams.

K/A 2.2.13 (3.6/3.8)

<p>STEP 1: Component verified to be isolated and drained.</p> <p>STANDARD: Candidate determines that the motor operator for 1RN347B is not listed on the R&R sheet and adds motor operator to the tagout. Verifies other isolations are correct on flow diagrams.</p> <p>EXAMINER CUE: Motor operator for valve 1RN347B will be added to the R&R Sheet.</p> <p>COMMENTS:</p>	<p>CRITICAL STEP</p> <p>___ SAT</p> <p>___ UNSAT</p>
<p>STEP 2: Identify correct sequence for tagout.</p> <p>STANDARD: Sequenced as per attached tagout.</p> <p>Examiner Note: It is critical that component isolation valves be closed prior to opening any vent and/or drain valves. The order in which the the isolation valves are sequenced is not critical. The order in which the vent and/or drain valves are sequenced is not critical.</p> <p>COMMENTS:</p>	<p>CRITICAL STEP</p> <p>___ SAT</p> <p>___ UNSAT</p>

TIME STOP: _____

CANDIDATE CUE SHEET
(TO BE RETURNED TO EXAMINER UPON COMPLETION OF TASK)

INITIAL CONDITIONS:

Unit 1 is at 100% power. An NLO has completed an R&R to isolate 1B KC Heat Exchanger due to a tube leak per W/O 1234. The NLO requests you to sequence and evaluate the tagout. OP/0/A/6100/006C, Enclosure 4.18 (RN System Alignment for Train B KC Hx Cleaning) and OP/1/A/6400/005, Enclosure 4.8 (KC Train 1A Alignment for KC Hx 1B Cleaning) have been performed.

INITIATING CUE:

Review and sequence R&R.

System Tagged: KC Hx 1B	Reason for Removal: Tube Plugging
-----------------------------------	---

Applicable Work Orders:
1234

Affected Procedures:
OP10/A/6100/006C (Nuclear Service Water System)
OP11/A/6400/005 (Component Cooling Water System)

Supervisor Responsible and/or Crew: Monroe Scott, Crew 5678, Beeper #8343	Modification: N/A
---	-----------------------------

Prepared By: REK	Date/Time: 8/26/99 1600	Reviewed By: JKM	Date/Time: 8/26/99 1630	Approved By:	Date/Time:
----------------------------	-----------------------------------	----------------------------	-----------------------------------	--------------	------------

Technical Specifications / SLC <u>Unit 1</u> 99-1234 99-1235	Mode Req'd By Prior to removal of 1A KC Train	Fire Impair N/A	SSF Degrade N/A	Containment Closure: N/A
---	---	---------------------------	---------------------------	------------------------------------

Pre Job Briefing:	Ctrl Rm SRO Ack	Ctrl Rm Ack <u>Unit 1</u> <u>Unit 2</u>	1.47 Panel <u>Unit 1</u> <u>Unit 2</u>	Ctrl Rm Log <u>Unit 1</u> <u>Unit 2</u>
-------------------	-----------------	--	---	--

Copies Filed By:	R&R Filed By:	Computer Updated By:	OAC Points Removed From Service
------------------	---------------	----------------------	---------------------------------

Remarks:



Unit 1

Tagout ID:

Removal

Block Tagout ID:

Seq#	Equipment ID 1ETB-6 (Component Cooling Water Pump Motor 1B1)	Position Racked Out	Part Approval:	Date / Time:
Red Tag ID 001	Equipment Description Component Cooling Water Pump Motor 1B1 Supply Breaker		Removed By:	Date / Time:
	Location: 1ETB Switchgear		IV Req'd?: Y	IV By:
Special Info:			LBL 1	OCG:

Seq#	Equipment ID 1ETB-7 (Component Cooling Water Pump Motor 1B2)	Position Racked Out	Part Approval:	Date / Time:
Red Tag ID 002	Equipment Description Component Cooling Water Pump Motor 1B2 Supply Breaker		Removed By:	Date / Time:
	Location: 1ETB Switchgear		IV Req'd?: Y	IV By:
Special Info:			LBL 1	OCG:

Seq#	Equipment ID 1KC-40	Position Closed	Part Approval:	Date / Time:
Red Tag ID 003	Equipment Description 1KC-40 (KC Hx 1B In let)		Removed By:	Date / Time:
	Location: AB-587, GG-55, Rm 400		IV Req'd?: Y	IV By:
Special Info:			LBL 0	OCG:

Seq#	Equipment ID 1KC-41	Position Closed	Part Approval:	Date / Time:
Red Tag ID 004	Equipment Description 1KC-41 (KC Hx 1B Out let)		Removed By:	Date / Time:
	Location: AB-587, JJ-55, Rm 400		IV Req'd?: Y	IV By:
Special Info:			LBL 0	OCG:

Seq#	Equipment ID 1KC-45	Position Closed	Part Approval:	Date / Time:
Red Tag ID 005	Equipment Description 1KC-45 (Train 1B Rad Mon In let)		Removed By:	Date / Time:
	Location: AB-579, HH-56, Rm 400		IV Req'd?: Y	IV By:
Special Info:			LBL 0	OCG:



Unit 1

Tagout ID:

Removal

Block Tagout ID:

Seq#	Equipment ID 1KC-42	Position Open	Part Approval:	Date / Time:
Red Tag ID 006	Equipment Description 1KC-42 (KC Hx IB Drn)		Removed By:	Date / Time:
	Location: AB-578, JJ-55, Rm 400		IV Req'd?: Y	IV By:
Special Info:			LBL 0	OCG:

Seq#	Equipment ID 1KC-92	Position Open	Part Approval:	Date / Time:
Red Tag ID 007	Equipment Description 1KC-92 (KC Hx IB Drn)		Removed By:	Date / Time:
	Location: AB-578, HH-55, Rm 400		IV Req'd?: Y	IV By:
Special Info:			LBL 0	OCG:

Seq#	Equipment ID 1KC-43	Position Open	Part Approval:	Date / Time:
Red Tag ID 008	Equipment Description 1KC-43 (KC Hx IB Vent)		Removed By:	Date / Time:
	Location: AB-587, HH-55, Rm 400		IV Req'd?: Y	IV By:
Special Info:			LBL 0	OCG:

Seq#	Equipment ID 1KC-44	Position Open	Part Approval:	Date / Time:
Red Tag ID 009	Equipment Description 1KC-44 (KC Hx IB Vent to KC Drn Sump)		Removed By:	Date / Time:
	Location: AB-583, HH-55, Rm 400		IV Req'd?: Y	IV By:
Special Info:			LBL 0	OCG:

Seq#	Equipment ID 1RN-347B	Position Closed	Part Approval:	Date / Time:
Red Tag ID 010	Equipment Description 1RN-347B (KC Hx IB Inlet Isol)		Removed By:	Date / Time:
	Location: AB-589, JJ-KK, 55-56, Rm 400		IV Req'd?: Y	IV By:
Special Info:			LBL 1	OCG:

Seq#	Equipment ID 1RN-E14	Position Closed	Part Approval:	Date / Time:
Red Tag ID 011	Equipment Description 1RN-E14(KC Hx IB Outlet Man Isol)		Removed By:	Date / Time:
	Location: AB-586, LL-56, Rm 400		IV Req'd?: Y	IV By:
Special Info:			LBL 0	OCG:

Seq#	Equipment ID 1RN-919	Position Open	Part Approval:	Date / Time:
Red Tag ID 012	Equipment Description 1RN-919(KC Hx IB Supply Line Vent)		Removed By:	Date / Time:
	Location: AB-590, KK-55, Rm 400		IV Req'd?: Y	IV By:
Special Info:			LBL 0	OCG:

Seq#	Equipment ID 1RN-C59	Position Open	Part Approval:	Date / Time:
Red Tag ID 013	Equipment Description 1RN-C59(KC Hx IB Drn)		Removed By:	Date / Time:
	Location: AB-577, GG-55, Rm 400		IV Req'd?: Y	IV By:
Special Info:			LBL 0	OCG:

Seq#	Equipment ID 1RN-C60	Position Open	Part Approval:	Date / Time:
Red Tag ID 014	Equipment Description 1RN-C60(KC Hx IB Drn)		Removed By:	Date / Time:
	Location: AB-577, JJ-55, Rm 400		IV Req'd?: Y	IV By:
Special Info:			LBL 0	OCG:

Seq#	Equipment ID 1RN-918	Position Open	Part Approval:	Date / Time:
Red Tag ID 015	Equipment Description 1RN-918(KC Hx IB Outlet Line Vent)		Removed By:	Date / Time:
	Location: AB-580, GG-55, Rm 400		IV Req'd?: Y	IV By:
Special Info:			LBL 0	OCG:

System Tagged: **KC Hx 1B** Reason for Removal: **Tube Plugging**

Applicable Work Orders:
1234

Affected Procedures:
 OP/10/A/6100/006C (Nuclear Service Water System)
 OP/11/A/6400/005 (Component Cooling Water System)

Supervisor Responsible and/or Crew: **Monroe Scott, Crew 5678, Reoper #8343** Modification: **N/A**

Prepared By: REK	Date/Time: 8/26/99 1600	Reviewed By: JKM	Date/Time: 8/26/99 1630	Approved By:	Date/Time:
----------------------------	-----------------------------------	----------------------------	-----------------------------------	--------------	------------

Unit 1 99-1234 99-1235	Technical Specifications / SLC <u>Unit 2</u>	Mode Req'd By Prior to removal of 1A KC Train	Fire Impair N/A	SSF Degrade N/A	Containment Closure: N/A
--	---	---	---------------------------	---------------------------	------------------------------------

Pre Job Briefing:	Ctrl Rm SRO Ack	Ctrl Rm Ack <u>Unit 1</u> <u>Unit 2</u>	1.47 Panel <u>Unit 1</u> <u>Unit 2</u>	Ctrl Rm Log <u>Unit 1</u> <u>Unit 2</u>
-------------------	-----------------	--	---	--

Copies Filed By:	R&R Filed By:	Computer Updated By:	OAC Points Removed From Service
------------------	---------------	----------------------	---------------------------------

Remarks:
Key

Seq# 1	Equipment ID 1ETB-6 (Component Cooling Water Pump Motor ^{1B1})	Position Racked Out	Part Approval:	Date / Time:
Req Tag ID 001	Equipment Description Component Cooling Water Pump Motor 1B1 Supply Breaker		Removed By:	Date / Time:
	Location: 1ETB Switchgear		IV Req'd?: Y	IV By:
Special Info:			LBL 1	OCG:

Seq# 1	Equipment ID 1ETB-7 (Component Cooling Water Pump Motor ^{1B2})	Position Racked Out	Part Approval:	Date / Time:
Req Tag ID 002	Equipment Description Component Cooling Water Pump Motor 1B2 Supply Breaker		Removed By:	Date / Time:
	Location: 1ETB Switchgear		IV Req'd?: Y	IV By:
Special Info:			LBL 1	OCG:

Seq# 2	Equipment ID 1KC-40	Position Closed	Part Approval:	Date / Time:
Req Tag ID 003	Equipment Description 1KC-40 (KC Hx 1B Inlet)		Removed By:	Date / Time:
	Location: AB-587, GG-55, Rm 400		IV Req'd?: Y	IV By:
Special Info:			LBL 0	OCG:

Seq# 2	Equipment ID 1KC-41	Position Closed	Part Approval:	Date / Time:
Req Tag ID 004	Equipment Description 1KC-41 (KC Hx 1B Outlet)		Removed By:	Date / Time:
	Location: AB-587, JJ-55, Rm 400		IV Req'd?: Y	IV By:
Special Info:			LBL 0	OCG:

Seq# 2	Equipment ID 1KC-45	Position Closed	Part Approval:	Date / Time:
Req Tag ID 005	Equipment Description 1KC-45 (Train 1B Rad Mon Inlet)		Removed By:	Date / Time:
	Location: AB-579, HH-56, Rm 400		IV Req'd?: Y	IV By:
Special Info:			LBL 0	OCG:



Unit 1

Tagout ID:

Removal

Block Tagout ID:

Seq# 3	Equipment ID 1KC-42	Position Open	Part Approval:	Date / Time:
Req. Tag ID 006	Equipment Description 1KC-42 (KC Hx IB Drn)		Removed By:	Date / Time:
	Location: AB-578, JJ-55, Rm 400		IV Req'd?: Y	IV By:
Special Info:			LBL 0	OCG:

Seq# 3	Equipment ID 1KC-92	Position Open	Part Approval:	Date / Time:
Req. Tag ID 007	Equipment Description 1KC-92 (KC Hx IB Drn)		Removed By:	Date / Time:
	Location: AB-578, HH-55, Rm 400		IV Req'd?: Y	IV By:
Special Info:			LBL 0	OCG:

Seq# 3	Equipment ID 1KC-43	Position Open	Part Approval:	Date / Time:
Req. Tag ID 008	Equipment Description 1KC-43 (KC Hx IB Vent)		Removed By:	Date / Time:
	Location: AB-587, HH-55, Rm 400		IV Req'd?: Y	IV By:
Special Info:			LBL 0	OCG:

Seq# 3	Equipment ID 1KC-44	Position Open	Part Approval:	Date / Time:
Req. Tag ID 009	Equipment Description 1KC-44 (KC Hx IB Vent to KC Drn Sump)		Removed By:	Date / Time:
	Location: AB-583, HH-55, Rm 400		IV Req'd?: Y	IV By:
Special Info:			LBL 0	OCG:

Seq# 2	Equipment ID 1RN-347B	Position Closed	Part Approval:	Date / Time:
Req. Tag ID 010	Equipment Description 1RN-347B (KC Hx IB Inlet Isol)		Removed By:	Date / Time:
	Location: AB-589, JJ-KK, 55-56, Rm 400		IV Req'd?: Y	IV By:
Special Info:			LBL 1	OCG:

**CATAWBA
INITIAL LICENSE EXAMINATION
JOB PERFORMANCE MEASURE**

JPM 5S/ADMIN

Classify an Event and Activate the Emergency Response
Organization

CANDIDATE

EXAMINER

**CATAWBA
INITIAL LICENSE EXAMINATION
JOB PERFORMANCE MEASURE**

Task:

Classify an Event and Activate the Emergency Response Organization

Alternate Path:

N/A

Facility JPM #:

OP-CN-EP-SEP-010 (Modified)

K/A Rating(s):

GKA 2.4.43 (2.8/3.5)

Task Standard:

The candidate correctly classifies the event in accordance with RP/0/A/5000/001 (Classification of Emergency) and activates the Emergency Response Organization in accordance with RP/0/A/5000/003 (Alert)

Preferred Evaluation Location:

Simulator In-Plant

Preferred Evaluation Method:

Perform Simulate

References:

RP/0/A/5000/001 (Classification of Emergency)
RP/0/A/5000/003 (Alert)

Validation Time: **Time Critical:** No

Candidate: _____
NAME

Time Start : _____
Time Finish: _____

Performance Rating: SAT _____ UNSAT _____ Performance Time _____

Examiner: _____
NAME

SIGNATURE

DATE

COMMENTS

Tools/Equipment/Procedures Needed:

RP/0/A/5000/001 (Classification of Emergency)

RP/0/A/5000/003 (Alert)

READ TO OPERATOR

DIRECTION TO TRAINEE:

I will explain the initial conditions, and state the task to be performed. All control room steps shall be performed for this JPM, including any required communications. I will provide initiating cues and reports on other actions when directed by you. Ensure you indicate to me when you understand your assigned task. To indicate that you have completed your assigned task return the handout sheet I provided you.

INITIAL CONDITIONS:

1. Unit 2 is in Mode 3 following a Tech Spec required shutdown due to inoperability of the 2B Diesel Generator.
2. Diesel Generator 2B is still inoperable.
3. All 4 unit tie PCB's on unit 2 open due to a fault.
4. Diesel Generator 2A fails to start and a NLO is dispatched to attempt to start Diesel Generator 2A locally.
5. Diesel Generator 2A is successfully started and 2ETA is energized from Diesel Generator 2A 10 minutes after the switchyard PCB's open.

INITIATING CUE:

Classify this event and activate the Emergency Response Organization.

JPM OVERALL STANDARD:

The event is correctly classified as an Alert and the ERO is activated per RP/0/A/5000/003 (Alert).

K/A 2.4.43 (2.8/3.5)

<p>STEP 1: Obtain a copy of the appropriate procedure.</p> <p>STANDARD: Operator obtains a copy of RP/0/A/5000/001.</p> <p>EXAMINER CUE: When the candidate locates the appropriate procedures, give him copies and tell him they are current and complete.</p> <p>COMMENTS:</p>	<p>___SAT</p> <p>___UNSAT</p>
<p>STEP 2: Classify the event.</p> <p>STANDARD: Candidate classifies the event as an ALERT in accordance with RP/001 Enclosure 4.1, Event #4.1.6. (loss of offsite and all onsite AC power for greater than 1 minute but less than 15 minutes in Modes 1 through 4).</p> <p>COMMENTS:</p>	<p>CRITICAL STEP</p> <p>___SAT</p> <p>___UNSAT</p>

<p>STEP 3: Complete the Emergency Notification Sheet.</p> <p>STANDARD: Candidate determines the need to complete an Emergency Notification Sheet.</p> <p>EXAMINER'S CUE: Once the candidate locates the Emergency Notification Sheets, give him/her a completed copy of the Emergency Notification Sheet.</p> <p>COMMENTS:</p>	<p>___ SAT</p> <p>___ UNSAT</p>
<p>STEP 4: Obtain a copy of the appropriate procedure.</p> <p>STANDARD: Operator obtains a copy of RP/0/A/5000/003.</p> <p>EXAMINER'S CUE: When the candidate locates the appropriate procedures, give him/her copies and tell him/her they are current and complete.</p> <p>COMMENTS:</p>	<p>CRITICAL STEP</p> <p>___ SAT</p> <p>___ UNSAT</p>

<p>STEP 5: Obtain a copy of the appropriate procedure.</p> <p>STANDARD: Operator obtains a copy of RP/0/A/5000/003.</p> <p>EXAMINER'S CUE: When the candidate locates the appropriate procedures, give him copies and tell him they are current and complete.</p> <p>COMMENTS:</p>	<p>CRITICAL STEP</p> <p>___ SAT</p> <p>___ UNSAT</p>
<p>STEP 6: Advise site personnel.</p> <p>STANDARD: Announcement is made over the PA system.</p> <p>EXAMINER'S NOTE: The steps in the procedure are numbered. By Catawba rules of usage, this means that they do NOT have to be performed in the sequence listed. The candidate may go directly to the step to activate the ERO in RP/0/A/5000/003 and bypass this step. This is acceptable.</p> <p>COMMENTS:</p>	<p>___ SAT</p> <p>___ UNSAT</p>

<p>STEP 7: Locate Quikpage Key Pad in the Control Room. Type ERO and press ENTER.</p> <p>STANDARD: Information correctly entered.</p> <p>EXAMINER'S CUE: ERO typed and entered.</p> <p>COMMENTS:</p>	<p>CRITICAL STEP</p> <p>__SAT</p> <p>__UNSAT</p>
<p>STEP 8: Press "M"</p> <p>STANDARD: Candidate presses "M" on the Quikpage Key Pad</p> <p>EXAMINERS CUE: "M" has been pressed.</p> <p>COMMENTS:</p>	<p>CRITICAL STEP</p> <p>__SAT</p> <p>__UNSAT</p>
<p>STEP 9: Press F6 message key for Catawba Emergency.</p> <p>STANDARD: F6 key pressed.</p> <p>EXAMINER'S CUE: F6 key pressed.</p> <p>COMMENTS:</p>	<p>CRITICAL STEP</p> <p>__SAT</p> <p>__UNSAT</p>

<p>STEP 10: Ensure the cursor is at the end of the line and type "Alert declared at (time). Activate TSC/OSC/EOF" and press enter.</p> <p>STANDARD: Information entered successfully.</p> <p>EXAMINER'S CUE: "Alert declared at (time). Activate TSC/OSC/EOF" entered.</p> <p>COMMENTS:</p>	<p>CRITICAL STEP</p> <p>__SAT</p> <p>__UNSAT</p>
<p>STEP 11: Monitor pager located at the Quikpage key pad to verify ERO pager activation.</p> <p>STANDARD: Locate page and activate the display..</p> <p>EXAMINER'S CUE: The pager has actuated and it displays the Message "Alert declared at (time). Activate the TSC/OSC/EOF"</p> <p>COMMENTS:</p>	<p>__SAT</p> <p>__UNSAT</p>

TIME STOP: _____

**CANDIDATE CUE SHEET
(TO BE RETURNED TO EXAMINER UPON COMPLETION OF TASK)**

INITIAL CONDITIONS:

1. Unit 2 is in Mode 3 following a Tech Spec required shutdown due to inoperability of the 2B Diesel Generator.
2. Diesel Generator 2B is still inoperable.
3. All 4 switchyard PCB's open due to a fault.
4. Diesel Generator 2A fails to start and a NLO is dispatched to attempt to start Diesel Generator 2A locally.
5. Diesel Generator 2A is successfully started and 2ETA is energized from Diesel Generator 2A 10 minutes after the switchyard PCB's open.

INITIATING CUE:

Classify this event and activate the Emergency Response Organization.

Duke Power Company
PROCEDURE PROCESS RECORD

(1) ID No. RP/0/A/5000/001

Revision No. 012

PREPARATION

Station Catawba Nuclear Station

(3) Procedure Title Classification of Emergency

(4) Prepared By SR Christopher Date 1/4/99

- (5) Requires 10CFR50.59 evaluation?
 Yes (New procedure or reissue with major changes)
 No (Revision with minor changes)
 No (To incorporate previously approved changes)

(6) Reviewed By Gary L Mitchell (QR) Date 1-10-99
Cross-Disciplinary Review By J Baumann (QR) NA Date 1-11-99
Reactivity Mgmt. Review By _____ (QR) NA CLM Date 1-10-99

(7) Additional Reviews

Reviewed By _____ Date _____
Reviewed By _____ Date _____

(8) Temporary Approval (if necessary)

By _____ (SRO/QR) Date _____
By _____ (QR) Date _____

(9) APPROVED BY Steve Bredlow Date 1/16/99

PERFORMANCE (Compare with control copy at least once every 14 calendar days while work is being performed)

(10) Compared with Control Copy _____ Date _____
Compared with Control Copy _____ Date _____
Compared with Control Copy _____ Date _____

(11) Dates(s) Performed _____
Work Order Number (W/O #) _____

COMPLETION

(12) Procedure Completion Verification

- Yes N/A Check lists and/or blanks properly initialed, signed, dated, or filled in NA, as appropriate?
 Yes N/A Listed enclosures attached?
 Yes N/A Data sheets attached, completed, dated and signed?
 Yes N/A Charts, graphs, etc. attached and properly dated, identified and marked?
 Yes N/A Procedure requirements met?

Verified By _____ Date _____

(13) Procedure Completion Approved _____ Date _____

Remarks (attach additional pages, if necessary)

Duke Power Company Catawba Nuclear Station	Procedure No. RP/0/A/5000/001
	Revision No. 012
	Electronic Reference No. CN005GNK
Classification of Emergency	
Multiple Use	

1. Symptoms

1.1 Notification of Unusual Event

- 1.1.1 Events are in process or have occurred which indicate a potential degradation of the level of safety of the plant.
- 1.1.2 No releases of radioactive material requiring offsite response or monitoring are expected unless further degradation of safety occurs.

1.2 Alert

- 1.2.1 Events are in process or have occurred which involve an actual or potential substantial degradation of the level of safety of the plant.
- 1.2.2 Any releases are expected to be limited to small fractions of the EPA Protective Action Guideline exposure levels.

1.3 Site Area Emergency

- 1.3.1 Events are in process or have occurred which involve actual or likely major failures of plant functions needed for protection of the public.
- 1.3.2 Any releases are not expected to exceed EPA Protective Action Guideline exposure levels except near the site boundary.

1.4 General Emergency

- 1.4.1 Events are in process or have occurred which involve actual or imminent substantial core degradation or melting with potential for loss of containment integrity.
- 1.4.2 Releases can be reasonably expected to exceed EPA Protective Action Guideline exposure levels offsite for more than the immediate site area.

2. Immediate Actions

NOTE: Unless otherwise noted, the term Tech Spec as used in this procedure refers to both Unit 1 and Unit 2 Technical Specifications.

- 2.1 Compare actual plant conditions to the Emergency Action Level(s) listed in Enclosure 4.1 then declare the appropriate Emergency Class as indicated.

2.2 Refer to the applicable Emergency Response Procedure (RP) for the classification found in Enclosure 4.1:

- Notification of Unusual Event RP/0/A/5000/002
- Alert RP/0/A/5000/003
- Site Area Emergency RP/0/A/5000/004
- General Emergency RP/0/A/5000/005

3. Subsequent Actions

3.1 To escalate, de-escalate or close out the Emergency, compare plant conditions to the Initiating Conditions of Enclosure 4.1.

3.2 Momentary entry into a higher classification:

If while in a current emergency classification the specified conditions of a higher classification EAL are momentarily met and in the judgement of the Emergency Coordinator are not likely to be repeated, the entry into the higher classification must be acknowledged. Acknowledgment is performed as follows:

- **IF** this condition occurs prior to the initial notification to emergency response organization and offsite agencies, the initial message should note that the site is currently in the lower classification but had momentarily met the criteria for the higher classification. It should also be noted that plant conditions have improved and stabilized to the point that the criteria for the higher classification are not expected to be repeated. The Emergency Coordinator shall determine the extent of implementing the higher classification's Response Procedure (RP).
- **IF** this condition occurs after the initial notification to emergency support personnel and offsite agencies, then acknowledge the occurrence with a follow-up message as outlined in bullet above. The Emergency Coordinator shall determine the extent of implementing the higher classification's Response Procedure (RP).

4. Enclosures

4.1 Emergency Event List for Emergency Classes

Event No.	Page(s)
4.1.1 Primary Coolant Leak	1 - 3
4.1.2 Fuel Damage	4 - 6
4.1.3 Steam System Failure	7 & 8
4.1.4 High Radiation/Radiological Effluents	9 & 10
4.1.5 Loss of Shutdown Function	11 - 14
4.1.6 Loss of Power	15 & 16
4.1.7 Fires and Security Actions	17 & 18
4.1.8 Spent Fuel Damage	19 & 20
4.1.9 Natural Disasters and Other Hazards	21 - 23
4.1.10 Other Abnormal Plant Conditions	24 - 25

**Emergency Event List for Emergency Classes
Event # 4.1.1 Primary Coolant Leak**

Notification of Unusual Event	Alert	Site Area Emergency	General Emergency
<p>1. INC System leakage greater than Tech Spec limits in Modes 1-4.</p> <ul style="list-style-type: none"> Greater than 1 gpm unidentified NC System leakage in Modes 1-4 <p style="text-align: center;"><u>AND</u></p> <p>Load reduction or plant cooldown initiated in accordance with Tech Spec 3.4.13.</p> <ul style="list-style-type: none"> Greater than 10 gpm identified NC System leakage in Modes 1-4 <p style="text-align: center;"><u>AND</u></p> <p>Load reduction or plant cooldown initiated in accordance with Tech Spec 3.4.13.</p> <ul style="list-style-type: none"> Greater than 150 gpd primary to secondary leakage in any S/G in Modes 1-4 <p style="text-align: center;"><u>AND</u></p> <p>Load reduction or plant cooldown initiated in accordance with Tech Spec 3.4.13.</p> <p style="text-align: center;"><u>(Continued)</u></p>	<p>1. NC System leakage greater than 50 gpm in Modes 1-4.</p> <ul style="list-style-type: none"> NC System leakage greater than 50 gpm in Modes 1-4 <p style="text-align: center;"><u>AND</u></p> <p>NC System subcooling greater than 0°F</p> <p style="text-align: center;"><u>AND</u></p> <p>Leak <u>cannot</u> be isolated within 15 minutes.</p> <p>2. S/G tube leak with loss of offsite power.</p> <ul style="list-style-type: none"> S/G tube leak greater than 10 gpm <p style="text-align: center;"><u>AND</u></p> <p>NC System subcooling greater than 0°F</p> <p style="text-align: center;"><u>AND</u></p> <p>Both A <u>AND</u> B main bus lines de-energized.</p> <p style="text-align: center;"><u>(Continued)</u></p>	<p>1. NC System leakage greater than available ECCS capacity.</p> <p>S/I actuated or required as a result of a known LOCA greater than makeup pump capacity.</p> <p style="text-align: center;"><u>AND</u></p> <p>Existing NV, NI and ND flow <u>cannot</u> maintain NC System subcooling greater than 0°F.</p> <p style="text-align: center;"><u>(Continued)</u></p>	<p>1. Any LOCA with failure of ECCS.</p> <ul style="list-style-type: none"> LOCA with failure of both trains of ECCS injection <p style="text-align: center;"><u>AND</u></p> <p>NC System subcooling <u>cannot</u> be maintained greater than 0°F.</p> <ul style="list-style-type: none"> LOCA with failure of both trains of ECCS recirculation capability <p style="text-align: center;"><u>AND</u></p> <p>NC System subcooling <u>cannot</u> be maintained greater than 0°F.</p> <ul style="list-style-type: none"> LOCA <p style="text-align: center;"><u>AND</u></p> <p>Plant conditions require entry into EP/1(2)/A/5000/FR-C.1, Inadequate Core Cooling.</p> <p style="text-align: center;"><u>(Continued)</u></p>

**Emergency Event List for Emergency Classes
Event # 4.1.1 Primary Coolant Leak**

Notification of Unusual Event	Alert	Site Area Emergency	General Emergency
<ul style="list-style-type: none"> Greater than 576 gpd total primary to secondary leakage in all S/Gs in Modes 1-4 <p align="center"><u>AND</u></p> <p>Load reduction or plant cooldown initiated in accordance with Tech Spec 3.4.13.</p> <ul style="list-style-type: none"> Any NC System pressure boundary leakage in Modes 1-4 <p align="center"><u>AND</u></p> <p>Load reduction or plant cooldown initiated in accordance with Tech Spec 3.4.13.</p> <ul style="list-style-type: none"> Greater than 40 gpm reactor coolant pump seal injection flow with NV pump operating and the charging flow control valve full open in Modes 1-3 <p align="center"><u>AND</u></p> <p>Load reduction or plant cooldown initiated in accordance with Tech Spec 3.5.5.</p> <p align="center"><u>(Continued)</u></p>	<p>3. S/G tube leak with an unisolable steam line break outside Containment.</p> <ul style="list-style-type: none"> S/G tube leak greater than 10 gpm but less than 50 gpm <p align="center"><u>AND</u></p> <p>Unisolable secondary (Main Steam or Feedwater) line break outside Containment on the ruptured steam generator</p> <p align="center"><u>AND</u></p> <p>NC System subcooling greater than 0°F.</p> <ul style="list-style-type: none"> Unisolable secondary (Main Steam or Feedwater) line break outside Containment <p align="center"><u>AND</u></p> <p>Field monitoring teams detect radioactivity at the Protected Area fence at greater than or equal to 2 mr/hr.</p> <p align="center"><u>END</u></p>	<p>2. S/G tube leak greater than 50 gpm with a steam line break.</p> <ul style="list-style-type: none"> S/G tube leak greater than 50 gpm <p align="center"><u>AND</u></p> <p>Unisolable secondary (Main Steam or Feedwater) line break inside Containment on the ruptured S/G</p> <p align="center"><u>AND</u></p> <p>Fuel clad failure greater than 5% per Chemistry analysis (or valid reading on EMF-53A or EMF-53B of 117 R/hr.</p> <ul style="list-style-type: none"> S/G tube leak greater than 50 gpm <p align="center"><u>AND</u></p> <p>Unisolable secondary (Main Steam or Feedwater) line break outside Containment on the ruptured S/G.</p> <p align="center"><u>END</u></p>	<p>2. LOCA with initially successful ECCS followed by failure of ECCS heat sink and failure of Containment heat removal.</p> <ul style="list-style-type: none"> LOCA <p align="center"><u>AND</u></p> <p>Loss of recirculation heat sink</p> <p align="center"><u>AND</u></p> <p>Loss of Containment spray heat sink.</p> <p align="center"><u>END</u></p>

Emergency Event List for Emergency Classes
Event # 4.1.1 Primary Coolant Leak

Notification of Unusual Event	Alert	Site Area Emergency	General Emergency
<ul style="list-style-type: none"> • Leakage from any NC pressure isolation valve greater than Tech Spec 3.4.14 limit in Modes 1-4. <p style="text-align: center;"><u>AND</u></p> <p>Load reduction or plant cooldown initiated in accordance with Tech Spec 3.4.14.</p> <ul style="list-style-type: none"> 2. Unisolable NC System leakage greater than 50 gpm in Modes 5 and 6. 3. Failure of an unisolable PZR PORV or a PZR safety valve to close following a reduction of NC System pressure. <p style="text-align: center;"><u>END</u></p>			

Emergency Event List for Emergency Classes
Event # 4.1.2 Fuel Damage

Notification of Unusual Event	Alert	Site Area Emergency	General Emergency
<p>1. NC System activity greater than Tech Spec limits in Modes 1-3.</p> <ul style="list-style-type: none"> Greater than 1.0 microCurie per gram dose equivalent I-131 for more than 48 continuous hours per Chemistry analysis in Modes 1, 2 and 3 with NCS average temperature > 500°F <p style="text-align: center;"><u>AND</u></p> <p>Load reduction or plant cooldown initiated in accordance with Tech Spec 3.4.16.</p> <ul style="list-style-type: none"> Dose equivalent I-131 in excess of Tech Spec Figure 3.4.16-1 per Chemistry analysis in Modes 1, 2 and 3 with NCS average temperature > 500°F <p style="text-align: center;"><u>AND</u></p> <p>Load reduction or plant cooldown initiated in accordance with Tech Spec 3.4.16.</p> <p style="text-align: center;"><u>(Continued)</u></p>	<p>1. Severe loss of fuel cladding.</p> <ul style="list-style-type: none"> Valid indication on any Reactor Building EMF reading greater than or equal to 1000 times background value. Valid indication on EMF-48 reading greater than or equal to 1000 times background value. Chemistry or other data analysis indicates that primary coolant dose equivalent I-131 concentration is greater than or equal to 300 microCuries per ml. Chemistry or other data analysis indicates greater than or equal to 5% total fuel clad failure. Chemistry or other data analysis indicates an increase of greater than 1% fuel failures within 30 minutes. <p style="text-align: center;"><u>END</u></p>	<p>1. Degraded core with possible loss of coolable geometry.</p> <ul style="list-style-type: none"> Plant conditions require entry into EP/1(2)/A/5000/FR-C.2, Degraded Core Cooling. Containment hydrogen concentration greater than or equal to 1.0% <p style="text-align: center;"><u>AND</u></p> <p>Hydrogen concentration increasing at a rate of greater than or equal to 0.1% per hour.</p> <ul style="list-style-type: none"> Valid indication on EMF-53A or 53B reading greater than or equal to 1250 R/hr. <p style="text-align: center;"><u>END</u></p>	<p>1. Loss of 2 of 3 fission product barriers <u>with</u> potential for loss of the third barrier. The three barriers are the fuel cladding, NC System and Containment.</p> <p>NOTE: To classify at this level, you must satisfy at least one condition from two of the three categories listed (A, B, C) <u>AND</u> have the potential for satisfying at least one condition from the remaining category.</p> <p>A. Loss of fuel cladding barrier.</p> <ul style="list-style-type: none"> Chemistry analysis indicates greater than 5% total fuel clad failure. <p style="text-align: center;"><u>(Continued)</u></p>

Emergency Event List for Emergency Classes
Event # 4.1.2 Fuel Damage

Notification of Unusual Event	Alert	Site Area Emergency	General Emergency
<ul style="list-style-type: none"> Specific activity greater than 100/E-bar microCuries per gram per Chemistry analysis in Modes 1, 2 and 3 with NCS average temperature > 500°F <p style="text-align: center;"><u>AND</u></p> <p>Load reduction or plant cooldown initiated in accordance with Tech Spec 3.4.16.</p> <p style="text-align: center;"><u>END</u></p>			<ul style="list-style-type: none"> Valid indication on EMF-53A or 53B reading greater than or equal to 117 R/hr. Plant conditions require entry into EP/1(2)/A/5000/FR-C.1, Inadequate Core Cooling. <p>B. Loss of NC System barrier.</p> <ul style="list-style-type: none"> NC System leakage greater than 50 gpm. <p>C. Loss of Containment barrier.</p> <ul style="list-style-type: none"> Incomplete Containment Integrity. Known Containment leakage in excess of Tech Specs. <p style="text-align: right;"><u>(Continued)</u></p>

Enclosure 4.1

Emergency Event List for Emergency Classes
Event # 4.1.2 Fuel Damage

Notification of Unusual Event	Alert	Site Area Emergency	General Emergency
			<ul style="list-style-type: none">• Containment pressure greater than or equal to 60 psig.• Containment hydrogen concentration greater than or equal to 9%. <p style="text-align: center;"><u>END</u></p>

**Emergency Event List for Emergency Classes
Event # 4.1.3 Steam System Failure**

Notification of Unusual Event	Alert	Site Area Emergency	General Emergency
<p>1. Secondary (Main Steam or Feedwater) line break which results in rapid depressurization of the secondary side.</p> <ul style="list-style-type: none"> Secondary (Main Steam or Feedwater) line depressurization resulting in Safety Injection or Main Steam Isolation. <p style="text-align: center;"><u>END</u></p>	<p>1. Unisolable Secondary (Steam or Main Feedwater) line break outside Containment with a S/G tube leak.</p> <ul style="list-style-type: none"> Unisolable secondary (Main Steam or Feedwater) line break outside Containment <p style="text-align: center;"><u>AND</u></p> <p>S/G tube leak greater than 10 gpm but less than 50 on the ruptured generator</p> <p style="text-align: center;"><u>AND</u></p> <p>NC System subcooling greater than 0°F.</p> <ul style="list-style-type: none"> Unisolable secondary (Main Steam or Feedwater) line break outside Containment <p style="text-align: center;"><u>AND</u></p> <p>Field monitoring teams detect activity at the Protected Area fence at greater than or equal to 2 mr/hr.</p> <p style="text-align: center;"><u>(Continued)</u></p>	<p>1. Steam line break with a S/G tube leak greater than 50 gpm.</p> <ul style="list-style-type: none"> Steam line break inside Containment on the ruptured S/G <p style="text-align: center;"><u>AND</u></p> <p>S/G tube leak greater than 50 gpm</p> <p style="text-align: center;"><u>AND</u></p> <p>Fuel clad failure greater than 5% per Chemistry analysis (or valid reading on EMF-53A or EMF-53B of 117 R/hr.</p> <ul style="list-style-type: none"> S/G tube leak greater than 50 gpm. <p style="text-align: center;"><u>AND</u></p> <p>Unisolable steam line break outside Containment on the ruptured S/G</p> <p style="text-align: center;"><u>END</u></p>	<p>N/A</p>

Emergency Event List for Emergency Classes
Event # 4.1.3 Steam System Failure

Notification of Unusual Event	Alert	Site Area Emergency	General Emergency
	<p>2. Secondary (Main Steam or Feedwater) line break with failure of ECCS or Main Steam Isolation.</p> <ul style="list-style-type: none"> Secondary (Main Steam or Feedwater) line depressurization resulting in Safety Injection signal <p style="text-align: center;"><u>AND</u></p> <p>Failure of both trains of ECCS injection.</p> <ul style="list-style-type: none"> Secondary (Main Steam or Feedwater) line depressurization resulting in Main Steam Isolation signal <p style="text-align: center;"><u>AND</u></p> <p>The failure of two or more MSIVs to close results in the depressurization of two or more S/Gs.</p> <p style="text-align: center;"><u>END</u></p>		

Emergency Event List for Emergency Classes
Event # 4.1.4 High Radiation/Radiological Effluents

Notification of Unusual Event	Alert	Site Area Emergency	General Emergency
<p>1. Gaseous or liquid radiological effluents exceed Selected Licensee Commitment (SLC) limits.</p> <ul style="list-style-type: none"> Gaseous radiological effluents exceed SLC limits as determined by Radiation Protection calculations. Valid indication on EMF-58 reading greater than or equal to 50 times the TRIP 2 setpoint. Valid TRIP 2 alarm on EMF-49L or EMF-57 	<p>1. High radiation levels or high airborne contamination.</p> <ul style="list-style-type: none"> Valid indication on any area EMF reading greater than or equal to 1000 times background value. Valid indication on EMF-41 reading greater than or equal to 1000 times background value. <p>2. Gaseous or liquid radiological effluents exceed 10 times Selected Licensee Commitment (SLC) limits.</p> <ul style="list-style-type: none"> Valid indication on any of the following effluent monitors reading greater than or equal to 10 times the TRIP 2 setpoint: <ul style="list-style-type: none"> EMF-35L EMF-36L EMF-37. 	<p>1. Accidental releases of gases.</p> <ul style="list-style-type: none"> Valid indication on EMF-36L reading greater than or equal to 1.5 E6 cpm. (See NOTE) Valid indication on EMF-37 reading greater than or equal to 5.2 E5 cpm. (See NOTE) Dose assessment team calculations project a dose at the Site Boundary of greater than or equal to 100 mrem Total Effective Dose Equivalent (TEDE) or 500 mrem Committed Dose Equivalent (CDE) thyroid. 	<p>1. Accidental releases of gases.</p> <ul style="list-style-type: none"> Valid indication on EMF-36H reading greater than or equal to 2.4 E3 cpm. Valid indication on EMF-37 reading greater than or equal to 5.2 E6 cpm.

AND

Failure of the release path to automatically isolate.

(Continued)

(Continued)

(Continued)

(Continued)

NOTE: This EMF setpoint is calculated based on worst case annual average meteorology, and a Unit Vent flowrate of 1.9 E5 cfm. Calculations by the dose assessment team use actual meteorology and Unit Vent flowrate. Therefore, this EMF setpoint should not be used if dose assessment team calculations are available.

Emergency Event List for Emergency Classes
Event # 4.1.4 High Radiation/Radiological Effluents

Notification of Unusual Event	Alert	Site Area Emergency	General Emergency
<ul style="list-style-type: none"> Liquid radiological effluents exceed Selected Licensee Commitment (SLC) limits as determined by Radiation Protection calculations. <p style="text-align: center;"><u>END</u></p>	<ul style="list-style-type: none"> Valid indication on EMF-58 reading greater than or equal to 500 times the TRIP 2 setpoint. Valid indication on EMF-49L or EMF-57 reading greater than or equal to 10 times the TRIP 2 setpoint <p style="text-align: center;"><u>AND</u></p> <ul style="list-style-type: none"> Failure of the release path to automatically isolate. Radiological effluents exceed 10 times Selected Licensee Commitment (SLC) limits as determined by Radiation Protection calculations. <p style="text-align: center;"><u>END</u></p>	<ul style="list-style-type: none"> Field monitoring team measurements determine the dose rate at the Site Boundary is greater than or equal to 100 mrem/hr or field survey samples indicate thyroid dose rates greater than or equal to .5 rem/hr. <p style="text-align: center;"><u>END</u></p>	<ul style="list-style-type: none"> Dose assessment team calculations project a dose at the Site Boundary of greater than or equal to 1 rem Total Effective Dose Equivalent (TEDE) or 5 rem Committed Dose Equivalent (CDE) thyroid. Field Monitoring measurements determine the dose rate at the Site Boundary is greater than or equal to 1 rem/hr or field survey samples indicate thyroid dose rates greater than or equal to 5 rem/hr. <p style="text-align: center;"><u>END</u></p>

Emergency Event List for Emergency Classes
Event # 4.1.5 Loss of Shutdown Function

Notification of Unusual Event	Alert	Site Area Emergency	General Emergency
N/A	<p>1. Complete loss of any function needed to maintain core cooling in Modes 5 and 6.</p> <ul style="list-style-type: none"> Failure of heat sink in Modes 5 and 6 results in uncontrolled heatup <p style="text-align: center;"><u>AND</u></p> <ul style="list-style-type: none"> Core exit thermocouples indicate greater than or equal to 200°F. <p style="text-align: center;"><u>(Continued)</u></p>	<p>1. Complete loss of any function needed for Hot Shutdown conditions in Modes 1-4.</p> <ul style="list-style-type: none"> Failure of heat sink in Mode 4 results in an uncontrolled heatup <p style="text-align: center;"><u>AND</u></p> <p>Core exit thermocouples indicate greater than or equal to 350°F.</p> <ul style="list-style-type: none"> Inability to feed S/Gs from any source in Modes 1-3 <p style="text-align: center;"><u>AND</u></p> <p>Feed and bleed cooling of the reactor core is necessary to remove core decay heat.</p> <p style="text-align: center;"><u>(Continued)</u></p>	<p>1. Transient initiated by loss of CF and CM Systems followed by failure of heat removal capability for an extended period in Modes 1-4.</p> <ul style="list-style-type: none"> Loss of CM/CF feedwater flow capability in Modes 1-4 <p style="text-align: center;"><u>AND</u></p> <p>CA flow <u>cannot</u> be established within 30 minutes</p> <p style="text-align: center;"><u>AND</u></p> <p>NC System feed and bleed flow <u>cannot</u> be established or maintained.</p> <p style="text-align: center;"><u>(Continued)</u></p>

Emergency Event List for Emergency Classes
Event # 4.1.5 Loss of Shutdown Function

Notification of Unusual Event	Alert	Site Area Emergency	General Emergency
	<p>2. Transient with failure of the Reactor Protection System to automatically initiate and complete a Reactor trip which brings the Reactor subcritical (ATWS).</p> <p style="text-align: center;"><u>END</u></p>	<p>2. Transient requiring operation of shutdown systems with failure to trip (power generation continues).</p> <ul style="list-style-type: none"> • Transient with failure of the Reactor Protection System to automatically initiate and complete a Reactor trip which brings the Reactor subcritical (ATWS) <p style="text-align: center;"><u>AND</u></p> <p>Control rods <u>cannot</u> be manually tripped or inserted from the Control Room.</p> <p style="text-align: center;"><u>(Continued)</u></p>	<p>2. Transient requiring a Reactor trip with failure to trip and failure of core cooling.</p> <ul style="list-style-type: none"> • Transient with failure of the Reactor Protection System to automatically initiate and complete a reactor trip which brings the Reactor subcritical (ATWS) <p style="text-align: center;"><u>AND</u></p> <p>Actions taken per EP/1(2)/A/5000/FR-S.1, Nuclear Power Generation/ATWS fail to bring the Reactor subcritical</p> <p style="text-align: center;"><u>AND</u></p> <p>Plant conditions require entry into EP/1(2)/A/5000/FR-C.2, Degraded Core Cooling.</p> <p style="text-align: center;"><u>(Continued)</u></p>

Emergency Event List for Emergency Classes
Event # 4.1.5 Loss of Shutdown Function

Notification of Unusual Event	Alert	Site Area Emergency	General Emergency
		<p>3. Inability to maintain Cold Shutdown with loss of Reactor Vessel Coolant Inventory in Modes 5 and 6.</p> <ul style="list-style-type: none"> • Failure of heat sink causes loss of Cold Shutdown conditions in Modes 5 and 6 <p style="text-align: center;"><u>AND</u></p> <p>NC System level less than 11% and continues to decrease after initiation of NC System make-up.</p> <ul style="list-style-type: none"> • Failure of heat sink causes loss of Cold Shutdown conditions in Modes 5 and 6 <p style="text-align: center;"><u>AND</u></p> <p>Lower Range RVLIS level decreasing after initiation of NC System make-up.</p> <p style="text-align: center;"><u>(Continued)</u></p>	<p>3. Loss of heat sink with subsequent core uncover in Modes 5 and 6.</p> <ul style="list-style-type: none"> • Failure of heat sink causes loss of Cold Shutdown conditions in Modes 5 and 6 <p style="text-align: center;"><u>AND</u></p> <p>Lower Range RVLIS level indicates core is uncovered.</p> <ul style="list-style-type: none"> • Failure of heat sink causes loss of Cold Shutdown conditions in Modes 5 and 6 <p style="text-align: center;"><u>AND</u></p> <p>Core Exit T/Cs indicate superheat at the core exit.</p> <p style="text-align: center;"><u>(Continued)</u></p>

Emergency Event List for Emergency Classes
Event # 4.1.5 Loss of Shutdown Function

Notification of Unusual Event	Alert	Site Area Emergency	General Emergency
		<ul style="list-style-type: none"> • Failure of heat sink causes loss of Cold Shutdown conditions in Modes 5 and 6 <p style="text-align: center;"><u>AND</u></p> <p>Reliable NC System level indication unavailable</p> <p style="text-align: center;"><u>AND</u></p> <p>Core exit T/Cs or AP/1(2)/A/5500/019, Loss of ND, Enclosure 3, indicate boiling in core</p> <p style="text-align: center;"><u>AND</u></p> <p>Available NC System make-up flow is less than applicable value given in AP/1(2)/A/5500/019, Loss of ND, Enclosure 4.</p> <p style="text-align: center;"><u>END</u></p>	<ul style="list-style-type: none"> • Failure of heat sink causes loss of Cold Shutdown conditions in Modes 5 and 6 <p style="text-align: center;"><u>AND</u></p> <p>NC System level below bottom range of available level indicators</p> <p style="text-align: center;"><u>AND</u></p> <p>Available NC System make-up flow is less than applicable value given in AP/1(2)/A/5500/019, Loss of ND, Enclosure 4</p> <p style="text-align: center;"><u>AND</u></p> <p>Emergency Coordinator judgement that core uncover is imminent.</p> <p style="text-align: center;"><u>END</u></p>

Emergency Event List for Emergency Classes
Event # 4.1.6 Loss of Power

Notification of Unusual Event	Alert	Site Area Emergency	General Emergency
<p>1. Loss of offsite power in Modes 1-6.</p> <ul style="list-style-type: none"> Both A <u>AND</u> B main bus lines de-energized in Modes 1-6. <p>2. Loss of onsite AC power in Modes 1-4.</p> <ul style="list-style-type: none"> Both D/Gs are incapable (for greater than 2 hours) of powering the 4160V Essential Buses in Modes 1-4. <p>3. Loss of onsite AC power in Modes 5 and 6.</p> <ul style="list-style-type: none"> Both D/Gs are incapable (for greater than 8 hours) of powering the 4160V Essential Buses in Modes 5 and 6. <p style="text-align: center;"><u>END</u></p>	<p>1. Loss of offsite power and loss of all onsite AC power for greater than 1 minute but less than or equal to 15 minutes in Modes 1-4.</p> <ul style="list-style-type: none"> Both 4160V Essential Buses are de-energized for greater than 1 minute but less than or equal to 15 minutes in Modes 1-4. <p>2. Loss of offsite power and loss of all onsite AC power for greater than 15 minutes in Modes 5 and 6.</p> <ul style="list-style-type: none"> Both 4160V Essential Buses are de-energized for greater than 15 minutes in Modes 5 and 6. <p style="text-align: center;"><u>(Continued)</u></p>	<p>1. Loss of offsite power and loss of all onsite AC power for greater than 15 minutes in Modes 1-4.</p> <ul style="list-style-type: none"> Both 4160V Essential Buses are de-energized for greater than 15 minutes in Modes 1-4. <p style="text-align: center;"><u>(Continued)</u></p>	<p>1. Loss of offsite power and loss of all onsite AC power with total loss of S/G feed capability in Modes 1-4.</p> <ul style="list-style-type: none"> Both 4160V Essential Buses are de-energized in Modes 1-4 <p style="text-align: center;"><u>AND</u></p> <p>Loss of CM/CF feedwater flow capacity</p> <p style="text-align: center;"><u>AND</u></p> <p>CA Flow <u>cannot</u> be established within 30 minutes.</p> <p style="text-align: center;"><u>END</u></p>

Enclosure 4.1

Emergency Event List for Emergency Classes
Event # 4.1.6 Loss of Power

Notification of
Unusual Event

Alert

Site Area Emergency

General Emergency

	<p>3. Loss of all vital DC power for up to 15 minutes in Modes 1-4.</p> <ul style="list-style-type: none">• Vital DC Buses EDA, EDD, EDE and EDF de-energized for up to 15 minutes in Modes 1-4. <p>4. Loss of all vital DC power for greater than 15 minutes in Modes 5 and 6.</p> <ul style="list-style-type: none">• Vital DC Buses EDA, EDD, EDE and EDF de-energized for greater than 15 minutes in Modes 5 and 6. <p><u>END</u></p>	<p>2. Loss of all vital DC power for greater than 15 minutes in Modes 1-4.</p> <ul style="list-style-type: none">• Vital DC Buses EDA, EDD, EDE and EDF de-energized for greater than 15 minutes in Modes 1-4. <p><u>END</u></p>	
--	---	--	--

**Emergency Event List for Emergency Classes
Event 4.1.7 Fires and Security Actions**

Notification of Unusual Event	Alert	Site Area Emergency	General Emergency
<p>1. Fire situation (as determined by the Operations Shift Manager or designee) within the Plant (see NOTE) lasting longer than 10 minutes.</p> <p>2. Security threat.</p> <ul style="list-style-type: none"> • Discovery of a bomb within the Site Boundary but outside the protected area. • Civil disturbance (hostile). • Intrusion/attempted intrusion (Protected Area). • Hostage situation/ extortion. • Security threat as determined by Operations Shift Manager/Emergency Coordinator and Security. <p style="text-align: center;"><u>END</u></p>	<p>1. Fires potentially affecting safety systems needed for current operating mode.</p> <ul style="list-style-type: none"> • Observation of a fire that could adversely affect safety systems needed for current operating mode. • Fire requiring evacuation of the Control Room <p style="text-align: center;"><u>AND</u></p> <p>Control of shutdown systems has been established or is in the process of being established from the Auxiliary Shutdown Panels.</p> <p style="text-align: center;"><u>(Continued)</u></p>	<p>1. Fire compromising the functions of safety systems.</p> <ul style="list-style-type: none"> • Observation of a fire that defeats both trains (or the single operable train) of safety systems needed for current operating mode. • Fire requiring evacuation of the Control Room <p style="text-align: center;"><u>AND</u></p> <p>Control of shutdown system <u>cannot</u> be established from the Auxiliary Shutdown Panels</p> <p style="text-align: center;"><u>AND</u></p> <p>Control of shutdown systems has been established or in the process of being established from the Standby Shutdown Facility.</p> <p style="text-align: center;"><u>(Continued)</u></p>	<p>1. Any major fire which could cause massive common damage or loss of control of the plant.</p> <ul style="list-style-type: none"> • Fire requiring evacuation of the Control Room <p style="text-align: center;"><u>AND</u></p> <p>Control of shutdown systems <u>cannot</u> be established from any plant location.</p> <p style="text-align: center;"><u>(Continued)</u></p>

NOTE: Plant is defined as Auxiliary Building, Turbine Building, Service Building, Reactor Building, Diesel Generator Rooms, Doghouses, Spent Fuel Building, Standby Shutdown Facility, RN Pumphouse and Monitor Tank Building.

Emergency Event List for Emergency Classes
Event 4.1.7 Fires and Security Actions

Notification of Unusual Event	Alert	Site Area Emergency	General Emergency
<p>N/A</p>	<p>2. Ongoing security compromise.</p> <ul style="list-style-type: none"> • Adversaries commandeer an area of the Plant.(See NOTE 1) • Discovery of a breached barrier caused by intrusion or sabotage in a vital area. (See NOTE 2) • Discovery of a bomb within the Protected Area. • Ongoing security compromise as determined by Emergency Coordinator and Security. <p><u>END</u></p>	<ul style="list-style-type: none"> • Fire requiring evacuation of the Control Room <p><u>AND</u></p> <p>Inability to establish control from the Auxiliary Shutdown Panels in less than or equal to 15 minutes.</p> <p>2. Imminent loss of physical control of the Plant. (See NOTE 1)</p> <ul style="list-style-type: none"> • Physical attack on the Plant (see NOTE 1) which leads to the imminent occupancy of the Control Room or Auxiliary Shutdown Panels. • Discovery of a bomb within a vital area. (See NOTE 2) <p><u>END</u></p>	<p>2. Loss of physical control of the Plant. (See NOTE 1)</p> <ul style="list-style-type: none"> • Physical attack on the Plant (see NOTE 1) has resulted in occupation of the Control Room <u>OR</u> Auxiliary Shutdown Panels. <p><u>END</u></p>

NOTE: 1. Plant is defined as Auxiliary Building, Turbine Building, Service Building, Reactor Building, Diesel Generator Rooms, Doghouses, Spent Fuel Building, Standby Shutdown Facility, RN Pumphouse and Monitor Tank Building.

2. For classification purposes, consider the RN Pumphouse as a vital area.

Emergency Event List for Emergency Classes
Event # 4.1.8 Spent Fuel Damage

Notification of Unusual Event	Alert	Site Area Emergency	General Emergency
N/A	<p>1. Damage to spent fuel with release of radioactivity.</p> <p><u>CONTAINMENT</u></p> <ul style="list-style-type: none"> Valid TRIP 2 alarm on 1EMF-17 (2EMF-2) (Reactor Bldg Refuel Bridge) <p><u>AND</u></p> <p>Report of fuel damage due to load dropped into the core or during core alterations or movement of spent fuel in Containmentment.</p> <p><u>(Continued)</u></p>	<p>1. Major damage to spent fuel with release of radioactivity.</p> <p><u>CONTAINMENT</u></p> <ul style="list-style-type: none"> Valid TRIP 2 alarm on 1EMF-17 (2EMF-2) (Reactor Bldg Refuel Bridge) <p><u>AND</u></p> <p>Valid indication on EMF-36L reading greater than or equal to 1.5 E6 cpm. (See NOTE)</p> <ul style="list-style-type: none"> Valid TRIP 2 alarm on 1EMF-17 (2EMF-2) (Reactor Bldg Refuel Bridge) <p><u>AND</u></p> <p>Dose assessment team calculations project a dose at the Site Boundary of greater than or equal to 100 mrem Total Effective Dose Equivalent (TEDE) or 500 mrem Committed Dose Equivalent (CDE) thyroid.</p> <p><u>(Continued)</u></p>	N/A

NOTE: This EMF setpoint is calculated based on worst case annual average meteorology and a Unit Vent flowrate of 1.9 E5 cfm. Calculations by the dose assessment team use actual meteorology and Unit Vent flowrate. Therefore, this EMF setpoint should not be used if dose assessment team calculations are available.

Enclosure 4.1

Emergency Event List for Emergency Classes
Event # 4.1.8 Spent Fuel Damage

Notification of
 Unusual Event

	Alert	Site Area Emergency	General Emergency
	<p><u>SPENT FUEL POOL</u></p> <ul style="list-style-type: none"> Valid TRIP 2 alarm on 1EMF-15 (2EMF-4) (Spent Fuel Bldg Refuel Bridge) <p><u>AND</u></p> <p>Report of fuel damage during movement of spent fuel or load over the spent fuel pool in the Fuel Building.</p> <p><u>END</u></p>	<p><u>SPENT FUEL POOL</u></p> <ul style="list-style-type: none"> Valid TRIP 2 alarm on 1EMF-15 (2EMF-4) (Spent Fuel Bldg Refuel Bridge) <p><u>AND</u></p> <p>Valid indication on EMF-36L reading greater than or equal to 1.5 E6 cpm. (See NOTE)</p> <ul style="list-style-type: none"> Valid TRIP 2 alarm on 1EMF-15 (2EMF-4) (Spent Fuel Bldg Refuel Bridge). <p><u>AND</u></p> <p>Dose assessment team calculations project a dose at the Site Boundary of greater than or equal to 100 mrem Total Effective Dose Equivalent (TEDE) or 500 mrem Committed Dose Equivalent (CDE) thyroid.</p> <p><u>END</u></p>	

NOTE: The EMF setpoint is calculated based on worst case annual average meteorology and a Unit Vent flowrate of 1.9 E5 cfm. Calculations by the dose assessment team use actual meteorology and Unit Vent flowrate. Therefore, this EMF setpoint should not be used if dose assessment team calculations are available.

Emergency Event List for Emergency Classes
Event # 4.1.9 Natural Disasters and Other Hazards

Notification of Unusual Event	Alert	Site Area Emergency	General Emergency
<p>1. Earthquake felt in plant and detected by seismic monitoring instruments.</p> <ul style="list-style-type: none"> Valid "Peak Shock Annunciator" alarm. <p>Valid alarm on "Strong Motion Accelerograph."</p> <p>2. Low water level.</p> <ul style="list-style-type: none"> Lake level less than or equal to 557.5 ft <p><u>AND</u></p> <p>SNSWP is available.</p> <p><u>(Continued)</u></p>	<p>1. Earthquake greater than OBE level.</p> <ul style="list-style-type: none"> Valid "OBE EXCEEDED" annunciator alarm (1AD-4, B-8). <p><u>(Continued)</u></p>	<p>1. Earthquake greater than SSE level.</p> <ul style="list-style-type: none"> Earthquake intensity greater than 0.15g Horizontal or 0.10g Vertical (SSE level). <p>2. Low water level.</p> <ul style="list-style-type: none"> Lake level less than or equal to 557.5 ft <p><u>AND</u></p> <p>SNSWP is not available.</p> <p><u>(Continued)</u></p>	<p>1. Any major internal or external event (e.g. aircraft impact, earthquakes substantially beyond design basis) which could cause massive damage to the Unit.</p> <p><u>END</u></p>

Emergency Event List for Emergency Classes
Event # 4.1.9 Natural Disasters and Other Hazards

Notification of Unusual Event	Alert	Site Area Emergency	General Emergency
<p>3. Any tornado/severe weather within the Site Boundary.</p> <ul style="list-style-type: none"> • Tornado/severe weather onsite. • Sustained (greater than 15 minutes) winds greater than or equal to 60 MPH. <p>4. Aircraft crash.</p> <ul style="list-style-type: none"> • Aircraft crash within the Site Boundary. <p>5. Train derailment onsite.</p> <ul style="list-style-type: none"> • Train derailment resulting in physical damage to equipment/structure within the Site Boundary needed for plant operation. <p style="text-align: center;"><u>(Continued)</u></p>	<p>2. Damage from tornado, severe weather, missile, explosion, aircraft crash or train derailment.</p> <ul style="list-style-type: none"> • Any tornado striking plant structures within the protected area fence. • Sustained (greater than 15 min) winds of greater than 75 mph but less than 95 mph as reported by the NWS. • Aircraft crash within the protected area fence affecting safe operation of the unit. • Missile impact within the protected area fence affecting safe operation of the unit. • Explosion damage within the protected area fence affecting safe operation of the unit. <p style="text-align: center;"><u>(Continued)</u></p>	<p>3. Damage from tornado, severe weather, missile, explosion, aircraft crash, or train derailment.</p> <ul style="list-style-type: none"> • Any tornado striking any plant vital area structure resulting in loss of any ESF function required for current operating mode. • Sustained (greater than 15 minutes) winds greater than 95 mph as reported by NWS. • Aircraft crash causing damage or fire to Containment Building, Control Room, Auxiliary Building, Fuel Building, or RN intake structures in Modes 1-4. • Damage from missile or explosion in Mode 1-4 causes inability to maintain or establish function required for hot shutdown. <p style="text-align: center;"><u>(Continued)</u></p>	

**Emergency Event List for Emergency Classes
Event # 4.1.9 Natural Disasters and Other Hazards**

Notification of Unusual Event	Alert	Site Area Emergency	General Emergency
<p>6. Explosion within the Site boundary.</p> <ul style="list-style-type: none"> Explosion within the Site boundary resulting in physical damage to equipment/structures needed for plant operation or injuries to personnel. <p>7. Release of toxic or flammable gases.</p> <ul style="list-style-type: none"> Release of toxic or flammable gas resulting in personnel injury or evacuation within the Protected Area. <p><u>END</u></p>	<p>3. Release of toxic or flammable gas.</p> <ul style="list-style-type: none"> Uncontrolled entry of toxic or flammable gas within protected area fence affecting safe operation of the unit. <p><u>END</u></p>	<p>4. Release of toxic or flammable gas in Modes 1-4.</p> <ul style="list-style-type: none"> Entry of uncontrolled toxic or flammable gases into the Control Room, Cable Spreading Room, Containment Buildings, Switchgear Rooms, Auxiliary Shutdown Panel area (CA Pump Room), or Emergency Diesel Generator Rooms affecting safe operation of the unit in Modes 1-4. <p><u>END</u></p>	

Emergency Event List for Emergency Classes
Event # 4.1.10 Other Abnormal Plant Conditions

Notification of Unusual Event	Alert	Site Area Emergency	General Emergency
<p>1. Inability to reach required shutdown within technical specification limits</p> <ul style="list-style-type: none"> Plant is not brought to required operating mode within Technical Specification LCO Action Statement Time in Modes 1-4. Plant is not brought to required operating mode within the required time limits of Technical Specification LCO 3.0.3. <p>2. Significant loss of assessment or communication capability.</p> <ul style="list-style-type: none"> Loss of all radio and telephone communication capability with all offsite agencies. Loss of 50% or more of the Control Room annunciators in Modes 5 and 6 for greater than 15 minutes. <p>3. Other Unit conditions exist that in the judgement of the Operations Shift Manager/Emergency Coordinator warrant increased awareness of local authorities.</p> <p>END</p>	<p>1. Evacuation of Control Room.</p> <ul style="list-style-type: none"> Evacuation of the Control Room required <p>AND</p> <p>Control established from the Auxiliary Shutdown Panels in less than or equal to 15 minutes.</p> <p>2. Most or all annunciator capability lost in Modes 1-4.</p> <ul style="list-style-type: none"> Loss of 50% or more of the Control Room annunciators in Modes 1-4 for greater than 15 minutes. <p>3. Other Unit conditions exist that in the judgement of the Emergency Coordinator warrant entry into the Alert Classification.</p> <p>END</p>	<p>1. Evacuation of Control Room.</p> <ul style="list-style-type: none"> Evacuation of the Control Room required <p>AND</p> <p>Control of shutdown systems <u>cannot</u> be established from the Auxiliary Shutdown Panels</p> <p>AND</p> <p>Control of shutdown systems has been established or is in the process of being established from the Standby Shutdown Facility.</p> <ul style="list-style-type: none"> Evacuation of the Control Room required <p>AND</p> <p>Inability to establish control from the Auxiliary Shutdown Panels in less than or equal to 15 minutes.</p> <p>2. Other Unit conditions exist that in the judgement of the Emergency Coordinator warrant declaration of Site Area Emergency.</p> <p>END</p>	<p>1. Evacuation of Control Room.</p> <ul style="list-style-type: none"> Evacuation of the Control Room required <p>AND</p> <p>Control of shutdown systems <u>cannot</u> be established from any plant location.</p> <p>2. Other Unit conditions exist that in the judgement of the Emergency Coordinator create the possibility of a release of large amounts of radioactivity in a short period of time.</p> <p>END</p>

Duke Power Company
PROCEDURE PROCESS RECORD

PREPARATION

(2) Station Catawba Nuclear Station

(3) Procedure Title Alert

(4) Prepared By Steve R. Christoph Date 2/24/99

- (5) Requires 10CFR50.59 evaluation?
 - Yes (New procedure or reissue with major changes)
 - No (Revision with minor changes)
 - No (To incorporate previously approved changes)

(6) Reviewed By Gary C Mitchell (QR) Date 3-1-99

Cross-Disciplinary Review By J Baum (QR) NA _____ Date 3-8-99

Reactivity Mgmt. Review By _____ (QR) NA GLM Date 3-1-99

(7) Additional Reviews

Reviewed By _____ Date _____

Reviewed By _____ Date _____

(8) Temporary Approval (if necessary)

By _____ (SRO/QR) Date _____

By _____ (QR) Date _____

(9) APPROVED BY A. Hood Date 3/9/99

PERFORMANCE (Compare with control copy at least once every 14 calendar days while work is being performed)

(10) Compared with Control Copy _____ Date _____

Compared with Control Copy _____ Date _____

Compared with Control Copy _____ Date _____

(11) Dates(s) Performed _____

Work Order Number (W/O #) _____

COMPLETION

(12) Procedure Completion Verification

- Yes N/A Check lists and/or blanks properly initialed, signed, dated, or filled in NA, as appropriate?
- Yes N/A Listed enclosures attached?
- Yes N/A Data sheets attached, completed, dated and signed?
- Yes N/A Charts, graphs, etc. attached and properly dated, identified and marked?
- Yes N/A Procedure requirements met?

Verified By _____ Date _____

(13) Procedure Completion Approved _____ Date _____

(14) Remarks (attach additional pages, if necessary)

Duke Power Company
Catawba Nuclear Station

Alert

Multiple Use

Procedure No.

RP/0/A/5000/003

Revision No.

034

Electronic Reference No.

CN005GNM

Alert**1. Symptoms**

- 1.1 Events are in process or have occurred which involve an actual or potential substantial degradation of the level of safety of the plant.

2. Immediate Actions

NOTE: Lines in left margin are for place keeping. Immediate actions may be performed simultaneously.

— Advise site personnel by making the following announcement over the plant PA system:
"This is the Operations Shift Manager. An Alert has been declared for Unit _____ based on _____ . Activate the TSC, OSC, and EOF." Repeat announcement.
 (brief description of event)

— Activate Emergency Organization by using Enclosure 4.1.

— Notify off-site agencies within 15 minutes of Emergency declaration time using an Emergency Notification Form. Refer to one of the following notification procedures for instructions:

- RP/0/A/5000/006A, "Notifications to States and Counties from the Control Room"
- RP/0/A/5000/006B, "Notifications to States and Counties from the Technical Support Center"
- RP/0/A/5000/006C, "Notifications to States and Counties from the Emergency Operations Facility"

— IF there is an indication of a radioactive release AND the TSC is not activated, contact RP shift to perform off-site dose assessment per HP/0/B/1009/026.

— IF a Security Event exists, discuss the feasibility of conducting a site assembly with the Security Shift Supervisor at extension 5364.

IF a Site Assembly is not feasible per Security,

— Announce over the plant PA System:

"This is the Operations Shift Manager. A security event is in progress. Do not move about the site. Remain at your present location until further notice. Report any suspicious activities to the CAS at extension 5364." Repeat Announcement.

— N/A the following step:

— Conduct a Site Assembly using RP/0/A/5000/010, "Conducting a Site Assembly or Preparing the Site for an Evacuation."

— **Notify the NRC** using RP/0/B/5000/013, "NRC Notification Requirements." This notification should be made as quickly as possible but shall be made within one hour of the emergency declaration time.

— Initiate Emergency Response Data System (ERDS) transmission by performing the following:

— Type "ERDS" or select "Main," then "General," then "ERDS" on a Control Room OAC workstation connected to the affected unit's OAC

— Initiate ERDS transmission by depressing F1 or clicking "Activate."

— **IF** ERDS transmission will not connect to the NRC, inform the NRC using ENS. The TSC Data Coordinator will troubleshoot and initiate ERDS transmission upon arrival in the TSC.

3. Subsequent Actions

NOTE: Subsequent Actions are not required to be followed in any particular sequence.

— Ensure RP has dispatched technicians for on-site monitoring/surveys per HP/0/B/1009/009, "Guidelines for Accident and Emergency Response."

— Make Follow-up Notifications using applicable RP/0/A/5000/006A (CR), RP/0/A/5000/006B (TSC), or RP/0/A/5000/006C (EOF).

— RP/0/A/5000/018, "Emergency Worker Dose Extension," shall be used to authorize emergency worker doses expected to exceed normal occupational exposure limits during a declared emergency event or exceed blanket dose extension limits authorized by the Radiation Protection Manager.

— Augment shift resources to assess and respond to the emergency situation as needed.

— Announce over the plant PA system the current emergency classification level and summary of plant status.

Assess emergency conditions and the corresponding emergency classification. See RP/0/A/5000/001, "Classification of Emergency," then:

Remain in an Alert

OR

Escalate to a more severe emergency classification

OR

Reduce to a less severe emergency classification
(Refer to Enclosure 4.3)

OR

Terminate the emergency (Refer to RP/0/A/5000/020 or SR/0/B/2000/003 for Termination Criteria).

- **Announce any emergency classification level changes over the plant PA; including a summary of plant status.**

IF Security Event announcement, discussed above, was made over the PA system, conduct a Site Assembly using RP/0/A/5000/010, "Conducting a Site Assembly or Preparing the Site for an Evacuation," and make the following announcement over the PA system after the Security Event has been terminated:

"This is the Operations Shift Manager. The Security Event has been terminated. Proceed to your Site Assembly point." **Repeat announcement**

Provide turnover to TSC Emergency Coordinator using Enclosure 4.2.

In the event that a worker's behavior or actions contributed to an actual or potential substantial degradation of the level of safety of the plant (incidents resulting in an Alert or higher emergency declaration), the supervisor must consider and establish whether or not a for cause drug/alcohol screen is required. The FFD Program Administrator or designee is available to discuss/assist with the incident.

The EOF Director shall close out the emergency with a verbal summary to county and state authorities. Document this summary using Enclosure 4.4.

The EOF Director shall assign an individual to provide a written report to county and state authorities within thirty days. This report could be an LER or a written report if an LER is not required.

Person assigned responsibility _____

4. Enclosures

- 4.1 Emergency Organization Activation
- 4.2 Emergency Coordinator Turnover Form
- 4.3 Criteria for Downgrading an Emergency Level
- 4.4 Alert Close Out Briefing with States and Counties

1. Activate ERO Pagers

- Use the Quikpage Key Pad located in the Control Room (***IF** Control Room key pad is unavailable, use key pad located in TSC Off-Site Communicator area*).
 - 1) Type "ERO" and press "ENTER"
 - 2) Press "M"
 - 3) Press appropriate message key:

F1 for Catawba Drill

OR

F6 for Catawba Emergency
 - 4) Ensure cursor is at the end of the line and type "Alert declared at (time). Activate TSC/OSC/EOF."
 - 5) Press "ENTER"
 - 6) Monitor pager located at the Quikpage key pad to verify ERO pager activation.
- **IF** Quikpage Key Pad is unavailable in both Control Room and TSC, dial 8-777-8376. When prompted, enter numeric password 2580. When prompted, enter activation code 6789#.

2. Activate Automatic Dialing Call Back System (Community Alert Network)

NOTE: Back-up telephone number for Community Alert Network is (518) 862-0987.

- 2.1 Dial 1-800-552-4226 (Hotline/Activation Line)
- 2.2 **IF CAN** is being activated for a **DRILL**, read one of the following messages depending on day and time.

IF Monday through Thursday between 0700 through 1730, read the following message:

"This is _____ (name) _____ from Duke Power, Catawba. The Password is Catawba. Please run Catawba Day List message number 5. Please call me back to verify system operation at _____."

(Phone # in Simulator)

IF not Monday through Thursday between 0700 through 1730, read the following message:

"This is _____ (name) _____ from Duke Power, Catawba. The Password is Catawba. Please run Catawba Night List message number 5. Please call me back to verify system operation at _____."

(Phone # in Simulator)

- 2.3 **IF CAN** is being activated for an **EMERGENCY**, read one of the following messages depending on day and time.

IF Monday through Thursday between 0700 through 1730, read the following message:

"This is _____ (name) _____ from Duke Power, Catawba. The Password is Catawba. Please run Catawba Day List message number 6. Please call me back to verify system operation at (803) 831-7332."

IF not Monday through Thursday between 0700 through 1730, read the following message:

"This is _____ (name) _____ from Duke Power, Catawba. The Password is Catawba. Please run Catawba Night List message number 6. Please call me back to verify system operation at (803) 831-7332."

Emergency Coordinator Turnover Form

1. Plant Status:

Unit 1: _____

Unit 2: _____

2. Emergency Classification:

Time Declared: _____

3. Off-Site Agency Notifications Turnover to TSC Complete? _____ (Y/N)

4. Time Next Notification due: _____

5. Significant Events:

_____ Radioactive Release

Y/N

_____ Injured Personnel

Y/N

_____ Other (Specify _____)

6. Protective Actions in Progress:

_____ Site Assembly (Time Initiated _____)

Y/N

_____ Off-Site Protective Actions Recommended

Y/N (List _____)

_____ Other (Specify _____)

Y/N

7. Response Procedure In Progress:

RP _____ RP _____ RP _____

8. Actions in Progress:

Criteria for Downgrading an Emergency Level

Date
Initial/Time

- _____ 1. The probability that plant conditions will continue to improve is evident.
 - _____ 2. All emergency action level notifications have been completed.
 - _____ 3. Emergency response facility staffing may be reduced.
 - _____ 4. The criteria established for the emergency classification has been evaluated. Conditions warrant a lower emergency action level.
 - _____ 5. The event related release of radioactive material to the environment is terminated.
 - _____ 6. The control of any fire, flood, earthquake or similar emergency condition is acceptable.
 - _____ 7. Any corrective actions specified by the Emergency Coordinator to place the plant in a safe condition have been completed and the plant has been placed in the appropriate operating mode.
 - _____ 8. The Emergency Coordinator has evaluated the plant status with respect to the Emergency Action Levels and recommends downgrading the emergency classification.
 - _____ 9. Emergency classification level downgraded to _____
-

Enclosure 4.4
Alert Close Out Briefing
with States and Counties

RP/0/A/5000/003
Page 1 of 1

Person Providing Verbal Summary: _____

Brief Event Description: _____

<u>Agency</u>	<u>Person Contacted</u>	<u>Date/Time</u>
South Carolina	_____	_____
North Carolina	_____	_____
York County	_____	_____
Gaston County	_____	_____
Mecklenburg County	_____	_____

Comments/Questions from States and Counties: _____

**CATAWBA
INITIAL LICENSE EXAMINATION
JOB PERFORMANCE MEASURE**

JPM 4/ADMIN

**Calculate Workers Dose in an Airborne
Contamination Area**

CANDIDATE

EXAMINER

Tools/Equipment/Procedures Needed:

None

READ TO OPERATOR

DIRECTION TO TRAINEE:

I will explain the initial conditions, and state the task to be performed. All control room steps shall be performed for this JPM, including any required communications. I will provide initiating cues and reports on other actions when directed by you. Ensure you indicate to me when you understand your assigned task. To indicate that you have completed your assigned task return the handout sheet I provided you.

INITIAL CONDITIONS:

1. Work must be performed in an area where the dose rate is 60 mr/hr.
2. Air samples have been taken and there is a small amount of airborne contamination in the area, 3 DAC.
3. History of this job performance shows that it takes 1 hour and 30 minutes to perform the job without a respirator and 1 hour and 45 minutes to perform the job with a respirator.

INITIATING CUE:

You are to perform a calculation of the workers dose and determine whether or not a respirator should be used.

JPM OVERALL STANDARD:

The candidate determines that the total dose for the job to be performed will be lower if no respirator is used.

K/A 2.3.4 (2.5/3.1)

<p>STEP 1: Determine dose received performing the job without a respirator.</p> <p>STANDARD: Candidate calculates a total dose of <u>101.25 mr</u> without a respirator as follows:</p> <p>60 mr/hr X 1.5 hrs = 90 mr</p> <p>2.5 mr/DAC X 3 DAC/hr = 7.5 mr/hr</p> <p>7.5 mr/hr X 1.5 hr = 11.25mr.</p> <p>Total dose received without a respirator</p> <p>90 mr + 11.25 mr = 101.25 mr without a respirator.</p> <p>COMMENTS:</p>	<p>CRITICAL STEP</p> <p><input type="checkbox"/> SAT</p> <p><input type="checkbox"/> UNSAT</p>
<p>STEP 2: Determine dose received performing the job with a respirator.</p> <p>STANDARD: Candidate calculates a total dose of <u>105 mr</u> with a respirator.</p> <p><u>60 mr/hr X 1.75 hr = 105 mr with a respirator</u></p> <p>COMMENTS:</p>	<p>CRITICAL STEP</p> <p><input type="checkbox"/> SAT</p> <p><input type="checkbox"/> UNSAT</p>
<p>STEP 3: Determines that performing the job without a respirator results in a lower dose.</p> <p>STANDARD: Determines that performing the job without a respirator results in a lower dose.</p> <p>COMMENTS:</p>	<p>CRITICAL STEP</p> <p><input type="checkbox"/> SAT</p> <p><input type="checkbox"/> UNSAT</p>

TIME STOP: _____

**CANDIDATE CUE SHEET
(TO BE RETURNED TO EXAMINER UPON COMPLETION OF TASK)**

INITIAL CONDITIONS:

1. Work must be performed in an area where the dose rate is 60 mr/hr.
2. Air samples have been taken and there is a small amount of airborne contamination in the area, 3 DAC.
3. History of this job performance shows that it takes 1 hour and 30 minutes to perform the job without a respirator and 1 hour and 45 minutes to perform the job with a respirator.

INITIATING CUE:

You are to perform a calculation of the workers dose and determine whether or not a respirator should be used.

**CATAWBA
INITIAL LICENSE EXAMINATION
JOB PERFORMANCE MEASURE**

JPM 5R/ADMIN

Activate the Emergency Response Organization

CANDIDATE

EXAMINER

Tools/Equipment/Procedures Needed:

RP/0/A/5000/003 (Alert)

READ TO OPERATOR

DIRECTION TO TRAINEE:

I will explain the initial conditions, and state the task to be performed. All control room steps shall be performed for this JPM, including any required communications. I will provide initiating cues and reports on other actions when directed by you. Ensure you indicate to me when you understand your assigned task. To indicate that you have completed your assigned task return the handout sheet I provided you.

INITIAL CONDITIONS:

An Alert has been declared on Unit 1 by the OSM.

INITIATING CUE:

Activate the Emergency Response Organization per RP/0/A/5000/003 (Alert).

JPM OVERALL STANDARD:

The Emergency Response Organization has been activated per RP/0/A/5000/003 (Alert).

K/A 2.4.43 (2.8/3.5)

<p>STEP 1: Obtain a copy of the appropriate procedure.</p> <p>STANDARD: Operator obtains a copy of RP/0/A/5000/003.</p> <p>EXAMINER'S CUE: When the candidate locates the appropriate procedures, give him copies and tell him they are current and complete.</p> <p>COMMENTS:</p>	<p>CRITICAL STEP</p> <p>___ SAT</p> <p>___ UNSAT</p>
<p>STEP 2: Advise site personnel.</p> <p>STANDARD: Announcement is made over the PA system.</p> <p>EXAMINER'S NOTE: The steps in the procedure are numbered. By Catawba rules of usage, this means that they do NOT have to be performed in the sequence listed. The candidate may go directly to the step to activate the ERO in RP/0/A/5000/003 and bypass this step. This is acceptable.</p> <p>COMMENTS:</p>	<p>___ SAT</p> <p>___ UNSAT</p>

<p>STEP 3: Locate Quikpage Key Pad in the Control Room. Type ERO and press ENTER.</p> <p>STANDARD: Information correctly entered.</p> <p>EXAMINER'S CUE: ERO typed and entered.</p> <p>COMMENTS:</p>	<p>CRITICAL STEP</p> <p>__ SAT</p> <p>__ UNSAT</p>
<p>STEP 4: Press "M"</p> <p>STANDARD: Candidate presses "M" on the Quikpage Key Pad</p> <p>EXAMINERS CUE: "M" has been pressed.</p> <p>COMMENTS:</p>	<p>CRITICAL STEP</p> <p>__ SAT</p> <p>__ UNSAT</p>
<p>STEP 5: Press F6 message key for Catawba Emergency.</p> <p>STANDARD: F6 key pressed.</p> <p>EXAMINER'S CUE: F6 key pressed.</p> <p>COMMENTS:</p>	<p>CRITICAL STEP</p> <p>__ SAT</p> <p>__ UNSAT</p>

<p>STEP 6: Ensure the cursor is at the end of the line and type "Alert declared at (time). Activate TSC/OSC/EOF" and press enter.</p> <p>STANDARD: Information entered successfully.</p> <p>EXAMINER'S CUE: "Alert declared at (time). Activate TSC/OSC/EOF" entered.</p> <p>COMMENTS:</p>	<p>CRITICAL STEP</p> <p>___ SAT</p> <p>___ UNSAT</p>
<p>STEP 7: Monitor pager located at the Quikpage key pad to verify ERO pager activation.</p> <p>STANDARD: Locate page and activate the display..</p> <p>EXAMINER'S CUE: The pager has actuated and it displays the Message "Alert declared at (time). Activate the TSC/OSC/EOF"</p> <p>COMMENTS:</p>	<p>___ SAT</p> <p>___ UNSAT</p>

TIME STOP: _____

**CANDIDATE CUE SHEET
(TO BE RETURNED TO EXAMINER UPON COMPLETION OF TASK)**

INITIAL CONDITIONS:

An Alert has been declared on Unit 1 by the OSM.

INITIATING CUE:

Activate the Emergency Response Organization per RP/0/A/5000/003 (Alert).

Duke Power Company PROCEDURE PROCESS RECORD

PREPARATION

(2) Station Catawba Nuclear Station

(3) Procedure Title Alert

(4) Prepared By Steve R Christoph Date 2/24/99

- (5) Requires 10CFR50.59 evaluation?
- Yes (New procedure or reissue with major changes)
 - No (Revision with minor changes)
 - No (To incorporate previously approved changes)

(6) Reviewed By Gary C Mitchell (QR) Date 3-1-99
 Cross-Disciplinary Review By J Baumgardner (QR) NA _____ Date 3-8-99
 Reactivity Mgmt. Review By _____ (QR) NA GLM Date 3-1-99

(7) Additional Reviews

Reviewed By _____ Date _____

Reviewed By _____ Date _____

(8) Temporary Approval (if necessary)

By _____ (SRO/QR) Date _____

By _____ (QR) Date _____

(9) APPROVED BY A Howard Date 3/9/99

PERFORMANCE (Compare with control copy at least once every 14 calendar days while work is being performed)

(10) Compared with Control Copy _____ Date _____
 Compared with Control Copy _____ Date _____
 Compared with Control Copy _____ Date _____

(11) Dates(s) Performed _____
 Work Order Number (W/O #) _____

COMPLETION

(12) Procedure Completion Verification

- Yes N/A Check lists and/or blanks properly initialed, signed, dated, or filled in NA, as appropriate?
- Yes N/A Listed enclosures attached?
- Yes N/A Data sheets attached, completed, dated and signed?
- Yes N/A Charts, graphs, etc. attached and properly dated, identified and marked?
- Yes N/A Procedure requirements met?

Verified By _____ Date _____

(13) Procedure Completion Approved _____ Date _____

(14) Remarks (attach additional pages, if necessary)

Duke Power Company
Catawba Nuclear Station

Alert

Multiple Use

Procedure No.

RP/0/A/5000/003

Revision No.

034

Electronic Reference No.

CN005GNM

Alert**1. Symptoms**

- 1.1 Events are in process or have occurred which involve an actual or potential substantial degradation of the level of safety of the plant.

2. Immediate Actions

NOTE: Lines in left margin are for place keeping. Immediate actions may be performed simultaneously.

___ **Advise site personnel** by making the following announcement over the plant PA system:

"This is the Operations Shift Manager. An Alert has been declared for Unit _____ based on _____ . Activate the TSC, OSC, and EOF." Repeat announcement.

(brief description of event)

___ **Activate Emergency Organization** by using Enclosure 4.1.

___ **Notify off-site agencies within 15 minutes of Emergency declaration time** using an Emergency Notification Form. Refer to one of the following notification procedures for instructions:

- RP/0/A/5000/006A, "Notifications to States and Counties from the Control Room"
- RP/0/A/5000/006B, "Notifications to States and Counties from the Technical Support Center"
- RP/0/A/5000/006C, "Notifications to States and Counties from the Emergency Operations Facility"

___ **IF** there is an indication of a radioactive release **AND** the TSC is not activated, contact RP shift to perform off-site dose assessment per HP/0/B/1009/026.

___ **IF** a Security Event exists, discuss the feasibility of conducting a site assembly with the Security Shift Supervisor at extension 5364.

IF a Site Assembly is not feasible per Security,

___ Announce over the plant PA System:

"This is the Operations Shift Manager. A security event is in progress. Do not move about the site. Remain at your present location until further notice. Report any suspicious activities to the CAS at extension 5364." Repeat Announcement.

___ N/A the following step:

___ **Conduct a Site Assembly** using RP/0/A/5000/010, "Conducting a Site Assembly or Preparing the Site for an Evacuation."

___ **Notify the NRC** using RP/0/B/5000/013, "NRC Notification Requirements." This notification should be made as quickly as possible but shall be made within one hour of the emergency declaration time.

___ Initiate Emergency Response Data System (ERDS) transmission by performing the following:

___ Type "ERDS" or select "Main," then "General," then "ERDS" on a Control Room OAC workstation connected to the affected unit's OAC

___ Initiate ERDS transmission by depressing F1 or clicking "Activate."

___ **IF** ERDS transmission will not connect to the NRC, inform the NRC using ENS. The TSC Data Coordinator will troubleshoot and initiate ERDS transmission upon arrival in the TSC.

3. Subsequent Actions

NOTE: Subsequent Actions are not required to be followed in any particular sequence.

___ Ensure RP has dispatched technicians for on-site monitoring/surveys per HP/0/B/1009/009, "Guidelines for Accident and Emergency Response."

___ Make Follow-up Notifications using applicable RP/0/A/5000/006A (CR), RP/0/A/5000/006B (TSC), or RP/0/A/5000/006C (EOF).

___ RP/0/A/5000/018, "Emergency Worker Dose Extension," shall be used to authorize emergency worker doses expected to exceed normal occupational exposure limits during a declared emergency event or exceed blanket dose extension limits authorized by the Radiation Protection Manager.

___ Augment shift resources to assess and respond to the emergency situation as needed.

___ Announce over the plant PA system the current emergency classification level and summary of plant status.

Assess emergency conditions and the corresponding emergency classification. See RP/0/A/5000/001, "Classification of Emergency," then:

Remain in an Alert

OR

Escalate to a more severe emergency classification

OR

Reduce to a less severe emergency classification
(Refer to Enclosure 4.3)

OR

Terminate the emergency (Refer to RP/0/A/5000/020 or SR/0/B/2000/003 for Termination Criteria).

- Announce any emergency classification level changes over the plant PA, including a summary of plant status.

IF Security Event announcement, discussed above, was made over the PA system, conduct a Site Assembly using RP/0/A/5000/010, "Conducting a Site Assembly or Preparing the Site for an Evacuation," and make the following announcement over the PA system after the Security Event has been terminated:

"This is the Operations Shift Manager. The Security Event has been terminated. Proceed to your Site Assembly point." **Repeat announcement**

Provide turnover to TSC Emergency Coordinator using Enclosure 4.2.

In the event that a worker's behavior or actions contributed to an actual or potential substantial degradation of the level of safety of the plant (incidents resulting in an Alert or higher emergency declaration), the supervisor must consider and establish whether or not a for cause drug/alcohol screen is required. The FFD Program Administrator or designee is available to discuss/assist with the incident.

The EOF Director shall close out the emergency with a verbal summary to county and state authorities. Document this summary using Enclosure 4.4.

The EOF Director shall assign an individual to provide a written report to county and state authorities within thirty days. This report could be an LER or a written report if an LER is not required.

Person assigned responsibility _____

4. Enclosures

- 4.1 Emergency Organization Activation
- 4.2 Emergency Coordinator Turnover Form
- 4.3 Criteria for Downgrading an Emergency Level
- 4.4 Alert Close Out Briefing with States and Counties

Enclosure 4.1
Emergency Organization Activation

RP/0/A/5000/003
Page 1 of 2

1. Activate ERO Pagers

- Use the Quikpage Key Pad located in the Control Room (***IF** Control Room key pad is unavailable, use key pad located in TSC Off-Site Communicator area*).
 - 1) Type "ERO" and press "ENTER"
 - 2) Press "M"
 - 3) Press appropriate message key:

F1 for Catawba Drill

OR

F6 for Catawba Emergency
 - 4) Ensure cursor is at the end of the line and type "Alert declared at (time). Activate TSC/OSC/EOF."
 - 5) Press "ENTER"
 - 6) Monitor pager located at the Quikpage key pad to verify ERO pager activation.
- **IF** Quikpage Key Pad is unavailable in both Control Room and TSC, dial 8-777-8376. When prompted, enter numeric password 2580. When prompted, enter activation code 6789#.

2. Activate Automatic Dialing Call Back System (Community Alert Network)

NOTE: Back-up telephone number for Community Alert Network is (518) 862-0987.

2.1 Dial 1-800-552-4226 (Hotline/Activation Line)

2.2 **IF CAN** is being activated for a **DRILL**, read one of the following messages depending on day and time.

IF Monday through Thursday between 0700 through 1730, read the following message:

"This is _____ (name) _____ from Duke Power, Catawba. The Password is Catawba. Please run Catawba Day List message number 5. Please call me back to verify system operation at _____."

(Phone # in Simulator)

IF not Monday through Thursday between 0700 through 1730, read the following message:

"This is _____ (name) _____ from Duke Power, Catawba. The Password is Catawba. Please run Catawba Night List message number 5. Please call me back to verify system operation at _____."

(Phone # in Simulator)

2.3 **IF CAN** is being activated for an **EMERGENCY**, read one of the following messages depending on day and time.

IF Monday through Thursday between 0700 through 1730, read the following message:

"This is _____ (name) _____ from Duke Power, Catawba. The Password is Catawba. Please run Catawba Day List message number 6. Please call me back to verify system operation at (803) 831-7332."

IF not Monday through Thursday between 0700 through 1730, read the following message:

"This is _____ (name) _____ from Duke Power, Catawba. The Password is Catawba. Please run Catawba Night List message number 6. Please call me back to verify system operation at (803) 831-7332."

Emergency Coordinator Turnover Form

1. Plant Status:

Unit 1: _____

Unit 2: _____

2. Emergency Classification:

Time Declared: _____

3. Off-Site Agency Notifications Turnover to TSC Complete? _____ (Y/N)

4. Time Next Notification due: _____

5. Significant Events:

_____ Radioactive Release
Y/N

_____ Injured Personnel
Y/N

_____ Other (Specify _____)

6. Protective Actions in Progress:

_____ Site Assembly (Time Initiated _____)
Y/N

_____ Off-Site Protective Actions Recommended
Y/N (List _____)

_____ Other (Specify _____)
Y/N

7. Response Procedure In Progress:

RP _____ RP _____ RP _____

8. Actions in Progress:

Criteria for Downgrading an Emergency Level

Date _____
Initial/Time

- _____ 1. The probability that plant conditions will continue to improve is evident.
 - _____ 2. All emergency action level notifications have been completed.
 - _____ 3. Emergency response facility staffing may be reduced.
 - _____ 4. The criteria established for the emergency classification has been evaluated. Conditions warrant a lower emergency action level.
 - _____ 5. The event related release of radioactive material to the environment is terminated.
 - _____ 6. The control of any fire, flood, earthquake or similar emergency condition is acceptable.
 - _____ 7. Any corrective actions specified by the Emergency Coordinator to place the plant in a safe condition have been completed and the plant has been placed in the appropriate operating mode.
 - _____ 8. The Emergency Coordinator has evaluated the plant status with respect to the Emergency Action Levels and recommends downgrading the emergency classification.
 - _____ 9. Emergency classification level downgraded to _____
-

Enclosure 4.4
Alert Close Out Briefing
with States and Counties

RP/0/A/5000/003
Page 1 of 1

Person Providing Verbal Summary: _____

Brief Event Description: _____

<u>Agency</u>	<u>Person Contacted</u>	<u>Date/Time</u>
South Carolina	_____	_____
North Carolina	_____	_____
York County	_____	_____
Gaston County	_____	_____
Mecklenburg County	_____	_____

Comments/Questions from States and Counties: _____

