

October 22, 1999

Mr. Thomas C. Thompson
Licensing Manager
NAC International, Inc.
655 Engineering Drive
Norcross, GA 30092

**SUBJECT: PRELIMINARY CERTIFICATE OF COMPLIANCE AND SAFETY EVALUATION
REPORT FOR THE NAC-UMS STORAGE SYSTEM (TAC NO. L22511)**

Dear Mr. Thompson:

By letter dated August 29, 1997, as supplemented, NAC International, Inc. (NAC) submitted an application to the Nuclear Regulatory Commission, in accordance with 10 CFR Part 72, for the review and approval of the NAC-UMS storage system.

As a result of our review of your application and its supplements, the staff has prepared a Certificate of Compliance (CoC) and Safety Evaluation Report (SER) pursuant to the requirements of 10 CFR Part 72. Enclosed is a preliminary copy of the CoC and SER for NAC's review and identification of inaccuracies and omissions. Please respond with any comments by noon on October 26, 1999. Please continue to reference Docket No. 72-1015 and TAC No. L22511 in future correspondence related to this request.

If you have any comment or question concerning this request, please contact me at 301-415-8580.

Sincerely,

Original /s/ by:

Timothy J. McGinty, Project Manager
Spent Fuel Licensing Section
Spent Fuel Project Office
Office of Nuclear Material Safety
and Safeguards

Docket No.: 72-1015

Enclosures: 1. Preliminary CoC
2. Preliminary SER

NFO7 1/1

cc: Mr. Scott Bauer
Arizona Public Service Company

Stone and Webster Engineering and Construction
c/o Maine Yankee Atomic Power Company

9

Distribution: w/o encis*

Docket	NRC File Center	PUBLIC	NMSS r/f*	SFPO r/f*	RParkhill*
EWBrach	WHodges	SShankman	DTang*	EEaston*	KGruss*
EKeegan*	DCarlson*	SColpo*	PBrochman*	LKokaiko*	PEng*

OFC	SFPO	E	SFPO	E	SFPO	C	SFPO		SFPO
NAME	TJMcGinty		WJharpe		CRChappell				
DATE	10/22/99		10/22/99		10/22/99		1/99		1/99

C = COVER

E = COVER & ENCLOSURE
OFFICIAL RECORD COPY

N = NO COPY
G:\NAC\UMSS\CoC\DRFTLTR.WPD

ENCLOSURE 1

Preliminary COC

w/Attachments
Appendix A and Appendix B

DRAFT

NRC FORM 657
(3-1999)
10 CFR 72

U.S. NUCLEAR REGULATORY COMMISSION

**CERTIFICATE OF COMPLIANCE
FOR SPENT FUEL STORAGE CASKS**

Page 1 of 4

The U.S. Nuclear Regulatory Commission is issuing this Certificate of Compliance pursuant to Title 10 of the Code of Federal Regulations, Part 72, "Licensing Requirements for Independent Storage of Spent Nuclear Fuel and High-Level Radioactive Waste" (10 CFR Part 72). This certificate is issued in accordance with 10 CFR 72.238, certifying that the storage design and contents described below meet the applicable safety standards set forth in 10 CFR Part 72, Subpart L, and on the basis of the Final Safety Analysis Report (FSAR) of the cask design. This certificate is conditional upon fulfilling the requirements of 10 CFR Part 72, as applicable, and the conditions specified below.

Certificate No.	Effective Date	Expiration Date	Docket Number	Amendment No.	Amendment Date	Package Identification No.
1015			72-1015			USA/72-1015

Issued To: (Name/Address)

NAC International, Inc.
655 Engineering Drive
Norcross, GA 30092

Safety Analysis Report Title

NAC International Inc., Safety Analysis Report for the UMS Universal Storage System, Revision 1
Docket No. 72-1015

CONDITIONS

This certificate is conditioned upon fulfilling the requirements of 10 CFR Part 72, as applicable, the attached Appendix A (Technical Specifications) and Appendix B (Approved Contents and Design Features), and the conditions specified below:

1. CASK

a. Model No. NAC-UMS

The NAC-UMS system (the cask) consists of the following components: (1) transportable storage canister (TSC), which contains the spent fuel; (2) vertical concrete cask (VCC), which contains the TSC during storage; and (3) a transfer cask, which contains the TSC during loading, unloading, and transfer operations. The cask stores up to 24 pressurized water reactor (PWR) fuel assemblies or 56 boiling water reactor (BWR) fuel assemblies.

b. Description

The NAC-UMS system is certified as described in the Safety Analysis Report (SAR) and in NRC's Safety Evaluation Report (SER) accompanying the Certificate of Compliance. The cask comprises three discrete components: the TSC, the VCC, and the transfer cask.

DRAFT

DRAFT

**CERTIFICATE OF COMPLIANCE
FOR SPENT FUEL STORAGE CASKS
Supplemental Sheet**

Certificate No. 1015

Page 2 of 4

1. b. Description (continued)

The TSC is the confinement system for the stored fuel. The TSC assembly consists of a right circular cylindrical shell with a welded bottom plate, a fuel basket, a shield lid, two penetration port covers, and a structural lid. The cylindrical shell, plus the bottom plate and lids, constitute the confinement boundary. The stainless steel fuel basket is a right circular cylinder configuration with either 24 (PWR) or 56 (BWR) stainless steel fuel tubes laterally supported by a series of stainless steel (PWR) or carbon steel (BWR) support disks. The square fuel tubes in the PWR basket are encased with Boral sheets on all four sides for criticality control. The square fuel tubes in the BWR basket may be encased with Boral sheets on up to two sides for criticality control. Aluminum heat transfer disks are spaced midway between the support disks and are the primary path for conducting heat from the spent fuel assemblies to the TSC wall for the PWR basket. A combination of the carbon steel support disks and aluminum heat transfer disks (in a ratio of 2.4 to 1, respectively) are the primary means of conducting heat from the spent fuel assemblies to the TSC wall for the BWR basket. There are three TSC configurations of different lengths for PWR contents and two TSC configurations of different lengths for BWR contents. All PWR and BWR spent fuel assemblies must be intact.

The VCC is the storage overpack for the TSC and provides structural support, shielding, protection from environmental conditions, and natural convection cooling of the TSC during long-term storage. The VCC is a reinforced concrete (Type II Portland cement) structure with a carbon steel inner liner. The VCC has an annular air passage to allow the natural circulation of air around the TSC. The air inlet and outlet vents take non-planar paths to the VCC cavity to minimize radiation streaming. The spent fuel decay heat is transferred from the fuel assemblies to the tubes in the fuel basket and through the heat transfer disks to the TSC wall. Heat flows by convection from the TSC wall to the circulating air, as well as by radiation from the TSC wall to the VCC inner liner. The heat flow to the circulating air from the TSC wall and the VCC liner is exhausted through the air outlet vents. The top of the VCC is closed by a shield plug, consisting of carbon steel plate (gamma shielding) and NS-4-FR (neutron shielding), and a carbon steel lid. The lid is bolted in place and has tamper indicating seals on two of the bolts. There are three VCC configurations of different lengths for PWR contents, and two VCC configurations of different lengths for BWR contents.

The transfer cask provides shielding during TSC movements between work stations, the VCC, or the transport cask. It is a multi-wall (steel/lead/NS-4-FR/steel) design and has a bolted top retaining ring to prevent a loaded canister from being inadvertently removed through the top of the transfer cask. Retractable (hydraulically operated) bottom shield doors on the transfer cask are used during loading and unloading operations. To minimize contamination of the transfer cask, clean water is circulated in the gap between the transfer cask and the TSC during spent fuel pool loading operations. A carbon steel extension ring can be bolted to the top of the transfer cask and used to extend the operational height of a transfer cask. This height extension allows a transfer cask designed for a specific TSC length to be used with the next longer TSC.

DRAFT

DRAFT

**CERTIFICATE OF COMPLIANCE
FOR SPENT FUEL STORAGE CASKS
Supplemental Sheet**

Certificate No. 1015

Page 3 of 4

2. OPERATING PROCEDURES

Written operating procedures shall be prepared for cask handling, loading, movement, surveillance, and maintenance. The user's site-specific written operating procedures shall be consistent with the technical basis described in Chapter 8 of the SAR.

3. ACCEPTANCE TESTS AND MAINTENANCE PROGRAM

Written cask acceptance tests and a maintenance program shall be prepared consistent with the technical basis described in Chapter 9 of the SAR.

4. QUALITY ASSURANCE

Activities in the areas of design, purchase, fabrication, assembly, inspection, testing, operation, maintenance, repair, modification of structures, systems and components, and decommissioning that are important to safety shall be conducted in accordance with a Commission-approved quality assurance program which satisfies the applicable requirements of 10 CFR Part 72, Subpart G, and which is established, maintained, and executed with regard to the cask system.

5. HEAVY LOADS REQUIREMENTS

Each lift of an NAC-UMS TSC, transfer cask, or VCC must be made in accordance with the existing heavy loads requirements and procedures of the licensed facility at which the lift is made. A plant-specific safety review (under 10 CFR 50.59 or 10 CFR 72.48 requirements, if applicable) is required to show operational compliance with existing plant-specific heavy loads requirements. Lifting operations outside of structures governed by 10 CFR Part 50 must be in accordance with Section 3.5 of Appendix B to this certificate.

6. APPROVED CONTENTS

Contents of the NAC-UMS storage system must meet the fuel specifications given in Appendix B to this certificate.

7. DESIGN FEATURES

Features or characteristics for the site, cask, or ancillary equipment must be in accordance with Appendix B to this certificate.

8. CHANGES TO THE CERTIFICATE OF COMPLIANCE

The holder of this certificate who desires to make changes to the certificate, which includes Appendix A (Technical Specifications) and Appendix B (Approved Contents and Design Features), shall submit an application for amendment of the certificate.

DRAFT

DRAFT

NRC FORM 651A
(3-1999)
10 CFR 72

U.S. NUCLEAR REGULATORY COMMISSION

**CERTIFICATE OF COMPLIANCE
FOR SPENT FUEL STORAGE CASKS
Supplemental Sheet**

Certificate No. 1015

Page 4 of 4

9. AUTHORIZATION

The NAC-UMS storage system, which is authorized by this certificate, is hereby approved for general use by holders of 10 CFR Part 50 licenses for nuclear reactors at reactor sites under the general license issued pursuant to 10 CFR 72.210, subject to the conditions specified by 10 CFR 72.212, and the attached Appendix A and Appendix B.

FOR THE NUCLEAR REGULATORY COMMISSION

DRAFT

E. William Brach, Director
Spent Fuel Project Office
Office of Nuclear Material Safety
and Safeguards

- Attachments:
1. Appendix A
2. Appendix B



DRAFT

DRAFT

APPENDIX A

**TECHNICAL SPECIFICATIONS
FOR THE NAC-UMS SYSTEM**

DRAFT

**Appendix A
Table of Contents**

A 1.0 USE AND APPLICATION.....	A1-1
A 1.1 Definitions.....	A1-1
A 1.2 Logical Connectors	A1-5
A 1.3 Completion Times	A1-8
A 1.4 Frequency	A1-13
A 2.0 [Reserved].....	A2-1
A 3.0 LIMITING CONDITION FOR OPERATION (LCO) APPLICABILITY.....	A3-1
SURVEILLANCE REQUIREMENT (SR) APPLICABILITY.....	A3-2
A 3.1 NAC-UMS SYSTEM Integrity.....	A3-4
A 3.1.1 CANISTER Maximum Time in Vacuum Drying.....	A3-4
A 3.1.2 CANISTER Vacuum Drying Pressure	A3-6
A 3.1.3 CANISTER Helium Backfill Pressure	A3-7
A 3.1.4 CANISTER Maximum Time in TRANSFER CASK.....	A3-8
A 3.1.5 CANISTER Helium Leak Rate.....	A3-10
A 3.1.6 CONCRETE CASK Heat Removal System	A3-11
A 3.1.7 Fuel Cooldown Requirements	A3-13
A 3.1.8 CANISTER Removal from the CONCRETE CASK.....	A3-17
A 3.2 NAC-UMS SYSTEM Radiation Protection.....	A3-20
A 3.2.1 CANISTER Surface Contamination	A3-20
A 3.2.2 CONCRETE CASK Average Surface Dose Rate.....	A3-22
Figure A3-1 CONCRETE CASK Surface Dose Rate Measurement	A3-24
Table A3-1 CANISTER Limits.....	A3-25
A 4.0 [Reserved].....	A4-1
A 5.0 ADMINISTRATIVE CONTROLS AND PROGRAMS.....	A5-1
A 5.1 Training Program	A5-1
A 5.2 Pre-Operational Testing and Training Exercises	A5-1
A 5.3 Special Requirements for the First System Placed in Service	A5-2
A 5.4 Surveillance After an Off-Normal, Accident, or Natural Phenomena Event	A5-2

Appendix A
Table of Contents (Continued)

A 5.5	Radioactive Effluent Control	A5-3
A 5.6	Program NAC-UMS SYSTEM Transport Evaluation Program	A5-3
Table A5-1	TRANSFER CASK and CONCRETE CASK Lifting Requirements	A5-5

A 1.0 USE AND APPLICATION
A 1.1 Definitions

NOTE

The defined terms of this section appear in capitalized type and are applicable throughout this section.

<u>Term</u>	<u>Definition</u>
ACTIONS	ACTIONS shall be that part of a Specification that prescribes Required Actions to be taken under designated Conditions within specified Completion Times.
CANISTER	See TRANSPORTABLE STORAGE CANISTER
CANISTER HANDLING FACILITY	The CANISTER HANDLING FACILITY includes the following components and equipment: (1) a canister transfer station that allows the staging of the TRANSFER CASK with the CONCRETE CASK or transport cask to facilitate CANISTER lifts involving spent fuel handling not covered by 10 CFR 50; and (2) either a stationary lift device or mobile lifting device used to lift the TRANSFER CASK and CANISTER .
CONCRETE CASK	See VERTICAL CONCRETE CASK
INDEPENDENT SPENT FUEL STORAGE INSTALLATION (ISFSI)	The facility within the perimeter fence licensed for storage of spent fuel within NAC-UMS SYSTEMs (see also 10 CFR 72.3).
INTACT FUEL ASSEMBLY	INTACT FUEL ASSEMBLY is a fuel assembly without known or suspected cladding defects greater than a pinhole leak or hairline crack and which can be handled by normal means. A fuel assembly with missing fuel rods shall not be classified as an INTACT FUEL ASSEMBLY unless solid Zircaloy or stainless steel rods are used to displace an amount of water equal to that displaced by the original fuel rod(s).

(continued)

INTACT FUEL ROD

INTACT FUEL ROD is a fuel rod without known or suspected cladding defects greater than a pinhole leak or hairline crack.

LOADING OPERATIONS

LOADING OPERATIONS include all licensed activities on an NAC-UMS SYSTEM while it is being loaded with fuel assemblies. **LOADING OPERATIONS** begin when the first fuel assembly is placed in the **CANISTER** and end when the NAC-UMS SYSTEM is secured on the transporter. **LOADING OPERATIONS** does not include post-storage operations, i.e., **CANISTER** transfer operations between the **TRANSFER CASK** and the **CONCRETE CASK** or transport cask after **STORAGE OPERATIONS**.

INITIAL PEAK PLANAR-AVERAGE ENRICHMENT

THE INITIAL PEAK PLANAR-AVERAGE ENRICHMENT is the maximum planar-average enrichment at any height along the axis of the fuel assembly. The 4.0 wt % ²³⁵U enrichment limit for BWR fuel applies along the full axial extent of the assembly. The **INITIAL PEAK PLANAR-AVERAGE ENRICHMENT** may be higher than the bundle (assembly) average enrichment.

NAC-UMS SYSTEM

NAC-UMS SYSTEM includes the components approved for loading and storage of spent fuel assemblies at the ISFSI. The **NAC-UMS SYSTEM** consists of a **CONCRETE CASK**, a **TRANSFER CASK**, and a **CANISTER**.

OPERABLE

The **CONCRETE CASK** heat removal system is **OPERABLE** if the difference between the ISFSI ambient temperature and the average outlet air temperature is $\leq 102^{\circ}\text{F}$ for the PWR **CANISTER** or $\leq 92^{\circ}\text{F}$ for the BWR **CANISTER**.

(continued)

STORAGE OPERATIONS

STORAGE OPERATIONS include all licensed activities that are performed at the ISFSI, while an **NAC-UMS SYSTEM** containing spent fuel is located on the storage pad within the ISFSI perimeter.

TRANSFER CASK

TRANSFER CASK is a shielded lifting device that holds the **CANISTER** during **LOADING** and **UNLOADING OPERATIONS** and during closure welding, vacuum drying, leak testing, and non-destructive examination of the **CANISTER** closure welds. The **TRANSFER CASK** is also used to transfer the **CANISTER** into and from the **CONCRETE CASK** and into the transport cask.

TRANSPORT OPERATIONS

TRANSPORT OPERATIONS include all licensed activities involved in moving a loaded **NAC-UMS CONCRETE CASK** and **CANISTER** to and from the ISFSI. **TRANSPORT OPERATIONS** begin when the **NAC-UMS SYSTEM** is first secured on the transporter and end when the **NAC-UMS SYSTEM** is at its destination and no longer secured on the transporter.

TRANSPORTABLE STORAGE CANISTER (CANISTER)

TRANSPORTABLE STORAGE CANISTER is the sealed container that consists of a tube and disk fuel basket in a cylindrical canister shell that is welded to a baseplate, shield lid with welded port covers, and structural lid. The **CANISTER** provides the confinement boundary for the confined spent fuel.

TRANSFER OPERATIONS

TRANSFER OPERATIONS include all licensed activities involved in transferring a loaded **CANISTER** from a **CONCRETE CASK** to another **CONCRETE CASK** or to a **TRANSPORT CASK**.

(continued)

UNLOADING OPERATIONS

UNLOADING OPERATIONS include all licensed activities on a NAC-UMS SYSTEM to be unloaded of the contained fuel assemblies. **UNLOADING OPERATIONS** begin when the NAC-UMS SYSTEM is no longer secured on the transporter and end when the last fuel assembly is removed from the NAC-UMS SYSTEM.

**VERTICAL CONCRETE CASK
(CONCRETE CASK)**

VERTICAL CONCRETE CASK is the cask that receives and holds the sealed **CANISTER**. It provides the gamma and neutron shielding and convective cooling of the spent fuel confined in the **CANISTER**.

A 1.0 USE AND APPLICATION

A 1.2 Logical Connectors

PURPOSE

The purpose of this section is to explain the meaning of logical connectors.

Logical connectors are used in Technical Specifications (TS) to discriminate between, and yet connect, discrete Conditions, Required Actions, Completion Times, Surveillances, and Frequencies. The only logical connectors that appear in Technical Specifications are "AND" and "OR." The physical arrangement of these connectors constitutes logical conventions with specific meanings.

BACKGROUND

Several levels of logic may be used to state Required Actions. These levels are identified by the placement (or nesting) of the logical connectors and by the number assigned to each Required Action. The first level of logic is identified by the first digit of the number assigned to a Required Action and the placement of the logical connector in the first level of nesting (i.e., left justified with the number of the Required Action). The successive levels of logic are identified by additional digits of the Required Action number and by successive indentations of the logical connectors.

When logical connectors are used to state a Condition, Completion Time, Surveillance, or Frequency, only the first level of logic is used; the logical connector is left justified with the statement of the Condition, Completion Time, Surveillance, or Frequency.

(continued)

EXAMPLES The following examples illustrate the use of logical connectors.

EXAMPLES EXAMPLE 1.2-1
ACTIONS

CONDITION	REQUIRED ACTION	COMPLETION TIME
A. LCO not met	A.1 Verify... <u>AND</u> A.2 Restore...	

In this example, the logical connector "AND" is used to indicate that when in Condition A, both Required Actions A.1 and A.2 must be completed.

(continued)

EXAMPLES
(continued)

EXAMPLE 1.2-2

ACTIONS

CONDITION	REQUIRED ACTION	COMPLETION TIME
A. LCO not met	A.1 Stop...	
	<u>OR</u>	
	A.2.1 Verify...	
	<u>AND</u>	
	A.2.2	
	A.2.2.1 Reduce...	
	<u>OR</u>	
	A.2.2.2 Perform...	
	<u>OR</u>	
	A.3 Remove...	

This example represents a more complicated use of logical connectors. Required Actions A.1, A.2, and A.3 are alternative choices, only one of which must be performed as indicated by the use of the logical connector "OR" and the left justified placement. Any one of these three Actions may be chosen. If A.2 is chosen, then both A.2.1 and A.2.2 must be performed as indicated by the logical connector "AND." Required Action A.2.2 is met by performing A.2.2.1 or A.2.2.2. The indented position of the logical connector "OR" indicated that A.2.2.1 and A.2.2.2 are alternative choices, only one of which must be performed.

A 1.0 USE AND APPLICATION

A 1.3 Completion Times

PURPOSE

The purpose of this section is to establish the Completion Time convention and to provide guidance for its use.

BACKGROUND

Limiting Conditions for Operations (LCOs) specify the lowest functional capability or performance levels of equipment required for safe operation of the NAC-UMS SYSTEM. The ACTIONS associated with an LCO state conditions that typically describe the ways in which the requirements of the LCO can fail to be met. Specified with each stated Condition are Required Action(s) and Completion Time(s).

DESCRIPTION

The Completion Time is the amount of time allowed for completing a Required Action. It is referenced to the time of discovery of a situation (e.g., equipment or variable not within limits) that requires entering an ACTIONS Condition, unless otherwise specified, provided that the NAC-UMS SYSTEM is in a specified Condition stated in the Applicability of the LCO. Prior to the expiration of the specified Completion Time, Required Actions must be completed. An ACTIONS Condition remains in effect and the Required Actions apply until the Condition no longer exists or the NAC-UMS SYSTEM is not within the LCO Applicability.

Once a Condition has been entered, subsequent subsystems, components, or variables expressed in the Condition, discovered to be not within limits, will not result in separate entry into the Condition, unless specifically stated. The Required Actions of the Condition continue to apply to each additional failure, with Completion Times based on initial entry into the Condition.

(continued)

EXAMPLES

The following examples illustrate the use of Completion Times with different types of Conditions and changing Conditions.

EXAMPLE 1.3-1

ACTIONS

CONDITION	REQUIRED ACTION	COMPLETION TIME
B. Required Action and associated Completion Time not met	B.1 Perform Action B.1 <u>AND</u>	12 hours
	B.2 Perform Action B.2	36 hours

Condition B has two Required Actions. Each Required Action has its own Completion Time. Each Completion Time is referenced to the time that Condition B is entered.

The Required Actions of Condition B are to complete action B.1 within 12 hours AND complete action B.2 within 36 hours. A total of 12 hours is allowed for completing action B.1 and a total of 36 hours (not 48 hours) is allowed for completing action B.2 from the time that Condition B was entered. If action B.1 is completed within six hours, the time allowed for completing action B.2 is the next 30 hours because the total time allowed for completing action B.2 is 36 hours.

(continued)

EXAMPLES
(continued)

EXAMPLE 1.3-2

ACTIONS

CONDITION	REQUIRED ACTION	COMPLETION TIME
A. One System not within limit	A.1 Restore System to within limit	7 days
B. Required Action and associated Completion Time not met	B.1 Complete action B.1	12 hours
	<u>AND</u> B.2 Complete action B.2	36 hours

When a System is determined not to meet the LCO, Condition A is entered. If the System is not restored within seven days, Condition B is also entered, and the Completion Time clocks for Required Actions B.1 and B.2 start. If the System is restored after Condition B is entered, Conditions A and B are exited; therefore, the Required Actions of Condition B may be terminated.

(continued)

EXAMPLES
(continued)

EXAMPLE 1.3-3

ACTIONS

NOTE

Separate Condition entry is allowed for each component.

CONDITION	REQUIRED ACTION	COMPLETION TIME
A. LCO not met	A.1 Restore compliance with LCO	4 hours
B. Required Action and associated Completion Time not met	B.1 Complete action B.1	6 hours
	<u>AND</u> B.2 Complete action B.2	12 hours

The Note above the ACTIONS table is a method of modifying how the Completion Time is tracked. If this method of modifying how the Completion Time is tracked was applicable only to a specific Condition, the Note would appear in that Condition rather than at the top of the ACTIONS Table.

The Note allows Condition A to be entered separately for each component, and Completion Times to be tracked on a per component basis. When a component is determined to not meet the LCO, Condition A is entered and its Completion Time starts. If subsequent components are determined to not meet the LCO, Condition A is entered for each component and separate Completion Times are tracked for each component.

(continued)

EXAMPLES
(continued)

EXAMPLE 1.3-3

**IMMEDIATE
COMPLETION
TIME**

When "Immediately" is used as a Completion Time, the Required Action should be pursued without delay and in a controlled manner.

A 1.0 USE AND APPLICATION

A 1.4 Frequency

PURPOSE The purpose of this section is to define the proper use and application of Frequency requirements.

DESCRIPTION Each Surveillance Requirement (SR) has a specified Frequency in which the Surveillance must be met in order to meet the associated Limiting Condition for Operation (LCO). An understanding of the correct application of the specified Frequency is necessary for compliance with the SR.

Each "specified Frequency" is referred to throughout this section and each of the Specifications of Section 3.0, Surveillance Requirement (SR) Applicability. The "specified Frequency" consists of requirements of the Frequency column of each SR.

Situations where a Surveillance could be required (i.e., its Frequency could expire), but where it is not possible or not desired that it be performed until sometime after the associated LCO is within its Applicability, represent potential SR 3.0.4 conflicts. To avoid these conflicts, the SR (i.e., the Surveillance or the Frequency) is stated such that it is only "required" when it can be and should be performed. With an SR satisfied, SR 3.0.4 imposes no restriction.

The use of "met" or "performed" in these instances conveys specific meanings. A Surveillance is "met" only after the acceptance criteria are satisfied. Known failure of the requirements of a Surveillance, even without a Surveillance specifically being "performed," constitutes a Surveillance not "met."

(continued)

EXAMPLES The following examples illustrate the various ways that Frequencies are specified.

EXAMPLE 1.4-1

SURVEILLANCE REQUIREMENTS

SURVEILLANCE	FREQUENCY
Verify pressure within limit	12 hours

Example 1.4-1 contains the type of SR most often encountered in the Technical Specifications (TS). The Frequency specifies an interval (12 hours) during which the associated Surveillance must be performed at least one time. Performance of the Surveillance initiates the subsequent interval. Although the Frequency is stated as 12 hours, SR 3.0.2 allows an extension of the time interval to 1.25 times the interval specified in the Frequency for operational flexibility. The measurement of this interval continues at all times, even when the SR is not required to be met per SR 3.0.1 (such as when the equipment or variables are outside specified limits, or the facility is outside the Applicability of the LCO). If the interval specified by SR 3.0.2 is exceeded while the facility is in a condition specified in the Applicability of the LCO, the LCO is not met in accordance with SR 3.0.1.

If the interval as specified by SR 3.0.2 is exceeded while the facility is not in a condition specified in the Applicability of the LCO for which performance of the SR is required, the Surveillance must be performed within the Frequency requirements of SR 3.0.2, prior to entry into the specified condition. Failure to do so would result in a violation of SR 3.0.4.

(continued)

EXAMPLE 1.4-2

SURVEILLANCE REQUIREMENTS

SURVEILLANCE	FREQUENCY
Verify flow is within limits	Once within 12 hours prior to starting activity <u>AND</u> 24 hours thereafter

Example 1.4-2 has two Frequencies. The first is a one time performance Frequency, and the second is of the type shown in Example 1.4-1. The logical connector "AND" indicates that both Frequency requirements must be met. Each time the example activity is to be performed, the Surveillance must be performed within 12 hours prior to starting the activity.

The use of "once" indicates a single performance will satisfy the specified Frequency (assuming no other Frequencies are connected by "AND"). This type of Frequency does not qualify for the 25% extension allowed by SR 3.0.2.

"Thereafter" indicates future performances must be established per SR 3.0.2, but only after a specified condition is first met (i.e., the "once" performance in this example). If the specified activity is canceled or not performed, the measurement of both intervals stops. New intervals start upon preparing to restart the specified activity.

A 2.0 [Reserved]

A 3.0 LIMITING CONDITION FOR OPERATION (LCO) APPLICABILITY

LCO 3.0.1 LCOs shall be met during specified conditions in the Applicability, except as provided in LCO 3.0.2.

LCO 3.0.2 Upon failure to meet an LCO, the Required Actions of the associated Conditions shall be met, except as provided in LCO 3.0.5.

If the LCO is met or is no longer applicable prior to expiration of the specified Completion Time(s), completion of the Required Action(s) is not required, unless otherwise stated.

LCO 3.0.3 Not applicable to a NAC-UMS SYSTEM.

LCO 3.0.4 When an LCO is not met, entry into a specified condition in the Applicability shall not be made except when the associated ACTIONS to be entered permit continued operation in the specified condition in the Applicability for an unlimited period of time. This Specification shall not prevent changes in specified conditions in the Applicability that are required to comply with ACTIONS or that are related to the unloading of an NAC-UMS SYSTEM.

Exceptions to this Condition are stated in the individual Specifications. These exceptions allow entry into specified conditions in the Applicability where the associated ACTIONS to be entered allow operation in the specified conditions in the Applicability only for a limited period of time.

LCO 3.0.5 Equipment removed from service or not in service in compliance with ACTIONS may be returned to service under administrative control solely to perform testing required to demonstrate it meets the LCO or that other equipment meets the LCO. This is an exception to LCO 3.0.2 for the System to return to service under administrative control to perform the testing.

A 3.0 SURVEILLANCE REQUIREMENT (SR) APPLICABILITY

SR 3.0.1

SRs shall be met during the specified conditions in the Applicability for individual LCOs, unless otherwise stated in the SR. Failure to meet a Surveillance, whether such failure is experienced during the performance of the Surveillance or between performances of the Surveillance, shall be a failure to meet the LCO. Failure to perform a Surveillance within the specified Frequency shall be a failure to meet the LCO, except as provided in SR 3.0.3. Surveillances do not have to be performed on equipment or variables outside specified limits.

SR 3.0.2

The specified Frequency for each SR is met if the Surveillance is performed within 1.25 times the interval specified in the Frequency, as measured from the previous performance or as measured from the time a specified condition of the Frequency is met.

For Frequencies specified as "once," the above interval extension does not apply. If a Completion Time requires periodic performance on a "once per..." basis, the above Frequency extension applies to each performance after the initial performance.

Exceptions to this Specification are stated in the individual Specifications.

SR 3.0.3

If it is discovered that a Surveillance was not performed within its specified Frequency, then compliance with the requirement to declare the LCO not met may be delayed from the time of discovery up to 24 hours or up to the limit of the specified Frequency, whichever is less. This delay period is permitted to allow performance of the Surveillance.

If the Surveillance is not performed within the delay period, the LCO must immediately be declared not met, and the applicable Condition(s) must be entered.

(continued)

SR 3.0.3 (continued) When the Surveillance is performed within the delay period and the Surveillance is not met, the LCO must immediately be declared not met, and the applicable Condition(s) must be entered.

SR 3.0.4 Entry into a specified Condition in the Applicability of an LCO shall not be made, unless the LCO's Surveillances have been met within their specified Frequency. This provision shall not prevent entry into specified conditions in the Applicability that are required to comply with Actions or that are related to the unloading of a NAC-UMS SYSTEM.

A 3.1 NAC-UMS SYSTEM Integrity
A 3.1.1 CANISTER Maximum Time in Vacuum Drying

LCO 3.1.1

The following limits for vacuum drying time shall be met, as appropriate:

1. The time duration from completion of draining the CANISTER through completion of vacuum dryness testing and the introduction of helium backfill shall not exceed 10 hours for either the PWR or BWR configuration.
2. The time duration from the end of in-pool cooling or of forced air cooling of the CANISTER through completion of vacuum dryness testing and the introduction of helium backfill shall not exceed 6 hours for either the PWR or BWR configuration.

APPLICABILITY: During **LOADING OPERATIONS**

ACTIONS

-----**NOTE**-----

Separate Condition entry is allowed for each NAC-UMS SYSTEM.

CONDITION	REQUIRED ACTION	COMPLETION TIME
A. LCO time limits not met	A.1 Commence filling CANISTER with helium	2 hours
	<u>AND</u>	
	A.2.1 Place TRANSFER CASK with helium filled loaded CANISTER in spent fuel pool	2 hours
	<u>AND</u>	
	A.2.2 Maintain TRANSFER CASK and CANISTER in spent fuel pool for a minimum of 24 hours	Prior to restart of LOADING OPERATIONS

(continued)

CANISTER Maximum Time in Vacuum Drying
A 3.1.1

CONDITION	REQUIRED ACTION	COMPLETION TIME
	<p><u>OR</u></p> <p>A.3.1 Commence supplying air to the TRANSFER CASK annulus fill/drain lines at a rate of 375 CFM and a maximum temperature of 75°F</p> <p><u>AND</u></p> <p>A.3.2 Maintain airflow for a minimum of 24 hours</p>	<p>2 hours</p> <p>Prior to restart of LOADING OPERATIONS</p>

SURVEILLANCE REQUIREMENTS

SURVEILLANCE	FREQUENCY
<p>SR 3.1.1.1 Monitor elapsed time from completion of CANISTER draining operations until start of helium backfill</p>	<p>Once after completion of CANISTER draining</p> <p><u>AND</u></p> <p>2 hours thereafter</p>
<p>SR 3.1.1.2 Monitor elapsed time from the end of in-pool cooling or of forced-air cooling until restart of helium backfill</p>	<p>Once at end of in-pool cooling or of forced-air cooling</p> <p><u>AND</u></p> <p>2 hours thereafter</p>

A 3.1 NAC-UMS SYSTEM Integrity
A 3.1.2 CANISTER Vacuum Drying Pressure

LCO 3.1.2 The CANISTER vacuum drying pressure shall meet the limit specified in Table A3-1.

APPLICABILITY: During **LOADING OPERATIONS**

ACTIONS

NOTE

Separate Condition entry is allowed for each NAC-UMS SYSTEM.

CONDITION	REQUIRED ACTION	COMPLETION TIME
A. CANISTER vacuum drying pressure limit not met	A.1 Establish CANISTER cavity vacuum drying pressure within limit	25 days
B. Required Action and associated Completion Time not met	B.1 Remove all fuel assemblies from the NAC-UMS SYSTEM	5 days

SURVEILLANCE REQUIREMENTS

SURVEILLANCE	FREQUENCY
SR 3.1.2.1 Verify CANISTER cavity vacuum drying pressure is within limit	Once within 10 hours (PWR or BWR configuration) after completion of CANISTER draining

A 3.1 NAC-UMS SYSTEM Integrity
A 3.1.3 CANISTER Helium Backfill Pressure

LCO 3.1.3 The CANISTER helium backfill pressure shall meet the limit specified in Table A3-1.

APPLICABILITY: During LOADING OPERATIONS

ACTIONS

NOTE

Separate Condition entry is allowed for each NAC-UMS SYSTEM.

CONDITION	REQUIRED ACTION	COMPLETION TIME
A. CANISTER helium backfill pressure limit not met	A.1 Establish CANISTER helium backfill pressure within limit	25 days
B. Required Action and associated Completion Time not met	B.1 Remove all fuel assemblies from the NAC-UMS SYSTEM	5 days

SURVEILLANCE REQUIREMENTS

SURVEILLANCE	FREQUENCY
SR 3.1.3.1 Verify CANISTER helium backfill pressure is within limit	Once within 10 hours (PWR or BWR configuration) after completion of CANISTER draining.

A 3.1 NAC-UMS SYSTEM Integrity

A 3.1.4 CANISTER Maximum Time in TRANSFER CASK

LCO 3.1.4

The following limits for CANISTER time in TRANSFER CASK shall be met, as appropriate:

1. The time duration from completion of backfilling the CANISTER with helium through completion of the CANISTER transfer operation from the TRANSFER CASK to the CONCRETE CASK shall not exceed 16 hours for the PWR configuration or 24 hours for the BWR configuration.
2. The time duration from completion of in-pool or external forced air cooling of the CANISTER through completion of the CANISTER transfer operation from the TRANSFER CASK to the CONCRETE CASK shall not exceed 6 hours for the PWR configuration or 15 hours for the BWR configuration. This LCO time limit is also applicable if SR 3.1.5.1 was not met during vacuum drying operations.

APPLICABILITY: During LOADING OPERATIONS

ACTIONS

-----NOTE-----

Separate Condition entry is allowed for each NAC-UMS SYSTEM.

CONDITION	REQUIRED ACTION	COMPLETION TIME
A. LCO time limits not met	A.1.1 Place TRANSFER CASK with helium filled loaded CANISTER in spent fuel pool <u>AND</u> A.1.2 Maintain TRANSFER CASK and CANISTER in spent fuel pool for a minimum of 24 hours	2 hours Prior to restart of LOADING OPERATIONS

(continued)

**CANISTER Maximum Time in TRANSFER CASK
A 3.1.4**

CONDITION	REQUIRED ACTION	COMPLETION TIME
	<p align="center"><u>OR</u></p> <p align="center">A.2.1 Commence supplying air to the TRANSFER CASK annulus fill/drain lines at a rate of 375 CFM and a maximum temperature of 75°F</p> <p align="center"><u>AND</u></p> <p align="center">A.2.2 Maintain airflow for a minimum of 24 hours</p>	<p align="center">2 hours</p> <p align="center">Prior to restart of LOADING OPERATIONS</p>

SURVEILLANCE REQUIREMENTS

SURVEILLANCE	FREQUENCY
<p>SR 3.1.4.1 Monitor elapsed time from completion of helium backfill until completion of transfer of loaded CANISTER into CONCRETE CASK</p>	<p>Once at completion of helium backfill <u>AND</u> 4 hours thereafter</p>
<p>SR 3.1.4.2 Monitor elapsed time from completion of in-pool or forced-air cooling until completion of transfer of loaded CANISTER into CONCRETE CASK</p>	<p>Once at completion of cooling operations <u>AND</u> 4 hours thereafter</p>

A 3.1 NAC-UMS SYSTEM Integrity
A 3.1.5 CANISTER Helium Leak Rate

LCO 3.1.5 There shall be no indication of a helium leak at a test sensitivity of 1×10^{-7} cm³/sec (helium) through the CANISTER shield lid to CANISTER shell confinement weld to demonstrate a helium leak rate less than 2×10^{-7} cm³/sec (helium) as specified in Table A3-1.

APPLICABILITY: During **LOADING OPERATIONS**

ACTIONS

NOTE

Separate Condition entry is allowed for each NAC-UMS SYSTEM.

CONDITION	REQUIRED ACTION	COMPLETION TIME
A. CANISTER helium leak rate limit not met	A.1 Establish CANISTER helium leak rate within limit	25 days
B. Required Action and associated Completion Time not met	B.1 Remove all fuel assemblies from the NAC-UMS SYSTEM	5 days

SURVEILLANCE REQUIREMENTS

SURVEILLANCE	FREQUENCY
SR 3.1.5.1 Verify CANISTER helium leak rate is within limit	Once prior to TRANSPORT OPERATIONS.

CONCRETE CASK Heat Removal System
A 3.1.6

A 3.1 NAC-UMS SYSTEM

A 3.1.6 CONCRETE CASK Heat Removal System

LCO 3.1.6 The **CONCRETE CASK Heat Removal System** shall be **OPERABLE**.

APPLICABILITY: During **STORAGE OPERATIONS**

ACTIONS

NOTE

Separate Condition entry is allowed for each **NAC-UMS SYSTEM**.

CONDITION	REQUIRED ACTION	COMPLETION TIME
A. CONCRETE CASK Heat Removal System inoperable	A.1 Restore CONCRETE CASK Heat Removal System to OPERABLE status	8 hours
B. Required Action A.1 and associated Completion Time not met	B.1 Perform SR 3.1.6.1 <u>AND</u> B.2.1 Restore CONCRETE CASK Heat Removal System to OPERABLE status <u>OR</u>	Immediately and every 6 hours thereafter 12 hours

(continued)

**CONCRETE CASK Heat Removal System
A 3.1.6**

CONDITION	REQUIRED ACTION	COMPLETION TIME
	<p align="center">B.2.2 Transfer the CANISTER into a TRANSFER CASK, and commence supplying air to the TRANSFER CASK bottom two fill/drain lines at a rate of 375 CFM and a maximum temperature of 75°F.</p>	<p align="center">12 hours</p>

SURVEILLANCE REQUIREMENTS

SURVEILLANCE	FREQUENCY
<p>SR 3.1.6.1 Verify the difference between the average CONCRETE CASK air outlet temperature and ISFSI ambient temperature is $\leq 102^{\circ}\text{F}$ (for the PWR CANISTER) and $\leq 92^{\circ}\text{F}$ (for the BWR CANISTER)</p> <p>SR 3.1.6.2 Verify the difference between the average CONCRETE CASK air outlet temperature and ISFSI ambient temperature is $\leq 102^{\circ}\text{F}$ (for the PWR CANISTER) and $\leq 92^{\circ}\text{F}$ (for the BWR CANISTER)</p>	<p align="center">24 hours</p> <p align="center">4 hours after an off-normal, accident, or natural phenomena</p>

A 3.1 NAC-UMS SYSTEM Integrity
A 3.1.7 Fuel Cooldown Requirements

LCO 3.1.7

Cooldown requirements for UNLOADING a CANISTER installed in the TRANSFER CASK occur in two steps. The first step is exterior cooling of the CANISTER (A.1). The second is interior cooling (A.2). The cooldown requirements of these steps shall be met as appropriate.

A.1. Prior to initiating CANISTER internal cooling:

1. The time duration for holding the CANISTER in the TRANSFER CASK shall not exceed 4 hours for either the PWR or BWR configurations, without forced air cooling.
2. The time duration for holding the CANISTER in the TRANSFER CASK using external forced air cooling of the CANISTER for either the PWR or BWR configurations is not limited.

A.2. Initiating CANISTER internal cooling:

1. Nitrogen gas flush for a minimum of 10 minutes
2. Minimum cooling water temperature of 70°F
3. Cooling water flow rate of 5 (+3, -0) gallons per minute at inlet pressure of 25 (+10, -0) psig
4. Maintain cooling water flow through CANISTER until outlet water temperature \leq 200°F
5. Maximum canister pressure \leq 50 psig

APPLICABILITY: During UNLOADING OPERATIONS

-----**NOTE**-----

The LCO is only applicable to wet UNLOADING OPERATIONS.

(continued)

SURVEILLANCE REQUIREMENTS (Step A.1)

SURVEILLANCE		FREQUENCY
SR 3.1.7.1	Condition A.1 Monitor elapsed time from closing of the TRANSFER CASK bottom shield doors until initiation of CANISTER internal cooling	Once at closing of the TRANSFER CASK bottom shield doors AND 2 hours thereafter
SR 3.1.7.2	Condition B.1 Monitor continuous forced air cooling operation until initiation of CANISTER internal cooling.	Once at start of cooling operations AND 6 hours thereafter

ACTIONS (Step A.2)

-----NOTE-----

Separate Condition entry is allowed for each NAC-UMS SYSTEM.

CONDITION	REQUIRED ACTION	COMPLETION TIME
A.2 CANISTER internal cooldown requirements not met	A.2 Initiate actions to meet CANISTER cooldown requirements	Immediately

(continued)

SURVEILLANCE REQUIREMENTS (Step A.2)

SURVEILLANCE		FREQUENCY
SR 3.1.7.3	Condition A.2 Initiate CANISTER internal cooldown water flow to loaded CANISTER	Within 4 hours of meeting the cooldown limits of Condition A.1
SR 3.1.7.4	Condition A.2 Verify that the cooldown water temperature and flow rate are within limits	Immediately upon initiation of flow and 1 hour thereafter

CANISTER Removal from the CONCRETE CASK
A 3.1.8

A 3.1 **NAC-UMS SYSTEM Integrity**

A 3.1.8 **CANISTER Removal from the CONCRETE CASK**

LCO 3.1.8 **The following limits for TRANSFER OPERATIONS shall be met, as appropriate:**

- 1. The time duration for holding the CANISTER in the TRANSFER CASK shall not exceed 4 hours for either the PWR or BWR configurations, without forced air cooling.**
- 2. The time duration for holding the CANISTER in the TRANSFER CASK using external forced air cooling of the CANISTER is not limited.**

APPLICABILITY: **During TRANSFER OPERATIONS**

ACTIONS

NOTE

Separate Condition entry is allowed for each NAC-UMS SYSTEM.

Separate Condition entry to this LCO is allowed following each 24-hour period of continuous forced air cooling.

(continued)

**CANISTER Removal from the CONCRETE CASK
A 3.1.8**

CONDITION	REQUIRED ACTION	COMPLETION TIME
A. Loaded CANISTER held in TRANSFER CASK	A.1.1 Load CANISTER into operable CONCRETE CASK	4 hours
	<u>OR</u> A.2.1 Load CANISTER into TRANSPORT CASK	4 hours
	<u>OR</u> A.3.1 Perform A.1.1 or A.2.1 following a minimum of 24-hours of forced air cooling	4 hours
B. Required Actions in A and associated Completion Time not met	B.1.1 Commence supplying air to the TRANSFER CASK annulus fill/drain lines at a rate of 375 CFM and a maximum temperature of 75°F	2 hours
	<u>AND</u> B.2.1 Maintain forced air cooling. Condition A of this LCO may be re-entered after 24 hours of forced air cooling	24 hours

(continued)

CANISTER Removal from the CONCRETE CASK
A 3.1.8

SURVEILLANCE REQUIREMENTS

SURVEILLANCE	FREQUENCY
SR 3.1.8.1 Monitor elapsed time from closing of the TRANSFER CASK bottom shield doors until unloading of the CANISTER from the TRANSFER CASK	Once at closing of the TRANSFER CASK bottom shield doors <u>AND</u> 2 hours thereafter
SR 3.1.8.2 Monitor continuous forced air cooling operation until unloading of the CANISTER from the TRANSFER CASK	Once at start of cooling operations <u>AND</u> 6 hours thereafter

A 3.2 NAC-UMS SYSTEM Radiation Protection
A 3.2.1 CANISTER Surface Contamination

LCO 3.2.1 Removable contamination on the accessible exterior surfaces of the CANISTER or accessible interior surfaces of the TRANSFER CASK shall each not exceed:

- a. 1000 dpm/100 cm² from beta and gamma sources; and
- b. 20 dpm/100 cm² from alpha sources.

APPLICABILITY: During LOADING OPERATIONS

ACTIONS

-----**NOTE**-----

Separate Condition entry is allowed for each NAC-UMS SYSTEM.

CONDITION	REQUIRED ACTION	COMPLETION TIME
A. CANISTER or TRANSFER CASK removable surface contamination limits not met	A.1 Restore CANISTER and TRANSFER CASK removable surface contamination to within limits	7 days

(continued)

SURVEILLANCE REQUIREMENTS

SURVEILLANCE	FREQUENCY
SR 3.2.1.1 Verify that the removable contamination on the accessible exterior surfaces of the CANISTER containing fuel is within limits	Once, prior to TRANSPORT OPERATIONS
SR 3.2.1.2 Verify that the removable contamination on the accessible interior surfaces of the TRANSFER CASK do not exceed limits	Once, prior to TRANSPORT OPERATIONS

A 3.2 NAC-UMS SYSTEM Radiation Protection
A 3.2.2 CONCRETE CASK Average Surface Dose Rates

LCO 3.2.2 The average surface dose rates of each CONCRETE CASK shall not exceed:

- a. 50 mrem/hour (neutron + gamma) on the side (on the concrete surfaces);
- b. 50 mrem/hour (neutron + gamma) on the top;
- c. 100 mrem/hour (neutron + gamma) at air inlets and outlets.

APPLICABILITY: During LOADING OPERATIONS

ACTIONS

-----NOTE-----

Separate Condition entry is allowed for each NAC-UMS SYSTEM.

CONDITION	REQUIRED ACTION	COMPLETION TIME
A. CONCRETE CASK average surface dose rate limits not met	A.1 Administratively verify correct fuel loading <u>AND</u>	24 hours

(continued)

**CONCRETE CASK Average Surface Dose Rate
A 3.2.2**

CONDITION	REQUIRED ACTION	COMPLETION TIME
	A.2 Perform analysis to verify compliance with the ISFSI offsite radiation protection requirements of 10 CFR 20 and 10 CFR 72	7 days
B. Required Action and associated Completion Time not met.	B.1 Remove all fuel assemblies from the NAC-UMS SYSTEM	30 days

SURVEILLANCE REQUIREMENTS

SURVEILLANCE	FREQUENCY
SR 3.2.2.1 Verify average surface dose rates of CONCRETE CASK loaded with a CANISTER containing fuel assemblies are within limits. Dose rates shall be measured at the locations shown in Figure A3-1.	Once after completion of transfer of CANISTER into CONCRETE CASK and prior to beginning STORAGE OPERATIONS.

Figure A3-1 CONCRETE CASK Surface Dose Rate Measurement

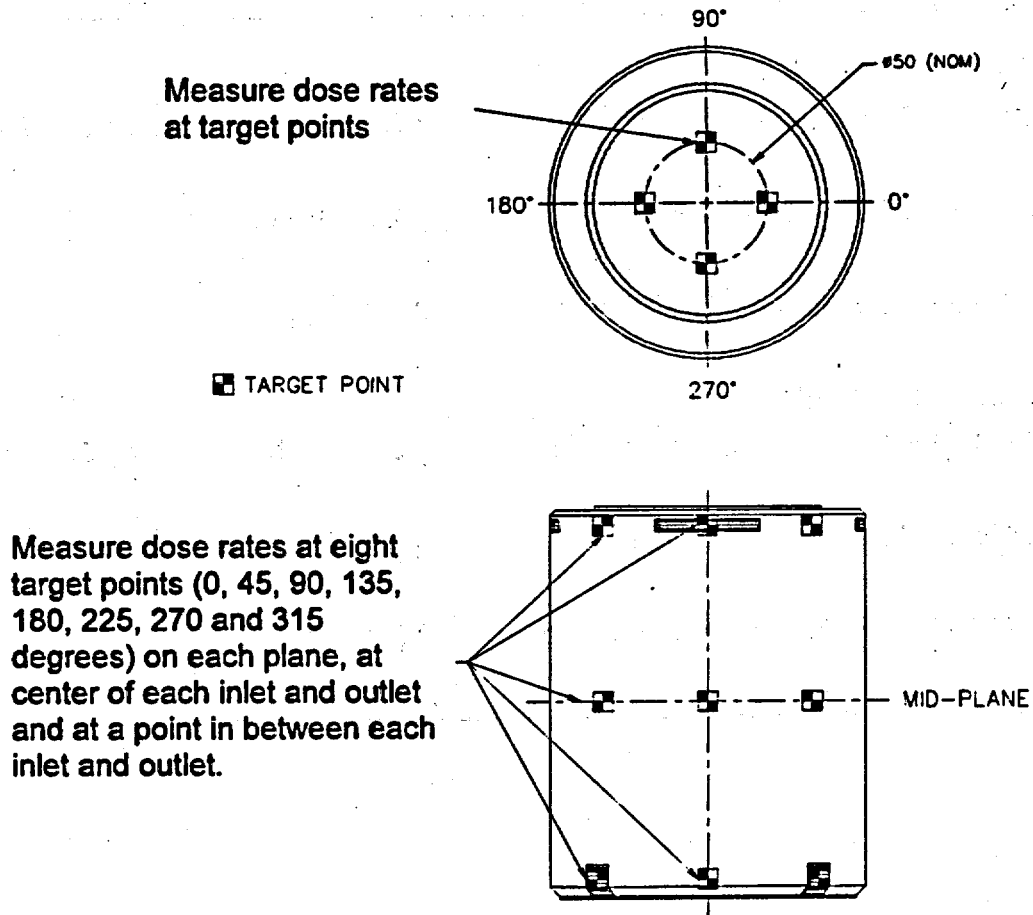

Table A3-1
CANISTER Limits

CANISTER	LIMITS
NAC-UMS CANISTER - PWR	
a. CANISTER Vacuum Drying Pressure	≤ 3 mm of Mercury for ≥ 30 min
b. CANISTER Helium Leak Rate	$\leq 2 \times 10^{-7}$ cm ³ /sec (helium)
c. CANISTER Helium Backfill Pressure	0 (+1, -0) psig
NAC-UMS CANISTER - BWR	
a. CANISTER Vacuum Drying Pressure	≤ 3 mm of Mercury for ≥ 30 min
b. CANISTER Helium Leak Rate	$\leq 2 \times 10^{-7}$ cm ³ /sec (helium)
c. CANISTER Helium Backfill Pressure	0 (+1, -0) psig

A 4.0

[Reserved]

A 5.0 ADMINISTRATIVE CONTROLS AND PROGRAMS

A 5.1 Training Program

A training program for the NAC-UMS Universal Storage System shall be developed under the general licensee's systematic approach to training (SAT). Training modules shall include comprehensive instructions for the operation and maintenance of the NAC-UMS Universal Storage System and the independent spent fuel storage installation (ISFSI).

A 5.2 Pre-Operational Testing and Training Exercises

A dry run training exercise on loading, closure, handling, unloading, and transfer of the NAC-UMS Storage System shall be conducted by the licensee prior to the first use of the system to load spent fuel assemblies. The training exercise shall not be conducted with spent fuel in the CANISTER. The dry run may be performed in an alternate step sequence from the actual procedures, but all steps must be performed. The dry run shall include, but is not limited to the following:

- a. Moving the CONCRETE CASK into its designated loading area
- b. Moving the TRANSFER CASK containing the empty CANISTER into the spent fuel pool
- c. Loading one or more dummy fuel assemblies into the CANISTER, including independent verification
- d. Selection and verification of fuel assemblies requiring preferential loading
- e. Installing the shield lid
- f. Removal of the TRANSFER CASK from the spent fuel pool
- g. Closing and sealing of the CANISTER to demonstrate pressure testing, vacuum drying, helium backfilling, welding, weld inspection and documentation, and leak testing
- h. TRANSFER CASK movement through the designated load path
- i. TRANSFER CASK installation on the CONCRETE CASK
- j. Transfer of the CANISTER to the CONCRETE CASK

(continued)

A 5.2 Pre-Operational Testing and Training Exercises (continued)

- k. CONCRETE CASK shield plug and lid installation
- l. Transport of the CONCRETE CASK to the ISFSI
- m. CANISTER unloading, including reflooding and weld removal or cutting
- n. CANISTER removal from the CONCRETE CASK

A 5.3 Special Requirements for the First System Placed in Service

The heat transfer characteristics and performance of the NAC-UMS SYSTEM will be recorded by temperature measurements on the first NAC-UMS SYSTEM placed in service with a heat load equal to or greater than 10 kW. A letter report summarizing the results of the measurements shall be submitted to the NRC. A separate report will also be submitted for each NAC-UMS SYSTEM subsequently loaded with a higher heat load, up to the 23.0 kW maximum heat load. The calculated and measured temperature data shall be reported to the NRC in accordance with 10 CFR 72.4. A report is not required to be submitted to the NRC for NAC-UMS SYSTEMS that are subsequently loaded with lesser loads than the latest reported case.

A 5.4 Surveillance After an Off-Normal, Accident, or Natural Phenomena Event

A Response Surveillance is required following off-normal, accident or natural phenomena events. The NAC-UMS SYSTEMS in use at an ISFSI shall be inspected within 4 hours after the occurrence of an off-normal, accident or natural phenomena event in the area of the ISFSI. This inspection must specifically verify that all the CONCRETE CASK inlets and outlets are not blocked or obstructed. At least one-half of the inlets and outlets on each CONCRETE CASK must be cleared of blockage or debris within 24 hours to restore air circulation.

The CONCRETE CASK and CANISTER shall be inspected if they experience a drop or a tipover.

(continued)

A 5.5 Radioactive Effluent Control Program

The program implements the requirements of 10 CFR 72.44(d).

- a. The NAC-UMS SYSTEM does not create any radioactive materials or have any radioactive waste treatment systems. Therefore, specific operating procedures for the control of radioactive effluents are not required. LCO 3.1.5, CANISTER Helium Leak Rate, provides assurance that there are no radioactive effluents from the NAC-UMS SYSTEM.
- b. This program includes an environmental monitoring program. Each general license user may incorporate NAC-UMS SYSTEM operations into their environmental monitoring program for 10 CFR Part 50 operations.
- c. An annual report shall be submitted pursuant to 10 CFR 72.44(d)(3).

A 5.6 NAC-UMS SYSTEM Transport Evaluation Program

This program provides a means for evaluating various transport configurations and transport route conditions to ensure that the design basis drop limits are met. For lifting of the loaded TRANSFER CASK or CONCRETE CASK using devices, which are integral to a structure governed by 10 CFR Part 50 regulations, 10 CFR 50 requirements apply. This program is not applicable when the TRANSFER CASK or CONCRETE CASK is in the fuel building or is being handled by a device providing support from underneath (i.e., on a rail car, heavy haul trailer, air pads, etc.).

Pursuant to 10 CFR 72.212, this program shall evaluate the site specific transport route conditions.

(continued)

A 5.6 NAC-UMS SYSTEM Transport Evaluation Program (continued)

- a. The lift height above the transport surface prescribed in Section B3.4.6 of Appendix B to Certificate of Compliance (CoC) No. 1015 shall not exceed the limits in Table A5-1. Also, the program shall ensure that the transport route conditions (i.e., surface hardness and pad thickness) are equivalent to or less limiting than those prescribed for the reference pad surface which forms the basis for the values cited in Section B3.4.6 of Appendix B to CoC No. 1015.
 - b. For site specific transport conditions which are not bounded by the surface characteristics in Section B3.4.6 of Appendix B to CoC No. 1015, the program may evaluate the site specific conditions to ensure that the impact loading due to design basis drop events does not exceed 60g. This alternative analysis shall be commensurate with the drop analyses described in the Safety Analysis Report for the NAC-UMS SYSTEM. The program shall ensure that these alternative analyses are documented and controlled.
 - c. The TRANSFER CASK and CONCRETE CASK may be lifted to those heights necessary to perform cask handling operations, including CANISTER transfer, provided the lifts are made with structures and components designed in accordance with the criteria specified in Section B3.5 of Appendix B to CoC No. 1015, as applicable.
-

TRANSFER CASK and CONCRETE CASK Lifting Requirements
Table A5-1

Table A5-1 TRANSFER CASK and CONCRETE CASK Lifting Requirements

Item	Orientation	Lifting Height Limit
TRANSFER CASK	Horizontal	None Established
TRANSFER CASK	Vertical	None Established¹
CONCRETE CASK	Horizontal	Not Permitted
CONCRETE CASK	Vertical	20 inches

Note:

- 1. See Technical Specification A5.6(c).**

DRAFT

APPENDIX B

**APPROVED CONTENTS AND DESIGN FEATURES
FOR THE NAC-UMS SYSTEM**

DRAFT

**Appendix B
Table of Contents**

B 1.0	Definitions	B1-1
B 2.0	Approved Contents	B2-1
B 2.1	Fuel Specifications and Loading Conditions	B2-1
B 2.2	Violations	B2-3
Figure B2-1	PWR Basket Fuel Loading Positions.....	B2-4
Figure B2-2	BWR Basket Fuel Loading Positions.....	B2-4
Table B2-1	Fuel Assembly Limits.....	B2-5
Table B2-2	PWR Fuel Assembly Characteristics.....	B2-8
Table B2-3	BWR Fuel Assembly Characteristics.....	B2-9
Table B2-4	Minimum Cooling Time Versus Burnup/Initial Enrichment for PWR Fuel	B2-10
Table B2-5	Minimum Cooling Time Versus Burnup/Initial Enrichment for BWR Fuel	B2-11
B 3.0	Design Features	B3-1
B 3.1	Site.....	B3-1
B 3.2	Design Features Important for Criticality Control	B3-1
B 3.3	Codes and Standards	B3-1
B 3.4	Site Specific Parameters and Analyses.....	B3-7
B 3.5	CANISTER HANDLING FACILITY (CHF).....	B3-9
Table B3-1	List of ASME Code Exceptions for the NAC-UMS SYSTEM.....	B3-3
Table B3-2	Load Combinations and Service Condition Definitions for the CANISTER HANDLING FACILITY (CHF) Structure.....	B3-11

B 1.0 DEFINITIONS

NOTE

The defined terms of this section appear in capitalized type and are applicable throughout this section.

<u>Term</u>	<u>Definition</u>
ACTIONS	ACTIONS shall be that part of a Specification that prescribes Required Actions to be taken under designated Conditions within specified Completion Times.
CANISTER	See TRANSPORTABLE STORAGE CANISTER
CANISTER HANDLING FACILITY	The CANISTER HANDLING FACILITY includes the following components and equipment: (1) a canister transfer station that allows the staging of the TRANSFER CASK with the CONCRETE CASK or transport cask to facilitate CANISTER lifts involving spent fuel handling not covered by 10 CFR 50; and (2) either a stationary lift device or mobile lifting device used to lift the TRANSFER CASK and CANISTER .
CONCRETE CASK	See VERTICAL CONCRETE CASK
INDEPENDENT SPENT FUEL STORAGE INSTALLATION (ISFSI)	The facility within the perimeter fence licensed for storage of spent fuel within NAC-UMS SYSTEMS (see also 10 CFR 72.3).
INTACT FUEL ASSEMBLY	INTACT FUEL ASSEMBLY is a fuel assembly without known or suspected cladding defects greater than a pinhole leak or hairline crack and which can be handled by normal means. A fuel assembly with missing fuel rods shall not be classified as an INTACT FUEL ASSEMBLY unless solid Zircaloy or stainless steel rods are used to displace an amount of water equal to that displaced by the original fuel rod(s).

(continued)

INTACT FUEL ROD

INTACT FUEL ROD is a fuel rod without known or suspected cladding defects greater than a pinhole leak or hairline crack.

LOADING OPERATIONS

LOADING OPERATIONS include all licensed activities on an **NAC-UMS SYSTEM** while it is being loaded with fuel assemblies. **LOADING OPERATIONS** begin when the first fuel assembly is placed in the **CANISTER** and end when the **NAC-UMS SYSTEM** is secured on the transporter. **LOADING OPERATIONS** does not include **CANISTER** transfer operations between the **TRANSFER CASK** and the **CONCRETE CASK** or transport cask.

INITIAL PEAK PLANAR-AVERAGE ENRICHMENT

THE INITIAL PEAK PLANAR-AVERAGE ENRICHMENT is the maximum planar-average enrichment at any height along the axis of the fuel assembly. The 4.0 wt % ^{235}U enrichment limit for BWR fuel applies along the full axial extent of the assembly. The **INITIAL PEAK PLANAR-AVERAGE ENRICHMENT** may be higher than the bundle (assembly) average enrichment.

NAC-UMS SYSTEM

NAC-UMS SYSTEM includes the components approved for loading and storage of spent fuel assemblies at the ISFSI. The **NAC-UMS SYSTEM** consists of a **CONCRETE CASK**, a **TRANSFER CASK**, and a **CANISTER**.

STORAGE OPERATIONS

STORAGE OPERATIONS include all licensed activities that are performed at the ISFSI, while an **NAC-UMS SYSTEM** containing spent fuel is located on the storage pad within the ISFSI perimeter.

(continued)

TRANSFER CASK

TRANSFER CASK is a shielded lifting device that holds the **CANISTER** during **LOADING** and **UNLOADING OPERATIONS** and during closure welding, vacuum drying, leak testing, and non-destructive examination of the **CANISTER** closure welds. The **TRANSFER CASK** is also used to transfer the **CANISTER** into and from the **CONCRETE CASK** and into the transport cask.

TRANSPORT OPERATIONS

TRANSPORT OPERATIONS include all licensed activities involved in moving a loaded **NAC-UMS CONCRETE CASK** and **CANISTER** to and from the **ISFSI**. **TRANSPORT OPERATIONS** begin when the **NAC-UMS SYSTEM** is first secured on the transporter and end when the **NAC-UMS SYSTEM** is at its destination and no longer secured on the transporter. **TRANSPORT OPERATIONS** include transfer of the **CANISTER** between the **TRANSFER CASK** and the **CONCRETE CASK** or transport cask.

TRANSPORTABLE STORAGE CANISTER (CANISTER)

TRANSPORTABLE STORAGE CANISTER is the sealed container that consists of a tube and disk fuel basket in a cylindrical canister shell that is welded to a baseplate, shield lid with welded port covers, and structural lid. The **CANISTER** provides the confinement boundary for the confined spent fuel.

(continued)

UNLOADING OPERATIONS

UNLOADING OPERATIONS include all licensed activities on an NAC-UMS SYSTEM to be unloaded of the contained fuel assemblies. **UNLOADING OPERATIONS** begin when the NAC-UMS SYSTEM is no longer secured on the transporter and end when the last fuel assembly is removed from the NAC-UMS SYSTEM.

**VERTICAL CONCRETE CASK
(CONCRETE CASK)**

VERTICAL CONCRETE CASK is the cask that receives and holds the sealed **CANISTER**. It provides the gamma and neutron shielding and convective cooling of the spent fuel confined in the **CANISTER**.

B 2.0 APPROVED CONTENTS

B 2.1 Fuel Specifications and Loading Conditions

B 2.1.1 Fuel to be Stored in the NAC-UMS SYSTEM

INTACT FUEL ASSEMBLIES meeting the limits specified in Tables B2-1 through B2-5 may be stored in the NAC-UMS SYSTEM.

B 2.1.2 Preferential Fuel Loading

Loading of the fuel assemblies designated for a given TRANSPORTABLE STORAGE CANISTER must be administratively controlled to ensure that the dry storage fuel cladding temperature limits are not exceeded for any fuel assembly, unless all of the designated fuel assemblies have a cooling time of 7 years or more. When preparing the loading schemes for each canister, ALARA principles will be used in determining the specific assemblies to be placed in each basket location. The fuel with shorter cooling times (thus, higher fuel cladding temperature allowable and higher radiation source strength) will be placed in the center of the basket.

CANISTERS containing fuel assemblies, all of which have a cooling time of 7 years, or more, do not require preferential loading, because analyses have shown that the fuel cladding temperature limits will always be met for those CANISTERS. CANISTERS containing fuel assemblies with cooling times from 5 to 7 years must be preferentially loaded based on cooling time. By controlling the placement of the fuel assemblies with the shortest cooling time (thermally hottest) in the basket interior, preferential loading ensures that the allowable fuel cladding temperature for a given fuel assembly is not exceeded. The preferential loading of fuel into the CANISTER based on cooling time is described below.

The normal temperature distribution in the loaded TRANSPORTABLE STORAGE CANISTER results in the basket having the highest temperature at its center and lowest temperature at the outer edge. Considering this temperature distribution, spent fuel with the shortest cooling time (and, therefore, having a higher allowable cladding temperature) is placed in the center of the basket. Fuel with the longest cooling time (and, therefore,

(continued)

having a lower allowable cladding temperature) is placed in the periphery of the basket. Using a similar argument, fuel assemblies with cooling times between the highest and lowest cooling times of the designated fuel, are placed in intermediate fuel positions.

For the PWR fuel basket configuration, shown in Figure B2-1, fuel positions are numbered using the drain line as the reference point. Fuel positions 9, 10, 15 and 16 are considered to be basket center positions for the purpose of meeting the preferential loading requirement. The fuel with the shortest cooling times from among the fuel designated for loading in the CANISTER will be placed in the center positions. A single fuel assembly having the shortest cooling time may be loaded in any of these four positions. Fuel positions 1, 2, 3, 6, 7, 12, 13, 18, 19, 22, 23 and 24 are periphery positions, where fuel with the longest cooling times will be placed. Fuel with the longest cooling times may be loaded in any of these 12 positions. Similarly, designated fuel assemblies with cooling times in the midrange of the shortest and longest cooling times will be loaded in the intermediate fuel positions - 4, 5, 8, 11, 14, 17, 20 and 21.

For the BWR fuel basket configuration, shown in Figure B2-2, fuel positions are also numbered using the drain line as the reference point. Fuel positions 23, 24, 25, 32, 33 and 34 are considered to be basket center positions for the purpose of meeting the preferential loading requirement. The fuel with the shortest cooling times from among the fuel designated for loading in the CANISTER will be placed in the center positions. However, the single fuel assembly having the shortest cooling time will be loaded in either position 24 or position 33. Fuel positions 1, 2, 3, 4, 5, 6, 12, 13, 19, 20, 28, 29, 37, 38, 44, 45, 51, 52, 53, 54, 55 and 56 are periphery positions, where fuel with the longest cooling times will be placed. Fuel with the longest cooling times may be loaded in any of these 23 positions. Designated fuel assemblies with cooling times in the midrange of the shortest and longest cooling times will be divided into two tiers. The fuel assemblies with the shorter cooling times in the midrange will be loaded in the inner intermediate fuel positions - 15, 16, 17, 22, 28, 31, 35, 40, 41, and 42. Fuel assemblies with the longer cooling times in the midrange will be loaded in the outer intermediate fuel positions - 7, 8, 9, 10, 11, 14, 18, 21, 27, 30, 36, 39, 43, 46, 47, 48, 49 and 50.

(continued)

These loading patterns result in the placement of fuel such that the shortest-cooled fuel is in the center of the basket and the longest-cooled fuel is on the periphery. Based on engineering evaluations, this loading pattern ensures that fuel assembly allowable cladding temperatures are satisfied.

B 2.2 Violations

If any Fuel Specification or Loading Condition of B2.1 is violated, the following actions shall be completed:

- B 2.2.1** The affected fuel assemblies shall be placed in a safe condition.
 - B 2.2.2** Within 24 hours, notify the NRC Operations Center.
 - B 2.2.3** Within 30 days, submit a special report that describes the cause of the violation and actions taken to restore compliance and prevent recurrence.
-

Figure B2-1

PWR Basket Fuel Loading Positions

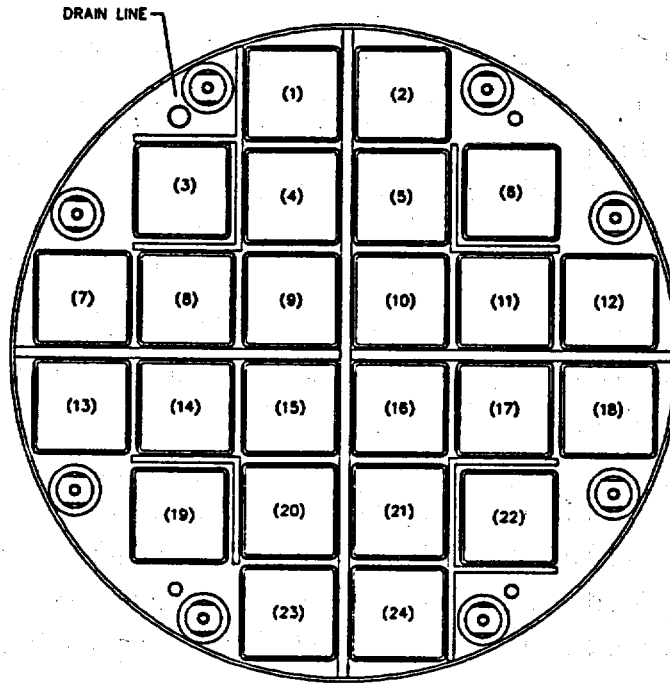

Figure B2-2

BWR Basket Fuel Loading Positions

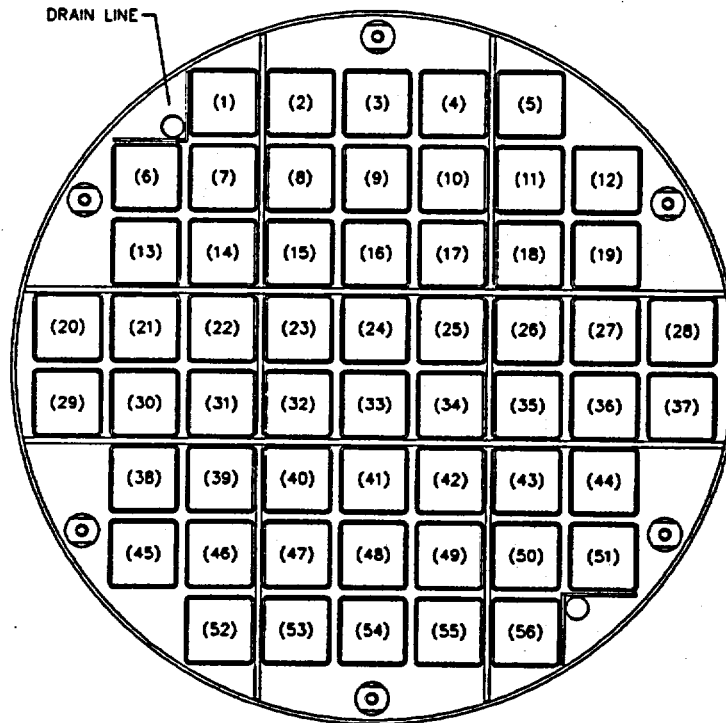

Table B2-1
Fuel Assembly Limits

I. NAC-UMS CANISTER: PWR FUEL

A. Allowable Contents

1. Uranium oxide PWR INTACT FUEL ASSEMBLIES listed in Table B2-2 and meeting the following specifications:

- a. Cladding Type: Zircaloy with thickness as specified in Table B2-2 for the applicable fuel assembly class
- b. Enrichment: Maximum and minimum initial enrichments are 4.2 and 1.9 wt % ²³⁵U, respectively. Fuel enrichment, burnup and cool time are related as shown in Table B2-4.
- c. Decay Heat Per Assembly: ≤ 958.3 watts
- d. Post-irradiation Cooling Time and Average Burnup Per Assembly: As specified in Table B2-4
- e. Nominal Fresh Fuel Assembly Length (in.): ≤ 178.3
- f. Nominal Fresh Fuel Assembly Width (in.): ≤ 8.54
- g. Fuel Assembly Weight (lbs.): ≤ 1,515

B. Quantity per CANISTER: Up to 24 PWR INTACT FUEL ASSEMBLIES.

C. PWR INTACT FUEL ASSEMBLIES may contain thimble plugs and burnable poison inserts (Class 1 and Class 2 contents).

D. PWR INTACT FUEL ASSEMBLIES shall not contain control components.

E. Stainless steel spacers may be used in CANISTERS to axially position PWR INTACT FUEL ASSEMBLIES that are shorter than the available cavity length to facilitate handling.

F. Unenriched fuel assemblies are not authorized for loading.

G. The minimum length of the PWR INTACT FUEL ASSEMBLY internal structure and bottom end fitting and/or spacers shall ensure that the minimum distance to the fuel region from the base of the CANISTER is 3.2 inches.

Table B2-1
Fuel Assembly Limits (continued)

II. NAC-UMS CANISTER: BWR FUEL

A. Allowable Contents

1. Uranium oxide BWR INTACT FUEL ASSEMBLIES listed in Table B2-3 and meeting the following specifications:

a. Cladding Type:	Zircaloy with thickness as specified in Table B2-3 for the applicable fuel assembly class.	
b. Enrichment:	Maximum and minimum INITIAL PEAK PLANAR-AVERAGE ENRICHMENTS are 4.0 and 1.9 wt % ²³⁵ U, respectively. Fuel enrichment, burnup and cooling time are related as shown in Table B2-5.	
c. Decay Heat per Assembly:	≤ 410.7 watts	
d. Post-irradiation Cooling Time and Average Burnup Per Assembly:	As specified in Table B2-5 and for the applicable fuel assembly class.	
e. Nominal Fresh Fuel Design Assembly Length (in.):	≤ 176.1	
f. Nominal Fresh Fuel Design Assembly Width (in.):	≤ 5.51	
g. Fuel Assembly Weight (lbs):	≤ 683, including channels	

Table B2-1
Fuel Assembly Limits (continued)

- B. Quantity per CANISTER: Up to 56 BWR INTACT FUEL ASSEMBLIES
- C. BWR INTACT FUEL ASSEMBLIES can be unchanneled or channeled with Zircaloy channels.
- D. BWR INTACT FUEL ASSEMBLIES with stainless steel channels shall not be loaded.
- E. Stainless steel fuel spacers may be used in CANISTERS to axially position BWR INTACT FUEL ASSEMBLIES that are shorter than the available cavity length to facilitate handling.
- F. Unenriched fuel assemblies are not authorized for loading.
- G. The minimum length of the BWR INTACT FUEL ASSEMBLY internal structure and bottom end fitting and/or spacers shall ensure that the minimum distance to the fuel region from the base of the CANISTER is 6.2 inches.

Table B2-2 PWR Fuel Assembly Characteristics

Fuel Class ¹	Vendor ²	Array	Max. MTU	No of Fuel Rods	Max. Pitch (in)	Min. Rod Dia. (in)	Min. Clad Thick (in)	Max. Pellet Dia.(in)	Max. Active Length (in)	Min. Guide Tube Thick (in)
1	CE	14x14	0.404	176	0.590	0.438	0.024	0.380	137.0	0.034
1	Ex/ANF	14x14	0.369	179	0.556	0.424	0.030	0.351	142.0	0.034
1	WE	14x14	0.382	179	0.556	0.400	0.024	0.345	144.0	0.034
1	WE	14x14	0.415	179	0.556	0.422	0.022	0.368	145.2	0.034
1	WE, Ex/ANF	15x15	0.465	204	0.563	0.422	0.024	0.366	144.0	0.015
1	Ex/ANF	17x17	0.413	264	0.496	0.360	0.025	0.303	144.0	0.016
1	WE	17x17	0.468	264	0.496	0.374	0.022	0.323	144.0	0.018
1	WE	17x17	0.429	264	0.496	0.360	0.022	0.309	144.0	0.016
2	B&W	15x15	0.481	208	0.568	0.430	0.026	0.369	144.0	0.016
2	B&W	17x17	0.466	264	0.502	0.379	0.024	0.324	143.0	0.017
3	CE	16x16	0.442	236	0.506	0.382	0.025	0.325	150.0	0.035
1	Ex/ANF ³	14x14	0.375	179	0.556	0.417	0.030	0.351	144.0	0.036
1	CE ³	15x15	0.432	216	0.550	0.418	0.026	0.358	132.0	—
1	Ex/ANF ³	15x15	0.431	216	0.550	0.417	0.030	0.358	131.8	—
1	CE ³	16x16	0.403	236	0.506	0.382	0.023	0.3255	136.7	0.035

1. Maximum Initial Enrichment: 4.2 wt % ²³⁵U. All fuel rods are Zircaloy clad.
2. Vendor ID indicates the source of assembly base parameters. Loading of assemblies meeting above limits is not restricted to the vendor(s) listed.
3. 14x14, 15x15 and 16x16 fuel manufactured for Prairie Island, Palisades and St. Lucie 2 cores, respectively. These are not generic fuel assemblies provided to multiple reactors.

Table B2-3 BWR Fuel Assembly Characteristics

Fuel Class ^{1,5}	Vendor ⁴	Array	Max. MTU	No of Fuel Rods	Max. Pitch (in)	Min. Rod Dia. (in)	Min. Clad Thick (in)	Max. Pellet Dia.(in)	Max. Active Length (in) ²
4 ^b	Ex/ANF	7 X 7	0.196	48	0.738	0.570	0.036	0.490	144.0
4	Ex/ANF	8 X 8	0.177	63	0.641	0.484	0.036	0.405	145.2
4	Ex/ANF	9 X 9	0.173	78	0.572	0.424	0.030	0.357	145.2
4	GE	7 X 7	0.199	49	0.738	0.570	0.036	0.488	144.0
4	GE	7 X 7	0.198	49	0.738	0.563	0.032	0.487	144.0
4	GE	8 X 8	0.173	60	0.640	0.484	0.032	0.410	145.2
4	GE	8 X 8	0.179	62	0.640	0.483	0.032	0.410	145.2
4	GE	8 X 8	0.186	63	0.640	0.493	0.034	0.416	144.0
5	Ex/ANF	8 X 8	0.180	62	0.641	0.484	0.036	0.405	150.0
5	Ex/ANF	9 X 9	0.167	74 ³	0.572	0.424	0.030	0.357	150.0
5 ^b	Ex/ANF	9 X 9	0.178	79 ³	0.572	0.424	0.030	0.357	150.0
5	GE	7 X 7	0.198	49	0.738	0.563	0.032	0.487	144.0
5	GE	8 X 8	0.179	60	0.640	0.484	0.032	0.410	150.0
5	GE	8 X 8	0.185	62	0.640	0.483	0.032	0.410	150.0
5	GE	8 X 8	0.188	63	0.640	0.493	0.034	0.416	146.0
5	GE	9 X 9	0.186	74 ³	0.566	0.441	0.028	0.376	150.0
5	GE	9 X 9	0.198	79 ³	0.566	0.441	0.028	0.376	150.0

1. Maximum Initial Peak Planar Average Enrichment 4.0 wt % ²³⁵U. All fuel rods are Zircaloy clad.
2. 150 inch active fuel length assemblies contain 6" natural uranium blankets on top and bottom.
3. Shortened active fuel length in some rods.
4. Vendor ID indicates the source of assembly base parameters. Loading of assemblies meeting above limits is not restricted to the vendor(s) listed.
5. UMS Class 4 and 5 for BWR 2/3 fuel.
6. Assembly width including channel. Unchanneled or channeled assemblies may be loaded based on a maximum channel thickness of 120 mil.

Table B2-4 Minimum Cooling Time Versus Burnup/Initial Enrichment for PWR Fuel

Minimum Initial Enrichment wt % ²³⁵ U (E)	Burnup ≤30 GWD/MTU Minimum Cooling Time [years]				30 < Burnup ≤35 GWD/MTU Minimum Cooling Time [years]			
	14x14	15x15	16x16	17x17	14x14	15x15	16x16	17x17
1.9 ≤ E < 2.1	5	5	5	5	7	7	5	7
2.1 ≤ E < 2.3	5	5	5	5	7	6	5	6
2.3 ≤ E < 2.5	5	5	5	5	6	6	5	6
2.5 ≤ E < 2.7	5	5	5	5	6	6	5	6
2.7 ≤ E < 2.9	5	5	5	5	6	5	5	5
2.9 ≤ E < 3.1	5	5	5	5	5	5	5	5
3.1 ≤ E < 3.3	5	5	5	5	5	5	5	5
3.3 ≤ E < 3.5	5	5	5	5	5	5	5	5
3.5 ≤ E < 3.7	5	5	5	5	5	5	5	5
3.7 ≤ E ≤ 4.2	5	5	5	5	5	5	5	5
Minimum Initial Enrichment wt % ²³⁵ U (E)	35 < Burnup ≤40 GWD/MTU Minimum Cooling Time [years]				40 < Burnup ≤45 GWD/MTU Minimum Cooling Time [years]			
	14x14	15x15	16x16	17x17	14x14	15x15	16x16	17x17
1.9 ≤ E < 2.1	10	10	7	10	15	15	11	15
2.1 ≤ E < 2.3	9	9	7	9	14	13	10	13
2.3 ≤ E < 2.5	8	8	6	8	12	13	10	12
2.5 ≤ E < 2.7	8	8	6	8	11	13	10	12
2.7 ≤ E < 2.9	7	8	6	8	10	12	9	12
2.9 ≤ E < 3.1	7	8	6	8	9	12	9	11
3.1 ≤ E < 3.3	6	8	6	7	8	12	9	10
3.3 ≤ E < 3.5	6	8	6	7	8	12	9	10
3.5 ≤ E < 3.7	6	8	6	6	8	11	9	10
3.7 ≤ E ≤ 4.2	6	7	6	6	8	10	9	10

Table B2-5 Minimum Cooling Time Versus Burnup/Initial Enrichment for BWR Fuel

Minimum Initial Enrichment wt % ²³⁵ U (E)	Burnup ≤30 GWD/MTU Minimum Cooling Time [years]			30 < Burnup ≤35 GWD/MTU Minimum Cooling Time [years]		
	7x7	8x8	9x9	7x7	8x8	9x9
1.9 ≤ E < 2.1	5	5	5	8	7	7
2.1 ≤ E < 2.3	5	5	5	6	6	6
2.3 ≤ E < 2.5	5	5	5	5	5	5
2.5 ≤ E < 2.7	5	5	5	5	5	5
2.7 ≤ E < 2.9	5	5	5	5	5	5
2.9 ≤ E < 3.1	5	5	5	5	5	5
3.1 ≤ E < 3.3	5	5	5	5	5	5
3.3 ≤ E < 3.5	5	5	5	5	5	5
3.5 ≤ E < 3.7	5	5	5	5	5	5
3.7 ≤ E ≤ 4.0	5	5	5	5	5	5
Minimum Initial Enrichment wt % ²³⁵ U (E)	35 < Burnup ≤40 GWD/MTU Minimum Cooling Time [years]			40 < Burnup ≤45 GWD/MTU Minimum Cooling Time [years]		
	7x7	8x8	9x9	7x7	8x8	9x9
1.9 ≤ E < 2.1	16	14	15	26	24	25
2.1 ≤ E < 2.3	13	12	12	23	21	22
2.3 ≤ E < 2.5	9	8	8	18	16	17
2.5 ≤ E < 2.7	8	7	7	15	14	14
2.7 ≤ E < 2.9	7	6	6	13	11	12
2.9 ≤ E < 3.1	6	6	6	11	10	10
3.1 ≤ E < 3.3	6	5	6	9	8	9
3.3 ≤ E < 3.5	6	5	6	8	7	8
3.5 ≤ E < 3.7	6	5	6	7	7	7
3.7 ≤ E ≤ 4.0	6	5	5	7	6	7

B 3.0 DESIGN FEATURES

B 3.1 Site

B 3.1.1 Site Location

The NAC-UMS SYSTEM is authorized for general use by 10 CFR 50 license holders at various site locations under the provisions of 10 CFR 72, Subpart K.

B 3.2 Design Features Important for Criticality Control

B 3.2.1 CANISTER-INTACT FUEL ASSEMBLIES

- a) Minimum ^{10}B loading in the Boral neutron absorbers:
 - 1. PWR – 0.025g/cm²
 - 2. BWR – 0.011g/cm²
 - b) Minimum length of INTACT FUEL ASSEMBLY internal structure and bottom end fitting and/or spacers shall ensure the minimum distance to the fuel region from the base of the CANISTER is:
 - 1. PWR – 3.2 inches
 - 2. BWR – 6.2 inches
-

B 3.3 Codes and Standards

The American Society of Mechanical Engineers Boiler and Pressure Vessel Code (ASME Code), 1995 Edition with Addenda through 1995, is the governing Code for the NAC-UMS CANISTER.

The American Concrete Institute Specifications ACI-349 (1985) and ACI-318 (1995) govern the NAC-UMS CONCRETE CASK design and construction, respectively.

The American National Standards Institute ANSI N14.6 (1993) and NUREG-0612 govern the NAC-UMS TRANSFER CASK design, operation, fabrication, testing, inspection and maintenance.

(continued)

B 3.3.1 Exceptions to Codes, Standards, and Criteria

Table B3-1 lists exceptions to the ASME Code for the design of the NAC-UMS SYSTEM.

B 3.3.2 Construction/Fabrication Exceptions to Codes, Standards, and Criteria

Proposed alternatives to ASME Code, Section III, 1995 Edition with Addenda, through 1995, including exceptions listed in Specification B3.3.1, may be used when authorized by the Director of the Office of Nuclear Material Safety and Safeguards or designee. The request for such alternatives should demonstrate that:

1. The proposed alternatives would provide an acceptable level of quality and safety, or
2. Compliance with the specified requirements of ASME Code, Section III, 1995 Edition with Addenda through 1995, would result in hardship or unusual difficulty without a compensating increase in the level of quality and safety.

Requests for exceptions shall be submitted in accordance with 10 CFR 72.4.

Table B3-1 List of ASME Code Exceptions for the NAC-UMS SYSTEM

Component	Reference ASME Code Section/Article	Code Requirement	Exception, Justification and Compensatory Measures
CANISTER	NB-1100	Statement of requirements for Code stamping of components.	CANISTER is designed and will be fabricated in accordance with ASME Code, Section III, Subsection NB to the maximum practical extent, but Code stamping is not required.
CANISTER	NB-2000	Requirements to be supplied by ASME-approved material supplier.	Materials will be supplied by NAC-approved suppliers with Certified Material Test Reports (CMTRs) in accordance to NB-2000 requirements.
CANISTER Shield Lid and Structural Lid Welds	NB-4243	Full penetration welds required for Category C joints (flat head to main shell per NB-3352.3).	Shield lid and structural lid to CANISTER shell welds are not full penetration welds. These field welds are performed independently to provide a redundant closure. Leaktightness of the CANISTER is verified by testing.
CANISTER Structural Lid Weld	NB-4421	Requires removal of backing ring.	Structural lid to CANISTER shell weld uses a backing ring that is not removed. The backing ring permits completion of the groove weld; it is not considered in any analyses; and it has no detrimental effect on the CANISTER's function.
CANISTER Vent Port Cover and Drain Port Cover to Shield Lid Welds; Shield Lid to Canister Shell Weld	NB-5230	Radiographic (RT) or ultrasonic (UT) examination required.	Root and final surface liquid penetrant examination to be performed per ASME Code Section V, Article 6, with acceptance in accordance with ASME Code, Section III, NB-5350.

Table B3-1 List of ASME Code Exceptions for the NAC-UMS SYSTEM(continued)

Component	Reference ASME Code Section/Article	Code Requirement	Exception, Justification and Compensatory Measures
CANISTER Structural Lid to Shell Weld	NB-5230	Radiographic (RT) or ultrasonic (UT) examination required.	<p>The CANISTER structural lid to CANISTER shell closure weld is performed in the field following fuel assembly loading. The structural lid-to-shell weld will be verified by either ultrasonic (UT) or progressive liquid penetrant (PT) examination. If progressive PT examination is used, at a minimum, it must include the root and final layers and each approximately 3/8 inch of weld depth. If UT examination is used, it will be followed by a final surface PT examination. For either UT or PT examination, the maximum, undetectable flaw size is demonstrated to be smaller than the critical flaw size. The critical flaw size is determined in accordance with ASME Code, Section XI methods. The examination of the weld will be performed by qualified personnel per ASME Code Section V, Articles 5 (UT) and 6 (PT) with acceptance per ASME Code Section III, NB-5332 (UT) per 1997 Addenda, and NB-5350 for (PT).</p>

Table B3-1 List of ASME Code Exceptions for the NAC-UMS SYSTEM(continued)

Component	Reference ASME Code Section/Article	Code Requirement	Exception, Justification and Compensatory Measures
CANISTER Vessel and Shield Lid	NB-6111	All completed pressure retaining systems shall be pressure tested.	The CANISTER shield lid to shell weld is performed in the field following fuel assembly loading. The CANISTER is then pneumatically (air-over-water) pressure tested as defined in Chapter 9 and described in Chapter 8. Accessibility for leakage inspections precludes a Code compliant hydrostatic test. The shield lid-to-shell weld is also leak tested to the leak-tight criteria of ANSI N14.5. The vent port and drain port cover welds are examined by root and final PT examination. The structural lid enclosure weld is examined by progressive PT or UT and final surface PT.
CANISTER Vessel	NB-7000	Vessels are required to have overpressure protection.	No overpressure protection is provided. The function of the CANISTER is to confine radioactive contents under normal, off-normal, and accident conditions of storage. The CANISTER vessel is designed to withstand a maximum internal pressure considering 100% fuel rod failure and maximum accident temperatures.

Table B3-1 List of ASME Code Exceptions for the NAC-UMS SYSTEM(continued)

Component	Reference ASME Code Section/Article	Code Requirement	Exception, Justification and Compensatory Measures
CANISTER Vessel	NB-8000	States requirements for nameplates, stamping and reports per NCA-8000.	The NAC-UMS SYSTEM is marked and identified in accordance with 10 CFR 72 requirements. Code stamping is not required. The QA data package will be in accordance with NAC's approved QA program.
CANISTER Basket Assembly	NG-2000	Requires materials to be supplied by ASME approved material supplier.	Materials to be supplied by NAC-approved suppliers with CMTRs in accordance with NG-2000 requirements.
CANISTER Basket Assembly	NG-8000	States requirements for nameplates, stamping and reports per NCA-8000.	The NAC-UMS SYSTEM will be marked and identified in accordance with 10 CFR 72 requirements. No Code stamping is required. The CANISTER basket data package will be in accordance with NAC's approved QA program.
CANISTER Vessel and Basket Assembly Material	NB-2130/ NG-2130	States requirements for certification of material organizations and materials to NCA-3861 and NCA-3862, respectively.	The NAC-UMS CANISTER and Basket Assembly component materials are procured in accordance with the specifications for materials in ASME Code Section II with Certified Material Test Reports. The component materials will be obtained from NAC approved Suppliers in accordance with NAC's approved QA program.

B 3.4 Site Specific Parameters and Analyses

Site-specific parameters and analyses that will require verification by the NAC-UMS SYSTEM user are, as a minimum, as follows:

1. The temperature of 76°F is the maximum average yearly temperature. The 3-day average ambient temperature shall be 106°F or less.
2. The allowed temperature extremes, averaged over a 3-day period, shall be greater than -40°F and less than 133°F.
3. The design basis earthquake horizontal and vertical seismic acceleration levels at the top surface of the ISFSI pad are bounded by the values shown:

Horizontal g-level in each of Two Orthogonal Directions	Corresponding Vertical g-level (upward)
0.26g	$0.26 \times 0.667 = 0.173g$

4. The analyzed flood condition of 15 fps water velocity and a height of 50 feet of water (full submergence of the loaded cask) are not exceeded.
5. The potential for fire and explosion shall be addressed, based on site-specific considerations. This includes the condition that the fuel tank of the cask handling equipment used to move the loaded CONCRETE CASK onto or from the ISFSI site contains no more than 50 gallons of fuel.

(continued)

B 3.4 Site Specific Parameters and Analyses (continued)

6. In addition to the requirements of 10 CFR 72.212(b)(2)(ii), the ISFSI pads and foundation shall include the following characteristics as applicable to the end drop and tip-over analyses:

a. Concrete thickness	36 inches maximum
b. Pad subsoil thickness	10 feet minimum
c. Specified concrete design strength	3,000 to 4,000 psi at 28 days
d. Concrete dry density (ρ)	$125 \leq \rho \leq 140$ lbs/ft ³
e. Soil in place density (ρ)	$100 \leq \rho \leq 120$ lbs/ft ³
f. Soil Modulus of Elasticity	$\leq 60,000$ psi (PWR); or $\leq 30,000$ psi (BWR)

The concrete pad maximum thickness excludes the ISFSI pad footer. The compressive strength of the concrete should be determined according to the test method given in Section 5.6 of ACI-318. Steel reinforcement is used in the pad footer. The basis for acceptance of concrete shall be as described in Section 5.6 of ACI-318. The soil modulus of elasticity should be determined according to the test method described in ASTM D4719.

7. In cases where engineered features (i.e., berms, shield walls) are used to ensure that requirements of 10 CFR 72.104(a) are met, such features are to be considered important to safety and must be evaluated to determine the applicable Quality Assurance Category on a site specific basis.
8. TRANSFER CASK OPERATIONS shall only be conducted with surrounding air temperatures $\geq 0^{\circ}\text{F}$.
9. The VERTICAL CONCRETE CASK shall only be lifted by the lifting lugs with surrounding air temperatures $\geq 0^{\circ}\text{F}$.
-

B 3.5 CANISTER HANDLING FACILITY (CHF)

B 3.5.1 TRANSFER CASK and CANISTER Lifting Devices

Movements of the TRANSFER CASK and CANISTER outside of the 10 CFR 50 licensed facilities, when loaded with spent fuel are not permitted unless the movements are made with a CANISTER HANDLING FACILITY designed, operated, fabricated, tested, inspected and maintained in accordance with the guidelines of NUREG-0612, "Control of Heavy Loads at Nuclear Power Plants" and the below clarifications. This Technical Specification does not apply to handling heavy loads under a 10 CFR 50 license.

B 3.5.2 CANISTER HANDLING FACILITY Structure Requirements

B 3.5.2.1 CANISTER Station and Stationary Lifting Devices

1. The weldment structure of the CANISTER HANDLING FACILITY shall be designed to comply with the stress limits of ASME Code, Section III, Subsection NF, Class 3 for linear structures. The applicable loads, load combinations, and associated service condition definitions are provided in Table B3-2. All compression loaded members shall satisfy the buckling criteria of ASME Code, Section III, Subsection NF.
2. If a portion of the CANISTER HANDLING FACILITY structure is constructed of reinforced concrete, then the factored load combinations set forth in ACI-318 (1995) for the loads defined in Table B3-2 shall apply.
3. The TRANSFER CASK and CANISTER lifting device used with the CANISTER HANDLING FACILITY shall be designed, fabricated, operated, tested, inspected and maintained in accordance with NUREG-0612, Section 5.1.

(continued)

B 3.5.2.1 CANISTER HANDLING Station and Stationary Lifting Devices
(continued)

4. The CHF design shall incorporate an impact limiter. The impact limiter must be designed and fabricated to ensure that, if a CANISTER is dropped, the confinement boundary of the CANISTER would not be breached.

B 3.5.2.2 Mobile Lifting Devices

If a mobile lifting device is used as the lifting device, in lieu of a stationary lifting device, it shall meet the guidelines of NUREG-0612, Section 5.1, with the following clarifications:

1. Mobile lifting devices shall have a minimum safety factor of two over the allowable load table for the lifting device in accordance with the guidance of NUREG-0612, Section 5.1.6(1)(a) and shall be capable of stopping and holding the load during a Design Basis Earthquake (DBE) event.
 2. Mobile lifting devices shall conform to the requirements of ANSI B30.5, "Mobile and Locomotive Cranes," in lieu of the requirements of ANSI B30.2, "Overhead and Gantry Cranes."
 3. Mobile cranes are not required to meet the requirements of NUREG-0612, Section 5.1.6(2) for new cranes.
-

Table B3-2 Load Combinations and Service Condition Definitions for the CANISTER HANDLING FACILITY (CHF) Structure

Load Combination	ASME Section III Service Condition for Definition of Allowable Stress	Comment
D*	Level A	All primary load bearing members must satisfy Level A stress limits
D + S		
D + M + W ¹	Level D	Factor of safety against overturning shall be ≥ 1.1
D + F		
D + E		
D + Y		

- D = Dead load
- D* = Apparent dead load
- S = Snow and ice load for the CHF site
- M = Tornado missile load of the CHF site¹
- W¹ = Tornado wind load for the CHF site¹
- F = Flood load for the CHF site
- E = Seismic load for the CHF site
- Y = Tsunami load for the CHF site

Note:

1. Tornado missile load may be reduced or eliminated based on a PRA for the CHF site.

ENCLOSURE 2

Preliminary SER

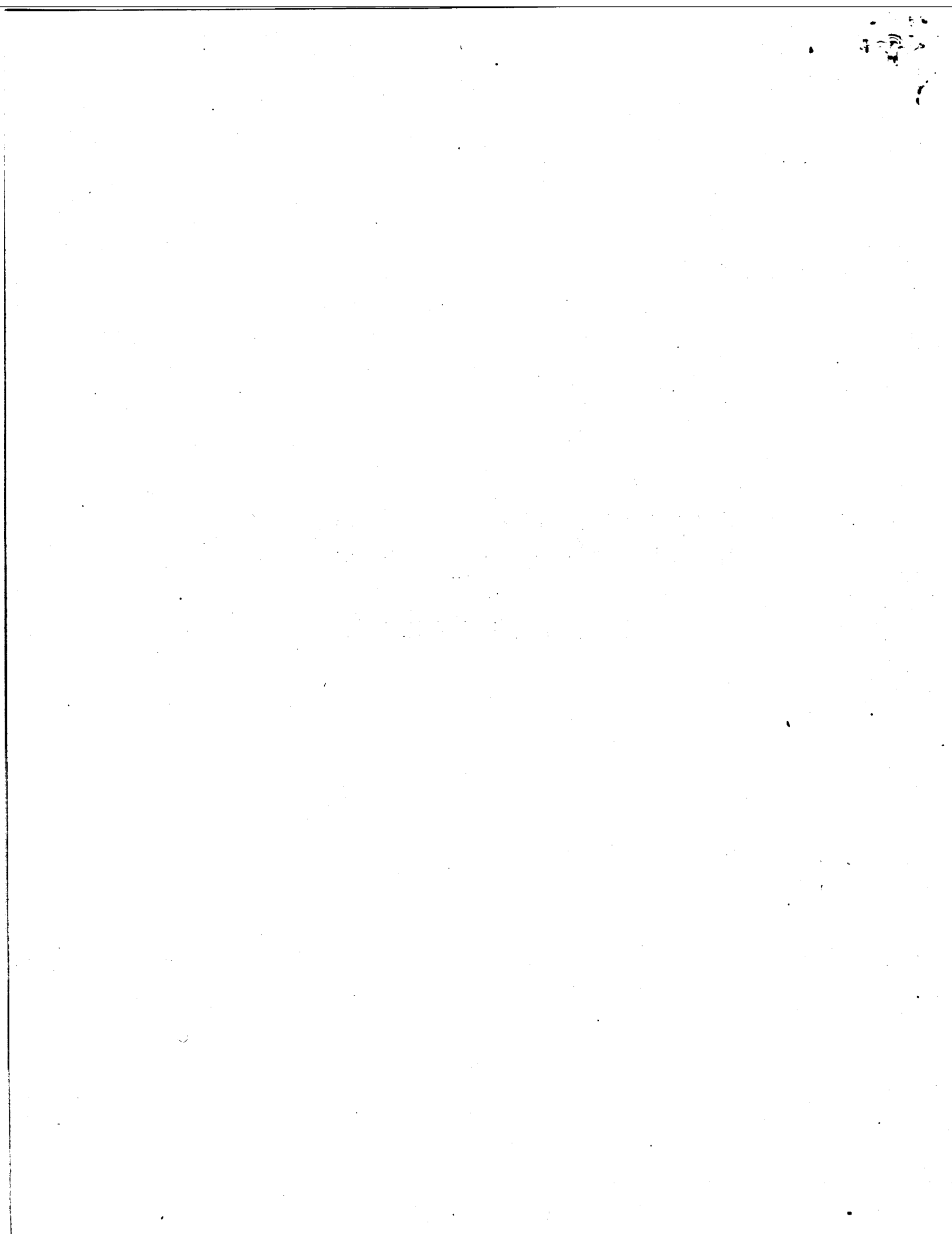

DRAFT

NAC INTERNATIONAL

**NAC UNIVERSAL MULTI-PURPOSE CANISTER
STORAGE (NAC-UMS) SYSTEM**

PRELIMINARY SAFETY EVALUATION REPORT

intentionally left blank

DRAFT

TABLE OF CONTENTS

INTRODUCTION	vii
LIST OF ACRONYMS USED	ix
1.0 GENERAL DESCRIPTION	1-1
1.1 System Description and Operational Features	1-1
1.1.1 Transportable Storage Canisters and Baskets	1-1
1.1.2 Vertical Concrete Cask	1-2
1.1.3 Transfer Cask	1-3
1.1.4 Auxiliary Equipment	1-3
1.1.5 NAC-UMS Cask Arrays	1-4
1.2 Drawings	1-4
1.3 Cask Contents	1-4
1.4 Qualifications of the Applicant	1-4
1.5 Quality Assurance	1-5
1.6 Evaluation Findings	1-5
2.0 PRINCIPAL DESIGN CRITERIA	2-1
2.1 Structures, Systems and Components Important to Safety	2-1
2.2 Design Bases for Structures, Systems and Components Important to Safety ...	2-1
2.2.1 Spent Fuel Specifications	2-1
2.2.2 External Conditions	2-1
2.3 Design Criteria for Safety Protection Systems	2-2
2.3.1 General	2-2
2.3.2 Structural	2-2
2.3.3 Thermal	2-2
2.3.4 Shielding/Confinement/Radiation Protection	2-2
2.3.5 Criticality	2-3
2.3.6 Operating Procedures	2-3
2.3.7 Acceptance Tests and Maintenance	2-3
2.3.8 Decommissioning	2-3
2.4 Evaluation Findings	2-3
3.0 STRUCTURAL EVALUATION	3-1
3.1 Structural Design Features and Design Criteria	3-1
3.1.1 Structural Design Features	3-1
3.1.1.1 Transportable Storage Canister	3-1
3.1.1.2 Vertical Concrete Cask	3-1
3.1.1.3 Transfer Cask	3-2
3.1.2 Structural Design Criteria	3-2
3.1.2.1 Codes and Standards	3-2
3.1.2.2 Site Environmental and Natural Phenomenon Loads	3-2
3.1.2.3 Load Combinations	3-3
3.1.2.4 Stress Allowables	3-4
3.1.3 Weights and Centers of Gravity	3-4

DRAFT

3.1.4	Materials	3-4
3.1.4.1	Structural Materials	3-4
3.1.4.2	Nonstructural Materials	3-5
3.1.4.3	Welds	3-6
3.1.4.4	Bolting Materials	3-7
3.1.4.5	Coatings	3-7
3.1.4.6	Mechanical Properties	3-7
3.1.5	General Standards for Cask	3-8
3.1.6	Supplemental Data	3-8
3.1.6.1	Finite Element Analysis Codes	3-8
3.1.6.2	Finite Element Structural Analysis Models	3-8
3.2	Normal Operating and Design Conditions	3-9
3.2.1	Chemical and Galvanic Reactions	3-9
3.2.2	Positive Closure	3-10
3.2.3	Lifting Devices Analysis	3-10
3.2.3.1	Transfer Cask Lift	3-10
3.2.3.2	Transportable Storage Canister Lift	3-11
3.2.3.3	Storage Cask Bottom Lift	3-11
3.2.3.4	Storage Cask Top Lift	3-12
3.2.4	Hot and Cold Temperature Effects	3-12
3.2.4.1	Internal Pressures and Temperatures	3-12
3.2.4.2	Differential Thermal Expansion	3-13
3.2.4.3	Cold Temperature	3-13
3.2.5	NAC-UMS System Components Structural Analysis	3-13
3.2.5.1	Transportable Storage Canister	3-13
3.2.5.2	Fuel Basket Support Disk	3-14
3.2.5.3	Fuel Basket Top and Bottom Weldments	3-14
3.2.5.4	Fuel Tube	3-14
3.2.5.5	Vertical Concrete Storage Cask	3-14
3.3	Off-Normal Events and Accident Conditions	3-14
3.3.1	Severe Ambient Temperature Conditions	3-15
3.3.2	Canister Off-Normal Handling Load	3-15
3.3.3	Accident Pressurization	3-15
3.3.4	Explosion	3-15
3.3.5	Vertical Concrete Cask 24-Inch Drop	3-16
3.3.5.1	Concrete Cask Analyses	3-16
3.3.5.2	Determination of Canister Deceleration g-Loads	3-16
3.3.5.3	NAC-UMS Canister Components Structural Analysis	3-16
3.3.6	Cask Tipover	3-18
3.3.6.1	Determination of NAC-UMS System Deceleration g-Loads	3-18
3.3.6.2	NAC-UMS Canister Components Structural Analysis	3-19
3.3.7	Fuel Rod Rupture	3-21
3.4	Natural Phenomenon Events	3-21
3.4.1	Flood	3-21
3.4.2	Tornado Wind and Tornado-Driven Missiles	3-21
3.4.3	Earthquake	3-22
3.4.4	Snow and Ice	3-22
3.5	Evaluation Findings	3-22

DRAFT

4.0 Thermal Evaluation	4-1
4.1 Spent Fuel Cladding	4-1
4.2 Cask System Thermal Design	4-2
4.2.1 Design Criteria	4-2
4.2.2 Design Features	4-3
4.3 Thermal Load Specifications	4-3
4.3.1 Normal Storage Conditions	4-4
4.3.2 Off-Normal Conditions	4-4
4.3.3 Accident Conditions	4-4
4.3.4 Transfer Conditions	4-5
4.4 Model Specification	4-5
4.4.1 Configuration	4-5
4.4.1.1 Air Flow and Concrete Cask Model	4-6
4.4.1.2 Canister Model	4-6
4.4.1.3 Two-Dimensional Axisymmetric Transfer Cask Models	4-7
4.4.1.4 Three- Dimensional Periodic Canister Internal Models	4-7
4.4.1.5 Fuel Model	4-8
4.4.1.6 Fuel Tube Model	4-8
4.4.2 Material Properties	4-8
4.4.3 Boundary Conditions	4-9
4.4.3.1 Normal Storage Conditions	4-9
4.4.3.2 Off-Normal Storage Conditions	4-9
4.4.3.3 Accident Conditions	4-9
4.5 Thermal Analysis	4-10
4.5.1 Computer Programs	4-10
4.5.2 Temperature Calculations	4-10
4.5.2.1 Normal Storage Conditions	4-10
4.5.2.2 Off-Normal Conditions	4-12
4.5.2.3 Accident Conditions	4-12
4.5.3 Pressure Analysis	4-13
4.5.3.1 Normal Conditions of Storage	4-13
4.5.3.2 Off-Normal Conditions	4-13
4.5.3.3 Accident Conditions	4-13
4.5.4 Confirmatory Analysis	4-14
4.6 Evaluation Findings	4-15
5.0 SHIELDING EVALUATION	5-1
5.1 Shielding Design Description	5-1
5.1.1 Shielding Design Criteria	5-1
5.1.2 Shielding Design Features	5-1
5.2 Radiation Source Definition	5-2
5.3 Model Specification	5-3
5.4 Shielding Analyses	5-3
5.4.1 Storage Cask	5-4
5.4.2 Transfer Cask	5-4
5.4.3 Off-site Dose Calculations	5-5
5.5 Evaluation Findings	5-6

DRAFT

6.0 CRITICALITY EVALUATION	<u>6-1</u>
6.1 Criticality Design Criteria and Features	<u>6-1</u>
6.2 Fuel Specification	<u>6-3</u>
6.3 Model Specification	<u>6-4</u>
6.3.1 Configuration	<u>6-4</u>
6.3.2 Material Properties	<u>6-5</u>
6.4 Criticality Analysis	<u>6-6</u>
6.4.1 Computer Programs	<u>6-6</u>
6.4.2 Multiplication Factor	<u>6-6</u>
6.4.3 Benchmark Comparisons	<u>6-7</u>
6.5 Supplemental Information	<u>6-7</u>
6.6 Evaluation Findings	<u>6-8</u>
7.0 CONFINEMENT EVALUATION	<u>7-1</u>
7.1 Confinement Design Characteristics	<u>7-2</u>
7.2 Confinement Monitoring Capability	<u>7-3</u>
7.3 Nuclides with Potential for Release	<u>7-3</u>
7.4 Confinement Analysis	<u>7-3</u>
7.5 Supplemental Information	<u>7-4</u>
7.6 Evaluation Findings	<u>7-4</u>
8.0 OPERATING PROCEDURES	<u>8-1</u>
8.1 Cask Loading	<u>8-1</u>
8.1.1 Fuel Specifications	<u>8-1</u>
8.1.2 ALARA	<u>8-1</u>
8.1.3 Draining and Drying	<u>8-2</u>
8.1.4 Welding and Sealing	<u>8-2</u>
8.2 Cask Handling and Storage Operations	<u>8-3</u>
8.3 Cask Unloading	<u>8-3</u>
8.3.1 Cooling Venting & Reflooding	<u>8-3</u>
8.3.2 ALARA	<u>8-4</u>
8.3.2 Fuel Crud	<u>8-4</u>
8.4 Evaluation Findings	<u>8-4</u>
9.0 ACCEPTANCE TESTS AND MAINTENANCE PROGRAM	<u>9-1</u>
9.1 Acceptance Tests	<u>9-1</u>
9.1.1 Visual and Nondestructive Examination Inspections	<u>9-1</u>
9.1.2 Structural/Pressure Tests	<u>9-3</u>
9.1.2.1 Transfer Cask Lifting Trunnions	<u>9-3</u>
9.1.2.2 Vertical Concrete Cask Lifting Lugs	<u>9-3</u>
9.1.2.3 Pneumatic Pressure Testing	<u>9-3</u>
9.1.2.4 Leak Testing	<u>9-4</u>
9.1.3 Shielding Tests	<u>9-4</u>
9.1.4 Neutron Absorber Tests	<u>9-5</u>
9.1.5 Thermal Tests	<u>9-5</u>
9.1.6 Cask Identification	<u>9-5</u>
9.2 Maintenance Program	<u>9-5</u>

DRAFT

9.3 Evaluation Findings	<u>9-6</u>
10.0 RADIATION PROTECTION EVALUATION	<u>10-1</u>
10.1 Radiation Protection Design Criteria and Design Features	<u>10-1</u>
10.1.1 Design Criteria	<u>10-1</u>
10.1.2 Design Features	<u>10-1</u>
10.2 ALARA	<u>10-2</u>
10.3 Occupational Exposures	<u>10-3</u>
10.4 Public Exposures	<u>10-3</u>
10.5 Accident Exposures	<u>10-4</u>
10.6 Evaluation Findings	<u>10-5</u>
11.0 ACCIDENT ANALYSES	<u>11-1</u>
11.1 Off-Normal Events	<u>11-1</u>
11.1.1 Severe Environmental Conditions (106°F and -40°F)	<u>11-1</u>
11.1.2 Blockage of Half of the Air Inlets	<u>11-2</u>
11.1.3 Canister Off-Normal Handling Load	<u>11-2</u>
11.1.4 Failure of Instrumentation	<u>11-2</u>
11.1.5 Small Release of Radioactive Particulate - Canister Exterior	<u>11-2</u>
11.2 Accident and Natural Phenomenon Events	<u>11-2</u>
11.2.1 Accident Pressurization	<u>11-3</u>
11.2.1.1 Cause of Accident Pressurization	<u>11-3</u>
11.2.1.2 Consequences of Accident Pressurization	<u>11-3</u>
11.2.2 Failure of All Fuel Rods With a Subsequent Canister Breach	<u>11-3</u>
11.2.3 Fresh Fuel Loading in the Canister	<u>11-4</u>
11.2.3.1 Cause of Fresh Fuel Loading in the Canister	<u>11-4</u>
11.2.3.2 Consequences of Fresh Fuel Loading in the Canister	<u>11-4</u>
11.2.4 24-Inch Drop of Vertical Concrete Cask	<u>11-4</u>
11.2.4.1 Cause of 24-Inch Drop of Vertical Concrete Cask	<u>11-4</u>
11.2.4.2 Consequences of 24-Inch Drop of Vertical Concrete Cask	<u>11-4</u>
11.2.5 Explosion	<u>11-5</u>
11.2.5.1 Cause of Explosion	<u>11-5</u>
11.2.5.2 Consequences of Explosion	<u>11-5</u>
11.2.6 Fire Accident	<u>11-5</u>
11.2.6.1 Cause of Fire Accident	<u>11-5</u>
11.2.6.2 Consequences of Fire Accident	<u>11-5</u>
11.2.7 Maximum Anticipated Heat Load (133°F Ambient Temperature)	<u>11-6</u>
11.2.7.1 Cause of Maximum Anticipated Heat Load	<u>11-6</u>
11.2.7.2 Consequences of Maximum Anticipated Heat Load	<u>11-6</u>
11.2.8 Earthquake	<u>11-6</u>
11.2.8.1 Cause of Earthquake Event	<u>11-6</u>
11.2.8.2 Consequences of Earthquake Event	<u>11-6</u>
11.2.9 Flood	<u>11-6</u>
11.2.9.1 Cause of Flood	<u>11-6</u>
11.2.9.2 Consequences of Flood	<u>11-6</u>
11.2.10 Lightning	<u>11-7</u>
11.2.10.1 Cause of Lightning	<u>11-7</u>
11.2.10.2 Consequences of Lightning	<u>11-7</u>

DRAFT

INTRODUCTION

This Safety Evaluation Report (SER) documents the review and evaluation of Revision 1 to the Safety Analysis Report (SAR) for the NAC International (NAC) Universal Multi-Purpose Canister Storage (UMS) system. The SAR was submitted by NAC following the format of Regulatory Guide 3.61. This SER primarily uses the Section-level format of NUREG-1536, Standard Review Plan for Dry Cask Storage Systems, with some differences implemented for clarity and consistency.

The review of the SAR addresses the handling and dry storage of spent fuel in a single dry storage cask design, the NAC-UMS. The cask may be used at an Independent Spent Fuel Storage Installation (ISFSI) licensed under Subpart K of 10 CFR Part 72 for a 10 CFR Part 50 licensee.

The staff's assessment is based on whether the applicant meets the applicable requirements of 10 CFR Part 72 for independent storage of spent fuel and of 10 CFR Part 20 for radiation protection. Decommissioning, to the extent that it is treated in the SAR, presumes that, as a bounding case, the NAC-UMS cask is unloaded and decontaminated as necessary before disposition or disposal.

While components of the NAC-UMS system are designed to be used in conjunction with the NAC-UMS transport cask for a dual-purpose function, the use or certification of the NAC-UMS transport cask under 10 CFR Part 71 for the off-site transport of the spent fuel contents is not a subject of this SER. Certification for transportation of the spent fuel contents occurs upon the completion of a separate staff review for a NAC-UMS transport cask 10 CFR Part 71 Certificate of Compliance (CoC) for transportation.

DRAFT

intentionally left blank

DRAFT

LIST OF ACRONYMS USED

ACI	American Concrete Institute
ALARA	As Low As Is Reasonably Achievable
ANS	American Nuclear Society
ANSI	American National Standards Institute
ASCE	American Society of Civil Engineers
ASME	American Society of Mechanical Engineers
ASTM	American Society for Testing and Materials
AWS	American Welding Society
BWR	Boiling Water Reactor
CoC	Certificate of Compliance
DBE	Design Basis Earthquake
DCSS	Dry Cask Storage System
DLF	Dynamic Load Factor
ISFSI	Independent Spent Fuel Storage Installation
ISG	Interim Staff Guidance
kW	Kilowatts
MPC	Multi-Purpose Canister
MT	Magnetic Particle Examination
NAC	NAC International, Inc.
NDE	Nondestructive Examination
NRC	Nuclear Regulatory Commission
PNL	Pacific Northwest Laboratory

DRAFT

PT	Liquid Penetrant Examination
PWR	Pressurized Water Reactor
QA	Quality Assurance
RT	Radiographic Examination
SAR	Safety Analysis Report
SER	Safety Evaluation Report
SRSS	Square-Root-of-Sum-of-the-Squares
SSCs	Structures, Systems and Components
STC	Storage Transport Cask
TS	Technical Specifications
TSC	Transportable Storage Canister
UT	Ultrasonic Examination
VCC	Vertical Concrete Cask
VT	Visual Examination

DRAFT

1.0 GENERAL DESCRIPTION

The objective of the review of the general description of the NAC- Universal Multi-Purpose Canister Storage (UMS) system is to ensure that NAC International Inc. (NAC) has provided a non-proprietary description that is adequate to familiarize reviewers and other interested parties with the pertinent features of the system.

1.1 System Description and Operational Features

The NAC-UMS system is a transport compatible dry storage system that uses a stainless steel transportable storage canister (TSC) stored within the central cavity of a vertical concrete cask (VCC). The TSC is designed to be compatible with the NAC-UMS transport cask to allow future shipment. The VCC provides radiation shielding and contains internal air flow paths that allow decay heat from the TSC spent fuel contents to be removed by natural air circulation around the canister wall.

The principal components of the NAC-UMS system are the TSC, the VCC, and the transfer cask. The transfer cask is used to move the loaded TSC to and from the VCC and provides radiation shielding while the TSC is being closed and sealed. The TSC is placed in the VCC by positioning the transfer cask on top of the VCC and subsequently lowering the TSC. Each NAC-UMS system component is assigned a safety classification (Category A, B, or C) in Table 2.3-1 of the Safety Analysis Report (SAR). The component safety classification is based on NUREG/CR-6407, "Classification of Transportation Packaging and Dry Spent Fuel Storage System Components According to Importance to Safety."

The NAC-UMS is designed to store up to 24 Pressurized Water Reactor (PWR) or up to 56 Boiling Water Reactor (BWR) spent fuel assemblies. Based on the length of the fuel assemblies, PWR fuels are grouped into three classes (Classes 1 through 3), and BWR fuels are grouped into two classes (Classes 4 and 5). Class 1 and 2 PWR fuel assemblies include non-fuel-bearing inserts (components which include thimble plugs and burnable poison rods installed in the guide tubes). Class 4 and 5 BWR assemblies include the Zircaloy channels. The spent fuel is loaded into a TSC which contains a stainless steel gridwork referred to as a basket.

1.1.1 Transportable Storage Canisters and Baskets

There are 5 TSCs of different lengths, each to accommodate a different class of PWR or BWR fuel assembly. Each TSC has an outside diameter of about 67 inches and the lengths vary from about 175- to 192-inches long. The maximum weight of a loaded PWR TSC is slightly less than 73,000 lbs. The maximum weight of a loaded BWR TSC is slightly less than 76,000 lbs. The TSC assembly consists of a right circular cylindrical shell with a welded bottom plate, a fuel basket, a shield lid, two penetration port covers, and a structural lid. The cylindrical shell, plus the bottom plate and welded lids, constitutes the confinement boundary.

The TSC assembly is designed to facilitate filling with water and subsequent draining and drying. Vent and drain ports through the shield lid allow the inner cavity to be drained, evacuated, and backfilled with helium to provide an inert atmosphere for long-term storage.

DRAFT

After draining, drying, backfilling, and testing operations are completed, port covers are installed and welded to the shield lid to seal the penetration. The designs of the shield and structural lids provide a redundant confinement seal at the top of the canister.

PWR Baskets

The stainless steel PWR fuel basket is a right circular cylinder configuration with 24 stainless steel fuel tubes for PWR contents. The fuel tubes are laterally supported by a series of up to 34 half-inch thick stainless steel support disks (depending on the length of the TSC), which are retained by spacers on 8 radially located stainless steel tie rods. The square fuel tubes are encased with Boral sheets on all four sides for criticality control. Aluminum heat transfer disks are spaced midway between the support disks and are the primary path for conducting heat from the spent fuel assemblies to the TSC wall.

BWR Baskets

The stainless steel BWR fuel basket is a right circular cylinder configuration with 56 stainless steel fuel tubes for BWR contents. The fuel tubes are laterally supported by a series of up to 41 5/8-inch-thick carbon steel support disks (depending on the length of the TSC), which are retained by spacers on 6 radially located tie rods. The carbon steel support disks are coated with electroless nickel. Three types of square fuel tubes are provided for criticality control: (1) Boral sheets on two sides, (2) Boral sheets on one side, and (3) no Boral sheets. Aluminum heat transfer disks are spaced midway between the support disks and are the primary path for conducting heat from the spent fuel assemblies to the TSC wall.

1.1.2 Vertical Concrete Cask

The VCC is the storage overpack for the TSC. Five concrete casks of different heights, ranging from about 209 to 226 inches, are each designed to accommodate a different TSC. Each VCC design has an outside diameter of about 136 inches. The five VCC's vary in weight between 221,000 and 238,000 lbs. The VCC side walls consist of about 28 inches of reinforced concrete (Type II Portland cement), with a 2.5-inch carbon steel liner. It provides structural support, shielding, protection from environmental conditions, and natural convection cooling of the TSC during long-term storage. The VCC has an annular air passage to allow the natural circulation of air around the TSC. The air inlet and outlets take non-planar paths to the VCC cavity to minimize radiation streaming. The spent fuel decay heat is transferred from the fuel assemblies to the tubes in the fuel basket and through the heat transfer disks to the TSC wall. Heat flows by radiation and convection from the TSC wall to the circulating air and is exhausted through the air outlets. The passive cooling system is designed to maintain acceptable reinforced concrete and peak cladding temperatures for the authorized fuel types during storage.

The top of the VCC is closed by an approximately 5-inch thick shield plug consisting of carbon steel plate (gamma shielding), NS-4-FR (neutron shielding), and a carbon steel lid. The lid is bolted in place and has tamper indicating seals on two of the bolts.

DRAFT

1.1.3 Transfer Cask

The transfer cask provides shielding during TSC movements between work stations, the VCC, or the NAC-UMS transport cask. Five transfer casks of different lengths are designed to handle the five TSC's of different lengths. The transfer cask is a multi-wall (steel/lead/NS-4-FR/steel) design, each with about an 85-inch outer diameter. The five transfer casks range in height between about 177 and 194 inches, and in empty weight from about 112,000 to 121,000 lbs. The transfer cask has a bolted top retaining ring to prevent a loaded canister from being inadvertently removed through the top of the transfer cask. Retractable (hydraulically operated) bottom shield doors on the transfer cask are used during unloading operations.

The transfer cask has eight supply and two discharge lines passing through its wall. Two of the lines are used to circulate clean water in the gap between the transfer cask and the TSC during spent fuel pool loading operations to minimize contamination of the transfer cask and TSC. The eight lines can also be used for the introduction of forced air at the bottom of the transfer cask to achieve cooling of the canister contents. This allows the canister to remain in the transfer cask for a longer period, if necessary, during canister closing operations, and also supports the use of the transfer cask in the event that a canister must be removed from a concrete cask.

A transfer cask extension is also designed to be used to extend the operational height of a transfer cask. This height extension allows a transfer cask designed for a specific canister class to be used with the next longer canister, and thus accommodates the increase in overall height of a standard fuel assembly resulting from the insertion of a control element assembly. The extension is a carbon steel ring that is bolted to the top of the transfer cask.

1.1.4 Auxiliary Equipment

Section 1.2.1.5 of the SAR describes the following principal auxiliary equipment necessary to operate the NAC-UMS system in accordance with its design:

- Adapter Plate - mates the transfer cask to the VCC or the NAC-UMS transport cask.
- Air Pad Rig Set - allows movement of the VCC on the storage pad.
- Automatic Welding System - minimizes radiation exposure during TSC closure welding.
- Draining and Drying System - used to remove moisture and establish a TSC vacuum.
- Helium Leak Test Equipment - mass spectrometer to verify the integrity of the shield lid weld.
- Heavy Haul Trailer - used to move the VCC.
- Lifting Jacks - used to lift the VCC to insert/remove the Air Pad Rig Set.
- Riggings and Slings - provided for major components such as shield and structural lids and the transfer cask.
- Temperature Instrumentation - located at VCC outlets for local and/or remote temperature indications and compared with the ambient temperature to verify performance of the cask heat removal system.

DRAFT

1.1.5 NAC-UMS Cask Arrays

Section 1.4 of the SAR describes and depicts a typical storage pad layout for an Independent Spent Fuel Storage Installation (ISFSI). Spacing limitations on cask arrays (15 feet minimum) are specified in Section 8.1.3 of the Operating Procedures. Technical Specification (TS) 3.2.2 controls the maximum allowable average surface dose rates for any individual cask.

1.2 Drawings

The drawings associated with the NAC-UMS structures, systems, and components (SSCs) important to safety are provided in Section 1.8 of the SAR. Sufficiently detailed drawings regarding dimensions, materials, and specifications were provided by the applicant and allow a thorough evaluation of the entire system. Specific SSCs are evaluated in Sections 3 through 14 of this SER.

1.3 Cask Contents

The approved contents for the NAC-UMS are: (1) up to 24 intact Zircaloy-clad PWR spent fuel assemblies with a maximum initial enrichment of 4.2 wt% ^{235}U , or (2) up to 56 intact Zircaloy-clad BWR spent fuel assemblies with a maximum initial peak planar-average enrichment of 4.0 wt% ^{235}U . Unenriched PWR or BWR spent fuel assemblies were not evaluated by the applicant and are not allowed as approved contents. The enrichment and physical, thermal, and radiological characteristics of the approved contents are given in the TS. The TS also provide definitions for intact fuel rods and assemblies.

If all spent PWR or BWR fuel assemblies to be loaded in a given TSC have cooling times greater than 7 years, they can be loaded in any basket position. However, any spent PWR or BWR fuel assemblies with cooling times between 5 and 7 years must be preferentially loaded and administratively controlled as described in Appendix B of the TS. Preferential loading provisions are based on cooling times to ensure that the allowable cladding temperature for a given intact BWR or PWR spent fuel assembly is not exceeded.

Intact PWR assemblies shall not contain control components but Class 1 and Class 2 PWR assemblies may contain non-fuel-bearing inserts (thimble plugs and burnable poison rods installed in the guide tubes). Stainless steel spacers may be used in TSCs to axially position intact PWR assemblies that are shorter than the available cavity length.

Intact BWR assemblies can be stored with or without the Zircaloy fuel channels. Intact BWR assemblies with stainless steel fuel channels are not authorized for storage. Stainless steel spacers may be used in TSCs to axially position intact BWR assemblies that are shorter than the available cavity length.

1.4 Qualifications of the Applicant

NAC is the prime contractor for the NAC-UMS design, and all design and specification activities are performed by NAC. Fabrication of steel and concrete components are specified to be performed by qualified vendors and in accordance with quality assurance (QA) programs

DRAFT

meeting the requirements of 10 CFR Parts 71 and 72. Section 1.6 of the SAR adequately details NAC's technical qualifications and previous experience in the area of dry cask storage licensing.

1.5 Quality Assurance

The QA program is evaluated in Section 13 of this SER.

1.6 Evaluation Findings

- F1.1** A general description and discussion of the NAC-UMS system is presented in Section 1 of the SAR, with special attention to design and operating characteristics, unusual or novel design features, and principal safety considerations.
- F1.2** Drawings for SSCs important to safety are presented in Section 1.8 of the SAR. Specific SSCs are evaluated in Sections 3 through 14 of this SER.
- F1.3** Specifications for the spent fuel to be stored in the dry cask storage system (DCSS) are provided in SAR Sections 1.3 and 2.1. Additional details concerning these specifications are presented in Section 2 of the SAR and in Appendix B of the CoC.
- F1.4** The technical qualifications of the applicant to engage in the proposed activities are identified in Section 1.6 of the SAR and are acceptable to the Nuclear Regulatory Commission (NRC) staff.
- F1.5** The QA program is described in Section 13 of the SAR and is evaluated in Section 13 of this SER.
- F1.6** The NAC-UMS transport cask system was not reviewed in this SER for use as a transportation cask.
- F1.7** The staff concludes that the information presented in this Section of the SAR satisfies the requirements for the general description under 10 CFR Part 72. This finding is based on a review that considered the regulation itself, Regulatory Guide 3.61, and accepted dry cask storage practices detailed in NUREG-1536.

intentionally left blank

DRAFT

2.0 PRINCIPAL DESIGN CRITERIA

The objective of evaluating the principal design criteria related to SSCs important to safety is to ensure that they comply with the relevant general criteria established in 10 CFR Part 72.

2.1 Structures, Systems and Components Important to Safety

A summary of the principal NAC-UMS system design criteria is presented in Table 2-1 of the SAR. Each NAC-UMS system component is assigned, in Table 2.3-1 of the SAR, a safety classification based on the component's function and an assessment of the consequences of component failure. The component safety classifications are based on the guidance in NUREG/CR-6407, "Classification of Transportation Packaging and Dry Spent Fuel Storage System Components According to Importance to Safety."

2.2 Design Bases for Structures, Systems and Components Important to Safety

The NAC-UMS system design bases summary identified the range of spent fuel configurations and characteristics, the enveloping conditions of use, and the bounding site characteristics.

2.2.1 Spent Fuel Specifications

The NAC-UMS is designed to store up to 24 intact PWR or 56 intact BWR spent fuel assemblies. Tables 2.1.1-1 through -3 and 2.1.2-1 through -3 of the SAR provide detailed fuel assembly characteristics for the authorized PWR and BWR contents, respectively. These characteristics include: manufacturer, assembly array, physical assembly dimensions, maximum and minimum enrichments, maximum burnup, minimum cool time, maximum decay heat, and maximum initial uranium mass per assembly.

SAR Sections 2.1.1 and 2.1.2 specify the bounding fuel types for the criticality and shielding evaluations and provide the design bases maximum decay heat load. The enrichments, burnups, decay heat rates, and cooling times vary for the different fuel types, based on the bounding shielding and thermal evaluations, and are specified in the TS. Sections 3 through 14 of this SER evaluate the bounding fuel types.

2.2.2 External Conditions

SAR Section 2.2 identifies the bounding site environmental conditions and natural phenomena for which the storage system is analyzed during the period of storage. These are evaluated in Sections 3 through 14 of this SER.

SAR Sections 2 and 11 identify the normal, off-normal, and accident conditions for which the NAC-UMS design has been evaluated. The staff's evaluation of the system's response to off-normal and accident conditions is located in Section 11 of this SER. The TS, in Section 3 of Appendix B, identifies the site-specific parameters and analyses that are required to be verified by the NAC-UMS system users.

DRAFT

2.3 Design Criteria for Safety Protection Systems

The principal design criteria for the TSC, VCC, and the transfer cask are summarized in SAR Tables 2-1 and 2.2-3.

2.3.1 General

SAR Section 2 states that the design life of the NAC-UMS system is 50 years. The adequacy of the TSC, VCC, and transfer cask for this design life is discussed in SAR Section 3. The system is approved for a 20-year storage period.

2.3.2 Structural

The structural analysis is presented in SAR Section 3. The NAC-UMS system components are designed to protect the cask contents from significant structural degradation, preserve retrievability, provide adequate shielding, and maintain subcriticality and confinement under the design basis normal, off-normal, and accident loads. The design bases normal, off-normal, and accident conditions are defined in SAR Section 2.2. The load combinations for the TSC and VCC and the design strength criteria for the transfer cask are defined in SAR Section 2.2.5.

2.3.3 Thermal

The passive heat removal capabilities of the NAC-UMS and the thermal analysis are presented in SAR Section 4. Heat removal from the TSC surface, by radiation and convection, is independent of intervening actions under normal and off-normal conditions. The thermal design criteria include maintaining fuel cladding integrity, maintaining stresses of structural components (including thermally induced stresses) below allowable material stress levels, and ensuring that temperatures of materials and components important to safety are within the design limits. Operating limits and verifications are established in the TS to ensure continued safe operation. A remote temperature monitoring system is used to measure the outlet air temperature of the system during long-term storage. The outlet temperature is recorded daily to check the thermal performance of the cask.

2.3.4 Shielding/Confinement/Radiation Protection

The shielding, confinement, and radiation protection capabilities of the NAC-UMS system are presented in SAR Sections 5, 7, and 10. The shielding associated with the system design meets the requirements of 10 CFR 72.104 and 72.106 for normal and accident conditions, respectively. Confinement is provided by the TSC, which has a welded closure. The confinement provided by the TSC is verified through pressure testing, helium leak testing, and weld examinations. Radiation exposure is minimized by the neutron and gamma shields and operational procedures.

2.3.5 Criticality

The criticality analysis is presented in SAR Section 6. The design criterion for criticality safety is that the effective neutron multiplication factor, including statistical biases and uncertainties, does not exceed 0.95 under normal, off-normal, and accident conditions. The design features relied upon to prevent criticality are the fuel basket geometry and permanent neutron poison sheets (Boral) attached to the fuel tubes in the PWR and BWR basket designs. The continued efficacy of the Boral over a 20-year storage period is assured by the system design. Depletion of the ^{10}B in the Boral is negligible because the neutron flux in the TSC is low over the storage period.

2.3.6 Operating Procedures

Generic operating procedures are described in SAR Section 8. This section outlines loading, unloading, and recovery operations and provides the basis and general guidance for more detailed, site-specific procedures.

2.3.7 Acceptance Tests and Maintenance

The acceptance tests and maintenance of the NAC-UMS system are presented in SAR Section 9, including the commitments, industry standards, and regulatory requirements used to establish the acceptance, maintenance, and periodic surveillance tests.

2.3.8 Decommissioning

Decommissioning considerations for the NAC-UMS system are presented in SAR Section 2.4 and evaluated in Section 14 of this SER.

2.4 Evaluation Findings

F2.1 The staff concludes that the principal design criteria for the NAC-UMS system are acceptable with regard to demonstrating compliance with the regulatory requirements of 10 CFR Part 72. This finding is based on a review that considered the regulation itself, appropriate regulatory guides, applicable codes and standards, and accepted engineering practices. More detailed evaluations of design criteria and assessments of compliance with those criteria are presented in Sections 3 through 14 of this SER.

intentionally left blank

DRAFT

3.0 STRUCTURAL EVALUATION

This section evaluates the structural designs of the NAC-UMS system. Structural design features and design criteria are reviewed, and analyses related to structural performance under normal, off-normal, accident, and natural phenomena events are evaluated.

3.1 Structural Design Features and Design Criteria

3.1.1 Structural Design Features

Section 1 of this SER provides a general description of the NAC-UMS system consisting of three principal components: (1) the TSC (canister), (2) the VCC (cask) and, (3) the transfer cask. Based on the length of fuel assemblies, the system is configured to store three classes of PWR spent fuel assemblies and two classes of BWR fuel assemblies. The major structural design features of these components are as follows.

3.1.1.1 Transportable Storage Canister

The TSC assembly features a circular cylindrical shell with a welded bottom plate, a fuel basket, a shield lid, two penetration port covers, and a structural lid. SAR Table 1.2-2 lists the major physical design parameters of the five TSC configurations, including a common outside diameter of about 67 inches, and an overall length ranging between about 175 to 192 inches.

The fuel basket is an assembly of fuel tubes laterally supported by stainless steel disks which, in turn, are axially retained by spacers aligned on either eight (for PWR baskets) or six (for BWR baskets) radially located tie rods. A top weldment and a bottom weldment are attached to the basket ends to support and position the fuel tubes. Type 304 (18 gage) stainless steel sheets are used to construct the fuel tubes. Boral plates are attached to some of the tube surfaces, to provide criticality safety.

Aluminum heat transfer disks, spaced midway between the support disks, are provided to facilitate heat conduction from the fuel assemblies to the TSC wall. Holes in the heat transfer disk are sized to allow the fuel tubes and tie rods to pass through, thus the heat transfer disks are not load bearing members for any structural loads other than their own dead weight.

SAR Table 1.2-4 lists the major physical design parameters of the five fuel basket configurations, including a common assembly diameter of 65.5 inches, the number of support disks and heat transfer disks for each fuel basket class, and an overall basket length ranging from about 163 to 180 inches. The baskets are equipped with 24 fuel tubes for PWR fuel assemblies and 56 for BWR fuel assemblies.

3.1.1.2 Vertical Concrete Cask

The VCC is a storage overpack of reinforced concrete cylindrical wall construction with a heavy structural steel inner liner. It is closed at the top by a shield plug. In addition to providing shielding, the concrete wall serves as a structural protective barrier for the TSC and its contents in natural phenomenon events, such as tornado winds and tornado driven missiles. SAR Table

DRAFT

1.2-5 lists major physical design parameters of the five VCC configurations, including a common outside diameter of 136 inches, concrete thickness of about 28 inches, an inner steel liner thickness of 2.5 inches, and an overall height ranging from about 209 to 226 inches.

3.1.1.3 Transfer Cask

The transfer cask is a multi-wall circular cylindrical construction for loading the TSC into the VCC. It is equipped with a set of retractable shield doors at the cask bottom and four lifting trunnions at the top. The transfer cask incorporates a bolted-in-place retaining ring to prevent a loaded TSC from being inadvertently removed out of the top of the transfer cask. SAR Table 1.2-7 lists the major physical design parameters of the five transfer cask configurations, including common inside and outside diameters of about 68 and 85 inches, respectively, and a cavity height ranging from about 177 to 194 inches.

The transfer cask extension is a low alloy steel ring designed to be bolted to the transfer cask, which allows the option of using a transfer cask designed for a specific TSC configuration to be used with the next longer TSC.

3.1.2 Structural Design Criteria

SAR Sections 2.2 and 3.1.2 summarize the structural design criteria for the NAC-UMS system. The criteria define, in general, the applicable codes and standards, individual loads as related to environmental conditions and natural phenomenon events, load combinations, and stress allowables for normal, off-normal, and accident-level conditions. As evaluated below, the structural design criteria are consistent with those of NUREG-1536 and are acceptable.

3.1.2.1 Codes and Standards

The TSC, as a confinement boundary, is designed per American Society of Mechanical Engineers (ASME) Code, Section III, Subsection NB. The fuel basket component stresses are evaluated in accordance with ASME Code, Section III, Subsection NG and for buckling with NUREG/CR-6322. American National Standards Institute (ANSI) N14.6 and NUREG-0612 are used for evaluating the transfer cask lifting trunnions and bottom shield door assembly. ANSI/American Nuclear Society (ANS) 57.9 or equivalent is considered for evaluating other transfer cask components, including the transfer cask extension and the retaining ring and their fastening bolts. The reinforced concrete of the VCC is designed and constructed to the respective American Concrete Institute (ACI) 349 and 318 requirements.

The use of the codes and standards for the NAC-UMS system is consistent with the guidance in NUREG-1536 and is acceptable.

3.1.2.2 Site Environmental and Natural Phenomenon Loads

The SAR defines the pressure, temperature, and mechanical loads typically associated with operating the NAC-UMS system under normal and off-normal conditions for the components structural evaluation. In the following text, the staff reviews the bases for the environmental and natural phenomenon loads that are considered as general license site parameters.

DRAFT

Tornado Wind and Tornado-Driven Missiles. SAR Section 2.2-1 presents the tornado wind characteristics. The design basis tornado wind loadings are in accordance with the Regulatory Guide 1.76, Region I, tornado with a maximum rotational wind speed of 290 mph and translational speed of 70 mph for a maximum combined speed of 360 mph.

SAR Section 2.2.1.3 lists three types of tornado-generated missiles that could impact the cask at normal incidence. In NUREG-0800, Section 3.5.1.4, Spectrum I, the three design basis missiles are: (1) a massive deformable missile of 3960 lbs, (2) a penetration missile of 275 lbs, and (3) a protective barrier missile of a 1-inch diameter solid steel sphere. The SAR assumes that all missiles are to impact the VCC horizontally at a speed of 126 mph per hour, which is 35% of the maximum combined speed of 360 mph. For missile impact in the vertical direction, the SAR assumes a missile speed of 88.2 miles per hour, which is 70% of the speed of a horizontal missile. These missile speeds are consistent with the NUREG-0800, Section 3.5.1.4, guidance.

Flood. SAR Section 2.2.2.1 considers a maximum allowable flood water velocity and a maximum allowable flood water depth for evaluating the NAC-UMS system. For a flood water depth of 50 feet above the base of the VCC, SAR Section 11.2.9 calculates a hydrostatic pressure of 22 psig to be exerted on the TSC and VCC. At a water velocity of 15 feet per second, the SAR calculates a drag force of 32,810 lbs for use in a bounding stability analysis against sliding and tipover. The hydrostatic pressure and drag force effects, as presented in SAR Section 11.2.9, are reviewed in SER Section 3.4.1.

Earthquake. SAR Section 2.2.3.1 defines earthquake motions at the top surface of the ISFSI pad for the NAC-UMS system. In the SAR Section 11.2.8 earthquake stability evaluation against cask tipover and sliding, the peak acceleration corresponding to the design basis earthquake motion is assumed to be 0.26 g for each of the two horizontal components and 0.173 g for the vertical component of the earthquake motion.

Snow and Ice. SAR Section 2.2.4 considers the ANSI/American Society of Civil Engineers (ASCE) 7-93 snow load criteria. On the basis of the exposure, thermal, and importance factors, a design snow and ice load of 100.8 psf is established for the VCC. The effect of this snow load is bounded by that of applying the weight of the loaded transfer cask to the top of the VCC, and is acceptable. As a result, no additional staff evaluation of the VCC is necessary.

3.1.2.3 Load Combinations

SAR Section 2.2.5 describes the load cases for evaluating the combined load effects on the structural performance of the NAC-UMS system. SAR Table 2.2-2 lists the load combinations for the TSC. In addition to the environmental conditions and natural phenomenon events, the loads considered include the dead weight, live load, thermal effects, internal pressure, handling load, and cask drop and tipover accident loads. SAR Table 2.2-1 summarizes the load combinations for the VCC designed by the factored load method, per ACI 349. The criteria are consistent with ANSI/ANS 57.9 and are acceptable.

DRAFT

3.1.2.4 Stress Allowables

SAR Table 2.2-3 lists structural evaluation criteria for the TSC components. The stress allowables are based on ASME Code, Section III, Subsections NB and NG. The stress design factors for the lifting devices are in accordance with ANSI N14.6 and NUREG-0612. The basket component buckling criteria are per NUREG/CR-6322.

SAR Section 2.2.5.1 considers concrete strength reduction factors, in accordance with ACI 349, for the VCC evaluation. SAR Section 2.2.5.3 considers ANSI N14.6 and NUREG-0612 for the lifting trunnions and bottom shield door assembly. The balance of the transfer cask is evaluated per ANSI/ANS 57.9. The stresses in the trunnions, in a non-redundant, two-trunnion lifting configuration, are evaluated for six times and ten times the weight of a fully loaded transfer cask for the respective yielding and ultimate material strengths.

3.1.3 Weights and Centers of Gravity

SAR Tables 3.2.1 and 3.2.2 list the calculated weights and centers of gravity of the major components and total system for the three PWR and two BWR configurations of the NAC-UMS storage design, respectively. For each configuration, the center of gravity locations are identified along the cask vertical axis. For the transfer cask, the heaviest loaded configuration at 207,616 lbs is enveloped by the weight of 210,000 lbs used for the lifting evaluation. The total weights of the loaded VCCs and their center of gravity locations provide the basis for selecting the VCC configurations with the least resistance to sliding and overturning for evaluating cask stability under accident-level conditions.

3.1.4 Materials

The applicant provided a general description of the materials of construction in SAR Sections 1.2 and 3.1. Additional information regarding the materials, fabrication details, and testing programs can be found in SAR Sections 7.1, 9.1, and 12.0. The staff reviewed the information contained in these sections and the information presented in the drawings to determine whether the NAC-UMS system meets the requirements of 10 CFR 72.24(c)(3) and (4); 72.122(a), (b), (c), (h), and (l); and 72.236(g) and (h). In particular, the following aspects were reviewed: materials selection, applicable codes and standards, weld design and specification, bolt fabrication and preparation, chemical and galvanic reactions, coatings, and long-term cask performance issues, such as delayed cracking, brittle failure, cladding creep, corrosion, lead slumping, changes in toughness, and thermal aging.

3.1.4.1 Structural Materials

Most of the structural components of the TSC (e.g., shell, bottom plate, shield lid, structural lid, basket fuel tubes, etc.) are fabricated from Types 304 or 304L austenitic stainless steel. These types of steels were selected because of their high strength, ductility, resistance to corrosion and metallurgical stability. Because there is no ductile-to-brittle transition temperature in the range of temperatures expected to be encountered prior to or during storage, the susceptibility of Types 304 and 304L stainless steel to brittle fracture is negligible. The support disks of the TSC baskets used to store PWR fuel are fabricated from Type 630 (H1150) precipitate-

DRAFT

hardened steel. This type of steel is heat treated to produce higher strengths (e.g., yield and ultimate tensile strengths) than those of Type 304 steel without a significant loss of corrosion resistance. The ductile-to-brittle transition temperature of Type 630 steel is below the expected operating temperatures, so brittle fracture of this material is also not expected. The support disks of the TSC baskets used to store BWR fuel are fabricated from ASME SA 533, Type B, carbon steel. To demonstrate that this material has adequate toughness at -40 degrees Fahrenheit (°F), Charpy impact testing will be performed on each plate of material in accordance with ASME Code Section III, Subsection NG-2320. The acceptance criteria for the impact test is a minimum average value (as defined in ASTM A 370) of 20 mils (e.g., 0.020 inch) lateral expansion at the lowest service temperature of -40 °F. This impact acceptance criteria is acceptable based on the requirements of ASME Code Section III, Subsection NG-2331, i.e., for components having a thickness of greater than 5/8 inch to 3/4 inch, the minimum lateral expansion is 20 mils. An electroless nickel coating is applied to the surfaces of these support disks to protect the carbon steel from corrosion prior to, and during, immersion in the spent fuel pool. Brittle fracture of the carbon steel is not expected since the ductile-to-brittle transition temperature is below the expected operating temperatures. Table 1.2-3 of the SAR provides a summary of the fabrication specifications for the TSC including welding, fabrications, packaging, and QA requirements. The staff concludes that the selection of these materials is acceptable for use in the TSC.

The main structural components of the VCC are fabricated with reinforced concrete and carbon steel. The VCC liner, lid, shield plug, and base weldment are fabricated from American Society for Testing and Materials (ASTM) A 36 steel, a commonly used steel for structural applications. The steel reinforced concrete shell is approximately 28-inches thick and has a minimum specified compressive strength and density of 4000 psi and 140 lb/ft³, respectively. The cement used to fabricate the concrete shell is Type II Portland cement meeting the requirements of ASTM C150; the reinforcing steel is an ASTM A615, Grade 60 steel; and the concrete aggregate meets the specifications of ASTM C33. The optional lifting anchors, including the lifting lugs and anchor base plate, are fabricated from ASTM A 537 ferritic steel. In accordance with ASME Code Section III, Subsection NF-2311(b)13 and Figure NF-2311(b)-1, the minimum allowable service temperature of A 537 ferritic steel is -5°F. Therefore, the lifting anchors are restricted from use for temperatures less than, or equal to, 0°F. Other fabrication specifications for the VCC, including the QA specifications, can be found in Table 1.2-6 of the SAR. The staff concludes that the concrete materials meet the requirements of ACI 349, and, the materials comprising the VCC are suitable for structural support, shielding, and protection of the TSC from environmental conditions.

Transfer cask structural components (including the inner and outer shells, trunnions, shield doors, etc.) are primarily fabricated with either ASTM A 588 or ASTM 350 high-strength, low-alloy steel. These types of steels are common structural materials and have ductile-to-brittle transition temperatures below the TS minimum temperature operating limit of 0 degrees Fahrenheit (°F). The staff concludes that these steels are suitable for use in the transfer cask.

3.1.4.2 Nonstructural Materials

Criticality control in the PWR TSC baskets is achieved by surrounding each fuel tube with stainless steel clad Boral sheets. In the BWR TSC baskets, criticality control is achieved by

DRAFT

placing the stainless steel clad Boral sheets on some sides of selected fuel tubes. Boral has a long, proven history in the nuclear industry and has been used in other spent fuel storage and transportation casks. The Boral sheets are enclosed within the welded stainless steel cladding to minimize its exposure to environments that could otherwise cause it to degrade. In accordance with Section 9.1.6 of the SAR, neutron attenuation techniques will be used to ensure that the Boral sheets have a minimum ^{10}B loading of 0.011 grams/cm² ^{10}B used in the BWR fuel tubes, and 0.025 grams/cm² ^{10}B used in the PWR fuel tubes.

Neutron absorbers and gamma shields will be fabricated from materials that can perform well under all conditions of service during the license period. Interlocking chemical lead bricks (ASTM B29) are used in the transfer cask for gamma shielding. The thermal analyses of SAR Section 4 and SAR Tables 4.4.3-3 and 4.4.3-4 show that the temperatures of the lead bricks during transfer operations (e.g., 199°F for PWR and 210°F for BWR) are well below the melting point of this material (e.g., 600°F). Therefore, the staff concludes that the lead will undergo minimal slumping and will perform its intended function of gamma shielding. The transfer cask also utilizes NS-4-FR neutron shielding. The NS-4-FR material is a high-hydrogen content, durable, fire resistant material that has been used reliably in several other storage cask systems. As SAR Tables 4.4.3-3 and 4.4.3-4 show, the temperatures experienced by the NS-4-FR are about 100°F lower than the temperature limit for the PWR and BWR configurations, respectively. As noted above, the concrete of the VCC provides neutron and gamma shielding during storage. The thermal analyses of SAR Section 4 indicates that the peak temperature of the concrete will be well below the ACI 349 prescribed temperature limits. The staff concludes that the chemical lead bricks, the NS-4-FR neutron shielding material, and the concrete in the VCC are suitable shielding materials for the NAC-UMS system.

3.1.4.3 Welds

The TSC shell is assembled using full penetration longitudinal and girth (if required) welded joints in the shell and circumferential welded joints at the junction between the bottom plate and the shell, as described in SAR Sections 7.1.3 and 9.1.1. These welds are performed, tested, and inspected in accordance with ASME Code Section III, Subsection NB-4000, unless otherwise specified in the drawings. The shield and structural lids are joined to the shell by partial penetration welds. The applicant has taken an exception to ASME Code, Section III, with respect to the design of this redundant closure. Visual (VT), radiographic (RT), ultrasonic (UT), and liquid penetrant (PT) examination requirements of these welds are summarized in Section 9 of this SER. All welding of components of the basket assembly are performed in accordance with ASME Code, Section III, NG-4000. Welding of other NAC-UMS system components (e.g., transfer cask and VCC) will be performed in accordance with either American Welding Society (AWS) D1.1-96 or ASME Code, Section VIII. All exceptions to the ASME Code are identified in a table in the design features section of Appendix B to the CoC.

The NAC-UMS system materials of construction (e.g., stainless, carbon, low alloy steels, etc.) are readily weldable using commonly available welding techniques. The cask welds were well-characterized on the drawings, and standard welding symbols and notations in accordance with AWS Standard A2.4, "Standard Symbols for Welding, Brazing, and Nondestructive Examination," were used.

DRAFT

The staff concludes that the welded joints of the TSC, transfer cask, and VCC meet the requirements of the ASME and AWS Codes, as applicable. Although the TSC closure welds are partial penetration welds, this configuration will perform its intended structural and confinement functions.

3.1.4.4 Bolting Materials

The TSC is an all-welded canister. The retaining ring bolts on the transfer cask are used to prevent the TSC from being pulled through the top of the transfer cask. These bolts are fabricated from ASME SA-193, Grade B6, ferritic high-strength steel. The ductile-to-brittle transition temperature of this steel is below the expected operating temperatures, so brittle fracture of the bolts is not expected. Procurement of the bolts in accordance with the ASME SA-193 specification will help to ensure that the material receives the proper heat treatment and possesses the required mechanical properties. The staff finds the bolting material acceptable.

3.1.4.5 Coatings

No coatings are applied to the support disks of the PWR fuel basket, and no zinc, zinc compounds, or zinc-based coatings are used in the NAC-UMS system.

The carbon steel support disks of the TSC BWR fuel basket assembly are coated with an electroless nickel coating to prevent oxidation and corrosion of the carbon steel. This nickel coating is a nickel/phosphorus metallic alloy that can be deposited uniformly on all exposed surfaces of the support disk and is applied in accordance with ASTM B 733-1997 (SC3, Type V, Class 1). Adhesion of the nickel coating to the carbon steel disk is assured by cleaning the carbon steel surfaces in accordance with ASTM B 733 prior to deposition of the coating. This coating is not expected to react with the spent fuel pool water to produce unsafe levels of flammable gas. However, SAR Sections 8.1 and 8.3 which specify that the user monitor the concentration of hydrogen gas during any welding or cutting operations ensure that accumulation of flammable gases is negligible. If flammable gases are detected at concentrations above 2.4% in air at anytime during these operations, the gas will be removed by flushing the suspect regions with ambient air before continuation of the operations.

All of the exposed surfaces of the transfer cask and VCC will be coated with either a Keeler and Long or a Carboline epoxy enamel paint coating. This coating will protect the steel from excessive oxidation and facilitate decontamination of the surfaces.

The staff concludes that the applications of the nickel coating to the carbon steel BWR support disks and the epoxy paint coating to the exposed surfaces of the transfer cask and VCC are acceptable.

3.1.4.6 Mechanical Properties

SAR Tables 3.3-1 through 3.3-13 provide mechanical property data for the major structural materials including stainless steels, precipitation-hardened steel, carbon steel, bolting materials, aluminum alloys (even though the aluminum components are not considered to be structural members), concrete, and NS-4-FR neutron shielding material. Most of the values in these

DRAFT

tables were obtained from ASME Code, Section II, Part D. However, some of the values were obtained from other acceptable references. The staff independently verified the temperature dependent values for the stress allowables, modulus of elasticity, Poisson's ratio, weight density, and coefficient of thermal expansion. The staff concludes that these material properties are acceptable and appropriate for the expected load conditions (e.g., hot or cold temperature, wet or dry conditions) during the license period.

3.1.5 General Standards for Cask

SAR Section 3.4 performs structural analyses of the NAC-UMS system components, under normal operating and certain off-normal temperature conditions, for meeting the general storage cask standards. The analyses also address the chemical and galvanic reactions and positive closure of the system. The accident analyses in SAR Sections 11.1 and 11.2 evaluate structural performance of the NAC-UMS system under off-normal events and accident-level conditions. The evaluations are used to demonstrate the structural capabilities that are relied on to preclude (1) criticality, (2) unacceptable release of radioactive materials to the environment, (3) unacceptable radiation dose to the public or workers, and (4) significant impairment of the ready retrievability of stored nuclear materials. The SAR evaluations are reviewed in SER Sections 3.2, 3.3, 3.4, and 11.

3.1.6 Supplemental Data

3.1.6.1 Finite Element Analysis Codes

The SAR uses two general purpose finite element codes, ANSYS and LS-DYNA, to perform structural analysis of the NAC-UMS system. The stresses in the canister, fuel basket support disks and tubes, transfer cask trunnion-to-shell interface, and concrete overpack are analyzed with ANSYS, a widely used code in the nuclear power industry. Decelerations in the VCC tipover and TSC 24-inch vertical drop accidents are calculated with LS-DYNA, a PC-based version of the DYNA3D code considered in NUREG/CR-6608. The two codes are commercially available.

3.1.6.2 Finite Element Structural Analysis Models

SAR Sections 3.4.3, 3.4.4, 11.1.3, 11.2.4, and 11.2.12 provide details of the ANSYS finite element models for the NAC-UMS system components subject to various pressure, temperature, and mechanical loading conditions. For ANSYS element selection, the SAR uses SOLID45 to model the canister shell and closure plates, SHELL63 for the fuel basket support disks and weldments, SHELL43 for the fuel tubes, BEAM4, SHELL93 and SOLID95 for the transfer cask trunnion-to-shell joint, SOLID45, LINK8, and CONTAC52 for the concrete overpack and its rebars, and CONTAC52 and COMBIN40 for the gap opening and closing between individual structural entities. The SAR considers temperature-dependent material properties, as appropriate, in the finite element modeling. As loading and component configurations permit, appropriate half-symmetry model configurations are used. Additionally, for canister lifting and tipover accident stress analyses, only the top portions of the TSC are used for the structural behavior simulation.

DRAFT

In stress evaluation, the SAR defines stress margin or margin of safety as the ratio of the stress allowable and the calculated stress minus one, for which the at-temperature stress allowables are considered. Positive design margins demonstrate structural acceptability for the component sections being evaluated.

The staff reviewed the SAR finite element modeling approaches, including finite element scheme, element selection, interaction among structural entities, loading application, and boundary conditions, and concludes that they are acceptable for the finite element structural analysis of NAC-UMS system components. The implementation of these approaches and additional analysis assumptions, as appropriate, are also reviewed together with the SAR analysis results in the following sections.

3.2 Normal Operating and Design Conditions

3.2.1 Chemical and Galvanic Reactions

In Section 3.4 of the SAR, the applicant evaluated whether chemical, galvanic, or other reactions among the materials and environments would occur. The staff reviewed the design drawings and applicable sections of the SAR to evaluate the effects, if any, of intimate contact between various NAC-UMS system materials of construction during all phases of operation. In particular, the staff evaluated whether these contacts could initiate a significant chemical or galvanic reaction that could result in component corrosion or combustible gas generation. Pursuant to NRC Bulletin 96-04, a review of the NAC-UMS system, its contents, and operating environments was performed to confirm that no operation (e.g., short-term loading/unloading or long-term storage) will produce adverse chemical or galvanic reactions.

The TSC is a stainless steel canister that contains a fuel basket assembly with PWR or BWR fuel. During storage, the TSC will be backfilled with helium (99.9% minimum purity) cover gas. Using this level of helium purity, the applicant calculated that a maximum of 0.3 gram-moles of oxidizing gases could exist in the cask for all loading conditions. This amount is well below the 1.0 gram-mole limit that is recommended in PNL-6365 and specified in NUREG-1536. The vacuum drying procedures of SAR Section 8.1.1, i.e., two cycles of sequentially evacuating and backfilling the TSC with helium, and the careful design, configuration, and operation of the vacuum drying equipment will ensure that contamination of the cover gas with air is minimal. The staff concludes that in this dry, inert environment, the TSC components are not expected to react with one another or with the cover gas. Further, corrosion or oxidation of the TSC internal components will effectively be eliminated during storage.

The applicant identified one potential chemical or galvanic reaction between the aluminum heat transfer disks of the TSC fuel basket and the relatively low pH (e.g., 4.0-4.5), borated water in PWR spent fuel pools. This reaction may produce small amounts of combustible gases, such as hydrogen, during loading and unloading operations. The safety hazards associated with ignition of this hydrogen gas are mitigated by employing the guidance contained in the generic procedures of SAR Sections 8.1 and 8.3 which specify that the user monitor the concentration of hydrogen gas during any welding or cutting operations. If hydrogen gas is detected at concentrations above 2.4% in air at anytime during these operations, the hydrogen gas will be removed by flushing the suspect regions with ambient air before continuation of the welding or

DRAFT

cutting process. The staff concludes that the guidance in the generic procedures is adequate to prevent ignition of any hydrogen gas that may be generated during welding operations. Further, the potential reaction of the aluminum with the spent fuel pool water will not impact the ability of the aluminum heat transfer disks to perform their intended heat transfer function because the loss of aluminum material is expected to be negligible.

The transfer cask is constructed from carbon and low alloy steels, NS-4-FR polymeric material, and lead. An epoxy enamel coating will be applied to all of the exposed surfaces of the transfer cask to minimize corrosion of its carbon steel components. The staff concludes that none of the transfer cask materials or the coating are expected to degrade, react with each other, or react with TSC components or fuel during the loading and unloading operations.

3.2.2 Positive Closure

The TSC is a structure system with multipass welds to join the canister shield lid and structural lid to the shell. The penetrations to the canister cavity, through the shield lid, are closed by welded port covers. These design features preclude inadvertent opening of the TSC. The top of the VCC is closed by a bolted lid weighing approximately 2,500 lbs. The weight of the lid, its inaccessibility, and the presence of the bolts effectively preclude inadvertent opening of the lid. The staff concurs with the SAR conclusion that the NAC-UMS employs an acceptable positive closure system.

3.2.3 Lifting Devices Analysis

SAR Section 3.4.3 evaluates the lifting devices of the NAC-UMS system. The transfer cask is lifted by either two or four trunnions. The loaded and closed TSC is lifted with two three-legged slings, through the six hoist rings threaded into the structural lid. The VCC is raised by four lifting jacks placed at the jacking pads near the end of the overpack air inlets. With a set of four lifting lugs anchored to the concrete wall, the VCC can be moved in a top lift configuration. The structural performance of these lifting devices is evaluated as follows.

3.2.3.1 Transfer Cask Lift

Four 10-inch diameter trunnions are welded to the transfer cask body at its inner and outer shells. SAR Section 3.4.3.3 states that the trunnion design meets ANSI N14.6 and NUREG-0612 requirements for non-redundant lift systems. For structural analysis, the loaded transfer cask is assumed to weigh 210,000 lbs, which envelopes the weights of all five transfer cask configurations. SAR Section 3.4.3.3.1 describes the finite element analysis of the trunnion-to-shell joint of the transfer cask. SAR Tables 3.4.3.3-1 and -2 summarize stress results for the top and bottom surfaces of the transfer cask outer shells, respectively. SAR Tables 3.4.3.3-3 and -4 summarize the corresponding results for the transfer cask inner shell. Except for localized over-stresses, as permitted by ANSI N14.6, stresses in the shells are shown to meet the stress design factors of 6 and 10 against the respective yield and ultimate strengths. The SAR calculates a maximum linearized trunnion bending stress of 3,377 psi, which corresponds to the stress design factors of 9.4 and 20.7 against the respective material yield and ultimate strengths.

DRAFT

The SAR evaluates other load bearing components of the transfer cask for the loading conditions and stress allowables commensurate with the postulated design events. This includes the Transfer Cask Extension and the bolted-in-place retaining ring assembly evaluated for inadvertent TSC lifting. The shield door assembly at the bottom of the transfer cask is shown to have the stress design factors larger than 6 and 10 against the yield and ultimate strengths, respectively.

On the basis of the above evaluation, the staff concurs with the SAR conclusion that the transfer cask is structurally adequate in meeting the non-redundant, heavy-lifting requirements of ANSI N14.6 and NUREG-0612.

3.2.3.2 Transportable Storage Canister Lift

SAR Section 3.4.3.2 evaluates structural performance of the hoist rings, the structural lid, and the weld that joins the structural lid to the shell for lifting a design basis loaded TSC of 76,000 lbs. Six hoist rings, each at a rated capacity of 30,000 lbs or ultimate capacity of 150,000 lbs, are used with two three-legged slings for the redundant lift of the TSC. On this basis, the SAR calculates a minimum sling length of 79.8 inches or a minimum distance of 74.3 inches between the master sling link and the top of the canister to ensure that the rated hoist ring capability is not exceeded. Considering a thread engagement length of 2.0 inches, the SAR calculates the shear stress in the structural lid bolt hole threads. The calculated stress design factors are 4.0 and 10.5 against the yield and ultimate strengths, respectively, which meet the criteria of NUREG-0612 and ANSI N14.6 for redundant lifting systems. As a result, the staff concurs with the SAR conclusion that the 2.0-inch thread engagement is adequate.

The SAR models the upper portion of the TSC in evaluating the structural lid and its weld to join the TSC shell. The hoist ring force on the structural lid is simulated with a six-point lifting configuration, and appropriate modeling consideration is given to the boundary condition associated with the truncated canister model and the anticipated symmetric stress distribution. The SAR calculates a maximum stress intensity of 2,825 psi in the structural lid, 1,510 psi in the structural lid-to-shell weld, and 3,002 psi in the canister shell. The maximum stress of 3,002 psi corresponds to stress design factors of 6.40 and 20.3 against the yield and ultimate strengths, respectively. The results demonstrate that, consistent with Regulatory Guide 3.61, the canister load bearing members are capable of supporting three times the weight of the loaded TSC without generating a stress, in any part of the canister, in excess of the material yield strength.

3.2.3.3 Storage Cask Bottom Lift

SAR Section 3.4.3.1.1 evaluates the structural performance of VCC components, considering the loading associated with the VCC bottom lift operation. The evaluation addresses concrete bearing stresses at the lifting jack locations, size and spacing of Nelson stud anchors for the cask base, and stresses in the TSC support pedestal. The evaluation is in accordance with ACI 349 and the American Institute of Steel Construction "Manual of Steel Construction," consistent with NUREG-1536. The staff reviewed the SAR results and agrees with the SAR conclusion that sufficient margins exist to demonstrate structural adequacy of the VCC to undergo the bottom lift operation.

DRAFT

3.2.3.4 Storage Cask Top Lift

A set of four lifting lugs is provided at the top of the VCC so that the cask, with a maximum weight of 312,210 lbs, may be lifted from the top end. SAR Section 3.4.3.1.3 analyzes the lifting lugs in accordance with ANSI N14.6 with the allowable stress the lesser of $S_y/3$ or $S_u/5$. The SAR uses the Air Force Flight Dynamics Laboratory "Stress Analysis Manual," AFFDL-TR-69-42, to compute stresses in the lifting lugs. The structural evaluation of the VCC components, including the selection of the rebar size and number and determination of rebar development length, is in accordance with ACI-349, which is consistent with NUREG-1536. The staff reviewed the SAR approaches and results and agrees with the SAR conclusion that sufficient margins exist to demonstrate structural adequacy of the VCC components for a top lift operation.

3.2.4 Hot and Cold Temperature Effects

The SAR analysis of the thermal performance of the NAC-UMS system is reviewed in SER Section 4. This section reviews the application of pressure and thermal loadings, on the basis of hot and cold temperature effects, for the structural analysis of the NAC-UMS components. The stress performance resulting from differential thermal expansions is also reviewed. The cold temperature effects on brittle fracture are evaluated in SER Section 3.1.4.

3.2.4.1 Internal Pressures and Temperatures

SAR Section 2.2.6 defines the design basis ambient temperatures of 76°, 106°, -40°, and 133°F for the normal, off-normal severe heat, off-normal severe cold, and accident extreme heat conditions, respectively. SAR Section 4.4.5 calculates, for normal conditions, a maximum internal pressure of 5.8 psig for the PWR canister and 5.9 psig for the BWR canister. This provides the basis for applying an internal pressure of 15 psi for the canister structural analysis. SAR Section 3.4.4.1.1 presents a finite element thermal stress analysis of the canister for a bounding combination of geometry and loading that envelops the PWR and BWR canisters. Considering a temperature distribution that envelops the conditions associated with the 106°F and -40°F ambient temperatures, the analysis uses bounding temperature gradients between key locations on the canister for calculating temperature distribution and performing subsequent thermal stress analysis.

For the fuel basket, SAR Sections 3.4.4.1.8 and 3.4.4.1.9 consider bounding temperatures at the center and circumference of the support disk as well as the top and bottom weldments, respectively, to perform temperature distribution and thermal stress analyses.

Section 4.4.1.1 describes the heat transfer analysis for determining temperature distribution of the concrete cask. The resulting nodal temperatures, with a load factor of 1.275 applied to those nodes along the steel liner interior and concrete shell, serve as the loading condition for thermal stress analysis of the VCC.

The staff reviewed the SAR approaches to applying thermal and pressure loadings for the NAC-UMS system structural analyses and concludes that the analyses follow acceptable engineering practices.

3.2.4.2 Differential Thermal Expansion

SAR Section 3.4.4.1 evaluates the effects of differential thermal expansions and thermal stresses for the TSC components. SAR Table 3.4.4.1-1 lists a maximum canister thermal stress intensity of 7.02 ksi, considering a temperature distribution that envelops all normal and off-normal conditions for storage. The canister load combinations, including thermal stresses, as considered in SAR Section 3.4.4.1.5, are reviewed in SER Section 3.2.5.

SAR Section 3.4.4.2.3 performs a stress analysis of the VCC for the thermal load. SAR Figures 3.4.4.2-1 through -5 delineate the ANSYS finite element analysis model for the VCC, including the use of LINK8 and CONTAC52 elements to simulate the interaction between the rebar and concrete. The analysis approach follows common finite element modeling practices and is acceptable. The thermal stress results are evaluated for load combinations in SER Section 3.2.5.5.

3.2.4.3 Cold Temperature

The temperature gradients which may cause thermal stresses to develop in the NAC-UMS system components are essentially the same for all of the design basis steady-state ambient temperatures, including the off-normal severe cold condition of -40°F. The canister design internal pressure of 15 psig bounds the maximum pressure of 5.9 psig associated with the normal-condition ambient temperature of 75°F, which bounds the off-normal severe cold temperature condition of -40°F. Therefore, the SAR has sufficiently considered the cold-temperature thermal and pressure effects for structural evaluation.

3.2.5 NAC-UMS System Components Structural Analysis

SER Section 3.1.6.2 reviews the finite element modeling for the NAC-UMS system components. In the following sections, the staff evaluates the SAR Section 3.4.4 analyses of the structural performance of system components under individual and combined dead weight, thermal, pressure, and handling loads.

3.2.5.1 Transportable Storage Canister

SAR Table 3.4.4.1-1 summarizes the maximum canister thermal stresses under the normal operating condition. SAR Tables 3.4.4.1-2 and -3 present the respective canister primary membrane and primary membrane-plus-bending stress results for the dead weight load. SAR Tables 3.4.4.1-9 and -10 present stress results for the canister subject to an internal pressure of 15 psig. SAR Tables 3.4.4.1-6, -7 and -8 list stresses under the combined load of normal handling and internal pressure. For the load combinations evaluation, the SAR reports a minimum stress margin of 0.09, which occurs in the canister shell.

On the basis of the above, the staff concurs with the SAR conclusion that the structural performance of the canister is acceptable for normal operating conditions.

DRAFT

3.2.5.2 Fuel Basket Support Disk

SAR Section 3.4.4.1.8 analyzes the PWR and BWR fuel basket support disks for the storage and handling condition. The analysis considers the out-of-plane dead weight and the temperatures at the center and around the outer edge of the fuel support disks. SAR Tables 3.4.4.1-12 and -13 summarize stress results, including thermal stress effects, for the PWR support disk with a minimum stress margin of 7.4. The corresponding results, with a minimum stress margin of 5.6, are reported in SAR Tables 3.4.4.1-15 and -16. These stress margins are acceptable.

3.2.5.3 Fuel Basket Top and Bottom Weldments

SAR Section 3.4.4.1.9 analyzes the top and bottom weldments of the PWR and BWR fuel baskets for the storage and handling conditions. The analysis considers appropriate dead weight, support condition, and temperatures at the center and circumference of a fuel basket weldment. For the top weldment, the temperature at its center is assumed to be 500°F and its circumference 275°F. For the bottom weldment, the corresponding temperatures are 250°F and 170°F. SAR Table 3.4.4.1-17 summarizes the load combination effects with a minimum stress margin of 0.46 for the PWR weldments and 0.70 for the BWR weldments. These results are acceptable.

3.2.5.4 Fuel Tube

The basket fuel tube, which rests on the bottom weldment and serves to position the spent fuel assembly, is free to expand in the axial direction to preclude the development of thermal stresses. In the canister storage configuration, the fuel tube does not serve any load bearing function other than to support its own weight. As evaluated in SAR Section 3.4.4.1.10, the stresses associated with the dead weight and thermal expansions are negligibly small.

3.2.5.5 Vertical Concrete Storage Cask

SAR Section 3.4.4.2 evaluates structural performance of the VCC for normal conditions of storage by considering the dead weight, live, and differential thermal expansion loads. SAR Table 3.4.4.2-1 provides a stress summary for the load combinations defined in SAR Table 2.2-1. The concrete stresses associated with the dead weight and live loads are negligibly small. The maximum compressive thermal stresses for the off-normal severe heat condition are 757 and 134 psi in the cask axial and circumferential directions, respectively. SAR Table 3.4.4.2-2 summarizes the maximum stresses in the concrete and rebars. The minimum margin of safety for concrete compressive stress is 2.4, and the stress margins for the rebars are large. On this basis, the staff concludes that the VCC is structurally acceptable for normal operating conditions.

3.3 Off-Normal Events and Accident Conditions

SAR Section 11 presents accident analyses, including structural evaluations, to demonstrate that the NAC-UMS system satisfies the requirements of 10 CFR 72.24 and 72.122. This

DRAFT

section evaluates the SAR analyses to support the SER Section 11 evaluation of the NAC-UMS components for the off-normal and accident conditions.

3.3.1 Severe Ambient Temperature Conditions

For thermal stress analysis of the VCC, SAR Section 11.1.1 determines that the off-normal severe conditions, with an ambient temperature of either -40° or 106°F , are bounded by the accident extreme heat condition with an ambient temperature of 133°F . In SER Section 3.2.4.2, the staff found that the SAR Section 3.4.4 bounding evaluations for differential thermal expansion and thermal stress effects were acceptable. On this basis, the staff concludes that the NAC-UMS system is structurally adequate to withstand the off-normal and accident temperature conditions.

3.3.2 Canister Off-Normal Handling Load

SAR Section 11.1.3 adds to the normal operating loads an inertia load of 0.5 g in each of the three orthogonal directions for evaluating the TSC off-normal handling load effects. The SAR continues to use the finite element models considered for the normal operating conditions analysis for this purpose. Additionally, for lateral loading, the canister is assumed to be handled inside the VCC in that the interface between the canister shell and concrete cask inner shell is simulated with the CONTAC52 elements. SAR Tables 11.1.3-1 through -12 present stress results, including stress margins for the TSC, support disks, and fuel basket top and bottom weldments. The staff reviewed the results and concurs with the SAR conclusion that the canister and its components will maintain positive stress margins for the off-normal handling condition.

3.3.3 Accident Pressurization

Based on a hypothetical event that assumes the failure of all of the fuel rods, SAR Section 11.2.1 considers an internal pressure of 65 psig, which envelops the maximum internal pressures of 56.1 psig and 35.3 psig for the PWR and BWR canisters, respectively, for the TSC stress analysis. SAR Tables 11.2.1-1 and -2 list the TSC primary membrane and primary membrane-plus-bending stresses due to internal pressures, respectively. SAR Tables 11.2.1-3 and -4 present results for the combined effects of the canister handling load and internal pressure with a minimum stress margin of 0.05. On this basis, the staff concurs with the SAR conclusion that there is no adverse consequence to the canister as a result of the combined normal handling and maximum internal pressure of 65 psig.

3.3.4 Explosion

The SAR states that an explosion affecting the site is extremely unlikely because administrative controls will exclude explosive substances in the vicinity of an ISFSI. SAR Section 11.2.5 references the SAR Section 11.2.9 analysis which demonstrates acceptable structural performance of the TSC when subjected to an external static pressure of 22 psig. On this basis, the staff concludes that there is no adverse consequences to the canister as a result of an explosion which exerts an equivalent static pressure of less than 22 psig on the TSC.

DRAFT

3.3.5 Vertical Concrete Cask 24-Inch Drop

SAR Section 11.2.4 evaluates structural performance of the NAC-UMS system for a 24-inch vertical VCC drop in a hypothetical failure of the cask top lift system. The drop distance also bounds the accident drop in a cask bottom lift of less than 6 inches in operating the lifting jacks and inflatable air pads for moving the VCC across the surfaces of the transporter and ISFSI pad.

3.3.5.1 Concrete Cask Analyses

The SAR uses an energy balance method to estimate the impact deformation for the VCC. The SAR assumes that the cylindrical concrete portion of the cask crushes squarely onto an infinitely rigid surface. By equating the total potential energy to the energy dissipated through concrete crushing, the SAR calculates a maximum concrete crush depth of 0.134 inches. The staff reviewed the SAR approach and concludes that the calculated concrete crush depth is bounding.

3.3.5.2 Determination of Canister Deceleration g-Loads

SAR Section 11.2.4.3 uses LS-DYNA to calculate deceleration g-loads for the TSC upon its end drop with the pedestal weldment onto an unyielding surface. The finite element analysis model considers brick and shell elements for the pedestal weldment. Lumped mass elements located in the canister bottom plate are used to simulate the loaded canister and its interaction with the pedestal weldment. In a September 16, 1999, submittal, NAC uses a sensitivity study in which the mechanical properties of the pedestal weldment, including strain rate effects, are varied to further demonstrate that the effects of the higher strain rate for the pedestal weldment on cask decelerations are minimal. Using the maximum canister weight, the SAR calculates a maximum deformation of about 1 inch for the air inlet of the pedestal weldment. Conversely, by considering the minimum canister weight, the analysis calculates a maximum axial deceleration of 45.0 g for the canister.

For the basket support disks, the SAR considers the LS-DYNA calculated canister pulse responses as input to determine, by direct integration, the dynamic load factors (DLFs) of 1.01 and 1.29 for the PWR and BWR configurations, respectively. These result in the static equivalent loads of 45.5 g and 58.1 g for the PWR and BWR support disks, respectively.

The SAR considers a 60-g static equivalent load for the end-drop structural analysis of the canister components. The load bounds the g-loads evaluated above and is acceptable.

3.3.5.3 NAC-UMS Canister Components Structural Analysis

SAR Section 11.2.4.3 performs structural analysis for the TSC components for a bottom end drop static equivalent load of 60 g. The analysis covers cases with and without an internal canister pressure of 26 psig.

Transportable Storage Canister. SAR Figures 11.2.4-4 and -5 depict schematically the TSC finite element stress analysis models, which are identical to those of SAR Section 3.4.4 for the

DRAFT

normal operating conditions analyses. The staff reviewed the application of loading and boundary conditions to the analysis models, including the gap and contact interfaces between structural entities. The staff concludes that the analysis approach follows standard engineering practices and is acceptable.

SAR Tables 11.2.4-1 and -2 summarize the primary membrane and primary membrane-plus-bending stresses, respectively, for the PWR canister under a static equivalent axial load of 60 g. The minimum stress margin is 4.01. SAR Tables 11.2.4-3 and -4 present corresponding results for the BWR canister with a minimum stress margin of 3.85. These results are acceptable.

The SAR evaluates the canister buckling strengths for a static equivalent axial load of 60 g, in accordance with ASME Code Case N-284-1. The evaluation considers the interaction equations for the maximum stresses associated with the canister longitudinal and circumferential compression as well as in-plane shear. SAR Table 11.2.4-8 presents the buckling interaction-equation ratios, which are all markedly less than the acceptable value of unity. This demonstrates that the canister has adequate buckling strength to resist an axial load of 60 g.

Basket Support Disk. The SAR evaluates the PWR and BWR fuel basket support disks for a bounding static equivalent load of 60 g. The analysis considers the models described in SAR Section 3.4.4.1-8 for canister normal operating conditions analyses. The disks are assumed to be supported at the split spacer locations to resist the out-of-plane inertia load. SAR Tables 11.2.4-9 and -10 evaluate the primary membrane-plus-bending stress results for the PWR and BWR fuel basket support disks, respectively. On the basis of the at-temperature stress allowables and in accordance with the ASME Code, Subsection NG, the minimum stress margins are 1.86 and 0.56 for the PWR and BWR disks, respectively. These results are acceptable.

Basket Weldment. The SAR evaluates the PWR and BWR fuel basket bottom weldments for a bounding static equivalent load of 60 g. The analysis considers the models described in SAR Section 3.4.4.1-8 for canister normal operating conditions analyses. SAR Table 11.2.4-5 summarizes the maximum primary membrane-plus-bending stress results for the PWR and BWR bottom weldments, on the basis of the at-temperature stress allowables and in accordance with the ASME Code, Subsection NG. The minimum stress margins are 1.31 and 0.26 for the PWR and BWR weldments, respectively. These results are acceptable.

Fuel Tube. The SAR performs an analysis of fuel tubes for a bounding static equivalent axial load of 60 g. The staff reviewed the evaluation and concurs with the SAR conclusion that the fuel tube geometry will be maintained such that the Boral neutron poison will remain in place under the impact conditions analyzed.

Fuel Basket Tie Rod and Tie Rod Spacer. The staff reviewed the SAR evaluations of the basket tie rods and tie rod spacers. The staff concurs with the SAR conclusion that the fuel basket tie rods and tie rod spacers are structurally adequate for a bounding static equivalent axial load of 60 g.

DRAFT

On the basis of the above evaluations, the staff concurs with the SAR conclusion that the canister components are structurally adequate for resisting a canister static equivalent axial load of 60 g, which envelops the maximum static equivalent g-loads associated with a 24-inch cask end-drop accident.

3.3.6 Cask Tipover

In the following, the staff reviewed the SAR evaluation of the TSC structural capabilities under a postulated cask tipover accident.

3.3.6.1 Determination of NAC-UMS System Deceleration g-Loads

SAR Section 11.2.12.3 performs finite element analyses of cask-pad-soil interaction systems to compute deceleration g-loads for five configurations of PWR and BWR VCCs tipping over onto the concrete storage pad. The LS-DYNA computer code is used for modeling the system and performing transient analysis. To demonstrate the adequacy of the analytical method, in accordance with NUREG-1536, the SAR follows the NUREG/CR-6608 model validation guidance by comparing the computed responses of a billet-pad-soil test system model to the test data. The staff notes that the NAC December 19, 1998, submittal for the NAC-MPC, provided further clarification on the validation of the LS-DYNA modeling approach to calculating tipover decelerations for storage cask scale models. Since the staff, in its SER for the NAC-MPC, found adequate correlation between the calculated and tested responses of a steel billet, which represents a storage cask scale model, the staff concludes that the LS-DYNA modeling approach, as implemented by NAC, is adequate.

The SAR adapts the validated billet-pad-soil model for developing the cask-pad-soil interaction model for the NAC-UMS system. By following standard engineering practice, which is also consistent with the NUREG/CR-6608 approach, the SAR develops the cask-pad-soil model in a two-step process: (1) all billet test system modeling parameters, including major interaction features such as sliding surfaces between structural entities, are retained, as appropriate, and applicable soil boundary conditions are considered; and (2) the finite element model of the billet itself is replaced with that of the cask. This results in a cask-pad-soil interaction model consisting of a 30 ft x 30 ft x 3 ft concrete pad, a 35 ft x 35 ft x 10 ft soil subgrade, and a 136-inch diameter circular hollow concrete cylinder with an inner steel liner. Other major modeling parameters and assumptions include: (1) the equivalent weights of the system components to be appropriately lumped on the steel liner portion of the model, (2) the soil subgrade configuration to simulate a non-transmitting boundary, (3) the concrete compressive strength of 4,000 psi for both the cask and pad, and (4) the subgrade soil moduli of elasticity of 60,000 psi and 30,000 psi for the PWR and BWR NAC-UMS systems, respectively.

The SAR combines the above parameters with the individual height and weight of each of the five VCC configurations to develop five cask-pad-soil interaction analysis models to calculate cask tipover decelerations. For each analysis model, depending on the mass and location of the center of gravity of the cask, the SAR simulates an at-rest, center-of-gravity-over-the-corner, tipover initial condition by applying a uniform angular velocity to the entire cask model. The SAR performs transient response analyses of the systems. By low-pass filtering the spurious components of the total response motions, the SAR determines peak rigid-body lateral

DRAFT

decelerations, as listed below, at the locations on the model corresponding to the canister structural lid and the top most fuel basket support disk.

Cask Configuration	Acceleration (g)	
	Top Support Disk	Top Structural Lid
PWR Class 1	29.1	31.8
PWR Class 2	32.1	35.1
PWR Class 3	34.3	36.9
BWR Class 4	24.4	27.9
BWR Class 5	25.3	29.1

The staff notes that a concrete strength of 4,000 psi, which amounts to an assumption of deformable concrete overpack, has been considered to obtain the above results. In general, the calculated decelerations for a VCC with a deformable overpack are less severe than those with a rigid overpack, which is bounding. However, as was presented for the NAC-MPC tipover analysis, NAC performed a sensitivity study which demonstrated that the rigid overpack assumption will result in cask decelerations only slightly higher than those for casks with deformable overpack. On this basis, the staff has reasonable assurance that, with the concrete strength assumed to be 4,000 psi, the above calculated cask decelerations are representative and acceptable for subsequent application to the analysis of cask components.

In its response to Question 11-10 in the staff's request for additional information dated May 27, 1999, NAC performs time history modal response analyses and combines the responses by a square-root-of-sum-of-the-squares (SRSS) approach to obtain the DLFs of 1.10 and 1.04 for the PWR and BWR basket fuel support disks, respectively. By applying these DLFs to the peak cask rigid-body decelerations, the SAR calculates the peak static equivalent inertia loads of 37.7 g and 26.4 g for the PWR and BWR support disks, respectively. These loads are bounded by the 40 g and 30 g used in analyzing the PWR and BWR support disks, respectively.

3.3.6.2 NAC-UMS Canister Components Structural Analysis

SAR Section 11.2.12.4 describes the ANSYS finite element model comprising the top portion of the canister, the top five fuel basket support disks, and the fuel basket top weldment for structural analysis of the canister components. The SAR performs analysis on one each of the PWR and BWR configuration classes, which bounds the maximum load-per-support disk for the individual PWR and BWR configurations. It also considers four basket orientations for the PWR configuration and five for the BWR configuration to ensure that the maximum stresses are evaluated for the support disks.

Transportable Storage Canister. SAR Figures 11.2.12.4.1-2 and -3 display schematically the fuel basket/canister interaction finite element models for the PWR fuel configuration. SAR Figure 11.2.12.4.2-2 displays corresponding modeling details for the BWR fuel configuration. The SAR performs stress analyses of the fuel basket/canister assemblies by applying the side

DRAFT

impact static equivalent loads of 40 g and 30 g to the entire analysis models for the PWR and BWR configurations, respectively. As evaluated in SER Section 3.3.6.1, these static equivalent loads are conservatively bounding.

The SAR evaluates stresses in the TSCs in accordance with ASME Code, Section III, Subsection NB and Appendix F. For the canister structural lid-to-shell weld with the weld ultimate tensile strength exceeding the base metal strength, the SAR considers a stress reduction factor of 0.8, per NRC Interim Staff Guidance No. 4, Rev. 1 (ISG-4, R1), for the stress intensity limits. SAR Tables 11.2.12.4.1-1 and -2 present, for 13 axial locations of the canister, the primary membrane and primary membrane-plus-bending stress results, respectively, for the PWR configuration. The minimum stress margin is 0.13. SAR Tables 11.2.12.4.2-1 and -2 list corresponding stress results for the BWR configuration with a minimum stress margin of 0.35. These stress margins are positive and acceptable.

Basket Support Disk. The finite element analyses of the fuel basket/canister interaction models, as reviewed above for the TSC, also provides stress results for the fuel basket support disks. The SAR evaluates stresses in the support disks in accordance with ASME Code, Section III, Subsection NG and Appendix F. SAR Tables 11.2.12.4.1-6 and -7 present primary membrane and primary membrane-plus-bending stress results for the PWR support disk at a disk drop orientation of 26.28°; the minimum stress margin is 0.05. SAR Tables 11.2.12.4.2-7 and -8 present corresponding stress results for the BWR support disk at a drop orientation of 77.92° with a minimum stress margin of 0.04. These stress margins are acceptable.

The SAR follows interaction equations 31 and 32 of NUREG/CR-6322 to evaluate buckling of the support disks subject to in-plane loads. The evaluation considers axial forces and bending moments in the ligaments. SAR Tables 11.2.12.4.1-5 lists the minimum margins of safety, based on the interaction equations, for the PWR support disks, for four drop orientations. SAR Table 11.2.12.4.2-5 presents the corresponding results for the BWR disks, for five drop orientations. The evaluation results show that the support disks meet the buckling criteria of NUREG/CR-6322.

Fuel Tube. The fuel tube provides structural support and a mounting location for BORAL neutron poison plates. During a tipover accident, it serves as an intervening structure to transfer the side impact inertia load of the fuel assembly to the fuel support disks. The SAR performs nonlinear structural analysis of the fuel tube for a static equivalent load of 60 g, which bounds the maximum static equivalent loads of 40 g and 30 g for the PWR and BWR support disks, respectively.

SAR Section 11.2.12.4 evaluates fuel tube stresses and deformations. Two load conditions are considered. The first simulates the fuel assembly load as a distributed pressure on the inside surface of the fuel tube. The second postulates that the fuel assembly grid is located at the center of the span between the support disks to impose a displacement constraint over the effective area of the grid to produce a localized distributed load. Considering a yield strength of 17.3 ksi for the Type 304 stainless steel at 750° F, the SAR calculates the maximum total strains of 0.11 in./in. and 0.10 in./in. for the PWR and BWR fuel tubes, respectively. These strains are far less than the material failure strain of 0.40 in./in. and are acceptable. This ensures that the fuel tube will maintain position and function as intended in a VCC tipover accident.

DRAFT

3.3.7 Fuel Rod Rupture

The TSC is designed to remain leaktight in a storage configuration. Because of this feature, the structural integrity of the fuel rod cladding is not considered in the evaluation of the confinement of radioactive material under accident conditions. The spent fuel assemblies may be subject to an axial impact associated with a 24-inch cask vertical drop accident. In accordance with NRC's ISG No. 3, however, the 10 CFR 72.122(l) regulation on fuel retrievability does not apply to post-accident recovery, and the fuel rod rupture needs not be addressed for this accident. Under normal and off-normal conditions, since the effects of pressure, thermal, and mechanical loadings on gross rupture of fuel rods are negligible, the staff has reasonable assurance that the spent fuel rods can readily be retrieved for further processing or disposal.

3.4 Natural Phenomenon Events

3.4.1 Flood

The design basis flood conditions of a 50-foot depth of water having a velocity of 15 feet/sec correspond to a hydrostatic pressure of 22 psig and a drag force of 32.8 kips on the bounding VCC configuration class. The drag force is less than the minimum force of 98.9 kips required to cause the VCC to overturn and is not large enough to overcome the friction between the VCC and the concrete pad to cause the VCC to slide. At a hydrostatic pressure of 22 psig, the SAR reports a maximum primary membrane stress intensity of 3.69 ksi and a maximum primary membrane-plus-bending stress of 15.07 ksi in the canister, which are below the stress intensity limits of 40.08 ksi and 60.12 ksi, respectively. On this basis, the staff concurs with the SAR Section 11.2.9 conclusion that the concrete cask will not overturn or slide and the NAC-UMS system will not suffer adverse structural consequences under the design basis flood conditions.

3.4.2 Tornado Wind and Tornado-Driven Missiles

SAR Section 11.2.11 evaluates structural performance of the NAC-UMS system under the design basis tornado winds and tornado-driven missiles described in SAR Section 2.2-1. The SAR evaluates the stability of the VCC in accordance with the ANSI/ASCE 7-93 wind pressure assumptions. Local damage to the VCC shell is assessed and the concrete shear capacity is evaluated, per ACI 349, for a concrete compressive strength of 4,000 psi.

At a tornado wind speed of 360 mph, the SAR calculates an effective pressure load of 36.1 kips as applied on the VCC. This results in a safety factor of more than 2.07 against overturning and a minimum friction coefficient of 0.12 between the cask base and the concrete pad for inhibiting cask sliding. These results are acceptable.

The staff agrees with the SAR assessment that a detailed analysis of the TSC is not needed for the impact of a 1-inch diameter steel sphere missile because it cannot directly enter the VCC interior.

The SAR calculates a penetration depth of 5.75 inches due to a 280 lb, 8-inch diameter armor piercing shell and determines that scabbing will not occur in the 28.25-inch thick concrete shell.

DRAFT

For the same armor piercing shell impacting the VCC steel closure plate at 126 mph, the SAR estimates a perforation thickness of 0.654 inch. This is less than the plate thickness of 1.5 inches and is acceptable.

Under the high energy deformable missile of 4,000 lbs impacting the concrete cask at 126 mph, the SAR estimates a cask rotation of 3.0 degrees. Considering an estimated impact force of 462.5 kips on the VCC top and the concrete punching shear capacity, the staff concurs with the SAR conclusion that the concrete shell has sufficient capacity to withstand the high energy missile impact.

Based on the above evaluation, the staff concurs with the SAR conclusion that the design basis tornado winds and tornado-driven missiles are not capable of overturning the cask or penetrating the VCC. Therefore, the TSC confinement boundary remains intact.

3.4.3 Earthquake

SAR Section 11.2.8 evaluates seismic stability of the VCC against sliding and tipover. The evaluation assumes, at the top of a storage pad, a design basis earthquake (DBE) motion of 0.26 g for the two horizontal components and 0.173 g for the vertical component. Considering the static equilibrium approach and the response combination criteria of ASCE 4-86, "Seismic Analysis of Safety-related Nuclear Structures," the SAR determines that a minimum horizontal component of 0.45 g is required to cause the VCC to tipover. This corresponds to a margin of 1.73 against tipover. The SAR also determines that a friction coefficient of 0.30 is adequate to prevent the VCC from sliding. On the basis of a commonly considered friction coefficient of 0.35 between the steel and concrete surfaces characteristic of the VCC base and the storage pad, the SAR calculates a margin of 1.17 against sliding. These margins are larger than the minimum of 1.1 per ANSI/ANS-57.9. As a result, the staff concurs with the SAR conclusion that the cask will not slide or tip over under the DBE condition.

3.4.4 Snow and Ice

The maximum VCC snow load of 10,201 lbs is much smaller than the transfer cask live load of 196,000 lbs considered in evaluating the VCC. Therefore, the staff concurs with the SAR conclusion that the snow and ice load are negligible.

3.5 Evaluation Findings

The NRC staff reviewed the SAR evaluation of the structural performance of the NAC-UMS system for compliance with 10 CFR Part 72. The review considered the regulation, appropriate Regulatory Guides, applicable codes and standards, and accepted engineering practices. The NRC staff concludes that the NAC-UMS system will allow safe storage of spent fuel on the basis of the findings as follows.

- F3.1** The SAR describes the SSCs important to safety in sufficient detail to enable an evaluation of the structural performance of the NAC-UMS systems capability to accommodate the combined loads of the normal, off-normal, and accident conditions and the natural phenomena events.

DRAFT

- F3.2** The NAC-UMS system is designed to allow ready retrieval of spent nuclear fuel for further processing or disposal. No normal or off-normal conditions analyzed will result in damage of the system that will prevent retrieval of the stored spent nuclear fuel.
- F3.3** The NAC-UMS system is designed and fabricated so that its structural performance is adequate for maintaining the spent nuclear fuel subcritical under normal, off-normal, and credible accident conditions. Additional criticality evaluations are discussed in Section 6 of this SER.
- F3.4** The cask and its systems important to safety are evaluated to demonstrate that they will reasonably maintain confinement of radioactive material under normal, off-normal, and credible accident conditions.
- F3.5** The SAR describes the materials that are used for SSCs important to safety and the suitability of those materials for their intended functions in sufficient detail to facilitate evaluation of their effectiveness.
- F3.6** The design of the NAC-UMS system and the selection of materials adequately protects the PWR and BWR spent fuel cladding against degradation that might otherwise lead to gross rupture.
- F3.7** The NAC-UMS system employs noncombustible and heat-resistant materials which will help prevent the spread of radioactive material and maintain safety control functions.
- F3.8** The materials that comprise the NAC-UMS system will maintain their mechanical properties during all conditions of operation so the spent fuel can be readily retrieved without posing operational safety problems.
- F3.9** The materials that comprise the NAC-UMS system will maintain their mechanical properties during all conditions of operation so the spent fuel can be safely stored for a minimum of 20 years and maintenance can be conducted as required.
- F3.10** The NAC-UMS system employs materials that are compatible with wet and dry spent fuel loading and unloading operations and facilities. These materials are not expected to degrade over time, or react with one another, during any conditions of storage.

intentionally left blank

DRAFT

4.0 THERMAL EVALUATION

The thermal review verifies that the cask and fuel material temperatures of the NAC-UMS system will remain within the allowable values or criteria for normal, off-normal, and accident conditions. This objective includes confirmation that the temperatures of the fuel cladding (fission product barrier) will be maintained throughout the storage period to protect the cladding against degradation which could lead to gross rupture. This portion of the review also confirms that the thermal design of the cask has been evaluated using acceptable analytical and/or testing methods.

4.1 Spent Fuel Cladding

The staff verified that the cladding temperatures for each fuel type proposed for storage are below the temperature limits which would preclude cladding damage that could lead to gross rupture.

The temperature limits for dry storage of zircaloy fuels are based on the technical justification provided in PNL-6189, "Recommended Temperature Limits for Dry Storage of Spent Light-Water Zircaloy Clad Rods in Inert Gas." This report concluded that multiple-temperature limits for long-term dry storage in an inert environment be established to account for variations in end-of-life internal rod pressures and spent fuel age. It also provided a methodology by which to calculate these multiple temperature limits, thus precluding failure of the spent fuel cladding by creep rupture. Further, requiring an inert gas environment in the cask will preclude the occurrences of general and localized corrosion. NAC established long-term temperature limits based on this methodology ranging from 333°C to 396°C with variances for fuel type, burnup, and cooling time as shown in Table 4.4.7-5 of the SAR. Preferential loading, which involves putting the fuel with the lowest cladding temperature limit in the basket's perimeter, is employed to prevent spent fuel cooled less than 7 years from exceeding its cladding temperature limit. As stated in the SRP for dry cask storage, NUREG-1536, Zircaloy clad fuel has a short-term temperature limit of 570°C (or 1058°F) per the PNL-4835 research report. Thus, NAC established for Zircaloy clad fuel a short-term limit of 570°C for off-normal and hypothetical accident conditions. The staff finds that the spent fuel cladding temperature limits have been adequately set to preclude cladding damage during the dry cask storage period.

For canister unloading operations, the applicant considered the effect of cladding integrity by employing a two step cooling process of the hot spent fuel as described in the SAR Chapter 12, Technical Specification 3.1.7, and SAR Section 8.3, Unloading the Transportable Storage Canister. The first step is to purge the cask of radioactive gases that may exist in the canister by purging with nitrogen for a minimum of 10 minutes and until there is no indication of fission gases. After purging, an open water cooling system is connected to the drain line (inlet) and vent connection (outlet) with the discharge emptying into the spent fuel pool. During this cooling operation, inlet water temperature and flowrate are controlled to ensure that spent fuel cladding thermal stresses are maintained within acceptable limits and to ensure that the canister is not over-pressurized. The applicant further ensures over pressure protection of the canister during cooling by employing a check valve in the water inlet line that will restrict cooling water if the pressure in the canister gets too high and also uses a pressure relief valve.

DRAFT

The staff finds that reasonable assurance has been provided to ensure that the spent fuel cladding will be adequately protected during unloading operations.

The staff reviewed the calculated values of cladding temperature for all storage conditions to ensure that they met the temperature limits. The closest that the cladding got to its temperature limit was during normal operation. A calculated 46°F temperature margin exists for the PWR fuel and a calculated 65°F margin exists for the BWR fuel. For off-normal and accident conditions a margin of over 300°F exists between the calculated maximum temperature and the short-term temperature limit of 1058°F. For the off-normal transfer operation, this relatively large short-term margin exists based on the assumption that the transfer operations are completed within their allotted time. The applicant has established adequate controls in the operating procedures and TS to ensure that the time limits associated with transfer operations do not result in exceeding the cladding temperature limits. Since the calculational methods are conservative and there is margin between the calculated cladding temperature and the temperature limit, the staff concludes that the cladding would not undergo degradation which could lead to gross failure and that there is reasonable assurance based on the PNL reports that the cladding would remain intact for the license period.

4.2 Cask System Thermal Design

4.2.1 Design Criteria

The design criteria for the NAC-UMS system have been formulated by the applicant to assure that public health and safety will be protected during the period that spent fuel is stored in the cask. These design criteria cover both the normal storage conditions for the 20-year approval period and postulated accidents that last a short time, such as a fire.

Section 4 of the SAR defines several primary design criteria for NAC-UMS components:

- 1) the long-term spent fuel cladding temperature limits range from 333°C (or 631°F) to 380°C (or 716°F) for PWR fuel, and from 340°C (or 644°F) to 396°C (or 745°F) for BWR fuel considering variances in burnup and cooling time as shown in Table 4.4.7-5. The temperature limits prevent cladding degradation during normal dry storage conditions for the NAC-UMS and are based on research report PNL-6189 for Zircaloy clad spent fuel;
- 2) the short-term spent fuel cladding temperature limit of 570°C (or 1058°F) to prevent cladding degradation during off-normal and accident storage conditions is justified for Zircaloy cladding based on PNL-4835;
- 3) the design temperatures for the structural steel components of the NAC-UMS system are based on the temperature limits provided in ASME Section II, Part D; other material design temperature limits are justified via consensus codes, military standards, or manufacturer's data; and
- 4) the thermal source term is based on fuel assembly types as noted in SAR Tables 2.1.1-1 (PWR) and 2.1.2-1 (BWR) which results in a maximum decay heat load

DRAFT

of 23 kW per canister for intact 5-year cooled spent fuel. Other thermal decay heat load limits are shown on Tables 2.1.1-2 (PWR) and 2.1.2-2 (BWR) and vary with burnup and cooling time.

4.2.2 Design Features

To provide adequate heat removal capability, the applicant designed the NAC-UMS system with the following features:

- 1) helium backfill gas for heat conduction which also provides an inert atmosphere for the fuel to prevent cladding oxidation and degradation; and
- 2) aluminum heat conduction elements for heat transfer from the fuel tubes to the canister shell.

The staff verified that all methods of heat transfer internal and external to the NAC-UMS storage cask are passive except for transfer operations which may require short-term cooling measures to ensure that the material temperature limits are met. The drawings in Section 1.8 of the SAR along with the material properties in Section 4.2 provide sufficient detail for the staff to perform an in-depth evaluation of the thermal performance of the entire package as required by 10 CFR 72.24(c)(3).

4.3 Thermal Load Specifications

The design basis fuel to be stored in the NAC-UMS system is described in SAR Tables 2.1.1.-1 and 2.1.2-1 for PWR and BWR fuel, respectively. The design basis spent fuel decay heat loading is 23 kW per canister for 5-year cooled fuel with lower decay heat loading limits described in Tables 2.1.1-2 (PWR) and 2.1.2-2 (BWR) for longer cooled fuel. Actual decay heat loads may be lower based on variances in burnup, decay time, enrichment, and amount of initial heavy metal in the fuel assembly. There can be up to 24 PWR or 56 BWR fuel assemblies in one NAC-UMS canister. The axial power distribution for PWR and BWR spent fuel is shown in Figures 4.4.1.1-3 and 4.4.1.1-4 of the SAR, respectively. The decay heat load will decrease with time over the storage period.

The staff reviewed and confirmed via analysis a sample of the decay heat loads identified in SAR Tables 2.1.1-3 (PWR) and 2.1.2-3 (BWR). The staff also verified that the design basis decay heat load is bounding through independent analysis providing reasonable assurance that the design basis decay heat load was determined properly.

The thermal loads are different for the normal storage conditions than for the accident conditions, such as fire. The difference between the thermal loads occurs at the surface of the canister or cask. The application of the surface thermal loads will be for a short time during an accident, while the thermal loads from the fuel assembly decay heat are applied continuously during normal storage conditions. The decay heat load during an accident will be the same as for the normal storage condition at the time of the accident.

DRAFT

4.3.1 Normal Storage Conditions

The external environment for normal storage conditions are described in SAR Table 4.1-1. The applicant evaluated the cask for normal conditions with an ambient temperature of 76°F and with solar insolation applied over a 12-hour period of 2950 BTU/ft² and 1475 BTU/ft² for horizontal flat and curved surfaces, respectively. The design basis spent fuel heat load of 23 kW was evaluated.

4.3.2 Off-Normal Conditions

The external environment for off-normal storage conditions associated with the thermal evaluation are described in Table 4.1-1 and Sections 11.1.1 and 11.1.2 of the SAR. The off-normal events analyzed include half of cask inlets blocked, severe environmental heat of 106°F, and severe environmental cold of -40°F.

The applicant evaluated the NAC-UMS for conditions associated with half of the cask inlets blocked, including an environmental temperature of 76°F and a 12-hour insolation period of 2950 BTU/ft² and 1475 BTU/ft² for horizontal flat and curved surfaces, respectively. The design basis spent fuel heat load of 23 kW is utilized in the evaluation.

The applicant evaluated the NAC-UMS for a severe environmental heat of 106°F and a 12-hour insolation period of 2950 BTU/ft² and 1475 BTU/ft² for horizontal flat and curved surfaces, respectively. Also, the design basis decay heat of 23 kW was modeled as identified in SAR Section 11.1.1.3.

The applicant also evaluated the NAC-UMS for conditions with ambient temperatures of -40°F, no solar insolation, and applied the design basis decay heat of 23 kW, as described in Section 11.1.1.3 of the SAR. The staff concurs with this approach since the largest radial thermal gradient would exist with the maximum decay heat load and thus produce the largest thermal stresses. Also, since the material of the canister is a ductile stainless steel, it would not be susceptible to brittle fracture associated with the colder temperatures.

4.3.3 Accident Conditions

Three thermal accidents are postulated and individually evaluated for the NAC-UMS system. They include a fire, an all air inlets and outlets blocked event, and an extreme environmental temperature of 125°F event.

The thermal accident postulated for the NAC-UMS is described in Section 11.2.6 of the SAR. A fire with an average flame temperature of 1475°F and duration of 8 minutes is postulated from the spillage and ignition of 50 gallons of combustible transporter fuel. The fire is assumed to spread along the ground and heat the air as it enters the cask. Solar insolation is applied during the fire since the fire is only assumed to occur at the base of the cask and a heat load of 23 kW is considered. The initial temperature distribution of the transient is based on the normal storage conditions. Following the fire, the cask is allowed to cool using the boundary conditions corresponding to the normal conditions of storage.

DRAFT

A full blockage of all air inlets and outlets on the cask is described in Section 11.2.13 of the SAR. The event initiates at normal conditions with an ambient air temperature of 76°F and is postulated to result from a greater than DBE or landside. Solar insolation is conservatively assumed to contribute to the heat up rate of the canister even though blockage of all vents would undoubtedly restrict the effects of insolation.

As described in Section 11.2.7 of the SAR, an extreme environmental heat of 133°F is analyzed for the NAC-UMS with a maximum decay heat of 23 kW and a 12-hour insolation period of 2950 BTU/ft² and 1475 BTU/ft² for horizontal flat and curved surfaces, respectively.

4.3.4 Transfer Conditions

The applicant analyzed the temperature rise of the transfer cask components and canister contents beginning with the placement of spent fuel in the canister within the transfer cask and concluding with the placement of the loaded canister in the VCC. This analysis is composed of three steps: (1) wet loading and draining of the canister, (2) vacuum drying, and (3) helium filling, canister final sealing, and placement in the VCC. During the initial wet loading operation, the applicant's consideration of the minimum time to boil avoids the potential for uncontrolled pressure increases due to the water boiling in the cask during transfer. By determining a bounding heat-up rate based on maximum heat load and minimum volume, the applicant established the time before water in the canister would boil as a function of the initial temperature of the NAC-UMS contents when removed from the pool. In addition, the applicant analyzed the temperature rise of the canister contents and transfer cask components during the vacuum drying operations and subsequent helium filling, sealing, and transfer to the VCC. The results of the analysis justify a time period for completion of the transfer operations, shown in Table 4.1-2 of the SAR, with all components being below their allowable temperature limits. Implementation of the transfer temperature limits is accomplished by establishing heat-up rates for water heat-up, vacuum drying, and helium filling with no external cooling. This permits flexibility between the three transfer conditions such that the time periods for each condition can be adjusted from the analyzed time period while providing assurance that the temperature limits of the components are not exceeded during transfer operations. The staff reviewed the associated analysis results, procedures, and technical specifications, including the required actions, and verified that the application of these heat-up rates for the time periods imposed is within the component temperature limits.

4.4 Model Specification

4.4.1 Configuration

The analytical model for the thermal design of the NAC-UMS system was developed using the industry standard ANSYS computer code. The computational fluid dynamics modeling that was performed utilized ANSYS FLOTRAN. Transport of heat from the fuel assemblies to the outside environment is analyzed in terms of six interdependent thermal models for each of the PWR and BWR storage systems. The first model considers air flow within the VCC, as well as, temperature distribution in the canister shell and VCC. The second model considers heat transport within the canister. The third model is to analyze the transfer mode, which includes removal of canister from spent fuel pool, vacuum drying, filling with helium, and TSC

DRAFT

placement in the VCC. The fourth model is used to determine the effective conductivity of the canister internals in the radial direction. The fifth model is used to determine the effective thermal conductivities of the various types of fuel assemblies. Finally, the sixth model is used to determine the effective conductivities of the fuel tube wall and the neutron absorber plate. Natural convection of air in the VCC, in addition to radiative heat transfer from the canister surface, cools the spent fuel cladding and storage cask components below their temperature limits.

4.4.1.1 Air Flow and Concrete Cask Model

The air flow and concrete cask model consists of the canister shell, steel inner liner of the concrete cask, concrete, air inlet and outlet, annulus region, and canister internals which are treated as three homogeneous regions with effective thermal conductivities. The canister internals are divided into the active fuel region and the regions above and below the active fuel region. The decay heat load of 23 kW is included in the active fuel region of the model and is applied based on the applicable axial power distribution for PWR or BWR fuels. Cooling of the canister shell is by natural convection in the annulus region between the canister and concrete cask and by radiation heat transfer between the canister shell and the VCC inner liner. Heat is also dissipated through the concrete and dissipated to the surroundings by natural convection and by radiation heat transfer. Since the four air inlets and four air outlets are symmetrical about the axis of the cask, a two-dimensional axisymmetrical air flow and concrete cask finite element model was used, as shown in Figure 4.4.1.1-2 of the SAR for the PWR configuration. Insolation is also added to the outer cask surface and is averaged over a 12-hour period. This thermal system, including mass, momentum, and energy was analyzed using ANSYS FLOTTRAN. Also, the applicant performed an accuracy check of the numerical solution to this model in three areas. First, the global convergence of the iteration process for the nonlinear system had been checked and all results were indicated to have converged. Second, the energy balance for the ratio of total heat output to total heat input was demonstrated to be within 2% for all design conditions. Third, the number of modeling elements was reduced by 21% which only produced a 1% maximum difference in the calculated temperatures. These results indicate to the staff that the numerical methods utilized are reasonable.

The applicant considered the thermal interaction among casks in an array. The view factor at the cask side has been reduced to account for the cask being surrounded by eight other casks.

4.4.1.2 Canister Model

The canister model as shown in Figure 4.4.1.2-1 for PWR fuel and Figure 4.4.1.2-3 for BWR fuel includes the canister shell, including the lids and bottom plate; and the internals including the fuel assemblies, fuel tubes, support disks, heat transfer disks, and helium. A three-dimensional model was used, and since the canister is symmetric, only half of it was modeled. Conduction heat transfer is modeled in the axial direction of the active fuel region. The fuel assemblies and fuel tubes are assumed in the model to be concentrically centered in the support/heat transfer disk slots with gaps existing all around. Likewise, the fuel bundle is assumed to be centered within the canister shell with a gap existing between the support/heat transfer disks and the canister shell. The size of the gaps used in the model were

DRAFT

demonstrated to be bounding of the nominal gaps adjusted for thermal expansion. A sensitivity analysis was performed at the request of the staff to evaluate the effect of fabrication tolerances on increasing the gaps and consequently on the canister's heat transfer analysis. The applicant analyzed the effect of fabrication tolerances on the gaps in the PWR canister model and the results indicated that the fuel cladding temperature would increase by 9°F. This reduced the normal temperature margin from 46°F to 37°F or a reduction of margin by approximately 20%. However, since adequate margin still exists and the calculational methods are conservative, the staff considers the effect of fabrication tolerances minimal.

Except for the BWR carbon steel support disks, radiation heat transfer was modeled across all gaps either by directly modeling radiation elements or by including it in the determination of an effective conductivity. The BWR carbon steel support disks were not modeled with consideration of radiation heat transfer since these disks are nickel coated and omitting the emissivity is conservative. An effective conductivity was determined via a separate ANSYS model for the region inside of the fuel tubes, including the helium gas. Additionally, an effective conductivity was determined via another separate ANSYS model for the fuel tube (including Boral plate), including helium gaps on both sides of the Boral plate and the helium gap between the fuel tube exterior surface and the heat transfer/structural disks. The decay heat load of 23 kW was applied in the active fuel region based on the axial power distribution shown in SAR Figures 4.4.1.1-3 and 4.4.1.1-4 for PWR and BWR fuels, respectively.

4.4.1.3 Two-Dimensional Axisymmetric Transfer Cask Models

A two-dimensional model is used to determine the maximum temperature of the fuel cladding, transfer cask, and canister, including internal components, for the transfer condition. A separate model is utilized for PWR and BWR fuels. Convection and radiation heat transfer are considered at the surfaces of the transfer cask and on top of the canister lid. An adiabatic boundary is assumed for the bottom of the transfer cask. The canister is assumed to be concentric with the transfer cask and radiation heat transfer is modeled across this gap. The canister contents are modeled as three regions. The area above the active fuel is modeled as air during draining, as vacuum during drying operations, and helium during back filling. Effective thermal conductivities are used for the active fuel region and for the region below the active fuel, except that for the radial direction of the region below the active fuel the conductivity is assumed to conservatively be that of the medium. A volumetric heat generation, determined from the maximum heat load of 23 kW, is applied to the active fuel region utilizing the axial power distribution from Figures 4.4.1.1-3 and 4.4.1.1-4 for PWR and BWR fuels, respectively. The PWR transfer cask and canister model is shown on SAR Figure 4.4.1.3-1.

4.4.1.4 Three-Dimensional Periodic Canister Internal Models

A three-dimensional periodic canister internal model is used to determine the effective thermal conductivity of the canister internals in the radial direction. Three separate models are used; one for PWR fuel and two for BWR fuel. The PWR model consists of one support disk, two one-half thickness heat transfer disks, fuel assemblies, fuel tubes, and the media in the canister. The first BWR model represents the center of the canister and includes one heat transfer disk with two one-half thick support disks, fuel assemblies, fuel tubes, and the media

DRAFT

in the canister. The other BWR model is similar except that it does not contain heat transfer disks. The fuel assemblies and fuel tubes are represented by homogeneous regions with effective thermal properties determined from the two-dimensional fuel model and fuel tube model.

4.4.1.5 Fuel Model

A cross-section of the fuel assembly is modeled to determine the effective conductivity of the fuel which is then utilized in the canister model and periodic canister internal model. To account for the various types of fuel assemblies, seven models were analyzed; four for PWR fuel and three for BWR fuel. The fuel assembly model includes the fuel pellets, helium gas in the fuel rod, cladding, and media between the fuel rods. The media is helium for storage conditions and either water, vacuum, or helium for transfer conditions. Conduction and radiation heat transfer are considered between individual fuel rods. Radiation between the fuel pellet and cladding is conservatively ignored. The design heat load of 23 kW is applied to the fuel pellets in the form of a volumetric heat generation. Figure 4.4.1.5-1 shows the two-dimensional fuel model.

4.4.1.6 Fuel Tube Model

A two-dimensional fuel tube model is used to determine the effective conductivity of the fuel tube and Boral plate as it varies with temperature. Six models were utilized; four PWR models and two BWR models, one with Boral plate and one without.

The PWR model includes the gap between the fuel assembly and the fuel tube, the fuel tube, the Boral plate (if utilized), gaps on both sides of the Boral plate, and the gap between the fuel tube exterior surface and the heat transfer/structural disks. The media of water, vacuum, and helium are evaluated. The model consists of conduction through all layers with radiation only at the gaps. SAR Figure 4.4.1.6-1 shows the two-dimensional PWR fuel tube model.

The BWR model differs from the PWR model in that not all sides of the fuel channels contain Boral. This results in two BWR models: one with Boral plate and the other with a gap replacing the Boral plate. SAR Figures 4.4.1.6-2 and -3 show the BWR model with and without Boral, respectively.

The design basis heat load of 23 kW is applied as a heat flux to the inside surface of the fuel tube or fuel channel. ANSYS results are used to calculate the maximum temperature at the inside surface of the fuel tube.

4.4.2 Material Properties

The material properties used in the thermal analysis of the storage cask system are listed in SAR Section 4.2. The applicant provided material compositions and thermal properties for all components used in the calculational model. The material properties given reflect the accepted values of the thermal properties of the materials specified for the construction of the cask. For homogenized materials, such as described in the fuel tube model, the applicant adequately described the manner in which the effective thermal properties were calculated.

DRAFT

4.4.3 Boundary Conditions

The boundary conditions for the NAC-UMS include the design basis decay heat of 23 kW and the external conditions on the cask surface. The distribution of the decay heat load is based on the axial power distribution curves shown on SAR Figures 4.4.1.1-3 and 4.4.1.1-4 for PWR and BWR fuels, respectively. From the curve, the peak power factor for the PWR fuel is 1.08 and for BWR fuel is 1.22, which are discussed in SAR Section 5.2.6.

The boundary conditions depend on the environment surrounding the cask. Three conditions are considered for the TSC. The first includes the conditions set forth for normal storage. The second case considers off-normal operation, like severe environmental temperatures. The third case considers the effect of accidents, such as a fire, on the thermal performance of the cask. A summary of the thermal design conditions for storage, including environmental temperature, insolation, and vent operation are provided in Table 4.1-1.

4.4.3.1 Normal Storage Conditions

The applicant evaluated the cask for conditions with an ambient temperature of 76°F and a 12-hour insolation period of 2950 BTU/ft² and 1475 BTU/ft² for horizontal flat and curved surfaces, respectively. VCC inlets and outlets were assumed to be free from any blockage and the design basis heat load of 23 kW was applied.

4.4.3.2 Off-Normal Storage Conditions

The applicant evaluated the cask for the severe heat condition of an ambient temperature of 106°F and a 12-hour insolation period of 2950 BTU/ft² and 1475 BTU/ft² for horizontal flat and curved surfaces, respectively. The design basis heat load of 23 kW was also applied. This off-normal condition is described in SAR Section 11.1.1.

The second off-normal condition evaluated a severe cold ambient temperature of -40°F, no solar insolation, but the design basis heat load of 23 kW was applied. The decay heat load was applied to this condition since brittle fracture of the canister is not a concern due to the ductility of the stainless steel and the maximum thermal stress would be associated with the largest decay heat. This off-normal condition is described in SAR Section 11.1.1.

The third off-normal condition evaluated the cask for half of the air inlets blocked, all air outlets open, and is described in SAR Section 11.1.2. The ambient temperature used for this condition was 76°F, solar insolation was applied as for the severe heat condition, and the design basis heat load of 23 kW was applied.

4.4.3.3 Accident Conditions

Three accident conditions were analyzed by the applicant: an extreme heat condition, a blockage of all cask air inlets and outlets, and a fire. The accident extreme heat condition of 133°F ambient was analyzed at steady-state conditions as described in SAR Section 11.2.7. Full solar insolation was applied in addition to the design basis heat load of 23 kW.

DRAFT

The second accident condition analyzed blockage of all cask inlets and outlets as described in SAR Section 11.2.13. Full solar insolation was applied in addition to the design basis heat load of 23 kW. Since the cask is postulated to be buried, all convective cooling is lost, but conductive cooling from the exterior surface of the cask is considered. As an added conservatism, solar insolation is considered which would not be applicable for a buried cask.

The third accident condition postulated a fire as described in SAR Section 11.2.6. A fire resulting from a spillage and ignition of 50 gallons of transporter diesel fuel with an average flame temperature of 1475°F is hypothesized to last 8 minutes. Since the cask air inlets are at grade elevation, the air entering the cask is heated by the postulated fire. At the start of the transient, the ambient air temperature is changed instantaneously to 1475°F, and the air inlet surfaces are changed to 1475°F. The initial temperature distribution of the transient is based on the normal storage conditions, including a decay heat load of 23 kW and solar insolation applied to the top and sides of the cask. Following the fire, the external conditions for normal operating steady-state conditions are applied and this cooldown phase is then analyzed for more than 10 hours to determine the maximum internal component temperatures.

4.5 Thermal Analysis

4.5.1 Computer Programs

The complete thermal analysis was performed by the applicant using the industry standard ANSYS finite element modeling package and its associated computational fluid dynamics code, FLOTRAN. ANSYS is capable of general three-dimensional steady-state and transient calculations. Based on the SAR drawings and the thermal property information contained in the SAR, the staff determined that sufficient information was available to perform confirmatory analysis. The staff reviewed selected applicant calculations to confirm that the modeling was performed in accordance with the drawings and the boundary conditions contained in the SAR and that the calculations agreed with the conclusions presented. The staff performed confirmatory calculations to verify the heat loads associated with the various proposed contents were bounded by the design basis heat load. Thus, the staff has reasonable assurance that the NAC-UMS spent fuel storage system provides adequate heat removal capacity without an active cooling system, as required by 10 CFR 72.236(f). The staff does not view the application of forced air cooling during transfer operations, where time limits could be exceeded, as conflicting with 10 CFR 72.236(f). Instead, forced air cooling during transfer operations is viewed as an appropriate remedial action to exceeding a limiting condition of operation.

4.5.2 Temperature Calculations

4.5.2.1 Normal Storage Conditions

The NAC-UMS system has been analyzed to determine the temperature distribution under long-term normal storage conditions. The canister has been considered to be loaded at design basis maximum heat load of 23 kW. The systems are considered to be arranged in an ISFSI array and subjected to design basis normal ambient conditions with insolation. The

DRAFT

maximum allowable temperatures of the components important to safety are listed in Table 4.1-3 of the SAR. Low temperature conditions were also considered.

The table below summarizes the applicant's calculated temperatures of key components associated with the storage of intact spent fuel for various environmental conditions.

Summary Thermal Evaluation of NAC-UMS for PWR & BWR Fuels

NAC-UMS Cask Component	Normal Conditions [°F]			Off-Normal & Accident Conditions [°F]								
	Normal Conditions		Allow- able (Long- term)	Severe Heat 106°F (Off-Normal)		Extreme Environmental Conditions 133°F (Accident)		Fire (Accident)		Helium Transfer		Allow- able (Short- term)
	PWR	BWR		PWR	BWR	PWR	BWR	PWR	BWR	PWR	BWR	
Fuel Cladding	670	651	716*	694	677	715	702	710	712	686	654	1058
Aluminum Heat Transfer Disk	612	622	650	638	648	661	675	652	654	NA	654	700
Support Disk PWR-SS BWR-CS	615	624	650- PWR & 700- BWR	642	651	664	677	655	657	NA	654	800- PWR & 700- BWR
Canister Shell	351	376	800	381	405	408	432	408	459	416	432	800
Concrete Liner	NA	NA	700	NA	NA	NA	NA	NA	NA	NA	NA	700
Concrete	186 local 135 bulk	192 local 136 bulk	200 local 150 bulk	228	231	262	266	244	244	NA	NA	350
Lead	NA	NA	NA	NA	NA	NA	NA	NA	NA	199	210	600
Neutron Shield	NA	NA	NA	NA	NA	NA	NA	NA	NA	195	206	300
Transfer Cask Shell	NA	NA	NA	NA	NA	NA	NA	NA	NA	237	251	700

* The exact fuel cladding temperature limit may be slightly higher provided it is determined in accordance with the methodology from PNL-6189.

As can be seen from the above table, all of the calculated component temperatures are below

DRAFT

their allowable temperature.

4.5.2.2 Off-Normal Conditions

The off-normal event considering an environmental temperature of 106°F for a duration sufficient to reach thermal equilibrium was evaluated by the applicant. The evaluation was performed with design basis fuel with maximum decay heat. The 106°F environmental temperature was applied with full solar insolation. All of the off-normal temperatures were below the short-term design basis temperatures.

The off-normal event considering an environmental temperature of -40°F, design basis decay heat, and no solar insolation for a duration sufficient to reach thermal equilibrium was evaluated by the applicant. The use of the maximum decay heat load produces the maximum thermal gradient with respect to the calculation of thermal stresses for this condition. Also, the structural evaluation in SAR Section 3.4.5 demonstrated the performance of the NAC-UMS system with respect to severe cold conditions.

Analysis of the off-normal event of blockage of half of the air inlets demonstrates that the cask has an adequate air supply since the results indicate only a few degree temperature rise above normal conditions.

Based on these analyses and review, the staff has reasonable assurance that the off-normal temperatures do not affect the safe operation of the NAC-UMS.

4.5.2.3 Accident Conditions

The extreme environmental conditions evaluated by the applicant consider an environmental temperature of 133°F for a duration sufficient to reach thermal equilibrium. The evaluation was performed with design basis fuel and with maximum decay heat. The 133°F environmental temperature was applied with full solar insolation. All of the extreme environmental temperatures were below the short-term design basis component temperature limits.

Based on these analyses and review, the staff has reasonable assurance that the extreme environmental conditions do not affect the safe operation of the NAC-UMS.

The applicant analyzed a fire accident on the NAC-UMS system using the conditions previously specified in SER Section 4.4.3.3. The peak temperatures of the key cask components due to an 8-minute fire with a maximum decay heat are shown in the table in SER Section 4.5.2.1. The staff verified, via independent calculation, using the method documented in NUREG-0360 that the duration of the fire is conservative. The initial temperatures are based on the normal storage conditions and an incident solar heat flux based on the specified insolation averaged over 12 hours. The components inside the canister were not modeled directly. Instead, the temperature of the canister shell was determined from the air flow and concrete cask model. The temperature of the canister's internal components was then determined by adding the difference in canister shell temperature (between the normal and fire accident) to the maximum normal temperature of the canister internal components. This

DRAFT

method results in a bounding cladding temperature that is independent of post fire cooling time scenarios. All of the fire accident temperatures were below the short-term design basis temperatures. Based on these analyses and review, the staff has reasonable assurance that the cladding integrity will not be compromised during the postulated fire.

The applicant analyzed the effect of blocking all the air inlets and outlets. This event was analyzed to determine the minimum time for reaching material temperature limits. The applicant was conservative in the assumptions for setting up the problem. Conduction heat transfer replaces convection at the surface of the cask, simulating burial in a landside, but full solar insolation was also applied. The design basis heat load was also used. The results from this unlikely scenario indicate that the cask should not be deprived of air flow for more than 24 hours, otherwise, the support disk and heat transfer disk may exceed their allowable temperature limit. The analysis also demonstrated that the fuel cladding would not approach its temperature limit for about 150 hours.

4.5.3 Pressure Analysis

4.5.3.1 Normal Conditions of Storage

The applicant determined the pressure in the TSC based on the average cavity gas temperature of 500°F and the normal storage conditions. The canister is sealed and backfilled to a pressure of 0.0 psig of helium at 70°F. During normal operating conditions, a conservative estimation of the design pressure was based on the calculation of the total moles of gas available for pressurizing the canister. The moles of gas available for pressurization of the canister due to decay heating include moles from: backfilling the canister with helium, 1% of the spent fuel leaking its initial helium fill gas at a pressure of 500 psig, 30% of the fission gas produced from the assumed 1% leaking spent fuel rods, and assuming a burnup of 55 GWD/MTU. Under these conditions, and with the average cavity gas temperature of 500°F, the applicant determined a design pressure of approximately 5.8 psig. Therefore, this determination of design pressure justifies the test pressure of 20 psig mentioned in SAR Section 9.1.2, since the ASME Code for Class 1 components only requires a pneumatic test at a factor of 1.2 of the design pressure.

4.5.3.2 Off-Normal Conditions

The applicant did not provide an explicit derivation of the off-normal pressure in the SAR. However, the staff considers this calculation straight forward in that it is derived from the methods employed in determining the design pressure, except that the fraction of damaged fuel rods is changed from 1% to 10% and a bulk average gas temperature coinciding with off-normal operation is used. This pressure would be used in determining stresses for off-normal loading combinations.

4.5.3.3 Accident Conditions

The applicant determined the pressure in the TSC based on the average cavity gas temperature of 580°F for PWR and 600°F for BWR. Using these gas temperatures, an assumed spent fuel rod cladding failure of 100%, and the methodology from the design

DRAFT

pressure calculation, the applicant determined an accident maximum canister pressure of 56.1 psig for PWR and 35.3 psig for BWR fuels. The applicant increased this pressure to 65 psig to bound all pressurization scenarios, including the canister reflooding operation, and used this value in the calculation of stresses due to internal canister pressurization as shown in SAR Tables 11.2.1-1 and 11.2.1-2.

4.5.4 Confirmatory Analysis

The confirmatory analysis of the NAC-UMS system SAR can be divided into seven categories: (1) review of the models used in the analyses, (2) review of the material properties used in the analyses, (3) review of the boundary conditions and assumptions, (4) performance of independent analyses, (5) review of selected applicant calculation packages, (6) comparison of the results of the analyses with the applicant's design criteria, and (7) assuring that the applicant's design criteria will satisfy the regulatory acceptance criteria and regulatory requirements.

The staff reviewed the models used by the applicant in the thermal analyses. The code inputs in the calculation packages were checked for consistency to confirm that the applicant used the appropriate material properties and boundary conditions where required. The engineering drawings were also consulted to verify that proper geometry dimensions were translated to the code model. The applicant justified their modeled gap values for consideration of fabrication tolerances, in addition to thermal growths. The material properties presented in the SAR were reviewed to verify that they were appropriately referenced and used conservatively. In addition, the staff performed a confirmatory analysis of the thermal heat loads to ensure that they were bounded by the design basis heat load.

The staff has determined that the thermal SSCs important to safety are described in sufficient detail in SAR Sections 1 and 4 to enable an evaluation of their effectiveness. Based on the applicant's analyses, there is reasonable assurance that the NAC-UMS is designed with a heat-removal capability having testability and reliability consistent with its importance to safety.

Based on the applicant's analyses, there is reasonable assurance that the NAC-UMS system provides adequate heat removal capacity without active cooling systems. The staff also has reasonable assurance that the spent fuel cladding will be protected against degradation that leads to gross ruptures by maintaining the clad temperature below the allowable criteria and by providing an inert environment in the cask cavity, thus assuring that the fuel can be readily retrieved for future processing or disposal without significant safety problems.

The staff has further concluded that the design of the heat removal system of the NAC-UMS storage cask is in compliance with 10 CFR Part 72 and that the applicable design and acceptance criteria have been satisfied. The evaluation of the thermal system design provides reasonable assurance that the NAC-UMS will enable safe storage of spent fuel. This finding is based on a review which considered the requirements of 10 CFR Part 72, appropriate regulatory guides, applicable codes and standards, and accepted practices.

DRAFT

4.6 Evaluation Findings

- F4.1** SSCs important to safety are described in sufficient detail in SAR Sections 1, 2 and 4 to enable an evaluation of their thermal effectiveness [10 CFR 72.24(c)(3)].
- F4.2** The staff has reasonable assurance that the spent fuel cladding will be protected against degradation that leads to gross ruptures by maintaining the clad temperature below maximum allowable limits and by providing an inert environment in the cask cavity [10 CFR 72.122(h)(1)].
- F4.3** Through the analysis, staff developed reasonable assurance that the NAC-UMS system is designed with a heat-removal capability having testability and reliability consistent with its importance to safety [10 CFR 72.128(a)(4)].
- F4.4** By analysis, the staff has reasonable assurance that the decay heat loads were determined appropriately and accurately reflect the burnup, cooling times, and initial enrichments specified [10 CFR 72.122].
- F4.5** By analysis, the staff has reasonable assurance that the NAC-UMS system provides adequate heat removal capacity without active cooling systems [10 CFR 72.236(f)].
- F4.6** By analysis, the staff has reasonable assurance that the temperatures of the cask components and the cask pressures under normal and accident conditions were determined correctly [10 CFR 72.122].
- F4.7** The staff concludes that the thermal design in the SAR is in compliance with 10 CFR Part 72 and that the applicable design and acceptance criteria have been satisfied. The evaluation of the thermal design provides reasonable assurance that the NAC-UMS system will allow safe storage of spent fuel for a certified life of 20 years. This finding is reached on the basis of a review that considered the regulation itself, appropriate regulatory guides, applicable codes and standards, and accepted engineering practices.

intentionally left blank

DRAFT

5.0 SHIELDING EVALUATION

The purpose of the shielding evaluation is to determine whether the NAC-UMS storage cask shielding features provide adequate protection against direct radiation from cask contents. The regulatory requirements for providing adequate shielding to protect licensee personnel and members of the public include 10 CFR Part 20, 10 CFR 72.24 (c)(3), 72.24(d), 72.104(a), 72.106(b), 72.128(a)(2), and 72.236(d). Because 10 CFR Part 72 dose requirements for members of the public include direct radiation, effluent releases, and radiation from other uranium fuel-cycle operations, an overall assessment of compliance with these regulatory limits is evaluated in SER Section 10 (Radiation Protection).

5.1 Shielding Design Description

5.1.1 Shielding Design Criteria

SAR Section 1 provides a general description of the NAC-UMS system. SAR Section 2 specifies the principal design criteria of the NAC-UMS system. SAR Section 5.1 provides the design criteria for the surface dose rates of the cask.

The average surface dose rate criteria for the NAC-UMS at the concrete cask side wall shall be less than 50 mrem/hr, at the top lid less than 50 mrem/hr, and at the air inlet and outlets less than 100 mrem/hr.

The fuel to be stored in the NAC-UMS is divided into five classes based upon length. There are three PWR classes and two BWR classes. The TSC will store up to 24 PWR or up to 56 BWR spent fuel assemblies. Based upon the evaluation performed by NAC, the design basis PWR fuel is the Westinghouse 17x17 Standard assembly with a burnup of 40,000 MWD/MTU, an initial enrichment of 3.7 wt. percent ²³⁵U, and a 5-year cooling time. The design basis BWR fuel has been determined to be the GE 9x9 assembly with a burnup of 40,000 MWD/MTU, an initial enrichment of 3.25 wt. percent ²³⁵U, and a 5-year cooling time.

5.1.2 Shielding Design Features

The NAC-UMS is designed to provide both gamma and neutron shielding. Some of the features of the cask which help ensure dose rates at the surface of the cask are low are:

Thick steel and concrete walls to reduce the side surface dose rate of the concrete cask.

Non-planar cooling air pathways to minimize radiation streaming at the inlets and outlets of the VCC.

Material selection and surface preparation that facilitate decontamination.

The TSC cylinder is fabricated from (5/8-inch thick) Type 304L stainless steel. The bottom plate is 1.75-inch thick Type 304L stainless steel. The TSC has a 7-inch thick shield lid made of Type 304 stainless steel and a 3-inch thick structural lid made of Type 304L stainless steel.

DRAFT

The transfer cask, used to hold the canister during fuel loading activities and to transfer the TSC to the storage cask, has a multi-wall radial shield comprised of 1.91 cm (0.75 in) of carbon steel, 8.89 cm (3.5 in) of lead, 5.08 cm (2 in) of solid borated polymer (NS-4-FR), and 3.18 cm (1.25 in) of carbon steel. An additional 0.16 cm (0.625 in) of stainless steel shielding is provided, radially, by the canister shell. Gamma shielding is provided primarily by the steel and lead layers. The NS-4-FR provides the neutron shielding. The transfer cask bottom shield door design is a solid section comprised of 19.05 cm (7.5 in) of carbon steel and 3.81 cm (1.5 in) of NS-4-FR. The top of the transfer cask is open but shielding is provided by the stainless steel canister shield and structural lids which are 17.78 cm (7 in) and 7.62 cm (3 in) thick, respectively. Additionally, there is a 12.70 cm (5 in) carbon steel temporary shield which is to be used during welding, draining, drying, and helium backfill operations.

The VCC is the storage overpack for the TSC. The VCC is 71.76 cm (28.25 in) of reinforced concrete (Type II Portland cement) structure with a 6.35 cm (2.5 in) thick carbon steel inner liner. The concrete wall and steel liner provide the neutron and gamma radiation shielding to reduce the average contact dose rate to less than 50 millirem per hour for the design basis fuel. An additional 0.16 cm (0.625 in) of stainless steel shielding is provided, radially, by the canister shell. The VCC top shielding is comprised of the 25.4 cm (10 in) of stainless steel from the canister lids, a shield plug containing 2.54 cm (1 in) NS-4-FR and 10.48 cm (4.125 in) of carbon steel, and a carbon steel lid 3.81 cm (1.5 in) thick. The storage cask bottom, which is composed of 4.45 cm (1.75 in) of stainless steel from the canister bottom plate, 5.08 cm (2 in) of carbon steel from the pedestal plate, and 2.54 cm (1 in) of carbon steel cask base plate, will rest on a concrete pad.

The staff evaluated the NAC-UMS system shielding design features and criteria and found them to be acceptable. The SAR analysis provides reasonable assurance that the shielding design features and criteria can meet the regulatory requirements in 10 CFR Part 20, 10 CFR 72.104(a), and 10 CFR 72.106(b). Cask surface dose limits are included in TS 3.2.2 of Appendix A to the CoC.

5.2 Radiation Source Definition

SAR Section 2.1 describes the spent fuel to be stored in the NAC-UMS and identifies the types of fuel which have been determined to be bounding for the shielding evaluation. Tables 2.1.1-1 and 2.1.2-1 contain the parameters for the PWR and BWR fuel assemblies to be stored, respectively. SAR Section 5.2 presents the source specifications for the fuel assemblies.

The SAS2H module of the SCALE 4.3 code package for the PC (ORNL) was used to generate gamma and neutron source terms. The 27-group neutron, 18-group gamma ENDF/B-IV cross-section library was used to determine the source term for the design basis PWR and BWR fuels. Source terms are comprised of fuel neutrons, fuel gammas, and activated hardware gammas. The fuel assembly hardware source term is calculated by light element transmutation using the incore neutron flux produced by the SAS2H model. The fuel hardware is assumed to be Type 304 stainless steel that has a ^{59}Co impurity level of 1.2 g/kg and some minor contaminants from ^{59}Ni and ^{58}Fe .

DRAFT

The staff performed confirmatory analyses of the design basis gamma and neutron source terms for the Zircaloy-clad and stainless steel clad fuels. Staff used SAS2H and Origen-S of the SCALE-4.4 computer code. The results of the confirmatory analyses correlate with the results obtained by NAC. Staff analyses resulted in a minimally higher source term which is a result of using the SCALE4.4 for the PC version and using 44GROUPNDF5 cross-section library. The staff reviewed the fuel parameters listed in SAR Tables 2.1.1-1 and 2.1.2-1 and has reasonable assurance that the design basis gamma and neutron source terms are adequate for the shielding analysis.

5.3 Model Specification

SAR Section 5.3 provides the model specifications for the shielding evaluation. NAC used the one-dimensional, SAS1, and three-dimensional, SAS4, models in the shielding evaluation for the NAC-UMS. The SAS1 module was used to perform one-dimensional radial and axial shielding analyses on the sides, top, and bottom of the storage and transfer casks.

The SAS4 three-dimensional model was used to estimate the dose profiles at the surfaces of the cask and at streaming paths, such as the storage cask inlets and outlets, and the canister vent and drain ports. SAS4 uses adjoint discrete ordinates and Monte Carlo methods in solving the shielding problem. Since SAS4 requires model symmetry at the fuel midpoint, two models are created for each cask, a top and bottom model. Radial biasing is performed to estimate the dose rates of the sides of the cask. Dose rates on the top and bottom surfaces of the cask are estimated by axial biasing.

NAC used SKYSHINE-III Version 5.0.1 to calculate the controlled area boundary dose for a proposed ISFSI for a 2 by 10 array of casks filled with either PWR or BWR design basis fuel (SAR Section 10.4). Contributions from both direct and air scatter radiation is included in the SKYSHINE-III dose rate calculations. The performance of the SKYSHINE-III code is benchmarked by modeling a set of Kansas State University ⁶⁰Co skyshine experiments and by modeling two Kansas State University neutron computational benchmarks.

Staff has reviewed the codes used by NAC to determine the source terms and dose rates for the VCC and the transfer cask. The codes used by NAC are commonly used throughout the industry to calculate source terms and dose rates. The input for these codes, submitted by NAC, has been reviewed and appears to be appropriate for the types of fuel used and for modeling the VCC and the transfer cask.

5.4 Shielding Analyses

The shielding evaluations for the NAC-UMS transfer and storage casks are presented in SAR Section 5.4. Shielding calculations were performed using the design basis fuel source terms for PWR and BWR fuels. ANSI/ANS Standard 6.1.1-1977 flux-to-dose conversion factors were used to calculate dose rates in the shielding analyses.

DRAFT

5.4.1 Storage Cask

The three-dimensional model dose rates are presented in SAR Figures 5.4-1 through 5.4-5 for PWR fuel and Figures 5.4-6 through 5.4-10 for BWR fuel. The axial dose rate profiles along the cask surface, broken down by contributing radiation type, are presented in Figure 5.4-1 for PWR fuel and Figure 5.4-6 for BWR fuel. The maximum axial dose rates occur at the openings of the VCC air outlets for both PWR and BWR contents. The peak dose rate is 66 mrem/hr for PWR fuel and 51 mrem/hr for BWR fuel. Dose rates at the inlets are considerably lower than at the outlets because of the 2.5-inch thick steel plate which forms the roof of the inlet channel.

SAR Figures 5.4-5 and 5.4-10, for PWR and BWR fuel respectively, present the radial dose rate profile at the top surface of the cask. Two peaks occur in the radial profile. One peak is observed above the canister/weldment annulus, where the dose contributions are equally from end fitting and plenum gammas and fuel neutrons. The second peak occurs above the upper vents and is due primarily to end-fitting gammas.

The staff has reviewed the input for the SAS1 and SAS4 dose model runs and has performed confirmatory dose rate analyses of the storage cask. Dose rate confirmatory calculations performed by staff, are in good agreement with the dose rates presented in the SAR. Based upon the information provided by the applicant and the confirmatory calculations, staff has reasonable assurance that the dose rates determined by NAC are representative of dose rates which would occur as a result of the storage cask being loaded with design basis PWR or BWR fuel.

5.4.2 Transfer Cask

Three-dimensional model dose rates of the transfer cask for PWR fuel are presented in SAR Figures 5.4-11 through 5.4-19 and in Figures 5.4-20 through 5.4-28 for BWR fuel. The transfer cask was modeled with both a dry cavity and a wet cavity.

The contributors to the dose rate of a transfer cask and canister with a wet cavity is from fuel gammas and activated non-fuel hardware gammas. The peak dose rate on the side of the transfer cask with a wet cavity has been determined to be 259 mrem/hr and 189 mrem/hr for PWR and BWR fuel, respectively.

In the wet condition, it is assumed the water level in the canister is lowered to the base of the upper end-fitting to facilitate the lid welding operations. During shield lid welding operations, the transfer cask with a wet canister and temporary shielding in place has a peak surface dose rate of the transfer cask top of 2092 mrem/hr and 1802 mrem/hr for PWR and BWR fuels, respectively. This peak dose rate is highly localized to the narrow gap between the temporary shield and the cask inner shell.

The transfer cask bottom dose rate for a wet canister filled with PWR fuel is 579 mrem/hr for a peak and 258 mrem/hr average. The peak and average dose rate for a transfer cask with a wet canister filled with BWR fuel is 539 mrem/hr and 254 mrem/hr, respectively.

DRAFT

For the transfer cask containing a canister with a dry cavity, the majority of the dose rate is from neutrons and gammas from the fuel with significant contributions from the end-fittings. NAC has calculated the peak dose rates on the side of the transfer cask containing a canister with a dry cavity to be 410 mrem/hr and 325 mrem/hr for PWR and BWR fuel, respectively.

After the shield and structural lids are welded and the canister cavity drained, the dose rate on the top of the transfer cask is from end-fitting gammas. The peak and average dose rates on the top of the transfer cask containing a sealed canister filled with PWR fuel is 715 mrem/hr and 369 mrem/hr, respectively. The peak and average dose rates on the top of the transfer cask containing a sealed canister filled with BWR fuel is 846 mrem/hr and 264 mrem/hr, respectively.

The peak and average dose rates at the bottom of a transfer cask with a dry canister filled with PWR fuel have been determined to be 819 mrem/hr and 374 mrem/hr, respectively. The peak and average dose rates at the bottom of a transfer cask with a dry canister filled with BWR fuel is 786 mrem/hr and 379 mrem/hr, respectively.

The transfer cask may also be lengthened by using a steel transfer cask extension. The extension is used when loading canisters with fuel assemblies that have the control element assemblies inserted. Fuel assemblies with control element assemblies inserted will be longer than fuel assemblies without. The transfer cask extension does not have the NS-4-FR neutron shield in it because the extra neutron shielding is not required since the extension is located axially above the active fuel region where the major contributor to the dose rate will be from the activated hardware regions.

The staff has reviewed the input for the SAS1 and SAS4 dose model runs and has performed confirmatory dose rate analyses of the transfer cask. Based upon the information provided by the licensee and the confirmatory calculations, staff has reasonable assurance that the dose rates determined by NAC are representative of dose rates which would occur as a result of the transfer cask containing a canister filled with design basis PWR or BWR fuel. While the dose rates for a transfer cask and filled canister are higher than for the concrete cask, work with the transfer cask will be performed by a licensee with a 10 CFR Part 50 license and will, therefore, have an appropriate radiation protection and ALARA program in place to adequately deal with the higher dose rates.

5.4.3 Off-site Dose Calculations

NAC used SKYSHINE-III, Version 5.0.1, to calculate off-site dose rates and to determine the minimum distance necessary to achieve a controlled area boundary of 25 mrem/yr as required by 10 CFR 72.104(a). A 2x10 cask array was modeled in the code with the source term from each cask represented as top and side surface sources. Using design basis PWR and BWR fuels, the SAS1 shielding evaluation provided the surface source emission fluxes. Figure 10.3-1 shows the typical ISFSI 20 cask array layout. Table 10.4-2 contains the summary of annual exposures at specific distances away from the cask array.

SER Section 10 evaluates the overall off-site dose rates from the NAC-UMS. The staff has reasonable assurance that compliance with 10 CFR 72.104(a) can be achieved by any site

DRAFT

licensee. A general licensee who intends to use the NAC-UMS must perform a site-specific evaluation, as required by 10 CFR 72.212(b), demonstrating compliance with 10 CFR 72.104(a). The limit of 25 mrem/year cited in 10 CFR 72.104(a) shall include all site sources. The actual doses to individuals beyond the controlled area boundary depend on site-specific conditions such as cask-array configuration, topography, demographics, and use of engineered features. Consequently, final determination of compliance with 72.104(a) is the responsibility of each applicant for a site license.

Appendix B of the CoC includes a provision regarding engineered features used for radiological protection. The license condition states that engineering features (e.g., berms and shield walls) used to ensure compliance with 10 CFR 72.104(a) are to be considered important to safety and must be evaluated to determine the applicable Quality Assurance Category.

5.5 Evaluation Findings

- F5.1** The SAR sufficiently describes shielding design features and design criteria for the SSCs important to safety.
- F5.2** Radiation shielding features are sufficient to meet the radiation protection requirements of 10 CFR Part 20, 10 CFR 72.104, and 10 CFR 72.106.
- F5.3** Operational restrictions to meet dose and ALARA requirements in 10 CFR Part 20, 10 CFR 72.104, and 10 CFR 72.06 are the responsibility of the site licensee. The NAC-UMS system shielding features are designed to assist in meeting these requirements.
- F5.4** The design of the shielding system for the NAC-UMS system is in compliance with 10 CFR Part 72 and the applicable design and acceptance criteria have been satisfied. The evaluation of the shielding system provides reasonable assurance that the NAC-UMS system will provide safe storage of spent fuel. This finding is based on a review that considered the regulations, appropriate regulatory guides, applicable codes and standards, and accepted engineering practices.

DRAFT

6.0 CRITICALITY EVALUATION

The staff's objective in reviewing the applicant's criticality evaluation of the NAC-UMS system design is to verify that the spent fuel contents remain subcritical under the normal, off-normal, and accident conditions of handling, packaging, transfer, and storage. The applicable regulatory requirements are those in 10 CFR 72.24(c)(3), 72.24(d), 72.124, 72.236(c), and 72.236(g).

The staff reviewed the information provided in the NAC-UMS SAR to determine whether the NAC-UMS system fulfills the acceptance criteria listed in Section 6 of NUREG-1536:

1. The multiplication factor (k_{eff}), including all biases and uncertainties at a 95% confidence level, should not exceed 0.95 under all credible normal, off-normal, and accident conditions.
2. At least two unlikely, independent, and concurrent or sequential changes to the conditions essential to criticality safety, under normal, off-normal, and accident conditions, should occur before an accidental criticality is deemed to be possible.
3. When practicable, criticality safety of the design should be established on the basis of favorable geometry, permanent fixed neutron-absorbing materials (poisons), or both. Where solid neutron-absorbing materials are used, the design should provide for a positive means to verify their continued efficacy during the storage period. Continued efficacy may be confirmed by a demonstration or analysis before use, showing that significant degradation of the neutron absorbing materials cannot occur over the storage period.
4. Criticality safety of the cask system should not rely on use of the following credits:
 - a. burnup of the fuel (see note below)*
 - b. fuel-related burnable neutron absorbers
 - c. more than 75% for fixed neutron absorbers when subject to standard acceptance tests.

*Note: Since publication of the SRP, the NRC has developed Interim Staff Guidance 8 (ISG-8), which describes acceptable methods and criteria for consideration of burnup credit in the criticality safety analysis of PWR spent fuel in transport and storage casks. Future revisions of the SRP will incorporate or reference the current staff guidance in this area.

Observations and conclusions from the staff's review are summarized below.

6.1 Criticality Design Criteria and Features

The design criterion for criticality safety of the cask system is that the calculated value of the effective neutron multiplication factor, k_{eff} , including biases and uncertainties, shall not exceed 0.95 under normal, off-normal, and accident conditions.

Criticality safety of the NAC-UMS system depends on the geometry of the fuel baskets and the use of fixed Boral panels for absorbing neutrons. The baskets for BWR and PWR fuel feature

DRAFT

56 and 24 square fuel tubes, respectively. A stainless steel cover plate attaches each Boral panel to the exterior wall of a fuel tube. In the BWR fuel baskets, a single Boral poison panel is located on one of the tube walls between all adjacent fuel positions. Each Boral panel in the BWR baskets has a minimum ^{10}B areal density of 0.011 g/cm^2 and a nominal thickness of 0.135 inches.

All 24 fuel tubes in the PWR fuel basket have Boral poison panels fixed to the four outer walls. Spaces between the two poison panels on neighboring fuel tubes form flux traps which enhance the effectiveness of neutron poisoning in a flooded basket. The primary design parameters that ensure subcriticality in the PWR fuel packages are the minimum flux-trap widths and the minimum ^{10}B content of the Boral panels. Each Boral panel on the PWR fuel tubes has a minimum ^{10}B areal density of 0.025 g/cm^2 and a nominal thickness of 0.075 inches.

The minimum width of an individual flux trap in the PWR fuel baskets is simply the minimum web thickness between the respective fuel-tube holes in the support disks. The actual or average widths of all 36 flux traps are governed by the dimensions and tolerances of the support-disk holes and by the outer widths of the fuel tubes with their Boral panels and cover plates. Tolerances and expansion effects that increase the overall widths of the poison-paneled fuel tubes make the system more reactive by effectively reducing the widths of the flux traps. Flux-trap widths are similarly reduced by bowing or uneven surface contact between the tube walls, Boral panels, and cover plates.

The most reactive credible configurations of the NAC-UMS system occur when the cask is flooded with water. The NAC-UMS does not rely on borated water as a means of criticality control. Therefore, the NAC-UMS would remain subcritical when flooded with pure water. Special features of the basket designs, as described in SAR Sections 1.2.1.2.1 and 1.2.1.2.2 and shown in the respective license drawings of SAR Section 1.8, ensure the free flow of water between the fuel tube contents and surrounding regions of the baskets. Uneven flooding within the baskets is therefore not a concern.

The staff reviewed Sections 1, 2, and 6 of the NAC-UMS SAR and verified that (1) the design features important to criticality safety are clearly identified and adequately described, (2) all criticality-related information shared between Sections 1, 2, and 6 is free of inconsistencies, and (3) the SAR's engineering drawings, figures, and tables are sufficiently detailed to support in-depth review and, as needed, confirmatory analysis by the staff.

The staff also verified that the design basis off-normal and postulated accident events would not adversely affect the design features important to criticality safety. In terms of maximum system reactivity, the flooded normal configurations, when modeled with waterlogged fuel rods, are identical to or bound the credible configurations resulting from an off-normal or accident event. Based on the information provided in the SAR, the staff concludes that the design of the NAC-UMS system meets the "double contingency" requirements of 10 CFR 72.124(a).

6.2 Fuel Specification

The NAC-UMS systems can transfer and store up to 24 intact PWR fuel assemblies or up to 56 intact BWR fuel assemblies. These systems may contain only intact fuel assemblies. To accommodate fuel assemblies of different lengths, the PWR system has three versions that differ only in their axial dimensions. Similarly, the BWR system comes in two versions identical in all but length. Allowed contents of intact fuel therefore include three classes of PWR fuel and two classes of BWR fuel, with each class characterized by a maximum assembly length. To axially position assemblies that are shorter than the available cavity length, stainless steel spacers may be placed on the floors of individual fuel tubes in PWR and BWR canisters.

The NAC-UMS fuel specifications establish comprehensive limits on the design parameters of allowed fuel contents. These limits are repeated in SAR Tables 12B2-1, 12B2-2, and 12B2-3. The initial enrichment of PWR fuels may not exceed 4.2 wt% ^{235}U . For BWR fuels, initial enrichment is limited to a peak planar average of no more than 4.0 wt% ^{235}U . Allowed types of PWR and BWR fuels are defined by the array size (e.g., 17x17, 9x9), the number of fuel rods, and the following limiting parameters:

- maximum mass of fuel
- maximum fuel rod pitch
- maximum fuel pellet diameter
- minimum fuel rod diameter
- minimum thickness of cladding
- minimum thickness of guide tube walls (PWR only)
- maximum active fuel length

The CoC's fuel specifications also includes requirements for the minimum lengths of the fuel assembly's bottom hardware. These minimum hardware lengths are defined as the sum of (a) the initial axial distance from the bottom extremity of the fuel assembly to the top surface of the bottom tie plate and (b) the initial axial distance between the bottom of the fuel pins and the bottom of the active fuel. Knowing the hardware lengths is essential to axially locating the active fuel region with respect to the bottom of the basket poison panels. When a fuel assembly's bottom hardware is too short, active fuel can extend significantly below the bottom of the poison panels, a configuration not considered in the applicant's criticality analyses. Therefore, requiring a minimum length of bottom hardware prevents material configurations that are potentially more reactive than those analyzed by the applicant.

All dimensional specifications for fuel assemblies are nominal pre-irradiation values derived from design drawings or other sources of fuel design information. Physical measurements on one or more assemblies of a given design are necessary only when bounding estimates of those dimensions cannot be established from the available records for that fuel design.

DRAFT

The staff reviewed the fuel parameters considered in the criticality analyses and verified that they are consistent with or bound the parameters in the CoC's fuel specifications and in Sections 1, 2, and 12 of the SAR. All fuel assembly parameters important to criticality safety have been included in the TS. The staff confirms that the fuel-assembly parameters and limits discussed above bound the maximum reactivity of an NAC-UMS system that does not rely on borated water for criticality control.

6.3 Model Specification

6.3.1 Configuration

The applicant's criticality calculations with KENO-Va apply periodic axial boundary conditions to explicit three-dimensional models of only the central axial region of the active fuel and NAC-UMS systems. By thus modeling infinitely long fuel assemblies within infinitely long packages, the applicant's analyses neglect the axial reflection of neutrons from one tube to another (i.e., axially bypassing the poison panels) under full or partial flooding conditions. The staff's independent calculations with MONK8a, however, confirm that flooded infinite-length models of the NAC-UMS are never significantly less reactive than the actual-length models with worst-case axial effects. This conclusion applies only to fuels that meet the specifications for minimum dimensions of the bottom fuel hardware. While the staff's analysis contradicts the claim that the infinite-length approximation adds conservatism, the staff does find the approximation acceptable.

Sketches of the applicant's calculational models appear in SAR Section 6.3. The models are based on the license drawings in SAR Section 1.8 and take into consideration the worst-case dimensional tolerance values. As previously stated, the design basis off-normal and accident events do not affect the performance of the cask design from a criticality standpoint. Thus, the calculational models for the normal, off-normal, and accident conditions are the same.

To determine the most reactive basket configurations for PWR fuel, considering basket component tolerances and relative shifting of the components and fuel, the applicant selectively applied both periodic and mirror boundary conditions to the sides of a KENO-Va model of a single fuel assembly in a basket cell. Results from geometric variations within this basket-lattice model, and supplemental variations on a cask model, showed that the most reactive basket configuration for the NAC-UMS transfer and storage casks is with fuel assemblies and fuel tubes shifted toward the center of the package, maximum width of fuel tube openings, minimum width of disk openings, maximum disk thickness, and minimum spacing of disk openings. The applicant used the full-cask calculational model to determine the most-reactive basket configurations for BWR fuel.

The calculational models also conservatively assumed the following:

- fresh-fuel composition (i.e., no burnup credit)
- no burnable absorbers
- 75% credit for the minimum ^{10}B loading in the Boral panels
- absence of the neutron shield
- pure-water flooding of the internal gaps between fuel pellets and cladding.

DRAFT

The fuel assemblies were modeled explicitly. Various moderating conditions, including flooding with full-density and reduced density water, were also considered in the calculational models. As previously stated, the baskets are designed to preclude uneven flooding within and between fuel tubes.

The staff reviewed the applicant's models and agrees that they are consistent with the design descriptions in SAR Sections 1 and 2, including the license drawings. The staff also reviewed the applicant's methods, calculations, and results for determining the worst-case manufacturing tolerances. Based on the information presented, the staff agrees that the calculations incorporate the most reactive combination of package parameters and dimensional tolerances.

For its confirmatory analyses with MONK8a, the staff independently modeled the transfer casks using the license drawings presented in SAR Section 1.8. Specifically, the staff used drawing nos. 790-560, -570, -573, -574, -575, -581, -582, -585, -593, -594, -595, and -605. Materials used in the staff's analyses were based on MONK8a standard mixtures that closely matched the cask materials indicated in the SAR. The staff's models for PWR fuel assemblies were derived from fuel design information found in DOE/RW-0184, Volume 3 of 6, "Characteristics of Spent Fuel, High-Level Waste, and Other Radioactive Wastes Which May Require Long-Term Storage," (1987). Design information for the staff's models of BWR fuel assemblies was taken from DOE/RW-0184 as well as from documents provided by the applicant and obtained from fuel vendors. The staff found its own models of the cask and contents to be compatible with those of the applicant.

6.3.2 Material Properties

The composition and densities of the materials considered in the calculational models are listed in SAR Sections 6.3.4, 6.3.4.1, 6.3.4.2, and 6.3.4.3.

The Boral neutron absorber is an important material for criticality safety of the NAC-UMS. In reviewing the Boral vendor's product literature, the staff noted that the ^{10}B areal density specified for the PWR baskets corresponds to standard Boral sheets that are thicker than specified in license drawing no. 790-581. Specifically, the product literature shows that the 0.075-inch thickness of Boral specified for the PWR baskets would have a maximum poison loading of $0.021 \text{ g } ^{10}\text{B}/\text{cm}^2$ and that the required minimum poison loading of $0.025 \text{ g } ^{10}\text{B}/\text{cm}^2$ would call for a Boral thickness of at least 0.085 inches. These minimum thicknesses for standard Boral sheets correspond to limiting the content of boron carbide (B_4C) particles in the Boral poison meat to less than 42 volume percent (i.e., 58 volume percent aluminum binder). Higher poison loadings in a given thickness of Boral require either a higher volume fraction of B_4C , with less binder, or the use of B_4C with ^{10}B -enriched boron.

In discussions with the NRC staff, the applicant stated that "nonstandard" Boral sheets, possibly using natural B_4C and less binder, will be provided to meet the applicant's requirement for 0.075-inch thick Boral panels with a poison loading of at least $0.025 \text{ g } ^{10}\text{B}/\text{cm}^2$. The staff verified the applicant's statements through independent discussions with the Boral vendor. In all cases, the minimum required ^{10}B content of the Boral will be verified through the acceptance testing described in SAR Section 9.1.6. Concerns over the potential to lessen the

DRAFT

durability of Boral when using less binder material in the poison meat are mitigated in part by noting that the stainless steel cover plates would help limit the mobility of any Boral fragments. Furthermore, as previously stated, only 75% credit is taken for the minimum ^{10}B content in the Boral panels. The SRP's recommendation of only 75% poison credit has been based in part on the need to bound the effects of neutron channeling between B_4C particles in the Boral. The staff notes that the use of Boral with a high volume fraction of B_4C reduces the neutron channeling effect and therefore increases the conservatism of allowing only 75% credit for the minimum poison content.

The staff reviewed the composition and number densities presented in the SAR and found them to be reasonable. The staff notes that these materials are not unique and are commonly used in other spent fuel storage and transportation applications. The staff reviewed the neutron absorber acceptance testing described in SAR Section 9.1.6. Acceptance of the absorber testing described in this section is based in part on the fact that the applicant assumed only 75% of the minimum required ^{10}B content in its homogenized model of the Boral poison material.

The staff has confirmed that the neutron fluence from irradiated fuel results in negligible depletion of Boral's ^{10}B content and concurs that the Boral panels will remain in place under accident conditions. Based on the information provided on the Boral material, the staff concludes that the continued efficacy of the Boral poison can be assured by the design of the NAC-UMS system, and a surveillance or monitoring program is not necessary.

6.4 Criticality Analysis

6.4.1 Computer Programs

The applicant's principal criticality computational tool was the CSAS25 sequence of SCALE4.3, which invokes the KENO-Va multigroup Monte Carlo code. The calculations used the SCALE system's 27GROUPNDF4, a 27-group cross-section library based on evaluated nuclear data from ENDF/B-IV. Within the CSAS25 sequence, the BONAMI and NITAWL modules of SCALE4.3 provide the necessary problem-specific preprocessing of the 27-group library's resonance data.

The staff agrees that the code and cross-section set used by the applicant are appropriate for this particular application and fuel system. The staff performed its independent criticality analyses using the MONK8a code, a continuous-energy Monte Carlo code with a quasi-pointwise (13,193 energy-group) cross-section library based on evaluated nuclear data from JEF2.2.

6.4.2 Multiplication Factor

The applicant's criticality analyses show that the k_{eff} in the NAC-UMS will not exceed 0.95 for all fuel loadings and conditions. Results of the applicant's CSAS25/KENO-Va criticality calculations for the bounding assemblies are given in SAR Section 6.1 and in the tables of Section 6.4. The maximum calculated values of k_{eff} , adjusted for bias and uncertainty, are 0.9475 for PWR fuel and 0.9233 for BWR fuel. The staff reviewed the applicant's calculated

k_{eff} values and agrees that they have been appropriately adjusted to include all biases and uncertainties at a 95% confidence level or better.

The staff performed independent MONK8a criticality calculations for fully loaded packages of PWR and BWR fuels under full and partial flooding conditions. Results of the staff's calculations confirmed the applicant's determination of the most-reactive fuel categories and were in close agreement with the applicant's k_{eff} results for the limiting conditions of full flooding with pure water.

Additional calculations by the staff simulated the reactivity effects in PWR packages of (a) radial gaps resulting from imperfect contact of the Boral panels against the fuel tube walls and cover plates and (b) any increase in the Boral panel thickness needed to achieve the minimum poison loading of 0.025 g $^{10}\text{B}/\text{cm}^2$. The calculations showed that increasing the effective combined thickness of the Boral and coverplate by 0.02 inches (from 0.093 to 0.113 inches), thereby reducing all flux-trap widths by 0.04 inches, would increase the limiting k_{eff} by 0.38 (± 0.03) percent. These results supported the staff's conclusion that the system's reactivity is not overly sensitive to a moderate increase in Boral thickness or to the presence of internal warping and contact gaps between the tube walls, Boral panels, and coverplates.

Based on the applicant's criticality evaluation, as confirmed by the staff's calculations, the staff concludes that the NAC-UMS will remain subcritical, with an adequate safety margin, under all credible normal, off-normal, and accident conditions.

6.4.3 Benchmark Comparisons

The applicant performed benchmark calculations on 63 selected critical experiments, chosen, as much as possible, to bound the range of parameters in the NAC-UMS design. The three most important parameters are the ^{10}B loading of the neutron absorbers, the flux trap size, and the fuel enrichment. Parameters such as reflector material and spacing, fuel pellet diameter, and fuel rod pitch were also considered in selecting the critical experiments.

Results of the benchmark calculations show no significant trends in the bias. The benchmark analysis yielded an eigenvalue calculational bias of 0.0052 ± 0.0043 . The uncertainty associated with each bias has been multiplied by the one-sided K-factor for 95% probability at the 95% confidence level. The applicant stated that the benchmark and cask calculations were performed with the same computer codes, cross-section data, and computer hardware.

The staff reviewed the applicant's benchmark analysis and agrees that the critical experiments chosen are relevant to the cask design. The staff found the applicant's method for determining and using the calculational bias to be acceptable and conservative. The staff also verified that only biases that increase k_{eff} have been applied.

6.5 Supplemental Information

All supportive information has been provided in the SAR, primarily in Sections 1, 2, 6, and 12.

DRAFT

6.6 Evaluation Findings

Based on the information provided in the SAR and verified by the staff's own confirmatory analyses, the staff concludes that the NAC-UMS system meets the acceptance criteria specified in NUREG-1536. In addition, the staff finds the following:

- F6.1** SSCs important to criticality safety are described in sufficient detail in Sections 1, 2, and 6 of the SAR to enable an evaluation of their effectiveness.
- F6.2** The NAC-UMS system is designed to be subcritical under all credible conditions.
- F6.3** The criticality design is based on favorable geometry and fixed neutron poisons. An appraisal of the fixed neutron poisons has shown that they will remain effective for the 20-year storage period. In addition, there is no credible way to lose the fixed neutron poisons; therefore, there is no need to provide a positive means to verify their continued efficacy during the storage period.
- F6.4** The analysis and evaluation of the criticality design and performance have demonstrated that the cask will enable the storage of spent fuel for 20 years with an adequate margin of safety.
- F6.5** The staff concludes that the criticality design features for the NAC-UMS system are in compliance with 10 CFR Part 72 and that the applicable design and acceptance criteria have been satisfied. The evaluation of the criticality design provides reasonable assurance that the NAC-UMS system will allow safe storage of spent fuel. In reaching this conclusion, the staff has considered the regulation itself, appropriate regulatory guides, applicable codes and standards, and accepted engineering practices.

DRAFT

7.0 CONFINEMENT EVALUATION

The confinement review ensures that radiological releases to the environment will be within the limits established by the regulations and that the spent fuel cladding and fuel assemblies will be sufficiently protected during storage against degradation that might otherwise lead to gross ruptures. The staff reviewed the information provided in the SAR to determine whether the NAC-UMS system fulfills the following acceptance criteria:

- The SAR must describe the confinement SSCs important to safety in sufficient detail to facilitate evaluation of their effectiveness. [10 CFR 72.24(c)(3) and 10 CFR 72.24(l)]
- The design must adequately protect the spent fuel cladding against degradation that might otherwise lead to gross ruptures during storage, or the fuel must be confined through other means such that fuel degradation during storage will not pose operational safety problems with respect to removal of the fuel from storage. [10 CFR 72.122(h)(1)]
- The cask design must provide redundant sealing of the confinement boundary. [10 CFR 72.236(e)]
- Storage confinement systems must allow continuous monitoring, such that the licensee will be able to determine when to take corrective action to maintain safe storage conditions. [10 CFR 72.122(h)(4) and 10 CFR 72.128(a)(1)]
- The design must provide instrumentation and controls to monitor systems that are important to safety over anticipated ranges for normal and off-normal operations. In addition, the applicant must identify those control systems that must remain operational under accident conditions. [10 CFR 72.122(i)]
- The applicant must estimate the quantity of radionuclides expected to be released annually to the environment. [10 CFR 72.24(l)(1)]
- The applicant must evaluate the cask and its systems important to safety, using appropriate tests or other means acceptable to the Commission, to demonstrate that they will reasonably maintain confinement of radioactive material under normal, off-normal, and credible accident conditions. [10 CFR 72.24(d)]
- SSCs important to safety must be designed to withstand the effects of credible accidents and severe natural phenomena without impairing their capability to perform safety functions. [10 CFR 72.122(b)]
- During normal operations and anticipated occurrences, the annual dose equivalent to any real individual who is located beyond the controlled area must not exceed 25 mrem to the whole body, 75 mrem to the thyroid, and 25 mrem to any other organ. [10 CFR 72.104(a)]
- From any design basis accident, an individual at or beyond the controlled area boundary may not receive the more limiting of (1) a total effective dose equivalent must not exceed 5 rem, or (2) the sum of the deep-dose equivalent plus the committed dose equivalent to any

DRAFT

organ or tissue may not exceed 50 rem. Additionally, the shallow dose equivalent to the skin or any extremity shall not exceed 50 rem, and the lens dose equivalent shall not exceed 15 rem. [10 CFR 72.106(a)]

7.1 Confinement Design Characteristics

The staff reviewed the applicant's confinement analyses in SAR Section 7 and the license drawings in SAR Section 1. The applicant clearly identified the confinement boundary. The confinement boundary includes the TSC shell, bottom baseplate, shield lid (including the vent and drain port cover plates), and the associated welds. There are no bolted closures or mechanical seals in the primary confinement boundary. The TSC is designed, fabricated, and tested in accordance with the applicable requirements of the ASME Code, Section III, Subsection NB, to the maximum extent practicable. Exceptions to the ASME Code, with respect to the confinement boundary, are identified in SAR Table 12B3-1 and repeated in Appendix B of the CoC. The shield lid (with the vent and drain port cover plates welded to the lid) and the structural lid are independently welded to the upper part of the TSC shell. This design provides redundant sealing of the confinement boundary and satisfies the requirements of 10 CFR 72.236(e). The design, testing, inspection, and examination of the welds forming the confinement boundary are described in detail in SAR Section 7.1.3.

The staff reviewed the cask vacuum drying and backfilling procedures that are used during loading operations. The procedures require that a vacuum pressure of 3 mm of mercury be maintained for 30 minutes, without the aid of vacuum equipment, to ensure that an acceptably low amount of water and potentially oxidizing gases remain in the TSC. The combination of an all-welded cask design and the use of these procedures will ensure that both the cladding and the confinement boundary integrity are maintained during normal, off-normal, and hypothetical accident conditions.

The staff also reviewed the applicant's helium leak testing procedures. A leak test of the shield lid will be performed to demonstrate that the cask is leak tight (i.e., will have a maximum allowable leakage rate of 2×10^{-7} cm³/sec (helium) at standard conditions) in accordance with ANSI N14.5-1997. The helium leak test will be performed in accordance with ANSI N14.5-1997 using the evacuated envelope test method, whereby, a test fixture will be used to create a head space above the shield lid. During the test, the cask will be pressurized with 1 atmosphere of helium, and the air in the head space will be evacuated with vacuum equipment. A mass spectrometer leak detector, having a sensitivity of 1×10^{-7} cm³/sec (helium) at standard conditions, will be used to measure the leakage rate. An additional leakage test, using the sniffer probe method in accordance with ANSI N14.5-1997, may be performed prior to the demonstration that the cask is leaktight. The purpose of this additional leakage test is to determine if there are any gross leaks that are caused by defects in the shield lid-to-shell weld. If this test indicates a leak, the weld will be repaired in accordance with ASME Code Section III. Note that the leakage test using the evacuated envelope method will be used to show compliance with ANSI N14.5-1997 for a leaktight cask.

For normal conditions of storage, the TSC relies on the fuel cladding and the TSC shell cavity as multiple confinement barriers to assure that there is no release of radioactive material to the environment. The TSC is backfilled with an inert gas (helium) to protect against degradation of

DRAFT

the cladding. As discussed in Sections 3 and 11 of this SER, there is reasonable assurance that the confinement boundary maintains its structural integrity during normal, off-normal, and hypothetical accident storage conditions. Further, Section 4 of this SER shows that the peak confinement boundary component temperatures and pressures are within the design basis limits for normal conditions of storage. The integrity of the TSC confinement boundary is assured through (1) nondestructive examinations (NDE), including multiple surface and/or volumetric examinations, of the TSC shield lid, structural lid, and vent and drain port cover plate welds; (2) leakage rate testing; and (3) pneumatic testing. The TSC inspection and test acceptance criteria are described in SAR Section 9.1. TSC closure weld examination and acceptance criteria are described in detail in Section 9.1.1.

The staff concludes that the all-welded construction of the TSC, with redundant welded shield and structural lids, and associated inspection and testing programs ensure that no release of radioactive material will occur under normal, off-normal, and hypothetical accident conditions.

7.2 Confinement Monitoring Capability

For cask systems having canisters with seal weld closures, continuous monitoring of the weld closures is unnecessary because there is no known plausible, long-term degradation mechanism which would cause the seal welds to fail. However, licensee monitoring programs, including periodic surveillance, inspection, and radiological and environmental surveys, will ensure that the operating controls and limits are met to maintain safe storage conditions.

7.3 Nuclides with Potential for Release

The confinement boundary of the TSC is designed to be leaktight in accordance with ANSI N14.5-1997 (i.e., maximum allowable leakage rate of 2×10^{-7} cm³/sec (helium) at standard conditions). In this consensus standard, the definition of leaktight (e.g., "a degree of package containment that, in a practical sense, precludes any significant release of radioactive materials") precludes the need for the applicant to determine the releaseable radiological source term and the corresponding dose consequence. Therefore, it was unnecessary for the applicant to specify the source term for the confinement analyses.

7.4 Confinement Analysis

The confinement boundary is completely welded, and the stresses, temperatures, and pressures of the TSC are within the design basis limits under normal, off-normal, and hypothetical accident conditions. The TSC is vacuum dried and backfilled with helium gas prior to final canister closure, so there is no potential for an increase in the canister pressure or degradation of the cladding due to radiolytic decomposition or other adverse reactions.

The staff concludes that (1) no discernable leakage of radioactive material from the TSC is credible, (2) the dose consequence due to leakage of radioactive material from the all-welded canister is negligible, and (3) the requirements of 10 CFR 72.104(a) and 10 CFR 72.106(a) are met.

DRAFT

7.5 Supplemental Information

Supplemental information, or documentation, in the form of justifications of assumptions and analytical procedures were provided as requested to complete this review.

7.6 Evaluation Findings

- F7.1** SAR Section 7 describes confinement structures, systems, and components important to safety in sufficient detail to permit evaluation of their effectiveness.
- F7.2** The design of the NAC-UMS system adequately protects the spent fuel cladding against degradation that might otherwise lead to gross rupture. SER Section 4 discusses the staff's relevant temperature considerations.
- F7.3** The design of the NAC-UMS system provides redundant sealing of the confinement system closure joints using dual welds on the TSC shield and structural lids.
- F7.4** The TSC has no bolted closures or mechanical seals. The confinement boundary contains no external penetrations for pressure monitoring or overpressure protection. No instrumentation is required to remain operational under accident conditions. Since the TSC uses an entirely welded redundant closure system, no direct monitoring of the closures is required.
- F7.5** The quantity of radioactive nuclides postulated to be released to the environment is negligible because the TSC is tested to the leaktight standards of ANSI N14.5-1997. The staff concludes that the confinement system will reasonably maintain confinement of radioactive material under normal, off-normal, and credible accident conditions. The corresponding dose from leakage of radioactive material from the TSC is also negligible. Thus, the NAC-UMS system satisfies the regulatory requirements of 10 CFR 72.104(a) and 10 CFR 72.106(b).
- F7.6** The staff concludes that the design of the confinement system of the NAC-UMS system is in compliance with 10 CFR Part 72 and that the applicable design and acceptance criteria have been satisfied. The evaluation of the confinement system design provides reasonable assurance that the NAC-UMS system will allow safe storage of spent fuel. This finding is based on a review of the regulation itself, appropriate regulatory guides, applicable codes and standards, the applicant's analysis, the staff's confirmatory analysis, and accepted engineering practices.

8.0 OPERATING PROCEDURES

The review of the operating procedures is to ensure that the applicant's SAR presents acceptable operating sequences, guidance, and generic procedures for key operations. The procedures incorporate and are compatible with the applicable operating and control limits specified in the TS. The operating procedures properly consider the prevention of hydrogen gas generation from any cause and include appropriate precautions to minimize occupational radiation exposures. The operating procedures contain a table listing the ancillary equipment necessary to support loading, storage, and unloading operations.

8.1 Cask Loading

Detailed loading procedures must be developed by each user.

The cask loading procedures described in the SAR include the appropriate key prerequisite, preparation, and receipt inspection provisions to be accomplished before loading. These include a visual inspection of the basket fuel tubes for obstructions, verification of welding zone preparations, reference to the site-specific procedures and TS applicable for activities carried out under 10 CFR Part 50, and references to the appropriate NAC-UMS system CoC provisions for (1) transfer cask lift temperature requirements, and (2) approved contents specifications, including preferential loading. The loading procedure describes the activities sequentially in the anticipated order of performance.

8.1.1 Fuel Specifications

The procedures described in the SAR provide for fuel assembly selection verification by the user to ensure that only fuel assemblies that meet all the conditions for loading have been pre-selected. Exact fuel specifications for fuel that is permitted to be loaded into a TSC is specifically designated in Section 2.0 of Appendix B to the CoC. Detailed site-specific procedures are necessary to ensure all fuel loaded in the cask meets the fuel specifications as delineated in the certificate. These procedures are subject to evaluation on a site-specific basis through the inspection process rather than during the licensing review.

8.1.2 ALARA

The NAC-UMS system loading procedures incorporate general ALARA principles and practices. ALARA practices include the use of temporary shielding during the setup of the automatic welding equipment, the use of automated welding equipment, and performing certain operations (decontamination of the exterior surface of the transfer cask, welding of the shield lid, and pressure testing of the TSC) while the TSC remains filled with water. The procedures incorporate TS 3.2.1 and 3.2.2, which specify limits for radionuclide contamination and surface dose rates. Each cask user will need to develop detailed loading procedures that incorporate the ALARA objectives of their site-specific radiation protection program.

DRAFT

8.1.3 Draining and Drying

The operating procedures for draining the water from and vacuum drying the TSC can be found in SAR Section 8.1. These procedures clearly describe the process of removing water vapor and oxidizing material to acceptable levels from the cask.

Once the shield has been welded in place and the PT examination of the weld has been completed, a suction pump is attached to the drain line, and the water in the cask is removed while the hose connected to the vent port remains open. After the drain port cover is welded to the shield lid and nondestructively examined, a vacuum system is connected to the vent port hose. The vacuum system is used to evacuate the air and water vapor from the cask until a steady pressure of less than or equal to 3 millimeters of mercury (mm Hg) is achieved, with the pump isolated, for 30 minutes. Then, the cask is backfilled with helium gas before a second cycle of vacuum drying (3 mm Hg for 30 minutes) is performed. Finally, the cask cavity is backfilled with helium (99.9% minimum purity) to 0 psig for subsequent helium leak testing. The operating controls and limits for this procedure are described in more detail in SAR Section 12.

The vacuum pressure of 3 mm Hg prescribed for the vacuum drying procedure is consistent with methodology described in NUREG-1536, which references PNL-6365. Moisture removal is inherent in the vacuum drying process, and levels at or below those evaluated in PNL-6365 are expected if the vacuum drying is performed as described in the SAR. This procedure will serve to reduce the amount of oxidants to below the levels where significant cladding degradation is expected.

The staff concludes that (1) helium (99.9% minimum purity) is an acceptable inert cover gas to minimize the source of potentially oxidizing impurity gases and vapors and (2) the NAC-UMS system operating procedures (i.e., two cycles of alternating vacuum drying and backfilling with a high purity cover gas) are adequate to sufficiently remove contaminants from the cask.

8.1.4 Welding and Sealing

A general description of the Automated Welding System can be found in SAR Section 1.2.1.5.3. This system will be used to weld the inner and outer lid closure welds of the TSC during cask loading operations to ensure the dose to welders will be ALARA. Prior to welding the shield lid (i.e., the inner closure weld), approximately 50 gallons of water will be removed from the TSC to keep moisture away from the weld region. SAR Section 8.1 describes the loading procedures that incorporate the welding, NDE, helium leak test, and pressure test procedures. As indicated in SAR Section 7.1.3, unacceptable weld defects will be repaired in accordance with ASME Code Section III, Subarticle NB-4450, and visually re-examined. The staff concludes the procedures for welding and NDE of the closure welds are acceptable.

Leak testing will be performed to demonstrate the leaktightness of the TSC shield lid in accordance with ANSI N14.5-1997. The helium leak test will demonstrate that the leakage rate under normal, off-normal, and hypothetical accident conditions will be less than 2×10^{-7} ref. cm^3 per second in accordance with SAR Sections 7.1.3 and 9.1.1 and the TS. The staff concluded these procedures provide for acceptable welding and NDE of the closure welds.

DRAFT

SAR Section 8.1.1 describes welding of the redundant TSC structural lid, which is placed over the shield lid. The structural lid to canister shell weld is either (1) UT examined, with the final surface PT examined, in accordance with ASME Code Section V, or (2) progressively PT examined in accordance with ASME Code Section V. SAR Section 8.1.2 describes the installation of the VCC lid, including bolts and tamper indication devices. The appropriate bolt torque values are listed in SAR Table 8.1-2. The staff concludes these procedures provide for acceptable sealing of the TSC structural lid and the VCC lid.

8.2 Cask Handling and Storage Operations

All accident events applicable to the transfer of the TSC to the VCC and of the VCC to the storage location are bounded by the design events described in SAR Sections 2 and 11. All conditions for lifting and handling methods are bounded by the evaluations in SAR Sections 3 and 4. Appendix A of the CoC, Section 5.5, requires that a cask transport evaluation program be established, implemented, and maintained. The program provides a means for evaluating various on-site transport configurations and route conditions to ensure that the design basis drop limits are met.

Inspection, surveillance, and maintenance requirements that are applicable during ISFSI storage are discussed in SAR Section 9. Surveillance and monitoring requirements to verify the proper operation of the passive heat removal system are included in TS. The staff determined that these discussions were acceptable.

Occupational and public exposure estimates are evaluated in SAR Section 10. Each cask user will develop detailed cask handling and storage procedures that incorporate the ALARA objectives of their site-specific radiation protection program.

8.3 Cask Unloading

Detailed unloading procedures must be developed by each cask user.

The NAC-UMS system unloading procedures describe the general actions necessary to remove the TSC from the VCC for placement in another VCC or transport cask or to unload the TSC in the spent fuel pool. The TSC unloading procedure describes the general actions necessary to remove the lid welds, cool the stored fuel assemblies, flood the TSC cavity, and unload the spent fuel assemblies. The operating procedure for transferring a loaded TSC from the VCC to the NAC-UMS transport cask is discussed in the NAC-UMS transport SAR and is not evaluated in this SER. Special precautions are outlined to ensure personnel safety during the unloading operations.

8.3.1 Cooling Venting & Reflooding

The operating procedures in Section 8 of the SAR specify, prior to initiating cooldown, the sampling for radioactive gases and the subsequent flushing of the radioactive gases with nitrogen while monitoring the exit temperatures. A cooldown system is subsequently attached to the drain connection (inlet) and the vent connection (outlet). A controlled water flow rate, with a specified minimum water temperature is established with the steam and water being

DRAFT

discharged to the spent fuel pool or radioactive water treatment system. The applicant's evaluation of the controlled TSC reflooding and cooling of the stored fuel assemblies determined that the associated thermal stresses on cladding and the steam pressures developed within the canister are acceptable. The procedures reflect the appropriate TS which stipulates the minimum cooling water temperature, maximum cooling water flow rate, and maximum canister pressure.

Procedures for obtaining a gas sample are included to provide for assessment of the condition of the fuel assembly cladding. This allows for detection of potentially damaged or oxidized fuel. The procedures include ALARA caution steps to prevent the possible spread of contamination and allow for the implementation of additional measures appropriate for the specific conditions.

8.3.2 ALARA

The unloading procedures incorporate general ALARA principles and practices. ALARA practices include provisions for radiological surveys, exposure and contamination control measures, temporary shielding, and caution statements related to specific actions that could change radiological conditions. Each cask user will develop detailed unloading procedures that incorporate the ALARA objectives of their site-specific radiation protection program.

8.3.2 Fuel Crud

The ALARA practices and procedures provide for the mitigation of the possibility of dispersal of fuel crud particulate material. However, experience with wet unloading of BWR fuel after transportation has involved handling significant amounts of crud. This fine crud includes ^{60}Co and ^{55}Fe and will remain suspended in water or air for extended periods. The TSC reflood process during unloading of BWR fuel has the potential to disperse crud into the fuel transfer pool and pool area atmosphere, thereby, creating airborne exposure and personnel contamination hazards. Therefore, detailed procedures incorporating provisions to mitigate the possibility of fuel crud particulate dispersal must be developed by each cask user.

8.4 Evaluation Findings

- F8.1 The NAC-UMS system is compatible with wet loading and unloading. General procedure descriptions for these operations are summarized in SAR Sections 8.1 and 8.3. Detailed procedures will be developed and approved on a site-specific basis.
- F8.2 The bolted VCC closure and welded TSC shield and structural lids of the cask allow ready retrieval of the spent fuel for further processing or disposal as required.
- F8.3 The general operating procedures are designed to minimize and facilitate decontamination. Routine decontamination will be necessary after the transfer cask is removed from the spent fuel pool.

DRAFT

- F8.4** No significant radioactive effluents are produced during storage. Any radioactive effluents generated during the cask loading and unloading will be governed by the 10 CFR Part 50 license conditions.
- F8.5** The contents of the general operating procedures described in the SAR are adequate to protect health and minimize danger to life and property. Detailed procedures will need to be developed and approved on a site-specific basis.
- F8.6** SER Section 10 assesses the operational restrictions to meet the limits of 10 CFR Part 20. Additional site-specific restrictions may also be established by the site licensee.
- F8.7** The staff concludes that the contents of the generic procedures and guidance for the operation of the NAC-UMS system are in compliance with 10 CFR Part 72 and that the applicable acceptance criteria have been satisfied. The evaluation of the operating procedure descriptions provided in the SAR offers reasonable assurance that the cask will enable safe storage of spent fuel. This finding is based on a review that considered the regulations, appropriate regulatory guides, applicable codes and standards, and accepted practices.

intentionally left blank

DRAFT

9.0 ACCEPTANCE TESTS AND MAINTENANCE PROGRAM

The objective of the review of the acceptance tests and maintenance program is to ensure that the SAR includes the appropriate acceptance tests and maintenance programs for the NAC-UMS system.

9.1 Acceptance Tests

The acceptance tests inspections to be performed on the NAC-UMS system are discussed in detail in SAR Section 9.1. These inspections and tests are intended to demonstrate that the NAC-UMS system has been fabricated, assembled, and examined in accordance with the design criteria given in SAR Section 2.

9.1.1 Visual and Nondestructive Examination Inspections

Except as identified herein, the components of the NAC-UMS confinement boundary are fabricated and inspected in accordance with ASME Code Section III, Subsection NB. Exceptions to the ASME Code are identified in the CoC and include (1) partial penetration welds of the shield lid- and structural lid-to-shell joints, (2) a remaining backing ring that is used to weld the structural lid to the shell, (3) root and final surface PT examination of the shield lid-to-shell weld and the vent and drain port cover-to-shield lid welds, and (4) either UT or progressive PT examination of the structural lid-to-shell weld. The shield and structural lids are welded independently to provide a redundant seal. The staff reviewed these exceptions, and the corresponding justifications, and found them to be in accordance with the guidelines of NUREG-1536 with the following clarifications:

In the confinement Section of NUREG-1536, it states that the staff has accepted meeting the examination requirements of the ASME Section III Code for Class 1 or Class 2 components. These Code requirements necessitate a volumetric examination of the canister closure weld, however, NRC's ISG No. 4, Revision 1, permits the use of multilayer PT and surface examination as a substitute for the ASME Code required volumetric examination.

The acceptance criteria for the UT volumetric examination of the closure weld shall be as stated in Paragraph NB-5332 of the ASME Section III Code which allows the use of Section XI fracture mechanics to justify maximum flaw size, in lieu of, the no crack criteria of Subarticle NB-5330.

The basket, basket support disks, and fuel tubes are fabricated and inspected in accordance with ASME Code, Section III, Subsection NG. The transfer cask is designed and fabricated in accordance with ANSI N14.6 and NUREG-0612. Welding of the VCC steel components is performed in accordance with either AWS D1.1-96, with visual inspection requirements contained in Section 8.15.1, or ASME Code Section VIII, using VT and magnetic particle (MT) examination techniques of ASME Code Section V.

DRAFT

The NDE of weldments is well-characterized on the drawings, and standard NDE symbols and/or notations are used in accordance with AWS 2.4, "Standard Symbols for Welding, Brazing, and Nondestructive Examination." Fabrication inspections include VT, PT, MT, UT, and RT examinations, as applicable.

Structural and confinement boundary weld examinations and acceptance criteria, in general, meet the applicable requirements of ASME Code, Section III. The majority of confinement boundary welds are volumetrically examined in accordance with Code requirements using RT with acceptance criteria per NB-5320. The bottom plate to canister shell weld is volumetrically examined in the shop, using UT, with acceptance criteria per NB-5330. For the confinement boundary welds made in the field, all will have their root and final weld passes PT examined. However, the closure weld for the structural lid-to-canister shell will be either (1) progressively PT examined with each layer not to exceed 0.375 inch or (2) UT examined. Use of a progressive PT examination for the confinement boundary welds is currently not in agreement with ASME Section III, Class 1 requirements. However, it is acceptable per NRC's ISG No. 4. The distance between progressive layered PT was justified per a fracture mechanics analysis which calculated a critical flaw size as discussed in SAR Section 3.4.4.1.11. The calculation of the critical flaw size of the closure weld assumes a 360 degree flaw that could exist under the weld pass surface that is PT examined. As allowed by the NRC's ISG No.4, postulated cracks under each PT examined surface are not required to be additive for comparison to the critical flaw size. The staff finds that the closure weld for the structural lid may be inspected using either volumetric or multiple pass dye penetrant techniques subject to the following conditions, as stated in ISG No.4, Revision 1:

- 1) PT examinations may be used in lieu of volumetric examinations only on austenitic stainless steels. PT should be done in accordance with ASME Section V, Article 6, "Liquid Penetrant Examination."
- 2) For either UT or multiple layer PT, the minimum detectable flaw size must be demonstrated to be less than the critical flaw size. The critical flaw size shall be calculated in accordance with ASME Section XI methodology; however, net section stress may be governing for austenitic stainless steels and must not violate Section III requirements.
- 3) If PT alone is used, at a minimum, it must include the root and final layers and sufficient intermediate layers to detect critical flaws.
- 4) The inspection of the weld must be performed by qualified personnel and shall meet the acceptance requirements of ASME Code Section III, NB-5350, for PT and NB-5332 for UT examinations.
- 5) If PT alone is used, a design stress-reduction factor of 0.8 must be applied to the weld design.
- 6) The results of the PT examination, including all relevant indications, shall be made a permanent part of the licensee's records by video, photographic, or other means providing a retrievable record of weld integrity. Video or photographic records should be taken during the final interpretation period described in ASME Section V, Article 6, T-676.

DRAFT

The staff finds that the NDE and acceptance criteria used on the NAC-UMS are acceptable based on meeting the governing Code's requirements or are permitted via guidance provided to the staff (i.e., ISG No. 4).

9.1.2 Structural/Pressure Tests

9.1.2.1 Transfer Cask Lifting Trunnions

The transfer cask lifting trunnions and bottom shield doors are load tested in accordance with ANSI N14.6. The lifting trunnions are tested by applying a vertical load of 660,000 lbs, which is greater than 300% of the maximum service load (loaded canister, with the shield lid and full of water). Similarly, the bottom shield doors are tested by applying a vertical load of 266,000 lbs, which is greater than 300% of the maximum service load. The loads are held for a minimum of 10 minutes. Following the load tests, all trunnion and door rail welds and all load bearing surfaces are visually inspected for permanent deformation, galling, or cracking and examined using MT or PT methods. The acceptance criteria for the MT and PT examinations are in accordance with ASME Code Section III, NF-5340 and NF-5350, respectively.

9.1.2.2 Vertical Concrete Cask Lifting Lugs

The VCC may be provided with lifting lugs, at the option of the user, to allow for the vertical handling and movement of the concrete cask. The lifting lugs are provided as two sets of two lugs each, through which a lifting pin is inserted and connected to a specially designed mobile lifting frame. The concrete cask lifting lug system and mobile lifting frame and pins are designed, analyzed, and load tested in accordance with ANSI N14.6. The concrete cask lifting lug load test shall consist of applying a vertical load of 515,200 pounds, which is greater than 150 percent of the maximum concrete cask weight of 312,210 pounds plus a 10 percent dynamic load factor. The test load shall be applied for a minimum of 10 minutes in accordance with approved, written procedures. Following completion of the load test, all load bearing surfaces of the lifting lugs shall be visually inspected for permanent deformation, galling, or cracking. Liquid penetrant examinations of load bearing surfaces shall be performed in accordance with ASME Code, Section V, Article 6, with acceptance criteria in accordance with ASME Code, Section III, Subsection NF, NF-5350. Any evidence of permanent deformation, cracking, or galling or unacceptable liquid penetrant examination results for the load bearing surfaces of the lifting anchors shall be cause for evaluation, rejection, or rework and retesting.

9.1.2.3 Pneumatic Pressure Testing

The TSC is pressure tested after approximately 50 gallons of water have been removed from the canister and the shield lid is welded in place. The pneumatic testing of the canister and shield lid weld is performed at greater than 1.2 times the normal conditions design pressure, in accordance with ASME Code, Section III, Subsection NB. A pressure of 20 psig is held for a minimum of 10 minutes with no loss of pressure. Following completion of the test, a final dye penetrant examination of the shield lid weld is performed.

DRAFT

9.1.2.4 Leak Testing

A helium leakage test is performed to verify that the shield lid weld is leaktight as defined by ANSI N14.5-1997. The helium leak test will be performed using the evacuated envelope test method, whereby, a test fixture will be used to create a head space above the shield lid. During the test, the cask will be pressurized with 1 atmosphere of helium, and the air in the head space will be evacuated with vacuum equipment. A mass spectrometer leak detector, having a sensitivity of 1×10^{-7} cm³/sec (helium) at standard conditions, will be used to measure the leakage rate. The maximum allowable leakage rate of 2×10^{-7} cm³/sec (helium) at standard conditions assures that the TSC is leaktight during normal, off-normal, and hypothetical accident conditions.

An additional leakage test, using the sniffer probe method in accordance with ANSI N14.5-1997, may be performed prior to the demonstration that the cask is leaktight. The purpose of this additional leakage test is to determine if there are any gross leaks that are caused by defects in the shield lid-to-shell weld. If this test indicates a leak, the weld will be repaired in accordance with ASME Code Section III.

Note that the leakage test using the evacuated envelope method will be used to show compliance with ANSI N14.5-1997 for a leaktight cask.

9.1.3 Shielding Tests

The storage cask radial shield design consists of a 2.5-inch thick carbon steel inner liner surrounded by 28.25 inches of reinforced concrete. Gamma shielding is provided by both the carbon steel and concrete, and neutron shielding is provided primarily by the concrete. Additional radial shielding is provided by the TSC stainless steel shell. The storage cask top shielding design is comprised of 10 inches of stainless steel from the canister lids, a shield plug containing 1 inch of NS-4-FR encased within 4.125 inches of carbon steel, and a 1.5-inch thick carbon steel lid. The bottom shielding of the concrete cask consists of the 1.75-inch stainless steel canister bottom and 3 inches of carbon steel plate.

The transfer cask, used to hold the canister during fuel loading activities and to transfer the TSC to the storage cask, has a multi-wall radial shield comprised of .75 inches of carbon steel, 3.5 inches of lead, 2 inches of solid borated polymer (NS-4-FR), and 1.25 inches of carbon steel. An additional 0.625 inches of stainless steel shielding is provided, radially, by the canister shell. Gamma shielding is provided primarily by the steel and lead layers. The NS-4-FR provides the neutron shielding. The transfer cask bottom shield door design is a solid section comprised of 7.5 inches of carbon steel and 1.5 inches of NS-4-FR. The top of the transfer cask is open but shielding is provided by the stainless steel canister shield and structural lids.

Construction of the NAC-UMS system is in accordance with detailed fabrication specifications, with all fabrication activities performed in accordance with NRC approved QA programs. The shielding materials of construction were reviewed in SER Section 3.1.4. The effectiveness of the neutron and gamma shielding for the storage cask is verified by the performance of external dose rate surveys. Appendix A of the CoC (TS 3.2.2) limits the acceptable storage

DRAFT

cask average radiation dose rates due to gammas and neutrons to 50 mr/hr, 50 mr/hr, and 100 mr/hr for the cask side, top, and inlets and outlets, respectively. The staff reviewed the shielding fabrication testing and controls and effectiveness tests and found them acceptable.

9.1.4 Neutron Absorber Tests

After manufacturing, each batch of Boral is tested using wet chemistry and/or neutron attenuation techniques to verify presence, proper distribution, and minimum ^{10}B content. The test shall be representative of each Boral panel. The minimum allowable ^{10}B content is 0.011 g/cm² for BWR fuel tube Boral panels and 0.025 g/cm² for PWR fuel tube Boral panels. Any panel with a ^{10}B loading less than the minimum allowed will be rejected.

The staff's acceptance of the neutron absorber test described above is based, in part, on the fact that the criticality analyses assumed only 75% of the minimum required ^{10}B content of the Boral. For greater credit allowance, special, comprehensive fabrication tests capable of verifying the presence, uniformity, and particle-size distribution of the neutron absorber are necessary.

Installation of the Boral panels on the fuel basket tubes shall be performed in accordance with written and approved procedures. Quality control procedures shall be in place to ensure that the TSC basket tube walls contain a Boral panel as specified in the SAR Section 1.8 license drawings.

9.1.5 Thermal Tests

A thermal performance program monitors daily the outlet temperature indicators of each NAC-UMS system cask. The outlet temperatures are recorded, compared with the ambient air temperature, and verified to have less than a 102°F or 92°F differential for PWR or BWR contents, respectively.

The first NAC-UMS system in place that has a heat load of greater than 10.0 kW will be analyzed by temperature measurements to confirm the overall heat transfer characteristics of the system. SAR Section 12.3 specifies submitting to NRC the results of the temperature measurements for the highest heat load in the NAC-UMS system, up to the authorized maximum of 23.0 kW.

9.1.6 Cask Identification

The cask will be marked with a model number, unique identification number, and empty weight. This information will appear on the stainless steel nameplate, which is permanently attached to the outer surface of the storage cask as shown on the drawings.

9.2 Maintenance Program

The NAC-UMS system is a passive system with a minimum amount of maintenance required over its lifetime. Each storage cask is visually inspected daily to detect any blockage of air inlets and outlets and to verify that the protection screens are in place. The temperatures of

DRAFT

the cask outlets are monitored daily. The concrete cask is visually inspected annually for chipping, spalling, or other surface defects. The staff concludes that these inspections are acceptable for initial and continued operation of the NAC-UMS system.

9.3 Evaluation Findings

- F9.1.** SAR Section 9.1 describes the applicant's proposed program for pre-operational testing and initial operations of the NAC-UMS system. Section 9.2 discusses the proposed maintenance program.
- F9.2** SSCs important to safety will be designed, fabricated, erected, tested, and maintained to quality standards commensurate with the importance to safety of the function they are intended to perform. SAR Table 2.3-1 identifies the safety importance of SSCs, and Section 1.2 presents the applicable standards for their design, fabrication, and testing.
- F9.3** The certificate holder/licensee will examine and/or test the NAC-UMS system to ensure that it does not exhibit any defects that could significantly reduce its confinement and shielding effectiveness. SAR Section 9.1 describes this inspection and testing.
- F9.4** The certificate holder/licensee will mark the cask with a data plate indicating its model number, unique identification number, and empty weight. Drawing 790-565 illustrates and describes this data plate.
- F9.5** The staff concludes that the acceptance tests and maintenance program for the NAC-UMS system are in compliance with 10 CFR Part 72 and that the applicable acceptance criteria have been satisfied. The evaluation of the acceptance tests and maintenance program provides reasonable assurance that the cask will allow safe storage of spent fuel throughout its licensed or certified term. This finding is reached on the basis of a review that considered the regulation itself, appropriate regulatory guides, applicable codes and standards, and accepted practices.

DRAFT

10.0 RADIATION PROTECTION EVALUATION

The purpose of this review is (1) to evaluate the radiation protection capabilities of the NAC-UMS system to ensure NRC's design criteria for direct radiation is met, (2) determine that the proposed engineering features and operating procedures for the storage system will maintain workers' exposure as low as is reasonably achievable (ALARA), and (3) ensure the radiation doses to workers and to the general public meet regulatory standards during both normal operation and accident situations. The regulatory requirements for providing adequate radiation protection to site licensee personnel and members of the public include 10 CFR Part 20, 10 CFR 72.104(a), 72.106(b), 72.212(b), and 72.236(d).

10.1 Radiation Protection Design Criteria and Design Features

10.1.1 Design Criteria

SAR Section 10.2 describes the radiological protection design criteria of the UMS to meet the limits and requirements in 10 CFR Part 20, 10 CFR 72.104, 10 CFR 72.106, and the guidance in Regulatory Guide 8.8. As required by 10 CFR 72.212, a general licensee will be responsible for demonstrating site-specific compliance with these requirements.

The design basis surface dose rates for normal storage conditions are listed in the following table. The calculated dose rates were determined from the shielding evaluation performed in SAR Chapter 5.

Vertical Concrete Cask	Design Basis Surface Dose Rate (mrem/hr)	Calculated Surface Dose Rate (mrem/hr)		Calculated 1 Meter Maximum Dose Rate (mrem/hr)	
		PWR	BWR	PWR	BWR
Side wall	50.0 (average)	37.3	22.7	25.3	15.4
Air inlet	100.0	6.8	8.5	<5.0	5.0
Air outlet	100.0	65.6	50.6	12.5	7.5
Top lid	50.0 (average)	26.1	19.7	13.3	8.5

10.1.2 Design Features

A general description of the NAC-UMS system is contained in SAR Chapter 1. SAR Sections 10.1 and 10.2 present those design features which enhance radiation protection to both onsite workers and members of the public beyond the controlled area fence. Design features discussed in the SAR include gamma and neutron shielding necessary to meet the design basis dose rate objectives, the placement of penetrations near the edge of the canister shield

DRAFT

lid to reduce operator exposure and handling times, and the use of shaped supplemental shielding for work on and around the shield lid.

The specific design features which demonstrate the ALARA philosophy include:

Thick steel and concrete walls to reduce the side surface dose rate of the concrete cask.

Nonplanar cooling air pathways to minimize radiation streaming at the inlets and outlets of the VCC.

Material selection and surface preparation that facilitate decontamination.

Positive clean water flow in the transfer cask/canister annulus to minimize the potential for contamination on the canister surface during in-pool work.

Passive confinement, thermal, criticality, and shielding systems that require no maintenance.

Use of remote, automated outlet air temperature equipment to reduce surveillance time.

The staff evaluated the radiation protection design features and design criteria for the NAC-UMS and found them acceptable. The SAR analysis provides reasonable assurance that use of the NAC-UMS storage cask can meet the regulatory requirements in 10 CFR Part 20, 10 CFR 72.104(a), and 10 CFR 72.106(b).

10.2 ALARA

Section 10.1 of the SAR presents the ALARA considerations for the NAC-UMS storage system. Radiation protection design features and the design criteria address ALARA requirements consistent with the requirements in 10 CFR Part 20 and guidance provided in Regulatory Guides 8.8 and 8.10. The NAC-UMS storage system features are designed to maintain radiation exposures ALARA and within the proposed design basis surface dose rates and surface contamination limits specified in SAR Chapter 12. SAR Section 10.1.3 includes the operational considerations for ALARA and describes optional auxiliary shielding devices to minimize occupational and public doses.

Each general licensee, in accordance with 10 CFR 72.212, will implement its existing site-specific radiation protection program, ALARA policies, and procedures for all cask operations to ensure that occupational personnel exposure requirements in 10 CFR Part 20 are met.

The staff evaluated the ALARA elements incorporated into the NAC-UMS storage system design and found them to be acceptable. Based upon the information presented in the SAR, there is reasonable assurance that the ALARA objectives in 10 CFR Part 20 will be met.

DRAFT

10.3 Occupational Exposures

SAR Section 8 discusses the general operating procedures that licensees will use for fuel loading, cask operation, and fuel unloading. SAR Section 10.3 discusses the estimated number of personnel, the estimated dose rates, and the estimated time for each task. The estimated occupational person-rem is based upon the minimum number of personnel needed to accomplish the activities in the general operating procedures and the dose rates determined from the shielding evaluation in SAR Section 5.

The person-mrem exposure for operation of the NAC-UMS system is presented in SAR Table 10.3.1. The dose estimates indicate that the total occupational dose in loading a single cask with design basis fuel is approximately 1.1 person-rem for PWR fuel and 0.8 person-rem for BWR fuel. The estimated yearly exposure for surveillance and cask maintenance for a 20 cask array with PWR fuel is approximately 1.1 person-rem. The estimated yearly exposure for surveillance and cask maintenance for a 20 cask array with BWR fuel is approximately 0.7 person-rem.

The staff reviewed the estimated occupational exposures and found them to be acceptable. The occupational exposure dose estimates provide reasonable assurance that occupational limits in 10 CFR Part 20 Subpart C can be achieved. Actual occupational doses will depend on site-specific parameters taken to maintain exposures ALARA. Each licensee will have an established radiation protection program, as required in 10 CFR Part 20 Subpart B. In addition, each licensee must demonstrate compliance with all dose limits in 10 CFR Part 20, 10 CFR Part 72, and any site-specific 10 CFR Part 50 license requirements with evaluations prior to loading of the casks.

10.4 Public Exposures

SAR Section 10.4 summarizes the calculated dose rates to members of the public located beyond the controlled area. As determined from the containment evaluation in SAR Chapter 7, the confinement boundary of the TSC is designed to be leak tight, and therefore, no discernable leakage of radioactive material from the TSC is credible. A discussion of the staff's evaluation and confirmatory analysis of the shielding and confinement dose calculations are presented in SAR Sections 5 and 7. The staff concludes that the dose rate from a non-mechanistic release is negligible. Therefore, direct radiation (including skyshine) is the primary dose pathway to individuals beyond the controlled area during normal and off-normal conditions.

Public exposure from normal and off-normal conditions will be from direct radiation from the storage casks. The SKYSHINE-III code was used to evaluate the placement of the controlled area boundary for a single cask containing design basis fuel and for a 20 cask array. For the 20-cask array, the casks are assumed to be loaded with design basis fuel at the rate of two casks per year.

SAR Table 10.4-1 presents a summary of the results of the SKYSHINE-III evaluation which determined the minimum distance necessary to achieve an annual dose of 25 mrem from a single cask containing design basis PWR or BWR fuel. Dose rates at 100 meters from a

DRAFT

single cask containing PWR design basis fuel would be 14.8 mrem/year. Dose rate at 100 meters from a single cask containing BWR design basis fuel would be 9.9 mrem/year.

Based upon NAC's evaluation for a 2 by 10 cask array of PWR design basis fuel, a minimum site boundary distance of 160 meters around the ISFSI will ensure compliance with the dose limit in 10 CFR 72.104(a). The minimum site boundary distance for a 2 by 10 cask array of BWR design basis fuel would be 150 meters. Each licensee who intends to use the NAC-UMS storage system must perform a site-specific dose analysis to demonstrate compliance with all the requirements in 10 CFR Part 72. Site-specific boundary distances may vary based on fuel type, fuel cooling time, natural site barriers, and number of casks in service.

The staff evaluated the public dose estimates from direct radiation for normal and off-normal (anticipated occurrences) conditions and found them to be acceptable. The staff has reasonable assurance that compliance with 10 CFR 72.104(a) can be achieved by each site licensee. The general license holder must perform a site-specific evaluation, as required by 10 CFR 72.212(b), to demonstrate compliance with 10 CFR 72.104(a). The actual doses to individuals beyond the controlled area boundary depend on site-specific conditions such as cask array configuration, topography, demographics, and use of engineered features (e.g., berms). In addition, the dose limits in 10 CFR 72.104(a) must include doses from all other fuel cycle activities located onsite such as reactor operations. Consequently, final determination of compliance with 10 CFR 72.104(a) is the responsibility of each site licensee.

The licensee will also have an established radiation protection program as required by 10 CFR Part 20, Subpart B, and will demonstrate compliance with dose limits to individual members of the public, as required by 10 CFR Part 20, Subpart D, by evaluations and measurements.

10.5 Accident Exposures

SAR Section 11 contains a description of accident conditions and natural phenomena events which could affect the ISFSI. The SAR evaluated and concluded that the confinement function of the NAC-UMS will not be breached by design-basis accidents or natural phenomena events, therefore, a non-mechanistic failure of the canister that hypothetically results in the release of the contents is not evaluated.

The types of accidents which could result in some sort of radiological impact are damage to the VCC from a tornado and tornado-driven missiles, tipover of the VCC, and full-blockage of VCC air inlets and outlets. None of these events will result in a radiation exposure at the controlled area boundary in excess of the limits specified in 10 CFR 72.106(b). Damage to the VCC from tornado-driven missiles would result in a VCC contact dose rate of less than 250 mrem/hr for either PWR or BWR fuel.

Tipover of the VCC would result in a dose rate of approximately 35 rem/hr at 1 meter from the bottom of the VCC. This high dose rate is because of the significantly less amount of shielding material on the bottom end of the VCC. As the distance from the cask bottom is increased, the dose rate drops off quickly, approximately 4 rem/hr at 4 meters. The dose rate at the site boundary located 100 meters from the tipped over cask would be less than 10 mrem/hr.

DRAFT

Following a tip-over accident, the licensee would construct additional shielding around the cask until the VCC could be uprighted, so that occupational exposures would be minimized.

In the event of full-blockage of VCC air inlets and outlets, there would be no radiological impact at the site boundary or beyond. The only impact would be the occupational exposure workers received while removing the blockages from the inlets and outlets.

The staff evaluated the public dose estimates from direct radiation for accident conditions and natural phenomena events and found them acceptable. A discussion of the staff's evaluation and confirmatory analysis of the shielding and confinement dose calculations are presented in SER Sections 5 and 7, respectively. The staff has reasonable assurance that the effects of direct radiation from bounding design basis accidents and natural phenomena will be below the regulatory limit of 5 rem specified in 10 CFR 72.106(b).

10.6 Evaluation Findings

- F10.1** The SAR sufficiently describes the radiation protection design bases and design criteria for the SSCs important to safety for the NAC-UMS storage system.
- F10.2** Radiation shielding and confinement features are sufficient to meet the radiation protection requirements of 10 CFR Part 20, 10 CFR 72.104, and 10 CFR 72.106.
- F10.3** The NAC-UMS storage system is designed to provide redundant sealing of confinement systems.
- F10.4** The NAC-UMS storage system is designed to facilitate decontamination to the extent practicable.
- F10.5** The SAR adequately evaluates the NAC-UMS storage system and its systems important to safety, to demonstrate that they will reasonably maintain confinement of radioactive material under normal, off-normal, and accident conditions.
- F10.6** The SAR sufficiently describes the means for controlling and limiting occupational exposures within the dose and ALARA requirements of 10 CFR Part 20.
- F10.7** Operational restrictions to meet dose and ALARA requirements in 10 CFR Part 20, 10 CFR 72.104, and 10 CFR 72.106 are the responsibility of the general licensee. The NAC-UMS storage system is designed to assist in meeting these requirements.
- F10.8** The staff concludes that the design of the radiation protection system for the NAC-UMS storage system is in compliance with 10 CFR Part 72 and the applicable design and acceptance criteria have been satisfied. The evaluation of the radiation protection system design provides reasonable assurance that the NAC-UMS storage system will provide safe storage of spent fuel. This finding is based on a review that considered the regulation itself, appropriate regulatory guides, applicable codes and standards, and accepted engineering practices.

intentionally left blank

DRAFT

11.0 ACCIDENT ANALYSES

The purpose of the review of the accident analyses is to evaluate the applicant's identification and analysis of hazards, as well as the summary analysis of system responses to both off-normal and accident or design basis events. This ensures that the applicant has conducted thorough accident analyses, as reflected by the following factors:

1. identified all credible accidents
2. provided complete information in the SAR
3. analyzed the safety performance of the cask system in each review area
4. fulfilled all applicable regulatory requirements

11.1 Off-Normal Events

SAR Section 11.1 examines the causes, radiological consequences, system performance, and corrective actions for off-normal conditions, as defined in ANSI/ANS 57.9-1992. These events can be expected to occur with moderate frequency or on the order of once per year. SAR Section 2.2.5 describes the load cases for evaluating the combined load effects on the structural performance of the NAC-UMS system. SAR Table 2.2-2 lists the load combinations for the TSC. In addition to the environmental conditions and natural phenomenon events, the loads considered include the dead weight, live load, thermal effects, internal pressure, handling load, and cask drop and tipover accident loads. SAR Table 2.2-1 summarizes the load combinations for the VCC designed by the factored load method, per ACI 349. The NRC staff reviewed the analyses for these conditions and found them to be acceptable. There is no adverse impact on the cask integrity from any off-normal event.

11.1.1 Severe Environmental Conditions (106°F and -40°F)

The applicant evaluated the NAC-UMS system for a severe environmental heat of 106°F and a 12-hour insolation period of 2950 BTU/ft² and 1475 BTU/ft² for horizontal flat and curved surfaces, respectively. Also, the maximum decay heat of 23 kW was modeled as identified in SAR Section 11.1.1.

The applicant also evaluated the NAC-UMS for conditions with ambient temperatures of -40°F, with no solar insolation, and applied the maximum decay heat of 23 kW, as described in SAR Section 11.1.1. The staff concurs with this approach since the largest radial thermal gradient would exist with the maximum decay heat load and, thus, produce the largest thermal stresses. Also, since the material of the canister is a ductile stainless steel, it would not be susceptible to brittle fracture associated with the colder temperatures. The staff further determined that material specifications ensure that the BWR canister carbon steel support disks are not susceptible to brittle fracture in the absence of a decay heat load.

The evaluations show that the component temperatures are within the allowable values for the off-normal ambient conditions. There are no radiological consequences for this event.

DRAFT

11.1.2 Blockage of Half of the Air Inlets

The applicant evaluated the NAC-UMS system for conditions associated with half of the cask inlets blocked, including an environmental temperature of 76°F and a 12-hour insolation period of 2950 BTU/ft² and 1475 BTU/ft² for horizontal flat and curved surfaces, respectively. The analysis showed that the resultant component temperatures are less than the allowable temperatures. The personnel dose received as a result of clearing the blockage was estimated to be a maximum of 60 mrem to extremities. The staff concludes that the effects and consequences of this off-normal event are in compliance with the radiological dose limits from normal operations and anticipated occurrences provided in 10 CFR 72.104(a).

11.1.3 Canister Off-Normal Handling Load

The applicant evaluated the consequences of loads on the TSC during the installation of the canister in the VCC or removal of the TSC from the VCC or transfer cask. In SER Section 3.3.2, the staff reviewed the SAR evaluation and concurred with its conclusion on the positive structural margins of safety. This demonstrates that the TSC will reasonably maintain confinement of radioactive material under the off-normal handling condition and that there are no radiological consequences for this event.

11.1.4 Failure of Instrumentation

The applicant evaluated the failure of the electronic temperature monitoring instrumentation. Temperature recordings and surveillance of the cask inlets and outlets occurs daily. The applicant determined in SAR Section 11.2.13 that no component will approach its allowable temperature limit within 24 hours if all of the cask inlets and outlets are blocked. Therefore, the SAR Section 11.2.13 analysis is bounding for component temperatures. There are no radiological consequences for this event.

11.1.5 Small Release of Radioactive Particulate - Canister Exterior

The applicant evaluated the effects of the airborne release of canister surface contamination as a result of air flow over the canister surface. The applicant calculated the surface contamination level for a design basis TSC which would result in an annual dose of 0.1 mrem at 100 meters. Such surface contamination levels are more than 10 times higher than the surface contamination limits in the TS for the accessible surfaces of the canister. The calculated low annual dose at 100 meters is a negligible radiological consequence.

11.2 Accident and Natural Phenomenon Events

SAR Section 11.2 determines the radiological dose consequences for the identified design basis accidents and natural phenomena events. The SAR determined that the NAC-UMS system has adequate design margins and would reasonably maintain its confinement function during and after design basis accidents. The staff concurs that all appropriate accident and natural phenomena events have been identified and all potential safety consequences considered.

DRAFT

11.2.1 Accident Pressurization

11.2.1.1 Cause of Accident Pressurization

Accident pressurization assumes the failure of all of the fuel rods contained within the canister while at the maximum internal temperature. No credible events are identified that would result in either condition.

11.2.1.2 Consequences of Accident Pressurization

There are no storage conditions that are expected to lead to the rupture of all of the fuel rods and none that result in the assumed maximum temperature of 650°F. SAR Section 11.2.1 assumes, however, the hypothetical failure of all of the fuel rods in the TSC at a bounding temperature of 580°F for PWR and 600 °F for BWR to calculate the maximum internal pressure of 56.1 psig and 35.3 psig, respectively for the TSCs. The SAR considers an internal pressure of 65 psig, which is bounding and conservative, for the TSC stress analysis. The staff agrees with the SAR results that all stress margins are adequate. This demonstrates that the TSC is structurally adequate to reasonably maintain confinement of radioactive material under the condition of accident pressurization. There are no radiological consequences for this accident.

11.2.2 Failure of All Fuel Rods With a Subsequent Canister Breach

Prior to the issuance of NRC's ISG No. 3, an analysis of the dose consequence of a ground level canister breach, with 100% fuel rod failure, was required to demonstrate compliance with 10 CFR 72.106(a). However, this staff guidance requires that only credible accidents and associated consequences be evaluated against the requirements of 10 CFR Part 72. A credible accident is one which may lead to the following events: failure of the confinement boundary, transformation of the radioactive material into a dispersible form, release of such material from the cask, off-site dispersion of released materials, and/or an associated dose.

It is the staff's view that a ground level breach of the cask is a non-mechanistic failure since the confinement boundary is completely welded and tested to ANSI leaktight standards, and the stresses, temperatures, and pressures of the TSC are within the design basis limits under off-normal and hypothetical accident conditions. The TSC is vacuum dried and backfilled with helium gas prior to final canister closure, so there is no potential for an increase in the canister pressure or degradation of the cladding due to radiolytic decomposition or other adverse reactions. Further, the TSC is designed to be leaktight in accordance with ANSI N14.5-1997, as described in SER Section 7.

The staff concludes that, under off-normal or hypothetical accident conditions, (1) an analysis of the dose consequence from this event is unnecessary since no discernable leakage of radioactive material from the TSC is credible (i.e., leaktight), (2) the dose consequence due to leakage of radioactive material from the all-welded canister is negligible, and (3) the requirements of 10 CFR 72.106(b) are met.

DRAFT

11.2.3 Fresh Fuel Loading in the Canister

11.2.3.1 Cause of Fresh Fuel Loading in the Canister

Due to the administrative controls associated with candidate assembly selection, this event is not considered to be credible. However, it is evaluated to analyze the radiological consequences and bound potential mis-loadings.

11.2.3.2 Consequences of Fresh Fuel Loading in the Canister

The criticality evaluation assumes no burnup for the design basis assemblies and has determined adequate margin to criticality assuming the most reactive configuration and optimum moderation. Therefore, there are no radiological consequences associated with this event.

11.2.4 24-Inch Drop of Vertical Concrete Cask

11.2.4.1 Cause of 24-Inch Drop of Vertical Concrete Cask

The loaded VCC may be manipulated to the final storage destination, using a mobile lifting frame, at heights not to exceed 20 inches. Consequently, a 24-inch drop is considered credible. A failure involving the VCC lifting lugs or the mobile frame is postulated to be the cause of the accident.

11.2.4.2 Consequences of 24-Inch Drop of Vertical Concrete Cask

The VCC, which contains the loaded TSC, may be raised approximately 20 inches above the ISFSI storage pad, using a mobile frame. SAR Section 11.2.4 assumes a 24-inch drop of the VCC onto an unyielding surface for calculating the maximum static equivalent loads on the concrete overpack and pedestal supported TSC. The SAR evaluates the consequences of the accident, including the structural performance of the TSC components, the crushing of the VCC concrete shell, and permanent deformation of the air inlet of the TSC pedestal. The consequences of the loss of part of the air inlets are evaluated in SAR Section 11.1.2 and reviewed in SER Section 11.1.2. SER Section 3.3.5 reviews the SAR evaluation of the performance of the NAC-UMS system and notes that the cask 24-inch drop accident may cause the VCC concrete shell to undergo an axial crush of 0.134 inches, which is negligibly small and will not affect its shielding effectiveness. The SER also concurs with the SAR conclusion that the TSC is structurally adequate under a bounding axial load of 60 g. On this basis, the staff concludes that the NAC-UMS system will reasonably maintain confinement of radioactive material under a cask 24-inch drop accident, and thus, there are no radiological consequences for this event.

DRAFT

11.2.5 Explosions

11.2.5.1 Cause of Explosion

An explosion event is unlikely due to the administrative and security controls associated with an ISFSI operation. However, an explosion involving combustible materials at reactor sites is credible.

11.2.5.2 Consequences of Explosion

SAR Section 11.2.5 references the SAR Section 11.2.9 analysis to demonstrate acceptable structural performance of the TSC under an external static pressure of 22 psig. On this basis, the staff concludes that, as a result of an explosion which exerts an equivalent static pressure of less than 22 psig on the canister, the NAC-UMS system will reasonably maintain confinement of radioactive material and that there are no radiological consequences for this accident event.

11.2.6 Fire Accident

11.2.6.1 Cause of Fire Accident

A major fire involving the NAC-UMS system is unlikely, due to the absence of flammable materials in the vicinity of a spent fuel storage area. A transport vehicle fire during transfer of the VCC to the pad is considered credible.

11.2.6.2 Consequences of Fire Accident

A fire with an average flame temperature of 1475°F and duration of 8 minutes is postulated from the spillage and ignition of 50 gallons of combustible transporter fuel. The fire is assumed to spread along the ground and heat the air as it enters the cask. Solar insolation is applied during the fire since the fire is only assumed to occur at the base of the cask and a heat load of 23 kW is applied to the cask walls. The initial temperature distribution of the transient is based on the normal storage conditions. Following the fire, the cask is cooled for 10 hours using normal steady-state conditions at an ambient temperature of 75°F.

The applicant's evaluation showed that component temperatures remain less than the allowable temperatures, and thus, there are no significant radiological consequences for this accident. Local spalling of concrete could lead to a minor reduction in shielding effectiveness. A post-event inspection will determine the corrective actions necessary to ensure the cask remains within the design basis.

DRAFT

11.2.7 Maximum Anticipated Heat Load (133°F Ambient Temperature)

11.2.7.1 Cause of Maximum Anticipated Heat Load

The assumed cause of this accident are weather events which subject the NAC-UMS to a 133°F ambient temperature with full solar insolation and maximum heat load.

11.2.7.2 Consequences of Maximum Anticipated Heat Load

An extreme environmental heat of 133°F is analyzed for the NAC-UMS cask with a maximum decay heat of 23 kW and a 12-hour insolation period of 2950 BTU/ft² and 1475 BTU/ft² for horizontal flat and curved surfaces, respectively. The evaluation shows that the component temperatures are within allowable temperatures for the accident conditions and that the calculated concrete thermal stresses are also acceptable. Therefore, there are no radiological consequences associated with this event.

11.2.8 Earthquake

11.2.8.1 Cause of Earthquake Event

It is possible that an earthquake could occur during the use of the NAC-UMS system.

11.2.8.2 Consequences of Earthquake Event

Earthquakes are natural phenomena that the NAC-UMS system might experience at an ISFSI. SAR Section 11.2.8 defines, at the top surface of the storage pad, the DBE motion of 0.26 g for the two horizontal acceleration components and 0.173 g for the vertical component. SER Section 3.4.3 reviewed the SAR evaluation and concluded that, with adequate margins per ANSI/ANS-57.9, the cask will not slide or tip over under the DBE condition. On this basis, the staff concurs with the SAR conclusion that the VCC performance is not affected by the DBE and there are no radiological consequences for this natural phenomenon accident.

11.2.9 Flood

11.2.9.1 Cause of Flood

A flood event involving the NAC-UMS cask is considered credible. Possible natural events such as unusually high water from a river, dam break, seismic event, and severe weather are potential causes of floods.

11.2.9.2 Consequences of Flood

A flood event is a site-specific natural phenomenon. SAR Section 11.2.9 considers, however, the design basis flood conditions of a 50-foot depth of water having a velocity of 15 feet per second for the fully immersed NAC-UMS cask. SER Section 3.4.1 reviews the SAR evaluation of the structural consequences of a flood to the NAC-UMS VCC and concurs with the SAR

DRAFT

conclusion that the VCC will not overturn or slide, and the TSC will not suffer adverse consequences under the design basis flood conditions. On this basis, the staff agrees with the SAR analysis that there are no radiological consequences for this natural phenomenon accident.

11.2.10 Lightning

11.2.10.1 Cause of Lightning

Lightning is an expected natural phenomena to occur at an ISFSI site.

11.2.10.2 Consequences of Lightning

The applicant's analysis assumes that the lightning strikes the highest metal surface and proceeds through the concrete cask liner to ground, resulting in heating along that path. The calculated increases in steel and concrete temperatures are small, and thus, there are no radiological consequences associated with this event.

11.2.11 Tornado and Tornado-Driven Missiles

11.2.11.1 Cause of Tornado and Tornado-Driven Missiles

It is possible that the NAC-UMS cask, which is placed on an unsheltered pad and subject to extreme weather, could be affected by the extreme winds associated with a tornado.

11.2.11.2 Consequences of Tornado and Tornado-Driven Missiles

A tornado is a random weather event having a higher probability of occurrence at certain times of the year and in certain geographical areas. SAR Section 11.2.11 considers wind pressures and tornado-driven missiles of the design basis tornado, for a maximum combined tornado wind speed of 360 mph, to evaluate the VCC for maintaining stability and providing protection of the TSC from missile penetration.

In SER Section 3.4.2, the staff reviewed the SAR evaluation and concurred with its conclusion that the tornado wind pressure and tornado-driven missiles are not capable of overturning the cask or penetrating the boundary established by the concrete cask to affect the performance of the TSC. The staff also concurred with the SAR evaluation that a localized removal of about 6 inches of concrete shield is possible but the resulting local surface radiation dose rate would be less than 250 mrem/hr. On this basis, the staff concludes that the system will reasonably maintain confinement of radioactive material when subject to tornado wind and tornado-driven missiles and that the radiological consequences are small.

DRAFT

11.2.12 Tipover of the Vertical Concrete Cask

11.2.12.1 Cause of Tipover of the Vertical Concrete Cask

A tipover is possible in an earthquake that exceeds the DBE previously analyzed. There are no credible events expected to result in a cask tipover.

11.2.12.2 Consequences of Tipover of the VCC

Considering the structural performance, the staff concurs with the SAR assessment that no credible accidents, such as the design basis earthquake, tornado, and flood will cause the VCC to tip over. To demonstrate the defense-in-depth design of the system, however, SER Section 3.3.6 reviewed the SAR evaluation of the NAC-UMS system subject to a tipover accident.

SER Sections 3.3.6.1 evaluated the SAR determination of deceleration g-loads applicable to the NAC-UMS components. SER Section 3.3.6.2 evaluated the SAR's structural capabilities analyses for the TSC and its support disks. The analyses support the SAR conclusion that the NAC-UMS cask does not suffer adverse structural consequences from the tipover accident and the VCC and TSC will maintain the design basis shielding, criticality control, and confinement performance requirements.

The SAR evaluates the radiological consequences in the hypothetical tipover accident and estimates that the 1-meter and 4-meter dose rates, due to the less shielding on the bottom of the cask, are approximately 34 and 4 rem/hr, respectively. The SAR notes that, following a tipover accident, supplemental shielding should be used and stringent access control must be applied to ensure that personnel do not enter the area of radiation shine from the exposed bottom of a tipped over cask. This radiological consequence is acceptable since the event is not considered to be credible.

11.2.13 Full Blockage of VCC Air Inlets and Outlets

11.2.13.1 Cause of Full Blockage of VCC Air Inlets and Outlets

The likely cause of a full blockage of the VCC air inlets and outlets is a cask burial associated seismic event or landslide. The event is analyzed as a bounding condition and is not considered credible.

11.2.13.2 Consequences of Full Blockage of VCC Air Inlets and Outlets

The applicant's evaluation assumed the sudden loss of convective cooling for the canister. The loss of convective cooling results in a sustained heat-up of the canister and concrete cask. The results from this unlikely scenario indicate that the cask should not be deprived of air flow for more than 24 hours, otherwise, the support disk and heat transfer disk may exceed their allowable temperature limit. The analysis also demonstrated that the fuel cladding would not approach its temperature limit for about 150 hours.

DRAFT

Since the NAC-UMS cask retains its shielding performance, the radiological consequences of this event are low. Personnel dose associated with recovery actions to restore the air flow path is the most significant consequence and was estimated by the applicant to be about 200 mrem to the extremities to clear all cask openings and 50 mrem to clear cask debris away from the cask body. Assuming debris is removed and the air flow path is restored in less than one day, the radiological consequences associated with this event are low.

11.3 Criticality

As discussed in SER Section 6, the applicant has shown, and the staff has verified, that the spent fuel remains subcritical ($k_{eff} < 0.95$) under all credible conditions from normal, off-normal, and postulated accident events. The design basis off-normal and accident events do not adversely affect the design features important to criticality safety. Therefore, based on the information provided in the SAR, the staff concludes that the NAC-UMS system design meets the "double contingency" requirements of 10 CFR 72.124(a).

11.4 Post-Accident Recovery

SAR Section 11.2 discusses corrective actions for each accident identified in Section 11.2. There are no credible, design basis accidents that would affect the canister confinement boundary or significantly damage the cask system at a level that could result in undue risk to public health and safety.

The staff reviewed the design basis accident analyses with respect to post-accident recovery and found them to be acceptable. The staff has reasonable assurance that the site licensee can recover the NAC-UMS storage cask from the analyzed design basis accidents and that the generic corrective actions outlined in the SAR are appropriate to protect public health and safety.

11.5 Instrumentation

Because of the passive nature of the NAC-UMS system, no instrumentation and control systems are needed to monitor SSCs important to safety. Therefore, there are no instrumentation and control systems that must remain operational under accident conditions. The confinement boundary contains no external penetrations for pressure monitoring or overpressure protection. Since the TSC uses an entirely welded redundant closure system and, under normal and off-normal conditions, there are no anticipated mechanisms that would cause weld failure, no direct monitoring of the closure is required.

11.6 Evaluation Findings

F11.1 The SSCs of the NAC-UMS system are adequate to prevent accidents and to mitigate the consequences of accidents and natural phenomena events that do occur.

F11.2 The spacing of casks, discussed in SAR Section 1.4, ensures accessibility of the equipment and services required for emergency response.

DRAFT

- F11.3** Table 12-1 of this SER lists the TS for the NAC-UMS system. These TS are further discussed in Section 12 of the SER.
- F11.4** The applicant has evaluated the NAC-UMS system to demonstrate that it will reasonably maintain confinement of radioactive material under credible accident conditions.
- F11.5** A design basis accident or a natural phenomena event will not prevent the retrieval of spent fuel for further processing or disposal.
- F11.6** The spent fuel will be maintained in a subcritical condition under accident conditions.
- F11.7** The applicant has evaluated off-normal and design basis accident conditions to demonstrate with reasonable assurance that the NAC-UMS system radiation shielding and confinement features are sufficient to meet the requirements in 10 CFR 72.104(a) and 10 CFR 72.106(b).
- F11.8** No instrumentation or control systems are required to remain operational under accident conditions.
- F11.9** The staff concludes that the accident design criteria for the NAC-UMS system are in compliance with 10 CFR Part 72 and the accident design and acceptance criteria have been satisfied. The applicant's accident evaluation of the cask adequately demonstrates that it will provide for safe storage of spent fuel during credible accident situations. This finding is reached on the basis of a review that considered independent confirmatory calculations, the regulation itself, appropriate regulatory guides, applicable codes and standards, and accepted engineering practices.

DRAFT

12.0 CONDITIONS FOR CASK USE —TECHNICAL SPECIFICATIONS

The purpose of the review of the conditions for cask use is to determine whether the applicant has fully evaluated the TS and to ensure that the SER incorporates any additional operating controls and limits that the staff deems necessary.

12.1 Conditions for Use

The conditions for use of the NAC-UMS system are fully defined in the CoC and the TS and Approved Contents and Design Features specifications that are appended to it.

12.2 Technical Specifications

Table 12-1 lists the TS for the NAC-UMS system. The staff has appended these TS to the CoC for the NAC-UMS system.

12.3 Evaluation Findings

F12.1 Table 12-1 of the SER lists the TS for the NAC-UMS system. These TS are further discussed in Section 12 of the SAR and are part of the CoC.

F12.2 The staff concludes that the conditions for use of the NAC-UMS system identify necessary TS to satisfy 10 CFR Part 72 and that the applicable acceptance criteria have been satisfied. The TS provide reasonable assurance that the cask will allow safe storage of spent fuel. This finding is reached on the basis of a review that considered the regulation itself, appropriate regulatory guides, applicable codes and standards, and accepted practices.

DRAFT

**TABLE 12-1
NAC-UMS system TECHNICAL SPECIFICATIONS**

NUMBER	TECHNICAL SPECIFICATION
1.0	USE AND APPLICATION
1.1	Definitions
1.2	Logical Connectors
1.3	Completion Times
1.4	Frequency
2.0	(intentionally left blank)
3.0	LIMITING CONDITION FOR OPERATION (LCO) APPLICABILITY/SURVEILLANCE REQUIREMENT (SR) APPLICABILITY
3.1	NAC-UMS SYSTEM Integrity
3.1.1	CANISTER Maximum Time in Vacuum Drying
3.1.2	CANISTER Vacuum Drying Pressure
3.1.3	CANISTER Helium Backfill Pressure
3.1.4	CANISTER Maximum Time in TRANSFER CASK
3.1.5	CANISTER Helium Leak Rate
3.1.6	CONCRETE CASK Heat Removal System
3.1.7	Fuel Cooldown Requirements
3.1.8	CANISTER Removal from the CONCRETE CASK
3.2	NAC-UMS SYSTEM Radiation Protection
3.2.1	CANISTER Surface Contamination
3.2.2	CONCRETE CASK Average Surface Dose Rates
Figure 3-1	CONCRETE CASK Surface Dose Rate Measurement
Table 3-1	CANISTER Limits
4.0	(intentionally left blank)
5.0	ADMINISTRATIVE CONTROLS AND PROGRAMS
5.1	Training Program
5.2	Pre-Operational Testing and Training Exercises
5.3	Special Requirements for the First System Placed In Service
5.4	Surveillance After an Off-Normal, Accident, or Natural Phenomena Event
5.5	NAC-UMS System Transport Evaluation Program
5.6	Radioactive Effluent Control Program
Table 5-1	TRANSFER CASK and CONCRETE CASK Lifting Requirements

DRAFT

13.0 QUALITY ASSURANCE

The purpose of this review and evaluation is to determine whether NAC has a QA program that complies with the requirements of 10 CFR Part 72, Subpart G.

13.1 Areas Reviewed

QA Organization
QA Program
Design Control
Procurement Document Control
Instructions, Procedures, and Drawings
Document Control
Control of Purchased Material, Equipment, and Services
Identification and Control of Materials, Parts, and Components
Control of Special Processes
Licensee Inspection
Test Control
Control of Measuring and Test Equipment
Handling, Storage, and Shipping Controls
Inspection, Test, and Operating Status
Nonconforming Materials, Parts, or Components
Corrective Action
QA Records
Audits

NUREG-1536 provides the criteria for evaluating the above 18 areas. As indicated in SAR Section 13.1, the NRC has issued a QA program approval for activities conducted under Subpart H of 10 CFR Part 71. Based on the review of the QA program described in the SAR and previous NRC determinations regarding NAC's 10 CFR Part 72 QA program, the staff has determined that it meets the requirements of Subpart G of 10 CFR Part 72.

13.2 Evaluation Findings

- F13.1** The QA program describes the requirements, procedures, and controls that, when properly implemented, comply with the requirements of 10 CFR Part 72, Subpart G and 10 CFR Part 21, "Reporting of Defects and Noncompliance."
- F13.2** The structure of the organization and assignment of responsibility for each activity ensure that designated parties will perform the work to achieve and maintain specified quality requirements.
- F13.3** Conformance to established requirements will be verified by qualified personnel and groups not directly responsible for the activity being performed. These personnel and groups report through a management hierarchy which grants the necessary authority and organizational freedom and provides sufficient independence from economic and scheduling influences.

DRAFT

- F13.4** The QA program is well-documented and provides adequate control over activities affecting quality, as well as SSCs important to safety, consistent with their relative importance to safety (graded approach).
- F13.5** NAC's QA program complies with the applicable NRC regulations and can be implemented for the design, fabrication, testing, modification, and use of the NAC-UMS system.
- F13.6** This SAR can be referenced without further QA review in a license application to receive and store spent fuel under 10 CFR Part 72, provided that the applicant applies its NRC-approved QA program meeting the requirements of 10 CFR Part 50, Appendix B, to the design, construction, and use of SSCs that are important to safety for a spent fuel storage installation.

DRAFT

14.0 DECOMMISSIONING

The purpose of the review of the conceptual decommissioning plan for the NAC-UMS system is to ensure that it provides reasonable assurance that the owner of the cask can conduct decontamination and decommissioning in a manner that adequately protects the health and safety of the public. Nothing in this review considers, or involves the review of, ultimate disposal of spent nuclear fuel.

14.1 Decommissioning Considerations

The conceptual decommissioning plan for the NAC-UMS system is provided in SAR Section 2.4. While NAC clearly anticipates that the NAC-UMS system could be used as part of a final geologic disposal system, the ability to decommission the NAC-UMS is also considered. For example, SAR Tables 2.4-1 through 2.4-4 of the SAR provide the activity concentrations of the major radiation sources in the VCC and TSC, for PWR and BWR design basis contents, which NAC has determined would exist after 40 years of irradiation while stored in the NAC-UMS system. The material activation results presented in the SAR Tables confirm that total system activation is low for all components. Therefore, the canister and concrete cask could be disposed in a near-surface facility as low-specific-activity material.

NAC determined that the VCC and TSC can be decommissioned using standard industry practices. Activated steel components can be decontaminated using existing mechanical or chemical methods.

14.2 Evaluation Findings

- F14.1** The NAC-UMS system design includes adequate provisions for decontamination and decommissioning. As discussed in SAR Section 2.4, these provisions include facilitating decontamination of the NAC-UMS system, if needed; storing the remaining components, if no waste facility is expected to be available; and disposing of any remaining low-level radioactive waste.
- F14.2** SAR Section 2.4 also presents information concerning the proposed practices and procedures for decontaminating the cask and disposing of residual radioactive materials after all spent fuel has been removed. This information provides reasonable assurance that the applicant will conduct decontamination and decommissioning in a manner that adequately protects public health and safety.
- F14.3** The staff concludes that the decommissioning considerations for the NAC-UMS system are in compliance with 10 CFR Part 72.

intentionally left blank

DRAFT

CONCLUSIONS

The staff has reviewed Revision 1 to the Safety Analysis Report for the NAC-UMS system. Based on the statements and representations contained in the SAR and the conditions given in the CoC, we conclude that the Model No. NAC-UMS spent fuel storage cask system meets the requirements of 10 CFR Part 72.

Principal Contributors:

D. Carlson
K. Gruss
E. Keegan
T. McGinty
R. Parkhill
D. Tang

DRAFT

REFERENCES

American Welding Society, "Standard Symbols for Welding, Brazing, and Nondestructive Examination," AWS Standard A2.4.

American Society of Mechanical Engineers, Boiler and Pressure Vessel Code, Section VIII, "Rules for the Construction of Pressure Vessels."

American National Standards Institute, Institute for Nuclear Materials Management, "American Standard for Radioactive Materials - Leakage Tests on Packages for Shipment," ANSI N14.5, January 1997.

American Welding Society, "Structural Welding Code Steel," AWS D1.1-96.

American Society of Civil Engineers, "Minimum Design Loads for Buildings and Other Structures," ASCE 7-93, May 1994.

American National Standards Institute, "American National Standards for Radioactive Material Lifting Devices for Shipping Containers Weighing 10,000 lbs (4500 kg) or More," ANSI N14.6, 1993.

American Society of Mechanical Engineers, Boiler and Pressure Vessel Code, Section III, "Rules for Construction of Nuclear Power Plant Components."

American Institute of Steel Construction, "Manual of Steel Construction."

American Society of Civil Engineers, "Seismic Analysis of Safety-Related Nuclear Structures," ASCE 4-86, September 1986.

American National Standards Institute/American Nuclear Society, "Design Criteria for an Independent Spent Fuel Storage Installation (Dry Storage Type)," ANSI/ANS-57.9, 1984.

American Concrete Institute, "Building Code Requirements for Reinforced Concrete," ACI 318.

American Concrete Institute, "Code Requirements for Nuclear Safety Related Concrete Structures," ACI 349.

Cunningham, M.E., et al., Pacific Northwest Laboratory, "Control of Degradation of Spent LWR Fuel During Dry Storage in an Inert Atmosphere," PNL-6364, September 1987.

DOE/RW-0184, Volume 3 of 6, "Characteristics of Spent Fuel, High-Level Waste, and Other Radioactive Wastes Which May Require Long-Term Storage," 1987.

Johnson, A.B. and Gilbert, E.R., Pacific Northwest Laboratory, "Technical Basis for Storage of Zircalloy-Clad Spent Fuel in Inert Gases," PNL-4835, September 1983.

Knoll, R.W., et al., Pacific Northwest Laboratory, "Evaluation of Cover Gas Impurities and Their Effects on the Dry Storage of LWR Spent Fuel," PNL-6365, November 1987.

DRAFT

Levy, I.S., et al., Pacific Northwest Laboratory, "Recommended Temperature Limits for Dry Storage of Spent Light-Water Zircalloy Clad Fuel Rods in Inert Gas," PNL-6189, May 1987.

Maddux, Gene E., "Stress Analysis Manual," AFFDL-TR-69-42, Air Force Flight Dynamics Laboratory, August 1969.

NAC International Inc., Safety Analysis Report for the NAC-UMS System, Revision 1.

Oak Ridge National Laboratory, "SCALE: A Modular Code System for Performing Standardized Computer Analyses for Licensing Evaluations," NUREG/CR-0200, Vol. 1-3, Revision 5, 1997.

Petrie, L.M., et al., Oak Ridge National Laboratory, "SCALE: A Modular Code System for Performing Standardized Computer Analyses for Licensing Evaluations," NUREG/CR-0200, Vol. 1-4, Revision 4, 1995.

Spent Fuel Project Office, Interim Staff Guidance No. 3, "Post Accident Recovery and Compliance with 10 CFR 72.122(l)," October 6, 1998.

Spent Fuel Project Office, Interim Staff Guidance No. 4, Revision 1, "Cask Closure Weld Inspections," May 21, 1999.

Spent Fuel Project Office, Interim Staff Guidance No. 8, Revision 1, "Burnup Credit in the Criticality Safety Analyses of PWR Spent Fuel in Transport and Storage Casks," July 30, 1999.

U.S. Nuclear Regulatory Commission, Bulletin 96-04, "Chemical, Galvanic, or other Reactions in Spent Fuel Storage and Transportation Casks," July 1996.

U.S. Nuclear Regulatory Commission, "Standard Format and Content for a Topical Safety Analysis Report for a Spent Fuel Dry Storage Cask," Regulatory Guide 3.61, February 1989.

U.S. Nuclear Regulatory Commission, "Design-Basis Tornado for Nuclear Power Plants," Regulatory Guide 1.76, April 1974.

U.S. Nuclear Regulatory Commission, NUREG-0800, "Standard Review Plan for Nuclear Power Plants."

U.S. Code of Federal Regulations, "Licensing Requirements for the Independent Storage of Spent Nuclear Fuel and High-Level Radioactive Waste," Title 10, Part 72.

U.S. Code of Federal Regulations, "Standards for Protection Against Radiation," Title 10, Part 20.

U.S. Nuclear Regulatory Commission, NUREG/CR-6322, "Buckling Analysis of Spent Fuel Basket," May 1995.

U.S. Nuclear Regulatory Commission, NUREG-0612, "Control of Heavy Loads at Nuclear Power Plants," July 1980.

U.S. Nuclear Regulatory Commission, NUREG-1536, "Standard Review Plan for Dry Cask

DRAFT

Storage Systems."

U.S. Nuclear Regulatory Commission, NUREG/CR-6407, "Classification of Transportation Packaging and Dry Spent Fuel Storage System Components According to Importance to Safety."

U.S. Nuclear Regulatory Commission, "Information Relevant to Ensuring that Occupational Radiation Exposures at Nuclear Power Stations Will Be As Low As Reasonably Achievable," Regulatory Guide 8.8, Revision 3, June 1978.

U.S. Nuclear Regulatory Commission, "Operating Philosophy for Maintaining Occupational Radiation Exposures As Low As is Reasonably Achievable," Regulatory Guide 8.10, Revision 1-R, May 1997.

U.S. Nuclear Regulatory Commission, NUREG/CR-6608, "Summary and Evaluation of Low-Velocity Impact Tests of Solid Steel Billet Onto Concrete Pads," February 1998.

U.S. Code of Federal Regulations, "Reporting of Defects and Noncompliance," Title 10, Part 21.