

TROJAN
NUCLEAR PLANT

RADIOLOGICAL
SITE
CHARACTERIZATION
REPORT

REVISION 0.1

Approved by: Tom Meil Date: 2/8/95

RADIOLOGICAL SITE CHARACTERIZATION PLAN

for the

TROJAN NUCLEAR POWER PLANT

APPROVED BY

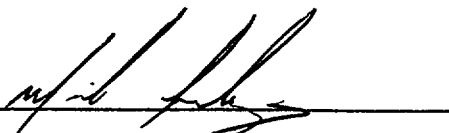

Stephen M. Jennings

TABLE OF CONTENTS

- 1.0 Background Information
- 2.0 Site Information
 - 2.1 Site Description
 - 2.2 Site Radiological Effluents
 - 2.2.1 Airborne
 - 2.2.2 Liquid
- 3.0 Characterization Overview
 - 3.1 Characterization Survey Objectives
 - 3.2 Definitions
 - 3.3 Identity of Contaminants
 - 3.4 Organization and Responsibilities
 - 3.5 Training and Qualifications
 - 3.6 Instrumentation/Counting Services
 - 3.7 General Survey Plan
 - 3.7.1 Environment
 - 3.7.2 Structures
 - 3.7.3 Systems
 - 3.7.4 Activation
 - 3.8 Tentative Schedule
 - 3.9 Survey Reports and Documentation
 - 3.10 Quality Assurance
 - 3.11 Cleanup Standards
- 4.0 Survey Plan and Procedures
 - 4.1 General
 - 4.2 Environmental Survey Plan
 - 4.2.1 Background Determination
 - 4.2.2 Sampling/Measurement Point Selection
 - 4.2.3 Exposure Rate Measurements
 - 4.2.4 Surface Activity Measurements
 - 4.2.5 Soil, Sediment and Water Sampling
 - 4.3 Structures
 - 4.3.1 Background Determination
 - 4.3.2 Sampling/Measurement Point Selection
 - 4.3.3 Exposure Rate Measurements
 - 4.3.4 Removable Contamination Measurements
 - 4.3.5 Surface Scans
 - 4.3.6 Sampling
 - 4.4 Systems
 - 4.4.1 Background Determination
 - 4.4.2 Sampling/Measurement Point Selection
 - 4.4.3 Exposure Rate Measurements
 - 4.4.4 Removable/Surface Contamination Measurements
 - 4.4.5 In-Field Gamma Ray Spectroscopy

TABLE OF CONTENTS (continued)

5.0 Data Interpretation

6.0 Reports

7.0 Records

8.0 References

1.0 BACKGROUND INFORMATION

The Trojan Nuclear Power Plant is located in Columbia County, in the state of Oregon, 42 miles north of Portland, Oregon. The plant location is shown on a regional map in Figure 1.1-1. The site consists of 623 acres incorporating a recreational area/park and various office buildings along with the industrial complex enclosed by the security fence (Figures 1.1-2 and 1.1-3).

The plant is jointly owned by Portland General Electric, Pacific Power and Eugene Water and Electric Board. The plant was designed by Bechtel Power Corporation as a single generating unit with a pressurized water reactor (PWR) supplied by Westinghouse Corporation. The nuclear steam supply system was capable of a thermal output of 3423 MWt with a net electrical output of 1170 MWe.

The Trojan Nuclear plant received its operating license on November 21, 1975, was declared commercial on December 24, 1975 and formally began commercial operation on May 20, 1976.

Portland General Corporation Board of Directors voted to permanently close the Trojan Nuclear Plant on January 4, 1993. This decision was based on the results of least cost planning, regulatory uncertainty and steam generator tube defects identified during the 1991 Refueling shutdown and noted again in 1992. The plant was forced off line on November 9, 1992 due to a steam generator tube leak.

Portland General Electric received a Possession Only License (POL) for the Trojan Nuclear Plant on May 5, 1993.

Portland General Electric is presently developing a Decommissioning Plan. The plan will include a review of the various decommissioning alternatives and a decision on the alternative selected for the Trojan plant.

2.0 SITE INFORMATION

2.1 Site Description

The Trojan site is located adjacent to the Columbia River, 42 miles north of Portland, Oregon. The site lies between the Cascade and Coast mountain ranges in the Puget Trough. The site elevation is approximately 55 feet and is surrounded by land used for residential, commercial and agricultural purposes. The site also contains a recreational park used by members of the public for various day uses.

The cooling water supply for the site is from the Columbia River. Drinking water is supplied from onsite wells.

2.2 Site Radiological Effluents

2.2.1 Airborne

The Auxiliary/Fuel building exhaust, the Containment building exhaust (purge) and the condenser Offgas System exhaust were monitored effluent airborne pathways during power operation. Other potential airborne release pathways not specifically monitored included the Main Steam Relief valves, Steam Packing Exhauster blower discharge and Turbine Building exhaust.

2.2.2 Liquid

The liquid discharge point for the Trojan plant was to the Columbia River. Various discharge pathways to the river included Liquid Radwaste discharge (from various in plant tanks), Steam Generator Blowdown and Turbine Building Sump/Oily water separator. Columbia River water was used for dilution of all releases.

3.0 CHARACTERIZATION OVERVIEW

3.1 Characterization Survey Objectives

The Site Characterization Plan (SCP) for the Trojan Nuclear Plant will be completed in three (3) phases.

Phase I Scoping Survey/Site Characterization - to determine the initial (post operation) radiological status of the facility, to estimate the site source term and isotopic mixture to support decommissioning cost estimation and decision making, to determine the location and extent of any contamination outside the radiological controlled areas. This phase will also collect background information to be used for decision making involved with returning the facility (or portions thereof) to unrestricted use.

Phase II Radiological Surveys conducted to support the dismantlement of the facility.

Phase III The final radiation survey conducted to verify the facility is available for unrestricted use.

This plan provides the details for Phase I of the Site Characterization. Phase II activities will be conducted using the existing Radiation Protection Program with expanded criteria for free release of bulk materials. The details of Phase III will be determined in conjunction with detailed planning for deferred decommissioning which is expected to follow the SAFSTOR period.

This document describes only the radiological portion of the plan. The evaluation of the site for non-radiological hazardous material is being handled separately by the corporate office and will be attached as an appendix to the report.

3.2 Definitions

3.2.1 Affected Area: Areas within the site that have potential radioactive contamination (based on operating history) or known contamination based on past surveys.

3.2.2 Unaffected Area: Areas within the site that are not expected to have detectable radioactive contamination above background levels.

3.2.3 Biased Survey: Survey that is conducted to quantify radioactivity based upon suspected or known contamination at a given location.

3.2.3 Unbiased Survey: Survey characterized by a systematic placement of sample/measurement locations, thus enabling an unbiased representation of areas that may or may not contain radioactivity.

3.3 Identification of Contaminants

The identity of the radionuclides are typical of those found in pressurized water reactor plants as detailed in NUREG/CR-0130, 'Technology, Safety and Costs of Decommissioning a Referenced Pressurized Water Reactor'. Trojan is the plant used as the reference plant in NUREG/CR-0130. The predominant radionuclides are Fe-55, Co-58, Co-60 and Cs-137. Radioactive waste stream characterization that has been completed as part of our compliance with 10CFR20.311 will be used to help define the radionuclide source term.

3.4 Organization and Responsibilities

The overall responsibility of the Site Characterization Plan for the Trojan Nuclear Plant rests with the Manager, Personnel Protection. The Manager, Radiation Protection and Manager, Radiation Protection Technical Support are responsible for the implementation of the plan. The organization for the SCP is shown on figure 3.4-1.

3.5 Training and Qualifications

All personnel conducting the SCP surveys meet or exceed the requirements of ANSI N18.1-1971, 'Selection and Training of Nuclear Power Plant Personnel'.

Training in the defueled mode is a task based training program using on-the-job training supplemented by reading assignments, group briefings and formal/informal classroom instruction.

3.6 Instrumentation/Counting Services

Counting equipment used during operation of the Trojan plant will be used to support sample analysis during the Phase I scoping survey. Additional equipment capable of measuring the background or near radiation levels expected to be found during the characterization surveys is being purchased. A portable gamma ray spectroscopy unit is being purchased for use in characterizing deposited and activated radioactivity in plant systems and structures.

The procedures used for counting activities meet or exceed the criteria contained in Nuclear Regulatory Commission Regulatory Guide 4.15, 'Quality Assurance for Radiological Monitoring Programs - Effluent Streams and the Environment'.

Contracted laboratory services will be used for specialized or difficult analyses. The contract laboratories will meet the same performance standards as the Trojan laboratories.

All instruments used for the site characterization surveys will be periodically calibrated in accordance with approved Radiation Protection department procedures and source checked daily before use.

Examples of instruments used for characterization surveys are shown on Table 3.6-1. Instruments will be replaced over time with equipment of equivalent or improved sensitivity.

3.7 General Survey Plan

The Site Characterization Plan survey is divided into four (4) areas. These areas are Environment, Structures, Systems and Activation.

3.7.1 Environment

This area of the survey focuses on the impact of Trojan operation on the environment due to the release of radioactive material. Preoperational and operational environmental monitoring data will be used to measure the impact. Additional sampling will be conducted as necessary to fill in gaps or to better define areas requiring biased surveys. This area will include all outdoor areas including inside the present security restricted area. Radiation survey data will be compared to background data (as determined by methods described in Section 4.2.1) to determine the impact of operation of Trojan.

3.7.2 Structures

This area of the survey is directed at determining the level of radioactive contamination found in the buildings located at the Trojan site. Operational radiation protection survey data will be supplemented by various surveys to determine the presence of or level of radioactive contamination. Areas outside the present Radiological Controlled Area (RCA) will receive the majority of the survey attention to determine the status for release for unrestricted use. Structures with known radioactivity will be surveyed to characterize the extent of contamination including area and depth of penetration.

3.7.3 Systems

The system survey is being developed to determine the list of contaminated systems and make an estimation of the quantity of contamination. The approach to this task involves grouping the plant systems into four (4) categories, C1 - contaminated; C2 - potentially contaminated due to cross contamination; I - indeterminate (need more data) and N - clean, free of contamination. Data will be collected for all four classes of systems.

3.7.4 Activation

The activation of plant components occurs due to neutron irradiation. The estimate of the activation of plant components will be made using operational data. TLG Corp. has been contracted to perform neutron transport calculations using Trojan specific data. Measurements will be made in place to verify the accuracy of the calculations. Computer modeling of various components using the TLG results are also being used to provide data for early component removal decision making.

3.8 Tentative Schedule

The Phase I survey is expected to be completed by October 1993. No schedule for the other two phases has been developed at this time.

3.9 Survey Reports and Documentation

Records of Radiation Protection surveys will be maintained until the Trojan license is terminated by the Nuclear Regulatory Commission.

3.10 Quality Assurance

Radiological Site Characterization Plan activities are subject to the requirements of the Portland General Electric Quality Assurance program. Periodic audits and surveillance of the activities associated with Radiation Protection and Site Characterization will be scheduled and performed.

3.11 Cleanup Standards

The Phase I survey of the Site Characterization Plan is designed to collect data for decommissioning cost estimation. As such, the Phase I survey is not designed to release the facility for unrestricted use.

The standard used for cost estimation is direct radiation levels less than 5 microroentgen/hour above background at 1 meter and deposited radionuclide committed dose of 10 millirem/year from all pathways excluding direct radiation.

Guidance contained in Regulatory Guide 1.86, "Termination of Operating Licenses for Nuclear Reactors" for surface contamination will also be used. The release limits are:

Total Beta-Gamma Surface Contamination

5000 dpm/100 cm²

Removable Beta-Gamma Contamination

1000 dpm/100 cm²

Total Alpha Contamination

1000 dpm/100 cm²

Removable Alpha Contamination

20 dpm/100 cm²

During SAFSTOR detectable radioactivity in outdoor locations within the Owner Controlled Area will be evaluated on a case by case basis to determine if any remedial action is warranted. The following factors will be used to determine the need for cleanup:

- * applicable regulatory guidance and rules
- * potential exposure of site workers and the public
- * residual radioactivity at the time of dismantlement

4.0 Survey Plan and Procedures

4.1 General

All characterization surveys will be conducted in accordance with approved plant procedures.

The survey plan will include a review of areas that are potentially contaminated with Trojan radioactive material due to activities that occurred during the period of plant operation. Surveys will be conducted in the radiologically controlled areas of the plant to define the level and extent of contamination and the depth of penetration of the contamination. Biased and Unbiased survey plans will be developed to quantify contamination at the Trojan site. Unbiased survey points will be randomly selected using manual means. Biased survey locations will be determined through the review of operational radiation protection surveys, incident reports, oral interviews and other methods to determine possible areas of interest.

Each area of the facility will have a survey plan developed that will be approved by the Manager Personnel Protection. The survey plan will define measurements to be taken, rationale for selection of survey points and extent of the area or system being included in the plan.

4.2 Environmental Survey Plan

4.2.1 Background Determination

Preoperational radiation survey data, including aerial surveillance data collected by the US Department of Energy will be reviewed. The data will be statistically analyzed by the methods of NUREG 5849 to ensure a sound basis for the determination of background. If additional background data are needed, surveys will be conducted in remote areas of the site or in offsite areas similar to the site. Background levels for the structures (sidewalks, roadways and parking lots) that have been assigned to the Environmental group will be determined from similar materials at remote locations onsite or near the site.

4.2.2 Sampling/Measurement Point Selection

Environmental sample locations will be based on a 100' x 100' grid system centered on the Containment Building. These outdoor areas may be further subdivided into smaller areas based on the potential for contamination or preliminary survey results.

Affected areas will be more intensively monitored and sampled than unaffected areas. In general, monitoring of unaffected areas will involve randomly selecting thirty 100' x 100' grid areas from which to sample. At least one of each type of relevant survey or sample will be taken from the selected grid areas.

4.2.3 Exposure Rate Measurements

Gamma exposure rates are measured with the detector at 1 meter above the ground. Exposure rate instruments will have a sensitivity of at least 1 μ R/hr.

Each affected area will be scanned with a portable gamma ray exposure instrument to characterize varying exposure rates in the area. If background levels permit, 100% of each affected area will be scanned.

In unaffected areas, a pressurized ion chamber will be used to take exposure rate measurements at a number of selected points.

Locations with readings greater than 5 μ R/hr above background will be investigated further.

4.2.4 Surface Activity Measurements

Those parking lot and sidewalk structures that have been assigned to the environmental group will be directly surveyed with beta-gamma sensitive instrumentation, if background levels permit. Readings will be recorded in units of disintegrations per minute above background per 100 square centimeters (dpm/100 cm²). Each measurement will be made with the detector held one centimeter or less from the surface of interest. The required sensitivity of the detector and associated electronics will be ≤ 1000 dpm/100 cm².

4.2.5 Soil, Sediment, and Water Sampling

Soil and sediment samples will consist of at least 1000 cc of material. Soil and sediment will be sampled from selected locations in affected and unaffected areas. In unaffected areas, one soil sample will be taken from each location designated for exposure rate measurements (see 4.2.3). Additional samples will be collected to determine the length, width and depth of areas with readings higher than background levels. The soil and sediment samples will be analyzed for gamma emitters by gamma spectroscopy. Selected soil and sediment samples may be analyzed for non-gamma emitting radionuclides.

At least 1 gallon of water will be sampled from selected locations in the Recreation Lake, Reflection Lake, and other surface water areas onsite. The water samples will be analyzed for gamma emitters and for tritium.

4.3 Structures

4.3.1 Background Determination

Background surveys will require measuring both direct radiation levels and concentrations of the potential radionuclide contaminants in construction materials. Background will be determined by measurements and sampling at locations onsite, or in the immediate vicinity of the site which have been unaffected by site operations.

4.3.2 Sampling/Measurement Point Selection

- a. Grid system: A grid will be used for reference purposes only and will not dictate the spacing of survey measurements or sampling. Architectural drawings with grids will be used wherever possible. A grid, based on 10'x 10' squares will be added to drawings originally without grids. The grid portion used for survey data may be limited to the floor and the lower wall (up to 6 feet) unless there is a potential for upper wall and ceiling contamination.
- b. Survey Areas: Structures will be divided into manageable survey areas such as a building elevation or outside wall of a building. An area will be divided into "units" which have a common history or other characteristics, or are distinguishable from other portions of the site. Survey units may combine contiguous rooms or areas having the same potential for classification. The size of a survey unit will be chosen to ensure that the total number of data points and/or spacing (frequency) of measurement and sampling satisfy the requirements for a confidence level of 95%. A survey unit will not include both affected and unaffected areas. Exposure rate measurement, surface scan and removable contamination data will be collected at each sample/measurement point.
- c. Affected Areas: Areas within the Radiologically Controlled Area have already been identified by surveys as affected and therefore additional surveys will not be required for Phase 1.

- d. Unaffected Areas: A minimum of 30 randomly selected measurement locations or an average of 1 measurement location per 500 ft² of building surface area, whichever is the greater number of locations, will be performed for each survey unit. These locations will be restricted to the floor and lower 6 feet of wall surface unless surveys indicate the potential for additional contaminated surfaces. Identification of activities > 25% of the release criteria will be used to either:

Reclassify the area to an affected area.

or

If beneficial, the set of initial 30 measurements will be used to divide the original unit into new contaminated and background units. A second set of 30 random measurements will then be collected for each of the new units.

4.3.4 Exposure Rate Measurements

A γ exposure rate measurement, conducted at one meter from the surface, will be performed at each sample/measurement location with a μ R meter.

4.3.5 Removable Contamination Measurements

Removable surface activity smears are obtained by wiping an area of approximately 100 cm² with a smear with moderate pressure. Small penetrations, such as cracks or anchor-bolt holes, are surveyed using cotton swabs. If activity is detected, smear samples with the highest gross β, γ, α from each survey population should be analyzed for qualitative and quantitative isotopic analysis. Additional radiochemical analysis should be performed if the gross smear results do not correlate with γ spectral analysis results. Smear samples with the highest alpha activity should be analyzed with alpha spectroscopy for isotopes specific to Trojan.

4.3.6 Surface Scans

Unaffected Area scans should cover a minimum of 10% of the floor and lower wall surface area. The scanning detector is normally kept at ≤ 2 cm from the surface. The scan speed should not exceed 1 detector width per second when surveying for particulate radiation (β, α). This speed should be reduced to 1/3 detector width per second when relatively low count rates may be indicating activity exceeding the release criteria. A serpentine pattern at higher scanning speeds (0.5 m per second) may be used for γ . Instrument response will be monitored via audible output when possible (headphones). Locations of activity 2 to 3 times the ambient count rate should be marked on maps and identified for further measurements.

Direct monitoring will be accomplished by using 100 cm² β and 59 cm² α detectors with scalers to obtain 1 minute integrated counts. This will provide detection sensitivities below the release criteria levels. The detector will be placed in direct contact with the surface unless scanning has indicated the presence of gross activity. The detected activity will be corrected for background, decay scheme(s) and non-detectable isotopes (H-3, Fe-55, Ni-63).

4.3.6 Sampling

Samples from a variety of inaccessible locations may be required since the locations cannot be adequately evaluated based on direct measurements and scans. Residual activity will often accumulate in cracks and joints in the floor. These will be sampled using a screwdriver or chisel and the residue analyzed.

Low energy β or α activity that has been painted over or received some other treatment may not be quantifiable based on measurements at the surface. The surface layer will then be removed from a known area (100 cm²) by stripping or abrasion and analyzed. The level will then be converted to dpm/100 cm² and compared to release criteria for surface activity.

In areas where significant contamination is found and it is likely that contaminants have penetrated the surface, it will be necessary to determine the depth of the contamination. Depth sampling for < 1" can be accomplished by removing approximately 1/16" of surface material by mechanical means and measuring the level of contamination on the freshly exposed surface(s) until the newly exposed surface is less than the release criteria. Depth sampling for > 1" can be accomplished by slicing core samples or analyzing horizontal sections of core samples. This allows a profile of the distribution and total radionuclide content to be determined.

Sample Preparation

The only treatment for smears before gross α, β counting is to wait until short-lived naturally occurring radon daughters have decayed. Rn-222 and Rn-220 series decay times of 4 hours and 72 hours respectively will be used.

Smear Counting

Smears will be screened by γ or gross GM counting. If little contamination is expected, all smears from a particular area can be assayed together on the detector. If contamination is found, the smears should be recounted in smaller groups until the contaminated smears are isolated. The smears should be left in their protective envelopes to avoid cross contamination.

A low-background gas proportional system will be used to count for gross α, β levels. Measurement sensitivities of < 10 dpm α and 20 dpm β can be achieved with reasonable count times.

4.4 Systems

4.4.1 Background Determination

Background levels of radioactivity for the systems at Trojan will be determined using similar or like materials that have not been exposed to radioactivity/contamination. Materials will be selected based on the physical and chemical properties of the materials used to construct the systems used at Trojan. Surface radiation levels will be measured using various detectors to determine the ambient radiation levels of piping and other materials.

4.4.2 Sampling/Measurement Point Selection

The systems at Trojan are being placed into four classifications dependent on the potential for contamination. The classifications are:

- C1 (contaminated)
- C2 (potential for cross contamination)
- I (Indeterminate)
- N (Clean, no contamination expected)

Classification into one of the above four categories is followed by establishing priorities for each classification. A sample and measurement plan for each system will then be developed for data collection to determine the presence of and quantity of contamination as necessary. Initial priority for sampling and survey will be placed on the C2 systems primarily the secondary systems. The priority on the secondary systems located in the Turbine building is to support validation of the TLG Decommissioning cost estimates. Biased survey locations will be determined using previously collected operational radiation survey data and/or system knowledge including crud traps, low flow areas and other pertinent physical data. The biased locations will concentrate on C2, I and N systems. Data collection for C1 systems will focus on the determination of the quantity and radionuclide distribution. Unbiased survey locations will be selected based on drawings and other aids.

4.4.3 Exposure Rate Measurements

Exposure rate measurements will be made to determine the relative contribution of the deposited radioactivity to the ambient radiation levels. The exposure rate measurements will not be used to determine the presence or absence of radioactivity but to determine the uniformity of deposition. Gamma ray detection instruments with the appropriate range will be used for these measurements.

4.4.4 Removable/Surface Contamination Measurements

Smears will be collected from selected locations inside systems where normal access to the system is provided. Smears will be counted for beta-gamma radiation with selected smears also counted for alpha. Smear analyses will be performed in accordance with approved procedures.

Residue can be collected from drains using a piece of wire or plumbers snake with a strip of cloth connected to the end. Deposits can be loosened by scraping with a hard-tipped tool into a drain opening. Low-points and traps should receive particular attention. The need for additional monitoring should be based on the residue samples and direct measurements at the inlet, outlet, cleanouts, and other access points to the pipe interior.

Total Surface Contamination will be measured using portable radiation detection instrumentation. Beta-gamma sensitive detection equipment will be used with appropriate shielding to allow determination of surface activity in the presence of high ambient radiation levels.

Where fixed contamination is identified additional samples of surface scrapings will be collected. The scrapings will be analyzed for radioactivity using gamma spectroscopy counting equipment (e.g. IGe or GeLi).

4.4.5 In-field Gamma Ray Spectroscopy

Field locations will be selected for counting using portable gamma ray spectroscopy equipment. The gamma spectrum will be used to determine the relative contribution of individual radionuclides to the total activity in the system/component. This data will not be used for quantifying activity since no calibration geometry is available.

5.0 Data Interpretation

Measured data will be reviewed and compared to background levels for similar terrain or materials. Guidance contained in NUREG/CR-5849 will be used for interpreting survey results.

6.0 Reports

An overall report of the results of the Phase I Site Characterization will be prepared and made available for review by the commission.

7.0 Records

Records generated as a result of the Site Characterization are considered decommissioning records and shall be handled in accordance with approved plant procedures.

8.0 References

Trojan Updated Final Safety Analysis Report

NUREG/CR-0130, 'Technology, Safety and Costs of Decommissioning a Referenced Pressurized Water Reactor'.

ANSI N18.1-1971, 'Selection and Training of Nuclear Power Plant Personnel'.

Reg Guide 4.15, 'Quality Assurance for Radiological Monitoring Programs - Effluent Streams and the Environment', USNRC

Reg Guide 1.86, 'Termination of Operating Licenses for Nuclear Reactors', USNRC

PGE 8010, 'Trojan Nuclear Plant Quality Assurance Program,

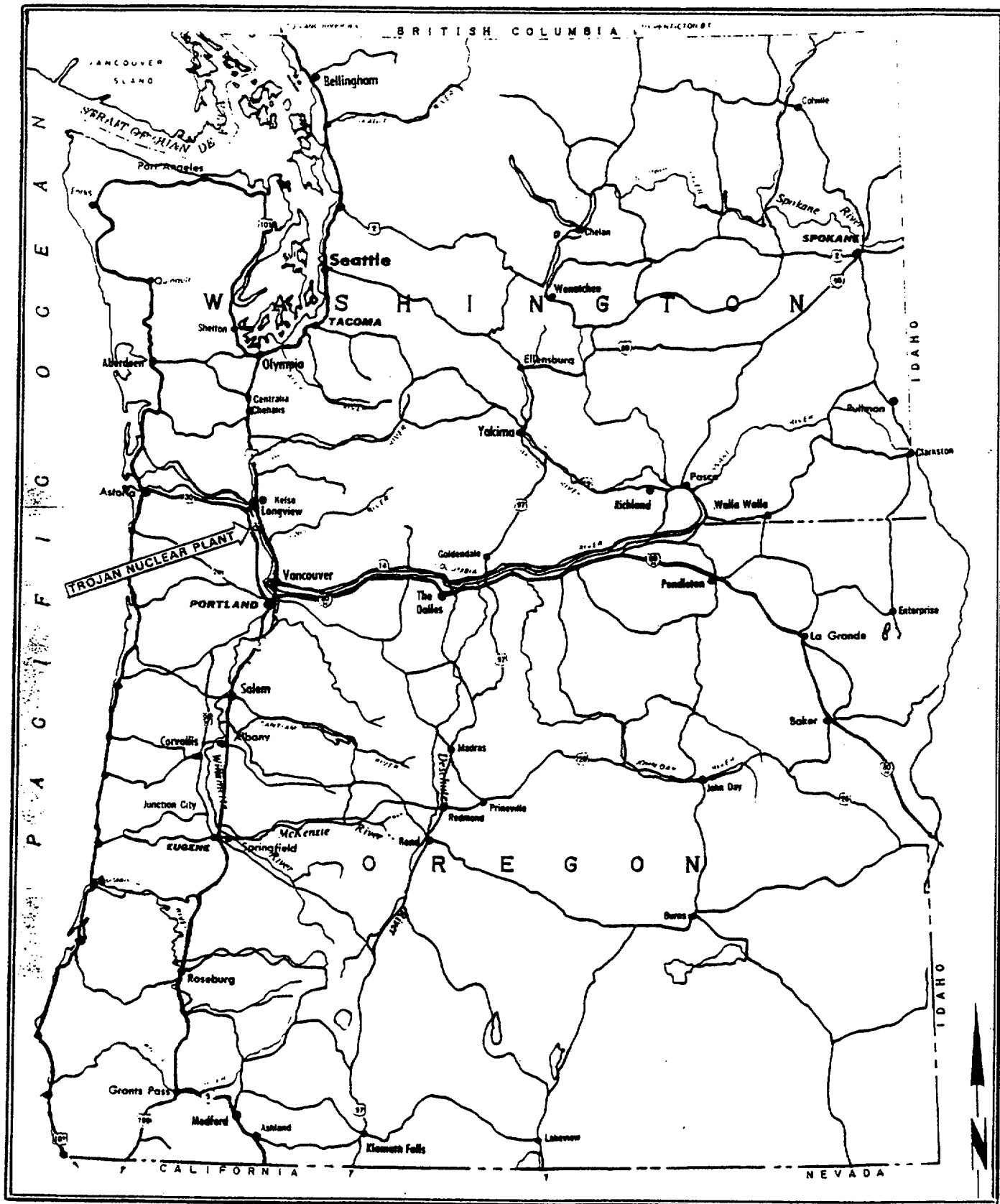
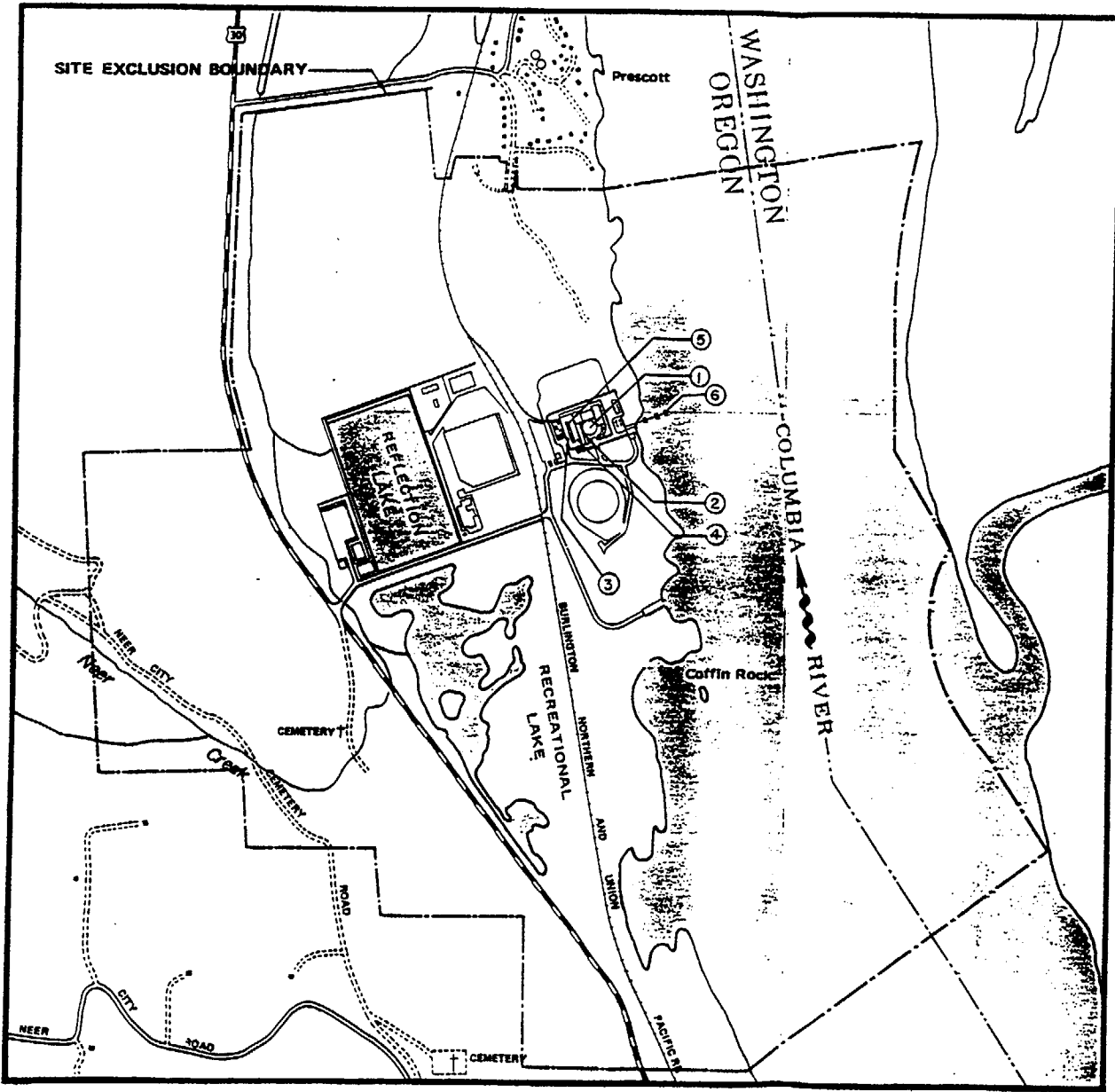

Figure 1.1-1 Regional Map



LEGEND

- 1 Gas Collection System
- 1 Vent Collection System
- 1 Containment Purge Exhaust
- 1 Fuel and Auxiliary Building Ventilation Exhaust
- 2 Main Steam Relief Valve Discharge
- 3 Condenser Air Ejector Exhaust
- 4 Steam Packing Exhauster Blower Discharge
- 5 Turbine Building Ventilation Exhaust
- 6 Liquid Discharge to River



TROJAN NUCLEAR PLANT
 Gaseous and Liquid Effluent
 Release Points
 Figure 1.1-2

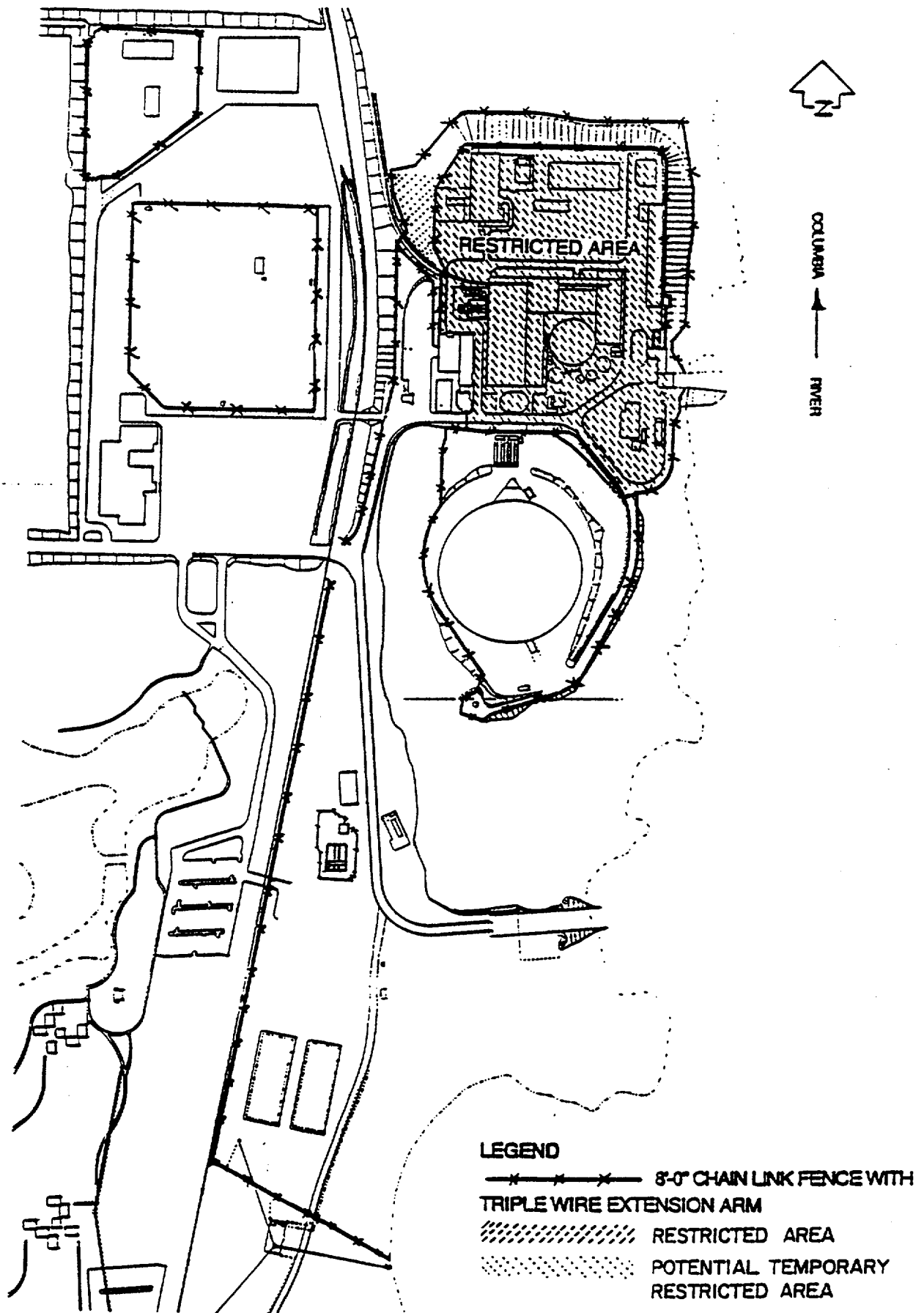

Trojan Plant Fence Layout
Figure 1.1-3

Site Characterization Organization

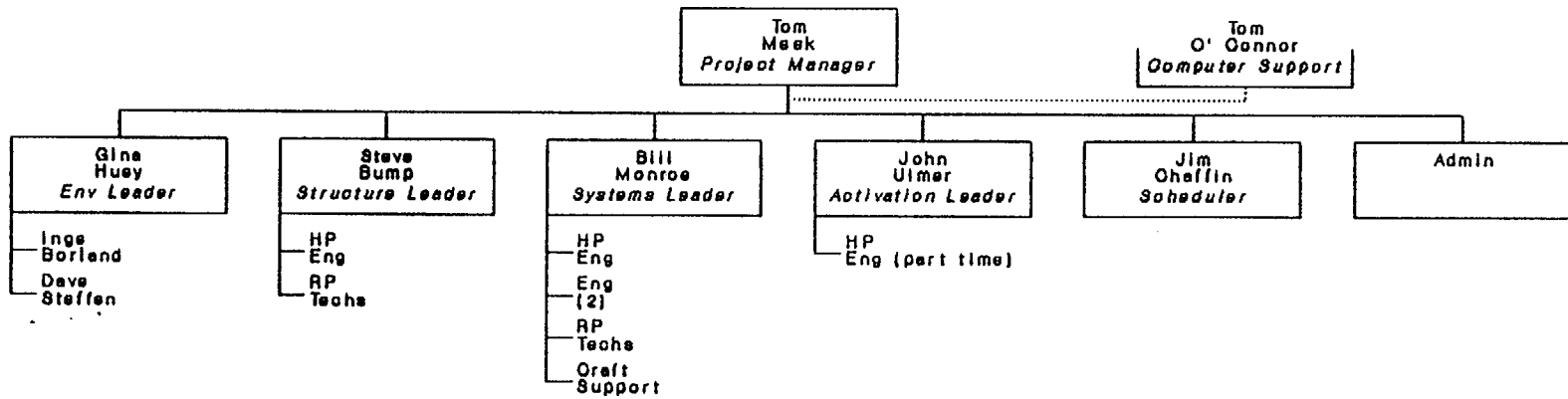

6/23/93

Figure 3.4-1

Table 7.6-1

TYPE OF MEASUREMENT	INSTRUMENT METER	INSTRUMENT DETECTOR	BACKGROUND	EFFICIENCY
Surface Scan - α	Eberline ESP-2	AC-3-8 α Scintillation Probe	To be determined	.18
Surface scan - α, β	Eberline ESP-2	BP-100 Scintillation Probe (National Nuclear)	To be determined	α - .29 Pu, β - .20 Tc 99
Surface scan - β	National Nuclear FCM-2 Floor Monitor	Two built-in 7"x13" Scintillation detectors	<25 cps at 25 μ R/hr.	β - .179 Cs-137
Exposure rate - γ	Reuter-Stokes RSS-112	Pressurized Ion Chamber	To be determined	
Exposure rate - γ	Eberline ESP-2	SPA - 8 Scintillation Probe	To be determined	
γ Spectroscopy (Portable)	Canberra	HpGe	To be determined	.1
Exposure rate	Eberline RO2/RO2A	Ion Chamber	<0.2/2 mR/hr	
Exposure rate	Eberline E-130	HP-270 Probe	<0.1 mR/hr	

TROJAN
NUCLEAR PLANT

RADIOLOGICAL
SITE
CHARACTERIZATION
REPORT

REVISION 0.1

Approved by: Tom Meek Date: 2/8/95

1.0 INTRODUCTION

1.1 Purpose

This report is the concluding document for the radiological characterization of the Trojan Nuclear Plant (TNP). The purpose of this report is the compilation of all data collected during characterization that depicts current radiological conditions in and on plant structures and systems and in the environment surrounding the TNP.

Data contained in this report will be used to assist in decommissioning decisions associated with the TNP. Radioactive material for disposal, decontamination requirements, decommissioning methodologies and radiological hazards that may be encountered during decommissioning are identified.

1.2 Scope

This characterization report is intended for use by Portland General Electric Company (PGE/PGC), its contractors and subcontractors, and by other organizations selected by PGE as having a viable interest in the fulfillment of the objectives of the overall Decommissioning Plan.

This report compiles all radiological characterization data gathered by PGE as required by the Radiological Site Characterization Plan¹ (SCP) and provides interpretation of the data and comparison to NRC criteria (as applicable). Each system and structure at TNP is identified and a conclusion is drawn as to the radiological status of each. These conclusions are supported by the data collected by each area of the SCP:

- Structure Characterization
- System Characterization
- Activated Components Characterization
- Environmental Characterization

1.3 Characterization Selection

1.3.1 Structures

The major structures located inside the security defined Industrial Area (previously termed Protected Area) which were associated with the operation of the TNP comprised the areas selected for characterization. The buildings are:

SITE CHARACTERIZATION REPORT

REVISION: 0.1

- Containment Building
- Auxiliary/Fuel Building
- Turbine Building
- Condensate Demineralizer Building
- Maintenance Building
- Control Building
- WSH Warehouse
- Intake Structure
- Central Building
- Main Warehouse
- Technical Support Center
- Security Building
- Radioactive Waste Storage Building
- Plant Mods shops
- Main Steam Support Structure
- Steam Generator Blowdown Building

These buildings were selected based on historical operational and radiological data which indicated the presence of radioactivity was either known or suspected. Buildings outside the Industrial Area were excluded based on the following:

- No potentially contaminated systems pass through these other structures;
- No significant releases of airborne materials occurred which could have resulted in the deposition of radioactive material on these structures;
- No indication of radioactive material being transported to these buildings from the site.

Walk through surveys using gamma sensitive instruments were conducted to verify the above assumptions.

1.3.2 Systems

Specific systems within the plant were selected for radiological characterization based on the potential for contamination during plant operation. The Trojan Plant Procedure, TPP 30-1, Nuclear Division Defueled Requirements and Defueled Systems List⁶ was used to select systems for review. All systems were categorized by potential for radioactivity content. All systems were placed into one of four (4) categories. Systems with known radioactive contamination (e.g., RCS, radwaste) were classified as C1. Systems with the potential for contamination (e.g., secondary systems) were classified as C2. Systems with insufficient information for decision making were classified as I (indeterminate). Systems that should have no potential for contamination (e.g. electrical, potable water, etc) were classified as N (non contaminated).

1.3.3 Activated Components

Computer models were utilized to estimate the neutron activation of various components subjected to neutron irradiation during plant operation. Components included in this section include the reactor vessel and internal, reactor primary (concrete) shielding and reactor vessel supports. The majority (approximately 95%) of the radioactivity identified by the SCP is contained in the activated components with most of this activity contained in the upper and lower core plates and the core baffle plates.

1.3.4 Environment

Samples of environmental media were collected from both randomly selected (unbiased) and chosen (biased) locations. All sample locations were located within the Trojan site (owner controlled area). Background sample locations were selected based on the similarity of the media to onsite locations without the potential for contamination from Trojan releases/operation.

Samples were collected using Trojan Environmental Monitoring program³ procedures. Analyses of samples were conducted both onsite (gamma spectroscopy, tritium) and offsite (⁹⁰Sr).

Direct radiation, soil and sediment samples, and surface scans were completed at applicable locations.

1.4 Decommissioning Release Criteria

1.4.1 Data collected during the SCR are compared to the Decommissioning Release criteria (DRC) contained in the Decommissioning Plan. The DCR are based on guidance contained in USNRC proposed regulations, criteria used in Decommissioning plans previously submitted to the USNRC and guidance contained in previously issued USNRC guidance documents. The release criteria are based on the expected committed doses from the residual radioactivity remaining following site remediation.

1.4.2 The specific release criteria are:

- <15 mrem/yr from all pathways for the applicable exposure scenario (NUREG/CR-5512 "Residual Radioactive Contamination from Decommissioning" Draft Report, January 1990;
- <5 μ R/hr at 3' from any surface of structures or equipment;

SITE CHARACTERIZATION REPORT

REVISION: 0.1

- Surface contamination levels as described in Regulatory Guide 1.86, Termination of Operating Licenses for Nuclear Reactors;
- EPA regulation 40CFR Part 141, National Primary Drinking Water Standards.

1.4.3 The SCP was based on a dose release criteria of 10 mrem/yr. The proposed USNRC decommissioning criteria were issued following development of the SCP. Release concentrations were calculated for the various materials and samples based on the guidance in draft NUREG/CR-5512 and the 15 mrem/yr guidance.

1.5 Report Format and Data Storage

The following report is divided into six sections:

- Structural Characterization
- Systems Characterization
- Activation Analysis
- Environmental Characterization
- Implications for decommissioning
- QA/QC Verification

The first four sections contain a brief description of the methodology utilized to achieve the results and then presents a summary of the results. The data are evaluated for the presence of radioactivity. If radioactivity levels are greater than Regulatory Guide 1.86⁴ criteria the radioactivity may be evaluated against the cleanup criteria defined in the Decommissioning Plan to determine the need for remediation.

1.6 Definitions

1.6.1 **Affected Area:** Areas within the site that have potential radioactive contamination (based on operating history) or known contamination (based on past surveys).

1.6.2 **Unaffected Area:** Areas within the site that are not expected to have detectable radioactive contamination above background levels.

1.6.3 **Biased Survey:** Survey that is conducted to quantify radioactivity based on suspected or known contamination at a given location. Locations for the survey points are determined from previous knowledge of radioactive contamination (Affected Areas).

1.6.4 **Unbiased Survey:** Survey characterized by a systematic placement of sample/measurement locations. Locations for survey points are randomly selected based on no previous knowledge of radioactive contamination in the area.

SITE CHARACTERIZATION REPORT

REVISION: 0.1

- 1.6.5 Release Guideline: Derived levels of radioactivity or radiation from the annual dose limits/guidelines for assuring that an individual would not exceed the annual dose limit (expressed in terms of direct radiation levels, surface activity levels and volume concentrations, e.g., mRem/hr, dpm/100 cm² or pCi/g).

2.0 STRUCTURAL CHARACTERIZATION**2.1 General Characterization Methodology**

Structural surveys for site characterization were performed in accordance with the Radiological SCP for the Trojan Nuclear Power Plant. As stated in the SCP, areas within the Radiologically Controlled Area (RCA) have already been identified by surveys as affected and additional surveys will not be required for Phase 1. Data on contact and general area dose rates and removable beta-gamma contamination levels were obtained from previous RCA surveys. Estimates of fixed contamination which may require remediation were made based on surveys of areas where ambient radiation levels allowed. Concrete coring samples were collected from four (4) locations in the containment building. Volumes of expected waste from surface activity removal assume a penetration of contamination to 1 cm. Removal of the top 1 cm layer will reduce the contamination levels allowing release of the facility using the release criteria discussed in section 1. Biased samples were not taken in the RCA for the structural survey.

Characterization of buildings outside of RCAs but inside the Industrial Area was performed by surveying and sampling these areas in accordance with the Plan. Exposure rates were measured, removable beta-gamma and alpha contamination levels were measured, and direct measurements of beta-gamma contamination were made. Some direct measurements of alpha contamination were made in the Turbine Building. However, due to the association of alpha-emitters with beta-emitters at Trojan, the decision was made to take direct measurements of alpha only if beta were detected or contamination were found in excess of the limits (SLB-030-93). Neither of these occurred, so additional direct alpha surveying was not performed.

Buildings outside of the Industrial Area were not extensively monitored due to the extremely low likelihood of contamination. Surveys were performed in the Trojan Visitors Information Center (TVIC) and the South Maintenance Building to obtain background data.

2.2 RCA Survey Data

Buildings in the current RCA include the Containment Building, the Auxiliary and Fuel Buildings, the Radwaste Annex, the Main Steam Support Structure and Electrical Facade, and the Radioactive Waste Storage Building. Due to past problems with discrete radioactive particles, all surfaces in the Containment, Auxiliary, and Fuel Buildings are assumed to be affected by plant operations and potentially contaminated. All surfaces will require a minimal wipe/wash down to remove loose surface contamination.

RCA surveys were reviewed to obtain the contamination levels and dose rates listed in Table 2.1. All contamination levels are removable beta-gamma contamination, unless specified otherwise. Estimates of fixed contamination, which are expected to require remediation of

the surface to meet the site release criteria, were made based on a review of plant operational history, fixed contamination surveys and professional judgement and are listed in Table 2.2. The following is a summary of radiological conditions and components that could affect radiological conditions in buildings within the RCA. Maps showing the radiological conditions in the RCA as they existed during the first quarter 1994 are contained in Appendix 2-A. The survey maps contain a "snapshot" of the radiological conditions as found on the radiation protection status board during March, 1994.

2.2.1 Containment Building - All Elevations:

Samples of containment concrete were collected by core boring at four locations. The bores were collected from the reactor shield wall, reactor vessel missile shield, secondary shield wall and containment dome. The samples consisted of 3 inch diameter bores. The bores were segmented and counted for radioactivity using gamma isotopic analysis. The cores were used to validate the neutron activation analysis discussed in section 4, to determine depth of penetration of activation products in concrete structures (other than the primary reactor vessel shield) and to estimate the area extent and levels of fixed surface contamination. The approximate locations of the concrete core bores are noted on the Containment Elevation 93 and 45 foot maps in Appendix 2-A. The locations are denoted by blackened hexagons.

2.2.2 Containment Building - 205-Foot Elevation:

The major components on this elevation are the Containment Air Coolers (CACs) and the polar crane. The highest general area radiation reading is 1.8 mrem/hour. Removable contamination levels vary from less than 1k to 150k dpm/100 cm². Fixed contamination levels are expected to be 1-5k dpm/100 cm². Material on this level consists of structural steel and grating.

2.2.3 Containment Building - 136/105-Foot Elevation:

This elevation has ventilation units and is primarily a storage area for the missile shields and head ventilation duct work during refueling operations. With no installed equipment, dose rates range from 0.3 to 0.5 mrem/hour general area. Highest removable contamination level is 2k dpm/100 cm². Fixed contamination levels are expected to be 1-5 k dpm/100 cm². Untreated concrete and structural steel are found on this level.

2.2.4 Containment Building - 93-Foot Elevation:

This elevation is the main refueling floor and the normal access path for containment. Access is provided to the refueling cavities, top levels of the Steam Generators and Pressurizer Shed, and to the seal table for the incore detectors. Storage area for the Reactor Vessel head is also provided. Installed equipment includes the incore detector drive boxes, ventilation units and electrical panels. General area dose rates range from less than 0.2 to

SITE CHARACTERIZATION REPORT

REVISION 0.1

100 mrem/hour. Highest removable contamination levels are on the refueling upender which has up to 200k dpm/100 cm². Fixed contamination levels of 5-25k dpm/100 cm² are estimated. Treated and untreated concrete, structural steel and grating make up the surfaces on this level. Neutron activation of the concrete in the containment wall, secondary shield wall (B Steam Generator cubicle) and reactor vessel missile shield were determined by core bore analysis. The primary radionuclides identified were Co⁶⁰ and Eu¹⁵² (see Tables 2.3-1,2 and 3 for results).

2.2.5 Containment Building - 77-Foot Elevation:

This elevation provides access to feed water piping. General area dose rates range from less than 0.2 to 1.5 mrem/hour. Removable contamination levels range up to 2k dpm/100 cm². Fixed contamination levels of 5-25k dpm/100 cm² are estimated. Treated and untreated concrete, structural steel and grating make up the surfaces on this level.

2.2.6 Containment Building - 61-Foot Elevation:

This elevation contains the Regenerative Heat Exchanger, Excess Letdown Heat Exchanger, Letdown piping, and access to the bottom of the Pressurizer Shed. The Regenerative Heat Exchanger room will need remediation based on past surveys. It is not normally accessed and survey data will need to be updated during Phase 2. The letdown piping west of the Regenerative Heat Exchanger room has an 800 mrem/hour hot spot. The Pressurizer shed has contact dose rates up to 280 mrem/hour and general area dose rates up to 120 mrem/hour. General area dose rates elsewhere range from less than 0.2 to 8 mrem/hr. Highest removable contamination levels measured on this level are 60k dpm/100 cm² in the Pressurizer shed. Fixed contamination levels of 5-50k dpm/100 cm² are estimated for this level. Treated and untreated concrete, structural steel and grating make up the surfaces on this level.

2.2.7 Containment Building - 45-Foot Elevation:

This elevation contains the emergency airlock for Containment, Safety Injection Accumulators, Pressurizer Relief Tank, Reactor Coolant Drain Tank, both recirculation sumps, and the primary access to the Bioshield Area. General area dose rates range from 0.2 to 170 mrem/hour outside of the Bioshield. Removable contamination levels range up to 30k dpm/100 cm² at the safety injection line area near the B/C Accumulators. Fixed contamination levels of 5-100k dpm/100 cm² are estimated for this level. Treated and untreated concrete, structural steel and grating make up the surfaces on this level.

2.2.8 Containment Building - Bioshield Area:

This area contains the Steam Generators (4), Reactor Coolant Pumps (4), and access to the under vessel area. Contact dose rates are up to 1000 mrem/hour on the RTD bypass manifolds. General area dose rates range from 10 to 250 mrem/hour. Removable

contamination levels up to 110k dpm/100 cm² are found in the bioshield. The under vessel area has not been surveyed since shutdown. The incore detectors are partially withdrawn making this area a High Radiation Exclusion Area. Fixed contamination levels of 5-500k dpm/100 cm² are estimated for this level. Treated concrete and structural steel make up the surfaces on this level. A concrete core bore was taken of the primary reactor vessel shield wall. A 3 inch diameter core was taken from the shield wall approximately 50' elevation (corresponding to near centerline of the reactor vessel). The core was segmented and analyzed for gamma ray emitters. Predominant radionuclides identified were Co⁶⁰, Eu¹⁵², Eu¹⁵⁴, Eu¹⁵⁵, and Cs¹³⁴. Radioactivity was detected to a depth of approximately 50 inches (total shield thickness is 102 inches). Close agreement is noted between the calculated neutron activation results in chapter 4 to the measured activation values. The comparison is very good for Eu¹⁵² in the first three inch segment. The calculated value is 0.29 μCi/g while the measured value is 0.25 μCi/g. The agreement is not as good for segments further from the inner wall. The calculated values are higher (see Table 2.3-5).

2.2.9 Auxiliary Building - 104-Foot Elevation:

This elevation contains the supply and exhaust ventilation filters for the Auxiliary and Fuel Buildings. All dose rates are less than 0.2 mrem/hour. Removable contamination levels are below 1k dpm/100 cm². (see 93' elevation)

2.2.10 Auxiliary Building - 93-Foot Elevation:

This elevation contains the supply and exhaust fans for the Auxiliary and Fuel Buildings, Containment purge exhaust unit, Containment access point, and access to the filter pits. Dose rates are less than or equal to 0.2 mrem/hour. Dose rates in the filter pits vary by system and age of filter. These will be surveyed at filter changes or when other access is required. Removable contamination levels outside of the filter pits are less than 1k dpm/100 cm². Fixed contamination at levels greater than 5k dpm/100 cm² is estimated to exist over 19% of the surface area. An average fixed contamination level of 10k dpm/100 cm² is assumed.

2.2.11 Auxiliary Building - 77-Foot Elevation:

Major equipment on this elevation includes the demineralizer valve galleries and access to the demineralizer vaults, radioactive waste filter glove boxes, and two boric acid evaporators. The highest dose rates are in the demineralizer valve galleries and are up to 350 mrem/hour contact and up to 50 mrem/hour general area. Removable contamination levels are up to 9k dpm/100 cm² in the filter valve gallery. Fixed contamination at levels greater than 5k dpm/100 cm² is estimated to exist over 19% of the surface area. An average fixed contamination level of 10k dpm/100 cm² is assumed.

2.2.12 Auxiliary Building - 61-Foot Elevation:

This elevation contains the radioactive waste evaporator, waste gas surge tank, waste compressors, waste gas decay tanks, spent resin storage tank and pump, and letdown heat exchanger. Dose rates in the letdown heat exchanger valve gallery range from 3 to 40 mrem/hr. Dose rates at the spent resin storage tank pump room range from 1.3 to 18 mrem/hr. Contact dose rates up to 400 mrem/hr are found on this elevation. Removable contamination levels are up to 7k dpm/100 cm² in the spent resin storage tank pump room. Fixed contamination at levels greater than 5k dpm/100 cm² is estimated to exist over 11% of the surface area. An average fixed contamination level of 10k dpm/100 cm² is assumed.

2.2.13 Auxiliary Building - 45-Foot Elevation:

Major components include the treated waste monitor tanks and pumps, dirty waste monitoring tank and pumps, spent fuel pool cooling pumps, spent fuel pool purification pump, Chemistry Hot Lab, and Hot Sample Room. Dose rates range from less than 0.2 to 5 mrem/hr in all areas. Removable contamination levels are less than 1k dpm/100 cm² with the exception of the hot sample sinks. Fixed contamination at levels greater than 5k dpm/100 cm² is estimated to exist over 15% of the surface area. An average fixed contamination level of 10k dpm/100 cm² is assumed.

2.2.14 Auxiliary Building - 25-Foot Elevation:

This elevation is below grade and contains the positive displacement pump, centrifugal charging pumps, sodium hydroxide tank, primary water makeup pumps, boron injection tank, reactor coolant drain tank pumps, chemical waste tank and pumps, and access to the clean waste receiver tanks. Accessible dose rates are up to 60 mrem/hour contact at the boron injection tank and range from less than 0.2 to 12 mrem/hour at the clean waste receiver tanks. Removable contamination levels are up to 3k dpm/100 cm² in the boron injection tank area. Fixed contamination at levels greater than 5k dpm/100 cm² is estimated to exist over 15% of the surface area. An average fixed contamination level of 25k dpm/100 cm² is assumed.

2.2.15 Auxiliary Building - 5-Foot Elevation:

This elevation contains the residual heat removal pumps and heat exchangers, clean waste receiver tanks and pumps, dirty waste drain tank and pumps, auxiliary building drain tank and pumps, safety injection pumps, containment spray pumps, and the auxiliary building and passageway sumps. The bottom level of the clean waste receiver tanks is not routinely accessed, however, the area is posted as a High Radiation Area. Contact dose rates range up to 100 mrem/hour, with general area dose rates ranging from less than 0.2 to 45 mrem/hour. Removable contamination levels are up to 35k dpm/100 cm² at the residual heat removal pumps. Fixed contamination at levels greater than 5k dpm/100 cm² is estimated to exist over 28% of the surface area. An average fixed contamination level of 25k dpm/100 cm² is

assumed.

2.2.16 Pipe Facade: 77-Foot Elevation:

This elevation contains the Component Cooling Water (CCW) Surge tanks, an emergency escape hatch between the pipe facade and the Auxiliary Building and the CCW penetrations into the containment. Dose rates are less than 0.2 to 1 mrem/hour general area. Dose rates have ranged up to 200 mrem/hr general area at the resin header. Removable contamination levels are less than 1k dpm/100 cm². Fixed contamination estimate for this elevation are included in the Aux building 77-foot elevation.

2.2.17 Pipe Facade: 61-Foot Elevation:

Major components include the Volume Control tank, Letdown system piping and penetrations, access to the vertical RHR pipe chase, and the fuel transfer tube. Dose rates are 1 to 40 mrem/hour general area, with some hot spots on the letdown lines and VCT. Contamination levels are up to 20k dpm/100 cm² at the Letdown line area. Fixed contamination estimate for this elevation are included in the Auxiliary building 61-foot elevation.

2.2.18 Pipe Facade: 45-Foot Elevation:

This level is the main access to the Pipe Facade. Components include the boric acid blender, RHR piping and containment penetrations. General Area dose rates range from less than 0.2 to 12 mrem/hour. Contamination levels of up to 2k dpm/100 cm² are found in this area. Fixed contamination estimate for this elevation are included in the Auxiliary building 45-foot elevation.

2.2.19 Fuel Building - 118-Foot Elevation:

This is the fuel building crane elevation. Dose rates are highly dependent on location of the crane. General area dose rates are normally less than 0.2 mrem/hour. Contamination levels are less than 1k dpm/100 cm². This elevation consists of structural steel. No fixed contamination is assumed to be present.

2.2.20 Fuel Building - 104-Foot Elevation:

This elevation is used primarily for equipment (both contaminated and clean) storage. Dose rates are dependent upon material stored at any given time. In the absence of material, dose rates are less than 0.2 mrem/hour. Contamination levels are less than 1k dpm/100 cm². Fixed contamination at levels greater than 5k dpm/100 cm² is estimated to exist over 5% of the surface area. An average contamination level of 10k dpm/100 cm² is assumed.

SITE CHARACTERIZATION REPORT

REVISION 0.1

2.2.21 Fuel Building: 93-Foot Elevation:

This is the main operating floor for the fuel building and includes the Spent Fuel Pool, decon shop, hot machine shop, radioactive material storage areas, the top of the boric acid storage tanks, and access to the containment equipment hatch. General area dose rates range from less than 0.2 to 0.8 mrem/hour. Contact dose rates above this are dependent on storage of radioactive material in the area. Removable contamination levels range to 1k dpm/100 cm². Fixed contamination at levels greater than 5k dpm/100 cm² is estimated to exist over 19% of the surface area. An average fixed contamination level of 10k dpm/100 cm² is assumed.

2.2.22 Fuel Building - 77-Foot Elevation:

Major components on this level include radioactive waste control panels, evaporator concentrates holding tanks, Chemical and Volume Control System (CVCS) surge tanks, CVCS concentrates pump, spent fuel pool skimmer pump, new fuel storage, and access to the cask washing pit. General area dose rates on the level range from less than 0.2 to 40 mrem/hour. Items stored in the cask wash pit could be high radiation sources. The evaporator concentrates holding tanks are not routinely accessed. Removable contamination levels are up to 3k dpm/100 cm² in the cask wash pit. Fixed contamination at levels greater than 5k dpm/100 cm² is estimated to exist over 15% of the surface area. An average fixed contamination level of 10k dpm/100 cm² is assumed.

2.2.23 Fuel Building - 61-Foot Elevation:

Major components on this elevation include the CVCS Monitor Tanks, Boric Acid Storage Tanks and pumps, Seal Water Heat Exchanger, Spent Fuel Pool Heat Exchanger, I & C Hot Shop, a respirator wash facility, and the Radioactive Waste Solidification Room. The solidification room was designed for use with a urea formaldehyde solidification system. This system was abandoned in place and the room is now used for storage and decontamination of equipment. Dose rates on this elevation are highly dependent on material stored in the area. General areas range from less than 0.2 to 18 mrem/hour and contact dose rates on installed equipment are up to 35 mrem/hour. Removable contamination levels are less than 1k dpm/100 cm². Fixed contamination at levels greater than 5k dpm/100 cm² is estimated to exist over 15% of the surface area. An average fixed contamination level of 10k dpm/100 cm² is assumed.

2.2.24 Fuel Building - 45-Foot Elevation:

This elevation contains the CVCS Hold Up Tanks, Hold Up Tank Recirculation Pump, Gas Stripper Pumps, Component Cooling Water pumps and heat exchangers, a respirator maintenance facility, a crane bay, and the fuel building annex, which is used for radioactive material storage and radioactive waste compacting. General area dose rates on this elevation are primarily less than 0.2 mrem/hour. The highest contact dose rate is 180 mrem/hour. Removable contamination levels are less than 1k dpm/100 cm². Fixed contamination at

levels greater than 5k dpm/100 cm² is estimated to exist over 8% of the surface area. An average fixed contamination level of 10k dpm/100 cm² is assumed.

2.2.25 Electrical Penetration Area - All Elevations:

All containment electrical penetrations are in this area. The entire area is a posted as a fixed contamination area. General area dose rates range from less than 0.2 to 5 mrem/hr. Removable contamination levels are less than 1k dpm/100 cm². Fixed contamination is known to exist under the RCS sample line isolation valves. Fixed contamination levels cannot be measured at this time due to background radiation levels. Additional fixed contamination surveys will be required when radiation levels are reduced in the future.

2.2.26 Main Steam Support Structure - All Elevations:

This area contains all of the main steam and steam generator blowdown penetrations and is a transition area between the containment and turbine buildings. A steam line relief valve lifted during primary-to-secondary leakage resulting in fixed contamination throughout this structure. General area dose rates are less than 0.2 mrem/hr at all elevations. Although removable contamination levels are less than 1k dpm/100 cm², there is fixed contamination and the area below the floor grating on the 45' elevation is posted as contaminated. Fixed contamination surveys indicate a 1300 ft² area is contaminated to levels > 5k dpm/100 cm². The average fixed contamination level is 50k dpm/100 cm².

2.2.27 Steam Generator Blowdown Building - All Elevations:

Due to primary-to-secondary leakage, this building has some fixed contamination. General area dose rates are less than 0.2 to 0.4 mrem/hr and removable contamination levels are less than 1k dpm/100 cm².

2.2.28 Radioactive Waste Storage Building:

This building was constructed in 1991 as a long-term storage area for waste ready for shipment. General area dose rates are less than 0.2 to 20 mrem/hr and are highly dependent on building contents. Removable contamination levels are less than 1k dpm/100 cm².

2.2.29 WSH Radioactive Material Storage Area:

General area dose rates range from less than 0.2 to 5 mrem/hr and contamination levels are less than 1k dpm.

2.3 Unbiased Survey Results

Structures selected for characterization were divided into manageable survey areas such as a

building elevation or group of buildings depending on size. For each survey area, a minimum of 30 randomly selected measurement locations were chosen or an average of 1 measurement location per 500 ft², whichever produced the greater number of locations. These locations were restricted to the floor and lower 6 feet of wall surface unless surveys indicated the potential for additional contaminated surfaces. A total of 840 sample points were established in the area surveyed for Phase 1 of the site characterization.

Only two of the sample points had detectable removable contamination levels. One point was on the roof of the Maintenance Building and had detectable alpha and beta activity. The other point was on the roof of the Turbine Building and had detectable alpha activity. At these locations, the beta-gamma contamination was below 1% of Reg. Guide 1.86 contamination limit and the alpha contamination was below 40% of the limit.

Within the Industrial Area, the following buildings had survey results that were all below cleanup criteria: Access Building, Administrative Building, Central Building, Condensate Demin. Building, and Guard House. Exposure rates in the rest of the buildings within the Industrial Area were increased by radiation from the RWST, radioactive material storage areas, or check sources in radiation monitors. The affected portions of these buildings will be surveyed when equipment removal is completed. Five areas were identified on the 63', 45', and 35' levels of the Turbine Building that will likely need remediation.

The buildings outside of the Industrial Area were not surveyed by all methods due to the remote possibility of contamination in them. Of the surveys that were performed, the only results above cleanup criteria were due to the radiation monitor check source in the TVIC, and the sources stored in the Dosimetry Lab.

2.4 Structures Within the Industrial Area

The following buildings are outside of the RCA but inside the Industrial Area and were surveyed specifically for Site Characterization. The Turbine Building and Control Building are most closely related to plant operation and will be discussed first. Subsequent buildings are not closely related to plant operation and floor-by-floor details of their contents will not be given.

2.4.1 Turbine Building - Roof:

Exposure rates at the southeast corner are higher than cleanup criteria due to shine from the RWST. This area should be resurveyed after the RWST is remediated. All contamination survey results were below cleanup criteria.

2.4.2 Turbine Building - 93-Foot Elevation:

This elevation is the main operating floor of the plant. The Turbine, Generator, Moisture

SITE CHARACTERIZATION REPORT

REVISION 0.1

Separator/Reheaters, Feedwater Heaters, and process radiation monitor for the Condenser off gas system are on this level. General area exposure rates are below cleanup criteria although exposure rates at the south end of the building are slightly higher due to the RWST. All unbiased contamination survey results were below cleanup criteria. Fixed contamination under the condenser off-gas grab sample rack has been measured at 15k dpm/100 cm² over an area of 25 ft².

2.4.3 Turbine Building - 63-Foot Elevation:

This elevation contains the steam jet air ejector, lube oil reservoir, main steam stop and throttle valves, feed water heaters, and the switchgear room. Three areas were identified with exposure rates above cleanup criteria. The first area is the alum tank. Exposure rates up to 12 μ R/hr were measured at the tank due to the uranium content of the alum. The second area is a location on the floor about 30 feet west and 15 feet south of the alum tank near the grating over the main steam stop valves. The exposure rate at this floor location is 28 μ R/hr and is probably due to fixed contamination under the paint. The third location is on the floor near the floor drain east of the steam jet air ejector. This area has been remediated in the past but exposure rates can still be measured to 22 μ R/hr. The drain is marked by a fixed contamination label. All unbiased contamination survey results were below cleanup criteria. Fixed contamination in two areas on this level are 5k dpm/100 cm² (10 ft²) near the drain in the SE corner and 50k dpm/100 cm² (32 ft²) near the drain on S end.

2.4.4 Turbine Building - 45-Foot Elevation:

This is the grade-level floor of the Turbine Building. The primary components on this floor include the main condensers, make up water treatment system, air compressors, and the Emergency Diesel Generators. One area was identified with exposure rates above cleanup criteria. This area is on the floor near the flow transmitter stand by the southwest corner of Condenser A. Exposure rates at this floor location are up to 18 net μ R/hr. All unbiased contamination survey results were below cleanup criteria. Fixed contamination was measured in the pipe trough between the Electric AFW pump and the Condensate pump pit. Contamination levels of 50k dpm/100 cm² (40 ft²) were found.

2.4.5 Turbine Building - 35 and 27-Foot Elevation:

These elevations contain the condensate pumps, neutralizing tank, and the turbine building sump and pump. The turbine building sump is a contaminated area. Site characterization loose contamination surveys were taken from areas other than sump and all results were below cleanup criteria. General area exposure rates were below cleanup criteria. However, exposure rates at the floor on the south end of the 35' elevation ranged up to 6 net μ R/hr. Fixed contamination levels of 5-50k dpm/100 cm² were identified over an area of 2181 ft². The contamination is a result of sump overflows and condensate pump and heater drain pump leaks during periods of primary to secondary leakage.

2.4.6 Control Building Roof:

All results were below cleanup criteria.

2.4.7 Control Building - 105-Foot Elevation:

This elevation is for control room ventilation systems and has the control room viewing gallery. All survey results were below cleanup criteria.

2.4.8 Control Building - 93-Foot Elevation:

The main areas include the main control room and the chemistry cold lab. The lab has numerous systems which are either contaminated or potentially contaminated. Equipment in the chemistry cold lab contains low levels of radioactivity due to primary to secondary leakage. However, the results of surveys of the room (structure) indicate all levels are less than the clean up criteria.

2.4.9 Control Building - 77-Foot Elevation:

The cable spreading room, computer room, and mechanical room occupy this entire elevation. All survey results were below cleanup criteria.

2.4.10 Control Building - 61-Foot Elevation:

Primary equipment on this level includes the electrical auxiliaries, emergency batteries, mechanical room, and the telephone equipment. All survey results were below cleanup criteria.

2.4.11 Control Building - 54-Foot Elevation:

This level contains some ventilation equipment and office areas. All survey results were below cleanup criteria.

2.4.12 Control Building - 45-Foot Elevation:

This elevation is the primary access area for the Radiologically Controlled Area. Also on this level are the Radiation Protection department offices, counting rooms, and calibration facility. Site characterization surveys were taken outside of the RCA and all results were below cleanup criteria.

2.4.13 Access Building:

This is the current access and egress point for the Industrial Area. Previous surveys have

shown no radiological impact on this building. All site characterization survey results were below cleanup criteria.

2.4.14 Administration Building - All Elevations:

This building is used only for office space. All survey results were below the cleanup criteria. The roof has not been surveyed due to difficulty in obtaining access.

2.4.15 Central Building- All Elevations:

This building has been used for office space. All survey results were below the cleanup criteria.

2.4.16 Chlorine Building:

This building is used to treat the Service Water system prior to use in the plant. All contamination survey results were below cleanup criteria. Exposure rates over most of the building were influenced by the RWST. Exposure rates must be remeasured after the RWST is remediated.

2.4.17 Condensate Demineralizer Building - All Elevations:

This building was used to treat condensate prior to return to the feedwater system. Due to primary-to-secondary leakage during plant operations, many of the systems in this building are potentially contaminated. All survey results were below cleanup criteria. The hopper room on the 19' elevation is currently posted as an RCA; however, recent survey results show contamination levels below 1k dpm/100 cm² and dose rates below 0.2 mrem/hr.

2.4.18 Discharge and Dilution Structure:

This is the main liquid effluent release point for the plant. Exposure rate measurements in this structure were above cleanup criteria due to proximity of the RWST. Results of contamination surveys taken on the 45' level are below cleanup criteria. Exposure rates will have to be remeasured after the RWST is remediated.

2.4.19 Guard House:

This was the primary access and egress point for the plant until replaced by the new Access Control facility in 1992. Survey results for this building have shown no historical impact from plant operations. Site characterization survey results are below cleanup criteria.

2.4.20 Intake Structure:

Exposure rate measurements in this structure were above cleanup criteria due to proximity of the RWST. All contamination survey results were below cleanup criteria.

2.4.21 Maintenance Building - All Elevations:

This is the primary maintenance support area for the plant. Exposure rates at the north end of the building were above cleanup criteria due to proximity to the radwaste storage building. Exposure rates at the south end of the building were above cleanup criteria due to proximity to the RWST. When all radioactive material has been removed from the radwaste storage building, and the RWST is remediated, the building should be resurveyed. Exposure rates by a granite slab in the tool room were up to 7 net $\mu\text{R/hr}$. Results of contamination surveys were below cleanup criteria.

2.4.22 Materials Building - All Elevations:

All contamination survey results were below the cleanup criteria. Exposure rates at the radioactive material storage area in the southwest corner of the building were close to cleanup criteria. Exposure rates were above cleanup criteria in the weld rod and radioactive material storage area at the north end of the building.

2.4.23 Plant Modification Shop:

This building was used for craft support during refueling outages. All contamination survey results were below cleanup criteria. Exposure rates were above cleanup criteria at the northwest part of the building due to proximity of the RWST.

2.4.24 Startup Boiler:

Exposure rates at this structure were higher than cleanup criteria due to proximity of the RWST. All contamination surveys were below cleanup criteria.

2.4.25 Technical Support Center - All Elevations:

This building has been used as office space and record storage as well as for emergency response. All site contamination survey results were below cleanup criteria. Exposure rates were below cleanup criteria except near the check source in radiation monitor PRM 25 in the TSC basement.

2.4.26 Wright, Schuchart, & Harbor (WSH) Warehouse:

This was one of the original structures built on the plant site and is used for radioactive material storage. All contamination survey results from outside of the radioactive material

storage area (RMSA) were below cleanup criteria. Inside the RMSA, dose rates are from 2.5 to 5 mrem/hr and removable contamination levels are less than 1k dpm/100 cm². Exposure rates were above cleanup criteria in the entire east half of the building due to radiation from the RMSA.

2.5 Structures Outside of the Industrial Area

2.5.1 Dosimetry Lab:

This building housed the Dosimetry and Environmental Monitoring groups. Sealed sources are stored in this building which caused exposure rates to be measured above cleanup criteria in the surrounding area during gamma surveys. Once the sealed sources are removed, there should be nothing else that would impact radiological conditions in the building.

2.5.2 Park Structures:

These buildings have not been used for plant activities and should be clean. A gamma scan performed on the Park Office did not identify exposure rates above the cleanup criteria.

2.5.3 Pebble Springs Warehouse:

A gamma scan of the building found no exposure rates above cleanup criteria.

2.5.4 Sewage Treatment Plant:

A gamma scan of the building did not identify exposure rates above cleanup criteria.

2.5.5 South Maintenance Building:

This building was surveyed at selected sites to provide background data. All survey results were below cleanup criteria.

2.5.6 Training Building - All Elevations:

This building was used only as a training facility. A gamma scan of the building did not identify exposure rates above cleanup criteria.

2.5.7 Trojan North Building - All Elevations:

This building was used for engineering and administrative office space. A gamma scan of the building found no exposure rates above cleanup criteria.

SITE CHARACTERIZATION REPORT

REVISION 0.1

2.5.8 TVIC:

This building was surveyed at selected sites to provide background data. All survey results were below cleanup criteria except for exposure rates near the check source for the radiation monitor.

**Table 2.1
Status of Buildings in the RCA**

Building	Survey Number	Elevation	Room or Component	Beta-Gamma Removable Contamination Level dpm/100 cm ²	General Area Dose Rate mrem/ hour	Max. Contact Dose Rate mrem/ hour
Containment	9301855	205	Containment Air Coolers	<2k to 150k	<0.2 to 1.8	NA
	9302356		Grating	<1k to 3k	0.4 to 0.6	NA
	9302354	105	General Area	<1k to 2k	0.3 to 0.5	NA
	9302353	93	General Area	<1k to 3k	<0.2 to 8	NA
	9300519		Refueling Bridge	4k	3 to 4	NA
	9300516 9300521		Upper Refueling Cavity	5k to 50k	40 to 70	NA
	9300245 9300522		Lower Refueling Cavity	1k to 20k	1.5 to 5	NA
	9300523		Refueling Upender	6k to 200k	20 to 100	
	9302352	77	General Area	<1 to 2k	<0.2 to 1.5	NA
	9301664	63	Seal Table	4k to 30k	2 to 6	NA
	9302351 9300279	61	General Area	<1k to 4k	<0.2 to 8	800
	9302355		Pressurizer Shed	1k to 60k	5 to 120	280
	9101256 (9-17-91)		Regenerative Heat Exchanger	N/A	1000 to 6000	N/A
	9101256 (9-17-91)		Excess Letdown Heat Exchanger	N/A	600	N/A
	9302350	45 Outside Bioshield	General Area	<1k to 3k	0.2 to 10	NA
	9300113 9207032		Safety Injection Line Area	<1k to 30k	20 to 170	600
Containment	9206710 9207021	45 Outside Bioshield	Reactor Coolant Drain Tank and Recirc Sump	2k to 5k	1.2 to 20	NA
	9302367		Pressurizer Relief Tank	8k to 70k 220 dpm alpha	5 to 30	NA
	9302262		Tendon Gallery	<1k	<0.2	NA

**Table 2.1
Status of Buildings in the RCA**

Building	Survey Number	Elevation	Room or Component	Beta-Gamma Removable Contamination Level dpm/100 cm ²	General Area Dose Rate mrem/hour	Max. Contact Dose Rate mrem/hour
	9302368 9301890	45 Inside Bioshield	General Area	2k to 110k	10 to 250	1000
	9301889	58	A/D Steam Generator Platform	<1k	18 to 250	700
	9301887		B/C Steam Generator Platform	<1k	18 to 100	1000
	9302124		A/D RTD Platform	10k to 30k	12 to 80	NA
	9302124		B/C RTD Platform	3k to 5k	10 to 80	NA
	9301888	67	A/D RCP Platform	2k	6 to 30	34
	9302170		B/C RCP Platform	4k	15 to 20	NA
Auxiliary	9302343	104	General Area	<1k	<0.2	NA
	9302340	93	General Area	<1k	<0.2	NA
	9301756	77	General Area	<1k	<0.2	NA
	9302375		Demin Valve Galleries	<1k to 3k	<0.2 to 50	NA
	9302375 9207276		Filter Valve Gallery	<1k to 9k	<0.2 to 30	350
Auxiliary	9302375 9302377	77	Boric Acid Evaporators	<1k to 1k	0.5 to 8	NA
	9302373	61	General Area	<1k	<0.2	NA
	9200625		Waste Gas Decay Tanks	<1k	<0.2 to 0.4	20
	9302373		Waste Gas Compressors	<1k	<0.2 to 0.3	NA
	9301956		SRST Pump Room	<1k to 7k	1.3 to 18	NA
	9301752		Letdown HX Valve Gallery	<1k to 6k	3 to 40	400
	9302357 9302358	45	General Area	<1k, 2k at hot sample sinks	<0.2 to 1	NA
	9302358		Dirty Waste Monitor Tank	<1k	1 to 5	NA
	9302358		Treated Waste Monitor tanks	<1k	1 to 1.8	NA

**Table 2.1
Status of Buildings in the RCA**

Building	Survey Number	Elevation	Room or Component	Beta-Gamma Removable Contamination Level dpm/100 cm ²	General Area Dose Rate mrem/ hour	Max. Contact Dose Rate mrem/ hour
	9302383		Spent Fuel Pool Cooling Pumps	<1k	<0.2 to 1.0	NA
	9302336	25	General Area	<1k	<0.2 to 0.4	NA
	9302336		Centrifugal Charging Pumps	<1k	0.5 to 0.7	10
	9300611		Boron Injection Tank	<1k to 3k	0.2 to 8	60
	9302336		Clean Waste Receiver Tanks	<1k	4 to 12	35
	9302337	5	General Area	<1k	<0.2 to 0.5	NA
Auxiliary	9302338 9302339	5	RHR Pumps	<1k to 35k	3 to 70	NA
	9302338 9302339		RHR HX	<1k to 30k	1 to 60	NA
	9302337		Clean Waste Pumps	<1k	<0.2 to 25	100
	9302337		Aux Building Drain Tank and Pumps	<1k	0.5 to 45	50
	9302337		Dirty Waste Drain tank and Pumps	<1k	0.2 to 30	NA
Pipe Facade	9302380	77	General Area	<1k	<0.2 to 1	NA
	9207271		Pipe Chase, Resin Header	N/A	1 to 200	800
	9302379	61	General Area	<1k to 4k	1 to 12	NA
	9302147		Letdown Line	1k to 20k	2 to 12	8
	9200251		Pipe Chase	1k	2 to 4	80
	9207017		Volume Control Tank	<1k	2 to 40	200
	9302378	45	General Area	<1k	<0.2 to 12	NA
	9301640	40	Pipe Chase	2k	0.6 to 3	NA
	9300636	25	Pipe Chase	<1k	1	NA
Fuel	9302345	118	Fuel Building Crane	<1k	<0.2	NA
	9302344	104	General Area	<1k	<0.2 to 2.5	NA

Table 2.1
Status of Buildings in the RCA

Building	Survey Number	Elevation	Room or Component	Beta-Gamma Removable Contamination Level dpm/100 cm ²	General Area Dose Rate mrem/hour	Max. Contact Dose Rate mrem/hour
Fuel	9302342	93	General Area	<1k to 1k	<0.2 to 0.8	7
	9302341		Spent Fuel Pool	<1k	<0.2 to 0.5	200
	9302376	77	General Area	<1k	<0.2 to 1	NA
	9302376		CVCS Surge Tank	<1k	0.5	NA
	9302376		CVCS Pump Room	<1k to 2k	1 to 6	NA
	9302409		Cask Wash Pit	3k	10 to 40	NA
	9302371	61	General Area	<1k	<0.2 to 1.4	8
	9302382		Spent Fuel Pool Heat Exchanger	<1k	0.2 to 1	NA
	9302371		Seal Water Heat Exchanger	<1k	4 to 18	35
	9302372		CVCS Monitor Tanks	<1k	<0.2	NA
	9302372		Boric Acid Storage Tanks	<1k	0.5 to 10	NA
	9302359 9302360	45	General Area	<1k to 1k at CCW HX A	<0.2 to 1	NA
	9302123		Radwaste Annex	<1k	<0.2	NA
	9302359		CVCS Hold Up Tank Pumps	<1k	0.2 to 1	180
Electrical Penetration	9302362	70 & 77	General Area	<1k	<0.2	NA
	9302362	61	General Area	<1k	<0.2 to 1.0	NA
Electrical Penetration	9302362	51	General Area	<1k	<0.2	NA
	9302361	45	General Area	<1k outside CA	<0.2 to 5	30
MSSS	93021979	77	General Area	<1k	<0.2	NA
	30219893	69	"	"	"	"
	02199	59	"	"	"	"
	9302200	45	"	"	"	"
SG Blowdown Building	9302198	55	General Area	<1k	<0.2	NA
	9302197	45	"	<1k	<0.2 to 0.4	"

Table 2.1
Status of Buildings in the RCA

Building	Survey Number	Elevation	Room or Component	Beta-Gamma Removable Contamination Level dpm/100 cm ²	General Area Dose Rate mrem/ hour	Max. Contact Dose Rate mrem/ hour
WSH RMSA	9302189	45	General Area	<1k	<0.2 to 5	NA
RWST	9302374	45	Ext. inside fence	<1k	2.5 to 5	NA
PWST	9302374	45	Exterior	<1k	<0.2	NA
Condensate Demin Building	9301983	33	Hopper Room, sump not included	<1k	NA	NA
Radwaste Storage Building	9302347	45	General Area	<1k	<0.2 to 20	NA

Table 2.2 Fixed Contamination Levels				
Building	Elevation (ft)	Area (ft ²)	Average Contamination (dpm/20 cm ²)	Estimated Activity (mCi)
Auxiliary	5	1705	25000	0.89
	25	895	25000	0.47
	45	1305	10000	0.27
	61	980	10000	0.21
	77	1690	10000	0.35
	93	560	10000	0.12
Fuel	45	795	10000	0.17
	61	1365	10000	0.29
	77	1290	10000	0.27
	93	1800	10000	0.38
	104	110	10000	0.02
Turbine	27+37	2181	50000	0.28
	45	40	50000	0.04
	63	50	50000	0.05
	93	25	40000	0.01
MSSS/EP	45	434	50000	0.45
	59	196	50000	0.21
	69	300	50000	0.31
	77	372	50000	0.39
Containment (floors)	16	435	50000	0.46
	46	9358	75000	14.69
	56	813	25000	0.43
	67	1182	50000	1.24
	77	2492	25000	1.30
	93	3932	25000	2.06
	98	1037	5000	0.11
	105	764	5000	0.08
	136	333	5000	0.03
Containment (walls)	Pressurizer shed inside	4919	5000	0.51
	outside	5911	1000	0.12
	Refuel cavity inside (under liner)	5966	5000	0.62
	outside	6894	1000	0.14
	Seal table	5125	5000	0.54
	Thimble tube area	1290	1000	0.03
	Primary Shield Wall outside surface	3284	1000	0.07
	Vessel Cavity	2883	(see Section 4)	—
Miscellaneous	32684	1000	0.68	
TOTAL		105395		30.30

Concrete Sample Table 2.3-1

Containment Wall
($\mu\text{Ci/g}$)

Sample Depth (in)	Sample Weight (g)	Co ⁶⁰	Eu ¹⁵²
1.75	551	3.6E-7	3.4E-7
4.4	540	2.2E-7	2.4E-7
7.0	630	1.1E-7	1.1E-7
10	683	3.5E-8	ND

ND = not detected

Concrete Sample Table 2.3-2
Secondary Shield Wall

($\mu\text{Ci/g}$)

Sample Depth (in)	Sample Weight (g)	Co ⁶⁰	Eu ¹⁵²
1.25	700	2.1E-7	1.2E-7
17	530	ND	ND
30	575	ND	ND

ND = not detected

Concrete Sample Table 2.3-3
Missile shield

($\mu\text{Ci/g}$)

Sample Depth (in)	Sample Weight (g)	Co ⁶⁰	Eu ¹⁵²	Cs ¹³⁷
1.5	625	3.3E-6	2.6E-6	ND
17.5	883	ND	ND	1.2E-6
25	820	6.8E-8	ND	ND

ND = not detected

SITE CHARACTERIZATION REPORT

REVISION 0.1

Concrete Sample Table 2.3-4
 Reactor Vessel Shield Wall
 ($\mu\text{Ci/g}$)

Sample Depth (in)	Sample Weight (g)	Mn ⁵⁴	Co ⁵⁸	Co ⁶⁰	Zn ⁶⁵	Eu ¹⁵²	Eu ¹⁵⁴	Eu ¹⁵⁵	Nb ⁹⁵	Zr ⁹⁵	Cs ¹³⁴	Cs ¹³⁷	Fe ⁵⁹
3	7.56	1.6E-3	1.0E-3	1.9E-1	3.4E-3	2.5E-1	2.7E-2	1.0E-3	5.7E-4	2.2E-3	9.5E-3	ND	ND
16.5	9.5	3.6E-5	1.4E-5	2.2E-3	ND	2.8E-3	2.8E-4	ND	ND	ND	5.0E-5	ND	ND
28.2	10.5	1.1E-5	ND	3.1E-4	ND	4.6E-4	5.5E-5	ND	ND	ND	7.5E-6	ND	ND
39.1	853	2.9E-7	ND	5.7E-6	ND	8.0E-6	9.1E-7	ND	ND	ND	2.0E-7	ND	ND
54.3	805	ND	ND	1.9E-7	ND	2.3E-7	ND	ND	ND	ND	ND	ND	ND
76.3	1115	ND	ND	ND	ND	ND	ND	ND	ND	ND	ND	2.5E-8	ND
97.1	950	ND	3.1E-8	ND	ND	ND	ND	ND	ND	ND	ND	ND	ND
101.5*	232	ND	ND	1.5E-6	8.2E-7	8.0E-7	ND	ND	ND	ND	1.0E-6	3.6E-5	ND
22.5+	433	4.1E-4	ND	4.8E-3	ND	ND	ND	ND	ND	ND	ND	ND	2.1E-5

* Sample consists of the outer wall surface with 5000 dpm/20 cm² fixed contamination

+ Sample of # 10 rebar without concrete

Table 2.3-5
 Comparison of Calculated to Measured Neutron Activation
 Reactor Vessel Shield Wall
 ($\mu\text{Ci/g}$)

Depth (inches)	Nuclides (measured/calculated)	
	Co^{60}	Eu^{152}
3	1.9E-1/3.0E-1	2.5E-1/2.9E-1
16.5	2.2E-3/2.5E-2	2.8e-3/2.9e-2
28.2	3.1E-4/5.9E-4	4.6E-4/6.9E-4
22.5 (rebar)	4.8E-3/5.6E-2	-----

Section 2
Structural Characterization

Appendix 2A

Radiological Status of Structures
Within the Plant Site

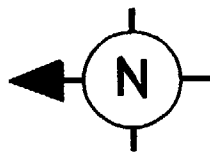

NOTES:

1. RADIATION LEVELS ARE IN mR/hr.
2. CONTAMINATION LEVELS ARE CIRCLED AND ARE dpm/100cm² UNLESS OTHERWISE NOTED.

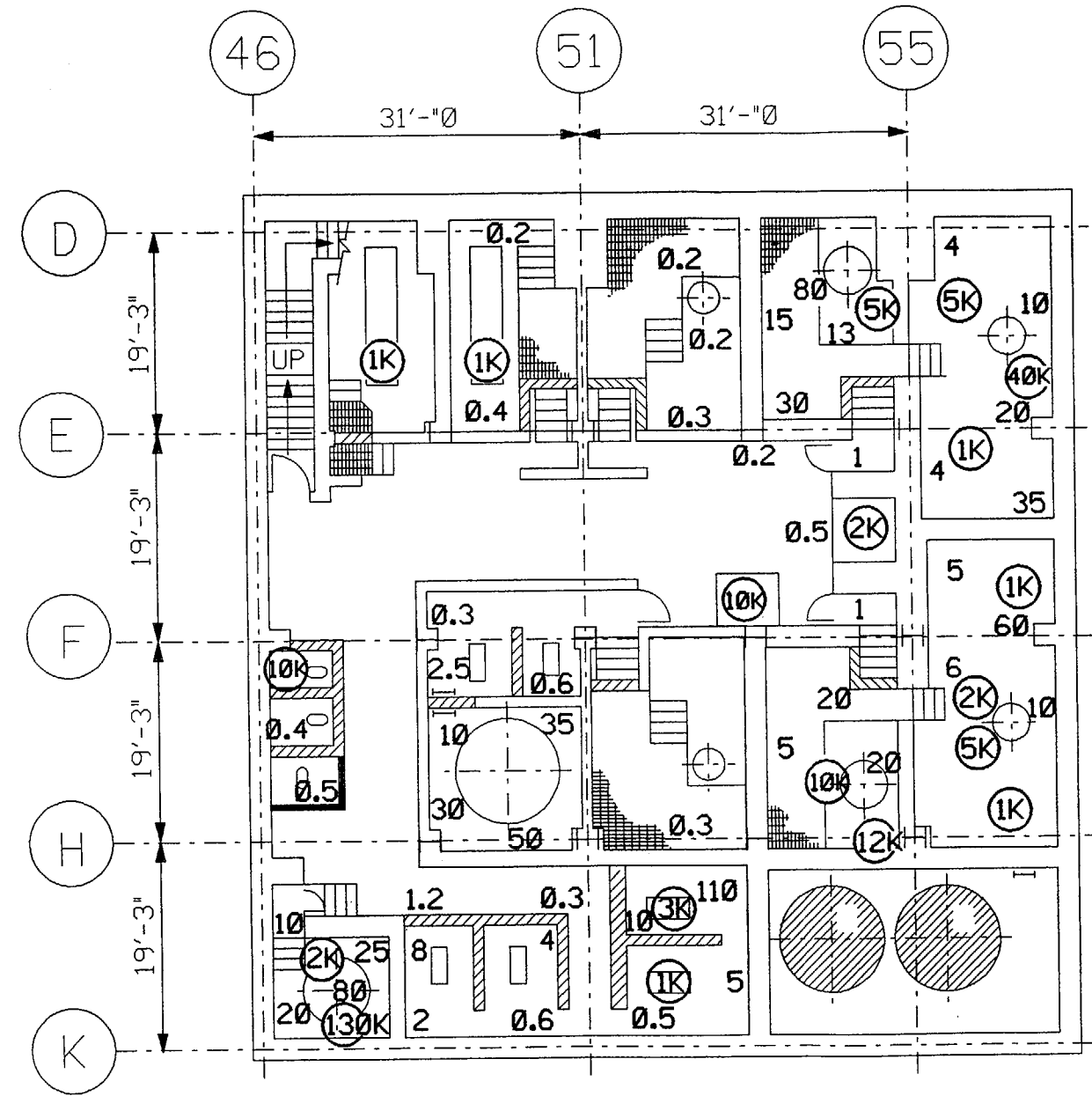

<p>Trojan Nuclear Plant SITE CHARACTERIZATION REPORT Revision 0.1</p>
<p>Appendix 2A Radiological Survey Data Auxiliary Building Elevation 5 FT</p>

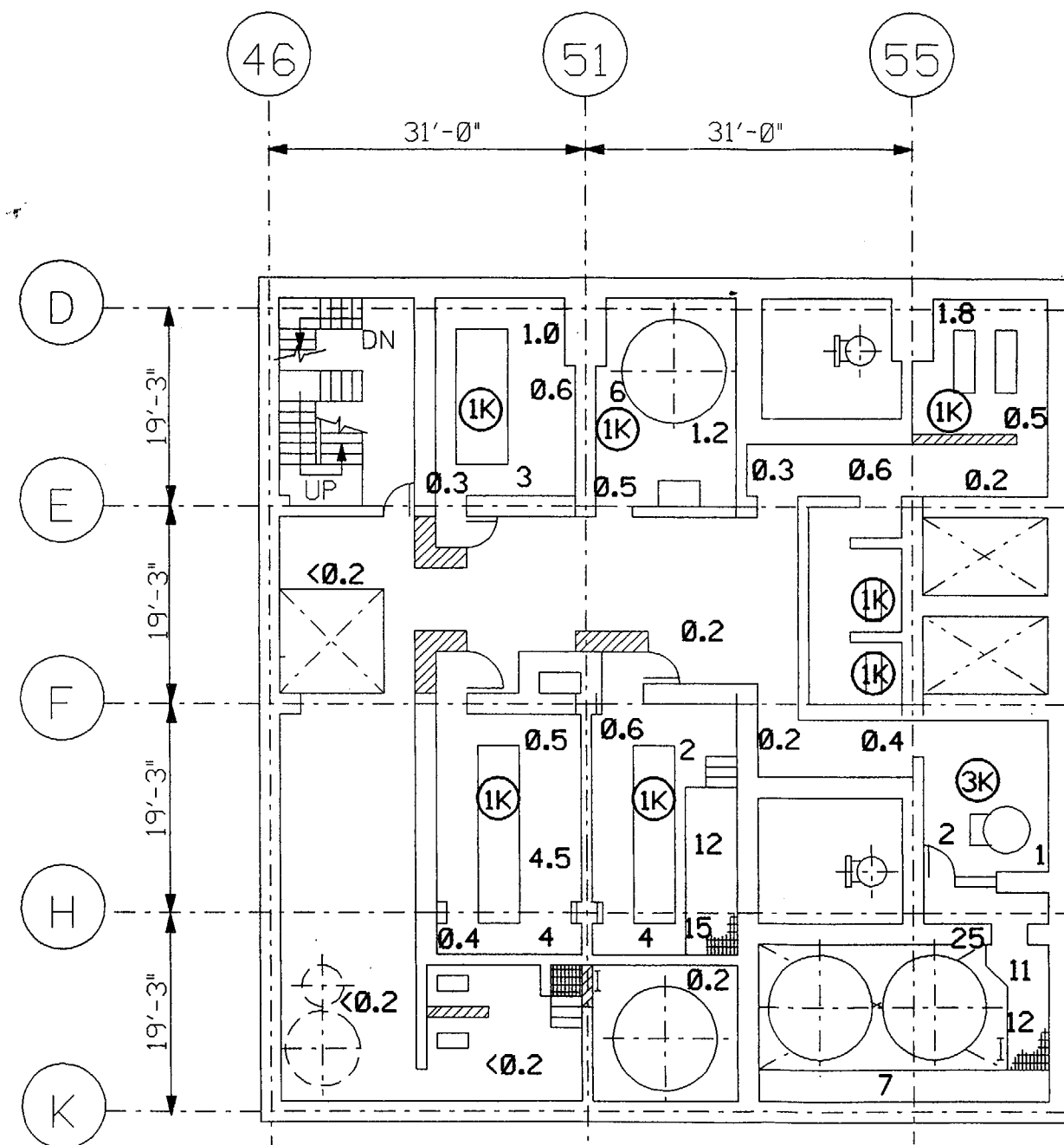
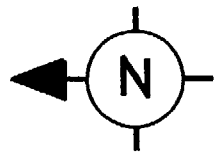

NOTES:

1. RADIATION LEVELS ARE IN mR/hr.
2. CONTAMINATION LEVELS ARE CIRCLED AND ARE dpm/100cm² UNLESS OTHERWISE NOTED.

Trojan Nuclear Plant
 SITE CHARACTERIZATION REPORT
 Revision 0.1

Appendix 2A
 Radiological Survey Data
 Auxiliary Building Elevation 25 FT

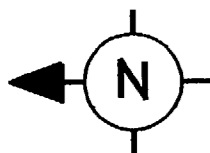

46 51 55 61 66

31'-0" 31'-0" 38'-9" 23'-3"

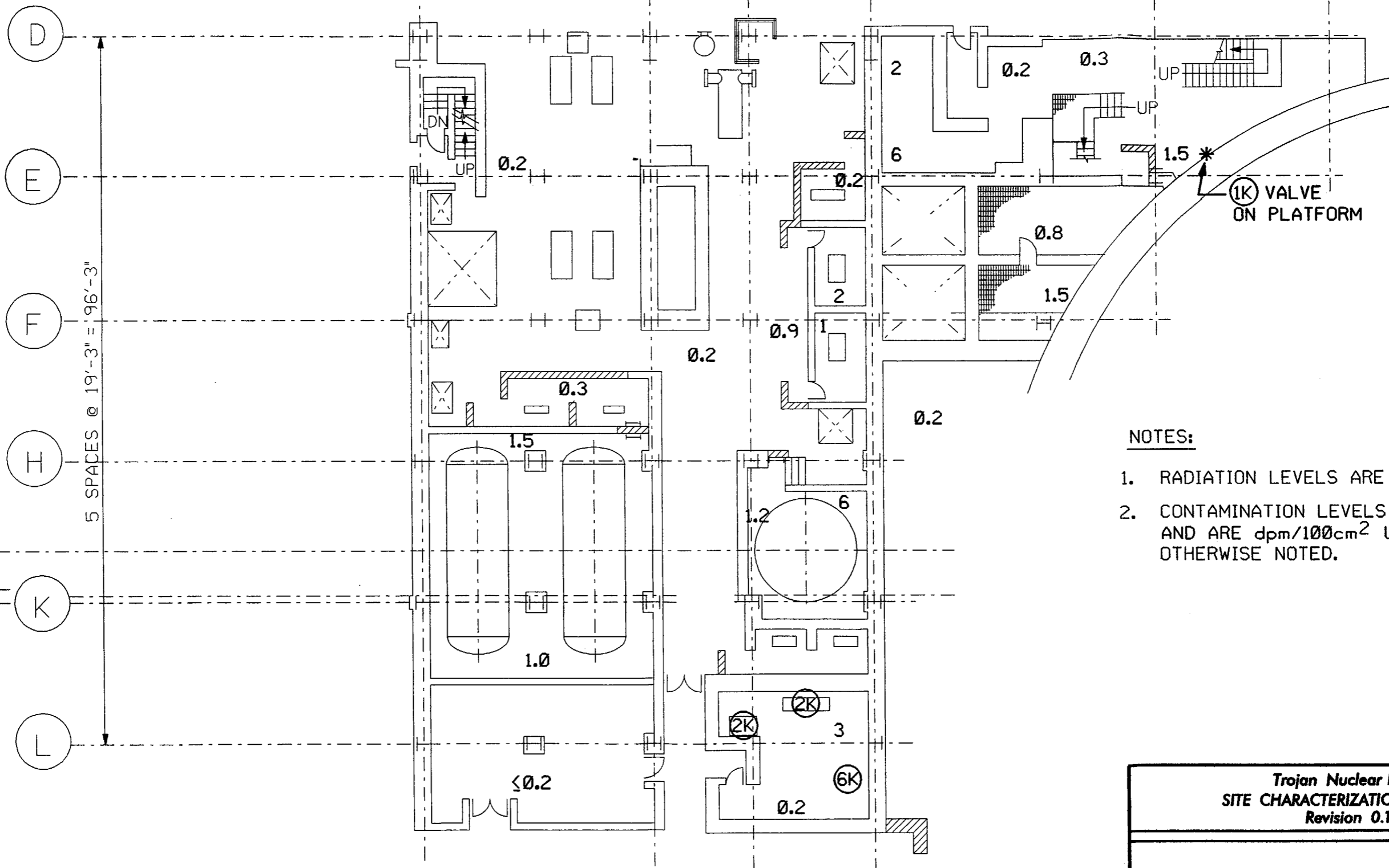

5 SPACES @ 19'-3" = 96'-3"

5'-0"
18"

NOTES:

- 1. RADIATION LEVELS ARE IN mR/hr.
- 2. CONTAMINATION LEVELS ARE CIRCLED AND ARE dpm/100cm² UNLESS OTHERWISE NOTED.

Trojan Nuclear Plant SITE CHARACTERIZATION REPORT Revision 0.1
Appendix 2A Radiological Survey Data Auxiliary Building Elevation 45 FT

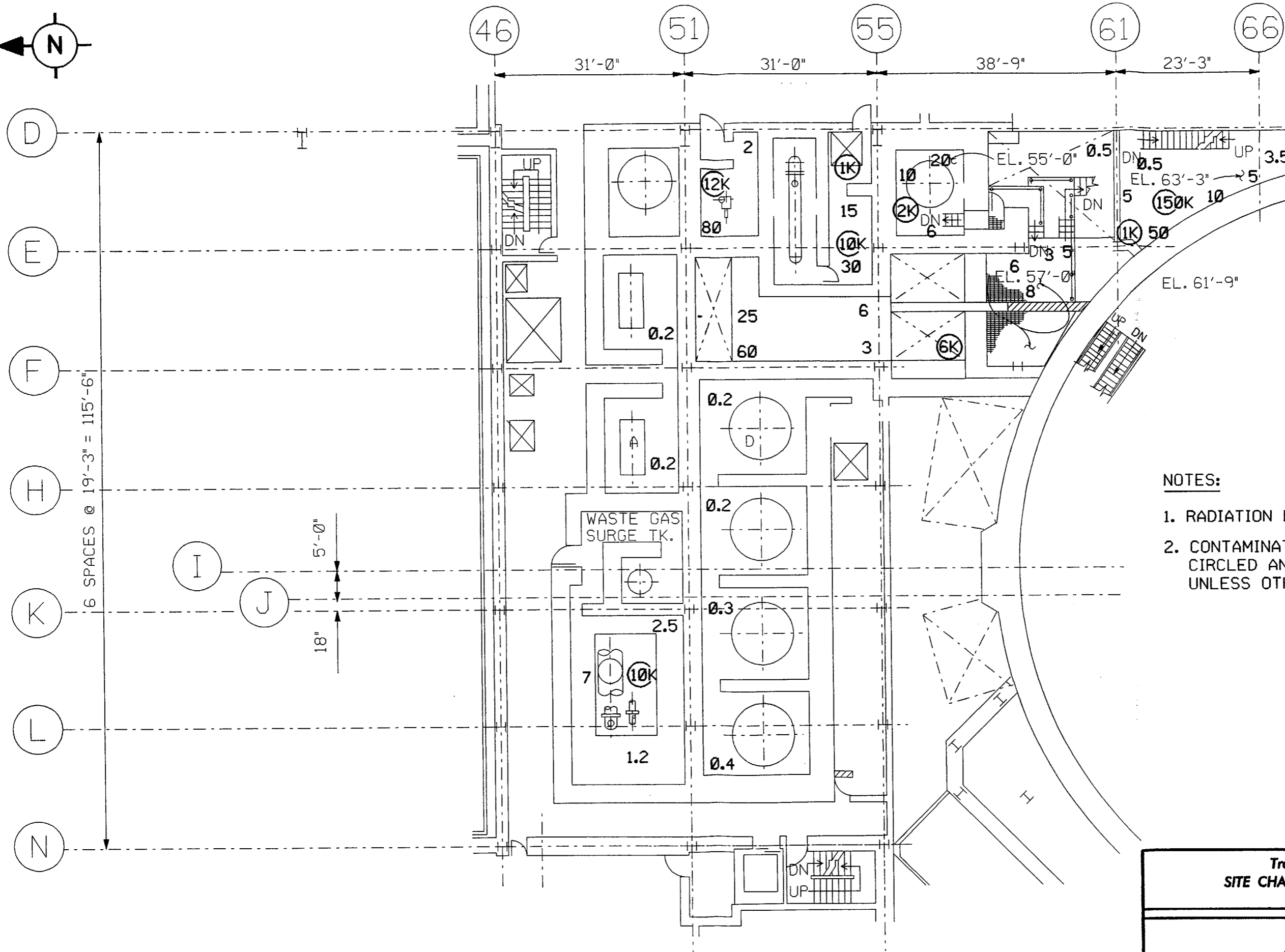
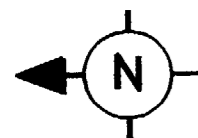

NOTES:

- 1. RADIATION LEVELS ARE IN mR/hr.
- 2. CONTAMINATION LEVELS ARE CIRCLED AND ARE dpm/100cm² UNLESS OTHERWISE NOTED.

Trojan Nuclear Plant
SITE CHARACTERIZATION REPORT
Revision 0.1

Appendix 2A
Radiological Survey Data
Auxiliary Building Elevation 61 FT

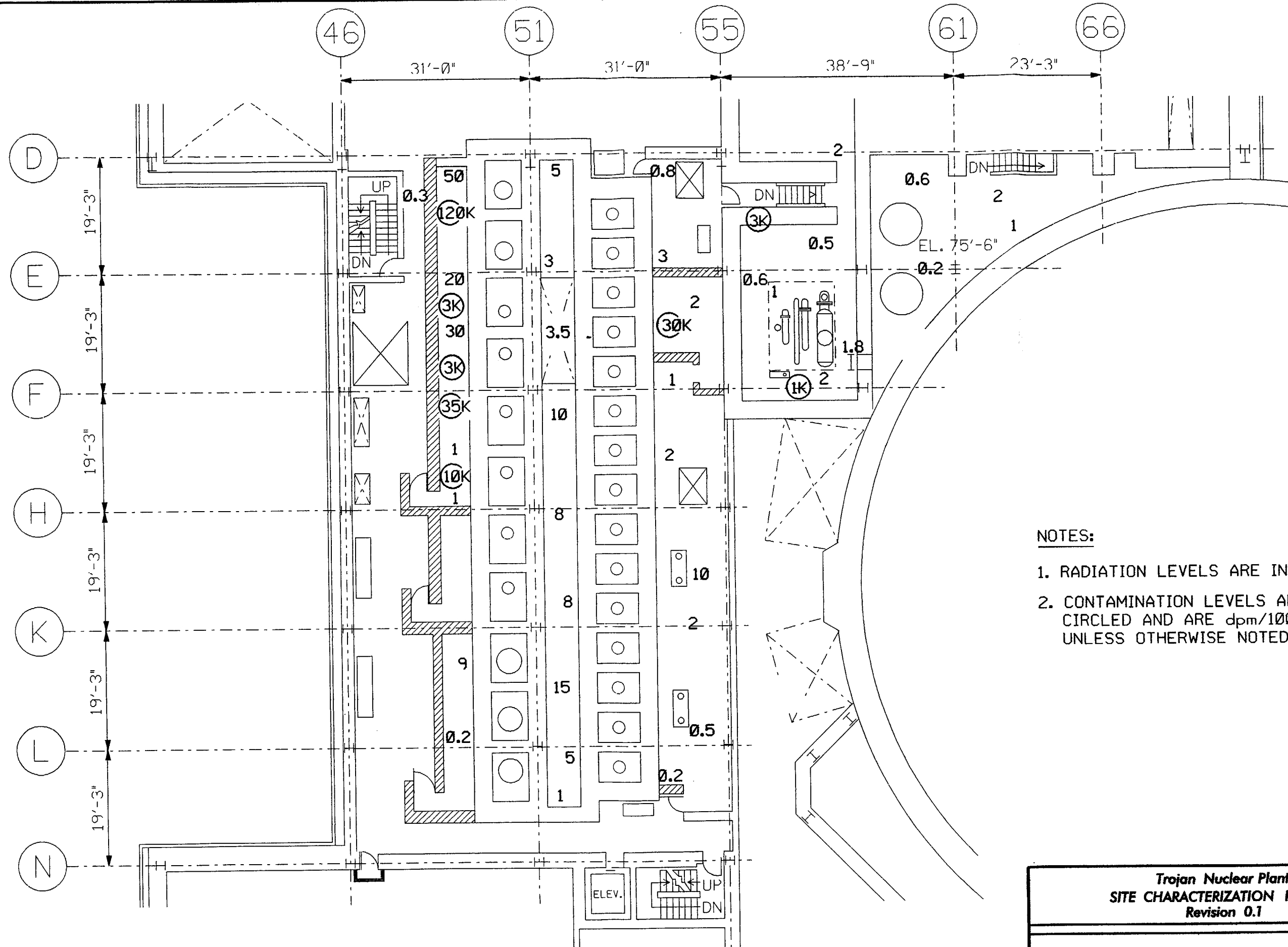
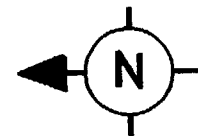

NOTES:

- 1. RADIATION LEVELS ARE IN mR/hr.
- 2. CONTAMINATION LEVELS ARE CIRCLED AND ARE dpm/100cm² UNLESS OTHERWISE NOTED.

Trojan Nuclear Plant
SITE CHARACTERIZATION REPORT
Revision 0.1

Appendix 2A
Radiological Survey Data
Auxiliary Building Elevation 77 FT

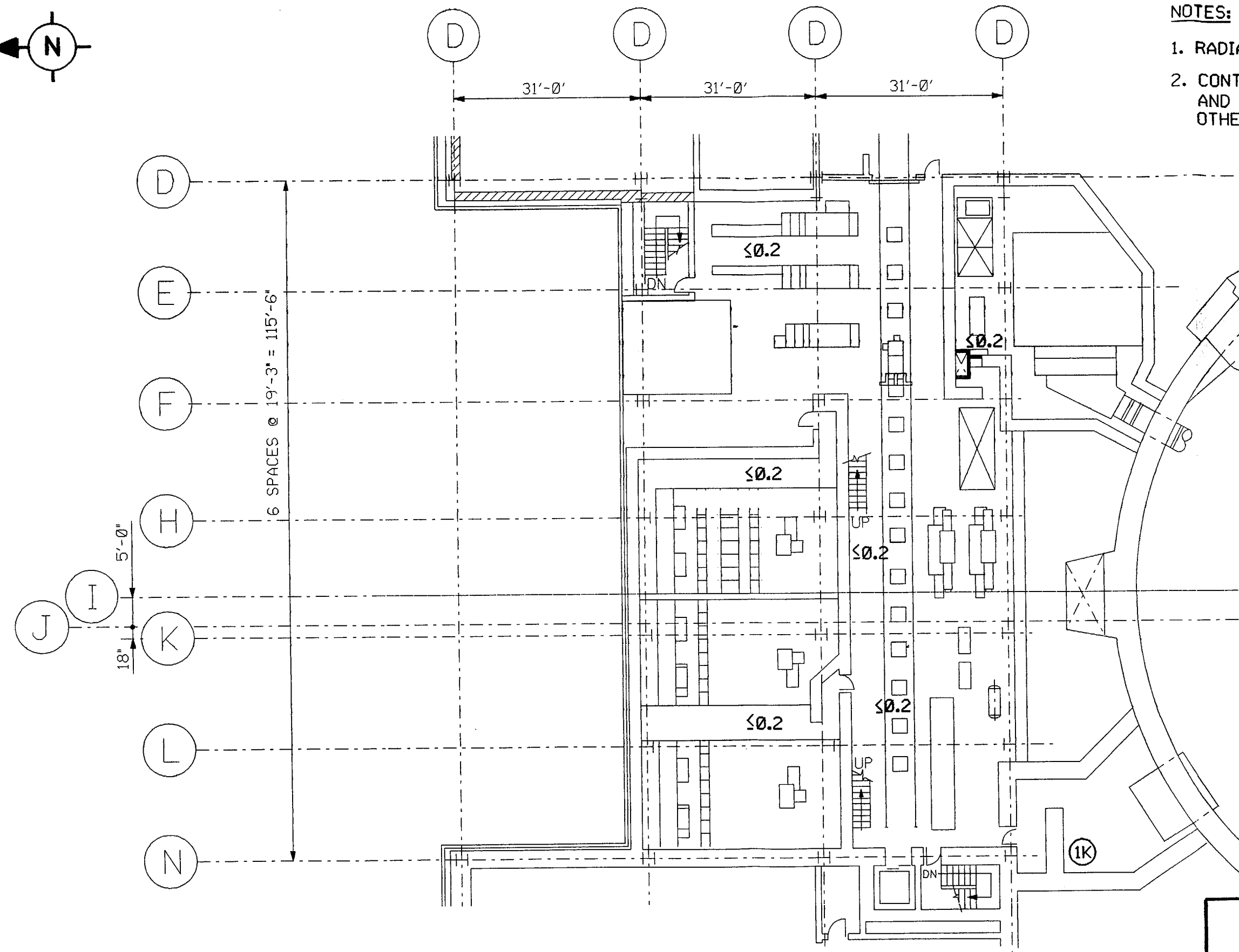
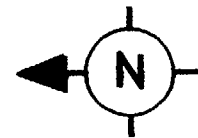

NOTES:

- 1. RADIATION LEVELS ARE IN mR/hr.
- 2. CONTAMINATION LEVELS ARE CIRCLED AND ARE dpm/100cm² UNLESS OTHERWISE NOTED.

Trojan Nuclear Plant
SITE CHARACTERIZATION REPORT
Revision 0.1

Appendix 2A
Radiological Survey Data
Auxiliary Building Elevation 93 FT

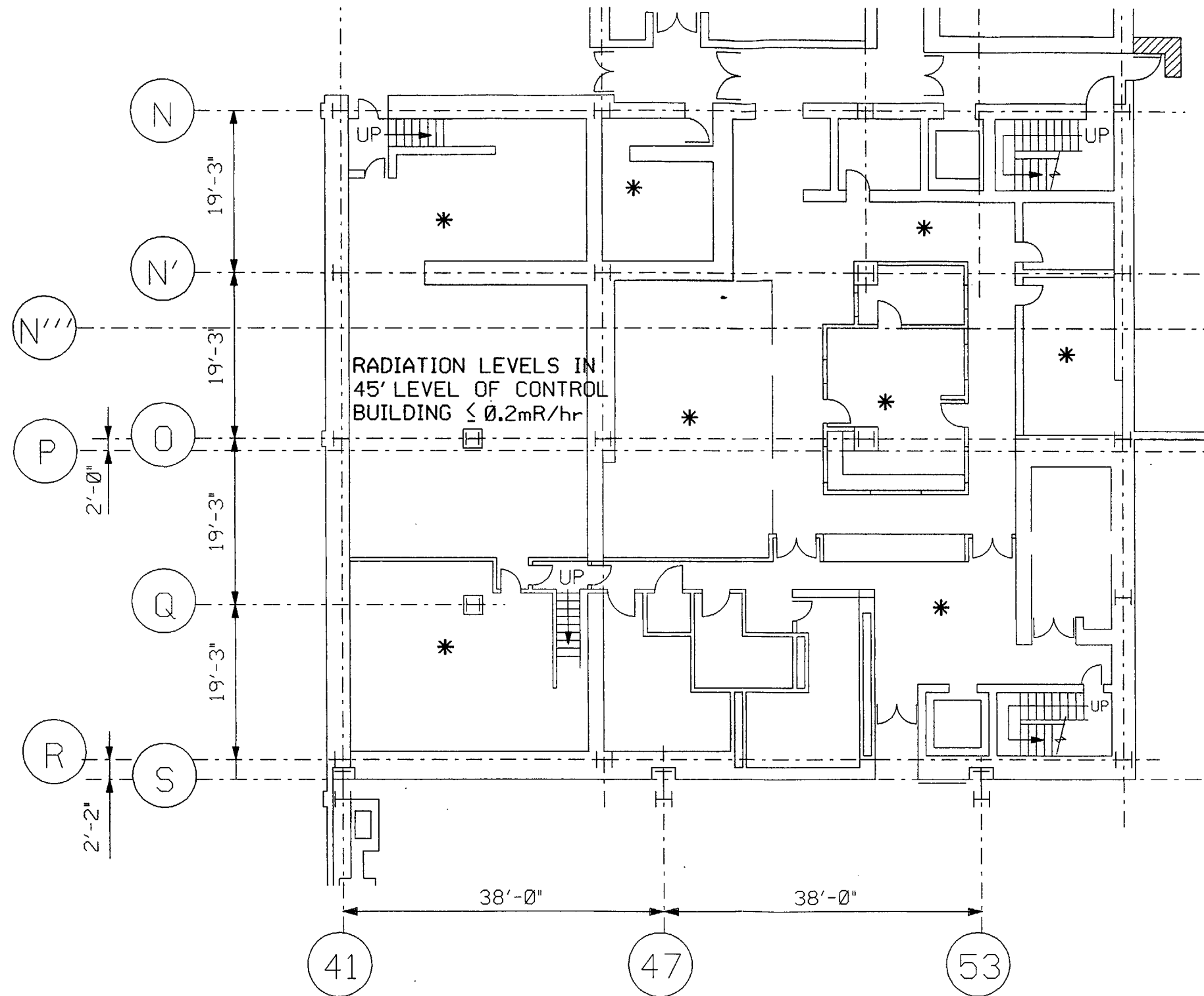
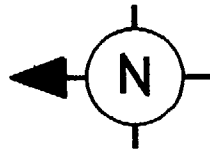

NOTES:

1. RADIATION LEVELS ARE IN mR/hr.
2. CONTAMINATION LEVELS ARE CIRCLED AND ARE dpm/100cm² UNLESS OTHERWISE NOTED.

* ALL CONTROL BUILDING SURFACES SMEAR SURVEY RESULTS ≤ 12.6 dpm/100cm²

Trojan Nuclear Plant
SITE CHARACTERIZATION REPORT
Revision 0.1

Appendix 2A
Radiological Survey Data
Control Building Elevation 45 FT

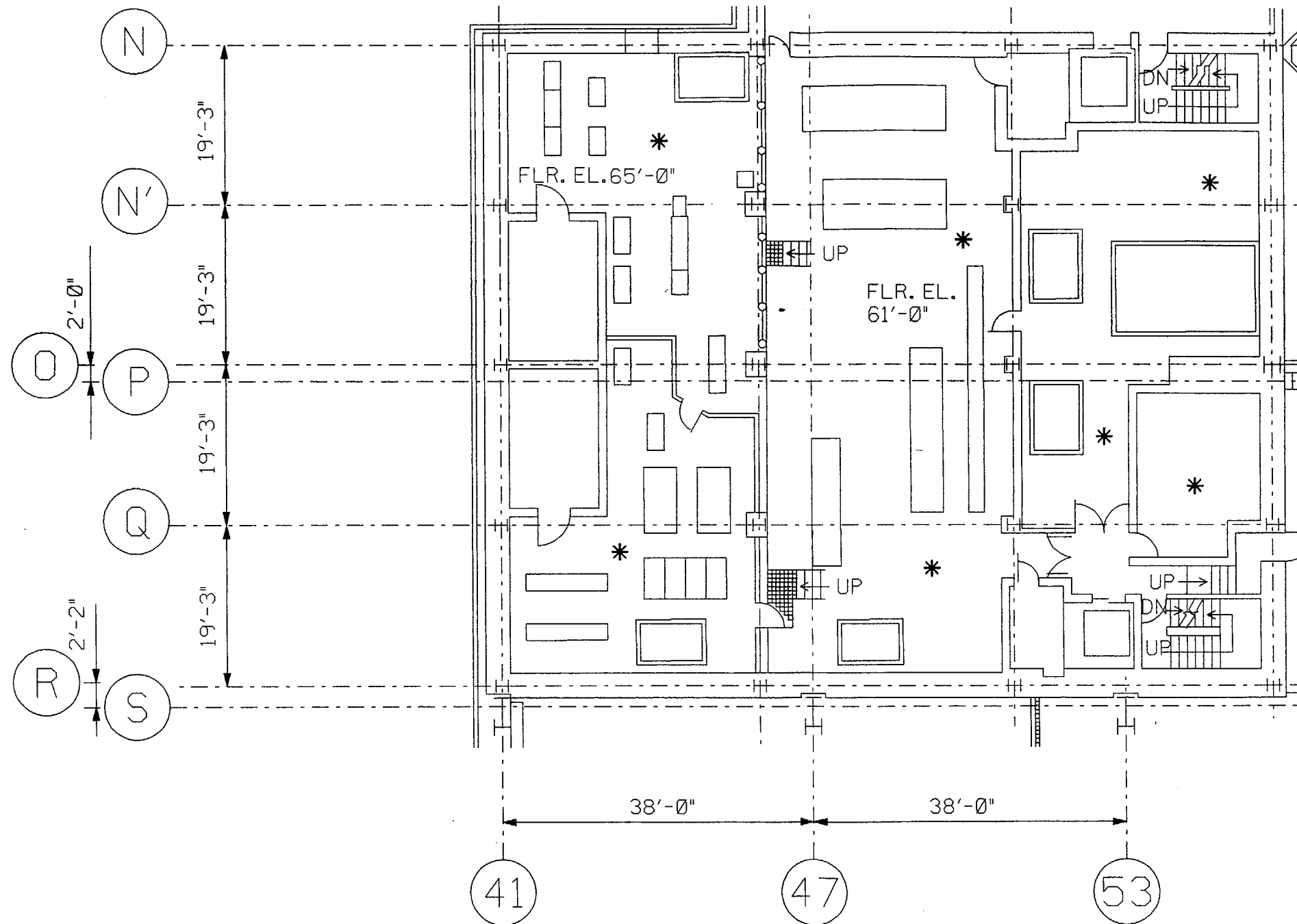
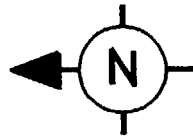

- NOTES:**
1. RADIATION LEVELS ARE IN mR/hr.
 2. CONTAMINATION LEVELS ARE CIRCLED AND ARE dpm/100cm² UNLESS OTHERWISE NOTED.

* SMEAR SURVEYS OF ALL 61' AND 65' CONTROL BUILDING SURFACES ≤ 12.3 dpm/100cm²

Trojan Nuclear Plant SITE CHARACTERIZATION REPORT Revision 0.1
Appendix 2A Radiological Survey Data Control Building Elevation 61 FT And 65 FT

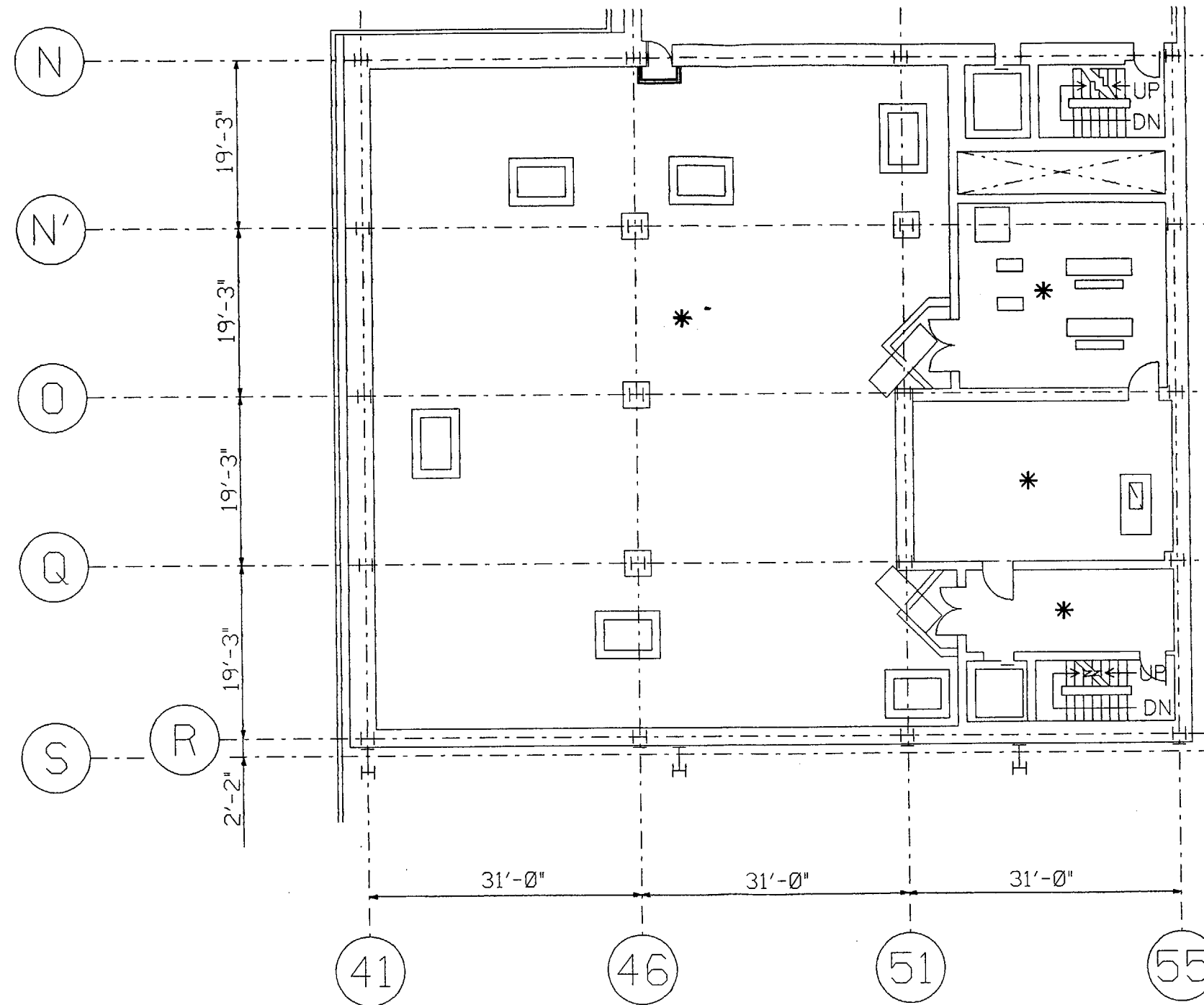
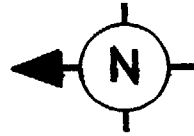

NOTES:

1. RADIATION LEVELS ARE IN mR/hr.
2. CONTAMINATION LEVELS ARE CIRCLED AND ARE dpm/100cm² UNLESS OTHERWISE NOTED.

* SMEAR SURVEYS OF ALL 77' CONTROL BUILDING SURFACES ≤ 12.3 dpm/100cm².

Trojan Nuclear Plant
SITE CHARACTERIZATION REPORT
Revision 0.1

Appendix 2A
Radiological Survey Data
Control Building Elevation 77 FT

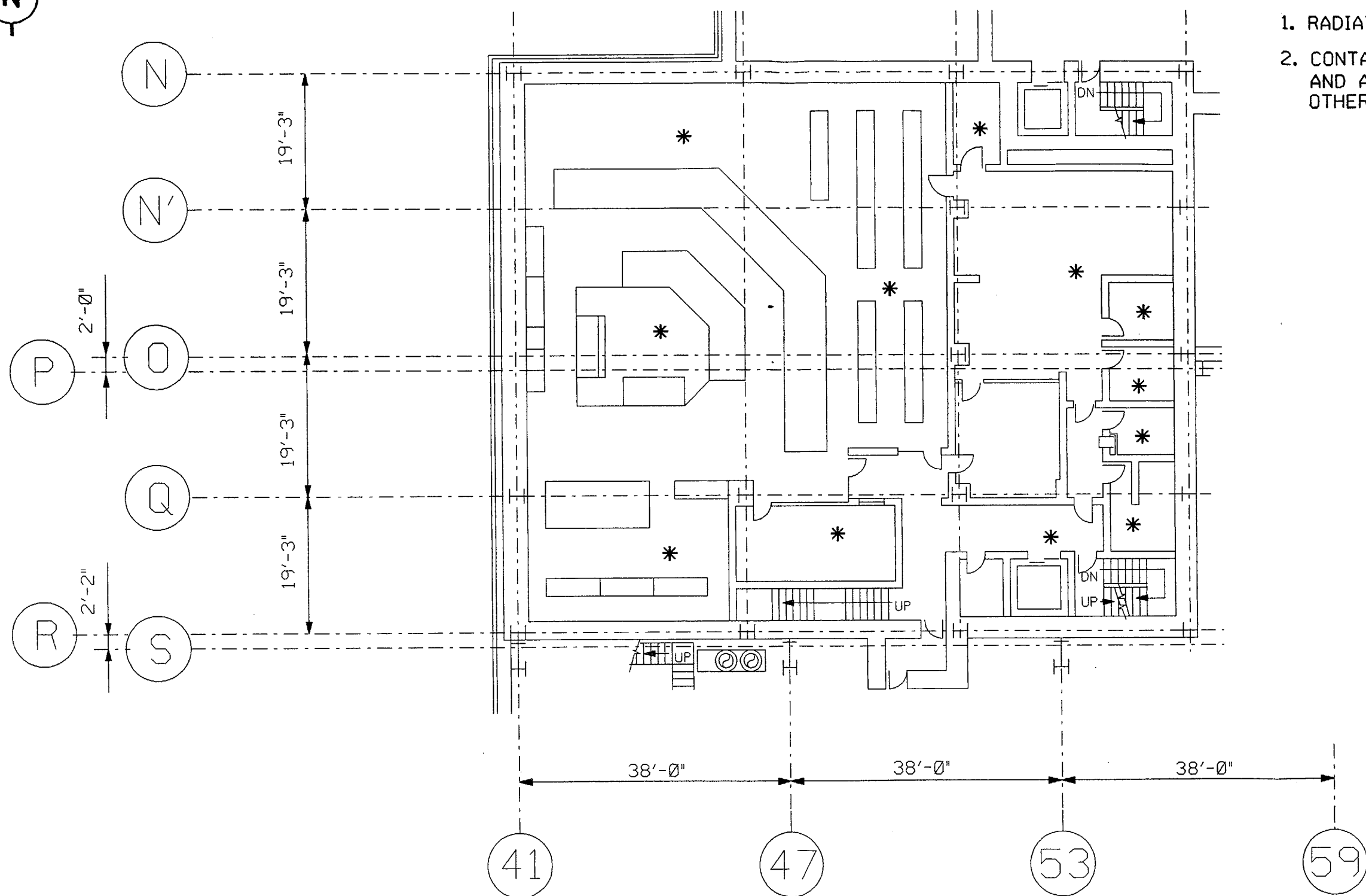
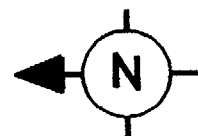

NOTES:

- 1. RADIATION LEVELS ARE IN mR/hr.
- 2. CONTAMINATION LEVELS ARE CIRCLED AND ARE dpm/100cm² UNLESS OTHERWISE NOTED.

* SMEAR SURVEYS OF ALL 93' CONTROL BUILDING SURFACES $\leq 10.5 \text{ dpm}/100 \text{ cm}^2$

Trojan Nuclear Plant SITE CHARACTERIZATION REPORT Revision 0.1
Appendix 2A Radiological Survey Data Control Building Elevation 93 FT

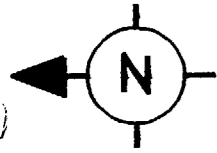

NOTES:

1. RADIATION LEVELS ARE IN mR/hr.
2. CONTAMINATION LEVELS ARE CIRCLED AND ARE dpm/100cm² UNLESS OTHERWISE NOTED.

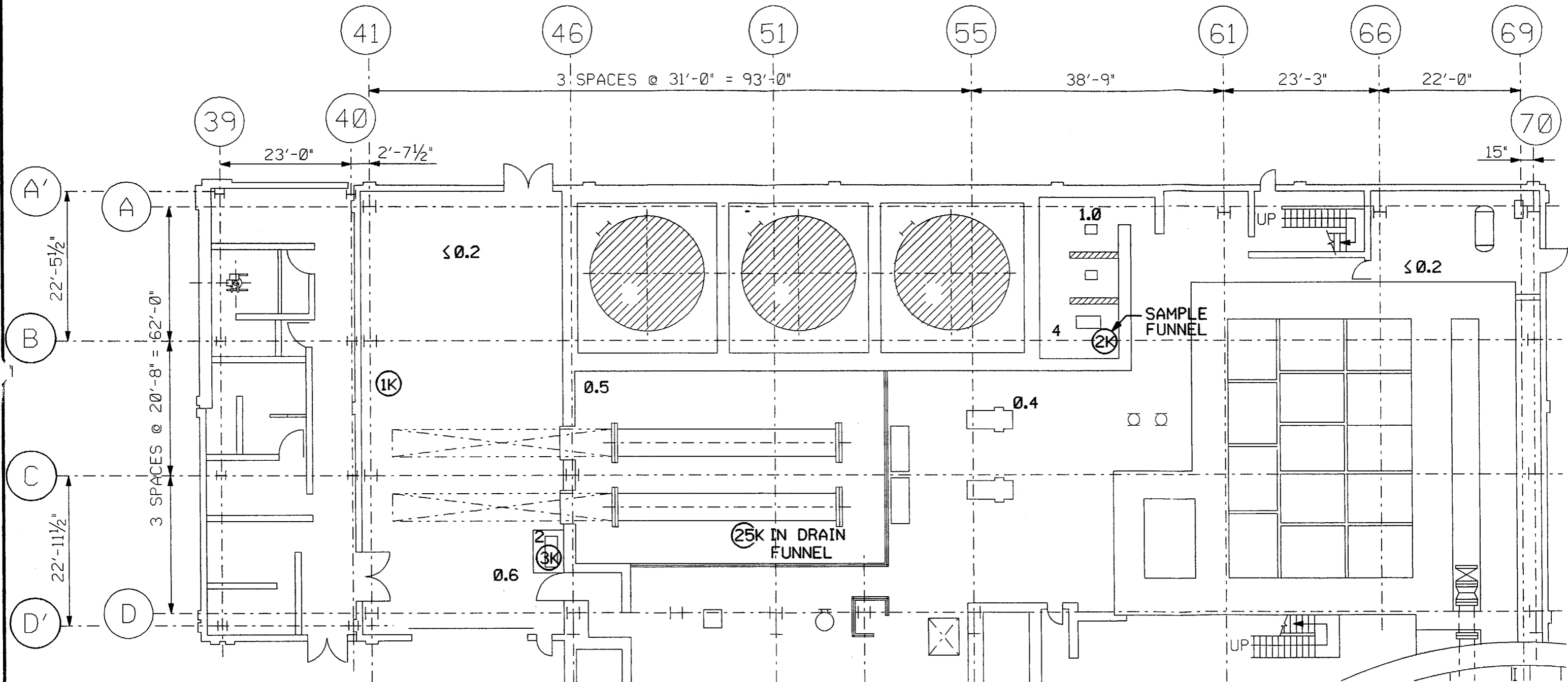

Trojan Nuclear Plant
SITE CHARACTERIZATION REPORT
Revision 0.1

Appendix 2A
Radiological Survey Data
Fuel Building Elevation 45 FT

NOTES:

1. RADIATION LEVELS ARE IN mR/hr.
2. CONTAMINATION LEVELS ARE CIRCLED AND ARE dpm/100cm² UNLESS OTHERWISE NOTED.

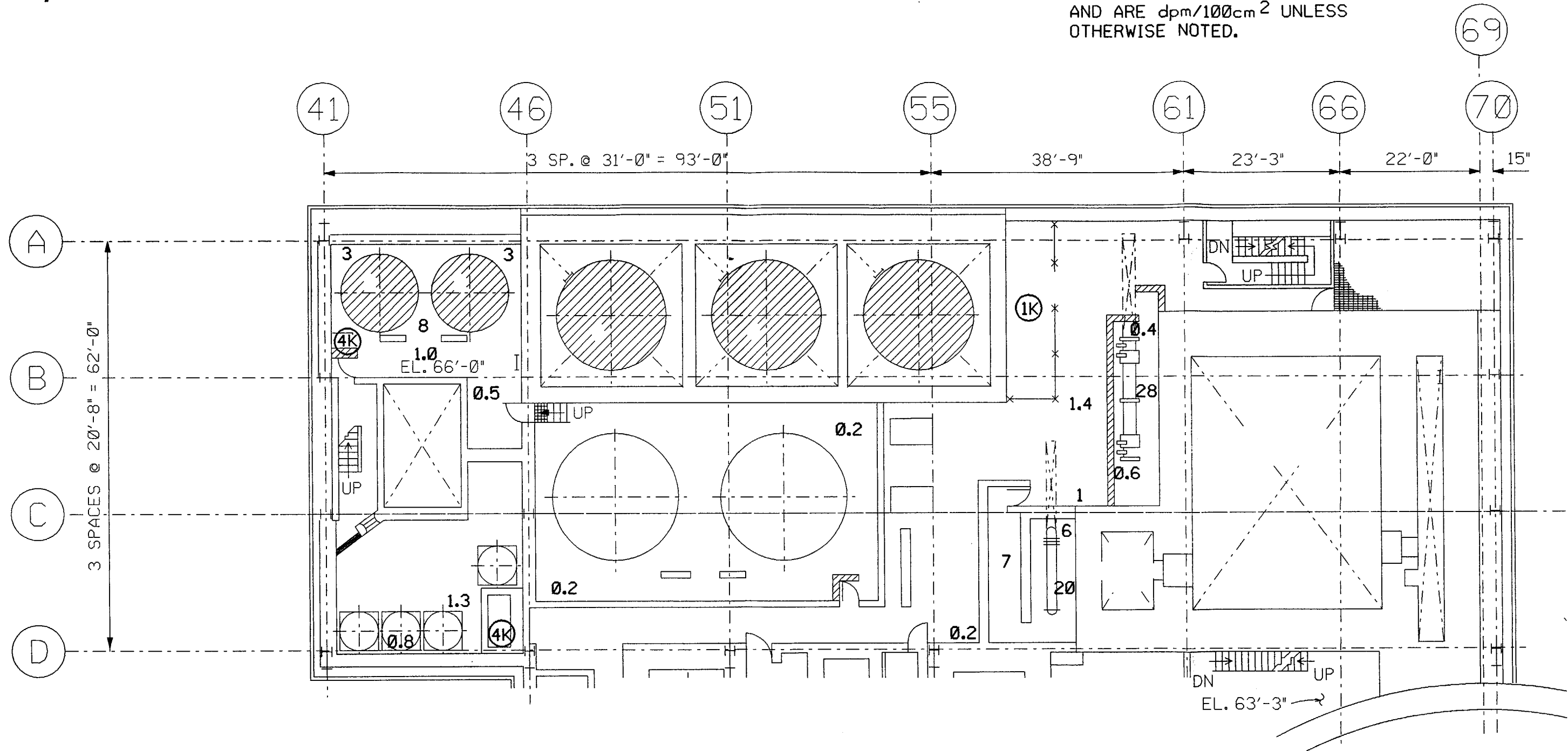
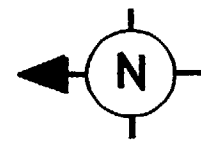

Trojan Nuclear Plant
SITE CHARACTERIZATION REPORT
 Revision 0.1

Appendix 2A
 Radiological Survey Data
 Fuel Building Elevation 61 FT

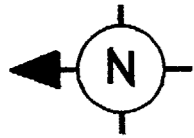

NOTES:

1. RADIATION LEVELS ARE IN mR/hr.
2. CONTAMINATION LEVELS ARE CIRCLED AND ARE dpm/100cm² UNLESS OTHERWISE NOTED.

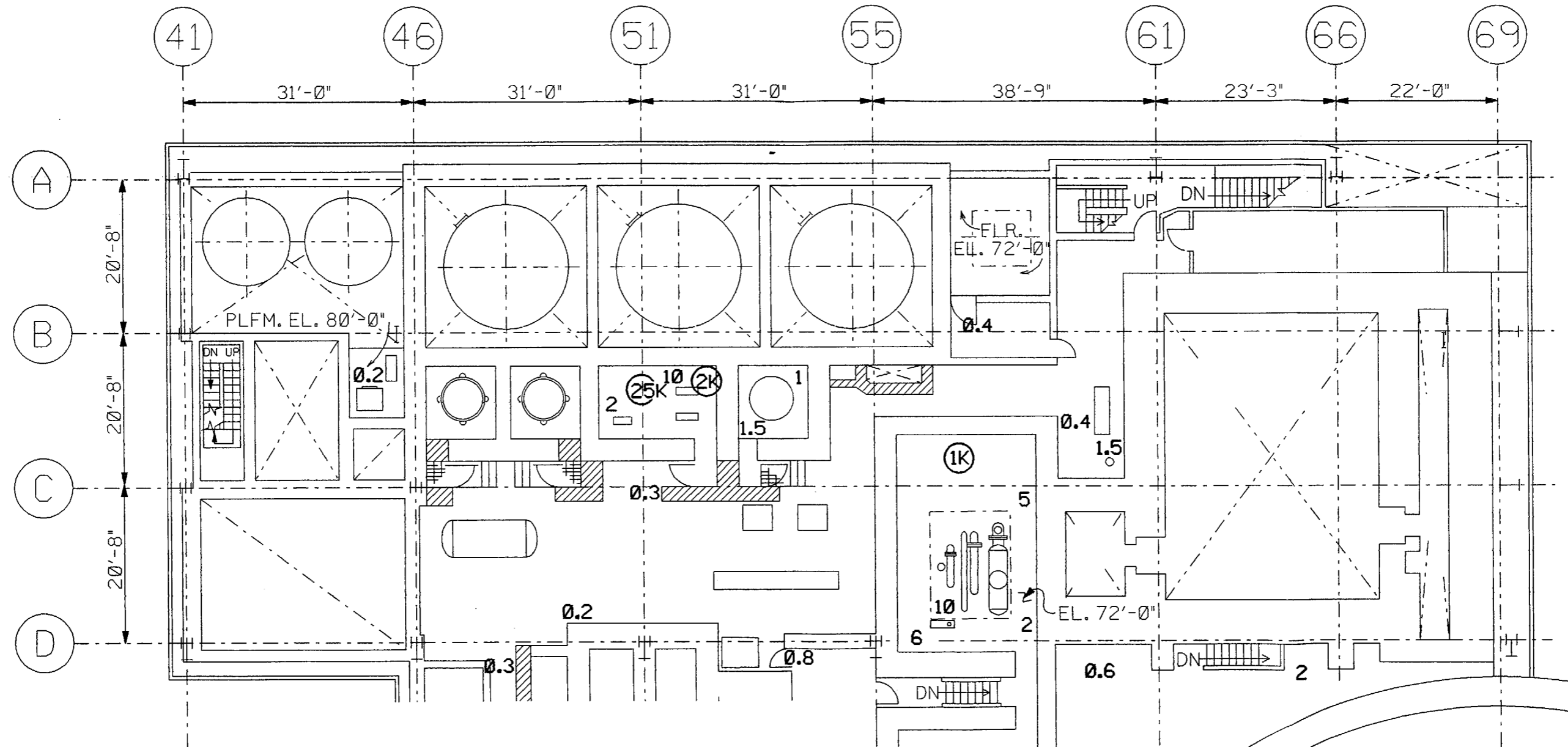

Trojan Nuclear Plant
SITE CHARACTERIZATION REPORT
Revision 0.1

Appendix 2A
Radiological Survey Data
Fuel Building Elevation 77 FT

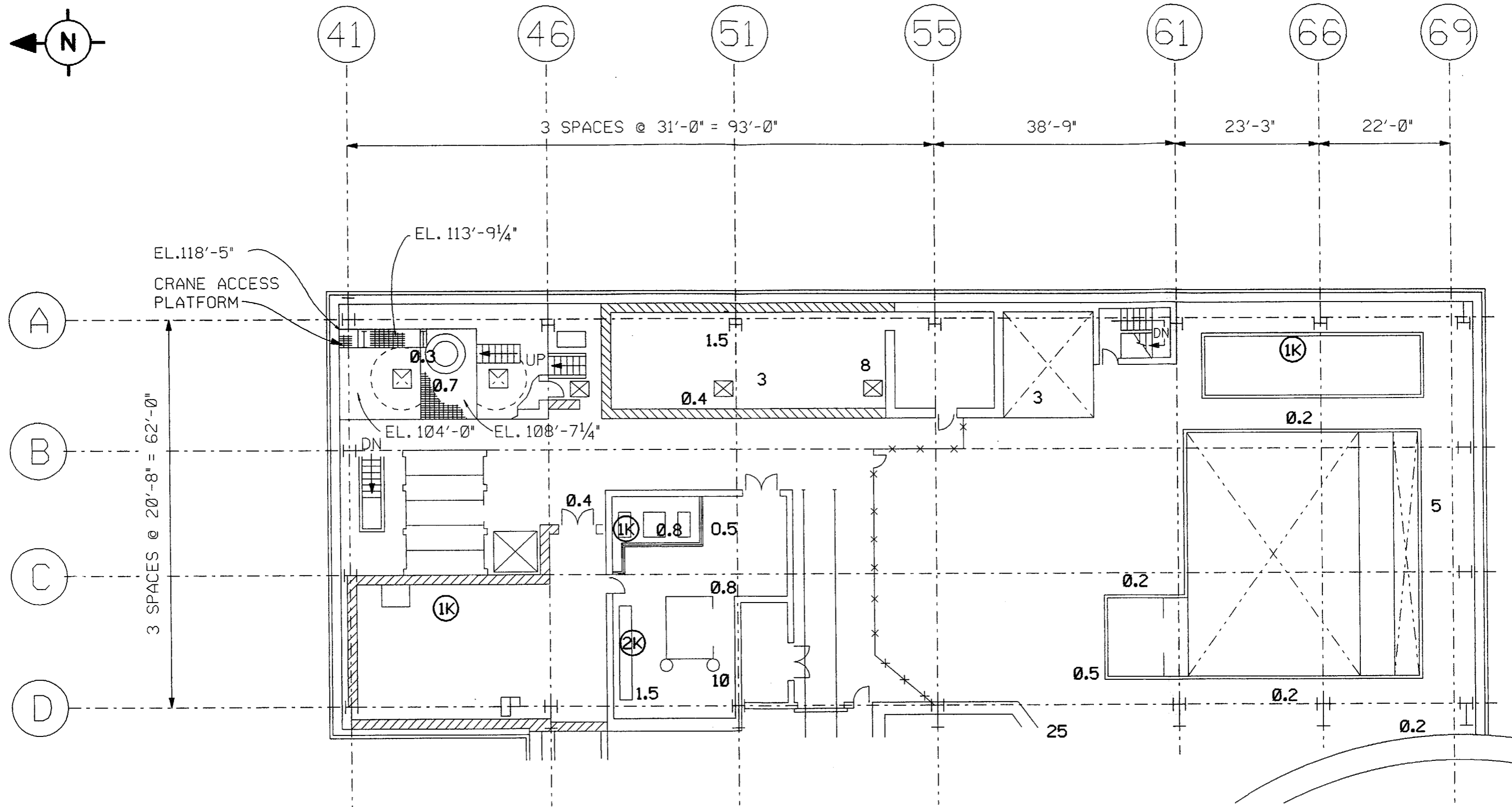
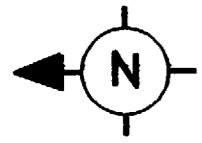

NOTES:

1. RADIATION LEVELS ARE IN mR/hr.
2. CONTAMINATION LEVELS ARE CIRCLED AND ARE dpm/100cm² UNLESS OTHERWISE NOTED.

Trojan Nuclear Plant
SITE CHARACTERIZATION REPORT
Revision 0.1

Appendix 2A
Radiological Survey Data
Fuel Building Elevation 93 FT

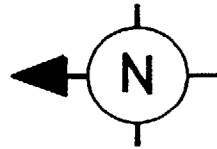

63 66 69 71 76

19'-6" 22'-0" 13'-0" 28'-6"

CAVITY DRAIN SPOOL PIECES

NOTES:

- 1. RADIATION LEVELS ARE IN mR/hr.
- 2. CONTAMINATION LEVELS ARE CIRCLED AND ARE dpm/100cm² UNLESS OTHERWISE NOTED.

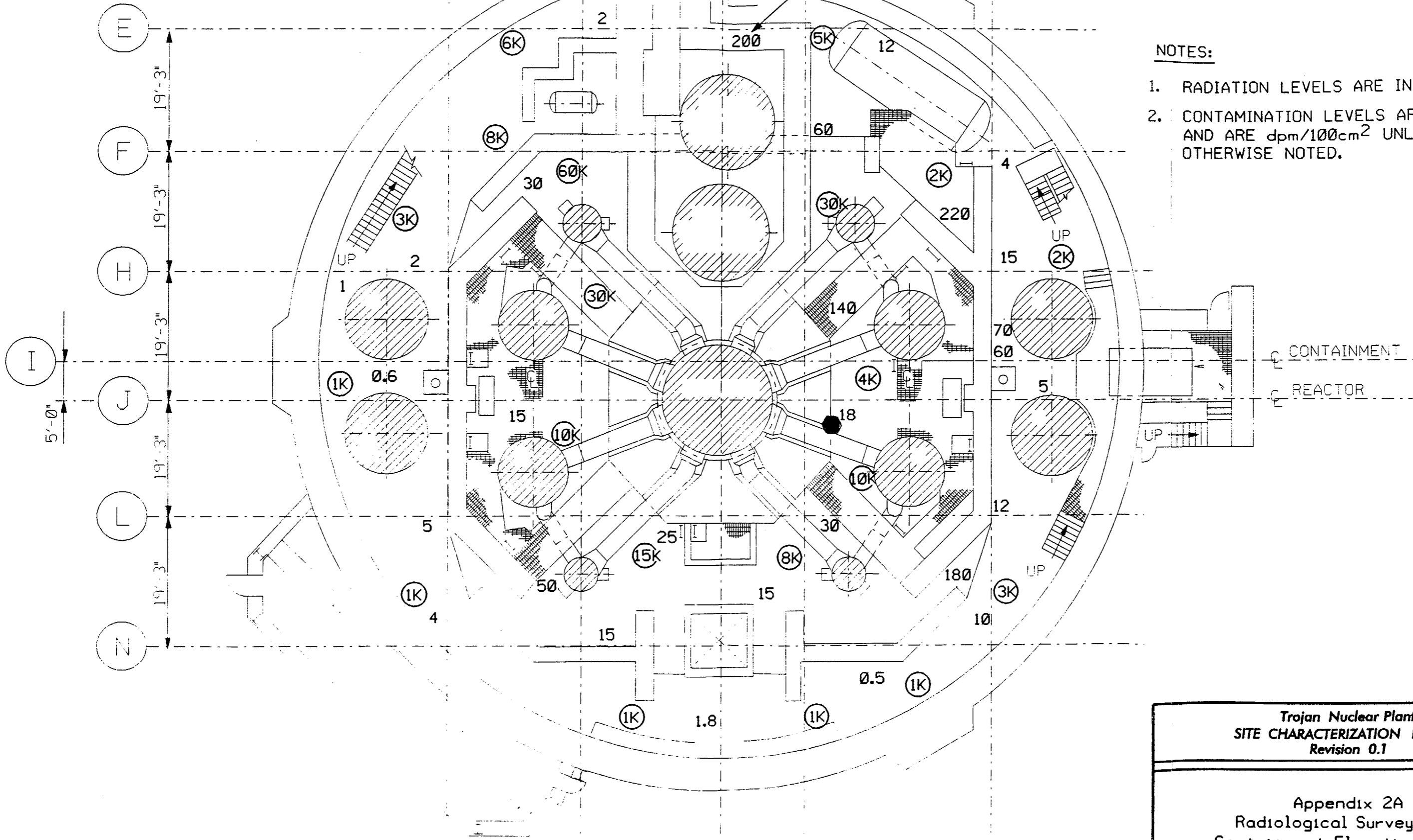

Trojan Nuclear Plant
SITE CHARACTERIZATION REPORT
Revision 0.1

Appendix 2A
Radiological Survey Data
Containment Elevation 45 FT

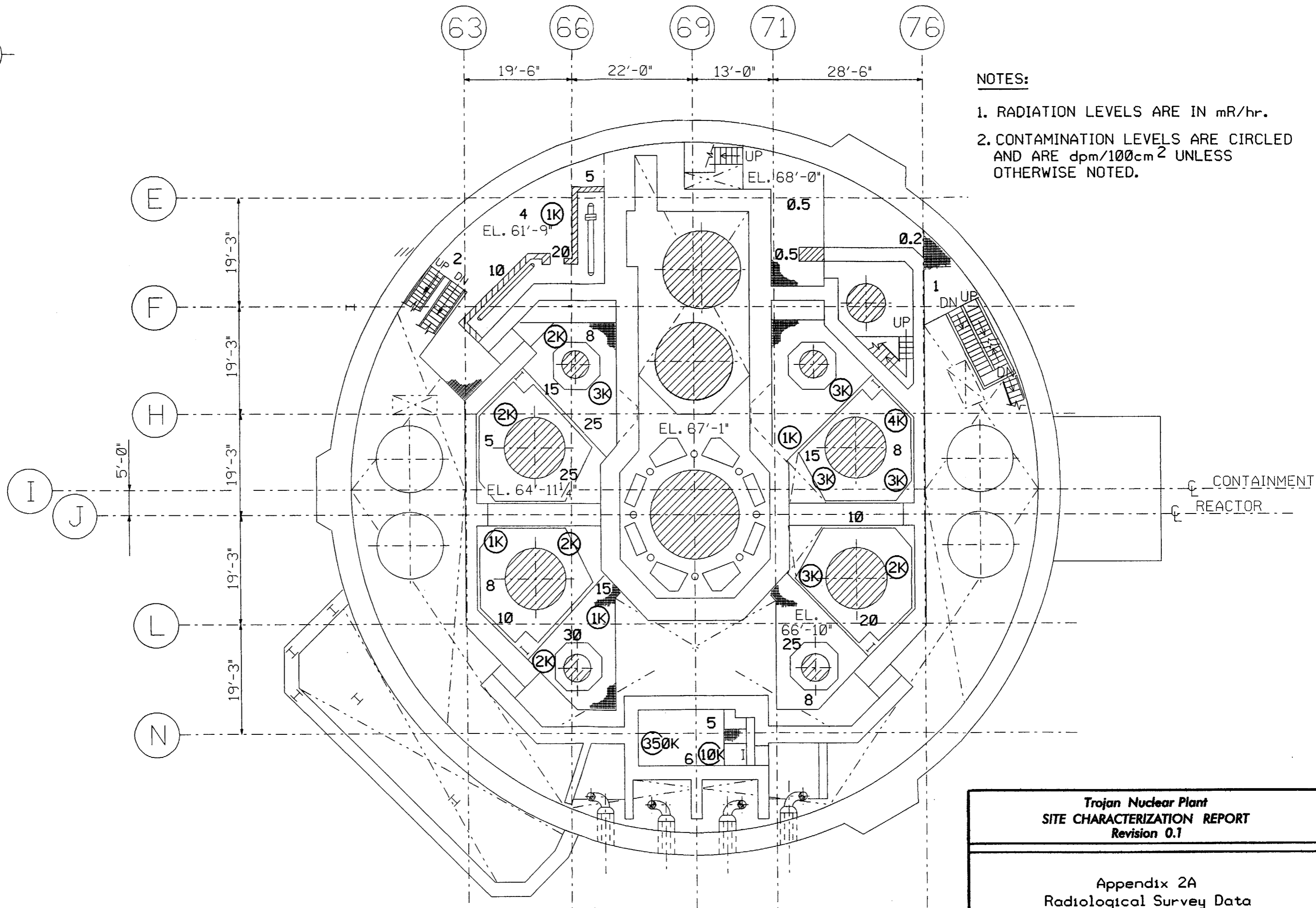
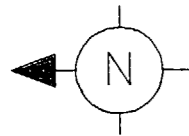

NOTES:

- 1. RADIATION LEVELS ARE IN mR/hr.
- 2. CONTAMINATION LEVELS ARE CIRCLED AND ARE dpm/100cm² UNLESS OTHERWISE NOTED.

Trojan Nuclear Plant
SITE CHARACTERIZATION REPORT
Revision 0.1

Appendix 2A
Radiological Survey Data
Containment Elevation 61 FT

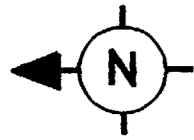

NOTES:

- 1. RADIATION LEVELS ARE IN mR/hr.
- 2. CONTAMINATION LEVELS ARE CIRCLED AND ARE dpm/100cm² UNLESS OTHERWISE NOTED.

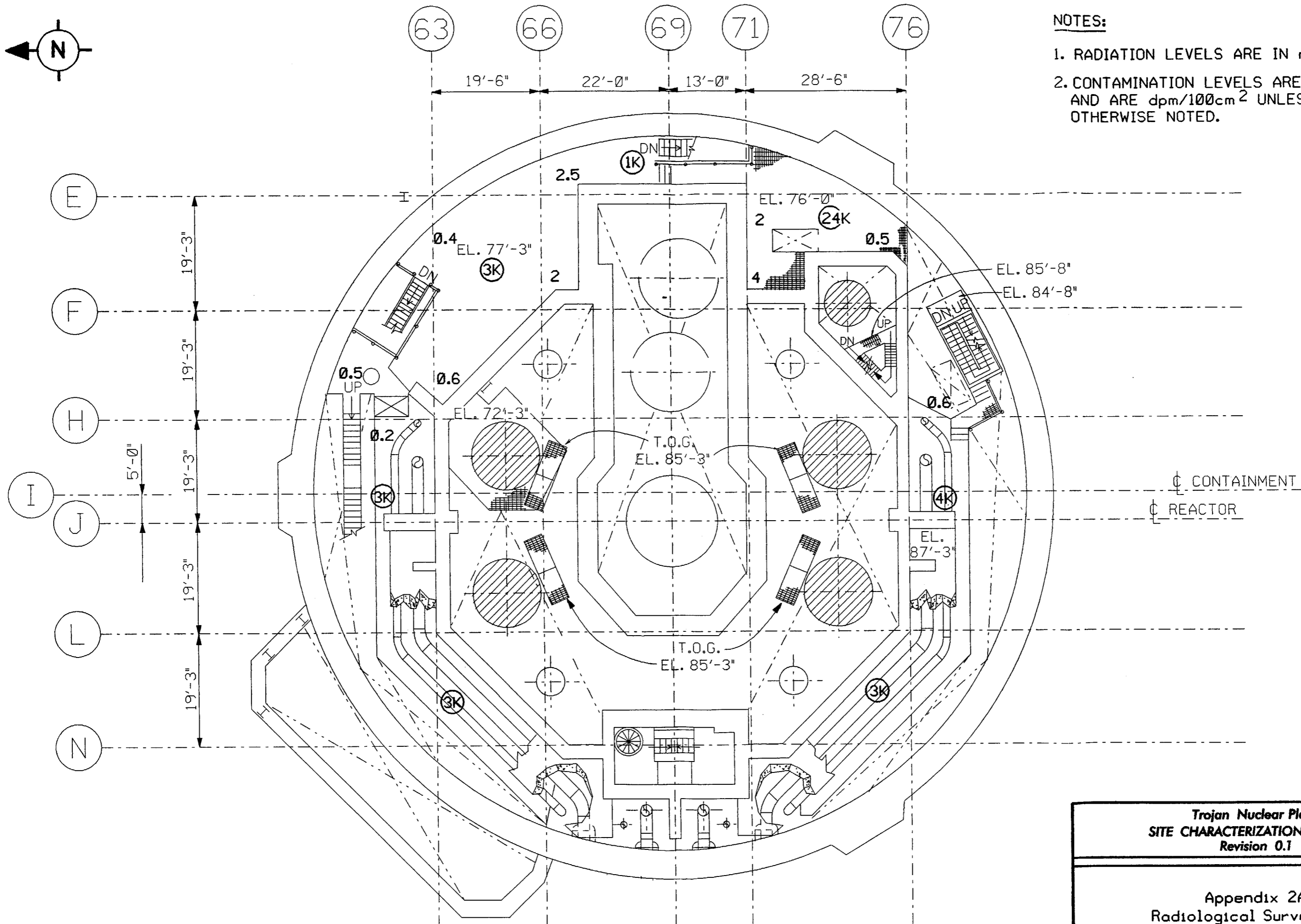

Trojan Nuclear Plant
SITE CHARACTERIZATION REPORT
Revision 0.1

Appendix 2A
Radiological Survey Data
Containment Elevation 77 FT

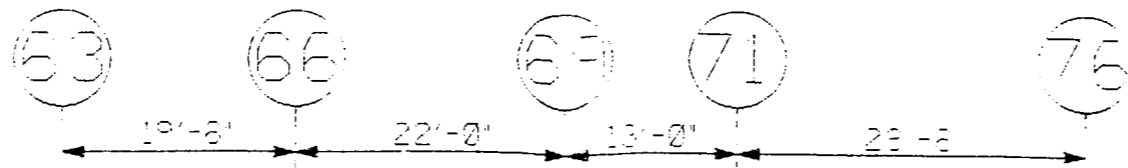
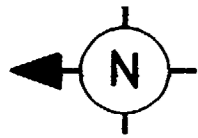

NOTES:

- 1. RADIATION LEVELS ARE IN mR/hr.
- 2. CONTAMINATION LEVELS ARE CIRCLED AND ARE dpm/100cm² UNLESS OTHERWISE NOTED.

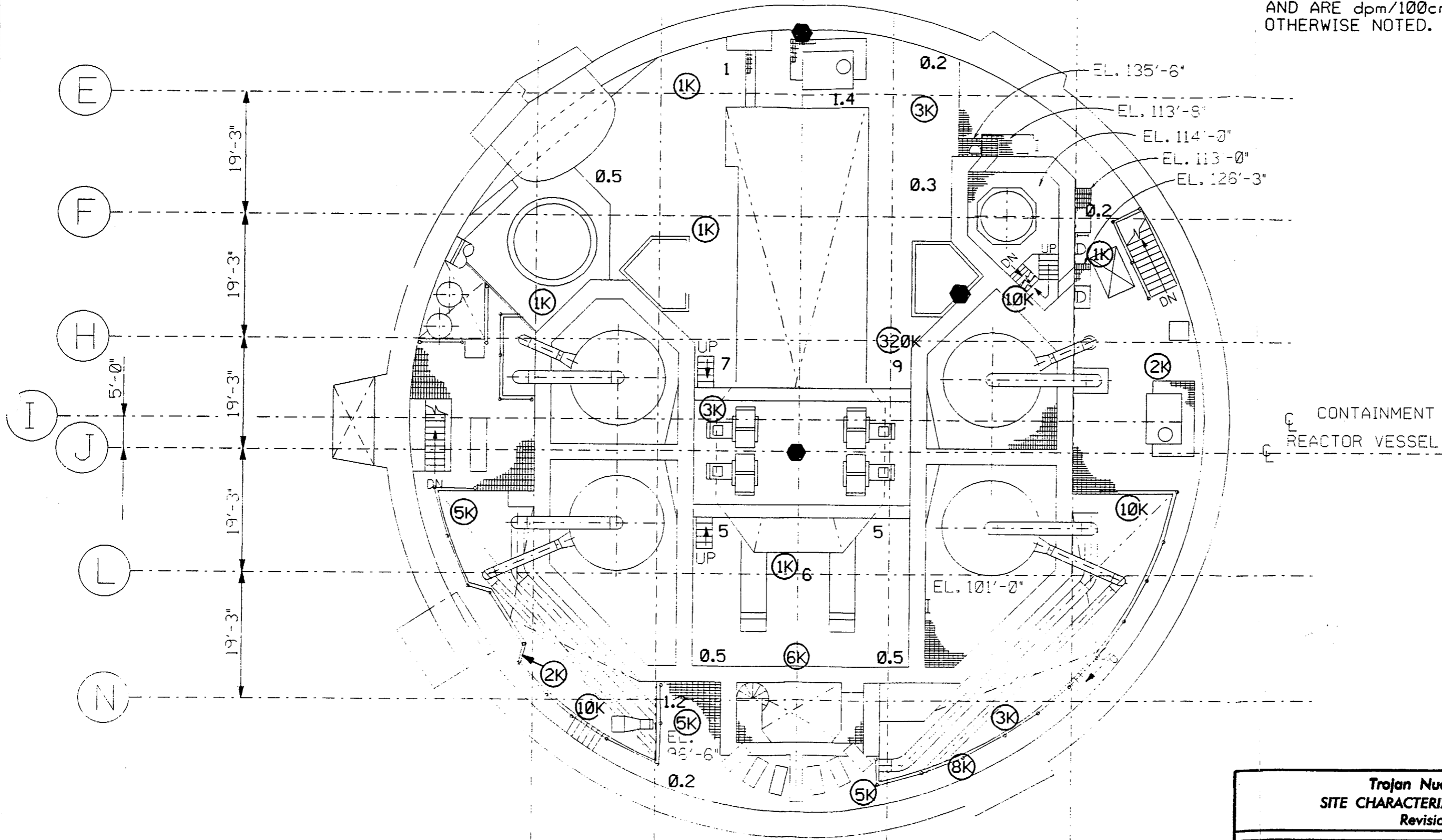

CONTAINMENT
REACTOR VESSEL

Trojan Nuclear Plant
SITE CHARACTERIZATION REPORT
Revision 0.1

Appendix 2A
Radiological Survey Data
Containment Elevation 93 FT

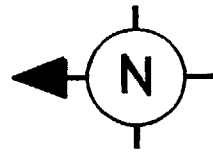

NOTES:

1. RADIATION LEVELS ARE IN mR/hr.
2. CONTAMINATION LEVELS ARE dpm/20cm² UNLESS OTHERWISE NOTED.

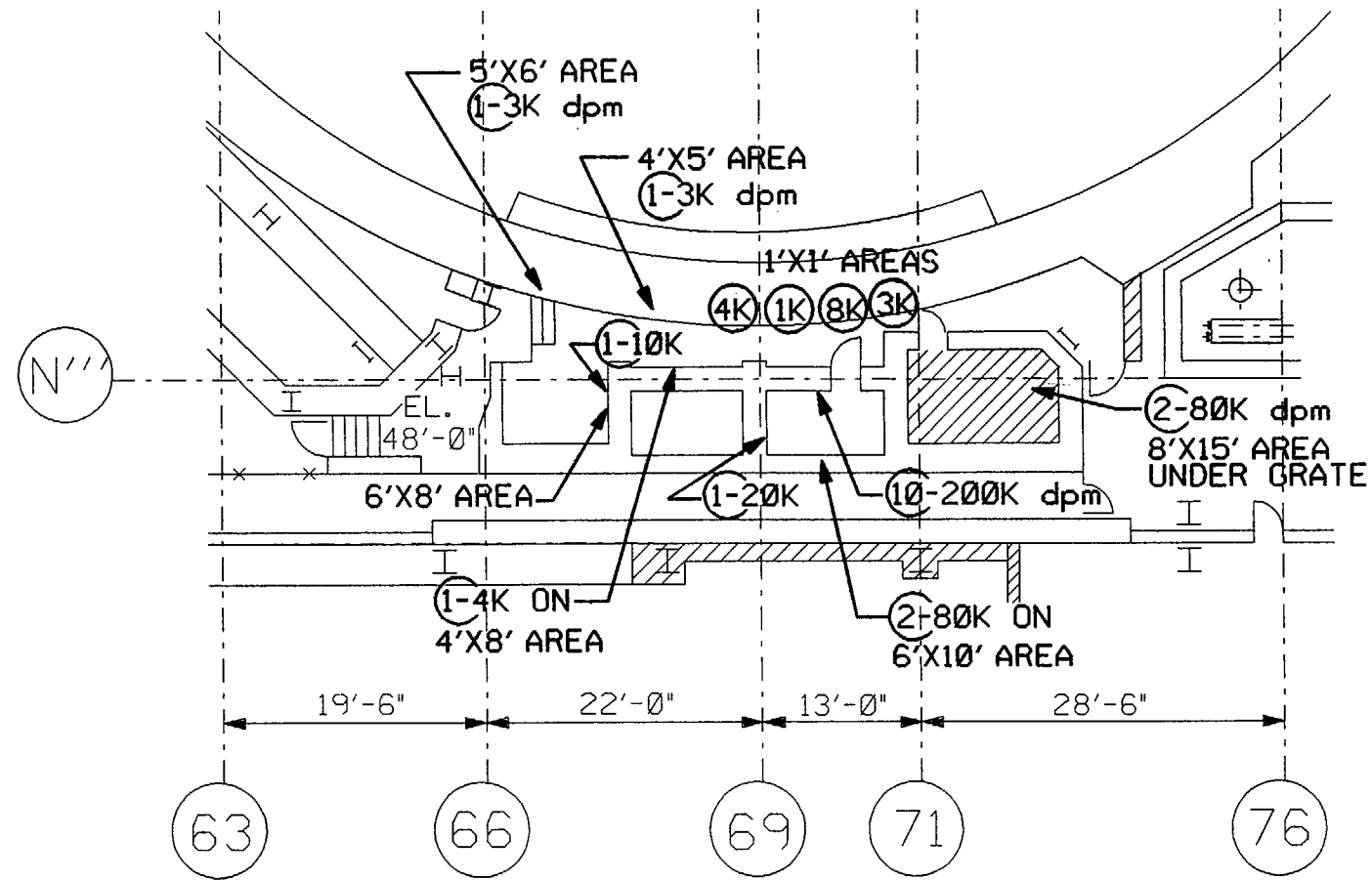

Trojan Nuclear Plant
SITE CHARACTERIZATION REPORT
Revision 0.1

Appendix 2A
Radiological Survey Data
Main Steam Support Structure
Elevation 45 FT

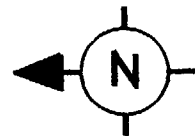

NOTES:

1. RADIATION LEVELS ARE IN mR/hr.
2. CONTAMINATION LEVELS ARE CIRCLED AND ARE dpm/20cm² UNLESS OTHERWISE NOTED.

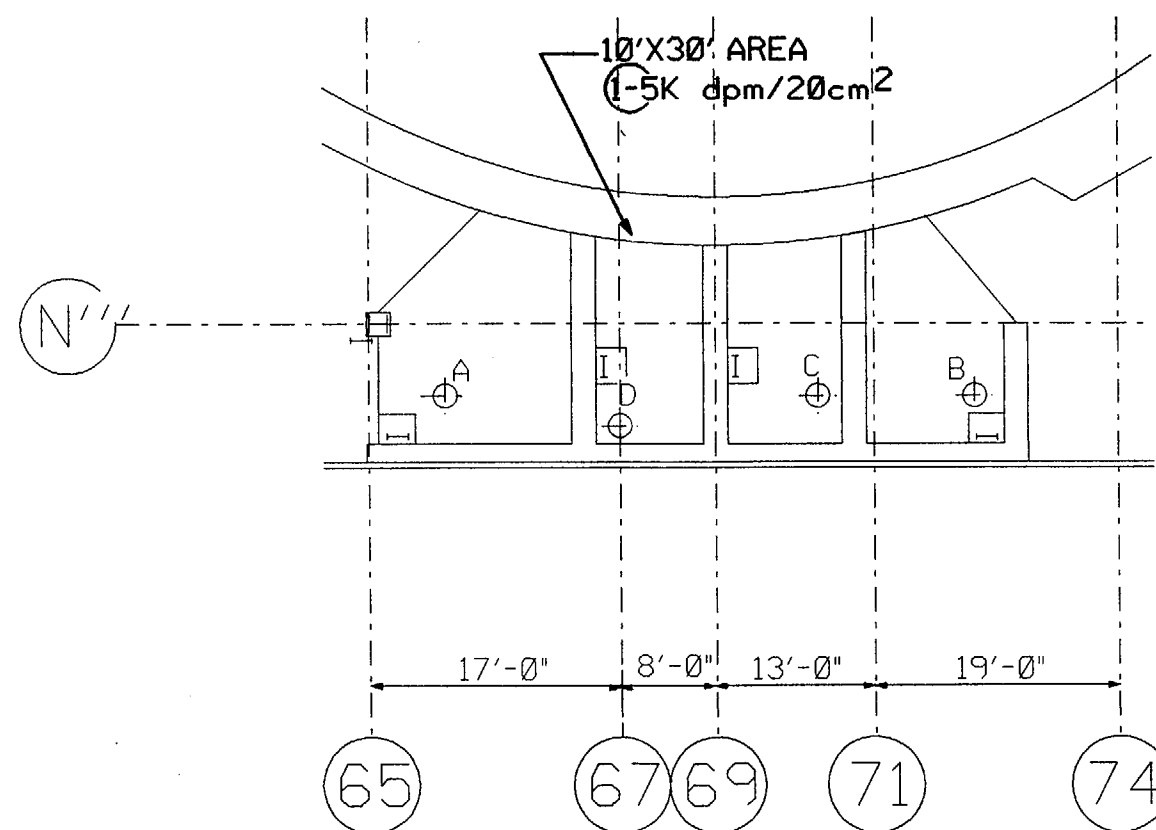

Trojan Nuclear Plant
SITE CHARACTERIZATION REPORT
Revision 0.1

Appendix 2A
Radiological Survey Data
Main Steam Support Structure
Elevation 69 FT

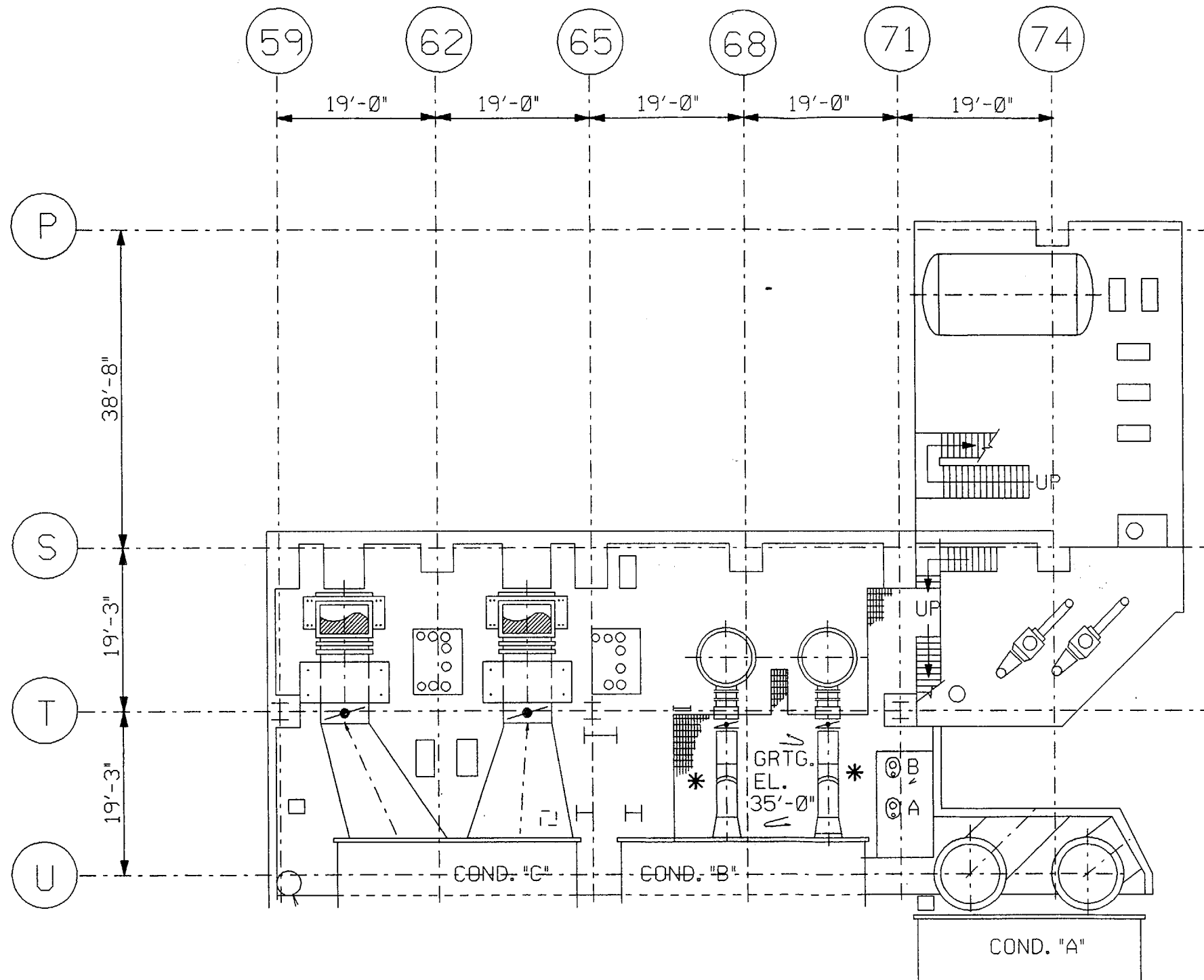
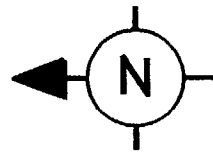

NOTES:

1. RADIATION LEVELS ARE IN mR/hr.
2. CONTAMINATION LEVELS ARE CIRCLED AND ARE dpm/100cm² UNLESS OTHERWISE NOTED.

* TURBINE BUILDING SUMP SURFACES ARE POSSIBLY CONTAMINATED BUT NOT SURVEYED DUE TO WATER IN THE SUMP.

Trojan Nuclear Plant
SITE CHARACTERIZATION REPORT
Revision 0.1

Appendix 2A
Radiological Survey Data
Turbine Building Elevation 27 FT

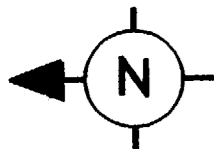

- NOTES:
1. RADIATION LEVELS ARE IN mR/hr.
 2. CONTAMINATION LEVELS ARE CIRCLED AND ARE dpm/100cm² UNLESS OTHERWISE NOTED.

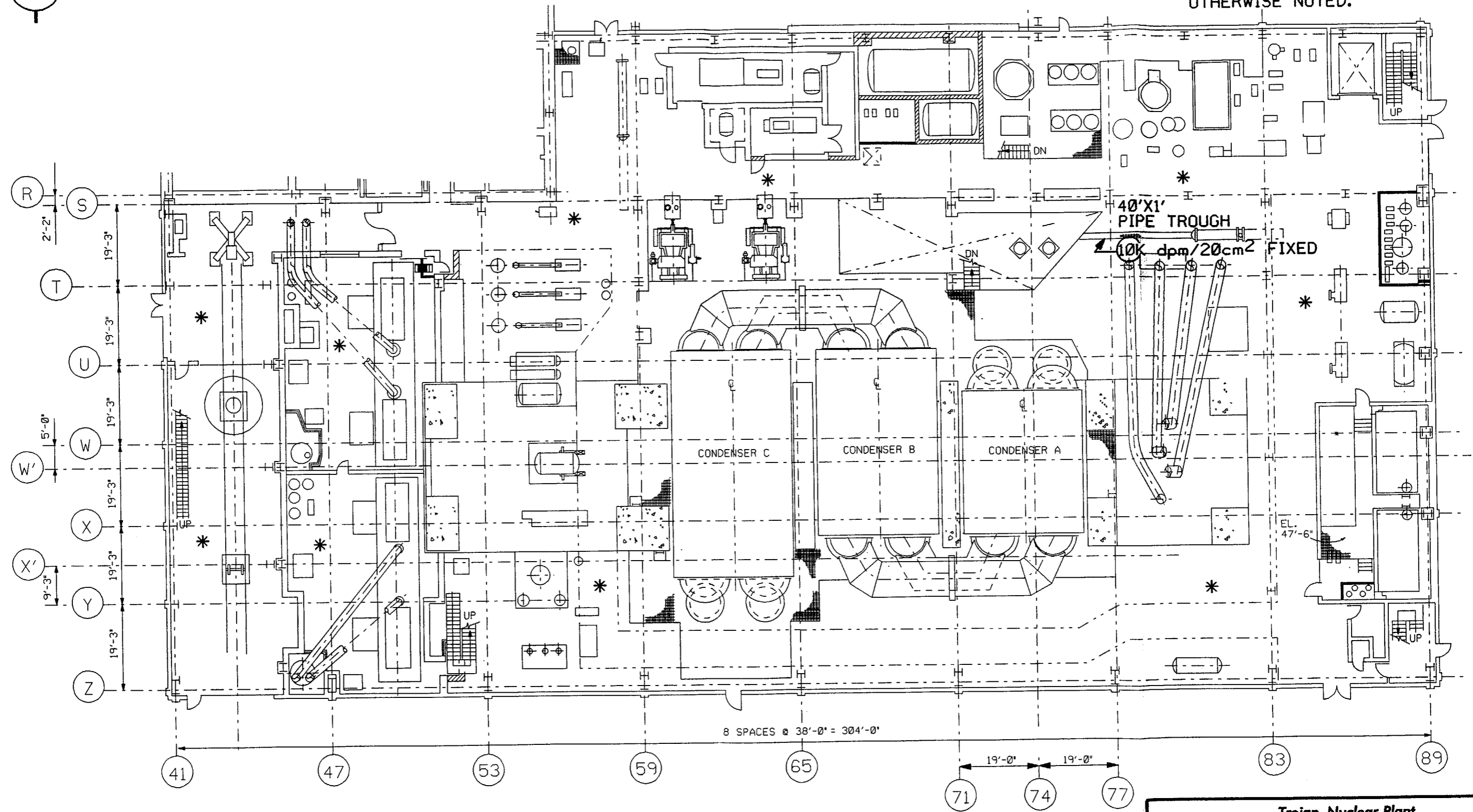

* SMEAR SURVEYS OF ALL 45FT TURBINE BUILDING SURFACES ≤ 10.1 dpm/100cm²; ALL RADIATION LEVELS ≤ 0.2 mR/hr.

Trojan Nuclear Plant
SITE CHARACTERIZATION REPORT
Revision 0.1

Appendix 2A
Radiological Survey Data
Turbine Building Elevation 45 FT

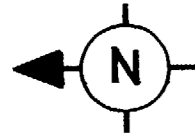

NOTES:

1. RADIATION LEVELS ARE IN mR/hr.
2. CONTAMINATION LEVELS ARE CIRCLED AND ARE dpm/20cm² UNLESS OTHERWISE NOTED.

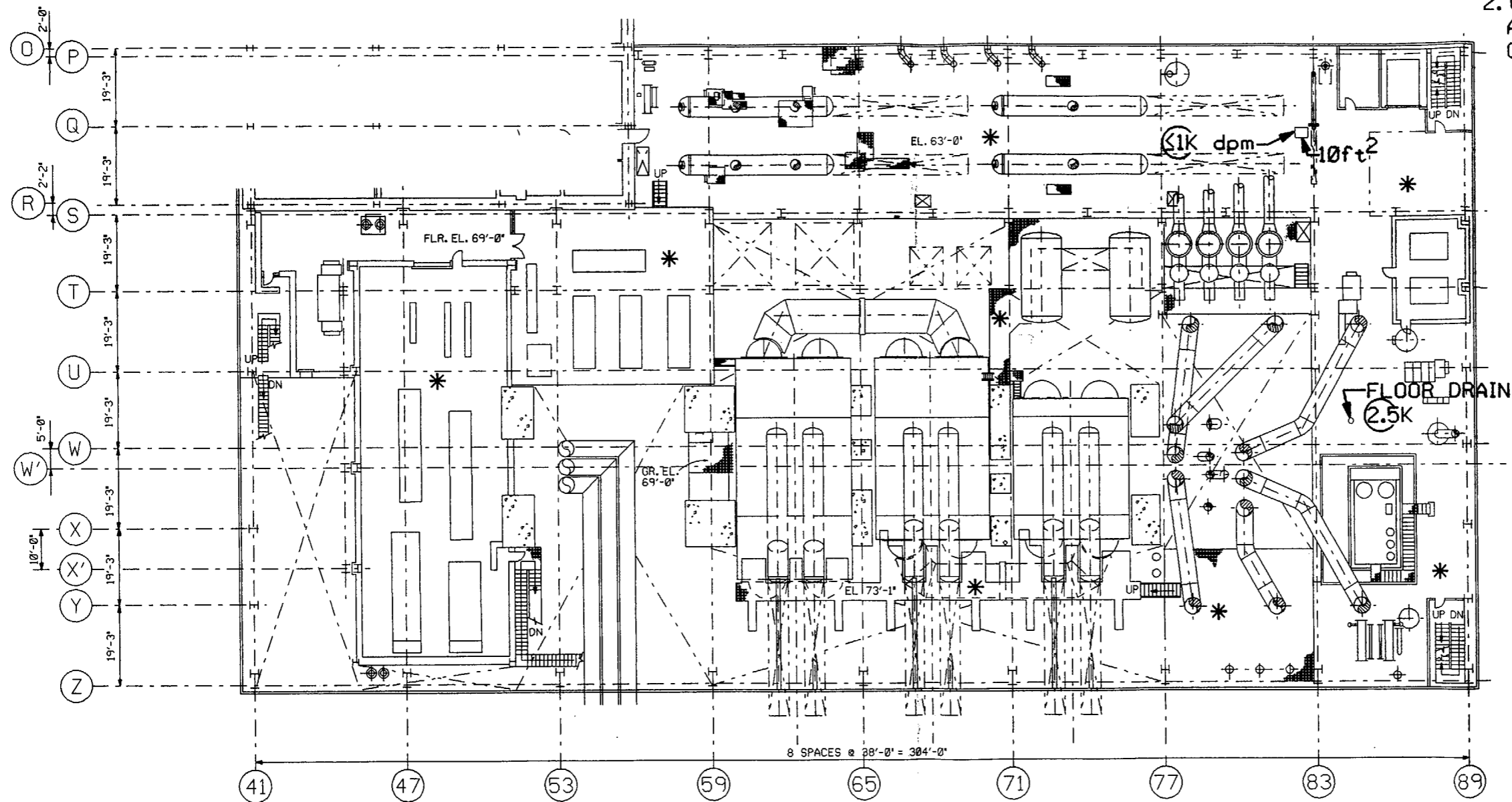

* SMEAR SURVEYS OF ALL 63' AND 69' TURBINE BUILDING SURFACES ≤ 13.7 dpm/100cm².

Trojan Nuclear Plant
SITE CHARACTERIZATION REPORT
Revision 0.1

Appendix 2A
Radiological Survey Data
Turbine Building Elevation 63 FT

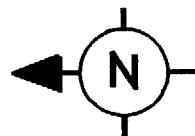

NOTES:

1. RADIATION LEVELS ARE IN mR/hr.
2. CONTAMINATION LEVELS ARE CIRCLED AND ARE dpm/100cm² UNLESS OTHERWISE NOTED.

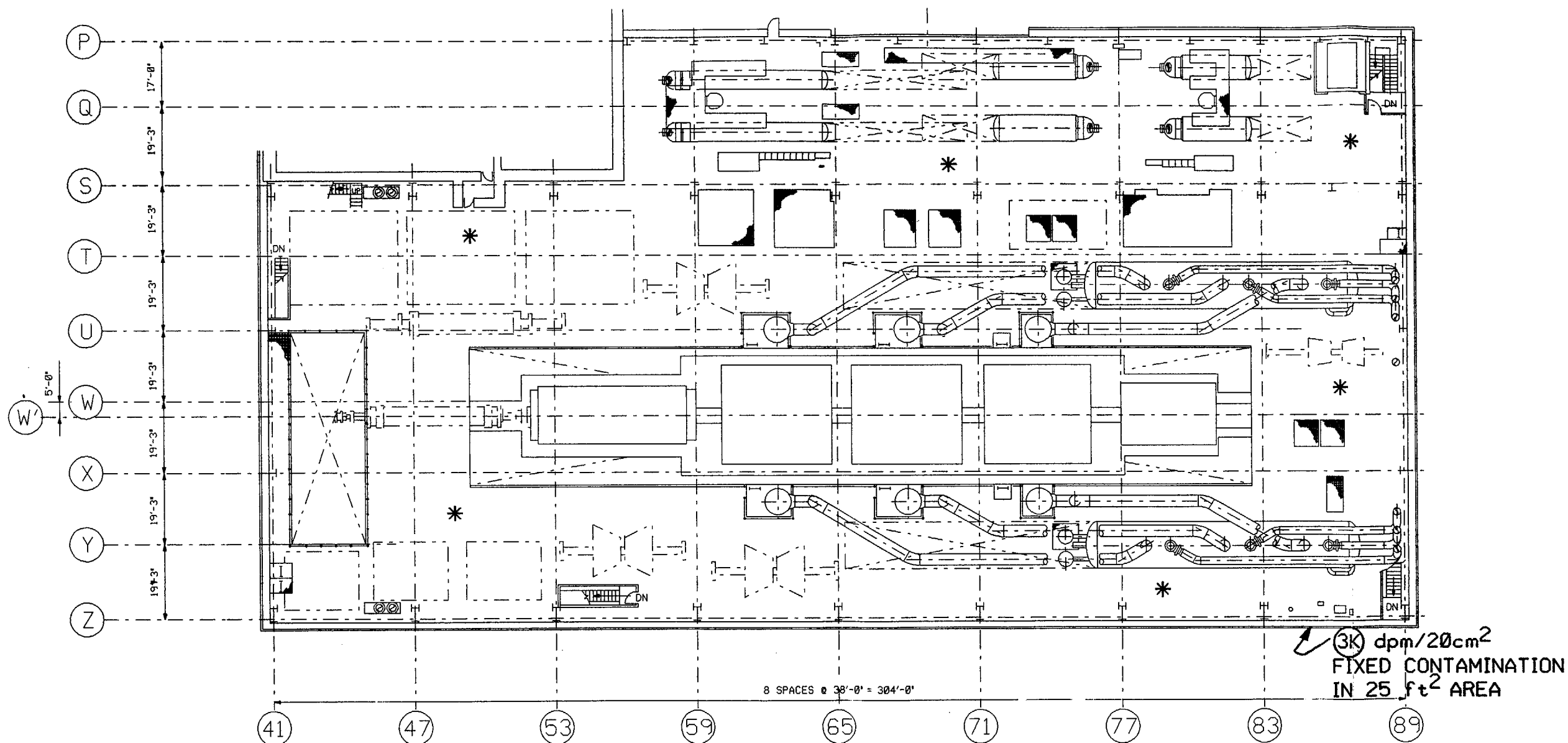

* SMEARS SURVEYS OF ALL 93' TURBINE BUILDING SURFACES ≤ 12.4 dpm/100cm².

Trojan Nuclear Plant
SITE CHARACTERIZATION REPORT
Revision 0.1

Appendix 2A
Radiological Survey Data
Turbine Building Elevation 93 FT

3.0 PLANT SYSTEMS CHARACTERIZATION

3.1 Summary

This section describes the methodology and results of the Trojan plant systems characterization. Each plant system was evaluated for its likelihood to be contaminated and sampled (direct survey, loose surface swipe, and metal scrapings) accordingly. The physical information for each contaminated system was researched and documented.

3.2 Background Determination

Any detected activity that could not be identified as naturally occurring was deemed to be caused by plant operations and the system was therefore classified as "affected". It was not practical to determine an ambient background level for piping and associated components, since sources of raw materials and hence relative radiological compositions could not be reliably determined.

3.3 Sampling/Measurement Point Selection

All Trojan systems were reviewed and were placed in one of four categories based on the answers to the following three questions:

- 1 Did the system normally contain or transport radioactive contaminants?
YES - Designate as C1
NO - Go to next question

- 2 Has the system ever been cross-contaminated?
YES - Designate as C2
NO - Go to next question

- 3 Does the system share a common pressure envelope or transfer path with a contaminated system?
YES - Designate as I
NO - Designate as N

Category Classifications:

- C1 Contaminated
- C2 Potentially Contaminated
- I Indeterminant
- N Not Contaminated (Clean)

Biased sampling points were selected based on obtaining conservative samples (i.e., most likely to find contamination) and ease of collection. Sample locations which required opening a system were minimized due to the limited Maintenance Department staff. If samples collected without maintenance assistance had suspect results, a maintenance request was generated to ensure a representative sample. Samples collected from drain lines were taken from the process side of the isolation when possible to ensure representative samples. Attachment 2 shows the instructions the technicians followed when taking system samples. System scrapings were not generally taken when the fixed or removable contamination was greater than 1000 dpm/100 cm².

Sampling of posted components was not considered adequate to release the posting. To release the posting, the entire component must be surveyed.

3.4 Exposure Rate Measurements

If a system is sufficiently contaminated, its curie content can be calculated from the dose rate from its piping. For systems classified as C1, the plant surveys determined the dose rate levels for each system. Conservative values (i.e., maximum average dose rate) were assumed for each system to provide a bounding estimate of curie content. The dose rate and pipe size was used to calculate the activity deposition (Ci/m²). This was then multiplied by the total contaminated surface area of the system to determine the system's curie content. Attachment 4 explains how the system curie content was determined.

For systems contaminated at much lower levels (C2/I/N), it was not possible to determine activity deposition by field dose rate measurements. Instead scrapings from the system were used or a nominal deposition level was assumed to estimate the activity deposition and therefore the curie content.

3.5 Removable/Surface Contamination Measurements

To determine the surface activity, direct surveys with beta-gamma detection equipment were performed in low ambient radiation areas where physical configuration allowed. Direct surveys were not performed on systems in high ambient radiation areas or where the physical configuration did not permit.

Swipes were taken to measure removable surface contamination and scrapings were taken to determine fixed surface contamination. Swipes and scrapings were analyzed in a low background area. Some swipes were limited to one location and some were composite swipes used to check large areas and/or various individual locations.

Due to the ratio of alpha to beta-gamma activity experienced in the plant, typically only samples which showed detectable activity were counted for alpha contamination.

3.6 Gamma Ray Spectroscopy

Equipment problems, delays, and personnel shortages precluded the use of in-field spectroscopy. Instead, individual system scrapings were counted in the laboratory to determine a qualitative radionuclide spectrum.

3.7 Results

Five attachments provide the results of Trojan plant system characterization.

Attachment 1 shows the final summary of the data for contaminated systems. The total burial volume is approximately 274,399 ft³ for approximately 2,469.6 curies.

Attachment 2 shows the instructions provided to the technician to actually obtain the samples.

Attachment 3 explains how the system physical data were compiled.

Attachment 4 explains how the system curie content was determined.

Attachment 5 shows the number of samples obtained for each system, the results for the system, and why some specific systems were not sampled for internal contamination. The systems are listed by classification as either C1, C2, I, or N. The "Explanations" at the front of the sheet clarifies the terminology. 197 samples were taken from 58 systems. 23 systems showed radioactivity greater than 1000 dpm/100 cm² and two systems (Component Cooling Water and Miscellaneous Drains) were contaminated below 1000 dpm/100 cm².

Attachment 6 shows the actual sample points and results for each sample. Samples were identified by a letter-number designation, assigned sequentially as the sample locations were requested. The attachment shows which system numbers correspond to each sample letter designation, e.g., sample series "D" relates to system number 42A, Circulating Water System. In some cases one sample letter designation pertains to more than one system number, or one system is sampled under more than one letter designation, e.g., Condensate and Feedwater includes system numbers 43, 44, and 45A under sample letters C, E, and F. In particular, Steam Traps (sample series X) covers many systems.

Several samples which were requested were not ultimately obtained due to various reasons, usually due to the presence of physical obstructions. Replacement samples were requested as necessary to characterize the system.

<p align="center">Attachment 1 System Characterization Data For Contaminated Systems</p>					
Sys #	System Name	Contamin. Surf. Area (ft ²)	Total Volume (ft ³)	Total Weight (lbs)	Activity (Ci)
16	Component Cooling Water	33,529	6,115	475,874	< 1
32	HVAC - Fuel & Aux Buildings	30,335	10,283	45,800	< 1
35	Spent Fuel Pool Cooling & Demin	5,257	970	57,281	5.6
36	Spent Fuel Pool	101,993	N/A	628,378	100
39	Condensate Demineralizers	980	2,262	18,000	< 1
42D	Discharge & Dilution System	4,939	3,834	63,505	< 1
49	Residual Heat Removal	13,816	1,702	183,855	36
50	Chemical & Volume Control	22,380	43,041	534,034	25
52	Safety Injection & Accumulators	7,077	9,680	493,765	< 1
55	Control Rod Drive Mechanisms	1,634	225	106,318	83
60	HVAC - Containment	32,838	18,307	407,328	< 1
61	Containment Spray	5,808	1,563	75,252	< 1
63A	Steam Generators	196,696	45,727	2,650,448	416
63B	SG Blowdown	2,689	1,183	39,449	< 1
64A	Reactor Coolant Pumps	2,644	3,912	768,400	134
64B	Reactor Coolant System Piping	4,352	2,205	296,460	221
64C	Pressurizer	1,371	2,459	195,508	52.1
64D	Reactor Vessel and internals (surface contamination only)	2,831	see chapt 4	see chapter 4	357.9
66	Hydrogen Recombiners	N/A	100	12,600	< 1
67AB	Primary Makeup Water System	10,338	31,330	90,006	< 1
67D	Refueling Water Storage Tank	9,401	69,942	97,928	7
68	Solid RadWaste	654	496	10,341	< 1
69	Clean RadWaste	9,610	13,021	110,634	14
71	Dirty RadWaste	2,106	2,147	24,116	< 1
72	Gaseous RadWaste	4,087	3,624	77,261	< 1
76	Process Sampling System	452	14	3,093	4
99A	Miscellaneous Sumps	1,512	257	19,136	< 1
		510,850	274,399	7,484,770	2469.6

Attachment 2
Instructions to Technician Obtaining the Sample

1. Take direct contamination reading if possible. Check for > 1K.
2. Obtain smear sample. Check for > 1K.
3. Document results, including date, time, location, instrument serial number, etc., on a standard non-specific survey form.
4. If both or the above measurements are < 1K, proceed with step #5. If measured contamination level (fixed or loose) is > 1K, skip to step #10 below.
5. Obtain a scraping sample of the system internal area of approximately 100 cm², if possible, using a finger wrapped in emery cloth. Be careful to collect any dust which may fall out of the end of vertical pipes. Wipe the scraped area with a smear disk to collect any loose material. Place all collected material including the emery cloth in a plastic bag or petri dish.
6. Clearly mark the sample and document the estimated surface area scraped on the survey form. As a rule of thumb, use the following:
 - 3.0" diameter piping, scraped to a depth of 2 inches, is = 120 cm².
 - 2.0" diameter piping, scraped to a depth of 1 finger length, is = 120 cm².
 - 1.5" diameter piping, scraped to a depth of 1 finger length, is = 90 cm².
 - 1.0" diameter piping, scraped to a depth of 1 finger length, is = 60 cm².
7. Count samples in hot lab to determine presence of detectable gamma emitter activity.
8. If no activity > LLD is measured in hot lab count, repackage sample for count in environmental counter, taking care to ensure no cross-contamination occurs.
9. Clearly label all samples retained for later environmental counting, and place in a safe storage location.
10. Proceed to the next system when either one of the following conditions applies:
 - Contamination- survey indicates that > 1K of fixed or loose contamination is present in any single sample from the system of interest, or
 - All samples for the system of interest have been obtained.
11. Return documented results to Pete Chadly (7864, TCB-3) or Bill Monroe (7574, TCB-3)

Attachment 3
System Characterization Physical Data Explanation

This attachment describes how the System Characterization Physical Data was compiled for contaminated systems. The symbols used in the following equations are: π is pi (3.14159), ℓ is the total linear feet of piping in a given size and schedule, ID is the inside diameter of the piping, OD is the outside diameter of the piping, L is the length of a tank along the major axis, d is the diameter of a tank, and ρ is the density of the metal, generally assumed to be 500 pounds per cubic foot.

Pipes

The list of piping for each contaminated system was taken from the Final Cost Estimate (*F23 Piping Contract* by Wright-Schuchart-Harbor) which lists the isometric drawings applicable to each system. The isometric drawings were examined to calculate the linear feet of piping in each size and schedule. Generally, piping smaller than 1 inch in diameter was ignored unless most of the system was smaller than 1 inch; however, in some cases $\frac{3}{4}$ inch piping was included. The size and schedule of the pipe determined the inside and outside diameters.

The *contaminated surface area* was calculated by multiplying the total linear feet of a given size and schedule of pipe by the inside surface area [$\ell \times \pi \times \text{ID}$]. The *total volume* is the volume of the pipe treated as a right circular cylinder including its inside space [$\pi/4 \times \ell \times \text{OD}^2$]. The *total weight* is the density of the pipe metal times its volume [$\rho \times \pi/4 \times \ell \times (\text{OD}^2 - \text{ID}^2)$].

Valves

The number, size, and type of valves for each contaminated system were determined using the isometric drawings as described above. Any valves which were neither gate nor check were characterized as globe valves. Generally, valves smaller than 1 inch in diameter were ignored.

The *weight* was calculated by multiplying the number of valves of each size and type (gate, globe, or check) by the approximate weight of a valve of that type and pressure rating. The approximate weight of valves was found in a piping support estimating manual (by NPS Industry). The *volume* is the weight of the valves divided by the density of steel (500 lb/ft³).

System Characterization Physical Data Explanation

Components

The system drawings (P&ID) were used to compile a list of the major components in each system. The dimensions and weight of each component were obtained from technical manuals or other references. Specific information could not be found for some components, so they were estimated from similar components. For simplification, most components were assumed to be right circular cylinders.

The *contaminated surface area* was generally calculated as the inside of a right circular cylinder [$\pi \times d \times (L + d/2)$]. Some components (e.g., heat exchangers) required more a specific calculation. The *total volume* is the volume of a right circular cylinder [$\pi \times L \times d^2$]. The *weight* was taken from the reference manual or drawing.

In some cases a piece of data was not meaningful or was of no use, so it was not calculated. Examples include the contaminated surface area and compacted metal volume of the hydrogen recombiners and the total in-place volume of the spent fuel pool.

Notes

The steam generator data includes the entire steam generator including the secondary side. The contaminated portion of the steam generator is the primary side (i.e., the U-tubes, tubesheet, and lower head) which weighs 900,000 lbs and has a metal volume is 1800 ft³. The data for the Chemical and Volume Control System includes the contaminated portion of the Miscellaneous Gas system, i.e., the nitrogen supply to the Volume Control Tank.

Attachment 4 System Curie Calculation Explanation

Isotopic analysis from system scrapings or system piping was used to determine the composition of the activity. The Microshield 3.13 program was used to determine the appropriate factor to convert the measured dose rate at 18 inches from the pipe into curies per square meter of interior piping (Ci/m²). This required a different factor for each system and each size and schedule of pipe. Field measurements were taken at 18 inches from representative piping for systems contaminated enough to produce a measurable and usable dose rate. If several dose rates were measured from a given pipe, the highest reading was used. The dose rate was converted into activity deposition with the conversion factor calculated above. A mean deposition level was calculated and multiplied by the system's contaminated surface area (with conversion for m² and ft²) to determine the total curies.

Using the highest dose rate was considered sufficiently conservative to bound inherent errors due to assuming that the deposition level was relatively similar throughout the system's components.

The deposition level calculated for the RCS was applied to the CRDMs, RCPs, and pressurizer. The deposition level calculated for the Spent Fuel Cooling System was also applied to the entire surface area of the Spent Fuel Pool and racks. This is very conservative.

For system with very low deposition, or if the calculation showed less than 1 curie, a bounding value of 1 curie was used.

The reactor vessel and internals are a special case and are not included in this section.

Attachment 5
System Sampling Summary

Samples Taken	Systems Sampled	Systems > 1K	Systems > GeLi
197	58	23	2

Explanations:

"Class" indicates how the system was initially classified (C1, C2, I, N).

"Samples Taken" indicates the number of samples taken for this survey from the system.

"Sample Activity" indicates if the samples were either:

- "Clean" (no detectable activity above background),
- "> 1K" (greater than 1000 dpm/100 cm² above background), or
- "GeLi" (less than 1000 dpm/100 cm² above background but had detectible activity on the highly sensitive "GeLi" detector).

Class	Sys #	System Name	Samples Taken	Sample Activity
C1	32	HVAC - Fuel & Aux Buildings	18	> 1K
C1	35	Spent Fuel Pool Cooling & Demin	Note 4	Note 1
C1	36	Spent Fuel Pool	Note 4	Note 1
C1	49	Residual Heat Removal	Note 4	Note 1
C1	50	Chemical & Volume Control	Note 4	Note 1
C1	52	Safety Injection & Accumulators	Note 4	Note 1
C1	55	Control Rod Drive Mechanisms	Note 4	Note 1
C1	62	Reactor Vessel and Internals	Note 4	Note 1
C1	63A	Steam Generators	Note 4	> 1K
C1	64	RCS & Pressurizer	Note 4	> 1K
C1	66	Hydrogen Recombiners	2	> 1K
C1	67D	Refueling Water Storage Tank	1	> 1K
C1	68	Solid RadWaste	Note 4	Note 1
C1	69	Clean RadWaste	Note 4	Note 1
C1	71	Dirty RadWaste	Note 4	Note 1
C1	72	Gaseous RadWaste	Note 4	Note 1
C1	76	Process Sampling System	Note 4	Note 1
C2	16	Component Cooling Water	6	GeLi
C2	25	Startup Boiler	2	Clean
C2	37	Condensate Storage/Transfer	3	Clean
C2	39	Condensate Demineralizers	5	Note 2
C2	43	Condenser & Air Removal	2	Clean
C2	44	Condensate System	9	Clean
C2	45	Feedwater System (& AFW)	5	Clean

Attachment 5
System Sampling Summary

Class	Sys #	System Name	Samples Taken	Sample Activity
C2	46	Extraction Steam	1	Clean
C2	47	Feedwater Heaters, Vents, Drains	4	Clean
C2	48	SG Feed Pump Turbine Drivers	4	Clean
C2	60	HVAC - Containment	8	> 1K
C2	61	Containment Spray	2	> 1K
C2	63B	SG Blowdown	6	> 1K
C2	65	Oily Waste & Storm Drains	11	Clean
C2	67AB	Primary Makeup Water System	2	> 1K
C2	67C	Degassifier System	1	Clean
C2	83	Main Steam System	13	Clean
C2	84	Reheat & Moisture Separators	9	Clean
C2	99A	Miscellaneous Sumps	21	> 1K
I	11	Service Water	2	Clean
I	15	Turbine Building Cooling Water	2	Clean
I	28	Process & Auxiliary Steam	1	Clean
I	33	HVAC - Turbine	4	Clean
I	42A	Circulating Water Pumps & Aux.	2	Clean
I	74	Miscellaneous Gas Supply	2	Note 3
I	82	Chemical Injection	4	Clean
I	93	Main Turbine	13	Clean
N	2	125 V dc	2	Clean
N	5	480 V ac Aux Load Centers	2	Clean
N	6	480 V ac Motor Control Centers	2	Clean
N	7	Lighting Panel Power Supply	1	Clean
N	8	Domestic Water	5	Clean
N	22	Makeup Demin Water	2	Clean
N	30	HVAC - Control Building	6	Clean
N	31A	P-250 Computer	1	Clean
N	57	120 V Preferred Instrument ac	1	Clean
N	90	Communications	2	Clean
N	91	Annunciators	1	Clean
N	97	Stator Cooling	1	Clean
N	98	Main Generator & Excitation	2	Clean
N	99G	Fish Rearing Facility	4	Clean

System Sampling Summary

- Note 1 These systems are assumed to be contaminated > 1K for the scoping survey. Actual samples, radiation surveys, historical data, or connected systems may be used to exactly quantify the contamination.
- Note 2 Although all the samples were clean, the backwash receiving tank is posted as potentially contaminated, so it will be considered as contaminated > 1K.
- Note 3 The line between the VCT and the nitrogen supply pressure regulator showed activity on the GeLi. This system's characterization is included in CVCS.
- Note 4 No specific samples taken in these systems due to radiation levels or continued operation

Systems which were not internally sampled because they are included in other assessments

C1	12	Refueling Equipment
C1	58	Containment Building
C1	78D	In-Core Neutron Flux Monitors
C1	78E	In-Core Temperature Monitors
C1	81	Fuel Handling & Refueling Cavity
C1	99B	Vacuum Cleaners
C2	20	Misc Bldgs/Structures
C2	27	Turbine & Turbine Aux Bldg
C2	38	Condensate Demin Bldg
C2	54	Seismic Monitor
C2	70	Fuel & Aux Bldgs
C2	85	Radiation Shielding
C2	101	Containment & Misc Cranes
I	19	Intake/ Discharge, & Chlorine Bldgs
I	41	Cooling Tower Structure
I	99C	Elevators
I	101C	Fuel Bldg Crane
N	77	Technical Support Center Bldg
N	100B	Turbine Building Crane
N	100D	Condensate Demin Building Crane

System Sampling Summary

Systems which were not internally sampled because they are entirely electrical (cabling etc.)

C2	51	Electric Heat Tracing Power
C2	75	Vibration & Loose Parts Monitor
C2	78	Nuclear Instrumentation
C2	79	Radiation Monitors
N	1	230 kV Switchyard
N	3	12.47 kV Startup Transformer
N	4	4.16 kV & Aux Power
N	17	120 V Non-preferred Instrument ac
N	31	Computers (other than P-250)
N	45E	Feedwater Flow & Level Control
N	45F	Feed Line Isolation Actuation
N	45G	Auxiliary Feedwater Autostart
N	53	Engineered Safeguards Actuation
N	56	Reactor Control & Protection
N	80	Reactor Non-nuclear Instrumentation
N	86	ATWS Mitigation & Actuation
N	87	Transformers & Auxiliaries
N	88	250 Vdc
N	94	Meteorological Equipment
N	99D	Welding Receptacles
N	99F	Cathodic Protection
N	99H	Vehicle Battery Charger
N	99I	Motor Operated Doors
N	102	Security System

Systems which were not internally sampled due to the low probability of contamination.

C2	13	Fire Protection: FP Engineer felt that even the portions of the FP system located within contaminated areas are highly unlikely to be contaminated since the system is maintained full of water.
C2	42	DD&DS, Dechlorination System: Assume to be contaminated. Will sample following PDTS approval which allows securing SW and therefore facilitates entry and sampling of D&DS bay.
I	18	Instrument & Service Air: System Engineer felt internal contamination was highly unlikely since it is always pressurized.

- I 24 Emergency Diesel Generators:
The two possible entry pathways for internal contamination (Service Water and Turbine Bldg Vent) are clean.
- I 34 HVAC - Misc Buildings:
Based on the results of the Control and Turbine Building HVAC samples.
- I 73 Sewage Treatment:
Based on physical location and likelihood of contamination.
- I 92 Turbine Steam Seal and Drain:
Based on Main Turbine, Main Steam, MSR, SUB, and Process/Aux Steam samples.
- N 9 Traveling Water Screens & Screen Wash:
Based on Service Water sample results and the likelihood of contamination.
- N 10 Chlorination:
Based on Service Water sample results and the likelihood of contamination.
- N 14 Bearing Cooling Water:
Closed system. The only possible contamination is from SW, which is clean.
- N 21 Water Pretreatment:
Based on physical location and likelihood of contamination.
- N 23 Diesel Fuel Oil:
Based on physical location and likelihood of contamination.
- N 29 HVAC - Admin Building & Gatehouse:
Based on the results of the Control and Turbine Building HVAC samples.
- N 40 Lube Oil Storage & Filtration:
Based on physical location and likelihood of contamination.
- N 42B Cooling Tower Makeup & Discharge:
Based on physical location and likelihood of contamination.
- N 42C Cooling Tower Acid Pump:
Based on physical location and likelihood of contamination.
- N 59 Primary Containment Testing:
Equipment which is found to be contaminated will be disposed of as LLW.
- N 89 Chilled Water:
Based on Service Water and Makeup Demin Systems.
- N 95 Generator & Hydrogen Seal Oil:
Based on limited interface and the Misc Gas samples.

Attachment 6
Results of Individual System Samples

	<u>System Name</u>	<u>System Number</u>
A	SERVICE WATER	11
B	TURBINE BUILDING COOLING WATER	15
C	CONDENSER AND AIR REMOVAL	43
D	CIRCULATING WATER SYSTEM	42A
E	CONDENSATE AND FEEDWATER	43, 44, 45A
F	FEEDWATER HEATERS	44 & 47
G	HEATER DRAIN PUMPS	47
H	STARTUP BOILER	25
I	CHEMICAL INJECTION TANKS	82
J	STEAM GENERATOR BLOWDOWN	63B
K	COMPONENT COOLING WATER	16
L	MAIN TURBINES & TURBINE CONTROLS	93
M	MISCELLANEOUS SUMPS	99A
N	FLOOR DRAINS	99A
O	HVAC SYSTEMS	30, 32, 33, 60, 66
P	OILY WASTE AND STORM DRAINS	65
Q	PRIMARY MAKEUP WATER	67B & 67D
R	CONDENSATE DEMINERALIZERS	39
S	CONTAINMENT SPRAY	61
T	MAKEUP DEMIN WATER	22
U	ELECTRICAL SYSTEMS	2, 5, 6, 7, 31, 57, 90, 91, 98
V	COND WATER STORAGE/TRANSFER	37
W	MISCELLANEOUS GAS SYSTEM	74
X	STEAM TRAPS	25, 28, 46, 48, 83, 84
Y	DOMESTIC WATER SYSTEM	8
Z	STATOR COOLING WATER SYSTEM	97
AA	MOISTURE SEPARATOR REHEATERS	84
BB	GASEOUS RADWASTE	72
CC	FISH REARING FACILITY	99G
DD	MAIN STEAM SAFETIES	83

Results of Individual System Samples

A SERVICE WATER [System # 11 M-218 SH1]

The Service Water System (SW) supplies raw water from the river to various in plant loads: Emergency Diesel Generators (EDGs), Component Cooling Water Heat Exchangers (CCW HXs), Essential Room Coolers, and emergency make-up to the Spent Fuel Pool.

Two samples were collected from the CCW HXs, which have the greatest potential for being contaminated. Both SW trains were sampled at their associated CCW HX. "A" train SW was sampled at the "A" CCW HX outlet drain (SW-037) and "B" train SW was sampled at the "B" CCW HX SW inlet drain (SW-222).

The inlet drain lines were used in the past to verify SW temperature and for draining the system and therefore they were representative samples. Also, recent maintenance on D SWBP did not identify internal contamination.

A-1 A CCW HX SW outlet drain line downstream of SW-037

A-2 B CCW HX SW inlet drain line downstream of SW-222

SAMPLING RESULTS

NO ACTIVITY DETECTED IN SAMPLES A-1 & A-2

A-1 < 1K dpm/100 cm² - smear
< 1K dpm/20 cm² - fixed
A-2 < 1K dpm/100 cm² - smear
< 1K dpm/20 cm² - fixed

Results of Individual System Samples

B TURBINE BUILDING COOLING WATER [System # 15 M-216 SH2]

The Turbine Building Cooling Water (TBCW) system gets its water from the Circulating Water System and supplies water to the Turbine Generator Lube Oil Coolers, Steam Generator Feed Pump Turbine Lube Oil Coolers, Generator Stator Coolers, Generator Hydrogen Coolers, and Exciter Cooler.

Two samples were collected from the TBCW strainers drains which are located just after the TBCW pumps. These two drains were easily accessible and provided representative samples since the drain valve size and piping configuration allowed access to the process side.

- B-1 TBCW Strainer Drain downstream of TB-047
- B-2 TBCW Strainer Drain downstream of TB-048

SAMPLING RESULTS

NO ACTIVITY DETECTED IN SAMPLES B-1 & B-2

- B-1 < 1K dpm/100 cm² - smear
- < 1K dpm/20 cm² - fixed
- B-2 < 1K dpm/100 cm² - smear
- < 1K dpm/20 cm² - fixed

Results of Individual System Samples

C CONDENSER AND AIR REMOVAL [System # 43 M-214 SH2]

The Main Condenser Evacuation System (MCES) removes noncondensable gases and in-leaking air from the steam space of the three shells of the main condenser. The noncondensable gases and vapor mixture discharge to atmosphere from the MCES is not normally radioactive; however, in the event of primary-to-secondary system leakage due to steam generator tube leak, it is possible for discharge to be radioactively contaminated.

One sample was obtained from the condenser exhaust to the atmosphere downstream of Process Radiation Monitor (PRM-6). The sample was collected by removal of a 1" pipe cap.

Also, the condenser hotwell sample showed no contamination.

C-1 Exhaust Line drain downstream of PRM-6

SAMPLING RESULTS
NO ACTIVITY DETECTED IN SAMPLE C-1

C-1 <1 dpm/100 cm² - smear
<1 dpm/20 cm² - fixed

E-11 Condenser hotwell (access via 33' manway east side)

SAMPLING RESULTS
NO ACTIVITY DETECTED IN SAMPLE E-11

E-11 <1K dpm/100 cm² - smear
<1K dpm/20 cm² - fixed

Results of Individual System Samples

D CIRCULATING WATER SYSTEM [System # 42A M-216 SH1]

The Circulating Water System (CWS) uses the cooling tower basin water to cool the main condenser during plant operation. The cooling tower basin makeup water is provided by pumps which take a suction on the make-up reservoir associated with the Dilution and Discharge Structure. The CWS also provides cooling water for the TBCW system.

Composite samples were collected from A and B Circulating Water Pump (CWP) suction and discharge cross-connect drain lines. These sample locations were easily accessible and the drain line isolation were under clearance as tagged open. The valves were of sufficient size to allow sampling the process side of the valves.

- D-1 Composite sample (A CWP suction drain & A CWP discharge cross connect drain)
- D-2 Composite sample (B CWP suction drain & B CWP discharge cross connect drain)
- D-3 NOT OBTAINED
- D-4 NOT OBTAINED

SAMPLING RESULTS

NO ACTIVITY DETECTED IN SAMPLES D-1 & D-2

- D-1 <1K dpm/100 cm² - smear
<1K dpm/20 cm² - fixed
- D-2 <1K dpm/100 cm² - smear
<1K dpm/20 cm² - fixed

Results of Individual System Samples

E CONDENSATE AND FEEDWATER [System # 43, 44, 45A M-212, M-213 SH1 & 2]

The Main Condensate Pumps (MCP) take a suction from the condenser hotwell and discharge the condensate into two parallel streams. The two streams combine to pass through the condensate demineralizers and separate again to pass through five stages of feedwater heating before entering the suction of the steam generator feedwater pumps (SGFP). The two parallel streams are cross-connected at the discharge of the MCPs and at the suction of the SGFPs. First and second stage feedwater heating in each stream is performed in three parallel heaters.

The extraction steam is condensed in the fifth, sixth, and seventh stage feedwater heaters and the moisture is separated in the moisture separator reheaters and drains to the heater drain tanks. The heater drain pumps (HDP) take suction from the heater drain tanks and discharge the condensate to the suction of the SGFPs. The drains from the other stages of feedwater heaters cascade down to the condenser hotwell.

The SGFPs take a suction from the outlets of the fifth stage of feedwater heaters and the HDPs and discharge into two cross-connected parallel streams. The two parallel streams pass through the sixth and seventh stages of feedwater heating and discharge into a common header before entering the four lines connecting to the steam generators.

During normal operations, condensate and feedwater contain no radioactive contaminants; however, in the event of primary-to-secondary system leakage, it is possible for the condensate and feedwater to become radioactively contaminated.

This set of samples includes seven from the Condensate System (System # 44), five from the Feedwater System (System # 45A) and one from the Condenser.

The Condensate samples were obtained from drain lines close to the MCPs and low point drains on both trains of condensate.

Four Feedwater samples were collected from the drain lines just downstream of the individual feedline check valves (FW-2017 through FW-2020). One sample came from the disassembly of a Auxiliary Feedwater supply check valve (FW-2010).

One sample was also collected at one of the access manways to a condenser hotwell (33' manway east side). See C Condenser for sample E-11 results.

Results of Individual System Samples

CONDENSATE SYSTEM [System # 44 M-212, M-213 SH1]

- E-1 A MCP suction line hose connection downstream of CO-4005
- E-2 MO-2998A BP line drain
- E-3 MO-2998B BP line drain
- E-4 NOT OBTAINED
- E-5 A Train low point drain (downstream of CO-131)
- E-6 B Train low point drain (downstream of CO-132)
- E-13 A MCP Suction Strainer Drain Line upstream of CO-223
- E-14 B MCP Suction Strainer Drain Line upstream of CO-224

SAMPLING RESULTS

NO ACTIVITY DETECTED IN SAMPLES E1, 2, 3, 5, 6, 13, & 14

- E-1 < 1K dpm/100 cm² - smear
< 1K dpm/20 cm² - fixed
- E-2 < 1K dpm/60 cm² - smear
< 1K dpm/20 cm² - fixed
- E-3 < 1K dpm/50 cm² - smear
< 1K dpm/20 cm² - fixed
- E-5 < 1K dpm/120 cm² - smear
< 1K dpm/20 cm² - fixed
- E-6 < 1K dpm/120 cm² - smear
< 1K dpm/20 cm² - fixed
- E-13 < 1K dpm/100 cm² - smear
< 1K dpm/20 cm² - fixed
- E-14 < 1K dpm/100 cm² - smear
< 1K dpm/20 cm² - fixed

- F-2 Composite sample (A Train #3 & #6 FW Heater tube side via manway screening removal)
- F-4 Composite sample (B Train #3 & #6 FW Heater tube side via manway screening removal)

SAMPLING RESULTS

NO ACTIVITY DETECTED IN SAMPLES F-2 & F-4

- F-2 < 1K dpm/400 cm² - smear
< 1K dpm/20 cm² - fixed
- F-4 < 1K dpm/400 cm² - smear
< 1K dpm/20 cm² - fixed

Results of Individual System Samples

FEEDWATER SYSTEM [System # 45 M-213 SH2]

- E-7 B SG Feedline drain (downstream of the check valve, MSSS)
- E-8 C SG Feedline drain (downstream of the check valve, MSSS)
- E-9 D SG Feedline drain (downstream of the check valve, MSSS)
- E-10 A SG Feedline drain (downstream of the check valve, MSSS)
- E-12 AFW Supply Line after FW-2010 was disassembled to allow access to the inside of the AFW line [MR Required]

SAMPLING RESULTS

NO ACTIVITY DETECTED IN SAMPLES E-7, 8, 9, 10, & 12

- E-7 < 1K dpm/60 cm² - smear
< 1K dpm/20 cm² - fixed
- E-8 < 1K dpm/60 cm² - smear
< 1K dpm/20 cm² - fixed
- E-9 < 1K dpm/60 cm² - smear
< 1K dpm/20 cm² - fixed
- E-10 < 1K dpm/50 cm² - smear
< 1K dpm/20 cm² - fixed
- E-12 < 1K dpm/100 cm² - smear
< 1K dpm/20 cm² - fixed

Results of Individual System Samples

F FEEDWATER HEATERS [System # 44 & 47 M-210 SH2, M-211, M-213 SH1&4]

Extraction steam is supplied to the feedwater heaters from the various stages of the high and low pressure turbines. Steam generator blowdown tank flash steam is supplied to feedwater heater E-103B during normal blowdown system operation.

Feedwater flow through the heaters condenses the extraction steam. The feedwater heaters are equipped with a cascading type drainage system. The extraction steam condensate from feedwater heaters 7A and B is drained to the feedwater heaters 6A and B, and condensate from these heaters drains to feedwater heaters 5A and B. Condensate from feedwater heaters 5A and B is drained into drain tanks and is pumped back into the suction of the SGFPs by the HDPs.

The extraction steam condensate from feedwater heaters 4, 3, and 2 is drained back to the next lower stage feedwater heater in each case. The condensate from heater 1 is finally drained to the main condenser. Main steam and extraction steam used for reheating the steam leaving the high pressure turbine are drained to the reheater drain tanks and from there to the extraction side of the feedwater heaters 6 and 7.

Two composite samples were collected from the tube side (Feed and Condensate side, System #44) of both the A and B trains #3 and #6 FW Heaters. These samples were obtained by removing the manway covers (screening) which has been installed instead of the actual manways.

Two composite samples were collected from the shell side (Feedwater Heaters, Vents and Drains, System #47) of both the A and B trains #3 and #6 FW Heaters. These samples were obtained using the shell side drains.

- F-1 Composite sample (A Train #3 & #6 FW Heater shell side via shell side drain pipe cap.
- F-3 Composite sample (B Train #3 & #6 FW Heater shell side via shell side drain pipe cap.

SAMPLING RESULTS

NO ACTIVITY DETECTED IN SAMPLES F-1 & F-3

- F-1 < 1K dpm/200 cm² - smear
< 1K dpm/20 cm² - fixed
- F-3 < 1K dpm/200 cm² - smear
< 1K dpm/20 cm² - fixed

Results of Individual System Samples

G HEATER DRAIN PUMPS [System # 47 M-211]

Condensate from the feedwater heaters 5A and B is drained into heaters 5A and B drain tanks and is pumped back into the suction of the SGFPs by the Heater Drain Pumps (HDP).

One sample was collected from a each HDP Discharge line drain.

- G-1 Sample from the discharge line drain for "A" HDP
- G-2 Sample from the discharge line drain for "B" HDP

SAMPLING RESULTS

NO ACTIVITY DETECTED IN SAMPLES G-1 & G-2

- G-1 < 1K dpm/60 cm² - smear
- < 1K dpm/20 cm² - fixed
- G-2 < 1K dpm/60 cm² - smear
- < 1K dpm/20 cm² - fixed

Results of Individual System Samples

H STARTUP BOILER [System # 25 M-425, M-228 SH2]

The startup boiler supplies the Process Steam system and is capable of supplying steam to the steam jet air ejectors to draw a vacuum in the main condenser during startup or shutdown and can supply steam to the turbine gland seal piping.

Feedwater for the packaged boiler is taken from the condensate storage tank or the demineralized water storage tank.

Two samples were collected from the startup boiler. One was from the Bottom Blowdown line drain and one was from the Mud Drum.

Also, three steam trap samples showed no contamination.

H-1 The bottom blowdown line drain (downstream of SB-088) [M-425]

H-2 South-East Manway [MR Required] [M-425]

SAMPLING RESULTS

NO ACTIVITY DETECTED IN SAMPLES H-1 & H-2

H-1 <1K dpm/120 cm² - smear

<1K dpm/20 cm² - fixed

H-2 <1K dpm/100 cm² - smear

<1K dpm/20 cm² - fixed

X-15 ST-051 Degasifer steam (63' Turbine Building South East corner - floor level) [M-228 SH2]

X-17 ST-052 Air ejector steam (45' Turbine Building South West corner - floor level south of cement stanchion) [M-425]

X-18 ST-056 Start up boiler steam supply (North end of the passage way between the MSSS and the Turbine Building) [M-425]

SAMPLING RESULTS

NO ACTIVITY DETECTED IN SAMPLES X-15, 17, & 18

X-15 <1K dpm/100 cm² - smear

<1K dpm/20 cm² - fixed

X-17 <1K dpm/100 cm² - smear

<1K dpm/20 cm² - fixed

X-18 <1K dpm/60 cm² - smear

<1K dpm/20 cm² - fixed

Results of Individual System Samples

I CHEMICAL INJECTION TANKS [System # 82 M-236]

The condensate and feedwater chemical injection system conditions the condensate and steam generator feedwater to prevent scaling and corrosion in the condensate and feedwater system.

The chemical injection system consists of chemical injection equipment which injects morpholine and/or hydrazine during normal plant operation or hot standby periods, and can be used for injection of boric acid.

Four samples were taken from the chemical injection system. Each chemical injection tank was sampled: T-137A/B (Shutdown Chemical Tanks), T-154 (Morpholine Tank), and T-155 (Hydrazine Tank).

- I-1 Inside tank T-137A
- I-2 Inside tank T-137B
- I-3 Inside tank T-154
- I-4 Inside tank T-155

SAMPLING RESULTS

NO ACTIVITY DETECTED IN SAMPLES I-1, 2, 3, & 4

- I-1 <1K dpm/200 cm² - smear
<1K dpm/20 cm² - fixed
- I-2 <1K dpm/200 cm² - smear
<1K dpm/20 cm² - fixed
- I-3 <1K dpm/200 cm² - smear
<1K dpm/20 cm² - fixed
- I-4 <1K dpm/200 cm² - smear
<1K dpm/20 cm² - fixed

Results of Individual System Samples

J STEAM GENERATOR BLOWDOWN [System # 63B M-348, M-368, HBD-144-80]

The Steam Generator Blowdown (SGBD) System works with the chemical feed system and the process sampling system to control the chemical compositions of water in the steam generator and assists in condensate system chemistry cleanup by continuous demineralization of the concentrated water. The SGBD tank receives effluent from the secondary side of the steam generators. The liquid effluent is then cooled, processed via ion exchangers, filtered and discharged to any one of several locations (D&DS, CST, Main Condenser, Solid Settling Basin). Steam from the blowdown tank is directed to either the main condenser or to extraction steam system.

The six samples were obtained from the SGBD system. Both the liquid and steam outlets from the SGBD tank were sampled at various locations in an attempt to identify a boundary for system activity. Three of the samples were taken at drain lines, one was taken at the SGBD tank, and two were taken on the steam lines to the "A" condenser.

- J-1 Drain line (downstream of SG-143)
- J-2 Drain line (inlet to SGBD IX)
- J-3 NOT OBTAINED
- J-4 Drain line (downstream of SG-154)
- J-5 NOT OBTAINED
- J-6 Steam side drain line to TB sump (downstream of SG-105)

SAMPLING RESULTS

ACTIVITY DETECTED IN SAMPLE J-1

Mn-54 6.86E-4 μ Ci	Co-57 1.08E-5 μ Ci	Co-58 1.23E-3 μ Ci
Co-60 4.77E-4 μ Ci	Sb-125 4.54E-4 μ Ci	

J-1 2K dpm/50 cm² - smear
ALPHA - 2 dpm/50 cm²

SAMPLING RESULTS

ACTIVITY DETECTED IN SAMPLES J-2, 4, & 6

Co-58 7.8E-8 μ Ci Co-60 2.7E-8 μ Ci

J-2 <1K dpm/60 cm² - smear
NO ALPHA
J-4 <1K dpm/50 cm² - smear
NO ALPHA
J-6 <1K dpm/50 cm² - smear
NO ALPHA

Results of Individual System Samples

STEAM GENERATOR BLOWDOWN - (Continued)

J-7 Upstream piping when SG-101 was disassembled. [DWGs M-348 F-5] [MR Required]

SAMPLING RESULTS
NO ACTIVITY DETECTED IN SAMPLE J-7

J-7 < 1K dpm/100 cm² - smear
< 1K dpm/20 cm² - fixed

J-8 Composite sample inside SGBD tank manway. [MR Required]

SAMPLING RESULTS
ACTIVITY DETECTED IN SAMPLE J-8
Mn-54 3.90E-4 μCi Co-57 1.05E-5 μCi Co-58 1.15E-3 μCi
Co-60 3.71E-4 μCi Sb-125 3.33E-4 μCi

J-8 1K dpm/100 cm² - smear
15K dpm/20 cm² - fixed
ALPHA - 5 dpm/100 cm²

Results of Individual System Samples

K COMPONENT COOLING WATER [System # 16 M-215 SH1 & SH2]

The Component Cooling Water (CCW) system is a closed-cycle system which provide a monitored intermediate barrier between components handling RCS fluids and the primary heat sink consisting of cooling water flow through the SW. The CCW system provides cooling for the Residual Heat Removal HXs, Letdown HX, RCP thermal barriers, Containment Air Coolers, Spent Fuel Pool Cooling HXs, and Seal Coolers for the Safety Injection Pumps and Containment Spray Pumps.

Six system samples were taken. The shell side of each CCW HX was sampled via drain lines. Two of the samples were from suction line drains associated with two of the three CCW Pumps (B and C). One sample came from a drain off the Non-Essential Cross-Tie Header and the last one was obtained from the "A" SFPC HX outlet drain line.

- K-1 A CCW Heat Exchanger shell side drain
- K-2 B CCW Heat Exchanger shell side drain
- K-3 C CCWP suction line drain (downstream of CC-4008)
- K-4 B CCWP suction line drain (downstream of CC-4007)

SAMPLING RESULTS

ACTIVITY DETECTED IN SAMPLES K-1, 2, 3, & 4

Co-60 7.66E-4 μ Ci

- K-1 <1K dpm/60 cm² - smear
<1K dpm/20 cm² - fixed
- K-2 <1K dpm/60 cm² - smear
<1K dpm/20 cm² - fixed
- K-3 <1K dpm/60 cm² - smear
<1K dpm/20 cm² - fixed
NO ALPHA
- K-4 <1K dpm/60 cm² - smear
<1K dpm/20 cm² - fixed
NO ALPHA

Results of Individual System Samples

COMPONENT COOLING WATER - (Continued)

- K-5 Drain off Non-essential X-tie header (downstream of CC-4041)
- K-6 E-205A SFPC HX outlet drain line (downstream of CC-4047)

SAMPLING RESULTS

NO ACTIVITY DETECTED IN SAMPLES K-5 & K-6

- K-5 < 1K dpm/60 cm² - smear
< 1K dpm/20 cm² - fixed
NO ALPHA
- K-6 < 1K dpm/60 cm² - smear
< 1K dpm/20 cm² - fixed
NO ALPHA

Results of Individual System Samples

L MAIN TURBINES AND TURBINE CONTROLS [System # 93 M-209]

The turbine consists of one double flow, high pressure element in tandem with three double flow, low pressure elements. Moisture separation and two stage reheating of the steam are provided between the high pressure and low pressure elements with two cylindrical shell, combined moisture separator reheater assemblies. One assembly is located on each side of the high pressure turbine element.

The sampling associated with this system encompasses the Control Valve Before Seat Drain Header, the Combined Intermediate Stop and Intercept Valve (CIVs) Drains, and the Low Pressure (LP) Turbine Hoods.

A total of thirteen samples were collected from this system. Of this thirteen, six of the samples were composite samples obtained from the drain lines off of the CIVs. Each CIV has four drain lines which feed a common funnel and drain to the Turbine Building Sump. The composite samples for each CIV were from these four drain lines.

Another six samples were from the LP turbine hoods: three hoods with two samples per hood. These samples came from just inside of the manways on both sides of each hood.

The last sample came from an inline Y-Strainer on the Control Valve Before Seat Drain Header.

- L-1 Through L-6 East & west sides of inside the turbine hoods
- L-7 NOT OBTAINED (no access to HP turbine)
- L-8 NOT OBTAINED (no access to HP turbine)
- L-9 Through L-14 Drain lines off the CIVs
- L-15 Inside of the Y strainer following disassembly [MR Required]

SAMPLING RESULTS

NO ACTIVITY DETECTED IN SAMPLES L-1 Through L-15

- L-1 Through L-6 < 1K dpm/200 cm² - smear
< 1K dpm/20 cm² - fixed
- L-9 Through L-14 < 1K dpm/200 cm² - smear
< 1K dpm/20 cm² - fixed
- L-15 < 1K dpm/100 cm² - smear
< 1K dpm/20 cm² - fixed

Results of Individual System Samples

M MISCELLANEOUS SUMPS [System # 99A M-17, M-190, M-229 SH1, M-429]

Only sumps outside the Fuel and Auxiliary Buildings were considered for sampling. The sumps selected had the potential for being contaminated or were already posted as contaminated. The following sumps were sampled for activity.

Turbine Building Sump
Steam Generator Blowdown Tank Room Sump
Demineralizer Building Sump
Demineralizer Building Floor Trough
Solid Settling Basin
Settler Filter Sump

A total of ten samples were collected from the six areas listed. Typically a sample was collected by obtaining a scraping from at least one of the walls of the sump. In some instances composite samples were gathered.

TURBINE BUILDING SUMP [M-190]

M-1 From the side of one wall of the sump

SAMPLING RESULTS
ACTIVITY DETECTED IN SAMPLE M-1
Cs-137 5.76E-5 μ Ci

M-1 < 1K dpm/200 cm² - smear
< 1K dpm/20 cm² - fixed
NO ALPHA

SETTLER FILTER SUMP [M-229 SH1]

M-2 From the 12" drain line located in the sump north of the Settler Filter Unit #1 (T-141A), 45' Turbine Building north of the Water Treatment Plant control panel

SAMPLING RESULTS
NO ACTIVITY DETECTED IN SAMPLE M-2

M-2 < 1K dpm/100 cm² - smear
< 1K dpm/20 cm² - fixed

Results of Individual System Samples

MISCELLANEOUS SUMPS [System # 99A] (Continued)

SGBD TANK ROOM SUMP [M-17]

M-3 Composite sample from the four walls of the sump located in the SGBD tank room

SAMPLING RESULTS

ACTIVITY DETECTED IN SAMPLE M-3

Mn-54 1.82E-5 μ Ci Co-58 5.30E-5 μ Ci

M-3 < 1K dpm/100 cm² - smear
< 1K dpm/20 cm² - fixed
ALPHA - 1 dpm/100 cm²

DEMIN BUILDING SUMP

M-4 Composite sample from the sump located in the basement of the Demin building

M-5 Composite sample from the floor drain trough which runs along the 25' of the Demin building

SAMPLING RESULTS

NO ACTIVITY DETECTED IN SAMPLES M-4 & M-5

M-4 < 1K dpm/100 cm² - smear
< 1K dpm/20 cm² - fixed
M-5 < 1K dpm/100 cm² - smear
< 1K dpm/20 cm² - fixed

SOLIDS SETTLING BASIN [M-429]

M-6 Through M-10 Samples collected from the basin walls

SAMPLING RESULTS

NO ACTIVITY DETECTED IN SAMPLES M-6 Through M-10

M-6 < 1K dpm/100 cm² - smear
M-7 < 1K dpm/100 cm² - smear
M-8 < 1K dpm/100 cm² - smear
M-9 < 1K dpm/100 cm² - smear
M-10 < 1K dpm/100 cm² - smear

Results of Individual System Samples

MISCELLANEOUS SUMPS [System # 99A] (Continued)

N FLOOR DRAINS [System # 99A M-178, M-187, M-188, M-190, XHG-1-300]

Floor drain samples are included in the Miscellaneous Sump systems (99A) because all of the sampled drains flow into the Turbine Building Sump (TBS). These floor drains were sampled because they are located in a contaminated area and/or because they feed a line already identified as contaminated. This selection defined the boundary for the contaminated drain piping supplying the Turbine Building Sump. Ten samples were collected from various drain lines which empty into the TBS.

- N-1 Under floor drain grating between MSSS and the Turbine Building, inside the drain line [M-178]
- N-2 Floor drain between MSSS and Turbine Building behind sheet metal [M-178] [MR Required]

SAMPLING RESULTS

ACTIVITY DETECTED IN SAMPLE N-1

Mn-54 8.90E-5 μCi Co-58 1.92E-4 μCi Co-60 7.87E-5 μCi Sb-125 7.34E-5 μCi

SAMPLE N-1 RECOUNT

ACTIVITY DETECTED IN SAMPLE N-1

Mn-54 3.32E-5 μCi Co-58 3.99E-5 μCi Cs-137 1.15E-4 μCi

N-1 < 1K dpm/100 cm² - smear
 < 1K dpm/20 cm² - fixed
 ALPHA - 2 dpm/100 cm²

SAMPLING RESULTS

ACTIVITY DETECTED IN SAMPLE N-2

Sb-125 5.24E-5 μCi Cs-134 2.50E-5 μCi Cs-137 7.09E-5 μCi

N-2 1K dpm/100 cm² - smear
 < 1K dpm/20 cm² - fixed
 ALPHA - 4 dpm/100 cm²

Results of Individual System Samples

MISCELLANEOUS SUMPS [System #99A] (Continued)

- N-3 Drain line which comes down from MSSS 69' between MSSS and Turbine Building behind sheet metal [XHG-1-300]
- N-4 Drain line which comes down from MSSS 69' between MSSS and Turbine Building (no MR required). [XHG-1-300]

SAMPLING RESULTS

NO ACTIVITY DETECTED IN SAMPLE N-3

- N-3 < 1K dpm/100 cm² - smear
< 1K dpm/20 cm² - fixed

SAMPLING RESULTS

ACTIVITY DETECTED IN SAMPLE N-4

Co-60 3.07E-5 μ Ci

- N-4 1K dpm/100 cm² - smear
< 1K dpm/20 cm² - fixed
ALPHA - 2 dpm/100 cm²

- N-5 Floor drain located between the MCPs 26' [M-190]
- N-6 Floor drain south of the "A" MCP 26
- N-7 45' floor drain south of diked AFWP room area across from the Eye Wash Station [M-187]
- N-8 45' floor drain just west of the old C-160 room outside of the diked AFWP room area [M-187]
- N-9 45' floor drain just north of the "C" Joy Air Compressor [M-190]

SAMPLING RESULTS

NO ACTIVITY DETECTED IN SAMPLES N-5 Through N-9

- N-5 < 1K dpm/100 cm² - smear
< 1K dpm/20 cm² - fixed
- N-6 < 1K dpm/100 cm² - smear
< 1K dpm/20 cm² - fixed
- N-7 < 1K dpm/100 cm² - smear
< 1K dpm/20 cm² - fixed
- N-8 < 1K dpm/100 cm² - smear
< 1K dpm/20 cm² - fixed
- N-9 < 1K dpm/100 cm² - smear
< 1K dpm/20 cm² - fixed

Results of Individual System Samples

MISCELLANEOUS SUMPS [System #99A] (Continued)

- N-10 Cleanout for the SGBD room sump pump discharge [M-188] [MR Required]
- N-11 Resampled cleanout for the SGBD room sump pump discharge

SAMPLING RESULTS

ACTIVITY DETECTED IN SAMPLE N-10

Mn-54 7.10E-5 μ Ci Co-58 4.70E-5 μ Ci

N-10 < 1K dpm/100 cm² - smear
< 1K dpm/20 cm² - fixed

SAMPLING RESULTS

ACTIVITY DETECTED IN SAMPLE N-11

Mn-54 4.79E-5 μ Ci

N-11 < 1K dpm/100 cm² - smear
< 1K dpm/20 cm² - fixed

Results of Individual System Samples

O HVAC SYSTEMS [System # 30, 32, 33, 60, & 66 M-242, M-243, M-268, M-364]

Forty samples were collected from five Heating & Ventilation Systems. The sampling breakdown is listed below:

System #30 - Control Building HVAC	6 samples
System #32 - Fuel and Auxiliary Building HVAC	18 samples
System #33 - Turbine Building HVAC	4 samples
System #60 - Containment HVAC	10 samples
System #66 - Hydrogen Recombiners	2 samples

Sample locations were based primarily on accessibility and the potential likelihood of detecting activity. Typically an upstream and downstream sample was collected on a filter housing or a fan coil unit.

CONTROL BUILDING HVAC [System # 30]

- O-31 V-145E Electrical auxiliaries room cooler - Inlet
- O-32 V-145E Electrical auxiliaries room cooler - Outlet

SAMPLING RESULTS
NO ACTIVITY DETECTED IN SAMPLES O-31 & O-32

- O-31 < 1K dpm/100 cm² - smear
- < 1K dpm/20 cm² - fixed
- O-32 < 1K dpm/100 cm² - smear
- < 1K dpm/20 cm² - fixed

- O-33 V-143A Cable spreading room cooler - Inlet
- O-34 V-143A Cable spreading room cooler - Outlet
- O-35 V-143F Cable spreading room cooler - Inlet
- O-36 V-143F Cable spreading room cooler - Outlet

SAMPLING RESULTS
NO ACTIVITY DETECTED IN SAMPLES O-33 Through O-36

- O-33 < 1K dpm/100 cm² - smear
- < 1K dpm/20 cm² - fixed
- O-34 < 1K dpm/100 cm² - smear
- < 1K dpm/20 cm² - fixed
- O-35 < 1K dpm/100 cm² - smear
- < 1K dpm/20 cm² - fixed
- O-36 < 1K dpm/100 cm² - smear
- < 1K dpm/20 cm² - fixed

Results of Individual System Samples

FUEL AND AUXILIARY BUILDING HVAC [System # 32]

AB-5 MAINTENANCE AREA SUPPLY (93')

- O-5 At supply grill located inside the Hot Shop
- O-6 Upstream of filter housing

SAMPLING RESULTS

NO ACTIVITY DETECTED IN SAMPLES O-5 & O-6

- O-5 < 1K dpm/100 cm² - smear
ALPHA - 2 dpm/100 cm²
- O-6 < 1K dpm/100 cm² - smear
< 1K dpm/20 cm² - fixed
NO ALPHA

AB-4 SFP EXHAUST

- O-7 Duct access door near the containment equipment hatch
- O-8 Inlet of VC-302 A inside AB-4 filter housing [M-242 SH1]
- O-9 Inlet of VC-302 B inside AB-4 filter housing

SAMPLING RESULTS

ACTIVITY DETECTED IN SAMPLES O-7,8, & O-9

Co-60 3.35E-3 μCi Cs-137 3.94E-4 μCi

- O-7 2K dpm/100 cm² - smear
ALPHA - 2 dpm/100 cm²
- O-8 1K dpm/100 cm² - smear
1K dpm/20 cm² - fixed
NO ALPHA
- O-9 2K dpm/100 cm² - smear
ALPHA - 10 dpm/100 cm²

Results of Individual System Samples

FUEL AND AUXILIARY BUILDING HVAC [System # 32] (Continued)

AB-3 FUEL AND AUX BUILDING EXHAUST SYSTEM [M-242 SH1]

- O-10 NOT OBTAINED
- O-11 NOT OBTAINED
- O-12 Upstream of filter associated with VC-303C
- O-13 NOT OBTAINED
- O-14 NOT OBTAINED
- O-15 NOT OBTAINED
- O-16 Outlet of VC-303C
- O-17 NOT OBTAINED

Six samples were not obtained because the initial samples of VC-303C was hot (O-12 & O-16). Radiation Protection was directed to go to the next system when either of the following conditions applied:

- 1 - Contamination survey indicates > 1K fixed, OR
- 2 - Loose contamination is present in any single sample

SAMPLING RESULTS

ACTIVITY DETECTED IN SAMPLES O-12 & O-16

Co-60 1.78E-4 μ Ci Cs-137 3.94E-5 μ Ci

O-12 1K dpm/100 cm² - smear
 5K dpm/20 cm² - fixed
 NO ALPHA

O-16 < 1K dpm/100 cm² - smear
 < 1K dpm/20 cm² - fixed
 ALPHA - 10 dpm/100 cm²

AB-9 RAD WASTE ANNEX SUPPLY & RETURN

- O-18 Sample upstream of prefilter
- O-19 Composite sample on discharge of VC-511 using test ports

SAMPLING RESULTS

ACTIVITY DETECTED IN SAMPLES O-18 & O-19

Co-60 3.09E-4 μ Ci Cs-137 6.63E-5 μ Ci

O-18 < 1K dpm/100 cm² - smear
 < 1K dpm/20 cm² - fixed
 NO ALPHA

O-19 < 1K dpm/100 cm² - smear
 < 1K dpm/20 cm² - fixed
 ALPHA - 5 dpm/100 cm²

FUEL AND AUXILIARY BUILDING HVAC [System # 32] (Continued)

Results of Individual System Samples

AB-10 RESPIRATOR MAINTENANCE FACILITY [M-242 SH3]

O-20 Hood inside the room

SAMPLING RESULTS

ACTIVITY DETECTED IN SAMPLE O-20

Co-60 5.62E-5 μ Ci Cs-134 7.40E-5 μ Ci Cs-137 3.37E-4 μ Ci

O-20 <1K dpm/100 cm² - smear
<1K dpm/20 cm² - fixed
ALPHA - 2 dpm/100 cm²

DB-1 AIR EJECTOR EXHAUST DEEP BED CHARCOAL ABSORBER [M-364]

O-21 Upstream of filter housing

O-22 Downstream of filter housing

SAMPLING RESULTS

NO ACTIVITY DETECTED IN SAMPLES O-21 & O-22

O-21 <1K dpm/100 cm² - smear
<1K dpm/20 cm² - fixed
NO ALPHA
O-22 <1K dpm/100 cm² - smear
<1K dpm/20 cm² - fixed
NO ALPHA

DB-2 LETDOWN HX ROOM DEEP BED CHARCOAL ABSORBER [M-365]

O-23 Upstream of filter housing

O-24 Downstream of filter housing

SAMPLING RESULTS

ACTIVITY DETECTED IN SAMPLES O-23 & O-24

Co-60 4.94E-5 μ Ci Cs-137 4.37E-5 μ Ci

O-23 <1K dpm/100 cm² - smear
HIGH BACKGROUND RATE
ALPHA - 5 dpm/100 cm²
O-24 <1K dpm/100 cm² - smear
HIGH BACKGROUND RATE
ALPHA - 5 dpm/100 cm²

FUEL AND AUXILIARY BUILDING HVAC [System # 32] (Continued)

Results of Individual System Samples

AB-1 PUMP COOLING UNITS [M-242 SH1]

- O-27 V-304A SWBP area cooler - Inlet
- O-28 V-304A SWBP area cooler - Outlet
- O-29 V-256B B CCW area cooler - Inlet
- O-30 V-256B B CCW area cooler - Outlet

SAMPLING RESULTS

NO ACTIVITY DETECTED IN SAMPLES O-27 Through O-30

- O-27 < 1K dpm/100 cm² - smear
< 1K dpm/20 cm² - fixed
- O-28 < 1K dpm/100 cm² - smear
< 1K dpm/20 cm² - fixed
- O-29 < 1K dpm/100 cm² - smear
< 1K dpm/20 cm² - fixed
- O-30 < 1K dpm/100 cm² - smear
< 1K dpm/20 cm² - fixed

TURBINE BUILDING HVAC [System #33]

- O-37 V-164 Turbine building switchgear room cooler - Inlet
- O-38 V-164 Turbine building switchgear room cooler - Outlet
- O-39 VC-166 Turbine AFP Supply Fan in the overhead of the room

SAMPLING RESULTS

NO ACTIVITY DETECTED IN SAMPLES O-37, O-38, & O-39

- O-37 < 1K dpm/100 cm² - smear
< 1K dpm/20 cm² - fixed
- O-38 < 1K dpm/100 cm² - smear
< 1K dpm/20 cm² - fixed
- O-39 < 1K dpm/100 cm² - smear
< 1K dpm/20 cm² - fixed

EMERGENCY DIESEL GENERATOR AIR INTAKE

- O-40 Composite sample on EDG air intake screening on west wall in turbine building access corridor just before double doors

SAMPLING RESULTS

NO ACTIVITY DETECTED IN SAMPLE O-40

- O-40 < 1K dpm/100 cm² - smear
< 1K dpm/20 cm² - fixed

Results of Individual System Samples

CONTAINMENT HVAC [System #60]

CS-2 CONTAINMENT PURGE EXHAUST [M-243]

- O-1 Upstream of roll filter
- O-2 Downstream of HEPA filter

SAMPLING RESULTS

ACTIVITY DETECTED IN SAMPLE O-1

Mn-54 1.62E-4 μ Ci Co-57 4.03E-5 μ Ci Co-58 1.38E-4 μ Ci Co-60 1.83E-3 μ Ci
 Nb-95 7.91E-4 μ Ci Cs-134 5.14E-5 μ Ci Cs-137 1.12E-3 μ Ci Ce-144 1.87E-4 μ Ci

O-1 12K dpm/100 cm² - smear
 ALPHA - 42 dpm/100 cm²

ACTIVITY DETECTED IN SAMPLE O-2

Co-60 2.53E-5 μ Ci Cs-137 2.67E-5 μ Ci

O-2 <1K dpm/100 cm² - smear
 NO ALPHA

CS-9 HYDROGEN VENT SYSTEM [M-243]

- O-3 Composite sample upstream of filter housing
- O-25 Inlet to the filter housing (VF-206B) [MR Required]
- O-26 Outlet of the filter housing (VF-206B) [MR Required]

SAMPLING RESULTS

NO ACTIVITY DETECTED IN SAMPLES O-3A & 3B

O-3A <1K dpm/100 cm² - smear
 ALPHA - 5 dpm/100 cm²
 O-3B <1K dpm/100 cm² - smear
 NO ALPHA

ACTIVITY DETECTED IN SAMPLE O-25

Co-60 2.44E-5 μ Ci Cs-137 8.79E-5 μ Ci

O-25 <1K dpm/100 cm² - smear
 NO ALPHA

NO ACTIVITY DETECTED IN SAMPLE O-26

O-25 <1K dpm/100 cm² - smear
 NO ALPHA

Results of Individual System Samples

CONTAINMENT HVAC [System #60] (Continued)

CS-1 CONTAINMENT PURGE SUPPLY [M-243]

O-4 Upstream of filter housing

SAMPLING RESULTS

NO ACTIVITY DETECTED IN SAMPLE O-4

O-4 < 1K dpm/100 cm² - smear
 < 1K dpm/20 cm² - fixed
 NO ALPHA

CS-11 CLEAN UP RECIRC SYSTEM [M-243, M-268]

- O-43 Inlet of VC-215A
- O-44 Outlet screen of VC-215A
- O-45 Inlet of VC-215B
- O-46 Outlet screen of VC-215B

SAMPLING RESULTS

ACTIVITY DETECTED IN SAMPLES O-43,44,45 & 46

Mn-54 8.52E-4 μCi	Co-58 2.73E-4 μCi	Co-60 3.77E-2 μCi
Cs-134 1.75E-2 μCi	Cs-137 1.25E-1 μCi	

- O-43 15K dpm/100 cm² - smear
 HIGH BACKGROUND
 80K dpm/100 cm² SCRAPING
 ALPHA - 14 dpm/100 cm²
- O-44 1K dpm/100 cm² - smear
 HIGH BACKGROUND
 1K dpm/100 cm² SCRAPING
 NO ALPHA
- O-45 30K dpm/100 cm² - smear
 HIGH BACKGROUND
 25K dpm/100 cm² SCRAPING
 ALPHA - 4 dpm/100 cm²
- O-46 4K dpm/100 cm² - smear
 HIGH BACKGROUND
 2K dpm/100 cm² SCRAPING
 ALPHA - 4 dpm/100 cm²

Results of Individual System Samples

HYDROGEN RECOMBINERS [System #66]

- O-41 Composite sample from the lower louvers (inlet) of the "A" Hydrogen Recombiner (X-318A) [M-243, Tech Manual M 87-8]
O-42 Composite sample from the lower louvers (inlet) of the "B" Hydrogen Recombiner (X-318B)

SAMPLING RESULTS

ACTIVITY DETECTED IN SAMPLES O-41 & O-42

Mn-54 8.52E-4 μCi Co-58 2.73E-4 μCi Co-60 3.77E-2 μCi
Cs-134 1.75E-2 μCi Cs-137 1.25E-1 μCi

- O-41 6K dpm/100 cm² - smear
HIGH BACKGROUND
20K dpm/100 cm² SCRAPING
ALPHA - 5 dpm/100 cm²
O-42 25K dpm/100 cm² - smear
HIGH BACKGROUND
50K dpm/100 cm² SCRAPING
ALPHA - 7 dpm/100 cm²

Results of Individual System Samples

P OILY WASTE & STORM DRAINS [System # 65 M-174, M-456, JBD-85-80, C-48]

The Oily Water Separator collects water from the Turbine Building Sump, the Demineralizer Building Sump, and the Backwash Filtrate Pump Discharge. Water from the Separator flows to the Oily Water Sump Pumps which discharge to the Solids Settling Basin or the Discharge and Dilution Structure.

Storm drains are routed throughout the plant site and discharge to either the Recreation Lake or the Columbia River via the Discharge and Dilution Structure.

Nine samples were obtained for this system. Two of the samples were collected from the discharge of the Oily Water Sump Pumps and the remaining seven samples were associated with yard storm drains, catch basins, and a drain box situated around the Tank Farm.

- P-1 Drain line off the composite sampler supply associated with Oily Water Sump Pump discharge (Pipe cap removal required). [M-456, JBD-85-80]
- P-2 Storm Drain Catch Basin (in the drain pipe) located next to the RWST on the West side within the fence (grating removal is required). [C-48, M-147]
- P-3 Storm Drain Catch Basin located north of the Demin Water Storage tank (grating removal required), from the drain line on the East wall of the basin. [C-48, M147]
- P-4 Drain line on the south wall at the bottom of the basin identified in P-3. [M147]
- P-5 Drain Box located just southeast of the Demin Water Storage Tank, from the drain line on the East side of the box. [C-48, M147]

SAMPLING RESULTS

NO ACTIVITY DETECTED IN SAMPLES P-1 Through P-5

Note: Initial collective count of P-2 through P-5 identified Co-60, but subsequent individual counts showed no activity.

- P-1 < 1K dpm/100 cm² - smear
< 1K dpm/20 cm² - fixed
- P-2 < 1K dpm/100 cm² - smear
HIGH BACKGROUND
NO ALPHA
- P-3 < 1K dpm/100 cm² - smear
< 1K dpm/20 cm² - fixed
- P-4 < 1K dpm/100 cm² - smear
< 1K dpm/20 cm² - fixed
- P-5 < 1K dpm/100 cm² - smear
< 1K dpm/20 cm² - fixed

Results of Individual System Samples

OILY WASTE AND STORM DRAINS [System #65] (Continued)

- P-6 4" storm drain line which empties into the manway. [MR Required] [M-147]
- P-7 10" storm drain line which empties into the manway. [MR Required] [M-147]
- P-8 18" storm drain line at the bottom of the manway. [MR Required] [M-147]

SAMPLING RESULTS

NO ACTIVITY DETECTED IN SAMPLES P-6, P-7, & P-8

- P-6 < 1K dpm/100 cm² - smear
< 1K dpm/20 cm² - fixed
- P-7 < 1K dpm/100 cm² - smear
< 1K dpm/20 cm² - fixed
- P-8 < 1K dpm/100 cm² - smear
< 1K dpm/20 cm² - fixed

Note: The above points were resampled and counted due to suspected error in counting the initial samples:

- P-10 4" storm drain line which empties into the manway. [MR Required] [M-147]
- P-11 10" storm drain line which empties into the manway. [MR Required] [M-147]
- P-12 18" storm drain line at the bottom of the manway. [MR Required] [M-147]

SAMPLING RESULTS

NO ACTIVITY DETECTED IN SAMPLES P-10, P-11, & P-12

- P-10 < 1K dpm/100 cm² - smear
< 1K dpm/20 cm² - fixed
- P-11 < 1K dpm/100 cm² - smear
< 1K dpm/20 cm² - fixed
- P-12 < 1K dpm/100 cm² - smear
< 1K dpm/20 cm² - fixed

- P-9 Internal pipe sample with Y-Strainer (YS-513) for the Oily Water Sump Pumps is disassembled. [MR Required] [M-456, JBD-85-300]

SAMPLING RESULTS

NO ACTIVITY DETECTED IN SAMPLE P-9

- P-9 < 1K dpm/100 cm² - smear
< 1K dpm/20 cm² - fixed

Results of Individual System Samples

Q PRIMARY MAKEUP WATER [System # 67B & 67D M-206 SH2, M-224, HCD-4-3]

Primary Make-up Water Pumps (PMWP) take a suction on the Primary Water Storage Tank which receives water from several sources including CVCS Monitor Tank Pumps and the Treated Waste Monitor Tank Pump. The PMWPs discharge to various tanks, ion exchangers, boric acid evaporators, the boric acid blender, and the spent resin discharge manifold.

Refueling Water Storage Tank (RWST) receives water from the CVCS Boric Acid Blender and provides a water supply to numerous safety related pumps (Safety Injection, Residual Heat Removal, Containment Spray, Charging) for injection into the Reactor Coolant System.

Three samples were collected from the Primary Make-up Water system. Two of the samples were from the discharge drain lines associated with the A and B Primary Make-up Pumps and the other sample was from the RWST via a manway.

PRIMARY WATER MAKEUP PUMPS & DISTRIBUTION [System # 67B]

- Q-1 Discharge drain line on A PWMP (P-219A). Pipe cap removal required. [M-224, HCD-4-3]
- Q-2 Discharge drain line on B PWMP (P-219B). Pipe cap removal required.

SAMPLING RESULTS

ACTIVITY DETECTED IN SAMPLES Q-1 & Q-2

Co-60 6.69E-5 μ Ci Cs-137 6.52E-5 μ Ci

- Q-1 < 1K dpm/100 cm² - smear
< 1K dpm/20 cm² - fixed
NO ALPHA
- Q-2 2K dpm/100 cm² - smear
1K dpm/20 cm² - fixed
NO ALPHA

RWST [System # 67D]

- Q-3 Composite sample of the inside surface of the RWST after the manway was removed, reaching in through the manway opening. [MR Required]

SAMPLING RESULTS

ACTIVITY DETECTED IN SAMPLE Q-3

Mn-54 9.41E-3 μ Ci Co-57 5.74E-4 μ Ci Co-58 8.40E-4 μ Ci Co-60 3.50E-1 μ Ci
Sb-125 8.01E-3 μ Ci Cs-137 3.55E-3 μ Ci Ce-144 2.48E-3 μ Ci Ru-Rh-106 5.03E-3 μ Ci

- Q-3 > 500K dpm/100 cm² - smear
HIGH BACKGROUND
ALPHA 1.715E4 dpm/100 cm²

Results of Individual System Samples

R CONDENSATE DEMINERALIZERS [System # 39 M-397]

Five samples were collected from the Condensate Demineralizer Backwash Handling system. Both Backwash Filters and Filtrate Tanks were sampled along with the Backwash Receiving Tank.

All samples were clean, but the Backwash Receiving Tank is posted "potential internal contamination". This component will be considered contaminated for characterization purposes since a full survey was required prior to removing the posting.

- R-1 Inside surface of the Backwash Filter (F-133A)
- R-2 Inside surface of the Backwash Filter (F-133B)
- R-3 Inside of the Backwash Filtrate Tank (T-195A)
- R-4 Inside of the Backwash Filtrate Tank (T-195B)
- R-5 Inside of the Backwash Receiving Tank (T-194)

SAMPLING RESULTS

NO ACTIVITY DETECTED IN SAMPLES R-1 Through R-5

- R-1 < 1K dpm/100 cm² - smear
< 1K dpm/20 cm² - fixed
- R-2 < 1K dpm/100 cm² - smear
< 1K dpm/20 cm² - fixed
- R-3 < 1K dpm/100 cm² - smear
< 1K dpm/20 cm² - fixed
- R-4 < 1K dpm/100 cm² - smear
< 1K dpm/20 cm² - fixed
- R-5 < 1K dpm/100 cm² - smear
< 1K dpm/20 cm² - fixed

Results of Individual System Samples

S CONTAINMENT SPRAY [System # 61 M-207, HCB-14-1 & 2]

The Containment Spray system can take a suction from the Sodium Hydroxide Tank and either the RWST or the Containment Recirculation Sump. It discharges to spray nozzles located in the top of the containment.

Two samples were collected from the Containment Spray Pump suction drain lines.

- S-1 CS-4024, CS Pump A suction drain line (DTO open with poly sleeve to floor drain) [Drawing M-207 & HCB-14-1]
- S-2 CS-4021, CS Pump B suction drain line (DTO open with poly sleeve to floor drain) [Drawing M-207 & HCB-14-2]

SAMPLING RESULTS
ACTIVITY DETECTED IN SAMPLES S-1 & S-2

Mn-54	1.59E-4 μ Ci	Co-57	2.69E-5 μ Ci	Co-58	2.16E-4 μ Ci
Co-60	3.02E-3 μ Ci	Cs-137	2.14E-4 μ Ci	Ce-144	2.10E-4 μ Ci

- S-1 <1K dpm/100 cm² - smear
HIGH BACKGROUND
NO ALPHA
- S-2 5K dpm/100 cm² - smear
HIGH BACKGROUND
ALPHA - 51 dpm/100 cm²

Results of Individual System Samples

T MAKEUP DEMIN WATER [System # 22 M-215 SH1, M-228 SH2, HCD-2-1]

The Demineralized Water Transfer Pumps take a suction on the Demineralized Water Storage Tank and discharge to various other systems such as Component Cooling Water (CCW) Make-up and the Primary Water Storage Tank.

Two samples were collected from this system, one from a CCW MU pump suction drain line and the other from the A Demineralized Water Transfer Pump suction spool piece.

T-1 A CCW MU Pump Suction line drain downstream of CC-201.

T-2 NOT OBTAINED

T-3 A train Demineralized Water Transfer Pump (P-131A) after the Startup Strainer Spool piece was removed. [MR Required]

SAMPLING RESULTS

NO ACTIVITY DETECTED IN SAMPLES T-1 & T-3

T-1 <1K dpm/50 cm² - smear

<1K dpm/20 cm² - fixed

T-3 <1K dpm/100 cm² - smear

<1K dpm/20 cm² - fixed

Results of Individual System Samples

U ELECTRICAL SYSTEMS [Systems # 2, 5, 6, 7, 31, 57, 90, 91, 98]

System characterization deals with internal contamination of plant systems. Since electrical systems cannot be sampled internally, it was decided to sample the inside of some load centers, motor control centers, and other panels. Thirteen samples were collected.

125 V DC [System # 2]

U-8 Battery Charger #3 (D23) - Control Bldg Switchgear Room.

SAMPLING RESULTS
NO ACTIVITY DETECTED IN SAMPLE U-8

U-8 < 1K dpm/100 cm² - smear
< 1K dpm/20 cm² - fixed

480 V AC AUX SYSTEM LOAD CENTERS [System # 5]

U-1 LC B04 - 61' Aux Bldg (Control Bldg Switchgear Room)
U-5 LC B01 - Turbine Bldg Switchgear Room.

SAMPLING RESULTS
NO ACTIVITY DETECTED IN SAMPLES U-1 & U-5

U-1 < 1K dpm/100 cm² - smear
< 1K dpm/20 cm² - fixed
U-5 < 1K dpm/100 cm² - smear
< 1K dpm/20 cm² - fixed

480 V AC MOTOR CONTROL CENTERS [System # 6]

U-2 MCC B26 - 65' Aux Bldg (Control Bldg Switchgear Room)
U-6 MCC B23 - Turbine Bldg Switchgear Room.

SAMPLING RESULTS
NO ACTIVITY DETECTED IN SAMPLES U-2 & U-6

U-2 < 1K dpm/100 cm² - smear
< 1K dpm/20 cm² - fixed
U-6 < 1K dpm/100 cm² - smear
< 1K dpm/20 cm² - fixed

Results of Individual System Samples

LIGHTING PANEL POWER SUPPLY [System # 7]

U-9 NOT OBTAINED

U-10 45' Penetration Area - in and around one of overhead lights.

SAMPLING RESULTS

NO ACTIVITY DETECTED IN SAMPLE U-10

U-10 <1K dpm/100 cm² - smear
<1K dpm/20 cm² - fixed

P-250 COMPUTER [System # 31A]

U-11 P-250 computer cabinet - 61' Control Building

SAMPLING RESULTS

NO ACTIVITY DETECTED IN SAMPLE U-11

U-11 <1K dpm/100 cm² - smear
<1K dpm/20 cm² - fixed

120 V PREFERRED INSTRUMENT AC [System # 57]

U-7 Instrument Bus Y11 - Control Bldg Switchgear Room.

SAMPLING RESULTS

NO ACTIVITY DETECTED IN SAMPLE U-7

U-7 <1K dpm/100 cm² - smear
<1K dpm/20 cm² - fixed

Results of Individual System Samples

COMMUNICATIONS [System # 90]

U-12 Rolm Phone on 45' Aux Bldg Facade.

U-13 Rolm Phone on 25' Aux Bldg.

SAMPLING RESULTS

NO ACTIVITY DETECTED IN SAMPLES U-12 & U-13

U-12 <1K dpm/100 cm² - smear

<1K dpm/20 cm² - fixed

U-13 <1K dpm/100 cm² - smear

<1K dpm/20 cm² - fixed

ANNUNCIATORS [System # 91]

U-14 Rad Waste Control Panel (C-151) - 77' Aux Bldg

SAMPLING RESULTS

NO ACTIVITY DETECTED IN SAMPLE U-14

U-14 <1K dpm/100 cm² - smear

<1K dpm/20 cm² - fixed

MAIN GENERATOR AND EXCITATION [System # 98]

U-3 Exciter Cabinet - 93' Turbine Bldg.

U-4 Main Generator - 93' Turbine Bldg.

SAMPLING RESULTS

NO ACTIVITY DETECTED IN SAMPLES U-3 & U-4

U-3 <1K dpm/100 cm² - smear

<1K dpm/20 cm² - fixed

U-4 <1K dpm/100 cm² - smear

<1K dpm/20 cm² - fixed

Results of Individual System Samples

V CONDENSATE WATER STORAGE/TRANSFER [System # 37 M-213 SH2 & SH4, HBD-43-1, HBD-132-300]

The Condensate Water Storage Tank (CST) provides an emergency supply of water to the Auxiliary Feedwater Pumps (AFWPs) for filling the Steam Generators. Two samples were collected from this system. One of the samples came from a drain line associated with the A AFWP and the other sample was obtained from the Electric AFWP Recirc line check valve.

- V-1 Drain line for the A AFWP supply, upstream of FW-116.
- V-2 Drain line for the B AFWP supply, upstream of FW-115.
- V-3 Electric AFWP Recirc Line following the disassembly of recirc line check valve (FW-2001). [MR Required]

SAMPLING RESULTS

NO ACTIVITY DETECTED IN SAMPLES V-1, V-2, & V-3

- V-1 <1K dpm/60 cm² - smear
<1K dpm/20 cm² - fixed
- V-2 <1K dpm/60 cm² - smear
<1K dpm/20 cm² - fixed
- V-3 <1K dpm/100 cm² - smear
<1K dpm/20 cm² - fixed

Results of Individual System Samples

W MISCELLANEOUS GAS SYSTEM [System # 74 M-202, CS-151R-25-52]

The Miscellaneous Gas system supplies cover gas to the Volume Control Tank during normal plant operation and purge gas when shutdown. Both of these gas supplies were sampled by the disassembly of diaphragm valves downstream of the associated pressure control valves.

Two samples obtained: One from the hydrogen supply and one from the nitrogen supply.

W-1 Process side of disassembled diaphragm valve (DV-8559). (H2 side) [MR Required]

SAMPLING RESULTS
NO ACTIVITY DETECTED IN SAMPLE W-1

W-1 <1K dpm/100 cm² - smear
<1K dpm/20 cm² - fixed

W-2 Process side of disassembled diaphragm valve (DV-8558). (N2 side) [MR Required]

SAMPLING RESULTS
ACTIVITY DETECTED IN SAMPLE W-2
Cs-137 5.06E-5 μ Ci

W-2 <1K dpm/100 cm² - smear
<1K dpm/20 cm² - fixed
ALPHA - 5 dpm/100 cm²

Results of Individual System Samples

X STEAM TRAPS [System # 25, 28, 46, 48, 83, 84 M-209, M-210 SH1, M-214 SH1 & SH2, M-228 SH2, M-237, M-425, EBD-2-55, EBD-8-50, GBD-42-4]

Steam traps were used as sample points because any contamination which carried over from SG tube leaks should concentrate in the steam traps and thus provide a conservative sample of the systems.

Eighteen steam traps were sampled from six systems. The results are listed here under the appropriate system name except that sample X-1 is listed under MSRs (AA), X-2 through X-9 are listed under Main Steam (DD), and samples X-15, X-17, and X-18 are listed under Start Up Boiler (H).

Sample Letter	# of Samples	System #	System Name
AA	1	84	Reheat and Moisture Separator (East MSR)
DD	8	83	Main Steam (Lead Drains and B/P Header Drains)
X	4	48	Steam Generator Main Feed Pump Turbine Steam Supply
X	1	28	Process and Auxiliary Steam
X	1	46	Extraction Steam (5th Stage Extraction Steam Line)
H	3	25	Startup Boiler

SG FEEDWATER PUMP TURBINE DRIVERS [System # 48]

- X-10 A SGFP High Pressure steam trap ST-039
- X-11 A SGFP Low Pressure steam trap ST-041
- X-12 B SGFP High Pressure steam trap ST-040
- X-13 B SGFP Low Pressure steam trap ST-042

SAMPLING RESULTS

NO ACTIVITY DETECTED IN SAMPLES X-10 Through X-13

- X-10 < 1K dpm/100 cm² - smear
< 1K dpm/20 cm² - fixed
- X-11 < 1K dpm/100 cm² - smear
< 1K dpm/20 cm² - fixed
- X-12 < 1K dpm/100 cm² - smear
< 1K dpm/20 cm² - fixed
- X-13 < 1K dpm/100 cm² - smear
< 1K dpm/20 cm² - fixed

Results of Individual System Samples

PROCESS & AUXILIARY STEAM [System # 28]

X-14 Steam to hogging air ejector ST-044

SAMPLING RESULTS
NO ACTIVITY DETECTED IN SAMPLE X-14

X-14 < 1K dpm/100 cm² - smear
< 1K dpm/20 cm² - fixed

EXTRACTION STEAM [System # 46]

X-16 5th stage extraction steam line trap ST-053 (93' Turbine Building North East of the 5B Feed Water Heater).

SAMPLING RESULTS
NO ACTIVITY DETECTED IN SAMPLE X-16

X-16 < 1K dpm/20 cm² - smear
< 1K dpm/20 cm² - fixed

Results of Individual System Samples

Y DOMESTIC WATER SYSTEM [System # 8 M-229 SH2]

The Domestic Water system is supplied by two wells located within the site boundary. Two samples were obtained, one from each of the Well Pump Discharge Bypass lines.

- Y-1 Discharge bypass line to the street. Downstream of DW-172, Well #2.
- Y-2 Discharge bypass line to the street. Downstream of DW-173, Well #1.

SAMPLING RESULTS

NO ACTIVITY DETECTED IN SAMPLES Y-1 & Y-2

- Y-1 < 1K dpm/100 cm² - smear
- < 1K dpm/20 cm² - fixed
- Y-2 < 1K dpm/100 cm² - smear
- < 1K dpm/20 cm² - fixed

Note: The following three samples were obtained due to activity identified around the Alum Storage Tank (T-149). Alum contains naturally occurring uranium and these samples were collected to check for similar activity.

- Y-3 Alum Storage Tank (T-149) drain line downstream of WP-097. (45' Turbine Building east side of the Alum Mixing Tank).
- Y-4 Alum Mixing Tank (T-143) inlet line downstream of WP-090 from the fill line just inside of the tank.
- Y-5 Blades of the mixer inside the Alum Mixing Tank (T-143).

SAMPLING RESULTS

NO ACTIVITY DETECTED IN SAMPLES Y-3, Y-4, & Y-5

- Y-3 < 1K dpm/50 cm² - smear
- < 1K dpm/20 cm² - fixed
- Y-4 < 1K dpm/50 cm² - smear
- < 1K dpm/20 cm² - fixed
- Y-5 < 1K dpm/50 cm² - smear
- < 1K dpm/20 cm² - fixed

Results of Individual System Samples

Z STATOR COOLING WATER SYSTEM [System # 97 M-458]

The Stator Cooling Water System is a closed cycle system used to cool the main generator stator. Makeup is from the demineralized water system via the degasifier.

One sample was collected from the Stator Cooling Water skid from the flush connection.

- Z-1 Removed the reducing fitting and collected a sample upstream of Y-62 (Makeup Water Line Flush Connection Isolation). [DWG M-458]

SAMPLING RESULTS

NO ACTIVITY DETECTED IN SAMPLE Z-1

- Z-1 < 1K dpm/100 cm² - smear
< 1K dpm/20 cm² - fixed

Results of Individual System Samples

AA MOISTURE SEPARATOR REHEATERS [System # 84 M-209 & M3J-8]

The Moisture Separator Reheaters (MSR) are integral components associated with the Main Turbine. Moisture separation and two-stage reheating of the steam are provided between the high-pressure and low-pressure elements, with two horizontal-axis, cylindrical-shell, combined moisture separator reheater assemblies. After Main Steam expands through the high-pressure turbine, it flows through moisture separators and reheaters to three low-pressure turbines. The reheated steam flows from the two moisture separator reheater vessels through a combined intermediate stop and intercept valve in each of six reheat steam lines.

A total of eight samples were obtained from the MSRs. Both of the MSRs were sampled via a manway access. Six other samples were collected via manway cover removal on the steam lines from the HP turbine to the West MSR.

Also, one steam trap showed no activity.

- AA-1 Composite sample from inside of the East MSR through manway. [MR Required]
- AA-2 Composite sample from inside of the West MSR through manway. [MR Required]

Two samples from each of the removed manways on the Main Steam Supply lines from the HP Turbine to the West MSR (6478-M3J-8).

- AA-3 & AA-4 MSR-1A
- AA-5 & AA-6 MSR-1B
- AA-7 & AA-8 MSR-1C

SAMPLING RESULTS

NO ACTIVITY DETECTED IN SAMPLES AA-1 Through AA-8

AA-1	< 1K dpm/100 cm ² - smear
	< 1K dpm/20 cm ² - fixed
AA-2	< 1K dpm/100 cm ² - smear
	< 1K dpm/20 cm ² - fixed
AA-3 & 4	< 1K dpm/100 cm ² - smear
	< 1K dpm/20 cm ² - fixed
AA-5 & 6	< 1K dpm/100 cm ² - smear
	< 1K dpm/20 cm ² - fixed
AA-7 & 8	< 1K dpm/100 cm ² - smear
	< 1K dpm/20 cm ² - fixed

Results of Individual System Samples

MOISTURE SEPARATOR REHEATERS [System # 84] (Continued)

X-1 Steam Trap ST-005 [M-209]

SAMPLING RESULTS
NO ACTIVITY DETECTED IN SAMPLE X-1

X-1 < 1K dpm/100 cm² - smear
< 1K dpm/20 cm² - fixed

Results of Individual System Samples

BB GASEOUS RADWASTE [System # 72 M-222, HCC-2-1, & HCC-63-55]

The gaseous waste management systems collect, store, process, and monitor gaseous effluent which potentially contain radioactive noble gases, iodine, and radioactive material in particulate form. The gas collection system processes gaseous effluent with potentially high levels of radioactivity. The vent collection system purges gaseous effluent with low levels of radioactivity.

Two samples were obtained from the Gaseous Radwaste system to determine the isotopic breakdown of the discharged effluent. One sample was collected upstream of the Gas Collection header filter assembly and the other sample from upstream of the Vent Collection header filter assembly.

BB-1 Test port upstream of the Vent Collection Header filter housing

BB-2 Test port upstream of the Gas Collection Header filter housing

SAMPLING RESULTS

ACTIVITY DETECTED IN SAMPLE BB-1

Co-60 3.74E-3 μCi Cs-137 1.78E-4 μCi

BB-1 <1K dpm/150 cm² - smear

<1K dpm/20 cm² - fixed

SAMPLING RESULTS

ACTIVITY DETECTED IN SAMPLE BB-2

Co-60 4.08E-5 μCi Cs-137 9.12E-5 μCi

BB-2 <1K dpm/50 cm² - smear

<1K dpm/20 cm² - fixed

Results of Individual System Samples

CC FISH REARING FACILITY [System # 99G M-354]

Two samples were collected from the supply piping to the Fish Rearing Ponds. This water is drawn in from the Intake Structure with Fish Rearing Facility pumps and is discharged via aerator piping to two ponds.

Two more samples were taken from the outfall piping associated with both of the fish ponds. This water is dumped back to the Columbia river.

- CC-1 Fish Pond #1 aerator piping from one of the 1" extensions which make up the aerator.
- CC-2 Fish Pond #1 outfall piping by reaching just inside the barrier on the outfall piping.
- CC-3 Fish Pond #2 aerator piping from one of the 1" extensions which make up the aerator.
- CC-4 Fish Pond #2 outfall piping by reaching just inside the barrier on the outfall piping.

SAMPLING RESULTS

NO ACTIVITY DETECTED IN SAMPLES CC-1 Through CC-4

- CC-1 < 1K dpm/100 cm² - smear
< 1K dpm/20 cm² - fixed
- CC-2 < 1K dpm/100 cm² - smear
< 1K dpm/20 cm² - fixed
- CC-3 < 1K dpm/100 cm² - smear
< 1K dpm/20 cm² - fixed
- CC-4 < 1K dpm/100 cm² - smear
< 1K dpm/20 cm² - fixed

Results of Individual System Samples

DD MAIN STEAM SYSTEM [System # 83 M-208 SH2, M-209, M-210 SH1, HBD-85-5]

The Main Steam Safeties have the potential to discharge gaseous radwaste in the event of a Steam Generator (SG) tube rupture. The tail-pipes associated with safeties and relief valves are physically located within an area which is roped-off as a contaminated area. In the past, fixed contamination has been found in this area. The system sampling performed on the safeties dealt with the internal surfaces of the tail-pipes and the drain collection header drain line which is directed to the Dirty Radwaste system.

Five samples were collected. One from the common drain collection header and one from a safety for each SG.

Additionally, eight steam traps for the Main Steam header were sampled.

DD-1 Main Steam Safety Valve drain line to Dirty Radwaste in the MSSS across from the Electrical Penetration Area doorway and stops just above a floor drain to DRW.

DD-2 PSV-2211 tail pipe right next to the valve body.

DD-3 PSV-2271 tail pipe right next to the valve body.

DD-4 PSV-2251 tail pipe right next to the valve body.

DD-5 PSV-2231 tail pipe right next to the valve body.

SAMPLING RESULTS

NO ACTIVITY DETECTED IN SAMPLES DD-1 Through DD-5

DD-1 < 1K dpm/100 cm² - smear

< 1K dpm/20 cm² - fixed

DD-2 < 1K dpm/100 cm² - smear

< 1K dpm/20 cm² - fixed

DD-3 < 1K dpm/100 cm² - smear

< 1K dpm/20 cm² - fixed

DD-4 < 1K dpm/100 cm² - smear

< 1K dpm/20 cm² - fixed

DD-5 < 1K dpm/100 cm² - smear

< 1K dpm/20 cm² - fixed

Results of Individual System Samples

MAIN STEAM SYSTEM [System # 83] (Continued)

- X-2 Main steam lead drain steam trap ST-006 [M-209, M-210 SH1]
- X-3 Main steam lead drain steam trap ST-007
- X-4 Main steam lead drain steam trap ST-008
- X-5 Main steam lead drain steam trap ST-009
- X-6 Main steam b/p header drain steam trap ST-018
- X-7 Main steam b/p header drain steam trap ST-019
- X-8 Main steam b/p header drain steam trap ST-020
- X-9 Main steam b/p header drain steam trap ST-021

SAMPLING RESULTS

NO ACTIVITY DETECTED IN SAMPLES X-2 Through X-9

- X-2 <1K dpm/100 cm² - smear
<1K dpm/20 cm² - fixed
- X-3 <1K dpm/100 cm² - smear
<1K dpm/20 cm² - fixed
- X-4 <1K dpm/100 cm² - smear
<1K dpm/20 cm² - fixed
- X-5 <1K dpm/100 cm² - smear
<1K dpm/20 cm² - fixed
- X-6 <1K dpm/100 cm² - smear
<1K dpm/20 cm² - fixed
- X-7 <1K dpm/100 cm² - smear
<1K dpm/20 cm² - fixed
- X-8 <1K dpm/100 cm² - smear
<1K dpm/20 cm² - fixed
- X-9 <1K dpm/100 cm² - smear
<1K dpm/20 cm² - fixed

4.0 ACTIVATION ANALYSIS**4.1 Purpose**

This report details the calculations performed by TLG Services, Inc. (TLG) to estimate the neutron-induced radionuclide inventory in support of the Portland General Electric Company (PGE Co.) Trojan Nuclear Plant (TNP) decommissioning campaign. The calculations consist of one-dimensional neutron transport and point neutron activation analyses of the reactor vessel, its internals and the concrete primary shield wall. These calculations have been performed using the FISSPEC [10] and O2FLUX [11] computer codes, written by TLG; and the ANISN [12] and ORIGEN2 [13] computer codes, obtained through the Oak Ridge National Laboratory's Radiation Shielding Information Center (RSIC). Reduction of the output from these programs and ancillary calculations were performed using the ANISNOUT [14] and O2READ [15] computer codes, written by TLG, and the Microsoft EXCEL [16] computer code.

4.2 Approach

TLG estimated the neutron-induced radionuclide inventories at the TNP using a two-step analytical approach. The first step was to determine the magnitude and spectrum of the neutron flux beyond the boundaries of the reactor core. This was accomplished using the ANISN one-dimensional neutron transport computer code with five (5) radial and axial geometric models. The results of the radial transport calculations were normalized against plant-specific neutron flux data obtained from an available reactor vessel neutron fluence surveillance capsule report.

The ANISN outputs were subsequently collapsed into two-energy group formats (fast and thermal) and input into a series of ORIGEN2 point activation/depletion calculations. Additional input to the ORIGEN2 calculations included material compositions and historical plant performance data. Wherever possible, data obtained through Portland General Electric Company has been employed. The balance of the input data was extracted from available literature and is referenced as such, or interpolated from available data. Conservative assumptions were made and justified whenever actual plant data was not available.

4.3 Trojan Nuclear Plant Operating History and Cycle Data

The TNP operating history and performance data was obtained from PGE Co. The data received included operating data through shutdown at the end of Cycle 14 [17] and reactor vessel neutron fluence data through the end of Cycle 12 [18]. Since this study required a plant shutdown at the end of Cycle 14, TLG conservatively extrapolated the vessel fluence data through the end of Cycle 14.

SITE CHARACTERIZATION REPORT

REVISION 0.1

Data provided by PGE Co. [17] was employed in order to estimate the effective full power years (EFPY), cycle fuel assembly burnup and cycle efficiencies for each cycle through Cycle 14. TLG used the neutron fluence above 1 MeV measured at the vessel/clad interface ($2.37\text{E}+19$ neutrons/cm.² at the end of Cycle 12) provided in the surveillance capsule report in order to extrapolate out through the end of Cycle 14. TLG conservatively determined that at final shutdown, the maximum neutron fluence above 1 MeV at the vessel/clad interface was $2.69\text{E}+19$ neutrons/cm.² (Note: Average full power neutron fluxes at the core boundary over the life of the plant were based upon an adjusted 8.96 total EFPY, as determined from the surveillance capsule report and PGE Co. data. An unadjusted cumulative value of 9.075 EFPY, as determined from PGE Co.-provided cycle data, was used in the ORIGEN2 activation calculations. This higher EFPY value will produce slightly conservative results, but more accurately reflects the data provided TLG by PGE Co.) Based upon data derived from the surveillance capsule report, a capsule lead factor of 4.33 was established. TLG assumed an axial assembly peaking factor of 1.25 for the peripheral assemblies.

Due to the presence of thermal pads attached to outside of the core barrel, azimuthal peaking factors were determined for neutron transport calculation radial geometries including (1.18) and excluding (1.21) the thermal pads. Radial neutron transport calculations were performed for each geometry, and the results combined assuming 37.5% of the circumference to be covered by the thermal pads. The azimuthally and axially-averaged neutron flux above 1 MeV at the vessel/clad interface beyond the thermal pads used in the analysis was $1.49\text{E}+10$ neutrons/cm.²- sec. Similarly, the azimuthally and axially-averaged neutron flux above 1 MeV in those regions not "shadowed" by the thermal pads used in the analysis was $1.20\text{E}+10$ neutrons/cm.²- sec.

The TNP operating history as used in the activation analysis is presented in Table 4.3.1. Data provided by PGE Co. [17] was used to determine the makeup of the average assembly over the life of the plant. The 781 fuel bundles irradiated during the plant lifetime had an average initial enrichment of 3.151w/0 ²³⁵U and an average burnup of 31017 MWd/MTU. The average cycle length was 308 days (average 252 EFPD) and the average refueling outage was 143 days.

SITE CHARACTERIZATION REPORT

REVISION 0.1

**TABLE 4.3.1
TROJAN NUCLEAR PLANT OPERATING HISTORY**

<u>Cycle Number</u>	<u>Refuel Number</u>	<u>Start Date</u>	<u>End Date</u>	<u>Number Of Days</u>	<u>Cycle Burnup MWd/MTU</u>	<u>Number Of EFPD</u>	<u>Number Of EFPY</u>	<u>Cumulative EFPY</u>	<u>Cycle Efficiency %</u>	<u>Plant Capacity %</u>
1	1	12/15/78	3/17/79	823 290	15998	420.47	1.151	1.151	51.09%	37.78%
2	2	1/1/80	4/11/80	466 96	11180	290.68	0.796	1.947	62.38%	51.72%
3	3	7/16/80	5/1/81	289 76	9790	259.55	0.711	2.658	89.81%	71.11%
4	4	7/16/81	3/27/82	254 146	8393	227.17	0.622	3.280	89.44%	56.79%
5	5	8/20/82	1/22/83	155 173	5056	136.77	0.374	3.654	88.24%	41.70%
6	6	7/14/83	4/27/84	288 144	9438	255.30	0.699	4.353	88.65%	59.10%
7	7	9/18/84	5/2/85	226 63	7075	189.50	0.519	4.872	83.85%	65.57%
8	8	7/4/85	4/16/86	286 61	9799	261.29	0.715	5.587	91.36%	75.30%
9	9	6/16/86	4/1/87	289 146	10316	267.90	0.733	6.321	92.70%	61.59%
10	10	8/25/87	4/13/88	232 88	6954	181.67	0.497	6.818	78.31%	56.77%
11	11	7/10/88	4/6/89	270 111	9122	238.69	0.653	7.472	88.40%	62.65%
12	12	7/26/89	3/19/90	236 110	7428	194.71	0.533	8.005*	82.50%	56.27%
13	13	7/7/90	3/4/91	240 357	8125	212.80	0.583	8.587	88.67%	35.64%
14		2/24/92	11/9/92	259	6841	178.17	0.488	9.075**	68.79%	68.79%

* Surveillance capsule report indicates 7.89 EFPY at the end of Cycle 12.

** An adjusted value of 8.96 EFPY was used to calculate average neutron flux over the operating life of the plant.

4.4.1. Material Compositions

The neutron-induced radionuclide inventories of four structural material compositions evaluated in this analysis were: Type 304 stainless steel, pressure vessel carbon steel, concrete and plate (rebar) carbon steel. There are other materials used in the construction of the components in this analysis. However, from the research performed, there does not appear to be any other component of significant mass or proximity to the core which would significantly affect the results of this study.

The four material compositions used in this analysis may be found in Tables 4.4.1 through 4.4.4. The information in these tables was extracted from References [18,19,20,21].

SITE CHARACTERIZATION REPORT

REVISION 0.1

TABLE 4.4.1
MATERIAL COMPOSITION - TYPE 304 STAINLESS STEEL
Grams Per Gram Material

H		Ge		Eu	2.000E-08
He		As	1.940E-04	Gd	
Li	1.300E-07	Se	3.500E-05	Tb	4.700E-07
Be		Br	2.000E-06	Dy	1.000E-06
B		Kr		Ho	1.000E-06
C	3.000E-04	Rb	1.000E-05	Er	
N	4.520E-04	Sr	2.000E-07	Tm	
O		Y	5.000E-06	Yb	2.000E-06
F		Zr	1.000E-05	Lu	8.000E-07
Ne		Nb	8.900E-05	Hf	2.000E-06
Na	9.700E-06	Mo	2.600E-03	Ta	
Mg		Tc		W	1.860E-04
Al	1.000E-04	Ru		Re	
Si	1.000E-02	Rh		Os	
P	4.500E-04	Pd		Ir	
S	3.000E-04	Ag	2.000E-06	Pt	
Cl	7.000E-05	Cd		Au	
Ar		In		Hg	
K	3.000E-06	Sn		Tl	
Ca	1.900E-05	Sb	1.230E-05	Pb	6.700E-05
Sc	3.000E-08	Te		Bi	
Ti	6.000E-04	I		Po	
V	4.560E-04	Xe		At	
Cr	1.900E-01	Cs	3.000E-07	Rn	
Mn	2.000E-02	Ba	5.000E-07	Fr	
Fe	6.790E-01	La	2.000E-07	Ra	
Co	1.414E-03	Ce	3.710E-04	Ac	
Ni	1.000E-01	Pr		Th	1.000E-06
Cu	3.080E-03	Nd		Pa	
Zn	4.570E-04	Pm		U	2.000E-06
Ga	1.290E-04	Sm	1.000E-07		

TABLE 4.4.2
MATERIAL COMPOSITION - TROJAN NUCLEAR PLANT REACTOR VESSEL
STEEL
Grams Per Gram Material

H		Ge		Eu	3.100E-08
He		As	5.320E-04	Gd	
Li	3.000E-07	Se	7.000E-07	Tb	4.500E-07
Be		Br	8.500E-07	Dy	
B		Kr		Ho	8.000E-07
C	2.100E-03	Rb	4.800E-05	Er	
N	7.000E-06	Sr	1.500E-07	Tm	
O		Y	2.000E-05	Yb	1.000E-06
F		Zr	1.000E-05	Lu	2.000E-07
Ne		Nb	1.880E-05	Hf	2.100E-07
Na	2.300E-05	Mo	4.300E-03	Ta	1.300E-07
Mg		Tc		W	5.500E-06
Al	2.100E-04	Ru		Re	
Si	2.000E-03	Rh		Os	
P	1.100E-04	Pd		Ir	
S	1.600E-04	Ag	2.000E-06	Pt	
Cl	4.000E-05	Cd		Au	
Ar		In		Hg	
K	1.200E-05	Sn	7.000E-06	Tl	
Ca	1.400E-05	Sb	1.100E-05	Pb	8.200E-04
Sc	2.600E-07	Te		Bi	
Ti	2.000E-06	I		Po	
V	2.000E-06	Xe		At	
Cr	4.800E-04	Cs	2.000E-07	Rn	
Mn	1.275E-02	Ba	2.730E-04	Fr	
Fe	9.842E-1	La	1.000E-07	Ra	
Co	1.900E-04	Ce	1.000E-06	Ac	
Ni	6.000E-03	Pr		Th	1.800E-07
Cu	1.500E-03	Nd		Pa	
Zn	1.000E-04	Pm		U	2.000E-07
Ga	8.000E-05	Sm	1.700E-08		

TABLE 4.4.3
MATERIAL COMPOSITION - CARBON STEEL
Grams Per Gram Material

H		Ge		Eu	3.100E-08
He		As	5.320E-04	Gd	
Li	3.000E-07	Se	7.000E-07	Tb	4.500E-07
Be		Br	8.500E-07	Dy	
B		Kr		Ho	8.000E-07
C	2.900E-03	Rb	4.800E-05	Er	
N	8.400E-05	Sr	1.500E-07	Tm	
O		Y	2.000E-05	Yb	1.000E-06
F		Zr	1.000E-05	Lu	2.000E-07
Ne		Nb	1.880E-05	Hf	2.100E-07
Na	2.300E-05	Mo	5.600E-07	Ta	1.300E-07
Mg		Tc		W	5.500E-06
Al	3.300E-04	Ru		Re	
Si		Rh		Os	
P	5.000E-04	Pd		Ir	
S	5.000E-04	Ag	2.000E-06	Pt	
Cl	4.000E-05	Cd		Au	
Ar		In		Hg	
K	1.200E-05	Sn	7.000E-06	Tl	
Ca	1.400E-05	Sb	1.100E-05	Pb	8.200E-04
Sc	2.600E-07	Te		Bi	
Ti	2.000E-06	I		Po	
V	8.000E-05	Xe		At	
Cr	1.700E-03	Cs	2.000E-07	Rn	
Mn	1.000E-02	Ba	2.730E-04	Fr	
Fe	9.842E-1	La	1.000E-07	Ra	
Co	1.220E-04	Ce	1.000E-06	Ac	
Ni	6.600E-03	Pr		Th	1.800E-07
Cu	2.000E-03	Nd		Pa	
Zn	1.000E-04	Pm		U	2.000E-07
Ga	8.000E-05	Sm	1.700E-08		

TABLE 4.4.4
MATERIAL COMPOSITION - ORDINARY CONCRETE
Grams Per Gram Material

H	1.000E-02	Ge		Eu	5.500E-07
He		As	7.900E-06	Gd	
Li	2.000E-05	Se	9.200E-07	Tb	4.100E-07
Be		Br	2.400E-06	Dy	2.300E-06
B	2.000E-05	Kr		Ho	9.000E-07
C	1.000E-03	Rb	3.500E-05	Er	
N	1.200E-04	Sr	4.380E-04	Tm	
O	5.290E-01	Y	1.820E-05	Yb	1.400E-06
F		Zr	7.100E-05	Lu	2.700E-07
Ne		Nb	4.300E-06	Hf	2.200E-06
Na	1.600E-02	Mo	1.030E-05	Ta	4.400E-07
Mg	2.000E-03	Tc		W	1.400E-06
Al	3.400E-02	Ru		Re	
Si	3.370E-01	Rh		Os	
P	5.000E-03	Pd	3.000E-06	Ir	
S	3.100E-03	Ag	2.000E-07	Pt	
Cl	4.500E-05	Cd	3.000E-07	Au	
Ar		In		Hg	
K	1.300E-02	Sn	7.000E-06	Tl	
Ca	4.400E-02	Sb	1.800E-06	Pb	6.100E-05
Sc	6.500E-06	Te		Bi	
Ti	2.121E-03	I		Po	
V	1.030E-04	Xe		At	
Cr	1.090E-04	Cs	1.300E-06	Rn	
Mn	3.770E-04	Ba	9.500E-04	Fr	
Fe	1.400E-02	La	1.300E-05	Ra	
Co	9.800E-06	Ce	2.430E-05	Ac	
Ni	3.800E-05	Pr		Th	3.500E-06
Cu	2.500E-05	Nd		Pa	
Zn	7.500E-05	Pm		U	2.700E-06
Ga	8.800E-06	Sm	2.000E-06		

4.5 Activation Analysis Calculations

The activation analysis for the TNP implements an approach developed by TLG. This approach uses available facility neutron fluence data to assist in the prediction of point neutron activation in the reactor vessel, its internals and the primary shield wall. The Westinghouse Electric Corporation (Westinghouse) report titled "Analysis of Capsule V from the Portland General Electric Company Trojan Reactor Vessel Radiation Surveillance Program" [17] was used as the source of neutron fluence data, against which one-dimensional neutron transport calculations were normalized to obtain a radial flux map beyond the reactor core boundary. The use of spectral information from the one-dimensional neutron transport calculations provides realistic activation analysis results when compared against simple hand-calculations which assume a thermal-only neutron spectrum beyond the core boundary.

4.5.1 One-Dimensional Neutron Transport Calculations

The ANISN computer code was used to perform the one-dimensional neutron transport calculations required for this analysis. The personal computer version received from RSIC was validated by TLG personnel on in-house computers, and the calculations performed for this study were performed on similar equipment. The ANISN cylindrical geometry source was used in the radial model calculations, and the slab geometry source was employed for the axial model calculations.

The SAILOR [22] coupled neutron-gamma cross section library was the source of neutron cross sections used in this study. This library contains third-order Legendre coefficients of the scattering cross sections (P_3), in a 47-neutron and 20-gamma group structure. The data in this library were collapsed from a fine-group structure using weighting functions which represent the reactor vessel, its internals and the biological shield wall during reactor operation. This library was originally constructed expressly for performing pressure vessel fluence calculations and was used in the aforementioned Westinghouse study.

TLG used two company-developed computer codes to assist in the performance of the one-dimensional neutron transport calculations. The first of these codes is FISSPEC, which generates the fission spectrum required by this analysis as input to ANISN. FISSPEC allows selection of the Watt or Cranberg fission distribution formulations to calculate a normalized neutron energy spectrum from the fission of ^{235}U , in either the CASK-81 or BUGLE-80 (SAILOR) energy spectrum formats. The Cranberg formulation in the BUGLE-80 energy group structure chosen for this analysis, as output by FISSPEC, is given in Table 4.5.1

The second computer code, ANISNOUT, was employed to read the ANISN output and tabulate the information in a format capable of being imported into an EXCEL spreadsheet. In this tabulation process, ANISNOUT performed the following data manipulations:

- The 47-group neutron data were collapsed down to a 4-group format for each ANISN output zone. The 4-group format fluxes (one fast, two epithermal and one thermal) were later collapsed to a 2-group format in order to determine fast-to-total and thermal-to-total neutron flux ratios.
- The thermal neutron flux at the midpoint of each radial mesh interval was tabulated.
- The radius, right boundary flux, zone volume, zone thermal neutron flux and zone total neutron flux were extracted and tabulated.

Five one-dimensional models were constructed for the calculations. They are discussed in extensive detail later in this report.

4.5.2 Point Neutron Activation Calculations

The ORIGEN2 computer code was used to calculate the activation and depletion of radionuclides for components exposed to the reactor neutron flux. One-group neutron cross sections for forty-eight reactor types are available as input to the code, two of which have been used specifically for this study. The first of these one-group cross section sets is representative of a neutron spectrum collapsed across the reactor core of a PWR (PWRUS). The second is a thermal cross section set (THERMAL) containing only thermal neutron cross sections.

For each location or component of interest and for each material of interest, the volume-averaged total neutron flux (neutrons/cm²-sec) as calculated by ANISN was input into two ORIGEN2 calculations. One calculation used the PWRUS cross section set as input, the other used the THERMAL cross section set. Thermal curie per gram results generated were adjusted for local area temperatures to reflect the decrease of thermal absorption cross sections at elevated temperatures. Based upon the ANISN spectral results of thermal-to-fast neutron flux ratios, the two ORIGEN2 calculations were weighted to obtain location or component-specific neutron activation.

Curie estimates have been decayed to 9 November 1993, 9 November 1994, 9 November 1997 and 9 November 2011. These dates represent one (1), two (2), five (5) and nineteen (19) years after final shutdown (the last date also corresponding approximately to the expiration of the current license). Additional decays to 9 November 2018, 9 November 2020, 9 November 2025 and 9 November 2030 have been added for reference, representing twenty-six (26), twenty-eight (28), thirty-three (33) and thirty-eight (38) years after final shutdown.

4.5.3 Trojan Nuclear Plant Operating History

The operating history used in this analysis was obtained from data provided by PGE Co. The cycle efficiency factors, as calculated and given in Table 4.3.1, were used to adjust the ANISN-calculated

neutron fluxes prior to input into the ORIGEN2 runs. An average plant power level (represented by the efficiency factor) was assumed for each operating cycle, and the neutron fluxes from the ANISN runs were adjusted accordingly.

4.5.4 Trojan Nuclear Plant Radial ANISN Models

The radial one-dimensional neutron transport modeling of the TNP facility for this study included geometric and material considerations. This input data is described in further detail below. Many of the considerations and assumptions used in the radial models also apply to the axial ANISN models discussed later. Three radial models were constructed for this analysis. Two of these models explicitly portray the various components, radially outward from the reactor core. The third model consists of the reactor core surrounded by water. Figure 4.5.1 depicts the TNP component radial ANISN model geometry.

4.5.4.1 Radial Model Geometries

The two component radial models generally consist of the reactor core, the core baffle and formers, the core barrel, the reactor vessel cladding and wall, the primary shield wall and an outer vacuum boundary in cylindrical geometry. The mirror insulation surrounding the vessel has not been included in either of these models - its impact upon the total neutron flux and energy spectrum is deemed relatively insignificant. Additionally, the primary shield wall liner and rebar have not been modeled explicitly. Again, these components do not significantly impact the total neutron flux and energy spectrum. One of these models includes the thermal shield pads; the other replaced this model region with water.

Radial distances from the core centerline at the core mid-plane elevation for these components were used. Small components which may be found as part of the reactor internals (such as surveillance capsules) were not included in this model. Both models include all air and water gaps.

The third radial model consisted of a cylinder of core material, similar to the component radial models, bounded on the outside by four feet of cold leg reactor core coolant and a vacuum boundary. This model was used to generate ex-core radial neutron flux reduction factors for those components modeled in the component axial models (see Section 4.5.5 below).

Since ANISN allows only one source/shield geometry (either slab, spherical or cylindrical) in a given problem, the reactor core, core baffle and core formers were modeled individually as homogenized, concentric cylinders. The TNP reactor core, which consisted of 193 fuel assemblies, was homogenized to a solid right cylinder using the reactor fuel assembly pitch of 8.466 inches. The resulting cylinder has an outer radius of 66.36 inches. A 41 mil average water gap exists between the core baffle and reactor core as determined from data supplied by PGE Co. [23]. The core baffle used in the ANISN model has a calculated equivalent inner radius of 66.40 inches, and from data

supplied by PGE Co., a thickness of 1.125 inches. The core formers are homogenized with reactor coolant in the region between the core baffle and the inner radius of the core barrel (74 inches). The radial dimensions of the reactor core, core baffle and core formers are of critical importance to this activation analysis. A large fraction (greater than 85%) of the activated radionuclide content contained in total induced inventory is contained in the core baffle and formers. These dimensions also determine the magnitude of neutron spectrum thermalization at the core baffle, which significantly impacts the activation of this component.

The core barrel has an inner radius of 74 inches and a thickness of 2.38 inches. The model containing the thermal pads places them on the outside of the core barrel with a thickness of 2.75 inches. The model without the thermal pads replaces this region with reactor coolant. The stainless steel cladding on the reactor vessel wall has a nominal thickness of 0.1875 inches and an inner radius of 86.5 inches. The carbon steel vessel has a nominal thickness of 8.5 inches and an inner radius of 86.69 inches.

Beyond the reactor vessel and insulation in the two explicit radial models is the primary shield wall. The primary shield wall liner was neglected in the ANISN geometry models (however, its curie contents were calculated in an ORIGEN2 run). The primary shield wall concrete has an inner radius of 121 inches and is modeled as ordinary concrete, 72 inches thick.

4.5.4.2 Radial Model Compositions

TLG assumed the reactor core region of all TNP radial ANISN models to be comprised of three radial regions utilizing an in-out fuel loading strategy. Fuel with the least exposure resides in the core center, once-exposed fuel lies in the intermediate region and fuel with the highest exposure is found around the core periphery. The core composition was determined in part by running ORIGEN2 with an average fuel enrichment of 3.151w/o ^{235}U , and an average cycle burnup of 10.34 GWd/MTU. A core thermal output of 3411 MWt was used, at an average cycle length of 308 days (average 252 EFPD), and an average refueling outage of 143 days.

Beginning with fresh, once-exposed and twice-exposed fuel, resulting ^{235}U , ^{236}U , ^{238}U , ^{237}Np , ^{239}Pu , ^{240}Pu , ^{241}Pu and ^{242}Pu concentrations for each core region at mid-cycle (5.17, 15.51 and 25.85 GWd/MTU) were calculated using ORIGEN2. These data were extracted and used as ANISN input. A cycle linearly-averaged boron concentration of 541 ppm and coolant densities based upon a cold leg temperature of 552.5°F. and a hot leg temperature of 619.4°F. were used [17,24]. Coolant, clad, fuel and void fractions of the reactor core were determined from the core geometries and Westinghouse 17x17 standard fuel assembly data [25]. Table 4.5.2 contains the core region composition summary for the TNP radial ANISN models.

Compositions of the primary coolant, stainless steel, reactor vessel carbon steel and concrete components were derived or calculated from various sources [18, 19, 20, 21]. The compositions used as ANISN input for these materials in the current analysis have been summarized in Table 4.5.2.

4.5.4.3 Radial Model Calculations

Three radial ANISN calculations, corresponding to the three model geometries, were performed in the course of this analysis. Each of these models assumed an axially-averaged, flat core power distribution, with the total neutron source equal to that calculated by ORIGEN2 for a three-region core - an average core total neutron flux of $3.153\text{E}+14$ n/cm²-sec.

The output from the radial model ANISN runs was transferred to three EXCEL spreadsheets, one for each model. In the two component radial models, the total neutron fluxes in each model zone (component) were adjusted based upon the normalization of the model-calculated neutron flux above 1 MeV to the derived neutron flux above 1 MeV as discussed in Section 4.3 above. No normalization was performed for the radial water ANISN model, since this model was used only to provide radial flux reduction factors. The results of these calculations for the thermal neutron energy group (the energy group which most significantly influences activation for most radionuclides) are plotted in Figures 4.5.2, 4.5.3, and 4.5.4.

4.5.5 Trojan Nuclear Plant Axial ANISN Models

Two axial ANISN models in slab geometry were established for performing the axial neutron flux calculations. Figure 4.5.5 shows the TNP explicit axial ANISN model. Since no data was available (similar to the surveillance capsule/vessel fluence data) against which normalization could be performed, the axial model reactor core region assumed ORIGEN2-calculated neutron sources and a constant power distribution.

4.5.5.1 Axial Model Geometries

The two axial models constructed for this analysis included one which explicitly modeled the various components, axially away from the reactor core; and a second model consisting of the reactor core surrounded by water. The component radial model consisted of the reactor core and below it regions containing homogenized stainless steel and water as follows (from the bottom of the active fuel on down):

- Homogenized cold leg water and Zircaloy cladding.
- Homogenized cold leg water and fuel assembly bottom nozzle.
- Homogenized cold leg water and lower core plate.
- Homogenized cold leg water and lower core support columns.
- Homogenized cold leg water and lower core support.
- Homogenized cold leg water and steel below the core support.

- Cold leg water reflector region with vacuum boundary.

Moving upward from the active fuel, the component axial model included:

- Plenum region - homogenized void, hot leg water and Zircaloy cladding.
- Homogenized hot leg water and Zircaloy cladding.
- Homogenized hot leg water and fuel assembly top nozzle.
- Homogenized hot leg water and upper core plate.
- Homogenized hot leg water and upper core support columns.
- Hot leg water reflector region with vacuum boundary.

Similar to the radial modeling, an axial water model, consisting of the reactor core bounded on one side by six feet of cold leg water, and the other by six feet of hot leg water, was constructed. This model was used to generate ex-core axial neutron flux reduction factors for those components modeled in the component radial models.

4.5.5.2 Axial Model Compositions

The reactor core region of the TNP axial ANISN models consisted of an average of the three core regions defined for the radial model. The component model contained homogenized regions of water and steel above and below the reactor core. The volume of metal in these regions was established from drawings provided to TLG by PGE Co. and from Westinghouse fuel assembly data. Material composition for all axial models may be found in Table 4.5.2.

4.5.5.3 Axial Model Calculations

Two axial ANISN calculations, corresponding to the two model geometries, were performed for this analysis. Each of these models assumed an axially-averaged, flat core power distribution, with the total neutron source equal to that calculated by ORIGEN2 for a three-region core - an average core total neutron flux of $3.153E+14$ n/cm²-sec.

Output from the axial model ANISN runs was transferred to two EXCEL spreadsheets, one for each model. No normalization was performed for either axial model. The results of these calculations for the thermal neutron energy group (the energy group which most significantly influences activation for most radionuclides) are plotted in Figures 4.5.6 and 4.5.7.

4.5.6 Results

The thermal and total neutron fluxes for various components and locations of interest in this analysis were extracted from the ANISN output using ANISNOUT. Total neutron fluxes, as obtained from the ANISN calculations and normalized as discussed above, were input into a pair of ORIGEN2 problems for each component, location and/or material of interest. The total neutron fluxes input were corrected for the plant efficiency factors found in Table 4.3.1.

The fraction of neutron flux which fell into the thermal energy range was calculated for each component from the ANISN output data, along with the fraction of neutron flux greater than thermal energies. These spectrum fractions were then compared to the epithermal and thermal spectrum fractions found in the reactor core region of the radial and axial ANISN models. ORIGEN2 calculations for the core spectrum activation (PWRUS cross section library) and thermal spectrum activation (THERMAL library) for each component and material of interest were then performed. A composite neutron activation result based upon contributions from the two ORIGEN2 runs was subsequently calculated.

Resultant specific curie per gram radioactivity for various components, materials and locations of interest in this activation analysis have been reproduced in Section 4.7.

**TABLE 4.5.1
CRANBERG FISSION SPECTRUM**

<u>Group Number</u>	<u>Upper Energy (MeV)</u>	<u>Fission Spectrum</u>
1	1.7333E+01	3.0727E-05
2	1.4191E+01	1.3937E-04
3	1.2214E+01	8.8602E-04
4	1.0000E+01	2.1758E-03
5	8.6071E+00	5.0640E-03
6	7.4082E+00	1.4930E-02
7	6.0653E+00	2.9341E-02
8	4.9659E+00	7.8886E-02
9	3.6788E+00	7.5235E-02
10	3.0119E+00	4.2879E-02
11	2.7253E+00	4.5335E-02
12	2.4660E+00	1.9428E-02
13	2.3653E+00	3.9054E-03
14	2.3457E+00	2.3620E-02
15	2.2313E+00	7.1581E-02
16	1.9205E+00	7.0649E-02
17	1.6530E+00	8.9113E-02
18	1.3534E+00	1.1641E-01
19	1.0026E+00	6.4048E-02
20	8.2085E-01	2.7920E-02
21	7.4274E-01	4.8115E-02
22	6.0810E-01	3.8772E-02
23	4.9787E-01	4.3549E-02
24	3.6883E-01	2.26970E-02
25	2.9720E-01	3.2565E-02
26	1.8316E-01	1.7139E-02
27	1.1109E-01	8.4151E-03
28	6.7379E-02	4.0683E-03
29	4.0868E-02	1.1527E-03
30	3.1828E-02	6.5991E-04
31	2.6058E-02	2.0109E-04
32	2.4176E-02	2.3572E-04
33	2.1875E-02	6.2846E-04
34	1.5034E-02	5.6466E-04
35	7.1017E-03	1.8407E-04
36-47		0.000E+00

TABLE 4.5.2
TROJAN NUCLEAR PLANT REGION COMPOSITION SUMMARIES
FOR RADIAL AND AXIAL ANISN MODEL GEOMETRIES

<i>Fuel Region #1 (a/b-cm) Radial Model</i>		
U-235		1.804E-04
U-236		7.110E-06
U-238		6.646E-03
Np-237		5.013E-07
Pu-239		1.438E-05
Pu-240		1.475E-06
Pu-241		3.564E-07
Pu-242		1.361E-08
<i>Fuel Region #2 (a/b-cm) Radial Model</i>		
U-235		1.196E-04
U-236		1.750E-05
U-238		6.600E-03
Np-237		5.382E-07
Pu-239		2.654E-05
Pu-240		6.143E-06
Pu-241		4.018E-06
Pu-242		5.365E-07
<i>Fuel Region #3 (a/b-cm) Radial Model</i>		
U-235		7.580E-05
U-236		2.413E-05
U-238		6.549E-03
Np-237		5.975E-07
Pu-239		2.975E-05
Pu-240		8.712E-06
Pu-241		8.410E-06
Pu-242		2.257E-06
<i>Homogenized Fuel Region (a/b-cm) Axial Model</i>		
U-235		1.253E-04
U-236		1.625E-05
U-238		6.598E-03
Np-237		5.457E-07
Pu-239		2.356E-05
Pu-240		5.443E-06
Pu-241		4.262E-06
Pu-242		9.356E-07
<i>All Fuel Regions (a/b-cm) Both Models</i>		
H		2.839E-02
B-10		2.747E-06
O (in moderator)		1.419E-02
O (in fuel)		1.214E-02
Cr		1.203E-05
Fe		1.091E-05
Ni		2.946E-05
Zr		4.381E-03
<i>Downcomer, Bypass and Core Inlet Water Regions (a/b-cm) Both Models</i>		
H		4.896E-02
B-10		4.737E-06
O		2.448E-02

**TROJAN NUCLEAR PLANT REGION COMPOSITION SUMMARIES
FOR RADIAL AND AXIAL ANISN MODEL GEOMETRIES**

<i>Stainless Steel Regions (a/b-cm) Both Models</i>		
	Cr	1.760E-02
	Mn	1.754E-03
	Fe	5.857E-02
	Ni	8.207E-03
<i>Core Former Region (a/b-cm) Radial Model</i>		
	Volume Fraction Water	0.9154
	Volume Fraction Stainless Steel	0.0846
	H	4.482E-02
	B-10	4.336E-06
	O	2.241E-02
	Cr	1.489E-03
	Mn	1.484E-04
	Fe	4.955E-03
	Ni	6.943E-04
<i>Carbon Steel Regions (a/b-cm) Radial Model</i>		
	Mn	8.605E-04
	Fe	8.329E-02
<i>Concrete (a/b-cm) Radial Model</i>		
	H	1.374E-02
	O	4.580E-02
	Na	9.639E-04
	Al	1.745E-03
	Si	1.662E-02
	K	4.605E-04
	Ca	1.521E-03
	Fe	3.472E-04
<i>Core Exit Water Region (a/b-cm) Axial Model</i>		
	H	4.342E-02
	B-10	4.222E-06
	O	2.171E-02
<i>Plenum Region (a/b-cm) Axial Model</i>		
	H	2.664E-02
	B-10	2.591E-06
	O	1.332E-02
	Cr	2.650E-04
	Fe	2.402E-04
	Ni	6.486E-04
	Zr	4.109E-03
<i>Bottom Nozzle Region (a/b-cm) Axial Model</i>		
	H	4.059E-02
	B-10	3.947E-06
	O	2.029E-02
	Cr	3.010E-03
	Mn	2.999E-04
	Fe	1.002E-02
	Ni	1.403E-03

**TROJAN NUCLEAR PLANT REGION COMPOSITION SUMMARIES
FOR RADIAL AND AXIAL ANISN MODEL GEOMETRIES**

Top Nozzle Region (a/b-cm) Axial Model

H	3.021E-02
B-10	2.937E-06
O	1.510E-02
Cr	5.372E-03
Mn	4.697E-04
Fe	1.628E-02
Ni	2.074E-04

Lower Core Plate Region (a/b-cm) Axial Model

Volume Fraction Water	0.3139
Volume Fraction Stainless Steel	0.6861
H	1.537E-02
B-10	1.487E-06
O	7.683E-03
Cr	1.208E-02
Mn	1.203E-03
Fe	4.019E-02
Ni	5.631E-03

Lower Core Support Column Region (a/b-cm) Axial Model

Volume Fraction Water	0.9450
Volume Fraction Stainless Steel	0.0550
H	4.627E-02
B-10	4.477E-06
O	2.313E-02
Cr	9.676E-04
Mn	9.640E-05
Fe	3.219E-03
Ni	4.511E-04

Lower Core Support Region (a/b-cm) Axial Model

Volume Fraction Water	0.4261
Volume Fraction Stainless Steel	0.5739
H	2.086E-02
B-10	2.018E-06
O	1.043E-02
Cr	1.010E-02
Mn	1.007E-03
Fe	3.362E-02
Ni	4.710E-03

Region Below Lower Core Support (a/b-cm) Axial Model

Volume Fraction Water	0.9553
Volume Fraction Stainless Steel	0.0447
H	4.677E-02
B-10	4.525E-06
O	2.338E-02
Cr	7.871E-04
Mn	7.842E-05
Fe	2.619E-03
Ni	3.669E-04

**TROJAN NUCLEAR PLANT REGION COMPOSITION SUMMARIES
FOR RADIAL AND AXIAL ANISN MODEL GEOMETRIES**

Upper Core Plate Region (a/b-cm) Axial Model

Volume Fraction Water	0.4596
Volume Fraction Stainless Steel	0.5404
H	1.995E-02
B-10	1.931E-06
O	9.976E-03
Cr	9.514E-03
Mn	9.479E-04
Fe	3.166E-02
Ni	4.436E-03

Upper Core Support Column Region (a/b-cm) Axial Model

Volume Fraction Water	0.9494
Volume Fraction Stainless Steel	0.0506
H	4.122E-02
B-10	3.988E-06
O	2.061E-02
Cr	8.906E-04
Mn	8.873E-05
Fe	2.963E-03
Ni	4.152E-04

FIGURE 4.5.1
TROJAN NUCLEAR PLANT COMPONENT RADIAL ANISN MODEL GEOMETRY

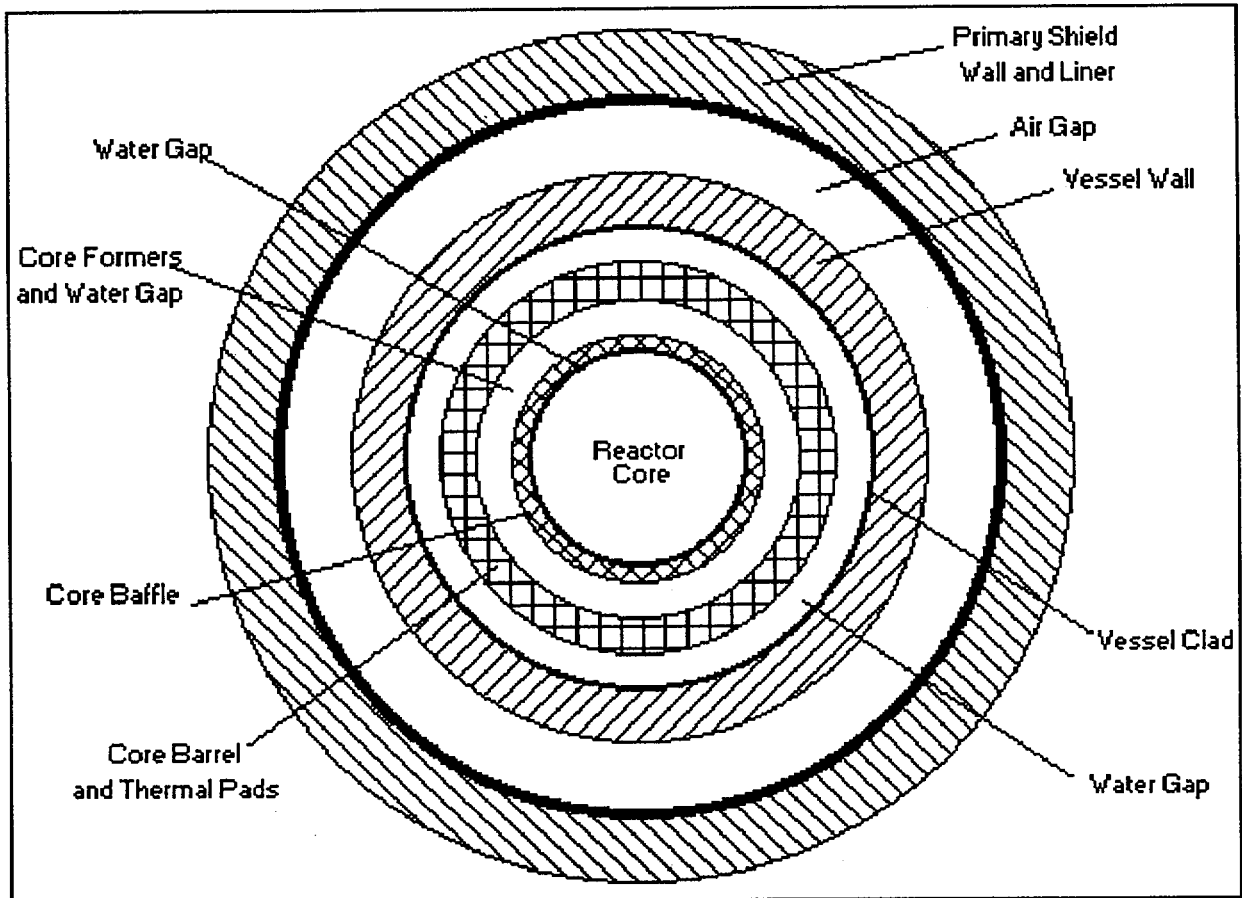

<u>Component</u>	<u>Outer Radius (cm.)</u>
Reactor Core	168.545
Water Gap	168.649
Core Baffle	171.507
Core Formers and Water Gap	187.960
Core Barrel	194.005
Thermal Pads	200.990
Water Gap	219.710
Vessel Clad	220.186
Vessel Wall	241.776
Air Gap	307.340
Primary Shield Wall (Liner and Rebar)	490.220

FIGURE 4.5.2
TROJAN NUCLEAR PLANT COMPONENT RADIAL ANISN MODEL
THERMAL NEUTRON FLUX - NEUTRON PADS

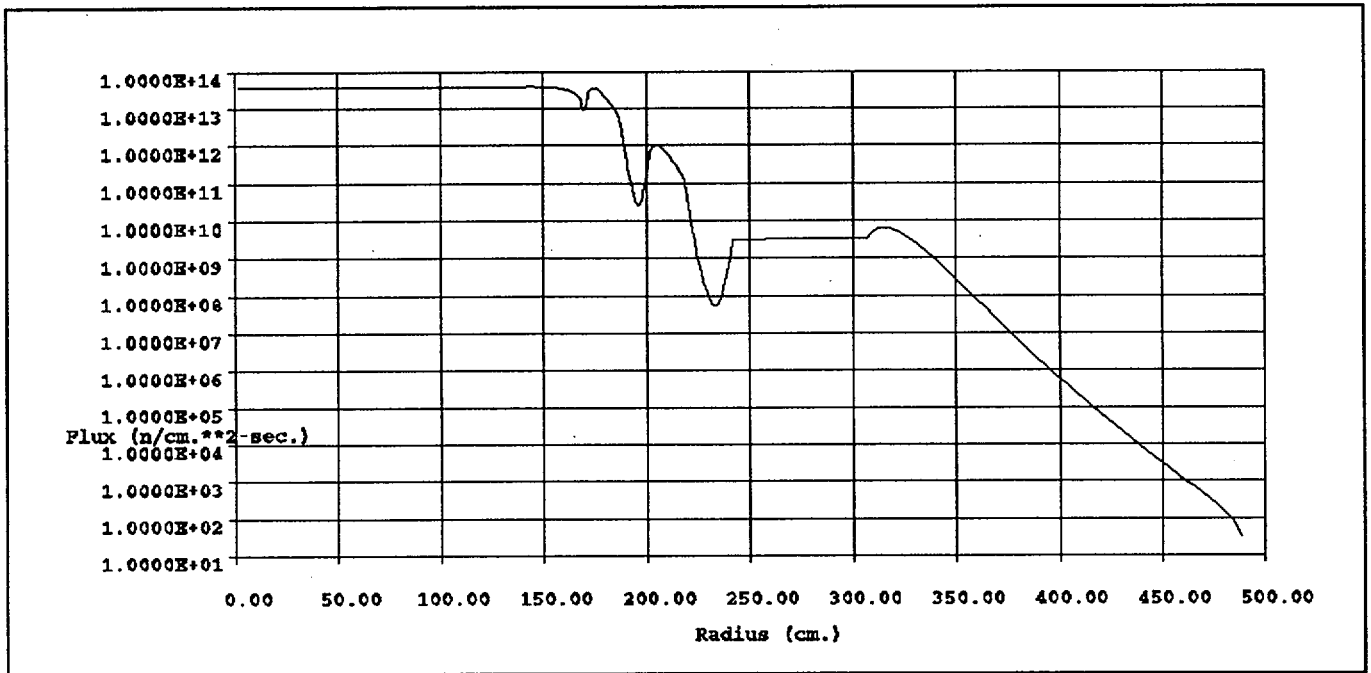

FIGURE 4.5.3

TROJAN NUCLEAR PLANT COMPONENT RADIAL ANISN MODEL
THERMAL NEUTRON FLUX - NO NEUTRON PADS

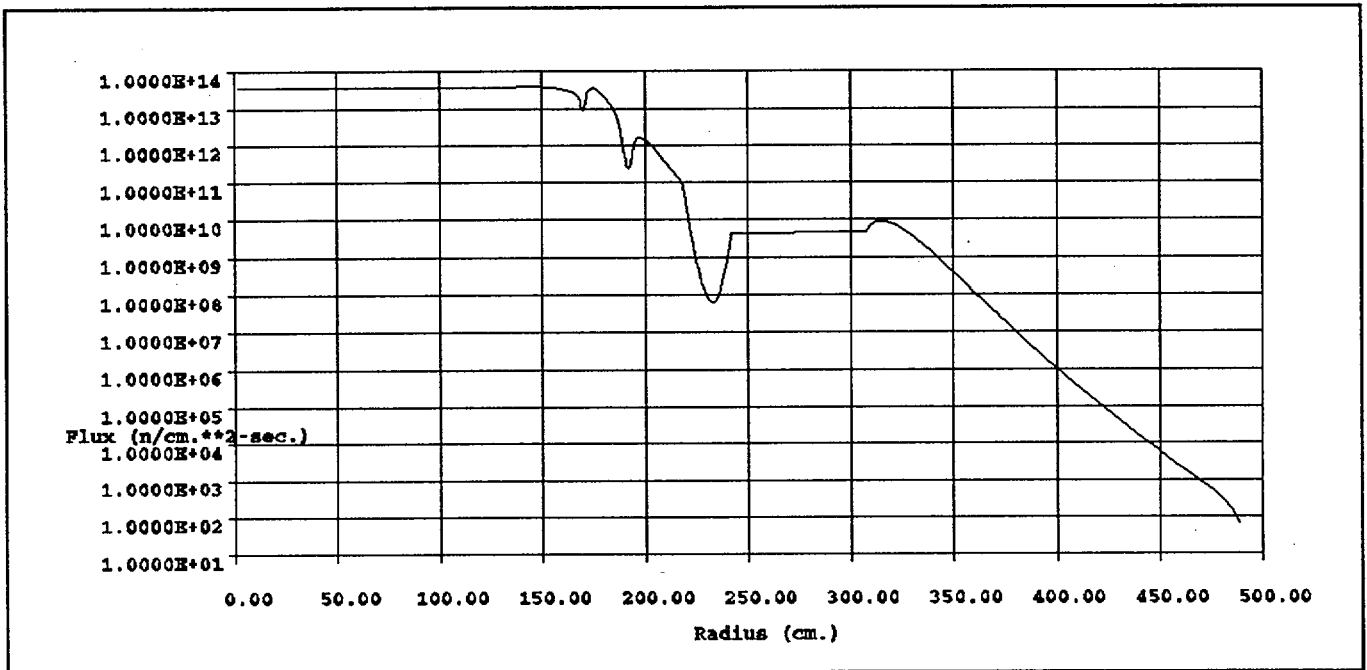

FIGURE 4.5.4

TROJAN NUCLEAR PLANT WATER RADIAL ANISN MODEL
THERMAL NEUTRON FLUX

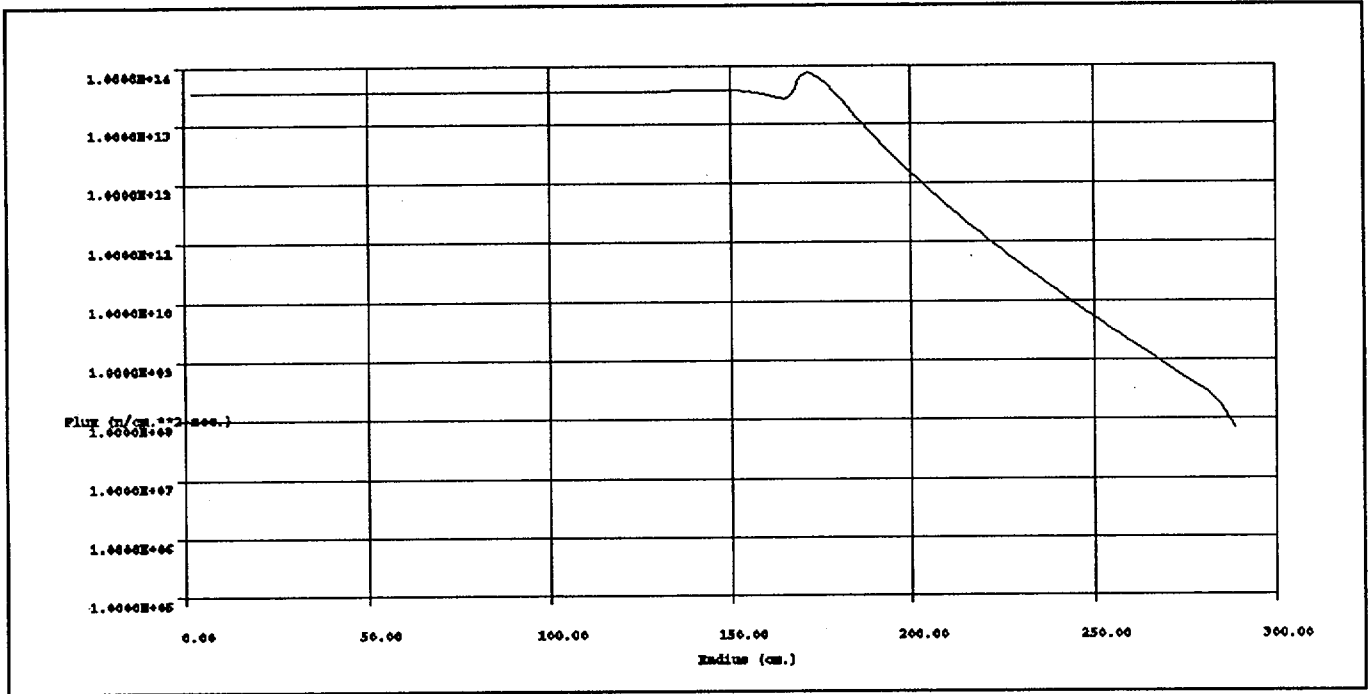
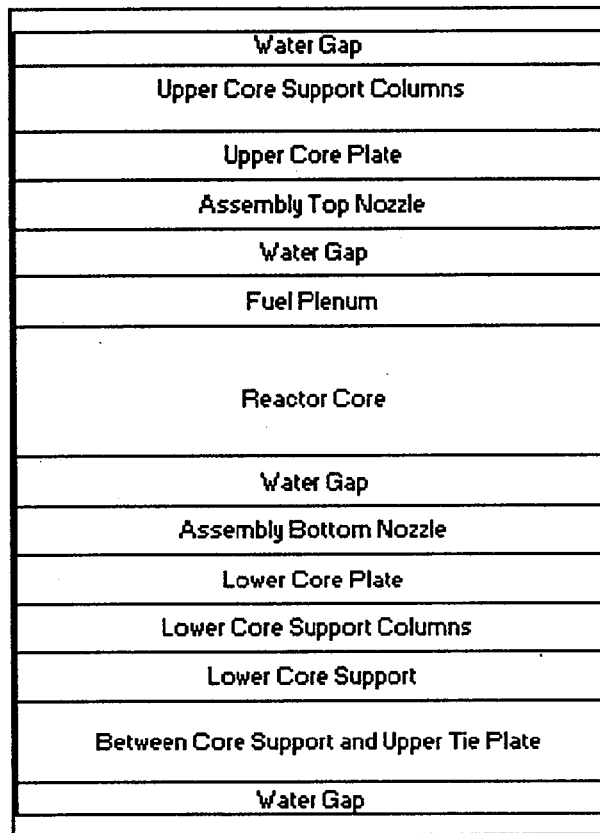

FIGURE 4.5.5
TROJAN NUCLEAR PLANT EXPLICIT AXIAL ANISN MODEL GEOMETRY



<u>Component</u>	<u>Outer Radius</u>
Water Reflector	30.480
Between Core Support and Upper Tie Plate	88.341
Lower Core Support	139.141
Lower Core Support Columns	198.196
Lower Core Plate	203.276
Fuel Assembly Bottom Nozzle	210.231
Water Gap	213.355
Reactor Core	579.115
Fuel Plenum	596.691
Water Gap	599.765
Fuel Assembly Top Nozzle	607.087
Upper Core Plate	616.707
Upper Core Support Columns	761.995
Water Reflector	792.475

FIGURE 4.5.6
TROJAN NUCLEAR PLANT COMPONENT AXIAL ANISN MODEL
THERMAL NEUTRON FLUX

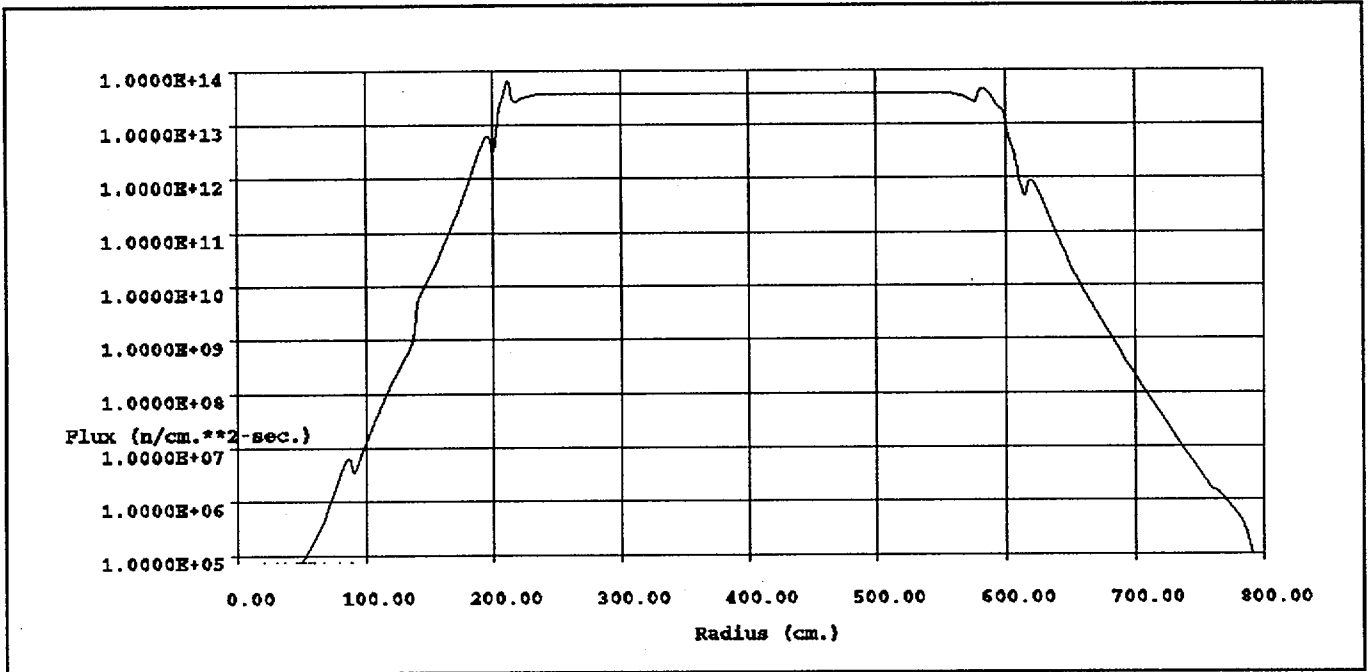
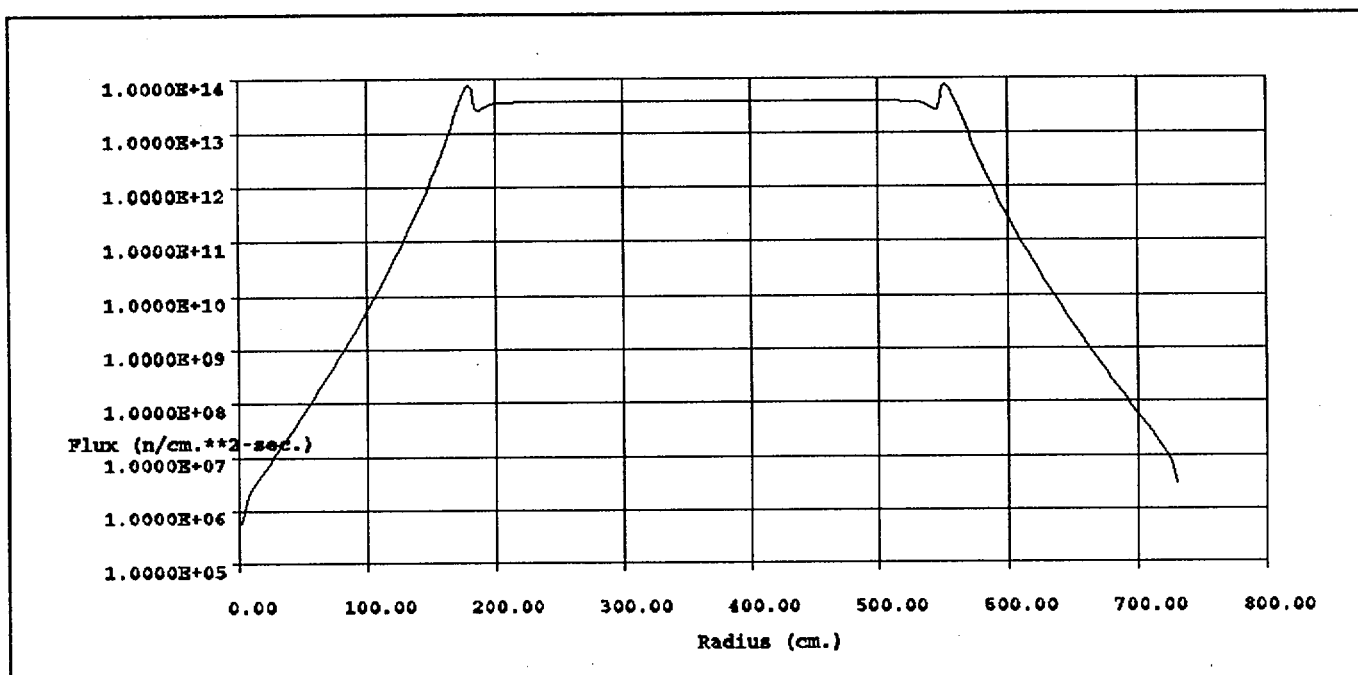

FIGURE 4.5.7

TROJAN NUCLEAR PLANT WATER AXIAL ANISN MODEL
THERMAL NEUTRON FLUX



4.6 COMPONENT DIMENSIONS AND MATERIALS

The Trojan Nuclear Plant is a large-size, Westinghouse pressurized-water nuclear reactor using four reactor coolant loops. This section describes each component within or immediately adjacent to the reactor vessel at TNP. The activation analysis model consists of portions of the reactor internals, the reactor vessel and the primary shield wall. Internal components outside the region of the activation analysis model are not described. Unless stated otherwise, all components are Type 304 stainless steel. Reactor internal components do not include the fuel assemblies, control element assemblies or the in-core instrumentation. These components are not within the scope of this analysis.

Many of the components in this study fall within two or more regions of the neutron activation analysis model and, as such, no single curie per gram value can be allocated to each component. The following describes the fifteen (15) individual components considered in the activation analysis model.

4.6.1 Core Baffle

The core baffle consists of a series of axial plates which are attached to the core barrel by the core formers (see below). The core baffle assembly provides lateral support for the fuel assemblies on the core periphery, as well as serving as a flow baffle by directing cooling water up through the core region and limiting bypass flow. The baffle consists of rectangular plates 1.125 inches thick, 154.94 inches long and of varying widths. The inside diameter of the cylindrical model used in the one-dimensional neutron transport analysis was 132.80 inches. The core baffle plates weight a total of 20684 pounds.

4.6.2 Core Formers

The core formers are basically structural support members, providing the form for the core baffle plates and attaching these plates to the core barrel. Core formers are located at several different elevations along the longitudinal axis of the reactor core. At each of eight (8) elevations, the formers consists of four units, for a total of thirty-two pieces. The formers weigh a total of 12740 pounds.

4.6.3 Core Barrel

The core barrel consist of two major sections, the upper and lower core barrels. The barrel is a right circular cylinder with a nominal inside diameter of 148 inches and a nominal wall thickness of 2.38 inches in the active core region. The activation analysis model includes all of the lower core barrel (61850 pounds) and a portion of the upper core barrel (14280 pounds).

The upper core barrel extends well beyond the upper boundary of the activation analysis model.

4.6.4 Thermal Pads

The TNP has thermal pads located at four azimuthal angles, attached to the outside of the lower core barrel. These thermal pads each consist of two pieces, and are axially centered on the reactor core midplane. Their purpose is to reduce the neutron flux to the vessel wall at locations where the core is closest radially to the wall. The thermal pads are 2.75 inches thick and 149.7 inches long. They cover approximately 135° azimuth, or about 37.5% of the circumference. The four sets of thermal pads weigh a total of 20950 pounds.

4.6.5 Lower Core Plate

The lower core plate supports the fuel assemblies from underneath, contacting the fuel assembly bottom nozzles. The plate is 2.00 inches thick and 146.66 inches diameter. The plate weighs 6700 pounds, and all of it was included in the activation analysis models.

4.6.6 Lower Core Support Columns

The region below the core support plate and above the core support contains the core support columns. Additionally, this region contains columns which support the travel path of instrumentation which is inserted into the reactor core. Conservative assumptions were made regarding the total weight of these columns. The regions was modeled 23.23 inches tall, and the weight of columns in this region used in the analysis was 5109 pounds.

4.6.7 Lower Core Support

The lower core support is a massive piece of metal which supports the entire weight of the reactor core, and some of the internal components. The support rests on radial supports welded to the reactor pressure vessel. A diameter of 151.75 inches, a thickness of 20 inches and an overall weight of 60000 pounds were determined from TNP drawings. All of its mass was included in the activation analysis model.

4.6.8 Region Below Core Support and Above Upper Tie Plate

This region below the lower core support contains fifty-six (56) instrument tubes and support columns. As with the lower core support column region, a conservative estimate was made of the total mass of stainless steel in this region. The region was modeled as being 22.78 inches tall, containing a total weight of 4072 pounds of metal.

4.6.9 Upper Core Plate

The upper core plate serves as the locating guide for the upper fuel assembly nozzles. The plate is 3.00 inches thick and 147.25 inches diameter. A weight from TNP drawings of 7980 pounds was used in this analysis.

4.6.10 Upper Core Support Columns

Above the upper core plate and attached to it, are the upper core support columns. These columns provide support for the control rod assemblies moved in and out of the core, as well as support for various pressure and temperature instrumentation. There are forty-eight (48) support columns and sixty-one (61) guide tubes in the region between the upper core plate and the upper support assembly. A conservative estimate of the mass of stainless steel was used in this activation analysis - 11569 pounds. This mass does not include all of the mass of the support tubes and guide columns which extend well beyond the upper bound of the analysis models.

4.6.11 Reactor Vessel Cladding

The reactor vessel is lined with a nominal 0.1875 inch cladding. This clad serves to prevent the carbon steel pressure vessel from directly contacting the reactor coolant. The inside diameter of the cladding is a nominal 173 inches. Approximately 8492 pounds of cladding were included in the activation analysis models.

4.6.12 Reactor Vessel

The reactor vessel consists of a cylindrical shell, a spherically-dished bottom head and a removable reactor closure head. The reactor closure head is approximately spherically-dished, and welded to a matching ring flange. The pressure vessel and its head are constructed of carbon steel. The reactor vessel has a nominal inside diameter of 173.38 inches and a minimum thickness of 8.50 inches at the core midplane. The activation analysis models included 396681 pounds of reactor vessel wall.

4.6.13 Reactor Insulation

Insulation surrounding the reactor pressure vessel consists of fiberglass, encased by 22 gauge stainless steel. Though not explicitly modeled, the activation of the insulation was calculated herein. The models included 2559 pounds of insulation (which does not include the weight of the fiberglass).

4.6.14 Primary Shield Wall Liner and First Layer of Shield Wall Rebar

The primary shield wall liner is a thin (0.25 inch) sheet of carbon steel affixed to the inner surface of the concrete primary shield wall. This liner protects the primary shield wall from direct exposure to environmental effects. The first layer of carbon steel rebar is found at a depth of approximately 5.00 inches into the concrete wall. This activation analysis did not explicitly model either component, assuming instead they (1) do not significantly perturb the magnitude or spectrum of the neutron flux, and (2) are both located 5.00 inches into the concrete (at a location of greater neutron thermalization).

4.6.15 Second Layer of Primary Shield Wall Rebar

The second layer of the primary shield wall carbon steel rebar is located approximately 17.00 inches into the concrete wall. Again, the same assumptions used for the first course of rebar, about the perturbation of the neutron flux by the presence of the rebar, was made here.

4.7 Activation Analysis Results

ANISN and ORIGEN2 calculations were performed following the methodology as outlined in Section 4.5, and using the input information from Sections 4.3, 4.4 and 4.6. The curie per gram values at plant shutdown for twenty (20) radial and six (6) axial components in the explicit models were input into an EXCEL spreadsheet. This spreadsheet calculated radionuclide contents in each region of the models for each component at reactor shutdown.

Additionally, this data was summed to obtain total curie contents by component, and manually decayed in the EXCEL spreadsheet to obtain radionuclide contents at various times after shutdown. This section presents the results of those calculations as well as some discussion of those results.

4.7.1 Curie Contents at Reactor Shutdown

ORIGEN2 outputs provided the curie per gram content for components in the various model regions. This data was subsequently transferred into an EXCEL spreadsheet to allow summation of the curie content for each component over all of the regions in the ANISN problem in which the component was modeled. Tables 4.7.1 through 4.7.26 present the relevant portions of this spreadsheet. Since the masses in each model region for each component are presented in these tables, the curie/gram specific concentrations for each radionuclide in each component region may be calculated.

4.7.2 Curie Contents at Various Times After Reactor Shutdown

The total curie content of each component has been summarized in Table 4.7.27 for reactor shutdown. Tables 4.7.28 through 4.7.31 present the summarized data for one (1), two (2) and five (5) years after shutdown, and at the end of the current license period (in the year 2011). Additional Tables 4.7.32 through 4.7.35 provide this data for twenty-six (26), twenty-eight (28), thirty-three (33) and thirty-eight (38) years after shutdown.

4.7.3 10 CFR Part 61 Classification

Tables 4.7.36 through 4.7.44 provide results of the 10 CFR Part 61 classification of the various components considered in this analysis, as a function of time. Note that the 10 CFR Part 61 classifications are based upon the sum of the regions considered in the activation analysis models.

As is clear from a review of these tables, none of the components will change classification over the thirty-eight (38) year decay period through 2030. Those components which are greater than Class C (GTCC), will remain so. The driver for classification is ^{63}Ni , in the 10 CFR Part 61 Table 2 sum of the fractions.

4.7.4 Discussion of Results

The neutron transport and activation calculations presented in this report estimate the neutron-induced activation of the reactor pressure vessel, internals and primary shield wall to be approximately 4.19 million curies one year after reactor shutdown. The bulk of the activation products are contained in the core baffle and formers, the lower core barrel and the lower core plate.

TABLE 4.7.1
CORE BAFFLE CURIE CONTENT AT SHUTDOWN

Location	Component		H-3 (Curies)	C-14	Ar-39	Ca-41	Ca-45	Mn-54	Fe-55	Co-60	Ni-59	Ni-63	Nb-94	Tc-99	Sn-118m	Sb-125	Te-125m	Eu-152	Total
	Volume (cm ³)	Mass (gm)																	
6th 12" Below Core																			
5th 12" Below Core																			
4th 12" Below Core																			
6th 8" Below Core																			
5th 8" Below Core																			
4th 8" Below Core																			
3rd 8" Below Core																			
2nd 8" Below Core																			
2nd 3" Below Core																			
1st 3" Below Core	2.937E+04	2.350E+05	3.487E+00	1.342E+00	2.584E+03	2.747E+04	1.033E+01	1.059E+03	1.600E+04	1.581E+04	6.024E+00	1.020E+03	2.515E+02	5.755E+03	6.072E+12	1.311E+02	6.237E+03	1.113E+04	3.390E+04
Reactor Core	1.080E+08	8.720E+08	3.014E+02	1.158E+02	2.227E+01	2.367E+02	8.903E+00	9.130E+04	1.379E+06	1.363E+06	5.192E+02	8.790E+04	2.168E+00	4.960E+01	5.233E+10	1.130E+00	5.376E+01	9.592E+03	2.922E+06
1st 3" Above Core	2.268E+04	1.814E+05	2.810E+00	1.078E+00	2.076E+03	2.207E+04	8.301E+02	8.512E+02	1.285E+04	1.271E+04	4.841E+00	8.195E+02	2.021E+02	4.825E+03	4.879E+12	1.054E+02	5.012E+03	8.943E+05	2.724E+04
2nd 3" Above Core	3.073E+04	2.458E+05	1.855E+00	6.348E+01	1.223E+03	1.300E+04	4.888E+02	5.013E+02	7.569E+03	7.483E+03	2.851E+00	4.826E+02	1.190E+02	2.723E+03	2.873E+12	6.205E+03	2.952E+03	5.266E+05	1.604E+04
2nd 6" Above Core																			
3rd 6" Above Core																			
4th 6" Above Core																			
5th 6" Above Core																			
6th 6" Above Core																			
4th 12" Above Core																			
5th 12" Above Core																			
6th 12" Above Core																			
Total	1.173E+08	9.382E+08	3.093E+02	1.187E+02	2.286E+01	2.430E+02	9.138E+00	9.371E+04	1.415E+06	1.398E+06	5.329E+02	9.022E+04	2.225E+00	5.091E+01	5.371E+10	1.160E+00	5.518E+01	9.845E+03	2.999E+06

TABLE 4.7.2
CORE FORMERS CURIE CONTENT AT SHUTDOWN

Location	Component	Component	H-3 (Curies)	C-14	Ar-39	Ca-41	Ca-45	Mn-54	Fe-55	Co-60	Ni-59	Ni-63	Nb-94	Tc-99	Sn-119m	Sb-125	Te-125m	Eu-152	Total	
	Volume (cm ³)	Mass (gm)																		
6th 12" Below Core																				
5th 12" Below Core																				
4th 12" Below Core																				
6th 6" Below Core																				
5th 6" Below Core																				
4th 6" Below Core																				
3rd 6" Below Core																				
2nd 6" Below Core																				
2nd 3" Below Core																				
1st 3" Below Core																				
Reactor Core	5.748E+05	4.599E+08	1.104E+02	6.681E+01	4.984E-02	1.477E-02	5.283E+00	1.154E+04	8.279E+05	4.435E+05	2.490E+02	4.728E+04	5.413E-01	7.287E-02	2.544E-11	1.700E-01	1.047E-01	1.450E-01	1.331E-01	1.331E+06
1st 3" Above Core																				
2nd 3" Above Core	1.474E+05	1.179E+08	5.513E+00	3.336E+00	2.489E-03	7.373E-04	2.638E-01	5.761E+02	4.134E+04	2.215E+04	1.243E+01	2.361E+03	2.703E-02	3.639E-03	1.270E-12	8.487E-03	5.230E-03	7.240E-03	6.844E-03	6.844E+04
2nd 6" Above Core																				
3rd 6" Above Core																				
4th 6" Above Core																				
5th 6" Above Core																				
6th 6" Above Core																				
4th 12" Above Core																				
5th 12" Above Core																				
6th 12" Above Core																				
Total	7.223E+05	5.779E+08	1.159E+02	7.014E+01	5.233E-02	1.550E-02	5.547E+00	1.211E+04	8.692E+05	4.658E+05	2.614E+02	4.964E+04	5.683E-01	7.651E-02	2.671E-11	1.785E-01	1.100E-01	1.522E-01	1.387E-01	1.387E+06

TABLE 4.7.3
LOWER CORE BARREL CURIE CONTENT AT SHUTDOWN

Location	Component		H-3 (Curies)	C-14	Ar-39	Ca-41	Ca-45	Mn-54	Fe-55	Co-60	Ni-59	Ni-63	Nb-94	Tc-99	Sn-119m	Sb-125	Te-125m	Eu-152	Total
	Volume (cm ³)	Mass (gm)																	
6th 12" Below Core																			
5th 12" Below Core																			
4th 12" Below Core																			
6th 6" Below Core																			
5th 6" Below Core	9.333E+04	7.466E+05	3.872E-04	6.337E-05	2.618E-07	1.294E-08	4.851E-06	6.018E-02	7.574E-01	8.836E-01	3.489E-04	5.089E-02	1.289E-06	3.266E-07	3.414E-21	2.952E-08	1.322E-08	5.431E-05	1.743E+00
4th 6" Below Core	1.037E+05	8.296E+05	2.132E-03	3.489E-04	1.441E-06	7.123E-08	2.671E-05	2.763E-01	4.170E+00	4.865E+00	1.921E-03	2.801E-01	7.098E-06	1.798E-06	1.879E-20	1.626E-07	7.277E-08	2.990E-04	9.596E+00
3rd 6" Below Core	1.037E+05	8.296E+05	1.239E-02	2.028E-03	8.377E-06	4.140E-07	1.553E-04	1.806E+00	2.424E+01	2.828E+01	1.117E-02	1.628E+00	4.126E-05	1.045E-05	1.092E-19	9.449E-07	4.230E-07	1.738E-03	5.578E+01
2nd 8" Below Core	1.037E+05	8.296E+05	9.780E-02	1.601E-02	6.612E-05	3.268E-06	1.225E-03	1.268E+01	1.913E+02	2.232E+02	8.812E-02	1.285E+01	3.256E-04	8.249E-04	8.623E-19	7.458E-06	3.339E-06	1.372E-02	4.402E+02
2nd 3" Below Core	5.182E+04	4.146E+05	2.374E-01	3.885E-02	1.605E-04	7.932E-06	2.974E-03	3.076E+01	4.843E+02	5.417E+02	2.139E-01	3.119E+01	7.904E-04	2.002E-04	2.093E-18	1.810E-05	8.103E-06	3.330E-02	1.069E+03
1st 3" Below Core	5.182E+04	4.146E+05	6.301E-01	1.031E-01	4.260E-04	2.105E-05	7.895E-03	8.167E+01	1.233E+03	1.438E+03	5.678E-01	8.280E+01	2.098E-03	5.315E-04	5.556E-18	4.805E-05	2.151E-05	8.839E-02	2.837E+03
Reactor Core	2.488E+08	1.991E+07	7.027E+01	1.150E+01	4.751E-02	2.348E-03	8.804E-01	9.107E+03	1.375E+05	1.604E+05	6.332E+01	9.233E+03	2.340E-01	5.927E-02	6.195E-16	5.358E-03	2.399E-03	9.857E+00	3.163E+05
1st 3" Above Core	5.182E+04	4.146E+05	6.558E-01	1.073E-01	4.433E-04	2.191E-05	8.216E-03	8.499E+01	1.283E+03	1.497E+03	5.909E-01	8.616E+01	2.183E-03	5.531E-04	5.781E-18	5.000E-05	2.239E-05	9.199E-02	2.952E+03
2nd 3" Above Core	5.182E+04	4.146E+05	2.850E-01	4.684E-02	1.927E-04	9.522E-06	3.571E-03	3.693E+01	5.575E+02	6.504E+02	2.568E-01	3.745E+01	9.489E-04	2.404E-04	2.513E-18	2.173E-05	9.728E-06	3.998E-02	1.283E+03
2nd 6" Above Core	1.037E+05	8.296E+05	1.374E-01	2.248E-02	9.288E-05	4.590E-06	1.721E-03	1.780E+01	2.687E+02	3.135E+02	1.238E-01	1.805E+01	4.574E-04	1.159E-04	1.211E-18	1.048E-05	4.690E-06	1.927E-02	6.184E+02
3rd 6" Above Core	1.037E+05	8.296E+05	2.065E-02	3.380E-03	1.396E-05	6.900E-07	2.587E-04	2.876E+00	4.040E+01	4.713E+01	1.861E-02	2.714E+00	6.876E-05	1.742E-05	1.821E-19	1.575E-06	7.050E-07	2.897E-03	9.286E+01
4th 6" Above Core	1.037E+05	8.296E+05	4.101E-03	6.711E-04	2.772E-06	1.370E-07	5.138E-05	5.315E-01	8.022E+00	9.358E+00	3.695E-03	5.389E-01	1.365E-05	3.459E-06	3.618E-20	3.127E-07	1.400E-07	5.753E-04	1.846E+01
5th 6" Above Core	9.554E+04	7.643E+05	8.695E-04	1.423E-04	5.878E-07	2.905E-08	1.089E-05	1.127E-01	1.701E+00	1.984E+00	7.835E-04	1.143E-01	2.895E-06	7.334E-07	7.666E-21	6.630E-08	2.968E-08	1.220E-04	3.914E+00
6th 6" Above Core																			
4th 12" Above Core																			
5th 12" Above Core																			
6th 12" Above Core																			
Total	3.507E+06	2.805E+07	7.235E+01	1.184E+01	4.891E-02	2.418E-03	9.065E-01	9.377E+03	1.415E+05	1.651E+05	6.519E+01	9.507E+03	2.409E-01	6.103E-02	6.379E-16	5.517E-03	2.470E-03	1.015E+01	3.257E+05

TABLE 4.7.4
UPPER CORE BARREL CURIE CONTENT AT SHUTDOWN

Location	Component		H-3 (Curies)	C-14	Ar-39	Ca-41	Ca-45	Mn-54	Fe-55	Co-60	Ni-59	Ni-63	Nb-94	Tc-99	Sn-119m	Sb-125	Te-125m	Eu-152	Total		
	Volume	Mass																			
	(cm ³)	(gm)																			
6th 12" Below Core																					
5th 12" Below Core																					
4th 12" Below Core																					
6th 6" Below Core																					
5th 6" Below Core																					
4th 6" Below Core																					
3rd 6" Below Core																					
2nd 6" Below Core																					
2nd 3" Below Core																					
1st 3" Below Core																					
Reactor Core																					
1st 3" Above Core																					
2nd 3" Above Core																					
2nd 6" Above Core																					
3rd 6" Above Core																					
4th 6" Above Core																					
5th 6" Above Core	3.572E+04	2.858E+05	3.251E-04	5.320E-05	2.198E-07	1.088E-08	4.073E-06	4.213E-02	6.359E-01	7.419E-04	2.929E-04	4.272E-02	1.082E-06	2.742E-07	2.866E-21	2.479E-08	1.110E-08	4.660E-05	1.463E+00		
6th 6" Above Core	1.108E+05	8.846E+05	2.563E-04	4.194E-05	1.733E-07	8.663E-09	3.211E-06	3.321E-02	5.013E-01	5.849E-01	2.309E-04	3.388E-02	8.533E-07	2.182E-07	2.280E-21	1.954E-08	8.749E-09	3.595E-05	1.154E+00		
4th 12" Above Core	2.211E+05	1.769E+06	9.131E-05	1.494E-05	6.173E-08	3.051E-09	1.144E-06	1.183E-02	1.788E-01	2.084E-01	8.227E-05	1.200E-02	3.040E-07	7.701E-08	8.050E-22	6.962E-09	3.117E-09	1.281E-05	4.110E-01		
5th 12" Above Core	2.211E+05	1.769E+06	8.392E-08	1.373E-08	5.673E-09	2.804E-10	1.051E-07	1.088E-03	1.641E-02	1.915E-02	7.561E-06	1.103E-03	2.794E-08	7.078E-09	7.399E-23	6.399E-10	2.865E-10	1.177E-06	3.777E-02		
6th 12" Above Core	2.211E+05	1.769E+06	8.667E-07	1.418E-07	5.860E-10	2.896E-11	1.086E-08	1.123E-04	1.695E-03	1.978E-03	7.810E-07	1.139E-04	2.886E-09	7.310E-10	7.642E-24	6.609E-11	2.959E-11	1.216E-07	3.802E-03		
Total	8.097E+05	6.477E+06	6.820E-04	1.116E-04	4.610E-07	2.279E-08	8.544E-06	8.838E-02	1.334E+00	1.556E+00	6.145E-04	8.961E-02	2.271E-06	5.752E-07	6.012E-21	5.200E-08	2.328E-08	9.568E-05	3.070E+00		

TABLE 4.7.5
THERMAL SHIELD PADS CURIE CONTENT AT SHUTDOWN

Location	Component	Component	Component																Total
	Volume (cm ³)	Mass (gm)	H-3 (Curies)	C-14	Ar-39	Ca-41	Ca-45	Mn-54	Fe-55	Co-60	Ni-59	Ni-63	Nb-94	Tc-99	Sn-119m	Sb-125	Te-125m	Eu-152	
8th 12" Below Core																			
5th 12" Below Core																			
4th 12" Below Core																			
8th 6" Below Core																			
5th 6" Below Core																			
4th 6" Below Core																			
3rd 6" Below Core																			
2nd 6" Below Core																			
2nd 3" Below Core																			
1st 3" Below Core	2.262E+04	1.810E+05	1.448E-01	2.375E-02	1.002E-04	4.847E-06	1.817E-03	1.885E+01	2.839E+02	3.328E+02	1.313E-01	1.908E+01	4.850E-04	1.231E-04	9.640E-18	5.864E-06	2.622E-06	3.240E-02	6.549E+02
Reactor Core	1.143E+06	9.141E+08	1.696E+01	2.785E+00	1.175E-02	6.685E-04	2.132E-01	2.211E+03	3.329E+04	3.904E+04	1.540E+01	2.239E+03	5.688E-02	1.444E-02	1.131E-15	6.878E-04	3.076E-04	3.801E+00	7.682E+04
1st 3" Above Core	2.262E+04	1.810E+05	1.504E-01	2.471E-02	1.043E-04	5.044E-06	1.991E-03	1.962E+01	2.954E+02	3.464E+02	1.367E-01	1.986E+01	5.047E-04	1.281E-04	1.003E-17	6.103E-06	2.729E-06	3.372E-02	6.816E+02
2nd 3" Above Core																			
2nd 6" Above Core																			
3rd 6" Above Core																			
4th 6" Above Core																			
5th 6" Above Core																			
6th 6" Above Core																			
4th 12" Above Core																			
5th 12" Above Core																			
8th 12" Above Core																			
Total	1.189E+06	9.503E+06	1.725E+01	2.834E+00	1.198E-02	5.784E-04	2.169E-01	2.250E+03	3.387E+04	3.972E+04	1.567E+01	2.278E+03	5.787E-02	1.469E-02	1.150E-15	6.998E-04	3.129E-04	3.867E+00	7.816E+04

TABLE 4.7.6
VESSEL CLAD CURIE CONTENT AT SHUTDOWN

Location	Component	Component	H-3 (Curies)	C-14	Ar-39	Ca-41	Ca-45	Mn-54	Fe-55	Co-60	Ni-59	Ni-63	Nb-94	Tc-99	Sn-119m	Sb-125	Te-125m	Eu-152	Total
	Volume (cm ³)	Mass (gm)																	
6th 12" Below Core	2.006E+04	1.805E+05	1.964E-08	3.245E-09	5.358E-12	7.009E-13	2.540E-10	9.996E-07	4.018E-05	3.051E-05	1.942E-08	2.720E-06	3.626E-11	6.825E-12	5.112E-25	5.949E-13	3.359E-13	1.773E-09	7.446E-05
5th 12" Below Core	2.006E+04	1.805E+05	2.357E-07	3.893E-08	6.430E-11	8.410E-12	3.048E-09	1.199E-05	4.821E-04	3.661E-04	2.331E-07	3.263E-05	4.350E-10	7.950E-11	6.134E-24	7.139E-12	4.031E-12	2.127E-08	8.934E-04
4th 12" Below Core	2.006E+04	1.805E+05	3.198E-08	5.283E-07	8.724E-10	1.141E-10	4.136E-08	1.627E-04	6.541E-03	4.968E-03	3.182E-06	4.428E-04	5.903E-09	1.079E-09	8.322E-23	9.686E-11	5.469E-11	2.886E-07	1.212E-02
6th 6" Below Core	1.003E+04	8.024E+04	1.029E-05	1.700E-06	2.807E-09	3.672E-10	1.331E-07	5.237E-04	2.105E-02	1.599E-05	1.018E-05	1.425E-03	1.900E-08	3.471E-09	2.678E-22	3.117E-10	1.760E-10	9.288E-07	3.901E-02
5th 6" Below Core	1.003E+04	8.024E+04	4.555E-05	7.523E-06	1.242E-08	1.625E-09	5.889E-07	2.318E-03	9.315E-02	7.074E-05	4.503E-05	6.305E-03	8.406E-08	1.536E-08	1.185E-21	1.379E-09	7.788E-10	4.110E-06	1.728E-01
4th 6" Below Core	1.003E+04	8.024E+04	2.257E-04	3.727E-05	6.156E-08	8.051E-09	2.918E-06	1.148E-02	4.616E-01	3.505E-01	2.231E-04	3.124E-02	4.165E-07	7.611E-08	5.872E-21	6.834E-09	3.859E-09	2.037E-05	8.553E-01
3rd 6" Below Core	1.003E+04	8.024E+04	1.312E-03	2.167E-04	3.578E-07	4.880E-08	1.696E-05	6.675E-02	2.683E+00	2.037E+00	1.297E-03	1.816E-01	2.421E-06	4.424E-07	3.413E-20	3.973E-08	2.243E-08	1.184E-04	4.972E+00
2nd 6" Below Core	1.003E+04	8.024E+04	1.035E-02	1.710E-03	2.824E-06	3.894E-07	1.339E-04	5.268E-01	2.118E+01	1.608E+01	1.024E-02	1.433E+00	1.911E-05	3.492E-06	2.694E-19	3.135E-07	1.770E-07	9.343E-04	3.924E+01
2nd 3" Below Core	5.015E+03	4.012E+04	2.514E-02	4.153E-03	6.858E-06	8.970E-07	3.251E-04	1.279E+00	5.143E+01	3.905E+01	2.486E-02	3.481E+00	4.640E-05	8.480E-06	6.542E-19	7.614E-07	4.299E-07	2.269E-03	9.529E+01
1st 3" Below Core	5.015E+03	4.012E+04	6.874E-02	1.102E-05	1.821E-06	2.381E-06	8.630E-04	3.396E+00	1.365E+02	1.037E+02	6.589E-02	9.240E+00	1.232E-04	2.251E-05	1.737E-18	2.021E-08	1.141E-06	6.023E-03	2.530E+02
Reactor Core	2.407E+05	1.926E+06	7.440E+00	1.229E+00	2.029E-03	2.654E-04	9.620E-02	3.786E+02	1.522E+04	1.156E+04	7.356E+00	1.030E+03	1.373E-02	2.509E-03	1.936E-16	2.253E-04	1.272E-04	6.714E-01	2.820E+04
1st 3" Above Core	5.015E+03	4.012E+04	6.946E-02	1.147E-05	1.895E-06	2.478E-06	8.981E-04	3.534E+00	1.421E+02	1.079E+02	6.868E-02	9.615E+00	1.282E-04	2.342E-05	1.807E-18	2.103E-08	1.188E-06	6.288E-03	2.632E+02
2nd 3" Above Core	5.015E+03	4.012E+04	3.019E-02	4.986E-03	8.234E-06	1.077E-06	3.903E-04	1.536E+00	6.174E+01	4.688E+01	2.985E-02	4.179E+00	5.671E-05	1.018E-05	7.854E-19	9.141E-07	5.161E-07	2.724E-03	1.144E+02
2nd 6" Above Core	1.003E+04	8.024E+04	1.454E-02	2.402E-03	3.967E-06	5.189E-07	1.881E-04	7.400E+01	2.975E+01	2.259E+01	1.439E-02	2.013E+00	2.684E-05	4.905E-06	3.784E-19	4.404E-07	2.487E-07	1.312E-03	5.512E+01
3rd 6" Above Core	1.003E+04	8.024E+04	2.188E-03	3.611E-04	5.963E-07	7.800E-08	2.827E-05	1.112E-01	4.471E+00	3.396E+00	2.182E-03	3.027E-01	4.035E-06	7.373E-07	5.889E-20	6.621E-08	3.738E-08	1.973E-04	8.286E+00
4th 6" Above Core	1.003E+04	8.024E+04	4.341E-04	7.171E-05	1.184E-07	1.549E-06	5.614E-06	2.209E-02	8.879E-01	6.743E-01	4.293E-04	6.010E-02	8.012E-07	1.464E-07	1.130E-20	1.315E-08	7.423E-09	3.918E-05	1.645E+00
5th 6" Above Core	1.003E+04	8.024E+04	9.991E-05	1.650E-05	2.725E-08	3.585E-09	1.292E-06	5.084E-03	2.044E-01	1.552E-01	8.879E-05	1.383E-02	1.844E-07	3.370E-08	2.800E-21	3.026E-09	1.708E-09	9.017E-06	3.787E-01
6th 6" Above Core	1.003E+04	8.024E+04	2.545E-05	4.203E-06	6.941E-09	9.079E-10	3.291E-07	1.295E-03	5.205E-02	3.953E-02	2.516E-05	3.523E-03	4.696E-08	8.582E-09	6.821E-22	7.707E-10	4.351E-10	2.297E-06	9.645E-02
4th 12" Above Core	2.006E+04	1.805E+05	9.066E-06	1.497E-08	2.473E-09	3.234E-10	1.172E-07	4.613E-04	1.854E-02	1.408E-02	8.964E-06	1.255E-03	1.673E-08	3.058E-09	2.359E-22	2.746E-10	1.550E-10	8.182E-07	3.436E-02
5th 12" Above Core	2.006E+04	1.805E+05	8.332E-07	1.378E-07	2.273E-10	2.973E-11	1.077E-08	4.240E-05	1.704E-03	1.284E-03	8.239E-07	1.154E-04	1.538E-09	2.810E-10	2.168E-23	2.523E-11	1.425E-11	7.520E-08	3.158E-03
6th 12" Above Core	2.006E+04	1.805E+05	8.606E-08	1.421E-08	2.347E-11	3.070E-12	1.113E-09	4.379E-06	1.780E-04	1.337E-04	8.509E-08	1.191E-05	1.588E-10	2.902E-11	2.239E-24	2.806E-12	1.472E-12	7.767E-09	3.262E-04
Total	4.815E+05	3.852E+06	7.661E+00	1.265E+00	2.090E-03	2.733E-04	9.906E-02	3.898E+02	1.567E+04	1.190E+04	7.575E+00	1.061E+03	1.414E-02	2.584E-03	1.993E-16	2.320E-04	1.310E-04	6.913E-01	2.903E+04

TABLE 4.7.7
VESSEL WALL CURIE CONTENT AT SHUTDOWN

Location	Component	Component	H-3 (Curies)	C-14	Ar-39	Ca-41	Ca-45	Mn-54	Fe-55	Co-60	Ni-59	Ni-63	Nb-94	Tc-99	Sn-119m	Sb-125	Te-125m	Eu-152	Total
	Volume (cm ³)	Mass (gm)																	
6th 12" Below Core	9.550E+05	7.497E+08	1.425E-08	1.597E-11	1.755E-11	1.547E-13	5.658E-11	1.184E-06	1.783E-05	1.944E-06	3.430E-10	4.898E-08	4.490E-12	1.140E-11	1.884E-10	1.193E-10	2.706E-11	3.779E-08	2.083E-05
5th 12" Below Core	9.550E+05	7.497E+08	1.710E-07	1.918E-10	2.108E-10	1.856E-12	6.790E-10	1.420E-05	2.116E-04	2.333E-05	4.116E-09	5.997E-07	5.387E-11	1.388E-10	2.281E-09	1.432E-09	3.247E-10	4.535E-08	2.499E-04
4th 12" Below Core	9.550E+05	7.497E+08	2.320E-08	2.599E-09	2.857E-09	2.518E-11	8.212E-09	1.827E-04	2.870E-03	3.165E-04	5.585E-08	8.137E-06	7.309E-10	1.856E-09	3.088E-08	1.943E-08	4.405E-09	6.153E-07	3.391E-03
6th 6" Below Core	4.775E+05	3.749E+08	7.467E-08	8.385E-09	9.194E-09	8.103E-11	2.965E-08	6.202E-04	9.237E-03	1.019E-03	1.797E-07	2.619E-06	2.352E-09	5.971E-08	9.872E-08	6.253E-08	1.418E-08	1.980E-06	1.091E-02
5th 6" Below Core	4.775E+05	3.749E+08	3.305E-05	3.702E-08	4.068E-08	3.586E-10	1.312E-07	2.744E-03	4.088E-02	4.507E-03	7.953E-07	1.159E-04	1.041E-08	2.642E-08	4.368E-07	2.767E-07	6.273E-08	8.782E-06	4.829E-02
4th 6" Below Core	4.775E+05	3.749E+08	1.837E-04	1.834E-07	2.016E-07	1.777E-09	6.500E-07	1.360E-02	2.025E-01	2.233E-02	3.940E-06	5.742E-04	5.158E-08	1.309E-07	2.165E-06	1.371E-06	3.108E-07	4.342E-05	2.393E-01
3rd 6" Below Core	4.775E+05	3.749E+08	9.517E-04	1.066E-08	1.172E-06	1.033E-08	3.778E-06	7.904E-02	1.177E-00	1.298E-01	2.290E-05	3.337E-03	2.998E-07	7.611E-07	1.258E-06	7.869E-08	1.807E-06	2.524E-04	1.391E-00
2nd 6" Below Core	4.775E+05	3.749E+08	7.512E-03	8.414E-06	9.248E-06	8.151E-08	2.982E-05	6.238E-01	9.292E-00	1.025E-00	1.808E-04	2.634E-02	2.368E-06	6.007E-06	9.930E-05	6.290E-05	1.426E-05	1.992E-03	1.098E-01
2nd 3" Below Core	2.388E+05	1.874E+08	1.824E-02	2.043E-05	2.246E-05	1.980E-07	7.242E-05	1.515E-00	2.257E-01	2.488E-00	4.390E-04	6.397E-02	6.748E-06	1.459E-05	2.412E-04	1.527E-04	3.463E-05	4.837E-03	2.666E-01
1st 3" Below Core	2.388E+05	1.874E+08	4.842E-02	5.424E-05	5.982E-05	5.255E-07	1.922E-04	4.022E-00	5.990E-01	6.805E-00	1.165E-03	1.698E-01	1.525E-05	3.872E-05	6.402E-04	4.055E-04	9.193E-05	1.284E-02	7.076E-01
Reactor Core	1.146E+07	8.997E+07	5.398E+00	6.047E-03	6.846E-03	5.858E-05	2.143E-02	4.483E-02	6.877E-03	7.383E-02	1.299E-01	1.893E-01	1.700E-03	4.317E-03	7.136E-02	4.520E-02	1.025E-02	1.431E-00	7.898E-03
1st 3" Above Core	2.388E+05	1.874E+08	5.039E-02	5.845E-05	6.204E-05	5.468E-07	2.001E-04	4.185E-00	6.234E-01	6.874E-00	1.213E-03	1.787E-01	1.587E-05	4.030E-05	6.682E-04	4.220E-04	9.568E-05	1.336E-02	7.364E-01
2nd 3" Above Core	2.388E+05	1.874E+08	2.190E-02	2.453E-05	2.696E-05	2.377E-07	8.694E-05	1.818E-00	2.709E-01	2.987E-00	5.271E-04	7.680E-02	6.899E-06	1.751E-05	2.895E-04	1.834E-04	4.157E-05	5.807E-03	3.200E-01
2nd 6" Above Core	4.775E+05	3.749E+08	1.055E-02	1.182E-05	1.299E-05	1.145E-07	4.189E-05	8.763E-01	1.305E-01	1.439E-00	2.539E-04	3.700E-02	3.324E-06	8.438E-06	1.395E-05	8.835E-05	2.003E-05	2.798E-03	1.542E-01
3rd 6" Above Core	4.775E+05	3.749E+08	1.586E-03	1.777E-06	1.953E-06	1.721E-08	6.297E-06	1.317E-01	1.962E-00	2.164E-01	3.817E-05	5.562E-03	4.998E-07	1.268E-06	2.097E-05	1.328E-05	3.011E-06	4.208E-04	2.318E-00
4th 6" Above Core	4.775E+05	3.749E+08	3.150E-04	3.528E-07	3.878E-07	3.418E-09	1.250E-06	2.616E-02	3.898E-01	4.296E-02	7.580E-08	1.105E-03	9.922E-08	2.519E-07	4.164E-06	2.637E-06	5.979E-07	8.352E-05	4.603E-01
5th 6" Above Core	4.775E+05	3.749E+08	7.249E-05	8.120E-08	8.925E-08	7.866E-10	2.878E-07	6.020E-03	8.967E-02	9.888E-03	1.745E-06	2.542E-04	2.283E-08	5.797E-08	9.583E-07	6.070E-07	1.378E-07	1.922E-05	1.059E-01
6th 6" Above Core	4.775E+05	3.749E+08	1.846E-05	2.068E-08	2.273E-08	2.004E-10	7.330E-08	1.533E-03	2.284E-02	2.518E-03	4.443E-07	6.474E-06	5.816E-09	1.476E-08	2.441E-07	1.546E-07	3.505E-08	4.896E-08	2.698E-02
4th 12" Above Core	9.550E+05	7.497E+08	6.578E-08	7.368E-09	8.098E-09	7.138E-11	2.611E-08	5.463E-04	8.137E-03	8.972E-04	1.583E-07	2.307E-05	2.072E-09	5.260E-08	8.698E-08	5.508E-08	1.249E-08	1.744E-06	9.612E-03
5th 12" Above Core	9.550E+05	7.497E+08	6.045E-07	6.772E-10	7.443E-10	6.560E-12	2.400E-09	5.021E-05	7.478E-04	8.246E-05	1.455E-08	2.120E-06	1.804E-10	4.834E-10	7.992E-09	5.062E-09	1.148E-09	1.603E-07	8.834E-04
6th 12" Above Core	9.550E+05	7.497E+08	6.244E-08	6.994E-11	7.987E-11	6.776E-13	2.479E-10	5.186E-06	7.724E-05	8.517E-06	1.503E-09	2.190E-07	1.967E-11	4.993E-11	8.254E-10	5.228E-10	1.185E-10	1.858E-08	9.124E-05
Total	2.292E+07	1.799E+08	5.558E+00	6.226E-03	6.843E-03	6.031E-05	2.207E-02	4.616E-02	6.875E-03	7.581E-02	1.338E-01	1.949E-01	1.751E-03	4.445E-03	7.348E-02	4.654E-02	1.055E-02	1.474E-00	8.122E-03

TABLE 4.7.8
VESSEL INSULATION CURIE CONTENT AT SHUTDOWN

Location	Component	Component	H-3 (Curies)	C-14	Ar-39	Ca-41	Ca-46	Mn-54	Fe-55	Co-60	Ni-59	Ni-63	Nb-94	Tc-99	Sn-119m	Sb-125	Te-125m	Eu-152	Total
	Volume (cm ³)	Mass (gm)																	
6th 12" Below Core	6.045E+03 11	4.836E+04 14	3.408E-12	5.327E-14	1.251E-14	1.134E-15	4.146E-13	2.301E-09	6.541E-08	5.685E-08	3.210E-11	4.453E-09	7.229E-14	1.589E-14	8.324E-30	7.228E-18	3.814E-18	1.114E-11	1.291E-07
5th 12" Below Core	6.045E+03 10	4.836E+04 13	4.087E-11	6.393E-13	1.601E-13	1.361E-14	4.975E-12	2.781E-08	7.849E-07	6.822E-07	3.851E-10	5.344E-08	8.675E-13	1.806E-13	9.989E-29	8.673E-17	4.577E-17	1.337E-10	1.549E-06
4th 12" Below Core	6.045E+03 09	4.836E+04 10	5.645E-09	8.673E-10	2.037E-12	1.848E-13	6.751E-11	3.747E-07	1.085E-05	8.256E-06	5.225E-09	7.250E-07	1.177E-11	2.586E-12	1.355E-27	1.177E-27	6.209E-16	1.814E-09	2.102E-05
6th 6" Below Core	3.022E+03 08	2.418E+04 12	1.784E-08	2.791E-09	6.555E-12	5.942E-13	2.172E-10	1.206E-08	3.427E-05	2.979E-05	1.682E-08	2.333E-06	3.788E-11	8.323E-12	4.361E-27	3.787E-15	1.998E-15	5.837E-09	6.764E-05
5th 6" Below Core	3.022E+03 08	2.418E+04 11	7.896E-08	1.235E-08	2.901E-11	2.630E-12	9.813E-10	5.335E-06	1.517E-04	1.318E-04	7.441E-08	1.032E-05	1.678E-10	3.683E-11	1.930E-26	1.678E-14	8.843E-15	2.583E-08	2.993E-04
4th 6" Below Core	3.022E+03 07	2.418E+04 10	3.912E-07	6.120E-08	1.437E-10	1.303E-11	4.763E-09	2.844E-05	7.514E-04	6.531E-04	3.687E-07	5.116E-06	8.305E-10	1.825E-10	9.563E-26	8.303E-14	4.381E-14	1.280E-07	1.483E-03
3rd 6" Below Core	3.022E+03 06	2.418E+04 10	2.274E-07	3.557E-07	8.354E-10	7.573E-11	2.789E-08	1.537E-04	4.388E-03	3.796E-03	2.143E-06	2.974E-04	4.827E-09	1.061E-09	5.558E-25	4.826E-13	2.547E-13	7.440E-07	8.621E-03
2nd 6" Below Core	3.022E+03 05	2.418E+04 09	1.795E-05	2.808E-08	6.594E-09	5.977E-10	2.185E-07	1.213E-03	3.447E-02	2.996E-02	1.692E-05	2.347E-03	3.810E-08	8.372E-09	4.387E-24	3.809E-12	2.010E-12	5.872E-06	6.804E-02
2nd 3" Below Core	1.511E+03 05	1.209E+04 08	4.359E-05	6.819E-08	1.601E-08	1.452E-09	5.307E-07	2.945E-03	8.372E-02	7.277E-02	4.108E-05	5.700E-03	9.253E-08	2.033E-08	1.085E-23	9.251E-12	4.881E-12	1.426E-05	1.652E-01
1st 3" Below Core	1.511E+03 04	1.209E+04 05	1.167E-04	1.810E-05	4.251E-08	3.853E-09	1.409E-06	7.819E-03	2.222E-01	1.832E-01	1.090E-04	1.613E-02	2.456E-07	5.397E-08	2.828E-23	2.456E-11	1.298E-11	3.785E-05	4.386E-01
Reactor Core	7.254E+04 02	5.803E+05 03	1.290E-02	2.018E-06	4.738E-06	4.295E-07	1.570E-04	8.715E-01	2.477E-01	2.153E-01	1.218E-02	1.687E-00	2.738E-05	6.016E-06	3.153E-21	2.737E-09	1.444E-08	4.220E-03	4.889E-01
1st 3" Above Core	1.511E+03 04	1.209E+04 05	1.204E-04	1.884E-05	4.423E-08	4.010E-09	1.486E-06	8.136E-03	2.313E-01	2.010E-01	1.135E-04	1.675E-02	2.558E-07	5.617E-08	2.943E-23	2.558E-11	1.348E-11	3.939E-05	4.565E-01
2nd 3" Above Core	1.511E+03 05	1.209E+04 08	5.233E-05	8.186E-06	1.922E-08	1.743E-09	6.371E-07	3.536E-03	1.005E-01	8.736E-02	4.932E-05	6.843E-03	1.111E-07	2.441E-08	1.279E-23	1.111E-12	5.860E-12	1.712E-05	1.984E-01
2nd 6" Above Core	3.022E+03 05	2.418E+04 09	2.521E-05	3.944E-08	9.262E-09	8.396E-10	3.070E-07	1.704E-03	4.842E-02	4.209E-02	2.376E-05	3.297E-03	5.352E-08	1.176E-08	6.163E-24	5.351E-12	2.824E-12	8.248E-06	9.557E-02
3rd 6" Above Core	3.022E+03 06	2.418E+04 07	3.790E-06	5.929E-07	1.392E-10	1.262E-10	4.614E-08	2.561E-04	7.279E-03	6.327E-03	3.572E-06	4.956E-04	8.045E-09	1.768E-09	9.264E-25	8.044E-13	4.244E-13	1.240E-06	1.437E-02
4th 6" Above Core	3.022E+03 07	2.418E+04 10	7.526E-07	1.177E-07	2.765E-11	2.508E-11	9.163E-08	5.088E-05	1.446E-03	1.256E-03	7.093E-06	9.841E-05	1.598E-09	3.511E-10	1.840E-25	1.597E-13	8.429E-14	2.462E-07	2.853E-03
5th 6" Above Core	3.022E+03 07	2.418E+04 11	1.732E-07	2.710E-08	6.363E-11	5.768E-12	2.109E-09	1.170E-05	3.327E-04	2.892E-04	1.632E-07	2.265E-05	3.677E-10	8.080E-11	4.234E-26	3.676E-14	1.940E-14	5.667E-08	6.566E-04
6th 6" Above Core	3.022E+03 08	2.418E+04 11	4.412E-08	6.901E-09	1.621E-12	1.469E-12	5.371E-10	2.981E-06	8.473E-05	7.365E-05	4.158E-08	5.769E-06	9.365E-11	2.056E-11	1.078E-26	9.363E-15	4.941E-15	1.443E-08	1.672E-04
4th 12" Above Core	6.045E+03 08	4.836E+04 12	1.572E-08	2.459E-09	5.774E-13	5.234E-13	1.914E-10	1.062E-08	3.019E-05	2.624E-05	1.481E-08	2.055E-06	3.336E-11	7.331E-12	3.842E-27	3.336E-15	1.780E-15	5.142E-09	5.958E-05
5th 12" Above Core	6.045E+03 09	4.836E+04 13	1.444E-09	2.260E-10	5.306E-14	4.811E-14	1.759E-11	9.781E-08	2.774E-06	2.411E-06	1.361E-09	1.889E-07	3.066E-12	6.739E-13	3.531E-28	3.066E-16	1.618E-16	4.726E-10	5.476E-06
6th 12" Above Core	6.045E+03 10	4.836E+04 14	1.492E-10	2.334E-11	5.481E-15	4.868E-15	1.816E-12	1.008E-08	2.865E-07	2.491E-07	1.408E-10	1.951E-08	3.167E-13	6.959E-14	3.647E-29	3.166E-17	1.671E-17	4.881E-11	5.656E-07
Total	1.451E+05 02	1.161E+06 03	1.328E-02	2.077E-03	4.879E-06	4.423E-07	1.617E-04	8.974E-01	2.551E-01	2.217E-01	1.252E-02	1.737E-00	2.819E-05	6.195E-06	3.246E-21	2.819E-09	1.487E-08	4.345E-03	5.034E-01

TABLE 4.7.9
FIRST 3" PRIMARY SHIELD WALL CURIE CONTENT AT SHUTDOWN

Location	Component	Component	H-3 (Curies)	C-14	Ar-39	Ca-41	Ca-45	Mn-54	Fe-55	Co-60	Ni-59	Ni-63	Nb-94	Tc-99	Sn-119m	Sb-125	Te-125m	Eu-152	Total
	Volume (cm ³)	Mass (gm)																	
8th 12" Below Core	4.541E+05	1.044E+08	2.017E-07	6.197E-11	7.827E-10	9.980E-11	3.566E-08	6.895E-10	5.057E-08	1.118E-08	4.752E-13	6.436E-11	8.145E-14	9.395E-16	7.981E-12	5.436E-12	1.232E-12	1.021E-08	3.111E-07
5th 12" Below Core	4.541E+05	1.044E+08	2.421E-06	7.438E-10	9.392E-09	1.198E-09	4.278E-07	8.273E-09	6.068E-07	1.342E-07	6.702E-12	7.722E-10	9.774E-13	1.126E-14	9.577E-11	6.522E-11	1.478E-11	1.225E-07	3.733E-06
4th 12" Below Core	4.541E+05	1.044E+08	3.284E-05	1.009E-08	1.274E-07	1.625E-08	5.806E-06	1.123E-07	8.234E-06	1.820E-06	7.736E-11	1.048E-08	1.328E-11	1.528E-09	1.299E-09	8.850E-10	2.008E-10	1.662E-06	5.064E-05
8th 6" Below Core	2.270E+05	5.222E+05	1.057E-04	3.247E-08	4.101E-07	5.229E-08	1.888E-05	3.612E-07	2.650E-05	5.858E-06	2.490E-10	3.372E-08	4.268E-11	4.917E-13	4.181E-09	2.848E-09	6.454E-10	5.349E-06	1.630E-04
5th 6" Below Core	2.270E+05	5.222E+05	4.677E-04	1.437E-07	1.815E-06	2.314E-07	8.268E-05	1.599E-08	1.173E-04	2.592E-05	1.102E-09	1.492E-07	1.888E-10	2.176E-12	1.850E-08	1.260E-08	2.856E-08	2.367E-05	7.212E-04
4th 6" Below Core	2.270E+05	5.222E+05	2.317E-03	7.119E-07	8.992E-06	1.146E-08	4.086E-04	7.920E-06	5.810E-04	1.284E-04	6.459E-09	7.393E-07	9.357E-10	1.078E-11	9.168E-08	6.244E-08	1.415E-08	1.173E-04	3.573E-03
3rd 6" Below Core	2.270E+05	5.222E+05	1.347E-02	4.138E-06	5.227E-05	6.664E-08	2.381E-03	4.604E-05	3.377E-03	7.466E-04	3.173E-08	4.297E-06	5.439E-09	6.266E-11	5.329E-07	3.630E-07	8.226E-08	6.817E-04	2.077E-02
2nd 6" Below Core	2.270E+05	5.222E+05	1.063E-01	3.266E-05	4.125E-04	5.260E-05	1.879E-02	3.634E-04	2.665E-02	5.893E-03	2.504E-07	3.392E-05	4.293E-08	4.946E-10	4.206E-06	2.865E-06	6.492E-07	5.380E-03	1.639E-01
2nd 3" Below Core	1.135E+05	2.611E+05	2.582E-01	7.931E-05	1.002E-03	1.277E-04	4.564E-02	8.825E-04	6.473E-02	1.431E-02	6.082E-07	8.237E-05	1.043E-07	1.201E-09	1.021E-05	6.957E-06	1.577E-06	1.307E-02	3.981E-01
1st 3" Below Core	1.135E+05	2.611E+05	6.854E-01	2.105E-04	2.659E-03	3.391E-04	1.212E-01	2.342E-03	1.718E-01	3.799E-02	1.614E-06	2.187E-04	2.767E-07	3.188E-09	2.712E-05	1.847E-05	4.185E-06	3.469E-02	1.057E+00
Reactor Core	5.449E+08	1.253E+07	7.640E+01	2.347E-02	2.964E-01	3.780E-02	1.351E+01	2.611E-01	1.915E+01	4.235E+00	1.800E-04	2.437E-02	3.085E-05	3.554E-07	3.023E-03	2.059E-03	4.665E-04	3.866E+00	1.178E+02
1st 3" Above Core	1.135E+05	2.611E+05	7.132E-01	2.191E-04	2.787E-03	3.529E-04	1.261E-01	2.438E-03	1.788E-01	3.953E-02	1.680E-06	2.275E-04	2.880E-07	3.318E-09	2.822E-05	1.922E-05	4.355E-06	3.610E-02	1.100E+00
2nd 3" Above Core	1.135E+05	2.611E+05	3.100E-01	9.522E-05	1.203E-03	1.533E-04	5.479E-02	1.059E-03	7.771E-02	1.718E-02	7.301E-07	9.889E-05	1.252E-07	1.442E-09	1.226E-05	8.352E-06	1.893E-06	1.569E-02	4.780E-01
2nd 6" Above Core	2.270E+05	5.222E+05	1.493E-01	4.588E-05	5.795E-04	7.388E-05	2.640E-02	5.104E-04	3.744E-02	8.278E-03	3.518E-07	4.784E-05	6.030E-08	6.847E-10	5.908E-06	4.024E-06	9.119E-07	7.558E-03	2.303E-01
3rd 6" Above Core	2.270E+05	5.222E+05	2.245E-02	6.896E-06	8.711E-05	1.111E-05	3.988E-03	7.673E-05	5.628E-03	1.244E-03	5.289E-08	7.182E-06	9.085E-09	1.044E-10	8.882E-07	6.049E-07	1.371E-07	1.136E-03	3.482E-02
4th 6" Above Core	2.270E+05	5.222E+05	4.458E-03	1.369E-06	1.730E-05	2.208E-06	7.880E-04	1.524E-05	1.118E-03	2.471E-04	1.050E-08	1.422E-06	1.800E-11	2.074E-07	1.764E-07	1.201E-07	2.722E-08	2.256E-04	6.874E-03
5th 6" Above Core	2.270E+05	5.222E+05	1.028E-03	3.152E-07	3.981E-06	5.076E-07	1.814E-04	3.507E-06	2.572E-04	5.887E-05	2.417E-09	3.273E-07	4.143E-10	4.773E-12	4.059E-08	2.765E-08	6.265E-09	5.192E-05	1.582E-03
6th 6" Above Core	2.270E+05	5.222E+05	2.613E-04	8.027E-08	1.014E-06	1.293E-07	4.619E-05	8.831E-07	6.551E-05	1.448E-05	6.155E-10	8.337E-08	1.055E-10	1.216E-12	1.034E-08	7.041E-09	1.596E-09	1.322E-05	4.030E-04
4th 12" Above Core	4.541E+05	1.044E+08	9.310E-05	2.860E-08	3.612E-07	4.606E-08	1.646E-05	3.182E-07	2.334E-05	5.160E-06	2.193E-10	2.970E-08	3.759E-11	4.331E-13	3.683E-09	2.509E-09	5.685E-10	4.711E-06	1.436E-04
5th 12" Above Core	4.541E+05	1.044E+08	8.556E-06	2.628E-08	3.320E-08	4.233E-09	1.512E-06	2.924E-08	2.145E-06	4.743E-07	2.015E-11	2.730E-09	3.455E-12	3.980E-14	3.385E-10	2.306E-10	5.225E-11	4.330E-07	1.319E-05
8th 12" Above Core	4.541E+05	1.044E+08	8.838E-07	2.715E-10	3.429E-09	4.372E-10	1.562E-07	3.020E-09	2.218E-07	4.898E-08	2.082E-12	2.819E-10	3.568E-13	4.111E-15	3.496E-11	2.381E-11	5.398E-12	4.472E-08	1.363E-06
Total	1.090E+07	2.508E+07	7.867E+01	2.417E-02	3.052E-01	3.892E-02	1.391E+01	2.689E-01	1.972E+01	4.360E+00	1.853E-04	2.510E-02	3.176E-05	3.660E-07	3.112E-03	2.120E-03	4.804E-04	3.981E+00	1.213E+02

TABLE 4.7.10
SECOND 3" PRIMARY SHIELD WALL CURIE CONTENT AT SHUTDOWN

Location	Component	Component	H-3 (Curies)	C-14	Ar-39	Ca-41	Ca-45	Mn-54	Fe-55	Co-60	Ni-59	Ni-63	Nb-94	Tc-99	Sn-119m	Sb-125	Te-125m	Eu-152	Total
	Volume (cm ³)	Mass (gm)																	
6th 12" Below Core	4.652E+05	1.070E+06	2.261E-07	6.837E-11	2.834E-10	1.112E-10	3.960E-08	2.584E-10	5.821E-08	1.073E-08	5.350E-13	7.149E-11	6.735E-14	3.805E-16	3.236E-12	2.542E-12	6.759E-13	1.083E-08	3.443E-07
5th 12" Below Core	4.652E+05	1.070E+06	2.713E-06	8.204E-10	3.520E-09	1.335E-09	4.752E-07	3.101E-09	6.745E-07	1.288E-07	6.420E-12	8.579E-10	8.082E-13	4.588E-15	3.883E-11	3.050E-11	6.911E-12	1.300E-07	4.131E-06
4th 12" Below Core	4.652E+05	1.070E+06	3.680E-05	1.113E-08	4.776E-08	1.811E-08	6.447E-06	4.207E-08	9.151E-06	1.747E-06	8.711E-11	1.164E-08	1.097E-11	6.185E-14	5.289E-10	4.139E-10	9.377E-11	1.763E-06	5.605E-05
6th 6" Below Core	2.326E+05	5.350E+05	1.184E-04	3.582E-08	1.537E-07	5.828E-08	2.075E-05	1.354E-07	2.945E-05	5.623E-06	2.803E-10	3.746E-08	3.529E-11	1.994E-13	1.696E-09	1.332E-09	3.018E-10	5.675E-06	1.804E-04
5th 6" Below Core	2.326E+05	5.350E+05	5.241E-04	1.585E-07	6.801E-07	2.579E-07	9.182E-05	5.991E-07	1.303E-04	2.488E-05	1.240E-09	1.658E-07	1.561E-10	8.822E-13	7.503E-09	5.894E-09	1.335E-09	2.511E-05	7.981E-04
4th 6" Below Core	2.326E+05	5.350E+05	2.597E-03	7.854E-07	3.370E-06	1.278E-06	4.549E-04	2.988E-06	6.457E-04	1.233E-04	6.146E-09	8.213E-07	7.737E-10	4.371E-12	3.718E-08	2.920E-08	6.816E-09	1.244E-04	3.955E-03
3rd 6" Below Core	2.326E+05	5.350E+05	1.510E-02	4.565E-06	1.959E-05	7.428E-06	2.844E-03	1.725E-05	3.753E-03	7.167E-04	3.573E-08	4.774E-06	4.497E-09	2.541E-11	2.161E-07	1.897E-07	3.846E-08	7.233E-04	2.299E-02
2nd 6" Below Core	2.326E+05	5.350E+05	1.191E-01	3.603E-05	1.546E-04	5.883E-05	2.087E-02	1.382E-04	2.982E-02	5.958E-03	2.820E-07	3.788E-05	3.550E-08	2.005E-10	1.708E-06	1.340E-06	3.035E-07	5.709E-03	1.814E-01
2nd 3" Below Core	1.163E+05	2.675E+05	2.893E-01	8.751E-05	3.755E-04	1.424E-04	5.069E-02	3.307E-04	7.184E-02	1.374E-02	6.848E-07	9.150E-05	8.820E-08	4.870E-10	4.142E-06	3.254E-06	7.371E-06	1.386E-02	4.408E-01
1st 3" Below Core	1.163E+05	2.675E+05	7.881E-01	2.323E-04	9.967E-04	3.780E-04	1.345E-01	8.779E-04	1.910E-01	3.648E-02	1.818E-06	2.429E-04	2.288E-07	1.293E-09	1.100E-05	8.637E-06	1.957E-06	3.880E-02	1.170E+00
Reactor Core	5.582E+08	1.284E+07	8.562E+01	2.589E-02	1.111E-01	4.213E-02	1.500E+01	9.786E-02	2.129E+01	4.065E+00	2.026E-04	2.708E-02	2.551E-05	1.441E-07	1.226E-03	9.627E-04	2.181E-04	4.102E+00	1.304E+02
1st 3" Above Core	1.163E+05	2.675E+05	7.993E-01	2.417E-04	1.037E-03	3.933E-04	1.400E-01	9.136E-04	1.987E-01	3.795E-02	1.892E-06	2.528E-04	2.381E-07	1.345E-09	1.144E-05	8.988E-06	2.036E-06	3.830E-02	1.217E+00
2nd 3" Above Core	1.163E+05	2.675E+05	3.474E-01	1.051E-04	4.608E-04	1.709E-04	8.085E-02	3.970E-04	8.637E-02	1.849E-02	8.221E-07	1.099E-04	1.035E-07	5.847E-10	4.973E-06	3.906E-06	8.850E-07	1.664E-02	5.290E-01
2nd 6" Above Core	2.326E+05	5.350E+05	1.674E-01	5.081E-05	2.172E-04	8.236E-05	2.932E-02	1.813E-04	4.181E-02	7.945E-03	3.961E-07	5.293E-05	4.986E-08	2.817E-10	2.396E-06	1.882E-06	4.284E-07	8.019E-03	2.549E-01
3rd 6" Above Core	2.326E+05	5.350E+05	2.518E-02	7.809E-06	3.285E-05	1.238E-05	4.407E-03	2.876E-05	6.255E-03	1.184E-03	5.954E-08	7.958E-06	7.495E-09	4.235E-11	3.602E-07	2.829E-07	6.410E-08	1.205E-03	3.831E-02
4th 6" Above Core	2.326E+05	5.350E+05	4.986E-03	1.511E-06	6.483E-06	2.458E-06	8.752E-04	5.710E-06	1.242E-03	2.372E-04	1.182E-08	1.580E-06	1.488E-08	8.409E-12	7.152E-08	5.618E-08	1.273E-08	2.394E-04	7.608E-03
5th 6" Above Core	2.326E+05	5.350E+05	1.150E-03	3.477E-07	1.492E-06	5.658E-07	2.014E-04	1.314E-06	2.859E-04	5.459E-05	2.721E-09	3.638E-07	3.425E-10	1.935E-12	1.646E-08	1.293E-08	2.929E-08	5.509E-05	1.751E-03
6th 6" Above Core	2.326E+05	5.350E+05	2.928E-04	8.858E-08	3.800E-07	1.441E-07	5.130E-05	3.347E-07	7.281E-05	1.390E-05	6.931E-10	9.261E-08	8.724E-11	4.929E-13	4.192E-09	3.293E-09	7.461E-10	1.403E-05	4.459E-04
4th 12" Above Core	4.652E+05	1.070E+06	1.043E-04	3.155E-08	1.354E-07	5.134E-08	1.828E-05	1.182E-06	2.584E-05	4.953E-08	2.469E-10	3.289E-08	3.108E-11	1.756E-13	1.494E-09	1.173E-09	2.858E-10	4.999E-06	1.589E-04
5th 12" Above Core	4.652E+05	1.070E+06	9.589E-06	2.900E-08	1.244E-08	4.719E-08	1.680E-06	1.098E-06	2.384E-06	4.552E-07	2.269E-11	3.032E-09	2.857E-12	1.614E-10	1.373E-10	1.078E-10	2.443E-11	4.594E-07	1.460E-05
6th 12" Above Core	4.652E+05	1.070E+06	8.903E-07	2.995E-10	1.285E-09	4.874E-10	1.735E-07	1.132E-08	2.482E-07	4.702E-08	2.344E-12	3.132E-10	2.950E-13	1.867E-11	1.418E-11	1.114E-11	2.523E-12	4.745E-08	1.508E-06
Total	1.118E+07	2.568E+07	8.816E+01	2.888E-02	1.144E-01	4.338E-02	1.544E+01	1.008E-01	2.192E+01	4.185E+00	2.086E-04	2.788E-02	2.626E-05	1.484E-07	1.262E-03	9.913E-04	2.246E-04	4.224E+00	1.342E+02

TABLE 4.7.11
 FIRST REBAR LAYER / PRIMARY SHIELD WALL INNER LINER
 CURIE CONTENT AT SHUTDOWN

Location	Component	Component	Curie Content																	Total
	Volume (cm ³)	Mass (gm)	H-3 (Curies)	C-14	Ar-39	Ca-41	Ca-45	Mn-54	Fe-55	Co-60	Ni-59	Ni-63	Nb-94	Tc-99	Sn-119m	Sb-125	Te-125m	Eu-152		
6th 12" Below Core	5.182E+04	4.068E+06	1.289E-09	1.529E-11	1.024E-13	1.346E-14	4.792E-12	6.809E-09	1.502E-06	5.081E-08	3.534E-11	4.718E-09	1.119E-13	7.863E-18	8.351E-30	4.082E-17	2.712E-17	2.321E-10	1.666E-08	
5th 12" Below Core	5.182E+04	4.068E+06	1.547E-08	1.835E-10	1.229E-12	1.615E-13	5.750E-11	8.290E-08	1.803E-05	6.097E-07	4.240E-10	5.661E-08	1.343E-12	9.438E-17	1.002E-28	4.899E-16	3.264E-16	2.785E-09	1.879E-05	
4th 12" Below Core	5.182E+04	4.068E+06	2.099E-07	2.490E-09	1.668E-11	2.191E-12	7.802E-10	1.125E-06	2.446E-04	8.273E-06	5.753E-08	7.681E-07	1.822E-11	1.280E-15	1.360E-27	6.646E-15	4.416E-15	3.779E-08	2.650E-04	
6th 6" Below Core	2.591E+04	2.034E+06	6.764E-07	8.013E-09	5.367E-11	7.051E-12	2.511E-09	3.620E-06	7.871E-04	2.662E-05	1.851E-08	2.472E-06	5.865E-11	4.120E-15	4.375E-27	2.139E-14	1.421E-14	1.216E-07	8.206E-04	
5th 6" Below Core	2.591E+04	2.034E+06	2.989E-06	3.546E-08	2.375E-10	3.120E-11	1.111E-08	1.602E-05	3.483E-03	1.178E-04	8.192E-08	1.094E-05	2.595E-10	1.823E-14	1.936E-26	9.465E-14	6.288E-14	5.381E-07	3.632E-03	
4th 6" Below Core	2.591E+04	2.034E+06	1.481E-05	1.767E-07	1.177E-09	1.546E-10	5.505E-08	7.937E-05	1.728E-02	5.837E-04	4.059E-07	5.420E-05	1.288E-08	9.033E-14	9.593E-26	4.690E-13	3.116E-13	2.666E-06	1.799E-02	
3rd 6" Below Core	2.591E+04	2.034E+06	8.608E-05	1.021E-06	6.840E-08	8.986E-10	3.200E-07	4.613E-04	1.003E-01	3.393E-03	2.359E-06	3.151E-08	7.474E-13	5.251E-13	5.576E-25	2.726E-12	1.811E-12	1.550E-05	1.046E-01	
2nd 6" Below Core	2.591E+04	2.034E+06	6.794E-04	8.061E-06	5.398E-08	7.093E-09	2.528E-06	3.641E-03	7.918E-01	2.678E-02	1.862E-05	2.497E-03	5.899E-08	4.144E-12	4.401E-24	2.152E-11	1.429E-11	1.223E-04	8.255E-01	
2nd 3" Below Core	1.296E+04	1.017E+06	1.650E-03	1.958E-05	1.311E-07	1.722E-08	6.133E-06	8.843E-03	1.923E+00	6.503E-02	4.523E-05	6.039E-07	1.433E-11	1.006E-11	1.069E-23	5.225E-11	3.471E-11	2.971E-04	2.005E+00	
1st 3" Below Core	1.296E+04	1.017E+06	4.380E-03	5.196E-05	3.480E-07	4.572E-08	1.628E-06	2.347E-02	5.104E+00	1.726E-01	1.201E-04	1.803E-02	3.803E-07	2.672E-11	2.837E-23	1.387E-10	9.215E-11	7.886E-04	5.322E+00	
Reactor Core	6.219E+06	4.882E+08	4.882E-01	5.792E-03	3.879E-05	5.097E-06	1.815E-03	2.617E+00	5.690E+02	1.924E+01	1.338E-02	1.787E+00	4.239E-05	2.978E-09	3.163E-21	1.546E-08	1.027E-08	8.780E-02	5.932E+02	
1st 3" Above Core	1.296E+04	1.017E+06	4.558E-03	5.408E-05	3.622E-07	4.758E-08	1.694E-06	2.443E-02	5.312E+00	1.797E-01	1.249E-04	1.668E-02	3.958E-07	2.780E-11	2.952E-23	1.443E-10	8.589E-11	8.206E-04	5.538E+00	
2nd 3" Above Core	1.296E+04	1.017E+06	1.981E-03	2.350E-05	1.574E-07	2.068E-08	7.363E-06	1.062E-02	2.308E+00	7.808E-02	5.429E-05	7.250E-03	1.720E-07	1.208E-11	1.283E-23	6.273E-11	4.167E-11	3.566E-04	2.407E+00	
2nd 6" Above Core	2.591E+04	2.034E+06	9.543E-04	1.132E-05	7.583E-08	9.863E-09	3.548E-06	5.115E-03	1.112E+00	3.782E-02	2.816E-05	3.493E-03	8.287E-08	5.821E-12	6.182E-24	3.022E-11	2.008E-11	1.718E-04	1.160E+00	
3rd 6" Above Core	2.591E+04	2.034E+06	1.435E-04	1.702E-06	1.140E-08	1.498E-09	5.333E-07	7.889E-04	1.672E-01	5.655E-03	3.932E-06	5.251E-04	1.246E-08	8.751E-13	9.293E-25	4.543E-12	3.018E-12	2.593E-05	1.743E-01	
4th 6" Above Core	2.591E+04	2.034E+06	2.849E-05	3.390E-07	2.284E-09	2.974E-10	1.059E-07	1.527E-04	3.320E-02	1.123E-03	7.809E-07	1.043E-04	2.474E-09	1.738E-13	1.845E-25	9.022E-13	5.994E-13	5.129E-06	3.461E-02	
5th 6" Above Core	2.591E+04	2.034E+06	6.558E-06	7.779E-08	5.210E-10	6.845E-11	2.437E-08	3.514E-05	7.641E-03	2.584E-04	1.797E-07	2.400E-05	5.893E-10	3.999E-14	4.247E-26	2.076E-13	1.379E-13	1.181E-06	7.966E-03	
6th 6" Above Core	2.591E+04	2.034E+06	1.670E-06	1.991E-08	1.327E-10	1.743E-11	6.208E-09	8.950E-06	1.946E-03	6.582E-05	4.577E-08	6.112E-06	1.450E-10	1.019E-14	1.082E-26	5.288E-14	3.513E-14	3.007E-07	2.029E-03	
4th 12" Above Core	5.182E+04	4.068E+06	5.949E-07	7.058E-09	4.727E-11	6.211E-12	2.212E-09	3.188E-06	6.933E-04	2.345E-05	1.831E-08	2.177E-06	5.166E-11	3.629E-15	3.854E-27	1.884E-14	1.252E-14	1.071E-07	7.229E-04	
5th 12" Above Core	5.182E+04	4.068E+06	5.468E-08	6.487E-10	4.345E-12	5.708E-13	2.033E-10	2.930E-07	6.372E-05	2.155E-06	1.499E-08	2.001E-07	4.748E-12	3.335E-16	3.542E-28	1.732E-15	1.150E-15	8.845E-09	6.844E-05	
6th 12" Above Core	5.182E+04	4.068E+06	5.647E-08	6.700E-11	4.487E-13	5.896E-14	2.099E-11	3.027E-08	6.581E-06	2.226E-07	1.548E-10	2.067E-08	4.904E-13	3.445E-17	3.658E-29	1.788E-16	1.188E-16	1.017E-09	6.862E-06	
Total	1.244E+08	9.763E+08	5.027E-01	5.864E-03	3.994E-05	5.248E-06	1.869E-03	2.694E+00	5.858E+02	1.982E+01	1.378E-02	1.840E+00	4.365E-05	3.066E-09	3.256E-21	1.592E-08	1.058E-08	9.051E-02	6.108E+02	

TABLE 4.7.12
SECOND 6" PRIMARY SHIELD WALL CURIE CONTENT AT SHUTDOWN

Location	Component	Component	H-3 (Curies)	C-14	Ar-39	Ca-41	Ca-45	Mn-54	Fe-55	Co-60	Ni-59	Ni-63	Nb-94	Tc-99	Sn-119m	Sb-125	Te-125m	Eu-152	Total
	Volume (cm ³)	Mass (gm)																	
6th 12" Below Core	9.637E+05	2.217E+06	2.241E-07	6.751E-11	1.200E-10	1.102E-10	3.918E-08	1.057E-10	5.563E-08	1.012E-08	5.315E-13	7.075E-11	5.979E-14	1.808E-16	1.537E-12	1.483E-12	3.356E-13	1.067E-08	3.402E-07
5th 12" Below Core	9.637E+05	2.217E+06	2.689E-06	8.101E-10	1.440E-09	1.322E-09	4.702E-07	1.268E-09	6.675E-07	1.214E-07	6.378E-12	8.489E-10	7.174E-13	2.170E-15	1.845E-11	1.779E-11	4.027E-12	1.280E-07	4.082E-06
4th 12" Below Core	9.637E+05	2.217E+06	3.649E-05	1.099E-08	1.953E-08	1.794E-08	6.379E-06	1.721E-08	9.057E-06	1.648E-06	8.653E-11	1.152E-08	9.733E-12	2.945E-14	2.503E-10	2.414E-10	5.464E-11	1.736E-06	5.539E-05
6th 6" Below Core	4.819E+05	1.108E+06	1.174E-04	3.537E-08	6.286E-08	5.773E-08	2.053E-05	5.538E-08	2.915E-05	5.302E-06	2.785E-10	3.707E-08	3.132E-11	9.476E-14	8.054E-10	7.789E-10	1.758E-10	5.588E-06	1.782E-04
5th 6" Below Core	4.819E+05	1.108E+06	5.196E-04	1.565E-07	2.782E-07	2.555E-07	9.084E-05	2.451E-07	1.290E-05	2.346E-05	1.232E-09	1.640E-07	1.388E-10	4.193E-13	3.564E-09	3.438E-09	7.781E-10	2.473E-05	7.888E-04
4th 6" Below Core	4.819E+05	1.108E+06	2.575E-03	7.755E-07	1.378E-06	1.266E-06	4.501E-04	1.214E-06	6.391E-04	1.183E-04	6.108E-09	8.127E-07	6.868E-10	2.078E-12	1.766E-08	1.704E-08	3.856E-09	1.225E-04	3.908E-03
3rd 6" Below Core	4.819E+05	1.108E+06	1.497E-02	4.508E-06	8.011E-06	7.368E-06	2.616E-03	7.058E-06	3.715E-03	6.758E-04	3.549E-08	4.724E-06	3.992E-11	1.208E-11	1.027E-07	9.902E-08	2.241E-08	7.122E-04	2.272E-02
2nd 6" Below Core	4.819E+05	1.108E+06	1.181E-01	3.558E-05	6.323E-05	5.807E-05	2.065E-02	5.571E-05	2.932E-02	5.334E-03	2.801E-07	3.729E-05	3.151E-08	9.532E-11	8.102E-07	7.815E-07	1.769E-07	5.621E-03	1.793E-01
2nd 3" Below Core	2.409E+05	5.541E+05	2.869E-01	8.641E-05	1.538E-04	1.410E-04	5.015E-02	1.353E-04	7.120E-02	1.295E-02	6.803E-07	9.055E-05	7.652E-08	2.315E-06	1.988E-06	1.898E-06	4.296E-06	1.365E-02	4.354E-01
1st 3" Below Core	2.409E+05	5.541E+05	7.615E-01	2.294E-04	4.076E-04	3.744E-04	1.331E-01	3.591E-04	1.890E-01	3.438E-02	1.808E-06	2.404E-04	2.031E-07	6.145E-10	5.223E-06	5.038E-06	1.140E-06	3.624E-02	1.156E+00
Reactor Core	1.156E+07	2.660E+07	8.488E+01	2.557E-02	4.544E-02	4.173E-02	1.484E+01	4.003E-02	2.107E+01	3.833E+00	2.013E-04	2.679E-02	2.264E-05	6.850E-08	5.822E-04	5.816E-04	1.271E-04	4.039E+00	1.288E+02
1st 3" Above Core	2.409E+05	5.541E+05	7.924E-01	2.387E-04	4.242E-04	3.896E-04	1.385E-01	3.737E-04	1.967E-01	3.578E-02	1.879E-06	2.501E-04	2.114E-07	6.395E-10	5.435E-06	5.243E-06	1.187E-06	3.771E-02	1.203E+00
2nd 3" Above Core	2.409E+05	5.541E+05	3.444E-01	1.037E-04	1.843E-04	1.693E-04	6.020E-02	1.624E-04	8.548E-02	1.555E-02	6.167E-07	1.087E-04	9.186E-08	2.779E-10	2.362E-06	2.279E-06	5.157E-07	1.639E-02	5.227E-01
2nd 6" Above Core	4.819E+05	1.108E+06	1.659E-01	4.998E-05	8.982E-05	8.157E-05	2.901E-02	7.825E-05	4.118E-02	7.492E-03	3.935E-07	5.238E-05	4.426E-08	1.339E-10	1.138E-06	1.098E-06	2.485E-07	7.896E-03	2.518E-01
3rd 6" Above Core	4.819E+05	1.108E+06	2.494E-02	7.513E-06	1.335E-05	1.226E-05	4.360E-03	1.176E-05	6.191E-03	1.126E-03	5.915E-08	7.873E-06	6.653E-09	2.013E-11	1.711E-07	1.650E-07	3.735E-08	1.187E-03	3.786E-02
4th 6" Above Core	4.819E+05	1.108E+06	4.953E-03	1.492E-06	2.651E-06	2.435E-06	8.959E-04	2.336E-06	1.229E-03	2.238E-04	1.175E-08	1.564E-06	1.321E-09	3.997E-12	3.397E-08	3.277E-08	7.417E-09	2.357E-04	7.518E-03
5th 6" Above Core	4.819E+05	1.108E+06	1.140E-03	3.434E-07	6.102E-07	5.804E-07	1.993E-04	5.376E-07	2.829E-04	5.147E-05	2.703E-09	3.598E-07	3.041E-10	8.199E-13	7.819E-09	7.542E-09	1.707E-09	5.424E-05	1.730E-03
6th 6" Above Core	4.819E+05	1.108E+06	2.903E-04	8.745E-08	1.554E-07	1.427E-07	5.076E-05	1.369E-07	7.206E-05	1.311E-05	6.885E-10	9.165E-08	7.744E-11	2.343E-13	1.991E-09	1.921E-09	4.348E-10	1.382E-05	4.407E-04
4th 12" Above Core	9.637E+05	2.217E+06	1.034E-04	3.116E-08	5.537E-08	5.085E-08	1.808E-05	4.878E-08	2.567E-05	4.670E-06	2.453E-10	3.265E-08	2.759E-11	8.347E-14	7.085E-10	6.844E-10	1.549E-10	4.922E-06	1.570E-04
5th 12" Above Core	9.637E+05	2.217E+06	9.507E-08	2.883E-09	5.089E-09	4.674E-09	1.662E-06	4.483E-09	2.380E-08	4.292E-07	2.254E-11	3.001E-09	2.536E-12	7.671E-15	6.521E-11	6.290E-11	1.424E-11	4.524E-07	1.443E-05
6th 12" Above Core	9.637E+05	2.217E+06	9.819E-07	2.957E-10	5.258E-10	4.827E-10	1.718E-07	4.630E-10	2.437E-07	4.433E-08	2.328E-12	3.099E-10	2.819E-13	7.923E-16	6.735E-12	6.496E-12	1.470E-12	4.672E-08	1.490E-06
Total	2.313E+07	5.320E+07	8.740E+01	2.633E-02	4.679E-02	4.297E-02	1.528E+01	4.122E-02	2.169E+01	3.946E+00	2.073E-04	2.759E-02	2.331E-05	7.053E-08	5.995E-04	5.783E-04	1.309E-04	4.159E+00	1.327E+02

TABLE 4.7.13
THIRD 6" PRIMARY SHIELD WALL CURIE CONTENT AT SHUTDOWN

Location	Component	Component	H-3 (Curies)	C-14	Ar-39	Ca-41	Ca-45	Mn-54	Fe-55	Co-60	Ni-59	Ni-63	Nb-94	Te-99	Sn-119m	Sb-125	Te-125m	Eu-152	Total
	Volume (cm ³)	Mass (gm)																	
6th 12" Below Core	1.008E+06	2.319E+06	4.800E-08	1.443E-11	1.088E-11	2.358E-11	8.385E-09	9.589E-12	1.190E-08	2.122E-09	1.139E-13	1.513E-11	1.220E-14	2.168E-17	1.843E-13	2.274E-13	6.145E-14	2.281E-09	7.276E-08
5th 12" Below Core	1.008E+06	2.319E+06	5.760E-07	1.731E-10	1.303E-10	2.830E-10	1.006E-07	1.148E-10	1.428E-08	2.548E-08	1.367E-12	1.816E-10	1.464E-13	2.601E-16	2.211E-12	2.729E-12	6.174E-13	2.737E-08	8.731E-07
4th 12" Below Core	1.008E+06	2.319E+06	7.815E-06	2.349E-09	1.768E-09	3.840E-09	1.365E-06	1.558E-09	1.938E-06	3.455E-07	1.855E-11	2.464E-09	1.987E-12	3.529E-15	3.000E-11	3.703E-11	8.377E-12	3.713E-07	1.185E-05
6th 6" Below Core	5.041E+05	1.159E+06	2.515E-05	7.559E-09	5.688E-09	1.236E-08	4.393E-08	5.013E-08	6.238E-06	1.112E-06	5.989E-11	7.928E-08	6.394E-12	1.136E-14	9.665E-11	1.192E-10	2.698E-10	1.195E-06	3.812E-05
5th 6" Below Core	5.041E+05	1.159E+06	1.113E-04	3.345E-08	2.517E-08	5.468E-08	1.844E-05	2.219E-08	2.759E-05	4.920E-06	2.642E-10	3.508E-08	2.829E-11	5.028E-14	4.273E-10	5.273E-10	1.193E-10	5.288E-06	1.887E-04
4th 6" Below Core	5.041E+05	1.159E+06	5.514E-04	1.657E-07	1.247E-07	2.709E-07	9.833E-05	1.099E-07	1.367E-04	2.438E-05	1.309E-09	1.738E-07	1.402E-10	2.490E-13	2.117E-09	2.613E-09	5.910E-10	2.620E-05	8.359E-04
3rd 6" Below Core	5.041E+05	1.159E+06	3.205E-03	9.634E-07	7.250E-07	1.575E-06	5.599E-04	6.389E-07	7.847E-04	1.417E-04	7.808E-09	1.010E-06	8.149E-10	1.447E-12	1.231E-08	1.519E-08	3.436E-09	1.523E-04	4.859E-03
2nd 6" Below Core	5.041E+05	1.159E+06	2.530E-02	7.603E-06	5.722E-06	1.243E-05	4.419E-03	5.043E-06	6.273E-03	1.118E-03	6.005E-08	7.975E-06	6.432E-09	1.142E-11	9.712E-08	1.199E-07	2.712E-08	1.202E-03	3.835E-02
2nd 3" Below Core	2.521E+05	5.797E+05	6.143E-02	1.847E-05	1.390E-05	3.018E-05	1.073E-02	1.225E-06	1.523E-02	2.716E-03	1.458E-07	1.937E-05	1.582E-08	2.774E-11	2.359E-07	2.911E-07	6.585E-08	2.919E-03	9.313E-02
1st 3" Below Core	2.521E+05	5.797E+05	1.631E-01	4.902E-05	3.689E-05	8.013E-05	2.848E-02	3.251E-06	4.044E-02	7.209E-03	3.871E-07	5.141E-05	4.146E-08	7.365E-11	6.261E-07	7.727E-07	1.748E-07	7.748E-03	2.472E-01
Reactor Core	1.210E+07	2.783E+07	1.818E+01	5.464E-03	4.112E-03	8.932E-03	3.178E+00	3.624E-03	4.508E+00	8.036E-01	4.315E-05	5.731E-03	4.822E-08	8.209E-09	6.979E-05	8.614E-05	1.849E-05	8.638E-01	2.756E+01
1st 3" Above Core	2.521E+05	5.797E+05	1.897E-01	5.101E-05	3.839E-05	8.338E-05	2.965E-02	3.383E-06	4.208E-02	7.502E-03	4.028E-07	5.350E-05	4.315E-08	7.664E-11	6.515E-07	8.042E-07	1.819E-07	8.064E-03	2.573E-01
2nd 3" Above Core	2.521E+05	5.797E+05	7.375E-02	2.217E-05	1.688E-05	3.624E-05	1.288E-02	1.470E-06	1.829E-02	3.260E-03	1.751E-07	2.325E-05	1.875E-08	3.331E-11	2.832E-07	3.495E-07	7.906E-08	3.505E-03	1.118E-01
2nd 6" Above Core	5.041E+05	1.159E+06	3.553E-02	1.088E-05	8.038E-06	1.748E-05	6.208E-03	7.084E-06	8.811E-03	1.571E-03	8.435E-08	1.120E-05	9.034E-09	1.805E-11	1.364E-07	1.884E-07	3.809E-08	1.888E-03	5.387E-02
3rd 6" Above Core	5.041E+05	1.159E+06	5.342E-03	1.606E-06	1.208E-06	2.825E-06	9.332E-04	1.065E-06	1.325E-03	2.361E-04	1.268E-08	1.684E-06	1.358E-08	2.412E-12	2.051E-08	2.531E-08	5.726E-09	2.538E-04	8.098E-03
4th 6" Above Core	5.041E+05	1.159E+06	1.081E-03	3.189E-07	2.399E-07	5.212E-07	1.853E-04	2.115E-07	2.630E-04	4.889E-06	2.518E-09	3.344E-07	2.697E-10	4.790E-13	4.072E-09	5.028E-09	1.137E-09	5.040E-05	1.608E-03
5th 6" Above Core	5.041E+05	1.159E+06	2.441E-04	7.338E-08	5.522E-08	1.199E-07	4.265E-05	4.867E-08	6.053E-05	1.079E-06	5.795E-10	7.697E-08	6.207E-11	1.102E-13	9.373E-10	1.157E-09	2.617E-10	1.180E-05	3.701E-04
6th 6" Above Core	5.041E+05	1.159E+06	6.218E-05	1.889E-08	1.406E-08	3.055E-08	1.086E-05	1.240E-08	1.542E-05	2.749E-06	1.476E-10	1.960E-08	1.581E-11	2.808E-14	2.387E-10	2.946E-10	6.665E-11	2.954E-06	9.426E-05
4th 12" Above Core	1.008E+06	2.319E+06	2.215E-05	6.658E-09	5.011E-09	1.088E-08	3.870E-06	4.418E-09	5.493E-06	9.793E-07	5.258E-11	6.984E-09	5.632E-12	1.000E-14	8.504E-11	1.050E-10	2.374E-11	1.053E-06	3.358E-05
5th 12" Above Core	1.008E+06	2.319E+06	2.036E-08	6.119E-10	4.605E-10	1.000E-09	3.557E-07	4.059E-10	5.048E-07	9.000E-08	4.833E-12	6.419E-10	5.178E-13	9.194E-16	7.816E-12	9.647E-12	2.182E-12	9.674E-08	3.086E-06
6th 12" Above Core	1.008E+06	2.319E+06	2.103E-07	6.320E-11	4.756E-11	1.033E-10	3.674E-08	4.192E-11	5.214E-08	9.296E-09	4.891E-13	6.629E-11	5.346E-14	9.496E-17	8.073E-13	9.964E-13	2.254E-13	9.992E-09	3.188E-07
Total	2.420E+07	5.565E+07	1.872E+01	5.626E-03	4.234E-03	9.197E-03	3.270E+00	3.731E-03	4.641E+00	8.275E-01	4.443E-05	5.901E-03	4.759E-08	8.453E-09	7.186E-05	8.989E-05	2.006E-05	8.894E-01	2.838E+01

TABLE 4.7.14
FOURTH 6" PRIMARY SHIELD WALL CURIE CONTENT AT SHUTDOWN

Location	Component	Component	H-3 (Curies)	C-14	Ar-39	Ca-41	Ca-45	Mn-54	Fe-55	Co-60	Ni-59	Ni-63	Nb-94	Tc-99	Sn-119m	Sb-125	Te-125m	Eu-152	Total
	Volume (cm ³)	Mass (gm)																	
6th 12" Below Core	1.053E+06	2.421E+08	7.803E-09	2.346E-12	1.499E-12	3.835E-12	1.363E-09	1.321E-12	1.835E-09	3.443E-10	1.853E-14	2.481E-12	1.974E-15	3.220E-18	2.736E-14	3.537E-14	8.000E-15	3.710E-10	1.183E-08
5th 12" Below Core	1.053E+06	2.421E+08	9.384E-08	2.815E-11	1.799E-11	4.602E-11	1.636E-08	1.685E-11	2.322E-08	4.132E-09	2.224E-13	2.953E-11	2.368E-14	3.863E-17	3.283E-13	4.244E-13	9.599E-14	4.452E-09	1.419E-07
4th 12" Below Core	1.053E+06	2.421E+08	1.270E-06	3.820E-10	2.441E-10	6.244E-10	2.219E-07	2.151E-10	3.151E-07	5.606E-08	3.017E-12	4.007E-10	3.213E-13	5.242E-16	4.454E-12	5.758E-12	1.302E-12	6.041E-08	1.926E-06
6th 6" Below Core	5.263E+05	1.211E+08	4.088E-06	1.229E-09	7.858E-09	2.009E-08	7.142E-07	6.921E-07	1.014E-06	1.804E-07	9.709E-12	1.289E-09	1.034E-12	1.687E-15	1.433E-11	1.853E-11	4.191E-11	1.944E-11	6.197E-06
5th 6" Below Core	5.263E+05	1.211E+08	1.809E-05	5.440E-09	3.478E-09	8.892E-09	3.161E-08	3.083E-09	4.487E-06	7.983E-07	4.296E-11	5.708E-09	4.578E-12	7.484E-15	6.343E-11	8.200E-11	1.855E-11	8.802E-11	2.743E-06
4th 6" Below Core	5.263E+05	1.211E+08	8.984E-05	2.695E-08	1.722E-08	4.408E-08	1.568E-05	1.518E-08	2.223E-06	3.956E-06	2.129E-08	2.827E-08	2.267E-11	3.698E-14	3.143E-10	4.083E-10	9.190E-11	4.262E-10	1.359E-04
3rd 6" Below Core	5.263E+05	1.211E+08	5.211E-04	1.567E-07	1.001E-07	2.561E-07	9.103E-05	8.821E-08	1.292E-04	2.299E-05	1.237E-09	1.643E-07	1.318E-10	2.150E-13	1.827E-09	2.382E-09	5.342E-10	2.478E-05	7.899E-04
2nd 6" Below Core	5.263E+05	1.211E+08	4.113E-03	1.237E-06	7.902E-07	2.021E-06	7.185E-04	6.962E-07	1.020E-03	1.815E-04	9.766E-09	1.297E-08	1.040E-09	1.697E-12	1.442E-08	1.864E-08	4.216E-08	1.955E-04	6.234E-03
2nd 3" Below Core	2.632E+05	6.053E+05	9.988E-03	3.003E-06	1.919E-06	4.909E-06	1.745E-03	1.691E-06	2.477E-03	4.407E-04	2.372E-08	3.150E-08	2.526E-09	4.121E-12	3.502E-08	4.527E-08	1.024E-08	4.749E-04	1.514E-02
1st 3" Below Core	2.632E+05	6.053E+05	2.651E-02	7.971E-06	5.084E-06	1.303E-05	4.632E-03	4.488E-06	6.575E-03	1.170E-03	6.296E-08	8.362E-08	6.705E-09	1.094E-11	8.295E-08	1.202E-07	2.718E-08	1.261E-03	4.019E-02
Reactor Core	1.263E+07	2.905E+07	2.955E+00	8.886E-04	5.679E-04	1.453E-03	5.163E-01	5.003E-04	7.330E-01	1.304E-01	7.018E-08	9.321E-04	7.474E-07	1.219E-09	1.036E-06	1.339E-05	3.030E-06	1.405E-01	4.480E+00
1st 3" Above Core	2.632E+05	6.053E+05	2.759E-02	8.295E-06	5.301E-06	1.356E-05	4.820E-03	4.671E-06	6.843E-03	1.217E-03	6.552E-08	8.702E-08	6.978E-09	1.138E-11	9.673E-08	1.250E-07	2.828E-08	1.312E-03	4.182E-02
2nd 3" Above Core	2.632E+05	6.053E+05	1.199E-02	3.605E-06	2.304E-06	5.893E-06	2.095E-03	2.030E-06	2.974E-03	5.291E-04	2.847E-08	3.782E-08	3.033E-09	4.947E-12	4.204E-08	5.434E-08	1.228E-08	5.701E-04	1.818E-02
2nd 6" Above Core	5.263E+05	1.211E+08	5.777E-03	1.737E-06	1.110E-06	2.839E-06	1.009E-03	9.780E-07	1.433E-03	2.549E-04	1.372E-08	1.822E-08	1.481E-09	2.383E-12	2.025E-08	2.618E-08	5.922E-09	2.747E-04	8.757E-03
3rd 6" Above Core	5.263E+05	1.211E+08	8.684E-04	2.611E-07	1.689E-07	4.268E-07	1.517E-04	1.470E-07	2.154E-04	3.832E-05	2.062E-09	2.739E-10	2.198E-13	3.583E-13	3.045E-09	3.936E-09	8.903E-10	4.129E-05	1.318E-03
4th 6" Above Core	5.263E+05	1.211E+08	1.724E-04	5.185E-08	3.144E-08	8.476E-08	3.013E-06	2.919E-08	4.277E-05	7.609E-06	4.095E-10	5.439E-08	4.381E-11	7.115E-14	6.048E-10	7.816E-10	1.788E-10	8.200E-06	2.814E-04
5th 6" Above Core	5.263E+05	1.211E+08	3.989E-05	1.193E-08	7.828E-09	1.951E-08	6.934E-06	6.719E-09	9.843E-06	1.751E-06	9.425E-11	1.252E-08	1.004E-11	1.637E-14	1.391E-10	1.799E-10	4.089E-11	1.887E-06	6.016E-05
6th 6" Above Core	5.263E+05	1.211E+08	1.011E-05	3.039E-09	1.942E-09	4.968E-09	1.766E-06	1.711E-09	2.507E-06	4.480E-07	2.400E-11	3.188E-09	2.557E-12	4.171E-15	3.544E-11	4.581E-11	1.036E-11	4.806E-07	1.532E-05
4th 12" Above Core	1.053E+06	2.421E+08	3.601E-08	1.083E-09	6.920E-10	1.770E-09	6.291E-07	6.097E-10	8.932E-07	1.589E-07	8.552E-12	1.136E-13	9.108E-15	1.488E-15	1.283E-11	1.632E-11	3.692E-12	1.712E-07	5.459E-06
5th 12" Above Core	1.053E+06	2.421E+08	3.310E-07	9.951E-11	6.360E-11	1.627E-10	5.782E-08	5.603E-11	8.209E-08	1.480E-08	7.880E-13	1.044E-10	8.371E-14	1.366E-16	1.180E-12	1.500E-12	3.393E-13	1.574E-08	5.017E-07
6th 12" Above Core	1.053E+06	2.421E+08	3.419E-08	1.028E-11	6.569E-12	1.680E-11	5.972E-09	5.787E-12	8.478E-09	1.508E-09	8.118E-14	1.078E-11	8.646E-15	1.410E-17	1.199E-13	1.549E-13	3.505E-14	1.825E-09	5.182E-08
Total	2.526E+07	5.811E+07	3.043E+00	9.149E-04	5.847E-04	1.486E-03	5.316E-01	5.152E-04	7.547E-01	1.343E-01	7.226E-06	9.598E-04	7.696E-07	1.258E-09	1.067E-05	1.379E-05	3.120E-06	1.447E-01	4.813E+00

TABLE 4.7.15
SECOND REBAR LAYER CURIE CONTENT AT SHUTDOWN

Location	Component		H-3 (Curies)	C-14	Ar-39	Ca-41	Ca-45	Mn-54	Fe-55	Co-60	Ni-59	Ni-63	Nb-94	Tc-99	Sn-119m	Sb-125	Te-125m	Eu-152	Total
	Volume (cm ³)	Mass (gm)																	
8th 12" Below Core	6.158E+04	4.834E+05	2.338E-11	2.755E-13	2.750E-16	2.437E-18	8.662E-14	1.855E-11	2.717E-08	8.558E-10	6.426E-13	8.533E-11	1.722E-15	3.495E-20	2.327E-34	6.349E-21	5.400E-21	4.175E-12	2.816E-08
5th 12" Below Core	6.158E+04	4.834E+05	2.808E-10	3.305E-12	3.300E-15	2.924E-15	1.039E-12	2.226E-10	3.260E-07	1.027E-08	7.711E-12	1.024E-08	2.067E-14	4.193E-19	2.793E-33	7.618E-20	6.478E-20	5.010E-11	3.378E-07
4th 12" Below Core	6.158E+04	4.834E+05	3.807E-09	4.485E-11	4.477E-14	3.987E-14	1.410E-11	3.020E-09	4.423E-06	1.393E-07	1.046E-10	1.389E-08	2.804E-13	5.690E-18	3.789E-32	1.034E-18	8.791E-18	6.788E-10	4.584E-06
8th 6" Below Core	3.079E+04	2.417E+05	1.225E-08	1.443E-10	1.441E-13	1.277E-13	4.538E-11	9.718E-08	1.423E-05	4.484E-07	3.397E-10	4.471E-08	9.023E-13	1.831E-17	1.219E-31	3.328E-18	2.828E-18	2.188E-09	1.475E-05
5th 6" Below Core	3.079E+04	2.417E+05	5.421E-08	6.386E-10	6.375E-13	5.649E-13	2.008E-10	4.301E-08	6.299E-05	1.984E-06	1.490E-09	1.978E-07	3.993E-12	8.102E-17	5.396E-31	1.472E-17	1.252E-17	9.681E-09	6.528E-05
4th 6" Below Core	3.079E+04	2.417E+05	2.686E-07	3.184E-09	3.159E-12	2.799E-12	9.950E-10	2.131E-07	3.121E-04	9.831E-06	7.392E-09	9.803E-07	1.878E-11	4.015E-16	2.674E-30	7.293E-17	6.203E-17	4.797E-08	3.235E-04
3rd 6" Below Core	3.079E+04	2.417E+05	1.561E-06	1.839E-08	1.838E-11	1.627E-11	5.784E-09	1.239E-06	1.814E-03	5.714E-05	4.291E-08	5.698E-06	1.150E-10	2.334E-15	1.554E-29	4.239E-16	3.608E-16	2.788E-07	1.880E-03
2nd 6" Below Core	3.079E+04	2.417E+05	1.232E-05	1.452E-07	1.449E-10	1.284E-10	4.565E-08	9.778E-06	1.432E-02	4.510E-04	3.387E-07	4.497E-05	9.077E-10	1.842E-14	1.227E-28	3.348E-15	2.848E-15	2.201E-06	1.484E-02
2nd 3" Below Core	1.540E+04	1.209E+05	2.993E-05	3.526E-07	3.519E-10	3.119E-10	1.109E-07	2.374E-05	3.477E-02	1.095E-03	8.224E-07	1.092E-04	2.204E-09	4.473E-14	2.979E-28	8.125E-15	6.911E-15	5.344E-06	3.804E-02
1st 3" Below Core	1.540E+04	1.209E+05	7.844E-05	9.359E-07	9.343E-10	8.279E-10	2.843E-07	6.302E-05	9.231E-02	2.908E-03	2.183E-06	2.899E-04	5.851E-09	1.187E-13	7.907E-28	2.157E-14	1.835E-14	1.419E-05	9.566E-02
Reactor Core	7.390E+06	5.801E+06	8.855E-03	1.043E-04	1.041E-07	9.229E-08	3.280E-05	7.025E-03	1.029E+01	3.241E-01	2.434E-04	3.232E-02	6.522E-07	1.324E-11	8.814E-26	2.404E-12	2.045E-12	1.581E-03	1.066E+01
1st 3" Above Core	1.540E+04	1.209E+05	8.267E-05	9.739E-07	9.722E-10	8.615E-10	3.062E-07	6.558E-05	9.806E-02	3.028E-03	2.272E-06	3.017E-04	6.089E-09	1.238E-13	8.228E-28	2.245E-14	1.909E-14	1.476E-05	9.955E-02
2nd 3" Above Core	1.540E+04	1.209E+05	3.593E-05	4.232E-07	4.225E-10	3.744E-10	1.331E-07	2.850E-05	4.175E-02	1.315E-03	9.874E-07	1.311E-04	2.646E-09	5.370E-14	3.576E-29	9.755E-15	8.297E-15	6.416E-06	4.328E-02
2nd 6" Above Core	3.079E+04	2.417E+05	1.731E-05	2.039E-07	2.036E-10	1.804E-10	6.412E-08	1.373E-05	2.011E-02	6.335E-04	4.757E-07	6.317E-05	1.275E-09	2.587E-14	1.723E-28	4.700E-15	3.997E-15	3.091E-06	2.084E-02
3rd 6" Above Core	3.079E+04	2.417E+05	2.802E-08	3.065E-08	3.060E-11	2.712E-11	9.639E-09	2.064E-06	3.024E-03	9.524E-05	7.151E-08	9.498E-06	1.917E-10	3.889E-15	2.590E-29	7.065E-16	6.098E-16	4.647E-07	3.134E-03
4th 6" Above Core	3.079E+04	2.417E+05	5.167E-07	6.087E-09	6.077E-12	5.385E-12	1.914E-09	4.099E-07	6.004E-04	1.891E-05	1.420E-08	1.886E-06	3.806E-11	7.723E-16	5.143E-30	1.403E-16	1.193E-16	8.227E-08	6.222E-04
5th 6" Above Core	3.079E+04	2.417E+05	1.189E-07	1.401E-09	1.399E-12	1.239E-12	4.405E-10	9.434E-08	1.382E-04	4.353E-06	3.269E-09	4.340E-07	8.759E-12	1.777E-16	1.184E-30	3.229E-17	2.746E-17	2.124E-08	1.432E-04
6th 6" Above Core	3.079E+04	2.417E+05	3.029E-08	3.568E-10	3.562E-13	3.158E-13	1.122E-10	2.403E-08	3.519E-05	1.109E-06	8.324E-10	1.105E-07	2.231E-12	4.527E-17	3.015E-31	8.224E-18	6.995E-18	5.409E-09	3.647E-05
4th 12" Above Core	6.158E+04	4.834E+05	1.079E-08	1.271E-10	1.269E-13	1.125E-13	3.997E-11	8.560E-09	1.254E-05	3.949E-07	2.966E-10	3.938E-08	7.948E-13	1.613E-17	1.074E-31	2.930E-18	2.492E-18	1.927E-09	1.299E-05
5th 12" Above Core	6.158E+04	4.834E+05	9.917E-10	1.168E-11	1.166E-14	1.034E-14	3.874E-12	7.868E-10	1.152E-06	3.830E-08	2.726E-11	3.619E-09	7.305E-14	1.482E-18	9.871E-33	2.893E-19	2.290E-19	1.771E-10	1.194E-06
6th 12" Above Core	6.158E+04	4.834E+05	1.024E-10	1.207E-12	1.205E-15	1.087E-15	3.795E-13	8.128E-11	1.180E-07	3.749E-09	2.815E-12	3.738E-10	7.545E-15	1.531E-19	1.020E-33	2.781E-20	2.366E-20	1.829E-11	1.234E-07
Total	1.478E+06	1.160E+07	9.118E-03	1.074E-04	1.072E-07	8.502E-08	3.378E-05	7.233E-03	1.059E+01	3.337E-01	2.508E-04	3.328E-02	6.719E-07	1.363E-11	9.076E-26	2.476E-12	2.106E-12	1.628E-03	1.098E+01

TABLE 4.7.16
FIFTH 6" PRIMARY SHIELD WALL CURIE CONTENT AT SHUTDOWN

Location	Component	Component																		Total
	Volume (cm ³)	Mass (gm)	H-3 (Curies)	C-14	Ar-39	Ca-41	Ca-45	Mn-54	Fe-55	Co-60	Ni-59	Ni-63	Nb-94	Tc-99	Sn-119m	Sb-125	Te-125m	Eu-152		
6th 12" Below Core	1.097E+08	2.523E+08	1.222E-09	3.878E-13	3.077E-13	6.007E-13	2.135E-10	2.711E-10	3.031E-10	5.414E-11	2.901E-11	3.855E-13	3.120E-16	5.880E-19	4.998E-15	5.982E-15	1.353E-15	5.820E-11	1.853E-09	
5th 12" Below Core	1.097E+08	2.523E+08	1.487E-08	4.410E-12	3.892E-12	7.207E-12	2.582E-09	3.253E-09	3.637E-09	6.496E-10	3.481E-10	4.828E-12	3.744E-15	7.055E-18	5.995E-14	7.178E-14	1.624E-14	6.984E-10	2.224E-08	
4th 12" Below Core	1.097E+08	2.523E+08	1.990E-07	5.984E-11	5.010E-11	9.778E-11	3.476E-08	4.414E-08	4.935E-08	8.814E-09	4.724E-09	6.278E-11	5.080E-14	9.572E-17	8.134E-13	9.739E-13	2.203E-13	9.476E-09	3.017E-07	
6th 6" Below Core	5.486E+05	1.262E+08	6.405E-07	1.928E-10	1.612E-10	3.147E-10	1.119E-07	1.420E-07	1.588E-07	2.837E-08	1.520E-08	2.020E-10	1.635E-13	3.080E-16	2.617E-12	3.134E-12	7.090E-13	3.049E-08	9.710E-07	
5th 6" Below Core	5.486E+05	1.262E+08	2.834E-06	8.522E-10	7.134E-10	1.393E-09	4.950E-07	6.285E-07	7.028E-07	1.255E-07	6.727E-07	8.937E-08	7.234E-13	1.363E-15	1.158E-11	1.387E-11	3.138E-12	1.349E-07	4.297E-06	
4th 6" Below Core	5.486E+05	1.262E+08	1.404E-05	4.222E-09	3.535E-09	6.900E-09	2.453E-06	3.114E-06	3.482E-06	6.219E-07	3.333E-07	4.428E-09	3.584E-12	6.754E-15	5.739E-11	6.872E-11	1.555E-11	6.886E-07	2.129E-05	
3rd 6" Below Core	5.486E+05	1.262E+08	8.163E-05	2.454E-08	2.055E-08	4.011E-08	1.428E-06	1.810E-06	2.024E-06	3.615E-06	1.937E-06	2.574E-08	2.084E-11	3.926E-14	3.336E-10	3.894E-10	9.037E-11	3.886E-06	1.238E-04	
2nd 6" Below Core	5.486E+05	1.262E+08	6.443E-04	1.937E-07	1.622E-07	3.168E-07	1.125E-04	1.429E-04	1.597E-04	2.853E-05	1.529E-05	2.032E-07	1.644E-10	3.099E-13	2.633E-09	3.153E-09	7.132E-10	3.067E-05	9.768E-04	
2nd 3" Below Core	2.743E+06	6.309E+06	1.565E-03	4.704E-07	3.938E-07	7.888E-07	2.733E-04	3.470E-04	3.880E-04	6.929E-05	3.713E-05	4.934E-07	3.994E-10	7.525E-13	6.394E-09	7.659E-09	1.732E-09	7.448E-05	2.372E-03	
1st 3" Below Core	2.743E+06	6.309E+06	4.153E-03	1.249E-06	1.045E-06	2.041E-06	7.254E-04	9.211E-04	1.030E-04	1.839E-04	9.857E-05	1.310E-06	1.060E-08	1.998E-12	1.897E-08	2.032E-08	4.598E-09	1.977E-04	6.297E-03	
Reactor Core	1.317E+07	3.028E+07	4.630E-01	1.392E-04	1.165E-04	2.275E-04	8.086E-02	1.027E-02	1.148E-01	2.050E-02	1.099E-02	1.460E-04	1.182E-07	2.227E-10	1.892E-06	2.268E-06	5.125E-07	2.204E-02	7.019E-01	
1st 3" Above Core	2.743E+06	6.309E+06	4.322E-03	1.300E-06	1.088E-06	2.124E-06	7.549E-04	9.585E-04	1.072E-03	1.914E-04	1.028E-04	1.363E-06	1.103E-08	2.079E-12	1.766E-08	2.115E-08	4.785E-09	2.058E-04	6.553E-03	
2nd 3" Above Core	2.743E+06	6.309E+06	1.878E-03	5.648E-07	4.728E-07	9.229E-07	3.281E-04	4.166E-04	4.657E-04	8.319E-05	4.458E-05	5.923E-07	4.794E-10	9.034E-13	7.878E-09	9.192E-09	2.079E-09	8.943E-05	2.848E-03	
2nd 6" Above Core	5.486E+05	1.262E+08	9.050E-04	2.721E-07	2.278E-07	4.447E-07	1.581E-04	2.007E-04	2.244E-04	4.008E-05	2.148E-05	2.854E-07	2.310E-10	4.353E-13	3.699E-09	4.429E-09	1.002E-09	4.308E-05	1.372E-03	
3rd 6" Above Core	5.486E+05	1.262E+08	1.360E-04	4.090E-08	3.424E-08	6.885E-08	2.376E-05	3.017E-05	3.373E-05	6.025E-06	3.229E-06	4.290E-08	3.472E-11	6.543E-14	5.560E-10	6.657E-10	1.508E-10	6.477E-06	2.063E-04	
4th 6" Above Core	5.486E+05	1.262E+08	2.702E-05	8.123E-09	6.800E-09	1.327E-08	4.719E-06	5.991E-06	6.699E-06	1.196E-06	6.412E-06	8.519E-08	6.896E-12	1.298E-14	1.104E-10	1.322E-10	2.991E-11	1.286E-06	4.086E-05	
5th 6" Above Core	5.486E+05	1.262E+08	6.218E-06	1.899E-09	1.565E-09	3.055E-09	1.086E-06	1.379E-06	1.542E-06	2.754E-07	1.478E-07	1.961E-09	1.587E-12	2.990E-15	2.541E-11	3.042E-11	6.893E-12	2.960E-07	9.428E-06	
6th 6" Above Core	5.486E+05	1.262E+08	1.584E-06	4.761E-10	3.988E-10	7.781E-10	2.768E-07	3.512E-07	3.928E-07	7.013E-08	3.758E-08	4.993E-10	4.042E-13	7.616E-16	6.472E-12	7.749E-12	1.753E-12	7.539E-08	2.401E-06	
4th 12" Above Core	1.097E+08	2.523E+08	5.642E-07	1.896E-10	1.420E-10	2.772E-10	9.853E-08	1.251E-08	1.399E-08	2.499E-09	1.339E-09	1.779E-12	1.440E-15	2.713E-18	2.306E-12	2.761E-12	6.248E-13	2.686E-08	8.553E-07	
5th 12" Above Core	1.097E+08	2.523E+08	5.185E-08	1.559E-11	1.305E-11	2.548E-11	9.058E-09	1.150E-09	1.286E-09	2.298E-10	1.231E-10	1.635E-13	2.494E-17	2.119E-20	2.537E-13	5.740E-13	2.489E-14	7.861E-08		
6th 12" Above Core	1.097E+08	2.523E+08	5.355E-09	1.610E-12	1.348E-12	2.631E-12	9.353E-10	1.189E-10	1.329E-10	2.372E-11	1.271E-11	1.689E-14	1.367E-17	2.576E-20	2.189E-14	2.621E-14	5.929E-15	2.550E-10	8.119E-09	
Total	2.833E+07	6.056E+07	4.787E-01	1.433E-04	1.200E-04	2.342E-04	8.326E-02	1.057E-02	1.182E-01	2.111E-02	1.131E-02	1.503E-04	1.217E-07	2.293E-10	1.948E-06	2.333E-06	5.277E-07	2.270E-02	7.228E-01	

TABLE 4.7.17
SIXTH 6" PRIMARY SHIELD WALL CURIE CONTENT AT SHUTDOWN

Location	Component	Component	H-3 (Curies)	C-14	Ar-39	Ca-41	Ca-45	Mn-54	Fe-55	Co-60	Ni-59	Ni-63	Nb-94	Te-99	Sn-119m	Sb-125	Te-125m	Eu-152	Total
	Volume (cm ³)	Mass (gm)																	
6th 12" Below Core	1.142E+06	2.626E+06	2.042E-10	6.146E-14	7.246E-14	1.004E-13	3.570E-11	6.383E-14	5.067E-11	9.111E-12	4.848E-16	6.443E-14	5.300E-17	1.224E-19	1.041E-15	1.127E-16	2.551E-16	9.748E-12	3.098E-10
5th 12" Below Core	1.142E+06	2.626E+06	2.451E-09	7.375E-13	8.695E-13	1.204E-12	4.283E-10	7.659E-13	6.080E-10	1.093E-10	5.817E-15	7.731E-13	6.360E-16	1.469E-18	1.249E-14	1.353E-14	3.081E-15	1.170E-10	3.718E-08
4th 12" Below Core	1.142E+06	2.626E+06	3.325E-08	1.001E-11	1.180E-11	1.634E-11	5.811E-09	1.039E-11	8.249E-09	1.483E-09	7.892E-14	1.049E-11	8.629E-15	1.993E-17	1.694E-13	1.835E-13	4.153E-14	1.587E-09	5.044E-08
6th 8" Below Core	5.708E+05	1.313E+06	1.070E-07	3.220E-11	3.798E-11	5.259E-11	1.870E-10	3.344E-10	2.855E-08	4.774E-08	2.540E-13	3.378E-11	2.777E-14	6.414E-17	5.452E-13	5.908E-13	1.337E-13	5.107E-09	1.623E-07
5th 8" Below Core	5.708E+05	1.313E+06	4.735E-07	1.425E-10	1.680E-10	2.327E-10	8.276E-08	1.480E-10	1.175E-07	2.112E-08	1.124E-10	1.494E-10	1.229E-13	2.838E-16	2.413E-12	2.614E-12	5.915E-13	2.290E-08	7.183E-07
4th 8" Below Core	5.708E+05	1.313E+06	2.348E-06	7.081E-10	8.324E-10	1.153E-09	4.100E-07	7.333E-10	5.821E-07	1.047E-07	5.668E-12	7.401E-10	6.088E-13	1.406E-11	1.195E-11	1.295E-11	2.931E-12	1.120E-07	3.559E-06
3rd 6" Below Core	5.708E+05	1.313E+06	1.364E-05	4.104E-09	4.839E-09	6.703E-09	2.384E-08	4.262E-08	3.383E-06	6.084E-07	3.237E-11	4.302E-09	3.539E-12	8.174E-15	6.948E-11	7.528E-11	1.703E-11	6.509E-07	2.069E-05
2nd 6" Below Core	5.708E+05	1.313E+06	1.078E-04	3.239E-05	3.819E-05	5.290E-05	1.881E-05	3.364E-05	2.670E-06	4.802E-06	2.555E-10	3.396E-08	2.793E-11	6.452E-14	5.484E-10	5.941E-10	1.345E-10	5.137E-06	1.633E-04
2nd 3" Below Core	2.854E+05	6.565E+05	2.614E-04	7.867E-08	9.274E-08	1.285E-07	4.569E-05	8.170E-08	6.485E-05	1.166E-05	6.204E-10	8.248E-11	6.783E-13	1.567E-13	1.332E-09	1.443E-09	3.265E-10	1.248E-05	3.965E-04
1st 3" Below Core	2.854E+05	6.565E+05	6.939E-04	2.088E-07	2.462E-07	3.410E-07	1.213E-04	2.189E-07	1.721E-04	3.096E-05	1.647E-09	2.189E-07	1.801E-10	4.159E-13	3.535E-09	3.830E-09	8.688E-10	3.312E-05	1.053E-03
Reactor Core	1.370E+07	3.151E+07	7.735E-02	2.328E-05	2.744E-05	3.801E-05	1.352E-02	2.417E-05	1.919E-02	3.451E-03	1.836E-07	2.440E-05	2.007E-08	4.838E-11	3.941E-07	4.270E-07	9.662E-08	3.692E-03	1.173E-01
1st 3" Above Core	2.854E+05	6.565E+05	7.221E-04	2.173E-07	2.562E-07	3.549E-07	1.262E-04	2.257E-07	1.791E-04	3.221E-05	1.714E-09	2.278E-07	1.874E-10	4.328E-13	3.679E-09	3.986E-09	9.020E-10	3.446E-05	1.095E-03
2nd 3" Above Core	2.854E+05	6.565E+05	3.138E-04	9.444E-08	1.113E-07	1.542E-07	5.485E-05	9.808E-08	7.795E-05	1.400E-05	7.449E-10	9.900E-08	8.144E-11	1.881E-13	1.599E-09	1.732E-09	3.920E-10	1.498E-05	4.760E-04
2nd 6" Above Core	5.708E+05	1.313E+06	1.512E-04	4.550E-08	5.364E-08	7.431E-08	2.643E-05	4.726E-05	3.751E-05	6.745E-06	3.589E-10	4.770E-08	3.924E-11	9.063E-14	7.703E-10	8.346E-10	1.889E-10	7.216E-06	2.284E-04
3rd 6" Above Core	5.708E+05	1.313E+06	2.273E-05	6.840E-09	8.064E-09	1.117E-08	3.972E-06	7.104E-06	5.639E-06	1.014E-06	5.395E-11	7.170E-09	5.898E-12	1.362E-14	1.158E-10	1.255E-10	2.839E-11	1.065E-06	3.448E-05
4th 8" Above Core	5.708E+05	1.313E+06	4.513E-06	1.358E-09	1.601E-09	2.218E-09	7.888E-07	1.411E-06	1.120E-06	2.014E-07	1.071E-11	1.424E-09	1.171E-12	2.705E-15	2.300E-11	2.491E-11	5.638E-12	2.154E-07	6.847E-06
5th 8" Above Core	5.708E+05	1.313E+06	1.039E-06	3.126E-10	3.885E-10	5.105E-10	1.815E-07	3.248E-07	2.577E-07	4.634E-08	2.465E-12	3.277E-10	2.696E-13	6.226E-16	5.292E-12	5.734E-12	1.298E-12	4.958E-08	1.576E-06
6th 8" Above Core	5.708E+05	1.313E+06	2.648E-07	7.962E-11	9.387E-11	1.300E-10	4.624E-08	8.269E-11	6.593E-08	1.180E-08	6.279E-13	8.346E-11	6.865E-14	1.586E-16	1.348E-12	1.480E-12	3.305E-13	1.263E-08	4.013E-07
4th 12" Above Core	1.142E+06	2.626E+06	9.425E-08	2.837E-11	3.344E-11	4.632E-11	1.647E-08	2.946E-11	2.338E-08	4.205E-09	2.237E-13	2.973E-11	2.446E-14	5.649E-17	4.802E-13	5.203E-13	1.177E-13	4.498E-09	1.430E-07
5th 12" Above Core	1.142E+06	2.626E+06	8.662E-08	2.607E-12	3.073E-12	4.257E-12	1.514E-09	2.707E-12	2.149E-09	3.885E-10	2.056E-14	2.733E-12	2.248E-15	5.192E-18	4.414E-14	4.782E-14	1.082E-14	4.134E-10	1.314E-08
6th 12" Above Core	1.142E+06	2.626E+06	8.847E-10	2.693E-13	3.174E-13	4.397E-13	1.564E-10	2.786E-13	2.220E-10	3.892E-11	2.124E-15	2.823E-13	2.322E-16	5.363E-19	4.559E-15	4.939E-15	1.118E-15	4.270E-11	1.357E-09
Total	2.740E+07	6.302E+07	7.964E-02	2.397E-05	2.826E-05	3.914E-05	1.392E-02	2.489E-05	1.976E-02	3.553E-03	1.890E-07	2.512E-05	2.067E-08	4.774E-11	4.058E-07	4.396E-07	9.948E-08	3.801E-03	1.208E-01

TABLE 4.7.18
FOURTH 12" PRIMARY SHIELD WALL CURIE CONTENT AT SHUTDOWN

Location	Component	Component	H-3 (Curies)	C-14	Ar-39	Ca-41	Ca-45	Mn-54	Fe-55	Co-60	Ni-59	Ni-63	Nb-94	Tc-99	Sn-119m	Sb-125	Te-125m	Eu-152	Total
	Volume (cm ³)	Mass (gm)																	
8th 12" Below Core	2.417E+08	5.559E+08	4.581E-11	1.374E-14	2.211E-14	2.242E-14	7.974E-12	1.848E-14	1.132E-11	2.053E-12	1.082E-16	1.440E-14	1.208E-17	3.415E-20	2.903E-16	2.877E-18	6.515E-17	2.184E-12	6.923E-11
5th 12" Below Core	2.417E+08	5.559E+08	6.472E-10	1.648E-13	2.653E-13	2.691E-13	9.588E-11	2.337E-13	1.358E-10	2.463E-11	1.298E-15	1.728E-13	1.449E-16	4.098E-19	3.484E-15	3.452E-15	7.818E-16	2.820E-11	8.307E-10
4th 12" Below Core	2.417E+08	5.559E+08	7.425E-09	2.238E-12	3.599E-12	3.861E-12	1.298E-09	3.171E-12	1.843E-09	3.342E-10	1.762E-14	2.344E-12	1.988E-15	5.580E-18	4.727E-14	4.684E-14	1.081E-14	3.555E-10	1.127E-08
6th 6" Below Core	1.208E+08	2.779E+08	2.389E-08	7.199E-12	1.158E-11	1.175E-11	4.178E-09	1.020E-11	5.929E-09	1.076E-09	5.869E-14	7.544E-12	6.327E-15	1.789E-17	1.521E-13	1.507E-13	3.413E-13	1.144E-09	3.627E-08
5th 6" Below Core	1.208E+08	2.779E+08	1.057E-07	3.185E-11	5.128E-11	5.199E-11	1.849E-09	4.516E-11	2.824E-08	4.780E-09	2.609E-13	3.338E-11	2.800E-14	7.918E-17	6.731E-13	6.870E-13	1.511E-13	5.063E-09	1.605E-07
4th 6" Below Core	1.208E+08	2.779E+08	5.239E-07	1.578E-10	2.540E-10	2.576E-10	9.180E-08	2.237E-10	1.300E-07	2.358E-08	1.243E-12	1.654E-10	1.387E-13	3.923E-16	3.335E-12	3.305E-12	7.484E-12	2.509E-08	7.953E-07
3rd 6" Below Core	1.208E+08	2.779E+08	3.045E-06	9.172E-10	1.478E-09	1.497E-09	5.324E-07	1.301E-09	7.557E-07	1.371E-07	7.225E-12	8.615E-10	8.064E-13	1.939E-15	1.921E-11	4.350E-11	1.458E-12	1.458E-07	4.623E-06
2nd 6" Below Core	1.208E+08	2.779E+08	2.404E-05	7.239E-09	1.165E-08	1.192E-08	4.202E-08	1.027E-08	5.865E-08	1.082E-08	5.703E-11	7.589E-09	6.365E-12	1.800E-14	1.530E-10	1.518E-10	3.434E-11	1.151E-08	3.648E-05
2nd 3" Below Core	6.042E+05	1.390E+08	5.837E-05	1.758E-08	2.830E-08	2.870E-08	1.021E-05	2.493E-08	1.448E-05	2.628E-06	1.385E-10	1.843E-08	1.548E-11	4.371E-14	3.716E-10	3.682E-10	8.339E-11	2.795E-08	8.880E-05
1st 3" Below Core	6.042E+05	1.390E+08	1.549E-04	4.867E-08	7.511E-08	7.619E-08	2.709E-05	6.818E-08	3.845E-05	6.875E-06	3.876E-10	4.992E-08	4.103E-11	1.160E-13	9.864E-10	9.775E-10	2.214E-10	7.419E-08	2.352E-04
Reactor Core	2.900E+07	6.870E+07	1.727E-02	5.202E-06	8.373E-06	8.493E-06	3.020E-03	7.377E-06	4.286E-03	7.775E-04	4.098E-08	5.453E-08	4.574E-09	1.293E-11	1.100E-07	1.090E-07	2.467E-08	8.270E-04	2.622E-02
1st 3" Above Core	6.042E+05	1.390E+08	1.612E-04	4.856E-08	7.817E-08	7.929E-08	2.819E-05	6.886E-08	4.001E-05	7.258E-06	3.826E-10	5.091E-08	4.270E-11	1.207E-13	1.027E-09	1.017E-09	2.304E-10	7.721E-08	2.448E-04
2nd 3" Above Core	6.042E+05	1.390E+08	7.008E-05	2.111E-08	3.397E-08	3.446E-08	1.225E-05	2.993E-08	1.739E-05	3.164E-06	1.693E-10	2.213E-08	1.856E-11	5.247E-14	4.461E-10	4.421E-10	1.001E-10	3.355E-08	1.064E-04
2nd 6" Above Core	1.208E+08	2.779E+08	3.376E-05	1.017E-08	1.637E-08	1.660E-08	5.903E-08	1.442E-08	8.378E-06	1.520E-06	8.010E-11	1.068E-08	8.940E-12	2.528E-14	2.149E-10	2.130E-10	4.823E-11	1.617E-08	5.125E-05
3rd 6" Above Core	1.208E+08	2.779E+08	5.075E-06	1.529E-09	2.460E-09	2.496E-09	8.874E-07	2.189E-08	1.259E-06	2.285E-07	1.204E-11	1.802E-09	1.344E-12	3.800E-15	3.231E-11	3.202E-11	7.251E-11	2.430E-07	7.704E-06
4th 6" Above Core	1.208E+08	2.779E+08	1.008E-06	3.035E-10	4.888E-10	4.956E-10	1.762E-07	4.304E-08	2.501E-07	4.537E-08	2.391E-12	3.182E-10	2.889E-13	7.547E-16	6.418E-12	6.358E-12	1.440E-12	4.826E-08	1.530E-06
5th 6" Above Core	1.208E+08	2.779E+08	2.320E-07	6.986E-11	1.124E-10	1.141E-10	4.055E-08	9.908E-11	5.756E-08	1.044E-08	5.503E-13	7.324E-11	6.142E-14	1.737E-16	1.477E-12	1.463E-12	3.314E-12	1.111E-08	3.521E-07
8th 6" Above Core	1.208E+08	2.779E+08	5.908E-08	1.778E-11	2.864E-11	2.905E-11	1.033E-08	2.523E-11	1.466E-08	2.659E-09	1.402E-13	1.865E-11	1.564E-14	4.424E-17	3.761E-13	3.727E-13	8.440E-14	2.829E-08	8.988E-08
4th 12" Above Core	2.417E+08	5.559E+08	2.105E-08	6.339E-12	1.020E-11	1.035E-11	3.890E-09	8.899E-12	5.223E-09	9.474E-10	4.894E-14	6.845E-12	5.573E-16	1.576E-17	1.340E-13	1.328E-13	3.007E-14	1.008E-09	3.195E-08
5th 12" Above Core	2.417E+08	5.559E+08	1.934E-09	5.828E-13	9.377E-13	9.511E-13	3.382E-10	8.261E-13	4.800E-10	8.708E-11	4.590E-15	6.107E-13	5.122E-16	1.448E-18	1.231E-14	1.220E-14	2.763E-15	8.262E-11	2.938E-09
6th 12" Above Core	2.417E+08	5.559E+08	1.988E-10	6.017E-14	9.885E-14	9.824E-14	3.493E-11	8.533E-14	4.958E-11	8.994E-12	4.740E-16	6.308E-14	5.291E-17	1.496E-18	1.272E-15	1.260E-15	2.854E-16	9.567E-12	3.033E-10
Total	5.900E+07	1.334E+08	1.778E-02	5.356E-06	8.622E-06	8.745E-06	3.109E-03	7.595E-06	4.413E-03	8.006E-04	4.220E-08	5.615E-08	4.709E-09	1.332E-11	1.132E-07	1.122E-07	2.541E-08	8.516E-04	2.700E-02

TABLE 4.7.19
FIFTH 12" PRIMARY SHIELD WALL CURIE CONTENT AT SHUTDOWN

Location	Component	Component	H-3 (Curies)	C-14	Ar-39	Ca-41	Ca-45	Mn-54	Fe-55	Co-60	Ni-59	Ni-63	Nb-94	Te-99	Sn-119m	Sb-125	Te-125m	Eu-152	Total
	Volume (cm ³)	Mass (gm)																	
6th 12" Below Core	2.595E+06	5.968E+06	2.044E-12	6.162E-16	1.321E-15	1.005E-15	3.577E-13	1.164E-15	5.078E-13	9.304E-14	4.849E-18	6.457E-16	5.549E-19	1.910E-21	1.824E-17	1.490E-17	3.365E-18	9.831E-14	3.108E-12
5th 12" Below Core	2.595E+06	5.968E+06	2.453E-11	7.394E-15	1.585E-14	1.207E-14	4.293E-12	1.396E-14	6.091E-12	1.116E-12	5.819E-17	7.748E-15	6.658E-18	2.292E-20	1.949E-16	1.788E-16	4.038E-17	1.180E-12	3.727E-11
4th 12" Below Core	2.595E+06	5.968E+06	3.328E-10	1.003E-13	2.151E-13	1.637E-13	5.824E-11	1.895E-13	8.284E-11	1.515E-11	7.895E-16	1.051E-13	9.034E-17	3.110E-19	2.645E-15	2.426E-15	5.479E-16	1.601E-11	5.058E-10
6th 8" Below Core	1.297E+06	2.984E+06	1.071E-09	3.228E-13	6.921E-13	5.288E-13	1.874E-10	6.097E-13	2.860E-10	4.874E-11	2.541E-15	3.383E-13	2.907E-16	1.001E-18	8.511E-15	7.807E-15	1.763E-15	5.151E-11	1.627E-09
5th 8" Below Core	1.297E+06	2.984E+06	4.739E-09	1.429E-12	3.063E-12	2.331E-12	8.294E-10	2.699E-12	1.177E-09	2.157E-10	1.124E-14	1.497E-12	1.286E-15	4.429E-18	3.768E-14	3.455E-14	7.802E-15	2.279E-10	7.200E-09
4th 8" Below Core	1.297E+06	2.984E+06	2.348E-08	7.079E-12	1.517E-11	1.155E-11	4.109E-09	1.337E-11	5.831E-09	1.089E-09	5.671E-14	7.418E-12	6.374E-15	2.194E-17	1.866E-13	1.712E-13	3.868E-14	1.129E-09	3.569E-08
3rd 8" Below Core	1.297E+06	2.984E+06	1.365E-07	4.115E-11	8.920E-11	6.714E-11	2.389E-08	7.771E-11	3.390E-08	6.213E-09	3.238E-13	4.312E-11	3.705E-14	1.276E-16	1.085E-12	9.950E-13	2.247E-13	6.565E-09	2.074E-07
2nd 8" Below Core	1.297E+06	2.984E+06	1.077E-06	3.248E-10	6.962E-10	5.299E-10	1.885E-07	6.133E-10	2.675E-07	4.903E-08	2.556E-12	3.403E-10	2.924E-13	1.007E-15	8.561E-12	7.853E-12	1.774E-12	5.181E-08	1.637E-06
2nd 3" Below Core	6.487E+05	1.492E+06	2.618E-06	7.897E-10	1.891E-09	1.287E-09	4.679E-07	1.489E-09	6.497E-07	1.191E-07	6.207E-12	8.264E-10	7.102E-13	2.445E-15	2.079E-11	1.907E-11	4.307E-12	1.258E-07	3.975E-06
1st 3" Below Core	6.487E+05	1.492E+06	6.945E-06	2.094E-09	4.488E-09	3.418E-09	1.215E-08	3.954E-08	1.725E-08	3.181E-07	1.648E-11	2.194E-09	1.885E-12	6.490E-15	5.519E-11	5.083E-11	1.143E-11	3.340E-07	1.055E-05
Reactor Core	3.114E+07	7.161E+07	7.742E-04	2.334E-07	5.003E-07	3.808E-07	1.355E-04	4.407E-07	1.922E-04	3.524E-05	1.837E-09	2.445E-07	2.101E-10	7.235E-13	6.152E-09	5.643E-09	1.274E-09	3.723E-05	1.178E-03
1st 3" Above Core	6.487E+05	1.492E+06	7.228E-06	2.179E-09	4.670E-09	3.555E-09	1.265E-08	4.115E-09	1.795E-08	3.289E-07	1.715E-11	2.283E-09	1.982E-12	6.754E-15	5.743E-11	5.288E-11	1.190E-11	3.476E-07	1.098E-05
2nd 3" Above Core	6.487E+05	1.492E+06	3.141E-06	9.468E-10	2.030E-09	1.545E-09	5.497E-07	1.788E-08	7.800E-07	1.430E-07	7.451E-12	9.922E-10	8.528E-13	2.935E-15	2.498E-11	2.290E-11	5.171E-12	1.511E-07	4.772E-06
2nd 8" Above Core	1.297E+06	2.984E+06	1.513E-06	4.562E-10	9.779E-10	7.444E-10	2.648E-07	8.615E-10	3.758E-07	6.888E-08	3.590E-12	4.780E-10	4.108E-13	1.414E-15	1.203E-11	1.103E-11	2.491E-12	7.278E-08	2.299E-06
3rd 8" Above Core	1.297E+06	2.984E+06	2.275E-07	6.858E-11	1.470E-10	1.119E-10	3.981E-08	1.295E-10	5.649E-08	1.035E-08	5.397E-13	7.186E-11	6.175E-14	2.126E-16	1.808E-12	1.658E-12	3.745E-13	1.084E-08	3.456E-07
4th 8" Above Core	1.297E+06	2.984E+06	4.518E-08	1.362E-11	2.919E-11	2.222E-11	7.906E-09	2.572E-11	1.122E-08	2.058E-09	1.072E-13	1.427E-11	1.226E-14	4.222E-17	3.590E-13	3.293E-13	7.437E-14	2.173E-09	6.863E-08
5th 8" Above Core	1.297E+06	2.984E+06	1.040E-08	3.134E-12	6.718E-12	5.114E-12	1.819E-09	5.919E-12	2.582E-09	4.732E-10	2.488E-14	3.284E-12	2.822E-15	9.716E-18	8.262E-14	7.579E-14	1.712E-14	5.000E-10	1.580E-08
6th 8" Above Core	1.297E+06	2.984E+06	2.649E-09	7.992E-13	1.711E-12	1.302E-12	4.634E-10	1.508E-12	6.576E-10	1.205E-10	6.282E-15	8.364E-13	7.188E-16	2.475E-18	2.104E-14	1.930E-14	4.359E-15	1.274E-10	4.023E-09
4th 12" Above Core	2.595E+06	5.968E+06	9.434E-10	2.844E-13	6.098E-13	4.640E-13	1.651E-10	5.371E-13	2.343E-10	4.294E-11	2.238E-15	2.980E-13	2.561E-16	8.816E-19	7.497E-15	6.877E-15	1.553E-15	4.537E-11	1.433E-09
5th 12" Above Core	2.595E+06	5.968E+06	8.671E-11	2.614E-14	5.803E-14	4.285E-14	1.517E-11	4.936E-14	2.153E-11	3.948E-12	2.057E-16	2.739E-14	2.364E-17	8.102E-20	6.890E-16	6.320E-16	1.427E-16	4.170E-12	1.317E-10
6th 12" Above Core	2.595E+06	5.968E+06	8.855E-12	2.699E-15	5.787E-15	4.405E-15	1.567E-12	5.099E-15	2.224E-12	4.078E-13	2.124E-17	2.829E-15	2.431E-18	8.368E-21	7.116E-17	6.528E-17	1.474E-17	4.307E-13	1.361E-11
Total	6.227E+07	1.432E+08	7.972E-04	2.403E-07	5.151E-07	3.921E-07	1.395E-04	4.538E-07	1.980E-04	3.628E-05	1.891E-09	2.518E-07	2.164E-10	7.449E-13	6.335E-09	5.811E-09	1.312E-09	3.834E-05	1.211E-03

TABLE 4.7.20
SIXTH 12" PRIMARY SHIELD WALL CURIE CONTENT AT SHUTDOWN

Location	Component		H-3 (Curies)	C-14	Ar-39	Ca-41	Ca-45	Mn-54	Fe-55	Co-60	Ni-59	Ni-63	Nb-94	Tc-99	Sn-119m	Sb-125	Te-125m	Eu-152	Total
	Volume (cm ³)	Mass (gm)																	
6th 12" Below Core	2.773E+06	6.377E+06	1.073E-13	3.234E-17	7.714E-17	5.275E-17	1.877E-14	6.788E-17	2.664E-14	4.905E-15	2.543E-19	3.388E-20	2.943E-22	1.093E-22	9.348E-19	8.370E-19	1.787E-19	5.167E-15	1.630E-13
5th 12" Below Core	2.773E+06	6.377E+06	1.287E-12	3.890E-18	9.257E-16	6.330E-16	2.253E-13	8.157E-16	3.187E-13	5.888E-14	3.052E-18	4.065E-18	3.532E-19	1.311E-21	1.122E-17	1.004E-17	2.144E-18	6.200E-14	1.858E-12
4th 12" Below Core	2.773E+06	6.377E+06	1.748E-11	5.265E-15	1.258E-14	8.588E-15	3.058E-12	1.107E-14	4.337E-12	7.988E-13	4.141E-17	5.518E-16	4.792E-20	1.779E-20	1.522E-16	1.363E-16	2.809E-17	8.412E-13	2.654E-11
6th 6" Below Core	1.388E+06	3.188E+06	5.619E-11	1.894E-14	4.042E-14	2.784E-14	9.835E-12	3.581E-14	1.396E-12	2.670E-12	1.332E-16	1.775E-14	1.542E-17	5.724E-20	4.898E-16	4.385E-16	9.363E-17	2.707E-12	8.540E-11
5th 6" Below Core	1.388E+06	3.188E+06	2.487E-10	7.497E-14	1.789E-13	1.223E-13	4.352E-11	1.578E-13	6.177E-11	1.137E-11	5.896E-16	7.855E-14	6.824E-17	2.533E-19	2.187E-15	1.941E-15	4.143E-16	1.188E-11	3.779E-10
4th 6" Below Core	1.388E+06	3.188E+06	1.232E-09	3.715E-13	8.862E-13	6.090E-13	2.157E-10	7.809E-13	3.081E-11	5.635E-11	2.922E-15	3.892E-13	3.381E-16	1.255E-18	1.074E-14	9.615E-15	2.053E-15	5.935E-11	1.873E-09
3rd 6" Below Core	1.388E+06	3.188E+06	7.182E-09	2.159E-12	5.151E-12	3.523E-12	1.254E-09	4.539E-12	1.779E-09	3.275E-10	1.698E-14	2.262E-12	1.965E-15	7.295E-18	6.242E-14	5.589E-14	1.193E-14	3.450E-10	1.088E-08
2nd 6" Below Core	1.388E+06	3.188E+06	5.653E-08	1.704E-11	4.068E-11	2.780E-11	9.894E-09	3.582E-11	1.404E-08	2.585E-08	1.340E-13	1.788E-11	1.551E-14	5.758E-17	4.927E-13	4.411E-13	9.418E-14	2.723E-09	8.591E-08
2nd 3" Below Core	6.931E+06	1.594E+06	1.373E-07	4.139E-11	9.873E-11	6.752E-11	2.403E-08	8.700E-11	3.410E-08	6.278E-09	3.255E-13	4.396E-11	3.787E-14	1.398E-16	1.198E-12	1.071E-12	2.287E-13	6.613E-09	2.086E-07
1st 3" Below Core	6.931E+06	1.594E+06	3.844E-07	1.099E-10	2.821E-10	1.792E-10	6.378E-08	2.309E-10	9.052E-08	1.687E-08	8.841E-13	1.151E-10	1.000E-13	3.712E-16	3.178E-12	2.844E-12	6.071E-13	1.755E-08	5.538E-07
Reactor Core	3.327E+07	7.852E+07	4.062E-05	1.225E-08	2.922E-08	1.998E-08	7.110E-06	2.574E-08	1.009E-05	1.858E-06	9.832E-11	1.283E-08	1.115E-11	4.138E-14	3.540E-10	3.170E-10	6.788E-11	1.957E-06	6.174E-05
1st 3" Above Core	6.931E+06	1.594E+06	3.792E-07	1.143E-10	2.727E-10	1.865E-10	6.637E-08	2.403E-10	9.420E-08	1.734E-08	8.992E-13	1.198E-10	1.041E-13	3.883E-16	3.305E-12	2.959E-12	6.318E-13	1.827E-08	5.763E-07
2nd 3" Above Core	6.931E+06	1.594E+06	1.648E-07	4.869E-11	1.185E-11	8.108E-11	2.884E-08	1.044E-10	4.084E-08	7.537E-09	3.908E-13	5.208E-11	4.523E-14	1.679E-16	1.438E-12	1.286E-12	2.746E-13	7.838E-09	2.505E-07
2nd 6" Above Core	1.388E+06	3.188E+06	7.840E-08	2.384E-11	5.711E-11	3.905E-11	1.390E-08	5.032E-11	1.972E-08	3.631E-09	1.883E-13	2.508E-11	2.179E-14	8.088E-17	6.920E-13	6.197E-13	1.323E-13	3.825E-09	1.207E-07
3rd 6" Above Core	1.388E+06	3.188E+06	1.184E-08	3.599E-12	8.585E-12	5.871E-12	2.089E-09	7.565E-12	2.865E-10	5.459E-10	2.830E-14	3.770E-12	3.278E-15	1.218E-17	1.040E-13	9.315E-14	1.989E-14	5.750E-10	1.814E-08
4th 6" Above Core	1.388E+06	3.188E+06	2.370E-09	7.146E-13	1.705E-12	1.168E-12	4.149E-10	1.502E-12	5.888E-10	1.084E-10	5.620E-15	7.487E-13	6.505E-16	2.414E-18	2.088E-14	1.850E-14	3.949E-15	1.142E-10	3.802E-09
5th 6" Above Core	1.388E+06	3.188E+06	5.455E-10	1.645E-13	3.924E-13	2.683E-13	9.548E-11	3.457E-13	1.355E-10	2.495E-11	1.293E-15	1.723E-13	1.497E-16	5.557E-19	4.754E-15	4.257E-15	9.089E-16	2.628E-11	8.291E-10
6th 6" Above Core	1.388E+06	3.188E+06	1.389E-10	4.189E-14	9.993E-14	6.833E-14	2.432E-11	8.805E-14	3.451E-11	6.354E-12	3.294E-16	4.389E-14	3.813E-17	1.415E-19	1.211E-15	1.084E-15	2.315E-16	6.893E-12	2.112E-10
4th 12" Above Core	2.773E+06	6.377E+06	4.950E-11	1.492E-14	3.560E-14	2.434E-14	8.863E-12	3.137E-14	1.230E-11	2.284E-12	1.174E-18	1.564E-14	1.358E-17	5.042E-20	4.314E-16	3.883E-16	8.247E-17	2.384E-12	7.523E-11
5th 12" Above Core	2.773E+06	6.377E+06	4.549E-12	1.372E-15	3.272E-15	2.238E-15	7.862E-13	2.883E-15	1.130E-12	2.081E-13	1.079E-17	1.437E-15	1.248E-18	4.834E-21	3.865E-17	3.550E-17	7.580E-18	2.191E-13	6.914E-12
6th 12" Above Core	2.773E+06	6.377E+06	4.699E-13	1.417E-16	3.379E-16	2.311E-16	8.224E-14	2.978E-16	1.167E-13	2.149E-14	1.114E-18	1.484E-16	1.289E-19	4.788E-22	4.095E-18	3.667E-18	7.829E-19	2.283E-14	7.141E-13
Total	6.854E+07	1.530E+08	4.183E-05	1.261E-08	3.008E-08	2.057E-08	7.321E-06	2.651E-08	1.039E-05	1.913E-06	9.918E-11	1.321E-08	1.148E-11	4.260E-14	3.645E-10	3.264E-10	6.969E-11	2.015E-06	6.357E-05

TABLE 4.7.21
LOWER CORE PLATE CURIE CONTENT AT SHUTDOWN

Location	Component	Component	H-3 (Curies)	C-14	Ar-39	Ca-41	Ca-45	Mn-54	Fe-55	Co-60	Ni-59	Ni-63	Nb-94	Tc-99	Sn-119m	Sb-125	Te-125m	Eu-152	Total	
	Volume (cm ³)	Mass (gm)																		
Reactor Core	3.111E+05	2.489E+08	3.648E+01	8.889E+00	2.020E+02	1.880E+03	6.897E+01	4.343E+03	1.081E+05	9.368E+04	4.489E+01	6.987E+03	1.275E+01	2.769E+02	5.014E+12	1.426E+02	7.324E+03	4.524E+01	2.132E+05	
1st 3" Outside Core	2.876E+04	2.300E+05	1.440E+00	3.603E+01	7.977E+04	7.424E+05	2.724E+02	1.716E+02	4.271E+03	3.899E+03	1.773E+00	2.769E+02	5.037E+03	1.094E+03	1.980E+13	6.630E+04	2.892E+04	1.787E+02	8.421E+03	
2nd 3" Outside Core	4.003E+04	3.202E+05	7.342E+01	1.786E+01	4.068E+04	3.788E+05	1.389E+02	8.748E+01	2.178E+03	1.887E+03	8.041E+01	1.407E+02	2.569E+03	5.577E+04	1.010E+13	2.871E+04	1.476E+04	9.111E+03	4.295E+03	
2nd 6" Outside Core																				
3rd 6" Outside Core																				
4th 6" Outside Core																				
5th 6" Outside Core																				
6th 6" Outside Core																				
Total	3.799E+05	3.039E+08	3.863E+01	9.398E+00	2.140E+02	1.992E+03	7.308E+01	4.602E+03	1.146E+05	9.926E+04	4.757E+01	7.403E+03	1.351E+01	2.934E+02	6.313E+12	1.511E+02	7.780E+03	4.794E+01	2.260E+05	

TABLE 4.7.22
 LOWER CORE SUPPORT COLUMNS CURIE CONTENT AT SHUTDOWN

Location	Component	Component	H-3 (Curies)	C-14	Ar-39	Ca-41	Ca-45	Mn-54	Fe-55	Co-60	Ni-59	Ni-63	Nb-94	Tc-99	Sn-119m	Sb-125	Te-125m	Eu-152	Total
	Volume (cm ³)	Mass (gm)																	
Reactor Core	2.897E+05	2.317E+08	1.180E +01	1.831E +00	1.383E- 03	4.030E- 04	1.445E- 01	2.536E +02	2.295E +04	1.432E +04	1.138E +01	1.561E +03	1.456E- 02	1.733E- 03	9.929E- 17	2.259E- 04	1.418E- 04	5.865E- 01	3.911E +04
1st 3" Outside Core																			
2nd 3" Outside Core																			
2nd 6" Outside Core																			
3rd 6" Outside Core																			
4th 6" Outside Core																			
5th 6" Outside Core																			
6th 6" Outside Core																			
Total	2.897E+05	2.317E+08	1.180E +01	1.831E +00	1.383E- 03	4.030E- 04	1.445E- 01	2.536E +02	2.295E +04	1.432E +04	1.138E +01	1.561E +03	1.456E- 02	1.733E- 03	9.929E- 17	2.259E- 04	1.418E- 04	5.865E- 01	3.911E +04

TABLE 4.7.23
LOWER CORE SUPPORT CURIE CONTENT AT SHUTDOWN

Location	Component	Component																		
	Volume (cm ³)	Mass (gm)	H-3 (Curies)	C-14	Ar-39	Ca-41	Ca-45	Mn-54	Fe-55	Co-60	Ni-59	Ni-63	Nb-94	Tc-99	Sn-119m	Sb-125	Te-125m	Eu-152	Total	
Reactor Core	2.602E+06	2.081E+07	2.525E-02	4.118E-03	1.505E-05	8.524E-07	3.169E-04	2.768E+00	4.966E+01	5.325E+01	2.353E-02	3.357E+00	7.473E-06	1.899E-05	8.331E-22	5.381E-10	2.550E-10	9.473E-03	1.091E+02	
1st 3" Outside Core	2.408E+05	1.925E+06	9.977E-04	1.628E-04	5.949E-07	3.369E-08	1.252E-05	1.094E-01	1.962E+00	2.104E+00	9.300E-04	1.327E-01	2.953E-06	7.505E-07	3.282E-23	2.126E-11	1.008E-11	3.744E-04	4.311E+00	
2nd 3" Outside Core	2.512E+05	2.009E+06	3.815E-04	6.224E-05	2.275E-07	1.288E-08	4.789E-06	4.183E-02	7.504E-01	8.046E-01	3.556E-04	5.073E-02	1.129E-06	2.870E-07	1.259E-23	8.131E-12	3.854E-12	1.432E-04	1.648E+00	
2nd 6" Outside Core	3.083E+05	2.467E+06	9.211E-05	1.503E-05	5.492E-08	3.110E-09	1.156E-06	1.010E-02	1.812E-01	1.943E-01	8.586E-05	1.225E-02	2.728E-07	6.929E-08	3.039E-24	1.963E-12	9.304E-13	3.456E-05	3.980E-01	
3rd 6" Outside Core																				
4th 6" Outside Core																				
5th 6" Outside Core																				
6th 6" Outside Core																				
Total	3.402E+06	2.722E+07	2.872E-02	4.359E-03	1.593E-05	9.021E-07	3.354E-04	2.929E+00	5.255E+01	5.635E+01	2.491E-02	3.553E+00	7.908E-06	2.010E-05	8.816E-22	5.695E-10	2.699E-10	1.003E-02	1.154E+02	

SITE CHARACTERIZATION REPORT

REVISION 0.1

**TABLE 4.7.24
BELOW LOWER CORE SUPPORT PLATE CURIE CONTENT AT SHUTDOWN**

Location	Component	Component	H-3 (Curies)	C-14	Ar-39	Ca-41	Ca-45	Mn-54	Fe-55	Co-60	Ni-59	Ni-63	Nb-94	Tc-99	Sn-119m	Sb-125	Te-125m	Eu-152	Total
	Volume (cm ³)	Mass (gm)																	
Reactor Core	2.309E+05	1.847E+08	1.001E-06	1.493E-06	1.058E-09	3.287E-10	1.178E-07	1.946E-04	1.873E-02	1.170E-02	9.577E-06	1.287E-03	1.168E-08	1.398E-09	0.000E+00	0.000E+00	0.000E+00	2.847E-06	3.193E-02
1st 3" Outside Core																			
2nd 3" Outside Core																			
2nd 6" Outside Core																			
3rd 6" Outside Core																			
4th 6" Outside Core																			
5th 6" Outside Core																			
6th 6" Outside Core																			
Total	2.309E+05	1.847E+08	1.001E-06	1.493E-06	1.058E-09	3.287E-10	1.178E-07	1.946E-04	1.873E-02	1.170E-02	9.577E-06	1.287E-03	1.168E-08	1.398E-09	0.000E+00	0.000E+00	0.000E+00	2.847E-06	3.193E-02

SITE CHARACTERIZATION REPORT

REVISION 0.1

TABLE 4.7.25
UPPER CORE PLATE CURIE CONTENT AT SHUTDOWN

Location	Component	Component	H-3 (Curies)	C-14	Ar-39	Ca-41	Ca-45	Mn-54	Fe-55	Co-60	Ni-59	Ni-63	Nb-94	Tc-99	Sn-119m	Sb-125	Te-125m	Eu-152	Total	
	Volume (cm ³)	Mass (gm)																		
Reactor Core	3.875E+05	2.840E+08	9.372E +00	1.577E +00	4.459E 03	3.320E 04	1.222E 01	8.411E +02	1.921E +04	1.817E +04	9.058E +00	1.285E +03	2.437E 02	5.513E 03	5.447E 16	4.248E 04	2.131E 04	1.260E +00	3.953E +04	
1st 3" Outside Core	3.396E+04	2.717E+05	3.701E 01	6.229E 02	1.761E 04	1.311E 05	4.826E 03	3.322E +01	7.588E +02	7.175E +02	3.578E 01	5.113E +01	9.625E 04	2.178E 04	2.151E 17	1.678E 06	8.417E 06	4.978E 02	1.561E +03	
2nd 3" Outside Core	5.097E+04	4.078E+05	2.035E 01	3.424E 02	9.881E 05	7.207E 06	2.853E 03	1.828E +01	4.171E +02	3.944E +02	1.967E 01	2.810E +01	5.290E 04	1.197E 04	1.183E 17	9.225E 06	4.627E 06	2.736E 02	8.583E +02	
2nd 6" Outside Core																				
3rd 6" Outside Core																				
4th 6" Outside Core																				
5th 6" Outside Core																				
6th 6" Outside Core																				
Total	4.525E+05	3.620E+08	9.945E +00	1.674E +00	4.732E 03	3.523E 04	1.297E 01	8.925E +02	2.039E +04	1.928E +04	9.613E +00	1.374E +03	2.586E 02	5.851E 03	5.780E 16	4.508E 04	2.262E 04	1.337E +00	4.185E +04	

SITE CHARACTERIZATION REPORT

REVISION 0.1

**TABLE 4.7.26
UPPER CORE SUPPORT COLUMNS CURIE CONTENT AT SHUTDOWN**

Location	Component	Component	H-3 (Curies)	C-14	Ar-39	Ca-41	Ca-45	Mn-54	Fe-55	Co-60	Ni-69	Ni-63	Nb-94	Tc-99	Sn-119m	Sb-125	Ta-125m	Eu-152	Total
	Volume (cm ³)	Mass (gm)																	
Reactor Core	6.559E+05	5.248E+08	1.853E +00	2.748E 01	2.118E 04	6.038E 05	2.185E 02	3.898E +01	3.442E +03	2.179E +03	1.754E +00	2.363E +02	2.208E 03	2.700E 04	1.023E 18	2.281E 08	1.428E 08	4.222E 01	5.901E +03
1st 3" Outside Core																			
2nd 3" Outside Core																			
2nd 6" Outside Core																			
3rd 6" Outside Core																			
4th 6" Outside Core																			
5th 6" Outside Core																			
6th 6" Outside Core																			
Total	6.559E+05	5.248E+08	1.853E +00	2.748E 01	2.118E 04	6.038E 05	2.185E 02	3.898E +01	3.442E +03	2.179E +03	1.754E +00	2.363E +02	2.208E 03	2.700E 04	1.023E 18	2.281E 08	1.428E 08	4.222E 01	5.901E +03

SITE CHARACTERIZATION REPORT

REVISION 0.1

TABLE 4.2.27

CURIE CONTENT AT SHUTDOWN - COMPONENT SUMMARY

Summary		H-3	C-14	Ar-39	Ca-41	Ca-45	Mn-54	Fe-55	Co-60	Ni-59	Ni-63	Nb-94	Ta-99	Sn-119m	Sb-125	Ta-125m	Eu-152	Total
By isotope	Component	(Curies)																
Scenario #1																		
Decay (years)	Core Baffle	3.093E+02	1.187E+02	2.288E+01	2.430E+02	9.138E+00	9.371E+04	1.415E+06	1.399E+06	5.328E+02	9.022E+04	2.225E+00	5.091E+01	5.371E+10	1.160E+00	5.518E+01	9.845E+03	2.898E+06
0.0	Core Formers	1.159E+02	7.014E+01	5.233E+02	1.550E+02	5.547E+00	1.211E+04	8.892E+05	4.658E+05	2.614E+02	4.964E+04	5.683E+01	7.651E+02	2.671E+11	1.765E+01	1.100E+01	1.522E+01	1.397E+08
	Lower Core Barrel	7.235E+01	1.184E+01	4.891E+02	2.418E+03	9.065E+01	9.377E+03	1.415E+05	1.651E+05	6.519E+01	9.507E+03	2.409E+01	6.103E+02	6.379E+16	5.517E+03	2.470E+03	1.015E+01	3.257E+05
	Upper Core Barrel	6.820E+04	1.116E+04	4.810E+07	2.279E+08	8.544E+08	8.838E+02	1.334E+00	1.556E+00	6.145E+04	8.981E+02	2.271E+08	5.752E+07	6.012E+21	5.200E+08	2.328E+08	9.588E+05	3.070E+00
	Thermal Shield Pads	1.725E+01	2.834E+00	1.186E+02	5.784E+04	2.169E+01	2.250E+03	3.367E+04	3.972E+04	1.567E+01	2.278E+03	5.787E+02	1.469E+02	1.150E+15	6.988E+04	3.129E+04	3.867E+00	7.816E+04
	Vessel Clad	7.661E+00	1.265E+00	2.080E+03	2.733E+04	9.906E+02	3.898E+02	1.567E+04	1.190E+04	7.575E+00	1.061E+03	1.414E+02	2.584E+03	1.993E+16	2.320E+04	1.310E+04	6.913E+01	2.903E+04
	Vessel Wall	5.558E+00	6.228E+03	6.843E+03	6.031E+05	2.207E+02	4.616E+02	6.875E+03	7.591E+02	1.338E+01	1.949E+01	1.751E+03	4.445E+03	7.348E+03	4.654E+02	1.055E+02	1.474E+00	8.122E+03
	Vessel Insulation	1.328E+02	2.077E+03	4.878E+08	4.423E+07	1.817E+04	8.974E+01	2.551E+01	2.217E+01	1.252E+02	1.737E+00	2.819E+05	6.185E+06	3.248E+21	2.819E+09	1.487E+09	4.345E+03	5.034E+01
	1st 3" Bioshield	7.887E+01	2.417E+02	3.052E+01	3.892E+02	1.391E+01	2.689E+01	1.872E+01	4.360E+00	1.853E+04	2.510E+02	3.176E+05	3.660E+07	3.112E+03	2.120E+03	4.804E+04	3.981E+04	1.213E+02
	2nd 3" Bioshield	8.816E+01	2.666E+02	1.144E+01	4.338E+02	1.544E+01	1.008E+01	2.192E+01	4.185E+00	2.086E+04	2.788E+02	2.626E+05	1.484E+07	1.262E+03	9.913E+04	2.248E+04	4.224E+04	1.342E+02
	1st Rebar/Liner	5.027E+01	5.984E+03	3.994E+05	5.248E+06	1.869E+03	2.694E+00	5.858E+02	1.982E+01	1.378E+02	1.840E+00	4.365E+05	3.068E+08	3.256E+21	1.592E+08	1.058E+08	9.051E+08	6.108E+02
	2nd 6" Bioshield	8.740E+01	2.633E+02	4.879E+02	4.297E+02	1.528E+01	4.122E+02	2.169E+01	3.846E+00	2.073E+04	2.759E+02	2.331E+05	7.053E+08	5.995E+04	5.783E+04	1.309E+04	4.159E+04	1.327E+02
	3rd 6" Bioshield	1.872E+01	5.628E+03	4.234E+03	9.197E+03	3.270E+00	3.731E+03	4.641E+00	8.275E+01	4.443E+05	5.901E+03	4.759E+08	8.453E+09	7.188E+05	8.869E+05	2.006E+05	8.894E+01	2.838E+01
	4th 6" Bioshield	3.043E+00	9.149E+04	5.847E+04	1.498E+03	5.316E+01	5.152E+04	7.547E+01	1.343E+01	7.226E+08	9.598E+04	7.896E+07	1.256E+09	1.067E+05	1.379E+05	3.120E+08	1.447E+08	4.813E+00
	2nd Bioshield Rebar	9.118E+03	1.074E+04	1.072E+07	9.502E+08	3.378E+05	7.233E+03	1.059E+01	3.337E+01	2.506E+04	3.328E+02	6.716E+07	1.363E+11	9.076E+28	2.476E+12	2.108E+12	1.628E+03	1.098E+01
	5th 6" Bioshield	4.767E+01	1.433E+04	1.200E+04	2.342E+04	8.326E+02	1.057E+04	1.182E+01	2.111E+02	1.131E+08	1.503E+04	1.217E+07	2.293E+10	1.848E+06	2.333E+06	5.277E+07	2.270E+02	7.228E+01
	6th 6" Bioshield	7.964E+02	2.397E+05	2.828E+05	3.914E+05	1.392E+02	2.489E+05	1.976E+02	3.553E+03	1.890E+07	2.512E+05	2.067E+08	4.774E+11	4.058E+07	4.396E+07	9.948E+08	3.801E+03	1.208E+01

SITE CHARACTERIZATION REPORT

REVISION 0.1

. TABLE 4.7.27

CURIE CONTENTS AT SHUTDOWN - COMPONENT SUMMARY

5th 12" Bioshield	7.972E-04	2.403E-07	5.151E-07	3.921E-07	1.395E-04	4.538E-07	1.980E-04	3.828E-05	1.891E-08	2.518E-07	2.164E-10	7.449E-13	8.335E-09	5.811E-09	1.312E-09	3.834E-05	1.211E-03
6th 12" Bioshield	4.183E-05	1.261E-08	3.008E-08	2.067E-08	7.321E-06	2.861E-08	1.039E-05	1.913E-08	9.918E-11	1.321E-08	1.148E-11	4.280E-14	3.645E-10	3.284E-10	6.989E-11	2.015E-06	6.357E-05
Lower Core Plate	3.883E+01	9.398E+00	2.140E-02	1.992E-03	7.308E-01	4.802E+03	1.148E+05	9.928E+04	4.757E+01	7.403E+03	1.351E-01	2.934E-02	5.313E-12	1.511E-02	7.780E-03	4.794E-01	2.280E+05
Lower Core Sup. Col.	1.180E+01	1.831E+00	1.383E-03	4.030E-04	1.445E-01	2.538E+02	2.295E+04	1.432E+04	1.138E+01	1.581E+03	1.458E-02	1.733E-03	9.929E-17	2.259E-04	1.418E-04	5.885E-01	3.911E+04
Lower Core Support	2.872E-02	4.359E-03	1.593E-05	9.021E-07	3.354E-04	2.929E+00	5.255E+01	5.635E+01	2.491E-02	3.553E+00	7.908E-05	2.010E-05	8.816E-22	5.895E-10	2.699E-10	1.003E-02	1.154E+02
Below Low. Core Sup.	1.001E-05	1.493E-06	1.058E-09	3.287E-10	1.178E-07	1.846E-04	1.873E-02	1.170E-02	9.577E-06	1.287E-03	1.168E-08	1.388E-09	0.000E+00	0.000E+00	0.000E+00	2.847E-06	3.193E-02
Upper Core Plate	9.845E+00	1.674E+00	4.732E-03	3.523E-04	1.297E-01	8.925E+02	2.039E+04	1.928E+04	9.613E+00	1.374E+03	2.588E-02	5.851E-03	5.780E-16	4.509E-04	2.262E-04	1.337E+00	4.195E+04
Upper Core Sup. Col.	1.853E+00	2.746E-01	2.118E-04	6.038E-05	2.165E-02	3.998E+01	3.442E+03	2.179E+03	1.754E+00	2.963E+02	2.208E-03	2.700E-04	1.023E-18	2.281E-06	1.428E-06	4.222E-01	5.901E+03
Totals	8.672E+02	2.180E+02	8.498E-01	1.822E-01	6.549E+01	1.241E+05	2.644E+08	2.217E+08	9.532E+02	1.633E+05	3.288E+00	7.056E-01	7.854E-02	1.411E+00	8.842E-01	3.270E+01	5.151E+08

SITE CHARACTERIZATION REPORT

REVISION 0.0

TABLE 4.7.28
CURIE CONTENTS ONE YEAR AFTER SHUTDOWN - COMPONENT SUMMARY

Summary																		
By isotope		H-3	C-14	Ar-39	Cs-137	Cs-135	Mn-54	Fe-55	Co-60	Ni-59	Ni-63	Nb-94	Tc-99	Sn-119m	Sb-125	Te-125m	Eu-152	Total
Scenario #1	Component	(Curies)																
Decay (years)	Core Baffle	2.924E	1.187E	2.280E	2.430E	1.935E	4.170E	1.084E	1.227E	5.329E	8.954E	2.225E	5.091E	1.913E	9.033E	7.035E	9.356E	2.443E
		+02	+02	01	02	+00	+04	+08	+06	+02	+04	+00	01	10	01	03	03	03
1.0	Core Formers	1.096E	7.013E	5.219E	1.550E	1.174E	5.391E	6.659E	4.083E	2.614E	4.927E	5.683E	7.651E	9.511E	1.390E	1.402E	1.447E	1.129E
		+02	+01	02	02	+00	+03	+05	+05	+02	+04	01	02	12	01	03	01	01
	Lower Core Barrel	6.841E	1.184E	4.879E	2.418E	1.919E	4.173E	1.084E	1.448E	6.519E	9.436E	2.409E	6.102E	2.272E	4.296E	3.149E	9.646E	2.670E
		+01	+01	02	03	01	+03	+05	+05	+01	+03	01	02	16	03	05	+00	+05
	Upper Core Barrel	6.448E	1.118E	4.598E	2.279E	1.809E	3.933E	1.022E	1.365E	6.145E	8.894E	2.271E	5.752E	2.141E	4.049E	2.968E	9.091E	2.516E
		04	04	07	08	06	02	+00	+00	04	02	06	07	21	08	10	05	+00
	Thermal Shield Pads	1.631E	2.833E	1.193E	5.783E	4.592E	1.001E	2.595E	3.483E	1.567E	2.260E	5.787E	1.489E	4.098E	5.450E	3.990E	3.975E	6.408E
		+01	+00	02	04	02	+03	+04	+04	+01	+03	02	02	16	04	06	+00	+04
	Vessel Clad	7.243E	1.265E	2.084E	2.733E	2.097E	1.735E	1.200E	1.043E	7.575E	1.053E	1.414E	2.584E	7.098E	1.807E	1.870E	6.570E	2.368E
		+00	+00	03	04	02	+02	+04	+04	+00	+03	02	03	17	04	06	01	+04
	Vessel Wall	5.256E	6.225E	6.825E	6.031E	4.872E	2.054E	5.287E	6.647E	1.338E	1.934E	1.751E	4.445E	2.617E	3.824E	1.345E	1.401E	6.184E
		+00	03	03	05	03	+02	+03	+02	01	+01	03	03	02	04	04	+00	+03
	Vessel Insulation	1.256E	2.077E	4.866E	4.423E	3.423E	3.894E	1.954E	1.944E	1.252E	1.724E	2.819E	6.195E	1.156E	2.195E	1.896E	4.129E	4.114E
		02	03	06	07	05	01	+01	+01	02	+00	05	06	21	09	11	03	+01
	1st 3" Bioshield	7.438E	2.418E	3.044E	3.892E	2.944E	1.197E	1.511E	3.823E	1.853E	2.491E	3.178E	3.680E	1.108E	1.851E	6.125E	3.783E	1.006E
		+01	02	01	02	+00	01	+01	+00	04	02	05	07	03	03	06	+00	+02
	2nd 3" Bioshield	8.335E	2.668E	1.141E	4.338E	3.270E	4.484E	1.679E	3.670E	2.086E	2.787E	2.826E	1.484E	4.494E	7.720E	2.864E	4.014E	1.114E
		+01	02	01	02	+00	02	+01	+00	04	02	05	07	04	04	06	+00	+02
	1st Rebar/Liner	4.753E	5.964E	3.984E	5.248E	3.956E	1.199E	4.488E	1.737E	1.378E	1.826E	4.365E	3.086E	1.180E	1.240E	1.349E	8.602E	4.698E
		01	03	05	06	04	+00	+02	+01	02	+00	05	08	21	08	10	02	+02
	2nd 6" Bioshield	8.284E	2.632E	4.667E	4.287E	3.236E	1.834E	1.662E	3.480E	2.073E	2.738E	2.331E	7.053E	2.135E	4.503E	1.669E	3.953E	1.101E
		+01	02	02	02	+00	02	+01	+00	04	02	05	08	04	04	06	+00	+02
	3rd 6" Bioshield	1.770E	5.625E	4.223E	9.197E	6.923E	1.661E	3.556E	7.256E	4.443E	5.857E	4.759E	8.453E	2.559E	6.907E	2.558E	8.453E	2.354E
		+01	03	03	03	01	03	+00	01	05	03	06	09	05	05	07	01	+01
	4th 6" Bioshield	2.877E	9.148E	5.832E	1.496E	1.126E	2.293E	5.782E	1.177E	7.226E	9.526E	7.896E	1.255E	3.798E	1.074E	3.978E	1.375E	3.827E
		+00	04	04	03	01	04	01	01	08	04	07	09	06	05	08	01	+00
	2nd Bioshield Rebar	9.118E	1.074E	1.072E	9.502E	3.378E	7.233E	1.059E	3.337E	2.508E	3.328E	6.718E	1.363E	9.076E	2.476E	2.106E	1.628E	1.098E
		03	04	07	08	05	03	+01	01	04	02	07	11	26	12	12	03	+01
	5th 6" Bioshield	4.507E	1.433E	1.197E	2.342E	1.763E	4.705E	9.056E	1.861E	1.131E	1.492E	1.217E	2.293E	6.938E	1.817E	6.729E	2.157E	5.997E
		01	04	04	04	02	05	02	02	06	04	07	10	07	06	09	02	01
	6th 6" Bioshield	7.530E	2.397E	2.818E	3.914E	2.947E	1.108E	1.514E	3.115E	1.890E	2.494E	2.067E	4.774E	1.445E	3.424E	1.268E	3.812E	1.002E
		02	05	05	05	03	05	02	03	07	05	08	11	07	07	09	03	01
	4th 12" Bioshield	1.681E	5.358E	8.599E	8.745E	6.583E	3.380E	3.381E	7.020E	4.220E	5.573E	4.709E	1.332E	4.032E	8.737E	3.239E	8.093E	2.240E
		02	06	06	06	04	06	03	04	06	08	09	11	08	08	10	04	02
	5th 12" Bioshield	7.537E	2.403E	5.138E	3.921E	2.954E	2.020E	1.517E	3.181E	1.991E	2.499E	2.164E	7.449E	2.256E	4.525E	1.673E	3.643E	1.005E
		04	07	07	07	05	07	04	05	09	07	10	13	09	09	11	05	03

SITE CHARACTERIZATION REPORT

REVISION 0.0

TABLE 4.7.28

CURIE CONTENTS ONE YEAR AFTER SHUTDOWN - COMPONENT SUMMARY

8th 12" Bioshield	3.954E-05	1.261E-08	3.001E-08	2.057E-08	1.550E-06	1.180E-08	7.959E-06	1.877E-06	9.917E-11	1.311E-08	1.148E-11	4.260E-14	1.298E-10	2.542E-10	8.885E-13	1.915E-06	5.273E-05
Lower Core Plate	3.852E+01	8.397E+00	2.135E+02	1.992E+03	1.547E+01	2.048E+03	8.779E+04	8.704E+04	4.757E+01	7.348E+03	1.351E+01	2.834E+02	1.892E+12	1.178E+02	9.895E+05	4.555E+01	1.843E+05
Lower Core Sup. Col.	1.098E+01	1.830E+00	1.379E+03	4.030E+04	3.059E+02	1.129E+02	1.758E+04	1.258E+04	1.138E+01	1.550E+03	1.456E+02	1.733E+03	3.538E+17	1.759E+04	1.807E+06	5.574E+01	3.182E+04
Lower Core Support	2.528E+02	4.358E+03	1.589E+05	9.021E+07	7.100E+05	1.304E+00	4.026E+01	4.941E+01	2.491E+02	3.528E+00	7.908E+05	2.010E+05	3.139E+22	4.435E+10	3.441E+12	9.528E+03	9.456E+01
Below Low. Core Sup.	9.487E+08	1.493E+06	1.055E+09	3.287E+10	2.494E+08	8.661E+05	1.435E+02	1.026E+02	9.577E+06	1.277E+03	1.188E+08	1.396E+09	0.000E+00	0.000E+00	0.000E+00	2.706E+06	2.599E+02
Upper Core Plate	9.403E+00	1.673E+00	4.720E+03	3.523E+04	2.745E+02	3.972E+02	1.582E+04	1.690E+04	9.613E+00	1.363E+03	2.588E+02	5.851E+03	2.058E+16	3.512E+04	2.884E+06	1.271E+00	3.431E+04
Upper Core Sup. Col.	1.752E+00	2.748E+01	2.113E+04	6.037E+05	4.584E+03	1.734E+01	2.637E+03	1.911E+03	1.754E+00	2.345E+02	2.208E+03	2.700E+04	3.842E+19	1.778E+06	1.821E+08	4.012E+01	4.804E+03
Totals	8.199E+02	2.180E+02	8.477E+01	1.822E+01	1.387E+01	5.523E+04	2.026E+06	1.944E+06	9.532E+02	1.621E+05	3.286E+00	7.056E+01	2.797E+02	1.099E+00	8.724E+03	3.108E+01	4.189E+06

SITE CHARACTERIZATION REPORT

REVISION 0.0

TABLE 4.7.29
CURIE CONTENTS TWO YEARS AFTER SHUTDOWN - COMPONENT SUMMARY

Summary		H-3	C-14	Ar-39	Ca-41	Ca-45	Mn-54	Fe-55	Co-60	Ni-59	Ni-63	Nb-94	Tc-99	Sn-119m	Sb-125	Ta-126m	Eu-152	Total
By isotope	Component	(Curie)																
Scenario #1	Component	(Curie)																
Decay (years)	Cora Baffle	2.785E	1.187E	2.274E	2.430E	4.098E	1.858E	8.305E	1.078E	5.329E	8.887E	2.225E	5.091E	6.811E	7.034E	8.970E	8.892E	2.014E
		+02	+02	01	02	01	+04	+05	+06	+02	+04	+00	01	11	01	05	03	+08
2.0	Core Formers	1.036E	7.013E	5.208E	1.550E	2.487E	2.399E	5.102E	3.580E	2.814E	4.890E	5.683E	7.651E	3.387E	1.082E	1.788E	1.375E	9.199E
		+02	+01	02	02	01	+03	+05	+05	+02	+04	01	02	12	01	05	01	+05
	Lower Core Barrel	6.488E	1.184E	4.868E	2.418E	4.063E	1.867E	8.307E	1.289E	6.519E	9.385E	2.409E	6.102E	8.089E	3.346E	4.015E	9.167E	2.214E
		+01	+01	02	03	02	+03	+04	+05	+01	+03	01	02	17	03	07	+00	+05
	Upper Core Barrel	6.096E	1.118E	4.587E	2.279E	3.830E	1.750E	7.830E	1.197E	6.145E	8.827E	2.271E	5.752E	7.624E	3.153E	3.784E	8.640E	2.087E
		04	04	07	08	07	02	01	+00	04	02	06	07	22	08	12	05	+00
	Thermal Shield Pads	1.642E	2.833E	1.190E	5.783E	9.721E	4.456E	1.988E	3.054E	1.567E	2.243E	5.787E	1.469E	1.459E	4.244E	5.087E	3.492E	5.314E
		+01	+00	02	04	03	+02	+04	+04	+01	+03	02	02	16	04	08	+00	+04
	Vessel Clad	6.848E	1.265E	2.078E	2.733E	4.440E	7.720E	9.198E	9.148E	7.575E	1.045E	1.414E	2.584E	2.528E	1.407E	2.129E	6.244E	1.948E
		+00	+00	03	04	03	+01	+03	+03	+00	+03	02	03	17	04	08	01	+04
	Vessel Wall	4.988E	6.224E	6.808E	6.031E	8.891E	9.142E	4.035E	5.829E	1.338E	1.920E	1.751E	4.445E	9.317E	2.822E	1.715E	1.331E	4.735E
		+00	03	03	05	04	+01	+03	+02	01	+01	03	03	03	02	06	+00	+03
	Vessel Insulation	1.187E	2.077E	4.854E	4.423E	7.248E	1.777E	1.497E	1.705E	1.252E	1.711E	2.819E	6.195E	4.116E	1.708E	2.418E	3.924E	3.394E
		02	03	06	07	06	01	+01	+01	02	+00	05	08	22	09	13	03	+01
	1st 3" Bioshield	7.032E	2.416E	3.037E	3.892E	6.293E	5.325E	1.158E	3.352E	1.853E	2.472E	3.176E	3.660E	3.947E	1.285E	7.809E	3.596E	8.991E
		+01	02	01	02	01	02	+01	+00	04	02	05	07	04	03	08	+00	+01
	2nd 3" Bioshield	7.890E	2.665E	1.138E	4.338E	6.822E	1.996E	1.287E	3.218E	2.086E	2.746E	2.626E	1.484E	1.600E	6.012E	3.651E	3.815E	9.862E
		+01	02	01	02	01	02	+01	+00	04	02	05	07	04	04	08	+00	+01
	1st Rebar/Liner	4.493E	5.963E	3.974E	5.248E	8.377E	5.336E	3.439E	1.523E	1.378E	1.812E	4.365E	3.066E	4.129E	9.654E	1.719E	8.175E	3.620E
		01	03	05	06	05	01	+02	+01	02	+00	05	08	22	09	12	02	+02
	2nd 6" Bioshield	7.813E	2.832E	4.655E	4.297E	6.849E	8.164E	1.273E	3.034E	2.073E	2.718E	2.331E	7.053E	7.602E	3.507E	2.128E	3.758E	9.849E
		+01	02	02	02	01	03	+01	+00	04	02	05	08	05	04	08	+00	+01
	3rd 6" Bioshield	1.673E	5.925E	4.212E	9.197E	1.466E	7.391E	2.724E	6.392E	4.443E	5.813E	4.759E	8.453E	9.113E	5.379E	3.262E	8.033E	2.107E
		+01	03	03	03	01	04	+00	01	05	03	06	09	06	05	09	01	+01
	4th 6" Bioshield	2.720E	9.147E	5.817E	1.496E	2.383E	1.020E	4.430E	1.032E	7.226E	9.454E	7.896E	1.255E	1.353E	8.364E	5.071E	1.307E	3.425E
		+00	04	04	03	02	04	01	01	06	04	07	08	06	06	10	01	+00
	2nd Bioshield Rebar	9.118E	1.074E	1.072E	9.502E	3.378E	7.233E	1.059E	3.337E	2.508E	3.328E	6.716E	1.363E	8.076E	2.478E	2.108E	1.628E	1.098E
		03	04	07	08	05	03	+01	01	04	02	07	11	26	12	12	03	+01
	5th 6" Bioshield	4.261E	1.433E	1.194E	2.342E	3.732E	2.094E	6.938E	1.823E	1.131E	1.481E	1.217E	2.293E	2.470E	1.415E	8.579E	2.050E	5.366E
		01	04	04	04	03	05	02	02	08	04	07	10	07	08	11	02	01
	6th 6" Bioshield	7.119E	2.398E	2.811E	3.914E	6.240E	4.930E	1.180E	2.732E	1.890E	2.475E	2.067E	4.774E	5.146E	2.666E	1.617E	3.433E	8.970E
		02	05	05	05	04	08	02	03	07	05	08	11	08	07	11	03	02
	4th 12" Bioshield	1.590E	5.355E	8.577E	8.745E	1.394E	1.504E	2.590E	6.155E	4.219E	5.531E	4.709E	1.332E	1.436E	6.804E	4.130E	7.691E	2.004E
		02	06	06	06	04	08	03	04	08	06	09	11	08	08	12	04	02

SITE CHARACTERIZATION REPORT

REVISION 0.0

TABLE 4.7.29

CURIE CONTENTS TWO YEARS AFTER SHUTDOWN - COMPONENT SUMMARY

5th 12" Bioshield	7.126E-04	2.402E-07	5.126E-07	3.921E-07	6.253E-06	8.988E-08	1.162E-04	2.789E-05	1.891E-09	2.480E-07	2.164E-10	7.449E-13	8.033E-10	3.524E-09	2.133E-13	3.462E-05	8.990E-04
6th 12" Bioshield	3.739E-05	1.261E-08	2.993E-08	2.067E-08	3.281E-07	5.250E-09	6.088E-08	1.471E-06	9.917E-11	1.301E-08	1.148E-11	4.260E-14	4.622E-11	1.979E-10	1.133E-14	1.820E-08	4.719E-05
Lower Core Plate	3.453E+01	9.395E+00	2.129E-02	1.992E-03	3.276E-02	9.116E+02	6.726E+04	7.632E+04	4.757E+01	7.293E+03	1.351E-01	2.934E-02	6.737E-13	9.161E-03	1.262E-06	4.329E-01	1.519E+05
Lower Core Sup. Col.	1.036E+01	1.830E+00	1.376E-03	4.030E-04	6.476E-03	5.023E+01	1.347E+04	1.101E+04	1.136E+01	1.538E+03	1.456E-02	1.733E-03	1.259E-17	1.370E-04	2.304E-08	5.297E-01	2.609E+04
Lower Core Support	2.388E-02	4.357E-03	1.585E-05	9.021E-07	1.503E-05	5.802E-01	3.084E+01	4.332E+01	2.491E-02	3.500E+00	7.908E-05	2.010E-05	1.118E-22	3.453E-10	4.387E-14	9.055E-03	7.831E+01
Below Low. Core Sup.	8.951E-06	1.493E-06	1.063E-08	3.287E-10	5.280E-08	3.854E-05	1.099E-02	8.995E-03	9.577E-06	1.268E-03	1.168E-08	1.386E-09	0.000E+00	0.000E+00	0.000E+00	2.572E-06	2.132E-02
Upper Core Plate	8.890E+00	1.673E+00	4.708E-03	3.523E-04	5.812E-03	1.768E+02	1.197E+04	1.482E+04	9.612E+00	1.353E+03	2.588E-02	5.851E-03	7.330E-17	2.735E-04	3.678E-08	1.208E+00	2.834E+04
Upper Core Sup. Col.	1.658E+00	2.745E-01	2.108E-04	6.037E-05	9.708E-04	7.717E+00	2.020E+03	1.678E+03	1.754E+00	2.328E+02	2.208E-03	2.700E-04	1.297E-19	1.383E-06	2.321E-10	3.813E-01	3.940E+03
Totals	7.752E+02	2.180E+02	8.455E-01	1.822E-01	2.936E+00	2.458E+04	1.552E+06	1.705E+06	9.532E+02	1.609E+05	3.286E+00	7.056E-01	9.959E-03	8.557E-01	1.112E-04	2.953E+01	3.444E+06

SITE CHARACTERIZATION REPORT

REVISION 0.0

TABLE 4.7.30

CURIE CONTENTS FIVE YEARS AFTER SHUTDOWN - COMPONENT SUMMARY

Summary By Isotope Scenario #1	Component	H-3 (Curies)	C-14	Ar-39	Ca-41	Ca-45	Mn-54	Fe-55	Co-60	Ni-59	Ni-63	Nb-94	Tc-99	Sn-119m	Sb-125	Ta-125m	Eu-152	Total
Decay (years)	Core Baffle	2.338E +02	1.188E +02	2.257E 01	2.430E 02	3.871E 03	1.632E +03	3.732E +05	7.248E +05	5.328E +02	8.688E +04	2.225E +00	5.081E 01	3.067E 12	3.320E 01	1.837E 10	7.631E 03	1.187E +08
	5.0 Core Formers	8.755E +01	7.010E +01	5.168E 02	1.550E 02	2.350E 03	2.110E +02	2.293E +05	2.412E +05	2.814E +02	4.781E +04	5.682E 01	7.650E 02	1.525E 13	5.108E 02	3.661E 11	1.180E 01	5.189E +05
	Lower Core Barrel	5.485E +01	1.183E +01	4.829E 02	2.417E 03	3.840E 04	1.833E +02	3.733E +04	8.555E +04	6.519E +01	9.156E +03	2.409E 01	6.102E 02	3.842E 18	1.579E 03	8.223E 13	7.867E +00	1.323E +05
	Upper Core Barrel	5.151E 04	1.115E 04	4.551E 07	2.279E 08	3.619E 09	1.539E 03	3.518E 01	8.083E 01	6.144E 04	8.829E 02	2.270E 06	5.752E 07	3.433E 23	1.488E 08	7.751E 18	7.415E 05	1.247E +00
	Thermal Shield Pads	1.303E +01	2.832E +00	1.181E 02	5.783E 04	9.187E 05	3.918E +01	8.933E +03	2.058E +04	1.567E +01	2.193E +03	5.788E 02	1.488E 02	6.668E 18	2.003E 04	1.042E 13	2.997E +00	3.178E +04
	Vessel Clad	5.786E +00	1.265E +00	2.063E 03	2.733E 04	4.198E 05	6.790E +00	4.132E +03	6.185E +03	7.574E +00	1.021E +03	1.414E 02	2.584E 03	1.138E 18	6.640E 05	4.361E 14	5.358E 01	1.134E +04
	Vessel Wall	4.198E +00	6.222E 03	6.755E 03	6.031E 05	9.347E 08	8.041E +00	1.813E +03	3.928E +02	1.338E 01	1.877E +01	1.751E 03	4.445E 03	4.195E 04	1.332E 02	3.513E 12	1.142E +00	2.238E +03
	Vessel Insulation	1.003E 02	2.078E 03	4.818E 08	4.423E 07	6.849E 08	1.563E 02	6.727E +00	1.149E +01	1.252E 02	1.672E +00	2.819E 05	6.195E 06	1.853E 23	8.067E 10	4.952E 19	3.388E 03	1.993E +01
	1st 3" Bioshield	5.942E +01	2.415E 02	3.013E 01	3.892E 02	5.891E 03	4.683E 03	5.201E +00	2.259E +00	1.853E 04	2.417E 02	3.176E 05	3.660E 07	1.777E 05	6.067E 04	1.589E 13	3.088E +00	7.037E +01
	2nd 3" Bioshield	6.659E +01	2.685E 02	1.129E 01	4.338E 02	6.542E 03	1.755E 03	5.781E +00	2.168E +00	2.086E 04	2.685E 02	2.826E 05	1.484E 07	7.206E 08	2.837E 04	7.478E 14	3.274E +00	7.803E +01
	1st Rebar/Liner	3.797E 01	5.981E 03	3.943E 05	5.248E 06	7.918E 07	4.693E 02	1.545E +02	1.027E +01	1.378E 02	1.772E +00	4.364E 05	3.086E 08	1.859E 23	4.556E 09	3.521E 18	7.015E 02	1.671E +02
	2nd 6" Bioshield	6.602E +01	2.631E 02	4.619E 02	4.297E 02	6.472E 03	7.180E 04	5.721E +00	2.045E +00	2.073E 04	2.657E 02	2.331E 05	7.053E 08	3.423E 08	1.655E 04	4.358E 14	3.224E +00	7.716E +01
	3rd 6" Bioshield	1.414E +01	5.623E 03	4.180E 03	9.196E 03	1.385E 03	6.500E 05	1.224E +00	4.287E 01	4.443E 05	5.683E 03	4.758E 08	8.453E 05	4.103E 07	2.538E 05	6.680E 15	6.884E 01	1.651E +01
	4th 6" Bioshield	2.288E +00	9.144E 04	5.772E 04	1.498E 03	2.252E 04	8.974E 06	1.891E 01	6.857E 02	7.226E 08	8.243E 04	7.895E 07	1.255E 09	6.082E 08	3.947E 08	1.039E 15	1.121E 01	2.683E +00
	2nd Bioshield Rebar	9.118E 03	1.074E 04	1.072E 07	9.502E 08	3.378E 05	7.233E 03	1.059E +01	3.337E 01	2.506E 04	3.328E 02	6.716E 07	1.363E 11	9.076E 26	2.476E 12	2.108E 12	1.628E 03	1.088E +01
	5th 6" Bioshield	3.801E 01	1.432E 04	1.185E 04	2.342E 04	3.527E 05	1.842E 08	3.117E 02	1.094E 02	1.131E 08	1.448E 04	1.217E 07	2.293E 10	1.112E 08	6.676E 07	1.757E 18	1.759E 02	4.205E 01
	6th 6" Bioshield	6.015E 02	2.395E 05	2.790E 05	3.914E 05	5.898E 06	4.336E 07	5.211E 03	1.841E 03	1.890E 07	2.420E 05	2.066E 08	4.774E 11	2.317E 09	1.258E 07	3.312E 17	2.846E 03	7.028E 02

SITE CHARACTERIZATION REPORT

REVISION 0.0

TABLE 4.7.30

CURIE CONTENTS FIVE YEARS AFTER SHUTDOWN - COMPONENT SUMMARY

4th 12" Bioshield	1.343E-02	5.363E-06	8.511E-06	8.744E-06	1.317E-08	1.323E-07	1.164E-03	4.148E-04	4.218E-08	5.408E-08	4.709E-09	1.332E-11	6.465E-10	3.211E-08	8.459E-18	6.800E-04	1.570E-02
5th 12" Bioshield	6.021E-04	2.402E-07	5.085E-07	3.921E-07	5.909E-08	7.905E-09	5.221E-05	1.880E-05	1.891E-09	2.425E-07	2.183E-10	7.449E-13	3.817E-11	1.663E-09	4.369E-19	2.971E-05	7.043E-04
6th 12" Bioshield	3.159E-05	1.260E-08	2.970E-08	2.057E-08	3.101E-09	4.617E-10	2.740E-06	9.911E-07	9.917E-11	1.272E-08	1.148E-11	4.260E-14	2.081E-12	9.342E-11	2.320E-20	1.562E-06	3.898E-05
Lower Core Plate	2.918E+01	9.392E+00	2.113E-02	1.992E-03	3.096E-04	8.017E+01	3.022E+04	5.143E+04	4.767E+01	7.130E+03	1.351E-01	2.934E-02	3.034E-14	4.323E-03	2.684E-12	3.715E-01	8.895E+04
Lower Core Sup. Col.	8.758E+00	1.829E+00	1.385E-03	4.030E-04	6.120E-05	4.417E+00	6.052E+03	7.419E+03	1.136E+01	1.504E+03	1.456E-02	1.733E-03	5.669E-19	6.465E-05	4.720E-14	4.546E-01	1.500E+04
Lower Core Support	2.018E-02	4.358E-03	1.573E-05	9.020E-07	1.421E-07	5.103E-02	1.386E+01	2.919E+01	2.490E-02	3.422E+00	7.907E-05	2.010E-05	5.034E-24	1.630E-10	8.985E-20	7.771E-03	4.668E+01
Below Low. Core Sup.	7.563E-06	1.492E-06	1.045E-09	3.287E-10	4.989E-11	3.390E-06	4.940E-03	6.062E-03	9.578E-08	1.239E-03	1.168E-08	1.396E-08	0.000E+00	0.000E+00	0.000E+00	2.207E-06	1.228E-02
Upper Core Plate	7.512E+00	1.873E+00	4.672E-03	3.523E-04	5.493E-05	1.655E+01	5.377E+03	9.888E+03	9.812E+00	1.323E+03	2.586E-02	5.851E-03	3.300E-18	1.291E-04	7.530E-14	1.037E+00	1.672E+04
Upper Core Sup. Col.	1.399E+00	2.744E-01	2.091E-04	6.037E-05	9.172E-06	6.787E-01	9.077E+02	1.129E+03	1.764E+00	2.275E+02	2.207E-03	2.700E-04	5.840E-21	6.527E-07	4.755E-16	3.272E-01	2.288E+03
Totals	6.550E+02	2.179E+02	8.390E-01	1.822E-01	2.778E-02	2.162E+03	6.974E+05	1.149E+06	9.532E+02	1.573E+05	3.285E+00	7.055E-01	4.484E-04	4.038E-01	2.299E-10	2.535E+01	2.007E+08

SITE CHARACTERIZATION REPORT

REVISION 0.0

TABLE 4.7.31

CURIE CONTENTS AT END OF CURRENT LICENSE - COMPONENT SUMMARY

Summary By Isotope Scenario #1	Component	H-3	C-14	Ar-39	Ca-41	Ca-45	Mn-54	Fe-55	Co-60	Ni-59	Ni-63	Nb-94	Tc-99	Sn-119m	Sb-125	Te-125m	Eu-152	Total
Decay (years)	Core Baffle	1.065E+02	1.184E+02	2.177E+01	2.430E+02	1.390E+12	1.939E+02	8.937E+03	1.150E+05	5.328E+02	7.818E+04	2.224E+00	5.091E+01	1.603E+18	9.994E+03	5.318E+37	3.739E+03	2.028E+05
19.0	Core Formers	3.990E+01	6.988E+01	4.983E+02	1.550E+02	8.438E+13	2.508E+03	5.490E+03	3.827E+04	2.613E+02	4.302E+04	5.880E+01	7.972E+02	1.538E+20	1.538E+03	1.080E+37	5.781E+02	8.715E+04
	Lower Core Barrel	2.491E+01	1.181E+01	4.658E+02	2.417E+03	1.378E+13	1.940E+03	8.938E+02	1.357E+04	6.518E+01	8.239E+03	2.408E+01	6.102E+02	1.904E+24	4.753E+05	2.380E+39	3.854E+00	2.281E+04
	Upper Core Barrel	2.348E+04	1.113E+04	4.390E+07	2.278E+08	1.299E+18	1.828E+08	8.425E+03	1.279E+01	6.144E+04	7.766E+02	2.269E+08	5.751E+07	1.795E+29	4.480E+10	2.244E+44	3.633E+05	2.150E+01
	Thermal Shield Pads	5.939E+00	2.827E+00	1.139E+02	5.783E+04	3.298E+14	4.654E+04	2.139E+02	3.264E+03	1.567E+01	1.974E+03	5.783E+02	1.469E+02	3.434E+24	6.029E+08	3.016E+40	1.468E+00	5.478E+03
	Vessel Clad	2.637E+00	1.262E+00	1.990E+03	2.733E+04	1.506E+14	8.064E+05	9.895E+01	9.778E+02	7.573E+01	9.191E+02	1.413E+02	2.583E+03	5.949E+25	1.999E+08	1.262E+40	2.625E+01	2.008E+03
	Vessel Wall	1.913E+00	6.212E+03	6.519E+03	6.030E+05	3.358E+15	9.549E+05	4.342E+01	6.230E+01	1.337E+01	1.689E+01	1.750E+03	4.444E+03	2.193E+10	4.010E+04	1.017E+38	5.597E+01	1.252E+02
	Vessel Insulation	4.572E+03	2.073E+03	4.646E+06	4.422E+07	2.459E+17	1.858E+07	1.811E+01	1.822E+01	1.251E+02	1.505E+02	2.817E+05	6.195E+06	9.689E+30	2.428E+11	1.433E+45	1.650E+03	3.509E+00
	1st 3" Bioshield	2.708E+01	2.411E+02	2.906E+01	3.891E+02	2.115E+12	5.582E+08	1.246E+01	3.583E+01	1.853E+04	2.175E+02	3.174E+05	3.859E+07	9.289E+12	1.826E+05	4.830E+40	1.512E+00	2.945E+01
	2nd 3" Bioshield	3.035E+01	2.660E+02	1.089E+01	4.337E+02	2.349E+12	2.084E+08	1.384E+01	3.439E+01	2.066E+01	2.416E+02	2.825E+05	1.484E+07	3.787E+12	8.541E+06	2.165E+40	1.804E+00	3.264E+01
	1st Rebar/Liner	1.731E+01	5.951E+03	3.804E+05	5.247E+06	2.842E+16	5.573E+07	3.700E+00	1.628E+00	1.378E+02	1.595E+02	4.382E+05	3.066E+09	9.720E+30	1.372E+10	1.019E+44	3.437E+02	7.150E+00
	2nd 6" Bioshield	3.009E+01	2.627E+02	4.455E+02	4.298E+02	2.324E+12	8.527E+09	1.370E+01	3.243E+01	2.072E+04	2.391E+02	2.330E+05	7.052E+08	1.789E+12	4.982E+06	1.261E+40	1.579E+00	3.227E+01
	3rd 6" Bioshield	6.444E+00	5.613E+03	4.032E+03	9.195E+03	4.973E+13	7.719E+10	2.931E+02	6.800E+02	4.442E+05	5.114E+03	4.756E+06	8.453E+09	2.146E+13	7.642E+07	1.934E+41	3.378E+01	6.903E+00
	4th 6" Bioshield	1.048E+00	9.128E+04	5.588E+04	1.495E+03	8.085E+14	1.068E+10	4.786E+03	1.103E+02	7.225E+06	8.318E+04	7.691E+07	1.255E+09	3.184E+14	1.188E+07	3.007E+42	5.495E+02	1.122E+00
	2nd Bioshield Rebar	9.118E+03	1.074E+04	1.072E+07	9.502E+08	3.378E+15	7.233E+03	1.059E+01	3.337E+01	2.506E+04	3.328E+02	6.716E+07	1.363E+11	9.076E+12	2.478E+12	2.106E+42	1.828E+03	1.098E+01
	5th 6" Bioshield	1.641E+01	1.430E+04	1.143E+04	2.342E+04	1.268E+14	2.187E+11	7.485E+04	1.735E+03	1.131E+06	1.303E+04	1.216E+07	2.293E+10	5.815E+15	2.010E+08	5.096E+43	8.819E+03	1.758E+01
	6th 6" Bioshield	2.742E+02	2.391E+05	2.691E+05	3.914E+05	2.117E+15	5.149E+12	1.248E+04	2.920E+04	1.880E+07	2.177E+05	2.085E+08	4.774E+11	1.211E+15	3.788E+08	9.588E+44	1.444E+03	2.939E+02
	4th 12" Bioshield	6.123E+03	5.344E+06	8.210E+06	8.743E+08	4.729E+16	1.571E+12	2.787E+06	6.579E+05	4.219E+08	4.866E+08	4.706E+08	1.332E+11	3.379E+16	9.666E+10	2.449E+44	3.234E+04	6.567E+03

SITE CHARACTERIZATION REPORT

REVISION 0.0

TABLE 4.7.31

CURIE CONTENTS AT END OF CURRENT LICENSE - COMPONENT SUMMARY

5th 12" Bioshield	2.744E-04	2.397E-07	4.905E-07	3.920E-07	2.122E-17	9.388E-14	1.250E-06	2.982E-06	1.891E-09	2.182E-07	2.182E-10	7.449E-13	1.891E-17	5.008E-11	1.265E-45	1.458E-06	2.946E-04
6th 12" Bioshield	1.440E-06	1.258E-08	2.865E-08	2.057E-08	1.113E-18	5.484E-15	6.561E-08	1.572E-07	9.918E-11	1.145E-08	1.147E-11	4.280E-14	1.088E-18	2.812E-12	6.718E-47	7.651E-07	1.548E-05
Lower Core Plate	1.330E+01	9.376E+00	2.038E-02	1.992E-03	1.111E-13	9.521E-04	7.237E+02	8.157E+03	4.758E+01	6.418E+03	1.351E-01	2.834E-02	1.588E-20	1.301E-04	7.479E-39	1.820E-01	1.637E+04
Lower Core Sup. Col.	3.992E+00	1.928E+00	1.317E-03	4.029E-04	2.197E-14	5.246E-05	1.449E+02	1.177E+03	1.138E+01	1.353E+03	1.455E-02	1.733E-03	2.963E-25	1.948E-06	1.388E-40	2.227E-01	2.692E+03
Lower Core Support	9.197E-03	4.349E-03	1.517E-05	9.019E-07	5.100E-17	6.060E-07	3.319E-01	4.631E+00	2.490E-02	3.078E-05	7.903E-05	2.010E-05	2.631E-30	4.908E-12	2.601E-46	3.807E-03	8.084E+00
Below Low. Core Sup.	3.447E-06	1.489E-06	1.008E-09	3.287E-10	1.791E-20	4.028E-11	1.183E-04	9.815E-04	9.575E-06	1.115E-03	1.167E-08	1.398E-09	0.000E+00	0.000E+00	0.000E+00	1.081E-06	2.211E-03
Upper Core Plate	3.424E+00	1.670E+00	4.508E-03	3.522E-04	1.972E-14	1.848E-04	1.288E+02	1.584E+03	9.811E+00	1.191E+03	2.584E-02	5.850E-03	1.725E-24	3.885E-06	2.180E-40	5.079E-01	2.918E+03
Upper Core Sup. Col.	6.378E-01	2.740E-01	2.017E-04	6.037E-05	3.293E-15	8.060E-06	2.174E+01	1.791E+02	1.753E+00	2.048E+02	2.208E-03	2.700E-04	3.053E-27	1.965E-08	1.376E-42	1.803E-01	4.084E+02
Totals	2.985E+02	2.175E+02	8.093E-01	1.922E-01	3.378E-05	3.290E-02	1.671E+04	1.822E+06	9.530E+02	1.415E+06	3.284E+00	7.055E-01	2.344E-10	1.218E-02	2.108E-12	1.242E+01	3.418E+05

SITE CHARACTERIZATION REPORT

REVISION 0.1

TABLE 4.7.32

CURIE CONTENTS TWENTY-SIX YEARS AFTER SHUTDOWN - COMPONENT SUMMARY

Summary By Isotope Scenario #7	Component	H-3 (Curies)	C-14	Ar-39	Ca-41	Ca-45	Mn-54	Fe-55	Co-60	Ni-59	Ni-63	Nb-94	Tc-99	Sn-119m	Sb-125	Ta-125m	Eu-152	Total
Decay (years)	Core Shroud	7.188E+01	1.183E+02	2.138E+01	2.429E+02	2.828E+17	6.673E+05	1.382E+03	4.678E+04	5.328E+02	7.417E+04	2.223E+00	5.090E+01	1.157E+21	1.733E+03	2.844E+50	2.617E+03	1.221E+06
	Core Formers	2.694E+01	6.992E+01	4.894E+02	1.550E+02	1.595E+17	8.628E+08	8.492E+02	1.524E+04	2.613E+02	4.081E+04	5.678E+01	7.650E+02	5.758E+23	2.867E+04	5.868E+51	4.048E+02	5.728E+04
28.0	Lower Core Barrel	1.681E+01	1.180E+01	4.574E+02	2.417E+03	2.607E+18	6.677E+08	1.383E+02	5.403E+03	6.518E+01	7.818E+03	2.407E+01	6.102E+27	1.375E+08	8.244E+06	1.273E+52	2.898E+00	1.345E+04
	Upper Core Barrel	1.585E+04	1.113E+04	4.312E+07	2.278E+08	2.457E+23	6.284E+11	1.303E+03	5.083E+02	6.143E+04	7.367E+02	2.289E+06	5.751E+07	1.296E+32	7.771E+11	1.200E+57	2.543E+05	1.268E+01
	Thermal Shield Pads	4.009E+00	2.825E+00	1.118E+02	5.782E+04	6.238E+19	1.602E+08	3.309E+01	1.300E+03	1.567E+01	1.872E+03	5.782E+02	1.489E+02	2.479E+27	1.048E+08	1.813E+53	1.028E+00	3.229E+03
	Vessel Clad	1.780E+00	1.261E+00	1.954E+03	2.733E+04	2.848E+19	2.776E+07	1.531E+01	3.894E+02	7.673E+00	8.718E+02	1.413E+02	2.583E+03	4.295E+28	3.467E+07	6.751E+54	1.838E+01	1.287E+03
	Vessel Wall	1.292E+00	6.208E+03	6.400E+03	8.030E+06	6.345E+20	3.287E+07	6.717E+00	2.481E+01	1.337E+01	1.602E+01	1.749E+03	4.444E+03	1.583E+13	6.955E+05	5.438E+52	3.917E+01	4.938E+01
	Vessel Insulation	3.088E+03	2.071E+03	4.563E+06	4.422E+07	4.648E+22	6.390E+10	2.492E+02	7.255E+01	1.251E+02	1.428E+00	2.817E+05	6.184E+06	6.995E+33	4.212E+12	7.668E+59	1.155E+03	2.197E+00
	1st 3" Bioshield	1.828E+01	2.409E+02	2.855E+01	3.891E+02	3.999E+17	1.915E+10	1.927E+02	1.427E+01	1.853E+04	2.063E+02	3.174E+05	3.659E+07	6.707E+15	3.168E+08	2.478E+53	1.058E+00	1.987E+01
	2nd 3" Bioshield	2.049E+01	2.658E+02	1.070E+01	4.337E+02	4.441E+17	7.175E+11	2.141E+02	1.370E+01	2.088E+04	2.292E+02	2.624E+05	1.484E+07	2.720E+15	1.481E+08	1.158E+53	1.123E+00	2.197E+01
	1st Bioshield Rebar/Lin.	1.188E+01	5.948E+03	3.738E+05	5.247E+06	5.373E+21	1.918E+09	5.723E+01	8.484E+01	1.378E+02	1.513E+00	4.361E+05	3.086E+09	7.017E+33	2.379E+11	5.451E+58	2.408E+02	2.894E+00
	2nd 6" Bioshield	2.031E+01	2.824E+02	4.375E+02	4.298E+02	4.394E+17	2.935E+11	2.119E+02	1.291E+01	2.072E+04	2.268E+02	2.329E+05	7.052E+08	1.292E+15	8.641E+07	6.746E+54	1.105E+00	2.170E+01
	3rd 6" Bioshield	4.350E+00	5.808E+03	3.960E+03	9.195E+03	9.403E+18	2.857E+12	4.534E+03	2.708E+02	4.442E+05	4.851E+03	4.755E+08	8.452E+09	1.549E+16	1.325E+07	1.034E+54	2.364E+01	4.842E+00
	4th 6" Bioshield	7.072E+01	9.120E+04	5.468E+04	1.495E+03	1.528E+18	3.689E+13	7.373E+04	4.394E+03	7.225E+06	7.890E+04	7.699E+07	1.255E+09	2.299E+17	2.081E+08	1.808E+55	3.846E+05	7.545E+01
	2nd Bioshield Rebar	9.118E+03	1.074E+04	1.072E+07	9.502E+08	3.378E+05	7.233E+03	1.059E+01	3.337E+01	2.506E+04	3.328E+02	6.718E+07	1.363E+11	9.078E+26	2.476E+12	2.108E+12	1.828E+03	1.098E+01
	5th 6" Bioshield	1.108E+01	1.429E+04	1.122E+04	2.342E+04	2.394E+19	7.528E+14	1.155E+04	6.909E+04	1.131E+08	1.238E+04	1.216E+07	2.293E+10	4.189E+18	3.486E+09	2.720E+56	6.033E+03	1.182E+01
	6th 6" Bioshield	1.851E+02	2.388E+05	2.843E+05	3.913E+05	4.003E+20	1.773E+14	1.930E+05	1.163E+04	1.890E+07	2.066E+05	2.085E+08	4.773E+11	8.744E+19	6.589E+10	5.128E+57	1.010E+03	1.978E+02

SITE CHARACTERIZATION REPORT*

REVISION 0.1

TABLE 4.7.32

CURIE CONTENTS TWENTY-SIX YEARS AFTER SHUTDOWN - COMPONENT SUMMARY

4th 12" Bioshield	4.133E-03	5.339E-06	8.063E-06	8.743E-08	8.841E-21	5.409E-15	4.312E-06	2.820E-06	4.219E-08	4.816E-06	4.705E-09	1.332E-11	2.440E-19	1.677E-10	1.309E-57	2.263E-04	4.417E-03
5th 12" Bioshield	1.853E-04	2.395E-07	4.817E-07	3.920E-07	4.011E-22	3.232E-16	1.834E-07	1.187E-06	1.891E-09	2.070E-07	2.182E-10	7.449E-13	1.365E-20	8.883E-12	6.764E-59	1.019E-05	1.882E-04
6th 12" Bioshield	9.720E-06	1.267E-08	2.813E-08	2.057E-08	2.105E-23	1.888E-17	1.015E-08	6.259E-08	9.915E-11	1.086E-08	1.147E-11	4.280E-14	7.855E-22	4.878E-13	3.592E-80	5.355E-07	1.040E-05
Lower Core Plate	8.877E+00	9.368E+00	2.002E-02	1.892E-03	2.101E-18	3.277E-06	1.119E+02	3.248E+03	4.758E+01	6.088E+03	1.350E-01	2.934E-02	1.145E-23	2.257E-05	4.000E-52	1.274E-01	9.513E+03
Lower Core Sup. Col.	2.895E+00	1.825E+00	1.293E-03	4.029E-04	4.154E-19	1.808E-07	2.242E+01	4.886E+02	1.135E+01	1.283E+03	1.455E-02	1.733E-03	2.140E-28	3.378E-07	7.306E-54	1.559E-01	1.791E+03
Lower Core Support	6.209E-03	4.345E-03	1.490E-05	9.019E-07	9.643E-22	2.088E-09	5.134E-02	1.844E+00	2.490E-02	2.921E+00	7.901E-05	2.010E-05	1.900E-33	8.510E-13	1.391E-59	2.685E-03	4.854E+00
Below Low. Core Sup.	2.327E-06	1.488E-06	9.896E-10	3.286E-10	3.387E-25	1.386E-13	1.830E-05	3.828E-04	8.575E-06	1.058E-03	1.187E-08	1.398E-08	0.000E+00	0.000E+00	0.000E+00	7.568E-07	1.473E-03
Upper Core Plate	2.311E+00	1.868E+00	4.426E-03	3.522E-04	3.728E-19	6.356E-07	1.992E+01	6.308E+02	9.610E+00	1.128E+03	2.584E-02	5.850E-03	1.246E-27	6.739E-07	1.166E-53	3.555E-01	1.794E+03
Upper Core Sup. Col.	4.306E-01	2.737E-01	1.981E-04	6.038E-05	6.226E-20	2.774E-08	3.362E+00	7.132E+01	1.753E+00	1.942E+02	2.208E-03	2.700E-04	2.204E-30	3.408E-09	7.360E-56	1.122E-01	2.715E+02
Totals	2.015E+02	2.174E+02	7.948E-01	1.822E-01	3.378E-05	7.322E-03	2.594E+03	7.255E+04	9.530E+02	1.343E+05	3.283E+00	7.055E-01	1.692E-13	2.108E-03	2.108E-12	8.893E+00	2.108E+05

SITE CHARACTERIZATION REPORT

REVISION 0.1

TABLE 4.7.33

CURIE CONTENTS TWENTY-EIGHT YEARS AFTER SHUTDOWN - COMPONENT SUMMARY

Summary		H-3	C-14	Ar-39	Ce-41	Ca-45	Mn-54	Fe-55	Co-60	Ni-59	Ni-63	Nb-94	Tc-99	Sn-119m	Sb-125	Te-125m	Eu-152	Total
By isotope	Component	(Curies)																
Scenario #8	Component	(Curies)																
Decay (years)	Core Shroud	6.425E+01	1.183E+02	2.127E+01	2.429E+02	1.173E+18	1.319E+05	8.108E+02	3.519E+04	5.328E+02	7.306E+04	2.223E+00	5.090E+01	1.463E+22	1.050E+03	4.588E+54	2.363E+03	1.098E+05
	Core Formers	2.407E+01	6.991E+01	4.888E+02	1.550E+02	7.120E+19	1.705E+06	4.981E+02	1.171E+04	2.613E+02	4.020E+04	5.678E+01	7.650E+02	7.278E+24	1.616E+04	9.105E+55	3.654E+02	5.276E+04
28.0	Lower Core Barrel	1.503E+01	1.180E+01	4.551E+02	2.417E+03	1.163E+19	1.320E+06	8.109E+01	4.153E+03	6.518E+01	7.889E+03	2.407E+01	6.102E+02	1.738E+28	4.998E+06	2.045E+56	2.436E+06	1.203E+04
	Upper Core Barrel	1.418E+04	1.112E+04	4.289E+07	2.278E+08	1.087E+24	1.244E+11	7.843E+04	3.914E+02	6.143E+04	7.258E+02	2.288E+06	5.751E+07	1.638E+33	4.709E+11	1.927E+61	2.286E+05	1.134E+01
	Thermal Shield Pads	3.583E+00	2.924E+00	1.113E+02	5.782E+04	2.783E+20	3.168E+07	1.841E+01	9.989E+02	1.567E+01	1.844E+03	5.782E+02	1.489E+02	3.135E+28	6.338E+07	2.591E+57	9.281E+01	2.886E+03
	Vessel Cled	1.591E+00	1.261E+00	1.944E+03	2.732E+04	1.271E+20	5.485E+08	8.978E+00	2.992E+02	7.573E+00	8.588E+02	1.412E+02	2.583E+03	5.431E+29	2.101E+07	1.084E+57	1.859E+01	1.178E+03
	Vessel Wall	1.154E+00	6.205E+03	6.367E+03	6.030E+05	2.832E+21	6.496E+08	3.840E+00	1.907E+01	1.337E+01	1.578E+01	1.749E+03	4.444E+03	2.002E+14	4.215E+05	8.736E+56	3.538E+01	4.045E+01
	Vessel Insulation	2.758E+03	2.070E+03	4.539E+06	4.422E+07	2.075E+23	1.263E+10	1.482E+02	5.578E+01	1.251E+02	1.408E+00	2.816E+05	6.194E+06	8.845E+34	2.553E+12	1.231E+62	1.043E+03	1.987E+00
	1st 3" Bioshield	1.634E+01	2.408E+02	2.840E+01	3.891E+02	1.785E+18	3.784E+11	1.130E+02	1.097E+01	1.853E+04	2.032E+02	3.173E+05	3.659E+07	8.480E+16	1.920E+06	3.977E+57	9.556E+01	1.778E+01
	2nd 3" Bioshield	1.831E+01	2.657E+02	1.084E+01	4.337E+02	1.982E+18	1.418E+11	1.266E+02	1.053E+01	2.086E+04	2.258E+02	2.624E+05	1.484E+07	3.439E+16	8.977E+07	1.859E+57	1.014E+06	1.964E+01
	1st Bioshield Rebar/Lin.	1.044E+01	5.944E+03	3.716E+05	5.247E+06	2.398E+22	3.791E+10	3.357E+01	4.983E+01	1.378E+02	1.490E+00	4.361E+05	3.066E+09	8.873E+34	1.442E+11	8.767E+62	2.173E+02	2.470E+00
	2nd 6" Bioshield	1.815E+01	2.624E+02	4.353E+02	4.298E+02	1.961E+18	5.800E+12	1.243E+02	9.925E+02	2.072E+04	2.234E+02	2.329E+05	7.052E+08	1.834E+16	5.237E+07	1.084E+57	9.983E+01	1.940E+01
	3rd 6" Bioshield	3.888E+00	5.807E+03	3.939E+03	9.185E+03	4.197E+19	5.251E+13	2.659E+03	2.081E+02	4.442E+05	4.779E+03	4.754E+06	8.452E+09	1.958E+17	8.032E+08	1.681E+58	2.135E+01	4.148E+00
	4th 6" Bioshield	6.320E+01	9.118E+04	5.440E+04	1.495E+03	6.823E+20	7.250E+14	4.324E+04	3.377E+03	7.225E+06	7.772E+04	7.889E+07	1.255E+09	2.907E+18	1.249E+08	2.583E+59	3.473E+02	6.743E+01
	2nd Bioshield Rebar	9.118E+03	1.074E+04	1.072E+07	9.502E+08	3.378E+05	7.233E+03	1.059E+01	3.337E+01	2.506E+04	3.328E+02	6.716E+07	1.363E+11	9.076E+28	2.476E+12	2.106E+12	1.628E+03	1.088E+01
	5th 6" Bioshield	9.902E+02	1.428E+04	1.116E+04	2.342E+04	1.089E+20	1.488E+14	6.773E+05	6.310E+04	1.131E+06	1.217E+04	1.216E+07	2.293E+10	5.309E+19	2.113E+09	4.389E+60	5.448E+03	1.057E+01
	6th 6" Bioshield	1.654E+02	2.389E+05	2.629E+05	3.913E+05	1.787E+21	3.503E+15	1.132E+05	8.936E+05	1.890E+07	2.035E+05	2.065E+08	4.773E+11	1.106E+19	3.981E+10	8.237E+61	9.124E+04	1.786E+02

SITE CHARACTERIZATION REPORT

REVISION 0.1

TABLE 4.7.33

CURIE CONTENTS TWENTY-EIGHT YEARS AFTER SHUTDOWN - COMPONENT SUMMARY

4th 12" Bioshield	3.694E-03	5.338E-06	8.021E-06	8.743E-06	3.991E-22	1.069E-15	2.529E-06	2.013E-05	4.219E-08	4.547E-06	4.705E-09	1.332E-11	3.085E-20	1.016E-10	2.103E-61	2.044E-04	3.948E-03
5th 12" Bioshield	1.656E-04	2.395E-07	4.793E-07	3.920E-07	1.790E-23	6.366E-17	1.134E-07	9.124E-07	1.891E-09	2.039E-07	2.162E-10	7.449E-13	1.726E-21	5.292E-12	1.086E-62	9.202E-06	1.771E-04
6th 12" Bioshield	8.687E-06	1.257E-08	2.799E-08	2.057E-08	9.396E-25	3.730E-18	6.953E-09	4.811E-08	9.915E-11	1.070E-08	1.147E-11	4.260E-14	9.933E-23	2.956E-13	5.769E-64	4.836E-07	9.297E-06
Lower Core Plate	8.023E+00	9.366E+00	1.991E-02	1.992E-03	9.380E-20	6.477E-07	6.566E+01	2.496E+03	4.756E+01	5.995E+03	1.350E-01	2.934E-02	1.448E-24	1.388E-05	6.425E-56	1.151E-01	8.622E+03
Lower Core Sup. Col.	2.408E+00	1.824E+00	1.286E-03	4.029E-04	1.854E-20	3.569E-08	1.315E+01	3.601E+02	1.135E+01	1.264E+03	1.455E-02	1.733E-03	2.705E-28	2.048E-07	1.174E-57	1.408E-01	1.653E+03
Lower Core Support	5.549E-03	4.344E-03	1.482E-05	9.018E-07	4.304E-23	4.122E-10	3.011E-02	1.417E+00	2.490E-02	2.877E+00	7.901E-05	2.010E-05	2.402E-34	5.157E-13	2.234E-63	2.408E-03	4.362E+00
Below Low. Core Sup.	2.080E-06	1.488E-06	9.845E-10	3.286E-10	1.512E-26	2.739E-14	1.073E-05	2.942E-04	9.574E-08	1.042E-03	1.167E-08	1.396E-09	0.000E+00	0.000E+00	0.000E+00	8.834E-07	1.361E-03
Upper Core Plate	2.068E+00	1.688E+00	4.403E-03	3.522E-04	1.864E-20	1.256E-07	1.168E+01	4.848E+02	9.810E+00	1.112E+03	2.584E-02	5.850E-03	1.575E-28	4.084E-07	1.872E-57	3.210E-01	1.623E+03
Upper Core Sup. Col.	3.848E-01	2.737E-01	1.971E-04	6.036E-05	2.779E-21	5.483E-09	1.972E+00	5.481E+01	1.753E+00	1.913E+02	2.206E-03	2.700E-04	2.787E-31	2.065E-09	1.182E-59	1.013E-01	2.506E+02
Totals	1.801E+02	2.173E+02	7.907E-01	1.821E-01	3.378E-05	7.251E-03	1.526E+03	5.576E+04	9.530E+02	1.322E+05	3.283E+00	7.055E-01	2.140E-14	1.278E-03	2.106E-12	7.850E+00	1.909E+05

CURIE CONTENTS THIRTY-THREE YEARS AFTER SHUTDOWN - COMPONENT SUMMARY

Summary		H-3	C-14	Ar-39	Ca-41	Ca-45	Mn-54	Fe-55	Co-60	Ni-59	Ni-63	Nb-94	Tc-99	Sn-119m	Sb-125	Te-126m	Eu-152	Total
By isotope	Component	(Curies)																
Scenario #9	Component	(Curies)																
Decay (years)	Core Shroud	4.863E+01	1.182E+02	2.100E+01	2.429E+02	4.988E+22	2.297E+07	2.138E+02	1.823E+04	5.327E+02	7.036E+04	2.223E+00	5.080E+01	8.356E+25	3.006E+04	1.521E+63	1.832E+03	8.950E+04
	33.0 Core Formers	1.818E+01	6.986E+01	4.806E+02	1.550E+02	3.016E+22	2.989E+08	1.314E+02	6.067E+03	2.813E+02	3.871E+04	5.677E+01	7.650E+02	4.155E+26	4.625E+05	3.031E+64	2.832E+02	4.526E+04
	Lower Core Barrel	1.135E+01	1.179E+01	4.483E+02	2.417E+03	4.929E+23	2.299E+08	2.139E+01	2.151E+03	6.517E+01	7.414E+03	2.406E+01	6.102E+02	9.924E+31	1.430E+08	6.808E+66	1.888E+00	9.678E+03
	Upper Core Barrel	1.070E+04	1.112E+04	4.235E+07	2.278E+08	4.645E+28	2.166E+13	2.018E+04	2.028E+02	6.143E+04	6.988E+02	2.268E+06	5.751E+07	9.354E+36	1.348E+11	6.417E+71	1.780E+05	9.121E+02
	Thermal Shield Pads	2.706E+00	2.822E+00	1.098E+02	5.782E+04	1.179E+23	5.514E+09	5.118E+00	5.175E+02	1.567E+01	1.778E+03	5.781E+02	1.469E+02	1.790E+30	1.814E+07	8.626E+67	7.194E+01	2.321E+03
	Vessel Clad	1.202E+00	1.260E+00	1.919E+03	2.732E+04	5.386E+24	9.555E+10	2.368E+00	1.550E+02	7.572E+00	8.271E+02	1.412E+02	2.583E+03	3.101E+31	6.013E+08	3.811E+67	1.286E+01	9.947E+02
	Vessel Wall	8.720E+01	6.201E+03	6.285E+03	6.030E+05	1.200E+24	1.132E+09	1.039E+00	9.878E+00	1.337E+01	1.520E+01	1.749E+03	4.444E+16	1.143E+16	1.206E+05	2.808E+65	2.742E+01	2.742E+01
	Vessel Insulation	2.083E+03	2.069E+03	4.481E+06	4.422E+07	8.791E+27	2.200E+12	3.855E+03	2.889E+01	1.251E+02	1.354E+00	2.816E+05	6.194E+06	5.050E+36	7.305E+13	4.100E+72	8.083E+04	1.665E+00
	1st 3" Bioshield	1.234E+01	2.407E+02	2.804E+01	3.891E+02	7.560E+22	6.591E+13	2.980E+03	5.681E+02	1.852E+04	1.957E+02	3.173E+05	3.659E+07	4.842E+18	5.494E+07	1.324E+66	7.406E+01	1.351E+01
	2nd 3" Bioshield	1.383E+01	2.656E+02	1.051E+01	4.337E+02	8.398E+22	2.470E+13	3.313E+03	5.453E+02	2.086E+04	2.174E+02	2.623E+05	1.484E+07	1.963E+18	2.569E+07	6.191E+67	7.858E+01	1.487E+01
	1st Bioshield Rebar/Lin.	7.886E+02	5.841E+03	3.689E+05	5.247E+06	1.018E+25	6.604E+12	8.853E+02	2.582E+01	1.378E+02	1.435E+00	4.380E+05	3.088E+09	5.086E+36	4.126E+12	2.915E+71	1.684E+02	1.897E+00
	2nd 6" Bioshield	1.371E+01	2.622E+02	4.297E+02	4.298E+02	8.307E+22	1.010E+13	3.278E+03	5.142E+02	2.072E+04	2.152E+02	2.329E+05	7.052E+08	9.327E+18	1.499E+07	3.808E+67	7.738E+01	1.467E+01
	3rd 6" Bioshield	2.937E+00	5.604E+03	3.889E+03	9.194E+03	1.778E+22	9.147E+15	7.014E+04	1.078E+02	4.442E+05	4.602E+03	4.753E+06	8.452E+09	1.118E+18	2.289E+08	5.531E+68	1.655E+01	3.137E+00
	4th 6" Bioshield	4.774E+01	9.113E+04	5.370E+04	1.495E+03	2.890E+23	1.263E+15	1.141E+04	1.750E+03	7.224E+06	7.485E+04	7.688E+07	1.255E+09	1.660E+20	3.575E+09	8.599E+69	2.892E+02	5.099E+01
	2nd Bioshield Rebar	9.118E+03	1.074E+04	1.072E+07	9.502E+08	3.378E+05	7.233E+03	1.059E+01	3.337E+01	2.506E+04	3.328E+02	6.716E+07	1.363E+11	9.076E+26	2.476E+12	2.106E+12	1.628E+03	1.088E+01
	5th 6" Bioshield	7.478E+02	1.428E+04	1.102E+04	2.342E+04	4.527E+24	2.591E+16	1.786E+05	2.751E+04	1.131E+06	1.172E+04	1.215E+07	2.293E+10	3.031E+21	6.046E+09	1.455E+69	4.222E+03	7.991E+02
	6th 6" Bioshield	1.249E+02	2.387E+05	2.595E+05	3.913E+05	7.668E+25	6.102E+17	2.986E+05	4.830E+05	1.890E+07	1.959E+05	2.064E+08	4.773E+11	6.313E+22	1.139E+10	2.742E+70	7.072E+04	1.336E+02
	4th 12" Bioshield	2.790E+03	5.335E+06	7.919E+06	8.742E+06	1.691E+26	1.862E+17	6.699E+07	1.043E+05	4.218E+08	4.379E+06	4.704E+09	1.332E+11	1.762E+22	2.908E+11	7.003E+71	1.584E+04	2.986E+03

CURIE CONTENTS THIRTY-THREE YEARS AFTER SHUTDOWN - COMPONENT SUMMARY

5th 12" Bioshield	1.251E-04	2.393E-07	4.731E-07	3.920E-07	7.584E-27	1.112E-18	2.991E-08	4.727E-07	1.891E-08	1.964E-07	2.161E-10	7.448E-13	9.856E-24	1.508E-12	3.617E-72	7.132E-08	1.340E-04
6th 12" Bioshield	6.562E-06	1.256E-08	2.783E-08	2.057E-08	3.980E-28	6.498E-20	1.570E-09	2.492E-08	9.915E-11	1.030E-08	1.147E-11	4.260E-14	5.671E-25	8.460E-14	1.921E-73	3.748E-07	7.034E-06
Lower Core Plate	6.080E+00	9.360E+00	1.866E-02	1.991E-03	3.973E-23	1.128E-08	1.732E+01	1.293E+03	4.765E+01	5.774E+03	1.350E-01	2.934E-02	8.266E-27	3.915E-06	2.139E-65	8.918E-02	7.148E+03
Lower Core Sup. Col.	1.819E+00	1.823E+00	1.270E-03	4.029E-04	7.854E-24	6.216E-10	3.468E+00	1.866E+02	1.135E+01	1.218E+03	1.454E-02	1.733E-03	1.645E-31	5.855E-08	3.907E-67	1.091E-01	1.423E+03
Lower Core Support	4.191E-03	4.341E-03	1.463E-05	9.018E-07	1.823E-26	7.181E-12	7.942E-03	7.342E-01	2.490E-02	2.771E+00	7.899E-05	2.010E-05	1.372E-36	1.476E-13	7.439E-73	1.865E-03	3.548E+00
Below Low. Core Sup.	1.571E-06	1.487E-06	9.719E-10	3.286E-10	6.404E-30	4.770E-16	2.830E-06	1.524E-04	9.574E-06	1.004E-03	1.167E-08	1.398E-09	0.000E+00	0.000E+00	0.000E+00	5.297E-07	1.172E-03
Upper Core Plate	1.560E+00	1.667E+00	4.347E-03	3.522E-04	7.050E-24	2.188E-08	3.081E+00	2.512E+02	9.610E+00	1.071E+03	2.583E-02	5.850E-03	8.993E-31	1.169E-67	6.234E-07	2.488E-01	1.339E+03
Upper Core Sup. Col.	2.908E-01	2.735E-01	1.848E-04	6.036E-05	1.177E-24	9.550E-11	5.201E-01	2.840E+01	1.753E+00	1.843E+02	2.205E-03	2.700E-04	1.591E-33	5.911E-10	3.936E-69	7.854E-02	2.156E+02
Totals	1.361E+02	2.172E+02	7.806E-01	1.821E-01	3.378E-05	7.234E-03	4.102E+02	2.889E+04	9.529E+02	1.274E+05	3.282E+00	7.055E-01	1.222E-16	3.657E-04	2.106E-12	6.085E+00	1.580E+05

CURIE CONTENTS THIRTY-EIGHT YEARS AFTER SHUTDOWN - COMPONENT SUMMARY

Summary		H-3	C-14	Ar-39	Ca-41	Ca-45	Mn-54	Fe-55	Co-60	Ni-59	Ni-63	Nb-94	Tc-99	Sn-119m	Sb-125	Te-125m	Eu-152	Total
By Isotope	Component	(Curies)																
Scenario #10	Component	(Curies)																
Decay (years)	Core Shroud	3.685E+01	1.181E+02	2.073E+01	2.429E+02	2.105E+25	4.001E+09	5.840E+01	9.444E+03	5.327E+02	6.776E+04	2.222E+00	5.090E+01	4.771E+27	8.604E+05	5.064E+73	1.420E+03	7.785E+04
	38.0	Core Formers	1.373E+01	8.982E+01	4.745E+02	1.560E+02	1.278E+25	5.172E+10	3.484E+01	3.143E+03	2.813E+02	3.728E+04	5.678E+01	7.650E+02	2.373E+28	1.324E+05	1.009E+73	2.195E+02
	Lower Core Barrel	8.574E+00	1.179E+01	4.435E+02	2.417E+03	2.088E+26	4.004E+10	5.941E+00	1.115E+03	6.517E+01	7.140E+03	2.406E+01	6.102E+02	5.687E+33	4.092E+07	2.267E+75	1.484E+00	8.348E+03
	Upper Core Barrel	8.081E+05	1.111E+04	4.180E+07	2.278E+08	1.988E+31	3.774E+15	5.317E+05	1.051E+02	6.143E+04	6.730E+02	2.268E+06	5.751E+07	5.341E+38	3.857E+12	2.138E+80	1.379E+05	7.868E+02
	Thermal Shield Pads	2.044E+00	2.821E+00	1.084E+02	5.782E+04	4.995E+27	9.806E+11	1.350E+00	2.881E+02	1.666E+01	1.710E+03	5.780E+02	1.489E+02	1.022E+32	5.191E+08	2.872E+78	5.578E+01	2.001E+03
	Vessel Clad	9.078E+01	1.260E+00	1.895E+03	2.732E+04	2.281E+27	1.664E+11	8.245E+01	8.032E+01	7.672E+00	7.885E+02	1.412E+02	2.583E+03	1.771E+33	1.721E+08	1.202E+78	9.989E+02	8.873E+02
	Vessel Wall	6.586E+01	6.187E+03	6.205E+03	6.030E+05	5.082E+28	1.971E+11	2.740E+01	5.118E+00	1.337E+01	1.464E+01	1.749E+03	4.444E+03	6.527E+18	3.452E+06	9.683E+75	2.125E+01	2.105E+01
	Vessel Insulation	1.574E+03	2.088E+03	4.424E+06	4.421E+07	3.724E+30	3.832E+14	1.017E+03	1.497E+01	1.251E+02	1.304E+00	2.815E+05	6.194E+06	2.884E+38	2.091E+13	1.385E+81	6.285E+04	1.472E+00
	1st 3" Bioshield	9.322E+00	2.405E+02	2.788E+01	3.891E+02	3.203E+26	1.148E+14	7.860E+04	2.944E+02	1.852E+04	1.885E+02	3.172E+05	3.659E+07	2.765E+20	1.572E+07	4.409E+78	5.741E+01	1.028E+01
	2nd 3" Bioshield	1.045E+01	2.654E+02	1.037E+01	4.337E+02	3.557E+26	4.303E+15	8.737E+04	2.825E+02	2.086E+04	2.094E+02	2.623E+05	1.484E+07	1.121E+20	7.353E+08	2.061E+78	6.081E+01	1.128E+01
	1st Bioshield Rebar/Lin.	5.957E+02	5.937E+03	3.622E+05	5.246E+06	4.304E+29	1.150E+13	2.335E+02	1.338E+01	1.377E+02	1.382E+00	4.359E+05	3.066E+09	2.893E+38	1.181E+12	9.707E+81	1.305E+02	1.631E+00
	2nd 6" Bioshield	1.038E+01	2.821E+02	4.242E+02	4.298E+02	3.519E+25	1.780E+15	8.848E+04	2.664E+02	2.072E+04	2.072E+02	2.328E+05	7.052E+08	5.325E+21	4.290E+08	1.201E+78	5.997E+01	1.112E+01
	3rd 6" Bioshield	2.218E+00	5.800E+03	3.839E+03	9.194E+03	7.531E+26	1.593E+16	1.850E+04	5.588E+03	4.442E+05	4.432E+03	4.753E+06	8.452E+09	6.384E+22	6.579E+09	1.841E+77	1.282E+01	2.375E+00
	4th 6" Bioshield	3.608E+01	9.107E+04	5.302E+04	1.495E+03	1.224E+26	2.200E+17	3.008E+05	9.065E+04	7.224E+06	7.208E+04	7.686E+07	1.255E+09	9.477E+23	1.023E+09	2.863E+78	2.086E+02	3.860E+01
	2nd Bioshield Rebar	9.118E+03	1.074E+04	1.072E+07	9.502E+08	3.378E+05	7.233E+03	1.059E+01	3.337E+01	2.606E+04	3.328E+02	6.716E+07	1.363E+11	9.076E+26	2.476E+12	2.106E+12	1.628E+03	1.098E+01
	5th 6" Bioshield	5.648E+02	1.427E+04	1.088E+04	2.342E+04	1.918E+27	4.514E+18	4.711E+08	1.425E+04	1.131E+06	1.129E+04	1.215E+10	2.293E+10	1.731E+23	1.730E+10	4.843E+78	3.273E+03	6.051E+02
	6th 6" Bioshield	9.437E+03	2.386E+05	2.562E+05	3.913E+05	3.206E+28	1.063E+18	7.875E+07	2.399E+05	1.890E+07	1.887E+05	2.064E+08	4.773E+11	3.605E+24	3.281E+11	8.130E+80	5.481E+04	1.012E+02

CURIE CONTENTS THIRTY-EIGHT YEARS AFTER SHUTDOWN - COMPONENT SUMMARY

4th 12" Bioshield	2.107E-03	5.332E-06	7.817E-06	8.742E-08	7.161E-29	3.243E-19	1.759E-07	5.404E-08	4.218E-08	4.217E-08	4.703E-09	1.332E-11	1.006E-24	8.322E-12	2.332E-80	1.228E-04	2.262E-03
5th 12" Bioshield	9.446E-05	2.392E-07	4.671E-07	3.920E-07	3.213E-30	1.938E-20	7.890E-09	2.448E-07	1.890E-08	1.891E-07	2.161E-10	7.448E-13	5.627E-26	4.310E-13	1.204E-81	5.528E-08	1.015E-04
6th 12" Bioshield	4.956E-08	1.255E-08	2.728E-08	2.056E-08	1.686E-31	1.132E-21	4.141E-10	1.291E-08	9.914E-11	9.822E-09	1.146E-11	4.280E-14	3.238E-27	2.421E-14	6.395E-83	2.905E-07	5.330E-08
Lower Core Plate	4.577E+00	9.355E+00	1.941E-02	1.991E-03	1.683E-26	1.965E-10	4.567E+00	6.701E+02	4.755E+01	5.560E+03	1.350E-01	2.934E-02	4.720E-29	1.121E-08	7.122E-75	6.812E-02	6.297E+03
Lower Core Sup. Col.	1.374E+00	1.822E+00	1.254E-03	4.029E-04	3.327E-27	1.083E-11	9.146E-01	9.687E+01	1.135E+01	1.173E+03	1.454E-02	1.733E-03	8.820E-34	1.676E-08	1.301E-78	8.457E-02	1.285E+03
Lower Core Support	3.166E-03	4.339E-03	1.444E-05	9.018E-07	7.724E-30	1.251E-13	2.095E-03	3.804E-01	2.490E-02	2.688E+00	7.888E-05	2.010E-05	7.832E-39	4.224E-14	2.477E-82	1.446E-03	3.085E+00
Below Low. Core Sup.	1.187E-06	1.486E-06	9.595E-10	3.286E-10	2.713E-33	8.309E-18	7.465E-07	7.898E-05	9.574E-06	9.664E-04	1.166E-08	1.396E-08	0.000E+00	0.000E+00	0.000E+00	4.106E-07	1.059E-03
Upper Core Plate	1.178E+00	1.666E+00	4.291E-03	3.522E-04	2.988E-27	3.811E-11	8.126E-01	1.301E+02	9.809E+00	1.032E+03	2.583E-02	5.850E-03	5.135E-33	3.345E-08	2.076E-78	1.929E-01	1.175E+03
Upper Core Sup. Col.	2.195E-01	2.733E-01	1.921E-04	6.036E-05	4.987E-28	1.664E-12	1.372E-01	1.471E+01	1.753E+00	1.775E+02	2.205E-03	2.700E-04	9.086E-38	1.692E-10	1.311E-78	6.087E-02	1.946E+02
Totals	1.028E+02	2.170E+02	7.706E-01	1.821E-01	3.378E-05	7.233E-03	1.160E+02	1.497E+04	9.529E+02	1.226E+05	3.282E+00	7.055E-01	6.977E-19	1.047E-04	2.106E-12	4.717E+00	1.390E+05

SITE CHARACTERIZATION REPORT

TABLE 4.7.36

REVISION 0.1

10 CFR PART 61 CLASSIFICATION BY COMPONENT AT SHUTDOWN

Decay (years)															Sum of	Sum of	Sum of	Sum of
0.0															Frac.	Frac.	Frac.	Frac.
Component	10 CFR 61 Class.	H-3 (Ci/m)	C-14	Ca-45	Mn-54	Fe-55	Co-60	Ni-59	Ni-63	Nb-94	Tc-99	Sn-119m	Sb-125	Ta-125m	Tab. 1	Tab. 2 Col. 1	Tab. 2 Col. 2	Tab. 2 Col. 3
Core Baffle	GTCC	2.638E+02	1.012E+00	7.792E+00	7.990E+04	1.207E+06	1.193E+06	4.544E+02	7.693E+04	1.897E+00	4.341E+01	4.580E+10	9.891E+01	4.705E+01	12.973	5746.434	109.897	10.890
Core Formers	GTCC	1.805E+02	9.710E+01	7.679E+00	1.677E+04	1.203E+06	6.446E+05	3.619E+02	6.872E+04	7.868E+01	1.059E+01	3.898E+11	2.471E+01	1.522E+01	6.843	4631.498	98.177	8.818
Lower Core Barrel	C	2.083E+01	3.377E+00	2.685E+01	2.674E+03	4.036E+04	4.709E+04	1.858E+01	2.711E+03	6.870E+02	1.740E+02	1.819E+16	1.673E+03	7.043E+04	0.470	206.713	3.873	0.387
Upper Core Barrel	A	8.423E+04	1.378E+04	1.055E+05	1.092E+01	1.648E+00	1.922E+00	7.589E+04	1.107E+01	2.804E+06	7.104E+07	7.426E+21	6.422E+08	2.875E+08	0.000	0.008	0.000	0.000
Thermal Shield Pads	C	1.452E+01	2.388E+00	1.826E+01	1.894E+03	2.851E+04	3.344E+04	1.319E+01	1.917E+03	4.872E+02	1.237E+02	9.885E+16	5.891E+04	2.635E+04	0.333	146.354	2.739	0.274
Vessel Clad	C	1.591E+01	2.628E+00	2.057E+01	8.098E+02	3.264E+04	2.471E+04	1.573E+01	2.203E+03	2.937E+02	5.366E+03	4.140E+16	4.819E+04	2.721E+04	0.251	146.287	3.147	0.315
Vessel Wall	A	2.425E+01	2.716E+04	9.627E+04	2.014E+01	3.000E+02	3.308E+01	5.836E+03	8.503E+01	7.638E+05	1.939E+04	3.206E+03	2.030E+03	4.603E+04	0.001	0.535	0.001	0.000
Vessel Insulation	A	9.154E+02	1.432E+02	1.115E+03	6.186E+00	1.756E+02	1.528E+02	8.627E+02	1.197E+01	1.943E+04	4.270E+05	2.238E+20	1.943E+08	1.025E+08	0.002	0.823	0.017	0.002
1st 3" Bioshield	A	7.219E+00	2.217E+03	1.276E+00	2.467E+02	1.810E+00	4.001E+01	1.700E+05	2.303E+03	2.915E+06	3.358E+08	2.858E+04	1.945E+04	4.408E+05	0.000	0.188	0.000	0.000
2nd 3" Bioshield	A	2.746E+01	8.306E+03	4.811E+00	3.139E+02	6.829E+00	1.304E+00	6.500E+05	8.686E+03	8.182E+06	4.623E+08	3.932E+04	3.088E+04	6.997E+05	0.000	0.705	0.000	0.000
1st Rebar/Liner	A	4.042E+01	4.795E+03	1.503E+03	2.166E+00	4.710E+02	1.593E+01	1.108E+02	1.479E+00	3.510E+05	2.465E+09	2.618E+21	1.280E+08	8.504E+09	0.000	0.751	0.002	0.000
2nd 6" Bioshield	A	1.314E+01	3.859E+03	2.298E+00	6.198E+03	3.262E+00	5.935E+00	3.117E+05	4.149E+03	3.506E+06	1.061E+08	9.015E+05	8.696E+05	1.968E+05	0.000	0.338	0.000	0.000
3rd 6" Bioshield	A	2.691E+00	8.087E+04	4.701E+01	5.364E+04	6.672E+01	1.189E+01	6.387E+06	8.483E+04	6.841E+07	1.215E+09	1.033E+05	1.275E+05	2.884E+06	0.000	0.069	0.000	0.000
4th 6" Bioshield	A	4.189E+01	1.260E+04	7.319E+03	7.093E+05	1.039E+01	1.849E+02	9.949E+07	1.321E+04	1.060E+07	1.728E+10	1.469E+06	1.899E+08	4.295E+07	0.000	0.011	0.000	0.000
2nd Bioshield Rebar	A	6.169E+03	7.268E+05	2.285E+05	4.894E+03	7.189E+00	2.258E+01	1.696E+04	2.252E+02	4.544E+07	9.221E+12	6.141E+28	1.675E+12	1.425E+12	0.000	0.011	0.000	0.000
5th 6" Bioshield	A	6.297E+02	1.893E+05	1.100E+02	1.396E+05	1.561E+02	2.789E+03	1.495E+07	1.986E+05	1.607E+08	3.029E+11	2.573E+07	3.081E+07	6.971E+08	0.000	0.002	0.000	0.000

SITE CHARACTERIZATION REPORT

TABLE 4.7.36

REVISION 0.1

10 CFR PART 61 CLASSIFICATION BY COMPONENT AT SHUTDOWN

6th 6" Bioshield	A	1.011E-02	3.043E-06	1.787E-03	3.180E-08	2.608E-03	4.610E-04	2.400E-08	3.189E-06	2.624E-09	6.060E-12	5.161E-08	5.581E-08	1.283E-08	0.000	0.000	0.000	0.000
4th 12" Bioshield	A	1.067E-03	3.212E-07	1.865E-04	4.555E-07	2.647E-04	4.801E-05	2.530E-09	3.367E-07	2.824E-10	7.988E-13	6.790E-09	6.728E-09	1.524E-09	0.000	0.000	0.000	0.000
5th 12" Bioshield	A	4.453E-05	1.342E-08	7.782E-06	2.535E-08	1.108E-05	2.027E-06	1.056E-10	1.408E-08	1.209E-11	4.161E-14	3.538E-10	3.248E-10	7.330E-11	0.000	0.000	0.000	0.000
6th 12" Bioshield	A	2.186E-06	6.692E-10	3.827E-07	1.386E-08	5.431E-07	9.999E-08	5.184E-12	8.906E-10	6.000E-13	2.227E-15	1.905E-11	1.706E-11	3.643E-12	0.000	0.000	0.000	0.000
Lower Core Plate	GTCC	1.017E+02	2.474E+01	1.924E+00	1.212E+04	3.016E+05	2.613E+05	1.252E+02	1.949E+04	3.558E+01	7.724E+02	1.399E+11	3.976E+02	2.043E+02	2.664	1380.864	27.841	2.784
Lower Core Sup. Columns	C	4.003E+01	6.319E+00	4.997E+01	8.755E+02	7.922E+04	4.943E+04	3.821E+01	5.380E+03	5.026E+02	5.982E+03	3.428E+16	7.798E+04	4.894E+04	0.509	340.029	7.699	0.770
Lower Core Support	A	7.853E-03	1.281E-03	9.858E-05	8.611E-01	1.545E+01	1.656E+01	7.321E-03	1.044E+00	2.325E-05	5.908E-06	2.592E-22	1.674E-10	7.933E-11	0.000	0.077	0.001	0.000
Below Lower Core Sup.	A	4.337E-05	6.468E-06	5.102E-07	8.429E-04	8.112E-02	5.068E-02	4.148E-05	5.573E-03	5.059E-08	6.047E-09	0.000E+00	0.000E+00	0.000E+00	0.000	0.000	0.000	0.000
Upper Core Plate	C	2.188E+01	3.699E+00	2.866E-01	1.973E+03	4.506E+04	4.261E+04	2.125E+01	3.036E+03	5.715E-02	1.293E-02	1.278E-15	9.967E-04	4.998E-04	0.429	215.358	4.338	0.434
Upper Core Sup. Columns	B	2.824E+00	4.186E-01	3.301E-02	5.940E+01	5.247E+03	3.323E+03	2.673E+00	3.602E+02	3.366E-03	4.116E-04	1.559E-18	3.477E-06	2.177E-06	0.034	22.690	0.515	0.051

SITE CHARACTERIZATION REPORT

REVISION 0.1

TABLE 4.7.37

10 CFR PART 61 CLASSIFICATION BY COMPONENT ONE YEAR AFTER SHUTDOWN

Decay (years)															Sum of	Sum of	Sum of	Sum of
1.0															Frac.	Frac.	Frac.	Frac.
Component	10 CFR 61 Classification	H-3 (Ci/m)	C-14	Ca-45	Mn-54	Fe-55	Co-60	Ni-59	Ni-63	Nb-94	Tc-99	Sn-119m	Sb-125	Te-125m	Tab. 1	Tab. 2 Col. 1	Tab. 2 Col. 2	Tab. 2 Col. 3
Core Baffle	GTCC	2.494E+02	1.012E+02	1.850E+00	3.558E+04	9.244E+05	1.046E+06	4.544E+02	7.935E+04	1.897E+00	4.341E+01	1.631E+10	7.702E+01	5.999E+03	12.818	5053.209	109.073	10.907
Core Formers	GTCC	1.517E+02	9.709E+01	1.626E+00	7.463E+03	9.219E+05	5.652E+05	3.618E+02	6.821E+04	7.868E+01	1.059E+01	1.317E+11	1.924E+01	1.841E+03	6.793	4087.766	97.441	9.744
Lower Core Barrel	C	1.951E+01	3.376E+00	5.473E-02	1.190E+03	3.092E+04	4.129E+04	1.859E+01	2.691E+03	6.870E+02	1.740E+02	6.478E+17	1.225E+03	8.980E+06	0.470	182.215	3.844	0.384
Upper Core Barrel	A	7.963E-04	1.378E-04	2.234E-06	4.858E-02	1.262E+00	1.685E+00	7.589E-04	1.098E-01	2.804E-06	7.104E-07	2.644E-21	5.001E-08	3.666E-10	0.000	0.007	0.000	0.000
Thermal Shield Pads	C	1.373E+01	2.386E+00	3.865E-02	8.428E+02	2.185E+04	2.932E+04	1.319E+01	1.903E+03	4.872E-02	1.237E-02	3.449E-16	4.588E-04	3.359E-06	0.333	129.011	2.719	0.272
Vessel Clad	C	1.504E+01	2.628E+00	4.356E-02	3.803E+02	2.493E+04	2.167E+04	1.573E+01	2.186E+03	2.938E-02	5.366E-03	1.474E-16	3.752E-04	3.469E-06	0.251	129.929	3.123	0.312
Vessel Wall	A	2.293E-01	2.716E-04	2.038E-04	8.962E+00	2.298E+02	2.900E+01	5.836E-03	8.439E-01	7.638E-05	1.939E-04	1.142E-03	1.581E-03	5.869E-06	0.000	0.412	0.001	0.000
Vessel Insulation	A	8.655E-02	1.432E-02	2.380E-04	2.753E+00	1.347E+02	1.340E+02	8.627E-02	1.188E+01	1.943E-04	4.270E-05	7.968E-21	1.513E-08	1.307E-10	0.002	0.729	0.017	0.002
1st 3" Bioshield	A	6.825E+00	2.217E-03	2.702E-01	1.088E-02	1.386E+00	3.508E-01	1.700E-05	2.286E-03	2.915E-06	3.358E-08	1.017E-04	1.515E-04	5.620E-07	0.000	0.174	0.000	0.000
2nd 3" Bioshield	A	2.597E+01	8.305E-03	1.019E+00	1.397E-02	5.232E+00	1.143E+00	6.500E-05	8.621E-03	8.182E-06	4.823E-08	1.400E-04	2.405E-04	8.922E-07	0.000	0.660	0.000	0.000
1st Rebar/Liner	A	3.821E-01	4.795E-03	3.181E-04	9.640E-01	3.609E+02	1.387E+01	1.108E-02	1.468E+00	3.509E-05	2.465E-09	9.324E-22	9.968E-08	1.084E-10	0.000	0.588	0.002	0.000
2nd 6" Bioshield	A	1.243E+01	3.959E-03	4.865E-01	2.759E-03	2.499E+00	5.204E-01	3.117E-05	4.118E-03	3.506E-06	1.061E-08	3.210E-05	6.772E-05	2.509E-07	0.000	0.316	0.000	0.000
3rd 6" Bioshield	A	2.544E+00	8.086E-04	9.952E-02	2.387E-04	5.111E-01	1.043E-01	6.387E-06	8.419E-04	6.840E-07	1.215E-09	3.679E-06	9.929E-06	3.677E-08	0.000	0.065	0.000	0.000
4th 6" Bioshield	A	3.961E-01	1.259E-04	1.550E-02	3.156E-05	7.960E-02	1.621E-02	9.949E-07	1.311E-04	1.060E-07	1.728E-10	5.230E-07	1.479E-06	5.478E-08	0.000	0.010	0.000	0.000
2nd Bioshield Rebar	A	6.169E-03	7.268E-05	2.265E-05	4.894E-03	7.169E+00	2.258E-01	1.696E-04	2.252E-02	4.544E-07	9.221E-12	6.141E-28	1.675E-12	1.425E-12	0.000	0.011	0.000	0.000
5th 6" Bioshield	A	5.954E-02	1.893E-05	2.328E-03	6.215E-08	1.186E-02	2.445E-03	1.495E-07	1.971E-05	1.607E-08	3.028E-11	9.164E-08	2.400E-07	8.888E-10	0.000	0.002	0.000	0.000

SITE CHARACTERIZATION REPORT

REVISION 0.1

TABLE 4.7.37

10 CFR PART 61 CLASSIFICATION BY COMPONENT ONE YEAR AFTER SHUTDOWN

6th 6" Bioshield	A	9.559E-03	3.042E-06	3.741E-04	1.406E-06	1.922E-03	3.955E-04	2.400E-08	3.166E-06	2.624E-09	6.060E-12	1.834E-08	4.346E-08	1.610E-10	0.000	0.000	0.000	0.000
4th 12" Bioshield	A	1.008E-03	3.212E-07	3.948E-05	2.027E-07	2.028E-04	4.210E-05	2.530E-09	3.242E-07	2.824E-10	7.986E-13	2.418E-09	5.239E-09	1.943E-11	0.000	0.000	0.000	0.000
5th 12" Bioshield	A	4.210E-05	1.342E-08	1.850E-06	1.128E-08	8.471E-06	1.777E-06	1.056E-10	1.396E-08	1.209E-11	4.161E-14	1.260E-10	2.528E-10	9.346E-13	0.000	0.000	0.000	0.000
6th 12" Bioshield	A	2.067E-06	6.591E-10	8.102E-08	6.166E-10	4.161E-07	8.767E-08	5.184E-12	6.854E-10	6.000E-13	2.227E-15	6.785E-12	1.329E-11	4.644E-14	0.000	0.000	0.000	0.000
Lower Core Plate	GTCC	9.614E+01	2.474E+01	4.073E+01	5.392E+03	2.311E+05	2.291E+05	1.252E+02	1.934E+04	3.557E+01	7.724E+02	4.980E+12	3.097E+02	2.805E+04	2.657	1220.184	27.632	2.763
Lower Core Sup. Columns	C	3.785E+01	6.318E+00	1.056E+01	3.896E+02	6.069E+04	4.335E+04	3.921E+01	5.349E+03	5.026E+02	5.982E+03	1.221E+16	6.073E+04	6.239E+06	0.508	302.959	7.642	0.764
Lower Core Support	A	7.425E-03	1.281E-03	2.087E-05	3.832E-01	1.183E+01	1.452E+01	7.321E-03	1.037E+00	2.325E-05	5.908E-08	8.228E-23	1.304E-10	1.011E-12	0.000	0.068	0.001	0.000
Below Lower Core Sup.	A	4.101E-05	6.465E-06	1.080E-07	3.751E-04	6.215E-02	4.443E-02	4.148E-05	5.532E-03	5.058E-08	6.047E-09	0.000E+00	0.000E+00	0.000E+00	0.000	0.000	0.000	0.000
Upper Core Plate	C	2.078E+01	3.699E+00	6.067E+02	8.779E+02	3.452E+04	3.736E+04	2.125E+01	3.014E+03	5.715E+02	1.283E+02	4.549E+16	7.761E+04	6.373E+06	0.429	180.561	4.305	0.431
Upper Core Sup. Columns	B	2.670E+00	4.186E-01	6.989E-03	2.643E+01	4.020E+03	2.913E+03	2.673E+00	3.575E+02	3.366E-03	4.116E-04	5.553E-19	2.707E-06	2.776E-08	0.034	20.224	0.511	0.051

SITE CHARACTERIZATION REPORT

REVISION 0.1

TABLE 4.7.38

10 CFR PART 61 CLASSIFICATION BY COMPONENT TWO YEARS AFTER SHUTDOWN

Decay (years)	Component	10 CFR 61 Classification	H-3 (Ci/m)	C-14	Ca-45	Mn-54	Fe-55	Co-60	Ni-59	Ni-63	Nb-94	Tc-99	Sn-119m	Sb-125	Te-125m	Sum of	Sum of	Sum of	Sum of
																Frac. Tab. 1	Frac. Tab. 2 Col. 1	Frac. Tab. 2 Col. 2	Frac. Tab. 2 Col. 3
2.0	Core Baffle	GTCC	2.358E+02	1.012E+02	3.493E-01	1.583E+04	7.082E+05	9.171E+05	4.544E+02	7.578E+04	1.897E+00	4.341E+01	5.807E+11	5.998E+01	7.649E+05	12.818	4515.428	108.254	10.825
	Core Formers	GTCC	1.434E+02	9.708E+01	3.442E-01	3.321E+03	7.063E+05	4.956E+05	3.818E+02	6.770E+04	7.867E+01	1.059E+01	4.689E+12	1.498E+01	2.475E+05	6.792	3659.543	96.710	9.671
	Lower Core Barrel	C	1.844E+01	3.376E+00	1.159E-02	5.296E+02	2.369E+04	3.620E+04	1.859E+01	2.671E+03	6.869E+02	1.740E+02	2.307E+17	9.541E+04	1.145E+07	0.470	163.073	3.815	0.382
	Upper Core Barrel	A	7.529E-04	1.378E-04	4.730E-07	2.182E-02	9.670E-01	1.478E+00	7.568E-04	1.090E-01	2.804E-08	7.104E-07	9.416E-22	3.895E-08	4.674E-12	0.000	0.007	0.000	0.000
	Thermal Shield Pads	C	1.288E+01	2.385E+00	8.184E-03	3.751E+02	1.674E+04	2.571E+04	1.319E+01	1.889E+03	4.872E-02	1.237E-02	1.228E-16	3.573E-04	4.283E-08	0.333	115.458	2.698	0.270
	Vessel Clad	C	1.422E+01	2.627E+00	9.223E-03	1.604E+02	1.910E+04	1.900E+04	1.573E+01	2.170E+03	2.936E-02	5.368E-03	5.250E-17	2.822E-04	4.423E-08	0.251	117.011	3.100	0.310
	Vessel Wall	A	2.169E-01	2.716E-04	4.315E-05	3.989E+00	1.761E+02	2.543E+01	5.836E-03	8.376E-01	7.638E-05	1.939E-04	4.065E-04	1.231E-03	7.483E-08	0.000	0.323	0.001	0.000
	Vessel Insulation	A	8.183E-02	1.432E-02	4.998E-05	1.225E+00	1.032E+02	1.175E+02	8.627E-02	1.179E+01	1.943E-04	4.270E-05	2.837E-21	1.178E-08	1.667E-12	0.002	0.856	0.017	0.002
	1st 3" Bioshield	A	6.453E+00	2.217E-03	5.720E-02	4.887E-03	1.082E+00	3.076E-01	1.700E-05	2.269E-03	2.915E-06	3.358E-08	3.621E-05	1.180E-04	7.166E-09	0.000	0.163	0.000	0.000
	2nd 3" Bioshield	A	2.455E+01	8.304E-03	2.157E-01	6.218E-03	4.008E+00	1.002E+00	6.500E-05	8.556E-03	8.182E-06	4.823E-08	4.986E-05	1.873E-04	1.137E-08	0.000	0.621	0.000	0.000
	1st Rebar/Liner	A	3.813E-01	4.794E-03	6.735E-05	4.290E-01	2.785E+02	1.225E+01	1.108E-02	1.457E+00	3.509E-05	2.465E-08	3.320E-22	7.782E-08	1.382E-12	0.000	0.464	0.002	0.000
	2nd 6" Bioshield	A	1.175E+01	3.958E-03	1.030E-01	1.228E-03	1.915E+00	4.563E-01	3.117E-05	4.087E-03	3.506E-06	1.061E-08	1.143E-05	5.274E-05	3.200E-09	0.000	0.297	0.000	0.000
	3rd 6" Bioshield	A	2.405E+00	8.085E-04	2.107E-02	1.062E-04	3.918E-01	9.145E-02	6.387E-06	8.358E-04	6.840E-07	1.215E-09	1.310E-06	7.732E-06	4.689E-10	0.000	0.081	0.000	0.000
	4th 6" Bioshield	A	3.745E-01	1.259E-04	3.281E-03	1.405E-05	6.099E-02	1.421E-02	9.849E-07	1.302E-04	1.059E-07	1.728E-10	1.883E-07	1.151E-06	8.982E-11	0.000	0.009	0.000	0.000
	2nd Bioshield Rebar	A	6.169E-03	7.288E-05	2.285E-05	4.894E-03	7.169E+00	2.258E-01	1.696E-04	2.252E-02	4.544E-07	9.221E-12	6.141E-26	1.675E-12	1.425E-12	0.000	0.011	0.000	0.000
	5th 6" Bioshield	A	5.829E-02	1.893E-05	4.930E-04	2.766E-06	9.184E-03	2.144E-03	1.494E-07	1.956E-05	1.607E-08	3.029E-11	3.263E-08	1.869E-07	1.133E-11	0.000	0.001	0.000	0.000

SITE CHARACTERIZATION REPORT

REVISION 0.1

TABLE 4.7.38

10 CFR PART 61 CLASSIFICATION BY COMPONENT TWO YEARS AFTER SHUTDOWN

6th 6" Bioshield	A	9.037E-03	3.042E-06	7.921E-05	6.268E-07	1.472E-03	3.468E-04	2.400E-08	3.142E-06	2.623E-09	6.060E-12	6.532E-09	3.384E-08	2.053E-12	0.000	0.000	0.000	0.000
4th 12" Bioshield	A	9.533E-04	3.211E-07	8.359E-08	9.021E-08	1.553E-04	3.691E-05	2.530E-08	3.317E-07	2.824E-10	7.986E-13	8.810E-10	4.080E-09	2.477E-13	0.000	0.000	0.000	0.000
5th 12" Bioshield	A	3.980E-05	1.342E-08	3.493E-07	5.021E-09	6.490E-06	1.558E-06	1.056E-10	1.385E-08	1.209E-11	4.161E-14	4.487E-11	1.968E-10	1.192E-14	0.000	0.000	0.000	0.000
6th 12" Bioshield	A	1.954E-06	6.590E-10	1.715E-08	2.744E-10	3.188E-07	7.687E-08	6.184E-12	6.803E-10	6.000E-13	2.227E-15	2.416E-12	1.035E-11	5.922E-16	0.000	0.000	0.000	0.000
Lower Core Plate	GTCC	9.090E+01	2.473E+01	8.824E+02	2.400E+03	1.770E+05	2.009E+05	1.252E+02	1.920E+04	3.557E+01	7.724E+02	1.774E+12	2.411E+02	3.321E+06	2.657	1094.109	27.425	2.742
Lower Core Sup. Columns	C	3.578E+01	6.318E+00	2.236E+02	1.734E+02	4.850E+04	3.801E+04	3.821E+01	5.309E+03	5.026E+02	5.982E+03	4.348E+17	4.729E+04	7.955E+08	0.508	273.548	7.584	0.758
Lower Core Support	A	7.020E-03	1.281E-03	4.419E-06	1.708E-01	9.087E+00	1.273E+01	7.321E-03	1.029E+00	2.325E-05	5.908E-06	3.286E-23	1.015E-10	1.290E-14	0.000	0.061	0.001	0.000
Below Lower Core Sup.	A	3.877E-05	6.485E-06	2.287E-08	1.669E-04	4.761E-02	3.896E-02	4.148E-05	5.490E-03	5.058E-08	6.047E-09	0.000E+00	0.000E+00	0.000E+00	0.000	0.000	0.000	0.000
Upper Core Plate	C	1.965E+01	3.698E+00	1.285E+02	3.907E+02	2.645E+04	3.276E+04	2.125E+01	2.991E+03	5.715E+02	1.293E+02	1.620E+16	6.044E+04	8.128E+08	0.429	171.084	4.273	0.427
Upper Core Sup. Columns	B	2.525E+00	4.185E-01	1.480E-03	1.176E+01	3.080E+03	2.554E+03	2.673E+00	3.548E+02	3.366E-03	4.116E-04	1.977E+19	2.108E+06	3.539E+10	0.034	18.267	0.507	0.051

SITE CHARACTERIZATION REPORT

TABLE 4.7.39

REVISION 0.1

10 CFR PART 61 CLASSIFICATION BY COMPONENT FIVE YEARS AFTER SHUTDOWN

Decay (years)															Sum of	Sum of	Sum of	Sum of
5.0	10 CFR 61	H-3	C-14	Ca-46	Mn-54	Fe-56	Co-60	Ni-59	Ni-63	Nb-94	Tc-99	Sn-119m	Sb-125	Te-126m	Fractions	Fractions	Fractions	Fractions
Component	Classification	(Ci/m)													Table 1	Table 2 Col. 1	Table 2 Col. 2	Table 2 Col. 3
Core Shroud	GTCC	1.892E+02	1.011E+02	3.301E-03	1.382E+03	3.182E+05	6.180E+05	4.544E+02	7.408E+04	1.897E+00	4.341E-01	2.615E-12	2.831E-01	1.566E-10	12.959	3461.137	105.834	10.583
Core Formers	GTCC	1.212E+02	9.705E+01	3.253E-03	2.921E+02	3.174E+05	3.340E+05	3.618E+02	6.818E+04	7.867E-01	1.059E-01	2.111E-13	7.071E-02	5.069E-11	8.826	2824.912	94.548	9.455
Lower Core Barrel	C	1.558E+01	3.374E+00	1.095E-04	4.658E+01	1.064E+04	2.439E+04	1.859E+01	2.611E+03	6.869E-02	1.740E-02	1.039E-18	4.503E-04	2.345E-13	0.476	125.107	3.730	0.373
Upper Core Barrel	A	6.362E-04	1.378E-04	4.470E-09	1.901E-03	4.345E-01	9.959E-01	7.589E-04	1.066E-01	2.804E-06	7.104E-07	4.240E-23	1.838E-08	9.573E-18	0.000	0.005	0.000	0.000
Thermal Shield Pads	C	1.097E+01	2.384E+00	7.734E-05	3.299E+01	7.520E+03	1.732E+04	1.319E+01	1.846E+03	4.871E-02	1.237E-02	5.630E-18	1.686E-04	8.771E-14	0.337	88.570	2.638	0.284
Vessel Clad	C	1.202E+01	2.626E+00	8.715E-05	1.410E+01	8.583E+03	1.280E+04	1.573E+01	2.121E+03	2.936E-02	5.366E-03	2.364E-18	1.379E-04	9.058E-14	0.253	91.483	3.030	0.303
Vessel Wall	A	1.832E-01	2.715E-04	4.078E-07	3.508E-01	7.911E+01	1.714E+01	5.836E-03	8.189E-01	7.637E-05	1.939E-04	1.830E-05	5.811E-04	1.533E-13	0.000	0.166	0.001	0.000
Vessel Insulation	A	6.914E-02	1.431E-02	4.721E-07	1.077E-01	4.637E+01	7.918E+01	8.627E-02	1.153E+01	1.843E-04	4.270E-05	1.278E-22	5.560E-09	3.413E-18	0.002	0.511	0.016	0.002
1st 3" Bioshield	A	5.453E+00	2.218E-03	5.405E-04	4.288E-04	4.773E-01	2.073E-01	1.700E-05	2.218E-03	2.914E-08	3.358E-08	1.631E-08	5.567E-05	1.468E-14	0.000	0.137	0.000	0.000
2nd 3" Bioshield	A	2.074E+01	8.301E-03	2.038E-03	5.468E-04	1.801E+00	6.756E-01	6.500E-05	8.365E-03	8.181E-06	4.623E-08	2.245E-08	8.839E-05	2.330E-14	0.000	0.522	0.000	0.000
1st Bioshield Rebar/Liner	A	3.053E-01	4.793E-03	6.365E-07	3.773E-02	1.242E+02	8.254E+00	1.108E-02	1.425E+05	3.509E-05	2.465E-09	1.495E-23	3.663E-09	2.831E-18	0.000	0.238	0.002	0.000
2nd 6" Bioshield	A	9.928E+00	3.957E-03	9.733E-04	1.080E-04	8.604E-01	3.075E-01	3.117E-05	3.996E-03	3.505E-08	1.061E-08	5.148E-07	2.489E-05	6.553E-15	0.000	0.250	0.000	0.000
3rd 6" Bioshield	A	2.032E+00	8.082E-04	1.991E-04	9.343E-06	1.780E-01	6.163E-02	6.387E-08	8.169E-04	6.840E-07	1.215E-09	5.898E-08	3.848E-08	9.602E-16	0.000	0.051	0.000	0.000
4th 6" Bioshield	A	3.164E-01	1.259E-04	3.100E-05	1.235E-06	2.740E-02	8.578E-03	9.948E-07	1.272E-04	1.059E-07	1.728E-10	8.387E-09	5.434E-07	1.430E-16	0.000	0.008	0.000	0.000
2nd Bioshield Rebar	A	6.169E-03	7.268E-05	2.285E-05	4.894E-03	7.169E+00	2.258E-01	1.696E-04	2.252E-02	4.544E-07	9.221E-12	6.141E-26	1.675E-12	1.425E-12	0.000	0.011	0.000	0.000
5th 6" Bioshield	A	4.756E-02	1.892E-05	4.659E-06	2.432E-07	4.118E-03	1.445E-03	1.494E-07	1.912E-05	1.607E-08	3.029E-11	1.469E-09	8.819E-08	2.321E-17	0.000	0.001	0.000	0.000
6th 6" Bioshield	A	7.638E-03	3.041E-08	7.485E-07	5.504E-08	6.615E-04	2.337E-04	2.400E-08	3.072E-06	2.623E-09	6.060E-12	2.841E-10	1.597E-08	4.205E-18	0.000	0.000	0.000	0.000
4th 12" Bioshield	A	8.056E-04	3.210E-07	7.899E-08	7.934E-09	6.890E-05	2.487E-05	2.530E-09	3.243E-07	2.824E-10	7.986E-13	3.877E-11	1.926E-09	5.073E-19	0.000	0.000	0.000	0.000

10 CFR PART 61 CLASSIFICATION BY COMPONENT FIVE YEARS AFTER SHUTDOWN

5th 12" Bioshield	A	3.363E-06	1.341E-08	3.301E-09	4.415E-10	2.816E-06	1.050E-08	1.056E-10	1.354E-08	1.208E-11	4.161E-14	2.020E-12	8.289E-11	2.440E-20	0.000	0.000	0.000	0.000
6th 12" Bioshield	A	1.651E-06	6.588E-10	1.621E-10	2.414E-11	1.432E-07	6.181E-08	5.184E-12	6.651E-10	5.999E-13	2.227E-16	1.088E-13	4.883E-12	1.213E-21	0.000	0.000	0.000	0.000
Lower Core Plate	GTCC	7.681E+01	2.472E+01	8.149E+04	2.110E+02	7.855E+04	1.354E+05	1.252E+02	1.877E+04	3.557E+01	7.724E+02	7.988E+14	1.138E+02	6.801E+12	2.682	845.508	26.812	2.681
Lower Core Support Columns	C	3.023E+01	6.315E+00	2.113E+04	1.525E+01	2.089E+04	2.561E+04	3.921E+01	5.190E+03	5.025E+02	5.982E+03	1.957E+18	2.232E+04	1.629E+13	0.510	215.508	7.415	0.741
Lower Core Support	A	5.932E-03	1.280E-03	4.176E-08	1.500E-02	4.074E+00	8.582E+00	7.321E-03	1.006E+00	2.324E-05	5.808E-06	1.480E-24	4.791E-11	2.641E-20	0.000	0.047	0.001	0.000
Below Lower Core Support	A	3.278E-05	6.462E-06	2.181E-10	1.468E-05	2.139E-02	2.626E-02	4.148E-05	5.367E-03	5.058E-08	6.047E-09	0.000E+00	0.000E+00	0.000E+00	0.000	0.000	0.000	0.000
Upper Core Plate	C	1.680E+01	3.697E+00	1.214E+04	3.436E+01	1.188E+04	2.208E+04	2.124E+01	2.924E+03	5.715E+02	1.293E+02	7.295E+18	2.852E+04	1.664E+13	0.433	132.522	4.177	0.418
Upper Core Support Columns	B	2.133E+00	4.184E-01	1.398E-05	1.035E+00	1.384E+03	1.721E+03	2.673E+00	3.469E+02	3.365E-03	4.116E-04	8.903E-21	9.950E-07	7.248E-16	0.034	14.402	0.496	0.050

10 CFR PART 61 CLASSIFICATION BY COMPONENT AT END OF CURRENT LICENSE

Decay (years)															Sum of	Sum of	Sum of	Sum of
19.0															Fractions	Fractions	Fractions	Fractions
Component	10 CFR 61 Classification	H-3 (Cl/m)	C-14	Ce-137	Mn-54	Fe-55	Co-60	Ni-59	Ni-63	Nb-94	Tc-99	Sr-90	Sr-137m	Sr-137	Table 1	Table 2 Col. 1	Table 2 Col. 2	Table 2 Col. 3
Core Shroud	GTCC	9.080E+01	1.010E+02	1.185E-12	1.863E-02	7.820E+03	9.802E+04	4.543E+02	6.667E+04	1.898E+00	4.341E-01	1.387E-18	8.522E-03	4.534E-37	12.952	2057.980	95.239	9.524
Core Formers	GTCC	5.624E+01	9.888E+01	1.188E-12	3.489E-03	7.800E+03	5.297E+04	3.818E+02	5.956E+04	7.863E-01	1.059E-01	1.104E-19	2.129E-03	1.467E-37	6.822	1789.572	85.083	8.508
Lower Core Barrel	C	7.103E+00	3.368E+00	3.931E-14	5.531E-04	2.549E+02	3.869E+03	1.859E+01	2.349E+03	6.865E-02	1.740E-02	5.429E-25	1.355E-05	6.788E-40	0.476	73.196	3.356	0.336
Upper Core Barrel	A	2.900E-04	1.375E-04	1.805E-18	2.258E-08	1.041E-02	1.580E-01	7.588E-04	9.591E-02	2.803E-08	7.104E-07	2.216E-29	5.533E-10	2.771E-44	0.000	0.003	0.000	0.000
Thermal Shield Pads	C	5.000E+00	2.380E+00	2.777E-14	3.918E-04	1.801E+02	2.748E+03	1.319E+01	1.662E+03	4.869E-02	1.237E-02	2.891E-24	5.076E-08	2.639E-40	0.337	51.783	2.374	0.237
Vessel Clad	C	5.478E+00	2.622E+00	3.129E-14	1.675E-04	2.055E+02	2.031E+03	1.573E+01	1.909E+03	2.935E-02	5.368E-03	1.236E-24	4.162E-08	2.622E-40	0.253	57.874	2.727	0.273
Vessel Wall	A	8.348E-02	2.710E-04	1.464E-18	4.186E-06	1.894E+00	2.718E+00	5.835E-03	7.389E-01	7.633E-05	1.939E-04	9.568E-12	1.749E-05	4.436E-40	0.000	0.030	0.001	0.000
Vessel Insulation	A	3.151E-02	1.429E-02	1.895E-18	1.280E-08	1.110E+00	1.258E+01	8.826E-02	1.037E+01	1.942E-04	4.270E-05	6.878E-29	1.674E-10	9.880E-45	0.002	0.317	0.015	0.001
1st 3" Bioshield	A	2.485E+00	2.212E-03	1.941E-13	5.104E-09	1.143E-02	3.288E-02	1.700E-05	1.998E-03	2.913E-06	3.358E-08	8.524E-13	1.676E-06	4.248E-41	0.000	0.062	0.000	0.000
2nd 3" Bioshield	A	9.455E+00	8.287E-03	7.317E-13	8.494E-09	4.313E-02	1.072E-01	6.499E-05	7.527E-03	8.177E-06	4.823E-08	1.174E-12	2.681E-06	8.743E-41	0.000	0.237	0.000	0.000
1st Bioshield Rebar/Liner	A	1.391E-01	4.784E-03	2.285E-16	4.481E-07	2.975E+00	1.309E+00	1.108E-02	1.282E+00	3.507E-05	2.465E-08	7.815E-30	1.103E-10	8.195E-45	0.000	0.046	0.002	0.000
2nd 6" Bioshield	A	4.525E+00	3.950E-03	3.494E-13	1.282E-09	2.080E-02	4.877E-02	3.116E-05	3.598E-03	3.504E-06	1.081E-08	2.691E-13	7.492E-07	1.897E-41	0.000	0.113	0.000	0.000
3rd 6" Bioshield	A	9.263E-01	8.069E-04	7.149E-14	1.110E-10	4.214E-03	9.775E-03	6.386E-06	7.351E-04	6.838E-07	1.215E-09	3.083E-14	1.088E-07	2.780E-42	0.000	0.023	0.000	0.000
4th 6" Bioshield	A	1.442E-01	1.257E-04	1.113E-14	1.487E-11	8.562E-04	1.519E-03	9.947E-07	1.145E-04	1.059E-07	1.728E-10	4.384E-15	1.636E-08	4.139E-43	0.000	0.004	0.000	0.000
2nd Bioshield Rebar	A	6.169E-03	7.268E-05	2.285E-05	4.894E-03	7.169E+00	2.258E-01	1.896E-04	2.252E-02	4.544E-07	9.221E-12	6.141E-26	1.675E-12	1.425E-12	0.000	0.011	0.000	0.000
5th 6" Bioshield	A	2.168E-02	1.889E-05	1.673E-15	2.889E-12	9.861E-05	2.292E-04	1.494E-07	1.721E-05	1.606E-08	3.028E-11	7.681E-16	2.655E-09	6.718E-44	0.000	0.001	0.000	0.000

SITE CHARACTERIZATION REPORT

TABLE 4.7.40

REVISION 0.1

10 CFR PART 61 CLASSIFICATION BY COMPONENT AT END OF CURRENT LICENSE

6th 6" Bioshield	A	3.480E-03	3.038E-06	2.687E-18	6.537E-13	1.584E-05	3.707E-05	2.389E-08	2.764E-06	2.622E-09	6.080E-12	1.537E-18	4.808E-10	1.217E-44	0.000	0.000	0.000	0.000
4th 12" Bioshield	A	3.672E-04	3.205E-07	2.836E-17	9.422E-14	1.671E-06	3.946E-08	2.530E-09	2.918E-07	2.822E-10	7.985E-13	2.027E-17	6.797E-11	1.468E-45	0.000	0.000	0.000	0.000
5th 12" Bioshield	A	1.533E-05	1.339E-08	1.185E-18	5.244E-15	6.983E-08	1.665E-07	1.056E-10	1.219E-08	1.208E-11	4.161E-14	1.056E-18	2.798E-12	7.064E-47	0.000	0.000	0.000	0.000
6th 12" Bioshield	A	7.527E-07	6.577E-10	5.819E-20	2.866E-16	3.430E-09	8.217E-09	5.183E-12	5.985E-10	5.996E-13	2.227E-15	5.687E-20	1.470E-13	3.511E-48	0.000	0.000	0.000	0.000
Lower Core Plate	GTCC	3.501E+01	2.468E+01	2.926E-13	2.508E-03	1.905E+03	2.147E+04	1.252E+02	1.689E+04	3.555E-01	7.723E-02	4.174E-20	3.428E-04	1.969E-38	2.681	516.828	24.128	2.413
Lower Core Support Columns	C	1.378E+01	6.305E+00	7.584E-14	1.811E-04	5.003E+02	4.062E+03	3.920E+01	4.671E+03	5.023E-02	5.981E-03	1.023E-24	6.718E-06	4.716E-40	0.510	140.313	6.673	0.687
Lower Core Support	A	2.704E-03	1.278E-03	1.499E-17	1.781E-07	9.766E-02	1.361E+00	7.320E-03	9.051E-01	2.323E-05	5.807E-06	7.735E-31	1.442E-12	7.645E-47	0.000	0.028	0.001	0.000
Below Lower Core Support	A	1.493E-05	6.451E-06	7.759E-20	1.744E-10	5.123E-04	4.164E-03	4.147E-05	4.830E-03	5.055E-08	6.047E-09	0.000E+00	0.000E+00	0.000E+00	0.000	0.000	0.000	0.000
Upper Core Plate	C	7.587E+00	3.691E+00	4.358E-14	4.081E-04	2.848E+02	3.501E+03	2.124E+01	2.631E+03	5.712E-02	1.293E-02	3.813E-24	8.587E-06	4.817E-40	0.433	80.778	3.759	0.376
Upper Core Support Columns	B	9.723E-01	4.176E-01	5.020E-15	1.229E-05	3.314E+01	2.730E+02	2.673E+00	3.122E+02	3.364E-03	4.116E-04	4.654E-27	2.995E-08	2.098E-42	0.034	9.381	0.446	0.045

SITE CHARACTERIZATION REPORT

TABLE 4.7.41

REVISION 0.1

10 CFR PART 61 CLASSIFICATION BY COMPONENT TWENTY-SIX YEARS AFTER SHUTDOWN

Decay (years)	10 CFR 61	H-3	C-14	Ca-45	Mn-54	Fe-55	Co-60	Ni-59	Ni-63	Nb-94	Tc-99	Sn-119m	Sb-125	Te-126m	Sum of	Sum of	Sum of	Sum of
															Fractions	Fractions	Fractions	Fractions
26.0	Classified	(Ci/m)													Table 1	Table 2 Col. 1	Table 2 Col. 2	Table 2 Col. 3
Component	on																	
Core Shroud	GTCC	6.129E+01	1.008E+02	2.241E-17	5.680E-05	1.179E+03	3.903E+04	4.543E+02	6.324E+04	1.898E+00	4.341E-22	9.869E-01	1.478E-03	2.425E-50	12.948	1865.892	80.348	9.035
Core Formers	GTCC	3.729E+01	8.680E+01	2.208E-17	1.194E-05	1.176E+03	2.108E+04	3.618E+02	5.650E+04	7.861E-01	1.059E-01	7.968E-23	3.692E-04	7.847E-51	6.820	1646.966	80.711	8.071
Lower Core Barrel	C	4.795E+00	3.366E+00	7.433E-19	1.904E-06	3.943E+01	1.541E+03	1.859E+01	2.229E+03	6.864E-02	1.740E-02	3.820E-28	2.351E-06	3.630E-53	0.476	66.055	3.184	0.318
Upper Core Barrel	A	1.957E-04	1.374E-04	3.034E-23	7.773E-11	1.610E-03	6.290E-02	7.588E-04	9.098E-02	2.802E-06	7.103E-07	1.600E-32	9.597E-11	1.482E-57	0.000	0.003	0.000	0.000
Thermal Shield Pads	C	3.375E+00	2.378E+00	5.250E-19	1.349E-06	2.786E+01	1.084E+03	1.319E+01	1.576E+03	4.868E-02	1.237E-02	2.087E-27	8.804E-07	1.358E-53	0.337	46.723	2.252	0.225
Vessel Clad	C	3.698E+00	2.820E+00	5.916E-19	5.765E-07	3.179E+01	8.087E+02	1.573E+01	1.811E+03	2.934E-02	5.366E-03	8.922E-28	7.201E-07	1.402E-53	0.253	53.033	2.587	0.259
Vessel Wall	A	5.635E-02	2.708E-04	2.768E-21	1.434E-08	2.930E-01	1.082E+00	5.835E-03	6.980E-01	7.632E-05	1.938E-04	6.908E-15	3.034E-06	2.373E-53	0.000	0.023	0.001	0.000
Vessel Insulation	A	2.127E-02	1.428E-02	3.205E-21	4.405E-09	1.718E-01	5.001E+00	8.625E-02	9.841E+00	1.941E-04	4.270E-05	4.822E-32	2.903E-11	5.284E-58	0.002	0.289	0.014	0.001
1st 3" Bioshield	A	1.678E+00	2.211E-03	3.689E-18	1.757E-11	1.768E-03	1.309E-02	1.700E-05	1.893E-03	2.912E-06	3.358E-08	6.154E-18	2.907E-07	2.272E-54	0.000	0.042	0.000	0.000
2nd 3" Bioshield	A	6.383E+00	8.280E-03	1.383E-17	2.235E-11	6.672E-03	4.267E-02	6.499E-05	7.140E-03	8.175E-06	4.622E-08	8.473E-16	4.615E-07	3.606E-54	0.000	0.160	0.000	0.000
1st Bioshield Rebar/Liner	A	9.393E-02	4.780E-03	4.320E-21	1.543E-09	4.802E-01	5.213E-01	1.108E-02	1.216E+00	3.508E-05	2.465E-09	5.642E-33	1.913E-11	4.383E-58	0.000	0.038	0.002	0.000
2nd 6" Bioshield	A	3.055E+00	3.947E-03	6.607E-18	4.414E-12	3.187E-03	1.942E-02	3.116E-05	3.411E-03	3.503E-06	1.081E-08	1.943E-16	1.300E-07	1.014E-54	0.000	0.078	0.000	0.000
3rd 6" Bioshield	A	6.253E-01	8.082E-04	1.352E-18	3.820E-13	6.518E-04	3.892E-03	6.385E-06	6.974E-04	6.835E-07	1.215E-09	2.228E-17	1.905E-08	1.487E-56	0.000	0.016	0.000	0.000
4th 6" Bioshield	A	9.736E-02	1.258E-04	2.105E-19	5.051E-14	1.015E-04	6.048E-04	9.946E-07	1.086E-04	1.059E-07	1.728E-10	3.165E-18	2.837E-09	2.214E-56	0.000	0.002	0.000	0.000
2nd Bioshield Rebar	A	6.169E-03	7.268E-05	2.285E-05	4.894E-03	7.169E+00	2.258E-01	1.696E-04	2.252E-02	4.544E-07	8.221E-12	6.141E-26	1.675E-12	1.425E-12	0.000	0.011	0.000	0.000
5th 6" Bioshield	A	1.463E-02	1.887E-05	3.162E-20	9.944E-15	1.525E-05	9.128E-05	1.494E-07	1.632E-05	1.608E-08	3.028E-11	5.645E-19	4.805E-10	3.593E-57	0.000	0.000	0.000	0.000
6th 6" Bioshield	A	2.350E-03	3.033E-06	5.081E-21	2.250E-15	2.450E-06	1.476E-05	2.399E-08	2.622E-06	2.621E-09	6.060E-12	1.110E-19	8.340E-11	6.509E-58	0.000	0.000	0.000	0.000

SITE CHARACTERIZATION REPORT

TABLE 4.7.41

REVISION 0.1

10 CFR PART 61 CLASSIFICATION BY COMPONENT TWENTY-SIX YEARS AFTER SHUTDOWN

4th 12" Bioshield	A	2.479E-04	3.202E-07	5.362E-22	3.244E-18	2.586E-07	1.571E-06	2.530E-09	2.768E-07	2.822E-10	7.985E-13	1.463E-20	1.005E-11	7.853E-59	0.000	0.000	0.000	0.000
5th 12" Bioshield	A	1.035E-05	1.338E-08	2.241E-23	1.805E-17	1.080E-08	6.631E-08	1.056E-10	1.156E-08	1.208E-11	4.161E-14	7.625E-22	4.850E-13	3.778E-60	0.000	0.000	0.000	0.000
6th 12" Bioshield	A	5.081E-07	6.571E-10	1.100E-24	9.867E-19	5.305E-10	3.272E-09	5.183E-12	5.677E-10	5.995E-13	2.227E-15	4.106E-23	2.550E-14	1.877E-61	0.000	0.000	0.000	0.000
Lower Core Plate	GTCC	2.363E+01	2.466E+01	5.532E-18	8.627E-06	2.947E+02	8.550E+03	1.252E+02	1.602E+04	3.554E-01	7.723E-02	3.014E-23	5.942E-05	1.053E-51	2.680	470.887	22.888	2.289
Lower Core Support Columns	C	9.302E+00	6.299E+00	1.434E-18	8.234E-07	7.739E+01	1.618E+03	3.920E+01	4.431E+03	5.022E-02	5.981E-03	7.386E-28	1.165E-06	2.522E-53	0.510	129.247	6.330	0.633
Lower Core Support	A	1.825E-03	1.277E-03	2.835E-22	6.132E-10	1.509E-02	5.420E-01	7.319E-03	8.586E-01	2.323E-05	5.907E-06	5.584E-34	2.501E-13	4.089E-60	0.000	0.025	0.001	0.000
Below Lower Core Support	A	1.008E-05	6.446E-08	1.487E-24	6.002E-13	7.925E-05	1.658E-03	4.147E-05	4.582E-03	5.054E-08	6.047E-09	0.000E+00	0.000E+00	0.000E+00	0.000	0.000	0.000	0.000
Upper Core Plate	C	5.108E+00	3.687E+00	8.241E-19	1.405E-08	4.402E+01	1.394E+03	2.124E+01	2.496E+03	5.710E-02	1.293E-02	2.753E-27	1.489E-06	2.576E-53	0.432	73.501	3.566	0.357
Upper Core Support Columns	B	6.564E-01	4.173E-01	9.492E-20	4.230E-08	5.126E+00	1.087E+02	2.873E+00	2.861E+02	3.363E-03	4.116E-04	3.380E-30	5.195E-09	1.122E-55	0.034	8.640	0.423	0.042

SITE CHARACTERIZATION REPORT

REVISION 0.1

TABLE 4.7.42

10 CFR PART 61 CLASSIFICATION BY COMPONENT TWENTY-EIGHT YEARS AFTER SHUTDOWN

Decay (years)																Sum of	Sum of	Sum of	Sum of
28.0																Fractions	Fractions	Fractions	Fractions
Component	10 CFR 61	H-3	C-14	Ca-45	Mn-54	Fe-55	Co-60	Ni-59	Ni-63	Nb-94	Tc-99	Sn-119m	Sb-125	Ta-125m	Table 1	Table 2 Col. 1	Table 2 Col. 2	Table 2 Col. 3	
	Classification	(Ci/m)																	
Core Shroud	GTCC	5.478E+01	1.009E+02	1.000E-18	1.124E-05	6.914E+02	3.000E+04	4.543E+02	6.230E+04	1.895E+00	4.341E-01	1.248E-22	8.957E-04	3.895E-54	12.947	1825.083	88.894	8.899	
Core Formers	GTCC	3.333E+01	9.878E+01	9.868E-19	2.360E-06	6.895E+02	1.621E+04	3.618E+02	5.565E+04	7.861E-01	1.059E-01	1.008E-23	2.237E-04	1.260E-54	6.820	1615.038	79.503	7.950	
Lower Core Barrel	C	4.285E+00	3.365E+00	3.318E-20	3.763E-07	2.312E+01	1.184E+03	1.859E+01	2.195E+03	6.863E-02	1.740E-02	4.857E-29	1.425E-08	5.831E-67	0.476	64.557	3.138	0.314	
Upper Core Barrel	A	1.749E-04	1.374E-04	1.354E-24	1.538E-11	9.440E-04	4.834E-02	7.587E-04	8.962E-02	2.802E-06	7.103E-07	2.023E-33	5.816E-11	2.380E-61	0.000	0.003	0.000	0.000	
Thermal Shield Pads	C	3.018E+00	2.377E+00	2.343E-20	2.665E-07	1.634E+01	8.408E+02	1.319E+01	1.553E+03	4.867E-02	1.237E-02	2.639E-28	5.335E-07	2.181E-57	0.337	45.662	2.218	0.222	
Vessel Clad	C	3.305E+00	2.819E+00	2.641E-20	1.139E-07	1.865E+01	6.215E+02	1.573E+01	1.784E+03	2.934E-02	5.368E-03	1.128E-28	4.364E-07	2.253E-57	0.253	51.962	2.548	0.255	
Vessel Wall	A	5.037E-02	2.707E-04	1.238E-22	2.834E-09	1.719E-01	8.318E-01	5.834E-03	6.886E-01	7.631E-05	1.939E-04	8.735E-16	1.839E-06	3.811E-57	0.000	0.022	0.001	0.000	
Vessel Insulation	A	1.801E-02	1.427E-02	1.430E-22	8.705E-10	1.007E-01	3.843E+00	8.625E-02	9.694E+00	1.941E-04	4.270E-05	6.097E-33	1.759E-11	8.488E-62	0.002	0.283	0.014	0.001	
1st 3" Bioshield	A	1.499E+00	2.210E-03	1.638E-19	3.472E-12	1.037E-03	1.006E-02	1.700E-05	1.885E-03	2.912E-08	3.358E-08	7.782E-17	1.761E-07	3.650E-58	0.000	0.038	0.000	0.000	
2nd 3" Bioshield	A	5.705E+00	8.278E-03	6.175E-19	4.418E-12	3.913E-03	3.279E-02	6.499E-05	7.034E-03	8.175E-08	4.622E-08	1.071E-16	2.797E-07	5.793E-58	0.000	0.143	0.000	0.000	
1st Bioshield Rebar/Liner	A	8.395E-02	4.779E-03	1.928E-22	3.048E-10	2.689E-01	4.007E-01	1.108E-02	1.198E+00	3.508E-05	2.485E-09	7.134E-34	1.159E-11	7.041E-62	0.000	0.037	0.002	0.000	
2nd 6" Bioshield	A	2.730E+00	3.946E-03	2.949E-19	8.723E-13	1.869E-03	1.493E-02	3.116E-05	3.360E-03	3.503E-08	1.061E-08	2.457E-17	7.875E-08	1.630E-58	0.000	0.088	0.000	0.000	
3rd 6" Bioshield	A	5.589E-01	8.080E-04	6.033E-20	7.548E-14	3.823E-03	2.991E-03	6.385E-08	6.869E-04	6.834E-07	1.215E-09	2.815E-18	1.155E-08	2.388E-59	0.000	0.014	0.000	0.000	
4th 6" Bioshield	A	8.701E-02	1.255E-04	9.394E-21	9.981E-15	5.954E-05	4.649E-04	9.946E-07	1.070E-04	1.059E-07	1.728E-10	4.002E-19	1.720E-09	3.556E-60	0.000	0.002	0.000	0.000	
2nd Bioshield Rebar	A	6.169E-03	7.288E-05	2.285E-05	4.894E-03	7.189E+00	2.258E-01	1.696E-04	2.252E-02	4.544E-07	9.221E-12	6.141E-26	1.675E-12	1.425E-12	0.000	0.011	0.000	0.000	
5th 6" Bioshield	A	1.308E-02	1.887E-05	1.412E-21	1.985E-15	8.948E-08	7.014E-05	1.494E-07	1.608E-05	1.608E-08	3.028E-11	7.012E-20	2.791E-10	5.772E-61	0.000	0.000	0.000	0.000	
6th 6" Bioshield	A	2.100E-03	3.032E-06	2.268E-22	4.447E-16	1.437E-08	1.134E-05	2.399E-08	2.583E-06	2.621E-09	6.060E-12	1.404E-20	5.054E-11	1.046E-61	0.000	0.000	0.000	0.000	

SITE CHARACTERIZATION REPORT

REVISION 0.1

TABLE 4.7.42

10 CFR PART 61 CLASSIFICATION BY COMPONENT TWENTY-EIGHT YEARS AFTER SHUTDOWN

4th 12" Bioshield	A	2.215E-04	3.201E-07	2.393E-23	6.410E-17	1.516E-07	1.207E-06	2.530E-09	2.727E-07	2.821E-10	7.885E-13	1.850E-21	6.093E-12	1.261E-92	0.000	0.000	0.000	0.000
5th 12" Bioshield	A	9.248E-06	1.338E-08	1.000E-24	3.567E-18	6.335E-09	5.088E-08	1.056E-10	1.139E-08	1.207E-11	4.160E-14	9.641E-23	2.939E-13	6.069E-84	0.000	0.000	0.000	0.000
6th 12" Bioshield	A	4.541E-07	6.568E-10	4.911E-26	1.950E-19	3.112E-10	2.515E-09	5.183E-12	5.592E-10	5.994E-13	2.227E-15	5.192E-24	1.545E-14	3.018E-85	0.000	0.000	0.000	0.000
Lower Core Plate	GTCC	2.112E+01	2.465E+01	2.469E-19	1.705E-08	1.728E+02	6.571E+03	1.252E+02	1.578E+04	3.554E-01	7.723E-02	3.811E-24	3.601E-05	1.691E-55	2.680	461.072	22.546	2.255
Lower Core Support Columns	C	8.314E+00	6.298E+00	6.401E-20	1.232E-07	4.539E+01	1.243E+03	3.920E+01	4.364E+03	5.021E-02	5.981E-03	9.339E-29	7.062E-07	4.051E-57	0.510	126.747	6.235	0.623
Lower Core Support	A	1.631E-03	1.277E-03	1.265E-23	1.212E-10	8.851E-03	4.166E-01	7.319E-03	8.457E-01	2.322E-05	5.907E-06	7.061E-35	1.516E-13	6.568E-64	0.000	0.025	0.001	0.000
Below Lower Core Support	A	9.008E-06	6.444E-06	6.548E-26	1.186E-13	4.648E-05	1.274E-03	4.147E-05	4.513E-03	5.054E-08	6.047E-09	0.000E+00	0.000E+00	0.000E+00	0.000	0.000	0.000	0.000
Upper Core Plate	C	4.585E+00	3.887E+00	3.678E-20	2.776E-07	2.582E+01	1.072E+03	2.124E+01	2.459E+03	5.710E-02	1.293E-02	3.481E-28	9.028E-07	4.138E-57	0.432	71.933	3.513	0.351
Upper Core Support Columns	B	5.866E-01	4.172E-01	4.237E-21	8.359E-09	3.007E+00	8.356E+01	2.673E+00	2.817E+02	3.363E-03	4.116E-04	4.249E-31	3.149E-09	1.802E-59	0.034	8.473	0.417	0.042

SITE CHARACTERIZATION REPORT

REVISION 0.1

TABLE 4.7.43

10 CFR PART 61 CLASSIFICATION BY COMPONENT THIRTY-THREE YEARS AFTER SHUTDOWN

Decay (years)															Sum of	Sum of	Sum of	Sum of
33.0															Fractions	Fractions	Fractions	Fractions
Component	10 CFR 61 Classification	H-3 (Ci/m)	C-14	Cs-137	Mn-54	Fa-255	Co-60	Ni-59	Ni-63	Nb-94	Tc-99	Sr-90	Sr-137m	Sr-137	Table 1	Table 2 Col. 1	Table 2 Col. 2	Table 2 Col. 3
Core Shroud	GTCC	4.138E+01	1.008E+02	4.236E-22	1.959E-07	1.823E+02	1.554E+04	4.543E+02	5.999E+04	1.895E+00	4.340E-01	7.125E-26	2.564E-04	1.297E-63	12.945	1737.569	85.704	8.570
Core Formers	GTCC	2.517E+01	9.672E+01	4.175E-22	4.111E-08	1.819E+02	8.399E+03	3.818E+02	5.359E+04	7.859E-01	1.059E-01	5.753E-26	6.403E-06	4.197E-64	6.918	1544.166	76.584	7.856
Lower Core Barrel	C	3.237E+00	3.383E+00	1.405E-23	6.555E-09	6.099E+00	6.135E+02	1.859E+01	2.114E+03	6.862E-02	1.740E-02	2.830E-31	4.078E-07	1.941E-66	0.475	61.372	3.020	0.302
Upper Core Barrel	A	1.321E-04	1.373E-04	5.737E-28	2.878E-13	2.490E-04	2.505E-02	7.587E-04	8.631E-02	2.801E-06	7.103E-07	1.155E-35	1.685E-11	7.926E-71	0.000	0.003	0.000	0.000
Thermal Shield Pads	C	2.278E+00	2.378E+00	9.926E-24	4.642E-09	4.309E+00	4.357E+02	1.319E+01	1.495E+03	4.887E-02	1.237E-02	1.507E-30	1.527E-07	7.262E-67	0.337	43.407	2.136	0.214
Vessel Clad	C	2.486E+00	2.618E+00	1.119E-23	1.985E-09	4.918E+00	3.220E+02	1.573E+01	1.718E+03	2.933E-02	5.366E-03	6.441E-31	1.249E-07	7.500E-67	0.253	49.610	2.454	0.245
Vessel Wall	A	3.804E-02	2.705E-04	5.234E-26	4.937E-11	4.533E-02	4.310E-01	5.834E-03	6.631E-01	7.630E-05	1.939E-04	4.987E-18	5.263E-07	1.269E-66	0.000	0.021	0.001	0.000
Vessel Insulation	A	1.438E-02	1.428E-02	6.080E-26	1.516E-11	2.857E-02	1.991E+00	8.625E-02	9.335E+00	1.941E-04	4.270E-05	3.481E-35	5.036E-12	2.828E-71	0.002	0.270	0.013	0.001
1st 3" Bioshield	A	1.132E+00	2.209E-03	8.938E-23	6.048E-14	2.735E-04	5.214E-03	1.700E-05	1.798E-03	2.911E-06	3.358E-08	4.443E-19	5.041E-08	1.215E-67	0.000	0.028	0.000	0.000
2nd 3" Bioshield	A	4.309E+00	8.273E-03	2.618E-22	7.695E-14	1.032E-03	1.699E-02	6.498E-05	6.774E-03	8.173E-06	4.622E-08	6.117E-19	8.004E-08	1.929E-67	0.000	0.108	0.000	0.000
1st Bioshield Rebar/Liner	A	6.341E-02	4.776E-03	8.169E-26	5.310E-12	7.118E-02	2.076E-01	1.108E-02	1.164E+00	3.508E-05	2.465E-09	4.073E-36	3.318E-12	2.344E-71	0.000	0.035	0.002	0.000
2nd 6" Bioshield	A	2.062E+00	3.943E-03	1.248E-22	1.519E-14	4.930E-04	7.733E-03	3.116E-05	3.236E-03	3.502E-06	1.081E-08	1.403E-19	2.254E-08	5.425E-68	0.000	0.052	0.000	0.000
3rd 6" Bioshield	A	4.221E-01	8.055E-04	2.556E-23	1.315E-15	1.008E-04	1.550E-03	6.385E-06	6.615E-04	6.833E-07	1.215E-09	1.807E-20	3.304E-09	7.950E-69	0.000	0.011	0.000	0.000
4th 6" Bioshield	A	6.572E-02	1.255E-04	3.979E-24	1.739E-16	1.570E-05	2.409E-04	9.946E-07	1.030E-04	1.058E-07	1.728E-10	2.285E-21	4.821E-10	1.184E-69	0.000	0.002	0.000	0.000
2nd Bioshield Rebar	A	6.189E-03	7.268E-05	2.285E-05	4.894E-03	7.169E+00	2.258E-01	1.696E-04	2.252E-02	4.544E-07	9.221E-12	6.141E-26	1.675E-12	1.425E-12	0.000	0.011	0.000	0.000
5th 6" Bioshield	A	9.879E-03	1.886E-05	5.979E-25	3.423E-17	2.360E-06	3.834E-05	1.494E-07	1.549E-05	1.805E-08	3.028E-11	4.004E-22	7.987E-11	1.922E-70	0.000	0.000	0.000	0.000
6th 6" Bioshield	A	1.586E-03	3.031E-06	9.607E-26	7.746E-18	3.791E-07	5.877E-06	2.399E-08	2.487E-06	2.821E-09	6.059E-12	8.014E-23	1.446E-11	3.481E-71	0.000	0.000	0.000	0.000

SITE CHARACTERIZATION REPORT

REVISION 0.1

TABLE 4.7.43

10 CFR PART 61 CLASSIFICATION BY COMPONENT THIRTY-THREE YEARS AFTER SHUTDOWN

4th 12" Bioshield	A	1.673E-04	3.199E-07	1.014E-26	1.117E-18	4.000E-08	6.255E-07	2.530E-09	2.626E-07	2.821E-10	7.985E-13	1.056E-23	1.744E-12	4.200E-72	0.000	0.000	0.000	0.000
5th 12" Bioshield	A	6.985E-06	1.337E-08	4.238E-28	6.214E-20	1.671E-09	2.641E-08	1.056E-10	1.097E-08	1.207E-11	4.160E-14	5.505E-25	8.412E-14	2.020E-73	0.000	0.000	0.000	0.000
6th 12" Bioshield	A	3.430E-07	6.565E-10	2.080E-29	3.396E-21	8.207E-11	1.303E-09	5.183E-12	5.388E-10	5.993E-13	2.227E-15	2.984E-26	4.422E-15	1.004E-74	0.000	0.000	0.000	0.000
Lower Core Plate	GTCC	1.595E+01	2.464E+01	1.048E-22	2.970E-08	4.558E+01	3.405E+03	1.252E+02	1.520E+04	3.554E-01	7.723E-02	2.176E-26	1.031E-05	5.631E-65	2.680	439.568	21.712	2.171
Lower Core Support Columns	C	6.290E+00	6.294E+00	2.711E-23	2.146E-09	1.197E+01	6.441E+02	3.920E+01	4.203E+03	5.020E-02	5.981E-03	5.333E-31	2.021E-07	1.349E-66	0.510	121.183	6.004	0.600
Lower Core Support	A	1.232E-03	1.276E-03	5.360E-27	2.111E-12	2.334E-03	2.158E-01	7.319E-03	8.145E-01	2.322E-05	5.907E-08	4.032E-37	4.339E-14	2.187E-73	0.000	0.024	0.001	0.000
Below Lower Core Support	A	6.804E-06	6.440E-06	2.774E-29	2.066E-15	1.226E-05	6.603E-04	4.147E-05	4.348E-03	5.053E-08	6.047E-09	0.000E+00	0.000E+00	0.000E+00	0.000	0.000	0.000	0.000
Upper Core Plate	C	3.448E+00	3.684E+00	1.556E-23	4.836E-09	6.809E+00	5.552E+02	2.124E+01	2.368E+03	5.709E-02	1.293E-02	1.988E-30	2.583E-07	1.378E-66	0.432	68.543	3.383	0.338
Upper Core Support Columns	B	4.431E-01	4.169E-01	1.795E-24	1.456E-10	7.929E-01	4.329E+01	2.673E+00	2.809E+02	3.362E-03	4.116E-04	2.426E-33	9.011E-10	6.001E-69	0.034	8.100	0.401	0.040

SITE CHARACTERIZATION REPORT

REVISION 0.1

TABLE 4.7.44

10 CFR PART 61 CLASSIFICATION BY COMPONENT THIRTY-EIGHT YEARS AFTER SHUTDOWN

Decay (years)															Sum of	Sum of	Sum of	Sum of
38.0															Fractions	Fractions	Fractions	Fractions
Component	10 CFR 61 Classification	H-3 (Ci/m)	C-14	Ce-45	Mn-54	Fe-55	Co-60	Ni-59	Ni-63	Nb-94	Tc-99	Sn-119m	Sb-125	Ta-125m	Table 1	Table 2 Col. 1	Table 2 Col. 2	Table 2 Col. 3
Core Shroud	GTCC	3.125E+01	1.007E+02	1.795E+25	3.412E+09	4.809E+01	8.053E+03	4.542E+02	5.777E+04	1.895E+00	4.340E+01	4.068E+27	7.337E+05	4.318E+73	12.943	1683.057	82.535	8.254
Core Formers	GTCC	1.801E+01	9.866E+01	1.789E+25	7.160E+10	4.798E+01	4.352E+03	3.817E+02	5.161E+04	7.858E+01	1.059E+01	3.285E+28	1.833E+05	1.397E+73	6.817	1481.428	73.733	7.373
Lower Core Barrel	C	2.445E+00	3.381E+00	5.853E+27	1.142E+10	1.608E+00	3.179E+02	1.858E+01	2.036E+03	6.861E+02	1.740E+02	1.816E+33	1.167E+07	6.464E+76	0.475	58.690	2.909	0.291
Upper Core Barrel	A	9.981E+05	1.372E+04	2.430E+31	4.661E+15	6.567E+05	1.298E+02	7.587E+04	8.312E+02	2.801E+06	7.103E+07	6.597E+38	4.784E+12	2.639E+80	0.000	0.002	0.000	0.000
Thermal Shield Pads	C	1.721E+00	2.375E+00	4.205E+27	8.087E+11	1.136E+00	2.257E+02	1.319E+01	1.440E+03	4.866E+02	1.237E+02	8.603E+33	4.370E+08	2.418E+76	0.337	41.509	2.057	0.208
Vessel Clad	C	1.885E+00	2.818E+00	4.738E+27	3.457E+11	1.297E+00	1.688E+02	1.573E+01	1.654E+03	2.933E+02	5.365E+03	3.678E+33	3.574E+08	2.497E+76	0.253	47.554	2.363	0.238
Vessel Wall	A	2.873E+02	2.704E+04	2.217E+29	8.599E+13	1.196E+02	2.233E+01	5.834E+03	6.386E+01	7.628E+05	1.939E+04	2.848E+20	1.508E+07	4.225E+76	0.000	0.019	0.001	0.000
Vessel Insulation	A	1.085E+02	1.425E+02	2.587E+29	2.841E+13	7.008E+03	1.032E+00	8.825E+02	8.990E+00	1.941E+04	4.270E+05	1.988E+37	1.441E+12	9.409E+81	0.002	0.259	0.013	0.001
1st 3" Bioshield	A	8.554E+01	2.207E+03	2.839E+26	1.053E+15	7.213E+05	2.701E+03	1.700E+05	1.730E+03	2.911E+06	3.358E+08	2.537E+21	1.443E+08	4.045E+77	0.000	0.021	0.000	0.000
2nd 3" Bioshield	A	3.254E+00	8.288E+03	1.108E+26	1.340E+15	2.722E+04	8.802E+03	6.498E+05	6.523E+03	8.172E+08	4.622E+08	3.493E+21	2.291E+08	6.422E+77	0.000	0.082	0.000	0.000
1st Bioshield Rebar/Liner	A	4.789E+02	4.773E+03	3.480E+29	9.249E+14	1.877E+02	1.076E+01	1.108E+02	1.111E+00	3.505E+05	2.485E+09	2.326E+38	9.495E+13	7.804E+81	0.000	0.033	0.002	0.000
2nd 6" Bioshield	A	1.557E+00	3.941E+03	5.292E+26	2.847E+16	1.300E+04	4.006E+03	3.116E+05	3.116E+03	3.501E+06	1.060E+08	8.008E+22	6.451E+09	1.806E+77	0.000	0.039	0.000	0.000
3rd 6" Bioshield	A	3.188E+01	8.050E+04	1.083E+26	2.290E+17	2.659E+05	8.030E+04	6.385E+06	6.371E+04	6.832E+07	1.215E+09	9.176E+23	9.457E+10	2.647E+78	0.000	0.008	0.000	0.000
4th 6" Bioshield	A	4.964E+02	1.254E+04	1.688E+27	3.028E+18	4.141E+06	1.248E+04	9.845E+07	9.824E+05	1.058E+07	1.728E+10	1.305E+23	1.408E+10	3.942E+79	0.000	0.001	0.000	0.000
2nd Bioshield Rebar	A	6.189E+03	7.288E+05	2.285E+06	4.894E+03	7.169E+00	2.258E+01	1.696E+04	2.252E+02	4.544E+07	9.221E+12	6.141E+26	1.675E+12	1.425E+12	0.000	0.011	0.000	0.000
5th 6" Bioshield	A	7.482E+03	1.885E+05	2.533E+08	5.993E+19	8.223E+07	1.883E+05	1.494E+07	1.491E+05	1.805E+08	3.028E+11	2.286E+24	2.288E+11	6.398E+80	0.000	0.000	0.000	0.000
6th 6" Bioshield	A	1.188E+03	3.029E+06	4.070E+09	1.349E+19	9.997E+08	3.045E+06	2.399E+08	2.395E+06	2.620E+09	6.059E+12	4.578E+25	4.140E+12	1.159E+80	0.000	0.000	0.000	0.000

SITE CHARACTERIZATION REPORT

REVISION 0.1

TABLE 4.7.44

10 CFR PART 61 CLASSIFICATION BY COMPONENT THIRTY-EIGHT YEARS AFTER SHUTDOWN

4th 12" Bioshield	A	1.264E-04	3.197E-07	4.284E-30	1.945E-20	1.055E-08	3.241E-07	2.530E-09	2.529E-07	2.820E-10	7.985E-13	6.031E-26	4.991E-13	1.398E-81	0.000	0.000	0.000	0.000
5th 12" Bioshield	A	5.278E-06	1.336E-08	1.785E-31	1.082E-21	4.407E-10	1.368E-08	1.056E-10	1.056E-08	1.207E-11	4.160E-14	3.143E-27	2.408E-14	6.727E-83	0.000	0.000	0.000	0.000
6th 12" Bioshield	A	2.591E-07	6.561E-10	8.813E-33	5.916E-23	2.164E-11	6.750E-10	5.182E-12	5.187E-10	5.992E-13	2.227E-15	1.693E-28	1.266E-15	3.343E-84	0.000	0.000	0.000	0.000
Lower Core Plate	GTCC	1.205E+01	2.463E+01	4.431E-26	5.173E-10	1.202E+01	1.764E+03	1.252E+02	1.464E+04	3.553E-01	7.723E-02	1.242E-28	2.950E-08	1.875E-74	2.679	421.025	20.909	2.091
Lower Core Support Columns	C	4.743E+00	6.290E+00	1.149E-26	3.738E-11	3.157E+00	3.337E+02	3.919E+01	4.048E+03	5.020E-02	5.981E-03	3.045E-33	5.784E-08	4.491E-76	0.510	116.249	5.782	0.578
Lower Core Support	A	9.306E-04	1.275E-03	2.270E-30	3.677E-14	6.157E-04	1.118E-01	7.319E-03	7.844E-01	2.322E-05	5.907E-06	2.302E-39	1.242E-14	7.281E-83	0.000	0.023	0.001	0.000
Below Lower Core Support	A	5.139E-06	6.437E-06	1.175E-32	3.599E-17	3.233E-06	3.421E-04	4.147E-05	4.186E-03	5.052E-08	6.047E-09	0.000E+00	0.000E+00	0.000E+00	0.000	0.000	0.000	0.000
Upper Core Plate	C	2.605E+00	3.982E+00	6.600E-27	8.423E-11	1.798E+00	2.876E+02	2.124E+01	2.280E+03	5.708E-02	1.293E-02	1.135E-32	7.393E-08	4.587E-76	0.432	65.631	3.258	0.328
Upper Core Support Columns	B	3.347E-01	4.167E-01	7.602E-28	2.538E-12	2.091E-01	2.243E+01	2.672E+00	2.705E+02	3.361E-03	4.116E-04	1.385E-35	2.579E-10	1.998E-78	0.034	7.770	0.386	0.039

5.0 ENVIRONMENTAL CHARACTERIZATION

During Phase 1 of the site characterization survey, soil, sediment, and surface water were sampled for radiological analysis in accordance with the Radiological SCP for the Trojan Nuclear Power Plant. Exposure rates were measured wherever soil was sampled with the exception of locations where the exposure rate was influenced by onsite structures. Paved areas on the site were scanned for alpha/beta contamination or sampled and analyzed for gamma emitters. A set of maps of the site are included in Appendix 5-A to this section. The maps show the sample locations by grid location. The data contained in Tables 5.2, 5.3, 5.5, 5.6, 5.7, and 5.8 can be located on the maps by using the grid ID. A general map is included which shows the total site divided into sixteen zones. Maps are included for Zones 1-3, 5-11 and 14. Maps for zones 4, 12, 13, 15 and 16 are not included since no data points were included in these areas.

Biased sample locations were determined from reviewing plant records that documented radiological incidents at TNP from 1975 to 1993. Indexes of the corrective action systems in effect at TNP since 1975 were reviewed to determine specific documents to be reviewed. Discussions with personnel knowledgeable in incidents were also completed to determine possible sample locations that might not be identified by the document review.

The results of sampling were compared to the release guideline values developed from the site release criteria. The concentration of radioactive material associated with the above dose was calculated using the guidance contained in draft NUREG/CR-5512.

5.1 Soil Sampling

Surface soil samples were obtained at 56 locations on PGE property contiguous with Trojan. Each sample of approximately 1 liter of material was collected from a one-foot-square area.

5.1.1 Analysis Methods

Soil samples were analyzed in-house for gamma emitters by gamma spectrometry. Control samples were analyzed by TMA/Eberline in Albuquerque, New Mexico for gamma emitters by gamma spectrometry and selected samples were analyzed for strontium-90.

5.1.2 Background

A total of 32 soil samples were collected from four (4) locations near the Trojan plant. Two of the samples were used as quality control checks and are not included with the data. The four background locations are:

SITE CHARACTERIZATION REPORT

REVISION 0.1

1. PGE owned property in Prescott, Oregon (0.75 miles NNW of Trojan containment),
2. water treatment facility in Rainier, Oregon near Radiological Environmental sample location 2 (approximately 3.8 miles NW of Trojan containment),
3. PGE owned property west of Highway 30 (approximately 1 mile W of Trojan containment) and
4. NW of Kalama, Washington near Radiological Environmental sample location 11B (approximately 1.4 miles ENE of Trojan containment).

The background data is contained in Table 5.1. The mean background Cs-137 concentration is 0.49 pCi/g. The standard deviation is 0.4 pCi/g. Substantial variation in the background Cs-137 concentrations was noted between soil types. The sandy soils found near the river contained very low levels while the clay soils contained higher concentrations. The background levels of Cs-137 will require further evaluation prior to completion of the final site survey.

5.1.3 Unbiased Survey of Unaffected Areas

Sample Population

For soil, there was one population of 30 indicator samples. The mean Cs-137 concentration is 0.77 pCi/g with a standard deviation of 0.86 pCi/g. Sample results are shown in Table 5.2.

Population Summary

The only nonnaturally-occurring isotopes found in the soil samples were Cs-137 and Sr-90. Cs-137 and Sr-90 are found in the environment as a result of fallout from atmospheric weapons tests and the Chernobyl accident.

The Cs-137 results were compared to the release guideline value for Cs-137 of 5.7 pCi/g. No Cs-137 results were above the release guideline value.

Strontium-90 results averaged 0.2 pCi/g. The Sr-90 levels measured during the preoperational period ranged from 0.01 to 1.28 pCi/g with a mean of 0.30 pCi/g. The average is also less than the release guideline value of 1.2 pCi/g. Table 5.12 lists the results of sediment and soil samples analyzed for Sr-90.

5.1.4 Biased Survey

Sample Population

Twenty-six soil samples were taken onsite where there was a reasonable possibility that soil contamination could have occurred. These locations are listed in Table 5.3. Subsurface soil

SITE CHARACTERIZATION REPORT

REVISION 0.1

samples taken in 1991 from the tank farm area are also included in this section. Samples were taken at 1, 2, and 3-foot depths at 5 locations. Results of the 1991 samples are presented in Table 5.4.

Population Summary

The predominant nonnaturally-occurring isotopes detected was Cs-137. One surface sample (TS-89) taken from the tank farm area also contained low levels of Cs-134 (0.010 pCi/g) and Co-60 (0.044 pCi/g). All of the samples contain Cs-137. All radionuclides in the samples were at concentrations below the release guideline value calculated for the mixture of radionuclides. The Cs-137 content of the 1991 samples were all below the guideline value.

The following table summarizes the release concentration values used to compare actual measurements to ensure predicted doses would be under the 15 mrem/yr TEDE limit that would allow release of the site license.

Guideline Values			
Nuclide	Mean Background (pCi/g)	NUREG/CR-5512 FACTOR (pCi/g)	Trojan Criteria (pCi/g)
Cs-137	0.49	5.7	6.1
Sr-90	0.30	0.91	1.2
Co-60	0	0.37	0.37

5.2 Water Sampling

Surface water was sampled from forty indicator sites on the PGE property surrounding Trojan. A one-gallon sample was obtained from each site for gamma and strontium-90 analysis and a 60-ml sample for tritium analysis.

5.2.1 Analysis Methods

The water samples were analyzed for gamma emitters with a gamma spectroscopy system located onsite. All water samples were analyzed for tritium in the onsite hot laboratory. Selected samples were analyzed for Sr-90 at the hot laboratory.

5.2.2 Background

A total of 32 water samples were collected from four locations around the Trojan plant. The locations (see figure 5.1) are:

SITE CHARACTERIZATION REPORT

REVISION 0.1

1. Fishhawk lake (approximately 18 miles W of Trojan containment),
2. Ponds at the intersection of Goble and Bishop roads (approximately 3 miles SW of Trojan containment),
3. Kress Lake (approximately 1 mile ENE of Trojan containment) and
4. Deer Island ponds (approximately 7 miles S of Trojan containment).

Analyses for gamma emitters and tritium were completed on the samples. No gamma emitters other than naturally occurring radionuclides were identified in the samples. Tritium values were all less than detectable. The four samples analyzed for Sr-90 were less than detectable. The detection levels for the samples were:

Nuclide	LLD (pCi/L)
Cs-137	4
H-3	450
Sr-90	0.3

5.2.3 Unbiased Survey of Unaffected Areas

Samples SW-33 through 64 were taken from random locations in Whistling Swan Lake and Reflection Lake. No nonnaturally-occurring radionuclides were detected in the samples by gamma spectrometry. The minimum detectable activity (MDA) for Cs-137 was approximately 4 pCi/L. Neither tritium nor strontium-90 were detected in the samples. The tritium MDA was approximately 450 pCi/L. The strontium-90 MDA was approximately 0.3 pCi/L.

5.2.4 Biased Survey

Samples SW-65 through SW-74 were taken from the Recreation Lake, which is an affected area. No nonnaturally occurring radionuclides were detected in the samples. MDAs for the biased survey analyses were identical to those for the unbiased survey analyses.

5.3 Bottom Sediment Sampling

Forty-one sediment samples were taken from the PGE property surrounding Trojan. Approximately 1 liter of sediment was obtained at each sampling site.

5.3.1 Analysis Methods

The sediment samples were dried and then analyzed for gamma emitters with a gamma spectroscopy system located onsite. Selected sediment samples were analyzed for Sr-90 by TMA/Eberline.

5.3.2 Background

Soil background samples will be used as the sediment background. Specific isotopic background sediment samples were not collected at Trojan. However, 30 background soil samples were analyzed as part of the Site Characterization effort, and the mean Cs-137 concentration for these interim background samples is 0.49 pCi/g. Background sediment samples will be collected if determined necessary as part of the final site survey. A comparison of the Cs-137 concentration in pre-operational sediment samples to the background soil samples showed a very high level of agreement, Sediment mean = 0.51 pCi/g; Soil mean = 0.49 pCi/g.

5.3.3 Unbiased Survey of Unaffected Areas

Sample Populations

Samples BS-1 through BS-33 were taken from Whistling Swan Lake and Reflection Lake, which are unaffected areas. The results of the analyses are shown in Table 5.5.

Population Summary

Per NUREG/CR-5849, scoping survey results are to be compared with guideline values to identify areas that need remediation. The Trojan SCP states that the guideline for radioactivity in sediment is that which results in a TEDE of 15 mrem/year above background.

Calculation of guideline values in accordance with NUREG/CR-5512 assuming an isotopic mix of Cs-137, Sr-90, and Co-60 results in a Cs-137 value of 5.7 pCi/g. The interim background Cs-137 plus the 5.7 pCi/g results in a guideline of 6.1 pCi/g for Cs-137.

All of the unaffected area sediment samples contain Cs-137 at levels below the guideline value of 6.1 pCi/g.

Strontium-90 content of two sediment samples sent to TMA/Eberline are 0.05 and 0.03 pCi/g. The lower level of detectability for the analysis is 0.02 pCi/g. These results are within the preoperational range of Sr-90 which was from 0.01 to 0.44 pCi/g with a mean of 0.08 pCi/g. The Sr-90 content of the sediment samples is also below the interim guideline value of 1.2 pCi/g. Table 5.12 lists the results of sediment and soil samples analyzed for Sr-90.

5.3.4 Biased Survey

Sample Population

Samples BS-34 through BS-43 were taken from the Recreation Lake. Samples BS-41 through

BS-43 were taken from the berm area of the Recreation Lake. The results of the analyses are shown in Table 5.6.

Population Summary

All of the affected area samples contain Cs-137 at levels below the interim guideline value of 6.1 pCi/g. No other gamma emitters were detected.

5.4 Pavement Sampling and Scanning

Pavement scans and sampling were performed in accordance with the scoping survey phase of the Radiological SCP for the Trojan Site.

5.4.1 Analysis Methods

Pavement was scanned for beta contamination. In areas where there was interference from the Refueling Water Storage Tank (RWST), a one-square-foot sample was taken and analyzed by gamma spectroscopy onsite.

5.4.2 Background

No specific background pavement locations were monitored for this survey. The sample locations starting with grid identifiers Bx ## and Cx ##(e.g. BB 23 and CB 28) are located in the Trojan park and recreational areas where radioactive material has not been used. The survey data for these locations are an acceptable estimate of background levels of radioactive material in pavement. The mean gross beta reading for the identified locations is 610 dpm/100 cm² with a standard deviation of 94 dpm/100 cm².

5.4.3 Unbiased Survey of Unaffected Areas

Sample Populations

Thirty-one randomly-selected 100-square-foot sections of pavement in unaffected areas of the Trojan site were scanned with an ESP-2 and BP-100 detector. Table 5.7 shows contamination levels for each survey location.

Population Summary

Surveys of the nineteen areas identified contamination levels ranging from 542 to 788 gross dpm/100 cm². The mean value for unbiased sample locations identified with an A (AF 27 through AX 22) was 657 dpm/100 cm² with a standard deviation of 74 dpm/100 cm². All

measured values are below the cleanup criteria (Reg Guide 1.86 e.g. 5000 dpm/100 cm² above background for total beta-gamma surface contamination).

5.4.4 Biased Survey

Sample Population

Affected areas consisted of pavement around the tank farm and its drainage to the west, pavement around the oil/separator, and the paved equipment laydown area around the Cooling Tower. Thirteen pavement samples were taken from affected areas with at least two samples from each affected area. Results are presented in Table 5.8.

Population Summary

The only detectable nonnaturally-occurring radionuclide found in the pavement samples is Cs-137 in low concentrations. The Cs-137 content of all of the samples is on the order of that found in background and indicator soil samples obtained for site characterization.

Sample PV-03, taken from the curb at the southeast corner of the Circ. Water Pump Pit area, had the highest Cs-137 concentration of 1.5 pCi/g. Assuming the Cs-137 was from the surface of the concrete and covered a 100 cm² area, then one can calculate a contamination level of 799 dpm/100 cm² which is below the cleanup criteria of 5000 dpm/100 cm²

5.5 Exposure Rate Surveys

Exposure rates were measured on the Trojan site where site characterization indicator soil samples had been taken. The measurements were made with a Reuter-Stokes pressurized ion chamber positioned one meter above the sample site.

5.5.1 Background

Data for the exposure rate background were collected during preoperational surveys at the Trojan site. The data were collected using a high pressure ion chamber (same type of instrument used during the Site Characterization survey). The mean reading was 7.1 μ R/hr with a standard deviation of 1.0 μ R/hr. The results of the preoperational survey are contained in Table 5.9. The survey locations coincide with the Radiological Environmental Monitoring Program (REMP) locations (Figures 5.2A and 5.2B).

5.5.2 Unbiased Survey of Unaffected Areas

Sample Populations

Thirty-one surveys were taken at the unaffected area soil sampling sites TS-33 through TS-64. The exposure rate at site TS-49 could not be measured because of instrument failure. Results of the surveys are shown in Table 5.10.

Population Summary

Exposure rates ranged from 5.2 to 9.0 $\mu\text{R/hr}$ at the unaffected area locations. The mean exposure rate was 6.4 $\mu\text{R/hr}$. These data compare favorably with preoperational data which range from 5.6 to 9.4 $\mu\text{R/hr}$ and have a mean value of 7.1 $\mu\text{R/hr}$. All readings were below the cleanup criteria of 5 $\mu\text{R/hr}$ above background, which is 12.1 $\mu\text{R/hr}$.

5.5.3 Biased Survey

Sample Population

Exposure rates were measured at affected area soil sample sites (TS-65 through TS-90) where it was judged that radioactive content of surrounding structures would not influence the measurements. Table 5.11 shows the exposure rates measured at the affected area sites. Measurements made at TS-83 and TS-84 were influenced by the RWST and are therefore not included. Exposure rates at sites TS-81 and TS-82 were not measured because of anticipated influence from the Radwaste Storage Building and Fuel Building. Exposure rates at sites TS-87 through TS-90 were not measured because of influence from the RWST.

Population Summary

The values ranged from 6.0 to 8.3 $\mu\text{R/hr}$ with a mean of 6.8 $\mu\text{R/hr}$. This compares favorably with background data and is below the cleanup criteria of 12.1 $\mu\text{R/hr}$.

5.6 Discussion of Results

5.6.1 Soil

All surface soil samples analyzed for the scoping survey phase are below the release guideline value with respect to Cs-137 activity. Subsurface samples taken in 1991 from the tank farm area are also below this guideline value. The 15 mrem/yr TEDE calculation was made assuming 0.91 pCi/g Sr-90. The soil samples analyzed for Sr-90 contained less than 0.91 pCi/g of Sr-90.

5.6.2 Water

None of the surface water samples analyzed for the scoping survey had detectable levels of nonnaturally-occurring radionuclides. Further water sampling is not necessary for site characterization.

5.6.3 Bottom Sediment

All bottom sediment samples analyzed for the scoping survey phase are below the release guideline value with respect to Cs-137 activity. Subsurface samples taken in 1991 from the tank farm area are also below this guideline value. The 15 mrem/yr TEDE calculation was made assuming 0.91 pCi/g Sr-90. The sediment samples analyzed for Sr-90 contained less than 0.91 pCi/g of Sr-90.

5.6.4 Pavement

All pavement scans in unaffected areas measured beta contamination levels below the cleanup criteria of 5000 dpm/100 cm² given in Radiological Site Characterization Plan for the Trojan Site. There are no release guidelines for activity per unit mass concentrations of radionuclides in pavement. However, Cs-137 activity detected in pavement samples was below the release guideline level of 6.1 pCi/g calculated for soil.

5.6.5 Exposure Rates

The unaffected area results are well below the cleanup criteria of 5 μ R/hr above background. The affected area samples listed in Table 5.11 have exposure rates below the cleanup criteria of 12.1 μ R/hr (clean up criteria plus background). Those affected area samples not surveyed during this phase should be surveyed when radioactive material has been removed from the structures that could influence the measurements.

SITE CHARACTERIZATION REPORT

REVISION 0.1

Table 5.1 Background Soil Sample Results		
Sample ID	Background Location	Cs-137 Concentration (pCi/g)
TS-1	Prescott, OR	0.8
TS-2	"	0.7
TS-3	"	0.6
TS-4	"	0.3
TS-5	"	0.1
TS-6	"	0.2
TS-7	"	QC Sample
TS-8	"	0.5
TS-9	"	0.6
TS-10	"	0.4
TS-11	"	0.1
TS-12	Rainier, OR	0.1
TS-13	"	0.2
TS-14	"	0.3
TS-15	"	0.4
TS-16	"	QC Sample
TS-17	Kalama, WA	0.03
TS-18	"	0.01
TS-19	"	0.02
TS-20	"	0.01
TS-21	"	0.02
TS-22	W Hwy 30	0.5
TS-23	"	1.0
TS-24	"	0.7
TS-25	"	1.2
TS-26	"	0.2
TS-27	"	1.2
TS-28	"	1.1
TS-29	"	0.9
TS-30	"	0.6
TS-31	"	1.3
TS-32	"	0.7

SITE CHARACTERIZATION REPORT

REVISION 0.1

	Mean = 0.49
	STD = 0.4

Table 5.2 Unaffected Soil Sample Results		
Sample ID	Grid ID	pCi/g Cs-137
TS-33	D 34	0.52
TS-34	N 15	0.18
TS-35	W 7	2.94
TS-36	R 7	1.01
TS-37	U 10	2.35
TS-38	AE 11	0.68
TS-40	W 16	1.26
TS-41	AB 15	1.80
TS-42	AF 17	0.55
TS-43	AC 17	2.48
TS-44	O 19	2.56
TS-45	AC 32	0.20
TS-46	AK 10	0.08
TS-47	AY 42	0.66
TS-48	BJ 42	0.67
TS-49	AO 58	1.39
TS-50	AU 40	0.34
TS-51	BA 13	1.32
TS-53	CB 32	0.62
TS-54	AR 36	0.09
TS-55	AZ 27	0.22
TS-56	BG 24	0.24
TS-57	BO 27	0.07
TS-58	CC 27	0.11
TS-59	BO 24	0.13
TS-60	AM 23	0.16
TS-61	AP 20	0.01
TS-62	AN 19	0.03
TS-63	AS 12	0.25
TS-64	AU 17	0.07
	Mean	0.77
	Std Dev	0.86
	Range	
	max	2.94
	min	0.01

Sample ID	Grid ID	pCi/g Cs-137
TS-65	AX 23	0.15
TS-66	AW 23	0.12
TS-67	AV 23	0.28
TS-68	AV 24	0.33
TS-69	AZ 18	0.04
TS-70	BA 18	0.11
TS-71	AD 20	0.09
TS-72	AQ 20	0.06
TS-73	AN 19	0.03
TS-74	AN 19	0.26
TS-75	AM 19	0.02
TS-76	AM 19	0.01
TS-77	AI 20	0.17
TS-78	AI 20	0.15
TS-79	AN 18	0.09
TS-80	AN 18	0.06
TS-81	AI 13	0.04
TS-82	AI 13	0.03
TS-83	AG 12	0.02
TS-84	AH 11	0.01
TS-85	AO 11	0.07
TS-86	AO 11	0.03
TS-87	AM 12	0.04
TS-88	AN 13	0.05
TS-89	AM 14	0.32
TS-90	AM 13	0.01
	Mean	0.10
	Std Dev	0.098

Table 5.4
1991 Tank Farm Soil Sample Results

Sample Point	Depth (feet)	pCi/g Cs-137
1	1	0.095
1	2	0.098
1	3	0.067
2	1	<MDA
2	2	0.088
2	3	<MDA
3	1	<MDA
3	2	<MDA
3	3	<MDA
4	1	0.46
4	2	0.25
4	3	0.46
5	1	0.20
5	2	0.066
5	3	0.050

MDA = 0.012 pCi/g

Table 5.5 Unaffected Sediment Sample Results		
Sample ID	Grid ID	pCi/g Cs-137
BS-1	C 32	0.47
BS-2	F 34	0.37
BS-3	H 35	0.55
BS-4	J 35	0.46
BS-6	M 33	0.78
BS-7	E 26	0.57
BS-8	F 21	0.27
BS-9	J 20	0.23
BS-10	T 24	0.62
BS-11	Z 24	0.61
BS-12	Z 27	0.02
BS-13	AA 33	0.45
BS-14	X 35	0.55
BS-15	U 38	0.86
BS-16	P 38	0.60
BS-17	J 36	0.09
BS-18	AQ 34	0.04
BS-19	AP 32	0.12
BS-20	AP 29	0.14
BS-21	AO 29	0.27
BS-22	AL 29	0.41
BS-24	AI 29	0.21
BS-25	AE 29	0.23
BS-26	AF 32	0.33
BS-27	AG 34	0.13
BS-28	AI 34	0.30
BS-29	AI 32	0.58
BS-30	AL 34	0.20
BS-31	AO 34	0.09
BS-32	AN 32	0.18
BS-33	AM 32	0.58
	Mean	0.36
	Std Dev	0.22

Table 5.6 Affected Sediment Sample Results		
Sample ID	Grid ID	pCi/g Cs-137
BS-34	AU 35	0.04
BS-35	AY 33	0.15
BS-36	BF 32	0.02
BS-37	BM 33	0.06
BS-38	BE 29	0.03
BS-39	AY 27	0.11
BS-40	AX 24	1.12
BS-41	AV 23	0.35
BS-42	AX 23	0.74
BS-43	AW 24	0.20
	Mean	0.28
	Std Dev	0.37

Table 5.7 Unaffected Pavement Scans	
Grid ID #	gross dpm/100 cm ²
AF 27	542
AG 22	567
AH 25	739
AJ 15	677
AJ 17	788
AK 12	739
AL 21	591
AM 38	665
AO 20	640
AQ 23	739
AS 22	665
AS 30	739
AT 12	616
AT 23	665
AU 19	616
AU 29	714
AV 25	542
AV 30	567
AX 22	690
BB 23	764
BC 18	579
BC 25	591
BE 27	493
BE 36	714
BG 23	690
BG 24	714
BH 30	567
BJ 20	456
BN 26	591
BV 30	616
CB 28	542

Table 5.8
Affected Pavement Sample Results

Sample #	Grid ID #	Cs-137 pCi/g
PV-01	AN 13	5.6E-2
PV-02	AN 12	4.7E-2
PV-03	AO 15	1.5E+0
PV-04	AO 18	3.4E-2
PV-05	AN 18	5.3E-2
PV-06	AT 17	4.2E-2
PV-07	AS 17	1.1E-1
PV-08	AR 17	2.6E-2
PV-09	AR 13	4.9E-2
PV-10	AS 13	1.9E-2
PV-11	AV 14	4.4E-2
PV-12	AV 15	3.4E-2
PV-13	AV 16	9.8E-2
	Mean	0.16
	Std Dev	0.40

Table 5.9 Background Exposure Rates (preoperational results)	
Station Identifier	Dose Rate (μ R/hr)
1A	6.3
1B	5.8
1C	6.8
1D	8.2
1E	5.9
1F	7.5
1I	5.6
1J	5.8
1M	5.7
2*	7.8
2*	7.3
3	8.3
4C	7.2
5	7.6
6A	9.4
6B	6.7
7	7.9
8	8.4
9B	7.0
11A	6.8
11B	6.6
12	6.5
13	8.1
14	7.2
CR5	7.6
Mean	7.1
Std Dev	1.0

* two ion chamber readings were made at this location. The first measurement was taken over a grass to soil surface within 4 feet of the TLD monitor. The second measurement was made over the adjacent concrete surface also within 4 feet of the TLD monitor.

Table 5.10
Unaffected Exposure Rates

Survey Point	$\mu\text{R/hr}$
TS-33	7.0
TS-34	5.5
TS-35	5.4
TS-36	5.7
TS-37	5.2
TS-38	7.4
TS-39	5.9
TS-40	6.1
TS-41	5.7
TS-42	5.9
TS-43	6.4
TS-44	6.1
TS-45	6.0
TS-46	9.0
TS-47	5.3
TS-48	5.8
TS-50	8.0
TS-51	5.3
TS-52	5.4
TS-53	5.5
TS-54	7.3
TS-55	7.7
TS-56	7.6
TS-57	7.7
TS-58	6.0
TS-59	7.9
TS-60	6.4
TS-61	6.9
TS-62	6.2
TS-63	6.5
TS-64	5.8
Mean	6.4
Std Dev	1.0

Survey Point	$\mu\text{R/hr}$
TS-65	6.9
TS-66	8.1
TS-67	7.0
TS-68	6.3
TS-69	6.7
TS-70	6.6
TS-71	6.4
TS-72	6.4
TS-73	6.2
TS-74	6.2
TS-75	6.0
TS-76	6.1
TS-77	6.0
TS-78	6.1
TS-79	7.6
TS-80	7.3
TS-85	8.3
TS-86	8.1
Mean	6.8
Std Dev	0.8

Table 5.12 Sr-90 Analyses of Duplicate Samples	
Sample ID	pCi/g Sr-90
BS-05	0.05
BS-23	0.03
TS-16	0.02
TS-39	0.27
TS-52	0.32

Figure 5.1

Background Sampling Sites - Water

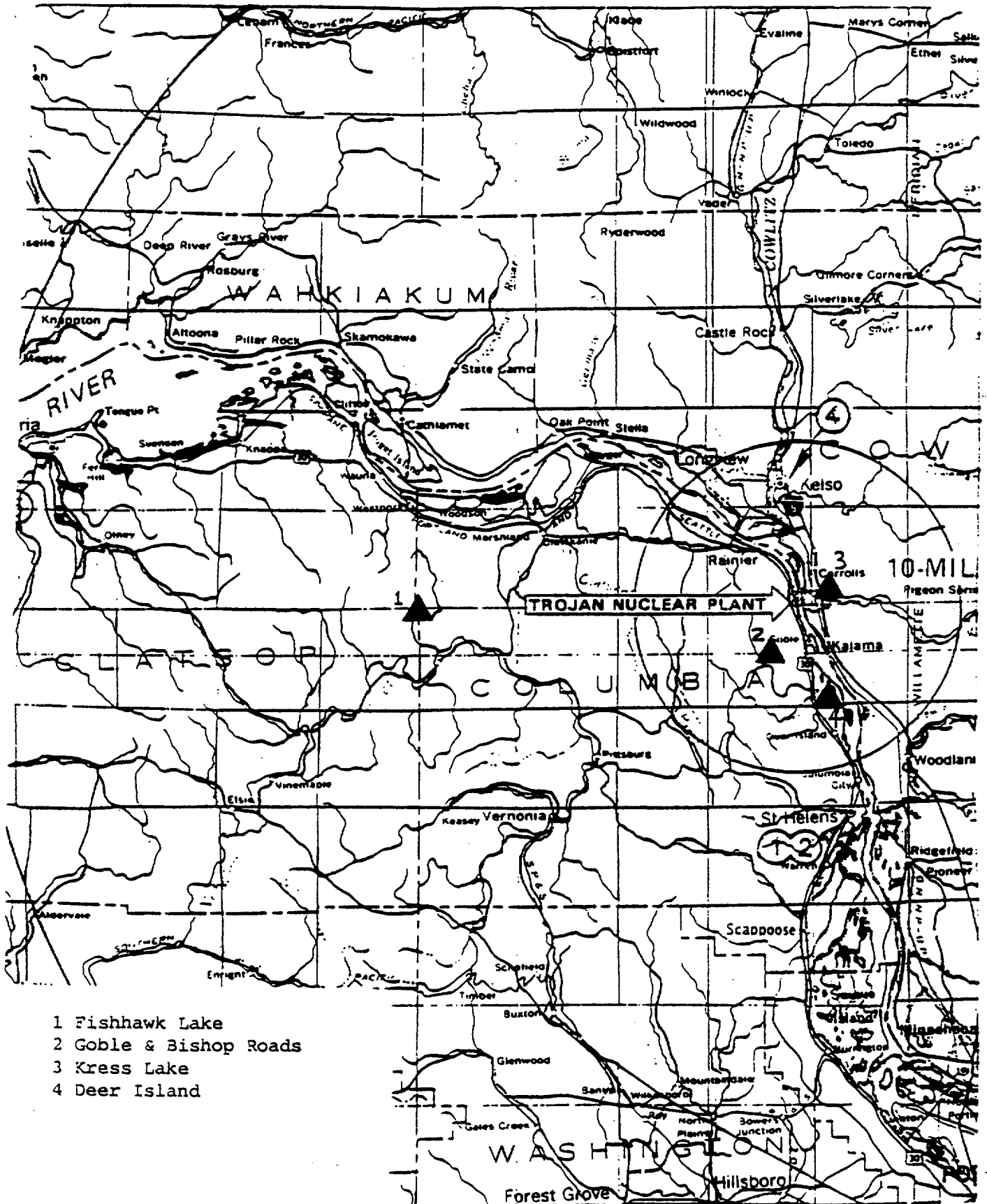

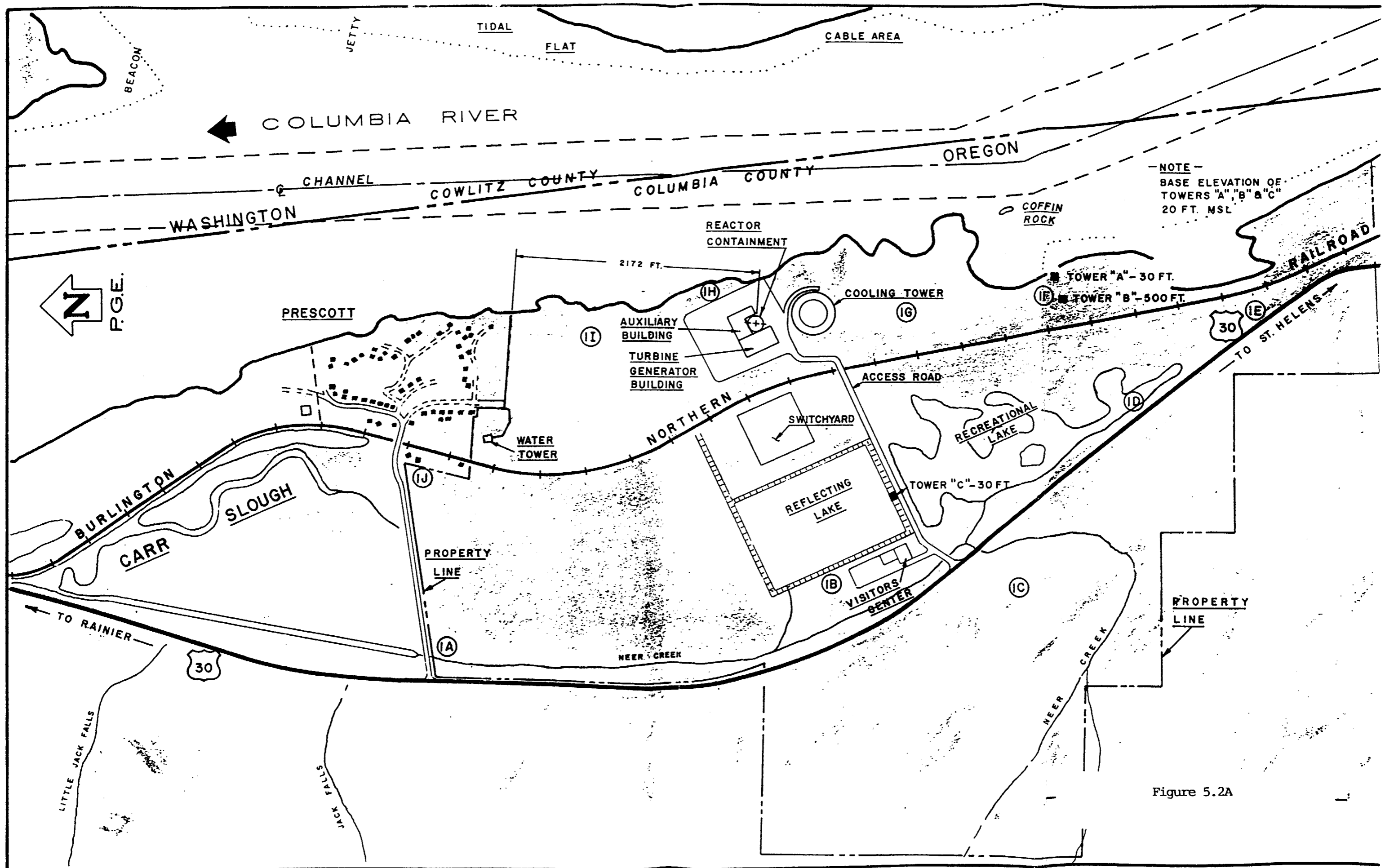

Figure 5.2A

TROJAN ON-SITE SAMPLE COLLECTION LOCATION

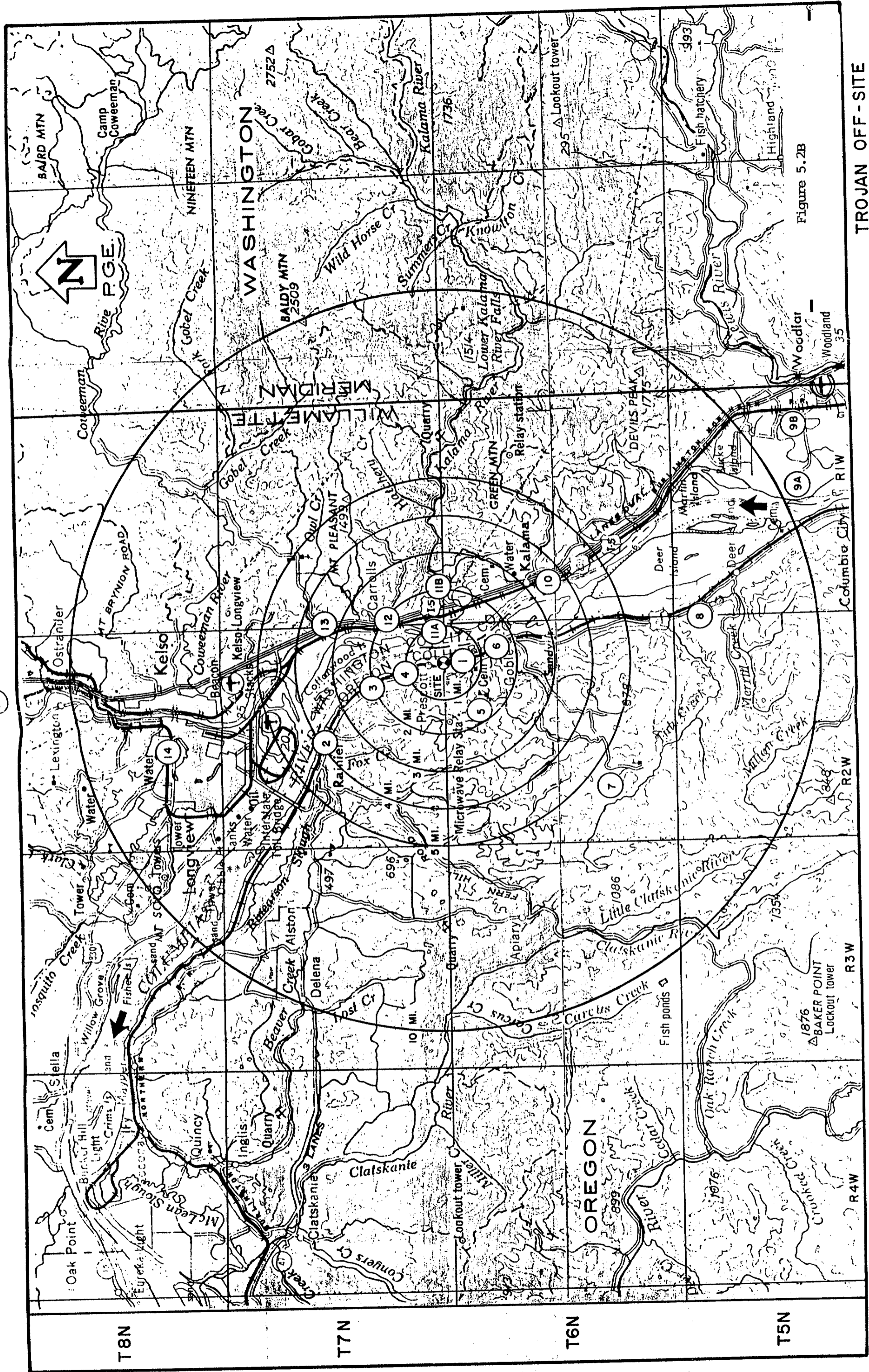

Figure 5.2B

TROJAN OFF-SITE
SAMPLE COLLECTION

SECTION 5

ENVIRONMENTAL CHARACTERIZATION
APPENDIX 5A

SURVEY
LOCATION
MAPS

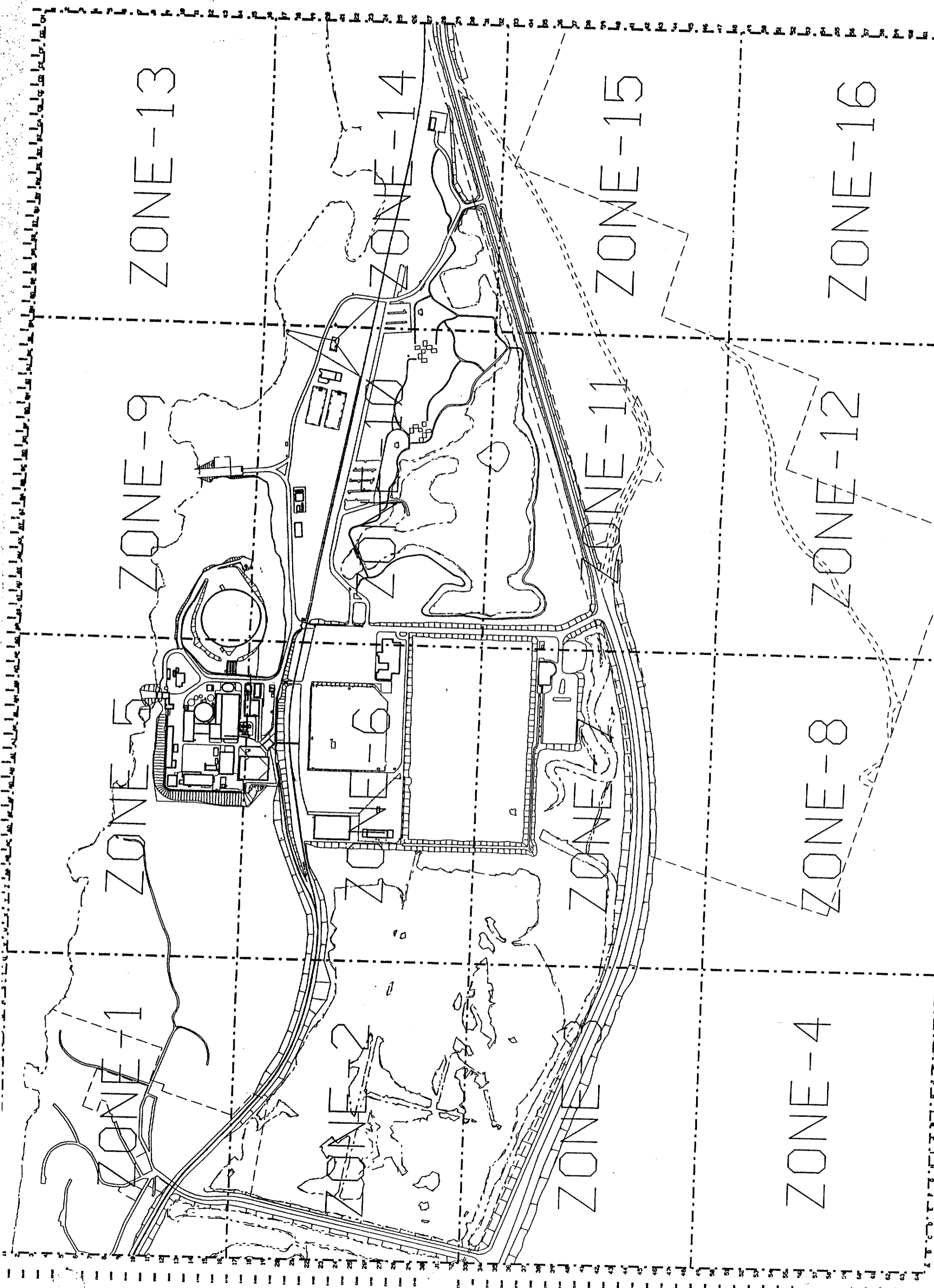

ZONE-13

ZONE-9

ZONE-14

ZONE-15

ZONE-16

ZONE-11

ZONE-12

ZONE-5

ZONE-6

ZONE-11

ZONE-8

ZONE-1

ZONE-2

ZONE-4

ZONE-4

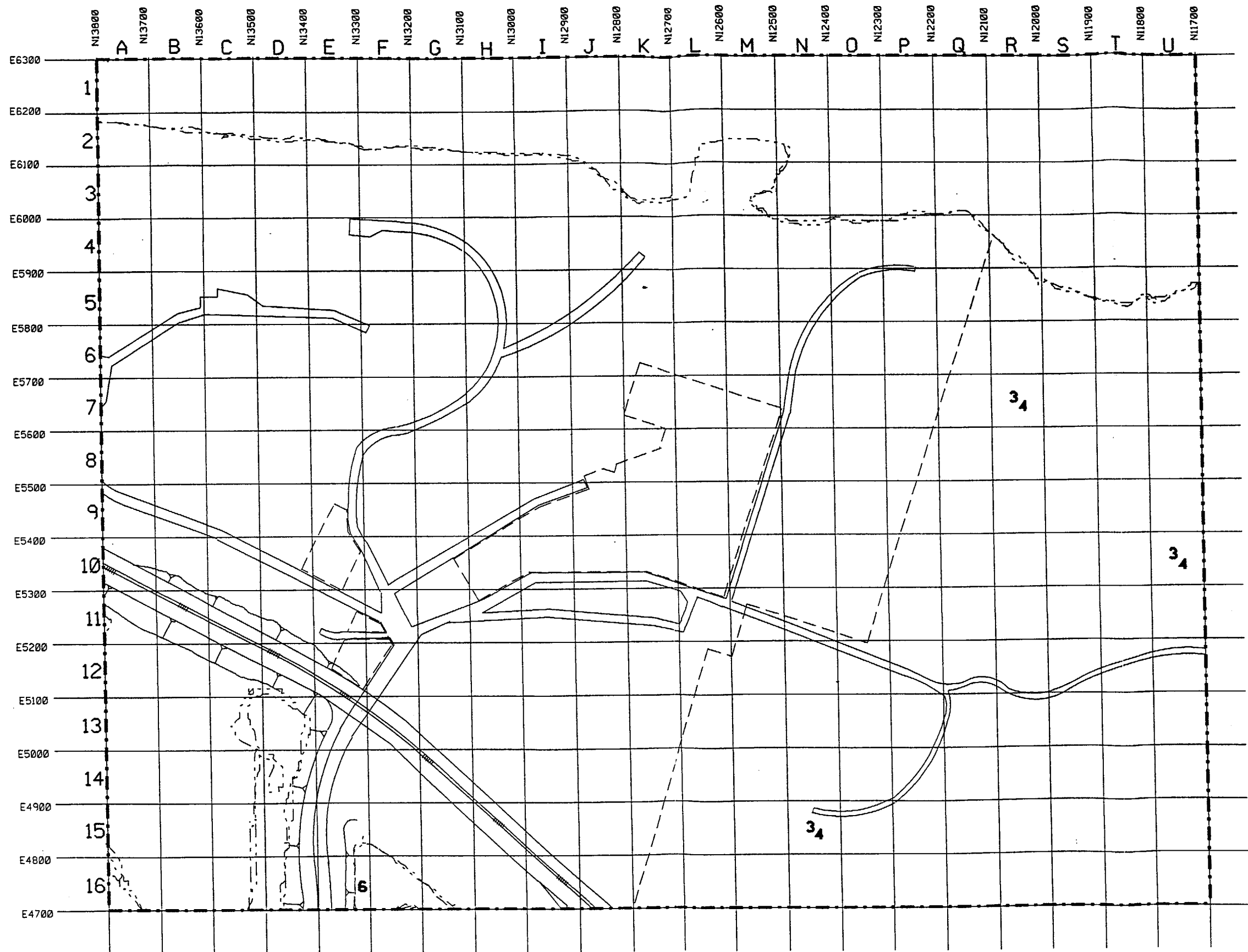

LEGEND

- 1 - PAVEMENT SAMPLE
- 2 - PAVEMENT/DIRECT SURFACE MEASUREMENT
- 3 - SOIL SAMPLE
- 4 - DIRECT RADIATION MEASUR
- 5 - BOTTOM SEDIMENT SAMPLE
- 6 - SURFACE WATER SAMPLE

ZONE-1

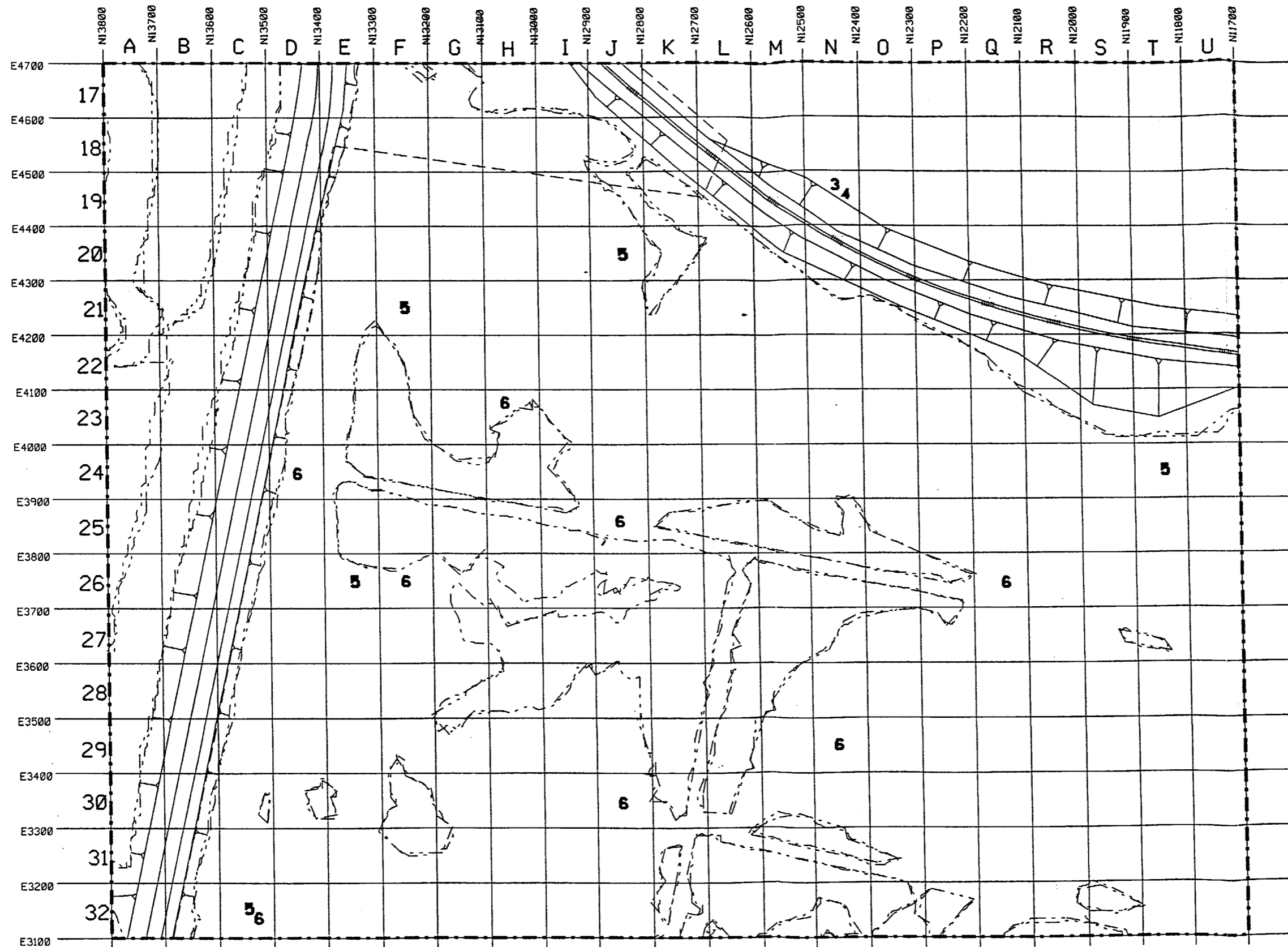

LEGEND

- 1 - PAVEMENT SAMPLE
- 2 - PAVEMENT/DIRECT SURFACE MEASUREMENT
- 3 - SOIL SAMPLE
- 4 - DIRECT RADIATION MEASUREMENT
- 5 - BOTTOM SEDIMENT SAMPLE
- 6 - SURFACE WATER SAMPLE

ZONE-2

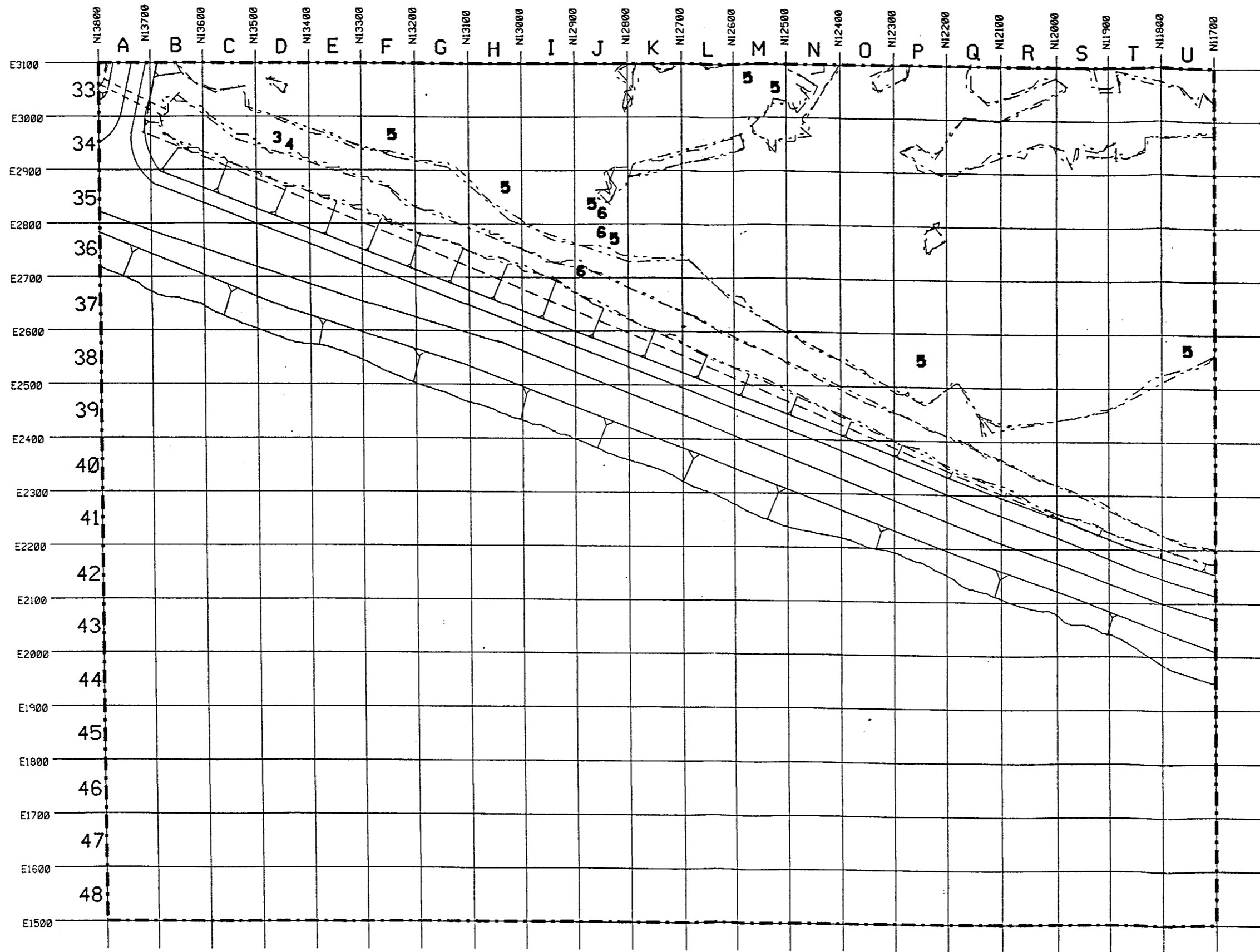

LEGEND

- 1 - PAVEMENT SAMPLE
- 2 - PAVEMENT/DIRECT SURFACE MEASUREMENT
- 3 - SOIL SAMPLE
- 4 - DIRECT RADIATION MEASURE
- 5 - BOTTOM SEDIMENT SAMPLE
- 6 - SURFACE WATER SAMPLE

ZONE-3

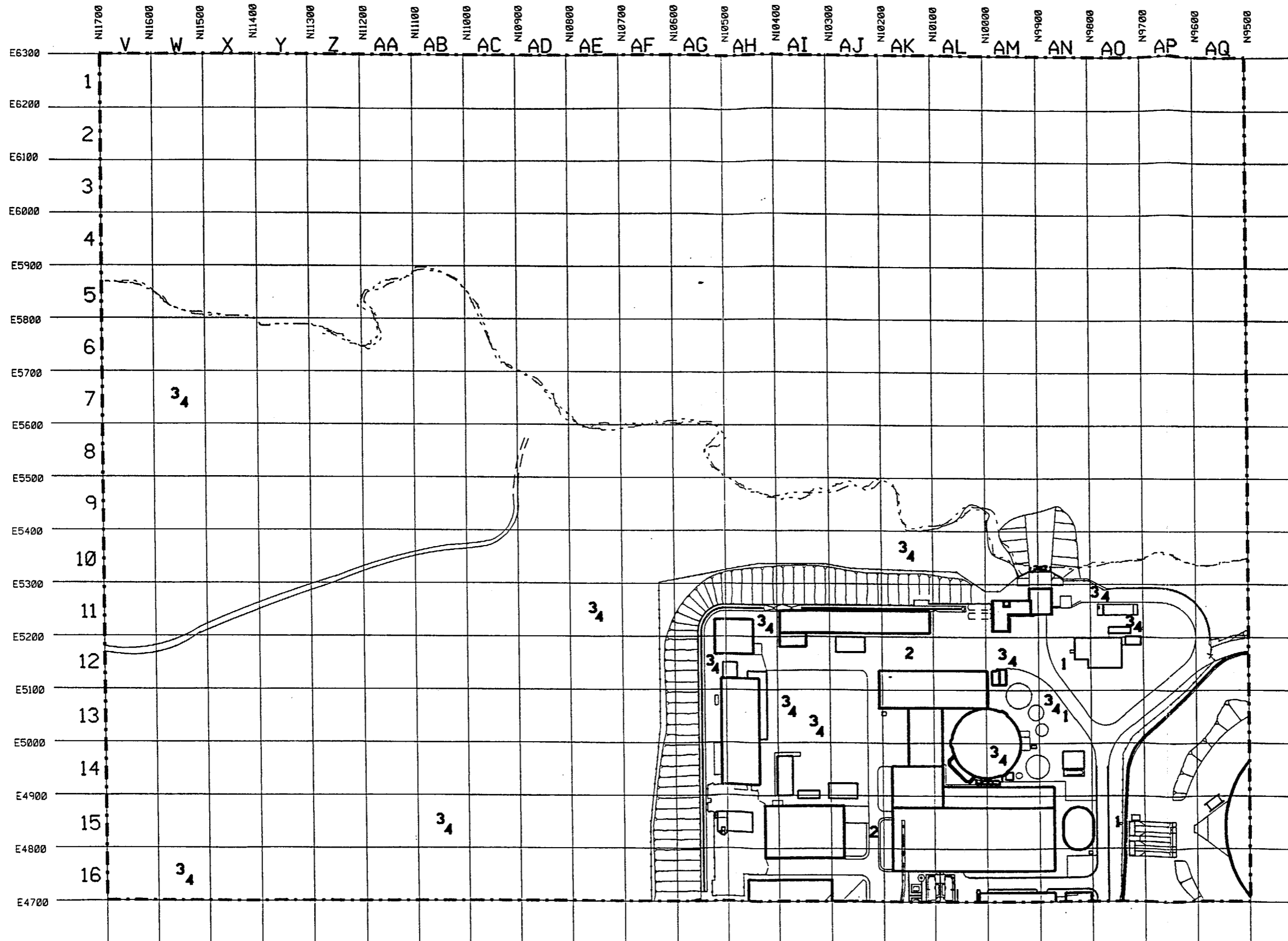

LEGEND

- 1 - PAVEMENT SAMPLE
- 2 - PAVEMENT/DIRECT SURFACE MEASUREMENT
- 3 - SOIL SAMPLE
- 4 - DIRECT RADIATION MEASURE
- 5 - BOTTOM SEDIMENT SAMPLE
- 6 - SURFACE WATER SAMPLE

ZONE-5

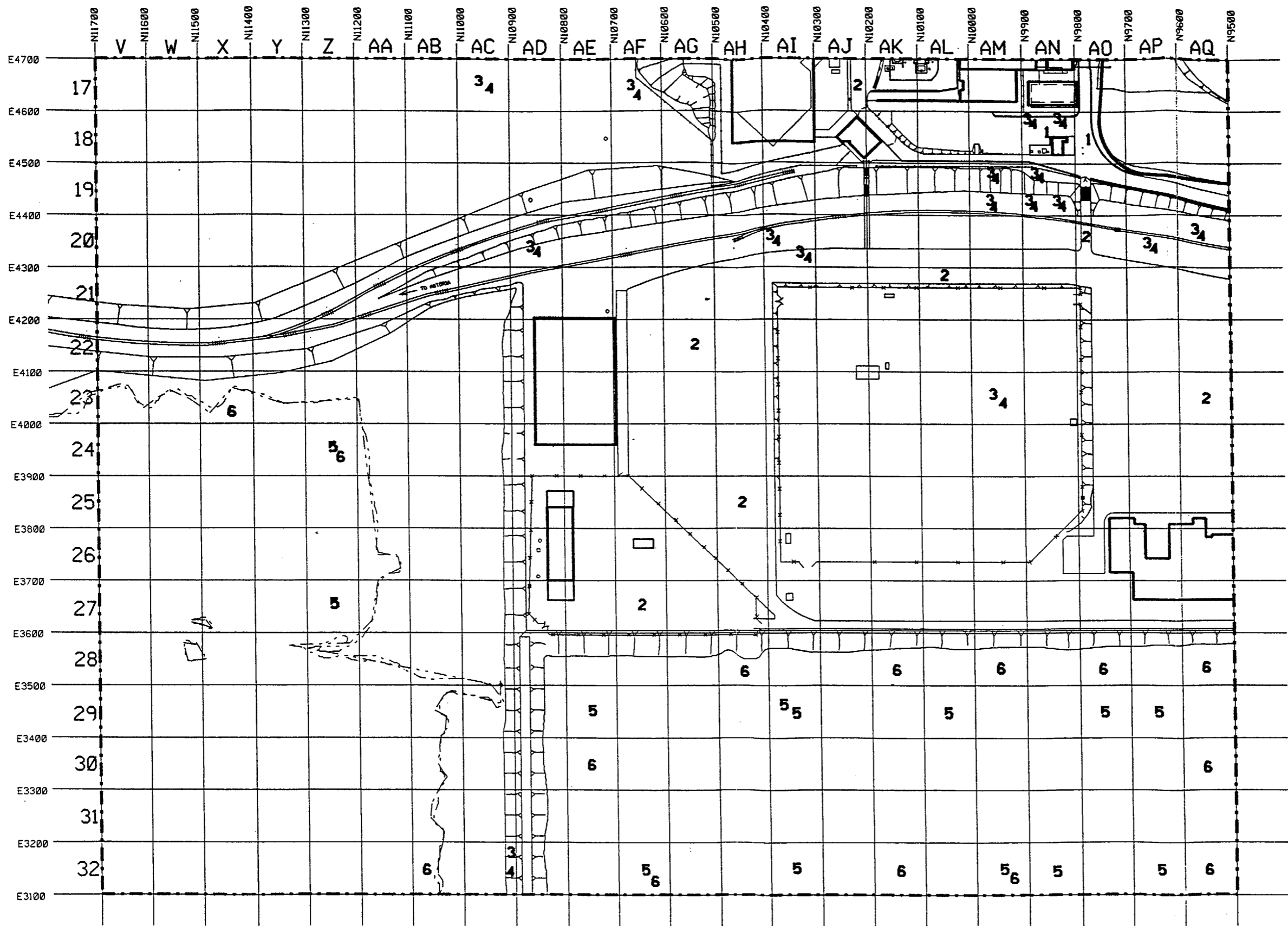

LEGEND

- 1 - PAVEMENT SAMPLE
- 2 - PAVEMENT/DIRECT SURFACE MEASUREMENT
- 3 - SOIL SAMPLE
- 4 - DIRECT RADIATION MEASUREMENT
- 5 - BOTTOM SEDIMENT SAMPLE
- 6 - SURFACE WATER SAMPLE

ZONE-6

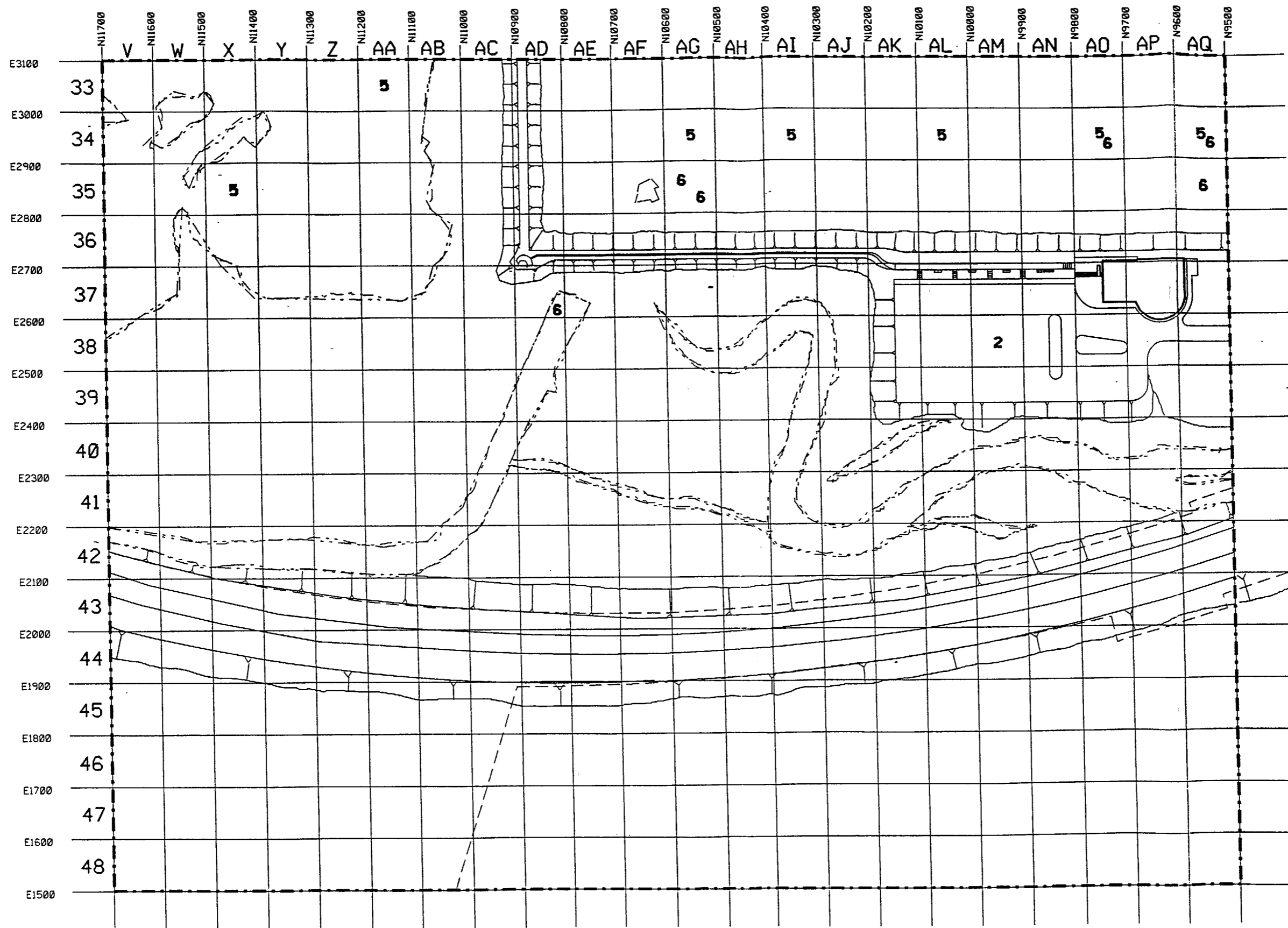

LEGEND

- 1 - PAVEMENT SAMPLE
- 2 - PAVEMENT/DIRECT SURFACE MEASUREMENT
- 3 - SOIL SAMPLE
- 4 - DIRECT RADIATION MEASUR
- 5 - BOTTOM SEDIMENT SAMPLE
- 6 - SURFACE WATER SAMPLE

ZONE-7

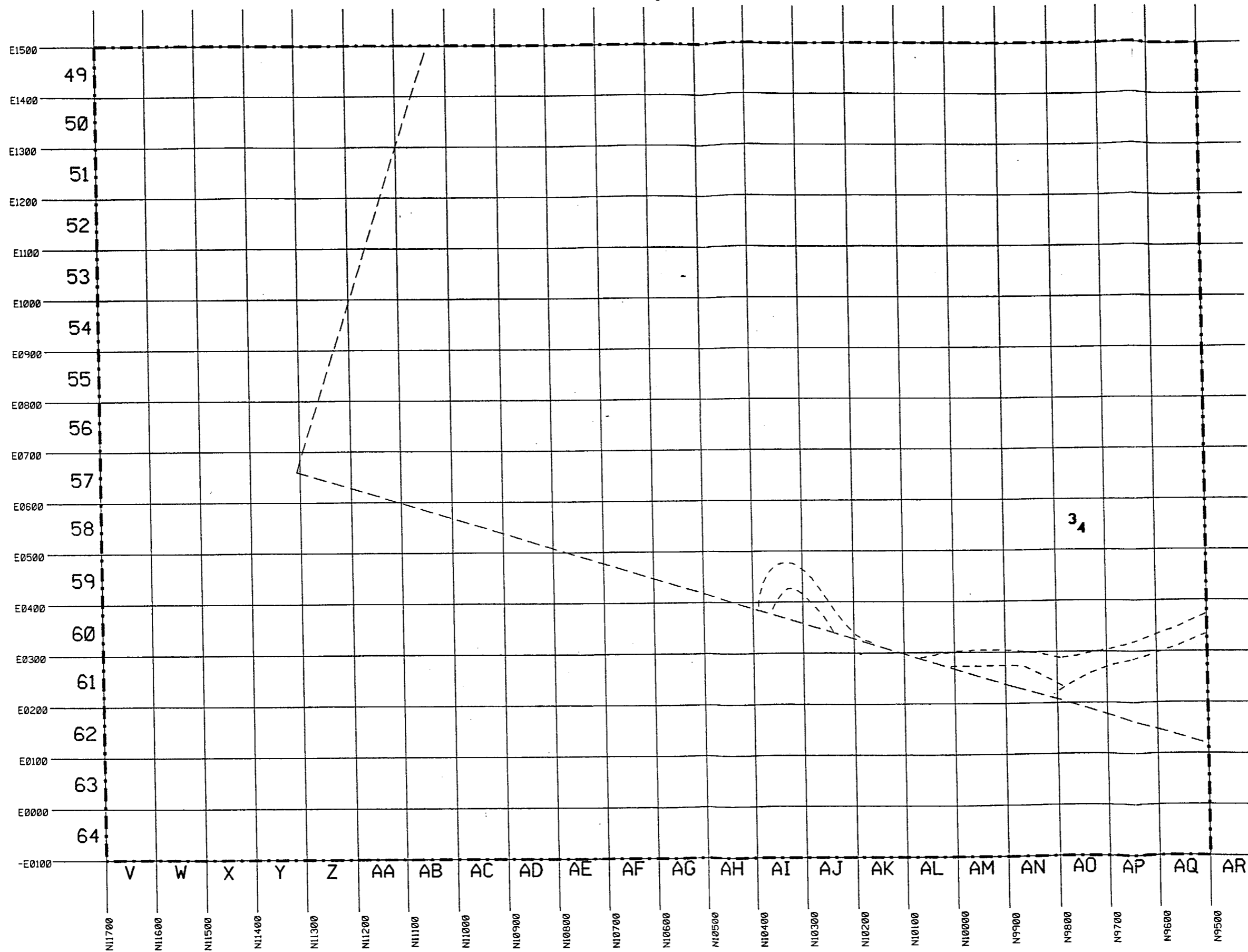

LEGEND

- 1 - PAVEMENT SAMPLE
- 2 - PAVEMENT/DIRECT SURFACE MEASUREMENT
- 3 - SOIL SAMPLE
- 4 - DIRECT RADIATION MEASURE
- 5 - BOTTOM SEDIMENT SAMPLE
- 6 - SURFACE WATER SAMPLE

ZONE-8

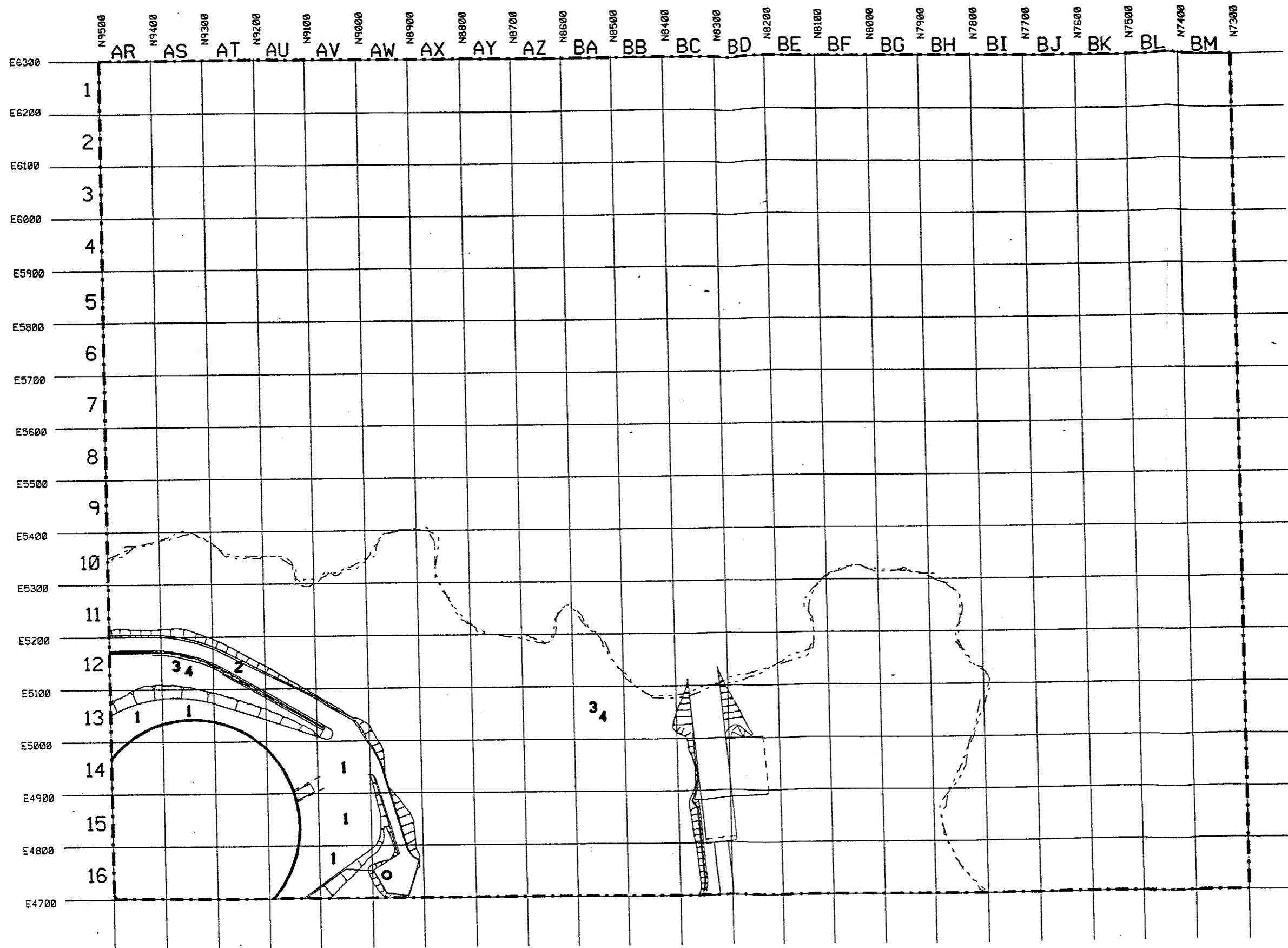

LEGEND

- 1 - PAVEMENT SAMPLE
- 2 - PAVEMENT/DIRECT SURFACE MEASUREMENT
- 3 - SOIL SAMPLE
- 4 - DIRECT RADIATION MEASUR
- 5 - BOTTOM SEDIMENT SAMPLE
- 6 - SURFACE WATER SAMPLE

ZONE-9

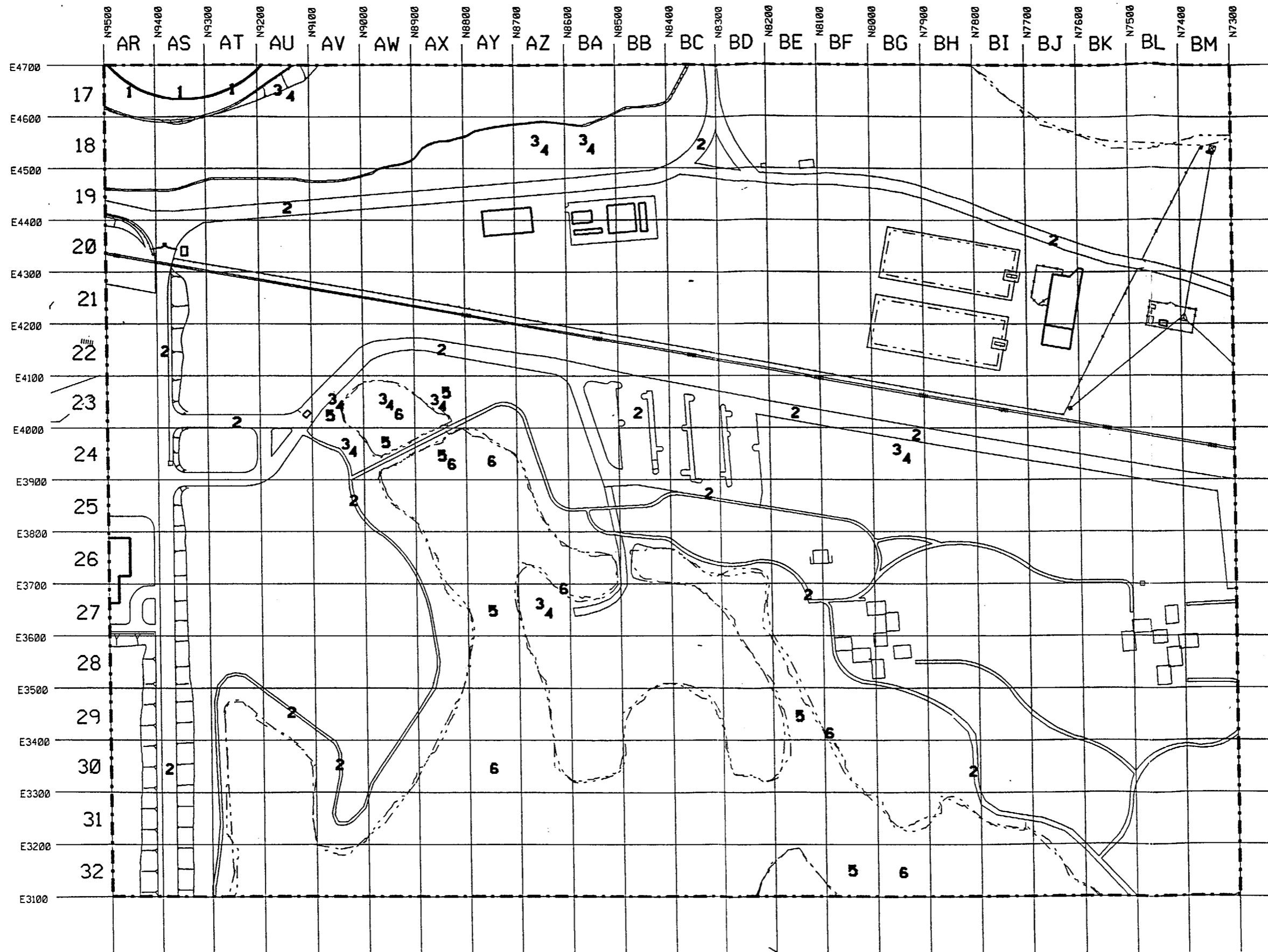

LEGEND

- 1 - PAVEMENT SAMPLE
- 2 - PAVEMENT/DIRECT SURFACE MEASUREMENT
- 3 - SOIL SAMPLE
- 4 - DIRECT RADIATION MEASURE
- 5 - BOTTOM SEDIMENT SAMPLE
- 6 - SURFACE WATER SAMPLE

ZONE-10

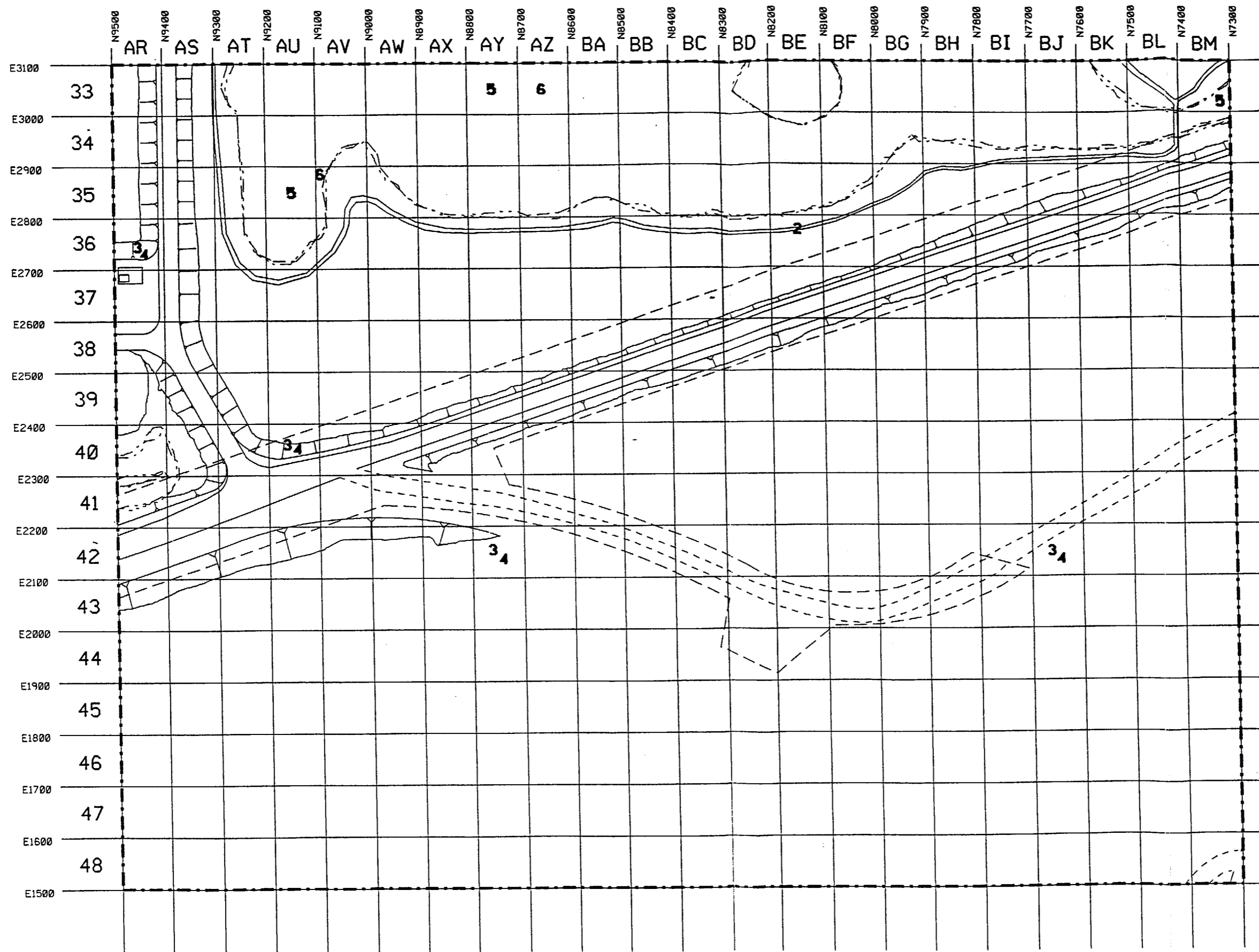

LEGEND

- 1 - PAVEMENT SAMPLE
- 2 - PAVEMENT/DIRECT SURFACE MEASUREMENT
- 3 - SOIL SAMPLE
- 4 - DIRECT RADIATION MEASUREMENT
- 5 - BOTTOM SEDIMENT SAMPLE
- 6 - SURFACE WATER SAMPLE

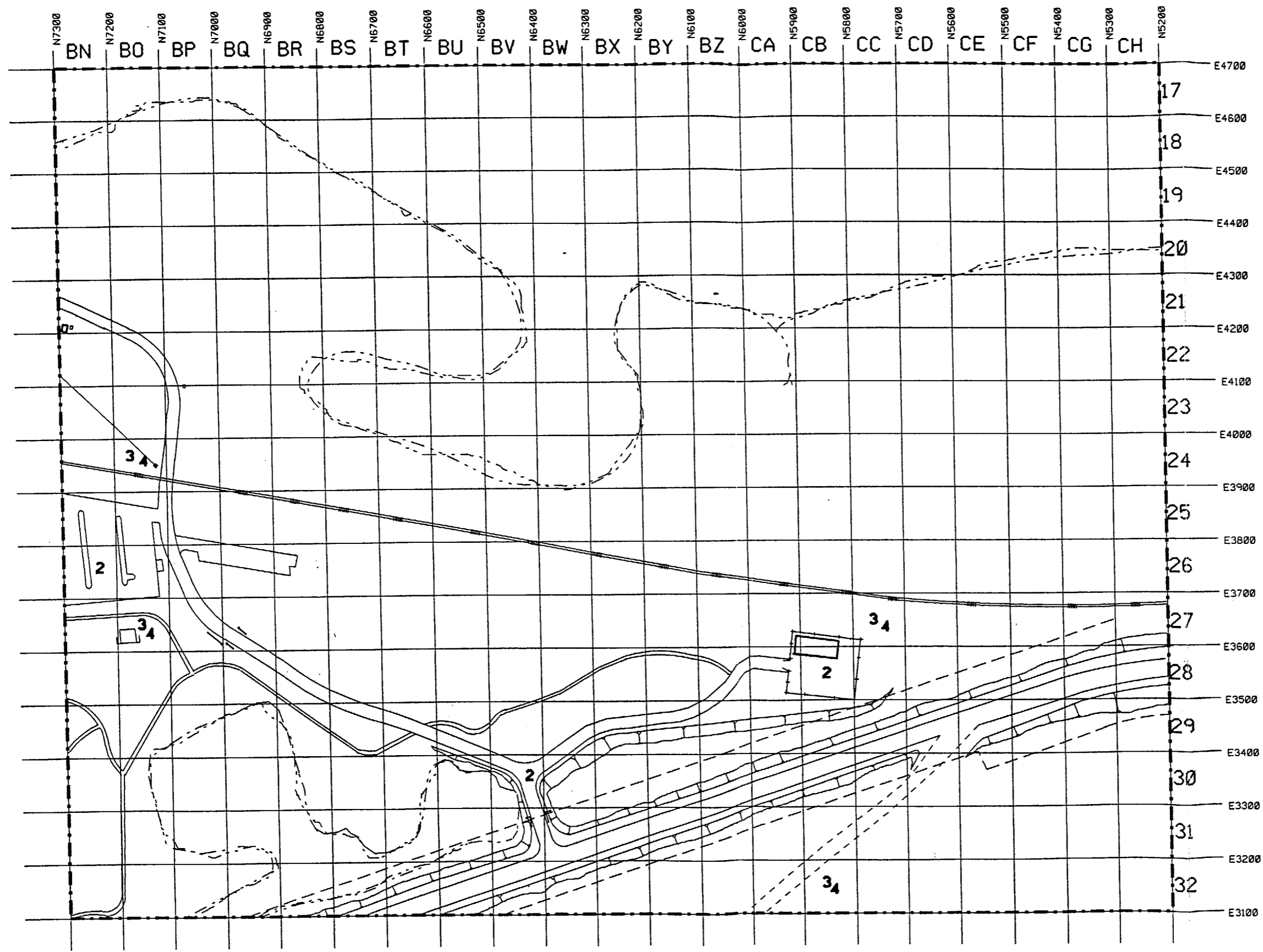

LEGEND

- 1 - PAVEMENT SAMPLE
- 2 - PAVEMENT/DIRECT SURFACE MEASUREMENT
- 3 - SOIL SAMPLE
- 4 - DIRECT RADIATION MEASUREMENT
- 5 - BOTTOM SEDIMENT SAMPLE
- 6 - SURFACE WATER SAMPLE

ZONE-14

6.0 IMPLICATIONS FOR DECOMMISSIONING

This section presents results of the Site Characterization Survey (SCS) which have an effect on the ultimate cost of decommissioning TNP. An upper bound estimate of the "in situ" volume is given. A calculated radioactivity inventory is also provided, including contamination of systems and structures and activation of components and structures. The "in situ" volumes are not necessarily directly comparable to shipping or disposal volumes since volume reduction techniques will be evaluated for each type of radioactive material to be removed.

It is also noted that the total waste volume and activity does not include the following materials:

- nuclear fuel
- control rod elements
- incore instrumentation (components contained in the fuel bundles only)
- radioactive fluids, filter media, resins contained in piping, equipment, sumps, etc.

These items are not included since they are not part of the physical plant requiring remediation. Nuclear fuel and related high level radioactive waste and waste greater than class C will be removed and handled as part of the contract with the Department of Energy. The operational materials such as fluids, filters, etc. will be removed as part of the continued operation of the TNP and disposed of as systems are no longer needed.

6.1 Waste Volumes

6.1.1 Structures

The survey results presented in Section 2 indicate a number of structural elements that exceed the criteria of RG 1.86. These areas are all contained within the areas included in the 'biased' or potentially contaminated population as identified in the development of the SCP.

No contamination in excess of the Decommissioning Plan clean up criteria were identified in the 'unbiased' survey locations. The unbiased areas include office buildings, turbine building, maintenance shops, etc..

The structural areas requiring remediation are expected to be easily decontaminated. Contamination consists of both removable and fixed radioactivity. The removable contamination will be decontaminated through simple means such as wiping or mopping. The fixed contamination appears to be deposited in the upper 1 cm of the concrete (based on operational data collected during routine clean up activities and NUREG/CR-4289) and can be removed using surface destructive techniques (e.g., scabbling). Table 6.1 contains the estimates of volume and radioactivity contained in the structures with contamination levels

requiring remediation. Fixed contamination levels were not measurable in many rooms in the biased survey locations because radioactivity in systems masked the surface contamination. Additional surveys for fixed contamination will be required as radiation levels are reduced either from decay or removal of the source of radiation. Radioactive waste volume estimates for each building by floor elevation have been calculated based on the total area of the elevation, the estimated percentage area contaminated to levels greater than RG 1.86 and an assumed depth of penetration of 1 cm (1/4-1/2 inch). The estimated area of contamination is based on historical data for spills and professional judgement. Additional data will be collected as necessary to ensure the assumptions used are accurate and conservative.

An additional 10% volume is added to the total to account for expected contamination of walls, ceilings and other non-floor surfaces. An additional 10% (of the new total) is added to account for the locations which will require additional removal of material to a depth greater than 1 cm. The expected areas requiring additional action to the greater than 1 cm depth include anchor bolt holes, floor joints, floor/wall interfaces, etc. The total expected volume and activity for structures is included in Table 6-1. The estimated total is 4184 ft³ of material. The estimate of the activated containment concrete volume requiring disposal has been evaluated through sampling. The samples indicate that all structural surfaces in the containment will require remediation of the upper 1 cm layer for contamination removal. Additional material removal will be required due to neutron activation of the concrete constituents. Concrete core bores taken from four (4) locations in containment indicate that removal of at least three feet of the primary shield wall surrounding the reactor vessel will be required to comply with the site clean up criteria contained in the Trojan Decommissioning Plan. Detectable radioactivity was found in all structures sampled to various depths. However, the levels were generally less than the RG 1.86 and below the clean up criteria. Therefore no remediation is expected to be required except the previously discussed primary shield wall and the contaminated surfaces.

The removal of concrete from the structures is expected to be complicated with subsequent increase in burial volume due to the imbedded systems, including radwaste drains.

6.1.2 Systems

Contamination found in the 26 contaminated systems sampled consist of both fixed and removable material. The total radioactivity is not expected to be substantially reduced through nonaggressive decontamination methods. Operational experience during activities such as steam generator primary bowl hydrolasing indicated that the radioactivity is tightly adherent to surfaces and will require disposal of the entire component.

Potential waste volumes and activities by system are contained in Table 6.3. The total volume for all systems is 274,399 ft³. The total activity is 2469.6 Ci. The Decommissioning Plan estimate completed by TLG Services was 219,220 ft³ and 1070.5 Ci. The TLG estimate assumes the four (4) steam generators and the pressurizer have been

SITE CHARACTERIZATION REPORT

REVISION 0.1

removed and buried as part of the Large Component Removal Project. The TLG estimate also includes miscellaneous material including conduit, cables and other material which was not included in this reports estimate. TLG also included package loading factors in their estimate to more closely approximate the actual burial volume expected to be generated during the decommissioning period.

The above estimate is considered bounding and conservative for three reasons:

- No credit is taken for the degree of contamination. Portions of the systems with contamination levels less than RG 1.86 criteria will not require remediation.
- No credit is taken for decontamination of systems in the future prior to beginning site decommissioning.
- Only minimal volume reduction techniques are assumed when calculating disposal volumes.

6.1.3 Activated Components

SCR Section 4 describes the calculations for the components activated by neutron irradiation. Calculations performed by TLG Engineering Inc. indicate the reactor vessel, internals and concrete shielding have levels of radioactivity which will require remediation.

Most parts of the reactor vessel are anticipated to meet class A radwaste criteria. The core baffle, core formers and lower core plate are greater than class C and not acceptable for shallow land disposal. Radwaste classification data for each portion of the reactor components are found in Tables 4.7.36. The expected unpackaged volumes of the major components are:

COMPONENT	VOLUME (ft ³)
Core Baffles *	41
Core Formers *	11
Lower Core Barrel	124
Upper Core Barrel	29
Thermal Shield Pads	42
Vessel Clad	17
Vessel Wall	809
Vessel Insulation	5
Primary Shield Wall	3078
Lower Core Plate *	13
Lower Core Support Columns	10
Lower Core Support	120
Below Lower Core Support	8
Upper Core Plate	16
Upper Core Support Columns	23
TOTAL	4346

6.1.4 Environment

Section 5 describes the results of the surveys of the environs of the TNP that could have been affected by plant releases of radioactive materials.

All survey results indicate levels of radioactivity less than the Decommissioning Plan clean up criteria. Soil, water, bottom sediment and pavement samples were collected from locations around the TNP. Where radioactivity was identified (Cs-137 in soil, pavement and bottom sediment), all concentrations of radioactivity were below guideline values calculated assuming a limit of 15 mrem/yr TEDE using methodology described in NUREG/CR-5512, 'Residual Radioactive Contamination From Decommissioning'.

Direct exposure rate measurements were all below the $5\mu\text{R/hr}$ above background cleanup criteria. Direct radiation measurements were not made in areas affected by current plant structures and will require surveying at a later time when the source of the high background radiation levels are removed. An example of an area with this problem is the vicinity of the Refueling Water Storage Tank (RWST) located on the south side of the Fuel Building.

6.2 Radionuclide Inventory

The following sections present an estimate of the radionuclide inventory of the activation and contamination at TNP (excluding fuel, control rods, etc.). These are rough estimates as they existed in the July/September 1993 time frame. We consider these estimates to be conservative based on the assumptions used in the calculations.

Contamination levels and radionuclide inventory will generally decrease in the future at TNP. Systems and structures that will continue to be used for safe storage of the spent nuclear fuel (not deactivated) may have stable or increasing radioactivity levels. This potential for increase is being minimized by:

- Near term dry layup of the reactor coolant and other systems.
- Use of in-place filtration and demineralization for operating systems to remove radionuclide inventory from the system for disposal.

6.2.1 Isotopic Distribution of Contamination

Various mixtures of radionuclides were evident in survey samples from throughout the affected areas. Predominant nuclides are shown in Table 6.2. The data for Table 6.2 Auxiliary systems was found in the 10CFR61 waste stream analysis results for the clean waste filter. The clean waste filter data is valid since the radioactive material found on the filter is the result of the leakage from the auxiliary systems. The primary system data was developed from steam generator tube honing analyses and Reactor Coolant system 10CFR61

waste stream results.

PGE has concluded that Fe-55 in contamination does not apply to the beta-gamma limits of Regulatory Guide 1.86 in large part because Fe-55 decays by electron capture and emits low energy x-rays (less than 6.5 keV) and very low yield (less than 0.004%). NRC has not required Fe-55 to be considered in past decommissioning submittals and Fe-55 is not a detectable contributor to either dose rate or contamination with typical measurement equipment.

Fe-55 is included in the activation analysis due to 1) the activated components are clearly radioactive and require remediation without consideration of Fe-55 activity and 2) the total activity for burial costs includes Fe-55.

6.2.2 Structural Contamination

The estimate of structural contamination activity was obtained using the following method:

- The areal extent of contamination was estimated by reviewing survey results and judgement based on historical knowledge including an evaluation of each building by elevation to determine the percent contamination.
- The maximum contamination level was applied to the total surface area to obtain a conservative value for each area.
- Multiplying the maximum contamination level by the surface area gives the total surface activity.
- An estimate of the composition of the contamination by radionuclide is completed by using the radionuclide mixture determined by counting swipes collected from contaminated areas in the affected areas.

The results of the structures assessment are given in Table 6.1.

6.2.3 Systems Contamination

The estimate of systems contamination activity was obtained using the following methods:

- Low activity level systems were analyzed by determining the maximum system contamination level and multiplying by the system area. The isotopic distribution was determined by using samples collected from the system and calculating the percentage by nuclide.
- High activity level systems were analyzed by measuring the external dose rate from selected locations of the affected system, calculating activity per unit length and

multiplying by the total length of the system. The isotopic distribution was determined by counting samples collected from the individual systems.

Table 6.3 contains the results of the systems radioactivity. The total radioactivity on structural surfaces is estimated to be 0.03 curies (30 mCi).

6.2.4 Activated Components

Detailed results of the activated components determination of radioactivity is thoroughly described in the Activation Analysis (SCP Section 4.0).

6.2.5 Environment

Section 5 describes the results of the measurements of radioactivity in the environment of the TNP. The survey indicated that radioactivity and radiation exposure levels were not greater than background levels. As such, the net activity above the natural background is determined to be zero.

Table 6.1
Contamination* Activity and
Structural Volume

Building	Area (ft ²)	Volume (ft ³)	Activity (millicuries)
Containment (floors)	20346	668	20.4
Containment (walls)	68956	2262	2.71
Auxiliary	7135	234	2.31
Fuel	5360	176	1.13
MSSS/EP	1302	43	1.36
Turbine	2296	75	2.39
TOTAL	105395	3458	30.30

* includes removable and fixed contamination

Table 6.2
Isotopic Distribution
(Decay corrected to 1994 and 1998)

Radionuclides	% Activity * Auxiliary Systems 1994 / 1998	% Activity ** Primary Systems 1994 / 1998
Mn-54	1.0 / <1	<1 / <1
Fe-55	5.9 / 2.6	61 / 43
Co-57	<1 / <1	NI
Co-58	<1 / <1	<1 / <1
Co-60	23 / 18	15 / 18
Ni-63	52 / 66	19 / 38
Sr-89	<1 / <1	<1 / <1
Sr-90	<1 / <1	<1 / <1
Zr-95	<1 / <1	<1 / <1
Ru-106	3.7 / <1	<1 / <1
Ag-108m	<1 / <1	NI
Ag-110m	<1 / <1	NI
Cd-109	1.3 / <1	NI
Sn-113	<1 / <1	NI
Sb-125	1.2 / <1	<1 / <1
I-129	<1 / <1	<1 / <1
Cs-134	<1 / <1	NI
Cs-137	<1 / <1	<1 / <1
Ce-144	<1 / <1	<1 / <1
Pu-238	<1 / <1	<1 / <1
Pu-239/240	<1 / <1	<1 / <1
Pu-241	11 / 11	<1 / <1
Am-241	<1 / <1	NI
Cm-242	<1 / <1	<1 / <1
Cm-243/244	<1 / <1	NI

NI = Not Identified

* = based on Clean Waste Filter analysis (10CFR61 Waste Stream 1992)

** = based on Steam Generator tube analysis (1992)

Table 6.3
Estimated Volumes and Activity: Systems

Sys #	System Name	Contamin. Surf. Area (ft ²)	Total Volume (ft ³)	Total Weight (lbs)	Activity (Ci)
16	Component Cooling Water	33,529	6,115	475,874	< 1
32	HVAC - Fuel & Aux Buildings	30,335	10,283	45,800	< 1
35	Spent Fuel Pool Cooling & Demin	5,257	970	57,281	5.6
36	Spent Fuel Pool	101,993	N/A	628,378	100
39	Condensate Demineralizers	980	2,262	18,000	< 1
42D	Discharge & Dilution System	4,939	3,834	63,505	< 1
49	Residual Heat Removal	13,816	1,702	183,855	36
50	Chemical & Volume Control	22,380	43,041	534,034	25
52	Safety Injection & Accumulators	7,077	9,680	493,765	< 1
55	Control Rod Drive Mechanisms	1,634	225	106,318	83
60	HVAC - Containment	32,838	18,307	407,328	< 1
61	Containment Spray	5,808	1,563	75,252	< 1
63A	Steam Generators	196,696	45,727	2,650,448	1416
63B	SG Blowdown	2,689	1,183	39,449	< 1
64A	Reactor Coolant Pumps	2,644	3,912	768,400	134
64B	Reactor Coolant System Piping	4,352	2,205	296,460	221
64C	Pressurizer	1,371	2,459	195,508	52.1
64D	Reactor Vessel and internals (surface contamination only)	2,831	see chapter 4	see chapter 4	357.9
67AB	Primary Makeup Water System	10,338	31,330	90,006	< 1
67D	Refueling Water Storage Tank	9,401	69,942	97,928	7
68	Solid RadWaste	654	496	10,341	< 1
69	Clean RadWaste	9,610	13,021	110,634	14
71	Dirty RadWaste	2,106	2,147	24,116	< 1
72	Gaseous RadWaste	4,087	3,624	77,261	< 1
76	Process Sampling System	452	14	3,093	4
99A	Miscellaneous Sumps	1,512	257	19,136	< 1
		510,850	274,399	7,484,770	2,469.6

7.0 QA/QC SITE CHARACTERIZATION VERIFICATION**7.1 Purpose**

The QA/QC Site Characterization Verification activities were implemented to ensure the data collected was reliable and accurate. The QA/QC Characterization Verification program consisted of the routine source checks and calibrations of the instruments used to collect the data. Samples collected for off-site analysis utilized the Radiological Environmental Monitoring Program procedures to ensure data/results were reliable and accurate.

7.2 Scope

The QA/QC verification program was performed within the scope of the PGE QA program utilizing the existing QA procedures.

7.3 Verification Criteria

Instruments used for the characterization surveys were calibrated and source checked in accordance with approved plant procedures. Individual instrument files contain the calibration and source check records for the time periods the instruments were in service.

Offsite laboratory analyses were conducted by TMA Eberline Analytical Corp. (REMP laboratory) using the same procedures as applied to the REMP. Split samples, backgrounds and spikes were analyzed by Eberline as part of their normal laboratory routine.

7.4 Verification Conclusions

All surveys and samples complied with the QA/QC verification criteria. All instruments met the calibration and source check standards required by plant procedures.

Laboratory instruments were within the designated specifications of the REMP Quality Assurance program.

All data accumulated during the SCP have been documented as QA related and filed appropriately.

Additional site characterization surveys are anticipated to be conducted during the SAFSTOR period. Comparisons of future data to information collected in this phase of the survey will be completed.

SITE CHARACTERIZATION REPORT

REVISION 0.1

8.0 REFERENCES

- 8.1 Radiological Site Characterization Plan for the Trojan Nuclear Power Plant.
- 8.2 Final Safety Analysis Report (FSAR), Trojan Nuclear Plant
- 8.3 Trojan Environmental Monitoring Program/Procedures
- 8.4 USNRC Regulatory Guide 1.86, "Termination of Operating licenses for Nuclear Power Reactors," USNRC, June 1974.
- 8.5 Personal Communication, SLB-030-93, memo from SLBump to TOMeek,
- 8.6 Trojan Plant Procedure (TPP) 30-1, 'Nuclear Division Defueled Requirements and Defueled Systems Lists, revision .
- 8.7 Final Cost Estimate (F23 Piping Contract) Wright-Schuchart-Harbor
- 8.8 Plant System Drawings, (P&IDs),
- 8.9 Microshield version 3.13 computer program, Grove Engineering, 4/12/88.
- 8.10 Levin, A., "FISSPEC - ²³⁵U Fission Spectrum Generator for the CASK-81 and BUGLE-80 Cross Section Libraries," TLG Services, Inc., March 1992.
- 8.11 Levin, A., "O2FLUX - A Computer Code to Prepare ORIGEN2 Input Files," TLG Services, Inc., March 1992.
- 8.12 CCC-254, "ANISN-ORNL - One-Dimensional Discrete Ordinates Transport Code System with Anisotropic Scattering," Oak Ridge National Laboratory Radiation Shielding Information Center, April 1991.
- 8.13 CCC-371, "ORIGEN2 - Isotope Generation and Depletion Code - Matrix Exponention Method," Oak Ridge National Laboratory Radiation Shielding Information Center, May 1991.
- 8.14 Levin, A., "ANISNOUT - A Compute Code to Collapse and Summarize ANISN-ORNL Output," TLG Services, Inc., March 1992.
- 8.15 Levin, A., "O2READ - A Computer Code System to Collapse ORIGEN2 Output," TLG Engineering, March 1992.
- 8.16. "Microsoft EXCEL - Spreadsheet with Business Graphics and Database," Version 4.0, Microsoft Corporation, Redmond, Washington, 1992.

SITE CHARACTERIZATION REPORT**REVISION 0.1**

- 8.17 Letter, C.K. Seaman (PGE Co.) to W.A. Cloutier (TLG), 9 February 1993.
- 8.18 WCAP-12868, Revision 2, "Analysis of Capsule V from the Portland General Electric Company Trojan Reactor Vessel Radiation Surveillance Program," Chicots, J.M., et. al., Westinghouse Electric Corporation, Pittsburgh, Pennsylvania, December 1991.
- 8.19 NUREG/CR-3474, "Long-Lived Activation Products in Reactor Materials," Evans, J.C., et. al., Pacific Northwest Laboratory, August 1984.
- 8.20 PNL-6046, "Spent Fuel Disassembly Hardware and Other Non-Fuel Bearing Components: Characterization, Disposal Cost Estimates, and Proposed Repository Acceptance Requirements," Luksic, A.T., et. al., Battelle Pacific Northwest Laboratory, October 1986.
- 8.21 ASM Metals Reference Handbook," 2nd Edition, American Society of Metals, March 1984.
- 8.22 DLC-76, "SAILOR - Coupled, Self-Shielded, 47-Neutron, 20-Gamma-Ray, P3, Cross Section Library for Light Water Reactors," Oak Ridge National Laboratory Radiation Shielding Information Center, April 1991.
- 8.23 Drawing No. 6117D46, "SCP (As Built 4 Loop Core Barrel Baffle Assy. Final Fit-Up," Westinghouse Electric Corporation, August 1984.
- 8.24 NRC Docket No. 50-344, "Trojan Nuclear Plant Final Safety Analysis Report," Portland General Electric Company, Revision 18, Table 4.1-1.
- 8.25 NUREG/CR-0184, "Characteristics of Spent Fuel, High-level Waste, and Other Radioactive Wastes Which May Require Long-Term Isolation," Volume 2, U.S. Department of Energy, Office of Civilian Waste Management, December 1987.
- 8.26 Nureg/CR-5849, "Manual for Conducting Radiological Surveys in Support of License Termination", USNRC 6/92.
- 8.27 Nureg/CR-4289, "Residual Contamination Within and Around Commercial Nuclear Power Plants", USNRC 2/86.
- 8.28 Nureg/CR-5512, "Residual Radioactive Contamination From Decommissioning", USNRC 1/90.
- 8.29 PGE-8010, "Portland General Electric Quality Assurance Program, Revision 16, 11/93.