

**ENGINE SYSTEMS, INC.**175 Freight Road
Rocky Mount, NC 27804Telephone: 252/977-2720
Fax: 252/446-1134**TELEFAX**

Date: December 21, 2018
Company: NRC Operations Center
Fax Number: 301/816-5151
Verification No.: 301/816-5100
Reference: Report No. 10CFR21-0123, Rev. 1
From: Dan Roberts
Page: 1 of 7

Dear Sir:

Following this cover is a copy of our report 10CFR21-0123, Rev. 1, for a 10CFR21 reportable notification on EMD fuel and soakback pumps.

A copy of the revised report will be mailed to the NRC Document Control Desk and to our affected nuclear customers.

Should you have questions, please let us know.

Sincerely,

ENGINE SYSTEMS, INC.

A handwritten signature in cursive script that reads 'Dan Roberts'.

Dan Roberts
Quality Manager



ENGINE SYSTEMS, INC.

175 Freight Road, Rocky Mount, NC 27804

Telephone: 252/977-2720
Fax: 252/446-1134

Report No. 10CFR21-0123
Rev. 0: 11/30/18
Rev. 1: 12/21/18

**10CFR21 REPORTING OF DEFECTS
AND NON-COMPLIANCE**

COMPONENT: EMD Fuel and Soakback Pumps – Potentially Undertorqued Cover Bolts

SYSTEM: Emergency Diesel Generator

CONCLUSION: Reportable in Accordance With 10CFR21

Prepared By: *Jim Kim*
Engineering Manager

Date: 12/21/18

Reviewed By: *Dan Robert*
Quality Manager

Date: 12/21/18

Report No. 10CFR21-0123

Record of Revisions
Page: 1 of 1

REV	DATE	PAGE	DESCRIPTION
1	12/21/18	2	In item (iv), added reference to F4B engine application. In item (vii), revised recommended correction action to include a shaft freeness check and provide guidance for reduced bolt torque for previously installed pumps.

Report No. 10CFR21-0123
 Revision: 1
 Date: 12/21/18
 Page: 1 of 2

Pursuant to 10 CFR 21.21(d)(4), ESI is presenting the required information as follows:

(i) Name and address of the individual or individuals informing the Commission.

Dan Roberts
 Quality Manager
 Engine Systems Inc.
 175 Freight Rd.
 Rocky Mount, NC 27804

John Kriesel
 Engineering Manager
 Engine Systems Inc.
 175 Freight Rd.
 Rocky Mount, NC 27804

(ii) Identification of the basic component supplied within the United States which fails to comply or contains a defect.

EMD fuel and soakback pumps of the following part numbers:

Part Number	Description
8410219	Fuel Pump, Flanged Connections
8080284	Fuel Pump, Threaded Connections
8417074	Lube Oil Scavenging and Fuel Pump Assembly (16, 20-645E4, E4B), includes P/N 8410219
8252842	Lube Oil Scavenging and Fuel Pump Assembly (16, 20-645E4), includes P/N 8080284
8417754	Lube Oil Scavenging and Fuel Pump Assembly (12-845E4, E4B), includes P/N 8410219
8447715	Fuel Pump and Motor Assembly, includes P/N 8410219
8455818	Soakback Pump and Motor Assembly
8460815	Lube Oil Soakback and Fuel Pump

(iii) Identification of the firm supplying the basic component which fails to comply or contains a defect.

Engine Systems Inc. (ESI)

(iv) Nature of the defect or failure to comply and the safety hazard which is created or could be created by such defect or failure to comply.

ESI was notified by a nuclear customer of two instances where a bolt was found loose or backed out of the cover of an EMD engine driven fuel pump P/N 8410219. Following notification, ESI inspected remaining pumps in inventory and found instances where one or more the pump cover bolts were loose or lightly torqued. See Figure 1 below for a visual depiction of the pump and bolts.

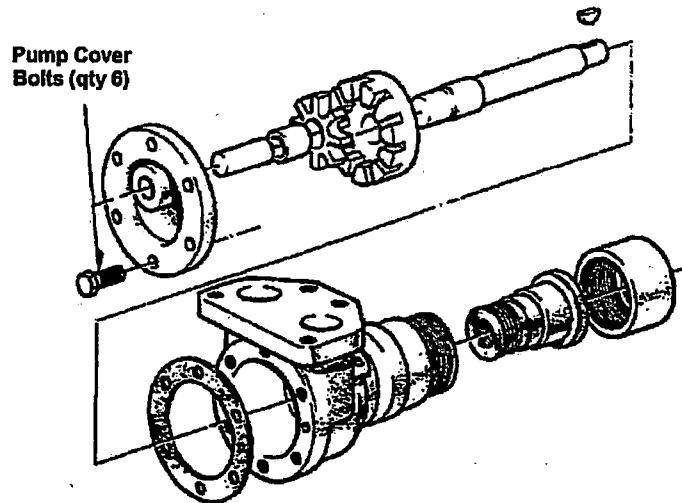

Figure 1: Exploded View of Pump P/N 8410219

Report No. 10CFR21-0123
Revision: 1
Date: 12/21/18
Page: 2 of 2

EMD fuel pump, P/N 8410219, is commonly used on all 12, 16, and 20-cylinder EMD model 645E4, E4B, and F4B engines. The pump is either mechanically driven from the engine (via the scavenging lube oil pump) or motor driven (as in the case of a backup/redundant fuel pump). The pump transfers fuel oil from the day tank to the fuel injectors to support fuel combustion. Without the supply of fuel oil, the diesel engine is unable to produce power which adversely affects the safety-related operation of the emergency diesel generator set.

- (v) The date on which the information of such defect or failure to comply was obtained.

October 24, 2018

- (vi) In the case of a basic component which contains a defect or fails to comply, the number and location of these components in use at, supplied for, being supplied for, or may be supplied for, manufactured, or being manufactured for one or more facilities or activities subject to the regulations in this part.

The extent of condition includes pump P/N 8410219 as well as the part numbers listed in Table 1 in Appendix A. Note that P/N 8080284 is otherwise identical to P/N 8410219 except that the ports are threaded as opposed to flanged. The scavenging pump assemblies listed are upper level assemblies that contain either P/N 8410219 or 8080284. The fuel pump and motor assembly utilizes P/N 8410219. The soakback pump assemblies listed use a pump made by the same manufacturer with similar construction and therefore are included in the extent of condition.

Based on ESI's investigation the issue may extend as far back as 2014. Therefore, any of the pumps supplied from 2014 through 2018 are considered suspect.

- (vii) The corrective action which has been, is being, or will be taken; the name of the individual or organization responsible for the action; and the length of time that has been or will be taken to complete the action.

For all affected customers:

ESI recommends inspecting the bolt tightness for all pumps. The recommended bolt torque is 108 to 120 in-lbs (12 to 13 Nm). After verifying bolt torque, a shaft freeness check is recommended. The pump shaft should be capable of being rotated by hand in either direction. Due to the small shaft size, this check is commonly performed with a small crescent wrench or with the coupling half installed on the shaft. Inability to rotate by hand indicates loss of end clearance and the pump should be returned to ESI for rework or replacement.

Note: For installed pumps where it is not possible to check shaft freeness, ESI recommends using a reduced bolt torque of 60 to 70 in-lbs (7 to 8 Nm). This is sufficient to ensure the bolts are snug while safeguarding against loss of end clearance that would otherwise go undetected.

This activity should be performed at the earliest opportunity; however, it is more important for the inspection to be performed on newly installed pumps. It is expected that for pumps supplied with low bolt torque, if a problem were to develop it would be in the form of a fuel leak soon after installation. For pumps that have been successfully installed for several months or years with no detectable leakage, it is less likely that bolt(s) are loose and therefore the urgency of this inspection is reduced.

For ESI:

The dedication procedures for these pumps have been revised or are being revised to add a step to verify proper bolt torque. This will be completed prior to any future shipments. In addition, ESI is in correspondence with the pump manufacturer to implement corrective actions to prevent recurrence.

- (viii) Any advice related to the potential defect or failure to comply about the facility, activity, or basic component that has been, is being, or will be given to purchasers or licensees.

Verification of bolt tightness is non-invasive and may be performed with the pump installed (and operating). The bolts are external to the pump and the cover is stationary; there is no impact to pump operation or functionality while performing this inspection.

Report No. 10CFR21-0123
Revision: 1

Appendix A List of Affected Customers
Page: 1 of 2

Part Number	Description	Customer	Customer PO	Customer Part Number	Qty Shipped	C of C Date	ESI Order	Line	Pump Serial Number(s)
8410219	FUEL PUMP, FLANGED CONNECTIONS, ENGINE DRIVEN	FLORIDA POWER & LIGHT - ST LUCIE	02913521/00043	0000368622 1	7	03/27/14	3012408	1.1	12710527 12710535 12710539 12710553 12710544 12710548 12710552
		TENNESSEE VALLEY AUTHORITY - BROWN'S FERRY	713665	8410219	4	08/21/14	8002290	20.1	12710671 12710666 12710651 12382313
		TENNESSEE VALLEY AUTHORITY - BROWN'S FERRY	713665	8410219	4	08/21/14	8002290	34.1	12710676 12710665 12710669 12710668
		ENTERGY OPERATIONS INC - GRAND GULF NUCLEAR	10428304	1281504299	1	01/28/15	3013513	1.1	12710673
		EXELON - NINE MILE POINT	00544836	0001679179 1	1	04/08/15	3013781	1.1	12710664
		ENTERGY OPERATIONS INC RIVER BEND	10439523	0032132608	1	04/08/15	3013974	1.1	12710675
		NEXTERA ENERGY POINT BEACH LLC	02313520/00080	0006559075 1	1	04/30/15	3014099	1.1	8497920094
		ENERGY NORTHWEST	00344808	0058165345	2	09/24/15	3014526	3.1	8497920122 8497920128
		EXELON - DRESDEN	703; Rel. 12686	000043611 1	1	02/25/16	3015071	1.1	8497750097
		NUCLEAR POWER PLANT KRSKO+	3151747/14625	105825	1	02/29/16	3014817	1.1	8497920112
		NUCLEAR POWER PLANT KRSKO+	3151747/14625	105825	1	03/03/16	3014817	1.1	8497920124
		EXELON - LASALLE	00572185	000043611 1	4	05/06/16	3015350	1.1	12548101 12710734 8591700274 8591700277
		SAVANNAH RIVER REMEDIATION LLC	5RRAD069144	8410219	2	12/06/16	3015928	39.1	12710697 8591700290
		ENTERGY OPERATIONS INC - GRAND GULF NUCLEAR	10529624	1281504299	2	01/08/18	3017555	2.1	12710403 8591700273
		ENERGY NORTHWEST	00351174	0058165345	1	03/09/18	3017807	1.1	8197960000
		TENNESSEE VALLEY AUTHORITY - BROWN'S FERRY	3418640	CVT548N	1	03/16/18	3017688	1.1	8591700281
		EXELON - DRESDEN	00646095	000043611 1	2	06/18/18	3018069	1.1	8197850294 8194960191
		ENERGY NORTHWEST	00351174	0058165345	4	06/20/18	3017807	1.1	8194890101 8194960189 8194960193 8194890099
		EXELON - NINE MILE POINT	00643368	0001679179 1	1	06/21/18	3018002	1.1	8194960194
		DUKE ENERGY CAROLINAS LLC - OCONEE NUCLEAR	03066435	0000157557	1	08/01/18	3018132	1.1	8196760103
		ENTERGY OPERATIONS INC - GRAND GULF NUCLEAR	10553808	1281504299	1	08/30/18	3018608	1.1	8194960190
		EXELON - LASALLE	703; Rel. 12989	000043611 1	3	08/30/18	3018649	1.1	8196760104 8196760106 8195690224
		EXELON - CLINTON POWER PLANT	703; Rel. 12988	000043611 1	3	09/20/18	3018650	1.1	8195690223 8195690229 8193840555
		P&S ENRIQUE MARIA HIERRO SL - ALMARAZ	N2018/018	8410219	2	10/16/18	3018083	1.1	8196760100 8196760105
8080284	FUEL PUMP, THREADED CONNECTIONS, ENGINE DRIVEN	FLORIDA POWER & LIGHT - TURKEY POINT	02318321/00043	0001700687 1	1	02/28/14	3012203	1.1	12523759
		OMAHA PUBLIC POWER DISTRICT	00204966	0000024379 1	3	08/15/14	3012980	1.1	12523604 12523608 12523800
		FIRST ENERGY CORP - BEAVER VALLEY	45458123	8523787	2	01/19/15	3013189	1.1	8591960081 8590700119
		P&S ENRIQUE MARIA HIERRO SL - NUCLEONOR	N2016/011	8080284	1	06/03/16	3015292	7.1	8591700267
		DOMINION VIRGINIA POWER - SLURRY POWER STATION	4500298167	06006510	1	07/07/16	3015625	2.1	8396760113
		EXELON - DRESDEN	703; Rel. 12731	0000019419 1	3	10/31/16	3016024	1.1	8396760112 8394860265 8392800023
		EXELON - FITZPATRICK	703; Rel. 12927	0006211221	2	03/27/18	3017678	1.1	8290730210 8394860261
		EXELON - NINE MILE POINT	703; Rel. 12937	0001579058 1	1	04/03/18	3017764	1.1	8288890252
ENTERGY OPERATIONS INC - ARKANSAS	10550517	000558-718	2	08/30/18	3018470	1.1	8194920089 8194920068		

Table 1: List of Affected Customers
(continued on next page)

Report No. 10CFR21-0123
Revision: 1

Appendix A List of Affected Customers
Page: 2 of 2

Part Number	Description	Customer	Customer PO	Customer Part Number	Qty Shipped	C of C Date	ESI Order	Line	Pump Serial Number(s)
8417074	LUBE OIL SCAVENGING AND FUEL PUMP ASSEMBLY (16,20-645E4,E4B) WITH P/N 8410219 FUEL PUMP	BMPC - KAPL	7017027	8417074	1	01/28/14	3012288	73.1	12548134
		TENNESSEE VALLEY AUTHORITY - WATTS BAR	2605647	CAW481V	1	04/05/17	3016354	1.1	12547923
8252842	LUBE OIL SCAVENGING & FUEL PUMP ASSEMBLY (15,20-645E4) WITH P/N 8080284 FUEL PUMP	OMAHA PUBLIC POWER DISTRICT	00200846	0000139165 1	1	10/20/14	3012561	2.1	12523773
8417754	LUBE OIL SCAVENGING AND FUEL PUMP ASSEMBLY (12-645E4, E4B) WITH P/N 8410219 FUEL PUMP	DUKE ENERGY CAROLINAS LLC - OCONEE NUCLEAR	03035494	0000330781 1	1	06/01/17	3016321	1.1	8492750228
8447715	FUEL PUMP AND MOTOR ASSEMBLY	EXELON - CLINTON POWER PLANT	00572667	0000032240	2	02/23/18	3015859	1.1	8295750088 8295750089
8455818	SOAKBACK PUMP & MOTOR ASSEMBLY	DOMINION VIRGINIA POWER - SURRY POWER STATION	4500386340	42026328	1	10/31/17	3017171	1.1	8387770061
		DOMINION VIRGINIA POWER - SURRY POWER STATION	4500394508	42026328	2	02/06/18	3017306	1.1	8489910003 8487970346
8460815	LUBE OIL SOAKBACK AND FUEL PUMP	ENERGY NORTHWEST	00345051	0058166535	3	01/12/16	3014666	3.1	8587900264 8497860219 8493900161
		ENERGY NORTHWEST	00351743	0058166535	2	05/25/18	3018195	1.1	8198820094 8198820096

Table 1: List of Affected Customers