

Keith J. Polson
Senior Vice President and CNO

DTE Energy Company
6400 N. Dixie Highway, Newport, MI 48166
Tel: 734.586.6515 Fax: 734.586.1431
Email: keith.polson@dteenergy.com



December 14, 2018
NRC-18-0054

Order No. EA-13-109

U.S. Nuclear Regulatory Commission
Attention: Document Control Desk
Washington, DC 20555-0001

Fermi 2 Power Plant
NRC Docket No. 50-341
NRC License No. NPF-43

Subject: Report of Full Compliance with Phase 1 and Phase 2 of June 6, 2013
Commission Order Modifying Licenses with Regard to Reliable Hardened
Containment Vents Capable of Operation Under Severe Accident Conditions
(Order Number EA-13-109)

References:

- 1) NRC Order EA-13-109, "Issuance of Order to Modify Licenses with Regard to Reliable Hardened Containment Vents Capable of Operation Under Severe Accident Conditions," dated June 6, 2013 (Accession No. ML13143A321)
- 2) DTE Electric Company Letter, "DTE Electric Company's Answer to June 6, 2013 Commission Order Modifying Licenses With Regard to Reliable Hardened Containment Vents Capable of Operation under Severe Accident Conditions (Order Number EA-13-109)," dated June 26, 2013 (Accession No. ML13178A026)
- 3) NRC Interim Staff Guidance JLD-ISG-2015-01, "Compliance with Phase 2 Order EA-13-109, Order Modifying Licenses with Regard to Reliable Hardened Containment Vents Capable of Operation under Severe Accident Conditions," Revision 0, dated April 2015 (Accession No. ML15104A118)
- 4) NEI 13-02, "Industry Guidance for Compliance with Order EA-13-109, BWR Mark I & II Reliable Hardened Containment Vents Capable of Operation Under Severe Accident Conditions," Revision 1, dated April 2015 (Accession No. ML15113B318)
- 5) DTE Electric Company Letter, NRC-14-0043, "DTE Electric Company's Phase 1 Integrated Plan in Response to June 6, 2013 Commission Order Modifying Licenses with Regard to Reliable Hardened Containment Vents Capable of Operation under Severe Accident Conditions (Order Number EA-13-109)," dated June 30, 2014 (Accession No. ML14182A203)

- 6) DTE Electric Company letter, NRC-14-0075, "DTE Electric Company's First Six Month Status Report in Response to June 6, 2013 Commission Order Modifying Licenses with Regard to Reliable Hardened Containment Vents Capable of Operation under Severe Accident Conditions (Order Number EA-13-109)," dated December 18, 2014 (Accession No. ML14352A174)
- 7) DTE Electric Company letter, NRC-15-0070, "DTE Electric Company's Second Six-Month Status Report in Response to June 6, 2013 Commission Order Modifying Licenses with Regard to Reliable Hardened Containment Vents Capable of Operation under Severe Accident Conditions (Order Number EA-13-109)," dated June 11, 2015 (Accession No. ML15162A729)
- 8) DTE Electric Company Letter, NRC-15-0105, "DTE Electric Company's Phase 1 and Phase 2 Overall Integrated Plan for Implementation of Order EA-13-109, Order Modifying Licenses with Regard to Reliable Hardened Containment Vents Capable of Operation Under Severe Accident Conditions," dated December 23, 2015 (Accession No. ML15357A289)
- 9) DTE Electric Company Letter, NRC-16-0039, "DTE Electric Company's Fourth Six-Month Status Report for Implementation of Order EA-13-109, Order Modifying Licenses with Regard to Reliable Hardened Containment Vents Capable of Operation Under Severe Accident Conditions," dated June 20, 2016 (Accession No. ML16172A209)
- 10) DTE Electric Company Letter, NRC-16-0069, "DTE Electric Company's Fifth Six-Month Status Report for Implementation of Order EA-13-109, Order Modifying Licenses with Regard to Reliable Hardened Containment Vents Capable of Operation Under Severe Accident Conditions," dated December 9, 2016 (Accession No. ML16344A252)
- 11) DTE Electric Company Letter, NRC-17-0043, "DTE Electric Company's Sixth Six-Month Status Report for Implementation of Order EA-13-109, Order Modifying Licenses with Regard to Reliable Hardened Containment Vents Capable of Operation Under Severe Accident Conditions," dated June 27, 2017 (Accession No. ML17178A343)
- 12) DTE Electric Company Letter, NRC-17-0079, "DTE Electric Company's Seventh Six-Month Status Report for Implementation of Order EA-13-109, Order Modifying Licenses with Regard to Reliable Hardened Containment Vents Capable of Operation Under Severe Accident Conditions," dated December 14, 2017 (Accession No. ML17348A784)
- 13) DTE Electric Company Letter, NRC-18-0037, "DTE Electric Company's Eighth Six-Month Status Report for Implementation of Order EA-13-109, Order Modifying Licenses with Regard to Reliable Hardened Containment Vents Capable of Operation Under Severe Accident Conditions," dated June 26, 2018 (Accession No. ML18177A259)
- 14) NRC Letter to DTE Electric Company, "Fermi Unit 2 – Interim Staff Evaluation Relating to Overall Integrated Plan in Response to Phase 1 of Order EA-13-109 (Severe Accident Capable Hardened Vents)," dated April 1, 2015 (Accession No. ML15077A574)

- 15) NRC Letter to DTE Electric Company, “Fermi Unit 2 – Interim Staff Evaluation Relating to Overall Integrated Plan in Response to Phase 2 of Order EA-13-109 (Severe Accident Capable Hardened Vents),” dated August 30, 2016 (Accession No. ML16231A443)
- 16) NRC Letter to DTE Electric Company, “Fermi Unit 2 – Report for the Audit of Licensee Responses to Interim Staff Evaluations Open Items Related to NRC Order EA-13-109 to Modify Licenses with Regard to Reliable Hardened Containment Vents Capable of Operation Under Severe Accident Conditions,” dated July 10, 2018 (Accession No. ML18186A421)

On June 6, 2013, the Nuclear Regulatory Commission (NRC) issued Order EA-13-109, “Order Modifying Licenses with Regard to Reliable Hardened Containment Vents Capable of Operation Under Severe Accident Conditions,” (Reference 1) to DTE Electric Company (DTE). Reference 1 was immediately effective and directs DTE to require Fermi Unit 2 (Fermi 2) to take certain actions to ensure the facility has a hardened containment vent system (HCVS) to remove decay heat from the containment and maintain control of containment pressure within acceptable limits following events that result in loss of active containment heat removal capability while maintaining the capability to operate under severe accident (SA) conditions resulting from an Extended Loss of AC Power (ELAP). Specific requirements are outlined in Attachment 2 of Reference 1. Reference 2 provided DTE’s initial response to the Order.

Reference 3 provided the NRC interim staff guidance on methodologies for compliance with Phases 1 and 2 of Reference 1 and endorsed industry guidance document NEI 13-02, Revision 1 (Reference 4) with clarifications and exceptions. Reference 5 provided the Fermi 2 Phase 1 Overall Integrated Plan (OIP), which was replaced with the Phase 1 (Updated) and Phase 2 OIP (Reference 8). References 14 and 15 provided the NRC review of the Phase 1 and Phase 2 OIP, respectively, in an Interim Staff Evaluation (ISE).

Reference 1 required submission of a status report at six-month intervals following the submittal of the OIP. References 6, 7, 8, 9, 10, 12, and 13 provided the first, second, third, fourth, fifth, sixth, seventh, and eighth six-month status reports, respectively, pursuant to Section IV, Condition D.3, of Reference 1 for Fermi 2.

The purpose of this letter is to provide the report of full compliance with Phase 1 and Phase 2 of the June 6, 2013 Commission Order Modifying Licenses with Regard to Reliable Hardened Containment Vents Capable of Operation Under Severe Accident Conditions (Order Number EA-13-109) (Reference 1) pursuant to Section IV, Condition D.4 of the Order for Fermi 2.

Fermi 2 has designed and installed a venting system that provides venting capability from the wetwell during severe accident conditions in response to Phase 1 of NRC Order EA-13-109. Fermi 2 has implemented a reliable containment venting strategy that makes it unlikely that the plant would need to vent from the containment drywell before alternative reliable containment heat removal and pressure control is reestablished in response to Phase 2 of NRC

Order EA-13-109. The information provided herein documents full compliance for Fermi 2 with NRC Order EA-13-109.

Fermi 2 Phase 1 OIP Open Items have been addressed and completed as documented in Reference 11. DTE's response to the Phase 1 ISE Open Items identified in Reference 14 have been addressed and completed as documented in Reference 11 and are considered closed per Reference 16. The following table provides completion and closure reference for each OIP and ISE Phase 1 Open Item.

Phase 1 OIP/ISE Items	Completion/Closure References
OIP Phase 1 Open Item No. 1 Confirm thermal environment for actions using GOTHIC.	Completed per Reference 11. References have been provided on the e-portal.
OIP Phase 1 Open Item No. 2 Confirm radiological environment.	Completed per Reference 11. References have been provided on the e-portal.
OIP Phase 1 Open Item No. 3 Confirm suppression pool heat capacity.	Completed per Reference 11. References have been provided on the e-portal.
OIP Phase 1 Open Item No. 4 Define tornado missile protection for RB 5 th floor components.	Completed per Reference 11. References have been provided on the e-portal.
ISE Phase 1 Open Item No. 1 Make available for NRC staff audit documentation confirming that all load stripping will be accomplished within one hour and fifteen minutes of event initiation and will occur at locations not impacted by a radiological event.	Completed per Reference 11 and closed per Reference 16.
ISE Phase 1 Open Item No. 2 Make available for NRC staff audit an evaluation of Section 3.2.1 temperature and radiological conditions to ensure that operating personnel can safely access and operate controls and support equipment.	Completed per Reference 11 and closed per Reference 16.

Phase 1 OIP/ISE Items	Completion/Closure References
<p>ISE Phase 1 Open Item No. 3</p> <p>Make available for NRC staff audit, analyses demonstrating that HCVS has the capacity to vent the steam/energy equivalent of one percent of licensed/rated thermal power (unless a lower value is justified), and that the suppression pool and the HCVS together are able to absorb and reject decay heat, such that following a reactor shutdown from full power containment pressure is restored and then maintained below the primary containment design pressure and the primary containment pressure limit.</p>	<p>Completed per Reference 11 and closed per Reference 16.</p>
<p>ISE Phase 1 Open Item No. 4</p> <p>Make available for NRC staff audit the descriptions of local conditions (temperature, radiation and humidity) anticipated during extended loss of alternating current (AC) power (ELAP) and severe accident for the components (valves, instrumentation, sensors, transmitters, indicators, electronics, control devices, etc.) required for HCVS venting including confirmation that the components are capable of performing their functions during ELAP and severe accident conditions.</p>	<p>Completed per Reference 11 and closed per Reference 16.</p>
<p>ISE Phase 1 Open Item No. 5</p> <p>Make available for NRC staff audit documentation of the HCVS nitrogen pneumatic system design including sizing and location.</p>	<p>Completed per Reference 11 and closed per Reference 16.</p>
<p>ISE Phase 1 Open Item No. 6</p> <p>Make available for NRC staff audit the final sizing evaluation for HCVS batteries/battery charger including incorporation into FLEX diesel generator (DG) loading calculation.</p>	<p>Completed per Reference 11 and closed per Reference 16.</p>
<p>ISE Phase 1 Open Item No. 7</p> <p>Make available for NRC staff audit documentation that demonstrates adequate communication between the remote HCVS operation locations and HCVS decision makers during ELAP and severe accident conditions.</p>	<p>Completed per Reference 11 and closed per Reference 16.</p>

Phase 1 OIP/ISE Items	Completion/Closure References
<p>ISE Phase 1 Open Item No. 8</p> <p>Provide a description of the final design of HCVS to address hydrogen detonation and deflagration.</p>	<p>Completed per Reference 11 and closed per Reference 16.</p>
<p>ISE Phase 1 Open Item No. 9</p> <p>Provide a description of the strategies for hydrogen control that minimizes the potential for hydrogen gas migration and ingress into the reactor building or other buildings.</p>	<p>Completed per Reference 11 and closed per Reference 16.</p>
<p>ISE Phase 1 Open Item No. 10</p> <p>Make available for NRC staff review design details to ensure the potential for cross flow between HCVS and Standby Gas Treatment System (SGTS) is minimized.</p>	<p>Completed per Reference 11 and closed per Reference 16.</p>
<p>ISE Phase 1 Open Item No. 11</p> <p>Provide a justification for deviating from the instrumentation seismic qualification guidance specified in Nuclear Energy Institute (NEI) 13-02, endorsed, in part, by JLD-ISG-2013-02 as an acceptable means for implementing applicable requirements of Order EA-13-109.</p>	<p>Completed per Reference 11 and closed per Reference 16.</p>
<p>ISE Phase 1 Open Item No. 12</p> <p>Make available for NRC staff audit description of all instrumentation and controls (existing and planned) necessary to implement this order including qualification methods.</p>	<p>Completed per Reference 11 and closed per Reference 16.</p>
<p>ISE Phase 1 Open Item No. 13</p> <p>Make available for NRC staff audit documentation of an evaluation verifying the existing containment isolation valves, relied upon for the HCVS, will open under the maximum expected differential pressure during beyond design basis external events (BDBEE) and severe accident wetwell venting.</p>	<p>Completed per Reference 11 and closed per Reference 16.</p>

Fermi 2 Phase 2 OIP and ISE Open Items have been addressed and completed as documented in the following table.

Phase 2 OIP/ISE Items	Closure References
<p>OIP Phase 2 Open Item No. 1</p> <p>Confirm that the thermal environment supports feasibility of staff actions.</p>	<p>Completed.</p> <p>The thermal environment was evaluated and supports the feasibility of staff actions.</p> <p>References have been provided on the e-portal.</p>
<p>OIP Phase 2 Open Item No. 2</p> <p>Confirm that the radiological environment supports feasibility of staff actions.</p>	<p>Completed.</p> <p>The radiological environment was evaluated and supports the feasibility of staff actions.</p> <p>References have been provided on the e-portal.</p>
<p>ISE Phase 2 Open Item No. 1</p> <p>Licensee to demonstrate that containment failure as a result of overpressure can be prevented without a drywell vent during severe accident conditions.</p>	<p>Completed.</p> <p>Analysis confirmed that containment failure as a result of overpressure is prevented without a drywell vent during severe accident conditions.</p> <p>Closed per Reference 16.</p> <p>References have been provided on the e-portal.</p>
<p>ISE Phase 2 Open Item No. 2</p> <p>Licensee to provide the site-specific MAAP evaluation that demonstrates Severe Accident Water Addition (SAWA) / Severe Accident Water Management (SAWM) can be maintained for greater than 7 days.</p>	<p>Completed.</p> <p>Analysis confirmed that SAWA/SAWM can be maintained for greater than 7 days.</p> <p>Closed per Reference 16.</p> <p>References have been provided on the e-portal.</p>

Phase 2 OIP/ISE Items	Closure References
<p>ISE Phase 2 Open Item No. 3</p> <p>Licensee to demonstrate that there is adequate communication between Main Control Room and the SAWM control location during severe accident conditions.</p>	<p>Completed.</p> <p>Testing has demonstrated that communication between the Main Control Room and the SAWM control location during severe accident conditions is adequate.</p> <p>Closed per Reference 16.</p> <p>References have been provided on the e-portal.</p>
<p>ISE Phase 2 Open Item No. 4</p> <p>Licensee to demonstrate the SAWM flow instrumentation qualification for the expected environmental conditions.</p>	<p>Completed.</p> <p>Analysis confirmed that the SAWM flow instrumentation qualification for the expected environmental conditions is acceptable.</p> <p>References have been provided on the e-portal.</p>

Milestone Schedule – Items Complete

Milestone	Target Completion Date	Activity Status	Comments
Phase 1 and 2 HCVS Milestone Table			
Submit Overall Integrated Plan	Jun 2014	Complete	
Submit 6 Month Updates			
Update 1	Dec 2014	Complete	
Update 2	Jun 2015	Complete	
Update 3 [with Phase 2 OIP]	Dec 2015	Complete	
Update 4	Jun 2016	Complete	
Update 5	Dec 2016	Complete	
Update 6	Jun 2017	Complete	
Update 7	Dec 2017	Complete	
Update 8	Jun 2018	Complete	
Update 9	Dec 2018	Not Required	
Phase 1 Specific Milestones			
Phase 1 Modifications			
Hold Preliminary/Conceptual Design Meeting	Jun 2014	Complete	
Modifications Evaluation	Jul 2014	Complete	
Design Engineering On-site/Complete	Apr 2017	Complete	
Implementation Outage	Apr 2017	Complete	
Walk Through Demonstration/Functional Test	Apr 2017	Complete	
Phase 1 Procedure Changes Active			
Operations Procedure Changes Developed	Apr 2017	Complete	
Site Specific Maintenance Procedure Developed	Apr 2017	Complete	
Procedure Changes Active	Apr 2017	Complete	
Phase 1 Training			
Training Complete	Apr 2017	Complete	
Phase 1 Completion			
Submit Completion Report [60 days after full site compliance]	Jun 2017	Not Required	Not required for Phase 1.
Phase 2 Specific Milestones			
Phase 2 Modifications			
Hold Preliminary/Conceptual Design Meeting	Sept 2016	Complete	
Modifications Evaluation	Sept 2016	Complete	
Design Engineering On-site/Complete	Oct 2018	Complete	
Implementation Outage	Oct 2018	Not Required	No modifications required for Phase 2.
Walk Through Demonstration/Functional Test	Oct 2018	Complete	
Phase 2 Procedure Changes Active			
Operations Procedure Changes Developed	Oct 2018	Complete	
Site Specific Maintenance Procedure Developed	Oct 2018	Complete	
Procedure Changes Active	Oct 2018	Complete	

Milestone	Target Completion Date	Activity Status	Comments
Phase 2 Training			
Training Complete	Oct 2018	Complete	
Phase 2 Completion			
Submit Completion Report [60 days after full site compliance]	Dec 2018	This Submittal	

Order EA-13-109 Compliance Elements Summary

The elements identified below for Fermi 2, as well as the Phase 1 (Updated) and Phase 2 OIP response submittal (Reference 8) and the 6-Month Status Reports (References 6, 7, 8, 9, 10, 11, 12, and 13), demonstrate compliance with NRC Order EA-13-109. The Fermi 2 Final Integrated Plan for reliable hardened containment vent Phase 1 and Phase 2 strategies is provided in the enclosure to this letter.

HCVS Phase 1 and Phase 2 Functional Requirements and Design Features – Complete

The Fermi 2 Phase 1 HCVS provides a vent path from the wetwell to remove decay heat, vent the containment atmosphere, and control containment pressure within acceptable limits. The Phase 1 HCVS will function for those accident conditions for which containment venting is relied upon to reduce the probability of containment failure, including accident sequences that result in the loss of active containment heat removal capability during an extended loss of alternating current power.

The Fermi 2 Phase 2 HCVS provides a reliable containment venting strategy that makes it unlikely that the plant would need to vent from the containment drywell before alternative reliable containment heat removal and pressure control is reestablished. The Fermi 2 Phase 2 HCVS strategies implement Severe Accident Water Addition (SAWA) with Severe Accident Water Management (SAWM) as an alternative venting strategy. This strategy consists of the use of the Phase 1 wetwell vent and SAWA hardware to implement a water management strategy that will preserve the wetwell vent path until alternate reliable containment heat removal can be established.

The Fermi 2 Phase 1 and Phase 2 HCVS strategies are in compliance with Order EA-13-109. The modifications required to support the HCVS strategies for Fermi 2 have been fully implemented in accordance with the station processes.

HCVS Phase 1 and Phase 2 Quality Standards – Complete

The design and operational considerations of the Phase 1 and Phase 2 HCVS installed at Fermi 2 complies with the requirements specified in the Order and described in NEI 13-02, Revision 1, “Industry Guidance for Compliance with Order EA-13-109.” The

Phase 1 and Phase 2 HCVS has been installed in accordance with the station design control process.

The Phase 1 and Phase 2 HCVS components including piping, piping supports, containment isolation valves, containment isolation valve actuators and containment isolation valve position indication have been designed consistent with the design basis of the plant. All other Phase 1 and Phase 2 HCVS components including electrical power supply, valve actuator pneumatic supply, and instrumentation have been designed for reliable and rugged performance that is capable of ensuring Phase 1 and Phase 2 HCVS functionality following a seismic event.

HCVS Phase 1 and Phase 2 Programmatic Features – Complete

Storage of portable equipment for Fermi 2 Phase 1 and Phase 2 HCVS use provides adequate protection from applicable site hazards, and identified paths and deployment areas will be accessible during all modes of operation and during severe accidents, as recommended in NEI 13-02, Revision 1, Section 6.1.2.

Training in the use of the Phase 1 and Phase 2 HCVS for Fermi 2 has been completed in accordance with an accepted training process as recommended in NEI 13-02, Revision 1, Section 6.1.3.

Operating and maintenance procedures for Fermi 2 have been developed and integrated with existing procedures to ensure safe operation of the Phase 1 and Phase 2 HCVS. Procedures have been verified and are available for use in accordance with the site procedure control program.

Site processes have been established to ensure the Phase 1 and Phase 2 HCVS is tested and maintained as recommended in NEI 13-02, Revision 1, Sections 5.4 and 6.2.

Fermi 2 has completed validation in accordance with industry developed guidance to assure required tasks, manual actions, and decisions for HCVS strategies are feasible and may be executed within the constraints identified in the HCVS Phases 1 and 2 OIP for Order EA-13-109 (Reference 8).

Fermi 2 has completed evaluations to confirm accessibility, habitability, staffing sufficiency, and communication capability in accordance with NEI 13-02, Revision 1, Sections 4.2.2 and 4.2.3.

No new commitments are being made in this submittal.

USNRC
NRC-18-0054
Page 12

Should you have any questions or require additional information, please contact Mr. Scott A. Maglio, Manager – Nuclear Licensing, at (734) 586-5076.

I declare under penalty of perjury that the foregoing is true and correct.

Executed on December 14, 2018

A handwritten signature in black ink, appearing to read "Keith J. Polson". The signature is fluid and cursive, with the first name "Keith" being the most prominent.

Keith J. Polson
Senior Vice President and CNO

Enclosure: Fermi 2 Final Integrated Plan Document – Hardened Containment Vent
System NRC Order EA-13-109

cc: NRC Project Manager
NRC Resident Office
Reactor Projects Chief, Branch 5, Region III
Regional Administrator, Region III
Michigan Public Service Commission
Regulated Energy Division (kindschl@michigan.gov)

**Enclosure to
NRC-18-0054**

**Fermi 2 NRC Docket No. 50-341
Operating License No. NPF-43**

**Final Integrated Plan Document – Hardened Containment Vent System
NRC Order EA-13-109**

Final Integrated Plan
HCVS Order EA-13-109
for
Enrico Fermi 2 Nuclear Power Plant



December 14, 2018

Final Integrated Plan
HCVS Order EA-13-109

Table of Contents

Section I: Introduction	1
Section I.A: Summary of Compliance	3
Section I.A.1: Summary of Phase 1 Compliance	3
Section I.A.2: Summary of Phase 2 Compliance	3
Section II: List of Acronyms.....	5
Section II: List of Acronyms (continued)	6
Section II: List of Acronyms (continued)	7
Section III: Phase 1 Final Integrated Plan Details	8
Section III.A: HCVS Phase 1 Compliance Overview	8
Section III.A.1: Generic Letter 89-16 Vent System	8
Section III.B: HCVS Phase 1 Evaluation Against Requirements	10
1. HCVS Functional Requirements	10
2. HCVS Quality Standards	29
Section IV: HCVS Phase 2 Final Integrated Plan.....	29
Section IV.A: The requirements of EA-13-109, Attachment 2, Section B for Phase 2	29
1. HCVS Drywell Vent Functional Requirements	30
2. Containment Venting Strategy Requirements.....	30
Section IV.B: HCVS Existing System	31
Section IV.C: HCVS Phase 2 SAWA System and SAWM Strategy.....	31
Section IV.C.1: Detailed SAWA Flow Path Description	31
Section IV.C.2: Severe Accident Assessment of Flow Path	32
Section IV.C.3: Severe Accident Assessment of Safety-Relief Valves	33
Section IV.C.4: Available Freeboard Use	33
Section IV.C.5: Upper range of Torus level indication.....	34
Section IV.C.6: Torus vent service time.....	34
Section IV.C.7: Strategy time line.....	34
Section IV.C.8: SAWA Flow Control.....	35
Section IV.C.9: SAWA/SAWM Element Assessment.....	35
Section IV.C.10: SAWA/SAWM Instrumentation.....	37
Section IV.C.11: SAWA/SAWM Severe Accident Considerations.....	40
Section V: HCVS Programmatic Requirements	42
Section V.A: HCVS Procedure Requirements.....	42
Section V.B: HCVS Out of Service Requirements	44

Final Integrated Plan
HCVS Order EA-13-109

Section V.C: HCVS Training Requirements.....	46
Section V.D: Demonstration with other Post Fukushima Measures	46
Section VI: References	48
Attachment 1: Phase 2 Freeboard diagram	53
Attachment 2: One Line Diagram of HCVS Vent Path.....	54
Attachment 3: One Line Diagram of HCVS Electrical Power Supply – Primary Method.....	55
Attachment 4: One Line Diagram of SAWA Flow Path	57
Attachment 5: One Line Diagram of SAWA Electrical Power Supply.....	58
Attachment 6: Plant Layout Showing Operator Action Locations (Overview).....	59
Attachment 6A: Yard Layout Showing Operator Action Locations (Overview).....	60
Attachment 6B: Plant Layout Showing Operator Action Locations HCVS Primary Controls ...	61
Attachment 6C: Plant Layout Showing Operator Action Locations RB-1/AB-1	62
Attachment 6D: Plant Layout Showing Operator Action Locations RB-2/AB-2.....	63
Attachment 6E: Plant Layout Showing Operator Action Locations RB-3/AB-3	64
Attachment 6F: Plant Layout Showing Operator Action Locations RB-4/AB-4	65
Attachment 6G: Plant Layout Showing Operator Action Locations RB-5/AB-5.....	66
Table 1: List of HCVS Component, Control and Instrument Qualifications	67
Table 2: Operator Actions Evaluation	71

Section I: Introduction

In 1989, the NRC issued Generic Letter 89-16, "Installation of a Hardened Wetwell Vent," (Reference 1) to all licensees of BWRs with Mark I containments to encourage licensees to voluntarily install a hardened Torus vent. In response, licensees installed a hardened vent pipe from the Torus to some point outside the secondary containment envelope (usually outside the reactor building). Some licensees also installed a hardened vent branch line from the drywell.

On March 19, 2013, the Nuclear Regulatory Commission (NRC) Commissioners directed the staff per Staff Requirements Memorandum (SRM) for SECY-12-0157, Consideration of Additional Requirements for Containment Venting Systems for Boiling Water Reactors with Mark I and Mark II Containments (References 2 and 3) to require licensees with Mark I and Mark II containments to "upgrade or replace the reliable hardened vents required by Order EA-12-050, Order to Modify Licenses with Regard to Reliable Hardened Containment Vents (Reference 4) with a containment venting system designed and installed to remain functional during severe accident conditions." In response, the NRC issued Order EA-13-109, Issuance of Order to Modifying Licenses with Regard to Reliable Hardened Containment Vents Capable of Operation Under Severe Accidents, June 6, 2013 (Reference 5). The Order (EA-13-109) requires that licensees of BWR facilities with Mark I and Mark II containment designs ensure that these facilities have a reliable hardened vent to remove decay heat from the containment, and to maintain control of containment pressure within acceptable limits following events that result in the loss of active containment heat removal capability while maintaining the capability to operate under severe accident (SA) conditions resulting from an Extended Loss of AC Power (ELAP).

Fermi 2 is required by NRC Order EA-13-109 to have a reliable, severe accident capable hardened containment venting system (HCVS). Order EA-13-109 allows implementation of the HCVS Order in two phases.

- Phase 1 upgraded the venting capabilities from the containment Torus to provide a reliable, severe accident capable hardened vent to assist in preventing core damage and, if necessary, to provide venting capability during severe accident conditions. Fermi 2 achieved Phase 1 compliance on April 18, 2017.
- Phase 2 provided additional protections for severe accident conditions through the development of a reliable containment venting strategy that makes it unlikely that Fermi 2 would need to vent from the containment drywell during severe accident conditions. Fermi 2 achieved Phase 2 compliance on October 15, 2018.

NEI developed guidance for complying with NRC Order EA-13-109 in NEI 13-02, Industry Guidance for Compliance with Order EA-13-109, BWR Mark I & II Reliable Hardened Containment Vents Capable of Operation Under Severe Accident Conditions, Revision 0 (Reference 6) with significant interaction with the NRC and Licensees. NEI issued Revision 1 to NEI 13-02 in April 2015 (Reference 7) which contained guidance for compliance with both Phase 1 and Phase 2 of the order. NEI 13-02, Revision 1 also includes HCVS- Frequently Asked Questions (FAQs) 01 through 09 and reference to white papers (HCVS-WP-01 through 03 (References 8 through 10)). The NRC endorsed NEI 13-02 Revision 0 as an acceptable approach

Final Integrated Plan
HCVS Order EA-13-109

for complying with Order EA-13-109 through Interim Staff Guidance JLD-ISG-2013-02, Compliance with Order EA-13-109, Order Modifying Licenses with Regard to Reliable Hardened Containment Vents Capable of Operation under Severe Accident Conditions, issued in November 2013 (Reference 12) and JLD-ISG-2015-01, Compliance with Order EA-13-109, Order Modifying Licenses with Regard to Reliable Hardened Containment Vents Capable of Operation under Severe Accident Conditions issued in April 2015 (Reference 13) for NEI 13-02 Revision 1 with some clarifications and exceptions. NEI 13-02 Revision 1 provides an acceptable method of compliance for both Phases of Order EA-13-109.

In addition to the endorsed guidance in NEI 13-02, the NRC staff endorsed several other documents that provide guidance for specific areas. HCVS-FAQs 10 through 13 (References 14 through 17) were endorsed by the NRC after NEI 13-02 Revision 1 on October 8, 2015. NRC staff also endorsed four White Papers, HCVS-WP-01 through 04 (References 8 through 11), which cover broader or more complex topics than the FAQs.

As required by the order, Fermi 2 submitted a phase 1 Overall Integrated Plan (OIP) in June of 2014 (Reference 18) and subsequently submitted a combined Phase 1 and 2 OIP in December 2015 (Reference 19). These OIPs followed the guidance NEI 13-02 Revision 0 and 1 respectively, Compliance with Order EA-13-109, Severe Accident Reliable Hardened Containment Vents. The NRC staff used the methods described in the ISGs to evaluate licensee compliance as presented in the Order EA-13-109 OIPs. While the Phase 1 and combined Phase 1 and 2 OIPs were written to different revisions of NEI 13-02, Fermi 2 conforms to NEI 13-02 Revision 1 for both Phases of Order EA-13-109.

The NRC performed a review of each OIP submittal and provided Fermi 2 with Interim Staff Evaluations (ISEs) (References 20 and 21) assessing the site's compliance methods. In the ISEs the NRC identified open items which the site needed to address before that phase of compliance was reached. Six-month progress reports (References 22 through 29) were provided consistent with the requirements of Order EA-13-109. These status reports were used to close many of the ISE open items. In addition, the site participated in NRC ISE Open Item audit calls where the information provided in the six-month updates and on the E-Portal were used by the NRC staff to determine whether the ISE Open Items appeared to be addressed.

By submittal of this Final Integrated Plan, Fermi 2 has addressed all the elements of NRC Order EA-13-109 utilizing the endorsed guidance in NEI 13-02 Revision 1 and the related HCVS-FAQ and HCVS-WP documents. In addition, the site has addressed the NRC Phase 1 and Phase 2 ISE Open Items as documented in References 30 and 31.

Section III contains the Fermi 2 Final Integrated Plan details for Phase 1 of the Order. Section IV contains the Final Integrated Plan details for Phase 2 of the Order. Section V details the programmatic elements of compliance.

Section I.A: Summary of Compliance

Section I.A.1: Summary of Phase 1 Compliance

The plant venting actions for the EA-13-109, Phase 1, severe accident capable venting scenario can be summarized by the following:

The HCVS is initiated via manual action from the HCVS Control Panel (H11P101) or the Main Control Room (MCR) at the appropriate time based on procedural guidance in response to plant conditions from observed or derived symptoms.

- The vent utilizes containment parameters of pressure and level from the MCR instrumentation to monitor effectiveness of the venting actions.
- The vent operation is monitored by HCVS valve position, temperature and effluent radiation levels.
- The HCVS motive force is monitored and has the capacity to operate for at least 24 hours with installed equipment. Replenishment of the motive force will be by use of portable equipment once the installed motive force is exhausted.
- Venting actions are capable of being maintained for a sustained period of at least 7 days.

The operation of the HCVS is designed to minimize the reliance on operator actions in response to external hazards. The screened in external hazards for Fermi 2 are seismic, external flooding, high winds, tornadoes, earthquakes, extreme high temperature, and extreme cold. Initial operator actions are completed by plant personnel and include the capability for remote-manual initiation from the HCVS control station. Attachment 2 contains a one-line diagram of the HCVS vent flow path.

Section I.A.2: Summary of Phase 2 Compliance

The Phase 2 actions can be summarized as follows:

- Utilization of Severe Accident Water Addition (SAWA) to initially inject water into the Reactor Pressure Vessel (RPV).
- Utilization of Severe Accident Water Management (SAWM) to control injection and Suppression Pool level to ensure the HCVS Phase 1 Torus vent will remain functional for the removal of heat from the containment.
- Heat can be removed from the containment for at least seven (7) days using the HCVS or until alternate means of heat removal are established that make it unlikely the drywell vent will be required for containment pressure control.
- The SAWA and SAWM actions can be manually activated and controlled from areas that are accessible during severe accident conditions.

Final Integrated Plan
HCVS Order EA-13-109

- Parameters measured are Drywell pressure, Suppression Pool level, SAWA flowrate and the HCVS Phase 1 vent path parameters.

The locations of the SAWA equipment and controls, as well as ingress and egress paths have been evaluated for the expected severe accident conditions (temperature, humidity, radiation) for the Sustained Operating period. Equipment has been evaluated to remain operational throughout the Sustained Operating period. Personnel radiological exposure, temperature and humidity conditions for operation of SAWA equipment will not exceed the limits for Emergency Response Organization (ERO) dose or plant safety guidelines for temperature and humidity.

The SAWA flow path is the same as the FLEX RPV injection flow path. The flow path is from the Circulating Water Pond through the N or N+1 Neptune pumps via the Hoses across the area from FSF-2 to FSF-1. From FSF-1, the flowpath is through the N or N+1 Dominator pump (to boost pressure as required), through the hose to the Manifold Trailer and into the Division 2 RHR connection point (South part of West Wall of RB).

The Manifold Trailer serves to reduce flow to the 500 gpm SAWA flow rate and subsequent lower SAWM flows. The SAWA flow passes through the Division 2 RHR Connection point (with downstream flow inside the Secondary Containment (Reactor Building)) into the installed RHR to FLEX cross-tie piping and valves and then through the Division 2 RHR piping into the RPV. Division 2 RHR valves E1150F015B must be opened and E1150F010 must be closed (done with FLEX Power credited for SAWA actions) to get alignment into the RPV with isolation from Division 1 by E1150F010 closure. Cross flow into other portions of the Division 2 RHR system is via normally closed (and fail closed on loss of power) RHR valves and other boundary valves. Division 2 RHR Pump Discharge Check valves (normally tested for back leakage) isolate the normally open Torus Suction valves.

Drywell (DW) pressure and Suppression Pool level are monitored at the HCVS Panel and in the Main Control Room. SAWA flow rate is adjusted by use of the Manifold Trailer branch line valves. Branch lines (2.5" (2), 4" (1), 6" (1)) contain mechanical flow meters that do not require any external power. Communication is established between the MCR and the FLEX Flow Control Trailer location using Satellite Phones for execution of SAWA and SAWM. Attachment 4 contains a one-line diagram of the SAWA flowpath.

The SAWA electrical loads are included in the FLEX Diesel Generator (DG) loading calculation that was reviewed for EA-12-049 compliance. The FLEX DGs are located North of the RB at FSF-1 and are a significant distance (approximately 350') from the discharge of the HCVS on the North side of the RB. See Attachment 6 for applicable locations. Refueling of the FLEX DG is accomplished from the EDG fuel oil tanks as described in the EA-12-049 FIP (Reference 60).

Evaluations for projected SA conditions (radiation / temperature) indicate that personnel and equipment used for SAWA can complete the initial and support activities without exceeding the ERO-allowable dose for equipment operation or site safety standards.

Electrical equipment and instrumentation is powered from the existing station batteries and from AC distribution systems that are powered from the FLEX generator(s). The battery chargers are also powered from the FLEX generator to maintain the battery capacities during the Sustained Operating period.

Section II: List of Acronyms

AC	Alternating Current
AOV	Air Operated Valve
BDBEE	Beyond Design Basis External Event
BOP	Balance of Plant
BWROG	Boiling Water Reactor Owners' Group
CAP	Containment Accident Pressure
DC	Direct Current
ECCS	Emergency Core Cooling Systems
EDP	Engineering Design Package
EF2	Enrico Fermi Unit 2, Nuclear Power Station
ELAP	Extended Loss of AC Power
EOP	Emergency Operating Procedure
EPG/SAG	Emergency Procedure and Severe Accident Guidelines EPRI Electric Power Research Institute
ERO	Emergency Response Organization
FAQ	Frequently Asked Question
FIP	Final Integrated Plan
FLEX	Diverse & Flexible Coping Strategy
FPCCS	Fuel Pool Cooling and Cleanup System
FSF-1	FLEX Storage Facility 1 (Inside Protected Area)
FSF-2	FLEX Storage Facility 2 (Outside Protected Area adjacent to Circulating Water Pond)
GPM	Gallons per minute

Section II: List of Acronyms (continued)

HCVS	Hardened Containment Vent System
ISE	Interim Staff Evaluation
ISG	Interim Staff Guidance
JLD	Japan Lessons Learned Project Directorate
MAAP	Modular Accident Analysis Program
MCR	Main Control Room
MOV	Motor Operated Valve
N ₂	Nitrogen
NEI	Nuclear Energy Institute
NIAS	Non-Interruptible Air Supply
NPSH	Net Positive Suction Head
NRC	Nuclear Regulatory Commission
OIP	Overall Integrated Plan
PCPL	Primary Containment Pressure Limit
RCIC	Reactor Core Isolation Cooling System
RHR	Residual Heat Removal
RM	Radiation Monitor
ROS	HCVS Control Panel (Remote Operating Station)
RPV	Reactor Pressure Vessel
RWA	Red Wolf Associates
RWCU	Reactor Water Cleanup
SA	Severe Accident

Section II: List of Acronyms (continued)

SAMG	Severe Accident Management Guidelines
SAWA	Severe Accident Water Addition
SAWM	Severe Accident Water Management
SGTS	Standby Gas Treatment System
SFP	Spent Fuel Pool
SRV	Safety-Relief Valve
UFSAR	Updated Final Safety Analysis Report
VAC	Voltage AC
VDC	Voltage DC
WW	Torus/Wetwell

Section III: Phase 1 Final Integrated Plan Details

Section III.A: HCVS Phase 1 Compliance Overview

Fermi 2 modified the existing hardened vent path installed in response to NRC Generic Letter 89-16 to comply with NRC Order EA-13-109.

Section III.A.1: Generic Letter 89-16 Vent System

Fermi 2 installed a hardened Torus vent in response to NRC Generic Letter (GL) 89-16 under Plant Modification EDP-10820. A 10-inch carbon steel pipe was routed from an existing 24-inch Standby Gas Treatment System (SGTS) inlet header on the RB 5th Floor through the RB siding into a new stack which discharges at an elevated location. The 10-inch pipe contains two Torus vent secondary containment fail closed isolation valves, T4600F420 and T4600F421. Both valves are Air Operated Valves (AOVs) supplied by the non-interruptible air system (NIAS). The solenoid valves for AOVs are powered by the Reactor Protection System.

Controls and position indications for the AOVs are in the control room and controls are keylocked to prevent inadvertent opening of these valves. Radiation monitor D11N551 is installed on the new 10-inch pipe. The monitor is powered from the Reactor Protection System and has indication and alarm in the Main Control Room (MCR) to alert the operators of a radiological release. The monitor is also interfaced with the emergency response information system.

The Fermi 2 GL 89-16 hardened torus vent system is a non-safety related system. It is not designed or required to prevent or mitigate any design bases accident. However, it is designed to mitigate the consequences of a severe containment over-pressurization accident. Torus venting is designed to function when the primary means of containment cooling are not available. Support systems were chosen based on the insight provided by the probabilistic risk assessment (PRA) and the individual plant examination (IPE).

The function and operation of SGTS and primary containment isolation system was not changed with installation of the Fermi 2 hardened torus vent system. Both Torus vent secondary containment isolation valves are normally closed to prevent in-leakage into the secondary containment.

The operation of the system is governed by the Fermi 2 emergency operating procedures.

Section III.A.2: EA-13-109 Hardened Containment Vent System (HCVS)

The EA-13-109 compliant HCVS system utilizes the GL-89-16 wetwell vent system. The vent system is initiated, operated and monitored from the HCVS Control Panel or MCR. The HCVS Control Panel has been installed in a readily accessible location and provides a means to manually operate the wetwell vent. The controls available at the HCVS Control Panel are accessible and functional under a range of plant conditions, including severe accident conditions. The HCVS Control Panel location is in the Auxiliary Building on the 3rd Floor, across from the MCR. Table 2 contains the evaluation of the acceptability of the HCVS Control Panel location

Final Integrated Plan
HCVS Order EA-13-109

with respect to severe accident conditions.

The HCVS Control Panel is the primary operating station for the HCVS. During an ELAP, electric power to operate the vent valves will be provided by batteries with a capacity to supply required loads for at least the first 24 hours. Before the batteries are depleted, the FLEX generator will supplement and recharge batteries to support operation of the vent valves.

At the HCVS Control Panel location, the operators can operate all the HCVS isolation valves except the Torus valves (T4600F400 and T4600F401) and check the status for the SGTS interface AOVs (T4600F408 and T4600F409). The locally available instrumentation includes Torus Level (T50R811), Torus Pressure (T50R812), Drywell Pressure (T50R813), Torus Hardened Vent Temperature (T50R803), and Hardened Vent System Rad Monitor (D11R838).

The MCR is designated as the alternate (secondary) control location and method. Since the Main Control requires FLEX Electrical to supply the original AC Solenoid valves, and FLEX Air to supply NIAS for pneumatics to the HCVS Valves, this method would only be credited after the 24-hour period established in EA-13-109. Attachment 2 shows the HCVS vent flow path.

At the MCR location, the operators can operate the HCVS isolation valves. Normal Division 2 powered instrumentation for Torus Level (T50R804B), Torus Pressure (T50R802B Point 2), Drywell Pressure (T50R802B Point 4), RPV Level, RPV Pressure, and Hardened Vent System Rad Monitor (D11R607) are available. Table 1 contains a complete list of instruments available to the operators for operating and monitoring the HCVS.

Attachments 3 and 3a contain one-line diagrams of the HCVS electrical distribution system.

The Torus vent up to, and including, the second containment isolation barrier is designed consistent with the design basis of the plant. These items include piping, piping supports, containment isolation valves, containment isolation valve actuators and containment isolation valve position indication components. The hardened vent piping, between the wetwell and the Reactor Building roof, is designed to 62 psig and 340°F.

NEI 13-02 suggests a 350°F value for HCVS design temperature based on the highest Primary Containment Pressure Limit (PCPL) among the Mark I and II plants. The Fermi 2 PCPL is 58.8 psig with a corresponding saturation temperature of 306.2°F. Fermi 2 used a design value of 340°F for the vent piping, corresponding to Primary Containment Design Temperature. This provides a 30.9°F margin to the 309.1°F saturation temperature at the Primary Containment maximum code allowable pressure of 62 psig. Thus, the temperature of 340°F will be retained as the pipe design temperature. Per NEI 13-02 Rev. 1, Section 2.4.3.1, it is acceptable to assume saturation conditions in containment so that these design parameters are acceptable.

To prevent leakage of vented effluent to other parts of the Reactor Building, valves T4600F407 and T4600F410 are manually closed from the HCVS Control panel. Standby Gas Treatment System (SGTS), boundary valves T4600F409 and T4600F408 must be closed before Torus venting. SGTS AOVs T4600F409 and T4600F408 are the boundary between the HCVS and the interfacing SGTS system which would allow Hydrogen and source term into the Auxiliary

Final Integrated Plan
HCVS Order EA-13-109

Building (AB). These valves are normally closed, fail closed, and are not required to change state to perform their safety related isolation function. Therefore, they can be assumed to be closed when required. AOVs T4600F409 and T4600F408 have valve position indications in both the MCR and at the HCVS Control Panel. These valves were added to 47.000.94, Local Leak Rate Testing for Hardened Vent, to conduct leak testing in accordance with 10CFR50, Appendix J. This is acceptable for prevention of inadvertent cross-flow of vented fluids per HCVS-FAQ-05.

The HCVS design includes several features to prevent inadvertent actuation. Key-lock handles are installed on the H21P101 Panel doors to prevent inadvertent operator action. Locked valves are also provided on the nitrogen system bottle racks to prevent inadvertent operator action. Pressure switch T46N423 is installed to provide annunciation in the Main Control Room during normal operation. This annunciates the manual override of the automatic isolation operation of Primary Containment Isolation Valves T4600F400 and T4600F401 when nitrogen is manually supplied to open these valves utilizing the new shuttle valves. Control circuits are modified to install key-lock switches to override the containment isolation signal to manipulate vent valves T4600F400, T4600F401, T4600F407, and T4600F410.

As required by EA-13-109, Section 1.2.11, the torus vent is designed to prevent air/oxygen backflow into the discharge piping to ensure the flammability limits of hydrogen, and other non-condensable gases, are not reached. EDP 37115 contains the design of Check Valve T4600F496 and 37115.B103 is the supporting analysis to preclude a flammable mixture in the vent pipe. Guidance for this design is contained in HCVS-WP-03.

Radiation Detector D11N552 with a range of 1E-4 to 1E+5 R/hr monitors the hardened vent radiation. Ratemeter D11K839 feeds the processed signal to MCR Ratemeter D11R607 and to the Panel H21P101 radiation detector instrument D11R838. An uninterruptible power supply (UPS) provides power that assures the vent radiation data is visible at D11R838 during the first 24 hours of ELAP. The MCR ratemeter power is provided from H11P930 to provide the ability to switch the power source from the normal BOP power source, MPU#3, to MPU#2 for ELAP.

The HCVS radiation monitor is qualified for the ELAP and external event conditions. In addition to the RM, a temperature element is installed on the vent line to allow the operators to monitor operation of the HCVS. Electrical and controls components are seismically qualified and include the ability to handle environmental conditions that exist for the equipment location although they are not considered part of the site Environmental Qualification (EQ) program.

Section III.B: HCVS Phase 1 Evaluation Against Requirements

The functional requirements of Phase 1 of NRC Order EA-13-109 are outlined below along with an evaluation of the Fermi 2 response to maintain compliance with the Order and guidance from JLD-ISG-2015-01. Due to the difference between NEI 13-02, Revision 0 and Revision 1, only Revision 1 will be evaluated. Per JLD-ISG-2015-01, this is acceptable as Revision 1 provides acceptable guidance for compliance with Phase 1 and Phase 2 of the Order.

1. HCVS Functional Requirements

1.1 The design of the HCVS shall consider the following performance objectives:

Final Integrated Plan
HCVS Order EA-13-109

- 1.1.1 The HCVS shall be designed to minimize the reliance on operator actions.

Evaluation:

The operation of the HCVS was designed to minimize the reliance on operator actions in response to hazards identified in NEI 12-06, *Diverse and Flexible Coping Strategies (FLEX) Implementation Guide* (Reference 31), which are applicable to the plant site. Operator actions to initiate the HCVS vent path can be completed by plant personnel and include the capability for remote-manual initiation from the HCVS Control Panel. A list of the remote manual actions performed by plant personnel to open the HCVS vent path is in the following table:

Final Integrated Plan
HCVS Order EA-13-109

Table 3-1: HCVS Operator Actions

Primary Action	Primary Location / Component	Notes
1. Inspect RB 5 th Floor HCVS Pipe and Components for damage	RB 5 th Floor	Conduct prior to 60 minutes post ELAP for dose considerations. Contingency in place if damage found.
2. At T46P411, open N2 bottle valves (3) and rack isolation valve	AB 4 th Floor	Aligns Primary N2 to RB 5 th Floor valves after damage inspection completed (no damage). Conduct prior to 60 minutes for Hydrogen control.
3. Energize H21P101 at 2PB2-15 Circuit 5, plug in Div 2 to Div 1 plug, turn on H21P640 and turn on Div 1 and Div 2 power on H21P101	AB 3 rd Floor, Div 2 Switchgear Room	Aligns power from Div 2 Battery to HCVS Control Panel. Conduct prior to 60 minutes for Hydrogen control.
4. Establish HCVS Piping integrity by verifying valves aligned in fail positions, repositioning T4600F407/F410 to close, and repositioning T4600F420 to open.	AB 3 rd Floor, Division 2 Switchgear Room at H21P101.	Conduct prior to 60 minutes for Hydrogen control.
5. Open HCVS Torus Valves T4600F400/F401.	AB 1 st Floor West wall in RBCCW area and T46P410.	Align wall valves to restore N2 to shuttles and then operate valves to open T4600F400/F401 with shuttles. Conduct prior to 60 minutes for Hydrogen control.
6. Open T50 Valves T5000F420B/F421B.	AB 3 rd Floor, Division 2 Switchgear Room at H21P101.	Open valves and verify Torus/Drywell pressures. Conduct prior to 60 minutes for Hydrogen control.
7. Verify pressures where expected and conduct HCVS purge. Close T4600F421 when purge completed.	AB 3 rd Floor, Division 2 Switchgear Room at H21P101.	Purge until 50% of initial Torus Pressure. Conduct prior to 60 minutes for Hydrogen control.
8. Operate HCVS System as directed by Emergency Director.	AB 3 rd Floor, Division 2 Switchgear Room at H21P101.	Typically, open one time when Torus Pressure shows steam generated. Leave open vice attempting to control between PSP and PCPL.

NOTE: Permanently installed electrical power and pneumatic supplies are available to support operation and monitoring of the HCVS for a minimum of 24 hours.

After 24 hours, available personnel will be able to connect supplemental electric power and pneumatic supplies for sustained operation of the HCVS for a minimum of 7 days. The FLEX generators and air compressors provide this motive force. These actions will be completed in less than 24 hours. However, the HCVS can be operated for at least 24 hours without any supplementation.

Final Integrated Plan
HCVS Order EA-13-109

The above set of actions conform to the guidance in NEI 13-02 Revision 1 Section 4.2.6 for minimizing reliance on Operator actions and are acceptable for compliance with Order element A.1.1.1. These were identified in the OIP and subsequent NRC ISE. Conduct of these activities earlier than about 70 minutes was not covered in the OIP as the final disposition of Hydrogen control had not been made.

Final Integrated Plan
HCVS Order EA-13-109

Table 3.2: Failure Evaluation

Functional Failure Mode	Failure Cause	Alternate Action	Failure with Alternate Action Impact on Containment Venting?
Failure of Vent to Open on Demand	Valves fail to open/close due to loss of normal AC power	Power will be tied into station battery for a minimum of 24 hours.	No
Failure of Vent to Open on Demand	Valves fail to open/close due to loss of alternate AC power (long term)	Connect station batteries to FLEX generator within 24 hours.	No
Failure of Vent to Open on Demand	Valves fail to open/close due to complete loss of batteries (long term)	Operate valves from MCR with AC power with FLEX provided generators.	No
Failure of Vent to Open on Demand	Valves fail to open/close due to loss of normal pneumatic air supply	No action needed, air will be supplied by locally installed gas bottles, which is sufficient for at least 8 cycles of valve T4600F420 over first 24 hours. Replace bottles as appropriate.	No
Failure of Vent to Open on Demand	Valves fail to open/close due to loss of alternate pneumatic air supply (long term)	FLEX provided compressor connected to charge NIAS system.	No
Failure of Vent to Open on Demand	Valves fail to open due to SOV failure	Redundant capability to open SOVs (AC and DC) to supply motive force.	No
Failure of Vent to close on demand	Valves fail to close due to SOV or motive force failure	Any of four independent valves fail close to isolate vent (T4600F400, T4600F401, T4600F420, T4600F421)	No

Final Integrated Plan
HCVS Order EA-13-109

- 1.1.2 The HCVS shall be designed to minimize plant operators' exposure to occupational hazards, such as extreme heat stress, while operating the HCVS system. (NRC OIP Open Item 1 addresses these concerns)

Evaluation:

Primary control of the HCVS is accomplished from the HCVS Panel (H21P101) in the Division 2 Switchgear Room. Alternate control of the HCVS is accomplished from the Main Control Room at H11P817 panel. FLEX actions that will maintain the HCVS Panel and MCR habitable were implemented in response to NRC Order EA-12-049 (Reference 32). These include:

1. Restoring RBHVAC via the FLEX Generator(s). RBHVAC was included as a load in the FLEX Generator sizing calculations and is acceptable.
2. Opening MCR doors to the Turbine Building (if required)
3. Operating portable fans to move outside air through the MCR (if required)

Table 2 contains a thermal evaluation of all the operator actions that may be required to support HCVS operation. Design Calculation DC-6639 (Reference 36) demonstrates that the unmitigated Temperature in the areas where operator actions occur meets the order requirements to minimize the plant operators' exposure to occupational hazards. Mitigation (as described above) merely increases margin or prevents having to use personnel protective equipment for heat exposure.

- 1.1.3 The HCVS shall also be designed to minimize radiological consequences that would impede personnel actions needed for event response (NRC OIP Open Item 2 addresses these concerns).

Evaluation:

Primary control of the HCVS is accomplished from HCVS Panel (H21P101) in the Division 2 Switchgear Room. Reviews conducted under RWA-1805-001, "Operator and EQ Source Terms in Support of the Fermi 2 Hardened Containment Vent System Phase 2" (Reference 37) and RWA-1805-002, "Fermi 2 Power Plant HCVS Radiological Dose Analysis" (Reference 38) for the duration of the event (168 hours) shows that the dose for operating equipment in this area remain below the NRC Annual dose limit of 5000 mRem/year. These reviews were conducted using the guidelines of HCVS-FAQ-12/ HCVS-WP-02 and the source term provided using MAAP 5.04 from Jensen-Hughes report, "Fermi 2 ELAP Mitigating Strategies – MAAP 5.04 Assessments (1DLL1-T007-RPT-001)" (Reference 40). Continuous manning at this panel is NOT required and during times when operation is NOT required the personnel manning this panel will most likely be in the Main Control Room where GDC-19 and HCVS-FAQ-06 apply.

Final Integrated Plan
HCVS Order EA-13-109

Alternate control of the HCVS is accomplished from the Main Control Room. Under the postulated scenarios of order EA-13-109 the control room is adequately protected from excessive radiation dose and no further evaluation of its use is required. (Ref. HCVS-FAQ-06)

Table 2 contains a radiological evaluation of the operator actions that may be required to support HCVS operation in a severe accident. There are no abnormal radiological conditions present for HCVS operation without core damage. The evaluation of radiological hazards demonstrates that the final design meets the order requirements to minimize the plant operators' exposure to radiological hazards.

The HCVS vent is routed away from the MCR intake structures. If venting operations create the potential for airborne contamination in the MCR, the ERO will provide personal protective equipment to minimize any operator exposure.

- 1.1.4 The HCVS controls and indications shall be accessible and functional under a range of plant conditions, including severe accident conditions, extended loss of AC power, and inadequate containment cooling (NRC OIP Open Items 1 & 2 address these concerns).

Evaluation:

Primary control of the HCVS is accomplished from the HCVS Control Panel on AB-3 (Division 2 Switchgear room). This area was evaluated for Thermal environment in DC-6639 (Reference 36) and was shown to be acceptable. Radiological conditions were evaluated by reviews conducted under References 37 and 38 for the duration of the event (168 hours). This evaluation shows that the dose for the Operators in this area remains below the NRC Annual dose limit of 5000 mRem/year. Equipment dose was evaluated against materials and mission time in Reference 39. No issue with equipment meeting function for mission time was found. These reviews were conducted using the guidelines of HCVS-FAQ-12/ HCVS-WP-02 and the source term provided using Reference 40. Continuous manning at this panel is NOT required and during times when operation is NOT required the personnel manning this panel will most likely be in the Main Control Room where GDC-19 and HCVS-FAQ-06 apply.

Alternate control of the HCVS is accomplished from the main control room. Under the postulated scenarios of order EA-13-109 the control room is adequately protected from excessive radiation dose and no further evaluation of its use is required (HCVS-FAQ-06).

For ELAP with injection, HCVS containment venting is not required to protect containment from over-pressure. Containment pressure was evaluated as part of Fermi 2 response to NRC Order EA-12-049 as stated in the FLEX FIP (Reference 60).

Final Integrated Plan
HCVS Order EA-13-109

Table 2 contains a thermal and radiological evaluation of all the operator actions at the MCR or alternate location that may be required to support HCVS operation during a severe accident. References 36 through 40 demonstrate that the final design meets the order requirements to minimize the plant operators' exposure to occupational and radiological hazards.

Table 1 contains an evaluation of the controls and indications that are or may be required to operate the HCVS during a severe accident. The evaluation demonstrates that the controls and indications are accessible and functional during a severe accident with a loss of AC power and inadequate containment cooling.

1.2 The HCVS shall include the following design features:

- 1.2.1 The HCVS shall have the capacity to vent the steam/energy equivalent of 1 percent of licensed /rated thermal power (unless a lower value is justified by analysis) and be able to maintain containment pressure below the primary containment design pressure.

Evaluation:

The existing torus hardened vent path that was previously installed in response to Reference 1 will be used to meet this requirement. This vent utilizes the 20" pipe that penetrates the torus and continues to the Reactor Building 5th floor with 24" pipe. The 10" HCVS exhaust stack branches off the 24 "pipe on the Reactor Building 5th floor and continues to an elevated release point on the Auxiliary Building roof. No modification to the existing vent was required as a result of the sizing and dynamic analysis (RELAP5) that was performed to show that the vent has the capacity to vent the steam/energy required. However, a check valve was installed and the stack was raised slightly, though not required to increase the vent capacity (See Requirements 1.2.2 and 1.2.11 for stack height and check valve requirements).

Design Calculation DC-6646 contains the verification of 1% power flow capacity at design pressure (56 psig). The purpose of this calculation is to verify that the HCVS has the required capacity to vent the steam/energy equivalent of one (1) percent of licensed/rated thermal power, and maintain containment pressure below the primary containment pressure limit to establish compliance with NRC Order EA-13-109. This calculation has determined that the steam energy equivalent of 1% reactor power is 130,182 lbm/hr. The maximum calculated flow rate through the HCVS, at containment lowest PCPL of 48 psig has been calculated to be 131,640 lbm/hr. Since the computed maximum flow rate exceeds the requirement, this acceptance criteria is satisfied.

The calculation determines the minimum allowable flow coefficient, Cv, for a new check valve to be installed near the discharge of the vent piping. Since the calculation establishes the check valve Cv, there is no acceptance criteria for this value.

Final Integrated Plan
HCVS Order EA-13-109

The calculation determines the maximum containment pressure due to presence of nitrogen in the vent flow following the first actuation of the system at a Torus pressure of 15 psig. The maximum containment pressure is calculated to be 47.2 psig, which is lower than the minimum PCPL of 48 psig. Therefore, this acceptance criteria is satisfied.

- 1.2.2 The HCVS shall discharge the effluent to a release point above main plant structures.

Evaluation:

The existing HCVS vent release point was modified in EDP-37115 to discharge the effluent to above main plant structures. The new release point elevation is greater than 3'-0" above the Reactor Building parapet wall. The effect to the HCVS effluent due to the nearby 36" Standby Gas Treatment System pipe that is higher in elevation was evaluated to have negligible effects. The vent pipe extends approximately 3 ft. above the parapet wall of the RB roof. This satisfies the guidance for height from HCVS-FAQ-04. As noted in the above response to Order Element 1.2.1, an analysis of the impact of this additional piping on required flow was conducted in Reference 41.

HCVS-WP-04 provides criteria that demonstrate robustness of the HCVS pipe under threats from high wind/Tornado driven missiles. Fermi 2 meets all the requirements of this white paper except for the small tubing on RB 5th Floor items, as described in 1.2.2.2.b. This evaluation documents that the HCVS main pipe is adequately protected from all external events and no further protection for the HCVS main pipe is required.

Fermi 2 evaluated the vent pipe robustness with respect to wind-borne missiles against the requirements contained in HCVS-WP-04. This evaluation demonstrated that the pipe was robust with respect to external missiles per HCVS-WP-04 in that:

1. For the portions of exposed piping below 30 feet above grade, all piping is in the East side of the Reactor Building and thus protected from wind driven missiles by analysis of the building and Safe Shutdown structures, systems, components contained therein.
2. The exposed piping greater than 30 feet above grade has the following characteristics:
 - a. The total vent pipe exposed area is 210 square feet which is less than the 300 square feet.
 - b. The pipe is made of schedule 40 stainless steel and is not plastic and the pipe components have no small tubing susceptible to missiles. Fermi 2

Final Integrated Plan
HCVS Order EA-13-109

does have small stainless steel tubing to the air operators for T4600F410/F420/F421 on RB-5 that is susceptible to wind borne missile damage, and therefore Fermi 2 conducted more extensive site specific FMEA (See EDP-37115.B125) for component failure with multiple plans to inspect and allow use of T4600F410 as a vent path for damage to the tubing on RB-5.

- c. There are no obvious sources of missiles located in the proximity of the exposed HCVS components. Conduct manuals reinforce removal of potential missiles on RB-5.
3. Fermi 2 maintains a large cutoff saw as part of the FLEX equipment. This saw is capable of cutting the vent pipe should it become damaged such that it restricts flow to an unacceptable level.
4. Hurricanes are not screened for Fermi 2.

Based on the above description of the vent pipe design, the Fermi 2 HCVS vent pipe design meets the order requirement to be robust with respect to all external hazards including wind-borne missiles. (EDP-37115.B125 documents this compliance to HCVS-WP-04 AND additional consideration for Fermi 2 RB-5 exposed tubing to wind borne missiles)

- 1.2.3 The HCVS shall include design features to minimize unintended cross flow of vented fluids within a unit and between units on the site.

Evaluation

Fermi 2 potential cross-flow paths for the HCVS vent consist of the following flow paths:

- SGTS inlet to Div 1 and Div 2 Trains (and Auxiliary Building Airspace) are blocked by T4600F409 and T4600F408 respectively. These two valves are fail close on loss of AC power or NIAS Div 1 or NIAS Div 2 (both of which occur during the ELAP). Additionally, these valves have indication of valve position in both the Main Control Room and the HCVS Control Panel. The RB-5 inspection verifies these valves are closed prior to HCVS use. The valves are also tested to 10CFR50 Appendix J standards by procedure 47.000.94, Local Leakage Rate Testing for Hardened Vent.
- HCVS Vent pipe to Reactor Building HVAC/SGTS connections occur on RB-3 at T4600F407 and on RB-5 at T4600F410. Both of these valves fail open on loss of AC power or NIAS Div 1 and Div 2 (both of which occur during the ELAP). These valves were modified to include HCVS DC operators and connections to the HCVS AB-4 Rack for Nitrogen so the valves can be closed as part of the HCVS pipe alignment. These

Final Integrated Plan
HCVS Order EA-13-109

valves have valve indications in both the Main Control Room and HCVS Control Panel. The valves are also tested to 10CFR50 Appendix J standards by procedure 47.000.94, Local Leakage Rate Testing for Hardened Vent.

- HCVS Vent pipe to HPCI Barometric Condenser Exhaust connection occurs on Auxiliary Building (AB) Sub-Basement: HPCI Room at T4600F406. This valve is normally closed and fails close on loss of AC power or NIAS Div 2 (both of which occur during the ELAP). This valve was repaired in RF-18 to ensure it met leak rate criteria. The valve is also tested to 10CFR50 Appendix J standards by procedure 47.000.94, Local Leakage Rate Testing for Hardened Vent.
- HCVS Vent Pipe to Nitrogen Inerting Bypass is normally closed and has a check valve to protect it from being a cross flow path, T4600F438. This check valve is normally closed and would be expected to close due to reverse seating when the HCVS pipe is pressurized. The valve is also tested to 10CFR50 Appendix J standards by procedure 47.000.94, Local Leakage Rate Testing for Hardened Vent.

Based on the above description, the Fermi 2 design meets the requirements to minimize unintended cross-flow of vented fluids within a unit.

- 1.2.4 The HCVS shall be designed to be manually operated during sustained operations from a control panel located in the main control room or a remote but readily accessible location.

Evaluation

The HCVS Control Panel allows initiation, operation, and monitoring of the existing Torus vent from a control panel located on AB-3 in the Division 2 Switchgear room (approximately 50' across the corridor from the Main Control Room). Accessibility is provided by two sets of double doors (one of which is a Security door). DC power is aligned to this HCVS Control Panel within the Division 2 Switchgear room and inside the panel to operate DC SOVs on RB-3 (1) and RB-5 (3) to align the HCVS Valves for venting. All primary and secondary containment interlocks are bypassed from this operating location. As described below, motive force is provided by Nitrogen Bottles on AB-1 and AB-4. Actions described in Table 3.1 have been validated to confirm accessibility and timing per the validation program (see Attachment 6).

The existing FLEX panel H21P101, located in the AB 3rd Floor Switchgear Room (EL 641'-6'), was replaced and is now used as the Primary HCVS Control Panel.

Dedicated nitrogen bottle racks T46P410 and T46P411 were installed in the AB-1 Floor Reactor Building Closed Cooling Water (RBCCW) Heat Exchanger Room

Final Integrated Plan
HCVS Order EA-13-109

(El. 583'-6") and AB-4 Floor Exhaust Fan room (El. 659'-6 ") respectively. These racks will require manual action to un-isolate the nitrogen supply to provide the motive force to operate the vent and instrument valves required in the HCVS.

HCVS process valves that require opening from fail closed position (T4600F400/F401/F420/F421) following an Extended Loss of AC Power (ELAP) have an alternate pneumatic supply provided from these nitrogen bottle racks. HCVS process valves T4600F400 and T4600F401 have shuttle valves installed to introduce this alternate pneumatic supply, while T4600F420 and T4600F421 have DC solenoid valves installed to perform this function.

HCVS boundary valves that require closing from their fail open position (T4600F407/F410) following an ELAP also have an alternate pneumatic supply provided from these nitrogen bottle racks. HCVS boundary valves T4600F407 and T4600F410 have DC solenoid valves installed to introduce this alternate pneumatic supply.

- 1.2.5 The HCVS shall be capable of manual operation (e.g., reach-rod with hand wheel or manual operation of pneumatic supply valves from a shielded location), which is accessible to plant operators during sustained operations.

Evaluation

To meet the requirement for an alternate means of operation, Fermi 2 utilizes the normal operational method for the HCVS valves as the alternate means of operation. This requires several items that were not allowed for the Primary method under EA-13-109 constraints. Normal operations method from the Main Control Room requires the following:

- AC power to the normal AC SOVs used to operate all six (6) of the HCVS valves. This AC power comes from MPU #1 and MPU #2 which must be energized from the FLEX Generators (contrary to the 24 hour no FLEX rule in EA-13-109)
- Power alignment for Primary and Secondary Containment Valves (T4600F400/F401 for Primary Containment Isolation Valves; T4600F407/F410 for Secondary Containment Isolation Valves) must be changed from normal power (RPS A/B based on Containment Reliability constraints) to MPU #1 / MPU #2 using the power plugs in H11P622/ H11P623.
- Interlock Defeats for Primary and Secondary Containment Valves (T4600F400/F401 for Primary Containment Isolation Valves; T4600F407/F410 for Secondary Containment Isolation Valves) must occur to allow operation from the H11P817 panel in the Main Control Room. This is done by operating the 6 Keylock Defeat Switches located

Final Integrated Plan
HCVS Order EA-13-109

on H11P617/H11P618/H11P915 panels.

- Pneumatic force restoration by restoring NIAS Division 1 and 2 to allow operation of these six (6) HCVS valves. This is done by providing compressed air from the FLEX Air Compressors (contrary to the 24 hour no FLEX rule in EA-13-109) and connecting this source to the Div 1 and Div 2 NIAS systems. Hoses and manual valves allow this connection from FLEX Air into Div 1 and Div 2 NIAS systems. Included in this realignment is opening of the Div 1 and Div 2 NIAS Isolation valves (P5000F440/P5000F441) that close on loss of power/pneumatic pressure. New connections were made to allow remote opening of the P5000F440/P5000F441 as local positioning of these NIAS Isolation valves is in an area that will be inaccessible in a Severe Accident.

The location for the Secondary HCVS Operating method is the Main Control Room (H11P817). The controls available in the Main Control Room are accessible and functional. Use of the Main Control room location provides all necessary controls and indications for HCVS operations and based on HCVS-FAQ-06 and GDC-19 is exempt from Thermal and Radiological analysis for feasibility of Operator actions.

- 1.2.6 The HCVS shall be capable of operating with dedicated and permanently installed equipment for at least 24 hours following the loss of normal power or loss of normal pneumatic supplies to air operated components during an extended loss of AC power.

Evaluation

HCVS-WP-01 contains clarification on the definition of “dedicated and permanently installed” with respect to the order. In summary, it is acceptable to use plant equipment that is used for other functions, but it is not acceptable to credit portable equipment that must be moved and connected for the first 24-hour period of the ELAP.

DC Power to the new HCVS primary panel is supplied by the existing station batteries (2B-1) via permanent connections. The station batteries will provide the assurance of HCVS operation during the first 24 hours of the severe accident. Calculation DC-6584 Vol. I, DCD 1, “FLEX DC Calculations” (Reference 43) justifies that the existing station batteries capacity will support the HCVS loading for the entire 24-hour period. FLEX portable generators will be available to support HCVS operation following the first 4 hours; however, credit for external devices is not allowed for 24 hours.

Dedicated nitrogen bottles will be sized for the first 24 hours of operation and to support sustained operation over the first seven days. Calculation DC-6636, Vol. I, Rev. 0, “Hardened Containment Vent System Bottle Sizing”, (Reference 44)

shows the Nitrogen Bottle Sizing calculation and shows greater than a 10% margin.

- 1.2.7 The HCVS shall include a means to prevent inadvertent actuation.

Evaluation

Emergency operating procedures provide clear guidance that the HCVS is not to be used to defeat containment integrity during any design basis transients and accidents. In addition, the HCVS was designed to provide features to prevent inadvertent actuation due to equipment malfunction or operator error. The containment isolation valves must be open to permit vent flow. The physical features that prevent inadvertent actuation are:

- Key-lock handles are installed on the H21P101 Panel doors to prevent inadvertent operator action.
- Locked valves are also provided on the nitrogen system bottle racks to prevent inadvertent operator action.
- A double block and bleed system is installed on AB-1 West Wall to prevent inadvertent operation of the T4600F400/F401 valves.
- Pressure switch T46N423 is installed to provide annunciation in the Main Control Room during normal operation. This annunciates the manual override of the automatic isolation operation of Primary Containment Isolation Valves T4600F400 and T4600F401 when nitrogen is manually supplied to open these valves utilizing the new shuttle valves.
- Control circuits are modified to install key-lock switches to override the containment isolation signal to manipulate vent valves T4600F400, T4600F401, T4600F407, and T4600F410.
- All mechanisms where a Primary Containment Interlock could be defeated are annunciated in the Main Control Room to alert the Operators or this potential.

- 1.2.8 The HCVS shall include a means to monitor the status of the vent system (e.g., valve position indication) from the control panel required by 1.2.4. The monitoring system shall be designed for sustained operation during an extended loss of AC power.

Evaluation

The HCVS includes indications for HCVS valve position, vent pipe temperature and effluent radiation levels at the HCVS Control Panel. Additionally, HCVS valve position and effluent radiation levels are supplied to the Main Control

Final Integrated Plan
HCVS Order EA-13-109

Room (H11P817) for Decision Maker information.

A new temperature element, T46N422, was installed to monitor hardened vent pipe temperature and a new radiation monitoring channel was installed replacing the old HCVS radiation monitor. The temperature is displayed only on the H21P101 panel.

The new radiation monitoring indication is displayed on both the H21P101 panel and, after FLEX generator power is available, in the MCR.

Valve position indication is displayed on both H21P101 and the appropriate MCR panel.

The replacement H21P101 panel is powered from station batteries for the first 24 hours and the radiation monitoring channel is supplied by its dedicated Uninterruptable Power Supply (UPS) during the first 24 hours.

After 24 hours, the monitoring and control functions can be transferred back to the control room utilizing FLEX generator powered buses or continued at the HCVS Control Panel as Battery Chargers are restored by the FLEX Generators and allowed to be credited after 24 hours.

In addition, the replacement Panel H21P101 was supplied with displays to read the existing Primary Containment Monitoring System (PCMS) sensors for Torus level, pressure and Drywell pressure as described in NEI 13-02.

The HCVS instruments, including valve position indication, vent pipe temperature, radiation monitoring, and support system monitoring, are seismically qualified as indicated on Table 1 and they include the ability to handle environmental conditions for the areas where they are located (although they may not be considered part of the site Environmental Qualification (EQ) program).

- 1.2.9 The HCVS shall include a means to monitor the effluent discharge for radioactivity that may be released from operation of the HCVS. The monitoring system shall provide indication from the control panel required by 1.2.4 and shall be designed for sustained operation during an extended loss of AC power.

Evaluation

Radiation Detector D11N552 with a range of 1E-4 to 1E+5 R/hr monitors the hardened vent radiation. Ratemeter D11K839 feeds the processed signal to MCR Ratemeter D11R607 and to the Panel H21P101 radiation detector instrument D11R838. An uninterruptible power supply (UPS) provides power that assures the vent radiation data is visible at D11R838 during the first 24 hours of ELAP. The MCR ratemeter power is provided from H11P930 to provide the ability to switch the power source from the normal BOP power source, MPU #3, to MPU

Final Integrated Plan
HCVS Order EA-13-109

#2 for ELAP. The HCVS radiation monitor is qualified for the ELAP and external event conditions. Electrical and controls components are seismically qualified and include the ability to handle environmental conditions that exist for the equipment location (although they are not considered part of the site Environmental Qualification (EQ) program).

- 1.2.10 The HCVS shall be designed to withstand and remain functional during severe accident conditions, including containment pressure, temperature, and radiation while venting steam, hydrogen, and other non-condensable gases and aerosols. The design is not required to exceed the current capability of the limiting containment components.

Evaluation

The Torus vent up to, and including, the second containment isolation valve is designed consistent with the design basis of the plant. These items include piping, piping supports, containment isolation valves, containment isolation valve actuators and containment isolation valve position indication components.

The existing hardened vent piping, between the Torus and the Reactor Building roof, was originally evaluated for 62 psig at 300° F (DC-5448, Vol. I, Piping Analysis-Hardened Torus Vent 10” Bypass Line). Torus vent piping and components installed downstream of the containment isolation boundary were analyzed for a new condition of 62 psig at 340 °F (DC-2991 Vol. IA., DCD 1, Piping Stress Analysis Line M-3093-1 (Reference 45); DC-5448 Vol. I., DCD 1, Piping Analysis-Hardened Torus Vent 10” Bypass Line M-5909 (Reference 46)). This new analysis in Reference 45 encompasses the Torus Hardened Vent Valves T4600F400/F401/ F412/F407/F406/F410. Valves T4600F420/F421 are covered by Reference 46.

HCVS piping and components have been analyzed and shown to perform under severe accident conditions using the guidance provided in HCVS- FAQ-08 and HCVS-WP-02. HCVS Phase 1 OIP Open Item 1 requires analysis of the HCVS Piping and components for severe accident conditions. The above Calculations in References 45 and 46 meet this requirement.

The HCVS was designed to withstand and remain functional during severe accident conditions, including containment pressure, temperature, and radiation while venting steam, hydrogen, and other non-condensable gases and aerosols. References 36 and DC-6645, “HCVS Radiological Assessment” (Reference 47) evaluated the conditions for Temperature and Radiation on both operator actions and equipment. No issues were identified with the installed equipment. Insights gained from these design calculations were used to select the new Shuttle valves for T4600F400/F401 as available DC SOVs had marginal Thermal design margins.

Final Integrated Plan
HCVS Order EA-13-109

Refer to EA-13-109, requirement 1.2.11 for a discussion on designing for combustible gas.

- 1.2.11 The HCVS shall be designed and operated to ensure the flammability limits of gases passing through the system are not reached; otherwise, the system shall be designed to withstand dynamic loading resulting from hydrogen deflagration and detonation.

Evaluation

In order to prevent a detonable mixture from developing in the pipe, a check valve is installed near the top of the pipe in accordance with HCVS-WP-03. This valve will open on venting, but will close to prevent air from migrating back into the pipe after a period of venting. The check valve is installed and tested to ensure that it limits back-leakage to preclude a detonable mixture from occurring in the case venting is stopped prior to the establishment of alternate reliable containment heat removal. The use of a check valve meets the requirement to ensure the flammability limits of gases passing through the vent pipe will not be reached.

Fermi 2 HCVS pipe is a part of the RBHVAC system and as such has a unique issue. Air would be present in the HCVS pipe prior to initial operation. Based on this, an operator purge of the air in the pipe is planned prior to generation of significant Hydrogen from the Zirconium-Water reaction at about 75 minutes into the Severe Accident sequence. The actions to conduct this initial purge (using the Drywell/ Torus Nitrogen) have been validated under the validation program at 51 minutes to conduct from ELAP event.

- 1.2.12 The HCVS shall be designed to minimize the potential for hydrogen gas migration and ingress into the reactor building or other buildings.

Evaluation

The response under Order element 1.2.3 explains how the potential for hydrogen migration into other systems, the reactor building or other buildings is minimized.

- 1.2.13 The HCVS shall include features and provisions for the operation, testing, inspection and maintenance adequate to ensure that reliable function and capability are maintained.

Evaluation:

As endorsed in the ISG, sections 5.4 and 6.2 of NEI 13-02 provide acceptable method(s) for satisfying the requirements for operation, testing, inspection, and maintenance of the HCVS.

Primary and secondary containment required leakage testing is covered under

Final Integrated Plan
HCVS Order EA-13-109

existing design basis testing programs with additional testing of boundary valves for the HCVS covered by new procedure 47.000.94, Local Leak Rate Testing for Hardened Vent. The HCVS components outboard of the primary containment boundary shall be tested to ensure that vent flow is released to the outside with minimal leakage, if any, through the interfacing boundaries with other systems or units.

Fermi 2 has implemented the following operation, testing and inspection requirements for the HCVS to ensure reliable operation of the system. These are from NEI 13-02, Table 6.1. The implementing modification packages contain these as well as additional testing in procedure 27.404.01, HCVS Testing Procedure required for post-modification/periodic testing.

Final Integrated Plan
HCVS Order EA-13-109

The HCVS OIP (Reference 19), submitted in December, 2015, describes that visual inspections and walk down of HCVS and installed SAWA components is performed once per every other operating cycle. However, as shown below, Fermi 2 follows NEI 13-02 Revision 1 guidance to perform these inspections and walk downs once per every operating cycle.

Table 3-3: Testing and Inspection Requirements

Description	Frequency
Cycle the HCVS and installed SAWA valves ¹ and the interfacing system boundary valves not used to maintain containment integrity during Mode 1, 2 and 3. For HCVS valves, this test may be performed concurrently with the control logic test described below.	Once per every ² operating cycle
Cycle the HCVS and installed SAWA check valves not used to maintain containment integrity during unit operations. ³	Once per every other ⁴ operating cycle
Perform visual inspections and a walk down of HCVS and installed SAWA components.	Once per every operating cycle
Functionally test the HCVS radiation monitors.	Once per operating cycle
Leak test the HCVS.	<ol style="list-style-type: none"> 1. Prior to first declaring the system functional; 2. Once every three operating cycles thereafter; and 3. After restoration of any breach of system boundary within the buildings.
Validate the HCVS operating procedures by conducting an open/close test of the HCVS control function from its control location (primary and alternate) and ensuring that all HCVS vent path and interfacing system boundary valves ⁵ move to their proper (intended) positions.	Once per every other operating cycle

¹ Not required for HCVS and SAWA check valves.

² After two consecutive successful performances, the test frequency may be reduced to a maximum of once per every other operating cycle.

³ Not required if integrity of check function (open and closed) is demonstrated by other plant testing requirements.

⁴ After two consecutive successful performances, the test frequency may be reduced by one operating cycle to a maximum of once per every fourth operating cycle.

⁵ Interfacing system boundary valves that are normally closed and fail closed under ELAP conditions (loss of power and/or air) do not require control function testing under this section. Performing existing plant design basis function testing or system operation that reposition the valve(s) to the HCVS required position will meet this requirement without the need for additional testing.

2. HCVS Quality Standards

- 2.1. The HCVS vent path up to and including the second containment isolation barrier shall be designed consistent with the design basis of the plant. Items in this path include piping, piping supports, containment isolation valves, containment isolation valve actuators, and containment isolation valve position indication components.

Evaluation:

The HCVS piping upstream of and including the second containment isolation valve T4600F401 and penetrations are not being modified for order compliance so that they continue to be designed consistent with the design basis of primary containment including pressure, temperature, radiation, and seismic loads.

- 2.2. All other HCVS components shall be designed for reliable and rugged performance that is capable of ensuring HCVS functionality following a seismic event. These items include electrical power supply, valve actuator pneumatic supply, and instrumentation (local and remote) components.

Evaluation:

The HCVS components downstream of the outboard containment isolation valve and components that interface with the HCVS are routed in seismically qualified structures or supported from seismically qualified structure(s).

The HCVS downstream of the outboard containment isolation valve, including piping and supports, electrical power supply, valve actuator pneumatic supply, and instrumentation (local and remote) components, have been designed and analyzed to conform to the requirements consistent with the applicable design codes for the plant and to ensure functionality following a design basis earthquake. This includes environmental qualification consistent with expected conditions at the equipment location.

Table 1 contains a list of components, controls and instruments required to operate HCVS, their qualification and evaluation against the expected conditions. All instruments are fully qualified for the expected seismic conditions so that they will remain functional following a seismic event.

Section IV: HCVS Phase 2 Final Integrated Plan

Section IV.A: The requirements of EA-13-109, Attachment 2, Section B for Phase 2

B. PHASE 2 (reliable, severe accident capable drywell venting system)

Licensees with BWRs Mark 1 and Mark II containments shall either:

- (1) Design and install a HCVS, using a vent path from the containment drywell, that meets the requirements in section B.1 below, or

Final Integrated Plan
HCVS Order EA-13-109

- (2) Develop and implement a reliable containment venting strategy that makes it unlikely that a licensee would need to vent from the containment drywell before alternate reliable containment heat removal and pressure control is reestablished and meets the requirements in Section B.2 below.

1. HCVS Drywell Vent Functional Requirements

- 1.1 The drywell venting system shall be designed to vent the containment atmosphere (including steam, hydrogen, non-condensable gases, aerosols, and fission products), and control containment pressure within acceptable limits during severe accident conditions.
- 1.2 The same functional requirements (reflecting accident conditions in the drywell), quality requirements, and programmatic requirements defined in Section A of this Attachment for the Torus venting system shall also apply to the drywell venting system.

2. Containment Venting Strategy Requirements

Licensees choosing to develop and implement a reliable containment venting strategy that does not require a reliable, severe accident capable drywell venting system shall meet the following requirements:

- 2.1 The strategy making it unlikely that a licensee would need to vent from the containment drywell during severe accident conditions shall be part of the overall accident management plan for Mark I and Mark II containments.
- 2.2 The licensee shall provide supporting documentation demonstrating that containment failure as a result of over-pressure can be prevented without a drywell vent during severe accident conditions.
- 2.3 Implementation of the strategy shall include licensees preparing the necessary procedures, defining and fulfilling functional requirements for installed or portable equipment (e.g., pumps and valves), and installing needed instrumentation.

Because the order contains just three requirements for the containment venting strategy, the compliance elements are in NEI 13-02, Revision 1. NEI 13-02, Revision 1, endorsed by NRC in JLD-ISG-2015-01, provides the guidance for the containment venting strategy (B.2) of the order. NEI 13-02, Revision 1, provides SAWA in conjunction with Severe Accident Water Management (SAWM), which is designed to maintain the Torus vent in service until alternate reliable containment heat removal and pressure control are established, as the means for compliance with part B of the order.

Fermi 2 has implemented Containment Venting Strategy (B.2), as the compliance method for Phase 2 of the Order and conforms to the associated guidance in NEI 13-02 Revision 1 for this compliance method.

Section IV.B: HCVS Existing System

There previously was neither a hardened drywell vent nor a strategy at Fermi 2 that complied with Phase 2 of the order.

Section IV.C: HCVS Phase 2 SAWA System and SAWM Strategy

The HCVS Phase 2 SAWA system and SAWM strategy utilize the FLEX mitigation equipment and strategies to the extent practical. This approach is reasonable because the external hazards and the event initiator (ELAP) are the same for both FLEX mitigation strategies and HCVS. For SAWA, it is assumed that the initial FLEX response actions are unsuccessful in providing core cooling such that core damage contributes to significant radiological impacts that may impede the deployment, connection and use of FLEX equipment. These radiological impacts, including dose from containment and HCVS vent line shine were evaluated and modifications made as necessary to mitigate the radiological impacts such that the actions needed to implement SAWA and SAWM are feasible in the timeframes necessary to protect the containment from over-pressure related failure. To the extent practical, the SAWA equipment, connection points, deployment locations and access routes are the same as the FLEX primary strategies so that a Unit that initially implements FLEX actions that later degrades to severe accident conditions can readily transition between FLEX and SAWA strategies. This approach further enhances the feasibility of SAWA under a variety of event sequences including timing.

Fermi 2 has implemented the containment venting strategy utilizing SAWA and SAWM. The SAWA system consists of FLEX (SAWA) pumps injecting into the Reactor Pressure Vessel (RPV) and SAWM consists of flow control at the FLEX (SAWA) Manifold Trailer along with instrumentation and procedures to ensure that the Torus vent is not submerged (SAWM). Procedures have been issued to implement this strategy including revision 3 to the Severe Accident Management Guidelines (SAMG). This strategy has been shown via Modular Accident Analysis Program (MAAP) analysis to protect containment without requiring a drywell vent for at least seven days which is the guidance from NEI 13-02 for the period of sustained operation.

Section IV.C.1: Detailed SAWA Flow Path Description

The SAWA flow path is the same as the FLEX primary injection path. The SAWA system, shown on Attachment 4, consists of a First FLEX Pump (Neptune Source (submerged) Pump) drawing water from the Circulating Water Pond, boosting this source of water in a second centrifugal pump to raise the discharge pressure to at least 70 psig, supplying this water to a duplex strainer to remove particulates, and supplying the water via 10" hoses routed from the strainer to a Second FLEX pump (Dominador Pump) to further boost the pressure (as needed) for RPV Injection. From the Second FLEX pump (Dominador Pump) water is routed via a hose to the Manifold Trailer that contains two Manifolds and four (4) branch lines to inject the water into the Residual Heat Removal (RHR) system. Four branch lines are used to allow up to 3500 gpm (all four lines used) of flow into the Torus for the Fermi 2 method of FLEX Containment cooling (Feed and Bleed). The remaining branch lines can be used to reduce flow for other injection paths such as RPV injection,

Final Integrated Plan
HCVS Order EA-13-109

Drywell Spray, or Torus Cooling/Spray. Division 1 RHR can be used for injection into the Spent Fuel Pool via the RHR to Fuel Pool Cooling and Cleanup (FPCC) cross-tie.

The SAWA flowpath requires use of the Division 2 RHR connection (South connection) to allow Division 1 RHR to be available to inject water into the Spent Fuel Pool. Division 1 RHR contains an RHR to FPCCU cross tie connection and can be isolated from Division 2 using the E1150F010 MOV. The following items are required for SAWA Injection:

- RB alignment for SAWA/SFP makeup
- FLEX Water alignment outside the RB and connection to the RB
- SAWA Fill, Vent, and Pressurization
- Restoration of Division 2 AC power to Bus 72C-F to allow remote valve positioning in the RB from the Main Control Room

The RB alignment of Division 1 RHR for SFP injection and Division 2 RHR for SAWA have been validated under the HCVS Validation process.

SFP makeup via the RHR to FPCCU cross tie is required due to the inability to access the RB during severe accidents. The RB-5 area contains the HCVS pipe and will be in excess of 25000 R/hr dose rates with most of the RB (specifically RB-2) above 10000 R/hr. These levels preclude entry for SFP makeup. Alignment of Division 1 RHR for SFP makeup has been validated under the HCVS Validation process. This is the difference from the FLEX water alignment where FLEX Water can be aligned to either RHR Connection based on access for SFP makeup methods.

The hoses and pumps are stored in the FLEX Storage Buildings (FSF-1 & FSF-2) which are protected from all hazards. BWROG generic assessment, BWROG-TP-15-008, provides the principles of Severe Accident Water Addition to ensure protection of containment. This SAWA injection path is qualified for the all the screened in hazards (Section III) in addition to severe accident conditions.

Section IV.C.2: Severe Accident Assessment of Flow Path

Validation for the required events to deploy and start SAWA injection was completed in 1.88 hours versus the industry standard injection time of 8 hours. This provides a significant margin (6.12 hours) to required injection time.

The required SAWA actions inside the RB where there could be a high radiation field due to a severe accident will be:

- Align Division 2 RHR valves for SAWA on RB-2 where the Division 2 RHR/FLEX Cross-tie line exists (SAWA-02)

Final Integrated Plan
HCVS Order EA-13-109

- Align portable Nitrogen bottles to the Drywell Pressure instrument rack (RB-2) and Torus Level instrument rack RBSB-SW (SAWA-02)
- Align Division 1 RHR valves for SFP injection on RB-1 (SAWA-02)

These actions inside the RB can be performed before the dose is unacceptable, under the worst-case scenario within the first hour, after the loss of RPV injection. This time was validated as part of the Time Sensitive Action validation for EA-13-109. Procedure 29.400.03 directs early accomplishment of actions that must be done early in the severe accident event where there is a loss of All AC power and a loss of all high-pressure injection to the core. In this event, core damage is not expected for at least one hour so that there will be no excessive radiation levels or heat related concerns in the RB when the valves are operated. The other SAWA actions all take place outside the RB and the deployment pathways. Since these locations are outside the RB, they are shielded from the severe accident radiation by the thick concrete walls of the RB. Once SAWA is initiated, the operators will monitor the response of containment from the MCR to determine that venting and SAWA are operating satisfactorily, maintaining containment pressure low to avoid containment failure. Stable or slowly rising trend in wetwell level with SAWA at the minimum flow rate indicates water on the drywell floor up to the vent pipe or downcomer openings. After some period of time, as decay heat levels decrease, the operators will be able to reduce SAWA flow to keep the core debris cool while avoiding overflow the torus to the point where the wetwell vent is submerged.

Section IV.C.3: Severe Accident Assessment of Safety-Relief Valves

Fermi 2 has methods available to extend the operational capability of manual pressure control using SRVs as provided in the plant specific order EA-12-049 submittal. Assessment of manual SRV pressure control capability for use of SAWA during the Order defined accident is unnecessary because RPV depressurization is directed by the EPGs in all cases prior to entry into the SAGs.

Section IV.C.4: Available Freeboard Use

The freeboard between -3.16' and 4.66' elevation in the Torus provides approximately 592,770 gallons of water volume before the level instrument would reach the top of the Narrow Range Torus Level instrument (4.66') or water level reaches the bottom of the vent pipe (-3.16'). From Fermi 2 Combined OIP, Attachment 2.1.B, an additional 10.33' (limited by procedure to 7.34') of freeboard is available prior to impacting the Torus Vent. This provides an additional 202,178 gallons of water volume before impacting the Torus Vent capability.

BWROG generic assessment BWROG-TP-15-011, provides the principles of Severe Accident Water Management to preserve the Torus vent for a minimum of seven days. After containment parameters are stabilized with SAWA flow, SAWA flow will be reduced to a point where containment pressure will remain low while Torus level is stable or very slowly rising.

Final Integrated Plan
HCVS Order EA-13-109

As shown in Reference 40, the Torus level peaked at 3' at the seven day point, thus providing a 1.66' margin to the normal freeboard limit of 4.66' and a 10.34' margin to available freeboard prior to impacting Torus Venting capability. Guidance for Torus Level control is found in the EOPs / SAGs. A diagram of the available freeboard is shown on Attachment 1.

Section IV.C.5: Upper range of Torus level indication

Fermi 2 has a Wide Range Containment Level indicator that indicates level from the bottom of the Torus to the Top of the Drywell so verification of level is not in doubt. The upper range of narrow Range Torus Level indication provided for SAWA/SAWM is +4.66 feet elevation. This Narrow Range Torus Level indication defines the desired (per the EOPs/SAGs) level of Torus volume that will preserve the Torus vent function. Limits in the EOPs/SAGs (+42") are based on coverage of the Drywell to Torus Vacuum Breakers but with a constant positive Drywell and Torus pressure, this limit would not be as important as maintaining the Torus Vent as a Containment heat removal mechanism. Torus level freeboard for venting is shown in Attachment 1.

Section IV.C.6: Torus vent service time

Reference 40 and BWROG-TP-15-011 demonstrate that throttling SAWA flow after containment parameters have stabilized, in conjunction with venting containment through the Torus vent will result in a stable or slowly rising Torus level. The references demonstrate that, for the scenario analyzed, the Torus level peaked at 3' at the seven day point thus providing a 1.66' margin to the normal freeboard limit of 4.66' and a 10.34' margin to available freeboard prior to impacting Torus Venting capability. This confirms a greater than seven-day period of sustained operation exists thus allowing significant time for restoration of alternate containment pressure control and heat removal.

Section IV.C.7: Strategy time line

The overall accident management plan for Fermi 2 is developed from the BWR Owner's Group Emergency Procedure Guidelines and Severe Accident Guidelines (EPG/SAG). As such, the SAWA/SAWM implementing procedures are integrated into the Fermi 2 SAGs (29.200.01). In particular, EPG/SAG Revision 3, when implemented with Emergency Procedures Committee Generic Issue 1314, allows throttling of SAWA in order to protect containment while maintaining the Torus vent in service. The SAMG flow charts direct use of the hardened vent as well as SAWA/SAWM when the appropriate plant conditions have been reached.

Using NEI 12-06 Appendix E, Fermi 2 has validated that the FLEX Water system pumps used for SAWA can be deployed and commence injection in 1.88 hours which complies with the industry position of SAWA injection in less than 8 hours. The studies referenced in NEI 13-02 demonstrated that establishing flow within 8 hours will protect containment. The initial SAWA flow rate will be at least 500 gpm. After a period of time, estimated to be about 4 hours, in which the maximum flow rate is maintained, the SAWA flow will be reduced. The reduction in flow rate and the timing of the reduction will be based on

stabilization of the containment parameters of drywell pressure and Torus level.

Reference 40 demonstrated that SAWA flow could be reduced to 100 gpm after four hours of initial SAWA flow rate and containment would be protected. At some point, Torus level will begin to rise indicating that the SAWA flow is greater than the steaming rate due to containment heat load such that flow can be reduced. While this is expected to be 4-6 hours, no time is specified in the procedures because the SAGs are symptom based guidelines.

Section IV.C.8: SAWA Flow Control

Fermi 2 will accomplish SAWA flow control by the use of throttle valves on the Manifold Trailer Branch lines (located outside the plant West of the Reactor Building). The operators at the Manifold Trailer will be in communication with the MCR via radios or runners and the exact time to throttle flow is not critical since there is a large margin between normal Torus level and the level at which the Torus vent will be submerged. The communications capabilities that will be used for communication between the MCR and the SAWA flow control location are the same as that evaluated and found acceptable for FLEX strategies. The communications capabilities have been tested to ensure functionality at the SAWA flow control and monitoring locations. (Refer to HCVS Phase 2 ISE Open Item 3 in Reference 30)

Section IV.C.9: SAWA/SAWM Element Assessment

Section IV.C.9.1: FLEX/SAWA pumps

Fermi 2 uses three portable diesel-driven fire pumps that operate in series for FLEX and SAWA. These pumps in series can supply 3,000 gpm at the pressures required for RPV injection during an ELAP and have been shown as capable of supplying the required flow rate to the RPV and the SFP for FLEX and for SAWA scenarios. The pumps are stored in the FSF-1 and FSF-2 where they are protected from all screened-in hazards and are rugged, over the road, trailer-mounted units, and therefore will be available to function after a seismic event.

Section IV.C.9.2: SAWA analysis of flow rates and timing

Reference 40, Case Run SBO-1, assumes a SAWA flow of 500 gpm starting within 8 hours after the loss of injection and demonstrates that containment is protected at this initial flow rate. Peak Containment pressure is approximately 20.2 psig at the time of RPV Breach with steady state pressure after SAWA injection at approximately 17.5 psig, considerably below the containment design pressure of 62 psig, therefore proving that this flow rate prevents containment failure by over pressurization as required by the order.

Section IV.C.9.3: FLEX/SAWA pumps Hydraulic Analysis

Calculation DC-0367 Vol. I Rev. Q, "Hydraulic Calculation for RHR System" (Reference 49), performed a hydraulic analysis for various operating configurations of the RHR system

and Calculation DC-0367 Vol. VIII, Rev. B, “FLEX RHR Injection Configuration-Pressure Drop Calculation” (Reference 50), analyzed the FLEX pumps and the lineup for RPV injection that would be used for SAWA. This calculation showed that the pumps have adequate capacity to meet the SAWA flow rate required to protect containment.

Section IV.C.9.4: SAWA Method of backflow prevention

The Fermi 2 SAWA flow path goes through check valves in the FLEX cross-tie and RHR systems. The RHR Check valves (E1100F050A and E1100F050B) are also Primary Containment Isolation Valves (PCIVs) whose integrity of check function (open and closed) is demonstrated by other plant testing requirements (ISI Program).

The FLEX cross-tie Check valve (E1100F619B) is tested by new procedure 27.404.01 per NEI 13-02 Revision 1, Section 6 of the table titled “Testing and Inspection requirements,” Note 3. Thus, backflow is prevented by tested check valves in the SAWA flow path inside the RB.

Section IV.C.9.5: SAWA Water Source

The source of water for SAWA must provide at least 168 hours of water injection without makeup based on the SAWA flow at 500 gpm (5,040,000 gallons). Actual projected use for SAWA/SAWM would be 4 hours flow at 500 gpm (120,000 gallons), injecting 8 hours after ELAP; followed by 156 hours flow at 100 gpm (936,000 gallons). This SAWM flow profile would require 1,056,000 gallons.

The Circulating Water Pond is the source of water for SAWA. The pond’s nominal operating level is approximately 33,130,000 gallons based on DC-5891 Vol. I, Rev.0, “Circulating Water Reservoir Size and Volume” (Reference 51). This number exceeds the available 21,070,000 gallons for Circulating Pump use due to the use of the floating Neptune Source pumps. These pumps can be deployed to the flat portion of the Circulating Water Reservoir and, thus, go below the Circulating Pump minimum operating level of 567’ 4” to the flat base section of the reservoir at the 562’ level.

This long-term strategy of water supply was qualified in response to order EA-12-049 and is available during a severe accident. Therefore, there will be sufficient water for injection to protect containment during the period of sustained operation.

Section IV.C.9.6: SAWA/SAWM Motive Force

Section IV.C.9.6.1: FLEX/SAWA pumps Power Source

The FLEX/SAWA pumps are stored in the FSF-1 and FSF-2 where they are protected from all screened-in hazards. The FLEX/SAWA pumps are commercial fire pumps rated for long-term outdoor use in emergency scenarios. The pumps are diesel-driven by engines mounted on the skids with the pumps. The pumps will be refueled by the FLEX refueling equipment that has been qualified for long-term refueling operations per EA-12-049. The action to refuel the FLEX/SAWA pumps was evaluated under severe accident conditions

Final Integrated Plan
HCVS Order EA-13-109

and demonstrated to be acceptable. Since the pumps are stored in protected structures, are qualified for the environment in which they will be used, and will be refueled by a qualified refueling strategy, they will perform their function to maintain SAWA flow needed to protect primary containment per EA-13-109.

Section IV.C.9.6.2: DG loading calculation for SAWA/SAWM equipment

Reference 43 shows the capability of the Plant ESF DC system to supply DC to the HCVS system and Instrumentation loads before and after DC Load shedding. Table 1 shows the electrical power source for the SAWA/SAWM instruments. This calculation also demonstrates that the Plant ESF batteries can provide power at sufficient capacity until the FLEX generator restores power to the battery chargers.

The FLEX load on the FLEX DG per EA-12-049 was evaluated in calculation DC-6583 Vol. I, Rev. A, "FLEX AC Calculations" (Reference 48). This calculation demonstrated that the required and Optional loads for FLEX could be accommodated within the capacity of the FLEX Generators. The loads on the FLEX Generators for SAWA and SAWM differ from those analyzed for FLEX but are bounded by the FLEX Loads. Required instruments for HCVS were the same as those identified and evaluated for FLEX (DC loads) in Reference 43.

The FLEX generator was qualified to carry the rest of the FLEX loads as part of Order EA-12-049 compliance.

Section IV.C.10: SAWA/SAWM Instrumentation

1) The Instruments credited for SAWA are:

- Torus Level: T50N406B (Instrument) / T50-R804B (CR Recorder) on H11P602 in MCR (also available at T50-R811 on HCVS Control Panel (H21P101))
- Drywell Pressure: T50N415B (Instrument) / T50-R802B (CR Recorder) Point 4 on H11P602 in MCR (also available at T50-R813 on HCVS Control Panel (H21P101))
- Torus Pressure: T50N414B (Instrument) / T50-R802B Point 2 on H11P602 in MCR (also available at T50-R812 on HCVS Control Panel (H21P101))
- SAWA Flowmeters: MT-001, MT-002, MT-003, MT-004 for 2.5", 2.5", 4", 6" branch lines located on Manifold Trailer (Stored in FSF-1)

2) SAWA Flowmeters (MT-001 through MT-004) are supplied by Global Vision (GVI Model numbers GVI Model 2.5"-100-F, GVI Model 4"-450-F, GVI Model 6"-1250-F) determine the flow passing through each branch of the four branches on the Manifold Trailer. The flow instruments use a Venturi that measures D/P and drives flow indication via a Diaphragm. No electrical power is required to indicate the flow. Portable lighting would be used in dark conditions to see the flow indication.

Final Integrated Plan
HCVS Order EA-13-109

- 3) Torus Level and Drywell pressure instruments (T50N406B / T50N415B) that feed the indications T50-R804B (Torus Level) and T50-R802B (Drywell Pressure), respectively, are classified as Regulatory Guide (RG) 1.97 Type A Category 1 indications and comply with the highest quality requirements for instruments at Fermi 2 including Severe Accident qualification per RG 1.97 qualification.

Torus Pressure instruments (T50N499B / T50N414B) that feed the indication T50-R802B are classified as Seismic 1, environmentally qualified instruments. Thus, the instruments meet the requirements for all areas EXCEPT Severe Accident qualification using the Design Basis credit for RG 1.97 qualification. As part of HCVS Phase 1 Radiation analysis for equipment function, Fermi 2 evaluated the Severe Accident impact on Torus Room located equipment (Appendix A of Reference 47). This evaluation compared the Severe Accident dose caused by a Severe Accident progression as specified in Regulatory Guide 1465 to the assumed dose in the Environmental Qualification Program (EF2-TMI-EQ-04 Rev 0). The results of Reference 47 indicated no issues with equipment performance over the mission time for Torus Room equipment (T50N414B transmitter is located on the RB 1st Floor at Grid A-11 with significant DW shielding). Other locations in the RB were found to be more impacted by HCVS pipe dose. Based on Reference 47 results, the dose to T50N414B would be sufficiently mitigated to meet its mission time.

The SAWA flow instrument has been evaluated as described previously by the Red Wolf Associates (RWA) reports conducted for HCVS Phase 2 and the answer for this qualification is the answer to HCVS-ISE Open Item 4.

- 4) The SAWA Flowmeter, as stated above, does not require any electrical power.
- 5) The other required SAWA/SAWM primary containment instruments are powered from the Division 2 ESF Batteries (with load shed) for the first 24 hours (credited) with the Division 2 ESF Battery Chargers supplying for the extended period (can be credited after 24 hours by EA-13-109 rules).

Section IV.C.10.1: SAWA/SAWM instruments

Table 1 contains a listing of all the instruments needed for SAWA and SAWM implementation. This table also contains the expected environmental parameters for each instrument, its qualifications, and its power supply for sustained operation.

Section IV.C.10.2: Describe SAWA instruments and guidance

The drywell pressure and Torus level instruments, used to monitor the condition of the containment, are pressure and differential pressure detectors that are safety-related and qualified for post-accident use. These instruments are referenced in Severe Accident Guidelines for control of SAWA flow to maintain the Torus vent in service while maintaining containment protection.

SAWA Instrumentation for both Primary and Secondary Operating methods are powered

Final Integrated Plan
HCVS Order EA-13-109

from Plant ESF Batteries for the first 24 hours and for the sustained operating period by the same batteries with restored ESF Battery Chargers when the FLEX Generators can be credited after 24 hours. By Validation, the ESF Battery Chargers are restored prior to 4 hours based on restoration of Division 2 480 VAC for SAWA valve operations. SAWA-07 validated the required time to restore Division 2 ESF Battery chargers at 108 minutes after ELAP and Division 1 ESF Battery chargers at 156 minutes after ELAP. Based on the Reference 43, the batteries that power the Division 2 instruments are available for at least 24 hours with just the battery alone. The Battery chargers restore this to two sources within 108 minutes of ELAP based on SAWA-07 Validation results.

These instruments are on buses included in the FLEX generator loading calculations for EA-12-049. Note that other indications of these parameters may be available depending on the exact scenario.

The SAWA flow meters use a venturi to sense differential pressure and drive a diaphragm that indicates flow independent of any electrical power source. The flow meters are mounted in the branch piping (one flowmeter per branch line) mounted on the Manifold trailer.

No containment temperature instrumentation is required for compliance with HCVS Phase 2. However, most FLEX electrical strategies repower other containment instruments that include drywell temperature, which may provide information for the operations staff to evaluate plant conditions under a severe accident and to provide confirmation for adjusting SAWA flow rates. SAMG strategies will evaluate and use drywell temperature indication if available consistent with the symptom based approach. NEI 13-02 Revision 1 Section C.8.3 discusses installed drywell temperature indication.

Section IV.C.10.3: Qualification of SAWA/SAWM instruments

The drywell pressure and Torus level instruments are pressure and differential pressure detectors that are safety-related and qualified for post-accident use. These instruments are qualified per RG-1.97 Revision 2 (Reference 34) which is the Fermi 2's committed version per UFSAR Section 7.5.1.4 as post-accident instruments and are therefore qualified for EA-13-109 events.

Torus Pressure instruments (T50N499B / T50N414B) that feed the indication T50-R802B are classified as Seismic 1, environmentally qualified instruments, thus meeting requirements for all areas except Severe Accident qualification using the Design Basis credit for RG 1.97 qualification. As part of HCVS Phase 1 Radiation analysis for equipment function, Fermi 2 evaluated the Severe Accident impact on Torus Room located equipment (Appendix A of Design Calculation DC-6645 Vol. I, Rev. 0, "HCVS (Hardened Containment Venting System) Radiological Assessment" (Reference 47). This evaluation compared the Severe Accident dose caused by a Severe Accident progression as specified in NUREG-1465 to the assumed dose in the Fermi 2 Environmental Qualification Program. The results of Reference 47 indicated no issues with equipment performance over the mission time for Torus Room equipment (T50N414B transmitter is located on the RB 1st Floor at Grid A-11 with significant DW shielding). Other locations in the RB were found

Final Integrated Plan
HCVS Order EA-13-109

to be more impacted by HCVS pipe dose. Based on Reference 47 results, the dose to T50N414B would be sufficiently mitigated to meet its mission time.

The SAWA flow meter is rated for continuous use under the expected ambient conditions (maximum temperature is 105°F) and will be available for the entire period of sustained operation. Furthermore, since the Manifold Trailer is deployed outside the RB, and on the opposite of the RB from the vent pipe, there is no concern for any effects of radiation exposure to the flow instrument.

Evaluation of the Radiation impacts on the SAWA Flowmeter has been conducted by Red Wolf Associates in References 37, 38, and 39 confirmed that the SAWA flowmeter would not be adversely impacted in its deployed position (approximately 60' West of RB) for the duration of the Event (168 hours) with the source term present (based on the Accident Progression in the Reference 40). This was reported separately to the NRC to close HCVS Phase 2 ISE Open Item 4.

Section IV.C.10.4: Instrument Power Supply through Sustained Operation

Fermi 2 FLEX strategies will restore the containment instruments, containment pressure and Torus level, necessary to successfully implement SAWA. The strategy will be to use the FLEX generator to re-power battery chargers before the batteries supplying the instruments are depleted. Since the FLEX generators are refueled per FLEX strategies for a sustained period of operation, the instruments will be powered for the sustained operating period.

Section IV.C.11: SAWA/SAWM Severe Accident Considerations

Evaluation of the radiation impacts on the Operator actions and equipment utilized for SAWA/SAWM has been conducted by Red Wolf Associates in References 37, 38, and 39.

These reports and subsequent evaluation of Total Integrated Dose derived in the reports confirmed that the operator actions were feasible and would not result in dose impacts to any single operator beyond normal annual dose limits or beyond allowable dose under allowable Accident limits per ERO procedures. Equipment utilized for SAWA/SAWM would not be adversely impacted in its deployed position for its mission time for the duration of the Event (168 hours) with the source term present (based on the Accident Progression in Reference 40). This was reported separately to the NRC to close HCVS Phase 2 OIP Open Item 2.

Section IV.C.11.1: Severe Accident Effect on FLEX/SAWA pumps and Flowpath

Since the FLEX/SAWA pumps, stored in FSF-1 and FSF-2, will be operated from outside the RB, there will be no issues with radiation dose rates at the FLEX/SAWA pumps control locations or Manifold Trailer location and there will be no significant dose to the FLEX/SAWA pumps.

Final Integrated Plan
HCVS Order EA-13-109

Inside the RB, the SAWA flow path consists of steel pipe which will remain unaffected by the radiation or elevated temperatures inside the RB. These pipes have been evaluated in the Design Basis of the plant and further evaluated for function in References 37, 38, and 39. Therefore, the SAWA flow path will not be affected by radiation or temperature effects due to a severe accident.

Section IV.C.11.2: Severe Accident Effect on SAWA/SAWM instruments

The SAWA/SAWM instruments are described in section IV.C.10.3; that section provides severe accident effects evaluation.

Section IV.C.11.3: Severe Accident Effect on personnel actions

Section IV.C.2 describes the RB actions within the first 7 hours. The actions for SAWA/SAWM are expected to be completed prior to first venting. Access routes outside the Reactor Building during severe accident conditions (such as refueling FLEX Generators and FLEX Pumps) are located such that they are either shielded from direct exposure to the vent line or are a significant distance from the vent line so that expected dose is maintained below the ERO exposure guidelines.

As part of the response to Order EA-12-049, Fermi 2 performed GOTHIC calculations of the temperature response of the Reactor and Control Buildings during the ELAP event. Since, in the severe accident, the core materials are contained inside the primary containment, the temperature response of the RB and AB is driven by the loss of ventilation and ambient conditions and therefore will not change. Thus, the FLEX GOTHIC calculations are acceptable for severe accident use. Additionally, for HCVS Phase 1, Design Calculation DC-6639 Vol. I, Rev. 0, "Loss of HVAC-Room Environmental Analysis in Support of Hard Vent" (Reference 36) was created to evaluate impacts for HCVS Vent operation in addition to thermal impacts from extended loss of HVAC. This analysis was reviewed for the thermal impact on HCVS Phase 2 (SAWA) actions and found to be bounding. No adverse impacts on SAWA deployment or Operation were found (See HCVS Phase 2 OIP Open Item 1).

Table 2 provides a list of SAWA/SAWM operator actions as well as an evaluation of each for suitability during a severe accident. Attachment 6 shows the approximate locations of the actions.

After the SAWA pipe is aligned inside the RB, the operators can control SAWA/SAWM as well as observe the necessary instruments from outside the RB. The concrete RB walls as well as the distance to the core materials mean that there is no radiological concern with any actions outside the RB. Therefore, all SAWA controls and indications are accessible during severe accident conditions. The RWA analyses for Dose to personnel and equipment (References 37, 38, and 39) confirm that the actions in the locations at the validated times so Dose and Dose Limits would not be challenged by the Severe Accident dose rates with ALARA practices in effect.

Final Integrated Plan
HCVS Order EA-13-109

The FLEX/SAWA pumps and monitoring equipment can all be operated from the MCR or from outside the RB at ground level. The Fermi 2 FLEX response ensures that the FLEX/SAWA pumps, FLEX air compressors, FLEX generators and other equipment can all be run for a sustained period by refueling. All the refueling locations are a significant distance from core materials during a severe accident. The refueling time would be short and analysis of the potential dose rates indicates that normal ALARA practices would keep the tasks feasible with respect to Dose and Dose Limits. The monitoring instrumentation includes SAWA flow at the Manifold Trailer, and Torus level and containment pressure in the MCR. Monitoring dose and time is similar for refueling time. Therefore, dose and dose limits would not be challenged by the Severe Accident dose rates with ALARA practices in effect.

Section V: HCVS Programmatic Requirements

Section V.A: HCVS Procedure Requirements

Licensees shall develop, implement, and maintain procedures necessary for the safe operation of the HCVS. Procedures shall be established for system operations when normal and backup power is available, and during an extended loss of AC power.

Evaluation:

Procedures have been established for system operations when normal and backup power is available, and during ELAP conditions.

The HCVS and SAWA procedures have been developed and implemented following Fermi 2's process for initiating and/or revising procedures and contain the following details:

- appropriate conditions and criteria for use of the system,
- when and how to place the system in operation,
- the location of system components,
- instrumentation available,
- normal and backup power supplies,
- directions for sustained operation, including the storage location of portable equipment,
- training on operating the portable equipment, and
- testing portable equipment

Fermi 2 has implemented the BWROG Emergency Procedures Committee Issue 1314 that implements the Severe Accident Water Management (SAWM) strategy in the Severe Accident Management Guidelines (SAMGs). The following general cautions,

Final Integrated Plan
HCVS Order EA-13-109

priorities and methods have been evaluated for plant specific applicability and incorporated as appropriate into the plant specific SAMGs using administrative procedures for EPG/SAG change control process and implementation. SAMGs are symptom based guidelines and therefore address a wide variety of possible plant conditions and capabilities. While these changes are intended to accommodate those specific conditions assumed in Order EA-13-109, the changes were made in a way that maintains the use of SAMGs in a symptom based mode while at the same time addressing those conditions that may exist under extended loss of AC power (ELAP) conditions with significant core damage including ex-vessel core debris.

Actual language that is incorporated into site SAMGs

Cautions:

- Adding water to hot core debris may pressurize the primary containment by rapid steam generation.
- Raising torus water level above 570 ft. will result in loss of the torus vent path.

Priorities – With significant core damage and RPV breach, SAMGs prioritize the preservation of primary containment integrity while limiting radioactivity releases as follows:

- Stabilize core debris in the primary containment (TSG-3.7).
- Primary Containment Venting
 - To control torus pressure below the Primary Containment Pressure Limit (see Containment Level/Pressure Limits above)
 - As required by SAG-2 for:
 - Primary containment pressure control
 - Primary containment hydrogen control
- Containment Level/Pressure Limits
 - Cannot maintain torus water level below 570 ft.:
 - Stop RPV and primary containment injection from outside the primary containment except injection needed for debris cooling.

Methods – Identify systems and capabilities to add water to the RPV or drywell, with the following generic guidance:

- Use any available injection source (Table 21)

Final Integrated Plan
HCVS Order EA-13-109

- Use only outside shroud injection if possible.
- Operate Core Spray if available.
- Add water from outside primary containment only if necessary to restore and maintain RPV water level above 0 in.
- Maintain injection from outside the primary containment as low as possible.
- Increase Injection slowly.
- Verify 100 gpm Severe Accident Water Addition capability.
- Inject into the RPV if possible
- Maintain injection from external sources of water as low as possible to preserve the suppression chamber vent capability

Section V.B: HCVS Out of Service Requirements

Provisions for out-of-service requirements of the HCVS and compensatory measures have been incorporated into MOP25 so that it is with the FLEX out-of-service program.

Programmatic controls have been implemented to document and control the following:

NOTE: Out of service times and required actions noted below are for HCVS and SAWA functions. Equipment that also supports a FLEX function that is found to be non-functional must also be addressed using the out of service times and actions in accordance with the FLEX program.

The provisions for out-of-service requirements for HCVS and SAWA functionality are applicable in Modes 1, 2, and 3 per NEI 13-02, 6.3.

- If for up to 90 consecutive days, the primary or alternate means of HCVS operation are non-functional, no compensatory actions are necessary.
- If up for to 30 days, the primary and alternate means of HCVS operation or SAWA are non-functional, no compensatory actions are necessary.
- If the out of service times projected to exceed 30 or 90 days as described above, the following actions will be performed through the corrective action system determine:
 - The cause(s) of the non-functionality,
 - The actions to be taken and the schedule for restoring the system to functional status and prevent recurrence,
 - Initiate action to implement appropriate compensatory actions, and

Final Integrated Plan
HCVS Order EA-13-109

- Restore full HCVS functionality at the earliest opportunity not to exceed one full operating cycle.

The HCVS system is functional when piping, valves, instrumentation and controls including motive force necessary to support system operation are available. Since the system is designed to allow a primary control and monitoring or alternate valve control by Order criteria 1.2.4 or 1.2.5, allowing for a longer out of service time with either of the functional capabilities maintained is justified. A shorter length of time when both primary control and monitoring and alternate valve control are unavailable is needed to restore system functionality in a timely manner while at the same time allowing for component repair or replacement in a time frame consistent with most high priority maintenance scheduling and repair programs, not to exceed 30 days unless compensatory actions are established per NEI 13-02 Section 6.3.1.3.3.

SAWA is functional when piping, valves, motive force, instrumentation and controls necessary to support system operation are functional.

The system functionality basis is for coping with beyond design basis events and therefore plant shutdown to address non-functional conditions is not warranted. However, such conditions should be addressed by the corrective action program and compensatory actions to address the non-functional condition should be established. These compensatory actions may include alternative containment venting strategies or other strategies needed to reduce the likelihood of loss of fission product cladding integrity during design basis and beyond design basis events even though the severe accident capability of the vent system is degraded or non-functional. Compensatory actions may include actions to reduce the likelihood of needing the vent but may not provide redundant vent capability.

Fermi 2 defined compensatory actions with HCVS non-functional include:

- Alternate venting paths such as SGTS up to 15 psig
- Drywell vent path with either no Severe Accident source term OR when Drywell flooded up to greater than 580'
- Containment Pressure reduction paths via RPV depressurization methods in EOPs/SAGs
- Use of RCIC Blackstart methods
- Use of HPCI Blackstart methods
- Minimizing RCIC and HPCI on-line work
- Minimizing RHR Division 2 on-line work
- Minimizing EDG on-line work

Final Integrated Plan
HCVS Order EA-13-109

- Minimizing CSS on-line work
- Minimizing CTG on-line work

Applicability for allowed out of service time for HCVS and SAWA for system functional requirements is limited to startup, power operation and hot shutdown conditions when primary containment is required to be operable and containment integrity may be challenged by decay heat generation.

Section V.C: HCVS Training Requirements

Licensee shall train appropriate personnel in the use of the HCVS. The training curricula shall include system operations when normal and backup power is available, and during an extended loss of AC power.

Evaluation:

Personnel expected to perform direct execution of the HCVS have received necessary training in the use of plant procedures for system operations when normal and backup power is available and during ELAP conditions. The training will be refreshed on a periodic basis and as any changes occur to the HCVS. The personnel trained and the frequency of training was determined using a systematic analysis of the tasks to be performed using the Systems Approach to Training (SAT) process.

In addition, per NEI 12-06, any non-trained personnel on-site will be available to supplement trained personnel.

Section V.D: Demonstration with other Post Fukushima Measures

Fermi 2 will demonstrate use of the HCVS and SAWA systems in drills, tabletops or exercises as follows:

1. Hardened containment vent operation on normal power sources (no ELAP)
2. During FLEX demonstrations (as required by EA-12-049: Hardened containment vent operation on backup power and from primary or alternate locations during conditions of ELAP/loss of UHS with no core damage) System use is for containment heat removal AND containment pressure control with events that cause loss of Feed and Bleed path due to damage to HPCI to GSW cross tie connection of GSW piping (e.g. Large Earthquakes).
3. HCVS operation on backup power and from primary or alternate location during conditions of ELAP/loss of UHS with core damage. System use is for containment heat removal AND containment pressure control with potential for combustible gases.

Final Integrated Plan
HCVS Order EA-13-109

Evaluation:

NOTE: Items 1 and 2 above are not applicable to SAWA. Item 2 is not applicable because Fermi 2 credits the Feed and Bleed method for containment heat removal and the HCVS is not needed to support FLEX strategies.

The use of the HCVS and SAWA capabilities will be demonstrated during drills, tabletops or exercises consistent with NEI 13-06 and on a frequency consistent with 10 CFR 50.155(e)(4) and in accordance with the evaluation above. Fermi 2 will perform the first drill demonstrating at least one of the above capabilities by October 15, 2022 which is within four years of compliance with Phase 2 of Order EA-13-109. Subsequent drills, tabletops or exercises will be performed to demonstrate the capabilities of different elements of Items 1, 2 and/or 3 above that is applicable to Fermi 2 in compliance with the frequency established as part of the order or rule change.

Final Integrated Plan
HCVS Order EA-13-109

Section VI: References

Number	Rev	Title	Location ¹
1. GL 89-16	0	Installation of a Hardened Wetwell Vent (Generic Letter 89-16), dated September 1, 1989.	ML031140220
2. SECY-12-0157	0	Consideration of Additional Requirements for Containment Venting Systems for Boiling Water Reactors with Mark I and Mark II Containments	ML12326A370
3. SRM-SECY-12-0157	0	Staff Requirements – SECY-12-0157 – Consideration of Additional Requirements for Containment Venting Systems for Boiling Water Reactors with Mark I and Mark II Containments	ML13078A017
4. EA-12-050	0	Issuance of Order to Modify Licenses with Regard to Reliable Hardened Containment Vents	ML12054A694
5. EA-13-109	0	Order Modifying Licenses with Regard to Reliable Hardened Containment Vents Capable of Operation Under Severe Accident Conditions	ML13130A067
6. NEI 13-02	0	Industry Guidance for Compliance with Order EA-13-109, BWR Mark I & II Reliable Hardened Containment Vents Capable of Operation Under Severe Accident Conditions	ML13316A853
7. NEI 13-02 ²	1	Industry Guidance for Compliance with Order EA-13-109, BWR Mark I & II Reliable Hardened Containment Vents Capable of Operation Under Severe Accident Conditions	ML15113B318
8. HCVS-WP-01	0	Hardened Containment Vent System Dedicated and Permanently Installed Motive Force, April 14, 2014	ML14120A295 ML14126A374
9. HCVS-WP-02	0	Sequences for HCVS Design and Method for Determining Radiological Dose from HCVS Piping, October 23, 2014	ML14358A038 ML14358A040
10. HCVS-WP-03	1	Hydrogen/Carbon Monoxide Control Measures October 2014	ML14302A066 ML15040A038
11. HCVS-WP-04	0	Missile Evaluation for HCVS Components 30 Feet Above Grade, August 17, 2015	ML15244A923 ML15240A072

¹ Where two ADAMS accession numbers are listed, the first is the reference document and the second is the NRC endorsement of that document.

² NEI 13-02 Revision 1 Appendix J contains HCVS-FAQ-01 through HCVS-FAQ-09.

Final Integrated Plan
HCVS Order EA-13-109

Number	Rev	Title	Location ¹
12. JLD-ISG-2013-02	0	Compliance with Order EA-13-109, Order Modifying Licenses with Regard to Reliable Hardened Containment Vents Capable of Operation under Severe Accident Conditions	ML13304B836
13. JLD-ISG-2015-01	0	Compliance with Phase 2 of Order EA-13-109, Order Modifying Licenses with Regard to Reliable Hardened Containment Vents Capable of Operation under Severe Accident Conditions	ML15104A118
14. HCVS-FAQ-10	1	Severe Accident Multiple Unit Response	ML15273A141 ML15271A148
15. HCVS-FAQ-11	0	Plant Response During a Severe Accident	ML15273A141 ML15271A148
16. HCVS-FAQ-12	0	Radiological Evaluations on Plant Actions Prior to HCVS Initial Use	ML15273A141 ML15271A148
17. HCVS-FAQ-13	0	Severe Accident Venting Actions Validation	ML15273A141 ML15271A148
18. Phase 1 OIP	0	HCVS Phase 1 Overall Integrated Plan (OIP)	ML14182A203
19. Combined OIP	0	Combined HCVS Phase 1 and 2 Overall Integrated Plan (OIP)	ML15357A289
20. Phase 1 ISE	0	HCVS Phase 1 Interim Staff Evaluation (ISE)	ML15077A574
21. Phase 2 ISE	0	HCVS Phase 2 Interim Staff Evaluation (ISE)	ML16231A443
22. NRC-14-0075	0	First Six Month Update	ML14352A174
23. NRC-15-0070	0	Second Six Month Update	ML15162A729
24. NRC-15-0105	0	Third Six Month Update (with Combined HCVS Phase 1 and 2 Overall Integrated Plan (OIP))	ML15357A289
25. NRC-16-0039	0	Fourth Six Month Update	ML16172A209
26. NRC-16-0069	0	Fifth Six Month Update	ML16344A252
27. NRC-17-0043	0	Sixth Six Month Update	ML17178A343
28. NRC-17-0079	0	Seventh Six Month Update	ML17348A784
29. NRC-18-0037	0	Eighth Six Month Update	ML18177A259
30. NRC HCVS Audit Response	0	NRC Report on ISE Open Items Response for HCVS	ML18186A421
31. HCVS Compliance Letter	0	HCVS Phase 2 Completion and Phase 1 and Phase 2 compliance letter (Internal: NPOP-18-0083)	N/A
32. NEI 12-06	0	Diverse and Flexible Coping Strategies (FLEX) Implementation Guide	ML12221A205

Final Integrated Plan
HCVS Order EA-13-109

Number	Rev	Title	Location¹
33. EA-12-049	0	Issuance of Order to Modify Licenses With Regard to Requirements for Mitigation Strategies for Beyond-Design-Basis External Events, dated March 12, 2012.	ML12054A735
34. RG 1.97	4	Instrumentation for Light-Water-Cooled Nuclear Power Plants to Assess Conditions During and Following an Accident	N/A
35. TR-1026539	0	EPRI Investigation of Strategies for Mitigating Radiological Releases in Severe Accidents BWR, Mark I and Mark II Studies, October 2012	N/A
36. DC-6639 VOL I	0	Loss of HVAC Room Environmental Analysis	N/A
37. RWA 1805 001	0	Operator and EQ Source Term in Support of the Fermi 2 Hardened Containment Vent System Phase 2.	N/A
38. RWA 1805 002	0	Fermi 2 Power Plant HCVS Radiological Dose Analysis	N/A
39. RWA 1805 002 Attachment A	0	Fermi 2 Power Plant HCVS Radiological Dose Analysis Attachment A: Letter Report RWA-L-1805-003, Fermi 2 Equipment Design Review for Severe Accident Water Addition and Management (SAWA/SAWM)	N/A
40. 1DLL1T007 RPT 001	0	Fermi 2 ELAP Mitigating Strategies-MAAP 5.04 Assessments	N/A
41. DC-6646 VOL I	0	Torus Hardened Vent Sizing Analysis and Dynamic Analysis	N/A
42. DC-6668 VOL I	0	Torus Capacity to Absorb Decay Heat Generated During First 3 Hours after Shutdown	N/A
43. DC-6584 VOL I	A	FLEX DC Calculations	N/A
44. DC-6636 VOL I	0	Hardened Containment Vent System Bottle Sizing	N/A
45. DC-2991 VOL IA DCD 1	0	Piping Stress Analysis Line M-3093-1	N/A

Final Integrated Plan
HCVS Order EA-13-109

Number	Rev	Title	Location¹
46. DC-5448 VOL I DCD 1	0	Piping Analysis-Hardened Torus Vent 10" Bypass Line M-5909	N/A
47. DC-6645 VOL I	0	HCVS Radiological Assessment	N/A
48. DC-6583 VOL I	A	FLEX AC Calculations	N/A
49. DC-0367 VOL I	Q	Hydraulic Calculation for RHR System	N/A
50. DC-0367 VOL VIII	B	FLEX RHR Injection Configuration-Pressure Drop Calculation	N/A
51. DC-5891 VOL I	0	Circulating Water Reservoir Size and Volume	N/A
52. 29.400.03	1	HCVS	N/A
53. 29.400.01	2	FLEX	N/A
54. NUREG 1465	0	Accident Source Terms for Light Water Nuclear Power Plants	ML041040063
55. 10820.004	0	Installation of a Hardened Containment Vent	N/A
56. 37115.004	0	Reliable, Severe Accident Capable Containment Wetwell venting Sys Mod for NRC Order EA-13-109	N/A
57. 29.FSG.19	2	FLEX RBHVAC RESTORATION	N/A
58. EQ0-EF2-018	N	Summary of Environmental Parameters for use in the Fermi EQ Program	N/A
59. Q1643 2	1	Temperature Verification Test Procedure for Curtiss- Wright HCVS Control Panel Components	N/A

Final Integrated Plan
HCVS Order EA-13-109

Number	Rev	Title	Location¹
60. NRC-16-0005	0	Fermi 2 Compliance with March 12, 2012 Commission Order Modifying Licenses with Regard to Requirements for Mitigation Strategies for Beyond-Design-Basis External Events (Order Number EA-12-049). Dated January 20, 2016	ML16022A118
61. 47.000.94	2B	Local Leakage Rate Testing for Hardened Vent	N/A
62. 37115.B103	0	Torus Hard Vent Check Valve Leakage Criteria to Prevent Combustion	N/A

Attachment 1: Phase 2 Freeboard diagram

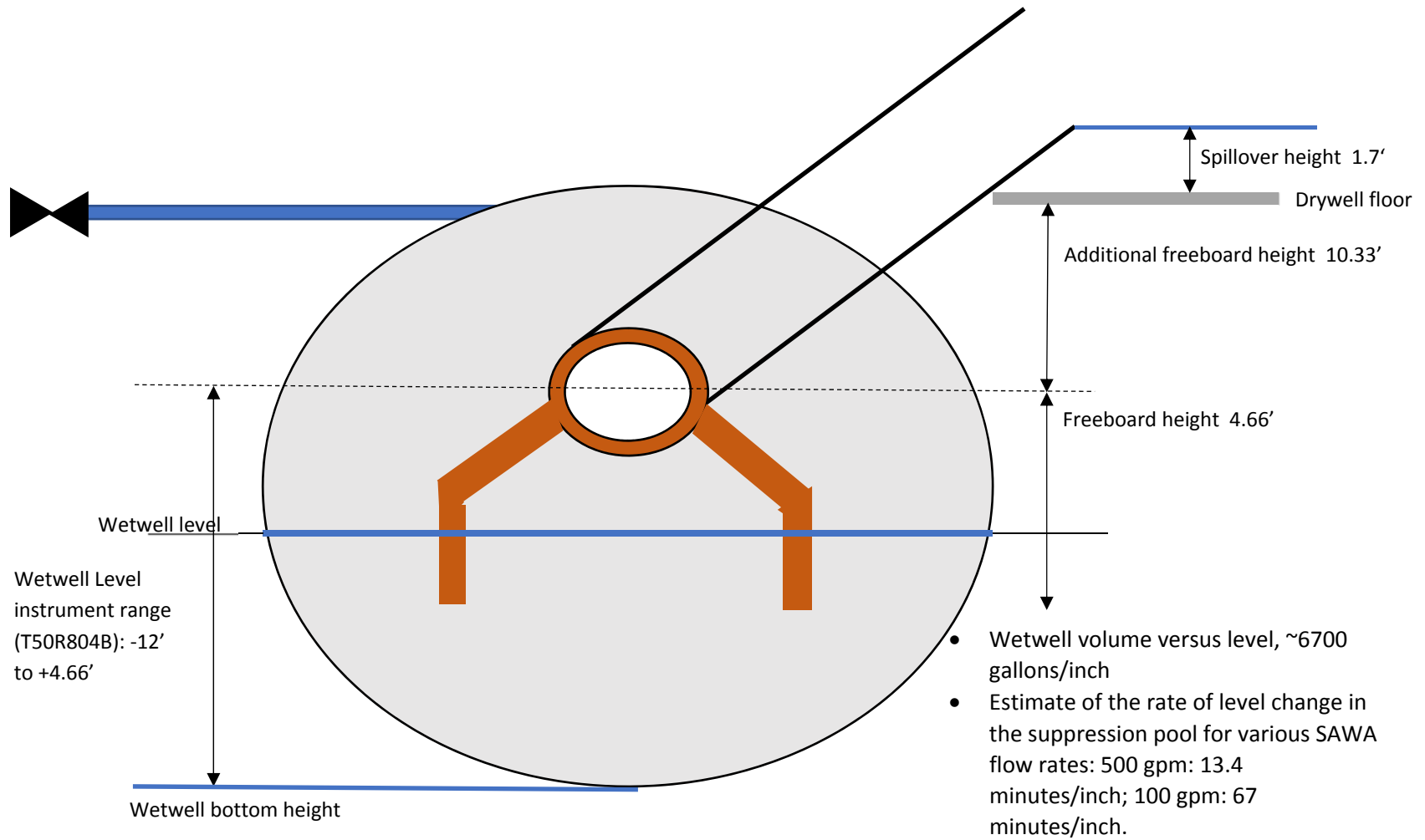

Attachment 2: One Line Diagram of HCVS Vent Path

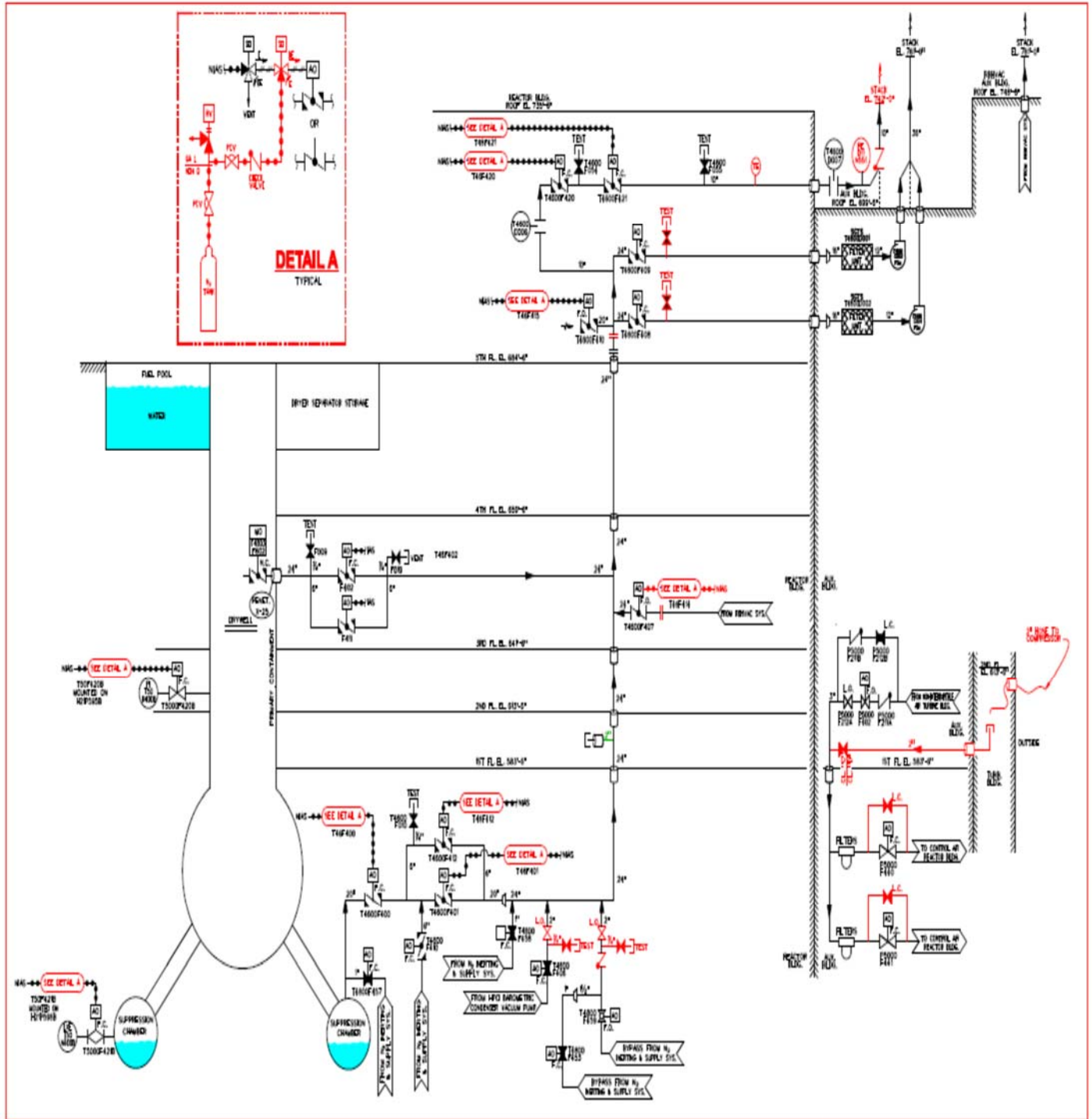

Attachment 3: One Line Diagram of HCVS Electrical Power Supply – Primary Method

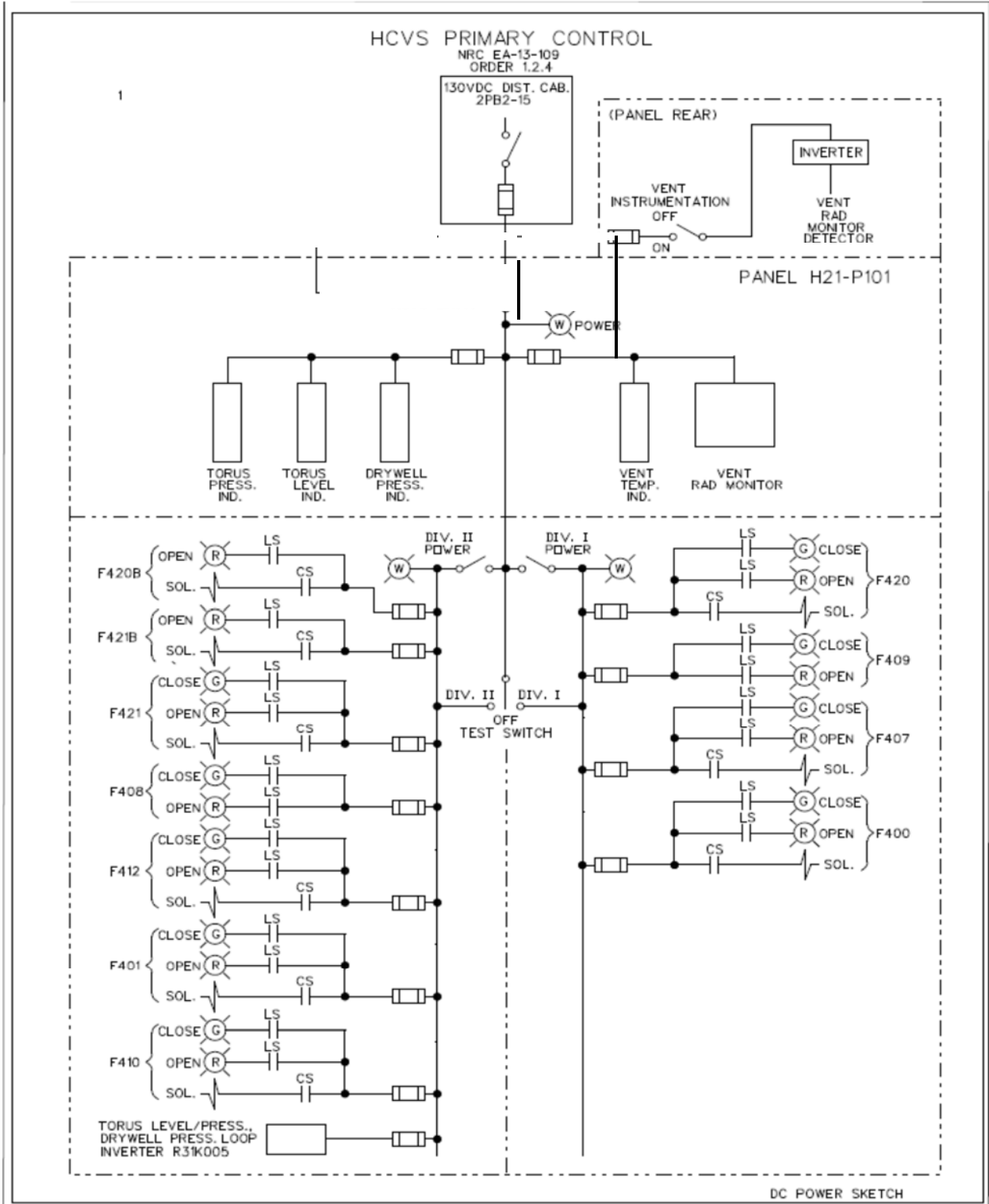

Final Integrated Plan
HCVS Order EA-13-109

Attachment 3a: One Line Diagram of HCVS Electrical Power Supply Alternate Method

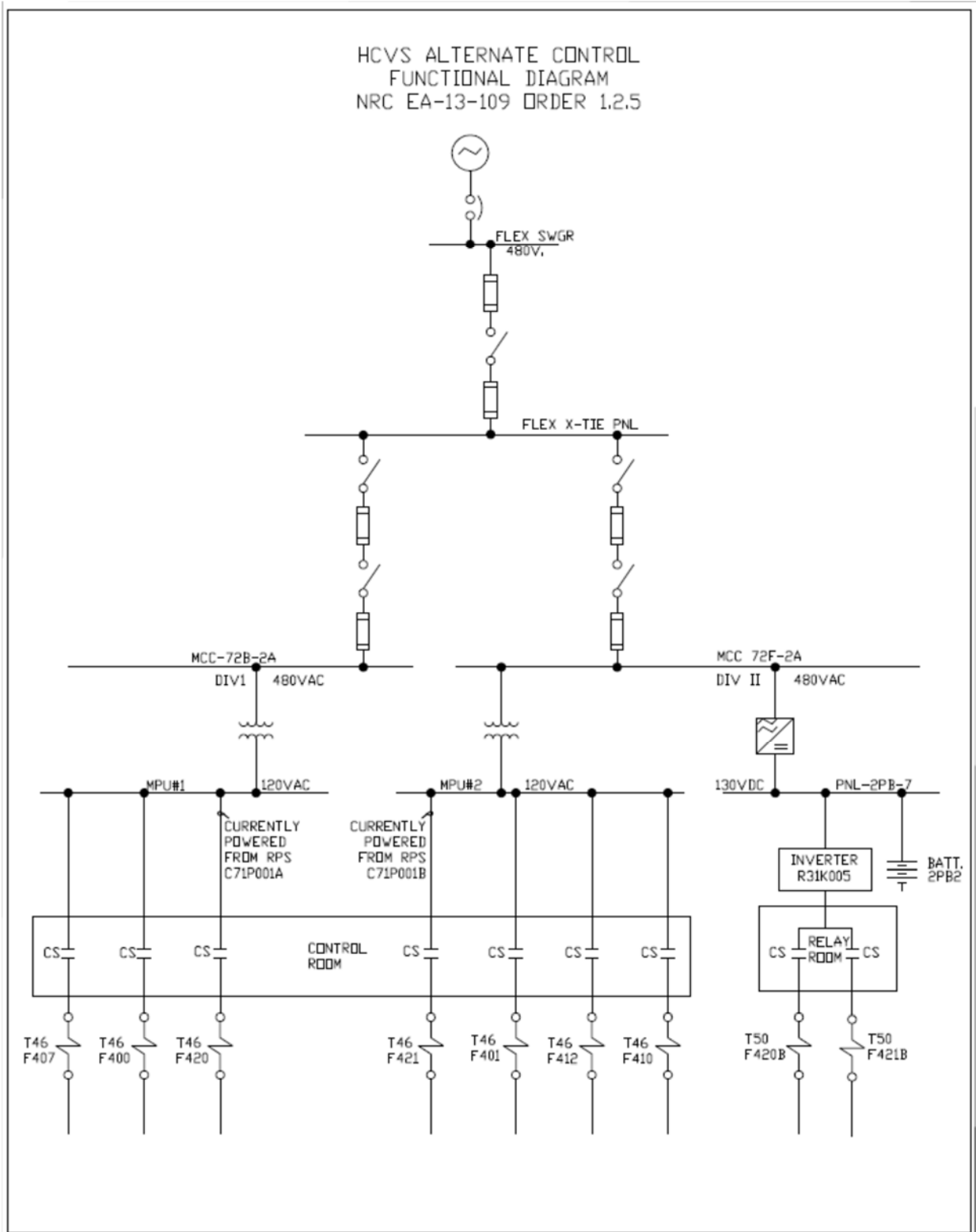

Final Integrated Plan
 HCVS Order EA-13-109

Attachment 4: One Line Diagram of SAWA Flow Path

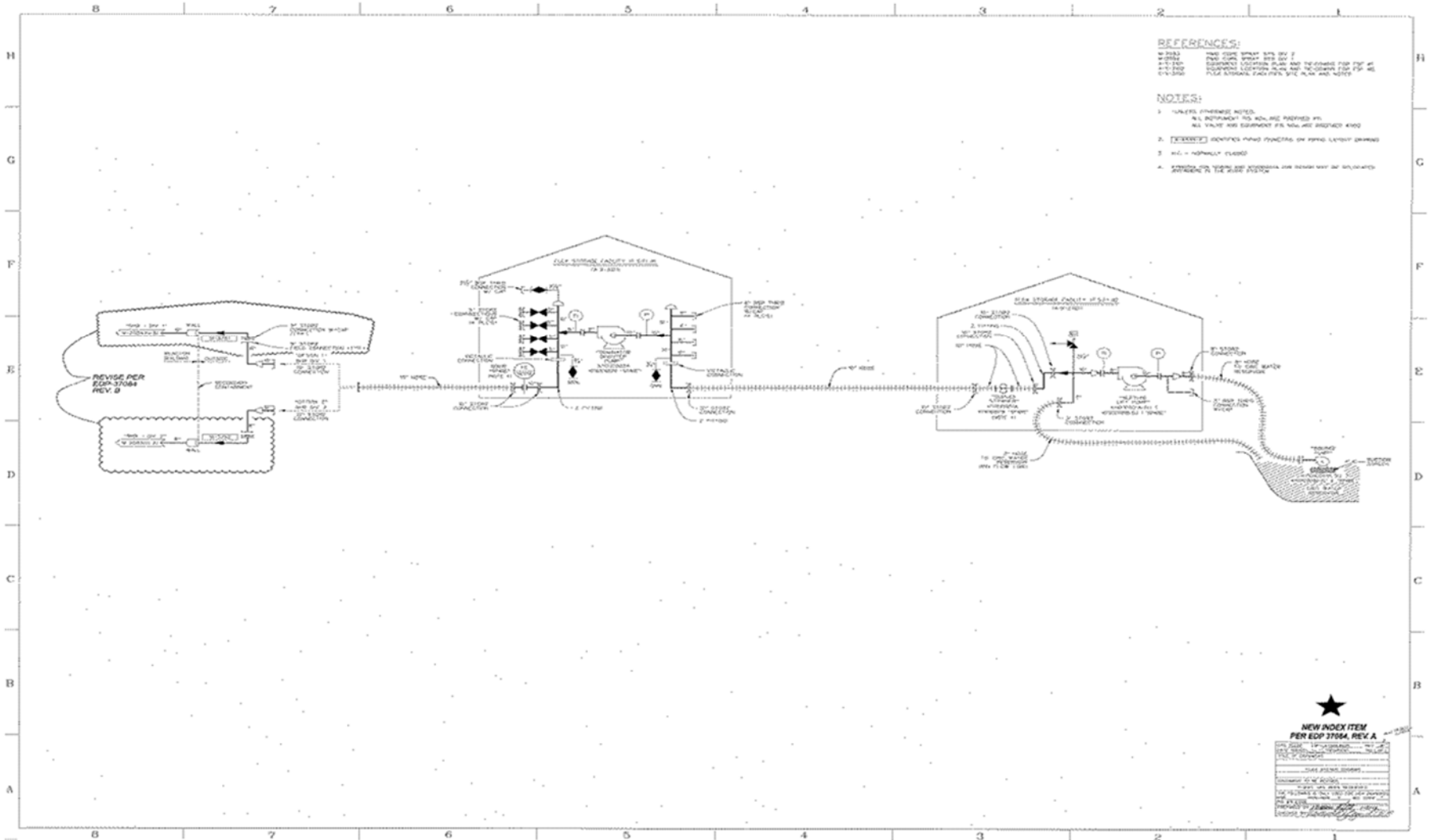

Attachment 5: One Line Diagram of SAWA Electrical Power Supply

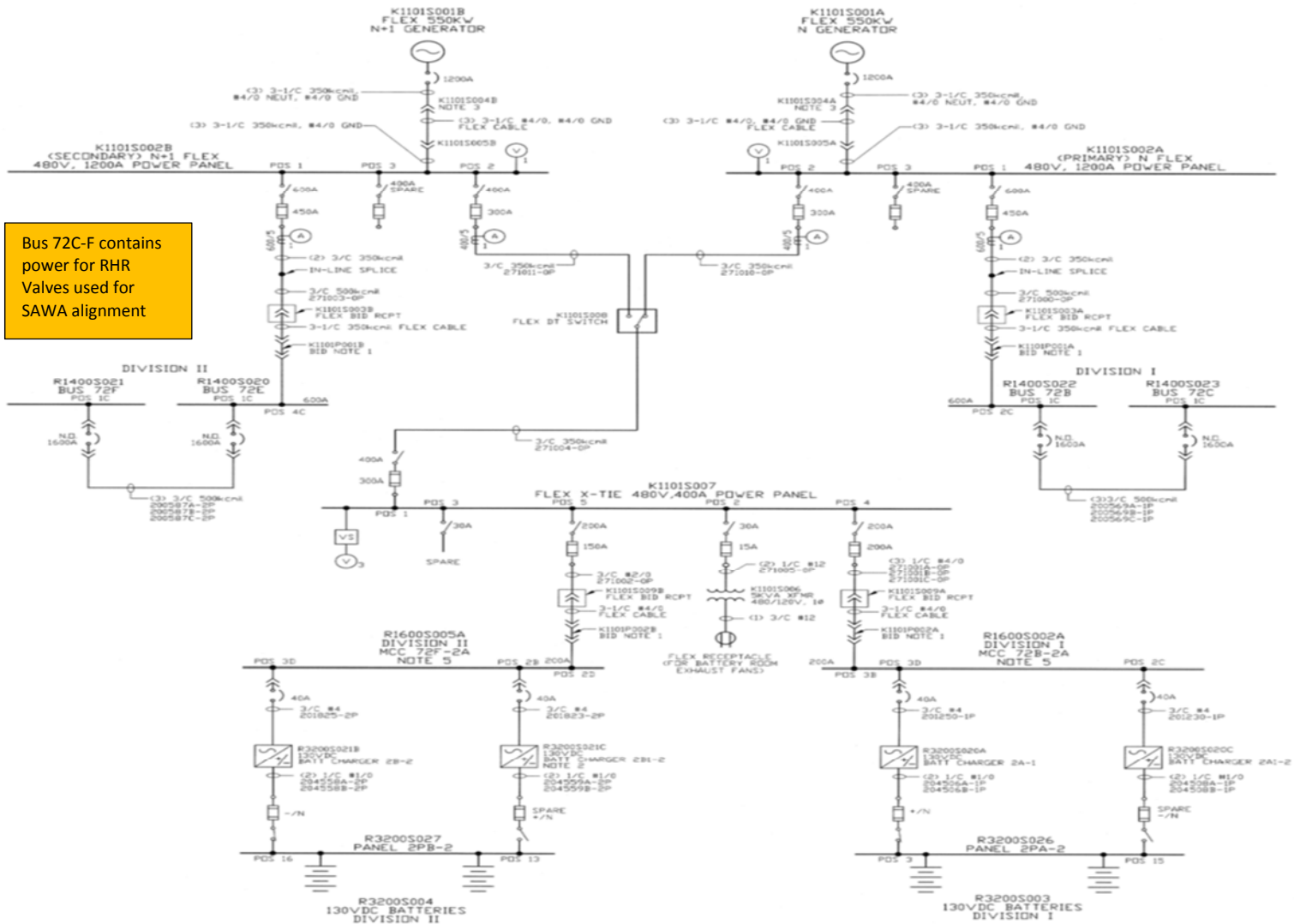

Bus 72C-F contains power for RHR Valves used for SAWA alignment

Attachment 6: Plant Layout Showing Operator Action Locations (Overview)

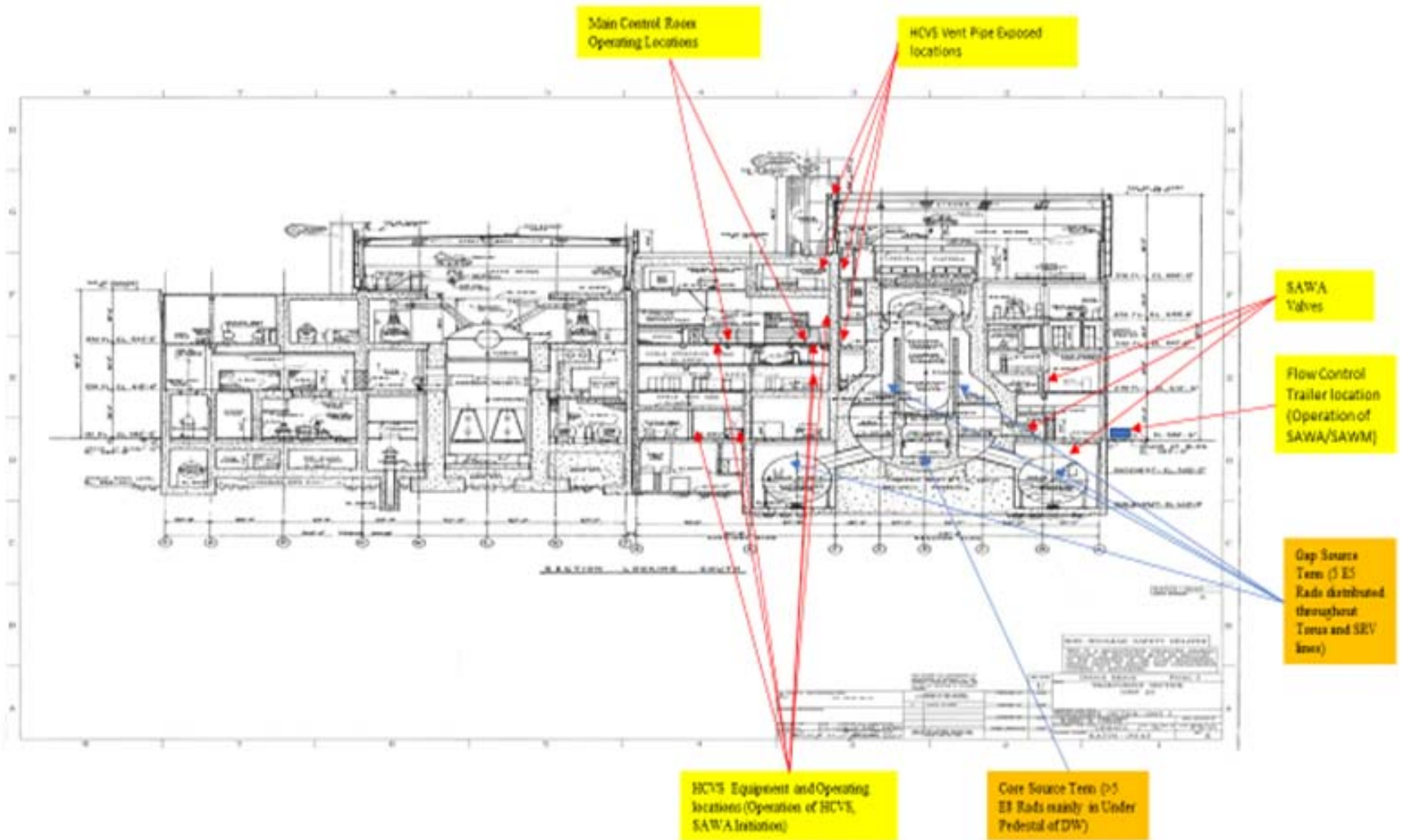

Attachment 6A: Yard Layout Showing Operator Action Locations (Overview)

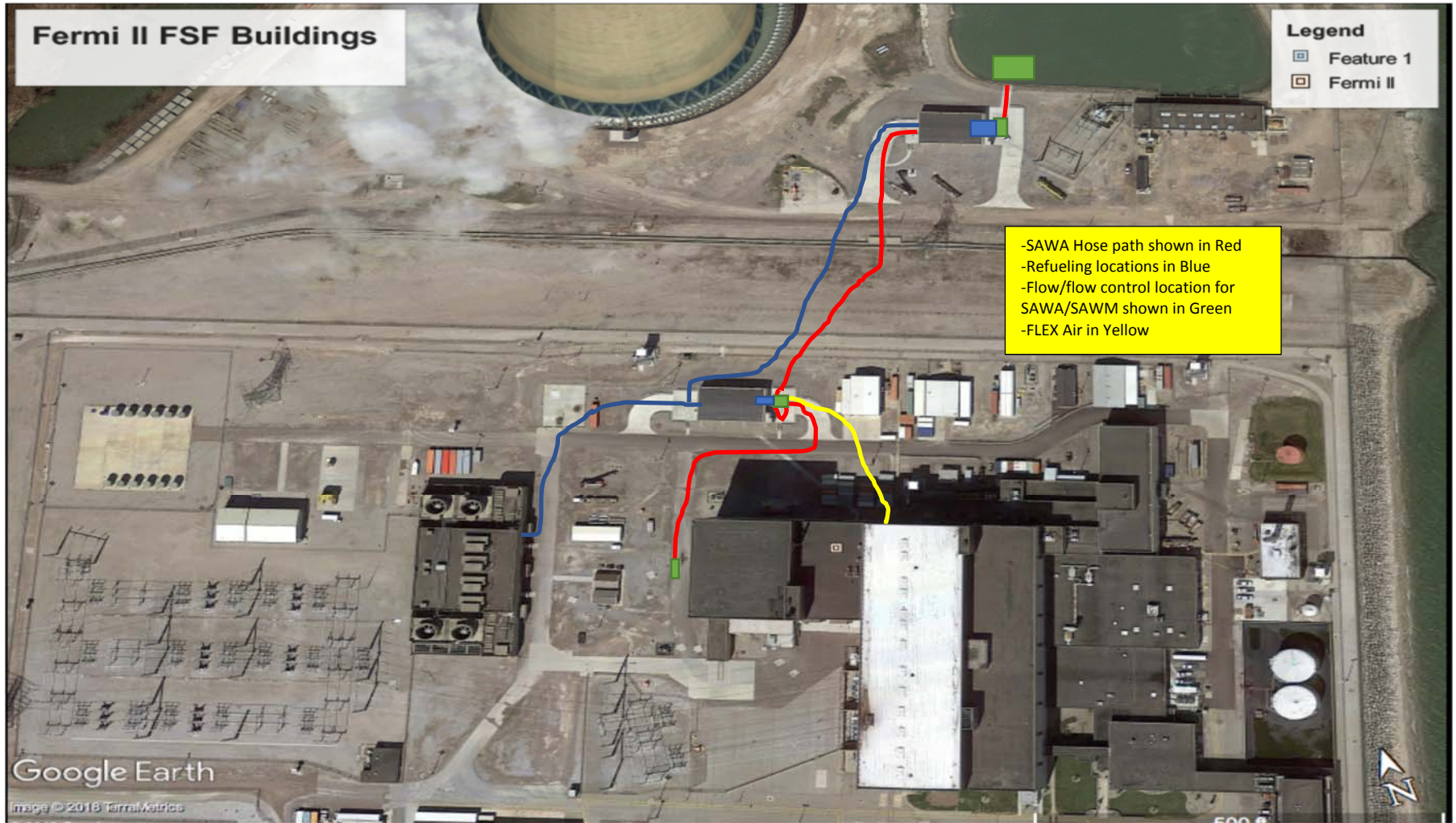

Final Integrated Plan
 HCVS Order EA-13-109

Attachment 6B: Plant Layout Showing Operator Action Locations HCVS Primary Controls

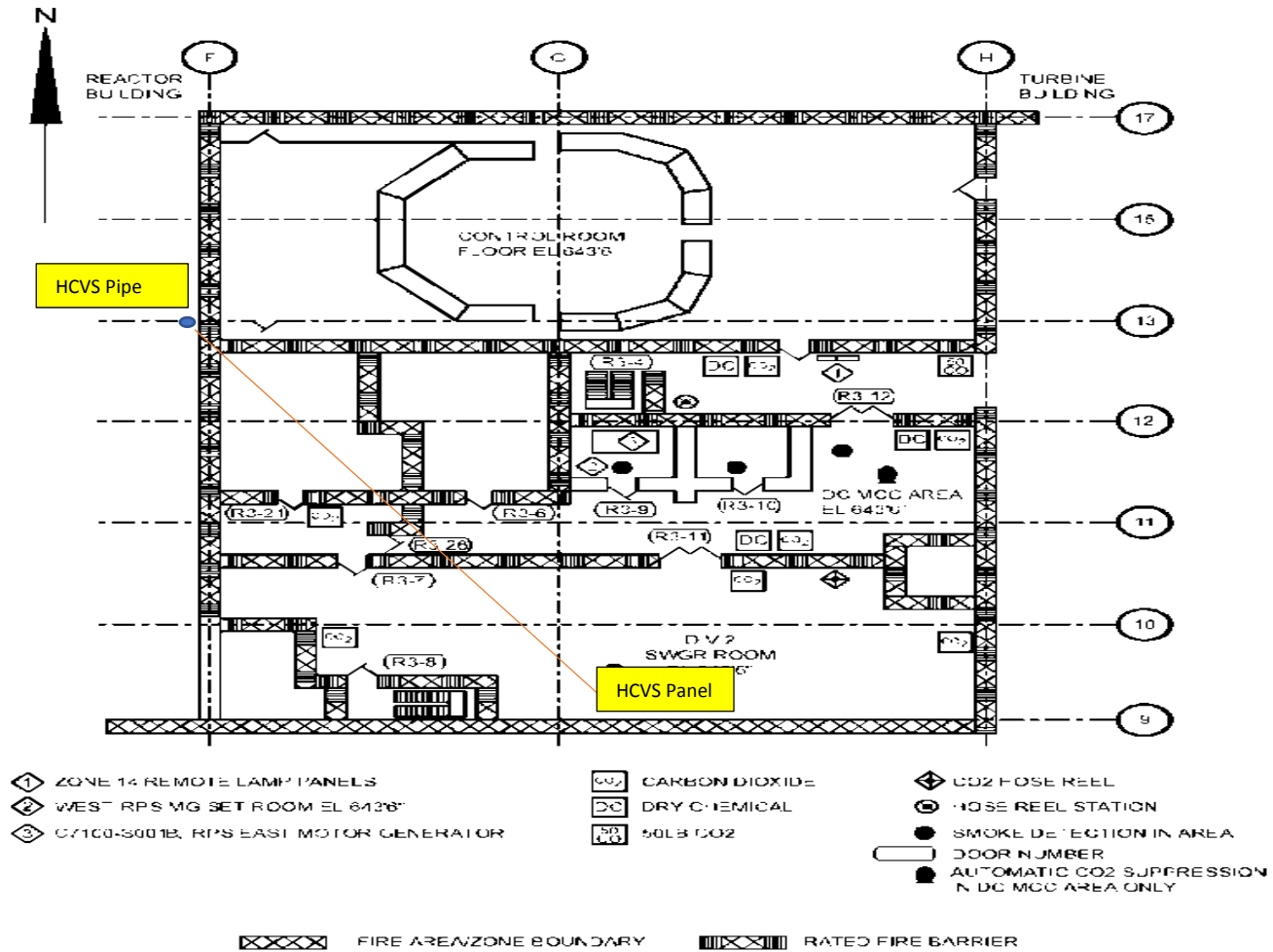

Final Integrated Plan
 HCVS Order EA-13-109

Attachment 6C: Plant Layout Showing Operator Action Locations RB-1/AB-1

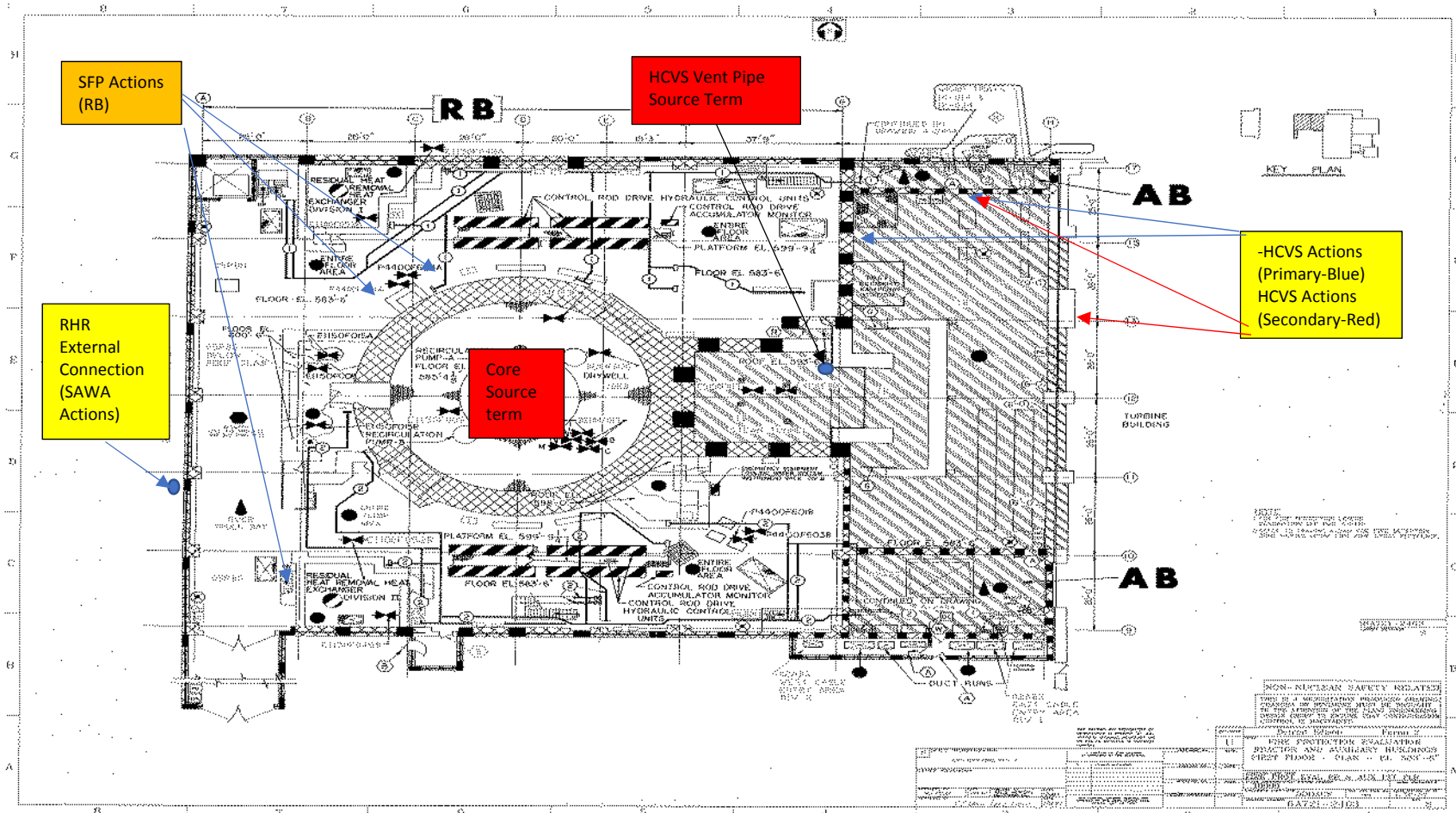

Attachment 6D: Plant Layout Showing Operator Action Locations RB-2/AB-2

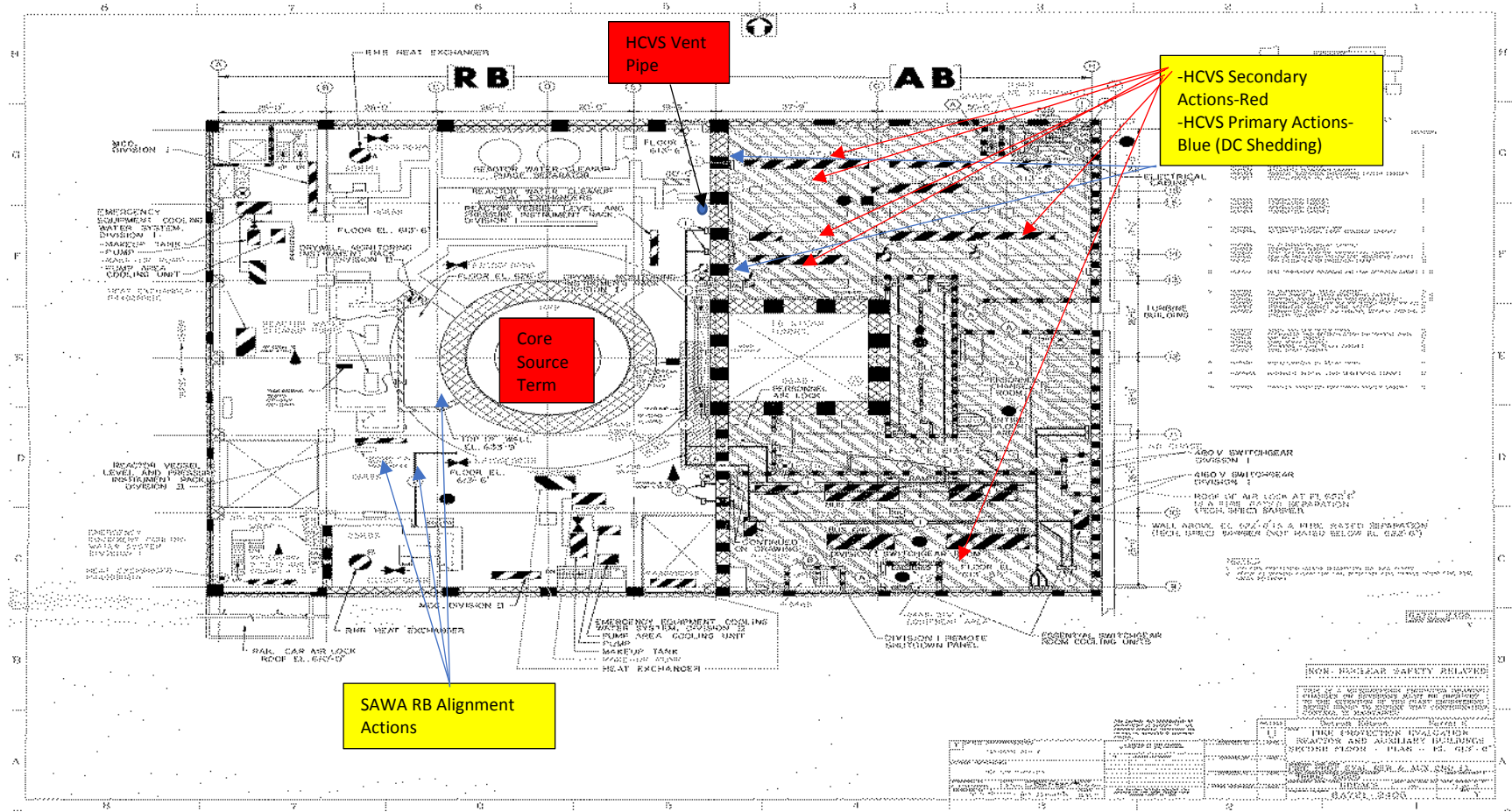

Final Integrated Plan
 HCVS Order EA-13-109

Attachment 6E: Plant Layout Showing Operator Action Locations RB-3/AB-3

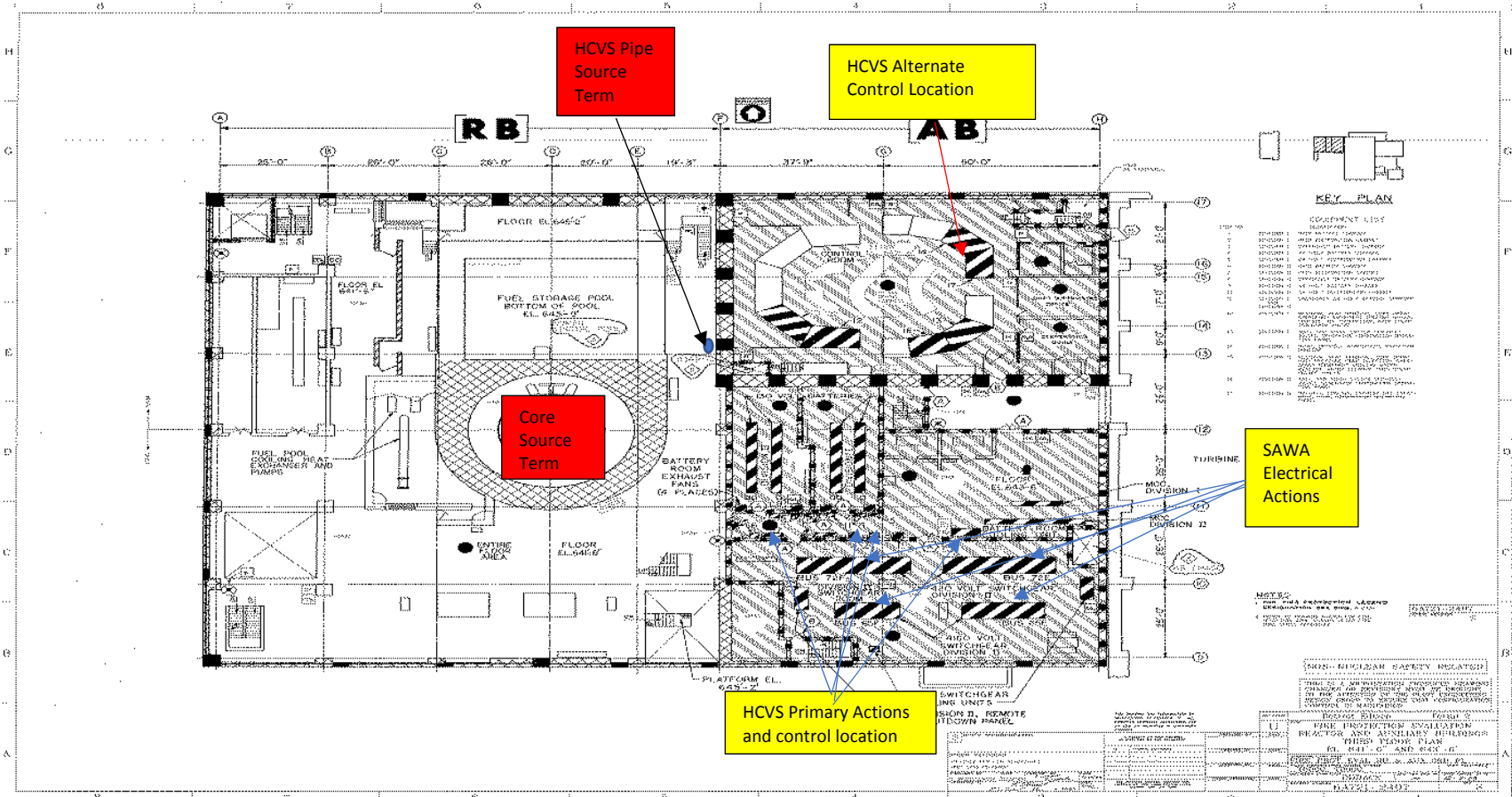

Final Integrated Plan
 HCVS Order EA-13-109

Attachment 6F: Plant Layout Showing Operator Action Locations RB-4/AB-4

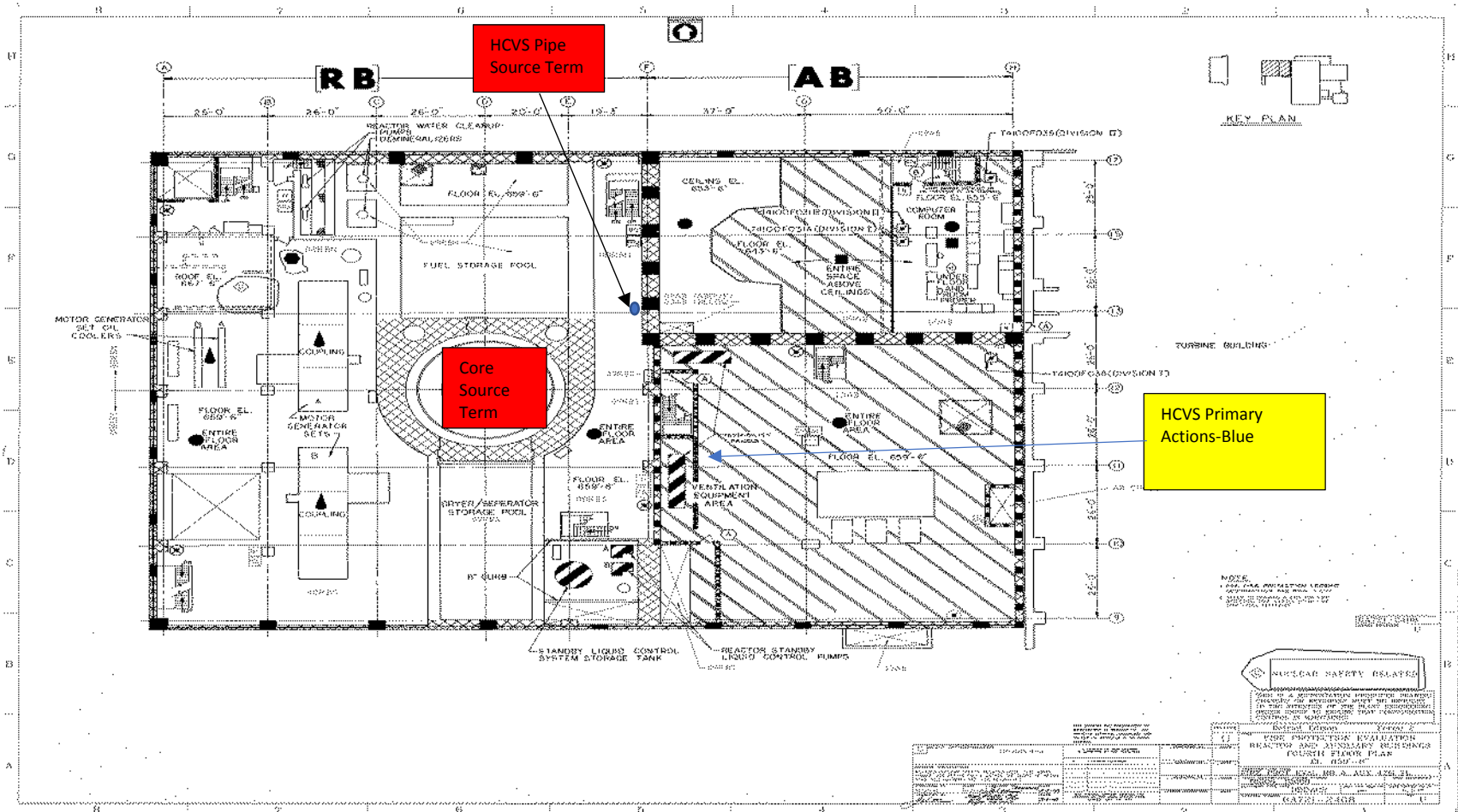

Final Integrated Plan
HCVS Order EA-13-109

Attachment 6G: Plant Layout Showing Operator Action Locations RB-5/AB-5

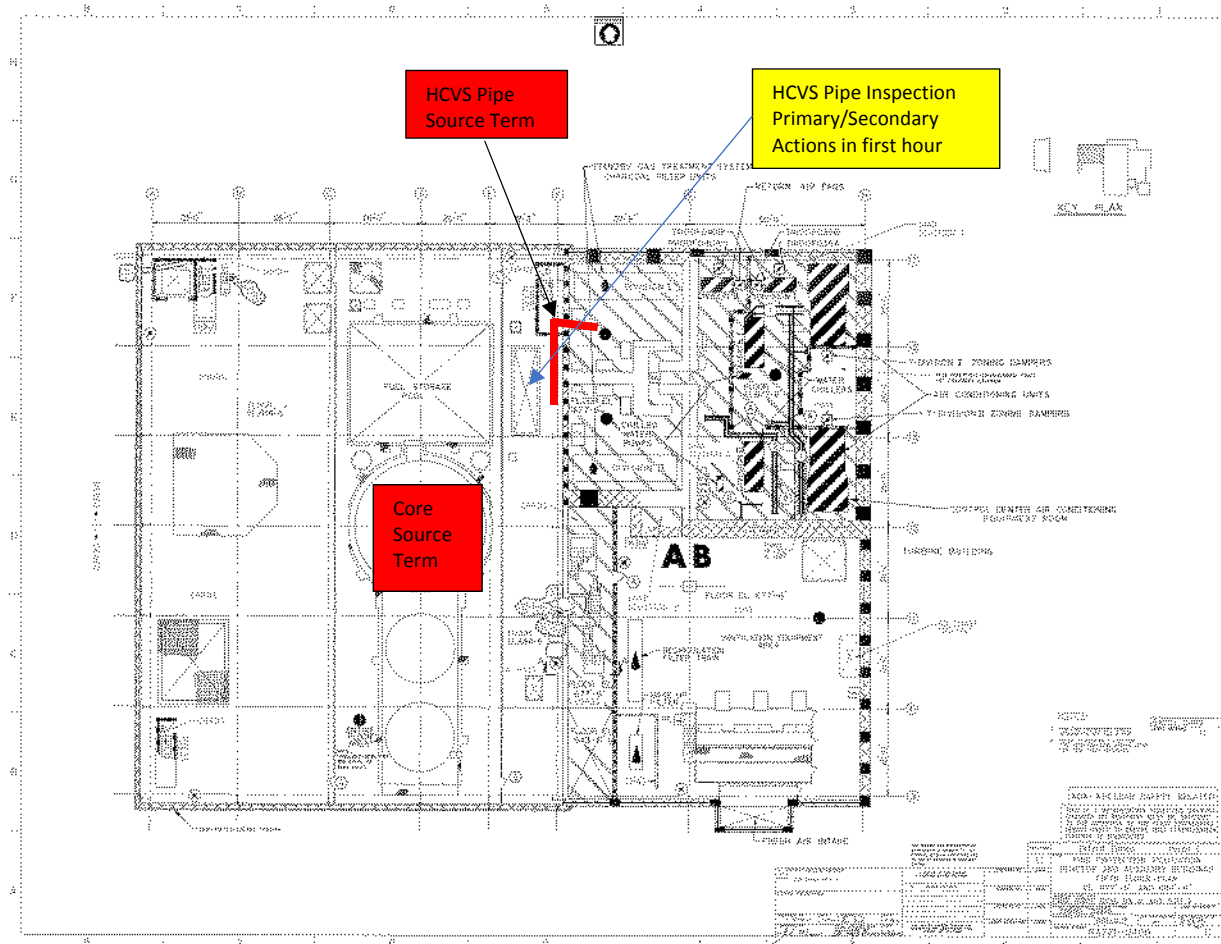

Final Integrated Plan
HCVS Order EA-13-109

Table 1: List of HCVS Component, Control and Instrument Qualifications

Component Name	Equipment ID	Range	Location	Local Accident Temp (DC-6639)	Local Accident Humidity (DC-6639)	Local Radiation Level (RWA)	Qualification ³	Qualification Temp	Qualification Humidity	Qualification Radiation	Power Supply
Wetwell Vent Instruments and Components											
SGTS Torus Hard Vent Temperature Element	T46N422	100-600 F	RB-4, B-12 T34	166.2 F	41%	5200 R/hr (Peak)	Seismic II/I IEEE-323-1974, IEEE 344-1975	700 F (Instrument Cut Sheets)	100% (Instrument Cut Sheets)	3E8 R (Instrument Cut Sheets)	Thermocouple: No power supply
Torus Hardened Vent Temp Indicator	T46R803	100-600 F	AB-3, H21P101 T65	146.2 F	41.4%	60 mR/hr (Peak)	C1-9558 (Seismic) IEEE-603 (2009) IEEE-323 (2004) IEEE-344 (2004)	160 F (Q1643 2)	95%	1E3 R (NRC Acceptance for Electronic components)	2B-1 from 2PB2-15 Ckt #5 to 24 VDC Converter in H21P101 to T46R803
Hardened Containment Vent System Radiation Detector	D11N552	1E-4 to 1E5 Rad/hr	RB-4, F-13 Mounted on H21P642 T42	167.4 F	57.9%	5200 R/hr (Peak)	IEEE-323-1974, IEEE 344-1985 Seismic II/I C1-9581 (Seismic)	350°F (RWA Report)	100% (RWA Report)	1.56E7 R (RWA Report)	Normal: MPU #3 H21P912A Circuit #2; Alternate is UPS (D11K840) via H11P903 from MPU #2
Torus Hardened Vent Rad Monitor (RB4)	D11K838/ K839	1E-4 to 1E5 Rad/hr	AB-4 F11 T67	141 F	62%	60 mR/hr (Peak)	IEEE-323-1974, IEEE 344-1985	Covered by RWA Analysis Table 5.6	98% (EQ0-EF2-018)	1E3 R (NRC Acceptance for Electronic components)	Normal: MPU #3 H21P912A Circuit #2; Alternate is UPS (D11K840) via H11P903 from MPU #2
Torus Hardened Vent Rad Monitor (MCR)	D11R607	1E-4 to 1E5 Rad/hr	MCR H11P808	131.1 F	30 %	GDC-19	IEEE-323-1974, IEEE 344-1985	RG 1.97	RG 1.97	1E3 R (NRC Acceptance for Electronic components)	Normal: MPU #3 H21P912A Circuit #2; Alternate is UPS (D11K840) via H11P903 from MPU #2
Torus Hardened Vent Rad Monitor (HCVS Panel)	D11R838	1E-4 to 1E5 Rad/hr	AB-4 F11 -AB-3, H21P101 T65	146.2 F	41.4%	60 mR/hr (Peak)	IEEE-323-1974, IEEE 344-1985 Seismic II/I C1-9581 (Seismic)	160 F (Q1643 2)	98% (EQ0-EF2-018)	1E3 R (NRC Acceptance for Electronic components)	Normal: MPU #3 H21P912A Circuit #2; Alternate is UPS(D11K840) via H11P903 from MPU #2

³ See UFSAR 3.11/7.6.1.12 for qualification code of record IEEE-323-1974 and IEEE-344-1975. Where later code years are referenced, this was reconciled in the design process.

Final Integrated Plan
HCVS Order EA-13-109

Component Name	Equipment ID	Range	Location	Local Accident Temp (DC-6639)	Local Accident Humidity (DC-6639)	Local Radiation Level (RWA)	Qualification ³	Qualification Temp	Qualification Humidity	Qualification Radiation	Power Supply
Torus Water Temperature Sensor	T50N404B	0-400 F (T50R800B Pt 11)	RBB Az-180 551'4" T7	232.3 F	32.3%	3E6 R/hr (Peak)	E5-779 (Seismic)	RG 1.97	RG 1.97	RG 1.97	Thermocouple: No power supply
Torus Water Temperature Sensor	T50N405B	0-400 F (T50R800B Pt 12)	RBB Az-90 551'4" T7	232.3 F	32.3%	3E6 R/hr (Peak)	E5-779 (Seismic) EQ1-EF2-039 (EQ)	RG 1.97	RG 1.97	RG 1.97	Thermocouple: No power supply
Torus Water Temperature Recorder	T50R800B	0-400 F	MCR H11P602	131.1 F	30 %	GDC-19	RG 1.189 (EQ) RG 1.100 (Seismic)	RG 1.97	RG 1.97	RG 1.97	T50K800B to Plug Mold AVA J5 (115 VAC) from R31K005 (2PB2-5 Ckt. 3)
Wetwell / Torus level sensor/ transmitter	T50N406B	-144" to +56"	RBSB B-9 T4	159.8 F	67.4 %	3E6 R/hr (Peak)	IEEE 323-1974, IEEE 344-1975 EQ1-EF2-063 (EQ) C01-2912 (Seismic)	RG 1.97	RG 1.97	RG 1.97	T50K800B from 115 VAC from R31K005 (2PB2-5 Ckt. 3)
Wetwell / Torus level Recorder	T50R804B	-144" to +56"	MCR H11P602	131.1 F	30 %	GDC-19	IEEE 323-1974, IEEE 344-1975 C1-9158 (Seismic)	RG 1.97	RG 1.97	RG 1.97	T50K800B to Plug Mold AVA J4 (115 VAC) from R31K005 (2PB2-5 Ckt. 3)
Drywell Pressure sensor/ transmitter Narrow Range	T50N401B	-5 to +5 psig	RB-2 C-13 T24	154.3 F	54.5 %	8000 R/hr	IEEE 323-1974, IEEE 344-1975 C01-2912 (Seismic)	RG 1.97	RG 1.97	RG 1.97	T50K800B from 115 VAC from R31K005 (2PB2-5 Ckt. 3)
Drywell Pressure sensor/ transmitter Wide Range	T50N415B	0-250 psig	RB-2 C-13 T24	154.3 F	54.5 %	8000 R/hr	IEEE 323-1974, IEEE 344-1975 EQ1-EF2-063 (EQ) C01-2912 (Seismic)	RG 1.97	RG 1.97	RG 1.97	T50K800B from 115 VAC from R31K005 (2PB2-5 Ckt. 3)
Drywell / Torus Pressure Recorder (Multi Pen Recorder)	T50R802B Pen 1: Torus NR Pen 2: Torus WR Pen 3: DW NR Pen 4: DW WR	Torus: 0-15 psig 0-80 psig DW: -5 to +5 psig 0-250 psig	MCR H11P602	131.1 F	30 %	GDC-19	IEEE 323-1974, IEEE 344-1975 C1-9672 (Seismic)	RG 1.97	RG 1.97	RG 1.97	T50K800B to Plug Mold AVA J6 (115 VAC) from R31K005 (2PB2-5 Ckt. 3)

Final Integrated Plan
HCVS Order EA-13-109

Component Name	Equipment ID	Range	Location	Local Accident Temp (DC-6639)	Local Accident Humidity (DC-6639)	Local Radiation Level (RWA)	Qualification ³	Qualification Temp	Qualification Humidity	Qualification Radiation	Power Supply
Torus Pressure sensor/transmitter Narrow Range	T50N499B	-5 to +15 psig	RB-1 A-11 T14	186 F	58.1 %	1.2E6 R/hr (Peak)	EQ1-EF2-063 (EQ) C01-2912 (Seismic)	318 F (EQ1-EF2-063)	59% (EQ1-EF2-063)	2E7 R (EQ1-EF2-063)	T50K800B from 115 VAC from R31K005 (2PB2-5 Ckt. 3)
Torus Pressure sensor/transmitter Wide Range	T50N414B	0-80 psig	RB-1 A-11 T14	186 F	58.1 %	1.2E6 R/hr (Peak)	EQ1-EF2-063 (EQ) C01-2912 (Seismic)	318 F (EQ1-EF2-063)	59% (EQ1-EF2-063)	2E7 R (EQ1-EF2-063)	T50K800B from 115 VAC from R31K005 (2PB2-5 Ckt. 3)
First Stage Regulator for T46P411	T46F457	110 +/- 5 psig	AB-4, F-12 T67	141 F	62%	60 mR/hr (Peak)	17QN10 SC 02 (Seismic)	250 F (CECO)	100% (EQ0-EF2-018)	1E4 R per EQ0-EF2-018 and DC-6645 (Section 2.1)	N/A
SGTS Torus Hard Vent T46P411 N2 Supply T46F457 Outlet Pressure Indicator	T46R807	0-300 psig	AB-4, F-12 T67	141 F	62%	60 mR/hr (Peak)	II/I (Seismic)	250 F (CECO)	100% (EQ0-EF2-018)	1E4 R per EQ0-EF2-018 and DC-6645 (Section 2.1)	N/A
SGTS Torus Hard Vent T46P411 N2 Supply Pressure Indicator	T46R802	0-300 psig	AB-4, F-12 T67	141 F	62%	60 mR/hr (Peak)	II/I (Seismic)	250 F (CECO)	100% (EQ0-EF2-018)	1E4 R per EQ0-EF2-018 and DC-6645 (Section 2.1)	N/A
SGTS Torus Hard Vent T46P410 N2 Supply Second Stage Pressure Control Valve	T46F475	98 +/- 5 psig	AB-1, G-17 T49	128.5 F	47.1%	1.5 R/hr (Peak)	17QN10 SC 01 (Seismic)	250 F (CECO)	100% (EQ0-EF2-018)	1E4 R per EQ0-EF2-018 and DC-6645 (Section 2.1)	N/A
SGTS Torus Hard Vent T46P410 N2 Supply First Stage Pressure Control Valve	T46F468	110 +/- 5 psig	AB-1, G-17 T49	128.5 F	47.1%	1.5 R/hr (Peak)	17QN10 SC 02 (Seismic)	250 F (CECO)	100% (EQ0-EF2-018)	1E4 R per EQ0-EF2-018 and DC-6645 (Section 2.1)	N/A
SGTS Torus Hard Vent T46P410 N2 Supply T46F468 Inlet Pressure indicator	T46R804	0-5000 psig	AB-1, G-17 T49	128.5 F	47.1%	1.5 R/hr (Peak)	II/I (Seismic)	250 F (CECO)	100% (EQ0-EF2-018)	1E4 R per EQ0-EF2-018 and DC-6645 (Section 2.1)	N/A
SGTS Torus Hard Vent T46P410 N2 Supply T46F468 Outlet Pressure Indicator	T46R806	0-300 psig	AB-1, G-17 T49	128.5 F	47.1%	1.5 R/hr (Peak)	II/I (Seismic)	250 F (CECO)	100% (EQ0-EF2-018)	1E4 R per EQ0-EF2-018 and DC-6645 (Section 2.1)	N/A

Final Integrated Plan
HCVS Order EA-13-109

Component Name	Equipment ID	Range	Location	Local Accident Temp (DC-6639)	Local Accident Humidity (DC-6639)	Local Radiation Level (RWA)	Qualification ³	Qualification Temp	Qualification Humidity	Qualification Radiation	Power Supply
SGTS Torus Hard Vent T46P410 N2 Supply Pressure Indicator	T46R801	0-300 psig	AB-1, G-17 T49	128.5 F	47.1%	1.5 R/hr (Peak)	II/I (Seismic)	250 F (CECO)	100% (EQ0-EF2-018)	1E4 R per EQ0-EF2-018 and DC-6645 (Section 2.1)	N/A
*SGTS Torus Hard Vent T46P410 N2 SPLY Pressure Switch	T46N423	0-30 psig (10 +/- 1 psig Setpoint)	AB-1, G-15 T51	128.3 F	52.2%	5000 R/hr (Peak)	II/I (Seismic)	250 F (CECO)	100% (EQ0-EF2-018)	1E4 R per EQ0-EF2-018 and DC-6645 (Section 2.1)	MPU #3 H11P912A Circuit #2
DC Batt 2B-1 Engineered Safeguard Systems 1-260V Voltmeter	R3200S053	0-150 VDC	AB-3, F11 T60	124.7 F	72.5%	130 mR/hr (Peak)	II/I (Seismic)	RG 1.97	RG 1.97	RG 1.97	N/A senses Battery output
DC Batt 2B-2 Engineered Safeguard Systems 1-260V Voltmeter	R3200S054	0-150 VDC	AB-3, F11 T60	124.7 F	72.5%	130 mR/hr (Peak)	II/I (Seismic)	RG 1.97	RG 1.97	RG 1.97	N/A senses Battery output
130/260VDC battery 2B-1	R3200S004 (half for R3200S008A)	0-130 VDC	AB-3, F11 T60	124.7 F Note 1	72.5%	130 mR/hr (Peak)	E11-180 (Seismic)	120 F (EQ0-EF2-018)	98% (EQ0-EF2-018)	1E4 R per EQ0-EF2-018 and DC-6645 (Section 2.1)	Self for 24 hours, then FLEX generator powers charger

SAWA/SAWM Instruments

SAWA flow instruments	MT-FI-001 (2.5"-100) MT-FI-002 (2.5"-100) MT-FI-003 (4"-450) MT-FI-004 (6"-1250)	0-200 gpm 0-200 gpm 0-900 gpm 0-2500 gpm	Manifold Trailer in FSF-1	105° F -19 ° F	100 %	3.68E4 Rad TID	Commercial instrument qualified for over the road use, therefore qualified per NEI 12-06	180°F	100%	5E5 TID for Polycarbonate (minimum value) 1E6 for meter overall	None, venturi to Diaphragm for meter movement
-----------------------	---	---	---------------------------	-------------------	-------	----------------	--	-------	------	--	---

* Denotes non-required item, added standby conditions.

Note 1: Per DC-6639, Loss of HVAC - Room Environmental Analysis in Support of Hardened Vent, attachment 2, Temperature Response T60 – Division 2 Battery room, using the most conservative plot of temperature (105 °F Ambient, H2 Mitigation Doors Open), will reach 120 °F at approximately 90 hours. 29.400.03, HCVS, section 3.5 directs restoration of RBHVAC between 200 minutes and 24 hours following the LOP per 29.FSG.19, FLEX RBHVAC restoration. At the 24 hour point using the most conservative plot of temperature (105 °F Ambient, H2 Mitigation Doors Open), the room temperature will be approximately 92 °F.

Final Integrated Plan
HCVS Order EA-13-109

Table 2: Operator Actions Evaluation

Operator Action		Evaluation Time ⁴	Validation Time	Location	Thermal conditions	Radiological Conditions	Evaluation
1	HCVS Pipe Inspection	0-1 hour	13-18 / SAWA-07; Task 3	RB-5 NE corner	129 F (105 F Amb) 64 F (-19 F Amb) Actions: May require short stay times (e.g. < 10 minutes).	Done in the first hour, so no concerns/TID: 0	Acceptable
2	SAWA Alignment Div 2 RHR cross-tie	0-1 hour	18-28 / SAWA-02; Task 1 & 2	RB-2 SW area by Crane Cut out	106 F (105 F Amb) 63 F (-19 F Amb)	Done in the first hour, so no concerns/TID: 0	Acceptable
3	HCVS Air Alignment T46P411	0-1 hour	18-22 / SAWA-07; Task 4	AB-4 West by Door to AB-5	104 F (105 F Amb) 62 F (-19 F Amb)	Done in the first hour, so no concerns/TID: 0	Acceptable
4	HCVS Power Alignment and initial positioning H21P101	0-1 hour	22-32 / SAWA-07; Task 4	AB-3 Division 2 Switchgear Room	101 F (105 F Amb) 59 F (-19 F Amb)	Done in the first hour, so no concerns/TID: 0	Acceptable
5	T50 Bottle opening T50-P406B/ T50P407B	0-1 hour	28-32 / SAWA-02; Task 3	RB-2 & RBSB-SW Quad	107 F (105 F Amb) 63 F (-19 F Amb) 95 F (105 F Amb) 66 F (-19 F Amb)	Done in the first hour, so no concerns/TID: 0	Acceptable
6	SFP Alignment Div 1 RHR cross-tie	0-1 hour	32-44 / SAWA-02; Task 4-6	RB-1 NW corner	108 F (105 F Amb) 63 F (-19 F Amb)	Done in the first hour, so no concerns/TID: 0	Acceptable

⁴ Evaluation timing is from NEI 13-02 to support radiological evaluations.

Final Integrated Plan
HCVS Order EA-13-109

Operator Action		Evaluation Time ⁴	Validation Time	Location	Thermal conditions	Radiological Conditions	Evaluation
7	HCVS Air Alignment and initial positioning AB-1 Wall and T46P410	0-1 hour	32-43 / SAWA-07; Task 4	AB-1: West Wall of RBCCW Area	105 F (105 F Amb) 57 F (-19 F Amb)	Done in the first hour, so no concerns.	Acceptable
8	HCVS Purge Operation H21P101	0-1 hour	43-51 / SAWA-07; Task 4	AB-3: Division 2 Switchgear Room	102 F (105 F Amb) 59 F (-19 F Amb)	Done in the first hour, so no concerns.	Acceptable
9	Alignment for RCIC Injection (Blackstart)	0-1 hour	19-27 / SAWA-03	RBSB NE and RB-1 Steam Tunnel	134 F (105 F Amb) 120 F (-19 F Amb) Actions: Will need to limit stay time to under 30 minutes.	Done in the first hour, so no concerns.	Acceptable
10	SAWA Interlock Defeat H11P618	0-1 hour	51-59 / SAWA-07; Task 5	AB-2: Relay Room	97 F (105 F Amb) 79 F (-19 F Amb)	Done in the first hour, so no concerns.	Acceptable
11	RCIC Blackstart actions	0-1 hour	19-37 / SAWA-03	RBSB NE	134 F (105 F Amb) 120 F (-19 F Amb) Actions: Limit stay time to under 30 minutes based on Emergency Activity	Done in the first hour, so no concerns.	Acceptable

Final Integrated Plan
HCVS Order EA-13-109

Operator Action		Evaluation Time ⁴	Validation Time	Location	Thermal conditions	Radiological Conditions	Evaluation
12	DC Restoration Alignment Check	0-1 hour	44-47 / SAWA-09; Task 0	AB-2: Division 1 Switchgear Room	107 F (105 F Amb) 60 F (-19 F Amb)	Done in the first hour, so no concerns.	Acceptable
13	DC Load Shed	0-1 hour	47-52 / SAWA-09; Task 1 & 2	AB-2: Relay Room	96 F (105 F Amb) 79 F (-19 F Amb)	Done in the first hour, so no concerns.	Acceptable
14	DC Load Shed	0-1 hour	52-57 / SAWA-09; Task 3	AB-3: DC MCC Area	118 F (105 F Amb) 80 F (-19 F Amb)	Done in the first hour, so no concerns.	Acceptable
15	Div 2 DC/AC alignment AC Stripping (72E/72F)	≤ 7 hours	57-61 / SAWA-09; Task 4	AB-3: Division 2 Switchgear Room	104 F (105 F Amb) 60 F (-19 F Amb)	2.13 mRem	Acceptable
16	Div 2 DC/AC alignment Protection and BID Installation	≤ 7 hours	61-95 / SAWA-09; Task 5	AB-3: Division 2 Switchgear Room	105 F (105 F Amb) 60 F (-19 F Amb)	72.58 mRem	Acceptable
17	Div 2 DC/AC Energization	≤ 7 hours	95-98 / SAWA-09; Task 6	AB-3: Division 2 Switchgear Room	105 F (105 F Amb) 60 F (-19 F Amb)	8.98 mRem	Acceptable

Final Integrated Plan
HCVS Order EA-13-109

Operator Action		Evaluation Time ⁴	Validation Time	Location	Thermal conditions	Radiological Conditions	Evaluation
18	Div 2 AC 72E/72F Cross tie and 72C-F energization	≤ 7 hours	98-102 / SAWA-09; Task 7	AB-3: Division 2 Switchgear Room	106 F (105 F Amb) 60 F (-19 F Amb)	5.99 mRem	Acceptable
19	Div 2 DC restoration (Control Power and Battery Chargers)	≤ 7 hours	102-108 / SAWA-09; Task 8	AB-3: Division 2 Switchgear Room	106 F (105 F Amb) 60 F (-19 F Amb)	5.99 mRem	Acceptable
20	Div 2 AC restoration	≤ 7 hours	108-112 / SAWA-09; Task 9	AB-3: Division 2 Switchgear Room	106 F (105 F Amb) 60 F (-19 F Amb)	19.40 mRem	Acceptable
21	Open FSF-1 and deploy trucks and fuel trailer	0-1 hour	22-27 / SAWA-04; Task 1-7	Yard inside Protected Area	Yard activity, so no issues based on environmental conditions	0	Acceptable
22	Deploy N Dominator	0-1 hour	27-42 / SAWA-04; Task 9	Yard inside Protected Area	Yard activity, so no issues based on environmental conditions	0	Acceptable
23	Deploy Bulldozer and Manifold trailer	0-1 hour	22-34 / SAWA-04; Task 8, 10 & 11	Yard inside Protected Area	Yard activity, so no issues based on environmental conditions	0	Acceptable

Final Integrated Plan
HCVS Order EA-13-109

Operator Action		Evaluation Time ⁴	Validation Time	Location	Thermal conditions	Radiological Conditions	Evaluation
24	Deploy Hoses inside PA	0-1 hour	34-52 / SAWA-04; Task 13	Yard inside Protected Area	Yard activity, so no issues based on environmental conditions	0	Acceptable
25	Connect hoses to Trailer and N Dominator	0-1 hour	49-51 / SAWA-04; Task 16	Yard inside Protected Area	Yard activity, so no issues based on environmental conditions	0	Acceptable
26	Connect hoses across VBS, deploy and connect remaining hose to N Dominator Suction, and check all connections inside PA	≤ 7 hours	51-66 / SAWA-04; Task 17-18, 21-22	Yard inside Protected Area	Yard activity, so no issues based on environmental conditions	251.87 mRem	Acceptable
27	Open FSF-2 and deploy trucks and fuel trailer	0-1 hour	39-51 / SAWA-05; Task 2-8	Yard outside Protected Area	Yard activity, so no issues based on environmental conditions	12.41 mRem	Acceptable
28	Deploy hoses and strainer to N-Neptune and VBS	≤ 7 hours	52-62 / SAWA-05; Task 9-11	Yard outside Protected Area	Yard activity, so no issues based on environmental conditions	8.59 mRem	Acceptable
29	Transit to FSF-2 and Deploy N-Neptune	≤ 7 hours	46-63 / SAWA-05; Task 12	Yard outside Protected Area	Yard activity, so no issues based on environmental conditions	32.95 mRem	Acceptable

Final Integrated Plan
HCVS Order EA-13-109

Operator Action		Evaluation Time ⁴	Validation Time	Location	Thermal conditions	Radiological Conditions	Evaluation
30	Connect N + 1 Generator Cables between connectors and Generator	≤ 7 hours	50-65 / SAWA-04; Task 20	Yard outside Protected Area	Yard activity, so no issues based on environmental conditions	950.35 mRem	Acceptable
31	Startup N + 1 Generator	≤ 7 hours	65-70 / SAWA-04; Task 24	Yard outside Protected Area	Yard activity, so no issues based on environmental conditions	172.10 mRem	Acceptable
32	Deploy N-Neptune Source Pump	≤ 7 hours	63-70 / SAWA-05; Task 14	Yard outside Protected Area	Yard activity, so no issues based on environmental conditions	55.39 mRem	Acceptable
33	Relocate Strainer and connect Hose Section 5 to N-Neptune	≤ 7 hours	65-70 / SAWA-05; Task 13	Yard outside Protected Area	Yard activity, so no issues based on environmental conditions	28.18 mRem	Acceptable
34	Deploy N-Neptune minimum flow line	≤ 7 hours	67-82 / SAWA-05; Task 15	Yard outside Protected Area	Yard activity, so no issues based on environmental conditions	170.15 mRem	Acceptable
35	Fill and Vent/Pressurize hoses and FLEX Water (FSF 1 and 2 dose)	≤ 7 hours	79-93 / SAWA-06; Task 1-7	Yard both inside and outside Protected Area	Yard activity, so no issues based on environmental conditions	231.77 mRem	Acceptable

Final Integrated Plan
HCVS Order EA-13-109

Operator Action		Evaluation Time ⁴	Validation Time	Location	Thermal conditions	Radiological Conditions	Evaluation
36	Fill and Vent hoses and FLEX Water (Yard dose west of RB1 at manifold trailer)	≤ 7 hours	79-82 / SAWA-06; Task 6	Yard both inside and outside Protected Area	Yard activity, so no issues based on environmental conditions	510.17 mRem	Acceptable
37	Pressurize hoses and FLEX Water (Yard dose west of RB1 at manifold trailer)	≤ 7 hours	82-85 / SAWA-06; Task 8	Yard both inside and outside Protected Area	Yard activity, so no issues based on environmental conditions	618.25 mRem	Acceptable
38	Start N Dominator with Clutch Disengaged	≤ 7 hours	90-93 / SAWA-12; Task 3	Yard inside Protected Area	Yard activity, so no issues based on environmental conditions	869.13 mRem	Acceptable
39	Inject SAWA and adjust SAWA flow at Manifold trailer	≤ 7 hours	105-108 / SAWA-12; Task 3	Yard inside Protected Area	Yard activity, so no issues based on environmental conditions	510.28 mRem	Acceptable
40	Adjust SAWA flow at Manifold trailer (SAWM initial)	≤ 24 hours	353-356 / SAWM-01; Task 1-3	Yard inside Protected Area	Yard activity, so no issues based on environmental conditions	192.74 mRem	Acceptable

Final Integrated Plan
 HCVS Order EA-13-109

Operator Action		Evaluation Time ⁴	Validation Time	Location	Thermal conditions	Radiological Conditions	Evaluation
41	Adjust SAWA flow at Manifold trailer (SAWM continuing)	>24 hours	840-843; 2280-2283; 3720-3723; 5160-5163; 6600-6603; 8040-8043; / SAWM-02; Task 1-3	Yard inside Protected Area	Yard activity, so no issues based on environmental conditions	604.80 mRem (6 adjustments, 100.75 mrem per adjustment)	Acceptable