

David B. Hamilton  
Vice President

440-280-5382

**May 1, 2018**  
**L-18-127****10CFR50.36(a)****ATTN: Document Control Desk**  
**U. S. Nuclear Regulatory Commission**  
**Washington, DC 20555-0001****SUBJECT:**  
**Perry Nuclear Power Plant**  
**Docket No. 50-440**  
**Annual Environmental and Effluent Release Report**

Enclosed is the Annual Environmental and Effluent Release Report for the Perry Nuclear Power Plant (PNPP) for the period of January 1, 2017 through December 31, 2017. This document includes the radiological environmental operating report, radioactive effluent release report, and the non-radiological environmental operating report, which satisfies the requirements of the PNPP Technical Specifications (TS), the PNPP Offsite Dose Calculation Manual (ODCM), and the Environmental Protection Plan, Appendix B of the PNPP Operating License. Also enclosed is a copy of the revised Offsite Dose Calculation Manual and support documentation.

There are no regulatory commitments contained in this letter. If there are any questions or if additional information is required, please contact Mr. Steven Benedict, Chemistry Manager at (440) 280-5032.

Sincerely,



David Hamilton

**Enclosures:**

- A PNPP 2017 Annual Environmental and Effluent Release Report**
- B Offsite Dose Calculation Manual, Revision 21**

**cc: NRC Project Manager**  
**NRC Resident Inspector**  
**NRC Region III**

**Enclosure A**

**L-18-127**

**PNPP 2017 Annual Environmental and Effluent Release Report**

**2017**

**ANNUAL ENVIRONMENTAL  
AND  
EFFLUENT RELEASE  
REPORT**

**for the  
Perry Nuclear Power Plant**

**PREPARED BY:  
CHEMISTRY SECTION  
PERRY NUCLEAR POWER PLANT  
FIRSTENERGY NUCLEAR OPERATING COMPANY  
PERRY, OHIO  
MARCH, 2018**

# 2017 ANNUAL ENVIRONMENTAL AND EFFLUENT RELEASE REPORT

## Table of Contents

<b>EXECUTIVE SUMMARY</b> .....	1
Radioactive Effluent Releases.....	1
Radiological Environmental Monitoring.....	2
Pre-Operational REMP.....	2
Operational REMP .....	2
Land Use Census.....	3
Clam/Mussel Monitoring.....	3
Herbicide Use.....	3
Special Environmental Reports .....	3
<b>INTRODUCTION</b> .....	4
Radiation Fundamentals.....	4
Radiation and Radioactivity.....	4
Lower Limit of Detection.....	6
Other Sources of Radiation Dose to the U.S. Population.....	6
Environmental Radionuclides .....	7
<b>RADIOACTIVE EFFLUENT RELEASES</b> .....	8
Introduction .....	8
Regulatory Limits.....	8
40CFR190 and 10CFR72.104 – Uranium Fuel Cycle Dose Assessment.....	9
Liquid Effluents.....	9
Gaseous Effluents.....	9
Independent Spent Fuel Storage Installation.....	10
Release Summary.....	11
Meteorological Data .....	19
Dose Assessment .....	19
<b>CARBON-14 SUPPLEMENTAL INFORMATION</b> .....	23
<b>GROUNDWATER MONITORING PROGRAM</b> .....	23
<b>RADIOLOGICAL ENVIRONMENTAL MONITORING</b> .....	26
Introduction .....	26
Sampling Locations.....	26
Sample Analysis.....	32
Sampling Program.....	33
Program Changes .....	33
Atmospheric Monitoring.....	33
Terrestrial Monitoring .....	34
Aquatic Monitoring.....	35
Direct Radiation Monitoring .....	36
Conclusion .....	37
Inter-Laboratory Cross-Check Comparison Program.....	38
Land Use Census.....	38
<b>CLAM/MUSSEL MONITORING</b> .....	42
Introduction .....	42
Corbicula Program .....	42
Dreissena Program .....	43
<b>HERBICIDE APPLICATIONS</b> .....	44
<b>SPECIAL REPORTS</b> .....	45
NPDES Permit Exceedances .....	45

# 2017 ANNUAL ENVIRONMENTAL AND EFFLUENT RELEASE REPORT

Environmental Protection Plan .....	45
Environmental Impact Evaluations .....	45

## **Appendices**

**Appendix A: 2017 Inter-Laboratory Cross Check Comparison Program Results**

**Appendix B: 2017 REMP Data Summary Reports**

**Appendix C: 2017 REMP Detailed Data Report**

**Appendix D: Corrections to Previous AEERR**

**Appendix E: Abnormal Releases**

**Appendix F: ODCM Non-Compliances**

**Appendix G: ODCM Changes**

**Appendix H: Changes to the Process Control Program**

# 2017 ANNUAL ENVIRONMENTAL AND EFFLUENT RELEASE REPORT

## EXECUTIVE SUMMARY

The Annual Environmental and Effluent Release Report (AEERR) details the results of environmental and effluent monitoring programs conducted at the Perry Nuclear Power Plant (PNPP) from January 01 through December 31, 2017. This report meets all of the requirements in PNPP Technical Specifications, the Offsite Dose Calculation Manual (ODCM), the Environmental Protection Plan (EPP) and Regulatory Guide 1.21. This report incorporates the requirements of the Annual Radioactive Effluent Release Report (ARERR), the Annual Radiological Environmental Operating Report (AREOR) and the Annual Environmental Operating Report (AEOR). Report topics include radioactive effluent releases, radiological environmental monitoring, land use census, clam/mussel monitoring, herbicide use, and special reports. The results of the environmental and effluent programs indicate that the operations of the PNPP did not result in any significant environmental impact.

## RADIOACTIVE EFFLUENT RELEASES

During the normal operation of a nuclear power plant, small quantities of radioactivity are released to the environment through liquid and gaseous effluents. Radioactive material is also shipped offsite as solid waste. PNPP maintains a comprehensive program to control and monitor the release of radioactive materials from the site in accordance with Nuclear Regulatory Commission (NRC) release regulations.

Dose to the general public from the plant's liquid and gaseous effluents was well below regulatory limits. The calculated maximum individual whole body dose potentially received by an individual resulting from PNPP liquid effluents was  $1.96\text{E-}03$  mrem (0.06% of the regulatory limit). The calculated maximum individual whole body dose potentially received by an individual resulting from PNPP gaseous effluents, excluding carbon-14 (C-14) was  $1.69\text{E-}03$  mrem (0.03% of the regulatory limit).

Radioactivity released to the environment in the form of gaseous C-14 was estimated based on plant type and power production. The calculation is based on an industry initiative supported by the Nuclear Energy Institute (NEI), the Electric Power Research Institute (EPRI) and the NRC. The calculated hypothetical maximum individual whole body dose potentially received by an individual resulting from PNPP gaseous effluents including C-14 is 0.26 mrem (5.1% of the limit). Refer to page 23 for additional C-14 information.

The summation of the hypothetical maximum individual dose from effluents is less than 1% of the total dose an individual living in the PNPP area receives from all sources of man-made and background radiation.

Shipments of solid waste consisted of waste generated during water treatment, radioactive material generated during normal daily operations and maintenance, and irradiated components. PNPP complied with regulations governing radioactive shipments of solid radioactive waste.

## 2017 ANNUAL ENVIRONMENTAL AND EFFLUENT RELEASE REPORT

### **RADIOLOGICAL ENVIRONMENTAL MONITORING**

The Radiological Environmental Monitoring Program (REMP) was established in 1981 to monitor the radiological conditions in the environment around PNPP. The operational REMP was initiated in 1986 and has continued through this reporting period. The REMP is conducted in accordance with the PNPP ODCM. This program includes collection and analysis of environmental samples and evaluation of results at indicator as well as control locations. Indicator samples are collected at locations determined to be most influenced by operation of the PNPP. Control samples are collected at locations beyond the measurable influence of the PNPP for data comparison.

### **PRE-OPERATIONAL REMP**

The REMP was established at PNPP six years before the plant became operational. Between 1981 and 1986, environmental monitoring involved collection and analysis of environmental samples. This pre-operational program was designed to provide data on background radiation levels and radioactivity normally present in the area in order to establish a baseline for data comparison prior to operation of the plant. PNPP has continued to monitor the environment during plant operation by collecting and analyzing samples of air, milk, fish, vegetation, water, and sediment, as well as by measuring radiation directly.

The contribution of radionuclides to the environment resulting from PNPP operation is assessed by comparing results from the environmental monitoring program with pre-operational data, operational data from previous years, and control location data. The results for each sample type are compared to historical data to determine whether trends or changes in concentrations are observable.

### **OPERATIONAL REMP**

Results of air samples collected to monitor the radioactivity in the atmosphere revealed normal background radionuclide concentrations. Terrestrial monitoring included the analysis of milk and vegetation; the results of which indicated concentrations of radioactivity similar to those found in previous years. Analyses of vegetation samples detected only natural radioactivity, similar to those observed in previous years and indicated no radioactivity attributable to operation of the PNPP.

Aquatic monitoring included the collection and analyses of water, fish, and shoreline sediments. The analytical results of these samples showed normal background radionuclide concentrations.

Direct radiation measurements showed no significant changes from previous years. The indicator locations averaged 12.0 mrem/quarter and control locations averaged 11.4 mrem/quarter. Radiation dose in the area of PNPP was similar to the radiation dose measured at locations greater than ten miles away from PNPP.

Results from indicator samples collected during this reporting period were compared to control sample results and pre-operational data. Based on the results, the operation of the PNPP resulted in no measurable increase in the radionuclide concentrations observed in the surrounding environment. The results of the REMP indicate adequate control of radioactivity released from PNPP effluents. These results also demonstrate that PNPP complies with federal regulations.

## 2017 ANNUAL ENVIRONMENTAL AND EFFLUENT RELEASE REPORT

### LAND USE CENSUS

In order to estimate radiation dose attributable to operation of the PNPP, the potential pathways through which public exposure can occur must be known. To identify these pathways, an Annual Land Use Census is performed as part of the REMP. During the census, PNPP personnel travel public roads within a five mile radius of the plant to locate key radiological exposure pathways. These key pathways include the nearest resident, garden, and milk animal in each of the ten meteorological land sectors that surround the plant. The information obtained from the census is entered into a computer program used to assess hypothetical dose to members of the public. The predominant land use within the census area continues to be rural and/or agricultural.

### CLAM/MUSSEL MONITORING

Clam and mussel shells can clog plant piping and components that use water from Lake Erie. For this reason, sampling for clams and mussels has been conducted in Lake Erie near PNPP since 1971. The monitoring is specifically for *Corbicula* (Asiatic clams) since their introduction into the Great Lakes in 1981, and for *Dreissena* (zebra mussels) since their discovery in Lake Erie in 1989. Since no *Corbicula* have been found at PNPP, routine *Corbicula* monitoring will provide early detection capability if this pest species arrives at PNPP. The *Dreissena* program includes both monitoring and control and is directed at minimizing impact of the mussels on plant operation. As in past years, this program has successfully prevented *Dreissena* from causing any significant operational problems at PNPP.

### HERBICIDE USE

The use of herbicides on the PNPP site is monitored to ensure compliance with Ohio Environmental Protection Agency (OEPA) requirements and to protect the site's natural areas. Based on weekly inspections, herbicide use has not had a negative impact on the environment around the plant.

### SPECIAL ENVIRONMENTAL REPORTS

Significant environmental events (e.g. spills, releases), noncompliance with environmental regulations (e.g., OEPA discharge limits), and changes in plant design or operation that affect the environment are reported to regulatory agencies as they occur. No reports were submitted in 2017 and further details can be found on page 45.



# 2017 ANNUAL ENVIRONMENTAL AND EFFLUENT RELEASE REPORT

## INTRODUCTION

Nuclear energy provides an alternative energy source that is readily available with a very limited impact upon the environment. To more fully understand nuclear energy as a source of generating electricity, it is helpful to understand basic radiation concepts and the occurrence of radioactivity in nature.

## RADIATION FUNDAMENTALS

Atoms are the basic building blocks of all matter. Simply described, atoms are made up of positively and negatively charged particles and particles which are neutral. These particles are called protons, electrons, and neutrons, respectively. The relatively large protons and neutrons are packed together in the center of the atom called the nucleus. Orbiting around the nucleus are one or more smaller electrons. In an electrically neutral atom, the positively charged protons in the nucleus balance the negatively charged electrons. Due to their dissimilar charges, the protons and electrons have a strong attraction for each other, which helps hold the atom together. Other attractive forces between the protons and neutrons keep the densely packed protons from repelling each other and prevent the nucleus from breaking apart.

Atoms with the same number of protons in their nuclei make up an element. The number of neutrons in the nuclei of an element may vary. Atoms with the same number of protons but different numbers of neutrons are called isotopes. All isotopes of the same element have the same chemical properties and many are stable or non-radioactive. An unstable or radioactive isotope of an element is called a radionuclide. Radionuclides contain an excess amount of energy in the nucleus, which is usually due to an excess number of neutrons.

Radioactive atoms attempt to reach a stable, non-radioactive state through a process known as radioactive decay. Radioactive decay is the release of energy from an atom's nucleus through the emission of alpha and beta particles and gamma rays. Radionuclides vary greatly in the rate in which they decay. The length of time an atom remains radioactive is defined in terms of its half-life. Half-life is defined as the time required for a radioactive substance to lose half its activity through the process of radioactive decay. Half-lives vary from millionths of a second to millions of years.

## RADIATION AND RADIOACTIVITY

Radioactive decay is a process in which the nucleus of an unstable atom becomes more stable by spontaneously emitting energy. Radiation refers to the energy that is released when radioactive decay occurs within the nucleus. This section includes a discussion on the three primary forms of radiation produced by radioactive decay.

### Alpha Particles

Alpha particles consist of two protons and two neutrons and have a positive charge. Because of their charge and large size, alpha particles do not travel very far when released (less than 4 inches in air). They are unable to penetrate any solid material, such as paper or skin, to any significant depth. If alpha particles are released inside the body, however, they can damage the soft internal tissues because they deposit all their energy in a small area.

## 2017 ANNUAL ENVIRONMENTAL AND EFFLUENT RELEASE REPORT

### Beta Particles

Beta particles have the same characteristics as electrons but originate from the nucleus. They are much smaller than alpha particles and travel at nearly the speed of light, thus they travel longer distances than alpha particles. External beta radiation primarily affects the skin. Because of their electrical charge, beta particles are stopped by paper, plastic or thin metal.

### Gamma Rays

Gamma rays are bundles of electromagnetic energy called photons. They are similar to visible light, but at a much higher energy. Gamma rays can travel long distances in air and are often released during radioactive decay along with alpha and beta particles. Potassium-40 is an example of a naturally-occurring radionuclide found in all humans that emits a gamma ray when it decays.

### Interaction with Matter

When radiation interacts with other materials, it affects the atoms of those materials principally by removing the negatively charged electrons out of their orbits. This causes an atom to lose its electrical neutrality and become positively charged. An atom that is charged, either positively or negatively, is called an ion, and the radiation is called ionizing radiation.

### Activity

Activity is the number of atoms in a material that decay per unit of time. Each time an atom decays, radiation is emitted. A curie (Ci) is the unit used to describe the activity of a material and indicates the rate at which the atoms are decaying. One curie of activity indicates the decay of 37 billion atoms per second. Smaller units of the curie are often used in this report. Two common units are the microcurie ( $\mu\text{Ci}$ ), one millionth of a curie, and the picocurie (pCi), one trillionth of a curie. The mass, or weight, of radioactive material, which would result in one curie of activity depends on the disintegration rate. For example, one gram of radium-226 is equivalent to one curie of activity. It would require about 1.5 million grams of natural uranium, however, to equal one curie.

### Dose

Biological damage due to alpha, beta, and gamma radiation may result from the ionization caused by these types of radiation. Some types of radiation, especially alpha particles that cause dense local ionization, can result in much more biological damage for the same energy imparted than does gamma or beta radiation. A quality factor, therefore, must be applied to account for the different ionizing capabilities of various types of ionizing radiation. When the quality factor is multiplied by the absorbed dose (as measured in rads), the result is the dose equivalent, which is an estimate of the possible biological damage resulting from exposure to any type of ionizing radiation. The dose equivalent is measured in terms of the Roentgen Equivalent Man (rem). When discussing environmental radiation effects, the rem is a large unit; therefore, a smaller unit, the millirem (mrem) is often used. One mrem is equivalent to 1/1000 of a rem.

## 2017 ANNUAL ENVIRONMENTAL AND EFFLUENT RELEASE REPORT

### LOWER LIMIT OF DETECTION

Sample results are often reported as below the Lower Limit of Detection (LLD). The LLD for an analysis is the smallest amount of radioactive material that will show a positive result, for which there can be a 95% confidence that radioactivity is present. This statistical parameter is used as a measure of the sensitivity of a sample analysis. When a measurement is reported as less than the LLD (<LLD), it means that no radioactivity was detected. Had radioactivity been present at or above the stated LLD value, it statistically would have been detected. The NRC has established the required LLD values for environmental and effluent sample analyses.

### OTHER SOURCES OF RADIATION DOSE TO THE U.S. POPULATION

This section discusses the doses that the average American typically receives each year from naturally-occurring background radiation and all other sources of radiation. With the information presented in this section, the reader can compare the doses received from Nuclear Power Plant (NPP) effluents with the doses received from natural, medical, and other sources of radiation. This comparison provides some context to the concept of radiation dose effects.

In March 2009, the National Council on Radiation Protection and Measurements (NCRP) published Report No. 160 as an update to the 1987 NCRP Report No. 93, Ionizing Radiation Exposure of the Population of the United States. Report No. 160 describes the doses to the U.S. population from all sources of ionizing radiation for 2006, the most recent data available at the time the NCRP report was written. The NCRP report also includes information on the variability of those doses from one individual to another. The NCRP estimated that the average person in the United States receives about 620 mrem of radiation dose each year. NCRP Report No. 160 describes each of the sources of radiation that contribute to this dose, including:

- Naturally-occurring sources (natural background) such as cosmic radiation from space, terrestrial radiation from radioactive materials in the earth, and naturally-occurring radioactive materials in the food people eat and in the air people breathe;
- Medical sources from diagnosis and treatment of health disorders using radioactive pharmaceuticals and radiation-producing equipment;
- Consumer products (such as household smoke detectors);
- Industrial processes, security devices, educational tools, and research activities; and
- Exposures of workers that result from their occupations.

# 2017 ANNUAL ENVIRONMENTAL AND EFFLUENT RELEASE REPORT

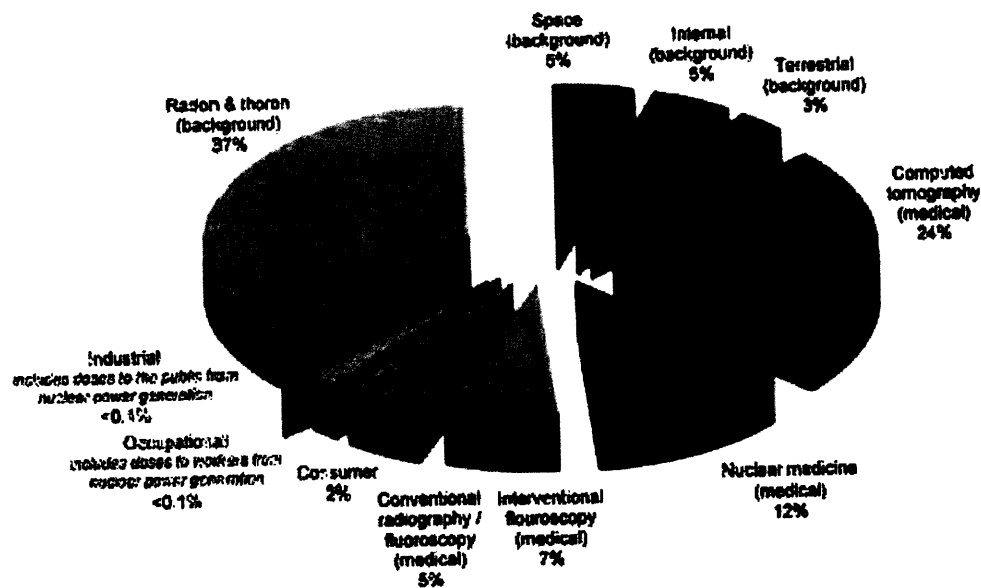

**Figure 1: Sources of Radiation Exposure to the U.S. Population**

Figure 1 shows the contribution of various sources of exposure to the total collective effective dose and the total effective dose per individual in the U.S. population in 2006. Larger contributors to dose are represented by proportionally larger slices of the pie. Doses to the public from NPPs are included in the Industrial category; doses to workers from nuclear power generation are included in the category of occupational dose. Doses to the public due to effluents from NPPs are less than 0.1% of what the average person receives each year from all other sources of radiation.

## ENVIRONMENTAL RADIONUCLIDES

Many radionuclides are present in the environment due to sources such as cosmic radiation and fallout from nuclear weapons testing. These radionuclides are expected to be present in many of the environmental samples collected in the vicinity of PNPP. Some of the radionuclides normally present include: beryllium-7, a result of the interaction of cosmic radiation with the upper atmosphere; potassium-40, a naturally-occurring radionuclide normally found in humans and throughout the environment; radionuclides from nuclear weapons testing fallout, including tritium and cesium-137; and tritium due to the interaction of nitrogen in the air and cosmic rays.

Beryllium-7 and potassium-40 are common in REMP samples. Since they are naturally-occurring and are expected to be present, positive results for these radionuclides are not discussed in the section for the Sampling Program results. These radionuclides are included; however, in Appendix A, 2017 Inter-Laboratory Cross Check Comparison Program Results.

## 2017 ANNUAL ENVIRONMENTAL AND EFFLUENT RELEASE REPORT

### RADIOACTIVE EFFLUENT RELEASES

#### INTRODUCTION

The source of radioactive material in a nuclear power plant is the generation of fission products (e.g., noble gas, iodine, and particulate) or neutron activation of water and corrosion products (e.g., tritium and cobalt). The majority of the fission products generated remain within the nuclear fuel pellet and fuel cladding. Most fission products that escape from the fuel cladding, as well as the majority of the activated corrosion products, are removed by plant processing equipment.

During the normal operation of a nuclear power plant, small amounts of radioactive material are released in the form of solids, liquids, and gases. PNPP was designed and is operated in such a manner as to control and monitor these effluent releases. Effluents are controlled to ensure any radioactivity released to the environment is minimal and within regulatory limits. Effluent release programs include the operation of monitoring systems, in-plant sampling and analysis, quality assurance, and detailed procedures covering all aspects of effluent monitoring.

The liquid and gaseous radioactive waste treatment systems at PNPP are designed to collect and process these wastes in order to remove most of the radioactivity. Effluent monitoring systems are used to provide continuous indication of the radioactivity present and are sensitive enough to measure several orders of magnitude lower than the release limits. This monitoring instrumentation is equipped with alarms and indicators in the plant control room. The alarms are set to provide warnings to alert plant operators when radioactivity levels reach a small fraction of the limits. The waste streams are sampled and analyzed to identify and quantify the radionuclides being released to the environment.

Gaseous effluent release data is coupled with on-site meteorological data in order to calculate the dose to the general public. Devices are maintained at various locations around PNPP to continuously sample the air in the surrounding environment. Frequent samples of other environmental media are also taken to determine if any radioactive material deposition has occurred. The REMP is described in detail later in this report.

Generation of solid waste is controlled to identify opportunities for minimization. Limiting the amount of material taken into the plant and sorting material as radioactive or non-radioactive waste helps to lower the volume of radioactive solid waste generated. After vendor processing, solid waste is shipped to a licensed burial site.

#### REGULATORY LIMITS

The Nuclear Regulatory Commission has established limits for liquid and gaseous effluents that comply with:

Title 10 of the Code of Federal Regulations, Part 20, Standards for Protection Against Radiation, Appendix B;

Title 10 of the Code of Federal Regulations, Part 50, Domestic Licensing of Production and Utilization Facilities, Appendix I;

Title 10 of the Code of Federal Regulations, Part 72.104, Criteria for Radioactive Materials in Effluents and Direct Radiation from an ISFSI or MRS

Title 40 of the Code of Federal Regulations, Part 190, Environmental Radiation Protection Standards for Nuclear Power Operations

## 2017 ANNUAL ENVIRONMENTAL AND EFFLUENT RELEASE REPORT

These limits were incorporated into the PNPP Technical Specifications, and subsequently into the PNPP ODCM. The ODCM prescribes the maximum doses and dose rates due to radioactive effluents resulting from the operation of PNPP. These limits are defined in several ways and serve to limit the overall impact on persons living near the plant. Since there are no other fuel sources near the PNPP, the 40CFR190 limits described below were not exceeded.

### 40CFR190 AND 10CFR72.104 – URANIUM FUEL CYCLE DOSE ASSESSMENT

The 40CFR190 limit for whole body dose is 25 mrem. Considering all sectors, the total whole body dose to a member of the general public was 0.26 mrem. This value was determined by summing the annual whole body doses from liquid and gaseous radioactive effluents and the annual gaseous C-14 dose. Since the direct radiation dose, as determined by TLD, was indistinguishable from natural background (Figure 8), it was not included in the calculation. More information regarding direct radiation dose and the Independent Spent Fuel Storage Installation (ISFSI), may be found on page 11.

### LIQUID EFFLUENTS

The concentration of radioactive material released in liquid effluents to unrestricted areas shall be limited to the concentrations specified in 10CFR20, Appendix B, Table 2, Column 2 for radionuclides other than dissolved or entrained noble gases, as required by the ODCM. For dissolved or entrained noble gases, the concentration is limited to a concentration of  $2.0E-04$   $\mu\text{Ci/ml}$ . These values are the maximum effluent concentrations.

The dose or dose commitment to a member of the public from radioactive materials in liquid effluents released to unrestricted areas shall be limited to the following:

During any calendar quarter:

- Less than or equal to 1.5 mrem to the whole body, and
- Less than or equal to 5 mrem to any organ

During any calendar year:

- Less than or equal to 3 mrem to the whole body, and
- Less than or equal to 10 mrem to any organ

### GASEOUS EFFLUENTS

The dose rate due to radioactive materials released in gaseous effluents from the site to areas at and beyond the site boundary are governed by 10CFR20 and shall be limited to the following as required by the PNPP ODCM:

- Noble gases:
  - Less than or equal to 500 mrem per year to the whole body, and
  - Less than or equal to 3000 mrem per year to the skin
- Iodine-131, iodine-133, tritium, and all radionuclides in particulate form with half-lives greater than eight days:
  - Less than or equal to 1500 mrem per year to any organ

## 2017 ANNUAL ENVIRONMENTAL AND EFFLUENT RELEASE REPORT

Air dose due to noble gases to areas at and beyond the site boundary are governed by 10CFR50 Appendix I and shall be limited to the following:

- During any calendar quarter:
  - Less than or equal to 5 mrad for gamma radiation, and
  - Less than or equal to 10 mrad for beta radiation
- During any calendar year:
  - Less than or equal to 10 mrad for gamma radiation, and
  - Less than or equal to 20 mrad for beta radiation
- Dose to a member of the public from iodine-131, iodine-133, tritium, and all radionuclides in particulate form with half-lives greater than eight days in gaseous effluents released to areas at and beyond the site boundary shall be limited to the following:
  - Less than or equal to 7.5 mrem to any organ per any calendar quarter, and
  - Less than or equal to 15 mrem to any organ per any calendar year

The PNPP ODCM does not contain a concentration limit for gaseous effluents. For this reason, effluent concentrations are not used to calculate maximum release rates for gaseous effluents.

### INDEPENDENT SPENT FUEL STORAGE INSTALLATION

During any calendar year:

- Less than or equal to 25 mrem whole body dose;
- Less than or equal to 75 mrem thyroid dose; and
- Less than or equal to 25 mrem to any other critical organ.

# 2017 ANNUAL ENVIRONMENTAL AND EFFLUENT RELEASE REPORT

## RELEASE SUMMARY

Effluents are sampled and analyzed to identify both the type and quantity of radionuclides present. This information is combined with effluent path flow measurements to determine the composition, concentration, and dose contribution of the radioactive effluents.

### 40CFR190 and 10CFR72.104 Compliance

Since implementation of the Independent Spent Fuel Storage Installation (ISFSI) in 2011, eight TLDs have been placed on the outer perimeter fence of the cask storage area (located within the site boundary) to monitor dose due to direct radiation from the spent fuel source. Two particular TLDs, those closest to the nearest resident, numbers 18 (NNE corner) and 19 (ENE corner) of the ISFSI pad, were used to calculate direct dose to the nearest resident to determine compliance with the 40CFR190 and 10CFR72.104 limits.

The dose calculation was performed using the location of the nearest residence, assuming they remain at the location all year, because that individual would incur the maximum potential dose from direct exposure. The TLD at REMP location 7 (refer to Figure 3), which is positioned neighboring the nearest resident, was also reviewed for significant changes in readings.

To determine the dose rate to the nearest resident and demonstrate compliance, the following equation was used:

$$D_1R_1^2=D_2R_2^2$$

Where:

$D_1$  = dose rate (mrem) at the pad perimeter

$D_2$  = dose rate (mrem) to nearest resident

$R_1$  = distance (feet) of nearest TLD location to max individual

$R_2$  = distance (feet) to nearest resident

The two nearest TLDs were chosen to estimate dose rates, but the higher of the two northeast corner TLDs was used for conservative estimates. The center of the pad was chosen as the highest point source.

Using the more conservative TLD result, the estimated dose to the nearest resident was 0.33 mrem/yr in 2017, not considering vegetation and shielding from buildings. In 2017, the calculated values were slightly lower, but statistically comparable to results of 2016. Unlike the whole body dose value of 0.26 mrem value presented on page 9, this dose rate of 0.33 mrem/yr is an estimate based on TLD readings to demonstrate compliance. The calculation confirms that direct dose from the ISFSI does not exceed the 40 CFR 190 limit of 25 mrem/year.

Review of the TLD results from 2017 have shown no detectable impact on dose to the public due to radiation from the ISFSI nor significant changes in results to the public since employment of the ISFSI.



## 2017 ANNUAL ENVIRONMENTAL AND EFFLUENT RELEASE REPORT

### Liquid Effluents

The PNPP liquid radioactive waste system is designed to collect and treat all radioactive liquid waste produced in the plant. The treatment process used for radioactive liquid waste depends on its physical and chemical properties. It is designed to reduce the concentration of radioactive material in the liquid by filtration to remove suspended solids and demineralization to remove dissolved solids. Normally, the effluent from the liquid radioactive waste system is returned to plant systems. To reduce the volume of water stored in plant systems, however, the processed liquid effluents may be discharged from the plant via a controlled release. In this case, effluent activity and dose calculations are performed prior to and after discharging this processed water to Lake Erie to ensure regulatory compliance and dose minimization principles are maintained.

Liquid radioactive waste system effluents may be intermittently released, which are considered to be "batch" releases. Table 1 provides information on the number and duration of these releases.

**Table 1: Liquid Batch Releases**

	Quarter 1	Quarter 2	Quarter 3	Quarter 4
Number of batch releases	13	5	4	5
Total time period for batch releases, min	4.38E+03	1.97E+03	1.18E+03	1.13E+03
Maximum time for a batch release, min	4.78E+02	9.01E+02	5.04E+02	2.31E+02
Average time period for a batch release, min	2.30E+02	3.94E+02	2.95E+02	2.27E+02
Minimum time for a batch release, min	7.00E+00	2.19E+02	2.23E+02	2.23E+02
Average quarterly flow rate, L/min	2.18E+05	2.63E+05	2.79E+05	1.48E+05

## 2017 ANNUAL ENVIRONMENTAL AND EFFLUENT RELEASE REPORT

Table 2 provides information on the nuclide composition for the liquid radioactive effluent system releases. In each case, LLDs were met or below the required values. Table 2a provides information specific to radioactive effluent batch releases and Table 2b provides information specific to continuous radioactive effluent releases.

**Table 2: Summation of All Liquid Effluent Releases**

	Quarter 1	Quarter 2	Quarter 3	Quarter 4	Est. Total Error, (%)
<b>A. Fission and Activation Products</b>					
1. Total Released, Ci (excluding tritium, gases, alpha)	3.41E-02	1.86E-02	8.75E-03	1.09E-03	1.00E+01
2. Average Diluted Concentration, $\mu\text{Ci/mL}$ *	1.72E-09	8.44E-10	2.66E-10	4.44E-11	
3. Percent of Applicable Limit, %	2.30E-02	2.26E-02	6.31E-03	1.40E-03	
<b>B. Tritium</b>					
1. Total Released, Ci	4.72E+00	1.43E+00	1.04E+00	1.24E+00	1.00E+01
2. Average Diluted Concentration, $\mu\text{Ci/mL}$	2.38E-07	6.49E-08	3.16E-08	5.05E-08	
3. Percent of Applicable Limit, %	2.38E-02	6.49E-03	3.16E-03	5.05E-03	
<b>C. Dissolved and Entrained Gases</b>					
1. Total Released, Ci	0.00E+00	0.00E+00	0.00E+00	0.00E+00	1.00E+01
2. Average Diluted Concentration, $\mu\text{Ci/mL}$	0.00E+00	0.00E+00	0.00E+00	0.00E+00	
3. Percent of Applicable Limit, %	0.00E+00	0.00E+00	0.00E+00	0.00E+00	
D. Gross Alpha Activity, Ci	0.00E+00	0.00E+00	0.00E+00	0.00E+00	1.00E+01
E. Waste Volume Released, Liters (prior to dilution)	1.71E+06	7.92E+05	5.23E+05	6.80E+05	
F. Dilution Water Volume Used, Liters	1.98E+10	2.20E+10	3.29E+10	2.46E+10	

\*Average diluted concentrations are based on total volume of water released during quarter.

## 2017 ANNUAL ENVIRONMENTAL AND EFFLUENT RELEASE REPORT

**Table 2a: Summation of Batch Liquid Effluent Releases**

	Quarter 1	Quarter 2	Quarter 3	Quarter 4	Est. Total Error, (%)
<b>A. Fission and Activation Products</b>					
Total Released, Ci (excluding tritium, gases, alpha)	3.41E-02	1.85E-02	8.74E-03	1.09E-03	1.00E+01
<b>B. Tritium</b>					
Total Released, Ci	4.72E+00	1.43E+00	1.04E+00	1.24E+00	1.00E+01
<b>C. Dissolved and Entrained Gases</b>					
Total Released, Ci	<LLD	<LLD	<LLD	<LLD	1.00E+01
<b>D. Gross Alpha Activity, Ci</b>					
Total Released, Ci	<LLD	<LLD	1.93E-06	<LLD	1.00E+01
<b>E. Waste Volume Released, Liters (prior to dilution)</b>					
	1.58E+06	6.54E+05	5.23E+05	6.54E+05	

<LLD – Less than the lower limit of detection

**Table 2b: Summation of Continuous Liquid Effluent Releases**

	Quarter 1	Quarter 2	Quarter 3	Quarter 4	Est. Total Error, (%)
<b>A. Fission and Activation Products</b>					
Total Released, Ci (excluding tritium, gases, alpha)	4.66E-06	1.50E-04	<LLD	2.01E-06	1.00E+01
<b>B. Tritium</b>					
Total Released, Ci	<LLD	<LLD	<LLD	<LLD	1.00E+01
<b>C. Dissolved and Entrained Gases</b>					
Total Released, Ci	<LLD	<LLD	<LLD	<LLD	1.00E+01
<b>D. Gross Alpha Activity, Ci</b>					
Total Released, Ci	<LLD	<LLD	<LLD	<LLD	1.00E+01
<b>E. Waste Volume Released, Liters (prior to dilution)</b>					
	1.38E+05	1.37E+05	0.00E+00	2.56E+04	

<LLD – Less than the lower limit of detection

## 2017 ANNUAL ENVIRONMENTAL AND EFFLUENT RELEASE REPORT

Table 3 lists the total number of curies of each radionuclide present in liquid effluent releases for each quarter. In each case, the LLDs were either met or were below the levels required by the ODCM.

**Table 3: Radioactive Liquid Effluent Nuclide Composition**

Isotope	Unit	Quarter 1	Quarter 2	Quarter 3	Quarter 4	Annual
Tritium	Ci	4.72E+00	1.43E+00	1.04E+00	1.24E+00	8.43E+00
Chromium-51	Ci	5.90E-03	6.08E-04	<5.0E-07 <sup>1</sup>	<5.0E-07 <sup>1</sup>	6.51E-03
Manganese-54	Ci	5.73E-04	8.23E-04	3.75E-04	6.94E-05	1.84E-03
Iron-55	Ci	1.21E-02	<1.0E-06 <sup>1</sup>	1.36E-03	<1.0E-06 <sup>1</sup>	1.35E-02
Iron-59	Ci	<5.0E-07 <sup>1</sup>	<5.0E-07 <sup>1</sup>	<5.0E-07 <sup>1</sup>	<5.0E-07 <sup>1</sup>	<5.0E-07 <sup>1</sup>
Cobalt-58	Ci	9.52E-04	8.22E-04	3.54E-04	<5.0E-07 <sup>1</sup>	2.13E-03
Cobalt-60	Ci	1.14E-02	1.28E-02	5.53E-03	1.02E-03	3.08E-02
Nickel-63	Ci	N/A	N/A	7.87E-05	<1.0E-06 <sup>1</sup>	7.87E-05
Zinc-65	Ci	7.75E-04	1.73E-03	5.24E-04	<5.0E-07 <sup>1</sup>	3.03E-03
Strontium-89	Ci	<5E-08 <sup>1</sup>	<5E-08 <sup>1</sup>	<5E-08 <sup>1</sup>	<5E-08 <sup>1</sup>	<5E-08 <sup>1</sup>
Strontium-90	Ci	<5E-08 <sup>1</sup>	<5E-08 <sup>1</sup>	<5E-08 <sup>1</sup>	<5E-08 <sup>1</sup>	<5E-08 <sup>1</sup>
Molybdenum-99	Ci	<5.0E-07 <sup>1</sup>	<5.0E-07 <sup>1</sup>	<5.0E-07 <sup>1</sup>	<5.0E-07 <sup>1</sup>	<5.0E-07 <sup>1</sup>
Silver-110M	Ci	2.38E-03	1.71E-03	5.21E-04	<5.0E-07 <sup>1</sup>	4.61E-03
Tin-113	Ci	<5.0E-07 <sup>1</sup>	<5.0E-07 <sup>1</sup>	<5.0E-07 <sup>1</sup>	<5.0E-07 <sup>1</sup>	<5.0E-07 <sup>1</sup>
Tin-124	Ci	<5.0E-07 <sup>1</sup>	1.22E-04	<5.0E-07 <sup>1</sup>	<5.0E-07 <sup>1</sup>	1.22E-04
Iodine-131	Ci	<1.0E-06 <sup>1</sup>	<1.0E-06 <sup>1</sup>	<1.0E-06 <sup>1</sup>	<1.0E-06 <sup>1</sup>	<1.0E-06 <sup>1</sup>
Cesium-134	Ci	<5.0E-07 <sup>1</sup>	<5.0E-07 <sup>1</sup>	<5.0E-07 <sup>1</sup>	<5.0E-07 <sup>1</sup>	<5.0E-07 <sup>1</sup>
Cesium-137	Ci	<5.0E-07 <sup>1</sup>	<5.0E-07 <sup>1</sup>	<5.0E-07 <sup>1</sup>	<5.0E-07 <sup>1</sup>	<5.0E-07 <sup>1</sup>
Cerium-141	Ci	<5.0E-07 <sup>1</sup>	<5.0E-07 <sup>1</sup>	<5.0E-07 <sup>1</sup>	<5.0E-07 <sup>1</sup>	<5.0E-07 <sup>1</sup>
Cerium-144	Ci	<5.0E-07 <sup>1</sup>	<5.0E-07 <sup>1</sup>	<5.0E-07 <sup>1</sup>	<5.0E-07 <sup>1</sup>	<5.0E-07 <sup>1</sup>
Krypton-88	Ci	<5.0E-07 <sup>1</sup>	<5.0E-07 <sup>1</sup>	<5.0E-07 <sup>1</sup>	<5.0E-07 <sup>1</sup>	<5.0E-07 <sup>1</sup>
Xenon-133	Ci	<5.0E-07 <sup>1</sup>	<5.0E-07 <sup>1</sup>	<5.0E-07 <sup>1</sup>	<5.0E-07 <sup>1</sup>	<5.0E-07 <sup>1</sup>
Gross Alpha	Ci	<1.0E-07 <sup>1</sup>	<1.0E-07 <sup>1</sup>	1.93E-06	<1.0E-07 <sup>1</sup>	1.93E-06

<sup>1</sup> – (<) Less than the ODCM-required lower limit of detection, units in  $\mu\text{Ci/mL}$

N/A – Samples not analyzed for Ni-63 until third quarter, when the isotope was added to the required analyses

## 2017 ANNUAL ENVIRONMENTAL AND EFFLUENT RELEASE REPORT

### Gaseous Effluents

Gaseous effluents are made up of fission and activation gases, iodine, and particulate releases. Gaseous effluents from PNPP exit the plant via one of four effluent vents. Each of these four effluent vents contains radiation detectors that continuously monitor the air to ensure that the levels of radioactivity released are below regulatory limits. Samples are also collected and analyzed on a periodic basis to ensure regulatory compliance. Gaseous effluents released from PNPP are considered continuous and at ground level.

In 2013, PNPP increased the volume of air sampled for tritium in gaseous effluents, increasing the detection capability by a factor of 20, which lowered the LLD. With the increased sample volume, gaseous effluent tritium releases can be detected; whereas, in previous years the concentration was too dilute to measure. This has resulted in increased reported tritium releases over the last few years. A summation of all gaseous radioactive effluent releases is given in Table 4.

**Table 4: Summation of All Gaseous Effluents**

	Quarter 1	Quarter 2	Quarter 3	Quarter 4	Est. Total Error, %
<b>A. Fission and Activation Products</b>					
1. Total Released, Ci	5.55E-01	2.65E-02	0.00E+00	3.24E-01	1.00E+01
2. Average Release Rate, $\mu\text{Ci}/\text{sec}$	7.14E-02	3.37E-02	0.00E+00	4.08E-02	
3. Percent of Applicable Limit, %	N/A	N/A	N/A	N/A	
<b>B. Iodine</b>					
1. Total Iodine-131 Released, Ci	3.26E-06	0.00E+00	0.00E+00	0.00E+00	1.00E+01
2. Average Release Rate, $\mu\text{Ci}/\text{sec}$	4.20E-07	0.00E+00	0.00E+00	0.00E+00	
3. Percent of Applicable Limit, %	N/A	N/A	N/A	N/A	
<b>C. Particulates with Half-Lives &gt; 8 days</b>					
1. Total Released, Ci	0.00E+00	0.00E+00	0.00E+00	0.00E+00	1.00E+01
2. Average Release Rate, $\mu\text{Ci}/\text{sec}$	0.00E+00	0.00E+00	0.00E+00	0.00E+00	
3. Percent of Applicable Limit, %	N/A	N/A	N/A	N/A	
D. Alpha Activity, Ci	2.76E-06	2.13E-06	4.80E-06	3.52E-06	1.00E+01
<b>E. Tritium</b>					
1. Total Released, Ci	1.45E+00	2.34E-01	6.43E-01	6.31E-01	1.00E+01
2. Average Release Rate, $\mu\text{Ci}/\text{sec}$	1.87E-01	2.98E-02	6.84E-02	7.93E-02	
3. Percent of Applicable Limit, %	N/A	N/A	N/A	N/A	
F. Carbon-14, Ci	2.99E+00	4.40E+00	4.75E+00	4.77E+00	1.00E+00

N/A – Not Applicable, the ODCM does not have a release rate limit for gaseous effluents

Carbon-14 activity was calculated based on power production and using the EPRI-provided spreadsheet

## 2017 ANNUAL ENVIRONMENTAL AND EFFLUENT RELEASE REPORT

The radionuclide composition of all gaseous radioactive effluents for a continuous-mode, ground-level release is given in Table 5. In each case, LLDs were met or were below the levels required by the ODCM.

**Table 5: Radioactive Gaseous Effluent Nuclide Composition**

Isotope	Unit	Quarter 1	Quarter 2	Quarter 3	Quarter 4	Annual
<b>1. Fission and Activation Gases</b>						
Tritium	Ci	1.45E+00	2.34E-01	5.43E-01	6.31E-01	2.86E+00
Argon-41	Ci	<1.0E-06 <sup>1</sup>	2.65E-01	<1.0E-06 <sup>1</sup>	3.24E-01	5.89E-01
Krypton-85m	Ci	3.78E-01	<1.0E-06 <sup>1</sup>	<1.0E-06 <sup>1</sup>	<1.0E-06 <sup>1</sup>	3.78E-01
Krypton-87	Ci	<1.0E-06 <sup>1</sup>	<1.0E-06 <sup>1</sup>	<1.0E-06 <sup>1</sup>	<1.0E-06 <sup>1</sup>	<1.0E-06 <sup>1</sup>
Krypton-88	Ci	<1.0E-06 <sup>1</sup>	<1.0E-06 <sup>1</sup>	<1.0E-06 <sup>1</sup>	<1.0E-06 <sup>1</sup>	<1.0E-06 <sup>1</sup>
Xenon-133m	Ci	<1.0E-06 <sup>1</sup>	<1.0E-06 <sup>1</sup>	<1.0E-06 <sup>1</sup>	<1.0E-06 <sup>1</sup>	<1.0E-06 <sup>1</sup>
Xenon-133	Ci	3.84E-02	<1.0E-06 <sup>1</sup>	<1.0E-06 <sup>1</sup>	<1.0E-06 <sup>1</sup>	3.84E-02
Xenon-135m	Ci	<1.0E-06 <sup>1</sup>	<1.0E-06 <sup>1</sup>	<1.0E-06 <sup>1</sup>	<1.0E-06 <sup>1</sup>	<1.0E-06 <sup>1</sup>
Xenon-135	Ci	1.38E-01	<1.0E-06 <sup>1</sup>	<1.0E-06 <sup>1</sup>	<1.0E-06 <sup>1</sup>	1.38E-01
Xenon-138	Ci	<1.0E-06 <sup>1</sup>	<1.0E-06 <sup>1</sup>	<1.0E-06 <sup>1</sup>	<1.0E-06 <sup>1</sup>	<1.0E-06 <sup>1</sup>
Total for Period	Ci	2.01E+00	4.99E-01	5.43E-01	9.55E-01	4.01E+00
<b>2. Iodine/Halogens</b>						
Iodine-131	Ci	3.26E-06	<1.0E-12 <sup>1</sup>	<1.0E-12 <sup>1</sup>	<1.0E-12 <sup>1</sup>	3.26E-06
Iodine-133	Ci	<1.0E-10 <sup>1</sup>	<1.0E-10 <sup>1</sup>	<1.0E-10 <sup>1</sup>	<1.0E-10 <sup>1</sup>	<1.0E-10 <sup>1</sup>
Total for Period	Ci	3.26E-06	<LLD	<LLD	<LLD	3.26E-06
<b>3. Particulates</b>						
Chromium-51	Ci	<1.0E-04 <sup>1</sup>	<1.0E-04 <sup>1</sup>	<1.0E-04 <sup>1</sup>	<1.0E-04 <sup>1</sup>	<1.0E-04 <sup>1</sup>
Manganese-54	Ci	<1.0E-04 <sup>1</sup>	<1.0E-04 <sup>1</sup>	<1.0E-04 <sup>1</sup>	<1.0E-04 <sup>1</sup>	<1.0E-04 <sup>1</sup>
Iron-59	Ci	<1.0E-04 <sup>1</sup>	<1.0E-04 <sup>1</sup>	<1.0E-04 <sup>1</sup>	<1.0E-04 <sup>1</sup>	<1.0E-04 <sup>1</sup>
Cobalt-58	Ci	<1.0E-04 <sup>1</sup>	<1.0E-04 <sup>1</sup>	<1.0E-04 <sup>1</sup>	<1.0E-04 <sup>1</sup>	<1.0E-04 <sup>1</sup>
Cobalt-60	Ci	<1.0E-04 <sup>1</sup>	<1.0E-04 <sup>1</sup>	<1.0E-04 <sup>1</sup>	<1.0E-04 <sup>1</sup>	<1.0E-04 <sup>1</sup>
Zinc-65	Ci	<1.0E-04 <sup>1</sup>	<1.0E-04 <sup>1</sup>	<1.0E-04 <sup>1</sup>	<1.0E-04 <sup>1</sup>	<1.0E-04 <sup>1</sup>
Strontium-89	Ci	<1.0E-11 <sup>1</sup>	<1.0E-11 <sup>1</sup>	<1.0E-11 <sup>1</sup>	<1.0E-11 <sup>1</sup>	<1.0E-11 <sup>1</sup>
Molybdenum-99	Ci	<1.0E-04 <sup>1</sup>	<1.0E-04 <sup>1</sup>	<1.0E-04 <sup>1</sup>	<1.0E-04 <sup>1</sup>	<1.0E-04 <sup>1</sup>
Cesium-134	Ci	<1.0E-04 <sup>1</sup>	<1.0E-04 <sup>1</sup>	<1.0E-04 <sup>1</sup>	<1.0E-04 <sup>1</sup>	<1.0E-04 <sup>1</sup>
Cesium-137	Ci	<1.0E-04 <sup>1</sup>	<1.0E-04 <sup>1</sup>	<1.0E-04 <sup>1</sup>	<1.0E-04 <sup>1</sup>	<1.0E-04 <sup>1</sup>
Cerium-141	Ci	<1.0E-04 <sup>1</sup>	<1.0E-04 <sup>1</sup>	<1.0E-04 <sup>1</sup>	<1.0E-04 <sup>1</sup>	<1.0E-04 <sup>1</sup>
Cerium-144	Ci	<1.0E-04 <sup>1</sup>	<1.0E-04 <sup>1</sup>	<1.0E-04 <sup>1</sup>	<1.0E-04 <sup>1</sup>	<1.0E-04 <sup>1</sup>
Total for Period	Ci	<LLD	<LLD	<LLD	<LLD	<LLD

<sup>1</sup> - (<) Less than the ODCM-required lower limit of detection, units in µCi/mL

<LLD - Less than the OCM-required lower limit of detection

## 2017 ANNUAL ENVIRONMENTAL AND EFFLUENT RELEASE REPORT

### Solid Waste

All solid radioactive waste from PNPP was processed and combined with waste from several other utilities by intermediate vendors (Energy Solutions and Erwin Resin Solutions). The final waste after processing is sent to EnergySolutions disposal facility in Clive, Utah for burial.

**Table 6: Solid Waste Shipped Offsite for Burial or Disposal**

1. Type of Solid Waste Shipped	Volume (m <sup>3</sup> )	Activity (Ci)	Est. Total Error (%)
a. Resins, Filters, and Evaporator Bottoms	1.35E+02	1.28E+03	± 25
b. Dry Active Waste	1.16E+03	6.94E-01	± 25
c. Irradiated components, control rods, etc.	0.00E+00	0.00E+00	± 25
d. Other Waste	6.85E+00	1.95E+00	± 25

2. Estimate of Major <sup>(1)</sup> Nuclide Composition (by type of waste)	Radionuclide	Abundance (%)	Est. Total Error, (%)
a. Resins, Filters and Evaporator Bottoms	Mn-54	4.61	± 25
	Fe-55	33.69	
	Co-60	54.81	
	Zn-65	4.28	
b. Dry Active Waste	Cr-51	1.38	± 25
	Mn-54	5.06	
	Fe-55	42.06	
	Co-60	46.13	
	Zn-65	1.30	
c. Irradiated Components, Control Rods, etc.	N/A	N/A	N/A
d. Other Waste	Mn-54	1.16	± 25
	Fe-55	20.55	
	Co-60	76.93	

(1) – "Major" is defined as any individual radionuclide identified as >1% of the waste type abundance.

N/A – Not applicable due to no shipments

3. Solid Waste Disposition		
Number of Shipments	Mode of Transportation	Destination
54	Hittman Transport	Energy Solutions Bear Creek Operations
1	Hittman Transport	Energy Solutions Gallaher Operations
6	Hittman Transport	Erwin ResinSolutions, LLC 151 T.C. Runion Rd.
1	Landstar	Energy Solutions Gallaher Operations

## 2017 ANNUAL ENVIRONMENTAL AND EFFLUENT RELEASE REPORT

### **METEOROLOGICAL DATA**

The Meteorological Monitoring System at PNPP consists of a 60-meter tower equipped with two independent systems for measuring wind speed, wind direction, and temperature at both 10-meter and 60-meter heights. The tower also has instrumentation to measure dew point and barometric pressure. Data is logged from the tower through separate data loggers and transmitted to a common plant computer. This program compiles the data and calculates a variety of atmospheric parameters, communicates with the Meteorological Information Dose Assessment System (MIDAS), and sends data over communication links to the plant Control Room.

A detailed report of the monthly and annual operation of the PNPP Meteorological Monitoring Program is produced as a separate document that is retained in PNPP Records and available upon request. The report substantiates the quality and quantity of meteorological data collected in accordance with applicable regulatory guidance.

### **DOSE ASSESSMENT**

The maximum concentration for any radioactive release is controlled by the limits set forth in Title 10 of the Code of Federal Regulations, Part 20 (10CFR20). Sampling, analyzing, processing, and monitoring the effluent streams ensures compliance with these concentration limits. Dose limit compliance is verified through periodic dose assessment calculations. Some dose calculations are conservatively performed for a hypothetical maximum individual who is assumed to reside on the site boundary at the highest potential dose location all year. This person, called the "maximum individual", would incur the maximum potential dose from direct exposure (air plus ground plus water), inhalation, and ingestion of water, milk, vegetation, and fish. Because no individual actually meets these criteria, the actual dose received by a real member of the public is significantly less than what is calculated for this hypothetical individual.

Dose calculations for this maximum individual at the site boundary are performed for two cases:

- Using data for a 360-degree radius around the plant site (land and water-based meteorological sectors); even though some of these sectors are over Lake Erie, which has no permanent residents;
- Considering only those sectors around the plant in which people reside (land-based meteorological sectors).

The calculated hypothetical, maximum individual dose values at the site boundary are provided in Table 7. This table considers all meteorological sectors around PNPP and provides whole body and worst-case organ-dose values.



## 2017 ANNUAL ENVIRONMENTAL AND EFFLUENT RELEASE REPORT

**Table 7: Maximum Yearly Individual Site Boundary Dose, Considering All Sectors**

Type of Dose	Organ	Estimated Dose, (mrem)	Limit (mrem)	% of Limit
Liquid Effluent	Whole body	1.96E-03	3.0E+00	6.5E-02
	Liver	2.71E-03	1.0E+01	2.7E-02
Noble Gas	Air Dose Gamma (mrad)	2.64E-03	1.0E+01	2.6E-02
	Air Dose Beta (mrad)	1.17E-03	2.0E+01	5.8E-03
Noble Gas	Whole body	1.69E-03	5.0E+00	3.4E-02
	Skin	2.71E-03	1.5E+01	1.8E-02
Particulate & Iodine	Thyroid	1.36E-03	1.5E+01	9.0E-03
Carbon-14 *	Whole Body	2.55E-01	5.0E+00	5.1E+00

\*C-14 dose calculated at nearest garden.

The hypothetical maximum dose within a 50-mile radius of site was calculated and is presented in Table 8. This table considers all meteorological sectors around PNPP and provides whole body and worst-case organ dose values.

**Table 8: Population Yearly Dose, Considering All Sectors out to 50 miles**

	Organ	Estimated Dose (person-rem)
Liquid Effluent	Whole body	2.5E-01
	Thyroid	8.3E-02
Gaseous Effluent	Whole body	3.1E-04
	Thyroid	3.1E-04

## 2017 ANNUAL ENVIRONMENTAL AND EFFLUENT RELEASE REPORT

Table 9 provides the calculated hypothetical maximum site boundary dose values considering only the land-based sectors.

**Table 9: Maximum Yearly Individual Site Boundary Dose (Only Land Sectors)**

Type of Dose	Organ	Estimated Dose, (mrem)	Limit (mrem)	% of Limit
Liquid Effluent	Whole Body	1.89E-03	3.0E+00	6.3E-02
	Liver	2.61E-03	1.0E+01	2.6E-02
Noble Gas	Air Dose Gamma (mrad)	3.95E-04	1.0E+01	4.0E-03
	Air Dose Beta (mrad)	1.39E-04	2.0E+01	7.0E-04
Noble Gas	Whole Body	4.25E-05	5.0E+00	8.5E-04
	Skin	6.81E-05	1.5E+01	4.5E-04
Particulate & Iodine	Thyroid	1.02E-04	1.5E+01	6.8E-04
Carbon-14 *	Whole Body	2.55E-01	5.0E+00	5.1E+00

\*C-14 dose calculated at nearest garden.

Other dose calculations are performed for a hypothetical individual assumed to be inside the site boundary for some specified amount of time. This person would receive the maximum dose during the time spent inside site boundary. Because no person actually meets the criteria established for these conservative calculations, the actual dose received by a member of the public is significantly less than what is calculated for this hypothetical individual. This dose is assessed relative to the offsite dose, and considers dilution, dispersion, and occupancy factors.

The highest hypothetical dose from liquid effluents to a member of the public inside the site boundary is to a person who is fishing on Lake Erie from the shore on PNPP property. The calculations assume that this person will spend 60 hours per year fishing, with a liquid dilution factor of 10. The ratio of the exposure pathway to the doses calculated for offsite locations yields the dose values shown in Table 10.

**Table 10: Maximum Site Dose from Liquid Effluents**

	Whole Body Dose, (mrem)	Organ Dose, (mrem)
First Quarter	4.6E-04	5.4E-04
Second Quarter	5.4E-04	6.4E-04
Third Quarter	2.1E-04	2.5E-04
Fourth Quarter	6.9E-05	8.2E-05
Annual	1.4E-03	1.6E-03

## 2017 ANNUAL ENVIRONMENTAL AND EFFLUENT RELEASE REPORT

Although several cases were evaluated to determine the highest hypothetical dose from gaseous effluents to members of the public inside site boundary, the activity inside the site boundary with the highest dose potential is also shoreline fishing. The cases evaluated included traversing a public road within the site boundary, shoreline fishing (assuming fishing 60 hours per year), non-plant related training, car-pooling, and job interviews. The maximum on-site gaseous doses generated are shown in Table 11.

**Table 11: Maximum Site Dose from Gaseous Effluents**

	Whole Body Dose, (mrem)	Organ Dose, (mrem)
First Quarter	1.2E-04	2.1E-04
Second Quarter	9.5E-05	1.5E-04
Third Quarter	2.3E-05	2.3E-05
Fourth Quarter	1.3E-04	1.9E-04
Annual	2.9E-04	1.1E-03

An average whole body dose to individual members of the public at or beyond the site boundary is then determined by combining the dose from gaseous and liquid radiological effluents. The dose from gaseous radiological effluents is based upon the population that lives within 50 miles of PNPP. The dose from liquid radiological effluents is determined for the population that receives drinking water from intakes within 50 miles of PNPP. The results of this calculation are provided in Table 12.

**Table 12: Average Individual Whole Body Dose**

	Liquid Effluents, (mrem)	Gaseous Effluents, (mrem)
First Quarter	3.5E-05	4.6E-08
Second Quarter	4.6E-05	1.9E-08
Third Quarter	1.5E-05	3.8E-08
Fourth Quarter	5.0E-06	2.6E-08
Annual	1.0E-04	1.3E-07

## 2017 ANNUAL ENVIRONMENTAL AND EFFLUENT RELEASE REPORT

### CARBON-14 SUPPLEMENTAL INFORMATION

Carbon-14, with a half-life of 5730 years, is a naturally-occurring isotope of carbon produced by cosmic ray interactions in the atmosphere. Nuclear weapons testing in the 1950s and 1960s significantly increased the amount of C-14 in the atmosphere. Carbon-14 is also produced in commercial nuclear reactors, but the amounts produced are much less than those produced naturally or from weapons testing. It is released primarily from Boiling Water Reactors through the Off-gas system in the form of carbon dioxide (CO<sub>2</sub>). The quantity of gaseous C-14 released to the environment can be estimated using a C-14 source term scaling factor based on power generation.

The U.S. Nuclear Regulatory Commission (NRC) requires an assessment of gaseous C-14 dose impact to a member of the public resulting from routine releases in radiological effluents. Prior to 2011, the industry did not estimate the dose impact of C-14 releases because the dose contribution had been considered negligible compared to the dose impact from effluent releases of noble gases, tritium, particulates and radioiodines. At PNPP, improvements over the years in effluent management practices and fuel performance have resulted in a decrease in the concentration and changes in the distribution of gaseous radionuclides released to the environment.

This report contains estimates of the gaseous C-14 radioactivity released and the resulting public dose resulting from this release. The calculation is performed using a spreadsheet provided by EPRI and is based on power production. This method for estimating C-14 released has been endorsed by the NRC. Because the dose contribution of C-14 from liquid radioactive waste is much less than that contributed by gaseous radioactive waste, evaluation of C-14 in liquid radioactive waste at PNPP is not required. Refer to Table 4, Table 7, and Table 9 for C-14 estimated release values and doses.

### GROUNDWATER MONITORING PROGRAM

Based on the Environmental Resource Management hydrogeology study, 12 monitoring wells were recommended for the site. Since most groundwater flow drains north toward Lake Erie, the majority of wells are drilled north of the plant. A set of control wells were drilled south of the plant to assess a typical groundwater profile.

There are sets of three wells installed at four locations. Each set has a shallow well of approximately 25 feet, a mid-depth well of approximately 50 feet, and a deep well of approximately 75 feet. These three depths are designated A, B, and C, from shallowest to deepest, respectively.

PNPP has an Underdrain system to prevent groundwater hydrostatic pressure buildup on plant structures. The Underdrain system has two installed radiation monitors that assess the process stream prior to flowing into the Emergency Service Water system.

Refer to Figure 2 for locations of Groundwater Wells 1A through 4C and Underdrain Manholes 20 and 23. These wells and manholes encompass the groundwater monitoring locations at PNPP.

2017 ANNUAL ENVIRONMENTAL AND EFFLUENT RELEASE REPORT

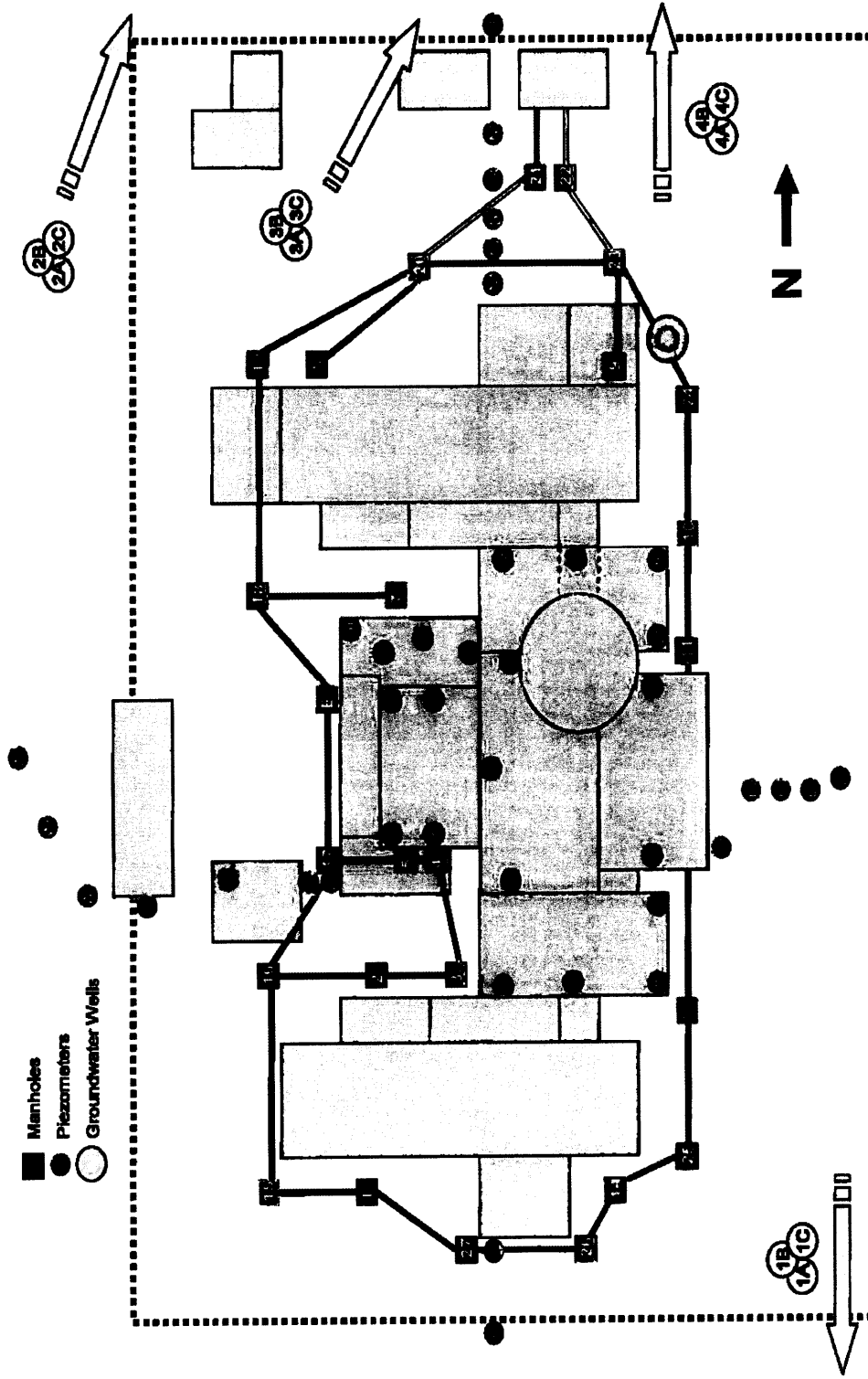

Figure 2: Underdrain System and Groundwater Monitoring Wells

## 2017 ANNUAL ENVIRONMENTAL AND EFFLUENT RELEASE REPORT

The monitoring wells are sampled twice annually, in spring and fall. The samples are shipped to a vendor for gamma isotopic and tritium analysis. Any positive result less than 500 pCi/L is considered as background activity and not due to plant operations. The ODCM reporting level for tritium in an environmental water sample is 20,000 pCi/L. The tritium results of samples obtained in 2017 can be found in Table 13. There was no indication of any effluent releases via groundwater.

**Table 13: Summary of Onsite Groundwater Samples**

Monitoring Well	Spring H-3, pCi/L	Fall H-3, pCi/L
1A	<155	<143
1B	<155	<143
1C	<155	<143
2A	<155	<143
2B	<155	<143
2C	<155	<143
3A	<155	<143
3B	<177	<143
3C	<177	<143
4A	<177	264 ± 81
4B	<177	<143
4C	<177	<143

(<) Less than values represent the MDA of the instrument at the time of analysis

The Underdrain manholes are sampled and analyzed quarterly for principal gamma emitters and tritium by PNPP personnel in accordance with site procedures. The tritium results of samples obtained in 2017 can be found in Table 14.

**Table 14: Summary of Underdrain Manhole Samples**

Underdrain Manhole	Quarter 1 H-3, pCi/L	Quarter 2 H-3, pCi/L	Quarter 3 H-3, pCi/L	Quarter 4 H-3, pCi/L
20	<1.0E-06	<1.0E-06	<1.0E-06	<1.0E-06
23	<1.0E-06	<1.0E-06	<1.0E-06	<1.0E-06

(<) Less than values represent the ODCM LLD value

## 2017 ANNUAL ENVIRONMENTAL AND EFFLUENT RELEASE REPORT

# RADIOLOGICAL ENVIRONMENTAL MONITORING

## INTRODUCTION

The REMP was established at PNPP for several reasons. First, it verifies the adequacy of plant design and operation to control radioactive materials and limit effluent releases. Second, it assesses the radiological impact, if any, that the plant has had on the surrounding environment. Third, it ensures compliance with regulatory guidelines. The REMP is conducted in accordance with the PNPP Operating License, Appendix B, Technical Specifications, and the ODCM. The Nuclear Regulatory Commission (NRC) established the REMP requirements.

A variety of samples are collected as part of the PNPP REMP. The selection of sample types, locations, and collection frequency are based on many variables. Potential pathways for the transfer of radionuclides through the environment to humans, sample availability, local meteorology, population characteristics, land use, and NRC requirements are all factors.

To ensure that the REMP data is significant and valuable, detailed sampling methods and procedures are followed to ensure that samples are collected in the same manner and from the same locations each time. All samples are packaged on site and then shipped to an independent vendor laboratory for analysis. The vendor laboratory analyzes the samples and reports results to the PNPP Chemistry Unit staff, the Lake County General Health District, and the State of Ohio Department of Health. Additionally, the Lake County General Health District obtains monthly "split" samples of milk, water, and vegetation to permit an independent verification of PNPP's REMP.

## SAMPLING LOCATIONS

REMP samples are collected at numerous locations, both on site and up to 16.2 miles away from the plant. Sampling locations are divided into two general categories: indicator and control. Indicator locations are relatively close to the plant that monitor for any environmental impact due to plant operations. Control locations are those that are unaffected by plant operation; they are a greater distance from the plant and in the least prevalent wind directions. Data obtained from the indicator locations are compared with data from the control locations. This comparison allows naturally-occurring background radiation to be taken into account when evaluating any radiological impact PNPP may have had on the environment. Table 15, Figure 3, Figure 4, and Figure 5 identify the PNPP REMP sampling locations.

Many REMP samples are collected in addition to those required by the PNPP ODCM. The ODCM requirements for each sample type are discussed in more detail later in the report.

## 2017 ANNUAL ENVIRONMENTAL AND EFFLUENT RELEASE REPORT

**Table 15: REMP Sampling Locations**

Location #	Description	Miles	Direction	Media (1)
1	Chapel Road	3.4	ENE	TLD, AIP
2	Kanda Garden	1.9	ENE	Broadleaf Vegetation
3	Meteorological Tower	1.0	SE	TLD, AIP
4	Site Boundary	0.7	S	TLD, AIP
5	Quincy Substation	0.6	SW	TLD, AIP
6	Concord Service Center	11.0	SSW	TLD, AIP
7	Site Boundary	0.6	NE	TLD, AIP
8	Site Boundary	0.8	E	TLD
9	Site Boundary	0.7	ESE	TLD
10	Site Boundary	0.8	SSE	TLD
11	Pamly Rd. at Center Rd.	0.6	SSW	TLD
12	Site Boundary	0.6	WSW	TLD
13	Madison-on-the-Lake	4.7	ENE	TLD
14	Hubbard Rd.	4.9	E	TLD
15	Eagle St. Substation	5.1	ESE	TLD
16	Eubank Garden	0.9	S	Broadleaf Vegetation
19	Goodfield Dairy	9.2	S	Milk
20	Rainbow Farms	1.9	E	Broadleaf Vegetation
21	Hardy Rd. – Painesville Township Park	5.1	WSW	TLD
23	High St. Substation	7.9	WSW	TLD
24	St. Clair Ave. at Mentor Substation	15.1	SW	TLD
25	Offshore - PNPP discharge	0.6	NNW	Fish
29	River Rd. at Turney Rd.	4.3	SSE	TLD
30	Lane Rd.	4.8	SSW	TLD
31	Wood Rd. at River Rd.	4.8	SE	TLD
32	Offshore – Mentor-on-the-Lake	15.8	WSW	Fish
33	River Rd. at Blair Rd.	4.5	S	TLD
34	PNPP Intake	0.2	NW	Surface Water
35	Site Boundary	0.6	E	TLD, AIP
36	Lake County Water Plant	3.9	WSW	TLD, Drinking Water
37	Gerlica Farm	1.5	ENE	Broadleaf Vegetation
39	Painesville Purification Plant	8.3	W	Drinking Water
51	Rettger Milk Farm	9.7	S	Milk
53	3715 Pamly Rd.	0.5	WSW	TLD
54	Hale Rd. School	4.6	SW	TLD
55	Center Rd. behind soccer field	2.5	S	TLD
56	Madison High School	4.0	ESE	TLD



## 2017 ANNUAL ENVIRONMENTAL AND EFFLUENT RELEASE REPORT

Location #	Description	Miles	Direction	Media (1)
57	Perry High School	1.7	S	TLD
58	Antioch Rd.	0.8	ENE	TLD
59	Lake Shoreline at Green Rd.	4.0	ENE	Surface Water
60	Lake Shoreline at Perry Park	1.0	WSW	Surface Water
64	Northwest Drain Mouth	0.4	WNW	Sediment
66	Lake Shore, Metropolitan Park	1.4	NE	Sediment
70	H&H Farm Stand	16.2	SSW	Broadleaf Vegetation

(1) AIP = Air, Iodine and Particulate  
TLD = Thermoluminescent Dosimeter

2017 ANNUAL ENVIRONMENTAL AND EFFLUENT RELEASE REPORT

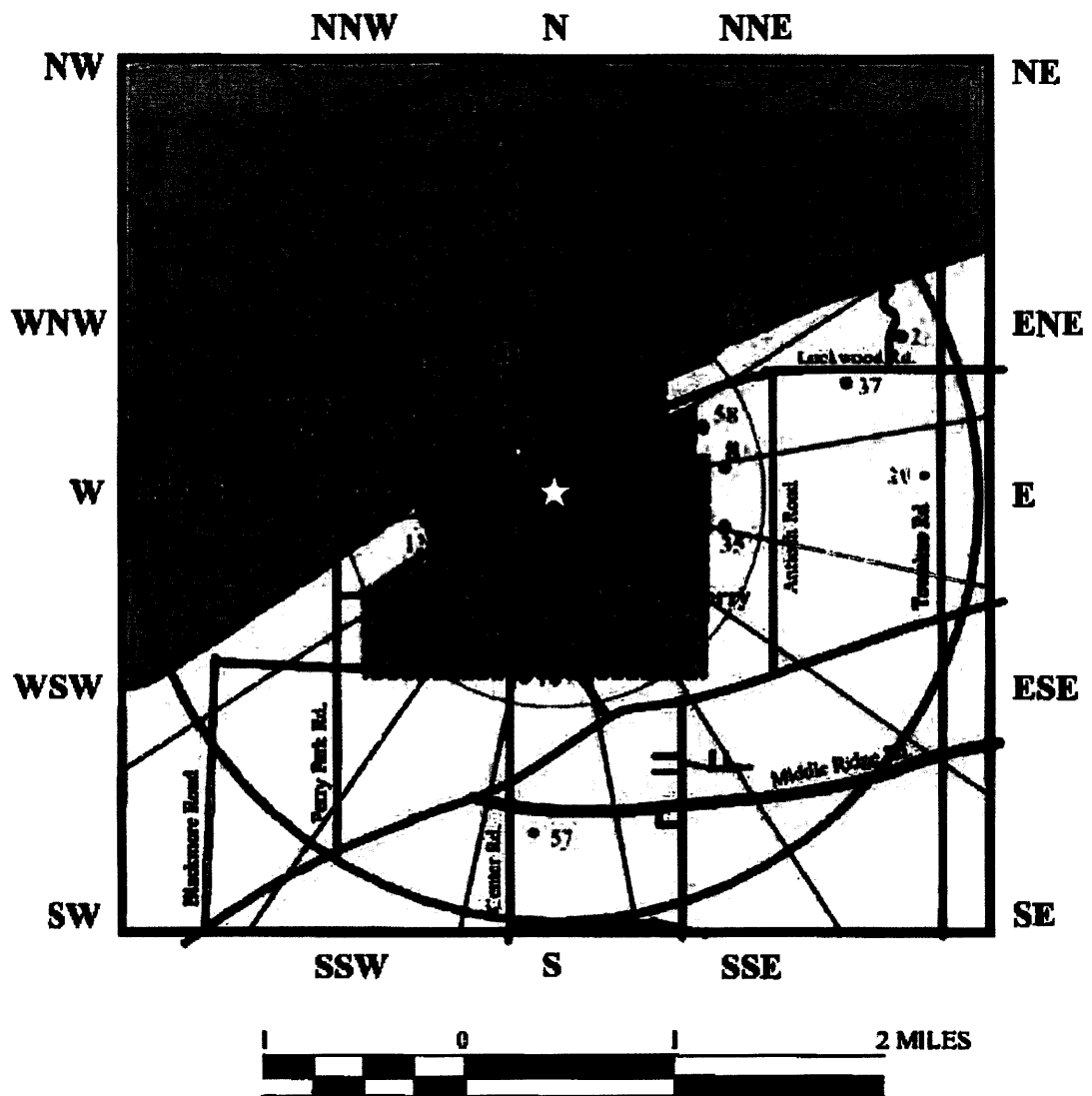

Figure 3: REMP Sampling Locations within Two Miles of the Plant Site

2017 ANNUAL ENVIRONMENTAL AND EFFLUENT RELEASE REPORT

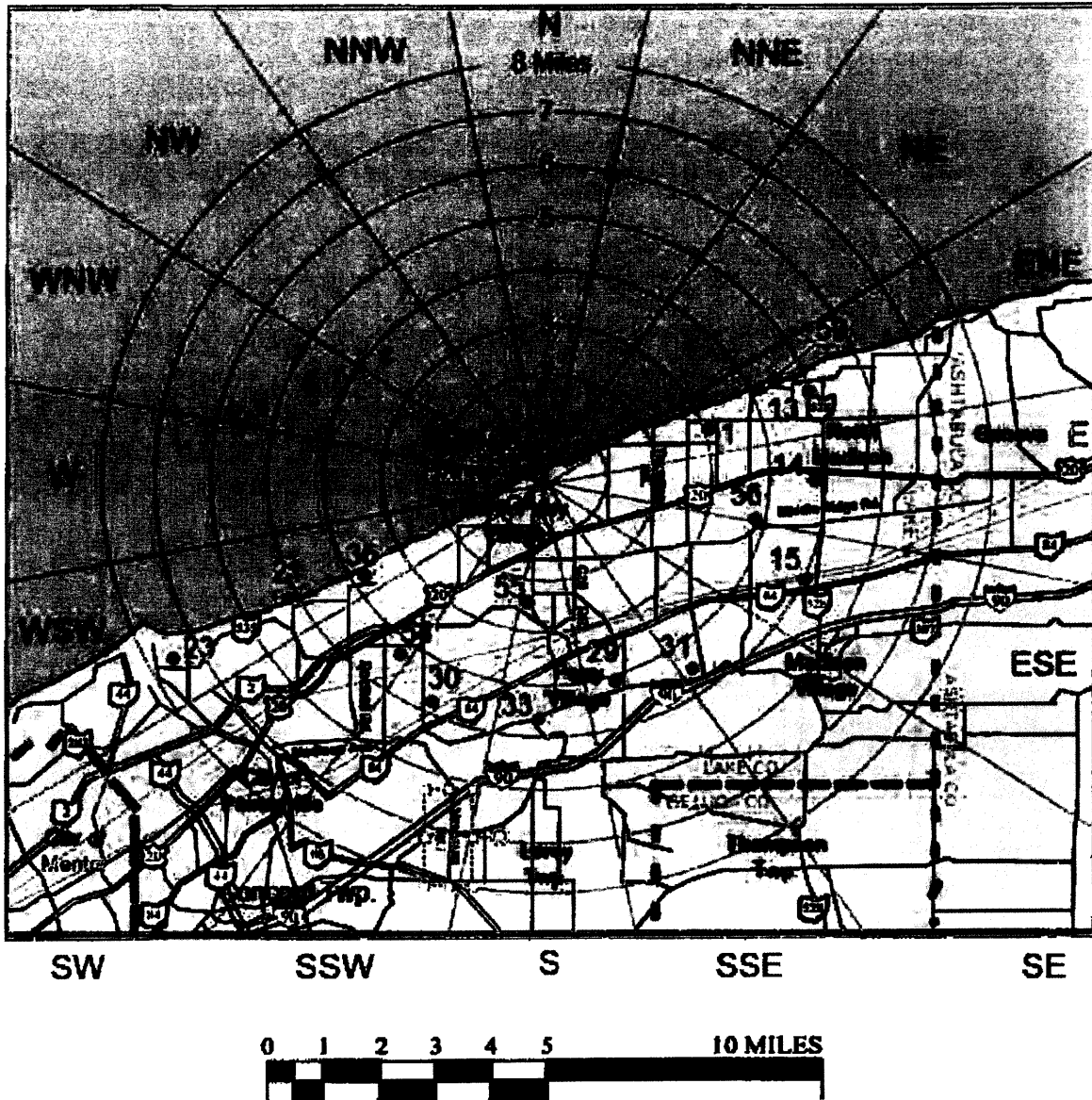
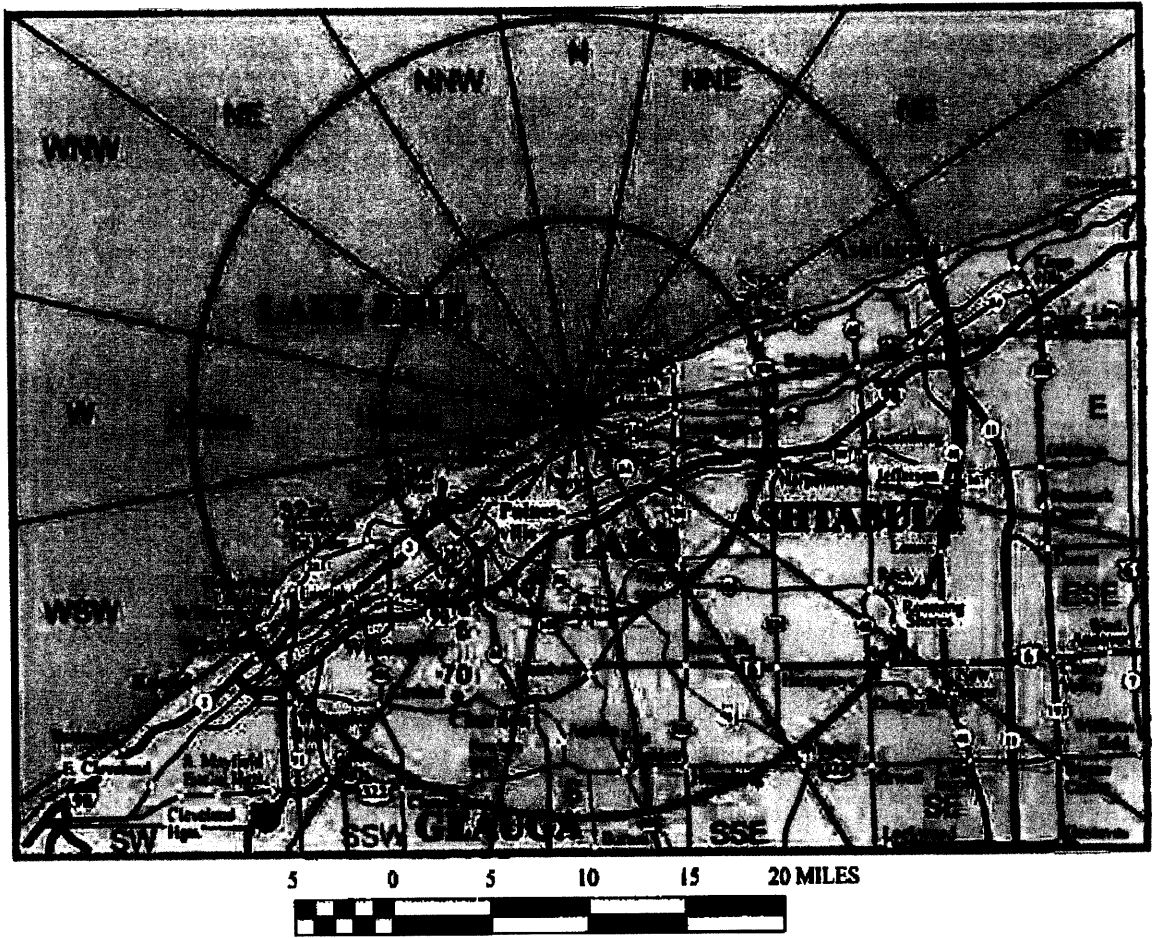

Figure 4: REMP Sampling Locations between Two and Eight Miles from the Plant Site

# 2017 ANNUAL ENVIRONMENTAL AND EFFLUENT RELEASE REPORT



**Figure 5: REMP Sampling Locations Greater Than Eight Miles from the Plant Site**

## 2017 ANNUAL ENVIRONMENTAL AND EFFLUENT RELEASE REPORT

### **SAMPLE ANALYSIS**

When environmental samples are analyzed for radioactivity, several types of measurements are performed to provide information about the types of radiation and radionuclides present. The major analyses that are performed are discussed below.

Gross beta activity measures the total amount of beta-emitting radioactivity present in a sample and acts as a tool to identify samples that may require further analysis. Beta radiation may be released by many different radionuclides. Since beta-decay results in a continuous energy spectrum rather than the discrete energy levels, or "peaks", associated with gamma radiation, identification of specific beta-emitting nuclides is more difficult. Therefore, gross beta activity only indicates whether the sample contains normal or abnormal amounts of beta-emitting radioactivity; it does not specifically identify the radionuclides present.

Gamma spectral analysis provides more specific information than does the analysis for gross beta activity. Gamma spectral analysis identifies each radionuclide, and the amount of radioactivity, present in the sample emitting gamma radiation. Each radionuclide has a very specific "fingerprint" that allows for accurate identification and quantification.

Iodine activity analysis measures the amount of radioactive iodine present in a sample. Some media (e.g. air sample charcoal cartridges) are analyzed directly by gamma spectral analysis. With other media (e.g. milk), the radioiodines are extracted by chemical separation before being analyzed by gamma spectral analysis.

Tritium activity analysis measures the amount of the radionuclide tritium (H-3) present in a sample. Tritium is an isotope of hydrogen that emits low-energy beta particles. Tritium occurs naturally from interactions with atmospheric cosmic rays and is also man-made from the nuclear fission process.

Gamma doses received by Thermoluminescent Dosimeters (TLD) while in the field are determined by a special laboratory procedure. Thermoluminescence is a process by which ionizing radiation interacts with the sensitive phosphor material in the TLD. Energy is trapped in the TLD material and can be stored for months or years. This capability provides a method to measure the dose received over long periods of time. The amount of energy that was stored in the TLD as a result of interaction with radiation is released by a controlled heating process and measured in a calibrated reading system. As the TLD is heated, the phosphor releases the stored energy as light. The amount of light is directly proportional to the amount of radiation to which the TLD was exposed. Table 16 provides a list of the analyses performed on environmental samples collected for the PNPP REMP.

The required REMP detection limits for samples is determined by sample media and the radionuclide that is being analyzed. The NRC has established LLDs for REMP sample analysis. These LLDs are listed in the PNPP ODCM. The vendor laboratory for REMP sample analysis has complied with these LLDs.

## 2017 ANNUAL ENVIRONMENTAL AND EFFLUENT RELEASE REPORT

**Table 16: REMP Sample Analyses**

Type	Sample	Frequency	Analysis
Atmospheric Monitoring	Airborne Particulates	Weekly & Quarterly	Gross Beta Activity & Gamma Spectral Analysis
	Airborne Radioiodine	Weekly	Iodine-131
Terrestrial Monitoring	Milk	Monthly & Semi-Monthly when cows are on pasture	Gamma Spectral Analysis & Iodine-131
	Broadleaf Vegetation	Monthly during growing season	Gamma Spectral Analysis
Aquatic Monitoring	Water	Monthly	Gross Beta Activity & Gamma Spectral Analysis
		Quarterly	Tritium Activity
	Fish	Semi-Annually	Gamma Spectral Analysis
	Sediment	Semi-annually	Gamma Spectral Analysis
Direct Radiation Monitoring	TLD	Quarterly & Annually	Gamma Dose

### SAMPLING PROGRAM

The contribution of radionuclides to the environment resulting from PNPP operation is assessed by comparing results from the environmental monitoring program with pre-operational data (i.e., data from before 1986), operational data from previous years, and control location data. The results for each sample type are discussed below and compared to historical data to determine if there are any observable trends. All results are expressed as concentrations. Refer to Appendix B, 2017 REMP Data Summary Reports for a detailed listing of these results. The NRC requires special reporting whenever sample analysis results exceed set limits. No values exceeded those limits.

### PROGRAM CHANGES

There were no changes to the REMP during this reporting period.

### ATMOSPHERIC MONITORING

#### Air

Air sampling is conducted to detect any increase in the concentration of airborne radionuclides. The PNPP REMP maintains an additional two air sampling locations above the five locations (four indicators and one control) required by the ODCM. Six of these locations are within four miles of the plant site; the seventh is used as a control location and is eleven miles from PNPP. Air sampling pumps draw continuous samples at a rate of approximately two cubic feet per minute. The air is drawn through glass fiber filters to collect

## 2017 ANNUAL ENVIRONMENTAL AND EFFLUENT RELEASE REPORT

particulate material and a charcoal cartridge to adsorb iodine. The samples are collected on a weekly basis, 52 weeks a year, from each of the seven air sampling stations.

Air samples are analyzed weekly for gross beta activity and radioiodine activity. The air samples are also analyzed by gamma spectral analysis quarterly. A total of 371 air particulate and 371 air radioiodine samples were collected and analyzed.

Gross beta activity was detected in 371 of the 371 air samples. The average gross beta activity for indicator locations was 0.023 pCi/m<sup>3</sup> and the controls was 0.026 pCi/m<sup>3</sup>. Historically, the concentration of gross beta in air has been essentially identical at indicator and control locations. Figure 6 reflects the average gross beta activity for 2017 and previous years. All radioiodine samples were less than the lower limit of detection for iodine-131.

With the exception of naturally-occurring beryllium-7, no radionuclides were identified in the quarterly gamma spectral analysis above the LLD values.

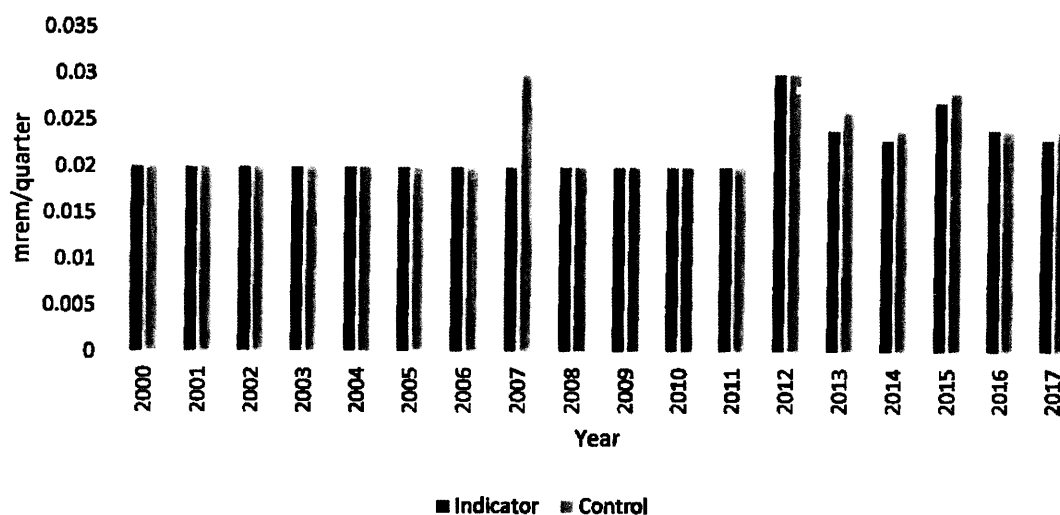

**Figure 6: Annual Average Gross Beta Activity, in Air**

### TERRESTRIAL MONITORING

Collecting and analyzing samples of milk and broadleaf vegetation provides data to assess the build-up of radionuclides that may be ingested by humans. The historical data from soil and vegetation samples provides information on atmospheric radionuclide deposition.

#### Milk

Samples of milk are collected once each month from November through March, and twice each month from April through October. Sampling is increased during the summer because animals usually feed outside on pasture rather than on stored feed. The PNPP REMP includes two milk locations.

## 2017 ANNUAL ENVIRONMENTAL AND EFFLUENT RELEASE REPORT

Since the milk sampling locations do not meet the requirements of the ODCM (no milk-producing animals are located within the required distance, yet two locations are required if available), broadleaf vegetation sampling (discussed below) is performed. Milk is collected from the available locations to augment vegetation sampling.

Milk samples are analyzed by gamma spectral analysis for radioiodines and other radionuclides. A total of 38 milk samples were collected. With the exception of naturally-occurring potassium-40, no other radionuclides were detected.

### **Broadleaf Vegetation**

Because there is not a milking animal within 5 km of the plant as required by the ODCM, the PNPP REMP samples broadleaf vegetation. These samples are collected monthly during the growing season from four gardens in the vicinity of PNPP and one control location 16.2 miles SSW from PNPP.

Sixty-five samples were collected and analyzed by gamma spectral analysis. Four vegetation types were grown and collected: collard greens, turnip greens, Japanese greens, and Swiss chard. Beryllium-7 and potassium-40, both naturally-occurring radionuclides, were found in the samples. No other radionuclides were detected.

### **AQUATIC MONITORING**

Radionuclides may be present in Lake Erie from many sources other than the PNPP. These sources include atmospheric deposition, run-off, soil erosion, and releases of radioactivity in liquid effluents from hospitals, universities, or other industrial facilities. These sources provide two forms of potential radiation exposure: external and internal. External exposure can occur from contact with water or shoreline sediments, while internal exposure can occur from either direct ingestion of radionuclides or the transfer of radionuclides through the aquatic food chain. Direct exposure can occur through ingestion by drinking the water, while the transfer via the aquatic food chain occurs from the eventual consumption of aquatic organisms, such as fish. PNPP samples water, shoreline sediments, and fish to monitor these pathways.

#### **Water**

Water is sampled from five locations along Lake Erie in the vicinity of the PNPP as required by the PNPP ODCM. Fifty-eight water samples were collected and analyzed for gross beta activity and gamma spectral analysis. From these monthly samples, 18 quarterly composite samples were analyzed for tritium activity.

Gross beta activity was detected in 42 of the 58 samples collected. The indicator average gross beta activity was 1.6 pCi/L and the control average gross beta activity was 1.4 pCi/L. Refer to Figure 7 for the annual average gross beta activity for both indicator and control locations. No tritium or gamma activity was detected.



## 2017 ANNUAL ENVIRONMENTAL AND EFFLUENT RELEASE REPORT

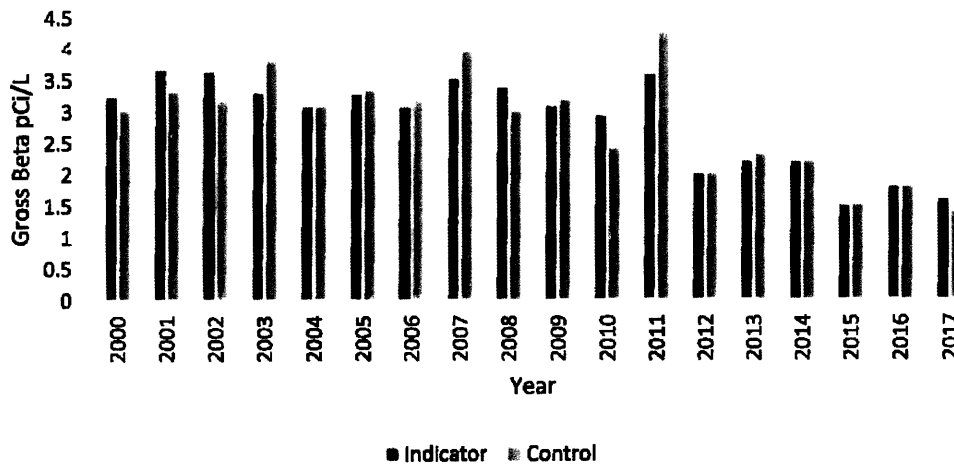

**Figure 7: Annual Average Gross Beta Activity, In Water**

### Sediment

Sampling shoreline sediments provides an indication of the accumulation of particulate radionuclides which may lead to an external radiation source to fishermen and swimmers from shoreline exposure. Sediment was sampled from two locations.

Four sediment samples were collected and analyzed by gamma spectroscopy. The only radionuclide detected was naturally-occurring potassium-40.

### Fish

Fish are analyzed primarily to quantify the radionuclide intake by humans and secondarily to serve as indicators of radioactivity in the aquatic ecosystem. Fish are collected from two locations annually during the fishing season as required by the ODCM. Important sport or commercial species are targeted, and only the fillets are sent to the laboratory for analysis.

Eleven fish samples were collected and analyzed: Five indicator and six control samples. The species were smallmouth bass, white perch, walleye, channel catfish, freshwater drum, rainbow trout, redhorse sucker and yellow perch. Only naturally-occurring potassium-40 was detected in the samples.

## DIRECT RADIATION MONITORING

### Thermoluminescent Dosimeter (TLD)

Environmental radiation is measured directly at 27 locations around the PNPP site and at two control locations. The locations are positioned in two rings around the plant as well as at the site boundary. The inner ring is within a one-mile radius of the plant site; the outer ring is four to five miles from the plant. The control locations are over ten miles from the plant in the two least prevalent wind directions. Each location has three TLDs, two of which are changed quarterly and one that is changed annually.

## 2017 ANNUAL ENVIRONMENTAL AND EFFLUENT RELEASE REPORT

A total of 261 TLDs were collected and analyzed. This includes 232 collected on a quarterly basis and 29 collected annually. Annual TLDs are not required per the ODCM and are used for supplemental data only.

The annual average dose for all indicator locations was 65.8 mrem and 61.8 mrem for the control locations.

The average quarterly dose for the indicator locations was 12.0 mrem, and 11.4 mrem for the control locations. Refer to Figure 8 for the average quarterly TLD dose rates for both indicator and control locations.

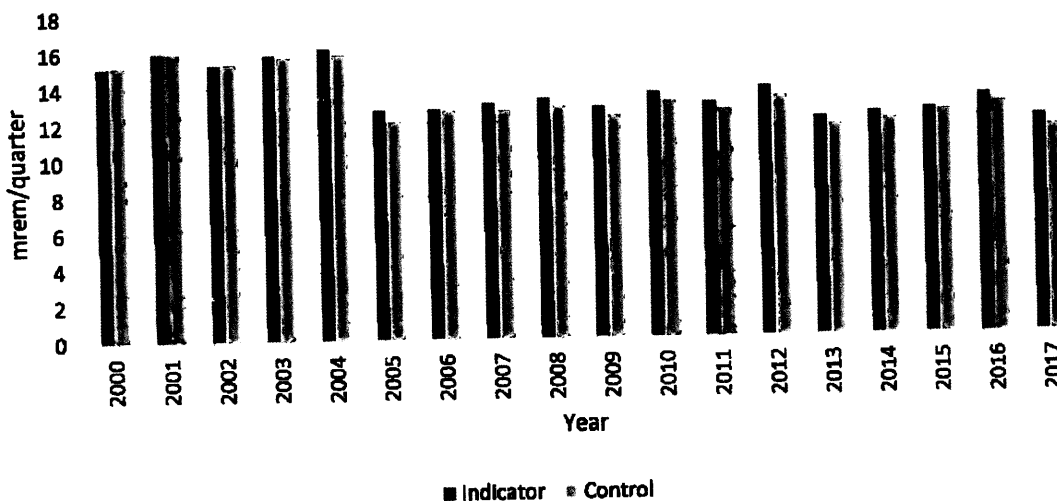

**Figure 8: Average Quarterly TLD Dose**

### CONCLUSION

There are no discernable trends or increase in radiological parameters when comparing current monitoring results to pre-operational studies. Non-routine analyses were not required during this reporting period. There is no detectable radiological effect on the surrounding environment due to operation of the Perry Nuclear Power Plant.

## 2017 ANNUAL ENVIRONMENTAL AND EFFLUENT RELEASE REPORT

### INTER-LABORATORY CROSS-CHECK COMPARISON PROGRAM

#### Introduction

The purpose of the Inter-laboratory Cross-Check Comparison Program is to provide an independent check on the vendor laboratory's analytical procedures. Samples with a known concentration of specific radionuclides are provided to the vendor laboratory. The vendor laboratory measures and reports the concentration of specified radionuclides. The known values are then compared to the vendor results. Results consistently outside established acceptance criteria indicate a need to check instruments or procedures. Regulatory Guide 4.15 specifically requires that contractor laboratories that performed environmental measurement participate in the EPA's Environmental Radioactivity Laboratory Inter-Comparison Studies Program, or an equivalent program.

The EPA's program is no longer funded or offered. The reason that the EPA program was referenced in the regulatory guide is that the EPA standards were traceable to National Bureau of Standards (now known as National Institute Standard Technology). In response to this problem, the vendor lab incorporated a program offered by Environmental Resource Associates (ERA Company), which covered the same analyses in the same matrix at the same frequency as the EPA program. The ERA Company has received NIST accreditation as an equivalent program. In addition to comparison cross checks performed with the ERA Company, the vendor laboratory routinely monitors the quality of their analyses by:

- Analyzing "spiked" samples (samples with a specific quantity of radioactive material present in them) and
- Participating in the Department of Energy's Mixed Analyte Performance Program (MAPEP).

See Appendix A, for the vendor Inter-Laboratory Cross-Check Comparison Program Results.

### LAND USE CENSUS

#### Introduction

Each year a Land Use Census is conducted to identify the locations of the nearest milking animal, garden (of greater than 500 square feet), and residence in each of the meteorological sectors that is over land. Information gathered during the Land Use Census is used for off-site dose assessment and to update sampling locations for the REMP. The census is conducted by traveling all roads within a five-mile radius of the plant site and recording and mapping the locations of the nearest resident, milk animal, and vegetable garden. The Land Use Census was conducted in August, 2017. The census identified the garden, residence and milking animal locations identified in Table 17 and Table 18 and depicted in Figure 9. Note that the W, WNW, NW, NNW, N, and NNE sectors extend over Lake Erie and are not included in the survey.

## 2017 ANNUAL ENVIRONMENTAL AND EFFLUENT RELEASE REPORT

### Discussions and Results

In general, the predominant land use within the census area continues to be rural/agricultural. In recent years, however, it has been noted that tracts of land once used for farming are now being developed as mini-industrial parks and residential housing. This is reflected in the loss of available milking animals within a five kilometer radius of PNPP to support the REMP.

There were no changes to the REMP sampling locations compared to the 2016 Land Use Census. Refer to Figure 3, 4 and 5 for the map identification.

Table 17 identifies the nearest residences, by sector, to the PNPP. There were no changes from the 2016 Land Use Census. Refer to Figure 9 for map identification.

**Table 17: Nearest Residence, By Sector**

Sector	Location Address	Miles from PNPP	Map Locator Number
NE	4384 Lockwood	0.7	1
ENE	4602 Lockwood	1.1	2
E	2626 Antioch	1.0	3
ESE	2836 Antioch	1.1	4
SE	4495 North Ridge	1.3	5
SSE	3119 Parmly	0.9	6
S	3121 Center	0.9	7
SSW	3850 Clark	0.9	8
SW	2997 Perry Park	1.2	9
WSW	3460 Parmly	1.0	10

## 2017 ANNUAL ENVIRONMENTAL AND EFFLUENT RELEASE REPORT

Table 18 lists the nearest gardens by sector to the PNPP consisting of at least 500 square feet. There are four changes to garden locations from the 2016 Land Use Census, which include those located in the northeast, east-northeast, east, and south-southwest sectors. These new locations were documented by confirming that the previous location either no longer exists or a closer location within the sector has more recently become available. Refer to Figure 9 for map identification.

**Table 18: Nearest Garden, By Sector**

<b>Sector</b>	<b>Location Address</b>	<b>Miles from PNPP</b>	<b>Map Locator Number</b>
NE	2348 W. Hemlock	0.9	11
ENE	2452 Antioch	1.1	12
E	2634 Antioch	1.1	3
ESE	2836 Antioch	1.1	4
SE	4671 North Ridge	1.3	15
SSE	4225 Red Mill Valley	1.1	16
S	3121 Center Rd.	0.9	7
SSW	3300 Ohio St.	2.3	17
SW	3021 Perry Park	1.3	13
WSW	3460 Parnly	1.0	14

2017 ANNUAL ENVIRONMENTAL AND EFFLUENT RELEASE REPORT

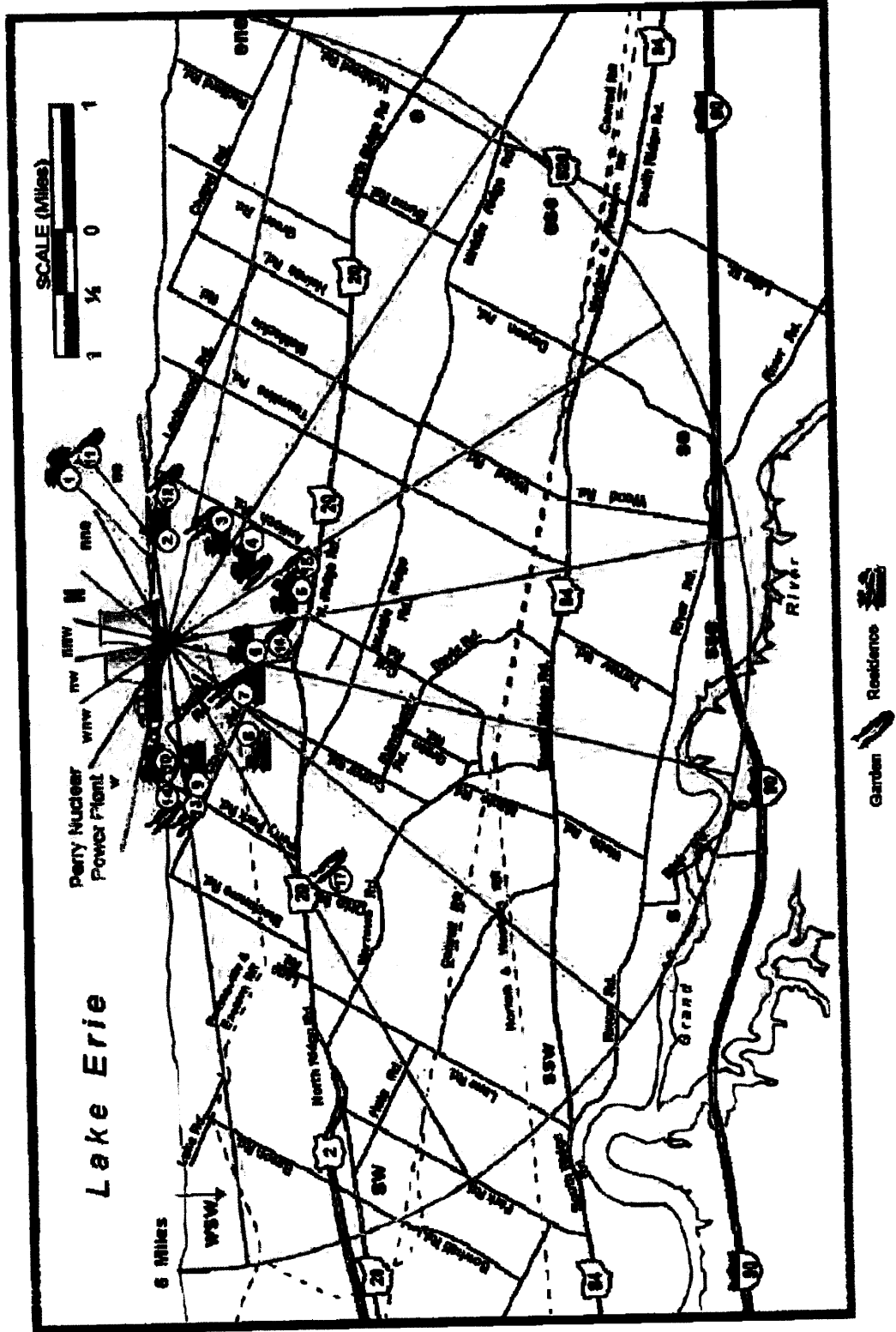

Figure 9: Land Use Census Map

## 2017 ANNUAL ENVIRONMENTAL AND EFFLUENT RELEASE REPORT

### CLAM/MUSSEL MONITORING

#### INTRODUCTION

Sampling for macro-invertebrates (clams and mussels) has been conducted in Lake Erie in the vicinity of PNPP since 1971. The clam/mussel program currently focuses on two species: *Corbicula fluminea* (Asiatic clam) and *Dreissena polymorpha* (zebra mussel).

#### CORBICULA PROGRAM

Monitoring for *Corbicula* was initiated in response to an NRC bulletin and concerns of the Atomic Safety and Licensing Board. The monitoring was done as part of the Environmental Protection Plan (Operating License, Appendix B). The program consists of visually inspecting the raw water systems, when they are opened for maintenance. The purpose of this program is to detect *Corbicula*, should it appear at PNPP.

#### Monitoring

Samples were collected from raw water systems and examined for shells and fragments. In addition to sample collections, plant components that use raw water are inspected when opened for maintenance or repair. Sample collection/inspection dates are listed in Table 19.

**Table 19: Corbicula Monitoring**

Date	Sample Location
01/25/2017	LP Condenser "C" Outlet Waterbox
01/27/2017	HP Condenser "C"
02/24/2017	P54 – Fire Protection
03/15/2017	ESW Strainer
06/09/2017	P54 – Fire Protection
07/01/2017	N34 – Turbine Lube Oil Cooler "B"
07/08/2017	N34 – Turbine Lube Oil Cooler "A"
07/31/2017	P45 – ESW "A" Discharge Strainer
08/11/2017	N34 – Turbine Lube Oil Cooler "B"
08/11/2017	N34 – Turbine Lube Oil Cooler "A"
08/11/2017	N34 – Turbine Lube Oil Cooler "B"
08/18/2017	N34 – Turbine Lube Oil Cooler "A"
09/03/2017	N34 – Turbine Lube Oil Cooler "A"
10/09/2017	N34 – Turbine Lube Oil Cooler "B"
12/21/2017	P54 – Fire Protection

# 2017 ANNUAL ENVIRONMENTAL AND EFFLUENT RELEASE REPORT

## Conclusions

Although Corbicula have been detected at the Eastlake Power Plant, it has not been demonstrated that their presence has created any operational problems at PNPP. As in the past, the monitoring program did not identify Corbicula in any sample collected.

## DREISSENA PROGRAM

Dreissena, or zebra mussels, were first discovered at PNPP in September 1988. The initial collection of 19 mussels was made as part of the Corbicula monitoring program. The Dreissena monitoring program began in 1989 with monitoring and testing. The current control program was designed and implemented in 1990.

## Monitoring

In addition to visually inspecting the plant's raw water systems when they are opened for maintenance or repair, monitoring methods include the use of commercial divers and side-stream monitors. Commercial divers monitor mussel infestation during the inspection of forebays, basins, and the intake and discharge structures. Divers have also been used to take underwater videos of the water basins and intake tunnel. Side-stream monitors are flow-through containers that receive water diverted from plant systems and are set up at two in-plant locations during the mussel season.

## Treatment

Chemicals used for mussel control included sodium hypochlorite and a commercial molluscicide. The chlorine is intermittently injected into the plant service water, emergency service water, and circulating water systems by metering sodium hypochlorite into each system's influent. Sodium bisulfite is added at the plant discharge structure for dechlorination prior to return into Lake Erie.

The OEPA has approved the use of a commercial molluscicide. The chemical selected for use at the PNPP was alkyl-dimethyl-benzyl-ammonium chloride. Treatment was applied once in 2017. The active ingredients were detoxified by adsorption using bentonite clay prior to discharge into Lake Erie.

## Results

The effectiveness of the intermittent biocide treatment has been determined in several ways. First, visual inspections of raw water system components are conducted when systems are open during maintenance or repair. In addition, settlement monitors were inspected for new settlement. No live settlement has been found in any plant component to date.

The effectiveness of the application of the commercial molluscicide was measured by observing mortality of mussels placed in a flow-through container installed in plant service water and subjected to the chemical treatment. The observed mortality rate utilizing the flow-through container was 100%. To date, PNPP has had no significant problems related to zebra mussels.



## 2017 ANNUAL ENVIRONMENTAL AND EFFLUENT RELEASE REPORT

### Conclusions

PNPP has taken the approach that the best method for avoiding problems with zebra mussels is preventive treatment of plant water systems. The current program of monitoring and chemical treatment will be continued to minimize the possibility that PNPP will experience future problems due to zebra mussels.

### HERBICIDE APPLICATIONS

Herbicides are used sparingly on the PNPP site. A request must be made to and approved by the PNPP Chemistry Unit prior to spraying to ensure that only approved chemicals are used, and only in approved areas. Each application was in compliance with the OEPA rules and regulations. There were no adverse environmental impacts observed during weekly site environmental inspections as a result of these applications. The herbicides used were Mojave, Glyphosate, Clipper Herbicide, and Round-Up. For each application, the type of weed to be treated dictated the herbicide and concentration to be used. Table 20 provides quantity for each chemical used. The quantity represents the amount of herbicide applied, prior to any dilution.

**Table 20: Herbicide Applications**

Chemical	Amount
Mojave	175 lb.
Glyphosate	520 gal.
Clipper Herbicide	1 gal.
Round-Up	110 oz.

## **2017 ANNUAL ENVIRONMENTAL AND EFFLUENT RELEASE REPORT**

### **SPECIAL REPORTS**

#### **NPDES PERMIT EXCEEDANCES**

The OEPA issues the National Pollutant Discharge Elimination System (NPDES) permit. It establishes monitoring requirements and limits for discharges from the PNPP. It also specifies the locations from which the plant is allowed to discharge.

There were no NPDES issues identified at PNPP in 2017.

#### **ENVIRONMENTAL PROTECTION PLAN**

The Environmental Protection Plan (EPP), which is Appendix B of the PNPP Operating License, requires a non-radiological environmental monitoring and reporting program be established at the PNPP.

There were no non-compliance reports submitted in 2017.

#### **ENVIRONMENTAL IMPACT EVALUATIONS**

All proposed changes to the PNPP design or operation, as well as tests or experiments, must be evaluated for potential environmental impacts in accordance with the EPP and administrative quality assurance procedures. There were no proposed changes to the facility or programs that if performed could have resulted in an adverse environmental impact in 2017.

**2017 ANNUAL ENVIRONMENTAL AND EFFLUENT RELEASE REPORT**

**Appendix A**  
**Inter-Laboratory Cross Check Comparison**  
**Program Results**



## APPENDIX A

### INTERLABORATORY COMPARISON PROGRAM RESULTS AND INTRALABORATORY COMPARISON PROGRAM RESULTS

**NOTE:** Appendix A is updated four times a year. The complete appendix is included in March, June, September and December monthly progress reports only.

January, 2017 through December, 2017

## Appendix A

### Interlaboratory/ Intralaboratory Comparison Program Results

Environmental, Inc., Midwest Laboratory has participated in Interlaboratory comparison (crosscheck) programs since the formulation of its quality control program in December 1971. These programs are operated by agencies which supply environmental type samples containing concentrations of radionuclides known to the issuing agency but not to participant laboratories. The purpose of such a program is to provide an independent check on a laboratory's analytical procedures and to alert it of any possible problems.

Participant laboratories measure the concentration of specified radionuclides and report them to the issuing agency. Several months later, the agency reports the known values to the participant laboratories and specifies control limits. Results consistently higher or lower than the known values or outside the control limits indicate a need to check the instruments or procedures used.

Results in Table A-1 were obtained through participation in the RAD PT Study Proficiency Testing Program administered by Environmental Resources Associates, serving as a replacement for studies conducted previously by the U.S. EPA Environmental Monitoring Systems Laboratory, Las Vegas, Nevada.

Table A-2 lists results for thermoluminescent dosimeters (TLDs), via irradiation and evaluation by the University of Wisconsin-Madison Radiation Calibration Laboratory at the University of Wisconsin Medical Radiation Research Center.

Table A-3 lists results of the analyses on in-house "spiked" samples for the past twelve months. All samples are prepared using NIST traceable sources. Data for previous years available upon request.

Table A-4 lists results of the analyses on in-house "blank" samples for the past twelve months. Data for previous years available upon request.

Table A-5 lists analytical results from the in-house "duplicate" program for the past twelve months. Acceptance is based on the difference of the results being less than the sum of the errors. Complete analytical data for duplicate analyses is available upon request.

The results in Table A-6 were obtained through participation in the Mixed Analyte Performance Evaluation Program.

Results in Table A-7 were obtained through participation in the MRAD PT Study Proficiency Testing Program administered by Environmental Resources Associates, serving as a replacement for studies conducted previously by the Environmental Measurement Laboratory Quality Assessment Program (EML).

Attachment A lists the laboratory precision at the 1 sigma level for various analyses. The acceptance criteria in Table A-3 is set at  $\pm 2$  sigma.

Out-of-limit results are explained directly below the result.

**Attachment A**

**ACCEPTANCE CRITERIA FOR "SPIKED" SAMPLES**

**LABORATORY PRECISION: ONE STANDARD DEVIATION VALUES FOR VARIOUS ANALYSES<sup>a</sup>**

<b>Analysis</b>	<b>Level</b>	<b>One standard deviation for single determination</b>
<b>Gamma Emitters</b>	<b>5 to 100 pCi/liter or kg &gt; 100 pCi/liter or kg</b>	<b>5.0 pCi/liter 10% of known value</b>
<b>Strontium-89<sup>b</sup></b>	<b>5 to 50 pCi/liter or kg &gt; 50 pCi/liter or kg</b>	<b>5.0 pCi/liter 10% of known value</b>
<b>Strontium-90<sup>b</sup></b>	<b>2 to 30 pCi/liter or kg &gt; 30 pCi/liter or kg</b>	<b>5.0 pCi/liter 10% of known value</b>
<b>Potassium-40</b>	<b>≥ 0.1 g/liter or kg</b>	<b>10% of known value</b>
<b>Gross alpha</b>	<b>≤ 20 pCi/liter &gt; 20 pCi/liter</b>	<b>5.0 pCi/liter 25% of known value</b>
<b>Gross beta</b>	<b>≤ 100 pCi/liter &gt; 100 pCi/liter</b>	<b>5.0 pCi/liter 10% of known value</b>
<b>Tritium</b>	<b>≤ 4,000 pCi/liter &gt; 4,000 pCi/liter</b>	<b>± 1σ = 169.85 x (known)<sup>0.0933</sup> 10% of known value</b>
<b>Radium-226,-228</b>	<b>≥ 0.1 pCi/liter</b>	<b>15% of known value</b>
<b>Plutonium</b>	<b>≥ 0.1 pCi/liter, gram, or sample</b>	<b>10% of known value</b>
<b>Iodine-131, Iodine-129<sup>b</sup></b>	<b>≤ 55 pCi/liter &gt; 55 pCi/liter</b>	<b>6 pCi/liter 10% of known value</b>
<b>Uranium-238, Nickel-63<sup>b</sup> Technetium-99<sup>b</sup></b>	<b>≤ 35 pCi/liter &gt; 35 pCi/liter</b>	<b>6 pCi/liter 15% of known value</b>
<b>Iron-55<sup>b</sup></b>	<b>50 to 100 pCi/liter &gt; 100 pCi/liter</b>	<b>10 pCi/liter 10% of known value</b>
<b>Other Analyses<sup>b</sup></b>	<b>—</b>	<b>20% of known value</b>

<sup>a</sup> From EPA publication, "Environmental Radioactivity Laboratory Intercomparison Studies Program", Fiscal Year, 1981-1982, EPA-800/4-81-004.

<sup>b</sup> Laboratory limit.

TABLE A-1. Interlaboratory Comparison Crosscheck program, Environmental Resource Associates (ERA)<sup>a</sup>.  
RAD study

Lab Code	Date	Analysis	Concentration (pCi/L)			Acceptance
			Laboratory Result	ERA Result	Control Limits	
ERW-95	1/9/2017	Sr-89	51.9 ± 4.6	55.5	44.3 - 63.2	Pass
ERW-95	1/9/2017	Sr-90	43.6 ± 2.4	43.1	31.8 - 49.5	Pass
ERW-97	1/9/2017	Ba-133	78.2 ± 4.1	85.6	72.0 - 94.2	Pass
ERW-97	1/9/2017	Cs-134	53.9 ± 3.8	52.6	42.4 - 57.9	Pass
ERW-97	1/9/2017	Cs-137	122 ± 6	112	101 - 126	Pass
ERW-97	1/9/2017	Co-60	117 ± 4	113	102 - 126	Pass
ERW-97	1/9/2017	Zn-65	208 ± 13	189	170 - 222	Pass
ERW-99	1/9/2017	Gr. Alpha	48.9 ± 2.4	52.3	27.3 - 65.5	Pass
ERW-99	1/9/2017	Gr. Beta	37.1 ± 1.3	41.6	27.7 - 49.0	Pass
ERW-101	1/9/2017	I-131	22.3 ± 0.6	24.3	20.2 - 28.8	Pass
ERW-103	1/9/2017	Ra-226	11.3 ± 0.4	12.7	9.5 - 14.7	Pass
ERW-103	1/9/2017	Ra-228	6.10 ± 0.90	6.20	3.8 - 8.1	Pass
ERW-103	1/9/2017	Uranium	11.8 ± 0.8	12.6	9.9 - 14.4	Pass
ERW-106	1/9/2017	H-3	12,600 ± 300	12,500	10,900 - 13,800	Pass
ERW-3344	7/10/2017	Sr-89	29.0 ± 10.0	26.4	18.4 - 32.9	Pass
ERW-3344	7/10/2017	Sr-90	33.8 ± 3.3	36.0	26.4 - 41.5	Pass
ERW-3346	7/10/2017	Ba-133	66.4 ± 4.1	66.3	55.2 - 72.9	Pass
ERW-3346	7/10/2017	Cs-134	27.0 ± 4.3	24.4	18.7 - 27.2	Pass
ERW-3346	7/10/2017	Cs-137	57.4 ± 4.5	51.6	46.4 - 59.6	Pass
ERW-3346	7/10/2017	Co-60	92.6 ± 4.4	88.6	79.7 - 99.8	Pass
ERW-3346	7/10/2017	Zn-65	32.4 ± 6.0	32.7	27.3 - 41.6	Pass
ERW-3348	7/10/2017	Gr. Alpha	23.7 ± 1.9	25.7	13.0 - 34.1	Pass
ERW-3348	7/10/2017	Gr. Beta	54.6 ± 1.6	63.0	43.5 - 69.6	Pass
ERW-3350	7/10/2017	I-131	25.4 ± 1.3	25.5	21.2 - 30.1	Pass
ERW-3352	7/10/2017	Ra-226	1.38 ± 0.15	1.29	1.07 - 1.95	Pass
ERW-3352	7/10/2017	Ra-228	6.70 ± 0.93	5.66	3.45 - 7.47	Pass
ERW-3352	7/10/2017	Uranium	58.4 ± 0.9	66.7	54.3 - 73.9	Pass
ERW-3354	7/10/2017	H-3	5,254 ± 224	5,060	4,340 - 5,570	Pass

<sup>a</sup> Results obtained by Environmental, Inc., Midwest Laboratory as a participant in the crosscheck program for proficiency testing in drinking water conducted by Environmental Resources Associates (ERA).

TABLE A-2. Thermoluminescent Dosimetry, (TLD, CaSO<sub>4</sub>: Dy Cards). <sup>a</sup>

Lab Code	Irradiation Date	Description	mrem		Performance <sup>c</sup> Quotient (P)	
			Delivered Dose	Reported <sup>b</sup> Dose		
<u>Environmental, Inc.</u>		Group 1				
2017-1	10/16/2017	Spike 1	59.0	49.3	-0.16	
2017-1	10/16/2017	Spike 2	59.0	53.2	-0.10	
2017-1	10/16/2017	Spike 3	59.0	52.7	-0.11	
2017-1	10/16/2017	Spike 4	59.0	53.4	-0.09	
2017-1	10/16/2017	Spike 5	59.0	51.8	-0.12	
2017-1	10/16/2017	Spike 6	59.0	54.0	-0.08	
2017-1	10/16/2017	Spike 7	59.0	52.0	-0.12	
2017-1	10/16/2017	Spike 8	59.0	52.6	-0.11	
2017-1	10/16/2017	Spike 9	59.0	54.6	-0.07	
2017-1	10/16/2017	Spike 10	59.0	50.4	-0.15	
2017-1	10/16/2017	Spike 11	59.0	53.9	-0.09	
2017-1	10/16/2017	Spike 12	59.0	55.7	-0.06	
2017-1	10/16/2017	Spike 13	59.0	50.2	-0.15	
2017-1	10/16/2017	Spike 14	59.0	52.4	-0.11	
2017-1	10/16/2017	Spike 15	59.0	54.3	-0.08	
2017-1	10/16/2017	Spike 16	59.0	53.2	-0.10	
2017-1	10/16/2017	Spike 17	59.0	50.1	-0.15	
2017-1	10/16/2017	Spike 18	59.0	52.3	-0.11	
2017-1	10/16/2017	Spike 19	59.0	50.3	-0.15	
2017-1	10/16/2017	Spike 20	59.0	50.7	-0.14	
2017-1	10/16/2017	Spike 21	59.0	53.1	-0.10	
2017-1	10/16/2017	Spike 22	59.0	51.5	-0.13	
2017-1	10/16/2017	Spike 23	59.0	54.4	-0.08	
2017-1	10/16/2017	Spike 24	59.0	53.3	-0.10	
2017-1	10/16/2017	Spike 25	59.0	53.7	-0.09	
2017-1	10/16/2017	Spike 26	59.0	51.6	-0.13	
2017-1	10/16/2017	Spike 27	59.0	51.5	-0.13	
2017-1	10/16/2017	Spike 28	59.0	51.6	-0.13	
2017-1	10/16/2017	Spike 29	59.0	49.9	-0.15	
2017-1	10/16/2017	Spike 30	59.0	55.3	-0.06	
Mean (Spike 1-30)				52.4	-0.11	Pass <sup>d</sup>
Standard Deviation (Spike 1-30)				1.7	0.03	Pass <sup>d</sup>

a TLD's were irradiated by the University of Wisconsin-Madison Radiation Calibration Laboratory following ANSI N13.37 protocol from a known air kerma rate. TLD's were read and the results were submitted by Environmental Inc. to the University of Wisconsin-Madison Radiation Calibration Laboratory for comparison to the delivered dose.

b Reported dose was converted from exposure (R) to Air Kerma (cGy) using a conversion of 0.876. Conversion from air kerma to ambient dose equivalent for Cs-137 at the reference dose point  $H^*(10)K_a = 1.20$ .  $mrem/cGy = 1000$ .

c Performance Quotient (P) is calculated as  $((\text{reported dose} - \text{conventionally true value}) / \text{conventionally true value})$  where the conventionally true value is the delivered dose.

d Acceptance is achieved when neither the absolute value of mean of the P values, nor the standard deviation of the P values exceed 0.15.



TABLE A-2. Thermoluminescent Dosimetry, (TLD, CaSO<sub>4</sub>: Dy Cards). <sup>a</sup>

Lab Code	Irradiation Date	Description	mrem		Performance <sup>c</sup> Quotient (P)	
			Delivered Dose	Reported <sup>b</sup> Dose		
<u>Environmental, Inc.</u>		Group 2				
2017-2	10/16/2017	Spike 31	186.0	184.7	-0.11	
2017-2	10/16/2017	Spike 32	186.0	172.0	-0.08	
2017-2	10/16/2017	Spike 33	186.0	167.3	-0.10	
2017-2	10/16/2017	Spike 34	186.0	160.6	-0.14	
2017-2	10/16/2017	Spike 35	186.0	171.7	-0.08	
2017-2	10/16/2017	Spike 36	186.0	177.0	-0.05	
2017-2	10/16/2017	Spike 37	186.0	176.7	-0.05	
2017-2	10/16/2017	Spike 38	186.0	165.5	-0.11	
2017-2	10/16/2017	Spike 39	186.0	174.6	-0.06	
2017-2	10/16/2017	Spike 40	186.0	172.7	-0.07	
2017-2	10/16/2017	Spike 41	186.0	167.8	-0.10	
2017-2	10/16/2017	Spike 42	186.0	161.0	-0.13	
2017-2	10/16/2017	Spike 43	186.0	166.3	-0.11	
2017-2	10/16/2017	Spike 44	186.0	172.4	-0.07	
2017-2	10/16/2017	Spike 45	186.0	173.0	-0.07	
2017-2	10/16/2017	Spike 46	186.0	169.5	-0.09	
2017-2	10/16/2017	Spike 47	186.0	169.0	-0.09	
2017-2	10/16/2017	Spike 48	186.0	166.9	-0.10	
2017-2	10/16/2017	Spike 49	186.0	165.9	-0.11	
2017-2	10/16/2017	Spike 50	186.0	166.7	-0.10	
2017-2	10/16/2017	Spike 51	186.0	161.1	-0.13	
2017-2	10/16/2017	Spike 52	186.0	173.4	-0.07	
2017-2	10/16/2017	Spike 53	186.0	173.1	-0.07	
2017-2	10/16/2017	Spike 54	186.0	160.0	-0.14	
2017-2	10/16/2017	Spike 55	186.0	166.1	-0.11	
2017-2	10/16/2017	Spike 56	186.0	164.5	-0.12	
2017-2	10/16/2017	Spike 57	186.0	163.8	-0.12	
2017-2	10/16/2017	Spike 58	186.0	159.9	-0.14	
2017-2	10/16/2017	Spike 59	186.0	165.6	-0.11	
2017-2	10/16/2017	Spike 60	186.0	165.0	-0.11	
Mean (Spike 31-60)				167.8	-0.10	Pass <sup>d</sup>
Standard Deviation (Spike 31-60)				5.0	0.03	Pass <sup>d</sup>

a TLD's were irradiated by the University of Wisconsin-Madison Radiation Calibration Laboratory following ANSI N13.37 protocol from a known air kerma rate. TLD's were read and the results were submitted by Environmental Inc. to the University of Wisconsin-Madison Radiation Calibration Laboratory for comparison to the delivered dose.

b Reported dose was converted from exposure (R) to Air Kerma (cGy) using a conversion of 0.876. Conversion from air kerma to ambient dose equivalent for Cs-137 at the reference dose point  $H^*(10)K_a = 1.20$  mrem/cGy = 1000.

c Performance Quotient (P) is calculated as  $((\text{reported dose} - \text{conventionally true value}) / \text{conventionally true value})$  where the conventionally true value is the delivered dose.

d Acceptance is achieved when neither the absolute value of mean of the P values, nor the standard deviation of the P values exceed 0.15.

TABLE A-3. In-House "Spiked" Samples

Lab Code <sup>b</sup>	Date	Analysis	Concentration <sup>a</sup>			Acceptance
			Laboratory results 2s, n=1 <sup>c</sup>	Known Activity	Control Limits <sup>d</sup>	
W-010417	4/29/2016	Cs-134	38.2 ± 8.1	36.2	29.0 - 43.4	Pass
W-010417	4/29/2016	Cs-137	78.0 ± 8.8	71.9	57.5 - 86.3	Pass
SPW-306	1/4/2017	Ra-226	18.1 ± 0.4	16.7	13.4 - 20.1	Pass
SPW-32	1/6/2017	H-3	17,849 ± 393	17,243	10,346 - 24,140	Pass
SPW-46	1/9/2017	Gr. Alpha	20.0 ± 0.4	20.1	16.1 - 24.1	Pass
SPW-46	1/9/2017	Gr. Beta	29.0 ± 0.3	28.9	23.1 - 34.6	Pass
SPW-92	1/11/2017	H-3	18,095 ± 397	17,243	10,346 - 24,140	Pass
SPW-142	1/12/2017	Sr-90	39.4 ± 2.3	36.6	29.3 - 43.9	Pass
SPW-155	1/19/2017	H-3	17,974 ± 400	17,243	10,346 - 24,140	Pass
SPW-186	1/23/2017	H-3	17,383 ± 366	17,243	10,346 - 24,140	Pass
SPW-232	1/19/2017	H-3	17,542 ± 366	17,243	10,346 - 24,140	Pass
SPW-304	1/26/2017	H-3	17,782 ± 400	17,243	10,346 - 24,140	Pass
SPW-333	1/30/2017	H-3	17,910 ± 406	17,243	10,346 - 24,140	Pass
W-020217	4/29/2016	Cs-134	33.7 ± 6.1	36.2	29.0 - 43.4	Pass
W-020217	4/29/2016	Cs-137	78.4 ± 7.3	71.9	57.5 - 86.3	Pass
SPW-412	2/6/2017	Sr-90	36.2 ± 2.4	36.6	29.3 - 43.9	Pass
SPW-465	2/8/2017	H-3	17,573 ± 396	17,243	10,346 - 24,140	Pass
SPW-561	2/15/2017	H-3	17,358 ± 395	17,243	10,346 - 24,140	Pass
SPW-605	2/16/2017	H-3	17,820 ± 401	17,243	10,346 - 24,140	Pass
SPW-657	2/17/2017	H-3	17,614 ± 376	17,243	10,346 - 24,140	Pass
SPW-714	2/23/2017	H-3	17,662 ± 400	17,243	10,346 - 24,140	Pass
SPW-737	2/28/2017	H-3	17,196 ± 395	17,243	10,346 - 24,140	Pass
SPAP-740	2/28/2017	Gr. Beta	38.9 ± 0.1	41.5	33.2 - 49.8	Pass
SPAP-742	2/24/2017	Cs-134	1.05 ± 0.60	0.98	0.78 - 1.18	Pass
SPAP-742	2/24/2017	Cs-137	90.4 ± 2.5	92.9	74.3 - 111.5	Pass
SPW-746	2/28/2017	Sr-90	42.8 ± 2.5	36.6	29.3 - 43.9	Pass
SPW-748	2/28/2017	C-14	4270 ± 17	4735	3788 - 5682	Pass
SPW-750	2/28/2017	Ni-63	463 ± 4	400	240 - 560	Pass
SPF-752	2/28/2017	Cs-134	1033 ± 38	1090	870 - 1300	Pass
SPF-752	2/28/2017	Cs-137	3071 ± 61	2820	2250 - 3380	Pass
SPW-781	3/1/2017	Ra-226	18.1 ± 0.4	16.7	13.4 - 20.1	Pass
SPW-783	3/1/2017	H-3	17,653 ± 400	17,243	13,794 - 20,692	Pass
W-030517	4/29/2016	Cs-134	38.0 ± 9.0	36.2	29.0 - 43.4	Pass
W-030517	4/29/2016	Cs-137	80.9 ± 9.2	71.9	57.5 - 86.3	Pass
SPW-1010	3/14/2017	H-3	17,312 ± 395	17,243	13,794 - 20,692	Pass
SPW-1026	3/16/2017	Gr. Alpha	22.4 ± 0.5	20.1	12.0 - 28.1	Pass
SPW-1026	3/16/2017	Gr. Beta	29.2 ± 0.3	28.9	17.3 - 40.4	Pass
SPW-1092	3/21/2017	H-3	17,252 ± 390	17,243	13,794 - 20,692	Pass
SPW-1151	3/24/2017	H-3	17,009 ± 388	17,243	13,794 - 20,692	Pass
SPW-1163	3/28/2017	Sr-90	39.0 ± 2.3	36.3	29.0 - 43.5	Pass
SPW-1178	3/29/2017	Ra-228	15.1 ± 1.9	16.0	9.6 - 22.4	Pass

TABLE A-3. In-House "Spiked" Samples

Lab Code <sup>b</sup>	Date	Analysis	Concentration <sup>a</sup>			Acceptance
			Laboratory results 2s, n=1 <sup>c</sup>	Known Activity	Control Limits <sup>d</sup>	
SPW-1232	3/30/2017	H-3	17,150 ± 390	17,243	13,794 - 20,692	Pass
SPW-1246	3/31/2017	I-131(G)	33.0 ± 7.3	36.6	29.3 - 43.9	Pass
SPW-1246	3/31/2017	Cs-134	28.9 ± 4.6	26.6	21.3 - 31.9	Pass
SPW-1246	3/31/2017	Cs-137	80.6 ± 8.2	70.4	56.3 - 84.5	Pass
SPMI-1248	3/31/2017	I-131(G)	39.8 ± 7.0	36.6	29.3 - 43.9	Pass
SPMI-1248	3/31/2017	Cs-134	26.9 ± 5.9	26.6	21.3 - 31.9	Pass
SPMI-1248	3/31/2017	Cs-137	70.4 ± 6.9	70.4	56.3 - 84.5	Pass
SPMI-1248	3/31/2017	I-131	36.2 ± 0.6	36.6	29.3 - 43.9	Pass
SPW-1295	3/31/2017	Ra-226	17.9 ± 0.4	16.7	13.4 - 20.1	Pass
SPW-1304	4/4/2017	H-3	17,741 ± 398	17,243	13,794 - 20,692	Pass
SPW-1359	4/5/2017	I-131	44.3 ± 0.5	47.6	38.1 - 57.1	Pass
SPW-1378	4/7/2017	H-3	17,528 ± 395	17,243	13,794 - 20,692	Pass
SPW-1391	4/7/2017	Gr. Alpha	21.1 ± 0.4	20.1	12.0 - 28.1	Pass
SPW-1391	4/7/2017	Gr. Beta	27.8 ± 0.3	28.2	17.3 - 40.4	Pass
SPW-1480	4/12/2017	H-3	17,399 ± 392	17,243	13,794 - 20,692	Pass
W-041317	4/29/2016	Cs-134	34.6 ± 5.6	36.2	29.0 - 43.4	Pass
W-041317	4/29/2016	Cs-137	81.9 ± 8.0	71.9	57.5 - 86.3	Pass
SPW-1480	4/12/2017	H-3	17,399 ± 392	17,243	13,794 - 20,692	Pass
SPW-1575	4/18/2017	H-3	17,419 ± 393	17,243	13,794 - 20,692	Pass
SPW-1626	4/20/2017	Sr-90	37.2 ± 2.4	36.3	29.0 - 43.5	Pass
SPW-1658	4/21/2017	H-3	17,194 ± 391	17,243	13,794 - 20,692	Pass
SPW-1776	4/26/2017	H-3	16,609 ± 386	17,243	13,794 - 20,692	Pass
SPW-1806	4/27/2017	H-3	17,203 ± 390	17,243	13,794 - 20,692	Pass
SPW-1937	5/3/2017	H-3	16,690 ± 385	17,243	13,794 - 20,692	Pass
SPW-1971	5/5/2017	Sr-90	41.5 ± 2.2	36.3	29.0 - 43.5	Pass
SPW-2033	5/8/2017	H-3	16,780 ± 386	17,243	13,794 - 20,692	Pass
SPW-2420	5/9/2017	Ra-226	16.3 ± 0.5	16.7	13.4 - 20.1	Pass
W-051517	4/29/2016	Cs-134	36.3 ± 5.0	36.2	29.0 - 43.4	Pass
W-051517	4/29/2016	Cs-137	68.9 ± 6.6	71.9	57.5 - 86.3	Pass
SPW-2284	5/22/2017	H-3	16,935 ± 389	16,703	13,362 - 20,043	Pass
SPW-2354	5/23/2017	H-3	17,006 ± 390	16,700	13,360 - 20,040	Pass
SPW-2891	5/23/2017	Ra-226	17.5 ± 0.4	16.7	13.4 - 20.1	Pass
SPW-2418	5/23/2017	Ra-228	14.0 ± 1.8	16.0	11.2 - 20.8	Pass
SPW-2439	5/25/2017	Ra-228	13.0 ± 1.8	16.0	11.2 - 20.8	Pass
SPMI-2378	5/24/2017	Sr-89	83.7 ± 4.9	98.4	78.7 - 118.1	Pass
SPMI-2378	5/24/2017	Sr-90	39.5 ± 1.5	36.1	26.9 - 43.4	Pass
SPW-2468	5/26/2017	H-3	17,065 ± 391	16,692	13,354 - 20,031	Pass
SPW-2848	5/28/2017	I-131	56.4 ± 0.6	58.3	46.6 - 70.0	Pass
SPW-2502	6/1/2017	H-3	17,596 ± 396	16,677	13,342 - 20,012	Pass
SPW-2659	6/5/2017	H-3	17,027 ± 390	16,677	13,342 - 20,012	Pass
SPW-2790	6/9/2017	H-3	17,101 ± 392	17,101	13,325 - 19,988	Pass

TABLE A-3. In-House "Spiked" Samples

Lab Code <sup>b</sup>	Date	Analysis	Concentration <sup>a</sup>			Acceptance
			Laboratory results 2s, n=1 <sup>c</sup>	Known Activity	Control Limits <sup>d</sup>	
SPW-2798	6/12/2017	H-3	16,683 ± 364	16,649	13,319 - 19,978	Pass
SPW-2943	6/19/2017	Sr-90	39.2 ± 2.3	36.1	28.9 - 43.4	Pass
SPW-3509	6/15/2017	Ra-226	17.6 ± 0.5	16.7	13.4 - 20.1	Pass
W-061317	4/29/2016	Cs-134	35.0 ± 6.2	36.2	29.0 - 43.4	Pass
W-061317	4/29/2016	Cs-137	77.4 ± 7.8	71.9	57.5 - 86.3	Pass
SPW-3041	6/23/2017	H-3	16,419 ± 378	16,620	13,296 - 19,945	Pass
SPW-3511	6/23/2017	Ra-226	15.5 ± 0.6	16.7	13.4 - 20.1	Pass
SPW-3103	6/28/2017	H-3	16,507 ± 380	16,507	13,286 - 19,929	Pass
SPW-3117	6/29/2017	Tc-99	112.7 ± 1.9	107.8	86.2 - 129.4	Pass
SPW-3513	6/29/2017	Ra-226	17.8 ± 0.5	16.7	13.4 - 20.1	Pass
SPW-3188	7/3/2017	Sr-90	38.1 ± 2.2	36.1	28.9 - 43.4	Pass
SPW-3283	7/11/2017	H-3	16,057 ± 347	16,649	13,319 - 19,978	Pass
SPW-4054	7/11/2017	Ra-226	17.7 ± 0.4	16.0	11.2 - 20.8	Pass
SPW-3467	7/14/2017	Gr. Alpha	22.3 ± 0.5	20.1	12.0 - 28.1	Pass
SPW-3467	7/14/2017	Gr. Beta	29.1 ± 0.3	28.2	17.3 - 40.4	Pass
SPW-3449	7/15/2017	H-3	17,196 ± 393	16,507	13,286 - 19,929	Pass
SPW-3548	7/19/2017	H-3	16,764 ± 386	16,507	13,286 - 19,929	Pass
SPW-3728	7/24/2017	H-3	16,117 ± 354	16,507	13,286 - 19,929	Pass
SPW-3794	7/28/2017	H-3	16,645 ± 384	16,507	13,286 - 19,929	Pass
W-072817	4/29/2016	Cs-134	36.6 ± 5.6	36.2	29.0 - 43.4	Pass
W-072817	4/29/2016	Cs-137	76.5 ± 7.6	71.9	57.5 - 86.3	Pass
SPW-3905	8/3/2017	Gr. Alpha	22.3 ± 0.5	20.1	12.0 - 28.1	Pass
SPW-3905	8/3/2017	Gr. Beta	27.6 ± 0.3	28.2	17.3 - 40.4	Pass
SPW-4030	8/9/2017	H-3	17,636 ± 403	16,507	13,286 - 19,929	Pass
SPW-4086	8/14/2017	H-3	17,472 ± 401	16,507	13,286 - 19,929	Pass
SPW-4207	8/17/2017	H-3	17,013 ± 393	16,507	13,286 - 19,929	Pass
W-083017	4/29/2016	Cs-134	34.7 ± 6.4	36.2	29.0 - 43.4	Pass
W-083017	4/29/2016	Cs-137	78.2 ± 6.7	71.9	57.5 - 86.3	Pass
SPW-4241	8/19/2017	H-3	17,222 ± 371	16,507	13,286 - 19,929	Pass
SPW-4458	9/1/2017	Ra-226	14.1 ± 1.8	16.7	13.4 - 20.1	Pass
SPW-4466	9/6/2017	Sr-89	22.8 ± 8.5	26.4	21.1 - 31.7	Pass
SPW-4466	9/6/2017	Sr-90	32.5 ± 2.1	33.8	27.0 - 40.6	Pass
SPW-4512	9/8/2017	Gr. Alpha	19.2 ± 0.4	20.1	10.1 - 30.2	Pass
SPW-4512	9/8/2017	Gr. Beta	27.8 ± 0.3	27.9	22.3 - 33.5	Pass
SPW-4586	9/9/2017	H-3	16,586 ± 362	16,507	13,286 - 19,929	Pass
SPW-4720	9/16/2017	H-3	16,439 ± 362	16,507	13,286 - 19,929	Pass
SPW-4834	9/22/2017	H-3	16,238 ± 378	16,507	13,286 - 19,929	Pass
SPW-4935	9/27/2017	H-3	16,595 ± 361	16,507	13,286 - 19,929	Pass
SPW-4937	9/27/2017	Ra-226	5.7 ± 0.9	5.8	4.1 - 7.5	Pass
W-092717	4/29/2016	Cs-134	36.0 ± 5.9	36.2	29.0 - 43.4	Pass
W-092717	4/29/2016	Cs-137	82.6 ± 8.5	71.9	57.5 - 86.3	Pass
SPW-5001	9/29/2017	H-3	16,446 ± 358	16,507	13,286 - 19,929	Pass

TABLE A-3. In-House "Spiked" Samples

Lab Code <sup>b</sup>	Date	Analysis	Concentration <sup>a</sup>			Acceptance
			Laboratory results 2s, n=1 <sup>c</sup>	Known Activity	Control Limits <sup>d</sup>	
SPW-5134	10/6/2017	H-3	16,128 ± 373	16,507	13,286 - 19,929	Pass
SPW-5274	10/12/2017	H-3	16,108 ± 374	16,507	13,286 - 19,929	Pass
W-101217S	10/12/2017	Fe-55	1,491 ± 77	1,482	1,186 - 01,778	Pass
SPW-5408	10/18/2017	Ni-63	203 ± 3	199	159 - 238	Pass
SPW-5430	10/19/2017	H-3	16,453 ± 380	16,507	13,286 - 19,929	Pass
W-102017	4/29/2016	Cs-134	31.3 ± 4.9	36.2	29.0 - 43.4	Pass
W-102017	4/29/2016	Cs-137	80.4 ± 6.9	71.9	57.5 - 86.3	Pass
SPW-5674	10/25/2017	H-3	16,313 ± 380	16,507	13,286 - 19,929	Pass
SPW-5719	10/27/2017	H-3	16,113 ± 360	16,507	13,286 - 19,929	Pass
SPW-5730	10/31/2017	H-3	16,776 ± 387	16,507	13,286 - 19,929	Pass
SPW-5944	10/27/2017	Ra-226	16.4 ± 0.5	16.7	13.4 - 20.1	Pass
SPW-5915	11/9/2017	H-3	16,930 ± 390	16,507	13,286 - 19,929	Pass
SPW-5989	11/11/2017	H-3	16,084 ± 352	16,507	13,286 - 19,929	Pass
W-111417	4/29/2016	Cs-134	38.1 ± 6.2	36.2	29.0 - 43.4	Pass
W-111417	4/29/2016	Cs-137	74.0 ± 7.5	71.9	57.5 - 86.3	Pass
SPW-6121	11/16/2017	H-3	16,276 ± 378	16,507	13,286 - 19,929	Pass
SPW-6132	11/20/2017	H-3	15,897 ± 374	16,507	13,286 - 19,929	Pass
SPW-6249	11/30/2017	Ra-226	12.2 ± 0.4	12.3	9.8 - 14.8	Pass
SPW-6226	12/1/2017	H-3	16,164 ± 378	16,507	13,286 - 19,929	Pass
SPW-6318	12/7/2017	H-3	15,779 ± 372	16,507	13,286 - 19,929	Pass
W-120817	4/29/2016	Cs-134	29.5 ± 5.6	36.2	29.0 - 43.4	Pass
W-120817	4/29/2016	Cs-137	78.8 ± 9.8	71.9	57.5 - 86.3	Pass
SPW-65	12/11/2017	Ra-226	12.5 ± 0.4	12.3	9.8 - 14.8	Pass
SPW-6437	12/13/2017	Gr. Alpha	19.6 ± 0.4	20.1	10.1 - 30.2	Pass
SPW-6437	12/13/2017	Gr. Beta	28.2 ± 0.3	27.9	22.3 - 33.5	Pass
SPW-6463	12/15/2017	H-3	15,560 ± 372	16,507	13,286 - 19,929	Pass

<sup>a</sup> Liquid sample results are reported in pCi/Liter, air filters (pCi/m<sup>3</sup>), charcoal (pCi/charcoal canister), and solid samples (pCi/kg).

<sup>b</sup> Laboratory codes : W (Water), Ml (milk), AP (air filter), SO (soil), VE (vegetation), CH (charcoal canister), F (fish), U (urine).

<sup>c</sup> Results are based on single determinations.

<sup>d</sup> Control limits are established from the precision values listed in Attachment A of this report, adjusted to ± 2s.

NOTE: For fish, gelatin is used for the spike matrix. For vegetation, cabbage is used for the spike matrix.

TABLE A-4. In-House "Blank" Samples

Lab Code	Sample Type	Date	Analysis <sup>b</sup>	Concentration <sup>a</sup>		Acceptance Criteria (4.66 $\sigma$ )
				Laboratory results (4.66 $\sigma$ )		
				LLD	Activity <sup>c</sup>	
SPW-31	Water	1/6/2017	H-3	143	71 $\pm$ 75	200
SPW-45	Water	1/9/2017	Gr. Alpha	0.41	0.09 $\pm$ 0.30	2
SPW-45	Water	1/9/2017	Gr. Beta	0.74	-0.56 $\pm$ 0.50	4
SPW-91	Water	1/11/2017	H-3	151	-23 $\pm$ 71	200
SPW-141	Water	1/12/2017	Sr-89	0.55	0.29 $\pm$ 0.47	5
SPW-141	Water	1/12/2017	Sr-90	0.67	-0.02 $\pm$ 0.31	1
SPW-154	Water	1/19/2017	H-3	155	-17 $\pm$ 73	200
SPW-185	Water	1/23/2017	H-3	176	44 $\pm$ 94	200
SPW-231	Water	1/19/2017	H-3	179	26 $\pm$ 87	200
SPW-303	Water	1/26/2017	H-3	160	8 $\pm$ 77	200
SPW-305	Water	1/4/2017	Ra-226	0.02	0.02 $\pm$ 0.01	2
SPW-307	Water	1/27/2017	I-131	0.21	0.01 $\pm$ 0.11	1.00
SPW-332	Water	1/30/2017	H-3	169	-52 $\pm$ 86	200
SPW-352	Water	2/2/2017	U-234	0.14	0.00 $\pm$ 0.08	1
SPW-352	Water	2/2/2017	U-238	0.14	0.12 $\pm$ 0.15	1
SPW-411	Water	2/6/2017	Sr-89	0.49	0.30 $\pm$ 0.35	5
SPW-411	Water	2/6/2017	Sr-90	0.52	-0.22 $\pm$ 0.21	1
SPW-464	Water	2/8/2017	H-3	155	2 $\pm$ 74	200
SPW-560	Water	2/15/2017	H-3	156	38 $\pm$ 77	200
SPW-604	Water	2/16/2017	H-3	154	59 $\pm$ 77	200
SPW-656	Water	2/17/2017	H-3	187	28 $\pm$ 94	200
SPW-713	Water	2/23/2017	H-3	161	20 $\pm$ 81	200
SPW-736	Water	2/28/2017	H-3	161	-75 $\pm$ 76	200
SPAP-739	AP	2/28/2017	Gr. Beta	0.002	0.004 $\pm$ 0.001	0.01
SPAP-741	AP	2/24/2017	Cs-134	2.27	-0.95 $\pm$ 1.29	100
SPAP-741	AP	2/24/2017	Cs-137	2.65	0.17 $\pm$ 1.67	100
SPW-747	Water	2/28/2017	C-14	161	-28 $\pm$ 97	200
SPW-749	Water	2/28/2017	Ni-63	17	-3 $\pm$ 10	200
SPF-751	Fish	2/28/2017	Cs-134	0.008	0.002 $\pm$ 0.004	100
SPF-751	Fish	2/28/2017	Cs-137	0.008	0.000 $\pm$ 0.005	100
SPW-780	Water	3/1/2017	Ra-226	0.02	0.02 $\pm$ 0.01	2
SPW-782	Water	3/1/2017	H-3	154	35 $\pm$ 78	200
SPW-3506	Water	3/1/2017	Ra-226	0.03	0.02 $\pm$ 0.02	2
SPW-838	Water	3/3/2017	I-131	0.38	0.04 $\pm$ 0.18	1
SPW-1009	Water	3/14/2017	H-3	154	-31 $\pm$ 72	200
SPW-1025	Water	3/16/2017	Gr. Alpha	0.43	-0.16 $\pm$ 0.28	2
SPW-1025	Water	3/16/2017	Gr. Beta	0.75	-0.24 $\pm$ 0.52	4
SPW-1091	Water	3/21/2017	H-3	145	80 $\pm$ 73	200
SPW-1150	Water	3/24/2017	H-3	152	-31 $\pm$ 71	200
SPW-1162	Water	3/28/2017	Sr-89	0.61	-0.39 $\pm$ 0.45	5
SPW-1162	Water	3/28/2017	Sr-90	0.52	0.18 $\pm$ 0.27	1

<sup>a</sup> Liquid sample results are reported in pCi/Liter, air filters (pCi/m<sup>3</sup>), charcoal (pCi/charcoal canister), and solid samples (pCi/g).

<sup>b</sup> I-131(G); iodine-131 as analyzed by gamma spectroscopy.

<sup>c</sup> Activity reported is a net activity result.

TABLE A-4. In-House "Blank" Samples

Lab Code	Sample Type	Date	Analysis <sup>b</sup>	Concentration <sup>a</sup>		Acceptance Criteria (4.66 $\sigma$ )
				Laboratory results (4.66 $\sigma$ )		
				LLD	Activity <sup>c</sup>	
SPW-1177	Water	3/29/2017	Ra-228	0.83	-0.14 ± 0.36	2
SPW-1231	Water	3/30/2017	H-3	150	24 ± 73	200
SPW-1245	Water	3/31/2017	Cs-134	3.73	0.43 ± 2.18	100
SPW-1245	Water	3/31/2017	Cs-137	3.01	-1.23 ± 2.12	100
SPW-1245	Water	3/31/2017	I-131(G)	5.39	0.92 ± 2.15	100
SPW-1245	Water	3/31/2017	I-131	0.32	0.03 ± 0.18	1
SPMI-1247	Milk	3/31/2017	Cs-134	3.70	1.23 ± 1.96	100
SPMI-1247	Milk	3/31/2017	Cs-137	3.62	-0.84 ± 2.15	100
SPMI-1247	Milk	3/31/2017	I-131(G)	4.42	0.39 ± 2.14	100
SPW-1294	Water	3/31/2017	Ra-226	0.02	0.18 ± 0.02	2
SPW-1303	Water	4/4/2017	H-3	151	8 ± 75	200
SPW-1377	Water	4/7/2017	H-3	150	29 ± 72	200
SPW-1390	Water	4/7/2017	Gr. Alpha	0.42	0.15 ± 0.31	2
SPW-1390	Water	4/7/2017	Gr. Beta	0.73	-0.17 ± 0.51	4
SPW-1479	Water	4/12/2017	H-3	151	89 ± 77	200
SPW-1574	Water	4/18/2017	H-3	144	55 ± 79	200
SPW-1625	Water	4/20/2017	Sr-89	0.59	-0.01 ± 0.50	5
SPW-1625	Water	4/20/2017	Sr-90	0.71	0.16 ± 0.35	1
SPW-1657	Water	4/21/2017	H-3	147	34 ± 73	200
SPW-1775	Water	4/26/2017	H-3	155	67 ± 80	200
SPW-1805	Water	4/27/2017	H-3	153	15 ± 74	200
SPW-1936	Water	5/3/2017	H-3	148	33 ± 71	200
SPW-1970	Water	5/5/2017	Sr-89	0.66	0.34 ± 0.54	5
SPW-1970	Water	5/5/2017	Sr-90	0.62	-0.08 ± 0.28	1
SPW-2032	Water	5/8/2017	H-3	147	66 ± 73	200
SPW-2419	Water	5/9/2017	Ra-226	0.03	0.01 ± 0.03	2
SPW-2283	Water	5/22/2017	H-3	155	24 ± 78	200
SPW-2353	Water	5/23/2017	H-3	151	56 ± 76	200
SPW-2890	Water	5/23/2017	Ra-226	0.03	-0.01 ± 0.02	2
SPMI-2377	Milk	5/24/2017	Sr-89	0.78	0.86 ± 0.93	5
SPMI-2377	Milk	5/24/2017	Sr-90	0.49	0.95 ± 0.33	1
SPW-2438	Water	5/25/2017	Ra-228	0.90	-0.28 ± 0.38	2
SPW-2467	Water	5/26/2017	H-3	152	27 ± 77	200
SPW-2417	Water	5/26/2017	Ra-228	0.80	1.58 ± 0.54	2
SPW-2447	Water	5/26/2017	I-131	0.21	-0.05 ± 0.12	1
SPW-2501	Water	6/1/2017	H-3	151	-23 ± 70	200
SPW-2658	Water	6/5/2017	H-3	152	107 ± 78	200
SPW-2789	Water	6/9/2017	H-3	150	52 ± 77	200
SPW-2797	Water	6/12/2017	H-3	177	7 ± 93	200
SPW-2847	Water	6/14/2017	I-131	0.18	0.03 ± 0.10	1

<sup>a</sup> Liquid sample results are reported in pCi/Liter, air filters (pCi/m<sup>3</sup>), charcoal (pCi/charcoal canister), and solid samples (pCi/g).

<sup>b</sup> I-131(G); iodine-131 as analyzed by gamma spectroscopy.

<sup>c</sup> Activity reported is a net activity result.

TABLE A-4. In-House "Blank" Samples

Lab Code	Sample Type	Date	Analysis <sup>b</sup>	Concentration <sup>a</sup>		Acceptance Criteria (4.66 $\sigma$ )
				Laboratory results (4.66 $\sigma$ )		
				LLD	Activity <sup>c</sup>	
SPW-3508	Water	8/15/2017	Ra-226	0.03	0.00 ± 0.02	2
SPW-2942	Water	8/19/2017	Sr-89	0.58	0.80 ± 0.53	5
SPW-2942	Water	8/19/2017	Sr-90	0.50	0.15 ± 0.25	1
SPW-3042	Water	8/23/2017	H-3	146	25 ± 74	200
SPW-3510	Water	8/23/2017	Ra-226	0.02	0.03 ± 0.02	2
SPW-3102	Water	8/28/2017	H-3	148	-7 ± 73	200
SPW-3116	Water	8/29/2017	Tc-99	5.91	-0.39 ± 3.58	10
SPW-3512	Water	8/29/2017	Ra-226	0.02	-0.01 ± 0.02	2
SPW-3187	Water	7/3/2017	Sr-89	0.62	0.00 ± 0.48	5
SPW-3187	Water	7/3/2017	Sr-90	0.48	0.07 ± 0.23	1
SPW-3282	Water	7/11/2017	H-3	178	-37 ± 84	200
SPW-4063	Water	7/11/2017	Ra-226	0.03	0.02 ± 0.02	2
SPW-3486	Water	7/14/2017	Gr. Alpha	0.42	-0.09 ± 0.28	2
SPW-3486	Water	7/14/2017	Gr. Beta	0.76	-0.18 ± 0.53	4
SPW-3448	Water	7/15/2017	H-3	150	54 ± 77	200
SPW-3727	Water	7/27/2017	Ni-63	90	18 ± 55	200
SPW-3793	Water	7/28/2017	H-3	151	47 ± 82	200
SPW-3904	Water	8/3/2017	Gr. Alpha	0.47	-0.02 ± 0.33	2
SPW-3904	Water	8/3/2017	Gr. Beta	0.75	-0.11 ± 0.52	4
SPW-4029	Water	8/9/2017	H-3	159	11 ± 79	200
SPW-4206	Water	8/17/2017	H-3	157	55 ± 76	200
SPW-4241	Water	8/19/2017	H-3	190	61 ± 96	200
SPW-4085	Water	8/14/2017	H-3	159	-28 ± 77	200
SPW-4206	Water	8/17/2017	H-3	157	55 ± 76	200
SPW-4241	Water	8/19/2017	H-3	190	61 ± 96	200
SPW-4457	Water	9/1/2017	Ra-228	0.78	-0.02 ± 0.36	2
SPW-4485	Water	9/8/2017	Sr-89	0.51	0.30 ± 0.37	5
SPW-4485	Water	9/8/2017	Sr-90	0.46	-0.09 ± 0.20	1
SPW-4585	Water	9/9/2017	H-3	187	-86 ± 83	200
SPW-5720	Water	9/13/2017	Ra-226	0.02	0.13 ± 0.02	2
SPW-4703	Water	9/15/2017	I-131	0.17	0.10 ± 0.10	1
SPW-4719	Water	9/16/2017	H-3	184	-86 ± 93	200
SPW-4833	Water	9/22/2017	H-3	160	5 ± 72	200
SPW-4833	Water	9/22/2017	H-3	148	5 ± 70	200
SPW-4934	Water	9/27/2017	H-3	148	5 ± 70	200
SPW-4936	Water	9/27/2017	Ra-228	0.80	0.55 ± 0.44	2
SPW-5000	Water	9/29/2017	H-3	183	-13 ± 90	200
SPW-5133	Water	10/6/2017	H-3	144	64 ± 71	200
SPW-5273	Water	10/12/2017	H-3	142	106 ± 72	200

<sup>a</sup> Liquid sample results are reported in pCi/Liter, air filters (pCi/m<sup>3</sup>), charcoal (pCi/charcoal canister), and solid samples (pCi/g).

<sup>b</sup> I-131(G); Iodine-131 as analyzed by gamma spectroscopy.

<sup>c</sup> Activity reported is a net activity result.



TABLE A-4. In-House "Blank" Samples

Lab Code	Sample Type	Date	Analysis <sup>b</sup>	Concentration <sup>a</sup>		
				Laboratory results (4.66σ)		Acceptance Criteria (4.66 σ)
				LLD	Activity <sup>c</sup>	
SPW-5407	Water	10/18/2017	Ni-63	69	43 ± 43	200
SPW-5429	Water	10/19/2017	H-3	148	54 ± 72	200
SPW-5603	Water	10/23/2017	Sr-89	0.57	0.16 ± 0.47	5
SPW-5603	Water	10/23/2017	Sr-90	0.70	-0.12 ± 0.31	1
SPW-5673	Water	10/25/2017	H-3	156	-36 ± 71	200
SPW-5718	Water	10/27/2017	H-3	182	45 ± 92	200
SPW-5943	Water	10/27/2017	Ra-226	0.02	0.08 ± 0.02	2
SPW-5723	Water	10/30/2017	I-131	0.10	0.03 ± 0.07	1
SPW-5914	Water	11/09/17	H-3	149	-39 ± 68	200
SPW-5988	Water	11/11/2017	H-3	183	-8 ± 88	200
SPW-6120	Water	11/16/2017	H-3	146	83 ± 75	200
SPW-6131	Water	11/20/2017	H-3	151	16 ± 72	200
SPW-6197	Water	11/29/2017	I-131	0.38	0.01 ± 0.18	1
SPW-6248	Water	11/30/2017	Ra-226	0.03	0.15 ± 0.03	2
SPW-6225	Water	12/1/2017	H-3	154	-10 ± 72	200
SPW-6317	Water	12/7/2017	H-3	148	44 ± 74	200
SPW-64	Water	12/11/2017	Ra-226	0.03	0.18 ± 0.03	2
SPW-6436	Water	12/13/2017	Gr. Alpha	0.54	-0.17 ± 0.37	2
SPW-6436	Water	12/13/2017	Gr. Beta	0.74	0.12 ± 0.52	4
SPW-6464	Water	12/15/2017	H-3	148	31 ± 75	200

<sup>a</sup> Liquid sample results are reported in pCi/Liter, air filters ( pCi/m<sup>3</sup>), charcoal (pCi/charcoal canister), and solid samples (pCi/g).

<sup>b</sup> I-131(G); Iodine-131 as analyzed by gamma spectroscopy.

<sup>c</sup> Activity reported is a net activity result.

TABLE A-5. In-House "Duplicate" Samples

Lab Code	Date	Analysis	Concentration <sup>a</sup>		Averaged Result	Acceptance
			First Result	Second Result		
AP-7178,7179	1/3/2017	Be-7	0.047 ± 0.015	0.062 ± 0.017	0.054 ± 0.012	Pass
SW-6986,6987	1/3/2017	Gr. Beta	1.39 ± 0.41	0.77 ± 0.41	1.08 ± 0.29	Pass
E-66,67	1/3/2017	Gr. Beta	1.62 ± 0.05	1.45 ± 0.04	1.54 ± 0.11	Pass
E-66,67	1/3/2017	K-40	1.26 ± 0.14	1.39 ± 0.16	1.32 ± 0.11	Pass
CF-87,88	1/3/2017	Be-7	0.25 ± 0.11	0.30 ± 0.12	0.28 ± 0.08	Pass
CF-87,88	1/3/2017	K-40	7.77 ± 0.39	8.84 ± 0.37	7.31 ± 0.27	Pass
AP-011217	1/12/2017	Be-7	0.137 ± 0.078	0.139 ± 0.082	0.138 ± 0.056	Pass
MI-212,213	1/16/2017	K-40	1,515 ± 98	1,347 ± 107	1,431 ± 73	Pass
WW-321,322	1/19/2017	H-3	675 ± 118	506 ± 133	590 ± 89	Pass
WW-674,675	1/20/2017	H-3	7,326 ± 254	7,717 ± 259	7,522 ± 181	Pass
AP-012317	1/23/2017	Gr. Beta	0.034 ± 0.005	0.038 ± 0.005	0.036 ± 0.004	Pass
WW-298,299	1/24/2017	H-3	5,916 ± 239	5764 ± 237	5840 ± 168	Pass
AP-013117	1/30/2017	Gr. Beta	0.027 ± 0.004	0.028 ± 0.004	0.028 ± 0.003	Pass
WW-500,501	1/31/2017	H-3	1,058 ± 122	1,054 ± 121	1,056 ± 86	Pass
SW-391,392	1/31/2017	Gr. Beta	1.40 ± 0.56	1.62 ± 0.61	1.51 ± 0.41	Pass
SPS-370,371	2/1/2017	K-40	23.47 ± 0.66	23.11 ± 0.72	23.29 ± 0.49	Pass
AP-456,457	2/2/2017	Be-7	0.129 ± 0.076	0.167 ± 0.092	0.148 ± 0.060	Pass
AP-020217	2/2/2017	Gr. Beta	0.021 ± 0.004	0.027 ± 0.004	0.024 ± 0.003	Pass
SPS-414,415	2/3/2017	K-40	19.45 ± 1.85	21.58 ± 1.99	20.52 ± 1.36	Pass
AP-020617	2/6/2017	Gr. Beta	0.023 ± 0.004	0.023 ± 0.004	0.023 ± 0.003	Pass
AP-021417A	2/14/2017	Gr. Beta	0.031 ± 0.004	0.030 ± 0.004	0.030 ± 0.003	Pass
SPW-543	2/14/2017	Gr. Beta	7.99 ± 0.82	9.45 ± 0.88	8.72 ± 0.60	Pass
AP-021417B	2/14/2017	Gr. Beta	0.024 ± 0.004	0.028 ± 0.004	0.026 ± 0.003	Pass
WW-718,719	2/14/2017	H-3	737 ± 113	643 ± 110	690 ± 79	Pass
AP-022017	2/20/2017	Gr. Beta	0.018 ± 0.005	0.021 ± 0.005	0.020 ± 0.004	Pass
WW-755,756	2/22/2017	H-3	3,709 ± 196	3,823 ± 198	3,766 ± 139	Pass
AP-022717	2/27/2017	Gr. Beta	0.021 ± 0.004	0.019 ± 0.004	0.020 ± 0.003	Pass
SPDW-80011,2	3/2/2017	Ra-226	7.29 ± 0.32	6.76 ± 0.30	7.03 ± 0.22	Pass
SPDW-80011,2	3/2/2017	Ra-228	4.68 ± 0.82	6.29 ± 1.03	5.49 ± 0.66	Pass
SPDW-80013,4	3/2/2017	Gr. Alpha	13.57 ± 1.43	12.44 ± 1.37	13.01 ± 0.99	Pass
WW-845,846	3/2/2017	H-3	314 ± 93	249 ± 90	281 ± 65	Pass
AP-030617	3/6/2017	Gr. Beta	0.022 ± 0.004	0.019 ± 0.004	0.020 ± 0.003	Pass
WW-1050,1051	3/8/2017	H-3	14,994 ± 364	14,745 ± 362	14,870 ± 257	Pass
SPS-920,921	3/9/2017	K-40	23.30 ± 1.76	23.13 ± 1.64	23.21 ± 1.20	Pass
WW-1004,1005	3/13/2017	H-3	182 ± 80	158 ± 79	170 ± 56	Pass
SPS-1029,1030	3/15/2017	K-40	11.82 ± 0.68	12.01 ± 0.68	11.92 ± 0.46	Pass
AP-031517	3/15/2017	Gr. Beta	0.020 ± 0.003	0.020 ± 0.003	0.020 ± 0.002	Pass
SPDW-80037,8	3/20/2017	Gr. Alpha	4.54 ± 0.82	5.29 ± 0.91	4.91 ± 0.61	Pass
AP-032017	3/20/2017	Gr. Beta	0.021 ± 0.005	0.021 ± 0.005	0.021 ± 0.005	Pass
WW-1094,1095	3/20/2017	H-3	1,571 ± 137	1,595 ± 138	1,583 ± 175	Pass

TABLE A-5. In-House "Duplicate" Samples

Lab Code	Date	Analysis	Concentration <sup>a</sup>		Averaged Result	Acceptance
			First Result	Second Result		
WW-1175,1176	3/20/2017	H-3	218 ± 84	211 ± 84	214 ± 59	Pass
WW-1129,1130	3/21/2017	Gr. Beta	3.51 ± 1.24	2.99 ± 1.17	3.25 ± 0.85	Pass
WW-1219,1220	3/22/2017	H-3	11,467 ± 322	11,516 ± 323	11,492 ± 200	Pass
SPS-1152,1153	3/27/2017	Ac-228	20.39 ± 0.75	20.43 ± 0.88	20.41 ± 0.58	Pass
SPS-1152,1153	3/27/2017	Pb-214	17.22 ± 0.50	16.44 ± 0.52	16.83 ± 0.36	Pass
SPDW-80047,8	3/28/2017	Ra-226	2.06 ± 0.23	1.80 ± 0.32	1.83 ± 0.20	Pass
SPDW-80047,8	3/28/2017	Ra-228	0.53 ± 0.48	0.78 ± 0.49	0.66 ± 0.34	Pass
SWU-1242,1243	3/28/2017	Gr. Beta	2.04 ± 0.81	2.47 ± 0.89	2.26 ± 0.53	Pass
SPS-1188,1189	3/29/2017	K-40	18.95 ± 1.85	18.33 ± 1.71	17.84 ± 1.28	Pass
SPDW-80060,1	3/29/2017	Gr. Alpha	3.19 ± 0.80	3.39 ± 0.78	3.29 ± 0.56	Pass
SPDW-80050,1	3/29/2017	Gr. Beta	1.58 ± 0.80	2.08 ± 0.83	1.83 ± 0.44	Pass
AP-1706,1707	3/30/2017	Be-7	0.068 ± 0.018	0.072 ± 0.017	0.070 ± 0.012	Pass
SW-1381,1382	4/5/2017	H-3	402 ± 92	309 ± 88	356 ± 64	Pass
WW-1446,1447	4/6/2017	H-3	305 ± 89	358 ± 91	332 ± 64	Pass
WW-1532,1533	4/10/2017	H-3	19,124 ± 412	18,991 ± 410	19,058 ± 291	Pass
WW-1618,1619	4/12/2017	H-3	4,187 ± 203	4,305 ± 205	4,248 ± 144	Pass
SS-1553,1554	4/13/2017	Gr. Beta	7.16 ± 0.99	6.09 ± 0.91	6.63 ± 0.67	Pass
SS-1553,1554	4/13/2017	K-40	4.60 ± 0.32	4.84 ± 0.34	4.72 ± 0.23	Pass
SS-1553,1554	4/13/2017	Tl-208	0.038 ± 0.016	0.032 ± 0.011	0.035 ± 0.010	Pass
SS-1553,1554	4/13/2017	Pb-212	0.101 ± 0.015	0.098 ± 0.015	0.098 ± 0.010	Pass
SS-1553,1554	4/13/2017	Bi-214	0.094 ± 0.032	0.109 ± 0.022	0.101 ± 0.019	Pass
SS-1553,1554	4/13/2017	Ac-228	0.089 ± 0.042	0.111 ± 0.046	0.100 ± 0.031	Pass
P-2015,2016	5/4/2017	H-3	189 ± 80	212 ± 81	200 ± 57	Pass
WW-2336,2337	5/8/2017	H-3	422 ± 97	298 ± 91	360 ± 66	Pass
AP-051117	5/11/2017	Gr. Beta	0.018 ± 0.003	0.025 ± 0.004	0.021 ± 0.002	Pass
WW-2497,2498	5/23/2017	H-3	1,288 ± 127	1,247 ± 126	1,257 ± 89	Pass
WW-2583,2584	5/23/2017	H-3	5,159 ± 224	5,223 ± 126	5,191 ± 129	Pass
WW-2732,2733	5/23/2017	H-3	8,559 ± 282	8,570 ± 283	8,564 ± 200	Pass
XW-1218,1219	5/23/2017	H-3	11,487 ± 282	11,516 ± 283	11,492 ± 200	Pass
MI-2428,2429	5/24/2017	K-40	1,762 ± 137	1,805 ± 132	1,778 ± 95	Pass
SO-2562,2563	5/24/2017	K-40	7.87 ± 0.50	8.64 ± 0.49	8.25 ± 0.36	Pass
WW-3023,3024	5/24/2017	H-3	27,388 ± 488	27,733 ± 489	27,565 ± 344	Pass
SO-2453,2454	5/25/2017	Gr. Beta	14.38 ± 0.93	15.70 ± 1.08	15.04 ± 0.70	Pass
SO-2453,2454	5/25/2017	Ca-137	0.17 ± 0.03	0.18 ± 0.03	0.17 ± 0.02	Pass
SO-2453,2454	5/25/2017	K-40	9.80 ± 0.50	9.19 ± 0.57	9.50 ± 0.38	Pass
SO-2453,2454	5/25/2017	Tl-208	0.09 ± 0.02	0.10 ± 0.03	0.09 ± 0.02	Pass
SO-2453,2454	5/25/2017	Pb-212	0.29 ± 0.03	0.30 ± 0.03	0.29 ± 0.02	Pass
SO-2453,2454	5/25/2017	Bi-214	0.24 ± 0.03	0.18 ± 0.04	0.21 ± 0.03	Pass
SO-2453,2454	5/25/2017	Ra-226	0.82 ± 0.22	0.62 ± 0.27	0.72 ± 0.17	Pass
SO-2453,2454	5/25/2017	Ac-228	0.32 ± 0.07	0.28 ± 0.08	0.30 ± 0.05	Pass

TABLE A-5. In-House "Duplicate" Samples

Lab Code	Date	Analysis	Concentration *		Averaged Result	Acceptance
			First Result	Second Result		
SWT-2625,2626	5/30/2017	Gr. Beta	0.84 ± 0.53	1.08 ± 0.55	0.86 ± 0.38	Pass
AP-053117	5/31/2017	Gr. Beta	0.013 ± 0.003	0.011 ± 0.003	0.012 ± 0.002	Pass
G-2646,2647	6/1/2017	Be-7	1.02 ± 0.17	1.06 ± 0.26	1.04 ± 0.15	Pass
G-2646,2647	6/1/2017	K-40	7.51 ± 0.49	6.55 ± 0.51	7.03 ± 0.36	Pass
SL-2669,70	6/1/2017	Be-7	0.34 ± 0.06	0.30 ± 0.06	0.32 ± 0.04	Pass
SL-2669,70	6/1/2017	K-40	4.35 ± 0.14	4.39 ± 0.15	4.37 ± 0.10	Pass
F-2711,2712	6/2/2017	K-40	2.56 ± 0.32	2.77 ± 0.44	2.66 ± 0.27	Pass
AP-060617	6/6/2017	Gr. Beta	0.026 ± 0.005	0.027 ± 0.005	0.027 ± 0.004	Pass
SW-2849,50	6/8/2017	H-3	8,178 ± 273	8,563 ± 279	8,371 ± 195	Pass
AP-061217	6/12/2017	Gr. Beta	0.027 ± 0.005	0.027 ± 0.005	0.027 ± 0.004	Pass
BS-3446,3447	6/12/2017	K-40	8.30 ± 0.47	8.57 ± 0.47	8.44 ± 0.33	Pass
VE-2870,2871	6/13/2017	K-40	3.65 ± 0.25	3.90 ± 0.26	3.77 ± 0.18	Pass
AP-2914,5	6/15/2017	Be-7	0.269 ± 0.146	0.212 ± 0.123	0.240 ± 0.085	Pass
AP-3067,8	6/15/2017	Be-7	0.204 ± 0.113	0.328 ± 0.126	0.266 ± 0.085	Pass
AP-061917	6/19/2017	Gr. Beta	0.020 ± 0.004	0.019 ± 0.004	0.020 ± 0.003	Pass
AP-3610,1	6/26/2017	Be-7	0.107 ± 0.015	0.116 ± 0.021	0.111 ± 0.013	Pass
AP-062617	6/26/2017	Gr. Beta	0.017 ± 0.004	0.021 ± 0.004	0.019 ± 0.003	Pass
AP-3673,3674	7/3/2017	Be-7	0.087 ± 0.008	0.078 ± 0.008	0.083 ± 0.006	Pass
AP-3287,3288	7/6/2017	Be-7	0.207 ± 0.112	0.244 ± 0.096	0.226 ± 0.074	Pass
WW-3308,3309	7/7/2017	H-3	549 ± 108	501 ± 107	525 ± 76	Pass
VE-3362,3363	7/12/2017	K-40	2.32 ± 0.17	2.40 ± 0.16	2.36 ± 0.12	Pass
VE-3589,3590	7/18/2017	K-40	5.25 ± 0.33	4.64 ± 0.33	4.94 ± 0.23	Pass
SG-3631,3632	7/18/2017	Pb-214	3.03 ± 0.11	2.97 ± 0.11	3.00 ± 0.08	Pass
SG-3631,3632	7/18/2017	Ac-228	2.47 ± 0.22	2.56 ± 0.23	2.52 ± 0.16	Pass
WW-3846,3847	7/25/2017	H-3	505 ± 101	446 ± 98	475 ± 70	Pass
F-4509,4510	7/26/2017	K-40	0.85 ± 0.25	1.00 ± 0.25	0.93 ± 0.18	Pass
F-4509,4510	7/26/2017	Gr. Beta	1.19 ± 0.03	1.18 ± 0.03	1.18 ± 0.02	Pass
G-3804,3805	7/27/2017	Be-7	3.72 ± 0.39	3.47 ± 0.40	3.59 ± 0.28	Pass
G-3804,3805	7/27/2017	K-40	4.21 ± 0.52	4.46 ± 0.52	4.34 ± 0.33	Pass
SL-3888,3889	8/1/2017	Be-7	0.77 ± 0.04	0.73 ± 0.07	0.75 ± 0.04	Pass
SL-3888,3889	8/1/2017	K-40	0.94 ± 0.04	0.87 ± 0.08	0.90 ± 0.23	Pass
WW-4158,4159	8/8/2017	H-3	321 ± 90	270 ± 88	295 ± 63	Pass
VE-4179,4180	8/14/2017	K-40	1.84 ± 0.18	1.90 ± 0.21	1.87 ± 0.14	Pass
AP-4289,4290	8/17/2017	Be-7	0.212 ± 0.095	0.162 ± 0.080	0.187 ± 0.062	Pass
F-4333,4334	8/18/2017	K-40	3.22 ± 0.41	3.62 ± 0.42	3.42 ± 0.29	Pass
CF-4310,4311	8/21/2017	K-40	10.94 ± 0.74	11.48 ± 0.50	11.21 ± 0.45	Pass
DW-80161,80162	8/22/2017	Ra-226	1.22 ± 0.15	1.19 ± 0.17	1.21 ± 0.11	Pass
DW-80161,80162	8/22/2017	Ra-228	1.99 ± 0.63	0.70 ± 0.49	1.35 ± 0.40	Pass
VE-4398,4399	8/28/2017	Be-7	0.13 ± 0.07	0.13 ± 0.08	0.13 ± 0.05	Pass

TABLE A-5. In-House "Duplicate" Samples

Lab Code	Date	Analysis	Concentration <sup>a</sup>		Averaged Result	Acceptance
			First Result	Second Result		
VE-4398,4399	8/28/2017	K-40	3.32 ± 0.22	3.48 ± 0.25	3.40 ± 0.17	Pass
SW-4463,4464	8/29/2017	H-3	495 ± 106	491 ± 106	493 ± 75	Pass
LW-4486,4487	8/31/2017	Gr. Beta	0.425 ± 0.471	1.358 ± 0.571	0.892 ± 0.370	Pass
VE-4561,4562	9/6/2017	Be-7	5.89 ± 0.29	5.76 ± 0.25	5.83 ± 0.19	Pass
VE-4561,4562	9/6/2017	K-40	3.73 ± 0.34	3.77 ± 0.29	3.75 ± 0.22	Pass
BO-5122,5123	9/8/2017	K-40	4.50 ± 0.36	4.50 ± 0.36	4.50 ± 0.25	Pass
VE-4692,4693	9/12/2017	K-40	5.16 ± 0.13	5.31 ± 0.36	5.24 ± 0.19	Pass
SS-4650,4651	9/12/2017	K-40	10.65 ± 0.51	10.41 ± 0.54	10.48 ± 0.37	Pass
MI-4671,4672	9/13/2017	K-40	1,347 ± 115	1,283 ± 118	1,315 ± 82	Pass
MI-4671,4672	9/13/2017	Sr-90	0.7 ± 0.3	0.5 ± 0.3	0.6 ± 0.2	Pass
VE-4973,4974	9/17/2017	K-40	1.11 ± 0.15	1.17 ± 0.13	1.14 ± 0.10	Pass
F-4928,4929	9/19/2017	K-40	1.84 ± 0.31	1.68 ± 0.34	1.76 ± 0.23	Pass
S-4865,4866	9/20/2017	K-40	21.07 ± 2.39	19.09 ± 2.51	20.08 ± 1.73	Pass
VE-4907,4908	9/20/2017	K-40	3.83 ± 0.44	4.28 ± 0.31	4.05 ± 0.27	Pass
VE-4844,4845	9/21/2017	K-40	1.81 ± 0.22	1.88 ± 0.21	1.84 ± 0.15	Pass
AP-5572,5573	9/27/2017	Be-7	0.082 ± 0.015	0.075 ± 0.014	0.078 ± 0.010	Pass
LW-5145,5146	9/28/2017	Gr. Beta	0.84 ± 0.49	1.47 ± 0.57	1.16 ± 0.38	Pass
AP-092917	9/29/2017	Gr. Beta	0.038 ± 0.004	0.031 ± 0.004	0.035 ± 0.003	Pass
WW-5080,5081	10/2/2017	H-3	208 ± 79	223 ± 80	215 ± 56	Pass
AP-100217	10/2/2017	Gr. Beta	0.025 ± 0.005	0.028 ± 0.005	0.028 ± 0.003	Pass
AP-100317	10/3/2017	Gr. Beta	0.037 ± 0.004	0.033 ± 0.004	0.036 ± 0.003	Pass
S-5165,5166	10/4/2017	K-40	15.93 ± 2.30	20.34 ± 3.15	18.14 ± 1.95	Pass
VE-5228,5229	10/5/2017	K-40	3.25 ± 0.25	2.82 ± 0.24	3.04 ± 0.17	Pass
AP-100917	10/9/2017	Gr. Beta	0.021 ± 0.004	0.025 ± 0.004	0.023 ± 0.003	Pass
VE-5293,5294	10/10/2017	K-40	3.89 ± 0.30	4.08 ± 0.34	3.99 ± 0.22	Pass
DW-80184,80185	10/11/2017	Gr. Alpha	2.17 ± 0.81	2.50 ± 0.81	2.34 ± 0.57	Pass
DW-80184,80185	10/11/2017	Gr. Beta	9.45 ± 0.79	10.20 ± 0.83	9.83 ± 0.57	Pass
S-5421,5422	10/12/2017	K-40	8.82 ± 1.94	7.97 ± 0.72	8.40 ± 1.03	Pass
AP-101617	10/16/2017	Gr. Beta	0.025 ± 0.005	0.022 ± 0.004	0.024 ± 0.003	Pass
F-5658,5659	10/19/2017	K-40	2.44 ± 0.41	2.57 ± 0.39	2.51 ± 0.28	Pass
SO-5704,5705	10/25/2017	Cs-137	0.05 ± 0.02	0.04 ± 0.02	0.04 ± 0.01	Pass
SO-5704,5705	10/25/2017	K-40	10.08 ± 0.51	9.57 ± 0.56	9.83 ± 0.38	Pass
SO-5704,5705	10/25/2017	Tl-208	0.10 ± 0.02	0.09 ± 0.02	0.10 ± 0.01	Pass
SO-5704,5705	10/25/2017	Bi-214	0.34 ± 0.04	0.27 ± 0.04	0.30 ± 0.03	Pass
SO-5704,5705	10/25/2017	Pb-212	0.28 ± 0.03	0.27 ± 0.03	0.27 ± 0.02	Pass
SO-5704,5705	10/25/2017	Ra-226	1.15 ± 0.52	0.59 ± 0.22	0.87 ± 0.28	Pass
SO-5704,5705	10/25/2017	Ac-228	0.33 ± 0.05	0.31 ± 0.07	0.32 ± 0.04	Pass
SO-5704,5705	10/25/2017	Gr. Beta	18.34 ± 1.80	16.50 ± 1.03	17.42 ± 1.04	Pass
AP-5732,5733	10/26/2017	Be-7	0.139 ± 0.064	0.175 ± 0.075	0.157 ± 0.049	Pass

TABLE A-5. In-House "Duplicate" Samples

Lab Code	Date	Analysis	Concentration <sup>a</sup>		Averaged Result	Acceptance
			First Result	Second Result		
SW-5753,5754	10/31/2017	H-3	220 ± 83	279 ± 86	249 ± 80	Pass
SWU-5816,5817	10/31/2017	Gr. Beta	1.51 ± 1.00	2.02 ± 1.02	1.76 ± 0.71	Pass
AP-103117	10/31/2017	Gr. Beta	0.015 ± 0.004	0.014 ± 0.004	0.015 ± 0.003	Pass
SO-5923,5924	11/1/2017	Cs-137	0.30 ± 0.04	0.31 ± 0.04	0.31 ± 0.03	Pass
SO-5923,5924	11/1/2017	K-40	10.52 ± 0.81	10.56 ± 0.87	10.54 ± 0.45	Pass
AP-5858,5859	11/2/2017	Be-7	0.145 ± 0.075	0.148 ± 0.084	0.145 ± 0.066	Pass
AP-110717	11/7/2017	Be-7	0.028 ± 0.004	0.030 ± 0.004	0.028 ± 0.003	Pass
WW-6032,6033	11/7/2017	H-3	204 ± 86	298 ± 80	251 ± 59	Pass
WW-6074,6075	11/8/2017	H-3	72,247 ± 786	73,062 ± 791	72,655 ± 558	Pass
BS-6053,6054	11/13/2017	K-40	7.99 ± 0.82	9.20 ± 0.88	8.60 ± 0.48	Pass
BS-6053,6054	11/13/2017	Cs-137	0.07 ± 0.03	0.08 ± 0.03	0.07 ± 0.02	Pass
DW-80211,80212	11/14/2017	Gr. Alpha	2.30 ± 0.80	3.60 ± 1.00	2.95 ± 0.64	Pass
DW-80211,80212	11/14/2017	Gr. Beta	9.32 ± 0.81	8.99 ± 0.81	9.16 ± 0.57	Pass
DW-80214,80215	11/14/2017	Ra-226	1.36 ± 0.22	1.35 ± 0.15	1.355 ± 0.13	Pass
DW-80214,80215	11/14/2017	Ra-228	1.41 ± 0.51	0.90 ± 0.45	1.16 ± 0.34	Pass
WW-6152,6153	11/15/2017	H-3	416 ± 94	328 ± 90	372 ± 65	Pass
SWU-6219,6220	11/28/2017	Gr. Beta	1.04 ± 0.54	1.75 ± 0.58	1.39 ± 0.39	Pass
SS-6242,6243	11/29/2017	K-40	24.17 ± 1.05	22.31 ± 1.03	23.24 ± 0.74	Pass
SS-6242,6243	11/29/2017	Cs-137	0.11 ± 0.03	0.08 ± 0.03	0.10 ± 0.02	Pass
SG-6938,6939	11/28/2017	Pb-214	15.28 ± 0.34	14.96 ± 0.43	15.12 ± 0.27	Pass
SG-6938,6939	11/28/2017	Ac-228	18.99 ± 0.59	19.92 ± 0.79	19.46 ± 0.49	Pass
AP-112817	11/28/2017	Gr. Beta	0.028 ± 0.004	0.030 ± 0.004	0.028 ± 0.003	Pass
SQ-6286,6287	12/1/2017	Gr. Alpha	70.6 ± 6.2	60.9 ± 6.0	65.8 ± 4.3	Pass
SQ-6286,6287	12/1/2017	Gr. Beta	48.9 ± 2.7	53.7 ± 2.8	51.3 ± 1.9	Pass
SQ-6286,6287	12/1/2017	Ra-226	11.3 ± 0.4	10.7 ± 0.5	11.0 ± 0.3	Pass
SQ-6286,6287	12/1/2017	Ra-228	13.5 ± 0.9	13.2 ± 1.0	13.4 ± 0.7	Pass
SG-6286,6287	12/1/2017	K-40	5.10 ± 1.82	6.65 ± 1.53	5.88 ± 1.19	Pass
AP-120417	12/4/2017	Gr. Beta	0.037 ± 0.006	0.035 ± 0.005	0.036 ± 0.004	Pass
WW-6548,6549	12/18/2017	H-3	8,428 ± 280	8,604 ± 282	8,516 ± 199	Pass
AP-122717	12/27/2017	Gr. Beta	0.047 ± 0.004	0.043 ± 0.004	0.045 ± 0.003	Pass
XAP-6762,6763	12/31/2017	Co-60	2.43 ± 1.30	2.24 ± 0.82	2.34 ± 0.77	Pass
XAP-6762,6763	12/31/2017	Cs-137	4.21 ± 1.11	4.05 ± 0.96	4.14 ± 0.73	Pass

Note: Duplicate analyses are performed on every twentieth sample received in-house. Results are not listed for those analyses with activities that measure below the LLD.

<sup>a</sup> Results are reported in units of pCi/L, except for air filters (pCi/Filter or pCi/m<sup>3</sup>), food products, vegetation, soil and sediment (pCi/g).

TABLE A-6. Department of Energy's Mixed Analyte Performance Evaluation Program (MAPEP).

Lab Code <sup>b</sup>	Reference Date	Analysis	Laboratory result	Concentration <sup>a</sup>		Acceptance
				Known Activity	Control Limits <sup>c</sup>	
MASO-903	2/1/2017	Am-241	60.9 ± 6.9	67.0	46.9 - 87.1	Pass
MASO-903	2/1/2017	Cs-134	1360 ± 14	1550	1085 - 2015	Pass
MASO-903	2/1/2017	Cs-137	678 ± 13	611	428 - 794	Pass
MASO-903	2/1/2017	Co-57	1.63 ± 1.69	0.00	NA <sup>c</sup>	Pass
MASO-903	2/1/2017	Co-60	909 ± 12	891	624 - 1158	Pass
MASO-903	2/1/2017	Mn-54	1052 ± 17	967	677 - 1257	Pass
MASO-903	2/1/2017	K-40	657 ± 68	607	425 - 789	Pass
MASO-903	2/1/2017	Zn-65	-0.52 ± 7.40	0.00	NA <sup>c</sup>	Pass
MASO-903	2/1/2017	Ni-63	3.25 ± 7.17	0.00	NA <sup>c</sup>	Pass
MASO-903	2/1/2017	Pu-238	0.46 ± 0.69	0.41	NA <sup>a</sup>	Pass
MASO-903	2/1/2017	Pu-239/240	56.8 ± 5.9	59.8	41.9 - 77.7	Pass
MASO-903	2/1/2017	Sr-90	501 ± 17	624	437 - 811	Pass
MASO-903	2/1/2017	Tc-99	748 ± 16	656	459 - 853	Pass
MAW-849	2/1/2017	I-129	-0.05 ± 0.12	0.00	NA <sup>c</sup>	Pass
MAVE-905	2/1/2017	Cs-134	6.61 ± 0.16	6.95	4.87 - 9.04	Pass
MAVE-905	2/1/2017	Cs-137	4.97 ± 0.18	4.60	3.22 - 5.98	Pass
MAVE-905	2/1/2017	Co-57	-0.01 ± 0.03	0.00	NA <sup>c</sup>	Pass
MAVE-905	2/1/2017	Co-60	9.51 ± 0.17	8.75	6.13 - 11.38	Pass
MAVE-905	2/1/2017	Mn-54	3.67 ± 0.17	3.28	2.30 - 4.26	Pass
MAVE-905	2/1/2017	Zn-65	6.12 ± 0.44	5.39	3.77 - 7.01	Pass
MAW-847	2/1/2017	Am-241	0.679 ± 0.079	0.846	0.592 - 1.100	Pass
MAW-847	2/1/2017	Cs-134	0.03 ± 0.10	0.00	NA <sup>c</sup>	Pass
MAW-847	2/1/2017	Cs-137	12.7 ± 0.4	11.1	7.8 - 14.4	Pass
MAW-847 <sup>d</sup>	2/1/2017	Co-57	2.7 ± 0.3	28.5	20.0 - 37.1	Fail
MAW-847	2/1/2017	Co-60	13.5 ± 0.3	12.3	8.6 - 16.0	Pass
MAW-847	2/1/2017	Mn-54	16.5 ± 0.4	14.9	10.4 - 19.4	Pass
MAW-847	2/1/2017	K-40	287 ± 6	254	178 - 330	Pass
MAW-847	2/1/2017	Zn-65	-0.15 ± 0.23	0.00	NA <sup>c</sup>	Pass
MAW-847	2/1/2017	H-3	275 ± 10	249	174 - 324	Pass
MAW-847	2/1/2017	Fe-55	2.4 ± 13.6	1.7	NA <sup>a</sup>	Pass
MAW-847	2/1/2017	Ni-63	10.1 ± 2.8	12.2	8.5 - 15.9	Pass
MAW-847	2/1/2017	Pu-238	0.729 ± 0.097	0.703	0.492 - 0.914	Pass
MAW-847	2/1/2017	Pu-239/240	0.866 ± 0.102	0.934	0.654 - 1.214	Pass
MAW-847	2/1/2017	Ra-226	0.506 ± 0.053	0.504	0.353 - 0.655	Pass
MAW-847	2/1/2017	Sr-90	10.0 ± 0.8	10.1	7.1 - 13.1	Pass

TABLE A-8. Department of Energy's Mixed Analyte Performance Evaluation Program (MAPEP).

Lab Code <sup>b</sup>	Reference Date	Analysis	Laboratory result	Concentration <sup>a</sup>		Acceptance
				Known Activity	Control Limits <sup>c</sup>	
MAW-847	2/1/2017	Tc-99	4.77 ± 0.62	6.25	4.38 - 8.13	Pass
MAW-847	2/1/2017	U-234/233	1.19 ± 0.10	1.16	0.81 - 1.51	Pass
MAW-847	2/1/2017	U-238	1.15 ± 0.10	1.20	0.84 - 1.56	Pass
MAAP-907 <sup>f</sup>	2/1/2017	Am-241	0.0540 ± 0.0140	0.0376	0.0263 - 0.0489	Fail
MAAP-907	2/1/2017	Cs-134	1.31 ± 0.06	1.42	0.99 - 1.85	Pass
MAAP-907	2/1/2017	Cs-137	0.797 ± 0.080	0.685	0.480 - 0.891	Pass
MAAP-907	2/1/2017	Co-57	1.86 ± 0.06	1.70	1.19 - 2.21	Pass
MAAP-907	2/1/2017	Co-60	0.86 ± 0.05	0.78	0.55 - 1.01	Pass
MAAP-907	2/1/2017	Mn-54	0.01 ± 0.03	0.00	NA <sup>c</sup>	Pass
MAAP-907	2/1/2017	Zn-65	1.62 ± 0.13	1.29	0.90 - 1.68	Pass
MAAP-907	2/1/2017	Pu-238	0.0530 ± 0.0190	0.0598	0.0419 - 0.0777	Pass
MAAP-907	2/1/2017	Pu-239/240	0.0490 ± 0.0160	0.0460	0.0322 - 0.0598	Pass
MAAP-907	2/1/2017	Sr-90	0.648 ± 0.120	0.651	0.456 - 0.846	Pass
MAAP-907	2/1/2017	U-234/233	0.086 ± 0.024	0.104	0.073 - 0.135	Pass
MAAP-907	2/1/2017	U-238	0.097 ± 0.024	0.107	0.075 - 0.139	Pass
MASO-4515	8/1/2017	Am-241	45.9 ± 7.0	58.8	41.2 - 76.4	Pass <sup>g</sup>
MASO-4515	8/1/2017	Cs-134	409 ± 7	448	314 - 582	Pass <sup>g</sup>
MASO-4515	8/1/2017	Cs-137	798 ± 12	722	505 - 939	Pass <sup>g</sup>
MASO-4515	8/1/2017	Co-57	1572 ± 10	1458	1021 - 1895	Pass <sup>g</sup>
MASO-4515	8/1/2017	Co-60	0.2 ± 1.4	0.00	NA <sup>c</sup>	Pass <sup>g</sup>
MASO-4515	8/1/2017	Mn-54	934 ± 13	825	578 - 1073	Pass <sup>g</sup>
MASO-4515	8/1/2017	K-40	704 ± 53	592	414 - 770	Pass <sup>g</sup>
MASO-4515	8/1/2017	Zn-65	667 ± 17	559	391 - 727	Pass <sup>g</sup>
MASO-4515	8/1/2017	Pu-238	101 ± 9	92	64 - 120	Pass <sup>g</sup>
MASO-4515	8/1/2017	Pu-239/240	74.8 ± 7.7	68.8	48.2 - 89.4	Pass <sup>g</sup>
MASO-4515	8/1/2017	Sr-90	252 ± 7	289	202 - 376	Pass <sup>g</sup>
MAW-4494	8/1/2017	I-129	2.31 ± 0.10	2.31	1.62 - 3.00	Pass
MAVE-4517	8/1/2017	Cs-134	2.40 ± 0.10	2.32	1.62 - 3.02	Pass
MAVE-4517	8/1/2017	Cs-137	-0.002 ± 0.048	0.000	NA <sup>o</sup>	Pass
MAVE-4517	8/1/2017	Co-57	3.3 ± 0.1	2.8	2.0 - 3.6	Pass
MAVE-4517	8/1/2017	Co-60	2.10 ± 0.10	2.07	1.45 - 2.69	Pass
MAVE-4517	8/1/2017	Mn-54	3.00 ± 0.20	2.62	1.83 - 3.41	Pass
MAVE-4517	8/1/2017	Zn-65	5.90 ± 0.30	5.37	3.76 - 6.98	Pass



TABLE A-6. Department of Energy's Mixed Analyte Performance Evaluation Program (MAPEP).

Lab Code <sup>b</sup>	Reference Date	Analysis	Laboratory result	Concentration <sup>a</sup>		Acceptance
				Known Activity	Control Limits <sup>c</sup>	
MAW-4513	8/1/2017	Am-241	0.820 ± 0.220	0.892	0.624 - 1.160	Pass
MAW-4513	8/1/2017	Cs-134	10.3 ± 0.3	11.5	8.1 - 15.0	Pass
MAW-4513	8/1/2017	Cs-137	17.2 ± 0.5	16.3	11.4 - 21.2	Pass
MAW-4513	8/1/2017	Co-57	12.7 ± 0.4	12.1	8.5 - 15.7	Pass
MAW-4513	8/1/2017	Co-60	10.6 ± 0.3	10.7	7.5 - 13.9	Pass
MAW-4513	8/1/2017	Mn-54	15.6 ± 0.4	14.9	10.4 - 19.4	Pass
MAW-4513	8/1/2017	Zn-65	15.9 ± 0.7	15.5	10.9 - 20.2	Pass
MAW-4513	8/1/2017	H-3	255 ± 9	258	181 - 335	Pass
MAW-4513	8/1/2017	Fe-55	21.6 ± 6.6	19.4	13.6 - 25.2	Pass
MAW-4513	8/1/2017	Ni-63	-0.1 ± 2.0	0.0	NA <sup>c</sup>	Pass
MAW-4513	8/1/2017	Pu-238	0.590 ± 0.080	0.603	0.422 - 0.784	Pass
MAW-4513	8/1/2017	Pu-239/240	0.740 ± 0.090	0.781	0.547 - 1.015	Pass
MAW-4513	8/1/2017	Ra-226	1.000 ± 0.100	0.858	0.601 - 1.115	Pass
MAW-4513	8/1/2017	Sr-90	7.80 ± 0.60	7.77	5.44 - 10.10	Pass
MAW-4513	8/1/2017	Tc-99	6.70 ± 0.40	6.73	4.71 - 8.75	Pass
MAW-4513	8/1/2017	U-234/233	0.94 ± 0.06	1.01	0.71 - 1.31	Pass
MAW-4513	8/1/2017	U-238	0.97 ± 0.07	1.04	0.73 - 1.35	Pass
MAAP-4519 <sup>h</sup>	8/1/2017	Am-241	0.0400 ± 0.0100	0.0612	0.0428 - 0.0796	Fail
MAAP-4519	8/1/2017	Cs-134	0.90 ± 0.10	1.00	0.70 - 1.30	Pass
MAAP-4519	8/1/2017	Cs-137	0.90 ± 0.10	0.82	0.57 - 1.07	Pass
MAAP-4519	8/1/2017	Co-57	0.01 ± 0.01	0.00	NA <sup>c</sup>	Pass
MAAP-4519	8/1/2017	Co-60	0.70 ± 0.10	0.68	0.48 - 0.88	Pass
MAAP-4519	8/1/2017	Mn-54	1.50 ± 0.10	1.30	0.91 - 1.69	Pass
MAAP-4519	8/1/2017	Zn-65	1.30 ± 0.10	1.08	0.76 - 1.40	Pass
MAAP-4519	8/1/2017	Pu-238	0.0300 ± 0.0100	0.0298	0.0209 - 0.0387	Pass
MAAP-4519	8/1/2017	Pu-239/240	0.0400 ± 0.0200	0.0468	0.0328 - 0.0608	Pass
MAAP-4519	8/1/2017	Sr-90	0.800 ± 0.100	0.801	0.561 - 1.041	Pass
MAAP-4519	8/1/2017	U-234/233	0.070 ± 0.010	0.084	0.059 - 0.109	Pass
MAAP-4519	8/1/2017	U-238	0.090 ± 0.010	0.087	0.061 - 0.113	Pass

<sup>a</sup> Results are reported in units of Bq/kg (soil), Bq/L (water) or Bq/total sample (filters, vegetation).

<sup>b</sup> Laboratory codes as follows: MAW (water), MAAP (air filter), MASO (soil), MAVE (vegetation).

<sup>c</sup> MAPEP results are presented as the known values and expected laboratory precision (1 sigma, 1 determination) and control limits as defined by the MAPEP. A known value of "zero" indicates an analysis was included in the testing series as a "false positive". MAPEP does not provide control limits.

<sup>d</sup> Decimal point was misplaced while performing a unit conversion. The result is within control limits when the proper unit conversion is performed.

<sup>e</sup> Provided in the series for "sensitivity evaluation". MAPEP does not provide control limits.

<sup>f</sup> Sample was reanalyzed in duplicate with acceptable results. Original plating was inferior to platings obtained during reanalysis. It is believed that isotopic tracer was not accurately quantified due to poor resolution of its peak.

<sup>g</sup> Data were erroneously submitted in units of Bq/g. All results pass MAPEP criteria when evaluated in units of Bq/Kg.

<sup>h</sup> Laboratory is not currently offering analysis for Am-241 in Air Particulate samples.

TABLE A-7. Interlaboratory Comparison Crosscheck Program, Environmental Resource Associates (ERA)<sup>a</sup>.

MRAD Study						
Lab Code <sup>b</sup>	Date	Analysis	Concentration <sup>a</sup>		Control Limits <sup>c</sup>	Acceptance
			Laboratory Result	ERA Result		
ERAP-1112	3/20/2017	Am-241	55.3 ± 2.8	76.4	47.1 - 103.0	Pass
ERAP-1112	3/20/2017	Co-60	1,230 ± 8	1030	797 - 1290	Pass
ERAP-1112	3/20/2017	Cs-134	1,110 ± 9	1100	700 - 1360	Pass
ERAP-1112	3/20/2017	Cs-137	1,810 ± 12	1,390	1,040 - 1,830	Pass
ERAP-1112 <sup>d</sup>	3/20/2017	Fe-55	590 ± 385	256	79.4 - 500	Fail
ERAP-1112	3/20/2017	Mn-54	< 5.14	< 50.0	0.00 - 50.0	Pass
ERAP-1112	3/20/2017	Pu-238	54.6 ± 2.8	54.3	37.2 - 71.4	Pass
ERAP-1112	3/20/2017	Pu-239/240	63.6 ± 3.0	62.0	44.9 - 81.0	Pass
ERAP-1112	3/20/2017	Sr-90	55.3 ± 8.3	52.4	25.6 - 78.5	Pass
ERAP-1112	3/20/2017	U-233/234	65.7 ± 3.0	73.1	45.3 - 110	Pass
ERAP-1112	3/20/2017	U-238	67.3 ± 3.0	72.4	46.8 - 100	Pass
ERAP-1112	3/20/2017	Zn-65	1,355 ± 16	984	705 - 1,360	Pass
ERAP-1114	3/20/2017	Gr. Alpha	106 ± 5	85.5	28.6 - 133	Pass
ERAP-1114 <sup>a</sup>	3/20/2017	Gr. Beta	67.6 ± 3.0	45.2	28.6 - 65.9	Fail
ERSO-1116	3/20/2017	Am-241	418 ± 98	448	262 - 582	Pass
ERSO-1116	3/20/2017	Ac-228	1,540 ± 260	1,240	795 - 1,720	Pass
ERSO-1116	3/20/2017	Bi-212	1,550 ± 90	1,240	330 - 1,820	Pass
ERSO-1116	3/20/2017	Bi-214	2,560 ± 20	2,750	1,660 - 3,960	Pass
ERSO-1116	3/20/2017	Co-60	4,620 ± 100	4,430	3,000 - 6,100	Pass
ERSO-1116	3/20/2017	Cs-134	8,340 ± 100	8,860	5,790 - 10,600	Pass
ERSO-1116	3/20/2017	Cs-137	8,420 ± 100	7,500	5,750 - 9,650	Pass
ERSO-1116	3/20/2017	K-40	13,600 ± 900	10,800	7,740 - 14,200	Pass
ERSO-1116	3/20/2017	Mn-54	< 66.1	< 1000	0.00 - 1,000	Pass
ERSO-1116	3/20/2017	Pb-212	1,060 ± 70	1,240	812 - 1,730	Pass
ERSO-1116	3/20/2017	Pb-214	2,620 ± 160	2,890	1,690 - 4,310	Pass
ERSO-1116	3/20/2017	Pu-238	424 ± 154	648	390 - 894	Pass
ERSO-1116 <sup>f</sup>	3/20/2017	Pu-239/240	252 ± 112	484	316 - 669	Fail
ERSO-1116 <sup>g</sup>	3/20/2017	Pu-239/240	438 ± 106	484	316 - 669	Pass
ERSO-1116	3/20/2017	Sr-90	7,930 ± 250	9,150	3,490 - 14,500	Pass
ERSO-1116	3/20/2017	Th-234	1,820 ± 200	1,940	814 - 3,850	Pass
ERSO-1116 <sup>h</sup>	3/20/2017	U-233/234	1,030 ± 130	1,950	1,190 - 2,500	Fail
ERSO-1116 <sup>i</sup>	3/20/2017	U-233/234	1,820 ± 200	1,950	1,190 - 2,500	Pass
ERSO-1116	3/20/2017	U-238	1,240 ± 140	1,940	1,200 - 2,460	Pass
ERSO-1116 <sup>j</sup>	3/20/2017	U-238	1,930 ± 200	1,940	1,200 - 2,460	Pass
ERSO-1116	3/20/2017	Zn-65	7,190 ± 240	6,090	4,850 - 8,090	Pass
ERW-1122	3/20/2017	Gr. Alpha	65.3 ± 2.4	89.5	31.8 - 139	Pass
ERW-1122	3/20/2017	Gr. Beta	54.8 ± 1.5	61.0	34.9 - 90.4	Pass
ERW-1124	3/20/2017	H-3	19,000 ± 410	19,400	13,000 - 27,700	Pass

TABLE A-7. Interlaboratory Comparison Crosscheck Program, Environmental Resource Associates (ERA)<sup>a</sup>.

MRAD Study						
Lab Code <sup>b</sup>	Date	Analysis	Concentration <sup>a</sup>		Control Limits <sup>c</sup>	Acceptance
			Laboratory Result	ERA Result		
ERVE-1118	3/20/2017	Am-241	1,560 ± 140	1,860	1,140 - 2,470	Pass
ERVE-1118	3/20/2017	Cm-244	530 ± 80	734	360 - 1,140	Pass
ERVE-1118	3/20/2017	Co-60	1,400 ± 350	1,390	959 - 1,940	Pass
ERVE-1118	3/20/2017	Cs-134	1,650 ± 460	1,830	1,180 - 2,380	Pass
ERVE-1118	3/20/2017	Cs-137	2,580 ± 540	2,500	1,810 - 3,480	Pass
ERVE-1118	3/20/2017	K-40	32,100 ± 700	30,900	22,300 - 43,400	Pass
ERVE-1118	3/20/2017	Mn-54	< 27.3	< 300	0.00 - 300	Pass
ERVE-1118	3/20/2017	Zn-65	889 ± 64	853	615 - 1,200	Pass
ERVE-1118	3/20/2017	Pu-238	3,250 ± 210	3,250	1,940 - 4,450	Pass
ERVE-1118	3/20/2017	Pu-239/240	2,180 ± 170	2,150	1,320 - 2,960	Pass
ERVE-1118	3/20/2017	Sr-90	665 ± 135	726	414 - 963	Pass
ERVE-1118	3/20/2017	U-233/234	2,840 ± 200	3,090	2,030 - 3,970	Pass
ERVE-1118	3/20/2017	U-238	2,990 ± 200	3,060	2,040 - 3,890	Pass
ERW-1120	3/20/2017	Am-241	108 ± 7	140	94.3 - 188	Pass
ERW-1120	3/20/2017	Co-60	2,600 ± 198	2,540	2,210 - 2,970	Pass
ERW-1120	3/20/2017	Cs-134	2,380 ± 250	2,510	1,840 - 2880	Pass
ERW-1120	3/20/2017	Cs-137	1,470 ± 243	1,400	1,190 - 1,680	Pass
ERW-1120	3/20/2017	Mn-54	< 12.3	< 100	0.00 - 100	Pass
ERW-1120	3/20/2017	Pu-238	117 ± 4	128	94.7 - 159	Pass
ERW-1120	3/20/2017	Pu-239/240	74.8 ± 3.3	85.8	66.6 - 108	Pass
ERW-1120	3/20/2017	U-233/234	75.3 ± 3.2	90.3	67.8 - 116	Pass
ERW-1120	3/20/2017	U-238	76.4 ± 3.2	89.5	68.2 - 110	Pass
ERW-1120	3/20/2017	Zn-65	2,130 ± 378	1,960	1630 - 2,470	Pass
ERW-1120 <sup>j</sup>	3/20/2017	Fe-55	1,400 ± 403	984	587 - 1,340	Fail
ERW-1120 <sup>k</sup>	3/20/2017	Fe-55	1,081 ± 383	984	587 - 1,340	Pass
ERW-1120	3/20/2017	Sr-90	652 ± 12	714	465 - 944	Pass

<sup>a</sup> Results obtained by Environmental, Inc., Midwest Laboratory as a participant in the crosscheck program for proficiency testing administered by Environmental Resources Associates, serving as a replacement for studies conducted previously by the Environmental Measurements Laboratory Quality Assessment Program (EML).

<sup>b</sup> Laboratory codes as follows: ERW (water), ERAP (air filter), ERSO (soil), ERVE (vegetation). Results are reported in units of pCi/L, except for air filters (pCi/Filter), vegetation and soil (pCi/kg).

<sup>c</sup> Results are presented as the known values, expected laboratory precision (2 sigma, 1 determination) and control limits as provided by ERA.

<sup>d</sup> Fe-55 analysis result was outside the acceptable range. Recounting the sample disk for 1000 minutes resulted in 254 ± 384 with an LLD calculation of < 342. Insufficient sample was available after performing other required analyses on the sample to quantify the activity with an uncertainty less than the activity.

<sup>e</sup> ERA appears to have applied the standard material to the filter in a pattern closer to the center of the filter compared to previous studies and different from the filter efficiency utilized by the laboratory. This likely caused the efficiency used the calculation to be understated and the result obtained by the laboratory to be overstated. For comparison the in-house spike for gross beta in AP (table A-3 SPAP-740 2/28/17) was acceptable with a ratio of 0.94 of lab result to known.

<sup>f</sup> Analysis result for Plutonium-239/240 was below the lower limit of acceptance.

<sup>g</sup> Samples were reanalyzed in duplicate with acceptable results for each. Original analysis had poor resolution possibly due to a poor electroplating and is suspected in contributing to poor results.

<sup>h</sup> Analysis result for U-233/234 was below the lower limit of acceptance.

<sup>i</sup> The reanalysis result for U-233/234 was within the acceptance limits and U-238 reanalysis result was closer to the known value. Original analysis had poor resolution possibly due to a poor electroplating and is suspected in contributing to poor results.

<sup>j</sup> Fe-55 analysis result was outside acceptable range.

<sup>k</sup> Result of recounting was acceptable. Using available aliquot after dividing sample for other analyses leaves insufficient sample to reliably determine the activity present in sample.

# **2017 ANNUAL ENVIRONMENTAL AND EFFLUENT RELEASE REPORT**

## **Appendix B 2017 REMP Data Summary Reports**

Environmental Radiological Monitoring Program Annual Summary  
Perry Nuclear Power Plant Docket Number 50-440/50-441  
Lake County, Ohio Reporting Period: 2017

Pathway Sampled Units	Type and Total Number of Analyses Performed	Lower Limit of Detection (LLD) *	Mean for All Locations Detected/Collected Range	Mean for Indicator Locations Detected/Collected Range	Location with Highest Annual Mean		Mean for Control Locations Detected/Collected Range	Number of Non-routine Reported Measurements
					Location # Distance & Direction	Mean Detected/Collected Range		
Air pCi/m3	Be-7 28	N/A	0.066	0.067	7	0.070	0.074	0
			28/28 0.049 - 0.084	24/24 0.049 - 0.083	0.6 NE	4/4 0.051 - 0.083	4/4 0.061 - 0.084	
Air pCi/m3	Co-58 28	N/A	< LLD	< LLD	—	—	< LLD	0
			0/28	0/24	—	—	0/4	
Air pCi/m3	Co-60 28	N/A	< LLD	< LLD	—	—	< LLD	0
			0/28	0/24	—	—	0/4	
Air pCi/m3	Cs-134 28	0.037	< LLD	< LLD	—	—	< LLD	0
			0/28	0/24	—	—	0/4	
Air pCi/m3	Cs-137 28	0.045	< LLD	< LLD	—	—	< LLD	0
			0/28	0/24	—	—	0/4	
Air pCi/m3	Gross Beta 371	0.0075	0.024	0.023	7	0.025	0.026	0
			371/371 0.009 - 0.058	318/318 0.009 - 0.058	0.6 NE	53/53 0.013 - 0.058	53/53 0.013 - 0.057	
			< LLD	< LLD	—	—	< LLD	
Air pCi/m3	I-131 371	0.05	0/371	0/318	—	—	< LLD	0
			< LLD	< LLD	—	—	0/53	

Environmental Radiological Monitoring Program Annual Summary  
Perry Nuclear Power Plant Docket Number 50-440/50-441  
Lake County, Ohio Reporting Period: 2017

Pathway Sampled Units	Type and Total Number of Analyses Performed	Lower Limit of Detection (LLD) *	Mean for All Locations Detected/Collected Range	Mean for Indicator Locations Detected/Collected Range	Location # Distance & Direction	Location with Highest Annual Mean		Mean for Control Locations Detected/Collected Range	Number of Non-routine Reported Measurements
						Mean Detected/Collected Range	Mean Detected/Collected Range		
Broadleaf Vegetation pCi/kg wet	Be-7 65	N/A	388.4 49/65 115 - 971	383.5 39/51 0 - 971	20 1.9 E	514.7 9/12 194 - 805	407.6 10/14 245 - 584	0	
Broadleaf Vegetation pCi/kg wet	K-40 65	N/A	4633.0 65/65 2709 - 9060	4600.6 51/51 2709 - 9060	20 1.9 E	5682.0 12/12 3681 - 9060	4751.0 14/14 3141 - 6869	0	
Broadleaf Vegetation pCi/kg wet	Co-58 65	N/A	<LLD 0/65 —	<LLD 0/51 —	—	—	<LLD 0/14 —	0	
Broadleaf Vegetation pCi/kg wet	Co-60 65	N/A	<LLD 0/65 —	<LLD 0/51 —	—	—	<LLD 0/14 —	0	
Broadleaf Vegetation pCi/kg wet	I-131 65	45	<LLD 0/65 —	<LLD 0/51 —	—	—	<LLD 0/14 —	0	
Broadleaf Vegetation pCi/kg wet	Ce-134 65	45	<LLD 0/65 —	<LLD 0/51 —	—	—	<LLD 0/14 —	0	
Broadleaf Vegetation pCi/kg wet	Ce-137 65	60	<LLD 0/65 —	<LLD 0/51 —	—	—	<LLD 0/14 —	0	

Environmental Radiological Monitoring Program Annual Summary  
 Perry Nuclear Power Plant Docket Number 50-440/50-441  
 Lake County, Ohio Reporting Period: 2017

Pathway Sampled Units	Type and Total Number of Analyses Performed	Lower Limit of Detection (LLD) *	Mean for All Locations Detected/Collected Range	Mean for Indicator Locations Detected/Collected Range	Location with Highest Annual Mean		Mean for Control Locations Detected/Collected Range	Number of Non-routine Reported Measurements
					Location # Distance & Direction	Mean Detected/Collected Range		
Fish pCi/kg wet	K-40 11	N/A	1473.2 11/11 768 - 2821	1398.4 5/5 1035 - 1745	32 15.8 WSW	1535.5 6/6 768 - 2821	1535.5 6/6 768 - 2821	0
Fish pCi/kg wet	Mn-54 11	94	<LLD 0/11 —	<LLD 0/5 —	—	—	<LLD 0/6 —	0
Fish pCi/kg wet	Fe-59 11	195	<LLD 0/11 —	<LLD 0/5 —	—	—	<LLD 0/6 —	0
Fish pCi/kg wet	Co-58 11	97	<LLD 0/11 —	<LLD 0/5 —	—	—	<LLD 0/6 —	0
Fish pCi/kg wet	Co-60 11	97	<LLD 0/11 —	<LLD 0/5 —	—	—	<LLD 0/6 —	0
Fish pCi/kg wet	Zn-65 11	195	<LLD 0/11 —	<LLD 0/5 —	—	—	<LLD 0/6 —	0
Fish pCi/kg wet	Cs-134 11	97	<LLD 0/11 —	<LLD 0/5 —	—	—	<LLD 0/6 —	0

Environmental Radiological Monitoring Program Annual Summary  
Perry Nuclear Power Plant Docket Number 50-440/50-441  
Lake County, Ohio Reporting Period: 2017

Pathway Sampled Units	Type and Total Number of Analyses Performed	Lower Limit of Detection (LLD) *	Mean for All Locations Detected/Collected Range	Mean for Indicator Locations Detected/Collected Range	Location with Highest Annual Mean		Mean for Control Locations Detected/Collected Range	Number of Non-routine Reported Measurements
					Location # Distance & Direction	Mean Detected/Collected Range		
Fish pCi/kg wet	Cs-137 11	112	<LLD 0/11 —	<LLD 0/5 —	—	—	<LLD 0/6 —	0
Milk pCi/L	K-40 38	N/A	1428.4 38/38 1190 - 2546	N/A N/A N/A	19 9.2 S	1489 19/19 1190 - 2546	1428.4 38/38 1190 - 2546	0
Milk pCi/L	I-131 38	0.8	<LLD 0/38 —	N/A N/A N/A	—	—	<LLD 0/38 —	0
Milk pCi/L	Cs-134 38	11	<LLD 0/38 —	N/A N/A N/A	—	—	<LLD 0/38 —	0
Milk pCi/L	Cs-137 38	13	<LLD 0/38 —	N/A N/A N/A	—	—	<LLD 0/38 —	0
Milk pCi/L	Ba-140 38	45	<LLD 0/38 —	N/A N/A N/A	—	—	<LLD 0/38 —	0
Milk pCi/L	La-140 38	11	<LLD 0/38 —	N/A N/A N/A	—	—	<LLD 0/38 —	0



Environmental Radiological Monitoring Program Annual Summary  
Perry Nuclear Power Plant Docket Number 50-440/50-441  
Lake County, Ohio Reporting Period: 2017

Pathway Sampled Units	Type and Total Number of Analyses Performed	Lower Limit of Detection (LLD) *	Mean for All Locations Detected/Collected Range	Mean for Indicator Locations Detected/Collected Range	Location with Highest Annual Mean		Mean for Control Locations Detected/Collected Range	Number of Non-routine Reported Measurements
					Location # Distance & Direction	Mean Detected/Collected Range		
Sediment pCi/kg wet	K-40 4	N/A	10048.0	10048.0	64	12099.5	N/A	0
			4/4	4/4	0.4	2/2	N/A	
Sediment pCi/kg wet	Co-58 4	50	7739 - 15112	7739 - 15112	WNW	9087 - 15112	N/A	0
			<LLD	<LLD	—	—	N/A	
Sediment pCi/kg wet	Co-60 4	40	<LLD	<LLD	—	—	N/A	0
			0/4	0/4	—	—	N/A	
Sediment pCi/kg wet	Cs-134 4	112	<LLD	<LLD	—	—	N/A	0
			0/4	0/4	—	—	N/A	
Sediment pCi/kg wet	Cs-137 4	135	<LLD	<LLD	—	—	N/A	0
			0/4	0/4	—	—	N/A	
TLD (E) mR/91 days	Direct 116	1.0	11.4	11.5	33	15.5	11.1	0
			116/116	108/108	4.7	4/4	8/8	
TLD (Q) mR/91 days	Direct 116	1.0	7.8 - 16.5	7.8 - 16.5	S	14.5 - 16.5	9.1 - 13.0	0
			12.5	12.8	33	17.0	11.8	
			8.5 - 18.7	8.5 - 18.7	S	16.3 - 17.3	11.3 - 12.7	

Environmental Radiological Monitoring Program Annual Summary  
Perry Nuclear Power Plant Docket Number 50-440/50-441  
Lake County, Ohio Reporting Period: 2017

Pathway Sampled Units	Type and Total Number of Analyses Performed	Lower Limit of Detection (LLD) *	Mean for All Locations Detected/Collected Range	Mean for Indicator Locations Detected/Collected Range	Location with Highest Annual Mean		Mean for Control Locations Detected/Collected Range	Number of Non-routine Reported Measurements
					Location # Distance & Direction	Mean Detected/Collected Range		
TLD mR/365 days	Direct	1.0	57	59.0	33	73.0	27.4	0
	31		31/31	29/29	4.5	1/1	2/2	
Water pCi/L	Gross Beta	3.0	1.5	1.8	60	1.8	1.4	0
	58		42/58	41/46	1.0	10/12	12/12	
Water pCi/L	H-3	1500	0.9 - 2.7	0.9 - 2.7	WSW	1.2 - 2.7	1.2 - 1.8	0
	20		<LLD	<LLD	—	—	<LLD	
Water pCi/L	Mn-54	11	<LLD	<LLD	—	—	<LLD	0
	58		0/58	0/46	—	—	0/12	
Water pCi/L	Fe-59	22	<LLD	<LLD	—	—	<LLD	0
	58		0/58	0/46	—	—	0/12	
Water pCi/L	Co-58	11	<LLD	<LLD	—	—	<LLD	0
	58		0/58	0/46	—	—	0/12	
Water pCi/L	Co-60	11	<LLD	<LLD	—	—	<LLD	0
	58		0/58	0/46	—	—	0/12	

Environmental Radiological Monitoring Program Annual Summary  
 Perry Nuclear Power Plant Docket Number 50-440/50-441  
 Lake County, Ohio Reporting Period: 2017

Pathway Sampled Units	Type and Total Number of Analyses Performed	Lower Limit of Detection (LLD)*	Mean for All Locations Detected/Collected Range	Mean for Indicator Locations Detected/Collected Range	Location with Highest Annual Mean		Mean for Control Locations Detected/Collected Range	Number of Non-routine Reported Measurements
					Location # Distance & Direction	Mean Detected/Collected Range		
Water pCi/L	Zn-65 58	22	<LLD 0/58 —	<LLD 0/46 —	—	—	<LLD 0/12 —	0
Water pCi/L	Zr-95 58	22	<LLD 0/58 —	<LLD 0/46 —	—	—	<LLD 0/12 —	0
Water pCi/L	Nb-95 58	11	<LLD 0/58 —	<LLD 0/46 —	—	—	<LLD 0/12 —	0
Water pCi/L	Cs-134 58	11	<LLD 0/58 —	<LLD 0/46 —	—	—	<LLD 0/12 —	0
Water pCi/L	Ce-137 58	13	<LLD 0/58 —	<LLD 0/46 —	—	—	<LLD 0/12 —	0
Water pCi/L	Ba-140 58	45	<LLD 0/58 —	<LLD 0/46 —	—	—	<LLD 0/12 —	0
Water pCi/L	La-140 58	11	<LLD 0/58 —	<LLD 0/46 —	—	—	<LLD 0/12 —	0

\*This value is the LLD that is met by the vendor and is lower than required by the ODCM

**2017 ANNUAL ENVIRONMENTAL AND EFFLUENT RELEASE REPORT**

**Appendix C**  
**2017 REMP Detailed Data Report**



Received by  
Environmental  
Lind Men 2/23/18

MONTHLY PROGRESS REPORT  
to  
FIRST ENERGY CORPORATION

RADIOLOGICAL ENVIRONMENTAL MONITORING PROGRAM (REMP)  
FOR THE  
PERRY NUCLEAR POWER PLANT

Reporting Period: January-December, 2017

Prepared and Submitted by  
ENVIRONMENTAL, INC.,  
MIDWEST LABORATORY

Project Number: 8033

Reviewed and  
Approved

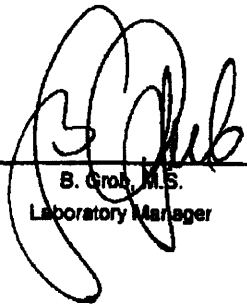
  
\_\_\_\_\_  
B. Grob, M.S.  
Laboratory Manager

Date 02-16-2018

Distribution: M. Baker  
P. Hintz, Ohio Department of Health  
B. Mechenbier, Lake County Health Department

PERRY NUCLEAR POWER PLANT

**TABLE OF CONTENTS**

<u>Section</u>		<u>Page</u>
	List of Tables .....	iii
1.0	INTRODUCTION .....	iv
2.0	LISTING OF MISSED SAMPLES .....	v
3.0	DATA TABLES .....	vi
 <u>Appendices</u>		
A	Interlaboratory Comparison Program Results .....	A-1
B	Data Reporting Conventions .....	B-1

PERRY NUCLEAR POWER PLANT

**LIST OF TABLES**

<b><u>No.</u></b>	<b><u>Title</u></b>	<b><u>Page</u></b>
1	Direct Radiation, Quarterly and Annual .....	1-1
2	Airborne Particulate Filters and Charcoal Canisters .....	2-1
3	Airborne Particulate Filters .....	3-1
4	Lake Water .....	4-1
5	Milk .....	5-1
7	Food Products .....	7-1
9	Fish .....	9-1
11	Sediments .....	11-1

# PERRY NUCLEAR POWER PLANT

## 1.0 INTRODUCTION

The following constitutes the final 2017 report for the Radiological Environmental Monitoring Program conducted at the Perry Nuclear Power Plant in Perry, Ohio. Results of completed analyses are presented in the attached tables.

The data obtained in the program were within ranges previously encountered and to be expected in the environmental media sampled.

All concentrations, except gross beta, are decay corrected to the time of collection. Airborne iodine is decay corrected to the midpoint of the collection period.

All samples were collected within the scheduled period, unless noted otherwise in Table 2.0, Listing of Missed Samples.



2.0 LISTING OF MISSED SAMPLES

---

Sample Type	Location	Expected Collection Date	Reason
LW	P-59	01-26-17	No sample sent.
LW	P-60	01-26-17	No sample sent.

---

Table 1. Direct Radiation (TLDs), Quarterly Exposure.  
Units: mR/91 days

	<u>1st Qtr.</u>	<u>2nd Qtr.</u>	<u>3rd Qtr.</u>	<u>4th Qtr.</u>
Date Placed	01-05-16	04-05-17	07-06-17	10-10-17
Date Removed	04-07-16	07-08-17	10-10-17	01-15-18
E-1	11.7 ± 0.5	11.3 ± 1.4	10.8 ± 1.1	9.8 ± 1.1
E-3	11.8 ± 0.6	10.4 ± 1.1	11.2 ± 1.6	8.8 ± 1.1
E-4	13.2 ± 0.6	11.8 ± 1.1	11.5 ± 0.8	10.2 ± 0.9
E-5	10.7 ± 0.7	8.5 ± 0.9	9.5 ± 0.8	8.0 ± 0.9
E-6	12.5 ± 0.9	10.0 ± 0.9	10.5 ± 0.9	9.1 ± 0.7
E-7	10.1 ± 0.6	11.4 ± 1.6	8.5 ± 0.6	9.9 ± 1.0
E-8	10.5 ± 0.7	9.5 ± 0.9	9.2 ± 0.7	8.6 ± 0.7
E-9	9.1 ± 0.5	8.8 ± 1.0	8.0 ± 0.8	8.8 ± 0.9
E-10	13.6 ± 0.7	9.9 ± 1.0	12.2 ± 0.5	9.1 ± 0.9
E-11	13.3 ± 1.1	13.1 ± 1.0	12.5 ± 0.9	12.5 ± 0.9
E-12	12.9 ± 0.8	10.2 ± 1.2	11.9 ± 0.8	10.5 ± 1.1
E-13	10.8 ± 1.5	10.4 ± 1.1	9.7 ± 1.0	10.1 ± 1.1
E-14	11.9 ± 0.7	11.2 ± 0.9	10.7 ± 0.8	9.9 ± 0.8
E-15	11.3 ± 0.8	10.5 ± 0.9	9.8 ± 0.7	9.2 ± 0.7
E-21	12.8 ± 0.8	10.6 ± 1.1	12.6 ± 0.8	11.3 ± 0.8
E-23	13.8 ± 0.8	12.3 ± 1.0	13.0 ± 1.1	11.8 ± 0.7
E-24	13.0 ± 1.2	10.7 ± 1.1	11.6 ± 1.4	11.0 ± 0.9
E-29	14.8 ± 1.3	14.5 ± 1.1	14.1 ± 0.8	13.8 ± 1.0
E-30	14.3 ± 0.8	14.3 ± 1.0	13.1 ± 0.8	12.3 ± 0.9
E-31	14.5 ± 0.9	13.2 ± 1.0	13.8 ± 1.2	12.6 ± 0.9
E-33	16.6 ± 1.0	14.5 ± 1.3	16.1 ± 0.8	14.7 ± 0.8
E-35	11.3 ± 0.7	11.2 ± 1.1	10.7 ± 0.7	11.0 ± 0.9
E-36	15.6 ± 0.7	13.6 ± 0.8	14.6 ± 0.5	12.8 ± 1.0
E-53	11.4 ± 0.6	10.8 ± 1.1	11.2 ± 0.6	10.7 ± 1.2
E-54	12.1 ± 1.0	10.4 ± 1.0	11.1 ± 0.7	10.0 ± 0.9
E-55	11.9 ± 1.4	11.4 ± 1.1	11.5 ± 1.2	11.5 ± 1.1
E-56	11.3 ± 0.6	12.0 ± 1.3	10.6 ± 0.6	10.5 ± 1.1
E-57	13.3 ± 0.8	12.7 ± 1.2	13.5 ± 0.9	11.5 ± 1.0
E-58	9.7 ± 0.6	9.0 ± 0.9	7.8 ± 1.4	8.3 ± 0.9
Mean ± s.d.	12.4 ± 1.8	11.3 ± 1.7	11.4 ± 2.0	10.6 ± 1.7
E-Control 1	7.0 ± 1.3	5.4 ± 1.0	6.2 ± 1.1	5.7 ± 1.0
E-Control 2	6.9 ± 0.8	5.2 ± 1.0	7.5 ± 0.7	5.3 ± 0.8

Table 1. Direct Radiation (TLDs), Quarterly Exposure.  
Units: mR/91 days

	<u>1st Qtr.</u>	<u>2nd Qtr.</u>	<u>3rd Qtr.</u>	<u>4th Qtr.</u>
Date Placed	01-12-15	04-05-17	07-06-17	10-10-17
Date Removed	04-03-15	07-06-17	10-10-17	01-15-18
Q-1	12.7 ± 1.1	10.3 ± 1.2	12.4 ± 1.2	10.9 ± 1.2
Q-3	10.6 ± 0.5	9.6 ± 1.0	10.4 ± 0.9	9.7 ± 1.2
Q-4	11.9 ± 0.7	10.6 ± 0.9	12.0 ± 0.7	11.6 ± 0.9
Q-5	11.7 ± 0.9	10.1 ± 1.1	11.7 ± 0.6	11.5 ± 1.1
Q-6	11.6 ± 0.7	11.5 ± 0.8	11.3 ± 0.6	11.6 ± 0.9
Q-7	15.6 ± 1.1	11.1 ± 0.9	13.2 ± 0.6	11.9 ± 1.5
Q-8	10.8 ± 0.6	9.5 ± 0.8	11.0 ± 0.5	10.4 ± 0.9
Q-9	12.6 ± 1.0	8.5 ± 0.9	11.8 ± 1.0	9.5 ± 0.9
Q-10	11.3 ± 0.4	10.4 ± 0.8	11.5 ± 0.6	10.6 ± 0.9
Q-11	13.3 ± 0.8	12.5 ± 0.9	13.3 ± 0.8	12.8 ± 1.0
Q-12	12.1 ± 0.8	10.5 ± 0.9	12.0 ± 0.5	10.9 ± 1.1
Q-13	12.2 ± 1.0	9.6 ± 1.1	12.0 ± 0.6	10.1 ± 1.2
Q-14	12.6 ± 0.7	11.2 ± 1.0	12.9 ± 0.5	11.6 ± 1.0
Q-16	11.6 ± 0.5	9.9 ± 0.9	12.6 ± 0.5	8.7 ± 1.0
Q-21	14.1 ± 0.5	13.8 ± 1.3	14.9 ± 0.4	12.9 ± 1.2
Q-23	14.9 ± 1.2	13.8 ± 1.4	15.3 ± 1.0	13.3 ± 1.4
Q-24	12.7 ± 1.7	11.8 ± 1.0	11.4 ± 1.1	12.2 ± 1.0
Q-29	17.6 ± 1.2	16.0 ± 1.3	18.7 ± 1.3	15.0 ± 1.1
Q-30	13.6 ± 0.7	11.7 ± 1.0	14.0 ± 0.5	11.2 ± 0.9
Q-31	16.3 ± 1.0	14.4 ± 0.9	17.6 ± 0.9	15.9 ± 1.1
Q-33	17.3 ± 0.7	17.0 ± 1.2	17.2 ± 0.8	16.3 ± 1.1
Q-35	11.7 ± 0.6	11.4 ± 0.8	13.0 ± 0.5	10.6 ± 0.9
Q-36	15.9 ± 0.6	14.6 ± 0.8	16.9 ± 0.4	14.0 ± 0.9
Q-53	13.2 ± 0.6	11.6 ± 1.0	13.0 ± 0.7	12.8 ± 1.8
Q-54	12.4 ± 0.6	12.3 ± 0.9	12.5 ± 0.4	11.6 ± 0.9
Q-55	14.7 ± 1.0	11.3 ± 1.0	15.1 ± 0.8	10.6 ± 0.9
Q-56	13.8 ± 0.8	12.1 ± 1.0	13.9 ± 0.6	11.7 ± 1.1
Q-57	13.4 ± 1.3	13.3 ± 0.9	14.1 ± 1.0	12.9 ± 1.0
Q-58	9.5 ± 0.9	11.1 ± 0.9	9.9 ± 0.9	9.9 ± 0.9
<b>Mean ± s.d.</b>	<b>13.2 ± 2.0</b>	<b>11.8 ± 2.0</b>	<b>13.3 ± 2.2</b>	<b>11.8 ± 1.8</b>
Q-Control 1	6.3 ± 0.5	6.8 ± 0.9	6.6 ± 0.5	6.6 ± 1.0
Q-Control 2	7.1 ± 0.8	6.9 ± 0.8	7.6 ± 0.5	6.2 ± 0.9

Table 1. Direct Radiation (TLDs), Annual Exposure.  
 Units: mR/365 days

	<u>2017</u>
Date Placed	01-11-17
Date Removed	01-15-18
A-1	54.4 ± 3.4
A-3	53.0 ± 2.3
A-4	55.2 ± 2.5
A-5	54.7 ± 2.2
A-6	56.8 ± 1.9
A-7	58.0 ± 2.1
A-8	52.7 ± 1.9
A-9	56.0 ± 3.3
A-10	53.5 ± 1.8
A-11	60.8 ± 4.3
A-12	58.1 ± 2.0
A-13	56.6 ± 3.0
A-14	60.1 ± 3.4
A-15	50.0 ± 2.7
A-21	63.2 ± 3.6
A-23	70.2 ± 2.0
A-24	59.2 ± 3.3
A-29	71.5 ± 2.7
A-30	61.4 ± 3.0
A-31	69.6 ± 2.7
A-33	73.0 ± 3.4
A-35	51.1 ± 2.6
A-36	71.3 ± 4.5
A-53	60.3 ± 3.2
A-54	57.9 ± 4.1
A-55	53.1 ± 2.2
A-56	61.5 ± 3.0
A-57	56.5 ± 2.7
A-58	51.3 ± 2.0
Mean ± s.d.	59.0 ± 6.8
A-Control 1	27.9 ± 1.5
A-Control 2	26.8 ± 1.6

Table 2. Airborne particulates and charcoal canisters, analyses for gross beta and iodine-131.

Location: P-1

Units: pCi/m<sup>3</sup>

Collection: Continuous, weekly exchange.

Date Collected	Volume (m <sup>3</sup> )	Gross Beta	I-131	Date Collected	Volume (m <sup>3</sup> )	Gross Beta	I-131
<b>Required LLD</b>		<b>0.0075</b>	<b>0.050</b>			<b>0.0075</b>	<b>0.050</b>
01-04-17	529	0.023 ± 0.003	< 0.006	07-05-17	576	0.019 ± 0.003	< 0.007
01-11-17	549	0.032 ± 0.003	< 0.005	07-13-17	676	0.025 ± 0.003	< 0.007
01-18-17	544	0.031 ± 0.003	< 0.007	07-19-17	496	0.021 ± 0.003	< 0.007
01-25-17	537	0.017 ± 0.003	< 0.009	07-26-17	566	0.023 ± 0.003	< 0.003
02-01-17	548	0.023 ± 0.003	< 0.008	08-02-17	578	0.021 ± 0.003	< 0.004
02-09-17	614	0.026 ± 0.003	< 0.006	08-09-17	573	0.022 ± 0.003	< 0.006
02-15-17	481	0.033 ± 0.004	< 0.007	08-16-17	560	0.031 ± 0.003	< 0.012
02-22-17	520	0.029 ± 0.003	< 0.007	08-23-17	582	0.034 ± 0.003	< 0.005
03-01-17	545	0.026 ± 0.003	< 0.006	08-30-17	574	0.018 ± 0.003	< 0.014
03-08-17	540	0.024 ± 0.003	< 0.011	09-06-17	561	0.024 ± 0.003	< 0.007
03-16-17	609	0.022 ± 0.003	< 0.006	09-13-17	580	0.014 ± 0.003	< 0.006
03-22-17	455	0.028 ± 0.004	< 0.009	09-20-17	591	0.037 ± 0.003	< 0.004
03-30-17	632	0.024 ± 0.003	< 0.005	09-27-17	549	0.050 ± 0.004	< 0.005
<b>1Q 2017 Mean ± s.d.</b>				<b>3Q 2017 Mean ± s.d.</b>			
		0.026 ± 0.005	< 0.011			0.026 ± 0.010	< 0.014
04-05-17	456	0.015 ± 0.003	< 0.012	10-04-17	583	0.025 ± 0.003	< 0.007
04-12-17	541	0.015 ± 0.003	< 0.009	10-11-17	570	0.027 ± 0.003	< 0.009
04-19-17	538	0.021 ± 0.003	< 0.012	10-18-17	567	0.021 ± 0.003	< 0.006
04-26-17	547	0.015 ± 0.003	< 0.008	10-25-17	586	0.041 ± 0.003	< 0.006
05-03-17	547	0.012 ± 0.003	< 0.003	11-01-17	564	0.019 ± 0.003	< 0.006
05-10-17	531	0.014 ± 0.003	< 0.007	11-08-17	571	0.027 ± 0.003	< 0.007
05-17-17	539	0.015 ± 0.003	< 0.006	11-15-17	596	0.033 ± 0.003	< 0.008
05-24-17	532	0.018 ± 0.003	< 0.008	11-22-17	555	0.027 ± 0.003	< 0.007
05-31-17	633	0.010 ± 0.002	< 0.006	11-29-17	587	0.036 ± 0.003	< 0.008
06-07-17	544	0.016 ± 0.003	< 0.006	12-06-17	576	0.033 ± 0.003	< 0.006
06-14-17	553	0.023 ± 0.003	< 0.006	12-13-17	583	0.027 ± 0.003	< 0.005
06-21-17	566	0.019 ± 0.003	< 0.005	12-20-17	566	0.035 ± 0.003	< 0.006
06-28-17	582	0.015 ± 0.003	< 0.007	12-27-17	587	0.030 ± 0.003	< 0.007
				01-03-18	566	0.024 ± 0.003	< 0.007
<b>2Q 2017 Mean ± s.d.</b>				<b>4Q 2017 Mean ± s.d.</b>			
		0.016 ± 0.004	< 0.012			0.029 ± 0.006	< 0.009
<b>Cumulative Average</b>						<b>0.024</b>	

Table 2. Airborne particulates and charcoal canisters, analyses for gross beta and iodine-131

Location: P-3

Units: pCi/m<sup>3</sup>

Collection: Continuous, weekly exchange.

Date Collected	Volume (m <sup>3</sup> )	Gross Beta	I-131	Date Collected	Volume (m <sup>3</sup> )	Gross Beta	I-131
<b>Required LLD</b>		<b>0.0075</b>	<b>0.050</b>			<b>0.0075</b>	<b>0.050</b>
01-04-17	531	0.023 ± 0.003	< 0.006	07-05-17	679	0.015 ± 0.002	< 0.006
01-11-17	544	0.029 ± 0.003	< 0.005	07-13-17	794	0.018 ± 0.002	< 0.006
01-18-17	530	0.029 ± 0.003	< 0.007	07-19-17	544	0.018 ± 0.003	< 0.007
01-25-17	536	0.019 ± 0.003	< 0.009	07-26-17	664	0.019 ± 0.003	< 0.003
02-01-17	522	0.022 ± 0.003	< 0.008	08-02-17	672	0.015 ± 0.002	< 0.004
02-09-17	602	0.027 ± 0.003	< 0.006	08-09-17	683	0.022 ± 0.003	< 0.005
02-15-17	464	0.031 ± 0.004	< 0.007	08-16-17	590	0.030 ± 0.003	< 0.011
02-22-17	535	0.028 ± 0.003	< 0.007	08-23-17	549	0.026 ± 0.003	< 0.006
03-01-17	524	0.025 ± 0.003	< 0.006	08-30-17	531	0.015 ± 0.003	< 0.015
03-08-17	532	0.024 ± 0.003	< 0.012	09-06-17	541	0.021 ± 0.003	< 0.007
03-16-17	597	0.024 ± 0.003	< 0.006	09-13-17	532	0.012 ± 0.003	< 0.007
03-22-17	459	0.024 ± 0.004	< 0.009	09-20-17	562	0.032 ± 0.003	< 0.005
03-30-17	628	0.027 ± 0.003	< 0.005	09-27-17	521	0.042 ± 0.004	< 0.005
<b>1Q 2017</b>	<b>Mean ± s.d.</b>	<b>0.026 ± 0.003</b>	<b>&lt; 0.012</b>	<b>3Q 2017</b>	<b>Mean ± s.d.</b>	<b>0.022 ± 0.009</b>	<b>&lt; 0.015</b>
04-05-17	435	0.014 ± 0.003	< 0.013	10-04-17	523	0.021 ± 0.003	< 0.007
04-12-17	523	0.015 ± 0.003	< 0.009	10-11-17	530	0.027 ± 0.003	< 0.010
04-19-17	673	0.018 ± 0.002	< 0.009	10-18-17	575	0.025 ± 0.003	< 0.006
04-26-17	672	0.011 ± 0.002	< 0.006	10-25-17	603	0.033 ± 0.003	< 0.006
05-03-17	683	0.012 ± 0.002	< 0.003	11-01-17	541	0.017 ± 0.003	< 0.006
05-10-17	650	0.013 ± 0.002	< 0.005	11-08-17	554	0.030 ± 0.003	< 0.007
05-17-17	707	0.014 ± 0.002	< 0.005	11-15-17	573	0.039 ± 0.003	< 0.008
05-24-17	652	0.014 ± 0.002	< 0.007	11-22-17	524	0.032 ± 0.004	< 0.007
05-31-17	549	0.012 ± 0.003	< 0.007	11-29-17	705	0.032 ± 0.003	< 0.006
06-07-17	691	0.016 ± 0.002	< 0.005	12-06-17	726	0.027 ± 0.003	< 0.005
06-14-17	681	0.021 ± 0.003	< 0.005	12-13-17	578	0.024 ± 0.003	< 0.005
06-21-17	659	0.019 ± 0.002	< 0.004	12-20-17	564	0.026 ± 0.003	< 0.006
06-28-17	670	0.013 ± 0.002	< 0.006	12-27-17	594	0.021 ± 0.003	< 0.007
				01-03-18	575	0.021 ± 0.003	< 0.006
<b>2Q 2017</b>	<b>Mean ± s.d.</b>	<b>0.015 ± 0.003</b>	<b>&lt; 0.013</b>	<b>4Q 2017</b>	<b>Mean ± s.d.</b>	<b>0.027 ± 0.006</b>	<b>&lt; 0.010</b>
				<b>Cumulative Average</b>		<b>0.022</b>	

Table 2. Airborne particulates and charcoal canisters, analyses for gross beta and iodine-131.

Location: P-4

Units: pCi/m<sup>3</sup>

Collection: Continuous, weekly exchange.

Date Collected	Volume (m <sup>3</sup> )	Gross Beta	I-131	Date Collected	Volume (m <sup>3</sup> )	Gross Beta	I-131
<b>Required LLD</b>		<b>0.0075</b>	<b>0.050</b>			<b>0.0075</b>	<b>0.050</b>
01-04-17	557	0.022 ± 0.003	< 0.006	07-05-17	568	0.017 ± 0.003	< 0.006
01-11-17	552	0.027 ± 0.003	< 0.005	07-13-17	647	0.024 ± 0.003	< 0.007
01-18-17	529	0.027 ± 0.003	< 0.007	07-19-17	451	0.021 ± 0.003	< 0.008
01-25-17	558	0.016 ± 0.003	< 0.008	07-26-17	543	0.022 ± 0.003	< 0.003
02-01-17	532	0.023 ± 0.003	< 0.008	08-02-17	651	0.021 ± 0.003	< 0.005
02-09-17	610	0.027 ± 0.003	< 0.006	08-09-17	568	0.022 ± 0.003	< 0.006
02-15-17	474	0.028 ± 0.004	< 0.007	08-18-17	532	0.032 ± 0.003	< 0.013
02-22-17	539	0.027 ± 0.003	< 0.007	08-23-17	551	0.028 ± 0.003	< 0.006
03-01-17	527	0.023 ± 0.003	< 0.006	08-30-17	543	0.019 ± 0.003	< 0.015
03-08-17	540	0.023 ± 0.003	< 0.011	09-06-17	543	0.021 ± 0.003	< 0.007
03-16-17	605	0.025 ± 0.003	< 0.006	09-13-17	543	0.015 ± 0.003	< 0.007
03-22-17	462	0.024 ± 0.004	< 0.009	09-20-17	570	0.041 ± 0.003	< 0.005
03-30-17	634	0.022 ± 0.003	< 0.005	09-27-17	520	0.049 ± 0.004	< 0.005
<b>1Q 2017</b>	<b>Mean ± s.d.</b>	<b>0.024 ± 0.003</b>	<b>&lt; 0.011</b>	<b>3Q 2017</b>	<b>Mean ± s.d.</b>	<b>0.026 ± 0.010</b>	<b>&lt; 0.015</b>
04-05-17	446	0.013 ± 0.003	< 0.013	10-04-17	541	0.023 ± 0.003	< 0.007
04-12-17	530	0.012 ± 0.003	< 0.009	10-11-17	545	0.028 ± 0.003	< 0.009
04-19-17	560	0.019 ± 0.003	< 0.011	10-18-17	558	0.023 ± 0.003	< 0.006
04-26-17	580	0.012 ± 0.003	< 0.008	10-25-17	571	0.040 ± 0.003	< 0.006
05-03-17	572	0.010 ± 0.003	< 0.003	11-01-17	568	0.017 ± 0.003	< 0.006
05-10-17	558	0.014 ± 0.003	< 0.006	11-08-17	582	0.024 ± 0.003	< 0.006
05-17-17	583	0.012 ± 0.003	< 0.006	11-15-17	584	0.031 ± 0.003	< 0.008
05-24-17	560	0.013 ± 0.003	< 0.008	11-22-17	571	0.026 ± 0.003	< 0.007
05-31-17	565	0.010 ± 0.003	< 0.007	11-29-17	570	0.032 ± 0.003	< 0.008
06-07-17	572	0.017 ± 0.003	< 0.006	12-06-17	588	0.036 ± 0.003	< 0.006
06-14-17	564	0.026 ± 0.003	< 0.006	12-13-17	566	0.026 ± 0.003	< 0.006
06-21-17	547	0.020 ± 0.003	< 0.005	12-20-17	545	0.036 ± 0.003	< 0.006
06-28-17	566	0.013 ± 0.003	< 0.007	12-27-17	583	0.025 ± 0.003	< 0.007
				01-03-18	556	0.023 ± 0.003	< 0.007
<b>2Q 2017</b>	<b>Mean ± s.d.</b>	<b>0.015 ± 0.005</b>	<b>&lt; 0.013</b>	<b>4Q 2017</b>	<b>Mean ± s.d.</b>	<b>0.028 ± 0.006</b>	<b>&lt; 0.009</b>
<b>Cumulative Average</b>						<b>0.023</b>	

Table 2. Airborne particulates and charcoal canisters, analyses for gross beta and iodine-131.

Location: P-5

Units: pCi/m<sup>3</sup>

Collection: Continuous, weekly exchange.

Date Collected	Volume (m <sup>3</sup> )	Gross Beta	I-131	Date Collected	Volume (m <sup>3</sup> )	Gross Beta	I-131
<b>Required LLD</b>		<b>0.0075</b>	<b>0.050</b>			<b>0.0075</b>	<b>0.050</b>
01-04-17	553	0.022 ± 0.003	< 0.006	07-05-17	553	0.018 ± 0.003	< 0.008
01-11-17	555	0.029 ± 0.003	< 0.005	07-13-17	626	0.024 ± 0.003	< 0.008
01-18-17	548	0.031 ± 0.003	< 0.007	07-19-17	458	0.020 ± 0.003	< 0.008
01-25-17	553	0.018 ± 0.003	< 0.008	07-26-17	526	0.023 ± 0.003	< 0.003
02-01-17	540	0.020 ± 0.003	< 0.008	08-02-17	539	0.021 ± 0.003	< 0.005
02-09-17	630	0.025 ± 0.003	< 0.006	08-09-17	557	0.021 ± 0.003	< 0.006
02-15-17	471	0.031 ± 0.004	< 0.007	08-16-17	516	0.030 ± 0.003	< 0.013
02-22-17	546	0.029 ± 0.003	< 0.007	08-23-17	541	0.029 ± 0.003	< 0.006
03-01-17	535	0.025 ± 0.003	< 0.006	08-30-17	535	0.017 ± 0.003	< 0.015
03-08-17	548	0.024 ± 0.003	< 0.011	09-06-17	532	0.022 ± 0.003	< 0.008
03-16-17	637	0.024 ± 0.003	< 0.008	09-13-17	533	0.012 ± 0.003	< 0.007
03-22-17	454	0.028 ± 0.004	< 0.009	09-20-17	560	0.039 ± 0.003	< 0.005
03-30-17	630	0.023 ± 0.003	< 0.005	09-27-17	518	0.045 ± 0.004	< 0.005
<b>1Q 2017 Mean ± s.d.</b>				<b>3Q 2017 Mean ± s.d.</b>			
		0.026 ± 0.004	< 0.011			0.025 ± 0.009	< 0.015
04-05-17	451	0.013 ± 0.003	< 0.013	10-04-17	523	0.025 ± 0.003	< 0.007
04-12-17	537	0.015 ± 0.003	< 0.009	10-11-17	514	0.024 ± 0.003	< 0.010
04-19-17	594	0.019 ± 0.003	< 0.011	10-18-17	561	0.024 ± 0.003	< 0.006
04-26-17	565	0.011 ± 0.003	< 0.007	10-25-17	583	0.040 ± 0.003	< 0.006
05-03-17	596	0.013 ± 0.003	< 0.003	11-01-17	540	0.016 ± 0.003	< 0.006
05-10-17	571	0.013 ± 0.003	< 0.006	11-08-17	564	0.029 ± 0.003	< 0.007
05-17-17	579	0.012 ± 0.003	< 0.006	11-15-17	574	0.033 ± 0.003	< 0.008
05-24-17	560	0.017 ± 0.003	< 0.008	11-22-17	536	0.028 ± 0.003	< 0.007
05-31-17	533	0.013 ± 0.003	< 0.007	11-29-17	542	0.029 ± 0.003	< 0.008
06-07-17	571	0.014 ± 0.003	< 0.006	12-06-17	543	0.035 ± 0.003	< 0.007
06-14-17	567	0.022 ± 0.003	< 0.006	12-13-17	529	0.029 ± 0.003	< 0.006
06-21-17	545	0.020 ± 0.003	< 0.005	12-20-17	534	0.034 ± 0.003	< 0.006
06-28-17	544	0.015 ± 0.003	< 0.007	12-27-17	544	0.026 ± 0.003	< 0.007
				01-03-18	517	0.027 ± 0.003	< 0.007
<b>2Q 2017 Mean ± s.d.</b>				<b>4Q 2017 Mean ± s.d.</b>			
		0.016 ± 0.003	< 0.013			0.029 ± 0.006	< 0.010
<b>Cumulative Average</b>						<b>0.024</b>	



Table 2. Airborne particulates and charcoal canisters, analyses for gross beta and iodine-131.

Location: P-6

Units: pCi/m<sup>3</sup>

Collection: Continuous, weekly exchange.

Date Collected	Volume (m <sup>3</sup> )	Gross Beta	I-131	Date Collected	Volume (m <sup>3</sup> )	Gross Beta	I-131
<b>Required LLD</b>		<b>0.0075</b>	<b>0.050</b>			<b>0.0075</b>	<b>0.050</b>
01-04-17	559	0.022 ± 0.003	< 0.006	07-05-17	548	0.020 ± 0.003	< 0.006
01-11-17	566	0.024 ± 0.003	< 0.005	07-13-17	628	0.032 ± 0.003	< 0.008
01-18-17	538	0.027 ± 0.003	< 0.007	07-19-17	460	0.027 ± 0.004	< 0.008
01-25-17	546	0.017 ± 0.003	< 0.009	07-26-17	533	0.026 ± 0.003	< 0.003
02-01-17	542	0.024 ± 0.003	< 0.008	08-02-17	540	0.022 ± 0.003	< 0.005
02-09-17	615	0.027 ± 0.003	< 0.008	08-09-17	553	0.024 ± 0.003	< 0.008
02-15-17	476	0.030 ± 0.004	< 0.007	08-16-17	528	0.036 ± 0.004	< 0.013
02-22-17	537	0.024 ± 0.003	< 0.007	08-23-17	535	0.036 ± 0.004	< 0.008
03-01-17	539	0.021 ± 0.003	< 0.006	08-30-17	538	0.018 ± 0.003	< 0.015
03-08-17	547	0.023 ± 0.003	< 0.011	09-06-17	534	0.026 ± 0.003	< 0.008
03-16-17	624	0.024 ± 0.003	< 0.006	09-13-17	528	0.015 ± 0.003	< 0.007
03-22-17	466	0.020 ± 0.003	< 0.009	09-20-17	547	0.042 ± 0.004	< 0.005
03-30-17	625	0.023 ± 0.003	< 0.005	09-27-17	513	0.057 ± 0.004	< 0.006
<b>1Q 2017 Mean ± s.d.</b>				<b>3Q 2017 Mean ± s.d.</b>			
		0.024 ± 0.003	< 0.011			0.029 ± 0.011	< 0.015
04-05-17	458	0.016 ± 0.003	< 0.012	10-04-17	525	0.032 ± 0.003	< 0.007
04-12-17	534	0.014 ± 0.003	< 0.009	10-11-17	491	0.033 ± 0.004	< 0.010
04-19-17	557	0.023 ± 0.003	< 0.011	10-18-17	551	0.027 ± 0.003	< 0.006
04-26-17	560	0.014 ± 0.003	< 0.008	10-25-17	556	0.043 ± 0.004	< 0.006
05-03-17	575	0.013 ± 0.003	< 0.003	11-01-17	515	0.019 ± 0.003	< 0.006
05-10-17	536	0.014 ± 0.003	< 0.006	11-08-17	540	0.029 ± 0.003	< 0.007
05-17-17	556	0.016 ± 0.003	< 0.006	11-15-17	538	0.036 ± 0.004	< 0.009
05-24-17	540	0.016 ± 0.003	< 0.008	11-22-17	519	0.028 ± 0.003	< 0.008
05-31-17	521	0.014 ± 0.003	< 0.007	11-29-17	520	0.031 ± 0.003	< 0.009
06-07-17	544	0.017 ± 0.003	< 0.006	12-06-17	516	0.036 ± 0.004	< 0.007
06-14-17	560	0.026 ± 0.003	< 0.006	12-13-17	490	0.031 ± 0.004	< 0.006
06-21-17	540	0.028 ± 0.003	< 0.005	12-20-17	485	0.039 ± 0.004	< 0.007
06-28-17	536	0.018 ± 0.003	< 0.007	12-27-17	498	0.027 ± 0.003	< 0.008
				01-03-18	463	0.034 ± 0.004	< 0.008
<b>2Q 2017 Mean ± s.d.</b>				<b>4Q 2017 Mean ± s.d.</b>			
		0.018 ± 0.005	< 0.012			0.032 ± 0.006	< 0.010
<b>Cumulative Average</b>						<b>0.026</b>	

Table 2 Airborne particulates and charcoal canisters, analyses for gross beta and iodine-131.

Location: P-7

Units: pCi/m<sup>3</sup>

Collection: Continuous, weekly exchange.

Date Collected	Volume (m <sup>3</sup> )	Gross Beta	I-131	Date Collected	Volume (m <sup>3</sup> )	Gross Beta	I-131	
<b>Required LLD</b>		<u>0.0075</u>	<u>0.050</u>			<u>0.0075</u>	<u>0.050</u>	
01-04-17	525	0.024 ± 0.003	< 0.006	07-05-17	567	0.021 ± 0.003	< 0.007	
01-11-17	521	0.026 ± 0.003	< 0.005	07-13-17	677	0.026 ± 0.003	< 0.007	
01-18-17	543	0.038 ± 0.004	< 0.007	07-19-17	494	0.025 ± 0.003	< 0.007	
01-25-17	535	0.016 ± 0.003	< 0.009	07-26-17	533	0.027 ± 0.003	< 0.003	
02-01-17	524	0.023 ± 0.003	< 0.008	08-02-17	544	0.025 ± 0.003	< 0.005	
02-09-17	595	0.024 ± 0.003	< 0.008	08-09-17	544	0.027 ± 0.003	< 0.008	
02-15-17	463	0.028 ± 0.004	< 0.007	08-16-17	526	0.036 ± 0.004	< 0.013	
02-22-17	511	0.027 ± 0.003	< 0.008	08-23-17	544	0.034 ± 0.003	< 0.008	
03-01-17	535	0.022 ± 0.003	< 0.008	08-30-17	537	0.021 ± 0.003	< 0.015	
03-08-17	518	0.021 ± 0.003	< 0.012	09-06-17	516	0.025 ± 0.003	< 0.008	
03-16-17	599	0.023 ± 0.003	< 0.008	09-13-17	515	0.016 ± 0.003	< 0.007	
03-22-17	450	0.027 ± 0.004	< 0.009	09-20-17	519	0.049 ± 0.004	< 0.005	
03-30-17	629	0.021 ± 0.003	< 0.006	09-27-17	509	0.058 ± 0.004	< 0.006	
<b>1Q 2017 Mean ± s.d.</b>		<b>0.025 ± 0.005</b>	<b>&lt; 0.012</b>	<b>3Q 2017 Mean ± s.d.</b>		<b>0.030 ± 0.012</b>	<b>&lt; 0.015</b>	
04-05-17	442	0.016 ± 0.003	< 0.013	10-04-17	535	0.040 ± 0.004	< 0.007	
04-12-17	529	0.013 ± 0.003	< 0.009	10-11-17	505	0.036 ± 0.004	< 0.010	
04-19-17	546	0.019 ± 0.003	< 0.012	10-18-17	534	0.023 ± 0.003	< 0.008	
04-26-17	540	0.016 ± 0.003	< 0.008	10-25-17	558	0.035 ± 0.003	< 0.006	
05-03-17	545	0.014 ± 0.003	< 0.003	11-01-17	525	0.015 ± 0.003	< 0.008	
05-10-17	520	0.020 ± 0.003	< 0.007	11-08-17	539	0.024 ± 0.003	< 0.007	
05-17-17	536	0.017 ± 0.003	< 0.008	11-15-17	559	0.032 ± 0.003	< 0.008	
05-24-17	518	0.019 ± 0.003	< 0.009	11-22-17	517	0.026 ± 0.003	< 0.008	
05-31-17	515	0.013 ± 0.003	< 0.007	11-29-17	547	0.031 ± 0.003	< 0.008	
06-07-17	538	0.019 ± 0.003	< 0.006	12-06-17	537	0.033 ± 0.003	< 0.007	
06-14-17	559	0.027 ± 0.003	< 0.008	12-13-17	530	0.024 ± 0.003	< 0.008	
06-21-17	534	0.025 ± 0.003	< 0.005	12-20-17	520	0.029 ± 0.003	< 0.008	
06-28-17	552	0.018 ± 0.003	< 0.007	12-27-17	537	0.022 ± 0.003	< 0.007	
<b>2Q 2017 Mean ± s.d.</b>		<b>0.018 ± 0.004</b>	<b>&lt; 0.013</b>	01-03-18	517	0.027 ± 0.003	< 0.007	
<b>4Q 2017 Mean ± s.d.</b>		<b>0.028 ± 0.007</b>	<b>&lt; 0.010</b>	<b>Cumulative Average</b>				<b>0.025</b>

Table 2. Airborne particulates and charcoal canisters, analyses for gross beta and iodine-131.

Location: P-35

Units: pCi/m<sup>3</sup>

Collection: Continuous, weekly exchange.

Date Collected	Volume (m <sup>3</sup> )	Gross Beta	I-131	Date Collected	Volume (m <sup>3</sup> )	Gross Beta	I-131
<b>Required LLD</b>		<b>0.0075</b>	<b>0.050</b>			<b>0.0075</b>	<b>0.050</b>
01-04-17	554	0.022 ± 0.003	< 0.014	07-05-17	562	0.016 ± 0.003	< 0.011
01-11-17	549	0.026 ± 0.003	< 0.011	07-13-17	650	0.023 ± 0.003	< 0.014
01-18-17	569	0.026 ± 0.003	< 0.006	07-19-17	484	0.020 ± 0.003	< 0.016
01-25-17	540	0.016 ± 0.003	< 0.013	07-26-17	562	0.022 ± 0.003	< 0.006
02-01-17	559	0.020 ± 0.003	< 0.008	08-02-17	554	0.018 ± 0.003	< 0.013
02-09-17	623	0.024 ± 0.003	< 0.011	08-09-17	567	0.026 ± 0.003	< 0.010
02-15-17	505	0.027 ± 0.003	< 0.013	08-16-17	544	0.034 ± 0.003	< 0.014
02-22-17	520	0.025 ± 0.003	< 0.010	08-23-17	551	0.033 ± 0.003	< 0.011
03-01-17	573	0.021 ± 0.003	< 0.013	08-30-17	552	0.016 ± 0.003	< 0.006
03-08-17	550	0.021 ± 0.003	< 0.012	09-06-17	535	0.022 ± 0.003	< 0.015
03-16-17	614	0.022 ± 0.003	< 0.005	09-13-17	548	0.018 ± 0.003	< 0.012
03-22-17	464	0.024 ± 0.004	< 0.011	09-20-17	565	0.038 ± 0.003	< 0.012
03-30-17	548	0.023 ± 0.003	< 0.010	09-27-17	540	0.049 ± 0.004	< 0.008
<b>1Q 2017</b>	<b>Mean ± s.d.</b>	<b>0.023 ± 0.003</b>	<b>&lt; 0.014</b>	<b>3Q 2017</b>	<b>Mean ± s.d.</b>	<b>0.026 ± 0.010</b>	<b>&lt; 0.016</b>
04-05-17	466	0.011 ± 0.003	< 0.012	10-04-17	554	0.025 ± 0.003	< 0.012
04-12-17	555	0.011 ± 0.003	< 0.011	10-11-17	543	0.025 ± 0.003	< 0.017
04-19-17	550	0.020 ± 0.003	< 0.009	10-18-17	570	0.023 ± 0.003	< 0.009
04-26-17	583	0.012 ± 0.003	< 0.008	10-25-17	596	0.034 ± 0.003	< 0.011
05-03-17	573	0.010 ± 0.003	< 0.011	11-01-17	535	0.017 ± 0.003	< 0.015
05-10-17	534	0.013 ± 0.003	< 0.013	11-08-17	584	0.023 ± 0.003	< 0.011
05-17-17	557	0.012 ± 0.003	< 0.011	11-15-17	584	0.033 ± 0.003	< 0.011
05-24-17	571	0.017 ± 0.003	< 0.011	11-22-17	524	0.025 ± 0.003	< 0.009
05-31-17	542	0.009 ± 0.003	< 0.013	11-29-17	551	0.029 ± 0.003	< 0.012
06-07-17	547	0.013 ± 0.003	< 0.007	12-06-17	568	0.031 ± 0.003	< 0.010
06-14-17	564	0.022 ± 0.003	< 0.011	12-13-17	540	0.023 ± 0.003	< 0.008
06-21-17	539	0.021 ± 0.003	< 0.011	12-20-17	528	0.028 ± 0.003	< 0.009
06-28-17	563	0.015 ± 0.003	< 0.006	12-27-17	621	0.022 ± 0.003	< 0.010
				01-03-18	460	0.027 ± 0.004	< 0.018
<b>2Q 2017</b>	<b>Mean ± s.d.</b>	<b>0.014 ± 0.004</b>	<b>&lt; 0.013</b>	<b>4Q 2017</b>	<b>Mean ± s.d.</b>	<b>0.026 ± 0.005</b>	<b>&lt; 0.018</b>
<b>Cumulative Average</b>						<b>0.022</b>	

Table 3. Airborne particulates, analyses for gamma-emitting isotopes.  
 Collection: Quarterly Composite  
 Units: pCi/m<sup>3</sup>

PE-1					
Location	1st Qtr.	2nd Qtr.	3rd Qtr.	4th Qtr.	Req. LLD
Lab Code	PEAP- 1725	PEAP- 3720	PEAP- 5595	PEAP- 6831	
Vol. (m <sup>3</sup> )	7102	7111	7460	8057	
Be-7	0.071 ± 0.010	0.075 ± 0.010	0.071 ± 0.009	0.062 ± 0.009	-
Co-58	< 0.0004	< 0.0003	< 0.0003	< 0.0004	-
Co-60	< 0.0004	< 0.0004	< 0.0004	< 0.0005	-
Cs-134	< 0.0003	< 0.0004	< 0.0004	< 0.0005	0.037
Cs-137	< 0.0004	< 0.0004	< 0.0003	< 0.0003	0.045
PE-3					
Location	1st Qtr.	2nd Qtr.	3rd Qtr.	4th Qtr.	Req. LLD
Lab Code	PEAP- 1726	PEAP- 3721	PEAP- 5596	PEAP- 6832	
Vol. (m <sup>3</sup> )	7004	8245	7862	8166	
Be-7	0.068 ± 0.010	0.072 ± 0.008	0.060 ± 0.009	0.049 ± 0.007	-
Co-58	< 0.0003	< 0.0005	< 0.0003	< 0.0002	-
Co-60	< 0.0002	< 0.0002	< 0.0003	< 0.0003	-
Cs-134	< 0.0005	< 0.0004	< 0.0003	< 0.0004	0.037
Cs-137	< 0.0005	< 0.0004	< 0.0002	< 0.0002	0.045
PE-4					
Location	1st Qtr.	2nd Qtr.	3rd Qtr.	4th Qtr.	Req. LLD
Lab Code	PEAP- 1727	PEAP- 3722	PEAP- 5597	PEAP- 6833	
Vol. (m <sup>3</sup> )	7121	7163	7121	7930	
Be-7	0.072 ± 0.008	0.074 ± 0.012	0.066 ± 0.009	0.065 ± 0.011	-
Co-58	< 0.0003	< 0.0004	< 0.0004	< 0.0006	-
Co-60	< 0.0004	< 0.0004	< 0.0002	< 0.0004	-
Cs-134	< 0.0004	< 0.0006	< 0.0003	< 0.0006	0.037
Cs-137	< 0.0003	< 0.0007	< 0.0004	< 0.0004	0.045
PE-5					
Location	1st Qtr.	2nd Qtr.	3rd Qtr.	4th Qtr.	Req. LLD
Lab Code	PEAP- 1729	PEAP- 3723	PEAP- 5598	PEAP- 6834	
Vol. (m <sup>3</sup> )	7200	7212	6993	7603	
Be-7	0.080 ± 0.012	0.070 ± 0.009	0.069 ± 0.008	0.057 ± 0.007	-
Co-58	< 0.0005	< 0.0004	< 0.0005	< 0.0003	-
Co-60	< 0.0003	< 0.0002	< 0.0004	< 0.0003	-
Cs-134	< 0.0005	< 0.0003	< 0.0005	< 0.0004	0.037
Cs-137	< 0.0003	< 0.0003	< 0.0002	< 0.0004	0.045

Table 3. Airborne particulates, analyses for gamma-emitting isotopes.  
 Collection: Quarterly Composite  
 Units: pCi/m<sup>3</sup>

PE-6					
Location	1st Qtr.	2nd Qtr.	3rd Qtr.	4th Qtr.	Req. LLD
Quarter					
Lab Code	PEAP- 1730	PEAP- 3724	PEAP- 5599	PEAP- 6835	
Vol. (m <sup>3</sup> )	7179	7016	6986	7207	
Be-7	0.070 ± 0.009	0.082 ± 0.013	0.084 ± 0.010	0.061 ± 0.009	-
Co-58	< 0.0005	< 0.0002	< 0.0003	< 0.0005	-
Co-60	< 0.0003	< 0.0003	< 0.0003	< 0.0004	-
Cs-134	< 0.0005	< 0.0006	< 0.0003	< 0.0004	0.037
Cs-137	< 0.0005	< 0.0004	< 0.0003	< 0.0003	0.045
PE-7					
Location					
Lab Code	PEAP- 1731	PEAP- 3725	PEAP- 5600	PEAP- 6836	
Vol. (m <sup>3</sup> )	6947	6875	7025	7460	
Be-7	0.063 ± 0.009	0.083 ± 0.011	0.081 ± 0.013	0.051 ± 0.007	-
Co-58	< 0.0005	< 0.0005	< 0.0007	< 0.0005	-
Co-60	< 0.0003	< 0.0005	< 0.0005	< 0.0003	-
Cs-134	< 0.0005	< 0.0005	< 0.0006	< 0.0004	0.037
Cs-137	< 0.0004	< 0.0003	< 0.0006	< 0.0003	0.045
PE-35					
Location					
Lab Code	PEAP- 1732	PEAP- 3726	PEAP- 5601	PEAP- 6837	
Vol. (m <sup>3</sup> )	7268	7143	7213	7759	
Be-7	0.063 ± 0.008	0.062 ± 0.011	0.069 ± 0.009	0.054 ± 0.009	-
Co-58	< 0.0004	< 0.0004	< 0.0006	< 0.0002	-
Co-60	< 0.0003	< 0.0004	< 0.0004	< 0.0004	-
Cs-134	< 0.0003	< 0.0005	< 0.0004	< 0.0005	0.037
Cs-137	< 0.0003	< 0.0004	< 0.0005	< 0.0004	0.045

Table 4. Lake water, analysis for gross beta and gamma emitting isotopes.

PNPP

	Location: P-34				Collection: Monthly composites	Units: pCi/L
Lab Code	PELW- 406	PELW- 785	PELW- 1306	PELW- 1902		
Start Date	12-29-16	01-26-17	02-23-17	03-30-17	Req. LLD	
End Date	01-26-17	02-23-17	03-30-17	04-27-17		
Gross beta	2.0 ± 0.6	1.3 ± 0.7	2.1 ± 0.7	2.3 ± 0.6		3.0
Mn-54	< 3.2	< 2.9	< 2.4	< 3.0		11
Fe-59	< 3.1	< 4.8	< 4.5	< 6.2		22
Co-58	< 1.8	< 2.9	< 2.5	< 3.1		11
Co-60	< 2.2	< 2.1	< 1.8	< 2.5		11
Zn-65	< 5.7	< 1.7	< 2.0	< 5.9		22
Zr-95	< 5.4	< 5.1	< 4.2	< 2.5		22
Nb-95	< 3.8	< 2.1	< 3.2	< 2.6		11
Cs-134	< 3.7	< 3.4	< 2.8	< 3.3		11
Cs-137	< 2.0	< 3.4	< 2.8	< 3.1		13
Ba-140	< 19.8	< 15.2	< 20.3	< 24.0		45
La-140	< 4.4	< 3.2	< 2.5	< 5.4		11
Lab Code	PELW- 2899	PELW- 3277	PELW- 3965	PELW- 4484		
Start Date	04-27-17	05-26-17	06-28-17	07-24-17	Req. LLD	
End Date	05-26-17	06-29-17	07-24-17	08-31-17		
Gross beta	1.1 ± 0.5	1.4 ± 0.6	< 0.9	1.1 ± 0.6		3.0
Mn-54	< 1.5	< 2.3	< 4.1	< 2.9		11
Fe-59	< 4.9	< 3.4	< 8.8	< 5.8		22
Co-58	< 2.7	< 1.7	< 2.6	< 2.9		11
Co-60	< 1.4	< 2.6	< 2.5	< 2.3		11
Zn-65	< 3.7	< 2.1	< 3.4	< 2.6		22
Zr-95	< 3.2	< 2.8	< 5.0	< 5.5		22
Nb-95	< 2.4	< 1.9	< 4.8	< 3.0		11
Cs-134	< 2.5	< 2.6	< 3.5	< 3.5		11
Cs-137	< 2.9	< 3.3	< 4.8	< 2.9		13
Ba-140	< 34.2	< 23.9	< 38.5	< 20.4		45
La-140	< 4.0	< 3.2	< 4.5	< 5.2		11
Lab Code	PELW- 5145	PELW- 5740	PELW- 6325	PELW- 6650		
Start Date	08-31-17	09-28-17	10-26-17	11-30-17	Req. LLD	
End Date	09-28-17	10-26-17	11-30-17	12-28-17		
Gross beta	1.5 ± 0.6	1.0 ± 0.5	1.6 ± 0.6	1.6 ± 0.6		3.0
Mn-54	< 2.7	< 4.3	< 1.7	< 2.0		11
Fe-59	< 3.6	< 4.4	< 2.8	< 3.9		22
Co-58	< 2.1	< 2.1	< 1.5	< 4.0		11
Co-60	< 2.2	< 1.3	< 2.9	< 2.9		11
Zn-65	< 5.1	< 6.3	< 4.0	< 6.6		22
Zr-95	< 2.7	< 5.8	< 4.4	< 5.9		22
Nb-95	< 3.1	< 2.6	< 2.3	< 2.7		11
Cs-134	< 3.1	< 3.0	< 2.9	< 4.3		11
Cs-137	< 3.4	< 2.0	< 2.8	< 3.3		13
Ba-140	< 22.4	< 16.3	< 11.7	< 25.9		45
La-140	< 3.3	< 3.0	< 3.3	< 4.6		11

Table 4. Lake water, analyses for gross beta and gamma emitting isotopes

	Location: P-36		Collection: Monthly composites		Units: pCi/L	
<b>Lab Code</b>	<b>PELW- 407</b>	<b>PELW- 786</b>	<b>PELW- 1307</b>	<b>PELW- 1903</b>		<b>Req. LLD</b>
<b>Start Date</b>	<b>12-29-16</b>	<b>01-26-17</b>	<b>02-23-17</b>	<b>03-30-17</b>		
<b>End Date</b>	<b>01-26-17</b>	<b>02-23-17</b>	<b>03-30-17</b>	<b>04-27-17</b>		
<b>Gross beta</b>	<b>2.5 ± 0.7</b>	<b>1.3 ± 0.7</b>	<b>1.9 ± 0.7</b>	<b>1.3 ± 0.5</b>		<b>3.0</b>
<b>Mn-54</b>	<b>&lt; 1.7</b>	<b>&lt; 1.8</b>	<b>&lt; 2.1</b>	<b>&lt; 2.5</b>		<b>11</b>
<b>Fe-59</b>	<b>&lt; 7.3</b>	<b>&lt; 2.2</b>	<b>&lt; 4.9</b>	<b>&lt; 4.2</b>		<b>22</b>
<b>Co-58</b>	<b>&lt; 1.8</b>	<b>&lt; 2.2</b>	<b>&lt; 3.1</b>	<b>&lt; 3.2</b>		<b>11</b>
<b>Co-60</b>	<b>&lt; 2.1</b>	<b>&lt; 2.2</b>	<b>&lt; 2.2</b>	<b>&lt; 2.1</b>		<b>11</b>
<b>Zn-65</b>	<b>&lt; 3.6</b>	<b>&lt; 5.1</b>	<b>&lt; 4.0</b>	<b>&lt; 3.1</b>		<b>22</b>
<b>Zr-95</b>	<b>&lt; 3.5</b>	<b>&lt; 3.8</b>	<b>&lt; 4.3</b>	<b>&lt; 4.2</b>		<b>22</b>
<b>Nb-95</b>	<b>&lt; 2.9</b>	<b>&lt; 2.5</b>	<b>&lt; 3.1</b>	<b>&lt; 2.4</b>		<b>11</b>
<b>Cs-134</b>	<b>&lt; 3.0</b>	<b>&lt; 2.8</b>	<b>&lt; 3.0</b>	<b>&lt; 3.0</b>		<b>11</b>
<b>Cs-137</b>	<b>&lt; 3.1</b>	<b>&lt; 2.2</b>	<b>&lt; 2.0</b>	<b>&lt; 2.3</b>		<b>13</b>
<b>Ba-140</b>	<b>&lt; 24.2</b>	<b>&lt; 13.6</b>	<b>&lt; 15.4</b>	<b>&lt; 27.8</b>		<b>45</b>
<b>La-140</b>	<b>&lt; 4.0</b>	<b>&lt; 2.0</b>	<b>&lt; 2.2</b>	<b>&lt; 3.0</b>		<b>11</b>
<b>Lab Code</b>	<b>PELW- 2700</b>	<b>PELW- 3278</b>	<b>PELW- 3966</b>	<b>PELW- 4485</b>		<b>Req. LLD</b>
<b>Start Date</b>	<b>04-27-17</b>	<b>05-26-17</b>	<b>06-29-17</b>	<b>07-24-17</b>		
<b>End Date</b>	<b>05-26-17</b>	<b>06-29-17</b>	<b>07-24-17</b>	<b>08-31-17</b>		
<b>Gross beta</b>	<b>0.9 ± 0.5</b>	<b>1.2 ± 0.5</b>	<b>1.3 ± 0.6</b>	<b>&lt; 0.8</b>		<b>3.0</b>
<b>Mn-54</b>	<b>&lt; 2.0</b>	<b>&lt; 2.1</b>	<b>&lt; 4.3</b>	<b>&lt; 2.2</b>		<b>11</b>
<b>Fe-59</b>	<b>&lt; 4.9</b>	<b>&lt; 2.6</b>	<b>&lt; 5.7</b>	<b>&lt; 3.5</b>		<b>22</b>
<b>Co-58</b>	<b>&lt; 2.3</b>	<b>&lt; 1.7</b>	<b>&lt; 2.5</b>	<b>&lt; 1.9</b>		<b>11</b>
<b>Co-60</b>	<b>&lt; 1.9</b>	<b>&lt; 1.2</b>	<b>&lt; 4.3</b>	<b>&lt; 2.7</b>		<b>11</b>
<b>Zn-65</b>	<b>&lt; 1.9</b>	<b>&lt; 3.6</b>	<b>&lt; 3.7</b>	<b>&lt; 1.8</b>		<b>22</b>
<b>Zr-95</b>	<b>&lt; 3.8</b>	<b>&lt; 3.9</b>	<b>&lt; 7.7</b>	<b>&lt; 3.9</b>		<b>22</b>
<b>Nb-95</b>	<b>&lt; 3.9</b>	<b>&lt; 4.0</b>	<b>&lt; 3.0</b>	<b>&lt; 2.7</b>		<b>11</b>
<b>Cs-134</b>	<b>&lt; 2.7</b>	<b>&lt; 2.9</b>	<b>&lt; 4.2</b>	<b>&lt; 2.6</b>		<b>11</b>
<b>Cs-137</b>	<b>&lt; 3.0</b>	<b>&lt; 1.7</b>	<b>&lt; 3.2</b>	<b>&lt; 1.6</b>		<b>13</b>
<b>Ba-140</b>	<b>&lt; 43.5</b>	<b>&lt; 29.1</b>	<b>&lt; 19.2</b>	<b>&lt; 23.1</b>		<b>45</b>
<b>La-140</b>	<b>&lt; 6.7</b>	<b>&lt; 3.4</b>	<b>&lt; 4.7</b>	<b>&lt; 2.2</b>		<b>11</b>
<b>Lab Code</b>	<b>PELW- 5147</b>	<b>PELW- 5741</b>	<b>PELW- 6326</b>	<b>PELW- 6651</b>		<b>Req. LLD</b>
<b>Start Date</b>	<b>08-31-17</b>	<b>09-28-17</b>	<b>10-26-17</b>	<b>11-30-17</b>		
<b>End Date</b>	<b>09-28-17</b>	<b>10-26-17</b>	<b>11-30-17</b>	<b>12-28-17</b>		
<b>Gross beta</b>	<b>1.5 ± 0.6</b>	<b>1.2 ± 0.6</b>	<b>1.1 ± 0.5</b>	<b>1.0 ± 0.5</b>		<b>3.0</b>
<b>Mn-54</b>	<b>&lt; 1.7</b>	<b>&lt; 2.3</b>	<b>&lt; 2.8</b>	<b>&lt; 3.1</b>		<b>11</b>
<b>Fe-59</b>	<b>&lt; 3.9</b>	<b>&lt; 4.6</b>	<b>&lt; 5.1</b>	<b>&lt; 3.3</b>		<b>22</b>
<b>Co-58</b>	<b>&lt; 2.2</b>	<b>&lt; 1.6</b>	<b>&lt; 4.1</b>	<b>&lt; 2.8</b>		<b>11</b>
<b>Co-60</b>	<b>&lt; 2.1</b>	<b>&lt; 2.1</b>	<b>&lt; 2.8</b>	<b>&lt; 1.8</b>		<b>11</b>
<b>Zn-65</b>	<b>&lt; 4.4</b>	<b>&lt; 3.9</b>	<b>&lt; 3.2</b>	<b>&lt; 2.3</b>		<b>22</b>
<b>Zr-95</b>	<b>&lt; 6.3</b>	<b>&lt; 5.8</b>	<b>&lt; 6.0</b>	<b>&lt; 5.9</b>		<b>22</b>
<b>Nb-95</b>	<b>&lt; 4.0</b>	<b>&lt; 3.6</b>	<b>&lt; 3.0</b>	<b>&lt; 3.3</b>		<b>11</b>
<b>Cs-134</b>	<b>&lt; 2.7</b>	<b>&lt; 3.6</b>	<b>&lt; 3.2</b>	<b>&lt; 2.8</b>		<b>11</b>
<b>Cs-137</b>	<b>&lt; 2.6</b>	<b>&lt; 3.6</b>	<b>&lt; 2.9</b>	<b>&lt; 3.8</b>		<b>13</b>
<b>Ba-140</b>	<b>&lt; 25.8</b>	<b>&lt; 18.0</b>	<b>&lt; 22.1</b>	<b>&lt; 23.9</b>		<b>45</b>
<b>La-140</b>	<b>&lt; 5.6</b>	<b>&lt; 3.1</b>	<b>&lt; 3.6</b>	<b>&lt; 2.8</b>		<b>11</b>

Table 4. Lake water, analyses for gross beta and gamma emitting isotopes.

PNPP

	Location: P-39		Collection: Monthly composites		Units: pCi/L	
Lab Code	PELW- 408	PELW- 787	PELW- 1308	PELW- 1904		
Start Date	12-29-16	01-26-17	02-23-17	03-30-17	Req. LLD	
End Date	01-26-17	02-23-17	03-30-17	04-27-17		
Gross beta	< 1.3	1.8 ± 0.7	1.6 ± 0.7	1.3 ± 0.5		3.0
Mn-54	< 2.4	< 1.9	< 1.3	< 2.8		11
Fe-59	< 3.7	< 4.0	< 5.1	< 4.6		22
Co-58	< 2.7	< 2.7	< 1.8	< 2.0		11
Co-60	< 1.2	< 2.6	< 1.7	< 2.2		11
Zn-65	< 3.9	< 2.3	< 2.3	< 1.8		22
Zr-95	< 4.4	< 4.5	< 3.4	< 1.8		22
Nb-95	< 1.8	< 2.7	< 2.5	< 3.2		11
Cs-134	< 3.3	< 3.3	< 2.1	< 2.5		11
Cs-137	< 3.6	< 2.3	< 2.1	< 3.4		13
Ba-140	< 19.3	< 21.2	< 17.2	< 21.2		45
La-140	< 2.0	< 3.9	< 2.2	< 6.4		11
Lab Code	PELW- 2701	PELW- 3279	PELW- 3967	PELW- 4486		
Start Date	04-27-17	05-26-17	06-29-17	07-24-17	Req. LLD	
End Date	05-26-17	06-29-17	07-24-17	08-31-17		
Gross beta	1.2 ± 0.6	< 0.9	< 0.9	1.4 ± 0.6		3.0
Mn-54	< 2.1	< 2.3	< 3.2	< 3.1		11
Fe-59	< 6.0	< 4.8	< 7.4	< 6.7		22
Co-58	< 2.8	< 2.2	< 3.0	< 3.3		11
Co-60	< 2.1	< 1.8	< 3.0	< 3.0		11
Zn-65	< 5.3	< 2.8	< 2.8	< 6.0		22
Zr-95	< 3.2	< 5.1	< 6.6	< 5.1		22
Nb-95	< 4.1	< 2.4	< 5.1	< 3.0		11
Cs-134	< 2.8	< 2.4	< 4.2	< 3.4		11
Cs-137	< 2.7	< 2.0	< 5.7	< 2.0		13
Ba-140	< 29.5	< 23.2	< 25.4	< 17.6		45
La-140	< 7.6	< 2.0	< 3.6	< 1.4		11
Lab Code	PELW- 5148	PELW- 5742	PELW- 6327	PELW- 6652		
Start Date	08-31-17	09-28-17	10-26-17	11-30-17	Req. LLD	
End Date	09-28-17	10-26-17	11-30-17	12-28-17		
Gross beta	1.3 ± 0.5	< 0.9	< 0.9	1.3 ± 0.6		3.0
Mn-54	< 2.0	< 1.9	< 2.6	< 2.1		11
Fe-59	< 7.6	< 5.0	< 4.9	< 3.6		22
Co-58	< 4.0	< 1.4	< 2.6	< 3.0		11
Co-60	< 3.7	< 2.0	< 2.7	< 2.2		11
Zn-65	< 4.3	< 3.3	< 5.5	< 2.7		22
Zr-95	< 6.0	< 4.7	< 5.7	< 5.4		22
Nb-95	< 2.9	< 3.9	< 3.7	< 2.4		11
Cs-134	< 3.7	< 3.1	< 3.2	< 2.7		11
Cs-137	< 4.4	< 3.7	< 2.2	< 2.2		13
Ba-140	< 29.9	< 17.0	< 17.2	< 18.1		45
La-140	< 5.0	< 4.2	< 2.9	< 3.6		11



Table 4. Lake water, analyses for gross beta and gamma emitting isotopes.

Location: P-59		Collection: Monthly composites			Units: pCi/L
<b>Lab Code</b>	<b>NS<sup>a</sup></b>	<b>PELW- 788</b>	<b>PELW- 1309</b>	<b>PELW- 1905</b>	
<b>Start Date</b>		<b>01-26-17</b>	<b>02-23-17</b>	<b>03-30-17</b>	<b>Req. LLD</b>
<b>End Date</b>		<b>02-23-17</b>	<b>03-30-17</b>	<b>04-27-17</b>	
<b>Gross beta</b>	-	<b>2.4 ± 0.7</b>	<b>2.1 ± 0.7</b>	<b>1.8 ± 0.6</b>	<b>3.0</b>
<b>Mn-54</b>	-	<b>&lt; 2.4</b>	<b>&lt; 2.1</b>	<b>&lt; 2.9</b>	<b>11</b>
<b>Fe-59</b>	-	<b>&lt; 5.3</b>	<b>&lt; 2.1</b>	<b>&lt; 6.8</b>	<b>22</b>
<b>Co-58</b>	-	<b>&lt; 2.0</b>	<b>&lt; 2.2</b>	<b>&lt; 2.5</b>	<b>11</b>
<b>Co-60</b>	-	<b>&lt; 2.9</b>	<b>&lt; 1.7</b>	<b>&lt; 2.4</b>	<b>11</b>
<b>Zn-65</b>	-	<b>&lt; 2.9</b>	<b>&lt; 3.9</b>	<b>&lt; 4.4</b>	<b>22</b>
<b>Zr-95</b>	-	<b>&lt; 2.4</b>	<b>&lt; 4.1</b>	<b>&lt; 4.2</b>	<b>22</b>
<b>Nb-95</b>	-	<b>&lt; 3.3</b>	<b>&lt; 1.9</b>	<b>&lt; 3.9</b>	<b>11</b>
<b>Cs-134</b>	-	<b>&lt; 2.0</b>	<b>&lt; 2.0</b>	<b>&lt; 3.5</b>	<b>11</b>
<b>Cs-137</b>	-	<b>&lt; 2.0</b>	<b>&lt; 2.1</b>	<b>&lt; 2.5</b>	<b>13</b>
<b>Ba-140</b>	-	<b>&lt; 23.1</b>	<b>&lt; 18.2</b>	<b>&lt; 23.3</b>	<b>45</b>
<b>La-140</b>	-	<b>&lt; 4.8</b>	<b>&lt; 2.8</b>	<b>&lt; 3.4</b>	<b>11</b>
<b>Lab Code</b>	<b>PELW- 2702</b>	<b>PELW- 3280</b>	<b>PELW- 3968</b>	<b>PELW- 4488</b>	
<b>Start Date</b>	<b>04-27-17</b>	<b>05-26-17</b>	<b>06-29-17</b>	<b>07-24-17</b>	<b>Req. LLD</b>
<b>End Date</b>	<b>05-26-17</b>	<b>06-29-17</b>	<b>07-24-17</b>	<b>08-31-17</b>	
<b>Gross beta</b>	<b>&lt; 0.9</b>	<b>1.0 ± 0.5</b>	<b>&lt; 0.9</b>	<b>1.5 ± 0.6</b>	<b>3.0</b>
<b>Mn-54</b>	<b>&lt; 2.3</b>	<b>&lt; 1.9</b>	<b>&lt; 3.7</b>	<b>&lt; 3.0</b>	<b>11</b>
<b>Fe-59</b>	<b>&lt; 6.4</b>	<b>&lt; 2.7</b>	<b>&lt; 9.4</b>	<b>&lt; 4.1</b>	<b>22</b>
<b>Co-58</b>	<b>&lt; 1.4</b>	<b>&lt; 1.7</b>	<b>&lt; 4.5</b>	<b>&lt; 1.6</b>	<b>11</b>
<b>Co-60</b>	<b>&lt; 2.0</b>	<b>&lt; 1.9</b>	<b>&lt; 2.4</b>	<b>&lt; 3.0</b>	<b>11</b>
<b>Zn-65</b>	<b>&lt; 3.7</b>	<b>&lt; 4.1</b>	<b>&lt; 5.3</b>	<b>&lt; 4.3</b>	<b>22</b>
<b>Zr-95</b>	<b>&lt; 5.3</b>	<b>&lt; 2.4</b>	<b>&lt; 6.6</b>	<b>&lt; 5.1</b>	<b>22</b>
<b>Nb-95</b>	<b>&lt; 3.3</b>	<b>&lt; 3.1</b>	<b>&lt; 4.3</b>	<b>&lt; 3.4</b>	<b>11</b>
<b>Cs-134</b>	<b>&lt; 2.6</b>	<b>&lt; 2.7</b>	<b>&lt; 3.9</b>	<b>&lt; 3.1</b>	<b>11</b>
<b>Cs-137</b>	<b>&lt; 2.3</b>	<b>&lt; 1.8</b>	<b>&lt; 2.6</b>	<b>&lt; 2.9</b>	<b>13</b>
<b>Ba-140</b>	<b>&lt; 38.4</b>	<b>&lt; 18.5</b>	<b>&lt; 34.6</b>	<b>&lt; 16.0</b>	<b>45</b>
<b>La-140</b>	<b>&lt; 9.0</b>	<b>&lt; 4.2</b>	<b>&lt; 3.5</b>	<b>&lt; 3.1</b>	<b>11</b>
<b>Lab Code</b>	<b>PELW- 5149</b>	<b>PELW- 5743</b>	<b>PELW- 6328</b>	<b>PELW- 6653</b>	
<b>Start Date</b>	<b>08-31-17</b>	<b>09-28-17</b>	<b>10-26-17</b>	<b>11-30-17</b>	<b>Req. LLD</b>
<b>End Date</b>	<b>09-28-17</b>	<b>10-26-17</b>	<b>11-30-17</b>	<b>12-28-17</b>	
<b>Gross beta</b>	<b>1.2 ± 0.6</b>	<b>1.3 ± 0.6</b>	<b>1.4 ± 0.6</b>	<b>1.1 ± 0.5</b>	<b>3.0</b>
<b>Mn-54</b>	<b>&lt; 2.1</b>	<b>&lt; 3.1</b>	<b>&lt; 2.1</b>	<b>&lt; 2.2</b>	<b>11</b>
<b>Fe-59</b>	<b>&lt; 5.0</b>	<b>&lt; 4.6</b>	<b>&lt; 3.1</b>	<b>&lt; 4.7</b>	<b>22</b>
<b>Co-58</b>	<b>&lt; 2.8</b>	<b>&lt; 2.0</b>	<b>&lt; 2.2</b>	<b>&lt; 1.9</b>	<b>11</b>
<b>Co-60</b>	<b>&lt; 1.3</b>	<b>&lt; 3.2</b>	<b>&lt; 1.9</b>	<b>&lt; 2.1</b>	<b>11</b>
<b>Zn-65</b>	<b>&lt; 3.0</b>	<b>&lt; 3.6</b>	<b>&lt; 3.0</b>	<b>&lt; 2.2</b>	<b>22</b>
<b>Zr-95</b>	<b>&lt; 4.9</b>	<b>&lt; 7.6</b>	<b>&lt; 4.1</b>	<b>&lt; 2.7</b>	<b>22</b>
<b>Nb-95</b>	<b>&lt; 4.1</b>	<b>&lt; 4.9</b>	<b>&lt; 4.5</b>	<b>&lt; 3.4</b>	<b>11</b>
<b>Cs-134</b>	<b>&lt; 2.5</b>	<b>&lt; 4.0</b>	<b>&lt; 3.4</b>	<b>&lt; 2.5</b>	<b>11</b>
<b>Cs-137</b>	<b>&lt; 1.9</b>	<b>&lt; 3.8</b>	<b>&lt; 2.7</b>	<b>&lt; 2.6</b>	<b>13</b>
<b>Ba-140</b>	<b>&lt; 16.6</b>	<b>&lt; 22.5</b>	<b>&lt; 18.7</b>	<b>&lt; 19.9</b>	<b>45</b>
<b>La-140</b>	<b>&lt; 5.1</b>	<b>&lt; 2.4</b>	<b>&lt; 4.0</b>	<b>&lt; 4.2</b>	<b>11</b>

<sup>a</sup> "ND" = No data; see Table 2.0, Listing of Missed Samples.

Table 4. Lake water, analyses for gross beta and gamma emitting isotopes.

Location: P-60		Collection: Monthly composites			Units: pCi/L
Lab Code	NS <sup>a</sup>	PELW- 789	PELW- 1310	PELW- 1906	
Start Date		01-26-17	02-23-17	03-30-17	Req. LLD
End Date		02-23-17	03-30-17	04-27-17	
Gross beta	-	2.3 ± 0.6	2.7 ± 0.8	1.7 ± 0.6	3.0
Mn-54	-	< 1.7	< 2.6	< 2.9	11
Fe-59	-	< 5.4	< 5.5	< 5.9	22
Co-58	-	< 1.9	< 2.7	< 3.3	11
Co-60	-	< 2.8	< 1.9	< 3.5	11
Zn-65	-	< 4.3	< 3.2	< 5.8	22
Zr-95	-	< 5.1	< 5.6	< 6.1	22
Nb-95	-	< 3.4	< 1.9	< 4.3	11
Cs-134	-	< 2.5	< 2.7	< 3.5	11
Cs-137	-	< 2.5	< 2.8	< 4.0	13
Ba-140	-	< 17.3	< 26.8	< 39.1	45
La-140	-	< 3.7	< 2.6	< 3.9	11
Lab Code	PELW- 2703	PELW- 3281	PELW- 3989	PELW- 4489	
Start Date	04-27-17	05-26-17	06-29-17	07-24-17	Req. LLD
End Date	05-26-17	06-29-17	07-24-17	08-31-17	
Gross beta	< 0.9	1.2 ± 0.6	1.4 ± 0.6	1.3 ± 0.6	3.0
Mn-54	< 2.3	< 1.9	< 4.1	< 3.4	11
Fe-59	< 4.4	< 6.4	< 7.1	< 4.6	22
Co-58	< 2.1	< 1.9	< 3.2	< 2.1	11
Co-60	< 1.6	< 1.1	< 2.0	< 2.4	11
Zn-65	< 1.9	< 2.7	< 4.3	< 3.5	22
Zr-95	< 4.2	< 5.1	< 7.5	< 6.6	22
Nb-95	< 3.2	< 3.1	< 4.4	< 3.2	11
Cs-134	< 2.0	< 2.0	< 3.2	< 3.4	11
Cs-137	< 2.3	< 2.4	< 2.5	< 3.3	13
Ba-140	< 32.5	< 43.6	< 25.3	< 24.7	45
La-140	< 5.5	< 10.7	< 4.6	< 2.7	11
Lab Code	PELW- 5150	PELW- 5744	PELW- 6329	PELW- 6854	
Start Date	08-31-17	09-28-17	10-26-17	11-30-17	Req. LLD
End Date	09-28-17	10-26-17	11-30-17	12-28-17	
Gross beta	2.2 ± 0.6	1.2 ± 0.6	2.0 ± 0.6	1.7 ± 0.6	3.0
Mn-54	< 1.8	< 2.8	< 1.5	< 3.3	11
Fe-59	< 5.0	< 4.8	< 4.4	< 4.8	22
Co-58	< 1.9	< 2.3	< 2.7	< 3.2	11
Co-60	< 2.4	< 0.8	< 2.4	< 2.6	11
Zn-65	< 3.2	< 3.4	< 4.7	< 6.5	22
Zr-95	< 4.2	< 5.5	< 3.7	< 4.8	22
Nb-95	< 3.5	< 3.2	< 3.6	< 4.2	11
Cs-134	< 2.7	< 2.7	< 2.9	< 3.9	11
Cs-137	< 2.7	< 2.2	< 3.1	< 3.2	13
Ba-140	< 24.9	< 17.8	< 19.3	< 29.6	45
La-140	< 3.3	< 3.9	< 2.5	< 7.7	11

<sup>a</sup> "ND" = No data; see Table 2.0, Listing of Missed Samples.

Table 4. Lake Water, analysis for triium.  
 Collection: Quarterly composites of monthly collections.  
 Units: pCi/L

Required limit of detection: 1500 pCi/L

Location				
P-34				
Period	1st Qtr.	2nd Qtr.	3rd Qtr.	4th Qtr.
Lab Code	PELW- 1332	PELW- 3408	PELW- 5523	PELW- 6698
H-3	< 150	< 149	< 157	< 152
Location				
P-36				
Period	1st Qtr.	2nd Qtr.	3rd Qtr.	4th Qtr.
Lab Code	PELW- 1333	PELW- 3409	PELW- 5524	PELW- 6700
H-3	< 150	< 149	< 157	< 152
Location				
P-39				
Period	1st Qtr.	2nd Qtr.	3rd Qtr.	4th Qtr.
Lab Code	PELW- 1334	PELW- 3410	PELW- 5525	PELW- 6701
H-3	< 150	< 149	< 157	< 152
Location				
P-59				
Period	1st Qtr.	2nd Qtr.	3rd Qtr.	4th Qtr.
Lab Code	PELW- 1338	PELW- 3411	PELW- 5526	PELW- 6702
H-3	< 150	< 149	< 157	< 152
Location				
P-60				
Period	1st Qtr.	2nd Qtr.	3rd Qtr.	4th Qtr.
Lab Code	PELW- 1337	PELW- 3412	PELW- 5527	PELW- 6703
H-3	< 150	< 149	< 157	< 152

Table 5. Milk, analyses for iodine-131 and gamma-emitting isotopes.  
Collection: Semimonthly during grazing season, monthly at other times.

Collection Date	Lab Code	Concentration (pCi/L)					
		I-131	Cs-134	Cs-137	Ba-140	La-140	K-40
Required LLD	(pCi/L)	0.8	11	13	45	11	-
<u>P-19</u>							
01-03-17	PEMI- 35	< 0.2	< 3.6	< 3.6	< 34.4	< 4.6	1477 ± 117
02-06-17	PEMI- 525	< 0.2	< 4.2	< 4.0	< 20.6	< 4.6	1196 ± 109
03-06-17	PEMI- 923	< 0.2	< 2.8	< 2.8	< 17.0	< 3.0	1191 ± 93
04-03-17	PEMI- 1366	< 0.2	< 3.2	< 3.7	< 21.4	< 1.6	1267 ± 103
04-17-17	PEMI- 1733	< 0.3	< 3.4	< 2.9	< 25.0	< 3.7	1308 ± 109
05-01-17	PEMI- 1931	< 0.3	< 3.6	< 1.9	< 23.2	< 3.6	1190 ± 94
05-15-17	PEMI- 2246	< 0.4	< 3.2	< 3.9	< 27.9	< 3.5	1247 ± 101
06-05-17	PEMI- 2745	< 0.3	< 3.8	< 2.5	< 14.4	< 1.9	1286 ± 115
06-20-17	PEMI- 3063	< 0.3	< 4.2	< 3.7	< 19.2	< 3.2	2017 ± 131
07-05-17	PEMI- 3275	< 0.4	< 3.0	< 2.9	< 13.9	< 1.0	1298 ± 93
07-17-17	PEMI- 3579	< 0.3	< 2.6	< 3.4	< 34.9	< 4.3	1356 ± 75
08-08-17	PEMI- 4047	< 0.4	< 1.3	< 1.6	< 13.6	< 4.2	1197 ± 42
08-21-17	PEMI- 4340	< 0.5	< 2.9	< 2.9	< 28.3	< 3.9	1345 ± 98
09-08-17	PEMI- 4642	< 0.3	< 4.0	< 3.1	< 17.9	< 3.2	1274 ± 116
09-20-17	PEMI- 4878	< 0.3	< 3.0	< 3.2	< 25.5	< 4.4	1387 ± 97
10-02-17	PEMI- 5113	< 0.3	< 3.9	< 2.7	< 20.6	< 3.2	2317 ± 137
10-16-17	PEMI- 5613	< 0.3	< 3.3	< 3.8	< 15.9	< 5.5	2067 ± 121
11-06-17	PEMI- 5935	< 0.3	< 4.8	< 3.5	< 20.9	< 3.4	2546 ± 152
12-04-17	PEMI- 6323	< 0.2	< 3.0	< 3.5	< 11.8	< 1.6	1359 ± 94
<u>P-51</u>							
01-03-17	PEMI- 36	< 0.2	< 3.0	< 2.9	< 24.2	< 4.6	1367 ± 104
02-06-17	PEMI- 526	< 0.2	< 3.1	< 3.7	< 16.9	< 3.4	1391 ± 98
03-06-17	PEMI- 924	< 0.5	< 2.9	< 3.3	< 17.5	< 2.9	1388 ± 98
04-03-17	PEMI- 1367	< 0.2	< 3.1	< 3.3	< 17.4	< 2.8	1383 ± 115
04-17-17	PEMI- 1734	< 0.3	< 3.3	< 2.1	< 28.9	< 4.1	1394 ± 103
05-01-17	PEMI- 1932	< 0.4	< 3.1	< 2.9	< 24.3	< 3.2	1312 ± 99
05-15-17	PEMI- 2247	< 0.4	< 2.5	< 3.0	< 19.0	< 5.3	1341 ± 108
06-05-17	PEMI- 2746	< 0.3	< 3.3	< 1.7	< 16.0	< 1.9	1491 ± 117
06-20-17	PEMI- 3064	< 0.3	< 4.8	< 4.4	< 23.9	< 6.2	1466 ± 134
07-05-17	PEMI- 3276	< 0.5	< 3.3	< 3.4	< 14.3	< 3.1	1394 ± 101
07-17-17	PEMI- 3580	< 0.4	< 2.7	< 2.8	< 20.7	< 4.2	1338 ± 75
08-08-17	PEMI- 4048	< 0.5	< 1.3	< 1.4	< 27.0	< 3.3	1344 ± 46
08-21-17	PEMI- 4341	< 0.4	< 3.2	< 4.0	< 38.5	< 3.8	1345 ± 106
09-08-17	PEMI- 4643	< 0.2	< 3.5	< 2.8	< 11.4	< 1.6	1402 ± 114
09-20-17	PEMI- 4879	< 0.4	< 3.2	< 3.8	< 19.3	< 6.9	1312 ± 108
10-02-17	PEMI- 5114	< 0.4	< 2.8	< 2.4	< 15.5	< 4.5	1250 ± 102
10-16-17	PEMI- 5614	< 0.4	< 3.3	< 4.2	< 27.9	< 4.5	1331 ± 107
11-06-17	PEMI- 5936	< 0.4	< 4.0	< 3.6	< 21.6	< 3.6	1354 ± 118
12-04-17	PEMI- 6324	< 0.3	< 3.2	< 3.9	< 10.6	< 1.9	1306 ± 104

Table 7. Food Products, analyses for gamma emitting isotopes.

Collection: Monthly

Units: pCi/kg wet

Location: P-2

Lab Code	PEVE- 3581	PEVE- 3582	PEVE- 3583	PEVE- 4243	Req. LLD
Date Collected	07-18-17	07-18-17	07-18-17	08-15-17	
Sample Type	Japanese greens	Swiss chard	Turnip greens	Japanese Greens	
Be-7	228 ± 101.70	407 ± 102	323 ± 91	777 ± 116	-
K-40	3392 ± 266.60	5247 ± 366	4012 ± 300	5755 ± 365	-
Co-58	< 5.80	< 11.6	< 5.6	< 9.2	-
Co-60	< 8.44	< 7.8	< 8.9	< 9.7	-
I-131	< 21.45	< 27.3	< 13.0	< 29.7	45
Cs-134	< 9.00	< 13.5	< 8.5	< 8.8	45
Cs-137	< 6.19	< 13.8	< 7.0	< 11.9	60

Lab Code	PEVE- 4244	PEVE- 4245	PEVE- 4246	PEVE- 4902	Req. LLD
Date Collected	08-15-17	08-15-17	08-15-17	09-20-17	
Sample Type	Swiss Chard	Turnip Greens	Collard Greens	Swiss Chard	
Be-7	568 ± 125	576 ± 120	123 ± 70	245 ± 105	-
K-40	5411 ± 340	4271 ± 335	3788 ± 225	4650 ± 302	-
Co-58	< 10.6	< 7.7	< 7.1	< 7.8	-
Co-60	< 10.1	< 7.4	< 5.7	< 9.9	-
I-131	< 24.5	< 22.1	< 21.7	< 23.8	45
Cs-134	< 10.0	< 9.5	< 6.7	< 8.6	45
Cs-137	< 10.3	< 11.0	< 6.3	< 8.5	60

Lab Code	PEVE- 4903	PEVE- 4904	PEVE- 5623	PEVE- 5624	Req. LLD
Date Collected	09-20-17	09-20-17	10-17-17	10-17-17	
Sample Type	Turnip Greens	Collard Greens	Collard Greens	Turnip Greens	
Be-7	247 ± 98	454 ± 132	971 ± 185	825 ± 127	-
K-40	4671 ± 373	5908 ± 401	4038 ± 391	4550 ± 312	-
Co-58	< 10.4	< 10.2	< 13.0	< 7.6	-
Co-60	< 8.2	< 9.1	< 10.7	< 8.6	-
I-131	< 41.7	< 40.7	< 22.8	< 8.7	45
Cs-134	< 9.9	< 12.4	< 12.3	< 9.3	45
Cs-137	< 11.5	< 9.5	< 7.2	< 8.9	60

Table 7. Food Products, analyses for gamma emitting isotopes.

Collection: Monthly		Units: pCi/kg wet			
Location: P-16					
Lab Code	PEVE- 3584	PEVE- 3585	PEVE- 3586	PEVE- 4248	
Date Collected	07-18-17	07-18-17	07-18-17	08-15-17	Req. LLD
Sample Type	Japanese greens	Collard greens	Turnip greens	Collard Greens	
Be-7	166 ± 65	< 86	121 ± 58	< 54	-
K-40	2709 ± 221	3795 ± 244	3181 ± 245	2742 ± 239	-
Co-58	< 7.0	< 9.9	< 6.3	< 5.4	-
Co-60	< 5.5	< 6.1	< 5.7	< 5.7	-
I-131	< 17.2	< 24.7	< 22.6	< 16.5	45
Cs-134	< 6.4	< 7.8	< 7.6	< 7.0	45
Cs-137	< 7.1	< 6.0	< 6.7	< 6.5	60
Lab Code	PEVE- 4249	PEVE- 4250	PEVE- 4251	PEVE- 4905	
Date Collected	08-15-17	08-15-17	08-15-17	09-20-17	Req. LLD
Sample Type	Turnip Greens	Japanese Greens	Swiss Chard	Collard Greens	
Be-7	200 ± 73	249 ± 67	327 ± 97	< 77	-
K-40	3105 ± 241	2979 ± 225	4373 ± 245	3063 ± 229	-
Co-58	< 5.9	< 7.3	< 7.3	< 7.8	-
Co-60	< 6.0	< 6.3	< 7.0	< 4.7	-
I-131	< 15.1	< 17.6	< 30.3	< 26.9	45
Cs-134	< 6.7	< 6.3	< 6.7	< 7.3	45
Cs-137	< 6.8	< 5.0	< 6.5	< 6.6	60
Lab Code	PEVE- 4906	PEVE- 4907	PEVE- 4909	PEVE- 5625	
Date Collected	09-20-17	09-20-17	09-20-17	10-17-17	Req. LLD
Sample Type	Turnip Greens	Japanese Greens	Swiss Chard	Collard Greens	
Be-7	< 99	< 97	146 ± 85	351 ± 106	-
K-40	3138 ± 255	4280 ± 315	4525 ± 267	3524 ± 264	-
Co-58	< 5.2	< 6.6	< 7.2	< 7.1	-
Co-60	< 5.9	< 9.5	< 7.5	< 6.2	-
I-131	< 22.6	< 29.0	< 26.1	< 26.9	45
Cs-134	< 6.2	< 9.1	< 6.5	< 7.8	45
Cs-137	< 6.5	< 5.4	< 6.5	< 5.7	60
Lab Code	PEVE- 5626				
Date Collected	10-17-17				
Sample Type	Turnip Greens				
Be-7	433 ± 87				
K-40	4279 ± 270				
Co-58	< 7.2				
Co-60	< 7.7				
I-131	< 13.7				
Cs-134	< 6.6				
Cs-137	< 7.3				

Table 7. Food Products, analyses for gamma emitting isotopes.

Collection: Monthly

Units: pCi/kg wet

Location: P-20

Lab Code	PEVE- 3587	PEVE- 3588	PEVE- 3589	PEVE- 4252	Req. LLD
Date Collected	07-18-17	07-18-17	07-18-17	08-15-17	
Sample Type	Japanese greens	Turnip greens	Collard greens	Japanese Greens	
Be-7	429 ± 126	548 ± 107	< 92	805 ± 164	-
K-40	4392 ± 307	5668 ± 316	4642 ± 333	7639 ± 443	-
Co-58	< 6.9	< 7.5	< 9.6	< 12.8	-
Co-60	< 5.6	< 6.7	< 7.5	< 12.4	-
I-131	< 27.9	< 23.0	< 23.9	< 42.1	45
Cs-134	< 9.3	< 8.3	< 10.0	< 12.4	45
Cs-137	< 8.2	< 9.4	< 9.4	< 7.6	60

Lab Code	PEVE- 4253	PEVE- 4254	PEVE- 4255	PEVE- 4910	Req. LLD
Date Collected	08-15-17	08-15-17	08-15-17	09-20-17	
Sample Type	Collard Greens	Swiss Chard	Turnip Greens	Collard Greens	
Be-7	< 60	618 ± 133	585 ± 107	< 135	-
K-40	3681 ± 203	6921 ± 420	4976 ± 305	4498 ± 338	-
Co-58	< 5.5	< 9.9	< 9.6	< 12.1	-
Co-60	< 4.4	< 6.3	< 7.0	< 9.1	-
I-131	< 23.0	< 33.4	< 37.7	< 36.4	45
Cs-134	< 5.2	< 10.0	< 7.9	< 11.4	45
Cs-137	< 4.9	< 10.7	< 5.0	< 11.8	60

Lab Code	PEVE- 4911	PEVE- 4912	PEVE- 5627	PEVE- 5628	Req. LLD
Date Collected	09-20-17	09-20-17	10-17-17	10-17-17	
Sample Type	Swiss Chard	Turnip Greens	Collard Greens	Turnip Greens	
Be-7	777 ± 124	204 ± 97	194 ± 70	472 ± 79	-
K-40	9060 ± 311	4878 ± 276	5478 ± 291	5151 ± 265	-
Co-58	< 7.6	< 7.7	< 7.1	< 7.4	-
Co-60	< 11.1	< 4.8	< 4.1	< 8.0	-
I-131	< 29.2	< 23.7	< 11.7	< 13.5	45
Cs-134	< 8.0	< 7.6	< 6.6	< 6.2	45
Cs-137	< 7.2	< 7.9	< 8.3	< 6.3	60

Table 7. Food Products, analyses for gamma emitting isotopes.

Collection: Monthly		Units: pCi/kg wet			
Location: P-37					
Lab Code	PEVE- 3591	PEVE- 3592	PEVE- 3593	PEVE- 3594	
Date Collected	07-18-17	07-18-17	07-18-17	07-18-17	Req. LLD
Sample Type	Japanese greens	Swiss chard	Turnip greens	Collard greens	
Be-7	223 ± 88	262 ± 146	< 92	115 ± 45	-
K-40	5994 ± 293	5668 ± 340	3042 ± 250	3730 ± 201	-
Co-58	< 8.8	< 7.3	< 6.2	< 5.9	-
Co-60	< 5.2	< 7.5	< 6.7	< 3.6	-
I-131	< 24.5	< 39.5	< 28.1	< 23.8	45
Cs-134	< 7.9	< 9.1	< 7.3	< 5.9	45
Cs-137	< 7.1	< 10.7	< 10.3	< 6.3	60
Lab Code	PEVE- 4256	PEVE- 4257	PEVE- 4258	PEVE- 4259	
Date Collected	08-15-17	08-15-17	08-15-17	08-15-17	Req. LLD
Sample Type	Collard Greens	Japanese Greens	Swiss Chard	Turnip Greens	
Be-7	< 83	217 ± 82	289 ± 90	303 ± 101	-
K-40	4764 ± 324	3472 ± 252	5084 ± 255	5908 ± 342	-
Co-58	< 6.1	< 6.4	< 7.9	< 7.8	-
Co-60	< 4.2	< 4.6	< 5.2	< 4.9	-
I-131	< 41.2	< 21.9	< 23.0	< 35.5	45
Cs-134	< 9.0	< 6.0	< 6.5	< 7.4	45
Cs-137	< 9.4	< 7.0	< 6.4	< 7.2	60
Lab Code	PEVE- 4913	PEVE- 4914	PEVE- 4915	PEVE- 5629	
Date Collected	09-20-17	09-20-17	09-20-17	10-17-17	Req. LLD
Sample Type	Collard Greens	Swiss Chard	Turnip Greens	Collard Greens	
Be-7	< 102	172 ± 100	< 92	211 ± 68	-
K-40	4002 ± 312	5140 ± 304	4551 ± 294	3908 ± 245	-
Co-58	< 10.4	< 5.3	< 10.8	< 3.7	-
Co-60	< 11.6	< 5.8	< 7.9	< 5.5	-
I-131	< 42.9	< 27.1	< 40.2	< 15.7	45
Cs-134	< 9.6	< 8.2	< 9.2	< 6.7	45
Cs-137	< 7.1	< 7.1	< 10.0	< 6.3	60
Lab Code	PEVE- 5630	PEVE- 5631			
Date Collected	10-17-17	10-17-17			
Sample Type	Turnip Greens	Swiss Chard			
Be-7	515 ± 124	280 ± 102			
K-40	4601 ± 318	6398 ± 371			
Co-58	< 9.3	< 4.8			
Co-60	< 6.8	< 6.3			
I-131	< 19.5	< 17.7			
Cs-134	< 9.4	< 10.0			
Cs-137	< 11.7	< 9.6			



Table 7. Food Products, analyses for gamma emitting isotopes.

Collection: Monthly

Units: pCi/kg wet

Location: P-70

Lab Code	PEVE- 3595	PEVE- 3598	PEVE- 3597	PEVE- 3598	Req. LLD
Date Collected	07-18-17	07-18-17	07-18-17	07-18-17	
Sample Type	Collard greens	Turnip greens	Japanese greens	Swiss chard	
Be-7	< 55	444 ± 114	< 59	427 ± 116	-
K-40	4655 ± 239	6397 ± 371	3969 ± 299	5191 ± 287	-
Co-58	< 7.3	< 8.3	< 6.8	< 9.6	-
Co-60	< 8.5	< 6.1	< 6.6	< 5.3	-
I-131	< 16.8	< 37.0	< 18.6	< 29.9	45
Cs-134	< 6.8	< 9.2	< 5.4	< 8.3	45
Cs-137	< 7.4	< 11.2	< 6.6	< 4.5	60

Lab Code	PEVE- 4260	PEVE- 4261	PEVE- 4262	PEVE- 4263	Req. LLD
Date Collected	08-15-17	08-15-17	08-15-17	08-15-17	
Sample Type	Collard Greens	Turnip Greens	Japanese Greens	Swiss Chard	
Be-7	< 81	362 ± 104	278 ± 120	364 ± 97	-
K-40	3554 ± 242	3943 ± 236	4218 ± 325	3979 ± 255	-
Co-58	< 8.8	< 6.4	< 7.9	< 6.6	-
Co-60	< 6.8	< 5.1	< 8.7	< 7.3	-
I-131	< 24.7	< 18.0	< 41.8	< 24.7	45
Cs-134	< 7.3	< 7.1	< 9.8	< 7.2	45
Cs-137	< 8.3	< 7.7	< 13.0	< 8.3	60

Lab Code	PEVE- 4916	PEVE- 4917	PEVE- 4918	PEVE- 5632	Req. LLD
Date Collected	09-20-17	09-20-17	09-20-17	10-17-17	
Sample Type	Collard Greens	Turnip Greens	Swiss Chard	Collard Greens	
Be-7	< 117	344 ± 103	485 ± 144	245 ± 112	-
K-40	3141 ± 296	6120 ± 353	6869 ± 458	3532 ± 293	-
Co-58	< 9.8	< 8.8	< 17.7	< 8.7	-
Co-60	< 3.8	< 10.0	< 10.5	< 6.3	-
I-131	< 36.4	< 30.9	< 29.2	< 22.8	45
Cs-134	< 8.0	< 9.5	< 11.8	< 9.1	45
Cs-137	< 8.2	< 11.9	< 11.8	< 8.9	60

Lab Code	PEVE- 5633	PEVE- 5634
Date Collected	10-17-17	10-17-17
Sample Type	Turnip Greens	Swiss Chard
Be-7	584 ± 113	543 ± 122
K-40	5937 ± 343	6009 ± 378
Co-58	< 6.3	< 9.0
Co-60	< 6.5	< 9.6
I-131	< 15.8	< 26.3
Cs-134	< 9.7	< 10.3
Cs-137	< 9.5	< 9.4

Table 9. Fish, analyses for gamma emitting isotopes.

Collection: Annually<sup>a</sup>

Units: pCi/kg wet

Location		P-25				
Lab Code	PEF- 4921	PEF- 4922	PEF- 4923	PEF- 4924		Req. LLD
Date Collected	09-19-17	09-19-17	09-19-17	09-19-17		
Sample Type	Smallmouth Bass	Walleye	Yellow Perch	Channel Catfish		
K-40	1035 ± 269	1643 ± 314	1172 ± 194	1397 ± 275		-
Mn-54	< 5.7	< 19.8	< 8.7	< 11.6		94
Fe-59	< 27.2	< 20.4	< 20.0	< 32.2		195
Co-58	< 14.1	< 10.5	< 11.6	< 13.4		97
Co-60	< 10.2	< 15.0	< 7.7	< 19.3		97
Zn-65	< 7.5	< 34.8	< 21.2	< 32.9		195
Cs-134	< 10.0	< 15.7	< 8.9	< 18.3		97
Cs-137	< 11.9	< 19.3	< 9.7	< 14.8		112

Location		P-25				
Lab Code	PEF- 4925					Req. LLD
Date Collected	09-19-17					
Sample Type	White Perch					
K-40	1745 ± 303					-
Mn-54	< 12.4					94
Fe-59	< 35.4					195
Co-58	< 8.2					97
Co-60	< 12.5					97
Zn-65	< 15.4					195
Cs-134	< 13.1					97
Cs-137	< 13.3					112

Location		P-25				
----------	--	------	--	--	--	--

<sup>a</sup> Delivery problems with fish collected 05-31-17; fish arrived very late. Unable to analyze due to overwhelming toxic odor from liquified samples.

Table 9. Fish, analyses for gamma emitting isotopes.

Collection: Annually<sup>a</sup>

Units: pCi/kg wet

Location		P-32				
Lab Code	PEF- 4927	PEF- 4928	PEF- 4930	PEF- 4931		Req. LLD
Date Collected	09-19-17	09-19-17	09-19-17	09-19-17		
Sample Type	Rainbow Trout	Smallmouth Bass	Freshwater Drum	White Perch		
K-40	1554 ± 211	1680 ± 341	768 ± 254	868 ± 180		-
Mn-54	< 5.8	< 15.1	< 20.8	< 8.5		94
Fe-59	< 27.2	< 42.3	< 45.9	< 20.6		195
Co-58	< 9.6	< 13.4	< 18.7	< 9.4		97
Co-60	< 8.3	< 11.5	< 7.1	< 9.4		97
Zn-65	< 19.2	< 30.8	< 35.6	< 22.7		195
Cs-134	< 9.5	< 16.3	< 16.0	< 11.9		97
Cs-137	< 10.1	< 11.6	< 14.6	< 11.8		112

Location		P-32		
Lab Code	PEF- 4932	PEF- 4933		Req. LLD
Date Collected	09-19-17	09-19-17		
Sample Type	Redhorse Sucker	Yellow Perch		
K-40	1522 ± 244	2821 ± 339		-
Mn-54	< 13.8	< 26.6		94
Fe-59	< 51.8	< 65.0		195
Co-58	< 10.0	< 26.3		97
Co-60	< 9.3	< 24.4		97
Zn-65	< 33.0	< 52.0		195
Cs-134	< 12.9	< 34.6		97
Cs-137	< 12.1	< 22.0		112

Location		P-32	
----------	--	------	--

<sup>a</sup> Delivery problems with fish collected 05-31-17; fish arrived very late. Unable to analyze due to overwhelming toxic odor from liquified samples.

Table 11. Sediments, analyses for gamma emitting isotopes.

Collection: Semiannually

Units: pCi/kg dry

Location		P-64		
Lab Code	PEBS- 1938	PEBS- 4919		Req. LLD
Date Collected	04-27-17	09-20-17		
K-40	15112 ± 663	9087 ± 484		-
Co-58	< 19.6	< 13.3		50
Co-60	< 14.3	< 7.7		40
Cs-134	< 17.3	< 0.0		112
Cs-137	< 10.8	< 0.0		135

Location		P-66		
Lab Code	PEBS- 1939	PEBS- 4920		Req. LLD
Date Collected	04-27-17	09-20-17		
K-40	8254 ± 440	7739 ± 437		-
Co-58	< 16.1	< 12.2		50
Co-60	< 11.0	< 13.0		40
Cs-134	< 13.8	< 0.0		112
Cs-137	< 9.1	< 0.0		135

**2017 ANNUAL ENVIRONMENTAL AND EFFLUENT RELEASE REPORT**

**Appendix D**  
**Corrections to Previous Annual**  
**Environmental and Effluent Release**  
**Reports**

## 2017 ANNUAL ENVIRONMENTAL AND EFFLUENT RELEASE REPORT

### APPENDIX D

#### **Corrections to Previous Annual Environmental and Effluent Release Reports**

There is one correction to the annual reports from 2013, 2014, 2015, and 2016, which reference "Great Lakes Nuclear Services" as a REMP-sampled location in Table 15, location 53. The title is not correct for the company that has resided at this location in recent years. The reference of the REMP location was corrected in the latest revision of the ODCM and was changed to list the address rather than a company title, which can change frequently.

# 2017 ANNUAL ENVIRONMENTAL AND EFFLUENT RELEASE REPORT

## Appendix E Abnormal Releases

## 2017 ANNUAL ENVIRONMENTAL AND EFFLUENT RELEASE REPORT

### APPENDIX E

#### Abnormal Releases

In November 2011, radioactivity was detected in the Nuclear Closed Cooling (NCC) system. The source of this activity is the primary coolant. There is some leakage from the NCC system to Service Water and from there to the environment. Residual activity remains in the NCC system and it is being tracked as a continuous abnormal release.

The calculated annual doses for the NCC abnormal releases were 7.10E-06 mrem whole body and 1.27E-05 mrem organ.

	Quarter 1	Quarter 2	Quarter 3	Quarter 4
Total time period for continuous release, min	4.46E+04*	4.32E+04*	NA	8.78E+04
Total volume released, liters	1.36E+05*	1.38E+05*	NA	2.57E+04
Average quarterly flow rate, L/min	1.28E+05*	8.71E+04*	NA	2.97E+05

\*Release continued, however, no activity was detected in January, February, May, June, nor October, these monthly volumes were omitted from all calculations

NA – no activity was detected during the quarter

	Quarter 1	Quarter 2	Quarter 3	Quarter 4	Annual
<b>A. Fission and Activation Products (Ci)</b>					
Mn-54	<LLD	2.06E-05	<LLD	<LLD	2.06E-05
Co-58	<LLD	1.12E-05	<LLD	<LLD	1.12E-05
Co-60	4.66E-06	1.18E-04	<LLD	1.01E-06	1.23E-04
Total Released	4.66E-06	1.49E-04	<LLD	1.01E-06	1.55E-04
<b>B. Tritium (Ci)</b>	<LLD	<LLD	<LLD	<LLD	<LLD
<b>C. Noble Gases (Ci)</b>	<LLD	<LLD	<LLD	<LLD	<LLD
<b>D. Gross Alpha (Ci)</b>	<LLD	<LLD	<LLD	<LLD	<LLD

There were no abnormal gaseous releases.



# 2017 ANNUAL ENVIRONMENTAL AND EFFLUENT RELEASE REPORT

## Appendix F ODCM Non-Compliances

# 2017 ANNUAL ENVIRONMENTAL AND EFFLUENT RELEASE REPORT

## APPENDIX F

### ODCM Non-Compliances

#### Effluent Monitoring

On 2/17/2017, the Service Water Discharge Header Flow was declared inoperable, and remained inoperable until 5/05/2017. The sensing tube had deteriorated and needed to be replaced. This also required excavation of the work site to replace the piping.

This instrument is the only channel meeting the minimum channels operable requirement. Per the ODCM and Technical Specifications, a notification is required to be made in this report for ODCM-equipment that is out of service for greater than 30 days. All contingency actions were taken in accordance with the ODCM, which requires recording flow rates every four hours.

#### Environmental Monitoring

On 05/30/17, semi-annual fish sampling was performed. The following species were obtained on May 31 at location 32: smallmouth bass, red horse sucker yellow perch, walleye, fresh water drum and white perch. The following species were obtained the same day at location 25: Walleye, channel catfish, sheep head, small mouth bass, and white perch. Samples were prepared, labeled, and shipped to the vendor; however, a different location received the boxes. Once the issue had been identified, it was promptly corrected, and the samples shipped to the correct location. Upon receipt at the vendor lab, it was determined that analysis could not be performed due to the condition of the samples. Semi-annual fish sampling is required by the ODCM, Table 3.12.1-1.4.b and to analyze edible portions for gamma isotopic. Annually, fish sampling is arranged in the spring and fall, typically May and September, weather dependent. Sampling was performed in the fall as expected and all samples analyzed.

Failed to capture Walleye at the indicator location during fall fish sampling. However, six species from this location were sent for analysis, including the other required species, yellow perch.

Water Shoreline samples (location #59 and #60) were not sampled for the month of January due to frozen shoreline conditions.

# 2017 ANNUAL ENVIRONMENTAL AND EFFLUENT RELEASE REPORT

## Appendix G ODCM Changes

# 2017 ANNUAL ENVIRONMENTAL AND EFFLUENT RELEASE REPORT

## APPENDIX G

### ODCM Changes

The scope of changes to the ODCM during this reporting period are listed as follows:

1. Commitment L02211 was closed and removed from:
  - a. Introduction, paragraph 6
  - b. Table 3.3.7.9-1.3.c.2
  - c. Table 3.3.7.10-1.2.a
  - d. Table 3.3.7.10-1.4.a
  - e. Table 3.3.7.10-1, action note 122
  - f. Controls section 3.11.2.4 under the description and footnote
2. Commitment R00449 was closed and removed from Table 4.11.1.1.1-1.B under the grab sample composite
3. Added clarification of a valid alert alarm in 3.1 note a
4. Combined the note in calculation 3.1-4 with the definition "F" and added note to reference table 3.1-2
5. Formalized table of Effluent Release Path flow rates listed under section 3.1.4 equation definitions, creating Table 3.1-2 and added table to List of Tables
6. Section 4.2: Removed requirement that specified that environmental TLDs will be changed out quarterly and annually. Now section contains a reference to Table 3.12-1, Radiological Environmental Monitoring Program
7. Section 5.1: Removed reference to site-specific environmental monitoring procedures
8. Table 5.1-1: shortened title; renamed location 53 to reflect current status; added new locations 16, 20, 39, 57 and 66; removed locations 18, 28 and 65; indicated that locations 36 and 39 are drinking water and locations 59 and 60 are surface water samples; changed "Food Products" to "Broadleaf Vegetation" at locations 2, 37, and 70
9. Figures 5.1-1, 5.1-2, and 5.1-3: Updated maps to reflect changed sample locations
10. Revised Table A-2: Added a new column showing distance in meters
11. Tables 3.3.7.10-1 and 4.3.7.10-1: Table Notations, Removed "\*\*\*During main condenser off-gas treatment system operation." There are no double asterisks in the tables
12. Table 3.3.7.10-1: Added action 124 to Unit 1 Vent noble gas channel during modes 4 and 5
13. Table 3.3.7.10-1: Removed footnote (1) from each page and added it to the notations portion
14. Table 3.12.1-1: Updated number of TLDs to 29
15. Table 3.12.1-1: modified wording to state that one sample of each commercially or recreationally important fish species will be collected; changed sampling frequency to semi-annually in section 3.b
16. Table 4.3.7.9-1.3: Updated NBS reference to NIST
17. Revised Section 6.9.1.7: moved the information denoted by an asterisk regarding maintaining the meteorological report separate from the Annual Report into paragraph b; split the paragraph into two for clarity purposes.
18. Removed asterisk and footnote from section 6.9.1.7
19. Added new section for commitments
20. Minor editorial and grammatical corrections, revision bars not used

# 2017 ANNUAL ENVIRONMENTAL AND EFFLUENT RELEASE REPORT

## Appendix H Changes to Process Control Program

# 2017 ANNUAL ENVIRONMENTAL AND EFFLUENT RELEASE REPORT

## **APPENDIX H**

### **Process Control Program Changes**

There were no changes to the Process Control Program during this reporting period.

**Enclosure B**

**L-18-127**

**Offsite Dose Calculation Manual, Revision 21**

## Offsite Dose Calculation Manual

Effective Date: 10-10-17

Preparer: Melanie Baker / 7-19-17  
Date

Approver: Steve Benedict / 10-10-17  
Program Manager Date



**TABLE OF CONTENTS**

1.0	INTRODUCTION.....	1
2.0	LIQUID EFFLUENTS .....	2
2.1	Batch Releases.....	2
2.1.1	Monitor Alarm Setpoint Determination .....	3
2.1.2	10CFR20 Compliance - Liquid Effluent Concentration .....	5
2.2	Continuous Releases .....	8
2.2.1	Monitor Alarm Setpoint Determination .....	9
2.3	10CFR50, Appendix I Compliance - Liquid Effluent Dose .....	10
2.3.1	Dose Calculations .....	10
2.3.2	Cumulation of Doses .....	12
2.3.3	Projection of Doses .....	12
2.3.4	Population Dose .....	12
3.0	GASEOUS EFFLUENTS .....	30
3.0.1	Batch Releases .....	30
3.0.2	Continuous Releases .....	30
3.1	Monitor Alarm Setpoint Determination.....	32
3.1.1	Determination of "Mix" (Noble Gas Radionuclide Composition) of Gaseous Effluents.....	33
3.1.2	Determination of the Maximum Acceptable Total Activity Release Rate of Noble Gas Radionuclides in Gaseous Effluent Based on Whole Body Dose Rate Limit .....	33
3.1.3	Determination of the Maximum Acceptable Total Activity Release Rate of Noble Gas Radionuclides in Gaseous Effluent Based on Skin Dose Rate Limit.....	34
3.1.4	Determination of the Maximum Acceptable Total Radioactivity Concentration of all Noble Gas Radionuclides in the Gaseous Effluent .....	35
3.1.5	Determination of the Maximum Acceptable Monitor Count Rate Above Background Attributed to Noble Gas Radionuclides.....	36
3.2	10CFR20 Compliance - Gaseous Effluent Dose Rate .....	37
3.2.1	Noble Gases.....	37
3.2.2	Radioiodines, Particulates, and Other Radionuclides .....	37
3.2.3	Dose Rate Calculations .....	37
3.3	10CFR50, Appendix I Compliance - Gaseous Effluent Dose.....	64
3.3.1	Noble Gases.....	64
3.3.2	Radioiodines, Particulates, and Other Radionuclides .....	64
3.3.3	Dose Calculations .....	65
3.3.4	Cumulation of Doses .....	66
3.3.5	Projection of Doses .....	67
3.4	Population Dose .....	67
4.0	TOTAL DOSE.....	68
4.1	40CFR190 and 10CFR72.104 Compliance - Uranium Fuel Cycle Dose .....	68
4.2	Direct Radiation Dose from PNPP (including the ISFSI).....	69
4.3	Dose to Members of the Public While Onsite.....	69
5.0	RADIOLOGICAL ENVIRONMENTAL MONITORING PROGRAM.....	71
5.1	Monitoring Program .....	71
5.2	Land Use Census Program .....	71
5.3	Inter-Laboratory Comparison Program.....	72
	Appendix A.....	77
	Appendix B.....	91
	Appendix C.....	94
	Records.....	168
	Commitments.....	168
	REFERENCES.....	169

List of Tables

<u>Table</u>	<u>Title</u>	<u>Page</u>
2.3-1	Organs Used for Liquid Effluent Dose Calculations	13
2.3-2	Age Groups Used for Liquid Effluent Dose Calculations	13
2.3-3	Liquid Effluent Dose Pathways	13
2.3-4	Bio-Accumulation Factors ( $B_{fp}$ ) (pCi/kg per pCi/liter)	14
2.3-5	Ingestion Dose Factors for Adult (mrem/pCi ingested)	15
2.3-6	Ingestion Dose Factors for Teenager (mrem/pCi ingested)	17
2.3-7	Ingestion Dose Factors for Child (mrem/pCi ingested)	19
2.3-8	Ingestion Dose Factors for Infant (mrem/pCi ingested)	21
2.3-9	External Dose Factors for Standing on Contaminated Ground	23
2.3-10	Liquid Effluent Dilution Factors ( $M_p$ )	25
2.3-11	Transit Times Required for Nuclides to Reach the Point of Exposure ( $t_p$ )	25
2.3-12	Usage Factors ( $U_{sp}$ )	26
2.3-13	Dilution Factors for Each of the Potable Water Intakes within 50 Miles of PNPP	27
2.3-14	Dilution Factors for the Fish Ingestion Pathway Individual Grid Locations	28
2.3-15	Dilution Factors for the Shore Exposure Pathway	29
3.1-1	Whole Body and Skin Dose Factors	34
3.1-2	Flow Rates and Effluent Monitor Efficiencies	35
3.2-1	Organs Used for Gaseous Effluent Dose Calculations	42
3.2-2	Age Groups Used for Gaseous Effluent Dose Calculations	42
3.2-3	Gaseous Effluent Dose Pathways	42
3.2-4	Dose Factors for Exposure to a Semi-Infinite Cloud of Noble Gases	43
3.2-5	External Dose Factors for Standing on Contaminated Ground	44
3.2-6	Inhalation Dose Factors for Adult (mrem/pCi inhaled)	46
3.2-7	Inhalation Dose Factors for Teenager (mrem/pCi inhaled)	48
3.2-8	Inhalation Dose Factors for Child (mrem/pCi inhaled)	50
3.2-9	Inhalation Dose Factors for Infant (mrem/pCi inhaled)	52
3.2-10	Ingestion Dose Factors for Adult (mrem/pCi ingested)	54
3.2-11	Ingestion Dose Factors for Teenager (mrem/pCi ingested)	56
3.2-12	Ingestion Dose Factors for Child (mrem/pCi ingested)	58
3.2-13	Ingestion Dose Factors for Infant (mrem/pCi ingested)	60
3.2-14	Annual Usage Factors for the Maximum Exposed Individual	62
3.2-15	Annual Usage Factors for the Average Individual	62
3.3-1	Gamma and Beta Air Dose Factors for Semi-Infinite Plume	66
5.1-1	ODCM REMP Sample Locations	73
A-1	Atmospheric Depletion and Deposition Factors	79
A-2	Site Boundary Atmospheric Dispersion ( $\chi/Q$ ) and Deposition Parameters (D/Q) for PNPP Unit 1	80
A-3	Atmospheric Dispersion ( $\chi/Q$ ) as a Function of Distance (s/m <sup>3</sup> )	81
A-4	Atmospheric Dispersion (D/Q) as a Function of Distance (m <sup>2</sup> )	86

| October 2017

List of Figures

<u>Figures</u>	<u>Title</u>	<u>Page</u>
2.1-1	Liquid Radioactive Waste (LRW) Discharge System	2
3.0-1	Gaseous Effluent System Flow Diagram	31
3.2-1	PNPP Site Boundary and Unrestricted Area	63
5.1-1	Technical Specification Required REMP Sampling Locations Within Two Miles of the Plant Site	74
5.1-2	Technical Specification Required REMP Sampling Locations Between Two and Eight Miles from the Plant Site	75
5.1-3	Technical Specification Required REMP Sampling Locations Greater Than Eight Miles from the Plant Site	76

**SCOPE OF REVISION:**

**Rev. 21:**

1. Commitment L02211 was closed and removed from:
  - Introduction, paragraph 6
  - Table 3.3.7.9-1.3.c.2
  - Table 3.3.7.10-1.2.a
  - Table 3.3.7.10-1.4.a
  - Table 3.3.7.10-1, action note 122
  - Controls section 3.11.2.4 under the description and footnote
2. Commitment R00449 was closed and removed from Table 4.11.1.1.1-B under the grab sample composite
3. Added clarification of a valid alert alarm in 3.1 note a
4. Combined the note in calculation 3.1-4 with the definition "f" and added note to reference table 3.1-2
5. Formalized table of Effluent Release Path flow rates listed under section 3.1.4 equation definitions, creating Table 3.1-2 and added table to List of Tables
6. Section 4.2: Removed requirement that specified that environmental TLDs will be changed out quarterly and annually. Now section contains a reference to Table 3.12-1, Radiological Environmental Monitoring Program
7. Section 5.1: Removed reference to site-specific environmental monitoring procedures
8. Table 5.1-1: shortened title; renamed location 53 to reflect current status; added new locations 16, 20, 39, 57 and 66; removed locations 18, 28 and 65; indicated that locations 36 and 39 are drinking water and locations 59 and 60 are surface water samples; changed "Food Products" to "Broadleaf Vegetation" at locations 2, 37, and 70
9. Figures 5.1-1, 5.1-2, and 5.1-3: Updated maps to reflect changed sample locations
10. Revised Table A-2: Added a new column showing distance in meters
11. Tables 3.3.7.10-1 and 4.3.7.10-1: Table Notations, Removed "\*\*\*During main condenser off-gas treatment system operation." There are no double asterisks in the tables
12. Table 3.3.7.10-1: Added action 124 to Unit 1 Vent noble gas channel during modes 4 and 5
13. Table 3.3.7.10-1: Removed footnote (1) from each page and added it to the notations portion
14. Table 3.12.1-1: Updated number of TLDs to 29
15. Table 3.12.1-1: modified wording to state that one sample of each commercially or recreationally important fish species will be collected; changed sampling frequency to semi-annually in section 3.b
16. Table 4.3.7.9-1.3: Updated NBS reference to NIST
17. Revised Section 6.9.1.7: moved the information denoted by an asterisk regarding maintaining the meteorological report separate from the Annual Report into paragraph b; split the paragraph into two for clarity purposes.
18. Removed asterisk and footnote from section 6.9.1.7
19. Added new section for commitments
20. Minor editorial and grammatical corrections, revision bars not used

## 1.0 INTRODUCTION

This Offsite Dose Calculation Manual (ODCM) contains information and methodologies to be used by the Perry Nuclear Power Plant (PNPP), Unit 1, to ensure compliance with PNPP Radiological Effluent Technical Specifications. The Technical Specifications and this ODCM are written to satisfy 10CFR20, 10CFR50.36 and Appendix I, 40CFR190 and 10CFR72.104 requirements. This ODCM applies to doses from radioactivity and radiation from the Perry Nuclear Power Plant, which is considered to include the onsite Independent Spent Fuel Storage Installation (ISFSI).

Sections 2 and 3 of this manual deal with liquid and gaseous radiological effluents, respectively. Each of these sections contain alarm setpoint determination, radiation dose and dose rate calculation methodologies, as well as limits and requirements. Section 4 covers uranium fuel cycle related radiation dose limits including direct dose from the Perry Nuclear Power Plant, including the ISFSI.

Also included in this manual, in Section 5, is information relating to the Radiological Environmental Monitoring Program (REMP). The figures and tables contained therein designate specific sample types and locations currently used to satisfy the Technical Specification requirements for the REMP as well as sampling reporting and detection capability limits. The sample types and locations are subject to change based on factors including the results of the annual Land Use Census.

The ODCM has been prepared, as generally as possible, in order to minimize future revisions. However, any such changes will be reviewed and approved as per the Administrative Control Section of the PNPP Technical Specifications.

Supplemental information needed to support calculations is contained in the appendices at the end of this manual. Appendix A contains atmospheric dispersion and deposition parameters and Appendix B presents the methodology for determining the lower limit of detection (LLD).

Appendix C of the ODCM was prepared based on guidance of NUREG-1302, "Offsite Dose Calculation Manual Guidance: Standard Radiological Effluent Controls for Boiling Water Reactors," Generic Letter 89-01, Supplement No. 1. This appendix along with plant procedures will be used by plant personnel to demonstrate compliance with Specification 5.5.4 (Radioactive Effluent Controls Program) of the PNPP Technical Specifications.

October  
2017

## 2.0 LIQUID EFFLUENTS

### 2.1 Batch Releases

A batch release is the discharge liquid radioactive waste of a discrete volume. Batch releases from the liquid radwaste system may occur from any of the following tanks: waste sample tank, floor drain sample tank, chemical waste distillate tank, and detergent drain tank (see Figure 2.1-1). The maximum release rate possible, due to pump capacity, is 200 gallons per minute from all release tanks except the detergent drain tanks, which have a maximum release rate of 50 gallons per minute. All of the above liquid radwaste releases go to the Emergency Service Water discharge which is then released through the discharge tunnel after mixing with Service Water effluent and/or and blowdown from Circulating Water system, if present.

Figure 2.1-1

Liquid Radioactive Waste (LRW) Discharge System

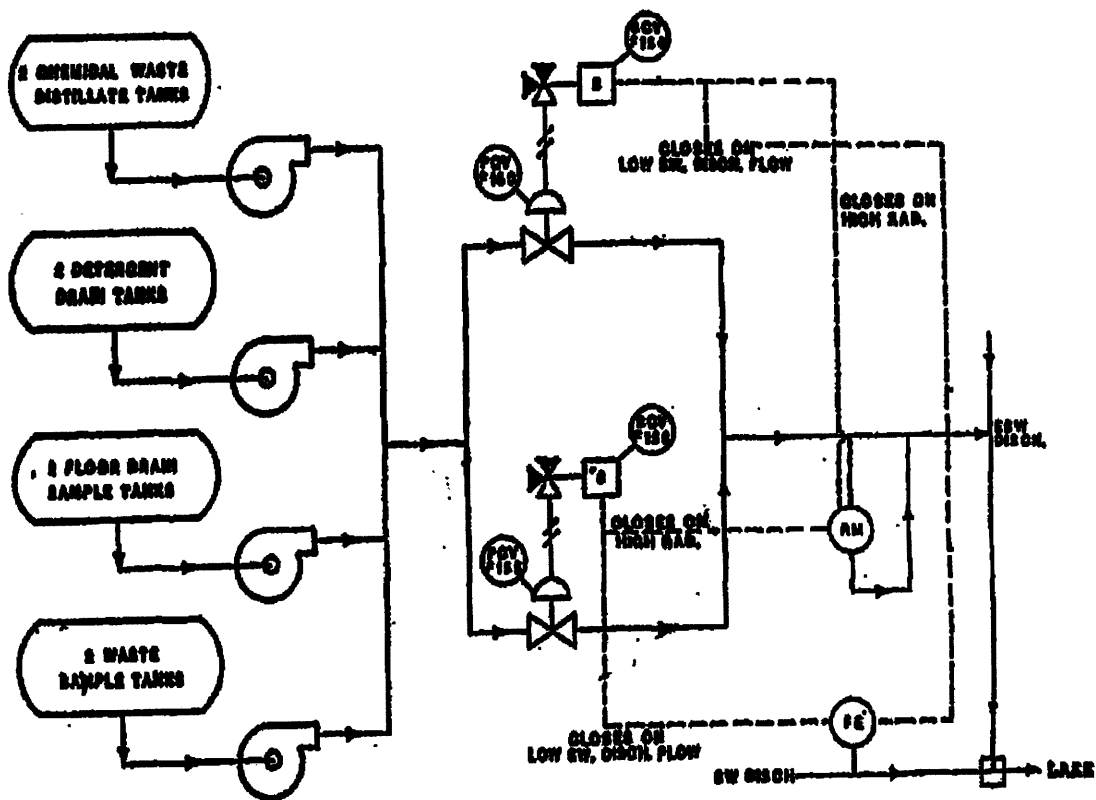

The type and frequency of sampling and analysis required by the ODCM is given in Appendix C, Table 4.11.1.1.1-1. Prior to sampling for analysis, each batch should be isolated, and thoroughly mixed to assure representative sampling. For mixing, the contents of the tank are recirculated by isolating the tank and turning on equipment that takes suction from and discharges back into the tank. Recycle lines are provided with one or more mixing eductors located near the bottom of the tanks to promote better mixing as well as reducing recirculation time. This ensures that the water in the tank will be mixed and will be representative of the activity in the tank. The minimum recirculation performed is the equivalent of two volumes of the tank contents.

Monitor alarm setpoints will be determined in order to ensure compliance with 10CFR20. The radioactive content of each batch release will be determined prior to release in accordance with ODCM, Appendix C, Table 4.11.1.1.1-1. Concentrations for tritium and other non-gamma emitting isotopes will be those most recently determined in the previous month/quarter. If there are no tritium results from the most recent month the most recent steam cycle value may be used as this will be a conservative number used for calculating batch releases. If there is sufficient time prior to a planned release, a composite of samples that are expected to be representative of the release may be analyzed for the tritium and other non-gamma emitting isotope values.

#### 2.1.1 Monitor Alarm Setpoint Determination

The following methodology is used to calculate the setpoints for the Radwaste Discharge Radiation Monitor - ESW Discharge and Liquid Radwaste Adjustable High Flow Trip Unit to ensure that liquid radwaste effluent releases from the site to unrestricted areas are below the limiting effluent concentrations (EC) specified in 10CFR20, Appendix B, Table 2, Column 2 for radionuclides other than noble gases. An EC of  $2.0E-4$   $\mu\text{Ci/ml}$  has been established for dissolved and entrained noble gases. The Radwaste Discharge Radiation Monitor - ESW Discharge provides alarm and automatic termination of releases prior to exceeding these limits.

**NOTE:** Liquid radwaste discharge flow rate shall be verified at least once per four hours, whenever the flow rate measuring device(s) is inoperable during actual releases.

##### 2.1.1.1 Minimum Acceptable Dilution Factor Determination:

$$DF_o = \sum \frac{C_i}{(EC_i)} \quad (2.1-1)$$

Where:

- DF<sub>o</sub> = the minimum acceptable dilution factor determined from analysis of the liquid effluent to be released;
- C<sub>i</sub> = the concentration of radionuclide "i" in the batch to be released,  $\mu\text{Ci/ml}$ . If the concentration of a radionuclide is below the lower limit of detection, the radionuclide shall not be included as a source term in the setpoint calculation.
- EC<sub>i</sub> = the effluent concentration of radionuclide "i", from 10CFR20, Appendix B, Table 2, Column 2, in  $\mu\text{Ci/ml}$ . ( $2.0E-4$   $\mu\text{Ci/ml}$  for noble gases).

$$DF = 10DF_o \quad (2.1-2)$$

Where:

- DF = the conservative dilution factor used by PNPP to calculate the maximum release rate prior to release in order to ensure compliance with 10CFR20;
- DF<sub>o</sub> = the minimum acceptable dilution factor, as per equation 2.1-1;
- 10 = a factor of ten less than 10CFR20, Appendix B, Table 2, Column 2, limits; which represents an order of magnitude of conservatism for liquid radwaste releases from PNPP.

### 2.1.1.2 Maximum Allowable Radwaste Tank Discharge Flow Rate

$$F_{max} = \frac{(0.64)MDF}{DF} \quad (2.1-3)$$

Where:

- $F_{max}$  = the maximum allowable radwaste tank discharge flow rate for the batch to be released, gpm;
- DF = the conservative dilution factor, per equation 2.1-2;
- MDF = the minimum dilution flow - supplied by the Service Water system, Emergency Service Water system, or Circulating Water system blowdown, gpm;
- 0.64 = an engineering factor to prevent spurious alarms

### 2.1.1.3 Liquid Radwaste Discharge Flow Monitor Alarm Setpoint <L00434>

Monitor alarm setpoints are determined to ensure that the concentration of radionuclides in the liquid radwaste effluent released from PNPP to unrestricted areas does not exceed the limits specified in 10CFR20, Appendix B, Table 2, Column 2, for radionuclides other than dissolved and entrained noble gases. A limiting effluent concentration of  $2.0E-4$   $\mu\text{Ci/ml}$  has been established for dissolved and entrained noble gases in liquid effluents.

$$SP_r = 1.25 (F_{act}) \quad (2.1-4)$$

Where:

- $SP_r$  = liquid radwaste adjustable high flow trip Unit (G50-K805A/B or G50-K926/7) alarm setpoint, gpm;
- $F_{act}$  = actual allowable radwaste tank discharge flow rate for the batch to be released, not to exceed the maximum allowable radwaste discharge flow rate  $F_{max}$  as defined in equation 2.1-3, gpm;
- 1.25 = an engineering safety factor to prevent spurious alarms

The liquid radwaste tank discharge flow should be maintained at or below this  $F_{act}$  value by proper regulation of the high or low volume discharge throttle valves (G50-F153 or G50-F155, respectively).

### 2.1.1.4 Liquid Radwaste Discharge Radiation Monitor Alarm/Trip Setpoint

Monitor alarm/trip setpoints are determined to ensure that the concentration of radionuclides in the liquid radwaste effluent released from PNPP to unrestricted areas does not exceed the limits specified in 10CFR20, Appendix B, Table 2, Column 2 for radionuclides other than dissolved or entrained noble gases. A limiting effluent concentration of  $2.0E-4$   $\mu\text{Ci/ml}$  has been established for dissolved and entrained noble gases in liquid effluents.

$$CR_c = \Sigma(C_i) (E_i) \quad (2.1-5)$$

Where:

- $CR_c$  = the calculated monitor count rate above background, cpm;
- $C_i$  = the concentration of radionuclide "i" in the batch to be released,  $\mu\text{Ci/ml}$ ;
- $E_i$  = the detector efficiency of the monitor for radionuclide "i",  $\text{cpm}/\mu\text{Ci/ml}$ .

OR



$$CR_x = (R_s) (F_x) (\Sigma C_i) \quad (2.1-6)$$

Where:

$CR_x$  = the cross-calibrated monitor count rate above background, cpm;  
 $F_x$  = the cross-calibration factor is used to ratio the liquid radwaste discharge radiation monitor actual response to the Cs-137 calibrated response;  
 $R_s$  = the response of the Liquid Radwaste Discharge Radiation Monitor to a Cs-137 calibrated standard, cpm/( $\mu$ Ci/ml).

$$SP_r = 1.25 \left( \frac{F_{max}}{F_{act}} \right) CR_n + BG \quad (2.1-7)$$

Where:

$SP_r$  = the Radwaste Discharge Radiation Monitor - ESW Discharge alarm/trip setpoint, in cpm;  
 $BG$  = background count rate due to internal contamination and radiation levels in the area of the monitor, cpm;  
 $CR_n$  = monitor net count rate, either  $CR_c$  or  $CR_x$ , per equation 2.1-5 or 2.1-6, cpm;  
1.25 = an engineering factor to prevent spurious alarms;  
 $F_{max}/F_{act}$  = an adjustment factor (to account for the difference between an actual radwaste discharge flow rate to be used for the discharge and maximum allowable radwaste discharge flow rate) to allow operational flexibility and to minimize spurious alarms;

Where:

$F_{act}$  = actual radwaste discharge flow rate, this value must always be less than or equal to  $F_{max}$ , gpm;  
 $F_{max}$  = maximum allowable radwaste discharge flow rate, per equation 2.1-3, gpm.

## 2.1.2 10CFR20 Compliance - Liquid Effluent Concentration

In order to show compliance with 10CFR20, the concentrations of radionuclides in liquid effluents will be determined and compared with the limiting effluent concentrations as defined in 10CFR20, Appendix B, Table 2, Column 2, ( $2.0E-4 \mu$ Ci/ml for dissolved and entrained noble gases). Concentrations of radioactivity in effluents prior to dilution will be determined. Concentration in diluted effluent will be calculated using these results prior to each batch release, and following each batch release.

### 2.1.2.1 Concentration of Radionuclides in Prerelease

The radioactivity content of each batch release will be determined prior to release. PNPP will show compliance with 10CFR20 in the following manner:

The concentration of the various radionuclides in batch releases prior to dilution is divided by the minimum dilution flow to obtain the concentration at the unrestricted area. This calculation is shown in the following equation:

$$Conc_i = \frac{(C_i)(f)}{MDF} \quad (2.1-8)$$

Where:

- $Conc_i$  = the concentration of radionuclide "i" at the unrestricted area,  $\mu\text{Ci/ml}$ ;
- $C_i$  = the concentration of radionuclide "i" in the batch to be released,  $\mu\text{Ci/ml}$ ;
- $f$  = the radwaste tank discharge flow rate for the batch to be released, gpm;
- $MDF$  = the minimum dilution flow, per equation 2.1-3, gpm.

The projected radionuclide concentrations in the unrestricted area are compared to the limiting effluent concentrations in 10CFR20, Appendix B, Table 2, Column 2 ( $2.0\text{E-}4 \mu\text{Ci/ml}$  for dissolved and entrained noble gases) in order to give a final 10CFR20 compliance check, i.e., the following equation must be met:

$$\sum \frac{Conc_i}{EC_i} \leq 1 \quad (2.1-9)$$

Where:

- $Conc_i$  = the concentration of radionuclide "i" at the unrestricted area,  $\mu\text{Ci/ml}$ ;
- $EC_i$  = the limiting effluent concentration of radionuclide "i", from 10CFR20, Appendix B, Table 2, Column 2 ( $2.0\text{E-}4 \mu\text{Ci/ml}$  for dissolved and entrained noble gases),  $\mu\text{Ci/ml}$ .

#### 2.1.2.2 Post Release

The actual radioactivity content of each batch release will be determined following release to show final compliance with 10CFR20.

The concentration of the various radionuclides in batch releases prior to dilution is divided by the actual dilution to obtain the concentration at the unrestricted area. This calculation is shown in the following equation:

$$Conc_i = \frac{(C_i)(V_{lrt})}{V_{dil}} \quad (2.1-10)$$

Where:

- $Conc_i$  = the actual concentration of radionuclide "i" at the unrestricted area for the release,  $\mu\text{Ci/ml}$ ;
- $C_i$  = the concentration of radionuclide "i" in the batch released,  $\mu\text{Ci/ml}$ ;
- $V_{dil}$  = the actual volume of dilution water during the release (total plant discharge flow, including Service Water, Emergency Service Water, and cooling tower blowdown), in gallons;
- $V_{lrt}$  = the actual volume of the liquid radwaste tank discharged for the batch, gal.

**ODCM**  
**Page: 7**  
**Rev.: 21**

The concentrations in the unrestricted area are compared to the limiting effluent concentrations in 10CFR20, Appendix B, Table 2, Column 2 (2.0E-4  $\mu\text{Ci/ml}$  for dissolved and entrained noble gases). In order to demonstrate final compliance with 10CFR20, the following equation must be met:

$$\sum \frac{Conc_i}{EC_i} \leq 1 \quad (2.1-11)$$

Where:

$Conc_i$  = concentration of radionuclide "i" at the unrestricted area,  $\mu\text{Ci/ml}$ ;

$EC_i$  = limiting effluent concentration of radionuclide "i", from 10CFR20, Appendix B, Table 2, Column 2,  $\mu\text{Ci/ml}$ .

## 2.2 Continuous Releases

A continuous release is the discharge of fluid wastes of a non-discrete volume, i.e., from a volume or system that has an input flow during the continuous release. Potential sources for a continuous release at Perry are RHR heat exchanger leakage into the Emergency Service Water system, tritium activity in the M35 Supply Plenum drain into storm drains, and Alternate Decay Heat Removal (ADHR) heat exchanger leakage into Service Water.

Potentially contaminated discharges from the ESW are monitored by an installed radiation monitoring system. This system consists of two channels, one for monitoring downstream of equipment in Emergency Service Water System Loop A and the other for Emergency Service Water Loop B. If radiation is detected, the affected Emergency Service Water line can be manually isolated. The decision of whether to isolate or not is dependent upon other conditions. The PNPP staff will take appropriate action to limit release.

The Emergency Service Water discharged will be sampled and analyzed in accordance with ODCM Appendix C, Table 4.11.1.1.1-1. To show compliance with 10CFR20, the sum of the concentrations of radionuclide "i" in unrestricted areas due to both continuous and batch releases divided by that isotope's limiting effluent concentration must be less than 1.

During the summer months, the Turbine Building Supply Plenums (1M35B0001A, B, C) are used as a cooling source; condensation from the cooling coils is collected in the M35 plenum drain pans. Moisture from the outside air is condensed and flows into the drain pan. The potential exists for the outside air to contain tritium from the plant vents, thus the M35 Turbine Building Supply Plenums could also contain tritium. During the summer months, the M35 drains are routed to storm drains due to the large quantity of condensation. Grab samples are obtained in accordance with ODCM Appendix C Table 4.11.1.1.1-1.

The ADHR system has an installed radiation monitor on the Service Water line that provides cooling to the ADHR heat exchanger. The Service Water (ADHR) system will be sampled and analyzed in accordance with ODCM Appendix C, Table 4.11.1.1.1-1. If radiation is detected, the ADHR system can be isolated. The decision of whether to isolate or not is dependent upon other conditions. The PNPP staff will take appropriate action to limit release.

## 2.2.1 Monitor Alarm Setpoint Determination

The following methodology is used to calculate the alarm setpoints for the Emergency Service Water loops A & B and Service Water (ADHR) Radiation Monitors. This methodology ensures an alarm will be received prior to exceeding the limiting effluent concentration listed in 10CFR20, Appendix B, Table 2, Column 2.

### 2.2.1.1. Alarm Setpoint

$$CR_C = (BG + MR) (0.75)$$

Where:

- CR<sub>C</sub> = the calculated monitor count rate in cpm;
- BG = the background count rate due to internal contamination and radiation levels in the area of the monitor in cpm;
- MR = expected monitor response due to 1.0 EC of a typical reactor water isotopic mix;
- 0.75 = engineering safety factor

### 2.2.1.2 Minimum Allowable Backgrounds

$$BG_{min} = CR_C - MR$$

Where:

- BG<sub>min</sub> = minimum allowable background to ensure monitor will alarm prior to exceeding 1.0 EC;
- CR<sub>C</sub> = the calculated monitor count rate in cpm;
- MR = expected monitor response due to 1.0 EC of a typical reactor water isotopic mix;

**NOTE:** If calculated value is negative, then 0 cpm will be used as the minimum allowable background.

### 2.2.1.3. Expected Monitor Response Based on the Reactor Water Source Term

$$MR = \sum (EC_i \times \%_i \times Eff_i)$$

Where:

- MR = expected monitor response due to 1.0 EC of a typical reactor water isotopic mix;
- %<sub>i</sub> = percent of isotope (i) in a typical reactor water isotopic mixture;
- Eff<sub>i</sub> = radiation monitor detector efficiency for isotope (i);
- EC<sub>i</sub> = Effluent concentration value for isotope (i), Appendix B, Table 2, Column 2, 10CFR20.

### 2.2.1.4. Minimum Allowable Setpoint Based on Monitor Background

$$CR_{min} = BG + \left( \sqrt{BG / ZFC} \right)$$

Where:

- CR<sub>min</sub> = Minimum allowable setpoint for a given monitor background (BG);
- BG = the background count rate due to internal contamination and radiation levels in the area of the monitor in cpm;
- 2 = 95% confidence level;
- 2TC = two times the instrument time constant where

$$TC = \frac{(\log_{10} BG - \log_{10} Lo_{cpm}) (TC_{Hi_{cpm}} - TC_{Lo_{cpm}})}{(\log_{10} Hi_{cpm} - \log_{10} Lo_{cpm})} + TC_{Lo_{cpm}}$$

Time Constants:

Hi/Lo cpm	TC Hi/Lo cpm
10 cpm	1.25 min
100 cpm	1.25 min
1,000 cpm	1.25 min
10,000 cpm	0.2 min
100,000 cpm	0.042 min
1,000,000 cpm	0.0033 min

For Backgrounds less than 400 cpm, the following values will be used:

Lo<sub>cpm</sub> = 100 cpm                      TC<sub>Lo<sub>cpm</sub></sub> = 1.25 min  
Hi<sub>cpm</sub> = 1000 cpm                      TC<sub>Hi<sub>cpm</sub></sub> = 1.25 min

For Backgrounds ≥ 400 cpm and less than 1,000 cpm, the following values will be used:

Lo<sub>cpm</sub> = 1,000 cpm                      TC<sub>Lo<sub>cpm</sub></sub> = 1.25 min  
Hi<sub>cpm</sub> = 10,000 cpm                      TC<sub>Hi<sub>cpm</sub></sub> = 0.2 min

### 2.3 10CFR50, Appendix I Compliance - Liquid Effluent Dose

Doses resulting from liquid effluents will be calculated at least monthly to show compliance with 10CFR50, Appendix I. A cumulative summation of whole body and organ doses for the current quarter and year will be maintained. Additionally, doses due to liquid releases are projected monthly.

#### 2.3.1 Dose Calculations

Radiation doses due to liquid radioactive effluents from PNPP are calculated based on three main dose pathways: potable water, aquatic foods (namely fresh water fish ingestion), and exposure to shoreline deposits. Irrigated food pathways, as discussed in Regulatory Guide 1.109, will not be of concern at PNPP as little or no water from Lake Erie is used for irrigation in the nearby Ohio counties of Lake, Ashtabula, Cuyahoga and Lorain. Nursery businesses and other agricultural activities that require supplemental water generally rely on water drawn from small ponds and streams.

Radiation dose to members of the public for liquid radioactive releases from PNPP will be calculated for the potable water, aquatic food, and shoreline deposit pathways using the following equations:

Potable Water

$$R_{ajp} = 1100 \frac{U_{ap}}{(M_p)(F)} \sum (Q_i)(D_{aipj}) \exp(-\lambda_i t_p) \quad (2.3-1)$$

Aquatic Foods

$$R_{ajp} = 1100 \frac{U_{ap}}{(M_p)(F)} \sum (C_i)(B_{ip})(D_{aipj}) \exp(-\lambda_i t_p) \quad (2.3-2)$$

Shoreline Deposits

$$R_{ajp} = 110,000 \frac{(U_{ap})(W)}{(M_p)(F)} \sum (Q_i)(T_i)(D_{aipj}) \left[ \exp(-\lambda_i t_p) \right] \left[ 1 - \exp(-\lambda_i t_b) \right] \quad (2.3-3)$$

**Where:**

- $R_{ajp}$  = the dose to individuals of age group "a" to organ "j" from all the radionuclides in pathway "p", in mrem;
- $B_{ip}$  = the equilibrium bioaccumulation factor for radionuclide "i" in pathway "p", expressed as the ratio of the concentration in biota (pCi/kg) to the radionuclide concentration in water (pCi/l), from Table 2.3-4, l/kg;
- $D_{aipj}$  = the dose factor, specific to a given age group "a", radionuclide "i", pathway "p", and organ "j", which can be used to calculate the radiation dose from an intake of a radionuclide (mrem/pCi); or from exposure to a given concentration of a radionuclide in sediment, expressed as a ratio of the dose rate (mrem/h), and the areal radionuclide concentration, (pCi/m<sup>2</sup>), from Tables 2.3-5 through 2.3-9;

$F$  = the flow rate of the liquid effluent, ft<sup>3</sup>/sec;

**NOTE:** The normal minimum dilution flow will be 30,000 gpm (USAR 11.2.3.2).

$x_p$  = the dilution factor at the midpoint of exposure (or the point of withdrawal of drinking water, point of harvest of aquatic food or shoreline), from Table 2.3-10, dimensionless;

$Q_i$  = the release of radionuclide "i", Ci;

$T_b$  = the period of time for which the sediment or soil is exposed to the contaminated water,  $1.75 \times 10^5$  hr (20 yrs);

$T_i$  = the half-life of radionuclide "i", days;

$t_p$  = the average transit time required for radionuclides to reach the point of exposure, from Table 2.3-11; for internal dose,  $t_p$  is the total time elapsed between release of the radionuclides and the ingestion of food or water, hr;

$U_{ap}$  = the usage factor that specifies the exposure time or intake rate for an individual of age group a associated with pathway "p", from Table 2.3-12, hr/yr, 1/yr, or kg/yr;

$W$  = the shoreline width factor, 0.3 (from Regulatory Guide 1.109);

$\lambda_i$  = radioactive decay constant of radionuclide "i", h<sup>-1</sup>;

1100 = a factor to convert from (Ci/yr)/(ft<sup>3</sup>/s) to pCi/l;

110,000 = a factor to convert from (Ci/yr)/(ft<sup>3</sup>/s) to pCi/l and to account for the proportionality constant used in the sediment radioactivity model.

### 2.3.2 Cumulation of Doses

The dose contribution from liquid effluents will be calculated at least monthly. Calculations will be performed to determine the maximum whole body as well as the maximum organ dose to an individual. These dose calculations will be summed for comparison with quarterly and annual limits. These results will be summed with the doses cumulated from the other months in the quarter of interest and in the year of interest. To assure compliance with the dose limits of 10CFR50, Appendix I the following relationships shall hold:

for the quarter:

Dose  $\leq 1.5$  mrem whole body;

Dose  $\leq 5$  mrem any organ;

for the year:

Dose  $\leq 3$  mrem whole body;

Dose  $\leq 10$  mrem any organ.

The quarterly limits given above represent one-half of the annual design objective. If these quarterly or annual limits are exceeded, a special report will be submitted to the NRC, in accordance with ODCM Appendix C controls, stating the reason and corrective action to be taken.

### 2.3.3 Projection of Doses

Anticipated doses resulting from the release of liquid effluents will be projected monthly. The doses calculated for the present month will be used as the projected doses unless information exists indicating that actual releases could differ significantly in the next month.

If the projected dose, when averaged over 31 days, exceeds 0.06 mrem to the whole body or 0.2 mrem to any organ, the liquid radwaste system will be used to process waste. The values for the projected dose impact levels correspond to approximately one forty-eighth of the 10CFR50, Appendix I design objective. If continued at this rate for one year, the projected impact would correspond to less than one-fourth of the 10CFR50, Appendix I limit. The projected doses will be calculated using equations 2.3-1, 2.3-2, and 2.3-3.

In this case, the source term will be adjusted to reflect this information and the justification for the adjustment noted. This adjustment should account for any radwaste equipment which was operated during the previous month that could be out of service in the coming month.

### 2.3.4 Population Dose

PNPP's Annual Radioactive Effluent Release Reports, as required by Regulatory Guide 1.21, will include total population dose and average individual doses calculated for radioactive effluent releases. The total population dose and average individual doses will be calculated using average individual transit times and usage factors, Table 2.3-12, (as compared to maximum exposed individual factors used for individual doses). The total population dose will be calculated by dose pathway and organ, with pathway doses being corrected for the fraction of the population assumed to be in each age group (adult, teen, child and infant: 0.71, 0.11, 0.18, 0.0 respectively).



**Table 2.3-1**

**Organs Used for Liquid Effluent Dose Calculations**

1. Bone
2. GI Tract
3. Kidney
4. Liver
5. Lung
6. Thyroid
7. Whole Body
8. Skin

**Table 2.3-2**

**Age Groups Used for Liquid Effluent Dose Calculations**

1. Adult (17 yrs. and older)
2. Teen (11 - 17 yrs)
3. Child (1 - 11 yrs)
4. Infant (0 - 1 yr)

**Table 2.3-3**

**Liquid Effluent Dose Pathways**

1. Water Ingestion
2. Shore Exposure
3. Fresh Water Fish Ingestion

Table 2.3-4

Bio-Accumulation Factors (B<sub>p</sub>) (pCi/kg per pCi/liter)

<u>Element</u>	<u>Fish</u>
H	9.0E-01
C	4.6E+03
Na	1.0E+02
P	1.0E+05
Cr	2.0E+02
Mn	4.0E+02
Fe	1.0E+02
Co	5.0E+01
Ni	1.0E+02
Cu	5.0E+01
Zn	2.0E+03
Br	4.2E+02
Rb	2.0E+03
Sr	3.0E+01
Y	2.5E+01
Zr	3.3E+00
Nb	3.0E+04
Mo	1.0E+01
Tc	1.5E+01
Ru	1.0E+01
Rh	1.0E+01
Sb	1.0E+00
Te	4.0E+02
I	1.5E+01
Cs	2.0E+03
Ba	4.0E+00
La	2.5E+01
Ce	1.0E+00
Pr	2.5E+01
Nd	2.5E+01
Ta	1.0E+00
W	1.2E+03
Re	1.0E+00
Au	1.0E+00
Np	1.0E+01

Table 2.3-5

Ingestion Dose Factors for Adult (mrem/pCi ingested)

ISOTOPE	BONE	LIVER	WHOLE BODY	THYROID	KIDNEY	LUNG	GI-LLI
H-3	0.00E+00	1.05E-07	1.05E-07	1.05E-07	1.05E-07	1.05E-07	1.05E-07
C-14	2.84E-08	5.68E-07	5.68E-07	5.68E-07	5.68E-07	5.68E-07	5.68E-07
Na-24	1.70E-06	1.70E-06	1.70E-06	1.70E-06	1.70E-06	1.70E-06	1.70E-06
P-32	1.93E-04	1.20E-05	7.48E-06	0.00E+00	0.00E+00	0.00E+00	2.17E-05
Cr-51	0.00E+00	0.00E+00	2.66E-09	1.59E-09	5.86E-10	3.53E-09	6.69E-07
Mn-54	0.00E+00	4.57E-06	8.72E-07	0.00E+00	1.36E-06	0.00E+00	1.40E-05
Mn-56	0.00E+00	1.15E-07	2.04E-08	0.00E+00	1.46E-07	0.00E+00	3.67E-06
Fe-55	2.75E-06	1.90E-06	4.43E-07	0.00E+00	0.00E+00	1.06E-06	1.09E-06
Fe-59	4.34E-06	1.02E-05	3.91E-06	0.00E+00	0.00E+00	2.85E-06	3.40E-05
Co-58	0.00E+00	7.45E-07	1.67E-06	0.00E+00	0.00E+00	0.00E+00	1.51E-05
Co-60	0.00E+00	2.14E-06	4.72E-06	0.00E+00	0.00E+00	0.00E+00	4.02E-05
Ni-63	1.30E-04	9.01E-06	4.36E-06	0.00E+00	0.00E+00	0.00E+00	1.88E-06
Ni-65	5.28E-07	6.86E-08	3.13E-08	0.00E+00	0.00E+00	0.00E+00	1.74E-06
Cu-64	0.00E+00	8.33E-08	3.91E-08	0.00E+00	2.10E-07	0.00E+00	7.10E-06
Cu-67	2.95E-07	8.41E-07	0.00E+00	2.24E-07	2.62E-07	2.27E-07	1.07E-05
Zn-65	4.84E-06	1.54E-05	6.96E-06	0.00E+00	1.03E-05	0.00E+00	9.70E-06
Zn-69	1.03E-08	1.97E-08	1.37E-09	0.00E+00	1.28E-08	0.00E+00	2.98E-09
Br-83	0.00E+00	0.00E+00	4.02E-08	0.00E+00	0.00E+00	0.00E+00	5.79E-08
Br-84	0.00E+00	0.00E+00	5.21E-08	0.00E+00	0.00E+00	0.00E+00	4.09E-13
Br-85	0.00E+00	0.00E+00	2.14E-09	0.00E+00	0.00E+00	0.00E+00	0.00E+00
Rb-86	0.00E+00	2.11E-05	9.83E-06	0.00E+00	0.00E+00	0.00E+00	4.16E-06
Rb-88	0.00E+00	6.05E-08	3.21E-08	0.00E+00	0.00E+00	0.00E+00	8.36E-19
Rb-89	0.00E+00	4.01E-08	2.82E-08	0.00E+00	0.00E+00	0.00E+00	2.33E-21
Sr-87M	1.52E-08	1.77E-08	0.00E+00	2.96E-09	2.58E-08	6.92E-09	2.15E-07
Sr-89	3.08E-04	0.00E+00	8.84E-06	0.00E+00	0.00E+00	0.00E+00	4.94E-05
Sr-90	7.58E-03	0.00E+00	1.86E-03	0.00E+00	0.00E+00	0.00E+00	2.19E-04
Sr-91	5.67E-06	0.00E+00	2.29E-07	0.00E+00	0.00E+00	0.00E+00	2.70E-05
Sr-92	2.15E-06	0.00E+00	9.30E-08	0.00E+00	0.00E+00	0.00E+00	4.26E-05
Y-90	9.62E-09	0.00E+00	2.58E-10	0.00E+00	0.00E+00	0.00E+00	1.02E-04
Y-91M	9.09E-11	0.00E+00	3.52E-12	0.00E+00	0.00E+00	0.00E+00	2.67E-10
Y-91	1.41E-07	0.00E+00	3.77E-09	0.00E+00	0.00E+00	0.00E+00	7.67E-05
Y-92	8.45E-10	0.00E+00	2.47E-11	0.00E+00	0.00E+00	0.00E+00	1.48E-05
Y-93	2.68E-09	0.00E+00	7.40E-11	0.00E+00	0.00E+00	0.00E+00	8.50E-05
Zr-95	3.04E-08	9.75E-09	6.60E-09	0.00E+00	1.53E-08	0.00E+00	3.09E-05
Zr-97	1.68E-09	3.39E-10	1.55E-10	0.00E+00	5.12E-10	0.00E+00	1.05E-04
Nb-95	6.22E-09	3.46E-09	1.86E-09	0.00E+00	3.42E-09	0.00E+00	2.10E-05
Mo-99	0.00E+00	4.31E-06	8.20E-07	0.00E+00	9.76E-06	0.00E+00	9.99E-06
Tc-99M	2.47E-10	6.98E-10	8.89E-09	0.00E+00	1.06E-08	3.42E-10	4.13E-07

Table 2.3-5 (Cont.)

Ingestion Dose Factors for Adult (mrem/pCi ingested)

ISOTOPE	BONE	LIVER	WHOLE BODY	THYROID	KIDNEY	LUNG	GI-LLI
Tc-101	2.54E-10	3.66E-10	3.59E-09	0.00E+00	6.59E-09	1.87E-10	1.10E-21
Ru-103	1.85E-07	0.00E+00	7.97E-08	0.00E+00	7.06E-07	0.00E+00	2.16E-05
Ru-105	1.54E-08	0.00E+00	6.08E-09	0.00E+00	1.99E-07	0.00E+00	9.42E-06
Ru-106	2.75E-06	0.00E+00	3.48E-07	0.00E+00	5.31E-06	0.00E+00	1.78E-04
Ag-110M	1.60E-07	1.48E-07	8.79E-08	0.00E+00	2.91E-07	0.00E+00	6.04E-05
Te-125M	2.68E-06	9.17E-07	3.59E-07	8.06E-07	1.09E-05	0.00E+00	1.07E-05
Te-127M	6.77E-06	2.42E-06	8.25E-07	1.73E-06	2.75E-05	0.00E+00	2.27E-05
Te-127	1.10E-07	3.95E-08	2.38E-08	8.15E-08	4.48E-07	0.00E+00	8.68E-06
Te-129M	1.15E-05	4.29E-06	1.82E-06	3.95E-06	4.80E-05	0.00E+00	5.79E-05
Te-129	3.14E-08	1.18E-08	7.65E-09	2.41E-08	1.32E-07	0.00E+00	2.37E-08
Te-131M	1.73E-06	8.46E-07	7.05E-07	1.34E-06	8.57E-06	0.00E+00	8.40E-05
Te-131	1.97E-08	8.23E-09	6.22E-09	1.62E-08	8.63E-08	0.00E+00	2.79E-09
Te-132	2.52E-06	1.63E-06	1.53E-06	1.80E-06	1.57E-05	0.00E+00	7.71E-05
I-130	7.56E-07	2.23E-06	8.80E-07	1.89E-04	3.48E-06	0.00E+00	1.92E-06
I-131	4.16E-06	5.95E-06	3.41E-06	1.95E-03	1.02E-05	0.00E+00	1.57E-06
I-132	2.03E-07	5.43E-07	1.90E-07	1.90E-05	8.65E-07	0.00E+00	1.02E-07
I-133	1.42E-06	2.47E-06	7.53E-07	3.63E-04	4.31E-06	0.00E+00	2.22E-06
I-134	1.06E-07	2.88E-07	1.03E-07	4.99E-06	4.58E-07	0.00E+00	2.51E-10
I-135	4.43E-07	1.16E-06	4.28E-07	7.65E-05	1.86E-06	0.00E+00	1.31E-06
Ce-134	6.22E-05	1.48E-04	1.21E-04	0.00E+00	4.79E-05	1.59E-05	2.59E-08
Ce-136	6.51E-06	2.67E-05	1.85E-05	0.00E+00	1.43E-05	1.98E-06	2.92E-06
Cs-137	7.97E-05	1.09E-04	7.14E-05	0.00E+00	3.70E-05	1.23E-05	2.11E-06
Cs-138	5.52E-08	1.09E-07	5.40E-08	0.00E+00	8.01E-08	7.91E-09	4.65E-13
Ba-139	9.70E-08	6.91E-11	2.84E-09	0.00E+00	6.46E-11	3.92E-11	1.72E-07
Ba-140	2.03E-05	2.55E-08	1.33E-06	0.00E+00	8.67E-09	1.46E-08	4.18E-05
Ba-141	4.71E-08	3.56E-11	1.59E-09	0.00E+00	3.31E-11	2.02E-11	2.22E-17
Ba-142	2.13E-08	2.19E-11	1.34E-09	0.00E+00	1.85E-11	1.24E-11	3.00E-26
La-140	2.50E-09	1.26E-09	3.33E-10	0.00E+00	0.00E+00	0.00E+00	9.25E-05
La-142	1.28E-10	5.82E-11	1.45E-11	0.00E+00	0.00E+00	0.00E+00	4.25E-07
Ce-141	9.36E-09	6.33E-09	7.18E-10	0.00E+00	2.94E-09	0.00E+00	2.42E-06
Ce-143	1.65E-09	1.22E-06	1.35E-10	0.00E+00	5.37E-10	0.00E+00	4.56E-05
Ce-144	4.88E-07	2.04E-07	2.62E-08	0.00E+00	1.21E-07	0.00E+00	1.65E-04
Pr-143	9.20E-09	3.69E-09	4.56E-10	0.00E+00	2.13E-09	0.00E+00	4.03E-05
Pr-144	3.01E-11	1.25E-11	1.53E-12	0.00E+00	7.05E-12	0.00E+00	4.33E-18
Nd-147	6.29E-09	7.27E-09	4.35E-10	0.00E+00	4.25E-09	0.00E+00	3.49E-05
Ta-183	4.77E-11	2.92E-10	2.39E-11	0.00E+00	1.66E-10	0.00E+00	1.76E-04
W-187	1.03E-07	8.61E-08	3.01E-08	0.00E+00	0.00E+00	0.00E+00	2.82E-05
Re-188	2.42E-07	1.90E-07	5.37E-07	1.26E-05	0.00E+00	0.00E+00	1.56E-05
Au-198	0.00E+00	1.12E-08	1.90E-08	0.00E+00	3.42E-08	0.00E+00	8.67E-06
Au-199	0.00E+00	7.00E-08	5.89E-08	0.00E+00	2.74E-07	0.00E+00	1.13E-05
Np-239	1.19E-09	1.17E-10	6.45E-11	0.00E+00	3.65E-10	0.00E+00	2.40E-05
Sb-124	2.80E-06	5.29E-06	1.11E-06	6.79E-09	0.00E+00	2.18E-06	7.95E-05
Sb-125	1.79E-06	2.00E-06	4.26E-07	1.82E-09	0.00E+00	1.38E-06	1.97E-05

Table 2.3-6

Ingestion Dose Factors for Teenager (mrem/pCi ingested)

ISOTOPE	BONE	LIVER	WHOLE BODY	THYROID	KIDNEY	LUNG	GI-LLI
H-3	0.00E+00	1.06E-07	1.06E-07	1.06E-07	1.06E-07	1.06E-07	1.06E-07
C-14	4.08E-06	8.12E-07	8.12E-07	8.12E-07	8.12E-07	8.12E-07	8.12E-07
Na-24	2.30E-06	2.30E-06	2.30E-06	2.30E-06	2.30E-06	2.30E-06	2.30E-06
P-32	2.76E-04	1.71E-05	1.07E-05	0.00E+00	0.00E+00	0.00E+00	2.32E-05
Cr-51	0.00E+00	0.00E+00	3.60E-09	2.00E-09	7.89E-10	5.14E-09	6.05E-07
Mn-54	0.00E+00	5.90E-06	1.17E-06	0.00E+00	1.76E-06	0.00E+00	1.21E-05
Mn-56	0.00E+00	1.58E-07	2.81E-08	0.00E+00	2.00E-07	0.00E+00	1.04E-05
Fe-55	3.78E-06	2.68E-06	6.25E-07	0.00E+00	0.00E+00	1.70E-06	1.16E-06
Fe-59	5.87E-06	1.37E-05	5.29E-06	0.00E+00	0.00E+00	4.32E-06	3.24E-05
Co-58	0.00E+00	9.72E-07	2.24E-06	0.00E+00	0.00E+00	0.00E+00	1.34E-05
Co-60	0.00E+00	2.81E-06	6.33E-06	0.00E+00	0.00E+00	0.00E+00	3.66E-05
Ni-63	1.77E-04	1.25E-05	6.00E-06	0.00E+00	0.00E+00	0.00E+00	1.99E-06
Ni-65	7.49E-07	9.57E-08	4.36E-08	0.00E+00	0.00E+00	0.00E+00	5.19E-06
Cu-64	3.54E-07	1.07E-06	0.00E+00	2.74E-07	3.19E-7	2.81E-07	1.32E-05
Cu-67	0.00E+00	1.15E-07	5.41E-08	0.00E+00	2.91E-07	0.00E+00	8.92E-06
Zn-65	5.76E-06	2.00E-05	9.33E-06	0.00E+00	1.28E-05	0.00E+00	8.47E-06
Zn-69	1.47E-08	2.80E-08	1.96E-09	0.00E+00	1.83E-08	0.00E+00	5.16E-08
Br-83	0.00E+00	0.00E+00	5.74E-08	0.00E+00	0.00E+00	0.00E+00	0.00E+00
Br-84	0.00E+00	0.00E+00	7.22E-08	0.00E+00	0.00E+00	0.00E+00	0.00E+00
Br-85	0.00E+00	0.00E+00	3.05E-09	0.00E+00	0.00E+00	0.00E+00	0.00E+00
Rb-86	0.00E+00	2.98E-05	1.40E-05	0.00E+00	0.00E+00	0.00E+00	4.41E-06
Rb-88	0.00E+00	8.52E-08	4.54E-08	0.00E+00	0.00E+00	0.00E+00	7.30E-15
Rb-89	0.00E+00	5.50E-08	3.89E-08	0.00E+00	0.00E+00	0.00E+00	8.43E-17
Sr-87M	2.81E-8	2.18E-08	0.00E+00	4.40E-9	3.00E-08	9.91E-09	2.42E-07
Sr-89	4.40E-04	0.00E+00	1.26E-05	0.00E+00	0.00E+00	0.00E+00	5.24E-05
Sr-90	8.30E-03	0.00E+00	2.05E-03	0.00E+00	0.00E+00	0.00E+00	2.33E-04
Sr-91	8.07E-06	0.00E+00	3.21E-07	0.00E+00	0.00E+00	0.00E+00	3.66E-05
Sr-92	3.05E-06	0.00E+00	1.30E-07	0.00E+00	0.00E+00	0.00E+00	7.77E-05
Y-90	1.37E-08	0.00E+00	3.69E-10	0.00E+00	0.00E+00	0.00E+00	1.13E-04
Y-91M	1.29E-10	0.00E+00	4.93E-12	0.00E+00	0.00E+00	0.00E+00	6.09E-09
Y-91	2.01E-07	0.00E+00	5.39E-09	0.00E+00	0.00E+00	0.00E+00	8.24E-05
Y-92	1.21E-09	0.00E+00	3.50E-11	0.00E+00	0.00E+00	0.00E+00	3.32E-05
Y-93	3.83E-09	0.00E+00	1.05E-10	0.00E+00	0.00E+00	0.00E+00	1.17E-04
Zr-95	4.12E-08	1.30E-08	8.94E-09	0.00E+00	1.91E-08	0.00E+00	3.00E-05
Zr-97	2.37E-09	4.69E-10	2.16E-10	0.00E+00	7.11E-10	0.00E+00	1.27E-04
Nb-95	8.22E-09	4.56E-09	2.51E-09	0.00E+00	4.42E-09	0.00E+00	1.95E-05
Mo-99	0.00E+00	6.03E-06	1.15E-06	0.00E+00	1.38E-05	0.00E+00	1.08E-05
Tc-99M	3.32E-10	9.26E-10	1.20E-08	0.00E+00	1.38E-08	5.14E-10	6.08E-07

Table 2.3-8 (Cont.)

Ingestion Dose Factors for Teenager (mrem/pCi ingested)

ISOTOPE	BONE	LIVER	WHOLE BODY	THYROID	KIDNEY	LUNG	GI-LI
Tc-101	3.60E-10	5.12E-10	5.03E-09	0.00E+00	9.26E-09	3.12E-10	8.75E-17
Ru-103	2.55E-07	0.00E+00	1.09E-07	0.00E+00	8.99E-07	0.00E+00	2.13E-05
Ru-105	2.18E-08	0.00E+00	8.46E-09	0.00E+00	2.75E-07	0.00E+00	1.76E-05
Ru-106	3.92E-06	0.00E+00	4.94E-07	0.00E+00	7.56E-06	0.00E+00	1.88E-04
Ag-110M	2.05E-07	1.94E-07	1.18E-07	0.00E+00	3.70E-07	0.00E+00	5.45E-05
Te-125M	3.83E-06	1.38E-06	5.12E-07	1.07E-06	0.00E+00	0.00E+00	1.13E-05
Te-127M	9.67E-06	3.43E-06	1.15E-06	2.30E-06	3.92E-05	0.00E+00	2.41E-05
Te-127	1.58E-07	5.60E-08	3.40E-08	1.09E-07	6.40E-07	0.00E+00	1.22E-05
Te-129M	1.63E-05	6.05E-06	2.58E-06	5.26E-06	6.82E-05	0.00E+00	6.12E-05
Te-129	4.48E-08	1.67E-08	1.09E-08	3.20E-08	1.88E-07	0.00E+00	2.45E-07
Te-131M	2.44E-06	1.17E-06	9.76E-07	1.76E-06	1.22E-05	0.00E+00	9.39E-05
Te-131	2.79E-08	1.15E-08	8.72E-09	2.15E-08	1.22E-07	0.00E+00	2.29E-09
Te-132	3.49E-06	2.21E-06	2.08E-06	2.33E-06	2.12E-05	0.00E+00	7.00E-05
I-130	1.03E-06	2.98E-06	1.19E-06	2.43E-04	4.59E-06	0.00E+00	2.29E-06
I-131	5.85E-06	8.19E-06	4.40E-06	2.39E-03	1.41E-05	0.00E+00	1.62E-06
I-132	2.79E-07	7.30E-07	2.62E-07	2.46E-05	1.15E-06	0.00E+00	3.18E-07
I-133	2.01E-06	3.41E-06	1.04E-06	4.76E-04	5.98E-06	0.00E+00	2.58E-06
I-134	1.46E-07	3.87E-07	1.39E-07	6.45E-06	8.10E-07	0.00E+00	5.10E-09
I-135	6.10E-07	1.57E-06	5.82E-07	1.01E-04	2.48E-06	0.00E+00	1.74E-06
Cs-134	8.37E-05	1.97E-04	9.14E-05	0.00E+00	6.26E-05	2.39E-05	2.45E-06
Cs-136	8.59E-06	3.38E-05	2.27E-05	0.00E+00	1.84E-05	2.90E-06	2.72E-06
Cs-137	1.12E-04	1.49E-04	5.19E-05	0.00E+00	5.07E-05	1.97E-05	2.12E-06
Cs-138	7.76E-08	1.49E-07	7.45E-08	0.00E+00	1.10E-07	1.28E-08	6.76E-11
Ba-139	1.39E-07	9.78E-11	4.05E-09	0.00E+00	9.22E-11	6.74E-11	1.24E-06
Ba-140	2.84E-05	3.48E-08	1.83E-06	0.00E+00	1.18E-08	2.34E-08	4.38E-05
Ba-141	6.71E-08	5.01E-11	2.24E-09	0.00E+00	4.65E-11	3.43E-11	1.43E-13
Ba-142	2.99E-08	2.99E-11	1.84E-09	0.00E+00	2.53E-11	1.99E-11	9.18E-20
La-140	3.48E-09	1.71E-09	4.55E-10	0.00E+00	0.00E+00	0.00E+00	9.82E-05
La-142	1.79E-10	7.95E-11	1.98E-11	0.00E+00	0.00E+00	0.00E+00	2.42E-06
Ce-141	1.33E-08	8.88E-09	1.02E-09	0.00E+00	4.18E-09	0.00E+00	2.54E-05
Ce-143	2.35E-09	1.71E-06	1.91E-10	0.00E+00	7.67E-10	0.00E+00	5.14E-05
Ce-144	6.96E-07	2.88E-07	3.74E-08	0.00E+00	1.72E-07	0.00E+00	1.75E-04
Pr-143	1.31E-08	5.23E-09	6.52E-10	0.00E+00	3.04E-09	0.00E+00	4.31E-05
Pr-144	4.30E-11	1.76E-11	2.18E-12	0.00E+00	1.01E-11	0.00E+00	4.74E-14
Nd-147	9.38E-09	1.02E-08	6.11E-10	0.00E+00	5.99E-09	0.00E+00	3.68E-05
Ta-183	6.81E-11	4.15E-10	3.42E-11	0.00E+00	2.37E-10	0.00E+00	1.86E-04
W-187	1.46E-07	1.19E-07	4.17E-08	0.00E+00	0.00E+00	0.00E+00	3.22E-05
Re-188	3.45E-07	2.70E-07	7.66E-07	1.68E-05	0.00E+00	0.00E+00	2.33E-05
Au-198	0.00E+00	1.60E-08	2.72E-08	0.00E+00	4.88E-08	0.00E+00	9.84E-06
Au-199	0.00E+00	9.92E-08	8.41E-08	0.00E+00	3.92E-07	0.00E+00	1.17E-05
Np-239	1.76E-09	1.66E-10	9.22E-11	0.00E+00	5.21E-10	0.00E+00	2.67E-05
Sb-124	3.87E-06	7.13E-08	1.51E-06	8.78E-09	0.00E+00	3.38E-06	7.80E-05
Sb-125	2.48E-06	2.71E-06	5.80E-07	2.37E-09	0.00E+00	2.18E-06	1.93E-05

Table 2.3-7

Ingestion Dose Factors for Child (mrem/μCi ingested)

ISOTOPE	BONE	LIVER	WHOLE BODY	THYROID	KIDNEY	LUNG	GI-LLI
H-3	0.00E+00	2.03E-07	2.03E-07	2.03E-07	2.03E-07	2.03E-07	2.03E-07
C-14	1.21E-05	2.42E-06	2.42E-06	2.42E-06	2.42E-06	2.42E-06	2.42E-06
Na-24	5.80E-06	5.80E-06	5.80E-06	5.80E-06	5.80E-06	5.80E-06	5.80E-06
P-32	8.25E-04	3.86E-05	3.18E-05	0.00E+00	0.00E+00	0.00E+00	2.28E-05
Cr-51	0.00E+00	0.00E+00	8.90E-09	4.94E-09	1.35E-09	9.02E-09	4.72E-07
Mn-54	0.00E+00	1.07E-05	2.85E-06	0.00E+00	3.00E-06	0.00E+00	8.98E-06
Mn-56	0.00E+00	3.34E-07	7.54E-08	0.00E+00	4.04E-07	0.00E+00	4.84E-05
Fe-55	1.15E-05	6.10E-06	1.89E-06	0.00E+00	0.00E+00	3.45E-06	1.13E-06
Fe-59	1.65E-05	2.67E-05	1.33E-05	0.00E+00	0.00E+00	7.74E-06	2.78E-05
Co-58	0.00E+00	1.80E-06	5.51E-06	0.00E+00	0.00E+00	0.00E+00	1.05E-05
Co-60	0.00E+00	5.29E-06	1.56E-05	0.00E+00	0.00E+00	0.00E+00	2.93E-05
Ni-63	5.38E-04	2.88E-05	1.83E-05	0.00E+00	0.00E+00	0.00E+00	1.94E-06
Ni-65	2.22E-06	2.09E-07	1.22E-07	0.00E+00	0.00E+00	0.00E+00	2.56E-05
Cu-64	9.21E-07	2.52E-06	0.00E+00	7.83E-07	8.74E-07	7.81E-07	3.89E-05
Cu-67	0.00E+00	2.45E-07	1.48E-07	0.00E+00	5.92E-07	0.00E+00	1.15E-05
Zn-65	1.37E-05	3.65E-05	2.27E-05	0.00E+00	2.30E-05	0.00E+00	6.41E-06
Zn-69	4.38E-08	6.33E-08	5.85E-09	0.00E+00	3.84E-08	0.00E+00	3.99E-06
Br-83	0.00E+00	0.00E+00	1.71E-07	0.00E+00	0.00E+00	0.00E+00	0.00E+00
Br-84	0.00E+00	0.00E+00	1.98E-07	0.00E+00	0.00E+00	0.00E+00	0.00E+00
Br-85	0.00E+00	0.00E+00	9.12E-09	0.00E+00	0.00E+00	0.00E+00	0.00E+00
Rb-86	0.00E+00	6.70E-05	4.12E-05	0.00E+00	0.00E+00	0.00E+00	4.31E-06
Rb-88	0.00E+00	1.90E-07	1.32E-07	0.00E+00	0.00E+00	0.00E+00	9.32E-09
Rb-89	0.00E+00	1.17E-07	1.04E-07	0.00E+00	0.00E+00	0.00E+00	1.02E-09
Sr-87M	5.47E-08	6.78E-08	0.00E+00	1.34E-08	6.65E-08	2.57E-08	6.66E-07
Sr-89	1.32E-03	0.00E+00	3.77E-05	0.00E+00	0.00E+00	0.00E+00	5.11E-05
Sr-90	1.70E-02	0.00E+00	4.31E-03	0.00E+00	0.00E+00	0.00E+00	2.29E-04
Sr-91	2.40E-05	0.00E+00	9.06E-07	0.00E+00	0.00E+00	0.00E+00	5.30E-05
Sr-92	9.03E-06	0.00E+00	3.62E-07	0.00E+00	0.00E+00	0.00E+00	1.71E-04
Y-90	4.11E-08	0.00E+00	1.10E-09	0.00E+00	0.00E+00	0.00E+00	1.17E-04
Y-91M	3.82E-10	0.00E+00	1.39E-11	0.00E+00	0.00E+00	0.00E+00	7.48E-07
Y-91	6.02E-07	0.00E+00	1.61E-08	0.00E+00	0.00E+00	0.00E+00	8.02E-05
Y-92	3.60E-09	0.00E+00	1.03E-10	0.00E+00	0.00E+00	0.00E+00	1.04E-04
Y-93	1.14E-08	0.00E+00	3.13E-10	0.00E+00	0.00E+00	0.00E+00	1.70E-04
Zr-95	1.18E-07	2.55E-08	2.27E-08	0.00E+00	3.65E-08	0.00E+00	2.66E-05
Zr-97	6.99E-09	1.01E-09	5.96E-10	0.00E+00	1.45E-09	0.00E+00	1.53E-04
Nb-95	2.25E-08	8.76E-09	6.26E-09	0.00E+00	8.23E-09	0.00E+00	1.62E-05
Mo-99	0.00E+00	1.33E-05	3.29E-06	0.00E+00	2.84E-05	0.00E+00	1.10E-05
Tc-99M	9.23E-10	1.81E-09	3.00E-08	0.00E+00	2.63E-08	9.19E-10	1.03E-06

Table 2.3-7 (Cont.)

Ingestion Dose Factors for Child (mrem/pCi ingested)

ISOTOPE	BONE	LIVER	WHOLE BODY	THYROID	KIDNEY	LUNG	GI-LLI
Tc-101	1.07E-09	1.12E-09	1.42E-08	0.00E+00	1.91E-08	5.92E-10	3.56E-09
Ru-103	7.31E-07	0.00E+00	2.81E-07	0.00E+00	1.84E-06	0.00E+00	1.89E-05
Ru-105	6.45E-08	0.00E+00	2.34E-08	0.00E+00	5.67E-07	0.00E+00	4.21E-05
Ru-106	1.17E-05	0.00E+00	1.46E-06	0.00E+00	1.58E-05	0.00E+00	1.82E-04
Ag-110M	5.39E-07	3.64E-07	2.91E-07	0.00E+00	6.78E-07	0.00E+00	4.33E-05
Te-125M	1.14E-05	3.09E-06	1.52E-06	3.20E-06	0.00E+00	0.00E+00	1.10E-05
Te-127M	2.89E-05	7.78E-06	3.43E-06	6.91E-06	8.24E-05	0.00E+00	2.34E-05
Te-127	4.71E-07	1.27E-07	1.01E-07	3.26E-07	1.34E-06	0.00E+00	1.84E-05
Te-129M	4.87E-05	1.36E-05	7.56E-06	1.57E-05	1.43E-04	0.00E+00	5.94E-05
Te-129	1.34E-07	3.74E-08	3.18E-08	9.56E-08	3.92E-07	0.00E+00	8.34E-06
Te-131M	7.20E-06	2.49E-06	2.65E-06	5.12E-06	2.41E-05	0.00E+00	1.01E-04
Te-131	8.30E-08	2.53E-08	2.47E-08	6.35E-08	2.51E-07	0.00E+00	4.36E-07
Te-132	1.01E-05	4.47E-06	5.40E-06	6.51E-06	4.15E-05	0.00E+00	4.50E-05
I-130	2.92E-06	5.90E-06	3.04E-06	6.50E-04	8.82E-06	0.00E+00	2.76E-06
I-131	1.72E-05	1.73E-05	9.83E-06	5.72E-03	2.84E-05	0.00E+00	1.54E-06
I-132	8.00E-07	1.47E-06	6.76E-07	6.82E-05	2.25E-06	0.00E+00	1.73E-06
I-133	5.92E-06	7.32E-06	2.77E-06	1.36E-03	1.22E-05	0.00E+00	2.95E-06
I-134	4.19E-07	7.78E-07	3.58E-07	1.79E-05	1.19E-06	0.00E+00	5.16E-07
I-135	1.75E-06	3.15E-06	1.49E-06	2.79E-04	4.83E-06	0.00E+00	2.40E-06
Cs-134	2.34E-04	3.84E-04	8.10E-05	0.00E+00	1.19E-04	4.27E-05	2.07E-06
Cs-136	2.35E-05	6.46E-05	4.18E-05	0.00E+00	3.44E-05	5.13E-06	2.27E-06
Cs-137	3.27E-04	3.13E-04	4.62E-05	0.00E+00	1.02E-04	3.67E-05	1.96E-06
Cs-138	2.28E-07	3.17E-07	2.01E-07	0.00E+00	2.23E-07	2.40E-08	1.46E-07
Ba-139	4.14E-07	2.21E-10	1.20E-08	0.00E+00	1.93E-10	1.30E-10	2.39E-05
Ba-140	8.31E-05	7.28E-08	4.85E-06	0.00E+00	2.37E-08	4.34E-08	4.21E-05
Ba-141	2.00E-07	1.12E-10	6.51E-09	0.00E+00	9.69E-11	6.58E-10	1.14E-07
Ba-142	8.74E-08	6.29E-11	4.88E-09	0.00E+00	5.09E-11	3.70E-11	1.14E-09
La-140	1.01E-08	3.53E-09	1.19E-09	0.00E+00	0.00E+00	0.00E+00	9.84E-05
La-142	5.24E-10	1.67E-10	5.23E-11	0.00E+00	0.00E+00	0.00E+00	3.31E-05
Ce-141	3.97E-08	1.98E-08	2.94E-09	0.00E+00	8.68E-09	0.00E+00	2.47E-05
Ce-143	6.99E-09	3.79E-08	5.49E-10	0.00E+00	1.59E-09	0.00E+00	5.55E-05
Ce-144	2.08E-06	6.52E-07	1.11E-07	0.00E+00	3.61E-07	0.00E+00	1.70E-04
Pr-143	3.93E-08	1.18E-08	1.95E-09	0.00E+00	6.39E-09	0.00E+00	4.24E-05
Pr-144	1.29E-10	3.99E-11	6.49E-12	0.00E+00	2.11E-11	0.00E+00	8.59E-08
Nd-147	2.79E-08	2.26E-08	1.75E-09	0.00E+00	1.24E-08	0.00E+00	3.58E-05
Ta-183	2.04E-10	9.40E-10	1.02E-10	0.00E+00	4.98E-10	0.00E+00	2.07E-04
W-187	4.29E-07	2.54E-07	1.14E-07	0.00E+00	0.00E+00	0.00E+00	3.57E-05
Re-188	1.03E-06	6.12E-07	2.29E-06	5.03E-05	0.00E+00	0.00E+00	4.12E-05
Au-198	0.00E+00	3.61E-08	8.12E-08	0.00E+00	1.02E-07	0.00E+00	1.20E-05
Au-199	0.00E+00	2.25E-07	2.51E-07	0.00E+00	8.23E-07	0.00E+00	1.27E-05
Np-239	5.25E-09	3.77E-10	2.65E-10	0.00E+00	1.09E-09	0.00E+00	2.79E-05
Sb-124	1.11E-05	1.44E-07	3.89E-06	2.45E-08	0.00E+00	6.16E-06	6.94E-05
Sb-125	7.16E-06	5.52E-08	1.50E-06	6.63E-09	0.00E+00	3.99E-06	1.71E-05



Table 2.3-8

Ingestion Dose Factors for Infant (mrem/pCi ingested)

ISOTOPE	BONE	LIVER	WHOLE BODY	THYROID	KIDNEY	LUNG	G-LLI
H-3	0.00E+00	3.08E-07	3.08E-07	3.08E-07	3.08E-07	3.08E-07	3.08E-07
C-14	2.37E-05	5.06E-06	5.06E-06	5.06E-06	5.06E-06	5.06E-06	5.06E-06
Na-24	1.01E-05	1.01E-05	1.01E-05	1.01E-05	1.01E-05	1.01E-05	1.01E-05
P-32	1.70E-03	1.00E-04	6.58E-05	0.00E+00	0.00E+00	0.00E+00	2.30E-05
Cr-51	0.00E+00	0.00E+00	1.41E-08	9.20E-09	2.01E-09	1.79E-08	4.11E-07
Mn-54	0.00E+00	1.99E-05	4.51E-06	0.00E+00	4.41E-06	0.00E+00	7.31E-06
Mn-56	0.00E+00	8.18E-07	1.41E-07	0.00E+00	7.03E-07	0.00E+00	7.43E-05
Fe-55	1.39E-05	8.98E-06	2.40E-06	0.00E+00	0.00E+00	4.39E-06	1.14E-06
Fe-59	3.08E-05	5.38E-05	2.12E-05	0.00E+00	0.00E+00	1.59E-05	2.57E-05
Co-58	0.00E+00	3.60E-06	8.98E-06	0.00E+00	0.00E+00	0.00E+00	8.97E-06
Co-60	0.00E+00	1.08E-05	2.55E-05	0.00E+00	0.00E+00	0.00E+00	2.57E-05
Ni-63	6.34E-04	3.92E-05	2.20E-05	0.00E+00	0.00E+00	0.00E+00	1.85E-08
Ni-65	4.70E-06	5.32E-07	2.42E-07	0.00E+00	0.00E+00	0.00E+00	4.05E-05
Cu-64	5.26E-06	1.42E-05	0.00E+00	4.93E-06	4.98E-06	4.87E-06	1.36E-05
Cu-67	0.00E+00	6.09E-07	2.82E-07	0.00E+00	1.03E-06	0.00E+00	1.25E-05
Zn-65	1.84E-05	6.31E-05	2.91E-05	0.00E+00	3.06E-05	0.00E+00	5.33E-05
Zn-69	9.33E-08	1.68E-07	1.25E-08	0.00E+00	6.98E-08	0.00E+00	1.37E-05
Br-83	0.00E+00	0.00E+00	3.63E-07	0.00E+00	0.00E+00	0.00E+00	0.00E+00
Br-84	0.00E+00	0.00E+00	3.82E-07	0.00E+00	0.00E+00	0.00E+00	0.00E+00
Br-85	0.00E+00	0.00E+00	1.94E-08	0.00E+00	0.00E+00	0.00E+00	0.00E+00
Rb-86	0.00E+00	1.70E-04	8.40E-05	0.00E+00	0.00E+00	0.00E+00	4.35E-06
Rb-88	0.00E+00	4.98E-07	2.73E-07	0.00E+00	0.00E+00	0.00E+00	4.85E-07
Rb-89	0.00E+00	2.86E-07	1.97E-07	0.00E+00	0.00E+00	0.00E+00	9.74E-08
Sr-87M	2.22E-07	1.56E-07	0.00E+00	4.70E-08	1.37E-07	7.71E-08	1.49E-06
Sr-89	2.51E-03	0.00E+00	7.20E-05	0.00E+00	0.00E+00	0.00E+00	5.16E-05
Sr-90	1.85E-02	0.00E+00	4.71E-03	0.00E+00	0.00E+00	0.00E+00	2.31E-04
Sr-91	5.00E-05	0.00E+00	1.81E-06	0.00E+00	0.00E+00	0.00E+00	5.92E-05
Sr-92	1.92E-05	0.00E+00	7.13E-07	0.00E+00	0.00E+00	0.00E+00	2.07E-04
Y-90	8.89E-08	0.00E+00	2.33E-09	0.00E+00	0.00E+00	0.00E+00	1.20E-04
Y-91M	8.10E-10	0.00E+00	2.76E-11	0.00E+00	0.00E+00	0.00E+00	2.70E-06
Y-91	1.13E-06	0.00E+00	3.01E-08	0.00E+00	0.00E+00	0.00E+00	8.10E-05
Y-92	7.65E-09	0.00E+00	2.15E-10	0.00E+00	0.00E+00	0.00E+00	1.46E-04
Y-93	2.43E-08	0.00E+00	6.62E-10	0.00E+00	0.00E+00	0.00E+00	1.92E-04
Zr-95	2.06E-07	5.02E-08	3.56E-08	0.00E+00	5.41E-08	0.00E+00	2.50E-05
Zr-97	1.48E-08	2.54E-09	1.16E-09	0.00E+00	2.56E-09	0.00E+00	1.62E-04
Nb-95	4.20E-08	1.73E-08	1.00E-08	0.00E+00	1.24E-08	0.00E+00	1.46E-05
Mo-99	0.00E+00	3.40E-05	6.63E-06	0.00E+00	5.08E-05	0.00E+00	1.12E-05
Tc-99M	1.92E-09	3.96E-09	5.10E-08	0.00E+00	4.26E-08	2.07E-09	1.15E-06

Table 2.3-8 (Cont.)

Ingestion Dose Factors for Infant (mrem/pCi ingested)

ISOTOPE	BONE	LIVER	WHOLE BODY	THYROID	KIDNEY	LUNG	GI-LLI
Tc-101	2.27E-09	2.86E-09	2.83E-08	0.00E+00	3.40E-08	1.56E-09	4.86E-07
Ru-103	1.48E-06	0.00E+00	4.95E-07	0.00E+00	3.08E-06	0.00E+00	1.80E-05
Ru-105	1.36E-07	0.00E+00	4.58E-08	0.00E+00	1.00E-06	0.00E+00	5.41E-05
Ru-106	2.41E-05	0.00E+00	3.01E-06	0.00E+00	2.85E-05	0.00E+00	1.83E-04
Ag-110M	9.96E-07	7.27E-07	4.81E-07	0.00E+00	1.04E-06	0.00E+00	3.77E-05
Te-125M	2.33E-05	7.79E-06	4.81E-06	7.84E-06	0.00E+00	0.00E+00	1.11E-05
Te-127M	5.85E-05	1.84E-05	7.08E-06	1.69E-05	1.44E-04	0.00E+00	2.36E-05
Te-127	1.00E-06	3.35E-07	2.15E-07	8.14E-07	2.44E-06	0.00E+00	2.10E-05
Te-129M	1.00E-04	3.43E-05	1.54E-05	3.84E-05	2.50E-04	0.00E+00	5.97E-05
Te-129	2.84E-07	9.79E-08	6.63E-08	2.38E-07	7.07E-07	0.00E+00	2.27E-05
Te-131M	1.52E-05	6.12E-06	5.05E-06	1.24E-05	4.21E-05	0.00E+00	1.03E-04
Te-131	1.76E-07	6.50E-08	4.94E-08	1.57E-07	4.50E-07	0.00E+00	7.11E-06
Te-132	2.08E-05	1.03E-05	9.61E-06	1.52E-05	6.44E-05	0.00E+00	3.81E-05
I-130	6.00E-06	1.32E-05	5.30E-06	1.48E-03	1.45E-05	0.00E+00	2.83E-06
I-131	3.59E-05	4.23E-05	1.86E-05	1.39E-02	4.94E-05	0.00E+00	1.51E-06
I-132	1.66E-06	3.37E-06	1.20E-06	1.58E-04	3.76E-06	0.00E+00	2.73E-06
I-133	1.25E-05	1.82E-05	5.33E-06	3.31E-03	2.14E-05	0.00E+00	3.08E-06
I-134	8.69E-07	1.78E-06	6.33E-07	4.15E-05	1.99E-06	0.00E+00	1.84E-06
I-135	3.64E-06	7.24E-06	2.64E-06	6.49E-04	8.07E-06	0.00E+00	2.62E-06
Cs-134	3.77E-04	7.03E-04	7.10E-05	0.00E+00	1.81E-04	7.42E-05	1.91E-06
Cs-136	4.59E-05	1.35E-04	5.04E-05	0.00E+00	5.38E-05	1.10E-05	2.05E-06
Cs-137	5.22E-04	6.11E-04	4.33E-05	0.00E+00	1.64E-04	6.64E-05	1.91E-06
Cs-138	4.81E-07	7.82E-07	3.79E-07	0.00E+00	3.90E-07	6.09E-08	1.25E-06
Ba-139	8.81E-07	5.84E-10	2.55E-08	0.00E+00	3.51E-10	3.54E-10	5.58E-05
Ba-140	1.71E-04	1.71E-07	8.81E-06	0.00E+00	4.06E-08	1.05E-07	4.20E-05
Ba-141	4.25E-07	2.91E-10	1.34E-08	0.00E+00	1.75E-10	1.77E-10	5.19E-06
Ba-142	1.84E-07	1.53E-10	9.06E-09	0.00E+00	8.81E-11	9.26E-11	7.59E-07
La-140	2.11E-08	8.32E-09	2.14E-09	0.00E+00	0.00E+00	0.00E+00	9.77E-05
La-142	1.10E-09	4.04E-10	9.67E-11	0.00E+00	0.00E+00	0.00E+00	6.86E-05
Ce-141	7.87E-08	4.80E-08	5.66E-09	0.00E+00	1.48E-08	0.00E+00	2.48E-06
Ce-143	1.48E-08	9.82E-08	1.12E-09	0.00E+00	2.86E-09	0.00E+00	5.73E-05
Ce-144	2.98E-06	1.22E-06	1.67E-07	0.00E+00	4.93E-07	0.00E+00	1.71E-04
Pr-143	8.13E-08	3.04E-08	4.03E-09	0.00E+00	1.13E-08	0.00E+00	4.29E-05
Pr-144	2.74E-10	1.06E-10	1.38E-11	0.00E+00	3.84E-11	0.00E+00	4.93E-06
Nd-147	5.53E-08	5.68E-08	3.48E-09	0.00E+00	2.19E-08	0.00E+00	3.60E-05
Ta-183	4.33E-10	2.49E-09	2.17E-10	0.00E+00	9.05E-10	0.00E+00	2.10E-04
W-187	9.03E-07	6.28E-07	2.17E-07	0.00E+00	0.00E+00	0.00E+00	3.69E-05
Re-188	2.20E-06	1.62E-06	4.86E-06	1.25E-04	0.00E+00	0.00E+00	4.72E-05
Au-198	0.00E+00	9.56E-08	1.73E-07	0.00E+00	1.86E-07	0.00E+00	1.25E-05
Au-199	0.00E+00	5.91E-07	5.32E-07	0.00E+00	1.49E-06	0.00E+00	1.28E-05
Np-239	1.11E-08	9.93E-10	5.61E-10	0.00E+00	1.98E-09	0.00E+00	2.87E-05
Sb-124	2.14E-05	3.15E-07	6.63E-06	5.08E-08	0.00E+00	1.34E-05	6.60E-05
Sb-125	1.23E-05	1.19E-07	2.53E-06	1.54E-08	0.00E+00	7.72E-06	1.64E-05

Table 2.3-9

External Dose Factors for Standing on Contaminated Ground

(mrem/h per pCi/m<sup>2</sup>)

<u>Element</u>	<u>Whole Body</u>	<u>Skin</u>
H-3	0.0	0.0
C-14	0.0	0.0
Na-24	2.50E-08	2.90E-08
P-32	0.0	0.0
Cr-51	2.20E-10	2.60E-10
Mn-54	5.80E-09	6.80E-09
Mn-56	1.10E-08	1.30E-08
Fe-55	0.0	0.0
Fe-59	8.00E-09	9.40E-09
Co-58	7.00E-09	8.20E-09
Co-60	1.70E-08	2.00E-08
Ni-63	0.0	0.0
Nr-65	3.70E-09	4.30E-09
Cu-64	1.50E-09	1.70E-09
Cu-67	1.40E-09	2.14E-9
Zn-65	4.00E-09	4.60E-09
Zn-69	0.0	0.0
Br-83	6.40E-11	9.30E-11
Br-84	1.20E-08	1.40E-08
Br-85	0.0	0.0
Rb-86	6.30E-10	7.20E-10
Rb-88	3.50E-09	4.00E-09
Rb-89	1.50E-08	1.80E-08
Sr-87M	4.05E-09	5.38E-09
Sr-89	5.80E-13	6.50E-13
Sr-91	7.10E-09	8.30E-09
Sr-92	9.00E-09	1.00E-08
Y-90	2.20E-12	2.60E-12
Y-91M	3.80E-09	4.40E-09
Y-91	2.40E-11	2.70E-11
Y-92	1.60E-09	1.90E-09
Y-93	5.70E-10	7.80E-10
Zr-95	5.00E-09	5.80E-09
Zr-97	5.50E-09	6.40E-09
Mo-95	5.10E-09	6.00E-09
Mo-99	1.90E-09	2.20E-09
Tc-99M	9.60E-10	1.10E-09
Tc-101	2.70E-09	3.00E-09
Ru-103	3.60E-09	4.20E-09
Ru-105	4.50E-09	5.10E-09
Ru-106	1.50E-09	1.80E-09

Table 2.3-9 (Cont.)

External Dose Factors for Standing on Contaminated Ground

(mrem/h per pCi/m<sup>2</sup>)

<u>Element</u>	<u>Whole Body</u>	<u>Skin</u>
Ag-110M	1.80E-08	2.10E-08
Te-125M	3.50E-11	4.80E-11
Te-127M	1.10E-12	1.30E-12
Te-127	1.00E-11	1.10E-11
Te-129M	7.70E-10	9.00E-10
Te-129	7.10E-10	8.40E-10
Te-131M	8.40E-09	9.90E-09
Te-131	2.20E-09	2.60E-08
Te-132	1.70E-09	2.00E-09
Sb-124	2.28E-08	6.93E-08
Sb-125	5.67E-09	7.96E-09
I-130	1.40E-08	1.70E-08
I-131	2.80E-09	3.40E-09
I-132	1.70E-08	2.00E-08
I-133	3.70E-09	4.50E-09
I-134	1.60E-08	1.90E-08
I-135	1.20E-08	1.40E-08
Cs-134	1.20E-08	1.40E-08
Cs-136	1.50E-08	1.70E-08
Cs-137	4.20E-09	4.90E-09
Cs-138	2.10E-08	2.40E-08
Ba-139	2.40E-09	2.70E-09
Ba-140	2.10E-09	2.40E-09
Ba-141	4.30E-09	4.90E-09
Ba-142	7.90E-09	9.00E-09
La-140	1.50E-08	1.70E-08
La-142	1.50E-08	1.80E-08
Ce-141	5.50E-10	6.20E-10
Ce-143	2.20E-09	2.50E-09
Ce-144	3.20E-10	3.70E-10
Pr-143	0.00E+00	0.00E+00
Pr-144	2.00E-10	2.30E-10
Nd-147	1.00E-09	1.20E-09
Ta-183	3.76E-09	7.30E-09
W-187	3.10E-09	3.60E-09
Re-188	7.86E-10	1.18E-07
Au-198	5.33E-09	3.36E-08
Au-199	1.13E-9	1.39E-09
Np-239	9.50E-10	1.10E-09

Table 2.3-10

Liquid Effluent Dilution Factors (M<sub>p</sub>)

Maximum Individual Dilution Factors

<u>Pathway</u>	<u>Location</u>	<u>M<sub>p</sub></u>
Potable Water Ingestion	3.9 miles WSW of site	32.2
Fresh Water Fish Ingestion	Near Discharge Structure	10.9
Shoreline Exposure	0.7 miles ENE of Site	14.5

Population Dose Dilution Factors<sup>a</sup>

<u>Pathway</u>	<u>Location</u>	<u>M<sub>p</sub></u>
Potable Water Ingestion	Population Weighted Average	314
Fresh Water Fish Ingestion	Catch Weighted Average	77.4
Shoreline Exposure	7.7 miles WSW of site	162

\*for total population and average individual dose calculations

Table 2.3-11

Transit Times Required for Nuclides to Reach the Point of Exposure (t<sub>p</sub>)

	<u>Maximum Exposed Individual</u>	<u>Average Exposed Individual*</u>
Eventual transit time for water ingestion	12 h	24 h
Eventual transit time for fish ingestion	24 h	168 h
Eventual transit time for shore exposure	0 h	0 h

\*for total population and average individual dose calculations

Table 2.3-12

Usage Factors (U<sub>sp</sub>)

	<u>Maximum Exposed Individual</u>	<u>Average Exposed Individual*</u>
Water ingestion (L/yr) Adult	730	370
Water ingestion (L/yr) Teen	510	260
Water ingestion (L/yr) Child	510	260
Water ingestion (L/yr) Infant	330	--
Fresh water fish ingestion (kg/yr) Adult	21	6.9
Fresh water fish ingestion (kg/yr) Teen	16	5.2
Fresh water fish ingestion (kg/yr) Child	6.9	2.2
Fresh water fish ingestion (kg/yr) Infant	--	--
Shore exposure (h/yr) Adult	12	8.3
Shore exposure (h/yr) Teen	67	47
Shore exposure (h/yr) Child	14	9.5
Shore exposure (h/yr) Infant	--	--

\* for total population and average individual dose calculations

Table 2.3-13

Dilution Factors for Each of the Potable Water Intakes  
within 50 Miles of PNPP

The total population dilution factor of 314 is population weighted using dilution factors for each of the potable water intakes within 50 miles of PNPP.

<u>Intake</u>	<u>Dist. (Mi)</u>	<u>Dir</u>	<u>Population</u>	<u>Fraction of Population</u>	<u>Dilution Factor</u>	<u>Weighted Dilution Factor</u>
Ohio American Water Serv. Co.	20	ENE	38,500	2.12E-02	187.7	3.98E+00
Conneaut	33	ENE	13,500	7.43E-03	238.2	1.77E+00
Avon Lake	50	WSW	99,500	5.48E-02	388.5	2.13E+01
Cleveland	35	SW	1,437,000	7.92E-01	326.7	2.59E+02
Fairport Harbor	7	WSW	3,200	1.76E-03	154.2	2.71E-01
Lake County East	3.5	WSW	10,258	5.65E-03	107.4	6.07E-01
Lake County West	15	WSW	85,000	4.68E-02	220.0	1.03E+01
Ohio Water Serv.	10	WSW	60,000	3.30E-02	181.9	6.00E+00
Painesville	7.5	WSW	27,000	1.49E-02	159.3	2.37E+00
Kent County Water Supply	50	NW	<u>42,000</u>	<u>2.31E-02</u>	388.5	<u>8.97E+00</u>
<b>TOTALS</b>			<b>1,815,958</b>	<b>1.00E+0</b>	<b>TOTAL DF</b>	<b>3.14E+02</b>

Dist, Dir Population = distance, direction, and population values obtained from the 1989 Engineering Report "Lake Erie Potable Water Facilities and Intakes within 50 Miles of PNPP" (Ref. SO-11552 "E").

Fraction of Population = The ratio of the population receiving drinking water from that intake to the total population number for all drinking water intakes located within 50 miles of PNPP.

Dilution Factor = Values obtained from the Perry Environmental Report - Operating License Stage, Table 5.1-10 "Annual Average Dilution Factors for Lake Water Intakes within 50 Miles of PNPP" and Q&R Page 2.1-2. Lake County West dilution factor per interpolation. Kent County Water Supply dilution factor was estimated.

The Weighted Dilution Factor = (Fraction of Population) x (Dilution Factor), based on the population for each drinking water intake; the sum of which is to be used as the potable water total population dilution factor for radioactive liquid effluent releases from PNPP.

Table 2.3-14

Dilution Factors for the Fish Ingestion Pathway Individual  
Grid Locations

The total population dilution factor of 77.4 is catch distance and volume weighted using dilution factors at those locations. Fish harvest is based on Ohio Department of Natural Resources the total angler catch (1987 annual) values for Lake Erie within 50 mile of PNPP.

<u>Grid</u>	<u>No. of Fish</u>	<u>Fraction of Fish</u>	<u>Distance (mi)</u>	<u>Dilution Factor</u>	<u>(Frac Fish)x (Dil Factor)</u>
617	52823	3.91E-02	29	92	3.60E+00
618	76004	5.63E-02	36	100	5.63E+00
714	102522	7.59E-02	9	52	3.96E+00
715	10743	7.95E-03	9	52	4.13E-01
716	19817	1.47E-02	11	56	8.21E-01
717	73401	5.43E-02	24	83	4.51E+00
718	118676	8.78E-02	33	95	8.34E+00
809	0	0.00E+00	48	115	0.00E+00
810	3953	2.93E-03	39	105	3.07E-01
811	13648	1.01E-02	30	92	9.29E-01
812	33923	2.51E-02	22	78	1.96E+00
813	182663	1.35E-01	13	61	8.25E+00
814	164369	1.22E-01	4	34	4.14E+00
909	80753	5.98E-02	50	116	6.93E+00
910	43800	3.24E-02	42	110	3.57E+00
911	117430	8.69E-02	33	95	8.26E+00
912	<u>256529</u>	<u>1.90E-01</u>	24	83	<u>1.58E+01</u>
TOTAL	1351054	1.00E+00		TOTAL D.F.	7.74E+01

Grid No. and No. of Fish = Total angler catch (1987 annual) for each grid location; per letter from Michael R. Rawson, Fairport Fisheries Research Station, Ohio Department of Natural Resources to Richard Cochran (6/20/88). Commercial harvest data were not used as they were differentiated by harbor location only, not by geographical grid location.

Fraction of Fish = The ratio of the fish caught in that grid to the total number of fish caught in all grids located within 50 miles of PNPP.

Distance = Distance to the center of that grid from PNPP, in miles.

Dilution Factor = Derived, for the appropriate distance (center of each grid), from annual average dilution factor data (non-adjusted), per Perry Environmental Report - Operating License Stage, Table 5.1-10 "Annual Average Dilution Factors for Lake Water Intakes within 50 Miles of PNPP."

(Fraction of Fish) x (Dilution Factor) = The weighted dilution factor, based on catch, for each grid; the sum of which is to be used as the fish ingestion total population dilution factor for radioactive liquid effluent releases from PNPP.



Table 2.3-15

Dilution Factors for the Shore Exposure Pathway

MAXIMUM EXPOSED INDIVIDUAL DILUTION FACTOR

The point of exposure assumed for this pathway is the shoreline at the PNPP site boundary 0.7 miles down shore from the plant discharge structure. Interpolation of the data presented in the Perry Environmental Report - Operating License Stage, Table 5.1-10, "Annual Average Dilution Factors for Lake Water Intakes within 50 Miles of PNPP" yields a maximum individual dose dilution factor of 14.5 (dilution factor unadjusted for current frequency).

TOTAL POPULATION DILUTION FACTOR

The total population dilution factor of 162 is that of the Headlands Beach State Park, 7.7 miles WSW of PNPP (interpolated, adjusted WSW dilution factor). This location was selected because of its lake site location and it has, by far, the highest attendance of any park located in vicinity of PNPP (Perry Environmental Report - Operating License Stage, Table 2.1-2 "Major Camps and Parks within 10 Miles of the PNPP").

### 3.0 GASEOUS EFFLUENTS

#### 3.0.1 Batch Releases

A batch release is the discontinuous discharge of gaseous radioactive effluents of known radionuclide concentration(s) and flowrate taking place over a finite period of time, usually hours or days. A batch release to the environment may occur as a result of an effluent flowpath that bypasses treatment or monitoring. Since radioactive releases approaching 10CFR20 limits are not anticipated, an ODCM Control is not entered for batch releases. Every reasonable effort will be made to maintain the levels of radioactive material in the gaseous effluents ALARA.

The radioactive gaseous effluent release flowpath is monitored for principal gamma emitters (noble gases, particulates, and halogens) as if the inoperable radioactive effluent monitor requirements of Table 3.3.7.10-1 had been entered. This action ensures the dose to a member of the general public is within the limits of Controls 3.11.2.2 and 3.11.2.3. If radioactivity is detected, the radionuclide concentration(s) is added to the dose calculations for the appropriate radioactive gaseous effluent continuous release point. Administrative instructions are employed to establish minimum monitoring requirements for these batch releases to ensure compliance with all regulatory requirements. The administrative instructions shall also ensure that the specific activity that will cause a batch release has been reviewed for the requirements of 10 CFR 50.59.

#### 3.0.2 Continuous Releases

There are four environmental release points for gaseous effluents used for Unit 1 operation of the Perry Nuclear Power Plant: Turbine Bldg/Heater Bay Vent, Off-Gas Vent, Unit 1 Vent, and Unit 2 Vent (see Figure 3.0-1). The Unit 1 and Unit 2 Vents are located on the top of the Intermediate Building, Elevation 753'9". The Turbine Bldg/Heater Bay Vent is located on the top of the Heater Bay Building, Elevation 722'0". The Off-Gas Vent is located on the top of the Off-Gas Building, Elevation 723'0". Site ground level elevation is 620'0". Radiological releases from each vent are monitored by a noble gas radiation monitor.

All gaseous effluent releases from PNPP via these vents will be continuous releases, and are considered to be long-term (i.e., greater than 500 hours per year) and ground level. Containment/drywell purges and vents will be considered periods of increased radiological release as they are vented through the Unit 1 Vent, concurrent with normal, continuous releases.



### 3.1 Monitor Alarm Setpoint Determination

The following calculation methods provide a means of determining the High Alarm Setpoint (HSP) and the Alert Setpoint (ASP) to ensure compliance with the regulatory dose rate limit to areas at or beyond the site boundary of 500 mrem/yr for the following noble gas monitors:

1. Unit 1 Vent radiation monitor (1D17K0786)
2. Unit 2 Vent radiation monitor (2D17K0786)
3. Off-Gas Vent radiation monitor (1D17K0836)
4. Turbine Building/Heater Bay Vent radiation monitor (1D17K0856)

The Unit 2 Vent radiation monitor is included for the operation of Unit 1 of the Perry Nuclear Power Plant because the second train of the Unit 1 Annulus Exhaust and the Control Complex and Intermediate Building ventilations are exhausted through the Unit 2 Vent.

The High Alarm Setpoint (HSP) for each release point radiation monitor will be set at 70% of the annual dose rate limit (350 mrem/yr) and the Alert Setpoint (ASP) will be at 10% of the annual dose rate limit (50 mrem/yr).

**NOTE:** These values are set as a small fraction of the total activity that may be released via the monitored pathways to ensure that the site boundary dose rate limits are not exceeded. Any single ASP can be exceeded without exceeding the 500 mrem/yr dose rate limit.

- a. Upon receipt of a valid alert alarm, a sample from the alarming effluent path will be obtained and analyzed. If two or more effluent monitors exceed the ASP or if any one effluent monitor exceeds the HSP, the potential exists that the 500 mrem/yr dose rate limit may be exceeded. In this case, all four effluent paths will be sampled and analyzed with the appropriate actions initiated to limit gaseous releases to below the annual dose rate limit.
- b. If a single high alarm setpoint continues to be exceeded, verification shall be made at least once per 4 hours, via the gaseous effluent radiation monitors, that plant releases are below the ODCM Appendix C 3.11.2.1 dose rate limits. Sampling and analysis shall be performed on the four gaseous effluent release points at least once per 12 hours.

October  
2017

This procedure determines the monitor alarm setpoints that indicate if the dose rate beyond the site boundary due to noble gas radionuclides in gaseous effluent released from the site exceeds 500 mrem/year to the whole body, or 3000 mrem/year to the skin.

3.1.1 Determination of "Mix" (Noble Gas Radionuclide Composition) of Gaseous Effluents

- a. The gaseous source terms that are representative of the "mix" of the gaseous effluent are determined. Gaseous source terms are the concentrations of the noble gas radionuclides in the effluent as determined by analysis of the various sources of gaseous effluents. During the early period of plant operation, before a sufficient operational effluent source term data base has been obtained, source terms will be those generated by the GALE code, Revision 0 for PNPP (FSAR Tables 11.3-9 and 11.3-10).
- b. Determination of the fraction of the total radioactivity in the gaseous effluent for each noble gas radionuclide in the gaseous effluent.

$$S_i = \frac{A_i}{\sum A_i} \quad (3.1-1)$$

Where:

$S_i$  = the fraction of the total for radionuclide "i" in the effluent;  
 $A_i$  = the activity of radionuclide "i" in the gaseous effluent.

**NOTE:** If the activity of a noble gas radionuclide is below the lower limit of detection the noble gas radionuclide is not included as a source term in this setpoint calculation.

3.1.2 Determination of the Maximum Acceptable Total Activity Release Rate of Noble Gas Radionuclides in Gaseous Effluent Based on Whole Body Dose Rate Limit

$$Q_b = \frac{500}{\left(\frac{\gamma}{Q}\right) \sum (k_i) (S_i)} \quad (3.1-2)$$

Where:

$Q_b$  = the maximum acceptable total activity release rate of all noble gas radionuclides in the effluent (for whole body exposure),  $\mu\text{Ci/s}$ ;  
 $k_i$  = the whole body dose factor for a semi-infinite cloud of radionuclide "i" (includes  $5\text{g/cm}^2$  tissue attenuation) from Table 3.1-1,  $(\text{mrem/yr})/(\mu\text{Ci/m}^3)$ ;  
 $S_i$  = the fraction of the total for radionuclide "i", as per equation 3.1.1;  
 $\gamma/Q$  = the annual average dispersion factor in  $\text{s/m}^3$  (see Appendix A);

**NOTE:** The dispersion parameters  $(\gamma/Q)$  used in these calculations are the highest calculated site boundary values for any of the land-based sectors only. At PNPP the site boundary locations in the following sectors are totally over water: N, NNE, NNW, NW, W, WNW.

500 = the whole body dose rate limit, in mrem/yr.

3.1.3 Determination of the Maximum Acceptable Total Activity Release Rate of Noble Gas Radionuclides in Gaseous Effluent Based on Skin Dose Rate Limit

$$Q_s = \frac{3000}{\left(\frac{\chi}{Q}\right) \sum (L_i + 1.11 M_i) (S_i)} \quad (3.1-3)$$

Where:

- $Q_s$  = the maximum acceptable total activity release rate of all noble gas radionuclides in the effluent (for skin exposure), in  $\mu\text{Ci/s}$ ;
- $L_i$  = the beta skin dose factor for a semi-infinite cloud of radionuclide "i" (includes attenuation by the outer "dead" layer of skin), in  $(\text{mrem/yr})/(\mu\text{Ci/m}^3)$ ;
- $M_i$  = the gamma air dose factor for a uniform semi-infinite cloud of radionuclide "i", in  $(\text{mrad/yr})/(\mu\text{Ci/m}^3)$ ;
- $S_i$  = the fraction of the total for radionuclide "i", per equation 3.1.1;
- $\chi/Q$  = the annual average dispersion factor in  $\text{s/m}^3$  (see Appendix A);
- 1.11 = the air dose to tissue dose equivalent conversion factor, in  $\text{mrem/mrad}$ ;
- 3000 = the skin dose rate limit, in  $\text{mrem/yr}$ .

$(L_i + 1.11 M_i)$  values are shown in Table 3.1-1.

Table 3.1-1

Whole Body and Skin Dose Factors

Radionuclide	Whole Body Dose Factor (K) ( $\text{mrem/yr}/\mu\text{Ci/m}^3$ )	Skin Dose Factor ( $L+1.11 M$ ) ( $\text{mrem/yr}/\mu\text{Ci/m}^3$ )
Kr-83m	7.56E-02	2.14E+01
Kr-85m	1.17E+03	2.83E+03
Kr-85	1.61E+01	1.36E+03
Kr-87	5.92E+03	1.66E+04
Kr-88	1.47E+04	1.92E+04
Kr-89	1.66E+04	2.93E+04
Xe-131m	9.15E+01	6.49E+02
Xe-133m	2.51E+02	1.36E+03
Xe-133	2.94E+02	6.97E+02
Xe-135	1.81E+03	3.99E+03
Xe-135m	3.12E+03	4.44E+03
Xe-137	1.42E+03	1.39E+04
Xe-138	8.83E+03	1.44E+04
Ar-41	8.84E+03	1.30E+04

3.1.4 **Determination of the Maximum Acceptable Total Radioactivity Concentration of all Noble Gas Radionuclides in the Gaseous Effluent**

$$C_t = \frac{(2.12 \times 10^{-3})(Q_t)}{f} \quad (3.1-4)$$

Where:

- $C_t$  = the maximum acceptable total radioactivity concentration of all noble gas radionuclides in the effluent, in  $\mu\text{Ci/cc}$ ;
- $f$  = the flow rate for the release point from the respective flow rate recorders, in  $\text{ft}^3/\text{min}$ ; design flow rates, which incorporate a 10% flow rate inaccuracy correction, may be used in lieu of actual flow rates (refer to flow rates in Table 3.1-2).
- $Q_t$  = the smaller of  $Q_D$  and  $Q_S$ , calculated in equations 3.1-2 and 3.1-3, respectively,  $\mu\text{Ci/s}$ ;
- $2.12\text{E-}03$  = the conversion factor to convert  $(\mu\text{Ci/s})(\text{ft}^3/\text{min})$ ,  $\mu\text{Ci/cc}$ .

October  
2017

Table 3.1-2

Flow Rates and Effluent Monitor Efficiencies

Effluent Pathway	Flow Rate (cfm)
Unit 1 Plant Vent	140,000
Unit 2 Plant Vent	60,000
Off Gas Vent Pipe	16,700
Turbine Building/Heater Bay	400,000 (summer) 220,000 (winter/reduced summer)

October  
2017

October  
2017

**3.1.5 Determination of the Maximum Acceptable Monitor Count Rate Above Background Attributed to Noble Gas Radionuclides**

$$CR_C = (0.8)(C_T)(E_m) \quad (3.1-5)$$

**Where:**

- $CR_C$  = the calculated monitor count rate above background attributed to noble gas radionuclides, in cpm;
- $C_T$  = the maximum acceptable radioactivity concentration, per equation 3.1-4,  $\mu\text{Ci/cc}$ ;
- $E_m$  = the detector efficiency of the monitor for the "mix" of noble gas radionuclides in the effluent, in  $\text{cpm}/(\mu\text{Ci/cc})$ ;  
= the total  $\mu\text{Ci/cc}$  concentration divided into the net monitor count rate taken at the time the sample was taken; during the early period of operation, before a sufficient operational effluent source term data base has been obtained, the value will be calculated using monitor calibration data;
- 0.8 = an engineering safety factor.

**3.1.5.1 Determination of the Monitor High Alarm Setpoint**

$$HSP = (0.70)(CR_C) + BG \quad (3.1-6)$$

**Where:**

- HSP = the high alarm setpoint (including background), in cpm;
- BG = the background count rate due to internal contamination and radiation levels in the area in which the monitor is installed when the monitor chamber is filled with uncontaminated air, in cpm;
- $CR_C$  = the calculated monitor net count rate, per equation 3.1-5, in cpm;
- 0.70 = the fraction of the maximum acceptable activity that may be released from the vent to ensure that the site boundary dose rate limits are not exceeded during concurrent releases from several pathways.

**3.1.5.2 Determination of the Monitor Alert Setpoint**

$$ASP = (0.10)(CR_C) + BG \quad (3.1-7)$$

**Where:**

- ASP = the alert setpoint (including background), in cpm;
- BG = the background count rate due to internal contamination and radiation levels in the area in which the monitor is installed when the monitor chamber is filled with uncontaminated air, in cpm;
- $CR_C$  = the calculated monitor net count rate, per equation 3.1-5, cpm;
- 0.10 = the fraction of the maximum acceptable activity that may be released from the vent to ensure that the site boundary dose rate limits are not exceeded during concurrent releases from several pathways.



### 3.2 10CFR20 Compliance - Gaseous Effluent Dose Rate

Dose rates resulting from the release of noble gases, radioiodines, tritium, and radionuclides in particulate form must be calculated to show compliance with 10CFR20. The limits of 10CFR20 are conservatively applied for the release period at the controlling location.

#### 3.2.1 Noble Gases

The dose rate in unrestricted areas resulting from noble gas effluents is limited, by ODCM Appendix C controls, to 500 mrem/yr to the whole body and 3000 mrem/yr to the skin. Only the external dose pathway will be considered for noble gases. Because all gaseous effluent releases from PNPP are considered ground level, the controlling location for these dose rate limits is the site boundary location (see Figure 3.3-1) with the highest relative dispersion factor ( $\chi/Q$ ). (See Appendix A for elaboration on atmospheric dispersion.)

The alarm setpoint determinations discussed in the previous section should ensure compliance with these dose rate limits. However, if any one high alarm or two or more alert alarms occur, the dose rates in unrestricted areas resulting from the release of noble gas radionuclides from all vents will be calculated. The calculations will be based on the results of analyses obtained pursuant to the ODCM, Appendix C, CONTROLS.

#### 3.2.2 Radioiodines, Particulates, and Other Radionuclides

The dose rate in unrestricted areas resulting from the release of iodine-131, iodine-133, tritium, and all radionuclides in particulate form with half-lives greater than eight days is limited, by ODCM Appendix C controls, to 1500 mrem/yr to any organ. The calculation of dose rate from these radionuclides will be performed based on results of analyses obtained pursuant to those Appendix C controls. The controlling location for this limit is the location of the highest relative deposition ( $D/Q$ ) for the period of release as well as the actual receptor pathway. The receptor pathway locations will be reviewed once per year following the performance of the Land Use Census to include consideration of nearest residences, garden, and farm animal locations in each sector.

#### 3.2.3 Dose Rate Calculations

The following is the equation used to calculate the dose rate resultant from the release of radioactive materials in gaseous effluents to areas at or beyond the site boundary for the purpose of showing compliance with ODCM Appendix C controls as related to 10CFR20.

$$D_{ajp} = (3.15 \times 10^1) \left( \chi/Q \text{ or } D/Q \right) \sum (DF_{aijp}) (Ci) \quad (3.2-1)$$

Where:

- $D_{ajp}$  = the organ "j" dose rate as a function of age group "a" and pathway "p", mrem/yr;
- $DF_{aijp}$  = the dose factor for organ type "j", age group "a", pathway "p" for isotope "i" (see Tables 3.2-1 through 3.2-3); units and equations used (equations 3.2-2 through 3.2-6) are provided later in this section;
- $\chi/Q$  or  $D/Q$  = the normal or depleted relative dispersion factor ( $\chi/Q$ ) in  $s/m^3$ , or relative deposition ( $D/Q$ ) in  $m^{-2}$ , at the receptor distance (see Appendix A);

$$\begin{aligned}
 3.15 \times 10^{-1} &= \text{conversion factor to convert } (\text{mrem} \cdot \mu\text{Ci}) / (\text{Ci} \cdot \text{s}) \text{ to mrem/yr;} \\
 Q_i &= \text{release rate of isotope "i" (annualized), } \mu\text{Ci/s} \\
 &= (472) (C_i) (f)
 \end{aligned}$$

Where:

$$\begin{aligned}
 C_i &= \text{the concentration of radionuclide "i" in the gaseous effluent,} \\
 &\quad \text{in } \mu\text{Ci/cc;} \\
 f &= \text{the gaseous effluent flow rate during the release, ft}^3/\text{min;} \\
 472 &= \text{conversion factor, } (\text{cc/ft}^3) / (\text{s/min}).
 \end{aligned}$$

The following relationships are used to derive the dose factors ( $DF_{i,p}$ ) for noble gases, tritium, radioiodines and particulates used in equation 3.2-1.

a. Whole Body Dose Factors from Exposure to a Semi-Infinite Plume

$$DF_i^T = (S_F) (\chi_i) (DFB_i) \quad (3.2-2)$$

Where:

$$\begin{aligned}
 DF_i^T &= \text{the whole body factor due to immersion in a semi-infinite cloud of} \\
 &\quad \text{radionuclide "i", } (\text{mrem} \cdot \text{m}^3) / (\text{Ci} \cdot \text{s}); \\
 DFB_i &= \text{the whole body gamma dose factor for a semi-infinite cloud of} \\
 &\quad \text{radionuclide "i" which includes the attenuation of 5 g/cm}^2 \text{ of tissue from} \\
 &\quad \text{Table 3.2-4, mrem/yr per pCi/m}^3; \\
 S_F &= \text{the attenuation factor that accounts for the dose reduction due to the} \\
 &\quad \text{shielding provided by residential structures, optional, dimensionless;} \\
 &\quad = \text{maximum exposed individual} = 0.7, \text{ population dose } 0.5 \text{ (Regulatory} \\
 &\quad \text{Guide 1.109), if calculating dose rate} = 1.0; \\
 \chi_i &= \text{the annual average concentration of radionuclide "i" in air (pCi/m}^3\text{), for a} \\
 &\quad \text{unit release rate (Ci/yr) and a unit } \chi/Q \text{ (s/m}^3\text{), (pCi/m}^3\text{)/(Ci/yr)(s/m}^3\text{).}
 \end{aligned}$$

b. Skin Dose Factors for Exposure to a Semi-Infinite Plume

$$DF_i^S = (\chi_i) \left[ (1.11) (S_F) (DF_i^\gamma) + (DFS_i) \right] \quad (3.2-3)$$

Where:

$$\begin{aligned}
 DF_i^S &= \text{the skin dose factor due to immersion in a semi-infinite cloud of} \\
 &\quad \text{radionuclide "i", } (\text{mrem} \cdot \text{m}^3) / (\text{Ci} \cdot \text{s}); \\
 DF_i^\gamma &= \text{the gamma air dose factor for a uniform semi-infinite cloud of} \\
 &\quad \text{radionuclide "i", from Table 3.2-4, mrad/yr per pCi/m}^3; \\
 DFS_i &= \text{the beta skin dose factor for a semi-infinite cloud of radionuclide "i"} \\
 &\quad \text{(includes attenuation by the outer "dead" layer of skin), from} \\
 &\quad \text{Table 3.2-4, mrem/yr per pCi/m}^3;
 \end{aligned}$$

- $S_F$  = the attenuation factor that accounts for the dose reduction due to the shielding provided by residential structures, optional, dimensionless:  
= maximum exposed individual = 0.7, population dose 0.5 (Regulatory Guide 1.109), if calculating dose rate = 1.0;
- $\chi_i$  = the annual average concentration of radionuclide "i" in air (pCi/m<sup>3</sup>), for a unit release rate (Ci/yr) and a unit  $\gamma/Q$  (s/m<sup>3</sup>), (pCi/m<sup>3</sup>)/(Ci/yr)(s/m<sup>3</sup>);
- 1.11 = the air dose to tissue dose equivalent conversion factor, mrem/mrad.

c. **Dose Factors from External Irradiation from Radionuclides Deposited onto the Ground Surface**

$$DF_{ij}^G = (8760) \left( C_i^G \right) \left( DFG_{ij} \right) \left( S_F \right) \quad (3.2-4)$$

Where:

- $DF_{ij}^G$  = the dose factor for radionuclide "i" to organ "j" resulting from exposure to radionuclides deposited onto the ground surface, (mrem \* m<sup>2</sup>)/Ci;
- $C_i^G$  = the ground plane concentration (pCi/m<sup>2</sup>) of radionuclide "i" for a unit release rate (Ci/yr) and a unit D/Q, relative ground deposition (m<sup>-2</sup>), (pCi/m<sup>2</sup>)/(Ci/yr)(m<sup>-2</sup>);
- $DFG_{ij}$  = the open field ground plane dose conversion factor for organ "j" from radionuclide "i", from Table 3.2-5, mrem/yr per pCi/m<sup>2</sup>;
- $S_F$  = the attenuation factor that accounts for the dose reduction due to the shielding provided by residential structures, optional, dimensionless:  
= maximum exposed individual = 0.7, population dose 0.5 (Regulatory Guide 1.109), if calculating dose rate = 1.0;
- 8760 = the number of hours per year.

d. **Dose Factors from Inhalation of Radionuclides in Air**

$$DF_{aij}^A = \left( DFA_{aij} \right) \left( \bar{r}_a \right) \left( \chi_i \right) \quad (3.2-5)$$

Where:

- $DF_{aij}^A$  = the dose factor for radionuclide "i" to organ "j" of an individual in age group "a" due to inhalation, (mrem m<sup>3</sup>)/(Ci s) [equivalent to (mrem/yr)(yr/Ci)(m<sup>3</sup>/s)];
- $DFA_{aij}$  = the inhalation dose factor for radionuclide "i", organ "j", and age group "a" (the value for skin is assumed to be 0), from Tables 3.2-6 through 3.2-9, mrem/pCi;
- $\bar{r}_a$  = the annual air intake for individuals in age group "a", from Table 3.2-14, m<sup>3</sup>/yr;

$\chi_i$  = the annual average concentration of radionuclide "I" in air (pCi/m<sup>3</sup>),  
for a unit release rate (Ci/yr) and a unit  $\chi/Q$  (s/m<sup>3</sup>),  
(pCi/m<sup>3</sup>)/(Ci/yr)(s/m<sup>3</sup>).

e. Dose Factors from the Ingestion of Atmospherically Released Radionuclides in Food

$$DF_{aij}^D = DFI_{aij} \left[ \left( U_a^F \right) \left( C_i^F \right) + \left( U_a^L \right) \left( f_L \right) \left( C_i^L \right) + \left( U_a^M \right) \left( C_i^M \right) + \left( U_a^V \right) \left( f_V \right) \left( C_i^V \right) \right] \quad (3.2-6)$$

Where:

$DF_{aij}^D$  = the dose factor for radionuclide "I" to organ "j" of an individual in age group "a" from the ingestion of meat, leafy vegetables, milk, and produce (non-leafy vegetables, fruits, and grains) in (mrem \* m<sup>2</sup>)/Ci, or in the cases of H-3 and C-14 in (mrem \* m<sup>3</sup>)/(Ci \* s);

$C_i^F, C_i^L, C_i^M, C_i^V$  = the concentrations of radionuclide "I" in meat, leafy vegetables, milk, and produce, respectively (pCi/kg or pCi/L) for a unit release rate (Ci/yr) and a unit D/Q, relative ground deposition (m<sup>-2</sup>), or in cases of H-3 and C-14, a unit  $\chi/Q$ , relative ground-level concentration (s/m<sup>3</sup>), in (pCi/kg)(Ci/yr)(m<sup>-2</sup>) or (pCi/kg)/(Ci/yr)(s/m<sup>3</sup>) or (pCi/L)(Ci/yr)(m<sup>-2</sup>) or (pCi/L)(yr/Ci)(s/m<sup>3</sup>);

$DFI_{aij}$  = the ingestion dose factor for radionuclide "I", organ "j", and age group "a", from Tables 3.2-10 through 3.2-13, mrem/pCi;

$f_L, f_V$  = the respective fractions of the ingestion rates of leafy vegetables and produce that are produced in the garden of interest, 1.0 and 0.76 respectively (Regulatory Guide 1.109);

$U_a^F, U_a^L, U_a^M, U_a^V$  = the annual intake (usage) of meat, leafy vegetables, milk, and produce respectively, for individuals in age group "a", from Table 3.2-14, kg/yr or l/yr.

f. Dose rate example problem:

- 1) For the purpose of this sample problem, the following assumptions are utilized: a release of Xe-133 at 1.0E-5  $\mu$ Ci/cc, a flow rate of 1.0E5 ft<sup>3</sup>/min, and a whole body dose factor of 2.94E-4 mrem/yr per pCi/m<sup>3</sup>. Dose rate and 1 hour cumulative dose are calculated.
- 2) Whole Body Dose Factor per ODCM equation 3.2-2.

For final dose calculation:

$$DF_1^T = (0.7) \left( 2.94E-04 \frac{\text{mrem/yr}}{\text{pCi/m}^3} \right) \left( \frac{1E+12 \text{ pCi/m}^3}{(\text{Ci/yr}) (3.15E+07 \text{ sec/m}^3)} \right) = 6.52 \frac{\text{mrem m}^3}{\text{Ci sec}}$$

For dose rate:

$$DR_1^2 = (1.0) \left( 2.94E-04 \frac{\text{mrem/yr}}{\text{pCi/m}^3} \right) \left( \frac{1E+12 \text{ pCi/m}^3}{(\text{Ci/yr}) (3.15E+07 \text{ sec/m}^3)} \right) = 9.33 \frac{\text{mrem m}^3}{\text{Ci sec}}$$

3) Dose Rate per ODCM equation 3.2-1.

For final dose calculation:

$$(3.15E1) \left( 5.8E-6 \frac{\text{sec}}{\text{m}^3} \right) \left( 6.52 \frac{\text{mrem m}^3}{\text{Ci sec}} \right) \left( 472 \frac{\text{cc min}}{\text{ft}^3 \text{ sec}} \right) \left( 1.05E-5 \frac{\mu\text{Ci}}{\text{cc}} \right) \left( 1E5 \frac{\text{ft}^3}{\text{min}} \right) = 0.590 \frac{\text{mrem}}{\text{yr}}$$

For dose rate:

$$(3.15E1) \left( 5.8E-6 \frac{\text{sec}}{\text{m}^3} \right) \left( 9.33 \frac{\text{mrem m}^3}{\text{Ci sec}} \right) \left( 472 \frac{\text{cc min}}{\text{ft}^3 \text{ sec}} \right) \left( 1.05E-5 \frac{\mu\text{Ci}}{\text{cc}} \right) \left( 1E5 \frac{\text{ft}^3}{\text{min}} \right) = 0.845 \frac{\text{mrem}}{\text{yr}}$$

Final dose calculation:

$$\left( 0.590 \frac{\text{mrem}}{\text{yr}} \right) (1 \text{ hr}) \left( \frac{1 \text{ yr}}{8760 \text{ hr}} \right) = 6.74E-5 \text{ mrem}$$

**Table 3.2-1**  
**Organ Used for Gaseous Effluent Dose Calculations**

1. Bone
2. GI Tract
3. Kidney
4. Liver
5. Lung
6. Thyroid
7. Whole Body
8. Skin

**Table 3.2-2**  
**Age Groups Used for Gaseous Effluent Dose Calculations**

1. Adult (17 yr and older)
2. Teen (11-17 yr)
3. Child (1-11 yr)
4. Infant (0-1 yr)

**Table 3.2-3**  
**Gaseous Effluent Dose Pathways**

1. Plume
2. Ground Shine
3. Vegetables
4. Meat
5. Cow Milk
6. Goat Milk
7. Inhalation

Table 3.2-4  
Dose Factors for Exposure to a Semi-Infinite  
Cloud of Noble Gases

<u>Nuclide</u>	<u>Whole Body* Gamma Dose Factor (DFB)</u>	<u>Beta Skin* Dose Factor (DFS)</u>	<u>Gamma Air** Dose Factor <math>\gamma</math> (DF)</u>
Kr-83m	7.56E-08	---	1.93E-05
Kr-85m	1.17E-03	1.46E-03	1.23E-03
Kr-85	1.61E-05	1.34E-03	1.72E-05
Kr-87	5.92E-03	9.73E-03	6.17E-03
Kr-88	1.47E-02	2.37E-03	1.52E-02
Kr-89	1.66E-02	1.01E-02	1.73E-02
Kr-90	1.56E-02	7.29E-03	1.63E-02
Xe-131m	9.15E-05	4.76E-04	1.56E-04
Xe-133m	2.51E-04	9.94E-04	3.27E-04
Xe-133	2.94E-04	3.06E-04	3.53E-04
Xe-135m	3.12E-03	7.11E-04	3.36E-03
Xe-135	1.81E-03	1.86E-03	1.92E-03
Xe-137	1.42E-03	1.22E-02	1.51E-03
Xe-138	8.83E-03	4.13E-03	9.21E-03
Ar-41	8.84E-03	2.69E-03	9.30E-03

\* mrem/yr per pCi/m<sup>3</sup>

\*\* mrad/yr per pCi/m<sup>3</sup>

Table 3.2-5  
External Dose Factors for Standing on Contaminated  
Ground  
(mrem/h per pCi/m<sup>2</sup>)

<u>Element</u>	<u>Whole Body</u>	<u>Skin</u>
H-3	0.00E+00	0.00E+00
C-14	0.00E+00	0.00E+00
Na-24	2.50E-08	2.90E-08
P-32	0.00E+00	0.00E+00
Cr-51	2.20E-10	2.60E-10
Mn-54	5.80E-09	6.80E-09
Mn-56	1.10E-08	1.30E-08
Fe-55	0.00E+00	0.00E+00
Fe-59	8.00E-09	9.40E-09
Co-58	7.00E-09	8.20E-09
Co-60	1.70E-08	2.00E-08
Ni-63	0.00E+00	0.00E+00
Nr-65	3.70E-09	4.30E-09
Cu-64	1.50E-09	1.70E-09
Zn-65	4.00E-09	4.60E-09
Zn-69	0.00E+00	0.00E+00
Br-83	6.40E-11	9.30E-11
Br-84	1.20E-08	1.40E-08
Br-85	0.00E+00	0.00E+00
Rb-86	6.30E-10	7.20E-10
Rb-88	3.50E-09	4.00E-09
Rb-89	1.50E-08	1.80E-08
Sr-89	5.60E-13	6.50E-13
Sr-91	7.10E-09	8.30E-09
Sr-92	9.00E-09	1.00E-08
Y-90	2.20E-12	2.60E-12
Y-91M	3.80E-09	4.40E-09
Y-91	2.40E-11	2.70E-11
Y-92	1.60E-09	1.90E-09
Y-93	5.70E-10	7.80E-10
Zr-95	5.00E-09	5.80E-09
Zr-97	5.50E-09	6.40E-09
Mo-95	5.10E-09	6.00E-09
Mo-99	1.90E-09	2.20E-09
Tc-99M	9.60E-10	1.10E-09
Tc-101	2.70E-09	3.00E-09
Ru-103	3.60E-09	4.20E-09
Ru-105	4.50E-09	5.10E-09
Ru-106	1.50E-09	1.80E-09
Ag-110M	1.80E-08	2.10E-08



Table 3.2-5 (Cont.)  
External Dose Factors for Standing on Contaminated  
Ground  
(mrem/h per pCi/m<sup>2</sup>)

<u>Element</u>	<u>Whole Body</u>	<u>Skin</u>
Te-125M	3.50E-11	4.80E-11
Te-127M	1.10E-12	1.30E-12
Te-127	1.00E-11	1.10E-11
Te-129M	7.70E-10	9.00E-10
Te-129	7.10E-10	8.40E-10
Te-131M	8.40E-09	9.90E-09
Te-131	2.20E-09	2.60E-06
Te-132	1.70E-09	2.00E-09
I-130	1.40E-08	1.70E-08
I-131	2.80E-09	3.40E-09
I-132	1.70E-08	2.00E-08
I-133	3.70E-09	4.50E-09
I-134	1.80E-08	1.90E-08
I-135	1.20E-08	1.40E-08
Cs-134	1.20E-08	1.40E-08
Cs-136	1.50E-08	1.70E-08
Cs-137	4.20E-09	4.90E-09
Cs-138	2.10E-08	2.40E-08
Ba-139	2.40E-09	2.70E-09
Ba-140	2.10E-09	2.40E-09
Ba-141	4.30E-09	4.90E-09
Ba-142	7.90E-09	9.00E-09
La-140	1.50E-08	1.70E-08
La-142	1.50E-08	1.80E-08
Ce-141	5.50E-10	6.20E-10
Ce-143	2.20E-09	2.50E-09
Ce-144	3.20E-10	3.70E-10
Pr-143	0.00E+00	0.00E+00
Pr-144	2.00E-10	2.30E-10
Nd-147	1.00E-09	1.20E-09
W-187	3.10E-09	3.60E-09
Np-239	9.50E-10	1.10E-09

Table 3.2-6  
Inhalation Dose Factors for Adult (mrem/pCi inhaled)

NUCLIDE	WHOLE						
	BONE	LIVER	BODY	THYROID	KIDNEY	LUNG	GI-LLI
H-3	NO DATA	1.58E-07	1.58E-07	1.58E-07	1.58E-07	1.58E-07	1.58E-07
C-14	2.27E-06	4.26E-07	4.26E-07	4.26E-07	4.26E-07	4.26E-07	4.26E-07
Na-24	1.28E-06	1.28E-06	1.28E-06	1.28E-06	1.28E-06	1.28E-06	1.28E-06
P-32	1.65E-04	9.64E-06	6.26E-06	NO DATA	NO DATA	NO DATA	1.08E-05
Cr-51	NO DATA	NO DATA	1.25E-08	7.44E-09	2.85E-09	1.80E-08	4.15E-07
Mn-54	NO DATA	4.95E-06	7.87E-07	NO DATA	1.23E-06	1.75E-04	9.67E-06
Mn-56	NO DATA	1.55E-10	2.29E-11	NO DATA	1.63E-10	1.18E-08	2.53E-06
Fe-55	3.07E-06	2.12E-06	4.23E-07	NO DATA	NO DATA	9.01E-08	7.54E-07
Fe-59	1.47E-06	3.47E-06	1.32E-08	NO DATA	NO DATA	1.27E-04	2.35E-05
Co-58	NO DATA	1.98E-07	2.59E-07	NO DATA	NO DATA	1.16E-04	1.33E-05
Co-60	NO DATA	1.44E-06	1.85E-06	NO DATA	NO DATA	7.46E-05	3.58E-05
Ni-63	5.40E-05	3.93E-06	1.81E-06	NO DATA	NO DATA	2.23E-05	1.67E-06
Ni-65	1.92E-10	2.62E-11	1.14E-11	NO DATA	NO DATA	7.00E-07	1.54E-06
Cu-64	NO DATA	1.83E-10	7.69E-11	NO DATA	5.78E-10	8.48E-07	6.12E-06
Zn-65	4.05E-06	1.29E-05	5.82E-06	NO DATA	8.62E-06	1.08E-04	6.68E-06
Zn-69	4.23E-12	8.14E-12	5.65E-13	NO DATA	5.27E-12	1.15E-07	2.04E-09
Br-83	NO DATA	NO DATA	3.01E-08	NO DATA	NO DATA	NO DATA	2.90E-08
Br-84	NO DATA	NO DATA	3.91E-08	NO DATA	NO DATA	NO DATA	2.05E-13
Br-85	NO DATA	NO DATA	1.60E-09	NO DATA	NO DATA	NO DATA	LT E-24
Rb-86	NO DATA	1.69E-05	7.37E-06	NO DATA	NO DATA	NO DATA	2.08E-06
Rb-88	NO DATA	4.84E-08	2.41E-08	NO DATA	NO DATA	NO DATA	4.18E-19
Rb-89	NO DATA	3.20E-08	2.12E-08	NO DATA	NO DATA	NO DATA	1.16E-21
Sr-89	3.80E-05	NO DATA	1.09E-06	NO DATA	NO DATA	1.75E-04	4.37E-05
Sr-90	1.24E-02	NO DATA	7.62E-04	NO DATA	NO DATA	1.20E-03	9.02E-05
Sr-91	7.74E-09	NO DATA	3.13E-10	NO DATA	NO DATA	4.56E-06	2.39E-05
Sr-92	8.43E-10	NO DATA	3.64E-11	NO DATA	NO DATA	2.06E-06	5.38E-06
Y-90	2.61E-07	NO DATA	7.01E-09	NO DATA	NO DATA	2.12E-05	6.32E-05
Y-91M	3.26E-11	NO DATA	1.27E-12	NO DATA	NO DATA	2.40E-07	1.66E-10
Y-91	5.78E-05	NO DATA	1.55E-06	NO DATA	NO DATA	2.13E-04	4.81E-05
Y-92	1.29E-09	NO DATA	3.77E-11	NO DATA	NO DATA	1.96E-06	9.19E-06
Y-93	1.18E-08	NO DATA	3.26E-10	NO DATA	NO DATA	6.06E-06	5.27E-05
Zr-95	1.34E-05	4.30E-06	2.91E-06	NO DATA	6.77E-06	2.21E-04	1.88E-05
Zr-97	1.21E-08	2.45E-09	1.13E-09	NO DATA	3.71E-09	9.84E-06	6.54E-05
Nb-95	1.76E-06	9.77E-07	5.26E-07	NO DATA	9.67E-07	6.31E-05	1.30E-05
Mo-99	NO DATA	1.51E-08	2.87E-09	NO DATA	3.64E-08	1.14E-05	3.10E-05
Tc-99M	1.29E-13	3.64E-13	4.63E-12	NO DATA	5.52E-12	9.55E-08	5.20E-07

Table 3.2-6 (Cont.)  
Inhalation Dose Factors for Adult (mrem/pCi inhaled)

NUCLIDE	WHOLE						
	BONE	LIVER	BODY	THYROID	KIDNEY	LUNG	GI-LLI
Tc-101	5.22E-15	7.52E-15	7.38E-14	NO DATA	1.35E-13	4.99E-08	1.38E-21
Ru-103	1.91E-07	NO DATA	8.23E-08	NO DATA	7.29E-07	6.31E-05	1.38E-05
Ru-105	9.88E-11	NO DATA	3.89E-11	NO DATA	1.27E-10	1.37E-06	6.02E-06
Ru-106	8.84E-08	NO DATA	1.00E-06	NO DATA	1.67E-05	1.17E-03	1.14E-04
Ag-110M	1.35E-06	1.25E-06	7.43E-07	NO DATA	2.46E-06	5.79E-04	3.78E-05
Te-125M	4.27E-07	1.98E-07	5.84E-08	1.31E-07	1.55E-06	3.92E-05	8.83E-05
Te-127M	1.58E-06	7.21E-07	1.96E-07	4.11E-07	5.72E-06	1.20E-04	1.87E-05
Te-127	1.75E-10	8.00E-11	3.87E-11	1.32E-10	6.37E-10	8.14E-07	7.17E-06
Te-129M	1.22E-06	5.84E-07	1.98E-07	4.30E-07	4.57E-06	1.45E-04	4.79E-05
Te-129	6.22E-12	2.99E-12	1.55E-12	4.87E-12	2.34E-11	2.42E-07	1.96E-08
Te-131M	8.74E-09	5.45E-09	3.63E-09	6.88E-09	3.86E-08	1.82E-05	6.95E-05
Te-131	1.39E-12	7.44E-13	4.49E-13	1.17E-12	5.46E-12	1.74E-07	2.30E-09
Te-132	3.25E-08	2.89E-08	2.02E-08	2.37E-08	1.82E-07	3.60E-05	6.37E-05
I-130	5.72E-07	1.68E-06	6.60E-07	1.42E-04	2.61E-06	NO DATA	9.61E-07
I-131	3.15E-06	4.47E-06	2.56E-06	1.49E-03	7.66E-06	NO DATA	7.85E-07
I-132	1.45E-07	4.07E-07	1.45E-07	1.43E-05	6.48E-07	NO DATA	5.08E-08
I-133	1.08E-06	1.85E-06	5.65E-07	2.69E-04	3.23E-06	NO DATA	1.11E-06
I-134	8.05E-08	2.16E-07	7.69E-08	3.73E-06	3.44E-07	NO DATA	1.26E-10
I-135	3.35E-07	8.73E-07	3.21E-07	5.60E-05	1.39E-06	NO DATA	6.56E-07
Cs-134	4.68E-05	1.06E-04	9.10E-05	NO DATA	3.59E-05	1.22E-05	1.30E-06
Cs-136	4.88E-08	1.83E-05	1.38E-05	NO DATA	1.07E-05	1.50E-06	1.46E-06
Cs-137	5.98E-05	7.76E-05	5.35E-05	NO DATA	2.78E-05	9.40E-06	1.05E-06
Cs-138	4.14E-08	7.76E-08	4.05E-08	NO DATA	6.00E-08	6.07E-09	2.33E-13
Ba-139	1.17E-10	8.32E-14	3.42E-12	NO DATA	7.78E-14	4.70E-07	1.12E-07
Ba-140	4.88E-06	6.13E-09	3.21E-07	NO DATA	2.09E-09	1.59E-04	2.73E-05
Ba-141	1.25E-11	9.41E-15	4.20E-13	NO DATA	8.75E-15	2.42E-07	1.45E-17
Ba-142	3.29E-12	3.38E-15	2.07E-13	NO DATA	2.86E-15	1.49E-07	1.96E-26
La-140	4.30E-08	2.17E-08	5.73E-09	NO DATA	NO DATA	1.70E-05	5.73E-05
La-142	8.54E-11	3.88E-11	9.85E-12	NO DATA	NO DATA	7.91E-07	2.64E-07
Ce-141	2.49E-06	1.89E-06	1.91E-07	NO DATA	7.83E-07	4.52E-05	1.50E-05
Ce-143	2.33E-08	1.72E-08	1.91E-09	NO DATA	7.60E-09	9.97E-06	2.83E-05
Ce-144	4.29E-04	1.79E-04	2.30E-05	NO DATA	1.06E-04	9.72E-04	1.02E-04
Pr-143	1.17E-06	4.69E-07	5.80E-08	NO DATA	2.70E-07	3.51E-05	2.50E-05
Pr-144	3.76E-12	1.56E-12	1.91E-13	NO DATA	8.81E-13	1.27E-07	2.69E-18
Nd-147	6.59E-07	7.62E-07	4.56E-08	NO DATA	4.45E-07	2.76E-05	2.16E-05
W-187	1.06E-09	8.85E-10	3.10E-10	NO DATA	NO DATA	3.63E-06	1.94E-05
Np-239	2.37E-08	2.82E-09	1.55E-09	NO DATA	8.75E-09	4.70E-06	1.49E-05

Table 3.2-7  
Inhalation Dose Factors for Teenager (mrem/pCi inhaled)

NUCLIDE	BONE	LIVER	WHOLE BODY	THYROID	KIDNEY	LUNG	GI-LI
H-3	NO DATA	1.59E-07	1.59E-07	1.59E-07	1.59E-07	1.59E-07	1.59E-07
C-14	3.25E-06	6.09E-07	6.09E-07	6.09E-07	6.09E-07	6.09E-07	6.09E-07
Na-24	1.72E-06	1.72E-06	1.72E-06	1.72E-06	1.72E-06	1.72E-06	1.72E-06
P-32	2.36E-04	1.37E-05	8.95E-06	NO DATA	NO DATA	NO DATA	1.16E-05
Cr-51	NO DATA	NO DATA	1.69E-08	9.37E-09	3.84E-09	2.62E-06	3.75E-07
Mn-54	NO DATA	6.32E-08	1.05E-06	NO DATA	1.59E-06	2.48E-04	8.35E-06
Mn-56	NO DATA	2.12E-10	3.15E-11	NO DATA	2.24E-10	1.90E-06	7.18E-06
Fe-55	4.18E-06	2.98E-06	6.93E-07	NO DATA	NO DATA	1.55E-05	7.99E-07
Fe-59	1.29E-06	4.62E-06	1.79E-06	NO DATA	NO DATA	1.91E-04	2.23E-05
Co-58	NO DATA	2.59E-07	3.47E-07	NO DATA	NO DATA	1.68E-04	1.19E-05
Co-60	NO DATA	1.89E-06	2.48E-06	NO DATA	NO DATA	1.09E-03	3.24E-05
Ni-63	7.25E-05	5.43E-06	2.47E-06	NO DATA	NO DATA	3.84E-05	1.77E-06
Ni-65	2.73E-10	3.66E-11	1.59E-11	NO DATA	NO DATA	1.17E-06	4.59E-06
Cu-64	NO DATA	2.54E-10	1.06E-10	NO DATA	8.01E-10	1.39E-06	7.68E-06
Zn-65	4.82E-06	1.67E-05	7.80E-06	NO DATA	1.08E-05	1.55E-04	5.83E-06
Zn-69	6.04E-12	1.15E-11	8.07E-13	NO DATA	7.53E-12	1.98E-07	3.56E-08
Br-83	NO DATA	NO DATA	4.30E-08	NO DATA	NO DATA	NO DATA	LT E-24
Br-84	NO DATA	NO DATA	5.41E-08	NO DATA	NO DATA	NO DATA	LT E-24
Br-85	NO DATA	NO DATA	2.29E-09	NO DATA	NO DATA	NO DATA	LT E-24
Rb-86	NO DATA	2.38E-05	1.05E-05	NO DATA	NO DATA	NO DATA	2.21E-06
Rb-88	NO DATA	6.82E-08	3.40E-08	NO DATA	NO DATA	NO DATA	3.65E-15
Rb-89	NO DATA	4.40E-08	2.91E-08	NO DATA	NO DATA	NO DATA	4.22E-17
Sr-89	5.43E-05	NO DATA	1.56E-06	NO DATA	NO DATA	3.02E-04	4.64E-05
Sr-90	1.35E-02	NO DATA	8.35E-04	NO DATA	NO DATA	2.06E-03	9.56E-05
Sr-91	1.10E-08	NO DATA	4.39E-10	NO DATA	NO DATA	7.59E-06	3.24E-05
Sr-92	1.19E-09	NO DATA	5.08E-11	NO DATA	NO DATA	3.43E-06	1.49E-05
Y-90	3.73E-07	NO DATA	1.00E-08	NO DATA	NO DATA	3.66E-05	6.99E-05
Y-91M	4.63E-11	NO DATA	1.77E-12	NO DATA	NO DATA	4.00E-07	3.77E-09
Y-91	8.26E-05	NO DATA	2.21E-06	NO DATA	NO DATA	3.67E-04	5.11E-05
Y-92	1.84E-09	NO DATA	5.36E-11	NO DATA	NO DATA	3.35E-06	2.06E-05
Y-93	1.69E-08	NO DATA	4.65E-10	NO DATA	NO DATA	1.04E-05	7.24E-05
Zr-95	1.82E-05	5.73E-06	3.94E-06	NO DATA	8.42E-06	3.36E-04	1.86E-05
Zr-97	1.72E-08	3.40E-09	1.57E-09	NO DATA	5.15E-09	1.62E-05	7.88E-05
Nb-95	2.32E-06	1.29E-06	7.08E-07	NO DATA	1.25E-06	8.39E-05	1.21E-05
Mo-99	NO DATA	2.11E-08	4.03E-09	NO DATA	5.14E-08	1.92E-05	3.36E-05
Tc-99M	1.73E-13	4.83E-13	6.24E-12	NO DATA	7.20E-12	1.44E-07	7.66E-07

Table 3.2-7 (Cont.)  
Inhalation Dose Factors for Teenager (mrem/pCi inhaled)

NUCLIDE	WHOLE						
	BONE	LIVER	BODY	THYROID	KIDNEY	LUNG	GI-LLI
Tc-101	7.40E-15	1.05E-14	1.03E-13	NO DATA	1.90E-13	8.34E-08	1.09E-16
Ru-103	2.63E-07	NO DATA	1.12E-07	NO DATA	9.29E-07	9.79E-05	1.36E-05
Ru-105	1.40E-10	NO DATA	5.42E-11	NO DATA	1.76E-10	2.27E-06	1.13E-05
Ru-106	1.23E-05	NO DATA	1.55E-06	NO DATA	2.38E-05	2.01E-03	1.20E-04
Ag-110M	1.73E-08	1.64E-08	9.99E-07	NO DATA	3.13E-06	8.44E-04	3.41E-05
Te-125M	6.10E-07	2.80E-07	8.34E-08	1.75E-07	NO DATA	6.70E-05	9.38E-06
Te-127M	2.25E-06	1.02E-06	2.73E-07	5.48E-07	8.17E-06	2.07E-04	1.99E-05
Te-127	2.51E-10	1.14E-10	5.52E-11	1.77E-10	9.10E-10	1.40E-06	1.01E-05
Te-129M	1.74E-06	8.23E-07	2.81E-07	5.72E-07	6.49E-06	2.47E-04	5.06E-05
Te-129	8.87E-12	4.22E-12	2.20E-12	6.48E-12	3.32E-11	4.12E-07	2.02E-07
Te-131M	1.23E-08	7.51E-09	5.03E-09	9.06E-09	5.49E-08	2.97E-05	7.76E-05
Te-131	1.97E-12	1.04E-12	6.30E-13	1.55E-12	7.72E-12	2.97E-07	1.89E-09
Te-132	4.50E-08	3.63E-08	2.74E-08	3.07E-08	2.44E-07	5.61E-05	5.79E-05
I-130	7.80E-07	2.24E-06	8.96E-07	1.86E-04	3.44E-06	NO DATA	1.14E-06
I-131	4.43E-06	6.14E-06	3.30E-06	1.83E-03	1.05E-05	NO DATA	8.11E-07
I-132	1.99E-07	5.47E-07	1.97E-07	1.89E-05	8.65E-07	NO DATA	1.59E-07
I-133	1.52E-06	2.58E-06	7.78E-07	3.65E-04	4.49E-06	NO DATA	1.29E-06
I-134	1.11E-07	2.90E-07	1.05E-07	4.94E-06	4.58E-07	NO DATA	2.55E-09
I-135	4.62E-07	1.18E-06	4.36E-07	7.76E-05	1.86E-06	NO DATA	8.69E-07
Cs-134	6.28E-05	1.41E-04	6.86E-05	NO DATA	4.69E-05	1.83E-05	1.22E-06
Cs-136	6.44E-06	2.42E-05	1.71E-05	NO DATA	1.38E-05	2.22E-06	1.36E-06
Cs-137	8.38E-05	1.06E-04	3.89E-05	NO DATA	3.80E-05	1.51E-05	1.06E-06
Cs-138	5.82E-08	1.07E-07	5.58E-08	NO DATA	8.28E-08	9.84E-09	3.38E-11
Ba-139	1.67E-10	1.18E-13	4.87E-12	NO DATA	1.11E-13	8.08E-07	8.06E-07
Ba-140	6.84E-06	8.38E-09	4.40E-07	NO DATA	2.85E-09	2.54E-04	2.86E-05
Ba-141	1.78E-11	1.32E-14	5.93E-13	NO DATA	1.23E-14	4.11E-07	9.33E-14
Ba-142	4.62E-12	4.63E-15	2.84E-13	NO DATA	3.92E-15	2.39E-07	5.99E-20
La-140	5.99E-08	2.95E-08	7.82E-09	NO DATA	NO DATA	2.68E-05	6.09E-05
La-142	1.20E-10	5.31E-11	1.32E-11	NO DATA	NO DATA	1.27E-06	1.50E-08
Ce-141	3.55E-06	2.37E-06	2.71E-07	NO DATA	1.11E-06	7.67E-05	1.58E-05
Ce-143	3.32E-08	2.42E-08	2.70E-09	NO DATA	1.08E-08	1.63E-05	3.19E-05
Ce-144	6.11E-04	2.53E-04	3.28E-05	NO DATA	1.51E-04	1.67E-03	1.08E-04
Pr-143	1.67E-06	6.64E-07	8.28E-08	NO DATA	3.86E-07	6.04E-05	2.67E-05
Pr-144	5.37E-12	2.20E-12	2.72E-13	NO DATA	1.26E-12	2.19E-07	2.94E-14
Nd-147	9.83E-07	1.07E-06	6.41E-08	NO DATA	6.28E-07	4.65E-05	2.28E-05
W-187	1.50E-09	1.22E-09	4.29E-10	NO DATA	NO DATA	5.92E-06	2.21E-05
Np-239	4.23E-08	3.99E-09	2.21E-09	NO DATA	1.75E-08	8.11E-06	1.65E-05

Table 3.2-8  
Inhalation Dose Factors for Child (mrem/pCi inhaled)

NUCLIDE	WHOLE						
	BONE	LIVER	BODY	THYROID	KIDNEY	LUNG	GI-LI
H-3	NO DATA	3.04E-07	3.04E-07	3.04E-07	3.04E-07	3.04E-07	3.04E-07
C-14	9.70E-06	1.82E-06	1.82E-06	1.82E-06	1.82E-06	1.82E-06	1.82E-06
Na-24	4.35E-06	4.35E-06	4.35E-06	4.35E-06	4.35E-06	4.35E-06	4.35E-06
P-32	7.04E-04	3.09E-05	2.67E-05	NO DATA	NO DATA	NO DATA	1.14E-05
Cr-51	NO DATA	NO DATA	4.17E-08	2.31E-08	6.57E-09	4.59E-06	2.93E-07
Mn-54	NO DATA	1.16E-05	2.57E-06	NO DATA	2.71E-06	4.26E-04	6.19E-06
Mn-56	NO DATA	4.48E-10	8.43E-11	NO DATA	4.52E-10	3.55E-06	3.33E-05
Fe-55	1.28E-05	6.80E-06	2.10E-06	NO DATA	NO DATA	3.00E-05	7.75E-07
Fe-59	5.59E-06	9.04E-06	4.51E-06	NO DATA	NO DATA	3.43E-04	1.91E-05
Co-58	NO DATA	4.70E-07	8.55E-07	NO DATA	NO DATA	2.99E-04	9.29E-06
Co-60	NO DATA	3.55E-06	6.12E-06	NO DATA	NO DATA	1.91E-03	2.60E-05
Ni-63	2.22E-04	1.25E-05	7.56E-06	NO DATA	NO DATA	7.43E-05	1.71E-06
Ni-65	8.08E-10	7.99E-11	4.44E-11	NO DATA	NO DATA	2.21E-06	2.27E-05
Cu-64	NO DATA	5.39E-10	2.90E-10	NO DATA	1.63E-09	2.59E-06	9.92E-06
Zn-65	1.15E-05	3.06E-05	1.90E-05	NO DATA	1.93E-05	2.69E-04	4.41E-06
Zn-69	1.81E-11	2.61E-11	2.41E-12	NO DATA	1.58E-11	3.84E-07	2.75E-06
Br-83	NO DATA	NO DATA	1.28E-07	NO DATA	NO DATA	NO DATA	LT E-24
Br-84	NO DATA	NO DATA	1.48E-07	NO DATA	NO DATA	NO DATA	LT E-24
Br-85	NO DATA	NO DATA	6.84E-09	NO DATA	NO DATA	NO DATA	LT E-24
Rb-86	NO DATA	5.36E-05	3.09E-05	NO DATA	NO DATA	NO DATA	2.16E-06
Rb-88	NO DATA	1.52E-07	9.90E-08	NO DATA	NO DATA	NO DATA	4.66E-09
Rb-89	NO DATA	9.33E-08	7.83E-08	NO DATA	NO DATA	NO DATA	5.11E-10
Sr-89	1.62E-04	NO DATA	4.66E-06	NO DATA	NO DATA	5.83E-04	4.52E-05
Sr-90	2.73E-02	NO DATA	1.74E-03	NO DATA	NO DATA	3.99E-03	9.28E-05
Sr-91	3.28E-08	NO DATA	1.24E-09	NO DATA	NO DATA	1.44E-05	4.70E-05
Sr-92	3.54E-09	NO DATA	1.42E-10	NO DATA	NO DATA	6.49E-06	6.55E-05
Y-90	1.11E-06	NO DATA	2.99E-08	NO DATA	NO DATA	7.07E-05	7.24E-05
Y-91M	1.37E-10	NO DATA	4.98E-12	NO DATA	NO DATA	7.60E-07	4.64E-07
Y-91	2.47E-04	NO DATA	6.59E-06	NO DATA	NO DATA	7.10E-04	4.97E-05
Y-92	5.50E-09	NO DATA	1.57E-10	NO DATA	NO DATA	6.46E-06	6.46E-05
Y-93	5.04E-08	NO DATA	1.38E-09	NO DATA	NO DATA	2.01E-05	1.05E-04
Zr-95	5.13E-05	1.13E-05	1.00E-05	NO DATA	1.61E-05	6.03E-04	1.65E-05
Zr-97	5.07E-08	7.34E-09	4.32E-09	NO DATA	1.05E-08	3.06E-05	9.49E-05
Nb-95	6.35E-06	2.48E-06	1.77E-06	NO DATA	2.33E-06	1.66E-04	1.00E-05
Mo-99	NO DATA	4.66E-08	1.15E-08	NO DATA	1.06E-07	3.66E-05	3.42E-05
Tc-99M	4.81E-13	9.41E-13	1.56E-11	NO DATA	1.37E-11	2.57E-07	1.30E-06

Table 3.2-8 (Cont.)  
Inhalation Dose Factors for Child (mrem/pCi inhaled)

NUCLIDE	BONE	LIVER	WHOLE BODY	THYROID	KIDNEY	LUNG	G-LLI
Tc-101	2.19E-14	2.30E-14	2.91E-13	NO DATA	3.92E-13	1.58E-07	4.41E-09
Ru-103	7.55E-07	NO DATA	2.90E-07	NO DATA	1.90E-06	1.79E-04	1.21E-05
Ru-105	4.13E-10	NO DATA	1.50E-10	NO DATA	3.63E-10	4.30E-06	2.69E-05
Ru-106	3.68E-05	NO DATA	4.57E-06	NO DATA	4.97E-05	3.87E-03	1.16E-04
Ag-110M	4.56E-06	3.08E-06	2.47E-06	NO DATA	5.74E-06	1.48E-03	2.71E-05
Te-125M	1.82E-06	6.29E-07	2.47E-07	5.20E-07	NO DATA	1.29E-04	9.13E-06
Te-127M	6.72E-06	2.31E-06	8.18E-07	1.64E-06	1.72E-05	4.00E-04	1.93E-05
Te-127	7.49E-10	2.57E-10	1.65E-10	5.30E-10	1.91E-09	2.71E-06	1.52E-05
Te-129M	5.19E-06	1.85E-06	8.22E-07	1.71E-06	1.36E-05	4.76E-04	4.91E-05
Te-129	2.64E-11	9.45E-12	6.44E-12	1.93E-11	6.94E-11	7.93E-07	6.89E-06
Te-131M	3.63E-08	1.60E-08	1.37E-08	2.64E-08	1.08E-07	5.56E-05	8.32E-05
Te-131	5.87E-12	2.28E-12	1.78E-12	4.59E-12	1.59E-11	5.56E-07	3.60E-07
Te-132	1.30E-07	7.36E-08	7.12E-08	8.58E-08	4.79E-07	1.02E-04	3.72E-05
I-130	2.21E-06	4.43E-06	2.28E-06	4.99E-04	6.81E-06	NO DATA	1.38E-06
I-131	1.30E-05	1.30E-05	7.37E-06	4.39E-03	2.13E-05	NO DATA	7.68E-07
I-132	5.72E-07	1.10E-06	5.07E-07	5.23E-05	1.69E-06	NO DATA	8.65E-07
I-133	4.48E-06	5.49E-06	2.08E-06	1.04E-03	9.13E-08	NO DATA	1.48E-06
I-134	3.17E-07	5.84E-07	2.09E-07	1.37E-05	8.92E-07	NO DATA	2.58E-07
I-135	1.33E-06	2.36E-06	1.12E-06	2.14E-04	3.62E-06	NO DATA	1.20E-06
Cs-134	1.76E-04	2.74E-04	6.07E-05	NO DATA	8.93E-05	3.27E-05	1.04E-06
Cs-136	1.76E-05	4.62E-05	3.14E-05	NO DATA	2.58E-05	3.93E-06	1.13E-06
Cs-137	2.45E-04	2.23E-04	3.47E-05	NO DATA	7.63E-05	2.81E-05	9.78E-07
Cs-138	1.71E-07	2.27E-07	1.50E-07	NO DATA	1.68E-07	1.84E-08	7.29E-08
Ba-139	4.98E-10	2.66E-13	1.45E-11	NO DATA	2.33E-13	1.56E-06	1.56E-05
Ba-140	2.00E-05	1.75E-08	1.17E-06	NO DATA	5.71E-09	4.71E-04	2.75E-05
Ba-141	5.29E-11	2.95E-14	1.72E-12	NO DATA	2.56E-14	7.89E-07	7.44E-08
Ba-142	1.35E-11	2.73E-15	7.54E-13	NO DATA	7.87E-15	4.44E-07	7.41E-10
La-140	1.74E-07	6.08E-08	2.04E-08	NO DATA	NO DATA	4.94E-05	6.10E-05
La-142	3.50E-10	1.11E-10	3.49E-11	NO DATA	NO DATA	2.35E-06	2.05E-06
Ce-141	1.06E-05	5.28E-06	7.83E-07	NO DATA	2.31E-06	1.47E-05	1.53E-05
Ce-143	9.89E-08	5.37E-08	7.77E-09	NO DATA	2.26E-08	3.12E-05	3.44E-05
Ce-144	1.83E-03	5.72E-04	9.77E-05	NO DATA	3.17E-04	3.23E-03	1.05E-04
Pr-143	4.99E-06	1.50E-06	2.47E-07	NO DATA	8.11E-07	1.17E-04	2.63E-05
Pr-144	1.61E-11	4.99E-12	8.10E-13	NO DATA	2.64E-12	4.23E-07	5.32E-08
Nd-147	2.92E-06	2.36E-06	1.84E-07	NO DATA	1.30E-06	8.87E-05	2.22E-05
W-187	4.41E-09	2.61E-09	1.17E-09	NO DATA	NO DATA	1.11E-05	2.46E-05
Np-239	1.26E-07	9.04E-09	6.35E-09	NO DATA	2.63E-08	1.57E-05	1.73E-05

Table 3.2-9  
Inhalation Dose Factors for Infant (mrem/pCi inhaled)

NUCLIDE	BONE	LIVER	WHOLE BODY	THYROID	KIDNEY	LUNG	G-LLI
H-3	NO DATA	4.62E-07	4.62E-07	4.62E-07	4.62E-07	4.62E-07	4.62E-07
C-14	1.89E-05	3.79E-06	3.79E-06	3.79E-06	3.79E-06	3.79E-06	3.79E-06
Na-24	7.54E-06	7.54E-06	7.54E-06	7.54E-06	7.54E-06	7.54E-06	7.54E-06
P-32	1.45E-03	8.03E-05	5.53E-05	NO DATA	NO DATA	NO DATA	1.15E-05
Cr-51	NO DATA	NO DATA	6.37E-08	4.11E-08	9.45E-09	9.17E-06	2.55E-07
Mn-54	NO DATA	1.81E-05	3.56E-06	NO DATA	3.56E-06	7.14E-04	5.04E-06
Mn-56	NO DATA	1.10E-09	1.58E-10	NO DATA	7.86E-10	8.95E-06	5.12E-05
Fe-55	1.41E-05	8.39E-06	2.38E-06	NO DATA	NO DATA	6.21E-05	7.82E-07
Fe-59	9.69E-06	1.68E-05	6.77E-06	NO DATA	NO DATA	7.25E-04	1.77E-06
Co-58	NO DATA	8.71E-07	1.30E-06	NO DATA	NO DATA	5.55E-04	7.95E-06
Co-60	NO DATA	5.73E-06	8.41E-06	NO DATA	NO DATA	3.22E-03	2.28E-05
Ni-63	2.42E-04	1.46E-05	8.29E-06	NO DATA	NO DATA	1.49E-04	1.73E-06
Ni-65	1.71E-09	2.03E-10	8.79E-11	NO DATA	NO DATA	5.80E-06	3.58E-05
Cu-64	NO DATA	1.34E-09	5.53E-10	NO DATA	2.84E-09	6.64E-06	1.07E-05
Zn-65	1.38E-05	4.47E-05	2.22E-05	NO DATA	2.32E-05	4.62E-04	3.67E-05
Zn-69	3.85E-11	6.91E-11	5.13E-12	NO DATA	2.87E-11	1.05E-06	9.44E-06
Br-83	NO DATA	NO DATA	2.72E-07	NO DATA	NO DATA	NO DATA	LT E-24
Br-84	NO DATA	NO DATA	2.86E-07	NO DATA	NO DATA	NO DATA	LT E-24
Br-85	NO DATA	NO DATA	1.48E-08	NO DATA	NO DATA	NO DATA	LT E-24
Rb-86	NO DATA	1.36E-04	6.30E-05	NO DATA	NO DATA	NO DATA	2.17E-06
Rb-88	NO DATA	3.98E-07	2.03E-07	NO DATA	NO DATA	NO DATA	2.42E-07
Rb-89	NO DATA	2.29E-07	1.47E-07	NO DATA	NO DATA	NO DATA	4.87E-08
Sr-89	2.84E-04	NO DATA	8.15E-06	NO DATA	NO DATA	1.45E-03	4.57E-05
Sr-90	2.92E-02	NO DATA	1.85E-03	NO DATA	NO DATA	8.03E-03	9.36E-05
Sr-91	6.83E-08	NO DATA	2.47E-09	NO DATA	NO DATA	3.76E-05	5.24E-05
Sr-92	7.50E-09	NO DATA	2.79E-10	NO DATA	NO DATA	1.70E-05	1.00E-04
Y-90	2.35E-06	NO DATA	6.30E-08	NO DATA	NO DATA	1.92E-04	7.43E-05
Y-91M	2.91E-10	NO DATA	9.90E-12	NO DATA	NO DATA	1.99E-06	1.68E-06
Y-91	4.20E-04	NO DATA	1.12E-05	NO DATA	NO DATA	1.75E-03	5.02E-05
Y-92	1.17E-08	NO DATA	3.29E-10	NO DATA	NO DATA	1.75E-05	9.04E-05
Y-93	1.07E-07	NO DATA	2.91E-09	NO DATA	NO DATA	5.46E-05	1.19E-04
Zr-95	8.24E-05	1.99E-05	1.45E-06	NO DATA	2.22E-05	1.25E-03	1.55E-05
Zr-97	1.07E-07	1.83E-08	8.38E-09	NO DATA	1.85E-08	7.88E-05	1.00E-04
Nb-95	1.12E-05	4.69E-06	2.70E-06	NO DATA	3.37E-06	3.42E-04	9.05E-06
Mo-99	NO DATA	1.18E-07	2.31E-08	NO DATA	1.89E-07	9.63E-05	3.48E-05
Tc-99M	9.98E-13	2.06E-12	2.66E-11	NO DATA	2.22E-11	5.79E-07	1.45E-06



Table 3.2-9 (Cont.)  
Inhalation Dose Factors for Infant (mrem/pCi inhaled)

NUCLIDE	WHOLE						
	BONE	LIVER	BODY	THYROID	KIDNEY	LUNG	GI-LLI
Tc-101	4.85E-14	5.58E-14	5.80E-13	NO DATA	6.99E-13	4.17E-07	6.03E-07
Ru-103	1.44E-06	NO DATA	4.85E-07	NO DATA	3.03E-06	3.94E-04	1.15E-05
Ru-105	8.74E-10	NO DATA	2.93E-10	NO DATA	6.42E-10	1.12E-05	3.46E-05
Ru-106	6.20E-05	NO DATA	7.77E-06	NO DATA	7.81E-05	8.26E-03	1.17E-04
Ag-110M	7.13E-06	5.16E-06	3.57E-08	NO DATA	7.80E-06	2.62E-03	2.36E-05
Te-125M	3.40E-06	1.42E-06	4.70E-07	1.16E-06	NO DATA	3.19E-04	9.22E-06
Te-127M	1.19E-05	4.93E-06	1.48E-06	3.48E-06	2.68E-05	9.37E-04	1.95E-05
Te-127	1.59E-09	6.81E-10	3.49E-10	1.32E-09	3.47E-09	7.39E-06	1.74E-05
Te-129M	1.01E-05	4.35E-06	1.59E-06	3.91E-06	2.27E-05	1.20E-03	4.93E-05
Te-129	5.63E-11	2.48E-11	1.34E-11	4.82E-11	1.25E-10	2.14E-06	1.88E-05
Te-131M	7.62E-08	3.93E-08	2.59E-08	6.38E-08	1.89E-07	1.42E-04	8.51E-05
Te-131	1.24E-11	5.87E-12	3.57E-12	1.13E-11	2.85E-11	1.47E-06	5.87E-06
Te-132	2.66E-07	1.69E-07	1.26E-07	1.99E-07	7.39E-07	2.43E-04	3.15E-05
I-130	4.54E-06	9.91E-06	3.98E-06	1.14E-03	1.09E-05	NO DATA	1.42E-06
I-131	1.71E-05	3.17E-05	1.40E-05	1.06E-02	3.70E-05	NO DATA	7.56E-07
I-132	1.21E-06	2.53E-06	8.99E-07	1.21E-04	2.82E-06	NO DATA	1.36E-06
I-133	9.46E-06	1.37E-05	4.00E-06	2.54E-03	1.60E-05	NO DATA	1.54E-06
I-134	6.58E-07	1.34E-06	4.75E-07	3.18E-05	1.49E-06	NO DATA	9.21E-07
I-135	2.76E-06	5.43E-06	1.98E-06	4.97E-04	6.05E-06	NO DATA	1.31E-06
Cs-134	2.83E-04	5.02E-04	5.32E-05	NO DATA	1.38E-04	5.89E-05	9.53E-07
Cs-136	3.45E-05	9.61E-05	3.78E-05	NO DATA	4.03E-05	8.40E-06	1.02E-06
Cs-137	3.92E-04	4.37E-04	3.25E-05	NO DATA	1.23E-04	5.09E-05	9.53E-07
Cs-138	3.61E-07	5.58E-07	2.84E-07	NO DATA	2.93E-07	4.67E-08	6.26E-07
Ba-139	1.06E-09	7.03E-13	3.07E-11	NO DATA	4.23E-13	4.25E-06	3.64E-05
Ba-140	4.00E-05	4.00E-08	2.07E-06	NO DATA	9.59E-09	1.14E-03	2.74E-05
Ba-141	1.12E-10	7.70E-14	3.55E-12	NO DATA	4.64E-14	2.12E-06	3.39E-06
Ba-142	2.84E-11	2.36E-14	1.40E-12	NO DATA	1.38E-14	1.11E-06	4.95E-07
La-140	3.61E-07	1.43E-07	3.68E-08	NO DATA	NO DATA	1.20E-04	6.06E-05
La-142	7.36E-10	2.69E-10	3.46E-11	NO DATA	NO DATA	5.87E-08	4.25E-05
Ce-141	1.98E-05	1.19E-05	1.42E-06	NO DATA	3.75E-06	3.69E-04	1.54E-05
Ce-143	2.09E-07	1.38E-07	1.58E-08	NO DATA	4.03E-08	8.30E-05	3.55E-05
Ce-144	2.28E-03	8.65E-04	1.26E-04	NO DATA	3.84E-04	7.03E-03	1.08E-04
Pr-143	1.00E-05	3.74E-06	4.99E-07	NO DATA	1.41E-06	3.09E-04	2.66E-05
Pr-144	3.42E-11	1.32E-11	1.72E-12	NO DATA	4.80E-12	1.15E-06	3.06E-06
Nd-147	5.87E-06	5.81E-06	3.57E-07	NO DATA	2.25E-06	2.30E-04	2.23E-05
W-187	9.26E-09	6.44E-09	2.23E-09	NO DATA	NO DATA	2.83E-05	2.54E-05
Np-239	2.65E-07	2.37E-08	1.34E-08	NO DATA	4.73E-08	4.25E-05	1.78E-05

Table 3.2-10  
Ingestion Dose Factors for Adult (mrem/pCi ingested)

ISOTOPE	BONE	LIVER	WHOLE BODY	THYROID	KIDNEY	LUNG	GI-LLI
H-3	0.00E+00	1.05E-07	1.05E-07	1.05E-07	1.05E-07	1.05E-07	1.05E-07
C-14	2.84E-06	5.68E-07	5.68E-07	5.68E-07	5.68E-07	5.68E-07	5.68E-07
Na-24	1.70E-06	1.70E-06	1.70E-06	1.70E-06	1.70E-06	1.70E-06	1.70E-06
P-32	1.93E-04	1.20E-05	7.46E-06	0.00E+00	0.00E+00	0.00E+00	2.17E-05
Cr-51	0.00E+00	0.00E+00	2.66E-09	1.59E-09	5.86E-10	3.53E-09	6.69E-07
Mn-54	0.00E+00	4.57E-06	8.72E-07	0.00E+00	1.36E-06	0.00E+00	1.40E-05
Mn-56	0.00E+00	1.15E-07	2.04E-08	0.00E+00	1.46E-07	0.00E+00	3.67E-06
Fe-55	2.75E-06	1.90E-06	4.43E-07	0.00E+00	0.00E+00	1.06E-06	1.09E-06
Fe-59	4.34E-06	1.02E-05	3.91E-06	0.00E+00	0.00E+00	2.85E-06	3.40E-05
Co-58	0.00E+00	7.45E-07	1.67E-06	0.00E+00	0.00E+00	0.00E+00	1.51E-05
Co-60	0.00E+00	2.14E-06	4.72E-06	0.00E+00	0.00E+00	0.00E+00	4.02E-05
Ni-63	1.30E-04	9.01E-06	4.36E-06	0.00E+00	0.00E+00	0.00E+00	1.88E-06
Ni-65	5.28E-07	6.86E-08	3.13E-08	0.00E+00	0.00E+00	0.00E+00	1.74E-06
Cu-64	0.00E+00	8.33E-08	3.91E-08	0.00E+00	2.10E-07	0.00E+00	7.10E-06
Zn-65	4.84E-06	1.54E-05	6.96E-06	0.00E+00	1.03E-05	0.00E+00	9.70E-06
Zn-69	1.03E-08	1.97E-08	1.37E-09	0.00E+00	1.28E-08	0.00E+00	2.96E-09
Br-83	0.00E+00	0.00E+00	4.02E-08	0.00E+00	0.00E+00	0.00E+00	5.79E-08
Br-84	0.00E+00	0.00E+00	5.21E-08	0.00E+00	0.00E+00	0.00E+00	4.09E-13
Br-85	0.00E+00	0.00E+00	2.14E-09	0.00E+00	0.00E+00	0.00E+00	0.00E+00
Rb-86	0.00E+00	2.11E-05	9.83E-06	0.00E+00	0.00E+00	0.00E+00	4.16E-06
Rb-88	0.00E+00	6.05E-08	3.21E-08	0.00E+00	0.00E+00	0.00E+00	8.36E-19
Rb-89	0.00E+00	4.01E-08	2.82E-08	0.00E+00	0.00E+00	0.00E+00	2.33E-21
Sr-89	3.08E-04	0.00E+00	8.84E-06	0.00E+00	0.00E+00	0.00E+00	4.94E-05
Sr-90	7.58E-03	0.00E+00	1.86E-03	0.00E+00	0.00E+00	0.00E+00	2.19E-04
Sr-91	5.67E-06	0.00E+00	2.29E-07	0.00E+00	0.00E+00	0.00E+00	2.70E-05
Sr-92	2.15E-06	0.00E+00	9.30E-08	0.00E+00	0.00E+00	0.00E+00	4.26E-05
Y-90	9.62E-09	0.00E+00	2.58E-10	0.00E+00	0.00E+00	0.00E+00	1.02E-04
Y-91M	9.09E-11	0.00E+00	3.52E-12	0.00E+00	0.00E+00	0.00E+00	2.67E-10
Y-91	1.41E-07	0.00E+00	3.77E-09	0.00E+00	0.00E+00	0.00E+00	7.67E-05
Y-92	8.45E-10	0.00E+00	2.47E-11	0.00E+00	0.00E+00	0.00E+00	1.48E-05
Y-93	2.68E-09	0.00E+00	7.40E-11	0.00E+00	0.00E+00	0.00E+00	8.50E-05
Zr-95	3.04E-08	9.75E-09	6.60E-09	0.00E+00	1.53E-08	0.00E+00	3.09E-05
Zr-97	1.68E-09	3.39E-10	1.55E-10	0.00E+00	5.12E-10	0.00E+00	1.05E-04
Nb-95	6.22E-09	3.46E-09	1.86E-09	0.00E+00	3.42E-09	0.00E+00	2.10E-05
Mo-99	0.00E+00	4.31E-06	8.20E-07	0.00E+00	9.76E-06	0.00E+00	9.99E-06
Tc-99M	2.47E-10	6.98E-10	6.89E-09	0.00E+00	1.06E-08	3.42E-10	4.13E-07

Table 3.2-10 (Cont.)  
Ingestion Dose Factors for Adult (mrem/pCi ingested)

ISOTOPE	BONE	LIVER	WHOLE BODY	THYROID	KIDNEY	LUNG	GI-LLI
Tc-101	2.54E-10	3.66E-10	3.59E-09	0.00E+00	6.59E-09	1.87E-10	1.10E-21
Ru-103	1.85E-07	0.00E+00	7.97E-08	0.00E+00	7.06E-07	0.00E+00	2.16E-05
Ru-105	1.54E-08	0.00E+00	6.08E-09	0.00E+00	1.99E-07	0.00E+00	9.42E-06
Ru-106	2.75E-06	0.00E+00	3.48E-07	0.00E+00	5.31E-06	0.00E+00	1.78E-04
Ag-110M	1.80E-07	1.48E-07	8.79E-08	0.00E+00	2.91E-07	0.00E+00	6.04E-05
Te-125M	2.68E-06	9.17E-07	3.59E-07	8.06E-07	1.09E-05	0.00E+00	1.07E-05
Te-127M	6.77E-06	2.42E-06	8.25E-07	1.73E-06	2.75E-05	0.00E+00	2.27E-05
Te-127	1.10E-07	3.95E-08	2.38E-08	8.15E-08	4.48E-07	0.00E+00	8.68E-06
Te-129M	1.15E-05	4.29E-06	1.82E-06	3.95E-06	4.80E-06	0.00E+00	5.79E-05
Te-129	3.14E-08	1.18E-08	7.65E-09	2.41E-08	1.32E-07	0.00E+00	2.37E-08
Te-131M	1.73E-06	8.46E-07	7.05E-07	1.34E-06	8.57E-06	0.00E+00	8.40E-05
Te-131	1.97E-08	8.23E-09	6.22E-09	1.62E-08	8.63E-08	0.00E+00	2.79E-09
Te-132	2.52E-06	1.63E-06	1.53E-06	1.80E-06	1.57E-05	0.00E+00	7.71E-05
I-130	7.56E-07	2.23E-06	8.80E-07	1.89E-04	3.48E-06	0.00E+00	1.92E-06
I-131	4.16E-06	5.95E-06	3.41E-06	1.95E-03	1.02E-05	0.00E+00	1.57E-08
I-132	2.03E-07	5.43E-07	1.90E-07	1.90E-05	8.65E-07	0.00E+00	1.02E-07
I-133	1.42E-06	2.47E-06	7.53E-07	3.63E-04	4.31E-06	0.00E+00	2.22E-06
I-134	1.06E-07	2.88E-07	1.03E-07	4.99E-06	4.58E-07	0.00E+00	2.51E-10
I-135	4.43E-07	1.16E-06	4.28E-07	7.65E-05	1.86E-06	0.00E+00	1.31E-06
Cs-134	6.22E-05	1.48E-04	1.21E-04	0.00E+00	4.79E-05	1.59E-05	2.59E-06
Cs-136	6.51E-06	2.57E-05	1.85E-05	0.00E+00	1.43E-05	1.96E-06	2.92E-06
Cs-137	7.97E-05	1.09E-04	7.14E-05	0.00E+00	3.70E-05	1.23E-05	2.11E-06
Cs-138	5.52E-08	1.09E-07	5.40E-08	0.00E+00	8.01E-08	7.91E-09	4.65E-13
Ba-139	9.70E-08	6.91E-11	2.84E-09	0.00E+00	6.48E-11	3.92E-11	1.72E-07
Ba-140	2.03E-05	2.55E-08	1.33E-06	0.00E+00	8.67E-09	1.48E-08	4.18E-05
Ba-141	4.71E-08	3.56E-11	1.59E-09	0.00E+00	3.31E-11	2.02E-11	2.22E-17
Ba-142	2.13E-08	2.19E-11	1.34E-09	0.00E+00	1.85E-11	1.24E-11	3.00E-26
La-140	2.50E-09	1.26E-09	3.33E-10	0.00E+00	0.00E+00	0.00E+00	9.25E-05
La-142	1.28E-10	5.82E-11	1.45E-11	0.00E+00	0.00E+00	0.00E+00	4.25E-07
Ce-141	9.36E-09	6.33E-09	7.18E-10	0.00E+00	2.94E-09	0.00E+00	2.42E-05
Ce-143	1.85E-09	1.22E-06	1.35E-10	0.00E+00	5.37E-10	0.00E+00	4.56E-05
Ce-144	4.88E-07	2.04E-07	2.62E-08	0.00E+00	1.21E-07	0.00E+00	1.65E-04
Pr-143	9.20E-09	3.69E-09	4.56E-10	0.00E+00	2.13E-09	0.00E+00	4.03E-05
Pr-144	3.01E-11	1.25E-11	1.53E-12	0.00E+00	7.05E-12	0.00E+00	4.33E-18
Nd-147	6.29E-09	7.27E-09	4.35E-10	0.00E+00	4.25E-09	0.00E+00	3.49E-05
W-187	1.03E-07	8.61E-08	3.01E-08	0.00E+00	0.00E+00	0.00E+00	2.82E-05
Np-239	1.19E-09	1.17E-10	6.45E-11	0.00E+00	3.65E-10	0.00E+00	2.40E-05

Table 3.2-11  
Ingestion Dose Factors for Teenager (mrem/pCi ingested)

ISOTOPE	BONE	LIVER	WHOLE BODY	THYROID	KIDNEY	LUNG	GI-LI
H-3	0.00E+00	1.06E-07	1.06E-07	1.06E-07	1.06E-07	1.06E-07	1.06E-07
C-14	4.06E-06	8.12E-07	8.12E-07	8.12E-07	8.12E-07	8.12E-07	8.12E-07
Na-24	2.30E-06	2.30E-06	2.30E-06	2.30E-06	2.30E-06	2.30E-06	2.30E-06
P-32	2.76E-04	1.71E-05	1.07E-05	0.00E+00	0.00E+00	0.00E+00	2.32E-05
Cr-51	0.00E+00	0.00E+00	3.60E-09	2.00E-09	7.89E-10	5.14E-09	6.05E-07
Mn-54	0.00E+00	5.90E-08	1.17E-06	0.00E+00	1.76E-06	0.00E+00	1.21E-05
Mn-56	0.00E+00	1.58E-07	2.81E-08	0.00E+00	2.00E-07	0.00E+00	1.04E-05
Fe-55	3.78E-06	2.68E-06	6.25E-07	0.00E+00	0.00E+00	1.70E-08	1.18E-06
Fe-59	5.87E-06	1.37E-05	5.29E-06	0.00E+00	0.00E+00	4.32E-08	3.24E-05
Co-58	0.00E+00	9.72E-07	2.24E-06	0.00E+00	0.00E+00	0.00E+00	1.34E-05
Co-60	0.00E+00	2.81E-06	6.33E-06	0.00E+00	0.00E+00	0.00E+00	3.66E-05
Ni-63	1.77E-04	1.25E-05	6.00E-06	0.00E+00	0.00E+00	0.00E+00	1.99E-06
Ni-65	7.49E-07	9.57E-08	4.36E-08	0.00E+00	0.00E+00	0.00E+00	5.19E-06
Cu-64	0.00E+00	1.15E-07	5.41E-08	0.00E+00	2.91E-07	0.00E+00	8.92E-06
Zn-65	5.76E-06	2.00E-05	9.33E-06	0.00E+00	1.28E-05	0.00E+00	8.47E-06
Zn-69	1.47E-08	2.80E-08	1.96E-09	0.00E+00	1.83E-08	0.00E+00	5.16E-08
Br-83	0.00E+00	0.00E+00	5.74E-08	0.00E+00	0.00E+00	0.00E+00	0.00E+00
Br-84	0.00E+00	0.00E+00	7.22E-08	0.00E+00	0.00E+00	0.00E+00	0.00E+00
Br-85	0.00E+00	0.00E+00	3.05E-09	0.00E+00	0.00E+00	0.00E+00	0.00E+00
Rb-86	0.00E+00	2.98E-06	1.40E-05	0.00E+00	0.00E+00	0.00E+00	4.41E-06
Rb-88	0.00E+00	8.52E-08	4.54E-08	0.00E+00	0.00E+00	0.00E+00	7.30E-15
Rb-89	0.00E+00	5.50E-08	3.89E-08	0.00E+00	0.00E+00	0.00E+00	8.43E-17
Sr-89	4.40E-04	0.00E+00	1.26E-05	0.00E+00	0.00E+00	0.00E+00	5.24E-05
Sr-90	8.30E-03	0.00E+00	2.05E-03	0.00E+00	0.00E+00	0.00E+00	2.33E-04
Sr-91	8.07E-06	0.00E+00	3.21E-07	0.00E+00	0.00E+00	0.00E+00	3.66E-05
Sr-92	3.05E-06	0.00E+00	1.30E-07	0.00E+00	0.00E+00	0.00E+00	7.77E-05
Y-90	1.37E-08	0.00E+00	3.89E-10	0.00E+00	0.00E+00	0.00E+00	1.13E-04
Y-91M	1.29E-10	0.00E+00	4.93E-12	0.00E+00	0.00E+00	0.00E+00	6.09E-09
Y-91	2.01E-07	0.00E+00	5.39E-09	0.00E+00	0.00E+00	0.00E+00	8.24E-05
Y-92	1.21E-09	0.00E+00	3.50E-11	0.00E+00	0.00E+00	0.00E+00	3.32E-05
Y-93	3.83E-09	0.00E+00	1.05E-10	0.00E+00	0.00E+00	0.00E+00	1.17E-04
Zr-95	4.12E-08	1.30E-08	8.94E-09	0.00E+00	1.91E-08	0.00E+00	3.00E-05
Zr-97	2.37E-09	4.69E-10	2.16E-10	0.00E+00	7.11E-10	0.00E+00	1.27E-04
Nb-95	8.22E-09	4.56E-09	2.51E-09	0.00E+00	4.42E-09	0.00E+00	1.95E-05
Mo-99	0.00E+00	6.03E-06	1.15E-06	0.00E+00	1.38E-06	0.00E+00	1.08E-05
Tc-99M	3.32E-10	9.26E-10	1.20E-08	0.00E+00	1.38E-08	5.14E-10	6.08E-07

Table 3.2-11 (Cont.)  
Ingestion Dose Factor for Teenager (mrem/pCi ingested)

ISOTOPE	BONE	LIVER	WHOLE BODY	THYROID	KIDNEY	LUNG	GI-LLI
Tc-101	3.60E-10	5.12E-10	5.03E-09	0.00E+00	9.26E-09	3.12E-10	8.75E-17
Ru-103	2.55E-07	0.00E+00	1.09E-07	0.00E+00	8.99E-07	0.00E+00	2.13E-05
Ru-105	2.18E-08	0.00E+00	8.46E-09	0.00E+00	2.75E-07	0.00E+00	1.76E-05
Ru-106	3.92E-06	0.00E+00	4.94E-07	0.00E+00	7.56E-06	0.00E+00	1.88E-04
Ag-110M	2.05E-07	1.94E-07	1.18E-07	0.00E+00	3.70E-07	0.00E+00	5.45E-05
Te-125M	3.83E-06	1.38E-06	5.12E-07	1.07E-06	0.00E+00	0.00E+00	1.13E-05
Te-127M	9.67E-06	3.43E-06	1.15E-06	2.30E-06	3.92E-05	0.00E+00	2.41E-05
Te-127	1.58E-07	5.60E-08	3.40E-08	1.09E-07	6.40E-07	0.00E+00	1.22E-05
Te-129M	1.63E-05	6.05E-06	2.58E-06	5.26E-06	6.82E-05	0.00E+00	6.12E-05
Te-129	4.48E-08	1.67E-08	1.09E-08	3.20E-08	1.88E-07	0.00E+00	2.45E-07
Te-131M	2.44E-06	1.17E-06	9.76E-07	1.76E-06	1.22E-05	0.00E+00	9.39E-05
Te-131	2.79E-08	1.15E-08	8.72E-09	2.15E-08	1.22E-07	0.00E+00	2.29E-09
Te-132	3.49E-06	2.21E-06	2.08E-06	2.33E-06	2.12E-05	0.00E+00	7.00E-05
I-130	1.03E-06	2.98E-06	1.19E-06	2.43E-04	4.59E-06	0.00E+00	2.29E-06
I-131	5.85E-06	8.19E-06	4.40E-06	2.39E-03	1.41E-05	0.00E+00	1.62E-06
I-132	2.79E-07	7.30E-07	2.62E-07	2.46E-05	1.15E-06	0.00E+00	3.18E-07
I-133	2.01E-06	3.41E-06	1.04E-06	4.76E-04	5.98E-06	0.00E+00	2.58E-06
I-134	1.46E-07	3.87E-07	1.39E-07	6.45E-06	6.10E-07	0.00E+00	5.10E-09
I-135	6.10E-07	1.57E-06	5.82E-07	1.01E-04	2.48E-06	0.00E+00	1.74E-06
Cs-134	8.37E-05	1.97E-04	9.14E-05	0.00E+00	6.26E-05	2.39E-05	2.45E-06
Cs-136	8.59E-06	3.38E-05	2.27E-05	0.00E+00	1.84E-05	2.90E-06	2.72E-06
Cs-137	1.12E-04	1.49E-04	5.19E-05	0.00E+00	5.07E-05	1.97E-05	2.12E-06
Cs-138	7.76E-08	1.49E-07	7.45E-08	0.00E+00	1.10E-07	1.28E-08	6.76E-11
Ba-139	1.39E-07	9.78E-11	4.05E-09	0.00E+00	9.22E-11	6.74E-11	1.24E-06
Ba-140	2.84E-05	3.48E-08	1.83E-06	0.00E+00	1.18E-08	2.34E-08	4.38E-05
Ba-141	6.71E-08	5.01E-11	2.24E-09	0.00E+00	4.65E-11	3.43E-11	1.43E-13
Ba-142	2.99E-08	2.99E-11	1.84E-09	0.00E+00	2.53E-11	1.99E-11	9.18E-20
La-140	3.48E-09	1.71E-09	4.55E-10	0.00E+00	0.00E+00	0.00E+00	9.82E-05
La-142	1.79E-10	7.95E-11	1.98E-11	0.00E+00	0.00E+00	0.00E+00	2.42E-06
Ce-141	1.33E-08	8.88E-09	1.02E-09	0.00E+00	4.18E-09	0.00E+00	2.54E-05
Ce-143	2.35E-09	1.71E-06	1.91E-10	0.00E+00	7.67E-10	0.00E+00	5.14E-05
Ce-144	6.96E-07	2.88E-07	3.74E-08	0.00E+00	1.72E-07	0.00E+00	1.75E-04
Pr-143	1.31E-08	5.23E-09	6.52E-10	0.00E+00	3.04E-09	0.00E+00	4.31E-05
Pr-144	4.30E-11	1.76E-11	2.18E-12	0.00E+00	1.01E-11	0.00E+00	4.74E-14
Nd-147	9.38E-09	1.02E-08	6.11E-10	0.00E+00	5.99E-09	0.00E+00	3.68E-05
W-187	1.46E-07	1.19E-07	4.17E-08	0.00E+00	0.00E+00	0.00E+00	3.22E-05
Np-239	1.76E-09	1.66E-10	9.22E-11	0.00E+00	5.21E-10	0.00E+00	2.67E-05

Table 3.2-12  
Ingestion Dose Factors for Child (mrem/pCi ingested)

ISOTOPE	BONE	LIVER	WHOLE BODY	THYROID	KIDNEY	LUNG	G-LLI
H-3	0.00E+00	2.03E-07	2.03E-07	2.03E-07	2.03E-07	2.03E-07	2.03E-07
C-14	1.21E-05	2.42E-06	2.42E-06	2.42E-06	2.42E-06	2.42E-06	2.42E-06
Na-24	5.80E-06	5.80E-06	5.80E-06	5.80E-06	5.80E-06	5.80E-06	5.80E-06
P-32	8.25E-04	3.86E-05	3.18E-05	0.00E+00	0.00E+00	0.00E+00	2.28E-05
Cr-51	0.00E+00	0.00E+00	8.90E-09	4.94E-09	1.35E-09	9.02E-09	4.72E-07
Mn-54	0.00E+00	1.07E-05	2.85E-06	0.00E+00	3.00E-06	0.00E+00	8.98E-06
Mn-56	0.00E+00	3.34E-07	7.54E-08	0.00E+00	4.04E-07	0.00E+00	4.84E-05
Fe-55	1.15E-05	6.10E-06	1.89E-06	0.00E+00	0.00E+00	3.45E-06	1.13E-06
Fe-59	1.65E-05	2.87E-05	1.33E-05	0.00E+00	0.00E+00	7.74E-06	2.78E-05
Co-58	0.00E+00	1.80E-06	5.51E-06	0.00E+00	0.00E+00	0.00E+00	1.05E-05
Co-60	0.00E+00	5.29E-06	1.56E-05	0.00E+00	0.00E+00	0.00E+00	2.93E-05
Ni-63	5.38E-04	2.88E-05	1.83E-05	0.00E+00	0.00E+00	0.00E+00	1.94E-06
Ni-65	2.22E-06	2.09E-07	1.22E-07	0.00E+00	0.00E+00	0.00E+00	2.56E-05
Cu-64	0.00E+00	2.45E-07	1.48E-07	0.00E+00	5.92E-07	0.00E+00	1.15E-05
Zn-65	1.37E-05	3.65E-05	2.27E-05	0.00E+00	2.30E-05	0.00E+00	6.41E-06
Zn-69	4.38E-08	6.33E-08	5.85E-08	0.00E+00	3.84E-08	0.00E+00	3.99E-06
Br-83	0.00E+00	0.00E+00	1.71E-07	0.00E+00	0.00E+00	0.00E+00	0.00E+00
Br-84	0.00E+00	0.00E+00	1.98E-07	0.00E+00	0.00E+00	0.00E+00	0.00E+00
Br-85	0.00E+00	0.00E+00	9.12E-09	0.00E+00	0.00E+00	0.00E+00	0.00E+00
Rb-86	0.00E+00	6.70E-05	4.12E-05	0.00E+00	0.00E+00	0.00E+00	4.31E-06
Rb-88	0.00E+00	1.90E-07	1.32E-07	0.00E+00	0.00E+00	0.00E+00	9.32E-09
Rb-89	0.00E+00	1.17E-07	1.04E-07	0.00E+00	0.00E+00	0.00E+00	1.02E-09
Sr-89	1.32E-03	0.00E+00	3.77E-05	0.00E+00	0.00E+00	0.00E+00	5.11E-05
Sr-90	1.70E-02	0.00E+00	4.31E-03	0.00E+00	0.00E+00	0.00E+00	2.29E-04
Sr-91	2.40E-05	0.00E+00	9.06E-07	0.00E+00	0.00E+00	0.00E+00	5.30E-05
Sr-92	9.03E-06	0.00E+00	3.62E-07	0.00E+00	0.00E+00	0.00E+00	1.71E-04
Y-90	4.11E-08	0.00E+00	1.10E-09	0.00E+00	0.00E+00	0.00E+00	1.17E-04
Y-91M	3.82E-10	0.00E+00	1.39E-11	0.00E+00	0.00E+00	0.00E+00	7.48E-07
Y-91	6.02E-07	0.00E+00	1.61E-08	0.00E+00	0.00E+00	0.00E+00	8.02E-05
Y-92	3.60E-09	0.00E+00	1.03E-10	0.00E+00	0.00E+00	0.00E+00	1.04E-04
Y-93	1.14E-08	0.00E+00	3.13E-10	0.00E+00	0.00E+00	0.00E+00	1.70E-04
Zr-95	1.18E-07	2.55E-08	2.27E-08	0.00E+00	3.65E-08	0.00E+00	2.66E-05
Zr-97	6.99E-09	1.01E-09	5.96E-10	0.00E+00	1.45E-09	0.00E+00	1.53E-04
Nb-95	2.25E-08	8.78E-09	6.26E-09	0.00E+00	8.23E-09	0.00E+00	1.82E-05
Mo-99	0.00E+00	1.33E-05	3.29E-06	0.00E+00	2.84E-05	0.00E+00	1.10E-05
Tc-99M	9.23E-10	1.81E-09	3.00E-08	0.00E+00	2.63E-08	9.19E-10	1.03E-06

Table 3.2-12 (Cont.)  
Ingestion Dose Factors for Child (mrem/pCi ingested)

ISOTOPE	BONE	LIVER	WHOLE BODY	THYROID	KIDNEY	LUNG	GI-LLI
Tc-101	1.07E-09	1.12E-09	1.42E-08	0.00E+00	1.91E-08	5.92E-10	3.58E-09
Ru-103	7.31E-07	0.00E+00	2.81E-07	0.00E+00	1.84E-06	0.00E+00	1.89E-05
Ru-105	6.45E-08	0.00E+00	2.34E-08	0.00E+00	5.67E-07	0.00E+00	4.21E-05
Ru-106	1.17E-05	0.00E+00	1.46E-06	0.00E+00	1.58E-05	0.00E+00	1.82E-04
Ag-110M	5.39E-07	3.64E-07	2.91E-07	0.00E+00	6.78E-07	0.00E+00	4.33E-05
Te-125M	1.14E-05	3.09E-06	1.52E-06	3.20E-06	0.00E+00	0.00E+00	1.10E-05
Te-127M	2.89E-05	7.78E-06	3.43E-06	6.91E-06	8.24E-05	0.00E+00	2.34E-05
Te-127	4.71E-07	1.27E-07	1.01E-07	3.26E-07	1.34E-06	0.00E+00	1.84E-05
Te-129M	4.87E-05	1.36E-05	7.56E-06	1.57E-05	1.43E-04	0.00E+00	5.94E-05
Te-129	1.34E-07	3.74E-08	3.18E-08	9.58E-08	3.92E-07	0.00E+00	8.34E-08
Te-131M	7.20E-06	2.49E-06	2.65E-06	5.12E-06	2.41E-05	0.00E+00	1.01E-04
Te-131	8.30E-08	2.53E-08	2.47E-08	6.35E-08	2.51E-07	0.00E+00	4.36E-07
Te-132	1.01E-05	4.47E-06	5.40E-06	6.51E-06	4.15E-05	0.00E+00	4.50E-05
I-130	2.92E-06	5.90E-06	3.04E-06	6.50E-04	8.82E-06	0.00E+00	2.76E-06
I-131	1.72E-05	1.73E-05	9.83E-06	5.72E-03	2.84E-05	0.00E+00	1.54E-06
I-132	8.00E-07	1.47E-06	6.76E-07	6.82E-05	2.25E-06	0.00E+00	1.73E-06
I-133	5.92E-06	7.32E-06	2.77E-06	1.36E-03	1.22E-05	0.00E+00	2.95E-06
I-134	4.19E-07	7.78E-07	3.58E-07	1.79E-05	1.19E-06	0.00E+00	5.16E-07
I-135	1.75E-06	3.15E-06	1.49E-06	2.79E-04	4.83E-06	0.00E+00	2.40E-06
Cs-134	2.34E-04	3.84E-04	8.10E-05	0.00E+00	1.19E-04	4.27E-05	2.07E-06
Cs-136	2.35E-05	6.46E-05	4.18E-05	0.00E+00	3.44E-05	5.13E-06	2.27E-06
Cs-137	3.27E-04	3.13E-04	4.62E-05	0.00E+00	1.02E-04	3.67E-05	1.96E-06
Cs-138	2.28E-07	3.17E-07	2.01E-07	0.00E+00	2.23E-07	2.40E-08	1.46E-07
Ba-139	4.14E-07	2.21E-10	1.20E-08	0.00E+00	1.93E-10	1.30E-10	2.39E-05
Ba-140	8.31E-05	7.28E-08	4.85E-06	0.00E+00	2.37E-08	4.34E-08	4.21E-05
Ba-141	2.00E-07	1.12E-10	6.51E-09	0.00E+00	9.69E-11	6.58E-10	1.14E-07
Ba-142	8.74E-08	6.29E-11	4.88E-09	0.00E+00	5.09E-11	3.70E-11	1.14E-09
La-140	1.01E-08	3.53E-09	1.19E-09	0.00E+00	0.00E+00	0.00E+00	9.84E-05
La-142	5.24E-10	1.67E-10	5.23E-11	0.00E+00	0.00E+00	0.00E+00	3.31E-05
Ce-141	3.97E-08	1.98E-08	2.94E-09	0.00E+00	8.68E-09	0.00E+00	2.47E-05
Ce-143	6.99E-09	3.79E-06	5.49E-10	0.00E+00	1.59E-09	0.00E+00	5.55E-05
Ce-144	2.08E-06	6.52E-07	1.11E-07	0.00E+00	3.61E-07	0.00E+00	1.70E-04
Pr-143	3.93E-08	1.18E-08	1.95E-09	0.00E+00	6.39E-09	0.00E+00	4.24E-05
Pr-144	1.29E-10	3.99E-11	6.49E-12	0.00E+00	2.11E-11	0.00E+00	8.59E-08
Nd-147	2.79E-08	2.26E-08	1.75E-09	0.00E+00	1.24E-08	0.00E+00	3.58E-05
W-187	4.29E-07	2.54E-07	1.14E-07	0.00E+00	0.00E+00	0.00E+00	3.57E-05
Np-239	5.25E-09	3.77E-10	2.65E-10	0.00E+00	1.09E-09	0.00E+00	2.79E-05

Table 3.2-13  
Ingestion Dose Factors for Infant (mrem/pCi ingested)

ISOTOPE	BONE	LIVER	WHOLE BODY	THYROID	KIDNEY	LUNG	GI-LLI
H-3	0.00E+00	3.08E-07	3.08E-07	3.08E-07	3.08E-07	3.08E-07	3.08E-07
C-14	2.37E-05	5.06E-06	5.06E-06	5.06E-06	5.06E-06	5.06E-06	5.06E-06
Na-24	1.01E-05	1.01E-05	1.01E-05	1.01E-05	1.01E-05	1.01E-05	1.01E-05
P-32	1.70E-03	1.00E-04	6.59E-05	0.00E+00	0.00E+00	0.00E+00	2.30E-05
Cr-51	0.00E+00	0.00E+00	1.41E-08	9.20E-09	2.01E-09	1.79E-08	4.11E-07
Mn-54	0.00E+00	1.99E-05	4.51E-06	0.00E+00	4.41E-06	0.00E+00	7.31E-06
Mn-56	0.00E+00	8.18E-07	1.41E-07	0.00E+00	7.03E-07	0.00E+00	7.43E-05
Fe-55	1.39E-05	8.98E-06	2.40E-06	0.00E+00	0.00E+00	4.39E-06	1.14E-06
Fe-59	3.08E-05	5.38E-05	2.12E-05	0.00E+00	0.00E+00	1.59E-05	2.57E-05
Co-58	0.00E+00	3.60E-06	8.98E-06	0.00E+00	0.00E+00	0.00E+00	8.97E-06
Co-60	0.00E+00	1.08E-05	2.55E-05	0.00E+00	0.00E+00	0.00E+00	2.57E-05
Ni-63	6.34E-04	3.92E-05	2.20E-05	0.00E+00	0.00E+00	0.00E+00	1.95E-06
Ni-65	4.70E-06	5.32E-07	2.42E-07	0.00E+00	0.00E+00	0.00E+00	4.05E-05
Cu-64	0.00E+00	6.09E-07	2.82E-07	0.00E+00	1.03E-06	0.00E+00	1.25E-05
Zn-65	1.84E-05	6.31E-05	2.91E-05	0.00E+00	3.06E-05	0.00E+00	5.33E-05
Zn-69	9.33E-08	1.68E-07	1.25E-08	0.00E+00	6.98E-08	0.00E+00	1.37E-05
Br-83	0.00E+00	0.00E+00	3.63E-07	0.00E+00	0.00E+00	0.00E+00	0.00E+00
Br-84	0.00E+00	0.00E+00	3.82E-07	0.00E+00	0.00E+00	0.00E+00	0.00E+00
Br-85	0.00E+00	0.00E+00	1.94E-08	0.00E+00	0.00E+00	0.00E+00	0.00E+00
Rb-86	0.00E+00	1.70E-04	8.40E-05	0.00E+00	0.00E+00	0.00E+00	4.35E-06
Rb-88	0.00E+00	4.98E-07	2.73E-07	0.00E+00	0.00E+00	0.00E+00	4.85E-07
Rb-89	0.00E+00	2.86E-07	1.97E-07	0.00E+00	0.00E+00	0.00E+00	9.74E-08
Sr-89	2.51E-03	0.00E+00	7.20E-05	0.00E+00	0.00E+00	0.00E+00	5.16E-05
Sr-90	1.85E-02	0.00E+00	4.71E-03	0.00E+00	0.00E+00	0.00E+00	2.31E-04
Sr-91	5.00E-05	0.00E+00	1.81E-06	0.00E+00	0.00E+00	0.00E+00	5.92E-05
Sr-92	1.92E-05	0.00E+00	7.13E-07	0.00E+00	0.00E+00	0.00E+00	2.07E-04
Y-90	8.69E-08	0.00E+00	2.33E-09	0.00E+00	0.00E+00	0.00E+00	1.20E-04
Y-91M	8.10E-10	0.00E+00	2.76E-11	0.00E+00	0.00E+00	0.00E+00	2.70E-06
Y-91	1.13E-06	0.00E+00	3.01E-08	0.00E+00	0.00E+00	0.00E+00	8.10E-05
Y-92	7.65E-09	0.00E+00	2.15E-10	0.00E+00	0.00E+00	0.00E+00	1.46E-04
Y-93	2.43E-08	0.00E+00	6.62E-10	0.00E+00	0.00E+00	0.00E+00	1.92E-04
Zr-95	2.06E-07	5.02E-08	3.56E-08	0.00E+00	5.41E-08	0.00E+00	2.50E-05
Zr-97	1.48E-08	2.54E-09	1.16E-09	0.00E+00	2.56E-09	0.00E+00	1.62E-04
Nb-95	4.20E-08	1.73E-08	1.00E-08	0.00E+00	1.24E-08	0.00E+00	1.46E-05
Mo-99	0.00E+00	3.40E-05	6.63E-06	0.00E+00	5.08E-05	0.00E+00	1.12E-05
Tc-99M	1.92E-09	3.96E-09	5.10E-08	0.00E+00	4.26E-08	2.07E-09	1.15E-06



Table 3.2-13 (Cont.)  
Ingestion Dose Factors for Infant

ISOTOPE	BONE	LIVER	WHOLE BODY	THYROID	KIDNEY	LUNG	GI-LLI
Tc-101	2.27E-09	2.86E-09	2.83E-08	0.00E+00	3.40E-08	1.56E-09	4.86E-07
Ru-103	1.48E-06	0.00E+00	4.95E-07	0.00E+00	3.08E-06	0.00E+00	1.80E-05
Ru-105	1.36E-07	0.00E+00	4.58E-08	0.00E+00	1.00E-06	0.00E+00	5.41E-05
Ru-106	2.41E-05	0.00E+00	3.01E-06	0.00E+00	2.85E-05	0.00E+00	1.83E-04
Ag-110M	9.96E-07	7.27E-07	4.81E-07	0.00E+00	1.04E-06	0.00E+00	3.77E-05
Te-125M	2.33E-05	7.79E-06	3.15E-06	7.84E-06	0.00E+00	0.00E+00	1.11E-05
Te-127M	5.85E-05	1.94E-05	7.08E-06	1.69E-05	1.44E-04	0.00E+00	2.36E-05
Te-127	1.00E-06	3.35E-07	2.15E-07	8.14E-07	2.44E-06	0.00E+00	2.10E-05
Te-129M	1.00E-04	3.43E-05	1.54E-05	3.84E-05	2.50E-04	0.00E+00	5.97E-05
Te-129	2.84E-07	9.79E-08	6.63E-08	2.38E-07	7.07E-07	0.00E+00	2.27E-05
Te-131M	1.52E-05	6.12E-06	5.05E-06	1.24E-05	4.21E-05	0.00E+00	1.03E-04
Te-131	1.76E-07	6.50E-08	4.94E-08	1.57E-07	4.50E-07	0.00E+00	7.11E-06
Te-132	2.08E-05	1.03E-05	9.61E-06	1.52E-05	6.44E-05	0.00E+00	3.81E-05
I-130	6.00E-06	1.32E-05	5.30E-06	1.48E-03	1.45E-05	0.00E+00	2.83E-06
I-131	3.59E-05	4.23E-05	1.86E-05	1.39E-02	4.94E-05	0.00E+00	1.51E-06
I-132	1.66E-06	3.37E-06	1.20E-06	1.58E-04	3.76E-06	0.00E+00	2.73E-06
I-133	1.25E-05	1.82E-05	5.33E-06	3.31E-03	2.14E-05	0.00E+00	3.08E-06
I-134	8.69E-07	1.78E-06	6.33E-07	4.15E-05	1.99E-06	0.00E+00	1.84E-06
I-135	3.64E-06	7.24E-06	2.64E-06	6.49E-04	8.07E-06	0.00E+00	2.82E-06
Cs-134	3.77E-04	7.03E-04	7.10E-05	0.00E+00	1.81E-04	7.42E-05	1.91E-06
Cs-136	4.59E-05	1.35E-04	5.04E-05	0.00E+00	5.38E-05	1.10E-05	2.05E-06
Cs-137	5.22E-04	6.11E-04	4.33E-05	0.00E+00	1.64E-04	6.64E-05	1.91E-06
Cs-138	4.81E-07	7.82E-07	3.79E-07	0.00E+00	3.90E-07	6.09E-08	1.25E-06
Ba-139	8.81E-07	5.84E-10	2.55E-08	0.00E+00	3.51E-10	3.54E-10	5.58E-05
Ba-140	1.71E-04	1.71E-07	8.81E-06	0.00E+00	4.06E-08	1.05E-07	4.20E-05
Ba-141	4.25E-07	2.91E-10	1.34E-08	0.00E+00	1.75E-10	1.77E-10	5.19E-06
Ba-142	1.84E-07	1.53E-10	9.06E-09	0.00E+00	8.81E-11	9.26E-11	7.59E-07
La-140	2.11E-08	8.32E-09	2.14E-09	0.00E+00	0.00E+00	0.00E+00	9.77E-05
La-142	1.10E-09	4.04E-10	9.67E-11	0.00E+00	0.00E+00	0.00E+00	6.86E-05
Ce-141	7.87E-08	4.80E-08	5.65E-09	0.00E+00	1.48E-08	0.00E+00	2.48E-05
Ce-143	1.48E-08	9.82E-06	1.12E-09	0.00E+00	2.86E-09	0.00E+00	5.73E-05
Ce-144	2.98E-06	1.22E-06	1.67E-07	0.00E+00	4.93E-07	0.00E+00	1.71E-04
Pr-143	8.13E-08	3.04E-08	4.03E-09	0.00E+00	1.13E-08	0.00E+00	4.29E-05
Pr-144	2.74E-10	1.06E-10	1.38E-11	0.00E+00	3.84E-11	0.00E+00	4.93E-06
Nd-147	5.53E-08	5.68E-08	3.48E-09	0.00E+00	2.19E-08	0.00E+00	3.60E-05
W-187	9.03E-07	6.28E-07	2.17E-07	0.00E+00	0.00E+00	0.00E+00	3.69E-05
Np-239	1.11E-08	9.93E-10	5.61E-10	0.00E+00	1.98E-09	0.00E+00	2.87E-05

**Table 3.2-14**  
**Annual Usage Factors for the Maximum Exposed Individual**

<u>Pathway</u>	<u>Infant</u>	<u>Child</u>	<u>Teen Adult</u>		
Fruits, vegetables & grain (kg/yr)*	--	520	630	520	
Leafy vegetables(kg/yr)	--	26	42	64	
Milk (L/yr)	330	330	400	310	
Meat & poultry (kg/yr)	--	41	65	110	
Inhalation (m <sup>3</sup> /yr)	1400	3700	8000	8000	

\* Consists of the following (on a mass basis): 22% fruit, 54% vegetables (including leafy vegetables), and 24% grain.

**Table 3.2-15**  
**Annual Usage Factors for the Average Individual\*\***

<u>Pathway</u>	<u>Infant</u>	<u>Child</u>	<u>Teen Adult</u>		
Fruits, vegetables & grain (kg/yr)*	--	200	240	190	
Milk (L/yr)	--	170	200	110	
Meat & poultry (kg/yr)	--	37	59	95	
Inhalation (m <sup>3</sup> /yr)	--	3700	8000	8000	

\* Consists of the following (on a mass basis): 22% fruit, 54% vegetables (including leafy vegetables), and 24% grain.

\*\* For total population and average individual dose calculations.

Figure 3.2-1  
PNPP Site Boundary and Unrestricted Area

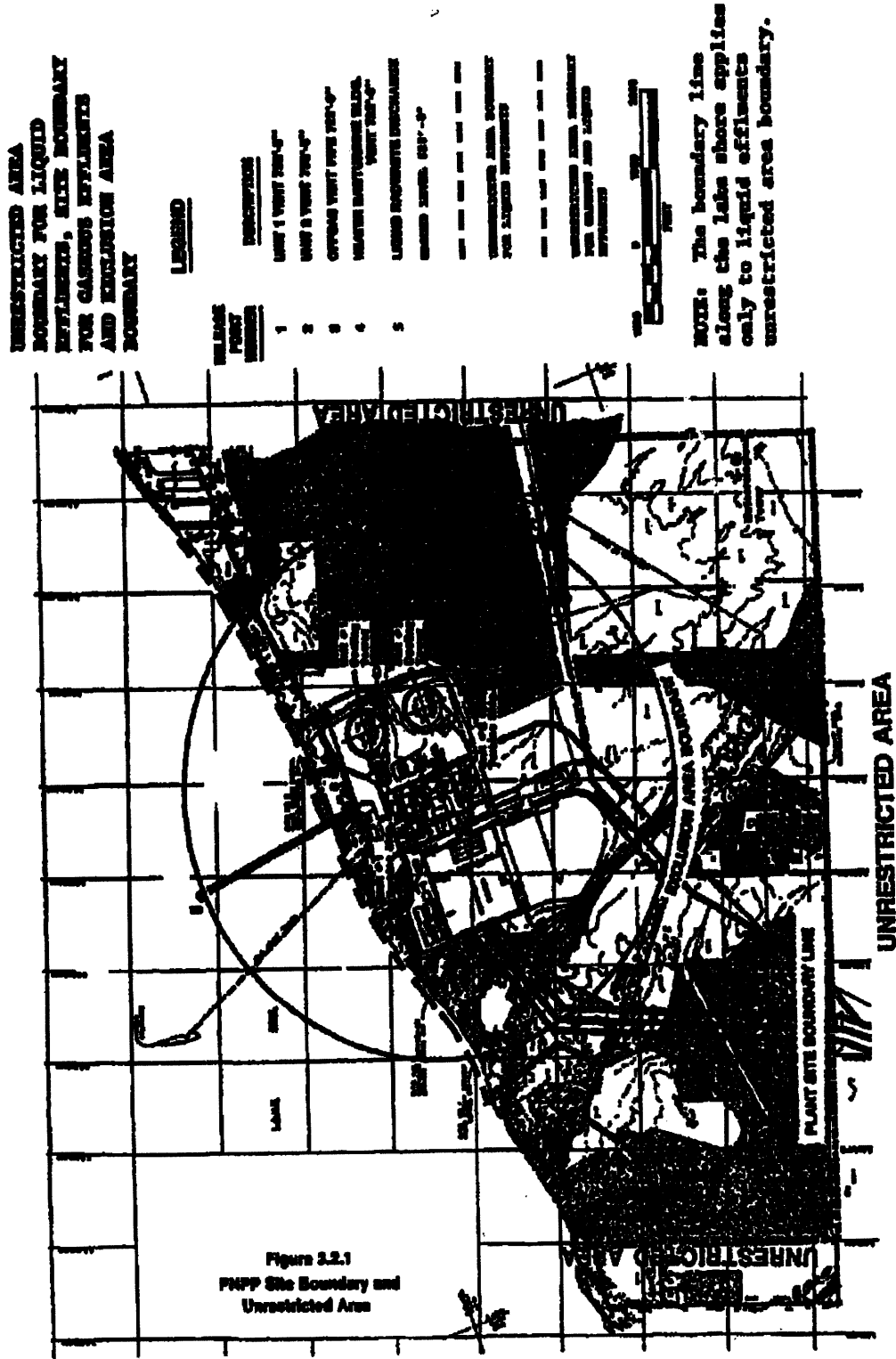

Figure 3.2.1  
PNPP Site Boundary and Unrestricted Area

### 3.3 10CFR50, Appendix I Compliance - Gaseous Effluent Dose

Doses resulting from the release of noble gases, radioiodines, tritium and radionuclides in particulate form must be calculated to show compliance with 10CFR50, Appendix I. The calculations will be performed at least monthly for all gaseous effluents.

#### 3.3.1 Noble Gases

10CFR50, Appendix I, Section II.B.1, limits the releases of gaseous effluents from each reactor to unrestricted areas such that the estimated annual gamma air dose is limited to 10 millirads and the beta air dose is limited to 20 millirads. The external dose pathway only will be considered for noble gases. The controlling location for the above stated dose limits is the nearest site boundary location for the period of release.

ODCM Appendix C controls limit the dose resulting from the release of noble gas radionuclides in gaseous effluents to the following:

- a. For gamma radiation, during the current quarter:

$$D_{\text{air}} \leq 5 \text{ mrad,}$$

- b. For beta radiation, during the current quarter:

$$D_{\text{air}} \leq 10 \text{ mrad,}$$

- c. For gamma radiation, during the current year:

$$D_{\text{air}} \leq 10 \text{ mrad,}$$

- d. For beta radiation, during the current year:

$$D_{\text{air}} \leq 20 \text{ mrad.}$$

#### 3.3.2 Radioiodines, Particulates, and Other Radionuclides

10CFR50, Appendix I, Section II.C, limits the annual release of radioiodines and radioactive materials in particulate form from each reactor such that estimated dose or dose commitment to an individual in an unrestricted area from all pathways of exposure is not in excess of 15 mrem to any organ. The controlling location for this organ dose limit is the nearest site boundary, the deposition (D/Q) for the period of release, and the receptor pathway. Receptor pathway locations will be reviewed once per year following the performance of the Land Use Census to include consideration of nearest residences, garden, and farm animal locations in each sector.

ODCM, Appendix C, CONTROLS limit the dose resultant from the release of iodine-131, iodine-133, tritium, and all radionuclides in particulate form with half-lives greater than eight days to the following:

- a. During the current quarter:  
Dose to Any Organ  $\leq$  7.5 mrem
- b. During the current year:  
Dose to Any Organ  $\leq$  15 mrem

### 3.3.3 Dose Calculations

The following calculations are used to determine gamma and beta air doses resultant from noble gas release to areas at or beyond the site boundary for purpose of showing compliance with 10CFR50, Appendix I. The equations used to calculate organ doses resultant from the release of iodine-131, iodine-133, tritium, and radionuclides in particulate form with half-lives greater than eight days are those found in Section 3.2.3.

Dose values are obtained by applying the dose rates over the appropriate surveillance or sampling time period.

- a. Gamma Air Dose from Noble Gas Releases

$$D_{air}^{\gamma} = (3.15 \times 10^1) \left( \frac{\chi}{Q} \right) \sum (Q_i) (DF_i^{\gamma})$$

Where:

- $D_{air}^{\gamma}$  = the annual gamma air dose due to noble gas radionuclides, mrad/yr;
- $DF_i^{\gamma}$  = the gamma air dose factor for a uniform semi-infinite cloud of radionuclide "i", from Table 3.3-1, (mrad m<sup>3</sup>)/(s Ci);
- $Q_i$  = the release rate of radionuclide "i",  $\mu$ Ci/s;
- $\chi/Q$  = the annual average dispersion factor (see Appendix A), s/m<sup>2</sup>;
- $3.15 \times 10^1$  = the conversion factor to convert (mrad\* $\mu$ Ci)/(Ci\*s) to mrad/yr.

b. Beta Air dose from Noble Gas Releases

$$D_{\text{air}}^{\beta} = (3.15 \times 10^1) \left( \frac{\chi}{Q} \right) \sum (Q_i) (DF_i^{\beta})$$

Where:

- $D_{\text{air}}^{\beta}$  = the annual beta air dose due to noble gas radionuclides, mrad/yr;
- $DF_i^{\beta}$  = the beta air dose factor for a uniform semi-infinite cloud of radionuclide "i", from Table 3.3-1, (mrad m<sup>3</sup>)/(Ci s);
- $Q_i$  = the release rate of radionuclide "i",  $\mu\text{Ci/s}$ ;
- $\chi/Q$  = the annual average dispersion factor (see Appendix A), s/m<sup>2</sup>;
- $3.15 \times 10^1$  = the conversion factor to convert (mrad\* $\mu\text{Ci}$ )/(Ci\*s) to mrad/yr.

3.3.4 Cumulation of Doses

The dose contribution from gaseous effluents will be calculated at least monthly. Calculations will be performed to determine the maximum air dose as well as the maximum organ dose to an individual. These dose calculations will be summed for comparison with quarterly and annual limits. To assure compliance with 10CFR50, Appendix I, the dose limits for air dose and organ dose are those found in Sections 3.3.1 and 3.3.2, respectively. The quarterly limits specified in those sections represent one half of the annual design objectives. If these limits are exceeded, a special report will be submitted to the NRC in accordance with ODCM Appendix C controls.

Table 3.3-1  
Gamma and Beta Air Dose Factors for Semi-Infinite Plume  
(mrad/s per Ci/m<sup>3</sup>)

	Gamma Air Dose Factor $\left( DF_i^{\gamma} \right)$	Beta Air Dose Factor $\left( DF_i^{\beta} \right)$
Ar-41	2.95E+02	1.04E+02
Kr-83m	6.12E-01	9.13E+00
Kr-85m	3.90E+01	6.24E+01
Kr-85	5.45E-01	6.18E+01
Kr-87	1.96E+02	3.27E+02
Kr-88	4.82E+02	9.29E+01
Kr-89	5.48E+02	3.36E+02
Kr-90	5.14E+02	2.48E+02
Xe-131m	4.95E+00	3.53E+01
Xe-133m	1.04E+01	4.69E+01
Xe-133	1.12E+01	3.33E+01
Xe-135m	1.07E+02	2.34E+01
Xe-135	6.09E+01	7.80E+01
Xe-137	4.79E+01	4.03E+02
Xe-138	2.92E+02	1.51E+02

### 3.3.5 Projection of Doses

Anticipated doses resulting from the release of gaseous effluents will be projected monthly. The doses calculated for the present month will be used as the projected doses unless information exists indicating that actual releases could differ significantly in the next month. In this case the source term will be adjusted to reflect this information and the justification for the adjustment noted.

If the sum of the projected doses for the 31-day period exceeds 0.3 mrem to any organ, appropriate portions of the ventilation exhaust treatment system will be operated to reduce releases. The values for the projected dose impact levels correspond to about one forty-eighth of the 10CFR50, Appendix I dose limits. If continued for a year, these values would correspond to less than one-fourth of the 10CFR50, Appendix I dose limits.

### 3.4 Population Dose

PNPP's Annual Radioactive Effluent Release Reports, as required by Regulatory Guide 1.21, will include total population dose and average individual doses calculated for all radioactive gaseous effluent releases. The total population dose and average individual dose will be computed, taking into account geographical population distribution and pathway(s) using the equations in Section 3.2. However, the dose factors,  $DF_{\text{airp}}$ , differ; total population and average individual doses are calculated in a manner similar to that used for maximum individuals except that Regulatory Guide 1.109, Revision 1, assumptions for average individuals are used rather than for maximum exposed individuals and they are averaged over all age groups after weighting by the fraction of population in each age group.

#### 4.0 TOTAL DOSE

##### 4.1 40CFR190 and 10CFR72.104 Compliance - Uranium Fuel Cycle Dose

Annual dose contributions from liquid and gaseous effluent releases, as discussed in Sections 2.3.2 and 3.3.4, are summed to evaluate compliance with the 40CFR190 and 10CFR72.104 annual limit of 25 mrem whole body or any organ (except the thyroid, which is 75 mrem).

PNPP does not intend to exceed 40CFR190 or 10CFR72.104 limits during normal operation. However, if such a situation should occur, violations would be handled as per ODCM Appendix C Control 3/4.11.4a. which requires the following:

With the calculated doses from the release of radioactive materials in liquid or gaseous effluents exceeding twice the limits of Control 3.11.1.2a., 3.11.1.2b., 3.11.2.2a., 3.11.2.2b., 3.11.2.3a. or 3.11.2.3b., calculations shall be made including direct radiation contributions from the reactor units, from the ISFSI and from outside storage tanks to determine whether the above limits of Control 3.11.4 have been exceeded. If such is the case, prepare and submit to the Commission within 30 days, pursuant to Control 6.9.2, a Special Report that defines the corrective action to be taken to reduce subsequent releases to prevent recurrence of exceeding the above limits and includes the schedule for achieving conformance with the above limits. This Special Report, as defined in 10CFR20.405c, shall include an analysis that estimates the radiation exposure (dose) to a MEMBER OF THE PUBLIC from uranium fuel cycle sources, including all effluent pathways and direct radiation, for the calendar year that includes the release(s) covered by this report. It shall also describe levels of radiation and concentrations of radioactive material involved, and the cause of the exposure levels or concentrations. If the estimated dose(s) exceeds the above limits, and if the release condition resulting in violation of 40CFR190 has not already been corrected, the Special Report shall include a request for a variance in accordance with the provisions of 40CFR190. Submittal of the report is considered a timely request, and a variance is granted until staff action on the request is complete.

This Special Report shall contain:

1. A determination of which fuel cycle facilities or operations, in addition to the nuclear power reactor unit(s) at the site, contribute to the annual dose to the maximum exposed individual. Nuclear fuel facilities over five miles from PNPP need not be considered in this determination.
2. A determination of the maximum exposed individual.
3. A determination of the total annual dose to this person from all existing pathways and sources of radioactive effluents and direct radiation using the methodologies described in this ODCM. Where additional information on pathways and nuclides is needed, the best available information will be used and documented.
4. A determination of the dose resulting from direct radiation from the plant and storage facilities, including the ISFSI.

The whole body and organ doses resulting from liquid effluents from the PNPP will be summed with the doses resulting from gaseous releases of noble gases, radiiodines, tritium, and particulates with half-lives greater than eight days when any of the dose limits outlined in Sections 2.3.2, 3.3.1 or 3.3.2 are exceeded by a factor of two. The doses from the PNPP will be summed with the dose to the maximum exposed individual contributed from other operations of the uranium fuel cycle.



#### 4.2 Direct Radiation Dose from PNPP (including the ISFSI)

Potential direct radiation dose to individuals outside PNPP will arise from (a) skyshine and direct dose from the turbines, (b) direct dose from the external surfaces of buildings, and (c) direct dose from stored radwaste.

Coolant activation by high energy neutrons, the  $O^{16}(n,p)N^{16}$  reaction, is of interest in boiling water reactors, like PNPP, because it can result in turbine skyshine and direct dose. The N-16 present in the steam of a direct cycle BWR is carried with the steam into the turbine moisture separators, and associated equipment. Although N-16 has a half-life of 7.13 seconds, its gamma emission can present a radiation dose problem to the site boundary as a result of the high energy gamma scatter from structures and the atmosphere.

All external walls of buildings at PNPP have been designed to attenuate radiation sources from within the plant to maximum of 0.5 mrem/h outside, with an expected radiation dose not to exceed 0.25 mrem/h.

Projected direct radiation dose assessment for normal operations was performed, based on 80% load factor and 100% occupancy, for the closest site boundary location (WSW sector). Direct dose from turbine skyshine was calculated to be 1.3 mrem/yr and direct dose from the surface of buildings was calculated to be 2.2 E-3 mrem/yr.

Direct radiation doses at PNPP will be measured by self-contained dosimeters encircling the site located in the general area of the site boundary. These self-contained dosimeters will be of the thermoluminescent variety (TLDs) with monitoring performed per Table 3.12.1-1, Radiological Environmental Monitoring Program.

October  
2017

#### 4.3 Dose to Members of the Public While Onsite

ODCM Appendix C Control 6.9.1.7 requires "assessment of the radiation doses from radioactive liquid and gaseous effluents to members of the public due to their activities inside the site boundary." This assessment is included in Annual Radioactive Effluent Release Reporting.

A member of the public is defined in ODCM Appendix C to include anyone who is not occupationally associated with the plant, i.e., not a utility employee, contractor or vendor. Also excluded from this category is any person who enters the site to service equipment or make deliveries.

Maximum dose to member of the public while onsite is conservatively assessed relative to offsite dose values. The assessment methodology incorporates use of appropriate dilution, dispersion, and occupancy factors for onsite activities.

The only liquid effluent dose pathway affecting members of the public while onsite is shore exposure, which is assumed to be fishing on the Lake Erie shoreline. Onsite dose assessment is made via ratio to the maximum calculated offsite shore exposure dose, using adjustments for occupancy factor and liquid effluent dilution.

Several cases are considered for gaseous effluent dose assessment to member of the public while onsite including: traversing a public road within the site boundary, lakeshore fishing, non-PNPP related training sessions at the Training and Education Center, car-pooling to the Primary Access Control Point (PACP) parking lot, and job applicant interviews. This evaluation is made using "relative  $\chi/Q$ " (atmospheric dispersion) values. "Relative  $\chi/Q$ " values are the product of the highest annual average  $\chi/Q$  for the point of concern, and occupancy factor for the case. The ratio of the highest onsite "relative  $\chi/Q$ " to the highest site boundary "relative  $\chi/Q$ " is used as an adjustment factor. (A unity occupancy factor is used in the determination of the highest site boundary "relative  $\chi/Q$ "). A conservative onsite dose determination is made by applying the "relative  $\chi/Q$ " adjustment factor for the highest potential onsite dose activity to the highest calculated gaseous effluent offsite dose.

## 5.0 RADIOLOGICAL ENVIRONMENTAL MONITORING PROGRAM

### 5.1 Monitoring Program

Environmental samples shall be collected and analyzed according to Table 3.12.1-1 at locations shown in Figures 5.1-1, 5.1-2 and 5.1-3. Analytical techniques used shall ensure that the detection capabilities in Table 4.12.1-1 are achieved.

October  
2017

Ground water sampling will not be conducted as part of PNPP's REMP because this source is not tapped for drinking or irrigation purposes in the area of the plant. The position of the plant and the underdrain system with respect to the hydraulic gradient is such that any leakage or overflow from the underdrain system will flow north towards Lake Erie. Local domestic wells outside the exclusion area boundary are up-gradient from the plant. As part of the REMP, samples will be routinely collected from the closest potable water intakes on Lake Erie.

The results of the radiological environmental monitoring program are intended to supplement the results of the radiological effluent monitoring by verifying that the measurable concentrations of radioactive materials and levels of radiation are not higher than expected on the basis of the effluent measurements and modeling of the environmental exposure pathways. Thus, the specified environmental monitoring program provides measurements of radiation and of radioactive materials in those exposure pathways and for those radionuclides which lead to the highest potential radiation exposures of individuals resulting from the station operation. The initial radiological environmental monitoring program was conducted for the first three years of commercial operation; program changes may now be proposed based on operational experience.

### 5.2 Land Use Census Program

A Land Use Census shall be conducted annually to identify, within a distance of 8 km (5 miles), the location in each of the meteorological sectors of the nearest residence, the nearest garden\* greater than 50m<sup>2</sup> (500 ft<sup>2</sup>) and the nearest milk-producing animal.

If a Land Use Census identifies a location(s) that yields a calculated dose or dose commitment (via the same exposure pathway) 20% greater than at the location from which samples are currently being obtained the new location(s) will be added to the radiological environmental monitoring program within 30 days. The sampling location(s), excluding the control station location, having the lowest calculated dose or dose commitment(s), via the same exposure pathway, may be deleted from this monitoring program after October 31 of the year in which this Land Use Census was conducted.

The Land Use Census shall be conducted during the growing season at least once per 12 months using that information that will provide the best results, such as by a door-to-door survey, aerial survey, general observations, or by consulting local agriculture authorities. The results of the Land Use Census shall be included in the Annual Radiological Environmental Operating Report.

- \* Broad leaf vegetation sampling of at least three different types of vegetation may be performed at the site boundary in each of two different sectors with the highest predicted D/Qs in lieu of the garden census. Specifications for broad leaf vegetation sampling in Table 3.12.1-1 shall be followed, including analysis of control samples.

**5.3 Inter-Laboratory Comparison Program**

The laboratories of the licensee and/or licensee's contractors which perform analyses shall participate in an Interlaboratory Comparison Program which has been approved by the Commission. This participation shall include all of the determinations (sample medium-radionuclide combinations) that are included in the monitoring program. The results of analysis of these comparison samples shall be included in the Annual Radiological Environmental Operating Report.

If the results of a determination in the comparison crosscheck program are outside the specified control limits, the laboratory shall investigate the cause of the problem and take steps to correct it. The results of this investigation and corrective action shall be included in the Annual Radiological Environmental Operating Report.

Table 5.1-1  
ODCM REMP Sample Locations

Location #	Description	Miles	Direction	Media <sup>(1)</sup>
1	Chapel Road	3.4	ENE	TLD, AIP
2	Kanda Garden	1.9	ENE	Broadleaf Vegetation
3	Meteorological Tower	1.0	SE	TLD
4	Site Boundary	0.7	S	TLD, AIP
5	Quincy Substation	0.6	SW	TLD
6	Concord Service Center	11.0	SSW	TLD, AIP
7	Site Boundary	0.6	NE	TLD, AIP
8	Site Boundary	0.8	E	TLD
9	Site Boundary	0.7	ESE	TLD
10	Site Boundary	0.8	SSE	TLD
11	Pamly Rd.	0.6	SSW	TLD
12	Site Boundary	0.6	WSW	TLD
13	Madison-on-the-Lake	4.7	ENE	TLD
14	Hubbard Rd.	4.9	E	TLD
15	Eagle St. Substation	5.1	ESE	TLD
16	Eubank Garden	0.9	S	Broadleaf Vegetation
20	Rainbow Farms	1.9	E	Broadleaf Vegetation
21	Hardy Rd.	5.1	WSW	TLD
23	High St. Substation	7.9	WSW	TLD
24	St. Clair Ave.	15.1	SW	TLD
25	Offshore - PNPP discharge	0.6	NNW	Fish
29	River Rd.	4.3	SSE	TLD
30	Lane Rd.	4.8	SSW	TLD
31	Wood and River Rd.	4.8	SE	TLD
32	Offshore - Mentor	15.8	WSW	Fish
33	River Rd.	4.5	S	TLD
35	Site Boundary	0.6	E	TLD, AIP
36	Lake County Water Plant	3.9	WSW	TLD, Drinking Water
37	Gerlica Farm	1.5	ENE	Broadleaf Vegetation
39	Painesville Purification Plant	8.3	W	Drinking Water
53	3715 Pamly Rd.	0.5	WSW	TLD
54	Hale Rd. School	4.6	SW	TLD
55	Center Rd.	2.5	S	TLD
56	Madison High School	4.0	ESE	TLD
57	Perry High School	1.7	S	TLD
58	Antioch Rd.	0.8	ENE	TLD
59	Lake Shoreline at Green Rd.	4.0	ENE	Surface Water
60	Lake Shoreline at Perry Park	1.0	WSW	Surface Water
66	Lake Shore Metropolitan Park	1.4	NE	Sediment
70	H&H Farm Stand	16.2	SSW	Broadleaf Vegetation

October 2017

October 2017

October 2017

October 2017

October 2017

October 2017

(1) AIP = Air, Iodine and Particulate  
TLD = Thermoluminescent Dosimeter

Figure 5.1-1  
ODCM REMP sample locations within two miles of PNPP

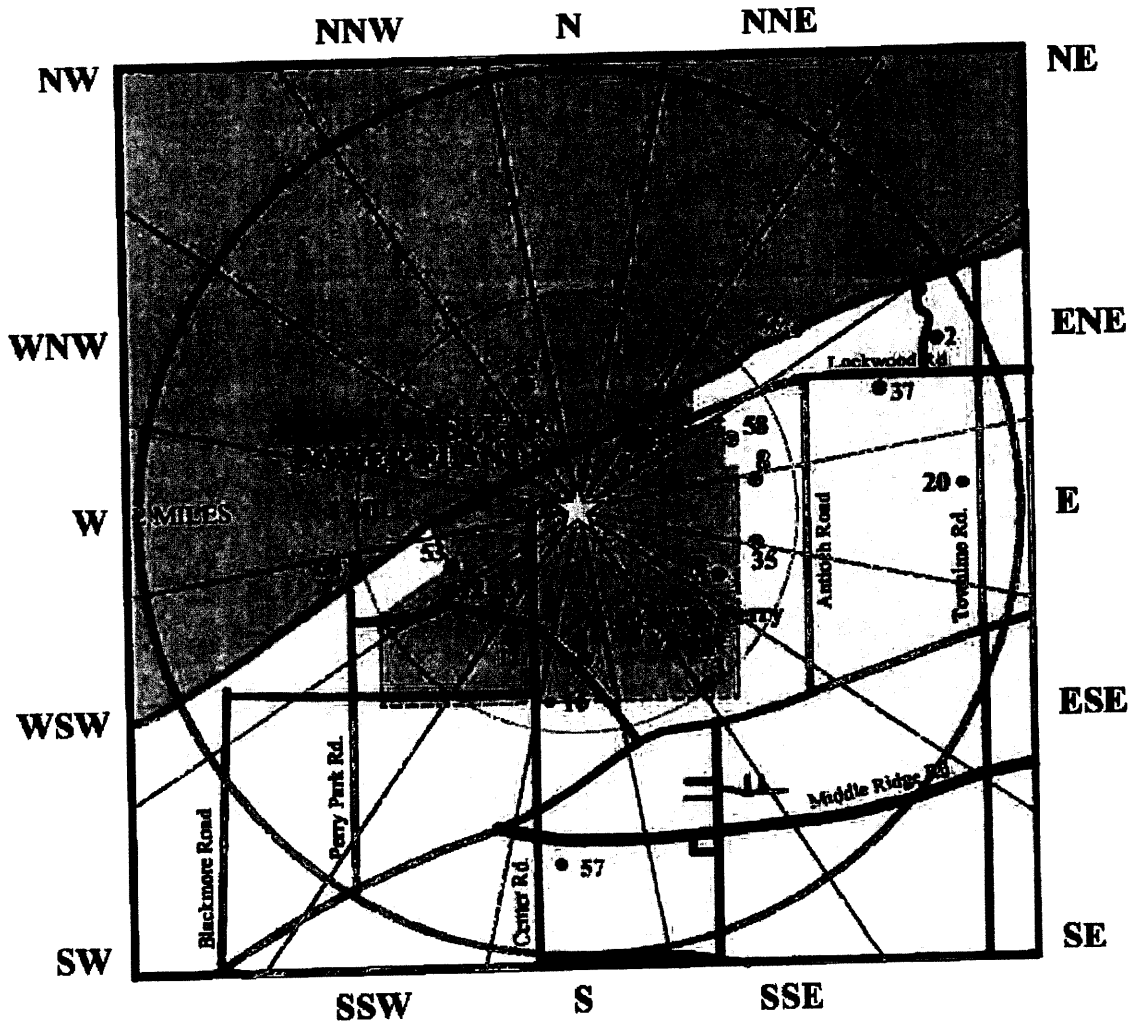

Updated October 2017

Figure 5.1-2

ODCM required REMP sample locations between two and eight miles of PNPP

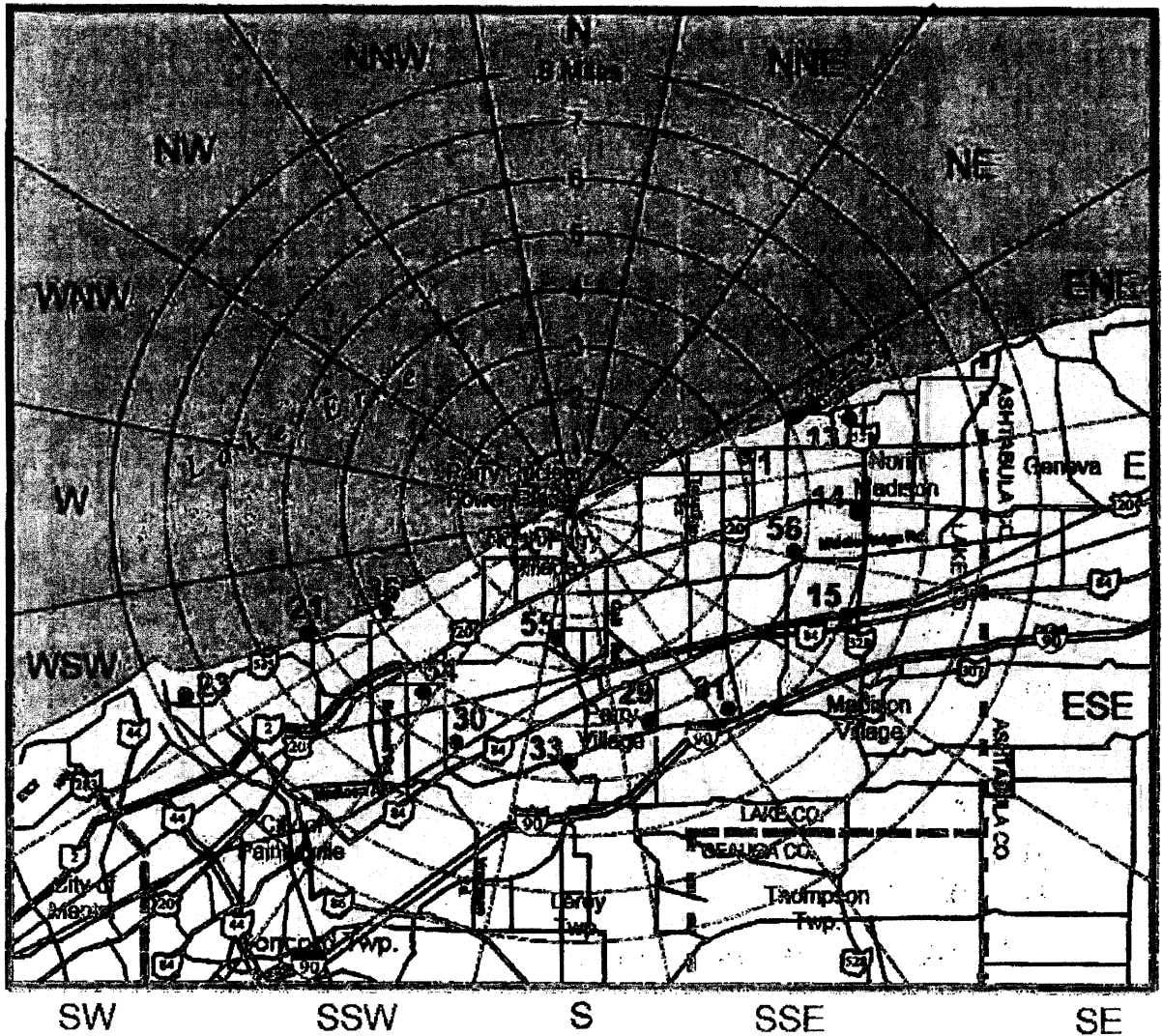

Updated October 2017





**APPENDIX A**  
**ATMOSPHERIC DISPERSION AND DEPOSITION PARAMETERS**

The atmospheric dispersion and deposition parameters used to calculate gaseous effluent doses will be calculated using the following equations. Dose calculations will be performed using meteorological conditions concurrent with the time of release of radioactive materials in gaseous effluents or using historical average atmospheric conditions. All atmospheric releases at PNPP are considered to be ground-level releases.

a. Constant Mean Wind Direction Relative Dispersion Factor

$$\chi/Q = \frac{(2.032)(T_F)}{(\bar{u})(x)(\sigma)} \quad (A-1)$$

Where:

- $\chi/Q$  = the annual average dispersion factor, s/m<sup>3</sup>;
- $T_F$  = the terrain correction factor, from FSAR Table 2.3-26, dimensionless;
- $\bar{u}$  = the wind speed (measured at 10m), in m/s;
- $X$  = the distance of calculation, in m;
- 2.032 =  $(2/\pi)^2$  divided by the width in radians of a 22.5° sector
- $\sigma$  = the lesser of  $\left(\sigma_z^2 + \frac{H_C^2}{2\pi}\right)^{1/2}$  or  $(\sigma_z)(3^{1/2})$

Where:

- $H_C$  = the building height (44.8m);
- $\sigma_z$  = the vertical dispersion coefficient, per Regulatory Guide 1.111, in m.

b. Depleted Relative Dispersion Factor

$$\chi/Q_d = (\chi/Q) (DPL_j) \quad (A-2)$$

Where:

- $\chi/Q_d$  = the depleted relative dispersion factor (for airborne halogens and particulates), in s/m<sup>3</sup>;
- $DPL_j$  = the ground depletion factor for the "j"th distance, interpolated from Table A-1, dimensionless;
- $\chi/Q$  = the annual average dispersion factor per equation A-1, s/m<sup>3</sup>.

c. Ground Deposition

$$D/Q = \frac{(DEP_j)(T_F)}{(0.3927)(x)} \quad (A-3)$$

Where:

- $D/Q$  = the relative deposition per unit area (for halogens and particulates), m<sup>-2</sup>;
- $DEP_j$  = the ground deposition factor for the "j"th distance, interpolated from Table A-1, m<sup>-1</sup>;
- $T_F$  = terrain correction factor, from FSAR Table 2.3-26, dimensionless;
- $x$  = the "j"th distance, m;
- 0.3927 = radians per 22.5° sector

**Table A-1**  
**Atmospheric Depletion and Deposition Factors**

		Depletion Factors (DPL)	Deposition Factors (DEP), m <sup>-1</sup>
Pasquill Stability	Class	All	All
Distance (meters)	200	0.970	1.25E-04
	500	0.938	8.0E-05
	1,000	0.900	5.4E-05
	2,000	0.860	3.2E-05
	3,000	0.832	2.6E-05
	6,000	0.770	1.5E-05
	10,000	0.714	9.9E-06
	30,000	0.590	4.5E-06
	50,000	0.517	3.0E-06
	80,000	0.440	2.0E-06

The following tables contain annual average atmospheric dispersion and deposition parameters for long-term releases at PNPP. Long-term releases are those that occur greater than 500 hours per year. The highest annual average relative concentration ( $\chi/Q$ ) value at the site boundary for sectors over land shall be used for radioactive gaseous effluent monitor setpoint calculations. The dispersion model used was XOQDOQ, with PNPP FSAR site-specific terrain adjustment factors included. Dispersion values are based on seven years of meteorological data (May 1, 1972 through April 30, 1974 and September 1, 1977 through August 31, 1982), ground-level releases, sector spread for purge calculations, and twelve wind speed classes.

Table A-2  
Site Boundary Atmospheric Dispersion ( $\chi/Q$ ) and Deposition  
Parameters (D/Q) for PNPP Unit 1

Sector	Distance (miles)	Distance (meters)	$\chi/Q$ (sec/m <sup>3</sup> )	D/Q (per m <sup>2</sup> )
N	0.18	294	5.7E-05*	1.6E-07
NNE	0.25	402	1.8E-05*	7.9E-08
NE	0.42	678	5.8E-06*	3.1E-08
ENE	0.67	1079	2.1E-06*	1.6E-08
E	0.67	1079	2.2E-06	1.8E-08
ESE	0.67	1079	1.6E-06	1.3E-08
SE	0.79	1271	1.4E-06	1.1E-08
SSE	0.82	1320	2.2E-06	1.4E-08
S	0.81	1304	2.7E-06	1.6E-08
SSW	0.80	1287	1.3E-06	6.8E-09
SW	0.65	1047	2.3E-06*	1.1E-08
WSW	0.56	900	4.2E-06*	1.5E-08
W	0.27	430	2.5E-05*	4.6E-08
WNW	0.18	283	5.9E-05*	8.4E-08
NW	0.17	273	6.6E-05*	1.1E-07
NNW	0.17	280	5.9E-05*	1.2E-07

October  
2017

**NOTE:** All  $\chi/Q$  and D/Q values are taken from the Updated Safety Analysis Report (USAR) Table 2.3-27. All marked values (\*) are from Unit 1 USAR values and the balance are Unit 2 values. In each case, the most conservative  $\chi/Q$  value is utilized.

Table A-3  
Atmospheric Dispersion ( $\gamma/Q$ ) as a Function of Distance ( $\sigma/m^3$ )

SECTOR	0.2 (MILES)	0.3 (MILES)	0.4 (MILES)	0.5 (MILES)	0.6 (MILES)
N	4.904E-05	2.453E-05	1.525E-05	1.057E-05	7.918E-06
NNE	2.656E-05	1.360E-05	8.640E-06	6.082E-06	4.612E-06
NE	1.859E-05	9.760E-06	6.293E-06	4.460E-06	3.383E-06
ENE	1.327E-05	7.129E-06	4.636E-06	3.293E-06	2.490E-06
E	1.363E-05	7.362E-06	4.760E-06	3.367E-06	2.538E-06
ESE	1.025E-05	5.566E-06	3.602E-06	2.547E-06	1.916E-06
SE	1.113E-05	6.061E-06	3.935E-06	2.788E-06	2.100E-06
SSE	1.894E-05	1.022E-05	6.647E-06	4.718E-06	3.560E-06
S	2.283E-05	1.227E-05	7.932E-06	5.615E-05	4.238E-06
SSW	1.142E-05	6.079E-06	3.925E-06	2.777E-06	2.097E-06
SW	1.449E-05	7.663E-06	4.928E-06	3.479E-06	2.622E-06
WSW	2.151E-05	1.111E-05	7.031E-06	4.934E-06	3.733E-06
W	4.184E-05	2.081E-05	1.281E-05	8.833E-06	6.606E-06
WNW	4.669E-05	2.298E-05	1.401E-05	9.573E-06	7.093E-06
NW	4.908E-05	2.423E-05	1.482E-05	1.015E-05	7.521E-06
NNW	4.580E-05	2.266E-05	1.390E-05	9.541E-06	7.083E-06
SECTOR	0.7 (MILES)	0.8 (MILES)	0.9 (MILES)	1.0 (MILES)	1.1 (MILES)
N	6.138E-06	4.968E-06	4.203E-06	3.636E-06	1.949E-06
NNE	3.622E-06	2.947E-06	2.481E-06	2.132E-06	1.278E-06
NE	2.662E-06	2.165E-06	1.815E-06	1.552E-06	9.269E-07
ENE	1.957E-06	1.588E-06	1.325E-06	1.129E-06	6.710E-07
E	1.991E-06	1.613E-06	1.343E-06	1.141E-06	6.768E-07
ESE	1.501E-06	1.215E-06	1.010E-06	8.571E-07	5.080E-07
SE	1.647E-06	1.334E-06	1.108E-06	9.402E-07	4.456E-07
SSE	2.796E-06	2.266E-06	1.885E-06	1.601E-06	5.524E-07
S	3.327E-06	2.697E-06	2.247E-06	1.911E-06	7.340E-07
SSW	1.646E-06	1.335E-06	1.114E-06	9.486E-07	5.223E-07
SW	2.053E-06	1.664E-06	1.391E-06	1.188E-06	5.667E-07
WSW	2.927E-06	2.380E-06	2.002E-06	1.719E-06	8.671E-07
W	5.110E-06	4.135E-06	3.504E-06	3.036E-06	1.630E-06
WNW	5.434E-06	4.378E-06	3.719E-06	3.235E-06	1.845E-06
NW	5.764E-06	4.643E-06	3.941E-06	3.425E-06	1.952E-06
NNW	5.439E-06	4.385E-06	3.720E-06	3.230E-06	1.839E-06

Table A-3 (Cont.)  
Atmospheric Dispersion ( $\gamma/Q$ ) as a Function of Distance ( $s/m^3$ )

SECTOR	1.2 (MILES)	1.3 (MILES)	1.4 (MILES)	1.5 (MILES)	1.6 (MILES)
N	1.729E-06	1.549E-06	1.399E-06	1.273E-06	1.166E-06
NNE	1.128E-06	1.006E-06	9.050E-07	8.202E-07	7.485E-07
NE	8.150E-07	7.243E-07	6.494E-07	5.867E-07	5.340E-07
ENE	5.878E-07	5.205E-07	4.652E-07	4.190E-07	3.803E-07
E	5.917E-07	5.230E-07	4.667E-07	4.197E-07	3.804E-07
ESE	4.437E-07	3.919E-07	3.494E-07	3.140E-07	2.843E-07
SE	3.891E-07	3.436E-07	3.062E-07	2.751E-07	2.491E-07
SSE	4.829E-07	4.267E-07	3.807E-07	3.423E-07	3.102E-07
S	6.424E-07	5.684E-07	5.076E-07	4.569E-07	4.145E-07
SSW	4.576E-07	4.054E-07	3.624E-07	3.266E-07	2.965E-07
SW	4.976E-07	4.417E-07	3.955E-07	3.570E-07	3.246E-07
WSW	7.648E-07	6.814E-07	6.125E-07	5.547E-07	5.060E-07
W	1.448E-06	1.299E-06	1.175E-06	1.070E-06	9.809E-07
WNW	1.644E-06	1.479E-06	1.341E-06	1.224E-06	1.124E-06
NW	1.733E-06	1.563E-06	1.416E-06	1.292E-06	1.186E-06
NNW	1.637E-06	1.471E-06	1.332E-06	1.214E-06	1.115E-06

SECTOR	1.7 (MILES)	1.8 (MILES)	1.9 (MILES)	2.0 (MILES)	2.1 (MILES)
N	1.074E-06	9.931E-07	9.226E-07	8.604E-07	8.052E-07
NNE	6.867E-07	6.331E-07	5.884E-07	5.453E-07	5.090E-07
NE	4.886E-07	4.494E-07	4.153E-07	3.854E-07	3.263E-07
ENE	3.471E-07	3.184E-07	2.938E-07	2.718E-07	2.526E-07
E	3.467E-07	3.177E-07	2.925E-07	2.705E-07	2.283E-07
ESE	2.590E-07	2.371E-07	2.182E-07	2.017E-07	1.871E-07
SE	2.268E-07	2.076E-07	1.910E-07	1.765E-07	1.637E-07
SSE	2.827E-07	2.590E-07	2.384E-07	2.205E-07	1.407E-07
S	3.780E-07	3.466E-07	3.194E-07	2.955E-07	1.373E-07
SSW	2.706E-07	2.484E-07	2.290E-07	2.121E-07	1.409E-07
SW	2.968E-07	2.727E-07	2.518E-07	2.335E-07	2.173E-07
WSW	4.639E-07	4.275E-07	3.957E-07	3.678E-07	5.303E-07
W	9.037E-07	8.365E-07	7.777E-07	7.258E-07	1.050E-06
WNW	1.038E-06	9.622E-07	8.960E-07	8.375E-07	1.142E-06
NW	1.095E-06	1.015E-06	9.445E-07	8.826E-07	8.275E-07
NNW	1.028E-06	9.527E-07	8.865E-07	8.281E-07	7.761E-07

Table A-3 (Cont.)  
Atmospheric Dispersion ( $\gamma/Q$ ) as a Function of Distance ( $s/m^3$ )

SECTOR	2.2 (MILES)	2.3 (MILES)	2.4 (MILES)	2.5 (MILES)	2.6 (MILES)
N	7.580E-07	7.118E-07	6.720E-07	6.359E-07	6.033E-07
NNE	4.766E-07	4.477E-07	4.217E-07	3.982E-07	3.770E-07
NE	3.050E-07	2.859E-07	2.688E-07	2.534E-07	2.395E-07
ENE	2.356E-07	2.205E-07	2.069E-07	1.947E-07	1.837E-07
E	2.127E-07	1.988E-07	1.864E-07	1.752E-07	1.652E-07
ESE	1.743E-07	1.628E-07	1.525E-07	1.433E-07	1.351E-07
SE	1.524E-07	1.424E-07	1.334E-07	1.253E-07	1.181E-07
SSE	1.311E-07	1.225E-07	1.149E-07	1.080E-07	1.018E-07
S	1.280E-07	1.197E-07	1.123E-07	1.056E-07	9.963E-08
SSW	1.314E-07	1.230E-07	1.154E-07	1.087E-07	1.025E-07
SW	2.030E-07	1.902E-07	1.787E-07	1.683E-07	1.590E-07
WSW	4.964E-07	4.661E-07	4.388E-07	4.142E-07	3.920E-07
W	9.867E-07	9.296E-07	8.780E-07	8.313E-07	7.891E-07
WNW	1.075E-06	1.014E-06	9.587E-07	9.088E-07	8.636E-07
NW	7.782E-07	7.339E-07	6.939E-07	6.576E-07	6.247E-07
NNW	7.297E-07	6.879E-07	6.502E-07	6.161E-07	5.852E-07

SECTOR	2.7 (MILES)	2.8 (MILES)	2.9 (MILES)	3.0 (MILES)	3.1 (MILES)
N	5.734E-07	5.480E-07	5.208E-07	4.976E-07	4.762E-07
NNE	3.578E-07	3.398E-07	3.235E-07	3.086E-07	2.948E-07
NE	2.268E-07	2.152E-07	2.046E-07	1.949E-07	1.859E-07
ENE	1.737E-07	1.645E-07	1.562E-07	1.485E-07	1.415E-07
E	1.580E-07	1.477E-07	1.401E-07	1.331E-07	1.267E-07
ESE	1.275E-07	1.207E-07	1.144E-07	1.087E-07	9.399E-08
SE	1.115E-07	1.064E-07	9.996E-08	9.493E-08	9.031E-08
SSE	9.613E-08	9.099E-08	8.630E-08	8.200E-08	7.805E-08
S	9.415E-08	8.917E-08	8.462E-08	8.044E-08	7.661E-08
SSW	9.697E-08	9.189E-08	8.725E-08	8.299E-08	7.907E-08
SW	1.505E-07	1.428E-07	1.357E-07	1.291E-07	1.231E-07
WSW	3.716E-07	3.531E-07	3.360E-07	3.204E-07	2.520E-07
W	7.503E-07	7.147E-07	6.820E-07	6.519E-07	5.874E-07
WNW	8.220E-07	7.838E-07	7.487E-07	7.164E-07	7.722E-07
NW	5.945E-07	5.668E-07	5.413E-07	5.178E-07	5.412E-07
NNW	5.587E-07	5.307E-07	5.067E-07	4.846E-07	4.642E-07

Table A-3 (Cont.)  
Atmospheric Dispersion ( $\gamma/Q$ ) as a Function of Distance ( $s/m^3$ )

SECTOR	3.2 (MILES)	3.3 (MILES)	3.4 (MILES)	3.5 (MILES)	3.6 (MILES)
N	4.563E-07	4.379E-07	4.208E-07	4.047E-07	3.899E-07
NNE	2.820E-07	2.702E-07	2.592E-07	2.489E-07	2.395E-07
NE	1.777E-07	1.700E-07	1.629E-07	1.562E-07	1.501E-07
ENE	1.350E-07	1.290E-07	1.234E-07	1.182E-07	1.135E-07
E	1.208E-07	1.154E-07	1.103E-07	1.056E-07	1.013E-07
ESE	8.958E-08	8.550E-08	8.173E-08	7.821E-08	7.499E-08
SE	8.606E-08	8.213E-08	7.849E-08	7.510E-08	7.200E-08
SSE	7.441E-08	7.105E-08	6.794E-08	6.503E-08	6.237E-08
S	7.307E-08	6.980E-08	6.678E-08	6.395E-08	6.136E-08
SSW	7.546E-08	7.212E-08	6.902E-08	6.613E-08	6.348E-08
SW	1.176E-07	1.125E-07	1.077E-07	1.033E-07	9.922E-08
WSW	2.410E-07	2.308E-07	2.214E-07	2.125E-07	2.044E-07
W	5.631E-07	5.406E-07	5.196E-07	4.999E-07	4.818E-07
WNW	7.409E-07	7.118E-07	6.848E-07	6.593E-07	6.359E-07
NW	5.192E-07	4.987E-07	4.797E-07	4.618E-07	4.454E-07
NNW	4.452E-07	4.276E-07	4.112E-07	3.958E-07	3.817E-07
SECTOR	3.7 (MILES)	3.8 (MILES)	3.9 (MILES)	4.0 (MILES)	4.1 (MILES)
N	3.759E-07	3.628E-07	3.504E-07	3.388E-07	2.981E-07
NNE	2.306E-07	2.222E-07	2.144E-07	2.070E-07	1.819E-07
NE	1.444E-07	1.390E-07	1.339E-07	1.292E-07	1.247E-07
ENE	1.090E-07	1.048E-07	1.009E-07	9.718E-08	9.373E-08
E	9.722E-08	9.342E-08	8.987E-08	8.653E-08	8.341E-08
ESE	7.196E-08	6.912E-08	6.647E-08	6.399E-08	6.166E-08
SE	6.908E-08	6.635E-08	6.380E-08	6.140E-08	5.378E-08
SSE	5.987E-08	5.753E-08	5.533E-08	5.328E-08	5.135E-08
S	5.892E-08	5.664E-08	5.451E-08	5.251E-08	5.063E-08
SSW	6.098E-08	5.865E-08	5.646E-08	5.441E-08	5.248E-08
SW	9.537E-08	9.178E-08	8.841E-08	8.525E-08	8.228E-08
WSW	1.967E-07	1.896E-07	1.828E-07	1.765E-07	1.462E-07
W	4.646E-07	4.485E-07	4.334E-07	4.191E-07	3.043E-07
WNW	6.137E-07	6.929E-07	5.733E-07	5.548E-07	4.180E-07
NW	4.298E-07	4.151E-07	4.013E-07	3.883E-07	3.761E-07
NNW	3.682E-07	3.556E-07	3.438E-07	3.326E-07	2.928E-07



Table A-3 (Cont.)  
Atmospheric Dispersion ( $\gamma/Q$ ) as a Function of Distance ( $s/m^3$ )

SECTOR	4.2 (MILES)	4.3 (MILES)	4.4 (MILES)	4.5 (MILES)	4.6 (MILES)
N	2.887E-07	2.798E-07	2.714E-07	2.634E-07	2.559E-07
NNE	1.759E-07	1.703E-07	1.650E-07	1.599E-07	1.552E-07
NE	1.205E-07	1.166E-07	1.128E-07	1.093E-07	1.059E-07
ENE	9.047E-08	8.740E-08	8.451E-08	8.176E-08	7.921E-08
E	8.046E-08	7.769E-08	7.508E-08	7.260E-08	7.030E-08
ESE	5.946E-08	5.740E-08	5.545E-08	5.361E-08	5.189E-08
SE	5.186E-08	5.005E-08	4.835E-08	4.673E-08	4.523E-08
SSE	4.954E-08	4.783E-08	4.622E-08	4.469E-08	4.327E-08
S	4.886E-08	4.719E-08	4.562E-08	4.413E-08	4.274E-08
SSW	5.067E-08	4.896E-08	4.735E-08	4.581E-08	4.439E-08
SW	7.948E-08	7.684E-08	7.435E-08	7.198E-08	6.978E-08
WSW	1.413E-07	1.368E-07	1.325E-07	1.284E-07	1.246E-07
W	2.948E-07	2.858E-07	2.773E-07	2.691E-07	2.616E-07
WNW	4.051E-07	3.930E-07	3.815E-07	3.706E-07	3.603E-07
NW	3.645E-07	3.536E-07	3.432E-07	3.333E-07	3.241E-07
NNW	2.837E-07	2.752E-07	2.671E-07	2.593E-07	2.521E-07
SECTOR	4.7 (MILES)	4.8 (MILES)	4.9 (MILES)	5.0 (MILES)	
N	2.487E-07	2.419E-07	2.354E-07	2.292E-07	
NNE	1.507E-07	1.464E-07	1.423E-07	1.384E-07	
NE	1.028E-07	9.975E-08	9.689E-08	9.416E-08	
ENE	7.676E-08	7.443E-08	7.223E-08	7.014E-08	
E	6.809E-08	6.600E-08	6.402E-08	6.214E-08	
ESE	5.025E-08	4.869E-08	4.722E-08	4.582E-08	
SE	4.379E-08	4.244E-08	4.115E-08	3.992E-08	
SSE	4.191E-08	4.063E-08	3.941E-08	3.825E-08	
S	4.141E-08	4.015E-08	3.896E-08	3.782E-08	
SSW	4.302E-08	4.173E-08	4.050E-08	3.934E-08	
SW	6.767E-08	6.567E-08	6.377E-08	6.196E-08	
WSW	1.210E-07	1.175E-07	1.142E-07	1.110E-07	
W	2.543E-07	2.474E-07	2.408E-07	2.345E-07	
WNW	3.505E-07	3.411E-07	3.322E-07	3.237E-07	
NW	3.152E-07	3.068E-07	2.987E-07	2.910E-07	
NNW	2.452E-07	2.336E-07	2.323E-07	2.263E-07	

Table A-4  
Atmospheric Dispersion (D/Q) as a Function of Distance (m<sup>-2</sup>)

SECTOR	0.2 (MILES)	0.3 (MILES)	0.4 (MILES)	0.5 (MILES)	0.6 (MILES)
N	1.396E-07	7.578E-08	4.836E-08	3.383E-08	2.516E-08
NNE	1.107E-07	6.008E-08	3.834E-08	2.682E-08	1.995E-08
NE	9.733E-08	5.284E-08	3.372E-08	2.359E-08	1.755E-08
ENE	1.067E-07	5.795E-08	3.698E-08	2.587E-08	1.924E-08
E	1.184E-07	6.429E-08	4.103E-08	2.870E-08	2.135E-08
ESE	8.865E-08	4.813E-08	3.071E-08	2.149E-08	1.598E-08
SE	9.402E-08	5.105E-08	3.258E-08	2.279E-08	1.695E-08
SSE	1.338E-07	7.268E-08	4.637E-08	3.244E-08	2.413E-08
S	1.429E-07	7.757E-08	4.951E-08	3.463E-08	2.576E-08
SSW	6.094E-08	3.309E-08	2.111E-08	1.477E-08	1.099E-08
SW	7.267E-08	3.945E-08	2.518E-08	1.761E-08	1.310E-08
WSW	7.117E-08	3.864E-08	2.466E-08	1.725E-08	1.283E-08
W	7.129E-08	3.870E-08	2.470E-08	1.728E-08	1.285E-08
WNW	6.970E-08	3.784E-08	2.415E-08	1.689E-08	1.256E-08
NW	8.904E-08	4.834E-08	3.085E-08	2.158E-08	1.605E-08
NNW	9.623E-08	5.225E-08	3.334E-08	2.332E-08	1.735E-08
SECTOR	0.7 (MILES)	0.8 (MILES)	0.9 (MILES)	1.0 (MILES)	1.1 (MILES)
N	1.954E-08	1.560E-08	1.277E-08	1.068E-08	5.545E-09
NNE	1.549E-08	1.237E-08	1.013E-08	8.465E-09	4.945E-09
NE	1.362E-08	1.088E-08	8.907E-09	7.445E-09	4.350E-09
ENE	1.494E-08	1.193E-08	9.768E-09	8.164E-09	4.770E-09
E	1.658E-08	1.323E-08	1.084E-08	9.058E-09	5.292E-09
ESE	1.241E-08	9.905E-09	8.112E-09	6.781E-09	3.961E-09
SE	1.316E-08	1.051E-08	8.605E-09	7.192E-09	3.361E-09
SSE	1.874E-08	1.496E-08	1.225E-08	1.024E-08	3.480E-09
S	2.000E-08	1.597E-08	1.308E-08	1.093E-08	4.128E-09
SSW	8.531E-09	6.810E-09	5.577E-09	4.662E-09	2.521E-09
SW	1.017E-08	8.120E-09	6.651E-09	5.559E-09	2.598E-09
WSW	9.963E-09	7.953E-09	6.513E-09	5.444E-09	2.678E-09
W	9.980E-09	7.966E-09	6.524E-09	5.453E-09	2.832E-09
WNW	9.757E-09	7.788E-09	6.379E-09	5.332E-09	2.932E-09
NW	1.246E-08	9.949E-09	8.148E-09	6.811E-09	3.745E-09
NNW	1.347E-08	1.075E-08	8.807E-09	7.361E-09	4.047E-09

Table A-4 (Cont.)  
Atmospheric Deposition (D/Q) as a Function of Distance (m<sup>2</sup>)

SECTOR	1.2 (MILES)	1.3 (MILES)	1.4 (MILES)	1.5 (MILES)	1.6 (MILES)
N	4.777E-09	4.163E-09	3.664E-09	3.252E-09	2.910E-09
NNE	4.260E-09	3.713E-09	3.268E-09	2.900E-09	2.595E-09
NE	3.747E-09	3.265E-09	2.874E-09	2.551E-09	2.283E-09
ENE	4.109E-09	3.581E-09	3.151E-09	2.797E-09	2.503E-09
E	4.559E-09	3.973E-09	3.497E-09	3.104E-09	2.777E-09
ESE	3.413E-09	2.974E-09	2.617E-09	2.323E-09	2.079E-09
SE	2.896E-09	2.524E-09	2.221E-09	1.971E-09	1.764E-09
SSE	2.998E-09	2.612E-09	2.299E-09	2.041E-09	1.826E-09
S	3.556E-09	3.099E-09	2.727E-09	2.421E-09	2.166E-09
SSW	2.172E-09	1.892E-09	1.666E-09	1.478E-09	1.323E-09
SW	2.238E-09	1.950E-09	1.717E-09	1.524E-09	1.363E-09
WSW	2.307E-09	2.011E-09	1.770E-09	1.571E-09	1.406E-09
W	2.440E-09	2.126E-09	1.871E-09	1.661E-09	1.486E-09
WNW	2.525E-09	2.201E-09	1.937E-09	1.719E-09	1.538E-09
NW	3.226E-09	2.811E-09	2.474E-09	2.196E-09	1.965E-09
NNW	3.487E-09	3.039E-09	2.674E-09	2.374E-09	2.124E-09
SECTOR	1.7 (MILES)	1.8 (MILES)	1.9 (MILES)	2.0 (MILES)	2.1 (MILES)
N	2.619E-09	2.371E-09	2.158E-09	1.973E-09	1.812E-09
NNE	2.336E-09	2.115E-09	1.925E-09	1.760E-09	1.616E-09
NE	2.055E-09	1.860E-09	1.693E-09	1.548E-09	1.292E-09
ENE	2.253E-09	2.040E-09	1.856E-09	1.697E-09	1.558E-09
E	2.500E-09	2.263E-09	2.059E-09	1.883E-09	1.572E-09
ESE	1.871E-09	1.694E-09	1.542E-09	1.410E-09	1.294E-09
SE	1.583E-09	1.437E-09	1.308E-09	1.196E-09	1.098E-09
SSE	1.644E-09	1.488E-09	1.354E-09	1.238E-09	7.816E-10
S	1.950E-09	1.765E-09	1.606E-09	1.469E-09	6.743E-10
SSW	1.191E-09	1.078E-09	9.810E-10	8.969E-10	5.883E-10
SW	1.227E-09	1.111E-09	1.011E-09	9.244E-10	8.488E-10
WSW	1.265E-09	1.145E-09	1.042E-09	9.530E-10	1.352E-09
W	1.338E-09	1.211E-09	1.102E-09	1.008E-09	1.430E-09
WNW	1.385E-09	1.254E-09	1.141E-09	1.043E-09	1.393E-09
NW	1.769E-09	1.601E-09	1.457E-09	1.333E-09	1.223E-09
NNW	1.912E-09	1.731E-09	1.575E-09	1.440E-09	1.322E-09

Table A-4 (Cont.)  
Atmospheric Deposition (D/Q) as a Function of Distance (m<sup>2</sup>)

SECTOR	2.2 (MILES)	2.3 (MILES)	2.4 (MILES)	2.5 (MILES)	2.6 (MILES)
N	1.670E-09	1.544E-09	1.433E-09	1.334E-09	1.245E-09
NNE	1.489E-09	1.377E-09	1.278E-09	1.189E-09	1.110E-09
NE	1.191E-09	1.101E-09	1.022E-09	9.511E-10	8.879E-10
ENE	1.436E-09	1.328E-09	1.233E-09	1.147E-09	1.071E-09
E	1.449E-09	1.340E-09	1.243E-09	1.157E-09	1.080E-09
ESE	1.193E-09	1.103E-09	1.024E-09	9.528E-10	8.895E-10
SE	1.012E-09	9.362E-10	8.687E-10	8.085E-10	7.548E-10
SSE	7.204E-10	6.663E-10	6.183E-10	5.754E-10	5.372E-10
S	6.215E-10	5.749E-10	5.334E-10	4.964E-10	4.634E-10
SSW	5.422E-10	5.015E-10	4.653E-10	4.331E-10	4.043E-10
SW	7.823E-10	7.236E-10	6.714E-10	6.249E-10	5.834E-10
WSW	1.246E-09	1.153E-09	1.070E-09	9.956E-10	9.294E-10
W	1.318E-09	1.219E-09	1.131E-09	1.053E-09	9.827E-10
WNW	1.284E-09	1.188E-09	1.102E-09	1.026E-09	9.575E-10
NW	1.128E-09	1.043E-09	9.678E-10	9.007E-10	8.409E-10
NNW	1.219E-09	1.127E-09	1.046E-09	9.735E-10	9.089E-10
SECTOR	2.7 (MILES)	2.8 (MILES)	2.9 (MILES)	3.0 (MILES)	3.1 (MILES)
N	1.165E-09	1.092E-09	1.026E-09	9.666E-10	9.120E-10
NNE	1.039E-09	9.742E-10	9.155E-10	8.621E-10	8.134E-10
NE	8.307E-10	7.789E-10	7.320E-10	6.893E-10	6.504E-10
ENE	1.002E-09	9.396E-10	8.830E-10	8.315E-10	7.845E-10
E	1.011E-09	9.477E-10	8.906E-10	8.387E-10	7.913E-10
ESE	8.322E-10	7.804E-10	7.334E-10	6.906E-10	6.523E-10
SE	7.061E-10	6.622E-10	6.223E-10	5.860E-10	5.529E-10
SSE	5.026E-10	4.713E-10	4.429E-10	4.171E-10	3.935E-10
S	4.336E-10	4.066E-10	3.821E-10	3.598E-10	3.395E-10
SSW	3.782E-10	3.547E-10	3.333E-10	3.139E-10	2.961E-10
SW	5.458E-10	5.118E-10	4.810E-10	4.529E-10	4.273E-10
WSW	8.695E-10	8.154E-10	7.663E-10	7.216E-10	6.807E-10
W	9.194E-10	8.621E-10	8.102E-10	7.630E-10	7.216E-10
WNW	8.958E-10	8.400E-10	7.894E-10	7.434E-10	7.000E-10
NW	7.867E-10	7.377E-10	6.933E-10	6.528E-10	6.159E-10
NNW	8.503E-10	7.973E-10	7.493E-10	7.056E-10	6.657E-10

Table A-4 (Cont.)  
Atmospheric Deposition (D/Q) as a Function of Distance (m<sup>2</sup>)

SECTOR	3.2 (MILES)	3.3 (MILES)	3.4 (MILES)	3.5 (MILES)	3.6 (MILES)
N	8.620E-10	8.161E-10	7.739E-10	7.347E-10	6.991E-10
NNE	7.688E-10	7.279E-10	6.902E-10	6.552E-10	6.235E-10
NE	6.147E-10	5.820E-10	5.518E-10	5.239E-10	4.985E-10
ENE	7.415E-10	7.020E-10	6.657E-10	6.320E-10	6.014E-10
E	7.479E-10	7.081E-10	6.714E-10	6.374E-10	6.066E-10
ESE	5.598E-10	5.300E-10	5.026E-10	4.771E-10	4.541E-10
SE	5.225E-10	4.947E-10	4.691E-10	4.454E-10	4.238E-10
SSE	3.719E-10	3.521E-10	3.339E-10	3.170E-10	3.016E-10
S	3.209E-10	3.038E-10	2.880E-10	2.735E-10	2.602E-10
SSW	2.799E-10	2.650E-10	2.513E-10	2.386E-10	2.270E-10
SW	4.039E-10	3.824E-10	3.626E-10	3.442E-10	3.278E-10
WSW	5.299E-10	5.017E-10	4.757E-10	4.516E-10	4.298E-10
W	6.403E-10	6.062E-10	5.749E-10	5.458E-10	5.193E-10
WNW	7.457E-10	7.060E-10	6.695E-10	6.356E-10	6.048E-10
NW	6.351E-10	6.013E-10	5.702E-10	5.413E-10	5.151E-10
NNW	6.292E-10	5.957E-10	5.649E-10	5.363E-10	5.103E-10

SECTOR	3.7 (MILES)	3.8 (MILES)	3.9 (MILES)	4.0 (MILES)	4.1 (MILES)
N	6.657E-10	6.347E-10	6.059E-10	5.791E-10	5.036E-10
NNE	5.937E-10	5.661E-10	5.404E-10	5.165E-10	4.492E-10
NE	4.747E-10	4.526E-10	4.321E-10	4.129E-10	3.951E-10
ENE	5.727E-10	5.460E-10	5.212E-10	4.981E-10	4.766E-10
E	5.776E-10	5.507E-10	5.257E-10	5.024E-10	4.807E-10
ESE	4.324E-10	4.122E-10	3.935E-10	3.761E-10	3.598E-10
SE	4.036E-10	3.848E-10	3.673E-10	3.510E-10	3.053E-10
SSE	2.872E-10	2.739E-10	2.614E-10	2.498E-10	2.390E-10
S	2.478E-10	2.363E-10	2.255E-10	2.155E-10	2.062E-10
SSW	2.162E-10	2.061E-10	1.968E-10	1.880E-10	1.799E-10
SW	3.119E-10	2.974E-10	2.839E-10	2.713E-10	2.596E-10
WSW	4.093E-10	3.902E-10	3.725E-10	3.560E-10	2.919E-10
W	4.945E-10	4.715E-10	4.501E-10	4.302E-10	3.087E-10
WNW	5.759E-10	5.491E-10	5.242E-10	5.010E-10	3.728E-10
NW	4.905E-10	4.677E-10	4.464E-10	4.266E-10	4.082E-10
NNW	4.895E-10	4.633E-10	4.423E-10	4.227E-10	3.676E-10

Table A-4 (Cont.)  
Atmospheric Deposition (D/Q) as a Function of Distance (m<sup>-2</sup>)

SECTOR	4.2 (MILES)	4.3 (MILES)	4.4 (MILES)	4.5 (MILES)	4.6 (MILES)
N	4.823E-10	4.624E-10	4.437E-10	4.260E-10	4.097E-10
NNE	4.302E-10	4.124E-10	3.957E-10	3.800E-10	3.654E-10
NE	3.784E-10	3.627E-10	3.480E-10	3.342E-10	3.214E-10
ENE	4.584E-10	4.375E-10	4.198E-10	4.031E-10	3.877E-10
E	4.603E-10	4.413E-10	4.234E-10	4.066E-10	3.910E-10
ESE	3.446E-10	3.303E-10	3.170E-10	3.044E-10	2.927E-10
SE	2.924E-10	2.803E-10	2.690E-10	2.583E-10	2.484E-10
SSE	2.289E-10	2.195E-10	2.106E-10	2.022E-10	1.944E-10
S	1.975E-10	1.893E-10	1.817E-10	1.744E-10	1.677E-10
SSW	1.723E-10	1.652E-10	1.585E-10	1.522E-10	1.463E-10
SW	2.486E-10	2.383E-10	2.287E-10	2.196E-10	2.112E-10
WSW	2.796E-10	2.680E-10	2.572E-10	2.469E-10	2.375E-10
W	2.956E-10	2.834E-10	2.719E-10	2.611E-10	2.511E-10
WNW	3.570E-10	3.422E-10	3.284E-10	3.153E-10	3.032E-10
NW	3.909E-10	3.747E-10	3.596E-10	3.453E-10	3.320E-10
NNW	3.521E-10	3.375E-10	3.239E-10	3.110E-10	2.991E-10

SECTOR	4.7 (MILES)	4.8 (MILES)	4.9 (MILES)	5.0 (MILES)
N	3.941E-10	3.795E-10	3.656E-10	3.525E-10
NNE	3.515E-10	3.384E-10	3.261E-10	3.144E-10
NE	3.092E-10	2.977E-10	2.868E-10	2.765E-10
ENE	3.729E-10	3.591E-10	3.460E-10	3.336E-10
E	3.762E-10	3.622E-10	3.489E-10	3.364E-10
ESE	2.816E-10	2.711E-10	2.612E-10	2.519E-10
SE	2.389E-10	2.300E-10	2.216E-10	2.137E-10
SSE	1.871E-10	1.801E-10	1.735E-10	1.673E-10
S	1.614E-10	1.554E-10	1.497E-10	1.443E-10
SSW	1.408E-10	1.355E-10	1.306E-10	1.259E-10
SW	2.031E-10	1.956E-10	1.884E-10	1.817E-10
WSW	2.285E-10	2.199E-10	2.119E-10	2.043E-10
W	2.415E-10	2.326E-10	2.241E-10	2.160E-10
WNW	2.917E-10	2.809E-10	2.706E-10	2.609E-10
NW	3.194E-10	3.075E-10	2.963E-10	2.857E-10
NNW	2.877E-10	2.770E-10	2.669E-10	2.573E-10

**APPENDIX B**  
**LOWER LIMIT OF DETECTION**

The lower limit of detection (LLD) is the smallest concentration of radioactive material in a sample that will be detected with a 95 percent probability with a 5 percent probability of falsely concluding that a blank observation represents a "real" signal.

The LLD is defined as an "a priori" (before the fact) limit representing the capability of a measurement system and not as an "a posteriori" (after the fact) limit for a particular measurement.

For a measurement system (which may include radiochemical separation) based on gross beta, gross alpha, liquid scintillation, or other analyses where a background count determined by a separate measurement with no sample (or blank sample) is subtracted from the gross sample count to obtain a net count due to sample activity:

$$LLD = \frac{3.3 \left( \frac{r_b}{t_s} + \frac{r_b}{t_b} \right)^{1/2}}{(C)(E)(V)(Y_C) \exp(-\lambda \Delta t)} \quad (B-1)$$

Where:

- LLD = the "a priori" lower limit of detection, as defined above;
- C = the conversion factor of transformations per unit time per  $\mu\text{Ci}$  or  $\text{pCi}$ ;
- E = the detector efficiency;
- $r_b$  = the background count rate in units of transformations per unit time;
- $t_b$  = the counting time of background;
- $t_s$  = the counting time of the sample;
- V = the sample size, in units of mass or volume;
- $Y_C$  = the fractional radiochemical sample collection or concentration yield (when applicable);
- $\Delta t$  = for plant effluents, the elapsed time between the midpoint of sample collection and time of counting; for environmental samples, the elapsed time between sample collection (or end of the sample collection period) and time of counting;
- $\lambda$  = the radioactive decay constant for the radionuclide in question.

For the purpose of routine analyses, count times for both the sample(s) and background(s) are equal. This satisfies the given ODCM Appendix C control for lower limit of detection definition, as the numerator of equation B-1 simplifies to  $4.66 S_b$ , where  $S_b$  is the standard deviation of the background count rate or the count rate of a blank sample, as appropriate.

For gamma ray spectroscopy analyses:

$$LLD = \frac{I_D \exp\left(0.693 \frac{\Delta t}{t^{1/2}}\right)}{(C)(E)(t)(V)(Y_C)(Y_\gamma)} \quad (B-2)$$

Where:

- LLD = the lower limit of detection, in  $\mu\text{Ci}$  or  $\text{pCi}$  per unit mass or volume;
- C = the conversion factor of transformations per unit time per  $\mu\text{Ci}$  or  $\text{pCi}$ ;
- E = the detector efficiency for the energy in question;
- t = the data collection (counting) time of sample;
- $t^{1/2}$  = the half-life of the radionuclide in question;
- V = the sample size, in units of mass or volume;



- $Y_C$  = the fractional radiochemical, sample collection, or concentration yield (when applicable);  
 $Y_\lambda$  = the yield of the gamma ray in question;  
 $\Delta t$  = for plant effluents the elapsed time between midpoint of sample collection and time of counting; for environmental samples, the elapsed time between sample collection (or end of the sample collection period) and the time of counting;  
 $I_{cd}$  = the detection limit

$$= k^2 + 2k \left( \frac{N}{2n} \left( 1 + \frac{N}{2n} \right) (\bar{B}_1 \cdot B_2) - I - \sigma_I^2 \right)^{1/2} \quad (B-3)$$

Where:

- $B_1$  = the number of counts in "n" background channels below the peak due to Compton scattering, etc., determined at the same time a photopeak is measured;  
 $B_2$  = the number of counts in the "n" background channels above the peak;  
 $k$  = an abscissa of the normal distribution corresponding to confidence level,  
= 1.645 at a confidence level of 95%;  
 $I$  = the measured value of interference in the photopeak of interest due to environmental background, detector contamination, etc., determined by a separate measurement with no sample;  
 $N$  = the number of channels in the photopeak of interest;  
 $n$  = the number of background channels on each side of the photopeak of interest;  
 $\sigma_I$  = the standard deviation of  $I$ .

Typical values of  $E$ ,  $V$ ,  $Y$ , and  $\Delta t$  shall be used in the calculation.

In calculating the LLD for a radionuclide determined by gamma-ray spectrometry, the background shall include the typical contributions of other radionuclides normally present in the samples (e.g., potassium-40 in milk samples).

Analyses shall be performed in such a manner that the LLD's listed in Tables 4.11.1.1.1-1, 4.11.2.1.2-1, and 4.12.1-1 of the ODCM Appendix C controls for the Perry Nuclear Power Plant will be achieved under routine conditions. Occasionally, background fluctuations, unavoidably small sample sizes, the presence of interfering nuclides, or other uncontrollable circumstances may render these LLDs unachievable. In such cases, the contributing factors will be identified and described in the Annual Radiological Environmental Operating Report.

**APPENDIX C**  
**CONTROLS**

INDEX

DEFINITIONS

SECTION	PAGE
1.0 DEFINITIONS.....	97
Table 1.1, Surveillance Frequency Notation.....	101
Table 1.2, MODES.....	102

CONTROLS AND SURVEILLANCE REQUIREMENTS

<u>3/4.0 APPLICABILITY</u> .....	104
----------------------------------	-----

3/4.3 INSTRUMENTATION

Radioactive Liquid Effluent Monitoring Instrumentation.....	106
Table 3.3.7.9-1 Radioactive Liquid Effluent Monitoring Instrumentation.....	107
Table 4.3.7.9-1 Radioactive Liquid Effluent Monitoring Instrumentation Surveillance Requirements.....	109
Radioactive Gaseous Effluent Monitoring Instrumentation.....	111
Table 3.3.7.10-1 Radioactive Gaseous Effluent Monitoring Instrumentation.....	112
Table 4.3.7.10-1 Radioactive Gaseous Effluent Monitoring Instrumentation Surveillance Requirements.....	115

3/4.11 RADIOACTIVE EFFLUENTS

<u>3/4.11.1 LIQUID EFFLUENTS</u>	
Concentration.....	118
Table 4.11.1.1.1-1 Radioactive Liquid Waste Sampling and Analysis Program.....	119
Dose.....	122
Liquid Radwaste Treatment System.....	123
<u>3/4.11.2 GASEOUS EFFLUENTS</u>	
Dose Rate.....	124
Table 4.11.2.1.2-1 Radioactive Gaseous Waste Sampling and Analysis Program.....	125
Dose - Noble Gases.....	128
Dose - Iodine-131, Iodine-133, Tritium and Radionuclides in Particulate Form.....	129
Gaseous Radwaste (Off-Gas) Treatment.....	130
Ventilation Exhaust Treatment Systems.....	131
<u>3/4.11.4 TOTAL DOSE</u> .....	132

3/4.12 RADIOLOGICAL ENVIRONMENTAL MONITORING

<u>3/4.12.1 MONITORING PROGRAM</u> .....	133
Table 3.12.1-1 Radiological Environmental Monitoring Program.....	135
Table 3.12.1-2 Reporting Levels for Radioactivity Concentrations In Environmental Samples.....	140
Table 4.12.1-1 Maximum Values for the Lower Limits of Detection (LLD) In Environmental Samples.....	141

**CONTROLS AND SURVEILLANCE REQUIREMENTS**

SECTION	PAGE
3/4.12.2 LAND USE CENSUS.....	144
3/4.12.3 INTERLABORATORY COMPARISON PROGRAM.....	145

**BASES**

<b><u>3/4.0 APPLICABILITY</u></b> .....	147
---	-----

**3/4.3 INSTRUMENTATION**

Radioactive Liquid Effluent Monitoring Instrumentation.....	155
Radioactive Gaseous Effluent Monitoring Instrumentation.....	155

**3/4.11 RADIOACTIVE EFFLUENTS**

<b>3/4.11.1 LIQUID EFFLUENTS</b>	
Concentration.....	156
Dose.....	156
Liquid Radwaste Treatment System.....	157

**3/4.11.2 GASEOUS EFFLUENTS**

Dose Rate.....	158
Dose - Noble Gases .....	158
Dose - Iodine-131, Iodine-133, Tritium and Radionuclides in Particulate Form.....	159
Gaseous Radwaste Treatment (Offgas) System and Ventilation Exhaust Treatment Systems.....	160

3/4.11.4 TOTAL DOSE.....	160
--------------------------	-----

**3/4.12 RADIOLOGICAL ENVIRONMENTAL MONITORING**

3/4.12.1 MONITORING PROGRAM.....	161
3/4.12.2 LAND USE CENSUS.....	161
3/4.12.3 INTERLABORATORY COMPARISON PROGRAM.....	161

**ADMINISTRATIVE CONTROLS**

**6.9 REPORTING REQUIREMENTS**

6.9.1.6 Annual Radiological Environmental Operating Report.....	163
6.9.1.7 Annual Radioactive Effluent Release Report .....	164
6.9.2 SPECIAL REPORTS .....	165

<b><u>6.10 RECORD RETENTION</u></b> .....	165
---	-----

<b><u>6.15 MAJOR CHANGES TO RADIOACTIVE WASTE TREATMENT SYSTEMS</u></b> .....	166
---	-----

**SECTION 1.0 DEFINITIONS**

## 1.0 DEFINITIONS

The following terms are defined so that uniform interpretation of these Controls may be achieved. The defined terms appear in capitalized type and shall be applicable throughout these Controls.

### ACTIONS

**ACTIONS** shall be that part of a Control that prescribes remedial measures to be taken under designated conditions.

### CHANNEL CALIBRATION

A **CHANNEL CALIBRATION** shall be the adjustment, as necessary, of the channel output such that it responds within the necessary range and accuracy to known values of the parameter which the channel monitors. The **CHANNEL CALIBRATION** shall encompass the entire channel, including the required sensor, alarm, display and trip functions, and shall include the **CHANNEL FUNCTIONAL TEST**. The **CHANNEL CALIBRATION** may be performed by means of any series of sequential, overlapping or total channel steps so that the entire channel is calibrated.

### CHANNEL CHECK

A **CHANNEL CHECK** shall be the qualitative assessment, by observation of channel behavior during operation. This determination shall include, where possible, comparison of the channel indication and status to other indications or status derived from independent instrument channels measuring the same parameter.

### CHANNEL FUNCTIONAL TEST

A **CHANNEL FUNCTIONAL TEST** shall be the injection of a simulated or actual signal into the channel as close to the sensor as practicable to verify **OPERABILITY**, including required alarm, interlock, display, and trip functions and channel failure trips. The **CHANNEL FUNCTIONAL TEST** may be performed by means of any series of sequential, overlapping, or total channel steps so that the entire channel is tested.

### DOSE EQUIVALENT I-131

**DOSE EQUIVALENT I-131** shall be that concentration of I-131 (microcuries per gram) that alone would produce the same thyroid dose as the quantity and isotopic mixture of I-131, I-132, I-133, I-134, and I-135 actually present. The thyroid dose conversion factors used for this calculation shall be those listed in Table III of TID-14844, AEC, 1962, "Calculation of Distance Factors for Power and Test Reactor Sites."

## DEFINITIONS

---

### FREQUENCY NOTATION

The FREQUENCY NOTATION specified for the performance of Surveillance Requirements shall correspond to the intervals defined in Table 1.1.

### GASEOUS RADWASTE TREATMENT (OFF-GAS) SYSTEM

The GASEOUS RADWASTE TREATMENT (OFF-GAS) SYSTEM is the system designed and installed to reduce radioactive gaseous effluents by collecting primary coolant system off-gasses from the main condenser evacuation system and providing for delay or holdup for the purpose of reducing the total radioactivity prior to release to the environment.

### LIQUID RADWASTE TREATMENT SYSTEM

The LIQUID RADWASTE TREATMENT SYSTEM is any process or control equipment used to reduce the amount or concentration of liquid radioactive materials prior to their discharge to UNRESTRICTED AREAS. It involves all the installed and available liquid radwaste management system equipment, as well as their controls, power instrumentation, and services that make the system functional.

### MEMBER OF THE PUBLIC

MEMBER OF THE PUBLIC means any individual except when that individual is receiving an OCCUPATIONAL DOSE.

### MODE

A MODE shall correspond to any one inclusive combination of mode switch position, average reactor coolant temperature, and reactor vessel head closure bolt tensioning specified in Table 1.2 with fuel in the reactor vessel.

### OCCUPATIONAL DOSE

OCCUPATIONAL DOSE means the dose received by an individual in the course of employment in which the individual's assigned duties involve exposure to radiation or to radioactive material from licensed and unlicensed sources of radiation, whether in the possession of the licensee or other person. Occupational dose does not include doses received from background radiation, from any medical administration the individual has received, from exposure to individuals administered radioactive material and released under § 35.75, from voluntary participation in medical research programs, or as a member of the public.

## DEFINITIONS

---

### OFFSITE DOSE CALCULATION MANUAL (ODCM)

The OFFSITE DOSE CALCULATION MANUAL shall contain the methodology and parameters used in the calculation of offsite doses resulting from radioactive gaseous and liquid effluents, in the calculation of gaseous and liquid effluent monitoring alarm/trip setpoints, and in the conduct of the radiological environmental monitoring program. The ODCM shall also contain the Radioactive Effluent Controls Program required by Technical Specification 5.5.4, the Radiological Environmental Monitoring Programs and descriptions of the information that should be included in the Annual Radioactive Effluent Release Report required by Technical Specifications 5.6.2 and 5.6.3.

### OPERABLE - OPERABILITY

A system, subsystem, division, component or device shall be OPERABLE or have OPERABILITY when it is capable of performing its specified function(s) and when all necessary attendant instrumentation, controls, normal or emergency electrical power, cooling and seal water, lubrication and other auxiliary equipment that are required for the system, subsystem, division, component or device to perform its specified safety function(s) are also capable of performing their related support function(s).

### PURGE - PURGING

PURGE or PURGING is the controlled process of discharging air or gas from a confinement to maintain temperature, pressure, humidity, concentration or other operating condition, in such a manner that replacement air or gas is required to purify the confinement.

### RATED THERMAL POWER

RATED THERMAL POWER shall be a total reactor core heat transfer rate to the reactor coolant of 3758 MWT.

### REPORTABLE EVENT

A REPORTABLE EVENT shall be any of those conditions specified in 10CFR50.73.

### SITE BOUNDARY

The SITE BOUNDARY shall be that line beyond which the land is neither owned, nor leased, nor otherwise controlled by the licensee.

### SOURCE CHECK

A SOURCE CHECK shall be the qualitative assessment of channel response when the channel sensor is exposed to a source of increased radioactivity.



## DEFINITIONS

---

### THERMAL POWER

**THERMAL POWER** shall be the total reactor core heat transfer rate to the reactor coolant.

### UNRESTRICTED AREA

An **UNRESTRICTED AREA** shall be any area at or beyond the **SITE BOUNDARY** access to which is not controlled by the licensee for purposes of protection of **MEMBERS OF THE PUBLIC** from exposure to radiation and radioactive materials, or any area within the **SITE BOUNDARY** used for residential quarters or for industrial, commercial, institutional, and/or recreational purposes.

### VENTILATION EXHAUST TREATMENT SYSTEMS

A **VENTILATION EXHAUST TREATMENT SYSTEM** is any system designed and installed to reduce gaseous radiiodine or radioactive material in particulate form in effluents by passing ventilation or vent exhaust gases through charcoal adsorbers and/or HEPA filters for the purpose of removing iodines or particulates from the gaseous exhaust stream prior to the release to the environment (such a system is not considered to have any effect on noble gas effluents). Engineered Safety Feature (ESF) atmospheric cleanup systems are not considered to be **VENTILATION EXHAUST TREATMENT SYSTEM** components provided the ESF system is not utilized to treat normal releases.

### VENTING

**VENTING** is the controlled process of discharging air or gas from a confinement to maintain temperature, pressure, humidity, concentration or other operating condition, in such a manner that replacement air or gas is not provided or required during **VENTING**. Vent, used in system names, does not imply a **VENTING** process.

TABLE 1.1  
SURVEILLANCE FREQUENCY NOTATION

<u>NOTATION</u>	<u>FREQUENCY</u>
S	At least once per 12 hours.
D	At least once per 24 hours.
W	At least once per 7 days.
M	At least once per 31 days.
Q	At least once per 92 days.
SA	At least once per 184 days.
A	At least once per 366 days.
R	At least once per 24 months.
S/U	Prior to each reactor startup.
P	Completed prior to each release.
4H	Every 4 hours when required.
N.A.	Not applicable.

TABLE 1.2

MODES

<u>MODE</u>	<u>TITLE</u>	<u>REACTOR MODE SWITCH POSITION</u>	<u>AVERAGE REACTOR COOLANT TEMPERATURE</u>
1	POWER OPERATION	Run	NA
2	STARTUP	Refuel (a) or Startup/Hot Standby	NA
3	HOT SHUTDOWN (a)	Shutdown	> 200°F
4	COLD SHUTDOWN (a)	Shutdown	≤ 200°F
5	REFUELING (b)	Shutdown or Refuel	NA

(a) All reactor vessel head closure bolts fully tensioned.

(b) One or more reactor vessel head closure bolts less than fully tensioned.

**SECTIONS 3.0 and 4.0**  
**CONTROLS AND SURVEILLANCE REQUIREMENTS**

### 3/4.0 APPLICABILITY

#### CONTROLS

---

**3.0.1 Controls shall be met during the MODES or other conditions specified in the Applicability except as provided in Control 3.0.2.**

**3.0.2 Upon discovery of a failure to meet a Control, the requirements of the Actions shall be met except as provided in Control 3.0.5. If the Control is met or is no longer applicable prior to expiration of the specified time interval(s), completion of the Action(s) is not required, unless otherwise stated.**

**3.0.3 When a Control is not met and the associated ACTIONS are not met, an associated ACTION is not provided, or if directed by the associated ACTIONS, the unit shall be placed in a MODE or other specified condition in which the Control is not applicable. Action shall be initiated within 1 hour to place the unit, as applicable, in:**

- a. **MODE 2 within 7 hours;**
- b. **MODE 3 within 13 hours; and**
- c. **MODE 4 within 37 hours.**

**Exceptions to this Control are stated in the individual Controls.**

**Where corrective measures are completed that permit operation in accordance with the Control or ACTIONS, completion of the actions required by Control 3.0.3 is not required.**

**Control 3.0.3 is only applicable in MODES 1, 2, and 3.**

**3.0.4 When a Control is not met, entry into a MODE or other specified condition in the Applicability shall only be made:**

- a. **When the associated ACTIONS to be entered permit continued operation in the MODE or other specified condition in the Applicability for an unlimited period of time;**
- b. **After performance of a risk assessment addressing inoperable systems and components, consideration of the results, determination of the acceptability of entering the MODE or other specified condition in the Applicability, and establishment of risk management actions, if appropriate; exceptions to this Control are stated in the individual Controls, or**
- c. **When an allowance is stated in the individual value, parameter, or other Control.**

**This Control shall not prevent changes in MODES or other specified conditions in the Applicability that are required to comply with ACTIONS, or that are part of a shutdown of the unit.**

### 3/4.0 APPLICABILITY

#### CONTROLS (Continued)

---

3.0.5 Equipment removed from service or declared Inoperable to comply with ACTIONS may be returned to service under administrative control solely to perform testing required to demonstrate its OPERABILITY or the OPERABILITY of other equipment. This is an exception to Control 3.0.2 for the system returned to service under administrative control to perform the testing required to demonstrate OPERABILITY.

#### SURVEILLANCE REQUIREMENT (SR)

---

4.0.1 SRs shall be met during the MODES or other specified conditions in the Applicability for individual Controls, unless otherwise stated in the SR. Failure to meet a Surveillance, whether such failure is experienced during the performance of the surveillance or between performances of the Surveillance, shall be failure to meet the Control. Failure to perform a Surveillance within the specified Frequency shall be failure to meet the Control except as provided in SR 4.0.3. Surveillances do not have to be performed on inoperable equipment or variables outside specified limits.

4.0.2 The specified frequency for each SR is met if the Surveillance is performed within 1.25 times the interval specified in the frequency, as measured from the previous performance or as measured from the time a specified condition of the frequency is met.

If a completion time for an action requires periodic performance on a "once per ..." basis, the above frequency extension applies to each performance after the initial performance.

Exceptions to this SR are stated in the individual SR's.

4.0.3 If it is discovered that a Surveillance was not performed within its specified frequency, then compliance with the requirement to declare the Control not met may be delayed, from the time of discovery, up to 24 hours or up to the limit of the specified frequency, whichever is less. This delay period is permitted to allow performance of the Surveillance.

If the Surveillance is not performed within the delay period, the Control must immediately be declared not met, and the applicable ACTION(s) must be entered. When the Surveillance is performed within the delay period and the Surveillance is not met, the Control must immediately be declared not met, and the applicable ACTION(s) must be entered.

4.0.4 Entry into a MODE or other specified condition in the Applicability of a Control shall only be made when the Control's Surveillances have been met within their specified frequency, except as provided by Surveillance Requirement 4.0.3. When a control is not met due to Surveillances not having been met, entry into a MODE or other specified Condition in the Applicability shall only be made in accordance with Control 3.0.4.

This provision shall not prevent entry into MODES or other specified conditions in the Applicability that are required to comply with ACTIONS or that are part of a shutdown of the unit.

### 3/4.3 INSTRUMENTATION

#### RADIOACTIVE LIQUID EFFLUENT MONITORING INSTRUMENTATION

##### CONTROLS

---

3.3.7.9 In accordance with Perry Nuclear Power Plant Unit 1 TS 5.5.4.a, the radioactive liquid effluent monitoring instrumentation channels shown in Table 3.3.7.9-1 shall be OPERABLE with their alarm/trip setpoints set to ensure that the limits of Control 3.11.1.1 are not exceeded. The alarm/trip setpoints of these channels shall be determined and adjusted in accordance with the OFFSITE DOSE CALCULATION MANUAL (ODCM).

APPLICABILITY: At all times.

##### ACTION:

- a. With a radioactive liquid effluent monitoring instrumentation channel alarm/trip setpoint less conservative than required by the above Control, immediately suspend the release of radioactive liquid effluents monitored by the affected channel or declare the channel inoperable, or change the setpoint so it is acceptably conservative.
- b. With less than the minimum number of radioactive liquid effluent monitoring instrumentation channels OPERABLE, take the ACTION shown in Table 3.3.7.9-1. Restore the inoperable instrumentation to OPERABLE status within 30 days and, if unsuccessful, explain why this inoperability was not corrected in a timely manner in the next Annual Radioactive Effluent Release Report.
- c. The provisions of Control 3.0.3 are not applicable.

##### SURVEILLANCE REQUIREMENTS

---

4.3.7.9 Each radioactive liquid effluent monitoring instrumentation channel shall be demonstrated OPERABLE by performance of the CHANNEL CHECK, SOURCE CHECK, CHANNEL CALIBRATION and CHANNEL FUNCTIONAL TEST operations at the frequencies shown in Table 4.3.7.9-1.

TABLE 3.3.7.9-1

RADIOACTIVE LIQUID EFFLUENT MONITORING INSTRUMENTATION

<u>INSTRUMENT</u>	<u>MINIMUM CHANNELS OPERABLE</u>	<u>ACTION</u>
1. GROSS RADIOACTIVITY MONITORS PROVIDING ALARM AND AUTOMATIC TERMINATION OF RELEASE		
a. Liquid Radwaste Discharge Radiation Monitor -- ESW Discharge	1	110
2. GROSS BETA OR GAMMA RADIOACTIVITY MONITORS PROVIDING ALARM BUT NOT PROVIDING AUTOMATIC TERMINATION OF RELEASE		
a. Emergency Service Water Loop A Radiation Monitor	1	111
b. Emergency Service Water Loop B Radiation Monitor	1	111
c. Service Water Radiation Monitor (ADHR)	1	111
3. FLOW RATE MEASUREMENT DEVICES		
a. Radwaste High-Flow Discharge Header Flow	1	112
b. Service Water Discharge Header Flow Monitor	1	113
c. Unit 1 Emergency Service Water Header Flow Monitor or Individual ESW HX Monitors	1	113
1) Emergency Service Water Flow Monitor, or		
2) Individual RHR, ECC and DG HX Flow Monitors		

October 2017



TABLE 3.3.7.9-1 (Continued)

RADIOACTIVE LIQUID EFFLUENT MONITORING INSTRUMENTATION

ACTION STATEMENTS

- ACTION 110 -** With the number of channels OPERABLE less than required by the Minimum Channels OPERABLE requirement, effluent releases from this pathway may continue provided that prior to initiating a release:
- a. At least two independent samples are analyzed in accordance with Control 4.11.1.1.1, and
  - b. At least two technically qualified members of the Facility Staff independently verify the release rate calculations and discharge line valve lineup;
- Otherwise, suspend release of radioactive effluents via this pathway.
- ACTION 111 -** With the number of channels OPERABLE less than required by the Minimum Channels OPERABLE requirement, effluent releases via this pathway may continue provided that, at least once per 12 hours, grab samples are collected and analyzed for gross radioactivity (beta or gamma) at a limit of detection of at least  $10^{-7}$   $\mu\text{Ci/ml}$ .
- ACTION 112 -** With the number of channels OPERABLE less than required by the Minimum Channels OPERABLE requirement, effluent releases via this pathway may continue provided the discharge valve position is verified to be consistent with the flow rate provisions of the release permit at least once per 4 hours during actual releases. Prior to initiating another release, at least two technically qualified members of the Facility Staff shall independently verify the discharge line valve lineup and that the discharge valve position corresponds to the desired flow rate. Otherwise, suspend release of radioactive effluents via this pathway.
- ACTION 113 -** With the number of channels OPERABLE less than required by the Minimum Channels OPERABLE requirement, effluent releases via this pathway may continue provided the flow rate is estimated at least once per 4 hours during actual releases. Pump performance curves generated in place as well as other curves generated using pump performance may be used to estimate flow.

TABLE 4.3.7.9-1

RADIOACTIVE LIQUID EFFLUENT MONITORING INSTRUMENTATION SURVEILLANCE REQUIREMENTS

<u>INSTRUMENT</u>	<u>CHANNEL CHECK</u>	<u>FLOW CHECK</u>	<u>SOURCE CHECK</u>	<u>CHANNEL CALIBRATION</u>	<u>CHANNEL FUNCTIONAL TEST</u>
1. GROSS RADIOACTIVITY MONITORS PROVIDING ALARM AND AUTOMATIC TERMINATION OF RELEASE					
a. Liquid Radwaste Discharge Radiation Monitor - ESW Discharge	D	N.A.	P	R(3)	Q(1)
2. GROSS BETA OR GAMMA RADIOACTIVITY MONITORS PROVIDING ALARM BUT NOT PROVIDING AUTOMATIC TERMINATION OF RELEASE					
a. Emergency Service Water Loop A Radiation Monitor	D	N.A.	M	R(3)	Q(2)
b. Emergency Service Water Loop B Radiation Monitor	D	N.A.	M	R(3)	Q(2)
c. Service Water Radiation Monitor (ADHR)(6)	D	N.A.	M	R(3)	Q(2)
3. FLOW RATE MEASUREMENT DEVICES					
a. Radwaste High-Flow Discharge Header Flow	D(4)	N.A.	N.A.	R	Q
b. Service Water Discharge Header Flow	D(4)	N.A.	N.A.	R	Q
c. Unit 1 Emergency Service Water Header Flow					
1) Emergency Service Water Flow, or	D(4)	N.A.	N.A.	R	Q
2) Combination of Individual RHR, ECC & DG HX Flows	D(4)	4H(5)	N.A.	N.A.	N.A.
3) Individual RHR, ECC, & DG HX Flows	N.A.	N.A.	N.A.	R	Q

TABLE 4.3.7.9-1 (Continued)

RADIOACTIVE LIQUID EFFLUENT MONITORING  
INSTRUMENTATION SURVEILLANCE REQUIREMENTS

TABLE NOTATION

- (1) The CHANNEL FUNCTIONAL TEST shall also demonstrate that automatic isolation of this pathway and control room alarm annunciation occur if any of the following conditions exists:
  1. Instrument indicates measured levels above the alarm/trip setpoint.
  2. Instrument indicates a downscale failure.
  3. Instrument controls not set in operate mode except in high voltage position.
- (2) The CHANNEL FUNCTIONAL TEST shall also demonstrate that control room alarm annunciation occurs if any of the following conditions exists:
  1. Instrument indicates measured levels above the alarm setpoint.
  2. Instrument indicates a downscale failure.
  3. Instrument controls not set in operate mode, except in high voltage position.
- (3) The initial CHANNEL CALIBRATION shall be performed using one or more of the reference standards certified by the National Institute of Standards and Technology (NIST) or using standards that have been obtained from suppliers that participate in measurement assurance activities with NIST. These standards shall permit calibrating the system over its intended range of energy and measurement range. For subsequent CHANNEL CALIBRATION, sources that have been related to the initial calibration shall be used.
- (4) CHANNEL CHECK shall consist of verifying indication of flow. A CHANNEL CHECK shall be made initially and at least once per 24 hours on days when continuous, periodic or batch releases occurs. Pump performance curves may be used to verify the indication of flow from flow instrumentation.
- (5) FLOW CHECK shall consist of verifying indication of flow by summing the individual RHR, ECC and DG heat exchanger flows. A FLOW CHECK shall be made initially, prior to securing ESW pumps, at least once per 4 hours during a Liquid Radwaste discharge, and at least once per 12 hours during operation of ESW pumps.
- (6) Surveillance requirements are in effect only when the system is in service.

October  
2017

TABLE 3.3.7.10-1

RADIOACTIVE GASEOUS EFFLUENT MONITORING INSTRUMENTATION

<u>INSTRUMENT</u>	<u>MINIMUM CHANNELS OPERABLE</u>	<u>APPLICABILITY</u>	<u>ACTION</u>
<b>1. OFF-GAS VENT RADIATION MONITOR</b>			
a. Noble Gas Activity Monitor	1	*	121, 124
b. Iodine Sampler <sup>(1)</sup>	1	*	122
c. Particulate Sampler <sup>(1)</sup>	1	*	122
d. Effluent System Flow Rate Monitor	1	*	123
e. Sampler Flow Rate Monitor (Victoreen Flow Monitor)	1	*	123
<b>2. UNIT 1 VENT RADIATION MONITOR</b>			
a. Noble Gas Activity Monitor	1	1, 2, 3	121, 124, 125   October 2017
b. Iodine Sampler <sup>(1)</sup>	1	4, 5	121, 124   October 2017
c. Particulate Sampler <sup>(1)</sup>	1	*	122
d. Effluent System Flow Rate Monitor	1	*	122
e. Sampler Flow Rate Monitor (Victoreen Flow Monitor)	1	*	123
			123   October 2017

**INSTRUMENTATION**

**RADIOACTIVE GASEOUS EFFLUENT MONITORING INSTRUMENTATION**

**CONTROLS**

---

3.3.7.10 In accordance with Perry Nuclear Power Plant Unit 1 TS 5.5.4.a, the radioactive gaseous effluent monitoring instrumentation channels shown in Table 3.3.7.10-1 shall be OPERABLE with their alarm/trip setpoints set to ensure that the limits of Control 3.11.2.1 are not exceeded. The alarm/trip setpoints of applicable channels shall be determined and adjusted in accordance with the methodology and parameters in the ODCM.

**APPLICABILITY:** As shown in Table 3.3.7.10-1

**ACTION:**

- a. With a radioactive gaseous effluent monitoring instrumentation channel alarm/trip setpoint less conservative than required by the above specification, declare the channel inoperable, or change the setpoint so it is acceptably conservative.
- b. With less than the minimum number of radioactive gaseous effluent monitoring instrumentation channels OPERABLE, take the ACTION shown in Table 3.3.7.10-1. Restore the inoperable instrumentation to OPERABLE status within 30 days and, if unsuccessful, explain why this inoperability was not corrected in a timely manner in the next Annual Radioactive Effluent Release Report.
- c. The provisions of Control 3.0.3 are not applicable.

**SURVEILLANCE REQUIREMENTS**

---

4.3.7.10 Each radioactive gaseous effluent monitoring instrumentation channel shall be demonstrated OPERABLE by performance of the CHANNEL CHECK, SOURCE CHECK, CHANNEL CALIBRATION and CHANNEL FUNCTIONAL TEST operations at the frequencies shown in Table 4.3.7.10-1.

TABLE 3.3.7.10-1 (Continued)

**RADIOACTIVE GASEOUS EFFLUENT MONITORING INSTRUMENTATION**

<u>INSTRUMENT</u>	<u>MINIMUM CHANNELS OPERABLE</u>	<u>APPLICABILITY</u>	<u>ACTION</u>
<b>3. UNIT 2 VENT RADIATION MONITOR</b>			
a. Noble Gas Activity Monitor	1	*	121, 124
b. Iodine Sampler <sup>(1)</sup>	1	*	122
c. Particulate Sampler <sup>(1)</sup>	1	*	122
d. Effluent System Flow Rate Monitor	1	*	123
e. Sampler Flow Rate Monitor (Victoreen Flow Monitor)	1	*	123
<b>4. TURBINE BUILDING/HEATER BAY VENT RADIATION MONITOR</b>			
a. Noble Gas Activity Monitor	1	*	121, 124
b. Iodine Sampler <sup>(1)</sup>	1	*	122
c. Particulate Sampler <sup>(1)</sup>	1	*	122
d. Effluent System Flow Rate Monitor	1	*	123
e. Sampler Flow Rate Monitor (Victoreen Flow Monitor)	1	*	123

October  
2017

TABLE 3.3.7.10-1 (Continued)

RADIOACTIVE GASEOUS EFFLUENT MONITORING INSTRUMENTATION

TABLE NOTATION

- (1) This encompasses the isokinetic and Victoreen photohelics | October 2017
- At all times | October 2017
- ACTION 121 -** With the number of channels OPERABLE less than required by the Minimum Channels OPERABLE requirement, effluent releases via this pathway may continue provided grab samples are taken at least once per 12 hours and these samples are analyzed for principal gamma emitters as required by Table 4.11.2.1.2-1.
- ACTION 122 -** With the number of channels OPERABLE less than required by the Minimum Channels OPERABLE requirement, effluent releases via this pathway may continue provided samples are continuously collected within 4 hours with auxiliary sampling equipment as required by Table 4.11.2.1.2-1. If the inoperability is due to failure of the AMC skid, the Victoreen skid alone can be used as the auxiliary sampling equipment for a maximum of 30 consecutive days. Loss of the isokinetic flow monitor constitutes inoperability of particulate and iodine channels (b, c). | October 2017
- ACTION 123 -** With the number of channels OPERABLE less than required by the Minimum Channels OPERABLE requirement, effluent release via this pathway may continue provided the flow rate is estimated at least once per 4 hours. This action applies to both the effluent system flow and Victoreen sample flow (d, e).
- ACTION 124 -** With the 1H13-P680 panel annunciator for noble gas channels locked in due to a downscale condition on the radiation monitoring panel, the affected noble gas monitor channels shall be verified in the Control Room at least once per 12 hours to ensure that no unmonitored high or alert level alarms are present.
- ACTION 125 -** With the number of channels OPERABLE less than required by the Minimum Channels OPERABLE requirement, except as a result of a non-conservative setpoint or within the criteria specified in Action 126, immediately suspend operation of the Containment Vessel and Drywell Purge (M14) system. Prior to resuming M14 System operation, ensure compliance with Control 3.11.2.1 requirements. If Control 3.11.2.1 compliance is met, operation of the M14 System may continue provided grab samples are taken at least once per 12 hours and analyzed for principal gamma emitters, as required by Table 4.11.2.1.2-1.
- ACTION 126 -** For periods of planned maintenance or performance of surveillance requirements in support of the requirements listed in Table 4.3.7.10-1, which will reduce the number of OPERABLE channels less than the Minimum Channels OPERABLE requirement, compliance with Control 3.11.2.1 may be verified prior to reducing the number of OPERABLE channels below the requirement. If Control 3.11.2.1 compliance is met, operation of the M14 System need not be suspended for the channel provided grab samples are taken at least once per 12 hours and analyzed for principal gamma emitters, as required by Table 4.11.2.1.2-1.

TABLE 4.3.7.10-1

RADIOACTIVE GASEOUS EFFLUENT MONITORING INSTRUMENTATION SURVEILLANCE REQUIREMENTS

<u>INSTRUMENT</u>	<u>CHANNEL SOURCE CHECK</u>		<u>CHANNEL CALIBRATION</u>	<u>CHANNEL MODES IN WHICH FUNCTIONAL SURVEILLANCE TEST _____ REQUIRED</u>	
	<u>CHECK</u>	<u>CHECK</u>		<u>TEST</u>	<u>REQUIRED</u>
<b>1. OFFGAS VENT RADIATION MONITOR</b>					
a. Noble Gas Activity Monitor	D	M	R <sup>(2)</sup>	Q <sup>(1)</sup>	*
b. Iodine Sampler	W <sup>(3)</sup>	N.A.	N.A.	N.A.	*
c. Particulate Sampler	W <sup>(3)</sup>	N.A.	N.A.	N.A.	*
d. Effluent System Flow Rate Monitor	D	N.A.	R	Q	*
e. Sampler Flow Rate Monitor	D	N.A.	R	Q	*
<b>2. UNIT 1 VENT RADIATION MONITOR</b>					
a. Noble Gas Activity Monitor	D	M	R <sup>(2)</sup>	Q <sup>(1)</sup>	*
b. Iodine Sampler	W <sup>(3)</sup>	N.A.	N.A.	N.A.	*
c. Particulate Sampler	W <sup>(3)</sup>	N.A.	N.A.	N.A.	*
d. Effluent System Flow Rate Monitor	D	N.A.	R	Q	*
e. Sampler Flow Rate Monitor	D	N.A.	R	Q	*



TABLE 4.3.7.10-1 (Continued)

RADIOACTIVE GASEOUS EFFLUENT MONITORING INSTRUMENTATION SURVEILLANCE REQUIREMENTS

<u>INSTRUMENT</u>	<u>CHANNEL CHECK</u>	<u>SOURCE CHECK</u>	<u>CHANNEL CALIBRATION</u>	<u>CHANNEL MODES IN WHICH FUNCTIONAL SURVEILLANCE TEST REQUIRED</u>	
				<u>TEST</u>	<u>REQUIRED</u>
<b>3. UNIT 2 VENT RADIATION MONITOR</b>					
a. Noble Gas Activity Monitor	D	M	R <sup>(2)</sup>	Q <sup>(1)</sup>	*
b. Iodine Sampler	W <sup>(3)</sup>	N.A.	N.A.	N.A.	*
c. Particulate Sampler	W <sup>(3)</sup>	N.A.	N.A.	N.A.	*
d. Effluent System Flow Rate Monitor	D	N.A.	R	Q	*
e. Sampler Flow Rate Monitor	D	N.A.	R	Q	*
<b>4. TURBINE BUILDING/HEATER BAY VENT RADIATION MONITOR</b>					
a. Noble Gas Activity Monitor	D	M	R <sup>(2)</sup>	Q <sup>(1)</sup>	*
b. Iodine Sampler	W <sup>(3)</sup>	N.A.	N.A.	N.A.	*
c. Particulate Sampler	W <sup>(3)</sup>	N.A.	N.A.	N.A.	*
d. Effluent System Flow Rate Monitor	D	N.A.	R	Q	*
e. Sampler Flow Rate Monitor	D	N.A.	R	Q	*

TABLE 4.3.7.10-1 (Continued)

RADIOACTIVE GASEOUS EFFLUENT MONITORING  
INSTRUMENTATION SURVEILLANCE REQUIREMENTS

TABLE NOTATION

- At all times
- (1) The CHANNEL FUNCTIONAL TEST shall also demonstrate that control room alarm annunciation occurs if any of the following conditions exists:
  1. Instrument indicates measured levels above the alarm setpoint.
  2. Instrument indicates a downscale failure.
  3. Instrument controls not set in operate mode.
- (2) The initial CHANNEL CALIBRATION shall be performed using one or more of the reference standards certified by the National Institute of Standards and Technology (NIST) or using standards that have been obtained from suppliers that participate in measurement assurance activities with NIST. These standards shall permit calibrating the system over its intended energy and measurement range. For subsequent CHANNEL CALIBRATION, sources that have been related to the initial calibration shall be used.
- (3) The iodine cartridges and particulate filters will be changed at least once per 7 days. Performance of this CHANNEL CHECK does not render the system inoperable, and the applicable ACTION statements need not be entered.

### 3/4.11 RADIOACTIVE EFFLUENTS

#### 3/4.11.1 LIQUID EFFLUENTS

##### CONCENTRATION

##### CONTROLS

---

3.11.1.1 In accordance with Perry Nuclear Power Plant TS 5.5.4.b and c, the concentration of radioactive material released in liquid effluents to UNRESTRICTED AREAS (see Figure 3.2-1) shall be limited to the concentrations specified in 10CFR20, Appendix B, Table 2, Column 2, for radionuclides other than dissolved or entrained noble gases. For dissolved and entrained noble gases, the concentration shall be limited to  $2 \times 10^{-4}$   $\mu\text{Ci/ml}$  total activity.

**APPLICABILITY:** At all times.

##### **ACTION:**

With the concentration of radioactive material released in liquid effluents to UNRESTRICTED AREAS exceeding the above limits, immediately restore the concentration to within the above limits.

##### SURVEILLANCE REQUIREMENTS

---

4.11.1.1.1 The radioactivity content of each batch of radioactive liquid waste shall be determined prior to release by sampling and analysis in accordance with Table 4.11.1.1.1-1. The results of pre-release analyses shall be used with the calculational methods in the ODCM to assure that the concentration at the point of release is maintained within the limits of Control 3.11.1.1.

4.11.1.1.2 Post-release analyses of samples composited from batch releases shall be performed in accordance with Table 4.11.1.1.1-1. The results of the radioactivity analysis shall be used in accordance with the methodology and parameters in the ODCM to assure that the concentrations at the point of release are maintained within the limits of Control 3.11.1.1.

4.11.1.1.3 Continuous releases of radioactive liquid effluents shall be sampled and analyzed in accordance with Table 4.11.1.1.1-1. The results of the radioactivity analyses shall be used in accordance with the methodology and parameters in the ODCM to assure that the concentrations at the point of release are maintained within the limits of Control 3.11.1.1.

**TABLE 4.11.1.1.1-1  
RADIOACTIVE LIQUID WASTE SAMPLING AND ANALYSIS PROGRAM**

Liquid Release Type	Sampling Frequency	Minimum Analysis Frequency	Type of Activity Analysis	Lower Limit of Detection (LLD) ( $\mu\text{Ci/ml}$ ) <sup>a</sup>		
A. Batch Waste Release Tanks <sup>c</sup>	P Each batch	P Each batch	Principal Gamma Emitters <sup>d</sup>	$5 \times 10^{-7}$		
			I-131	$1 \times 10^{-6}$		
	P One Batch/M	M	Dissolved and Entrained Gases (Gamma emitters)	$1 \times 10^{-5}$		
			P Each Batch	M Composite <sup>b</sup>	H-3	$1 \times 10^{-5}$
					Gross Alpha	$1 \times 10^{-7}$
P Each Batch	Q Composite <sup>b</sup>	Sr-89, Sr-90	$5 \times 10^{-8}$			
		Fe-55	$1 \times 10^{-6}$			
B. Continuous Releases <sup>e</sup> RHR Heat Exchanger ESW Outlet, M35 Drains, or Service Water <sup>g</sup>	D Grab Sample <sup>f,s</sup>	W Composite <sup>b,f,s,h</sup>	Principal Gamma Emitters <sup>d</sup>	$5 \times 10^{-7}$		
			I-131	$1 \times 10^{-6}$		
	M <sup>g</sup> Grab Sample	M	Dissolved and Entrained Gases (Gamma emitters)	$1 \times 10^{-5}$		
			D Grab Sample <sup>g</sup>	M Composite <sup>b,s</sup>	H-3	$1 \times 10^{-5}$
	Gross Alpha	$1 \times 10^{-7}$				
	D Grab Sample <sup>g</sup>	Q Composite <sup>b,s</sup>	Sr-89, Sr-90	$5 \times 10^{-8}$		
			Fe-55	$1 \times 10^{-6}$		

October  
2017

TABLE 4.11.1.1.1-1 (Continued)

RADIOACTIVE LIQUID WASTE SAMPLING AND ANALYSIS PROGRAM

TABLE NOTATION

- a. The LLD is the smallest concentration of radioactive material in a sample that will yield a net count (above system background) that will be detected with 95% probability with only 5% probability of falsely concluding that a blank observation represents a "real" signal.

It should be recognized that the LLD is defined as an "a priori" (before the fact) limit representing the capability of a measurement system and not as an "a posteriori" (after the fact) limit for a particular measurement.

For a particular measurement system (which may include radiochemical separation):

$$LLD = \frac{4.66s_b}{(E)(V)(2.22 \times 10^6)(Y) \exp(-\lambda \Delta t)}$$

Where:

- LLD is the "a priori" lower limit of detection as defined above (as  $\mu\text{Ci}$  per unit mass or volume).
- $s_b$  is the standard deviation of the background counting rate or of the counting rate of a blank sample as appropriate (as counts per minute)
- E is the counting efficiency (as counts per disintegration)
- V is the sample size (in units of mass or volume)
- $2.22 \times 10^6$  is the number of disintegrations per minute per microcurie
- Y is the fractional radiochemical yield (when applicable)
- $\lambda$  is the radioactive decay constant for the particular radionuclide ( $\text{sec}^{-1}$ )
- $\Delta t$  is the elapsed time between sample collection (or end of the sample collection period) and time of counting (sec)

Typical values of E, V, Y and  $\Delta t$  should be used in the calculation.

TABLE 4.11.1.1.1-1 (Continued)

RADIOACTIVE LIQUID WASTE SAMPLING AND ANALYSIS PROGRAM

TABLE NOTATION (Continued)

- b. A composite sample is one in which the quantity of liquid sampled is proportional to the quantity of liquid waste discharged and in which the method of sampling employed results in a specimen which is representative of the liquids released. A composite sample may also be obtained from liquid batches of similar origin that are not discharged as these liquid batches are expected to be representative of samples that could be discharged. Composite samples for batch liquids that were not released is performed to provide non-gamma emitting isotopic values to verify other batches are within limits prior to release when recent non-gamma emitting isotopic values for discharged liquids are not available.
- c. A batch release is the discharge of liquid wastes of a discrete volume. Prior to sampling for analyses, each batch shall be isolated, and then thoroughly mixed to assure representative sampling.
- d. The principal gamma emitters for which the LLD specification applies exclusively are the following radionuclides: Mn-54, Fe-59, Co-58, Co-60, Zn-65, Mo-99, Cs-134, Cs-137, and Ce-141. Ce-144 shall also be measured, but with an LLD of  $5 \times 10^{-6}$ . This list does not mean that only these nuclides are to be detected and reported. Other peaks which are measurable and identifiable, together with the above nuclides, shall also be identified and reported in the Annual Radioactive Effluent Release Report pursuant to Control 6.9.1.7 in the format outlined in Regulatory Guide 1.21, Appendix B, Revision 1, June 1974.
- e. A continuous release is the discharge of liquid wastes of a non-discrete volume, e.g., from a volume of a system that has an input flow during the continuous release. Sampling/Analysis of RHR Heat Exchanger is only applicable when there is ESW flow through the RHR Heat Exchanger.
- f. Sampling and analysis is required of the RHR heat exchanger ESW outlet every 12 hours when the samples indicate levels greater than LLD.
- g. Sampling is only required for M35 drains, when the M35 drains have been lined up to storm drains. If activity other than tritium or naturally occurring isotopes is detected in the M35 drains, then these drains shall be lined up to radwaste
- h. Sampling/Analysis of Service Water is only applicable when there is Service Water flow through the ADHR Heat Exchanger.

**RADIOACTIVE EFFLUENTS**

**DOSE**

**CONTROLS**

---

3.11.1.2 In accordance with Perry Nuclear Power Plant Unit 1 TS 5.5.4.d and e, the dose or dose commitment to a MEMBER OF THE PUBLIC from radioactive materials in liquid effluents released, from each reactor unit, to UNRESTRICTED AREAS (see Figure 3.2-1) shall be limited:

- a. During the current quarter to less than or equal to 1.5 mrem to the whole body and to less than or equal to 5 mrem to any organ; and
- b. During the current year to less than or equal to 3 mrem to the whole body and to less than or equal to 10 mrem to any organ.

**APPLICABILITY:** At all times.

**ACTION:**

- a. With the calculated dose from the release of radioactive materials in liquid effluents exceeding any of the above limits, prepare and submit to the Commission within 30 days, pursuant to Control 6.9.2, a Special Report which identifies the cause(s) for exceeding the limit(s) and defines the corrective actions that have been taken to reduce the releases and the corrective actions to be taken to ensure that future releases will be in compliance with the above limits.
- b. The provisions of Control 3.0.3 are not applicable.

**SURVEILLANCE REQUIREMENTS**

---

4.11.1.2 Dose Calculations. Cumulative dose contributions from liquid effluents for the current quarter and the current year shall be determined in accordance with the methodology and parameters of the ODCM at least once per 31 days.

RADIOACTIVE EFFLUENTS

LIQUID RADWASTE TREATMENT SYSTEM

CONTROLS

---

3.11.1.3 In accordance with Perry Nuclear Power Plant Unit 1 TS 5.5.4.f, the LIQUID RADWASTE TREATMENT SYSTEM shall be OPERABLE and appropriate portions of the system shall be used to reduce the release of radioactivity when the projected doses due to the liquid effluent from each reactor unit to UNRESTRICTED AREAS (see Figure 3.2-1) would exceed 0.06 mrem to the whole body or 0.2 mrem to any organ, in a 31-day period.

APPLICABILITY: At all times.

ACTION:

- a. With radioactive liquid waste being discharged without treatment and in excess of the above limits, and any portion of the liquid radwaste treatment system not in operation, prepare and submit to the Commission, within 30 days pursuant to Control 6.9.2, a Special Report which includes the following information:
  1. Explanation of why liquid radwaste was being discharged without treatment, identification of any inoperable equipment or subsystems, and the reason for the inoperability, and
  2. Action(s) taken to restore the inoperable equipment to OPERABLE status, and
  3. Summary description of action(s) taken to prevent a recurrence.
- b. The provisions of Control 3.0.3 are not applicable.

SURVEILLANCE REQUIREMENTS

---

4.11.1.3.1 Doses due to liquid releases from each reactor unit to UNRESTRICTED AREAS shall be projected at least once per 31 days, in accordance with methodology and parameters in the ODCM.

4.11.1.3.2 The installed LIQUID RADWASTE TREATMENT SYSTEM shall be demonstrated OPERABLE by meeting Controls 3.11.1.1 and 3.11.1.2.



## RADIOACTIVE EFFLUENTS

### 3/4.11.2 GASEOUS EFFLUENTS

#### DOSE RATE

#### CONTROLS

---

3.11.2.1 In accordance with Perry Nuclear Power Plant Unit 1 TS 5.5.4.c and g, the dose rate due to radioactive materials released in gaseous effluents from the site to areas at and beyond the SITE BOUNDARY (see Figure 3.2-1) shall be limited to the following:

- a. For noble gases: Less than or equal to 500 mrem/yr to the whole body and less than or equal to 3000 mrem/yr to the skin, and
- b. For all iodine-131, iodine-133, tritium and all radionuclides in particulate form with half-lives greater than 8 days: Less than or equal to 1500 mrem/yr to any organ.

APPLICABILITY: At all times.

#### ACTION:

With the dose rate(s) exceeding the above limits, immediately decrease the release rate(s) to within the above limit(s).

#### SURVEILLANCE REQUIREMENTS

---

4.11.2.1.1 The dose rate due to noble gases in gaseous effluents shall be determined to be within the above limits in accordance with the methodology and parameters of the ODCM.

4.11.2.1.2 The dose rate due to iodine-131, iodine-133, tritium and to radionuclides in particulate form with half-lives greater than 8 days in gaseous effluents shall be determined to be within the above limits in accordance with the methodology and parameters of the ODCM by obtaining representative samples and performing analyses in accordance with the sampling and analysis program specified in Table 4.11.2.1.2-1.

TABLE 4.11.2.1.2-1  
RADIOACTIVE GASEOUS WASTE SAMPLING AND ANALYSIS PROGRAM

GASEOUS RELEASE PATH	SAMPLING FREQUENCY	MINIMUM ANALYSIS FREQUENCY	TYPE OF ACTIVITY ANALYSIS	LOWER LIMIT OF DETECTION (LLD) <sup>(e)</sup> (μCi/mL)
A. Containment Vessel and Drywell Purge (M14) System, and Combustible Gas Control (M51) System	Each PURGE <sup>(b)</sup> and VENT	Each PURGE <sup>(b)</sup> and VENT	Principal Gamma Emitters <sup>(e)</sup>	1x10 <sup>-4</sup>
	Grab Sample			
B. Offgas Vent, Unit 1 Vent, Unit 2 Vent, and Turbine Bldg/Heater Bay Vent	M	M	H-3	1x10 <sup>-6</sup>
	Grab Sample	Grab Sample	Principal Gamma Emitters <sup>(b,e)</sup>	1x10 <sup>-4</sup>
C. All Release Paths as listed in B above	Continuous <sup>(d)</sup>	W <sup>(e)</sup> Charcoal Sample	I-131	1x10 <sup>-12</sup>
	Continuous <sup>(d)</sup>	W <sup>(e)</sup> Particulate Sample	I-133	1x10 <sup>-10</sup>
	Continuous <sup>(d)</sup>	M Composite Particulate Filter	Principal Gamma Emitters <sup>(e)</sup> Gross Alpha	1x10 <sup>-11</sup>
	Continuous <sup>(d)</sup>	Q Composite Particulate Filter	Sr-89, Sr-90	1x10 <sup>-11</sup>
	Continuous <sup>(d)</sup>	Noble Gas Monitor <sup>(f)</sup>	Noble Gases Gross Beta or Gamma	1x10 <sup>-6</sup>
				(Xe-133 equivalent)

TABLE 4.11.2.1.2-1 (Continued)

RADIOACTIVE GASEOUS WASTE SAMPLING AND ANALYSIS PROGRAM

TABLE NOTATION

- a. The LLD is the smallest concentration of radioactive material in a sample that will yield a net count (above system background) that will be detected with 95% probability with only 5% probability of falsely concluding that a blank observation represents a "real" signal.

It should be recognized that the LLD is defined as an "a priori" (before the fact) limit representing the capability of a measurement system and not as an "a posteriori" (after the fact) limit for a particular measurement.

For a particular measurement system (which may include radiochemical separation):

$$LLD = \frac{4.66 S_b}{(E)(V) \left( 2.22 \times 10^6 \right) (Y) \exp(-\lambda \Delta t)}$$

Where:

- LLD is the "a priori" lower limit of detection as defined above (as  $\mu\text{Ci}$  per unit mass or volume).
- $S_b$  is the standard deviation of the background counting rate or of the counting rate of a blank sample as appropriate (as counts per minute)
- E is the counting efficiency (as counts per disintegration)
- V is the sample size (in units of mass or volume)
- $2.22 \times 10^6$  is the number of disintegrations per minute per microcurie
- Y is the fractional radiochemical yield (when applicable)
- $\lambda$  is the radioactive decay constant for the particular radionuclide ( $\text{sec}^{-1}$ )
- $\Delta t$  is the elapsed time between sample collection (or end of the sample collection period) and time of counting (sec)

Typical values of E, V, Y and  $\Delta t$  should be used in the calculation.

TABLE 4.11.2.1.2-1 (Continued)

RADIOACTIVE GASEOUS WASTE SAMPLING AND ANALYSIS PROGRAM

TABLE NOTATION (Continued)

- b. Analyses shall also be performed following startup, shutdown, or a THERMAL POWER change exceeding 15 percent of the RATED THERMAL POWER within a one hour period. This requirement does not apply if (1) analysis shows that the DOSE EQUIVALENT I-131 concentration in the primary coolant has not increased more than a factor of 3; and (2) the noble gas monitor shows that effluent activity has not increased more than a factor of 3.
- c. Samples shall be changed at least once per 7 days and analyses shall be completed within 48 hours after changing or after removal from sampler. Sampling and analyses shall also be performed at least daily ( $\geq 24$  hours) for at least 7 days following each shutdown, startup or THERMAL POWER change exceeding 15 percent of RATED THERMAL POWER in one hour. When samples collected for 24 hours are analyzed, the corresponding LLD's may be increased by a factor of 10. This requirement does not apply if:
- (1) Analysis shows that the DOSE EQUIVALENT I-131 concentration in the primary coolant has not increased more than a factor of 3; and
  - (2) The noble gas monitor shows that effluent activity has not increased more than a factor of 3. If the noble gas monitor is not operable, then a grab sample may be used to demonstrate that activity has not increased by a factor of 3.
- d. The ratio of the sample flow rate to the sampled stream flow rate shall be known for the time period covered by each dose or dose rate calculation made in accordance with Control 3.11.2.1, 3.11.2.2 and 3.11.2.3.
- e. The principal gamma emitters for which the LLD specification applies exclusively are the following radionuclides: Kr-87, Kr-88, Xe-133, Xe-133m, Xe-135, and Xe-138 for gaseous emissions and Mn-54, Fe-59, Co-58, Co-60, Zn-65, Mo-99, I-131, Cs-134, Cs-137, Ce-141 and Ce-144 for particulate emissions. This list does not mean that only these nuclides are to be detected and reported. Other peaks which are measurable and identifiable, together with the above nuclides, shall also be identified and reported in the Annual Radioactive Effluent Release Report pursuant to Control 6.9.1.7 in the format outlined in Regulatory Guide 1.21, Appendix B, Revision 1, June 1974.
- f. Sampling and analysis of gaseous release points shall be performed initially whenever a high alarm setpoint is exceeded or whenever two or more of the alert setpoints are exceeded. If the high alarm setpoint or two or more of the alert setpoints continue to be exceeded, verify at least once per 4 hours via the radiation monitors that plant releases are below the Control 3.11.2.1 dose rate limits and sampling and analysis shall be performed at least once per 12 hours.

**RADIOACTIVE EFFLUENTS**

**DOSE - NOBLE GASES**

**CONTROLS**

---

**3.11.2.2** In accordance with Perry Nuclear Power Plant Unit 1 TS 5.5.4.e and h, the air dose due to noble gases released in gaseous effluents, from each reactor unit, from the site to areas at and beyond the SITE BOUNDARY (see Figure 3.2-1) shall be limited to the following:

- a. During the current quarter: Less than or equal to 5 mrad for gamma radiation and less than or equal to 10 mrad for beta radiation; and
- b. During the current year: Less than or equal to 10 mrad for gamma radiation and less than or equal to 20 mrad for beta radiation.

**APPLICABILITY:** At all times.

**ACTION:**

- a. With the calculated air dose from the radioactive noble gases in gaseous effluents exceeding any of the above limits, prepare and submit to the Commission within 30 days, pursuant to Control 6.9.2, a Special Report which identifies the cause(s) for exceeding the limit(s) and defines the corrective actions to be taken to ensure that future releases will be in compliance with Control 3.11.2.2.
- b. The provisions of Control 3.0.3 are not applicable.

**SURVEILLANCE REQUIREMENTS**

---

**4.11.2.2 Dose Calculations.** Cumulative dose contributions for noble gases for the current quarter and current year shall be determined in accordance with the methodology and parameters in the ODCM at least once per 31 days.

## RADIOACTIVE EFFLUENTS

### DOSE - IODINE-131, IODINE-133, TRITIUM AND RADIONUCLIDES IN PARTICULATE FORM

#### CONTROLS

---

3.11.2.3 In accordance with Perry Nuclear Power Plant Unit 1 TS 5.5.4.e and i, the dose to a MEMBER OF THE PUBLIC from iodine-131, iodine-133, tritium and radionuclides in particulate form with half-lives greater than 8 days in gaseous effluents released, from each reactor unit, from the site to areas at and beyond the SITE BOUNDARY (see Figure 3.2-1) shall be limited to the following:

- a. During the current quarter: Less than or equal to 7.5 mrem to any organ; and
- b. During the current year: Less than or equal to 15 mrem to any organ.

**APPLICABILITY:** At all times.

#### ACTION:

- a. With the calculated dose from the release of iodine-131, iodine-133, tritium and radionuclides in particulate form, with half-lives greater than 8 days, in gaseous effluents exceeding any of the above limits, prepare and submit to the Commission within 30 days, pursuant to Control 6.9.2, a Special Report which identifies the cause(s) for exceeding the limit and defines the corrective actions that have been taken to reduce releases and the proposed corrective actions to be taken to ensure that future releases will be in compliance with Control 3.11.2.3.
- b. The provisions of Control 3.0.3 are not applicable.

#### SURVEILLANCE REQUIREMENTS

---

4.11.2.3 Dose Calculations. Cumulative dose contributions from iodine-131, iodine-133, tritium and radionuclides in particulate form with half-lives greater than 8 days for the current quarter and current year shall be determined in accordance with the methodology and parameters in the ODCM at least once per 31 days.

RADIOACTIVE EFFLUENTS

GASEOUS RADWASTE (OFF-GAS) TREATMENT

CONTROLS

---

3.11.2.4 The GASEOUS RADWASTE TREATMENT (OFFGAS) SYSTEM shall be in operation\*. The Charcoal bypass mode shall not be used unless the off-gas post-treatment radiation monitor is OPERABLE.

October  
2017

APPLICABILITY: Whenever the main condenser air ejector evacuation system is in operation.

ACTION:

- a. With gaseous radwaste from the main condenser air ejector system being discharged without treatment for more than 7 consecutive days, prepare and submit to the Commission within 30 days, pursuant to Control 6.9.2, a Special Report which includes the following information:
  1. Explanation of why gaseous radwaste was being discharged without treatment, identification of the inoperable equipment or subsystems which resulted in gaseous radwaste being discharged without treatment, and the reason for inoperability.
  2. Action(s) taken to restore the inoperable equipment to OPERABLE status, and
  3. Summary description of action(s) taken to prevent a recurrence.
- b. The provisions of Control 3.0.3 are not applicable.

SURVEILLANCE REQUIREMENTS

---

4.11.2.4 The readings of relevant instrumentation shall be checked at least once per 12 hours when the main condenser air ejector is in use to ensure that the gaseous radwaste treatment system is functioning.

\* Flow directed through the adsorber beds.

October  
2017

**RADIOACTIVE EFFLUENTS**

**VENTILATION EXHAUST TREATMENT SYSTEMS**

**CONTROLS**

---

3.11.2.5 The VENTILATION EXHAUST TREATMENT SYSTEMS shall be OPERABLE and appropriate portions of the system shall be used to reduce releases of radioactivity when the projected dose due to gaseous effluent releases from each reactor unit to areas at and beyond the SITE BOUNDARY (see Figure 3.2-1) in a 31 day period would exceed 0.3 mrem to any organ of a MEMBER OF THE PUBLIC.

**APPLICABILITY:** At all times.

**ACTION:**

- a. With radioactive gaseous waste being discharged without treatment and in excess of the above limits, prepare and submit to the Commission within 30 days, pursuant to Control 6.9.2, a Special Report which includes the following information:
  1. Explanation of why gaseous radwaste was being discharged without treatment, identification of any inoperable equipment or subsystems which resulted in gaseous radwaste being discharged without treatment, and the reason for the inoperability,
  2. Action(s) taken to restore the inoperable equipment to OPERABLE status, and
  3. Summary description of action(s) taken to prevent a recurrence.
- b. The provisions of Control 3.0.3 are not applicable.

**SURVEILLANCE REQUIREMENTS**

---

4.11.2.5.1 Doses due to gaseous releases from each reactor unit to areas at and beyond the SITE BOUNDARY shall be projected at least once per 31 days in accordance with the methodology and parameters in the ODCM.

4.11.2.5.2 The installed VENTILATION EXHAUST TREATMENT SYSTEMS shall be demonstrated OPERABLE by meeting Controls 3.11.2.1 and 3.11.2.3.



## RADIOACTIVE EFFLUENTS

### 3/4.11.4 TOTAL DOSE

#### CONTROLS

---

3.11.4 In accordance with Perry Nuclear Power Plant Unit 1 TS 5.5.4.j, the current year dose or dose commitment to any MEMBER of THE PUBLIC, due to releases of radioactivity and radiation, from uranium fuel cycle sources shall be limited to less than or equal to 25 mrem to the whole body or any organ, except the thyroid, which shall be limited to less than or equal to 75 mrem.

APPLICABILITY: At all times.

#### ACTION:

- a. With the calculated doses from the release of radioactive materials in liquid or gaseous effluents exceeding twice the limits of Control 3.11.1.2a., 3.11.1.2b., 3.11.2.2a., 3.11.2.2b., 3.11.2.3a, or 3.11.2.3b., calculations shall be made including direct radiation contributions from the reactor units, from the ISFSI and from outside storage tanks to determine whether the above limits of Control 3.11.4 have been exceeded.
  1. If such is the case, prepare and submit to the Commission within 30 days, pursuant to Control 6.9.2, a Special Report that defines the corrective action to be taken to reduce subsequent releases to prevent recurrence of exceeding the above limits and includes the schedule for achieving conformance with the above limits.
  2. This Special Report, as defined in 10CFR20.405c, shall include an analysis that estimates the radiation exposure (dose) to a MEMBER OF THE PUBLIC from uranium fuel cycle sources, including all effluent pathways and direct radiation, for the current year that includes the release(s) covered by this report. It shall also describe levels of radiation and concentrations of radioactive material involved, and the cause of the exposure levels or concentrations.
  3. If the estimated dose(s) exceeds the above limits, and if the release condition resulting in violation of 40CFR190 has not already been corrected, the Special Report shall include a request for a variance in accordance with the provisions of 40CFR190. Submittal of the report is considered a timely request, and a variance is granted until staff action on the request is complete.
- b. The provisions of Control 3.0.3 are not applicable.

## SURVEILLANCE REQUIREMENTS

---

4.11.4.1 Cumulative dose contributions from liquid and gaseous effluents shall be determined in accordance with Controls 4.11.1.2, 4.11.2.2, and 4.11.2.3, and in accordance with the methodology and parameters in the ODCM.

4.11.4.2 If the cumulative dose contributions exceed the limits defined in 3.11.4, ACTION a, cumulative dose contributions from direct radiation from unit operation including from the ISFSI and outside storage tanks shall be determined in accordance with the methodology and parameters in the ODCM.

3/4.12 RADIOLOGICAL ENVIRONMENTAL MONITORING

3/4.12.1 MONITORING PROGRAM

CONTROLS

---

3.12.1 The radiological environmental monitoring program shall be conducted as specified in Table 3.12.1-1.

APPLICABILITY: At all times.

ACTION:

- a. With the radiological environmental monitoring program not being conducted as specified in Table 3.12.1-1, prepare and submit to the Commission, in the Annual Environmental and Effluent Release Report per Control 6.9.1.6, a description of the reasons for not conducting the program as required and the plans for preventing a recurrence.
- b. With the level of radioactivity as the result of plant effluents in an environmental sampling medium at a specified location exceeding the reporting levels of Table 3.12.1-2 when averaged over the current quarter, prepare and submit to the Commission within 30 days pursuant to Control 6.9.2 a Special Report that identifies the cause(s) for exceeding the limit(s) and defines the corrective actions to be taken to reduce radioactive effluents so that the potential annual dose to a MEMBER OF THE PUBLIC is less than the current year limits of Control 3.11.1.2, 3.11.2.2 and 3.11.2.3. When more than one of the radionuclides in Table 3.12.1-2 are detected in the sampling medium, this report shall be submitted if:

$$\frac{\text{concentration (1)}}{\text{reporting level (1)}} + \frac{\text{concentration (2)}}{\text{reporting level (2)}} + \dots \geq 1.0$$

When radionuclides other than those in Table 3.12.1-2 are detected and are the result of plant effluents, this report shall be submitted if the potential annual dose\* to a MEMBER OF THE PUBLIC is equal to or greater than the current year limits of Control 3.11.1.2, 3.11.2.2 and 3.11.2.3. This report is not required if the measured level of radioactivity was not the result of plant effluents; however, in such an event, the condition shall be reported and described in the annual Radiological Environmental Operating Report required by Control 6.9.1.6.

---

\* The methodology and parameters used to estimate the potential annual dose to a MEMBER OF THE PUBLIC shall be indicated in this report.

**RADIOLOGICAL ENVIRONMENTAL MONITORING**

**CONTROLS**

---

- c. With milk or broad leaf vegetation samples unavailable from one or more of the sample locations required by Table 3.12.1-1, identify specific locations for obtaining replacement samples and add them within 30 days to the Radiological Environmental Monitoring Program given in the ODCM. The specific locations from which samples were unavailable may then be deleted from the monitoring program. Pursuant to Control 6.9.1.7, submit in the next Annual Radiological Effluent Release Report documentation for a change in the ODCM including a revised figure(s) and table for the ODCM reflecting the new location(s) with supporting information identifying the cause of the unavailability of samples and justifying the selection of the new location(s) for obtaining samples.
  
- d. The provisions of Control 3.0.3 are not applicable.

**SURVEILLANCE REQUIREMENTS**

---

4.12.1 The radiological environmental monitoring samples shall be collected pursuant to Table 3.12.1-1 from the specific locations given in the table and figures in the ODCM and shall be analyzed pursuant to the requirements of Table 3.12.1-1 and the detection capabilities required by Table 4.12.1-1.

TABLE 3.12.1-1

RADIOLOGICAL ENVIRONMENTAL MONITORING PROGRAM\*

<u>Exposure Pathway and/or Sample</u>	<u>Number of Samples and (1) Sample Locations</u>	<u>Sampling and Collection Frequency</u>	<u>Type and Frequency of Analysis</u>
1. Direction Radiation(2)	<p>Twenty-nine routine monitoring stations either with two or more dosimeters or with one instrument for measuring and recording dose rate continuously, placed as follows:</p> <p>An inner ring of stations, one in each meteorological sector, other than those sectors entirely over water (N, NNE, NNW, NW, W, WNW), in the general area of the SITE BOUNDARY;</p> <p>An outer ring of stations, one in each meteorological sector, other than those sectors entirely over water (N, NE, NNE, NNW, NW, W, WNW), in the 6- to 8-km range from the site; and</p> <p>The balance of the stations to be placed in special interest areas such as population centers, nearby residences, schools, and in one or two areas to serve as control stations</p>	Quarterly	Gamma dose quarterly

October  
2017

TABLE 3.12.1-1 (Continued)

RADIOLOGICAL ENVIRONMENTAL MONITORING PROGRAM

<u>Exposure Pathway and/or Sample</u>	<u>Number of Samples and (1) Sample Locations</u>	<u>Sampling and Collection Frequency</u>	<u>Type and Frequency of Analysis</u>
2. Airborne	<p>Samples from five locations:</p> <p>Three samples from close to the three SITE BOUNDARY locations, in different sectors, of the highest calculated annual average ground-level D/Q;</p> <p>One sample from the vicinity of a community having the highest calculated annual average ground-level D/Q; and</p> <p>One sample from a control location, as for example 15 to 30 km distant and in the least prevalent wind direction</p>	<p>Continuous sampler operation with sample collection weekly, or more frequently if required by dust loading</p>	<p><b>Radioiodine Canister:</b> I-131 analysis weekly</p> <p><b>Particulate Sampler:</b> Gross beta radioactivity analysis following filter replacement (3), and gamma isotopic analysis (4) of composite (by location) quarterly</p>
3. Waterborne a. Surface	Two samples	Composite sample over a 1-month period (5)	Gamma isotopic analysis (4) monthly. Composite for tritium analysis quarterly

TABLE 3.12.1-1 (Continued)

RADIOLOGICAL ENVIRONMENTAL MONITORING PROGRAM

<u>Exposure Pathway and/or Sample</u>	<u>Number of Samples and (1) Sample Locations</u>	<u>Sampling and Collection Frequency</u>	<u>Type and Frequency of Analysis</u>
3. Waterborne (Continued)			
b. Drinking	One sample of each of one to three of the nearest water supplies that could be affected by its discharge  One sample from a control location	Composite sample over 2-week period (6) when I-131 analysis is performed; monthly composite otherwise	I-131 analysis on each composite when the dose calculated from the consumption of the water is greater than 1 mrem per year (6). Composite for gross beta and gamma isotopic analyses (4) monthly. Composite for tritium analysis quarterly
c. Sediment from shoreline	One sample from area with existing or potential recreational value	Semi-annually	Gamma isotopic analysis (4) semi-annually
4. Ingestion			
a. Milk	Samples from milking animals in three locations within 5 km distance having the highest dose potential. If there are none, then one sample from milking animals in each of between 5 to 8 km distant where doses are three areas calculated to be greater than 1 mrem per yr (6). One sample from milking animals at a control location 15 to 30 km distant and in the least prevalent wind direction.	Semi-monthly when animals are on pasture; monthly at other times	Gamma isotopic analysis (4) and I-131 analysis semi-monthly, when animals are on pasture; monthly at other times

TABLE 3.12.1-1 (Continued)

RADIOLOGICAL ENVIRONMENTAL MONITORING PROGRAM

Exposure Pathway and/or Sample	Number of Samples and <sup>(1)</sup> Sample Locations	Sampling and Collection Frequency	Type and Frequency of Analysis
4. Ingestion (Continued)			
b. Fish and Invertebrates	One sample of each commercially and recreationally important species (if seasonal) in vicinity of plant discharge area	One sample in season or semiannually if they are not seasonal	Gamma isotopic analysis <sup>(4)</sup> on edible portions
	One sample of same species in areas not influenced by plant discharge		
c. Food Products	Sample of three different kinds of broad leaf vegetation grown nearest each of two different offsite locations of highest predicted annual average ground level D/Q if milk sampling is not performed	Monthly during growing season	Gamma isotopic analysis <sup>(4)</sup> and I-131 analysis
	One sample of each of the similar broad leaf vegetation grown 15 to 30 km distant in the least prevalent wind direction if milk sampling is not performed	Monthly during growing season	Gamma isotopic analysis <sup>(4)</sup> and I-131 analysis

October 2017

TABLE 3.12.1-1 (Continued)

RADIOLOGICAL ENVIRONMENTAL MONITORING PROGRAM

TABLE NOTATIONS

- Sample locations are given on the figure and the table in the ODCM.
- (1) Specific parameters of distance and direction sector from the centerline of one reactor, and additional description where pertinent, shall be provided for each and every sample location in Table 3.12-1 in a table and figure(s) in the ODCM. Refer to NUREG-0133, "Preparation of Radiological Effluent Technical Specifications for Nuclear Power Plants," October 1978, and to Radiological Assessment Branch Technical Position, Revision 1, November 1979. Deviations are permitted from the required sampling schedule if specimens are unobtainable due to circumstances such as hazardous conditions, seasonal unavailability, and malfunction of automatic sampling equipment. If specimens are unobtainable due to sampling equipment malfunction, effort shall be made to complete corrective action prior to the end of the next sampling period. All deviations from the sampling schedule shall be documented in the annual Radiological Environmental Operating Report pursuant to Control 6.9.1.6. It is recognized that, at times, it may not be possible or practicable to continue to obtain samples of the media of choice at the most desired location or time. In these instances, suitable specific alternative media and locations may be chosen for the particular pathway in question and appropriate substitutions made with 30 days in the Radiological Environmental Monitoring Program given in the ODCM. Pursuant to Control 6.9.1.7, submit in the next annual Radioactive Effluent Release Report documentation for a change in the ODCM, including a revised figure(s) and table for the ODCM reflecting the new location(s) with supporting information identifying the cause of the unavailability of samples for that pathway and justifying the selection of the new location(s) for obtaining samples.
  - (2) One or more instruments, such as a pressurized ion chamber, for measuring and recording dose rate continuously may be used in place of, or in addition to, integrating dosimeters. For the purposes of this table, a thermoluminescent dosimeter (TLD) is considered to be one phosphor; two or more phosphors in a packet are considered as two or more dosimeters. Film badges shall not be used as dosimeters for measuring direct radiation. (The frequency of analysis or readout for TLD systems will depend upon the characteristics of the specific system used and should be selected to obtain optimum dose information with minimal fading.)
  - (3) Airborne particulate sample filters shall be analyzed for gross beta radioactivity 24 hours or more after sampling to allow for radon and thoron daughter decay. If gross beta activity in air particulate samples is greater than 10 times the yearly mean of control samples, gamma isotopic analysis shall be performed on the individual samples.
  - (4) Gamma isotopic analysis means the identification and quantification of gamma-emitting radionuclides that may be attributable to the effluents from the facility.
  - (5) A composite sample is one in which the quantity (aliquot) of liquid sampled is proportional to the quantity of flowing liquid and in which the method of sampling employed results in a specimen that is representative of the liquid flow. In this program composite sample aliquots shall be collected at time intervals that are very short (e.g., hourly) relative to the compositing period (e.g., monthly) in order to assure obtaining a representative sample.
  - (6) The dose shall be calculated for the maximum organ and age group, using the methodology and parameters in the ODCM.



TABLE 3.12.1-2

**REPORTING LEVELS FOR RADIOACTIVITY CONCENTRATIONS IN ENVIRONMENTAL SAMPLES**

Analysis	Water (pCi/L)	Reporting Levels				
		Airborne Particulate or Gases (pCi/m <sup>3</sup> )	Fish (pCi/kg, wet)	Milk (pCi/L)	Broodleaf Vegetation (pCi/kg, wet)	
H-3	$2 \times 10^{4a}$	N.A.	N.A.	N.A.	N.A.	
Mn-54	$1 \times 10^3$	N.A.	$3 \times 10^4$	N.A.	N.A.	
Fe-59	$4 \times 10^2$	N.A.	$1 \times 10^4$	N.A.	N.A.	
Co-58	$1 \times 10^3$	N.A.	$3 \times 10^4$	N.A.	N.A.	
Co-60	$3 \times 10^2$	N.A.	$1 \times 10^4$	N.A.	N.A.	
Zn-65	$3 \times 10^2$	N.A.	$2 \times 10^4$	N.A.	N.A.	
Zr-Nb-95	$4 \times 10^2$	N.A.	N.A.	N.A.	N.A.	
I-131	$2^b$	0.9	N.A.	3	$1 \times 10^2$	
Cs-134	30	10	$1 \times 10^3$	60	$1 \times 10^3$	
Cs-137	50	20	$2 \times 10^3$	70	$2 \times 10^3$	
Ba-La-140	$2 \times 10^2$	N.A.	N.A.	$3 \times 10^2$	N.A.	

<sup>a</sup>For drinking water samples. This is a 40CFR141 value. If no drinking water pathway exists, a value of 30,000 pCi/L may be used.

<sup>b</sup>If no drinking water pathway exists, a value of 20 pCi/L may be used.

TABLE 4.12.1-1

(a),(b),(c)

**MAXIMUM VALUES FOR THE LOWER LIMITS OF DETECTION (LLD)  
IN ENVIRONMENTAL SAMPLES**

Analysis	Water (pCi/l)	Airborne Particulate or Gases (pCi/m <sup>3</sup> )	Fish (pCi/kg, wet)	Milk (pCi/l)	Broad Leaf Vegetation (pCi/kg, wet)	Sediment (pCi/kg, wet)
Gross beta	4	1 x 10 <sup>-2</sup>	N.A.	N.A.	N.A.	N.A.
H-3	2000*	N.A.	N.A.	N.A.	N.A.	N.A.
Mn-54	15	N.A.	130	N.A.	N.A.	N.A.
Fe-59	30	N.A.	260	N.A.	N.A.	N.A.
Co-58,60	15	N.A.	130	N.A.	N.A.	N.A.
Zn-65	30	N.A.	260	N.A.	N.A.	N.A.
Zr-95	30	N.A.	N.A.	N.A.	N.A.	N.A.
Nb-95	15	N.A.	N.A.	N.A.	N.A.	N.A.
I-131	1**	7 x 10 <sup>-2</sup>	N.A.	1	60	N.A.
Cs-134	15	5 x 10 <sup>-3</sup>	130	15	60	150
Cs-137	18	6 x 10 <sup>-2</sup>	150	18	80	180
Ba-140	60	N.A.	N.A.	60	N.A.	N.A.
La-140	15	N.A.	N.A.	15	N.A.	N.A.

\*If no drinking water pathway exists, a value of 3000 pCi/l may be used.

\*\*If no drinking water pathway exists, a value of 15 pCi/l may be used.

TABLE 4.12.1-1 (Continued)

MAXIMUM VALUES FOR THE LOWER LIMITS OF DETECTION (LLD)

TABLE NOTATION

<sup>a</sup> Acceptable detection capabilities for thermoluminescent dosimeters used for environmental measurements are given in Regulatory Guide 4.13.

<sup>b</sup> Table 4.12-1 indicates acceptable detection capabilities for radioactive materials in environmental samples. These detection capabilities are tabulated in terms of the lower limits of detection (LLDs). The LLD is defined, for purposes of this guide, as the smallest concentration of radioactive material in a sample that will yield a net count (above system background) that will be detected with 95% probability with only 5% probability of falsely concluding that a blank observation represents a "real" signal.

For a particular measurement system (which may include radiochemical separation):

$$LLD = \frac{4.66 S_B}{(E)(V)(2.22 \times 10^6)(Y) \exp(-\lambda \Delta t)}$$

Where:

- LLD is the "a priori" lower limit of detection as defined above (as  $\mu\text{Ci}$  per unit mass or volume).
- $S_B$  is the standard deviation of the background counting rate or of the counting rate of a blank sample as appropriate (as counts per minute)
- E is the counting efficiency (as counts per disintegration)
- V is the sample size (in units of mass or volume)
- $2.22 \times 10^6$  is the number of disintegrations per minute per microcurie
- Y is the fractional radiochemical yield (when applicable)
- $\lambda$  is the radioactive decay constant for the particular radionuclide ( $\text{sec}^{-1}$ )
- $\Delta t$  is the elapsed time between sample collection (or end of the sample collection period) and time of counting (sec)

Typical values of E, V, Y and  $\Delta t$  should be used in the calculation.

TABLE 4.12.1-1 (Continued)

MAXIMUM VALUES FOR THE LOWER LIMITS OF DETECTION (LLD)

TABLE NOTATION (continued)

It should be recognized that the LLD is defined as an "a priori" (before the fact) limit representing the capability of a measurement system and not as an "a posteriori" (after the fact) limit for a particular measurement.

Occasionally background fluctuations, unavoidable small sample size, the presence of interfering nuclides, or other uncontrollable circumstances may render these LLDs unachievable. In such cases, the contributing factors should be identified and described in the annual Radiological Environmental Operating Report pursuant to Control 6.9.1.6.

The value of  $s_b$  used in the calculation of the LLD for a particular measurement system should be based on the actual observed variance of the background counting rate or of the counting rate of the blank samples (as appropriate) rather than on an unverified theoretically predicated variance.

<sup>c</sup>This list does not mean that only these nuclides are to be considered. Other peaks that are identifiable, together with those of the above nuclides, shall also be analyzed and reported in the Annual Radiological Environmental Operating Report pursuant to Control 6.9.16.

## RADIOLOGICAL ENVIRONMENTAL MONITORING

### 3/4.12.2 LAND USE CENSUS

#### CONTROLS

---

3.12.2 A land use census shall be conducted and shall identify within a distance of 8 km (5 miles) the location in each of the 16 meteorological sectors of the nearest milk animal, the nearest residence and the nearest garden\* of greater than 50 m<sup>2</sup> (500 ft<sup>2</sup>) producing broad leaf vegetation.

APPLICABILITY: At all times.

#### ACTION:

- a. With a land use census identifying a location(s) which yields a calculated dose or dose commitment greater than the values currently being calculated in Control 4.11.2.3, identify the new location(s)\* in the next Annual Radioactive Effluent Release Report, pursuant to Control 6.9.1.7.
- b. With a land use census identifying a location(s) which yields a calculated dose or dose commitment (via the same exposure pathway) 20 percent greater than at a location from which milk and/or broad leaf vegetation samples are currently being obtained in accordance with Control 3.12.1, add the new location(s) to the radiological environmental monitoring program within 30 days. If no milk and/or broad leaf vegetation samples are identified in the new sector with the highest D/Q value, then the next sector with the highest D/Q value will be considered and so on until a sampling location can be established. The sampling location(s), excluding the control station location, having the lowest calculated dose or dose commitment(s), via the same exposure pathway may be deleted from this monitoring program after October 31 of the year in which this land use census was conducted.\* Identify the new location(s) in the next annual Radioactive Effluent Release Report and also include in the report a revised figure(s) and table(s) for the ODCM reflecting the new location(s).
- c. The provisions of Control 3.0.3 are not applicable.

#### SURVEILLANCE REQUIREMENTS

---

4.12.2 The land use census shall be conducted during the growing season at least once per 12 months using that information that will provide the best results, such as by a door-to-door survey, aerial survey, or by consulting local agriculture authorities. The results of the land use census shall be included in the annual Radiological Environmental Operating Report pursuant to Control 6.9.1.6.

\*Broad leaf vegetation sampling of at least three different kinds of vegetation may be performed at the site boundary in each of two different direction sectors with the highest predicted D/Qs in lieu of the garden census. Controls for broad leaf vegetation sampling in Table 3.12.1-1 shall be followed, including analysis of control samples.

**RADIOLOGICAL ENVIRONMENTAL MONITORING**

**3/4.12.3 INTERLABORATORY COMPARISON PROGRAM**

**CONTROLS**

---

**3.12.3 Analyses shall be performed on radioactive materials that correspond to samples required by Table 3.12.1-1. These materials are supplied as part of an Inter-laboratory Comparison Program.**

**APPLICABILITY: At all times.**

**ACTION:**

- a. **With analyses not being performed as required above, report the corrective actions taken to prevent a recurrence to the Commission in the Annual Environmental and Effluent Release Report pursuant to Control 6.9.1.6.**
- b. **The provisions of Control 3.0.3 are not applicable.**

**SURVEILLANCE REQUIREMENTS**

---

**4.12.3 A summary of the results obtained as part of the above required Inter-Laboratory Comparison Program shall be included in the annual Radiological Environmental Operating Report pursuant to Control 6.9.1.6.**

**BASES FOR SECTIONS 3.0 AND 4.0  
CONTROLS AND SURVEILLANCE REQUIREMENTS**

**NOTE: The BASES contained in succeeding pages summarize the reasons for the Controls in Section 3.0 and 4.0, but are not part of these Controls.**

## 3/4 CONTROLS AND SURVEILLANCE REQUIREMENTS

### 3/4.0 APPLICABILITY

#### BASES

---

Controls 3.0.1 through 3.0.5 establish the general requirements applicable to Appendix C Controls and apply at all times, unless otherwise stated.

Control 3.0.1 establishes the Applicability statement within each individual control as the requirement for when the Control is required to be met (i.e., when the unit is in the MODES or other specified conditions of the Applicability statement of each Control).

Control 3.0.2 establishes that upon discovery of a failure to meet a Control, the associated ACTIONS shall be met. The Completion Time of each ACTION condition is applicable from the point in time that an ACTIONS condition is entered. The ACTIONS establish those remedial measures that must be taken within specified times when the requirements of a Control are not met. This Control establishes that:

- a. Completion of the ACTIONS within the specified times constitutes compliance with a Control; and
- b. Completion of the ACTIONS is not required when a Control is met within the specified time, unless otherwise specified.

There are two basic types of ACTION requirements. The first type of ACTIONS specifies a time limit in which the Control must be met. This time limit is the time to restore an inoperable system or component to OPERABLE status or to restore variables to within specified limits. If this type of ACTION is not completed within the specified completion time, a shutdown may be required to place the unit in a MODE or condition in which the Control is not applicable. (Whether stated as an ACTION or not, correction of the entered condition is an action that may always be considered upon entering ACTIONS.) The second type of ACTION specifies the remedial measures that permit continued operation of the unit that is not further restricted by the completion time. In this case, compliance with the ACTIONS provides an acceptable level of safety for continued operation.

Completing the ACTIONS is not required when a Control is met or is no longer applicable, unless otherwise stated in the individual Control.

The nature of some ACTIONS of some conditions necessitates that, once the condition is entered, the ACTIONS must be completed even though the associated condition no longer exists. The individual Control's ACTIONS specify where this is the case.



### 3/4.0 APPLICABILITY

#### BASES (Continued)

---

The completion times of the ACTIONS are also applicable when a system or component is removed from service intentionally. The reasons for intentionally relying on the ACTIONS include, but are not limited to, performance of Surveillances, preventive maintenance, corrective maintenance, or investigation of operational problems. Entering ACTIONS for these reasons must be done in a manner that does not compromise safety. Intentional entry into ACTIONS should not be made for operational convenience. Alternatives that would not result in redundant equipment being inoperable should be used instead. Doing so limits the time both subsystems/divisions of a safety function are inoperable and limits the time other conditions exist which result in Control 3.0.3 being entered. Individual Controls may specify a time limit for performing an SR when equipment is removed from service or bypassed for testing. In this case, the completion times of ACTIONS are applicable when this time limit expires, if the equipment remains removed from service or bypassed.

When a change in MODE or other specified condition is required to comply with an ACTION, the unit may enter a MODE or other specified condition in which another Control becomes applicable. In this case, the completion times of the associated ACTIONS would apply from the point in time that the new Control becomes applicable and the ACTIONS condition(s) are entered.

Control 3.0.3 establishes the actions that must be implemented when a Control is not met and:

- a. An associated ACTION and completion time is not met and no other condition applies; or
- b. The condition of the unit is not specifically addressed by the associated ACTIONS. This means that no combination of conditions stated in the ACTIONS can be made that exactly corresponds to the actual condition of the unit. Sometimes, possible combinations of conditions are such that entering Control 3.0.3 is warranted; in such cases, the ACTIONS specifically state a condition corresponding to such combinations and also that Control 3.0.3 be entered immediately.

This Control delineates the time limits for placing the unit in a safe MODE or other specified condition when operation cannot be maintained within the limits for safe operation as defined by the Control and its ACTIONS. It is not intended to be used as an operational convenience that permits routine voluntary removal of redundant systems or components from service in lieu of other alternatives that would not result in redundant systems or components being inoperable.

### 3/4.0 APPLICABILITY

#### BASES (Continued)

---

Upon entering Control 3.0.3, 1 hour is allowed to prepare for an orderly shutdown before initiating a change in unit operation. This includes time to permit the operator to coordinate the reduction in electrical generation with the load dispatcher to ensure the stability and availability of the electrical grid. The time limits specified to reach lower MODES of operation permit the shutdown to proceed in a controlled and orderly manner that is well within the specified maximum cooldown rate and within the capabilities of the unit, assuming that only the minimum required equipment is OPERABLE. This reduces thermal stresses on components of the Reactor Coolant System and the potential for a plant upset that could challenge safety systems under conditions to which this Control applies.

A unit shutdown required in accordance with Control 3.0.3 may be terminated and Control 3.0.3 exited if any of the following occurs:

- a. The Control is met.
- b. A condition exists for which the ACTIONS have now been performed.
- c. ACTIONS exist that do not have expired completion times. These completion times are applicable from the point in time that the condition is initially entered and not from the time Control 3.0.3 is exited.

The time limits of Control 3.0.3 allow 37 hours for the unit to be in MODE 4 when a shutdown is required during MODE 1 operation. If the unit is in a lower MODE of operation when a shutdown is required, the time limit for reaching the next lower MODE applies. If a lower MODE of operation is reached in less time than allowed, however, the total allowable time to reach MODE 4, or other applicable MODE, is not reduced. For example, if MODE 2 is reached in 2 hours, then the time allowed for reaching MODE 3 is the next 11 hours, because the total time for reaching MODE 3 is not reduced from the allowable limit of 13 hours. Therefore, if remedial measures are completed that would permit a return to MODE 1, a penalty is not incurred by having to reach a lower MODE of operation in less than the total time allowed.

In MODES 1, 2, and 3, Control 3.0.3 provides actions for conditions not covered in other Controls. The requirements of Control 3.0.3 do not apply in MODES 4 and 5 because the unit is already in the most restrictive condition required by Control 3.0.3. The requirements of Control 3.0.3 do not apply in other specified conditions of the Applicability (unless in MODE 1, 2, or 3) because the ACTIONS of individual Controls sufficiently define the remedial measures to be taken.

Exceptions to Control 3.0.3 are provided in instances where requiring a unit shutdown, in accordance with Control 3.0.3, would not provide appropriate remedial measures for the associated condition of the unit. These exceptions are addressed in the individual Controls.

### 3/4.0 APPLICABILITY

#### BASES (Continued)

---

**Control 3.0.4** establishes limitations on changes in MODES or other specified conditions in the Applicability when a Control is not met. It allows placing the Unit in a MODE or other specified condition stated in that Applicability (e.g., Applicability desired to be entered) when unit conditions are such that the requirements of the LCO would not be met, in accordance with Control 3.0.4.a, 3.0.4.b, or 3.0.4.c.

Per Control 3.0.4.a, compliance with ACTION requirements that permit continued operation of the facility for an unlimited period of time in a MODE or other specified condition provides an acceptable level of safety for continued operation. This is without regard to the status of the plant before or after the MODE change. Therefore, in such cases, entry into a MODE or other specified condition in the Applicability may be made in accordance with the provisions of the ACTION requirements.

Per Control 3.0.4.b, changes in MODE may be made even if the ACTION requirements include a requirement to exit the Applicability, PROVIDED a risk assessment is performed (and is determined to be acceptable) which addresses the inoperable systems/components, and any appropriate risk management actions are put in place.

The provisions of this control should not be interpreted as endorsing the failure to exercise the good practice of restoring systems or components to OPERABLE status before Unit startup.

The provisions of Control 3.0.4 shall not prevent changes in MODES or other specified conditions in the Applicability that are required to comply with ACTIONS. In addition, the provisions of Control 3.0.4 shall not prevent changes in MODES or other specified conditions in the Applicability that result from any unit shutdown. In this context, a unit shutdown is defined as a change in MODE associated with transitioning from MODE 1 to MODE 2 or 3, MODE 2 to 3, and MODE 3 to 4.

Surveillances do not have to be performed on the associated inoperable equipment (or on variables outside the specified limits), as permitted by SR 3.0.1. Therefore, utilizing Control 3.0.4 is not a violation of SR 4.0.1 or SR 4.0.4 for any Surveillances that have not been performed on inoperable equipment. However, SRs must be met to ensure OPERABILITY prior to declaring the associated equipment OPERABLE (or variable within limits) and restoring compliance with the affected Control.

### 3/4.0 APPLICABILITY

#### BASES (Continued)

---

**Control 3.0.5** establishes the allowance for restoring equipment to service under administrative controls when it has been removed from service or declared inoperable to comply with ACTIONS. The sole purpose of this Control is to provide an exception to Control 3.0.2 (e.g., to not comply with the applicable ACTION(s)) to allow the performance of SRs to demonstrate:

- a. The OPERABILITY of the equipment being returned to service; or
- b. The OPERABILITY of other equipment.

The administrative controls ensure the time the equipment is returned to service in conflict with the requirements of the ACTIONS is limited to the time absolutely necessary to perform the allows SRs. This Control does not provide time to perform any other preventative or corrective maintenance.

**SR 4.0.1 through 4.0.5** establish the general requirements applicable to all Controls and apply at all times, unless otherwise stated.

**SR 4.0.1** establishes the requirement that SRs must be met during the MODES or other specified conditions in the Applicability for which the requirements of the Control apply, unless otherwise specified in the individual SRs. This Control is to ensure that Surveillances are performed to verify the OPERABILITY of systems and components, and that variables are within specified limits. Failure to meet a Surveillance within the specified frequency, in accordance with SR 4.0.2, constitutes a failure to meet a Control.

Systems and components are assumed to be OPERABLE when the associated SRs have been met. Nothing in this Control, however, is to be construed as implying that systems or components are OPERABLE when:

- a. The systems or components are known to be inoperable, although still meeting the SRs; or
- b. The requirements of the Surveillance(s) are known to be not met between required Surveillance performances.

Surveillances do not have to be performed when the unit is in a MODE or other specified condition for which the requirements of the associated Control are not applicable, unless otherwise specified. The SRs associated with a Special Operations Control are only applicable when the Special Operations Control is used as an allowable exception to the requirements of a Control.

Surveillances, including Surveillances invoked by ACTIONS, do not have to be performed on inoperable equipment because the ACTIONS define the remedial measures that apply. Surveillances have to be met and performed in accordance with SR 4.0.2, prior to returning equipment to OPERABLE status.

### 3/4.0 APPLICABILITY

#### BASES (Continued)

---

Upon completion of maintenance, appropriate post maintenance testing is required to declare equipment OPERABLE. This includes ensuring applicable Surveillances are not failed and their most recent performance is in accordance with SR 4.0.2. Post maintenance testing may not be possible in the current MODE or other specified conditions in the Applicability due to the necessary unit parameters not having been established. In these situations, the equipment may be considered OPERABLE provided testing has been satisfactorily completed to the extent possible and the equipment is not otherwise believed to be incapable of performing its function. This will allow operation to proceed to a MODE or other specified condition where other necessary post maintenance tests can be completed.

SR 4.0.2 establishes the requirements for meeting the specified frequency for Surveillances and any ACTIONS with a completion time that requires the periodic performance of the ACTION on a "once per ..." interval.

SR 4.0.2 permits a 25% extension of the interval specified in the frequency. This extension facilitates Surveillance scheduling and considers plant operating conditions that may not be suitable for conducting the Surveillance (e.g., transient conditions or other ongoing Surveillance or maintenance activities).

The 25% extension does not significantly degrade the reliability that results from performing the Surveillance at its specified frequency. This is based on the recognition that the most probable result of any particular Surveillance being performed is the verification of conformance with the SRs. The exceptions to SR 4.0.2 are those Surveillances for which the 25% extension of the interval specified in the frequency does not apply. These exceptions are stated in the individual Controls.

As stated in SR 4.0.2, the 25% extension also does not apply to the initial portion of a periodic completion time that requires performance on a "once per ..." basis. The 25% extension applies to each performance after the initial performance. The initial performance of the ACTION, whether it is a particular Surveillance or some other remedial action, is considered a single action with a single completion time. One reason for not allowing the 25% extension to this completion time is that such an action usually verifies that no loss of function has occurred by checking the status of redundant or diverse components or accomplishes the function of the inoperable equipment in an alternative manner.

The provisions of SR 4.0.2 are not intended to be used repeatedly merely as an operational convenience to extend Surveillance intervals (other than those consistent with refueling intervals) or periodic completion time intervals beyond those specified.

### 3/4.0 APPLICABILITY

#### BASES (Continued)

---

**SR 4.0.3** establishes the flexibility to defer declaring affected equipment inoperable or an affected variable outside the specified limits when a Surveillance has not been completed within the specified frequency. A delay period of up to 24 hours or up to the limit of the specified frequency, whichever is less, applies from the point in time that it is discovered that the Surveillance has not been performed in accordance with SR 4.0.2, and not at the time that the specified frequency was not met. This delay period provides adequate time to complete Surveillances that have been missed. This delay period permits the completion of a Surveillance before complying with ACTIONS or other remedial measures that might preclude completion of the Surveillance.

The basis for this delay period includes consideration of unit conditions, adequate planning, availability of personnel, the time required to perform the Surveillance, the safety significance of the delay in completing the required Surveillance, and the recognition that the most probable result of any particular Surveillance being performed is the verification of conformance with the requirements.

When a Surveillance with a frequency based not on time intervals, but upon specified unit conditions or operational situations, is discovered not to have been performed when specified, SR 4.0.3 allows the full delay period of 24 hours to perform the Surveillance.

SR 4.0.3 also provides a time limit for completion of Surveillances that become applicable as a consequence of MODE changes imposed by ACTIONS.

Failure to comply with specified frequencies for Surveillance Requirements is expected to be an infrequent occurrence. Use of the delay period established by SR 4.0.3 is a flexibility which is not intended to be used as an operational convenience to extend Surveillance intervals.

If a Surveillance is not completed within the allowed delay period, then the equipment is considered inoperable or the variable then is considered outside the specified limits and the completion times of the ACTIONS for the applicable Control conditions begin immediately upon expiration of the delay period. If a Surveillance is failed within the delay period, then the equipment is inoperable, or the variable is outside the specified limits and the completion times of the required ACTIONS for the applicable Control conditions begin immediately upon failure of the Surveillance.

Completion of the Surveillance within the delay period allowed by this Control, or within the completion time of the ACTIONS, restores compliance with SR 4.0.1.

**SR 4.0.4** establishes the requirement that all applicable SRs must be met before entry into a MODE or other specified condition in the Applicability, with two exceptions as described in SR 4.0.4.

### 3/4.0 APPLICABILITY

#### BASES (Continued)

---

This Control ensures that system and component OPERABILITY requirements and variable limits are met before entry into MODES or other specified conditions in the Applicability for which these systems and components ensure safe operation of the unit.

However, in certain circumstances, failing to meet an SR will not result in SR 4.0.4 restricting a MODE change or other specified condition change. When a system, subsystem, division, component, device, or variable is inoperable or outside its specified limits, the associated SR(s) are not required to be performed, per SR 4.0.1, which states that surveillances do not have to be performed on inoperable equipment or variables outside specified limits. When equipment is inoperable, or variables are outside their specified limits, SR 4.0.4 does not apply to the associated SR(s) since the requirement for the SR(s) to be performed is removed. Therefore, failing to perform the Surveillance(s) within the specified frequency, on equipment that is inoperable, or on variables that are outside specified limits, does not result in an SR 4.0.4 restriction to changing MODES or other specified conditions in the Applicability. However, since the Control is not met in this instance, Control 3.0.4 will govern any restrictions that may (or may not) apply to MODE or other specified condition changes.

The provisions of this Control should not be interpreted as endorsing the failure to exercise the good practice of restoring systems or components to OPERABLE status before entering an associated MODE or other specified condition in the Applicability.

The provisions of SR 4.0.4 shall not prevent changes in MODES or other specified conditions in the Applicability that are required to comply with ACTIONS. In addition, the provisions of SR 4.0.4 shall not prevent changes in MODES or other specified conditions in the Applicability that result from any unit shutdown. In this context, a unit shutdown is defined as a change in MODE associated with transitioning from MODE 1 to MODE 2 or 3, MODE 2 to 3, and MODE 3 to 4.

The precise requirements for performance of SRs are specified such that exceptions to SR 4.0.4 are not necessary. The specific time frames and conditions necessary for meeting the SRs are specified in the frequency, in the Surveillance, or both. This allows performance of Surveillances when the prerequisite condition(s) specified in a Surveillance procedure require entry into the MODE or other specified condition in the Applicability of the associated Control prior to the performance or completion of a Surveillance. A Surveillance that could not be performed until after entering the Control's Applicability would have its frequency specified such that it is not "due" until the specific conditions needed are met. Alternately, the Surveillance may be stated in the form of a note as not required (to be met or performed) until a particular event, condition, or time has been reached.

### 3/4.3 INSTRUMENTATION

#### BASES

---

#### 3/4.3.7 MONITORING INSTRUMENTATION

##### 3/4.3.7.9 RADIOACTIVE LIQUID EFFLUENT MONITORING INSTRUMENTATION

The radioactive liquid effluent instrumentation is provided to monitor and control, as applicable, the releases of radioactive materials in liquid effluents during actual or potential releases of liquid effluents. The alarm/trip setpoints for these instruments shall be calculated in accordance with the procedures in the ODCM to ensure that the alarm/trip will occur prior to exceeding the limits of 10CFR20. The OPERABILITY and use of this instrumentation is consistent with the requirements of 10CFR50, Appendix A, General Design Criteria 60, 63, and 64.

##### 3/4.3.7.10 RADIOACTIVE GASEOUS EFFLUENT MONITORING INSTRUMENTATION

The radioactive gaseous effluent instrumentation is provided to monitor and control, as applicable, the releases of radioactive materials in gaseous effluents during actual or potential releases of gaseous effluents. The alarm setpoints for these instruments shall be calculated in accordance with the procedures in the ODCM to ensure that the alarm will occur prior to exceeding the limits of 10CFR20. The OPERABILITY and use of this instrumentation is consistent with the requirements of 10CFR50, Appendix A, General Design Criteria 60, 63, and 64.



### 3/4.11 RADIOACTIVE EFFLUENTS

#### BASES

---

#### 3/4.11.1 LIQUID EFFLUENTS

##### 3/4.11.1.1 CONCENTRATION

This Control is provided to ensure that the concentration of radioactive materials released in liquid waste effluents to UNRESTRICTED AREAS will be less than the concentration levels specified in 10CFR20, Appendix B, Table 2, Column 2. This limitation provides additional assurance that the levels of radioactive materials in bodies of water in UNRESTRICTED AREAS will result in exposures within (1) the Section II.A. design objectives of 10CFR50, Appendix I, to a MEMBER OF THE PUBLIC, and (2) the limits of 10CFR20 to the population. The concentration limit for dissolved and entrained noble gases is based upon the assumption that Xe-135 is the controlling radioisotope and its limiting effluent concentration in air (submersion) was converted to an equivalent concentration in water using the methods described in International Commission on Radiological Protection (ICRP) Publication 2.

This Control applies to the release of radioactive materials in liquid effluents from all units at the site.

The required detection capabilities for radioactive materials in liquid waste samples are tabulated in terms of the lower limits of detection (LLDs). Detailed discussion of the LLD, and other detection limits, can be found in:

- (1) Currie, L. A., "Lower Limit of Detection: Definition and Elaboration of a Proposed Position for Radiological Effluent and Environmental Measurements," NUREG/CR-4007 (September, 1984).
- (2) HASL Procedures Manual, HASL-300 (revised annually).

##### 3/4.11.1.2 DOSE

This Control is provided to implement the requirements of 10CFR50, Appendix I, Sections II.A, III.A and IV.A. The Control implements the guides set forth in of 10CFR50, Appendix I, Section II.A. The ACTION statements provide the required operating flexibility and at the same time implement the guides set forth in of 10CFR50, Appendix I, Section IV.A which assure that the releases of radioactive material in liquid effluents to UNRESTRICTED AREAS will be kept "as low as is reasonably achievable." Also, for fresh water sites with drinking water supplies which can be potentially affected by plant operations, there is reasonable assurance that the operation of the facility will not result in radionuclide concentrations in the finished drinking water that are in excess of the requirements of 40CFR141. The dose calculations in the ODCM implement the requirements in 10CFR50, Appendix I, Section III.A that conformance with the guides of 10CFR50, Appendix I be shown by calculational procedures based on models and data, such that the actual exposure of a MEMBER OF THE PUBLIC through appropriate pathways is unlikely to be substantially underestimated. The equations specified in the ODCM for calculating the doses due to the actual release rates of radioactive

## RADIOACTIVE EFFLUENTS

### BASES

---

#### 3/4.11.1.2 DOSE (Continued)

materials in liquid effluents are consistent with the methodology provided in Regulatory Guide 1.109, "Calculation of Annual Doses to Man from Routine Releases of Reactor Effluents for the Purpose of Evaluating Compliance with 10 CFR Part 50, Appendix I, Revision 1", October 1977, and Regulatory Guide 1.113, "Estimating Aquatic Dispersion of Effluent from Accidental and Routine Reactor Releases for the Purpose of Implementing Appendix I," April 1977.

This Control applies to the release of liquid effluents from each reactor at the site. For units with shared radwaste treatment systems, the liquid effluents from the shared system are proportioned among the units sharing that system.

#### 3/4.11.1.3 LIQUID RADWASTE TREATMENT SYSTEM

The OPERABILITY of the liquid radwaste treatment system ensures that this system will be available for use whenever liquid effluents require treatment prior to release to the environment.

The requirement that the appropriate portions of this system be used when specified provides assurance that the releases of radioactive materials in liquid effluents will be kept "as low as is reasonably achievable." This Control implements the requirements of 10CFR50.36a; 10CFR50, Appendix A, General Design Criterion 60; and the design objective given in 10CFR50, Appendix I, Section II.D. The specified limit governing the use of appropriate portions of the liquid radwaste treatment system were specified as a suitable fraction of the dose design objectives set forth in 10CFR50, Appendix I, Section II.A, for liquid effluents.

This Control applies to the release of liquid effluents from each reactor at the site. For units with shared radwaste treatment systems, the liquid effluents from the shared system are proportioned among the units sharing the system.

## RADIOACTIVE EFFLUENTS

### BASES

---

#### 3/4.11.2 GASEOUS EFFLUENTS

##### 3/4.11.2.1 DOSE RATE

This Control is provided to ensure that the dose any time at and beyond the SITE BOUNDARY from gaseous effluents from all units on the site will be within the annual dose limits of 10CFR20 for UNRESTRICTED AREAS. The annual dose rate limits are those associated with the concentrations of those limiting effluent concentrations, as described in Regulatory Guide 1.109. These limits provide reasonable assurance that radioactive material discharged in gaseous effluents will not result in the exposure of a MEMBER OF THE PUBLIC in an UNRESTRICTED AREA, either within or outside the SITE BOUNDARY, to annual average concentrations exceeding the limits specified in 10CFR20, Appendix B, Table II. For MEMBERS OF THE PUBLIC who may at times be within the SITE BOUNDARY, the occupancy of the MEMBER OF THE PUBLIC will be sufficiently low to compensate for any increase in the atmospheric diffusion factor above that for the SITE BOUNDARY. Examples of calculations for such MEMBERS OF THE PUBLIC, with appropriate occupancy factors, shall be given in the ODCM. The specified release rate limits restrict, at all times, the corresponding gamma and beta dose rates above background to a MEMBER OF THE PUBLIC at or beyond the SITE BOUNDARY to less than or equal to 500 mrem/year to the whole body or to less than or equal to 3000 mrem/year to the skin. These release rate limits also restrict, at all times, the corresponding thyroid dose rate above background to a child via the inhalation pathway to less than or equal to 1500 mrem/year.

This Control applies to the release of radioactive materials in gaseous effluents from all reactors at the site. The required detection capabilities for radioactive material in gaseous waste samples are tabulated in terms of the lower limit of detection (LLDs). Detailed discussion of the LLD and other detection limits can be found in:

- (1) Currie, L. A., "Lower Limit of Detection: Definition and Elaboration of a Proposed Position for Radiological Effluent and Environmental Measurements," NUREG/CR-4007 (September 1984).
- (2) HASL Procedures Manual, HASL-300 (revised annually).

##### 3/4.11.2.2 DOSE - NOBLE GASES

This Control is provided to implement the requirements of 10CFR50, Appendix I, Sections II.B, III.A and IV.A. The Control implements the guides set forth in 10CFR50, Appendix I, Section II.B. The ACTION statements provide the required operating flexibility and at the same time implement the guides set forth in 10CFR50, Appendix I, Section IV.A to assure that the releases of radioactive material in gaseous effluents to UNRESTRICTED AREAS will be kept "as low as is reasonably achievable." The Surveillance Requirements implement the requirements in 10CFR50, Appendix I, Section III.A that conformance with the guides of 10CFR50, Appendix I, be shown by calculational procedures based on models and data such that the actual exposure of a MEMBER OF THE PUBLIC through appropriate pathways is unlikely to be substantially underestimated.

## RADIOACTIVE EFFLUENTS

### BASES

---

#### 3/4.11.2.2 DOSE - NOBLE GASES (Continued)

The dose calculations established in the ODCM for calculating the doses due to the actual release rates of radioactive noble gases in gaseous effluents are consistent with the methodology provided in Regulatory Guide 1.109, "Calculation of Annual Doses to Man from Routine Releases of Reactor Effluents for the Purpose of Evaluating Compliance with 10CFR50, Appendix I, Revision 1", October 1977, and Regulatory Guide 1.111, "Methods for Estimating Atmospheric Transport and Dispersion of Gaseous Effluents in Routine Releases from Light-Water Cooled Reactors," Revision 1, July 1977. The ODCM equations provided for determining the air doses at and beyond the SITE BOUNDARY are made using meteorological conditions concurrent with the time of release of radioactive materials in gaseous effluents or are based upon the historical average atmospheric conditions.

This Control applies to the release of radioactive materials in gaseous effluents from each reactor at the site. For units with shared radwaste treatment systems, the gaseous effluents from the shared system are proportioned among the units sharing that system.

#### 3/4.11.2.3 DOSE - IODINE-131, IODINE-133, TRITIUM AND RADIONUCLIDES IN PARTICULATE FORM

This Control is provided to implement the requirements of 10CFR50, Appendix I, Sections II.C, III.A and IV.A. The Controls are the guides set forth in 10CFR50, Appendix I, Section II.C. The ACTION statements provide the required operating flexibility and at the same time implement the guides set forth in 10CFR50, Appendix I, Section IV.A, to assure that the releases of radioactive materials in gaseous effluents to UNRESTRICTED AREAS will be kept "as low as is reasonably achievable." The ODCM calculational methods specified in the Surveillance Requirements implement the requirements in 10CFR50, Appendix I, Section III.A, that conformance with the guides of 10CFR50, Appendix I be shown by calculational procedures based on models and data, such that the actual exposure of a MEMBER OF THE PUBLIC through appropriate pathways is unlikely to be substantially underestimated. The ODCM calculational methods for calculating the doses due to the actual release rates of the subject materials are consistent with the methodology provided in Regulatory Guide 1.109, "Calculation of Annual Doses to Man from Routine Releases of Reactor Effluents for the Purpose of Evaluating Compliance with 10CFR50, Appendix I," Revision 1, October 1977, and Regulatory Guide 1.111, "Methods for Estimating Atmospheric Transport and Dispersion of Gaseous Effluents in Routine Releases from Light-Water-Cooled Reactors," Revision 1, July 1977. These equations also provide for determining the actual doses using meteorological conditions concurrent with the time of release of radioactive materials in gaseous effluents or are based upon the historical average atmospheric conditions. The release rate specifications for iodine-131, iodine-133, tritium and radionuclides in particulate form are dependent on the existing radionuclide pathway to man in the areas at and beyond the SITE BOUNDARY. The pathways which were examined in the development of these calculations were: (1) individual inhalation of airborne radionuclides, (2) deposition of radionuclides onto green leafy vegetation with subsequent consumption by man, (3) deposition onto grassy areas where milk animals and meat-producing animals graze with consumption of the milk and meat by man, and (4) deposition on the ground with subsequent exposure of man.

This Control applies to the release of radioactive materials in gaseous effluents from each reactor at the site. For units with shared radwaste treatment systems, the gaseous effluents from the shared system are proportioned among the units sharing that system.

## RADIOACTIVE EFFLUENTS

### BASES

---

#### 3/4.11.2.4 AND 3/4.11.2.5 GASEOUS RADWASTE TREATMENT (OFFGAS) SYSTEM AND VENTILATION EXHAUST TREATMENT SYSTEMS

The OPERABILITY of the GASEOUS RADWASTE TREATMENT (OFFGAS) SYSTEM and the VENTILATION EXHAUST TREATMENT SYSTEMS ensures that the systems will be available for use whenever gaseous effluents require treatment prior to release to the environment. The requirement that the appropriate portions of the systems be used, when specified, provides reasonable assurance that the releases of radioactive materials in gaseous effluents will be kept "as low as is reasonably achievable." This Control implements the requirements of 10CFR50.36a; 10CFR50, Appendix A, General Design Criterion; and the design objectives given in 10CFR50, Appendix I, Section II.D. The specified limits governing the use of appropriate portions of the systems were specified as a suitable fraction of the dose design objectives set forth in 10CFR50, Appendix I, Sections II.B and II.C, for gaseous effluents.

This Control applies to the release of radioactive materials in gaseous effluents from each reactor at the site. For units with shared radwaste treatment systems, the gaseous effluents from the shared system are proportional among the units sharing that system.

#### 3/4.11.4 TOTAL DOSE

This Control is provided to meet the dose limitations of 40CFR190 that have been incorporated into 10CFR20 by 46 FR 18525 and the dose limitations of 10CFR72.104. The Control requires the preparation and submittal of a Special Report whenever the calculated doses due to releases of radioactivity and to radiation from uranium fuel cycle sources exceed 25 mrem to the whole body or any organ, except the thyroid, which shall be limited to less than or equal to 75 mrem. For sites containing up to four reactors, it is highly unlikely that the resultant dose to a MEMBER OF THE PUBLIC will exceed the dose limits of 40CFR190, if the individual reactors remain within twice the dose design objectives of 10CFR50, Appendix I, and if direct radiation doses from the units including outside storage tanks, etc. are kept small. The Special Report will describe a course of action that should result in the limitation of the annual dose to a MEMBER OF THE PUBLIC to within the 40CFR190 limits. For the purposes of the Special Report, it may be assumed that the dose commitment to the MEMBER OF THE PUBLIC from other uranium fuel cycle sources is negligible, with the exception that dose contributions from other nuclear fuel cycle facilities at the same site or within a radius of 8 km must be considered. If the dose to any MEMBER OF THE PUBLIC is estimated to exceed the requirements of 40CFR190, the Special Report with a request for a variance (provided the release conditions resulting in violation of 40CFR190 have not already been corrected), in accordance with the provisions of 40CFR190.11 and 10CFR20.405c, is considered to be a timely request and fulfills the requirements of 40CFR190 until NRC staff action is completed. The variance only relates to the limits of 40CFR190, and does not apply in any way to the other requirements for dose limitation of 10CFR20, as addressed in ODCM Controls 3.11.1.1 and 3.11.2.1. An individual is not considered a MEMBER OF THE PUBLIC during any period in which he/she is engaged in carrying out any operation that is part of the nuclear fuel cycle.

### 3/4.12 RADIOLOGICAL ENVIRONMENTAL MONITORING

#### BASES

---

##### 3/4.12.1 MONITORING PROGRAM

The Radiological Environmental Monitoring Program required by this Control provides representative measurements of radiation and of radioactive materials in those exposure pathways and for those radionuclides that lead to the highest potential radiation exposures of MEMBERS OF THE PUBLIC resulting from the plant operation. This monitoring program implements 10CFR50, Appendix I, Section IV.B.2, and thereby supplements the Radiological Effluent Monitoring Program by verifying that the measurable concentrations of radioactive materials and levels of radiation are not higher than expected on the basis of the effluent measurements and the modeling of the environmental exposure pathways. Guidance for this monitoring program is provided by the Radiological Assessment Branch Technical Position on Environmental Monitoring, Revision 1, November 1979. The initially specified monitoring program will be effective for at least the first 3 years of commercial operation. Following this period, program changes may be initiated based on operational experience.

The required detection capabilities for environmental sample analyses are tabulated in terms of the lower limits of detection (LLDs). The LLDs required by ODCM Table 4.12-1 are considered optimum for routine environmental measurements in industrial laboratories. It should be recognized that the LLD is defined as an *a priori* (before the fact) limit representing the capability of a measurement system and not as an *a posteriori* (after the fact) limit for a particular measurement.

Detailed discussion of the LLD, and other detection limits, can be found in:

- (1) Currie, L. A. "Lower Limit of Detection: Definition and Elaboration of a Proposed Position for Radiological Effluent and Environmental Measurements," NUREG/CR-4007 (September 1984).
- (2) HASL Procedure Manual, HASL-300 (revised annually).

##### 3/4.12.2 LAND USE CENSUS

This Control is provided to ensure that changes in the use of areas at and beyond the SITE BOUNDARY are identified and that modifications to the radiological environmental monitoring program given in the ODCM are made if required by the results of the census. The best information from door-to-door survey, visual or aerial survey or from consulting with local agricultural authorities shall be used. This census satisfies the requirements of 10CFR50, Appendix I, Section IV.B.3. Restricting the census to gardens of greater than 50 m<sup>2</sup> provides assurance that significant exposure pathways via leafy vegetables will be identified and monitored since a garden of this size is the minimum required to produce the quantity (26 kg/year) of leafy vegetables assumed in Regulatory Guide 1.109 for consumption by a child. To determine this minimum garden size, the following assumptions were made: (1) 20% of the garden was used for growing broad leaf vegetation (i.e., similar to lettuce and cabbage), and (2) a vegetation yield of 2 kg/m<sup>2</sup>.

##### 3/4.12.3 INTERLABORATORY COMPARISON PROGRAM

The requirement for participation in an approved Interlaboratory Comparison Program is provided to ensure that independent checks on the precision and accuracy of the measurements of radioactive material in environmental sample matrices are performed as part of the quality assurance program for environmental monitoring in order to demonstrate that the results are valid for the purposes of 10CFR50, Appendix I, Section IV.B.2.

## **6.0 ADMINISTRATIVE CONTROLS**

ADMINISTRATIVE CONTROLS

---

ANNUAL REPORTS

ANNUAL RADIOLOGICAL ENVIRONMENTAL OPERATING REPORT

6.9.1.6 Routine radiological environmental operating reports covering the operation of the unit during the previous year shall be submitted by May 1 of each year.

The annual Radiological Environmental Operating Report shall include:

- a. Summaries, interpretations, and an analysis of trends of the results of the radiological environmental surveillance activities for the report period, including a comparison with pre-operational studies, operational controls (as appropriate), and previous environmental surveillance reports and an assessment of the observed impacts of the plant operation on the environment;
- b. The results of land use censuses required by Control 3.12.2;
- c. The results of analysis of all radiological environmental samples and of all locations specified in the table and figures in the Offsite Dose Calculation Manual, as well as summarized and tabulated results of these analyses and measurements in the format of the table in the Radiological Assessment Branch Technical Position, Revision 1, November 1979. In the event that some individual results are not available for inclusion with the report, the report shall be submitted noting and explaining the reasons for the missing results. The missing data shall be submitted as soon as possible in a supplementary report;
- d. A summary description of the Radiological Environmental Monitoring Program; at least two legible maps\* covering all sampling locations keyed to a table giving distances and directions from the centerline of one reactor; the results of licensee participation in the Inter-laboratory Comparison Program and the corrective action taken if the specified program is not being performed as required by Control 3.12.3; reasons for not conducting the Radiological Environmental Monitoring Program as required by Control 3.12.1, and discussion of all deviations from the sampling schedule of Table 3.12.1-1; discussion of environmental sample measurements that exceed the reporting levels of Table 3.12.1-2 but are not the result of plant effluents, pursuant to ACTION b of Control 3.12.1; and discussion of all analyses in which the LLD required by Table 4.12.1-1 was not achievable.

---

\* One map shall cover stations near the SITE BOUNDARY; a second shall include the more distant stations.



ADMINISTRATIVE CONTROLS

ANNUAL RADIOACTIVE EFFLUENT RELEASE REPORT

6.9.1.7 Routine radioactive release reports covering the operation of the unit during the previous year shall be submitted annually. The Report shall be submitted by May 1 of each year.

The Annual Radioactive Effluent Release Report shall include:

- a. A summary of the quantities of radioactive liquid and gaseous effluents released from the unit as outlined in Regulatory Guide 1.21, "Measuring, Evaluating, and Reporting Radioactivity in Solid Wastes and Releases of Radioactive Materials in Liquid and Gaseous Effluents from Light-Water-Cooled Nuclear Power Plants," Revision 1, June 1974, with data summarized on a quarterly basis following the format of Appendix B thereof.
- b. A summary of hourly meteorological data collected over the previous year. This annual summary may be either in the form of an hour-by-hour listing on magnetic tape of wind speed, wind direction, atmospheric stability, and precipitation (if measured), or in the form of joint frequency distributions of wind speed, wind direction, and atmospheric stability. In lieu of submission with the annual Radioactive Effluent Release Report, the licensee has the option of retaining this summary of required meteorological data on site in a file that shall be provided to the NRC upon request.
- c. An assessment of the radiation doses due to the radioactive liquid and gaseous effluents released from the unit or station during the previous year. This report shall also include an assessment of the radiation doses from radioactive liquid and gaseous effluents to MEMBERS OF THE PUBLIC due to their activities inside the SITE BOUNDARY (see Figure 3.2-1) during the report period. All assumptions used in making these assessments, i.e., specific activity, exposure time, and location, shall be included in these reports. The assessment of radiation doses shall be performed in accordance with the methodology and parameters in the OFFSITE DOSE CALCULATION MANUAL (ODCM).
- d. An assessment of radiation doses to the likely most exposed MEMBER OF THE PUBLIC from reactor releases and other nearby uranium fuel cycle sources, including doses from primary effluent pathways and direct radiation, for the previous calendar year to show conformance with 40CFR190, "Environmental Radiation Protection Standards for Nuclear Power Operation." Acceptable methods for calculating the dose contribution from liquid and gaseous effluents are given in Regulatory Guide 1.109, Rev. 1, October 1977.
- e. A list and description of unplanned releases from the site to UNRESTRICTED AREAS (see Figure 3.2-1) of radioactive materials in gaseous and liquid effluents made during the reporting period.
- f. Any changes made during the reporting period to the OFFSITE DOSE CALCULATION MANUAL (ODCM), pursuant to PNPP Technical Specification 5.5.1 as well as any major change to Liquid or Gaseous Treatment Systems pursuant to Control 6.15. It shall also include a listing of new locations for dose calculations and/or environmental monitoring identified by the Land Use Census pursuant to Control 3.12.2.
- g. The report shall also include the following: an explanation as to why the inoperability of liquid or gaseous effluent monitoring instrumentation was not corrected within the time specified in Control 3.3.7.9 or 3.3.7.10, respectively; and description of the events leading to liquid holdup tanks exceeding total curie limits

October  
2017

**SPECIAL REPORTS**

- 6.9.2 Special reports shall be submitted in accordance with 10CFR50.4 within the time period specified for each report.

**6.10 RECORD RETENTION**

- 6.10.1 In addition to the applicable record retention requirements of Title 10 Code of Federal Regulations, the following records shall be retained for at least the minimum period indicated.
- 6.10.2 Records of surveillance activities, inspections, and calibrations required by these Controls shall be retained for at least 5 years.

**ADMINISTRATIVE CONTROLS**

---

**6.15 MAJOR CHANGES TO RADIOACTIVE WASTE TREATMENT SYSTEMS\***

**6.15.1 Licensee initiated major changes to the radioactive waste systems, liquid, gaseous and solid:**

- 1. Shall be reported to the Commission in the annual Radioactive Effluent Release Report for the period in which the evaluation was reviewed by the PORC. The discussion of each change shall contain:**
  - a. A summary of the evaluation that led to the determination that the change could be made in accordance with 10CFR50.59;**
  - b. Sufficient detailed information to totally support the reason for the change without benefit of additional or supplemental information;**
  - c. A detailed description of the equipment, components and processes involved and the interfaces with other plant systems**
  - d. An evaluation of the change which shows the predicted releases of radioactive materials in liquid and gaseous effluents and/or quantity of solid waste that differ from those previously predicted in the license application and amendments thereto;**
  - e. An evaluation of the change which shows the expected maximum exposures to MEMBERS OF THE PUBLIC in the UNRESTRICTED AREA and to the general population that differ from those previously estimated in the license application and amendments thereto;**
  - f. A comparison of the predicted releases of radioactive materials, in liquid and gaseous effluents and in solid waste, to the actual releases for the period prior to when the changes are to be made;**
  - g. An estimate of the exposure to plant operating personnel as a result of the change; and**
- 2. Shall become effective upon review and approval by the Plant Manager.**

---

\* Licensee may choose to submit the information called for in this Control as part of the annual USAR update.

**RECORDS**

The following records are completed/generated by this document:

**Quality Records**

Annual Radioactive Effluent Release Report

**Non-Quality Records**

None

**Commitments**

**L00434**

October  
2017

REFERENCES

1. Title 10, "Energy," Chapter 1, Code of Federal Regulations; Part 20, U.S. Government Printing Office, Washington, D.C. 20402, May 21, 1991.
2. Title 10, "Energy," Chapter 1, Code of Federal Regulations; Part 50; U.S. Government Printing Office, Washington, D.C. 20402, January 1, 1984.
3. Title 40, "Protection of Environment," Chapter 1, Code of Federal Regulations, Part 190, Federal Register, Vol. 42, Washington, D.C. 20402, January 13, 1977.
4. U.S. Nuclear Regulatory Commission, "Preparation of Radiological Effluent Technical Specifications for Nuclear Power Plants," USNRC NUREG-0133, Washington, D.C. 20555, October, 1981.
5. U.S. Nuclear Regulatory Commission, "Draft Radiological Effluent Technical Specifications for PWR's," USNRC NUREG-0473, Revision 2, Washington, D.C. 20555, February, 1980.
6. Regulatory Guide 1.21, "Measuring, Evaluating, and Reporting Radioactivity in Solid Wastes and Releases of Radioactive Materials in Liquid and Gaseous Effluents from Light-Water-Cooled Nuclear Power Plants," Revision 1, U.S. Nuclear Regulatory Commission, Washington, D.C. 20555, June 1974.
7. Regulatory Guide 1.109, "Calculation of Annual Doses to Man from Routine Releases of Reactor Effluents for the Purpose of Evaluating Compliance with 10CFR 50, Appendix I," Revision 0, U.S. Nuclear Regulatory Commission, Washington, D.C. 20555, March 1976.
8. Regulatory Guide 1.109, "Calculation of Annual Doses to Man from Routine Releases of Reactor Effluents for the Purpose of Evaluating Compliance with 10CFR Part 50, Appendix I," Revision 1, U.S. Nuclear Regulatory Commission, Washington, D.C. 20555, October 1977.
9. Regulatory Guide 1.111, "Methods for Estimating Atmospheric Transport and Dispersion of Gaseous Effluents in Routine Releases from Light-Water-Cooled Reactors," Revision 1, U.S. Nuclear Regulatory Commission, Washington, D.C. 20555, July 1977.
10. Regulatory Guide 1.113, "Estimating Aquatic Dispersion of Effluents from Accidental and Routine Reactor Releases for the Purpose of Implementing Appendix I," Revision 1, U.S. Nuclear Regulatory Commission, Washington, D.C. 20555, April 1977.
11. Regulatory Guide 4.15, "Quality Assurance for Radiological Monitoring Programs (Normal Operation) - Effluent Streams and the Environment," U.S. Nuclear Regulatory Commission, Washington, D.C. 20555, February 1979.
12. U.S. Nuclear Regulatory Commission, "Branch Technical Position," Revision 1, Washington, D.C. 20555, November 1979.
13. Perry Nuclear Power Plant, Unit 1 and 2, "Final Safety Analysis Report," Amendment 14, The Cleveland Electric Illuminating Company, Perry, Ohio 44081, August 1984.
14. Perry Nuclear Power Plant, Units 1 and 2, "Environmental Report, Operating License Stage," Supplement 3, The Cleveland Electric Illuminating Company, Perry, Ohio 44081, November 1981.
15. Perry Nuclear Power Plant, Units 1 and 2, "Radiological Environmental Monitoring Program Manual," The Cleveland Electric Illuminating Company, Perry, Ohio 44081, February 1985.

REFERENCES (Cont.)

16. "Midas User's Manual, for the Cleveland Electric Illuminating Company, Perry Nuclear Power Plant," Pickard, Lowe and Garrick, Washington, D.C. 20036, July 1983.
17. Kocher, D.C., "Radioactive Decay Data Tables," Technical Information Center, U.S. Department of Energy, Springfield, Virginia 22161, September 1985.
18. 1989 Engineering Report "Lake Erie Potable Water Facilities and Intakes within 50 Miles of PNPP, (Ref. SO-11552 "E").
19. Perry Environmental Report Operating License Stage, Table 5.1-10 "Annual Average Dilution Factors for Lake Water Intakes within 50 Miles of PNPP and Q&R Page 2.1-2.
20. PNPP Ohio Power Siting Commission application of August 1974, Appendix 1304-C-2, Table IV-A-2.
21. Total Angler Catch (1987 annual) for Each Grid Location; per letter from Michael R. Rawson, Fairport Fisheries Research Station, Ohio Department of Natural Resources (6-20-88).
22. Offsite Dose Calculation Manual Guidance: Standard Radiological Effluent Controls for Boiling Water Reactors; Generic Letter 89-01, Supplement No. 1.
23. Federal Guidance Report 13 CD Supplement: Cancer Risk Coefficients for Environmental Exposure to Radionuclides.



	<b>REGULATORY APPLICABILITY DETERMINATION</b> NOP-LP-4003-01 Rev. 04	No. 17-02381 Rev. 00
	Page 1 of 8	
Initiating Activity No. Procedure CHI-ODCM		Rev. 21
<input type="checkbox"/> BVPS 1 <input type="checkbox"/> BVPS 2 <input type="checkbox"/> DBNPS		<input checked="" type="checkbox"/> PNPP

**Title:**

**Offsite Dose Calculation Manual**

**Brief description of activity (what is being changed and why):**

- 1. References to closed commitment L02211 were removed.**  
 Administrative change to the remove reference to a closed commitment. L02211 tracked changes necessary with license amendment 72 to Technical Specifications - RETS. Commitment text reads as follows: "The Commission has issued the enclosed Amendment no. 72 to Facility Operating License No. NPF-58 for the Perry Nuclear Power Plant, Unit No. 1. Amendment 72 revises the Technical Specifications consistent with Generic Letter 89-01, implementation of programmatic controls for Radiological Effluent Technical Specifications in the Administrative Controls section of Technical Specifications and the relocation of procedural details of RETS to the Offsite Dose Calculation Manual or to the Process Control Program." Compliance with TS 5.5.1 and 5.5.4 is maintained.
- 2. Reference to closed commitment R00449 was removed from Table 4.11.1.1.1-B under the grab sample composite.**  
 Administrative change to remove reference to closed commitment. R00449 required a quarterly analysis for Sr-89 and Sr-90 on a composite made on particulate filters from each sampling location collected. This requirements is contained in Table 4.11.1.1.1-B of the ODCM.
- 3. Section 3.1.a: Clarified that the alert alarm received must be valid.**
- 4. Created formal Table 3.1-2 from table of Effluent Release Path flow rates listed under section 3.1.4 equation definitions.**  
 Administrative change to give table an official table title for easier reference.
- 5. Added new Table 3.1-2 to list of Tables on page III.**  
 Administrative change to update List of Tables to include new Table 3.1-2.
- 6. Combined the note in step 3.1.4 with the definition of "f" and added note to reference table 3.1-2.**  
 Editorial change for clarity.
- 7. Section 5.1: Removed reference to site-specific environmental monitoring procedure REMP-0013. Editorial change to remove unnecessary information. The site-specific REMP-0013 procedure lists locations in addition to those required by the ODCM. It should not be referenced in the ODCM as a required list.**
- 8. Table 5.1-1: Shortened title of Table to remove extra unnecessary information.**  
 Editorial change to remove extraneous material from Table title.
- 9. Table 5.1-1: Renamed location 53 to reflect location's address instead of name of company in business at that location.**  
 Editorial change to reflect location's address instead of name of company in business at that location. TLD location does not change, no matter what the name of the company in business at this location at a given time.
- 10. Table 5.1-1: Clarified that locations 36 and 39 are drinking water.**  
 Clarification as to which type of water sample is taken at these locations. As both are municipal water purification plants, drinking water was implied, but not clearly stated.
- 11. Table 5.1-1: Clarified that locations 59 and 60 are surface water sample locations.**  
 Clarification as to which type of water sample is taken at these locations. As both are shoreline locations, surface water was implied, but not clearly stated.
- 12. Table 5.1-1: Changed "Food Products" to "Broadleaf Vegetation" at locations 2, 37, and 70.**  
 Clarification to specify the type of Food Products (broadleaf vegetation) as required by Table 3.12.1-1.
- 13. Figures 5.1-1, 5.1-2, and 5.1-3: Updated maps to reflect changed sample locations.**  
 Administrative update of maps related to changes 23 through 28.



	<b>REGULATORY APPLICABILITY DETERMINATION</b>		No. 17-02381
	NOP-LP-4003-01 Rev. 04	Page 2 of 8	Rev. 00
Initiating Activity No. Procedure CHI-ODCM			Rev. 21
<input type="checkbox"/> BVPS 1 <input type="checkbox"/> BVPS 2 <input type="checkbox"/> DBNPS <input checked="" type="checkbox"/> PNPP			

14. Revised Table A-2 to add a new column showing distance in meters. Clarification to provide conversion of miles (previously in the table) to meters from UFSAR Table 2.3-27. Distance in meters is used in calculations in Appendix A.
15. Tables 3.3.7.10-1 and 4.3.7.10-1 Table Notations: Removed "During main condenser off-gas treatment system operation." Editorial correction to remove footnote that does not apply in Table 3.3.7.10-1 and 4.3.7.10-1 in the Perry ODCM. The Perry ODCM contains only single asterisks which signify "at all times" for a mode of applicability.
16. Table 3.3.7.10-1: Removed footnote (1) from each page and added it to the table notations. Editorial change to remove the footnote from each page of the table and make it a table endnote for formatting consistency in the document.
17. Table 3.3.7.10-1: Added action 124 to Unit 1 Vent noble gas channel during modes 4 and 5. Procedure correction. When the original change was drafted into the ODCM, the fact that the Unit 1 Vent has a potential source term during modes 4 and 5 from the spent fuel pool was overlooked and Action 124 was omitted for Unit 1 Plant Vent for Modes 4 and 5.
18. Table 3.12.1-1: Changed number of TLDs to 29. Editorial change to update number of TLDs listed in table to reflect change made in Item 22.
19. Table 4.3.7.9-1 Table Notation 3: Updated NBS reference to NIST. Administrative change to change title of department. The National Bureau of Standards, or NBS, became the National Institute of Standards and Technology, or NIST, in 1988.
20. Revised Section 6.9.1.7 to move the information denoted by an asterisk regarding maintaining the meteorological report separate from the Annual Report into paragraph b; split the paragraph into two for clarity purposes. Editorial change for clarity to bring pertinent information into the text, rather than a note.
21. Removed asterisk footnote contained in ODCM revision 20 page 178 which contains a continuation of Section 6.9.1.7 and Sections 6.9.2 and 6.10. This page contains no asterisks. Asterisk footnote discussed the option of submittal as part of the annual USAR update. Editorial correction to remove asterisk footnote that is not applicable to the page on which it was located. The asterisk applies to Section 6.15, Major Changes to Radioactive Waste Treatment Systems, where the "Licensee may choose to submit the information called for in this Control as part of the annual USAR update". The footnote appears correctly for Section 6.15. In revision 19, Section 6.15 started on the same page as the end of section 6.9.1.7. With ODCM revision 20, pagination was changed to start section 6.15 on a separate page. The footnote was inadvertently left on the previous page with the remainder of Section 6.9.1.7, Section 6.9.2, and 6.10 in revision 20.
22. Added new section for commitments. Administrative change for clarification by adding list of commitments implemented in this document.
23. Minor editorial and grammatical corrections. Editorial changes.
- 
24. Section 4.2: Removed requirement that specified that environmental TLDs will be changed out quarterly and annually and replaced with a reference to Table 3.12.1-1, Radiological Environmental Monitoring Program. This change ensures there is only one location in the ODCM that specifies monitoring frequency and directs to the appropriate table. The additional administrative burden of collecting TLDs annually as well as quarterly was removed by this change. Only quarterly TLD collection is required by NUREG-1302. Each TLD location contains at least two TLDs as required which are collected and analyzed quarterly.
25. Table 5.1-1: Added new TLD location 57. The TLD at Location 57, Perry High School, was added when the old school on Center Road was demolished and a school was built at the new location. According to ODCM

	<b>REGULATORY APPLICABILITY DETERMINATION</b> NOP-LP-4003-01 Rev. 04	No. 17-02381 Rev. 00
	Page 3 of 8	
Initiating Activity No. Procedure CHI-ODCM		Rev. 21
<input type="checkbox"/> BVPS 1 <input type="checkbox"/> BVPS 2 <input type="checkbox"/> DBNPS <input checked="" type="checkbox"/> PNPP		

Table 3.12.1-1, Exposure Pathway/Sample 1, Direct Radiation, TLDs should be placed "in special interest areas... such as schools." The TLD in Location 65 at the previous school location remains in place due to the location remaining a special interest area as a public soccer field.

26. Table 5.1-1: Removed location 18 for milk sampling due to death of the goat. The goat was not replaced by the owner. There are no additional milking animals within the prescribed distance from the plant whose owners wish to participate in the Perry Nuclear Power Plant Radiological Environmental Monitoring Program. PNPP performs broad leaf vegetation as required by Table 3.12-1, Radiological Environmental Monitoring Program, Section 4.c Food Products when milk sampling is not performed.

27. Table 5.1-1: Removed location 18 in the East sector for broadleaf vegetation sampling as owners chose not to continue participation in the PNPP REMP. This location was replaced with location 20, also in the East sector (see change 26). Table 3.12.1-1.4.c requires two different offsite locations for broadleaf vegetation sampling. The REMP as outlined in Table 5.1-1 contains more than two indicator locations (2, 16, 20, and 37) as well as a control (70).

28. Table 5.1-1: Added new broadleaf vegetation sampling locations 16 and 20.  
 With no milking animals within the required five km distance from the PNPP, the ODCM requires that food product sampling is performed at two locations of the highest D/Q sectors. Locations 16 and 20 have participated in the broadleaf vegetation sampling program for years and satisfy the requirements of the ODCM because they lie in two of the three highest D/Q sectors: location 20 in the East and location 16 in the South. The addition of food product sampling locations in the East and South sectors aligns ODCM Table 5.1-1 sampling locations to compliance with the environmental monitoring requirements contained in NUREG-1302 and ODCM Table 13.12.1-1.

29. Table 5.1-1: Removed location 28 (Ashtabula Plant that closed) and added new location 39 (Painesville Water Plant). When the control drinking/surface water location, Ashtabula Plant, closed, it was replaced with the Painesville Purification Plant, which is outside of the influence of PNPP. A Control location is one that could not be affected and/or influenced by plant discharge. The new water control location at the Painesville Purification Plant is located 8.6 miles west of the plant. The current in Lake Erie flows in the easterly direction toward Niagara Falls. Additionally, the Grand River discharges to the lake between the plant and the new location, further limiting any influence the plant may have on this new Control location.

30. Table 5.1-1: removed location 65 (Major Stream Mouth) and added new location 66 (Lakeshore Metropark Reservation) due to loss of sampling location due to erosion. Location 65, Major Stream Mouth, for sediment collection became inaccessible in July of 2014 due to shoreline erosion. Location 66, Lakeshore Metropark Reservation, was identified as a replacement location for the major stream sediment location after it became inaccessible. Table 3.12.1-1 3.c requires one sample from an area with existing or potential recreational value for shoreline sediment. The Lakeshore Metropark Reservation is downstream of the influence of the plant and has recreational significance because it is a public beach.

31. Table 3.12.1-1: reduced number samples of fish species required for commercially and recreationally important species from two samples of each species to one sample of each species in both areas affected and unaffected by the plant discharge. Updated to be consistent with wording in NUREG-1302, which states, "One sample of each commercially and recreationally important species in vicinity of plant discharge area" and "One sample of same species in areas not influenced by plant discharge". Reduces extra sampling that is not required.

32. Table 3.12.1-1 Section 4.b: revised sampling frequency from "one sample in season" to "one sample in season or semiannually if they are not seasonal." Updated to be consistent with wording in NUREG-1302 which states, "Sample in season, or semiannually if they are not seasonal."

	<b>REGULATORY APPLICABILITY DETERMINATION</b> NOP-LP-4003-01 Rev. 04	No. 17-02381 Rev. 00
	Page 4 of 8	
Initiating Activity No. Procedure CHI-ODCM		Rev. 21
<input type="checkbox"/> BVPS 1 <input type="checkbox"/> BVPS 2 <input type="checkbox"/> DBNPS <input checked="" type="checkbox"/> PNPP		

**1. EXEMPTIONS**

Is the scope of the entire activity exempt from the 10CFR50.59 process because it is limited to:

- 1.1 Managerial or administrative changes.....  YES  NO
- 1.2 UFSAR changes (or equivalent information) excluded from the requirement to perform a 10CFR50.59 Screen and Evaluation by NEI 96-07 or NEI 98-03?.....  YES  NO
- 1.3 Maintenance activities and temporary alterations in support of maintenance planned for 90 days or less while at power.....  YES  NO
- 1.4 Changes evaluated under another program that included a 10CFR50.59 Screen.....  YES  NO

**2. OTHER REGULATIONS**

- 2.1 Does the activity require a license amendment?
  - 2.1.1 Operating License.....  YES  NO
  - 2.1.2 Technical Specifications.....  YES  NO
  - 2.1.3 Environmental Protection Plan (BVPS and PNPP only).....  YES  NO
- 2.2 Is the activity or any portion of the activity governed by one or more of the following regulations:
  - 2.2.1 Quality Assurance Program (10CFR50.54(a)).....  YES  NO
  - 2.2.2 Security Plans (10CFR50.54(p)).....  YES  NO
  - 2.2.3 Emergency Plan (10CFR50.54(q)).....  YES  NO
  - 2.2.4 IST Program Plan (10CFR50.55(a)(f)).....  YES  NO
  - 2.2.5 ISI Program Plan (10CFR50.55(a)(g)).....  YES  NO
  - 2.2.6 Fire Protection Program (10CFR50.48).....  YES  NO
  - 2.2.7 Independent Spent Fuel Storage Facility (10CFR72.48).....  YES  NO
  - 2.2.8 Another regulation:
    - Standards For Protection Against Radiation (10 CFR 20 including ODCM).....  YES  NO
    - Specific Exemptions (10 CFR 50.12).....  YES  NO
    - ECCS Acceptance Criteria (10 CFR 50.48).....  YES  NO
    - Environmental Protection (DBNPS only).....  YES  NO
    - Other - list the regulation(s): see below.....  YES  NO

	<b>REGULATORY APPLICABILITY DETERMINATION</b> NOP-LP-4003-01 Rev. 04	No. 17-02381 Rev. 00
	Page 5 of 8	
Initiating Activity No. Procedure CHI-ODCM		Rev. 21
<input type="checkbox"/> BVP8 1		<input type="checkbox"/> BVP8 2
		<input type="checkbox"/> DBNP8
		<input checked="" type="checkbox"/> PNPP

**3. CONCLUSION**

3.1 Does 10CFR50.59 apply? .....  YES  NO

3.2 Does this activity require a change to the UFSAR? Change Request No: .....  YES  NO

3.3 Summarize the bases for responses: Include Keywords used to search documents.

**Keywords:** Radiological Environmental Monitoring Program, REMP, fish, TLD, drinking water, milk, sediment, downscale, gaseous effluent, radiation monitor, ODCM, Offsite Dose Calculation Manual, NUREG 1302, 89-01, Reg Guide 1.21

The UFSAR word search for the keywords above revealed no results which would require changes to the UFSAR. Changes made maintain compliance with UFSAR Table 1.8-1: Conformance to NRC Regulatory Guides; 3.1.2.6.5: Criterion 64 - Monitoring Radioactivity Releases; 11.3 Gaseous Waste Management Systems; and 11.5 Process And Effluent Radiological Monitoring And Sampling Systems.

A review of the regulations listed in section 2.1 was performed and it was concluded that this change to the ODCM neither directly nor indirectly affects the Operating License, Technical Specifications (specifically 5.5.1 and 5.5.4), or the Environmental Protection Plan. The proposed procedure change does not change any part of these documents such that a license amendment is required.

Technical Specifications 5.0, Administrative Controls, Section 5.5 Programs and Manuals requires that the following programs and manuals shall be established, implemented, and maintained for the Offsite Dose Calculation Manual (ODCM).

In Section 5.5.1: Licensee initiated changes to the ODCM:

a. Shall be documented and records of reviews performed shall be retained. This documentation shall contain:

1. sufficient information to support the change(s) together with the appropriate analyses or evaluations justifying the change(s), and

2. a determination that the change(s) maintain the levels of radioactive effluent control required by 10 CFR 20.1302, 40 CFR 190, 10 CFR 50.36a, and 10 CFR 50 Appendix I, and not adversely impact the accuracy or reliability of effluent, dose, or setpoint calculations

b. Shall become effective after review and acceptance including approval by the procedurally authorized individual.

This change to the ODCM is documented in accordance with REC-0107, Control of the Offsite Dose Calculation Manual. The REC-0107 evaluation determined that the change maintains the level of radioactive effluent control required by 10 CFR 20.1302, 40 CFR 190, 10 CFR 50.36a, and 10 CFR 50 Appendix I. The REC-0107 evaluation determined that the proposed changes do not adversely impact the accuracy or reliability of effluent calculations, dose calculations, or setpoint calculations. The procedure change package, including REC-0107 Attachment 1, is retained as a quality record and documents the information required in Section 5.5.1 a.1 and a.2 for Licensee-initiated changes. The ODCM becomes effective after reviews and acceptance in accordance with the process outlined in NOP-SS-3001, Procedure Review and Approval.

A review of the section 2.2.1 through 2.2.7 regulations was performed and it was concluded that this change to the ODCM does not result in a change or deviation from any of the program requirements referenced in section 2.2 of this form. The Quality Assurance (QA) Program is unaffected by this change. This procedure change does not impact the Fire Protection Program, the Security Plan or the Emergency Plan. There is no effect on the In-Service Test Program Plan, the In-Service Inspection Program Plan and is not related to an Independent Spent Fuel Storage Facility.

Other Regulations which apply per section 2.2.8:

- 10 CFR 20, Standards for Protection Against Radiation, Including 10 CFR 20.1302
- 40 CFR Part 190, Environmental Radiation Protection Standards for Nuclear Power Operations
- 10 CFR 50.36a, Technical Specifications on Effluents from Nuclear Power Reactors.
- 10 CFR 50 Appendix I, Numerical Guides for Design Objectives and Limiting Conditions for Operation to Meet the Criterion "As Low as is Reasonably Achievable" for Radioactive Material in Light-Water-Cooled Nuclear Power Reactor Effluents
- Regulatory Guide 1.21, Measuring, Evaluating and Reporting Radioactivity in Solid Wastes and Release of Radioactivity in Liquid and Gaseous Effluents from Light-Water Cooled Nuclear Power Plants

	<b>REGULATORY APPLICABILITY DETERMINATION</b> NCP-LP-4003-01 Rev. 04	No. 17-02381 Rev. 00
	Page 6 of 8	
Initiating Activity No. Procedure CHI-ODCM		Rev. 21
<input type="checkbox"/> BVPS 1 <input type="checkbox"/> BVPS 2 <input type="checkbox"/> DBNPS <input checked="" type="checkbox"/> PNPP		

- Generic Letter 89-01, Supplement No. 1, Implementation for Programmatic Controls for Radiological Effluent Technical Specification in the Administrative Controls Section of the Technical Specifications and the Relocation of Procedural Details of RETS to the Offsite Dose Calculation Manual or to the Process Control Program.
- NUREG-1302, Offsite Dose Calculation Manual Guidance: Standard Radiological Effluent Controls for Boiling Water Reactors
- Perry Nuclear Power Plant, Units 1 and 2 Environmental Report, Operating License Stage. Sections 5.2.4 and 5.2.5

The first 23 items described in the "Brief Description Of Activity" above fall under the administrative definition in section 1.1 and do not need to be evaluated under 50.59. These items are editorial or clarifying in nature and move, add, or delete information throughout the ODCM. No changes will occur as a result of the first 23 items in the ODCM change that would impact compliance with Technical Specifications 5.5.1 or 5.5.4, 10 CFR 20 (including 10 CFR 20.1302), 40 CFR Part 190, 10 CFR 80.36a, 10 CFR 50 Appendix I, Reg. Guide 1.21, Generic Letter 89-01, Supplement No. 1, NUREG-1302, or the Environmental Report.

Items 24 through 32 in the "Brief Description of Activity" involve changes to the Radiological Environmental Monitoring Program (REMP) sampling locations and frequency of collection. The Radiological Environmental Monitoring Program (REMP) is not discussed in the UFSAR. These changes to the REMP do not constitute modifications or additions to, or removal from, the facility or procedures that affect a design function, method of performing or controlling the function, or an evaluation that demonstrates that intended functions will be accomplished. The REMP is conducted outside the facility and is a monitoring program to evaluate the environmental impact of site radiological releases. As such, it does not affect the Facility as Described in the UFSAR (The structures, systems and components that are described in the UFSAR, the design and performance requirements for such SSCs described in the UFSAR, and the evaluations or methods of evaluation included in the UFSAR to demonstrate that the intended function(s) of such SSCs will be accomplished.) The REMP has no adverse impact on SSC operation or function and 50.59 does not apply. These changes require evaluation to the other regulations which apply per section 2.2.8.

**24. Section 4.2: Removed requirement that specified that environmental TLDs will be changed out quarterly and annually and replaced with a reference to Table 3.12.1-1, Radiological Environmental Monitoring Program.**

This change ensures there is only one location in the ODCM that specifies monitoring frequency and directs to the appropriate table. Annual collection of TLDs is over and above the requirements set forth in NUREG-1302. The additional administrative burden of collecting TLDs annually as well as quarterly was removed by this change. NUREG-1302 does not require annual TLDs. Only quarterly TLD collection is required by the NUREG.

For the purposes of ODCM Table 13.12.1-1, a thermoluminescent dosimeter (TLD) is considered to be one phosphor; two or more phosphors in a packet are considered as two or more dosimeters (see table note 2). Each quarterly TLD contains two or more phosphors and, therefore, meets the requirement of NUREG-1302.

Quarterly TLD collection is more restrictive than annual collection. As quarterly TLD collection remains a requirement in the ODCM, this change does not affect PNPP's compliance with the environmental monitoring requirements contained in Reg. Guide 1.21, NUREG-1302 (GL 89-01), or the Environmental Report. This change has no adverse effect on compliance with Technical Specifications 5.5.1 or 5.5.4.

**25. Table 5.1-1; added new location 57**

The TLD at Location 57, Perry High School, was added when the old school on Center Rd. was demolished and a school was built at the new location. According to ODCM Table 3.12.1-1, Exposure Pathway/Sample 1, Direct Radiation, TLDs should be placed "in special interest areas... such as schools." The TLD in Location 55 at the previous school location remains in place due to the land being repurposed as a special interest area as a public soccer field. Addition of another TLD to the ODCM increases the monitoring performed and monitors offsite dose at an additional location. Addition of new location 57 maintains PNPP in compliance with the environmental monitoring requirements contained in Reg. Guide 1.21, NUREG-1302 (GL 89-01), the Environmental Report, and the ODCM. This change has no adverse effect on compliance with Technical Specifications 5.5.1 or 5.5.4.

	<b>REGULATORY APPLICABILITY DETERMINATION</b> NOP-LP-4003-01 Rev. 04	No. 17-02381 Rev. 00
	Page 7 of 8	
Initiating Activity No. Procedure CHI-ODCM		Rev. 21
<input type="checkbox"/> BVPS 1 <input type="checkbox"/> BVPS 2 <input type="checkbox"/> DBNPS <input checked="" type="checkbox"/> PNPP		

26. Table 5.1-1: removed location 18 for milk sampling.

Milk sampling at location 18 was lost due to the death of the goat. The goat was not replaced. There are no additional milking animals within the prescribed distance from the plant whose owners wish to participate in the Perry Nuclear Power Plant Radiological Environmental Monitoring Program. (Documented in Chemistry Technical Assignment File 15-009.)

ODCM Table 3.12-1, Radiological Environmental Monitoring Program, Section 4.c Food Products requires sampling of broadleaf vegetation if milk sampling is not performed. PNPP performs broadleaf vegetation sampling in accordance with ODCM Table 3.12-1 requirements and has been doing so for many years. With removal of location 18 for milk sampling, PNPP remains in compliance with the environmental monitoring requirements contained in Reg. Guide 1.21, NUREG-1302 (GL 89-01), the Environmental Report, and the ODCM. This change has no adverse effect on compliance with Technical Specifications 5.5.1 or 5.5.4.

27. Table 5.1-1: Removed location 18 in the East sector for broadleaf vegetation sampling as owners chose not to continue participation in the PNPP REMP. This location was replaced with location 20, also in the East sector (see change 26). Table 3.12.1-1.4.c requires two different offsite locations for broadleaf vegetation sampling in the highest D/Q sectors. The REMP as outlined in ODCM Table 5.1-1 contains more than two indicator locations (2, 16, 20, and 37) in the highest D/Q sectors as well as a control (70) in the least prevalent D/Q sector. With the removal of location 18 and concurrent addition of locations 16 and 20, PNPP remains in compliance with the environmental monitoring requirements contained in Reg. Guide 1.21, NUREG-1302 (GL 89-01), the Environmental Report, and the ODCM. This change has no adverse effect on compliance with Technical Specifications 5.5.1 or 5.5.4.

28. Table 5.1-1: Added new broadleaf vegetation sampling locations 16 and 20.

With no milking animals within the required five km distance from the PNPP, the ODCM requires that food product sampling is performed at two locations of the highest D/Q sectors. Using ODCM Table A-2, the highest D/Q sector on land is the East (with a D/Q of 1.8E-08 per square meter). The second highest sector is a tie between the South and the East Northeast (ENE) (with a D/Q of 1.6E-08 per square meter).

ODCM Table 3.12.1-1, Radiological Environmental Monitoring Program, Section 4.c Food Products requires "Sample of three different kinds of broad leaf vegetation grown nearest each of two different offsite locations of highest predicted annual average ground level D/Q if milk sampling is not performed" and "One sample of each of the similar broad leaf vegetation grown 15 to 30 km distant in the least prevalent wind direction if milk sampling is not performed."

The two broadleaf vegetation collection locations listed in revision 20 of the ODCM (locations 2 and 37) are in one of the three highest D/Q sectors (ENE). Two other locations are being sampled in addition to the ODCM-required locations. Locations 16 and 20 have participated in the broadleaf vegetation sampling program for years and satisfy the requirements of the ODCM because they lie in other two highest D/Q sectors: location 20 in the East and location 16 in the South. These changes maintain the PNPP REMP in line with historically-sampled sectors. Location 70 remains unchanged as the control location in the least prevalent SSW D/Q sector. (Documented in Chemistry Technical Assignment File 17-004.)

The addition of food product sampling locations in the East and South sectors aligns ODCM Table 5.1-1 sampling locations to compliance with the environmental monitoring requirements contained in NUREG-1302 and ODCM Table 3.12.1-1. With this change, PNPP is in compliance with the environmental monitoring requirements contained in Reg. Guide 1.21, NUREG-1302 (GL 89-01), the Environmental Report, and the ODCM. This change has no adverse effect on compliance with Technical Specifications 5.5.1 or 5.5.4.

29. Table 5.1-1: removed location 28 and added new location 39.

Location 28, Ashtabula Plant, was closed in 2015, at which time water collection was no longer available. Location 39: Painesville Plant: When the control drinking/surface water location, Ashtabula Plant, closed, it was replaced with the Painesville Purification Plant, which is outside of the influence of PNPP. (Documented in Chemistry Technical Assignment File 15-004.)

In the ODCM Table 3.12-1, the Waterborne - Drinking section contains a requirement for a control sample but does not specify its location. A control location is one that could not be affected or influenced by plant discharge. The new water control location at the Painesville Purification Plant is located 8.6 miles west of the plant. The current in Lake Erie flows in the easterly direction toward Niagara Falls. Additionally, the Grand River discharges to the lake between the plant and the new location, further limiting any influence the plant may have on this new control location. The new water control location meets the

	<b>REGULATORY APPLICABILITY DETERMINATION</b> NOP-LP-4003-01 Rev. 04	No. 17-02381 Rev. 00
	Page 8 of 8	
Initiating Activity No. Procedure CHI-ODCM		Rev. 21
<input type="checkbox"/> BVPS 1	<input type="checkbox"/> BVPS 2	<input type="checkbox"/> DBNPS
		<input checked="" type="checkbox"/> PNPP

requirements of Reg. Guide 1.21, NUREG-1302 (GL 89-01), the Environmental Report, and the ODCM. This change has no adverse effect on compliance with Technical Specifications 5.5.1 or 5.5.4.

**30. Table 5.1-1: removed location 65 and added new location 66.**

Location 65, Major Stream Mouth, for sediment collection became inaccessible in July of 2014 due to shoreline erosion.

Location 66, Lakeshore Metropark Reservation, was identified as a replacement location for the Major Stream sediment location after it became inaccessible. The Lakeshore Metropark Reservation location is an acceptable replacement for the lost Major Stream sediment sampling location. Table 3.12.1-1 3.c requires one sample from an area with existing or potential recreational value for shoreline sediment. The Lakeshore Metropark Reservation is downstream of the influence of the plant and has recreational significance because it is a public beach.

The new Sediment location meets the requirements of Reg. Guide 1.21, NUREG-1302 (GL 89-01), the Environmental Report, and the ODCM. This change has no adverse effect on compliance with Technical Specifications 5.5.1 or 5.5.4.



**31. Table 3.12.1-1: reduced number samples of fish species required for commercially and recreationally important species from two samples of each species to one sample of each species in both areas affected and unaffected by the plant discharge.**

Updated to be consistent with wording in NUREG-1302, which states, "One sample of each commercially and recreationally important species in vicinity of plant discharge area" and "One sample of same species in areas not influenced by plant discharge". This change removes an administrative burden which required two samples of each species. One sample of each commercially and recreationally important fish species is an adequate sample size for performance of required laboratory analyses. This change removes extra sampling that is not required to comply with NUREG-1302. This change has no adverse effect on compliance with Reg. Guide 1.21, NUREG-1302 (GL 89-01), 10 CFR 20.1302, 40 CFR Part 190, 10 CFR 50.36a, the Environmental Report, or 10 CFR 50 Appendix I. This change has no adverse effect on compliance with Technical Specifications 5.5.1 or 5.5.4.

**32. Table 3.12.1-1 Section 3.b: revised sampling frequency from "one sample in season" to "One sample in season or semiannually if they are not seasonal."**

Updated to be consistent with wording in NUREG-1302, which states, "Sample in season, or semiannually if they are not seasonal". The fish which follow seasonal migratory patterns in the lake are not always present and can only be caught when in season, hence one sample in season. This change imposes more restrictive requirements for obtaining samples semiannually for fish which are not seasonal. This change has no adverse effect on compliance with Reg. Guide 1.21, NUREG-1302 (GL 89-01), 10 CFR 20.1302, 40 CFR Part 190, 10 CFR 50.36a, the Environmental Report, or 10 CFR 50 Appendix I. This change has no adverse effect on compliance with Technical Specifications 5.5.1 or 5.5.4.

Items 24 through 32 described in the "Brief Description Of Activity" have been reviewed against the Other Regulations listed above and are in compliance with the requirements of those regulations. No further evaluation is necessary for these changes

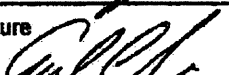
Preparer (Print name) Gehring-Ohrablo, Kristine M.	Signature 	Date 10/9/2017
Reviewer (Print name) Bates, Carl	Signature 	Date 10/9/17
Database Updated <input checked="" type="checkbox"/>	Signature 	Date 10/9/17

PERRY NUCLEAR POWER PLANT		Procedure Number: REC-0107	
Title: Control of the Offsite Dose Calculation Manual		Use Category: General Skill Reference	
		Revision: 2	Page: 8 of 9

**ATTACHMENT 1: ODCM CHANGE DETERMINATION**  
Page 1 of 2

**Description of Changes:**

Provide a description of each change with sufficient information to support each change together with appropriate analyses or evaluations justifying the change(s)

Description of Change

*see attachment*

Justification for Change

Description of Change

Justification for Change

(Add additional as necessary to address each change.)

**Change Determination:**

For each question, provide sufficient information for an informed reviewer to arrive at the same conclusion. *Information to draw conclusions supported in attached justification of changes package*

- A. Does the proposed change maintain the level of radioactive effluent control required by 10 CFR 20.1302? (Compliance with dose limits for individual members of the public, where annual average concentrations of radioactive material released in gaseous and liquid effluents at the boundary of the unrestricted area do not exceed the values specified in Table 2 of Appendix B Part 20.)

Yes       No

- B. Does the proposed change maintain the level of radioactive effluent control required by 40 CFR 190? (Total dose uranium fuel cycle - less than or equal to 25 mrem total body or any organ, or less than or equal to 75 mrem thyroid.)

Yes       No

- C. Does the proposed change maintain the level of radioactive effluent control required by 10 CFR 50.36a? (Technical Specifications on effluents from nuclear power reactors, where the Offsite Dose Calculation Manual is the document where the effluent controls are specified, and all the requirements of this regulation are demonstrated.)

Yes       No



<b>PERRY NUCLEAR POWER PLANT</b>	Procedure Number: <b>REC-0107</b>	
Title: <b>Control of the Offsite Dose Calculation Manual</b>	Use Category: <b>General Skill Reference</b>	
	Revision: <b>2</b>	Page: <b>9 of 9</b>

**ATTACHMENT A: ODCM CHANGE DETERMINATION**  
Page 2 of 2

D. Does the proposed change maintain the level of radioactive effluent control required by 10 CFR 50, Appendix I? (Numerical guides for design objectives and limiting conditions for operation to meet the criterion "as low as reasonably achievable," for radioactive material in light-water-cooled nuclear power reactor effluents, lists the annual dose commitments to unrestricted areas for liquid and gaseous effluents.)

Yes       No

E. Does the proposed change adversely impact the accuracy or reliability of effluent calculations?

Yes       No

F. Does the proposed change adversely impact the accuracy or reliability of dose calculations?

The changes have no effect on the accuracy or reliability of dose calculations. Therefore they do not adversely impact the accuracy or reliability of effluent calculations.

G. Does the proposed change adversely impact the accuracy or reliability of setpoint calculations?

Yes       No

**Conclusion:**

Will the change(s) to the ODCM maintain the level of radioactive effluent control required by regulation as required by of Technical Specification 5.5.1(a)?

Yes       No

Prepared by: Muhammad Baker M Baker

Date: 08/09/17

**ODCM Rev. 21 Justification of Changes:**

1. **Commitment L02211 was closed and removed from:**
  - Introduction, paragraph 6
  - Table 3.3.7.9-1.3.c.2
  - Table 3.3.7.10-1.2.a
  - Table 3.3.7.10-1.4.a
  - Table 3.3.7.10-1, action note 122
  - Controls section 3.11.2.4 under the description and footnoteCommitment was closed
  
2. **Commitment R00449 was closed and removed from Table 4.11.1.1-1.B under the grab sample composite**  
Commitment was closed
  
3. **Added clarification of a valid alert alarm in 3.1 note a**  
Added clarification of need for a valid alert alarm before sampling
  
4. **Combined note in calculation 3.1-4 with the definition "f" and added note to reference table 3.1-2**  
Editorial change for clarity
  
5. **Formalized table of Effluent Release Path flow rates listed under section 3.1.4 equation definitions, creating Table 3.1-2 and added table to List of Tables**  
Administrative change to give table official table title for easier reference.
  
6. **Section 4.2: Removed requirement that specified that environmental TLDs will be changed out quarterly and annually. Now section contains a reference to Table 3.12-1, Radiological Environmental Monitoring Program.**  
Change ensures only one location in the ODCM that specifies monitoring frequency; removes annual TLD replacement (not required per Table 3.12-1). Per NUREG-1302, only the quarterly TLD analysis is required.
  
7. **Section 5.1: Removed reference to site-specific environmental monitoring procedures.**  
REMP-0013 should reference the ODCM as the governing document. The procedure lists locations in addition to those required by the ODCM and therefore, should not be referenced in the ODCM as a required list.
  
8. **Table 5.1-1: shortened title; renamed location 53 to reflect current status; added new locations 16, 20, 39, 57 and 66; removed locations 18, 28 and 65; indicated that locations 36 and 39 are drinking water and locations 59 and 60 are surface water samples; changed "Food Products" to "Broadleaf Vegetation" at locations 2, 37, and 70.**  
Updated to reflect current locations (location 53 lists address rather than facility name); title changes made to better specify water and food types

**Removed locations:**

- 18 Kijauskas Farm: milking goat died (refer to TAF 15-009), owners also chose to discontinue participation in the broadleaf vegetable portion of the program. This location was not replaced. Table 3.12.1-1.4.c states that only two different offsite locations are required. There are still two indicator locations as well as a control.
- 28 Ashtabula Plant: plant was closed in 2015, at which time water collection was terminated (refer to TAF 15-004)
- 65 Major Stream: The access point for sediment collection became inaccessible in July of 2014 as the shoreline eroded. This issue is documented in REMF-0013.

**New locations:**

- 16 Eubank Garden: Food product sampling required in south sector, which is the second-highest D/Q sector, per Table 3.12.1-1 section 4.c. Refer to TAF 17-004
  - 20 Rainbow Farms: Food product sampling required in east sector, which is the highest D/Q sector, per Table 3.12.1-1 section 4.c. Refer to TAF 17-004
  - 39 Painesville Plant: When the control drinking/surface water location, Ashtabula Plant, closed, it was replaced with the Painesville Purification Plant, which is outside of the influence of PNPP (refer to TAF 15-004).
  - 57 Perry High School: The TLD at this location was added when the old school on Center Rd. was demolished and new school established. TLDs should be placed "in special interest areas" ... "such as schools" according to Table 3.12.1-1.1. The TLD at on Center Rd. remains in the program (location 55) due to historical data collection and it is still recreationally significant since there is now a football and soccer field in the vicinity. Location 57 was inadvertently never added to the ODCM, but is documented in REMP-0013.
  - 66 Lakeshore Reservation: When the major stream sediment location became inaccessible, it was replaced with the Lakeshore Metropark location, which is sufficient because it is also downstream of the influence of the plant and has recreational significance (as required by Table 3.12.1-1.3.c) because it is a public beach.
9. **Figures 5.1-1, 5.1-2, and 5.1-3: Updated maps to reflect changed sample locations.**  
Reference change #8
  10. **Revised Table A-2: added a new column showing distance in meters**  
The column displaying distance in meters was added because the dispersion and deposition calculations use meter units
  11. **Tables 3.3.7.10-1 and 4.3.7.10: Table Notations, Removed \*\*\*During main condenser off-gas treatment system operation.** There are no double asterisks in the tables.  
Correction not previously changed; Previous revisions show no double asterisk notation in the table either. This may have been inadvertently copied from NUREG-1302, which also lists the footnote without any notations in the tables.
  12. **Table 3.3.7.10-1: Added action 124 to Unit 1 Vent noble gas channel during modes 4 and 5**  
Correction to table not previously changed; Unit 1 vent still has a source term during modes 4 and 5 from the spent fuel pool. If the annunciator downscale alarm locks in, action 124 is applicable in all modes, not just 1, 2, and 3.
  13. **Table 3.3.7.10-1: Removed footnote (1) from each page and added it to the notations portion**  
Editorial correction
  14. **Table 3.12.1-1: Changed number of TLDs to 29.**  
Reference change #8, added TLD at Perry High School
  15. **Table 3.12.1-1: modified wording to state that one species of each commercially or recreationally important fish will be collected; changed sampling frequency to semi-annually in section 3.b**  
Updated for consistency with wording in NUREG 1302, which states, "One sample of each commercially and recreationally important species in vicinity of plant discharge area" and "One sample of same species in areas not influenced by plant discharge".
  16. **Table 4.3.7.9-1.3: Updated NBS reference to NIST**  
Correction not previously changed
  17. **Revised Section 6.9.1.7: moved the information denoted by an asterisk regarding maintaining the meteorological report separate from the Annual Report into paragraph b; split the paragraph into two for clarity purposes.**

Changed for clarification of how the met report will be distributed. It was requested to be changed by the NRC to clarify that we will retain the met data report and distribute as requested, but it will not be submitted each year.

**18. Removed asterisk and footnote from second page of section 6.9.1.7**

When table was updated in previous revisions, the asterisk was not removed. The asterisk on the second page, "Licensee may choose to submit the information called for in this Control as part of the annual USAR update", applied to section 6.15 Major Changes to Radioactive Waste Treatment System. In revision 19, section 6.15 started on the same page as the end of section 6.9.1.7. With revision 20, pagination was changed to start section 6.15 on a separate page. The footnote was inadvertently not removed from the previous page, but was correctly carried on with section 6.15.

**19. Added new section for commitments**

Section was previously missing

**20. Minor editorial and grammatical corrections, revision bars not used**

Editorial corrections

