



**ENGINE SYSTEMS, INC.**

175 Freight Road  
Rocky Mount, NC 27804

Telephone: 252/977-2720  
Fax: 252/446-1134

January 5, 2018

U.S. Nuclear Regulatory Commission  
Document Control Desk  
Washington, DC 20555-0001

Subject: 10CFR21 Reporting of Defects and Non-Compliance -  
Engine Systems, Inc. Report No. 10CFR21-0120, Rev. 0  
  
Thermostatic Valve Assembly, P/N 6BOCF14001

Dear Sir:

The enclosed report addresses a reportable notification on a thermostatic valve assembly, P/N 6BOCF14001.

A copy of the report has been mailed to our affected nuclear customer.

Please sign below, acknowledging receipt of this report, and return a copy to the attention of Document Control at the address above (or, fax to number 252/446-1134) within 10 working days after receipt.

Yours very truly,

ENGINE SYSTEMS, INC.

Susan Woolard  
Document Control

**Please let us know if ANY of your mailing information changes - name of recipient, name of company/facility, address, etc. Mark the changes on this acknowledgment form and send to us by mail or FAX to the number above.**

RECEIVED: \_\_\_\_\_

93

DATE: \_\_\_\_\_

TE 19  
NRR



# ENGINE SYSTEMS, INC.

175 Freight Road, Rocky Mount, NC 27804

Telephone: 252/977-2720

Fax: 252/446-1134

**Report No. 10CFR21-0120**

Rev. 0: 01/05/18

## 10CFR21 REPORTING OF DEFECTS AND NON-COMPLIANCE

COMPONENT: Thermostatic Valve Assembly  
P/N 6BOCF14001

SYSTEM: Emergency Diesel Generator

CONCLUSION: Reportable in Accordance With 10CFR21

Prepared By: Ja Lin  
Engineering Manager

Date: 1/5/18

Reviewed By: Thomas W. M.  
Quality Manager

Date: 1-5-18

| REV | DATE     | PAGE | DESCRIPTION    |
|-----|----------|------|----------------|
| 0   | 01/05/18 |      | Initial issue. |

**Pursuant to 10 CFR 21.21(d)(4), ESI is presenting the required information as follows:**

- (i) Name and address of the individual or individuals informing the Commission.

Thomas Horner  
Quality Manager  
Engine Systems Inc.  
175 Freight Rd.  
Rocky Mount, NC 27804

John Kriesel  
Engineering Manager  
Engine Systems Inc.  
175 Freight Rd.  
Rocky Mount, NC 27804

- (ii) Identification of the basic component supplied within the United States which fails to comply or contains a defect.

*Thermostatic Valve Assembly, P/N 6BOCF14001.*

- (iii) Identification of the firm supplying the basic component which fails to comply or contains a defect.

*Engine Systems Inc.*

- (iv) Nature of the defect or failure to comply and the safety hazard which is created or could be created by such defect or failure to comply.

*Two thermostatic valve assemblies were supplied by ESI that were found to have retaining straps, subcomponents of the internal thermostatic element, detached from the correct position. For each valve assembly, one of the thermostatic elements (the centrally located element) contained this defect. The straps are used in conjunction with a spring to retain the element in a closed position. As the temperature of the sensed fluid increases, a temperature sensitive wax expands to open the element while acting against the spring. As the temperature of the fluid decreases, the wax contracts and the spring returns the element to its closed position. Absence or failure of the straps would prevent proper operation of the element. See Figures 1 and 2 below for visual representation of an element.*

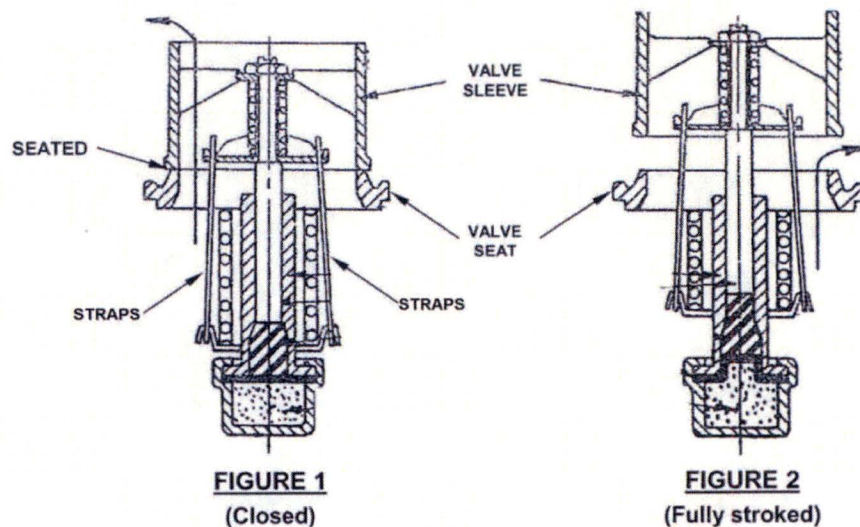

*The thermostatic valve assembly is used on an emergency diesel generator set to regulate the temperature of lubricating oil (other EDGs use this same type of valve for jacket water temperature regulation). If one of the elements within the assembly were to fail, as is the case with a missing strap, regulating capacity of the thermostatic valve could be affected. However, the failure mode in the case of missing straps is in the open position (element does not return closed) and the remaining eight elements would compensate by closing to regulate the fluid temperature. More importantly, detached retaining straps could migrate to other components in the lube oil system. Acting as foreign material, the straps could adversely affect the ability of these critical components to perform their safety-related function within the emergency diesel generator's lube oil piping. The foreign material aspect of this defect makes it a reportable issue. See Figure 3 on the following page for an outline drawing showing typical installation of elements in the valve assembly. Appendix A contains photos of the assembly.*

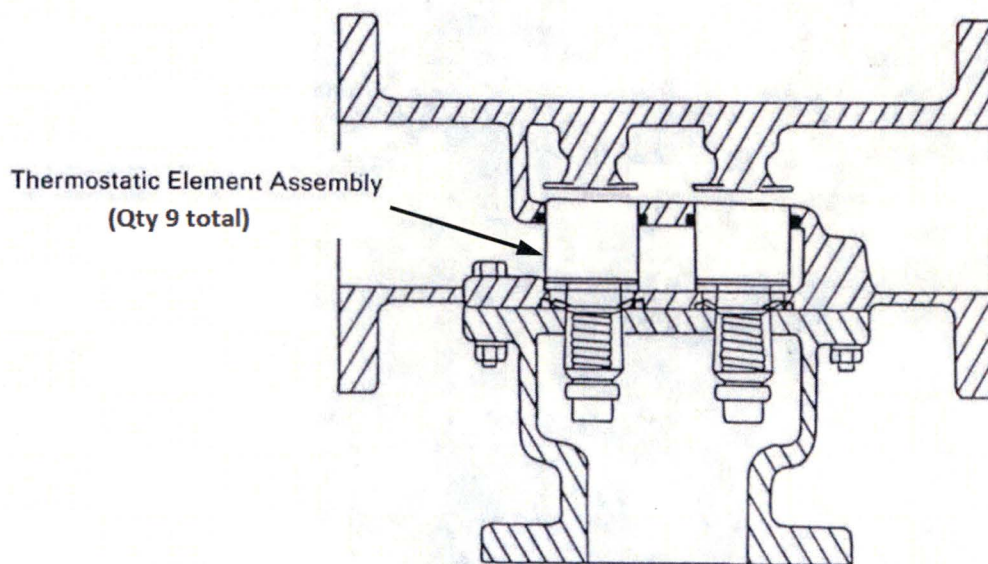

**FIGURE 3**  
Thermostatic Valve Assembly

(v) The date on which the information of such defect or failure to comply was obtained.

*November 22, 2017*

(vi) In the case of a basic component which contains a defect or fails to comply, the number and location of these components in use at, supplied for, being supplied for, or may be supplied for, manufactured, or being manufactured for one or more facilities or activities subject to the regulations in this part.

*This issue is an isolated incident affecting two thermostatic valves supplied to one nuclear plant. The nuclear plant detected the issue during inspection and returned the assemblies to ESI.*

| <b>ESI Sales Order</b> | <b>Customer</b>                                 | <b>Customer P.O.</b> | <b>Qty</b> | <b>C-of-C Date</b> | <b>ESI Serial Numbers</b>     |
|------------------------|---|----------------------|------------|--------------------|-------------------------------|
| 3016263                | American Electric Power - DC Cook Nuclear Plant | 01581583             | 2          | 04/03/2017         | 3016263-1.1-1 & 3016263-1.1-2 |

(vii) The corrective action which has been, is being, or will be taken; the name of the individual or organization responsible for the action; and the length of time that has been or will be taken to complete the action.

*For DC Cook: No further action is required, the suspect assemblies have been returned to ESI for rework.*

*For ESI: The dedication package for this assembly has been revised to add inspection criteria for the strap inspection and clarification has been added to the functional test procedure to ensure the assembly is drained following hydrostatic testing by tilting the assembly, not by manually actuating the element.*

(viii) Any advice related to the potential defect or failure to comply about the facility, activity, or basic component that has been, is being, or will be given to purchasers or licensees.

*ESI's investigation revealed that this issue was induced by a test technician who, in an effort to minimize the amount of test fluid remaining in the assembly after pressure testing, manually actuated the center thermostatic element (there are 9 total elements) to drain a small pocket of residual fluid. This effort to prevent the formation of oxidation had an unintended consequence and resulted in a more serious issue. Though this is an isolated incident as it pertains to items supplied from ESI, this same model thermostatic valve assembly is used extensively on EDGs in the nuclear industry. Those customers that perform valve maintenance, including thermostatic element replacement, should be aware of the possibility of the straps becoming detached if care is not taken.*

