

Part 21 (PAR)

Event # 52762

Rep Org: EMERSON AUTOMATION SOLUTIONS	Notification Date / Time: 05/18/2017 12:24 (EDT)
Supplier: VALVE AUTOMATION, INC.	Event Date / Time: 03/14/2017 (CDT)
	Last Modification: 05/18/2017
Region: 4	Docket #:
City: HOUSTON	Agreement State: Yes
County:	License #:
State: TX	
NRC Notified by: SUE OOI	Notifications: GEOFFREY MILLER R4DO
HQ Ops Officer: STEVE SANDIN	JAMNES CAMERON R3DO
Emergency Class: NON EMERGENCY	ALAN BLAMEY R2DO
10 CFR Section:	ART BURRITT R1DO
21.21(a)(2) INTERIM EVAL OF DEVIATION	PART 21/50.55 REACTORS EMAIL

NOTIFICATION UNDER 10 CFR PART 21 OF BETTIS BRAND SEISMIC QUALIFIED G SERIES SPRING RETURN ACTUATORS

The following report was received via fax:

"Pursuant to 10 CFR Part 21, Valve Automation, Inc. (VAI) is writing to inform the Nuclear Regulatory Commission that, due to a retroactive application of a more stringent parts classification analysis, the adaptor plate contained in Bettis Brand Seismic Qualified G Series Spring Return Actuators (the 'Affected Actuators') is now classified as 'critical,' and therefore subject to certain inspection and dedication requirements which may not have been satisfied in Affected Actuators sold in the period between 2010 and 2016.

"VAI has not received any information that absence of the inspection and dedication activities as a result of the prior classification has resulted in a safety hazard. In addition, VAI does not have the ability to determine whether or not a defect or non-compliance as defined in Part 21 exists. We are notifying customers and recommending remedial inspection of the Affected Actuators.

"1.0 Name and address of individual providing this information:

Sue Ooi
 Vice President
 Actuation Technologies
 Emerson Automation Solutions
 19200 Northwest Freeway Houston, Texas 17065
 T + 12814774170

IE19
 NRR

"2.0 Identification of the basic component at issue:

Adaptor plates bearing the following part numbers:

- VA600688
- VA600692
- VA600873
- VA600988

"3.0 Nature of the issue:

VAI is not aware of a 'defect' in the adapter plates of Affected Actuators, but due to a retroactive application of a more stringent parts classification analysis, an inspection and dedication noncompliance may exist concerning these adaptor plates.

"4.0 Number and location of affected components in use:

42 Affected Actuators, sold to direct customers located in the United States.

"5.0 Date the issue was discovered:

March 14, 2017

"6.0 Corrective action and advice given to purchasers:

Inspection Recommendation

Certain measurements should be taken to remedy the inspection nonconformance. All measurements may be taken in situ with the actuator assembled to the valve. Please refer to Figure A (attached) depicting the feature to be measured. The numbered measurements in Figure A correspond to the numbered measurement inspection procedure below. Table 1 provides measurement values for reference [Figure A and Table 1 were supplied with the original submittal and may be viewed at <https://www.nrc.gov/reading-rm/doc-collections/event-status/part21/> when posted]. Remedial inspection recommendations are to:

1. Confirm the thickness of the plate at the point where the bolt head & washer engage the flange surface. This location may be a milled flat section or counter sunk hole depending on the actuator size.
2. Verify full thread engagement for nuts installed on bolts for the housing flange.
3. Perform hardness testing on a small area on the outside diameter of the adaptor plate. The paint will need to be removed at the point of hardness testing.

Should the adaptor plate fail to meet the above specifications, please contact us promptly.

"7.0 Other advice to purchasers:

VAI recommends that users review applications where any Affected Actuators are used to determine any safety considerations in the operation of the plant.

"VAI is committed to the highest standards of safety and customer service in the nuclear industry, and remains dedicated to the supply of world class products to our customers. If you have any questions or require additional information related to this issue, please contact: Justin DeClue, Director of Global Quality, [Tel:] 281 477 4631."



Emerson Automation Solutions
Actuation Technologies
19200 Northwest Freeway
Houston, Texas 77065
USA

May 11, 2017
U.S Nuclear Regulatory Commission
Washington, DC 20555-0001
Attn: Document Control Desk

Re: Notification under 10 CFR Part 21 of Bettis Brand Seismic Qualified G Series Spring Return Actuators

Pursuant to 10 CR Part 21, Valve Automation, Inc. (VAI) is writing to inform the Nuclear Regulatory Commission that, due to a retroactive application of a more stringent parts classification analysis, the adaptor plate contained in Bettis Brand Seismic Qualified G Series Spring Return Actuators (the "Affected Actuators") is now classified as "critical," and therefore subject to certain inspection and dedication requirements which may not have been satisfied in Affected Actuators sold in the period between 2010 and 2016.

VAI has not received any information that absence of the inspection and dedication activities as a result of the prior classification has resulted in a safety hazard. In addition, VAI does not have the ability to determine whether or not a defect or non-compliance as defined in Part 21 exists. We are notifying customers and recommending remedial inspection of the Affected Actuators.

1.0 Name and address of individual providing this information:

Sue Ooi
Vice President
Actuation Technologies
Emerson Automation Solutions
19200 Northwest Freeway Houston, Texas 77065
T +12814774170

2.0 Identification of the basic component at issue:

Adaptor plates bearing the following part numbers:

- VA600688
- VA600692
- VA600873
- VA600988

3.0 Nature of the issue:

VAI is not aware of a "defect" in the adapter plates of Affected Actuators, but due to a retroactive application of a more stringent parts classification analysis, an inspection and dedication noncompliance may exist concerning these adaptor plates.

4.0 Number and location of affected components in use:

42 Affected Actuators, sold to direct customers located in the United States.

5.0 Date the issue was discovered:

March 14, 2017

6.0 Corrective action and advice given to purchasers:**Inspection Recommendation**

Certain measurements should be taken to remedy the inspection nonconformance. All measurements may be taken in situ with the actuator assembled to the valve. Please refer to Figure A (attached) depicting the feature to be measured. The numbered measurements in Figure A correspond to the numbered measurement inspection procedure below. Table 1 provides measurement values for reference. Remedial inspection recommendations are to:

1. Confirm the thickness of the plate at the point where the bolt head & washer engage the flange surface. This location may be a milled flat section or counter sunk hole depending on the actuator size.
2. Verify full thread engagement for nuts installed on bolts for the housing flange.
3. Perform hardness testing on a small area on the outside diameter of the adaptor plate. The paint will need to be removed at the point of hardness testing.

Should the adaptor plate fail to meet the above specifications, please contact us promptly.

7.0 Other advice to purchasers:

VAI recommends that users review applications where any Affected Actuators are used to determine any safety considerations in the operation of the plant.

VAI is committed to the highest standards of safety and customer service in the nuclear industry, and remains dedicated to the supply of world class products to our customers. If you have any questions or require additional information related to this issue, please contact: Justin DeClue, Director of Global Quality, 281 477 4631.

Sincerely,

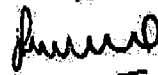

Sue Ooi

FIGURE A

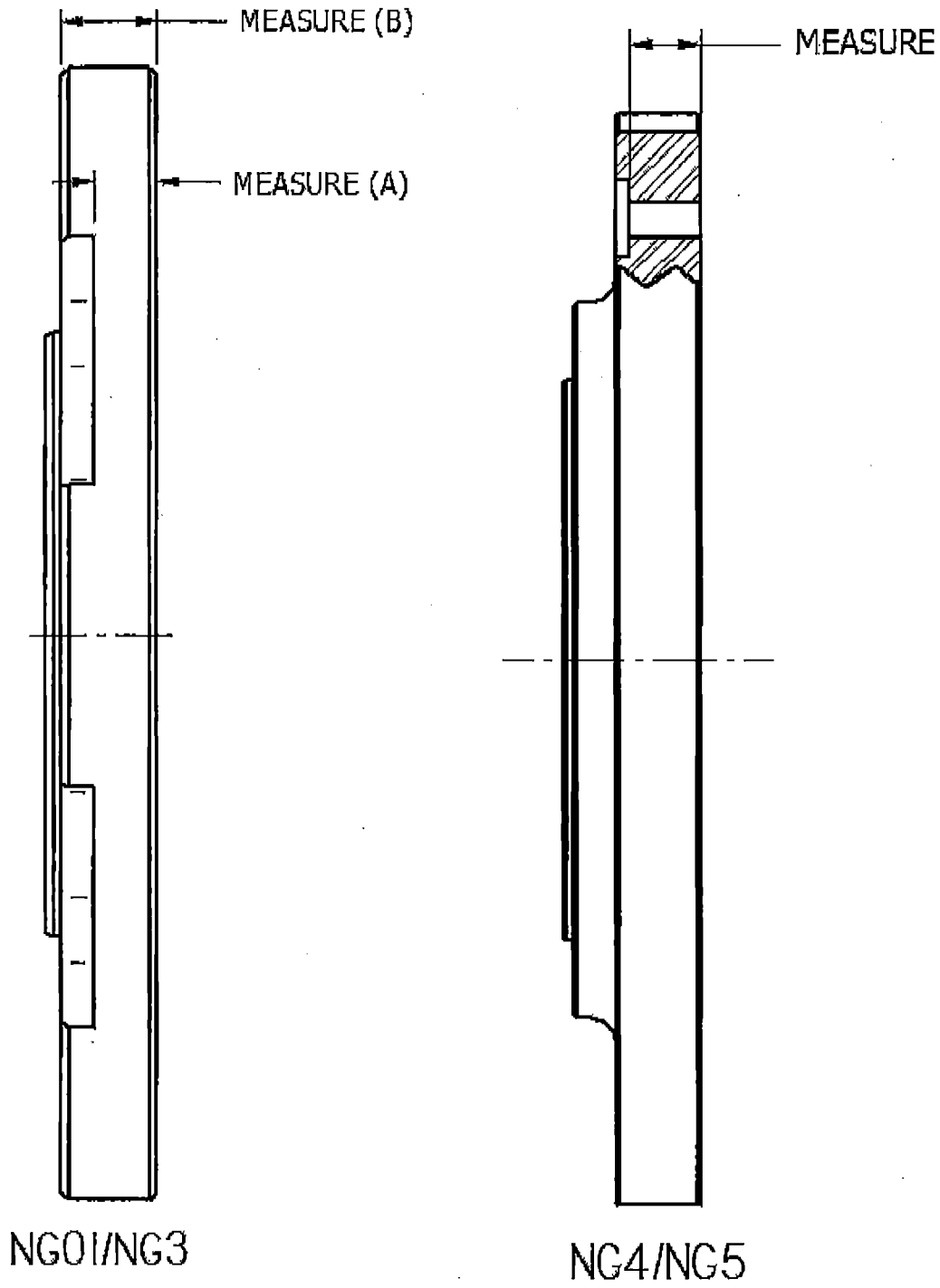

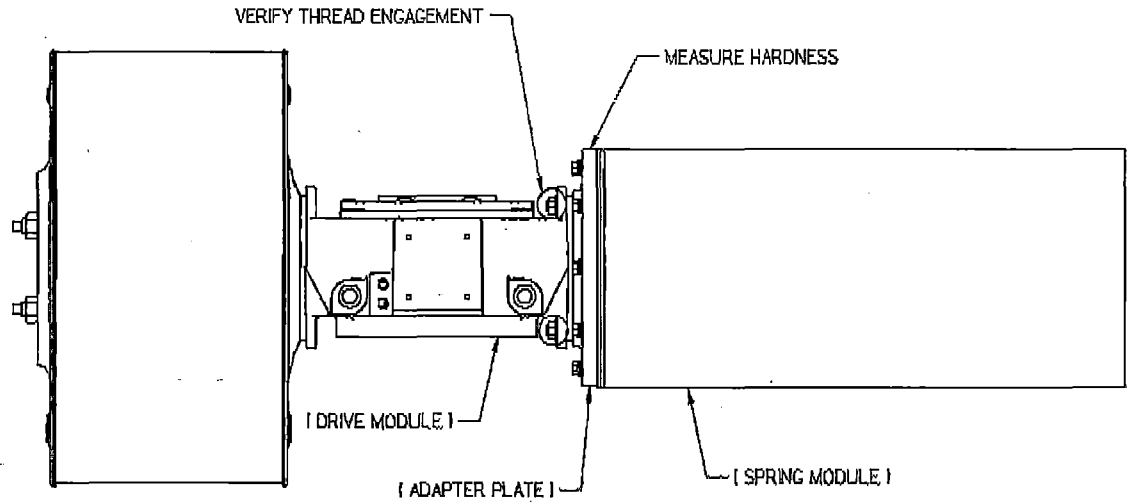

TABLE 1

	Max. Measurement [inches]		Min. Hardness [BHN]
NG01	.57 (A)	.81 (B)	235
NG3	.85 (A)	1.09 (B)	
NG4	1.04		
NG5	1.41		