



Catawba Nuclear Station Units 1 and 2

Annual Radioactive Effluent Release Report

January 1, 2016 through December 31, 2016

Dockets 50-413 and 50-414



Introduction

The Annual Radioactive Effluent Release Report is pursuant to Catawba Nuclear Station Technical Specification 5.6.3 and Selected Licensee Commitment 16.11-16. The below listed attachments to this report provide the required information. In addition, the ODCM is included pursuant to Catawba Nuclear Station Technical Specification 5.5.1.

- Attachment 1 Summary of Gaseous and Liquid Effluents
- Attachment 2 Supplemental Information
- Attachment 3 Solid Radioactive Waste Disposal
- Attachment 4 Meteorological Data
- Attachment 5 Unplanned Offsite Releases
- Attachment 6 Assessment of Radiation Dose from Radioactive Effluents to Members of the Public
- Attachment 7 Information to Support the NEI Ground Water Protection Initiative
- Attachment 8 Inoperable Equipment
- Attachment 9 Summary of Changes to the Offsite Dose Calculation Manual
- Attachment 10 Summary of Changes to the Process Control Program
- Attachment 11 Summary of Major Modifications to the Radioactive Waste Treatment Systems
- Attachment 12 Errata to a Previous Year's ARERR

Attachment 1
Summary of Gaseous and Liquid Effluents

Catawba Nuclear Station Units 1 & 2
Period 1/1/2016 - 12/31/2016

ATTACHMENT 1

Summary of Gaseous and Liquid Effluents

This attachment includes a summary of the quantities of radioactive liquid and gaseous effluents as outlined in Regulatory Guide 1.21, Appendix B.

Attachment 1
Summary of Gaseous and Liquid Effluents

Catawba Nuclear Station Units 1 & 2
Period 1/1/2016 - 12/31/2016

Gaseous Effluents - Summation of All Releases

	<u>Units</u>	<u>Qtr 1</u>	<u>Qtr 2</u>	<u>Qtr 3</u>	<u>Qtr 4</u>	<u>Year</u>
A. Fission and Activation Gases						
1. Total Release	Ci	1.13E+00	8.58E-01	1.05E+00	9.95E-01	4.03E+00
2. Avg. Release Rate	μCi/sec	1.44E-01	1.09E-01	1.32E-01	1.25E-01	1.28E-01
B. Iodine-131						
1. Total Release	Ci	0.00E+00	0.00E+00	0.00E+00	0.00E+00	0.00E+00
2. Avg. Release Rate	μCi/sec	0.00E+00	0.00E+00	0.00E+00	0.00E+00	0.00E+00
C. Particulates Half-Life ≥ 8 days						
1. Total Release	Ci	0.00E+00	0.00E+00	0.00E+00	0.00E+00	0.00E+00
2. Avg. Release Rate	μCi/sec	0.00E+00	0.00E+00	0.00E+00	0.00E+00	0.00E+00
D. Tritium						
1. Total Release	Ci	4.06E+01	3.04E+01	6.99E+01	5.01E+01	1.91E+02
2. Avg. Release Rate	μCi/sec	5.16E+00	3.87E+00	8.79E+00	6.30E+00	6.04E+00
E. Carbon-14						
1. Total Release	Ci	5.47E+00	5.40E+00	4.82E+00	5.29E+00	2.10E+01
2. Avg. Release Rate	μCi/sec	6.96E-01	6.87E-01	6.07E-01	6.66E-01	6.64E-01
F. Gross Alpha						
1. Total Release	Ci	0.00E+00	0.00E+00	0.00E+00	0.00E+00	0.00E+00
2. Avg. Release Rate	μCi/sec	0.00E+00	0.00E+00	0.00E+00	0.00E+00	0.00E+00

Attachment 1
Summary of Gaseous and Liquid Effluents

Catawba Nuclear Station Units 1 & 2
 Period 1/1/2016 - 12/31/2016

Gaseous Effluents - Elevated Releases - Continuous Mode *

	<u>Units</u>	<u>Qtr 1</u>	<u>Qtr 2</u>	<u>Qtr 3</u>	<u>Qtr 4</u>	<u>Year</u>
A. Fission and Activation Gases						
N/A	Ci	-	-	-	-	-
Total for Period	Ci	-	-	-	-	-
B. Iodines						
N/A	Ci	-	-	-	-	-
Total for Period	Ci	-	-	-	-	-
C. Particulates Half-Life ≥ 8 days						
N/A	Ci	-	-	-	-	-
Total for Period	Ci	-	-	-	-	-
D. Tritium						
N/A	Ci	-	-	-	-	-
E. Carbon-14						
N/A	Ci	-	-	-	-	-
F. Gross Alpha						
Total for Period	Ci	-	-	-	-	-

* Catawba Nuclear Station Units 1 and 2 do not have elevated releases.

Attachment 1
Summary of Gaseous and Liquid Effluents

Catawba Nuclear Station Units 1 & 2
 Period 1/1/2016 - 12/31/2016

Gaseous Effluents - Elevated Releases - Batch Mode *

	<u>Units</u>	<u>Qtr 1</u>	<u>Qtr 2</u>	<u>Qtr 3</u>	<u>Qtr 4</u>	<u>Year</u>
A. Fission and Activation Gases						
N/A	Ci	-	-	-	-	-
Total for Period	Ci	-	-	-	-	-
B. Iodines						
N/A	Ci	-	-	-	-	-
Total for Period	Ci	-	-	-	-	-
C. Particulates Half-Life ≥ 8 days						
N/A	Ci	-	-	-	-	-
Total for Period	Ci	-	-	-	-	-
D. Tritium						
N/A	Ci	-	-	-	-	-
E. Carbon-14						
N/A	Ci	-	-	-	-	-
F. Gross Alpha						
Total for Period	Ci	-	-	-	-	-

* Catawba Nuclear Station Units 1 and 2 do not have elevated releases.

Attachment 1
Summary of Gaseous and Liquid Effluents

Catawba Nuclear Station Units 1 & 2
 Period 1/1/2016 - 12/31/2016

Gaseous Effluents - Ground Releases - Continuous Mode

	<u>Units</u>	<u>Qtr 1</u>	<u>Qtr 2</u>	<u>Qtr 3</u>	<u>Qtr 4</u>	<u>Year</u>
A. Fission and Activation Gases						
None	Ci	-	-	-	-	-
Total for Period	Ci	0.00E+00	0.00E+00	0.00E+00	0.00E+00	0.00E+00
B. Iodines						
None	Ci	-	-	-	-	-
Total for Period	Ci	0.00E+00	0.00E+00	0.00E+00	0.00E+00	0.00E+00
C. Particulates Half-Life ≥ 8 days						
None	Ci	-	-	-	-	-
Total for Period	Ci	0.00E+00	0.00E+00	0.00E+00	0.00E+00	0.00E+00
D. Tritium						
H-3	Ci	4.04E+01	3.03E+01	6.97E+01	4.98E+01	1.90E+02
E. Carbon-14 *						
C-14	Ci	1.64E+00	1.62E+00	1.45E+00	1.59E+00	6.30E+00
F. Gross Alpha						
Total for Period	Ci	0.00E+00	0.00E+00	0.00E+00	0.00E+00	0.00E+00

* 30% of total C-14 released is assumed to be in continuous mode. See Attachment 2, Supplemental Information, of this report.

Attachment 1
Summary of Gaseous and Liquid Effluents

Catawba Nuclear Station Units 1 & 2
Period 1/1/2016 - 12/31/2016

Gaseous Effluents - Ground Releases - Batch Mode

	<u>Units</u>	<u>Qtr 1</u>	<u>Qtr 2</u>	<u>Qtr 3</u>	<u>Qtr 4</u>	<u>Year</u>
A. Fission and Activation Gases						
AR-41	Ci	7.35E-01	7.46E-01	9.33E-01	9.82E-01	3.39E+00
KR-85	Ci	2.68E-01	0.00E+00	0.00E+00	0.00E+00	2.68E-01
XE-133	Ci	1.13E-01	1.01E-01	1.05E-01	1.36E-02	3.32E-01
XE-135	Ci	1.22E-02	1.19E-02	1.35E-02	0.00E+00	3.75E-02
Total for Period	Ci	1.13E+00	8.58E-01	1.05E+00	9.95E-01	4.03E+00
B. Iodines						
None	Ci	-	-	-	-	-
Total for Period	Ci	0.00E+00	0.00E+00	0.00E+00	0.00E+00	0.00E+00
C. Particulates Half-Life ≥ 8 days						
None	Ci	-	-	-	-	-
Total for Period	Ci	0.00E+00	0.00E+00	0.00E+00	0.00E+00	0.00E+00
D. Tritium						
H-3	Ci	1.54E-01	1.56E-01	2.25E-01	2.44E-01	7.80E-01
E. Carbon-14 *						
C-14	Ci	3.83E+00	3.78E+00	3.37E+00	3.70E+00	1.47E+01
F. Gross Alpha						
Total for Period	Ci	0.00E+00	0.00E+00	0.00E+00	0.00E+00	0.00E+00

* 70% of total C-14 released is assumed to be in batch mode. See Attachment 2, Supplemental Information, of this report.

Attachment 1
Summary of Gaseous and Liquid Effluents

Catawba Nuclear Station Units 1 & 2
 Period 1/1/2016 - 12/31/2016

Gaseous Effluents - Mixed-Mode Releases - Continuous Mode *

	<u>Units</u>	<u>Qtr 1</u>	<u>Qtr 2</u>	<u>Qtr 3</u>	<u>Qtr 4</u>	<u>Year</u>
A. Fission and Activation Gases						
N/A	Ci	-	-	-	-	-
Total for Period	Ci	-	-	-	-	-
B. Iodines						
N/A	Ci	-	-	-	-	-
Total for Period	Ci	-	-	-	-	-
C. Particulates Half-Life ≥ 8 days						
N/A	Ci	-	-	-	-	-
Total for Period	Ci	-	-	-	-	-
D. Tritium						
N/A	Ci	-	-	-	-	-
E. Carbon-14						
N/A	Ci	-	-	-	-	-
F. Gross Alpha						
Total for Period	Ci	-	-	-	-	-

* Catawba Nuclear Station Units 1 and 2 do not have mixed-mode releases.

Attachment 1
Summary of Gaseous and Liquid Effluents

Catawba Nuclear Station Units 1 & 2
 Period 1/1/2016 - 12/31/2016

Gaseous Effluents - Mixed-Mode Releases - Batch Mode *

	<u>Units</u>	<u>Qtr 1</u>	<u>Qtr 2</u>	<u>Qtr 3</u>	<u>Qtr 4</u>	<u>Year</u>
A. Fission and Activation Gases						
N/A	Ci	-	-	-	-	-
Total for Period	Ci	-	-	-	-	-
B. Iodines						
N/A	Ci	-	-	-	-	-
Total for Period	Ci	-	-	-	-	-
C. Particulates Half-Life ≥ 8 days						
N/A	Ci	-	-	-	-	-
Total for Period	Ci	-	-	-	-	-
D. Tritium						
N/A	Ci	-	-	-	-	-
E. Carbon-14						
N/A	Ci	-	-	-	-	-
F. Gross Alpha						
Total for Period	Ci	-	-	-	-	-

* Catawba Nuclear Station Units 1 and 2 do not have mixed-mode releases.

Attachment 1
Summary of Gaseous and Liquid Effluents

Catawba Nuclear Station Units 1 & 2
 Period 1/1/2016 - 12/31/2016

Liquid Effluents - Summation of All Releases

	<u>Units</u>	<u>Qtr 1</u>	<u>Qtr 2</u>	<u>Qtr 3</u>	<u>Qtr 4</u>	<u>Year</u>
A. Fission and Activation Products *						
1. Total Release	Ci	3.52E-03	2.46E-03	3.62E-03	3.40E-03	1.30E-02
2. Avg. Diluted Conc.	µCi/ml	1.30E-10	8.57E-11	1.63E-12	1.36E-10	4.66E-12
3. Batch Releases	µCi/ml	1.30E-10	8.57E-11	8.76E-11	1.36E-10	1.06E-10
B. Tritium						
1. Total Release	Ci	1.81E+02	1.93E+02	3.55E+02	1.25E+02	8.54E+02
2. Avg. Diluted Conc.	µCi/ml	6.66E-06	6.74E-06	2.77E-07	5.00E-06	3.45E-07
3. Batch Releases	µCi/ml	6.66E-06	6.74E-06	8.59E-06	5.00E-06	6.99E-06
C. Dissolved & Entrained Gases						
1. Total Release	Ci	0.00E+00	0.00E+00	0.00E+00	0.00E+00	0.00E+00
2. Avg. Diluted Conc.	µCi/ml	0.00E+00	0.00E+00	0.00E+00	0.00E+00	0.00E+00
3. Batch Releases	µCi/ml	0.00E+00	0.00E+00	0.00E+00	0.00E+00	0.00E+00
D. Gross Alpha						
1. Total Release	Ci	0.00E+00	0.00E+00	0.00E+00	0.00E+00	0.00E+00
2. Avg. Diluted Conc.	µCi/ml	0.00E+00	0.00E+00	0.00E+00	0.00E+00	0.00E+00
3. Batch Releases	µCi/ml	0.00E+00	0.00E+00	0.00E+00	0.00E+00	0.00E+00
E. Volume of Liquid Waste						
1. Continuous Releases	liters	0.00E+00	0.00E+00	7.42E+07	0.00E+00	7.42E+07
2. Batch Releases	liters	6.84E+05	6.68E+05	1.41E+06	6.36E+05	3.40E+06
F. Volume of Dilution Water						
1. Continuous Releases	liters	2.72E+09	2.87E+09	4.13E+09	2.50E+09	1.22E+10
2. Batch Releases	liters	2.72E+10	2.87E+10	4.13E+10	2.50E+10	1.22E+11

* Excludes tritium, dissolved and entrained noble gases, and gross alpha.

Attachment 1
Summary of Gaseous and Liquid Effluents

Catawba Nuclear Station Units 1 & 2
 Period 1/1/2016 - 12/31/2016

Liquid Effluents - Continuous Mode

	<u>Units</u>	<u>Qtr 1</u>	<u>Qtr 2</u>	<u>Qtr 3</u>	<u>Qtr 4</u>	<u>Year</u>
A. Fission and Activation Products						
None	Ci	-	-	-	-	-
Total for Period	Ci	0.00+00	0.00+00	0.00+00	0.00+00	0.00+00
B. Tritium						
H-3	Ci	0.00+00	0.00+00	4.99E-01	0.00+00	4.99E-01
C. Dissolved & Entrained Gases						
None	Ci	-	-	-	-	-
Total for Period	Ci	0.00+00	0.00+00	0.00+00	0.00+00	0.00+00
D. Gross Alpha						
Total for Period	Ci	0.00+00	0.00+00	0.00+00	0.00+00	0.00+00

Attachment 1
Summary of Gaseous and Liquid Effluents

Catawba Nuclear Station Units 1 & 2
Period 1/1/2016 - 12/31/2016

Liquid Effluents - Batch Mode

	<u>Units</u>	<u>Qtr 1</u>	<u>Qtr 2</u>	<u>Qtr 3</u>	<u>Qtr 4</u>	<u>Year</u>
A. Fission and Activation Products						
AG-108M	Ci	0.00E+00	1.71E-06	0.00E+00	0.00E+00	1.71E-06
AG-110M	Ci	0.00E+00	1.27E-05	1.67E-05	0.00E+00	2.95E-05
BI-214	Ci	0.00E+00	1.43E-06	4.50E-06	0.00E+00	5.93E-06
CO-58	Ci	2.00E-04	3.67E-05	1.46E-04	9.57E-04	1.34E-03
CO-60	Ci	3.76E-04	6.00E-04	1.40E-03	5.69E-04	2.94E-03
CR-51	Ci	1.84E-04	1.46E-05	2.45E-05	1.16E-04	3.38E-04
CS-134	Ci	1.66E-06	8.77E-06	0.00E+00	2.27E-06	1.27E-05
CS-137	Ci	3.70E-06	8.16E-06	2.16E-05	5.96E-06	3.95E-05
F-18	Ci	0.00E+00	0.00E+00	5.24E-07	0.00E+00	5.24E-07
FE-55	Ci	3.37E-04	4.46E-04	5.29E-04	4.87E-04	1.80E-03
K-40	Ci	0.00E+00	0.00E+00	2.58E-06	0.00E+00	2.58E-06
MN-54	Ci	0.00E+00	3.60E-06	4.43E-06	2.45E-05	3.25E-05
NB-95	Ci	3.17E-06	0.00E+00	0.00E+00	0.00E+00	3.17E-06
NB-97	Ci	0.00E+00	6.31E-06	3.36E-06	0.00E+00	9.67E-06
NI-63	Ci	1.47E-03	7.75E-04	7.53E-04	8.08E-04	3.81E-03
PB-212	Ci	0.00E+00	2.41E-06	0.00E+00	0.00E+00	2.41E-06
PB-214	Ci	0.00E+00	1.79E-06	4.97E-06	0.00E+00	6.76E-06
SB-124	Ci	1.50E-04	2.81E-06	0.00E+00	7.31E-06	1.60E-04
SB-125	Ci	7.98E-04	5.38E-04	7.07E-04	4.25E-04	2.47E-03
Total for Period	Ci	3.52E-03	2.46E-03	3.62E-03	3.40E-03	1.30E-02
B. Tritium						
H-3	Ci	1.81E+02	1.93E+02	3.54E+02	1.25E+02	8.54E+02
C. Dissolved & Entrained Gases						
None	Ci	-	-	-	-	-
Total for Period	Ci	0.00E+00	0.00E+00	0.00E+00	0.00E+00	0.00E+00
D. Gross Alpha						
Total for Period	Ci	0.00E+00	0.00E+00	0.00E+00	0.00E+00	0.00E+00

**Attachment 2
Supplemental Information**

Catawba Nuclear Station Units 1 & 2
Period 1/1/2016 - 12/31/2016

ATTACHMENT 2

Supplemental Information

This attachment includes supplemental information to the gaseous and liquid effluents report.

Attachment 2 Supplemental Information

Catawba Nuclear Station Units 1 & 2 Period 1/1/2016 - 12/31/2016

I. Regulatory Limits - Per Unit

A. Noble Gases - Air Dose

1. Calendar Quarter Gamma Dose	= 5	mRAD
2. Calendar Quarter Beta Dose	= 10	mRAD
3. Calendar Year Gamma Dose	= 10	mRAD
4. Calendar Year Beta Dose	= 20	mRAD

B. Liquid Effluents - Dose

1. Calendar Quarter Total Body Dose	= 1.5	mREM
2. Calendar Quarter Organ Dose	= 5	mREM
3. Calendar Year Total Body Dose	= 3	mREM
4. Calendar Year Organ Dose	= 10	mREM

C. Gaseous Effluents - Iodine-131 & 133, Tritium, and Particulates with Half-lives > 8 days

1. Calendar Quarter Organ Dose	= 7.5	mREM
2. Calendar Year Organ Dose	= 15	mREM

II. Maximum Permissible Effluent Concentrations

A. Gaseous Effluents

1. Information found in Offsite Dose Calculation Manual

B. Liquid Effluents

1. Information found in 10 CFR Part 20, Appendix B, Table 2, Column 2

III. Average Energy

(not applicable)

IV. Measurements and Approximations of Total Radioactivity

Analyses of specific radionuclides in selected or composited samples as described in the Selected Licensee Commitments are used to determine the radionuclide composition of the effluent. A summary description of the method used for estimating overall errors associated with radioactivity measurements is provided as part of this attachment.

V. Batch Releases

A. Liquid Effluents

1. Total Number of Batch Releases	=	7.90E+01
2. Total Time (min) for Batch Releases	=	4.87E+03
3. Maximum Time (min) for a Batch Release	=	8.50E+01
4. Average Time (min) for Batch Releases	=	6.17E+01
5. Minimum Time (min) for a Batch Release	=	2.30E+01
6. Average Dilution Water Flow During Release (gpm)	=	6.12E+04

B. Gaseous Effluents

1. Total Number of Batch Releases	=	4.90E+01
2. Total Time (min) for Batch Releases	=	1.04E+06
3. Maximum Time (min) for a Batch Release	=	4.53E+04
4. Average Time (min) for Batch Releases	=	2.11E+04
5. Minimum Time (min) for a Batch Release	=	2.75E+02

VI. Abnormal Releases

See Attachment 5, Unplanned Offsite Releases.

Attachment 2 Supplemental Information

Catawba Nuclear Station Units 1 & 2
Period 1/1/2016 - 12/31/2016

Carbon-14

Carbon-14 (C-14), with a half-life of 5730 years, is a naturally occurring isotope of carbon produced by cosmic ray interactions in the atmosphere. Nuclear weapons testing in the 1950s and 1960s significantly increased the amount of C-14 in the atmosphere. C-14 is also produced in commercial nuclear reactors, but the amounts produced are much less than those produced naturally or from weapons testing.

In Regulatory Guide 1.21, Revision 2, "Measuring, Evaluating, and Reporting Radioactive Material in Liquid and Gaseous Effluents and Solid Waste", the NRC recommends U.S. nuclear power plants evaluate whether C-14 is a "principal radionuclide", and if so, report the amount of C-14 released. Improvements over the years in effluent management practices and fuel performance have resulted in a decrease in gaseous radionuclide (non-C-14) concentrations, and a change in the distribution of gaseous radionuclides released to the environment. As a result, many sites show C-14 has become a "principal radionuclide" for the gaseous effluent pathway, as defined in Regulatory Guide 1.21, Rev. 2. Catawba Nuclear Station 2016 ARERR contains estimates of C-14 radioactivity released in 2016, and estimates of public dose resulting from the C-14 effluent.

Because the dose contribution of C-14 from liquid radioactive waste is much less than that contributed by gaseous radioactive waste, evaluation of C-14 in liquid radioactive waste is not required (Ref. Reg. Guide 1.21, Rev. 2). The quantity of gaseous C-14 released to the environment can be estimated by use of a C-14 source term scaling factor based on power generation (Ref. Reg. Guide 1.21, Rev. 2). Many documents provide information related to the magnitude of C-14 in typical effluents from commercial nuclear power plants. Those documents suggest that nominal annual releases of C-14 in gaseous effluents are approximately 5 to 7.3 curies from PWRs (Ref. Reg. Guide 1.21, Rev. 2). A more recent study recommends a higher C-14 gaseous source term scaling factor of approximately 9.0 to 9.8 Ci/GWe-yr for a PWR (Westinghouse) (Ref. EPRI 1021106). For the Catawba Nuclear Station 2016 ARERR a source term scaling factor of 9.4 Ci/GWe-yr is assumed. Using a source term scaling factor of 9.4 Ci/GWe-yr and actual electric generation (MWe-hrs) from Catawba Nuclear Station in 2016 results in a site total C-14 gaseous release estimate to the environment of 2.10E+01 Curies. 70% of the C-14 gaseous effluent is assumed to be from batch releases (e.g. WGDTS), and 30% of C-14 gaseous effluent is assumed to be from continuous releases through the unit vents (ref. IAEA Technical Reports Series no. 421, "Management of Waste Containing Tritium and Carbon-14", 2004).

C-14 releases in PWRs occur primarily as a mix of organic carbon and carbon dioxide released from the waste gas system. Since the PWR operates with a reducing chemistry, most, if not all, of the C-14 species initially produced are organic (e.g., methane). As a general rule, C-14 in the primary coolant is essentially all organic with a large fraction as a gaseous species. Any time the RCS liquid or gas is exposed to an oxidizing environment (e.g. during shutdown or refueling), a slow transformation from an organic to an inorganic chemical form can occur. Various studies documenting measured C-14 releases from PWRs suggest a range of 70% to 95% organic with an average of 80% organic with the remainder being CO₂ (Ref. EPRI TR-105715). For the Catawba Nuclear Station 2016 ARERR a value of 80% organic C-14 is assumed.

Public dose estimates from airborne C-14 are performed using dose models in NUREG-0133 and Regulatory Guide 1.109. The dose models and assumptions used are documented in the Catawba ODCM. The estimated C-14 dose impact on the maximum organ dose from airborne effluents released from Catawba Nuclear Station in 2016 is well below the 10CFR50, Appendix I, ALARA design objective (i.e., 15 mrem/yr per unit).

Attachment 2
Supplemental Information

Catawba Nuclear Station Units 1 & 2
Period 1/1/2016 - 12/31/2016

Overall Estimate of Error for Effluent Radioactivity Release Reported

The estimated percentage of overall error for both Liquid and Gaseous effluent release data at Catawba Nuclear Station has been determined to be $\pm 30.3\%$. This value was derived by taking the square root of the sum of the squares of the following discrete individual estimates of error:

1. Flow Rate Determining Devices = $\pm 20\%$
2. Counting Statistical Error = $\pm 20\%$
3. Calibration Error = $\pm 10\%$
4. Calibration Source Error = $\pm 2.5\%$
5. Sample Preparation Error = $\pm 3\%$

Attachment 2
Supplemental Information

Catawba Nuclear Station Units 1 & 2
Period 1/1/2016 - 12/31/2016

Summary of Changes in Land Use Census Affecting Effluent Dose Calculations

The 2016 Land Use Census was performed July 13-14 and 20, 2016, and the results were certified and made available for use on September 7, 2016. The following are changes to residences, gardens, and milk animals from the previous year.

Residences

No changes to nearest residences in each sector.

Gardens

The non-irrigated garden in the N sector at 1.38 miles was replaced by an irrigated garden at 1.55 miles.
The non-irrigated garden in the NE sector at 2.39 miles was replaced by an irrigated garden at 0.67 miles.
The non-irrigated garden in the SSW sector at 0.89 miles was replaced by a non-irrigated garden at 1.33 miles.
The irrigated garden in the SW sector at 0.78 miles was replaced by a non-irrigated garden at 2.02 miles.
The non-irrigated garden in the WSW sector at 1.98 miles was replaced by a non-irrigated garden at 0.91 miles.
The non-irrigated garden in the WNW sector at 1.18 miles was replaced by a non-irrigated garden at 2.53 miles.
The non-irrigated garden in the NNW sector at 1.19 miles was replaced by a non-irrigated garden at 2.13 miles.

Milk Animals

No changes to nearest milk animal in each sector.

Environmental Monitoring Locations

No changes to environmental monitoring locations in each sector.

Attachment 3
Solid Radioactive Waste Disposal

Catawba Nuclear Station Units 1 & 2
Period 1/1/2016 - 12/31/2016

ATTACHMENT 3

Solid Radioactive Waste Disposal

This attachment includes a summary of the solid waste shipped off-site for burial and/or disposal, including:

- Container volume
- Total Curie content
- Principal Radionuclides
- Source/Type of waste
- Solidification agent or absorbent
- Type of shipping container
- Number of shipments
- Other relevant information as necessary

**Attachment 3
Solid Radioactive Waste Disposal**

Catawba Nuclear Station Units 1 & 2
Period 1/1/2016 - 12/31/2016

Type of Waste Shipped	Number of Shipments	Number of Containers	Waste Class	Container Type	Solidification Agent	Burial Volume (m³)	Total Activity (Curies)
1. <u>Waste from Liquid Systems</u>							
a. Dewatered Secondary Resins	3	15	A	B-25	NA	58.43	1.15E-05
b. Dewatered Primary Resins	3	3	B	HIC	NA	10.22	159
c. Evaporator Concentrates	-	-	-	-	-	-	-
d. Dewatered Mechanical Filters	1	1	C	HIC	NA	3.410	55.70
e. Dewatered Demineralizers	-	-	-	-	-	-	-
f. Solidified (cement) Acids, Oils, Sludge	-	-	-	-	-	-	-
2. <u>Dry Solid Waste</u>							
a. Dry Active Waste (compacted)	-	-	-	-	-	-	-
b. Dry Active Waste (non-compacted)	-	-	-	-	-	-	-
c. Dry Active Waste (brokered)	44	68	A	GDP	NA	475.5	0.9921
d. Irradiated Components	-	-	-	-	-	-	-
3. <u>Total Solid Waste</u>	51	87				547.6	215.7

Attachment 3
Solid Radioactive Waste Disposal

Catawba Nuclear Station Units 1 & 2
Period 1/1/2016 - 12/31/2016

Type of Waste Shipped	Radionuclide	% Abundance
1. <u>Waste from Liquid Systems</u>		
a. Dewatered Secondary Resins	Mn-54	3.30%
	Co-60	7.90%
	Cs-137	19.4%
	Ce-144	69.3%
b. Dewatered Primary Resins	H-3	0.11%
	Be-7	0.12%
	Mn-54	2.43%
	Co-57	0.11%
	Co-58	0.73%
	Co-60	21.3%
	Zn-65	0.30%
	Sn-113	0.01%
	Sb-125	0.84%
	Cs-134	0.27%
	Cs-137	0.28%
	Ce-144	0.01%
	C-14	0.45%
	Fe-55	17.4%
	Ni-59	0.42%
	Ni-63	55.2%
	Sr-90	0.01%
	Tc-99	0.01%
c. Evaporator Concentrates	N/A	N/A
d. Dewatered Mechanical Filters	H-3	0.57%
	Cr-51	0.11%
	Mn-54	2.32%
	Co-57	0.05%
	Co-58	1.46%
	Fe-59	0.01%
	Co-60	22.8%
	Zn-65	0.33%
	Nb-95	0.10%
	Zr-95	0.23%
	Sn-113	0.05%
	Sb-125	0.10%
	Cs-137	0.01%
	Ce-144	0.01%
	C-14	0.05%
	Fe-55	70.9%
	Ni-63	0.89%
e. Dewatered Demineralizers	N/A	N/A
f. Solidified (cement) Acids, Oils, Sludge	N/A	N/A
2. <u>Dry Solid Waste</u>		
a. Dry Active Waste (compacted)	N/A	N/A
b. Dry Active Waste (non-compacted)	N/A	N/A

Attachment 3
Solid Radioactive Waste Disposal

Catawba Nuclear Station Units 1 & 2
Period 1/1/2016 - 12/31/2016

c. Dry Active Waste (brokered)	Cr-51	8.51%
	Mn-54	2.78%
	Co-57	0.12%
	Co-58	18.9%
	Fe-59	1.02%
	Co-60	15.7%
	Zn-65	0.26%
	Nb-95	11.8%
	Zr-95	7.35%
	Sn-113	0.42%
	Sb-124	0.04%
	Sb-125	1.36%
	Cs-137	0.03%
	Ce-144	0.11%
	C-14	0.03%
	Fe-55	27.7%
Ni-63	3.84%	
d. Irradiated Components	N/A	N/A

**Attachment 4
Meteorological Data**

Catawba Nuclear Station Units 1 & 2
Period 1/1/2016 - 12/31/2016

ATTACHMENT 4

Meteorological Data

This attachment includes a summary of meteorological joint frequency distributions of wind speed, wind direction, and atmospheric stability (hours of occurrence).

Attachment 4 Meteorological Data

Catawba Nuclear Station Units 1 & 2
Period 1/1/2016 - 12/31/2016

Stability Class	Wind Speed (m/s)	Hours of Occurrence															
		Sector															
		N	NNE	NE	ENE	E	ESE	SE	SSE	S	SSW	SW	WSW	W	WNW	NW	NNW
A	0.46-0.75	0	0	0	0	0	0	0	0	0	0	0	0	0	0	0	
	0.76-1.00	0	0	0	0	0	0	0	0	0	0	0	0	0	0	0	
	1.01-1.25	0	0	0	0	0	0	0	0	0	0	0	0	0	0	0	
	1.26-1.50	0	0	0	0	0	0	0	0	0	0	0	0	0	0	2	
	1.51-2.00	0	0	1	0	0	1	3	2	3	2	3	1	5	1	1	0
	2.01-3.00	1	1	0	0	1	3	3	29	16	86	102	50	28	9	1	0
	3.01-4.00	8	4	4	1	0	1	3	15	13	47	52	19	18	10	3	1
	4.01-5.00	20	30	6	0	1	0	1	1	4	11	12	2	4	1	6	9
	5.01-6.00	19	13	3	0	0	0	0	0	0	0	0	0	0	2	8	13
	6.01-8.00	4	3	0	0	0	0	0	0	0	0	0	0	0	0	2	4
	8.01-10.00	0	0	0	0	0	0	0	0	0	0	0	0	0	0	0	0
10.01-max	0	0	0	0	0	0	0	0	0	0	0	0	0	0	0	0	
B	0.46-0.75	0	0	0	0	0	0	0	0	0	0	0	0	0	0	0	
	0.76-1.00	0	0	0	0	0	0	0	0	0	0	0	0	0	0	0	
	1.01-1.25	0	0	0	0	0	0	0	0	0	0	0	0	0	0	0	
	1.26-1.50	0	1	0	1	0	0	1	1	0	0	0	0	0	0	0	
	1.51-2.00	2	0	0	1	0	2	4	10	7	8	13	10	9	3	1	0
	2.01-3.00	4	5	4	4	2	6	4	20	24	57	43	16	27	10	4	3
	3.01-4.00	27	16	7	0	1	0	3	6	1	12	10	0	5	14	8	8
	4.01-5.00	12	21	2	0	0	0	0	0	3	0	2	1	2	6	5	13
	5.01-6.00	8	7	7	0	0	0	0	0	0	0	0	0	1	4	2	1
	6.01-8.00	2	7	1	1	0	0	0	0	0	0	0	0	0	0	3	2
	8.01-10.00	0	0	0	0	0	0	0	0	0	0	0	0	0	0	0	0
10.01-max	0	0	0	0	0	0	0	0	0	0	0	0	0	0	0	0	

Attachment 4 Meteorological Data

Catawba Nuclear Station Units 1 & 2
Period 1/1/2016 - 12/31/2016

Stability Class	Wind Speed (m/s)	Hours of Occurrence															
		Sector															
		N	NNE	NE	ENE	E	ESE	SE	SSE	S	SSW	SW	WSW	W	WNW	NW	NNW
C	0.46-0.75	0	0	0	0	0	0	0	0	0	0	0	0	0	0	0	
	0.76-1.00	0	0	0	0	0	0	0	0	0	0	0	1	0	0	0	
	1.01-1.25	0	0	0	0	0	0	0	0	0	0	0	1	0	1	1	
	1.26-1.50	0	0	0	0	1	0	0	1	2	1	2	3	0	1	0	
	1.51-2.00	1	2	2	0	3	4	10	15	14	20	16	10	10	2	1	
	2.01-3.00	22	11	5	5	2	2	7	17	19	38	30	14	6	7	6	
	3.01-4.00	33	31	6	4	1	1	2	4	4	16	7	5	2	5	3	
	4.01-5.00	15	31	11	5	0	0	1	0	0	3	0	0	0	3	4	
	5.01-6.00	5	17	8	1	0	0	0	0	0	1	0	0	0	1	0	
	6.01-8.00	4	4	0	0	0	0	0	0	0	0	0	0	0	1	1	
	8.01-10.00	0	0	0	0	0	0	0	0	0	0	0	0	0	0	0	
	10.01-max	0	0	0	0	0	0	0	0	0	0	0	0	0	0	0	
D	0.46-0.75	0	0	0	0	0	0	1	1	0	1	0	2	1	0		
	0.76-1.00	2	0	0	0	0	0	3	4	5	5	11	13	4	4		
	1.01-1.25	4	0	1	1	0	1	3	6	8	12	25	6	6	12		
	1.26-1.50	13	4	5	2	1	6	9	8	35	50	37	25	15	17		
	1.51-2.00	33	9	13	7	10	13	24	45	87	101	66	30	20	25		
	2.01-3.00	151	96	28	21	21	11	29	73	108	98	75	18	20	26		
	3.01-4.00	169	171	91	27	8	2	15	27	33	32	23	4	4	12		
	4.01-5.00	81	116	66	16	0	0	1	5	9	9	5	3	1	12		
	5.01-6.00	17	25	17	4	0	0	0	1	4	0	4	0	0	0		
	6.01-8.00	10	3	3	0	0	0	0	0	1	1	4	0	0	0		
	8.01-10.00	4	4	0	0	0	0	0	0	0	0	0	0	0	0		
	10.01-max	0	0	0	0	0	0	0	0	0	0	0	0	0	0		

Attachment 4 Meteorological Data

Catawba Nuclear Station Units 1 & 2
Period 1/1/2016 - 12/31/2016

Stability Class	Wind Speed (m/s)	Hours of Occurrence															
		Sector															
		N	NNE	NE	ENE	E	ESE	SE	SSE	S	SSW	SW	WSW	W	WNW	NW	NNW
E	0.46-0.75	0	0	0	1	0	0	0	2	2	2	4	1	2	3	1	0
	0.76-1.00	0	0	0	1	0	0	0	3	18	31	46	32	24	8	6	1
	1.01-1.25	3	0	0	0	0	1	0	8	32	66	59	34	28	21	12	4
	1.26-1.50	2	2	1	0	0	0	3	19	86	114	49	31	27	27	22	13
	1.51-2.00	12	2	0	0	2	3	17	31	145	87	31	20	48	45	45	47
	2.01-3.00	79	17	3	5	6	8	23	45	118	59	21	4	13	47	67	116
	3.01-4.00	57	12	12	5	1	5	18	14	17	13	6	0	3	13	15	23
	4.01-5.00	11	8	15	7	2	0	4	0	5	1	0	0	0	2	2	5
	5.01-6.00	1	1	17	2	0	0	0	0	1	0	0	0	0	0	0	1
	6.01-8.00	0	1	0	0	0	0	0	0	0	0	0	0	0	0	0	0
	8.01-10.00	0	0	0	0	0	0	0	0	0	0	0	0	0	0	0	0
	10.01-max	0	0	0	0	0	0	0	0	0	0	0	0	0	0	0	0
F	0.46-0.75	0	0	0	0	0	0	0	0	2	10	6	2	4	4	0	0
	0.76-1.00	0	0	1	0	0	1	0	0	12	24	22	20	13	14	8	3
	1.01-1.25	0	0	0	0	0	0	2	0	23	44	13	24	8	6	22	7
	1.26-1.50	0	0	0	0	0	1	1	5	40	43	18	15	15	21	15	8
	1.51-2.00	6	0	0	1	0	0	2	7	17	15	5	14	19	20	18	45
	2.01-3.00	24	3	0	0	0	0	2	8	3	0	0	1	18	12	14	32
	3.01-4.00	1	1	0	0	0	0	6	1	0	0	0	0	1	0	1	1
	4.01-5.00	0	1	0	0	0	0	1	2	0	0	0	0	1	0	0	0
	5.01-6.00	0	0	1	0	0	0	0	0	0	0	0	0	0	0	0	0
	6.01-8.00	0	0	0	0	0	0	0	0	0	0	0	0	0	0	0	0
	8.01-10.00	0	0	0	0	0	0	0	0	0	0	0	0	0	0	0	0
	10.01-max	0	0	0	0	0	0	0	0	0	0	0	0	0	0	0	0

Attachment 4 Meteorological Data

Catawba Nuclear Station Units 1 & 2
Period 1/1/2016 - 12/31/2016

Stability Class	Wind Speed (m/s)	Hours of Occurrence																
		Sector																
		N	NNE	NE	ENE	E	ESE	SE	SSE	S	SSW	SW	WSW	W	WNW	NW	NNW	
G	0.46-0.75	0	0	0	0	0	0	0	0	0	0	0	0	0	0	0	0	
	0.76-1.00	0	0	0	0	0	0	0	0	1	1	6	13	4	12	8	9	0
	1.01-1.25	0	0	0	0	0	0	0	0	0	25	21	37	30	19	18	23	1
	1.26-1.50	0	0	0	0	0	0	0	0	0	41	47	23	20	13	13	15	9
	1.51-2.00	0	0	0	0	0	0	0	0	2	44	31	13	19	7	6	15	7
	2.01-3.00	3	0	0	0	0	0	0	0	0	6	15	17	8	10	5	18	21
	3.01-4.00	15	0	0	0	0	0	0	0	0	0	1	1	1	7	3	1	13
	4.01-5.00	0	0	0	0	0	0	0	0	0	0	0	0	0	0	0	0	2
	5.01-6.00	0	0	0	0	0	0	0	0	0	0	0	0	0	0	0	0	0
	6.01-8.00	0	0	0	0	0	0	0	0	0	0	0	0	0	0	0	0	0
	8.01-10.00	0	0	0	0	0	0	0	0	0	0	0	0	0	0	0	0	0
	10.01-max	0	0	0	0	0	0	0	0	0	0	0	0	0	0	0	0	0

Attachment 5
Unplanned Offsite Releases

Catawba Nuclear Station Units 1 & 2
Period 1/1/2016 - 12/31/2016

ATTACHMENT 5

Unplanned Offsite Releases

This attachment includes a summary of the unplanned offsite releases of gaseous and liquid radioactive effluents.

Attachment 5
Unplanned Offsite Releases

Catawba Nuclear Station Units 1 & 2
Period 1/1/2016 - 12/31/2016

Catawba Nuclear Station had no unplanned liquid releases in 2016.

Catawba Nuclear Station had no unplanned gaseous releases in 2016.

Attachment 6
Assessment of Radiation Dose from Radioactive Effluents to Members of the Public

Catawba Nuclear Station Units 1 & 2
Period 1/1/2016 - 12/31/2016

ATTACHMENT 6

Assessment of Radiation Dose from Radioactive Effluents to Members of the Public
(includes fuel cycle dose calculation results)

This attachment includes an assessment of radiation doses to the maximum exposed member of the public due to radioactive liquid and gaseous effluents released from the site for each calendar quarter for the calendar year of the report as well as the total dose for the calendar year.

This attachment also includes an assessment of radiation doses to the maximum exposed member of the public from all uranium fuel cycle sources within 8 km of the site for the calendar year of this report to show conformance with 40 CFR Part 190.

Methods for calculating the dose contribution from liquid and gaseous effluents are given in the Offsite Dose Calculation Manual (ODCM).

Attachment 6
Assessment of Radiation Dose from Radioactive Effluents to Members of the Public

Catawba Nuclear Station Units 1 & 2
 Period 1/1/2016 - 12/31/2016

Gaseous Effluents Dose Summary

	<u>Units</u>	<u>Qtr 1</u>	<u>Qtr 2</u>	<u>Qtr 3</u>	<u>Qtr 4</u>	<u>Year</u>
A. Noble Gases						
1. Maximum Gamma Air	mRAD	7.68E-03	7.78E-03	9.72E-03	1.02E-02	3.53E-02
(a) Limit	mRAD	1.00E+01	1.00E+01	1.00E+01	1.00E+01	2.00E+01
(b) % of Limit		7.68E-02	7.78E-02	9.72E-02	1.02E-01	1.77E-01
2. Maximum Beta Air	mRAD	3.43E-03	2.87E-03	3.56E-03	3.60E-03	1.35E-02
(a) Limit	mRAD	2.00E+01	2.00E+01	2.00E+01	2.00E+01	4.00E+01
(b) % of Limit		1.72E-02	1.44E-02	1.78E-02	1.80E-02	3.37E-02

Receptor Location **0.5 miles NNE**

B. Iodine, H-3, & Particulates

1. Maximum Organ Dose	mREM	1.54E+00	1.52E+00	1.36E+00	1.49E+00	5.91E+00
(a) Limit	mREM	1.50E+01	1.50E+01	1.50E+01	1.50E+01	3.00E+01
(b) % of Limit		1.03E+01	1.01E+01	9.05E+00	9.93E+00	1.97E+01

Receptor Location **0.5 miles NNE**

Critical Age **CHILD**

Critical Organ **BONE**

Critical Pathway **VEGETATION**

Attachment 6
Assessment of Radiation Dose from Radioactive Effluents to Members of the Public

Catawba Nuclear Station Units 1 & 2
 Period 1/1/2016 - 12/31/2016

Liquid Effluents Dose Summary

	<u>Units</u>	<u>Qtr 1</u>	<u>Qtr 2</u>	<u>Qtr 3</u>	<u>Qtr 4</u>	<u>Year</u>
A. Batch Mode						
1. Maximum Organ Dose	mREM	1.98E-02	2.04E-02	2.59E-02	1.53E-02	8.43E-02
(a) Limit	mREM	1.00E+01	1.00E+01	1.00E+01	1.00E+01	2.00E+01
(b) % of Limit		1.98E-01	2.04E-01	2.59E-01	1.53E-01	4.22E-01
2. Maximum Total Body Dose	mREM	1.95E-02	1.98E-02	2.54E-02	1.49E-02	8.25E-02
(a) Limit	mREM	3.00E+00	3.00E+00	3.00E+00	3.00E+00	6.00E+00
(b) % of Limit		6.52E-01	6.61E-01	8.47E-01	4.98E-01	1.38E+00

Critical Age **CHILD**
Critical Organ **LIVER**
Critical Pathway **POTABLE WATER**

B. Continuous Mode						
1. Maximum Organ Dose	mREM	0.00E+00	0.00E+00	3.48E-04	0.00E+00	4.73E-04
(a) Limit	mREM	1.00E+01	1.00E+01	1.00E+01	1.00E+01	2.00E+01
(b) % of Limit		0.00E+00	0.00E+00	3.48E-03	0.00E+00	2.36E-03
2. Maximum Total Body Dose	mREM	0.00E+00	0.00E+00	3.48E-04	0.00E+00	4.73E-04
(a) Limit	mREM	3.00E+00	3.00E+00	3.00E+00	3.00E+00	6.00E+00
(b) % of Limit		0.00E+00	0.00E+00	1.16E-02	0.00E+00	7.88E-03

Critical Age **CHILD**
Critical Organ **LIVER**
Critical Pathway **POTABLE WATER**

Attachment 6
Assessment of Radiation Dose from Radioactive Effluents to Members of the Public

Catawba Nuclear Station Units 1 & 2
Period 1/1/2016 - 12/31/2016

40 CFR Part 190 Uranium Fuel Cycle Dose Calculation Results

In accordance with the requirements of 40 CFR Part 190, the annual dose commitment to any member of the general public shall be calculated to assure that doses are limited to 25 millirems to the total body or any organ with the exception of the thyroid which is limited to 75 millirems. The fuel cycle dose assessment for Catawba Nuclear Station includes liquid and gaseous effluent dose contributions from Catawba Nuclear Station and direct and air-scatter dose from the onsite ISFSI. No other uranium fuel cycle facility contributes significantly to the maximum exposed individual. Included in the gaseous effluent dose calculations is an estimate of the dose contributed by Carbon-14 (Ref. Attachment 2, Supplemental Information, of this report for further information). The combined dose to a maximum exposed individual from effluent releases and direct and air-scatter dose from the ISFSI is below 40 CFR Part 190 limits as shown by the following summary.

Note: The 40 CFR Part 190 effluent dose analysis to the maximum exposed individual from liquid and gas releases includes the dose from noble gases (i.e., total body and skin).

40 CFR Part 190 Effluent Dose Summary

A. Maximum Organ Dose (other than TB)	5.92E+00 mREM
1. Location	0.5 miles NNE
2. Critical Age	CHILD
3. Critical Organ	BONE
4. Gas Contribution %	99.75%
5. Liquid Contribution %	0.25%
B. Maximum Total Body Dose	2.38E+00 mREM
1. Location	0.5 miles NNE
2. Critical Age	CHILD
3. Gas non-NG Contribution %	95.12%
4. Gas Contribution %	1.41%
5. Liquid Contribution %	3.47%

Direct and air-scatter radiation dose contributions from the onsite ISFSI have been determined from the 10 CFR 72.212 Evaluation Report, MAGNASTOR[®], Revision 1. The maximum dose rate to the nearest real individual from the ISFSI is conservatively calculated to be less than 14.7 mrem/yr.

The attached excerpt from the 10 CFR 72.212 Evaluation Report, MAGNASTOR[®], Revision 1 is provided to document the method used to calculate the dose from ISFSI as less than 14.7 mrem/yr to the nearest real individual.

Total dose from liquid and gaseous effluents from Catawba Nuclear Station and direct and air-scatter dose from the onsite ISFSI is conservatively estimated to be less than 21 mrem/yr to the nearest real individual. This meets the 40 CFR Part 190 requirements of an annual dose commitment to any member of the general public of less than 25 mrem total body or any organ and 75 mrem to the thyroid.

Attachment 6

Assessment of Radiation Dose from Radioactive Effluents to Members of the Public

Catawba Nuclear Station Units 1 & 2
Period 1/1/2016 - 12/31/2016

10 CFR 72.212 Evaluation Report, MAGNASTOR[®], Revision 0

6.0 10 CFR 72.212(b)(5)(iii)- Radioactive Materials in Effluents and Direct Radiation

6.1 Purpose

10 CFR 72.212(b)(5)(iii) requires the general licensee to perform written evaluations, before use and before applying the changes authorized by an amended CoC to a cask loaded under the initial CoC or an earlier amended CoC, that establish that the requirements of 10 CFR 72.104 have been met. A copy of this record shall be retained until spent fuel is no longer stored under the general license issued under 10 CFR 72.210.

10 CFR 72.104 provides the regulatory criteria for radioactive materials in effluents and direct radiation from an ISFSI during normal operation and anticipated occurrences. Specifically, 10 CFR 72.104(a) limits the annual dose equivalent to any real individual who is located beyond the controlled area to 25 mrem to the whole body, 75 mrem to the thyroid, and 25 mrem to any other critical organ. This dose equivalent must include contributions from (1) planned discharges of radioactive materials (radon and its decay products excepted) to the general environment, (2) direct radiation from ISFSI operations, and (3) any other radiation from uranium fuel cycle operations within the region. In addition, 10 CFR 72.104(b) requires that operational restrictions be established to meet As Low As is Reasonably Achievable (ALARA) objectives for radioactive materials in effluents and direct radiation levels associated with ISFSI operations. Also, 10 CFR 72.104(c) requires that operational limits be established for radioactive materials in effluents and direct radiation levels associated with ISFSI operations to meet the above-mentioned dose limits.

This section provides the written evaluation required by 10 CFR 72.212(b)(5)(iii), demonstrating Duke Energy's compliance with the requirements of 10 CFR 72.104 for the CNS ISFSI.

6.2 Evaluation

This evaluation addresses the radiological dose rate from a composite population of all CNS ISFSI cask types.

6.2.1 §72.104(a) - Dose Limits

Duke Energy Calculation DPC-1229.00-00-0011, "Distance Measurements from ISFSI to Nearest Residents" determined that the nearest residence to the ISFSI is 0.35 miles (563.27 meters).

Calculation CNC-1229.00-00-0061, "UMS Cask Array Dose Analysis for Duke Catawba (NAC International Calculation 12418-5004, Revision 1)" determined the annual total dose (gamma plus neutron) at a distance of 495 meters from a 2x12 array of NAC-UMS[®] casks to be approximately 6.7 mrem. The evaluation was conservatively based on full cask loads of 24 bounding fuel assemblies (52,000 MWD/MTU, 3.45 wt% U-235, and 8 years cooling) as well as bounding activated components. The cask decay heat load was conservatively assumed to be 20 kW. The distance at which this dose was calculated (495 meters) is conservative compared to the distance to the closest real individual.

Calculation CNC-1229.00-00-0067, "MAGNASTOR Cask Array Dose Analysis for Duke Catawba" determined the annual total dose (gamma plus neutron) at a distance of 535 meters from a (future) 2x12 array of MAGNASTOR[®] casks to be approximately 7.97 mrem. The evaluation was conservatively based on full cask loads of 37 bounding fuel assemblies at a decay heat load of 35.5 kW. The distance at which this dose is calculated (535 meters) is conservative compared to the distance to the closest real individual.

The total calculated annual public dose from liquid and gaseous effluent pathways reviewed over the past 10 years is bounded by 5 mrem. No other uranium fuel cycle facility contributes significantly to the dose received by the closest real individual.

Attachment 6
Assessment of Radiation Dose from Radioactive Effluents to Members of the Public

Catawba Nuclear Station Units 1 & 2
Period 1/1/2016 - 12/31/2016

Based on the above, the calculated annual dose to the closest real individual due to the ISFSI, which is comprised of the currently existing 24 NAC-UMS[®] casks, and up to one 2x12 array of MAGNASTOR[®] casks, is determined to be less than 14.7 mrem, and the estimated annual dose due to Catawba power generation is less than 5 mrem. Hence, the total annual dose to the closest real individual (less than 19.7 mrem) is within the 10 CFR 72.104(a) limit.

Attachment 7
Information to Support the NEI Ground Water Protection Initiative

Catawba Nuclear Station Units 1 & 2
Period 1/1/2016 - 12/31/2016

ATTACHMENT 7

Information to Support the NEI Ground Water Protection Initiative

This attachment includes a summary of voluntary reports made in accordance with the NEI Ground Water Protection Initiative and a summary of ground water well sample data.

Attachment 7
Information to Support the NEI Ground Water Protection Initiative

Catawba Nuclear Station Units 1 & 2
Period 1/1/2016 - 12/31/2016

Duke Energy implemented a Ground Water Protection program in 2007. This initiative was developed to ensure timely and effective management of situations involving inadvertent releases of licensed material to ground water. As part of this program, Catawba Nuclear Station monitored 53 wells and 1 outfall from the Conventional Wastewater Treatment Ponds in 2016.

Wells are typically sampled quarterly or semi-annually. Ground water samples are regularly analyzed for tritium and gamma emitters, with select wells being analyzed for difficult-to-detect radionuclides. No gamma or difficult-to-detect radionuclides, other than naturally occurring radionuclides, were identified in well samples during 2016. Results from sampling during 2016 confirmed existing knowledge of tritium concentrations in site ground water.

Results from sampling during 2016 are shown in the table below.

No events meeting the criteria for voluntary notification per NEI 07-07, Industry Ground Water Protection Initiative, occurred at Catawba Nuclear Station in 2016.

Key to below table.

- NS - Not scheduled to be sampled, not sampled due to insufficient volume in well, or well inaccessible during outage.
- pCi/l - picocuries per liter.
- < MDA - less than minimum detectable activity, typically 250 pCi/l.
- 20,000 pCi/l - the Environmental Protection Agency drinking water standard for tritium. This standard applies only to water used for drinking.
- 1,000,000 pCi/l - the 10 CFR Part 20, Appendix B, Table 2, Column 2, Effluent Concentration Limit for tritium.

Attachment 7
Information to Support the NEI Ground Water Protection Initiative

Catawba Nuclear Station Units 1 & 2
 Period 1/1/2016 - 12/31/2016

Well Name	Location / Description	Tritium Concentration (pCi/l)				# of Samples
		1st Qtr	2nd Qtr	3rd Qtr	4th Qtr	
C-100DR	CNS GWPI / C-100DR / U-1 SFP	2.78E+02	<MDA	2.12E+02	<MDA	4
C-101DR	CNS GWPI / C-101DR / U-1 SFP	4.11E+02	3.37E+02	4.56E+02	3.58E+02	4
C-101R	CNS GWPI / C-101R / U-1 SFP	4.56E+02	5.76E+02	3.81E+02	4.09E+02	4
C-102	CNS GWPI / C-102 / E of U1 SFP O/S protected area	4.52E+02	3.60E+02	3.29E+02	3.09E+02	4
C-103	CNS GWPI / C-103 / E of U1 SFP @ Cooling Towers	3.00E+02	2.95E+02	3.12E+02	3.06E+02	4
C-104	CNS GWPI / C-104 / U-1 RMWST	4.16E+02	4.35E+02	4.92E+02	4.65E+02	4
C-105R	CNS GWPI / C-105R / Engr. Bldg.	4.81E+02	3.74E+02	NS	4.71E+02	3
C-106	CNS GWPI / C-106 / W Parking Lot	<MDA	<MDA	<MDA	<MDA	4
C-106R	CNS GWPI / C-106R / W Parking Lot	<MDA	<MDA	2.50E+02	<MDA	4
C-107	CNS GWPI / C-107 / MET Tower Hill	8.64E+02	6.81E+02	6.45E+02	8.94E+02	4
C-108	CNS GWPI / C-108	<MDA	<MDA	<MDA	<MDA	4
C-109	CNS GWPI / C-109	5.85E+02	6.63E+02	6.14E+02	7.27E+02	4
C-200DR	CNS GWPI / C-200DR / U-2 SFP	3.54E+02	2.82E+02	2.92E+02	3.32E+02	4
C-200R	CNS GWPI / C-200R / U-2 SFP	5.32E+02	5.01E+02	5.33E+02	4.84E+02	4
C-201DR	CNS GWPI / C-201DR / U-2 SFP	3.75E+02	4.60E+02	4.12E+02	3.75E+02	4
C-201R	CNS GWPI / C-201R / U-2 SFP	4.09E+03	2.35E+03	3.95E+03	2.99E+03	4
C-202	CNS GWPI / C-202 / S of RMC Tent	6.28E+02	4.65E+02	5.16E+02	5.83E+02	4
C-203	CNS GWPI / C-203 / E of RMC Tent @ Cooling Towers	3.20E+02	3.18E+02	2.59E+02	3.00E+02	4
C-204	CNS GWPI / C-204 / S of RMC Tent	2.72E+02	<MDA	<MDA	2.73E+02	4
C-205	CNS GWPI / C-205 / Adm. Parking	<MDA	<MDA	<MDA	<MDA	4
C-205R	CNS GWPI / C-205R / Adm. Parking	<MDA	<MDA	<MDA	<MDA	4
C-206	CNS GWPI / C-206 / W Parking Lot	<MDA	<MDA	<MDA	<MDA	4
C-207	CNS GWPI / C-207 / Mon. Tank B	3.57E+02	3.19E+02	3.08E+02	3.14E+02	4
C-207R	CNS GWPI / C-207R / Mon. Tank B	<MDA	<MDA	<MDA	1.94E+02	4
C-209	CNS GWPI / C-209 / MTUville S of light pole 23A	<MDA	<MDA	<MDA	2.49E+02	4
C-210	CNS GWPI / C-210 / N of U2 Mech Equip Bldg	<MDA	<MDA	<MDA	<MDA	4
C-211	CNS GWPI / C-211 / W of RL Intake O/S Protected Area	4.06E+02	5.25E+02	3.83E+02	4.45E+02	4
C-212	CNS GWPI / C-212 / Behind Aquatic Center	<MDA	<MDA	<MDA	<MDA	4
C-213	CNS GWPI / C-213 / Mon. Tank B	4.91E+03	6.14E+03	3.75E+03	3.09E+03	4
C-213R	CNS GWPI / C-213R / Mon. Tank B	<MDA	<MDA	<MDA	<MDA	4
C-214	CNS GWPI / C-214 / N of U2 TB	9.55E+02	8.01E+02	8.26E+02	6.21E+02	4
C-215	CNS GWPI / C-215 / N of U2 TB	2.08E+02	2.05E+02	2.73E+02	3.97E+02	4
C-217	CNS GWPI / C-217 / N of U2 TB	6.50E+02	7.26E+02	5.75E+02	6.02E+02	4
C-218	CNS GWPI / C-218 / N of U2 TB	4.15E+02	2.91E+02	1.15E+03	NS	3
C-220	CNS GWPI / C-220 / N of U2 TB	1.62E+03	2.08E+03	1.91E+03	1.84E+03	4
C-221	CNS GWPI / C-221 / N of U2 TB	3.22E+02	4.29E+02	3.74E+02	3.31E+02	4
LMW-1B	CNS Landfill / LMW-1B / Landfill	NS	<MDA	NS	<MDA	2
LMW-2A	CNS Landfill / LMW-2A / Landfill	NS	<MDA	NS	<MDA	2
LMW-3A	CNS Landfill / LMW-3A / Landfill	NS	<MDA	NS	<MDA	2
LMW-4	CNS Landfill / LMW-4 / Landfill	NS	<MDA	NS	<MDA	2
LMW-5D	CNS Landfill / LMW-5D / Landfill	NS	<MDA	NS	<MDA	2
LMW-5S	CNS Landfill / LMW-5S / Landfill	NS	<MDA	NS	<MDA	2
OUTFALL017	CNS WC Ponds / OUTFALL-017 / WC Ponds	5.74E+02	1.12E+03	8.00E+02	NS	3
WC-AOW	CNS WC AOW	NS	NS	NS	3.84E+03	1

Attachment 7
Information to Support the NEI Ground Water Protection Initiative

Catawba Nuclear Station Units 1 & 2
 Period 1/1/2016 - 12/31/2016

Well Name	Location / Description	Tritium Concentration (pCi/l)				# of Samples
		1st Qtr	2nd Qtr	3rd Qtr	4th Qtr	
WC-B-BASIN	CNS WC Basin	NS	NS	NS	3.30E+03	1
WCMW-3	CNS WC Ponds / WCMW-3 / WC Ponds	7.49E+02	1.62E+03	8.88E+02	8.31E+02	4
WCMW-4	CNS WC Ponds / WCMW-4 / WC Ponds	4.92E+02	5.01E+02	5.62E+02	3.80E+02	4
WCMW-5	CNS WC Ponds / WCMW-5 / WC Ponds	<MDA	<MDA	<MDA	<MDA	4

Well Name	Location / Description	Tritium Concentration (pCi/l) ⁽³⁾			# of Samples
		Min	Avg	Max	
C-105 ⁽¹⁾	CNS GWPI / C-105 / Engr. Bldg.	463	1043	1610	7
C-110 ⁽¹⁾	CNS GWPI / C-110	1770	2034	2350	8
C-208 ⁽¹⁾	CNS GWPI / C-208 / N of MTB	237	250	262	7
WCMW-2 ⁽²⁾	CNS WC Ponds / WCMW-2 / WC Ponds	5050	6221	7220	8

(1) Increased sampling frequency, NCR # 01998302

(2) Increased sampling frequency, NCR 01939441, NCR # 01948296

(3) "MDA" values were not used for determining the Minimum, Average, and Maximum Tritium concentrations indicated.

**Attachment 8
Inoperable Equipment**

Catawba Nuclear Station Units 1 & 2
Period 1/1/2016 - 12/31/2016

ATTACHMENT 8

Inoperable Equipment

This attachment includes an explanation of inoperable instruments related to effluent monitoring in excess of allowed time defined by licensing bases and an explanation of permanent or temporary outside liquid storage tanks exceeding 10 Curies total activity (excluding tritium and dissolved or entrained noble gases).

Attachment 8 Inoperable Equipment

Catawba Nuclear Station Units 1 & 2 Period 1/1/2016 - 12/31/2016

Catawba Nuclear Station experienced three (3) instances of inoperable equipment relevant to effluent monitoring in excess of SLC 16.11 limits during 2016. Details of each are described below.

Catawba Nuclear Station did not experience permanent or temporary unprotected outside liquid storage tanks exceeding 10 Curies total activity (excluding tritium and dissolved or entrained noble gases) during 2016.

SLC # from Table 16.11-7-1	Title	Completion Time	Determination and Data Reviewed
1.a	0EMF 50 (L)	14 Days	For 0EMF50(L), out of service time for 2016 is 31.92 days (5/30/2016 to 6/30/2016 LCOTR A-0-16-00768

For 2016, 0EMF-50 was non-functional from 5/30/2016 to 6/30/2016. During Channel calibration of 0EMF50L, the acceptance criteria of the detector low range was unable to be met and detector replacement was required. Following replacement, channel calibration was performed on 0EMF50L and 0EMF50H with no issues.

- WO 20018012-01

SLC # from Table 16.11-7-1	Title	Completion Time	Determination and Data Reviewed
4	1EMF-39L	30 Days	For 1EMF-39L, out of service time for 2016 was 131.49 days (8/22/2016 to 12/31/2016 LCOTR A-1-16-01267.

For year 2016, 1EMF-39L was non-functional from 8/22/2016 to 12/31/2016 due to loss of indication of 1MISV5231 and 1MISV5233, supply and return isolation valves for 1EMF-39L. Valves are scheduled to be repaired at next available opportunity during 1EOC23.

- WO 20105672-01

SLC # from Table 16.11-2-1	Title	Completion Time	Determination and Data Reviewed
3.d	Monitor Tank Building Discharge Flow to RL	30 Days	For 0WLFT8260, out of service time for 2016 was 42.21 days (6/23/2016 to 8/04/2016 LCOTR A-0-16-00925.

For year 2016, Monitor Tank Building Discharge Flow to RL was non-functional from 6/23/2016 to 8/04/2016 due to erratic indications during release. Troubleshooting determined low pressure sensing lines for the flow transmitter were not filled. This cause the erratic indications seen during the release. Both impulse lines were filled and vented and readings were verified to be accurate during release.

- WR 20040055

Attachment 9
Summary of Changes to the Offsite Dose Calculation Manual

Catawba Nuclear Station Units 1 & 2
Period 1/1/2016 - 12/31/2016

ATTACHMENT 9

Summary of Changes to the Offsite Dose Calculation Manual

This attachment includes a summary of changes to the ODCM and Radiological Effluent Controls.

Attachment 9 Summary of Changes to the Offsite Dose Calculation Manual

Catawba Nuclear Station Units 1 & 2
Period 1/1/2016 - 12/31/2016

ODCM Revision 60

ODCM Revision 60 is provided in entirety in this section.

ODCM Revision 60 was approved by the Radiation Protection Manager on October 27, 2016. Some changes reflected in ODCM Revision 60 were implemented prior to October 27, 2016 under a different change and approval process (e.g., land use census), and in those cases the implementation date is noted below. Changes driven by Document Revision Requests (DRR) are noted with DRR number.

Table of Contents - Page i and ii

Marked 6.0-3, Land Use Census Map, as deleted in List of Figures. Marked 6.0-3, Land Use Census Results, as deleted in List of Tables. Adjusted remaining sub-section, Figure, and Table page numbers for Section 6 based on moving Section 6.0.2.

Change made based on recommendation in DRR 02068932 to improve efficiency by eliminating annual ODCM revisions. This does not adversely impact the accuracy or reliability of dose calculations, as records of the Land Use Census are maintained in EnRad files and documented with procedure AD-CP-ALL-0014, Land Use Census Evaluation. Changes to Effluent Management Software are implemented based on results of annual Land Use Census, once approved.

Executive Summary - Page 2

Revised statements in second paragraph from:

"The ODCM has been prepared as generically as possible in order to minimize the need for revisions. However, some changes to the ODCM such as land use census data are expected on an annual basis. Any changes to the methodology and parameters to be used in this ODCM shall be reviewed by knowledgeable individual(s), and approved by the Station Manager prior to implementation. Changes to the ODCM shall be submitted to the Nuclear Regulatory Commission in accordance with the SLCs and Technical Specifications."

to:

"The ODCM has been prepared as generically as possible in order to minimize the need for revisions. Any changes to the methodology and parameters to be used in this ODCM shall be reviewed by knowledgeable individual(s), and approved by the Station Manager or Radiation Protection Manager prior to implementation. Changes to the ODCM shall be submitted to the Nuclear Regulatory Commission in accordance with the SLCs and Technical Specifications."

Change made based on recommendation in DRR 02068932 to improve efficiency by eliminating annual ODCM revisions. Also updated ODCM approval authority statement based on NRC approved license amendments 273 and 269 to Technical Specification 5.5.1, allowing for Radiation Protection Manager approval.

Section 3.0.2.3 - Page 23

Revise definition for "bkg" from:

"bkg = EMF 50 background."

to:

"bkg = EMF 36 background."

Change made to correct editorial error identified in DRR 02008824. Definition for "bkg" is under section for determining EMF 36 setpoints, not EMF 50. EMF 50 setpoints described prior in section.

Attachment 9 Summary of Changes to the Offsite Dose Calculation Manual

Catawba Nuclear Station Units 1 & 2
Period 1/1/2016 - 12/31/2016

Section 4 - Page 8

Removed reference to Table 6.0-3 in "" note. Statement changed from:

"Dose is calculated only for pathways (e.g., garden, milk animal, etc.) that actually exist at each location as determined by the land use census shown in Table 6.0-3."

to:

"Dose is calculated only for pathways (e.g., garden, milk animal, etc.) that actually exist at each location as determined by the land use census."

Change made based on recommendation in DRR 02068932 to improve efficiency by eliminating annual ODCM revisions.

Section 6.0.2 - Page 2

Revised from (previously on page 1):

"The Annual Land Use Census, required by Selected Licensee Commitments, is performed to ensure that changes in the use of areas at or beyond the site boundary are identified, and that modifications to the Radiological Environmental Monitoring Program are made if required by changes in land use. This census satisfies the requirements of Section IV.B.3 of Appendix I to 10CFR50. Results are shown in Table 6.0-3 and Figure 6.0-3."

to:

"The Annual Land Use Census, required by Selected Licensee Commitments, is performed to ensure that changes in the use of areas at or beyond the site boundary are identified, and that modifications to the Radiological Environmental Monitoring Program are made if required by changes in land use. This census satisfies the requirements of Section IV.B.3 of Appendix I to 10CFR50. The land use census identifies nearest pathways to the exclusion area boundary (EAB, ~ 0.5 mile) for each of the 16 meteorological sectors. Global Positioning System field measurements are taken as close as possible to the item of interest and are accurate to within 2-5 meters. Locations beyond the nearest pathway for each sector are assumed to contain that pathway for dose calculation purposes. For the 4.5-5.0 mile sector all pathways, i.e., residence, garden, milk animal (goat), and meat animal (cow), are assumed to exist for dose calculation purposes. Results are maintained on file and data reviewed in accordance with procedure AD-CP-ALL-0014, Land Use Census Evaluation."

Change made based on recommendation in DRR 02068932 to improve efficiency by eliminating annual ODCM revisions. This does not adversely impact the accuracy or reliability of dose calculations, as records of the Land Use Census are maintained in EnRad files and documented with procedure AD-CP-ALL-0014, Land Use Census Evaluation. Changes to Effluent Management Software are implemented based on results of annual Land Use Census, once approved.

Section 6.0.2 - Page 4 (previously)

Deleted Table 6.0-3 and moved relevant information from "" and "" Note paragraphs to Section 6.0.2.

Change made based on recommendation in DRR 02068932 to improve efficiency by eliminating annual ODCM revisions. This does not adversely impact the accuracy or reliability of dose calculations, as records of the Land Use Census are maintained in EnRad files and documented with procedure AD-CP-ALL-0014, Land Use Census Evaluation. Changes to Effluent Management Software are implemented based on results of annual Land Use Census, once approved.

Attachment 9
Summary of Changes to the Offsite Dose Calculation Manual

Catawba Nuclear Station Units 1 & 2
Period 1/1/2016 - 12/31/2016

Section 6.0.2 - Page 7 (previously)
Deleted Figure 6.0-3.

Change made based on recommendation in DRR 02068932 to improve efficiency by eliminating annual ODCM revisions. This does not adversely impact the accuracy or reliability of dose calculations, as records of the Land Use Census are maintained in EnRad files and documented with procedure AD-CP-ALL-0014, Land Use Census Evaluation. Changes to Effluent Management Software are implemented based on results of annual Land Use Census, once approved.

Attachment 9
Summary of Changes to the Offsite Dose Calculation Manual

Catawba Nuclear Station Units 1 & 2
Period 1/1/2016 - 12/31/2016

Radiological Effluent Controls (SLC 16.11)

The Catawba Nuclear Station Radiological Effluent Controls are contained in SLC 16.11 and shown in this section.

One revision was made to the Catawba Nuclear Station Updated Final Safety Analysis Report, Section 16.11, Radiological Controls, in 2016:

- Section 16.11-20, "Explosive Gas Monitoring Instrumentation," was changed on 03/28/16.

As per TS 5.5.5.b, "Licensee initiated changes to the Radiological Effluent Controls of the UFSAR," Catawba is attaching the entire Section 16.11 of the UFSAR and the List of Effective Sections which will demonstrate when each section was revised.



Catawba Nuclear Station Units 1 and 2



ODCM

Offsite Dose
Calculation Manual



Catawba Nuclear Station Units 1 and 2

OFFSITE DOSE CALCULATION MANUAL (ODCM)

Revision 60



Prepared By: Christopher C. Courtenay Fleet Scientific Services RP		10/12/2016
	Signature	Date
Reviewed By: Jonathan B. Hanni CNS Radiation Protection		10/25/2016
	Signature	Date
Approved By: Joe W. Smith CNS Radiation Protection Manager		10/27/16
	Signature	Date



TABLE OF CONTENTS

Executive Summary	Executive Summary-1
1.0 Radwaste Systems	1-1
1.0.1 Liquid Radwaste Processing	1-1
1.0.2 Gaseous Radwaste Processing	1-4
1.0.2.1 Gas Collection System	1-4
1.0.2.2 Containment and Auxiliary Building Ventilation	1-4
1.0.2.3 Secondary Systems	1-5
2.0 Release Rate Calculations	2-1
2.0.1 Liquid Release Rate Limit Calculations	2-1
2.0.1.1 RL/RN Discharge Release Rate Limit Calculation	2-1
2.0.1.2 WC Discharge Continuous Releases	2-2
2.0.2 Gaseous Release Rate Limit Calculations	2-5
2.0.2.1 Unit Vent Discharge Release Rate Limit Calculation	2-5
3.0 Setpoint Calculations	3-1
3.0.1 Liquid Radiation Monitor Setpoint Calculations	3-1
3.0.1.1 WMT and RMT Setpoints (EMF 49)	3-2
3.0.1.2 AMT Setpoints (EMF 57)	3-4
3.0.1.3 Turbine Building Sump to WC Setpoints (EMF 31)	3-5
3.0.2 Gaseous Radiation Monitor Setpoint Calculations	3-11
3.0.2.1 Containment Air Release and Addition (VQ) Setpoints (EMF 39, EMF 36)	3-14
3.0.2.2 Containment Purge (VP) and Incore Purge (IP) Setpoints (EMF 39, EMF 36)	3-17
3.0.2.3 Waste Gas Decay Tank (WGDT) Setpoints (EMF 50, EMF 36)	3-20
4.0 Effluent Dose Models	4-1
4.0.1 Liquid Effluent Dose Model for the Maximum Exposed Individual	4-1
4.0.2 Gaseous Effluent Dose Model for the Maximum Exposed Individual	4-7
4.0.3 Direct Radiation	4-22
4.0.4 Effluent Apportionment	4-22
5.0 Fuel Cycle Calculations	5-1
5.0.1 Milling	5-1
5.0.2 Conversion	5-1
5.0.3 Enrichment	5-1
5.0.4 Fuel Fabrication	5-1
5.0.5 Nuclear Power Production	5-2
5.0.6 Fuel Reprocessing	5-2
5.0.7 40CFR190 Total Dose Determination	5-2
6.0 Environmental Locations	6-1
6.0.1 Site Description and Sample Locations	6-1
6.0.2 Land Use Census Data	6-2
6.0.3 Catawba Meteorology: Relative Air Concentrations and Deposition	6-9
6.0.3.1 XOQDOQ Methodology and Assumptions	6-9
6.0.3.2 Meteorological Data	6-9
6.0.3.3 Annual XOQDOQ Comparison to the ODCM	6-10
7.0 Licensee Initiated Changes	7-1

Catawba Nuclear Station Units 1 & 2
Period 1/1/2016 - 12/31/2016

Catawba Nuclear Station
Offsite Dose Calculation Manual (ODCM)

Appendices

Appendix A: Dose Factors for Exposure to a Semi-Infinite Cloud of Noble Gas	A-1
Appendix B: P _i Dose Factors for use in the Gaseous Release Rate Limit Calculations	B-1
Appendix C: A _i Adult Dose Factors for use in the Liquid Dose Calculations	C-1
Appendix D: A _i Teen Dose Factors for use in the Liquid Dose Calculations	D-1
Appendix E: A _i Child Dose Factors for use in the Liquid Dose Calculations	E-1
Appendix F: A _i Infant Dose Factors for use in the Liquid Dose Calculations	F-1
Appendix G: R _i Adult Dose Factors for use in the Gaseous Dose Calculations	G-1
Appendix H: R _i Teen Dose Factors for use in the Gaseous Dose Calculations	H-1
Appendix I: R _i Child Dose Factors for use in the Gaseous Dose Calculations	I-1
Appendix J: R _i Infant Dose Factors for use in the Gaseous Dose Calculations	J-1

LIST OF FIGURES

1.0-1 Liquid Radwaste System	1-3
1.0-2 Gaseous Radwaste System (2 pages)	1-6
2.0-1 Liquid Radwaste Discharge Locations	2-3
2.0-2 Liquid Radwaste Discharge to Lake Wylie	2-4
2.0-3 Unit Vent Release Points	2-9
6.0-1 Sampling Locations Map (Site Boundary)	6-5
6.0-2 Sampling Locations Map (Ten Mile Radius)	6-6
6.0-3 Land Use Census Map (<i>Deleted</i>)	6-8

LIST OF TABLES

3.0-1 EMF 49 and EMF 31 Cs-137 Equivalence Factors	3-9
3.0-2 EMF 57 Cs-137 Equivalence Factors	3-10
3.0-3 Xe-133 Equivalentents	3-23
6.0-1 Sampling Locations	6-3
6.0-2 TLD Sites	6-4
6.0-3 Land Use Census Results (<i>Deleted</i>)	6-5
6.0-4 CNS Atmospheric Stability Frequency (1988 - 1992)	6-10
6.0-5 CNS Frequency of Wind Direction and Speed (1988 - 1992)	6-10
6.0-6 CNS Limiting χ/Q and D/Q Values (1988 - 1992)	6-11
6.0-7 CNS Delta-T Ranges per Vertical Separation Distances	6-11
6.0-8 Catawba χ/Q Average Values (1988-1992)	6-12
6.0-9 Catawba D/Q Average Values (1988-1992)	6-13

EXECUTIVE SUMMARY

The Catawba Nuclear Station (CNS) Offsite Dose Calculation Manual (ODCM) provides the methodology and parameters to be used in the calculation of offsite doses due to normal operation radioactive liquid and gaseous effluents to assure compliance with the dose limitations of the Selected Licensee Commitments (SLCs, UFSAR Chapter 16) and Technical Specifications (TSs). These dose limitations assure that:

- (1) the concentration of radioactive liquid effluents released from the site to the unrestricted area will be limited to 10 times the effluent concentration (EC) levels of 10CFR20, Appendix B, Table 2, and 2.0E-04 $\mu\text{Ci/ml}$ for dissolved and entrained noble gases (TS 5.5.5(a)(2), SLC 16.11-1);
- (2) the exposures to any individual member of the public from radioactive liquid effluents will not result in doses greater than the ALARA design objectives of 10CFR50, Appendix I or the 10CFR20 limits (TS 5.5.5(a)(4), SLC 16.11-3);
- (3) the dose rate at any time at the site boundary from radioactive gaseous effluents will be limited to: for noble gases; less than or equal to 500 mrem/yr to the whole body, and less than or equal to 3000 mrem/yr to the skin; and for iodine-131 and iodine-133, for tritium, and for all radioactive materials in particulate form with half-lives greater than 8 days; less than or equal to 1500 mrem/yr to any organ (TS 5.5.5(a)(7), SLC 16.11-6);
- (4) the exposure to any individual member of the public from radioactive gaseous effluents will not result in doses greater than the ALARA design objectives of 10CFR50, Appendix I or the 10CFR20 limits (TS 5.5.5(a) (8 and 9), SLCs 16.11-8 and 16.11-9); and
- (5) the dose to any individual member of the public from the nuclear fuel cycle will not exceed the limits of 40CFR190 (TS 5.5.5(a)(10), SLC 16.11-12).

The methodology and parameters used to assure compliance with the dose limitations described above shall be used to prepare the radioactive liquid and gaseous effluent reports required by the SLCs and Technical Specifications. Dose calculations that demonstrate compliance with 40CFR190 will be considered to demonstrate



Catawba Nuclear Station Units 1 & 2
Period 1/1/2016 - 12/31/2016

Catawba Nuclear Station
Offsite Dose Calculation Manual (ODCM)

compliance with the 10CFR20 0.1-rem annual dose limit. The ODCM also provides the methodology and parameters to be used in the calculation of radioactive liquid and gaseous effluent monitoring instrumentation alarm/trip setpoints to assure compliance with the concentration and dose rate limitations of the SLCs and Technical Specifications. Normally RETDAS, a computer code that implements NUREG-0133 methodology, is used for the calculation of offsite doses, but the ODCM also provides a method for the calculation of offsite doses when RETDAS is not available.

The ODCM has been prepared as generically as possible in order to minimize the need for revisions. Any changes to the methodology and parameters to be used in this ODCM shall be reviewed by knowledgeable individual(s), and approved by the Station Manager or Radiation Protection Manager prior to implementation. Changes to the ODCM shall be submitted to the Nuclear Regulatory Commission in accordance with the SLCs and Technical Specifications.

The ODCM does not replace any station implementing procedures. Programmatic controls for radioactive effluents and radiological environmental monitoring are contained in the Administrative Controls chapter of the Technical Specifications. Procedural details for radioactive effluents and radiological environmental monitoring consisting of licensee commitments, applicability, remedial actions, surveillance requirements, and the bases for these requirements are contained in Section 16.11 of the SLCs.

1.0 RADWASTE SYSTEMS

1.0.1 LIQUID RADWASTE PROCESSING

The liquid radwaste system at Catawba Nuclear Station is used to collect and treat liquid chemical and radiochemical byproducts of unit operation. The system produces effluents that can be reused in the plant or discharged in small, dilute quantities to the environment. The means of treatment vary with waste type and desired product in the various systems:

- (A) Filtration - Waste sources may be filtered during processing.
- (B) Adsorption - Adsorption of halides and organic chemicals by activated charcoal (carbon filter) may be used as needed in treating waste streams in the Liquid Radwaste System (WL). The carbon filter is designed to remove organophosphates and free chlorine. Activated charcoal need not be used when these chemicals are not present (e.g., phosphate detergents are not used at the station). Ion exchange resin or other media may be used in the carbon filter vessel as desired.
- (C) Ion Exchange - Ion exchange is used to remove radioactive ions from solution, as in the case of the Floor and Equipment drain waste in WL, after removal of organics by carbon filtration (adsorption). Ion exchange is also used in removing both radioactive and non-radioactive ions from evaporator distillates in order to purify the distillates for reuse as makeup water. Distillate from the Boron Recycle Evaporator in the Boron Recycle System (NB) can be treated by this method, as well as WL waste, and reactor bleed.
- (D) Gas Stripping - Removal of gaseous radioactive fission products is accomplished in recycled water by the NB Evaporator.
- (E) Distillation - Production of pure water from reactor coolant by boiling it away from the contaminated solution which it was originally contained is accomplished by the NB evaporator. Proper control of the process will yield water that can be reused for makeup. Polishing of this product can be achieved by ion exchange as discussed above.
- (F) Concentration - In the NB Evaporator dissolved chemicals are concentrated in the lower shell as water is boiled away. The WL Evaporator is no longer utilized due to more cost effective process options for floor and equipment drains, e.g., ion exchange. In the NB Evaporator the dilute boron is normally concentrated to 4% so that it may be reused for makeup to the reactor coolant system.

Catawba Nuclear Station Units 1 & 2
Period 1/1/2016 - 12/31/2016

Catawba Nuclear Station
Offsite Dose Calculation Manual (ODCM)

Figure 1.0-1 is a schematic representation of the liquid radwaste system at Catawba.

Catawba Nuclear Station Units 1 & 2
Period 1/1/2016 - 12/31/2016

Catawba Nuclear Station
Offsite Dose Calculation Manual (ODCM)

Figure 1.0-1 Catawba Nuclear Station Liquid Radwaste System

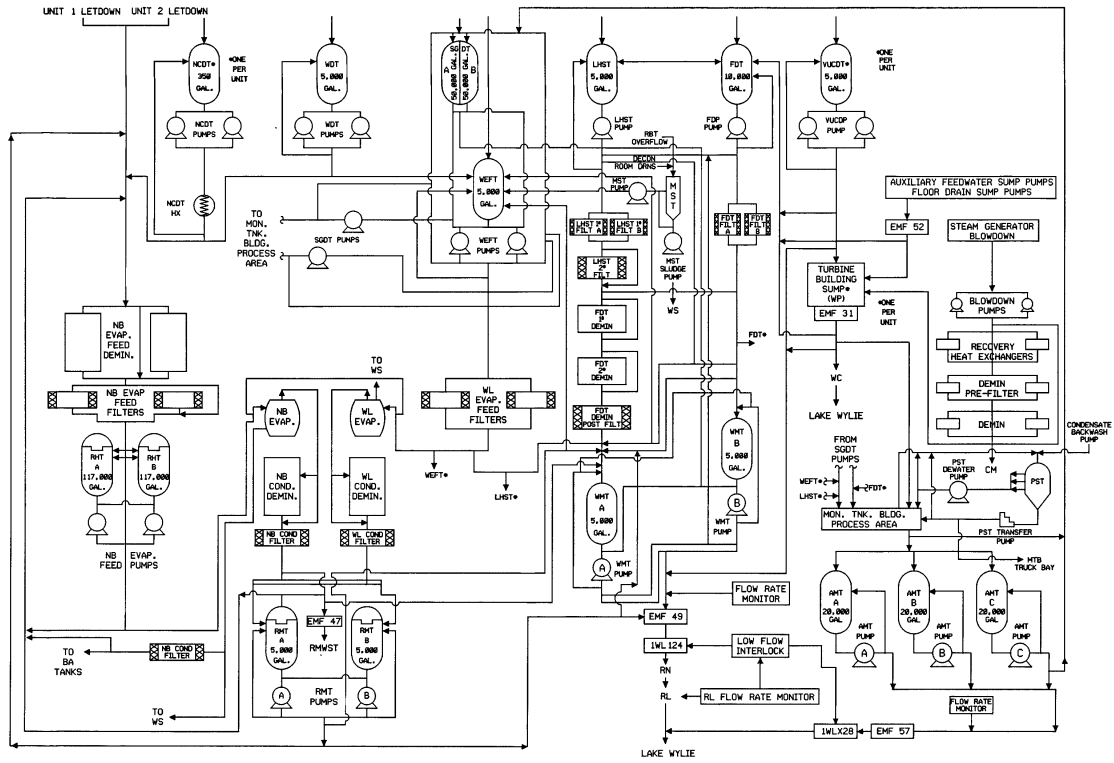

1.0.2 GASEOUS RADWASTE PROCESSING

The Gaseous Waste System (WG) for Catawba is designed with the capability of processing the fission product gases from contaminated reactor coolant fluids resulting from operation. The design basis for the WG shown schematically in Figure 1.0-2 is the retention, through the plant lifetime, of all the gaseous fission products to be discharged from the reactor coolant system to the Chemical and Volume Control System (NV) and other plant systems to eliminate the need for intentional discharge of radioactive gases from the waste gas holdup tanks. Actual system operation is aimed at maximizing storage time for decay prior to infrequent releases. Unavoidable sources of low level radioactive gaseous discharge to the environment will be from periodic purging operations of the containment, and through the secondary system air ejector. With respect to the former, the potential contamination is expected to arise from non-recyclable reactor coolant leakage. With respect to the air ejector, the potential source of contamination will be from leakage of the reactor coolant to the secondary system through defects in steam generator tubes. The gaseous waste disposal system includes two waste gas compressors, two catalytic hydrogen recombiners, six gas decay storage tanks for use during normal power generation, and two gas decay storage tanks for use during shutdown and startup operations, and for pressure relief.

1.0.2.1 GAS COLLECTION SYSTEM

The gas collection system combines the waste hydrogen and fission gases from the volume control tanks, the boron recycle and liquid waste gas stripper evaporators, and other sources produced during normal operation or the gas collected during the shutdown degasification (high percentage of hydrogen), and cycles it through the catalytic recombiners to convert hydrogen to water. After the water vapor is removed, the resulting gas stream is transferred from the recombiner into the waste gas decay tanks (WGDTs), where the accumulated activity may be contained in six approximately equal parts. From the decay tanks, the gas flows back to the compressor suction to complete the circuit.

1.0.2.2 CONTAINMENT AND AUXILIARY BUILDING VENTILATION

Non-recyclable reactor coolant leakage occurring either inside the containment or inside the auxiliary building will generate gaseous activity. Gases resulting from leakage inside the containment will be contained until the containment air is released through either the Containment Air Release and Addition System (VQ) or the Containment Purge System (VP). The containment atmosphere will be discharged through charcoal adsorbers and HEPA filters to reduce releases to the environment.

Gases resulting from leakage inside the auxiliary building are released, without further decay, to the atmosphere. The ventilation exhaust from potentially contaminated areas in the auxiliary building is passed through charcoal adsorbers and HEPA filters to reduce releases to the atmosphere upon a radiation monitor alarm.

1.0.2.3 SECONDARY SYSTEMS

Normally, condensate flow and steam generator blowdown will go parallel through 4 of the 5 condensate polishing demineralizers to remove activity and harmful ions from the water. Non-condensable gases will be taken from the secondary system by the condenser steam air ejector, and are passed through a radiation monitor to the unit vent.

Some low radioactivity secondary system steam releases can occur at the site such as from infrequent lifts of the main steam relief valves and testing of the main steam manual atmospheric dump valves. Radioactivity released from secondary system steam releases is documented and included in the site effluent release total.

Figure 1.0-2 is a schematic representation of the gaseous radwaste system at Catawba.

Catawba Nuclear Station Units 1 & 2
 Period 1/1/2016 - 12/31/2016

Catawba Nuclear Station
 Offsite Dose Calculation Manual (ODCM)

Figure 1.0-2 Catawba Nuclear Station Gaseous Radwaste System
 Page 1 of 2

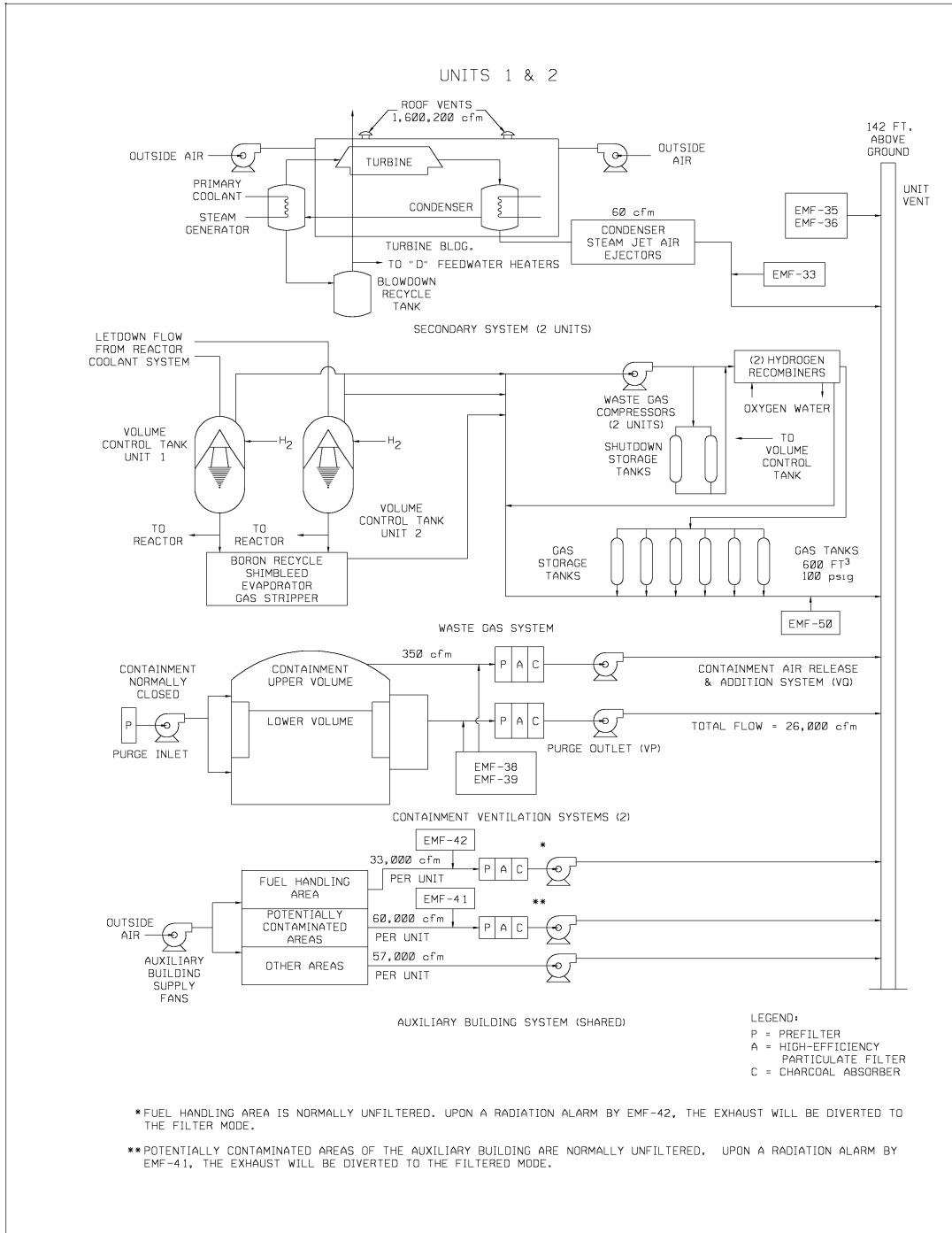

**Figure 1.0-2 Catawba Nuclear Station Gaseous Radwaste System
Page 2 of 2**

AUXILIARY MONITOR TANK BUILDING

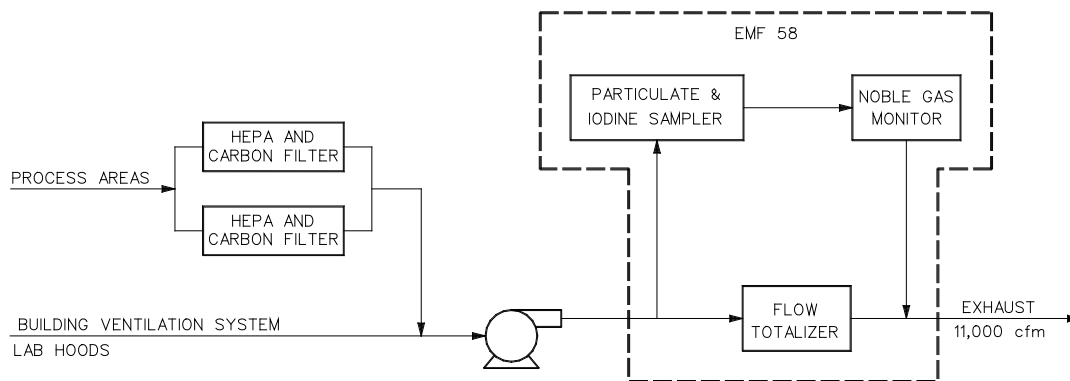

2.0 RELEASE RATE CALCULATIONS

2.0.1 LIQUID RELEASE RATE LIMIT CALCULATIONS

There are two liquid radwaste discharge points to the environment at Catawba; (1) the Low Pressure Service Water System (RL) and Nuclear Service Water System (RN) discharge point to Lake Wylie, and (2) the Conventional Waste Water Treatment System (WC) discharge point to Lake Wylie (See Figure 2.0-1).

2.0.1.1 RL/RN DISCHARGE RELEASE RATE LIMIT CALCULATION

Liquid releases to Lake Wylie through the RL/RN pathway normally contain the radioactive releases from the site including effluents from the waste monitor tanks, recycle monitor tanks, and auxiliary monitor tanks. The RL/RN discharge point can also contain turbine building sump (TBS) releases, however TBS effluent is normally released through the WC discharge point. There are three RL pumps with a minimum flow rate of 19,000 gpm each, and four RN pumps with a minimum flow rate of 8,600 gpm each which provide the required dilution water needed for a release. Each release path has a radiation monitor (EMF) that is used to monitor the liquid effluent (See Figure 2.0-2).

To comply with Technical Specifications and Selected Licensee Commitments, and to assure that the concentration of radioactive liquid effluents released from the site to the unrestricted area is limited to 10 times the effluent concentrations (ECs) of 10CFR20, Appendix B, Table 2, Column 2, and 2.0E-04 $\mu\text{Ci/ml}$ for dissolved and entrained noble gases, the following release rate limit calculation shall be performed for liquid releases to Lake Wylie via the RL/RN discharge point:

$$f \leq (F \div (DF - 1)) \quad \text{Condition: } DF > 1.0 \quad \text{Equation 2.1}$$

where:

f = the undiluted effluent flow, in gpm.

F = the dilution flow available depending on the number of RL/RN pumps in service, in gpm for batch releases, e.g., Waste Monitor Tank.

DF = required dilution factor to be applied to the undiluted effluent flow, unitless.

$$DF = \sigma \times \sum_i \frac{C_i}{(10 \times EC_i)} \quad \text{Equation 2.2}$$

Note:

If $DF \leq 1.0$ then no dilution is required and the release rate is unrestricted.

If $DF > 1.0$ then dilution flow is required and the release rate is calculated using Equation 2.1. Equation 2.1 is used only when $DF > 1.0$.

σ = the most restrictive recirculation factor at equilibrium, (dimensionless). The recirculation factor accounts for the fraction of discharged water reused by the station. For Catawba the recirculation factor equals 1.0 since discharged liquid effluent is not reused by the station.

C_i = the concentration of radionuclide, 'i', in the undiluted liquid effluent, in $\mu\text{Ci/ml}$.

EC_i = the concentration of radionuclide, 'i', from 10CFR20, Appendix B, Table 2, Column 2, in $\mu\text{Ci/ml}$. Note: if radionuclide, 'i', is a dissolved noble gas, then $EC_i = 2.00\text{E-}05 \mu\text{Ci/ml}$.

2.0.1.2 WC DISCHARGE CONTINUOUS RELEASES

Liquid releases to Lake Wylie via the WC discharge point normally contain little measurable activity above background. Although designed for continuous discharge, inputs to WC, primarily from the Unit 1 and Unit 2 turbine building sumps, are normally held up in one of three WC Ponds, then released as a batch. There is a composite sampler at the discharge to the lake. An EMF monitors the TBS/Condenser Drain output (See Figure 2.0-2). It is assumed that no activity is present in the TBS effluent until indicated by radiation monitoring measurements. If radioactivity is detected above the monitor's alarm setpoint, an alternate discharge route may be used. A control room alarm indicates this radioactivity. At this time the discharge may be routed to WL for processing rather than through WC. Liquid effluent releases through WC typically account for less than 1% of tritium releases from Catawba.

Catawba Nuclear Station Units 1 & 2
Period 1/1/2016 - 12/31/2016

Catawba Nuclear Station
Offsite Dose Calculation Manual (ODCM)

Figure 2.0-1 Liquid Radwaste Discharge Locations

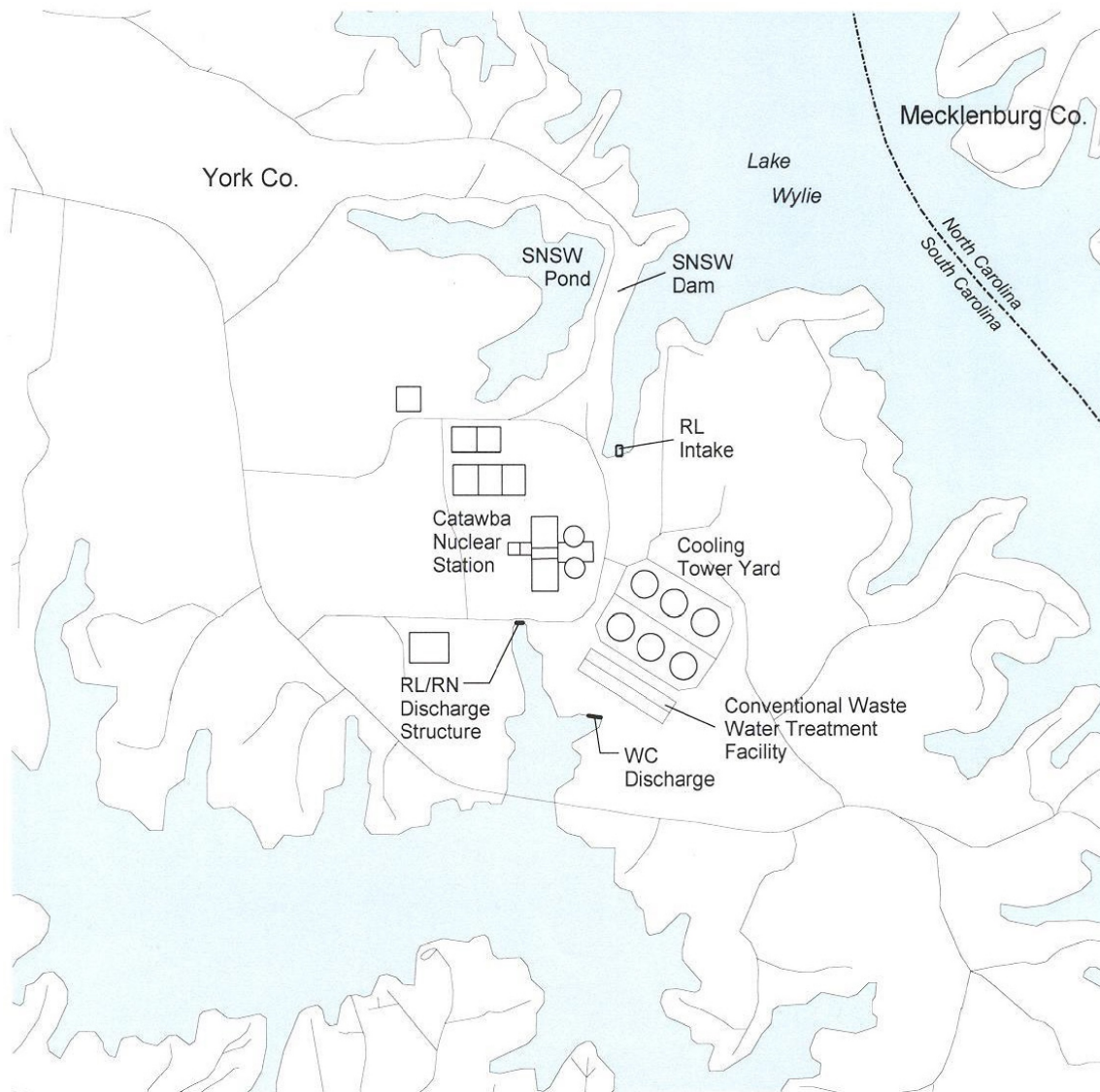

Catawba Nuclear Station Units 1 & 2
Period 1/1/2016 - 12/31/2016

Catawba Nuclear Station
Offsite Dose Calculation Manual (ODCM)

Figure 2.0-2 Liquid Radwaste Discharge to Lake Wylie

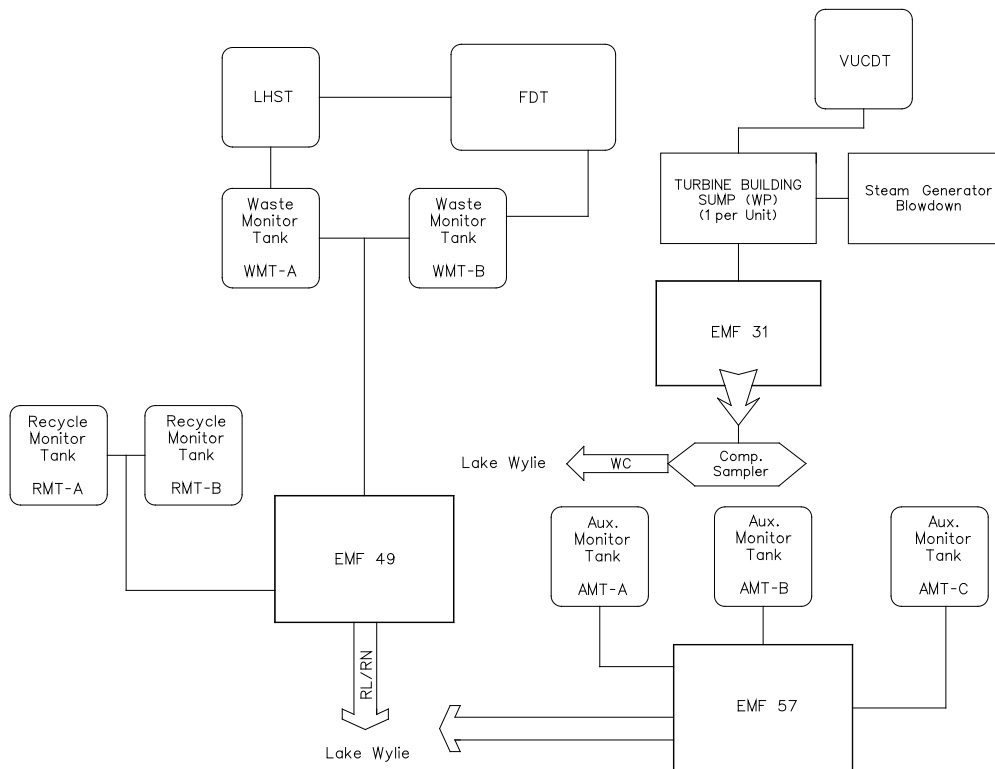

2.0.2 GASEOUS RELEASE RATE LIMIT CALCULATIONS

The two unit vents are the primary gaseous radioactive release points at Catawba. The unit vents are the release points for waste gas decay tanks, containment building purges, auxiliary building ventilation, and the condenser air ejector (see Figure 2.0-3). Each unit vent has multi-range radiation monitors and flow rate measuring instrumentation.

There is one other separate gaseous effluent release point at Catawba, the Auxiliary Monitor Tank Building (AMTB), that is normally considered non-radioactive; that is, it is possible but unlikely that the effluent will contain measurable activity above background. However, the potential for release of radioactive effluents remains with certain job evolutions that may take place in the AMTB. The process areas of the AMTB ventilation pass through particulate and charcoal filters. The AMTB release point has an EMF, effluent sampler, and flow totalizer (see Figure 1.0-2).

2.0.2.1 UNIT VENT DISCHARGE RELEASE RATE LIMIT CALCULATION

In order to comply with Technical Specifications and SLCs and to assure that the dose rate, at any time, at or beyond the site boundary due to radioactive materials released in gaseous effluents from the site is limited to: ≤ 500 mrem/yr to the total body, and ≤ 3000 mrem/yr to the skin for the noble gases, and is limited to ≤ 1500 mrem/yr to any organ for radioiodine and for radioactive materials in particulate form, and radionuclides other than noble gases with half lives greater than 8 days, the following release rate and radiation monitor setpoint calculations shall be performed for releases from the waste gas decay tanks and the containment building. The release rate calculations when solved for the flow rate, Q , are the release rates for noble gases and for radioiodines, particulates and other radionuclides with half-lives greater than 8 days. The most conservative release rate calculated shall control the flow rate. The following equations are based on the site dose rate limits. When applied to the individual release points the site dose rate values are apportioned 49% to each unit vent and 2% to the AMTB vent assuring that simultaneous releases from all release points do not exceed the controlling release rate for a single point.

a. Noble Gases

Total Body:

$$\sum_i \left(K_i \times \frac{\lambda}{Q} \times Q_i \right) < 500 \text{ mrem/yr} \quad \text{Equation 2.3}$$

Skin:

$$\sum_i \left((L_i + 1.1M_i) \times \frac{\lambda}{Q} \times Q_i \right) < 3000 \text{ mrem/yr} \quad \text{Equation 2.4}$$

Catawba Nuclear Station
Offsite Dose Calculation Manual (ODCM)

b. Radioiodines, Particulates, and Others

Inhalation, Ingestion and Ground Organ Pathways:

$$\sum_p \sum_i (P_{opi} \times W \times Q_i \times E_i) < 1500 \text{ mrem/yr}$$

To include both the food and ground organ dose and the inhalation organ dose the equation can be expanded to:

$$\sum_p \sum_i \{ (P_{opi})_{\text{food/gr}} \times W_{D/Q} + (P_{opi})_{\text{inhal}} \times W_{\chi/Q} \} \times Q_i \times E_i < 1500 \text{ mrem/yr}$$

Equation 2.5

where:

K_i = the total body dose factor due to gamma emissions for each identified noble gas radionuclide, 'i', in mrem/yr per $\mu\text{Ci}/\text{m}^3$ (See Appendix A).

L_i = the skin dose factor due to beta emissions for each identified noble gas radionuclide, 'i', in mrem/yr per $\mu\text{Ci}/\text{m}^3$ (See Appendix A).

M_i = the air dose factor due to gamma emissions for each identified noble gas radionuclide, 'i', in mrad/yr per $\mu\text{Ci}/\text{m}^3$ (See Appendix A).

1.1 = ratio to convert dose (mrad) to dose equivalent (mrem).

P_{opi} = the dose parameter for radionuclides other than noble gases for the inhalation pathway, in mrem/yr per $\mu\text{Ci}/\text{m}^3$ and for the food and ground plane pathways in ($\text{m}^2 \times (\text{mrem}/\text{yr per } \mu\text{Ci}/\text{sec})$) for organ, 'o', and radionuclide, 'i', (See Appendix B for the pathway specific dose commitment factors). Note: NUREG-1301, page 75, specifies use of the Child age group, Inhalation pathway, for the P_{opi} values.

χ/Q = the highest calculated annual average dispersion parameter for any area at or beyond the site boundary in sec/m^3 . For Catawba this value is $3.510\text{E}-5 \text{ sec}/\text{m}^3$. The location is the NNE sector at 0.5 mile. As discussed in Catawba UFSAR Section 2.1.1.3, the boundary for establishing gaseous effluent release limits is the exclusion area boundary (EAB). The EAB is defined as a 2500-ft. (~0.5 mile) radius from the station center.

W = the highest calculated annual average dispersion or deposition parameter for estimating the maximum dose rate to an individual from the total inhalation, food, and ground plane pathways:

Catawba Nuclear Station
Offsite Dose Calculation Manual (ODCM)

$W_{\chi/Q}$ = 3.510E-5 sec/m³, for the inhalation pathway and the airborne H-3 food pathway. The location is the NNE sector at 0.5 mile.

$W_{D/Q}$ = 1.078E-7 m⁻², for the food and ground plane pathways. The location is the NNE sector at 0.5 mile.

E_i = the filter removal factor for radionuclide, 'i', e.g., for 99% removal $E_i = 0.01$. For VQ, VP and AMTB releases $E_i = 0.1$ for iodine, 0.01 for particulates. There is no filtration for WGDT releases.

Q_i = the release rate of radionuclide, 'i', in gaseous effluent from all release points at the site, in $\mu\text{Ci}/\text{sec}$.

$$Q_i = k_1 C_i f \div k_2 = 472 \times C_i f \quad \text{Equation 2.6}$$

where:

C_i = the concentration of radionuclide, 'i', in undiluted gaseous effluent, in $\mu\text{Ci}/\text{ml}$.

f = the undiluted effluent flow, in ft³/min.

k_1 = conversion factor, 2.83E+04 cc/ft³.

k_2 = conversion factor, 60 sec/min.

Substituting the expression for Q_i in Equation 2.6 into Equations 2.3, 2.4, and 2.5, and solving for the flow rate, ' f ', in each equation gives:

Noble Gases - Total Body Maximum Release Rate:

$$f_{ib} < \frac{500}{472 \times \chi/Q \times \sum_i (K_i \times C_i)}$$

Noble Gases - Skin Maximum Release Rate:

$$f_{sk} < \frac{3000}{472 \times \chi/Q \times \sum_i [(L_i + 1.1M_i) \times C_i]}$$

Radioiodines, Particulates, and Others - Organ Maximum Release Rate:

$$f_{or} < \frac{1500}{472 \times \sum_p \sum_i \{ (P_{opi})_{food/gr} \times W_{D/Q} + (P_{opi})_{inhal} \times W_{\chi/Q} \} \times E_i \times C_i}$$

Attachment 9
Summary of Changes to the Offsite Dose Calculation Manual

Catawba Nuclear Station Units 1 & 2
Period 1/1/2016 - 12/31/2016

Catawba Nuclear Station
Offsite Dose Calculation Manual (ODCM)

f_{ib} , f_{sk} , and f_{or} , are calculated for each batch prior to release. The most limiting gaseous release rate is used to assure that no instantaneous dose rate limit is exceeded.

Catawba Nuclear Station Units 1 & 2
Period 1/1/2016 - 12/31/2016

Catawba Nuclear Station
Offsite Dose Calculation Manual (ODCM)

Figure 2.0-3 Unit Vent Release Points

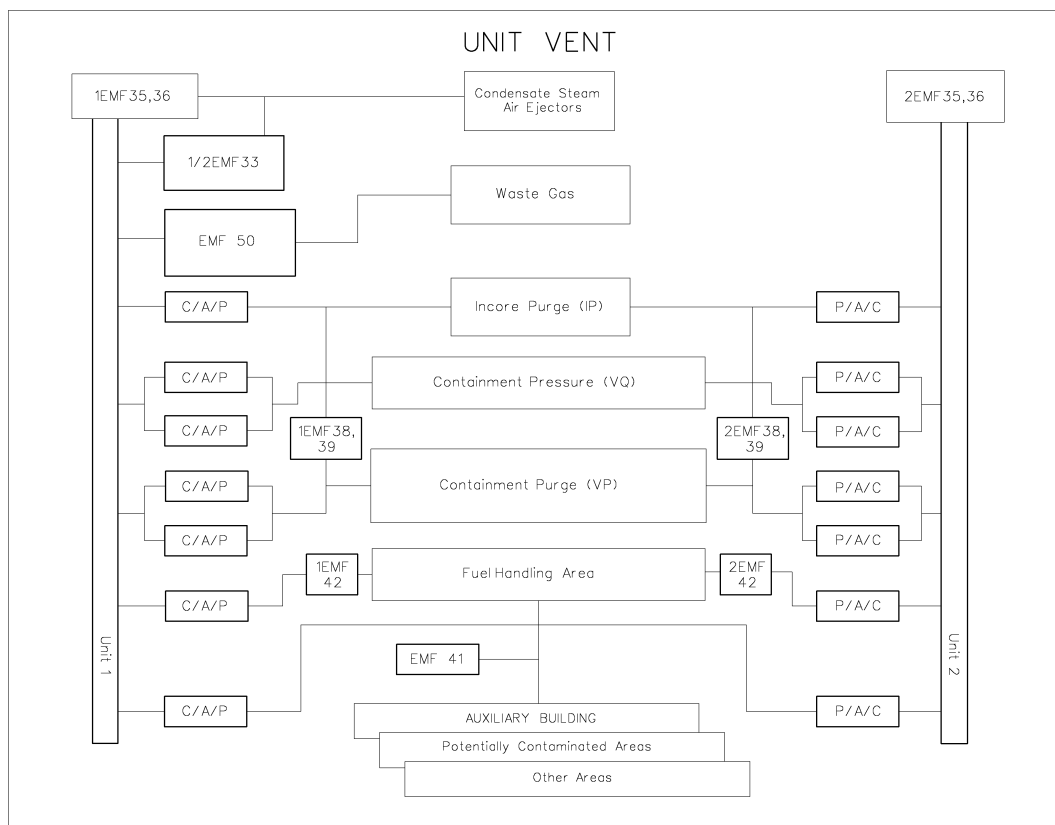

Derivations of Iodine, Particulate, and H-3 Dose Commitment Factors (P_{opi})

Inhalation Pathway - Child Age Group

$$P_{opi} = K'(BR)(DFA_{oi})$$

Formula: from NUREG-0133, page 25.	
Where:	
P_{opi}	Dose commitment factor for child age group, organ o, nuclide i, for the inhalation pathway (mrem/yr per $\mu\text{Ci}/\text{m}^3$). (See Appendix B for the pathway specific dose commitment factors).
K'	Units conversion factor pCi/ μCi (10^6).
BR	Breathing rate for the child age group (m^3/yr , from Regulatory Guide 1.109): Child – 3700
DFA_{oi}	Organ inhalation dose conversion factor for child age group, organ o, nuclide i, (mrem/pCi), from Table E-9 of Regulatory Guide 1.109.

3.0 SETPOINT CALCULATIONS

3.0.1 LIQUID RADIATION MONITOR SETPOINT CALCULATIONS

Once the liquid release rate parameters have been established radiation monitor setpoints shall be calculated to assure that the concentration of radioactive liquid effluents released from the site to the unrestricted area is limited to ten times the effluent concentrations (ECs) of 10CFR20, Appendix B, Table 2, Column 2, and 2.0E-04 $\mu\text{Ci/ml}$ for dissolved and entrained noble gases. By substituting the dilution factor (DF) from Equation 2.2 into Equation 2.1, solving for the undiluted liquid effluent concentration, C_i , and accounting for the monitor background reading, the liquid radiation monitor setpoint can be readily obtained by multiplying C_i by the radiation monitor correlation factor, CF_i , as follows:

$$C_i \leq \frac{(F + f) \times (10 \times EC_i)}{\sigma \times f} \quad \text{Equation 3.1}$$

$$SP \leq \sum_i (C_i \times CF_i) + bkg \quad \text{Equation 3.2}$$

where:

C_i = the maximum allowable concentration of radionuclide, 'i', in the undiluted liquid effluent, in $\mu\text{Ci/ml}$.

SP = radiation monitor setpoint, in cpm.

CF_i = radiation monitor correlation factor for radionuclide, 'i', in cpm/ $\mu\text{Ci/ml}$.

bkg = background reading for the radiation monitor, in cpm.

All other parameters were previously defined.

Using conservative or "worst-case" parameters in Equation 3.1 and Equation 3.2 can provide a liquid radiation monitor setpoint that does not need to be revised for every release if activity is low enough to allow for this type of operation. Prior to the release to assure that the standard setpoints will not be exceeded for the batch release, the "Expected cpm" is calculated. In general, liquid radiation monitors are calibrated to Cs-137, and their "Expected cpm" is calculated as follows:

$$C_{Cs-137} = \sum_i (C_i \times Eq_i)$$

$$Expected\ cpm = (C_{Cs-137} \times CF_{Cs-137}) + bkg \quad \text{Equation 3.3}$$

where:

C_{Cs-137} = Cs-137 equivalent concentration, in $\mu\text{Ci/ml}$.

Eq_i = Cs-137 equivalence factor for each isotope, excluding tritium, to that of Cs-137 due to different gamma energies and abundance. This factor includes a 4-hour decay time due to the average time between sample and release. (See Table 3.0-1 and Table 3.0-2).

All other parameters were previously defined.

3.0.1.1 WMT AND RMT SETPOINTS (EMF 49)

As shown on Figure 2.0-2, EMF 49 is the controlling radiation monitor for Waste Monitor Tank (WMT) and Recycle Monitor Tank (RMT) releases. As discussed previously, standard setpoints are calculated for EMF 49 based on "worst-case" parameters using Equation 3.1 and Equation 3.2 as follows:

$$C_i \leq \frac{(F + f) \times (10 \times EC_i)}{\sigma \times f}$$

Trip 2 setpoint is the lower of the values calculated below.

Maximum EMF 49 Trip 2 setpoint based on discharge concentration limits

$$C \leq \frac{(27,600 + 100) \times (7 \times 9.0E-07)}{1.0 \times 100} \leq 1.745E-03 \mu\text{Ci/ml}$$

$$SP \leq \sum_i (C_i \times CF_i) + bkg$$

$$Trip\ 2 \cong 1.745E-03 \times 3.49E+08 \cong 6.090E+05 \text{ cpm} + bkg$$

A Trip 2 setpoint of 6.00E+05 cpm is used for conservatism.

$$Trip\ 1 = Trip\ 2 \times 0.75 = 4.50E+05 \text{ cpm}$$

Catawba Nuclear Station
Offsite Dose Calculation Manual (ODCM)

where:

27,600 = RL/RN minimum dilution flow available (gpm) with 1 RL pump at 19,000 gpm minimum, and 1 RN pump at 8,600 gpm minimum.

100 = Flow from WMT or RMT (gpm).

7 = 10CFR20, Appendix B, Table 2, Column 2, EC multiplier used for instantaneous liquid release rate concentration limit. Technical Specifications allow a multiplier of 10. A value of 7 is used for added conservatism.

9.0E-07 = EC for Cs-134 which is the lowest effluent concentration value for any detectable radionuclide not known to be absent from the liquid effluent ($\mu\text{Ci/ml}$).

1.0 = The recirculation value for Catawba (unitless).

3.49E+08 = The radiation monitor correlation value for EMF 49 (cpm/ $\mu\text{Ci/ml}$).

EMF 49 Trip 2 setpoint based on sample concentration

When $C_{\text{Cs-137}}$ equivalent concentration $\leq 4.58\text{E-}05$ $\mu\text{Ci/ml}$:

$Trip\ 2\ setpoint = (C_{\text{Cs-137}} \times CF_{\text{Cs-137}} \times 2.0) + bkg$ **or** $3 \times bkg$, whichever is higher.

When $C_{\text{Cs-137}}$ equivalent concentration $> 4.58\text{E-}05$ $\mu\text{Ci/ml}$:

$Trip\ 2\ setpoint = (C_{\text{Cs-137}} \times CF_{\text{Cs-137}} \times 2.0) + bkg$

$Trip\ 1 = Trip\ 2 \times 0.75$

where:

$C_{\text{Cs-137}}$ = Cs-137 equivalent concentration, in $\mu\text{Ci/ml}$.

$CF_{\text{Cs-137}}$ = EMF 49 Cs-137 correlation factor, 3.49E+08 cpm/ $\mu\text{Ci/ml}$.

bkg = Background reading from EMF 49 after flushed from previous releases.

If the Cs-137 equivalent concentration is $\leq 4.58\text{E-}05$ $\mu\text{Ci/ml}$, then 4.58E-05 may be used in the Trip 1 and Trip 2 setpoint calculations. This is an indication of a low activity tank, and normal EMF fluctuation may cause Trip 2 alarms and release termination.

Prior to the release to assure that the standard Trip 1 and Trip 2 setpoints are not exceeded for the batch release, the "Expected cpm" is calculated based on actual tank activity as previously shown in Equation 3.3. For the "Expected cpm" calculation the applicable EMF 49 correlation value is used.

3.0.1.2 AMT SETPOINTS (EMF 57)

As shown on Figure 2.0-2, EMF 57 is the controlling radiation monitor for Auxiliary Monitor Tank (AMT) releases. As discussed previously, standard setpoints are calculated for EMF 57 based on "worst-case" parameters using Equation 3.1 and Equation 3.2 as follows:

$$C_i \leq \frac{(F + f) \times (10 \times EC_i)}{\sigma \times f}$$

Trip 2 setpoint is the lower of the values calculated below.

Maximum EMF 57 Trip 2 setpoint based on discharge concentration limits

$$C \leq \frac{(27,600 + 250) \times (7 \times 9.0E-07)}{1.0 \times 250} \leq 7.018E - 04 \text{ } \mu\text{Ci/ml}$$

$$SP \leq \sum_i (C_i \times CF_i) + bkg$$

$$Trip\ 2 \cong 7.018E - 04 \times 9.60E + 07 \cong 6.737E + 04 \text{ cpm} + bkg$$

A Trip 2 setpoint of 6.00E+04 cpm is used for conservatism.

$$Trip\ 1 = Trip\ 2 \times 0.75 = 4.50E + 04 \text{ cpm}$$

where:

27,600 = RL/RN minimum dilution flow available (gpm) with 1 RL pump at 19,000 gpm, and 1 RN pump at 8,600 gpm minimum.

250 = Flow from AMT (gpm).

7 = 10CFR20, Appendix B, Table 2, Column 2, EC multiplier used for instantaneous liquid release rate concentration limit. Technical Specifications allow a multiplier of 10. A value of 7 is used for added conservatism.

Catawba Nuclear Station Units 1 & 2
Period 1/1/2016 - 12/31/2016

Catawba Nuclear Station
Offsite Dose Calculation Manual (ODCM)

9.0E-07 = EC for Cs-134 which is the lowest effluent concentration value for any detectable radionuclide not known to be absent from the liquid effluent ($\mu\text{Ci/ml}$).

1.0 = The recirculation value for Catawba (unitless).

9.60E+07 = The radiation monitor correlation value for EMF 57 (cpm/ $\mu\text{Ci/ml}$).

EMF 57 Trip 2 setpoint based on sample concentration

When $C_{\text{Cs-137}}$ equivalent concentration $\leq 1.66\text{E-}04 \mu\text{Ci/ml}$:

$Trip\ 2\ setpoint = (C_{\text{Cs-137}} \times CF_{\text{Cs-137}} \times 2.0) + bkg$ or $3 \times bkg$, whichever is higher.

When $C_{\text{Cs-137}}$ equivalent concentration $> 1.66\text{E-}04 \mu\text{Ci/ml}$:

$Trip\ 2\ setpoint = (C_{\text{Cs-137}} \times CF_{\text{Cs-137}} \times 2.0) + bkg$

$Trip\ 1 = Trip\ 2 \times 0.75$

where:

$C_{\text{Cs-137}}$ = Cs-137 equivalent concentration, in $\mu\text{Ci/ml}$.

$CF_{\text{Cs-137}}$ = EMF 57 Cs-137 correlation factor, $9.60\text{E+}07$ cpm/ $\mu\text{Ci/ml}$.

bkg = Background reading from EMF 57 after flushed from previous releases.

If the Cs-137 equivalent concentration is $\leq 1.66\text{E-}04 \mu\text{Ci/ml}$, then $1.66\text{E-}04$ may be used in the Trip 1 and Trip 2 setpoint calculations. This is an indication of a low activity tank, and normal EMF fluctuation may cause Trip 2 alarms and release termination.

Prior to the release to assure that the standard Trip 1 and Trip 2 setpoints are not exceeded for the batch release, the "Expected cpm" is calculated based on actual tank activity as previously shown in Equation 3.3. For the "Expected cpm" calculation the applicable EMF 57 correlation value is used.

3.0.1.3 TURBINE BUILDING SUMP TO WC SETPOINTS (EMF 31)

As shown on Figure 2.0-2, EMF 31 is the controlling radiation monitor for releases from the Turbine Building Sump (TBS) to the Conventional Waste Water Treatment System (WC). EMF 31 setpoints are used to terminate the release to WC if there is any detectable activity in the effluent. The setpoints are calculated using Equation 3.2 as follows:

Typical EMF 31 Setpoint without a Liquid Waste Release (LWR)

$$\text{Trip 2} = 1.0E - 06 \times 3.49E + 08 + \text{existing reading}$$

$$\text{Trip 2} = 3.49E + 02 \text{ cpm} + \text{existing reading}$$

$$\text{Trip 1} = \text{Trip 2} \times 0.70$$

where:

1.0E-06 = Minimum practical detectable Cs-137 equivalent concentration, in $\mu\text{Ci/ml}$.

3.49E+08 = EMF 31 Cs-137 correlation factor, in $\text{cpm}/\mu\text{Ci/ml}$.

Existing reading = Reading from EMF 31.

Special EMF 31 Setpoint without a Liquid Waste Release (LWR)

During heavy rains, both units' EMF 31 sometimes alarm due to the high input of water into the sumps agitating sediment in the sumps. Therefore, the EMF 31 setpoints can be increased for up to 6 hours as described below with Radiation Protection Supervision approval. The EMF 31 setpoints are determined as described below in this situation.

$$C \leq \frac{(50\{dil\} + 50\{tbs\}) \times (7 \times 9.0E-07)}{1.0 \times 50\{tbs\}} \leq 1.260E - 05 \mu\text{Ci/ml}$$

$$SP \leq \sum_i (C_i \times CF_i) + bkg$$

$$\text{Trip 2} \cong 1.260E - 05 \times 3.49E + 08 \cong 4.39E + 03 \text{ cpm} + \text{bkg}$$

$$\text{Trip 1} = \text{Trip 2} \times 0.70 = 3.07E + 03 \text{ cpm}$$

where:

50 {dil} = 50 gpm is the assumed average available non-radioactive dilution flow into the WC ponds. Based on 9.6E+7 gallons released from WC ponds in 231.5 days or ~271 gpm total input. 271 gpm - 50 gpm (TBS) = 221 gpm available dilution flow. 50 gpm used for conservatism.

50 {tbs} = 50 gpm is the assumed average Turbine Building Sump (TBS) flow. Based on TBS pumps running 945 minutes in 30.55 days (2.15%) at 1,300 gpm or ~27.95 gpm effective flow rate. 50 gpm used for conservatism.

Catawba Nuclear Station
Offsite Dose Calculation Manual (ODCM)

- 7 = 10CFR20, Appendix B, Table 2, Column 2, EC multiplier used for instantaneous liquid release rate concentration limit. Technical Specifications allow a multiplier of 10. A value of 7 is used for added conservatism.
- 9.0E-07 = EC for Cs-134 which is the lowest effluent concentration value for any detectable radionuclide not known to be absent from the liquid effluent ($\mu\text{Ci/ml}$).
- 1.0 = The recirculation value for Catawba (unitless).
- 3.49E+08 = The radiation monitor correlation value for EMF 31 (cpm/ $\mu\text{Ci/ml}$).

EMF 31 Setpoint with a Liquid Waste Release (LWR)

When activity above typical levels is present in the sumps due an LWR may be used to release the activity into the WC ponds. This allows for some operational flexibility while administratively controlling the addition of activity to the WC ponds. The EMF 31 setpoints are determined as described below in this situation.

$$C \leq \frac{(150\{dil\} + 50\{tbs\}) \times (7 \times 9.0E-07)}{1.0 \times 50\{tbs\}} \leq 2.520E-05 \mu\text{Ci/ml}$$

$$SP \leq \sum_i (C_i \times CF_i) + bkg$$

$$Trip 2 \cong 2.520E-05 \times 3.49E+08 \cong 8.79E+03 \text{ cpm} + bkg$$

$$Trip 1 = Trip 2 \times 0.75 \text{ cpm}$$

Where:

150 {dil} = 150 gpm is the assumed average available non-radioactive dilution flow into the WC ponds. Based on 9.6E+7 gallons released from WC ponds in 231.5 days or ~271 gpm total input. 271 gpm - 50 gpm (TBS) = 221 gpm available dilution flow. 150 gpm used for conservatism.

50 {tbs} = 50 gpm is the assumed average Turbine Building Sump (TBS) flow. Based on TBS pumps running 945 minutes in 30.55 days (2.15%) at 1,300 gpm or ~27.95 gpm effective flow rate. 50 gpm used for conservatism.

7 = 10CFR20, Appendix B, Table 2, Column 2, EC multiplier used for instantaneous liquid release rate concentration limit. Technical Specifications allow a multiplier of 10. A value of 7 is used for added conservatism.

Catawba Nuclear Station Units 1 & 2
Period 1/1/2016 - 12/31/2016

Catawba Nuclear Station
Offsite Dose Calculation Manual (ODCM)

9.0E-07 = EC for Cs-134 which is the lowest effluent concentration value for any detectable radionuclide not known to be absent from the liquid effluent ($\mu\text{Ci/ml}$).

1.0 = The recirculation value for Catawba (unitless).

3.49E+08 = The radiation monitor correlation value for EMF 31 ($\text{cpm}/\mu\text{Ci/ml}$).

To assure that the standard Trip 1 and Trip 2 setpoints are not exceeded for TBS releases, the "Expected cpm" is calculated based on actual TBS sample activity as previously shown in Equation 3.3.

Catawba Nuclear Station Units 1 & 2
Period 1/1/2016 - 12/31/2016

Catawba Nuclear Station
Offsite Dose Calculation Manual (ODCM)

Table 3.0-1

EMF 49 and EMF 31 Cs-137 Equivalence Factors

Isotope	Equivalence Factor	Isotope	Equivalence Factor	Isotope	Equivalence Factor
Be-7	0.1282	Mo-99	0.3135	La-141	0.0132
F-18	0.5238	Tc-99m	0.5788	La-142	0.2785
Na-24	1.3013	Tc-101	0.00	Ce-141	0.4966
Cl-38	0.0068	Ru-103	1.1798	Ce-143	0.7066
K-40	0.0913	Ru-105	0.8673	Ce-144	0.1321
Cr-51	0.1207	Ru-106	0.4097	I-130	3.1610
Mn-54	1.0871	Ag-108m	3.2676	I-131	1.2074
Mn-56	0.4826	Ag-110m	3.5043	I-132	1.0137
Fe-59	0.9915	Cd-115	0.4739	I-133	1.0971
Co-57	0.8892	Cd-115m	0.0228	I-134	0.1396
Co-58	1.4883	In-115m	0.3048	I-135	0.8432
Co-60	1.8564	Sb-122	0.8691	Ar-41	0.1987
Cu-64	0.3577	Sb-124	2.0195	Kr-85	0.0054
Ni-65	0.1389	Sb-125	1.0467	Kr-85m	0.5240
Zn-65	0.5278	Sb-126	5.0018	Kr-87	0.1020
Zn-69m	0.9788	Sn-113	0.8413	Kr-88	0.4607
Se-75	1.9710	Sn-123	0.0062	Kr-89	0.00
Br-80m	0.0821	Sn-126	0.1747	Xe-131m	0.0211
Br-82	3.3664	Te-125m	0.0023	Xe-133	0.0520
Br-83	0.0054	Te-127	0.0116	Xe-133m	0.1176
Br-84	0.0056	Te-127m	0.0005	Xe-135	0.8334
Br-85	0.00	Te-129	0.0122	Xe-135m	0.00
Rb-86	0.0873	Te-129m	0.0526	Xe-137	0.00
Rb-88	0.00	Te-131	0.0016	Xe-138	0.00
Rb-89	0.00	Te-131m	1.9281	Nd-147	0.3706
Sr-89	0.0002	Te-132	1.0302	Hf-181	1.7053
Sr-91	0.6398	Te-134	0.0402	W-187	0.8499
Sr-92	0.3415	Cs-134	2.5843	Tl-208	0.00
Y-91	0.0028	Cs-136	3.1799	Bi-212	0.0140
Y-91m	0.0403	Cs-137	1.00	Bi-214	0.0003
Y-92	0.1281	Cs-138	0.0110	Pb-212	0.4507
Y-93	0.1009	Ba-133	1.2331	Pb-214	0.0018
Zr-95	1.1163	Ba-139	0.0255	Ra-226	0.0386
Zr-97	1.1163	Ba-140	0.5022	Ac-228	0.8370
Nb-95	1.1114	Ba-141	0.0002	Th-228	0.0090
Nb-95m	0.2929	Ba-142	0.00	Np-239	0.8989
Nb-97	0.1164	La-140	2.0586		

Catawba Nuclear Station Units 1 & 2
Period 1/1/2016 - 12/31/2016

Catawba Nuclear Station
Offsite Dose Calculation Manual (ODCM)

Table 3.0-2

EMF 57 Cs-137 Equivalence Factors

Isotope	Equivalence Factor	Isotope	Equivalence Factor	Isotope	Equivalence Factor
Be-7	0.1462	Mo-99	0.2668	La-141	0.0155
F-18	0.5788	Tc-99m	0.00	La-142	0.2942
Na-24	0.8519	Tc-101	0.00	Ce-141	0.00
Cl-38	0.0090	Ru-103	1.3368	Ce-143	0.7826
K-40	0.1094	Ru-105	0.8783	Ce-144	0.0273
Cr-51	0.1438	Ru-106	0.4429	I-130	3.3095
Mn-54	1.0617	Ag-108m	3.4473	I-131	1.4051
Mn-56	0.4992	Ag-110m	3.5179	I-132	1.0259
Fe-59	1.0556	Cd-115	0.5201	I-133	1.1857
Co-57	0.0022	Cd-115m	0.0235	I-134	0.1388
Co-58	1.4735	In-115m	0.3631	I-135	0.9374
Co-60	2.0495	Sb-122	0.9218	Ar-41	0.2229
Cu-64	0.3954	Sb-124	2.1617	Kr-85	0.0059
Ni-65	0.1591	Sb-125	1.1308	Kr-85m	0.4280
Zn-65	0.5584	Sb-126	5.1762	Kr-87	0.1213
Zn-69m	1.1391	Sn-113	0.9971	Kr-88	0.5278
Se-75	1.3092	Sn-123	0.0066	Kr-89	0.00
Br-80m	0.0860	Sn-126	0.00	Xe-131m	0.0167
Br-82	3.4691	Te-125m	0.00	Xe-133	0.0006
Br-83	0.0059	Te-127	0.0134	Xe-133m	0.1172
Br-84	0.0053	Te-127m	0.0001	Xe-135	0.8564
Br-85	0.00	Te-129	0.0138	Xe-135m	0.00
Rb-86	0.0894	Te-129m	0.0507	Xe-137	0.00
Rb-88	0.00	Te-131	0.0008	Xe-138	0.00
Rb-89	0.00	Te-131m	1.8463	Nd-147	0.2619
Sr-89	0.0002	Te-132	0.9766	Hf-181	1.4209
Sr-91	0.6460	Te-134	0.0408	W-187	0.8027
Sr-92	0.3900	Cs-134	2.5804	Tl-208	0.00
Y-91	0.0031	Cs-136	3.1916	Bi-212	0.0144
Y-91m	0.0439	Cs-137	1.00	Bi-214	0.0003
Y-92	0.1334	Cs-138	0.0120	Pb-212	0.4497
Y-93	0.1091	Ba-133	1.3648	Pb-214	0.0020
Zr-95	1.0909	Ba-139	0.0203	Ra-226	0.0320
Zr-97	1.1210	Ba-140	0.5307	Ac-228	0.8261
Nb-95	1.0821	Ba-141	0.0002	Th-228	0.0038
Nb-95m	0.2919	Ba-142	0.00	Np-239	0.3996
Nb-97	0.1164	La-140	2.3237		

3.0.2 GASEOUS RADIATION MONITOR SETPOINT CALCULATIONS

In general, gaseous radiation monitors (EMFs) are calibrated to Xe-133, and for continuous release points, e.g., the two unit vents, are preset at a maximum value based on the 500 mrem/year total body gaseous release rate limit according to the following methodology.

Note: when applied to the individual release points the 500 mrem/year site dose rate value is apportioned 49% to each unit vent and 2% to the Auxiliary Monitor Tank Building.

$$K_{Xe-133} \times \chi/Q \times Q_{Xe-133} < 500 \text{ mrem/yr}$$

Solve for Q_{Xe-133} :

$$Q_{Xe-133} < \frac{500}{K_{Xe-133} \times \chi/Q} \quad \text{Equation 3.4}$$

From Equation 2.6:

$$Q_{Xe-133} = 472 \times C_{Xe-133} \times f \quad \text{Equation 3.5}$$

Substitute Equation 3.5 into Equation 3.4:

$$472 \times C_{Xe-133} \times f < \frac{500}{K_{Xe-133} \times \chi/Q}$$

Solve for C_{Xe-133} :

$$C_{Xe-133} < \frac{500}{472 \times f \times K_{Xe-133} \times \chi/Q}$$

$$SP = (C_{Xe-133} \times CF) + bkg \quad \text{Equation 3.6}$$

where:

K_{Xe-133} = 2.94E+02, the total body dose factor due to gamma emissions for Xe-133, in mrem/year per $\mu\text{Ci}/\text{m}^3$ (See Appendix A).

χ/Q = the highest calculated annual average dispersion parameter for any area at or beyond the site boundary in sec/m^3 . For Catawba this value is 3.510E-5 sec/m^3 . The location is the NNE sector at 0.5 mile.

Catawba Nuclear Station
Offsite Dose Calculation Manual (ODCM)

- Q_{Xe-133} = Xe-133 equivalent release rate limit for the noble gas total body dose pathway, in $\mu\text{Ci}/\text{sec}$.
- 472 = conversion factor, $(\text{cc}/\text{ft}^3)/(\text{sec}/\text{min})$.
- C_{Xe-133} = the maximum allowable Xe-133 equivalent concentration in the gaseous effluent, in $\mu\text{Ci}/\text{cc}$.
- f = the gaseous effluent flow from the tank, building, or vent, in ft^3/min .
- SP = radiation monitor setpoint, in cpm.
- CF = the Xe-133 equivalent monitor correlation factor, in $\text{cpm}/\mu\text{Ci}/\text{cc}$.
- bkg = the radiation monitor background reading, in cpm.

Equation 3.6 provides the methodology to calculate the maximum setpoint for continuous releases such as for the unit vent radiation monitors 1 and 2 EMF 36 and Auxiliary Monitor Tank Building (AMTB) vent radiation monitor EMF 58. The maximum setpoints for these EMFs are:

1 and 2 EMF 36 - Maximum Setpoint

If the other unit's EMF 36 Trip 2 setpoint is reduced, the applicable unit's EMF 36 Trip 2 setpoint may be increased by the value the other unit's setpoint was reduced.

$$C_{Xe-133} < \frac{500}{472 \times 1.60E+05 \times 2.94E+02 \times 3.51E-05} = 6.416E-04 \mu\text{Ci}/\text{ml}$$

$$SP \leq \sum_i (C_i \times CF_i \times 0.49) + bkg$$

$$Trip\ 2 \cong 6.416E-04 \times 2.66E+07 \times 0.49 \cong 8.362E+03 \text{ cpm} + bkg$$

$$Trip\ 1 = Trip\ 2 \times 0.7$$

Where:

1.60E+05 = flow in cfm: 1.34E+05 cfm Unit Vent + 2.6E+04 cfm Containment Purge.

2.66E+07 = EMF 36 Xe-133 Correlation Factor, $\text{cpm}/\mu\text{Ci}/\text{ml}$

0.49 = apportioned 49% to each unit vent.

EMF 58 - Maximum Setpoint

$$C_{Xe-133} < \frac{500}{472 \times 1.10E+04 \times 2.94E+02 \times 3.51E-05} = 9.332E-03 \mu\text{Ci/ml}$$

$$SP \leq \sum_i (C_i \times CF_i \times 0.02) + bkg$$

$$Trip\ 2 \cong 9.332E-03 \times 1.41E+07 \times 0.02 \cong 2.632E+03 \text{ cpm} + bkg$$

$$Trip\ 1 = Trip\ 2 \times 0.7$$

where:

1.10E+04 = AMTB Vent flow in cfm.

1.41E+07 = EMF58 Xe-133 Correlation Factor, cpm/ $\mu\text{Ci/ml}$

0.02 = apportioned 2% to AMTB vent.

However, most gaseous releases at Catawba are batch releases, e.g., Containment Purge (VP), in which the radiation monitor setpoint is calculated based on actual activity expected in the release. For batch releases with a low activity release rate, the expected monitor response is essentially no greater than background and the trip setpoints are based on practical minimum detectable activity to prevent spurious alarms. For batch releases where the effluent can contain activity significantly above background the following setpoint methodology is used:

$$C_{Xe-133} = \sum_i (C_i \times Eq_i)$$

$$Expected\ Cpm = (C_{Xe-133} \times CF_{Xe-133}) + bkg \quad \text{Equation 3.7}$$

"Trip" setpoints are set based on a multiplier factor above the "expected" cpm calculated in Equation 3.7.

where:

C_{Xe-133} = Xe-133 equivalent concentration, in $\mu\text{Ci/ml}$.

Eq_i = Xe-133 equivalence factor for each isotope, excluding tritium, to that of Xe-133 due to different beta energies and abundance. (See Table 3.0-3).

All other parameters were previously defined.

3.0.2.1 CONTAINMENT AIR RELEASE AND ADDITION (VQ) SETPOINTS (EMF 39, EMF 36)

As shown on Figure 2.0-3, EMF 39 (when operable) and EMF 36 (when EMF 39 is inoperable) are the controlling radiation monitors for VQ releases from Containment to the Unit Vent.

EMF 39 setpoints for VQ releases are the lower of the setpoint as calculated below:

Maximum EMF 39 Trip 2 Setpoint

$$Trip2 \leq \frac{(134,000 + 350) \times (8.362E+03)}{350} \leq 3.20E+06 \text{ cpm} + \text{bkg}$$

A Trip 2 setpoint of 3.00E+06 cpm is used for conservatism.

$$Trip1 = Trip2 \times 0.7 = 2.10E+06 \text{ cpm}$$

where:

134,000 = Unit Vent dilution flow available (cfm).

350 = Flow from VQ (cfm).

8.362E+03 = Maximum Unit Vent radiation monitor setpoint (cpm).

bkg = EMF 39 background.

Both EMF 39 and Unit Vent radiation monitor (EMF 36) correlation factors are 2.66E+07 cpm/ μ Ci/cc.

EMF 39 Trip 2 Setpoint Based on Sample Concentration

For EMF 39 if the containment Xe-133 equivalent is $\leq 2.0E-05$ μ Ci/ml, then 2.0E-05 μ Ci/ml may be used in the Trip 1 and 2 setpoint calculations. This is an indication of low activity in containment and normal EMF fluctuation may cause Trip 2 alarms and release termination.

When Xe-133 equivalent concentration $\leq 2.0E-05$ μ Ci/ml:

Trip 2 setpoint = $(C_{Xe-133} \times CF_{Xe-133} \times 2.0) + \text{bkg}$ **or** $3 \times \text{bkg}$, whichever is higher.

Catawba Nuclear Station
Offsite Dose Calculation Manual (ODCM)

When $Xe-133$ equivalent concentration $> 2.0E-05 \mu Ci/ml$:

$$\text{Trip 2 setpoint} = (C_{Xe-133} \times CF_{Xe-133} \times 2.0) + \text{bkg}$$

$$\text{Trip 1} = \text{Trip 2} \times 0.7$$

where:

C_{Xe-133} = Xe-133 equivalent concentration (containment), in $\mu Ci/ml$.

CF_{Xe-133} = EMF 39 Xe-133 correlation factor, $2.66E+07 \text{ cpm}/\mu Ci/ml$.

2.0 = Multiplier to increase alarm value to 2 times process activity.

bkg = EMF 39 background.

$$\text{Expected EMF 39 cpm} = (C_{Xe-133} \times CF) + \text{bkg}$$

If EMF 39 is inoperable for a VQ release then the unit vent radiation monitor, EMF 36, is the controlling EMF for the release.

When EMF 36 must be used as the controlling monitor for VQ releases the EMF 36 setpoints are calculated as described below. If the EMF 36 reading significantly exceeds the expected cpm then the release is manually or automatically terminated.

The EMF 36 expected cpm from VQ activity is calculated as follows:

$$\text{Expected EMF 36 cpm} = \frac{350 \text{ cfm} \times C_{Xe-133} \times CF_{Xe-133}}{F_{UV}} + \text{bkg}$$

where:

C_{Xe-133} = Xe-133 equivalent concentration, in $\mu Ci/ml$.

CF_{Xe-133} = EMF 36 Xe-133 correlation factor, $2.66E+07 \text{ cpm}/\mu Ci/ml$.

bkg = EMF 36 background.

350 cfm = Maximum VQ flow rate.

F_{UV} = Current Unit Vent flow rate.

If the EMF 36 expected cpm is $< 7.50E+01 \text{ cpm}$, the normal (typical) EMF 36 Trip 2 setpoints of $1.50E+02 \text{ cpm} + \text{existing EMF 36 reading}$ are used. This is a conservative

setpoint to provide early indication of change in radiological conditions without inducing spurious alarms.

If the EMF 36 expected cpm is $\geq 7.50E+01$ cpm, the EMF 36 setpoints are the lower setpoint as calculated below.

Maximum EMF 36 Trip 2 Setpoint

8.362E+03 cpm based on Section 3.0.2 above. If the other unit's EMF 36 Trip 2 setpoint is reduced, the applicable unit's EMF 36 Trip 2 setpoint may be increased by the value the other unit's setpoint was reduced.

EMF 36 Trip 2 Setpoint Based on Sample Concentration

For EMF 36 if the containment Xe-133 equivalent is $\leq 1.07E-03$ $\mu\text{Ci/ml}$, then 1.07E-03 $\mu\text{Ci/ml}$ may be used in the Trip 1 and 2 setpoint calculations. This is an indication of low activity in unit vent due to dilution and normal EMF fluctuation may cause Trip 2 alarms and release termination.

When $Xe-133$ equivalent concentration $\leq 1.07E-03$ $\mu\text{Ci/ml}$:

$$\text{EMF 36 Trip 2 cpm} = \frac{350 \text{ cfm} \times C_{Xe-133} \times CF_{Xe-133} \times 2.0}{F_{UV}} + \text{bkg or } 3 \times \text{bkg},$$

whichever is higher.

When $Xe-133$ equivalent concentration $> 1.07E-03$ $\mu\text{Ci/ml}$:

$$\text{EMF 36 Trip 2 cpm} = \frac{350 \text{ cfm} \times C_{Xe-133} \times CF_{Xe-133} \times 2.0}{F_{UV}} + \text{bkg}$$

$$\text{Trip 1} = \text{Trip 2} \times 0.7$$

where:

350 cfm = VQ flow rate.

C_{Xe-133} = Xe-133 equivalent concentration, in $\mu\text{Ci/ml}$.

CF_{Xe-133} = EMF 36 Xe-133 correlation factor, 2.66E+07 cpm/ $\mu\text{Ci/ml}$.

2.0 = Multiplier to increase alarm value to 2 times process activity.

bkg = EMF 36 background.

3.0.2.2 CONTAINMENT PURGE (VP) AND INCORE PURGE (IP) SETPOINTS (EMF 39, EMF 36)

As shown on Figure 2.0-3 EMF 39 (when operable) and EMF 36 (when EMF 39 is inoperable) are the controlling radiation monitors for VP and IP releases from Containment to the Unit Vent.

EMF 39 setpoints for VP and IP releases are the lower of the setpoint as calculated below:

Maximum EMF 39 Trip 2 Setpoint

$$Trip2 \leq \frac{(134,000 + 26,000) \times (8.362E + 03)}{26,000} \leq 5.14E + 04 \text{ cpm} + \text{bkg}$$

A Trip 2 setpoint of 5.00E+04 cpm is used for conservatism.

$$Trip1 = Trip2 \times 0.7 = 3.50E + 04 \text{ cpm}$$

where:

134,000 = Unit Vent dilution flow available (cfm).

26,000 = Flow from VP (cfm).

8.362E+03 = Maximum Unit Vent radiation monitor setpoint (cpm).

bkg = EMF 39 background.

Both EMF 39 and Unit Vent radiation monitor (EMF 36) correlation factors are 2.66E+07 cpm/ μ Ci/cc.

EMF 39 Trip 2 Setpoint Based on Sample Concentration

For EMF 39 if the containment Xe-133 equivalent is $\leq 2.0E-05 \mu\text{Ci/ml}$, then 2.0E-05 $\mu\text{Ci/ml}$ may be used in the Trip 1 and 2 setpoint calculations. This is an indication of low activity in containment and normal EMF fluctuation may cause Trip 2 alarms and release termination.

When Xe-133 equivalent concentration $\leq 2.0E - 05 \mu\text{Ci/ml}$:

$$Trip2 \text{ setpoint} = (C_{Xe-133} \times CF_{Xe-133} \times 2.0) + \text{bkg} \text{ or } 3 \times \text{bkg}, \text{ whichever is higher.}$$

When Xe-133 equivalent concentration $> 2.0E - 05 \mu\text{Ci/ml}$:

Catawba Nuclear Station
Offsite Dose Calculation Manual (ODCM)

$$\text{Trip 2 setpoint} = (C_{\text{Xe-133}} \times CF_{\text{Xe-133}} \times 2.0) + \text{bkg}$$

$$\text{Trip 1} = \text{Trip 2} \times 0.7$$

where:

$C_{\text{Xe-133}}$ = Xe-133 equivalent concentration, in $\mu\text{Ci/ml}$.

$CF_{\text{Xe-133}}$ = EMF 39 Xe-133 correlation factor, $2.66\text{E}+07$ cpm/ $\mu\text{Ci/ml}$.

2.0 = Multiplier to increase alarm value to 2 times process activity.

bkg = EMF 39 background.

$$\text{Expected cpm} = (C_{\text{Xe-133}} \times CF) + \text{bkg}$$

If EMF 39 is inoperable for a VP release then the unit vent radiation monitor, EMF 36, is the controlling EMF for the release.

When EMF 36 must be used as the controlling monitor for VP releases the EMF 36 setpoints are calculated as described below. If the EMF 36 reading significantly exceeds the expected cpm then the release is manually or automatically terminated.

The EMF 36 expected cpm from VP activity is calculated as follows:

$$\text{Expected cpm} = \frac{26,000 \text{ cfm} \times C_{\text{Xe-133}} \times CF_{\text{Xe-133}}}{F_{\text{UV}}} + \text{bkg}$$

where:

$C_{\text{Xe-133}}$ = Xe-133 equivalent concentration, in $\mu\text{Ci/ml}$.

$CF_{\text{Xe-133}}$ = EMF 36 Xe-133 correlation factor, $2.66\text{E}+07$ cpm/ $\mu\text{Ci/ml}$.

bkg = EMF 36 background.

26,000 cfm = Maximum VP flow rate.

F_{UV} = Current Unit Vent flow rate.

If the EMF 36 expected cpm is $< 7.50\text{E}+01$ cpm, the normal (typical) EMF 36 Trip 2 setpoints of $1.50\text{E}+02$ cpm + existing EMF 36 reading are used. This is a conservative setpoint to provide early indication of change in radiological conditions without inducing spurious alarms.

If the EMF 36 expected cpm is $\geq 7.50E+01$ cpm, the EMF 36 setpoints are the lower setpoint as calculated below.

Maximum EMF 36 Trip 2 Setpoint

8.362E+03 cpm based on Section 3.0.2 above. If other unit's EMF 36 Trip 2 setpoint is reduced, applicable unit's EMF 36 Trip 2 setpoint may be increased by the value the other unit's setpoint was reduced.

EMF 36 Trip 2 Setpoint Based on Sample Concentration

For EMF 36 if the containment Xe-133 equivalent is $\leq 1.45E-05$ $\mu\text{Ci/ml}$, then $1.45E-05$ $\mu\text{Ci/ml}$ may be used in the Trip 1 and 2 setpoint calculations. This is an indication of low activity in unit vent due to dilution and normal EMF fluctuation may cause Trip 2 alarms and release termination.

When Xe-133 equivalent concentration $\leq 1.45E-05$ $\mu\text{Ci/ml}$:

$$\text{EMF 36 Trip 2 cpm} = \frac{26,000 \text{ cfm} \times C_{\text{Xe-133}} \times CF_{\text{Xe-133}} \times 2.0}{F_{\text{UV}}} + \text{bkg} \text{ or } 3 \times \text{bkg},$$

whichever is higher.

When Xe-133 equivalent concentration $> 1.45E-05$ $\mu\text{Ci/ml}$:

$$\text{EMF 36 Trip 2 cpm} = \frac{26,000 \text{ cfm} \times C_{\text{Xe-133}} \times CF_{\text{Xe-133}} \times 2.0}{F_{\text{UV}}} + \text{bkg}$$

$$\text{Trip 1} = \text{Trip 2} \times 0.7$$

where:

$C_{\text{Xe-133}}$ = Xe-133 equivalent concentration, in $\mu\text{Ci/ml}$.

$CF_{\text{Xe-133}}$ = EMF 36 Xe-133 correlation factor, $2.66E+07$ cpm/ $\mu\text{Ci/ml}$.

2.0 = Multiplier to increase alarm value to 2 times process activity.

bkg = EMF 36 background.

3.0.2.3 WASTE GAS DECAY TANK (WGDT) SETPOINTS (EMF 50, EMF 36)

As shown on Figure 2.0-3, EMF 50 (when operable) and EMF 36 (when EMF 50 is not operable) are the controlling radiation monitors for WGDT releases to the Unit Vent. EMF 50 setpoints are based on actual tank activity, and are the lower of the setpoints as calculated below:

Maximum EMF 50 Trip 2 Setpoint

$$Trip2 \leq \frac{(134,000 + 50) \times (8.362E + 03) \times (1.39E + 06)}{50 \times (2.66E + 07)} \leq 1.17E + 06 \text{ cpm} + \text{bkg}$$

A Trip 2 setpoint of 1.10E+06 cpm is used for conservatism and as maximum EMF 50 setpoint based on EMF scale.

$$Trip1 = Trip2 \times 0.7 = 7.70E + 05 \text{ cpm}$$

where:

134,000 = Unit Vent dilution flow available (cfm).

50 = Flow from WG (cfm).

8.362E+03 = Maximum Unit Vent radiation monitor setpoint (cpm).

1.39E+06 = EMF 50 correlation factor (cpm/ μ Ci/cc) corrected to 6 psig. EMF 50 Xe-133 correlation factor of 1.15E+06 cpm/ μ Ci/cc (CNC-1346.05-00-0001 Rev. 0) times 121% pressure correction (CNM-1346.05-0115.001 Rev. 0).

2.66E+07 = Unit Vent radiation monitor (EMF 36) correlation factor (cpm/ μ Ci/cc).

bkg = EMF 50 background.

EMF 50 Trip 2 Setpoint Based on Sample Concentration

When $Xe-133$ equivalent concentration $\leq 1.00E - 04 \mu$ Ci/ml:

Trip 2 setpoint = 10% of Maximum EMF 50 Trip 2 Setpoint = 1.10E +05 cpm

Trip 1 setpoint = 1% of Maximum EMF 50 Trip 2 Setpoint = 1.10E +04 cpm

When $Xe-133$ equivalent concentration $> 1.00E - 04 \mu$ Ci/ml:

$$Trip2 \text{ setpoint} = (C_{Xe-133} \times CF_{Xe-133} \times 2.0) + \text{bkg}$$

Catawba Nuclear Station
Offsite Dose Calculation Manual (ODCM)

$$Trip1 = Trip2 \times 0.7$$

where:

Maximum EMF 50 Trip 2 Setpoint = 1.10E +06 cpm

C_{Xe-133} = Xe-133 equivalent concentration, in $\mu\text{Ci/ml}$.

CF_{Xe-133} = EMF 50 Xe-133 pressure corrected correlation factor, 1.39E+06 cpm/ $\mu\text{Ci/ml}$.

2.0 = Multiplier to increase alarm value to 2 times process activity.

bkg = EMF 50 background.

For EMF 50 if the WG Tank Xe-133 equivalent concentration is $\leq 1.00E -04 \mu\text{Ci/ml}$, this is an indication of a low activity tank. Normal EMF fluctuation may cause Trip 2 alarms and release termination. Setpoint determination may be made using 10% of the Maximum Trip 2 Setpoint for Trip 2 and 1% of the Maximum EMF 50 Trip 2 Setpoint for Trip 1.

The EMF 50 expected cpm is calculated as follows:

$$\text{Expected cpm} = (C_{Xe-133} \times CF_{Xe-133}) + bkg$$

where:

C_{Xe-133} = Xe-133 equivalent concentration (WG tank), in $\mu\text{Ci/ml}$.

CF_{Xe-133} = EMF 50 Xe-133 pressure corrected correlation factor, 1.39E+06 cpm/ $\mu\text{Ci/ml}$.

bkg = EMF 50 background.

When EMF 36 must be used as the controlling monitor for WG releases the EMF 36 setpoints are calculated as described below. If the EMF 36 reading significantly exceeds the expected cpm then the release is manually or automatically terminated.

The EMF 36 expected cpm from WG activity is calculated as follows:

$$\text{Expected cpm} = \frac{50 \text{ cfm} \times C_{Xe-133} \times CF_{Xe-133}}{F_{UV}} + bkg$$

where:

C_{Xe-133} = Xe-133 equivalent concentration, in $\mu\text{Ci/ml}$.

CF_{Xe-133} = EMF 36 Xe-133 correlation factor, $2.66E+07$ cpm/ μ Ci/ml.

bkg = EMF 36 background.

50 cfm = Maximum WG flow rate.

F_{UV} = Current Unit Vent flow rate (cfm).

If the EMF 36 expected cpm is $< 7.50E+01$ cpm, the normal (typical) EMF 36 Trip 2 setpoints of $1.50E+02$ cpm + existing EMF 36 reading are used. This is a conservative setpoint to provide early indication of change in radiological conditions without inducing spurious alarms.

If the EMF 36 expected cpm is $\geq 7.50E+01$ cpm, the EMF 36 setpoints are the lower setpoint as calculated below.

Maximum EMF 36 Trip 2 Setpoint

$8.362E+03$ cpm based on Section 3.0.2 above. If other unit's EMF 36 Trip 2 setpoint is reduced, applicable unit's EMF 36 Trip 2 setpoint may be increased by the value the other unit's setpoint was reduced.

EMF 36 Trip 2 Setpoint Based on Sample Concentration

For EMF 36 if the WG Tank Xe-133 equivalent is $\leq 7.50E-03$ μ Ci/ml, then $7.50E-03$ μ Ci/ml may be used in the Trip 1 and 2 setpoint calculations. This is an indication of low activity in unit vent due to dilution and normal EMF fluctuation may cause Trip 2 alarms and release termination.

When $Xe-133$ equivalent concentration $\leq 7.50E-03$ μ Ci/ml:

$$\text{EMF 36 Trip 2 cpm} = \frac{50 \text{ cfm} \times C_{Xe-133} \times CF_{Xe-133} \times 2.0}{F_{UV}} + \text{bkg} \text{ or } 3 \times \text{bkg},$$

whichever is higher.

When $Xe-133$ equivalent concentration $> 7.50E-03$ μ Ci/ml:

$$\text{EMF 36 Trip 2 cpm} = \frac{50 \text{ cfm} \times C_{Xe-133} \times CF_{Xe-133} \times 2.0}{F_{UV}} + \text{bkg}$$

$$\text{Trip 1} = \text{Trip 2} \times 0.7$$

where:

C_{Xe-133} = Xe-133 equivalent concentration, in μ Ci/ml.

Catawba Nuclear Station Units 1 & 2
Period 1/1/2016 - 12/31/2016

Catawba Nuclear Station
Offsite Dose Calculation Manual (ODCM)

CF_{Xe-133} = EMF 36 Xe-133 correlation factor, $2.66E+07$ cpm/ μ Ci/ml.

2.0 = Multiplier to increase alarm value to 2 times process activity.

bkg = EMF 36 background.

Catawba Nuclear Station Units 1 & 2
Period 1/1/2016 - 12/31/2016

Catawba Nuclear Station
Offsite Dose Calculation Manual (ODCM)

Table 3.0-3

Xe-133 Equivalents

Isotope	EMF 36/39 Equivalence Factor	EMF 50 Equivalence Factor
Kr-83m	0.00	0.00
Kr-85m	2.14	10.87
Kr-85	2.56	10.87
Kr-87	2.93	10.87
Kr-88	2.74	6.26
Kr-89	2.93	10.87
Kr-90	2.90	10.87
Xe-131m	1.65	0.00
Xe-133m	1.98	0.00
Xe-133	1.00	1.00
Xe-135m	0.56	6.38
Xe-135	2.63	10.87
Xe-137	2.93	10.87
Xe-138	2.93	10.87
Ar-41	2.93	10.87

4.0 EFFLUENT DOSE MODELS

The effluent dose models used to show compliance with 10CFR50, Appendix I ALARA design objectives, 40CFR190 fuel cycle dose limits, and the dose values given in station SLCs are based on the methodology given in NUREG-0133 and Regulatory Guide 1.109. Dose contributions to the maximum individual shall be calculated at least every 31 days, quarterly, and annually using the RETDAS computer code which implements the ODCM methodology. RETDAS, Radioactive Effluent Tracking and Dose Assessment Software, is a database application designed by Canberra Industries, Inc. to automate many of the tasks required in the administration of effluent releases at Catawba. RETDAS performs normal operation effluent dose assessment using NUREG-0133 and Regulatory Guide 1.109 methodology.

Station long-term historical and dose projection calculations are performed periodically to determine the station's status with respect to meeting annual ALARA goals specified in the Catawba SLCs. Such calculations are used to verify that adequate margin remains during a report period to allow normal station and radwaste system operation, including anticipated operational occurrences, for the remainder of the report period without exceeding applicable goals. Station 31-day dose projections that are used to assess the need to reduce effluent releases with the Gaseous Waste (WG) or Liquid Waste (WL) systems as required in the Catawba SLCs are estimated by the previous month's calculated dose results.

Fuel cycle dose calculations shall be performed annually or as required by special reports. Dose contributions shall be calculated using the RETDAS computer program.

4.0.1 LIQUID EFFLUENT DOSE MODEL FOR THE MAXIMUM EXPOSED INDIVIDUAL

Of the possible exposure pathways in the aquatic environment, only three contribute significantly to the total dose; these pathways are ingestion of potable water and aquatic foods, and direct exposure from radioactivity deposited on the shoreline. The dose contribution from these pathways for measured quantities of radioactive materials identified in liquid effluents released to unrestricted areas shall be calculated for the maximum exposed individual in each age group using the methodology provided in this section.

There are two liquid discharge points to the environment at Catawba; (1) the Low Pressure Service Water System (RL) and Nuclear Service Water System (RN) discharge point to Lake Wylie, and (2) the Conventional Waste Water Treatment System (WC) discharge point to Lake Wylie (See Figure 2.0-1). Liquid dose calculations for the maximum exposed individual are performed and documented in the Annual Radioactive Effluent Release Report for both locations using the applicable activity release and

Catawba Nuclear Station Units 1 & 2
Period 1/1/2016 - 12/31/2016

Catawba Nuclear Station
Offsite Dose Calculation Manual (ODCM)

dilution data for each liquid effluent release point. The primary liquid effluent discharge point for Catawba is through RL/RN to Lake Wylie. In general, only low activity tritium releases (<1% station total) occur through the WC discharge point to Lake Wylie. Dose calculations are performed for each of the two liquid discharge points for dose reporting purposes. The highest calculated dose from the two dose calculations is used to define the maximum individual dose from liquid releases at Catawba.

Liquid Dose Calculations

The following equation is used for calculating liquid dose to the maximum exposed individual from each of the two liquid effluent release points:

$$Dose_{oa} = \sum_p \sum_i (A_{oapi} \times C_i) \times \Delta t \times F_n \times \frac{1}{D_w}$$

$$F_n = \frac{f}{f + F} \times \sigma$$

Formula: adapted from NUREG-0133, pages 15-17.	
Where:	
Dose _{oa}	The cumulative dose commitment for organ o and age group a, from the liquid effluent for the total time period, Δt. (mrem)
A _{oapi}	Dose commitment factor for organ o, age group a, pathway p, and nuclide i (mrem/hr per μCi/ml). (See Appendices C through F for age group and pathway specific dose commitment factors).
C _i	The average concentration of nuclide i, in undiluted liquid effluent during the time period, Δt. (μCi/ml)
Δt	The length of time over which C _i and F _n are averaged for all liquid releases. (hr)
F _n	The near field average dilution factor for C _i during the period of interest, Δt. Includes the recirculation factor. (dimensionless)
f	Average liquid radwaste flow during the period of interest, Δt. (gpm)
F	Average dilution flow during the period of interest, Δt. (gpm)
	RL/RN primary discharge location: RL/RN average dilution flow
	WC discharge location: 10% of RL/RN average dilution flow
σ	Recirculation factor.* (dimensionless)
D _w	Dilution factor from the near field area to the potable water intake; = 43.4 for Catawba. This factor applies to the potable water pathway only. The factor is calculated by (Average Wylie Dam Flow (4453 cfs) + Average Radwaste Flow (105 cfs)) divided by the (Average Radwaste Flow (105 cfs)). This value can be modified to account for deviations from average in a particular year, or for added conservatism such as accounting for minor radioactivity contributions from McGuire Nuclear Station. A D _w value of 10 is currently being used.

* The recirculation factor accounts for the fraction of discharged water reused by the station. Liquid effluent discharge cannot be recirculated back into the Catawba station. Therefore, the recirculation factor is 1.0 at Catawba.

Derivation of Liquid Dose Commitment Factors (A_{oapi})

Potable Water

$$A_{oapi} = 1.14 \times 10^5 \times U_{aw} \times D_{aoi} \times e^{-\lambda_i t_p}$$

Formula: from NUREG-0133, page 16, and Regulatory Guide 1.109, page 1.109-12.	
Where:	
A_{oapi}	Dose commitment factor for organ o, age group a, pathway p, and nuclide i, (mrem/hr per $\mu\text{Ci/ml}$). (See Appendices C through F for age group and pathway specific dose commitment factors).
1.14×10^5	Units conversion factor ($\text{pCi-yr-ml}/(\mu\text{Ci-hr-l})$).
U_{aw}	Water consumption rate in liters per year for age group a. From Table E-5, Regulatory Guide 1.109. Adult – 730 Teen – 510 Child – 510 Infant – 330
D_{aoi}	Dose factor for age group a, organ o, nuclide i, in mrem/pCi. From tables E-11 through E-14 of Regulatory Guide 1.109.
λ_i	Decay constant for nuclide i, in sec^{-1} .
t_p	Environmental transit time from release to receptor. Default = $4.32\text{E}+04$ sec (12 hours). From Regulatory Guide 1.109, Table E-15.

Aquatic Foods

$$A_{oapi} = 1.14 \times 10^5 \times U_{af} \times BF_i \times D_{aoi} \times e^{-\lambda_i t_p}$$

**Formula: from NUREG-0133, page 16, and Regulatory Guide 1.109, page 1.109-12.
Where:**

A_{oapi}	Dose commitment factor for organ o, age group a, pathway p, and nuclide i, (mrem/hr per $\mu\text{Ci/ml}$). (See Appendices C through F for age group and pathway specific dose commitment factors).
1.14×10^5	Units conversion factor ($\text{pCi-yr-ml}/(\mu\text{Ci-hr-l})$).
U_{af}	Fish consumption rate for age group a (kg/yr). From Table E-5, Regulatory Guide 1.109. Adult – 21 Teen – 16 Child – 6.9 Infant – 0
BF_i	Bioaccumulation factor for nuclide i, in fish, in units of pCi/kg per pCi/liter . From Table A-1 of Regulatory Guide 1.109.
D_{aoi}	Dose factor for age group a, organ o, nuclide i, in mrem/pCi . From tables E-11 through E-14 of Regulatory Guide 1.109.
λ_i	Decay constant for nuclide i, in sec^{-1} .
t_p	Environmental transit time from release to receptor. Default = $8.64\text{E}+04$ sec (1 day). From Regulatory Guide 1.109, Table E-15.

Shoreline Sediment

$$A_{oapi} = 1.14 \times 10^5 \times 100 \times DFG_{oi} \times w \times U_{as} \times T_i^{\frac{1}{2}} \times e^{-\lambda_i t_p} \times (1 - e^{-\lambda_i t_b})$$

Formula: adapted from Regulatory Guide 1.109, page 1.109-14.	
Where:	
A_{oapi}	Dose commitment factor for organ o, age group a, pathway p, and nuclide i, (mrem/hr per $\mu\text{Ci/ml}$). (See Appendices C through F for age group and pathway specific dose commitment factors).
1.14×10^5	Units conversion factor ($\text{pCi-yr-ml}/(\mu\text{Ci-hr-l})$).
100	Proportionality constant used in the sediment radioactivity model, ($\text{liters}/(\text{m}^2\text{-day})$).
DFG_{oi}	Ground plane dose conversion factor for organ o, nuclide i ($\text{mrem/hr per pCi}/\text{m}^2$), from Table E-6 of Regulatory Guide 1.109.
w	Shoreline width factor. For Catawba = 0.3, from Table A-2, Regulatory Guide 1.109.
U_{as}	Shoreline exposure rate for age group a (hr/yr), From Table E-5, Regulatory Guide 1.109. Adult – 12 Teen – 67 Child – 14 Infant – 0
$T_i^{1/2}$	Nuclide half life for nuclide i, in days.
λ_i	Nuclide decay constant for nuclide i.
t_p	Average transit time to point of exposure (0 hours).
t_b	Sediment exposure time (15 years). Page 1.109-14.

4.0.2 GASEOUS EFFLUENT DOSE MODEL FOR THE MAXIMUM EXPOSED INDIVIDUAL

The dose contributions from measured quantities of radioactive materials identified in gaseous effluent released to unrestricted areas shall be calculated for the maximum gamma and beta air dose from noble gases, and for the maximum exposed individual from radioiodines, particulates, and others using the following equations:

Gaseous Dose Calculations

Noble Gas Dose Calculations

Gamma Air Dose

$$Dose_{\gamma} = 3.17 \times 10^{-8} \times \chi / Q \times \sum_i (M_i \times Q_i)$$

Formula: adapted from NUREG-0133, page 28.

Where:

$Dose_{\gamma}$	Gamma air dose for the time period of interest (mrad).
3.17×10^{-8}	Inverse number of seconds in year (year/seconds).
M_i	Gamma air dose factor due to gamma emissions for nuclide i (mrad/yr per $\mu\text{Ci}/\text{m}^3$). (See Appendix A).
χ/Q	The highest calculated annual average relative concentration for any area at or beyond the site boundary (sec/m^3). (See Table 6.0-8).
Q_i	Activity for nuclide i released during the time period of interest (μCi).

Beta Air Dose

$$Dose_{\beta} = 3.17 \times 10^{-8} \times \chi / Q \times \sum_i (N_i \times Q_i)$$

Formula: adapted from NUREG-0133, page 28.

Where:

$Dose_{\beta}$	Beta air dose for the time period of interest (mrad).
3.17×10^{-8}	Inverse number of seconds in year (year/seconds).
N_i	Beta air dose factor due to beta emissions for nuclide i (mrad/yr per $\mu\text{Ci}/\text{m}^3$). (See Appendix A).
χ/Q	The highest calculated annual average relative concentration for any area at or beyond the site boundary (sec/m^3). (See Table 6.0-8).
Q_i	Activity for nuclide i released during the time period of interest (μCi).

Catawba Nuclear Station Units 1 & 2
Period 1/1/2016 - 12/31/2016

Catawba Nuclear Station
Offsite Dose Calculation Manual (ODCM)

Iodine, Particulates, and H-3 Dose Organ Dose Calculation

$$Dose_{oa} = 3.17 \times 10^{-8} \times W \times \sum_p \sum_i (R_{oapi} \times Q_i)$$

Formula: adapted from NUREG-0133, pages 29 & 30.		
Where:		
Dose _{oa}	The cumulative dose commitment to the total body or any organ o, for an individual of age group a (mrem).	
3.17×10 ⁻⁸	Inverse number of seconds in year (year/seconds).	
R _{oapi}	Dose commitment factor for organ o, age group a, pathway p, and nuclide i. The units are based on whether a dispersion or deposition factor is used. When a χ/Q is used the units are mrem/yr per μCi/m ³ . When a D/Q is used the units are (m ² · mrem/yr) per μCi/sec. (See Appendices G through J for age group and pathway specific dose commitment factors).	
W*	Dispersion (χ/Q) or deposition factor (D/Q). The factor used is based upon the pathway. Note: χ/Q is always used for tritium and C-14.	
	Pathway	Factor Used
	Ground Plane Deposition	D/Q (m ⁻²)
	Inhalation	χ/Q (sec/m ³)
	Vegetation	D/Q (m ⁻²)
	Grass/Cow/Milk	D/Q (m ⁻²)
	Grass/Goat/Milk	D/Q (m ⁻²)
	Grass/Cow/Meat	D/Q (m ⁻²)
Q _i **	Activity for nuclide i, released during the time period of interest (μCi).	

* Maximum individual organ dose is determined by calculating the organ dose at each of the χ/Q and D/Q locations shown in Table 6.0-8 and Table 6.0-9 (144 locations), and then choosing the maximum dose. Dose is calculated only for pathways (e.g., garden, milk animal, etc.) that actually exist at each location as determined by the land use census. As discussed in Catawba UFSAR Section 2.1.1.3, the boundary for establishing gaseous effluent release limits is the exclusion area boundary (EAB). The EAB is defined as a 2500-ft. (~0.5 mile) radius from the station center.

** C-14 airborne activity released to the environment is estimated based on actual power generation as discussed in Regulatory Guide 1.21, Revision 2. A value of 9.4 Ci/GWe-yr is used along with actual power generation to estimate C-14 activity released to the environment via gaseous effluents from Catawba. 9.4 Ci/GWe-yr is based on information from "Estimation of Carbon-14 in Nuclear Power Plant Gaseous Effluents", EPRI, Palo Alto, CA: 2010. 1021106.

Derivations of Iodine, Particulate, and H-3 Dose Commitment Factors (R_{oapi})

Ground Plane Deposition Pathway

$$R_{oapi} = K'K''(SF)DFG_{oi} \left[\frac{(1 - e^{-\lambda_i t})}{\lambda_i} \right]$$

Formula: from NUREG-0133, page 32.

Where:

R_{oapi}	Dose commitment factor for organ o, age group a, nuclide i, for ground plane deposition pathway ($m^2 \cdot mrem/yr$ per $\mu Ci/sec$). (See Appendices G through J for age group and pathway specific dose commitment factors).
K'	Units conversion factor $pCi/\mu Ci$ (10^6).
K''	Units conversion factor 8760 hr/year.
SF	Shielding factor (dimensionless) (0.7, from Regulatory Guide 1.109).
DFG_{oi}	Ground plane dose conversion factor for organ o, nuclide i ($mrem/hr$ per pCi/m^2), from Table E-6 of Regulatory Guide 1.109.
λ_i	Nuclide decay constant for nuclide i (sec^{-1}).
t	Exposure time, 4.73×10^8 seconds (15 years).

Inhalation Pathway

$$R_{oapi} = K'(BR_a)(DFA_{oi})_a$$

Formula: from NUREG-0133, page 31.

Where:

R_{oapi}	Dose commitment factor for organ o, age group a, nuclide i, for inhalation pathway ($mrem/yr$ per $\mu Ci/m^3$). (See Appendices G through J for age group and pathway specific dose commitment factors).
K'	Units conversion factor $pCi/\mu Ci$ (10^6).
BR_a	Breathing rate for age group (m^3/yr), from Regulatory Guide 1.109: Adult – 8000 Teen – 8000 Child – 3700 Infant – 1400
$(DFA_{oi})_a$	Organ inhalation factor dose conversion factor for organ o, nuclide i, age group a ($mrem/pCi$), from Tables E-7 through E-10 of Regulatory Guide 1.109.

Vegetation

$$R_{oapi} = K' \left[\frac{(r)}{Y_v(\lambda_i + \lambda_w)} \right] \times (DFL_{oi})_a \times \left[U_a^L f_L e^{-\lambda_i t_L} + U_a^S f_g e^{-\lambda_i t_h} \right]$$

Formula: from NUREG-0133, page 35. Where:	
R_{oapi}	Dose commitment factor for organ o, age group a, nuclide i, for vegetation pathway ($m^2 \cdot mrem/yr$ per $\mu Ci/sec$). (See Appendices G through J for age group and pathway specific dose commitment factors).
K'	Units conversion factor $pCi/\mu Ci$ (10^6).
r	Fraction of deposited activity retained on vegetation, from Regulatory Guide 1.109. 1.0 for radioiodine. 0.2 for particulates.
Y_v	Vegetation areal density (kg/m^2) (2.0, from Regulatory Guide 1.109).
λ_i	Nuclide decay constant for nuclide i (sec^{-1}).
λ_w	Decay constant for removal of activity on leaf and plant surfaces by weathering ($5.73 \times 10^{-7} sec^{-1}$, from NUREG-0133).
$(DFL_{oi})_a$	Ingestion dose conversion factor for nuclide i, organ o, and age group a, from Tables E-11 through E-14 of Reg. Guide 1.109 ($mrem/pCi$).
U_a^L	Consumption rate of fresh leafy vegetation for age group a (kg/yr) (from Regulatory Guide 1.109). Adult – 64 Teen – 42 Child – 26 Infant – 0
f_L	Fraction of annual intake of fresh leafy vegetation grown locally (1.0, from NUREG-0133).
t_L	Average time between harvest of leafy vegetation and consumption (8.6×10^4 seconds, (1 day), from Regulatory Guide 1.109).
U_a^S	Consumption rate of stored vegetation for age group a (kg/yr) (from Regulatory Guide 1.109). Adult – 520 Teen – 630 Child – 520 Infant – 0
f_g	Fraction of annual intake of stored vegetation (0.76, from Regulatory Guide 1.109).
t_h	Average time between harvest of stored vegetation and consumption (5.18×10^6 seconds, (60 days), from Regulatory Guide 1.109).

Vegetation – Tritium

$$R_{oapi} = K' K''' \left[U_a^L f_L + U_a^S f_g \right] (DFL_{oi})_a \left[0.75(0.5 / H) \right]$$

Formula: from NUREG-0133, page 36.	
Where:	
R_{oapi}	Dose commitment factor for organ o, age group a, for vegetation pathway and tritium (mrem/yr per $\mu\text{Ci}/\text{m}^3$). (See Appendices G through J for age group and pathway specific dose commitment factors).
K'	Units conversion factor pCi/ μCi (10^6).
K'''	Units conversion factor gm/kg (10^3).
U_a^L	Consumption rate of fresh leafy vegetation for age group a (kg/yr) (from Regulatory Guide 1.109). Adult – 64 Teen – 42 Child – 26 Infant – 0
f_L	Fraction of annual intake of fresh leafy vegetation grown locally (1.0, from NUREG-0133).
U_a^S	Consumption rate of stored vegetation for age group a (kg/yr) (from Regulatory Guide 1.109). Adult – 520 Teen – 630 Child – 520 Infant – 0
f_g	Fraction of annual intake of stored vegetation (0.76, from Regulatory Guide 1.109).
$(DFL_{oi})_a$	Ingestion dose conversion factor for nuclide i, organ o, and age group a, from Tables E-11 through E-14 of Regulatory Guide 1.109 (mrem/pCi).
0.75	Fraction of total feed that is water. (From NUREG-0133).
0.5	Ratio of specific activity of feed grass water to atmospheric water. (From NUREG-0133).
H	Absolute humidity of the atmosphere ($8 \text{ gm}/\text{m}^3$, from Regulatory Guide 1.109).

Catawba Nuclear Station Units 1 & 2
Period 1/1/2016 - 12/31/2016

Catawba Nuclear Station
Offsite Dose Calculation Manual (ODCM)

Vegetation – Carbon-14

$$R_{oapi} = K'K''' \left[U_a^L f_L + U_a^S f_g \right] (DFL_{oi})_a [0.11/0.16] (p) (f_I)$$

Formula: from NUREG-0133, page 36 and Regulatory Guide 1.109, page 26.

Where:

R_{oapi}	Dose commitment factor for organ o, age group a, for vegetation pathway and carbon-14 (mrem/yr per $\mu\text{Ci}/\text{m}^3$). (See Appendices G through J for age group and pathway specific dose commitment factors).
K'	Units conversion factor pCi/ μCi (10^6).
K'''	Units conversion factor gm/kg (10^3).
U_a^L	Consumption rate of fresh leafy vegetation for age group a (kg/yr) (from Regulatory Guide 1.109). Adult – 64 Teen – 42 Child – 26 Infant – 0
f_L	Fraction of annual intake of fresh leafy vegetation grown locally (1.0, from NUREG-0133).
U_a^S	Consumption rate of stored vegetation for age group a (kg/yr) (from Regulatory Guide 1.109). Adult – 520 Teen – 630 Child – 520 Infant – 0
f_g	Fraction of annual intake of stored vegetation (0.76, from Regulatory Guide 1.109).
$(DFL_{oi})_a$	Ingestion dose conversion factor for nuclide i, organ o, and age group a, from Tables E-11 through E-14 of Regulatory Guide 1.109 (mrem/pCi).
0.11	Fraction of total plant mass that is natural carbon.
0.16	Concentration of natural carbon in the atmosphere (gm/m^3).
p	Ratio of the total annual C-14 release time to the total annual time during which photosynthesis occurs. This value is assumed to be 0.31, based on 70% of C-14 releases being from WGDTs, and 30% of C-14 releases being continuous from the unit vents (ref. IAEA Technical Reports Series no. 421, "Management of Waste Containing Tritium and Carbon-14", 2004).
f_I	The fraction of C-14 assumed to be in inorganic form (e.g., CO_2). Assumed to be 20%. Reference EPRI TR-105715, "Characterization of Carbon-14 Generated by the Nuclear Power Industry", Table 5-1.

Catawba Nuclear Station Units 1 & 2
Period 1/1/2016 - 12/31/2016

Catawba Nuclear Station
Offsite Dose Calculation Manual (ODCM)

Grass/Cow/Milk

$$R_{oapi} = K' \frac{Q_F (U_{ap})}{\lambda_i + \lambda_w} F_{mi}(r) (DFL_{oi})_a \left[\frac{f_p f_s}{Y_p} + \frac{(1 - f_p f_s) e^{-\lambda_i t_h}}{Y_s} \right] e^{-\lambda_i t_f}$$

Formula: from NUREG-0133, pages 32 & 33. Where:	
R_{oapi}	Dose commitment factor for organ o, age group a, nuclide i, for grass/cow/milk pathway ($m^2 \cdot mrem/yr$ per $\mu Ci/sec$). (See Appendices G through J for age group and pathway specific dose commitment factors).
K'	Units conversion factor $pCi/\mu Ci$ (10^6).
Q_F	Cow consumption rate (50 kg/day, from Regulatory Guide 1.109)
U_{ap}	Consumption rate of cow milk for age group a (liters/yr, from Regulatory Guide 1.109). Adult – 310 Teen – 400 Child – 330 Infant – 330
r	Fraction of deposited activity retained on cow's feed grass, (from Regulatory Guide 1.109). 1.0 for radioiodine. 0.2 for particulates.
Y_p	Agricultural productivity by unit area of pasture feed grass ($0.7 kg/m^2$, from Regulatory Guide 1.109).
Y_s	Agricultural productivity by unit area of stored feed ($2.0 kg/m^2$, from Regulatory Guide 1.109).
λ_i	Nuclide decay constant for nuclide i (sec^{-1}).
λ_w	Decay constant for removal of activity on leaf and plant surfaces by weathering ($5.73 \times 10^{-7} sec^{-1}$, from NUREG-0133).
$(DFL_{oi})_a$	Ingestion dose conversion factor for nuclide i, organ o, and age group a, from Tables E-11 through E-14 of Regulatory Guide 1.109 ($mrem/pCi$).
F_{mi}	Stable element transfer coefficient for nuclide i, in days/liter, from Table E-1 of Regulatory Guide 1.109 for cow milk.
f_p	Fraction of year that the cow is on pasture (1.0, from RG 1.109).
f_s	Fraction of the cow feed that is pasture grass while the cow is on pasture (1.0, from Regulatory Guide 1.109).
t_f	Transport time for pasture to cow, to milk, to receptor ($1.73E+05$ seconds, from Regulatory Guide 1.109).
t_h	Transport time from pasture, to harvest, to cow, to milk, to receptor ($7.78E+06$ seconds, from Regulatory Guide 1.109).

Catawba Nuclear Station Units 1 & 2
Period 1/1/2016 - 12/31/2016

Catawba Nuclear Station
Offsite Dose Calculation Manual (ODCM)

Grass/Cow/Milk – Tritium

$$R_{oapi} = K' K''' F_{mi} Q_f U_{ap} (DFL_{io})_a [0.75(0.5 / H)]$$

Formula: from NUREG-0133, page 34.	
Where:	
R_{oapi}	Dose commitment factor for organ o, age group a, nuclide i, for grass/cow/milk pathway (mrem/yr per $\mu\text{Ci}/\text{m}^3$). (See Appendices G through J for age group and pathway specific dose commitment factors).
K'	Units conversion factor pCi/ μCi (10^6).
K'''	Units conversion factor gm/kg (10^3).
Q_F	Cow consumption rate (50 kg/day, from Regulatory Guide 1.109).
U_{ap}	Consumption rate of cow milk for age group a (liters/yr, from Regulatory Guide 1.109). Adult – 310 Teen – 400 Child – 330 Infant – 330
$(DFL_{oi})_a$	Ingestion dose conversion factor for nuclide i, organ o, and age group a, from Tables E-11 through E-14 of Regulatory Guide 1.109 (mrem/pCi).
F_{mi}	Stable element transfer coefficient for nuclide i, in days/liter, from Table E-1 of Regulatory Guide 1.109 for cow milk.
0.75	Fraction of total feed that is water (from NUREG-0133).
0.5	Ratio of specific activity of feed grass water to atmospheric water (from NUREG-0133).
H	Absolute humidity of the atmosphere ($8 \text{ gm}/\text{m}^3$, from Regulatory Guide 1.109).

Grass/Cow/Milk – Carbon-14

$$R_{oapi} = K'K''' F_{mi} Q_F U_{ap} (DFL_{oi})_a [0.11/0.16](p)(f_I)$$

Formula: from NUREG-0133, page 34 and Regulatory Guide 1.109, page 26.	
Where:	
R_{oapi}	Dose commitment factor for organ o, age group a, nuclide i, for grass/cow/meat pathway (mrem/yr per $\mu\text{Ci}/\text{m}^3$). (See Appendices G through J for age group and pathway specific dose commitment factors).
K'	Units conversion factor pCi/ μCi (10^6).
K'''	Units conversion factor gm/kg (10^3).
F_{mi}	Stable element transfer coefficient for nuclide i, in days/liter, from Table E-1 of Regulatory Guide 1.109 for cow milk.
Q_F	Cow consumption rate (50 kg/day, from Regulatory Guide 1.109).
U_{ap}	Consumption rate of cow milk for age group a (liters/yr) (from Regulatory Guide 1.109). Adult – 310 Teen – 400 Child – 330 Infant – 330
$(DFL_{oi})_a$	Ingestion dose conversion factor for nuclide i, organ o, and age group a, from Tables E-11 through E-14 of Regulatory Guide 1.109 (mrem/pCi).
0.11	Fraction of total plant mass that is natural carbon.
0.16	Concentration of natural carbon in the atmosphere (gm/m^3).
p	Ratio of the total annual C-14 release time to the total annual time during which photosynthesis occurs. This value is assumed to be 0.31, based on 70% of C-14 releases being from WGDTs, and 30% of C-14 releases being continuous from the unit vents (ref. IAEA Technical Reports Series no. 421, "Management of Waste Containing Tritium and Carbon-14", 2004).
f_I	The fraction of C-14 assumed to be in inorganic form (e.g., CO_2). Assumed to be 20%. Reference EPRI TR-105715, "Characterization of Carbon-14 Generated by the Nuclear Power Industry", Table 5-1.

Grass/Goat/Milk

$$R_{oapi} = K' \frac{Q_F (U_{ap})}{\lambda_i + \lambda_w} F_{mi}(r) (DFL_{oi})_a \left[\frac{f_p f_s}{Y_p} + \frac{(1 - f_p f_s) e^{-\lambda_i t_h}}{Y_s} \right] e^{-\lambda_i t_f}$$

Formula: from NUREG-0133, pages 32 & 33. Where:

R_{oapi}	Dose commitment factor for organ o, age group a, nuclide i, for grass/goat/milk pathway ($m^2 \cdot mrem/yr$ per $\mu Ci/sec$). (See Appendices G through J for age group and pathway specific dose commitment factors).
K'	Units conversion factor $pCi/\mu Ci$ (10^6).
Q_F	Goat consumption rate (6 kg/day, from Regulatory Guide 1.109).
U_{ap}	Consumption rate of goat milk for age group a (liters/yr, from Regulatory Guide 1.109). Adult – 310 Teen – 400 Child – 330 Infant – 330
r	Fraction of deposited activity retained on goat's feed grass, from Regulatory Guide 1.109. 1.0 for radioiodine. 0.2 for particulates.
Y_p	Agricultural productivity by unit area of pasture feed grass ($0.7 kg/m^2$, from Regulatory Guide 1.109).
Y_s	Agricultural productivity by unit area of stored feed ($2.0 kg/m^2$, from Regulatory Guide 1.109).
λ_i	Nuclide decay constant for nuclide i (sec^{-1}).
λ_w	Decay constant for removal of activity on leaf and plant surfaces by weathering ($5.73 \times 10^{-7} sec^{-1}$, from NUREG-0133).
$(DFL_{oi})_a$	Ingestion dose conversion factor for nuclide i, organ o, and age group a, from Tables E-11 through E-14 of Regulatory Guide 1.109 (mrem/pCi).
F_{mi}	Stable element transfer coefficient for nuclide i, in days/liter, from Table E-2 of Regulatory Guide 1.109 for goat milk.
f_p	Fraction of year that the goat is on pasture (1.0, from RG 1.109).
f_s	Fraction of the goat feed that is pasture grass while the goat is on pasture (1.0, from Regulatory Guide 1.109).
t_f	Transport time for pasture to goat, to milk, to receptor ($1.73E+05$ seconds, from Regulatory Guide 1.109).
t_h	Transport time from pasture, to harvest, to goat, to milk, to receptor ($7.78E+06$ seconds, from Regulatory Guide 1.109).

Catawba Nuclear Station Units 1 & 2
Period 1/1/2016 - 12/31/2016

Catawba Nuclear Station
Offsite Dose Calculation Manual (ODCM)

Grass/Goat/Milk – Tritium

$$R_{oapi} = K' K''' F_{mi} Q_f U_{ap} (DFL_{oi})_a [0.75(0.5 / H)]$$

Formula: from NUREG-0133, page 34.

Where:

R_{oapi}	Dose commitment factor for organ o, age group a, nuclide i, for grass/goat/milk pathway (mrem/yr per $\mu\text{Ci}/\text{m}^3$). (See Appendices G through J for age group and pathway specific dose commitment factors).
K'	Units conversion factor pCi/ μCi (10^6).
K'''	Units conversion factor gm/kg (10^3).
Q_F	Goat consumption rate (6 kg/day, from Regulatory Guide 1.109).
U_{ap}	Consumption rate of goat milk for age group a (liters/yr, from Regulatory Guide 1.109). Adult – 310 Teen – 400 Child – 330 Infant – 330
$(DFL_{oi})_a$	Ingestion dose conversion factor for nuclide i, organ o, and age group a, from Tables E-11 through E-14 of Regulatory Guide 1.109 (mrem/pCi).
F_{mi}	Stable element transfer coefficient for nuclide i, in days/liter, from Table E-2 of Regulatory Guide 1.109 for goat milk.
0.75	Fraction of total feed that is water (from NUREG-0133).
0.5	Ratio of specific activity of feed grass water to atmospheric water (from NUREG-0133).
H	Absolute humidity of the atmosphere ($8 \text{ gm}/\text{m}^3$, from Regulatory Guide 1.109).

Grass/Goat/Milk – Carbon-14

$$R_{oapi} = K'K''' F_{mi} Q_F U_{ap} (DFL_{oi})_a [0.11/0.16](p)(f_I)$$

Formula: from NUREG-0133, page 34 and Regulatory Guide 1.109, page 26.	
Where:	
R_{oapi}	Dose commitment factor for organ o, age group a, nuclide i, for grass/cow/meat pathway (mrem/yr per $\mu\text{Ci}/\text{m}^3$). (See Appendices G through J for age group and pathway specific dose commitment factors).
K'	Units conversion factor pCi/ μCi (10^6).
K'''	Units conversion factor gm/kg (10^3).
F_{mi}	Stable element transfer coefficient for nuclide i, in days/liter, from Table E-2 of Regulatory Guide 1.109 for goat milk (0.10).
Q_F	Goat consumption rate (6 kg/day, from Regulatory Guide 1.109).
U_{ap}	Consumption rate of goat milk for age group a (liters/yr) (from Regulatory Guide 1.109). Adult – 310 Teen – 400 Child – 330 Infant – 330
$(DFL_{oi})_a$	Ingestion dose conversion factor for nuclide i, organ o, and age group a, from Tables E-11 through E-14 of Regulatory Guide 1.109 (mrem/pCi).
0.11	Fraction of total plant mass that is natural carbon.
0.16	Concentration of natural carbon in the atmosphere (gm/m^3).
p	Ratio of the total annual C-14 release time to the total annual time during which photosynthesis occurs. This value is assumed to be 0.31, based on 70% of C-14 releases being from WGDTs, and 30% of C-14 releases being continuous from the unit vents (ref. IAEA Technical Reports Series no. 421, "Management of Waste Containing Tritium and Carbon-14", 2004).
f_I	The fraction of C-14 assumed to be in inorganic form (e.g., CO_2). Assumed to be 20%. Reference EPRI TR-105715, "Characterization of Carbon-14 Generated by the Nuclear Power Industry", Table 5-1.

Grass/Cow/Meat

$$R_{oapi} = K' \frac{Q_F (U_{ap})}{\lambda_i + \lambda_w} F_{fi}(r) (DFL_{oi})_a \left[\frac{f_p f_s}{Y_p} + \frac{(1 - f_p f_s) e^{-\lambda_i t_h}}{Y_s} \right] e^{-\lambda_i t_f}$$

Formula: from NUREG-0133, pages 34 & 35. Where:

R_{oapi}	Dose commitment factor for organ o, age group a, nuclide i, for grass/cow/meat pathway ($m^2 \cdot mrem/yr$ per $\mu Ci/sec$). (See Appendices G through J for age group and pathway specific dose commitment factors).
K'	Units conversion factor $pCi/\mu Ci$ (10^6).
Q_F	Cow consumption rate (50 kg/day, from Regulatory Guide 1.109).
U_{ap}	Consumption rate of cow meat for age group a (kg/yr, from Regulatory Guide 1.109). Adult – 110 Teen – 65 Child – 41 Infant – 0
r	Fraction of deposited activity retained on cow's feed grass (from Regulatory Guide 1.109). 1.0 for radioiodine. 0.2 for particulates.
Y_p	Agricultural productivity by unit area of pasture feed grass ($0.7 kg/m^2$, from Regulatory Guide 1.109).
Y_s	Agricultural productivity by unit area of stored feed ($2.0 kg/m^2$, from Regulatory Guide 1.109).
λ_i	Nuclide decay constant for nuclide i (sec^{-1}).
λ_w	Decay constant for removal of activity on leaf and plant surfaces by weathering ($5.73 \times 10^{-7} sec^{-1}$, from NUREG-0133).
$(DFL_{oi})_a$	Ingestion dose conversion factor for nuclide i, organ o, and age group a, from Tables E-11 through E-14 of Regulatory Guide 1.109 (mrem/pCi).
F_{fi}	Stable element transfer coefficient for nuclide i, in days/kg, from Table E-1 of Regulatory Guide 1.109 for cow meat.
f_p	Fraction of year that the cow is on pasture (1.0, from RG 1.109).
f_s	Fraction of the cow feed that is pasture grass while the cow is on pasture (1.0, from Regulatory Guide 1.109).
t_f	Transport time from pasture to receptor ($1.73E+06$ seconds, from Regulatory Guide 1.109).
t_h	Transport time from crop field to receptor ($7.78E+06$ seconds, from Regulatory Guide 1.109).

Grass/Cow/Meat – Tritium

$$R_{oapi} = K' K''' F_{fi} Q_F U_{ap} (DFL_{oi})_a [0.75(0.5 / H)]$$

Formula: from NUREG-0133, page 35.	
Where:	
R_{oapi}	Dose commitment factor for organ o, age group a, nuclide i, for grass/cow/meat pathway (mrem/yr per $\mu\text{Ci}/\text{m}^3$). (See Appendices G through J for age group and pathway specific dose commitment factors).
K'	Units conversion factor pCi/ μCi (10^6).
K'''	Units conversion factor gm/kg (10^3).
Q_F	Cow consumption rate (50 kg/day, from Regulatory Guide 1.109).
U_{ap}	Consumption rate of cow meat for age group a (kg/yr, from Regulatory Guide 1.109). Adult – 110 Teen – 65 Child – 41 Infant – 0
$(DFL_{oi})_a$	Ingestion dose conversion factor for nuclide i, organ o, and age group a, from Tables E-11 through E-14 of Regulatory Guide 1.109 (mrem/pCi).
F_{fi}	Stable element transfer coefficient for nuclide i, in days/liter, from Table E-1 of Regulatory Guide 1.109 for cow meat.
0.75	Fraction of total feed that is water (from NUREG-0133).
0.5	Ratio of specific activity of feed grass water to atmospheric water (from NUREG-0133).
H	Absolute humidity of the atmosphere ($8 \text{ gm}/\text{m}^3$, from Regulatory Guide 1.109).

Grass/Cow/Meat – Carbon-14

$$R_{oapi} = K'K''' F_{fi} Q_F U_{ap} (DFL_{oi})_a [0.11/0.16](p)(f_I)$$

Formula: from NUREG-0133, page 35 and Regulatory Guide 1.109, page 26.

Where:

R_{oapi}	Dose commitment factor for organ o, age group a, nuclide i, for grass/cow/meat pathway (mrem/yr per $\mu\text{Ci}/\text{m}^3$). (See Appendices G through J for age group and pathway specific dose commitment factors).
K'	Units conversion factor pCi/ μCi (10^6).
K'''	Units conversion factor gm/kg (10^3).
F_{fi}	Stable element transfer coefficient for nuclide i, in days/liter, from Table E-1 of Regulatory Guide 1.109 for cow meat.
Q_F	Cow consumption rate (50 kg/day, from Regulatory Guide 1.109).
U_{ap}	Consumption rate of cow meat for age group a (kg/yr) (from Regulatory Guide 1.109). Adult – 110 Teen – 65 Child – 41 Infant – 0
$(DFL_{oi})_a$	Ingestion dose conversion factor for nuclide i, organ o, and age group a, from Tables E-11 through E-14 of Regulatory Guide 1.109 (mrem/pCi).
0.11	Fraction of total plant mass that is natural carbon.
0.16	Concentration of natural carbon in the atmosphere (gm/m^3).
p	Ratio of the total annual C-14 release time to the total annual time during which photosynthesis occurs. This value is assumed to be 0.31, based on 70% of C-14 releases being from WGDTs, and 30% of C-14 releases being continuous from the unit vents (ref. IAEA Technical Reports Series no. 421, "Management of Waste Containing Tritium and Carbon-14", 2004).
f_I	The fraction of C-14 assumed to be in inorganic form (e.g., CO_2). Assumed to be 20%. Reference EPRI TR-105715, "Characterization of Carbon-14 Generated by the Nuclear Power Industry", Table 5-1.

4.0.3 DIRECT RADIATION

Direct radiation is that radiation from confined sources, and does not include any external component from radioactive effluents. The Point Kernel method has been used to calculate offsite dose rates from radioactive materials stored in the refueling water storage tanks, reactor makeup water storage tanks, and temporary onsite radwaste storage tanks. Dose calculations using this method performed for Catawba Nuclear Station indicate direct radiation doses are much less than 0.01 mrem/yr and, therefore, make a negligible contribution to individual dose. Likewise, direct and air-scatter radiation dose contributions from the onsite Independent Spent Fuel Storage Installation (ISFSI) at Catawba have been calculated and documented in the Catawba 10CFR72.212 evaluation report. The results of the calculation demonstrate that the annual dose to any "real individual" beyond the controlled area boundary is below the 10CFR72.104(a) and 40CFR190.10(a) limit of 25 mrem from direct and skyshine radiation, and all other fuel cycle sources (e.g., effluent). Direct radiation doses will not be calculated routinely.

4.0.4 EFFLUENT APPORTIONMENT

For the Catawba Nuclear Station the effluent releases are apportioned equally to each unit for each site as recommended by Section 3.1 of NUREG-0133, because the shared radwaste treatment systems at each site make it impractical to accurately ascribe releases to a specific reactor unit. For Annual Radiological Effluent Release Report purposes effluent releases are summed for each unit, and the maximum individual dose to the public is reported as a site total.

5.0 FUEL CYCLE CALCULATIONS

In accordance with the requirements of 40CFR190, the annual dose commitment to any member of the general public shall be calculated to assure that doses are limited to 25 millirems to the total body or any organ with the exception of the thyroid which is limited to 75 millirems. In accordance with the requirements of the Selected Licensee Commitments, the annual dose commitment shall also be calculated any time twice the specified quarterly dose limit of the Selected Licensee Commitments is exceeded; these annual dose commitments may not just be calculated for the calendar year.

The "Uranium fuel cycle" is defined in 40CFR Part 190.02(b) as:

"Uranium fuel cycle means the operations of milling of uranium ore, chemical conversion of uranium, isotopic enrichment of uranium, fabrication of uranium fuel, generation of electricity by a light-water-cooled nuclear power plant using uranium fuel, and reprocessing of spent uranium fuel, to the extent that these directly support the production of electrical power for public use utilizing nuclear energy, but excludes mining operations, operations at waste disposal sites, transportation of any radioactive material in support of these operations, and the reuse of recovered non-uranium special nuclear and by-product materials from the cycle."

Based on this definition of the fuel cycle and the information in 10CFR51, Table S-3, and Wash-1248, the radiological impact of the following operations has been assessed for Catawba Nuclear Station:

5.0.1 MILLING

No milling operations occur within fifty miles of the Catawba Nuclear Station.

5.0.2 CONVERSION

No uranium hexafluoride production occurs within fifty miles of the Catawba Nuclear Station.

5.0.3 ENRICHMENT

No uranium enrichment operations occur within fifty miles of the Catawba Nuclear Station.

5.0.4 FUEL FABRICATION

No fuel fabrication operations occur within fifty miles of the Catawba Nuclear Station.

5.0.5 NUCLEAR POWER PRODUCTION

The production of electricity for public use using light-water-cooled nuclear power stations results in increments of dose to individuals within fifty miles of any station due to liquid and gaseous effluent releases and direct radiation or skyshine. The increments of dose resulting from liquid and gaseous effluent releases will be calculated using the ODCM methodology implemented in the RETDAS computer program. The dose from direct radiation, skyshine, and radiation from the station storage facilities has been estimated using conservative assumptions (see Section 4.0.3).

In certain situations more than one nuclear power station site may contribute to the doses to be considered in making fuel cycle dose assessments in accordance with 40CFR190. However, since the Catawba and McGuire nuclear stations are located approximately 30 miles apart the relative dose contribution from each site to the other is insignificant, and can be ignored in assessing compliance with 40CFR190.

5.0.6 FUEL REPROCESSING

No fuel reprocessing operations occur within fifty miles of the Catawba Nuclear Station.

5.0.7 40CFR190 TOTAL DOSE DETERMINATION

To summarize, only dose increments from nuclear power production operations (Section 5.0.5) need be considered in calculations to demonstrate compliance with the requirements of 40CFR190. The fuel cycle dose assessments for Catawba Nuclear Station only include liquid and gaseous dose contributions from Catawba and dose from Catawba's ISFSI since no other uranium fuel cycle facility contributes significantly to Catawba's maximum exposed individual. For this dose assessment, the total body and maximum organ dose contributions to the maximum exposed individual from Catawba's liquid and gaseous effluents are estimated using the following calculations:

$$D_{wb}(T) = D_{wb}(l) + D_{wb}(g)$$

$$D_{mo}(T) = D_{mo}(l) + D_{mo}(g)$$

where:

$D_{wb}(T)$ = Total estimated fuel cycle whole body dose commitment resulting from the combined liquid and gaseous effluents of Catawba during the calendar year of interest, in mrem.

$D_{mo}(T)$ = Total estimated fuel cycle maximum organ dose commitment resulting from the combined liquid and gaseous effluents of Catawba during the calendar year of interest, in mrem.

6.0 ENVIRONMENTAL LOCATIONS

6.0.1 SITE DESCRIPTION AND SAMPLE LOCATIONS

Catawba Nuclear Station is located geographically near the center of a highly industrialized region of the Carolinas. The land is predominantly rural non-farm with a small amount of land being used to support beef cattle and farming. Recreation in the area is confined mostly to the lake and shores of Lake Wylie. The site is located in the northeastern portion of York County, South Carolina, on a peninsula bounded by Beaver Dam Creek to the north, Big Allison Creek



Fish Sampling

to the south, the main body of Lake Wylie to the east, and private property to the west. The Duke Power Company Wylie Dam and Hydroelectric Station are located approximately 4.5 miles southeast of the site. Rock Hill, South Carolina and Charlotte, North Carolina are the nearest large cities. The city limit of Rock Hill is located approximately 5.8 miles south-southeast of the site and the Charlotte city limit is located approximately 10.5 miles east-northeast of the site. The CNS site exclusion radius is 2500 feet.

Table 6.0-1 and Table 6.0-2 define the sampling and TLD locations for the Catawba Radiological Monitoring Program. Figure 6.0-1 and Figure 6.0-2 illustrate these locations as compared to Catawba Nuclear Station.

6.0.2 LAND USE CENSUS DATA

The Annual Land Use Census, required by Selected Licensee Commitments, is performed to ensure that changes in the use of areas at or beyond the site boundary are identified, and that modifications to the Radiological Environmental Monitoring Program are made if required by changes in land use. This census satisfies the requirements of Section IV.B.3 of Appendix I to 10CFR50. The land use census identifies nearest pathways to the exclusion area boundary (EAB, ~ 0.5 mile) for each of the 16 meteorological sectors. Global Positioning System field measurements are taken as close as possible to the item of interest and are accurate to within 2-5 meters. Locations beyond the nearest pathway for each sector are assumed to contain that pathway for dose calculation purposes. For the 4.5-5.0 mile sector all pathways, i.e., residence, garden, milk animal (goat), and meat animal (cow), are assumed to exist for dose calculation purposes. Results are maintained on file and data reviewed in accordance with procedure AD-CP-ALL-0014, Land Use Census Evaluation.

Catawba Nuclear Station Units 1 & 2
Period 1/1/2016 - 12/31/2016

Catawba Nuclear Station
Offsite Dose Calculation Manual (ODCM)

**TABLE 6.0-1
CATAWBA RADIOLOGICAL MONITORING PROGRAM
SAMPLING LOCATIONS**

Table 6.0-1 Codes			
W	Weekly	SM	Semimonthly
BW	BiWeekly	Q	Quarterly
M	Monthly	SA	Semiannually
C	Control		

Site #	Location Description*	Air Rad. & Part.	Surface Water	Drinking Water	Shoreline Sediment	Food Products (a)	Fish	Milk	Broad Leaf Veg. (b)	Ground Water **
200	Site Boundary (0.63 mi NNE)	W							M	
201	Site Boundary (0.53 mi NE)	W							M	
208	Discharge Canal (0.45 mi S)	W	M		SA		SA			
210	Ebenezer Access (2.31 mi SE)				SA					
211	Wylie Dam (4.06 mi ESE)		M							
212	Tega Cay (3.32 mi E)	W								
214	Rock Hill Water Supply (7.30 mi SSE)			M						
215 C	River Pointe - Hwy 49 (4.21 mi NNE)		M		SA					
216 C	Hwy 49 Bridge (4.19 mi NNE)						SA			
218 C	Belmont Water Supply (13.5 mi NNE)			M						
221 C	Dairy (14.5 mi NW)							SM		
222	Site Boundary (0.70 mi N)								M	
226	Site Boundary (0.48 mi S)								M	
258 C	Fairhope Road (9.84 mi W)	W							M	
260	Irrigated Gardens (2.00 mi SSE)					M(a)				
261	Firing Range - Site Boundary (0.72 mi N)	W								

- (a) During Harvest Season
- (b) When Available

* GPS data reflect approximate accuracy to within 2-5 meters. GPS field measurements were taken as close as possible to the item of interest.

** Currently no off-site ground water monitoring locations available that are used for drinking or irrigation purposes where hydraulic gradient or recharge properties are suitable for contamination.

Catawba Nuclear Station Units 1 & 2
Period 1/1/2016 - 12/31/2016

Catawba Nuclear Station
Offsite Dose Calculation Manual (ODCM)

TABLE 6.0-2

**CATAWBA RADIOLOGICAL MONITORING PROGRAM
SAMPLING LOCATIONS**

(TLD SITES)

Site #	Location*	Distance	Sector	Site #	Location*	Distance	Sector
200	SITE BOUNDARY	0.63 miles	NNE	234	WELLS FARGO BANK	4.50 miles	E
201	SITE BOUNDARY	0.53 miles	NE	235	LAKE WYLIE DAM	4.07 miles	ESE
203	SITE BOUNDARY	0.38 miles	ESE	236	SC WILDLIFE FEDERATION OFFICE	4.25 miles	SE
204	SITE BOUNDARY	0.48 miles	SSW	237	TWIN LAKES ROAD AND HOMESTEAD ROAD	4.75 miles	SSE
205	SITE BOUNDARY	0.50 miles	SW	238	PENNINGTON ROAD AND WEST OAK ROAD	4.02 miles	S
206	SITE BOUNDARY	0.67 miles	WNW	239	CARTER LUMBER COMPANY	4.49 miles	SSW
207	SITE BOUNDARY	0.95 miles	NNW	240	PARAHAM ROAD	4.07 miles	SW
212 SI	TEGA CAY AIR SITE	3.32 miles	E	241	CAMPBELL ROAD	4.58 miles	WSW
217 C	BLACKMON ROAD	10.3 miles	SSE	242	TRANSMISSION TOWER ON PARAHAM ROAD	4.56 miles	W
222	SITE BOUNDARY	0.71 miles	N	243	KINGSBURY ROAD	4.39 miles	WNW
223	SITE BOUNDARY	0.57 miles	E	244	BETHEL ELEMENTARY SCHOOL	4.02 miles	NW
225	SITE BOUNDARY	0.68 miles	SE	245	CROWDERS CREEK BOAT LANDING	4.01 miles	NNW
226	SITE BOUNDARY	0.48 miles	S	246 SI	CAROWINDS GUARD HOUSE	7.87 miles	ENE
227	SITE BOUNDARY	0.52 miles	WSW	247 C	FORT MILL	7.33 miles	ESE
228	SITE BOUNDARY	0.61 miles	W	248 SI	PIEDMONT MEDICAL CENTER	6.54 miles	S
229	SITE BOUNDARY	0.84 miles	NW	249 SI	YORK COUNTY OPERATIONS CENTER	7.17 miles	S
230	RIVER HILLS COMMUNITY CHURCH	4.37 miles	N	250 SI	YORK DUKE POWER OFFICE	10.4 miles	WSW
231	RIVER HILLS FRONT ENTRANCE	4.21 miles	NNE	251 C	CLOVER	9.72 miles	WNW
232	PLEASANT HILL ROAD	4.18 miles	NE	255	SITE BOUNDARY	0.61 miles	ENE
233	ZOAR ROAD AND THOMAS DRIVE	3.95 miles	ENE	256	SITE BOUNDARY	0.58 miles	SSE
				258	FAIRHOPE ROAD	9.84 miles	W

C = Control
SI = Special Interest

* GPS data reflect approximate accuracy to within 2-5 meters. GPS field measurements were taken as close as possible to the item of interest.

Catawba Nuclear Station Units 1 & 2
Period 1/1/2016 - 12/31/2016

Catawba Nuclear Station
Offsite Dose Calculation Manual (ODCM)

TABLE 6.0-3

Land Use Census Results

Deleted in ODCM Revision 60.

Catawba Nuclear Station Units 1 & 2
Period 1/1/2016 - 12/31/2016

Catawba Nuclear Station
Offsite Dose Calculation Manual (ODCM)

Figure 6.0-1 Sampling Locations Map (Site Boundary)

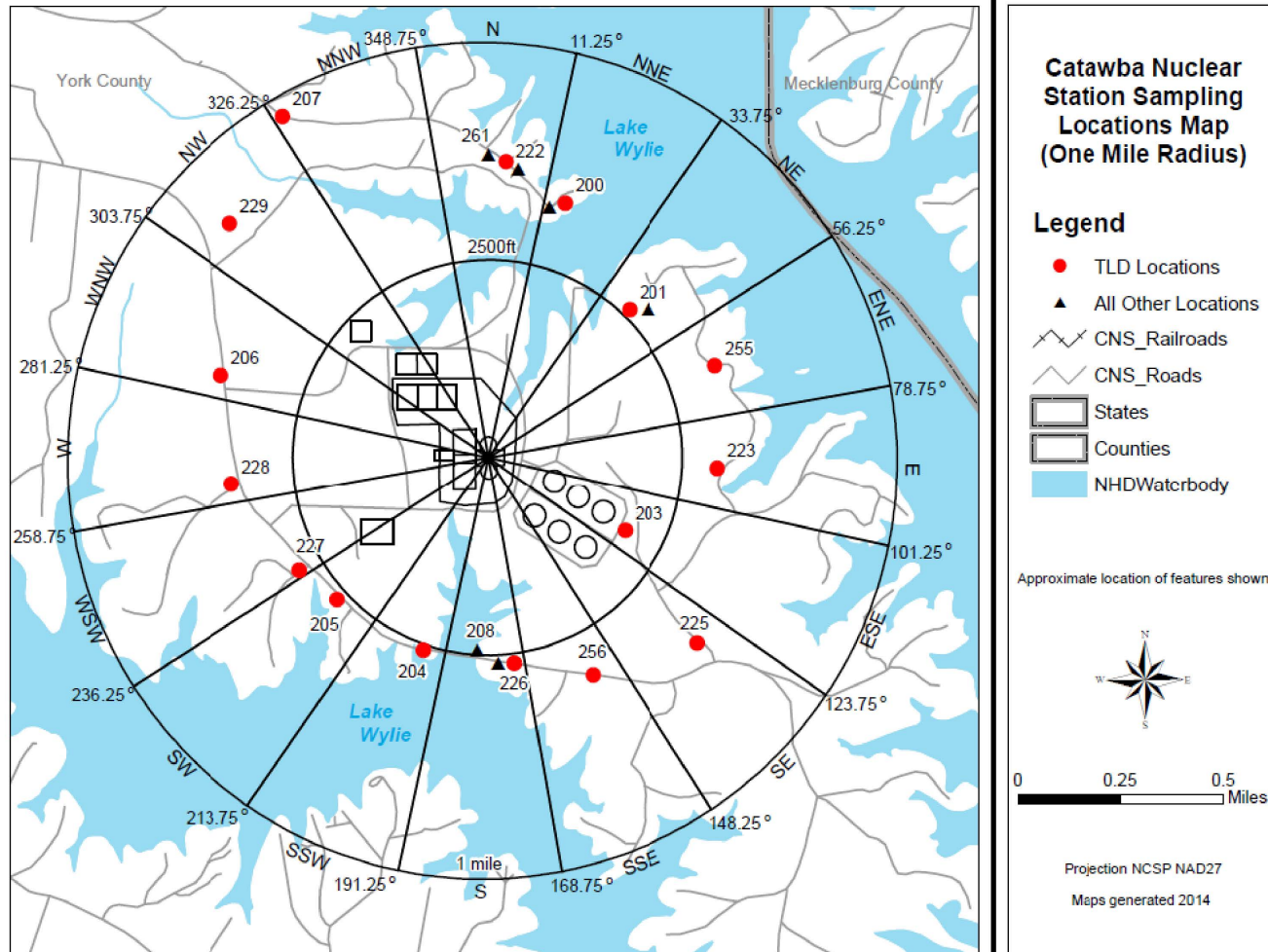

Catawba Nuclear Station Units 1 & 2
 Period 1/1/2016 - 12/31/2016

Catawba Nuclear Station
 Offsite Dose Calculation Manual (ODCM)

Figure 6.0-2 Sampling Locations Map (Ten Mile Radius)

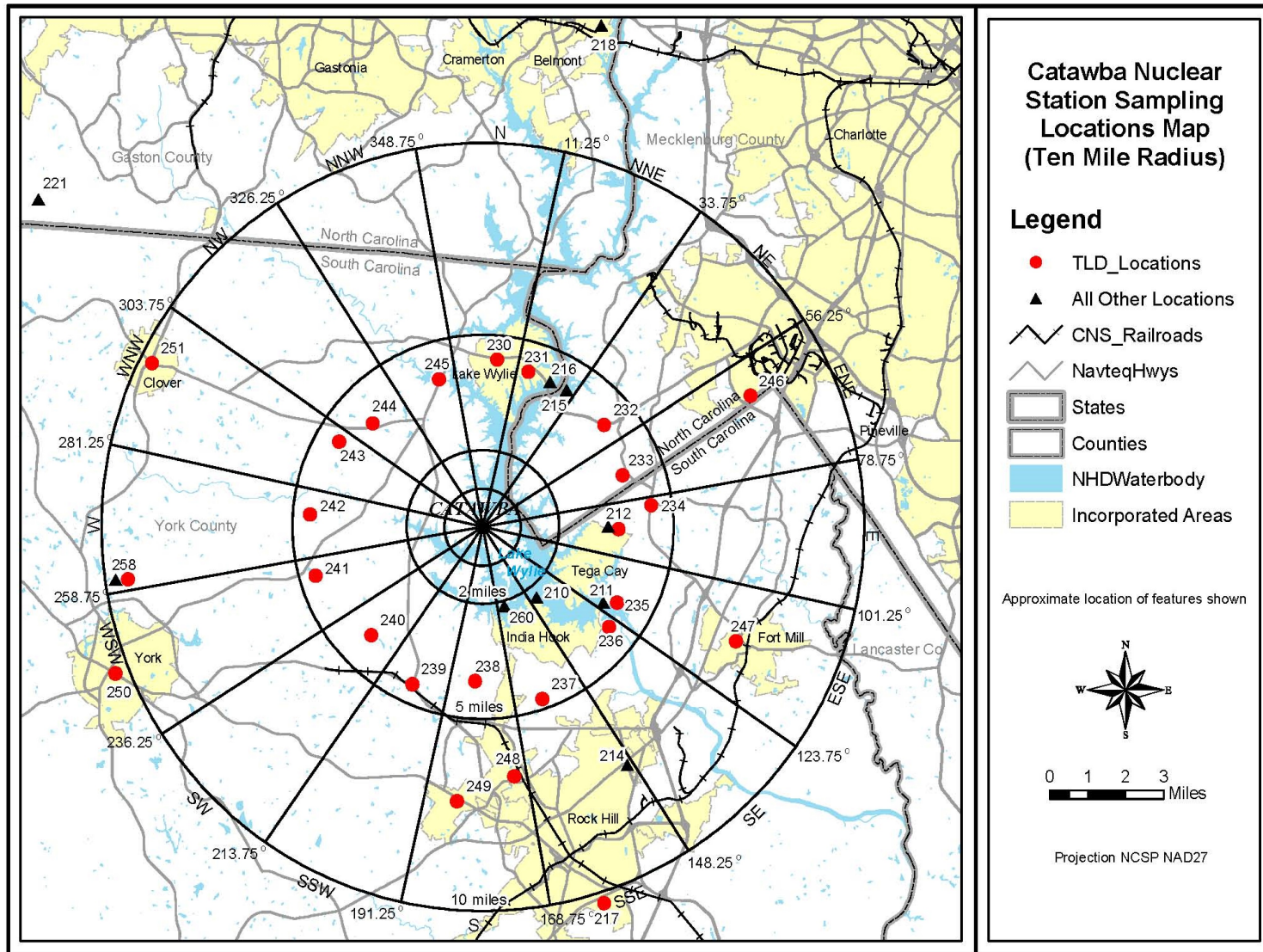

Catawba Nuclear Station Units 1 & 2
Period 1/1/2016 - 12/31/2016

Catawba Nuclear Station
Offsite Dose Calculation Manual (ODCM)

Figure 6.0-3 Land Use Census Map

Deleted in ODCM Revision 60.

6.0.3 CATAWBA METEOROLOGY: RELATIVE AIR CONCENTRATIONS AND DEPOSITION

Calculations of annually averaged air concentrations and deposition values from routine releases provide the air dispersion and deposition factors needed for dose assessment. The methodology is based upon Regulatory Guide 1.111, as implemented by the NRC's computer model "XOQDOQ: Computer Program for the Meteorological Evaluation of Routine Effluent Releases at Nuclear Power Stations," NUREG/CR-2919, PNL-4380, September 1982. The calculation is documented in CNC-1108.01-00-0002 "Annual Air Dispersion and Deposition Factors for Routine Releases (ODCM)."

Five years of hourly meteorological data from the onsite instruments are processed into a representative joint frequency distribution of winds and atmospheric stability for input into the XOQDOQ model (Version 2.0). Thus, the air dispersion and deposition factors (X/Q and D/Q) output by the model are based on a five-year climatology for the site.

6.0.3.1 XOQDOQ METHODOLOGY AND ASSUMPTIONS

A continuous, routine release (non-purge) is simulated from each unit vent. The release type is treated as "ground-level" in the model, for which surrounding terrain elevations are not input. The locale does consist of gently rolling to flat terrain, so the default open terrain recirculation factor is applied in XOQDOQ [KOPT(8)=1]. This correction factor is recommended in RG 1.111 to adjust the straight-line airflow of the model for spatial and temporal variations that are produced by large-scale weather patterns, or other non-linear flow conditions at local and regional scales.

In order for XOQDOQ to treat the plume as a ground-level release, the exit velocity and the inside diameter of the unit vent must be input as zero. The heat emission rate of each vent is also assumed to be zero, as recommended by the model. The height of the vent (38 m) above plant grade elevation (594 ft msl) is then used to determine the plume centerline height. Using the building height (41 m) and minimum cross-sectional area of the containment building (1616 m²), XOQDOQ applies a building wake correction to the relative air concentrations from the ground level release.

Calculations of relative air concentrations and deposition are made for grid receptor distances per directional sector. The "no decay" assumption is used in the XOQDOQ model.

6.0.3.2 METEOROLOGICAL DATA

Five years (1988-1992) of hourly, onsite meteorological data are used to produce the joint frequency distributions of wind speed and direction per stability class. The 10 m level winds are used. It is these joint frequency distributions which are input to the XOQDOQ model. Hours of calm winds are distributed by direction with the same frequency as the lowest "noncalm" wind speed class [KOPT(1)=1]. Thus, wind speed classes are established so that the lowest wind speed class is the starting threshold of the anemometer

(i.e. the "calm" wind speed class). The largest wind speed class has the upper bound of (5 m/s + max hourly wind speed). Stability classes (A-G) are based on the vertical temperature gradient, measured by the hourly averaged delta-T variable.

6.0.3.3 ANNUAL XOQDOQ COMPARISON TO THE ODCM

Each year, the prevailing winds and stability class frequencies for CNS are compared to the 5-year period (1988-1992) upon which the χ/Q and D/Q calculations have been made. The 5-year climatology is summarized in Table 6.0-4 and Table 6.0-5 below. Since the comparison is being made to a 5-year climatology, significant differences should not occur in the meteorological variables of concern (i.e. winds and delta-T). The meteorological comparison serves to verify this assumption.

**Table 6.0-4
CNS Atmospheric Stability Frequency (1988-1992)**

	A	B	C	D	E	F	G
Frequency (%)	10.9	4.3	5.5	31.1	26.9	10.3	10.9

**Table 6.0-5
CNS Frequency of Wind Direction (From) and Speed (1988-1992)**

Sector	Wind Direction Frequency (%)	Wind Speed Class (m/s)	Wind Speed Frequency (%)
N	10.1	CALM	0.9
NNE	8.7	0.45 - 0.74 m/s	2.8
NE	5.0	0.75 - 0.99 m/s	4.8
ENE	1.9	1.00 - 1.24 m/s	6.4
E	1.0	1.25 - 1.49 m/s	9.9
ESE	1.4	1.50 - 1.99 m/s	17.8
SE	2.9	2.00 - 2.99 m/s	25.5
SSE	6.2	3.00 - 3.99 m/s	16.8
S	11.2	4.00 - 4.99 m/s	9.6
SSW	13.8	5.00 - 5.99 m/s	3.6
SW	9.8	6.00 - 7.99 m/s	1.6
WSW	5.3	8.00 - 9.99 m/s	0.1
W	4.1	> 9.99 m/s	0.2
WNW	4.9		
NW	4.9		
NNW	9.0		

The joint frequency distributions of wind speed and direction versus atmospheric stability class are also determined from the annual data to provide input to the XOQDOQ model.

Catawba Nuclear Station Units 1 & 2
Period 1/1/2016 - 12/31/2016

Catawba Nuclear Station
Offsite Dose Calculation Manual (ODCM)

Modeled χ/Q and D/Q values for the 0.5 mile Exclusion Area Boundary at CNS are compared to the maximum of the (1988-1992) χ/Q and D/Q values from all sectors. If the newly calculated annual dispersion and deposition values do not result in a significant increase in the calculated offsite dose relative to the 10CFR50, Appendix I dose objectives then the 5-year χ/Q and D/Q values used in the Annual Radiological Effluent Release Report (ARERR) are not revised. An increase in calculated offsite dose that is greater than five percent of the 10CFR50, Appendix I dose objectives would be considered significant enough to warrant a change in the χ/Q and D/Q values used in the ARERR. If an increasing trend in the annual χ/Q and D/Q values compared to the 5-year values is noted then a revised set of 5-year χ/Q and D/Q values will be generated. These limiting values are listed in Table 6.0-6. The entire χ/Q and D/Q list based on directional sector and distance is given in Table 6.0-8 and 6.0-9.

Table 6.0-6
CNS Limiting χ/Q and D/Q Values (1988-1992)

	$(\chi/Q, s/m^3)$ $(D/Q, 1/m^2)$	Distance	Sector
Maximum X/Q	3.510E-5	0.5 mile EAB	NNE
Maximum D/Q	1.078E-7	0.5 mile EAB	NNE

Note:

The Catawba meteorological instruments were moved from the 40 m microwave tower to a new 60 m meteorological tower in June 1996. The taller tower became operational at 1900 hours on June 11, 1996. Therefore, determination of atmospheric stability prior to this time uses the 30 m separation criteria shown in Table 6.0-7, while data after this time uses the 50.9 m separation criteria.

Table 6.0-7
CNS Delta-T Ranges per Vertical Separation Distances

Stability Class	30 m separation Delta-T (between 40m-10m levels)	50.9 m separation Delta-T (between 60.2m-9.3m levels) Starting at 1900 hours on June 11, 1996.
A	$dT \leq -0.57$	$dT \leq -0.97$
B	$-0.57 < dT \leq -0.51$	$-0.97 < dT \leq -0.87$
C	$-0.51 < dT \leq -0.45$	$-0.87 < dT \leq -0.76$
D	$-0.45 < dT \leq -0.15$	$-0.76 < dT \leq -0.25$
E	$-0.15 < dT \leq 0.45$	$-0.25 < dT \leq 0.76$
F	$0.45 < dT \leq 1.2$	$0.76 < dT \leq 2.04$
G	$1.2 < dT$	$2.04 < dT$

Catawba Nuclear Station Units 1 & 2
Period 1/1/2016 - 12/31/2016

Catawba Nuclear Station
Offsite Dose Calculation Manual (ODCM)

Table 6.0-8

**Catawba χ/Q Average Values (1988-1992)
(sec/m³)**

Sector	0.5-1.0*	1.0-1.5	1.5-2.0	2.0-2.5	2.5-3.0	3.0-3.5	3.5-4.0	4.0-4.5	4.5-5.0
N	2.959E-05	7.879E-06	3.222E-06	1.768E-06	1.133E-06	7.978E-07	5.987E-07	4.701E-07	3.818E-07
NNE	3.510E-05	9.342E-06	3.814E-06	2.091E-06	1.338E-06	9.420E-07	7.066E-07	5.546E-07	4.503E-07
NE	2.927E-05	7.738E-06	3.166E-06	1.738E-06	1.114E-06	7.848E-07	5.891E-07	4.627E-07	3.759E-07
ENE	2.208E-05	5.813E-06	2.406E-06	1.330E-06	8.573E-07	6.065E-07	4.568E-07	3.598E-07	2.931E-07
E	1.858E-05	4.895E-06	2.032E-06	1.126E-06	7.266E-07	5.147E-07	3.880E-07	3.059E-07	2.493E-07
ESE	1.962E-05	5.223E-06	2.163E-06	1.197E-06	7.712E-07	5.457E-07	4.110E-07	3.238E-07	2.637E-07
SE	1.965E-05	5.167E-06	2.151E-06	1.194E-06	7.717E-07	5.471E-07	4.128E-07	3.257E-07	2.656E-07
SSE	2.561E-05	6.751E-06	2.798E-06	1.548E-06	9.982E-07	7.064E-07	5.323E-07	4.194E-07	3.416E-07
S	1.552E-05	4.101E-06	1.642E-06	8.878E-07	5.624E-07	3.926E-07	2.924E-07	2.282E-07	1.843E-07
SSW	8.747E-06	2.267E-06	8.761E-07	4.621E-07	2.872E-07	1.973E-07	1.450E-07	1.118E-07	8.939E-08
SW	5.071E-06	1.328E-06	5.087E-07	2.666E-07	1.648E-07	1.127E-07	8.249E-08	6.340E-08	5.052E-08
WSW	3.265E-06	8.730E-07	3.413E-07	1.815E-07	1.135E-07	7.839E-08	5.786E-08	4.479E-08	3.592E-08
W	2.024E-06	5.307E-07	2.058E-07	1.088E-07	6.771E-08	4.657E-08	3.426E-08	2.644E-08	2.115E-08
WNW	3.468E-06	9.193E-07	3.595E-07	1.913E-07	1.197E-07	8.267E-08	6.104E-08	4.727E-08	3.793E-08
NW	6.249E-06	1.680E-06	6.638E-07	3.558E-07	2.239E-07	1.555E-07	1.153E-07	8.959E-08	7.212E-08
NNW	1.406E-05	3.723E-06	1.508E-06	8.221E-07	5.242E-07	3.678E-07	2.752E-07	2.155E-07	1.747E-07

* Units are in miles from the station. Each χ/Q value is calculated at the closest location for the sector, e.g., 2.959E-05 sec/m³ is the χ/Q value at 0.5 miles (N) from the station. As discussed in Catawba UFSAR Section 2.1.1.3, the boundary for establishing gaseous effluent release limits is the exclusion area boundary (EAB). The EAB is defined as a 2500-ft. (~0.5 mile) radius from the station center.

Catawba Nuclear Station Units 1 & 2
Period 1/1/2016 - 12/31/2016

Catawba Nuclear Station
Offsite Dose Calculation Manual (ODCM)

Table 6.0-9

**Catawba D/Q Average Values (1988-1992)
(m⁻²)**

Sector	0.5-1.0*	1.0-1.5	1.5-2.0	2.0-2.5	2.5-3.0	3.0-3.5	3.5-4.0	4.0-4.5	4.5-5.0
N	8.799E-08	2.148E-08	7.715E-09	3.826E-09	2.253E-09	1.475E-09	1.038E-09	7.693E-10	5.928E-10
NNE	1.078E-07	2.630E-08	9.448E-09	4.686E-09	2.759E-09	1.807E-09	1.271E-09	9.421E-10	7.260E-10
NE	7.653E-08	1.868E-08	6.710E-09	3.328E-09	1.960E-09	1.283E-09	9.028E-10	6.691E-10	5.156E-10
ENE	4.135E-08	1.009E-08	3.626E-09	1.798E-09	1.059E-09	6.933E-10	4.878E-10	3.615E-10	2.786E-10
E	3.246E-08	7.924E-09	2.846E-09	1.411E-09	8.311E-10	5.442E-10	3.829E-10	2.838E-10	2.187E-10
ESE	3.810E-08	9.301E-09	3.341E-09	1.657E-09	9.755E-10	6.388E-10	4.495E-10	3.331E-10	2.567E-10
SE	3.799E-08	9.274E-09	3.331E-09	1.652E-09	9.727E-10	6.369E-10	4.482E-10	3.321E-10	2.560E-10
SSE	7.019E-08	1.713E-08	6.154E-09	3.052E-09	1.797E-09	1.177E-09	8.280E-10	6.136E-10	4.729E-10
S	7.881E-08	1.924E-08	6.910E-09	3.427E-09	2.018E-09	1.321E-09	9.297E-10	6.890E-10	5.310E-10
SSW	6.787E-08	1.657E-08	5.951E-09	2.951E-09	1.738E-09	1.138E-09	8.007E-10	5.934E-10	4.573E-10
SW	3.877E-08	9.464E-09	3.399E-09	1.686E-09	9.926E-10	6.500E-10	4.573E-10	3.389E-10	2.612E-10
WSW	1.476E-08	3.604E-09	1.295E-09	6.420E-10	3.780E-10	2.475E-10	1.742E-10	1.291E-10	9.947E-11
W	7.895E-09	1.927E-09	6.922E-10	3.433E-10	2.021E-10	1.324E-10	9.313E-11	6.902E-11	5.319E-11
WNW	1.087E-08	2.654E-09	9.534E-10	4.728E-10	2.784E-10	1.823E-10	1.283E-10	9.507E-11	7.326E-11
NW	2.319E-08	5.661E-09	2.033E-09	1.008E-09	5.938E-10	3.888E-10	2.736E-10	2.027E-10	1.562E-10
NNW	4.863E-08	1.187E-08	4.264E-09	2.114E-09	1.245E-09	8.152E-10	5.736E-10	4.251E-10	3.276E-10

* Units are in miles from the station. Each D/Q value is calculated at the closest location for the sector, e.g., 8.799E-08 m⁻² is the D/Q value at 0.5 miles (N) from the station. As discussed in Catawba UFSAR Section 2.1.1.3, the boundary for establishing gaseous effluent release limits is the exclusion area boundary (EAB). The EAB is defined as a 2500-ft. (~0.5 mile) radius from the station center.

7.0 LICENSEE INITIATED CHANGES

All ODCM changes are reviewed by knowledgeable individual(s), and approved by either the Station Manager or Radiation Protection Manager. The below changes do not adversely impact the accuracy or reliability of effluent, dose, or setpoint calculations.

ODCM Revision 60 - Implementation Date: October 27, 2016

ODCM Revision 60 was approved by the Radiation Protection Manager on October 27, 2016. Some changes reflected in ODCM Revision 60 were implemented prior to October 27, 2016 under a different change and approval process (e.g., land use census), and in those cases the implementation date is noted below. Changes driven by Document Revision Requests (DRR) are noted with DRR number.

Table of Contents - Page i and ii

Marked 6.0-3, Land Use Census Map, as deleted in List of Figures. Marked 6.0-3, Land Use Census Results, as deleted in List of Tables. Adjusted remaining sub-section, Figure, and Table page numbers for Section 6 based on moving Section 6.0.2.

Change made based on recommendation in DRR 02068932 to improve efficiency by eliminating annual ODCM revisions. This does not adversely impact the accuracy or reliability of dose calculations, as records of the Land Use Census are maintained in EnRad files and documented with procedure AD-CP-ALL-0014, Land Use Census Evaluation. Changes to Effluent Management Software are implemented based on results of annual Land Use Census, once approved.

Executive Summary - Page 2

Revised statements in second paragraph from:

"The ODCM has been prepared as generically as possible in order to minimize the need for revisions. However, some changes to the ODCM such as land use census data are expected on an annual basis. Any changes to the methodology and parameters to be used in this ODCM shall be reviewed by knowledgeable individual(s), and approved by the Station Manager prior to implementation. Changes to the ODCM shall be submitted to the Nuclear Regulatory Commission in accordance with the SLCs and Technical Specifications."

to:

"The ODCM has been prepared as generically as possible in order to minimize the need for revisions. Any changes to the methodology and parameters to be used in this ODCM shall be reviewed by knowledgeable individual(s), and approved by the Station Manager or Radiation Protection Manager prior to implementation. Changes to the ODCM shall be submitted to the Nuclear Regulatory Commission in accordance with the SLCs and Technical Specifications."

Change made based on recommendation in DRR 02068932 to improve efficiency by eliminating annual ODCM revisions. Also updated ODCM approval authority statement based on NRC approved license amendments 273 and 269 to Technical Specification 5.5.1, allowing for Radiation Protection Manager approval.

Section 3.0.2.3 - Page 23

Revise definition for "bkg" from:

"bkg = EMF 50 background."

to:

"bkg = EMF 36 background."

Change made to correct editorial error identified in DRR 02008824. Definition for "bkg" is under section for determining EMF 36 setpoints, not EMF 50. EMF 50 setpoints described prior in section.

Section 4 - Page 8

Removed reference to Table 6.0-3 in "*" note. Statement changed from:

"Dose is calculated only for pathways (e.g., garden, milk animal, etc.) that actually exist at each location as determined by the land use census shown in Table 6.0-3."

to:

"Dose is calculated only for pathways (e.g., garden, milk animal, etc.) that actually exist at each location as determined by the land use census."

Change made based on recommendation in DRR 02068932 to improve efficiency by eliminating annual ODCM revisions.

Section 6.0.2 - Page 2

Revised from (previously on page 1):

"The Annual Land Use Census, required by Selected Licensee Commitments, is performed to ensure that changes in the use of areas at or beyond the site boundary are identified, and that modifications to the Radiological Environmental Monitoring Program are made if required by changes in land use. This census satisfies the requirements of Section IV.B.3 of Appendix I to 10CFR50. Results are shown in Table 6.0-3 and Figure 6.0-3."

to:

"The Annual Land Use Census, required by Selected Licensee Commitments, is performed to ensure that changes in the use of areas at or beyond the site boundary are identified, and that modifications to the Radiological Environmental Monitoring Program are made if required by changes in land use. This census satisfies the requirements of Section IV.B.3 of Appendix I to 10CFR50. The land use census identifies nearest pathways to the exclusion area boundary (EAB, ~ 0.5 mile) for each of the 16 meteorological sectors. Global Positioning System field measurements are taken as close as possible to the item of interest and are accurate to within 2-5 meters. Locations beyond the nearest pathway for each sector are assumed to contain that pathway for dose calculation purposes. For the 4.5-5.0 mile sector all pathways, i.e., residence, garden, milk animal (goat), and meat animal (cow), are assumed to exist for dose calculation purposes. Results are maintained on file and data reviewed in accordance with procedure AD-CP-ALL-0014, Land Use Census Evaluation."

Change made based on recommendation in DRR 02068932 to improve efficiency by eliminating annual ODCM revisions. This does not adversely impact the accuracy or reliability of dose calculations, as records of the Land Use Census are maintained in EnRad files and documented with procedure AD-CP-ALL-0014, Land Use Census Evaluation. Changes to Effluent Management Software are implemented based on results of annual Land Use Census, once approved.

Section 6.0.2 - Page 4 (previously)

Deleted Table 6.0-3 and moved relevant information from "*" and "***" Note paragraphs to Section 6.0.2.

Change made based on recommendation in DRR 02068932 to improve efficiency by eliminating annual ODCM revisions. This does not adversely impact the accuracy or reliability of dose calculations, as records of the Land Use Census are maintained in EnRad files and documented with procedure AD-CP-ALL-0014, Land Use Census Evaluation. Changes to Effluent Management Software are implemented based on results of annual Land Use Census, once approved.

Section 6.0.2 - Page 7 (previously)

Deleted Figure 6.0-3.

Change made based on recommendation in DRR 02068932 to improve efficiency by eliminating annual ODCM revisions. This does not adversely impact the accuracy or reliability of dose calculations, as records of the Land Use Census are maintained in EnRad files and documented with procedure AD-CP-ALL-0014, Land Use Census Evaluation. Changes to Effluent Management Software are implemented based on results of annual Land Use Census, once approved.

Catawba Nuclear Station Units 1 & 2
Period 1/1/2016 - 12/31/2016

Catawba Nuclear Station
Offsite Dose Calculation Manual (ODCM)

APPENDIX A

Dose Factors for Exposure to a Semi-Infinite Cloud of Noble Gases *

Nuclide	K_i Total Body mrem/yr/ μCi/m³	L_i Skin mrem/yr/ μCi/m³	M_i Gamma Air mrad/yr/ μCi/m³	N_i Beta Air mrad/yr/ μCi/m³
AR-41	8.840E+03	2.690E+03	9.300E+03	3.280E+03
KR-83M	7.560E-02	0.000E+00	1.930E+01	2.880E+02
KR-85M	1.170E+03	1.460E+03	1.230E+03	1.970E+03
KR-85	1.610E+01	1.340E+03	1.720E+01	1.950E+03
KR-87	5.920E+03	9.730E+03	6.170E+03	1.030E+04
KR-88	1.470E+04	2.370E+03	1.520E+04	2.930E+03
KR-89	1.660E+04	1.010E+04	1.730E+04	1.060E+04
KR-90	1.560E+04	7.290E+03	1.630E+04	7.830E+03
XE-131M	9.150E+01	4.760E+02	1.560E+02	1.110E+03
XE-133M	2.510E+02	9.940E+02	3.270E+02	1.480E+03
XE-133	2.940E+02	3.060E+02	3.530E+02	1.050E+03
XE-135M	3.120E+03	7.110E+02	3.360E+03	7.390E+02
XE-135	1.810E+03	1.860E+03	1.920E+03	2.460E+03
XE-137	1.420E+03	1.220E+04	1.510E+03	1.270E+04
XE-138	8.830E+03	4.130E+03	9.210E+03	4.750E+03

* Reference Regulatory Guide 1.109, Table B-1

Catawba Nuclear Station Units 1 & 2
Period 1/1/2016 - 12/31/2016

Catawba Nuclear Station
Offsite Dose Calculation Manual (ODCM)

APPENDIX B

P_i Dose Factors for use in the Gaseous Release Rate Limit Calculations

Agegroup:	CHILD	Pathway:	Inhalation (INHL)			Units:	mrem/yr / $\mu\text{Ci}/\text{m}^3$	
Nuclide	Bone	Liver	Thyroid	Kidney	Lung	Gilli	Skin	Total Body
H-3	0.000E+00	1.120E+03	1.120E+03	1.120E+03	1.120E+03	1.120E+03	0.000E+00	1.120E+03
C-14	3.590E+04	6.730E+03	6.730E+03	6.730E+03	6.730E+03	6.730E+03	0.000E+00	6.730E+03
NA-24	1.610E+04	1.610E+04	1.610E+04	1.610E+04	1.610E+04	1.610E+04	0.000E+00	1.610E+04
P-32	2.600E+06	1.140E+05	0.000E+00	0.000E+00	0.000E+00	4.220E+04	0.000E+00	9.880E+04
CR-51	0.000E+00	0.000E+00	8.550E+01	2.430E+01	1.700E+04	1.080E+03	0.000E+00	1.540E+02
MN-54	0.000E+00	4.290E+04	0.000E+00	1.000E+04	1.580E+06	2.290E+04	0.000E+00	9.510E+03
MN-56	0.000E+00	1.660E+00	0.000E+00	1.670E+00	1.310E+04	1.230E+05	0.000E+00	3.120E-01
FE-55	4.740E+04	2.520E+04	0.000E+00	0.000E+00	1.110E+05	2.870E+03	0.000E+00	7.770E+03
FE-59	2.070E+04	3.340E+04	0.000E+00	0.000E+00	1.270E+06	7.070E+04	0.000E+00	1.670E+04
CO-58	0.000E+00	1.770E+03	0.000E+00	0.000E+00	1.110E+06	3.440E+04	0.000E+00	3.160E+03
CO-60	0.000E+00	1.310E+04	0.000E+00	0.000E+00	7.070E+06	9.620E+04	0.000E+00	2.260E+04
NI-63	8.210E+05	4.620E+04	0.000E+00	0.000E+00	2.750E+05	6.330E+03	0.000E+00	2.800E+04
NI-65	2.990E+00	2.960E-01	0.000E+00	0.000E+00	8.180E+03	8.400E+04	0.000E+00	1.640E-01
CU-64	0.000E+00	1.990E+00	0.000E+00	6.030E+00	9.580E+03	3.670E+04	0.000E+00	1.070E+00
ZN-65	4.260E+04	1.130E+05	0.000E+00	7.140E+04	9.950E+05	1.630E+04	0.000E+00	7.030E+04
ZN-69	6.700E-02	9.660E-02	0.000E+00	5.850E-02	1.420E+03	1.020E+04	0.000E+00	8.920E-03
BR-83	0.000E+00	0.000E+00	0.000E+00	0.000E+00	0.000E+00	0.000E+00	0.000E+00	4.740E+02
BR-84	0.000E+00	0.000E+00	0.000E+00	0.000E+00	0.000E+00	0.000E+00	0.000E+00	5.480E+02
BR-85	0.000E+00	0.000E+00	0.000E+00	0.000E+00	0.000E+00	0.000E+00	0.000E+00	2.530E+01
RB-86	0.000E+00	1.980E+05	0.000E+00	0.000E+00	0.000E+00	7.990E+03	0.000E+00	1.140E+05
RB-88	0.000E+00	5.620E+02	0.000E+00	0.000E+00	0.000E+00	1.720E+01	0.000E+00	3.660E+02
RB-89	0.000E+00	3.450E+02	0.000E+00	0.000E+00	0.000E+00	1.890E+00	0.000E+00	2.900E+02
SR-89	5.990E+05	0.000E+00	0.000E+00	0.000E+00	2.160E+06	1.670E+05	0.000E+00	1.720E+04
SR-90	1.010E+08	0.000E+00	0.000E+00	0.000E+00	1.480E+07	3.430E+05	0.000E+00	6.440E+06
SR-91	1.210E+02	0.000E+00	0.000E+00	0.000E+00	5.330E+04	1.740E+05	0.000E+00	4.590E+00

Catawba Nuclear Station Units 1 & 2
Period 1/1/2016 - 12/31/2016

Catawba Nuclear Station
Offsite Dose Calculation Manual (ODCM)

APPENDIX B

P_i Dose Factors for use in the Gaseous Release Rate Limit Calculations

Agegroup:	CHILD	Pathway:	Inhalation (INHL)			Units:	mrem/yr / $\mu\text{Ci}/\text{m}^3$	
Nuclide	Bone	Liver	Thyroid	Kidney	Lung	Gilli	Skin	Total Body
SR-92	1.310E+01	0.000E+00	0.000E+00	0.000E+00	2.400E+04	2.420E+05	0.000E+00	5.250E-01
Y-90	4.110E+03	0.000E+00	0.000E+00	0.000E+00	2.620E+05	2.680E+05	0.000E+00	1.110E+02
Y-91	9.140E+05	0.000E+00	0.000E+00	0.000E+00	2.630E+06	1.840E+05	0.000E+00	2.440E+04
Y-91M	5.070E-01	0.000E+00	0.000E+00	0.000E+00	2.810E+03	1.720E+03	0.000E+00	1.840E-02
Y-92	2.030E+01	0.000E+00	0.000E+00	0.000E+00	2.390E+04	2.390E+05	0.000E+00	5.810E-01
Y-93	1.860E+02	0.000E+00	0.000E+00	0.000E+00	7.440E+04	3.880E+05	0.000E+00	5.110E+00
ZR-95	1.900E+05	4.180E+04	0.000E+00	5.960E+04	2.230E+06	6.110E+04	0.000E+00	3.700E+04
ZR-97	1.880E+02	2.720E+01	0.000E+00	3.880E+01	1.130E+05	3.510E+05	0.000E+00	1.600E+01
NB-95	2.350E+04	9.180E+03	0.000E+00	8.620E+03	6.140E+05	3.700E+04	0.000E+00	6.550E+03
MO-99	0.000E+00	1.720E+02	0.000E+00	3.920E+02	1.350E+05	1.270E+05	0.000E+00	4.260E+01
TC-99M	1.780E-03	3.480E-03	0.000E+00	5.070E-02	9.510E+02	4.810E+03	0.000E+00	5.770E-02
TC-101	8.100E-05	8.510E-05	0.000E+00	1.450E-03	5.850E+02	1.630E+01	0.000E+00	1.080E-03
RU-103	2.790E+03	0.000E+00	0.000E+00	7.030E+03	6.620E+05	4.480E+04	0.000E+00	1.070E+03
RU-105	1.530E+00	0.000E+00	0.000E+00	1.340E+00	1.590E+04	9.950E+04	0.000E+00	5.550E-01
RU-106	1.360E+05	0.000E+00	0.000E+00	1.840E+05	1.430E+07	4.290E+05	0.000E+00	1.690E+04
AG-110M	1.690E+04	1.140E+04	0.000E+00	2.120E+04	5.480E+06	1.000E+05	0.000E+00	9.140E+03
TE-125M	6.730E+03	2.330E+03	1.920E+03	0.000E+00	4.770E+05	3.380E+04	0.000E+00	9.140E+02
TE-127	2.770E+00	9.510E-01	1.960E+00	7.070E+00	1.000E+04	5.620E+04	0.000E+00	6.100E-01
TE-127M	2.490E+04	8.550E+03	6.070E+03	6.360E+04	1.480E+06	7.140E+04	0.000E+00	3.020E+03
TE-129	9.770E-02	3.500E-02	7.140E-02	2.570E-01	2.930E+03	2.550E+04	0.000E+00	2.380E-02
TE-129M	1.920E+04	6.840E+03	6.330E+03	5.030E+04	1.760E+06	1.820E+05	0.000E+00	3.040E+03
TE-131	2.170E-02	8.440E-03	1.700E-02	5.880E-02	2.050E+03	1.330E+03	0.000E+00	6.590E-03
TE-131M	1.340E+02	5.920E+01	9.770E+01	4.000E+02	2.060E+05	3.080E+05	0.000E+00	5.070E+01
TE-132	4.810E+02	2.720E+02	3.170E+02	1.770E+03	3.770E+05	1.380E+05	0.000E+00	2.630E+02
I-130	8.180E+03	1.640E+04	1.850E+06	2.450E+04	0.000E+00	5.110E+03	0.000E+00	8.440E+03

Catawba Nuclear Station Units 1 & 2
Period 1/1/2016 - 12/31/2016

Catawba Nuclear Station
Offsite Dose Calculation Manual (ODCM)

APPENDIX B

P_i Dose Factors for use in the Gaseous Release Rate Limit Calculations

Agegroup:	CHILD	Pathway:	Inhalation (INHL)			Units:	mrem/yr / $\mu\text{Ci}/\text{m}^3$	
Nuclide	Bone	Liver	Thyroid	Kidney	Lung	Gilli	Skin	Total Body
I-131	4.810E+04	4.810E+04	1.620E+07	7.880E+04	0.000E+00	2.840E+03	0.000E+00	2.730E+04
I-132	2.120E+03	4.070E+03	1.940E+05	6.250E+03	0.000E+00	3.200E+03	0.000E+00	1.880E+03
I-133	1.660E+04	2.030E+04	3.850E+06	3.380E+04	0.000E+00	5.480E+03	0.000E+00	7.700E+03
I-134	1.170E+03	2.160E+03	5.070E+04	3.300E+03	0.000E+00	9.550E+02	0.000E+00	9.950E+02
I-135	4.920E+03	8.730E+03	7.920E+05	1.340E+04	0.000E+00	4.440E+03	0.000E+00	4.140E+03
CS-134	6.510E+05	1.010E+06	0.000E+00	3.300E+05	1.210E+05	3.850E+03	0.000E+00	2.250E+05
CS-136	6.510E+04	1.710E+05	0.000E+00	9.550E+04	1.450E+04	4.180E+03	0.000E+00	1.160E+05
CS-137	9.060E+05	8.250E+05	0.000E+00	2.820E+05	1.040E+05	3.620E+03	0.000E+00	1.280E+05
CS-138	6.330E+02	8.400E+02	0.000E+00	6.220E+02	6.810E+01	2.700E+02	0.000E+00	5.550E+02
BA-139	1.840E+00	9.840E-04	0.000E+00	8.620E-04	5.770E+03	5.770E+04	0.000E+00	5.360E-02
BA-140	7.400E+04	6.480E+01	0.000E+00	2.110E+01	1.740E+06	1.020E+05	0.000E+00	4.330E+03
BA-141	1.960E-01	1.090E-04	0.000E+00	9.470E-05	2.920E+03	2.750E+02	0.000E+00	6.360E-03
BA-142	5.000E-02	3.600E-05	0.000E+00	2.910E-05	1.640E+03	2.740E+00	0.000E+00	2.790E-03
LA-140	6.440E+02	2.250E+02	0.000E+00	0.000E+00	1.830E+05	2.260E+05	0.000E+00	7.550E+01
LA-142	1.300E+00	4.110E-01	0.000E+00	0.000E+00	8.700E+03	7.580E+04	0.000E+00	1.290E-01
CE-141	3.920E+04	1.950E+04	0.000E+00	8.550E+03	5.440E+05	5.660E+04	0.000E+00	2.900E+03
CE-143	3.660E+02	1.990E+02	0.000E+00	8.360E+01	1.150E+05	1.270E+05	0.000E+00	2.870E+01
CE-144	6.770E+06	2.120E+06	0.000E+00	1.170E+06	1.200E+07	3.880E+05	0.000E+00	3.610E+05
PR-143	1.850E+04	5.550E+03	0.000E+00	3.000E+03	4.330E+05	9.730E+04	0.000E+00	9.140E+02
PR-144	5.960E-02	1.850E-02	0.000E+00	9.770E-03	1.570E+03	1.970E+02	0.000E+00	3.000E-03
ND-147	1.080E+04	8.730E+03	0.000E+00	4.810E+03	3.280E+05	8.210E+04	0.000E+00	6.810E+02
W-187	1.630E+01	9.660E+00	0.000E+00	0.000E+00	4.110E+04	9.100E+04	0.000E+00	4.330E+00
NP-239	4.660E+02	3.340E+01	0.000E+00	9.730E+01	5.810E+04	6.400E+04	0.000E+00	2.350E+01

Catawba Nuclear Station Units 1 & 2
Period 1/1/2016 - 12/31/2016

Catawba Nuclear Station
Offsite Dose Calculation Manual (ODCM)

APPENDIX C

A_i Adult Dose Factors for use in the Liquid Dose Calculations

Agegroup:	ADULT	Pathway:	Potable Water (PWtr)			Units:	mrem/hr / μCi/ml	
Nuclide	Bone	Liver	Thyroid	Kidney	Lung	Gilli	Skin	Total Body
H-3	0.000E+00	8.740E+00	8.740E+00	8.740E+00	8.740E+00	8.740E+00	0.000E+00	8.740E+00
C-14	2.360E+02	4.730E+01	4.730E+01	4.730E+01	4.730E+01	4.730E+01	0.000E+00	4.730E+01
NA-24	8.140E+01	8.140E+01	8.140E+01	8.140E+01	8.140E+01	8.140E+01	0.000E+00	8.140E+01
P-32	1.570E+04	9.750E+02	0.000E+00	0.000E+00	0.000E+00	1.760E+03	0.000E+00	6.060E+02
CR-51	0.000E+00	0.000E+00	1.310E-01	4.820E-02	2.900E-01	5.500E+01	0.000E+00	2.190E-01
MN-54	0.000E+00	3.800E+02	0.000E+00	1.130E+02	0.000E+00	1.160E+03	0.000E+00	7.250E+01
MN-56	0.000E+00	3.800E-01	0.000E+00	4.820E-01	0.000E+00	1.210E+01	0.000E+00	6.740E-02
FE-55	2.290E+02	1.580E+02	0.000E+00	0.000E+00	8.820E+01	9.070E+01	0.000E+00	3.690E+01
FE-59	3.580E+02	8.420E+02	0.000E+00	0.000E+00	2.350E+02	2.810E+03	0.000E+00	3.230E+02
CO-58	0.000E+00	6.170E+01	0.000E+00	0.000E+00	0.000E+00	1.250E+03	0.000E+00	1.380E+02
CO-60	0.000E+00	1.780E+02	0.000E+00	0.000E+00	0.000E+00	3.340E+03	0.000E+00	3.930E+02
NI-63	1.080E+04	7.500E+02	0.000E+00	0.000E+00	0.000E+00	1.560E+02	0.000E+00	3.630E+02
NI-65	1.620E+00	2.100E-01	0.000E+00	0.000E+00	0.000E+00	5.340E+00	0.000E+00	9.600E-02
CU-64	0.000E+00	3.590E+00	0.000E+00	9.060E+00	0.000E+00	3.060E+02	0.000E+00	1.690E+00
ZN-65	4.020E+02	1.280E+03	0.000E+00	8.560E+02	0.000E+00	8.060E+02	0.000E+00	5.780E+02
ZN-69	1.070E-04	2.050E-04	0.000E+00	1.330E-04	0.000E+00	3.080E-05	0.000E+00	1.430E-05
BR-83	0.000E+00	0.000E+00	0.000E+00	0.000E+00	0.000E+00	1.480E-01	0.000E+00	1.030E-01
BR-84	0.000E+00	0.000E+00	0.000E+00	0.000E+00	0.000E+00	5.270E-12	0.000E+00	6.710E-07
BR-85	0.000E+00	0.000E+00	0.000E+00	0.000E+00	0.000E+00	0.000E+00	0.000E+00	4.380E-77
RB-86	0.000E+00	1.720E+03	0.000E+00	0.000E+00	0.000E+00	3.400E+02	0.000E+00	8.030E+02
RB-88	0.000E+00	3.360E-12	0.000E+00	0.000E+00	0.000E+00	4.640E-23	0.000E+00	1.780E-12
RB-89	0.000E+00	3.090E-14	0.000E+00	0.000E+00	0.000E+00	1.790E-27	0.000E+00	2.170E-14
SR-89	2.550E+04	0.000E+00	0.000E+00	0.000E+00	0.000E+00	4.080E+03	0.000E+00	7.310E+02
SR-90	6.310E+05	0.000E+00	0.000E+00	0.000E+00	0.000E+00	1.820E+04	0.000E+00	1.550E+05
SR-91	1.960E+02	0.000E+00	0.000E+00	0.000E+00	0.000E+00	9.350E+02	0.000E+00	7.930E+00

Catawba Nuclear Station Units 1 & 2
Period 1/1/2016 - 12/31/2016

Catawba Nuclear Station
Offsite Dose Calculation Manual (ODCM)

APPENDIX C

A_i Adult Dose Factors for use in the Liquid Dose Calculations

Agegroup:	ADULT	Pathway:	Potable Water (PWtr)			Units:	mrem/hr / μCi/ml	
Nuclide	Bone	Liver	Thyroid	Kidney	Lung	Gilli	Skin	Total Body
SR-92	8.290E+00	0.000E+00	0.000E+00	0.000E+00	0.000E+00	1.640E+02	0.000E+00	3.590E-01
Y-90	7.030E-01	0.000E+00	0.000E+00	0.000E+00	0.000E+00	7.460E+03	0.000E+00	1.890E-02
Y-91	1.170E+01	0.000E+00	0.000E+00	0.000E+00	0.000E+00	6.420E+03	0.000E+00	3.120E-01
Y-91M	3.360E-07	0.000E+00	0.000E+00	0.000E+00	0.000E+00	9.860E-07	0.000E+00	1.300E-08
Y-92	6.710E-03	0.000E+00	0.000E+00	0.000E+00	0.000E+00	1.170E+02	0.000E+00	1.960E-04
Y-93	9.770E-02	0.000E+00	0.000E+00	0.000E+00	0.000E+00	3.100E+03	0.000E+00	2.700E-03
ZR-95	2.520E+00	8.070E-01	0.000E+00	1.270E+00	0.000E+00	2.560E+03	0.000E+00	5.460E-01
ZR-97	8.540E-02	1.720E-02	0.000E+00	2.600E-02	0.000E+00	5.340E+03	0.000E+00	7.880E-03
NB-95	5.130E-01	2.850E-01	0.000E+00	2.820E-01	0.000E+00	1.730E+03	0.000E+00	1.530E-01
MO-99	0.000E+00	3.160E+02	0.000E+00	7.160E+02	0.000E+00	7.330E+02	0.000E+00	6.020E+01
TC-99M	5.160E-03	1.460E-02	0.000E+00	2.210E-01	7.140E-03	8.630E+00	0.000E+00	1.860E-01
TC-101	1.130E-17	1.630E-17	0.000E+00	2.930E-16	8.320E-18	4.890E-29	0.000E+00	1.600E-16
RU-103	1.530E+01	0.000E+00	0.000E+00	5.820E+01	0.000E+00	1.780E+03	0.000E+00	6.570E+00
RU-105	1.970E-01	0.000E+00	0.000E+00	2.540E+00	0.000E+00	1.200E+02	0.000E+00	7.760E-02
RU-106	2.290E+02	0.000E+00	0.000E+00	4.410E+02	0.000E+00	1.480E+04	0.000E+00	2.890E+01
AG-110M	1.330E+01	1.230E+01	0.000E+00	2.420E+01	0.000E+00	5.020E+03	0.000E+00	7.300E+00
TE-125M	2.220E+02	8.030E+01	6.670E+01	9.020E+02	0.000E+00	8.850E+02	0.000E+00	2.970E+01
TE-127	3.780E+00	1.360E+00	2.800E+00	1.540E+01	0.000E+00	2.980E+02	0.000E+00	8.170E-01
TE-127M	5.620E+02	2.010E+02	1.440E+02	2.280E+03	0.000E+00	1.880E+03	0.000E+00	6.840E+01
TE-129	1.920E-03	7.230E-04	1.480E-03	8.080E-03	0.000E+00	1.450E-03	0.000E+00	4.690E-04
TE-129M	9.470E+02	3.530E+02	3.250E+02	3.950E+03	0.000E+00	4.770E+03	0.000E+00	1.500E+02
TE-131	3.520E-09	1.470E-09	2.900E-09	1.540E-08	0.000E+00	4.990E-10	0.000E+00	1.110E-09
TE-131M	1.090E+02	5.340E+01	8.450E+01	5.400E+02	0.000E+00	5.300E+03	0.000E+00	4.450E+01
TE-132	1.880E+02	1.220E+02	1.350E+02	1.170E+03	0.000E+00	5.770E+03	0.000E+00	1.140E+02
I-130	3.210E+01	9.460E+01	8.020E+03	1.480E+02	0.000E+00	8.140E+01	0.000E+00	3.730E+01

Catawba Nuclear Station Units 1 & 2
Period 1/1/2016 - 12/31/2016

Catawba Nuclear Station
Offsite Dose Calculation Manual (ODCM)

APPENDIX C

A_i Adult Dose Factors for use in the Liquid Dose Calculations

Agegroup:	ADULT	Pathway:	Potable Water (PWtr)			Units:	mrem/hr / μ Ci/ml	
	Nuclide		Bone	Liver	Thyroid		Kidney	Lung
I-131	3.320E+02	4.740E+02	1.550E+05	8.130E+02	0.000E+00	1.250E+02	0.000E+00	2.720E+02
I-132	4.540E-01	1.220E+00	4.250E+01	1.940E+00	0.000E+00	2.280E-01	0.000E+00	4.250E-01
I-133	7.920E+01	1.380E+02	2.020E+04	2.400E+02	0.000E+00	1.240E+02	0.000E+00	4.200E+01
I-134	6.580E-04	1.790E-03	3.100E-02	2.840E-03	0.000E+00	1.560E-06	0.000E+00	6.390E-04
I-135	1.050E+01	2.750E+01	1.810E+03	4.400E+01	0.000E+00	3.100E+01	0.000E+00	1.010E+01
CS-134	5.170E+03	1.230E+04	0.000E+00	3.980E+03	1.320E+03	2.150E+02	0.000E+00	1.010E+04
CS-136	5.280E+02	2.080E+03	0.000E+00	1.160E+03	1.590E+02	2.370E+02	0.000E+00	1.500E+03
CS-137	6.630E+03	9.070E+03	0.000E+00	3.080E+03	1.020E+03	1.760E+02	0.000E+00	5.940E+03
CS-138	8.450E-07	1.670E-06	0.000E+00	1.230E-06	1.210E-07	7.120E-12	0.000E+00	8.260E-07
BA-139	1.990E-02	1.420E-05	0.000E+00	1.330E-05	8.050E-06	3.530E-02	0.000E+00	5.830E-04
BA-140	1.640E+03	2.070E+00	0.000E+00	7.020E-01	1.180E+00	3.390E+03	0.000E+00	1.080E+02
BA-141	5.440E-12	4.120E-15	0.000E+00	3.830E-15	2.340E-15	2.570E-21	0.000E+00	1.840E-13
BA-142	6.290E-21	6.470E-24	0.000E+00	5.460E-24	3.660E-24	8.860E-39	0.000E+00	3.960E-22
LA-140	1.690E-01	8.530E-02	0.000E+00	0.000E+00	0.000E+00	6.260E+03	0.000E+00	2.250E-02
LA-142	5.720E-05	2.600E-05	0.000E+00	0.000E+00	0.000E+00	1.900E-01	0.000E+00	6.480E-06
CE-141	7.710E-01	5.210E-01	0.000E+00	2.420E-01	0.000E+00	1.990E+03	0.000E+00	5.910E-02
CE-143	1.070E-01	7.890E+01	0.000E+00	3.470E-02	0.000E+00	2.950E+03	0.000E+00	8.730E-03
CE-144	4.060E+01	1.700E+01	0.000E+00	1.010E+01	0.000E+00	1.370E+04	0.000E+00	2.180E+00
PR-143	7.460E-01	2.990E-01	0.000E+00	1.730E-01	0.000E+00	3.270E+03	0.000E+00	3.700E-02
PR-144	7.350E-16	3.050E-16	0.000E+00	1.720E-16	0.000E+00	1.060E-22	0.000E+00	3.730E-17
ND-147	5.070E-01	5.860E-01	0.000E+00	3.430E-01	0.000E+00	2.810E+03	0.000E+00	3.510E-02
W-187	6.050E+00	5.050E+00	0.000E+00	0.000E+00	0.000E+00	1.660E+03	0.000E+00	1.770E+00
NP-239	8.550E-02	8.400E-03	0.000E+00	2.620E-02	0.000E+00	1.720E+03	0.000E+00	4.630E-03

Catawba Nuclear Station Units 1 & 2
Period 1/1/2016 - 12/31/2016

Catawba Nuclear Station
Offsite Dose Calculation Manual (ODCM)

APPENDIX C

A_i Adult Dose Factors for use in the Liquid Dose Calculations

Agegroup:	ADULT	Pathway:	Fresh Water Fish - Sport (FFSP)			Units:	mrem/hr / μCi/ml	
Nuclide	Bone	Liver	Thyroid	Kidney	Lung	Gilli	Skin	Total Body
H-3	0.000E+00	2.260E-01	2.260E-01	2.260E-01	2.260E-01	2.260E-01	0.000E+00	2.260E-01
C-14	3.130E+04	6.260E+03	6.260E+03	6.260E+03	6.260E+03	6.260E+03	0.000E+00	6.260E+03
NA-24	1.350E+02	1.350E+02	1.350E+02	1.350E+02	1.350E+02	1.350E+02	0.000E+00	1.350E+02
P-32	1.320E+06	8.210E+04	0.000E+00	0.000E+00	0.000E+00	1.480E+05	0.000E+00	5.100E+04
CR-51	0.000E+00	0.000E+00	7.420E-01	2.740E-01	1.650E+00	3.120E+02	0.000E+00	1.240E+00
MN-54	0.000E+00	4.370E+03	0.000E+00	1.300E+03	0.000E+00	1.340E+04	0.000E+00	8.330E+02
MN-56	0.000E+00	1.730E-01	0.000E+00	2.200E-01	0.000E+00	5.530E+00	0.000E+00	3.070E-02
FE-55	6.580E+02	4.550E+02	0.000E+00	0.000E+00	2.540E+02	2.610E+02	0.000E+00	1.060E+02
FE-59	1.020E+03	2.400E+03	0.000E+00	0.000E+00	6.720E+02	8.010E+03	0.000E+00	9.220E+02
CO-58	0.000E+00	8.830E+01	0.000E+00	0.000E+00	0.000E+00	1.790E+03	0.000E+00	1.980E+02
CO-60	0.000E+00	2.560E+02	0.000E+00	0.000E+00	0.000E+00	4.810E+03	0.000E+00	5.650E+02
NI-63	3.110E+04	2.160E+03	0.000E+00	0.000E+00	0.000E+00	4.500E+02	0.000E+00	1.040E+03
NI-65	1.720E-01	2.230E-02	0.000E+00	0.000E+00	0.000E+00	5.660E-01	0.000E+00	1.020E-02
CU-64	0.000E+00	2.680E+00	0.000E+00	6.760E+00	0.000E+00	2.290E+02	0.000E+00	1.260E+00
ZN-65	2.310E+04	7.350E+04	0.000E+00	4.920E+04	0.000E+00	4.630E+04	0.000E+00	3.320E+04
ZN-69	7.730E-07	1.480E-06	0.000E+00	9.610E-07	0.000E+00	2.220E-07	0.000E+00	1.030E-07
BR-83	0.000E+00	0.000E+00	0.000E+00	0.000E+00	0.000E+00	5.500E-02	0.000E+00	3.820E-02
BR-84	0.000E+00	0.000E+00	0.000E+00	0.000E+00	0.000E+00	9.850E-18	0.000E+00	1.250E-12
BR-85	0.000E+00	0.000E+00	0.000E+00	0.000E+00	0.000E+00	0.000E+00	0.000E+00	0.000E+00
RB-86	0.000E+00	9.730E+04	0.000E+00	0.000E+00	0.000E+00	1.920E+04	0.000E+00	4.530E+04
RB-88	0.000E+00	1.290E-22	0.000E+00	0.000E+00	0.000E+00	1.780E-33	0.000E+00	6.830E-23
RB-89	0.000E+00	1.640E-26	0.000E+00	0.000E+00	0.000E+00	9.560E-40	0.000E+00	1.160E-26
SR-89	2.180E+04	0.000E+00	0.000E+00	0.000E+00	0.000E+00	3.500E+03	0.000E+00	6.260E+02
SR-90	5.440E+05	0.000E+00	0.000E+00	0.000E+00	0.000E+00	1.570E+04	0.000E+00	1.340E+05
SR-91	7.050E+01	0.000E+00	0.000E+00	0.000E+00	0.000E+00	3.360E+02	0.000E+00	2.850E+00

Catawba Nuclear Station Units 1 & 2
Period 1/1/2016 - 12/31/2016

Catawba Nuclear Station
Offsite Dose Calculation Manual (ODCM)

APPENDIX C

A_i Adult Dose Factors for use in the Liquid Dose Calculations

Agegroup:	ADULT	Pathway:	Fresh Water Fish - Sport (FFSP)			Units:	mrem/hr / μCi/ml	
Nuclide	Bone	Liver	Thyroid	Kidney	Lung	Gilli	Skin	Total Body
SR-92	3.320E-01	0.000E+00	0.000E+00	0.000E+00	0.000E+00	6.570E+00	0.000E+00	1.430E-02
Y-90	4.440E-01	0.000E+00	0.000E+00	0.000E+00	0.000E+00	4.710E+03	0.000E+00	1.190E-02
Y-91	8.340E+00	0.000E+00	0.000E+00	0.000E+00	0.000E+00	4.590E+03	0.000E+00	2.230E-01
Y-91M	1.070E-11	0.000E+00	0.000E+00	0.000E+00	0.000E+00	3.150E-11	0.000E+00	4.150E-13
Y-92	4.600E-04	0.000E+00	0.000E+00	0.000E+00	0.000E+00	8.060E+00	0.000E+00	1.340E-05
Y-93	3.080E-02	0.000E+00	0.000E+00	0.000E+00	0.000E+00	9.770E+02	0.000E+00	8.500E-04
ZR-95	2.380E-01	7.620E-02	0.000E+00	1.200E-01	0.000E+00	2.410E+02	0.000E+00	5.160E-02
ZR-97	4.960E-03	1.000E-03	0.000E+00	1.510E-03	0.000E+00	3.100E+02	0.000E+00	4.570E-04
NB-95	4.380E+02	2.440E+02	0.000E+00	2.410E+02	0.000E+00	1.480E+06	0.000E+00	1.310E+02
MO-99	0.000E+00	8.020E+01	0.000E+00	1.820E+02	0.000E+00	1.860E+02	0.000E+00	1.530E+01
TC-99M	5.590E-04	1.580E-03	0.000E+00	2.400E-02	7.740E-04	9.340E-01	0.000E+00	2.010E-02
TC-101	2.610E-33	3.760E-33	0.000E+00	6.770E-32	1.920E-33	1.130E-44	0.000E+00	3.690E-32
RU-103	4.350E+00	0.000E+00	0.000E+00	1.660E+01	0.000E+00	5.080E+02	0.000E+00	1.870E+00
RU-105	8.670E-03	0.000E+00	0.000E+00	1.120E-01	0.000E+00	5.300E+00	0.000E+00	3.420E-03
RU-106	6.570E+01	0.000E+00	0.000E+00	1.270E+02	0.000E+00	4.250E+03	0.000E+00	8.320E+00
AG-110M	8.790E-01	8.130E-01	0.000E+00	1.600E+00	0.000E+00	3.320E+02	0.000E+00	4.830E-01
TE-125M	2.540E+03	9.190E+02	7.630E+02	1.030E+04	0.000E+00	1.010E+04	0.000E+00	3.400E+02
TE-127	1.790E+01	6.440E+00	1.330E+01	7.300E+01	0.000E+00	1.410E+03	0.000E+00	3.880E+00
TE-127M	6.440E+03	2.300E+03	1.650E+03	2.620E+04	0.000E+00	2.160E+04	0.000E+00	7.850E+02
TE-129	1.630E-05	6.120E-06	1.250E-05	6.850E-05	0.000E+00	1.230E-05	0.000E+00	3.970E-06
TE-129M	1.080E+04	4.020E+03	3.710E+03	4.500E+04	0.000E+00	5.430E+04	0.000E+00	1.710E+03
TE-131	8.710E-17	3.640E-17	7.160E-17	3.820E-16	0.000E+00	1.230E-17	0.000E+00	2.750E-17
TE-131M	9.510E+02	4.650E+02	7.370E+02	4.710E+03	0.000E+00	4.620E+04	0.000E+00	3.880E+02
TE-132	1.950E+03	1.260E+03	1.390E+03	1.210E+04	0.000E+00	5.960E+04	0.000E+00	1.180E+03
I-130	7.050E+00	2.080E+01	1.760E+03	3.250E+01	0.000E+00	1.790E+01	0.000E+00	8.210E+00

Catawba Nuclear Station Units 1 & 2
Period 1/1/2016 - 12/31/2016

Catawba Nuclear Station
Offsite Dose Calculation Manual (ODCM)

APPENDIX C

A_i Adult Dose Factors for use in the Liquid Dose Calculations

Agegroup:	ADULT	Pathway:	Fresh Water Fish - Sport (FFSP)			Units:	mrem/hr / μCi/ml	
Nuclide	Bone	Liver	Thyroid	Kidney	Lung	Gilli	Skin	Total Body
I-131	1.370E+02	1.960E+02	6.420E+04	3.360E+02	0.000E+00	5.170E+01	0.000E+00	1.120E+02
I-132	5.270E-03	1.410E-02	4.940E-01	2.250E-02	0.000E+00	2.650E-03	0.000E+00	4.940E-03
I-133	2.290E+01	3.990E+01	5.860E+03	6.950E+01	0.000E+00	3.580E+01	0.000E+00	1.210E+01
I-134	2.120E-08	5.750E-08	9.960E-07	9.140E-08	0.000E+00	5.010E-11	0.000E+00	2.060E-08
I-135	1.290E+00	3.370E+00	2.220E+02	5.410E+00	0.000E+00	3.810E+00	0.000E+00	1.240E+00
CS-134	2.980E+05	7.080E+05	0.000E+00	2.290E+05	7.610E+04	1.240E+04	0.000E+00	5.790E+05
CS-136	2.960E+04	1.170E+05	0.000E+00	6.500E+04	8.900E+03	1.330E+04	0.000E+00	8.400E+04
CS-137	3.820E+05	5.220E+05	0.000E+00	1.770E+05	5.890E+04	1.010E+04	0.000E+00	3.420E+05
CS-138	8.940E-12	1.770E-11	0.000E+00	1.300E-11	1.280E-12	7.530E-17	0.000E+00	8.750E-12
BA-139	5.650E-06	4.030E-09	0.000E+00	3.760E-09	2.280E-09	1.000E-05	0.000E+00	1.660E-07
BA-140	1.840E+02	2.310E-01	0.000E+00	7.860E-02	1.320E-01	3.790E+02	0.000E+00	1.210E+01
BA-141	8.700E-25	6.580E-28	0.000E+00	6.120E-28	3.730E-28	4.100E-34	0.000E+00	2.940E-26
BA-142	2.570E-42	2.640E-45	0.000E+00	2.230E-45	1.490E-45	3.620E-60	0.000E+00	1.610E-43
LA-140	9.900E-02	4.990E-02	0.000E+00	0.000E+00	0.000E+00	3.660E+03	0.000E+00	1.320E-02
LA-142	2.210E-07	1.000E-07	0.000E+00	0.000E+00	0.000E+00	7.330E-04	0.000E+00	2.500E-08
CE-141	2.190E-02	1.480E-02	0.000E+00	6.890E-03	0.000E+00	5.670E+01	0.000E+00	1.680E-03
CE-143	2.380E-03	1.760E+00	0.000E+00	7.760E-04	0.000E+00	6.590E+01	0.000E+00	1.950E-04
CE-144	1.170E+00	4.870E-01	0.000E+00	2.890E-01	0.000E+00	3.940E+02	0.000E+00	6.260E-02
PR-143	5.230E-01	2.100E-01	0.000E+00	1.210E-01	0.000E+00	2.290E+03	0.000E+00	2.590E-02
PR-144	1.550E-28	6.440E-29	0.000E+00	3.630E-29	0.000E+00	2.230E-35	0.000E+00	7.880E-30
ND-147	3.530E-01	4.080E-01	0.000E+00	2.390E-01	0.000E+00	1.960E+03	0.000E+00	2.440E-02
W-187	1.470E+02	1.230E+02	0.000E+00	0.000E+00	0.000E+00	4.030E+04	0.000E+00	4.300E+01
NP-239	2.120E-02	2.090E-03	0.000E+00	6.510E-03	0.000E+00	4.280E+02	0.000E+00	1.150E-03

Catawba Nuclear Station Units 1 & 2
Period 1/1/2016 - 12/31/2016

Catawba Nuclear Station
Offsite Dose Calculation Manual (ODCM)

APPENDIX C

A_i Adult Dose Factors for use in the Liquid Dose Calculations

Agegroup:	ADULT	Pathway:	Shoreline Sediment (SHDp)			Units:	mrem/hr / μCi/ml	
Nuclide	Bone	Liver	Thyroid	Kidney	Lung	Gilli	Skin	Total Body
H-3	0.000E+00	0.000E+00	0.000E+00	0.000E+00	0.000E+00	0.000E+00	0.000E+00	0.000E+00
C-14	0.000E+00	0.000E+00	0.000E+00	0.000E+00	0.000E+00	0.000E+00	0.000E+00	0.000E+00
NA-24	6.410E-01	6.410E-01	6.410E-01	6.410E-01	6.410E-01	6.410E-01	7.440E-01	6.410E-01
P-32	0.000E+00	0.000E+00	0.000E+00	0.000E+00	0.000E+00	0.000E+00	0.000E+00	0.000E+00
CR-51	2.500E-01	2.500E-01	2.500E-01	2.500E-01	2.500E-01	2.500E-01	2.960E-01	2.500E-01
MN-54	7.440E+01	7.440E+01	7.440E+01	7.440E+01	7.440E+01	7.440E+01	8.720E+01	7.440E+01
MN-56	4.840E-02	4.840E-02	4.840E-02	4.840E-02	4.840E-02	4.840E-02	5.720E-02	4.840E-02
FE-55	0.000E+00	0.000E+00	0.000E+00	0.000E+00	0.000E+00	0.000E+00	0.000E+00	0.000E+00
FE-59	1.460E+01	1.460E+01	1.460E+01	1.460E+01	1.460E+01	1.460E+01	1.720E+01	1.460E+01
CO-58	2.030E+01	2.030E+01	2.030E+01	2.030E+01	2.030E+01	2.030E+01	2.380E+01	2.030E+01
CO-60	1.150E+03	1.150E+03	1.150E+03	1.150E+03	1.150E+03	1.150E+03	1.360E+03	1.150E+03
NI-63	0.000E+00	0.000E+00	0.000E+00	0.000E+00	0.000E+00	0.000E+00	0.000E+00	0.000E+00
NI-65	1.590E-02	1.590E-02	1.590E-02	1.590E-02	1.590E-02	1.590E-02	1.850E-02	1.590E-02
CU-64	3.260E-02	3.260E-02	3.260E-02	3.260E-02	3.260E-02	3.260E-02	3.690E-02	3.260E-02
ZN-65	4.010E+01	4.010E+01	4.010E+01	4.010E+01	4.010E+01	4.010E+01	4.610E+01	4.010E+01
ZN-69	0.000E+00	0.000E+00	0.000E+00	0.000E+00	0.000E+00	0.000E+00	0.000E+00	0.000E+00
BR-83	2.620E-04	2.620E-04	2.620E-04	2.620E-04	2.620E-04	2.620E-04	3.800E-04	2.620E-04
BR-84	1.090E-02	1.090E-02	1.090E-02	1.090E-02	1.090E-02	1.090E-02	1.270E-02	1.090E-02
BR-85	0.000E+00	0.000E+00	0.000E+00	0.000E+00	0.000E+00	0.000E+00	0.000E+00	0.000E+00
RB-86	4.820E-01	4.820E-01	4.820E-01	4.820E-01	4.820E-01	4.820E-01	5.510E-01	4.820E-01
RB-88	1.780E-03	1.780E-03	1.780E-03	1.780E-03	1.780E-03	1.780E-03	2.030E-03	1.780E-03
RB-89	6.600E-03	6.600E-03	6.600E-03	6.600E-03	6.600E-03	6.600E-03	7.920E-03	6.600E-03
SR-89	1.160E-03	1.160E-03	1.160E-03	1.160E-03	1.160E-03	1.160E-03	1.350E-03	1.160E-03
SR-90	0.000E+00	0.000E+00	0.000E+00	0.000E+00	0.000E+00	0.000E+00	0.000E+00	0.000E+00
SR-91	1.150E-01	1.150E-01	1.150E-01	1.150E-01	1.150E-01	1.150E-01	1.350E-01	1.150E-01

Catawba Nuclear Station Units 1 & 2
Period 1/1/2016 - 12/31/2016

Catawba Nuclear Station
Offsite Dose Calculation Manual (ODCM)

APPENDIX C

A_i Adult Dose Factors for use in the Liquid Dose Calculations

Agegroup:	ADULT	Pathway:	Shoreline Sediment (SHDp)			Units:	mrem/hr / μCi/ml	
Nuclide	Bone	Liver	Thyroid	Kidney	Lung	Gilli	Skin	Total Body
SR-92	4.170E-02	4.170E-02	4.170E-02	4.170E-02	4.170E-02	4.170E-02	4.630E-02	4.170E-02
Y-90	2.410E-04	2.410E-04	2.410E-04	2.410E-04	2.410E-04	2.410E-04	2.850E-04	2.410E-04
Y-91	5.760E-02	5.760E-02	5.760E-02	5.760E-02	5.760E-02	5.760E-02	6.480E-02	5.760E-02
Y-91M	5.380E-03	5.380E-03	5.380E-03	5.380E-03	5.380E-03	5.380E-03	6.230E-03	5.380E-03
Y-92	9.680E-03	9.680E-03	9.680E-03	9.680E-03	9.680E-03	9.680E-03	1.150E-02	9.680E-03
Y-93	9.840E-03	9.840E-03	9.840E-03	9.840E-03	9.840E-03	9.840E-03	1.350E-02	9.840E-03
ZR-95	1.310E+01	1.310E+01	1.310E+01	1.310E+01	1.310E+01	1.310E+01	1.520E+01	1.310E+01
ZR-97	1.590E-01	1.590E-01	1.590E-01	1.590E-01	1.590E-01	1.590E-01	1.850E-01	1.590E-01
NB-95	7.340E+00	7.340E+00	7.340E+00	7.340E+00	7.340E+00	7.340E+00	8.630E+00	7.340E+00
MO-99	2.140E-01	2.140E-01	2.140E-01	2.140E-01	2.140E-01	2.140E-01	2.480E-01	2.140E-01
TC-99M	9.880E-03	9.880E-03	9.880E-03	9.880E-03	9.880E-03	9.880E-03	1.130E-02	9.880E-03
TC-101	1.090E-03	1.090E-03	1.090E-03	1.090E-03	1.090E-03	1.090E-03	1.210E-03	1.090E-03
RU-103	5.810E+00	5.810E+00	5.810E+00	5.810E+00	5.810E+00	5.810E+00	6.780E+00	5.810E+00
RU-105	3.420E-02	3.420E-02	3.420E-02	3.420E-02	3.420E-02	3.420E-02	3.870E-02	3.420E-02
RU-106	2.270E+01	2.270E+01	2.270E+01	2.270E+01	2.270E+01	2.270E+01	2.720E+01	2.270E+01
AG-110M	1.850E+02	1.850E+02	1.850E+02	1.850E+02	1.850E+02	1.850E+02	2.150E+02	1.850E+02
TE-125M	8.330E-02	8.330E-02	8.330E-02	8.330E-02	8.330E-02	8.330E-02	1.140E-01	8.330E-02
TE-127	1.600E-04	1.600E-04	1.600E-04	1.600E-04	1.600E-04	1.600E-04	1.760E-04	1.600E-04
TE-127M	4.920E-03	4.920E-03	4.920E-03	4.920E-03	4.920E-03	4.920E-03	5.810E-03	4.920E-03
TE-129	1.410E-03	1.410E-03	1.410E-03	1.410E-03	1.410E-03	1.410E-03	1.670E-03	1.410E-03
TE-129M	1.060E+00	1.060E+00	1.060E+00	1.060E+00	1.060E+00	1.060E+00	1.240E+00	1.060E+00
TE-131	1.570E-03	1.570E-03	1.570E-03	1.570E-03	1.570E-03	1.570E-03	1.850E+00	1.570E-03
TE-131M	4.310E-01	4.310E-01	4.310E-01	4.310E-01	4.310E-01	4.310E-01	5.080E-01	4.310E-01
TE-132	2.270E-01	2.270E-01	2.270E-01	2.270E-01	2.270E-01	2.270E-01	2.670E-01	2.270E-01
I-130	2.960E-01	2.960E-01	2.960E-01	2.960E-01	2.960E-01	2.960E-01	3.590E-01	2.960E-01

Catawba Nuclear Station Units 1 & 2
Period 1/1/2016 - 12/31/2016

Catawba Nuclear Station
Offsite Dose Calculation Manual (ODCM)

APPENDIX C

A_i Adult Dose Factors for use in the Liquid Dose Calculations

Agegroup:	ADULT	Pathway:	Shoreline Sediment (SHDp)			Units:	mrem/hr / μCi/ml	
Nuclide	Bone	Liver	Thyroid	Kidney	Lung	Gilli	Skin	Total Body
I-131	9.240E-01	9.240E-01	9.240E-01	9.240E-01	9.240E-01	9.240E-01	1.120E+00	9.240E-01
I-132	6.680E-02	6.680E-02	6.680E-02	6.680E-02	6.680E-02	6.680E-02	7.860E-02	6.680E-02
I-133	1.320E-01	1.320E-01	1.320E-01	1.320E-01	1.320E-01	1.320E-01	1.600E-01	1.320E-01
I-134	2.400E-02	2.400E-02	2.400E-02	2.400E-02	2.400E-02	2.400E-02	2.850E-02	2.400E-02
I-135	1.360E-01	1.360E-01	1.360E-01	1.360E-01	1.360E-01	1.360E-01	1.580E-01	1.360E-01
CS-134	3.680E+02	3.680E+02	3.680E+02	3.680E+02	3.680E+02	3.680E+02	4.300E+02	3.680E+02
CS-136	8.100E+00	8.100E+00	8.100E+00	8.100E+00	8.100E+00	8.100E+00	9.180E+00	8.100E+00
CS-137	5.520E+02	5.520E+02	5.520E+02	5.520E+02	5.520E+02	5.520E+02	6.440E+02	5.520E+02
CS-138	1.930E-02	1.930E-02	1.930E-02	1.930E-02	1.930E-02	1.930E-02	2.200E-02	1.930E-02
BA-139	5.680E-03	5.680E-03	5.680E-03	5.680E-03	5.680E-03	5.680E-03	6.390E-03	5.680E-03
BA-140	1.100E+00	1.100E+00	1.100E+00	1.100E+00	1.100E+00	1.100E+00	1.260E+00	1.100E+00
BA-141	2.240E-03	2.240E-03	2.240E-03	2.240E-03	2.240E-03	2.240E-03	2.550E-03	2.240E-03
BA-142	2.410E-03	2.410E-03	2.410E-03	2.410E-03	2.410E-03	2.410E-03	2.740E-03	2.410E-03
LA-140	1.030E+00	1.030E+00	1.030E+00	1.030E+00	1.030E+00	1.030E+00	1.170E+00	1.030E+00
LA-142	4.080E-02	4.080E-02	4.080E-02	4.080E-02	4.080E-02	4.080E-02	4.890E-02	4.080E-02
CE-141	7.330E-01	7.330E-01	7.330E-01	7.330E-01	7.330E-01	7.330E-01	8.270E-01	7.330E-01
CE-143	1.240E-01	1.240E-01	1.240E-01	1.240E-01	1.240E-01	1.240E-01	1.410E-01	1.240E-01
CE-144	3.730E+00	3.730E+00	3.730E+00	3.730E+00	3.730E+00	3.730E+00	4.320E+00	3.730E+00
PR-143	0.000E+00	0.000E+00	0.000E+00	0.000E+00	0.000E+00	0.000E+00	0.000E+00	0.000E+00
PR-144	9.850E-05	9.850E-05	9.850E-05	9.850E-05	9.850E-05	9.850E-05	1.130E-04	9.850E-05
ND-147	4.510E-01	4.510E-01	4.510E-01	4.510E-01	4.510E-01	4.510E-01	5.410E-01	4.510E-01
W-187	1.260E-01	1.260E-01	1.260E-01	1.260E-01	1.260E-01	1.260E-01	1.470E-01	1.260E-01
NP-239	9.180E-02	9.180E-02	9.180E-02	9.180E-02	9.180E-02	9.180E-02	1.060E-01	9.180E-02

Catawba Nuclear Station Units 1 & 2
Period 1/1/2016 - 12/31/2016

Catawba Nuclear Station
Offsite Dose Calculation Manual (ODCM)

APPENDIX D

A_i Teen Factors for use in the Liquid Dose Calculations

Agegroup:	TEEN	Pathway:	Potable Water (PWtr)			Units:	mrem/hr / μCi/ml	
Nuclide	Bone	Liver	Thyroid	Kidney	Lung	Gilli	Skin	Total Body
H-3	0.000E+00	6.160E+00	6.160E+00	6.160E+00	6.160E+00	6.160E+00	0.000E+00	6.160E+00
C-14	2.360E+02	4.720E+01	4.720E+01	4.720E+01	4.720E+01	4.720E+01	0.000E+00	4.720E+01
NA-24	7.690E+01	7.690E+01	7.690E+01	7.690E+01	7.690E+01	7.690E+01	0.000E+00	7.690E+01
P-32	1.570E+04	9.700E+02	0.000E+00	0.000E+00	0.000E+00	1.320E+03	0.000E+00	6.070E+02
CR-51	0.000E+00	0.000E+00	1.150E-01	4.530E-02	2.950E-01	3.470E+01	0.000E+00	2.070E-01
MN-54	0.000E+00	3.430E+02	0.000E+00	1.020E+02	0.000E+00	7.030E+02	0.000E+00	6.790E+01
MN-56	0.000E+00	3.640E-01	0.000E+00	4.610E-01	0.000E+00	2.400E+01	0.000E+00	6.480E-02
FE-55	2.200E+02	1.560E+02	0.000E+00	0.000E+00	9.880E+01	6.740E+01	0.000E+00	3.630E+01
FE-59	3.390E+02	7.900E+02	0.000E+00	0.000E+00	2.490E+02	1.870E+03	0.000E+00	3.050E+02
CO-58	0.000E+00	5.620E+01	0.000E+00	0.000E+00	0.000E+00	7.750E+02	0.000E+00	1.300E+02
CO-60	0.000E+00	1.630E+02	0.000E+00	0.000E+00	0.000E+00	2.130E+03	0.000E+00	3.680E+02
NI-63	1.030E+04	7.270E+02	0.000E+00	0.000E+00	0.000E+00	1.160E+02	0.000E+00	3.490E+02
NI-65	1.610E+00	2.050E-01	0.000E+00	0.000E+00	0.000E+00	1.110E+01	0.000E+00	9.350E-02
CU-64	0.000E+00	3.470E+00	0.000E+00	8.770E+00	0.000E+00	2.690E+02	0.000E+00	1.630E+00
ZN-65	3.340E+02	1.160E+03	0.000E+00	7.430E+02	0.000E+00	4.920E+02	0.000E+00	5.420E+02
ZN-69	1.070E-04	2.040E-04	0.000E+00	1.330E-04	0.000E+00	3.760E-04	0.000E+00	1.430E-05
BR-83	0.000E+00	0.000E+00	0.000E+00	0.000E+00	0.000E+00	0.000E+00	0.000E+00	1.030E-01
BR-84	0.000E+00	0.000E+00	0.000E+00	0.000E+00	0.000E+00	0.000E+00	0.000E+00	6.500E-07
BR-85	0.000E+00	0.000E+00	0.000E+00	0.000E+00	0.000E+00	0.000E+00	0.000E+00	4.360E-77
RB-86	0.000E+00	1.700E+03	0.000E+00	0.000E+00	0.000E+00	2.520E+02	0.000E+00	7.990E+02
RB-88	0.000E+00	3.300E-12	0.000E+00	0.000E+00	0.000E+00	2.830E-19	0.000E+00	1.760E-12
RB-89	0.000E+00	2.960E-14	0.000E+00	0.000E+00	0.000E+00	4.540E-23	0.000E+00	2.090E-14
SR-89	2.540E+04	0.000E+00	0.000E+00	0.000E+00	0.000E+00	3.030E+03	0.000E+00	7.280E+02
SR-90	4.830E+05	0.000E+00	0.000E+00	0.000E+00	0.000E+00	1.350E+04	0.000E+00	1.190E+05
SR-91	1.950E+02	0.000E+00	0.000E+00	0.000E+00	0.000E+00	8.850E+02	0.000E+00	7.760E+00

Catawba Nuclear Station Units 1 & 2
Period 1/1/2016 - 12/31/2016

Catawba Nuclear Station
Offsite Dose Calculation Manual (ODCM)

APPENDIX D

A_i Teen Factors for use in the Liquid Dose Calculations

Agegroup:	TEEN	Pathway:	Potable Water (PWtr)			Units:	mrem/hr / μCi/ml	
Nuclide	Bone	Liver	Thyroid	Kidney	Lung	Gilli	Skin	Total Body
SR-92	8.220E+00	0.000E+00	0.000E+00	0.000E+00	0.000E+00	2.090E+02	0.000E+00	3.500E-01
Y-90	7.000E-01	0.000E+00	0.000E+00	0.000E+00	0.000E+00	5.770E+03	0.000E+00	1.880E-02
Y-91	1.160E+01	0.000E+00	0.000E+00	0.000E+00	0.000E+00	4.760E+03	0.000E+00	3.120E-01
Y-91M	3.330E-07	0.000E+00	0.000E+00	0.000E+00	0.000E+00	1.570E-05	0.000E+00	1.270E-08
Y-92	6.710E-03	0.000E+00	0.000E+00	0.000E+00	0.000E+00	1.840E+02	0.000E+00	1.940E-04
Y-93	9.760E-02	0.000E+00	0.000E+00	0.000E+00	0.000E+00	2.980E+03	0.000E+00	2.670E-03
ZR-95	2.380E+00	7.520E-01	0.000E+00	1.100E+00	0.000E+00	1.730E+03	0.000E+00	5.170E-01
ZR-97	8.420E-02	1.670E-02	0.000E+00	2.530E-02	0.000E+00	4.510E+03	0.000E+00	7.670E-03
NB-95	4.730E-01	2.630E-01	0.000E+00	2.540E-01	0.000E+00	1.120E+03	0.000E+00	1.440E-01
MO-99	0.000E+00	3.090E+02	0.000E+00	7.070E+02	0.000E+00	5.530E+02	0.000E+00	5.890E+01
TC-99M	4.840E-03	1.350E-02	0.000E+00	2.010E-01	7.500E-03	8.870E+00	0.000E+00	1.750E-01
TC-101	1.120E-17	1.590E-17	0.000E+00	2.880E-16	9.700E-18	2.720E-24	0.000E+00	1.560E-16
RU-103	1.470E+01	0.000E+00	0.000E+00	5.180E+01	0.000E+00	1.230E+03	0.000E+00	6.280E+00
RU-105	1.940E-01	0.000E+00	0.000E+00	2.450E+00	0.000E+00	1.570E+02	0.000E+00	7.540E-02
RU-106	2.280E+02	0.000E+00	0.000E+00	4.390E+02	0.000E+00	1.090E+04	0.000E+00	2.870E+01
AG-110M	1.190E+01	1.130E+01	0.000E+00	2.150E+01	0.000E+00	3.160E+03	0.000E+00	6.850E+00
TE-125M	2.210E+02	7.980E+01	6.180E+01	0.000E+00	0.000E+00	6.530E+02	0.000E+00	2.960E+01
TE-127	3.790E+00	1.340E+00	2.610E+00	1.530E+01	0.000E+00	2.930E+02	0.000E+00	8.150E-01
TE-127M	5.600E+02	1.990E+02	1.330E+02	2.270E+03	0.000E+00	1.400E+03	0.000E+00	6.660E+01
TE-129	1.920E-03	7.150E-04	1.370E-03	8.040E-03	0.000E+00	1.050E-02	0.000E+00	4.660E-04
TE-129M	9.380E+02	3.480E+02	3.030E+02	3.920E+03	0.000E+00	3.520E+03	0.000E+00	1.480E+02
TE-131	3.490E-09	1.440E-09	2.690E-09	1.520E-08	0.000E+00	2.860E-10	0.000E+00	1.090E-09
TE-131M	1.080E+02	5.150E+01	7.750E+01	5.380E+02	0.000E+00	4.140E+03	0.000E+00	4.300E+01
TE-132	1.820E+02	1.150E+02	1.220E+02	1.110E+03	0.000E+00	3.660E+03	0.000E+00	1.090E+02
I-130	3.050E+01	8.830E+01	7.200E+03	1.360E+02	0.000E+00	6.790E+01	0.000E+00	3.530E+01

Catawba Nuclear Station Units 1 & 2
Period 1/1/2016 - 12/31/2016

Catawba Nuclear Station
Offsite Dose Calculation Manual (ODCM)

APPENDIX D

A_i Teen Factors for use in the Liquid Dose Calculations

Agegroup:	TEEN	Pathway:	Potable Water (PWtr)			Units:	mrem/hr / μCi/ml	
Nuclide	Bone	Liver	Thyroid	Kidney	Lung	Gilli	Skin	Total Body
I-131	3.260E+02	4.560E+02	1.330E+05	7.850E+02	0.000E+00	9.020E+01	0.000E+00	2.450E+02
I-132	4.360E-01	1.140E+00	3.850E+01	1.800E+00	0.000E+00	4.970E-01	0.000E+00	4.100E-01
I-133	7.830E+01	1.330E+02	1.860E+04	2.330E+02	0.000E+00	1.010E+02	0.000E+00	4.050E+01
I-134	6.330E-04	1.680E-03	2.800E-02	2.640E-03	0.000E+00	2.210E-05	0.000E+00	6.020E-04
I-135	1.010E+01	2.600E+01	1.670E+03	4.100E+01	0.000E+00	2.880E+01	0.000E+00	9.630E+00
CS-134	4.860E+03	1.140E+04	0.000E+00	3.640E+03	1.390E+03	1.420E+02	0.000E+00	5.310E+03
CS-136	4.860E+02	1.910E+03	0.000E+00	1.040E+03	1.640E+02	1.540E+02	0.000E+00	1.290E+03
CS-137	6.510E+03	8.660E+03	0.000E+00	2.950E+03	1.150E+03	1.230E+02	0.000E+00	3.020E+03
CS-138	8.300E-07	1.590E-06	0.000E+00	1.180E-06	1.370E-07	7.230E-10	0.000E+00	7.970E-07
BA-139	1.990E-02	1.400E-05	0.000E+00	1.320E-05	9.670E-06	1.780E-01	0.000E+00	5.810E-04
BA-140	1.610E+03	1.970E+00	0.000E+00	6.680E-01	1.320E+00	2.480E+03	0.000E+00	1.040E+02
BA-141	5.420E-12	4.050E-15	0.000E+00	3.760E-15	2.770E-15	1.150E-17	0.000E+00	1.810E-13
BA-142	6.170E-21	6.170E-24	0.000E+00	5.220E-24	4.100E-24	1.890E-32	0.000E+00	3.800E-22
LA-140	1.650E-01	8.090E-02	0.000E+00	0.000E+00	0.000E+00	4.640E+03	0.000E+00	2.150E-02
LA-142	5.590E-05	2.480E-05	0.000E+00	0.000E+00	0.000E+00	7.550E-01	0.000E+00	6.180E-06
CE-141	7.650E-01	5.110E-01	0.000E+00	2.400E-01	0.000E+00	1.460E+03	0.000E+00	5.870E-02
CE-143	1.060E-01	7.730E+01	0.000E+00	3.460E-02	0.000E+00	2.320E+03	0.000E+00	8.630E-03
CE-144	4.040E+01	1.670E+01	0.000E+00	9.990E+00	0.000E+00	1.020E+04	0.000E+00	2.170E+00
PR-143	7.420E-01	2.960E-01	0.000E+00	1.720E-01	0.000E+00	2.440E+03	0.000E+00	3.700E-02
PR-144	7.330E-16	3.000E-16	0.000E+00	1.720E-16	0.000E+00	8.080E-19	0.000E+00	3.720E-17
ND-147	5.280E-01	5.750E-01	0.000E+00	3.370E-01	0.000E+00	2.070E+03	0.000E+00	3.440E-02
W-187	5.990E+00	4.880E+00	0.000E+00	0.000E+00	0.000E+00	1.320E+03	0.000E+00	1.710E+00
NP-239	8.830E-02	8.330E-03	0.000E+00	2.610E-02	0.000E+00	1.340E+03	0.000E+00	4.630E-03

Catawba Nuclear Station Units 1 & 2
Period 1/1/2016 - 12/31/2016

Catawba Nuclear Station
Offsite Dose Calculation Manual (ODCM)

APPENDIX D

A_i Teen Dose Factors for use in the Liquid Dose Calculations

Agegroup:	TEEN	Pathway:	Fresh Water Fish - Sport (FFSP)			Units:	mrem/hr / μCi/ml	
Nuclide	Bone	Liver	Thyroid	Kidney	Lung	Gilli	Skin	Total Body
H-3	0.000E+00	1.740E-01	1.740E-01	1.740E-01	1.740E-01	1.740E-01	0.000E+00	1.740E-01
C-14	3.410E+04	6.810E+03	6.810E+03	6.810E+03	6.810E+03	6.810E+03	0.000E+00	6.810E+03
NA-24	1.390E+02	1.390E+02	1.390E+02	1.390E+02	1.390E+02	1.390E+02	0.000E+00	1.390E+02
P-32	1.440E+06	8.910E+04	0.000E+00	0.000E+00	0.000E+00	1.210E+05	0.000E+00	5.580E+04
CR-51	0.000E+00	0.000E+00	7.120E-01	2.810E-01	1.830E+00	2.150E+02	0.000E+00	1.280E+00
MN-54	0.000E+00	4.300E+03	0.000E+00	1.280E+03	0.000E+00	8.810E+03	0.000E+00	8.520E+02
MN-56	0.000E+00	1.810E-01	0.000E+00	2.300E-01	0.000E+00	1.190E+01	0.000E+00	3.230E-02
FE-55	6.890E+02	4.880E+02	0.000E+00	0.000E+00	3.100E+02	2.110E+02	0.000E+00	1.140E+02
FE-59	1.050E+03	2.460E+03	0.000E+00	0.000E+00	7.760E+02	5.820E+03	0.000E+00	9.500E+02
CO-58	0.000E+00	8.780E+01	0.000E+00	0.000E+00	0.000E+00	1.210E+03	0.000E+00	2.020E+02
CO-60	0.000E+00	2.560E+02	0.000E+00	0.000E+00	0.000E+00	3.340E+03	0.000E+00	5.770E+02
NI-63	3.230E+04	2.280E+03	0.000E+00	0.000E+00	0.000E+00	3.630E+02	0.000E+00	1.090E+03
NI-65	1.860E-01	2.370E-02	0.000E+00	0.000E+00	0.000E+00	1.290E+00	0.000E+00	1.080E-02
CU-64	0.000E+00	2.820E+00	0.000E+00	7.140E+00	0.000E+00	2.190E+02	0.000E+00	1.330E+00
ZN-65	2.100E+04	7.280E+04	0.000E+00	4.660E+04	0.000E+00	3.080E+04	0.000E+00	3.390E+04
ZN-69	8.410E-07	1.600E-06	0.000E+00	1.050E-06	0.000E+00	2.950E-06	0.000E+00	1.120E-07
BR-83	0.000E+00	0.000E+00	0.000E+00	0.000E+00	0.000E+00	0.000E+00	0.000E+00	4.160E-02
BR-84	0.000E+00	0.000E+00	0.000E+00	0.000E+00	0.000E+00	0.000E+00	0.000E+00	1.320E-12
BR-85	0.000E+00	0.000E+00	0.000E+00	0.000E+00	0.000E+00	0.000E+00	0.000E+00	0.000E+00
RB-86	0.000E+00	1.050E+05	0.000E+00	0.000E+00	0.000E+00	1.550E+04	0.000E+00	4.920E+04
RB-88	0.000E+00	1.380E-22	0.000E+00	0.000E+00	0.000E+00	1.180E-29	0.000E+00	7.360E-23
RB-89	0.000E+00	1.720E-26	0.000E+00	0.000E+00	0.000E+00	2.630E-35	0.000E+00	1.220E-26
SR-89	2.370E+04	0.000E+00	0.000E+00	0.000E+00	0.000E+00	2.830E+03	0.000E+00	6.800E+02
SR-90	4.540E+05	0.000E+00	0.000E+00	0.000E+00	0.000E+00	1.270E+04	0.000E+00	1.120E+05
SR-91	7.640E+01	0.000E+00	0.000E+00	0.000E+00	0.000E+00	3.470E+02	0.000E+00	3.040E+00

Catawba Nuclear Station Units 1 & 2
Period 1/1/2016 - 12/31/2016

Catawba Nuclear Station
Offsite Dose Calculation Manual (ODCM)

APPENDIX D

A_i Teen Dose Factors for use in the Liquid Dose Calculations

Agegroup:	TEEN	Pathway:	Fresh Water Fish - Sport (FFSP)			Units:	mrem/hr / μCi/ml	
Nuclide	Bone	Liver	Thyroid	Kidney	Lung	Gilli	Skin	Total Body
SR-92	3.590E-01	0.000E+00	0.000E+00	0.000E+00	0.000E+00	9.130E+00	0.000E+00	1.530E-02
Y-90	4.820E-01	0.000E+00	0.000E+00	0.000E+00	0.000E+00	3.980E+03	0.000E+00	1.300E-02
Y-91	9.060E+00	0.000E+00	0.000E+00	0.000E+00	0.000E+00	3.710E+03	0.000E+00	2.430E-01
Y-91M	1.160E-11	0.000E+00	0.000E+00	0.000E+00	0.000E+00	5.470E-10	0.000E+00	4.430E-13
Y-92	5.020E-04	0.000E+00	0.000E+00	0.000E+00	0.000E+00	1.380E+01	0.000E+00	1.450E-05
Y-93	3.350E-02	0.000E+00	0.000E+00	0.000E+00	0.000E+00	1.020E+03	0.000E+00	9.190E-04
ZR-95	2.450E-01	7.740E-02	0.000E+00	1.140E-01	0.000E+00	1.790E+02	0.000E+00	5.320E-02
ZR-97	5.330E-03	1.050E-03	0.000E+00	1.600E-03	0.000E+00	2.850E+02	0.000E+00	4.860E-04
NB-95	4.410E+02	2.450E+02	0.000E+00	2.370E+02	0.000E+00	1.050E+06	0.000E+00	1.350E+02
MO-99	0.000E+00	8.550E+01	0.000E+00	1.960E+02	0.000E+00	1.530E+02	0.000E+00	1.630E+01
TC-99M	5.720E-04	1.600E-03	0.000E+00	2.380E-02	8.860E-04	1.050E+00	0.000E+00	2.070E-02
TC-101	2.820E-33	4.010E-33	0.000E+00	7.240E-32	2.440E-33	6.840E-40	0.000E+00	3.930E-32
RU-103	4.570E+00	0.000E+00	0.000E+00	1.610E+01	0.000E+00	3.820E+02	0.000E+00	1.950E+00
RU-105	9.350E-03	0.000E+00	0.000E+00	1.180E-01	0.000E+00	7.550E+00	0.000E+00	3.630E-03
RU-106	7.140E+01	0.000E+00	0.000E+00	1.380E+02	0.000E+00	3.420E+03	0.000E+00	8.990E+00
AG-110M	8.580E-01	8.120E-01	0.000E+00	1.550E+00	0.000E+00	2.280E+02	0.000E+00	4.940E-01
TE-125M	2.760E+03	9.950E+02	7.710E+02	0.000E+00	0.000E+00	8.150E+03	0.000E+00	3.690E+02
TE-127	1.960E+01	6.950E+00	1.350E+01	7.940E+01	0.000E+00	1.510E+03	0.000E+00	4.220E+00
TE-127M	7.010E+03	2.490E+03	1.670E+03	2.840E+04	0.000E+00	1.750E+04	0.000E+00	8.340E+02
TE-129	1.770E-05	6.600E-06	1.260E-05	7.430E-05	0.000E+00	9.680E-05	0.000E+00	4.310E-06
TE-129M	1.160E+04	4.320E+03	3.760E+03	4.870E+04	0.000E+00	4.370E+04	0.000E+00	1.840E+03
TE-131	9.400E-17	3.870E-17	7.240E-17	4.110E-16	0.000E+00	7.710E-18	0.000E+00	2.940E-17
TE-131M	1.020E+03	4.900E+02	7.370E+02	5.110E+03	0.000E+00	3.930E+04	0.000E+00	4.090E+02
TE-132	2.060E+03	1.300E+03	1.370E+03	1.250E+04	0.000E+00	4.130E+04	0.000E+00	1.230E+03
I-130	7.320E+00	2.120E+01	1.730E+03	3.260E+01	0.000E+00	1.630E+01	0.000E+00	8.460E+00

Catawba Nuclear Station Units 1 & 2
Period 1/1/2016 - 12/31/2016

Catawba Nuclear Station
Offsite Dose Calculation Manual (ODCM)

APPENDIX D

A_i Teen Dose Factors for use in the Liquid Dose Calculations

Agegroup:	TEEN	Pathway:	Fresh Water Fish - Sport (FFSP)			Units:	mrem/hr / μ Ci/ml	
	Nuclide		Bone	Liver	Thyroid	Kidney	Lung	Gilli
I-131	1.470E+02	2.060E+02	6.000E+04	3.540E+02	0.000E+00	4.070E+01	0.000E+00	1.100E+02
I-132	5.520E-03	1.440E-02	4.870E-01	2.280E-02	0.000E+00	6.290E-03	0.000E+00	5.180E-03
I-133	2.470E+01	4.190E+01	5.850E+03	7.350E+01	0.000E+00	3.170E+01	0.000E+00	1.280E+01
I-134	2.220E-08	5.890E-08	9.810E-07	9.280E-08	0.000E+00	7.760E-10	0.000E+00	2.110E-08
I-135	1.350E+00	3.480E+00	2.240E+02	5.490E+00	0.000E+00	3.850E+00	0.000E+00	1.290E+00
CS-134	3.050E+05	7.180E+05	0.000E+00	2.280E+05	8.710E+04	8.930E+03	0.000E+00	3.330E+05
CS-136	2.970E+04	1.170E+05	0.000E+00	6.370E+04	1.000E+04	9.410E+03	0.000E+00	7.860E+04
CS-137	4.090E+05	5.440E+05	0.000E+00	1.850E+05	7.190E+04	7.730E+03	0.000E+00	1.890E+05
CS-138	9.580E-12	1.840E-11	0.000E+00	1.360E-11	1.580E-12	8.340E-15	0.000E+00	9.190E-12
BA-139	6.170E-06	4.340E-09	0.000E+00	4.090E-09	2.990E-09	5.510E-05	0.000E+00	1.800E-07
BA-140	1.960E+02	2.410E-01	0.000E+00	8.160E-02	1.620E-01	3.030E+02	0.000E+00	1.260E+01
BA-141	9.450E-25	7.050E-28	0.000E+00	6.550E-28	4.830E-28	2.010E-30	0.000E+00	3.150E-26
BA-142	2.750E-42	2.750E-45	0.000E+00	2.320E-45	1.830E-45	8.430E-54	0.000E+00	1.690E-43
LA-140	1.050E-01	5.160E-02	0.000E+00	0.000E+00	0.000E+00	2.960E+03	0.000E+00	1.370E-02
LA-142	2.350E-07	1.040E-07	0.000E+00	0.000E+00	0.000E+00	3.180E-03	0.000E+00	2.600E-08
CE-141	2.370E-02	1.590E-02	0.000E+00	7.460E-03	0.000E+00	4.540E+01	0.000E+00	1.820E-03
CE-143	2.590E-03	1.880E+00	0.000E+00	8.450E-04	0.000E+00	5.660E+01	0.000E+00	2.100E-04
CE-144	1.270E+00	5.240E-01	0.000E+00	3.130E-01	0.000E+00	3.180E+02	0.000E+00	6.810E-02
PR-143	5.680E-01	2.270E-01	0.000E+00	1.320E-01	0.000E+00	1.870E+03	0.000E+00	2.830E-02
PR-144	1.690E-28	6.900E-29	0.000E+00	3.960E-29	0.000E+00	1.860E-31	0.000E+00	8.550E-30
ND-147	4.020E-01	4.370E-01	0.000E+00	2.560E-01	0.000E+00	1.580E+03	0.000E+00	2.620E-02
W-187	1.590E+02	1.300E+02	0.000E+00	0.000E+00	0.000E+00	3.510E+04	0.000E+00	4.540E+01
NP-239	2.390E-02	2.260E-03	0.000E+00	7.080E-03	0.000E+00	3.630E+02	0.000E+00	1.250E-03

Catawba Nuclear Station Units 1 & 2
Period 1/1/2016 - 12/31/2016

Catawba Nuclear Station
Offsite Dose Calculation Manual (ODCM)

APPENDIX D

A_i Teen Dose Factors for use in the Liquid Dose Calculations

Agegroup:	TEEN	Pathway:	Shoreline Sediment (SHDp)			Units:	mrem/hr / μCi/ml	
Nuclide	Bone	Liver	Thyroid	Kidney	Lung	Gilli	Skin	Total Body
H-3	0.000E+00	0.000E+00	0.000E+00	0.000E+00	0.000E+00	0.000E+00	0.000E+00	0.000E+00
C-14	0.000E+00	0.000E+00	0.000E+00	0.000E+00	0.000E+00	0.000E+00	0.000E+00	0.000E+00
NA-24	3.580E+00	3.580E+00	3.580E+00	3.580E+00	3.580E+00	3.580E+00	4.150E+00	3.580E+00
P-32	0.000E+00	0.000E+00	0.000E+00	0.000E+00	0.000E+00	0.000E+00	0.000E+00	0.000E+00
CR-51	1.400E+00	1.400E+00	1.400E+00	1.400E+00	1.400E+00	1.400E+00	1.650E+00	1.400E+00
MN-54	4.150E+02	4.150E+02	4.150E+02	4.150E+02	4.150E+02	4.150E+02	4.870E+02	4.150E+02
MN-56	2.700E-01	2.700E-01	2.700E-01	2.700E-01	2.700E-01	2.700E-01	3.200E-01	2.700E-01
FE-55	0.000E+00	0.000E+00	0.000E+00	0.000E+00	0.000E+00	0.000E+00	0.000E+00	0.000E+00
FE-59	8.180E+01	8.180E+01	8.180E+01	8.180E+01	8.180E+01	8.180E+01	9.610E+01	8.180E+01
CO-58	1.140E+02	1.140E+02	1.140E+02	1.140E+02	1.140E+02	1.140E+02	1.330E+02	1.140E+02
CO-60	6.440E+03	6.440E+03	6.440E+03	6.440E+03	6.440E+03	6.440E+03	7.580E+03	6.440E+03
NI-63	0.000E+00	0.000E+00	0.000E+00	0.000E+00	0.000E+00	0.000E+00	0.000E+00	0.000E+00
NI-65	8.900E-02	8.900E-02	8.900E-02	8.900E-02	8.900E-02	8.900E-02	1.030E-01	8.900E-02
CU-64	1.820E-01	1.820E-01	1.820E-01	1.820E-01	1.820E-01	1.820E-01	2.060E-01	1.820E-01
ZN-65	2.240E+02	2.240E+02	2.240E+02	2.240E+02	2.240E+02	2.240E+02	2.580E+02	2.240E+02
ZN-69	0.000E+00	0.000E+00	0.000E+00	0.000E+00	0.000E+00	0.000E+00	0.000E+00	0.000E+00
BR-83	1.460E-03	1.460E-03	1.460E-03	1.460E-03	1.460E-03	1.460E-03	2.120E-03	1.460E-03
BR-84	6.070E-02	6.070E-02	6.070E-02	6.070E-02	6.070E-02	6.070E-02	7.080E-02	6.070E-02
BR-85	0.000E+00	0.000E+00	0.000E+00	0.000E+00	0.000E+00	0.000E+00	0.000E+00	0.000E+00
RB-86	2.690E+00	2.690E+00	2.690E+00	2.690E+00	2.690E+00	2.690E+00	3.080E+00	2.690E+00
RB-88	9.910E-03	9.910E-03	9.910E-03	9.910E-03	9.910E-03	9.910E-03	1.130E-02	9.910E-03
RB-89	3.680E-02	3.680E-02	3.680E-02	3.680E-02	3.680E-02	3.680E-02	4.420E-02	3.680E-02
SR-89	6.490E-03	6.490E-03	6.490E-03	6.490E-03	6.490E-03	6.490E-03	7.530E-03	6.490E-03
SR-90	0.000E+00	0.000E+00	0.000E+00	0.000E+00	0.000E+00	0.000E+00	0.000E+00	0.000E+00
SR-91	6.440E-01	6.440E-01	6.440E-01	6.440E-01	6.440E-01	6.440E-01	7.530E-01	6.440E-01

Catawba Nuclear Station Units 1 & 2
Period 1/1/2016 - 12/31/2016

Catawba Nuclear Station
Offsite Dose Calculation Manual (ODCM)

APPENDIX D

A_i Teen Dose Factors for use in the Liquid Dose Calculations

Agegroup:	TEEN	Pathway:	Shoreline Sediment (SHDp)			Units:	mrem/hr / μCi/ml	
Nuclide	Bone	Liver	Thyroid	Kidney	Lung	Gilli	Skin	Total Body
SR-92	2.330E-01	2.330E-01	2.330E-01	2.330E-01	2.330E-01	2.330E-01	2.590E-01	2.330E-01
Y-90	1.350E-03	1.350E-03	1.350E-03	1.350E-03	1.350E-03	1.350E-03	1.590E-03	1.350E-03
Y-91	3.220E-01	3.220E-01	3.220E-01	3.220E-01	3.220E-01	3.220E-01	3.620E-01	3.220E-01
Y-91M	3.010E-02	3.010E-02	3.010E-02	3.010E-02	3.010E-02	3.010E-02	3.480E-02	3.010E-02
Y-92	5.410E-02	5.410E-02	5.410E-02	5.410E-02	5.410E-02	5.410E-02	6.420E-02	5.410E-02
Y-93	5.500E-02	5.500E-02	5.500E-02	5.500E-02	5.500E-02	5.500E-02	7.520E-02	5.500E-02
ZR-95	7.330E+01	7.330E+01	7.330E+01	7.330E+01	7.330E+01	7.330E+01	8.510E+01	7.330E+01
ZR-97	8.870E-01	8.870E-01	8.870E-01	8.870E-01	8.870E-01	8.870E-01	1.030E+00	8.870E-01
NB-95	4.100E+01	4.100E+01	4.100E+01	4.100E+01	4.100E+01	4.100E+01	4.820E+01	4.100E+01
MO-99	1.200E+00	1.200E+00	1.200E+00	1.200E+00	1.200E+00	1.200E+00	1.390E+00	1.200E+00
TC-99M	5.520E-02	5.520E-02	5.520E-02	5.520E-02	5.520E-02	5.520E-02	6.320E-02	5.520E-02
TC-101	6.100E-03	6.100E-03	6.100E-03	6.100E-03	6.100E-03	6.100E-03	6.780E-03	6.100E-03
RU-103	3.250E+01	3.250E+01	3.250E+01	3.250E+01	3.250E+01	3.250E+01	3.790E+01	3.250E+01
RU-105	1.910E-01	1.910E-01	1.910E-01	1.910E-01	1.910E-01	1.910E-01	2.160E-01	1.910E-01
RU-106	1.270E+02	1.270E+02	1.270E+02	1.270E+02	1.270E+02	1.270E+02	1.520E+02	1.270E+02
AG-110M	1.030E+03	1.030E+03	1.030E+03	1.030E+03	1.030E+03	1.030E+03	1.200E+03	1.030E+03
TE-125M	4.650E-01	4.650E-01	4.650E-01	4.650E-01	4.650E-01	4.650E-01	6.380E-01	4.650E-01
TE-127	8.920E-04	8.920E-04	8.920E-04	8.920E-04	8.920E-04	8.920E-04	9.820E-04	8.920E-04
TE-127M	2.750E-02	2.750E-02	2.750E-02	2.750E-02	2.750E-02	2.750E-02	3.250E-02	2.750E-02
TE-129	7.860E-03	7.860E-03	7.860E-03	7.860E-03	7.860E-03	7.860E-03	9.300E-03	7.860E-03
TE-129M	5.930E+00	5.930E+00	5.930E+00	5.930E+00	5.930E+00	5.930E+00	6.930E+00	5.930E+00
TE-131	8.750E-03	8.750E-03	8.750E-03	8.750E-03	8.750E-03	8.750E-03	1.030E+01	8.750E-03
TE-131M	2.410E+00	2.410E+00	2.410E+00	2.410E+00	2.410E+00	2.410E+00	2.840E+00	2.410E+00
TE-132	1.270E+00	1.270E+00	1.270E+00	1.270E+00	1.270E+00	1.270E+00	1.490E+00	1.270E+00
I-130	1.650E+00	1.650E+00	1.650E+00	1.650E+00	1.650E+00	1.650E+00	2.010E+00	1.650E+00

Catawba Nuclear Station Units 1 & 2
Period 1/1/2016 - 12/31/2016

Catawba Nuclear Station
Offsite Dose Calculation Manual (ODCM)

APPENDIX D

A_i Teen Dose Factors for use in the Liquid Dose Calculations

Agegroup:	TEEN	Pathway:	Shoreline Sediment (SHDp)			Units:	mrem/hr / μCi/ml	
Nuclide	Bone	Liver	Thyroid	Kidney	Lung	Gilli	Skin	Total Body
I-131	5.160E+00	5.160E+00	5.160E+00	5.160E+00	5.160E+00	5.160E+00	6.260E+00	5.160E+00
I-132	3.730E-01	3.730E-01	3.730E-01	3.730E-01	3.730E-01	3.730E-01	4.390E-01	3.730E-01
I-133	7.350E-01	7.350E-01	7.350E-01	7.350E-01	7.350E-01	7.350E-01	8.930E-01	7.350E-01
I-134	1.340E-01	1.340E-01	1.340E-01	1.340E-01	1.340E-01	1.340E-01	1.590E-01	1.340E-01
I-135	7.570E-01	7.570E-01	7.570E-01	7.570E-01	7.570E-01	7.570E-01	8.830E-01	7.570E-01
CS-134	2.060E+03	2.060E+03	2.060E+03	2.060E+03	2.060E+03	2.060E+03	2.400E+03	2.060E+03
CS-136	4.520E+01	4.520E+01	4.520E+01	4.520E+01	4.520E+01	4.520E+01	5.130E+01	4.520E+01
CS-137	3.080E+03	3.080E+03	3.080E+03	3.080E+03	3.080E+03	3.080E+03	3.590E+03	3.080E+03
CS-138	1.080E-01	1.080E-01	1.080E-01	1.080E-01	1.080E-01	1.080E-01	1.230E-01	1.080E-01
BA-139	3.170E-02	3.170E-02	3.170E-02	3.170E-02	3.170E-02	3.170E-02	3.570E-02	3.170E-02
BA-140	6.150E+00	6.150E+00	6.150E+00	6.150E+00	6.150E+00	6.150E+00	7.030E+00	6.150E+00
BA-141	1.250E-02	1.250E-02	1.250E-02	1.250E-02	1.250E-02	1.250E-02	1.420E-02	1.250E-02
BA-142	1.340E-02	1.340E-02	1.340E-02	1.340E-02	1.340E-02	1.340E-02	1.530E-02	1.340E-02
LA-140	5.760E+00	5.760E+00	5.760E+00	5.760E+00	5.760E+00	5.760E+00	6.530E+00	5.760E+00
LA-142	2.280E-01	2.280E-01	2.280E-01	2.280E-01	2.280E-01	2.280E-01	2.730E-01	2.280E-01
CE-141	4.090E+00	4.090E+00	4.090E+00	4.090E+00	4.090E+00	4.090E+00	4.620E+00	4.090E+00
CE-143	6.930E-01	6.930E-01	6.930E-01	6.930E-01	6.930E-01	6.930E-01	7.870E-01	6.930E-01
CE-144	2.080E+01	2.080E+01	2.080E+01	2.080E+01	2.080E+01	2.080E+01	2.410E+01	2.080E+01
PR-143	0.000E+00	0.000E+00	0.000E+00	0.000E+00	0.000E+00	0.000E+00	0.000E+00	0.000E+00
PR-144	5.500E-04	5.500E-04	5.500E-04	5.500E-04	5.500E-04	5.500E-04	6.320E-04	5.500E-04
ND-147	2.520E+00	2.520E+00	2.520E+00	2.520E+00	2.520E+00	2.520E+00	3.020E+00	2.520E+00
W-187	7.050E-01	7.050E-01	7.050E-01	7.050E-01	7.050E-01	7.050E-01	8.190E-01	7.050E-01
NP-239	5.130E-01	5.130E-01	5.130E-01	5.130E-01	5.130E-01	5.130E-01	5.930E-01	5.130E-01

Catawba Nuclear Station Units 1 & 2
Period 1/1/2016 - 12/31/2016

Catawba Nuclear Station
Offsite Dose Calculation Manual (ODCM)

APPENDIX E

A_i Child Dose Factors for use in the Liquid Dose Calculations

Agegroup:	CHILD	Pathway:	Potable Water (PWtr)			Units:	mrem/hr / μCi/ml	
Nuclide	Bone	Liver	Thyroid	Kidney	Lung	Gilli	Skin	Total Body
H-3	0.000E+00	1.180E+01	1.180E+01	1.180E+01	1.180E+01	1.180E+01	0.000E+00	1.180E+01
C-14	7.030E+02	1.410E+02	1.410E+02	1.410E+02	1.410E+02	1.410E+02	0.000E+00	1.410E+02
NA-24	1.940E+02	1.940E+02	1.940E+02	1.940E+02	1.940E+02	1.940E+02	0.000E+00	1.940E+02
P-32	4.680E+04	2.190E+03	0.000E+00	0.000E+00	0.000E+00	1.290E+03	0.000E+00	1.800E+03
CR-51	0.000E+00	0.000E+00	2.840E-01	7.750E-02	5.180E-01	2.710E+01	0.000E+00	5.110E-01
MN-54	0.000E+00	6.210E+02	0.000E+00	1.740E+02	0.000E+00	5.220E+02	0.000E+00	1.660E+02
MN-56	0.000E+00	7.700E-01	0.000E+00	9.320E-01	0.000E+00	1.120E+02	0.000E+00	1.740E-01
FE-55	6.680E+02	3.550E+02	0.000E+00	0.000E+00	2.010E+02	6.570E+01	0.000E+00	1.100E+02
FE-59	9.520E+02	1.540E+03	0.000E+00	0.000E+00	4.470E+02	1.600E+03	0.000E+00	7.670E+02
CO-58	0.000E+00	1.040E+02	0.000E+00	0.000E+00	0.000E+00	6.070E+02	0.000E+00	3.190E+02
CO-60	0.000E+00	3.080E+02	0.000E+00	0.000E+00	0.000E+00	1.700E+03	0.000E+00	9.070E+02
NI-63	3.130E+04	1.670E+03	0.000E+00	0.000E+00	0.000E+00	1.130E+02	0.000E+00	1.060E+03
NI-65	4.760E+00	4.480E-01	0.000E+00	0.000E+00	0.000E+00	5.490E+01	0.000E+00	2.610E-01
CU-64	0.000E+00	7.390E+00	0.000E+00	1.780E+01	0.000E+00	3.470E+02	0.000E+00	4.460E+00
ZN-65	7.950E+02	2.120E+03	0.000E+00	1.340E+03	0.000E+00	3.720E+02	0.000E+00	1.320E+03
ZN-69	3.190E-04	4.610E-04	0.000E+00	2.800E-04	0.000E+00	2.900E-02	0.000E+00	4.260E-05
BR-83	0.000E+00	0.000E+00	0.000E+00	0.000E+00	0.000E+00	0.000E+00	0.000E+00	3.060E-01
BR-84	0.000E+00	0.000E+00	0.000E+00	0.000E+00	0.000E+00	0.000E+00	0.000E+00	1.780E-06
BR-85	0.000E+00	0.000E+00	0.000E+00	0.000E+00	0.000E+00	0.000E+00	0.000E+00	1.300E-76
RB-86	0.000E+00	3.820E+03	0.000E+00	0.000E+00	0.000E+00	2.460E+02	0.000E+00	2.350E+03
RB-88	0.000E+00	7.360E-12	0.000E+00	0.000E+00	0.000E+00	3.610E-13	0.000E+00	5.110E-12
RB-89	0.000E+00	6.300E-14	0.000E+00	0.000E+00	0.000E+00	5.490E-16	0.000E+00	5.600E-14
SR-89	7.620E+04	0.000E+00	0.000E+00	0.000E+00	0.000E+00	2.950E+03	0.000E+00	2.180E+03
SR-90	9.880E+05	0.000E+00	0.000E+00	0.000E+00	0.000E+00	1.330E+04	0.000E+00	2.510E+05
SR-91	5.810E+02	0.000E+00	0.000E+00	0.000E+00	0.000E+00	1.280E+03	0.000E+00	2.190E+01

Catawba Nuclear Station Units 1 & 2
Period 1/1/2016 - 12/31/2016

Catawba Nuclear Station
Offsite Dose Calculation Manual (ODCM)

APPENDIX E

A_i Child Dose Factors for use in the Liquid Dose Calculations

Agegroup:	CHILD	Pathway:	Potable Water (PWtr)			Units:	mrem/hr / μCi/ml	
Nuclide	Bone	Liver	Thyroid	Kidney	Lung	Gilli	Skin	Total Body
SR-92	2.430E+01	0.000E+00	0.000E+00	0.000E+00	0.000E+00	4.610E+02	0.000E+00	9.760E-01
Y-90	2.100E+00	0.000E+00	0.000E+00	0.000E+00	0.000E+00	5.980E+03	0.000E+00	5.620E-02
Y-91	3.480E+01	0.000E+00	0.000E+00	0.000E+00	0.000E+00	4.640E+03	0.000E+00	9.310E-01
Y-91M	9.860E-07	0.000E+00	0.000E+00	0.000E+00	0.000E+00	1.930E-03	0.000E+00	3.590E-08
Y-92	2.000E-02	0.000E+00	0.000E+00	0.000E+00	0.000E+00	5.770E+02	0.000E+00	5.710E-04
Y-93	2.900E-01	0.000E+00	0.000E+00	0.000E+00	0.000E+00	4.330E+03	0.000E+00	7.970E-03
ZR-95	6.710E+00	1.470E+00	0.000E+00	2.110E+00	0.000E+00	1.540E+03	0.000E+00	1.310E+00
ZR-97	2.480E-01	3.590E-02	0.000E+00	5.150E-02	0.000E+00	5.440E+03	0.000E+00	2.120E-02
NB-95	1.300E+00	5.040E-01	0.000E+00	4.740E-01	0.000E+00	9.330E+02	0.000E+00	3.600E-01
MO-99	0.000E+00	6.820E+02	0.000E+00	1.460E+03	0.000E+00	5.640E+02	0.000E+00	1.690E+02
TC-99M	1.350E-02	2.640E-02	0.000E+00	3.840E-01	1.340E-02	1.500E+01	0.000E+00	4.380E-01
TC-101	3.330E-17	3.480E-17	0.000E+00	5.940E-16	1.840E-17	1.110E-16	0.000E+00	4.410E-16
RU-103	4.210E+01	0.000E+00	0.000E+00	1.060E+02	0.000E+00	1.090E+03	0.000E+00	1.620E+01
RU-105	5.750E-01	0.000E+00	0.000E+00	5.060E+00	0.000E+00	3.750E+02	0.000E+00	2.090E-01
RU-106	6.800E+02	0.000E+00	0.000E+00	9.180E+02	0.000E+00	1.060E+04	0.000E+00	8.480E+01
AG-110M	3.130E+01	2.110E+01	0.000E+00	3.940E+01	0.000E+00	2.510E+03	0.000E+00	1.690E+01
TE-125M	6.590E+02	1.790E+02	1.850E+02	0.000E+00	0.000E+00	6.360E+02	0.000E+00	8.780E+01
TE-127	1.130E+01	3.050E+00	7.820E+00	3.210E+01	0.000E+00	4.410E+02	0.000E+00	2.420E+00
TE-127M	1.670E+03	4.510E+02	4.000E+02	4.780E+03	0.000E+00	1.360E+03	0.000E+00	1.990E+02
TE-129	5.730E-03	1.600E-03	4.090E-03	1.680E-02	0.000E+00	3.570E-01	0.000E+00	1.360E-03
TE-129M	2.800E+03	7.830E+02	9.030E+02	8.230E+03	0.000E+00	3.420E+03	0.000E+00	4.350E+02
TE-131	1.040E-08	3.160E-09	7.930E-09	3.140E-08	0.000E+00	5.450E-08	0.000E+00	3.090E-09
TE-131M	3.170E+02	1.100E+02	2.260E+02	1.060E+03	0.000E+00	4.450E+03	0.000E+00	1.170E+02
TE-132	5.280E+02	2.340E+02	3.400E+02	2.170E+03	0.000E+00	2.350E+03	0.000E+00	2.820E+02
I-130	8.650E+01	1.750E+02	1.930E+04	2.610E+02	0.000E+00	8.180E+01	0.000E+00	9.010E+01

Catawba Nuclear Station Units 1 & 2
Period 1/1/2016 - 12/31/2016

Catawba Nuclear Station
Offsite Dose Calculation Manual (ODCM)

APPENDIX E

A_i Child Dose Factors for use in the Liquid Dose Calculations

Agegroup:	CHILD	Pathway:	Potable Water (PWtr)			Units:	mrem/hr / μCi/ml	
Nuclide	Bone	Liver	Thyroid	Kidney	Lung	Gilli	Skin	Total Body
I-131	9.580E+02	9.630E+02	3.190E+05	1.580E+03	0.000E+00	8.580E+01	0.000E+00	5.470E+02
I-132	1.250E+00	2.300E+00	1.070E+02	3.520E+00	0.000E+00	2.710E+00	0.000E+00	1.060E+00
I-133	2.310E+02	2.850E+02	5.300E+04	4.750E+02	0.000E+00	1.150E+02	0.000E+00	1.080E+02
I-134	1.820E-03	3.370E-03	7.760E-02	5.160E-03	0.000E+00	2.240E-03	0.000E+00	1.550E-03
I-135	2.890E+01	5.210E+01	4.610E+03	7.990E+01	0.000E+00	3.970E+01	0.000E+00	2.460E+01
CS-134	1.360E+04	2.230E+04	0.000E+00	6.920E+03	2.480E+03	1.200E+02	0.000E+00	4.710E+03
CS-136	1.330E+03	3.660E+03	0.000E+00	1.950E+03	2.910E+02	1.290E+02	0.000E+00	2.370E+03
CS-137	1.900E+04	1.820E+04	0.000E+00	5.930E+03	2.130E+03	1.140E+02	0.000E+00	2.690E+03
CS-138	2.440E-06	3.390E-06	0.000E+00	2.380E-06	2.570E-07	1.560E-06	0.000E+00	2.150E-06
BA-139	5.940E-02	3.170E-05	0.000E+00	2.770E-05	1.860E-05	3.430E+00	0.000E+00	1.720E-03
BA-140	4.700E+03	4.120E+00	0.000E+00	1.340E+00	2.460E+00	2.380E+03	0.000E+00	2.740E+02
BA-141	1.620E-11	9.050E-15	0.000E+00	7.830E-15	5.310E-14	9.210E-12	0.000E+00	5.260E-13
BA-142	1.800E-20	1.300E-23	0.000E+00	1.050E-23	7.630E-24	2.350E-22	0.000E+00	1.010E-21
LA-140	4.780E-01	1.670E-01	0.000E+00	0.000E+00	0.000E+00	4.650E+03	0.000E+00	5.630E-02
LA-142	1.640E-04	5.210E-05	0.000E+00	0.000E+00	0.000E+00	1.030E+01	0.000E+00	1.630E-05
CE-141	2.280E+00	1.140E+00	0.000E+00	4.990E-01	0.000E+00	1.420E+03	0.000E+00	1.690E-01
CE-143	3.160E-01	1.710E+02	0.000E+00	7.180E-02	0.000E+00	2.510E+03	0.000E+00	2.480E-02
CE-144	1.210E+02	3.790E+01	0.000E+00	2.100E+01	0.000E+00	9.870E+03	0.000E+00	6.450E+00
PR-143	2.230E+00	6.690E-01	0.000E+00	3.620E-01	0.000E+00	2.400E+03	0.000E+00	1.110E-01
PR-144	2.200E-15	6.800E-16	0.000E+00	3.600E-16	0.000E+00	1.460E-12	0.000E+00	1.110E-16
ND-147	1.570E+00	1.270E+00	0.000E+00	6.990E-01	0.000E+00	2.020E+03	0.000E+00	9.860E-02
W-187	1.760E+01	1.040E+01	0.000E+00	0.000E+00	0.000E+00	1.460E+03	0.000E+00	4.680E+00
NP-239	2.630E-01	1.890E-02	0.000E+00	5.470E-02	0.000E+00	1.400E+03	0.000E+00	1.330E-02

Catawba Nuclear Station Units 1 & 2
Period 1/1/2016 - 12/31/2016

Catawba Nuclear Station
Offsite Dose Calculation Manual (ODCM)

APPENDIX E

A_i Child Dose Factors for use in the Liquid Dose Calculations

Agegroup:	CHILD	Pathway:	Fresh Water Fish - Sport (FFSP)			Units:	mrem/hr / μCi/ml	
Nuclide	Bone	Liver	Thyroid	Kidney	Lung	Gilli	Skin	Total Body
H-3	0.000E+00	1.440E-01	1.440E-01	1.440E-01	1.440E-01	1.440E-01	0.000E+00	1.440E-01
C-14	4.380E+04	8.760E+03	8.760E+03	8.760E+03	8.760E+03	8.760E+03	0.000E+00	8.760E+03
NA-24	1.510E+02	1.510E+02	1.510E+02	1.510E+02	1.510E+02	1.510E+02	0.000E+00	1.510E+02
P-32	1.850E+06	8.680E+04	0.000E+00	0.000E+00	0.000E+00	5.130E+04	0.000E+00	7.150E+04
CR-51	0.000E+00	0.000E+00	7.580E-01	2.070E-01	1.380E+00	7.240E+01	0.000E+00	1.370E+00
MN-54	0.000E+00	3.360E+03	0.000E+00	9.420E+02	0.000E+00	2.820E+03	0.000E+00	8.950E+02
MN-56	0.000E+00	1.650E-01	0.000E+00	2.000E-01	0.000E+00	2.400E+01	0.000E+00	3.730E-02
FE-55	9.040E+02	4.790E+02	0.000E+00	0.000E+00	2.710E+02	8.880E+01	0.000E+00	1.490E+02
FE-59	1.280E+03	2.070E+03	0.000E+00	0.000E+00	5.990E+02	2.150E+03	0.000E+00	1.030E+03
CO-58	0.000E+00	7.010E+01	0.000E+00	0.000E+00	0.000E+00	4.090E+02	0.000E+00	2.150E+02
CO-60	0.000E+00	2.080E+02	0.000E+00	0.000E+00	0.000E+00	1.150E+03	0.000E+00	6.130E+02
NI-63	4.230E+04	2.270E+03	0.000E+00	0.000E+00	0.000E+00	1.530E+02	0.000E+00	1.440E+03
NI-65	2.370E-01	2.230E-02	0.000E+00	0.000E+00	0.000E+00	2.740E+00	0.000E+00	1.300E-02
CU-64	0.000E+00	2.590E+00	0.000E+00	6.260E+00	0.000E+00	1.220E+02	0.000E+00	1.570E+00
ZN-65	2.150E+04	5.730E+04	0.000E+00	3.610E+04	0.000E+00	1.010E+04	0.000E+00	3.560E+04
ZN-69	1.080E-06	1.560E-06	0.000E+00	9.470E-07	0.000E+00	9.840E-05	0.000E+00	1.440E-07
BR-83	0.000E+00	0.000E+00	0.000E+00	0.000E+00	0.000E+00	0.000E+00	0.000E+00	5.340E-02
BR-84	0.000E+00	0.000E+00	0.000E+00	0.000E+00	0.000E+00	0.000E+00	0.000E+00	1.570E-12
BR-85	0.000E+00	0.000E+00	0.000E+00	0.000E+00	0.000E+00	0.000E+00	0.000E+00	0.000E+00
RB-86	0.000E+00	1.020E+05	0.000E+00	0.000E+00	0.000E+00	6.530E+03	0.000E+00	6.250E+04
RB-88	0.000E+00	1.330E-22	0.000E+00	0.000E+00	0.000E+00	6.510E-24	0.000E+00	9.220E-23
RB-89	0.000E+00	1.580E-26	0.000E+00	0.000E+00	0.000E+00	1.370E-28	0.000E+00	1.400E-26
SR-89	3.070E+04	0.000E+00	0.000E+00	0.000E+00	0.000E+00	1.190E+03	0.000E+00	8.780E+02
SR-90	4.010E+05	0.000E+00	0.000E+00	0.000E+00	0.000E+00	5.400E+03	0.000E+00	1.020E+05
SR-91	9.800E+01	0.000E+00	0.000E+00	0.000E+00	0.000E+00	2.160E+02	0.000E+00	3.700E+00

Catawba Nuclear Station Units 1 & 2
Period 1/1/2016 - 12/31/2016

Catawba Nuclear Station
Offsite Dose Calculation Manual (ODCM)

APPENDIX E

A_i Child Dose Factors for use in the Liquid Dose Calculations

Agegroup:	CHILD	Pathway:	Fresh Water Fish - Sport (FFSP)			Units:	mrem/hr / μCi/ml	
Nuclide	Bone	Liver	Thyroid	Kidney	Lung	Gilli	Skin	Total Body
SR-92	4.580E-01	0.000E+00	0.000E+00	0.000E+00	0.000E+00	8.670E+00	0.000E+00	1.840E-02
Y-90	6.240E-01	0.000E+00	0.000E+00	0.000E+00	0.000E+00	1.780E+03	0.000E+00	1.670E-02
Y-91	1.170E+01	0.000E+00	0.000E+00	0.000E+00	0.000E+00	1.560E+03	0.000E+00	3.130E-01
Y-91M	1.480E-11	0.000E+00	0.000E+00	0.000E+00	0.000E+00	2.900E-08	0.000E+00	5.390E-13
Y-92	6.440E-04	0.000E+00	0.000E+00	0.000E+00	0.000E+00	1.860E+01	0.000E+00	1.840E-05
Y-93	4.300E-02	0.000E+00	0.000E+00	0.000E+00	0.000E+00	6.420E+02	0.000E+00	1.180E-03
ZR-95	2.980E-01	6.550E-02	0.000E+00	9.370E-02	0.000E+00	6.830E+01	0.000E+00	5.830E-02
ZR-97	6.780E-03	9.790E-04	0.000E+00	1.410E-03	0.000E+00	1.480E+02	0.000E+00	5.780E-04
NB-95	5.210E+02	2.030E+02	0.000E+00	1.900E+02	0.000E+00	3.750E+05	0.000E+00	1.450E+02
MO-99	0.000E+00	8.130E+01	0.000E+00	1.740E+02	0.000E+00	6.720E+01	0.000E+00	2.010E+01
TC-99M	6.860E-04	1.350E-03	0.000E+00	1.950E-02	6.830E-04	7.650E-01	0.000E+00	2.230E-02
TC-101	3.610E-33	3.780E-33	0.000E+00	6.440E-32	2.000E-33	1.200E-32	0.000E+00	4.790E-32
RU-103	5.650E+00	0.000E+00	0.000E+00	1.420E+01	0.000E+00	1.460E+02	0.000E+00	2.170E+00
RU-105	1.190E-02	0.000E+00	0.000E+00	1.050E-01	0.000E+00	7.790E+00	0.000E+00	4.330E-03
RU-106	9.190E+01	0.000E+00	0.000E+00	1.240E+02	0.000E+00	1.430E+03	0.000E+00	1.150E+01
AG-110M	9.720E-01	6.570E-01	0.000E+00	1.220E+00	0.000E+00	7.810E+01	0.000E+00	5.250E-01
TE-125M	3.540E+03	9.610E+02	9.950E+02	0.000E+00	0.000E+00	3.420E+03	0.000E+00	4.730E+02
TE-127	2.520E+01	6.800E+00	1.750E+01	7.170E+01	0.000E+00	9.850E+02	0.000E+00	5.410E+00
TE-127M	9.040E+03	2.430E+03	2.160E+03	2.580E+04	0.000E+00	7.320E+03	0.000E+00	1.070E+03
TE-129	2.280E-05	6.370E-06	1.630E-05	6.680E-05	0.000E+00	1.420E-03	0.000E+00	5.420E-06
TE-129M	1.500E+04	4.190E+03	4.840E+03	4.410E+04	0.000E+00	1.830E+04	0.000E+00	2.330E+03
TE-131	1.210E-16	3.680E-17	9.220E-17	3.650E-16	0.000E+00	6.330E-16	0.000E+00	3.590E-17
TE-131M	1.300E+03	4.500E+02	9.250E+02	4.350E+03	0.000E+00	1.820E+04	0.000E+00	4.790E+02
TE-132	2.570E+03	1.140E+03	1.650E+03	1.050E+04	0.000E+00	1.140E+04	0.000E+00	1.370E+03
I-130	8.950E+00	1.810E+01	1.990E+03	2.700E+01	0.000E+00	8.460E+00	0.000E+00	9.320E+00

Catawba Nuclear Station Units 1 & 2
Period 1/1/2016 - 12/31/2016

Catawba Nuclear Station
Offsite Dose Calculation Manual (ODCM)

APPENDIX E

A_i Child Dose Factors for use in the Liquid Dose Calculations

Agegroup:	CHILD	Pathway:	Fresh Water Fish - Sport (FFSP)			Units:	mrem/hr / μ Ci/ml	
	Nuclide	Bone	Liver	Thyroid	Kidney	Lung	Gilli	Skin
I-131	1.860E+02	1.870E+02	6.190E+04	3.070E+02	0.000E+00	1.670E+01	0.000E+00	1.060E+02
I-132	6.830E-03	1.250E-02	5.820E-01	1.920E-02	0.000E+00	1.480E-02	0.000E+00	5.770E-03
I-133	3.140E+01	3.880E+01	7.210E+03	6.470E+01	0.000E+00	1.560E+01	0.000E+00	1.470E+01
I-134	2.750E-08	5.100E-08	1.170E-06	7.800E-08	0.000E+00	3.380E-08	0.000E+00	2.350E-08
I-135	1.670E+00	3.010E+00	2.660E+02	4.610E+00	0.000E+00	2.290E+00	0.000E+00	1.420E+00
CS-134	3.680E+05	6.040E+05	0.000E+00	1.870E+05	6.710E+04	3.250E+03	0.000E+00	1.270E+05
CS-136	3.510E+04	9.640E+04	0.000E+00	5.130E+04	7.660E+03	3.390E+03	0.000E+00	6.240E+04
CS-137	5.140E+05	4.920E+05	0.000E+00	1.600E+05	5.770E+04	3.080E+03	0.000E+00	7.270E+04
CS-138	1.210E-11	1.690E-11	0.000E+00	1.190E-11	1.280E-12	7.770E-12	0.000E+00	1.070E-11
BA-139	7.930E-06	4.230E-09	0.000E+00	3.700E-09	2.490E-09	4.580E-04	0.000E+00	2.300E-07
BA-140	2.480E+02	2.170E-01	0.000E+00	7.060E-02	1.290E-01	1.250E+02	0.000E+00	1.450E+01
BA-141	1.210E-24	6.800E-28	0.000E+00	5.880E-28	3.990E-27	6.920E-25	0.000E+00	3.950E-26
BA-142	3.460E-42	2.490E-45	0.000E+00	2.020E-45	1.470E-45	4.510E-44	0.000E+00	1.930E-43
LA-140	1.310E-01	4.590E-02	0.000E+00	0.000E+00	0.000E+00	1.280E+03	0.000E+00	1.550E-02
LA-142	2.970E-07	9.470E-08	0.000E+00	0.000E+00	0.000E+00	1.880E-02	0.000E+00	2.960E-08
CE-141	3.060E-02	1.520E-02	0.000E+00	6.680E-03	0.000E+00	1.900E+01	0.000E+00	2.260E-03
CE-143	3.320E-03	1.800E+00	0.000E+00	7.550E-04	0.000E+00	2.640E+01	0.000E+00	2.610E-04
CE-144	1.630E+00	5.120E-01	0.000E+00	2.830E-01	0.000E+00	1.330E+02	0.000E+00	8.710E-02
PR-143	7.340E-01	2.200E-01	0.000E+00	1.190E-01	0.000E+00	7.920E+02	0.000E+00	3.640E-02
PR-144	2.180E-28	6.750E-29	0.000E+00	3.570E-29	0.000E+00	1.450E-25	0.000E+00	1.100E-29
ND-147	5.150E-01	4.170E-01	0.000E+00	2.290E-01	0.000E+00	6.610E+02	0.000E+00	3.230E-02
W-187	2.010E+02	1.190E+02	0.000E+00	0.000E+00	0.000E+00	1.680E+04	0.000E+00	5.350E+01
NP-239	3.080E-02	2.210E-03	0.000E+00	6.390E-03	0.000E+00	1.630E+02	0.000E+00	1.550E-03

Catawba Nuclear Station Units 1 & 2
Period 1/1/2016 - 12/31/2016

Catawba Nuclear Station
Offsite Dose Calculation Manual (ODCM)

APPENDIX E

A_i Child Dose Factors for use in the Liquid Dose Calculations

Agegroup:	CHILD	Pathway:	Shoreline Sediment (SHDp)			Units:	mrem/hr / μCi/ml	
Nuclide	Bone	Liver	Thyroid	Kidney	Lung	Gilli	Skin	Total Body
H-3	0.000E+00	0.000E+00	0.000E+00	0.000E+00	0.000E+00	0.000E+00	0.000E+00	0.000E+00
C-14	0.000E+00	0.000E+00	0.000E+00	0.000E+00	0.000E+00	0.000E+00	0.000E+00	0.000E+00
NA-24	7.480E-01	7.480E-01	7.480E-01	7.480E-01	7.480E-01	7.480E-01	8.680E-01	7.480E-01
P-32	0.000E+00	0.000E+00	0.000E+00	0.000E+00	0.000E+00	0.000E+00	0.000E+00	0.000E+00
CR-51	2.920E-01	2.920E-01	2.920E-01	2.920E-01	2.920E-01	2.920E-01	3.450E-01	2.920E-01
MN-54	8.680E+01	8.680E+01	8.680E+01	8.680E+01	8.680E+01	8.680E+01	1.020E+02	8.680E+01
MN-56	5.650E-02	5.650E-02	5.650E-02	5.650E-02	5.650E-02	5.650E-02	6.680E-02	5.650E-02
FE-55	0.000E+00	0.000E+00	0.000E+00	0.000E+00	0.000E+00	0.000E+00	0.000E+00	0.000E+00
FE-59	1.710E+01	1.710E+01	1.710E+01	1.710E+01	1.710E+01	1.710E+01	2.010E+01	1.710E+01
CO-58	2.370E+01	2.370E+01	2.370E+01	2.370E+01	2.370E+01	2.370E+01	2.780E+01	2.370E+01
CO-60	1.350E+03	1.350E+03	1.350E+03	1.350E+03	1.350E+03	1.350E+03	1.580E+03	1.350E+03
NI-63	0.000E+00	0.000E+00	0.000E+00	0.000E+00	0.000E+00	0.000E+00	0.000E+00	0.000E+00
NI-65	1.860E-02	1.860E-02	1.860E-02	1.860E-02	1.860E-02	1.860E-02	2.160E-02	1.860E-02
CU-64	3.800E-02	3.800E-02	3.800E-02	3.800E-02	3.800E-02	3.800E-02	4.310E-02	3.800E-02
ZN-65	4.680E+01	4.680E+01	4.680E+01	4.680E+01	4.680E+01	4.680E+01	5.380E+01	4.680E+01
ZN-69	0.000E+00	0.000E+00	0.000E+00	0.000E+00	0.000E+00	0.000E+00	0.000E+00	0.000E+00
BR-83	3.050E-04	3.050E-04	3.050E-04	3.050E-04	3.050E-04	3.050E-04	4.430E-04	3.050E-04
BR-84	1.270E-02	1.270E-02	1.270E-02	1.270E-02	1.270E-02	1.270E-02	1.480E-02	1.270E-02
BR-85	0.000E+00	0.000E+00	0.000E+00	0.000E+00	0.000E+00	0.000E+00	0.000E+00	0.000E+00
RB-86	5.630E-01	5.630E-01	5.630E-01	5.630E-01	5.630E-01	5.630E-01	6.430E-01	5.630E-01
RB-88	2.070E-03	2.070E-03	2.070E-03	2.070E-03	2.070E-03	2.070E-03	2.370E-03	2.070E-03
RB-89	7.700E-03	7.700E-03	7.700E-03	7.700E-03	7.700E-03	7.700E-03	9.240E-03	7.700E-03
SR-89	1.360E-03	1.360E-03	1.360E-03	1.360E-03	1.360E-03	1.360E-03	1.570E-03	1.360E-03
SR-90	0.000E+00	0.000E+00	0.000E+00	0.000E+00	0.000E+00	0.000E+00	0.000E+00	0.000E+00
SR-91	1.350E-01	1.350E-01	1.350E-01	1.350E-01	1.350E-01	1.350E-01	1.570E-01	1.350E-01

Catawba Nuclear Station Units 1 & 2
Period 1/1/2016 - 12/31/2016

Catawba Nuclear Station
Offsite Dose Calculation Manual (ODCM)

APPENDIX E

A_i Child Dose Factors for use in the Liquid Dose Calculations

Agegroup:	CHILD	Pathway:	Shoreline Sediment (SHDp)			Units:	mrem/hr / μ Ci/ml	
Nuclide	Bone	Liver	Thyroid	Kidney	Lung	Gilli	Skin	Total Body
SR-92	4.860E-02	4.860E-02	4.860E-02	4.860E-02	4.860E-02	4.860E-02	5.410E-02	4.860E-02
Y-90	2.810E-04	2.810E-04	2.810E-04	2.810E-04	2.810E-04	2.810E-04	3.320E-04	2.810E-04
Y-91	6.720E-02	6.720E-02	6.720E-02	6.720E-02	6.720E-02	6.720E-02	7.560E-02	6.720E-02
Y-91M	6.280E-03	6.280E-03	6.280E-03	6.280E-03	6.280E-03	6.280E-03	7.270E-03	6.280E-03
Y-92	1.130E-02	1.130E-02	1.130E-02	1.130E-02	1.130E-02	1.130E-02	1.340E-02	1.130E-02
Y-93	1.150E-02	1.150E-02	1.150E-02	1.150E-02	1.150E-02	1.150E-02	1.570E-02	1.150E-02
ZR-95	1.530E+01	1.530E+01	1.530E+01	1.530E+01	1.530E+01	1.530E+01	1.780E+01	1.530E+01
ZR-97	1.850E-01	1.850E-01	1.850E-01	1.850E-01	1.850E-01	1.850E-01	2.160E-01	1.850E-01
NB-95	8.560E+00	8.560E+00	8.560E+00	8.560E+00	8.560E+00	8.560E+00	1.010E+01	8.560E+00
MO-99	2.500E-01	2.500E-01	2.500E-01	2.500E-01	2.500E-01	2.500E-01	2.900E-01	2.500E-01
TC-99M	1.150E-02	1.150E-02	1.150E-02	1.150E-02	1.150E-02	1.150E-02	1.320E-02	1.150E-02
TC-101	1.270E-03	1.270E-03	1.270E-03	1.270E-03	1.270E-03	1.270E-03	1.420E-03	1.270E-03
RU-103	6.780E+00	6.780E+00	6.780E+00	6.780E+00	6.780E+00	6.780E+00	7.910E+00	6.780E+00
RU-105	3.990E-02	3.990E-02	3.990E-02	3.990E-02	3.990E-02	3.990E-02	4.520E-02	3.990E-02
RU-106	2.640E+01	2.640E+01	2.640E+01	2.640E+01	2.640E+01	2.640E+01	3.170E+01	2.640E+01
AG-110M	2.150E+02	2.150E+02	2.150E+02	2.150E+02	2.150E+02	2.150E+02	2.510E+02	2.150E+02
TE-125M	9.720E-02	9.720E-02	9.720E-02	9.720E-02	9.720E-02	9.720E-02	1.330E-01	9.720E-02
TE-127	1.860E-04	1.860E-04	1.860E-04	1.860E-04	1.860E-04	1.860E-04	2.050E-04	1.860E-04
TE-127M	5.740E-03	5.740E-03	5.740E-03	5.740E-03	5.740E-03	5.740E-03	6.780E-03	5.740E-03
TE-129	1.640E-03	1.640E-03	1.640E-03	1.640E-03	1.640E-03	1.640E-03	1.940E-03	1.640E-03
TE-129M	1.240E+00	1.240E+00	1.240E+00	1.240E+00	1.240E+00	1.240E+00	1.450E+00	1.240E+00
TE-131	1.830E-03	1.830E-03	1.830E-03	1.830E-03	1.830E-03	1.830E-03	2.160E+00	1.830E-03
TE-131M	5.030E-01	5.030E-01	5.030E-01	5.030E-01	5.030E-01	5.030E-01	5.920E-01	5.030E-01
TE-132	2.650E-01	2.650E-01	2.650E-01	2.650E-01	2.650E-01	2.650E-01	3.120E-01	2.650E-01
I-130	3.450E-01	3.450E-01	3.450E-01	3.450E-01	3.450E-01	3.450E-01	4.190E-01	3.450E-01

Catawba Nuclear Station Units 1 & 2
Period 1/1/2016 - 12/31/2016

Catawba Nuclear Station
Offsite Dose Calculation Manual (ODCM)

APPENDIX E

A_i Child Dose Factors for use in the Liquid Dose Calculations

Agegroup:	CHILD	Pathway:	Shoreline Sediment (SHDp)			Units:	mrem/hr / μCi/ml	
Nuclide	Bone	Liver	Thyroid	Kidney	Lung	Gilli	Skin	Total Body
I-131	1.080E+00	1.080E+00	1.080E+00	1.080E+00	1.080E+00	1.080E+00	1.310E+00	1.080E+00
I-132	7.800E-02	7.800E-02	7.800E-02	7.800E-02	7.800E-02	7.800E-02	9.180E-02	7.800E-02
I-133	1.540E-01	1.540E-01	1.540E-01	1.540E-01	1.540E-01	1.540E-01	1.870E-01	1.540E-01
I-134	2.800E-02	2.800E-02	2.800E-02	2.800E-02	2.800E-02	2.800E-02	3.320E-02	2.800E-02
I-135	1.580E-01	1.580E-01	1.580E-01	1.580E-01	1.580E-01	1.580E-01	1.850E-01	1.580E-01
CS-134	4.300E+02	4.300E+02	4.300E+02	4.300E+02	4.300E+02	4.300E+02	5.010E+02	4.300E+02
CS-136	9.450E+00	9.450E+00	9.450E+00	9.450E+00	9.450E+00	9.450E+00	1.070E+01	9.450E+00
CS-137	6.440E+02	6.440E+02	6.440E+02	6.440E+02	6.440E+02	6.440E+02	7.510E+02	6.440E+02
CS-138	2.250E-02	2.250E-02	2.250E-02	2.250E-02	2.250E-02	2.250E-02	2.570E-02	2.250E-02
BA-139	6.630E-03	6.630E-03	6.630E-03	6.630E-03	6.630E-03	6.630E-03	7.460E-03	6.630E-03
BA-140	1.290E+00	1.290E+00	1.290E+00	1.290E+00	1.290E+00	1.290E+00	1.470E+00	1.290E+00
BA-141	2.610E-03	2.610E-03	2.610E-03	2.610E-03	2.610E-03	2.610E-03	2.980E-03	2.610E-03
BA-142	2.810E-03	2.810E-03	2.810E-03	2.810E-03	2.810E-03	2.810E-03	3.200E-03	2.810E-03
LA-140	1.200E+00	1.200E+00	1.200E+00	1.200E+00	1.200E+00	1.200E+00	1.360E+00	1.200E+00
LA-142	4.760E-02	4.760E-02	4.760E-02	4.760E-02	4.760E-02	4.760E-02	5.710E-02	4.760E-02
CE-141	8.560E-01	8.560E-01	8.560E-01	8.560E-01	8.560E-01	8.560E-01	9.650E-01	8.560E-01
CE-143	1.450E-01	1.450E-01	1.450E-01	1.450E-01	1.450E-01	1.450E-01	1.650E-01	1.450E-01
CE-144	4.350E+00	4.350E+00	4.350E+00	4.350E+00	4.350E+00	4.350E+00	5.040E+00	4.350E+00
PR-143	0.000E+00	0.000E+00	0.000E+00	0.000E+00	0.000E+00	0.000E+00	0.000E+00	0.000E+00
PR-144	1.150E-04	1.150E-04	1.150E-04	1.150E-04	1.150E-04	1.150E-04	1.320E-04	1.150E-04
ND-147	5.260E-01	5.260E-01	5.260E-01	5.260E-01	5.260E-01	5.260E-01	6.310E-01	5.260E-01
W-187	1.470E-01	1.470E-01	1.470E-01	1.470E-01	1.470E-01	1.470E-01	1.710E-01	1.470E-01
NP-239	1.070E-01	1.070E-01	1.070E-01	1.070E-01	1.070E-01	1.070E-01	1.240E-01	1.070E-01

Catawba Nuclear Station Units 1 & 2
Period 1/1/2016 - 12/31/2016

Catawba Nuclear Station
Offsite Dose Calculation Manual (ODCM)

APPENDIX F

A_i Infant Dose Factors for use in the Liquid Dose Calculations

Agegroup:	INFANT	Pathway:	Potable Water (PWtr)			Units:	mrem/hr / μCi/ml	
Nuclide	Bone	Liver	Thyroid	Kidney	Lung	Gilli	Skin	Total Body
H-3	0.000E+00	1.160E+01	1.160E+01	1.160E+01	1.160E+01	1.160E+01	0.000E+00	1.160E+01
C-14	8.920E+02	1.900E+02	1.900E+02	1.900E+02	1.900E+02	1.900E+02	0.000E+00	1.900E+02
NA-24	2.190E+02	2.190E+02	2.190E+02	2.190E+02	2.190E+02	2.190E+02	0.000E+00	2.190E+02
P-32	6.240E+04	3.670E+03	0.000E+00	0.000E+00	0.000E+00	8.450E+02	0.000E+00	2.420E+03
CR-51	0.000E+00	0.000E+00	3.420E-01	7.470E-02	6.650E-01	1.530E+01	0.000E+00	5.240E-01
MN-54	0.000E+00	7.480E+02	0.000E+00	1.660E+02	0.000E+00	2.750E+02	0.000E+00	1.690E+02
MN-56	0.000E+00	1.220E+00	0.000E+00	1.050E+00	0.000E+00	1.110E+02	0.000E+00	2.100E-01
FE-55	5.230E+02	3.380E+02	0.000E+00	0.000E+00	1.650E+02	4.290E+01	0.000E+00	9.030E+01
FE-59	1.150E+03	2.010E+03	0.000E+00	0.000E+00	5.940E+02	9.590E+02	0.000E+00	7.910E+02
CO-58	0.000E+00	1.350E+02	0.000E+00	0.000E+00	0.000E+00	3.360E+02	0.000E+00	3.360E+02
CO-60	0.000E+00	4.060E+02	0.000E+00	0.000E+00	0.000E+00	9.670E+02	0.000E+00	9.590E+02
NI-63	2.390E+04	1.470E+03	0.000E+00	0.000E+00	0.000E+00	7.340E+01	0.000E+00	8.280E+02
NI-65	6.520E+00	7.380E-01	0.000E+00	0.000E+00	0.000E+00	5.620E+01	0.000E+00	3.360E-01
CU-64	0.000E+00	1.190E+01	0.000E+00	2.010E+01	0.000E+00	2.440E+02	0.000E+00	5.500E+00
ZN-65	6.910E+02	2.370E+03	0.000E+00	1.150E+03	0.000E+00	2.000E+03	0.000E+00	1.090E+03
ZN-69	4.390E-04	7.910E-04	0.000E+00	3.290E-04	0.000E+00	6.450E-02	0.000E+00	5.890E-05
BR-83	0.000E+00	0.000E+00	0.000E+00	0.000E+00	0.000E+00	0.000E+00	0.000E+00	4.200E-01
BR-84	0.000E+00	0.000E+00	0.000E+00	0.000E+00	0.000E+00	0.000E+00	0.000E+00	2.220E-06
BR-85	0.000E+00	0.000E+00	0.000E+00	0.000E+00	0.000E+00	0.000E+00	0.000E+00	1.800E-76
RB-86	0.000E+00	6.280E+03	0.000E+00	0.000E+00	0.000E+00	1.610E+02	0.000E+00	3.100E+03
RB-88	0.000E+00	1.250E-11	0.000E+00	0.000E+00	0.000E+00	1.220E-11	0.000E+00	6.840E-12
RB-89	0.000E+00	9.960E-14	0.000E+00	0.000E+00	0.000E+00	3.390E-14	0.000E+00	6.860E-14
SR-89	9.380E+04	0.000E+00	0.000E+00	0.000E+00	0.000E+00	1.930E+03	0.000E+00	2.690E+03
SR-90	6.960E+05	0.000E+00	0.000E+00	0.000E+00	0.000E+00	8.690E+03	0.000E+00	1.770E+05
SR-91	7.830E+02	0.000E+00	0.000E+00	0.000E+00	0.000E+00	9.270E+02	0.000E+00	2.830E+01

Catawba Nuclear Station Units 1 & 2
Period 1/1/2016 - 12/31/2016

Catawba Nuclear Station
Offsite Dose Calculation Manual (ODCM)

APPENDIX F

A_i Infant Dose Factors for use in the Liquid Dose Calculations

Agegroup:	INFANT	Pathway:	Potable Water (PWtr)			Units:	mrem/hr / μCi/ml	
Nuclide	Bone	Liver	Thyroid	Kidney	Lung	Gilli	Skin	Total Body
SR-92	3.350E+01	0.000E+00	0.000E+00	0.000E+00	0.000E+00	3.610E+02	0.000E+00	1.240E+00
Y-90	2.870E+00	0.000E+00	0.000E+00	0.000E+00	0.000E+00	3.970E+03	0.000E+00	7.700E-02
Y-91	4.230E+01	0.000E+00	0.000E+00	0.000E+00	0.000E+00	3.030E+03	0.000E+00	1.130E+00
Y-91M	1.350E-06	0.000E+00	0.000E+00	0.000E+00	0.000E+00	4.510E-03	0.000E+00	4.610E-08
Y-92	2.740E-02	0.000E+00	0.000E+00	0.000E+00	0.000E+00	5.240E+02	0.000E+00	7.710E-04
Y-93	4.010E-01	0.000E+00	0.000E+00	0.000E+00	0.000E+00	3.170E+03	0.000E+00	1.090E-02
ZR-95	7.710E+00	1.880E+00	0.000E+00	2.020E+00	0.000E+00	9.350E+02	0.000E+00	1.330E+00
ZR-97	3.400E-01	5.840E-02	0.000E+00	5.890E-02	0.000E+00	3.720E+03	0.000E+00	2.670E-02
NB-95	1.560E+00	6.440E-01	0.000E+00	4.620E-01	0.000E+00	5.440E+02	0.000E+00	3.720E-01
MO-99	0.000E+00	1.130E+03	0.000E+00	1.680E+03	0.000E+00	3.710E+02	0.000E+00	2.200E+02
TC-99M	1.810E-02	3.740E-02	0.000E+00	4.020E-01	1.950E-02	1.090E+01	0.000E+00	4.820E-01
TC-101	4.570E-17	5.750E-17	0.000E+00	6.840E-16	3.140E-17	9.780E-15	0.000E+00	5.690E-16
RU-103	5.520E+01	0.000E+00	0.000E+00	1.150E+02	0.000E+00	6.710E+02	0.000E+00	1.850E+01
RU-105	7.850E-01	0.000E+00	0.000E+00	5.770E+00	0.000E+00	3.120E+02	0.000E+00	2.640E-01
RU-106	9.060E+02	0.000E+00	0.000E+00	1.070E+03	0.000E+00	6.880E+03	0.000E+00	1.130E+02
AG-110M	3.740E+01	2.730E+01	0.000E+00	3.910E+01	0.000E+00	1.420E+03	0.000E+00	1.810E+01
TE-125M	8.710E+02	2.910E+02	2.930E+02	0.000E+00	0.000E+00	4.150E+02	0.000E+00	1.180E+02
TE-127	1.550E+01	5.200E+00	1.260E+01	3.790E+01	0.000E+00	3.260E+02	0.000E+00	3.340E+00
TE-127M	2.190E+03	7.280E+02	6.340E+02	5.400E+03	0.000E+00	8.850E+02	0.000E+00	2.660E+02
TE-129	7.860E-03	2.710E-03	6.590E-03	1.960E-02	0.000E+00	6.280E-01	0.000E+00	1.840E-03
TE-129M	3.720E+03	1.280E+03	1.430E+03	9.310E+03	0.000E+00	2.220E+03	0.000E+00	5.730E+02
TE-131	1.420E-08	5.250E-09	1.270E-08	3.640E-08	0.000E+00	5.750E-07	0.000E+00	3.990E-09
TE-131M	4.330E+02	1.740E+02	3.540E+02	1.200E+03	0.000E+00	2.940E+03	0.000E+00	1.440E+02
TE-132	7.030E+02	3.480E+02	5.140E+02	2.180E+03	0.000E+00	1.290E+03	0.000E+00	3.250E+02
I-130	1.150E+02	2.530E+02	2.840E+04	2.780E+02	0.000E+00	5.430E+01	0.000E+00	1.020E+02

Catawba Nuclear Station Units 1 & 2
Period 1/1/2016 - 12/31/2016

Catawba Nuclear Station
Offsite Dose Calculation Manual (ODCM)

APPENDIX F

A_i Infant Dose Factors for use in the Liquid Dose Calculations

Agegroup:	INFANT	Pathway:	Potable Water (PWtr)			Units:	mrem/hr / μ Ci/ml	
	Nuclide		Bone	Liver	Thyroid		Kidney	Lung
I-131	1.290E+03	1.520E+03	5.010E+05	1.780E+03	0.000E+00	5.440E+01	0.000E+00	6.700E+02
I-132	1.680E+00	3.410E+00	1.600E+02	3.800E+00	0.000E+00	2.760E+00	0.000E+00	1.210E+00
I-133	3.150E+02	4.590E+02	8.350E+04	5.400E+02	0.000E+00	7.770E+01	0.000E+00	1.340E+02
I-134	2.440E-03	4.990E-03	1.160E-01	5.580E-03	0.000E+00	5.160E-03	0.000E+00	1.780E-03
I-135	3.900E+01	7.750E+01	6.950E+03	8.640E+01	0.000E+00	2.800E+01	0.000E+00	2.830E+01
CS-134	1.420E+04	2.640E+04	0.000E+00	6.810E+03	2.790E+03	7.180E+01	0.000E+00	2.670E+03
CS-136	1.680E+03	4.950E+03	0.000E+00	1.970E+03	4.030E+02	7.510E+01	0.000E+00	1.850E+03
CS-137	1.960E+04	2.300E+04	0.000E+00	6.170E+03	2.500E+03	7.190E+01	0.000E+00	1.630E+03
CS-138	3.330E-06	5.410E-06	0.000E+00	2.700E-06	4.210E-07	8.650E-06	0.000E+00	2.620E-06
BA-139	8.180E-02	5.420E-05	0.000E+00	3.260E-05	3.290E-05	5.180E+00	0.000E+00	2.370E-03
BA-140	6.260E+03	6.260E+00	0.000E+00	1.490E+00	3.840E+00	1.540E+03	0.000E+00	3.230E+02
BA-141	2.220E-11	1.520E-14	0.000E+00	9.140E-15	9.250E-15	2.710E-10	0.000E+00	7.000E-13
BA-142	2.460E-20	2.040E-23	0.000E+00	1.180E-23	1.240E-23	1.010E-19	0.000E+00	1.210E-21
LA-140	6.460E-01	2.550E-01	0.000E+00	0.000E+00	0.000E+00	2.990E+03	0.000E+00	6.550E-02
LA-142	2.220E-04	8.160E-05	0.000E+00	0.000E+00	0.000E+00	1.390E+01	0.000E+00	1.950E-05
CE-141	2.930E+00	1.790E+00	0.000E+00	5.510E-01	0.000E+00	9.230E+02	0.000E+00	2.100E-01
CE-143	4.330E-01	2.870E+02	0.000E+00	8.360E-02	0.000E+00	1.670E+03	0.000E+00	3.270E-02
CE-144	1.120E+02	4.580E+01	0.000E+00	1.850E+01	0.000E+00	6.430E+03	0.000E+00	6.270E+00
PR-143	2.980E+00	1.110E+00	0.000E+00	4.140E-01	0.000E+00	1.570E+03	0.000E+00	1.480E-01
PR-144	3.020E-15	1.170E-15	0.000E+00	4.240E-16	0.000E+00	5.440E-11	0.000E+00	1.520E-16
ND-147	2.020E+00	2.070E+00	0.000E+00	7.980E-01	0.000E+00	1.310E+03	0.000E+00	1.270E-01
W-187	2.400E+01	1.670E+01	0.000E+00	0.000E+00	0.000E+00	9.790E+02	0.000E+00	5.760E+00
NP-239	3.600E-01	3.220E-02	0.000E+00	6.430E-02	0.000E+00	9.320E+02	0.000E+00	1.820E-02

Catawba Nuclear Station Units 1 & 2
Period 1/1/2016 - 12/31/2016

Catawba Nuclear Station
Offsite Dose Calculation Manual (ODCM)

APPENDIX G

R_i Adult Dose Factors for use in the Gaseous Dose Calculations

Agegroup:	ADULT	Pathway:	Grs/Cow/Milk (CMILK)			Units:	m²·mrem/yr / μCi/sec; mrem/yr / μCi/m³ (H-3, C-14)	
Nuclide	Bone	Liver	Thyroid	Kidney	Lung	Gilli	Skin	Total Body
H-3	0.000E+00	7.630E+02	7.630E+02	7.630E+02	7.630E+02	7.630E+02	0.000E+00	7.630E+02
C-14	2.250E+04	4.500E+03	4.500E+03	4.500E+03	4.500E+03	4.500E+03	0.000E+00	4.500E+03
NA-24	2.440E+06	2.440E+06	2.440E+06	2.440E+06	2.440E+06	2.440E+06	0.000E+00	2.440E+06
P-32	1.710E+10	1.060E+09	0.000E+00	0.000E+00	0.000E+00	1.920E+09	0.000E+00	6.610E+08
CR-51	0.000E+00	0.000E+00	1.710E+04	6.300E+03	3.790E+04	7.190E+06	0.000E+00	2.860E+04
MN-54	0.000E+00	8.410E+06	0.000E+00	2.500E+06	0.000E+00	2.580E+07	0.000E+00	1.610E+06
MN-56	0.000E+00	4.090E-03	0.000E+00	5.190E-03	0.000E+00	1.310E-01	0.000E+00	7.260E-04
FE-55	2.510E+07	1.740E+07	0.000E+00	0.000E+00	9.680E+06	9.950E+06	0.000E+00	4.050E+06
FE-59	2.970E+07	6.980E+07	0.000E+00	0.000E+00	1.950E+07	2.330E+08	0.000E+00	2.680E+07
CO-58	0.000E+00	4.710E+06	0.000E+00	0.000E+00	0.000E+00	9.550E+07	0.000E+00	1.060E+07
CO-60	0.000E+00	1.640E+07	0.000E+00	0.000E+00	0.000E+00	3.080E+08	0.000E+00	3.620E+07
NI-63	6.730E+09	4.660E+08	0.000E+00	0.000E+00	0.000E+00	9.730E+07	0.000E+00	2.260E+08
NI-65	3.700E-01	4.810E-02	0.000E+00	0.000E+00	0.000E+00	1.220E+00	0.000E+00	2.190E-02
CU-64	0.000E+00	2.380E+04	0.000E+00	6.010E+04	0.000E+00	2.030E+06	0.000E+00	1.120E+04
ZN-65	1.370E+09	4.370E+09	0.000E+00	2.920E+09	0.000E+00	2.750E+09	0.000E+00	1.970E+09
ZN-69	2.090E-12	4.000E-12	0.000E+00	2.600E-12	0.000E+00	6.010E-13	0.000E+00	2.780E-13
BR-83	0.000E+00	0.000E+00	0.000E+00	0.000E+00	0.000E+00	1.400E-01	0.000E+00	9.720E-02
BR-84	0.000E+00	0.000E+00	0.000E+00	0.000E+00	0.000E+00	1.260E-28	0.000E+00	1.610E-23
BR-85	0.000E+00	0.000E+00	0.000E+00	0.000E+00	0.000E+00	0.000E+00	0.000E+00	0.000E+00
RB-86	0.000E+00	2.590E+09	0.000E+00	0.000E+00	0.000E+00	5.120E+08	0.000E+00	1.210E+09
RB-88	0.000E+00	2.140E-45	0.000E+00	0.000E+00	0.000E+00	2.960E-56	0.000E+00	1.140E-45
RB-89	0.000E+00	4.330E-53	0.000E+00	0.000E+00	0.000E+00	2.510E-66	0.000E+00	3.040E-53
SR-89	1.450E+09	0.000E+00	0.000E+00	0.000E+00	0.000E+00	2.330E+08	0.000E+00	4.160E+07
SR-90	4.680E+10	0.000E+00	0.000E+00	0.000E+00	0.000E+00	1.350E+09	0.000E+00	1.150E+10
SR-91	2.890E+04	0.000E+00	0.000E+00	0.000E+00	0.000E+00	1.380E+05	0.000E+00	1.170E+03

Catawba Nuclear Station Units 1 & 2
Period 1/1/2016 - 12/31/2016

Catawba Nuclear Station
Offsite Dose Calculation Manual (ODCM)

APPENDIX G

R_i Adult Dose Factors for use in the Gaseous Dose Calculations

Agegroup:	ADULT	Pathway:	Grs/Cow/Milk (CMILK)			Units:	m²·mrem/yr / μCi/sec; mrem/yr / μCi/m³ (H-3, C-14)	
Nuclide	Bone	Liver	Thyroid	Kidney	Lung	Gilli	Skin	Total Body
SR-92	4.880E-01	0.000E+00	0.000E+00	0.000E+00	0.000E+00	9.680E+00	0.000E+00	2.110E-02
Y-90	7.080E+01	0.000E+00	0.000E+00	0.000E+00	0.000E+00	7.510E+05	0.000E+00	1.900E+00
Y-91	8.590E+03	0.000E+00	0.000E+00	0.000E+00	0.000E+00	4.730E+06	0.000E+00	2.300E+02
Y-91M	5.980E-20	0.000E+00	0.000E+00	0.000E+00	0.000E+00	1.760E-19	0.000E+00	2.320E-21
Y-92	5.580E-05	0.000E+00	0.000E+00	0.000E+00	0.000E+00	9.770E-01	0.000E+00	1.630E-06
Y-93	2.230E-01	0.000E+00	0.000E+00	0.000E+00	0.000E+00	7.090E+03	0.000E+00	6.170E-03
ZR-95	9.430E+02	3.030E+02	0.000E+00	4.750E+02	0.000E+00	9.590E+05	0.000E+00	2.050E+02
ZR-97	4.330E-01	8.740E-02	0.000E+00	1.320E-01	0.000E+00	2.710E+04	0.000E+00	4.000E-02
NB-95	8.260E+04	4.590E+04	0.000E+00	4.540E+04	0.000E+00	2.790E+08	0.000E+00	2.470E+04
MO-99	0.000E+00	2.480E+07	0.000E+00	5.610E+07	0.000E+00	5.740E+07	0.000E+00	4.710E+06
TC-99M	3.320E+00	9.380E+00	0.000E+00	1.420E+02	4.600E+00	5.550E+03	0.000E+00	1.200E+02
TC-101	2.590E-60	3.740E-60	0.000E+00	6.730E-59	1.910E-60	1.120E-71	0.000E+00	3.670E-59
RU-103	1.020E+03	0.000E+00	0.000E+00	3.890E+03	0.000E+00	1.190E+05	0.000E+00	4.390E+02
RU-105	8.570E-04	0.000E+00	0.000E+00	1.110E-02	0.000E+00	5.240E-01	0.000E+00	3.380E-04
RU-106	2.040E+04	0.000E+00	0.000E+00	3.940E+04	0.000E+00	1.320E+06	0.000E+00	2.580E+03
AG-110M	5.820E+07	5.390E+07	0.000E+00	1.060E+08	0.000E+00	2.200E+10	0.000E+00	3.200E+07
TE-125M	1.630E+07	5.900E+06	4.900E+06	6.630E+07	0.000E+00	6.500E+07	0.000E+00	2.180E+06
TE-127	6.530E+02	2.340E+02	4.840E+02	2.660E+03	0.000E+00	5.150E+04	0.000E+00	1.410E+02
TE-127M	4.580E+07	1.640E+07	1.170E+07	1.860E+08	0.000E+00	1.540E+08	0.000E+00	5.580E+06
TE-129	2.830E-10	1.060E-10	2.170E-10	1.190E-09	0.000E+00	2.130E-10	0.000E+00	6.880E-11
TE-129M	6.020E+07	2.250E+07	2.070E+07	2.510E+08	0.000E+00	3.030E+08	0.000E+00	9.530E+06
TE-131	3.600E-33	1.500E-33	2.960E-33	1.580E-32	0.000E+00	5.100E-34	0.000E+00	1.140E-33
TE-131M	3.610E+05	1.770E+05	2.800E+05	1.790E+06	0.000E+00	1.750E+07	0.000E+00	1.470E+05
TE-132	2.400E+06	1.550E+06	1.720E+06	1.500E+07	0.000E+00	7.350E+07	0.000E+00	1.460E+06
I-130	4.200E+05	1.240E+06	1.050E+08	1.930E+06	0.000E+00	1.070E+06	0.000E+00	4.890E+05

Catawba Nuclear Station Units 1 & 2
Period 1/1/2016 - 12/31/2016

Catawba Nuclear Station
Offsite Dose Calculation Manual (ODCM)

APPENDIX G

R_i Adult Dose Factors for use in the Gaseous Dose Calculations

Agegroup:	ADULT	Pathway:	Grs/Cow/Milk (CMILK)			Units:	m ² ·mrem/yr / μCi/sec; mrem/yr / μCi/m ³ (H-3, C-14)	
			Bone	Liver	Thyroid		Kidney	Lung
I-131	2.960E+08	4.230E+08	1.390E+11	7.260E+08	0.000E+00	1.120E+08	0.000E+00	2.430E+08
I-132	1.640E-01	4.390E-01	1.540E+01	7.000E-01	0.000E+00	8.250E-02	0.000E+00	1.540E-01
I-133	3.870E+06	6.730E+06	9.890E+08	1.170E+07	0.000E+00	6.050E+06	0.000E+00	2.050E+06
I-134	2.020E-12	5.480E-12	9.490E-11	8.710E-12	0.000E+00	4.770E-15	0.000E+00	1.960E-12
I-135	1.280E+04	3.360E+04	2.220E+06	5.390E+04	0.000E+00	3.800E+04	0.000E+00	1.240E+04
CS-134	5.650E+09	1.350E+10	0.000E+00	4.350E+09	1.450E+09	2.350E+08	0.000E+00	1.100E+10
CS-136	2.630E+08	1.040E+09	0.000E+00	5.780E+08	7.930E+07	1.180E+08	0.000E+00	7.480E+08
CS-137	7.380E+09	1.010E+10	0.000E+00	3.430E+09	1.140E+09	1.950E+08	0.000E+00	6.610E+09
CS-138	9.050E-24	1.790E-23	0.000E+00	1.310E-23	1.300E-24	7.620E-29	0.000E+00	8.850E-24
BA-139	4.420E-08	3.150E-11	0.000E+00	2.940E-11	1.790E-11	7.830E-08	0.000E+00	1.290E-09
BA-140	2.690E+07	3.380E+04	0.000E+00	1.150E+04	1.930E+04	5.530E+07	0.000E+00	1.760E+06
BA-141	4.090E-46	3.090E-49	0.000E+00	2.880E-49	1.760E-49	1.930E-55	0.000E+00	1.380E-47
BA-142	2.640E-80	2.720E-83	0.000E+00	2.300E-83	1.540E-83	3.720E-98	0.000E+00	1.660E-81
LA-140	4.510E+00	2.270E+00	0.000E+00	0.000E+00	0.000E+00	1.670E+05	0.000E+00	6.010E-01
LA-142	1.860E-11	8.460E-12	0.000E+00	0.000E+00	0.000E+00	6.170E-08	0.000E+00	2.110E-12
CE-141	4.840E+03	3.280E+03	0.000E+00	1.520E+03	0.000E+00	1.250E+07	0.000E+00	3.720E+02
CE-143	4.160E+01	3.070E+04	0.000E+00	1.350E+01	0.000E+00	1.150E+06	0.000E+00	3.400E+00
CE-144	3.580E+05	1.500E+05	0.000E+00	8.870E+04	0.000E+00	1.210E+08	0.000E+00	1.920E+04
PR-143	1.580E+02	6.330E+01	0.000E+00	3.660E+01	0.000E+00	6.920E+05	0.000E+00	7.830E+00
PR-144	5.870E-54	2.440E-54	0.000E+00	1.380E-54	0.000E+00	8.450E-61	0.000E+00	2.990E-55
ND-147	9.420E+01	1.090E+02	0.000E+00	6.360E+01	0.000E+00	5.220E+05	0.000E+00	6.510E+00
W-187	6.510E+03	5.450E+03	0.000E+00	0.000E+00	0.000E+00	1.780E+06	0.000E+00	1.900E+03
NP-239	3.670E+00	3.610E-01	0.000E+00	1.130E+00	0.000E+00	7.410E+04	0.000E+00	1.990E-01

Catawba Nuclear Station Units 1 & 2
Period 1/1/2016 - 12/31/2016

Catawba Nuclear Station
Offsite Dose Calculation Manual (ODCM)

APPENDIX G

R_i Adult Dose Factors for use in the Gaseous Dose Calculations

Agegroup:	ADULT	Pathway:	Grs/Goat/Milk (GMILK)			Units:	m²·mrem/yr / μCi/sec; mrem/yr / μCi/m³ (H-3, C-14)	
Nuclide	Bone	Liver	Thyroid	Kidney	Lung	Gilli	Skin	Total Body
H-3	0.000E+00	1.560E+03	1.560E+03	1.560E+03	1.560E+03	1.560E+03	0.000E+00	1.560E+03
C-14	2.250E+04	4.500E+03	4.500E+03	4.500E+03	4.500E+03	4.500E+03	0.000E+00	4.500E+03
NA-24	2.930E+05	2.930E+05	2.930E+05	2.930E+05	2.930E+05	2.930E+05	0.000E+00	2.930E+05
P-32	2.050E+10	1.280E+09	0.000E+00	0.000E+00	0.000E+00	2.310E+09	0.000E+00	7.930E+08
CR-51	0.000E+00	0.000E+00	2.050E+03	7.550E+02	4.550E+03	8.620E+05	0.000E+00	3.430E+03
MN-54	0.000E+00	1.010E+06	0.000E+00	3.000E+05	0.000E+00	3.090E+06	0.000E+00	1.930E+05
MN-56	0.000E+00	4.910E-04	0.000E+00	6.230E-04	0.000E+00	1.570E-02	0.000E+00	8.710E-05
FE-55	3.260E+05	2.260E+05	0.000E+00	0.000E+00	1.260E+05	1.290E+05	0.000E+00	5.260E+04
FE-59	3.860E+05	9.070E+05	0.000E+00	0.000E+00	2.540E+05	3.020E+06	0.000E+00	3.480E+05
CO-58	0.000E+00	5.660E+05	0.000E+00	0.000E+00	0.000E+00	1.150E+07	0.000E+00	1.270E+06
CO-60	0.000E+00	1.970E+06	0.000E+00	0.000E+00	0.000E+00	3.700E+07	0.000E+00	4.340E+06
NI-63	8.070E+08	5.600E+07	0.000E+00	0.000E+00	0.000E+00	1.170E+07	0.000E+00	2.710E+07
NI-65	4.440E-02	5.770E-03	0.000E+00	0.000E+00	0.000E+00	1.460E-01	0.000E+00	2.630E-03
CU-64	0.000E+00	2.660E+03	0.000E+00	6.700E+03	0.000E+00	2.260E+05	0.000E+00	1.250E+03
ZN-65	1.650E+08	5.240E+08	0.000E+00	3.500E+08	0.000E+00	3.300E+08	0.000E+00	2.370E+08
ZN-69	2.510E-13	4.800E-13	0.000E+00	3.120E-13	0.000E+00	7.210E-14	0.000E+00	3.340E-14
BR-83	0.000E+00	0.000E+00	0.000E+00	0.000E+00	0.000E+00	1.680E-02	0.000E+00	1.170E-02
BR-84	0.000E+00	0.000E+00	0.000E+00	0.000E+00	0.000E+00	1.520E-29	0.000E+00	1.930E-24
BR-85	0.000E+00	0.000E+00	0.000E+00	0.000E+00	0.000E+00	0.000E+00	0.000E+00	0.000E+00
RB-86	0.000E+00	3.110E+08	0.000E+00	0.000E+00	0.000E+00	6.140E+07	0.000E+00	1.450E+08
RB-88	0.000E+00	2.570E-46	0.000E+00	0.000E+00	0.000E+00	3.550E-57	0.000E+00	1.360E-46
RB-89	0.000E+00	5.190E-54	0.000E+00	0.000E+00	0.000E+00	3.020E-67	0.000E+00	3.650E-54
SR-89	3.050E+09	0.000E+00	0.000E+00	0.000E+00	0.000E+00	4.890E+08	0.000E+00	8.750E+07
SR-90	9.830E+10	0.000E+00	0.000E+00	0.000E+00	0.000E+00	2.840E+09	0.000E+00	2.410E+10
SR-91	6.070E+04	0.000E+00	0.000E+00	0.000E+00	0.000E+00	2.890E+05	0.000E+00	2.450E+03

Catawba Nuclear Station Units 1 & 2
Period 1/1/2016 - 12/31/2016

Catawba Nuclear Station
Offsite Dose Calculation Manual (ODCM)

APPENDIX G

R_i Adult Dose Factors for use in the Gaseous Dose Calculations

Agegroup:	ADULT	Pathway:	Grs/Goat/Milk (GMILK)			Units:	m²·mrem/yr / μCi/sec; mrem/yr / μCi/m³ (H-3, C-14)	
Nuclide	Bone	Liver	Thyroid	Kidney	Lung	Gilli	Skin	Total Body
SR-92	1.030E+00	0.000E+00	0.000E+00	0.000E+00	0.000E+00	2.030E+01	0.000E+00	4.440E-02
Y-90	8.500E+00	0.000E+00	0.000E+00	0.000E+00	0.000E+00	9.010E+04	0.000E+00	2.280E-01
Y-91	1.030E+03	0.000E+00	0.000E+00	0.000E+00	0.000E+00	5.670E+05	0.000E+00	2.760E+01
Y-91M	7.170E-21	0.000E+00	0.000E+00	0.000E+00	0.000E+00	2.110E-20	0.000E+00	2.780E-22
Y-92	6.690E-06	0.000E+00	0.000E+00	0.000E+00	0.000E+00	1.170E-01	0.000E+00	1.960E-07
Y-93	2.680E-02	0.000E+00	0.000E+00	0.000E+00	0.000E+00	8.500E+02	0.000E+00	7.400E-04
ZR-95	1.130E+02	3.630E+01	0.000E+00	5.700E+01	0.000E+00	1.150E+05	0.000E+00	2.460E+01
ZR-97	5.200E-02	1.050E-02	0.000E+00	1.580E-02	0.000E+00	3.250E+03	0.000E+00	4.800E-03
NB-95	9.910E+03	5.510E+03	0.000E+00	5.450E+03	0.000E+00	3.340E+07	0.000E+00	2.960E+03
MO-99	0.000E+00	2.970E+06	0.000E+00	6.730E+06	0.000E+00	6.890E+06	0.000E+00	5.660E+05
TC-99M	3.980E-01	1.130E+00	0.000E+00	1.710E+01	5.520E-01	6.660E+02	0.000E+00	1.430E+01
TC-101	3.110E-61	4.490E-61	0.000E+00	8.080E-60	2.290E-61	1.350E-72	0.000E+00	4.400E-60
RU-103	1.220E+02	0.000E+00	0.000E+00	4.660E+02	0.000E+00	1.430E+04	0.000E+00	5.260E+01
RU-105	1.030E-04	0.000E+00	0.000E+00	1.330E-03	0.000E+00	6.290E-02	0.000E+00	4.060E-05
RU-106	2.450E+03	0.000E+00	0.000E+00	4.730E+03	0.000E+00	1.580E+05	0.000E+00	3.100E+02
AG-110M	6.990E+06	6.460E+06	0.000E+00	1.270E+07	0.000E+00	2.640E+09	0.000E+00	3.840E+06
TE-125M	1.950E+06	7.080E+05	5.880E+05	7.950E+06	0.000E+00	7.800E+06	0.000E+00	2.620E+05
TE-127	7.830E+01	2.810E+01	5.800E+01	3.190E+02	0.000E+00	6.180E+03	0.000E+00	1.700E+01
TE-127M	5.490E+06	1.960E+06	1.400E+06	2.230E+07	0.000E+00	1.840E+07	0.000E+00	6.690E+05
TE-129	3.390E-11	1.270E-11	2.600E-11	1.430E-10	0.000E+00	2.560E-11	0.000E+00	8.260E-12
TE-129M	7.220E+06	2.690E+06	2.480E+06	3.020E+07	0.000E+00	3.640E+07	0.000E+00	1.140E+06
TE-131	4.320E-34	1.810E-34	3.550E-34	1.890E-33	0.000E+00	6.120E-35	0.000E+00	1.360E-34
TE-131M	4.330E+04	2.120E+04	3.360E+04	2.150E+05	0.000E+00	2.100E+06	0.000E+00	1.770E+04
TE-132	2.880E+05	1.860E+05	2.060E+05	1.800E+06	0.000E+00	8.820E+06	0.000E+00	1.750E+05
I-130	5.040E+05	1.490E+06	1.260E+08	2.320E+06	0.000E+00	1.280E+06	0.000E+00	5.870E+05

Catawba Nuclear Station Units 1 & 2
Period 1/1/2016 - 12/31/2016

Catawba Nuclear Station
Offsite Dose Calculation Manual (ODCM)

APPENDIX G

R_i Adult Dose Factors for use in the Gaseous Dose Calculations

Agegroup:	ADULT	Pathway:	Grs/Goat/Milk (GMILK)			Units:	m ² ·mrem/yr / μCi/sec; mrem/yr / μCi/m ³ (H-3, C-14)	
			Bone	Liver	Thyroid		Kidney	Lung
I-131	3.550E+08	5.080E+08	1.670E+11	8.710E+08	0.000E+00	1.340E+08	0.000E+00	2.910E+08
I-132	1.970E-01	5.270E-01	1.840E+01	8.400E-01	0.000E+00	9.900E-02	0.000E+00	1.840E-01
I-133	4.640E+06	8.080E+06	1.190E+09	1.410E+07	0.000E+00	7.260E+06	0.000E+00	2.460E+06
I-134	2.420E-12	6.570E-12	1.140E-10	1.050E-11	0.000E+00	5.730E-15	0.000E+00	2.350E-12
I-135	1.540E+04	4.030E+04	2.660E+06	6.470E+04	0.000E+00	4.560E+04	0.000E+00	1.490E+04
CS-134	1.700E+10	4.040E+10	0.000E+00	1.310E+10	4.340E+09	7.060E+08	0.000E+00	3.300E+10
CS-136	7.900E+08	3.120E+09	0.000E+00	1.730E+09	2.380E+08	3.540E+08	0.000E+00	2.240E+09
CS-137	2.210E+10	3.030E+10	0.000E+00	1.030E+10	3.420E+09	5.860E+08	0.000E+00	1.980E+10
CS-138	2.710E-23	5.360E-23	0.000E+00	3.940E-23	3.890E-24	2.290E-28	0.000E+00	2.650E-23
BA-139	5.300E-09	3.780E-12	0.000E+00	3.530E-12	2.140E-12	9.400E-09	0.000E+00	1.550E-10
BA-140	3.230E+06	4.050E+03	0.000E+00	1.380E+03	2.320E+03	6.640E+06	0.000E+00	2.110E+05
BA-141	4.910E-47	3.710E-50	0.000E+00	3.450E-50	2.110E-50	2.310E-56	0.000E+00	1.660E-48
BA-142	3.170E-81	3.260E-84	0.000E+00	2.750E-84	1.850E-84	0.000E+00	0.000E+00	2.000E-82
LA-140	5.410E-01	2.730E-01	0.000E+00	0.000E+00	0.000E+00	2.000E+04	0.000E+00	7.210E-02
LA-142	2.230E-12	1.010E-12	0.000E+00	0.000E+00	0.000E+00	7.410E-09	0.000E+00	2.530E-13
CE-141	5.810E+02	3.930E+02	0.000E+00	1.830E+02	0.000E+00	1.500E+06	0.000E+00	4.460E+01
CE-143	4.990E+00	3.690E+03	0.000E+00	1.620E+00	0.000E+00	1.380E+05	0.000E+00	4.080E-01
CE-144	4.290E+04	1.790E+04	0.000E+00	1.060E+04	0.000E+00	1.450E+07	0.000E+00	2.300E+03
PR-143	1.890E+01	7.600E+00	0.000E+00	4.390E+00	0.000E+00	8.300E+04	0.000E+00	9.390E-01
PR-144	7.050E-55	2.930E-55	0.000E+00	1.650E-55	0.000E+00	1.010E-61	0.000E+00	3.580E-56
ND-147	1.130E+01	1.310E+01	0.000E+00	7.630E+00	0.000E+00	6.270E+04	0.000E+00	7.810E-01
W-187	7.820E+02	6.530E+02	0.000E+00	0.000E+00	0.000E+00	2.140E+05	0.000E+00	2.280E+02
NP-239	4.410E-01	4.330E-02	0.000E+00	1.350E-01	0.000E+00	8.890E+03	0.000E+00	2.390E-02

Catawba Nuclear Station Units 1 & 2
Period 1/1/2016 - 12/31/2016

Catawba Nuclear Station
Offsite Dose Calculation Manual (ODCM)

APPENDIX G

R_i Adult Dose Factors for use in the Gaseous Dose Calculations

Agegroup:	ADULT	Pathway:	Grs/Cow/Meat (CMEAT)			Units:	m²·mrem/yr / μCi/sec; mrem/yr / μCi/m³ (H-3, C-14)	
Nuclide	Bone	Liver	Thyroid	Kidney	Lung	Gilli	Skin	Total Body
H-3	0.000E+00	3.250E+02	3.250E+02	3.250E+02	3.250E+02	3.250E+02	0.000E+00	3.250E+02
C-14	2.060E+04	4.130E+03	4.130E+03	4.130E+03	4.130E+03	4.130E+03	0.000E+00	4.130E+03
NA-24	1.360E-03	1.360E-03	1.360E-03	1.360E-03	1.360E-03	1.360E-03	0.000E+00	1.360E-03
P-32	4.660E+09	2.900E+08	0.000E+00	0.000E+00	0.000E+00	5.240E+08	0.000E+00	1.800E+08
CR-51	0.000E+00	0.000E+00	4.210E+03	1.550E+03	9.350E+03	1.770E+06	0.000E+00	7.050E+03
MN-54	0.000E+00	9.180E+06	0.000E+00	2.730E+06	0.000E+00	2.810E+07	0.000E+00	1.750E+06
MN-56	0.000E+00	1.320E-53	0.000E+00	1.680E-53	0.000E+00	4.220E-52	0.000E+00	2.350E-54
FE-55	2.930E+08	2.030E+08	0.000E+00	0.000E+00	1.130E+08	1.160E+08	0.000E+00	4.720E+07
FE-59	2.660E+08	6.240E+08	0.000E+00	0.000E+00	1.740E+08	2.080E+09	0.000E+00	2.390E+08
CO-58	0.000E+00	1.820E+07	0.000E+00	0.000E+00	0.000E+00	3.690E+08	0.000E+00	4.090E+07
CO-60	0.000E+00	7.520E+07	0.000E+00	0.000E+00	0.000E+00	1.410E+09	0.000E+00	1.660E+08
NI-63	1.890E+10	1.310E+09	0.000E+00	0.000E+00	0.000E+00	2.730E+08	0.000E+00	6.330E+08
NI-65	2.250E-52	2.920E-53	0.000E+00	0.000E+00	0.000E+00	7.400E-52	0.000E+00	1.330E-53
CU-64	0.000E+00	2.710E-07	0.000E+00	6.830E-07	0.000E+00	2.310E-05	0.000E+00	1.270E-07
ZN-65	3.560E+08	1.130E+09	0.000E+00	7.570E+08	0.000E+00	7.130E+08	0.000E+00	5.120E+08
ZN-69	0.000E+00	0.000E+00	0.000E+00	0.000E+00	0.000E+00	0.000E+00	0.000E+00	0.000E+00
BR-83	0.000E+00	0.000E+00	0.000E+00	0.000E+00	0.000E+00	8.650E-57	0.000E+00	6.000E-57
BR-84	0.000E+00	0.000E+00	0.000E+00	0.000E+00	0.000E+00	0.000E+00	0.000E+00	0.000E+00
BR-85	0.000E+00	0.000E+00	0.000E+00	0.000E+00	0.000E+00	0.000E+00	0.000E+00	0.000E+00
RB-86	0.000E+00	4.870E+08	0.000E+00	0.000E+00	0.000E+00	9.600E+07	0.000E+00	2.270E+08
RB-88	0.000E+00	0.000E+00	0.000E+00	0.000E+00	0.000E+00	0.000E+00	0.000E+00	0.000E+00
RB-89	0.000E+00	0.000E+00	0.000E+00	0.000E+00	0.000E+00	0.000E+00	0.000E+00	0.000E+00
SR-89	3.020E+08	0.000E+00	0.000E+00	0.000E+00	0.000E+00	4.840E+07	0.000E+00	8.660E+06
SR-90	1.240E+10	0.000E+00	0.000E+00	0.000E+00	0.000E+00	3.590E+08	0.000E+00	3.050E+09
SR-91	1.520E-10	0.000E+00	0.000E+00	0.000E+00	0.000E+00	7.240E-10	0.000E+00	6.140E-12

Catawba Nuclear Station Units 1 & 2
Period 1/1/2016 - 12/31/2016

Catawba Nuclear Station
Offsite Dose Calculation Manual (ODCM)

APPENDIX G

R_i Adult Dose Factors for use in the Gaseous Dose Calculations

Agegroup:	ADULT	Pathway:	Grs/Cow/Meat (CMEAT)			Units:	m²·mrem/yr / μCi/sec; mrem/yr / μCi/m³ (H-3, C-14)	
Nuclide	Bone	Liver	Thyroid	Kidney	Lung	Gilli	Skin	Total Body
SR-92	1.180E-49	0.000E+00	0.000E+00	0.000E+00	0.000E+00	2.340E-48	0.000E+00	5.100E-51
Y-90	1.080E+02	0.000E+00	0.000E+00	0.000E+00	0.000E+00	1.140E+06	0.000E+00	2.890E+00
Y-91	1.130E+06	0.000E+00	0.000E+00	0.000E+00	0.000E+00	6.230E+08	0.000E+00	3.030E+04
Y-91M	0.000E+00	0.000E+00	0.000E+00	0.000E+00	0.000E+00	0.000E+00	0.000E+00	0.000E+00
Y-92	1.520E-39	0.000E+00	0.000E+00	0.000E+00	0.000E+00	2.660E-35	0.000E+00	4.430E-41
Y-93	4.690E-12	0.000E+00	0.000E+00	0.000E+00	0.000E+00	1.490E-07	0.000E+00	1.300E-13
ZR-95	1.870E+06	6.010E+05	0.000E+00	9.420E+05	0.000E+00	1.900E+09	0.000E+00	4.070E+05
ZR-97	2.070E-05	4.170E-06	0.000E+00	6.300E-06	0.000E+00	1.290E+00	0.000E+00	1.910E-06
NB-95	2.300E+06	1.280E+06	0.000E+00	1.260E+06	0.000E+00	7.760E+09	0.000E+00	6.870E+05
MO-99	0.000E+00	1.000E+05	0.000E+00	2.260E+05	0.000E+00	2.320E+05	0.000E+00	1.900E+04
TC-99M	4.450E-21	1.260E-20	0.000E+00	1.910E-19	6.150E-21	7.430E-18	0.000E+00	1.600E-19
TC-101	0.000E+00	0.000E+00	0.000E+00	0.000E+00	0.000E+00	0.000E+00	0.000E+00	0.000E+00
RU-103	1.050E+08	0.000E+00	0.000E+00	4.010E+08	0.000E+00	1.230E+10	0.000E+00	4.530E+07
RU-105	5.780E-28	0.000E+00	0.000E+00	7.460E-27	0.000E+00	3.530E-25	0.000E+00	2.280E-28
RU-106	2.800E+09	0.000E+00	0.000E+00	5.400E+09	0.000E+00	1.810E+11	0.000E+00	3.540E+08
AG-110M	6.680E+06	6.180E+06	0.000E+00	1.220E+07	0.000E+00	2.520E+09	0.000E+00	3.670E+06
TE-125M	3.590E+08	1.300E+08	1.080E+08	1.460E+09	0.000E+00	1.430E+09	0.000E+00	4.810E+07
TE-127	2.120E-10	7.610E-11	1.570E-10	8.640E-10	0.000E+00	1.670E-08	0.000E+00	4.590E-11
TE-127M	1.120E+09	3.990E+08	2.850E+08	4.530E+09	0.000E+00	3.740E+09	0.000E+00	1.360E+08
TE-129	0.000E+00	0.000E+00	0.000E+00	0.000E+00	0.000E+00	0.000E+00	0.000E+00	0.000E+00
TE-129M	1.130E+09	4.230E+08	3.900E+08	4.730E+09	0.000E+00	5.710E+09	0.000E+00	1.790E+08
TE-131	0.000E+00	0.000E+00	0.000E+00	0.000E+00	0.000E+00	0.000E+00	0.000E+00	0.000E+00
TE-131M	4.510E+02	2.210E+02	3.490E+02	2.230E+03	0.000E+00	2.190E+04	0.000E+00	1.840E+02
TE-132	1.420E+06	9.180E+05	1.010E+06	8.840E+06	0.000E+00	4.340E+07	0.000E+00	8.620E+05
I-130	2.110E-06	6.220E-06	5.270E-04	9.700E-06	0.000E+00	5.350E-06	0.000E+00	2.450E-06

Catawba Nuclear Station Units 1 & 2
Period 1/1/2016 - 12/31/2016

Catawba Nuclear Station
Offsite Dose Calculation Manual (ODCM)

APPENDIX G

R_i Adult Dose Factors for use in the Gaseous Dose Calculations

Agegroup:	ADULT	Pathway:	Grs/Cow/Meat (CMEAT)			Units:	m ² ·mrem/yr / μCi/sec; mrem/yr / μCi/m ³ (H-3, C-14)	
Nuclide	Bone	Liver	Thyroid	Kidney	Lung	Gilli	Skin	Total Body
I-131	1.070E+07	1.540E+07	5.030E+09	2.630E+07	0.000E+00	4.050E+06	0.000E+00	8.800E+06
I-132	6.970E-59	1.860E-58	6.530E-57	2.970E-58	0.000E+00	3.500E-59	0.000E+00	6.530E-59
I-133	3.650E-01	6.350E-01	9.340E+01	1.110E+00	0.000E+00	5.710E-01	0.000E+00	1.940E-01
I-134	0.000E+00	0.000E+00	0.000E+00	0.000E+00	0.000E+00	0.000E+00	0.000E+00	0.000E+00
I-135	4.420E-17	1.160E-16	7.640E-15	1.860E-16	0.000E+00	1.310E-16	0.000E+00	4.270E-17
CS-134	6.580E+08	1.560E+09	0.000E+00	5.060E+08	1.680E+08	2.740E+07	0.000E+00	1.280E+09
CS-136	1.210E+07	4.760E+07	0.000E+00	2.650E+07	3.630E+06	5.410E+06	0.000E+00	3.420E+07
CS-137	8.720E+08	1.190E+09	0.000E+00	4.050E+08	1.350E+08	2.310E+07	0.000E+00	7.810E+08
CS-138	0.000E+00	0.000E+00	0.000E+00	0.000E+00	0.000E+00	0.000E+00	0.000E+00	0.000E+00
BA-139	0.000E+00	0.000E+00	0.000E+00	0.000E+00	0.000E+00	0.000E+00	0.000E+00	0.000E+00
BA-140	2.870E+07	3.610E+04	0.000E+00	1.230E+04	2.070E+04	5.920E+07	0.000E+00	1.880E+06
BA-141	0.000E+00	0.000E+00	0.000E+00	0.000E+00	0.000E+00	0.000E+00	0.000E+00	0.000E+00
BA-142	0.000E+00	0.000E+00	0.000E+00	0.000E+00	0.000E+00	0.000E+00	0.000E+00	0.000E+00
LA-140	3.710E-02	1.870E-02	0.000E+00	0.000E+00	0.000E+00	1.370E+03	0.000E+00	4.940E-03
LA-142	3.470E-92	1.580E-92	0.000E+00	0.000E+00	0.000E+00	1.150E-88	0.000E+00	3.940E-93
CE-141	1.400E+04	9.500E+03	0.000E+00	4.410E+03	0.000E+00	3.630E+07	0.000E+00	1.080E+03
CE-143	2.010E-02	1.480E+01	0.000E+00	6.530E-03	0.000E+00	5.550E+02	0.000E+00	1.640E-03
CE-144	1.460E+06	6.090E+05	0.000E+00	3.610E+05	0.000E+00	4.930E+08	0.000E+00	7.830E+04
PR-143	2.100E+04	8.410E+03	0.000E+00	4.850E+03	0.000E+00	9.180E+07	0.000E+00	1.040E+03
PR-144	0.000E+00	0.000E+00	0.000E+00	0.000E+00	0.000E+00	0.000E+00	0.000E+00	0.000E+00
ND-147	7.070E+03	8.170E+03	0.000E+00	4.780E+03	0.000E+00	3.920E+07	0.000E+00	4.890E+02
W-187	2.070E-02	1.730E-02	0.000E+00	0.000E+00	0.000E+00	5.660E+00	0.000E+00	6.040E-03
NP-239	2.590E-01	2.550E-02	0.000E+00	7.950E-02	0.000E+00	5.230E+03	0.000E+00	1.400E-02

Catawba Nuclear Station Units 1 & 2
Period 1/1/2016 - 12/31/2016

Catawba Nuclear Station
Offsite Dose Calculation Manual (ODCM)

APPENDIX G

R_i Adult Dose Factors for use in the Gaseous Dose Calculations

Agegroup:	ADULT	Pathway:	Vegetation (VEG)			Units:	m²·mrem/yr / μCi/sec; mrem/yr / μCi/m³ (H-3, C-14)	
Nuclide	Bone	Liver	Thyroid	Kidney	Lung	Gilli	Skin	Total Body
H-3	0.000E+00	2.260E+03	2.260E+03	2.260E+03	2.260E+03	2.260E+03	0.000E+00	2.260E+03
C-14	5.560E+04	1.110E+04	1.110E+04	1.110E+04	1.110E+04	1.110E+04	0.000E+00	1.110E+04
NA-24	2.690E+05	2.690E+05	2.690E+05	2.690E+05	2.690E+05	2.690E+05	0.000E+00	2.690E+05
P-32	1.400E+09	8.730E+07	0.000E+00	0.000E+00	0.000E+00	1.580E+08	0.000E+00	5.430E+07
CR-51	0.000E+00	0.000E+00	2.780E+04	1.020E+04	6.160E+04	1.170E+07	0.000E+00	4.640E+04
MN-54	0.000E+00	3.130E+08	0.000E+00	9.310E+07	0.000E+00	9.590E+08	0.000E+00	5.970E+07
MN-56	0.000E+00	1.580E+01	0.000E+00	2.000E+01	0.000E+00	5.040E+02	0.000E+00	2.800E+00
FE-55	2.100E+08	1.450E+08	0.000E+00	0.000E+00	8.080E+07	8.310E+07	0.000E+00	3.380E+07
FE-59	1.260E+08	2.960E+08	0.000E+00	0.000E+00	8.280E+07	9.880E+08	0.000E+00	1.140E+08
CO-58	0.000E+00	3.070E+07	0.000E+00	0.000E+00	0.000E+00	6.230E+08	0.000E+00	6.890E+07
CO-60	0.000E+00	1.670E+08	0.000E+00	0.000E+00	0.000E+00	3.140E+09	0.000E+00	3.690E+08
NI-63	1.040E+10	7.210E+08	0.000E+00	0.000E+00	0.000E+00	1.500E+08	0.000E+00	3.490E+08
NI-65	6.150E+01	7.990E+00	0.000E+00	0.000E+00	0.000E+00	2.030E+02	0.000E+00	3.640E+00
CU-64	0.000E+00	9.200E+03	0.000E+00	2.320E+04	0.000E+00	7.840E+05	0.000E+00	4.320E+03
ZN-65	3.170E+08	1.010E+09	0.000E+00	6.750E+08	0.000E+00	6.360E+08	0.000E+00	4.560E+08
ZN-69	5.490E-06	1.050E-05	0.000E+00	6.830E-06	0.000E+00	1.580E-06	0.000E+00	7.310E-07
BR-83	0.000E+00	0.000E+00	0.000E+00	0.000E+00	0.000E+00	4.470E+00	0.000E+00	3.110E+00
BR-84	0.000E+00	0.000E+00	0.000E+00	0.000E+00	0.000E+00	1.940E-16	0.000E+00	2.480E-11
BR-85	0.000E+00	0.000E+00	0.000E+00	0.000E+00	0.000E+00	0.000E+00	0.000E+00	0.000E+00
RB-86	0.000E+00	2.190E+08	0.000E+00	0.000E+00	0.000E+00	4.330E+07	0.000E+00	1.020E+08
RB-88	0.000E+00	3.430E-22	0.000E+00	0.000E+00	0.000E+00	4.740E-33	0.000E+00	1.820E-22
RB-89	0.000E+00	3.890E-26	0.000E+00	0.000E+00	0.000E+00	2.260E-39	0.000E+00	2.730E-26
SR-89	9.970E+09	0.000E+00	0.000E+00	0.000E+00	0.000E+00	1.600E+09	0.000E+00	2.860E+08
SR-90	6.050E+11	0.000E+00	0.000E+00	0.000E+00	0.000E+00	1.750E+10	0.000E+00	1.480E+11
SR-91	3.050E+05	0.000E+00	0.000E+00	0.000E+00	0.000E+00	1.450E+06	0.000E+00	1.230E+04

Catawba Nuclear Station Units 1 & 2
Period 1/1/2016 - 12/31/2016

Catawba Nuclear Station
Offsite Dose Calculation Manual (ODCM)

APPENDIX G

R_i Adult Dose Factors for use in the Gaseous Dose Calculations

Agegroup:	ADULT	Pathway:	Vegetation (VEG)			Units:	m²·mrem/yr / μCi/sec; mrem/yr / μCi/m³ (H-3, C-14)	
Nuclide	Bone	Liver	Thyroid	Kidney	Lung	Gilli	Skin	Total Body
SR-92	4.270E+02	0.000E+00	0.000E+00	0.000E+00	0.000E+00	8.450E+03	0.000E+00	1.850E+01
Y-90	1.330E+04	0.000E+00	0.000E+00	0.000E+00	0.000E+00	1.410E+08	0.000E+00	3.570E+02
Y-91	5.110E+06	0.000E+00	0.000E+00	0.000E+00	0.000E+00	2.810E+09	0.000E+00	1.370E+05
Y-91M	5.220E-09	0.000E+00	0.000E+00	0.000E+00	0.000E+00	1.530E-08	0.000E+00	2.020E-10
Y-92	9.150E-01	0.000E+00	0.000E+00	0.000E+00	0.000E+00	1.600E+04	0.000E+00	2.680E-02
Y-93	1.700E+02	0.000E+00	0.000E+00	0.000E+00	0.000E+00	5.380E+06	0.000E+00	4.680E+00
ZR-95	1.170E+06	3.770E+05	0.000E+00	5.910E+05	0.000E+00	1.190E+09	0.000E+00	2.550E+05
ZR-97	3.370E+02	6.810E+01	0.000E+00	1.030E+02	0.000E+00	2.110E+07	0.000E+00	3.110E+01
NB-95	1.420E+05	7.920E+04	0.000E+00	7.830E+04	0.000E+00	4.810E+08	0.000E+00	4.260E+04
MO-99	0.000E+00	6.150E+06	0.000E+00	1.390E+07	0.000E+00	1.430E+07	0.000E+00	1.170E+06
TC-99M	3.100E+00	8.770E+00	0.000E+00	1.330E+02	4.300E+00	5.190E+03	0.000E+00	1.120E+02
TC-101	8.220E-31	1.180E-30	0.000E+00	2.130E-29	6.050E-31	3.560E-42	0.000E+00	1.160E-29
RU-103	4.770E+06	0.000E+00	0.000E+00	1.820E+07	0.000E+00	5.570E+08	0.000E+00	2.060E+06
RU-105	5.390E+01	0.000E+00	0.000E+00	6.960E+02	0.000E+00	3.290E+04	0.000E+00	2.130E+01
RU-106	1.930E+08	0.000E+00	0.000E+00	3.720E+08	0.000E+00	1.250E+10	0.000E+00	2.440E+07
AG-110M	1.050E+07	9.750E+06	0.000E+00	1.920E+07	0.000E+00	3.980E+09	0.000E+00	5.790E+06
TE-125M	9.660E+07	3.500E+07	2.900E+07	3.930E+08	0.000E+00	3.860E+08	0.000E+00	1.290E+07
TE-127	5.660E+03	2.030E+03	4.190E+03	2.310E+04	0.000E+00	4.470E+05	0.000E+00	1.220E+03
TE-127M	3.490E+08	1.250E+08	8.920E+07	1.420E+09	0.000E+00	1.170E+09	0.000E+00	4.260E+07
TE-129	7.630E-04	2.870E-04	5.850E-04	3.210E-03	0.000E+00	5.760E-04	0.000E+00	1.860E-04
TE-129M	2.510E+08	9.380E+07	8.630E+07	1.050E+09	0.000E+00	1.270E+09	0.000E+00	3.980E+07
TE-131	1.500E-15	6.270E-16	1.230E-15	6.570E-15	0.000E+00	2.130E-16	0.000E+00	4.740E-16
TE-131M	9.120E+05	4.460E+05	7.060E+05	4.520E+06	0.000E+00	4.430E+07	0.000E+00	3.720E+05
TE-132	4.300E+06	2.780E+06	3.070E+06	2.680E+07	0.000E+00	1.320E+08	0.000E+00	2.610E+06
I-130	3.920E+05	1.160E+06	9.810E+07	1.810E+06	0.000E+00	9.960E+05	0.000E+00	4.570E+05

Catawba Nuclear Station Units 1 & 2
Period 1/1/2016 - 12/31/2016

Catawba Nuclear Station
Offsite Dose Calculation Manual (ODCM)

APPENDIX G

R_i Adult Dose Factors for use in the Gaseous Dose Calculations

Agegroup:	ADULT	Pathway:	Vegetation (VEG)			Units:	m ² ·mrem/yr / μCi/sec; mrem/yr / μCi/m ³ (H-3, C-14)	
			Bone	Liver	Thyroid		Kidney	Lung
I-131	8.080E+07	1.160E+08	3.790E+10	1.980E+08	0.000E+00	3.050E+07	0.000E+00	6.620E+07
I-132	5.760E+01	1.540E+02	5.390E+03	2.450E+02	0.000E+00	2.890E+01	0.000E+00	5.390E+01
I-133	2.090E+06	3.630E+06	5.330E+08	6.330E+06	0.000E+00	3.260E+06	0.000E+00	1.110E+06
I-134	9.650E-05	2.620E-04	4.540E-03	4.170E-04	0.000E+00	2.290E-07	0.000E+00	9.380E-05
I-135	3.900E+04	1.020E+05	6.730E+06	1.640E+05	0.000E+00	1.150E+05	0.000E+00	3.770E+04
CS-134	4.670E+09	1.110E+10	0.000E+00	3.590E+09	1.190E+09	1.940E+08	0.000E+00	9.080E+09
CS-136	4.270E+07	1.680E+08	0.000E+00	9.380E+07	1.290E+07	1.910E+07	0.000E+00	1.210E+08
CS-137	6.360E+09	8.700E+09	0.000E+00	2.950E+09	9.810E+08	1.680E+08	0.000E+00	5.700E+09
CS-138	3.920E-11	7.730E-11	0.000E+00	5.680E-11	5.610E-12	3.300E-16	0.000E+00	3.830E-11
BA-139	2.860E-02	2.030E-05	0.000E+00	1.900E-05	1.150E-05	5.060E-02	0.000E+00	8.360E-04
BA-140	1.280E+08	1.610E+05	0.000E+00	5.490E+04	9.240E+04	2.650E+08	0.000E+00	8.420E+06
BA-141	1.150E-21	8.700E-25	0.000E+00	8.090E-25	4.940E-25	5.430E-31	0.000E+00	3.890E-23
BA-142	5.960E-39	6.120E-42	0.000E+00	5.170E-42	3.470E-42	8.390E-57	0.000E+00	3.750E-40
LA-140	1.980E+03	9.970E+02	0.000E+00	0.000E+00	0.000E+00	7.320E+07	0.000E+00	2.630E+02
LA-142	2.020E-04	9.190E-05	0.000E+00	0.000E+00	0.000E+00	6.710E-01	0.000E+00	2.290E-05
CE-141	1.970E+05	1.330E+05	0.000E+00	6.190E+04	0.000E+00	5.100E+08	0.000E+00	1.510E+04
CE-143	9.980E+02	7.380E+05	0.000E+00	3.250E+02	0.000E+00	2.760E+07	0.000E+00	8.160E+01
CE-144	3.290E+07	1.380E+07	0.000E+00	8.160E+06	0.000E+00	1.110E+10	0.000E+00	1.770E+06
PR-143	6.260E+04	2.510E+04	0.000E+00	1.450E+04	0.000E+00	2.740E+08	0.000E+00	3.100E+03
PR-144	3.090E-26	1.280E-26	0.000E+00	7.230E-27	0.000E+00	4.440E-33	0.000E+00	1.570E-27
ND-147	3.330E+04	3.850E+04	0.000E+00	2.250E+04	0.000E+00	1.850E+08	0.000E+00	2.310E+03
W-187	3.800E+04	3.180E+04	0.000E+00	0.000E+00	0.000E+00	1.040E+07	0.000E+00	1.110E+04
NP-239	1.430E+03	1.400E+02	0.000E+00	4.380E+02	0.000E+00	2.880E+07	0.000E+00	7.740E+01

Catawba Nuclear Station Units 1 & 2
Period 1/1/2016 - 12/31/2016

Catawba Nuclear Station
Offsite Dose Calculation Manual (ODCM)

APPENDIX G

R_i Adult Dose Factors for use in the Gaseous Dose Calculations

Agegroup:	ADULT	Pathway:	Inhalation (INHL)			Units:	mrem/yr / $\mu\text{Ci}/\text{m}^3$	
Nuclide	Bone	Liver	Thyroid	Kidney	Lung	Gilli	Skin	Total Body
H-3	0.000E+00	1.260E+03	1.260E+03	1.260E+03	1.260E+03	1.260E+03	0.000E+00	1.260E+03
C-14	1.820E+04	3.410E+03	3.410E+03	3.410E+03	3.410E+03	3.410E+03	0.000E+00	3.410E+03
NA-24	1.020E+04	1.020E+04	1.020E+04	1.020E+04	1.020E+04	1.020E+04	0.000E+00	1.020E+04
P-32	1.320E+06	7.710E+04	0.000E+00	0.000E+00	0.000E+00	8.640E+04	0.000E+00	5.010E+04
CR-51	0.000E+00	0.000E+00	5.950E+01	2.280E+01	1.440E+04	3.320E+03	0.000E+00	1.000E+02
MN-54	0.000E+00	3.960E+04	0.000E+00	9.840E+03	1.400E+06	7.740E+04	0.000E+00	6.300E+03
MN-56	0.000E+00	1.240E+00	0.000E+00	1.300E+00	9.440E+03	2.020E+04	0.000E+00	1.830E-01
FE-55	2.460E+04	1.700E+04	0.000E+00	0.000E+00	7.210E+04	6.030E+03	0.000E+00	3.940E+03
FE-59	1.180E+04	2.780E+04	0.000E+00	0.000E+00	1.020E+06	1.880E+05	0.000E+00	1.060E+04
CO-58	0.000E+00	1.580E+03	0.000E+00	0.000E+00	9.280E+05	1.060E+05	0.000E+00	2.070E+03
CO-60	0.000E+00	1.150E+04	0.000E+00	0.000E+00	5.970E+06	2.850E+05	0.000E+00	1.480E+04
NI-63	4.320E+05	3.140E+04	0.000E+00	0.000E+00	1.780E+05	1.340E+04	0.000E+00	1.450E+04
NI-65	1.540E+00	2.100E-01	0.000E+00	0.000E+00	5.600E+03	1.230E+04	0.000E+00	9.120E-02
CU-64	0.000E+00	1.460E+00	0.000E+00	4.620E+00	6.780E+03	4.900E+04	0.000E+00	6.150E-01
ZN-65	3.240E+04	1.030E+05	0.000E+00	6.900E+04	8.640E+05	5.340E+04	0.000E+00	4.660E+04
ZN-69	3.380E-02	6.510E-02	0.000E+00	4.220E-02	9.200E+02	1.630E+01	0.000E+00	4.520E-03
BR-83	0.000E+00	0.000E+00	0.000E+00	0.000E+00	0.000E+00	2.320E+02	0.000E+00	2.410E+02
BR-84	0.000E+00	0.000E+00	0.000E+00	0.000E+00	0.000E+00	1.640E-03	0.000E+00	3.130E+02
BR-85	0.000E+00	0.000E+00	0.000E+00	0.000E+00	0.000E+00	0.000E+00	0.000E+00	1.280E+01
RB-86	0.000E+00	1.350E+05	0.000E+00	0.000E+00	0.000E+00	1.660E+04	0.000E+00	5.900E+04
RB-88	0.000E+00	3.870E+02	0.000E+00	0.000E+00	0.000E+00	3.340E-09	0.000E+00	1.930E+02
RB-89	0.000E+00	2.560E+02	0.000E+00	0.000E+00	0.000E+00	9.280E-12	0.000E+00	1.700E+02
SR-89	3.040E+05	0.000E+00	0.000E+00	0.000E+00	1.400E+06	3.500E+05	0.000E+00	8.720E+03
SR-90	9.920E+07	0.000E+00	0.000E+00	0.000E+00	9.600E+06	7.220E+05	0.000E+00	6.100E+06
SR-91	6.190E+01	0.000E+00	0.000E+00	0.000E+00	3.650E+04	1.910E+05	0.000E+00	2.500E+00

Catawba Nuclear Station Units 1 & 2
Period 1/1/2016 - 12/31/2016

Catawba Nuclear Station
Offsite Dose Calculation Manual (ODCM)

APPENDIX G

R_i Adult Dose Factors for use in the Gaseous Dose Calculations

Agegroup:	ADULT	Pathway:	Inhalation (INHL)			Units:	mrem/yr / $\mu\text{Ci}/\text{m}^3$	
Nuclide	Bone	Liver	Thyroid	Kidney	Lung	Gilli	Skin	Total Body
SR-92	6.740E+00	0.000E+00	0.000E+00	0.000E+00	1.650E+04	4.300E+04	0.000E+00	2.910E-01
Y-90	2.090E+03	0.000E+00	0.000E+00	0.000E+00	1.700E+05	5.060E+05	0.000E+00	5.610E+01
Y-91	4.620E+05	0.000E+00	0.000E+00	0.000E+00	1.700E+06	3.850E+05	0.000E+00	1.240E+04
Y-91M	2.610E-01	0.000E+00	0.000E+00	0.000E+00	1.920E+03	1.330E+00	0.000E+00	1.020E-02
Y-92	1.030E+01	0.000E+00	0.000E+00	0.000E+00	1.570E+04	7.350E+04	0.000E+00	3.020E-01
Y-93	9.440E+01	0.000E+00	0.000E+00	0.000E+00	4.850E+04	4.220E+05	0.000E+00	2.610E+00
ZR-95	1.070E+05	3.440E+04	0.000E+00	5.420E+04	1.770E+06	1.500E+05	0.000E+00	2.330E+04
ZR-97	9.680E+01	1.960E+01	0.000E+00	2.970E+01	7.870E+04	5.230E+05	0.000E+00	9.040E+00
NB-95	1.410E+04	7.820E+03	0.000E+00	7.740E+03	5.050E+05	1.040E+05	0.000E+00	4.210E+03
MO-99	0.000E+00	1.210E+02	0.000E+00	2.910E+02	9.120E+04	2.480E+05	0.000E+00	2.300E+01
TC-99M	1.030E-03	2.910E-03	0.000E+00	4.420E-02	7.640E+02	4.160E+03	0.000E+00	3.700E-02
TC-101	4.180E-05	6.020E-05	0.000E+00	1.080E-03	3.990E+02	1.090E-11	0.000E+00	5.900E-04
RU-103	1.530E+03	0.000E+00	0.000E+00	5.830E+03	5.050E+05	1.100E+05	0.000E+00	6.580E+02
RU-105	7.900E-01	0.000E+00	0.000E+00	1.020E+00	1.100E+04	4.820E+04	0.000E+00	3.110E-01
RU-106	6.910E+04	0.000E+00	0.000E+00	1.340E+05	9.360E+06	9.120E+05	0.000E+00	8.720E+03
AG-110M	1.080E+04	1.000E+04	0.000E+00	1.970E+04	4.630E+06	3.020E+05	0.000E+00	5.940E+03
TE-125M	3.420E+03	1.580E+03	1.050E+03	1.240E+04	3.140E+05	7.060E+04	0.000E+00	4.670E+02
TE-127	1.400E+00	6.420E-01	1.060E+00	5.100E+00	6.510E+03	5.740E+04	0.000E+00	3.100E-01
TE-127M	1.260E+04	5.770E+03	3.290E+03	4.580E+04	9.600E+05	1.500E+05	0.000E+00	1.570E+03
TE-129	4.980E-02	2.390E-02	3.900E-02	1.870E-01	1.940E+03	1.570E+02	0.000E+00	1.240E-02
TE-129M	9.760E+03	4.670E+03	3.440E+03	3.660E+04	1.160E+06	3.830E+05	0.000E+00	1.580E+03
TE-131	1.110E-02	5.950E-03	9.360E-03	4.370E-02	1.390E+03	1.840E+01	0.000E+00	3.590E-03
TE-131M	6.990E+01	4.360E+01	5.500E+01	3.090E+02	1.460E+05	5.560E+05	0.000E+00	2.900E+01
TE-132	2.600E+02	2.150E+02	1.900E+02	1.460E+03	2.880E+05	5.100E+05	0.000E+00	1.620E+02
I-130	4.580E+03	1.340E+04	1.140E+06	2.090E+04	0.000E+00	7.690E+03	0.000E+00	5.280E+03

Catawba Nuclear Station Units 1 & 2
Period 1/1/2016 - 12/31/2016

Catawba Nuclear Station
Offsite Dose Calculation Manual (ODCM)

APPENDIX G

R_i Adult Dose Factors for use in the Gaseous Dose Calculations

Agegroup:	ADULT	Pathway:	Inhalation (INHL)			Units:	mrem/yr / $\mu\text{Ci}/\text{m}^3$	
	Nuclide		Bone	Liver	Thyroid		Kidney	Lung
I-131	2.520E+04	3.580E+04	1.190E+07	6.130E+04	0.000E+00	6.280E+03	0.000E+00	2.050E+04
I-132	1.160E+03	3.260E+03	1.140E+05	5.180E+03	0.000E+00	4.060E+02	0.000E+00	1.160E+03
I-133	8.640E+03	1.480E+04	2.150E+06	2.580E+04	0.000E+00	8.880E+03	0.000E+00	4.520E+03
I-134	6.440E+02	1.730E+03	2.980E+04	2.750E+03	0.000E+00	1.010E+00	0.000E+00	6.150E+02
I-135	2.680E+03	6.980E+03	4.480E+05	1.110E+04	0.000E+00	5.250E+03	0.000E+00	2.570E+03
CS-134	3.730E+05	8.480E+05	0.000E+00	2.870E+05	9.760E+04	1.040E+04	0.000E+00	7.280E+05
CS-136	3.900E+04	1.460E+05	0.000E+00	8.560E+04	1.200E+04	1.170E+04	0.000E+00	1.100E+05
CS-137	4.780E+05	6.210E+05	0.000E+00	2.220E+05	7.520E+04	8.400E+03	0.000E+00	4.280E+05
CS-138	3.310E+02	6.210E+02	0.000E+00	4.800E+02	4.860E+01	1.860E-03	0.000E+00	3.240E+02
BA-139	9.360E-01	6.660E-04	0.000E+00	6.220E-04	3.760E+03	8.960E+02	0.000E+00	2.740E-02
BA-140	3.900E+04	4.900E+01	0.000E+00	1.670E+01	1.270E+06	2.180E+05	0.000E+00	2.570E+03
BA-141	1.000E-01	7.530E-05	0.000E+00	7.000E-05	1.940E+03	1.160E-07	0.000E+00	3.360E-03
BA-142	2.630E-02	2.700E-05	0.000E+00	2.290E-05	1.190E+03	1.570E-16	0.000E+00	1.660E-03
LA-140	3.440E+02	1.740E+02	0.000E+00	0.000E+00	1.360E+05	4.580E+05	0.000E+00	4.580E+01
LA-142	6.830E-01	3.100E-01	0.000E+00	0.000E+00	6.330E+03	2.110E+03	0.000E+00	7.720E-02
CE-141	1.990E+04	1.350E+04	0.000E+00	6.260E+03	3.620E+05	1.200E+05	0.000E+00	1.530E+03
CE-143	1.860E+02	1.380E+02	0.000E+00	6.080E+01	7.980E+04	2.260E+05	0.000E+00	1.530E+01
CE-144	3.430E+06	1.430E+06	0.000E+00	8.480E+05	7.780E+06	8.160E+05	0.000E+00	1.840E+05
PR-143	9.360E+03	3.750E+03	0.000E+00	2.160E+03	2.810E+05	2.000E+05	0.000E+00	4.640E+02
PR-144	3.010E-02	1.250E-02	0.000E+00	7.050E-03	1.020E+03	2.150E-08	0.000E+00	1.530E-03
ND-147	5.270E+03	6.100E+03	0.000E+00	3.560E+03	2.210E+05	1.730E+05	0.000E+00	3.650E+02
W-187	8.480E+00	7.080E+00	0.000E+00	0.000E+00	2.900E+04	1.550E+05	0.000E+00	2.480E+00
NP-239	2.300E+02	2.260E+01	0.000E+00	7.000E+01	3.760E+04	1.190E+05	0.000E+00	1.240E+01

Catawba Nuclear Station Units 1 & 2
Period 1/1/2016 - 12/31/2016

Catawba Nuclear Station
Offsite Dose Calculation Manual (ODCM)

APPENDIX G

R_i Adult Dose Factors for use in the Gaseous Dose Calculations

Agegroup:	ADULT	Pathway:	Ground Plane Deposition (GPD)			Units:	m ² ·mrem/yr / μCi/sec	
Nuclide	Bone	Liver	Thyroid	Kidney	Lung	Gilli	Skin	Total Body
H-3	0.000E+00	0.000E+00	0.000E+00	0.000E+00	0.000E+00	0.000E+00	0.000E+00	0.000E+00
C-14	0.000E+00	0.000E+00	0.000E+00	0.000E+00	0.000E+00	0.000E+00	0.000E+00	0.000E+00
NA-24	1.190E+07	1.190E+07	1.190E+07	1.190E+07	1.190E+07	1.190E+07	1.390E+07	1.190E+07
P-32	0.000E+00	0.000E+00	0.000E+00	0.000E+00	0.000E+00	0.000E+00	0.000E+00	0.000E+00
CR-51	4.660E+06	4.660E+06	4.660E+06	4.660E+06	4.660E+06	4.660E+06	5.510E+06	4.660E+06
MN-54	1.390E+09	1.390E+09	1.390E+09	1.390E+09	1.390E+09	1.390E+09	1.630E+09	1.390E+09
MN-56	9.020E+05	9.020E+05	9.020E+05	9.020E+05	9.020E+05	9.020E+05	1.070E+06	9.020E+05
FE-55	0.000E+00	0.000E+00	0.000E+00	0.000E+00	0.000E+00	0.000E+00	0.000E+00	0.000E+00
FE-59	2.730E+08	2.730E+08	2.730E+08	2.730E+08	2.730E+08	2.730E+08	3.210E+08	2.730E+08
CO-58	3.790E+08	3.790E+08	3.790E+08	3.790E+08	3.790E+08	3.790E+08	4.440E+08	3.790E+08
CO-60	2.150E+10	2.150E+10	2.150E+10	2.150E+10	2.150E+10	2.150E+10	2.530E+10	2.150E+10
NI-63	0.000E+00	0.000E+00	0.000E+00	0.000E+00	0.000E+00	0.000E+00	0.000E+00	0.000E+00
NI-65	2.970E+05	2.970E+05	2.970E+05	2.970E+05	2.970E+05	2.970E+05	3.450E+05	2.970E+05
CU-64	6.070E+05	6.070E+05	6.070E+05	6.070E+05	6.070E+05	6.070E+05	6.880E+05	6.070E+05
ZN-65	7.470E+08	7.470E+08	7.470E+08	7.470E+08	7.470E+08	7.470E+08	8.590E+08	7.470E+08
ZN-69	0.000E+00	0.000E+00	0.000E+00	0.000E+00	0.000E+00	0.000E+00	0.000E+00	0.000E+00
BR-83	4.870E+03	4.870E+03	4.870E+03	4.870E+03	4.870E+03	4.870E+03	7.080E+03	4.870E+03
BR-84	2.030E+05	2.030E+05	2.030E+05	2.030E+05	2.030E+05	2.030E+05	2.360E+05	2.030E+05
BR-85	0.000E+00	0.000E+00	0.000E+00	0.000E+00	0.000E+00	0.000E+00	0.000E+00	0.000E+00
RB-86	8.990E+06	8.990E+06	8.990E+06	8.990E+06	8.990E+06	8.990E+06	1.030E+07	8.990E+06
RB-88	3.310E+04	3.310E+04	3.310E+04	3.310E+04	3.310E+04	3.310E+04	3.780E+04	3.310E+04
RB-89	1.230E+05	1.230E+05	1.230E+05	1.230E+05	1.230E+05	1.230E+05	1.480E+05	1.230E+05
SR-89	2.160E+04	2.160E+04	2.160E+04	2.160E+04	2.160E+04	2.160E+04	2.510E+04	2.160E+04
SR-90	0.000E+00	0.000E+00	0.000E+00	0.000E+00	0.000E+00	0.000E+00	0.000E+00	0.000E+00
SR-91	2.150E+06	2.150E+06	2.150E+06	2.150E+06	2.150E+06	2.150E+06	2.510E+06	2.150E+06

Catawba Nuclear Station Units 1 & 2
Period 1/1/2016 - 12/31/2016

Catawba Nuclear Station
Offsite Dose Calculation Manual (ODCM)

APPENDIX G

R_i Adult Dose Factors for use in the Gaseous Dose Calculations

Agegroup:	ADULT	Pathway:	Ground Plane Deposition (GPD)			Units:	m²·mrem/yr / μCi/sec	
Nuclide	Bone	Liver	Thyroid	Kidney	Lung	Gilli	Skin	Total Body
SR-92	7.770E+05	7.770E+05	7.770E+05	7.770E+05	7.770E+05	7.770E+05	8.630E+05	7.770E+05
Y-90	4.490E+03	4.490E+03	4.490E+03	4.490E+03	4.490E+03	4.490E+03	5.310E+03	4.490E+03
Y-91	1.070E+06	1.070E+06	1.070E+06	1.070E+06	1.070E+06	1.070E+06	1.210E+06	1.070E+06
Y-91M	1.000E+05	1.000E+05	1.000E+05	1.000E+05	1.000E+05	1.000E+05	1.160E+05	1.000E+05
Y-92	1.800E+05	1.800E+05	1.800E+05	1.800E+05	1.800E+05	1.800E+05	2.140E+05	1.800E+05
Y-93	1.830E+05	1.830E+05	1.830E+05	1.830E+05	1.830E+05	1.830E+05	2.510E+05	1.830E+05
ZR-95	2.450E+08	2.450E+08	2.450E+08	2.450E+08	2.450E+08	2.450E+08	2.840E+08	2.450E+08
ZR-97	2.960E+06	2.960E+06	2.960E+06	2.960E+06	2.960E+06	2.960E+06	3.440E+06	2.960E+06
NB-95	1.370E+08	1.370E+08	1.370E+08	1.370E+08	1.370E+08	1.370E+08	1.610E+08	1.370E+08
MO-99	3.990E+06	3.990E+06	3.990E+06	3.990E+06	3.990E+06	3.990E+06	4.630E+06	3.990E+06
TC-99M	1.840E+05	1.840E+05	1.840E+05	1.840E+05	1.840E+05	1.840E+05	2.110E+05	1.840E+05
TC-101	2.040E+04	2.040E+04	2.040E+04	2.040E+04	2.040E+04	2.040E+04	2.260E+04	2.040E+04
RU-103	1.080E+08	1.080E+08	1.080E+08	1.080E+08	1.080E+08	1.080E+08	1.260E+08	1.080E+08
RU-105	6.360E+05	6.360E+05	6.360E+05	6.360E+05	6.360E+05	6.360E+05	7.210E+05	6.360E+05
RU-106	4.220E+08	4.220E+08	4.220E+08	4.220E+08	4.220E+08	4.220E+08	5.070E+08	4.220E+08
AG-110M	3.440E+09	3.440E+09	3.440E+09	3.440E+09	3.440E+09	3.440E+09	4.010E+09	3.440E+09
TE-125M	1.550E+06	1.550E+06	1.550E+06	1.550E+06	1.550E+06	1.550E+06	2.130E+06	1.550E+06
TE-127	2.980E+03	2.980E+03	2.980E+03	2.980E+03	2.980E+03	2.980E+03	3.280E+03	2.980E+03
TE-127M	9.160E+04	9.160E+04	9.160E+04	9.160E+04	9.160E+04	9.160E+04	1.080E+05	9.160E+04
TE-129	2.620E+04	2.620E+04	2.620E+04	2.620E+04	2.620E+04	2.620E+04	3.100E+04	2.620E+04
TE-129M	1.980E+07	1.980E+07	1.980E+07	1.980E+07	1.980E+07	1.980E+07	2.310E+07	1.980E+07
TE-131	2.920E+04	2.920E+04	2.920E+04	2.920E+04	2.920E+04	2.920E+04	3.450E+07	2.920E+04
TE-131M	8.030E+06	8.030E+06	8.030E+06	8.030E+06	8.030E+06	8.030E+06	9.460E+06	8.030E+06
TE-132	4.230E+06	4.230E+06	4.230E+06	4.230E+06	4.230E+06	4.230E+06	4.980E+06	4.230E+06
I-130	5.510E+06	5.510E+06	5.510E+06	5.510E+06	5.510E+06	5.510E+06	6.690E+06	5.510E+06

Catawba Nuclear Station Units 1 & 2
Period 1/1/2016 - 12/31/2016

Catawba Nuclear Station
Offsite Dose Calculation Manual (ODCM)

APPENDIX G

R_i Adult Dose Factors for use in the Gaseous Dose Calculations

Agegroup:	ADULT	Pathway:	Ground Plane Deposition (GPD)			Units:	m ² ·mrem/yr / μCi/sec	
	Nuclide		Bone	Liver	Thyroid		Kidney	Lung
I-131	1.720E+07	1.720E+07	1.720E+07	1.720E+07	1.720E+07	1.720E+07	2.090E+07	1.720E+07
I-132	1.250E+06	1.250E+06	1.250E+06	1.250E+06	1.250E+06	1.250E+06	1.470E+06	1.250E+06
I-133	2.450E+06	2.450E+06	2.450E+06	2.450E+06	2.450E+06	2.450E+06	2.980E+06	2.450E+06
I-134	4.470E+05	4.470E+05	4.470E+05	4.470E+05	4.470E+05	4.470E+05	5.300E+05	4.470E+05
I-135	2.530E+06	2.530E+06	2.530E+06	2.530E+06	2.530E+06	2.530E+06	2.950E+06	2.530E+06
CS-134	6.860E+09	6.860E+09	6.860E+09	6.860E+09	6.860E+09	6.860E+09	8.000E+09	6.860E+09
CS-136	1.510E+08	1.510E+08	1.510E+08	1.510E+08	1.510E+08	1.510E+08	1.710E+08	1.510E+08
CS-137	1.030E+10	1.030E+10	1.030E+10	1.030E+10	1.030E+10	1.030E+10	1.200E+10	1.030E+10
CS-138	3.590E+05	3.590E+05	3.590E+05	3.590E+05	3.590E+05	3.590E+05	4.100E+05	3.590E+05
BA-139	1.060E+05	1.060E+05	1.060E+05	1.060E+05	1.060E+05	1.060E+05	1.190E+05	1.060E+05
BA-140	2.050E+07	2.050E+07	2.050E+07	2.050E+07	2.050E+07	2.050E+07	2.350E+07	2.050E+07
BA-141	4.170E+04	4.170E+04	4.170E+04	4.170E+04	4.170E+04	4.170E+04	4.750E+04	4.170E+04
BA-142	4.490E+04	4.490E+04	4.490E+04	4.490E+04	4.490E+04	4.490E+04	5.110E+04	4.490E+04
LA-140	1.920E+07	1.920E+07	1.920E+07	1.920E+07	1.920E+07	1.920E+07	2.180E+07	1.920E+07
LA-142	7.600E+05	7.600E+05	7.600E+05	7.600E+05	7.600E+05	7.600E+05	9.120E+05	7.600E+05
CE-141	1.370E+07	1.370E+07	1.370E+07	1.370E+07	1.370E+07	1.370E+07	1.540E+07	1.370E+07
CE-143	2.310E+06	2.310E+06	2.310E+06	2.310E+06	2.310E+06	2.310E+06	2.630E+06	2.310E+06
CE-144	6.950E+07	6.950E+07	6.950E+07	6.950E+07	6.950E+07	6.950E+07	8.040E+07	6.950E+07
PR-143	0.000E+00	0.000E+00	0.000E+00	0.000E+00	0.000E+00	0.000E+00	0.000E+00	0.000E+00
PR-144	1.830E+03	1.830E+03	1.830E+03	1.830E+03	1.830E+03	1.830E+03	2.110E+03	1.830E+03
ND-147	8.390E+06	8.390E+06	8.390E+06	8.390E+06	8.390E+06	8.390E+06	1.010E+07	8.390E+06
W-187	2.350E+06	2.350E+06	2.350E+06	2.350E+06	2.350E+06	2.350E+06	2.730E+06	2.350E+06
NP-239	1.710E+06	1.710E+06	1.710E+06	1.710E+06	1.710E+06	1.710E+06	1.980E+06	1.710E+06

Catawba Nuclear Station Units 1 & 2
Period 1/1/2016 - 12/31/2016

Catawba Nuclear Station
Offsite Dose Calculation Manual (ODCM)

APPENDIX H

R_i Teen Dose Factors for use in the Gaseous Dose Calculations

Agegroup:	TEEN		Pathway:			Units:	m ² ·mrem/yr / μCi/sec; mrem/yr / μCi/m ³ (H-3, C-14)	
	Nuclide	Bone	Liver	Thyroid	Kidney		Lung	Gilli
H-3	0.000E+00	9.940E+02	9.940E+02	9.940E+02	9.940E+02	9.940E+02	0.000E+00	9.940E+02
C-14	4.150E+04	8.310E+03	8.310E+03	8.310E+03	8.310E+03	8.310E+03	0.000E+00	8.310E+03
NA-24	4.260E+06	4.260E+06	4.260E+06	4.260E+06	4.260E+06	4.260E+06	0.000E+00	4.260E+06
P-32	3.150E+10	1.950E+09	0.000E+00	0.000E+00	0.000E+00	2.650E+09	0.000E+00	1.220E+09
CR-51	0.000E+00	0.000E+00	2.770E+04	1.090E+04	7.130E+04	8.390E+06	0.000E+00	4.990E+04
MN-54	0.000E+00	1.400E+07	0.000E+00	4.180E+06	0.000E+00	2.870E+07	0.000E+00	2.780E+06
MN-56	0.000E+00	7.250E-03	0.000E+00	9.180E-03	0.000E+00	4.770E-01	0.000E+00	1.290E-03
FE-55	4.450E+07	3.160E+07	0.000E+00	0.000E+00	2.000E+07	1.370E+07	0.000E+00	7.360E+06
FE-59	5.180E+07	1.210E+08	0.000E+00	0.000E+00	3.810E+07	2.860E+08	0.000E+00	4.670E+07
CO-58	0.000E+00	7.940E+06	0.000E+00	0.000E+00	0.000E+00	1.090E+08	0.000E+00	1.830E+07
CO-60	0.000E+00	2.780E+07	0.000E+00	0.000E+00	0.000E+00	3.620E+08	0.000E+00	6.260E+07
NI-63	1.180E+10	8.350E+08	0.000E+00	0.000E+00	0.000E+00	1.330E+08	0.000E+00	4.010E+08
NI-65	6.770E-01	8.650E-02	0.000E+00	0.000E+00	0.000E+00	4.690E+00	0.000E+00	3.940E-02
CU-64	0.000E+00	4.250E+04	0.000E+00	1.070E+05	0.000E+00	3.290E+06	0.000E+00	2.000E+04
ZN-65	2.110E+09	7.320E+09	0.000E+00	4.680E+09	0.000E+00	3.100E+09	0.000E+00	3.410E+09
ZN-69	3.850E-12	7.330E-12	0.000E+00	4.790E-12	0.000E+00	1.350E-11	0.000E+00	5.130E-13
BR-83	0.000E+00	0.000E+00	0.000E+00	0.000E+00	0.000E+00	0.000E+00	0.000E+00	1.790E-01
BR-84	0.000E+00	0.000E+00	0.000E+00	0.000E+00	0.000E+00	0.000E+00	0.000E+00	2.880E-23
BR-85	0.000E+00	0.000E+00	0.000E+00	0.000E+00	0.000E+00	0.000E+00	0.000E+00	0.000E+00
RB-86	0.000E+00	4.730E+09	0.000E+00	0.000E+00	0.000E+00	7.000E+08	0.000E+00	2.220E+09
RB-88	0.000E+00	3.890E-45	0.000E+00	0.000E+00	0.000E+00	3.330E-52	0.000E+00	2.070E-45
RB-89	0.000E+00	7.660E-53	0.000E+00	0.000E+00	0.000E+00	1.170E-61	0.000E+00	5.420E-53
SR-89	2.670E+09	0.000E+00	0.000E+00	0.000E+00	0.000E+00	3.190E+08	0.000E+00	7.660E+07
SR-90	6.610E+10	0.000E+00	0.000E+00	0.000E+00	0.000E+00	1.860E+09	0.000E+00	1.630E+10
SR-91	5.310E+04	0.000E+00	0.000E+00	0.000E+00	0.000E+00	2.410E+05	0.000E+00	2.110E+03

Catawba Nuclear Station Units 1 & 2
Period 1/1/2016 - 12/31/2016

Catawba Nuclear Station
Offsite Dose Calculation Manual (ODCM)

APPENDIX H

R_i Teen Dose Factors for use in the Gaseous Dose Calculations

Agegroup:	TEEN	Pathway:	Grs/Cow/Milk (CMILK)			Units:	m ² ·mrem/yr / μCi/sec; mrem/yr / μCi/m ³ (H-3, C-14)	
	Nuclide		Bone	Liver	Thyroid	Kidney	Lung	Gilli
SR-92	8.940E-01	0.000E+00	0.000E+00	0.000E+00	0.000E+00	2.280E+01	0.000E+00	3.810E-02
Y-90	1.300E+02	0.000E+00	0.000E+00	0.000E+00	0.000E+00	1.070E+06	0.000E+00	3.510E+00
Y-91	1.580E+04	0.000E+00	0.000E+00	0.000E+00	0.000E+00	6.480E+06	0.000E+00	4.240E+02
Y-91M	1.090E-19	0.000E+00	0.000E+00	0.000E+00	0.000E+00	5.170E-18	0.000E+00	4.180E-21
Y-92	1.030E-04	0.000E+00	0.000E+00	0.000E+00	0.000E+00	2.830E+00	0.000E+00	2.980E-06
Y-93	4.120E-01	0.000E+00	0.000E+00	0.000E+00	0.000E+00	1.260E+04	0.000E+00	1.130E-02
ZR-95	1.650E+03	5.200E+02	0.000E+00	7.650E+02	0.000E+00	1.200E+06	0.000E+00	3.580E+02
ZR-97	7.880E-01	1.560E-01	0.000E+00	2.370E-01	0.000E+00	4.220E+04	0.000E+00	7.190E-02
NB-95	1.410E+05	7.810E+04	0.000E+00	7.570E+04	0.000E+00	3.340E+08	0.000E+00	4.300E+04
MO-99	0.000E+00	4.470E+07	0.000E+00	1.020E+08	0.000E+00	8.010E+07	0.000E+00	8.530E+06
TC-99M	5.760E+00	1.610E+01	0.000E+00	2.390E+02	8.920E+00	1.050E+04	0.000E+00	2.080E+02
TC-101	4.740E-60	6.750E-60	0.000E+00	1.220E-58	4.110E-60	1.150E-66	0.000E+00	6.630E-59
RU-103	1.810E+03	0.000E+00	0.000E+00	6.380E+03	0.000E+00	1.510E+05	0.000E+00	7.740E+02
RU-105	1.560E-03	0.000E+00	0.000E+00	1.970E-02	0.000E+00	1.260E+00	0.000E+00	6.070E-04
RU-106	3.750E+04	0.000E+00	0.000E+00	7.240E+04	0.000E+00	1.800E+06	0.000E+00	4.730E+03
AG-110M	9.630E+07	9.110E+07	0.000E+00	1.740E+08	0.000E+00	2.560E+10	0.000E+00	5.540E+07
TE-125M	3.000E+07	1.080E+07	8.390E+06	0.000E+00	0.000E+00	8.860E+07	0.000E+00	4.020E+06
TE-127	1.210E+03	4.290E+02	8.350E+02	4.900E+03	0.000E+00	9.340E+04	0.000E+00	2.600E+02
TE-127M	8.440E+07	2.990E+07	2.010E+07	3.420E+08	0.000E+00	2.100E+08	0.000E+00	1.000E+07
TE-129	5.200E-10	1.940E-10	3.720E-10	2.180E-09	0.000E+00	2.840E-09	0.000E+00	1.270E-10
TE-129M	1.100E+08	4.090E+07	3.550E+07	4.610E+08	0.000E+00	4.130E+08	0.000E+00	1.740E+07
TE-131	6.580E-33	2.710E-33	5.070E-33	2.880E-32	0.000E+00	5.400E-34	0.000E+00	2.060E-33
TE-131M	6.570E+05	3.150E+05	4.740E+05	3.290E+06	0.000E+00	2.530E+07	0.000E+00	2.630E+05
TE-132	4.290E+06	2.720E+06	2.870E+06	2.610E+07	0.000E+00	8.610E+07	0.000E+00	2.560E+06
I-130	7.380E+05	2.140E+06	1.740E+08	3.290E+06	0.000E+00	1.640E+06	0.000E+00	8.530E+05

Catawba Nuclear Station Units 1 & 2
Period 1/1/2016 - 12/31/2016

Catawba Nuclear Station
Offsite Dose Calculation Manual (ODCM)

APPENDIX H

R_i Teen Dose Factors for use in the Gaseous Dose Calculations

Agegroup:	TEEN	Pathway:	Grs/Cow/Milk (CMILK)			Units:	m ² ·mrem/yr / μCi/sec; mrem/yr / μCi/m ³ (H-3, C-14)	
	Bone		Liver	Thyroid	Kidney	Lung	Gilli	Skin
I-131	5.370E+08	7.520E+08	2.190E+11	1.290E+09	0.000E+00	1.490E+08	0.000E+00	4.040E+08
I-132	2.910E-01	7.620E-01	2.570E+01	1.200E+00	0.000E+00	3.320E-01	0.000E+00	2.740E-01
I-133	7.070E+06	1.200E+07	1.670E+09	2.100E+07	0.000E+00	9.070E+06	0.000E+00	3.660E+06
I-134	3.580E-12	9.500E-12	1.580E-10	1.500E-11	0.000E+00	1.250E-13	0.000E+00	3.410E-12
I-135	2.280E+04	5.870E+04	3.780E+06	9.270E+04	0.000E+00	6.510E+04	0.000E+00	2.180E+04
CS-134	9.820E+09	2.310E+10	0.000E+00	7.340E+09	2.800E+09	2.870E+08	0.000E+00	1.070E+10
CS-136	4.480E+08	1.760E+09	0.000E+00	9.600E+08	1.510E+08	1.420E+08	0.000E+00	1.180E+09
CS-137	1.340E+10	1.780E+10	0.000E+00	6.060E+09	2.350E+09	2.530E+08	0.000E+00	6.200E+09
CS-138	1.640E-23	3.150E-23	0.000E+00	2.330E-23	2.710E-24	1.430E-26	0.000E+00	1.580E-23
BA-139	8.170E-08	5.750E-11	0.000E+00	5.420E-11	3.960E-11	7.290E-07	0.000E+00	2.380E-09
BA-140	4.850E+07	5.950E+04	0.000E+00	2.020E+04	4.000E+04	7.480E+07	0.000E+00	3.130E+06
BA-141	7.520E-46	5.620E-49	0.000E+00	5.210E-49	3.850E-49	1.600E-51	0.000E+00	2.510E-47
BA-142	4.790E-80	4.790E-83	0.000E+00	4.050E-83	3.190E-83	1.470E-91	0.000E+00	2.950E-81
LA-140	8.100E+00	3.980E+00	0.000E+00	0.000E+00	0.000E+00	2.290E+05	0.000E+00	1.060E+00
LA-142	3.360E-11	1.490E-11	0.000E+00	0.000E+00	0.000E+00	4.540E-07	0.000E+00	3.710E-12
CE-141	8.880E+03	5.930E+03	0.000E+00	2.790E+03	0.000E+00	1.700E+07	0.000E+00	6.810E+02
CE-143	7.640E+01	5.560E+04	0.000E+00	2.490E+01	0.000E+00	1.670E+06	0.000E+00	6.210E+00
CE-144	6.580E+05	2.720E+05	0.000E+00	1.630E+05	0.000E+00	1.660E+08	0.000E+00	3.540E+04
PR-143	2.900E+02	1.160E+02	0.000E+00	6.730E+01	0.000E+00	9.540E+05	0.000E+00	1.440E+01
PR-144	1.080E-53	4.430E-54	0.000E+00	2.540E-54	0.000E+00	1.190E-56	0.000E+00	5.490E-55
ND-147	1.810E+02	1.970E+02	0.000E+00	1.160E+02	0.000E+00	7.110E+05	0.000E+00	1.180E+01
W-187	1.190E+04	9.710E+03	0.000E+00	0.000E+00	0.000E+00	2.630E+06	0.000E+00	3.400E+03
NP-239	7.010E+00	6.610E-01	0.000E+00	2.070E+00	0.000E+00	1.060E+05	0.000E+00	3.670E-01

Catawba Nuclear Station Units 1 & 2
Period 1/1/2016 - 12/31/2016

Catawba Nuclear Station
Offsite Dose Calculation Manual (ODCM)

APPENDIX H

R_i Teen Dose Factors for use in the Gaseous Dose Calculations

Agegroup:	TEEN	Pathway:	Grs/Goat/Milk (GMILK)			Units:	m ² ·mrem/yr / μCi/sec; mrem/yr / μCi/m ³ (H-3, C-14)	
	Nuclide		Bone	Liver	Thyroid	Kidney	Lung	Gilli
H-3	0.000E+00	2.030E+03	2.030E+03	2.030E+03	2.030E+03	2.030E+03	0.000E+00	2.030E+03
C-14	4.150E+04	8.310E+03	8.310E+03	8.310E+03	8.310E+03	8.310E+03	0.000E+00	8.310E+03
NA-24	5.110E+05	5.110E+05	5.110E+05	5.110E+05	5.110E+05	5.110E+05	0.000E+00	5.110E+05
P-32	3.780E+10	2.340E+09	0.000E+00	0.000E+00	0.000E+00	3.180E+09	0.000E+00	1.470E+09
CR-51	0.000E+00	0.000E+00	3.330E+03	1.310E+03	8.550E+03	1.010E+06	0.000E+00	5.990E+03
MN-54	0.000E+00	1.680E+06	0.000E+00	5.020E+05	0.000E+00	3.450E+06	0.000E+00	3.340E+05
MN-56	0.000E+00	8.700E-04	0.000E+00	1.100E-03	0.000E+00	5.730E-02	0.000E+00	1.550E-04
FE-55	5.790E+05	4.110E+05	0.000E+00	0.000E+00	2.600E+05	1.780E+05	0.000E+00	9.570E+04
FE-59	6.740E+05	1.570E+06	0.000E+00	0.000E+00	4.960E+05	3.720E+06	0.000E+00	6.070E+05
CO-58	0.000E+00	9.520E+05	0.000E+00	0.000E+00	0.000E+00	1.310E+07	0.000E+00	2.190E+06
CO-60	0.000E+00	3.340E+06	0.000E+00	0.000E+00	0.000E+00	4.350E+07	0.000E+00	7.520E+06
NI-63	1.420E+09	1.000E+08	0.000E+00	0.000E+00	0.000E+00	1.590E+07	0.000E+00	4.810E+07
NI-65	8.120E-02	1.040E-02	0.000E+00	0.000E+00	0.000E+00	5.630E-01	0.000E+00	4.730E-03
CU-64	0.000E+00	4.730E+03	0.000E+00	1.200E+04	0.000E+00	3.670E+05	0.000E+00	2.230E+03
ZN-65	2.530E+08	8.780E+08	0.000E+00	5.620E+08	0.000E+00	3.720E+08	0.000E+00	4.100E+08
ZN-69	4.620E-13	8.800E-13	0.000E+00	5.750E-13	0.000E+00	1.620E-12	0.000E+00	6.160E-14
BR-83	0.000E+00	0.000E+00	0.000E+00	0.000E+00	0.000E+00	0.000E+00	0.000E+00	2.150E-02
BR-84	0.000E+00	0.000E+00	0.000E+00	0.000E+00	0.000E+00	0.000E+00	0.000E+00	3.450E-24
BR-85	0.000E+00	0.000E+00	0.000E+00	0.000E+00	0.000E+00	0.000E+00	0.000E+00	0.000E+00
RB-86	0.000E+00	5.670E+08	0.000E+00	0.000E+00	0.000E+00	8.400E+07	0.000E+00	2.670E+08
RB-88	0.000E+00	4.670E-46	0.000E+00	0.000E+00	0.000E+00	4.000E-53	0.000E+00	2.490E-46
RB-89	0.000E+00	9.190E-54	0.000E+00	0.000E+00	0.000E+00	1.410E-62	0.000E+00	6.500E-54
SR-89	5.620E+09	0.000E+00	0.000E+00	0.000E+00	0.000E+00	6.690E+08	0.000E+00	1.610E+08
SR-90	1.390E+11	0.000E+00	0.000E+00	0.000E+00	0.000E+00	3.900E+09	0.000E+00	3.430E+10
SR-91	1.120E+05	0.000E+00	0.000E+00	0.000E+00	0.000E+00	5.060E+05	0.000E+00	4.440E+03

Catawba Nuclear Station Units 1 & 2
Period 1/1/2016 - 12/31/2016

Catawba Nuclear Station
Offsite Dose Calculation Manual (ODCM)

APPENDIX H

R_i Teen Dose Factors for use in the Gaseous Dose Calculations

Agegroup:	TEEN	Pathway:	Grs/Goat/Milk (GMILK)			Units:	m ² ·mrem/yr / μCi/sec; mrem/yr / μCi/m ³ (H-3, C-14)	
	Nuclide		Bone	Liver	Thyroid		Kidney	Lung
SR-92	1.880E+00	0.000E+00	0.000E+00	0.000E+00	0.000E+00	4.780E+01	0.000E+00	8.000E-02
Y-90	1.560E+01	0.000E+00	0.000E+00	0.000E+00	0.000E+00	1.290E+05	0.000E+00	4.210E-01
Y-91	1.900E+03	0.000E+00	0.000E+00	0.000E+00	0.000E+00	7.770E+05	0.000E+00	5.080E+01
Y-91M	1.310E-20	0.000E+00	0.000E+00	0.000E+00	0.000E+00	6.200E-19	0.000E+00	5.020E-22
Y-92	1.240E-05	0.000E+00	0.000E+00	0.000E+00	0.000E+00	3.390E-01	0.000E+00	3.580E-07
Y-93	4.940E-02	0.000E+00	0.000E+00	0.000E+00	0.000E+00	1.510E+03	0.000E+00	1.360E-03
ZR-95	1.980E+02	6.250E+01	0.000E+00	9.180E+01	0.000E+00	1.440E+05	0.000E+00	4.300E+01
ZR-97	9.460E-02	1.870E-02	0.000E+00	2.840E-02	0.000E+00	5.070E+03	0.000E+00	8.620E-03
NB-95	1.690E+04	9.370E+03	0.000E+00	9.080E+03	0.000E+00	4.010E+07	0.000E+00	5.160E+03
MO-99	0.000E+00	5.370E+06	0.000E+00	1.230E+07	0.000E+00	9.610E+06	0.000E+00	1.020E+06
TC-99M	6.910E-01	1.930E+00	0.000E+00	2.870E+01	1.070E+00	1.270E+03	0.000E+00	2.500E+01
TC-101	5.690E-61	8.100E-61	0.000E+00	1.460E-59	4.930E-61	1.380E-67	0.000E+00	7.950E-60
RU-103	2.170E+02	0.000E+00	0.000E+00	7.660E+02	0.000E+00	1.810E+04	0.000E+00	9.290E+01
RU-105	1.880E-04	0.000E+00	0.000E+00	2.370E-03	0.000E+00	1.520E-01	0.000E+00	7.290E-05
RU-106	4.500E+03	0.000E+00	0.000E+00	8.680E+03	0.000E+00	2.160E+05	0.000E+00	5.670E+02
AG-110M	1.160E+07	1.090E+07	0.000E+00	2.080E+07	0.000E+00	3.070E+09	0.000E+00	6.650E+06
TE-125M	3.600E+06	1.300E+06	1.010E+06	0.000E+00	0.000E+00	1.060E+07	0.000E+00	4.820E+05
TE-127	1.450E+02	5.150E+01	1.000E+02	5.880E+02	0.000E+00	1.120E+04	0.000E+00	3.120E+01
TE-127M	1.010E+07	3.590E+06	2.410E+06	4.100E+07	0.000E+00	2.520E+07	0.000E+00	1.200E+06
TE-129	6.240E-11	2.330E-11	4.460E-11	2.620E-10	0.000E+00	3.410E-10	0.000E+00	1.520E-11
TE-129M	1.320E+07	4.900E+06	4.260E+06	5.530E+07	0.000E+00	4.960E+07	0.000E+00	2.090E+06
TE-131	7.900E-34	3.260E-34	6.090E-34	3.450E-33	0.000E+00	6.480E-35	0.000E+00	2.470E-34
TE-131M	7.880E+04	3.780E+04	5.690E+04	3.940E+05	0.000E+00	3.030E+06	0.000E+00	3.150E+04
TE-132	5.150E+05	3.260E+05	3.440E+05	3.130E+06	0.000E+00	1.030E+07	0.000E+00	3.070E+05
I-130	8.860E+05	2.560E+06	2.090E+08	3.950E+06	0.000E+00	1.970E+06	0.000E+00	1.020E+06

Catawba Nuclear Station Units 1 & 2
Period 1/1/2016 - 12/31/2016

Catawba Nuclear Station
Offsite Dose Calculation Manual (ODCM)

APPENDIX H

R_i Teen Dose Factors for use in the Gaseous Dose Calculations

Agegroup:	TEEN	Pathway:	Grs/Goat/Milk (GMILK)			Units:	m²·mrem/yr / μCi/sec; mrem/yr / μCi/m³ (H-3, C-14)	
Nuclide	Bone	Liver	Thyroid	Kidney	Lung	Gilli	Skin	Total Body
I-131	6.450E+08	9.030E+08	2.630E+11	1.550E+09	0.000E+00	1.790E+08	0.000E+00	4.850E+08
I-132	3.500E-01	9.150E-01	3.080E+01	1.440E+00	0.000E+00	3.980E-01	0.000E+00	3.280E-01
I-133	8.480E+06	1.440E+07	2.010E+09	2.520E+07	0.000E+00	1.090E+07	0.000E+00	4.390E+06
I-134	4.300E-12	1.140E-11	1.900E-10	1.800E-11	0.000E+00	1.500E-13	0.000E+00	4.090E-12
I-135	2.740E+04	7.040E+04	4.530E+06	1.110E+05	0.000E+00	7.810E+04	0.000E+00	2.610E+04
CS-134	2.940E+10	6.930E+10	0.000E+00	2.200E+10	8.410E+09	8.620E+08	0.000E+00	3.220E+10
CS-136	1.340E+09	5.290E+09	0.000E+00	2.880E+09	4.540E+08	4.260E+08	0.000E+00	3.550E+09
CS-137	4.020E+10	5.340E+10	0.000E+00	1.820E+10	7.060E+09	7.600E+08	0.000E+00	1.860E+10
CS-138	4.920E-23	9.450E-23	0.000E+00	6.980E-23	8.120E-24	4.290E-26	0.000E+00	4.730E-23
BA-139	9.800E-09	6.900E-12	0.000E+00	6.500E-12	4.750E-12	8.750E-08	0.000E+00	2.860E-10
BA-140	5.820E+06	7.130E+03	0.000E+00	2.420E+03	4.800E+03	8.980E+06	0.000E+00	3.750E+05
BA-141	9.030E-47	6.740E-50	0.000E+00	6.260E-50	4.610E-50	1.920E-52	0.000E+00	3.010E-48
BA-142	5.750E-81	5.750E-84	0.000E+00	4.860E-84	3.820E-84	1.760E-92	0.000E+00	3.540E-82
LA-140	9.720E-01	4.780E-01	0.000E+00	0.000E+00	0.000E+00	2.740E+04	0.000E+00	1.270E-01
LA-142	4.030E-12	1.790E-12	0.000E+00	0.000E+00	0.000E+00	5.440E-08	0.000E+00	4.450E-13
CE-141	1.070E+03	7.120E+02	0.000E+00	3.350E+02	0.000E+00	2.040E+06	0.000E+00	8.170E+01
CE-143	9.170E+00	6.670E+03	0.000E+00	2.990E+00	0.000E+00	2.000E+05	0.000E+00	7.450E-01
CE-144	7.900E+04	3.270E+04	0.000E+00	1.950E+04	0.000E+00	1.990E+07	0.000E+00	4.240E+03
PR-143	3.480E+01	1.390E+01	0.000E+00	8.080E+00	0.000E+00	1.150E+05	0.000E+00	1.730E+00
PR-144	1.300E-54	5.320E-55	0.000E+00	3.050E-55	0.000E+00	1.430E-57	0.000E+00	6.590E-56
ND-147	2.170E+01	2.360E+01	0.000E+00	1.390E+01	0.000E+00	8.530E+04	0.000E+00	1.420E+00
W-187	1.430E+03	1.170E+03	0.000E+00	0.000E+00	0.000E+00	3.150E+05	0.000E+00	4.080E+02
NP-239	8.410E-01	7.930E-02	0.000E+00	2.490E-01	0.000E+00	1.280E+04	0.000E+00	4.410E-02

Catawba Nuclear Station Units 1 & 2
Period 1/1/2016 - 12/31/2016

Catawba Nuclear Station
Offsite Dose Calculation Manual (ODCM)

APPENDIX H

R_i Teen Dose Factors for use in the Gaseous Dose Calculations

Agegroup:	TEEN	Pathway:	Grs/Cow/Meat (CMEAT)			Units:	m²·mrem/yr / μCi/sec; mrem/yr / μCi/m³ (H-3, C-14)	
Nuclide	Bone	Liver	Thyroid	Kidney	Lung	Gilli	Skin	Total Body
H-3	0.000E+00	1.940E+02	1.940E+02	1.940E+02	1.940E+02	1.940E+02	0.000E+00	1.940E+02
C-14	1.740E+04	3.490E+03	3.490E+03	3.490E+03	3.490E+03	3.490E+03	0.000E+00	3.490E+03
NA-24	1.080E-03	1.080E-03	1.080E-03	1.080E-03	1.080E-03	1.080E-03	0.000E+00	1.080E-03
P-32	3.930E+09	2.440E+08	0.000E+00	0.000E+00	0.000E+00	3.310E+08	0.000E+00	1.530E+08
CR-51	0.000E+00	0.000E+00	3.130E+03	1.240E+03	8.050E+03	9.470E+05	0.000E+00	5.640E+03
MN-54	0.000E+00	7.000E+06	0.000E+00	2.090E+06	0.000E+00	1.440E+07	0.000E+00	1.390E+06
MN-56	0.000E+00	1.070E-53	0.000E+00	1.360E-53	0.000E+00	7.070E-52	0.000E+00	1.910E-54
FE-55	2.380E+08	1.690E+08	0.000E+00	0.000E+00	1.070E+08	7.310E+07	0.000E+00	3.940E+07
FE-59	2.120E+08	4.950E+08	0.000E+00	0.000E+00	1.560E+08	1.170E+09	0.000E+00	1.910E+08
CO-58	0.000E+00	1.410E+07	0.000E+00	0.000E+00	0.000E+00	1.940E+08	0.000E+00	3.240E+07
CO-60	0.000E+00	5.830E+07	0.000E+00	0.000E+00	0.000E+00	7.600E+08	0.000E+00	1.310E+08
NI-63	1.520E+10	1.070E+09	0.000E+00	0.000E+00	0.000E+00	1.710E+08	0.000E+00	5.150E+08
NI-65	1.880E-52	2.410E-53	0.000E+00	0.000E+00	0.000E+00	1.300E-51	0.000E+00	1.100E-53
CU-64	0.000E+00	2.210E-07	0.000E+00	5.600E-07	0.000E+00	1.720E-05	0.000E+00	1.040E-07
ZN-65	2.500E+08	8.690E+08	0.000E+00	5.560E+08	0.000E+00	3.680E+08	0.000E+00	4.050E+08
ZN-69	0.000E+00	0.000E+00	0.000E+00	0.000E+00	0.000E+00	0.000E+00	0.000E+00	0.000E+00
BR-83	0.000E+00	0.000E+00	0.000E+00	0.000E+00	0.000E+00	0.000E+00	0.000E+00	5.070E-57
BR-84	0.000E+00	0.000E+00	0.000E+00	0.000E+00	0.000E+00	0.000E+00	0.000E+00	0.000E+00
BR-85	0.000E+00	0.000E+00	0.000E+00	0.000E+00	0.000E+00	0.000E+00	0.000E+00	0.000E+00
RB-86	0.000E+00	4.070E+08	0.000E+00	0.000E+00	0.000E+00	6.020E+07	0.000E+00	1.910E+08
RB-88	0.000E+00	0.000E+00	0.000E+00	0.000E+00	0.000E+00	0.000E+00	0.000E+00	0.000E+00
RB-89	0.000E+00	0.000E+00	0.000E+00	0.000E+00	0.000E+00	0.000E+00	0.000E+00	0.000E+00
SR-89	2.550E+08	0.000E+00	0.000E+00	0.000E+00	0.000E+00	3.030E+07	0.000E+00	7.290E+06
SR-90	8.050E+09	0.000E+00	0.000E+00	0.000E+00	0.000E+00	2.260E+08	0.000E+00	1.990E+09
SR-91	1.280E-10	0.000E+00	0.000E+00	0.000E+00	0.000E+00	5.800E-10	0.000E+00	5.090E-12

Catawba Nuclear Station Units 1 & 2
Period 1/1/2016 - 12/31/2016

Catawba Nuclear Station
Offsite Dose Calculation Manual (ODCM)

APPENDIX H

R_i Teen Dose Factors for use in the Gaseous Dose Calculations

Agegroup:	TEEN	Pathway:	Grs/Cow/Meat (CMEAT)			Units:	m²·mrem/yr / μCi/sec; mrem/yr / μCi/m³ (H-3, C-14)	
Nuclide	Bone	Liver	Thyroid	Kidney	Lung	Gilli	Skin	Total Body
SR-92	9.880E-50	0.000E+00	0.000E+00	0.000E+00	0.000E+00	2.520E-48	0.000E+00	4.210E-51
Y-90	9.060E+01	0.000E+00	0.000E+00	0.000E+00	0.000E+00	7.470E+05	0.000E+00	2.440E+00
Y-91	9.540E+05	0.000E+00	0.000E+00	0.000E+00	0.000E+00	3.910E+08	0.000E+00	2.560E+04
Y-91M	0.000E+00	0.000E+00	0.000E+00	0.000E+00	0.000E+00	0.000E+00	0.000E+00	0.000E+00
Y-92	1.280E-39	0.000E+00	0.000E+00	0.000E+00	0.000E+00	3.520E-35	0.000E+00	3.710E-41
Y-93	3.960E-12	0.000E+00	0.000E+00	0.000E+00	0.000E+00	1.210E-07	0.000E+00	1.090E-13
ZR-95	1.500E+06	4.730E+05	0.000E+00	6.950E+05	0.000E+00	1.090E+09	0.000E+00	3.250E+05
ZR-97	1.720E-05	3.410E-06	0.000E+00	5.170E-06	0.000E+00	9.230E-01	0.000E+00	1.570E-06
NB-95	1.790E+06	9.950E+05	0.000E+00	9.650E+05	0.000E+00	4.260E+09	0.000E+00	5.480E+05
MO-99	0.000E+00	8.270E+04	0.000E+00	1.890E+05	0.000E+00	1.480E+05	0.000E+00	1.580E+04
TC-99M	3.530E-21	9.850E-21	0.000E+00	1.470E-19	5.470E-21	6.470E-18	0.000E+00	1.280E-19
TC-101	0.000E+00	0.000E+00	0.000E+00	0.000E+00	0.000E+00	0.000E+00	0.000E+00	0.000E+00
RU-103	8.570E+07	0.000E+00	0.000E+00	3.020E+08	0.000E+00	7.160E+09	0.000E+00	3.660E+07
RU-105	4.830E-28	0.000E+00	0.000E+00	6.090E-27	0.000E+00	3.900E-25	0.000E+00	1.880E-28
RU-106	2.360E+09	0.000E+00	0.000E+00	4.550E+09	0.000E+00	1.130E+11	0.000E+00	2.970E+08
AG-110M	5.060E+06	4.790E+06	0.000E+00	9.130E+06	0.000E+00	1.340E+09	0.000E+00	2.910E+06
TE-125M	3.030E+08	1.090E+08	8.470E+07	0.000E+00	0.000E+00	8.940E+08	0.000E+00	4.050E+07
TE-127	1.800E-10	6.380E-11	1.240E-10	7.290E-10	0.000E+00	1.390E-08	0.000E+00	3.870E-11
TE-127M	9.410E+08	3.340E+08	2.240E+08	3.820E+09	0.000E+00	2.350E+09	0.000E+00	1.120E+08
TE-129	0.000E+00	0.000E+00	0.000E+00	0.000E+00	0.000E+00	0.000E+00	0.000E+00	0.000E+00
TE-129M	9.500E+08	3.530E+08	3.070E+08	3.970E+09	0.000E+00	3.570E+09	0.000E+00	1.500E+08
TE-131	0.000E+00	0.000E+00	0.000E+00	0.000E+00	0.000E+00	0.000E+00	0.000E+00	0.000E+00
TE-131M	3.760E+02	1.800E+02	2.710E+02	1.880E+03	0.000E+00	1.450E+04	0.000E+00	1.500E+02
TE-132	1.160E+06	7.360E+05	7.750E+05	7.060E+06	0.000E+00	2.330E+07	0.000E+00	6.920E+05
I-130	1.700E-06	4.910E-06	4.000E-04	7.560E-06	0.000E+00	3.770E-06	0.000E+00	1.960E-06

Catawba Nuclear Station Units 1 & 2
Period 1/1/2016 - 12/31/2016

Catawba Nuclear Station
Offsite Dose Calculation Manual (ODCM)

APPENDIX H

R_i Teen Dose Factors for use in the Gaseous Dose Calculations

Agegroup:	TEEN	Pathway:	Grs/Cow/Meat (CMEAT)			Units:	m ² ·mrem/yr / μCi/sec; mrem/yr / μCi/m ³ (H-3, C-14)	
	Bone		Liver	Thyroid	Kidney		Lung	Gilli
I-131	8.920E+06	1.250E+07	3.650E+09	2.150E+07	0.000E+00	2.470E+06	0.000E+00	6.710E+06
I-132	5.660E-59	1.480E-58	4.990E-57	2.330E-58	0.000E+00	6.450E-59	0.000E+00	5.320E-59
I-133	3.050E-01	5.180E-01	7.230E+01	9.090E-01	0.000E+00	3.920E-01	0.000E+00	1.580E-01
I-134	0.000E+00	0.000E+00	0.000E+00	0.000E+00	0.000E+00	0.000E+00	0.000E+00	0.000E+00
I-135	3.600E-17	9.260E-17	5.960E-15	1.460E-16	0.000E+00	1.030E-16	0.000E+00	3.430E-17
CS-134	5.230E+08	1.230E+09	0.000E+00	3.910E+08	1.490E+08	1.530E+07	0.000E+00	5.710E+08
CS-136	9.400E+06	3.700E+07	0.000E+00	2.010E+07	3.170E+06	2.980E+06	0.000E+00	2.480E+07
CS-137	7.240E+08	9.630E+08	0.000E+00	3.280E+08	1.270E+08	1.370E+07	0.000E+00	3.360E+08
CS-138	0.000E+00	0.000E+00	0.000E+00	0.000E+00	0.000E+00	0.000E+00	0.000E+00	0.000E+00
BA-139	0.000E+00	0.000E+00	0.000E+00	0.000E+00	0.000E+00	0.000E+00	0.000E+00	0.000E+00
BA-140	2.380E+07	2.910E+04	0.000E+00	9.870E+03	1.960E+04	3.660E+07	0.000E+00	1.530E+06
BA-141	0.000E+00	0.000E+00	0.000E+00	0.000E+00	0.000E+00	0.000E+00	0.000E+00	0.000E+00
BA-142	0.000E+00	0.000E+00	0.000E+00	0.000E+00	0.000E+00	0.000E+00	0.000E+00	0.000E+00
LA-140	3.050E-02	1.500E-02	0.000E+00	0.000E+00	0.000E+00	8.610E+02	0.000E+00	3.990E-03
LA-142	2.870E-92	1.280E-92	0.000E+00	0.000E+00	0.000E+00	3.880E-88	0.000E+00	3.180E-93
CE-141	1.180E+04	7.870E+03	0.000E+00	3.710E+03	0.000E+00	2.250E+07	0.000E+00	9.040E+02
CE-143	1.690E-02	1.230E+01	0.000E+00	5.510E-03	0.000E+00	3.690E+02	0.000E+00	1.370E-03
CE-144	1.230E+06	5.080E+05	0.000E+00	3.040E+05	0.000E+00	3.090E+08	0.000E+00	6.600E+04
PR-143	1.760E+04	7.040E+03	0.000E+00	4.090E+03	0.000E+00	5.800E+07	0.000E+00	8.780E+02
PR-144	0.000E+00	0.000E+00	0.000E+00	0.000E+00	0.000E+00	0.000E+00	0.000E+00	0.000E+00
ND-147	6.230E+03	6.770E+03	0.000E+00	3.980E+03	0.000E+00	2.440E+07	0.000E+00	4.060E+02
W-187	1.730E-02	1.410E-02	0.000E+00	0.000E+00	0.000E+00	3.820E+00	0.000E+00	4.940E-03
NP-239	2.260E-01	2.140E-02	0.000E+00	6.700E-02	0.000E+00	3.440E+03	0.000E+00	1.190E-02

Catawba Nuclear Station Units 1 & 2
Period 1/1/2016 - 12/31/2016

Catawba Nuclear Station
Offsite Dose Calculation Manual (ODCM)

APPENDIX H

R_i Teen Dose Factors for use in the Gaseous Dose Calculations

Agegroup:	TEEN	Pathway:	Vegetation (VEG)			Units:	m²·mrem/yr / μCi/sec; mrem/yr / μCi/m³ (H-3, C-14)	
Nuclide	Bone	Liver	Thyroid	Kidney	Lung	Gilli	Skin	Total Body
H-3	0.000E+00	2.590E+03	2.590E+03	2.590E+03	2.590E+03	2.590E+03	0.000E+00	2.590E+03
C-14	9.010E+04	1.800E+04	1.800E+04	1.800E+04	1.800E+04	1.800E+04	0.000E+00	1.800E+04
NA-24	2.390E+05	2.390E+05	2.390E+05	2.390E+05	2.390E+05	2.390E+05	0.000E+00	2.390E+05
P-32	1.610E+09	9.970E+07	0.000E+00	0.000E+00	0.000E+00	1.350E+08	0.000E+00	6.240E+07
CR-51	0.000E+00	0.000E+00	3.430E+04	1.350E+04	8.810E+04	1.040E+07	0.000E+00	6.170E+04
MN-54	0.000E+00	4.540E+08	0.000E+00	1.360E+08	0.000E+00	9.320E+08	0.000E+00	9.010E+07
MN-56	0.000E+00	1.420E+01	0.000E+00	1.800E+01	0.000E+00	9.360E+02	0.000E+00	2.530E+00
FE-55	3.260E+08	2.310E+08	0.000E+00	0.000E+00	1.470E+08	1.000E+08	0.000E+00	5.390E+07
FE-59	1.790E+08	4.190E+08	0.000E+00	0.000E+00	1.320E+08	9.900E+08	0.000E+00	1.620E+08
CO-58	0.000E+00	4.360E+07	0.000E+00	0.000E+00	0.000E+00	6.010E+08	0.000E+00	1.000E+08
CO-60	0.000E+00	2.490E+08	0.000E+00	0.000E+00	0.000E+00	3.240E+09	0.000E+00	5.600E+08
NI-63	1.610E+10	1.130E+09	0.000E+00	0.000E+00	0.000E+00	1.810E+08	0.000E+00	5.450E+08
NI-65	5.720E+01	7.310E+00	0.000E+00	0.000E+00	0.000E+00	3.970E+02	0.000E+00	3.330E+00
CU-64	0.000E+00	8.340E+03	0.000E+00	2.110E+04	0.000E+00	6.470E+05	0.000E+00	3.920E+03
ZN-65	4.240E+08	1.470E+09	0.000E+00	9.420E+08	0.000E+00	6.230E+08	0.000E+00	6.870E+08
ZN-69	5.140E-06	9.800E-06	0.000E+00	6.400E-06	0.000E+00	1.810E-05	0.000E+00	6.860E-07
BR-83	0.000E+00	0.000E+00	0.000E+00	0.000E+00	0.000E+00	0.000E+00	0.000E+00	2.910E+00
BR-84	0.000E+00	0.000E+00	0.000E+00	0.000E+00	0.000E+00	0.000E+00	0.000E+00	2.250E-11
BR-85	0.000E+00	0.000E+00	0.000E+00	0.000E+00	0.000E+00	0.000E+00	0.000E+00	0.000E+00
RB-86	0.000E+00	2.740E+08	0.000E+00	0.000E+00	0.000E+00	4.050E+07	0.000E+00	1.290E+08
RB-88	0.000E+00	3.170E-22	0.000E+00	0.000E+00	0.000E+00	2.720E-29	0.000E+00	1.690E-22
RB-89	0.000E+00	3.500E-26	0.000E+00	0.000E+00	0.000E+00	5.360E-35	0.000E+00	2.470E-26
SR-89	1.510E+10	0.000E+00	0.000E+00	0.000E+00	0.000E+00	1.800E+09	0.000E+00	4.340E+08
SR-90	7.510E+11	0.000E+00	0.000E+00	0.000E+00	0.000E+00	2.110E+10	0.000E+00	1.850E+11
SR-91	2.850E+05	0.000E+00	0.000E+00	0.000E+00	0.000E+00	1.290E+06	0.000E+00	1.130E+04

Catawba Nuclear Station Units 1 & 2
Period 1/1/2016 - 12/31/2016

Catawba Nuclear Station
Offsite Dose Calculation Manual (ODCM)

APPENDIX H

R_i Teen Dose Factors for use in the Gaseous Dose Calculations

Agegroup:	TEEN	Pathway:	Vegetation (VEG)			Units:	m ² ·mrem/yr / μCi/sec; mrem/yr / μCi/m ³ (H-3, C-14)	
Nuclide	Bone	Liver	Thyroid	Kidney	Lung	Gilli	Skin	Total Body
SR-92	3.970E+02	0.000E+00	0.000E+00	0.000E+00	0.000E+00	1.010E+04	0.000E+00	1.690E+01
Y-90	1.240E+04	0.000E+00	0.000E+00	0.000E+00	0.000E+00	1.020E+08	0.000E+00	3.350E+02
Y-91	7.840E+06	0.000E+00	0.000E+00	0.000E+00	0.000E+00	3.210E+09	0.000E+00	2.100E+05
Y-91M	4.860E-09	0.000E+00	0.000E+00	0.000E+00	0.000E+00	2.290E-07	0.000E+00	1.860E-10
Y-92	8.600E-01	0.000E+00	0.000E+00	0.000E+00	0.000E+00	2.360E+04	0.000E+00	2.490E-02
Y-93	1.590E+02	0.000E+00	0.000E+00	0.000E+00	0.000E+00	4.860E+06	0.000E+00	4.360E+00
ZR-95	1.720E+06	5.430E+05	0.000E+00	7.980E+05	0.000E+00	1.250E+09	0.000E+00	3.730E+05
ZR-97	3.120E+02	6.180E+01	0.000E+00	9.370E+01	0.000E+00	1.670E+07	0.000E+00	2.850E+01
NB-95	1.920E+05	1.070E+05	0.000E+00	1.030E+05	0.000E+00	4.560E+08	0.000E+00	5.870E+04
MO-99	0.000E+00	5.650E+06	0.000E+00	1.290E+07	0.000E+00	1.010E+07	0.000E+00	1.080E+06
TC-99M	2.740E+00	7.630E+00	0.000E+00	1.140E+02	4.240E+00	5.010E+03	0.000E+00	9.890E+01
TC-101	7.640E-31	1.090E-30	0.000E+00	1.970E-29	6.620E-31	1.860E-37	0.000E+00	1.070E-29
RU-103	6.820E+06	0.000E+00	0.000E+00	2.400E+07	0.000E+00	5.700E+08	0.000E+00	2.920E+06
RU-105	5.000E+01	0.000E+00	0.000E+00	6.310E+02	0.000E+00	4.040E+04	0.000E+00	1.940E+01
RU-106	3.100E+08	0.000E+00	0.000E+00	5.970E+08	0.000E+00	1.480E+10	0.000E+00	3.900E+07
AG-110M	1.520E+07	1.430E+07	0.000E+00	2.740E+07	0.000E+00	4.030E+09	0.000E+00	8.720E+06
TE-125M	1.480E+08	5.340E+07	4.140E+07	0.000E+00	0.000E+00	4.370E+08	0.000E+00	1.980E+07
TE-127	5.330E+03	1.890E+03	3.680E+03	2.160E+04	0.000E+00	4.120E+05	0.000E+00	1.150E+03
TE-127M	5.510E+08	1.960E+08	1.310E+08	2.240E+09	0.000E+00	1.370E+09	0.000E+00	6.560E+07
TE-129	7.140E-04	2.660E-04	5.100E-04	3.000E-03	0.000E+00	3.910E-03	0.000E+00	1.740E-04
TE-129M	3.620E+08	1.340E+08	1.170E+08	1.510E+09	0.000E+00	1.360E+09	0.000E+00	5.730E+07
TE-131	1.390E-15	5.750E-16	1.070E-15	6.100E-15	0.000E+00	1.140E-16	0.000E+00	4.360E-16
TE-131M	8.440E+05	4.050E+05	6.090E+05	4.220E+06	0.000E+00	3.250E+07	0.000E+00	3.380E+05
TE-132	3.910E+06	2.470E+06	2.610E+06	2.370E+07	0.000E+00	7.840E+07	0.000E+00	2.330E+06
I-130	3.510E+05	1.010E+06	8.280E+07	1.560E+06	0.000E+00	7.800E+05	0.000E+00	4.050E+05

Catawba Nuclear Station Units 1 & 2
Period 1/1/2016 - 12/31/2016

Catawba Nuclear Station
Offsite Dose Calculation Manual (ODCM)

APPENDIX H

R_i Teen Dose Factors for use in the Gaseous Dose Calculations

Agegroup:	TEEN	Pathway:	Vegetation (VEG)			Units:	m ² ·mrem/yr / μCi/sec; mrem/yr / μCi/m ³ (H-3, C-14)	
	Bone		Liver	Thyroid	Kidney		Lung	Gilli
I-131	7.690E+07	1.080E+08	3.140E+10	1.850E+08	0.000E+00	2.130E+07	0.000E+00	5.780E+07
I-132	5.190E+01	1.360E+02	4.580E+03	2.140E+02	0.000E+00	5.920E+01	0.000E+00	4.880E+01
I-133	1.940E+06	3.290E+06	4.590E+08	5.760E+06	0.000E+00	2.490E+06	0.000E+00	1.000E+06
I-134	8.720E-05	2.310E-04	3.850E-03	3.640E-04	0.000E+00	3.050E-06	0.000E+00	8.310E-05
I-135	3.520E+04	9.070E+04	5.830E+06	1.430E+05	0.000E+00	1.000E+05	0.000E+00	3.360E+04
CS-134	7.100E+09	1.670E+10	0.000E+00	5.310E+09	2.030E+09	2.080E+08	0.000E+00	7.750E+09
CS-136	4.370E+07	1.720E+08	0.000E+00	9.370E+07	1.480E+07	1.380E+07	0.000E+00	1.160E+08
CS-137	1.010E+10	1.350E+10	0.000E+00	4.590E+09	1.780E+09	1.920E+08	0.000E+00	4.690E+09
CS-138	3.610E-11	6.940E-11	0.000E+00	5.120E-11	5.960E-12	3.150E-14	0.000E+00	3.470E-11
BA-139	2.690E-02	1.890E-05	0.000E+00	1.780E-05	1.300E-05	2.400E-01	0.000E+00	7.830E-04
BA-140	1.380E+08	1.690E+05	0.000E+00	5.740E+04	1.140E+05	2.130E+08	0.000E+00	8.900E+06
BA-141	1.080E-21	8.040E-25	0.000E+00	7.460E-25	5.500E-25	2.290E-27	0.000E+00	3.590E-23
BA-142	5.490E-39	5.490E-42	0.000E+00	4.640E-42	3.650E-42	1.680E-50	0.000E+00	3.380E-40
LA-140	1.810E+03	8.880E+02	0.000E+00	0.000E+00	0.000E+00	5.100E+07	0.000E+00	2.360E+02
LA-142	1.850E-04	8.240E-05	0.000E+00	0.000E+00	0.000E+00	2.510E+00	0.000E+00	2.050E-05
CE-141	2.830E+05	1.890E+05	0.000E+00	8.890E+04	0.000E+00	5.400E+08	0.000E+00	2.170E+04
CE-143	9.330E+02	6.790E+05	0.000E+00	3.040E+02	0.000E+00	2.040E+07	0.000E+00	7.580E+01
CE-144	5.270E+07	2.180E+07	0.000E+00	1.300E+07	0.000E+00	1.330E+10	0.000E+00	2.830E+06
PR-143	7.000E+04	2.800E+04	0.000E+00	1.630E+04	0.000E+00	2.300E+08	0.000E+00	3.490E+03
PR-144	2.900E-26	1.190E-26	0.000E+00	6.800E-27	0.000E+00	3.190E-29	0.000E+00	1.470E-27
ND-147	3.620E+04	3.940E+04	0.000E+00	2.310E+04	0.000E+00	1.420E+08	0.000E+00	2.360E+03
W-187	3.540E+04	2.880E+04	0.000E+00	0.000E+00	0.000E+00	7.800E+06	0.000E+00	1.010E+04
NP-239	1.390E+03	1.310E+02	0.000E+00	4.100E+02	0.000E+00	2.100E+07	0.000E+00	7.260E+01

Catawba Nuclear Station Units 1 & 2
Period 1/1/2016 - 12/31/2016

Catawba Nuclear Station
Offsite Dose Calculation Manual (ODCM)

APPENDIX H

R_i Teen Dose Factors for use in the Gaseous Dose Calculations

Agegroup:	TEEN	Pathway:	Inhalation (INHL)			Units:	mrem/yr / $\mu\text{Ci}/\text{m}^3$	
Nuclide	Bone	Liver	Thyroid	Kidney	Lung	Gilli	Skin	Total Body
H-3	0.000E+00	1.270E+03	1.270E+03	1.270E+03	1.270E+03	1.270E+03	0.000E+00	1.270E+03
C-14	2.600E+04	4.870E+03	4.870E+03	4.870E+03	4.870E+03	4.870E+03	0.000E+00	4.870E+03
NA-24	1.380E+04	1.380E+04	1.380E+04	1.380E+04	1.380E+04	1.380E+04	0.000E+00	1.380E+04
P-32	1.890E+06	1.100E+05	0.000E+00	0.000E+00	0.000E+00	9.280E+04	0.000E+00	7.160E+04
CR-51	0.000E+00	0.000E+00	7.500E+01	3.070E+01	2.100E+04	3.000E+03	0.000E+00	1.350E+02
MN-54	0.000E+00	5.110E+04	0.000E+00	1.270E+04	1.980E+06	6.680E+04	0.000E+00	8.400E+03
MN-56	0.000E+00	1.700E+00	0.000E+00	1.790E+00	1.520E+04	5.740E+04	0.000E+00	2.520E-01
FE-55	3.340E+04	2.380E+04	0.000E+00	0.000E+00	1.240E+05	6.390E+03	0.000E+00	5.540E+03
FE-59	1.590E+04	3.700E+04	0.000E+00	0.000E+00	1.530E+06	1.780E+05	0.000E+00	1.430E+04
CO-58	0.000E+00	2.070E+03	0.000E+00	0.000E+00	1.340E+06	9.520E+04	0.000E+00	2.780E+03
CO-60	0.000E+00	1.510E+04	0.000E+00	0.000E+00	8.720E+06	2.590E+05	0.000E+00	1.980E+04
NI-63	5.800E+05	4.340E+04	0.000E+00	0.000E+00	3.070E+05	1.420E+04	0.000E+00	1.980E+04
NI-65	2.180E+00	2.930E-01	0.000E+00	0.000E+00	9.360E+03	3.670E+04	0.000E+00	1.270E-01
CU-64	0.000E+00	2.030E+00	0.000E+00	6.410E+00	1.110E+04	6.140E+04	0.000E+00	8.480E-01
ZN-65	3.860E+04	1.340E+05	0.000E+00	8.640E+04	1.240E+06	4.660E+04	0.000E+00	6.240E+04
ZN-69	4.830E-02	9.200E-02	0.000E+00	6.020E-02	1.580E+03	2.850E+02	0.000E+00	6.460E-03
BR-83	0.000E+00	0.000E+00	0.000E+00	0.000E+00	0.000E+00	0.000E+00	0.000E+00	3.440E+02
BR-84	0.000E+00	0.000E+00	0.000E+00	0.000E+00	0.000E+00	0.000E+00	0.000E+00	4.330E+02
BR-85	0.000E+00	0.000E+00	0.000E+00	0.000E+00	0.000E+00	0.000E+00	0.000E+00	1.830E+01
RB-86	0.000E+00	1.900E+05	0.000E+00	0.000E+00	0.000E+00	1.770E+04	0.000E+00	8.400E+04
RB-88	0.000E+00	5.460E+02	0.000E+00	0.000E+00	0.000E+00	2.920E-05	0.000E+00	2.720E+02
RB-89	0.000E+00	3.520E+02	0.000E+00	0.000E+00	0.000E+00	3.380E-07	0.000E+00	2.330E+02
SR-89	4.340E+05	0.000E+00	0.000E+00	0.000E+00	2.420E+06	3.710E+05	0.000E+00	1.250E+04
SR-90	1.080E+08	0.000E+00	0.000E+00	0.000E+00	1.650E+07	7.650E+05	0.000E+00	6.680E+06
SR-91	8.800E+01	0.000E+00	0.000E+00	0.000E+00	6.070E+04	2.590E+05	0.000E+00	3.510E+00

Catawba Nuclear Station Units 1 & 2
Period 1/1/2016 - 12/31/2016

Catawba Nuclear Station
Offsite Dose Calculation Manual (ODCM)

APPENDIX H

R_i Teen Dose Factors for use in the Gaseous Dose Calculations

Agegroup:	TEEN	Pathway:	Inhalation (INHL)			Units:	mrem/yr / $\mu\text{Ci}/\text{m}^3$	
Nuclide	Bone	Liver	Thyroid	Kidney	Lung	Gilli	Skin	Total Body
SR-92	9.520E+00	0.000E+00	0.000E+00	0.000E+00	2.740E+04	1.190E+05	0.000E+00	4.060E-01
Y-90	2.980E+03	0.000E+00	0.000E+00	0.000E+00	2.930E+05	5.590E+05	0.000E+00	8.000E+01
Y-91	6.610E+05	0.000E+00	0.000E+00	0.000E+00	2.940E+06	4.090E+05	0.000E+00	1.770E+04
Y-91M	3.700E-01	0.000E+00	0.000E+00	0.000E+00	3.200E+03	3.020E+01	0.000E+00	1.420E-02
Y-92	1.470E+01	0.000E+00	0.000E+00	0.000E+00	2.680E+04	1.650E+05	0.000E+00	4.290E-01
Y-93	1.350E+02	0.000E+00	0.000E+00	0.000E+00	8.320E+04	5.790E+05	0.000E+00	3.720E+00
ZR-95	1.460E+05	4.580E+04	0.000E+00	6.740E+04	2.690E+06	1.490E+05	0.000E+00	3.150E+04
ZR-97	1.380E+02	2.720E+01	0.000E+00	4.120E+01	1.300E+05	6.300E+05	0.000E+00	1.260E+01
NB-95	1.860E+04	1.030E+04	0.000E+00	1.000E+04	7.510E+05	9.680E+04	0.000E+00	5.660E+03
MO-99	0.000E+00	1.690E+02	0.000E+00	4.110E+02	1.540E+05	2.690E+05	0.000E+00	3.220E+01
TC-99M	1.380E-03	3.860E-03	0.000E+00	5.760E-02	1.150E+03	6.130E+03	0.000E+00	4.990E-02
TC-101	5.920E-05	8.400E-05	0.000E+00	1.520E-03	6.670E+02	8.720E-07	0.000E+00	8.240E-04
RU-103	2.100E+03	0.000E+00	0.000E+00	7.430E+03	7.830E+05	1.090E+05	0.000E+00	8.960E+02
RU-105	1.120E+00	0.000E+00	0.000E+00	1.410E+00	1.820E+04	9.040E+04	0.000E+00	4.340E-01
RU-106	9.840E+04	0.000E+00	0.000E+00	1.900E+05	1.610E+07	9.600E+05	0.000E+00	1.240E+04
AG-110M	1.380E+04	1.310E+04	0.000E+00	2.500E+04	6.750E+06	2.730E+05	0.000E+00	7.990E+03
TE-125M	4.880E+03	2.240E+03	1.400E+03	0.000E+00	5.360E+05	7.500E+04	0.000E+00	6.670E+02
TE-127	2.010E+00	9.120E-01	1.420E+00	7.280E+00	1.120E+04	8.080E+04	0.000E+00	4.420E-01
TE-127M	1.800E+04	8.160E+03	4.380E+03	6.540E+04	1.660E+06	1.590E+05	0.000E+00	2.180E+03
TE-129	7.100E-02	3.380E-02	5.180E-02	2.660E-01	3.300E+03	1.620E+03	0.000E+00	1.760E-02
TE-129M	1.390E+04	6.580E+03	4.580E+03	5.190E+04	1.980E+06	4.050E+05	0.000E+00	2.250E+03
TE-131	1.580E-02	8.320E-03	1.240E-02	6.180E-02	2.340E+03	1.510E+01	0.000E+00	5.040E-03
TE-131M	9.840E+01	6.010E+01	7.250E+01	4.390E+02	2.380E+05	6.210E+05	0.000E+00	4.020E+01
TE-132	3.600E+02	2.900E+02	2.460E+02	1.950E+03	4.490E+05	4.630E+05	0.000E+00	2.190E+02
I-130	6.240E+03	1.790E+04	1.490E+06	2.750E+04	0.000E+00	9.120E+03	0.000E+00	7.170E+03

Catawba Nuclear Station Units 1 & 2
Period 1/1/2016 - 12/31/2016

Catawba Nuclear Station
Offsite Dose Calculation Manual (ODCM)

APPENDIX H

R_i Teen Dose Factors for use in the Gaseous Dose Calculations

Agegroup:	TEEN	Pathway:	Inhalation (INHL)			Units:	mrem/yr / $\mu\text{Ci}/\text{m}^3$	
Nuclide	Bone	Liver	Thyroid	Kidney	Lung	Gilli	Skin	Total Body
I-131	3.540E+04	4.910E+04	1.460E+07	8.400E+04	0.000E+00	6.490E+03	0.000E+00	2.640E+04
I-132	1.590E+03	4.380E+03	1.510E+05	6.920E+03	0.000E+00	1.270E+03	0.000E+00	1.580E+03
I-133	1.220E+04	2.050E+04	2.920E+06	3.590E+04	0.000E+00	1.030E+04	0.000E+00	6.220E+03
I-134	8.880E+02	2.320E+03	3.950E+04	3.660E+03	0.000E+00	2.040E+01	0.000E+00	8.400E+02
I-135	3.700E+03	9.440E+03	6.210E+05	1.490E+04	0.000E+00	6.950E+03	0.000E+00	3.490E+03
CS-134	5.020E+05	1.130E+06	0.000E+00	3.750E+05	1.460E+05	9.760E+03	0.000E+00	5.490E+05
CS-136	5.150E+04	1.940E+05	0.000E+00	1.100E+05	1.780E+04	1.090E+04	0.000E+00	1.370E+05
CS-137	6.700E+05	8.480E+05	0.000E+00	3.040E+05	1.210E+05	8.480E+03	0.000E+00	3.110E+05
CS-138	4.660E+02	8.560E+02	0.000E+00	6.620E+02	7.870E+01	2.700E-01	0.000E+00	4.460E+02
BA-139	1.340E+00	9.440E-04	0.000E+00	8.880E-04	6.460E+03	6.450E+03	0.000E+00	3.900E-02
BA-140	5.470E+04	6.700E+01	0.000E+00	2.280E+01	2.030E+06	2.290E+05	0.000E+00	3.520E+03
BA-141	1.420E-01	1.060E-04	0.000E+00	9.840E-05	3.290E+03	7.460E-04	0.000E+00	4.740E-03
BA-142	3.700E-02	3.700E-05	0.000E+00	3.140E-05	1.910E+03	4.790E-10	0.000E+00	2.270E-03
LA-140	4.790E+02	2.360E+02	0.000E+00	0.000E+00	2.140E+05	4.870E+05	0.000E+00	6.260E+01
LA-142	9.600E-01	4.250E-01	0.000E+00	0.000E+00	1.020E+04	1.200E+04	0.000E+00	1.060E-01
CE-141	2.840E+04	1.900E+04	0.000E+00	8.880E+03	6.140E+05	1.260E+05	0.000E+00	2.170E+03
CE-143	2.660E+02	1.940E+02	0.000E+00	8.640E+01	1.300E+05	2.550E+05	0.000E+00	2.160E+01
CE-144	4.890E+06	2.020E+06	0.000E+00	1.210E+06	1.340E+07	8.640E+05	0.000E+00	2.620E+05
PR-143	1.340E+04	5.310E+03	0.000E+00	3.090E+03	4.830E+05	2.140E+05	0.000E+00	6.620E+02
PR-144	4.300E-02	1.760E-02	0.000E+00	1.010E-02	1.750E+03	2.350E-04	0.000E+00	2.180E-03
ND-147	7.860E+03	8.560E+03	0.000E+00	5.020E+03	3.720E+05	1.820E+05	0.000E+00	5.130E+02
W-187	1.200E+01	9.760E+00	0.000E+00	0.000E+00	4.740E+04	1.770E+05	0.000E+00	3.430E+00
NP-239	3.380E+02	3.190E+01	0.000E+00	1.000E+02	6.490E+04	1.320E+05	0.000E+00	1.770E+01

Catawba Nuclear Station Units 1 & 2
Period 1/1/2016 - 12/31/2016

Catawba Nuclear Station
Offsite Dose Calculation Manual (ODCM)

APPENDIX H

R_i Teen Dose Factors for use in the Gaseous Dose Calculations

Agegroup:	TEEN	Pathway:	Ground Plane Deposition (GPD)			Units:	m²·mrem/yr / μCi/sec	
Nuclide	Bone	Liver	Thyroid	Kidney	Lung	Gilli	Skin	Total Body
H-3	0.000E+00	0.000E+00	0.000E+00	0.000E+00	0.000E+00	0.000E+00	0.000E+00	0.000E+00
C-14	0.000E+00	0.000E+00	0.000E+00	0.000E+00	0.000E+00	0.000E+00	0.000E+00	0.000E+00
NA-24	1.190E+07	1.190E+07	1.190E+07	1.190E+07	1.190E+07	1.190E+07	1.390E+07	1.190E+07
P-32	0.000E+00	0.000E+00	0.000E+00	0.000E+00	0.000E+00	0.000E+00	0.000E+00	0.000E+00
CR-51	4.660E+06	4.660E+06	4.660E+06	4.660E+06	4.660E+06	4.660E+06	5.510E+06	4.660E+06
MN-54	1.390E+09	1.390E+09	1.390E+09	1.390E+09	1.390E+09	1.390E+09	1.630E+09	1.390E+09
MN-56	9.020E+05	9.020E+05	9.020E+05	9.020E+05	9.020E+05	9.020E+05	1.070E+06	9.020E+05
FE-55	0.000E+00	0.000E+00	0.000E+00	0.000E+00	0.000E+00	0.000E+00	0.000E+00	0.000E+00
FE-59	2.730E+08	2.730E+08	2.730E+08	2.730E+08	2.730E+08	2.730E+08	3.210E+08	2.730E+08
CO-58	3.790E+08	3.790E+08	3.790E+08	3.790E+08	3.790E+08	3.790E+08	4.440E+08	3.790E+08
CO-60	2.150E+10	2.150E+10	2.150E+10	2.150E+10	2.150E+10	2.150E+10	2.530E+10	2.150E+10
NI-63	0.000E+00	0.000E+00	0.000E+00	0.000E+00	0.000E+00	0.000E+00	0.000E+00	0.000E+00
NI-65	2.970E+05	2.970E+05	2.970E+05	2.970E+05	2.970E+05	2.970E+05	3.450E+05	2.970E+05
CU-64	6.070E+05	6.070E+05	6.070E+05	6.070E+05	6.070E+05	6.070E+05	6.880E+05	6.070E+05
ZN-65	7.470E+08	7.470E+08	7.470E+08	7.470E+08	7.470E+08	7.470E+08	8.590E+08	7.470E+08
ZN-69	0.000E+00	0.000E+00	0.000E+00	0.000E+00	0.000E+00	0.000E+00	0.000E+00	0.000E+00
BR-83	4.870E+03	4.870E+03	4.870E+03	4.870E+03	4.870E+03	4.870E+03	7.080E+03	4.870E+03
BR-84	2.030E+05	2.030E+05	2.030E+05	2.030E+05	2.030E+05	2.030E+05	2.360E+05	2.030E+05
BR-85	0.000E+00	0.000E+00	0.000E+00	0.000E+00	0.000E+00	0.000E+00	0.000E+00	0.000E+00
RB-86	8.990E+06	8.990E+06	8.990E+06	8.990E+06	8.990E+06	8.990E+06	1.030E+07	8.990E+06
RB-88	3.310E+04	3.310E+04	3.310E+04	3.310E+04	3.310E+04	3.310E+04	3.780E+04	3.310E+04
RB-89	1.230E+05	1.230E+05	1.230E+05	1.230E+05	1.230E+05	1.230E+05	1.480E+05	1.230E+05
SR-89	2.160E+04	2.160E+04	2.160E+04	2.160E+04	2.160E+04	2.160E+04	2.510E+04	2.160E+04
SR-90	0.000E+00	0.000E+00	0.000E+00	0.000E+00	0.000E+00	0.000E+00	0.000E+00	0.000E+00
SR-91	2.150E+06	2.150E+06	2.150E+06	2.150E+06	2.150E+06	2.150E+06	2.510E+06	2.150E+06

Catawba Nuclear Station Units 1 & 2
Period 1/1/2016 - 12/31/2016

Catawba Nuclear Station
Offsite Dose Calculation Manual (ODCM)

APPENDIX H

R_i Teen Dose Factors for use in the Gaseous Dose Calculations

Agegroup:	TEEN	Pathway:	Ground Plane Deposition (GPD)			Units:	m²·mrem/yr / μCi/sec	
Nuclide	Bone	Liver	Thyroid	Kidney	Lung	Gilli	Skin	Total Body
SR-92	7.770E+05	7.770E+05	7.770E+05	7.770E+05	7.770E+05	7.770E+05	8.630E+05	7.770E+05
Y-90	4.490E+03	4.490E+03	4.490E+03	4.490E+03	4.490E+03	4.490E+03	5.310E+03	4.490E+03
Y-91	1.070E+06	1.070E+06	1.070E+06	1.070E+06	1.070E+06	1.070E+06	1.210E+06	1.070E+06
Y-91M	1.000E+05	1.000E+05	1.000E+05	1.000E+05	1.000E+05	1.000E+05	1.160E+05	1.000E+05
Y-92	1.800E+05	1.800E+05	1.800E+05	1.800E+05	1.800E+05	1.800E+05	2.140E+05	1.800E+05
Y-93	1.830E+05	1.830E+05	1.830E+05	1.830E+05	1.830E+05	1.830E+05	2.510E+05	1.830E+05
ZR-95	2.450E+08	2.450E+08	2.450E+08	2.450E+08	2.450E+08	2.450E+08	2.840E+08	2.450E+08
ZR-97	2.960E+06	2.960E+06	2.960E+06	2.960E+06	2.960E+06	2.960E+06	3.440E+06	2.960E+06
NB-95	1.370E+08	1.370E+08	1.370E+08	1.370E+08	1.370E+08	1.370E+08	1.610E+08	1.370E+08
MO-99	3.990E+06	3.990E+06	3.990E+06	3.990E+06	3.990E+06	3.990E+06	4.630E+06	3.990E+06
TC-99M	1.840E+05	1.840E+05	1.840E+05	1.840E+05	1.840E+05	1.840E+05	2.110E+05	1.840E+05
TC-101	2.040E+04	2.040E+04	2.040E+04	2.040E+04	2.040E+04	2.040E+04	2.260E+04	2.040E+04
RU-103	1.080E+08	1.080E+08	1.080E+08	1.080E+08	1.080E+08	1.080E+08	1.260E+08	1.080E+08
RU-105	6.360E+05	6.360E+05	6.360E+05	6.360E+05	6.360E+05	6.360E+05	7.210E+05	6.360E+05
RU-106	4.220E+08	4.220E+08	4.220E+08	4.220E+08	4.220E+08	4.220E+08	5.070E+08	4.220E+08
AG-110M	3.440E+09	3.440E+09	3.440E+09	3.440E+09	3.440E+09	3.440E+09	4.010E+09	3.440E+09
TE-125M	1.550E+06	1.550E+06	1.550E+06	1.550E+06	1.550E+06	1.550E+06	2.130E+06	1.550E+06
TE-127	2.980E+03	2.980E+03	2.980E+03	2.980E+03	2.980E+03	2.980E+03	3.280E+03	2.980E+03
TE-127M	9.160E+04	9.160E+04	9.160E+04	9.160E+04	9.160E+04	9.160E+04	1.080E+05	9.160E+04
TE-129	2.620E+04	2.620E+04	2.620E+04	2.620E+04	2.620E+04	2.620E+04	3.100E+04	2.620E+04
TE-129M	1.980E+07	1.980E+07	1.980E+07	1.980E+07	1.980E+07	1.980E+07	2.310E+07	1.980E+07
TE-131	2.920E+04	2.920E+04	2.920E+04	2.920E+04	2.920E+04	2.920E+04	3.450E+07	2.920E+04
TE-131M	8.030E+06	8.030E+06	8.030E+06	8.030E+06	8.030E+06	8.030E+06	9.460E+06	8.030E+06
TE-132	4.230E+06	4.230E+06	4.230E+06	4.230E+06	4.230E+06	4.230E+06	4.980E+06	4.230E+06
I-130	5.510E+06	5.510E+06	5.510E+06	5.510E+06	5.510E+06	5.510E+06	6.690E+06	5.510E+06

Catawba Nuclear Station Units 1 & 2
Period 1/1/2016 - 12/31/2016

Catawba Nuclear Station
Offsite Dose Calculation Manual (ODCM)

APPENDIX H

R_i Teen Dose Factors for use in the Gaseous Dose Calculations

Agegroup:	TEEN	Pathway:	Ground Plane Deposition (GPD)			Units:	m²·mrem/yr / μCi/sec	
Nuclide	Bone	Liver	Thyroid	Kidney	Lung	Gilli	Skin	Total Body
I-131	1.720E+07	1.720E+07	1.720E+07	1.720E+07	1.720E+07	1.720E+07	2.090E+07	1.720E+07
I-132	1.250E+06	1.250E+06	1.250E+06	1.250E+06	1.250E+06	1.250E+06	1.470E+06	1.250E+06
I-133	2.450E+06	2.450E+06	2.450E+06	2.450E+06	2.450E+06	2.450E+06	2.980E+06	2.450E+06
I-134	4.470E+05	4.470E+05	4.470E+05	4.470E+05	4.470E+05	4.470E+05	5.300E+05	4.470E+05
I-135	2.530E+06	2.530E+06	2.530E+06	2.530E+06	2.530E+06	2.530E+06	2.950E+06	2.530E+06
CS-134	6.860E+09	6.860E+09	6.860E+09	6.860E+09	6.860E+09	6.860E+09	8.000E+09	6.860E+09
CS-136	1.510E+08	1.510E+08	1.510E+08	1.510E+08	1.510E+08	1.510E+08	1.710E+08	1.510E+08
CS-137	1.030E+10	1.030E+10	1.030E+10	1.030E+10	1.030E+10	1.030E+10	1.200E+10	1.030E+10
CS-138	3.590E+05	3.590E+05	3.590E+05	3.590E+05	3.590E+05	3.590E+05	4.100E+05	3.590E+05
BA-139	1.060E+05	1.060E+05	1.060E+05	1.060E+05	1.060E+05	1.060E+05	1.190E+05	1.060E+05
BA-140	2.050E+07	2.050E+07	2.050E+07	2.050E+07	2.050E+07	2.050E+07	2.350E+07	2.050E+07
BA-141	4.170E+04	4.170E+04	4.170E+04	4.170E+04	4.170E+04	4.170E+04	4.750E+04	4.170E+04
BA-142	4.490E+04	4.490E+04	4.490E+04	4.490E+04	4.490E+04	4.490E+04	5.110E+04	4.490E+04
LA-140	1.920E+07	1.920E+07	1.920E+07	1.920E+07	1.920E+07	1.920E+07	2.180E+07	1.920E+07
LA-142	7.600E+05	7.600E+05	7.600E+05	7.600E+05	7.600E+05	7.600E+05	9.120E+05	7.600E+05
CE-141	1.370E+07	1.370E+07	1.370E+07	1.370E+07	1.370E+07	1.370E+07	1.540E+07	1.370E+07
CE-143	2.310E+06	2.310E+06	2.310E+06	2.310E+06	2.310E+06	2.310E+06	2.630E+06	2.310E+06
CE-144	6.950E+07	6.950E+07	6.950E+07	6.950E+07	6.950E+07	6.950E+07	8.040E+07	6.950E+07
PR-143	0.000E+00	0.000E+00	0.000E+00	0.000E+00	0.000E+00	0.000E+00	0.000E+00	0.000E+00
PR-144	1.830E+03	1.830E+03	1.830E+03	1.830E+03	1.830E+03	1.830E+03	2.110E+03	1.830E+03
ND-147	8.390E+06	8.390E+06	8.390E+06	8.390E+06	8.390E+06	8.390E+06	1.010E+07	8.390E+06
W-187	2.350E+06	2.350E+06	2.350E+06	2.350E+06	2.350E+06	2.350E+06	2.730E+06	2.350E+06
NP-239	1.710E+06	1.710E+06	1.710E+06	1.710E+06	1.710E+06	1.710E+06	1.980E+06	1.710E+06

Catawba Nuclear Station Units 1 & 2
Period 1/1/2016 - 12/31/2016

Catawba Nuclear Station
Offsite Dose Calculation Manual (ODCM)

APPENDIX I

R_i Child Dose Factors for use in the Gaseous Dose Calculations

Agegroup:	CHILD	Pathway:	Grs/Cow/Milk (CMILK)			Units:	m²·mrem/yr / μCi/sec; mrem/yr / μCi/m³ (H-3, C-14)	
Nuclide	Bone	Liver	Thyroid	Kidney	Lung	Gilli	Skin	Total Body
H-3	0.000E+00	1.570E+03	1.570E+03	1.570E+03	1.570E+03	1.570E+03	0.000E+00	1.570E+03
C-14	1.020E+05	2.040E+04	2.040E+04	2.040E+04	2.040E+04	2.040E+04	0.000E+00	2.040E+04
NA-24	8.850E+06	8.850E+06	8.850E+06	8.850E+06	8.850E+06	8.850E+06	0.000E+00	8.850E+06
P-32	7.780E+10	3.640E+09	0.000E+00	0.000E+00	0.000E+00	2.150E+09	0.000E+00	3.000E+09
CR-51	0.000E+00	0.000E+00	5.650E+04	1.540E+04	1.030E+05	5.400E+06	0.000E+00	1.020E+05
MN-54	0.000E+00	2.100E+07	0.000E+00	5.880E+06	0.000E+00	1.760E+07	0.000E+00	5.590E+06
MN-56	0.000E+00	1.260E-02	0.000E+00	1.530E-02	0.000E+00	1.830E+00	0.000E+00	2.860E-03
FE-55	1.120E+08	5.930E+07	0.000E+00	0.000E+00	3.350E+07	1.100E+07	0.000E+00	1.840E+07
FE-59	1.200E+08	1.950E+08	0.000E+00	0.000E+00	5.640E+07	2.030E+08	0.000E+00	9.690E+07
CO-58	0.000E+00	1.210E+07	0.000E+00	0.000E+00	0.000E+00	7.070E+07	0.000E+00	3.710E+07
CO-60	0.000E+00	4.320E+07	0.000E+00	0.000E+00	0.000E+00	2.390E+08	0.000E+00	1.270E+08
NI-63	2.960E+10	1.590E+09	0.000E+00	0.000E+00	0.000E+00	1.070E+08	0.000E+00	1.010E+09
NI-65	1.660E+00	1.560E-01	0.000E+00	0.000E+00	0.000E+00	1.910E+01	0.000E+00	9.100E-02
CU-64	0.000E+00	7.460E+04	0.000E+00	1.800E+05	0.000E+00	3.500E+06	0.000E+00	4.510E+04
ZN-65	4.130E+09	1.100E+10	0.000E+00	6.940E+09	0.000E+00	1.930E+09	0.000E+00	6.850E+09
ZN-69	9.460E-12	1.370E-11	0.000E+00	8.300E-12	0.000E+00	8.620E-10	0.000E+00	1.260E-12
BR-83	0.000E+00	0.000E+00	0.000E+00	0.000E+00	0.000E+00	0.000E+00	0.000E+00	4.400E-01
BR-84	0.000E+00	0.000E+00	0.000E+00	0.000E+00	0.000E+00	0.000E+00	0.000E+00	6.510E-23
BR-85	0.000E+00	0.000E+00	0.000E+00	0.000E+00	0.000E+00	0.000E+00	0.000E+00	0.000E+00
RB-86	0.000E+00	8.770E+09	0.000E+00	0.000E+00	0.000E+00	5.640E+08	0.000E+00	5.390E+09
RB-88	0.000E+00	7.160E-45	0.000E+00	0.000E+00	0.000E+00	3.510E-46	0.000E+00	4.970E-45
RB-89	0.000E+00	1.340E-52	0.000E+00	0.000E+00	0.000E+00	1.170E-54	0.000E+00	1.190E-52
SR-89	6.620E+09	0.000E+00	0.000E+00	0.000E+00	0.000E+00	2.560E+08	0.000E+00	1.890E+08
SR-90	1.120E+11	0.000E+00	0.000E+00	0.000E+00	0.000E+00	1.510E+09	0.000E+00	2.830E+10
SR-91	1.300E+05	0.000E+00	0.000E+00	0.000E+00	0.000E+00	2.880E+05	0.000E+00	4.920E+03

Catawba Nuclear Station Units 1 & 2
Period 1/1/2016 - 12/31/2016

Catawba Nuclear Station
Offsite Dose Calculation Manual (ODCM)

APPENDIX I

R_i Child Dose Factors for use in the Gaseous Dose Calculations

Agegroup:	CHILD	Pathway:	Grs/Cow/Milk (CMILK)			Units:	m²·mrem/yr / μCi/sec; mrem/yr / μCi/m³ (H-3, C-14)	
Nuclide	Bone	Liver	Thyroid	Kidney	Lung	Gilli	Skin	Total Body
SR-92	2.180E+00	0.000E+00	0.000E+00	0.000E+00	0.000E+00	4.130E+01	0.000E+00	8.750E-02
Y-90	3.220E+02	0.000E+00	0.000E+00	0.000E+00	0.000E+00	9.170E+05	0.000E+00	8.620E+00
Y-91	3.900E+04	0.000E+00	0.000E+00	0.000E+00	0.000E+00	5.200E+06	0.000E+00	1.040E+03
Y-91M	2.670E-19	0.000E+00	0.000E+00	0.000E+00	0.000E+00	5.240E-16	0.000E+00	9.730E-21
Y-92	2.530E-04	0.000E+00	0.000E+00	0.000E+00	0.000E+00	7.310E+00	0.000E+00	7.240E-06
Y-93	1.010E+00	0.000E+00	0.000E+00	0.000E+00	0.000E+00	1.510E+04	0.000E+00	2.780E-02
ZR-95	3.830E+03	8.420E+02	0.000E+00	1.210E+03	0.000E+00	8.790E+05	0.000E+00	7.500E+02
ZR-97	1.920E+00	2.770E-01	0.000E+00	3.980E-01	0.000E+00	4.200E+04	0.000E+00	1.640E-01
NB-95	3.180E+05	1.240E+05	0.000E+00	1.160E+05	0.000E+00	2.290E+08	0.000E+00	8.840E+04
MO-99	0.000E+00	8.140E+07	0.000E+00	1.740E+08	0.000E+00	6.730E+07	0.000E+00	2.010E+07
TC-99M	1.320E+01	2.590E+01	0.000E+00	3.760E+02	1.320E+01	1.470E+04	0.000E+00	4.290E+02
TC-101	1.160E-59	1.220E-59	0.000E+00	2.080E-58	6.440E-60	3.870E-59	0.000E+00	1.540E-58
RU-103	4.280E+03	0.000E+00	0.000E+00	1.080E+04	0.000E+00	1.110E+05	0.000E+00	1.650E+03
RU-105	3.820E-03	0.000E+00	0.000E+00	3.360E-02	0.000E+00	2.490E+00	0.000E+00	1.390E-03
RU-106	9.240E+04	0.000E+00	0.000E+00	1.250E+05	0.000E+00	1.440E+06	0.000E+00	1.150E+04
AG-110M	2.090E+08	1.410E+08	0.000E+00	2.630E+08	0.000E+00	1.680E+10	0.000E+00	1.130E+08
TE-125M	7.380E+07	2.000E+07	2.070E+07	0.000E+00	0.000E+00	7.120E+07	0.000E+00	9.840E+06
TE-127	2.980E+03	8.020E+02	2.060E+03	8.470E+03	0.000E+00	1.160E+05	0.000E+00	6.380E+02
TE-127M	2.080E+08	5.600E+07	4.970E+07	5.930E+08	0.000E+00	1.680E+08	0.000E+00	2.470E+07
TE-129	1.280E-09	3.580E-10	9.160E-10	3.750E-09	0.000E+00	7.990E-08	0.000E+00	3.050E-10
TE-129M	2.710E+08	7.580E+07	8.750E+07	7.970E+08	0.000E+00	3.310E+08	0.000E+00	4.210E+07
TE-131	1.620E-32	4.920E-33	1.240E-32	4.890E-32	0.000E+00	8.490E-32	0.000E+00	4.810E-33
TE-131M	1.600E+06	5.530E+05	1.140E+06	5.350E+06	0.000E+00	2.240E+07	0.000E+00	5.890E+05
TE-132	1.020E+07	4.530E+06	6.600E+06	4.210E+07	0.000E+00	4.570E+07	0.000E+00	5.480E+06
I-130	1.730E+06	3.490E+06	3.840E+08	5.220E+06	0.000E+00	1.630E+06	0.000E+00	1.800E+06

Catawba Nuclear Station Units 1 & 2
Period 1/1/2016 - 12/31/2016

Catawba Nuclear Station
Offsite Dose Calculation Manual (ODCM)

APPENDIX I

R_i Child Dose Factors for use in the Gaseous Dose Calculations

Agegroup:	CHILD		Pathway:			Units:	m ² ·mrem/yr / μCi/sec; mrem/yr / μCi/m ³ (H-3, C-14)	
	Nuclide	Bone	Liver	Thyroid	Kidney		Lung	Gilli
I-131	1.300E+09	1.310E+09	4.330E+11	2.150E+09	0.000E+00	1.170E+08	0.000E+00	7.450E+08
I-132	6.890E-01	1.270E+00	5.870E+01	1.940E+00	0.000E+00	1.490E+00	0.000E+00	5.820E-01
I-133	1.720E+07	2.120E+07	3.940E+09	3.540E+07	0.000E+00	8.560E+06	0.000E+00	8.030E+06
I-134	8.480E-12	1.570E-11	3.620E-10	2.410E-11	0.000E+00	1.040E-11	0.000E+00	7.250E-12
I-135	5.400E+04	9.720E+04	8.610E+06	1.490E+05	0.000E+00	7.400E+04	0.000E+00	4.600E+04
CS-134	2.260E+10	3.720E+10	0.000E+00	1.150E+10	4.130E+09	2.000E+08	0.000E+00	7.840E+09
CS-136	1.010E+09	2.780E+09	0.000E+00	1.480E+09	2.210E+08	9.770E+07	0.000E+00	1.800E+09
CS-137	3.220E+10	3.090E+10	0.000E+00	1.010E+10	3.620E+09	1.930E+08	0.000E+00	4.550E+09
CS-138	3.980E-23	5.530E-23	0.000E+00	3.890E-23	4.190E-24	2.550E-23	0.000E+00	3.510E-23
BA-139	2.010E-07	1.070E-10	0.000E+00	9.360E-11	6.300E-11	1.160E-05	0.000E+00	5.820E-09
BA-140	1.170E+08	1.030E+05	0.000E+00	3.340E+04	6.120E+04	5.930E+07	0.000E+00	6.840E+06
BA-141	1.850E-45	1.040E-48	0.000E+00	8.960E-49	6.090E-48	1.050E-45	0.000E+00	6.020E-47
BA-142	1.150E-79	8.310E-83	0.000E+00	6.720E-83	4.890E-83	1.510E-81	0.000E+00	6.450E-81
LA-140	1.940E+01	6.780E+00	0.000E+00	0.000E+00	0.000E+00	1.890E+05	0.000E+00	2.290E+00
LA-142	8.100E-11	2.580E-11	0.000E+00	0.000E+00	0.000E+00	5.120E-06	0.000E+00	8.090E-12
CE-141	2.190E+04	1.090E+04	0.000E+00	4.780E+03	0.000E+00	1.360E+07	0.000E+00	1.620E+03
CE-143	1.870E+02	1.020E+05	0.000E+00	4.260E+01	0.000E+00	1.490E+06	0.000E+00	1.470E+01
CE-144	1.620E+06	5.090E+05	0.000E+00	2.820E+05	0.000E+00	1.330E+08	0.000E+00	8.660E+04
PR-143	7.180E+02	2.160E+02	0.000E+00	1.170E+02	0.000E+00	7.750E+05	0.000E+00	3.560E+01
PR-144	2.680E-53	8.290E-54	0.000E+00	4.380E-54	0.000E+00	1.780E-50	0.000E+00	1.350E-54
ND-147	4.450E+02	3.600E+02	0.000E+00	1.980E+02	0.000E+00	5.700E+05	0.000E+00	2.790E+01
W-187	2.890E+04	1.710E+04	0.000E+00	0.000E+00	0.000E+00	2.400E+06	0.000E+00	7.670E+03
NP-239	1.720E+01	1.240E+00	0.000E+00	3.580E+00	0.000E+00	9.170E+04	0.000E+00	8.710E-01

Catawba Nuclear Station Units 1 & 2
Period 1/1/2016 - 12/31/2016

Catawba Nuclear Station
Offsite Dose Calculation Manual (ODCM)

APPENDIX I

R_i Child Dose Factors for use in the Gaseous Dose Calculations

Agegroup:	CHILD	Pathway:	Grs/Goat/Milk (GMILK)			Units:	m²·mrem/yr / μCi/sec; mrem/yr / μCi/m³ (H-3, C-14)	
Nuclide	Bone	Liver	Thyroid	Kidney	Lung	Gilli	Skin	Total Body
H-3	0.000E+00	3.200E+03	3.200E+03	3.200E+03	3.200E+03	3.200E+03	0.000E+00	3.200E+03
C-14	1.020E+05	2.040E+04	2.040E+04	2.040E+04	2.040E+04	2.040E+04	0.000E+00	2.040E+04
NA-24	1.060E+06	1.060E+06	1.060E+06	1.060E+06	1.060E+06	1.060E+06	0.000E+00	1.060E+06
P-32	9.330E+10	4.370E+09	0.000E+00	0.000E+00	0.000E+00	2.580E+09	0.000E+00	3.600E+09
CR-51	0.000E+00	0.000E+00	6.780E+03	1.850E+03	1.240E+04	6.480E+05	0.000E+00	1.220E+04
MN-54	0.000E+00	2.520E+06	0.000E+00	7.060E+05	0.000E+00	2.110E+06	0.000E+00	6.700E+05
MN-56	0.000E+00	1.520E-03	0.000E+00	1.840E-03	0.000E+00	2.200E-01	0.000E+00	3.430E-04
FE-55	1.450E+06	7.710E+05	0.000E+00	0.000E+00	4.360E+05	1.430E+05	0.000E+00	2.390E+05
FE-59	1.560E+06	2.530E+06	0.000E+00	0.000E+00	7.330E+05	2.630E+06	0.000E+00	1.260E+06
CO-58	0.000E+00	1.450E+06	0.000E+00	0.000E+00	0.000E+00	8.490E+06	0.000E+00	4.450E+06
CO-60	0.000E+00	5.180E+06	0.000E+00	0.000E+00	0.000E+00	2.870E+07	0.000E+00	1.530E+07
NI-63	3.560E+09	1.900E+08	0.000E+00	0.000E+00	0.000E+00	1.280E+07	0.000E+00	1.210E+08
NI-65	1.990E-01	1.870E-02	0.000E+00	0.000E+00	0.000E+00	2.290E+00	0.000E+00	1.090E-02
CU-64	0.000E+00	8.320E+03	0.000E+00	2.010E+04	0.000E+00	3.900E+05	0.000E+00	5.020E+03
ZN-65	4.960E+08	1.320E+09	0.000E+00	8.330E+08	0.000E+00	2.320E+08	0.000E+00	8.220E+08
ZN-69	1.140E-12	1.640E-12	0.000E+00	9.960E-13	0.000E+00	1.030E-10	0.000E+00	1.520E-13
BR-83	0.000E+00	0.000E+00	0.000E+00	0.000E+00	0.000E+00	0.000E+00	0.000E+00	5.280E-02
BR-84	0.000E+00	0.000E+00	0.000E+00	0.000E+00	0.000E+00	0.000E+00	0.000E+00	7.820E-24
BR-85	0.000E+00	0.000E+00	0.000E+00	0.000E+00	0.000E+00	0.000E+00	0.000E+00	0.000E+00
RB-86	0.000E+00	1.050E+09	0.000E+00	0.000E+00	0.000E+00	6.770E+07	0.000E+00	6.470E+08
RB-88	0.000E+00	8.590E-46	0.000E+00	0.000E+00	0.000E+00	4.210E-47	0.000E+00	5.970E-46
RB-89	0.000E+00	1.610E-53	0.000E+00	0.000E+00	0.000E+00	1.410E-55	0.000E+00	1.430E-53
SR-89	1.390E+10	0.000E+00	0.000E+00	0.000E+00	0.000E+00	5.380E+08	0.000E+00	3.970E+08
SR-90	2.350E+11	0.000E+00	0.000E+00	0.000E+00	0.000E+00	3.160E+09	0.000E+00	5.950E+10
SR-91	2.740E+05	0.000E+00	0.000E+00	0.000E+00	0.000E+00	6.040E+05	0.000E+00	1.030E+04

Catawba Nuclear Station Units 1 & 2
Period 1/1/2016 - 12/31/2016

Catawba Nuclear Station
Offsite Dose Calculation Manual (ODCM)

APPENDIX I

R_i Child Dose Factors for use in the Gaseous Dose Calculations

Agegroup:	CHILD	Pathway:	Grs/Goat/Milk (GMILK)			Units:	m ² ·mrem/yr / μCi/sec; mrem/yr / μCi/m ³ (H-3, C-14)	
Nuclide	Bone	Liver	Thyroid	Kidney	Lung	Gilli	Skin	Total Body
SR-92	4.580E+00	0.000E+00	0.000E+00	0.000E+00	0.000E+00	8.680E+01	0.000E+00	1.840E-01
Y-90	3.870E+01	0.000E+00	0.000E+00	0.000E+00	0.000E+00	1.100E+05	0.000E+00	1.030E+00
Y-91	4.680E+03	0.000E+00	0.000E+00	0.000E+00	0.000E+00	6.240E+05	0.000E+00	1.250E+02
Y-91M	3.210E-20	0.000E+00	0.000E+00	0.000E+00	0.000E+00	6.280E-17	0.000E+00	1.170E-21
Y-92	3.040E-05	0.000E+00	0.000E+00	0.000E+00	0.000E+00	8.770E-01	0.000E+00	8.690E-07
Y-93	1.210E-01	0.000E+00	0.000E+00	0.000E+00	0.000E+00	1.810E+03	0.000E+00	3.330E-03
ZR-95	4.600E+02	1.010E+02	0.000E+00	1.450E+02	0.000E+00	1.050E+05	0.000E+00	9.000E+01
ZR-97	2.300E-01	3.330E-02	0.000E+00	4.780E-02	0.000E+00	5.040E+03	0.000E+00	1.960E-02
NB-95	3.810E+04	1.490E+04	0.000E+00	1.400E+04	0.000E+00	2.750E+07	0.000E+00	1.060E+04
MO-99	0.000E+00	9.760E+06	0.000E+00	2.090E+07	0.000E+00	8.080E+06	0.000E+00	2.420E+06
TC-99M	1.590E+00	3.110E+00	0.000E+00	4.520E+01	1.580E+00	1.770E+03	0.000E+00	5.150E+01
TC-101	1.400E-60	1.460E-60	0.000E+00	2.490E-59	7.720E-61	4.640E-60	0.000E+00	1.850E-59
RU-103	5.140E+02	0.000E+00	0.000E+00	1.290E+03	0.000E+00	1.330E+04	0.000E+00	1.980E+02
RU-105	4.580E-04	0.000E+00	0.000E+00	4.030E-03	0.000E+00	2.990E-01	0.000E+00	1.660E-04
RU-106	1.110E+04	0.000E+00	0.000E+00	1.500E+04	0.000E+00	1.720E+05	0.000E+00	1.380E+03
AG-110M	2.510E+07	1.690E+07	0.000E+00	3.150E+07	0.000E+00	2.010E+09	0.000E+00	1.350E+07
TE-125M	8.850E+06	2.400E+06	2.480E+06	0.000E+00	0.000E+00	8.540E+06	0.000E+00	1.180E+06
TE-127	3.570E+02	9.630E+01	2.470E+02	1.020E+03	0.000E+00	1.390E+04	0.000E+00	7.660E+01
TE-127M	2.500E+07	6.720E+06	5.970E+06	7.120E+07	0.000E+00	2.020E+07	0.000E+00	2.960E+06
TE-129	1.540E-10	4.300E-11	1.100E-10	4.510E-10	0.000E+00	9.590E-09	0.000E+00	3.660E-11
TE-129M	3.260E+07	9.090E+06	1.050E+07	9.560E+07	0.000E+00	3.970E+07	0.000E+00	5.060E+06
TE-131	1.940E-33	5.910E-34	1.480E-33	5.860E-33	0.000E+00	1.020E-32	0.000E+00	5.770E-34
TE-131M	1.920E+05	6.640E+04	1.360E+05	6.420E+05	0.000E+00	2.690E+06	0.000E+00	7.060E+04
TE-132	1.230E+06	5.440E+05	7.920E+05	5.050E+06	0.000E+00	5.480E+06	0.000E+00	6.570E+05
I-130	2.070E+06	4.190E+06	4.610E+08	6.260E+06	0.000E+00	1.960E+06	0.000E+00	2.160E+06

Catawba Nuclear Station Units 1 & 2
Period 1/1/2016 - 12/31/2016

Catawba Nuclear Station
Offsite Dose Calculation Manual (ODCM)

APPENDIX I

R_i Child Dose Factors for use in the Gaseous Dose Calculations

Agegroup:	CHILD	Pathway:	Grs/Goat/Milk (GMILK)			Units:	m²·mrem/yr / μCi/sec; mrem/yr / μCi/m³ (H-3, C-14)	
Nuclide	Bone	Liver	Thyroid	Kidney	Lung	Gilli	Skin	Total Body
I-131	1.560E+09	1.570E+09	5.200E+11	2.580E+09	0.000E+00	1.400E+08	0.000E+00	8.940E+08
I-132	8.270E-01	1.520E+00	7.050E+01	2.330E+00	0.000E+00	1.790E+00	0.000E+00	6.990E-01
I-133	2.060E+07	2.550E+07	4.730E+09	4.250E+07	0.000E+00	1.030E+07	0.000E+00	9.640E+06
I-134	1.020E-11	1.890E-11	4.350E-10	2.890E-11	0.000E+00	1.250E-11	0.000E+00	8.700E-12
I-135	6.480E+04	1.170E+05	1.030E+07	1.790E+05	0.000E+00	8.880E+04	0.000E+00	5.520E+04
CS-134	6.790E+10	1.110E+11	0.000E+00	3.450E+10	1.240E+10	6.010E+08	0.000E+00	2.350E+10
CS-136	3.030E+09	8.340E+09	0.000E+00	4.440E+09	6.630E+08	2.930E+08	0.000E+00	5.400E+09
CS-137	9.670E+10	9.260E+10	0.000E+00	3.020E+10	1.090E+10	5.800E+08	0.000E+00	1.370E+10
CS-138	1.190E-22	1.660E-22	0.000E+00	1.170E-22	1.260E-23	7.640E-23	0.000E+00	1.050E-22
BA-139	2.410E-08	1.290E-11	0.000E+00	1.120E-11	7.560E-12	1.390E-06	0.000E+00	6.980E-10
BA-140	1.410E+07	1.230E+04	0.000E+00	4.010E+03	7.340E+03	7.120E+06	0.000E+00	8.200E+05
BA-141	2.220E-46	1.240E-49	0.000E+00	1.080E-49	7.300E-49	1.270E-46	0.000E+00	7.230E-48
BA-142	1.390E-80	9.970E-84	0.000E+00	8.070E-84	5.870E-84	1.810E-82	0.000E+00	7.740E-82
LA-140	2.330E+00	8.140E-01	0.000E+00	0.000E+00	0.000E+00	2.270E+04	0.000E+00	2.740E-01
LA-142	9.730E-12	3.100E-12	0.000E+00	0.000E+00	0.000E+00	6.140E-07	0.000E+00	9.710E-13
CE-141	2.620E+03	1.310E+03	0.000E+00	5.740E+02	0.000E+00	1.630E+06	0.000E+00	1.940E+02
CE-143	2.250E+01	1.220E+04	0.000E+00	5.120E+00	0.000E+00	1.790E+05	0.000E+00	1.770E+00
CE-144	1.950E+05	6.110E+04	0.000E+00	3.380E+04	0.000E+00	1.590E+07	0.000E+00	1.040E+04
PR-143	8.620E+01	2.590E+01	0.000E+00	1.400E+01	0.000E+00	9.300E+04	0.000E+00	4.280E+00
PR-144	3.220E-54	9.950E-55	0.000E+00	5.260E-55	0.000E+00	2.140E-51	0.000E+00	1.620E-55
ND-147	5.330E+01	4.320E+01	0.000E+00	2.370E+01	0.000E+00	6.850E+04	0.000E+00	3.350E+00
W-187	3.470E+03	2.050E+03	0.000E+00	0.000E+00	0.000E+00	2.880E+05	0.000E+00	9.210E+02
NP-239	2.070E+00	1.490E-01	0.000E+00	4.300E-01	0.000E+00	1.100E+04	0.000E+00	1.040E-01

Catawba Nuclear Station Units 1 & 2
Period 1/1/2016 - 12/31/2016

Catawba Nuclear Station
Offsite Dose Calculation Manual (ODCM)

APPENDIX I

R_i Child Dose Factors for use in the Gaseous Dose Calculations

Agegroup:	CHILD	Pathway:	Grs/Cow/Meat (CMEAT)			Units:	m²·mrem/yr / μCi/sec; mrem/yr / μCi/m³ (H-3, C-14)	
Nuclide	Bone	Liver	Thyroid	Kidney	Lung	Gilli	Skin	Total Body
H-3	0.000E+00	2.340E+02	2.340E+02	2.340E+02	2.340E+02	2.340E+02	0.000E+00	2.340E+02
C-14	3.280E+04	6.560E+03	6.560E+03	6.560E+03	6.560E+03	6.560E+03	0.000E+00	6.560E+03
NA-24	1.720E-03	1.720E-03	1.720E-03	1.720E-03	1.720E-03	1.720E-03	0.000E+00	1.720E-03
P-32	7.420E+09	3.470E+08	0.000E+00	0.000E+00	0.000E+00	2.050E+08	0.000E+00	2.860E+08
CR-51	0.000E+00	0.000E+00	4.880E+03	1.330E+03	8.910E+03	4.660E+05	0.000E+00	8.790E+03
MN-54	0.000E+00	8.010E+06	0.000E+00	2.250E+06	0.000E+00	6.720E+06	0.000E+00	2.130E+06
MN-56	0.000E+00	1.430E-53	0.000E+00	1.730E-53	0.000E+00	2.070E-51	0.000E+00	3.230E-54
FE-55	4.570E+08	2.420E+08	0.000E+00	0.000E+00	1.370E+08	4.490E+07	0.000E+00	7.510E+07
FE-59	3.760E+08	6.090E+08	0.000E+00	0.000E+00	1.770E+08	6.340E+08	0.000E+00	3.030E+08
CO-58	0.000E+00	1.640E+07	0.000E+00	0.000E+00	0.000E+00	9.580E+07	0.000E+00	5.020E+07
CO-60	0.000E+00	6.930E+07	0.000E+00	0.000E+00	0.000E+00	3.840E+08	0.000E+00	2.040E+08
NI-63	2.910E+10	1.560E+09	0.000E+00	0.000E+00	0.000E+00	1.050E+08	0.000E+00	9.910E+08
NI-65	3.520E-52	3.310E-53	0.000E+00	0.000E+00	0.000E+00	4.060E-51	0.000E+00	1.930E-53
CU-64	0.000E+00	2.970E-07	0.000E+00	7.180E-07	0.000E+00	1.390E-05	0.000E+00	1.800E-07
ZN-65	3.750E+08	1.000E+09	0.000E+00	6.300E+08	0.000E+00	1.760E+08	0.000E+00	6.220E+08
ZN-69	0.000E+00	0.000E+00	0.000E+00	0.000E+00	0.000E+00	0.000E+00	0.000E+00	0.000E+00
BR-83	0.000E+00	0.000E+00	0.000E+00	0.000E+00	0.000E+00	0.000E+00	0.000E+00	9.520E-57
BR-84	0.000E+00	0.000E+00	0.000E+00	0.000E+00	0.000E+00	0.000E+00	0.000E+00	0.000E+00
BR-85	0.000E+00	0.000E+00	0.000E+00	0.000E+00	0.000E+00	0.000E+00	0.000E+00	0.000E+00
RB-86	0.000E+00	5.770E+08	0.000E+00	0.000E+00	0.000E+00	3.710E+07	0.000E+00	3.550E+08
RB-88	0.000E+00	0.000E+00	0.000E+00	0.000E+00	0.000E+00	0.000E+00	0.000E+00	0.000E+00
RB-89	0.000E+00	0.000E+00	0.000E+00	0.000E+00	0.000E+00	0.000E+00	0.000E+00	0.000E+00
SR-89	4.820E+08	0.000E+00	0.000E+00	0.000E+00	0.000E+00	1.870E+07	0.000E+00	1.380E+07
SR-90	1.040E+10	0.000E+00	0.000E+00	0.000E+00	0.000E+00	1.400E+08	0.000E+00	2.640E+09
SR-91	2.400E-10	0.000E+00	0.000E+00	0.000E+00	0.000E+00	5.300E-10	0.000E+00	9.050E-12

Catawba Nuclear Station Units 1 & 2
Period 1/1/2016 - 12/31/2016

Catawba Nuclear Station
Offsite Dose Calculation Manual (ODCM)

APPENDIX I

R_i Child Dose Factors for use in the Gaseous Dose Calculations

Agegroup:	CHILD	Pathway:	Grs/Cow/Meat (CMEAT)			Units:	m²·mrem/yr / μCi/sec; mrem/yr / μCi/m³ (H-3, C-14)	
Nuclide	Bone	Liver	Thyroid	Kidney	Lung	Gilli	Skin	Total Body
SR-92	1.850E-49	0.000E+00	0.000E+00	0.000E+00	0.000E+00	3.490E-48	0.000E+00	7.400E-51
Y-90	1.710E+02	0.000E+00	0.000E+00	0.000E+00	0.000E+00	4.880E+05	0.000E+00	4.590E+00
Y-91	1.800E+06	0.000E+00	0.000E+00	0.000E+00	0.000E+00	2.400E+08	0.000E+00	4.820E+04
Y-91M	0.000E+00	0.000E+00	0.000E+00	0.000E+00	0.000E+00	0.000E+00	0.000E+00	0.000E+00
Y-92	2.410E-39	0.000E+00	0.000E+00	0.000E+00	0.000E+00	6.960E-35	0.000E+00	6.890E-41
Y-93	7.440E-12	0.000E+00	0.000E+00	0.000E+00	0.000E+00	1.110E-07	0.000E+00	2.040E-13
ZR-95	2.660E+06	5.850E+05	0.000E+00	8.380E+05	0.000E+00	6.110E+08	0.000E+00	5.210E+05
ZR-97	3.200E-05	4.630E-06	0.000E+00	6.650E-06	0.000E+00	7.010E-01	0.000E+00	2.730E-06
NB-95	3.100E+06	1.210E+06	0.000E+00	1.130E+06	0.000E+00	2.230E+09	0.000E+00	8.620E+05
MO-99	0.000E+00	1.150E+05	0.000E+00	2.460E+05	0.000E+00	9.510E+04	0.000E+00	2.840E+04
TC-99M	6.190E-21	1.210E-20	0.000E+00	1.760E-19	6.160E-21	6.910E-18	0.000E+00	2.010E-19
TC-101	0.000E+00	0.000E+00	0.000E+00	0.000E+00	0.000E+00	0.000E+00	0.000E+00	0.000E+00
RU-103	1.550E+08	0.000E+00	0.000E+00	3.900E+08	0.000E+00	4.010E+09	0.000E+00	5.960E+07
RU-105	9.020E-28	0.000E+00	0.000E+00	7.930E-27	0.000E+00	5.890E-25	0.000E+00	3.270E-28
RU-106	4.440E+09	0.000E+00	0.000E+00	5.990E+09	0.000E+00	6.900E+10	0.000E+00	5.540E+08
AG-110M	8.390E+06	5.670E+06	0.000E+00	1.060E+07	0.000E+00	6.740E+08	0.000E+00	4.530E+06
TE-125M	5.690E+08	1.540E+08	1.600E+08	0.000E+00	0.000E+00	5.490E+08	0.000E+00	7.590E+07
TE-127	3.380E-10	9.120E-11	2.340E-10	9.630E-10	0.000E+00	1.320E-08	0.000E+00	7.260E-11
TE-127M	1.770E+09	4.780E+08	4.240E+08	5.060E+09	0.000E+00	1.440E+09	0.000E+00	2.110E+08
TE-129	0.000E+00	0.000E+00	0.000E+00	0.000E+00	0.000E+00	0.000E+00	0.000E+00	0.000E+00
TE-129M	1.790E+09	5.000E+08	5.770E+08	5.260E+09	0.000E+00	2.180E+09	0.000E+00	2.780E+08
TE-131	0.000E+00	0.000E+00	0.000E+00	0.000E+00	0.000E+00	0.000E+00	0.000E+00	0.000E+00
TE-131M	7.000E+02	2.420E+02	4.980E+02	2.340E+03	0.000E+00	9.820E+03	0.000E+00	2.580E+02
TE-132	2.120E+06	9.380E+05	1.370E+06	8.710E+06	0.000E+00	9.450E+06	0.000E+00	1.130E+06
I-130	3.030E-06	6.130E-06	6.750E-04	9.160E-06	0.000E+00	2.870E-06	0.000E+00	3.160E-06

Catawba Nuclear Station Units 1 & 2
Period 1/1/2016 - 12/31/2016

Catawba Nuclear Station
Offsite Dose Calculation Manual (ODCM)

APPENDIX I

R_i Child Dose Factors for use in the Gaseous Dose Calculations

Agegroup:	CHILD	Pathway:	Grs/Cow/Meat (CMEAT)			Units:	m²·mrem/yr / μCi/sec; mrem/yr / μCi/m³ (H-3, C-14)	
Nuclide	Bone	Liver	Thyroid	Kidney	Lung	Gilli	Skin	Total Body
I-131	1.650E+07	1.660E+07	5.500E+09	2.730E+07	0.000E+00	1.480E+06	0.000E+00	9.460E+06
I-132	1.020E-58	1.880E-58	8.730E-57	2.880E-58	0.000E+00	2.210E-58	0.000E+00	8.650E-59
I-133	5.670E-01	7.020E-01	1.300E+02	1.170E+00	0.000E+00	2.830E-01	0.000E+00	2.660E-01
I-134	0.000E+00	0.000E+00	0.000E+00	0.000E+00	0.000E+00	0.000E+00	0.000E+00	0.000E+00
I-135	6.510E-17	1.170E-16	1.040E-14	1.800E-16	0.000E+00	8.930E-17	0.000E+00	5.550E-17
CS-134	9.220E+08	1.510E+09	0.000E+00	4.690E+08	1.680E+08	8.160E+06	0.000E+00	3.190E+08
CS-136	1.620E+07	4.460E+07	0.000E+00	2.370E+07	3.540E+06	1.570E+06	0.000E+00	2.880E+07
CS-137	1.330E+09	1.280E+09	0.000E+00	4.160E+08	1.500E+08	7.990E+06	0.000E+00	1.880E+08
CS-138	0.000E+00	0.000E+00	0.000E+00	0.000E+00	0.000E+00	0.000E+00	0.000E+00	0.000E+00
BA-139	0.000E+00	0.000E+00	0.000E+00	0.000E+00	0.000E+00	0.000E+00	0.000E+00	0.000E+00
BA-140	4.380E+07	3.840E+04	0.000E+00	1.250E+04	2.290E+04	2.220E+07	0.000E+00	2.560E+06
BA-141	0.000E+00	0.000E+00	0.000E+00	0.000E+00	0.000E+00	0.000E+00	0.000E+00	0.000E+00
BA-142	0.000E+00	0.000E+00	0.000E+00	0.000E+00	0.000E+00	0.000E+00	0.000E+00	0.000E+00
LA-140	5.590E-02	1.950E-02	0.000E+00	0.000E+00	0.000E+00	5.440E+02	0.000E+00	6.580E-03
LA-142	5.300E-92	1.690E-92	0.000E+00	0.000E+00	0.000E+00	3.350E-87	0.000E+00	5.290E-93
CE-141	2.220E+04	1.110E+04	0.000E+00	4.850E+03	0.000E+00	1.380E+07	0.000E+00	1.640E+03
CE-143	3.170E-02	1.720E+01	0.000E+00	7.210E-03	0.000E+00	2.520E+02	0.000E+00	2.490E-03
CE-144	2.320E+06	7.260E+05	0.000E+00	4.020E+05	0.000E+00	1.890E+08	0.000E+00	1.240E+05
PR-143	3.340E+04	1.000E+04	0.000E+00	5.430E+03	0.000E+00	3.600E+07	0.000E+00	1.660E+03
PR-144	0.000E+00	0.000E+00	0.000E+00	0.000E+00	0.000E+00	0.000E+00	0.000E+00	0.000E+00
ND-147	1.170E+04	9.470E+03	0.000E+00	5.190E+03	0.000E+00	1.500E+07	0.000E+00	7.330E+02
W-187	3.210E-02	1.900E-02	0.000E+00	0.000E+00	0.000E+00	2.670E+00	0.000E+00	8.530E-03
NP-239	4.260E-01	3.060E-02	0.000E+00	8.850E-02	0.000E+00	2.260E+03	0.000E+00	2.150E-02

Catawba Nuclear Station Units 1 & 2
Period 1/1/2016 - 12/31/2016

Catawba Nuclear Station
Offsite Dose Calculation Manual (ODCM)

APPENDIX I

R_i Child Dose Factors for use in the Gaseous Dose Calculations

Agegroup:	CHILD	Pathway:	Vegetation (VEG)			Units:	m²·mrem/yr / μCi/sec; mrem/yr / μCi/m³ (H-3, C-14)	
Nuclide	Bone	Liver	Thyroid	Kidney	Lung	Gilli	Skin	Total Body
H-3	0.000E+00	4.010E+03	4.010E+03	4.010E+03	4.010E+03	4.010E+03	0.000E+00	4.010E+03
C-14	2.170E+05	4.340E+04	4.340E+04	4.340E+04	4.340E+04	4.340E+04	0.000E+00	4.340E+04
NA-24	3.730E+05	3.730E+05	3.730E+05	3.730E+05	3.730E+05	3.730E+05	0.000E+00	3.730E+05
P-32	3.370E+09	1.580E+08	0.000E+00	0.000E+00	0.000E+00	9.310E+07	0.000E+00	1.300E+08
CR-51	0.000E+00	0.000E+00	6.500E+04	1.780E+04	1.190E+05	6.210E+06	0.000E+00	1.170E+05
MN-54	0.000E+00	6.650E+08	0.000E+00	1.860E+08	0.000E+00	5.580E+08	0.000E+00	1.770E+08
MN-56	0.000E+00	1.860E+01	0.000E+00	2.250E+01	0.000E+00	2.700E+03	0.000E+00	4.200E+00
FE-55	8.010E+08	4.250E+08	0.000E+00	0.000E+00	2.400E+08	7.870E+07	0.000E+00	1.320E+08
FE-59	3.980E+08	6.430E+08	0.000E+00	0.000E+00	1.860E+08	6.700E+08	0.000E+00	3.200E+08
CO-58	0.000E+00	6.440E+07	0.000E+00	0.000E+00	0.000E+00	3.760E+08	0.000E+00	1.970E+08
CO-60	0.000E+00	3.780E+08	0.000E+00	0.000E+00	0.000E+00	2.100E+09	0.000E+00	1.120E+09
NI-63	3.950E+10	2.110E+09	0.000E+00	0.000E+00	0.000E+00	1.420E+08	0.000E+00	1.340E+09
NI-65	1.050E+02	9.890E+00	0.000E+00	0.000E+00	0.000E+00	1.210E+03	0.000E+00	5.770E+00
CU-64	0.000E+00	1.100E+04	0.000E+00	2.660E+04	0.000E+00	5.160E+05	0.000E+00	6.640E+03
ZN-65	8.130E+08	2.160E+09	0.000E+00	1.360E+09	0.000E+00	3.800E+08	0.000E+00	1.350E+09
ZN-69	9.490E-06	1.370E-05	0.000E+00	8.320E-06	0.000E+00	8.640E-04	0.000E+00	1.270E-06
BR-83	0.000E+00	0.000E+00	0.000E+00	0.000E+00	0.000E+00	0.000E+00	0.000E+00	5.370E+00
BR-84	0.000E+00	0.000E+00	0.000E+00	0.000E+00	0.000E+00	0.000E+00	0.000E+00	3.820E-11
BR-85	0.000E+00	0.000E+00	0.000E+00	0.000E+00	0.000E+00	0.000E+00	0.000E+00	0.000E+00
RB-86	0.000E+00	4.520E+08	0.000E+00	0.000E+00	0.000E+00	2.910E+07	0.000E+00	2.780E+08
RB-88	0.000E+00	4.380E-22	0.000E+00	0.000E+00	0.000E+00	2.150E-23	0.000E+00	3.040E-22
RB-89	0.000E+00	4.610E-26	0.000E+00	0.000E+00	0.000E+00	4.020E-28	0.000E+00	4.090E-26
SR-89	3.600E+10	0.000E+00	0.000E+00	0.000E+00	0.000E+00	1.390E+09	0.000E+00	1.030E+09
SR-90	1.240E+12	0.000E+00	0.000E+00	0.000E+00	0.000E+00	1.670E+10	0.000E+00	3.150E+11
SR-91	5.240E+05	0.000E+00	0.000E+00	0.000E+00	0.000E+00	1.160E+06	0.000E+00	1.980E+04

Catawba Nuclear Station Units 1 & 2
Period 1/1/2016 - 12/31/2016

Catawba Nuclear Station
Offsite Dose Calculation Manual (ODCM)

APPENDIX I

R_i Child Dose Factors for use in the Gaseous Dose Calculations

Agegroup:	CHILD	Pathway:	Vegetation (VEG)			Units:	m ² ·mrem/yr / μCi/sec; mrem/yr / μCi/m ³ (H-3, C-14)	
Nuclide	Bone	Liver	Thyroid	Kidney	Lung	Gilli	Skin	Total Body
SR-92	7.280E+02	0.000E+00	0.000E+00	0.000E+00	0.000E+00	1.380E+04	0.000E+00	2.920E+01
Y-90	2.310E+04	0.000E+00	0.000E+00	0.000E+00	0.000E+00	6.570E+07	0.000E+00	6.180E+02
Y-91	1.860E+07	0.000E+00	0.000E+00	0.000E+00	0.000E+00	2.480E+09	0.000E+00	4.990E+05
Y-91M	8.910E-09	0.000E+00	0.000E+00	0.000E+00	0.000E+00	1.740E-05	0.000E+00	3.240E-10
Y-92	1.580E+00	0.000E+00	0.000E+00	0.000E+00	0.000E+00	4.580E+04	0.000E+00	4.530E-02
Y-93	2.930E+02	0.000E+00	0.000E+00	0.000E+00	0.000E+00	4.370E+06	0.000E+00	8.040E+00
ZR-95	3.860E+06	8.480E+05	0.000E+00	1.210E+06	0.000E+00	8.850E+08	0.000E+00	7.550E+05
ZR-97	5.700E+02	8.240E+01	0.000E+00	1.180E+02	0.000E+00	1.250E+07	0.000E+00	4.860E+01
NB-95	4.110E+05	1.600E+05	0.000E+00	1.500E+05	0.000E+00	2.960E+08	0.000E+00	1.140E+05
MO-99	0.000E+00	7.710E+06	0.000E+00	1.650E+07	0.000E+00	6.380E+06	0.000E+00	1.910E+06
TC-99M	4.710E+00	9.230E+00	0.000E+00	1.340E+02	4.690E+00	5.260E+03	0.000E+00	1.530E+02
TC-101	1.410E-30	1.470E-30	0.000E+00	2.510E-29	7.780E-31	4.680E-30	0.000E+00	1.870E-29
RU-103	1.530E+07	0.000E+00	0.000E+00	3.860E+07	0.000E+00	3.970E+08	0.000E+00	5.900E+06
RU-105	9.160E+01	0.000E+00	0.000E+00	8.050E+02	0.000E+00	5.980E+04	0.000E+00	3.320E+01
RU-106	7.450E+08	0.000E+00	0.000E+00	1.010E+09	0.000E+00	1.160E+10	0.000E+00	9.300E+07
AG-110M	3.210E+07	2.170E+07	0.000E+00	4.040E+07	0.000E+00	2.580E+09	0.000E+00	1.730E+07
TE-125M	3.510E+08	9.500E+07	9.840E+07	0.000E+00	0.000E+00	3.380E+08	0.000E+00	4.670E+07
TE-127	9.850E+03	2.650E+03	6.810E+03	2.800E+04	0.000E+00	3.850E+05	0.000E+00	2.110E+03
TE-127M	1.320E+09	3.560E+08	3.160E+08	3.770E+09	0.000E+00	1.070E+09	0.000E+00	1.570E+08
TE-129	1.320E-03	3.690E-04	9.430E-04	3.870E-03	0.000E+00	8.230E-02	0.000E+00	3.140E-04
TE-129M	8.410E+08	2.350E+08	2.710E+08	2.470E+09	0.000E+00	1.030E+09	0.000E+00	1.310E+08
TE-131	2.570E-15	7.830E-16	1.960E-15	7.770E-15	0.000E+00	1.350E-14	0.000E+00	7.640E-16
TE-131M	1.540E+06	5.330E+05	1.100E+06	5.160E+06	0.000E+00	2.160E+07	0.000E+00	5.680E+05
TE-132	7.000E+06	3.100E+06	4.510E+06	2.880E+07	0.000E+00	3.120E+07	0.000E+00	3.740E+06
I-130	6.160E+05	1.240E+06	1.370E+08	1.860E+06	0.000E+00	5.820E+05	0.000E+00	6.410E+05

Catawba Nuclear Station Units 1 & 2
Period 1/1/2016 - 12/31/2016

Catawba Nuclear Station
Offsite Dose Calculation Manual (ODCM)

APPENDIX I

R_i Child Dose Factors for use in the Gaseous Dose Calculations

Agegroup:	CHILD		Vegetation (VEG)			Units:	m ² ·mrem/yr / μCi/sec; mrem/yr / μCi/m ³ (H-3, C-14)	
	Bone	Liver	Thyroid	Kidney	Lung	Gilli	Skin	Total Body
I-131	1.430E+08	1.440E+08	4.750E+10	2.360E+08	0.000E+00	1.280E+07	0.000E+00	8.170E+07
I-132	9.220E+01	1.690E+02	7.860E+03	2.590E+02	0.000E+00	1.990E+02	0.000E+00	7.790E+01
I-133	3.530E+06	4.370E+06	8.110E+08	7.280E+06	0.000E+00	1.760E+06	0.000E+00	1.650E+06
I-134	1.550E-04	2.880E-04	6.620E-03	4.400E-04	0.000E+00	1.910E-04	0.000E+00	1.320E-04
I-135	6.260E+04	1.130E+05	9.970E+06	1.730E+05	0.000E+00	8.580E+04	0.000E+00	5.330E+04
CS-134	1.600E+10	2.630E+10	0.000E+00	8.150E+09	2.930E+09	1.420E+08	0.000E+00	5.550E+09
CS-136	8.240E+07	2.270E+08	0.000E+00	1.210E+08	1.800E+07	7.960E+06	0.000E+00	1.470E+08
CS-137	2.390E+10	2.290E+10	0.000E+00	7.460E+09	2.680E+09	1.430E+08	0.000E+00	3.380E+09
CS-138	6.570E-11	9.130E-11	0.000E+00	6.430E-11	6.920E-12	4.210E-11	0.000E+00	5.790E-11
BA-139	4.950E-02	2.640E-05	0.000E+00	2.310E-05	1.560E-05	2.860E+00	0.000E+00	1.440E-03
BA-140	2.770E+08	2.420E+05	0.000E+00	7.890E+04	1.450E+05	1.400E+08	0.000E+00	1.610E+07
BA-141	1.990E-21	1.110E-24	0.000E+00	9.620E-25	6.530E-24	1.130E-21	0.000E+00	6.460E-23
BA-142	9.930E-39	7.150E-42	0.000E+00	5.780E-42	4.200E-42	1.300E-40	0.000E+00	5.540E-40
LA-140	3.250E+03	1.130E+03	0.000E+00	0.000E+00	0.000E+00	3.160E+07	0.000E+00	3.820E+02
LA-142	3.360E-04	1.070E-04	0.000E+00	0.000E+00	0.000E+00	2.120E+01	0.000E+00	3.350E-05
CE-141	6.560E+05	3.270E+05	0.000E+00	1.430E+05	0.000E+00	4.080E+08	0.000E+00	4.860E+04
CE-143	1.720E+03	9.310E+05	0.000E+00	3.910E+02	0.000E+00	1.360E+07	0.000E+00	1.350E+02
CE-144	1.270E+08	3.980E+07	0.000E+00	2.210E+07	0.000E+00	1.040E+10	0.000E+00	6.780E+06
PR-143	1.460E+05	4.370E+04	0.000E+00	2.370E+04	0.000E+00	1.570E+08	0.000E+00	7.230E+03
PR-144	5.380E-26	1.660E-26	0.000E+00	8.800E-27	0.000E+00	3.580E-23	0.000E+00	2.710E-27
ND-147	7.150E+04	5.790E+04	0.000E+00	3.180E+04	0.000E+00	9.170E+07	0.000E+00	4.480E+03
W-187	6.430E+04	3.810E+04	0.000E+00	0.000E+00	0.000E+00	5.350E+06	0.000E+00	1.710E+04
NP-239	2.560E+03	1.840E+02	0.000E+00	5.310E+02	0.000E+00	1.360E+07	0.000E+00	1.290E+02

Catawba Nuclear Station Units 1 & 2
Period 1/1/2016 - 12/31/2016

Catawba Nuclear Station
Offsite Dose Calculation Manual (ODCM)

APPENDIX I

R_i Child Dose Factors for use in the Gaseous Dose Calculations

Agegroup:	CHILD	Pathway:	Inhalation (INHL)			Units:	mrem/yr / $\mu\text{Ci}/\text{m}^3$	
Nuclide	Bone	Liver	Thyroid	Kidney	Lung	Gilli	Skin	Total Body
H-3	0.000E+00	1.120E+03	1.120E+03	1.120E+03	1.120E+03	1.120E+03	0.000E+00	1.120E+03
C-14	3.590E+04	6.730E+03	6.730E+03	6.730E+03	6.730E+03	6.730E+03	0.000E+00	6.730E+03
NA-24	1.610E+04	1.610E+04	1.610E+04	1.610E+04	1.610E+04	1.610E+04	0.000E+00	1.610E+04
P-32	2.600E+06	1.140E+05	0.000E+00	0.000E+00	0.000E+00	4.220E+04	0.000E+00	9.880E+04
CR-51	0.000E+00	0.000E+00	8.550E+01	2.430E+01	1.700E+04	1.080E+03	0.000E+00	1.540E+02
MN-54	0.000E+00	4.290E+04	0.000E+00	1.000E+04	1.580E+06	2.290E+04	0.000E+00	9.510E+03
MN-56	0.000E+00	1.660E+00	0.000E+00	1.670E+00	1.310E+04	1.230E+05	0.000E+00	3.120E-01
FE-55	4.740E+04	2.520E+04	0.000E+00	0.000E+00	1.110E+05	2.870E+03	0.000E+00	7.770E+03
FE-59	2.070E+04	3.340E+04	0.000E+00	0.000E+00	1.270E+06	7.070E+04	0.000E+00	1.670E+04
CO-58	0.000E+00	1.770E+03	0.000E+00	0.000E+00	1.110E+06	3.440E+04	0.000E+00	3.160E+03
CO-60	0.000E+00	1.310E+04	0.000E+00	0.000E+00	7.070E+06	9.620E+04	0.000E+00	2.260E+04
NI-63	8.210E+05	4.620E+04	0.000E+00	0.000E+00	2.750E+05	6.330E+03	0.000E+00	2.800E+04
NI-65	2.990E+00	2.960E-01	0.000E+00	0.000E+00	8.180E+03	8.400E+04	0.000E+00	1.640E-01
CU-64	0.000E+00	1.990E+00	0.000E+00	6.030E+00	9.580E+03	3.670E+04	0.000E+00	1.070E+00
ZN-65	4.260E+04	1.130E+05	0.000E+00	7.140E+04	9.950E+05	1.630E+04	0.000E+00	7.030E+04
ZN-69	6.700E-02	9.660E-02	0.000E+00	5.850E-02	1.420E+03	1.020E+04	0.000E+00	8.920E-03
BR-83	0.000E+00	0.000E+00	0.000E+00	0.000E+00	0.000E+00	0.000E+00	0.000E+00	4.740E+02
BR-84	0.000E+00	0.000E+00	0.000E+00	0.000E+00	0.000E+00	0.000E+00	0.000E+00	5.480E+02
BR-85	0.000E+00	0.000E+00	0.000E+00	0.000E+00	0.000E+00	0.000E+00	0.000E+00	2.530E+01
RB-86	0.000E+00	1.980E+05	0.000E+00	0.000E+00	0.000E+00	7.990E+03	0.000E+00	1.140E+05
RB-88	0.000E+00	5.620E+02	0.000E+00	0.000E+00	0.000E+00	1.720E+01	0.000E+00	3.660E+02
RB-89	0.000E+00	3.450E+02	0.000E+00	0.000E+00	0.000E+00	1.890E+00	0.000E+00	2.900E+02
SR-89	5.990E+05	0.000E+00	0.000E+00	0.000E+00	2.160E+06	1.670E+05	0.000E+00	1.720E+04
SR-90	1.010E+08	0.000E+00	0.000E+00	0.000E+00	1.480E+07	3.430E+05	0.000E+00	6.440E+06
SR-91	1.210E+02	0.000E+00	0.000E+00	0.000E+00	5.330E+04	1.740E+05	0.000E+00	4.590E+00

Catawba Nuclear Station Units 1 & 2
Period 1/1/2016 - 12/31/2016

Catawba Nuclear Station
Offsite Dose Calculation Manual (ODCM)

APPENDIX I

R_i Child Dose Factors for use in the Gaseous Dose Calculations

Agegroup:	CHILD	Pathway:	Inhalation (INHL)			Units:	mrem/yr / $\mu\text{Ci}/\text{m}^3$	
Nuclide	Bone	Liver	Thyroid	Kidney	Lung	Gilli	Skin	Total Body
SR-92	1.310E+01	0.000E+00	0.000E+00	0.000E+00	2.400E+04	2.420E+05	0.000E+00	5.250E-01
Y-90	4.110E+03	0.000E+00	0.000E+00	0.000E+00	2.620E+05	2.680E+05	0.000E+00	1.110E+02
Y-91	9.140E+05	0.000E+00	0.000E+00	0.000E+00	2.630E+06	1.840E+05	0.000E+00	2.440E+04
Y-91M	5.070E-01	0.000E+00	0.000E+00	0.000E+00	2.810E+03	1.720E+03	0.000E+00	1.840E-02
Y-92	2.030E+01	0.000E+00	0.000E+00	0.000E+00	2.390E+04	2.390E+05	0.000E+00	5.810E-01
Y-93	1.860E+02	0.000E+00	0.000E+00	0.000E+00	7.440E+04	3.880E+05	0.000E+00	5.110E+00
ZR-95	1.900E+05	4.180E+04	0.000E+00	5.960E+04	2.230E+06	6.110E+04	0.000E+00	3.700E+04
ZR-97	1.880E+02	2.720E+01	0.000E+00	3.880E+01	1.130E+05	3.510E+05	0.000E+00	1.600E+01
NB-95	2.350E+04	9.180E+03	0.000E+00	8.620E+03	6.140E+05	3.700E+04	0.000E+00	6.550E+03
MO-99	0.000E+00	1.720E+02	0.000E+00	3.920E+02	1.350E+05	1.270E+05	0.000E+00	4.260E+01
TC-99M	1.780E-03	3.480E-03	0.000E+00	5.070E-02	9.510E+02	4.810E+03	0.000E+00	5.770E-02
TC-101	8.100E-05	8.510E-05	0.000E+00	1.450E-03	5.850E+02	1.630E+01	0.000E+00	1.080E-03
RU-103	2.790E+03	0.000E+00	0.000E+00	7.030E+03	6.620E+05	4.480E+04	0.000E+00	1.070E+03
RU-105	1.530E+00	0.000E+00	0.000E+00	1.340E+00	1.590E+04	9.950E+04	0.000E+00	5.550E-01
RU-106	1.360E+05	0.000E+00	0.000E+00	1.840E+05	1.430E+07	4.290E+05	0.000E+00	1.690E+04
AG-110M	1.690E+04	1.140E+04	0.000E+00	2.120E+04	5.480E+06	1.000E+05	0.000E+00	9.140E+03
TE-125M	6.730E+03	2.330E+03	1.920E+03	0.000E+00	4.770E+05	3.380E+04	0.000E+00	9.140E+02
TE-127	2.770E+00	9.510E-01	1.960E+00	7.070E+00	1.000E+04	5.620E+04	0.000E+00	6.100E-01
TE-127M	2.490E+04	8.550E+03	6.070E+03	6.360E+04	1.480E+06	7.140E+04	0.000E+00	3.020E+03
TE-129	9.770E-02	3.500E-02	7.140E-02	2.570E-01	2.930E+03	2.550E+04	0.000E+00	2.380E-02
TE-129M	1.920E+04	6.840E+03	6.330E+03	5.030E+04	1.760E+06	1.820E+05	0.000E+00	3.040E+03
TE-131	2.170E-02	8.440E-03	1.700E-02	5.880E-02	2.050E+03	1.330E+03	0.000E+00	6.590E-03
TE-131M	1.340E+02	5.920E+01	9.770E+01	4.000E+02	2.060E+05	3.080E+05	0.000E+00	5.070E+01
TE-132	4.810E+02	2.720E+02	3.170E+02	1.770E+03	3.770E+05	1.380E+05	0.000E+00	2.630E+02
I-130	8.180E+03	1.640E+04	1.850E+06	2.450E+04	0.000E+00	5.110E+03	0.000E+00	8.440E+03

Catawba Nuclear Station Units 1 & 2
Period 1/1/2016 - 12/31/2016

Catawba Nuclear Station
Offsite Dose Calculation Manual (ODCM)

APPENDIX I

R_i Child Dose Factors for use in the Gaseous Dose Calculations

Agegroup:	CHILD	Pathway:	Inhalation (INHL)			Units:	mrem/yr / $\mu\text{Ci}/\text{m}^3$	
Nuclide	Bone	Liver	Thyroid	Kidney	Lung	Gilli	Skin	Total Body
I-131	4.810E+04	4.810E+04	1.620E+07	7.880E+04	0.000E+00	2.840E+03	0.000E+00	2.730E+04
I-132	2.120E+03	4.070E+03	1.940E+05	6.250E+03	0.000E+00	3.200E+03	0.000E+00	1.880E+03
I-133	1.660E+04	2.030E+04	3.850E+06	3.380E+04	0.000E+00	5.480E+03	0.000E+00	7.700E+03
I-134	1.170E+03	2.160E+03	5.070E+04	3.300E+03	0.000E+00	9.550E+02	0.000E+00	9.950E+02
I-135	4.920E+03	8.730E+03	7.920E+05	1.340E+04	0.000E+00	4.440E+03	0.000E+00	4.140E+03
CS-134	6.510E+05	1.010E+06	0.000E+00	3.300E+05	1.210E+05	3.850E+03	0.000E+00	2.250E+05
CS-136	6.510E+04	1.710E+05	0.000E+00	9.550E+04	1.450E+04	4.180E+03	0.000E+00	1.160E+05
CS-137	9.060E+05	8.250E+05	0.000E+00	2.820E+05	1.040E+05	3.620E+03	0.000E+00	1.280E+05
CS-138	6.330E+02	8.400E+02	0.000E+00	6.220E+02	6.810E+01	2.700E+02	0.000E+00	5.550E+02
BA-139	1.840E+00	9.840E-04	0.000E+00	8.620E-04	5.770E+03	5.770E+04	0.000E+00	5.360E-02
BA-140	7.400E+04	6.480E+01	0.000E+00	2.110E+01	1.740E+06	1.020E+05	0.000E+00	4.330E+03
BA-141	1.960E-01	1.090E-04	0.000E+00	9.470E-05	2.920E+03	2.750E+02	0.000E+00	6.360E-03
BA-142	5.000E-02	3.600E-05	0.000E+00	2.910E-05	1.640E+03	2.740E+00	0.000E+00	2.790E-03
LA-140	6.440E+02	2.250E+02	0.000E+00	0.000E+00	1.830E+05	2.260E+05	0.000E+00	7.550E+01
LA-142	1.300E+00	4.110E-01	0.000E+00	0.000E+00	8.700E+03	7.580E+04	0.000E+00	1.290E-01
CE-141	3.920E+04	1.950E+04	0.000E+00	8.550E+03	5.440E+05	5.660E+04	0.000E+00	2.900E+03
CE-143	3.660E+02	1.990E+02	0.000E+00	8.360E+01	1.150E+05	1.270E+05	0.000E+00	2.870E+01
CE-144	6.770E+06	2.120E+06	0.000E+00	1.170E+06	1.200E+07	3.880E+05	0.000E+00	3.610E+05
PR-143	1.850E+04	5.550E+03	0.000E+00	3.000E+03	4.330E+05	9.730E+04	0.000E+00	9.140E+02
PR-144	5.960E-02	1.850E-02	0.000E+00	9.770E-03	1.570E+03	1.970E+02	0.000E+00	3.000E-03
ND-147	1.080E+04	8.730E+03	0.000E+00	4.810E+03	3.280E+05	8.210E+04	0.000E+00	6.810E+02
W-187	1.630E+01	9.660E+00	0.000E+00	0.000E+00	4.110E+04	9.100E+04	0.000E+00	4.330E+00
NP-239	4.660E+02	3.340E+01	0.000E+00	9.730E+01	5.810E+04	6.400E+04	0.000E+00	2.350E+01

Catawba Nuclear Station Units 1 & 2
Period 1/1/2016 - 12/31/2016

Catawba Nuclear Station
Offsite Dose Calculation Manual (ODCM)

APPENDIX I

R_i Child Dose Factors for use in the Gaseous Dose Calculations

Agegroup:	CHILD	Pathway:	Ground Plane Deposition (GPD)			Units:	m ² ·mrem/yr / μCi/sec	
Nuclide	Bone	Liver	Thyroid	Kidney	Lung	Gilli	Skin	Total Body
H-3	0.000E+00	0.000E+00	0.000E+00	0.000E+00	0.000E+00	0.000E+00	0.000E+00	0.000E+00
C-14	0.000E+00	0.000E+00	0.000E+00	0.000E+00	0.000E+00	0.000E+00	0.000E+00	0.000E+00
NA-24	1.190E+07	1.190E+07	1.190E+07	1.190E+07	1.190E+07	1.190E+07	1.390E+07	1.190E+07
P-32	0.000E+00	0.000E+00	0.000E+00	0.000E+00	0.000E+00	0.000E+00	0.000E+00	0.000E+00
CR-51	4.660E+06	4.660E+06	4.660E+06	4.660E+06	4.660E+06	4.660E+06	5.510E+06	4.660E+06
MN-54	1.390E+09	1.390E+09	1.390E+09	1.390E+09	1.390E+09	1.390E+09	1.630E+09	1.390E+09
MN-56	9.020E+05	9.020E+05	9.020E+05	9.020E+05	9.020E+05	9.020E+05	1.070E+06	9.020E+05
FE-55	0.000E+00	0.000E+00	0.000E+00	0.000E+00	0.000E+00	0.000E+00	0.000E+00	0.000E+00
FE-59	2.730E+08	2.730E+08	2.730E+08	2.730E+08	2.730E+08	2.730E+08	3.210E+08	2.730E+08
CO-58	3.790E+08	3.790E+08	3.790E+08	3.790E+08	3.790E+08	3.790E+08	4.440E+08	3.790E+08
CO-60	2.150E+10	2.150E+10	2.150E+10	2.150E+10	2.150E+10	2.150E+10	2.530E+10	2.150E+10
NI-63	0.000E+00	0.000E+00	0.000E+00	0.000E+00	0.000E+00	0.000E+00	0.000E+00	0.000E+00
NI-65	2.970E+05	2.970E+05	2.970E+05	2.970E+05	2.970E+05	2.970E+05	3.450E+05	2.970E+05
CU-64	6.070E+05	6.070E+05	6.070E+05	6.070E+05	6.070E+05	6.070E+05	6.880E+05	6.070E+05
ZN-65	7.470E+08	7.470E+08	7.470E+08	7.470E+08	7.470E+08	7.470E+08	8.590E+08	7.470E+08
ZN-69	0.000E+00	0.000E+00	0.000E+00	0.000E+00	0.000E+00	0.000E+00	0.000E+00	0.000E+00
BR-83	4.870E+03	4.870E+03	4.870E+03	4.870E+03	4.870E+03	4.870E+03	7.080E+03	4.870E+03
BR-84	2.030E+05	2.030E+05	2.030E+05	2.030E+05	2.030E+05	2.030E+05	2.360E+05	2.030E+05
BR-85	0.000E+00	0.000E+00	0.000E+00	0.000E+00	0.000E+00	0.000E+00	0.000E+00	0.000E+00
RB-86	8.990E+06	8.990E+06	8.990E+06	8.990E+06	8.990E+06	8.990E+06	1.030E+07	8.990E+06
RB-88	3.310E+04	3.310E+04	3.310E+04	3.310E+04	3.310E+04	3.310E+04	3.780E+04	3.310E+04
RB-89	1.230E+05	1.230E+05	1.230E+05	1.230E+05	1.230E+05	1.230E+05	1.480E+05	1.230E+05
SR-89	2.160E+04	2.160E+04	2.160E+04	2.160E+04	2.160E+04	2.160E+04	2.510E+04	2.160E+04
SR-90	0.000E+00	0.000E+00	0.000E+00	0.000E+00	0.000E+00	0.000E+00	0.000E+00	0.000E+00
SR-91	2.150E+06	2.150E+06	2.150E+06	2.150E+06	2.150E+06	2.150E+06	2.510E+06	2.150E+06

Catawba Nuclear Station Units 1 & 2
Period 1/1/2016 - 12/31/2016

Catawba Nuclear Station
Offsite Dose Calculation Manual (ODCM)

APPENDIX I

R_i Child Dose Factors for use in the Gaseous Dose Calculations

Agegroup:	CHILD	Pathway:	Ground Plane Deposition (GPD)			Units:	m²·mrem/yr / μCi/sec	
Nuclide	Bone	Liver	Thyroid	Kidney	Lung	Gilli	Skin	Total Body
SR-92	7.770E+05	7.770E+05	7.770E+05	7.770E+05	7.770E+05	7.770E+05	8.630E+05	7.770E+05
Y-90	4.490E+03	4.490E+03	4.490E+03	4.490E+03	4.490E+03	4.490E+03	5.310E+03	4.490E+03
Y-91	1.070E+06	1.070E+06	1.070E+06	1.070E+06	1.070E+06	1.070E+06	1.210E+06	1.070E+06
Y-91M	1.000E+05	1.000E+05	1.000E+05	1.000E+05	1.000E+05	1.000E+05	1.160E+05	1.000E+05
Y-92	1.800E+05	1.800E+05	1.800E+05	1.800E+05	1.800E+05	1.800E+05	2.140E+05	1.800E+05
Y-93	1.830E+05	1.830E+05	1.830E+05	1.830E+05	1.830E+05	1.830E+05	2.510E+05	1.830E+05
ZR-95	2.450E+08	2.450E+08	2.450E+08	2.450E+08	2.450E+08	2.450E+08	2.840E+08	2.450E+08
ZR-97	2.960E+06	2.960E+06	2.960E+06	2.960E+06	2.960E+06	2.960E+06	3.440E+06	2.960E+06
NB-95	1.370E+08	1.370E+08	1.370E+08	1.370E+08	1.370E+08	1.370E+08	1.610E+08	1.370E+08
MO-99	3.990E+06	3.990E+06	3.990E+06	3.990E+06	3.990E+06	3.990E+06	4.630E+06	3.990E+06
TC-99M	1.840E+05	1.840E+05	1.840E+05	1.840E+05	1.840E+05	1.840E+05	2.110E+05	1.840E+05
TC-101	2.040E+04	2.040E+04	2.040E+04	2.040E+04	2.040E+04	2.040E+04	2.260E+04	2.040E+04
RU-103	1.080E+08	1.080E+08	1.080E+08	1.080E+08	1.080E+08	1.080E+08	1.260E+08	1.080E+08
RU-105	6.360E+05	6.360E+05	6.360E+05	6.360E+05	6.360E+05	6.360E+05	7.210E+05	6.360E+05
RU-106	4.220E+08	4.220E+08	4.220E+08	4.220E+08	4.220E+08	4.220E+08	5.070E+08	4.220E+08
AG-110M	3.440E+09	3.440E+09	3.440E+09	3.440E+09	3.440E+09	3.440E+09	4.010E+09	3.440E+09
TE-125M	1.550E+06	1.550E+06	1.550E+06	1.550E+06	1.550E+06	1.550E+06	2.130E+06	1.550E+06
TE-127	2.980E+03	2.980E+03	2.980E+03	2.980E+03	2.980E+03	2.980E+03	3.280E+03	2.980E+03
TE-127M	9.160E+04	9.160E+04	9.160E+04	9.160E+04	9.160E+04	9.160E+04	1.080E+05	9.160E+04
TE-129	2.620E+04	2.620E+04	2.620E+04	2.620E+04	2.620E+04	2.620E+04	3.100E+04	2.620E+04
TE-129M	1.980E+07	1.980E+07	1.980E+07	1.980E+07	1.980E+07	1.980E+07	2.310E+07	1.980E+07
TE-131	2.920E+04	2.920E+04	2.920E+04	2.920E+04	2.920E+04	2.920E+04	3.450E+07	2.920E+04
TE-131M	8.030E+06	8.030E+06	8.030E+06	8.030E+06	8.030E+06	8.030E+06	9.460E+06	8.030E+06
TE-132	4.230E+06	4.230E+06	4.230E+06	4.230E+06	4.230E+06	4.230E+06	4.980E+06	4.230E+06
I-130	5.510E+06	5.510E+06	5.510E+06	5.510E+06	5.510E+06	5.510E+06	6.690E+06	5.510E+06

Catawba Nuclear Station Units 1 & 2
Period 1/1/2016 - 12/31/2016

Catawba Nuclear Station
Offsite Dose Calculation Manual (ODCM)

APPENDIX I

R_i Child Dose Factors for use in the Gaseous Dose Calculations

Agegroup:	CHILD	Pathway:	Ground Plane Deposition (GPD)			Units:	m²·mrem/yr / μCi/sec	
Nuclide	Bone	Liver	Thyroid	Kidney	Lung	Gilli	Skin	Total Body
I-131	1.720E+07	1.720E+07	1.720E+07	1.720E+07	1.720E+07	1.720E+07	2.090E+07	1.720E+07
I-132	1.250E+06	1.250E+06	1.250E+06	1.250E+06	1.250E+06	1.250E+06	1.470E+06	1.250E+06
I-133	2.450E+06	2.450E+06	2.450E+06	2.450E+06	2.450E+06	2.450E+06	2.980E+06	2.450E+06
I-134	4.470E+05	4.470E+05	4.470E+05	4.470E+05	4.470E+05	4.470E+05	5.300E+05	4.470E+05
I-135	2.530E+06	2.530E+06	2.530E+06	2.530E+06	2.530E+06	2.530E+06	2.950E+06	2.530E+06
CS-134	6.860E+09	6.860E+09	6.860E+09	6.860E+09	6.860E+09	6.860E+09	8.000E+09	6.860E+09
CS-136	1.510E+08	1.510E+08	1.510E+08	1.510E+08	1.510E+08	1.510E+08	1.710E+08	1.510E+08
CS-137	1.030E+10	1.030E+10	1.030E+10	1.030E+10	1.030E+10	1.030E+10	1.200E+10	1.030E+10
CS-138	3.590E+05	3.590E+05	3.590E+05	3.590E+05	3.590E+05	3.590E+05	4.100E+05	3.590E+05
BA-139	1.060E+05	1.060E+05	1.060E+05	1.060E+05	1.060E+05	1.060E+05	1.190E+05	1.060E+05
BA-140	2.050E+07	2.050E+07	2.050E+07	2.050E+07	2.050E+07	2.050E+07	2.350E+07	2.050E+07
BA-141	4.170E+04	4.170E+04	4.170E+04	4.170E+04	4.170E+04	4.170E+04	4.750E+04	4.170E+04
BA-142	4.490E+04	4.490E+04	4.490E+04	4.490E+04	4.490E+04	4.490E+04	5.110E+04	4.490E+04
LA-140	1.920E+07	1.920E+07	1.920E+07	1.920E+07	1.920E+07	1.920E+07	2.180E+07	1.920E+07
LA-142	7.600E+05	7.600E+05	7.600E+05	7.600E+05	7.600E+05	7.600E+05	9.120E+05	7.600E+05
CE-141	1.370E+07	1.370E+07	1.370E+07	1.370E+07	1.370E+07	1.370E+07	1.540E+07	1.370E+07
CE-143	2.310E+06	2.310E+06	2.310E+06	2.310E+06	2.310E+06	2.310E+06	2.630E+06	2.310E+06
CE-144	6.950E+07	6.950E+07	6.950E+07	6.950E+07	6.950E+07	6.950E+07	8.040E+07	6.950E+07
PR-143	0.000E+00	0.000E+00	0.000E+00	0.000E+00	0.000E+00	0.000E+00	0.000E+00	0.000E+00
PR-144	1.830E+03	1.830E+03	1.830E+03	1.830E+03	1.830E+03	1.830E+03	2.110E+03	1.830E+03
ND-147	8.390E+06	8.390E+06	8.390E+06	8.390E+06	8.390E+06	8.390E+06	1.010E+07	8.390E+06
W-187	2.350E+06	2.350E+06	2.350E+06	2.350E+06	2.350E+06	2.350E+06	2.730E+06	2.350E+06
NP-239	1.710E+06	1.710E+06	1.710E+06	1.710E+06	1.710E+06	1.710E+06	1.980E+06	1.710E+06

Catawba Nuclear Station Units 1 & 2
Period 1/1/2016 - 12/31/2016

Catawba Nuclear Station
Offsite Dose Calculation Manual (ODCM)

APPENDIX J

R_i Infant Dose Factors for use in the Gaseous Dose Calculations

Agegroup:	INFANT	Pathway:	Grs/Cow/Milk (CMILK)			Units:	m²·mrem/yr / μCi/sec; mrem/yr / μCi/m³ (H-3, C-14)	
Nuclide	Bone	Liver	Thyroid	Kidney	Lung	Gilli	Skin	Total Body
H-3	0.000E+00	2.380E+03	2.380E+03	2.380E+03	2.380E+03	2.380E+03	0.000E+00	2.380E+03
C-14	2.000E+05	4.270E+04	4.270E+04	4.270E+04	4.270E+04	4.270E+04	0.000E+00	4.270E+04
NA-24	1.540E+07	1.540E+07	1.540E+07	1.540E+07	1.540E+07	1.540E+07	0.000E+00	1.540E+07
P-32	1.600E+11	9.430E+09	0.000E+00	0.000E+00	0.000E+00	2.170E+09	0.000E+00	6.210E+09
CR-51	0.000E+00	0.000E+00	1.050E+05	2.300E+04	2.050E+05	4.700E+06	0.000E+00	1.610E+05
MN-54	0.000E+00	3.900E+07	0.000E+00	8.640E+06	0.000E+00	1.430E+07	0.000E+00	8.840E+06
MN-56	0.000E+00	3.100E-02	0.000E+00	2.660E-02	0.000E+00	2.810E+00	0.000E+00	5.340E-03
FE-55	1.350E+08	8.730E+07	0.000E+00	0.000E+00	4.270E+07	1.110E+07	0.000E+00	2.330E+07
FE-59	2.240E+08	3.920E+08	0.000E+00	0.000E+00	1.160E+08	1.870E+08	0.000E+00	1.540E+08
CO-58	0.000E+00	2.420E+07	0.000E+00	0.000E+00	0.000E+00	6.040E+07	0.000E+00	6.050E+07
CO-60	0.000E+00	8.820E+07	0.000E+00	0.000E+00	0.000E+00	2.100E+08	0.000E+00	2.080E+08
NI-63	3.490E+10	2.160E+09	0.000E+00	0.000E+00	0.000E+00	1.070E+08	0.000E+00	1.210E+09
NI-65	3.510E+00	3.970E-01	0.000E+00	0.000E+00	0.000E+00	3.020E+01	0.000E+00	1.800E-01
CU-64	0.000E+00	1.850E+05	0.000E+00	3.140E+05	0.000E+00	3.810E+06	0.000E+00	8.590E+04
ZN-65	5.550E+09	1.900E+10	0.000E+00	9.230E+09	0.000E+00	1.610E+10	0.000E+00	8.780E+09
ZN-69	2.020E-11	3.630E-11	0.000E+00	1.510E-11	0.000E+00	2.960E-09	0.000E+00	2.700E-12
BR-83	0.000E+00	0.000E+00	0.000E+00	0.000E+00	0.000E+00	0.000E+00	0.000E+00	9.340E-01
BR-84	0.000E+00	0.000E+00	0.000E+00	0.000E+00	0.000E+00	0.000E+00	0.000E+00	1.260E-22
BR-85	0.000E+00	0.000E+00	0.000E+00	0.000E+00	0.000E+00	0.000E+00	0.000E+00	0.000E+00
RB-86	0.000E+00	2.230E+10	0.000E+00	0.000E+00	0.000E+00	5.690E+08	0.000E+00	1.100E+10
RB-88	0.000E+00	1.880E-44	0.000E+00	0.000E+00	0.000E+00	1.830E-44	0.000E+00	1.030E-44
RB-89	0.000E+00	3.290E-52	0.000E+00	0.000E+00	0.000E+00	1.120E-52	0.000E+00	2.260E-52
SR-89	1.260E+10	0.000E+00	0.000E+00	0.000E+00	0.000E+00	2.590E+08	0.000E+00	3.610E+08
SR-90	1.220E+11	0.000E+00	0.000E+00	0.000E+00	0.000E+00	1.520E+09	0.000E+00	3.100E+10
SR-91	2.720E+05	0.000E+00	0.000E+00	0.000E+00	0.000E+00	3.220E+05	0.000E+00	9.830E+03

Catawba Nuclear Station Units 1 & 2
Period 1/1/2016 - 12/31/2016

Catawba Nuclear Station
Offsite Dose Calculation Manual (ODCM)

APPENDIX J

R_i Infant Dose Factors for use in the Gaseous Dose Calculations

Agegroup:	INFANT	Pathway:	Grs/Cow/Milk (CMILK)			Units:	m²·mrem/yr / μCi/sec; mrem/yr / μCi/m³ (H-3, C-14)	
Nuclide	Bone	Liver	Thyroid	Kidney	Lung	Gilli	Skin	Total Body
SR-92	4.640E+00	0.000E+00	0.000E+00	0.000E+00	0.000E+00	5.000E+01	0.000E+00	1.720E-01
Y-90	6.810E+02	0.000E+00	0.000E+00	0.000E+00	0.000E+00	9.410E+05	0.000E+00	1.830E+01
Y-91	7.330E+04	0.000E+00	0.000E+00	0.000E+00	0.000E+00	5.250E+06	0.000E+00	1.950E+03
Y-91M	5.670E-19	0.000E+00	0.000E+00	0.000E+00	0.000E+00	1.890E-15	0.000E+00	1.930E-20
Y-92	5.380E-04	0.000E+00	0.000E+00	0.000E+00	0.000E+00	1.030E+01	0.000E+00	1.510E-05
Y-93	2.160E+00	0.000E+00	0.000E+00	0.000E+00	0.000E+00	1.700E+04	0.000E+00	5.870E-02
ZR-95	6.800E+03	1.660E+03	0.000E+00	1.790E+03	0.000E+00	8.260E+05	0.000E+00	1.180E+03
ZR-97	4.060E+00	6.970E-01	0.000E+00	7.030E-01	0.000E+00	4.450E+04	0.000E+00	3.180E-01
NB-95	5.930E+05	2.440E+05	0.000E+00	1.750E+05	0.000E+00	2.060E+08	0.000E+00	1.410E+05
MO-99	0.000E+00	2.080E+08	0.000E+00	3.110E+08	0.000E+00	6.850E+07	0.000E+00	4.060E+07
TC-99M	2.750E+01	5.670E+01	0.000E+00	6.100E+02	2.960E+01	1.650E+04	0.000E+00	7.300E+02
TC-101	2.470E-59	3.110E-59	0.000E+00	3.700E-58	1.700E-59	5.280E-57	0.000E+00	3.080E-58
RU-103	8.670E+03	0.000E+00	0.000E+00	1.800E+04	0.000E+00	1.050E+05	0.000E+00	2.900E+03
RU-105	8.050E-03	0.000E+00	0.000E+00	5.920E-02	0.000E+00	3.200E+00	0.000E+00	2.710E-03
RU-106	1.900E+05	0.000E+00	0.000E+00	2.250E+05	0.000E+00	1.440E+06	0.000E+00	2.380E+04
AG-110M	3.860E+08	2.820E+08	0.000E+00	4.030E+08	0.000E+00	1.460E+10	0.000E+00	1.860E+08
TE-125M	1.510E+08	5.040E+07	5.070E+07	0.000E+00	0.000E+00	7.180E+07	0.000E+00	2.040E+07
TE-127	6.320E+03	2.120E+03	5.140E+03	1.540E+04	0.000E+00	1.330E+05	0.000E+00	1.360E+03
TE-127M	4.210E+08	1.400E+08	1.220E+08	1.040E+09	0.000E+00	1.700E+08	0.000E+00	5.100E+07
TE-129	2.720E-09	9.380E-10	2.280E-09	6.770E-09	0.000E+00	2.170E-07	0.000E+00	6.350E-10
TE-129M	5.570E+08	1.910E+08	2.140E+08	1.390E+09	0.000E+00	3.330E+08	0.000E+00	8.580E+07
TE-131	3.430E-32	1.270E-32	3.060E-32	8.760E-32	0.000E+00	1.380E-30	0.000E+00	9.610E-33
TE-131M	3.380E+06	1.360E+06	2.750E+06	9.350E+06	0.000E+00	2.290E+07	0.000E+00	1.120E+06
TE-132	2.110E+07	1.040E+07	1.540E+07	6.530E+07	0.000E+00	3.870E+07	0.000E+00	9.750E+06
I-130	3.550E+06	7.810E+06	8.750E+08	8.580E+06	0.000E+00	1.670E+06	0.000E+00	3.130E+06

Catawba Nuclear Station Units 1 & 2
Period 1/1/2016 - 12/31/2016

Catawba Nuclear Station
Offsite Dose Calculation Manual (ODCM)

APPENDIX J

R_i Infant Dose Factors for use in the Gaseous Dose Calculations

Agegroup:	INFANT	Pathway:	Grs/Cow/Milk (CMILK)			Units:	m²·mrem/yr / μCi/sec; mrem/yr / μCi/m³ (H-3, C-14)	
Nuclide	Bone	Liver	Thyroid	Kidney	Lung	Gilli	Skin	Total Body
I-131	2.720E+09	3.200E+09	1.050E+12	3.740E+09	0.000E+00	1.140E+08	0.000E+00	1.410E+09
I-132	1.430E+00	2.900E+00	1.360E+02	3.240E+00	0.000E+00	2.350E+00	0.000E+00	1.030E+00
I-133	3.630E+07	5.280E+07	9.600E+09	6.210E+07	0.000E+00	8.930E+06	0.000E+00	1.550E+07
I-134	1.760E-11	3.600E-11	8.400E-10	4.030E-11	0.000E+00	3.720E-11	0.000E+00	1.280E-11
I-135	1.120E+05	2.230E+05	2.000E+07	2.490E+05	0.000E+00	8.080E+04	0.000E+00	8.140E+04
CS-134	3.650E+10	6.800E+10	0.000E+00	1.750E+10	7.180E+09	1.850E+08	0.000E+00	6.870E+09
CS-136	1.980E+09	5.810E+09	0.000E+00	2.320E+09	4.740E+08	8.820E+07	0.000E+00	2.170E+09
CS-137	5.150E+10	6.020E+10	0.000E+00	1.620E+10	6.550E+09	1.880E+08	0.000E+00	4.270E+09
CS-138	8.390E-23	1.360E-22	0.000E+00	6.800E-23	1.060E-23	2.180E-22	0.000E+00	6.610E-23
BA-139	4.270E-07	2.830E-10	0.000E+00	1.700E-10	1.720E-10	2.710E-05	0.000E+00	1.240E-08
BA-140	2.410E+08	2.410E+05	0.000E+00	5.720E+04	1.480E+05	5.920E+07	0.000E+00	1.240E+07
BA-141	3.930E-45	2.690E-48	0.000E+00	1.620E-48	1.640E-48	4.800E-44	0.000E+00	1.240E-46
BA-142	2.430E-79	2.020E-82	0.000E+00	1.160E-82	1.220E-82	1.000E-78	0.000E+00	1.200E-80
LA-140	4.050E+01	1.600E+01	0.000E+00	0.000E+00	0.000E+00	1.880E+05	0.000E+00	4.110E+00
LA-142	1.700E-10	6.250E-11	0.000E+00	0.000E+00	0.000E+00	1.060E-05	0.000E+00	1.500E-11
CE-141	4.340E+04	2.640E+04	0.000E+00	8.150E+03	0.000E+00	1.370E+07	0.000E+00	3.110E+03
CE-143	3.970E+02	2.630E+05	0.000E+00	7.670E+01	0.000E+00	1.540E+06	0.000E+00	3.000E+01
CE-144	2.330E+06	9.520E+05	0.000E+00	3.850E+05	0.000E+00	1.330E+08	0.000E+00	1.300E+05
PR-143	1.490E+03	5.550E+02	0.000E+00	2.060E+02	0.000E+00	7.840E+05	0.000E+00	7.360E+01
PR-144	5.690E-53	2.200E-53	0.000E+00	7.980E-54	0.000E+00	1.020E-48	0.000E+00	2.870E-54
ND-147	8.810E+02	9.050E+02	0.000E+00	3.490E+02	0.000E+00	5.740E+05	0.000E+00	5.550E+01
W-187	6.080E+04	4.230E+04	0.000E+00	0.000E+00	0.000E+00	2.480E+06	0.000E+00	1.460E+04
NP-239	3.650E+01	3.260E+00	0.000E+00	6.510E+00	0.000E+00	9.430E+04	0.000E+00	1.840E+00

Catawba Nuclear Station Units 1 & 2
Period 1/1/2016 - 12/31/2016

Catawba Nuclear Station
Offsite Dose Calculation Manual (ODCM)

APPENDIX J

R_i Infant Dose Factors for use in the Gaseous Dose Calculations

Agegroup:	INFANT	Pathway:	Grs/Goat/Milk (GMILK)			Units:	m²·mrem/yr / μCi/sec; mrem/yr / μCi/m³ (H-3, C-14)	
Nuclide	Bone	Liver	Thyroid	Kidney	Lung	Gilli	Skin	Total Body
H-3	0.000E+00	4.860E+03	4.860E+03	4.860E+03	4.860E+03	4.860E+03	0.000E+00	4.860E+03
C-14	2.000E+05	4.270E+04	4.270E+04	4.270E+04	4.270E+04	4.270E+04	0.000E+00	4.270E+04
NA-24	1.850E+06	1.850E+06	1.850E+06	1.850E+06	1.850E+06	1.850E+06	0.000E+00	1.850E+06
P-32	1.920E+11	1.130E+10	0.000E+00	0.000E+00	0.000E+00	2.600E+09	0.000E+00	7.460E+09
CR-51	0.000E+00	0.000E+00	1.260E+04	2.760E+03	2.460E+04	5.640E+05	0.000E+00	1.940E+04
MN-54	0.000E+00	4.680E+06	0.000E+00	1.040E+06	0.000E+00	1.720E+06	0.000E+00	1.060E+06
MN-56	0.000E+00	3.720E-03	0.000E+00	3.190E-03	0.000E+00	3.380E-01	0.000E+00	6.410E-04
FE-55	1.760E+06	1.130E+06	0.000E+00	0.000E+00	5.550E+05	1.440E+05	0.000E+00	3.030E+05
FE-59	2.920E+06	5.100E+06	0.000E+00	0.000E+00	1.510E+06	2.430E+06	0.000E+00	2.010E+06
CO-58	0.000E+00	2.910E+06	0.000E+00	0.000E+00	0.000E+00	7.250E+06	0.000E+00	7.260E+06
CO-60	0.000E+00	1.060E+07	0.000E+00	0.000E+00	0.000E+00	2.520E+07	0.000E+00	2.500E+07
NI-63	4.190E+09	2.590E+08	0.000E+00	0.000E+00	0.000E+00	1.290E+07	0.000E+00	1.450E+08
NI-65	4.210E-01	4.760E-02	0.000E+00	0.000E+00	0.000E+00	3.620E+00	0.000E+00	2.170E-02
CU-64	0.000E+00	2.070E+04	0.000E+00	3.500E+04	0.000E+00	4.240E+05	0.000E+00	9.570E+03
ZN-65	6.660E+08	2.280E+09	0.000E+00	1.110E+09	0.000E+00	1.930E+09	0.000E+00	1.050E+09
ZN-69	2.420E-12	4.360E-12	0.000E+00	1.810E-12	0.000E+00	3.550E-10	0.000E+00	3.240E-13
BR-83	0.000E+00	0.000E+00	0.000E+00	0.000E+00	0.000E+00	0.000E+00	0.000E+00	1.120E-01
BR-84	0.000E+00	0.000E+00	0.000E+00	0.000E+00	0.000E+00	0.000E+00	0.000E+00	1.510E-23
BR-85	0.000E+00	0.000E+00	0.000E+00	0.000E+00	0.000E+00	0.000E+00	0.000E+00	0.000E+00
RB-86	0.000E+00	2.670E+09	0.000E+00	0.000E+00	0.000E+00	6.830E+07	0.000E+00	1.320E+09
RB-88	0.000E+00	2.250E-45	0.000E+00	0.000E+00	0.000E+00	2.190E-45	0.000E+00	1.230E-45
RB-89	0.000E+00	3.940E-53	0.000E+00	0.000E+00	0.000E+00	1.340E-53	0.000E+00	2.720E-53
SR-89	2.640E+10	0.000E+00	0.000E+00	0.000E+00	0.000E+00	5.430E+08	0.000E+00	7.580E+08
SR-90	2.550E+11	0.000E+00	0.000E+00	0.000E+00	0.000E+00	3.190E+09	0.000E+00	6.500E+10
SR-91	5.700E+05	0.000E+00	0.000E+00	0.000E+00	0.000E+00	6.750E+05	0.000E+00	2.060E+04

Catawba Nuclear Station Units 1 & 2
Period 1/1/2016 - 12/31/2016

Catawba Nuclear Station
Offsite Dose Calculation Manual (ODCM)

APPENDIX J

R_i Infant Dose Factors for use in the Gaseous Dose Calculations

Agegroup:	INFANT	Pathway:	Grs/Goat/Milk (GMILK)			Units:	m²·mrem/yr / μCi/sec; mrem/yr / μCi/m³ (H-3, C-14)	
Nuclide	Bone	Liver	Thyroid	Kidney	Lung	Gilli	Skin	Total Body
SR-92	9.750E+00	0.000E+00	0.000E+00	0.000E+00	0.000E+00	1.050E+02	0.000E+00	3.620E-01
Y-90	8.170E+01	0.000E+00	0.000E+00	0.000E+00	0.000E+00	1.130E+05	0.000E+00	2.190E+00
Y-91	8.790E+03	0.000E+00	0.000E+00	0.000E+00	0.000E+00	6.300E+05	0.000E+00	2.340E+02
Y-91M	6.810E-20	0.000E+00	0.000E+00	0.000E+00	0.000E+00	2.270E-16	0.000E+00	2.320E-21
Y-92	6.450E-05	0.000E+00	0.000E+00	0.000E+00	0.000E+00	1.230E+00	0.000E+00	1.810E-06
Y-93	2.590E-01	0.000E+00	0.000E+00	0.000E+00	0.000E+00	2.040E+03	0.000E+00	7.050E-03
ZR-95	8.170E+02	1.990E+02	0.000E+00	2.140E+02	0.000E+00	9.910E+04	0.000E+00	1.410E+02
ZR-97	4.870E-01	8.360E-02	0.000E+00	8.430E-02	0.000E+00	5.340E+03	0.000E+00	3.820E-02
NB-95	7.120E+04	2.930E+04	0.000E+00	2.100E+04	0.000E+00	2.480E+07	0.000E+00	1.700E+04
MO-99	0.000E+00	2.500E+07	0.000E+00	3.730E+07	0.000E+00	8.220E+06	0.000E+00	4.870E+06
TC-99M	3.300E+00	6.800E+00	0.000E+00	7.320E+01	3.550E+00	1.970E+03	0.000E+00	8.760E+01
TC-101	2.960E-60	3.730E-60	0.000E+00	4.440E-59	2.030E-60	6.340E-58	0.000E+00	3.690E-59
RU-103	1.040E+03	0.000E+00	0.000E+00	2.170E+03	0.000E+00	1.270E+04	0.000E+00	3.480E+02
RU-105	9.660E-04	0.000E+00	0.000E+00	7.110E-03	0.000E+00	3.840E-01	0.000E+00	3.250E-04
RU-106	2.280E+04	0.000E+00	0.000E+00	2.700E+04	0.000E+00	1.730E+05	0.000E+00	2.850E+03
AG-110M	4.630E+07	3.380E+07	0.000E+00	4.830E+07	0.000E+00	1.750E+09	0.000E+00	2.240E+07
TE-125M	1.810E+07	6.050E+06	6.090E+06	0.000E+00	0.000E+00	8.620E+06	0.000E+00	2.450E+06
TE-127	7.580E+02	2.540E+02	6.170E+02	1.850E+03	0.000E+00	1.590E+04	0.000E+00	1.630E+02
TE-127M	5.050E+07	1.680E+07	1.460E+07	1.240E+08	0.000E+00	2.040E+07	0.000E+00	6.120E+06
TE-129	3.260E-10	1.130E-10	2.740E-10	8.130E-10	0.000E+00	2.610E-08	0.000E+00	7.620E-11
TE-129M	6.690E+07	2.290E+07	2.570E+07	1.670E+08	0.000E+00	3.990E+07	0.000E+00	1.030E+07
TE-131	4.110E-33	1.520E-33	3.670E-33	1.050E-32	0.000E+00	1.660E-31	0.000E+00	1.150E-33
TE-131M	4.050E+05	1.630E+05	3.310E+05	1.120E+06	0.000E+00	2.750E+06	0.000E+00	1.350E+05
TE-132	2.530E+06	1.250E+06	1.850E+06	7.840E+06	0.000E+00	4.640E+06	0.000E+00	1.170E+06
I-130	4.260E+06	9.370E+06	1.050E+09	1.030E+07	0.000E+00	2.010E+06	0.000E+00	3.760E+06

Catawba Nuclear Station Units 1 & 2
Period 1/1/2016 - 12/31/2016

Catawba Nuclear Station
Offsite Dose Calculation Manual (ODCM)

APPENDIX J

R_i Infant Dose Factors for use in the Gaseous Dose Calculations

Agegroup:	INFANT	Pathway:	Grs/Goat/Milk (GMILK)			Units:	m²·mrem/yr / μCi/sec; mrem/yr / μCi/m³ (H-3, C-14)	
Nuclide	Bone	Liver	Thyroid	Kidney	Lung	Gilli	Skin	Total Body
I-131	3.260E+09	3.850E+09	1.260E+12	4.490E+09	0.000E+00	1.370E+08	0.000E+00	1.690E+09
I-132	1.720E+00	3.480E+00	1.630E+02	3.890E+00	0.000E+00	2.820E+00	0.000E+00	1.240E+00
I-133	4.350E+07	6.340E+07	1.150E+10	7.450E+07	0.000E+00	1.070E+07	0.000E+00	1.860E+07
I-134	2.110E-11	4.320E-11	1.010E-09	4.830E-11	0.000E+00	4.470E-11	0.000E+00	1.540E-11
I-135	1.350E+05	2.680E+05	2.400E+07	2.990E+05	0.000E+00	9.700E+04	0.000E+00	9.770E+04
CS-134	1.090E+11	2.040E+11	0.000E+00	5.250E+10	2.150E+10	5.540E+08	0.000E+00	2.060E+10
CS-136	5.930E+09	1.740E+10	0.000E+00	6.950E+09	1.420E+09	2.650E+08	0.000E+00	6.510E+09
CS-137	1.540E+11	1.810E+11	0.000E+00	4.850E+10	1.960E+10	5.650E+08	0.000E+00	1.280E+10
CS-138	2.520E-22	4.090E-22	0.000E+00	2.040E-22	3.190E-23	6.540E-22	0.000E+00	1.980E-22
BA-139	5.130E-08	3.400E-11	0.000E+00	2.040E-11	2.060E-11	3.250E-06	0.000E+00	1.480E-09
BA-140	2.890E+07	2.890E+04	0.000E+00	6.870E+03	1.780E+04	7.100E+06	0.000E+00	1.490E+06
BA-141	4.720E-46	3.230E-49	0.000E+00	1.940E-49	1.960E-49	5.760E-45	0.000E+00	1.490E-47
BA-142	2.920E-80	2.430E-83	0.000E+00	1.400E-83	1.470E-83	1.200E-79	0.000E+00	1.440E-81
LA-140	4.860E+00	1.920E+00	0.000E+00	0.000E+00	0.000E+00	2.250E+04	0.000E+00	4.930E-01
LA-142	2.040E-11	7.500E-12	0.000E+00	0.000E+00	0.000E+00	1.270E-06	0.000E+00	1.790E-12
CE-141	5.200E+03	3.170E+03	0.000E+00	9.790E+02	0.000E+00	1.640E+06	0.000E+00	3.740E+02
CE-143	4.760E+01	3.160E+04	0.000E+00	9.200E+00	0.000E+00	1.840E+05	0.000E+00	3.600E+00
CE-144	2.790E+05	1.140E+05	0.000E+00	4.620E+04	0.000E+00	1.600E+07	0.000E+00	1.560E+04
PR-143	1.780E+02	6.670E+01	0.000E+00	2.480E+01	0.000E+00	9.410E+04	0.000E+00	8.840E+00
PR-144	6.830E-54	2.640E-54	0.000E+00	9.570E-55	0.000E+00	1.230E-49	0.000E+00	3.440E-55
ND-147	1.060E+02	1.090E+02	0.000E+00	4.190E+01	0.000E+00	6.880E+04	0.000E+00	6.650E+00
W-187	7.300E+03	5.070E+03	0.000E+00	0.000E+00	0.000E+00	2.980E+05	0.000E+00	1.750E+03
NP-239	4.380E+00	3.910E-01	0.000E+00	7.810E-01	0.000E+00	1.130E+04	0.000E+00	2.210E-01

Catawba Nuclear Station Units 1 & 2
Period 1/1/2016 - 12/31/2016

Catawba Nuclear Station
Offsite Dose Calculation Manual (ODCM)

APPENDIX J

R_i Infant Dose Factors for use in the Gaseous Dose Calculations

Agegroup:	INFANT	Pathway:	Inhalation (INHL)			Units:	mrem/yr / $\mu\text{Ci}/\text{m}^3$	
Nuclide	Bone	Liver	Thyroid	Kidney	Lung	Gilli	Skin	Total Body
H-3	0.000E+00	6.470E+02	6.470E+02	6.470E+02	6.470E+02	6.470E+02	0.000E+00	6.470E+02
C-14	2.650E+04	5.310E+03	5.310E+03	5.310E+03	5.310E+03	5.310E+03	0.000E+00	5.310E+03
NA-24	1.060E+04	1.060E+04	1.060E+04	1.060E+04	1.060E+04	1.060E+04	0.000E+00	1.060E+04
P-32	2.030E+06	1.120E+05	0.000E+00	0.000E+00	0.000E+00	1.610E+04	0.000E+00	7.740E+04
CR-51	0.000E+00	0.000E+00	5.750E+01	1.320E+01	1.280E+04	3.570E+02	0.000E+00	8.950E+01
MN-54	0.000E+00	2.530E+04	0.000E+00	4.980E+03	1.000E+06	7.060E+03	0.000E+00	4.980E+03
MN-56	0.000E+00	1.540E+00	0.000E+00	1.100E+00	1.250E+04	7.170E+04	0.000E+00	2.210E-01
FE-55	1.970E+04	1.170E+04	0.000E+00	0.000E+00	8.690E+04	1.090E+03	0.000E+00	3.330E+03
FE-59	1.360E+04	2.350E+04	0.000E+00	0.000E+00	1.010E+06	2.480E+04	0.000E+00	9.480E+03
CO-58	0.000E+00	1.220E+03	0.000E+00	0.000E+00	7.770E+05	1.110E+04	0.000E+00	1.820E+03
CO-60	0.000E+00	8.020E+03	0.000E+00	0.000E+00	4.510E+06	3.190E+04	0.000E+00	1.180E+04
NI-63	3.390E+05	2.040E+04	0.000E+00	0.000E+00	2.090E+05	2.420E+03	0.000E+00	1.160E+04
NI-65	2.390E+00	2.840E-01	0.000E+00	0.000E+00	8.120E+03	5.010E+04	0.000E+00	1.230E-01
CU-64	0.000E+00	1.880E+00	0.000E+00	3.980E+00	9.300E+03	1.500E+04	0.000E+00	7.740E-01
ZN-65	1.930E+04	6.260E+04	0.000E+00	3.250E+04	6.470E+05	5.140E+04	0.000E+00	3.110E+04
ZN-69	5.390E-02	9.670E-02	0.000E+00	4.020E-02	1.470E+03	1.320E+04	0.000E+00	7.180E-03
BR-83	0.000E+00	0.000E+00	0.000E+00	0.000E+00	0.000E+00	0.000E+00	0.000E+00	3.810E+02
BR-84	0.000E+00	0.000E+00	0.000E+00	0.000E+00	0.000E+00	0.000E+00	0.000E+00	4.000E+02
BR-85	0.000E+00	0.000E+00	0.000E+00	0.000E+00	0.000E+00	0.000E+00	0.000E+00	2.040E+01
RB-86	0.000E+00	1.900E+05	0.000E+00	0.000E+00	0.000E+00	3.040E+03	0.000E+00	8.820E+04
RB-88	0.000E+00	5.570E+02	0.000E+00	0.000E+00	0.000E+00	3.390E+02	0.000E+00	2.870E+02
RB-89	0.000E+00	3.210E+02	0.000E+00	0.000E+00	0.000E+00	6.820E+01	0.000E+00	2.060E+02
SR-89	3.980E+05	0.000E+00	0.000E+00	0.000E+00	2.030E+06	6.400E+04	0.000E+00	1.140E+04
SR-90	4.090E+07	0.000E+00	0.000E+00	0.000E+00	1.120E+07	1.310E+05	0.000E+00	2.590E+06
SR-91	9.560E+01	0.000E+00	0.000E+00	0.000E+00	5.260E+04	7.340E+04	0.000E+00	3.460E+00

Catawba Nuclear Station Units 1 & 2
Period 1/1/2016 - 12/31/2016

Catawba Nuclear Station
Offsite Dose Calculation Manual (ODCM)

APPENDIX J

R_i Infant Dose Factors for use in the Gaseous Dose Calculations

Agegroup:	INFANT	Pathway:	Inhalation (INHL)			Units:	mrem/yr / $\mu\text{Ci}/\text{m}^3$	
Nuclide	Bone	Liver	Thyroid	Kidney	Lung	Gilli	Skin	Total Body
SR-92	1.050E+01	0.000E+00	0.000E+00	0.000E+00	2.380E+04	1.400E+05	0.000E+00	3.910E-01
Y-90	3.290E+03	0.000E+00	0.000E+00	0.000E+00	2.690E+05	1.040E+05	0.000E+00	8.820E+01
Y-91	5.880E+05	0.000E+00	0.000E+00	0.000E+00	2.450E+06	7.030E+04	0.000E+00	1.570E+04
Y-91M	4.070E-01	0.000E+00	0.000E+00	0.000E+00	2.790E+03	2.350E+03	0.000E+00	1.390E-02
Y-92	1.640E+01	0.000E+00	0.000E+00	0.000E+00	2.450E+04	1.270E+05	0.000E+00	4.610E-01
Y-93	1.500E+02	0.000E+00	0.000E+00	0.000E+00	7.640E+04	1.670E+05	0.000E+00	4.070E+00
ZR-95	1.150E+05	2.790E+04	0.000E+00	3.110E+04	1.750E+06	2.170E+04	0.000E+00	2.030E+04
ZR-97	1.500E+02	2.560E+01	0.000E+00	2.590E+01	1.100E+05	1.400E+05	0.000E+00	1.170E+01
NB-95	1.570E+04	6.430E+03	0.000E+00	4.720E+03	4.790E+05	1.270E+04	0.000E+00	3.780E+03
MO-99	0.000E+00	1.650E+02	0.000E+00	2.650E+02	1.350E+05	4.870E+04	0.000E+00	3.230E+01
TC-99M	1.400E-03	2.880E-03	0.000E+00	3.110E-02	8.110E+02	2.030E+03	0.000E+00	3.720E-02
TC-101	6.510E-05	8.230E-05	0.000E+00	9.790E-04	5.840E+02	8.440E+02	0.000E+00	8.120E-04
RU-103	2.020E+03	0.000E+00	0.000E+00	4.240E+03	5.520E+05	1.610E+04	0.000E+00	6.790E+02
RU-105	1.220E+00	0.000E+00	0.000E+00	8.990E-01	1.570E+04	4.840E+04	0.000E+00	4.100E-01
RU-106	8.680E+04	0.000E+00	0.000E+00	1.070E+05	1.160E+07	1.640E+05	0.000E+00	1.090E+04
AG-110M	9.980E+03	7.220E+03	0.000E+00	1.090E+04	3.670E+06	3.300E+04	0.000E+00	5.000E+03
TE-125M	4.760E+03	1.990E+03	1.620E+03	0.000E+00	4.470E+05	1.290E+04	0.000E+00	6.580E+02
TE-127	2.230E+00	9.530E-01	1.850E+00	4.860E+00	1.030E+04	2.440E+04	0.000E+00	4.890E-01
TE-127M	1.670E+04	6.900E+03	4.870E+03	3.750E+04	1.310E+06	2.730E+04	0.000E+00	2.070E+03
TE-129	7.880E-02	3.470E-02	6.750E-02	1.750E-01	3.000E+03	2.630E+04	0.000E+00	1.880E-02
TE-129M	1.410E+04	6.090E+03	5.470E+03	3.180E+04	1.680E+06	6.900E+04	0.000E+00	2.230E+03
TE-131	1.740E-02	8.220E-03	1.580E-02	3.990E-02	2.060E+03	8.220E+03	0.000E+00	5.000E-03
TE-131M	1.070E+02	5.500E+01	8.930E+01	2.650E+02	1.990E+05	1.190E+05	0.000E+00	3.630E+01
TE-132	3.720E+02	2.370E+02	2.790E+02	1.030E+03	3.400E+05	4.410E+04	0.000E+00	1.760E+02
I-130	6.360E+03	1.390E+04	1.600E+06	1.530E+04	0.000E+00	1.990E+03	0.000E+00	5.570E+03

Catawba Nuclear Station Units 1 & 2
Period 1/1/2016 - 12/31/2016

Catawba Nuclear Station
Offsite Dose Calculation Manual (ODCM)

APPENDIX J

R_i Infant Dose Factors for use in the Gaseous Dose Calculations

Agegroup:	INFANT	Pathway:	Inhalation (INHL)			Units:	mrem/yr / $\mu\text{Ci}/\text{m}^3$	
Nuclide	Bone	Liver	Thyroid	Kidney	Lung	Gilli	Skin	Total Body
I-131	3.790E+04	4.440E+04	1.480E+07	5.180E+04	0.000E+00	1.060E+03	0.000E+00	1.960E+04
I-132	1.690E+03	3.540E+03	1.690E+05	3.950E+03	0.000E+00	1.900E+03	0.000E+00	1.260E+03
I-133	1.320E+04	1.920E+04	3.560E+06	2.240E+04	0.000E+00	2.160E+03	0.000E+00	5.600E+03
I-134	9.210E+02	1.880E+03	4.450E+04	2.090E+03	0.000E+00	1.290E+03	0.000E+00	6.650E+02
I-135	3.860E+03	7.600E+03	6.960E+05	8.470E+03	0.000E+00	1.830E+03	0.000E+00	2.770E+03
CS-134	3.960E+05	7.030E+05	0.000E+00	1.900E+05	7.970E+04	1.330E+03	0.000E+00	7.450E+04
CS-136	4.830E+04	1.350E+05	0.000E+00	5.640E+04	1.180E+04	1.430E+03	0.000E+00	5.290E+04
CS-137	5.490E+05	6.120E+05	0.000E+00	1.720E+05	7.130E+04	1.330E+03	0.000E+00	4.550E+04
CS-138	5.050E+02	7.810E+02	0.000E+00	4.100E+02	6.540E+01	8.760E+02	0.000E+00	3.980E+02
BA-139	1.480E+00	9.840E-04	0.000E+00	5.920E-04	5.950E+03	5.100E+04	0.000E+00	4.300E-02
BA-140	5.600E+04	5.600E+01	0.000E+00	1.340E+01	1.600E+06	3.840E+04	0.000E+00	2.900E+03
BA-141	1.570E-01	1.080E-04	0.000E+00	6.500E-05	2.970E+03	4.750E+03	0.000E+00	4.970E-03
BA-142	3.980E-02	3.300E-05	0.000E+00	1.900E-05	1.550E+03	6.930E+02	0.000E+00	1.960E-03
LA-140	5.050E+02	2.000E+02	0.000E+00	0.000E+00	1.680E+05	8.480E+04	0.000E+00	5.150E+01
LA-142	1.030E+00	3.770E-01	0.000E+00	0.000E+00	8.220E+03	5.950E+04	0.000E+00	9.040E-02
CE-141	2.770E+04	1.670E+04	0.000E+00	5.250E+03	5.170E+05	2.160E+04	0.000E+00	1.990E+03
CE-143	2.930E+02	1.930E+02	0.000E+00	5.640E+01	1.160E+05	4.970E+04	0.000E+00	2.210E+01
CE-144	3.190E+06	1.210E+06	0.000E+00	5.380E+05	9.840E+06	1.480E+05	0.000E+00	1.760E+05
PR-143	1.400E+04	5.240E+03	0.000E+00	1.970E+03	4.330E+05	3.720E+04	0.000E+00	6.990E+02
PR-144	4.790E-02	1.850E-02	0.000E+00	6.720E-03	1.610E+03	4.280E+03	0.000E+00	2.410E-03
ND-147	7.940E+03	8.130E+03	0.000E+00	3.150E+03	3.220E+05	3.120E+04	0.000E+00	5.000E+02
W-187	1.300E+01	9.020E+00	0.000E+00	0.000E+00	3.960E+04	3.560E+04	0.000E+00	3.120E+00
NP-239	3.710E+02	3.320E+01	0.000E+00	6.620E+01	5.950E+04	2.490E+04	0.000E+00	1.880E+01

Catawba Nuclear Station Units 1 & 2
Period 1/1/2016 - 12/31/2016

Catawba Nuclear Station
Offsite Dose Calculation Manual (ODCM)

APPENDIX J

R_i Infant Dose Factors for use in the Gaseous Dose Calculations

Agegroup:	INFANT	Pathway:	Ground Plane Deposition (GPD)			Units:	m²·mrem/yr / μCi/sec	
Nuclide	Bone	Liver	Thyroid	Kidney	Lung	Gilli	Skin	Total Body
H-3	0.000E+00	0.000E+00	0.000E+00	0.000E+00	0.000E+00	0.000E+00	0.000E+00	0.000E+00
C-14	0.000E+00	0.000E+00	0.000E+00	0.000E+00	0.000E+00	0.000E+00	0.000E+00	0.000E+00
NA-24	1.190E+07	1.190E+07	1.190E+07	1.190E+07	1.190E+07	1.190E+07	1.390E+07	1.190E+07
P-32	0.000E+00	0.000E+00	0.000E+00	0.000E+00	0.000E+00	0.000E+00	0.000E+00	0.000E+00
CR-51	4.660E+06	4.660E+06	4.660E+06	4.660E+06	4.660E+06	4.660E+06	5.510E+06	4.660E+06
MN-54	1.390E+09	1.390E+09	1.390E+09	1.390E+09	1.390E+09	1.390E+09	1.630E+09	1.390E+09
MN-56	9.020E+05	9.020E+05	9.020E+05	9.020E+05	9.020E+05	9.020E+05	1.070E+06	9.020E+05
FE-55	0.000E+00	0.000E+00	0.000E+00	0.000E+00	0.000E+00	0.000E+00	0.000E+00	0.000E+00
FE-59	2.730E+08	2.730E+08	2.730E+08	2.730E+08	2.730E+08	2.730E+08	3.210E+08	2.730E+08
CO-58	3.790E+08	3.790E+08	3.790E+08	3.790E+08	3.790E+08	3.790E+08	4.440E+08	3.790E+08
CO-60	2.150E+10	2.150E+10	2.150E+10	2.150E+10	2.150E+10	2.150E+10	2.530E+10	2.150E+10
NI-63	0.000E+00	0.000E+00	0.000E+00	0.000E+00	0.000E+00	0.000E+00	0.000E+00	0.000E+00
NI-65	2.970E+05	2.970E+05	2.970E+05	2.970E+05	2.970E+05	2.970E+05	3.450E+05	2.970E+05
CU-64	6.070E+05	6.070E+05	6.070E+05	6.070E+05	6.070E+05	6.070E+05	6.880E+05	6.070E+05
ZN-65	7.470E+08	7.470E+08	7.470E+08	7.470E+08	7.470E+08	7.470E+08	8.590E+08	7.470E+08
ZN-69	0.000E+00	0.000E+00	0.000E+00	0.000E+00	0.000E+00	0.000E+00	0.000E+00	0.000E+00
BR-83	4.870E+03	4.870E+03	4.870E+03	4.870E+03	4.870E+03	4.870E+03	7.080E+03	4.870E+03
BR-84	2.030E+05	2.030E+05	2.030E+05	2.030E+05	2.030E+05	2.030E+05	2.360E+05	2.030E+05
BR-85	0.000E+00	0.000E+00	0.000E+00	0.000E+00	0.000E+00	0.000E+00	0.000E+00	0.000E+00
RB-86	8.990E+06	8.990E+06	8.990E+06	8.990E+06	8.990E+06	8.990E+06	1.030E+07	8.990E+06
RB-88	3.310E+04	3.310E+04	3.310E+04	3.310E+04	3.310E+04	3.310E+04	3.780E+04	3.310E+04
RB-89	1.230E+05	1.230E+05	1.230E+05	1.230E+05	1.230E+05	1.230E+05	1.480E+05	1.230E+05
SR-89	2.160E+04	2.160E+04	2.160E+04	2.160E+04	2.160E+04	2.160E+04	2.510E+04	2.160E+04
SR-90	0.000E+00	0.000E+00	0.000E+00	0.000E+00	0.000E+00	0.000E+00	0.000E+00	0.000E+00
SR-91	2.150E+06	2.150E+06	2.150E+06	2.150E+06	2.150E+06	2.150E+06	2.510E+06	2.150E+06

Catawba Nuclear Station Units 1 & 2
Period 1/1/2016 - 12/31/2016

Catawba Nuclear Station
Offsite Dose Calculation Manual (ODCM)

APPENDIX J

R_i Infant Dose Factors for use in the Gaseous Dose Calculations

Agegroup:	INFANT	Pathway:	Ground Plane Deposition (GPD)			Units:	m²·mrem/yr / μCi/sec	
Nuclide	Bone	Liver	Thyroid	Kidney	Lung	Gilli	Skin	Total Body
SR-92	7.770E+05	7.770E+05	7.770E+05	7.770E+05	7.770E+05	7.770E+05	8.630E+05	7.770E+05
Y-90	4.490E+03	4.490E+03	4.490E+03	4.490E+03	4.490E+03	4.490E+03	5.310E+03	4.490E+03
Y-91	1.070E+06	1.070E+06	1.070E+06	1.070E+06	1.070E+06	1.070E+06	1.210E+06	1.070E+06
Y-91M	1.000E+05	1.000E+05	1.000E+05	1.000E+05	1.000E+05	1.000E+05	1.160E+05	1.000E+05
Y-92	1.800E+05	1.800E+05	1.800E+05	1.800E+05	1.800E+05	1.800E+05	2.140E+05	1.800E+05
Y-93	1.830E+05	1.830E+05	1.830E+05	1.830E+05	1.830E+05	1.830E+05	2.510E+05	1.830E+05
ZR-95	2.450E+08	2.450E+08	2.450E+08	2.450E+08	2.450E+08	2.450E+08	2.840E+08	2.450E+08
ZR-97	2.960E+06	2.960E+06	2.960E+06	2.960E+06	2.960E+06	2.960E+06	3.440E+06	2.960E+06
NB-95	1.370E+08	1.370E+08	1.370E+08	1.370E+08	1.370E+08	1.370E+08	1.610E+08	1.370E+08
MO-99	3.990E+06	3.990E+06	3.990E+06	3.990E+06	3.990E+06	3.990E+06	4.630E+06	3.990E+06
TC-99M	1.840E+05	1.840E+05	1.840E+05	1.840E+05	1.840E+05	1.840E+05	2.110E+05	1.840E+05
TC-101	2.040E+04	2.040E+04	2.040E+04	2.040E+04	2.040E+04	2.040E+04	2.260E+04	2.040E+04
RU-103	1.080E+08	1.080E+08	1.080E+08	1.080E+08	1.080E+08	1.080E+08	1.260E+08	1.080E+08
RU-105	6.360E+05	6.360E+05	6.360E+05	6.360E+05	6.360E+05	6.360E+05	7.210E+05	6.360E+05
RU-106	4.220E+08	4.220E+08	4.220E+08	4.220E+08	4.220E+08	4.220E+08	5.070E+08	4.220E+08
AG-110M	3.440E+09	3.440E+09	3.440E+09	3.440E+09	3.440E+09	3.440E+09	4.010E+09	3.440E+09
TE-125M	1.550E+06	1.550E+06	1.550E+06	1.550E+06	1.550E+06	1.550E+06	2.130E+06	1.550E+06
TE-127	2.980E+03	2.980E+03	2.980E+03	2.980E+03	2.980E+03	2.980E+03	3.280E+03	2.980E+03
TE-127M	9.160E+04	9.160E+04	9.160E+04	9.160E+04	9.160E+04	9.160E+04	1.080E+05	9.160E+04
TE-129	2.620E+04	2.620E+04	2.620E+04	2.620E+04	2.620E+04	2.620E+04	3.100E+04	2.620E+04
TE-129M	1.980E+07	1.980E+07	1.980E+07	1.980E+07	1.980E+07	1.980E+07	2.310E+07	1.980E+07
TE-131	2.920E+04	2.920E+04	2.920E+04	2.920E+04	2.920E+04	2.920E+04	3.450E+07	2.920E+04
TE-131M	8.030E+06	8.030E+06	8.030E+06	8.030E+06	8.030E+06	8.030E+06	9.460E+06	8.030E+06
TE-132	4.230E+06	4.230E+06	4.230E+06	4.230E+06	4.230E+06	4.230E+06	4.980E+06	4.230E+06
I-130	5.510E+06	5.510E+06	5.510E+06	5.510E+06	5.510E+06	5.510E+06	6.690E+06	5.510E+06

Catawba Nuclear Station Units 1 & 2
Period 1/1/2016 - 12/31/2016

Catawba Nuclear Station
Offsite Dose Calculation Manual (ODCM)

APPENDIX J

R_i Infant Dose Factors for use in the Gaseous Dose Calculations

Agegroup:	INFANT	Pathway:	Ground Plane Deposition (GPD)			Units:	m²·mrem/yr / μCi/sec	
Nuclide	Bone	Liver	Thyroid	Kidney	Lung	Gilli	Skin	Total Body
I-131	1.720E+07	1.720E+07	1.720E+07	1.720E+07	1.720E+07	1.720E+07	2.090E+07	1.720E+07
I-132	1.250E+06	1.250E+06	1.250E+06	1.250E+06	1.250E+06	1.250E+06	1.470E+06	1.250E+06
I-133	2.450E+06	2.450E+06	2.450E+06	2.450E+06	2.450E+06	2.450E+06	2.980E+06	2.450E+06
I-134	4.470E+05	4.470E+05	4.470E+05	4.470E+05	4.470E+05	4.470E+05	5.300E+05	4.470E+05
I-135	2.530E+06	2.530E+06	2.530E+06	2.530E+06	2.530E+06	2.530E+06	2.950E+06	2.530E+06
CS-134	6.860E+09	6.860E+09	6.860E+09	6.860E+09	6.860E+09	6.860E+09	8.000E+09	6.860E+09
CS-136	1.510E+08	1.510E+08	1.510E+08	1.510E+08	1.510E+08	1.510E+08	1.710E+08	1.510E+08
CS-137	1.030E+10	1.030E+10	1.030E+10	1.030E+10	1.030E+10	1.030E+10	1.200E+10	1.030E+10
CS-138	3.590E+05	3.590E+05	3.590E+05	3.590E+05	3.590E+05	3.590E+05	4.100E+05	3.590E+05
BA-139	1.060E+05	1.060E+05	1.060E+05	1.060E+05	1.060E+05	1.060E+05	1.190E+05	1.060E+05
BA-140	2.050E+07	2.050E+07	2.050E+07	2.050E+07	2.050E+07	2.050E+07	2.350E+07	2.050E+07
BA-141	4.170E+04	4.170E+04	4.170E+04	4.170E+04	4.170E+04	4.170E+04	4.750E+04	4.170E+04
BA-142	4.490E+04	4.490E+04	4.490E+04	4.490E+04	4.490E+04	4.490E+04	5.110E+04	4.490E+04
LA-140	1.920E+07	1.920E+07	1.920E+07	1.920E+07	1.920E+07	1.920E+07	2.180E+07	1.920E+07
LA-142	7.600E+05	7.600E+05	7.600E+05	7.600E+05	7.600E+05	7.600E+05	9.120E+05	7.600E+05
CE-141	1.370E+07	1.370E+07	1.370E+07	1.370E+07	1.370E+07	1.370E+07	1.540E+07	1.370E+07
CE-143	2.310E+06	2.310E+06	2.310E+06	2.310E+06	2.310E+06	2.310E+06	2.630E+06	2.310E+06
CE-144	6.950E+07	6.950E+07	6.950E+07	6.950E+07	6.950E+07	6.950E+07	8.040E+07	6.950E+07
PR-143	0.000E+00	0.000E+00	0.000E+00	0.000E+00	0.000E+00	0.000E+00	0.000E+00	0.000E+00
PR-144	1.830E+03	1.830E+03	1.830E+03	1.830E+03	1.830E+03	1.830E+03	2.110E+03	1.830E+03
ND-147	8.390E+06	8.390E+06	8.390E+06	8.390E+06	8.390E+06	8.390E+06	1.010E+07	8.390E+06
W-187	2.350E+06	2.350E+06	2.350E+06	2.350E+06	2.350E+06	2.350E+06	2.730E+06	2.350E+06
NP-239	1.710E+06	1.710E+06	1.710E+06	1.710E+06	1.710E+06	1.710E+06	1.980E+06	1.710E+06

Catawba Nuclear Station Units 1 & 2
Period 1/1/2016 - 12/31/2016

LIST OF EFFECTIVE SECTIONS

<u>SECTION</u>	<u>REVISION NUMBER</u>	<u>REVISION DATE</u>
TABLE OF CONTENTS	15	05/10/16
16.1	1	08/27/08
16.2	2	08/21/09
16.3	1	08/21/09
16.5-1	4	09/15/16
16.5-2	Deleted	
16.5-3	1	02/20/04
16.5-4	0	10/09/02
16.5-5	1	01/28/10
16.5-6	1	08/21/09
16.5-7	2	02/06/15
16.5-8	2	12/22/08
16.5-9	1	02/20/12
16.5-10	Deleted	
16.6-1	0	10/09/02
16.6-2	Deleted	
16.6-3	1	08/21/09
16.6-4	1	08/21/09
16.6-5	2	01/09/13
16.7-1	1	08/21/09
16.7-2	4	02/03/11
16.7-3	4	07/27/13
16.7-4	2	08/21/09
16.7-5	2	08/21/09

Catawba Nuclear Station Units 1 & 2
Period 1/1/2016 - 12/31/2016

LIST OF EFFECTIVE SECTIONS

<u>SECTION</u>	<u>REVISION NUMBER</u>	<u>REVISION DATE</u>
16.7-6	3	06/10/16
16.7-7	1	08/21/09
16.7-8	2	08/21/09
16.7-9	9	06/06/13
16.7-10	7	03/28/16
16.7-11	1	08/21/09
16.7-12	1	08/21/09
16.7-13	3	06/10/16
16.7-14	1	08/21/09
16.7-15	1	08/21/09
16.7-16	0	06/08/09
16.7-17	0	02/10/15
16.7-18	0	05/10/16
16.8-1	6	12/10/15
16.8-2	2	02/20/12
16.8-3	1	10/24/06
16.8-4	2	11/05/07
16.8-5	3	08/21/09
16.9-1	7	10/24/11
16.9-2	5	10/24/11
16.9-3	3	02/03/11
16.9-4	3	08/21/09
16.9-5	6	06/23/10
16.9-6	10	02/10/15

Catawba Nuclear Station Units 1 & 2
Period 1/1/2016 - 12/31/2016

LIST OF EFFECTIVE SECTIONS

<u>SECTION</u>	<u>REVISION NUMBER</u>	<u>REVISION DATE</u>
16.9-7	4	08/21/09
16.9-8	5	08/21/09
16.9-9	3	08/21/09
16.9-10	5	08/21/09
16.9-11	3	08/21/09
16.9-12	3	02/10/15
16.9-13	4	09/27/16
16.9-14	1	09/25/06
16.9-15	2	08/21/09
16.9-16	2	08/21/09
16.9-17	0	10/09/02
16.9-18	0	10/09/02
16.9-19	3	02/20/12
16.9-20	0	10/09/02
16.9-21	0	10/09/02
16.9-22	1	08/21/09
16.9-23	4	10/24/11
16.9-24	2	10/24/06
16.9-25	2	08/21/09
16.9-26	0	03/05/12
16.10-1	1	08/21/09
16.10-2	1	10/24/06
16.10-3	1	08/21/09
16.11-1	1	07/27/13

Catawba Nuclear Station Units 1 & 2
Period 1/1/2016 - 12/31/2016

LIST OF EFFECTIVE SECTIONS

<u>SECTION</u>	<u>REVISION NUMBER</u>	<u>REVISION DATE</u>
16.11-2	4	02/10/15
16.11-3	0	10/09/02
16.11-4	1	08/21/09
16.11-5	0	10/09/02
16.11-6	3	08/03/15
16.11-7	9	02/10/15
16.11-8	0	10/09/02
16.11-9	0	10/09/02
16.11-10	1	08/21/09
16.11-11	1	03/20/03
16.11-12	0	10/09/02
16.11-13	1	07/27/13
16.11-14	0	10/09/02
16.11-15	0	10/09/02
16.11-16	1	10/24/11
16.11-17	0	10/09/02
16.11-18	1	08/21/09
16.11-19	0	10/09/02
16.11-20	2	03/28/16
16.11-21	0	10/09/02
16.12-1	0	10/09/02
16.13-1	0	10/09/02
16.13-2	Deleted	
16.13-3	Deleted	

Catawba Nuclear Station Units 1 & 2
Period 1/1/2016 - 12/31/2016

LIST OF EFFECTIVE SECTIONS

<u>SECTION</u>	<u>REVISION NUMBER</u>	<u>REVISION DATE</u>
16.13-4	0	10/09/02

16.11 RADIOLOGICAL EFFLUENTS CONTROLS

16.11-1 Liquid Effluents

COMMITMENT: The concentration of radioactive material released in liquid effluents to UNRESTRICTED AREAS (see Figure 16.11-16-1 in SLC 16.11-16) shall be limited to:

- a. For radionuclides other than dissolved or entrained noble gases, 10 times the effluent concentrations specified in 10 CFR Part 20, Appendix B, Table 2, Column 2, and
- b. For dissolved or entrained noble gases, the concentration shall be limited to 2×10^{-4} microCurie/ml total activity.

APPLICABILITY: At all times.

REMEDIAL ACTIONS

CONDITION	REQUIRED ACTION	COMPLETION TIME
A. Concentration of radioactive material released in liquid effluents to UNRESTRICTED AREAS not within limits.	A.1 Restore the concentration to within limits.	Immediately

TESTING REQUIREMENTS

TEST	FREQUENCY
TR 16.11-1-1 -----NOTE----- The results of the radioactivity analyses shall be used in accordance with the methodology and parameters in the ODCM to assure that the concentrations at the point of release are maintained within the limits. ----- Sample and analyze radioactive liquid wastes according to Table 16.11-1-1.	According to Table 16.11-1-1

Table 16.11-1-1

Radioactive Liquid Waste Sampling and Analysis Program (page 1 of 3)

LIQUID RELEASE TYPE	SAMPLING FREQUENCY	MINIMUM ANALYSIS FREQUENCY	TYPE OF ACTIVITY ANALYSIS	LOWER LIMIT OF DETECTION (LLD) ⁽¹⁾ (μCi/ml)		
1. Batch Waste Release Tanks ⁽²⁾ Any tank which discharges liquid wastes by either liquid effluent monitor, EMF-49 or EMF-57	Prior to each release Each Batch	Prior to each release Each Batch	Principal Gamma Emitters ⁽³⁾	5x10 ⁻⁷		
			I-131	1x10 ⁻⁶		
	Prior to each release One Batch/31 days	31 days	Dissolved and Entrained Gases (Gamma Emitters)	1x10 ⁻⁵		
			Prior to each release Each Batch	31 days Composite ⁽⁴⁾	H-3	1x10 ⁻⁵
					Gross Alpha	1x10 ⁻⁷
Prior to each release Each Batch	92 days Composite ⁽⁴⁾	Sr-89, Sr-90	5x10 ⁻⁸			
2. Continuous Releases ⁽⁵⁾ Conventional Waste Water Treatment Line	Continuous ⁽⁶⁾	7 days Composite ⁽⁶⁾	Principal Gamma Emitters ⁽³⁾	5x10 ⁻⁷		
			I-131	1x10 ⁻⁶		
	31 days Grab Sample	31 days	Dissolved and Entrained Gases (Gamma Emitters)	1x10 ⁻⁵		
	Continuous ⁽⁶⁾	31 days Composite ⁽⁶⁾	H-3	1x10 ⁻⁵		
			Gross Alpha	1x10 ⁻⁷		
	Continuous ⁽⁶⁾	92 days Composite ⁽⁶⁾	Sr-89, Sr-90	5x10 ⁻⁸		

Table 16.11-1-1

Radioactive Liquid Waste Sampling and Analysis Program (page 2 of 3)

NOTES:

- (1) The LLD is defined, for purposes of these commitments, as the smallest concentration of radioactive material in a sample that will yield a net count, above system background, that will be detected with 95% probability with only 5% probability of falsely concluding that a blank observation represents a "real" signal.

For a particular measurement system, which may include radiochemical separation:

$$LLD = \frac{(2.71/T) + 4.65 s_b}{E \cdot V \cdot 2.22 \times 10^6 \cdot Y \cdot \exp(-\lambda \Delta t)}$$

Where:

LLD = the "a priori" lower limit of detection (microCurie per unit mass or volume),

s_b = the standard deviation of the background counting rate or of the counting rate of a blank sample as appropriate (counts per minute),

E = the counting efficiency (counts per disintegration),

V = the sample size (units of mass or volume),

2.22×10^6 = the number of disintegrations per minute per microCurie,

Y = the fractional radiochemical yield, when applicable,

λ = the radioactive decay constant for the particular radionuclide (sec^{-1}),

Δt = the elapsed time between midpoint of sample collection and time of counting (sec), and

T = the sample counting time (min).

Typical values of E, V, Y and Δt shall be used in the calculation.

It should be recognized that the LLD is defined as an a priori (before the fact) limit representing the capability of a measurement system and not as an a posteriori (after the fact) limit for a particular measurement.

- (2) A batch release is the discharge of liquid wastes of a discrete volume. Prior to sampling for analyses, each batch shall be isolated, and then thoroughly mixed to assure representative sampling.

Table 16.11-1-1

Radioactive Liquid Waste Sampling and Analysis Program (page 3 of 3)

- (3) The principal gamma emitters for which the LLD specification applies include the following radionuclides:

Mn-54, Fe-59, Co-58, Co-60, Zn-65, Mo-99, Cs-134, Cs-137, and Ce-141. The LLD for Ce-144 is 5×10^{-6} $\mu\text{Ci/ml}$. This list does not mean that only these nuclides are to be considered. Other gamma peaks that are identifiable, together with those of the above nuclides, shall also be analyzed and reported in the Radioactive Effluent Release Report pursuant to Technical Specification 5.6.3 in the format outlined in Regulatory Guide 1.21, Appendix B, Revision 1, June 1974.
- (4) A composite sample is one in which the quantity of liquid sampled is proportional to the quantity of liquid waste discharged and in which the method of sampling employed results in a specimen that is representative of the liquids released.
- (5) A continuous release is the discharge of liquid wastes of a non-discrete volume, e.g., from a volume of a system that has an input flow during the continuous release.
- (6) To be representative of the quantities and concentrations of radioactive materials in liquid effluents, samples shall be collected continuously in proportion to the rate of flow of the effluent stream. Prior to analyses, all samples taken for the composite shall be thoroughly mixed in order for the composite sample to be representative of the effluent release.

BASES

The basic requirements for SLCs concerning effluents from nuclear power reactors are stated in 10 CFR 50.36a. These requirements indicate that compliance with effluent SLCs will keep average annual releases of radioactive material in effluents to small percentages of the limits specified in the old 10 CFR 20.106 (new 10 CFR 20.1302). These requirements further indicate that operational flexibility is allowed, compatible with considerations of health and safety, which may temporarily result in releases higher than such small percentages, but still within the limits specified in the old 10 CFR 20.106 which references Appendix B, Table II concentrations (MPCs). These referenced concentrations are specific values which relate to an annual dose of 500 mrem. It is further indicated in 10 CFR 50.36a that when using operational flexibility, best efforts shall be exerted to keep levels of radioactive materials in effluents as low as is reasonably achievable (ALARA) as set forth in 10 CFR 50, Appendix I.

As stated in the Introduction to Appendix B of the new 10 CFR 20, the liquid effluent concentration (EC) limits given in Appendix B, Table 2, Column 2, are based on an annual dose of 50 mrem. Since a release concentration corresponding to a limiting dose rate of 500 mrem/year has been acceptable as a SLC limit for liquid effluents, which applies at all times as an assurance that the limits of 10 CFR 50, Appendix I are not likely to be exceeded, it should not be necessary to reduce this limit by a factor of 10.

Operational history at Catawba has demonstrated that the use of the concentration values associated with the old 10 CFR 20.106 as SLC limits has resulted in calculated maximum individual doses to a MEMBER OF THE PUBLIC that are small percentages of the limits of 10 CFR 50, Appendix I. Therefore, the use of concentration values which correspond to an annual dose of 500 mrem (ten times the concentration values stated in the new 10 CFR 20, Appendix B, Table 2, Column 2) should not have a negative impact on the ability to continue to operate within the limits of 10 CFR 50, Appendix I and 40 CFR 190.

Having sufficient operational flexibility is especially important in establishing a basis for effluent monitor setpoint calculations. As discussed above, the concentrations stated in the new 10 CFR 20, Appendix B, Table 2, Column 2, relate to a dose of 50 mrem in a year. When applied on an instantaneous basis, this corresponds to a dose rate of 50 mrem/year. This low value is impractical upon which to base effluent monitor setpoint calculations for many liquid effluent release situations when monitor background, monitor sensitivity, and monitor performance must be taken into account.

Therefore, to accommodate operational flexibility needed for effluent releases, the limits associated with SLC 16.11-1 are based on ten times the concentrations stated in the new 10 CFR 20, Appendix B, Table 2, Column 2, to apply at all times. The multiplier of ten is proposed because the annual dose of 500 mrem, upon which the concentrations in the old 10 CFR 20, Appendix B, Table II, Column 2, are based, is a factor of 10 higher than annual dose of 50 mrem, upon which the concentrations in the new 10 CFR

BASES (continued)

20, Appendix B, Table 2, Column 2, are based. Compliance with the limits of the new 10 CFR 20.1301 will be demonstrated by operating within the limits of 10 CFR 50, Appendix I and 40 CFR 190. The concentration limit for dissolved or entrained noble gases is based upon the assumption that Xe-135 is the controlling radioisotope and its MPC in air (submersion) was converted to an equivalent concentration in water using the methods described in International Commission on Radiological Protection (ICRP) Publication 2.

This commitment applies to the release of radioactive materials in liquid effluents from all units at the site.

The required detection capabilities for radioactive materials in liquid waste samples are tabulated in terms of the lower limits of detection (LLDs). Detailed discussion of the LLD, and other detection limits can be found in HASL Procedures Manual, HASL-300 (revised annually), Currie, L. A., "Limits for Qualitative Detection and Quantitative Determination – Application to Radiochemistry," Annal. Chem. 40, 586-93 (1968), and Hartwell, J. K., "Detection Limits for Radioanalytical Counting Techniques," Atlantic Richfield Hanford Company Report ARH-SA-215 (June 1975).

- REFERENCES
1. Catawba Offsite Dose Calculation Manual.
 2. 10 CFR Part 20, Appendix B.

Radioactive Liquid Effluent Monitoring Instrumentation
 16.11-2

16.11 RADIOLOGICAL EFFLUENTS CONTROLS

16.11-2 Radioactive Liquid Effluent Monitoring Instrumentation

COMMITMENT The Radioactive Liquid Effluent Monitoring Instrumentation channels shown in Table 16.11-2-1 shall be FUNCTIONAL with their Alarm/Trip Setpoints set to ensure that the limits of SLC 16.11-1 are not exceeded.

AND

The Alarm/Trip Setpoints of these channels shall be determined and adjusted in accordance with the methodology and parameters in the OFFSITE DOSE CALCULATION MANUAL (ODCM).

APPLICABILITY: At all times, except when the effluent pathway is mechanically isolated; thus, a release to the environment is not possible.

REMEDIAL ACTIONS

-----NOTE-----
 Separate Condition entry is allowed for each Function.

CONDITION		REQUIRED ACTION	COMPLETION TIME
A.	One or more Radioactive Liquid Effluent Monitoring Instrumentation channel(s) Alarm/Trip Setpoint less conservative than required.	A.1 Suspend the release of radioactive liquid effluents monitored by the affected channel(s).	Immediately
		<u>OR</u>	
		A.2 Declare the channel(s) non-functional.	Immediately
B.	One or more Radioactive Liquid Effluent Monitoring Instrumentation channel(s) non-functional.	B.1 Enter the applicable Conditions and Required Actions specified in Table 16.11-2-1 for the channel(s).	Immediately

(continued)

Catawba Nuclear Station Units 1 & 2
 Period 1/1/2016 - 12/31/2016

Radioactive Liquid Effluent Monitoring Instrumentation
 16.11-2

REMEDIAL ACTIONS (continued)

CONDITION	REQUIRED ACTION	COMPLETION TIME
C. One channel non-functional.	C.1.1 Analyze two independent samples per Testing Requirement 16.11-1-1.	Prior to initiating a release
	<u>AND</u>	
	C.1.2 Perform independent verification of the discharge line valving.	Prior to initiating a release
	<u>AND</u>	
	C.1.3.1 Perform independent verification of manual portion of the computer input for release rate calculations performed by computer.	Prior to initiating a release
	<u>OR</u>	
C.1.3.2 Perform independent verification of entire calculations for release rate calculations performed manually.	Prior to initiating a release	
<u>AND</u>		
C.1.4 Restore channel to FUNCTIONAL status.	14 days	
<u>OR</u>		
C.2 Suspend release of radioactive effluents via this pathway.	Immediately	

(continued)

Catawba Nuclear Station Units 1 & 2
 Period 1/1/2016 - 12/31/2016

Radioactive Liquid Effluent Monitoring Instrumentation
 16.11-2

REMEDIAL ACTIONS (continued)

CONDITION	REQUIRED ACTION	COMPLETION TIME
D. One flow rate measurement device channel non-functional.	D.1 -----NOTE----- Pump performance curves generated in place may be used to estimate flow. ----- Estimate the flow rate of the release. <u>AND</u> D.2 Restore channel to FUNCTIONAL status.	Once per 4 hours during releases 30 days
E. One channel non-functional.	E.1 Perform an analysis of grab samples for radioactivity at a lower limit of detection of 10^{-7} microCurie/ml. <u>AND</u> E.2 Restore channel to FUNCTIONAL status.	Once per 12 hours during releases when secondary specific activity is > 0.01 microCurie/gm DOSE EQUIVALENT I-131 <u>AND</u> Once per 24 hours during releases when secondary specific activity is \leq 0.01 microCurie/gm DOSE EQUIVALENT I-131 30 days

(continued)

Radioactive Liquid Effluent Monitoring Instrumentation
16.11-2

REMEDIAL ACTIONS (continued)

CONDITION	REQUIRED ACTION	COMPLETION TIME
F. One channel non-functional.	F.1 Collect and analyze grab samples for principal gamma emitters (listed in Table 16.11-1-1, NOTE 3) at a lower limit of detection of no more than 5×10^{-7} microCurie/ml.	Once per 12 hours
	<u>AND</u> F.2 Restore non-functional channel to FUNCTIONAL status.	30 days
G. Required Action and associated Completion Time of Condition C, D, E, or F not met.	G.1 Explain why the non-functionality was not corrected within the specified Completion Time.	In the next scheduled Radioactive Effluent Release Report pursuant to Technical Specification 5.6.3

Radioactive Liquid Effluent Monitoring Instrumentation
 16.11-2

TESTING REQUIREMENTS

-----NOTE-----
 Refer to Table 16.11-2-1 to determine which TRs apply for each Radioactive Liquid Effluent Monitoring Instrumentation channel.

TEST	FREQUENCY
TR 16.11-2-1 Perform CHANNEL CHECK.	24 hours
TR 16.11-2-2 -----NOTE----- The CHANNEL CHECK shall consist of verifying indication of flow. ----- Perform CHANNEL CHECK.	24 hours during periods of release
TR 16.11-2-3 Perform SOURCE CHECK.	Prior to each release
TR 16.11-2-4 Perform SOURCE CHECK.	31 days
TR 16.11-2-5 Perform COT.	92 days
TR 16.11-2-6 -----NOTE----- For Instrument 1, the COT shall also demonstrate that automatic isolation of this pathway and control room alarm annunciation (for EMF-57, alarm annunciation is in the Monitor Tank Building control room and on the Monitor Tank Building control panel remote annunciator panel) occur if any of the following conditions exist: a. Instrument indicates measured levels above the Alarm/Trip Setpoint, or b. Circuit failure/instrument downscale failure (alarm only) ----- Perform COT.	9 months

(continued)

Radioactive Liquid Effluent Monitoring Instrumentation
 16.11-2

TESTING REQUIREMENTS (continued)

TEST	FREQUENCY
<p>TR 16.11-2-7 -----NOTE----- For Instrument 1, the initial CHANNEL CALIBRATION shall be performed using one or more of the reference standards certified by the National Bureau of Standards (NBS) or using standards that have been obtained from suppliers that participate in measurement assurance activities with NBS. These standards shall permit calibrating the system over its intended range of energy and measurement range. For subsequent CHANNEL CALIBRATION, sources that have been related to the initial calibration shall be used. ----- Perform CHANNEL CALIBRATION.</p>	<p>18 months</p>

Catawba Nuclear Station Units 1 & 2
Period 1/1/2016 - 12/31/2016

Radioactive Liquid Effluent Monitoring Instrumentation
16.11-2

Table 16.11-2-1

Radioactive Liquid Effluent Monitoring Instrumentation

INSTRUMENT	REQUIRED CHANNELS	CONDITIONS	TESTING REQUIREMENTS
1. Radioactivity Monitors Providing Alarm and Automatic Termination of Release			
1.a Waste Liquid Discharge Monitor (EMF-49 – Low Range)	1 per station	A, C, G	TR 16.11-2-1 TR 16.11-2-3 TR 16.11-2-6 TR 16.11-2-7
1.b Turbine Building Sump Monitor (EMF-31)	1	A, E, G	TR 16.11-2-1 TR 16.11-2-4 TR 16.11-2-6 TR 16.11-2-7
1.c Monitor Tank Building Liquid Discharge Monitor (EMF-57 – Low Range)	1 per station	A, C, G	TR 16.11-2-1 TR 16.11-2-3 TR 16.11-2-6 TR 16.11-2-7
2. Continuous Composite Samplers and Sampler Flow Monitor			
2.a Conventional Waste Water Treatment Line (no alarm/trip function)	1 per station	E, G	TR 16.11-2-2 TR 16.11-2-7
3. Flow Rate Measurement Devices			
3.a Waste Liquid Effluent Line (no alarm/trip function)	1 per station	D, G	TR 16.11-2-2 TR 16.11-2-7
3.b Conventional Waste Water Treatment Line (no alarm/trip function)	1 per station	D, G	TR 16.11-2-2 TR 16.11-2-7
3.c Low Pressure Service Water Minimum Flow Interlock	1 per station	D, G	TR 16.11-2-2 TR 16.11-2-5 TR 16.11-2-7
3.d Monitor Tank Building Waste Liquid Effluent Line (no alarm/trip function)	1 per station	D, G	TR 16.11-2-2 TR 16.11-2-7
4. Radioactivity Monitors Providing Alarm			
4.a Service Water Monitor on Containment Spray Heat Exchanger (EMF-45 A & B – Low Range)	1 per heat exchanger	A, F, G	TR 16.11-2-1 TR 16.11-2-4 TR 16.11-2-6 TR 16.11-2-7

Radioactive Liquid Effluent Monitoring Instrumentation
16.11-2

BASES

The Radioactive Liquid Effluent Monitoring Instrumentation is provided to monitor and control, as applicable, the releases of radioactive materials in liquid effluents during actual or potential releases of liquid effluents. The Alarm/Trip Setpoints for these instruments shall be calculated and adjusted in accordance with the methodology and parameters in the ODCM to ensure that the Alarm/Trip will occur prior to exceeding the limits of 10 CFR Part 20. The FUNCTIONALITY and use of this instrumentation is consistent with the requirements of General Design Criteria 60, 63, and 64 of Appendix A to 10 CFR Part 50.

Regarding the COMMITMENT APPLICABILITY, isolation of the effluent pathway is to be by mechanical means (e.g., valve closure). Electrical or pneumatic isolation is not required, unless the isolation is designed to receive an automatic signal to open.

REFERENCES

1. Catawba Offsite Dose Calculation Manual.
2. 10 CFR Part 20.
3. 10 CFR Part 50, Appendix A.

Gaseous Radwaste Treatment System
 16.11-10

16.11 RADIOLOGICAL EFFLUENTS CONTROLS

16.11-10 Gaseous Radwaste Treatment System

COMMITMENT The VENTILATION EXHAUST TREATMENT SYSTEM and the WASTE GAS HOLDUP SYSTEM shall be FUNCTIONAL and appropriate portions of these systems shall be used to reduce releases of radioactivity when the projected doses in 31 days due to gaseous effluent releases, from each unit, to areas at and beyond the SITE BOUNDARY (see Figure 16.11-16-1 in SLC 16.11-16) would exceed either:

- a. 0.2 mrad to air from gamma radiation, or
- b. 0.4 mrad to air from beta radiation, or
- c. 0.3 mrem to any organ of a MEMBER OF THE PUBLIC.

APPLICABILITY: At all times.

REMEDIAL ACTIONS

CONDITION	REQUIRED ACTION	COMPLETION TIME
A. Radioactive gaseous waste being discharged without treatment and in excess of above limits.	A.1 Prepare and submit a Special Report to the NRC which identifies non-functional equipment and reasons for non-functionality, actions taken to restore the equipment to FUNCTIONAL status, and actions taken to prevent recurrence.	30 days

Gaseous Radwaste Treatment System
 16.11-10

TESTING REQUIREMENTS

-----NOTE-----
 The installed VENTILATION EXHAUST TREATMENT SYSTEM and WASTE GAS HOLDUP SYSTEM shall be demonstrated FUNCTIONAL by meeting SLC 16.11-6, SLC 16.11-8, and SLC 16.11-9.

TEST	FREQUENCY
TR 16.11-10-1 Project gaseous release doses from each unit to areas at and beyond the SITE BOUNDARY, in accordance with the methodology and parameters in the ODCM, when Gaseous Radwaste Treatment Systems are not being fully utilized.	31 days

BASES The FUNCTIONALITY of the WASTE GAS HOLDUP SYSTEM and the VENTILATION EXHAUST TREATMENT SYSTEM ensures that the systems will be available for use whenever gaseous effluents require treatment prior to release to the environment. The requirement that the appropriate portions of these systems be used, when specified, provides reasonable assurance that the releases of radioactive materials in gaseous effluents will be kept “as low as is reasonably achievable”. This COMMITMENT implements the requirements of 10 CFR 50.36a, General Design Criterion 60 of Appendix A to 10 CFR Part 50, and the design objectives given in Section II.D of Appendix I to 10 CFR Part 50. The specified limits governing the use of appropriate portions of the systems were specified as a suitable fraction of the dose design objectives set forth in Sections II.B and II.C of Appendix I, 10 CFR Part 50, for gaseous effluents.

This SLC applies to the release of radioactive materials in gaseous effluents from each unit at the site. When shared radwaste treatment systems are used by more than one unit on a site, the wastes from all units are mixed for shared treatment; by such mixing, the effluent releases cannot accurately be ascribed to a specific unit. An estimate should be made of the contributions from each unit based on input conditions, e.g., flow rates and radioactivity concentrations, or, if not practicable, the treated effluent releases may be allocated equally to each of the radioactive waste producing units sharing the radwaste treatment system. For determining conformance to COMMITMENTS, these allocations from shared radwaste treatment systems are to be added to the releases specifically attributed to each unit to obtain the total releases per unit.

Gaseous Radwaste Treatment System
16.11-10

- REFERENCES
1. Catawba Offsite Dose Calculation Manual.
 2. 10 CFR Part 50, Appendix I.

Solid Radioactive Wastes
 16.11-11

16.11 RADIOLOGICAL EFFLUENTS CONTROLS

16.11-11 Solid Radioactive Wastes

COMMITMENT Radioactive wastes shall be processed and packaged to ensure compliance with the applicable requirements of 10 CFR Part 20, 10 CFR Part 61, 10 CFR Part 71, and state regulations governing the transportation and disposal of radioactive wastes.

The Solid Radwaste System or an approved alternative process shall be used in accordance with the PROCESS CONTROL PROGRAM for the solidification of liquid or wet radioactive wastes or the dewatering of wet radioactive wastes to be shipped for direct disposal at a 10 CFR Part 61 licensed disposal site. Wastes shipped for offsite processing in accordance with the processor's specifications and transportation requirements are not required to be solidified or dewatered to meet disposal requirements.

APPLICABILITY: At all times.

REMEDIAL ACTIONS

CONDITION	REQUIRED ACTION	COMPLETION TIME
A. Applicable regulatory requirements for solidified or dewatered wastes not satisfied.	A.1 Suspend shipment of inadequately processed waste. <u>AND</u> A.2 Take action to correct the PROCESS CONTROL PROGRAM, procedures, or solid waste equipment as necessary to prevent recurrence.	Immediately Prior to next shipment for disposal of solidified or dewatered wastes

(continued)

Solid Radioactive Wastes
16.11-11

REMEDIAL ACTIONS (continued)

CONDITION	REQUIRED ACTION	COMPLETION TIME
<p>B. Solidification test as described in the PROCESS CONTROL PROGRAM fails to verify solidification.</p>	<p>B.1 Suspend solidification of the batch under test and follow PROCESS CONTROL PROGRAM guidance for test failures.</p> <p><u>AND</u></p> <p>B.2 -----NOTE----- Once a subsequent test verifies solidification, solidification of the batch may be resumed as directed by the PROCESS CONTROL PROGRAM. ----- Modify the PROCESS CONTROL PROGRAM as required to assure solidification of subsequent batches of waste.</p>	<p>Immediately</p> <p>Prior to next solidification for shipment of waste for disposal at a 10 CFR Part 61 disposal site</p>
<p>C. Solidification or dewatering for disposal not performed in accordance with the PROCESS CONTROL PROGRAM.</p>	<p>C.1 Reprocess the waste in accordance with PROCESS CONTROL PROGRAM requirements.</p> <p><u>OR</u></p> <p>C.2 Follow PROCESS CONTROL PROGRAM or procedure guidance for alternative free-standing liquid verification to ensure the waste in each container meets disposal requirements and take appropriate administrative action to prevent recurrence.</p>	<p>Prior to shipment for disposal of the inadequately processed waste that requires solidification or dewatering</p> <p>Prior to shipment for disposal of the inadequately processed waste that requires solidification or dewatering</p>

(continued)

Solid Radioactive Wastes
 16.11-11

REMEDIAL ACTIONS (continued)

CONDITION	REQUIRED ACTION	COMPLETION TIME
D. Solid waste equipment incapable of supporting COMMITMENT.	D.1 Restore the equipment to a status capable of supporting COMMITMENT.	In a time frame supporting COMMITMENT
	<u>OR</u> D.2 Provide for alternative capability to process wastes as necessary to satisfy all applicable transportation and disposal requirements.	

TESTING REQUIREMENTS

TEST	FREQUENCY
TR 16.11-11-1 Verify, using the PROCESS CONTROL PROGRAM, the solidification of at least one representative test specimen from at least every tenth batch of each type of radioactive waste to be solidified for disposal at a 10 CFR Part 61 disposal site.	Every tenth batch of each type of radioactive waste to be solidified

BASES This SLC implements the requirements of 10 CFR Part 50.36a and General Design Criterion 60 of Appendix A to 10 CFR Part 50 and requirements to use a PROCESS CONTROL PROGRAM to meet applicable 10 CFR Part 61 waste form criteria for solidified and dewatered radioactive wastes.

- The PROCESS CONTROL PROGRAM describes administrative and operational controls used for the solidification of liquid or wet solid radioactive wastes in order to meet applicable 10 CFR Part 61 waste form requirements.
- The PROCESS CONTROL PROGRAM describes the administrative and operational controls used for the dewatering of wet radioactive wastes to meet 10 CFR Part 61 free-standing water requirements.
- The process parameters used in establishing the PROCESS CONTROL PROGRAM shall be based on demonstrated processing of actual or simulated liquid or wet solid wastes and must adequately verify that the final product of solidification or dewatering meets all applicable federal, state, and disposal site requirements.

- REFERENCES
1. 10 CFR Part 50, "Domestic Licensing of Production and Utilization Facilities."
 2. 10 CFR Part 50, Appendix A.
 3. 10 CFR Part 20, "Standards for Protection Against Radiation."
 4. 10 CFR Part 61, "Licensing Requirements for Land Disposal of Radioactive Waste."
 5. 10 CFR Part 71, "Packaging and Transportation of Radioactive Materials."
 6. PROCESS CONTROL PROGRAM Manual.
 7. Generic Letter 84-12, "Compliance with 10 CFR Part 61 and Implementation of the Radiological Effluent Technical Specifications (RETS) and Attendant Process Control Program (PCP)."
 8. Generic Letter 89-01, "Implementation of Programmatic Controls for Radiological Effluent Technical Specifications in the Administrative Controls Section of the Technical Specifications and the Relocation of Procedural Details of RETS to the Offsite Dose Calculation Manual or to the Process Control Program."

TESTING REQUIREMENTS

-----NOTE-----
 Cumulative dose contributions from liquid and gaseous effluents shall be determined in accordance with SLC 16.11-3, SLC 16.11-8, and SLC 16.11-9, and in accordance with the methodology and parameters specified in the ODCM.

TEST	FREQUENCY
TR 16.11-12-1 Determine cumulative dose contributions from direct radiation from the units and from radwaste storage tanks in accordance with the methodology and parameters specified in the ODCM.	When calculated doses from effluent releases exceed twice the limits of SLC 16.11-3, SLC 16.11-8, or SLC 16.11-9

BASES This SLC is provided to meet the dose limitations of 40 CFR Part 190 that have been incorporated into 10 CFR Part 20 by 46 FR 18525. The SLC requires the preparation and submittal of a Special Report whenever the calculated doses due to releases of radioactivity and to radiation from uranium fuel cycle sources exceed 25 mrem to the whole body or any organ, except the thyroid, which shall be limited to less than or equal to 75 mrem. For sites containing up to four reactors, it is highly unlikely that the resultant dose to a MEMBER OF THE PUBLIC will exceed the dose limits of 40 CFR Part 190 if the individual reactors remain within twice the dose design objectives of Appendix I, and if direct radiation doses from the units and from outside storage tanks are kept small.

This Special Report, as defined in 10 CFR 20.2203(a)(4), shall include an analysis that estimates the radiation exposure (dose) to a MEMBER OF THE PUBLIC from uranium fuel cycle sources, including all effluent pathways and direct radiation, for the calendar year that includes the release(s) covered by this report. It shall also describe levels of radiation and concentrations of radioactive material involved, and the cause of the exposure levels or concentrations. The Special Report will describe a course of action that should result in the limitation of the annual dose to a MEMBER OF THE PUBLIC to within the 40 CFR Part 190 limits. For the purposes of the Special Report, it may be assumed that the dose commitment to the MEMBER OF THE PUBLIC from other uranium fuel cycle sources is negligible, with the exception that dose contributions from other nuclear fuel cycle facilities at the same site or within a radius of 8 km must be considered.

BASES (continued)

If the dose to any MEMBER OF THE PUBLIC is estimated to exceed the requirements of 40 CFR Part 190, the Special Report with a request for a variance (provided the release conditions resulting in violation of 40 CFR Part 190 have not already been corrected), in accordance with the provisions of 40 CFR 190.11 and 10 CFR 20.2203(a)(4), is considered to be a timely request and fulfills the requirements of 40 CFR Part 190 and a variance is granted until NRC staff action is completed. The variance only relates to the limits of 40 CFR Part 190, and does not apply in any way to the other requirements for dose limitation of 10 CFR Part 20, as addressed in SLC 16.11-1 and SLC 16.11-6.

An individual is not considered a MEMBER OF THE PUBLIC during any period in which he/she is engaged in carrying out any operation that is part of the nuclear fuel cycle.

- REFERENCES
1. Catawba Offsite Dose Calculation Manual.
 2. 10 CFR Part 20.
 3. 40 CFR Part 190.

16.11 RADIOLOGICAL EFFLUENTS CONTROLS

16.11-13 Monitoring Program

COMMITMENT The Radiological Environmental Monitoring Program shall be conducted as specified in Table 16.11-13-1.

APPLICABILITY: At all times.

REMEDIAL ACTIONS

CONDITION	REQUIRED ACTION	COMPLETION TIME
A. Radiological Environmental Monitoring Program not being conducted as specified in Table 16.11-13-1.	A.1 Identify the reasons for not conducting the program as required and the plans for preventing a recurrence in the Annual Radiological Environmental Operating Report.	In the next scheduled Annual Radiological Environmental Operating Report pursuant to Technical Specification 5.6.2
B. Radioactivity level resulting from plant effluents of environmental sampling medium at a specified location in excess of reporting limits of Table 16.11-13-2 when averaged over any calendar quarter.	B.1 Prepare and submit a Special Report that identifies the cause(s) for exceeding the limits and defines the corrective actions to be taken to reduce radioactive effluents so that the potential annual dose to a MEMBER OF THE PUBLIC is less than the calendar year limits of SLC 16.11-3, SLC 16.11-8, and SLC 16.11-9.	30 days

(continued)

REMEDIAL ACTIONS (continued)

CONDITION	REQUIRED ACTION	COMPLETION TIME
<p>C. Milk or fresh leafy vegetation samples unavailable from one or more sample location(s) required by Table 16.11-13-1.</p>	<p>C.1 -----NOTE----- Specific location(s) from which samples were unavailable may be deleted from the program. -----</p> <p>Revise the Radiological Environmental Monitoring Program to identify location(s) for obtaining replacement samples.</p> <p><u>AND</u></p> <p>C.2 Identify the cause of the unavailability of samples and identify and justify new location(s) for obtaining replacement samples in the Annual Radioactive Effluent Release Report and also include in the report a revised figure(s) and table for the ODCM reflecting the new location(s).</p>	<p>30 days</p> <p>In the next scheduled Annual Radioactive Effluent Release Report pursuant to Technical Specification 5.5.1</p>

TESTING REQUIREMENTS

TEST	FREQUENCY
<p>TR 16.11-13-1-----NOTE----- The maximum values for the lower limits of detection shall be as specified in Table 16.11-13-3. -----</p> <p>Collect and analyze radiological environmental monitoring samples pursuant to Table 16.11-13-1 from the specific locations given in the table and figure(s) in the ODCM.</p>	<p>In accordance with Table 16.11-13-1</p>

Table 16.11-13-1
Radiological Environmental Monitoring Program (page 1 of 7)

EXPOSURE PATHWAY AND/OR SAMPLE	NUMBER OF REPRESENTATIVE SAMPLES AND SAMPLE LOCATIONS ⁽¹⁾	SAMPLING AND COLLECTION FREQUENCY	TYPE AND FREQUENCY OF ANALYSIS
1. Direct Radiation ⁽²⁾	<p>Forty routine monitoring stations either with two or more dosimeters or with one instrument for measuring and recording dose rate continuously, placed as follows:</p> <p>An inner ring of stations, one in each meteorological sector in the general area of the SITE BOUNDARY;</p> <p>An outer ring of stations, one in each meteorological sector in the 6- to 8-km range from the site; and</p> <p>The balance of the stations to be placed in special interest areas such as population centers, nearby residences, schools, and in one or two areas to serve as control stations.</p>	Quarterly	Gamma dose quarterly

(continued)

Table 16.11-13-1
Radiological Environmental Monitoring Program (page 2 of 7)

EXPOSURE PATHWAY AND/OR SAMPLE	NUMBER OF REPRESENTATIVE SAMPLES AND SAMPLE LOCATIONS ⁽¹⁾	SAMPLING AND COLLECTION FREQUENCY	TYPE AND FREQUENCY OF ANALYSIS
<p>2. Airborne Radioiodine and Particulates</p>	<p>Samples from five locations.</p> <p>Three samples from close to the three SITE BOUNDARY locations, in different sectors, of the highest calculated annual average ground-level D/Q;</p> <p>One sample from the vicinity of a community having the highest calculated annual average ground-level D/Q; and</p> <p>One sample from a control location, as for example 15 to 30 km distant and in the least prevalent wind direction.</p>	<p>Continuous sampler operation with sample collection weekly, or more frequently if required by dust loading.</p>	<p><u>Radioiodine Canister:</u> I-131 analysis weekly.</p> <p><u>Particulate Sampler:</u> Gross beta radioactivity analysis following filter change; ⁽³⁾ and gamma isotopic analysis ⁽⁴⁾ of composite (by location) quarterly.</p>

(continued)

Catawba Nuclear Station Units 1 & 2
 Period 1/1/2016 - 12/31/2016

Monitoring Program
 16.11-13

Table 16.11-13-1
 Radiological Environmental Monitoring Program (page 3 of 7)

EXPOSURE PATHWAY AND/OR SAMPLE	NUMBER OF REPRESENTATIVE SAMPLES AND SAMPLE LOCATIONS ⁽¹⁾	SAMPLING AND COLLECTION FREQUENCY	TYPE AND FREQUENCY OF ANALYSIS
3. Waterborne a. Surface ⁽⁵⁾ b. Ground c. Drinking d. Sediment from Shoreline	One sample upstream. One sample downstream. Samples from one or two sources only if likely to be affected ⁽⁷⁾ . One sample of each of one to three of the nearest water supplies that could be affected by its discharge. One sample from a control location. One sample from downstream area with existing or potential recreational value.	Composite sample over 1-month period ⁽⁶⁾ . Quarterly Composite sample over 2-week period ⁽⁶⁾ when I-131 analysis is performed; monthly composite otherwise. Semiannually	Gamma isotopic analysis ⁽⁴⁾ monthly. Composite for tritium analysis quarterly. Gamma isotopic ⁽⁴⁾ and tritium analysis quarterly. I-131 analysis on each composite when the dose calculated for the consumption of the water is greater than 1 mrem per year ⁽⁸⁾ . Composite for gross beta and gamma isotopic analyses ⁽⁴⁾ monthly. Composite for tritium analysis quarterly. Gamma isotopic analysis ⁽⁴⁾ semiannually.

(continued)

Catawba Nuclear Station Units 1 & 2
 Period 1/1/2016 - 12/31/2016

Monitoring Program
 16.11-13

Table 16.11-13-1
 Radiological Environmental Monitoring Program (page 4 of 7)

EXPOSURE PATHWAY AND/OR SAMPLE	NUMBER OF REPRESENTATIVE SAMPLES AND SAMPLE LOCATIONS ⁽¹⁾	SAMPLING AND COLLECTION FREQUENCY	TYPE AND FREQUENCY OF ANALYSIS
4. Ingestion a. Milk b. Fish and Invertebrates	<p>Samples from milking animals in three locations within 5-km distance having the highest dose potential. If there are none, then one sample from milking animals in each of three areas between 5 to 8 km distant where doses are calculated to be greater than 1 mrem per year⁽⁶⁾. One sample from milking animals at a control location 15 to 30 km distant and in the least prevalent wind direction.</p> <p>One sample each of a predatory species, a bottom feeder and a forage species in vicinity of plant discharge area.</p> <p>One sample each of a predatory species, a bottom feeder and a forage species in areas not influenced by plant discharge.</p>	<p>Semimonthly when animals are on pasture; monthly at other times.</p> <p>Sample in season, or semiannually if they are not seasonal.</p>	<p>Gamma isotopic⁽⁴⁾ and I-131 analysis semi-monthly when animals are on pasture; monthly at other times.</p> <p>Gamma isotopic analysis⁽⁴⁾ on edible portions.</p>

(continued)

Catawba Nuclear Station Units 1 & 2
 Period 1/1/2016 - 12/31/2016

Monitoring Program
 16.11-13

Table 16.11-13-1
 Radiological Environmental Monitoring Program (page 5 of 7)

EXPOSURE PATHWAY AND/OR SAMPLE	NUMBER OF REPRESENTATIVE SAMPLES AND SAMPLE LOCATIONS ⁽¹⁾	SAMPLING AND COLLECTION FREQUENCY	TYPE AND FREQUENCY OF ANALYSIS
4. Ingestion (Continued) c. Food Products	<p>One sample of each principal class of food products from any area that is irrigated by water in which liquid plant wastes have been discharged.</p> <p>Samples of three different kinds of broad leaf vegetation grown nearest each of two different offsite locations of highest predicted annual average ground level D/Q if milk sampling is not performed.</p> <p>One sample of each of the similar broad leaf vegetation grown 15 to 30 km distant in the least prevalent wind direction if milk sampling is not performed.</p>	<p>At time of harvest⁽⁹⁾.</p> <p>Monthly, when available.</p> <p>Monthly, when available.</p>	<p>Gamma isotopic analyses⁽⁴⁾ on edible portion.</p> <p>Gamma isotopic⁽⁴⁾ and I-131 analysis.</p> <p>Gamma isotopic⁽⁴⁾ and I-131 analysis.</p>

Catawba Units 1 and 2

16.11-13-7

Revision 1

Table 16.11-13-1

Radiological Environmental Monitoring Program (page 6 of 7)

NOTES:

- (1) Specific parameters of distance and direction sector from the centerline of the station, and additional description where pertinent, shall be provided for each and every sample location in Table 16.11-13-1 in a table and figure(s) in the ODCM. Refer to NUREG-0133, "Preparation of Radiological Effluent Technical Specifications for Nuclear Power Plants," October 1978, and to Radiological Assessment Branch Technical Position, Revision 1, November 1979. Deviations are permitted from the required sampling schedule if specimens are unobtainable due to circumstances such as hazardous conditions, seasonal unavailability, and malfunction of automatic sampling equipment. If specimens are unobtainable due to sampling equipment malfunction, effort shall be made to complete corrective action prior to the end of the next sampling period. All deviations from the sampling schedule shall be documented in the Annual Radiological Environmental Operating Report pursuant to Technical Specification 5.6.2. It is recognized that, at times, it may not be possible or practicable to continue to obtain samples of the media of choice at the most desired location or time. In these instances suitable alternative media and locations may be chosen for the particular pathway in question and appropriate substitutions made within 30 days in the Radiological Environmental Monitoring Program. In lieu of any Licensee Event Report required by 10 CFR 50.73 and pursuant to Technical Specification 5.6.3, identify the cause of the unavailability of samples for that pathway and identify the new location(s) for obtaining replacement samples in the next Radioactive Effluent Release Report and also include in the report a revised figure(s) and table for the ODCM reflecting the new location(s).
- (2) One or more instruments, such as a pressurized ion chamber, for measuring and recording dose rate continuously may be used in place of, or in addition to, integrating dosimeters. For the purposes of this table, a thermoluminescent dosimeter (TLD) is considered to be one phosphor; two or more phosphors in a packet are considered as two or more dosimeters. Film badges shall not be used as dosimeters for measuring direct radiation. (The 40 stations is not an absolute number. The number of direct radiation monitoring stations may be reduced according to geographical limitations; e.g., at an ocean site, some sectors will be over water so that the number of dosimeters may be reduced accordingly. The frequency of analysis or readout for TLD systems will depend upon the characteristics of the specific system used and should be selected to obtain optimum dose information within minimal fading.)
- (3) Airborne particulate sample filters shall be analyzed for gross beta radioactivity 24 hours or more after sampling to allow for radon and thoron daughter decay. If gross beta activity in air particulate samples is greater than 10 times the yearly mean of control samples, gamma isotopic analysis shall be performed on the individual samples.

Table 16.11-13-1

Radiological Environmental Monitoring Program (page 7 of 7)

- (4) Gamma isotopic analysis means the identification and quantification of gamma-emitting radionuclides that may be attributable to the effluents from the facility.
- (5) The “upstream sample” shall be taken at a distance beyond significant influence of the discharge. The “downstream” sample shall be taken in an area beyond but near the mixing zone. “Upstream” samples in an estuary must be taken far enough upstream to be beyond the plant influence. Salt water shall be sampled only when the receiving water is utilized for recreational activities.
- (6) A composite sample is one in which the rate at which the liquid sampled is uniform and in which the method of sampling employed results in a specimen that is representative of the time-averaged concentration at the location being sampled. In this program composite sample aliquots shall be collected at time intervals that are very short (e.g., hourly) relative to the compositing period (e.g., monthly) in order to assure obtaining a representative sample.
- (7) Groundwater samples shall be taken when this source is tapped for drinking or irrigation purposes in areas where the hydraulic gradient or recharge properties are suitable for contamination.
- (8) The dose shall be calculated for the maximum organ and age group, using the methodology and parameters in the ODCM.
- (9) If harvest occurs more than once a year, sampling shall be performed during each discrete harvest. If harvest occurs continuously, sampling shall be monthly. Attention shall be paid to including samples of tuberous and root food products.

Table 16.11-13-2
 Reporting Levels for Radioactivity Concentrations in Environmental Samples

ANALYSIS	WATER (pCi/l)	AIRBORNE PARTICULATE OR GASES (pCi/m ³)	FISH (pCi/kg, wet)	MILK (pCi/l)	FOOD PRODUCTS (pCi/kg, wet)
H-3	20,000 ⁽¹⁾				
Mn-54	1,000		30,000		
Fe-59	400		10,000		
Co-58	1,000		30,000		
Co-60	300		10,000		
Zn-65	300		20,000		
Zr-Nb-95	400				
I-131	2	0.9		3	100
Cs-134	30	10	1,000	60	1,000
Cs-137	50	20	2,000	70	2,000
Ba-La-140	200			300	

(1) For drinking water samples. This is 40 CFR Part 141 value. If no drinking water pathway exists, a value of 30,000 pCi/l may be used.

Table 16.11-13-3
 Lower Limit of Detection (LLD)⁽³⁾ (page 1 of 3)

ANALYSIS	WATER (pCi/l)	AIRBORNE PARTICULATE OR GASES (pCi/m ³)	FISH (pCi/kg, wet)	MILK (pCi/l)	FOOD PRODUCTS (pCi/kg, wet)	SEDIMENT (pCi/kg, dry)
Gross Beta	4	0.01				
H-3	2000 ⁽⁶⁾					
Mn-54	15		130			
Fe-59	30		260			
Co-58, 60	15		130			
Zn-65	30		260			
Zr-Nb-95	15					
I-131	1 ⁽⁴⁾	0.07		1	60	
Cs-134	15	0.05	130	15	60	150
Cs-137	18	0.06	150	18	80	180
Ba-La-140	15			15		

Table 16.11-13-3

Lower Limit of Detection (LLD)⁽³⁾ (page 2 of 3)

NOTES:

- (1) This list does not mean that only these nuclides are to be considered. Other peaks that are identifiable, together with those of the above nuclides, shall also be analyzed and reported in the Annual Radiological Environmental Operating Report pursuant to Technical Specification 5.6.2.
- (2) Required detection capabilities for thermoluminescent dosimeters used for environmental measurements shall be in accordance with the recommendations of Regulatory Guide 4.13.
- (3) The LLD is defined, for purposes of these commitments, as the smallest concentrations of radioactive material in a sample that will yield a net count, above system background, that will be detected with 95% probability with only 5% probability of falsely concluding that a blank observation represents a "real" signal.

For a particular measurement system, which may include radiochemical separation:

$$LLD = \frac{(2.71/T) + 4.65 s_b}{E \cdot V \cdot 2.22 \cdot Y \cdot \exp(-\lambda \Delta t)}$$

Where:

LLD = the "a priori" lower limit of detection (picoCuries per unit mass or volume);

s_b = the standard deviation of the background counting rate or of the counting rate of a blank sample as appropriate (counts per minute);

E = the counting efficiency (counts per disintegration);

V = the sample size (units of mass or volume);

2.22 = the number of disintegrations per minute per picoCurie;

Y = the fractional radiochemical yield, when applicable;

λ = the radioactive decay constant for the particular radionuclide (sec^{-1});

Δt = the elapsed time between environmental collection, or end of the sample collection period, and time of counting (sec); and

T = the sample counting time (min).

Table 16.11-13-3

Lower Limit of Detection (LLD)⁽³⁾ (page 3 of 3)

Typical values of E, V, Y and Δt shall be used in the calculation.

It should be recognized that the LLD is defined as an a priori (before the fact) limit representing the capability of a measurement system and not as an a posteriori (after the fact) limit for a particular measurement. Analyses shall be performed in such a manner that the stated LLDs will be achieved under routine conditions. Occasionally background fluctuations, unavoidable small sample sizes, the presence of interfering nuclides, or other uncontrollable circumstances may render these LLDs unachievable. In such cases, the contributing factors shall be identified and described in the Annual Radiological Environmental Operating Report pursuant to Technical Specification 5.6.2.

- (4) LLD for drinking water samples. If no drinking water pathway exists, the LLD of gamma isotopic analysis may be used.
- (5) If no drinking water pathway exists, a value of 3000 pCi/l may be used.

BASES The Radiological Environmental Monitoring Program required by this SLC provides representative measurements of radiation and of radioactive materials in those exposure pathways and for those radionuclides that lead to the highest potential radiation exposures of MEMBERS OF THE PUBLIC resulting from the plant operation. This Monitoring Program implements Section IV.B.2 of Appendix I to 10 CFR Part 50 and thereby supplements the Radiological Effluent Monitoring Program by verifying that the measurable concentrations of radioactive materials and levels of radiation are not higher than expected on the basis of the effluent measurements and the modeling of the environmental exposure pathways. Guidance for this Monitoring Program is provided by the Radiological Assessment Branch Technical Position on Environmental Monitoring. The initially specified Monitoring Program will be effective for at least the first 3 years of commercial operation. Following this period, program changes may be initiated based on operational experience.

The required detection capabilities for environmental sample analyses are tabulated in terms of the lower limits of detection (LLDs). The LLDs required by Table 16.11-13-3 are considered optimum for routine environmental measurements in industrial laboratories. It should be recognized that the LLD is defined as an a priori (before the fact) limit representing the capability of a measurement system and not as an a posteriori (after the fact) limit for a particular measurement.

With the level of radioactivity in an environmental sampling medium at a specified location exceeding the reporting levels of Table 16.11-13-2 when averaged over any calendar quarter, in lieu of a Licensee Event Report, prepare and submit to the Commission within 30 days a Special Report that defines the corrective actions to be taken to reduce radioactive effluents so that the potential annual dose to a MEMBER OF THE PUBLIC is less than the calendar year limits of SLC 16.11-3, SLC 16.11-8, and SLC 16.11-9. When more than one of the radionuclides in Table 16.11-13-2 are detected in the sampling medium, this report shall be submitted if:

$$\frac{\text{concentration (1)}}{\text{reporting level (1)}} + \frac{\text{concentration (2)}}{\text{reporting level (2)}} + \dots \geq 1.0$$

When radionuclides other than those in Table 16.11-13-2 are detected and are the result of plant effluents, this report shall be submitted if the potential annual dose to a MEMBER OF THE PUBLIC from all radionuclides is equal to or greater than the calendar year limits of SLC 16.11-3, SLC 16.11-8, and SLC 16.11-9. This report is not required if the measured level of radioactivity was not the result of plant effluents; however, in such an event, the condition shall be reported and described in the Annual Radiological Environmental Operating Report required by Technical Specification 5.6.2. The methodology and parameters used to estimate the potential annual dose to a MEMBER OF THE PUBLIC shall be indicated in the 30-day Special Report.

BASES (continued)

Detailed discussion of the LLD, and other detection limits, can be found in HASL Procedures Manual, HASL-300 (revised annually), Currie, L.A., "Limits for Qualitative Detection and Quantitative Determination – Application to Radiochemistry," Anal. Chem. **40**, 586-93 (1968), and Hartwell, J.K., "Detection Limits for Radioanalytical Counting Techniques," Atlantic Richfield Hanford Company Report ARH-SA-215 (June 1975).

- REFERENCES
1. Catawba Offsite Dose Calculation Manual.
 2. 10 CFR Part 50, Appendix I.

16.11 RADIOLOGICAL EFFLUENTS CONTROLS

16.11-14 Land Use Census

COMMITMENT

-----NOTE-----
 Broad leaf vegetation sampling of at least three different kinds of vegetation may be performed at the SITE BOUNDARY in each of two different direction sectors with the highest predicted D/Qs in lieu of the garden census. Requirements for broad leaf vegetation sampling in Table 16.11-13-1 (Item 4c) shall be followed, including analysis of control samples.

A Land Use Census shall be conducted and shall identify within a distance of 8 km (5 miles) the location in each of the 16 meteorological sectors of the nearest milk animal, the nearest residence, and the nearest garden of > 50 m² (500 ft²) producing broad leaf vegetation.

APPLICABILITY: At all times.

REMEDIAL ACTIONS

CONDITION	REQUIRED ACTION	COMPLETION TIME
A. Location(s) identified which yield a calculated dose or dose commitment greater than values currently calculated in SLC 16.11-9.	A.1 Identify the new location(s) in the Annual Radioactive Effluent Release Report.	In the next scheduled Annual Radioactive Effluent Release Report pursuant to Technical Specification 5.6.3
B. Location(s) identified which yield a calculated dose or dose commitment (via same exposure pathway) 20% greater than at a location from which samples are currently being obtained in accordance with SLC 16.11-13.	B.1 Add the new location(s) to the Radiological Environmental Monitoring Program. <u>AND</u>	30 days

(continued)

REMEDIAL ACTIONS

CONDITION	REQUIRED ACTION	COMPLETION TIME
B. (continued)	B.2 Identify the new location(s), revised figure(s) and table(s) for the ODCM, and information supporting the change in sampling location(s) in the Annual Radioactive Effluent Release Report.	In the next scheduled Annual Radioactive Effluent Release Report pursuant to Technical Specification 5.5.1

TESTING REQUIREMENTS

TEST	FREQUENCY
TR 16.11-14-1-----NOTE----- The results of the Land Use Census shall be included in the Annual Radiological Environmental Operating Report pursuant to Technical Specification 5.6.2. ----- Conduct a Land Use Census during the growing season using the information which will provide the best results such as a door-to-door survey, aerial survey, or consultation with local agricultural authorities.	12 months

BASES

This SLC is provided to ensure that changes in the use of areas at and beyond the SITE BOUNDARY are identified and that modifications to the Radiological Environmental Monitoring Program given in the ODCM are made if required by the results of this census. The best information from the door-to-door survey, from aerial survey, or from consulting with local agricultural authorities shall be used. This census satisfies the requirements of Section IV.B.3 of Appendix I to 10 CFR Part 50. Restricting the census to gardens of greater than 50 m² provides assurance that significant exposure pathways via leafy vegetables will be identified and monitored since a garden of this size is the minimum required to produce the quantity (26 kg/year) of leafy vegetables assumed in Regulatory Guide 1.109 for consumption by a child. To determine this minimum garden size, the following assumptions were made: (1) 20% of the garden was used for growing broad leaf vegetation (i.e., similar to lettuce and cabbage), and (2) a vegetation yield of 2 kg/m².

BASES (continued)

With a Land Use Census identifying a location(s) which yield a calculated dose or dose commitment (via the same exposure pathway) 20% greater than at a location from which samples are currently being obtained in accordance with SLC 16.11-13, add the new location(s) within 30 days to the Radiological Environmental Monitoring Program given in the ODCM. The sampling location(s), excluding the control station location, having the lowest calculated dose or dose commitment, via the same exposure pathway, may be deleted from this monitoring program after October 31 of the year in which this Land Use Census was conducted.

- REFERENCES
1. Catawba Offsite Dose Calculation Manual.
 2. 10 CFR Part 50, Appendix I.

Interlaboratory Comparison Program
 16.11-15

16.11 RADIOLOGICAL EFFLUENTS CONTROLS

16.11-15 Interlaboratory Comparison Program

COMMITMENT Analyses shall be performed on all radioactive materials, supplied as part of an Interlaboratory Comparison Program, that correspond to samples required by SLC 16.11-13.

APPLICABILITY: At all times.

REMEDIAL ACTIONS

CONDITION	REQUIRED ACTION	COMPLETION TIME
A. Analyses not being performed as required.	A.1 Report corrective actions taken to prevent recurrence in the Annual Radiological Environmental Operating Report.	In the next scheduled Annual Radiological Environmental Operating Report pursuant to Technical Specification 5.6.2

TESTING REQUIREMENTS

TEST	FREQUENCY
TR 16.11-15-1 Report a summary of the results of the Interlaboratory Comparison Program in the Annual Radiological Environmental Operating Report.	In the Annual Radiological Environmental Operating Report pursuant to Technical Specification 5.6.2

BASES The requirement for participation in an Interlaboratory Comparison Program is provided to ensure that independent checks on the precision and accuracy of the measurements of radioactive material in environmental sample matrices are performed as part of the quality assurance program for environmental monitoring in order to demonstrate that the results are valid for the purposes of Section IV.B.2 of Appendix I to 10 CFR Part 50.

BASES (continued)

The Interlaboratory Comparison Program shall be described in the Annual Radiological Environmental Operating Report.

REFERENCES 1. 10 CFR Part 50, Appendix I.

Annual Radiological Environmental Operating Report
And Radioactive Effluent Release Report
16.11-16

16.11 RADIOLOGICAL EFFLUENTS CONTROLS

16.11-16 Annual Radiological Environmental Operating Report and Radioactive
Effluent Release Report

COMMITMENT Annual Radiological Environmental Operating Report

Routine Annual Radiological Environmental Operating Reports covering the operation of the unit during the previous calendar year shall be submitted prior to May 15 of each year.

The Annual Radiological Environmental Operating Reports shall include summaries, interpretations, and an analysis of trends of the results of the radiological environmental surveillance activities for the report period, including a comparison with preoperational studies, with operational controls as appropriate, and with previous environmental surveillance reports, and an assessment of the observed impacts of the plant operation on the environment. The reports shall also include the results of the Land Use Census.

The Annual Radiological Environmental Operating Reports shall include the results of analysis of all radiological environmental samples and of all environmental radiation measurements taken during the period pursuant to the locations specified in the table and figures in the ODCM, as well as summarized and tabulated results of these analyses and measurements in the format of the table in the Radiological Assessment Branch Technical Position, Revision 1, November 1979. In the event that some individual results are not available for inclusion with the report, the report shall be submitted noting and explaining the reasons for the missing results. The missing data shall be submitted as soon as possible in a supplementary report.

The reports shall also include the following: a summary description of the Radiological Environmental Monitoring Program; at least two legible maps (one map shall cover stations near the SITE BOUNDARY, and a second map shall include the more distant stations) covering all sampling locations keyed to a table giving distances and directions from the centerline of one reactor; the results of licensee participation in the Interlaboratory Comparison Program, required by SLC 16.11-15; discussion of all deviations from the sampling schedule of Table 16.11-13-1; and discussion of all analyses in which the LLD required by Table 16.11-13-3 was not achievable.

A single submittal may be made for the station.

(continued)

Annual Radiological Environmental Operating Report
And Radioactive Effluent Release Report
16.11-16

COMMITMENT (continued)

Radioactive Effluent Release Report

The Radioactive Effluent Release Report covering the operation of the unit during the previous calendar year shall be submitted before May 1 of each year. The Radioactive Effluent Release Reports shall include a summary of the quantities of radioactive liquid and gaseous effluents and solid waste released from the unit.

The Radioactive Effluent Release Report shall include an annual summary of hourly meteorological data collected over the previous year. This annual summary may be either in the form of an hour-by-hour listing on magnetic tape of wind speed, wind direction, atmospheric stability, and precipitation (if measured), or in the form of joint frequency distributions of wind speed, wind direction, and atmospheric stability. (In lieu of submission with the Radioactive Effluent Release Report, the licensee has the option of retaining this summary of required meteorological data on site in a file that shall be provided to the NRC upon request.) This same report shall include an assessment of the radiation doses due to the radioactive liquid and gaseous effluents released from the unit or station during the previous calendar year. A five-year average of representative onsite meteorological data shall be used in the gaseous effluent dose pathway calculations. Dispersion factors (X/Qs) and deposition factors (D/Qs) shall be generated using the computer code XOQDOQ (NUREG/CR-2919) which implements NRC Regulatory Guide 1.111. The meteorological conditions concurrent with the time of release shall be reviewed annually to determine if the five-year average values should be revised. The assessment of radiation doses shall be performed in accordance with the methodology and parameters in the ODCM.

The Radioactive Effluent Release Report shall also include an assessment of radiation doses to the likely most exposed MEMBER OF THE PUBLIC from reactor releases and other nearby uranium fuel cycle sources, including doses from primary effluent pathways and direct radiation, for the previous calendar year to show conformance with 40 CFR Part 190, "Environmental Radiation Protection Standards for Nuclear Power Operation." Acceptable methods for calculating the dose contribution from liquid and gaseous effluents are given in Regulatory Guide 1.109, Rev. 1, October 1977.

The Radioactive Effluent Release Reports shall include the following information for each type of solid waste shipped offsite during the report period:

(continued)

Annual Radiological Environmental Operating Report
And Radioactive Effluent Release Report
16.11-16

COMMITMENT (continued)

- a. Total container volume, in cubic meters,
- b. Total Curie quantity (determined by measurement or estimate),
- c. Principal radionuclides (determined by measurement or estimate),
- d. Type of waste (e.g., dewatered spent resin, compacted dry waste, evaporator bottoms),
- e. Number of shipments, and
- f. Solidification agent or absorbent (e.g., cement or other approved agents (media)).

The Radioactive Effluent Release Reports shall include a list and description of unplanned releases from the site to UNRESTRICTED AREAS of radioactive materials in gaseous and liquid effluents made during the reporting period.

The Radioactive Effluent Release Reports shall include any changes made during the reporting period to the PROCESS CONTROL PROGRAM (PCP) and to the ODCM, as well as a listing of new locations for dose calculations and/or environmental monitoring identified by the Land Use Census pursuant to SLC 16.11-14.

A single submittal may be made for the station. The submittal should combine those sections that are common to both units.

APPLICABILITY: At all times.

REMEDIAL ACTIONS None

TESTING REQUIREMENTS None

BASES None

REFERENCES None

Catawba Nuclear Station Units 1 & 2
Period 1/1/2016 - 12/31/2016

Annual Radiological Environmental Operating Report
And Radioactive Effluent Release Report
16.11-16

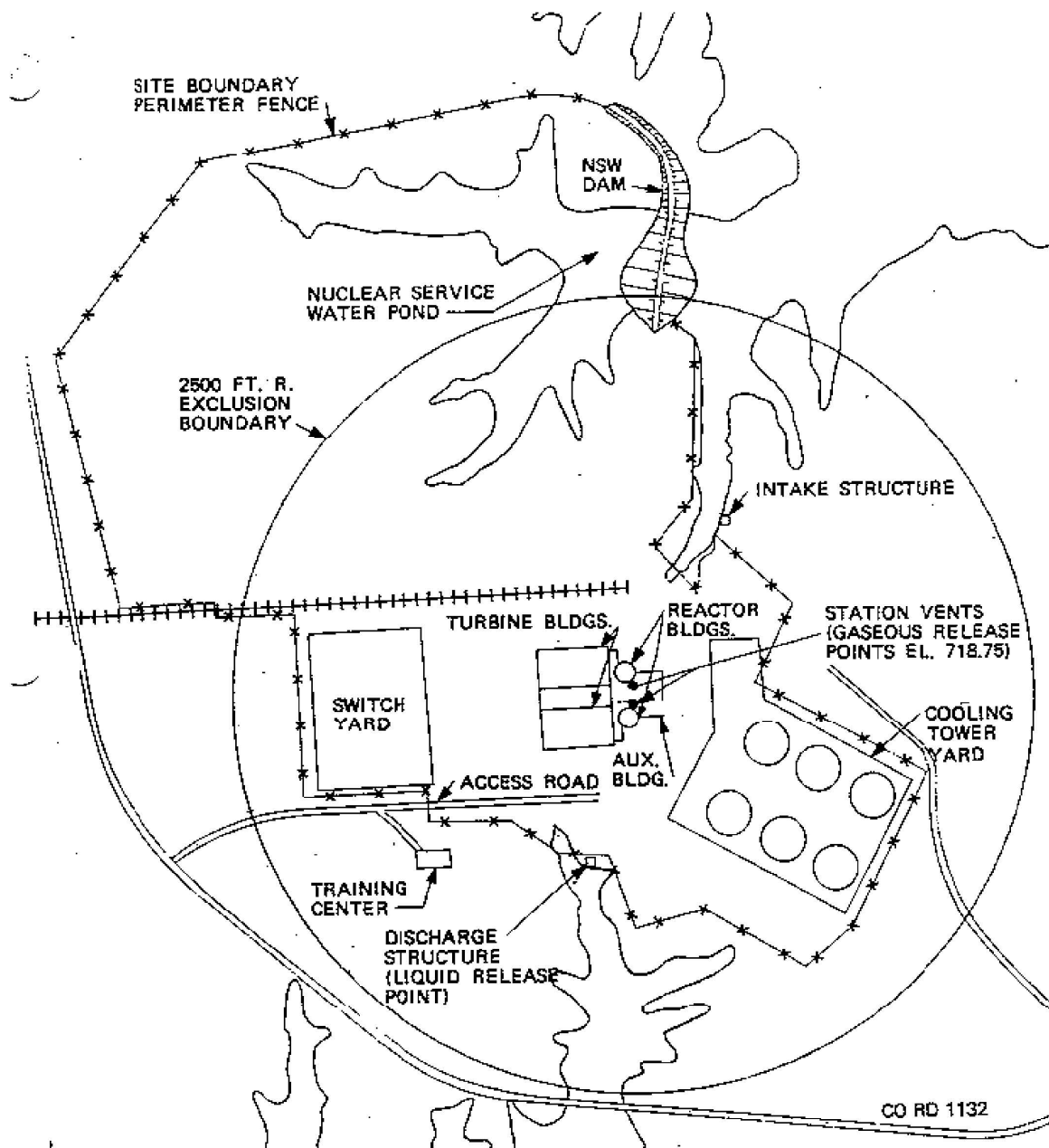

Figure 16.11-16-1

UNRESTRICTED AREA and SITE BOUNDARY for Radioactive Effluents

16.11 RADIOLOGICAL EFFLUENTS CONTROLS

16.11-17 Liquid Holdup Tanks

COMMITMENT The quantity of radioactive material contained in each temporary unprotected outdoor tank shall be limited to ≤ 10 Curies, excluding tritium and dissolved or entrained noble gases.

APPLICABILITY: At all times.

REMEDIAL ACTIONS

CONDITION	REQUIRED ACTION	COMPLETION TIME
A. Quantity of radioactive material in tank(s) exceeding limit.	A.1 Suspend all additions of radioactive material to the tank(s).	Immediately
	<u>AND</u>	
	A.2 Reduce tank(s) contents to within limit.	48 hours
	<u>AND</u>	
	A.3 Describe the events leading to this condition in the Radioactive Effluent Release Report.	In the next scheduled Radioactive Effluent Release Report pursuant to Technical Specification 5.6.3

TESTING REQUIREMENTS

TEST	FREQUENCY
TR 16.11-17-1 Verify that the quantity of radioactive material contained in each tank is within limits by analyzing a representative sample of the tank(s) contents when radioactive materials are being added to the tank(s).	7 days

Liquid Holdup Tanks
16.11-17

BASES The tanks included in this SLC are all those outdoor radwaste tanks that are not surrounded by liners, dikes, or walls capable of holding the tank contents and that do not have tank overflows and surrounding area drains connected to the liquid radwaste treatment system.

Restricting the quantity of radioactive material contained in the specified tanks provides assurance that in the event of an uncontrolled release of the tank's contents, the resulting concentrations would be less than the limits of 10 CFR Part 20, Appendix B, Table II, Column 2, at the nearest potable water supply and the nearest surface water supply in an UNRESTRICTED AREA.

- REFERENCES**
1. Letter from NRC to Gary R. Peterson, Duke, Issuance of Improved Technical Specifications Amendments for Catawba, September 30, 1998.

 2. Technical Specification 5.5.12, Explosive Gas and Storage Tank Radioactivity Monitoring Program.

16.11 RADIOLOGICAL EFFLUENTS CONTROLS

16.11-18 Explosive Gas Mixture

COMMITMENT The concentration of oxygen in the WASTE GAS HOLDUP SYSTEM shall be limited to $\leq 2\%$ by volume whenever the hydrogen concentration is $> 4\%$ by volume.

APPLICABILITY: At all times.

REMEDIAL ACTIONS

CONDITION	REQUIRED ACTION	COMPLETION TIME
A. Concentration of oxygen in the WASTE GAS HOLDUP SYSTEM $> 2\%$ but $\leq 4\%$ by volume and hydrogen concentration $> 4\%$ by volume.	A.1 Reduce oxygen concentration to within limits.	48 hours
B. Concentration of oxygen in the WASTE GAS HOLDUP SYSTEM $> 4\%$ by volume and hydrogen concentration $> 4\%$ by volume.	B.1 Suspend all additions of waste gases to the system.	Immediately
	<u>AND</u> B.2 Reduce the concentration of oxygen to $\leq 4\%$ by volume.	Immediately
	<u>AND</u> B.3 Reduce oxygen concentration to within limits.	48 hours

TESTING REQUIREMENTS

TEST	FREQUENCY
TR 16.11-18-1 Verify that the concentrations of hydrogen and oxygen in the WASTE GAS HOLDUP SYSTEM are within limits by continuously monitoring the waste gases in the WASTE GAS HOLDUP SYSTEM with the hydrogen and oxygen monitors required FUNCTIONAL by SLC 16.11-20.	During WASTE GAS HOLDUP SYSTEM operation

BASES This SLC is provided to ensure that the concentration of potentially explosive gas mixtures contained in the WASTE GAS HOLDUP SYSTEM is maintained below the flammability limits of hydrogen and oxygen. Automatic control features are included in the system to prevent the hydrogen and oxygen concentrations from reaching these flammability limits. These automatic control features include isolation of the source of hydrogen and/or oxygen, automatic diversion to recombiners, or injection of dilutants to reduce the concentration below the flammability limits. Maintaining the concentration of hydrogen and oxygen below their flammability limits provides assurance that the releases of radioactive materials will be controlled in conformance with the requirements of General Design Criterion 60 of Appendix A to 10 CFR Part 50.

- REFERENCES**
1. Letter from NRC to Gary R. Peterson, Duke, Issuance of Improved Technical Specifications Amendments for Catawba, September 30, 1998.
 2. Technical Specification 5.5.12, Explosive Gas and Storage Tank Radioactivity Monitoring Program.

16.11 RADIOLOGICAL EFFLUENTS CONTROLS

16.11-19 Gas Storage Tanks

COMMITMENT The quantity of radioactivity contained in each gas storage tank shall be limited to $\leq 97,000$ Curies of noble gases (considered as Xe-133 equivalent).

APPLICABILITY: At all times.

REMEDIAL ACTIONS

CONDITION	REQUIRED ACTION	COMPLETION TIME
A. Quantity of radioactive material in tank(s) exceeding limit.	A.1 Suspend all additions of radioactive material to the tank(s).	Immediately
	<u>AND</u>	
	A.2 Reduce tank(s) contents to within limit.	48 hours
	<u>AND</u>	
	A.3 Describe the events leading to this condition in the Radioactive Effluent Release Report.	In the next scheduled Radioactive Effluent Release Report pursuant to Technical Specification 5.6.3

TESTING REQUIREMENTS

TEST	FREQUENCY
TR 16.11-19-1 Verify that the quantity of radioactive material contained in each tank is within limits when radioactive materials are being added to the tank(s).	24 hours

Gas Storage Tanks
16.11-19

BASES The tanks included in this SLC are those tanks for which the quantity of radioactivity contained is not limited directly or indirectly by another SLC. Restricting the quantity of radioactivity contained in each gas storage tank provides assurance that in the event of an uncontrolled release of the tank's contents, the resulting whole body exposure to a MEMBER OF THE PUBLIC at the nearest SITE BOUNDARY will not exceed 0.5 rem. This is consistent with Standard Review Plan 11.3, Branch Technical Position ETSB 11-5, "Postulated Radioactive Releases Due to a Waste Gas System Leak or Failure," in NUREG-0800, July 1981.

- REFERENCES**
1. Letter from NRC to Gary R. Peterson, Duke, Issuance of Improved Technical Specifications Amendments for Catawba, September 30, 1998.

 2. Technical Specification 5.5.12, Explosive Gas and Storage Tank Radioactivity Monitoring Program.

Explosive Gas Monitoring Instrumentation
 16.11-20

16.11 RADIOLOGICAL EFFLUENTS CONTROLS

16.11-20 Explosive Gas Monitoring Instrumentation

COMMITMENT The Explosive Gas Monitoring Instrumentation channels shown in Table 16.11-20-1 shall be FUNCTIONAL with their Alarm/Trip Setpoints set to ensure that the limits of SLC 16.11-18 are not exceeded.

APPLICABILITY: During WASTE GAS HOLDUP SYSTEM operation.

REMEDIAL ACTIONS

CONDITION	REQUIRED ACTION	COMPLETION TIME
A. One or more required Explosive Gas Monitoring Instrumentation channel(s) Alarm/Trip Setpoint less conservative than required.	A.1 Declare the channel(s) non-functional.	Immediately
B. One required hydrogen monitor channel non-functional.	B.1 Suspend oxygen supply to the recombiner.	Immediately
	<u>AND</u> B.2 Restore channel to FUNCTIONAL status.	30 days
C. One required oxygen monitor channel non-functional.	C.1 Obtain and analyze grab samples.	24 hours
	<u>AND</u> C.2 Restore channel to FUNCTIONAL status.	30 days

(continued)

Explosive Gas Monitoring Instrumentation
 16.11-20

REMEDIAL ACTIONS (continued)

CONDITION	REQUIRED ACTION	COMPLETION TIME
D. Two required oxygen monitor channels non-functional.	D.1 Obtain and analyze grab samples. AND D.2 Restore channels to FUNCTIONAL status.	Once per 4 hours during degassing operations AND Once per 24 hours during other operations 30 days
E. Required Action and associated Completion Time of Condition B, C, or D not met.	E.1 Prepare and submit a Special Report to the NRC to explain why the non-functionality was not corrected within the time specified.	30 days

TESTING REQUIREMENTS

-----NOTE-----
 Refer to Table 16.11-20-1 to determine which TRs apply for each Explosive Gas Monitoring Instrumentation channel.

TEST	FREQUENCY
TR 16.11-20-1 Perform CHANNEL CHECK.	24 hours
TR 16.11-20-2 Perform COT.	31 days

(continued)

Explosive Gas Monitoring Instrumentation
 16.11-20

TESTING REQUIREMENTS (continued)

TEST	FREQUENCY
<p>TR 16.11-20-3-----NOTE-----</p> <p>The CHANNEL CALIBRATION shall include the use of standard gas samples in accordance with the manufacturer's recommendations. In addition, a standard gas sample of nominal four volume percent hydrogen (for the hydrogen monitors) and four volume percent oxygen (for the oxygen monitors), with the balance nitrogen, shall be used in the calibration to check linearity of the analyzer.</p> <p>-----</p> <p>Perform CHANNEL CALIBRATION.</p>	<p>92 days</p>

Explosive Gas Monitoring Instrumentation
 16.11-20

Table 16.11-20-1

Explosive Gas Monitoring Instrumentation

INSTRUMENT	REQUIRED CHANNELS	TESTING REQUIREMENTS
WASTE GAS HOLDUP SYSTEM Explosive Gas Monitoring Instrumentation		
1. Hydrogen Monitors	1/in-service train per station	TR 16.11-20-1 TR 16.11-20-2 TR 16.11-20-3
2. Oxygen Monitors	2/in-service train per station	TR 16.11-20-1 TR 16.11-20-2 TR 16.11-20-3

Explosive Gas Monitoring Instrumentation
16.11-20

BASES The Explosive Gas Monitoring Instrumentation is provided for monitoring and controlling the concentrations of potentially explosive gas mixtures in the WASTE GAS HOLDUP SYSTEM.

If an instrument has alarm and trip capability, then both the alarm and the trip setpoints are required to be verified for the instrument to remain FUNCTIONAL. For instruments with alarm-only capability, the alarm setpoint must be verified for the instrument to remain FUNCTIONAL.

0WGMT6540 and 0WGMT6560 provide both an alarm and a trip function. 0WGMT6160 and 0WGMT6161 provide an alarm-only function.

REFERENCES 1. Letter from NRC to Gary R. Peterson, Duke, Issuance of Improved Technical Specifications Amendments for Catawba, September 30, 1998.

Major Changes to Liquid, Gaseous, and Solid Radwaste Treatment Systems
16.11-21

16.11 RADIOLOGICAL EFFLUENTS CONTROLS

16.11-21 Major Changes to Liquid, Gaseous, and Solid Radwaste Treatment Systems

COMMITMENT

Licensee-initiated major changes to the Radwaste Treatment Systems (liquid, gaseous, and solid):

1. Shall be reported to the NRC in the Radioactive Effluent Release Report for the period in which the evaluation was reviewed by the Station Manager. Licensees may choose to submit the information called for in this SLC as part of the periodic Updated Final Safety Analysis Report update. The discussion of each change shall contain:
 - a. A summary of the evaluation that led to the determination that the change could be made in accordance with 10 CFR 50.59;
 - b. Sufficient detailed information to totally support the reason for the change without benefit of additional or supplemental information;
 - c. A detailed description of the equipment, components, and processes involved and the interfaces with other plant systems;
 - d. An evaluation of the change, which shows the predicted releases of radioactive materials in liquid and gaseous effluents and/or quantity of solid waste that differ from those previously predicted in the license application and amendments thereto;
 - e. An evaluation of the change, which shows the expected maximum exposures to a MEMBER OF THE PUBLIC in the UNRESTRICTED AREA and to the general population that differ from those previously estimated in the license application and amendments thereto;
 - f. A comparison of the predicted releases of radioactive materials, in liquid and gaseous effluents and in solid waste, to the actual releases for the period prior to when the changes are to be made;
 - g. An estimate of the exposure to plant operating personnel as a result of the change; and

(continued)

Major Changes to Liquid, Gaseous, and Solid Radwaste Treatment Systems
16.11-21

COMMITMENT (continued)

- h. Documentation of the fact that the change was reviewed and found acceptable by the Station Manager or the Chemistry Manager.
- 2. Shall become effective upon review and acceptance by a qualified individual/organization.

APPLICABILITY: At all times.

REMEDIAL ACTIONS None

TESTING REQUIREMENTS None

BASES None

REFERENCES 1. Letter from NRC to Gary R. Peterson, Duke, Issuance of Improved Technical Specifications Amendments for Catawba, September 30, 1998.

Attachment 10
Summary of Changes to the Process Control Program

Catawba Nuclear Station Units 1 & 2
Period 1/1/2016 - 12/31/2016

ATTACHMENT 10

Summary of Changes to the Process Control Program

This attachment includes a summary of changes to the PCP.

Attachment 10
Summary of Changes to the Process Control Program

Catawba Nuclear Station Units 1 & 2
Period 1/1/2016 - 12/31/2016

The Catawba Nuclear Station PCP was not revised in 2016. The most recent revision was provided with the Catawba Nuclear Station 2014 ARERR.

Attachment 11
Summary of Major Modifications to the Radioactive Waste Treatment Systems

Catawba Nuclear Station Units 1 & 2
Period 1/1/2016 - 12/31/2016

ATTACHMENT 11

Summary of Major Modifications to the Radioactive Waste Treatment Systems

This attachment includes a description of major modifications to the radioactive waste treatment systems that are anticipated to affect effluent releases.

Attachment 11
Summary of Major Modifications to the Radioactive Waste Treatment Systems

Catawba Nuclear Station Units 1 & 2
Period 1/1/2016 - 12/31/2016

No major modifications to the Catawba Nuclear Station liquid, gaseous, solid, or mobile radioactive waste treatment systems occurred in 2016.

Attachment 12
Errata to a Previous Year's ARERR

Catawba Nuclear Station Units 1 & 2
Period 1/1/2016 - 12/31/2016

ATTACHMENT 12

Errata to a Previous Year's ARERR

This attachment includes any amended pages from a previous year's ARERR.

Attachment 12
Errata to a Previous Year's ARERR

Catawba Nuclear Station Units 1 & 2
Period 1/1/2016 - 12/31/2016

There are no changes to a previous year's ARERR.