



Exelon Generation Company LLC

James A. FitzPatrick NPP
P.O. Box 110
Lycoming, NY 13093
315-342-3840

William C. Drews
Regulatory Assurance Manager - JAF

JAFP-17-0037
April 27, 2017

United States Nuclear Regulatory Commission
Attn: Document Control Desk
Washington, D.C. 20555-0001

SUBJECT: 2016 Annual Radioactive Effluent Release Report
James A. FitzPatrick Nuclear Power Plant
Docket No. 50-333
License No. DPR-59

Dear Sir or Madam:

This letter transmits the James A. FitzPatrick Nuclear Power Plant's (JAF) Annual Radioactive Effluent Release Report, for the period of January 1, 2016 through December 31, 2016. The enclosure is submitted in accordance with 10 CFR 50.36a and the Reporting Requirements of Technical Specifications Section 5.6.3 and Technical Requirements Manual Appendix H, Offsite Dose Calculation Manual (ODCM), Part 1 Section 6.2, Radioactive Effluent Release Report.

This report (Enclosure 1) includes, as an Addendum, an Assessment of the Radiation Doses to the Public due to the radioactive liquid and gaseous effluents released during the 2016 calendar year. The format used for the effluent data is outlined in Appendix B of Regulatory Guide 1.21, Revision 1. Distribution is in accordance with Regulatory Guide 10.1, Revision 4.

Included in this letter are the current revision of the ODCM Rev. 14, Parts 1 and 2 (Enclosure 2) and the previous revision of the ODCM Rev. 13, Part 1 only (Enclosure 3).

There are no new regulatory commitments contained in this letter.

This report is transmitted by Exelon Generation Company as the current licensee for JAF. The 2016 releases from JAF took place while the facility was under the possession and ownership of Entergy Nuclear FitzPatrick, LLC and Entergy Nuclear Operations, Inc.

If you have any questions concerning the enclosed report, please contact Mr. Jeff Gerber, Chemistry Manager, at (315) 349-6635.

Sincerely,



William C. Drews
Regulatory Assurance Manager - JAF

WCD/JG/dc

Enclosure 1: Annual Radioactive Effluent Release Report, January 1 – December 31, 2016

Enclosure 2: Offsite Dose Calculation Manual Revision 14 Parts 1 and 2

Enclosure 3: Offsite Dose Calculation Manual Revision 13 Part 1

cc:

Regional Administrator, Region I
U. S. Nuclear Regulatory Commission
2100 Renaissance Blvd., Suite 100
King of Prussia, PA 19406-2713

Resident Inspector's Office
U.S. Nuclear Regulatory Commission
James A. FitzPatrick Nuclear Power Plant
P.O. Box 136
Lycoming, NY 13093

Diane Render
Project Manager of James A. FitzPatrick NPP
Plant Licensing Branch LPLI-1
Division of Operating Reactor Licensing
Office of Nuclear Reactor Regulation
U.S. Nuclear Regulatory Commission
Mail Stop O8 C2A
Rockville, MD 20852

J. Gerber (CHEM/JAF)
B. Landers (CHEM/JAF)
K. Stoffle (NMP)

JAFP-17-0037

Enclosure 1

2016 Annual Radioactive Effluent Release Report

(38 Pages)

EXELON GENERATION COMPANY, LLC
JAMES A. FITZPATRICK NUCLEAR POWER PLANT
ANNUAL RADIOACTIVE EFFLUENT RELEASE REPORT

JANUARY 1, 2016 - DECEMBER 31, 2016

DOCKET NO. 50-333

LICENSE NO. DPR-59

EXELON GENERATION COMPANY, LLC
JAMES A. FITZPATRICK NUCLEAR POWER PLANT
ANNUAL RADIOACTIVE EFFLUENT RELEASE REPORT
JANUARY 2016 - DECEMBER 2016

SUPPLEMENTAL INFORMATION

FACILITY: JAFNPP

LICENSEE: EXELON GENERATION COMPANY, LLC

1. Offsite Dose Calculation Manual Part 1 Radiological Effluent Controls

a. Fission and Activation Gases:

(1) The dose rate at or beyond the site boundary due to radioactive materials released from the plant in gaseous effluent shall be limited as follows:

(a) Less than or equal to 500 mrem/year to the whole body and less than or equal to 3000 mrem/year to the skin from noble gases.

(2) The air dose to areas at or beyond the site boundary from noble gases released from the plant in gaseous effluent shall be limited:

(a) During any calendar quarter, to less than or equal to 5 mrad from gamma radiation, and less than or equal to 10 mrad from beta radiation; and,

(b) During any calendar year, to less than or equal to 10 mrad from gamma radiation and less than or equal to 20 mrad from beta radiation.

b. Tritium, Iodines and Particulates, Half Lives > 8 days:

(1) The dose to a member of the public at or beyond the site boundary from Iodine-131, Iodine-133, Tritium, and radionuclides in particulate form with half-lives greater than 8 days released from the plant in gaseous effluent shall be limited:

(a) During any calendar quarter to less than or equal to 7.5 mrem to any organ; and,

(b) During any calendar year to less than or equal to 15 mrem to any organ.

(c) Less than 0.1% of the limits of Specification 3.4.1.c.1.a and 3.4.1.c.1.b as a result of burning contaminated oil.

(2) The dose rate at or beyond the site boundary due to radioactive materials released from the plant in gaseous effluents shall be limited as follows:

(a) Less than or equal to 1500 mrem/year to any organ from Iodine-131, Iodine-133, Tritium and for radioactive materials in particulate form with half-lives greater than 8 days (inhalation pathway only).

EXELON GENERATION COMPANY, LLC
 JAMES A. FITZPATRICK NUCLEAR POWER PLANT
 ANNUAL RADIOACTIVE EFFLUENT RELEASE REPORT
 JANUARY 2016 - DECEMBER 2016

SUPPLEMENTAL INFORMATION (continued)

c. Liquid Effluents:

- (1) The concentration of radioactive materials released to the unrestricted areas shall not exceed ten times the values specified in 10 CFR 20.1001-20.2402, Appendix B, Table 2, column 2. For dissolved or entrained noble gases the concentration shall be limited to 2.00E-04 $\mu\text{Ci/ml}$.
- (2) The dose to a member of the public from radioactive materials released from the plant in liquid effluents to unrestricted areas shall be limited as follows:
 - (a) During any calendar quarter, limited to less than or equal to 1.5 mrem to the whole body and to less than or equal to 5 mrem to any organ; and,
 - (b) During any calendar year, limited to less than or equal to 3 mrem to the whole body and to less than or equal to 10 mrem to any organ.

2. 10X Effluent Concentrations

a. Fission and activation gases:	(None specified)			
b. Iodines:	(None specified)			
c. Particulates, half-lives >8 days:	(None specified)			
d. Liquid effluents:	<u>Quarter 1</u>	<u>Quarter 2</u>	<u>Quarter 3</u>	<u>Quarter 4</u>
(1) Fission and activation products (mixture EC) ($\mu\text{Ci/ml}$)	None	None	None	None
(2) Tritium ($\mu\text{Ci/ml}$)	1.00E-02	1.00E-02	1.00E-02	1.00E-02
(3) Dissolved and entrained gases ($\mu\text{Ci/ml}$)	2.00E-04	2.00E-04	2.00E-04	2.00E-04

EXELON GENERATION COMPANY, LLC
JAMES A. FITZPATRICK NUCLEAR POWER PLANT
ANNUAL RADIOACTIVE EFFLUENT RELEASE REPORT
JANUARY 2016 - DECEMBER 2016

SUPPLEMENTAL INFORMATION (continued)

3. **Average Energy** (None specified)

4. **Measurements and Approximations of Total Radioactivity**

- a. Fission and Activation Gases: Continuous monitor on each release path calibrated to a marinelli grab sample analyzed by gamma spectroscopy; bubbler grab sample analyzed for Tritium.
- b. Iodines: Gamma spectral analysis of charcoal cartridge and particulate filter on each release path.
- c. Particulates: Gamma spectral analysis of each particulate filter and charcoal cartridge for each release path. A four week per quarter composite of particulate filters for each release path for Strontium-89 and Strontium-90. One week per month particulate filter for each release path for gross alpha.
- d. Liquid Effluents: Gamma spectral analysis of each batch discharged, except composite analysis for Strontium-89, Strontium-90, Iron-55, Tritium, and Alpha.
- e. Solid Waste: Gamma spectral analysis of a representative sample of each waste shipment. Scaling factors established from off-site composite sample analyses to estimate concentration of non-gamma emitters. Low activity trash shipments curie content is estimated by dose rate measurement and application of appropriate scaling factors.
- f. Error Estimation Method: Overall error for sampling and analysis estimated by combining individual errors using error propagation methods. This process is composed of determinate and undeterminate errors.

Determinate - Pump flowrates, volume measurements and analysis collection yields

Undeterminate - Random counting error estimated using accepted statistical calculations

EXELON GENERATION COMPANY, LLC
 JAMES A. FITZPATRICK NUCLEAR POWER PLANT
 ANNUAL RADIOACTIVE EFFLUENT RELEASE REPORT
 JANUARY 2016 - DECEMBER 2016

SUPPLEMENTAL INFORMATION (continued)

5. Batch Releases

a. <u>Liquid: Canal</u>	<u>Quarter 1</u>	<u>Quarter 2</u>	<u>Quarter 3</u>	<u>Quarter 4</u>
(1) Number of batch releases:	6.00E+00	3.00E+00	1.00E+00	1.00E+00
(2) Total time period for batch release: (min)	8.20E+01	6.00E+01	5.60E+01	7.00E+01
(3) Maximum time period for batch release: (min)	3.80E+01	3.60E+01	5.60E+01	7.00E+01
(4) Average time period for batch release: (min)	1.37E+01	2.00E+01	5.60E+01	7.00E+01
(5) Minimum time period for batch release: (min)	4.00E+00	1.20E+01	5.60E+01	7.00E+01
(6) Total Activity Released (Ci)	4.95E-05	2.09E-04	8.71E-07	6.73E-07
(7) Total Volume Released (liters)	1.75E+04	9.99E+03	9.39E+02	7.83E+02
b. <u>Liquid: Non-Canal</u>	<u>Quarter 1</u>	<u>Quarter 2</u>	<u>Quarter 3</u>	<u>Quarter 4</u>
(1) Number of batch releases:	1.50E+01	3.50E+01	5.00E+01	1.80E+01
(2) Total time period for batch release: (min)	3.80E+01	1.54E+02	5.33E+02	1.93E+03
(3) Maximum time period for batch release: (min)	4.00E+00	6.10E+01	2.79E+02	7.69E+02
(4) Average time period for batch release: (min)	2.53E+00	4.40E+00	1.07E+01	1.07E+02
(5) Minimum time period for batch release: (min)	1.00E+00	1.00E+00	1.00E+00	1.00E+00
(6) Total Activity Released (Ci)	2.30E-05	0.00E+00	2.17E-04	1.59E-04
(7) Total Volume Released (liters)	1.68E+04	6.15E+04	8.31E+04	1.25E+05

c. Gaseous

There were no gaseous batch releases for this report period.

EXELON GENERATION COMPANY, LLC
 JAMES A. FITZPATRICK NUCLEAR POWER PLANT
 ANNUAL RADIOACTIVE EFFLUENT RELEASE REPORT
 JANUARY 2016 - DECEMBER 2016

SUPPLEMENTAL INFORMATION (continued)

6. Continuous Releases

a. <u>Liquid: Non-Canal</u>	<u>Quarter 1</u>	<u>Quarter 2</u>	<u>Quarter 3</u>	<u>Quarter 4</u>
(1) Number of releases:	1.80E+01	1.40E+01	2.10E+01	1.60E+01
(2) Total Activity Released (Ci)	1.10E-02	3.13E-02	4.60E-02	2.82E-02
(3) Total Volume Released (liters)	8.04E+06	6.15E+06	4.87E+06	6.45E+06
b. <u>Liquid: Canal</u>	<u>Quarter 1</u>	<u>Quarter 2</u>	<u>Quarter 3</u>	<u>Quarter 4</u>
(1) Number of releases:	0	0	0	0
(2) Total Activity Released (Ci)	N/A	N/A	N/A	N/A

EXELON GENERATION COMPANY, LLC
 JAMES A. FITZPATRICK NUCLEAR POWER PLANT
 ANNUAL RADIOACTIVE EFFLUENT RELEASE REPORT
 JANUARY 2016 - DECEMBER 2016

**TABLE 1A
 GASEOUS EFFLUENTS - SUMMATION OF ALL RELEASES**

	<u>UNIT</u>	<u>QTR 1</u>	<u>QTR 2</u>	<u>QTR 3</u>	<u>QTR 4</u>	<u>EST TOTAL ERROR %</u>
A. FISSION AND ACTIVATION GASES						
1. Total Release	Ci	9.82E+00	9.76E+00	3.91E+01	7.71E+00	≤2.50E+01
2. Average release rate for period	μCi/sec	1.25E+00	1.24E+00	4.92E+00	9.70E-01	
3. Percentage ODCM Limit	%	*	*	*	*	
B. IODINE-131						
1. Total Iodine-131	Ci	7.51E-05	6.56E-05	9.92E-05	1.90E-04	≤2.50E+01
2. Average release rate for period	μCi/sec	9.56E-06	8.35E-06	1.25E-05	2.39E-05	
3. Percentage ODCM Limit	%	*	*	*	*	
C. PARTICULATES						
1. Particulates with half-lives >8 days	Ci	2.32E-06	2.29E-06	2.73E-06	1.09E-07	≤3.60E+01
2. Average release rate for period	μCi/sec	2.95E-07	2.92E-07	3.44E-07	1.38E-08	
3. Percentage ODCM Limit	%	*	*	*	*	
4. Gross alpha radioactivity	Ci	5.91E-07	3.24E-07	2.00E-07	1.56E-07	≤2.50E+01
D. TRITIUM						
1. Total Release	Ci	1.57E+00	2.40E+00	3.95E+00	5.91E+00	≤2.50E+01
2. Average release rate for period	μCi/sec	1.99E-01	3.05E-01	4.97E-01	7.43E-01	
3. Percentage ODCM Limit	%	*	*	*	*	
E. CARBON-14 (See Attachment 8)						
*F. PERCENT OF APPLICABLE ODCM LIMITS						
FISSION AND ACTIVATION GASES	<u>UNIT</u>	<u>QTR 1</u>	<u>QTR 2</u>	<u>QTR 3</u>	<u>QTR 4</u>	
1. Quarterly gamma air dose limit	%	5.96E-03	5.57E-03	1.90E-02	4.16E-03	
2. Quarterly beta air dose limit	%	3.25E-04	2.61E-04	1.51E-03	2.52E-04	
3. Yearly gamma air dose limit	%	2.98E-03	2.79E-03	9.50E-03	2.08E-03	
4. Yearly beta air dose limit	%	1.63E-04	1.30E-04	7.57E-04	1.26E-04	
5. Whole body dose rate limit	%	4.19E-03	1.25E-03	8.45E-03	1.29E-03	
6. Skin dose rate limit	%	8.94E-04	3.93E-04	1.85E-03	3.33E-04	
HALOGENS, TRITIUM AND PARTICULATES WITH HALF-LIVES >8 DAYS						
7. Quarterly dose limit (organ)	%	1.27E-02	1.08E-02	1.73E-02	3.72E-02	
8. Yearly dose limit (organ)	%	6.35E-03	5.42E-03	8.66E-03	1.86E-02	
9. Organ dose rate limit	%	2.49E-05	1.90E-05	1.75E-05	3.18E-05	

EXELON GENERATION COMPANY, LLC
 JAMES A. FITZPATRICK NUCLEAR POWER PLANT
 ANNUAL RADIOACTIVE EFFLUENT RELEASE REPORT
 JANUARY 2016 - DECEMBER 2016

TABLE 1B
GASEOUS EFFLUENTS - ELEVATED RELEASE

CONTINUOUS MODE

NUCLIDES RELEASED

<u>1. Fission Gases</u>	<u>UNIT</u>	<u>QUARTER 1</u>	<u>QUARTER 2</u>	<u>QUARTER 3</u>	<u>QUARTER 4</u>
Argon-41	Ci	4.41E+00	5.04E+00	7.55E+00	3.61E+00
Krypton-85	Ci	ND	ND	ND	ND
Krypton-85m	Ci	9.26E-01	1.49E+00	3.05E+00	1.29E+00
Krypton-87	Ci	4.22E-01	ND	5.17E+00	3.71E-02
Krypton-88	Ci	1.19E+00	1.47E+00	3.35E+00	9.29E-01
Krypton-89	Ci	ND	ND	ND	1.86E-01
Xenon-133	Ci	3.83E-01	1.06E+00	1.25E+00	8.28E-01
Xenon-133m	Ci	ND	ND	ND	ND
Xenon-135	Ci	2.43E-01	ND	7.85E+00	1.53E-02
Xenon-135m	Ci	3.86E-01	1.93E-01	2.00E+00	8.38E-02
Xenon-137	Ci	ND	ND	2.51E-01	3.91E-01
Xenon-138	Ci	1.84E+00	4.77E-01	8.67E+00	3.37E-01
TOTAL	Ci	9.80E+00	9.72E+00	3.91E+01	7.71E+00
2. Iodines					
Iodine-131	Ci	3.23E-05	3.12E-05	3.31E-05	1.39E-05
Iodine-132	Ci	ND	ND	ND	ND
Iodine-133	Ci	6.39E-05	7.44E-05	1.19E-04	3.65E-05
Iodine-134	Ci	ND	ND	ND	ND
Iodine-135	Ci	ND	ND	8.08E-06	ND
TOTAL	Ci	9.62E-05	1.06E-04	1.60E-04	5.04E-05
3. Particulates					
Barium-140	Ci	ND	ND	3.10E-07	ND
Cobalt-60	Ci	ND	ND	ND	ND
Cesium-137	Ci	ND	ND	ND	ND
Manganese-54	Ci	ND	3.68E-07	ND	ND
Strontium-89	Ci	2.32E-06	1.93E-06	2.42E-06	1.09E-07
Zinc-65	Ci	ND	ND	ND	ND
TOTAL	Ci	2.32E-06	2.29E-06	2.73E-06	1.09E-07
4. Tritium					
Hydrogen-3	Ci	1.73E-01	3.25E-01	4.18E-01	2.95E-01

Note: There were no batch releases for this report period.

EXELON GENERATION COMPANY, LLC
 JAMES A. FITZPATRICK NUCLEAR POWER PLANT
 ANNUAL RADIOACTIVE EFFLUENT RELEASE REPORT
 JANUARY 2016 - DECEMBER 2016

**TABLE 1C
 GASEOUS EFFLUENTS - GROUND LEVEL RELEASES**

CONTINUOUS MODE

NUCLIDES RELEASED

1. <u>Fission Gases</u>	<u>UNIT</u>	<u>QUARTER 1</u>	<u>QUARTER 2</u>	<u>QUARTER 3</u>	<u>QUARTER 4</u>
Argon-41	Ci	ND	ND	ND	ND
Krypton-85	Ci	ND	ND	ND	ND
Krypton-85m	Ci	ND	ND	ND	ND
Krypton-87	Ci	ND	ND	ND	ND
Krypton-88	Ci	ND	ND	ND	ND
Krypton-89	Ci	ND	ND	ND	ND
Xenon-133	Ci	1.59E-02	1.96E-02	ND	ND
Xenon-133m	Ci	ND	ND	ND	ND
Xenon-135	Ci	9.51E-03	1.13E-02	ND	ND
Xenon-135m	Ci	2.76E-03	6.53E-04	ND	ND
Xenon-137	Ci	ND	ND	ND	ND
Xenon-138	Ci	ND	ND	ND	1.41E-03
TOTAL	Ci	2.82E-02	3.15E-02	ND	1.41E-03
2. <u>Iodines</u>					
Iodine-131	Ci	4.29E-05	3.44E-05	6.61E-05	1.76E-04
Iodine-132	Ci	ND	ND	ND	ND
Iodine-133	Ci	3.90E-04	2.50E-04	3.89E-04	1.01E-03
Iodine-134	Ci	ND	ND	ND	ND
Iodine-135	Ci	ND	ND	ND	ND
TOTAL	Ci	4.33E-04	2.85E-04	4.55E-04	1.19E-03
3. <u>Particulates</u>					
Silver-110M	Ci	ND	ND	ND	ND
Cobalt-58	Ci	ND	ND	ND	ND
Cobalt-60	Ci	ND	ND	ND	ND
Manganese-54	Ci	ND	ND	ND	ND
Selenium-75	Ci	ND	ND	ND	ND
Strontium-89	Ci	ND	ND	ND	ND
Zinc-65	Ci	ND	ND	ND	ND
TOTAL	Ci	ND	ND	ND	ND
4. <u>Tritium</u>					
Hydrogen-3	Ci	1.39E+00	2.08E+00	3.54E+00	5.61E+00

Note: There were no batch releases for this report period.

EXELON GENERATION COMPANY, LLC
 JAMES A. FITZPATRICK NUCLEAR POWER PLANT
 ANNUAL RADIOACTIVE EFFLUENT RELEASE REPORT
 JANUARY 2016 - DECEMBER 2016

TABLE 2A
LIQUID EFFLUENTS - SUMMATION OF ALL RELEASES

	<u>UNIT</u>	<u>QTR 1</u>	<u>QTR 2</u>	<u>QTR 3</u>	<u>QTR 4</u>	<u>EST TOTAL ERROR %</u>
A. FISSION AND ACTIVATION PRODUCTS						
1. Total Release (not including tritium, gases and alpha)	Ci	ND	ND	ND	ND	NA
2. Average diluted concentration during period	μCi/ml	ND	ND	ND	ND	
3. Percentage ODCM Limit	%	NA	NA	NA	NA	
B. TRITIUM						
1. Total Release	Ci	1.11E-02	3.15E-02	4.63E-02	2.84E-02	≤2.50E+01
2. Average diluted concentration during period (Note 1)	μCi/ml	1.37E-06	5.03E-06	9.34E-06	4.32E-06	
3. Percentage ODCM Limit	%	*	*	*	*	
C. DISSOLVED AND ENTRAINED GASES						
1. Total Release	Ci	ND	ND	ND	ND	NA
2. Average diluted concentration during period	μCi/ml	ND	ND	ND	ND	
3. Percentage ODCM Limit	%	NA	NA	NA	NA	
D. GROSS ALPHA RADIOACTIVITY						
1. Total Release	Ci	ND	ND	2.54E-07	7.35E-07	≤4.20E+01
E. VOLUME OF WASTE RELEASED (PRIOR TO DILUTION)						
	liters	8.07E+06	6.22E+06	4.95E+06	6.57E+06	
F. VOLUME OF DILUTION WATER USED DURING PERIOD						
	liters	1.32E+08	9.27E+07	6.27E+07	1.13E+08	
*G. PERCENT OF APPLICABLE ODCM LIMITS						
1. Quarterly Whole Body Dose	%	2.73E-04	9.41E-05	3.15E-04	3.19E-04	
2. Quarterly Organ Dose	%	8.19E-05	2.82E-05	9.44E-05	9.57E-05	
3. Annual Whole Body Dose	%	1.36E-04	4.70E-05	1.57E-04	1.59E-04	
4. Annual Organ Dose	%	4.09E-05	1.41E-05	4.72E-05	4.78E-05	

Note 1: Concentration includes summation from diluted and undiluted values from Canal and Non-Canal releases (Table 2B).

EXELON GENERATION COMPANY, LLC
 JAMES A. FITZPATRICK NUCLEAR POWER PLANT
 ANNUAL RADIOACTIVE EFFLUENT RELEASE REPORT
 JANUARY 2016 - DECEMBER 2016

TABLE 2B
LIQUID EFFLUENTS CANAL

BATCH MODE

<u>NUCLIDES RELEASED</u>	<u>UNIT</u>	<u>QUARTER 1</u>	<u>QUARTER 2</u>	<u>QUARTER 3</u>	<u>QUARTER 4</u>
1. <u>Fission and Activation Products</u>					
ND	Ci	ND	ND	ND	ND
2. <u>Tritium</u>					
Hydrogen-3	Ci	4.95E-05	2.08E-04	8.71E-07	6.73E-07
3. <u>Dissolved and Entrained Gases</u>					
ND	Ci	ND	ND	ND	ND

TABLE 2B
LIQUID EFFLUENTS CANAL

CONTINUOUS MODE

<u>NUCLIDES RELEASED</u>	<u>UNIT</u>	<u>QUARTER 1</u>	<u>QUARTER 2</u>	<u>QUARTER 3</u>	<u>QUARTER 4</u>
1. <u>Fission and Activation Products</u>					
ND	Ci	ND	ND	ND	ND
2. <u>Tritium</u>					
Hydrogen-3	Ci	ND	ND	ND	ND
3. <u>Dissolved and Entrained Gases</u>					
ND	Ci	ND	ND	ND	ND

EXELON GENERATION COMPANY, LLC
 JAMES A. FITZPATRICK NUCLEAR POWER PLANT
 ANNUAL RADIOACTIVE EFFLUENT RELEASE REPORT
 JANUARY 2016 - DECEMBER 2016

**TABLE 2B (SUPPLEMENT)
 LIQUID EFFLUENTS NON-CANAL**

<u>CONTINUOUS MODE</u>						
<u>NUCLIDES RELEASED</u>	<u>UNIT</u>	<u>QUARTER 1</u>	<u>QUARTER 2</u>	<u>QUARTER 3</u>	<u>QUARTER 4</u>	
1. <u>Fission and Activation Products</u>						
ND	Ci	ND	ND	ND	ND	
2. <u>Tritium</u>						
Hydrogen-3	Ci	1.10E-02	3.13E-02	4.60E-02	2.82E-02	
3. <u>Dissolved and Entrained Gases</u>						
ND	Ci	ND	ND	ND	ND	

EXELON GENERATION COMPANY, LLC
 JAMES A. FITZPATRICK NUCLEAR POWER PLANT
 ANNUAL RADIOACTIVE EFFLUENT RELEASE REPORT
 JANUARY 2016 - DECEMBER 2016

**TABLE 2B (SUPPLEMENT)
 LIQUID EFFLUENTS NON-CANAL**

<u>NUCLIDES RELEASED</u>	<u>UNIT</u>	<u>BATCH MODE</u>			
		<u>QUARTER 1</u>	<u>QUARTER 2</u>	<u>QUARTER 3</u>	<u>QUARTER 4</u>
1. <u>Fission and Activation Products</u>					
ND	Ci	ND	ND	ND	ND
2. <u>Tritium</u>					
Hydrogen-3	Ci	7.25E-05	2.08E-04	2.18E-04	1.60E-04
3. <u>Dissolved and Entrained Gases</u>					
ND	Ci	ND	ND	ND	ND

EXELON GENERATION COMPANY, LLC
 JAMES A. FITZPATRICK NUCLEAR POWER PLANT
 ANNUAL RADIOACTIVE EFFLUENT RELEASE REPORT
 JANUARY 2016 - DECEMBER 2016

TABLE 2B (continued)
ABNORMAL RELEASE
LIQUID EFFLUENTS CANAL

CONTINUOUS MODE

<u>NUCLIDES RELEASED</u>	<u>UNIT</u>	<u>QUARTER 1</u>	<u>QUARTER 2</u>	<u>QUARTER 3</u>	<u>QUARTER 4</u>
1. <u>Fission and Activation Products</u>					
ND	Ci	ND	ND	ND	ND
2. <u>Tritium</u>					
ND	Ci	ND	ND	ND	ND
3. <u>Dissolved and Entrained Gases</u>					
ND	Ci	ND	ND	ND	ND

EXELON GENERATION COMPANY, LLC
 JAMES A. FITZPATRICK NUCLEAR POWER PLANT
 ANNUAL RADIOACTIVE EFFLUENT RELEASE REPORT
 JANUARY 2016 - DECEMBER 2016

**TABLE 3A
 SOLID WASTE AND IRRADIATED FUEL SHIPMENTS**

A. SOLID WASTE SHIPPED OFFSITE FOR BURIAL OR DISPOSAL (NOT IRRADIATED FUEL)

1. <u>Type of Waste</u>	<u>UNIT</u>	<u>CLASS A</u>	<u>CLASS B</u>	<u>CLASS C</u>	<u>EST. TOTAL ERROR %</u>
a. Spent resins, filter sludges, evaporator bottoms, etc.	m ³	1.35E+02	0.00E+00	0.00E+00	1.00E+01
	Ci	2.38E+02	0.00E+00	0.00E+00	
b. Dry compressible waste, contaminated equipment, etc.	m ³	3.08E+02	0.00E+00	0.00E+00	1.00E+01
	Ci	5.32E+00	0.00E+00	0.00E+00	
c. Irradiated components, control rods, etc.	m ³	1.22E-01	0.00E+00	0.00E+00	1.00E+01
	Ci	4.55E+00	0.00E+00	0.00E+00	
d. Other: Dry compressible waste, contaminated equipment, spent resins for volume reduction.	m ³	1.67E+01	0.00E+00	0.00E+00	1.00E+01
	Ci	1.73E-02	0.00E+00	0.00E+00	

2. Estimate of Major Nuclide Composition (by type of waste)

a. Spent resins, filter sludges, evaporator bottoms, etc.

<u>Isotope</u>	<u>Percent</u>	<u>Curies</u>		<u>Isotope</u>	<u>Percent</u>	<u>Curies</u>	
Ce-144	3.00E-02	7.54E-02	E	Co-58	1.00E-01	2.34E-01	E
Co-60	2.03E+01	4.86E+01	E	Fe-59	8.00E-02	1.91E-01	E
Cs-137	3.16E+00	7.56E+00	E	Fe-55	4.93E+01	1.18E+02	E
C-14	1.60E-01	3.85E-01	E	Mn-54	5.00E+00	1.19E+01	E
Ni-63	5.95E+00	1.42E+01	E	Tc-99	3.00E-02	6.31E-02	E
Zn-65	1.55E+01	3.69E+01	E	H-3	2.30E-01	5.46E-01	E
Sr-90	3.00E-02	7.16E-02	E	Sb-124	1.00E-02	1.67E-02	E
Cr-51	4.00E-02	1.00E-01	E	I-129	1.00E-02	1.29E-02	E
Cs-134	3.00E-02	7.92E-02	E				

(E- Estimated M- Measured)

b. Dry compressible waste, contaminated equipment, etc.

<u>Isotope</u>	<u>Percent</u>	<u>Curies</u>		<u>Isotope</u>	<u>Percent</u>	<u>Curies</u>	
Ce-144	2.00E-02	1.57E-03	E	Co-58	6.00E-02	5.28E-03	E
Co-60	4.54E+00	3.97E-01	E	Fe-59	1.60E-01	1.37E-02	E
Cs-137	4.30E-01	3.72E-02	E	Fe-55	4.87E+01	4.26E+00	E
C-14	1.37E+01	1.19E+00	E	Mn-54	2.83E+00	2.48E-01	E
Ni-63	5.70E-01	4.97E-02	E	I-129	3.90E-01	3.45E-02	E
Zn-65	1.48E+00	1.29E-01	E	H-3	2.19E+01	1.92E+00	E
Sb-124	4.00E-02	3.48E-03	E	Tc-99	5.02E+00	4.39E-01	E
Sb-125	4.00E-02	3.52E-03	E	Cr-51	1.40E-01	1.22E-02	E

(E- Estimated M- Measured)

EXELON GENERATION COMPANY, LLC
 JAMES A. FITZPATRICK NUCLEAR POWER PLANT
 ANNUAL RADIOACTIVE EFFLUENT RELEASE REPORT
 JANUARY 2016 - DECEMBER 2016

TABLE 3A (continued)
SOLID WASTE AND IRRADIATED FUEL SHIPMENTS

c. Irradiated components, control rods, etc.

<u>Isotope</u>	<u>Percent</u>	<u>Curies</u>		<u>Isotope</u>	<u>Percent</u>	<u>Curies</u>	
C-14	1.00E-02	4.28E-04	E	Co-58	1.00E-02	2.52E-04	E
Co-60	5.53E+01	2.51E+00	E	Zn-65	2.00E-02	9.12E-04	E
Ni-59	1.20E-01	5.53E-03	E	Fe-55	3.79E+01	1.73E+00	E
Ni-63	5.96E+00	2.71E-01	E	Mn-54	6.00E-01	2.73E-02	E

(E- Estimated M- Measured)

d. Other: Dry compressible waste, contaminated equipment, spent resins, contaminated oil, glycol and water for volume reduction.

<u>Isotope</u>	<u>Percent</u>	<u>Curies</u>		<u>Isotope</u>	<u>Percent</u>	<u>Curies</u>	
H-3	7.86E+01	4.35E+00	E	Cs-137	1.00E-02	3.02E-04	E
Tc-99	1.18E+01	6.54E-01	E	Co-60	1.00E-02	6.44E-04	E
C-14	8.28E+00	4.58E-01	E	Cs-144	3.00E-02	1.57E-03	E
I-129	1.28E+00	7.07E-02	E				

(E- Estimated M- Measured)

Percentage of nuclides and total activities are based on a combination of direct measurements and scaling for non-gamma emitting nuclides.

EXELON GENERATION COMPANY, LLC
 JAMES A. FITZPATRICK NUCLEAR POWER PLANT
 ANNUAL RADIOACTIVE EFFLUENT RELEASE REPORT
 JANUARY 2016 - DECEMBER 2016

TABLE 3A (continued)
SOLID WASTE AND IRRADIATED FUEL SHIPMENTS

3. Solid Waste Disposition

<u>No. of Shipments</u>	<u>Mode of Transportation</u>	<u>Destination</u>
47	Trucks	*Energy Solutions Oak Ridge, TN
3	Trucks	*Energy Solutions Kingston, TN
1	Truck	Perma-Fix of Florida INC. Gainesville, FL
		* Volume Reduction Facility

B. IRRADIATED FUEL SHIPMENTS (Disposition)

<u>No. of Shipments</u>	<u>Mode of Transportation</u>	<u>Destination</u>
None	-----	-----

EXELON GENERATION COMPANY, LLC
 JAMES A. FITZPATRICK NUCLEAR POWER PLANT
 ANNUAL RADIOACTIVE EFFLUENT RELEASE REPORT
 JANUARY 2016 - DECEMBER 2016

TABLE 3B
SOLID WASTE AND IRRADIATED FUEL SHIPMENTS

A. NRC CLASS A

<u>SOURCE OF WASTE</u>	<u>PROCESSING EMPLOYED</u>	<u>CONTAINER VOLUME</u>	<u>TYPE OF CONTAINER</u>	<u>NUMBER OF CONTAINERS</u>
Dry compressible Waste (DAW), Contaminated Equipment, etc.	Non-compacted	1280 ft ³ (36.2 m ³)	STC	9
Dry compressible Waste (DAW), Contaminated Equipment, etc.	Non-compacted	96 ft ³ (2.72 m ³)	STC	12
Dry compressible Waste (DAW), Contaminated Equipment, etc.	Non-compacted	92 ft ³ (2.61m ³)	STC	1
Dry compressible Waste(DAW), Contaminated Equipment etc.	Non-compacted	1033.5 ft ³ (29.3 m ³)	STC	2
Spent Resins, Filter Sludges, evaporator Bottoms, etc.	Air Drying Non-compacted	205.8 ft ³ (5.83 m ³)	HIC	30
Spent Resins, Filter Sludges, evaporator Bottoms, etc.	Air Drying Non-compacted	120.3 ft ³ (3.41 m ³)	HIC	4
Contaminated Oil/Water.	Non-compacted	1280 ft ³ (36.2 m ³)	STC	1

B. NRC CLASS B

<u>SOURCE OF WASTE</u>	<u>PROCESSING EMPLOYED</u>	<u>CONTAINER VOLUME</u>	<u>TYPE OF CONTAINER</u>	<u>NUMBER OF CONTAINERS</u>
------------------------	----------------------------	-------------------------	--------------------------	-----------------------------

None

C. NRC CLASS C

<u>SOURCE OF WASTE</u>	<u>PROCESSING EMPLOYED</u>	<u>CONTAINER VOLUME</u>	<u>TYPE OF CONTAINER</u>	<u>NUMBER OF CONTAINERS</u>
------------------------	----------------------------	-------------------------	--------------------------	-----------------------------

None

HIC- High Integrity Container
 STC- Strong Tight Container

EXELON GENERATION COMPANY, LLC
JAMES A. FITZPATRICK NUCLEAR POWER PLANT
ANNUAL RADIOACTIVE EFFLUENT RELEASE REPORT
JANUARY 2016 - DECEMBER 2016

ATTACHMENT NO. 1

CHANGES TO THE OFFSITE DOSE CALCULATION MANUAL (ODCM)

In accordance with the James A. FitzPatrick Nuclear Power Plant Offsite Dose Calculation Manual (ODCM), Part 1 Radiological Effluent Controls (REC) Section 6.2.3, changes made to the Offsite Dose Calculation Manual (ODCM) during the reporting period shall be included in the Annual Radioactive Effluent Release Report.

Revision 13 and Revision 14 of the ODCM became effective during calendar year 2016. Changes to the ODCM Procedure are identified on the Revision Summary Sheet found in the front of each procedure revision. Please find copies of both revisions attached to cover letter for this report.

EXELON GENERATION COMPANY, LLC
JAMES A. FITZPATRICK NUCLEAR POWER PLANT
ANNUAL RADIOACTIVE EFFLUENT RELEASE REPORT
JANUARY 2016 - DECEMBER 2016

ATTACHMENT NO. 2

SUMMARY OF CHANGES TO THE PROCESS CONTROL PROGRAM

In accordance with the James A. FitzPatrick Nuclear Power Plant Offsite Dose Calculation Manual (ODCM), Part 1 Radiological Effluent Controls (REC) Section 6.2.3, changes made to the Process Control Program (PCP) during the reporting period shall be included in the Annual Radioactive Effluent Release Report.

EN-RW-105 Process Control Program Revision 5 became Headquarters effective 8/27/15. There were no changes to the James A. FitzPatrick Process Control Program (PCP) for the calendar year 2016.

EN-RW-102, "Radioactive Shipping Procedure", Rev.14:

The primary purpose of this revision is to update the procedure to ensure compliance with current and upcoming changes to 49 CFR, especially those changes stemming from HM-215M and HM-250 (changes are as recommended by review of EN-RW-102 by WMG). Additionally, the issue identified in NIOS audit QA-14/15-2015-IP-01 regarding retention of DOT Spec 7A test and engineering evaluation is addressed.

- Added a bullet item to step 7.0[2] specifying that shipment records are to include documentation of tests and engineering evaluations for DOT Spec 7A packages
- Step 2.0[10]: Corrected reference to WMG software packages
- Step 5.1[12]: replaced specific shipping names with generic statement regarding Marking and Labeling
- Step 5.2[11](c), Attachment 9.10: Updated terminology for Industrial Package
- Step 5.2[11](c): Added requirement to cover Specification Marking
- Step 5.2[16]: Added reference for requirements for multiple hazard radioactive material
- Step 5.2[19]: Revised step to indicate that the survey only releases the vehicle back to exclusive use service
- Added step 5.2[20] for unconditional release of formerly exclusive use vehicle.
- Step 7.0[1]: Added an additional reference for record retention
- Step 7.0[2]: Added bullet item requiring that documentation of tests and engineering evaluations be kept for records
- Attachment 9.1: replaced RAMSHP with RADMAN and replaced obsolete reference to Studsvik with Erwin Resin Solutions
- Attachment 9.2, step 21: replaced Studsvik with Erwin Resin Solutions
- Attachment 9.3, step 12: combined sub-step "a" with step 12 as there is no step "b"
- Attachment 9.3, step 13: replaced Studsvik with Erwin Resin Solutions
- Attachment 9.3, step 24: added requirement for DOT 7A test and engineering documentation
- Attachment 9.4, step 14: replaced Studsvik with Erwin Resin Solutions
- Attachment 9.4: Added a new step #5 for verifying the licensee is a registered user of Type B package
- Attachment 9.5, step #9: added reference to requirements of 49 CFR 173.422
- Attachment 9.6, step #8: added reference to requirements of 49 CFR 173.422
- Attachment 9.7, step #10: added reference to requirements of 49 CFR 173.422
- Attachment 9.8, step #7: added reference to requirements of 49 CFR 173.422

EXELON GENERATION COMPANY, LLC
JAMES A. FITZPATRICK NUCLEAR POWER PLANT
ANNUAL RADIOACTIVE EFFLUENT RELEASE REPORT
JANUARY 2016 - DECEMBER 2016

ATTACHMENT NO. 2 (Cont'd)

EN-RW-102, "Radioactive Shipping Procedure", Rev. 14 (cont'd)

- Attachment 9.9, step #6: added reference to requirements of 49 CFR 173.422
- Attachment 9.10: updated references for Industrial Package (I, II, and III changed to Type 1,2,3)
- Attachment 9.11, sheet 2: updated contamination limits to reflect latest regulations
- Attachment 9.14: updated definition of Exclusive Use according to WMG recommendation
- Updated section 8.0 and related procedure steps per GGNS Commitment Review

EN-RW-106, "Integrated Transportation Security Plan", Rev.5:

The purpose of this revision is to address:

- A QA-identified issue regarding documentation of preplanning activities
- Correct the NRC email address
- Add a requirement for contacting ANI
- Added step 2.0[20] for reference to NUREG-2155 (which is the basis for preplanning documentation requirements)
- Step 3.0[1] added: ANI (American Nuclear Insurers), MCC – Movement Control Center, SAS – Secondary Alarm Station
- Step 5.3[4]: corrected step reference
- Step 5.7.4.1[3]: corrected the NRC email address
- Added steps 5.7.5.2[8] and 5.7.5.3[7] for ANI notification in the event of an accident.
- Step 5.7.6.1[2]: expanded requirements for documentation of preplanning activities
- Step 5.8[2] is reworded for clarity

EN-RW-108, "Radioactive Shipment Accident Response", Rev.2:

The primary purpose of this revision is to add instruction for contacting ANI in the event of an accident covered

by this procedure. Specifically:

- ANI is added to the definitions section, section 3.0
- Step 5.4[1] is expanded to address contacting ANI

This is a complete rewrite of the procedure in order to align the procedure format with EN-AD-101-01. Content changes are made only to correct grammatical errors or to change step levels to correct formatting and are editorial. No change bars are used to reflect the changes made due to the rewrite. Changes worth noting are:

- Sections 5.1 and 5.2 are reversed in order for alignment with EN-AD-101-01
- Section 5.3.2: "CAUTION" is changed to "NOTE" in the box associated with ion chambers versus GM instruments as the associated statement does not qualify as a caution statement.
- The Note statement in section 5.4[3] (of Rev. 1) regarding evaluation for fatigue is changed to an instructional step as the statement is not appropriate for a Note statement.
- The statement in section 5.4[3] (of Rev. 1) regarding the reference to EN-OM-123 is changed to an instructional step as the statement is not appropriate for a Note statement or a Caution statement.
- The last Note statement in section 5.0 regarding disposition of documents is changed to a step as the contents are not appropriate for a Note statement
- Attachment 9.1: changed note on page one to a step because the content is inappropriate for a Note.

EXELON GENERATION COMPANY, LLC
JAMES A. FITZPATRICK NUCLEAR POWER PLANT
ANNUAL RADIOACTIVE EFFLUENT RELEASE REPORT
JANUARY 2016 - DECEMBER 2016

ATTACHMENT NO. 3

**SUMMARY OF CHANGES TO THE ENVIRONMENTAL
MONITORING AND DOSE CALCULATION LOCATIONS**

In accordance with the James A. FitzPatrick Nuclear Power Plant Offsite Dose Calculation Manual (ODCM), Part 1, Radiological Effluent Controls (REC) Section 6.2.3 a listing of new locations for dose calculation and/or environmental monitoring identified by the land use census shall be included in the Annual Radioactive Effluent Release Report.

During the reporting period, no changes in Dose Calculation Receptor Locations and/or the Environmental Monitoring were required based on the results of the land use census.

There was one milk location removed from the 2016 Milk Animal Census due to no longer being in the dairy business.

New construction located in the Southern Sector at 294 Miner Road, Lycoming, N.Y. was determined to be 1.57 miles from the James A. FitzPatrick Reactor Building centerline at 179 degrees. The previous closest residence in the Southern Sector was located at 268 Miner Road and 1.59 miles from the James A. FitzPatrick Reactor Building centerline at 173 degrees.

EXELON GENERATION COMPANY, LLC
JAMES A. FITZPATRICK NUCLEAR POWER PLANT
ANNUAL RADIOACTIVE EFFLUENT RELEASE REPORT
JANUARY 2016 - DECEMBER 2016

ATTACHMENT NO. 4

**DEVIATIONS FROM THE REQUIRED
ENVIRONMENTAL SAMPLING SCHEDULE**

In accordance with the James A. FitzPatrick Nuclear Power Plant Offsite Dose Calculation Manual (ODCM), Part 1, Radiological Effluent Controls (REC) Section 6.2.7, the cause for the unavailability of any environmental samples required during the report period shall be included in the Annual Radioactive Effluent Release Report.

The following reports samples that were a deviation from the requirements of ODCM Part 1, Table 5.1-1. ODCM Part Section 5.1.1.c.1 allows for deviations from the program due to hazardous conditions, seasonal unavailability, theft, uncooperative residents, or to a malfunction of automatic sampling equipment.

A. ODCM Program Deviations

The following are deviations from the program specified by the ODCM:

- 03/24/16 - 03/29/16 Air Station R2 Offsite sample pump was inoperable for approximately 126 hours. Out of service time was determined based upon sample pump run time integrator. The inoperability was due to loss of power to the sample station. Use of alternate power supply in cabinet was used to restore power to the station.

- 07/18/16 – 07/26/16 Air Stations R1, R2, R3, R4 and R5 Offsite samples were not shipped in a timely manner. The I-131 concentration was not determined within the one week requirement. Vendor Laboratory received samples on 08/03/16 and all samples met the required Lower Limit of Detection (LLD) for I-131.

- 10/29/16 – 11/01/16 Air Station R-1 Offsite sample pump was inoperable for approximately 61 hours. Out of service time was determined based upon sample pump run time integrator. The inoperability was due to sample pump overheating when installed cabinet cooling fan failed. Sample pump and cooling fan were replaced.

- 10/25/16 – 11/01/16 Air Station R-4 Offsite particulate filter was found misaligned in filter housing resulting in partial sample collection for approximately 168 hrs. Technician installing particulate filter validated position as procedure requires. Cabinet cooling fan was not operating during the 10/25/16 particulate filter change. Maintenance replaced the cabinet cooling fan later that day. Turning the sample pump on and off, to support fan replacement, may have disturbed the particulate filter positioning.

EXELON GENERATION COMPANY, LLC
JAMES A. FITZPATRICK NUCLEAR POWER PLANT
ANNUAL RADIOACTIVE EFFLUENT RELEASE REPORT
JANUARY 2016 - DECEMBER 2016

B. Air Sampling Station Operability Assessment

The ODCM required air sampling program consists of 5 individual sampling locations. The collective operable time period for the air monitoring stations was 43,733 hours out of a possible 43,920 hours. The air sampling availability factor for the report period was 99.6%. Air sampling equipment found inoperable was returned to service. Identification of locations for obtaining replacement samples was not required.

EXELON GENERATION COMPANY, LLC
JAMES A. FITZPATRICK NUCLEAR POWER PLANT
ANNUAL RADIOACTIVE EFFLUENT RELEASE REPORT
JANUARY 2016 - DECEMBER 2016

ATTACHMENT NO. 5

ANNUAL SUMMARY OF HOURLY METEOROLOGICAL DATA

The James A. FitzPatrick Nuclear Power Plant Offsite Dose Calculation Manual (ODCM), Part 1, Radiological Effluent Controls (REC) Section 6.2 and 6.2.2 states in part: The Annual Radioactive Effluent Release Report submitted prior to May 1 of each year may include an annual summary of meteorological data collected over the previous year. If the meteorological data is not included, the licensee shall retain it on file and provide it to the U.S. Nuclear Regulatory Commission upon request.

In accordance with the aforementioned ODCM requirement, meteorological data is not included in this report. It is retained on file and is available upon request.

EXELON GENERATION COMPANY, LLC
JAMES A. FITZPATRICK NUCLEAR POWER PLANT
ANNUAL RADIOACTIVE EFFLUENT RELEASE REPORT
JANUARY 2016 - DECEMBER 2016

ATTACHMENT NO. 6

**MAJOR MODIFICATIONS TO RADIOACTIVE LIQUID,
GASEOUS AND SOLID WASTE TREATMENT SYSTEMS**

In accordance with the James A. FitzPatrick Nuclear Power Plant Offsite Dose Calculation Manual (ODCM), Part 1 Radiological Effluent Controls (REC) Section 7.0, Major Modifications to Radioactive Waste Treatment Systems (liquid, gaseous and solid) shall be reported in the Annual Radioactive Effluent Release Report for the period in which the modification is completed and made operational.

There were no major modifications to any liquid, gaseous, or solid radioactive waste treatment systems.

EXELON GENERATION COMPANY, LLC
JAMES A. FITZPATRICK NUCLEAR POWER PLANT
ANNUAL RADIOACTIVE EFFLUENT RELEASE REPORT
JANUARY 2016 - DECEMBER 2016

ATTACHMENT NO. 7

ONSITE GROUNDWATER MONITORING

In response to the Nuclear Energy Institute (NEI) Groundwater Protection Initiative, JAF instituted a groundwater monitoring program in 2007. Five monitoring wells were installed during the fourth quarter of 2007. The first samples were collected in November 2007. Starting in March 2010, 16 additional monitoring wells were drilled in the area of the Reactor Building and nearby SSCs. In August 2013, 3 additional wells and 2 piezometers were installed on site.

All samples collected were analyzed for tritium and gamma emitting radionuclides. The detection limits and results are reported in the following tables. Analysis results of tritium ranged from non-detectable, a minimum positive indication of 3,620 pCi/L and a maximum concentration of 15,725 pCi/L for a CST-B sample from 02/03/16. Such levels are below the Reporting Level of the James A. FitzPatrick Nuclear Power Plant Offsite Dose Calculation Manual (ODCM), Part 1, Table 5.1-2, for tritium. The Reporting Level for tritium is 30,000 pCi/L. No drinking water sources are affected by this tritium. All of the effected wells are onsite. As such, there is no potential to influence any off-site drinking well. No drinking water pathway exists at the James A. FitzPatrick site under normal operating conditions due to the direction and distance of the nearest water intake (Oswego, 8.5 miles west of the JAF discharge).

In conclusion, the only radionuclide detected in groundwater during the 2016 monitoring effort that is attributable to James A. FitzPatrick operations is tritium, and all concentrations were below any reporting criteria.

EXELON GENERATION COMPANY, LLC
 JAMES A. FITZPATRICK NUCLEAR POWER PLANT
 ANNUAL RADIOACTIVE EFFLUENT RELEASE REPORT
 JANUARY 2016 - DECEMBER 2016

ATTACHMENT NO. 7 (continued)

ONSITE GROUNDWATER MONITORING

A) Gamma Isotopic Monitoring

For 2016, the 24 monitoring wells were sampled quarterly, providing enough water was present, and analyzed below the required lower limits of detection in accordance with the Offsite Dose Calculation Manual (ODCM) Part 1, Table 5.1-3.

Radionuclide	LLD Value (pCi/L)
Tritium (H-3)	3000
Manganese-54	15
Cobalt-58	15
Iron-59	30
Cobalt-60	15
Zinc-65	30

Radionuclide	LLD Value (pCi/L)
Zirconium-95	15
Niobium-95	15
Iodine-131	15
Cesium-134	15
Cesium-137	18
Barium/Lanthanum-140	15

There were no plant related gamma emitting nuclides detected in the samples. Gross Beta and Hard to Detect nuclide analysis not required.

Per Note 2 on page 28, the CST-B groundwater monitoring sample detected tritium (H-3). Four of the five sample results were greater than the LLD value of 3,000 pCi/L for H-3.

EXELON GENERATION COMPANY, LLC
 JAMES A. FITZPATRICK NUCLEAR POWER PLANT
 ANNUAL RADIOACTIVE EFFLUENT RELEASE REPORT
 JANUARY 2016 - DECEMBER 2016

ATTACHMENT NO. 7 (continued)

ONSITE GROUNDWATER MONITORING

B) Tritium Summary

Well Name	# Samples in 2016	# Positive Samples in 2016	Minimum Positive Concentration	Maximum Positive Concentration
MW-1A	4	0		
MW-1B	3	0		
MW-2A	4	0		
MW-2B	4	0		
MW-3A	4	0		
MW-3B	4	0		
MW-4A	4	0		
MW-4B	3	0		
MW-5	4	0		
MW-6	4	0		
MW-7	4	0		
MW-8	4	0		
MW-9	4	0		
MW-10A	4	0		
MW-10B	4	0		
MW-13	5	0		
MW-14	4	0		
MW-15	4	0		
MW-16	4	0		
MW-19	4	0		
MW-20	3	0		
MW-21	4	0		
CST-A	5	0		
CST-B	5	4	3,620	15,725

Note 1: All results are in pCi/L.

Note 2: A total of 96 samples were analyzed for H-3 in 2016 with 4 positive results.

EXELON GENERATION COMPANY, LLC
 JAMES A. FITZPATRICK NUCLEAR POWER PLANT
 ANNUAL RADIOACTIVE EFFLUENT RELEASE REPORT
 JANUARY 2016 - DECEMBER 2016

ATTACHMENT NO. 8

GASEOUS EFFLUENTS – CARBON-14

- a) **Date:** January 01, 2016 – December 31, 2016
- b) **Location:** Elevated Release – Main Stack
- c) **Duration:** 366 Days
- d) **Flow rate:** N/A
- e) **Volume Released:** N/A
- f) **Nuclides Released:** Carbon-14

g) **Curies Released⁽¹⁾:**

<u>UNIT</u>	<u>QTR 1</u>	<u>QTR 2</u>	<u>QTR 3</u>	<u>QTR 4</u>
Ci	2.89E+00	2.93E+00	2.40E+00	2.18E+00
μCi/sec	4.06E-01	4.06E-01	4.06E-01	4.07E-01

- h) **Resultant Doses:** See Addendum 1—Assessment of Radiation Doses to the Public January-December 2016 Table 1D
- i) **Dose Calculations:** Doses were calculated in accordance with the Offsite Dose Calculation Manual (ODCM) Part 2, Section 4.4.1

⁽¹⁾Curies released calculated using the methodology in EPRI Technical Report 1021106
“Estimation of Carbon-14 in Nuclear Power Plant Gaseous Effluents”.

EXELON GENERATION COMPANY, LLC
JAMES A. FITZPATRICK NUCLEAR POWER PLANT
ANNUAL RADIOACTIVE EFFLUENT RELEASE REPORT
JANUARY 2016 - DECEMBER 2016

ATTACHMENT NO. 9

**EVENTS LEADING TO CONDITIONS WHICH RESULTED IN EXCEEDING
RADIOACTIVITY LIMITS.**

In accordance with the James A. FitzPatrick Nuclear Power Plant Offsite Dose Calculation Manual (ODCM), Part 1 Radiological Effluent Controls (REC) Section 6.2.9, the report shall contain the events leading to the conditions which resulted in exceeding the radioactivity limits for the specified outdoor radioactive radwaste tanks specified in the Technical Requirements Manual, TRM 3.7.E

The radioactivity limits for the specified outdoor radioactive radwaste tanks were not exceeded.

EXELON GENERATION COMPANY, LLC
JAMES A. FITZPATRICK NUCLEAR POWER PLANT
ANNUAL RADIOACTIVE EFFLUENT RELEASE REPORT
JANUARY 2016 - DECEMBER 2016

ADDENDUM 1

**ASSESSMENT OF RADIATION DOSES TO THE PUBLIC
JANUARY - DECEMBER 2016**

1. INTRODUCTION

The James A. FitzPatrick Nuclear Power Plant Offsite Dose Calculation Manual (ODCM), Part 1 Radiological Effluent Controls (REC), requires an assessment of the radiation doses to the likely most exposed member of the public due to radioactive liquid and gaseous effluents. This assessment of doses to the likely most exposed member of the public is based on accepted methodologies found in the Offsite Dose Calculation Manual (ODCM).

2. DOSE LIMITS

A. DOSE FROM LIQUID EFFLUENTS (ODCM, Part 1, REC 2.3)

Applicability

Applies to doses from radioactive material in liquid effluents.

Objective

To ensure that the dose limitations of 10 CFR 50, Appendix I, are met.

Specifications

The dose to a member of the public from radioactive materials released from the plant in liquid effluents to Unrestricted Areas shall be limited as follows:

1. During any calendar quarter, limited to less than or equal to 1.5 mrem to the whole body and to less than or equal to 5 mrem to any organ.
2. During any calendar year, limited to less than or equal to 3 mrem to the whole body and to less than or equal to 10 mrem to any organ.

B. GASEOUS DOSE RATES (ODCM, Part 1, REC 3.2)

Applicability

Applies to the radiation dose from radioactive material in gaseous effluents.

Objective

To ensure that the dose rates at or beyond the site boundary from gaseous effluents do not exceed the annual dose limits of 10 CFR 20 for Unrestricted Areas.

EXELON GENERATION COMPANY, LLC
JAMES A. FITZPATRICK NUCLEAR POWER PLANT
ANNUAL RADIOACTIVE EFFLUENT RELEASE REPORT
JANUARY 2016 - DECEMBER 2016

ADDENDUM 1 (continued)

Specifications

The dose rate at or beyond the Site Boundary due to radioactive materials released from the plant in gaseous effluents shall be limited as follows:

1. Less than or equal to 500 mrem/year to the whole body and less than or equal to 3000 mrem/year to the skin from noble gases; and,
2. Less than or equal to 1500 mrem/year to any organ from Iodine-131, Iodine-133, Tritium and for radioactive materials in particulate form with half-lives greater than 8 days (inhalation pathway only).

C. AIR DOSE, NOBLE GASES (ODCM, Part 1, REC 3.3)

Applicability

Applies to the air dose due to noble gases in gaseous effluents.

Objective

To ensure that the noble gas dose limitations of 10 CFR 50, Appendix I, are met.

Specifications

The air dose to areas at or beyond the Site Boundary from noble gases released from the plant in gaseous effluents shall be limited:

1. During any calendar quarter, to less than or equal to 5 mrad from gamma radiation, and less than or equal to 10 mrad from beta radiation; and,
2. During any calendar year, to less than or equal to 10 mrad from gamma radiation and less than or equal to 20 mrad from beta radiation.

EXELON GENERATION COMPANY, LLC
JAMES A. FITZPATRICK NUCLEAR POWER PLANT
ANNUAL RADIOACTIVE EFFLUENT RELEASE REPORT
JANUARY 2016 - DECEMBER 2016

ADDENDUM 1 (continued)

D. DOSE DUE TO IODINE-131, IODINE-133, TRITIUM AND RADIONUCLIDES IN PARTICULATE FORM (ODCM, Part 1, REC 3.4)

Applicability

Applies to the cumulative dose from Iodine-131, Iodine-133, Tritium, and radionuclides in particulate form with half-lives greater than 8 days in gaseous effluents.

Objective

To ensure that the dose limitations of 10 CFR 50, Appendix I, are met.

Specifications

The dose to a member of the public at or beyond the Site Boundary from Iodine-131, Iodine-133, Tritium, and radionuclides in particulate form with half-lives greater than 8 days released from the plant in gaseous effluents shall be limited:

- a. During any calendar quarter to less than or equal to 7.5 mrem to any organ; and,
- b. During any calendar year to less than or equal to 15 mrem to any organ.
- c. Less than 0.1% of the limits of Specifications 3.4.1.c.1.a and 3.4.1.c.1.b as a result of burning contaminated oil.

E. TOTAL DOSE FROM URANIUM FUEL CYCLE (ODCM, Part 1, REC 4.0)

Applicability

Applies to radiation dose from releases of radioactivity and radiation from uranium fuel cycle sources.

Objective

1. To assure that the requirements of 40 CFR 190 are met.
2. To assure that the requirements of 10 CFR 72.104 are met in accordance with Section 3.2.3, Required Action A.2, Certificate of Compliance 1014 Appendix A, Technical Specifications for the Hi-Storm 100 Cask System.

Specifications

The dose or dose commitment to any member of the public, due to releases of radioactivity and radiation, from uranium fuel cycle sources shall be limited as follows:

1. Less than or equal to 25 mrem/year to the whole body; and,
2. Less than or equal to 25 mrem/year to any organ except the thyroid which shall be limited to less than or equal to 75 mrem/year.

EXELON GENERATION COMPANY, LLC
JAMES A. FITZPATRICK NUCLEAR POWER PLANT
ANNUAL RADIOACTIVE EFFLUENT RELEASE REPORT
JANUARY 2016 - DECEMBER 2016

ADDENDUM 1 (continued)

3. DOSE ASSESSMENT

A. METHODOLOGY

The assessment of radiation doses to the public due to radioactive liquid and gaseous effluents is performed in accordance with the ODCM. The ODCM is based on methodologies and models suggested by the Guidance Manual For "Preparation of Radiological Effluent Technical Specifications for Nuclear Power Plants" (NUREG-0133) and "Calculation of Annual Doses to Man from Routine Releases of Reactor Effluents for the Purpose of Evaluating Compliance with 10 CFR 50, Appendix I" (Regulatory Guide 1.109).

B. ASSUMPTIONS

Dose calculations are performed using formulas and constants defined in the ODCM. Specific radioactive release activities used in the dose calculations are listed in the Annual Radioactive Effluent Release Report (1.21 Report) for the period of January 1, 2016 to December 31, 2016. Historical meteorological data was used to generate tables of average dispersion factors. Locations of interest were identified from the 2016 land use census. These tables are available upon request.

C. ASSESSMENT RESULTS SUMMARY

The calculated doses to the public due to radioactive effluents are listed in Table 1. The calculated doses are small fractions of their respective dose limits.

4. 40 CFR 190 DOSE ASSESSMENT

A. METHODOLOGY

Evaluation to demonstrate compliance with the 40 CFR 190 dose limits must be performed when the doses calculated for 10 CFR 50 compliance exceed twice their respective limits. When additional dose assessment is required to demonstrate compliance with 40 CFR 190 it is performed in accordance with the ODCM.

B. RESULTS SUMMARY

The cumulative dose contribution from liquid and gaseous effluents for this report period were calculated and are listed in Table 1. The cumulative dose contribution from direct radiation from the reactor unit and from radwaste storage tanks is measured by environmental thermoluminescent dosimeters for the report period. This data is contained in the Annual Environmental Operating Report. The calculated doses from liquid and gaseous effluents are less than twice their respective 10 CFR 50 limits; therefore, additional calculations are not necessary to demonstrate compliance with 40 CFR 190 dose limits.

EXELON GENERATION COMPANY, LLC
 JAMES A. FITZPATRICK NUCLEAR POWER PLANT
 ANNUAL RADIOACTIVE EFFLUENT RELEASE REPORT
 JANUARY 2016 - DECEMBER 2016

ADDENDUM 1 (continued)

**TABLE 1
 ANNUAL DOSE ASSESSMENT 2016**

A. LIQUIDS

<u>QUARTER</u>	<u>1</u>	<u>2</u>	<u>3</u>	<u>4</u>	<u>ANNUAL</u>
	(a)	(a)	(a)	(a)	(a)
Organ (mrem)	4.09E-06	1.41E-06	4.72E-06	4.78E-06	1.50E-05
% of Limit	8.19E-05	2.82E-05	9.44E-05	9.57E-05	1.50E-04
	(b)	(b)	(b)	(b)	(b)
Whole Body (mrem)	4.09E-06	1.41E-06	4.72E-06	4.78E-06	1.50E-05
% of Limit	2.73E-04	9.41E-05	3.15E-04	3.19E-04	5.00E-04

(a) Dose to the Child Liver primarily by the potable water pathway.

(b) Dose to the Child Whole Body primarily by the potable water pathway.

EXELON GENERATION COMPANY, LLC
 JAMES A. FITZPATRICK NUCLEAR POWER PLANT
 ANNUAL RADIOACTIVE EFFLUENT RELEASE REPORT
 JANUARY 2016 - DECEMBER 2016

ADDENDUM 1 (continued)

TABLE 1 (cont)
ANNUAL DOSE ASSESSMENT 2016

B. NOBLE GASES

<u>QUARTER</u>	<u>1</u>	<u>2</u>	<u>3</u>	<u>4</u>	<u>ANNUAL</u>
Total Body (mrem/yr)	2.09E-02	6.26E-03	4.23E-02	6.43E-03	4.23E-02
% of Limit	4.19E-03	1.25E-03	8.45E-03	1.29E-03	8.45E-03
Skin (mrem/yr)	2.68E-02	1.18E-02	5.55E-02	9.98E-03	5.55E-02
% of Limit	8.94E-04	3.93E-04	1.85E-03	3.33E-04	1.85E-03
Gamma (mrad)	2.98E-04	2.79E-04	9.50E-04	2.08E-04	1.73E-03
% of Limit	5.96E-03	5.57E-03	1.90E-02	4.16E-03	1.73E-02
Beta (mrad)	3.25E-05	2.61E-05	1.51E-04	2.52E-05	2.35E-04
% of Limit	3.25E-04	2.61E-04	1.51E-03	2.52E-04	1.18E-03

C. IODINES AND PARTICULATES

<u>QUARTER</u>	<u>1</u>	<u>2</u>	<u>3</u>	<u>4</u>	<u>ANNUAL</u>
	(a)	(a)	(a)	(b)	(c)
Organ (mrem)	9.53E-04	8.14E-04	1.30E-03	2.79E-03	5.79E-03
% of Limit	1.27E-02	1.08E-02	1.73E-02	3.72E-02	3.86E-02
	(b)	(b)	(b)	(b)	(b)
Organ Dose Rate (mrem/yr)	3.74E-04	2.84E-04	2.62E-04	4.77E-04	4.77E-04
% of Limit	2.49E-05	1.90E-05	1.75E-05	3.18E-05	3.18E-05

- (a) Dose to the Infant Thyroid primarily by the Grs/Goat/Milk pathway.
 (b) Dose to the Child Thyroid primarily by the Vegetation pathway.
 (c) Dose to the Infant Thyroid primarily by the Grs/Cow/Milk pathway.

EXELON GENERATION COMPANY, LLC
 JAMES A. FITZPATRICK NUCLEAR POWER PLANT
 ANNUAL RADIOACTIVE EFFLUENT RELEASE REPORT
 JANUARY 2016 - DECEMBER 2016

ADDENDUM 1 (continued)

TABLE 1 (cont)
ANNUAL DOSE ASSESSMENT 2016

D. CARBON 14

<u>QUARTER</u>	<u>1</u>	<u>2</u>	<u>3</u>	<u>4</u>	<u>ANNUAL</u>
	(a)	(a)	(a)	(a)	(a)
Organ (mrem)	9.21E-03	9.35E-03	7.66E-03	6.94E-03	3.32E-02
% of Limit	1.28E-01	1.25E-01	1.02E-01	9.25E-02	2.21E-01
					(a)
Organ Dose Rate (mrem/yr)	NA	NA	NA	NA	3.32E-02
% of Limit	NA	NA	NA	NA	2.21E-03

(a) Dose to the Child Bone primarily by the vegetation pathway.

JAFP-17-0037

Enclosure 2

Offsite Dose Calculation Manual Rev. 14 Part 1 and 2

ENTERGY NUCLEAR OPERATIONS, INC.
JAMES A. FITZPATRICK NUCLEAR POWER PLANT
DOCUMENTS AND VENDOR PROCEDURES

OFFSITE DOSE CALCULATION MANUAL
DVP-01.02
REV. 14

EFFECTIVE DATE: 10-31-16

*****	*****
* REFERENCE *	* QUALITY RELATED *
*****	*****
*****	*****
* TECHNICAL *	* OSRC *
*****	*****

REVISION SUMMARY SHEET

REVCHANGE AND REASON FOR CHANGE

14

1. Part 1
Page 2
Section 1.2 Updated the Revision History of the ODCM. This is an editorial change.
2. Part 1
Page 3
Definitions E Add the definition of Gaseous Radwaste Treatment System to Section 1.3 This change increases the accuracy of the ODCM.
3. Part 1
Page 3
Definition H Removed reference to specific utility owner names. Make reference to employees of the utilities vice utility owner's name. This change increases the accuracy of the ODCM.
4. Part 1
Page 4
Definition L Added Operability to definition to stay aligned with the Technical Specification definition. This change increases the accuracy of the ODCM.
5. Part 1
Page 4
Definition N Add the definition of Purging to Section 1.3. This change increases the accuracy of the ODCM.
6. Part 1
Page 5
Definition P Removed reference to specific utility owner names. This change increases the accuracy of the ODCM.
7. Part 1
Page 6
Definition T Add the definition of Thermal Power to Section 1.3. This change increases the accuracy of the ODCM.

REVISION SUMMARY SHEET

<u>REV</u>		<u>CHANGE AND REASON FOR CHANGE</u>
14	8. Part 1 Page 6 Definition W	Add the definition of Ventilation Exhaust Treatment System to Section 1.3. This change increases the accuracy of the ODCM.
	9. Part 1 Page 7 Definition X	Add the definition of Venting to Section 1.3. This change increases the accuracy of the ODCM
	10. Part 1 Page 32 Note (b)	Added Ce-141 and Ce-144 to note (b) to be consistent with all isotopes required for LLD. Supported by NUREG-1302. This change increases the accuracy of the ODCM.
	11. Part 2 Page 76 Section 5.1	Removed reference to specific utility owner's name.
	12. Part 2 Page 78 Section 5.4	Update description of ISFSI pad to include discussion on new Expanded pad and update referenced material.
	13. Part 2 Page 80 Section 6	Added references SCR-E1-98-0031, Chemistry Technical Information Document CTID-13-006, Rev. 0. Updated reference and JAF-CALC-SFS-03346 to Rev 3.
	14. Appendix A Multiple Pages Tables A-2 and A-3	Updated Dose Conversion Factor's to correct for disparities and rounding errors.
	15. Appendix B Multiple Pages Tables B-4 and B-5	Updated Dose Conversion Factor's to correct for disparities and rounding errors.

-
- | | | |
|-----|--|---|
| 16. | Appendix B
Multiple pages
Tables B-3,B-4, and
B-5 | Added R_i Dose Factors for Se-75 to the referenced tables. |
| 17. | Appendix H
Page H-3
Section 1.1 | Remover reference to specific utility owner names. This change increases the accuracy of the ODCM. |
| 18. | Appendix H
Page H-14
Figure H-4 | Show location of Expanded ISFSI pad. |
| 19. | Part 1
Page 16
Note (c) | Added Ce-141 and Ce-144 to note (c) to be consistent with all isotopes required for LLD. Supported by NUREG-1302. |
| 20. | Part 2
Page 41
Section 4.3.2.b | Changed reference from MCM-8A to SCR-E1-98-0031 which references actions to take if Stack Set Point limit is changed. |
| 21. | Appendix I
Page I-6
Table I-2 | Changed Corresponding Limiting Values for Vent Release to 7.515×10^4 uCi/sec. Reference 4.3.2.b of Part 2. |
| 22. | Part 2
Page 2
Section 1.3 | Updated revision numbers in Document Revision Overview. |
| 23. | Part 2
Page 12
Section 3.3.3.1.g | Editorial change to correct 3.3.3.g to 3.3.3.1.g. |
| 24. | Appendix B
R_i Values for
Ground Plane
Tables | Individual tables for Ground Plane Adult, Teen, Child, and Infant removed. Values combined in one table - Ground Plane - All Ages |
| 25. | Appendix H
Page H-16 | Moved water intake point 6 to west side of City of Oswego. |

PART I – RADIOLOGICAL EFFLUENT CONTROLS (REC)

TABLE OF CONTENTS

1.0 INTRODUCTION.....	2
2.0 LIQUID EFFLUENTS	8
2.2 CONCENTRATION OF LIQUID EFFLUENTS	12
3.0 GASEOUS EFFLUENTS	21
4.0 TOTAL DOSE.....	43
5.0 RADIOLOGICAL ENVIRONMENTAL MONITORING.....	48
7.0 MAJOR MODIFICATIONS TO RADIOACTIVE LIQUID, GASEOUS, AND SOLID WASTE TREATMENT SYSTEMS*.....	64
8.0 PURGING OF THE PRIMARY CONTAINMENT	65

1.0 INTRODUCTION

1.1 Purpose

This Radioactive Effluent Controls Program (REC) was added to the Offsite Dose Calculation Manual (ODCM) in response to NRC Generic Letter 89-01. The program intent is to conform with 10 CFR 50.36a for the control of radioactive effluents and for maintaining the doses to members of the public "as low as is reasonably achievable." Generic Letter 89-01 described the NRC's determination that the Radiological Effluent Technical Specifications (RETS) should be simplified to improve Technical Specifications (TS) by implementing programmatic controls into the TS and procedural details into the ODCM.

The surveillance frequency for this procedure has been relocated to the Surveillance Frequency Control Program located in the Technical Requirements Manual (TRM).

1.2 Document Revision Overview

This is Revision 14 of the ODCM under the procedure designation of DVP-01.02. There were 9 revisions under the previous procedure designation of CDP-15. This revision constitutes the 23rd revision of the ODCM since its inception as Rev. 0 of CDP-15.

1.3 Definitions

A. Channel Calibration

See Technical Specifications.

B. Channel Check

See Technical Specifications.

C. Channel Functional Test

See Technical Specifications.

D. Dose Equivalent I-131

Dose Equivalent I-131 shall be that concentration of I-131 (microcurie/gram) that alone would produce the same thyroid dose as the quantity and isotopic mixture of I-131, I-132, I-133, I-134 and I-135 actually present. The thyroid dose conversion factors used for this calculation shall be those listed in International Commission on Radiological Protection Publication 30 (ICRP-30), "Limits for Intake by Workers", or in NRC Regulatory Guide 1.109, Revision 1, October 1977.

E. Gaseous Radwaste Treatment System

A Gaseous Radwaste Treatment System (e.g., the "augmented offgas system") is any system designed and installed to reduce radioactive gaseous effluents by collecting primary coolant system offgases from the main condenser evacuation system and providing for delay or holdup for the purpose of reducing the total radioactivity prior to release to the environment.

F. Independent Spent Fuel Storage Installation (ISFSI) Controlled Area

The JAFNPP ISFSI is defined to be the same area as the JAFNPP Exclusion Area, which is the combined JAFNPP and Nine Mile Point Nuclear Station (NMPNS) reactor site area. The boundary of the JAFNPP exclusion area traces the perimeter of the combined JAFNPP - NMPNS reactor sites. (See Figure 4.1-1, Site Boundary Map).

G. Logic System Functional Test

See Technical Specifications.

H. Member(s) of the Public

Member(s) of the Public includes all persons who are not occupationally associated with the facilities on the Nine Mile Point Nuclear Site. This category does not include employees of the utilities, its contractors or vendors. Also excluded from this category are persons who enter the site to service equipment or to make deliveries. This category does include persons who use portions of the site for recreational, occupational, or other purposes not associated with the plants.

I. Mode

See Technical Specifications.

J. Offgas Treatment System

The Offgas Treatment System is the system designed and installed to: reduce radioactive gaseous effluents by collecting primary coolant system offgases from the main condenser; and, providing for delay of the offgas for the purpose of reducing the total radioactivity prior to release to the environment.

K. Offsite Dose Calculation Manual

The ODCM describes the methodology and parameters to be used in the calculation of the offsite doses resulting from radioactive gaseous and liquid effluents, in the calculation of gaseous and liquid effluents monitoring alarm and trip setpoints, and in the conduct of the radiological environmental monitoring program.

The ODCM shall also contain the radioactive effluent controls and radiological environmental monitoring activities and descriptions of the information that should be included in the Annual Radiological Environment Operating and Radioactive Effluent Release reports required by Technical Specifications 5.6.2 and 5.6.3.

L. Operable - Operability

See Technical Specifications.

M. Process Control Program (PCP)

The PCP is a document which identifies the current formulas, sampling methods, analyses, tests, and determinations used to control the processing and packaging of solid radioactive wastes. The PCP controls these activities in such a way as to assure compliance with 10 CFR 20, 10 CFR 61, 10 CFR 71, and other applicable regulatory requirements governing the disposal of the radioactive waste.

N. Purge - Purging

Purge or Purging shall be any controlled process of discharging air or gas from a confinement to maintain temperature, pressure, humidity, concentration or other operating condition, in such a manner that replacement air or gas is required to purify the confinement.

O. Rated Thermal Power

See Rated Thermal Power, Technical Specifications.

P. Site Boundary

The Site Boundary is that line beyond which the land is not owned, leased, or otherwise controlled by Nine Mile Point Nuclear Facilities. Refer to Figure 4.1-1 for the map of the Site Boundary with regard to liquid and gaseous releases.

Q. Solidification

Solidification is the conversion of wet wastes into a form that meets shipping and burial ground requirements.

R. Source Check

A Source Check is the qualitative assessment of channel response when the channel sensor is exposed to a source of increased radioactivity.

S. Surveillance Frequency Notations/Intervals

The Surveillance Frequency Notations/Intervals used in these specifications are defined as follows:

Notifications	Intervals	Frequency
D	Daily	At least once per 24 hours
W	Weekly	At least once per 7 days
M	Monthly	At least once per 31 days
Q	Quarterly	At least once per 92 days (3 months)
SA	Semiannually	At least once per 184 days
A	Annually or Yearly	At least once per 366 days
18M	18 Months	At least once per 18 months (550 days)
R	Operating Cycle	At least once per 24 months(731 days)

T. Thermal Power

Thermal Power shall be the total reactor core heat transfer rate to the reactor coolant.

U. Treatment

Any process which effectively reduces the amount of radioactive material released to the environment. This includes such processes as filtration, evaporation/ condensation, settling/decanting, and solidification.

V. Unrestricted Area

An Unrestricted Area shall be any area at or beyond the Site Boundary where access is neither limited nor controlled by Entergy for purposes of protecting individuals against undue risk from exposure to radiation and radioactive materials, or any area within the Site Boundary used for residential quarters or for industrial, commercial, institutional, and/or recreational purposes

The definition of Unrestricted Area used in implementing the radiological effluent and radiological environmental monitoring controls has been expanded over that in 10 CFR 20.1003. The Unrestricted Area boundary may coincide with the exclusion (fenced) area boundary, as defined in 10 CFR 100.3(a), but the Unrestricted Area does not include areas over water bodies. The concept of Unrestricted Areas, established at or beyond the Site Boundary, is utilized in the Limiting Conditions for Operation to keep levels of radioactive materials in liquid and gaseous effluents as low as is reasonably achievable, pursuant to 10 CFR 50.36a.

W. Ventilation Exhaust Treatment System

A Ventilation Exhaust Treatment System shall be any system designed and installed to reduce gaseous radioiodine or radioactive material in particulate form in the effluents by passing ventilation or vent exhaust gases through charcoal adsorbers and/or HEPA filters for the purpose of removing iodines or particulates from the gaseous exhaust stream prior to the release to the environment. Such a system is not considered to have any effect on noble gas effluents. Engineered Safety Features Atmospheric Cleanup Systems are not considered to be Ventilation Exhaust Treatment System components.

X. Venting

Venting shall be the controlled process of discharging air or gas from a confinement to maintain temperature, pressure, humidity, concentration, or other operating condition, in such a manner that replacement air or gas is not provided or required during venting. Vent, used in system names, does not imply a venting process.

1.4 Rules for Limiting Condition for Operation and Surveillance Requirements

The provisions of Technical Specifications LCO 3.0.5 are applicable to Part 1, Radioactive Effluent Controls Program, Limiting Conditions for Operation.

The provisions of Technical Specification SR 3.0.2 and SR 3.0.3 are applicable to the Part 1, Radioactive Effluent Controls Program Surveillance Frequency.

2.0 LIQUID EFFLUENTS

2.1 Liquid Effluent Monitors

2.1.1 Limiting Conditions For Operation

a. Applicability

Applies to the instrumentation required for monitoring radioactive liquid effluent discharges to the environment as specified in Table 2.1-1.

b. Objective

To ensure that radioactive liquid effluent discharges are properly monitored and recorded during release.

c. Specifications

1. The limiting conditions for operation of the instruments that monitor radioactive liquid effluents are given in Table 2.1-1. With a radioactive liquid effluent monitoring instrumentation channel alarm/trip set point less conservative than required by the ODCM (Part 2, Section 3.3), without delay suspend the release of radioactive liquid effluents monitored by the affected channel, or declare the channel inoperable, or change the set point so it is acceptably conservative.
2. With less than the minimum number of radioactive liquid effluent monitoring instrumentation channels operable, take the action shown in Table 2.1-1. Take corrective actions to return the instruments to operable status within 30 days and, if unsuccessful, explain in the next Radioactive Effluent Release Report why the inoperability was not corrected in a timely manner.

2.1.2 Surveillance Requirements

a. Applicability

Applies to the instrumentation for monitoring radioactive liquid effluent discharges.

b. Objective

To ensure that instrumentation required for radioactive liquid effluent discharges are maintained and calibrated.

c. Specifications

1. The alarm/trip set points of these channels shall be determined and adjusted in accordance with the methodology and parameters in the ODCM (Part 2, Section 3.3).
2. The surveillance requirements for the radioactive liquid effluent monitoring instrumentation is shown on Table 2.1-2.

2.1.3 Bases

The radioactive liquid effluent instrumentation is provided to monitor and control the releases of radioactive materials in liquid effluents during planned or unplanned releases. The alarm/trip set points for these instruments shall be calculated in accordance with methods in the ODCM (Part 2, Section 3.3) to ensure that the alarm/trip will occur prior to exceeding Part 1, Section 2.2.1.c.1 limits. The operability and use of this instrumentation is consistent with the requirements of 10 CFR 50, Appendix A, General Design Criteria 60, 63, and 64.

TABLE 2.1-1

RADIOACTIVE LIQUID EFFLUENT MONITORING INSTRUMENTATION

Instrument	Minimum Channels Operable	Action
Gross radioactivity monitors providing alarm and automatic termination of release		
Liquid radwaste effluent line	1	(a)
Gross beta or gamma radioactivity monitors providing alarm but not providing automatic termination of release		
Service water system effluent line	1	(b)
Flow rate measurement devices		
Liquid radwaste effluent line	1	(c)

NOTES FOR TABLE 2.1-1

- (a) With the number of operable channels less than the required minimum number, effluent releases may continue provided that prior to initiating a release:

1. Two independent samples are analyzed;
2. Two technically qualified members of the facility staff verify the discharge line valving;

Otherwise, suspend release of radioactive effluents via this pathway.

- (b) With the number of operable channels less than the required minimum number, effluent releases in this pathway may continue provided that, at least once per 12 hours, grab samples are collected and analyzed for principal gamma emitters at a limit of detection of at least 5×10^{-7} microcuries/ml. The principal gamma emitters for which the LLD specification applies exclusively are described in Note (c) to Table 2.2-1.
- (c) With the number of operable channels less than the required minimum number, effluent releases via this pathway may continue provided the flow rate is estimated at least once per four hours during actual releases. Pump curves or tank level decreases generated in situ may be used to estimate flow.

TABLE 2.1-2

MINIMUM TEST AND CALIBRATION FREQUENCY
FOR RADIATION MONITORING SYSTEMS^(a)

Instrument Channels	Channel Check(b)	Channel Functional Test(g)	Channel Calibration (g)	Logic System Functional Test (f)
Liquid Radwaste Discharge Monitor/ Isolation (c)(d)(e)(f)	Daily When Discharging	---	Quarterly	Once per 24 months
Liquid Radwaste Discharge Radioactivity Recorder(d)	Daily	Quarterly	Once per 18 months	---
Liquid Radwaste Discharge Flow Rate Measuring Devices(d)	Daily	Quarterly	Once per 18 months	---
Normal Service Water Effluent	Daily	---	Quarterly	---

NOTES FOR TABLE 2.1-2

- (a) Functional tests, calibrations and Channel Checks need not be performed when these instruments are not required to be operable or are tripped.
- (b) Channel Checks shall be performed at least once per day during these periods when the instruments are required to be operable.
- (c) A Source Check shall be performed prior to each release.
- (d) Liquid radwaste effluent line instrumentation surveillance requirements need not be performed when the instruments are not required as the result of the discharge path not being utilized.
- (e) An instrument Channel Calibration shall be performed with known radioactive sources standardized on plant equipment which has been calibrated with NIST traceable standards.
- (f) Simulated automatic actuation shall be performed once per 24 months. Simulated automatic action means applying a simulated signal to the sensor to actuate the circuit.
- (g) A successful test of the required contact(s) of a channel relay may be performed by the verification of the change of state of a single contact of the relay. This clarifies what is an acceptable Channel Functional Test of a relay. This is acceptable because all of the other required contacts of the relay are verified by other Technical Specifications and non-Technical Specification tests at least once per refueling interval with the applicable extension.

2.2 Concentration of Liquid Effluents

2.2.1 Limiting Conditions For Operation

a. Applicability

Applies to the concentration of radioactive materials in liquid effluents.

b. Objective

To ensure that the concentrations of radioactive materials in liquid effluents are kept to acceptable levels.

c. Specifications

1. The concentration of radioactive materials released from the plant to the Unrestricted Areas shall be limited to ten times the concentration values specified in 10 CFR 20, Appendix B, Table 2, Column 2 for radionuclides other than dissolved or entrained noble gases. For dissolved or entrained noble gases, the concentration shall be limited to $2 \times 10^{-4} \mu\text{Ci/ml}$ total activity.
2. With the concentration of radioactive material released from the plant to Unrestricted Areas exceeding the above limits, restore the concentration to within the above limits or terminate the release.

2.2.2 Surveillance Requirements

a. Applicability

Applies to the analysis of radioactive liquid wastes from the plant through a liquid pathway to an Unrestricted Area.

b. Objective

To ensure that analyses are performed and concentration determined for radioactive liquid releases.

c. Specifications

1. Radioactive liquid wastes shall be sampled and analyzed according to the sampling and analyses program of Table 2.2-1.

2. The results of the radioactivity analyses shall be used in accordance with the methods in the ODCM (Part 2, Section 3.2) to ensure that the concentrations at the point of release are maintained within the limits of Section 2.2.1.

2.2.3 Bases

This specification is provided to ensure that the concentration of radioactive materials released in liquid waste effluents from the site to Unrestricted Areas will be less than ten times the concentration values specified in 10 CFR 20, Appendix B, Table 2, Column 2 for radionuclides other than dissolved or entrained noble gases. This limitation provides additional assurance that the levels of radioactive materials in bodies of water outside the site will not result in exposure above (1) the design objectives of 10 CFR 50, Appendix I, Section II.A, to a Member(s) of the Public and (2) the limits of 10 CFR 20.1301 to the population. The concentration limit for dissolved or entrained noble gases is based on Xe-135 as the controlling radioisotope and its MPC in air (submersion) was converted to an equivalent concentration in water using methods described in ICRP Publication 2.

TABLE 2.2-1

RADIOACTIVE LIQUID WASTE SAMPLING AND ANALYSIS PROGRAM

Liquid Release Type	Sampling Frequency	Minimum Analysis Frequency	Type of Activity Analysis	Lower Limit of Detection (LLD) ^(a) (μCi/ml)
Batch Waste Release Tanks ^(b)	Prior to each batch	Each batch	Principal gamma emitters ^(c)	5×10^{-7}
			I-131	1×10^{-6}
	One batch per month	Monthly	Dissolved and entrained gases (gamma emitters)	1×10^{-5}
	Prior to each batch	Quarterly composite ^(d)	H-3	1×10^{-5}
			Gross alpha	1×10^{-7}
	Prior to each batch	Quarterly composite ^(d)	Sr-89, Sr-90	5×10^{-8}
			Fe-55	1×10^{-5}
	Continuous Releases ^(e)	Continuous ^(f)	Weekly composite ^(f)	Principle Gamma Emitters ^(c)
I-131				1×10^{-6}
Monthly grab sample		Monthly	Dissolved and entrained gases (gamma emitters)	1×10^{-5}
Continuous ^(f)		Monthly composite ^(f)	H-3	1×10^{-5}
			Gross alpha	1×10^{-7}
Continuous ^(f)		Quarterly composite ^(f)	Sr-89, Sr-90	5×10^{-8}
			Fe-55	1×10^{-5}

See notes next page

NOTES FOR TABLE 2.2-1

- (a) The LLD (Lower Limit of Detection) is defined, for the purpose of these specifications, as the smallest concentration of radioactive material in a sample that will yield a net count (above system background) that will be detected with 95% probability and with only 5% probability of falsely concluding that a blank observation represents a "real" signal.

For a particular measurement system (which may include radiochemical separation):

$$LLD = \frac{4.66 s_b}{E \cdot V \cdot 2.22 \times 10^6 \cdot Y \cdot \exp(-\lambda \Delta t)}$$

Where:

LLD is the a priori lower limit of detection, as defined above (in microCuries per unit mass or volume);

s_b is the standard deviation of the background counting rate or of the counting rate of a blank sample, as appropriate (in counts per minute);

E is the counting efficiency (in counts per disintegration);

V is the sample size (in units of mass or volume);

2.22×10^6 is the number of disintegrations per minute per microCurie;

Y is the fractional radiochemical yield (when applicable);

λ is the radioactive decay constant for the particular radionuclide; and

Δt for plant effluents is the elapsed time between the midpoint of sample collection and time of counting.

Typical values of E, V, Y, and Δt should be used in the calculations.

It should be recognized that the LLD is defined as an a priori (before the fact) limit representing the capability of a measurement system and not as an a posteriori (after the fact) limit for a particular measurement.

- (b) A batch release is the discharge of liquid waste of a discrete volume. Prior to sampling for analyses, each batch shall be isolated, and then mixed to assure representative sampling.

-
- (c) The principal gamma emitters for which the LLD specification applies exclusively are the following radionuclides: Mn-54, Fe-59, Co-58, Co-60, Zn-65, Mo-99, Cs-134, Cs-137, Ce-141 and Ce-144. This list does not mean that only these nuclides are to be detected and reported. Other peaks that are measurable and identifiable, together with the above nuclides, shall also be identified and reported in the Radioactive Effluent Release Report. The LLD for Mo-99, Ce-141, and Ce-144 is 5×10^{-5} .
 - (d) A composite sample is one in which the quantity of liquid sampled is proportional to the quantity of liquid waste discharged and in which the method of sampling employed results in a specimen that is representative of the liquids released.
 - (e) A continuous release is the discharge of liquid wastes of a non-discrete volume, e.g., from a volume of a system that has an input flow during the continuous release.
 - (f) To be representative of the quantities and concentrations of radioactive materials in liquid effluents, samples shall be collected continuously in proportion to the rate of flow of the effluent stream. Prior to analyses, all samples taken for the composite shall be thoroughly mixed in order for the composite sample to be representative of the effluent release.

2.3 Dose From Liquid Effluents

2.3.1 Limiting Conditions For Operation

a. Applicability

Applies to radiation doses from liquid effluents containing radioactive materials.

b. Objective

To ensure that the dose limitations of 10 CFR 50, Appendix I for liquids are met.

c. Specifications

1. The dose to a Member(s) of the Public from radioactive materials released from the plant in liquid effluents to Unrestricted Areas shall be limited as follows:
 - a. During any calendar quarter, limited to less than or equal to 1.5 mrem to the whole body and to less than or equal to 5 mrem to any organ; and,
 - b. During any calendar year, limited to less than or equal to 3 mrem to the whole body and to less than or equal to 10 mrem to any organ.
2. With the calculated dose from the release of radioactive materials in liquid effluents exceeding any of the above limits, the following shall be done:
 - a. Identify the causes for such release rates;
 - b. Define and initiate a program of corrective action; and
 - c. Prepare and submit a report to the NRC within 30 days.

2.3.2 Surveillance Requirements

a. Applicability

Applies to the calculation of the radiation dose from liquid effluents containing radioactive materials.

b. Objective

To ensure that the radiation dose from radioactive liquid effluents is determined.

c. Specifications

1. Cumulative dose contributions from liquid effluents shall be determined in accordance with the ODCM (Part 2, Section 3.4) at least monthly for the current calendar quarter and current calendar year.

2.3.3 Bases

This specification is provided to ensure that the requirements of 10 CFR 50, Appendix I, Section II.A, III.A and IV.A are met. The specification ensures that the guides set forth in 10 CFR 50, Appendix I, Section II.A are met. The specification provides the required operating flexibility and, at the same time, implements the guides set forth in 10 CFR 50, Appendix I, Section IV.A, to assure that the releases of radioactive material in liquid effluents will be kept "as low as is reasonably achievable."

2.4 Liquid Radioactive Waste Treatment System Operations

2.4.1 Limiting Conditions For Operation

a. Applicability

Applies to the operability of radioactive liquid processing equipment.

b. Objective

To ensure liquid radwaste treatment system(s) are operated to prevent exceeding the dose limits of Part 1, Section 2.3.1.c.1.

c. Specifications

1. The liquid radioactive waste treatment system shall be used when the projected dose from untreated liquid releases, over a 31 day period, to a Member(s) of the Public would exceed:
 - a. 0.06 mrem to the whole body; or,
 - b. 0.2 mrem to any organ.
2. With radioactive liquid waste being discharged without treatment and in excess of the above limits, prepare and submit to the Commission within 30 days a report that includes the following information:
 - a. Explanation if liquid radwaste was being discharged without treatment; and if so:
 - b. Identification of any inoperable equipment or subsystems and the reason for the inoperability;
 - c. Action(s) taken to restore the inoperable equipment to operable status; and
 - d. Summary description of action(s) taken to prevent a recurrence.

2.4.2 Surveillance Requirements

a. Applicability

Dose projections apply to liquid effluents released to Unrestricted Areas.

b. Objective

To ensure that action levels to require operation of waste treatment systems are determined.

c. Specifications

1. Doses to individuals in Unrestricted Areas due to liquid releases shall be projected at least monthly in accordance with the ODCM (Part 2, Section 3.5).

2.4.3 Bases

The requirement that the appropriate portions of this system be used when specified provides assurance that the releases of radioactive materials in liquid effluents will be kept "as low as is reasonably achievable". This specification assures that the requirements of 10 CFR 50.36a, 10 CFR 50, Appendix A, General Design Criterion 60, and design objective of 10 CFR 50, Appendix I, Section II.D are met. The specified limits governing the use of appropriate portions of the liquid radwaste treatment system were specified as a suitable fraction of the dose design objectives set forth in 10 CFR 50, Appendix I, Section II.A, for liquid effluents.

3.0 GASEOUS EFFLUENTS

3.1 Gaseous Effluent Monitors

3.1.1 Limiting Conditions For Operation

a. Applicability

Applies to the instrumentation required for monitoring the radioactive gaseous effluent pathways to the environment.

b. Objective

To ensure that radioactive gaseous effluent discharges are properly monitored and recorded during release.

c. Specifications

1. Radioactive gaseous wastes released to the environment via the below listed pathways shall be monitored and recorded during release from the respective pathway.
 - a. Main stack exhaust
 - b. Refuel floor exhaust
 - c. Reactor building exhaust
 - d. Turbine building exhaust
 - e. Radwaste building exhaust
2. Each pathway listed above shall also be sampled for iodine and particulate radioactivity on a continuous basis during release from the respective pathway.
3. If Sections 3.1.1.c.1 and 3.1.1.c.2 above, cannot be met, effluent releases may continue via the respective pathway provided gaseous grab samples are collected in the case of a monitor out of service or auxiliary samplers are used in case a particulate and iodine sampler is out of service:
 - a. Return the instrument to operable status within 30 days; or
 - b. Provide an explanation in the next Radioactive Release Report as to why the inoperability was not corrected within 30 days.

-
4. Alarm/Trip Setpoints are determined in accordance with Part 2, Section 4.3.2 to ensure the limits of Section 3.2.1 are not exceeded. With a radioactive gaseous effluent monitoring instrumentation channel alarm/trip setpoint less conservative than required by the above control:
 - a. Without delay, suspend the release of radioactive gaseous effluents monitored by the affected channel; or
 - b. Declare the channel inoperable; or
 - c. Change the setpoint so it is acceptably conservative.

3.1.2 Surveillance Requirements

a. Applicability

Applies to instrumentation listed in Section 3.1.1.c.1 and analyses of gaseous effluent releases.

b. Objective

To ensure that instrumentation required for gaseous effluent releases is maintained and calibrated and the radioactivity of gaseous releases is determined.

c. Specifications

1. Operation of the gaseous effluent monitors and recorders shall be verified by performing instrument surveillance as specified on Table 3.1-2.
2. The iodine cartridge and the particulate filter for each pathway listed in Section 3.1.1.c.1 shall be changed out at least weekly.
3. Grab samples, when required, shall be collected at least once per 12 hours and analyzed within 24 hours of collection. Auxiliary samplers shall run continuously and be changed out at least weekly.

3.1.3 Bases

The radioactive gaseous effluent instrumentation is provided to monitor and control the releases of radioactive materials in gaseous effluents during planned or unplanned releases. The alarm/trip set points for these instruments shall be calculated in accordance with methods in the ODCM to ensure that the alarm/trip will occur prior to exceeding the limits of Part 1, Section 3.2.1.c.1.

The operability and use of this instrumentation is consistent with the requirements of 10 CFR 50, Appendix A, General Design Criteria 60, 63 and 64.

Refer to Technical Specification Bases 3.3.6.2 for references pertaining to surveillance and allowable outage times for selected monitors listed on Table 3.1-1 and Table 3.1-2.

TABLE 3.1-1
RADIATION MONITORING SYSTEMS

Minimum No. of Operable Instrument Channels per Trip System	Function	Alarm/Trip Level Setting	Total No. of Instrument Channels Provided by Design	Action
1	Main Stack Exhaust Monitors	(b)	2	(f)
1(a)(h)	Refuel Area Exhaust Monitors(c)	(i)	2	(f)(g)
1(a)(h)	Reactor Building Area Exhaust Monitors(c)	(i)	2	(f)(g)
1(a)(h)	Turbine Building Exhaust Monitors	(b)	2	(f)
1(a)(h)	Radwaste Building Exhaust Monitors	(b)	2	(f)

NOTES FOR TABLE 3.1-1

- (a) A channel may be placed in an inoperable status for up to six hours during periods of required surveillance without placing the Trip System in the tripped condition provided the other OPERABLE channel is monitoring that Trip Function, that is, trip capability is maintained.
- (b) Alarm/Trip level setting is in accordance with the methods and procedures of the ODCM (Part 2, Section 4.3.2). These alarm/trip level settings are set to ensure the limits in Specification 3.2.1.c.1 are not exceeded.
- (c) Operability includes alarm.
- (d) Deleted
- (e) Deleted
- (f) Refer to Specification 3.1.1.c.3 and 3.1.1.c.4.
- (g) Refer to Technical Specification 3.3.6.2 for additional Required Actions.
- (h) An inoperable channel need not be placed in the tripped condition where this would cause the Trip to occur. In these cases, the inoperable channel shall be restored to operable status within 24 hours, or the indicated action shall be taken.
- (i) The allowable values are specified in Technical Specification Table 3.3.6.2-1.

TABLE 3.1-2

MINIMUM TEST AND CALIBRATION FREQUENCY FOR
RADIATION MONITORING SYSTEMS(a)

Instrument Channels	Channel Check(b)	Channel Calibration(d)	Logic System Functional Test (c)
Main Stack Exhaust Monitors and Recorders	Daily	Quarterly	---
Refuel Area Exhaust Monitors and Recorders	Daily	Quarterly	---
Reactor Building Area Exhaust Monitors, Recorders and Isolation	Daily	Quarterly	R
Turbine Building Exhaust Monitors and Recorders	Daily	Quarterly	---
Radwaste Building Exhaust Monitors and Recorders	Daily	Quarterly	---
SBGT Actuation	---	---	R

NOTES FOR TABLE 3.1-2

- (a) Channel Calibrations and Channel Checks need not be performed when these instruments are not required to be operable or are tripped.
- (b) Channel Checks shall be performed at least once per day during these periods when the instruments are required to be operable.
- (c) Simulated automatic actuation shall be performed once per 24 months. Simulated automatic actuation means applying a simulated signal to the sensor to actuate the circuit.
- (d) A successful test of the required contact(s) of a channel relay may be performed by the verification of the change of state of a single contact of the relay. This clarifies what is an acceptable Channel Functional Test of a relay. This is acceptable because all of the other required contacts of the relay are verified by other Technical Specification and non-Technical Specification tests at least once per refueling interval with the applicable extension.

TABLE 3.1-3
RADIATION AND EFFLUENT FLOW INSTRUMENTATION

Instrument Channels	Minimum No. of Operable Channels	Applicability	Action
Main Stack Exhaust			
1. Noble Gas Monitor ^(a)	1	Note (b)	
2. Iodine & Particulate Sampler ^(a)	1	Note(b)	
3. Discharge Flow Rate Monitor	1	Note (b)	Note (c)
Refuel Floor Exhaust			
1. Noble Gas Monitor	1	Note (b)	
2. Iodine & Particulate Sampler	1	Note (b)	
3. Discharge Flow Rate Monitor	1	Note (b)	Note (c)
Reactor Building Exhaust			
1. Noble Gas Monitor ^(a)	1	Note (b)	
2. Iodine & Particulate Sampler ^(a)	1	Note (b)	
3. Discharge Flow Rate Monitor	1	Note (b)	Note (c)
Turbine Building Exhaust			
1. Noble Gas Monitor	1	Note (b)	
2. Iodine & Particulate Sampler	1	Note (b)	
3. Discharge Flow Rate Monitor	1	Note (b)	Note (c)
Radwaste Building Exhaust			
1. Noble Gas Monitor	1	Note (b)	
2. Iodine & Particulate Sampler	1	Note (b)	
3. Discharge Flow Rate Monitor	1	Note (b)	Note (c)

(a) The same instrument is used for the monitor and sampler

(b) All modes

(c) With the number of channels OPERABLE less than the required by the minimum channels operable requirement, effluent releases via this pathway may continue provided the design flow rate is used for all effluent release calculations.

TABLE 3.1-4

MINIMUM TEST AND CALIBRATION FREQUENCY FOR RADIATION MONITORING
EFFLUENT FLOW INSTRUMENTATION

Instrument Channels	Calibration ^(b)	Calibration
Main Stack Exhaust		
1. Noble Gas Monitor ^(a)	Q	R
2. Iodine & Particulate Sampler ^(a)	Q	R
3. Discharge Flow Rate Monitor	-----	R
Refuel Floor Exhaust		
1. Noble Gas Monitor	-----	R
2. Iodine & Particulate Sampler	Q	R
3. Discharge Flow Rate Monitor	-----	R
Reactor Building Exhaust		
1. Noble Gas Monitor ^(a)	Q	R
2. Iodine & Particulate Sampler ^(a)	Q	R
3. Discharge Flow Rate Monitor	-----	R
Turbine Building Exhaust		
1. Noble Gas Monitor	-----	R
2. Iodine & Particulate Sampler	Q	R
3. Discharge Flow Rate Monitor	-----	R
Radwaste Building Exhaust		
1. Noble Gas Monitor	-----	R
2. Iodine & Particulate Sampler	Q	R
3. Discharge Flow Rate Monitor	-----	R

^(a) The same instrument is used for the monitor and sampler.

^(b) This calibration consists of verifying the flowrate with an independent calibrated instrument and adjusting flowrate as necessary.

3.2 Gaseous Dose Rates

3.2.1 Limiting Conditions For Operation

a. Applicability

Applies to the radiation dose rate from radioactive material in gaseous effluents from the plant.

b. Objective

To ensure that the dose rates at or beyond the Site Boundary from gaseous effluents do not exceed the annual dose limits of 10 CFR 20 for Unrestricted Areas.

c. Specifications

1. The dose rate at or beyond the Site Boundary due to radioactive materials released from the plant in gaseous effluents shall be limited as follows:
 - a. ≤ 500 mrem/year to the whole body and ≤ 3000 mrem/year to the skin from noble gases; and,
 - b. ≤ 1500 mrem/year to any organ from Iodine-131, Iodine-133, Tritium and for radioactive materials in particulate form with half-lives greater than 8 days (inhalation pathway only).
2. With the dose rates exceeding the above limits, without delay restore the release rate to within the above limits.

3.2.2 Surveillance Requirements

a. Applicability

Applies to the calculation of the dose rates from radioactive materials in gaseous effluents from the plant.

b. Objective

To ensure that appropriate calculations are performed to determine the dose rates from gaseous effluents from the plant.

c. Specifications

1. The dose rate due to noble gases in gaseous effluents shall be determined to be continuously within the limits of Section 3.2.1.c.1, in accordance with the methods and procedures of the ODCM (Part 2, Section 4.3.1).
2. The dose rate due to Iodine-131, Iodine-133, Tritium and radionuclides in particulate form with half-lives greater than 8 days in gaseous effluents, shall be determined to be within the above limits in accordance with the methods and procedures of the ODCM (Part 2, Section 4.3.3). This will be done by obtaining representative samples and performing analyses in accordance with the sampling and analyses program specified in Table 3.2-1.

3.2.3 Bases

This specification provides reasonable assurance that radioactive material discharged in gaseous effluents will not result in the exposure of a Member(s) of the Public in an Unrestricted Area, either at or beyond the Site Boundary in excess of the design objectives of Appendix I to 10CFR50. This specification is provided to ensure that gaseous effluents from the plant will be appropriately controlled. It provides operational flexibility for releasing gaseous effluents to satisfy the Section II.A and II.C design objectives of Appendix I to 10CFR50. The specified limits restrict, at all times, the corresponding gamma and beta dose rates above background to an individual at or beyond the exclusion area boundary to ≤ 500 mrem/year to the whole body or to ≤ 3000 mrem/year to the skin. These limits also restrict the corresponding thyroid dose rate above background to a child via the inhalation pathway to ≤ 1500 mrem/year.

TABLE 3.2-1
RADIOACTIVE GASEOUS WASTE SAMPLING AND ANALYSIS PROGRAM

Gaseous Release Type	Sampling Frequency	Minimum Analysis Frequency	Type of Activity Analysis	Lower Limit of Detection (LLD) ^(a) (μCi/ml)
Main Stack Refuel Floor Vent Reactor Building Vent Turbine Building Vent Radwaste Building Vent	Monthly Grab Sample ^(d)	Monthly Noble Gases ^(b)	Principal Gamma Emitters ^(b)	1 x 10 ⁻⁴
	Quarterly Grab Sample	Quarterly	H-3	1 x 10 ⁻⁶
	Continuous ^(c)	Weekly Charcoal Sample ^(e)	I-131	1 x 10 ⁻¹²
			I-133	None
	Continuous ^(c)	Weekly Particulate Sample ^(e)	Principal Gamma Emitters ^(b)	1 x 10 ⁻¹¹
			(I-131, I-133, others)	None
	Continuous ^(c)	1 Wk/Mo Particulate Sample	Gross Alpha	1 x 10 ⁻¹¹
	Continuous ^(c)	4 Wk/Qr Composite Particulate Sample	Sr-89, Sr-90	1 x 10 ⁻¹¹
Continuous ^(c)	Noble Gas Monitor	Noble Gases Gross Beta or Gamma	1 x 10 ⁻⁵	
Incinerated Oil ^(f)	Prior to Each Batch ^(g)	Each Batch ^(g)	Principal Gamma Emitters ^(b)	5 x 10 ⁻⁷
			I-131	1 x 10 ⁻⁶

See notes next page

NOTES FOR TABLE 3.2-1

- (a) The LLD is defined, for purpose of these specifications, as the smallest concentration of radioactive material in a sample that will yield a net count (above system background) that will be detected with 95% probability and with only 5% probability of falsely concluding that a blank observation represents a "real" signal.
For a particular measurement system (which may include radiochemical separation):

$$LLD = \frac{4.66 s_b}{E \cdot V \cdot 2.22 \cdot 10^6 \cdot Y \cdot \exp(-\lambda \Delta t)}$$

Where:

LLD is the a priori lower limit of detection, as defined above (in microcuries per unit mass or volume);

s_b is the standard deviation of the background counting rate or of the counting rate of a blank sample, as appropriate (in counts per minute);

E is the counting efficiency (in counts per disintegration);

V is the sample size (in units of mass or volume);

2.22×10^6 is the number of disintegrations per minute per microcurie;

Y is the fractional radiochemical yield (when applicable);

λ is the radioactive decay constant for the particular radionuclide; and

Δt for plant effluents is the elapsed time between the midpoint of sample collection and time of counting.

Typical values of E, V, Y, and Δt should be used in the calculations.

It should be recognized that the LLD is defined as an a priori (before the fact) limit representing the capability of a measurement system and not as an a posteriori (after the fact) limit for a particular measurement.

- (b) The principal gamma emitters for which the LLD specification applies exclusively are the following radionuclides: Kr-87, Kr-88, Xe-133, Xe-133m, Xe-135, Xe-135m, and Xe-138 for gaseous emissions; and, Mn-54, Fe-59, Co-58, Co-60, Zn-65, Mo-99, Cs-134, Cs-137, Ce-141 and Ce-144 for particulate emissions. This list does not mean that only these nuclides are to be detected and reported. Other peaks that are measurable and identifiable, together with the above nuclides, shall also be identified and reported in the Radioactive Effluent Release Report. The LLD for Mo-99, Ce-141, and Ce-144 is 5×10^{-11} . For oil samples, Table 2.2-1, Note (c) applies.
- (c) The ratio of the sample flow rate to the sampled stream flow rate shall be known for the time period covered by each dose or dose rate calculation made in accordance with Specifications. This determination shall be made using design flow rates if flow meters are not provided or are inoperable.
- (d) Main stack gaseous sampling and analysis shall also be performed following shutdown, startup, or a thermal power change exceeding 20% of Rated Thermal Power in one hour.
1. This requirement applies only if:
 - Analysis shows that the Dose Equivalent I-131 concentration in the primary coolant has increased more than a factor of 3; and
 - The noble gas monitor shows that effluent activity has increased more than a factor of 3; and
 - Corrections for increases due to changes in thermal power level have been made in both cases.
- (e) Main stack iodine and particulate sampling shall also be performed daily following each shutdown, startup or thermal power change exceeding 20% of Rated Thermal Power in one hour.
1. Daily sampling is not required for thermal power changes if the offgas charcoal filters are in service.
 2. In addition, this requirement applies only if:
 - Analysis shows that the Dose Equivalent I-131 concentration in the primary coolant has increased more than a factor of 3; and
 - The noble gas monitor shows that effluent activity has increased more than a factor of 3; and
 - Corrections for increases due to changes in thermal power level have been made in both cases.
 3. Daily sampling shall be performed until two consecutive samples show no increase in concentration but not to exceed 7 consecutive days.
 4. LLDs may be increased by a factor of 10 for analysis of daily samples.
 5. Analysis of daily and weekly samples shall be completed within 48 hours of changing.
- (f) Incinerated oil may be discharged via points other than the main stack and building vents (i.e., auxiliary boiler). Release shall be accounted for based on pre-release grab sample data.

- (g) Samples of incinerated oil releases shall be collected from and representative of filtered oil in liquid form. Whenever oil samples cannot be filtered such as No. 6 bunker fuel oil, raw oil samples shall be collected and analyzed.

3.3 Air Dose, Noble Gases

3.3.1 Limiting Conditions For Operation

a. Applicability

Applies to the air dose due to noble gases released from the plant.

b. Objective

To ensure that the noble gas dose limitations of 10 CFR 50, Appendix I, are met.

c. Specifications

1. The air dose to areas at or beyond the Site Boundary from noble gases released from the plant in gaseous effluents shall be limited:
 - a. During any calendar quarter, to less than or equal to 5 mrad from gamma radiation, and less than or equal to 10 mrad from beta radiation; and,
 - b. During any calendar year, to less than or equal to 10 mrad from gamma radiation and less than or equal to 20 mrad from beta radiation.
2. With the calculated air dose from radioactive noble gases in gaseous effluents exceeding any of the above limits, prepare and submit to the Commission, within 30 days, a report that:
 - a. Identifies the cause(s) for exceeding the limit(s); and
 - b. Defines the corrective actions that have been taken to reduce the releases; and
 - c. Identifies the proposed corrective actions to be taken to ensure that subsequent releases will be in compliance with the above limits.

3.3.2 Surveillance Requirements

a. Applicability

Applies to the calculation of the air dose due to noble gas effluent.

b. Objective

To ensure that appropriate calculations are performed to determine the air dose from noble gas effluents.

c. Specifications

1. Cumulative air dose contributions for noble gases shall be calculated at least monthly in accordance with the ODCM (Part 2, Section 4.4.2) for the current calendar quarter and the current calendar year.

3.3.3 Bases

This specification is provided to assure that the requirements of 10 CFR 50, Appendix I, Section II.B, III.A and IV.A are met. This specification implements the guides set forth in Appendix I, Section II.B. The specification provides the required operating flexibility and, at the same time, implements the guides set forth in Appendix I, Section IV.A, to assure that the releases of radioactive material in gaseous effluents will be kept "as low as is reasonably achievable."

3.4 Dose Due to Iodine-131, Iodine-133, Tritium and Radionuclides in Particulate Form

3.4.1 Limiting Conditions For Operation

a. Applicability

Applies to the cumulative dose from Iodine-131, Iodine-133, Tritium, and radionuclides in particulate form with half-lives greater than 8 days in gaseous effluents.

b. Objective

To ensure that the dose limitations of 10 CFR 50, Appendix I, are met.

c. Specifications

1. The dose to a Member(s) of the Public at or beyond the Site Boundary from Iodine-131, Iodine-133, Tritium, and radionuclides in particulate form with half-lives greater than 8 days released from the plant in gaseous effluents shall be limited:
 - a. During any calendar quarter to less than or equal to 7.5 mrem to any organ; and,
 - b. During any calendar year to less than or equal to 15 mrem to any organ.
 - c. Less than 0.1% of the limits of Specifications 3.4.1.c.1.a and 3.4.1.c.1.b as a result of burning contaminated oil.
2. With the calculated dose from the release of Iodine-131, Iodine-133, Tritium, and radionuclides in particulate form with half-lives greater than 8 days, in gaseous effluents exceeding any of the above limits, prepare and submit to the Commission within 30 days a report that:
 - a. Identifies the cause(s) for exceeding the limit; and
 - b. Defines the corrective actions that have been taken to reduce the releases; and
 - c. Identifies the proposed corrective actions to be taken to ensure that subsequent releases will be in compliance with the above limits.

3.4.2 Surveillance Requirements

a. Applicability

Applies to the calculation of the dose due to Iodine-131, Iodine-133, Tritium, and radionuclides in particulate form with half-lives greater than 8 days in gaseous effluents.

b. Objective

To ensure that appropriate calculations are performed to determine the dose from Iodine-131, Iodine-133, Tritium, and radionuclides in particulate form with half-lives greater than 8 days.

c. Specifications

1. Cumulative dose contributions shall be calculated at least monthly in accordance with the ODCM (Part 2, Section 4.4.2.c) for the current calendar quarter and the current calendar year.

3.4.3 Bases

This specification is provided to assure that the requirements of 10 CFR 50, Appendix I, Section II.C, III.A and IV.A are met. This specification implements the guides set forth in Appendix I, Section II.C. The specification provides the required operating flexibility and, at the same time, implements the guides set forth in Appendix I, Section IV.A, to assure that the releases of radioactive materials in gaseous effluents will be kept "as low as is reasonably achievable."

3.5 Offgas Treatment System

3.5.1 Limiting Conditions For Operation

a. Applicability

Applies to the system installed for reduction of radioactive materials in gaseous waste prior to discharge.

b. Objective

To minimize concentration of radioactive materials released from the site.

c. Specifications

1. The Offgas Treatment System shall be used to reduce the concentration of radioactive materials in gaseous effluents prior to release from the plant within 24 hours after the start-up of the second turbine driven feedwater pump.
2. The offgas charcoal beds shall be used, when Offgas Treatment System operation is required and the projected doses over a 31 day period due to gaseous effluent releases to a Member(s) of the Public at or beyond the site boundary would exceed:
 - a. 0.2 mrad for gamma radiation; or
 - b. 0.4 mrad for beta radiation; or
 - c. 0.3 mrem to any organ
3. With gaseous effluent from the main condenser being discharged without use of the charcoal beds for greater than seven days when treatment is required, and projected doses are in excess of the above limits, prepare and submit to the Commission, within 30 days, a Special Report that includes the following information:
 - a. Explanation of why gaseous effluent is being discharged without charcoal bed treatment, identification of any inoperable equipment or subsystems, and the reason for the inoperability.
 - b. Action(s) taken to restore the inoperable equipment to operable status; and
 - c. Summary description of action(s) taken to prevent a recurrence.

3.5.2 Surveillance Requirements

a. Applicability

Applies to the calculation of the radiation dose from gaseous effluents containing radioactive materials.

b. Objective

To ensure that treatment of gaseous wastes by the offgas system is implemented when required.

c. Specifications

1. If the charcoal beds are not in service when the Offgas Treatment System is required, doses due to gaseous releases from the site shall be projected at least monthly in accordance with the ODCM (Part 2, Section 4.5).

3.5.3 Bases

This specification is provided to ensure that the system will be available for use when required to reduce projected doses due to gaseous releases. This specification assures that the requirements of 10 CFR 50.36a, 10 CFR 50, Appendix A, General Design Criterion 60, and design objective in 10 CFR 50, Appendix I, Section II.D are met. The specified limits governing the use of appropriate portions of the systems are specified as a suitable fraction of the guide values set forth in 10 CFR 50, Appendix I, Sections II.B and II.C, for gaseous effluents.

The requirement for Offgas Treatment System operability provides assurance that the release of radioactive materials in gaseous waste will be kept "as low as is reasonably achievable." Operability of the system is based upon start-up of the second turbine driven feedwater pump. This is due to the fact that excess air in-leakages in the main condenser as a result of operating only one turbine driven feedwater pump will exceed Offgas Treatment System limitations and consequently render the system inoperable. Start-up of the second turbine driven feedwater pump will decrease air in-leakages and assure Offgas Treatment System availability.

3.6 Main Condenser Steam Jet Air Ejector Radiation Monitors

3.6.1 Limiting Conditions For Operation

a. Applicability

Applies to the instrumentation required for monitoring the main condenser offgas steam jet air ejector (SJAE) radiation when the reactor is in Mode 1, and Mode 2 or 3 with any main steam line not isolated and SJAE is in operation.

b. Objective

To ensure that the SJAE release rates are maintained at a level compatible for further treatment and release.

c. Specifications

Except as specified in 1. and 2. below, both SJAE system radiation monitors shall be operable with a trip level setting of $\leq 500,000 \mu\text{Ci}/\text{sec}$. The trip time delay setting for closure of the SJAE isolation valve shall be ≤ 15 minutes.

1. A channel may be placed in an inoperable status for up to six hours during periods of required surveillance without placing the Trip System in the tripped condition provided the other operable channel is monitoring that Trip Function. Otherwise, in the event that one of the two SJAE radiation monitors is made or found to be inoperable, continued operation is permissible provided that the inoperable monitor is tripped.
2. Upon the loss of both SJAE system radiation monitors, either:
 - a. Monitor radiation levels at the SJAE within 36 hours

OR

 - b. Sample SJAE system daily to ensure the release rate is $\leq 500,000 \mu\text{Ci}/\text{sec}$

OR

 - c. Enter Tech Spec 3.7.5, Main Condenser Steam Jet Air Ejector (SJAE) Offgas

3.6.2 Surveillance Requirements

a. Applicability

Applies to the instrumentation required for monitoring the main condenser offgas steam jet air ejector (SJAE) radiation when the reactor is in Mode 1, and Mode 2 or 3 with any main steam line not isolated and SJAE is in operation.

b. Objective

To ensure that the SJAE release rates are properly monitored.

c. Specifications

Operation of the SJAE radioactive offgas monitors shall be verified by performing instrument surveillance as specified on Table 3.6-1.

3.6.3 Bases

This specification is provided to assure that remedial action is taken to limit the noble gas release rate at the SJAE. The requirement provides reasonable assurance that the amount of noble gas that must be treated and/or released is controlled to a level that prevents exceeding the limits specified in Part 1, Section 3.2.1.

Two air ejector offgas monitors are provided and when their trip point is reached; cause an isolation of the air ejector offgas line. Isolation is initiated when one instrument reaches its high-high trip point and the other has a high-high trip, an inoperative trip or a downscale trip. There is a 15 minute delay before the air ejector offgas isolation valve is closed. This delay is accounted for by the 30 minute holdup time of the offgas before it is released to the stack. Both instruments are required for an isolation of the air ejector offgas line but the instruments are so designed that any instrument failure gives a downscale or inoperative alarm.

Upon the loss of both SJAE system radiation monitors, installation of temporary monitoring or daily sampling at the SJAE is acceptable. These actions provide regular monitoring of the system radiation levels. If temporary monitoring is not installed or daily sampling is not performed, TS 3.7.5 is entered since the ability to monitor radiation levels (gross gamma activity rate of noble gases) is lost.

Table 3.6-1
 MINIMUM TEST AND CALIBRATION FREQUENCY FOR
 RADIATION MONITORING SYSTEMS ^(a)

Instrument Channels	Channel Check (b)	Channel Calibration (e)(f)	Logic System Functional Test (c)(d)
SJAE Radiation Monitors/Offgas Line Isolation	Daily	Quarterly	Once per 24 months

- a. Channel Calibrations and Channel Checks need not be performed when these instruments are not required to be operable or are tripped.
- b. Channel Checks shall be performed at least once per day during these periods when the instruments are required to be operable.
- c. Simulated automatic actuation shall be performed once every 24 months. Simulated automatic actuation means applying a simulated signal to the sensor to actuate the circuit.
- d. The Logic System Functional Test shall include a calibration of time delay relay necessary for proper functioning of the trip system.
- e. The radiation sensors are excluded from the quarterly calibration. The radiation sensors shall be calibrated every 24 month
- f. A successful test of the required contact(s) of a channel relay may be performed by the verification of the change of state of a single contact of the relay. This clarifies what is an acceptable Channel Functional Test of a relay. This is acceptable because all of the other required contacts of the relay are verified by other Technical Specifications and non-Technical Specification tests at least once per refueling interval with the applicable extension.

4.0 TOTAL DOSE

4.1 Gaseous Effluent Monitors

4.1.1 Limiting Conditions For Operation

a. Applicability

Applies to radiation dose from releases of radioactivity and radiation from uranium fuel cycle sources.

b. Objective

1. To assure that the requirements of 40 CFR 190 are met.
2. To assure that the requirements of 10 CFR 72.104 are met in accordance with Section 3.2.3, Required Action A.2, Certificate of Compliance 1014, Appendix A, Technical Specifications for the Hi-Storm 100 Cask System.

c. Specifications

1. The dose or dose commitment to any Member(s) of the Public, due to releases of radioactivity and radiation, from uranium fuel cycle sources shall be limited as follows:
 - a. Less than or equal to 25 mrem/year to the whole body; and,
 - b. Less than or equal to 25 mrem/year to any organ except the thyroid which shall be limited to less than or equal to 75 mrem/year.

2. With the calculated doses from the release of radioactive materials in liquid or gaseous effluents exceeding twice the limits of Section 2.3.1.c.1, 3.3.1.c.1, 3.4.1.c.1.a or 3.4.1.c.1.b, calculations shall be made including an estimate of direct radiation contributions to determine whether the limits of Section 4.1.1.c.1 have been exceeded. If this is the case, a report defining corrective actions to be taken to reduce subsequent releases to levels within limits, along with a schedule for achieving conformance, shall be prepared and submitted to the Commission within 30 days. This report, as defined in 10 CFR 20.2203(c), shall include estimates of the radiation exposure (dose) to a Member(s) of the Public from uranium fuel cycle sources, including all effluent pathways and direct radiation, for the calendar year that includes the release(s) covered by this report. It shall also describe levels of radiation and concentration of radioactive material involved, and the cause of the exposure levels or concentrations. If the estimated dose(s) exceed(s) the above limits, and if the release condition resulting in violation of 40 CFR 190 and 10 CFR 72.104(a) has not already been corrected, the report shall include a request for variance in accordance with the provisions of 40 CFR 190 and 10 CFR 72. Submittal of the report is considered a timely request, and a variance is granted until staff action on the request is complete.

4.1.2 Surveillance Requirements

a. Applicability

Applies to the calculation of total dose due to releases of radioactivity and radiation from uranium fuel cycle sources.

b. Objective

To ensure that appropriate calculations are performed to determine total dose to a Member(s) of the Public.

c. Specifications

1. Dose Calculations: Cumulative dose contributions from liquid and gaseous effluents shall be determined in accordance with Sections 2.3.2.c.1, 3.3.2.c.1, and 3.4.2.c.1 and in accordance with the ODCM (Part 2, Section 5.0).
2. Cumulative dose contributions from direct radiation from the reactor units and from radwaste storage tanks shall be determined in accordance with the methodology and parameters in the ODCM (Part 2, Section 5.4). This requirement is applicable only under conditions set forth in Section 4.1.1.c.2.

4.1.3 Bases

This specification is provided to meet the dose limitations of 40 CFR 190 and 10 CFR 72.104(a). This specification requires the preparation and submittal of a report whenever the calculated dose from plant radioactive effluents exceed twice the design objective doses of 10 CFR 50, Appendix I. The report will describe a course of action that should result in the limitation of the annual dose to a Member(s) of the Public to within the limits of 40 CFR 190 and 10 CFR 72.104(a). For the purpose of the report, it may be assumed the dose commitment to the Member(s) of the Public from other uranium fuel cycle sources is negligible. However, dose contributions from other nuclear fuel cycle facilities at the same site or within a radius of 5 miles must be considered. If the dose to any Member(s) of the Public is estimated to exceed the requirements of 40 CFR 190 or 10 CFR 72.104(a), the report, with a request for variance (provided the release conditions resulting in a violation of 40 CFR 190 or 10 CFR 72.104(a) have not already been corrected), shall be submitted in accordance with provisions of 40 CFR 190.11 and 10 CFR 20.2203(c). This request is considered a timely request and fulfills the requirements of 40 CFR 190 and 10 CFR 72 until NRC staff action is completed. The variance only relates to the limits of 40 CFR 190 or 10 CFR 72.104(a) and does not apply in any way to the requirements for dose limitation addressed in Specifications 2.0 and 3.0. An individual is not considered a Member(s) of the Public during any period in which he/she is engaged in carrying out any operation that is part of the nuclear fuel cycle.

FIGURE 4.1-1
SITE BOUNDARY MAP

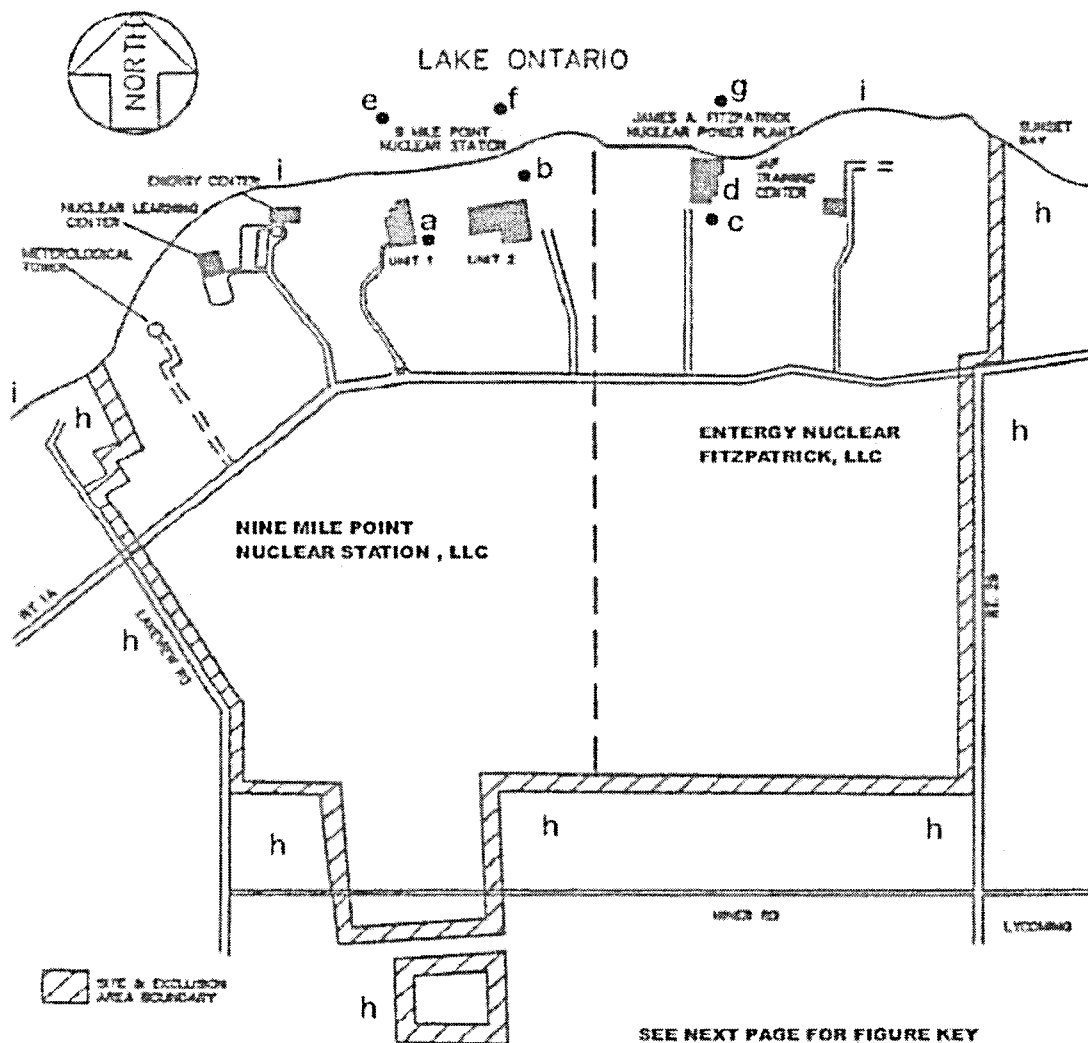

NOTES TO FIGURE 4.1-1

- (a) NMP1 stack (height is 350 feet)
- (b) NMP2 stack (height is 430 feet)
- (c) JAFNPP stack (height is 385 feet)
- (d) Building vents
- (e) NMP1 radioactive liquid discharge (Lake Ontario, bottom)
- (f) NMP2 radioactive liquid discharge (Lake Ontario, bottom)
- (g) JAFNPP radioactive liquid discharge (Lake Ontario, bottom)
- (h) Site Boundary
- (i) Lake Ontario shoreline

Additional Information:

- NMP2 reactor building vent is located 187 feet above ground level
- JAFNPP reactor and turbine building vents are located 173 feet above ground level
- JAFNPP radwaste building vent is 112 feet above ground level

5.0 RADIOLOGICAL ENVIRONMENTAL MONITORING

5.1 Monitoring Program

5.1.1 Limiting Conditions For Operation

a. Applicability

At all times.

b. Objective

To evaluate the effects of plant operation on the environs and to verify the effectiveness of the controls on radioactive material.

c. Specifications

1. With the radiological environmental monitoring program not being conducted as specified in Table 5.1-1, prepare and submit to the Commission, in the Annual Radiological Environmental Operating Report, a description of the reasons for not conducting the program as required and the plans for preventing a recurrence.

(Deviations are permitted from the required sampling schedule if samples are unobtainable due to hazardous conditions, seasonal unavailability, theft, uncooperative residents, or to malfunction of automatic sampling equipment. If the latter, efforts shall be made to complete corrective action prior to the end of the next sampling period.)

2. With the level of radioactivity (as the result of plant effluents) in an environmental sampling medium at a specified location exceeding the reporting levels of Table 5.1-2 when averaged over any calendar quarter, prepare and submit to the Commission a report within thirty (30) days from the end of the affected calendar quarter or within thirty (30) days from the time it is determined that a reporting level has been exceeded. This report shall identify the cause(s) for exceeding the limits(s) and define the corrective action(s) to be taken to reduce radioactive effluents so that the calculated annual dose to a Member(s) of the Public is less than the calendar year limits of Specifications 2.3.1.c.1.b, 3.3.1.c.1.b, and 3.4.1.c.1.b. When more than one of the radionuclides in Table 5.1-2 are detected in the sampling medium, this report shall be submitted if:

$$\frac{\text{concentration (1)}}{\text{reporting level (1)}} + \frac{\text{concentration (2)}}{\text{reporting level (2)}} + \dots \geq 1.0$$

When radionuclides other than those in Table 5.1-2 are detected and are the result of plant effluents, this report shall be submitted if the calculated annual dose to an individual is equal to or greater than the calendar year limits of Specifications 2.3.1.c.1.b, 3.3.1.c.1.b, and 3.4.1.c.1.b.

This report is not required if the measured level of radioactivity was not the result of plant effluents; however, in such an event, the condition shall be reported and described in the Annual Radiological Environmental Operating Report.

3. With milk or fresh leafy vegetable samples unavailable from one or more of the sample locations required by Table 5.1-1, locations for obtaining replacement samples shall be identified and added to the radiological environmental monitoring program within 30 days. The specific locations from which samples were unavailable may then be deleted from the monitoring program. The cause of the unavailability of samples and the new location(s) for obtaining replacement samples shall be identified in the next Radioactive Effluent Release Report. Also included in the report shall be a revised figure(s) and table for the ODCM reflecting the new location(s).

5.1.2 Surveillance Requirements

The radiological environmental monitoring samples shall be collected, pursuant to Table 5.1-1, from the locations given in the table and figure(s) in the ODCM (Appendix H) and shall be analyzed pursuant to the requirements of Table 5.1-1, and the detection capabilities required by Table 5.1-3.

5.1.3 Bases

The radiological environmental monitoring program required by this specification provides measurements of radiation and of radioactive materials in those exposure pathways and for those radionuclides that lead to the highest potential radiation exposures to members of the public resulting from station operation. This monitoring program ensures that 10 CFR 50, Appendix I, Section IV.B.2 is met. It thereby supplements the radiological effluent monitoring program by verifying that the measurable concentrations of radioactive materials and levels of radiation are not higher than expected, based on the effluent measurements and the modeling of the environmental exposure pathways. The initial specified monitoring program will be effective for at least the first three years of commercial operation. Following this period, program changes may be initiated based on operational experience.

The required detection capabilities for environmental sample analyses are tabulated in terms of the Lower Limit of Detection (LLDs). The LLDs required by Table 5.1-3 are considered optimum for routine environmental measurements in industrial laboratories. It should be recognized that the LLD is defined as an a priori (before the fact) limit representing the capability of a measurement system. The LLD is not an a posteriori (after the fact) limit for a particular measurement.

TABLE 5.1-1
OPERATIONAL RADIOLOGICAL ENVIRONMENTAL MONITORING PROGRAM

Exposure Pathway and/or Sample	Number of Samples ^(a) and Locations	Sampling and Collection Frequency ^(a)	Type and Frequency of Analysis
<p>AIRBORNE Radioiodine and Particulates</p>	<p>Samples from 5 locations:</p> <ul style="list-style-type: none"> a. 3 samples from offsite locations in different sectors of the highest calculated site average D/Q (based on all licensed site reactors) b. 1 sample from the vicinity of a community having the highest calculated site average D/Q (based on all licensed site reactors) c. 1 sample from a control location 9 to 20 miles distant and in the least prevalent wind direction^(d) 	<p>Continuous sample operation with sample collection weekly or as required by dust loading, whichever is more frequent</p>	<p><u>Radioiodine Canisters:</u> Analyze weekly for I-131</p> <p><u>Particulate Samples:</u> Gross beta radioactivity following filter change^(b), composite (by location) for gamma isotopic^(c) quarterly (as a minimum)</p>
<p>Direct Radiation^(e)</p>	<p>32 stations with two or more dosimeters placed as follows:</p> <ul style="list-style-type: none"> a. An inner ring of stations in the general area of the Site Boundary b. An outer ring in the 4 to 5 mile range from the site with a station in each of the land based sectors. There are 16 land based sectors in the inner ring and 8 land based sectors in the outer ring c. The balance of the stations (8) are placed in special interest areas such as population centers, nearby residences, schools, and in 2 or 3 areas to serve as control stations 	<p>Quarterly</p>	<p>Gamma dose monthly or quarterly</p>

See notes following table

TABLE 5.1-1 (continued)
 OPERATIONAL RADIOLOGICAL ENVIRONMENTAL MONITORING PROGRAM

Exposure Pathway and/or Sample	Number of Samples ^(a) and Locations	Sampling and Collection Frequency ^(a)	Type and Frequency of Analysis
<u>WATERBORNE</u>			
Surface ^(f)	a. 1 sample upstream ^(d) b. 1 sample from the site's most downstream cooling water intake	Composite sample over one month period ^(g)	Gamma isotopic analysis monthly. Composite for Tritium analysis quarterly ^(c)
Sediment from Shoreline	1 sample from a downstream area with existing or potential recreational value	Twice per year	Gamma isotopic analysis semi-annually ^(c)
<u>INGESTION</u>			
Milk	a. Samples from milch animals in 3 locations within 3.5 miles distant having the highest calculated site average D/Q. If there are none, then 1 sample from milch animals in each of 3 areas 3.5 to 5.0 miles distant having the highest calculated site average D/Q (based on all licensed site reactors) ^(h) b. 1 sample from milch animals at a control location (9 to 20 miles distant and in a less prevalent wind direction) ^(d)	Twice per month, April through December (samples will be collected in January through March if I-131 is detected in November and December of the preceding year)	Gamma isotopic and I-131 analysis twice per month when milch animals are on pasture (April through December); monthly (January through March), if required ^(c)

See notes following table

TABLE 5.1-1 (continued)
 OPERATIONAL RADIOLOGICAL ENVIRONMENTAL MONITORING PROGRAM

Exposure Pathway and/or Sample	Number of Samples ^(a) and Locations	Sampling and Collection Frequency ^(a)	Type and Frequency of Analysis
Fish	a. 1 sample of 2 commercially or recreationally important species in the vicinity of a site discharge point b. 1 sample of 2 species (same as in a. above or of a species with similar feeding habits) from an area at least 5 miles distant from the site ^(d)	Twice per year	Gamma isotopic ^(c) analysis of edible portions
Food Products	a. In lieu of the garden census as specified in Part 1, Section 5.2, samples of at least 3 different kinds of broad leaf vegetation (such as vegetables) grown nearest each of two different offsite locations of highest predicted site average D/Q (Based on all licensed site Reactors) One (1) sample of each of the similar broad leaf vegetation grown at least 9.3 miles distant in a least prevalent wind direction sector ^(d)	Once during harvest season	Gamma isotopic ^(c) analysis of edible portions. (Isotopic to include I-131)

See notes following table

NOTES FOR TABLE 5.1-1

- (a) It is recognized that, at times, it may not be possible or practical to obtain samples of the media of choice at the most desired location or time. In these instances suitable alternative media and locations may be chosen for the particular pathway in question. Actual locations (distance and directions) from the site shall be provided in the Annual Radiological Environmental Operating Report. Calculated site averaged D/Q values and meteorological parameters are based on historical data (specified in the ODCM) for all licensed site reactors.
- (b) Particulate sample filters should be analyzed for gross beta 24 hours or more after sampling to allow for radon and thoron daughter decay. If gross beta activity in air particulate samples is greater than 10 times a historical yearly mean of control samples, gamma isotopic analysis shall be performed on the individual samples.
- (c) Gamma isotopic analysis means the identification and quantification of gamma emitting radionuclides that may be attributable to the effluents from the plant.
- (d) The purpose of these samples is to obtain background information. If it is not practical to establish control locations in accordance with the distance and wind direction criteria, other sites which provide valid background data may be substituted.
- (e) One or more instruments, such as a pressurized ion chamber, for measuring and recording dose rate continuously may be used in place of, or in addition to, integrating dosimeters. For the purpose of this table, a thermoluminescent dosimeter may be considered to be one phosphor and two or more phosphors in a packet may be considered as two or more dosimeters. Film badges shall not be used for measuring direct radiation.
- (f) The "upstream sample" shall be taken at a distance beyond significant influence of the discharge. The "downstream sample" shall be taken in an area beyond, but near, the mixing zone, if practical.
- (g) Composite samples should be collected with equipment (or equivalent) which is capable of collecting an aliquot at time intervals which are very short (e.g., hourly) relative to the compositing period (e.g., monthly) in order to ensure that a representative sample is obtained.
- (h) A milk sampling location, as required in Table 5.1-1 is defined as a location having at least 10 milking cows present at a designated milk sample location. It has been found from past experience, and as a result of conferring with local farmers, that a minimum of 10 milking cows is necessary to guarantee an adequate supply of milk twice per month for analytical purposes. Locations with less than 10 milking cows are usually utilized for breeding purposes which eliminates a stable supply of milk for samples as a result of suckling calves and periods when the adult animals are dry. In the event that 3 milk sample locations cannot meet the requirement for 10 milking cows, then a sample location having less than 10 milking cows can be used if an adequate supply of milk can reasonably and reliably be obtained based on communications with the farmer.

TABLE 5.1-2
REPORTING LEVELS
FOR RADIOACTIVITY CONCENTRATIONS IN ENVIRONMENTAL SAMPLES

Analysis	Water (pCi/l)	Airborne Particulate or Gases (pCi/m ³)	Fish (pCi/kg, wet)	Milk (pCi/l)	Food Products (pCi/kg, wet)
H-3	30,000 ^(a)				
Mn-54	1,000		30,000		
Fe-59	400		10,000		
Co-58	1,000		30,000		
Co-60	300		10,000		
Zn-65	300		20,000		
Zr/Nb-95	400				
I-131	20 ^(a)	0.9		3	100
Cs-134	30	10	1,000	60	1,000
Cs-137	50	20	2,000	70	2,000
Ba/La-140	200			300	

- (a) No drinking water pathway exists at the James A. FitzPatrick/Nine Mile Point sites under normal operating conditions due to the distance and direction of the nearest drinking water intake. Therefore, value of 30,000 pCi/liter is used for tritium and 20 pCi/liter is used for I-131.

TABLE 5.1-3

DETECTION CAPABILITIES
FOR ENVIRONMENTAL SAMPLE ANALYSIS^(a)LOWER LIMIT OF DETECTION (LLD)^(b)

Analysis	Water (pCi/l)	Airborne Particulate or Gases (pCi/m ³)	Fish (pCi/kg, wet)	Milk (pCi/l)	Food Products (pCi/kg, wet)	Sediment (pCi/kg, dry)
Gross Beta	4	0.01				
H-3	3,000 ^(c)					
Mn-54	15		130			
Fe-59	30		260			
Co-58,60	15		130			
Zn-65	30		260			
Zr/Nb-95	15					
I-131	15 ^(c)	0.07		1	60	
Cs-134	15	0.05	130	15	60	150
Cs-137	18	0.06	150	18	80	180
Ba/La-140	15			15		

NOTES FOR TABLE 5.1-3

- (a) The LLD is the smallest concentration of radioactive material in a sample that will be detected with 95% probability and with 5% probability of falsely concluding that a blank observation represents a "real" signal.

For a particular measurement system (which may include radiochemical separation),

$$LLD = \frac{4.66 s_b}{E \cdot V \cdot 2.22 \cdot Y \cdot \exp(-\lambda \Delta t)}$$

Where:

LLD is the a priori lower limit of detection, as defined above (in picoCurie per unit mass or volume);

s_b is the standard deviation of the background counting rate or of the counting rate of a blank sample, as appropriate (in counts per minute);

E is the counting efficiency (in counts per transformation);

V is the sample size (in units of mass or volume);

2.22 is the number of transformations per minute per picoCurie;

Y is the fractional radiochemical yield (when applicable);

λ is the radioactive decay constant for the particular radionuclide;

Δt is the elapsed time between sample collection (or end of the sample collection period) and time of counting.

Typical values of E, V, Y, and Δt should be used in the calculations.

- (b) It should be recognized that the LLD is defined as an a priori (before the fact) limit representing the capability of a measurement system and not as an a posteriori (after the fact) limit for a particular measurement. Analyses shall be performed in such a manner that the stated LLDs will be achieved under routine conditions. Occasionally background fluctuations, unavoidable small sample sizes, the presence of interfering nuclides, or other uncontrollable circumstances may render these LLDs unachievable. In such cases, the contributing factors shall be identified and described in the Annual Radiological Environmental Operating Report.
- (c) No drinking water pathway exists at the James A. FitzPatrick/ Nine Mile Point sites under normal operating conditions due to the direction and distance of the nearest drinking water intake. Therefore, an LLD value of 15 pCi/liter is used for I-131 and 3,000 pCi/liter is used for tritium.

5.2 Land Use Census Program

5.2.1 Limiting Conditions For Operation

a. Applicability

At all times.

b. Objective

To identify locations of milch animals and gardens of greater than 50 square meters within 5 miles of the site.

c. Specifications

1. A land use census shall be conducted and shall identify the locations of all milch animals, the nearest residence, and all gardens¹ of greater than 50 square meters producing fresh leafy vegetables, in each of the 16 meteorological sectors within a distance of 5 miles from the site.⁽¹⁾
2. With a land use census identifying a milch animal in a location(s) which represents a calculated D/Q value greater than the values currently being used in calculating Surveillance Requirement 3.4.2.c.1, identify the new location(s) in the next Radioactive Effluent Release Report.
3. With the land use census identifying a milch animal location(s) that represents a calculated D/Q (via the same exposure pathway) 50% greater than at a location from which samples are currently being obtained in accordance with Table 5.1-1, add the new location(s) to the radiological environmental monitoring program within 30 days. The sampling location(s), excluding the control station location, having the lowest calculated D/Q (via the same exposure pathway) may be deleted from this monitoring program after October 31 of the year in which this land use census is conducted. Identify the new location(s) in the next Radioactive Effluent Release Report and include the additions in the ODCM.

⁽¹⁾ Broad leaf vegetation sampling may be performed in lieu of the garden census as specified in Table 5.1-1.

5.2.2 Surveillance Requirements

The land use census shall be conducted during the growing season at least once per 12 months using the information that will provide the best results, such as by a door-to-door survey, aerial survey, or by consulting local agriculture authorities, etc. The results of the land use census shall be included in the Annual Radiological Environmental Operating Report.

5.2.3 Bases

This specification is provided to ensure that changes in the use of areas at and beyond the Site Boundary are identified and that modifications to the monitoring program are made if required by the results of this census. The best survey information, such as that from door-to-door surveys, aerial surveys, consultations with local agricultural authorities, etc., shall be used. This census satisfies the requirements of 10 CFR 50, Appendix I, Section IV.B.3. Restricting the census to gardens of greater than 50 m² provides assurance that significant exposure pathways via leafy vegetables will be identified and monitored since a garden of this size is the minimum required to produce the quantity (26 kg/year) of leafy vegetables assumed in Regulatory Guide 1.109, Revision 1, October 1977, for consumption by a child. To determine this minimum garden size, the following assumptions were made: (1) 20% of the garden was used for growing broad leaf vegetation (i.e., similar to lettuce and cabbage), and, (2) a vegetable yield of 2 kg/m². In lieu of the garden census the significance of the garden exposure pathway can be evaluated by the sampling of green leafy vegetables as specified in Table 5.1-1.

5.3 Interlaboratory Comparison Program

5.3.1 Limiting Conditions For Operation

a. **Applicability**

At all times.

b. **Objective**

To provide quality control of environmental sample analyses.

c. **Specifications**

1. Analyses shall be performed on radioactive materials supplied as part of an Interlaboratory Comparison Program. Participation in this program shall include all media for which samples are routinely collected and for which intercomparison samples are available.
2. With analyses not being performed as required above, report the corrective actions taken to prevent a recurrence in the Annual Radiological Environmental Operating Report.

5.3.2 Surveillance Requirements

A summary of the results obtained as part of the above required Interlaboratory Comparison Program shall be included in the Annual Radiological Environmental Operating Report.

5.3.3 Bases

The requirement for participation in an Interlaboratory Comparison Program is provided to ensure that independent checks on the precision and accuracy of the measurements of radioactive material in the environmental sample matrices are performed as part of the quality assurance program for environmental monitoring in order to demonstrate that the results are valid for the purposes of 10 CFR 50, Appendix I, Section IV.B.2.

6.0 REPORTS

6.1 Annual Radiological Environmental Operating Report

The Annual Radiological Environmental Operating Report covering the operation of the plant during the previous calendar year shall be submitted by May 15 of each year.

The report shall include summaries, interpretations, and analyses of trends of the results of the Radiological Environmental Monitoring Program for the reporting period. The material provided shall be consistent with the objectives outlined in the Offsite Dose Calculation Manual (ODCM), and in 10 CFR 50, Appendix I, Sections IV.B.2, IV.B.3, and IV.C. The report shall include a comparison with preoperational studies, operational controls (as appropriate), and environmental surveillance reports from the previous five years, and an assessment of the observed impacts of the plant operation on the environment. The reports shall also include the results of the Land Use Census required by Specification 5.2.

The report shall include the results of analyses of all radiological environmental samples and of all environmental radiation measurements taken during the period at the locations specified in Table 5.1-1, as well as summarized and tabulated results of these analyses and measurements in the format of the table in the Radiological Assessment Branch Technical Position, Revision 1, November 1979. In the event that some individual results are not available for inclusion with the report, the report shall be submitted noting and explaining the reasons for the missing results. This missing data shall be submitted in a supplementary report as soon as possible.

The report shall also include the following: A summary description of the Radiological Environmental Monitoring Program; at least two legible maps (one map shall cover stations near the Site Boundary; a second shall include the more distant stations) covering all sampling locations and keyed to a table giving distances and directions from the centerline of one reactor; the results of participation in the Interlaboratory Comparison Program required by Specification 5.3, and discussion of all analyses in which the LLDs required by Table 5.1-3 were not routinely achievable.

6.2 Radioactive Effluent Release Report

The Radioactive Effluent Release Report covering the operation of the plant during the previous year shall be submitted prior to May 1 of each year in accordance with 10 CFR 50.36a.

-
- 6.2.1 The report shall include a summary of the quantities of radioactive liquid and gaseous effluents and solid waste released from the plant. The material provided shall be consistent with the objectives outlined in the ODCM (Part 2) and Process Control Program and in conformance with 10 CFR 50.36a and 10 CFR 50, Appendix I, Section IV.B.1. The summary can be provided using as guidance Regulatory Guide 1.21, Revision 1, June 1974, "Measuring, Evaluating, and Reporting Radioactivity in Solid Wastes and Releases of Radioactive Materials in Liquid and Gaseous Effluents from Light-Water-Cooled Nuclear Power Plant", with data summarized on a quarterly basis following the format of Appendix B thereof.
- 6.2.2 The report may include an annual summary of meteorological data collected over the previous year. If the meteorological data is not included, ENO shall retain it on file and provide it to the US Nuclear Regulatory Commission upon request. This same report shall include an assessment of the radiation doses due to the radioactive liquid and gaseous effluents released from the plant during the previous calendar year to the public. All assumptions used in making these assessments (i.e., specific activity, exposure time and location) shall be included in these reports. The assessment of radiation doses shall be performed in accordance with the ODCM.
- 6.2.3 The report shall include any change to the PCP or the ODCM made during the reporting period, as well as a listing of new locations for dose calculations and/or environmental monitoring identified by the land use census pursuant to Specification 5.2.
- 6.2.4 The report shall also include an assessment of radiation doses to the likely most exposed Member(s) of the Public from reactor releases and other nearby uranium fuel cycle sources (including doses from primary effluent pathways and direct radiation) during the previous calendar year, to show conformance with 40 CFR 190, Environmental Radiation Protection Standards for Nuclear Power Operations. This assessment of radiation doses is performed in accordance with the ODCM.
- 6.2.5 The report shall include the following information for each class of solid waste (defined by 10 CFR 61) shipped offsite during the report period:
- a. Container volume;
 - b. Total curie quantity (specify whether determined by measurement or estimate);
 - c. Principal radionuclides (specify whether determined by measurement or estimate);
 - d. Source of waste and processing employed (e.g., dewatered spent resin, compacted dry waste, evaporator bottoms);
 - e. Type of container (e.g., LSA, Type A, Large Quantity), and,
 - f. Solidification agent or absorbent (e.g., cement, Dow media, etc.)

-
- 6.2.6 The report shall include a list and description of unplanned releases, to Unrestricted Areas of radioactive materials in gaseous and liquid effluents made during the reporting period.
- 6.2.7 The report shall contain the cause for unavailability of any environmental sample required by Table 5.1-1 and shall identify the locations for obtaining replacement samples. This shall also include a revised figure(s) and table for the ODCM reflecting the new location(s). Refer to Section 5.1.1.c.3.
- 6.2.8 The report shall contain new locations identified in the land use census in accordance with Sections 5.2.1.c.2 or 5.2.1.c.3.
- 6.2.9 The report shall contain the events leading to the conditions which resulted in exceeding the radioactivity limits for the specified outdoor liquid radwaste tanks specified in the Technical Requirements Manual, TRM 3.7.E.
- 6.2.10 The report shall contain details of any major modifications to Radioactive Liquid, Gaseous, and Solid Waste Treatment Systems as discussed in Section 7.0.

7.0 MAJOR MODIFICATIONS TO RADIOACTIVE LIQUID, GASEOUS, AND SOLID WASTE TREATMENT SYSTEMS*

Major modifications to radioactive waste systems (liquid, gaseous, and solid):

1. Shall be reported to the Commission in the Radioactive Effluent Release Report for the period in which the modification is completed and made operational. The discussion of each modification shall contain:
 - a. A summary of the evaluation that led to the determination that the modification could be made in accordance with 10 CFR 50.59,
 - b. Sufficient information to support the reason for the modification without benefit of additional or supplemental information; and
 - c. A description of the equipment, components, and processes involved and the interfaces with other plant systems.
 2. The following evaluations shall be reported to the Commission in the Radioactive Effluent Release Report, where such evaluations are required to be performed in order to assure compliance with the requirements of 10 CFR 50.59.
 - a. An evaluation of the modifications, which show the predicted releases of radioactive materials in liquid and gaseous effluents and/or quantity of solid waste that differ from those previously predicted in the license application and amendments thereto.
 - b. An evaluation of the modification, which shows expected maximum exposure to individuals in the Unrestricted Area and to the general population that differ from those previously estimated in the license application and amendments thereto; and
 - c. A comparison of the predicted release of radioactive materials, in liquid and gaseous effluents and in solid waste, to the actual releases for the period prior to when the modifications are to be made.
- (*) Entergy Nuclear Operations, Inc. may elect to submit the information called for in this Specification as part of the annual 10 CFR 50.59 Safety Evaluation Report.

8.0 PURGING OF THE PRIMARY CONTAINMENT

8.1 Limiting Conditions for Operation

a. Applicability

Applies to the purging operations of the primary containment purge system.

b. Objective

To ensure that the primary containment is purged through the Standby Gas Treatment System.

c. Specifications

1. The containment shall be purged through the Standby Gas Treatment System whenever the primary containment is required to be Operable per the Technical Specifications (TS). If this requirement cannot be met, then purging shall be discontinued without delay.
2. With the requirements of Part 1, Section 8.1.c.1 not met, enter the applicable TS LCO Conditions and Required Actions.

8.2 Bases

Limitations on purging the containment are established to maintain releases as low as reasonably achievable.

The TS provide the appropriate actions and restrictions if the requirements above are not met. The inability to purge through the Standby Gas Treatment System could be caused by a number of reasons, and thus, various TS 3.6 Sections could apply. The applicable TS LCO Conditions and Required Actions will be entered as required.

Last Page of Part I

DVP-01.02

PART 2 - OFFSITE DOSE CALCULATION MANUAL*

TABLE OF CONTENTS

1.0	INTRODUCTION.....	2
2.0	DEFINITIONS.....	3
3.0	LIQUID EFFLUENT METHODOLOGY.....	7
4.0	GASEOUS EFFLUENT METHODOLOGY.....	30
5.0	40 CFR 190 AND 10 CFR 72.104(a) DOSE EVALUATION.....	76
6.0	REFERENCES.....	79

1.0 INTRODUCTION

1.1 Purpose

This manual provides the methodology to calculate radiation doses to individuals in the vicinity of the James A. FitzPatrick Nuclear Power Plant. It also provides methodology for calculating effluent monitor set points and allowable release rates to ensure compliance with Technical Specifications 5.5.1 and 5.5.4, James A. FitzPatrick Nuclear Power Plant, Docket Number 50-333, and 10 CFR 20 1001-20.2402 release criteria.

1.2 Methodologies and Parameters

The ODCM follows the methodology and models suggested by the "Guidance Manual For Preparation of Radiological Effluent Technical Specifications for Nuclear Power Plants" (NUREG-0133 October 1978) and "Calculation of Annual Doses to Man from Routine Releases of Reactor Effluents for the Purpose of Evaluating Compliance with 10 CFR 50, Appendix I" (Regulatory Guide 1.109, Revision 1 dated October 1977). Simplifying assumptions have been made and justified where applicable to provide a more workable document for implementing programmatic controls in the Technical Specifications 5.5.1 and 5.5.4, as well as the procedural details of Part 1 of this document. Alternate calculating methods to those presented here may be used provided the general methodology is similar, well documented and the results are more precise. Additionally, as available, the most up-to-date revision of the Regulatory Guide 1.109 dose conversion factors and site specific environmental transfer factors may be substituted for those currently included and used in this document.

1.3 Document Revision Overview

This is Revision 14 of the ODCM under the procedure designation of DVP-01.02. There were 9 revisions under the previous procedure designation of CDP-15. This revision constitutes the 23rd revision of the ODCM since its inception as Rev. 0 of CDP-15.

2.0 DEFINITIONS

Age Groups	Infants, children, teens and adults are age groups evaluated by this ODCM.
Beta	A beta particle (electron)
Beta Dose	The dose component to skin dose due to beta emitting radionuclides in air.
cc	Cubic Centimeter
Ci	Curie. A unit of radioactivity equal to $3.7E+10$ disintegrations per second. See also microCurie (μCi).
C_i	Concentration of a nuclide in the release source. Units of $\mu\text{Ci}/\text{cc}$ or $\mu\text{Ci}/\text{ml}$.
CFR	Code of Federal Regulations
Dose	A measure of the radiation energy deposited per unit mass (in mrem or mrad), that the organ or the individual receives from exposure to radioactive effluents dispersed in the environment.
Dose Commitment	
	The total dose delivered to the organ or whole body over a 50 year period resulting from uptake of radioactive material.
Dose Factor	Normally, a factor that converts the effect of ingesting or inhaling radioactive material into the body, to dose to a specific organ. Body elimination, radioactive decay, and organ uptake are some of the factors that determine a dose factor for a given nuclide.
Dose Pathway	
	A specific path that radioactive material physically travels through in the environment prior to exposing an individual to its emitted radiation. The grass/cow/milk food chain is a dose pathway.

Dose Rate	The dose received per unit time.
(d/q)	The short-term atmospheric deposition factor (m^{-2}) for ground-level releases and a specified release duration.
$\overline{(D/Q)}$	A long term relative deposition coefficient. A factor with units of $1/m^2$ which describes the deposition of particulate matter from a plume at a point downrange from the source. It can be thought of as the part of the cloud that will fall out and deposit over one square meter of ground.
ECL	The Effluent Concentration Limit (ECL) is equal to 10 times the effluent concentration values listed in 10 CFR 20, Appendix B, Table 2, Column 2.
Gamma	A gamma photon
Gamma Dose	The dose component to skin or whole body dose due to gamma-emitting radionuclides in air.
Ground Plane	Radioactive material deposited uniformly over the ground emits radiation that produces an exposure pathway when an individual is present in the area. It is assumed that an adult receives the same exposure as an infant, regardless of the physical height differences. Only the whole body and skin is considered for the purpose of the ODCM.
H-3	Hydrogen-3, or tritium. An isotope of hydrogen that is a low-energy beta emitter.
I&8DP	Radioiodines and particulates with half-lives greater than eight days (includes H-3 where applicable).
LLD	Lower Limit of Detection. The smallest concentration of radioactive material in a sample that will yield a net count, above system background, that will be detected with 95 percent probability and with only 5 percent probability of falsely concluding that a blank observation represents a "real" signal.
LCO	Limiting Conditions for Operation in Part 1
m^3	Cubic meters
m^2	Square meters

Nuclide	An atomic nucleus that contains a specified number of protons and neutrons. Nuclide (i) signifies a specific nuclide under consideration (e.g., 1st, 2nd, 3rd, etc.). If nuclide (i) is I-131, then the M_i (dose factor) under consideration should be M_{I-131} , for example.
Organ	For the purpose of the ODCM, either the bone, liver, thyroid, kidney, lung, GI-LLI, skin or the W. Body (Whole body). W. Body is considered an organ for consistency with the ODCM nomenclature.
\dot{Q}_i	\dot{Q}_i (dotted) denotes a release rate in Ci/sec or $\mu\text{Ci}/\text{sec}$ for nuclide (i).
Q_i	Denotes Ci of nuclide (i) released over a specified time interval.
Receptor	The individual receiving radiation exposure from effluent releases at JAFNPP at a given location, or who ingests food products contained with trace amounts of radioactive materials. A receptor can receive dose from one or more dose pathways.

Release Source

A subsystem, tank, vent or stack where radioactive material can be released independently of other radioactive release points.

Restricted Area

An area access to which is limited by Entergy for the purpose of protecting individuals against risks from exposure to radiation and radioactive materials.

μCi	MicroCuries. 1 Ci = $1\text{E}+6$ μCuries . The μCi is the standard unit of radioactivity for all dose calculations in the JAFNPP ODCM.
(x/q)	The short-term atmospheric deposition factor (sec/m^3) for ground-level releases and a specified release duration.
$\overline{(X/Q)}$	A long term relative atmospheric dispersion coefficient. It describes the physical dispersion characteristics of a semi-infinite cloud of noble gases as the cloud travels downwind from the release point.
$\overline{(X/Q)}_r$	Long term finite cloud atmospheric dispersion parameter for computation of external gamma radiation exposures (sec/m^3). (By definition, the gamma (X/Q) is the equivalent relative concentration of radioactivity in a semi-infinite cloud that would yield the same radiation exposure as a finite cloud aloft; it accounts for the actual plume dimensions and elevation above the receptor, and gamma radiation spectra.)

Unrestricted Area

An unrestricted area shall be any area at or beyond the site boundary where access is neither limited nor controlled by Entergy for purposes of protecting individuals against undue risk from exposure to radiation and radioactive materials, or any area within the site boundary used for residential quarters or for industrial, commercial, institutional, and/or recreational purposes.

Vent Building ventilation air exhausts via roof top ducts.

(X/W) The annual average relative concentration (sec/m^3) for a given liquid pathway (potable water or fish ingestion) for a specified release duration.

3.0 LIQUID EFFLUENT METHODOLOGY

3.1 Applicable Site Characteristics

The JAFNPP Final Safety Analysis Report (FSAR) contains the official description of the site characteristics. The description that follows is a brief summary for dose calculation purposes.

The James A. FitzPatrick Nuclear Power Plant is located on the eastern portion of the Nine Mile Point promontory on Lake Ontario in Oswego County, NY. The site is approximately seven miles northeast of the City of Oswego. Radioactive liquid releases normally enter Lake Ontario where the Circulating Water Discharge Tunnel terminates on the lake bottom approximately 1,400 feet from the shoreline.

3.2 10 CFR 20, ECL Limits-Determination of the Fraction (F_L) of Release Limits and Minimum Required Dilution

3.2.1 Requirements

In accordance with Part 1, Section 2.2.1.c.1, the concentration of liquid radioactive material released to unrestricted areas (Appendix G) shall not exceed 10 times the concentrations specified in 10 CFR 20, Appendix B, Table 2, Column 2 for radionuclides other than dissolved or entrained noble gases. Concentration of radionuclides in liquid waste is determined by sampling and analyses in accordance with Part 1, Radiological Effluent Controls, Section 2.2.

In accordance with Part 1, Radiological Effluent Controls, Section 2.2 for dissolved or entrained noble gases, the concentration shall be limited to $2E-4$ $\mu\text{Ci/ml}$.

3.2.2 Methodology

This section presents the calculating method to be used for determining F_L , the fraction of Part 1, Section 2.2.1.c.1 limits, of release concentrations of liquid radioactive effluents.

This method addresses the calculation for a specific release source. Administrative controls are applied to assure that the summation of F_L values for each release source does not exceed the Part 1, Section 2.2.1.c.1 limit. Normally, all potentially radioactive liquid effluents are released to the unrestricted area through a single monitored release path as indicated in Appendix F. However, the service water system presents a potential release point for radioactive liquid effluents. To assure the combined releases do not exceed Part 1, Section 2.2.1.c.1 effluent concentration limits (ECLs), the alarm set point, as determined in Section 3.3 includes a conservatism factor of 0.5.

The basic equation which determines the fraction (F_L) of the ECL is:

Eq. 3-1

$$F_L = \left[\frac{f_1}{f_2} \right] \times \sum_{i=1}^n \left[\frac{C_i}{ECL_i} \right]$$

Where:

- F_L = The fraction of ECLs resulting from the release source being discharged (dimensionless)
- f_1 = The undiluted release rate of the release source as measured at the liquid effluent monitor location, in gpm.
- f_2 = The discharge structure exit flow in gpm. (Summation of circulating water pump and service water pump discharge flow; minus the flow redirected for tempering)
- C_i = Each undiluted concentration of nuclide (i) in $\mu\text{Ci/ml}$ (includes both gamma and beta emitters)
- ECL_i = The ECL for nuclide (i) in $\mu\text{Ci/ml}$. The ECL_i is equal to 10 times the corresponding effluent concentration value listed in 10 CFR 20, Appendix B, Table 2, Column 2.

Using this approach, the fraction of the ECL is determined using a nuclide-by-nuclide evaluation.

3.2.3 Calculating Process for Determining f_2/f_1

The following section provides a procedure for determining the minimum required dilution factor (f_2/f_1) to ensure that $F_L \leq 1$ during the actual release. With $F_L \leq 1$, the minimum required dilution factor can be expressed as:

Eq. 3-2

$$\left(\frac{f_2}{f_1} \right)_{\min} = \sum_{i=1}^n \frac{C_i}{ECL_i}$$

- a. Obtain (C_i), the undiluted assay value of nuclide (i), in $\mu\text{Ci/ml}$.
- b. From Appendix A, Table A-1, obtain the corresponding ECL_i for nuclide (i) in $\mu\text{Ci/ml}$. The ECL_i is equal to 10 times the corresponding effluent concentration value listed in 10 CFR 20, Appendix B, Table 2, Column 2.
- c. Divide C_i by ECL_i .
- d. Repeat steps b and c above for each nuclide and sum the totals.
- e. Enter only the total Gamma activity and the minimum required dilution factor $(f_2/f_1)_{\min}$ on the liquid release permit.

3.3 Determination of Setpoints for Radioactive Liquid Effluent Monitors

3.3.1 Requirements

Part 1, Section 2.1.1.c.1 requires that the radioactive liquid effluent monitor be operable and set to initiate an alarm and/or trip in the event that the limits of Part 1, Section 2.2.1.c.1 are approached. The alarm and/or trip setpoints shall be determined and adjusted by the methodology which follows. The setpoint values should be applied above normal background levels.

The alarm setpoint for the liquid effluent radiation monitor is derived from the ECLs applied at the unrestricted area boundary where the discharge tunnel flows into Lake Ontario.

An Implementation Plan as defined in AP-02.04 shall be initiated and included in any ODCM revision whenever the methodology for calculating liquid setpoints is changed and the change in methodology results in a new calculated setpoint.

3.3.2 Methodology

The alarm setpoints do not consider dilution, dispersion, or decay of radioactive material beyond the unrestricted area boundary (i.e., the alarm setpoints are based on a concentration limit at the end of the discharge tunnel).

3.3.3 Radwaste Liquid Effluent Monitor

- a. A sample of each batch of liquid radwaste is analyzed for I-131 and other principal gamma emitters prior to release. The fraction F_L of 10 CFR 20, ECLs, and the minimum required dilution factor to achieve $F_L = 1$ is determined in accordance with the preceding section for the activity to be released. For cases other than minimum dilution calculation, $F_L < 0.5$.
- b. A conservative alarm and/or trip setpoint ($\mu\text{Ci/ml}$) is determined in accordance with the following equation:

Eq. 3-3

$$S = 0.5 \times \frac{C_g}{F_L}$$

Where:

- S = The alarm and/or trip set point above background corresponding to the limiting concentration of undiluted liquid effluent ($\mu\text{Ci/ml}$).
- 0.5 = Conservatism factor to account for releases from multiple points, and to allow for nuclides not detected by the monitor.

- C_g = Total undiluted concentration of gamma emitters in $\mu\text{Ci/ml}$ as determined in the laboratory.
- F_L = The fraction of the Part 1, Section 2.2.1.c.1, ECLs for unrestricted areas resulting from the release source being discharged.

3.3.3.1 Calculating Process

The following section provides a procedure for determining the radwaste liquid effluent monitor set point. Typical parameter values are used for illustration.

- Determine the undiluted gamma concentrations from laboratory analysis of the liquid effluent sample. For the purpose of this example, assume only Co-60 is present at a concentration of $3.0\text{E}-05 \mu\text{Ci/ml}$.
- Determine the beta activity from the most recent composite results (C_b). For the purposes of this example, assume only H-3 is present at a concentration of $2.2\text{E}-02 \mu\text{Ci/ml}$.
- Determine f_2 from pump curves and current plant operating configuration. A typical value is $3.78\text{E}+5$ gpm.
- Determine the minimum required dilution factor in accordance with equation 3-2.

$$\left[\frac{f_2}{f_1} \right]_{\min} = \sum_{i=1}^n \frac{C_i}{(ECL)_i}$$

For this example, ECL values for Cobalt-60 and Tritium are obtained from Appendix A, Table A-1 (ECLs):

$$\left[\frac{f_2}{f_1} \right]_{\min} = \frac{3\text{E}-05}{3\text{E}-05} + \frac{2.2\text{E}-02}{1\text{E}-2}$$

$$\left[\frac{f_2}{f_1} \right]_{\min} = 3.2$$

- Determine or calculate the required f_1 at the liquid effluent monitor location. A typical value is 100 gpm.

- f. A typical value of the dilution factor from current plant operating conditions is:

$(3.78\text{E}+5 \text{ gpm})/100 \text{ gpm} = 3,780$, which is >3.2 . Therefore the release can be made at the current release rates and concentrations maintained within the 10 CFR 20 Part 1, Section 2.2.1.c.1 ECLs.

- g. Determine F_L , the fraction of 10 CFR 20 ECLs resulting from the release source being discharged at a dilution factor of 3,780, in accordance with equation 3-1.

$$F_L = \left[\frac{f_1}{f_2} \right] \times \sum_{i=1}^n \frac{C_i}{(ECL)_i}$$

$$= (100/3.78\text{E}+5) \times 3.2 \text{ (from 3.3.3.1.d)}$$

$$= (2.65\text{E}-4) \times 3.2$$

$$= 8.47\text{E}-4$$

- h. The liquid effluent monitor setpoint, S in $\mu\text{Ci}/\text{ml}$, from equation 3-3 is:

Eq. 3-3a

$$S = 0.5 \times \frac{C_g}{F_L}$$

$$= 0.5 \times [(3\text{E}-5)/(8.47\text{E}-4)]$$

$$= 1.77\text{E}-2$$

- i. Appropriate calibration factors are applied to this limiting concentration determined in step 3.3.3.1.g to determine an effluent monitor alarm potentiometer set point.

3.3.4 Service Water Liquid Effluent Monitor

- a. A conservative alarm setpoint (cps) for the service water liquid effluent monitor is determined in accordance with the following methodology:

$$DF = \frac{f_2}{f_1} \quad \text{Eq. 3-3b}$$

Where:

- DF = dilution factor resulting from the flow rate in the discharge structure divided by the undiluted release rate of the effluent release source.
- f_1 = the undiluted release rate of the effluent source measured at the service water liquid effluent monitor (gpm).
- f_2 = the discharge structure flow rate in gpm (summation of circulating water pumps and service water pumps discharge flows; minus the flow redirected for tempering).

$$SP = \frac{0.5 \times ECL_w \times DF}{Eff} + Bkg \quad \text{Eq. 3-3c}$$

Where:

- SP = set point of liquid effluent monitor in cps.
- 0.5 = conservatism factor to account for releases from multiple points or a reduction in the DF value due to changes in discharge canal flow, and to allow for nuclides not detected by the monitor.
- C_g = Total undiluted concentration of gamma emitters in $\mu\text{Ci/ml}$

$$= \frac{C_g}{n \sum_{i=1}^n \left[\frac{C_i}{ECL_i} \right]}$$

- ECL_w = weighted ECL for historical nuclide mix (See Section 3.3.4.b)
- Eff = efficiency of the liquid effluent monitor in $\mu\text{Ci/ml/cps}$.
- Bkg = normal monitor background (cps).

- b. Those nuclides present in previous batch releases from the liquid radwaste effluent system, nuclides present in historical Radioactive Effluent Release Reports or those nuclides present in the service water system may be used to calculate the ECL_w value. Other values for ECL_w may be used based on plant conditions (i.e. in the event of known leakage into the RBCLC system).

3.4 Dose Determination for Radioactive Liquid Effluents

3.4.1 Annual Dose Assessment-Radioactive Effluent Release Report Submittal

a. Requirements

Technical Specification 5.6.3 requires a Radioactive Effluent Release Report to be submitted that includes an assessment of the radiation doses to the public due to the radioactive liquid and gaseous effluents released from the unit during the previous calendar year. The dose assessment required by this report is due prior to May 1 of each year in accordance with 10 CFR 50.36a.

b. Methodology

This section provides the methodology to calculate the doses to all age groups and organs from all radionuclides identified in the liquid effluents. The method is based on the methodology suggested by NUREG-0133, October 1978, Sections 4.3 and 4.3.1 and Regulatory Guide 1.109. The determination of viable liquid dose pathways is described in Appendix A, Table A-4.3. The site-related dose factors for all viable pathways are listed in Appendix A, Tables A-2 and A-3. Table A-3 dose factors are compiled by age groups, for all organs and radionuclides common to a Boiling Water Reactor (BWR).

The following equation provides for a dose calculation to the whole body or any organ for a given age group based on actual release conditions during a calendar year for radioactive liquid releases. The equation for $D_{i\tau}$ is to be summed over all i nuclides:

$$D_{i\tau} = \frac{A_{i\tau} \Delta t_l Q_{il}}{(DF)_{il}} \quad \text{Eq. 3-4a}$$

$$D_{\tau} = \sum_{i=1}^n D_{i\tau} \quad \text{Eq. 3-4b}$$

Where:

- D_{τ} = Total dose commitment for organ τ of an age group.
- $D_{i\tau}$ = Dose commitment in mrem received by organ τ of age group (to be specified) resulting from releases during time interval Δt_l for nuclide (l).
- $A_{i\tau}$ = The site-related dose commitment factor to the whole body or any organ τ for each identified radionuclide (i). The $A_{i\tau}$ values listed in Appendix A, Tables A-2 and A-3 are site specific, in mrem/hr per $\mu\text{Ci/ml}$. Dose commitment factors are compiled by age groups, for organs and radionuclides common to a BWR environment. The derivation of $A_{i\tau}$ values is described in Appendix A, Table A-4.1.

- Δt_1 = The number of hours in the calendar year.
- Q_{i1} = The total quantity of nuclide (i) released during the time period Δt_1 , in μCi .
- $(DF)_1$ = The total volume of dilution released during Δt_1 (i.e., summation of circulating water pump and service water pump discharge flow; minus the flow redirected for tempering).

By entering the appropriate annual parameter values onto a form similar to that shown in Table 3.4.2, whole body or organ doses may be calculated as outlined in step 3.4.2.c.

In addition, more realistic assumptions may be made concerning the dilution and ingestion of fish and potable water by individuals who live and fish in the area.

3.4.2 Monthly Dose Assessment - Verification of Compliance with 10 CFR 50, Appendix I Limits

a. Requirements

Part 1, Section 2.3.2 requires an assessment to be performed at least once every month in any quarter in which radioactive effluent is discharged, to verify that radioactive liquid effluents from the plant do not result in a cumulative dose in excess of 1.5 mrem to the whole body and 5 mrem to any organ in a calendar quarter, and to verify that radioactive liquid effluents from the plant do not result in a cumulative dose in excess of 3.0 mrem to the whole body and 10 mrem to any organ during a calendar year.

b. Methodology

This section presents the calculating method to be used for the 10 CFR 50 Appendix I compliance verification. The method is based on the models suggested by NUREG-0133 October 1978 Sections 4.3 and 4.3.1 and Regulatory Guide 1.109.

1. General Approach

The general approach used is similar to that described for use in calculations for the Annual Dose Assessment Report. The liquid effluent dose pathways considered are fresh water fish, potable water and lake shoreline deposits (Appendix D). These pathways need to be considered for verifying compliance with the requirements specified above.

Site-specific dose factors for the fresh water fish, potable water and shoreline pathways are provided in Appendix A, Tables A-2 and A-3.

For JAFNPP, both the adult and teenager are normally the most limiting age groups (Appendix D), but the dose for child and infant may also be calculated by this method using the appropriate dose factors from Appendix A, Table A-3.

The following equation is used to determine a dose to the whole body or any organ for a given age group based on actual release conditions during a specified time interval for radioactive liquid releases. The equation for $D_{i\tau}$ is to be summed over all i nuclides:

$$D_{i\tau} = \frac{A_{i\tau} \Delta t_1 Q_{i1}}{(DF)_{i1}} \quad \text{Eq. 3-5a}$$

$$D_{\tau} = \sum_{i=1}^n D_{i\tau} \quad \text{Eq. 3-5b}$$

Where:

- D_{τ} = Dose commitment for organ τ of an age group.
- $D_{i\tau}$ = Dose commitment in mrem received by organ τ of age group (to be specified) from release time interval Δt_1 for nuclide (i).
- $A_{i\tau}$ = The dose factor for the fresh water fish, potable water lake shoreline deposits pathways for nuclide (i) for organ τ of age group (to be specified). (Appendix A, Tables A-2 and A-3 for $A_{i\tau f}$, $A_{i\tau w}$ and $A_{i\tau sh}$).
- Δt_1 = The number of hours in the reporting period.
- Q_{i1} = The total quantity of nuclide (i) released during the time period Δt_1 in μCi .
- $(DF)_{i1}$ = The total volume of dilution released during Δt_1 (i.e., the summation of circulating water pumps and service water pumps discharge volumes; minus the volume redirected for tempering).

2. Limited Analysis Approach

Based on the radionuclide distribution typical in radioactive effluents at JAFNPP, the calculated dose to individuals are dominated by the radionuclides, Cs-134, Cs-137, Zn-65, Mn-54 and Co-60. From 1980 through 1987, these nuclides, in the fresh water fish and potable water pathways, contributed at least 92 percent of the adult's whole body dose and at least 81 percent of the teenager's liver dose, which is the critical organ. Liquid effluent for the years 2002 through 2009 were also reviewed. Liquid releases have decreased dramatically as compared to 1980 – 1987. H-3 liquid releases have decreased; however, not as dramatically as the other nuclides and is added to this list. Therefore, the dose commitment due to radioactivity in liquid effluents may be reasonably evaluated by limiting the dose calculating process to these six radionuclides for the adult's whole body and the teenager's liver dose.

To allow for any unexpected variability in the radionuclide distribution, a conservatism factor of 0.8 is introduced into the equation. After calculating the dose based on these six nuclides, the cumulative dose should therefore be divided by 0.8. (Refer to Appendix D for a detailed evaluation and explanation of this limited analysis approach).

If the limited analysis approach is used, the calculation should be limited to the adult's whole body dose and teenager's liver dose from the fish and potable water pathways. Only the five previously specified nuclides need be evaluated.

3. Approach Selection Criteria

The limited analysis approach fully satisfies the requirements and can thus be used for routine releases. The more general approach may be used for more refined calculations for routine releases.

For non-routine releases, i.e., other than through the discharge canal, Section 3.4.3 is to be used.

c. Calculating Method

The methodology that follows is a step-by-step breakdown to calculate doses based on equation 3-5a. If the limited analysis approach is used, the calculation should be limited to the adult whole body dose and teenager's liver dose from the fish and potable water pathways. Only the five previously specified radionuclides need to be evaluated for the limited approach.

NOTE: Table 3.4.2 provides a convenient form for compiling the dose accounting information.

1. Determine (Δt_1) the number of hours of the reporting period.
2. Obtain $(DF)_1$ for the time period Δt_1 for the release source(s) of interest. DF_1 is the total volume of dilution, (i.e. the circulating water flow multiplied by the time) in milliliters.

3. Obtain Q_{i1} (μCi) for nuclide (i) for the time period Δt_1 .
4. Obtain $A_{i\tau}$ from the appropriate Liquid Dose Factor Table: Appendix A, Table A-2 for the fish and potable water pathways; Appendix A, Table A-3 for all other pathways.
5. Solve for Dose (i)

$$D_{i\tau} = \frac{A_{i\tau} \times \Delta t_1 \times Q_{i1}}{(DF)_{i1}} \quad \text{Eq. 3-6a}$$

6. Repeat steps 3 through 5 above for each nuclide reported and each organ required. If the limited analysis method is used, limit the radionuclides to H-3, Co-60, Mn-54, Zn-65, Cs-134 and Cs-137 and determine the adult's whole body dose and the teenager's liver dose.
7. Sum the $D_{i\tau}$ values to obtain the total dose. If the limited analysis method is being used, divide the cumulative dose by a conservatism factor of 0.8 to account for any unexpected variability in radionuclide distribution and any contribution from the lake shoreline deposits pathway.

$$D_{\tau} = \frac{\sum_{i=1}^n D_{i\tau}}{(0.8^*)} \quad \text{Eq. 3-6b}$$

* When limited analysis method is used

TABLE 3.4.2
FISH PATHWAY

Time/Date Start: _____ Time/Date Stop: _____ Δt_1 hours

Total Dilution Volume (DF)₁: _____ mls

Age Group: _____ Organ: _____ Dose Factor Table No. _____

Nuclide (i)	Q _{i1}	A _{it}	Dose (i) mrem
H-3			
Mn-54			
Co-60			
Zn-65			
Cs-134			
Cs-137			
Others:			
Total Dose $\tau =$			mrem
Eq. 3-6a If based on limited analysis, divided by 0.8			mrem

3.4.3 Dose Assessment - Methodology For Liquid Releases Through the Storm Drain

This section provides the methodology to calculate the doses to all age groups and organs from liquid releases other than routine releases through the discharge canal, such as releases via the storm drain.

a. Requirements

Non-routine liquid releases, when they occur, are to be added into the Radioactive Effluent Release Report(s) and the annual dose assessment report (Section 3.4.1) and the verification of compliance with 10 CFR 50 Appendix I regulatory guidelines (Section 3.4.2). The following are the Technical Specification requirements for non-routine liquid releases, other than through the discharge canal.

Technical Specification 5.6.3 requires a Radioactive Effluent Release Report to be submitted prior to May 1 of each year in accordance with 10 CFR 50.36a that includes an assessment of the radiation doses to the public due to the radioactive liquid and gaseous effluents released from the unit during the previous calendar year.

Part 1, Section 2.3.2.c requires an assessment to be performed at least once every month in any quarter in which radioactive effluent is discharged, to verify that radioactive liquid effluents from the plant do not result in a cumulative dose in excess of 1.5 mrem to the whole body and 5 mrem to any organ in a calendar quarter, and to verify that radioactive liquid effluents from the plant do not result in a cumulative dose in excess of 3.0 mrem to the whole body and 10 mrem to any organ during a calendar year.

b. Methodology

Exposure pathways of interest are the ingestion of contaminated fish and drinking of contaminated water. Exposure from shoreline deposits following non-routine releases was determined to be insignificant and has been excluded from this section.

The model used accommodates (in a single unified approach) releases ranging from instantaneous (slug) to continuous (steady-state).

The method of analysis selected for dilution of the released radioactivity in the lake makes use of the continuous-release model in Regulatory Guide 1.113, adapted to provide annual average concentrations for releases of shorter duration (including instantaneous). The model assumes an exposure interval of one year, regardless of the duration of the release.

For the fish-ingestion pathway, the fish is assumed to be adjacent to the release point for the duration of the release, and then to follow the radioactive plume for an overall exposure interval of one year. For the potable water pathway, the water supply is at 8.5 miles west of the plant (Oswego water intake), and is assumed to be continuously contaminated as a result of frequent current reversals.

The following equations present the annual dose due to the potable water and freshwater fish pathways for any given release, regardless of the release duration. These doses are to be assigned to an appropriate reporting interval (e.g., quarter) during which the release occurred.

Potable Water Pathway

Eq. 3-7a

$$D_{i\tau} = K_a \times U_f \times DF_{i\tau} \times C_i \times \dot{q} \times (X/W) \times \Delta t$$

$$D_{\tau} = \sum_{i=1}^n D_{i\tau}$$

Eq. 3-7b

Where:

- D_{τ} = Dose commitment for organ τ of an age group (mrem).
- $D_{i\tau}$ = Dose commitment received by organ τ of an age group (to be specified) for nuclide i (mrem).
- K_a = Is the unit conversion factor, 1.0E+09 (ml-pCi per liter- μ Ci).
- U_f = Is the water consumption rate for the age group of interest.

Adult:	730 liters/yr
Teen:	510 liters/yr
Child:	510 liters/yr
Infant:	330 liters/yr
- $DF_{i\tau}$ = Dose conversion factor (mrem per pCi ingested) for radionuclide i , for organ τ and age group of interest, from Tables E-11 through E-14 of Regulatory Guide 1.109.
- C_i = The average activity concentration of nuclide i in the effluent at the release point into the lake (μ Ci/ml).

- \dot{q} = The volumetric discharge rate of the effluent (m³/sec).
 \dot{q} is equal to the total volume of contaminated liquid release (m³) divided by the duration of the release.
- (X/W) = The annual average relative concentration (sec/m³) for the potable water pathway, as shown in Table 3.4.3 for a list of release durations. Release durations were selected to accommodate a change of no more than 20% between consecutive X/Ws.
- Δt = The exposure period which is one year (yr).

Freshwater Fish Pathway

$$D_{i\tau} = K_a \times U_f \times BF_i \times DF_{i\tau} \times C_i \times \dot{q} \times (X/W) \times \Delta t$$

Eq. 3-8a

$$D_\tau = \sum_{i=1}^n D_{i\tau}$$

Eq. 3-8b

Where:

- D_τ = Dose commitment of organ τ of an age group (mrem).
- $D_{i\tau}$ = Dose commitment received by organ τ of an age group (to be specified) for nuclide i (mrem).
- K_a = Is the unit conversion factor, 1.0E+09 (ml-pCi per liter- μ Ci).
- U_f = Is the freshwater fish consumption rate for the age group of interest, as follows:
- Adult: 21 (kg/yr)
 Teen: 16 (kg/yr)
 Child: 6.9 (kg/yr)
- BF_i = The bioaccumulation factor for radionuclide i , in freshwater fish (pCi/kg per pCi/liter), from Table A-1 of Regulatory Guide 1.109.

- DF_{it} = Dose conversion factor (mrem per pCi ingested) for radionuclide i, for organ and age group of interest, from Tables E-11 through E-14 of Regulatory Guide 1.109.
- C_i = The average activity concentration of nuclide i in the effluent ($\mu\text{Ci/ml}$) at the release point into the lake.
- q = The volumetric discharge rate of the effluent (m^3/sec).
 q is equal to the total volume of contaminated liquid released (m^3) divided by the duration of the release.
- (X/W) = The annual average relative concentration (sec/m^3) for the fish ingestion pathway, as shown in Table 3.4.3 for a list of release durations. Release durations were selected to accommodate a change of no more than 20% between consecutive X/W s.
- Δt = The exposure period which is one year (yr).

TABLE 3.4.3

RELEASE INTERVAL VERSUS ANNUAL AVERAGE CONCENTRATION (X/W)

Release Duration (days)	(X/W) (sec/m ³)	
	Fish Ingestion	Potable Water
0.0	3.49E-04*	1.84E-04*
> 0.0 - 0.5	3.89E-04	1.88E-04
> 0.5 - 1.0	4.28E-04	1.92E-04
> 1.0 - 1.5	4.68E-04	1.96E-04
> 1.5 - 2.5	5.47E-04	2.04E-04
> 2.5 - 3.5	6.26E-04	2.12E-04
> 3.5 - 5.0	7.44E-04	2.25E-04
> 5.0 - 6.5	8.62E-04	2.37E-04
> 6.5 - 8.5	1.02E-03	2.54E-04
> 8.5 - 11.0	1.22E-03	2.75E-04
> 11.0 - 13.5	1.41E-03	2.95E-04
> 13.5 - 17.0	1.69E-03	3.24E-04
> 17.0 - 21.0	2.01E-03	3.57E-04
> 21.0 - 25.5	2.36E-03	3.95E-04
> 25.5 - 31.0	2.80E-03	4.40E-04
> 31.0 - 38.0	3.35E-03	4.98E-04
> 38.0 - 46.0	3.98E-03	5.64E-04
> 46.0 - 56.0	4.77E-03	6.47E-04
> 56.0 - 68.0	5.71E-03	7.46E-04
> 68.0 - 82.0	6.82E-03	8.61E-04
> 82.0 - 99.0	8.16E-03	1.00E-03
> 99.0 - 119.5	9.77E-03	1.17E-03
> 119.5 - 144.0	1.17E-02	1.37E-03
> 144.0 - 173.5	1.40E-02	1.62E-03
> 173.5 - 209.0	1.68E-02	1.91E-03
> 209.0 - 251.5	2.02E-02	2.25E-03
> 251.5 - 302.5	2.42E-02	2.67E-03
> 302.5 - 365.0	2.90E-02**	3.13E-03**

* Instantaneous release (for reference)

** Continuous release

3.5 Dose Projections - Determination of Need to Operate Liquid Radwaste Treatment System

3.5.1 Requirements

Part 1, Section 2.4.1.c requires that appropriate subsystems of the liquid radwaste treatment system be used to reduce radioactive material in untreated liquid effluents when the projected monthly dose due to liquid releases to unrestricted areas, averaged over 31 days, would exceed 0.06 mrem to the whole body or 0.2 mrem to any organ. Doses are to be projected at least once per month.

3.5.2 Calculating Methodology

The method is based on whole body dose and limiting organ dose (liver) as calculated for the Monthly Dose Assessment. The adult is normally the limiting age group to be used for the dose projection to the whole body. The teen is normally the limiting age group to be used for the dose projection to the liver. Other age groups and/or limiting organs may be used if previous dose calculations indicate that the adult and teen are not the limiting age groups and the liver is not the limiting organ.

The following calculating methodology is provided for performing this dose projection.

a. Monthly Dose Projection

Each month the expected dose to man shall be projected. Projections shall be based on historical or prior month dose/Curie and historical or prior month concentration conversion factors. The historical factors are calculated from historical release data for both a refuel outage year and a non-refuel outage year. The current historical factors are on file within the Chemistry Department.

1. Each month make an estimate of the volume of liquid radwaste to be discharged during that month. The following variables should be considered in estimating radwaste volumes to be released:
 - (a) Projected plant operational status (run, shutdown, refuel, etc.).
 - (b) Status of radwaste treatment equipment. Equipment which is inoperable, such as the waste concentrator, should be factored into the source term or volume of liquid waste to be discharged from the plant.
 - (c) Additional factors indicating that actual liquid releases could differ significantly in the next month.
 - (d) Historical liquid waste discharge volumes.

2. Determine which dose/Ci and Ci/gal conversion factors should be used. Historical conversion factors can be used. Prior month conversion factors may be used if they are more representative of current release conditions. In the event that there was no release of liquid radwaste during the prior month, then the historical conversion factors can be used if liquid releases are expected during the projection month.
 - (a) The prior month dose/Ci conversion factors are calculated by obtaining the results of the prior month adult whole body and teen liver dose calculation.
 - (b) Divide the doses by the total number of Curies released from the plant during this same time period. This calculation yields a dose per Curie conversion factor for the adult whole body and teen liver for the most recent prior calendar month.
 - (c) The prior month Ci/gal concentration factor is calculated by obtaining the total number of Curies released from the plant during the prior month. Divide the Curie total by the total number of gallons of waste discharged during this same time period. This calculation yields the Ci/gal concentration conversion factor for the most recent month.
3. Multiply the estimated volume of liquid radwaste to be discharged, by the historical or prior month dose/Ci and Ci/gal conversion factors. This calculation yields a dose estimate to the adult whole body and teen liver for the projected month.
 - (a) Adult Whole Body Dose

$$TD_{tb} = T_v \times C_g \times D_{ctb}$$

- (b) Teen Liver Dose

$$TD_l = T_v \times C_g \times D_{cl}$$

Where:

T_v = Total volume of radwaste to be discharged during the month in gallons (estimated)

C_g = Curies per gallon conversion factor (historical or prior month)

D_{ctb} = Dose per Curies adult whole body (historical or prior month) in mrem

TD_{tb} = Total dose for adult whole body in mrem

D_{cl} = Dose per Curies teen liver (historical or prior month) in mrem

TD_1 = Total dose for teen liver in mrem

If the calculated doses are greater than 0.06 mrem to the whole body or 0.2 mrem to the liver, the appropriate subsystems of the liquid radwaste system shall be used to reduce the radioactivity levels prior to release.

b. Batch Dose Projections

The projected dose due to release of each batch can be made prior to the release of the batch. The projection of the dose related to each batch allows for an accurate method of estimating the dose from each batch prior to release and confirms the need to operate the subsystems of the radwaste system. The projection of dose based on each batch release helps to eliminate any inaccuracies as a result of using historical or estimated values in the monthly projection. The use of this dose projection on a batch release basis is not required by the technical specification and is used at the discretion of the Chemistry/Environmental Management.

The method is based on whole body dose and limiting organ dose (liver) as calculated in step 3.4.2. The adult is the limiting age group for projecting dose to the whole body and the teen is the limiting age group for projecting dose to the liver.

The following calculating methodology is provided for performing this dose projection:

1. Obtain the latest result of the monthly calculation of the adult whole body and teen liver dose (step 3.4.2).
2. Divide the doses by the total number of Curies released from the plant during the month. This yields a dose per Curie conversion factor for the adult whole body and teen liver for the most recent calendar month.
3. Maintain a running total of the Curies released during the past 30 days. Add to this the Curie content of the current batch to be released (31 day total).

4. Multiply the 31 day total from step (3), above by the dose per Curie conversion factors calculated in step (2), above. This yields the 31 day, whole body and liver doses projected for the release of the current batch.
5. If the calculated doses are greater than 0.06 mrem to the whole body or 0.2 mrem to the liver, the appropriate subsystems of the liquid radwaste system shall be used to reduce the radioactivity levels prior to release.

c. Continuous Liquid Release Dose Projections

Each month that a continuous liquid release is in progress, or is anticipated, the expected dose to man can be projected. The projection shall be based on historical, prior month or current dose/Curie and nuclide concentration (Curie/gallon) conversion factors. The historical conversion factors are calculated from prior releases. The prior month conversion factors are calculated from the prior month continuous liquid releases if such releases occurred. Current conversion factors are calculated from samples obtained at or near the beginning of the dose projection month.

1. Determine which dose/Ci and Ci/gal conversion factors should be used. Historical conversion factors can be used. Prior month or current conversion factors should be used if they are more representative of current release conditions.
 - (a) The current month Ci/gal concentration is calculated by using current sample results for radionuclide concentration and converting the results to Ci/gal.
 - (b) The current month estimated Curies released is calculated by multiplying the concentration by the known or expected flow rates for the effluent pathway times the period of release.
 - (c) Using the dose assessment methodology specified in section 3.4, calculate the adult whole body and teen liver doses using known or estimated flow rates and dilution factors.
 - (d) Divide the doses calculated in section (c) above by the estimated number of Curies to be released. This calculation yields a dose per Curie conversion factor for the current release parameters.
 - (e) The prior month dose/Ci conversion factors are calculated by obtaining the results of the prior month adult whole body and teen liver dose calculations.
 - (f) Divide the doses by the total number of Curies released from the plant via continuous releases during this same time period. This calculation yields a dose per Curie conversion factor for the adult whole body and teen liver for the most recent prior calendar month.

- (g) The prior month Ci/gal concentration factor is calculated by obtaining the total number of Curies released from the plant via continuous releases during the prior month. Divide the Curie total by the total number of gallons of waste discharged during this same time period. This calculation yields the Ci/gal concentration conversion factor for the most recent month.
2. Multiply the estimated volume of continuous liquid effluent to be discharged by the historical, prior month or current dose/Ci and Ci/gal conversion factors. This calculation yields dose estimates to the adult whole body and teen liver for the projected month.

(a) Adult Whole Body Dose $TD_{tb} = T_v \times C_g \times D_{ctb}$

(b) Teen Liver Dose $TD_l = T_v \times C_g \times D_{cl}$

Where:

T_v = Total volume of radwaste to be discharged during the month in gallons (estimated)

C_g = Curies per gallon conversion factor (historical, prior month, or current)

D_{ctb} = Dose per Curies adult whole body (historical, prior month, or current) in mrem

TD_{tb} = Total dose for adult whole body in mrem

D_{cl} = Dose per Curie teen liver (historical, prior month, or current) in mrem

TD_l = Total dose for teen liver in mrem

If the calculated doses are greater than 0.06 mrem to the whole body or 0.2 mrem to the liver or other critical organ, efforts should be made to reduce the effluent release rate or concentration.

d. Total Liquid Release Dose Projections

Doses from continuous releases, when they occur, should be added to doses from batch releases to ensure that the limits, 0.06 mrem to the whole body or 0.2 mrem to any organ, are not exceeded.

4.0 GASEOUS EFFLUENT METHODOLOGY

4.1 Gaseous Waste Streams

James A. FitzPatrick Nuclear Power Plant (JAFNPP) discharges gaseous effluents through a stack, and discharges ventilation air from the reactor building, turbine building, radwaste building, and refuel floor through separately monitored vent release points. There are three vent release locations. The refuel floor and reactor building vent is a combined release point. Normal gaseous effluent streams, and effluent discharge points are tabulated in Appendix F, Table F-1.

For the purpose of estimating offsite radionuclide concentrations and radiation doses, radionuclide concentrations are first measured in gaseous effluents and ventilation air exhausted from the plant. Part 1, Radiological Effluent Controls, Table 3.2-1 identifies the specific radionuclides in gaseous discharges for which sampling and analysis is done.

4.2 Data Requirements for Gaseous Effluent Calculations

Dose calculations to demonstrate compliance with Part 1, Sections 3.2, 3.3 and 3.4 are normally performed using historical meteorological data and receptor location(s). Historical meteorological data for use in performing dose calculations are provided in Appendix C. Dose calculations to show conformance with Part 1 dose limits may be performed using real meteorological data, real receptor locations, and sector wind frequency distribution if desired.

Historical meteorological data factors are calculated and used in dose calculations for the Radioactive Effluent Release Report. The report shall be submitted prior to May 1 of each year in accordance with 10 CFR 50.36a. Historical information and conservative receptor assumptions, are also used for ease of Part 1, Limiting Conditions for Operation (LCO) dose limit calculations. JAFNPP uses an elevated release model for stack discharges and mixed mode model for reactor, turbine, radwaste and refuel floor vents. Those radionuclides that appear in the gaseous effluent dose factor tables are representative of BWR isotopes that may be considered in dose calculations.

The historical meteorological data and associated dispersion factors (X/Q, D/Q) are found in Appendix C. The dispersion factors used for receptor dose calculations are calculated based on site meteorological data and plant specific release point parameters.

4.3 Instantaneous Release Rate and Set Point Determination

4.3.1 Determining Instantaneous Noble Gas Release Rates

a. Requirements

Part 1, Radiological Effluent Controls, Section 3.2.1.c limit the instantaneous dose rate from noble gases in airborne releases from the plant to ≤ 500 mrem/yr - whole body, and $\leq 3,000$ mrem/yr - skin.

The results of the sampling and analysis program of Part 1, Radiological Effluent Controls, Table 3.2-1 are used to demonstrate compliance with these limits.

b. Methodology

The instantaneous dose rates to the whole body and skin from noble gases are evaluated to determine gaseous effluent release rates and alarm and/or trip set points.

The following calculating method is provided for determining the instantaneous dose rates to the whole body and skin from noble gases in all monitored airborne release paths from JAFNPP. Conservatism factors in the instantaneous release rate equations are adequate to account for simultaneous releases from the NMP stack and vent. JAFNPP discharges gaseous effluents through a stack, and ventilation air from the reactor building, turbine building, radwaste building, and refuel floor through monitored vent release points.

The calculating methods are in accordance with NUREG-0133, October 1978, Section 5.1 and 5.2.

The equations for computing instantaneous dose rates are:

Whole Body Dose Rate

Vent

Eq. 4-1a

$$DR_{TB} = \sum_{i=1}^n K_i x(\overline{X/Q}) x \dot{Q}_i$$

Elevated Stack

Eq. 4-1b

$$DR_{TB} = \sum_{i=1}^n K_i x(\overline{X/Q})_{\gamma} x \dot{Q}_i$$

The equations for DR_{TB} are to be summed over all vent and elevated stack release sources.

Skin Dose Rate**Vent**

$$DR_{SKIN} = \sum_{i=1}^n [L_i + 1.1 M_i] (\overline{X/Q}) x \dot{Q}_i \quad \text{Eq. 4-2a}$$

Elevated Stack

$$DR_{SKIN} = \sum_{i=1}^n [L_i (\overline{X/Q}) + 1.1 M_i (\overline{X/Q})_{\gamma}] x \dot{Q}_i \quad \text{Eq. 4-2b}$$

Where:

- DR_{TB} = Whole body dose rate from noble gases in airborne releases, in mrem/sec.
- DR_{SKIN} = Skin dose rate from noble gases in airborne releases in mrem/sec.
- K_i = The whole body dose factor due to gamma emissions for each noble gas nuclide (i) reported in the release source, in mrem-m³/μCi-sec.
- L_i = The skin dose factor due to beta emissions for each noble gas nuclide (i) reported in the assay of the release source in mrem-m³/μCi-sec.
- M_i = The air dose factor due to gamma emissions for each noble gas nuclide (i) reported in the assay of the release source. The constant 1.1 converts 'mrad' to 'mrem' since the units of M_i are in: (mrad-m³/μCi-sec)

$\overline{(X/Q)}$ = For vent or elevated stack releases, the highest annual average, concentration X/Q, calculated using long term historic meteorological data, for any land sector, at or beyond the site boundary, in sec/m³ (Appendix C, Table C-1).

$\overline{(X/Q)}_y$ = For elevated stack releases, the highest annual average, finite cloud X/Q, calculated using long term historic meteorological data, for any land sector, at or beyond the site boundary, in sec/m³ (Appendix C, Table C-2).

\dot{Q}_i = The release rate of noble gas nuclide (i) from the release source of interest, in $\mu\text{Ci}/\text{sec}$.

The equations for DR_{SKIN} are to be summed over all vent and elevated stack release sources.

1. Limited Analysis Approach - Instantaneous Noble Gas Release Rate

The above methodology can be simplified to provide for a rapid determination of cumulative noble gas release limits based on the requirements specified above. For ease of calculation and without unduly reducing the conservatism of the calculations, all releases may be treated as if discharged from two release points, an elevated stack and the reactor vent. The reactor vent is used to represent the combined discharge of the reactor building, turbine building, radwaste building, and refuel floor vents. Beginning with equations 4-1a and 4-1b, the simplification proceeds as follows.

From an evaluation of past releases, an effective whole body dose factor (K_{eff}) can be derived. This dose factor is, in effect, a weighted average whole body dose factor (i.e., weighted by the radionuclide distribution typical of past operation). See Appendix E for a detailed explanation and evaluation of K_{eff} . The value of K_{eff} has been derived from the radioactive noble gas effluents for the years 1985 through 1991 for the plant vents and the years 1999 through 2003 for the elevated stack release sources.

To compensate for any unusual variability in the radionuclide distribution, 3 sigma was added to the average K_{eff} values and are as follows:

$$\begin{aligned} K_{\text{eff}} &= 9.27\text{E-}5 + 3\sigma \\ &= 9.27\text{E-}5 + (3 \times 4.78\text{E-}5) \\ &= 2.36\text{E-}4 \text{ (mrem-m}^3\text{)/}(\mu\text{Ci-sec)} \end{aligned}$$

(Vent Releases based on 1985 through 1991 Vent Release Data)

$$\begin{aligned}
K_{eff} &= 2.32E-4 + 3\sigma \\
&= 2.32E-4 + (3 \times 1.38E-5) \\
&= 2.73E-4 \text{ (mrem-m}^3/\mu\text{Ci-sec)} \\
&\text{(Stack Releases)}
\end{aligned}$$

Either of these values, as appropriate, may be used in conjunction with the total noble gas release rate ($\sum Q_i$) to verify that the instantaneous dose rate is within the allowable limits. The simplified dose equations are as follows:

Vent

$$DR_{TB} = K_{eff} \times (\overline{X/Q}) \times \sum_{i=1}^n \dot{Q}_i \quad \text{Eq. 4-3a}$$

Elevated Stack

$$DR_{TB} = K_{eff} \times (\overline{X/Q})_y \times \sum_{i=1}^n \dot{Q}_i \quad \text{Eq. 4-3b}$$

Where:

- DR_{TB} = Whole body dose rate from noble gases in airborne releases, in mrem/sec.
- $(\overline{X/Q})$ = For vent releases, the highest annual average reactor vent concentration X/Q , calculated using long term historic meteorological data, for any land sector, at or beyond the site boundary, in sec/m^3 . (Appendix C, Table C-1)
- $(\overline{X/Q})_y$ = For elevated stack releases, the highest annual average finite cloud X/Q , calculated using long term historic meteorological data, for any land sector, at or beyond the site boundary, in sec/m^3 . (Appendix C, Table C-2)
- $\sum_{i=1}^n \dot{Q}_i$ = The total release rate of all noble gas nuclides from the release source of interest, in $\mu\text{Ci/sec}$.

A single cumulative (or gross) noble gas release rate limit for elevated stack releases (Q stack) and vent releases (Q vent) may be derived by combining equations 4-3a and 4-3b.

$$DR_{TB} = [K_{eff} (vent) x (\overline{X/Q}) x \dot{Q} (vent)] + [K_{eff} (stack) x (\overline{X/Q})_y x \dot{Q} (stack)] \quad \text{Eq. 4-4a}$$

These limits may be determined by taking the highest calculated annual average $(\overline{X/Q})_y$, for elevated stack releases and the highest calculated annual average reactor vent $(\overline{X/Q})$ for vent releases, at any of the land based sectors, at or beyond the site boundary. From Appendix C, Tables C-1 and C-2, these values are:

$$(\overline{X/Q})_y = 1.16E-7 \frac{\text{sec}}{\text{m}^3} \text{ (Stack Releases)}$$

$$(\overline{X/Q}) = 3.58E-7 \frac{\text{sec}}{\text{m}^3} \text{ (Reactor Vent Releases)}$$

Also, the Part 1 dose limit of Section 3.2.1.c.1.a is $DR_{TB} = 500 \text{ mrem/yr} = 1.585E-5 \text{ mrem/sec}$. $Q(\text{stack})$ was selected by requiring the stack not to yield a dose in excess of 300 mrem/yr or $9.51E-6 \text{ mrem/sec}$.

$$\dot{Q}(\text{stack}) = \frac{DR_{TB}(\text{stack})}{[K_{eff}(\text{stack}) x (\overline{X/Q})_y]} \quad \text{Eq. 4-4b}$$

Substituting the preceding values into equation 4-4b, $Q(\text{stack}) = 3.003E+5 \mu\text{Ci/sec}$ which was rounded to $3.0E+5 \mu\text{Ci/sec}$. $Q(\text{stack})$ was then substituted into equation 4-4a and solved for $Q(\text{vent})$. Therefore, the following are the cumulative (or gross) noble gas release rate limits:

Elevated Stack Release Rate Limit = $3.00E+5 \mu\text{Ci/sec}$

Vent Release Rate Limit = $7.515E+4 \mu\text{Ci/sec}$

As long as the noble gas release rates do not exceed these values (3.00E+5 μCi/sec for elevated stack releases and 7.515E+4 μCi/sec for vent releases), no additional dose rate calculations are needed to verify compliance with the instantaneous release rate limits of Part 1, Radiological Effluent Controls, Section 3.2.1.c.

2. **General Approach - Whole Body and Skin Nuclide Specific Instantaneous Release Rate Calculations**

The methods described herein may be used for more refined calculations or used if the actual releases exceed the values of:

Elevated Stack Release = 3.00E+5 μCi/sec

Vent Release = 7.515E+4 μCi/sec

Whole Body Dose Rate Vent

$$DR_{TB} = \sum_{i=1}^n K_i \times (\overline{X/Q}) \times \dot{Q}_i \quad \text{Eq. 4-5a}$$

The equation for DR_{TB} is to be summed over all vent release sources.

Eq. 4-5b

Elevated Stack

$$DR_{TB} = \sum_{i=1}^n K_i \times (\overline{X/Q})_y \times \dot{Q}_i$$

Where:

DR_{TB} = Dose rate to the whole body due to gamma emissions from all noble gas nuclides, mrem/sec.

K_i = The whole body dose factor due to gamma emissions from noble gas radionuclide (i), in mrem-m³/μCi-sec (see Appendix B, Table B-1).

$\overline{(X/Q)}$ = For vent releases, the highest annual average concentration X/Q , calculated using long term historic meteorological data, for any land sector, at or beyond the site boundary, in sec/m^3 (Appendix C, Table C-1).

$\overline{(X/Q)}_\gamma$ = For elevated stack releases, the highest annual average finite cloud $\overline{X/Q}$, calculated using long term historic meteorological data, for any land sector, at or beyond the site boundary, in sec/m^3 (Appendix C, Table C-2).

$$\text{Stack } \overline{(X/Q)}_\gamma = 1.16\text{E-}7 \text{ sec}/\text{m}^3$$

$$\text{Vent } \overline{(X/Q)} = 3.58\text{E-}7 \text{ sec}/\text{m}^3$$

\dot{Q}_i = Release rate of the i th nuclide from the release source of interest, in $\mu\text{Ci}/\text{sec}$.

Skin Dose Rate

Vent

$$DR_{SKIN} = \sum_{i=1}^n [L_i + 1.1 M_i] (\overline{X/Q}) x \dot{Q}_i \quad \text{Eq. 4-6a}$$

The equation for DR_{SKIN} is to be summed over all vent release sources.

Elevated Stack

$$DR_{SKIN} = \sum_{i=1}^n [L_i (\overline{X/Q}) + 1.1 M_i (\overline{X/Q})_\gamma] x \dot{Q}_i \quad \text{Eq. 4-6b}$$

Where:

DR_{SKIN} = Dose rate to skin due to beta and gamma radiation from all noble gas nuclides (mrem/ sec).

L_i = The skin dose factor due to beta emissions from noble gas nuclide (i), in $\text{mrem m}^3/\mu\text{Ci-sec}$ (Appendix B, Table B-1).

M_i = The air dose factor due to gamma emissions from noble gas nuclide (i), in $\text{mrad m}^3/\mu\text{Ci-sec}$ (Appendix B, Table B-2).

1.1 = Conversion factor for M_i from mrad to mrem.

$\overline{X/Q}$ = For vent or elevated stack releases, the highest annual average concentration X/Q , calculated using long term historic meteorological data, for any land sector, at or beyond the site boundary, in sec/m^3 (Appendix C, Table C-1).

$(\overline{X/Q})_y$ = For elevated stack releases, the highest annual average finite cloud X/Q , calculated using long term meteorological data, for any land sector, at or beyond the site boundary, in sec/m^3 (Appendix C, Table C-2).

Q_i = Release rate of the i^{th} nuclide from the release source of interest in $\mu\text{Ci}/\text{sec}$.

c. **Calculating Process**

The following outline provides a step-by-step explanation of how the whole body and skin dose rates are calculated on a nuclide-by-nuclide basis to evaluate compliance with Part 1, Radiological Effluent Controls, Section 3.2. This method is used for more refined calculations or if the actual releases exceed the value specified in the Limited Analysis Approach - Instantaneous Noble Gas Release Rate.

1. For a vent, the X/Q value = _____ sec/m ; and _____ is the most limiting land sector at or beyond the site boundary.

For an elevated stack release, the $\overline{X/Q}$ value = _____ sec/m ; and _____ is the most limiting land sector at or beyond the site boundary and the $(\overline{X/Q})_y$ value = _____ sec/m ; and _____ is the most limiting land sector at or beyond the site boundary.

2. Enter the release rate in ft^3/min of the release source and convert it to cc/sec ;

$$= \left(\frac{\quad}{\text{min}} \right) \text{ft}^3 \times \frac{2.8317\text{E}+4 \text{ cc}}{\text{ft}^3} \times \frac{\text{min}}{60 \text{ sec}}$$

$$= \text{_____ cc/sec volume release rate}$$

- Determine \dot{Q}_i for nuclide (i) by obtaining the $\mu\text{Ci}/\text{cc}$ assay value of the release source and multiplying it by the release rate computed in the previous steps.

$$\dot{Q}_i = \left(\frac{\quad}{\text{cc}} \right) \mu\text{Ci} \times \left(\frac{\quad}{\text{sec}} \right) \text{cc}$$

$$\dot{Q}_i = \text{_____} \mu\text{Ci}/\text{sec for nuclide (i)}$$

- To evaluate the whole body dose rate, obtain the K_i value for nuclide (i) from Appendix B, Table B-2.
- Solve for DR_{TBI} :

Vent

$$DR_{\text{TBI}} = K_i \times \left(\overline{X/Q} \right) \times \dot{Q}_i = \frac{\text{mrem} \cdot \text{m}^3}{\mu\text{Ci} \cdot \text{sec}} \times \frac{\text{sec}}{\text{m}^3} \times \frac{\mu\text{Ci}}{\text{sec}}$$

Elevated Stack

$$DR_{\text{TBI}} = K_i \times \left(\overline{X/Q} \right) \times \dot{Q}_i = \frac{\text{mrem} \cdot \text{m}^3}{\mu\text{Ci} \cdot \text{sec}} \times \frac{\text{sec}}{\text{m}^3} \times \frac{\mu\text{Ci}}{\text{sec}}$$

DR_{TBI} = Whole body dose rate from nuclide (i) for the specified release source in mrem/sec

- To evaluate the skin dose rate obtain the L_i and M_i values from Appendix B Table B-2 for nuclide (i).
- Solve for $DR_{\text{SKIN}i}$:

Vent

$$DR_{\text{SKIN}i} = [L_i + 1.1 M_i] \left(\overline{X/Q} \right) \times \dot{Q}_i$$

Elevated Stack

$$DR_{SKIN i} = \left[L_i (\overline{X/Q}) + 1.1 M_i (\overline{X/Q})_y \right] x \dot{Q}_i$$

$DR_{SKIN i}$ = Skin dose rate from nuclide (i) for the specified release source, in mrem/sec

8. Repeat steps 1 through 7 above for each noble gas nuclide (i) reported in the assay of the release source.
9. The dose rate to the whole body from radioactive noble gas gamma radiation from the specified release source is:

$$DR_{TB} = \sum_{i=1}^n DR_{TBi}$$

10. The dose rate to the skin due to noble gas radiation from the specified release source is:

$$DR_{SKIN} = \sum_{i=1}^n DR_{SKIN i}$$

The dose rate contribution of this release source shall be added to all other gaseous release sources that are in progress at the time of interest.

Part 1, Radiological Effluent Controls, Section 3.2.1.c.1.a requires the following:

$$DR_{TB} \leq 500 \text{ mrem/yr (1.585E-5 mrem/sec)}$$

$$DR_{SKIN} \leq 3,000 \text{ mrem/yr (9.513E-5 mrem/sec)}$$

Where:

DR_{TB} = The sum of the whole body dose rate contributions (mrem/sec) from all noble gas nuclides from all concurrent releases.

DR_{SKIN} = The sum of skin dose rate contributions (mrem/sec) from all noble gas nuclides from all concurrent releases.

4.3.2 Setpoint Determination

a. Requirements

To comply with Part 1, Specification 3.2.1.c.1.a, the alarm/trip setpoints are established to ensure that the Noble gas releases do not exceed the appropriate cumulative (or gross) Noble gas release rate limit specified in Limited Analysis Approach - Instantaneous Noble Gas Release Rate.

An Implementation Plan as defined in AP-02.04 shall be initiated and included in any ODCM revision whenever the methodology for calculating gaseous setpoints or gaseous monitor k-factors are changed and the change to the methodology or k-factors results in a new calculated setpoint.

If the stack setpoint limit is changed in the ODCM, refer to required actions found in SCR-E1-98-0031 to maintain proper configuration.

b. Methodology

This section describes the methodology for determining alarm/trip setpoints for the stack and vent gaseous release pathways. To allow for multiple sources of releases from different or common release points, the allowable operating setpoints will be administratively controlled to allocate a percentage of the total allowable release to each of the release sources. The cumulative Noble gas release rate limit for the stack (elevated) release is $3.0E+5$ $\mu\text{Ci}/\text{sec}$. The individual release rate limits for the other gaseous release points (assumed to be vent releases), are based upon an allocated percentage of the cumulative vent release rate limit ($7.515E+4$ $\mu\text{Ci}/\text{sec}$).

The sum of the four vent release points cannot exceed $7.515E+4$ $\mu\text{Ci}/\text{sec}$. The setpoint release rates for the vents follow.

<u>Release Point</u>	<u>Setpoint Release Rate ($\mu\text{Ci}/\text{sec}$)</u>	<u>K-factor ($\mu\text{Ci}/(\text{sec-cpm})$)</u>	<u>Nominal Setpoint Value (cpm)</u>
Turbine Building	46,500	0.62	75,000
Reactor Building	10,800	0.36	30,000*
Refuel Floor	12,000	0.40	30,000
Radwaste Building	5,700	0.19	30,000

* Maximum allowable value by Technical Specification table 3.3.6.2-1 is $\leq 24,800$ cpm. Nominal setpoint value is the bases for the maximum allowable value.

The K-factors for the vents were calculated by multiplying the calculated efficiency for Kr-85, $1.11E-8 \mu\text{Ci}/(\text{cc-cpm})$ derived from the manufacturer's sensitivity equation, by the flow rate for the release point.

<u>Release Point</u>	<u>Flow rate* (cfm)</u>	<u>K factor (μCi)/(sec-cpm)</u>
Turbine Building	118,000	0.62
Reactor Building	68,000	0.36
Refuel Floor	77,000	0.40
Radwaste Building	36,000	0.19

* Reference 6.20

Stack monitor K-factors are reviewed on a periodic basis. A conservative factor of 1.2 $\mu\text{Ci}/(\text{sec-cps})$ was selected taking into account potential worst case conditions of standby gas treatment in service. The alarm/setpoint value for the stack was calculated by dividing the setpoint release rate by the K-factor. The setpoint limit for the stack follows.

	<u>Setpoint Release Rate ($\mu\text{Ci}/\text{sec}$)</u>	<u>K-factor (μCi)/(sec-cps)</u>	<u>Nominal Setpoint Value (cps)</u>
Stack	300,000	1.2	250,000

The whole body dose is more limiting than the calculated skin dose. Therefore, the skin dose rate calculations are not required if the simplified dose rate calculation is used (i.e., using K_{eff} to determine release rate limits).

The calculating processes of step 4.3.1.c are to be used if the actual releases of noble gases exceed the predetermined limits of $3.0E+5 \mu\text{Ci}/\text{sec}$ for elevated stack releases or $7.515E+4 \mu\text{Ci}/\text{sec}$ for vent releases.

Under these conditions, a nuclide-by-nuclide evaluation is required to evaluate compliance with the dose rate limits of Part 1, Section 3.2.1.c.1.a.

4.3.3 Determining the Radioiodine, Tritium, and Eight Day Particulate Instantaneous Release Rates

a. Requirements

Part 1, Radiological Effluent Controls, Section 3.2.1.c.1.b limits the instantaneous dose rate from I-131, I-133, tritium, and particulate with half-lives greater than eight days released from the plant to $\leq 1,500$ mrem/yr to any organ, from the inhalation pathway only.

b. Methodology

The following calculating method is provided for determining the dose rate from radioiodines, tritium, and particulate. It is based on NUREG-0133, October 1978, Sections 5.2.1 and 5.2.1.1.

Actual concentrations of Iodine-131, Iodine-133, and radionuclides in particulate form with half-life greater than 8 days released from the plant in gaseous effluents shall be determined using gamma isotopic analysis. Tritium and strontium are determined by offsite analysis. Sampling and analysis shall be performed in accordance with frequency specified in Table 3.2-1 of Part 1, Radiological Effluents Controls.

The limiting age groups are the child and teen, and the limiting organ is the thyroid, per Table B-6.5, Appendix B. Based on an analysis of doses to various organs and age groups for the inhalation pathway, the child and teen were verified as being the controlling age groups and the thyroid as being the limiting organ. This pathway is the only one that need be considered for instantaneous releases. The long term sector average concentration (\bar{X}/Q) values are based on historical meteorological data. Dose factors for nuclides listed in Appendix B, Table B-3 will be used.

Inhalation Pathway

The equation for $DR_{I\&8DP_{\tau}}$ is to be summed over all release sources (s).

Eq. 4-9

$$DR_{I\&8DP_{\tau}} = \sum_{s=1}^m \sum_{i=1}^n P_{i,s} \times (\bar{X}/Q)_s \times \dot{Q}_{is}$$

Where:

- τ = The organ of interest (thyroid) for the age group of interest.
- \dot{Q}_{is} = Total release rate of nuclide (i), ($\mu\text{Ci}/\text{sec}$) for each release source (s).
- $DR_{i\&8DP_\tau}$ = Total dose rate to the thyroid of the limiting age group from iodines, tritium, and eight day particulate via the inhalation pathway (mrem/yr) for all release points p.
- $\overline{(X/Q)}_s$ = The long term sector average concentration X/Q value based on historical meteorological data in (sec/m^3) for release sources (Appendix C).
- P_{it} = The dose factor for the inhalation pathway in (mrem/yr per $\mu\text{Ci}/\text{m}^3$) for nuclide (i) (Appendix B, Table B-3). The derivation of P_i values is given in Appendix B, Table B-6.1.
- m = The number of release sources of interest.

The maximum allowable release rate of all radioiodines, tritium, and particulate, summed together, is determined by the following relationship:

$$\dot{Q}_I = \sum_{s=1}^m \left[\frac{(FRAC)_s DR_{Thyroid}}{(\overline{X/Q})_s P_{i(Thyroid)}} \right] \times 0.8$$

Eq. 4-10

Where:

- $DR_{Thyroid}$ = Dose rate to the thyroid from the inhalation pathway set equal to Part 1, Radiological Effluent Controls, Section 3.2.1.c.1.b limit of $\leq 1,500$ mrem/year.
- $P_{i(Thyroid)}$ = The dose factor of I-131 for the inhalation pathway, $1.62\text{E}+7$ mrem/yr per $\mu\text{Ci}/\text{m}^3$ (Appendix B, Table B-3).
- $\overline{(X/Q)}_s$ = The long term sector average concentration X/Q value for any land sector value based on historical meteorological data in (sec/m^3) for release sources (Appendix C).

- \dot{Q}_i = Maximum allowable release rate of all radioiodines, tritium, and particulate summed together in $\mu\text{Ci}/\text{sec}$.
- $(\text{FRAC})_s$ = Fraction of 1500 mrem/yr limit allocated to release source s , such that $\sum (\text{Frac})_s = 1.0$.
- 0.8 = A conservatism factor.

4.4 Dose Determination for Radioactive Gaseous Effluents

This section addresses the methodologies for calculating the offsite radiation exposures (to all age groups and organs) from radionuclides in the gaseous effluents for the following:

- (a) Long-term (routine) releases - Annual dose assessment for inclusion in the Radioactive Effluent Release Report (Sec. 4.4.1),
- (b) Long-term (routine) releases - Verification of compliance with 10 CFR 50 Appendix I (Sec. 4.4.2), and
- (c) Short term releases (Sec. 4.4.3).

As described in NUREG-0133 (Ref. 6.2, Sec. 3.3), gaseous releases are characterized as "long" or "short" term depending on the frequency and duration of the releases. This characterization forms the basis for more accurate offsite dose assessments by matching the releases with more appropriate atmospheric dispersion and decay conditions.

Long-term gaseous releases refer to releases that are generally continuous and stable, with small fractional variations. Short-term releases, on the other hand, are intermittent or infrequent, with a defined total cumulative duration of 500 hours or less during a calendar year, and no more than 150 hours per quarter; they also include anticipated non-routine operational occurrences.

Offsite radiation doses from short-term releases [item (c) above], when they occur, are to be incorporated into both the annual dose assessment [item (a)] and the verification of compliance with regulatory guidelines [item (b)]. However, routine releases from JAF are essentially all long term and are continuously monitored by stack and vent effluent radiation monitors. Therefore, short-term releases at JAF are considered to be only unmonitored non-routine releases and are not applicable for definition of the alarm/trip setpoints for the stack and vent effluent monitors. In addition, in line with NUREG-0133, short-term releases are not used in assessing compliance with the Part 1, Section 3.2.1.c release limits as discussed in Section 4.3 of the ODCM.

4.4.1 Annual Dose Assessment - Radioactive Effluent Release Report Submittal

a. Requirements

Technical Specification 5.6.3 requires a Radioactive Effluent Release Report be submitted prior to May 1 of each year covering the operation of the plant during the previous year. The report shall include a summary of the quantities of radioactive liquid and gaseous effluents and solid waste released from the plant. The material provided shall be consistent with the objectives outlined in Part 1, Section 6.2.

b. Methodology

This section provides the methodology to calculate the doses to all age groups and organs from radionuclides identified in the gaseous effluents.

The method is based on the methodology suggested by NUREG-0133, October 1978, Sections 5.3 and 5.3.1. The determination of viable gaseous dose pathways is described in Appendix B, Table B-6.4. The site related dose factors for viable pathways are listed in Appendix B. Dose factors are compiled by age groups, for organs and radionuclides common to a BWR environment. Normally calculated annual long term historical atmospheric dispersion factors are used to perform the annual dose assessment. Actual meteorological data and sector wind frequency distributions for the year of interest may be used in lieu of the annual long term historical factors.

The following equations provide for a dose calculation to the whole body or any organ for a given age group based on actual releases during a specific time interval for radioactive gaseous release sources:

1. Annual Air Dose Due to Noble Gases

Vent

Eq. 4-11a

$$D_{\text{Gamma-Air}} = \sum_{i=1}^n M_i x (\overline{X/Q}) x Q_i$$

Elevated Stack

Eq. 4-11b

$$D_{Gamma-Air} = \sum_{i=1}^n M_i x (\overline{X/Q})_{\gamma} x Q_i$$

Where:

$D_{Gamma-Air}$ = The gamma air dose from radioactive noble gases, in mrad.

M_i = The gamma air dose factor for radioactive noble gas nuclide 'i', in mrad-m³/μCi-sec (Appendix B, Table B-2).

$(\overline{X/Q})$ = The long term historical atmospheric dispersion factors for vent releases (annual average) for the location of interest. Actual meteorological data and sector wind frequency distributions may be used to determine annual X/Q for the year of interest in sec/m³.

$(\overline{X/Q})_{\gamma}$ = The long term historical atmospheric dispersion factor for elevated stack releases (annual average) for the location of interest based on the finite cloud methodology. Actual meteorological data and sector wind frequency distributions may be used to determine annual X/Q for the year of interest in sec/m³.

Q_i = The number of μCi of nuclide 'i' released during the year of interest from the release source of interest.

The equations for $D_{Gamma-Air}$ are to be summed over all vent and elevated stack release sources.

Eq.4-12

$$D_{Beta-Air} = \sum_{i=1}^n N_i x (\overline{X/Q}) x Q_i$$

Where:

$D_{\text{Beta-Air}}$ = Beta air dose from radioactive noble gases in mrad.

N_i = The beta air dose factor for radioactive noble gas nuclide (i) in mrad-m³/μCi-sec (see Appendix B, Table B-2).

$\overline{(X/Q)}$ = The long term historical atmospheric dispersion factors for vent or elevated stack releases (annual average) for the location of interest. Actual meteorological data and sector wind frequency distributions may be used to determine annual X/Q for the year of interest in sec/m³.

Q_i = The number of μCi of nuclide 'i' released during the year of interest from the release source of interest.

The equations for $D_{\text{Beta-Air}}$ are to be summed over all vent and elevated stack release sources.

2. Annual Whole body Dose Due to Noble Gases

Vent

$$D_{TB} = \sum_{i=1}^n K_i x (\overline{X/Q}) x Q_i \quad \text{Eq. 4-12a}$$

Elevated Stack

Eq. 4-12b

$$D_{TB} = \sum_{i=1}^n K_i x (\overline{X/Q})_y x Q_i$$

Where:

D_{TB} = Whole body dose from noble gases in airborne releases, in mrem.

K_i = The whole body dose factor due to gamma emissions for each noble gas nuclide (i) reported in the release source, in mrem-m³/μCi-sec (Appendix B, Table B-1).

$\overline{(X/Q)}$ = The long term historical atmospheric dispersion factors for vent or elevated stack releases (annual average) for the location of interest. Actual meteorological data and sector wind frequency distributions may be used to determine annual X/Q for the year of interest in sec/m³.

$(\overline{X/Q})_y$ = The long term historical atmospheric dispersion factor for elevated stack releases (annual average) for the location of interest based on the finite cloud methodology. Actual meteorological data and sector wind frequency distributions may be used to determine annual X/Q for the year of interest in sec/m³.

Q_i = The number of microCuries for each noble gas nuclide (i) released during the year of interest from the release source of interest.

The equations for D_{TB} are to be summed over all vent and elevated stack release sources.

3. Annual Total Skin Dose Due to Noble Gases

Vent Eq. 4-12c

$$D_{SKIN} = \sum_{i=1}^n [L_i + 1.1 M_i] (\overline{X/Q}) x Q_i$$

Elevated Stack Eq. 4-12d

$$D_{SKIN} = \sum_{i=1}^n [L_i (\overline{X/Q}) + 1.1 M_i (\overline{X/Q})_y] x Q_i$$

Where:

D_{SKIN} = Skin dose from noble gases in airborne releases in mrem.

L_i = The skin dose factor due to beta emissions for each noble gas nuclide (i) reported in the assay of the release source in mrem-m³/μCi-sec (Appendix B, Table B-1).

M_i = The air dose factor due to gamma emissions for each noble gas nuclide (i) reported in the assay of the release source. The constant 1.1 converts 'mrad' to 'mrem' since the units of M_i are in mrad-m³/μCi-sec (Appendix B, Table B-2).

$\overline{(X/Q)}$ = The long term historical atmospheric dispersion factors for vent or elevated stack releases (annual average) for the location of interest. Actual meteorological data and sector wind frequency distributions may be used to determine annual X/Q for the year of interest in sec/m³.

$\overline{(X/Q)}_y$ = The long term historical atmospheric dispersion factor for elevated stack releases (annual average) for the location of interest based on the finite cloud methodology. Actual meteorological data and sector wind frequency distributions may be used to determine annual X/Q for the year of interest in sec/m³.

Q_i = The number of microCuries for each noble gas nuclide (i) released during the year of interest from the release source of interest.

The equations for D_{SKIN} are to be summed over all vent and elevated stack release sources.

4. Annual Dose Due to Radioiodines, Tritium, and Eight Day Particulate

Inhalation Pathways

Eq. 4-13

$$(D_{I\&8DP})_r = (3.17E-8) \sum_{i=1}^n R_i \times (\overline{X/Q}) \times Q_i$$

Ground Plane Deposition Pathway

Eq. 4-14

$$(D_{I\&8DP})_r = (3.17E-8) \sum_{i=1}^n R_i \times (\overline{D/Q}) \times Q_i$$

Cow's Milk Pathway

Eq. 4-15

$$(D_{I\&8DP})_{\tau} = (3.17E-8) \sum_{i=1}^n R_{i_{\tau}} x(\overline{D/Q}) x Q_i$$

Goat's Milk Pathway

Eq. 4-16

$$(D_{I\&8DP})_{\tau} = (3.17E-8) \sum_{i=1}^n R_{i_{\tau}} x(\overline{D/Q}) x Q_i$$

Meats

Eq. 4-17

$$(D_{I\&8DP})_{\tau} = (3.17E-8) \sum_{i=1}^n R_{i_{\tau}} x(\overline{D/Q}) x Q_i$$

Vegetation

Eq. 4-18

$$(D_{I\&8DP})_{\tau} = (3.17E-8) \sum_{i=1}^n R_{i_{\tau}} x(\overline{D/Q}) x Q_i$$

For tritium, the dose is calculated by substituting

$\overline{X/Q}$ for $\overline{D/Q}$ and $R_{H-3_{\tau}}$ for $R_{i_{\tau}}$ in equations 4-15 to 4-18.

Total Annual Dose From Release Source of Interest

$$D_{\tau s} = \sum_{z=1}^p (D_{I\&8DP})_{\tau z} \quad \text{Eq. 4-19a}$$

Total Annual Dose

Eq. 4-19b

$$D_{\tau} = \sum_{s=1}^m (D_{\tau s})$$

Where:

- τ = The organ of interest for the age group of interest.
- s = The release source of interest.
- z = Pathway of interest.
- p = The number of pathways of interest.
- m = Number of release sources of interest.
- $(D_{I\&8DP})_{\tau}$ = Annual dose to the organ τ for the age group of interest from iodines, tritium, and eight day particulate via the pathway of interest in (mrem).
- $3.17E-8$ = The inverse of the number of seconds per year in (years/sec).
- $D_{\tau s}$ = Total annual dose to organ τ from all applicable pathways for the age group of interest and for the release source of interest in (mrem).
- D_{τ} = Total annual dose to organ τ from all applicable pathways for the age group of interest and for all release sources of interest in (mrem).
- Q_i = The number of μCi of nuclide 'i' released during the year of interest from the release source of interest.
- $R_{i\tau}$ = The dose factor for nuclide (i) for organ τ for the pathway specified, units vary with pathway. The derivation of $R_{i\tau}$ values is given in Appendix B, Table B-6.2.

$\overline{(D/Q)}$ = The long term historical annual average relative deposition values for elevated stack or vent releases for the ground plane deposition pathway. For the meat, cow, goat, and vegetable pathways, the long term historical grazing average deposition values for elevated stack and vent releases are used (Appendix C). A factor with units of m^2 which describes the deposition of particulate matter from a plume at a point downrange from the source. Actual meteorological data and sector wind frequency distribution may be used to determine annual average D/Q for the year of interest. D/Q is not used to calculate doses associated with H-3 releases.

$\overline{(X/Q)}$ = The long term historical annual average atmospheric dispersion factors for vent or elevated stack releases for the location of interest (Appendix C). Actual meteorological data and sector wind frequency distributions may be used to determine annual X/Q for the year of interest in sec/m^3 . The X/Q is used to determine doses for H-3 releases.

4.4.2 **Monthly Dose Assessment - Verification of Compliance with 10 CFR 50, Appendix I**

a. **Determining the Gamma Air Dose for Radioactive Noble Gas Release Source(s)**

1. **Requirement**

Part 1, Radiological Effluent Controls, Section 3.3.2.c.1 limits the air dose from gamma radiation due to noble gases released from the plant in the gaseous effluent ≤ 10 mrad during any calendar year, and ≤ 5 mrad in any calendar quarter.

Part 1, Section 3.3.2.c.1, requires that cumulative air dose contributions from noble gases be calculated at least monthly for the current calendar quarter and current calendar year.

2. Methodology

The following calculational method is provided for determining the noble gas gamma air dose and is based on NUREG-0133 October 1978 Section 5.3.1. The dose calculation is independent of age group. The equation may be used for Part 1, Section 3.3.2.c.1 dose calculations, the dose calculation for the annual report, or for projecting dose, provided that the appropriate value of (X/Q) is used. The equation for gamma air dose is:

Vent Eq. 4-20a

$$D_{\text{Gamma-Air}} = \sum_{i=1}^n M_i \times (\overline{X/Q}) \times Q_i$$

Elevated Stack Eq. 4-20b

$$D_{\text{Gamma-Air}} = \sum_{i=1}^n M_i \times (\overline{X/Q})_y \times Q_i$$

Where:

- $D_{\text{Gamma-Air}}$ = The gamma air dose from radioactive noble gases in mrad.
- M_i = The gamma air dose factor for radioactive noble gas nuclide 'i', in mrad-m³/μCi-sec (Appendix B, Table B-2).
- $(\overline{X/Q})$ = The highest long term annual average atmospheric dispersion factors for vent releases for any land sector, in sec/m³ (Appendix C, Table C-1).
- $(\overline{X/Q})_y$ = The highest long term annual average atmospheric dispersion factor for elevated stack releases for any land sector based on the finite cloud methodology, in sec/m³ (Appendix C, Table C-2).
- Q_i = The number of μCi of nuclide 'i' released (or projected to be released) during the dose calculation exposure period (e.g., month, quarter, or year) from the release source of interest.

The equations for $D_{\text{Gamma-Air}}$ are to be summed over all vent and elevated stack release sources.

(a) **Limited Analysis Approach**

The following limited analysis approach may be used to establish monthly release objectives ($\mu\text{Ci}/\text{month}$) that will ensure compliance with 10 CFR 50, Appendix I gamma dose limits.

From an evaluation of past releases, a single effective gamma air dose factor (M_{eff}) has been derived, which is representative of the radionuclide abundances and corresponding dose contributions typical of past operation. (Appendix E has a detailed explanation and evaluation of M_{eff}). The value of M_{eff} has been derived from the radioactive noble gas effluents for the years 1985 through 1991.

To compensate for any unusual variability in the radionuclide distribution, 3 sigma was added to the average M_{eff} value, and are as follows.

$$\begin{aligned}M_{\text{eff}} &= 9.75\text{E-}5 + 3\sigma \\ &= 9.75\text{E-}5 + (3 \times 4.95\text{E-}5) \\ &= 2.46\text{E-}4 \text{ (mrad-m}^3\text{)/}(\mu\text{Ci-sec)} \\ &\quad \text{(vent release)}\end{aligned}$$

$$\begin{aligned}M_{\text{eff}} &= 1.57\text{E-}4 + 3\sigma \\ &= 1.57\text{E-}4 + (3 \times 4.70\text{E-}5) \\ &= 2.98\text{E-}4 \text{ (mrad-m}^3\text{)/}(\mu\text{Ci-sec)} \\ &\quad \text{(stack release)}\end{aligned}$$

The effective gamma air dose factor may be used in conjunction with the total noble gas release to simplify the dose evaluation and to verify that the cumulative gamma air dose is within the equivalence of the limits of Part 1, Radiological Effluent Controls, Section 3.3.1.c.1.

Equations 4-20a and 4-20b can be used to establish monthly release objectives. Combining equations 4-20a and 4-20b yields the following:

$$D_{\text{Gamma-air}} = [M_{\text{eff}}(\text{vent}) \times (\overline{X/Q}) \times Q(\text{vent})] + [M_{\text{eff}}(\text{stack}) \times (\overline{X/Q})_{\gamma} \times Q(\text{stack})] \quad \text{Eq. 4-21}$$

Part 1, Radiological Effluent Controls, Section 3.3.2.c states that the doses must be evaluated once per month. The yearly dose limit is 10 mrad, which corresponds to a monthly allotment of 0.83 mrad. 0.83 mrad can be substituted into equation 4-21 for $D_{\text{Gamma-air}}$. The highest calculated annual average

$(\overline{X/Q})_{\gamma}$, $1.16\text{E-}7 \text{ sec/m}^3$, for elevated stack releases and the highest calculated annual average reactor vent (X/Q) , $3.58\text{E-}7 \text{ sec/m}^3$, for vent releases, can be substituted into equation 4-21. $Q(\text{stack})$ and $Q(\text{vent})$ were selected so that the technical specifications limit of 10 mrad/yr or 0.83 mrad/month would not be exceeded. In addition, $Q(\text{stack})$ was selected by requiring the stack not to exceed 60% of 0.83 mrad/month.

$$Q(\text{stack}) = \frac{D_{\text{Gamma-air}}(\text{stack})}{[M_{\text{eff}}(\text{stack}) \times (\overline{X/Q})_{\gamma}]} \quad \text{Eq. 4-22}$$

Substituting the preceding values into equation 4-22, yields $Q(\text{stack}) = 1.44\text{E}10 \mu\text{Ci/month}$. $Q(\text{stack})$ was then substituted into equation 4-21 and solved for $Q(\text{vent})$. Therefore, the following are the cumulative noble gas monthly release objectives.

$$Q(\text{vent release}) = 3.77\text{E}+9 \mu\text{Ci/month}$$

$$Q(\text{elevated stack release}) = 1.44\text{E}+10 \mu\text{Ci/month}$$

As long as these values are not exceeded during any month, compliance with the quarterly and annual noble gas release limits of Part 1, Radiological Effluent Controls, Section 3.3.1.c.1 is demonstrated. When the limited approach method is used, the calculations of 4.4.2.a(2) must be performed monthly at a minimum.

The gamma air dose limit does not cause the beta air dose limit to be exceeded when the limited analysis approach of this section is used.

b. **Determining the Beta Air Dose for Radioactive Noble Gas Release Sources**

The beta air dose calculations of this step are required to be performed when the radionuclide specific dose analysis of Gamma Air Dose is performed. The radionuclide specific dose analysis is performed at least monthly in accordance with Part 1, Section 3.3.2.c.1.

1. **Requirement**

Part 1, Radiological Effluent Controls, Section 3.3.1.c.1 limits the air dose from beta radiation, due to noble gases released from the plant in the gaseous effluents, to less than or equal to 20 mrad during any calendar year and less than or equal to 10 mrad in any calendar quarter.

Part 1, Section 3.3.2.c.1 requires that cumulative air dose contributions from noble gases released from the plant be calculated at least monthly for the current calendar quarter and current calendar year.

When the nuclide specific dose calculation is used to evaluate compliance with the gamma air dose limits, the beta air dose shall be evaluated on a nuclide specific basis using the methodology presented below.

2. **Methodology**

The following calculating method is provided for determining the beta air dose and is based on NUREG-0133, October 1978, Section 5.3.1. The dose calculation is independent of any age group. The equation may be used for dose calculations for Part 1, Section 3.3.2.c.1, Radiological Effluent Release Reports, or for projecting dose, provided that the appropriate value of (X/Q) is used.

The equation for beta air dose is:

$$D_{\text{Beta-Air}} = \sum_{i=1}^n N_i \times (\overline{X/Q}) \times Q_i \quad \text{Eq. 4-23}$$

Where:

- $D_{\text{Beta-Air}}$ = Beta air dose from radioactive noble gases in (mrad).
- N_i = The beta air dose factor for radioactive noble gas nuclide 'i' in mrad-m³/μCi-sec (Appendix B, Table B-2).
- $(\overline{X/Q})$ = For vent or elevated stack releases, the highest annual average, X/Q, calculated using long term historic meteorological data, for any land sector, at or beyond the site boundary, in sec/m³ (Appendix C).
- Q_i = The number of μCi of nuclide 'i' released (or projected to be released) during the dose calculation exposure period from the release source of interest.

The equation for $D_{\text{Beta-Air}}$ is to be summed over all release sources.

c. **Determining the Radioiodine, Tritium, and Eight Day Particulate Dose to any Organ from Cumulative Releases**

1. **Requirement**

Part 1, Radiological Effluent Controls, Section 3.4.1.c limits the dose to the whole body or any organ resulting from the release of radioiodines, tritium, and particulate with half-lives greater than eight days released from the plant to less than 7.5 mrem/quarter and less than 15 mrem/yr to any organ.

Part 1, Section 3.4.2.c requires that cumulative dose contributions be calculated at least monthly for the current calendar quarter and current calendar year.

2. Methodology

The following calculating method is provided for determining the organ dose due to releases of radioiodines (I-131, I-133), tritium, and particulate with half-lives greater than 8 days. It is based on NUREG-0133, October 1978, Section 5.3.1. The equations can be used for any age group provided that the appropriate dose factors are used and the total dose reflects only those pathways that are applicable to the age group and the receptor location. The deposition factor, (D/Q), represents the rate of fallout from the cloud that affects a square meter of ground at various distances from the site. The total dose to an organ can then be determined by summing the pathways that apply to the receptor in the sector. The equations are:

Inhalation Pathway Eq. 4-24

$$(D_{I\&SDP})_r = (3.17E-8) \sum_{i=1}^n R_i \times (\overline{X/Q}) \times Q_i$$

Ground Plane Pathway Eq. 4-25

$$(D_{I\&SDP})_r = (3.17E-8) \sum_{i=1}^n R_i \times (\overline{D/Q}) \times Q_i$$

Cow's Milk Pathway Eq. 4-26a

$$(D_{I\&SDP})_r = (3.17E-8) \sum_{i=1}^n R_i \times (\overline{D/Q}) \times Q_i$$

Goat's Milk Pathway Eq. 4-26b

$$(D_{I\&SDP})_r = (3.17E-8) \sum_{i=1}^n R_i \times (\overline{D/Q}) \times Q_i$$

Meats

Eq. 4-26c

$$(D_{I\&SDP})_{\tau} = (3.17E-8) \sum_{i=1}^n R_{i\tau} x(\overline{D/Q}) x Q_i$$

Vegetation

Eq. 4-26d

$$(D_{I\&SDP})_{\tau} = (3.17E-8) \sum_{i=1}^n R_{i\tau} x(\overline{D/Q}) x Q_i$$

For tritium, the dose is calculated by substituting $\overline{X/Q}$ for $\overline{D/Q}$ and $R_{H-3\tau}$ in $R_{i\tau}$ equations 4-26a to 4-26d.

Total Dose From a Release Source for Applicable Pathways

$$D_{\tau z} = \sum_{z=1}^p (D_{I\&SDP})_{\tau z}$$

Eq. 4-27a

Total Annual Dose From All Release Sources of Interest

Eq. 4-27b

$$D_{\tau} = \sum_{s=1}^m (D_{\tau s})$$

Where:

- τ = The organ of interest in a specified age group.
- s = The release source of interest.
- z = The pathway of interest.
- p = The number of pathways of interest.

- m = The number of release sources of interest.
- $(D_{I\&8DP})_{\tau}$ = Dose in mrem to the organ τ of a specified age group from radioiodines, tritium, and 8 day particulate due to a particular pathway.
- $D_{\tau s}$ = Total dose to organ τ from all applicable pathways for a specified age group for the release source of interest in (mrem).
- D_{τ} = Total dose to organ τ from all applicable pathways for a specified age group and for all release sources of interest in (mrem).
- $3.17E-8$ = The inverse of the number of seconds per year in (years/sec).
- R_{ir} = The dose factor for nuclide (i) organ τ of the specified age group. The units are either mrem- m^3 /yr- μ Ci for pathways using (X/Q), or mrem- m^2 -sec/yr- μ Ci for pathways using (D/Q) (Appendix B, Tables B-4 and B-5).
- $\overline{(X/Q)}$ = The concentration (X/Q) value for a specific location where the receptor is located. The units are (sec/ m^3) (Appendix C). The X/Q is used to determine doses for H-3 releases.
- $\overline{(D/Q)}$ = The deposition value for a specific location where the receptor is located. The units are m^2 (Appendix C). D/Q is not used to calculate doses associated with H-3 releases.
- Q_i = The number of μ Ci of nuclide (i) released (or projected to be released) during the dose calculation exposure period from the release source of interest.

(a) **Limited Analysis Approach**

Based on an analysis of doses to all organs and age groups from all monitored atmospheric release pathways, the milk and vegetation pathways have been identified as being the most significant pathways. The infant's thyroid (milk pathway) and child's thyroid (vegetation pathway) have been identified as being the limiting age groups and organ. These pathways contribute the majority of the total dose received by the infant and child thyroid. The radioiodines and tritium contribute essentially all of the dose via the milk and vegetation pathways. Therefore, it is possible to demonstrate compliance with the dose limit Part 1, Radiological Effluent Controls, Section 3.4.1.c.1 for radioiodines, tritium, and particulate with half-lives greater than 8 days by evaluating only the infant and child thyroid dose due to radioiodines and tritium in the milk and vegetation pathways.

The calculating method to be used includes a conservatism factor of 0.5 which assures that the calculated dose is always greater than or equal to the actual dose despite possible atypical distributions of radionuclides in the gaseous effluent. The following equations are used to calculate the doses from the milk and vegetation pathways.

$$D_{\text{mlk-inf } \tau s} = \frac{3.17E-8}{0.5} \left[\left(\overline{D/Q} \right)_s \sum_{\text{iodines}} R_{\text{mlk- chd } i \tau} \times Q_{is} \right] + \left[\left(\overline{X/Q} \right)_s \times R_{\text{mlk- chd } H-3\tau} \times Q_{H-3S} \right]$$

Eq. 4-28a

$$D_{\text{veg-inf } \tau s} = \frac{3.17E-8}{0.5} \left[\left(\overline{D/Q} \right)_s \sum_{\text{iodines}} R_{\text{veg- chd } i \tau} \times Q_{is} \right] + \left[\left(\overline{X/Q} \right)_s \times R_{\text{veg- chd } H-3\tau} \times Q_{H-3S} \right]$$

Eq. 4-28b

$$D_{\tau} = \sum_{s=1}^m D_{\tau s} \quad \text{Eq. 4-28c}$$

Select the equation (i.e., either 4-28a or 4-28b) that yields the highest dose. Substitute that equation into 4-28c for $D_{\tau s}$ and solve for D_{τ} .

Where:

$R_{\text{milk-inf } i\tau}$ = The dose factor for iodine nuclide (i), organ τ (thyroid), of the specified age group (infant) for the milk pathway. The units are either $\text{mrem}\cdot\text{m}^3/\text{yr}\cdot\mu\text{Ci}$ for pathways using (X/Q), or $\text{mrem}\cdot\text{m}^2\cdot\text{sec}/\text{yr}\cdot\mu\text{Ci}$ for pathways using (D/Q). (See Appendix B).

$R_{\text{milk-inf H-3}\tau}$ = The dose factor for iodine nuclide (tritium), organ τ (thyroid), of the specified age group (infant) for the milk pathway. The units are either $\text{mrem}\cdot\text{m}^3/\text{yr}\cdot\mu\text{Ci}$ for pathways using (X/Q), or $\text{mrem}\cdot\text{m}^2\cdot\text{sec}/\text{yr}\cdot\mu\text{Ci}$ for pathways using (D/Q). (See Appendix B).

$R_{\text{veg-chd } i\tau}$ = The dose factor for iodine nuclide (i), organ τ (thyroid), of the specified age group (child) for the vegetation pathway. The units are either $\text{mrem}\cdot\text{m}^3/\text{yr}\cdot\mu\text{Ci}$ for pathways using (X/Q), or $\text{mrem}\cdot\text{m}^2\cdot\text{sec}/\text{yr}\cdot\mu\text{Ci}$ for pathways using (D/Q). (See Appendix B).

$R_{\text{veg-H-3}\tau}$ = The dose factor for iodine nuclide (tritium), organ τ (thyroid), of the specified age group (infant) for the milk pathway. The units are either $\text{mrem}\cdot\text{m}^3/\text{yr}\cdot\mu\text{Ci}$ for pathways using (X/Q), or $\text{mrem}\cdot\text{m}^2\cdot\text{sec}/\text{yr}\cdot\mu\text{Ci}$ for pathways using (D/Q). (See Appendix B).

$D_{\text{mik-inf } \tau s}$ = Dose in mrem to the infant's thyroid due to radioiodines and H-3 in the milk pathway for the release source of interest.

$D_{\text{veg-chd } \tau s}$ = Dose in mrem to the child's thyroid due to radioiodines and H-3 in the vegetation pathway for the release source of interest.

$D_{\tau s}$ = Dose in mrem to the most limiting age group's thyroid, from all pathways.

D_{τ} = Total dose in mrem to the most limiting age group's thyroid, from all pathways for all release sources of interest.

s = The release source of interest.

- m = The number of release sources of interest.
- Q_{is} = For elevated stack releases, Q_{is} is the total number of microCuries of nuclide i released from the stack during the dose calculation exposure period. For vent releases, Q_{is} is the total number of microCuries of nuclide i released from the four vents during the dose calculation period.
- $Q_{H-3 S}$ = For elevated stack releases, $Q_{H-3 S}$ is the total number of microCuries of nuclide tritium released from the stack during the dose calculation exposure period. For vent releases, $Q_{H-3 S}$ is the total number of microCuries of nuclide tritium released from the four vents during the dose calculation period.
- $\overline{D/Q_s}$ = The deposition value for a specific location where the receptor is located in (m^{-2}). For elevated stack releases the grazing season D/Q for the stack will be used. For vent releases, the grazing season D/Q for the reactor vent will be used.
- $\overline{X/Q_s}$ = The concentration (X/Q) value for a specific location where the receptor is located. The units are sec/m^3 . The grazing season X/Q is used to determine doses for H-3 releases. For elevated stack releases the grazing season X/Q for the stack will be used. For vent releases, the grazing season X/Q for the reactor vent will be used.

(b) **Approach Selection Criteria**

The limited analysis approach may be used for long-term (routine) releases to demonstrate compliance with the dose limit of Part 1, Radiological Effluent Controls, Sections 3.4.1.c.1.a and 3.4.1.c.1.b (7.5 mrem/qtr and 15 mrem/yr) for radioiodines, tritium, and particulate.

However, for the dose assessment included in the Radioactive Effluent Release Report, doses will be evaluated for designated age groups and organs via designated pathways from radioiodines, tritium, and particulates measured in the gaseous effluents according to sampling and analyses required by Part 1, Section 3.4.2.c.1.

4.4.3 Short Term Releases

As described in the introductory part to Sec. 4.4 (and in NUREG-0133), short-term releases are intermittent or infrequent, with a defined total cumulative duration of 500 hours or less during a calendar year, and no more than 150 hours per quarter. Radiological impact assessment models for short-term releases may make use of the long-term atmospheric dispersion factors (as described in Sections 4.4.1 and 4.4.2) if it can be demonstrated that past short-term releases were sufficiently random in both time of day and duration to be represented by the annual average dispersion conditions. Otherwise, use should be made of the short-term dose equations, as described below.

a. Requirements

Short-term releases, when they occur, are to be incorporated into the Radioactive Effluent Release Report(s) and the annual dose assessment report (Section 4.4.1) and the verification of compliance with 10 CFR 50 Appendix I, regulatory guidelines (Section 4.4.2). The following are the Technical Specification requirements for short-term releases.

Technical Specification 5.6.3 requires a Radioactive Effluent Release Report covering the operation of the unit during the previous year, be submitted prior to May 1 of each year in accordance with 10 CFR 50.36a. Part 1, Section 6.2 also requires that this report includes an assessment of the radiation doses to the public due to the radioactive liquid and gaseous effluents released from the unit during the previous calendar year.

Part 1, Section 3.3.1.c.1 limits the air dose from gamma radiation due to noble gases released from the plant in the gaseous effluent to ≤ 10 mrad during any calendar year, and ≤ 5 mrad in any calendar quarter.

Part 2, Section 3.3.2.c, requires that cumulative air dose contributions from noble gases be calculated at least monthly for the current calendar quarter and current calendar year.

b. Methodology

Routine releases via the main stack and vents are continuous. The methodology described below for short-term releases is thus for non-routine unmonitored ground-level releases.

The equations for offsite radiation exposures resulting from short-term releases are similar to those provided for vent releases in Sections 4.4.1 and 4.4.2. They are as follows:

1. **Air Dose Due to Noble Gases**

$$D_{Short\ Gamma-Air} = \sum_{i=1}^n M_i x(x/q) x q_i \quad \text{Eq. 4-29}$$

$$D_{Short\ Beta-Air} = \sum_{i=1}^n N_i x(x/q) x q_i \quad \text{Eq. 4-30}$$

Where:

q_i = The overall total activity (μCi) of radionuclide "i" released (or projected to be released) during the dose calculation exposure period (month, quarter, or year, as applicable) from a selected vent or unmonitored path, as a result of short-term releases.

(x/q) = The short term atmospheric dispersion factor (sec/m^3) for ground-level releases and the receptor of interest, defined as (from NUREG-0324):

$$(x/q) = (x/q)_{\text{Hourly PC}} \quad (t \leq 2 \text{ hr})$$

$$(x/q) = (x/q)_{\text{Hourly PC}} \times t^m \quad (2 < t \leq 500 \text{ hr})$$

$$(x/q) = (X/Q)_{\text{Annual SA}} \quad (t > 500 \text{ hr})$$

Where:

$$m = \frac{\log [(X/Q)_{\text{Annual SA}} / (x/q)_{\text{Hourly PC}}]}{\log (8760)}$$

t = release duration (hrs) (or the total sum of frequent short-term release durations) during the dose calculation exposure period

(Note: The limits $2 < t \leq 500$ are for annual analysis; for quarterly analysis, they are $2 < t \leq 150$)

$(X/Q)_{\text{Annual SA}}$ = long-term sector average (SA) atmospheric dispersion factor (sec/m^3) for ground level releases and the selected receptor, for distances out to 45 miles [from Table C-15 for the site boundary, Table C-18 for annual (all-season) meteorology, and Table C-22 for grazing-season meteorology]

$(x/q)_{\text{Hourly PC}}$ = short-term 85th percentile hourly plume centerline (PC) atmospheric dispersion factor (sec/m^3) for ground-level releases and the selected receptor [from Table C-15 for the site boundary, Table C-17 for annual meteorology, and Table C-21 for grazing-season meteorology]

All other parameters have been defined in Section 4.4.1.b.(1).

Short-term gamma air doses are to be added to the long term gamma air doses. Combining equations 4-11a, 4-11b, (or 4-20a, 4-20b for quarterly) and 4-29 results in the following:

$$D_{\text{Total Gamma-Air}} = D_{\text{Gamma-Air}}(\text{STACK}) + D_{\text{Gamma-Air}}(\text{Vents}) + D_{\text{Short Gamma-Air}}(\text{Unmonitored Non - routine Releases})$$

Eq. 4-31

Short-term beta air doses are to be added to the long term beta air doses. Combining equations 4-12 (or 4-23 for quarterly) and 4-30 results in the following:

$$D_{\text{Total Beta-Air}} = D_{\text{Beta-Air}} + D_{\text{Short Beta-Air}}(\text{Unmonitored Non - routine Releases})$$

Eq. 4-32

2. Annual Whole Body Dose and Skin Dose Due to Noble Gases

The equations for whole body dose and skin dose which follow may be used in the preparation of the Radioactive Effluent Release Report (described above in Section 4.4.1). They are not applicable for the verification of compliance with 10 CFR 50, Appendix I (Section 4.4.2).

$$D_{shortTB} = K_i x(x/q) x q_i \quad \text{Eq. 4-32a}$$

$$D_{shortskin} = [L_i + 1.1M_i] x(x/q) x q_i \quad \text{Eq. 4-32b}$$

All parameters in Equations 4-32a and 4-32b are as previously defined in Sections 4.4.1.b(2) and 4.4.1.b(3).

Short-term whole body and skin doses are to be added to the corresponding doses from long-term releases. Combining Equations 4-12a, 4-12b and 4-32a yields the following equation for the total TB dose:

$$D_{TotalTB} = D_{TB}(STACK) + D_{TB}(Vents) + D_{ShortTB}(Unmonitored Non - routine Releases) \quad \text{Eq. 4-32c}$$

Similarly, combining Equations 4-12c, 4-12d and 4-32b for the skin, yields:

$$D_{TotalSkin} = D_{Skin}(STACK) + D_{Skin}(Vents) + D_{ShortSkin}(Unmonitored Non - routine Releases) \quad \text{Eq. 4-32d}$$

3. Dose Due to Radioiodines, Tritium, and Eight Day Particulates

Inhalation Pathway

$$(D_{Short I \& 8DPT})_r = (3.17E - 8) \sum_{i=1}^n R_{i,r} x(x/q) x q_i \quad \text{Eq. 4-33}$$

All parameters have been defined previously. Short-term doses from the inhalation pathway are to be added to the corresponding long term doses from the same pathway. Combining equations 4-13 (or 4-24 for quarterly) and 4-33 results in the following:

$$[D_{Total\ I\ \&\ 8DPT}]_{\tau} = [D_{I\ \&\ 8DPT}]_{\tau} + [D_{Short\ I\ \&\ 8DPT}]_{\tau} \text{ (Unmonitored Non - routine Releases)}$$

Eq. 4-34

Ground Plane Deposition Pathway

$$(D_{Short\ I\ \&\ 8DPT})_{\tau} = (3.17E - 8) \sum_{i=1}^n R_{i_r} x (d/q) x q_i$$

Eq. 4-35

Where:

(d/q) = The short term deposition factor (1/m²) for ground-level releases and the receptor of interest, defined as:

(d/q) = (d/q)_{Hourly PC} (t ≤ 2 hr)

(d/q) = (d/q)_{Hourly PC} x t^m (2 < t ≤ 500 hr)

(d/q) = (D/Q)_{Annual SA} (t > 500 hr)

Where:

$$m = \frac{\log [(D/Q)_{AnnualSA} / (d/q)_{HourlyPC}]}{\log (8760)}$$

t = release duration (hrs) (or the total sum of frequent short-term release durations) during the dose calculation exposure period (Note: the limits 2 < t ≤ 500 are for annual analysis; for quarterly analysis, they are 2 < t ≤ 150)

(D/Q)_{Annual SA} = long-term sector average (SA) deposition (1/m²) for ground level releases and the selected receptor, for distances out to 45 miles [from Table C-16 for the site boundary, Table C-20 for annual (all-season) meteorology, and Table C-24 for grazing-season meteorology]

$(d/q)_{\text{Hourly PC}}$ = short-term 85th percentile hourly plume centerline (PC) deposition factor ($1/m^2$) for ground-level releases and the selected receptor [from Table C-16 for the site boundary, Table C-19 for annual meteorology, and Table C-23 for grazing-season meteorology]

All other parameters have been defined in Section 4.4.1.b (4).

Short-term doses from the ground plane pathway are to be added to the corresponding long term doses from the same pathway. Combining equations 4-14 (or 4-25 for quarterly) with 4-35 results in the following:

$$[D_{\text{Total I\&8DPT}}]_r = [D_{\text{I\&8DPT}}]_r + [D_{\text{Short I\&8DPT}}]_r (\text{Unmonitored Non - routine Releases}) \quad \text{Eq. 4-36}$$

Cow's Milk Pathway

$$(D_{\text{Short I\&8DPT}})_r = (3.17E - 8) \sum_{i=1}^n R_{i_r} x (d/q) x q_i \quad \text{Eq. 4-37}$$

All parameters have been defined previously. Short-term doses from the cow's milk pathway are to be added to the corresponding long term doses from the same pathway. Combining equations 4-15 (or 4-26a for quarterly) with 4-37 results in the following:

$$[D_{\text{Total I\&8DPT}}]_r = [D_{\text{I\&8DPT}}]_r + [D_{\text{Short I\&8DPT}}]_r (\text{Unmonitored Non - routine Releases}) \quad \text{Eq. 4-38}$$

Goat's Milk Pathway

$$(D_{Short\ I\ \&DPT})_r = (3.17E-8) \sum_{i=1}^n R_{i_r} x (d/q) x q_i \quad \text{Eq. 4-39}$$

All parameters have been defined previously. Short-term doses from the goat's milk pathway are to be added to the corresponding long term doses from the same pathway. Combining equations 4-16 (or 4-26b for quarterly) with 4-39 results in the following:

$$\begin{aligned} [D_{Total\ I\ \&DPT}]_r &= [D_{I\ \&DPT}]_r \\ &+ [D_{Short\ I\ \&DPT}]_r (Unmonitored\ Non - routine\ Releases) \end{aligned} \quad \text{Eq. 4-40}$$

$$(D_{Short\ I\ \&DPT})_r = (3.17E-8) \sum_{i=1}^n R_{i_r} x (d/q) x q_i \quad \text{Eq. 4-41}$$

Meats

All parameters have been defined previously. Short-term doses from the meat pathway are to be added to the corresponding long term doses from the same pathway. Combining equations 4-17 (or 4-26c for quarterly) with 4-41 results in the following:

$$\begin{aligned} [D_{Total\ I\ \&DPT}]_r &= [D_{I\ \&DPT}]_r \\ &+ [D_{Short\ I\ \&DPT}]_r (Unmonitored\ Non - routine\ Releases) \end{aligned} \quad \text{Eq. 4-42}$$

Vegetation

$$(D_{Short\ I\ \&\ 8DPT})_{\tau} = (3.17E-8) \sum_{i=1}^n R_{i,\tau} x(d/q) x q_i \quad \text{Eq. 4-43}$$

All parameters have been defined previously. Short-term doses from the vegetation pathway are to be added to the corresponding long term doses from the same pathway. Combining equations 4-18 (or 4-26d for quarterly) with 4-43 results in the following:

$$[D_{Total\ I\ \&\ 8DPT}]_{\tau} = [D_{I\ \&\ 8DPT}]_{\tau} + [D_{Short\ I\ \&\ 8DPT}]_{\tau} \text{ (Unmonitored Non - routine Releases)} \quad \text{Eq. 4-44}$$

For tritium, the dose is calculated by substituting x/q for d/q, and $R_{H-3\tau}$ for $R_{i,\tau}$ in Equations 4-37, 4-39, 4-41, and 4-43.

Total Annual Dose From Release Point of Interest

$$D_{Short,\tau} = \sum_{z=1}^p (D_{Short\ i\ \&\ 8DP})_{\tau z} \quad \text{Eq. 4-45}$$

Short-term doses from unmonitored non-routine releases are to be added to the corresponding long term doses from the stack and vents. Combining Equations 4-19b (or 4-27b for quarterly) and 4-45, results in the following:

Total Annual Dose

$$D_{Total,\tau} = D_{\tau} + D_{Short,\tau} \quad \text{Eq. 4-46}$$

4.5 Dose Projections - Determination of Need to Operate Offgas Radwaste Treatment System

4.5.1 Requirement

Part 1, Section 3.5.2.c requires that doses to gaseous releases from the site be projected at least monthly if the charcoal beds are not in service when offgas treatment system operation is required.

4.5.2 Methodology

The following calculational method is provided for determining the projected doses.

$$PD_{\gamma} = \frac{31}{X} \times D_{\gamma} \times 1.2 \quad \text{Eq. 4-47}$$

$$PD_{\beta} = \frac{31}{X} \times D_{\beta} \times 1.2 \quad \text{Eq. 4-48}$$

$$PD_{I\&P} = \frac{31}{X} \times D_{I\&P} \times 1.2 \quad \text{Eq. 4-49}$$

Where:

PD_{γ} = Projected air dose due to noble gas gamma radiation during the current month (mrad) from all routine effluent pathways

PD_{β} = Projected air dose due to noble gas beta radiation during the current month (mrad) from all routine effluent pathways

$PD_{I\&P}$ = Projected dose to any organ due to Tritium, Iodine-131, Iodine-133 and particulates with half-lives greater than 8 days (mrem)

31 = Time period for projection (days)

X = Number of days to date during sample period used to project the doses

- D_{γ} = Air dose due to noble gas gamma radiation corresponding to the time period X (mrad)
- D_{β} = Air dose due to noble gas beta radiation corresponding to the time period X (mrad)
- $D_{I\&P}$ = Organ dose due to Iodines, Tritium and Particulates corresponding to the time period X (mrem)
- 1.2 = Conservatism factor to provide a margin for changes in mixture and operational line up, etc.

A formal dose projection would be based on the most appropriate results of the monthly calculations of the gamma air dose, the beta air dose, and the organ dose due to Tritium, Iodines and particulates with half-lives greater than 8 days. The doses calculated will be divided by the number of days in the sample period determined to be most appropriate for projecting doses. An appropriate period to base projection on should reflect similar radioactive release rates effective at the time of the projection. The per-day doses will be multiplied by 31 days, i.e., the time period for projection. The product is the projected dose for the coming 31 day period. Its value may be adjusted to account for any changes in operating conditions that could significantly alter the actual releases, such as failed fuel.

The calculated projected doses, PD_{γ} , PD_{β} , and $PD_{I\&P}$ will be compared to the following Part 1, Radiological Effluent Controls, Section 3.5.1.c.2 limits:

- 0.2 mrad for gamma radiation,
- 0.4 mrad for beta radiation, or
- 0.3 mrem to any organ.

If any doses exceed the above limits, the offgas charcoal beds will be used whenever the operation of the offgas treatment system is required during the projected time period.

a. **Limited Analysis Approach and Selection Criteria**

A simpler approach, a linear extrapolation of the most recent three-month dose for the coming month, could be used as long as the limits of Part 1, Radiological Effluent Controls, Section 3.5.1.c.2 are not reached, and that releases of radioactive material have not changed significantly during the time period used for projection.

5.0 40 CFR 190 AND 10 CFR 72.104(a) DOSE EVALUATION

Part 1, Radiological Effluent Controls, Section 4.1.1.c requires that the annual (calendar year) dose or dose commitment to any member of the public from uranium fuel cycle sources be limited to ≤ 25 mrem to the whole body or any organ (except the thyroid which is limited to ≤ 75 mrem). Compliance with the dose limits of 40 CFR 190 will be deemed to demonstrate compliance with the 100 mrem/yr limits of 10 CFR 20.1301 (a) (1).

5.1 Evaluation Bases

Dose evaluation to demonstrate compliance with the 40 CFR 190 and 10 CFR 72.104(a) dose limits need only be performed if the quarterly or annual doses calculated in steps 3.4.1, 3.4.2, 4.4.1, 4.4.2, and 4.4.3 exceed twice the dose limits of Part 1, Radiological Effluent Controls, Sections 2.3, 3.3 or 3.4 respectively. Quarterly doses exceeding 3 mrem to the whole body (liquid releases), 10 mrem to any organ (liquid releases), 10 mrad equivalent gamma air dose, 20 mrad equivalent beta air dose, or 15 mrem to the thyroid or any organ from radioiodines and particulates (atmospheric releases) and annual doses exceeding 6 mrem to the whole body (liquid releases), 20 mrem to any organ (liquid releases), 20 mrad equivalent gamma air dose, 40 mrad equivalent beta air dose, or 30 mrem to the thyroid or any organ from radioiodines and particulate (atmospheric releases) would require 40 CFR 190 and 10 CFR 72.104(a) evaluation. The dose evaluation includes dose contributions to a maximally exposed real individual from the calendar quarter in which the quarterly or annual limits were exceeded in addition to plant offsite dose contributions during the balance of the current calendar year.

40 CFR 190 and 10 CFR 72.104(a) dose assessments, when required, will be made using actual meteorological data and frequency distribution data for the year covered by the evaluation.

For purposes of the evaluation, if required, it may be assumed that the dose commitment to the maximally exposed real individual from other uranium fuel cycle sources is negligible. However, doses from JAFNPP will be added to the doses to the maximum exposed individual at Nine Mile Point Unit 1 and Unit 2, or to the nuclear fuel cycle facilities within a radius 8 km of the site.

As part of the Radiological Environmental Monitoring Program (REMP), JAF and Nine Mile Point Unit 1 & 2 jointly support a TLD program that monitors the doses on and off-site. The environmental TLDs measure the direct gamma radiation from the sites; contributions from JAF, Nine Mile Units 1 and 2. The TLD results are presented annually in the JAF Radiological Environmental Operating Report (AREOR).

JAF and Nine Mile Point Unit 1 & 2 issue Radioactive Effluent Release Reports. The dose contributions from effluents from the plant can be found in these reports.

JAF also reports annually to the commission, in accordance with 10 CFR 72.4 and 72.44(d)(3), the quantity of each of the principal radionuclides released to the environment in liquid and gaseous effluents during the previous 12 months of operation, and such other information as may be required by the commission to estimate maximum potential radiation dose commitment to the public resulting from effluent releases (Per JAF AP-03.04).

5.2 Doses From Liquid Releases

For the evaluation of doses to real individuals from liquid releases, the same calculating method as employed for Liquid Effluents Annual Dose Assessment will be used. However, more realistic assumptions and any current field data or updated estimates may be used, if available, concerning the dilution and ingestion of fish and potable water by individuals who live and fish in the area. Also, the results of the Radiological Environmental Monitoring Program will be included in determining more refined estimates of doses to real individuals by providing data on actual measured levels of plant-related radionuclides in the environment.

5.3 Doses From Atmospheric Releases

For the evaluation of doses to real individuals from the atmospheric releases, the same calculating methods as employed for Gaseous Effluent Annual Dose Assessment will be used except that the gamma and beta air doses are not calculated. Otherwise the same calculating sequence applies. However, any current field data or updated estimates may be used, if available, concerning the actual location of real individuals, the meteorological conditions, and the consumption of food (e.g., milk, meat and vegetation). Data obtained from the latest land use census Part 1, Section 5.2 should be used to determine locations for evaluating doses. Also, the results of the Radiological Environmental Monitoring Program will be included in determining more refined dose estimates to real individuals by providing data on actual measured levels of radioactivity and radiation at locations of interest.

5.4 Doses From Direct Radiation

Because 40 CFR 190 and 10 CFR 72.104(a) requirements include consideration of the offsite dose contribution from direct radiation, an estimate must be provided in the evaluation.

The direct radiation dose contribution from turbine shine (N-16) under hydrogen water chemistry conditions was evaluated to determine the need for additional shielding. Site boundary doses at the land based sectors of the site are less than 1 mrem/yr from this source.

The Interim Radioactive Waste Storage Facility (IRWSF) was evaluated for doses to the site boundary from a fully loaded facility in JAF-CALC-RAD-00030, Rev. 1. The calculation shows the site boundary gamma dose for the land based sectors of the site from the contained sources within the Interim Waste Storage Facility to be less than 1 mrem/yr.

The Independent Spent Fuel Storage Installation (ISFSI) was evaluated for doses to the site boundary from a Phase I and Expanded configuration and cask storage source term. The Phase I ISFSI is postulated to be loaded with 22 storage casks in a 11 x 2 array. The Expanded ISFSI is postulated to be loaded with 33 storage casks in a 3 x 11 array. Each cask is loaded with 68 spent fuel bundles. Calculations in JAF-CALC-SFS-03346, Rev. 4 demonstrate that the site boundary gamma dose for the closest land based sector of the site is significantly less than 25 mrem/yr from a fully loaded Expanded ISFSI.

Turbine shine, a fully loaded IRWSF, and the Phase I loaded ISFSI are the major contributors to direct radiation exposure at the site boundary. New sources will be analyzed on a case by case basis.

5.5 Doses to Members of the Public due to On-Site Activities

Members of the public are occasionally granted access to areas within the site boundary. Exposure to these members of the public due to liquid releases while on-site is highly unlikely and is not considered. Therefore, only exposure due to gaseous releases and direct radiation are considered. TLD and periodic area survey information is used to ensure that the dose and dose rates to such members of the public are within the limits of 10 CFR 1301 (a)(1).

6.0 REFERENCES

- 6.1 Regulatory Guide 1.109, Rev. 1, October 1977
- 6.2 NUREG-0133, October 1978
- 6.3 EN-AD-103, Document Control and Records Management Programs, Revision 03, April 29, 2005
- 6.4 Technical Specifications
- 6.5 James A. FitzPatrick Nuclear Power Plant, Docket 50-333, Compliance with 10 CFR 50, Appendix I
- 6.6 Final Environmental Impact Statement Related to Operation of James A. FitzPatrick Nuclear Power Plant, New York Power Authority; Docket No. 50-333, March 1973
- 6.7 Environmental Report, Operating License Stage, James A. FitzPatrick Plant, New York Power Authority, May 1971
 - 6.7.1 Supplement Environmental Report, Operating License Stage, November 1971
 - 6.7.2 Supplement #2 Environmental Report, Benefit/Cost Analysis, May 1972
 - 6.7.3 Supplement #3 Environmental Report, Answers to Atomic Energy Commission Questions, August 1982
- 6.8 Final Safety Analysis Report, James A. FitzPatrick Plant, New York Power Authority, Docket No. 50-333, Operating License No. DPR-59
- 6.9 New York Power Authority, Internal Memorandum from D. Dunning to G. Re, September 20, 1988
- 6.10 New York Power Authority, Corporate Radiological Engineering Calculation No. JAF-CALC-RAD-00025, Revision 1, Atmospheric Dispersion and Deposition Parameters for Routine Releases (1995)
- 6.11 CHAS. T. Main, Inc. X/Q and D/Q Tables for Nine Mile Point Unit 1, Nine Mile Point Unit 2 and James A. FitzPatrick Nuclear Power Plant, November 1985 (Contain 5 years of meteorological data, 1978 through 1982)
- 6.12 Idaho National Engineering Laboratory Technical Evaluation Report (TER) of the JAF ODCM for the NRC (EGG-PHY-8153, July 1988)

- 6.13 New York Power Authority Corporate Radiological Engineering Calculation Number JAF-CALC-RAD-00010, Revision 0, Verification Document for Radiological Effluent Controls and Offsite Dose Calculation Manual (Date Pending)
- 6.14 New York Power Authority Corporate Radiological Engineering Calculation Number JAF-CALC-RAD-00029, Aquatic Dispersion and Dose Assessment Methodology for Non-Routine Releases (1995)
- 6.15 Entergy Nuclear FitzPatrick, LLC and Entergy Nuclear Operations, Inc., James A. FitzPatrick Independent Spent Fuel Storage Installation JAF-CALC-SFS-03346, Rev. 3, Dose Rates in the Vicinity of the Hi-Storm Storage Cask and ISFSI
- 6.16 Entergy Nuclear FitzPatrick, LLC and Entergy Nuclear Operations, Inc., James A. FitzPatrick Independent Spent Fuel Storage Installation JAF-CALC-SFS-04025, Rev. 1, Confinement Analysis and Compliance with Applicable Regulations for the Phase I ISFSI
- 6.17 Entergy Nuclear FitzPatrick, LLC and Entergy Nuclear Operations, Inc., James A. FitzPatrick Independent Spent Fuel Storage Installation, 10 CFR 72.212 Evaluation Report
- 6.18 AP-03.04, Information Reporting Requirements, Revision 12
- 6.19 Certificate of Compliance No. 1014, Appendix A. Technical Specifications for the Hi-Storm 100 Cask System, Amendments 1 and 2
- 6.20 JAF-ICD-RBC-04561, Interface Control Document, Offsite Dose Manual Effluent Airflows, 04/23/03, Rev. 0
- 6.21 EPRI, Estimation of Carbon-14 in Nuclear Power Gaseous Effluents, December 2010
- 6.22 Entergy Echelon Nuclear Engineering, BWR Input Parameters for Determining Carbon-14 in Gaseous Effluent, NEAD-NS-11/006, Rev. 0
- 6.23 SCR-E1-98-0031
- 6.24 Chemistry Technical Information Document, CTID-13-006, Rev. 0, Inhalation Dose Factors for Se-75, 3/21/13.

APPENDIX A
LIQUID DOSE CALCULATION DATA

APPENDIX A
LIQUID DOSE CALCULATION DATA

TABLE	TITLE	PAGE
A-1	Effluent Concentration Limits for Water in Unrestricted Areas	A-3
A-2	Dose Factors, Limited Analysis Approach	A-4
A-3	Dose Factors, All Remaining Pathways	A-9
A-4	Dose Factor Derivation	A-18

**TABLE A-1
EFFLUENT CONCENTRATION LIMITS FOR WATER IN UNRESTRICTED AREAS**

NUCLIDE¹	ECL (μCi/ml)	NUCLIDE¹	ECL(μCi/ml)
H-3	1.000E-02	Ru-103	3.000E-04
Be-7	6.000E-03	Ru-105	7.000E-04
Na-24	5.000E-04	Ru-106	3.000E-05
P-32	9.000E-05	Cd-109	6.000E-05
K-40	4.000E-05	Ag-110m	6.000E-05
Cr-51	5.000E-03	Sn-113	3.000E-04
Mn-54	3.000E-04	In-113m	7.000E-03
Mn-56	7.000E-04	Sb-122	1.000E-04
Fe-55	1.000E-03	Sb-124	7.000E-05
Fe-59	1.000E-04	Sb-125	3.000E-04
Co-57	6.000E-04	Te-123M	9.000E-05
Co-58	2.000E-04	Te-125m	2.000E-04
Co-60	3.000E-05	Te-127	1.000E-03
Ni-63	1.000E-03	Te-127m	9.000E-05
Ni-65	1.000E-03	Te-129m	7.000E-05
Cu-64	2.000E-03	Te-129	4.000E-03
Zn-65	5.000E-05	Te-131m	8.000E-05
Zn-69	8.000E-03	Te-131	8.000E-04
Zn-69m	6.000E-04	Te-132	9.000E-05
As-76	1.000E-04	Te-134	3.000E-03
Br-82	4.000E-04	I-130	2.000E-04
Br-83	9.000E-03	I-131	1.000E-05
Br-84	4.000E-03	I-132	1.000E-03
Br-85	1.000E-05	I-133	7.000E-05
Rb-86	7.000E-05	I-134	4.000E-03
Rb-88	4.000E-03	I-135	3.000E-04
Rb-89	9.000E-03	Cs-134	9.000E-06
Sr-85	4.000E-04	Cs-136	6.000E-05
Sr-89	8.000E-05	Cs-137	1.000E-05
Sr-90	5.000E-06	Cs-138	4.000E-03
Sr-91	2.000E-04	Ba-133	2.000E-04
Sr-92	4.000E-04	Ba-139	2.000E-03
Y-88	1.000E-04	Ba-140	8.000E-05
Y-90	7.000E-05	Ba-141	3.000E-03
Y-91m	2.000E-02	Ba-142	7.000E-03
Y-91	8.000E-05	La-140	9.000E-05
Y-92	4.000E-04	La-142	1.000E-03
Y-93	2.000E-04	Ce-139	7.000E-04
Zr-95	2.000E-04	Ce-141	3.000E-04
Zr-97	9.000E-05	Ce-143	2.000E-04
Nb-94	1.000E-04	Ce-144	3.000E-05
Nb-95	3.000E-04	Pr-143	2.000E-04
Nb-95m	3.000E-04	Pr-144	6.000E-03
Nb-97	3.000E-03	Nd-147	2.000E-04
Mo-99	2.000E-04	W-187	3.000E-04
Tc-99m	1.000E-02	Np-239	2.000E-04
Tc-101	2.000E-02		

(1) All ECL values are taken from 10 times 10CFR20 EC values.

TABLE A-2 DOSE
CONVERSION FACTORS FOR LIQUID DISCHARGES

<u>Limited Analysis Approach</u>	<u>PAGE</u>
Freshwater Fish (A_{if}) - Adult	A-5
Potable Water (A_{itw}) - Adult	A-6
Freshwater Fish (A_{if}) - Teenager	A-7
Potable Water (A_{itw}) - Teenager	A-8

TABLE A-2
A_{iff} VALUES - FRESHWATER FISH - ADULT
(mrem/hr per μ Ci/ml)

Nuclide	Bone	Liver	Thyroid	Kidney	Lung	GI-LLI	Skin	T.Body
H-3	0.00E+00	1.89E-02	1.89E-02	1.89E-02	1.89E-02	1.89E-02	0.00E+00	1.89E-02
Na-24	3.40E+01	3.40E+01	3.40E+01	3.40E+01	3.40E+01	3.40E+01	0.00E+00	3.40E+01
Cr-51	0.00E+00	0.00E+00	6.35E-02	2.34E-02	1.41E-01	2.67E+01	0.00E+00	1.06E-01
Mn-54	0.00E+00	3.65E+02	0.00E+00	1.09E+02	0.00E+00	1.12E+03	0.00E+00	6.97E+01
Fe-55	5.49E+01	3.80E+01	0.00E+00	0.00E+00	2.12E+01	2.18E+01	0.00E+00	8.85E+00
Fe-59	8.67E+01	2.04E+02	0.00E+00	0.00E+00	5.69E+01	6.79E+02	0.00E+00	7.81E+01
Co-57	0.00E+00	1.75E+00	0.00E+00	0.00E+00	0.00E+00	4.43E+01	0.00E+00	2.91E+00
Co-58	0.00E+00	7.44E+00	0.00E+00	0.00E+00	0.00E+00	1.51E+02	0.00E+00	1.67E+01
Co-60	0.00E+00	2.14E+01	0.00E+00	0.00E+00	0.00E+00	4.02E+02	0.00E+00	4.71E+01
Cu-64	0.00E+00	8.32E-01	0.00E+00	2.10E+00	0.00E+00	7.09E+01	0.00E+00	3.91E-01
Zn-65	1.93E+03	6.15E+03	0.00E+00	4.12E+03	0.00E+00	3.88E+03	0.00E+00	2.78E+03
Sr-89	1.85E+03	0.00E+00	0.00E+00	0.00E+00	0.00E+00	2.96E+02	0.00E+00	5.30E+01
Sr-90	4.54E+04	0.00E+00	0.00E+00	0.00E+00	0.00E+00	1.31E+03	0.00E+00	1.11E+04
Nb-95	3.73E+01	2.07E+01	0.00E+00	2.05E+01	0.00E+00	1.26E+05	0.00E+00	1.11E+01
Zr-95	2.00E-02	6.43E-03	0.00E+00	1.01E-02	0.00E+00	2.04E+01	0.00E+00	4.35E-03
As-76	0.00E+00	9.45E-01	0.00E+00	1.78E+00	0.00E+00	2.29E+03	0.00E+00	9.02E-01
Nb-95m	3.73E+01	2.08E+01	0.00E+00	2.04E+01	0.00E+00	1.26E+05	0.00E+00	1.11E+01
Zr-97	1.11E-03	2.23E-04	0.00E+00	3.38E-04	0.00E+00	6.92E+01	0.00E+00	1.02E-04
Mo-99	0.00E+00	8.61E+00	0.00E+00	1.95E+01	0.00E+00	2.00E+01	0.00E+00	1.64E+00
Tc-99m	7.40E-04	2.09E-03	0.00E+00	3.18E-02	1.02E-03	1.24E+00	0.00E+00	2.66E-02
Ag-110m	7.35E-02	6.80E-02	0.00E+00	1.34E-01	0.00E+00	2.78E+01	0.00E+00	4.04E-02
Sb-124	5.59E-01	1.06E-02	1.36E-03	0.00E+00	4.36E-01	1.59E+01	0.00E+00	2.22E-01
I-131	1.25E+01	1.78E+01	5.84E+03	3.06E+01	0.00E+00	4.70E+00	0.00E+00	1.02E+01
I-133	4.26E+00	7.40E+00	1.09E+03	1.29E+01	0.00E+00	6.65E+00	0.00E+00	2.26E+00
I-135	1.33E+00	3.48E+00	2.29E+02	5.57E+00	0.00E+00	3.93E+00	0.00E+00	1.28E+00
Cs-134	2.49E+04	5.91E+04	0.00E+00	1.91E+04	6.35E+03	1.03E+03	0.00E+00	4.83E+04
Cs-137	3.18E+04	4.36E+04	0.00E+00	1.48E+04	4.91E+03	8.43E+02	0.00E+00	2.85E+04
Ba-140	1.62E+01	2.04E-02	0.00E+00	6.93E-03	1.17E-02	3.34E+01	0.00E+00	1.06E+00
La-140	1.25E-02	6.29E-03	0.00E+00	0.00E+00	0.00E+00	4.62E+02	0.00E+00	1.66E-03
Ce-141	1.87E-03	1.26E-03	0.00E+00	5.87E-04	0.00E+00	4.83E+00	0.00E+00	1.43E-04
Ce-144	9.75E-02	4.08E-02	0.00E+00	2.42E-02	0.00E+00	3.30E+01	0.00E+00	5.23E-03
W-187	2.47E+01	2.06E+01	0.00E+00	0.00E+00	0.00E+00	6.76E+03	0.00E+00	7.22E+00
Np-239	2.38E-03	2.34E-04	0.00E+00	7.29E-04	0.00E+00	4.79E+01	0.00E+00	1.29E-04

TABLE A-2
A_{itr} VALUES - POTABLE WATER - ADULT
(mrem/hr per μ Ci/ml)

Nuclide	Bone	Liver	Thyroid	Kidney	Lung	GI-LLI	Skin	T.Body
H-3	0.00E+00	5.30E-02	5.30E-02	5.30E-02	5.30E-02	5.30E-02	0.00E+00	5.30E-02
Cr-51	0.00E+00	0.00E+00	8.03E-04	2.96E-04	1.78E-03	3.38E-01	0.00E+00	1.34E-03
Mn-54	0.00E+00	2.31E+00	0.00E+00	6.87E-01	0.00E+00	7.07E+00	0.00E+00	4.40E-01
Fe-55	1.39E+00	9.60E-01	0.00E+00	0.00E+00	5.35E-01	5.51E-01	0.00E+00	2.24E-01
Fe-59	2.19E+00	5.15E+00	0.00E+00	0.00E+00	1.44E+00	1.72E+01	0.00E+00	1.97E+00
Co-57	0.00E+00	8.84E-02	0.00E+00	0.00E+00	0.00E+00	2.24E+00	0.00E+00	1.47E-01
Co-58	0.00E+00	3.76E-01	0.00E+00	0.00E+00	0.00E+00	7.63E+00	0.00E+00	8.43E-01
Co-60	0.00E+00	1.08E+00	0.00E+00	0.00E+00	0.00E+00	2.03E+01	0.00E+00	2.38E+00
Zn-65	2.44E+00	7.78E+00	0.00E+00	5.20E+00	0.00E+00	4.90E+00	0.00E+00	3.52E+00
Sr-89	1.56E+02	0.00E+00	0.00E+00	0.00E+00	0.00E+00	2.49E+01	0.00E+00	4.46E+00
Sr-90	3.83E+03	0.00E+00	0.00E+00	0.00E+00	0.00E+00	1.11E+02	0.00E+00	9.39E+02
Zr-95	1.54E-02	4.92E-03	0.00E+00	7.73E-03	0.00E+00	1.56E+01	0.00E+00	3.33E-03
Zr-97	8.48E-04	1.71E-04	0.00E+00	2.59E-04	0.00E+00	5.30E+01	0.00E+00	7.83E-05
Nb-95	3.14E-03	1.75E-03	0.00E+00	1.73E-03	0.00E+00	1.06E+01	0.00E+00	9.39E-04
Mo-99	0.00E+00	2.18E+00	0.00E+00	4.93E+00	0.00E+00	5.05E+00	0.00E+00	4.14E-01
Ag-110m	8.08E-02	7.47E-02	0.00E+00	1.47E-01	0.00E+00	3.05E+01	0.00E+00	4.44E-02
Sb-124	1.41E+00	2.67E-02	3.43E-03	0.00E+00	1.10E+00	4.02E+01	0.00E+00	5.61E-01
I-131	2.10E+00	3.01E+00	9.85E+02	5.15E+00	0.00E+00	7.93E-01	0.00E+00	1.72E+00
I-133	7.17E-01	1.25E+00	1.83E+02	2.18E+00	0.00E+00	1.12E+00	0.00E+00	3.80E-01
I-135	2.24E-01	5.86E-01	3.86E+01	9.39E-01	0.00E+00	6.62E-01	0.00E+00	2.16E-01
Cs-134	3.14E+01	7.47E+01	0.00E+00	2.42E+01	8.03E+00	1.31E+00	0.00E+00	6.11E+01
Cs-137	4.03E+01	5.51E+01	0.00E+00	1.87E+01	6.21E+00	1.07E+00	0.00E+00	3.61E+01
Ba-140	1.03E+01	1.29E-02	0.00E+00	4.38E-03	7.37E-03	2.11E+01	0.00E+00	6.72E-01
La-140	1.26E-03	6.36E-04	0.00E+00	0.00E+00	0.00E+00	4.67E+01	0.00E+00	1.68E-04
Ce-141	4.73E-03	3.20E-03	0.00E+00	1.48E-03	0.00E+00	1.22E+01	0.00E+00	3.63E-04
Ce-144	2.46E-01	1.03E-01	0.00E+00	6.11E-02	0.00E+00	8.33E+01	0.00E+00	1.32E-02
Na-24	8.59E-01	8.59E-01	8.59E-01	8.59E-01	8.59E-01	8.59E-01	0.00E+00	8.59E-01
Cu-64	0.00E+00	4.21E-02	0.00E+00	1.06E-01	0.00E+00	3.59E+00	0.00E+00	1.97E-02
W-187	5.20E-02	4.35E-02	0.00E+00	0.00E+00	0.00E+00	1.42E+01	0.00E+00	1.52E-02
Np-239	6.01E-04	5.91E-05	0.00E+00	1.84E-04	0.00E+00	1.21E+01	0.00E+00	3.26E-05
Tc-99m	1.25E-04	3.53E-04	0.00E+00	5.35E-03	1.73E-04	2.09E-01	0.00E+00	4.49E-03
As-76	0.00E+00	2.39E-02	0.00E+00	4.50E-02	0.00E+00	5.80E+01	0.00E+00	2.28E-02
Nb-95m	3.14E-03	1.75E-03	0.00E+00	1.72E-03	0.00E+00	1.06E+01	0.00E+00	9.38E-04

TABLE A-2
A_{itw} VALUES - FRESHWATER FISH - TEENAGER
(mrem/hr per μ Ci/ml)

Nuclide	Bone	Liver	Thyroid	Kidney	Lung	GI-LLI	Skin	T.Body
H-3	0.00E+00	1.45E-02	1.45E-02	1.45E-02	1.45E-02	1.45E-02	0.00E+00	1.45E-02
Na-24	3.50E+01	3.50E+01	3.50E+01	3.50E+01	3.50E+01	3.50E+01	0.00E+00	3.50E+01
Cr-51	0.00E+00	0.00E+00	6.09E-02	2.40E-02	1.56E-01	1.84E+01	0.00E+00	1.10E-01
Mn-54	0.00E+00	3.59E+02	0.00E+00	1.07E+02	0.00E+00	7.37E+02	0.00E+00	7.12E+01
Fe-55	5.75E+01	4.08E+01	0.00E+00	0.00E+00	2.59E+01	1.77E+01	0.00E+00	9.51E+00
Fe-59	8.93E+01	2.09E+02	0.00E+00	0.00E+00	6.58E+01	4.93E+02	0.00E+00	8.05E+01
Co-57	0.00E+00	1.81E+00	0.00E+00	0.00E+00	0.00E+00	3.38E+01	0.00E+00	3.04E+00
Co-58	0.00E+00	7.40E+00	0.00E+00	0.00E+00	0.00E+00	1.02E+02	0.00E+00	1.70E+01
Co-60	0.00E+00	2.14E+01	0.00E+00	0.00E+00	0.00E+00	2.79E+02	0.00E+00	4.82E+01
Cu-64	0.00E+00	8.75E-01	0.00E+00	2.21E+00	0.00E+00	6.79E+01	0.00E+00	4.12E-01
Zn-65	1.75E+03	6.09E+03	0.00E+00	3.90E+03	0.00E+00	2.58E+03	0.00E+00	2.84E+03
Sr-89	2.01E+03	0.00E+00	0.00E+00	0.00E+00	0.00E+00	2.39E+02	0.00E+00	5.75E+01
Sr-90	3.79E+04	0.00E+00	0.00E+00	0.00E+00	0.00E+00	1.06E+03	0.00E+00	9.36E+03
Nb-95	3.75E+01	2.08E+01	0.00E+00	2.02E+01	0.00E+00	8.90E+04	0.00E+00	1.15E+01
Zr-95	2.07E-02	6.53E-03	0.00E+00	9.59E-03	0.00E+00	1.51E+01	0.00E+00	4.49E-03
As-76	0.00E+00	1.02E+00	0.00E+00	1.93E+00	0.00E+00	1.96E+03	0.00E+00	9.84E-01
Nb-95m	3.75E+01	2.08E+01	0.00E+00	2.02E+01	0.00E+00	8.89E+04	0.00E+00	1.14E+01
Zr-97	1.19E-03	2.36E-04	0.00E+00	3.57E-04	0.00E+00	6.38E+01	0.00E+00	1.08E-04
Mo-99	0.00E+00	9.18E+00	0.00E+00	2.10E+01	0.00E+00	1.64E+01	0.00E+00	1.75E+00
Tc-99m	7.58E-04	2.11E-03	0.00E+00	3.15E-02	1.17E-03	1.39E+00	0.00E+00	2.74E-02
Ag-110m	7.18E-02	6.79E-02	0.00E+00	1.30E-01	0.00E+00	1.91E+01	0.00E+00	4.13E-02
Sb-124	5.89E-01	1.09E-02	1.34E-03	0.00E+00	5.14E-01	1.19E+01	0.00E+00	2.30E-01
I-131	1.34E+01	1.87E+01	5.46E+03	3.22E+01	0.00E+00	3.70E+00	0.00E+00	1.00E+01
I-133	4.59E+00	7.79E+00	1.09E+03	1.37E+01	0.00E+00	5.89E+00	0.00E+00	2.37E+00
I-135	1.39E+00	3.58E+00	2.31E+02	5.66E+00	0.00E+00	3.97E+00	0.00E+00	1.33E+00
Cs-134	2.55E+04	6.00E+04	0.00E+00	1.91E+04	7.28E+03	7.46E+02	0.00E+00	2.78E+04
Cs-137	3.41E+04	4.54E+04	0.00E+00	1.54E+04	6.00E+03	6.45E+02	0.00E+00	1.58E+04
Ba-140	1.73E+01	2.12E-02	0.00E+00	7.18E-03	1.42E-02	2.67E+01	0.00E+00	1.11E+00
La-140	1.32E-02	6.51E-03	0.00E+00	0.00E+00	0.00E+00	3.74E+02	0.00E+00	1.73E-03
Ce-141	2.02E-03	1.35E-03	0.00E+00	6.36E-04	0.00E+00	3.87E+00	0.00E+00	1.55E-04
Ce-144	1.06E-01	4.38E-02	0.00E+00	2.62E-02	0.00E+00	2.66E+01	0.00E+00	5.69E-03
W-187	2.67E+01	2.17E+01	0.00E+00	0.00E+00	0.00E+00	5.88E+03	0.00E+00	7.62E+00
Np-239	2.68E-03	2.53E-04	0.00E+00	7.93E-04	0.00E+00	4.06E+01	0.00E+00	1.40E-04

TABLE A-2
A_{itw} VALUES - POTABLE WATER - TEENAGER
(mrem/hr per μ Ci/ml)

Nuclide	Bone	Liver	Thyroid	Kidney	Lung	GI-LLI	Skin	T.Body
H-3	0.00E+00	3.74E-02	3.74E-02	3.74E-02	3.74E-02	3.74E-02	0.00E+00	3.74E-02
Cr-51	0.00E+00	0.00E+00	7.06E-04	2.78E-04	1.81E-03	2.13E-01	0.00E+00	1.27E-03
Mn-54	0.00E+00	2.08E+00	0.00E+00	6.21E-01	0.00E+00	4.27E+00	0.00E+00	4.13E-01
Fe-55	1.33E+00	9.46E-01	0.00E+00	0.00E+00	6.00E-01	4.09E-01	0.00E+00	2.21E-01
Fe-59	2.07E+00	4.83E+00	0.00E+00	0.00E+00	1.52E+00	1.14E+01	0.00E+00	1.87E+00
Co-57	0.00E+00	8.40E-02	0.00E+00	0.00E+00	0.00E+00	1.57E+00	0.00E+00	1.41E-01
Co-58	0.00E+00	3.43E-01	0.00E+00	0.00E+00	0.00E+00	4.73E+00	0.00E+00	7.90E-01
Co-60	0.00E+00	9.91E-01	0.00E+00	0.00E+00	0.00E+00	1.29E+01	0.00E+00	2.23E+00
Zn-65	2.03E+00	7.06E+00	0.00E+00	4.52E+00	0.00E+00	2.99E+00	0.00E+00	3.29E+00
Sr-89	1.55E+02	0.00E+00	0.00E+00	0.00E+00	0.00E+00	1.85E+01	0.00E+00	4.45E+00
Sr-90	2.93E+03	0.00E+00	0.00E+00	0.00E+00	0.00E+00	8.22E+01	0.00E+00	7.23E+02
Zr-95	1.45E-02	4.59E-03	0.00E+00	6.74E-03	0.00E+00	1.06E+01	0.00E+00	3.15E-03
Zr-97	8.36E-04	1.65E-04	0.00E+00	2.51E-04	0.00E+00	4.48E+01	0.00E+00	7.62E-05
Nb-95	2.90E-03	1.61E-03	0.00E+00	1.56E-03	0.00E+00	6.88E+00	0.00E+00	8.86E-04
Mo-99	0.00E+00	2.13E+00	0.00E+00	4.87E+00	0.00E+00	3.81E+00	0.00E+00	4.06E-01
Ag-110m	7.23E-02	6.85E-02	0.00E+00	1.31E-01	0.00E+00	1.92E+01	0.00E+00	4.16E-02
Sb-124	1.37E+00	2.52E-02	3.10E-03	0.00E+00	1.19E+00	2.75E+01	0.00E+00	5.33E-01
I-131	2.06E+00	2.89E+00	8.43E+02	4.98E+00	0.00E+00	5.72E-01	0.00E+00	1.55E+00
I-133	7.09E-01	1.20E+00	1.68E+02	2.11E+00	0.00E+00	9.10E-01	0.00E+00	3.67E-01
I-135	2.15E-01	5.54E-01	3.56E+01	8.75E-01	0.00E+00	6.14E-01	0.00E+00	2.05E-01
Cs-134	2.95E+01	6.95E+01	0.00E+00	2.21E+01	8.43E+00	8.64E-01	0.00E+00	3.22E+01
Cs-137	3.95E+01	5.26E+01	0.00E+00	1.79E+01	6.95E+00	7.48E-01	0.00E+00	1.83E+01
Ba-140	1.00E+01	1.23E-02	0.00E+00	4.16E-03	8.26E-03	1.55E+01	0.00E+00	6.46E-01
La-140	1.23E-03	6.03E-04	0.00E+00	0.00E+00	0.00E+00	3.46E+01	0.00E+00	1.61E-04
Ce-141	4.69E-03	3.13E-03	0.00E+00	1.47E-03	0.00E+00	8.96E+00	0.00E+00	3.60E-04
Ce-144	2.46E-01	1.02E-01	0.00E+00	6.07E-02	0.00E+00	6.17E+01	0.00E+00	1.32E-02
Na-24	8.12E-01	8.12E-01	8.12E-01	8.12E-01	8.12E-01	8.12E-01	0.00E+00	8.12E-01
Cu-64	0.00E+00	4.06E-02	0.00E+00	1.03E-01	0.00E+00	3.15E+00	0.00E+00	1.91E-02
W-187	5.15E-02	4.20E-02	0.00E+00	0.00E+00	0.00E+00	1.14E+01	0.00E+00	1.47E-02
Np-239	6.21E-04	5.86E-05	0.00E+00	1.84E-04	0.00E+00	9.42E+00	0.00E+00	3.25E-05
Tc-99m	1.17E-04	3.27E-04	0.00E+00	4.87E-03	1.81E-04	2.15E-01	0.00E+00	4.23E-03
As-76	0.00E+00	2.36E-02	0.00E+00	4.48E-02	0.00E+00	4.55E+01	0.00E+00	2.28E-02
Nb-95m	2.90E-03	1.61E-03	0.00E+00	1.56E-03	0.00E+00	6.87E+00	0.00E+00	8.84E-04

TABLE A-3

DOSE CONVERSION FACTORS FOR LIQUID DISCHARGES

All Remaining Pathways		Page
Lake Shoreline Deposits (A_{itsh})	- Adult	A-10
Lake Shoreline Deposits (A_{itsh})	- Teenager	A-11
Potable Water (A_{itw})	- Child	A-12
Freshwater Fish (A_{itf})	- Child	A-13
Lake Shoreline Deposits (A_{itsh})	- Child	A-14
Potable Water (A_{itw})	- Infant	A-15
Freshwater Fish (A_{itf})	- Infant	A-16
Lake Shoreline Deposits (A_{itsh})	- Infant	A-17

TABLE A-3
A_{itsh} VALUES - LAKE SHORELINE DEPOSITS - ADULT
(mrem/hr per μ Ci/ml)

Nuclide	Bone	Liver	Thyroid	Kidney	Lung	GI-LLI	Skin	T.Body
H-3	0.00E+00	0.00E+00	0.00E+00	0.00E+00	0.00E+00	0.00E+00	0.00E+00	0.00E+00
Na-24	3.57E-02	3.57E-02	3.57E-02	3.57E-02	3.57E-02	3.57E-02	4.14E-02	3.57E-02
Cr-51	1.39E-02	1.39E-02	1.39E-02	1.39E-02	1.39E-02	1.39E-02	1.64E-02	1.39E-02
Mn-54	4.14E+00	4.14E+00	4.14E+00	4.14E+00	4.14E+00	4.14E+00	4.85E+00	4.14E+00
Fe-55	0.00E+00	0.00E+00	0.00E+00	0.00E+00	0.00E+00	0.00E+00	0.00E+00	0.00E+00
Fe-59	8.15E-01	8.15E-01	8.15E-01	8.15E-01	8.15E-01	8.15E-01	9.58E-01	8.15E-01
Co-57	5.63E-01	5.63E-01	5.63E-01	5.63E-01	5.63E-01	5.63E-01	6.18E-01	5.63E-01
Co-58	1.13E+00	1.13E+00	1.13E+00	1.13E+00	1.13E+00	1.13E+00	1.33E+00	1.13E+00
Co-60	6.43E+01	6.43E+01	6.43E+01	6.43E+01	6.43E+01	6.43E+01	7.57E+01	6.43E+01
Cu-64	1.81E-03	1.81E-03	1.81E-03	1.81E-03	1.81E-03	1.81E-03	2.05E-03	1.81E-03
Zn-65	2.23E+00	2.23E+00	2.23E+00	2.23E+00	2.23E+00	2.23E+00	2.57E+00	2.23E+00
Sr-89	6.46E-05	6.46E-05	6.46E-05	6.46E-05	6.46E-05	6.46E-05	7.50E-05	6.46E-05
Sr-90	0.00E+00	0.00E+00	0.00E+00	0.00E+00	0.00E+00	0.00E+00	0.00E+00	0.00E+00
Nb-95	4.08E-01	4.08E-01	4.08E-01	4.08E-01	4.08E-01	4.08E-01	4.80E-01	4.08E-01
Zr-95	7.31E-01	7.31E-01	7.31E-01	7.31E-01	7.31E-01	7.31E-01	8.48E-01	7.31E-01
As-76	1.14E-02	1.14E-02	1.14E-02	1.14E-02	1.14E-02	1.14E-02	3.96E-01	1.14E-02
Nb-95m	5.85E-03	5.85E-03	5.85E-03	5.85E-03	5.85E-03	5.85E-03	3.67E-02	5.85E-03
Zr-97	8.84E-03	8.84E-03	8.84E-03	8.84E-03	8.84E-03	8.84E-03	1.03E-02	8.84E-03
Mo-99	1.19E-02	1.19E-02	1.19E-02	1.19E-02	1.19E-02	1.19E-02	1.38E-02	1.19E-02
Tc-99m	5.50E-04	5.50E-04	5.50E-04	5.50E-04	5.50E-04	5.50E-04	6.30E-04	5.50E-04
Ag-110m	1.03E+01	1.03E+01	1.03E+01	1.03E+01	1.03E+01	1.03E+01	1.20E+01	1.03E+01
Sb-124	1.79E+00	1.79E+00	1.79E+00	1.79E+00	1.79E+00	1.79E+00	2.06E+00	1.79E+00
I-131	5.14E-02	5.14E-02	5.14E-02	5.14E-02	5.14E-02	5.14E-02	6.24E-02	5.14E-02
I-133	7.32E-03	7.32E-03	7.32E-03	7.32E-03	7.32E-03	7.32E-03	8.90E-03	7.32E-03
I-135	7.55E-03	7.55E-03	7.55E-03	7.55E-03	7.55E-03	7.55E-03	8.80E-03	7.55E-03
Cs-134	2.05E+01	2.05E+01	2.05E+01	2.05E+01	2.05E+01	2.05E+01	2.39E+01	2.05E+01
Cs-137	3.08E+01	3.08E+01	3.08E+01	3.08E+01	3.08E+01	3.08E+01	3.59E+01	3.08E+01
Ba-140	6.13E-02	6.13E-02	6.13E-02	6.13E-02	6.13E-02	6.13E-02	7.01E-02	6.13E-02
La-140	5.74E-02	5.74E-02	5.74E-02	5.74E-02	5.74E-02	5.74E-02	6.50E-02	5.74E-02
Ce-141	4.08E-02	4.08E-02	4.08E-02	4.08E-02	4.08E-02	4.08E-02	4.60E-02	4.08E-02
Ce-144	2.08E-01	2.08E-01	2.08E-01	2.08E-01	2.08E-01	2.08E-01	2.40E-01	2.08E-01
W-187	7.03E-03	7.03E-03	7.03E-03	7.03E-03	7.03E-03	7.03E-03	8.16E-03	7.03E-03
Np-239	5.11E-03	5.11E-03	5.11E-03	5.11E-03	5.11E-03	5.11E-03	5.91E-03	5.11E-03

TABLE A-3 (Continued)
A_{itsh} VALUES - LAKE SHORELINE DEPOSITS - TEENAGER
(mrem/hr per μ Ci/ml)

Nuclide	Bone	Liver	Thyroid	Kidney	Lung	GI-LLI	Skin	T.Body
H-3	0.00E+00	0.00E+00	0.00E+00	0.00E+00	0.00E+00	0.00E+00	0.00E+00	0.00E+00
Na-24	1.99E-01	1.99E-01	1.99E-01	1.99E-01	1.99E-01	1.99E-01	2.31E-01	1.99E-01
Cr-51	7.77E-02	7.77E-02	7.77E-02	7.77E-02	7.77E-02	7.77E-02	9.18E-02	7.77E-02
Mn-54	2.31E+01	2.31E+01	2.31E+01	2.31E+01	2.31E+01	2.31E+01	2.71E+01	2.31E+01
Fe-55	0.00E+00	0.00E+00	0.00E+00	0.00E+00	0.00E+00	0.00E+00	0.00E+00	0.00E+00
Fe-59	4.55E+00	4.55E+00	4.55E+00	4.55E+00	4.55E+00	4.55E+00	5.35E+00	4.55E+00
Co-57	3.14E+00	3.14E+00	3.14E+00	3.14E+00	3.14E+00	3.14E+00	3.45E+00	3.14E+00
Co-58	6.32E+00	6.32E+00	6.32E+00	6.32E+00	6.32E+00	6.32E+00	7.40E+00	6.32E+00
Co-60	3.59E+02	3.59E+02	3.59E+02	3.59E+02	3.59E+02	3.59E+02	4.23E+02	3.59E+02
Cu-64	1.01E-02	1.01E-02	1.01E-02	1.01E-02	1.01E-02	1.01E-02	1.15E-02	1.01E-02
Zn-65	1.25E+01	1.25E+01	1.25E+01	1.25E+01	1.25E+01	1.25E+01	1.43E+01	1.25E+01
Sr-89	3.61E-04	3.61E-04	3.61E-04	3.61E-04	3.61E-04	3.61E-04	4.19E-04	3.61E-04
Sr-90	0.00E+00	0.00E+00	0.00E+00	0.00E+00	0.00E+00	0.00E+00	0.00E+00	0.00E+00
Nb-95	2.28E+00	2.28E+00	2.28E+00	2.28E+00	2.28E+00	2.28E+00	2.68E+00	2.28E+00
Zr-95	4.08E+00	4.08E+00	4.08E+00	4.08E+00	4.08E+00	4.08E+00	4.73E+00	4.08E+00
As-76	6.36E-02	6.36E-02	6.36E-02	6.36E-02	6.36E-02	6.36E-02	2.21E+00	6.36E-02
Nb-95m	3.27E-02	3.27E-02	3.27E-02	3.27E-02	3.27E-02	3.27E-02	2.05E-01	3.27E-02
Zr-97	4.94E-02	4.94E-02	4.94E-02	4.94E-02	4.94E-02	4.94E-02	5.74E-02	4.94E-02
Mo-99	6.66E-02	6.66E-02	6.66E-02	6.66E-02	6.66E-02	6.66E-02	7.71E-02	6.66E-02
Tc-99m	3.07E-03	3.07E-03	3.07E-03	3.07E-03	3.07E-03	3.07E-03	3.52E-03	3.07E-03
Ag-110m	5.73E+01	5.73E+01	5.73E+01	5.73E+01	5.73E+01	5.73E+01	6.69E+01	5.73E+01
Sb-124	9.98E+00	9.98E+00	9.98E+00	9.98E+00	9.98E+00	9.98E+00	1.15E+01	9.98E+00
I-131	2.87E-01	2.87E-01	2.87E-01	2.87E-01	2.87E-01	2.87E-01	3.48E-01	2.87E-01
I-133	4.09E-02	4.09E-02	4.09E-02	4.09E-02	4.09E-02	4.09E-02	4.97E-02	4.09E-02
I-135	4.21E-02	4.21E-02	4.21E-02	4.21E-02	4.21E-02	4.21E-02	4.92E-02	4.21E-02
Cs-134	1.14E+02	1.14E+02	1.14E+02	1.14E+02	1.14E+02	1.14E+02	1.34E+02	1.14E+02
Cs-137	1.72E+02	1.72E+02	1.72E+02	1.72E+02	1.72E+02	1.72E+02	2.01E+02	1.72E+02
Ba-140	3.42E-01	3.42E-01	3.42E-01	3.42E-01	3.42E-01	3.42E-01	3.91E-01	3.42E-01
La-140	3.20E-01	3.20E-01	3.20E-01	3.20E-01	3.20E-01	3.20E-01	3.63E-01	3.20E-01
Ce-141	2.28E-01	2.28E-01	2.28E-01	2.28E-01	2.28E-01	2.28E-01	2.57E-01	2.28E-01
Ce-144	1.16E+00	1.16E+00	1.16E+00	1.16E+00	1.16E+00	1.16E+00	1.34E+00	1.16E+00
W-187	3.92E-02	3.92E-02	3.92E-02	3.92E-02	3.92E-02	3.92E-02	4.56E-02	3.92E-02
Np-239	2.85E-02	2.85E-02	2.85E-02	2.85E-02	2.85E-02	2.85E-02	3.30E-02	2.85E-02

TABLE A-3 (Continued)
A_{itw} VALUES - POTABLE WATER - CHILD
(mrem/hr per μ Ci/ml)

Nuclide	Bone	Liver	Thyroid	Kidney	Lung	GI-LLI	Skin	T.Body
H-3	0.00E+00	7.16E-02	7.16E-02	7.16E-02	7.16E-02	7.16E-02	0.00E+00	7.16E-02
Cr-51	0.00E+00	0.00E+00	1.74E-03	4.76E-04	3.18E-03	1.67E-01	0.00E+00	3.14E-03
Mn-54	0.00E+00	3.78E+00	0.00E+00	1.06E+00	0.00E+00	3.17E+00	0.00E+00	1.01E+00
Fe-55	4.06E+00	2.15E+00	0.00E+00	0.00E+00	1.22E+00	3.99E-01	0.00E+00	6.67E-01
Fe-59	5.82E+00	9.42E+00	0.00E+00	0.00E+00	2.73E+00	9.81E+00	0.00E+00	4.69E+00
Co-57	0.00E+00	1.74E-01	0.00E+00	0.00E+00	0.00E+00	1.43E+00	0.00E+00	3.52E-01
Co-58	0.00E+00	6.35E-01	0.00E+00	0.00E+00	0.00E+00	3.70E+00	0.00E+00	1.94E+00
Co-60	0.00E+00	1.87E+00	0.00E+00	0.00E+00	0.00E+00	1.03E+01	0.00E+00	5.50E+00
Zn-65	4.83E+00	1.29E+01	0.00E+00	8.12E+00	0.00E+00	2.26E+00	0.00E+00	8.01E+00
Sr-89	4.66E+02	0.00E+00	0.00E+00	0.00E+00	0.00E+00	1.80E+01	0.00E+00	1.33E+01
Sr-90	6.00E+03	0.00E+00	0.00E+00	0.00E+00	0.00E+00	8.08E+01	0.00E+00	1.52E+03
Zr-95	4.09E-02	9.00E-03	0.00E+00	1.29E-02	0.00E+00	9.39E+00	0.00E+00	8.01E-03
Zr-97	2.47E-03	3.56E-04	0.00E+00	5.12E-04	0.00E+00	5.40E+01	0.00E+00	2.10E-04
Nb-95	7.94E-03	3.09E-03	0.00E+00	2.90E-03	0.00E+00	5.72E+00	0.00E+00	2.21E-03
Mo-99	0.00E+00	4.69E+00	0.00E+00	1.00E+01	0.00E+00	3.88E+00	0.00E+00	1.16E+00
Ag-110m	1.90E-01	1.28E-01	0.00E+00	2.39E-01	0.00E+00	1.53E+01	0.00E+00	1.03E-01
Sb-124	3.92E+00	5.08E-02	8.64E-03	0.00E+00	2.17E+00	2.45E+01	0.00E+00	1.37E+00
I-131	6.07E+00	6.10E+00	2.02E+03	1.00E+01	0.00E+00	5.43E-01	0.00E+00	3.47E+00
I-133	2.09E+00	2.58E+00	4.80E+02	4.30E+00	0.00E+00	1.04E+00	0.00E+00	9.77E-01
I-135	6.17E-01	1.11E+00	9.84E+01	1.70E+00	0.00E+00	8.47E-01	0.00E+00	5.26E-01
Cs-134	8.26E+01	1.35E+02	0.00E+00	4.20E+01	1.51E+01	7.30E-01	0.00E+00	2.86E+01
Cs-137	1.15E+02	1.10E+02	0.00E+00	3.60E+01	1.29E+01	6.92E-01	0.00E+00	1.63E+01
Ba-140	2.93E+01	2.57E-02	0.00E+00	8.36E-03	1.53E-02	1.49E+01	0.00E+00	1.71E+00
La-140	3.56E-03	1.25E-03	0.00E+00	0.00E+00	0.00E+00	3.47E+01	0.00E+00	4.20E-04
Ce-141	1.40E-02	6.99E-03	0.00E+00	3.06E-03	0.00E+00	8.72E+00	0.00E+00	1.04E-03
Ce-144	7.34E-01	2.30E-01	0.00E+00	1.27E-01	0.00E+00	6.00E+01	0.00E+00	3.92E-02
Na-24	2.05E+00	2.05E+00	2.05E+00	2.05E+00	2.05E+00	2.05E+00	0.00E+00	2.05E+00
Cu-64	0.00E+00	8.64E-02	0.00E+00	2.09E-01	0.00E+00	4.06E+00	0.00E+00	5.22E-02
W-187	1.51E-01	8.96E-02	0.00E+00	0.00E+00	0.00E+00	1.26E+01	0.00E+00	4.02E-02
Np-239	1.85E-03	1.33E-04	0.00E+00	3.85E-04	0.00E+00	9.84E+00	0.00E+00	9.35E-05
Tc-99m	3.26E-04	6.39E-04	0.00E+00	9.28E-03	3.24E-04	3.63E-01	0.00E+00	1.06E-02
As-76	0.00E+00	5.36E-02	0.00E+00	9.44E-02	0.00E+00	5.43E+01	0.00E+00	6.80E-02
Nb-95m	7.93E-03	3.09E-03	0.00E+00	2.90E-03	0.00E+00	5.71E+00	0.00E+00	2.21E-03

TABLE A-3 (Continued)
A_{itw} VALUES - FRESHWATER FISH - CHILD
(mrem/hr per μ Ci/ml)

Nuclide	Bone	Liver	Thyroid	Kidney	Lung	GI-LLI	Skin	T.Body
H-3	0.00E+00	1.20E-02	1.20E-02	1.20E-02	1.20E-02	1.20E-02	0.00E+00	1.20E-02
Na-24	3.81E+01	3.81E+01	3.81E+01	3.81E+01	3.81E+01	3.81E+01	0.00E+00	3.81E+01
Cr-51	0.00E+00	0.00E+00	6.49E-02	1.77E-02	1.18E-01	6.20E+00	0.00E+00	1.17E-01
Mn-54	0.00E+00	2.81E+02	0.00E+00	7.88E+01	0.00E+00	2.36E+02	0.00E+00	7.48E+01
Fe-55	7.55E+01	4.00E+01	0.00E+00	0.00E+00	2.26E+01	7.42E+00	0.00E+00	1.24E+01
Fe-59	1.08E+02	1.75E+02	0.00E+00	0.00E+00	5.08E+01	1.82E+02	0.00E+00	8.73E+01
Co-57	0.00E+00	1.62E+00	0.00E+00	0.00E+00	0.00E+00	1.33E+01	0.00E+00	3.28E+00
Co-58	0.00E+00	5.91E+00	0.00E+00	0.00E+00	0.00E+00	3.45E+01	0.00E+00	1.81E+01
Co-60	0.00E+00	1.74E+01	0.00E+00	0.00E+00	0.00E+00	9.62E+01	0.00E+00	5.12E+01
Cu-64	0.00E+00	8.04E-01	0.00E+00	1.94E+00	0.00E+00	3.77E+01	0.00E+00	4.86E-01
Zn-65	1.80E+03	4.79E+03	0.00E+00	3.02E+03	0.00E+00	8.41E+02	0.00E+00	2.98E+03
Sr-89	2.60E+03	0.00E+00	0.00E+00	0.00E+00	0.00E+00	1.01E+02	0.00E+00	7.42E+01
Sr-90	3.35E+04	0.00E+00	0.00E+00	0.00E+00	0.00E+00	4.51E+02	0.00E+00	8.49E+03
Nb-95	4.43E+01	1.73E+01	0.00E+00	1.62E+01	0.00E+00	3.19E+04	0.00E+00	1.23E+01
Zr-95	2.51E-02	5.52E-03	0.00E+00	7.91E-03	0.00E+00	5.76E+00	0.00E+00	4.92E-03
As-76	0.00E+00	9.97E-01	0.00E+00	1.76E+00	0.00E+00	1.01E+03	0.00E+00	1.27E+00
Nb-95m	4.43E+01	1.72E+01	0.00E+00	1.62E+01	0.00E+00	3.19E+04	0.00E+00	1.23E+01
Zr-97	1.51E-03	2.19E-04	0.00E+00	3.14E-04	0.00E+00	3.31E+01	0.00E+00	1.29E-04
Mo-99	0.00E+00	8.73E+00	0.00E+00	1.86E+01	0.00E+00	7.22E+00	0.00E+00	2.16E+00
Tc-99m	9.09E-04	1.78E-03	0.00E+00	2.59E-02	9.05E-04	1.01E+00	0.00E+00	2.95E-02
Ag-110m	8.14E-02	5.50E-02	0.00E+00	1.02E-01	0.00E+00	6.54E+00	0.00E+00	4.39E-02
Sb-124	7.29E-01	9.45E-03	1.61E-03	0.00E+00	4.04E-01	4.56E+00	0.00E+00	2.55E-01
I-131	1.69E+01	1.70E+01	5.63E+03	2.80E+01	0.00E+00	1.52E+00	0.00E+00	9.68E+00
I-133	5.83E+00	7.21E+00	1.34E+03	1.20E+01	0.00E+00	2.90E+00	0.00E+00	2.73E+00
I-135	1.72E+00	3.10E+00	2.75E+02	4.76E+00	0.00E+00	2.36E+00	0.00E+00	1.47E+00
Cs-134	3.07E+04	5.04E+04	0.00E+00	1.56E+04	5.61E+03	2.72E+02	0.00E+00	1.06E+04
Cs-137	4.29E+04	4.11E+04	0.00E+00	1.34E+04	4.82E+03	2.57E+02	0.00E+00	6.07E+03
Ba-140	2.18E+01	1.91E-02	0.00E+00	6.22E-03	1.14E-02	1.11E+01	0.00E+00	1.27E+00
La-140	1.66E-02	5.79E-03	0.00E+00	0.00E+00	0.00E+00	1.61E+02	0.00E+00	1.95E-03
Ce-141	2.61E-03	1.30E-03	0.00E+00	5.70E-04	0.00E+00	1.62E+00	0.00E+00	1.93E-04
Ce-144	1.37E-01	4.28E-02	0.00E+00	2.37E-02	0.00E+00	1.12E+01	0.00E+00	7.29E-03
W-187	3.38E+01	2.00E+01	0.00E+00	0.00E+00	0.00E+00	2.81E+03	0.00E+00	8.98E+00
Np-239	3.45E-03	2.47E-04	0.00E+00	7.15E-04	0.00E+00	1.83E+01	0.00E+00	1.74E-04

TABLE A-3 (Continued)
A_{itsh} VALUES - LAKE SHORELINE DEPOSITS - CHILD
(mrem/hr per μ Ci/ml)

Nuclide	Bone	Liver	Thyroid	Kidney	Lung	GI-LLI	Skin	T.Body
H-3	0.00E+00	0.00E+00	0.00E+00	0.00E+00	0.00E+00	0.00E+00	0.00E+00	0.00E+00
Na-24	4.16E-02	4.16E-02	4.16E-02	4.16E-02	4.16E-02	4.16E-02	4.83E-02	4.16E-02
Cr-51	1.62E-02	1.62E-02	1.62E-02	1.62E-02	1.62E-02	1.62E-02	1.92E-02	1.62E-02
Mn-54	4.83E+00	4.83E+00	4.83E+00	4.83E+00	4.83E+00	4.83E+00	5.66E+00	4.83E+00
Fe-55	0.00E+00	0.00E+00	0.00E+00	0.00E+00	0.00E+00	0.00E+00	0.00E+00	0.00E+00
Fe-59	9.51E-01	9.51E-01	9.51E-01	9.51E-01	9.51E-01	9.51E-01	1.12E+00	9.51E-01
Co-57	6.57E-01	6.57E-01	6.57E-01	6.57E-01	6.57E-01	6.57E-01	7.22E-01	6.57E-01
Co-58	1.32E+00	1.32E+00	1.32E+00	1.32E+00	1.32E+00	1.32E+00	1.55E+00	1.32E+00
Co-60	7.51E+01	7.51E+01	7.51E+01	7.51E+01	7.51E+01	7.51E+01	8.83E+01	7.51E+01
Cu-64	2.11E-03	2.11E-03	2.11E-03	2.11E-03	2.11E-03	2.11E-03	2.40E-03	2.11E-03
Zn-65	2.60E+00	2.60E+00	2.60E+00	2.60E+00	2.60E+00	2.60E+00	2.99E+00	2.60E+00
Sr-89	7.54E-05	7.54E-05	7.54E-05	7.54E-05	7.54E-05	7.54E-05	8.75E-05	7.54E-05
Sr-90	0.00E+00	0.00E+00	0.00E+00	0.00E+00	0.00E+00	0.00E+00	0.00E+00	0.00E+00
Nb-95	4.76E-01	4.76E-01	4.76E-01	4.76E-01	4.76E-01	4.76E-01	5.60E-01	4.76E-01
Zr-95	8.53E-01	8.53E-01	8.53E-01	8.53E-01	8.53E-01	8.53E-01	9.89E-01	8.53E-01
As-76	1.33E-02	1.33E-02	1.33E-02	1.33E-02	1.33E-02	1.33E-02	4.62E-01	1.33E-02
Nb-95m	6.82E-03	6.82E-03	6.82E-03	6.82E-03	6.82E-03	6.82E-03	4.28E-02	6.82E-03
Zr-97	1.03E-02	1.03E-02	1.03E-02	1.03E-02	1.03E-02	1.03E-02	1.20E-02	1.03E-02
Mo-99	1.39E-02	1.39E-02	1.39E-02	1.39E-02	1.39E-02	1.39E-02	1.61E-02	1.39E-02
Tc-99m	6.41E-04	6.41E-04	6.41E-04	6.41E-04	6.41E-04	6.41E-04	7.35E-04	6.41E-04
Ag-110m	1.20E+01	1.20E+01	1.20E+01	1.20E+01	1.20E+01	1.20E+01	1.40E+01	1.20E+01
Sb-124	2.08E+00	2.08E+00	2.08E+00	2.08E+00	2.08E+00	2.08E+00	2.41E+00	2.08E+00
I-131	6.00E-02	6.00E-02	6.00E-02	6.00E-02	6.00E-02	6.00E-02	7.28E-02	6.00E-02
I-133	8.54E-03	8.54E-03	8.54E-03	8.54E-03	8.54E-03	8.54E-03	1.04E-02	8.54E-03
I-135	8.80E-03	8.80E-03	8.80E-03	8.80E-03	8.80E-03	8.80E-03	1.03E-02	8.80E-03
Cs-134	2.39E+01	2.39E+01	2.39E+01	2.39E+01	2.39E+01	2.39E+01	2.79E+01	2.39E+01
Cs-137	3.59E+01	3.59E+01	3.59E+01	3.59E+01	3.59E+01	3.59E+01	4.19E+01	3.59E+01
Ba-140	7.15E-02	7.15E-02	7.15E-02	7.15E-02	7.15E-02	7.15E-02	8.18E-02	7.15E-02
La-140	6.70E-02	6.70E-02	6.70E-02	6.70E-02	6.70E-02	6.70E-02	7.59E-02	6.70E-02
Ce-141	4.76E-02	4.76E-02	4.76E-02	4.76E-02	4.76E-02	4.76E-02	5.37E-02	4.76E-02
Ce-144	2.42E-01	2.42E-01	2.42E-01	2.42E-01	2.42E-01	2.42E-01	2.80E-01	2.42E-01
W-187	8.20E-03	8.20E-03	8.20E-03	8.20E-03	8.20E-03	8.20E-03	9.52E-03	8.20E-03
Np-239	5.96E-03	5.96E-03	5.96E-03	5.96E-03	5.96E-03	5.96E-03	6.90E-03	5.96E-03

TABLE A-3 (Continued)
A_{itw} VALUES - POTABLE WATER - INFANT
(mrem/hr per μ Ci/ml)

Nuclide	Bone	Liver	Thyroid	Kidney	Lung	GI-LLI	Skin	T.Body
H-3	0.00E+00	7.03E-02	7.03E-02	7.03E-02	7.03E-02	7.03E-02	0.00E+00	7.03E-02
Cr-51	0.00E+00	0.00E+00	2.10E-03	4.59E-04	4.09E-03	9.38E-02	0.00E+00	3.22E-03
Mn-54	0.00E+00	4.54E+00	0.00E+00	1.01E+00	0.00E+00	1.67E+00	0.00E+00	1.03E+00
Fe-55	3.17E+00	2.05E+00	0.00E+00	0.00E+00	1.00E+00	2.60E-01	0.00E+00	5.48E-01
Fe-59	7.03E+00	1.23E+01	0.00E+00	0.00E+00	3.63E+00	5.87E+00	0.00E+00	4.84E+00
Co-57	0.00E+00	2.63E-01	0.00E+00	0.00E+00	0.00E+00	8.95E-01	0.00E+00	4.27E-01
Co-58	0.00E+00	8.22E-01	0.00E+00	0.00E+00	0.00E+00	2.05E+00	0.00E+00	2.05E+00
Co-60	0.00E+00	2.47E+00	0.00E+00	0.00E+00	0.00E+00	5.87E+00	0.00E+00	5.82E+00
Zn-65	4.20E+00	1.44E+01	0.00E+00	6.99E+00	0.00E+00	1.22E+01	0.00E+00	6.64E+00
Sr-89	5.73E+02	0.00E+00	0.00E+00	0.00E+00	0.00E+00	1.18E+01	0.00E+00	1.64E+01
Sr-90	4.22E+03	0.00E+00	0.00E+00	0.00E+00	0.00E+00	5.27E+01	0.00E+00	1.08E+03
Zr-95	4.70E-02	1.15E-02	0.00E+00	1.24E-02	0.00E+00	5.71E+00	0.00E+00	8.13E-03
Zr-97	3.38E-03	5.80E-04	0.00E+00	5.84E-04	0.00E+00	3.70E+01	0.00E+00	2.65E-04
Nb-95	9.59E-03	3.95E-03	0.00E+00	2.83E-03	0.00E+00	3.33E+00	0.00E+00	2.28E-03
Mo-99	0.00E+00	7.76E+00	0.00E+00	1.16E+01	0.00E+00	2.56E+00	0.00E+00	1.51E+00
Ag-110m	2.27E-01	1.66E-01	0.00E+00	2.37E-01	0.00E+00	8.61E+00	0.00E+00	1.10E-01
Sb-124	4.89E+00	7.19E-02	1.30E-02	0.00E+00	3.06E+00	1.51E+01	0.00E+00	1.51E+00
I-131	8.20E+00	9.66E+00	3.17E+03	1.13E+01	0.00E+00	3.45E-01	0.00E+00	4.25E+00
I-133	2.85E+00	4.16E+00	7.56E+02	4.89E+00	0.00E+00	7.03E-01	0.00E+00	1.22E+00
I-135	8.31E-01	1.65E+00	1.48E+02	1.84E+00	0.00E+00	5.98E-01	0.00E+00	6.03E-01
Cs-134	8.61E+01	1.61E+02	0.00E+00	4.13E+01	1.69E+01	4.36E-01	0.00E+00	1.62E+01
Cs-137	1.19E+02	1.39E+02	0.00E+00	3.74E+01	1.52E+01	4.36E-01	0.00E+00	9.89E+00
Ba-140	3.90E+01	3.90E-02	0.00E+00	9.27E-03	2.40E-02	9.59E+00	0.00E+00	2.01E+00
La-140	4.82E-03	1.90E-03	0.00E+00	0.00E+00	0.00E+00	2.23E+01	0.00E+00	4.89E-04
Ce-141	1.80E-02	1.10E-02	0.00E+00	3.38E-03	0.00E+00	5.66E+00	0.00E+00	1.29E-03
Ce-144	6.80E-01	2.79E-01	0.00E+00	1.13E-01	0.00E+00	3.90E+01	0.00E+00	3.81E-02
Na-24	2.31E+00	2.31E+00	2.31E+00	2.31E+00	2.31E+00	2.31E+00	0.00E+00	2.31E+00
Cu-64	0.00E+00	1.39E-01	0.00E+00	2.35E-01	0.00E+00	2.85E+00	0.00E+00	6.44E-02
W-187	2.06E-01	1.43E-01	0.00E+00	0.00E+00	0.00E+00	8.42E+00	0.00E+00	4.95E-02
Np-239	2.53E-03	2.27E-04	0.00E+00	4.52E-04	0.00E+00	6.55E+00	0.00E+00	1.28E-04
Tc-99m	4.38E-04	9.04E-04	0.00E+00	9.73E-03	4.73E-04	2.63E-01	0.00E+00	1.16E-02
As-76	0.00E+00	9.14E-02	0.00E+00	1.11E-01	0.00E+00	3.65E+01	0.00E+00	9.33E-02
Nb-95m	9.58E-03	3.94E-03	0.00E+00	2.83E-03	0.00E+00	3.33E+00	0.00E+00	2.28E-03

TABLE A-3 (Continued)
A_{itr} VALUES - FRESHWATER FISH - INFANT
(mrem/hr per μ Ci/ml)

NUCLIDE	BONE	LIVER	THYROID	KIDNEY	LUNG	GI-LLI	SKIN	T. BODY
H-3	0	0	0	0	0	0	0	0
Na-24	0	0	0	0	0	0	0	0
Cr-51	0	0	0	0	0	0	0	0
Mn-54	0	0	0	0	0	0	0	0
Fe-55	0	0	0	0	0	0	0	0
Fe-59	0	0	0	0	0	0	0	0
Co-57	0	0	0	0	0	0	0	0
Co-58	0	0	0	0	0	0	0	0
Co-60	0	0	0	0	0	0	0	0
Cu-64	0	0	0	0	0	0	0	0
Zn-65	0	0	0	0	0	0	0	0
Sr-89	0	0	0	0	0	0	0	0
Sr-90	0	0	0	0	0	0	0	0
Nb-95	0	0	0	0	0	0	0	0
Zr-95	0	0	0	0	0	0	0	0
As-76	0	0	0	0	0	0	0	0
Nb-95m	0	0	0	0	0	0	0	0
Zr-97	0	0	0	0	0	0	0	0
Mo-99	0	0	0	0	0	0	0	0
Tc-99m	0	0	0	0	0	0	0	0
Ag-110m	0	0	0	0	0	0	0	0
Sb-124	0	0	0	0	0	0	0	0
I-131	0	0	0	0	0	0	0	0
I-133	0	0	0	0	0	0	0	0
I-135	0	0	0	0	0	0	0	0
Cs-134	0	0	0	0	0	0	0	0
Cs-137	0	0	0	0	0	0	0	0
Ba-140	0	0	0	0	0	0	0	0
La-140	0	0	0	0	0	0	0	0
Ce-141	0	0	0	0	0	0	0	0
Ce-144	0	0	0	0	0	0	0	0
W-187	0	0	0	0	0	0	0	0
Np-239	0	0	0	0	0	0	0	0

TABLE A-3 (Continued)
A_{itsh} VALUES - LAKE SHORELINE DEPOSITS - INFANT
(mrem/hr per μ Ci/ml)

NUCLIDE	BONE	LIVER	THYROID	KIDNEY	LUNG	GI-LLI	SKIN	T. BODY
H-3	0	0	0	0	0	0	0	0
Na-24	0	0	0	0	0	0	0	0
Cr-51	0	0	0	0	0	0	0	0
Mn-54	0	0	0	0	0	0	0	0
Fe-55	0	0	0	0	0	0	0	0
Fe-59	0	0	0	0	0	0	0	0
Co-57	0	0	0	0	0	0	0	0
Co-58	0	0	0	0	0	0	0	0
Co-60	0	0	0	0	0	0	0	0
Cu-64	0	0	0	0	0	0	0	0
Zn-65	0	0	0	0	0	0	0	0
Sr-89	0	0	0	0	0	0	0	0
Sr-90	0	0	0	0	0	0	0	0
Nb-95	0	0	0	0	0	0	0	0
Zr-95	0	0	0	0	0	0	0	0
As-76	0	0	0	0	0	0	0	0
Nb-95m	0	0	0	0	0	0	0	0
Zr-97	0	0	0	0	0	0	0	0
Mo-99	0	0	0	0	0	0	0	0
Tc-99m	0	0	0	0	0	0	0	0
Ag-110m	0	0	0	0	0	0	0	0
Sb-124	0	0	0	0	0	0	0	0
I-131	0	0	0	0	0	0	0	0
I-133	0	0	0	0	0	0	0	0
I-135	0	0	0	0	0	0	0	0
Cs-134	0	0	0	0	0	0	0	0
Cs-137	0	0	0	0	0	0	0	0
Ba-140	0	0	0	0	0	0	0	0
La-140	0	0	0	0	0	0	0	0
Ce-141	0	0	0	0	0	0	0	0
Ce-144	0	0	0	0	0	0	0	0
W-187	0	0	0	0	0	0	0	0
Np-239	0	0	0	0	0	0	0	0

TABLE A-4

DERIVATION OF LIQUID DOSE FACTORS

Table	Title	Page
A-4.1	Dose Factor (A_{it}) Derivation	A-19
A-4.2	Parameters for the Liquid Effluent Pathway	A-22
A-4.3	Justification for Liquid Pathways Used to Assess Dose to Man	A-24

TABLE A-4.1

LIQUID DOSE FACTOR (A_{it}) DERIVATION

For purposes of calculating the dose contribution to organs of various receptor age groups, a composite dose factor, A_{it} , may be used for each radionuclide i . The composite dose factor, A_{it} , is the sum of the freshwater fish, A_{itf} , potable water, A_{itw} , and shoreline deposits pathway, A_{itsh} , dose factors. A_{it} embodies pathway transfer parameters (e.g., bioaccumulation factors), pathway usage factors, organ dose conversion factors, and dilution factors between the release point and assumed point of exposure pathway. The composite dose factor may be expressed as:

$$A_{it} = (K_o (U_w / D_w) + K_o U_f B F_i / D_f) D F_i + (K S U B_o Z W T_i U_{sh} / D_{sh}) (1 - e^{-\lambda_i T_b}) D E$$

(A-4.1)

Where:

- A_{it} = is the composite dose parameter for the total body or organ of an age group for radionuclide, i , for all appropriate pathways, mrem/hr per μ Ci/ml.
- K_o = is a unit conversion factor, $1.14E5$ yr-pCi-ml per μ Ci-hr-l (NUREG-0133).
- U_w = water consumption rate for age group of interest (Table A-4.2).
- U_f = freshwater fish consumption rate for age group of interest (Table A-4.2).
- U_{sh} = duration of time an individual is located on the beach (Table A-4.2).
- D_w = dilution factor which reflects the dilution from the point of release to the nearest potable water intake (Table A-4.2).
- D_f = dilution factor which reflects the dilution from the point of release to the nearest point assumed for the freshwater fish catch (Table A-4.2).
- D_{sh} = dilution factor which reflects the dilution from the point of release to the nearest point assumed for shoreline deposit (Table A-4.2).
- $B F_i$ = bioaccumulation factor for radionuclide i , in freshwater fish, pCi/kg per pCi/l, from Table A-1 of Regulatory Guide 1.109.
- T_i = is the radiological half-life of radionuclide, i , in days.
- λ_i = is the radiological decay constant for radionuclide, i , in sec^{-1} .
- W = is the shoreline width factor (Table A-4.2).
- T_b = the period of time for which sediment or soil is exposed to the contaminated water (Table A-4.2).

- K_c = assumed transfer constant from water to sediment, in liters/kg per hr as defined in Z.
- M_s = mass of sediment, in kg/m² of surface as defined in Z.
- Z = $K_c \times M_s \times (24/693)$, in l per m²-day (Table A-4.2).
- DF_i = dose conversion factor for radionuclide, i, for organ and age group of interest. Used to calculate the radiation dose from an intake of a radionuclide, mrem/pCi (Regulatory Guide 1.109, Tables E-11 to E-14).
- DE_i = dose conversion factor for radionuclide, i, for organ and age group of interest. Used to calculate the radiation dose from an external exposure of a radionuclide, mrem/hr per pCi/m² (Regulatory Guide 1.109, Table E-6).

Example Calculation:

I. Potable Water

The potable water pathway dose factor, A_{itw} , is calculated from Equation A-4.1 by setting the usage factors for freshwater fish and shoreline deposits equal to zero. Equation A-4.1 reduces to the following:

$$A_{itw} = K_o (U_w / D_w) DF_i$$

For Co-60, the total body dose factor for an adult due to the ingestion of potable water is:

$$DF_i = 4.72E-06 \text{ mrem/pCi}$$

$$U_w = 730 \text{ liters/yr}$$

$$D_w = 165$$

$$K_o = 1.14E5 \text{ yr-pCi-ml per } \mu\text{Ci-hr-l}$$

These values yield an A_{itw} factor of 2.38 mrem/hr per $\mu\text{Ci/ml}$ as listed in Table A-2 of this appendix.

II. Freshwater Fish

The freshwater fish pathway dose factor, A_{itf} , is calculated from Equation A-4.1 by setting the usage factors for potable water and shoreline deposits equal to zero.

$$A_{itf} = K_o (U_f BF_i / D_f) DF_i$$

Equation A-4.1 reduces to the following:

For Co-60, the total body dose factor for an adult due to the ingestion of freshwater fish is:

$$DF_i = 4.72E-06 \text{ mrem/pCi}$$

$$U_f = 21 \text{ kg/yr}$$

$$D_f = 12$$

$$BF_i = 50 \text{ pCi/kg per pCi/l}$$

$$K_o = 1.14E5 \text{ yr-pCi-ml per } \mu\text{Ci-hr-l}$$

These values yield an A_{itf} factor of 47.1 mrem/hr per $\mu\text{Ci/ml}$ as listed in Table A-2 of this appendix.

III. Lake Shoreline Deposits

The shoreline deposits pathway dose factor, A_{itsh} , is calculated from Equation A-4.1 by setting the usage factors for potable water and freshwater fish equal to zero. Equation

$$A_{itsh} = (K_o Z W T_i U_{sh} / D_{sh}) (1 - e^{-\lambda_i T_b}) DE_i$$

A-4.1 reduces to the following:

For Co-60, the total body dose factor for an adult from shoreline deposits is:

$$U_{sh} = 12 \text{ hrs/yr}$$

$$D_{sh} = 18$$

$$W = 0.30$$

$$T_i = 1.92E3 \text{ days}$$

$$T_b = 15 \text{ years or } 4.73E8 \text{ sec}$$

$$K_o = 1.14E5 \text{ yr-pCi-ml per } \mu\text{Ci-hr-l}$$

$$Z = 100 \text{ l per m}^2\text{-day}$$

$$\lambda_i = 4.2E-9 \text{ sec}^{-1}$$

$$DE_i = 1.70E-8 \text{ mrem/hr per pCi/m}^2 \text{ (Regulatory Guide 1.109, Table E-6)}$$

These values will yield an A_{itsh} factor of 64.2 mrem/hr per $\mu\text{Ci/ml}$ as listed in Table A-3 of this appendix.

TABLE A-4.2

PARAMETER FOR THE LIQUID EFFLUENT PATHWAY

PARAMETER	VALUE	REFERENCE	TABLE
U _w (liters/yr)-Potable Water/			
- infant	330	R.G. 1.109	E-5
- child	510	R.G. 1.109	E-5
- teen	510	R.G. 1.109	E-5
- adult	730	R.G. 1.109	E-5
U _f (kg/yr)-Freshwater Fish/			
- infant	0	R.G. 1.109	E-5
- child	6.9	R.G. 1.109	E-5
- teen	16	R.G. 1.109	E-5
- adult	21	R.G. 1.109	E-5
U _{sh} (hr/yr)-Lake Shoreline Deposits/			
- infant	0	R.G. 1.109	E-5
- child	14	R.G. 1.109	E-5
- teen	67	R.G. 1.109	E-5
- adult	12	R.G. 1.109	E-5
BF _f (pCi/kg per pCi/l)- Freshwater Fish	Each Radionuclide	R.G. 1.109	A-1
D _w (dimensionless)-Potable Water	165	Site Specific (JAF FSAR Fig. 16.1-19)	
D _f (dimensionless)-Freshwater Fish	12	Site Specific (JAF FSAR Fig. 16.1-19)	
D _{sh} (dimensionless)-Lake Shoreline Deposits	18	Site Specific (JAF FSAR Fig. 16.1-19)	

TABLE A-4.2 (Continued)

PARAMETER FOR THE LIQUID EFFLUENT PATHWAY

PARAMETER	VALUE	REFERENCE	TABLE
DF _i Potable Water/Freshwater Fish (mrem/pCi)	Each Radionuclide	R.G. 1.109	E-11 to E-14
DE _i Lake Shoreline Deposits (mrem/hr per pCi/m ²)	Each Radionuclide	R.G. 1.109	E-6
Z (l per m ² -day)-Lake Shoreline Deposits	100	R.G. 1.109	pg-14
W (dimensionless)-Lake Shoreline Deposits	0.3	R.G. 1.109	A-2
T _b (sec)-Lake Shoreline Deposits	4.73E8	R.G. 1.109	E-15
* Transit Time (hours)-Potable Water	31	Site Specific (Based on a current speed of 0.4 ft./sec JAF FSAR Fig. 16.1-19)	
* Transit Time (hours)-Freshwater Fish Consumption	0	Site Specific (JAF FSAR Fig. 16.1-19)	
* Transit Time (hours)-Lake Shoreline Deposits	2.9	Site Specific (JAF FSAR Fig. 16.1-19)	

* Location of maximally exposed individual for potable water is Oswego, 8.5 miles west of JAF discharge. Location of maximally exposed individual for freshwater fish consumption is the JAF discharge vicinity. Location of maximally exposed individual for lake shoreline deposits is Sunset Bay, 0.8 miles east of JAF discharge.

TABLE A-4.3

JUSTIFICATION FOR LIQUID PATHWAYS USED TO ASSESS DOSE TO MAN

PATHWAY	JUSTIFICATION FOR OMISSION OR INCLUSION
1. POTABLE WATER	This pathway is considered for all required analysis.
2. FRESHWATER FISH	This pathway is considered for all required analysis.
3. FRESHWATER SHELL	This pathway was not considered for the annual dose calculations and the 40CFR190 dose analysis. Reference 6.9 states that direct ingestion of aquatic invertebrates from Lake Ontario is not a common practice.
4. FRESHWATER PLANTS	No known pathway exists for the J.A. FitzPatrick plant and none is included in the dose analysis of References 6.5 through 6.8. Regulatory Guide 1.109, Appendix E, Section 2, page 1.109-36, states "Ingestion of aquatic plant material is not normally assumed."
5. SALTWATER FISH	Not applicable to a freshwater site.
6. SALTWATER SHELL FISH	Not applicable to a freshwater site.
7. SALTWATER PLANTS	Not applicable to a freshwater site.
8. DISCHARGE CANAL SHORELINE	This pathway is not applicable since the J.A. FitzPatrick Plant discharges through a tunnel to a diffuser offshore.
9. RIVER SHORELINE DEPOSITS	Not applicable to a Great Lake site.
10. LAKE SHORELINE DEPOSITS	This pathway is not necessary to demonstrate compliance with 10CFR20 and 10CFR50 as specified in Sections 4.2, and 4.3.1 of NUREG-0133. This pathway is considered for the annual dose calculations, the 40CFR190 dose analysis, and Section 3.4.2.b (1).
11. OCEAN SHORELINE DEPOSITS	Not applicable to a Great Lake Site.

TABLE A-4.3 (Continued)

JUSTIFICATION FOR LIQUID PATHWAYS USED TO ASSESS DOSE TO MAN

PATHWAY	JUSTIFICATION FOR OMISSION OR INCLUSION
12. TIDAL BASIN DEPOSITS	Not applicable to a Great Lake site.
13. SWIMMING	This pathway is not necessary to demonstrate compliance with 10CFR20 and 10CFR50 as specified in Sections 4.2, and 4.3.1 of NUREG-0133. This pathway is not used in the ODCM since its dose contribution is very small (Appendix D, Table D-8).
14. BOATING	This pathway is not necessary to demonstrate compliance with 10CFR20 and 10CFR50 as specified in Sections 4.2, and 4.3.1 of NUREG-0133. This pathway is not used in the ODCM since its dose contribution is very small (See Appendix D, Table D-8).
15. STORED FRUITS AND VEGETABLES	There are two possible methods of establishing this pathway; by using water from the lake for irrigation or using well water for irrigation, which may have become contaminated through discharges to the lake. References 6.6 and 6.7 document that a limited irrigation pathway exists; however, Reference 6.5 states that recent surveys indicate that the irrigation pathways discussed in the other documents no longer use lake water for irrigation. Since Reference 6.5 is the most recent document it is concluded that the irrigation pathway does not exist and need not be considered in any dose analysis. References 6.5 through 6.8 state that the possibility of groundwater contamination is extremely remote and no impact on groundwater is expected.
16. FRESH FRUITS AND VEGETABLES	This pathway need not be considered. See justification for pathway 15.
17. MEAT (CONTAMINATED FORAGE)	This pathway need not be considered. See justification for pathway 15.

TABLE A-4.3 (Continued)

JUSTIFICATION FOR LIQUID PATHWAYS USED TO ASSESS DOSE TO MAN

<u>PATHWAY</u>	<u>JUSTIFICATION FOR OMISSION OR INCLUSION</u>
18. MEAT (CONTAMINATED FEED)	This pathway need not be considered. See Justification for pathway 15.
19. MEAT (CONTAMINATED WATER)	This pathway is not necessary to demonstrate compliance with 10CFR20 and 10CFR50 as specified in Section 4.2 and 4.3.1 of NUREG-0133. The dose calculations shown in References 6.5 through 6.8 do not consider this pathway as a part of the analysis; hence, it is concluded that this pathway is insignificant and need not be considered for annual and 40CFR190 dose calculations.
20. COWS MILK (CONTAMINATED FORAGE)	This pathway need not be considered. See justification for pathway 15.
21. COWS MILK (CONTAMINATED FEED)	This pathway need not be considered. See justification for pathway 15.
22. COWS MILK (CONTAMINATED WATER)	This pathway need not be considered. See justification for pathway 19.
23. GOATS MILK (CONTAMINATED FORAGE)	This pathway need not be considered. See justification for pathway 15.
24. GOATS MILK (CONTAMINATED FEED)	This pathway need not be considered. See justification for pathway 15.
25. GOATS MILK (CONTAMINATED WATER)	This pathway need not be considered. See justification for pathway 19.

APPENDIX B

GASEOUS DOSE CALCULATION DATA

APPENDIX B
GASEOUS DOSE CALCULATION DATA

TABLE	TITLE	PAGE
B-1	Noble Gas Data Transfer Factors (K_i , L_i)	B-3
B-2	Air Dose Transfer Factors (M_i , N_i)	B-4
B-3	Inhalation Environmental Pathway Dose Conversion Factors (P_i) - Limiting Age Groups - Instantaneous	B-5
B-4	Limited Analysis Approach - Limiting Age Groups and Pathways - Gaseous Discharge Environmental Pathway Dose Conversion Factors (R_i)	B-7
B-5	Environmental Pathway Dose Conversion Factors (R_i) for All Remaining Pathways	B-10
B-6	Derivation of Gaseous Dose Factors	B-27
B-7	Quantification and Reporting of C-14 in JAF Releases	B-44

TABLE B-1

TRANSFER FACTORS FOR MAXIMUM DOSE TO A
PERSON OFFSITE DUE TO RADIOACTIVE NOBLE GASES

Dose Transfer Factors

RADIONUCLIDE	<u>GAMMA</u> K_i	<u>BETA</u> L_i	<u>GAMMA + BETA</u> $(L + 1.1 M) i$
	$\frac{\text{mrem}}{\mu\text{Ci sec/m}^3}$	$\frac{\text{mrem}}{\mu\text{Ci sec/m}^3}$	$\frac{\text{mrem}}{\mu\text{Ci sec/m}^3}$
Kr-83m	2.4E-9	--	6.7E-7
Kr-85m	3.7E-5	4.6E-5	8.9E-5
Kr-85	5.1E-7	4.2E-5	4.3E-5
Kr-87	1.9E-4	3.1E-4	5.3E-4
Kr-88	4.7E-4	7.5E-5	6.0E-4
Kr-89	5.3E-4	3.2E-4	9.3E-4
Kr-90	4.9E-4	2.3E-4	8.0E-4
Xe-131m	2.9E-6	1.5E-5	2.0E-5
Xe-133m	8.0E-6	3.1E-5	4.2E-5
Xe-133	9.3E-6	9.7E-6	2.2E-5
Xe-135m	9.9E-5	2.3E-5	1.4E-4
Xe-135	5.7E-5	5.9E-5	1.3E-4
Xe-137	4.5E-5	3.9E-4	4.4E-4
Xe-138	2.8E-4	1.3E-4	4.5E-4
Ar-41	2.8E-4	8.5E-5	4.0E-4

Ref: Regulatory Guide 1.109, Revision 1, Table B-1.

TABLE B-2
TRANSFER FACTORS FOR MAXIMUM OFFSITE AIR DOSE

Air Dose Transfer Factors

RADIONUCLIDE	<u>GAMMA</u> M_i $\frac{\text{mrad}}{\mu\text{Ci sec/m}^3}$	<u>BETA</u> N_i $\frac{\text{mrad}}{\mu\text{Ci sec/m}^3}$
Kr-83m	6.1E-7	9.1E-6
Kr-85m	3.9E-5	6.2E-5
Kr-85	5.4E-7	6.2E-5
Kr-87	2.0E-4	3.3E-4
Kr-88	4.8E-4	9.3E-5
Kr-89	5.5E-4	3.4E-4
Kr-90	5.2E-4	2.5E-4
Xe-131m	4.9E-6	3.5E-5
Xe-133m	1.0E-5	4.7E-5
Xe-133	1.1E-5	3.3E-5
Xe-135m	1.1E-4	2.3E-5
Xe-135	6.1E-5	7.8E-5
Xe-137	4.8E-5	4.0E-4
Xe-138	2.9E-4	1.5E-4
Ar-41	2.9E-4	1.0E-4

Ref: Regulatory Guide 1.109, Revision 1, Table B-1.

TABLE B-3

P_i VALUES - INHALATION - CHILD
$$\frac{\text{mrem/yr}}{\mu\text{Ci/m}^3}$$

NUCLIDE	BONE	LIVER	THYROID	KIDNEY	LUNG	GI-LLI	SKIN	T. BODY
H-3	0	1.12E 03	1.12E 03	1.12E 03	1.12E 03	1.12E 03	0	1.12E 03
Cr-51	0	0	8.55E 01	2.43E 01	1.70E 04	1.08E 03	0	1.54E 02
Mn-54	0	4.29E 04	0	1.00E 04	1.58E 06	2.29E 04	0	9.51E 03
Fe-55	4.74E 04	2.52E 04	0	0	1.11E 05	2.87E 03	0	7.77E 03
Fe-59	2.07E 04	3.34E 04	0	0	1.27E 06	7.07E 04	0	1.67E 04
Co-57	0	9.03E 02	0	0	5.07E 05	1.32E 04	0	1.07E 03
Co-58	0	1.77E 03	0	0	1.11E 06	3.44E 04	0	3.16E 03
Co-60	0	1.31E 04	0	0	7.07E 06	9.62E 04	0	2.26E 04
Zn-65	4.26E 04	1.13E 05	0	7.14E 04	9.95E 05	1.63E 04	0	7.03E 04
Se-75	0	0	0	0	0	0		0
Sr-89	5.99E 05	0	0	0	2.16E 06	1.67E 05	0	1.72E 04
Sr-90	1.01E 08	0	0	0	1.48E 07	3.43E 05	0	6.44E 06
Zr-95	1.90E 05	4.18E 04	0	5.96E 04	2.23E 06	6.11E 04	0	3.70E 04
Nb-95	2.35E 04	9.18E 03	0	8.62E 03	6.14E 05	3.70E 04	0	6.55E 03
Mo-99	0	1.72E 02	0	3.92E 02	1.35E 05	1.27E 05	0	4.25E 01
Ag-110m	1.69E 04	1.14E 04	0	2.12E 04	5.48E 06	1.00E 05	0	9.14E 03
Sb-124	5.74E 04	7.40E 02	1.26E 02	0	3.24E 06	1.64E 05	0	2.00E 04
I-131	4.81E 04	4.81E 04	1.62E 07	7.88E 04	0	2.84E 03	0	2.73E 04
I-133	1.66E 04	2.03E 04	3.85E 06	3.38E 04	0	5.48E 03	0	7.70E 03
I-135	4.92E 03	8.73E 03	7.92E 05	1.34E 04	0	4.44E 03	0	4.14E 03
Cs-134	6.51E 05	1.01E 06	0	3.30E 05	1.21E 05	3.85E 03	0	2.25E 05
Cs-136	6.51E 04	1.71E 05	0	9.55E 04	1.45E 04	4.18E 03	0	1.16E 05
Cs-137	9.07E 05	8.25E 05	0	2.82E 05	1.04E 05	3.62E 03	0	1.28E 05
Ba-140	7.40E 04	6.48E 01	0	2.11E 01	1.74E 06	1.02E 05	0	4.33E 03
La-140	6.44E 02	2.25E 02	0	0	1.83E 05	2.26E 05	0	7.55E 01
Ce-141	3.92E 04	1.95E 04	0	8.55E 03	5.44E 05	5.66E 04	0	2.90E 03
Ce-144	6.77E 06	2.12E 06	0	1.17E 06	1.20E 07	3.89E 05	0	3.61E 05

TABLE B-3 (Continued)

P_i VALUES - INHALATION - TEEN
$$\frac{\text{mrem/yr}}{\mu\text{Ci/m}^3}$$

NUCLIDE	BONE	LIVER	THYROID	KIDNEY	LUNG	GI-LLI	SKIN	T. BODY
H-3	0	1.27E 03	1.27E 03	1.27E 03	1.27E 03	1.27E 03	0	1.27E 03
Cr-51	0	0	7.50E 01	3.07E 01	2.10E 04	3.00E 03	0	1.35E 02
Mn-54	0	5.11E 04	0	1.27E 04	1.98E 06	6.68E 04	0	8.40E 03
Fe-55	3.34E 04	2.38E 04	0	0	1.24E 05	6.39E 03	0	5.54E 03
Fe-59	1.59E 04	3.70E 04	0	0	1.53E 06	1.78E 05	0	1.43E 04
Co-57	0	9.44E 02	0	0	5.86E 05	3.14E 04	0	9.20E 02
Co-58	0	2.07E 03	0	0	1.34E 06	9.52E 04	0	2.78E 03
Co-60	0	1.51E 04	0	0	8.72E 06	2.59E 05	0	1.98E 04
Zn-65	3.86E 04	1.34E 05	0	8.64E 04	1.24E 06	4.66E 04	0	6.24E 04
Se-75	0	0	0	0	0	0	0	0
Sr-89	4.34E 05	0	0	0	2.42E 06	3.71E 05	0	1.25E 04
Sr-90	1.08E 08	0	0	0	1.65E 07	7.65E 05	0	6.68E 06
Zr-95	1.46E 05	4.58E 04	0	6.74E 04	2.69E 06	1.49E 05	0	3.15E 04
Nb-95	1.86E 04	1.03E 04	0	1.00E 04	7.51E 05	9.68E 04	0	5.66E 03
Mo-99	0	1.69E 02	0	4.11E 02	1.54E 05	2.69E 05	0	3.22E 01
Ag-110m	1.38E 04	1.31E 04	0	2.50E 04	6.75E 06	2.73E 05	0	7.99E 03
Sb-124	4.30E 04	7.94E 02	9.76E 01	0	3.85E 06	3.98E 05	0	1.68E 04
I-131	3.54E 04	4.91E 04	1.46E 07	8.40E 04	0	6.49E 03	0	2.64E 04
I-133	1.22E 04	2.05E 04	2.92E 06	3.59E 04	0	1.03E 04	0	6.22E 03
I-135	3.70E 03	9.44E 03	6.21E 05	1.49E 04	0	6.95E 03	0	3.49E 03
Cs-134	5.02E 05	1.13E 06	0	3.75E 05	1.46E 05	9.76E 03	0	5.49E 05
Cs-136	5.15E 04	1.94E 05	0	1.10E 05	1.78E 04	1.09E 04	0	1.37E 05
Cs-137	6.70E 05	8.48E 05	0	3.04E 05	1.21E 05	8.48E 03	0	3.11E 05
Ba-140	5.47E 04	6.70E 01	0	2.28E 01	2.03E 06	2.29E 05	0	3.52E 03
La-140	4.79E 02	2.36E 02	0	0	2.14E 05	4.87E 05	0	6.26E 01
Ce-141	2.84E 04	1.90E 04	0	8.88E 03	6.14E 05	1.26E 05	0	2.17E 03
Ce-144	4.89E 06	2.02E 06	0	1.21E 06	1.34E 07	8.64E 05	0	2.62E 05

TABLE B-4

R_i VALUES - COW MILK - INFANT
$$\frac{\text{m}^2\text{-mrem/yr}}{\mu\text{Ci/sec}}$$

Nuclide	Bone	Liver	Thyroid	Kidney	Lung	GI-LLI	Skin	T.Body
H-3*	0.00E+00	2.38E+03	2.38E+03	2.38E+03	2.38E+03	2.38E+03	0.00E+00	2.38E+03
Cr-51	0.00E+00	0.00E+00	5.45E+04	1.19E+04	1.06E+05	2.44E+06	0.00E+00	8.36E+04
Mn-54	0.00E+00	2.51E+07	0.00E+00	5.56E+06	0.00E+00	9.22E+06	0.00E+00	5.69E+06
Fe-55	8.98E+07	5.80E+07	0.00E+00	0.00E+00	2.83E+07	7.36E+06	0.00E+00	1.55E+07
Fe-59	1.22E+08	2.13E+08	0.00E+00	0.00E+00	6.29E+07	1.02E+08	0.00E+00	8.39E+07
Co-57	0.00E+00	5.72E+06	0.00E+00	0.00E+00	0.00E+00	1.95E+07	0.00E+00	9.30E+06
Co-58	0.00E+00	1.39E+07	0.00E+00	0.00E+00	0.00E+00	3.46E+07	0.00E+00	3.46E+07
Co-60	0.00E+00	5.90E+07	0.00E+00	0.00E+00	0.00E+00	1.40E+08	0.00E+00	1.39E+08
Zn-65	3.53E+09	1.21E+10	0.00E+00	5.87E+09	0.00E+00	1.02E+10	0.00E+00	5.58E+09
Se-75	0.00E+00	0.00E+00	0.00E+00	0.00E+00	0.00E+00	0.00E+00	0.00E+00	0.00E+00
Sr-89	6.93E+09	0.00E+00	0.00E+00	0.00E+00	0.00E+00	1.43E+08	0.00E+00	1.99E+08
Sr-90	8.19E+10	0.00E+00	0.00E+00	0.00E+00	0.00E+00	1.02E+09	0.00E+00	2.09E+10
Zr-95	3.85E+03	9.39E+02	0.00E+00	1.01E+03	0.00E+00	4.67E+05	0.00E+00	6.66E+02
Nb-95	3.14E+05	1.29E+05	0.00E+00	9.28E+04	0.00E+00	1.09E+08	0.00E+00	7.48E+04
Mo-99	0.00E+00	1.04E+08	0.00E+00	1.55E+08	0.00E+00	3.43E+07	0.00E+00	2.03E+07
Ag-110m	2.46E+08	1.79E+08	0.00E+00	2.56E+08	0.00E+00	9.29E+09	0.00E+00	1.19E+08
Sb-124	1.18E+08	1.73E+06	3.12E+05	0.00E+00	7.37E+07	3.63E+08	0.00E+00	3.65E+07
I-131	1.36E+09	1.60E+09	5.27E+11	1.87E+09	0.00E+00	5.72E+07	0.00E+00	7.05E+08
I-133	1.81E+07	2.64E+07	4.80E+09	3.10E+07	0.00E+00	4.47E+06	0.00E+00	7.73E+06
I-135	5.61E+04	1.12E+05	1.00E+07	1.24E+05	0.00E+00	4.04E+04	0.00E+00	4.07E+04
Cs-134	2.41E+10	4.50E+10	0.00E+00	1.16E+10	4.75E+09	1.22E+08	0.00E+00	4.54E+09
Cs-136	9.91E+08	2.91E+09	0.00E+00	1.16E+09	2.37E+08	4.43E+07	0.00E+00	1.09E+09
Cs-137	3.47E+10	4.06E+10	0.00E+00	1.09E+10	4.41E+09	1.27E+08	0.00E+00	2.88E+09
Ba-140	1.21E+08	1.21E+05	0.00E+00	2.87E+04	7.42E+04	2.97E+07	0.00E+00	6.23E+06
La-140	2.03E+01	7.99E+00	0.00E+00	0.00E+00	0.00E+00	9.38E+04	0.00E+00	2.06E+00
Ce-141	2.28E+04	1.39E+04	0.00E+00	4.29E+03	0.00E+00	7.18E+06	0.00E+00	1.64E+03
Ce-144	1.49E+06	6.10E+05	0.00E+00	2.46E+05	0.00E+00	8.55E+07	0.00E+00	8.35E+04

* $\frac{\text{mrem/yr}}{\mu\text{Ci/m}^3}$

TABLE B-4 (Continued)

R_i VALUES - GOAT MILK - INFANT
 $\frac{\text{m}^2\text{-mrem/yr}}{\mu\text{Ci/sec}}$

Nuclide	Bone	Liver	Thyroid	Kidney	Lung	GI-LLI	Skin	T.Body
H-3*	0.00E+00	4.86E+03	4.86E+03	4.86E+03	4.86E+03	4.86E+03	0.00E+00	4.86E+03
Cr-51	0.00E+00	0.00E+00	6.54E+03	1.43E+03	1.27E+04	2.92E+05	0.00E+00	1.00E+04
Mn-54	0.00E+00	3.01E+06	0.00E+00	6.67E+05	0.00E+00	1.11E+06	0.00E+00	6.82E+05
Fe-55	1.17E+06	7.54E+05	0.00E+00	0.00E+00	3.69E+05	9.57E+04	0.00E+00	2.01E+05
Fe-59	1.58E+06	2.77E+06	0.00E+00	0.00E+00	8.18E+05	1.32E+06	0.00E+00	1.09E+06
Co-57	0.00E+00	6.86E+05	0.00E+00	0.00E+00	0.00E+00	2.34E+06	0.00E+00	1.12E+06
Co-58	0.00E+00	1.67E+06	0.00E+00	0.00E+00	0.00E+00	4.15E+06	0.00E+00	4.16E+06
Co-60	0.00E+00	7.08E+06	0.00E+00	0.00E+00	0.00E+00	1.69E+07	0.00E+00	1.67E+07
Zn-65	4.23E+08	1.45E+09	0.00E+00	7.04E+08	0.00E+00	1.23E+09	0.00E+00	6.70E+08
Se-75	0.00E+00	0.00E+00	0.00E+00	0.00E+00	0.00E+00	0.00E+00	0.00E+00	0.00E+00
Sr-89	1.46E+10	0.00E+00	0.00E+00	0.00E+00	0.00E+00	2.99E+08	0.00E+00	4.18E+08
Sr-90	1.72E+11	0.00E+00	0.00E+00	0.00E+00	0.00E+00	2.15E+09	0.00E+00	4.38E+10
Zr-95	4.62E+02	1.13E+02	0.00E+00	1.21E+02	0.00E+00	5.61E+04	0.00E+00	7.99E+01
Nb-95	3.77E+04	1.55E+04	0.00E+00	1.11E+04	0.00E+00	1.31E+07	0.00E+00	8.98E+03
Mo-99	0.00E+00	1.25E+07	0.00E+00	1.86E+07	0.00E+00	4.11E+06	0.00E+00	2.43E+06
Ag-110m	2.95E+07	2.15E+07	0.00E+00	3.08E+07	0.00E+00	1.12E+09	0.00E+00	1.42E+07
Sb-124	1.41E+07	2.08E+05	3.75E+04	0.00E+00	8.84E+06	4.36E+07	0.00E+00	4.38E+06
I-131	1.63E+09	1.92E+09	6.32E+11	2.25E+09	0.00E+00	6.86E+07	0.00E+00	8.46E+08
I-133	2.18E+07	3.17E+07	5.76E+09	3.72E+07	0.00E+00	5.36E+06	0.00E+00	9.28E+06
I-135	6.74E+04	1.34E+05	1.20E+07	1.49E+05	0.00E+00	4.85E+04	0.00E+00	4.89E+04
Cs-134	7.23E+10	1.35E+11	0.00E+00	3.47E+10	1.42E+10	3.66E+08	0.00E+00	1.36E+10
Cs-136	2.97E+09	8.74E+09	0.00E+00	3.48E+09	7.12E+08	1.33E+08	0.00E+00	3.26E+09
Cs-137	1.04E+11	1.22E+11	0.00E+00	3.27E+10	1.32E+10	3.81E+08	0.00E+00	8.63E+09
Ba-140	1.45E+07	1.45E+04	0.00E+00	3.44E+03	8.90E+03	3.56E+06	0.00E+00	7.47E+05
La-140	2.43E+00	9.59E-01	0.00E+00	0.00E+00	0.00E+00	1.13E+04	0.00E+00	2.47E-01
Ce-141	2.74E+03	1.67E+03	0.00E+00	5.14E+02	0.00E+00	8.62E+05	0.00E+00	1.96E+02
Ce-144	1.79E+05	7.32E+04	0.00E+00	2.96E+04	0.00E+00	1.03E+07	0.00E+00	1.00E+04

* $\frac{\text{mrem/yr}}{\mu\text{Ci/m}^3}$

TABLE B-4 (Continued)

R_i VALUES - VEGETATION - CHILD
 $\frac{\text{m}^2\text{-mrem/yr}}{\mu\text{Ci/sec}}$

Nuclide	Bone	Liver	Thyroid	Kidney	Lung	GI-LLI	Skin	T.Body
H-3*	0.00E+00	4.01E+03	4.01E+03	4.01E+03	4.01E+03	4.01E+03	0.00E+00	4.01E+03
Cr-51	0.00E+00	0.00E+00	6.50E+04	1.78E+04	1.19E+05	6.21E+06	0.00E+00	1.17E+05
Mn-54	0.00E+00	6.65E+08	0.00E+00	1.86E+08	0.00E+00	5.58E+08	0.00E+00	1.77E+08
Fe-55	8.01E+08	4.25E+08	0.00E+00	0.00E+00	2.40E+08	7.87E+07	0.00E+00	1.32E+08
Fe-59	3.98E+08	6.43E+08	0.00E+00	0.00E+00	1.86E+08	6.70E+08	0.00E+00	3.20E+08
Co-57	0.00E+00	2.99E+07	0.00E+00	0.00E+00	0.00E+00	2.45E+08	0.00E+00	6.04E+07
Co-58	0.00E+00	6.44E+07	0.00E+00	0.00E+00	0.00E+00	3.76E+08	0.00E+00	1.97E+08
Co-60	0.00E+00	3.78E+08	0.00E+00	0.00E+00	0.00E+00	2.10E+09	0.00E+00	1.12E+09
Zn-65	8.13E+08	2.16E+09	0.00E+00	1.36E+09	0.00E+00	3.80E+08	0.00E+00	1.35E+09
Se-75	0.00E+00	0.00E+00	0.00E+00	0.00E+00	0.00E+00	0.00E+00	0.00E+00	0.00E+00
Sr-89	3.60E+10	0.00E+00	0.00E+00	0.00E+00	0.00E+00	1.39E+09	0.00E+00	1.03E+09
Sr-90	1.24E+12	0.00E+00	0.00E+00	0.00E+00	0.00E+00	1.67E+10	0.00E+00	3.15E+11
Zr-95	3.86E+06	8.48E+05	0.00E+00	1.21E+06	0.00E+00	8.85E+08	0.00E+00	7.55E+05
Nb-95	4.10E+05	1.60E+05	0.00E+00	1.50E+05	0.00E+00	2.96E+08	0.00E+00	1.14E+05
Mo-99	0.00E+00	7.70E+06	0.00E+00	1.64E+07	0.00E+00	6.37E+06	0.00E+00	1.91E+06
Ag-110m	3.21E+07	2.17E+07	0.00E+00	4.04E+07	0.00E+00	2.58E+09	0.00E+00	1.73E+07
Sb-124	3.52E+08	4.56E+06	7.77E+05	0.00E+00	1.95E+08	2.20E+09	0.00E+00	1.23E+08
I-131	1.43E+08	1.44E+08	4.75E+10	2.36E+08	0.00E+00	1.28E+07	0.00E+00	8.17E+07
I-133	3.52E+06	4.35E+06	8.08E+08	7.25E+06	0.00E+00	1.75E+06	0.00E+00	1.65E+06
I-135	6.18E+04	1.11E+05	9.86E+06	1.71E+05	0.00E+00	8.48E+04	0.00E+00	5.26E+04
Cs-134	1.60E+10	2.63E+10	0.00E+00	8.15E+09	2.93E+09	1.42E+08	0.00E+00	5.55E+09
Cs-136	8.24E+07	2.27E+08	0.00E+00	1.21E+08	1.80E+07	7.96E+06	0.00E+00	1.47E+08
Cs-137	2.39E+10	2.29E+10	0.00E+00	7.46E+09	2.68E+09	1.43E+08	0.00E+00	3.38E+09
Ba-140	2.77E+08	2.42E+05	0.00E+00	7.89E+04	1.44E+05	1.40E+08	0.00E+00	1.61E+07
La-140	3.24E+03	1.13E+03	0.00E+00	0.00E+00	0.00E+00	3.16E+07	0.00E+00	3.82E+02
Ce-141	6.56E+05	3.27E+05	0.00E+00	1.43E+05	0.00E+00	4.08E+08	0.00E+00	4.86E+04
Ce-144	1.27E+08	3.98E+07	0.00E+00	2.21E+07	0.00E+00	1.04E+10	0.00E+00	6.78E+06

* $\frac{\text{mrem/yr}}{\mu\text{Ci/m}^3}$

TABLE B-5

R_i VALUES - INHALATION - ADULT
$$\frac{\text{mrem/yr}}{\mu\text{Ci/m}^3}$$

Nuclide	Bone	Liver	Thyroid	Kidney	Lung	GI-LLI	Skin	T.Body
H-3	0.00E+00	1.26E+03	1.26E+03	1.26E+03	1.26E+03	1.26E+03	0.00E+00	1.26E+03
Cr-51	0.00E+00	0.00E+00	5.95E+01	2.28E+01	1.44E+04	3.32E+03	0.00E+00	1.00E+02
Mn-54	0.00E+00	3.96E+04	0.00E+00	9.84E+03	1.40E+06	7.74E+04	0.00E+00	6.30E+03
Fe-55	2.46E+04	1.70E+04	0.00E+00	0.00E+00	7.21E+04	6.03E+03	0.00E+00	3.94E+03
Fe-59	1.18E+04	2.78E+04	0.00E+00	0.00E+00	1.02E+06	1.88E+05	0.00E+00	1.06E+04
Co-57	0.00E+00	6.92E+02	0.00E+00	0.00E+00	3.70E+05	3.14E+04	0.00E+00	6.71E+02
Co-58	0.00E+00	1.58E+03	0.00E+00	0.00E+00	9.28E+05	1.06E+05	0.00E+00	2.07E+03
Co-60	0.00E+00	1.15E+04	0.00E+00	0.00E+00	5.97E+06	2.85E+05	0.00E+00	1.48E+04
Zn-65	3.24E+04	1.03E+05	0.00E+00	6.90E+04	8.64E+05	5.34E+04	0.00E+00	4.66E+04
Se-75	0.00E+00	4.96E+04	0.00E+00	1.20E+05	6.88E+05	7.04E+04	0.00E+00	1.28E+03
Sr-89	3.04E+05	0.00E+00	0.00E+00	0.00E+00	1.40E+06	3.50E+05	0.00E+00	8.72E+03
Sr-90	9.92E+07	0.00E+00	0.00E+00	0.00E+00	9.60E+06	7.22E+05	0.00E+00	6.10E+06
Zr-95	1.07E+05	3.44E+04	0.00E+00	5.42E+04	1.77E+06	1.50E+05	0.00E+00	2.33E+04
Nb-95	1.41E+04	7.82E+03	0.00E+00	7.74E+03	5.05E+05	1.04E+05	0.00E+00	4.21E+03
Mo-99	0.00E+00	1.21E+02	0.00E+00	2.91E+02	9.12E+04	2.48E+05	0.00E+00	2.30E+01
Ag-110m	1.08E+04	1.00E+04	0.00E+00	1.97E+04	4.63E+06	3.02E+05	0.00E+00	5.94E+03
Sb-124	3.12E+04	5.89E+02	7.55E+01	0.00E+00	2.48E+06	4.06E+05	0.00E+00	1.24E+04
I-131	2.52E+04	3.58E+04	1.19E+07	6.13E+04	0.00E+00	6.28E+03	0.00E+00	2.05E+04
I-133	8.64E+03	1.48E+04	2.15E+06	2.58E+04	0.00E+00	8.88E+03	0.00E+00	4.52E+03
I-135	2.68E+03	6.98E+03	4.48E+05	1.11E+04	0.00E+00	5.25E+03	0.00E+00	2.57E+03
Cs-134	3.73E+05	8.48E+05	0.00E+00	2.87E+05	9.76E+04	1.04E+04	0.00E+00	7.28E+05
Cs-136	3.90E+04	1.46E+05	0.00E+00	8.56E+04	1.20E+04	1.17E+04	0.00E+00	1.10E+05
Cs-137	4.78E+05	6.21E+05	0.00E+00	2.22E+05	7.52E+04	8.40E+03	0.00E+00	4.28E+05
Ba-140	3.90E+04	4.90E+01	0.00E+00	1.67E+01	1.27E+06	2.18E+05	0.00E+00	2.57E+03
La-140	3.44E+02	1.74E+02	0.00E+00	0.00E+00	1.36E+05	4.58E+05	0.00E+00	4.58E+01
Ce-141	1.99E+04	1.35E+04	0.00E+00	6.26E+03	3.62E+05	1.20E+05	0.00E+00	1.53E+03
Ce-144	3.43E+06	1.43E+06	0.00E+00	8.48E+05	7.78E+06	8.16E+05	0.00E+00	1.84E+05

TABLE B-5 (Continued)

R_i VALUES - VEGETATION - ADULT

$$\frac{\text{m}^2\text{-mrem/yr}}{\mu\text{Ci/sec}}$$

Nuclide	Bone	Liver	Thyroid	Kidney	Lung	GI-LLI	Skin	T.Body
H-3*	0.00E+00	2.26E+03	2.26E+03	2.26E+03	2.26E+03	2.26E+03	0.00E+00	2.26E+03
Cr-51	0.00E+00	0.00E+00	2.78E+04	1.02E+04	6.16E+04	1.17E+07	0.00E+00	4.64E+04
Mn-54	0.00E+00	3.13E+08	0.00E+00	9.31E+07	0.00E+00	9.59E+08	0.00E+00	5.97E+07
Fe-55	2.10E+08	1.45E+08	0.00E+00	0.00E+00	8.08E+07	8.31E+07	0.00E+00	3.38E+07
Fe-59	1.26E+08	2.96E+08	0.00E+00	0.00E+00	8.28E+07	9.88E+08	0.00E+00	1.14E+08
Co-57	0.00E+00	1.17E+07	0.00E+00	0.00E+00	0.00E+00	2.97E+08	0.00E+00	1.95E+07
Co-58	0.00E+00	3.07E+07	0.00E+00	0.00E+00	0.00E+00	6.23E+08	0.00E+00	6.89E+07
Co-60	0.00E+00	1.67E+08	0.00E+00	0.00E+00	0.00E+00	3.14E+09	0.00E+00	3.69E+08
Zn-65	3.17E+08	1.01E+09	0.00E+00	6.75E+08	0.00E+00	6.36E+08	0.00E+00	4.56E+08
Se-75	0.00E+00	4.96E+04	0.00E+00	1.20E+05	0.00E+00	0.00E+00	0.00E+00	0.00E+00
Sr-89	9.97E+09	0.00E+00	0.00E+00	0.00E+00	0.00E+00	1.60E+09	0.00E+00	2.86E+08
Sr-90	6.05E+11	0.00E+00	0.00E+00	0.00E+00	0.00E+00	1.75E+10	0.00E+00	1.48E+11
Zr-95	1.17E+06	3.77E+05	0.00E+00	5.91E+05	0.00E+00	1.19E+09	0.00E+00	2.55E+05
Nb-95	1.42E+05	7.92E+04	0.00E+00	7.83E+04	0.00E+00	4.81E+08	0.00E+00	4.26E+04
Mo-99	0.00E+00	6.14E+06	0.00E+00	1.39E+07	0.00E+00	1.42E+07	0.00E+00	1.17E+06
Ag-110m	1.05E+07	9.75E+06	0.00E+00	1.92E+07	0.00E+00	3.98E+09	0.00E+00	5.79E+06
Sb-124	1.04E+08	1.96E+06	2.51E+05	0.00E+00	8.07E+07	2.94E+09	0.00E+00	4.11E+07
I-131	8.07E+07	1.15E+08	3.78E+10	1.98E+08	0.00E+00	3.05E+07	0.00E+00	6.62E+07
I-133	2.08E+06	3.61E+06	5.31E+08	6.31E+06	0.00E+00	3.25E+06	0.00E+00	1.10E+06
I-135	3.85E+04	1.01E+05	6.65E+06	1.62E+05	0.00E+00	1.14E+05	0.00E+00	3.72E+04
Cs-134	4.67E+09	1.11E+10	0.00E+00	3.59E+09	1.19E+09	1.94E+08	0.00E+00	9.08E+09
Cs-136	4.27E+07	1.68E+08	0.00E+00	9.37E+07	1.28E+07	1.91E+07	0.00E+00	1.21E+08
Cs-137	6.36E+09	8.70E+09	0.00E+00	2.95E+09	9.81E+08	1.68E+08	0.00E+00	5.70E+09
Ba-140	1.28E+08	1.61E+05	0.00E+00	5.49E+04	9.24E+04	2.65E+08	0.00E+00	8.42E+06
La-140	1.97E+03	9.95E+02	0.00E+00	0.00E+00	0.00E+00	7.30E+07	0.00E+00	2.63E+02
Ce-141	1.97E+05	1.33E+05	0.00E+00	6.19E+04	0.00E+00	5.10E+08	0.00E+00	1.51E+04
Ce-144	3.29E+07	1.38E+07	0.00E+00	8.16E+06	0.00E+00	1.11E+10	0.00E+00	1.77E+06

* $\frac{\text{mrem/yr}}{\mu\text{Ci/m}^3}$

TABLE B-5 (Continued)
R_i VALUES - COW MEAT - ADULT
 $\frac{\text{m}^2\text{-mrem/yr}}{\mu\text{Ci/sec}}$

Nuclide	Bone	Liver	Thyroid	Kidney	Lung	GI-LLI	Skin	T.Body
H-3	0.00E+00	3.25E+02	3.25E+02	3.25E+02	3.25E+02	3.25E+02	0.00E+00	3.25E+02
Cr-51	0.00E+00	0.00E+00	2.18E+03	8.05E+02	4.85E+03	9.19E+05	0.00E+00	3.65E+03
Mn-54	0.00E+00	5.91E+06	0.00E+00	1.76E+06	0.00E+00	1.81E+07	0.00E+00	1.13E+06
Fe-55	1.95E+08	1.35E+08	0.00E+00	0.00E+00	7.51E+07	7.72E+07	0.00E+00	3.14E+07
Fe-59	1.44E+08	3.39E+08	0.00E+00	0.00E+00	9.47E+07	1.13E+09	0.00E+00	1.30E+08
Co-57	0.00E+00	3.60E+06	0.00E+00	0.00E+00	0.00E+00	9.14E+07	0.00E+00	5.99E+06
Co-58	0.00E+00	1.04E+07	0.00E+00	0.00E+00	0.00E+00	2.12E+08	0.00E+00	2.34E+07
Co-60	0.00E+00	5.03E+07	0.00E+00	0.00E+00	0.00E+00	9.46E+08	0.00E+00	1.11E+08
Zn-65	2.26E+08	7.20E+08	0.00E+00	4.81E+08	0.00E+00	4.53E+08	0.00E+00	3.25E+08
Se-75	0.00E+00	0.00E+00	0.00E+00	0.00E+00	0.00E+00	0.00E+00	0.00E+00	0.00E+00
Sr-89	1.66E+08	0.00E+00	0.00E+00	0.00E+00	0.00E+00	2.66E+07	0.00E+00	4.77E+06
Sr-90	8.38E+09	0.00E+00	0.00E+00	0.00E+00	0.00E+00	2.42E+08	0.00E+00	2.06E+09
Zr-95	1.06E+06	3.40E+05	0.00E+00	5.33E+05	0.00E+00	1.08E+09	0.00E+00	2.30E+05
Nb-95	1.22E+06	6.77E+05	0.00E+00	6.69E+05	0.00E+00	4.11E+09	0.00E+00	3.64E+05
Mo-99	0.00E+00	5.00E+04	0.00E+00	1.13E+05	0.00E+00	1.16E+05	0.00E+00	9.51E+03
Ag-110m	4.25E+06	3.93E+06	0.00E+00	7.73E+06	0.00E+00	1.61E+09	0.00E+00	2.34E+06
Sb-124	1.11E+07	2.10E+05	2.70E+04	0.00E+00	8.66E+06	3.16E+08	0.00E+00	4.41E+06
I-131	5.37E+06	7.68E+06	2.52E+09	1.32E+07	0.00E+00	2.03E+06	0.00E+00	4.40E+06
I-133	1.83E-01	3.18E-01	4.67E+01	5.54E-01	0.00E+00	2.85E-01	0.00E+00	9.68E-02
I-135	2.21E-17	5.79E-17	3.82E-15	9.29E-17	0.00E+00	6.54E-17	0.00E+00	2.14E-17
Cs-134	4.35E+08	1.03E+09	0.00E+00	3.35E+08	1.11E+08	1.81E+07	0.00E+00	8.46E+08
Cs-136	6.04E+06	2.39E+07	0.00E+00	1.33E+07	1.82E+06	2.71E+06	0.00E+00	1.72E+07
Cs-137	5.88E+08	8.04E+08	0.00E+00	2.73E+08	9.07E+07	1.56E+07	0.00E+00	5.27E+08
Ba-140	1.44E+07	1.81E+04	0.00E+00	6.15E+03	1.04E+04	2.97E+07	0.00E+00	9.44E+05
La-140	1.85E-02	9.35E-03	0.00E+00	0.00E+00	0.00E+00	6.86E+02	0.00E+00	2.47E-03
Ce-141	7.38E+03	4.99E+03	0.00E+00	2.32E+03	0.00E+00	1.91E+07	0.00E+00	5.66E+02
Ce-144	9.34E+05	3.90E+05	0.00E+00	2.31E+05	0.00E+00	3.16E+08	0.00E+00	5.01E+04

* $\frac{\text{mrem/yr}}{\mu\text{Ci/m}^3}$

TABLE B-5 (Continued)

R_i VALUES - COW MILK - ADULT
 $\frac{\text{m}^2\text{-mrem/yr}}{\mu\text{Ci/sec}}$

Nuclide	Bone	Liver	Thyroid	Kidney	Lung	GI-LLI	Skin	T.Body
H-3*	0.00E+00	7.63E+02	7.63E+02	7.63E+02	7.63E+02	7.63E+02	0.00E+00	7.63E+02
Cr-51	0.00E+00	0.00E+00	8.85E+03	3.26E+03	1.97E+04	3.73E+06	0.00E+00	1.48E+04
Mn-54	0.00E+00	5.41E+06	0.00E+00	1.61E+06	0.00E+00	1.66E+07	0.00E+00	1.03E+06
Fe-55	1.67E+07	1.15E+07	0.00E+00	0.00E+00	6.43E+06	6.61E+06	0.00E+00	2.69E+06
Fe-59	1.61E+07	3.79E+07	0.00E+00	0.00E+00	1.06E+07	1.26E+08	0.00E+00	1.45E+07
Co-57	0.00E+00	8.18E+05	0.00E+00	0.00E+00	0.00E+00	2.07E+07	0.00E+00	1.36E+06
Co-58	0.00E+00	2.70E+06	0.00E+00	0.00E+00	0.00E+00	5.47E+07	0.00E+00	6.05E+06
Co-60	0.00E+00	1.10E+07	0.00E+00	0.00E+00	0.00E+00	2.06E+08	0.00E+00	2.42E+07
Zn-65	8.72E+08	2.77E+09	0.00E+00	1.86E+09	0.00E+00	1.75E+09	0.00E+00	1.25E+09
Se-75	0.00E+00	0.00E+00	0.00E+00	0.00E+00	0.00E+00	0.00E+00	0.00E+00	0.00E+00
Sr-89	7.99E+08	0.00E+00	0.00E+00	0.00E+00	0.00E+00	1.28E+08	0.00E+00	2.29E+07
Sr-90	3.15E+10	0.00E+00	0.00E+00	0.00E+00	0.00E+00	9.11E+08	0.00E+00	7.74E+09
Zr-95	5.34E+02	1.71E+02	0.00E+00	2.69E+02	0.00E+00	5.43E+05	0.00E+00	1.16E+02
Nb-95	4.37E+04	2.43E+04	0.00E+00	2.40E+04	0.00E+00	1.48E+08	0.00E+00	1.31E+04
Mo-99	0.00E+00	1.24E+07	0.00E+00	2.80E+07	0.00E+00	2.87E+07	0.00E+00	2.36E+06
Ag-110m	3.70E+07	3.43E+07	0.00E+00	6.74E+07	0.00E+00	1.40E+10	0.00E+00	2.04E+07
Sb-124	1.45E+07	2.73E+05	3.51E+04	0.00E+00	1.13E+07	4.11E+08	0.00E+00	5.73E+06
I-131	1.48E+08	2.12E+08	6.94E+10	3.63E+08	0.00E+00	5.59E+07	0.00E+00	1.21E+08
I-133	1.93E+06	3.37E+06	4.95E+08	5.87E+06	0.00E+00	3.02E+06	0.00E+00	1.03E+06
I-135	6.42E+03	1.68E+04	1.11E+06	2.70E+04	0.00E+00	1.90E+04	0.00E+00	6.20E+03
Cs-134	3.74E+09	8.89E+09	0.00E+00	2.88E+09	9.55E+08	1.56E+08	0.00E+00	7.27E+09
Cs-136	1.32E+08	5.21E+08	0.00E+00	2.90E+08	3.98E+07	5.92E+07	0.00E+00	3.75E+08
Cs-137	4.98E+09	6.80E+09	0.00E+00	2.31E+09	7.68E+08	1.32E+08	0.00E+00	4.46E+09
Ba-140	1.35E+07	1.69E+04	0.00E+00	5.75E+03	9.69E+03	2.77E+07	0.00E+00	8.83E+05
La-140	2.26E+00	1.14E+00	0.00E+00	0.00E+00	0.00E+00	8.35E+04	0.00E+00	3.00E-01
Ce-141	2.55E+03	1.72E+03	0.00E+00	8.00E+02	0.00E+00	6.58E+06	0.00E+00	1.95E+02
Ce-144	2.29E+05	9.58E+04	0.00E+00	5.68E+04	0.00E+00	7.75E+07	0.00E+00	1.23E+04

* $\frac{\text{mrem/yr}}{\mu\text{Ci/m}^3}$

TABLE B-5 (Continued)

R_i VALUES - GOAT MILK - ADULT
 $\frac{\text{m}^2\text{-mrem/yr}}{\mu\text{Ci/sec}}$

Nuclide	Bone	Liver	Thyroid	Kidney	Lung	GI-LLI	Skin	T.Body
H-3*	0.00E+00	1.56E+03	1.56E+03	1.56E+03	1.56E+03	1.56E+03	0.00E+00	1.56E+03
Cr-51	0.00E+00	0.00E+00	1.06E+03	3.92E+02	2.36E+03	4.47E+05	0.00E+00	1.78E+03
Mn-54	0.00E+00	6.50E+05	0.00E+00	1.93E+05	0.00E+00	1.99E+06	0.00E+00	1.24E+05
Fe-55	2.17E+05	1.50E+05	0.00E+00	0.00E+00	8.36E+04	8.60E+04	0.00E+00	3.49E+04
Fe-59	2.10E+05	4.93E+05	0.00E+00	0.00E+00	1.38E+05	1.64E+06	0.00E+00	1.89E+05
Co-57	0.00E+00	9.81E+04	0.00E+00	0.00E+00	0.00E+00	2.49E+06	0.00E+00	1.63E+05
Co-58	0.00E+00	3.24E+05	0.00E+00	0.00E+00	0.00E+00	6.56E+06	0.00E+00	7.26E+05
Co-60	0.00E+00	1.32E+06	0.00E+00	0.00E+00	0.00E+00	2.48E+07	0.00E+00	2.91E+06
Zn-65	1.05E+08	3.33E+08	0.00E+00	2.23E+08	0.00E+00	2.10E+08	0.00E+00	1.50E+08
Se-75	0.00E+00	0.00E+00	0.00E+00	0.00E+00	0.00E+00	0.00E+00	0.00E+00	0.00E+00
Sr-89	1.68E+09	0.00E+00	0.00E+00	0.00E+00	0.00E+00	2.69E+08	0.00E+00	4.82E+07
Sr-90	6.62E+10	0.00E+00	0.00E+00	0.00E+00	0.00E+00	1.91E+09	0.00E+00	1.63E+10
Zr-95	6.41E+01	2.05E+01	0.00E+00	3.22E+01	0.00E+00	6.51E+04	0.00E+00	1.39E+01
Nb-95	5.25E+03	2.92E+03	0.00E+00	2.88E+03	0.00E+00	1.77E+07	0.00E+00	1.57E+03
Mo-99	0.00E+00	1.49E+06	0.00E+00	3.37E+06	0.00E+00	3.44E+06	0.00E+00	2.83E+05
Ag-110m	4.45E+06	4.11E+06	0.00E+00	8.09E+06	0.00E+00	1.68E+09	0.00E+00	2.44E+06
Sb-124	1.74E+06	3.28E+04	4.21E+03	0.00E+00	1.35E+06	4.93E+07	0.00E+00	6.88E+05
I-131	1.78E+08	2.54E+08	8.33E+10	4.36E+08	0.00E+00	6.71E+07	0.00E+00	1.46E+08
I-133	2.32E+06	4.04E+06	5.93E+08	7.05E+06	0.00E+00	3.63E+06	0.00E+00	1.23E+06
I-135	7.70E+03	2.02E+04	1.33E+06	3.23E+04	0.00E+00	2.28E+04	0.00E+00	7.44E+03
Cs-134	1.12E+10	2.67E+10	0.00E+00	8.63E+09	2.87E+09	4.67E+08	0.00E+00	2.18E+10
Cs-136	3.96E+08	1.56E+09	0.00E+00	8.70E+08	1.19E+08	1.78E+08	0.00E+00	1.13E+09
Cs-137	1.49E+10	2.04E+10	0.00E+00	6.93E+09	2.30E+09	3.95E+08	0.00E+00	1.34E+10
Ba-140	1.62E+06	2.03E+03	0.00E+00	6.91E+02	1.16E+03	3.33E+06	0.00E+00	1.06E+05
La-140	2.71E-01	1.36E-01	0.00E+00	0.00E+00	0.00E+00	1.00E+04	0.00E+00	3.61E-02
Ce-141	3.06E+02	2.07E+02	0.00E+00	9.60E+01	0.00E+00	7.90E+05	0.00E+00	2.34E+01
Ce-144	2.75E+04	1.15E+04	0.00E+00	6.82E+03	0.00E+00	9.30E+06	0.00E+00	1.48E+03

* $\frac{\text{mrem/yr}}{\mu\text{Ci/m}^3}$

TABLE B-5 (Continued)

R_i VALUES - INHALATION - TEEN
$$\frac{\text{mrem/yr}}{\mu\text{Ci/m}^3}$$

Nuclide	Bone	Liver	Thyroid	Kidney	Lung	GI-LLI	Skin	T.Body
H-3	0.00E+00	1.27E+03	1.27E+03	1.27E+03	1.27E+03	1.27E+03	0.00E+00	1.27E+03
Cr-51	0.00E+00	0.00E+00	7.50E+01	3.07E+01	2.10E+04	3.00E+03	0.00E+00	1.35E+02
Mn-54	0.00E+00	5.11E+04	0.00E+00	1.27E+04	1.98E+06	6.68E+04	0.00E+00	8.40E+03
Fe-55	3.34E+04	2.38E+04	0.00E+00	0.00E+00	1.24E+05	6.39E+03	0.00E+00	5.54E+03
Fe-59	1.59E+04	3.70E+04	0.00E+00	0.00E+00	1.53E+06	1.78E+05	0.00E+00	1.43E+04
Co-57	0.00E+00	9.44E+02	0.00E+00	0.00E+00	5.86E+05	3.14E+04	0.00E+00	9.20E+02
Co-58	0.00E+00	2.07E+03	0.00E+00	0.00E+00	1.34E+06	9.52E+04	0.00E+00	2.78E+03
Co-60	0.00E+00	1.51E+04	0.00E+00	0.00E+00	8.72E+06	2.59E+05	0.00E+00	1.98E+04
Zn-65	3.86E+04	1.34E+05	0.00E+00	8.64E+04	1.24E+06	4.66E+04	0.00E+00	6.24E+04
Se-75	0.00E+00	8.00E+04	0.00E+00	1.76E+05	1.04E+06	6.32E+04	0.00E+00	2.08E+03
Sr-89	4.34E+05	0.00E+00	0.00E+00	0.00E+00	2.42E+06	3.71E+05	0.00E+00	1.25E+04
Sr-90	1.08E+08	0.00E+00	0.00E+00	0.00E+00	1.65E+07	7.65E+05	0.00E+00	6.68E+06
Zr-95	1.46E+05	4.58E+04	0.00E+00	6.74E+04	2.69E+06	1.49E+05	0.00E+00	3.15E+04
Nb-95	1.86E+04	1.03E+04	0.00E+00	1.00E+04	7.51E+05	9.68E+04	0.00E+00	5.66E+03
Mo-99	0.00E+00	1.69E+02	0.00E+00	4.11E+02	1.54E+05	2.69E+05	0.00E+00	3.22E+01
Ag-110m	1.38E+04	1.31E+04	0.00E+00	2.50E+04	6.75E+06	2.73E+05	0.00E+00	7.99E+03
Sb-124	4.30E+04	7.94E+02	9.76E+01	0.00E+00	3.85E+06	3.98E+05	0.00E+00	1.68E+04
I-131	3.54E+04	4.91E+04	1.46E+07	8.40E+04	0.00E+00	6.49E+03	0.00E+00	2.64E+04
I-133	1.22E+04	2.05E+04	2.92E+06	3.59E+04	0.00E+00	1.03E+04	0.00E+00	6.22E+03
I-135	3.70E+03	9.44E+03	6.21E+05	1.49E+04	0.00E+00	6.95E+03	0.00E+00	3.49E+03
Cs-134	5.02E+05	1.13E+06	0.00E+00	3.75E+05	1.46E+05	9.76E+03	0.00E+00	5.49E+05
Cs-136	5.15E+04	1.94E+05	0.00E+00	1.10E+05	1.78E+04	1.09E+04	0.00E+00	1.37E+05
Cs-137	6.70E+05	8.48E+05	0.00E+00	3.04E+05	1.21E+05	8.48E+03	0.00E+00	3.11E+05
Ba-140	5.47E+04	6.70E+01	0.00E+00	2.28E+01	2.03E+06	2.29E+05	0.00E+00	3.52E+03
La-140	4.79E+02	2.36E+02	0.00E+00	0.00E+00	2.14E+05	4.87E+05	0.00E+00	6.26E+01
Ce-141	2.84E+04	1.90E+04	0.00E+00	8.88E+03	6.14E+05	1.26E+05	0.00E+00	2.17E+03
Ce-144	4.89E+06	2.02E+06	0.00E+00	1.21E+06	1.34E+07	8.64E+05	0.00E+00	2.62E+05

TABLE B-5 (Continued)

R_i VALUES - VEGETATION - TEEN

$\frac{m^2 \cdot mrem/yr}{\mu Ci/sec}$

Nuclide	Bone	Liver	Thyroid	Kidney	Lung	GI-LLI	Skin	T.Body
H-3*	0.00E+00	2.59E+03	2.59E+03	2.59E+03	2.59E+03	2.59E+03	0.00E+00	2.59E+03
Cr-51	0.00E+00	0.00E+00	3.43E+04	1.35E+04	8.81E+04	1.04E+07	0.00E+00	6.17E+04
Mn-54	0.00E+00	4.54E+08	0.00E+00	1.36E+08	0.00E+00	9.32E+08	0.00E+00	9.01E+07
Fe-55	3.26E+08	2.31E+08	0.00E+00	0.00E+00	1.47E+08	1.00E+08	0.00E+00	5.39E+07
Fe-59	1.79E+08	4.19E+08	0.00E+00	0.00E+00	1.32E+08	9.90E+08	0.00E+00	1.62E+08
Co-57	0.00E+00	1.79E+07	0.00E+00	0.00E+00	0.00E+00	3.33E+08	0.00E+00	3.00E+07
Co-58	0.00E+00	4.36E+07	0.00E+00	0.00E+00	0.00E+00	6.01E+08	0.00E+00	1.00E+08
Co-60	0.00E+00	2.49E+08	0.00E+00	0.00E+00	0.00E+00	3.24E+09	0.00E+00	5.60E+08
Zn-65	4.24E+08	1.47E+09	0.00E+00	9.42E+08	0.00E+00	6.23E+08	0.00E+00	6.87E+08
Se-75	0.00E+00	0.00E+00	0.00E+00	0.00E+00	0.00E+00	0.00E+00	0.00E+00	0.00E+00
Sr-89	1.51E+10	0.00E+00	0.00E+00	0.00E+00	0.00E+00	1.80E+09	0.00E+00	4.34E+08
Sr-90	7.51E+11	0.00E+00	0.00E+00	0.00E+00	0.00E+00	2.11E+10	0.00E+00	1.85E+11
Zr-95	1.72E+06	5.43E+05	0.00E+00	7.98E+05	0.00E+00	1.25E+09	0.00E+00	3.73E+05
Nb-95	1.92E+05	1.07E+05	0.00E+00	1.03E+05	0.00E+00	4.56E+08	0.00E+00	5.87E+04
Mo-99	0.00E+00	5.64E+06	0.00E+00	1.29E+07	0.00E+00	1.01E+07	0.00E+00	1.08E+06
Ag-110m	1.52E+07	1.43E+07	0.00E+00	2.74E+07	0.00E+00	4.03E+09	0.00E+00	8.72E+06
Sb-124	1.54E+08	2.84E+06	3.50E+05	0.00E+00	1.35E+08	3.11E+09	0.00E+00	6.02E+07
I-131	7.68E+07	1.08E+08	3.14E+10	1.85E+08	0.00E+00	2.13E+07	0.00E+00	5.78E+07
I-133	1.93E+06	3.27E+06	4.57E+08	5.74E+06	0.00E+00	2.48E+06	0.00E+00	9.99E+05
I-135	3.48E+04	8.96E+04	5.76E+06	1.42E+05	0.00E+00	9.93E+04	0.00E+00	3.32E+04
Cs-134	7.10E+09	1.67E+10	0.00E+00	5.31E+09	2.03E+09	2.08E+08	0.00E+00	7.75E+09
Cs-136	4.37E+07	1.72E+08	0.00E+00	9.37E+07	1.48E+07	1.38E+07	0.00E+00	1.16E+08
Cs-137	1.01E+10	1.35E+10	0.00E+00	4.59E+09	1.78E+09	1.92E+08	0.00E+00	4.69E+09
Ba-140	1.38E+08	1.69E+05	0.00E+00	5.74E+04	1.14E+05	2.13E+08	0.00E+00	8.90E+06
La-140	1.80E+03	8.86E+02	0.00E+00	0.00E+00	0.00E+00	5.09E+07	0.00E+00	2.36E+02
Ce-141	2.83E+05	1.89E+05	0.00E+00	8.89E+04	0.00E+00	5.40E+08	0.00E+00	2.17E+04
Ce-144	5.27E+07	2.18E+07	0.00E+00	1.30E+07	0.00E+00	1.33E+10	0.00E+00	2.83E+06

* $\frac{mrem/yr}{\mu Ci/m^3}$

TABLE B-5 (Continued)

R_i VALUES - COW MEAT - TEEN
 $\frac{\text{m}^2\text{-mrem/yr}}{\mu\text{Ci/sec}}$

Nuclide	Bone	Liver	Thyroid	Kidney	Lung	GI-LLI	Skin	T.Body
H-3*	0.00E+00	1.94E+02	1.94E+02	1.94E+02	1.94E+02	1.94E+02	0.00E+00	1.94E+02
Cr-51	0.00E+00	0.00E+00	1.62E+03	6.40E+02	4.17E+03	4.91E+05	0.00E+00	2.92E+03
Mn-54	0.00E+00	4.51E+06	0.00E+00	1.34E+06	0.00E+00	9.24E+06	0.00E+00	8.93E+05
Fe-55	1.58E+08	1.12E+08	0.00E+00	0.00E+00	7.12E+07	4.86E+07	0.00E+00	2.62E+07
Fe-59	1.15E+08	2.69E+08	0.00E+00	0.00E+00	8.48E+07	6.36E+08	0.00E+00	1.04E+08
Co-57	0.00E+00	2.89E+06	0.00E+00	0.00E+00	0.00E+00	5.40E+07	0.00E+00	4.85E+06
Co-58	0.00E+00	8.04E+06	0.00E+00	0.00E+00	0.00E+00	1.11E+08	0.00E+00	1.85E+07
Co-60	0.00E+00	3.91E+07	0.00E+00	0.00E+00	0.00E+00	5.09E+08	0.00E+00	8.80E+07
Zn-65	1.59E+08	5.52E+08	0.00E+00	3.53E+08	0.00E+00	2.34E+08	0.00E+00	2.58E+08
Se-75	0.00E+00	0.00E+00	0.00E+00	0.00E+00	0.00E+00	0.00E+00	0.00E+00	0.00E+00
Sr-89	1.40E+08	0.00E+00	0.00E+00	0.00E+00	0.00E+00	1.67E+07	0.00E+00	4.02E+06
Sr-90	5.42E+09	0.00E+00	0.00E+00	0.00E+00	0.00E+00	1.52E+08	0.00E+00	1.34E+09
Zr-95	8.49E+05	2.68E+05	0.00E+00	3.94E+05	0.00E+00	6.18E+08	0.00E+00	1.84E+05
Nb-95	9.50E+05	5.27E+05	0.00E+00	5.11E+05	0.00E+00	2.25E+09	0.00E+00	2.90E+05
Mo-99	0.00E+00	4.13E+04	0.00E+00	9.46E+04	0.00E+00	7.40E+04	0.00E+00	7.88E+03
Ag-110m	3.22E+06	3.05E+06	0.00E+00	5.81E+06	0.00E+00	8.56E+08	0.00E+00	1.85E+06
Sb-124	9.08E+06	1.67E+05	2.06E+04	0.00E+00	7.93E+06	1.83E+08	0.00E+00	3.54E+06
I-131	4.46E+06	6.25E+06	1.82E+09	1.08E+07	0.00E+00	1.24E+06	0.00E+00	3.36E+06
I-133	1.53E-01	2.59E-01	3.62E+01	4.54E-01	0.00E+00	1.96E-01	0.00E+00	7.90E-02
I-135	1.80E-17	4.63E-17	2.98E-15	7.32E-17	0.00E+00	5.14E-17	0.00E+00	1.72E-17
Cs-134	3.46E+08	8.14E+08	0.00E+00	2.59E+08	9.87E+07	1.01E+07	0.00E+00	3.78E+08
Cs-136	4.71E+06	1.85E+07	0.00E+00	1.01E+07	1.59E+06	1.49E+06	0.00E+00	1.25E+07
Cs-137	4.88E+08	6.49E+08	0.00E+00	2.21E+08	8.59E+07	9.24E+06	0.00E+00	2.26E+08
Ba-140	1.19E+07	1.46E+04	0.00E+00	4.95E+03	9.81E+03	1.84E+07	0.00E+00	7.67E+05
La-140	1.53E-02	7.50E-03	0.00E+00	0.00E+00	0.00E+00	4.31E+02	0.00E+00	1.99E-03
Ce-141	6.20E+03	4.14E+03	0.00E+00	1.95E+03	0.00E+00	1.18E+07	0.00E+00	4.75E+02
Ce-144	7.87E+05	3.26E+05	0.00E+00	1.94E+05	0.00E+00	1.98E+08	0.00E+00	4.23E+04

* $\frac{\text{mrem/yr}}{\mu\text{Ci/m}^3}$

TABLE B-5 (Continued)

R_i VALUES - COW MILK - TEEN
 $\frac{m^2 \cdot mrem/yr}{\mu Ci/sec}$

Nuclide	Bone	Liver	Thyroid	Kidney	Lung	GI-LLI	Skin	T.Body
H-3*	0.00E+00	9.94E+02	9.94E+02	9.94E+02	9.94E+02	9.94E+02	0.00E+00	9.94E+02
Cr-51	0.00E+00	0.00E+00	1.44E+04	5.67E+03	3.69E+04	4.35E+06	0.00E+00	2.59E+04
Mn-54	0.00E+00	9.02E+06	0.00E+00	2.69E+06	0.00E+00	1.85E+07	0.00E+00	1.79E+06
Fe-55	2.96E+07	2.10E+07	0.00E+00	0.00E+00	1.33E+07	9.08E+06	0.00E+00	4.89E+06
Fe-59	2.82E+07	6.57E+07	0.00E+00	0.00E+00	2.07E+07	1.55E+08	0.00E+00	2.54E+07
Co-57	0.00E+00	1.43E+06	0.00E+00	0.00E+00	0.00E+00	2.68E+07	0.00E+00	2.41E+06
Co-58	0.00E+00	4.54E+06	0.00E+00	0.00E+00	0.00E+00	6.26E+07	0.00E+00	1.05E+07
Co-60	0.00E+00	1.86E+07	0.00E+00	0.00E+00	0.00E+00	2.42E+08	0.00E+00	4.19E+07
Zn-65	1.34E+09	4.65E+09	0.00E+00	2.98E+09	0.00E+00	1.97E+09	0.00E+00	2.17E+09
Se-75	0.00E+00	0.00E+00	0.00E+00	0.00E+00	0.00E+00	0.00E+00	0.00E+00	0.00E+00
Sr-89	1.47E+09	0.00E+00	0.00E+00	0.00E+00	0.00E+00	1.75E+08	0.00E+00	4.22E+07
Sr-90	4.46E+10	0.00E+00	0.00E+00	0.00E+00	0.00E+00	1.25E+09	0.00E+00	1.10E+10
Zr-95	9.34E+02	2.95E+02	0.00E+00	4.33E+02	0.00E+00	6.80E+05	0.00E+00	2.03E+02
Nb-95	7.45E+04	4.13E+04	0.00E+00	4.01E+04	0.00E+00	1.77E+08	0.00E+00	2.28E+04
Mo-99	0.00E+00	2.24E+07	0.00E+00	5.12E+07	0.00E+00	4.00E+07	0.00E+00	4.26E+06
Ag-110m	6.13E+07	5.80E+07	0.00E+00	1.11E+08	0.00E+00	1.63E+10	0.00E+00	3.53E+07
Sb-124	2.58E+07	4.75E+05	5.85E+04	0.00E+00	2.25E+07	5.20E+08	0.00E+00	1.01E+07
I-131	2.69E+08	3.76E+08	1.10E+11	6.47E+08	0.00E+00	7.44E+07	0.00E+00	2.02E+08
I-133	3.53E+06	5.99E+06	8.37E+08	1.05E+07	0.00E+00	4.54E+06	0.00E+00	1.83E+06
I-135	1.14E+04	2.94E+04	1.89E+06	4.64E+04	0.00E+00	3.25E+04	0.00E+00	1.09E+04
Cs-134	6.49E+09	1.53E+10	0.00E+00	4.85E+09	1.85E+09	1.90E+08	0.00E+00	7.09E+09
Cs-136	2.25E+08	8.85E+08	0.00E+00	4.82E+08	7.59E+07	7.12E+07	0.00E+00	5.94E+08
Cs-137	9.02E+09	1.20E+10	0.00E+00	4.08E+09	1.59E+09	1.71E+08	0.00E+00	4.18E+09
Ba-140	2.43E+07	2.98E+04	0.00E+00	1.01E+04	2.00E+04	3.75E+07	0.00E+00	1.57E+06
La-140	4.05E+00	1.99E+00	0.00E+00	0.00E+00	0.00E+00	1.14E+05	0.00E+00	5.30E-01
Ce-141	4.67E+03	3.12E+03	0.00E+00	1.47E+03	0.00E+00	8.92E+06	0.00E+00	3.58E+02
Ce-144	4.22E+05	1.74E+05	0.00E+00	1.04E+05	0.00E+00	1.06E+08	0.00E+00	2.27E+04

* $\frac{mrem/yr}{\mu Ci/m^3}$

TABLE B-5 (Continued)

R_i VALUES - GOAT MILK - TEEN

$$\frac{\text{m}^2\text{-mrem/yr}}{\mu\text{Ci/sec}}$$

Nuclide	Bone	Liver	Thyroid	Kidney	Lung	GI-LLI	Skin	T.Body
H-3*	0.00E+00	2.03E+03	2.03E+03	2.03E+03	2.03E+03	2.03E+03	0.00E+00	2.03E+03
Cr-51	0.00E+00	0.00E+00	1.72E+03	6.80E+02	4.43E+03	5.22E+05	0.00E+00	3.10E+03
Mn-54	0.00E+00	1.08E+06	0.00E+00	3.23E+05	0.00E+00	2.22E+06	0.00E+00	2.15E+05
Fe-55	3.85E+05	2.73E+05	0.00E+00	0.00E+00	1.73E+05	1.18E+05	0.00E+00	6.36E+04
Fe-59	3.66E+05	8.54E+05	0.00E+00	0.00E+00	2.69E+05	2.02E+06	0.00E+00	3.30E+05
Co-57	0.00E+00	1.72E+05	0.00E+00	0.00E+00	0.00E+00	3.21E+06	0.00E+00	2.89E+05
Co-58	0.00E+00	5.45E+05	0.00E+00	0.00E+00	0.00E+00	7.52E+06	0.00E+00	1.26E+06
Co-60	0.00E+00	2.23E+06	0.00E+00	0.00E+00	0.00E+00	2.91E+07	0.00E+00	5.03E+06
Zn-65	1.61E+08	5.58E+08	0.00E+00	3.57E+08	0.00E+00	2.36E+08	0.00E+00	2.60E+08
Se-75	0.00E+00	0.00E+00	0.00E+00	0.00E+00	0.00E+00	0.00E+00	0.00E+00	0.00E+00
Sr-89	3.09E+09	0.00E+00	0.00E+00	0.00E+00	0.00E+00	3.68E+08	0.00E+00	8.86E+07
Sr-90	9.36E+10	0.00E+00	0.00E+00	0.00E+00	0.00E+00	2.63E+09	0.00E+00	2.31E+10
Zr-95	1.12E+02	3.54E+01	0.00E+00	5.19E+01	0.00E+00	8.16E+04	0.00E+00	2.43E+01
Nb-95	8.94E+03	4.96E+03	0.00E+00	4.81E+03	0.00E+00	2.12E+07	0.00E+00	2.73E+03
Mo-99	0.00E+00	2.68E+06	0.00E+00	6.14E+06	0.00E+00	4.81E+06	0.00E+00	5.12E+05
Ag-110m	7.35E+06	6.96E+06	0.00E+00	1.33E+07	0.00E+00	1.95E+09	0.00E+00	4.23E+06
Sb-124	3.10E+06	5.70E+04	7.02E+03	0.00E+00	2.70E+06	6.24E+07	0.00E+00	1.21E+06
I-131	3.22E+08	4.51E+08	1.32E+11	7.77E+08	0.00E+00	8.93E+07	0.00E+00	2.42E+08
I-133	4.24E+06	7.19E+06	1.00E+09	1.26E+07	0.00E+00	5.44E+06	0.00E+00	2.19E+06
I-135	1.37E+04	3.52E+04	2.27E+06	5.56E+04	0.00E+00	3.90E+04	0.00E+00	1.31E+04
Cs-134	1.95E+10	4.58E+10	0.00E+00	1.46E+10	5.56E+09	5.70E+08	0.00E+00	2.13E+10
Cs-136	6.74E+08	2.65E+09	0.00E+00	1.44E+09	2.28E+08	2.14E+08	0.00E+00	1.78E+09
Cs-137	2.71E+10	3.60E+10	0.00E+00	1.23E+10	4.76E+09	5.12E+08	0.00E+00	1.25E+10
Ba-140	2.92E+06	3.58E+03	0.00E+00	1.21E+03	2.41E+03	4.50E+06	0.00E+00	1.88E+05
La-140	4.86E-01	2.39E-01	0.00E+00	0.00E+00	0.00E+00	1.37E+04	0.00E+00	6.36E-02
Ce-141	5.60E+02	3.74E+02	0.00E+00	1.76E+02	0.00E+00	1.07E+06	0.00E+00	4.30E+01
Ce-144	5.06E+04	2.09E+04	0.00E+00	1.25E+04	0.00E+00	1.27E+07	0.00E+00	2.72E+03

* $\frac{\text{mrem/yr}}{\mu\text{Ci/m}^3}$

TABLE B-5 (Continued)

R_i VALUES - GROUND PLANE - All Ages
 $\frac{m^2 \cdot mrem}{yr}$
 $\mu Ci/sec$

Nuclide	Bone	Liver	Thyroid	Kidney	Lung	GI-LLI	Skin	T.Body
H-3	0.00E+00	0.00E+00	0.00E+00	0.00E+00	0.00E+00	0.00E+00	0.00E+00	0.00E+00
Cr-51	4.66E+06	4.66E+06	4.66E+06	4.66E+06	4.66E+06	4.66E+06	5.51E+06	4.66E+06
Mn-54	1.39E+09	1.39E+09	1.39E+09	1.39E+09	1.39E+09	1.39E+09	1.63E+09	1.39E+09
Fe-55	0.00E+00	0.00E+00	0.00E+00	0.00E+00	0.00E+00	0.00E+00	0.00E+00	0.00E+00
Fe-59	2.73E+08	2.73E+08	2.73E+08	2.73E+08	2.73E+08	2.73E+08	3.21E+08	2.73E+08
Co-57	1.88E+08	1.88E+08	1.88E+08	1.88E+08	1.88E+08	1.88E+08	2.07E+08	1.88E+08
Co-58	3.79E+08	3.79E+08	3.79E+08	3.79E+08	3.79E+08	3.79E+08	4.44E+08	3.79E+08
Co-60	2.15E+10	2.15E+10	2.15E+10	2.15E+10	2.15E+10	2.15E+10	2.53E+10	2.15E+10
Zn-65	7.47E+08	7.47E+08	7.47E+08	7.47E+08	7.47E+08	7.47E+08	8.59E+08	7.47E+08
Se-75	0.00E+00	0.00E+00	0.00E+00	0.00E+00	0.00E+00	0.00E+00	0.00E+00	0.00E+00
Sr-89	2.16E+04	2.16E+04	2.16E+04	2.16E+04	2.16E+04	2.16E+04	2.51E+04	2.16E+04
Sr-90	0.00E+00	0.00E+00	0.00E+00	0.00E+00	0.00E+00	0.00E+00	0.00E+00	0.00E+00
Zr-95	2.45E+08	2.45E+08	2.45E+08	2.45E+08	2.45E+08	2.45E+08	2.84E+08	2.45E+08
Nb-95	1.37E+08	1.37E+08	1.37E+08	1.37E+08	1.37E+08	1.37E+08	1.61E+08	1.37E+08
Mo-99	3.99E+06	3.99E+06	3.99E+06	3.99E+06	3.99E+06	3.99E+06	4.63E+06	3.99E+06
Ag-110m	3.44E+09	3.44E+09	3.44E+09	3.44E+09	3.44E+09	3.44E+09	4.01E+09	3.44E+09
Sb-124	5.98E+08	5.98E+08	5.98E+08	5.98E+08	5.98E+08	5.98E+08	6.90E+08	5.98E+08
I-131	1.72E+07	1.72E+07	1.72E+07	1.72E+07	1.72E+07	1.72E+07	2.09E+07	1.72E+07
I-133	2.45E+06	2.45E+06	2.45E+06	2.45E+06	2.45E+06	2.45E+06	2.98E+06	2.45E+06
I-135	2.53E+06	2.53E+06	2.53E+06	2.53E+06	2.53E+06	2.53E+06	2.95E+06	2.53E+06
Cs-134	6.86E+09	6.86E+09	6.86E+09	6.86E+09	6.86E+09	6.86E+09	8.01E+09	6.86E+09
Cs-136	1.51E+08	1.51E+08	1.51E+08	1.51E+08	1.51E+08	1.51E+08	1.71E+08	1.51E+08
Cs-137	1.03E+10	1.03E+10	1.03E+10	1.03E+10	1.03E+10	1.03E+10	1.20E+10	1.03E+10
Ba-140	2.05E+07	2.05E+07	2.05E+07	2.05E+07	2.05E+07	2.05E+07	2.35E+07	2.05E+07
La-140	1.92E+07	1.92E+07	1.92E+07	1.92E+07	1.92E+07	1.92E+07	2.18E+07	1.92E+07
Ce-141	1.37E+07	1.37E+07	1.37E+07	1.37E+07	1.37E+07	1.37E+07	1.54E+07	1.37E+07
Ce-144	6.95E+07	6.95E+07	6.95E+07	6.95E+07	6.95E+07	6.95E+07	8.04E+07	6.95E+07

TABLE B-5 (Continued)

R_i VALUES - INHALATION - CHILD

$\frac{\text{mrem/yr}}{\mu\text{Ci/m}^3}$

Nuclide	Bone	Liver	Thyroid	Kidney	Lung	GI-LLI	Skin	T.Body
H-3	0.00E+00	1.12E+03	1.12E+03	1.12E+03	1.12E+03	1.12E+03	0.00E+00	1.12E+03
Cr-51	0.00E+00	0.00E+00	8.55E+01	2.43E+01	1.70E+04	1.08E+03	0.00E+00	1.54E+02
Mn-54	0.00E+00	4.29E+04	0.00E+00	1.00E+04	1.58E+06	2.29E+04	0.00E+00	9.51E+03
Fe-55	4.74E+04	2.52E+04	0.00E+00	0.00E+00	1.11E+05	2.87E+03	0.00E+00	7.77E+03
Fe-59	2.07E+04	3.34E+04	0.00E+00	0.00E+00	1.27E+06	7.07E+04	0.00E+00	1.67E+04
Co-57	0.00E+00	9.03E+02	0.00E+00	0.00E+00	5.07E+05	1.32E+04	0.00E+00	1.07E+03
Co-58	0.00E+00	1.77E+03	0.00E+00	0.00E+00	1.11E+06	3.44E+04	0.00E+00	3.16E+03
Co-60	0.00E+00	1.31E+04	0.00E+00	0.00E+00	7.07E+06	9.62E+04	0.00E+00	2.26E+04
Zn-65	4.26E+04	1.13E+05	0.00E+00	7.14E+04	9.95E+05	1.63E+04	0.00E+00	7.03E+04
Se-75	0.00E+00	6.29E+04	0.00E+00	1.30E+05	8.88E+05	2.33E+04	0.00E+00	2.11E+03
Sr-89	5.99E+05	0.00E+00	0.00E+00	0.00E+00	2.16E+06	1.67E+05	0.00E+00	1.72E+04
Sr-90	1.01E+08	0.00E+00	0.00E+00	0.00E+00	1.48E+07	3.43E+05	0.00E+00	6.44E+06
Zr-95	1.90E+05	4.18E+04	0.00E+00	5.96E+04	2.23E+06	6.11E+04	0.00E+00	3.70E+04
Nb-95	2.35E+04	9.18E+03	0.00E+00	8.62E+03	6.14E+05	3.70E+04	0.00E+00	6.55E+03
Mo-99	0.00E+00	1.72E+02	0.00E+00	3.92E+02	1.35E+05	1.27E+05	0.00E+00	4.26E+01
Ag-110m	1.69E+04	1.14E+04	0.00E+00	2.12E+04	5.48E+06	1.00E+05	0.00E+00	9.14E+03
Sb-124	5.74E+04	7.40E+02	1.26E+02	0.00E+00	3.24E+06	1.64E+05	0.00E+00	2.00E+04
I-131	4.81E+04	4.81E+04	1.62E+07	7.88E+04	0.00E+00	2.84E+03	0.00E+00	2.73E+04
I-133	1.66E+04	2.03E+04	3.85E+06	3.38E+04	0.00E+00	5.48E+03	0.00E+00	7.70E+03
I-135	4.92E+03	8.73E+03	7.92E+05	1.34E+04	0.00E+00	4.44E+03	0.00E+00	4.14E+03
Cs-134	6.51E+05	1.01E+06	0.00E+00	3.30E+05	1.21E+05	3.85E+03	0.00E+00	2.25E+05
Cs-136	6.51E+04	1.71E+05	0.00E+00	9.55E+04	1.45E+04	4.18E+03	0.00E+00	1.16E+05
Cs-137	9.07E+05	8.25E+05	0.00E+00	2.82E+05	1.04E+05	3.62E+03	0.00E+00	1.28E+05
Ba-140	7.40E+04	6.48E+01	0.00E+00	2.11E+01	1.74E+06	1.02E+05	0.00E+00	4.33E+03
La-140	6.44E+02	2.25E+02	0.00E+00	0.00E+00	1.83E+05	2.26E+05	0.00E+00	7.55E+01
Ce-141	3.92E+04	1.95E+04	0.00E+00	8.55E+03	5.44E+05	5.66E+04	0.00E+00	2.90E+03
Ce-144	6.77E+06	2.12E+06	0.00E+00	1.17E+06	1.20E+07	3.89E+05	0.00E+00	3.61E+05

TABLE B-5 (Continued)

R_i VALUES - COW MEAT - CHILD
$$\frac{\text{m}^2\text{-mrem/yr}}{\mu\text{Ci/sec}}$$

Nuclide	Bone	Liver	Thyroid	Kidney	Lung	GI-LLI	Skin	T.Body
H-3*	0.00E+00	2.34E+02	2.34E+02	2.34E+02	2.34E+02	2.34E+02	0.00E+00	2.34E+02
Cr-51	0.00E+00	0.00E+00	2.53E+03	6.91E+02	4.62E+03	2.42E+05	0.00E+00	4.56E+03
Mn-54	0.00E+00	5.15E+06	0.00E+00	1.45E+06	0.00E+00	4.33E+06	0.00E+00	1.37E+06
Fe-55	3.04E+08	1.61E+08	0.00E+00	0.00E+00	9.11E+07	2.98E+07	0.00E+00	4.99E+07
Fe-59	2.04E+08	3.31E+08	0.00E+00	0.00E+00	9.59E+07	3.44E+08	0.00E+00	1.65E+08
Co-57	0.00E+00	3.78E+06	0.00E+00	0.00E+00	0.00E+00	3.10E+07	0.00E+00	7.66E+06
Co-58	0.00E+00	9.40E+06	0.00E+00	0.00E+00	0.00E+00	5.48E+07	0.00E+00	2.88E+07
Co-60	0.00E+00	4.64E+07	0.00E+00	0.00E+00	0.00E+00	2.57E+08	0.00E+00	1.37E+08
Zn-65	2.39E+08	6.36E+08	0.00E+00	4.01E+08	0.00E+00	1.12E+08	0.00E+00	3.95E+08
Se-75	0.00E+00	0.00E+00	0.00E+00	0.00E+00	0.00E+00	0.00E+00	0.00E+00	0.00E+00
Sr-89	2.65E+08	0.00E+00	0.00E+00	0.00E+00	0.00E+00	1.03E+07	0.00E+00	7.58E+06
Sr-90	7.01E+09	0.00E+00	0.00E+00	0.00E+00	0.00E+00	9.44E+07	0.00E+00	1.78E+09
Zr-95	1.51E+06	3.31E+05	0.00E+00	4.74E+05	0.00E+00	3.46E+08	0.00E+00	2.95E+05
Nb-95	1.64E+06	6.39E+05	0.00E+00	6.00E+05	0.00E+00	1.18E+09	0.00E+00	4.56E+05
Mo-99	0.00E+00	5.75E+04	0.00E+00	1.23E+05	0.00E+00	4.76E+04	0.00E+00	1.42E+04
Ag-110m	5.34E+06	3.61E+06	0.00E+00	6.72E+06	0.00E+00	4.29E+08	0.00E+00	2.88E+06
Sb-124	1.64E+07	2.13E+05	3.63E+04	0.00E+00	9.12E+06	1.03E+08	0.00E+00	5.76E+06
I-131	8.28E+06	8.32E+06	2.75E+09	1.37E+07	0.00E+00	7.41E+05	0.00E+00	4.73E+06
I-133	2.84E-01	3.51E-01	6.52E+01	5.85E-01	0.00E+00	1.41E-01	0.00E+00	1.33E-01
I-135	3.26E-17	5.87E-17	5.19E-15	8.99E-17	0.00E+00	4.47E-17	0.00E+00	2.77E-17
Cs-134	6.10E+08	1.00E+09	0.00E+00	3.10E+08	1.11E+08	5.39E+06	0.00E+00	2.11E+08
Cs-136	8.13E+06	2.24E+07	0.00E+00	1.19E+07	1.78E+06	7.86E+05	0.00E+00	1.45E+07
Cs-137	8.99E+08	8.60E+08	0.00E+00	2.80E+08	1.01E+08	5.39E+06	0.00E+00	1.27E+08
Ba-140	2.20E+07	1.93E+04	0.00E+00	6.27E+03	1.15E+04	1.11E+07	0.00E+00	1.28E+06
La-140	2.79E-02	9.76E-03	0.00E+00	0.00E+00	0.00E+00	2.72E+02	0.00E+00	3.29E-03
Ce-141	1.17E+04	5.82E+03	0.00E+00	2.55E+03	0.00E+00	7.26E+06	0.00E+00	8.64E+02
Ce-144	1.48E+06	4.65E+05	0.00E+00	2.57E+05	0.00E+00	1.21E+08	0.00E+00	7.92E+04

* $\frac{\text{mrem/yr}}{\mu\text{Ci/m}^3}$

TABLE B-5 (Continued)

R_i VALUES - COW MILK - CHILD

$\frac{\text{m}^2\text{-mrem/yr}}{\mu\text{Ci/sec}}$

Nuclide	Bone	Liver	Thyroid	Kidney	Lung	GI-LLI	Skin	T.Body
H-3*	0.00E+00	1.57E+03	1.57E+03	1.57E+03	1.57E+03	1.57E+03	0.00E+00	1.57E+03
Cr-51	0.00E+00	0.00E+00	2.93E+04	8.00E+03	5.35E+04	2.80E+06	0.00E+00	5.28E+04
Mn-54	0.00E+00	1.35E+07	0.00E+00	3.78E+06	0.00E+00	1.13E+07	0.00E+00	3.59E+06
Fe-55	7.43E+07	3.94E+07	0.00E+00	0.00E+00	2.23E+07	7.30E+06	0.00E+00	1.22E+07
Fe-59	6.53E+07	1.06E+08	0.00E+00	0.00E+00	3.06E+07	1.10E+08	0.00E+00	5.26E+07
Co-57	0.00E+00	2.45E+06	0.00E+00	0.00E+00	0.00E+00	2.01E+07	0.00E+00	4.96E+06
Co-58	0.00E+00	6.94E+06	0.00E+00	0.00E+00	0.00E+00	4.05E+07	0.00E+00	2.12E+07
Co-60	0.00E+00	2.89E+07	0.00E+00	0.00E+00	0.00E+00	1.60E+08	0.00E+00	8.52E+07
Zn-65	2.63E+09	7.00E+09	0.00E+00	4.41E+09	0.00E+00	1.23E+09	0.00E+00	4.35E+09
Se-75	0.00E+00	0.00E+00	0.00E+00	0.00E+00	0.00E+00	0.00E+00	0.00E+00	0.00E+00
Sr-89	3.65E+09	0.00E+00	0.00E+00	0.00E+00	0.00E+00	1.41E+08	0.00E+00	1.04E+08
Sr-90	7.53E+10	0.00E+00	0.00E+00	0.00E+00	0.00E+00	1.01E+09	0.00E+00	1.91E+10
Zr-95	2.17E+03	4.77E+02	0.00E+00	6.82E+02	0.00E+00	4.97E+05	0.00E+00	4.24E+02
Nb-95	1.68E+05	6.55E+04	0.00E+00	6.16E+04	0.00E+00	1.21E+08	0.00E+00	4.68E+04
Mo-99	0.00E+00	4.07E+07	0.00E+00	8.69E+07	0.00E+00	3.36E+07	0.00E+00	1.01E+07
Ag-110m	1.33E+08	8.97E+07	0.00E+00	1.67E+08	0.00E+00	1.07E+10	0.00E+00	7.17E+07
Sb-124	6.10E+07	7.92E+05	1.35E+05	0.00E+00	3.39E+07	3.82E+08	0.00E+00	2.14E+07
I-131	6.52E+08	6.55E+08	2.17E+11	1.08E+09	0.00E+00	5.83E+07	0.00E+00	3.72E+08
I-133	8.59E+06	1.06E+07	1.97E+09	1.77E+07	0.00E+00	4.28E+06	0.00E+00	4.02E+06
I-135	2.70E+04	4.86E+04	4.30E+06	7.45E+04	0.00E+00	3.70E+04	0.00E+00	2.30E+04
Cs-134	1.50E+10	2.46E+10	0.00E+00	7.61E+09	2.73E+09	1.32E+08	0.00E+00	5.18E+09
Cs-136	5.07E+08	1.39E+09	0.00E+00	7.43E+08	1.11E+08	4.90E+07	0.00E+00	9.02E+08
Cs-137	2.17E+10	2.08E+10	0.00E+00	6.78E+09	2.44E+09	1.30E+08	0.00E+00	3.07E+09
Ba-140	5.87E+07	5.14E+04	0.00E+00	1.67E+04	3.07E+04	2.97E+07	0.00E+00	3.43E+06
La-140	9.70E+00	3.39E+00	0.00E+00	0.00E+00	0.00E+00	9.45E+04	0.00E+00	1.14E+00
Ce-141	1.15E+04	5.73E+03	0.00E+00	2.51E+03	0.00E+00	7.15E+06	0.00E+00	8.51E+02
Ce-144	1.04E+06	3.26E+05	0.00E+00	1.80E+05	0.00E+00	8.50E+07	0.00E+00	5.55E+04

* $\frac{\text{mrem/yr}}{\mu\text{Ci/m}^3}$

TABLE B-5 (Continued)

R_i VALUES - GOAT MILK - CHILD

$$\frac{\text{m}^2\text{-mrem/yr}}{\mu\text{Ci/sec}}$$

Nuclide	Bone	Liver	Thyroid	Kidney	Lung	GI-LLI	Skin	T.Body
H-3*	0.00E+00	3.20E+03	3.20E+03	3.20E+03	3.20E+03	3.20E+03	0.00E+00	3.20E+03
Cr-51	0.00E+00	0.00E+00	3.51E+03	9.60E+02	6.42E+03	3.36E+05	0.00E+00	6.33E+03
Mn-54	0.00E+00	1.62E+06	0.00E+00	4.54E+05	0.00E+00	1.36E+06	0.00E+00	4.31E+05
Fe-55	9.65E+05	5.12E+05	0.00E+00	0.00E+00	2.90E+05	9.49E+04	0.00E+00	1.59E+05
Fe-59	8.49E+05	1.37E+06	0.00E+00	0.00E+00	3.98E+05	1.43E+06	0.00E+00	6.84E+05
Co-57	0.00E+00	2.94E+05	0.00E+00	0.00E+00	0.00E+00	2.41E+06	0.00E+00	5.96E+05
Co-58	0.00E+00	8.33E+05	0.00E+00	0.00E+00	0.00E+00	4.86E+06	0.00E+00	2.55E+06
Co-60	0.00E+00	3.47E+06	0.00E+00	0.00E+00	0.00E+00	1.92E+07	0.00E+00	1.02E+07
Zn-65	3.15E+08	8.40E+08	0.00E+00	5.29E+08	0.00E+00	1.48E+08	0.00E+00	5.22E+08
Se-75	0.00E+00	0.00E+00	0.00E+00	0.00E+00	0.00E+00	0.00E+00	0.00E+00	0.00E+00
Sr-89	7.66E+09	0.00E+00	0.00E+00	0.00E+00	0.00E+00	2.96E+08	0.00E+00	2.19E+08
Sr-90	1.58E+11	0.00E+00	0.00E+00	0.00E+00	0.00E+00	2.13E+09	0.00E+00	4.01E+10
Zr-95	2.60E+02	5.72E+01	0.00E+00	8.19E+01	0.00E+00	5.97E+04	0.00E+00	5.09E+01
Nb-95	2.02E+04	7.86E+03	0.00E+00	7.39E+03	0.00E+00	1.45E+07	0.00E+00	5.62E+03
Mo-99	0.00E+00	4.88E+06	0.00E+00	1.04E+07	0.00E+00	4.04E+06	0.00E+00	1.21E+06
Ag-110m	1.59E+07	1.08E+07	0.00E+00	2.01E+07	0.00E+00	1.28E+09	0.00E+00	8.61E+06
Sb-124	7.33E+06	9.50E+04	1.62E+04	0.00E+00	4.07E+06	4.58E+07	0.00E+00	2.57E+06
I-131	7.82E+08	7.87E+08	2.60E+11	1.29E+09	0.00E+00	7.00E+07	0.00E+00	4.47E+08
I-133	1.03E+07	1.27E+07	2.37E+09	2.12E+07	0.00E+00	5.13E+06	0.00E+00	4.82E+06
I-135	3.24E+04	5.83E+04	5.16E+06	8.94E+04	0.00E+00	4.44E+04	0.00E+00	2.76E+04
Cs-134	4.49E+10	7.37E+10	0.00E+00	2.28E+10	8.19E+09	3.97E+08	0.00E+00	1.55E+10
Cs-136	1.52E+09	4.18E+09	0.00E+00	2.23E+09	3.32E+08	1.47E+08	0.00E+00	2.71E+09
Cs-137	6.52E+10	6.24E+10	0.00E+00	2.03E+10	7.32E+09	3.91E+08	0.00E+00	9.21E+09
Ba-140	7.05E+06	6.17E+03	0.00E+00	2.01E+03	3.68E+03	3.57E+06	0.00E+00	4.11E+05
La-140	1.16E+00	4.07E-01	0.00E+00	0.00E+00	0.00E+00	1.13E+04	0.00E+00	1.37E-01
Ce-141	1.38E+03	6.88E+02	0.00E+00	3.02E+02	0.00E+00	8.58E+05	0.00E+00	1.02E+02
Ce-144	1.25E+05	3.91E+04	0.00E+00	2.17E+04	0.00E+00	1.02E+07	0.00E+00	6.66E+03

* $\frac{\text{mrem/yr}}{\mu\text{Ci/m}^3}$

TABLE B-5 (Continued)

R_i VALUES - INHALATION - INFANT
$$\frac{\text{mrem/yr}}{\mu\text{Ci/m}^3}$$

Nuclide	Bone	Liver	Thyroid	Kidney	Lung	GI-LLI	Skin	T.Body
H-3	0.00E+00	6.47E+02	6.47E+02	6.47E+02	6.47E+02	6.47E+02	0.00E+00	6.47E+02
Cr-51	0.00E+00	0.00E+00	5.75E+01	1.32E+01	1.28E+04	3.57E+02	0.00E+00	8.95E+01
Mn-54	0.00E+00	2.53E+04	0.00E+00	4.98E+03	1.00E+06	7.06E+03	0.00E+00	4.98E+03
Fe-55	1.97E+04	1.17E+04	0.00E+00	0.00E+00	8.69E+04	1.09E+03	0.00E+00	3.33E+03
Fe-59	1.36E+04	2.35E+04	0.00E+00	0.00E+00	1.02E+06	2.48E+04	0.00E+00	9.48E+03
Co-57	0.00E+00	6.51E+02	0.00E+00	0.00E+00	3.79E+05	4.86E+03	0.00E+00	6.41E+02
Co-58	0.00E+00	1.22E+03	0.00E+00	0.00E+00	7.77E+05	1.11E+04	0.00E+00	1.82E+03
Co-60	0.00E+00	8.02E+03	0.00E+00	0.00E+00	4.51E+06	3.19E+04	0.00E+00	1.18E+04
Zn-65	1.93E+04	6.26E+04	0.00E+00	3.25E+04	6.47E+05	5.14E+04	0.00E+00	3.11E+04
Se-75	0.00E+00	4.06E+04	0.00E+00	6.72E+04	6.86E+05	7.70E+03	0.00E+00	1.16E+03
Sr-89	3.98E+05	0.00E+00	0.00E+00	0.00E+00	2.03E+06	6.40E+04	0.00E+00	1.14E+04
Sr-90	4.09E+07	0.00E+00	0.00E+00	0.00E+00	1.12E+07	1.31E+05	0.00E+00	2.59E+06
Zr-95	1.15E+05	2.79E+04	0.00E+00	3.11E+04	1.75E+06	2.17E+04	0.00E+00	2.03E+04
Nb-95	1.57E+04	6.43E+03	0.00E+00	4.72E+03	4.79E+05	1.27E+04	0.00E+00	3.78E+03
Mo-99	0.00E+00	1.65E+02	0.00E+00	2.65E+02	1.35E+05	4.87E+04	0.00E+00	3.23E+01
Ag-110m	9.98E+03	7.22E+03	0.00E+00	1.09E+04	3.67E+06	3.30E+04	0.00E+00	5.00E+03
Sb-124	3.79E+04	5.56E+02	1.01E+02	0.00E+00	2.65E+06	5.91E+04	0.00E+00	1.20E+04
I-131	3.79E+04	4.44E+04	1.48E+07	5.18E+04	0.00E+00	1.06E+03	0.00E+00	1.96E+04
I-133	1.32E+04	1.92E+04	3.56E+06	2.24E+04	0.00E+00	2.16E+03	0.00E+00	5.60E+03
I-135	3.86E+03	7.60E+03	6.96E+05	8.47E+03	0.00E+00	1.83E+03	0.00E+00	2.77E+03
Cs-134	3.96E+05	7.03E+05	0.00E+00	1.90E+05	7.97E+04	1.33E+03	0.00E+00	7.45E+04
Cs-136	4.83E+04	1.35E+05	0.00E+00	5.64E+04	1.18E+04	1.43E+03	0.00E+00	5.29E+04
Cs-137	5.49E+05	6.12E+05	0.00E+00	1.72E+05	7.13E+04	1.33E+03	0.00E+00	4.55E+04
Ba-140	5.60E+04	5.60E+01	0.00E+00	1.34E+01	1.60E+06	3.84E+04	0.00E+00	2.90E+03
La-140	5.05E+02	2.00E+02	0.00E+00	0.00E+00	1.68E+05	8.48E+04	0.00E+00	5.15E+01
Ce-141	2.77E+04	1.67E+04	0.00E+00	5.25E+03	5.17E+05	2.16E+04	0.00E+00	1.99E+03
Ce-144	3.19E+06	1.21E+06	0.00E+00	5.38E+05	9.84E+06	1.48E+05	0.00E+00	1.76E+05

TABLE B-5 (Continued)

R_i VALUES - VEGETATION – INFANT AND
R_i VALUES - COW MEAT - INFANT
 $\frac{m^2 \cdot mrem/yr}{\mu Ci/sec}$

NUCLIDE	BONE	LIVER	THYROID	KIDNEY	LUNG	GI-LLI	SKIN	T. BODY
H-3*	0	0	0	0	0	0	0	0
Cr-51	0	0	0	0	0	0	0	0
Mn-54	0	0	0	0	0	0	0	0
Fe-55	0	0	0	0	0	0	0	0
Fe-59	0	0	0	0	0	0	0	0
Co-57	0	0	0	0	0	0	0	0
Co-58	0	0	0	0	0	0	0	0
Co-60	0	0	0	0	0	0	0	0
Zn-65	0	0	0	0	0	0	0	0
Se-75	0	0	0	0	0	0	0	0
Sr-89	0	0	0	0	0	0	0	0
Sr-90	0	0	0	0	0	0	0	0
Zr-95	0	0	0	0	0	0	0	0
Nb-95	0	0	0	0	0	0	0	0
Mo-99	0	0	0	0	0	0	0	0
Ag-110m	0	0	0	0	0	0	0	0
Sb-124	0	0	0	0	0	0	0	0
I-131	0	0	0	0	0	0	0	0
I-133	0	0	0	0	0	0	0	0
I-135	0	0	0	0	0	0	0	0
Cs-134	0	0	0	0	0	0	0	0
Cs-136	0	0	0	0	0	0	0	0
Cs-137	0	0	0	0	0	0	0	0
Ba-140	0	0	0	0	0	0	0	0
La-140	0	0	0	0	0	0	0	0
Ce-141	0	0	0	0	0	0	0	0
Ce-144	0	0	0	0	0	0	0	0

* $\frac{mrem/yr}{\mu Ci/m^3}$

TABLE B-6
DERIVATION OF GASEOUS DOSE FACTORS

TABLE	TITLE	PAGE
B-6.1	Derivation of (P _i) Values	B-28
B-6.2	Derivation of Gaseous Dose Factors (R _i)	B-29
B-6.3	Parameters for the Gaseous Effluent Pathway	B-38
B-6.4	Justification for Gaseous Pathways Used to Assess Dose	B-41
B-6.5	Organ Doses for Gaseous Releases - Inhalation Pathway	B-43

TABLE B-6.1

DERIVATION OF (P_i) VALUES

The pathway dose factor, P_i, for radioiodines, tritium, and 8-day particulates includes transport parameters of the ith nuclide, the receptor usage rate of the pathway media, and the appropriate dose conversion factor. For the inhalation pathway, the value of P_i is calculated as follows:

$$P_i = K' (BR) DFA_i \text{ (mrem/yr per } \mu\text{Ci/ m}^3 \text{)}$$

Where:

K' = a constant of unit conversion, 10⁶ pCi/μCi.

(BR) = the breathing rate of the age group, in m³/yr (Table E-5 of Regulatory Guide 1.109).

DFA_i = the maximum organ inhalation dose factor for the appropriate age group for the ith radionuclide, in mrem/pCi (Tables E-7 to E-10 of Regulatory Guide 1.109).

Example Calculation:

For the I-131 child thyroid dose factor for exposure from inhalation:

DFA_i = 4.39E-03 mrem/pCi

BR = 3700 m³/yr

These values will yield a P_i factor of 1.62E7 mrem/yr per μCi/m³ as listed in Table B-3 of this appendix.

TABLE B-6.2

DERIVATION OF GASEOUS DOSE FACTORS (R_i)

The pathway dose factor R_i for radioiodines, tritium, and 8 day particulates include transport parameters of the ith nuclide, the receptor usage rate of the pathway media, and the appropriate dose conversion factor. In developing the R_i values, separate expressions are written for each of the potential pathways.

I. INHALATION

For the inhalation pathway, the value of R_i is calculated as follows:

$$R_i = K' (BR)_a (DFA_i)_a (mrem/yr \text{ per } \mu Ci / m^3)$$

Where:

- K' = a constant of unit conversion, 10⁶ pCi/μCi.
- (BR)_a = the breathing rate of the receptor of age group (a) in m³/yr (Table B-6.3).
- (DFA_i)_a = the organ inhalation dose factor for the receptor of age group (a) for the ith radionuclide, in mrem/pCi (Tables E-7 to E-10 of Regulatory Guide 1.109).

Example Calculation:

For the Co-60 child whole body dose factor from exposure due to inhalation:

$$(DFA_i)_a = 6.12E-6 \text{ mrem/pCi}$$

$$(BR)_a = 3700 \text{ m}^3/\text{yr}$$

These values yield a R_i factor of 2.26E4 mrem/yr per μCi/m³ as listed in Table B-5 of this appendix.

II. GROUND PLANE

For the ground plane pathway, the value of R_i is calculated as follows:

$$R_i = K' K'' (SF) DFG_i \left[(1 - e^{-\lambda_i t}) / \lambda_i \right]$$

$$(m^2 - mrem / yr \text{ per } \mu Ci / \text{sec})$$

TABLE B-6.2 (Continued)

DERIVATION OF GASEOUS DOSE FACTORS (R_i)

Where:

- K' = a constant of unit conversion, 10⁶ pCi/μCi.
- K'' = a constant of unit conversion, 8760 hr/yr.
- λ_i = the decay constant for the ith radionuclide, sec⁻¹.
- t = the exposure time, 4.73E8 sec (Table B-6.3).
- DFG_i = the ground plane dose conversion factor for the ith radionuclide, mrem/hr per pCi/m². (See Table E-6 of Regulatory Guide 1.109).
- SF = the shielding factor, 0.7, dimensionless (Table B-6.3).

Example Calculation:

For the Co-60 child whole body dose factor from exposure due to the ground plane:

- λ_i = 4.20E-9 sec⁻¹
- DFG_i = 1.70E-8 mrem/hr per pCi/m²

These values yield a R_i factor of 2.15E10 m²-mrem/yr per μCi/sec as listed in Table B-5 of this appendix.

III. VEGETATION

A. Radioiodines And Eight Day Particulates

For the vegetation pathway, R_i, is calculated as follows:

$$R_i = K' \frac{(r)}{Y_v (\lambda_i + \lambda_w)} (DFL_i)_a \left[U_a^L f_L e^{-\lambda_i t_L} + U_a^S f_g e^{-\lambda_i t_h} \right]$$

(m² - mrem / yr per μCi / sec)

Where:

- K' = a Constant of unit conversion, 10⁶ pCi/μCi.
- U_a^L = the consumption rate of fresh leafy vegetation by the receptor in age group (a), in kg/yr (Table B-6.3).

TABLE B-6.2 (Continued)

DERIVATION OF GASEOUS DOSE FACTORS (R_i)

U_a^s	=	the consumption rate of stored vegetation by the receptor in age group (a), in kg/yr (Table B-6.3).
f_L	=	the fraction of the annual intake of fresh leafy vegetation grown locally (Table B-6.3).
f_g	=	the fraction of the annual intake of stored vegetation grown locally (Table B-6.3).
t_L	=	the average time between harvest of leafy vegetation and its consumption, in seconds (Table B-6.3).
t_h	=	the average time between harvest of stored vegetation and its consumption, in seconds (Table B-6.3).
Y_v	=	the vegetation areal density, in kg/m ² (Table B-6.3).
r	=	fraction of deposited activity retained on vegetation (Table B-6.3).
λ_i	=	the decay constant for the <i>i</i> th radionuclide, in sec ⁻¹ .
λ_w	=	the decay constant for removal of activity on leaf and plant surfaces by weathering, 5.73E-7 sec ⁻¹ (corresponding to a 14 day half-life).
$(DFL_i)_a$	=	the maximum organ ingestion dose factor for the <i>i</i> th radionuclide for the receptor in age group (a), in mrem/pCi (Tables E-11 to E-14 of Regulatory Guide 1.109).

Example Calculation:

For the Co-60 child whole body dose factor from exposure due to ingestion of vegetation:

U_a^L	=	26 kg/yr
U_a^s	=	520 kg/yr
f_L	=	1
f_g	=	0.76
t_L	=	8.6E4 sec
t_h	=	5.18E6 sec
Y_v	=	2 kg/m ²

$$r = 0.2$$

TABLE B-6.2 (Continued)

DERIVATION OF GASEOUS DOSE FACTORS (R_i)

$$\lambda_i = 4.2E-9 \text{ sec}^{-1}$$

$$\lambda_w = 5.73E-7 \text{ sec}^{-1}$$

$$(DFL_i)_a = 1.56E-5 \text{ mrem/pCi}$$

These values yield an R_i factor of 1.12E9 m²-mrem/yr per μCi/sec as listed in Table B-4 of this appendix.

B. Tritium

The concentration of tritium in vegetation is based on the airborne concentration rather than the deposition. R_i is calculated as follows:

$$R_i = K' K''' (U_a^L f_L + U_a^s f_g) (DFL_i)_a [0.75(0.5/H)]$$

(mrem / yr per μCi / m³)

Where:

K' = unit conversion constant, 10⁶ pCi/μCi.

K''' = unit conversion constant, 10³ gm/kg.

0.75 = the fraction of vegetation which is water (NUREG-0133).

0.50 = the ratio of the specific activity of the vegetation that is water to the atmospheric water (NUREG-0133).

H = absolute atmospheric humidity, in gm/m³ (Table B-6.3).

All other parameters are as previously defined above.

TABLE B-6.2 (Continued)

DERIVATION OF GASEOUS DOSE FACTORS (R_i)

Example Calculation

For the H-3 child whole body dose factor from exposure due to ingestion of vegetation:

$$\begin{aligned}
 U_a^L &= 26 \text{ kg/yr} \\
 U_a^S &= 520 \text{ kg/yr} \\
 f_L &= 1 \\
 f_g &= 0.76 \\
 (DFL_i)_a &= 2.03E-7 \text{ mrem/pCi} \\
 H &= 8 \text{ gm/m}^3 \text{ (NUREG-0133)}
 \end{aligned}$$

These values yield a R_i factor of 4.01E3 mrem/yr per μCi/m³ as listed in Table B-4 of this appendix.

IV. MEAT

A. Radioiodines And Eight Day Particulates

$$R_i = K \cdot \frac{Q_F(U_{ap})}{(\lambda_i + \lambda_w)} F_f(r) (DFL_i)_a \left[\frac{f_p f_s}{Y_p} + \frac{(1 - f_p f_s) e^{-\lambda_i t_h}}{Y_s} \right] e^{-\lambda_i t_f}$$

(m² - mrem / yr per μCi / sec)

Where:

- U_{ap} = the receptor's meat consumption rate for age (a), in kg/yr (Table B-6.3).
- F_f = the stable element transfer coefficients, in days/kg (Table E-1 of Regulatory Guide 1.109).
- t_f = the transport time from pasture to receptor, in sec (Table B-6.3).
- t_h = the transport time from crop field to receptor, in sec (Table B-6.3).

TABLE B-6.2 (Continued)

DERIVATION OF GASEOUS DOSE FACTORS (R_i)

- f_p = fraction of the year that the cow is on pasture (Table B-6.3).
 f_s = fraction of the cow feed that is pasture grass while the cow is on pasture (Table B-6.3).
 Q_f = the cow's consumption rate, in kg/day (wet weight). See Table B-6.3.

All other parameters were defined previously.

Example Calculation:

For the Co-60 child whole body dose factor from exposure due to ingestion of meat:

- U_{ap} = 41 kg/yr
 F_f = 1.3E-2 days/kg
 t_h = 7.78E6 sec
 t_f = 1.73E6 sec
 f_p = 6/12 = 0.5
 f_s = 1
 $(DFL_i)_a$ = 1.56E-5 mrem/pCi
 Y_p = 0.7 kg/m²
 Y_s = 2.0 kg/m²
 Q_F = 50 kg/day

These values yield a R_i factor of 1.37E8 m²-mrem/yr per μCi/sec as listed in Table B-5 of this appendix.

TABLE B-6.2 (Continued)

DERIVATION OF GASEOUS DOSE FACTORS (R_i)

B. Tritium

The concentration of tritium in meat is based on the airborne concentration rather than the deposition. R_i is calculated as follows:

$$R_i = K' K''' F_f Q_F U_{ap} (DFL_i)_a [0.75(0.5/H)]$$

$$(mrem / yr \text{ per } \mu Ci / m^3)$$

Example Calculation:

All parameters have been defined in the previous sections for the H-3 child whole body dose factor from exposure due to ingestion of meat. Substituting values into the preceding equation, results in a R_i factor of 2.33E2 mrem/yr per μCi/m³ as listed in Table B-5 of this appendix.

V. COW'S MILK

A. Radioiodines and Eight Day Particulates

For the cow's milk pathway, R_i is calculated as follows:

$$R_i = K' \frac{Q_F (U_{ap})}{(\lambda_i + \lambda_w)} F_m (r) (DFL_i)_a \left[\frac{f_p f_s}{Y_p} + \frac{(1 - f_p f_s) e^{-\lambda_i t_f}}{Y_s} \right] e^{-\lambda_i t_f}$$

$$(m^2 - mrem / yr \text{ per } \mu Ci / sec)$$

Where:

U_{ap} = the receptor's milk consumption rate for age (a), in liters/yr (Table B-6.3).

t_f = the transport time from pasture to cow, to milk, to receptor in sec (Table B-6.3).

F_m = the stable element transfer coefficients, in days/liter (from Regulatory Guide 1.109, Table E-1).

All other parameters were defined previously.

TABLE B-6.2 (Continued)

DERIVATION OF GASEOUS DOSE FACTORS (R_i)

Example Calculation:

For the Co-60 child whole body dose factor from exposure due to ingestion of cow's milk:

$$\begin{aligned} t_f &= 1.73E5 \text{ sec} \\ U_{ap} &= 330 \text{ l/yr} \\ F_m &= 1.0E-3 \text{ days/l} \end{aligned}$$

These values yield a R_i factor of 8.52E7 m²-mrem/yr per μCi/sec as listed in Table B-5 of this appendix.

B. Tritium

The concentration of tritium in cow's milk is based on the airborne concentration rather than the deposition. R_i is calculated as follows:

$$R_i = K' K''' F_m Q_F U_{ap} (DFL_i)_a [0.75 (0.5/H)]$$

(mrem / year per μCi / m³)

Example Calculation:

All parameters have been defined in the previous sections for the H-3 child whole body dose factor from exposure due to ingestion of cow's milk. Substituting values into the preceding equation, results in a R_i factor of 1.57E3 mrem/yr per μCi/m³ as listed in Table B-5 of this appendix.

VI. GOAT'S MILK

A. Radioiodines and Eight Day Particulates

For the goat's milk pathway, R_i is calculated as follows:

$$R_i = K' \frac{Q_F (U_{ap})}{(\lambda_i + \lambda_w)} F_m (r) (DFL_i)_a \left[\frac{f_p f_s}{Y_p} + \frac{(1 - f_p f_s) e^{-\lambda_i t_h}}{Y_s} \right] e^{-\lambda_i t_f}$$

(m² - mrem / yr per μCi / sec)

TABLE B-6.2 (Continued)

DERIVATION OF GASEOUS DOSE FACTORS (R_i)

Where:

t_f = the transport time from pasture to goat, to milk, to receptor in sec (Table B-6.3).

F_m = the stable element transfer coefficients. For the radionuclide in question, use Table E-2 of Regulatory Guide 1.109. If the radionuclide is not listed in Table E-2, use Table E-1 (i.e., the same value used for the cow's milk pathway).

All other parameters were defined previously.

Example Calculation:

For the Co-60 child whole body dose factor from exposure due to ingestion of goat's milk:

Q_F = 6 kg/day (wet weight)

F_m = 1.0E-3 days/l

t_f = 1.73E5 sec

These values yield a R_i factor of 1.02E7 m²-mrem/yr per μCi/sec as listed in Table B-5 of this appendix.

B. Tritium

The concentration of tritium in goat's milk is based on the airborne concentration rather than the deposition. R_i is calculated as follows:

$$R_i = K' K''' F_m Q_F U_{ap} (DFL_i)_a [0.75 (0.5 / H)]$$

$$(\text{mrem} / \text{yr per } \mu\text{Ci} / \text{m}^3)$$

Example Calculation:

All parameters have been defined in the previous sections for the H-3 child whole body dose factor from exposure due to ingestion of goat's milk. Substituting values into the preceding equation, result in a R_i factor of 3.20E3 mrem/yr per μCi/m³ as listed in Table B-5 of this appendix.

TABLE B-6.3

PARAMETER FOR THE GASEOUS EFFLUENT PATHWAY

PARAMETERS	VALUE	REFERENCE	TABLE
U _{ap} (liters/yr)-cow's milk/			
-infant	330	R.G.1.109	E-5
-child	330	R.G.1.109	E-5
-teen	400	R.G.1.109	E-5
-adult	310	R.G.1.109	E-5
U _{ap} (liters/yr)-goat's milk/			
-infant	330	R.G.1.109	E-5
-child	330	R.G.1.109	E-5
-teen	400	R.G.1.109	E-5
-adult	310	R.G.1.109	E-5
U _a ^L (kg/yr)-vegetation/			
-infant	0	R.G.1.109	E-5
-child	26	R.G.1.109	E-5
-teen	42	R.G.1.109	E-5
-adult	64	R.G.1.109	E-5
U _a ^S (kg/yr)-vegetation/			
-infant	0	R.G.1.109	E-5
-child	520	R.G.1.109	E-5
-teen	630	R.G.1.109	E-5
-adult	520	R.G.1.109	E-5
U _{ap} (kg/yr)-meat/			
-infant	0	R.G.1.109	E-5
-child	41	R.G.1.109	E-5
-teen	65	R.G.1.109	E-5
-adult	110	R.G.1.109	E-5
(BR) _a (m ³ /yr)-inhalation/			
-infant	1400	R.G.1.109	E-5
-child	3700	R.G.1.109	E-5
-teen	8000	R.G.1.109	E-5
-adult	8000	R.G.1.109	E-5

TABLE B-6.3 (Continued)

PARAMETER FOR THE GASEOUS EFFLUENT PATHWAY

PARAMETERS	VALUE	REFERENCE	TABLE
r (dimensionless)	1.0 for Radioiodine	R.G. 1.109	E-15
	0.2 for Particulates	R.G. 1.109	E-15
fl (dimensionless)	1.0	R.G. 1.109	E-15
fg (dimensionless)	0.76	R.G. 1.109	E-15
tL (sec)-vegetation	8.6E4	R.G. 1.109	E-15
th (sec)-vegetation	5.18E6	R.G. 1.109	E-15
(DFAi)a (mrem/pCi)- inhalation	Each Radionuclide	R.G. 1.109	E-7 to E-10
DFGi (mrem/hr per pCi/m ²) ground plane	Each Radionuclide	R.G. 1.109	E-6
SF (dimensionless)	0.7	R.G. 1.109	E-15
t (sec)-ground plane	4.73E8	R.G. 1.109	E-15
QF (kg/day)-cow milk	50	R.G. 1.109	E-3
QF (kg/day)-goat milk	6	R.G. 1.109	E-3
Yp (kg/m ²)	0.7	R.G. 1.109	E-15
Ys (kg/m ²)	2.0	R.G. 1.109	E-15
(DFLi)a (mrem/pCi)- meat/milk/vegetation	Each Radionuclide	R.G. 1.109	E-11 to E-14
λw (sec ⁻¹)	5.73E-7	R.G. 1.109	E-15
tf (sec)-cow milk/ goat milk	1.73E5	R.G. 1.109	E-15
th (sec)-cow milk/ goat milk	7.78E6	R.G. 1.109	E-15
Yv (kg/m ²)	2.0	R.G. 1.109	E-15

TABLE B-6.3 (Continued)

PARAMETER FOR THE GASEOUS EFFLUENT PATHWAY

PARAMETERS	VALUE	REFERENCE	TABLE
fp (dimensionless)	0.5	site specific	
fs (dimensionless)	1.0	NUREG-0133	page 33
Fm (days/liter)	Each Radionuclide	R. G. 1.109	E-1
Ff (days/kg)	Each Stable Element	R.G. 1.109	E-1
tf (sec)-meat	1.73E6	R.G. 1.109	E-15
th (sec)-meat	7.78E6	R.G. 1.109	E-15
H (gm/m3)	8.0	NUREG-0133	page 34

TABLE B-6.4

**JUSTIFICATION FOR GASEOUS PATHWAYS USED TO ASSESS
DOSE AT THE J. A. FITZPATRICK NUCLEAR POWER PLANT**

PATHWAY	JUSTIFICATION FOR USAGE
1. NOBLE GAS EXPOSURE (GAMMA)	
a. Whole body	This pathway is used in the ODCM to calculate dose rates only. This pathway is required by Part 1 (REC) and NUREG-0133.
b. Gamma Air	This pathway is used in the ODCM. This pathway is required by Part 1 (REC) and NUREG-0133.
2. NOBLE GAS EXPOSURE (BETA)	
a. Skin	This pathway is used in the ODCM to calculate dose rates only. This pathway is required by Part 1 (REC) and NUREG-0133.
b. Beta Air	This pathway is used in the ODCM. This pathway is required by Part 1 (REC) and NUREG-0133.
3. GROUND PLANE DEPOSITION	This pathway is used in the ODCM to calculate dose only. It is not used to calculate dose rates. This pathway is required for use in dose calculation by Part 1 (REC). Part 1 (REC) does not require it to be used for dose rate calculations.
4. INHALATION	This pathway is used in the ODCM to calculate dose and dose rates. This pathway is required for use in dose and dose rate calculations by the Part 1 (REC) and NUREG-0133.
5. VEGETATION	This pathway is used in the ODCM to calculate dose only. It is not used to calculate dose rates. This pathway is required for use in dose calculations by NUREG-0133. Part 1 (REC) and NUREG-0133 do not require it to be used for dose rate calculations. The calculation of dose factors for stored fruit and vegetables and fresh is combined in one equation in both the ODCM and NUREG-0133.

TABLE B-6.4 (Continued)

JUSTIFICATION FOR GASEOUS PATHWAYS USED TO ASSESS
DOSE AT THE J. A. FITZPATRICK NUCLEAR POWER PLANT

<u>PATHWAY</u>	<u>JUSTIFICATION FOR USAGE</u>
6. MEAT	This pathway is used in the ODCM to calculate dose only. It is not used to calculate dose rates. This pathway is required for use in dose calculations by NUREG-0133. Part 1 (REC) does not require it to be used for dose rate calculations. The calculation of dose factors for Meat Contaminated Feed and Meat Contaminated Forage is combined in one equation in both the ODCM and NUREG-0133.
7. COW'S MILK	This pathway is used in the ODCM to calculate dose only. It is not used to calculate dose rates. This pathway is required for use in dose calculations by NUREG-0133. Part 1 (REC) does not require it to be used for dose rate calculations. The calculation of dose factors for Milk Contaminated Feed and Milk Contaminated Forage is combined in one equation in both the ODCM and NUREG-0133.
8. GOAT'S MILK	This pathway is used in the ODCM to calculate dose only. It is not used to calculate dose rates. This pathway is required for use in dose calculations by NUREG-0133. Part 1 (REC) and NUREG-0133 do not require it to be used for dose rate calculations. The calculation of dose factors for Milk Contaminated Feed and Milk Contaminated Forage is combined in one equation in both the ODCM and NUREG-0133.

**TABLE B-6.5
ORGAN DOSES FOR GASEOUS RELEASES (INHALATION PATHWAYS)***

ADULT							
YEAR	BONE (mrem)	LIVER (mrem)	THYROID (mrem)	KIDNEY (mrem)	LUNG (mrem)	GI-LLI (mrem)	T. BODY (mrem)
1997	1.89E-07	7.25E-04	7.34E-04	7.25E-04	7.27E-04	7.25E-04	7.25E-04
1996	5.06E-07	1.88E-04	2.84E-04	1.89E-04	1.91E-04	1.88E-04	1.88E-04
1995	7.91E-07	5.34E-05	1.51E-04	5.37E-05	5.65E-05	5.34E-05	5.28E-05
1994	7.63E-07	6.17E-05	2.53E-04	6.23E-05	7.46E-05	6.19E-05	6.10E-05
1993	1.05E-06	6.07E-05	1.32E-04	6.07E-05	8.13E-05	6.11E-05	6.00E-05
TEEN							
YEAR	BONE (mrem)	LIVER (mrem)	THYROID (mrem)	KIDNEY (mrem)	LUNG (mrem)	GI-LLI (mrem)	T. BODY (mrem)
1997	2.68E-07	7.31E-04	7.42E-04	7.31E-04	7.34E-04	7.31E-04	7.31E-04
1996	7.11E-07	1.91E-04	3.15E-04	1.91E-04	1.95E-04	1.90E-04	1.90E-04
1995	7.04E-07	5.40E-05	1.84E-04	5.46E-05	5.91E-05	5.40E-05	5.33E-05
1994	1.07E-06	6.26E-05	3.09E-04	6.35E-05	8.17E-05	6.24E-05	6.16E-05
1993	6.56E-07	6.16E-05	1.55E-04	6.16E-05	9.21E-05	6.15E-05	6.06E-05
CHILD							
YEAR	BONE (mrem)	LIVER (mrem)	THYROID (mrem)	KIDNEY (mrem)	LUNG (mrem)	GI-LLI (mrem)	T. BODY (mrem)
1997	3.67E-07	6.44E-04	6.59E-04	6.44E-04	6.47E-04	6.44E-04	6.44E-04
1996	9.69E-07	1.68E-04	3.20E-04	1.68E-04	1.71E-04	1.67E-04	1.67E-04
1995	1.53E-06	4.78E-05	2.08E-04	4.82E-05	5.19E-05	4.72E-05	4.71E-05
1994	1.44E-06	5.53E-05	3.52E-04	5.61E-05	7.07E-05	5.44E-05	5.45E-05
1993	1.96E-06	5.44E-05	1.72E-04	5.43E-05	7.92E-05	5.36E-05	5.36E-05
INFANT							
YEAR	BONE (mrem)	LIVER (mrem)	THYROID (mrem)	KIDNEY (mrem)	LUNG (mrem)	GI-LLI (mrem)	T. BODY (mrem)
1997	2.50E-07	3.72E-04	3.85E-04	3.72E-04	3.74E-04	3.72E-04	3.72E-04
1996	7.13E-07	9.71E-05	2.37E-04	9.72E-05	9.96E-05	9.66E-05	9.68E-05
1995	9.91E-07	2.79E-05	1.74E-04	2.79E-05	3.09E-05	2.72E-05	2.72E-05
1994	1.09E-06	3.25E-05	3.04E-04	3.26E-05	4.22E-05	3.13E-05	3.15E-05
1993	1.12E-06	3.16E-05	1.39E-04	3.14E-05	4.80E-05	3.10E-05	3.09E-05

* The critical organ is the thyroid for the years 1993 to 1997.
The critical age group is the teen for 1997 and the child for 1993 to 1996

TABLE B-7
QUANTIFICATION AND REPORTING OF C-14 IN JAF RELEASES

QUANTIFICATION AND REPORTING OF C-14 IN JAF RELEASES

In 2009, the NRC informed the nuclear power industry that it would require the industry to report releases of radioactive Carbon-14 in gaseous effluents beginning with the Annual Radioactive Effluent Release Report for calendar year 2010. In order to support this industry-wide effort, EPRI began to establish a standard methodology for estimating Carbon-14 (^{14}C) production in power plants, in addition to equations to estimate gaseous releases and chemical forms. EPRI published these standard methodologies in EPRI Technical Report 1021106, "Estimation of Carbon-14 in Nuclear Power Plant Gaseous Effluents". This report was used as the basis for estimating C-14 production rates and release activity for the James A. FitzPatrick NPP for 2010.

Carbon-14 Production Rate

The ^{14}C production rate from the $^{17}\text{O}(n,\alpha)^{14}\text{C}$ reaction is calculated using the equation in Section 3.2.2.1 from EPRI Report 1021106, modified for the two energy group flux distribution as follows:

$$\text{Production Rate } (\mu\text{Ci/sec} - \text{kg}) = \frac{N * [\sigma_{th} * \phi_{th} + \sigma_{if} * \phi_{if}] * 1\text{E-}24 * \lambda}{3.7\text{E}4}$$

where:

- N = 1.27E22 atoms $^{17}\text{O}/\text{kg H}_2\text{O}$
- σ_{th} = "effective" thermal cross-section, b
- ϕ_{th} = thermal neutron flux, n/cm²-sec
- σ_{if} = "effective" intermediate+fast cross-section, b
- ϕ_{if} = intermediate+fast neutron flux, n/cm²-sec
- 1.0E-24 = conversion factor, 1.0E-24 cm²/b
- λ = ^{14}C decay constant, 3.833E-12/sec
- 3.7E4 = conversion factor, 3.7E4 d/sec- μCi

Combining common constants in the equation, the formula is simplified as follows:

$$(1.27\text{E}+22 * 1\text{E-}24 * 3.833\text{E-}12) \div 3.7\text{E}4 = 1.316\text{E-}18$$

$$\text{Production Rate } (\mu\text{Ci/sec} - \text{kg}) = 1.316\text{E-}18 * [\sigma_{th} * \phi_{th} + \sigma_{if} * \phi_{if}]$$

In accordance with EPRI Report 1021106, the production of ¹⁴C from the ¹⁴N(n,p)¹⁴C contributes less than 0.1% to the total production, and is considered to be insignificant and negligible.

Neutron flux data for the James A. FitzPatrick (JAF) Station's reactor were derived in calculation NEAD-NS-11/006 performed by Entergy Echelon Nuclear Engineering. Flux data for the beginning-of-cycle, mid-cycle, and end-of-cycle periods in the moderator and bypass regions are presented in Table 2-1 of the Calculation Package. The JAF-specific neutron flux data in units of n/cm²-sec are as follows:

Period of Cycle	Moderator Region		Bypass Region	
	Thermal	Intermed+Fast	Thermal	Intermed+Fast
BOC	2.964E+13	1.962E+14	5.825E+13	1.810E+14
MOC	3.125E+13	2.028E+14	6.142E+13	1.871E+14
EOC	3.423E+13	2.062E+14	6.728E+13	1.901E+14

Effective neutron cross-section data for the ¹⁷O(n,α)¹⁴C reaction in the two energy groups and regions of the reactor in a BWR are provided in Table 3-5 in EPRI Report 1021106. Data for the two neutron energy groups used in the JAF model are as follows:

Neutron Group	Effective Cross-Section - barns	
	Moderator	Bypass
Thermal	1.325E-01	1.386E-01
Intermediate+Fast	4.58E-02	4.32E-02

Combining the JAF-specific data in accordance with Section 3.3.2.1 of EPRI Report 1021106 yields the following ¹⁴C production rates in units of uCi/sec-kg:

$$\text{BOC, Thermal, Moderator: } 1.316\text{E-}18 * 2.964\text{E+}13 * 0.1325 = 5.168\text{E-}6$$

$$\text{BOC, I+F, Moderator: } 1.316\text{E-}18 * 1.962\text{E+}14 * 0.0458 = 1.183\text{E-}5$$

$$\text{BOC Moderator Subtotal: } (5.168\text{E-}6 + 1.183\text{E-}5) = 1.699\text{E-}5 \text{ uCi/sec-kg}$$

$$\text{MOC, Thermal, Moderator: } 1.316\text{E-}18 * 3.125\text{E+}13 * 0.1325 = 5.449\text{E-}6$$

MOC, I+F, Moderator: $1.316E-18 * 2.028E+14 * 0.0458 = 1.222E-5$
MOC Moderator Subtotal: $(5.449E-6 + 1.222E-5) = 1.767E-5$ uCi/sec-kg
EOC,Thermal, Moderator: $1.316E-18 * 3.423E+13 * 0.1325 = 5.969E-6$
EOC, I+F, Moderator: $1.316E-18 * 2.062E+14 * 0.0458 = 1.243E-5$
EOC Moderator Subtotal: $(5.969E-6 + 1.243E-5) = 1.840E-5$ uCi/sec-kg
Moderator Average: $(1.699E-5 + 1.767E-5 + 1.840E-5) \div 3 = 1.769E-5$ uCi/sec-kg
BOC,Thermal, Bypass: $1.316E-18 * 5.825E+13 * 0.1386 = 1.062E-5$
BOC, I+F, Bypass: $1.316E-18 * 1.810E+14 * 0.0432 = 1.029E-05$
BOC Bypass Subtotal: $(1.062E-5 + 1.029E-05) = 2.091E-5$ uCi/sec-kg
MOC,Thermal, Bypass: $1.316E-18 * 6.142E+13 * 0.1386 = 1.120E-5$
MOC, I+F, Bypass: $1.316E-18 * 1.871E+14 * 0.0432 = 1.064E-5$
MOC Bypass Subtotal: $(1.120E-5 + 1.064E-5) = 2.184E-5$ uCi/sec-kg
EOC,Thermal, Bypass: $1.316E-18 * 6.728E+13 * 0.1386 = 1.227E-5$
EOC, I+F, Bypass: $1.316E-18 * 1.901E+14 * 0.0432 = 1.081E-5$
EOC Bypass Subtotal: $(1.227E-5 + 1.081E-05) = 2.308E-5$ uCi/sec-kg
Bypass Average: $(2.091E-5 + 2.184E-5 + 2.308E-5) \div 3 = 2.194E-5$ uCi/sec-kg

The final set of parameters required to calculate the carbon-14 production is the mass of coolant in each region of the reactor. These data are provided in Table 2-2 of calculation NEAD-NS-11/006 and are as follows:

Moderator Region: 11005.9 kg

Bypass Region: 6931.6 kg

Multiplying the JAF-specific ^{14}C production rates by the coolant masses in accordance with Sections 3.3.3 and 3.3.4 from EPRI Report 1021106 yields the following:

Moderator: $1.769E-5$ uCi/sec-kg * 11005.9 kg = $1.947E-1$ uCi/sec

Bypass: $2.194E-5$ uCi/sec-kg * 6931.6 kg = $1.521E-1$ uCi/sec

Combined: $(1.947E-1 + 1.521E-1) = 3.468E-1$ uCi/sec

JAF- Curies of C-14 Released per Effective Full-Power Year:

Curies Produced per Full-Power Year (FPY):

$$3.468\text{E-}1 \text{ uCi/sec} * 3600 \text{ sec/hr} * 24 \text{ hr/d} * 365.25 \text{ d/yr} * 1\text{E-}6 \text{ Ci/uCi} = 10.9 \text{ Ci/FPY}$$

Applying a correction factor for effective full power days (EFPD, Obtained from Corporate Reactor Engineering) provides actual curies for each year. For example, JAF's EFPD for 2010 was 316, the factor would be 316/365 or 0.87.

Information presented in EPRI Report 1021106 indicates that approximately 95% to 99% of all Carbon-14 produced in a BWR reactor vessel is released as a gaseous effluent. For conservative purposes, 99% of all C-14 produced in the reactor is assumed to be released as gaseous effluents.

For 2010, this would result in a release rate of:

$$10.9 \text{ Ci/FPY} * 0.87 * 0.99 \text{ release fraction} = 9.4 \text{ Ci of C-14/EFPY}$$

Carbon-14 Dose Pathways Resulting from Gaseous Effluents

The following assumptions and equations can be used for estimating C-14 doses from gaseous effluents. Examples are presented for calculating doses to the child from the inhalation and vegetation (ingestion) pathways. Regulatory Guide 1.109 methodology is used.

1. Assumptions

- a. Q_{C14} = gaseous effluent C-14 release rate, Ci/yr.
($10.9 \text{ Ci/FPY} * \text{EFPD}_{\text{Fraction}} * 0.99 \text{ release fraction}$)
- b. Q = C-14 gaseous release rate that is carbon dioxide, Ci/yr.
($10.9 \text{ Ci/FPY} * \text{EFPD}_{\text{Fraction}} * 0.99 \text{ release fraction} * 0.95 \{95\% \text{ as } \text{CO}_2\}$)
- c. p = ratio of C-14 releases to total release time = 1 (very conservative)
- d. X/Q @ Primary Receptor
- e. Fraction of total plant mass that is natural carbon = 0.11 (RG 1.109, C-8)
- f. Concentration (g/m^3) of natural carbon = 0.16 (RG 1.109, C-8)
- g. Child dose at the Primary Receptor is most limiting
- h. Dose Factors used from Reg Guide 1.109

Note: Values for c, e, and f are conservative and offered by RG 1.109. Better (site specific) data is being evaluated at JAF and throughout the industry for application in the future.

2. Vegetative Pathway Calculation from Reg Guide (see RG 1.109, equation C-8)

$$C_{14}^V \text{ pCi/kg} = 3.17E7 \{(\text{pCi-g-yr})/(\text{Ci-kg-sec})\} * p * Q * X/Q * (0.11/0.16)$$

3. Child Ingestion (uses 95% of total C-14 released, or just the CO₂ portion)

$$\text{Dose}_{C-14} = DF * [u^v f_g + u^l] * C_{14}^V \text{ pCi/kg}$$

Where: DF = 1.21E-5 mrem/pCi Bone Child [RG 1.109, E-13]

2.42E-6 mrem/pCi TB Child [RG 1.109, E-13]

$u^v = 520 \text{ kg/yr}$ {child; $u^l = 26 \text{ kg/yr}$ [usage factors, RG 1.109, E-5]}

$f_g = 0.76$ [fraction of produce ingested in garden of interest, E-15]

4. Child Inhalation (uses all released C-14, not just CO₂)

$$\text{Dose}_{C-14} = BR * C_{14}^a \text{ pCi/m}^3 * DFI$$

Where: $C_{14}^a \text{ pCi/m}^3 = 3.17E+4 (\text{pCi-yr})/(\text{Ci-sec}) * (Q_{C14}) * (X/Q)$

$BR_{\text{child}} = 3700 \text{ m}^3/\text{yr};$

DFI = 9.70E-6 mrem/pCi_{Child Bone}

DFI = 1.82E-6 mrem/pCi_{Child TB}

APPENDIX C
METEOROLOGICAL INDEX

APPENDIX C

METEOROLOGICAL INDEX

The atmospheric dispersion and deposition tables presented in this Appendix were prepared using 8 years' worth of hourly meteorological data (at 10 m and 61 m above grade) collected on site by Niagara Mohawk during the period 1985 through 1992. The tables include the following:

- (a) Long-term annual average concentration (X/Q)s, finite-cloud gamma (X/Q)s, and (D/Q)s for the main stack, the four building vents, and unmonitored ground-level releases (site boundary and offsite receptors) [Tables C-1 through C-8, C-18, and C-20],
- (b) Long-term grazing season concentration (X/Q)s and (D/Q)s for the main stack, the four building vents, and unmonitored ground-level releases (offsite receptors excluding the site boundary) [Tables C-9 through C-13, C-22 and C-24],
- (c) Short-term 85th percentile hourly plume centerline concentration (X/Q)s and (D/Q)s for unmonitored ground-level releases, based on year-round meteorological data (site boundary and offsite receptors) [Tables C-15, C-16, C-17 and C-19],
- (d) Short-term 85th percentile hourly plume centerline concentration (X/Q)s and (D/Q)s for unmonitored ground-level releases, based on meteorological data for the grazing season (offsite receptors excluding the site boundary) [Tables C-21 and C-23],
- (e) Critical receptor long-term dispersion and deposition parameters for vent and elevated releases, year-round and grazing season averages [Table C-14].

The receptors of interest include the site boundary (SB) and various offsite locations in each sector at distances out to 45 miles. Note the following:

- (1) The long-term annual average concentration (X/Q)s and finite-cloud gamma (X/Q)s which were based on the sector-average model, are for use in assessing the air doses (gamma and beta), total body and skin dose, and doses due to inhalation from the various release points. The long-term annual average (D/Q)s are for assessing the radiation exposures due to ground plane deposition of radioactivity.
- (2) The long-term grazing season concentration (X/Q)s and (D/Q)s are for use in assessing the radiation exposures for the ingestion pathway. Based on census data, the grazing season was taken to be six months (May through October).

- (3) The 85th percentile hourly concentration (X/Q)s and (D/Q)s were based on the plume-centerline model and are for use in conjunction with short-term releases, as described in Section 4.4.3 of the ODCM. The selected percentile (85%) is applicable for the assessment of intermittent releases; it implies that the probability of exceeding the calculated hourly dispersion and deposition values is only 15%.
- (4) The dispersion and deposition parameters for the stack were based on the "elevated plume" model (with plume rise effects, and terrain features, but without building wake effects), and the meteorological data collected on the 61-m elevation of the meteorological tower. The dispersion and deposition parameters for the building vents (reactor building, refuel floor, turbine building, and radwaste building) were based on the "mixed-mode" release (with plume rise and building wake effects), and the data collected on the 10-m elevation of the tower. Unmonitored ground-level releases made use for the "ground release" model (with building wake effects, but without plume rise) and the meteorological data collected on the 10-m elevation of the tower.
- (5) For vent releases and unmonitored ground-level releases, the equations for gamma air dose, total body dose, and the gamma portion of skin dose make use of the concentration (X/Q) (i.e., the semi-infinite cloud model). For stack releases, on the other hand, the equations for the said exposures make use of the finite-cloud gamma (X/Q). By definition, the gamma (X/Q) is the equivalent relative concentration of radioactivity in a semi-infinite cloud that would yield the same radiation exposure as a finite cloud aloft; it accounts for the actual plume dimensions, elevation above the receptor, and gamma radiation spectra.

Complete details on the definition of the dispersion and deposition values presented in this appendix may be found in Reference 6.10.

APPENDIX C

METEOROLOGICAL DATA

<u>TABLE</u>	<u>TITLE</u>	<u>PAGE</u>
C-1	Concentration X/Q Values for Site Boundary Determined From Annual Average Meteorological Data	C-7
C-2	Finite Cloud Gamma X/Q Values for Site Boundary Determined From Annual Average Meteorological Data	C-8
C-3	Deposition D/Q Values for Site Boundary Determined From Annual Average Meteorological Data	C-9
C-4	Sector Average Dispersion And Deposition Values For Reactor Vent Determined From Annual Average Meteorological Data	C-10
C-5	Sector Average Dispersion And Deposition Values For Refuel Floor Vent Determined From Annual Average Meteorological Data	C-12
C-6	Sector Average Dispersion And Deposition Values For Turbine Vent Determined From Annual Average Meteorological Data	C-14
C-7	Sector Average Dispersion And Deposition Values For Radwaste Vent Determined From Annual Average Meteorological Data	C-16
C-8	Sector Average Dispersion And Deposition Values For The Stack Determined From Annual Average Meteorological Data	C-18
C-9	Sector Average Dispersion And Deposition Values For Reactor Vent Determined From Grazing Meteorological Data	C-21
C-10	Sector Average Dispersion And Deposition Values For Refuel Floor Vent Determined From Grazing Meteorological Data	C-23
C-11	Sector Average Dispersion And Deposition Values For Turbine Vent Determined From Grazing Meteorological Data	C-25
C-12	Sector Average Dispersion And Deposition Values For Radwaste Vent Determined From Grazing Meteorological Data	C-27
C-13	Sector Average Dispersion And Deposition Values For The Stack Determined From Grazing Meteorological Data	C-29

APPENDIX C

METEOROLOGICAL DATA (CONTINUED)

<u>TABLE</u>	<u>TITLE</u>	<u>PAGE</u>
C-14	Critical Receptor Dispersion And Deposition Parameters For Vent And Elevated Releases	C-32
C-15	85th Percentile Hourly Plume Centerline Dispersion Values and Annual Sector Average Dispersion Values For Unmonitored Ground Level Releases Determined From Annual Average Meteorological Data (1985-1992) (For Use With Short Term Releases)	C-33
C-16	85th Percentile Hourly Plume Centerline Deposition Values and Annual Sector Average Deposition Values For Unmonitored Ground Level Releases Determined From Annual Average Meteorological Data (1985-1992) (For Use With Short Term Releases)	C-34
C-17	85th Percentile Hourly Plume Centerline Dispersion Values For Unmonitored Ground Level Releases Determined From Annual Average Meteorological Data (1985-1992) (For Use With Short Term Releases)	C-35
C-18	Sector Average Dispersion Values For Unmonitored Ground Level Releases Determined From Annual Average Meteorological Data (1985-1992) (For Use With Long Term Releases)	C-36
C-19	85th Percentile Hourly Plume Centerline Deposition Values For Unmonitored Ground Level Releases Determined From Annual Average Meteorological Data (1985-1992) (For Use With Short Term Releases)	C-37
C-20	Sector Average Deposition Values For Unmonitored Ground Level Releases Determined From Annual Average Meteorological Data (1985-1992) (For Use With Long Term Releases)	C-38
C-21	85th Percentile Hourly Plume Centerline Dispersion Values For Unmonitored Ground Level Releases Determined From Grazing Meteorological Data (1985-1992) (For Use With Short Term Releases)	C-39

APPENDIX C

METEOROLOGICAL DATA (CONTINUED)

<u>TABLE</u>	<u>TITLE</u>	<u>PAGE</u>
C-22	Sector Average Dispersion Values For Unmonitored Ground Level Releases Determined From Grazing Meteorological Data (1985-1992) (For Use With Long Term Releases)	C-40
C-23	85th Percentile Hourly Plume Centerline Deposition Values For Unmonitored Ground Level Releases Determined From Grazing Meteorological Data (1985-1992) (For Use With Short Term Releases)	C-41
C-24	Sector Average Deposition Values For Unmonitored Ground Level Releases Determined From Grazing Meteorological Data (1985-1992) (For Use With Long Term Releases)	C-42

TABLE C-1

CONCENTRATION X/Q VALUES FOR SITE BOUNDARY DETERMINED
FROM ANNUAL AVERAGE METEROLOGICAL DATA (1985 To 1992)

Sector Average Concentration X/Q

(sec/m³)

Direction	Distance (m)	Stack	Turbine Building Vent	Refuel Floor Vent	Radwaste Building Vent	Reactor Building Vent	Unmonitored Ground Level Release	
N	w	225	1.05E-10	3.81E-06	4.65E-06	5.75E-06	4.65E-06	3.50E-05
NNE	w	225	3.58E-11	1.68E-06	2.05E-06	2.60E-06	2.05E-06	1.78E-05
NE	w	354	7.52E-10	6.53E-07	8.02E-07	1.12E-06	8.02E-07	5.34E-06
ENE	w	563	1.51E-08	7.82E-07	9.21E-07	1.35E-06	9.21E-07	3.43E-06
E	l	950	1.64E-08	3.19E-07	3.58E-07	5.39E-07	3.58E-07	1.05E-06
ESE	l	1030	1.78E-08	1.78E-07	1.97E-07	3.02E-07	1.97E-07	5.86E-07
SE	l	1110	1.94E-08	1.22E-07	1.33E-07	2.28E-07	1.33E-07	4.17E-07
SSE	l	1754	1.57E-08	4.74E-08	4.94E-08	9.17E-08	4.94E-08	1.73E-07
S	l	2205	1.79E-08	4.71E-08	4.80E-08	8.30E-08	4.80E-08	1.36E-07
SSW	l	2269	2.19E-08	6.11E-08	6.25E-08	1.14E-07	6.25E-08	2.00E-07
SW	l	2382	1.64E-08	7.97E-08	8.17E-08	1.60E-07	8.17E-08	3.14E-07
WSW	w	1867	3.55E-09	4.08E-08	4.52E-08	1.23E-07	4.52E-08	4.14E-07
W	w	644	1.33E-09	9.17E-08	1.43E-07	2.48E-07	1.43E-07	2.68E-06
WNW	w	370	1.87E-09	6.82E-07	9.99E-07	1.37E-06	9.99E-07	1.39E-05
NW	w	306	2.50E-09	1.77E-06	2.37E-06	3.09E-06	2.37E-06	2.60E-05
NNW	w	241	3.96E-10	2.98E-06	3.85E-06	4.81E-06	3.85E-06	3.68E-05

l = land

w = water

TABLE C-2

FINITE CLOUD GAMMA X/Q VALUES FOR SITE BOUNDARY DETERMINED
FROM ANNUAL AVERAGE METEROLOGICAL DATA (1985 To 1992)

Finite Cloud Gamma X/Q

(sec/m³)

<u>Direction</u>		<u>Distance</u> (m)	<u>Stack</u>
N	w	225	1.32E-07
NNE	w	225	1.06E-07
NE	w	354	1.12E-07
ENE	w	563	1.82E-07
E	l	950	1.16E-07
ESE	l	1030	7.71E-08
SE	l	1110	6.23E-08
SSE	l	1754	3.34E-08
S	l	2205	3.02E-08
SSW	l	2269	3.89E-08
SW	l	2382	3.45E-08
WSW	w	1867	2.20E-08
W	w	644	5.43E-08
WNW	w	370	8.40E-08
NW	w	306	1.38E-07
NNW	w	241	1.38E-07

l = land

w = water

TABLE C-3

DEPOSITION D/Q VALUES FOR SITE BOUNDARY DETERMINED FROM
ANNUAL AVERAGE METEOROLOGICAL DATA (1985 To 1992)

(D/Q) Sector Average Deposition (1/m²)

SEGMENT BOUNDARIES IN MILES

Direction		Distance (m)	Stack	Turbine Building Vent	Refuel Floor Vent	Radwaste Building Vent	Reactor Building Vent	Unmonitored Ground Level Release
N	w	225	2.95E-10	2.27E-08	2.65E-08	3.63E-08	2.65E-08	1.33E-07
NNE	w	225	9.26E-11	1.02E-08	1.18E-08	1.65E-08	1.18E-08	7.09E-08
NE	w	354	9.30E-11	6.21E-09	7.30E-09	1.05E-08	7.30E-09	3.00E-08
ENE	w	563	1.65E-09	1.40E-08	1.55E-08	2.00E-08	1.55E-08	3.23E-08
E	l	950	1.73E-09	9.03E-09	9.49E-09	1.11E-08	9.49E-09	1.35E-08
ESE	l	1030	1.70E-09	6.22E-09	6.49E-09	7.43E-09	6.49E-09	8.76E-09
SE	l	1110	1.61E-09	4.37E-09	4.54E-09	5.42E-09	4.54E-09	6.46E-09
SSE	l	1754	7.57E-10	1.16E-09	1.19E-09	1.39E-09	1.19E-09	1.85E-09
S	l	2205	5.52E-10	9.15E-10	9.31E-10	1.06E-09	9.31E-10	1.41E-09
SSW	l	2269	6.50E-10	7.66E-10	7.76E-10	9.33E-10	7.76E-10	1.37E-09
SW	l	2382	3.23E-10	7.01E-10	7.09E-10	9.00E-10	7.09E-10	1.51E-09
WSW	w	1867	9.10E-11	2.97E-10	3.08E-10	4.68E-10	3.08E-10	1.25E-09
W	w	644	7.43E-11	7.58E-10	9.15E-10	1.59E-09	9.15E-10	7.79E-09
WNW	w	370	1.89E-10	4.56E-09	5.56E-09	8.40E-09	5.56E-09	4.10E-08
NW	w	306	4.28E-10	1.22E-08	1.45E-08	2.08E-08	1.45E-08	8.55E-08
NNW	w	241	3.63E-10	1.71E-08	2.03E-08	2.80E-08	2.03E-08	1.14E-07

l = land

w = water

TABLE C-4

SECTOR AVERAGE DISPERSION VALUES FOR REACTOR VENT DETERMINED
FROM ANNUAL AVERAGE METEOROLOGICAL DATA (1985 To 1992)

Sector Average Concentration X/Q (sec/m³)

SEGMENT BOUNDARIES IN MILES

<u>Direction</u>	0.5	0.75	1.0	1.5	2.5	3.5
N	5.667E-07	3.319E-07	2.409E-07	1.596E-07	9.380E-08	6.472E-08
NNE	2.600E-07	1.591E-07	1.198E-07	8.235E-08	4.960E-08	3.446E-08
NE	2.296E-07	1.410E-07	1.048E-07	7.034E-08	4.129E-08	2.830E-08
ENE	5.479E-07	3.185E-07	2.260E-07	1.452E-07	7.962E-08	5.287E-08
E	4.528E-07	2.601E-07	1.808E-07	1.132E-07	5.918E-08	3.843E-08
ESE	2.804E-07	1.631E-07	1.142E-07	6.935E-08	3.941E-08	2.559E-08
SE	1.991E-07	1.204E-07	8.715E-08	5.609E-08	3.276E-08	2.602E-08
SSE	1.071E-07	6.936E-08	5.348E-08	3.911E-08	2.835E-08	2.013E-08
S	1.150E-07	7.388E-08	5.963E-08	4.379E-08	3.218E-08	2.223E-08
SSW	1.388E-07	9.086E-08	7.603E-08	5.888E-08	3.860E-08	2.786E-08
SW	1.688E-07	1.129E-07	1.094E-07	8.073E-08	5.290E-08	3.576E-08
WSW	8.263E-08	5.551E-08	4.795E-08	4.949E-08	3.369E-08	2.430E-08
W	1.040E-07	6.463E-08	5.213E-08	4.115E-08	2.881E-08	2.151E-08
WNW	2.926E-07	1.754E-07	1.326E-07	9.420E-08	5.955E-08	4.260E-08
NW	5.036E-07	3.005E-07	2.226E-07	1.520E-07	9.183E-08	6.416E-08
NNW	5.247E-07	3.041E-07	2.202E-07	1.468E-07	8.737E-08	6.082E-08
	4.5	7.5	15.0	25.0	35.0	45.0
N	4.865E-08	2.687E-08	1.186E-08	6.640E-09	4.458E-09	3.915E-09
NNE	2.595E-08	1.428E-08	6.212E-09	4.945E-09	3.183E-09	2.299E-09
NE	2.110E-08	1.138E-08	5.166E-09	3.338E-09	2.130E-09	1.530E-09
ENE	3.870E-08	2.034E-08	1.024E-08	5.223E-09	3.362E-09	2.430E-09
E	2.779E-08	1.440E-08	7.309E-09	3.751E-09	2.434E-09	1.772E-09
ESE	1.849E-08	1.133E-08	4.571E-09	2.357E-09	1.535E-09	1.121E-09
SE	1.833E-08	9.165E-09	3.693E-09	1.922E-09	1.261E-09	9.270E-10
SSE	1.438E-08	7.159E-09	2.869E-09	1.492E-09	9.784E-10	7.185E-10
S	1.595E-08	7.922E-09	3.182E-09	1.659E-09	1.091E-09	8.025E-10
SSW	2.231E-08	1.089E-08	4.278E-09	2.156E-09	1.385E-09	1.002E-09
SW	2.896E-08	1.667E-08	6.450E-09	3.357E-09	2.135E-09	1.532E-09
WSW	1.856E-08	1.029E-08	4.799E-09	2.500E-09	1.783E-09	1.393E-09
W	1.690E-08	9.922E-09	4.586E-09	2.552E-09	1.729E-09	1.294E-09
WNW	3.276E-08	1.885E-08	8.746E-09	4.942E-09	3.391E-09	2.562E-09
NW	4.862E-08	2.733E-08	1.241E-08	6.932E-09	4.729E-09	3.560E-09
NNW	4.607E-08	2.596E-08	1.186E-08	6.657E-09	4.554E-09	3.433E-09

TABLE C-4 (CONTINUED)

SECTOR AVERAGE DEPOSITION VALUES FOR REACTOR VENT DETERMINED
FROM ANNUAL AVERAGE METEOROLOGICAL DATA (1985 To 1992)

(D/Q) Sector Average Deposition (1/m²)

SEGMENT BOUNDARIES IN MILES

<u>Direction</u>	0.5	0.75	1.0	1.5	2.5	3.5
N	4.951E-09	2.856E-09	1.927E-09	1.065E-09	4.777E-10	2.756E-10
NNE	2.348E-09	1.421E-09	9.951E-10	5.692E-10	2.619E-10	1.528E-10
NE	2.456E-09	1.458E-09	1.004E-09	5.654E-10	2.556E-10	1.477E-10
ENE	9.540E-09	5.276E-09	3.429E-09	1.835E-09	8.030E-10	4.595E-10
E	1.212E-08	6.587E-09	4.219E-09	2.224E-09	9.594E-10	5.450E-10
ESE	9.330E-09	5.097E-09	3.260E-09	1.707E-09	7.428E-10	4.219E-10
SE	7.165E-09	3.997E-09	2.587E-09	1.378E-09	6.078E-10	3.473E-10
SSE	3.529E-09	2.047E-09	1.348E-09	7.357E-10	3.353E-10	1.926E-10
S	3.791E-09	2.219E-09	1.477E-09	8.098E-10	3.723E-10	2.142E-10
SSW	2.906E-09	1.760E-09	1.231E-09	7.082E-10	3.322E-10	1.950E-10
SW	2.421E-09	1.564E-09	1.185E-09	6.960E-10	3.340E-10	1.972E-10
WSW	6.780E-10	4.656E-10	3.626E-10	2.368E-10	1.188E-10	7.206E-11
W	7.119E-10	4.615E-10	3.455E-10	2.100E-10	1.041E-10	6.282E-11
WNW	2.129E-09	1.329E-09	9.567E-10	5.617E-10	2.648E-10	1.561E-10
NW	4.192E-09	2.500E-09	1.735E-09	9.847E-10	4.514E-10	2.629E-10
NNW	4.251E-09	2.462E-09	1.669E-09	9.270E-10	4.186E-10	2.423E-10
	4.5	7.5	15.0	25.0	35.0	45.0
N	1.805E-10	7.499E-11	2.350E-11	1.000E-11	5.731E-12	5.309E-11
NNE	1.006E-10	4.197E-11	1.303E-11	1.958E-11	9.064E-12	5.188E-12
NE	9.681E-11	4.014E-11	1.237E-11	9.909E-12	5.316E-12	3.291E-12
ENE	2.998E-10	1.245E-10	9.570E-11	2.256E-11	1.210E-11	7.496E-12
E	3.539E-10	1.462E-10	6.692E-11	2.192E-11	1.176E-11	7.287E-12
ESE	2.738E-10	1.133E-10	4.636E-11	1.651E-11	8.777E-12	5.439E-12
SE	2.252E-10	9.507E-11	3.796E-11	1.493E-11	7.928E-12	4.765E-12
SSE	1.266E-10	5.635E-11	2.578E-11	1.172E-11	4.605E-12	2.811E-12
S	1.434E-10	6.420E-11	2.776E-11	1.370E-11	5.149E-12	3.137E-12
SSW	1.279E-10	5.527E-11	3.074E-11	1.119E-11	5.882E-12	3.129E-12
SW	1.318E-10	5.575E-11	3.290E-11	1.541E-11	7.800E-12	4.596E-12
WSW	4.828E-11	2.055E-11	6.450E-12	2.997E-12	2.323E-11	2.807E-12
W	4.194E-11	1.780E-11	5.615E-12	2.418E-12	1.384E-12	9.038E-13
WNW	1.032E-10	4.323E-11	1.338E-11	5.670E-12	3.207E-12	2.082E-12
NW	1.730E-10	7.212E-11	2.246E-11	9.534E-12	5.405E-12	3.520E-12
NNW	1.590E-10	6.621E-11	2.081E-11	8.887E-12	5.062E-12	3.309E-12

TABLE C-5

SECTOR AVERAGE DISPERSION VALUES FOR REFUEL FLOOR VENT
 DETERMINED FROM ANNUAL AVERAGE METEOROLOGICAL DATA
 (1985 To 1992)

Sector Average Concentration X/Q (sec/m³)

SEGMENT BOUNDARIES IN MILES

<u>Direction</u>	0.5	0.75	1.0	1.5	2.5	3.5
N	5.667E-07	3.319E-07	2.409E-07	1.596E-07	9.380E-08	6.472E-08
NNE	2.600E-07	1.591E-07	1.198E-07	8.235E-08	4.960E-08	3.446E-08
NE	2.296E-07	1.410E-07	1.048E-07	7.034E-08	4.129E-08	2.830E-08
ENE	5.479E-07	3.185E-07	2.260E-07	1.452E-07	7.962E-08	5.287E-08
E	4.528E-07	2.601E-07	1.808E-07	1.132E-07	5.918E-08	3.843E-08
ESE	2.804E-07	1.631E-07	1.142E-07	6.935E-08	3.941E-08	2.559E-08
SE	1.991E-07	1.204E-07	8.715E-08	5.609E-08	3.276E-08	2.602E-08
SSE	1.071E-07	6.936E-08	5.348E-08	3.911E-08	2.835E-08	2.013E-08
S	1.150E-07	7.388E-08	5.963E-08	4.379E-08	3.218E-08	2.223E-08
SSW	1.388E-07	9.086E-08	7.603E-08	5.888E-08	3.860E-08	2.786E-08
SW	1.688E-07	1.129E-07	1.094E-07	8.073E-08	5.290E-08	3.576E-08
WSW	8.263E-08	5.551E-08	4.795E-08	4.949E-08	3.369E-08	2.430E-08
W	1.040E-07	6.463E-08	5.213E-08	4.115E-08	2.881E-08	2.151E-08
WNW	2.926E-07	1.754E-07	1.326E-07	9.420E-08	5.955E-08	4.260E-08
NW	5.036E-07	3.005E-07	2.226E-07	1.520E-07	9.183E-08	6.416E-08
NNW	5.247E-07	3.041E-07	2.202E-07	1.468E-07	8.737E-08	6.082E-08
	4.5	7.5	15.0	25.0	35.0	45.0
N	4.865E-08	2.687E-08	1.186E-08	6.640E-09	4.458E-09	3.915E-09
NNE	2.595E-08	1.428E-08	6.212E-09	4.945E-09	3.183E-09	2.299E-09
NE	2.110E-08	1.138E-08	5.166E-09	3.338E-09	2.130E-09	1.530E-09
ENE	3.870E-08	2.034E-08	1.024E-08	5.223E-09	3.362E-09	2.430E-09
E	2.779E-08	1.440E-08	7.309E-09	3.751E-09	2.434E-09	1.772E-09
ESE	1.849E-08	1.133E-08	4.571E-09	2.357E-09	1.535E-09	1.121E-09
SE	1.833E-08	9.165E-09	3.693E-09	1.922E-09	1.261E-09	9.270E-10
SSE	1.438E-08	7.159E-09	2.869E-09	1.492E-09	9.784E-10	7.185E-10
S	1.595E-08	7.922E-09	3.182E-09	1.659E-09	1.091E-09	8.025E-10
SSW	2.231E-08	1.089E-08	4.278E-09	2.156E-09	1.385E-09	1.002E-09
SW	2.896E-08	1.667E-08	6.450E-09	3.357E-09	2.135E-09	1.532E-09
WSW	1.856E-08	1.029E-08	4.799E-09	2.500E-09	1.783E-09	1.393E-09
W	1.690E-08	9.922E-09	4.586E-09	2.552E-09	1.729E-09	1.294E-09
WNW	3.276E-08	1.885E-08	8.746E-09	4.942E-09	3.391E-09	2.562E-09
NW	4.862E-08	2.733E-08	1.241E-08	6.932E-09	4.729E-09	3.560E-09

NNW 4.607E-08 2.596E-08 1.186E-08 6.657E-09 4.554E-09 3.433E-09

TABLE C-5 (CONTINUED)

SECTOR AVERAGE DEPOSITION VALUES FOR REFUEL FLOOR VENT
 DETERMINED FROM ANNUAL AVERAGE METEOROLOGICAL DATA
 (1985 To 1992)

(D/Q) Sector Average Deposition (1/m²)

SEGMENT BOUNDARIES IN MILES

<u>Direction</u>	0.5	0.75	1.0	1.5	2.5	3.5
N	4.951E-09	2.856E-09	1.927E-09	1.065E-09	4.777E-10	2.756E-10
NNE	2.348E-09	1.421E-09	9.951E-10	5.692E-10	2.619E-10	1.528E-10
NE	2.456E-09	1.458E-09	1.004E-09	5.654E-10	2.556E-10	1.477E-10
ENE	9.540E-09	5.276E-09	3.429E-09	1.835E-09	8.030E-10	4.595E-10
E	1.212E-08	6.587E-09	4.219E-09	2.224E-09	9.594E-10	5.450E-10
ESE	9.330E-09	5.097E-09	3.260E-09	1.707E-09	7.428E-10	4.219E-10
SE	7.165E-09	3.997E-09	2.587E-09	1.378E-09	6.078E-10	3.473E-10
SSE	3.529E-09	2.047E-09	1.348E-09	7.357E-10	3.353E-10	1.926E-10
S	3.791E-09	2.219E-09	1.477E-09	8.098E-10	3.723E-10	2.142E-10
SSW	2.906E-09	1.760E-09	1.231E-09	7.082E-10	3.322E-10	1.950E-10
SW	2.421E-09	1.564E-09	1.185E-09	6.960E-10	3.340E-10	1.972E-10
WSW	6.780E-10	4.656E-10	3.626E-10	2.368E-10	1.188E-10	7.206E-11
W	7.119E-10	4.615E-10	3.455E-10	2.100E-10	1.041E-10	6.282E-11
WNW	2.129E-09	1.329E-09	9.567E-10	5.617E-10	2.648E-10	1.561E-10
NW	4.192E-09	2.500E-09	1.735E-09	9.847E-10	4.514E-10	2.629E-10
NNW	4.251E-09	2.462E-09	1.669E-09	9.270E-10	4.186E-10	2.423E-10
	4.5	7.5	15.0	25.0	35.0	45.0
N	1.805E-10	7.499E-11	2.350E-11	1.000E-11	5.731E-12	5.309E-11
NNE	1.006E-10	4.197E-11	1.303E-11	1.958E-11	9.064E-12	5.188E-12
NE	9.681E-11	4.014E-11	1.237E-11	9.909E-12	5.316E-12	3.291E-12
ENE	2.998E-10	1.245E-10	9.570E-11	2.256E-11	1.210E-11	7.496E-12
E	3.539E-10	1.462E-10	6.692E-11	2.192E-11	1.176E-11	7.287E-12
ESE	2.738E-10	1.133E-10	4.636E-11	1.651E-11	8.777E-12	5.439E-12
SE	2.252E-10	9.507E-11	3.796E-11	1.493E-11	7.928E-12	4.765E-12
SSE	1.266E-10	5.635E-11	2.578E-11	1.172E-11	4.605E-12	2.811E-12
S	1.434E-10	6.420E-11	2.776E-11	1.370E-11	5.149E-12	3.137E-12
SSW	1.279E-10	5.527E-11	3.074E-11	1.119E-11	5.882E-12	3.129E-12
SW	1.318E-10	5.575E-11	3.290E-11	1.541E-11	7.800E-12	4.596E-12
WSW	4.828E-11	2.055E-11	6.450E-12	2.997E-12	2.323E-11	2.807E-12
W	4.194E-11	1.780E-11	5.615E-12	2.418E-12	1.384E-12	9.038E-13
WNW	1.032E-10	4.323E-11	1.338E-11	5.670E-12	3.207E-12	2.082E-12
NW	1.730E-10	7.212E-11	2.246E-11	9.534E-12	5.405E-12	3.520E-12

NNW 1.590E-10 6.621E-11 2.081E-11 8.887E-12 5.062E-12 3.309E-12

TABLE C-6

SECTOR AVERAGE DISPERSION VALUES FOR TURBINE VENT DETERMINED
FROM ANNUAL AVERAGE METEOROLOGICAL DATA (1985 To 1992)

Sector Average Concentration X/Q (sec/m³)

SEGMENT BOUNDARIES IN MILES

<u>Direction</u>	0.5	0.75	1.0	1.5	2.5	3.5
N	4.745E-07	2.863E-07	2.135E-07	1.455E-07	8.729E-08	6.072E-08
NNE	2.185E-07	1.391E-07	1.080E-07	7.646E-08	4.692E-08	3.283E-08
NE	1.908E-07	1.216E-07	9.320E-08	6.460E-08	3.878E-08	2.680E-08
ENE	4.685E-07	2.784E-07	2.016E-07	1.333E-07	7.437E-08	4.972E-08
E	4.004E-07	2.349E-07	1.660E-07	1.065E-07	5.619E-08	3.664E-08
ESE	2.495E-07	1.493E-07	1.063E-07	6.567E-08	3.806E-08	2.477E-08
SE	1.786E-07	1.116E-07	8.218E-08	5.383E-08	3.190E-08	2.554E-08
SSE	9.585E-08	6.492E-08	5.110E-08	3.820E-08	2.809E-08	1.988E-08
S	1.034E-07	6.930E-08	5.745E-08	4.300E-08	3.197E-08	2.199E-08
SSW	1.215E-07	8.350E-08	7.256E-08	5.767E-08	3.815E-08	2.758E-08
SW	1.416E-07	1.007E-07	1.047E-07	7.883E-08	5.215E-08	3.523E-08
WSW	5.908E-08	4.428E-08	4.183E-08	4.757E-08	3.288E-08	2.378E-08
W	6.826E-08	4.692E-08	4.159E-08	3.599E-08	2.653E-08	2.013E-08
WNW	2.087E-07	1.345E-07	1.079E-07	8.132E-08	5.342E-08	3.877E-08
NW	3.914E-07	2.458E-07	1.897E-07	1.349E-07	8.370E-08	5.909E-08
NNW	4.173E-07	2.514E-07	1.883E-07	1.300E-07	7.933E-08	5.580E-08
	4.5	7.5	15.0	25.0	35.0	45.0
N	4.584E-08	2.550E-08	1.134E-08	6.384E-09	4.294E-09	3.815E-09
NNE	2.481E-08	1.372E-08	5.996E-09	4.845E-09	3.117E-09	2.252E-09
NE	2.007E-08	1.089E-08	4.994E-09	3.250E-09	2.074E-09	1.489E-09
ENE	3.653E-08	1.930E-08	9.903E-09	5.042E-09	3.245E-09	2.346E-09
E	2.656E-08	1.381E-08	7.100E-09	3.641E-09	2.362E-09	1.720E-09
ESE	1.792E-08	1.108E-08	4.459E-09	2.297E-09	1.496E-09	1.093E-09
SE	1.797E-08	8.964E-09	3.605E-09	1.875E-09	1.230E-09	9.044E-10
SSE	1.416E-08	7.035E-09	2.816E-09	1.463E-09	9.598E-10	7.048E-10
S	1.571E-08	7.792E-09	3.126E-09	1.629E-09	1.071E-09	7.880E-10
SSW	2.205E-08	1.074E-08	4.204E-09	2.118E-09	1.360E-09	9.842E-10
SW	2.862E-08	1.648E-08	6.362E-09	3.300E-09	2.098E-09	1.506E-09
WSW	1.817E-08	1.008E-08	4.723E-09	2.459E-09	1.757E-09	1.368E-09
W	1.593E-08	9.451E-09	4.406E-09	2.462E-09	1.672E-09	1.253E-09
WNW	3.006E-08	1.752E-08	8.236E-09	4.686E-09	3.228E-09	2.445E-09
NW	4.505E-08	2.558E-08	1.174E-08	6.598E-09	4.516E-09	3.407E-09
NNW	4.254E-08	2.422E-08	1.119E-08	6.323E-09	4.340E-09	3.279E-09

TABLE C-6 (CONTINUED)

SECTOR AVERAGE DEPOSITION VALUES FOR TURBINE VENT DETERMINED
FROM ANNUAL AVERAGE METEOROLOGICAL DATA (1985 To 1992)

(D/Q) Sector Average Deposition (1/m²)

SEGMENT BOUNDARIES IN MILES

<u>Direction</u>	0.5	0.75	1.0	1.5	2.5	3.5
N	4.471E-09	2.622E-09	1.788E-09	9.981E-10	4.499E-10	2.601E-10
NNE	2.162E-09	1.335E-09	9.453E-10	5.462E-10	2.521E-10	1.472E-10
NE	2.186E-09	1.329E-09	9.286E-10	5.298E-10	2.409E-10	1.395E-10
ENE	8.763E-09	4.896E-09	3.204E-09	1.729E-09	7.605E-10	4.363E-10
E	1.148E-08	6.289E-09	4.047E-09	2.149E-09	9.307E-10	5.299E-10
ESE	8.909E-09	4.906E-09	3.151E-09	1.660E-09	7.258E-10	4.130E-10
SE	6.876E-09	3.858E-09	2.503E-09	1.341E-09	5.937E-10	3.397E-10
SSE	3.429E-09	1.995E-09	1.315E-09	7.210E-10	3.289E-10	1.890E-10
S	3.698E-09	2.171E-09	1.447E-09	7.965E-10	3.662E-10	2.108E-10
SSW	2.822E-09	1.722E-09	1.209E-09	6.997E-10	3.281E-10	1.923E-10
SW	2.314E-09	1.520E-09	1.164E-09	6.882E-10	3.299E-10	1.945E-10
WSW	6.070E-10	4.358E-10	3.469E-10	2.310E-10	1.159E-10	7.021E-11
W	6.082E-10	4.138E-10	3.183E-10	1.977E-10	9.874E-11	5.972E-11
WNW	1.870E-09	1.209E-09	8.870E-10	5.293E-10	2.511E-10	1.483E-10
NW	3.749E-09	2.290E-09	1.611E-09	9.262E-10	4.269E-10	2.492E-10
NNW	3.807E-09	2.246E-09	1.540E-09	8.652E-10	3.928E-10	2.280E-10
	4.5	7.5	15.0	25.0	35.0	45.0
N	1.706E-10	7.094E-11	2.218E-11	9.588E-12	5.736E-12	8.525E-11
NNE	9.706E-11	4.050E-11	1.253E-11	1.916E-11	8.919E-12	5.122E-12
NE	9.157E-11	3.799E-11	1.175E-11	9.911E-12	5.318E-12	3.292E-12
ENE	2.851E-10	1.186E-10	9.504E-11	2.256E-11	1.211E-11	7.499E-12
E	3.447E-10	1.427E-10	6.735E-11	2.192E-11	1.177E-11	7.290E-12
ESE	2.684E-10	1.124E-10	4.674E-11	1.645E-11	8.781E-12	5.440E-12
SE	2.212E-10	9.493E-11	3.784E-11	1.485E-11	7.867E-12	4.731E-12
SSE	1.257E-10	5.742E-11	2.530E-11	1.104E-11	4.586E-12	2.812E-12
S	1.444E-10	6.569E-11	2.721E-11	1.289E-11	5.120E-12	3.138E-12
SSW	1.262E-10	5.539E-11	2.941E-11	1.103E-11	5.812E-12	3.129E-12
SW	1.299E-10	5.523E-11	3.711E-11	1.548E-11	7.792E-12	4.577E-12
WSW	4.707E-11	2.001E-11	6.249E-12	3.103E-12	3.395E-11	2.790E-12
W	3.996E-11	1.697E-11	5.314E-12	2.295E-12	1.321E-12	8.690E-13
WNW	9.827E-11	4.117E-11	1.267E-11	5.391E-12	3.075E-12	2.019E-12
NW	1.642E-10	6.851E-11	2.125E-11	9.075E-12	5.220E-12	3.464E-12
NNW	1.498E-10	6.246E-11	1.958E-11	8.426E-12	4.885E-12	3.267E-12

TABLE C-7

SECTOR AVERAGE DISPERSION VALUES FOR RADWASTE VENT DETERMINED
FROM ANNUAL AVERAGE METEOROLOGICAL DATA (1985 To 1992)

Sector Average Concentration X/Q (sec/m³)

SEGMENT BOUNDARIES IN MILES

<u>Direction</u>	0.5	0.75	1.0	1.5	2.5	3.5
N	9.289E-07	6.007E-07	4.440E-07	2.832E-07	1.567E-07	1.052E-07
NNE	4.668E-07	3.155E-07	2.371E-07	1.529E-07	8.435E-08	5.617E-08
NE	4.087E-07	2.683E-07	1.978E-07	1.247E-07	6.698E-08	4.381E-08
ENE	8.420E-07	5.096E-07	3.592E-07	2.227E-07	1.142E-07	7.324E-08
E	6.787E-07	3.900E-07	2.660E-07	1.626E-07	8.118E-08	5.158E-08
ESE	4.270E-07	2.525E-07	1.727E-07	1.002E-07	5.512E-08	3.467E-08
SE	3.397E-07	2.050E-07	1.413E-07	8.476E-08	4.607E-08	3.077E-08
SSE	1.996E-07	1.413E-07	1.017E-07	6.620E-08	3.908E-08	2.419E-08
S	2.112E-07	1.498E-07	1.138E-07	7.360E-08	4.310E-08	2.660E-08
SSW	2.970E-07	2.024E-07	1.587E-07	1.052E-07	5.857E-08	3.831E-08
SW	3.696E-07	2.716E-07	2.542E-07	1.569E-07	8.631E-08	5.441E-08
WSW	1.939E-07	1.634E-07	1.376E-07	1.185E-07	6.500E-08	4.262E-08
W	2.088E-07	1.643E-07	1.369E-07	9.847E-08	5.958E-08	4.143E-08
WNW	5.250E-07	3.657E-07	2.845E-07	1.925E-07	1.135E-07	7.900E-08
NW	8.757E-07	5.846E-07	4.402E-07	2.869E-07	1.634E-07	1.120E-07
NNW	8.560E-07	5.557E-07	4.144E-07	2.685E-07	1.531E-07	1.051E-07
	4.5	7.5	15.0	25.0	35.0	45.0
N	7.785E-08	4.199E-08	1.805E-08	9.939E-09	6.584E-09	5.508E-09
NNE	4.127E-08	2.189E-08	9.195E-09	5.947E-09	3.828E-09	2.766E-09
NE	3.177E-08	1.642E-08	7.167E-09	3.976E-09	2.538E-09	1.823E-09
ENE	5.250E-08	2.670E-08	1.191E-08	6.030E-09	3.879E-09	2.803E-09
E	3.681E-08	1.868E-08	8.370E-09	4.283E-09	2.778E-09	2.022E-09
ESE	2.458E-08	1.326E-08	5.225E-09	2.684E-09	1.747E-09	1.276E-09
SE	2.154E-08	1.063E-08	4.246E-09	2.205E-09	1.446E-09	1.062E-09
SSE	1.695E-08	8.373E-09	3.340E-09	1.733E-09	1.136E-09	8.335E-10
S	1.865E-08	9.222E-09	3.690E-09	1.920E-09	1.261E-09	9.272E-10
SSW	2.696E-08	1.300E-08	4.993E-09	2.515E-09	1.615E-09	1.168E-09
SW	4.155E-08	2.103E-08	7.964E-09	3.960E-09	2.520E-09	1.809E-09
WSW	3.087E-08	1.587E-08	6.862E-09	3.473E-09	2.331E-09	1.681E-09
W	3.125E-08	1.729E-08	7.572E-09	4.088E-09	2.722E-09	2.012E-09
WNW	5.992E-08	3.374E-08	1.518E-08	8.361E-09	5.637E-09	4.201E-09
NW	8.418E-08	4.678E-08	2.083E-08	1.141E-08	7.675E-09	5.711E-09
NNW	7.914E-08	4.414E-08	1.974E-08	1.085E-08	7.307E-09	5.443E-09

TABLE C-7 (CONTINUED)

SECTOR AVERAGE DEPOSITION VALUES FOR RADWASTE VENT DETERMINED
FROM ANNUAL AVERAGE METEOROLOGICAL DATA (1985 To 1992)

(D/Q) Sector Average Deposition (1/m²)

SEGMENT BOUNDARIES IN MILES

<u>Direction</u>	0.5	0.75	1.0	1.5	2.5	3.5
N	7.139E-09	3.957E-09	2.509E-09	1.308E-09	5.489E-10	3.053E-10
NNE	3.697E-09	2.120E-09	1.363E-09	7.217E-10	3.046E-10	1.697E-10
NE	3.738E-09	2.100E-09	1.337E-09	6.993E-10	2.930E-10	1.625E-10
ENE	1.197E-08	6.395E-09	3.998E-09	2.058E-09	8.649E-10	4.834E-10
E	1.429E-08	7.542E-09	4.691E-09	2.400E-09	1.006E-09	5.616E-10
ESE	1.088E-08	5.771E-09	3.590E-09	1.833E-09	7.733E-10	4.331E-10
SE	8.853E-09	4.728E-09	2.941E-09	1.510E-09	6.410E-10	4.709E-10
SSE	4.668E-09	2.551E-09	1.593E-09	8.277E-10	3.887E-10	3.189E-10
S	5.074E-09	2.781E-09	1.752E-09	9.121E-10	4.447E-10	3.448E-10
SSW	4.395E-09	2.459E-09	1.585E-09	8.439E-10	3.627E-10	2.380E-10
SW	4.104E-09	2.423E-09	1.653E-09	8.807E-10	3.772E-10	2.107E-10
WSW	1.314E-09	8.355E-10	5.716E-10	3.315E-10	1.429E-10	8.030E-11
W	1.257E-09	7.732E-10	5.198E-10	2.877E-10	1.248E-10	7.047E-11
WNW	3.526E-09	2.077E-09	1.355E-09	7.280E-10	3.094E-10	1.727E-10
NW	6.440E-09	3.665E-09	2.353E-09	1.242E-09	5.239E-10	2.917E-10
NNW	6.161E-09	3.436E-09	2.187E-09	1.144E-09	4.817E-10	2.683E-10
	4.5	7.5	15.0	25.0	35.0	45.0
N	1.960E-10	8.595E-11	1.329E-10	3.272E-10	3.824E-10	2.186E-11
NNE	1.089E-10	4.740E-11	6.689E-11	1.218E-11	6.526E-12	4.037E-12
NE	1.040E-10	4.433E-11	5.931E-11	9.899E-12	5.306E-12	3.283E-12
ENE	3.114E-10	1.326E-10	8.260E-11	2.254E-11	1.209E-11	7.484E-12
E	3.613E-10	1.508E-10	6.296E-11	2.190E-11	1.175E-11	7.278E-12
ESE	2.795E-10	1.565E-10	4.490E-11	1.635E-11	8.770E-12	5.432E-12
SE	3.152E-10	1.283E-10	3.658E-11	1.382E-11	7.413E-12	4.590E-12
SSE	2.167E-10	8.427E-11	2.362E-11	8.810E-12	4.534E-12	2.805E-12
S	2.195E-10	8.754E-11	2.582E-11	9.909E-12	5.060E-12	3.130E-12
SSW	2.885E-10	1.221E-10	2.685E-11	9.418E-12	5.047E-12	3.122E-12
SW	1.536E-10	1.603E-10	4.503E-11	1.117E-11	5.944E-12	3.669E-12
WSW	5.191E-11	2.346E-11	3.839E-11	4.126E-11	4.659E-12	1.963E-12
W	4.561E-11	1.917E-11	2.377E-11	8.037E-11	1.204E-10	1.255E-10
WNW	1.110E-10	4.715E-11	6.492E-11	1.955E-10	2.750E-10	2.777E-10
NW	1.873E-10	8.094E-11	1.173E-10	3.145E-10	4.176E-10	4.099E-10
NNW	1.725E-10	7.523E-11	1.182E-10	3.151E-10	4.133E-10	4.025E-10

TABLE C-8

SECTOR AVERAGE DISPERSION VALUES FOR THE STACK DETERMINED
FROM ANNUAL AVERAGE METEOROLOGICAL DATA (1985 To 1992)

Sector Average Concentration X/Q (sec/m³)

SEGMENT BOUNDARIES IN MILES

<u>Direction</u>	0.5	0.75	1.0	1.5	2.5	3.5
N	6.304E-09	7.537E-09	9.600E-09	1.382E-08	1.504E-08	1.366E-08
NNE	2.263E-09	3.378E-09	5.419E-09	9.466E-09	1.092E-08	1.011E-08
NE	1.092E-09	2.089E-09	4.269E-09	8.509E-09	1.005E-08	9.366E-09
ENE	1.260E-08	1.222E-08	1.454E-08	2.100E-08	2.117E-08	1.845E-08
E	1.547E-08	1.816E-08	2.136E-08	2.978E-08	2.655E-08	2.150E-08
ESE	1.888E-08	1.914E-08	2.056E-08	2.174E-08	2.283E-08	1.737E-08
SE	2.187E-08	1.933E-08	1.993E-08	2.243E-08	2.028E-08	2.229E-08
SSE	1.833E-08	1.560E-08	1.566E-08	1.731E-08	2.077E-08	1.817E-08
S	1.747E-08	1.440E-08	1.540E-08	1.730E-08	2.211E-08	1.900E-08
SSW	1.689E-08	1.479E-08	1.724E-08	2.180E-08	2.270E-08	1.996E-08
SW	6.866E-09	6.874E-09	1.247E-08	1.675E-08	1.789E-08	1.442E-08
WSW	1.163E-09	1.723E-09	2.811E-09	6.821E-09	7.244E-09	6.414E-09
W	1.151E-09	1.393E-09	2.274E-09	4.102E-09	4.796E-09	4.483E-09
WNW	2.266E-09	3.077E-09	4.890E-09	8.276E-09	9.171E-09	8.262E-09
NW	5.561E-09	6.833E-09	9.696E-09	1.511E-08	1.648E-08	1.481E-08
NNW	6.602E-09	7.476E-09	9.456E-09	1.365E-08	1.498E-08	1.370E-08
	4.5	7.5	15.0	25.0	35.0	45.0
N	1.190E-08	7.990E-09	4.005E-09	2.317E-09	1.572E-09	1.348E-09
NNE	8.882E-09	6.046E-09	3.081E-09	4.716E-09	3.041E-09	2.200E-09
NE	8.270E-09	5.697E-09	3.376E-09	5.591E-09	3.622E-09	2.629E-09
ENE	1.569E-08	1.021E-08	8.735E-09	6.410E-09	4.121E-09	2.977E-09
E	1.748E-08	1.059E-08	7.444E-09	4.667E-09	2.974E-09	2.137E-09
ESE	1.362E-08	1.066E-08	4.756E-09	3.000E-09	1.917E-09	1.381E-09
SE	1.624E-08	8.678E-09	3.802E-09	2.282E-09	1.464E-09	1.059E-09
SSE	1.421E-08	7.626E-09	3.217E-09	1.770E-09	1.263E-09	9.154E-10
S	1.632E-08	8.545E-09	3.558E-09	1.953E-09	1.440E-09	1.045E-09
SSW	1.910E-08	1.011E-08	4.845E-09	2.835E-09	1.813E-09	1.306E-09
SW	1.354E-08	9.554E-09	4.078E-09	2.987E-09	1.946E-09	1.454E-09
WSW	5.511E-09	3.659E-09	2.100E-09	1.197E-09	9.790E-10	1.201E-09
W	3.977E-09	2.773E-09	1.472E-09	8.742E-10	6.133E-10	4.701E-10
WNW	7.135E-09	4.716E-09	2.335E-09	1.322E-09	9.004E-10	6.765E-10
NW	1.277E-08	8.409E-09	4.115E-09	2.298E-09	1.548E-09	1.152E-09
NNW	1.198E-08	8.121E-09	4.120E-09	2.355E-09	1.608E-09	1.207E-09

TABLE C-8 (CONTINUED)

SECTOR AVERAGE DISPERSION VALUES FOR THE STACK DETERMINED
FROM ANNUAL AVERAGE METEOROLOGICAL DATA (1985 To 1992)

Sector Average Finite Cloud Gamma X/Q (sec/m³)

SEGMENT BOUNDARIES IN MILES

<u>Direction</u>	0.5	0.75	1.0	1.6	2.5	3.5
N	1.056E-07	7.326E-08	5.707E-08	4.048E-08	2.615E-08	1.930E-08
NNE	8.423E-08	5.830E-08	4.543E-08	3.233E-08	2.100E-08	1.554E-08
NE	8.669E-08	5.979E-08	4.651E-08	3.304E-08	2.144E-08	1.588E-08
ENE	1.359E-07	9.388E-08	7.314E-08	5.381E-08	3.443E-08	2.522E-08
E	1.345E-07	9.409E-08	7.352E-08	5.582E-08	3.486E-08	2.500E-08
ESE	9.666E-08	6.962E-08	5.419E-08	3.785E-08	2.627E-08	1.849E-08
SE	8.156E-08	5.786E-08	4.497E-08	3.227E-08	2.186E-08	1.919E-08
SSE	6.370E-08	4.642E-08	3.607E-08	2.673E-08	2.041E-08	1.573E-08
S	6.367E-08	4.638E-08	3.736E-08	2.774E-08	2.192E-08	1.668E-08
SSW	8.747E-08	6.029E-08	4.886E-08	3.679E-08	2.549E-08	1.958E-08
SW	7.805E-08	5.421E-08	4.798E-08	3.412E-08	2.313E-08	1.662E-08
WSW	4.633E-08	3.206E-08	2.498E-08	2.009E-08	1.289E-08	9.455E-09
W	4.390E-08	3.020E-08	2.344E-08	1.660E-08	1.074E-08	7.954E-09
WNW	6.518E-08	4.519E-08	3.531E-08	2.520E-08	1.636E-08	1.207E-08
NW	1.075E-07	7.471E-08	5.846E-08	4.177E-08	2.713E-08	2.002E-08
NNW	1.090E-07	7.544E-08	5.873E-08	4.163E-08	2.689E-08	1.987E-08
	4.5	7.5	15.0	25.0	35.0	45.0
N	1.520E-08	9.085E-09	4.282E-09	2.428E-09	1.640E-09	1.343E-09
NNE	1.228E-08	7.377E-09	3.510E-09	3.242E-09	2.140E-09	1.574E-09
NE	1.255E-08	7.577E-09	3.990E-09	3.674E-09	2.441E-09	1.803E-09
ENE	1.975E-08	1.168E-08	7.533E-09	4.588E-09	3.017E-09	2.213E-09
E	1.925E-08	1.103E-08	6.332E-09	3.583E-09	2.329E-09	1.695E-09
ESE	1.405E-08	9.511E-09	4.144E-09	2.339E-09	1.522E-09	1.110E-09
SE	1.411E-08	7.582E-09	3.268E-09	1.809E-09	1.181E-09	8.637E-10
SSE	1.197E-08	6.451E-09	2.751E-09	1.485E-09	1.011E-09	7.413E-10
S	1.317E-08	7.027E-09	2.988E-09	1.616E-09	1.116E-09	8.202E-10
SSW	1.669E-08	8.946E-09	4.025E-09	2.212E-09	1.441E-09	1.051E-09
SW	1.405E-08	8.902E-09	3.815E-09	2.323E-09	1.522E-09	1.125E-09
WSW	7.417E-09	4.409E-09	2.259E-09	1.259E-09	9.433E-10	8.792E-10
W	6.295E-09	3.815E-09	1.849E-09	1.061E-09	7.318E-10	5.545E-10
WNW	9.503E-09	5.659E-09	2.658E-09	1.485E-09	1.006E-09	7.536E-10
NW	1.574E-08	9.343E-09	4.349E-09	2.405E-09	1.617E-09	1.203E-09
NNW	1.567E-08	9.395E-09	4.454E-09	2.499E-09	1.696E-09	1.269E-09

TABLE C-8 (CONTINUED)

SECTOR AVERAGE DEPOSITION VALUES FOR THE STACK DETERMINED
FROM ANNUAL AVERAGE METEOROLOGICAL DATA (1985 To 1992)

(D/Q) Sector Average Deposition (1/m²)

SEGMENT BOUNDARIES IN MILES

<u>Direction</u>	0.5	0.75	1.0	1.5	2.5	3.5
N	5.867E-10	5.512E-10	5.298E-10	3.807E-10	2.303E-10	1.496E-10
NNE	2.220E-10	2.564E-10	2.787E-10	2.173E-10	1.374E-10	9.029E-11
NE	1.569E-10	2.254E-10	2.692E-10	2.210E-10	1.434E-10	9.484E-11
ENE	1.440E-09	1.219E-09	1.078E-09	7.247E-10	4.209E-10	2.708E-10
E	1.868E-09	1.566E-09	1.378E-09	9.226E-10	5.343E-10	3.433E-10
ESE	1.970E-09	1.546E-09	1.277E-09	8.070E-10	4.493E-10	2.857E-10
SE	2.009E-09	1.513E-09	1.195E-09	7.215E-10	3.920E-10	2.675E-10
SSE	1.472E-09	1.088E-09	8.401E-10	4.952E-10	2.782E-10	1.783E-10
S	1.432E-09	1.062E-09	8.226E-10	4.864E-10	2.765E-10	1.758E-10
SSW	1.448E-09	1.145E-09	9.499E-10	6.029E-10	3.398E-10	2.227E-10
SW	4.816E-10	4.577E-10	4.424E-10	3.191E-10	1.934E-10	1.258E-10
WSW	7.953E-11	9.105E-11	9.852E-11	7.657E-11	4.834E-11	3.175E-11
W	7.596E-11	8.732E-11	9.453E-11	7.349E-11	4.641E-11	3.049E-11
WNW	2.259E-10	2.548E-10	2.733E-10	2.114E-10	1.331E-10	8.739E-11
NW	5.672E-10	5.729E-10	5.770E-10	4.285E-10	2.640E-10	1.724E-10
NNW	6.313E-10	5.755E-10	5.408E-10	3.820E-10	2.288E-10	1.483E-10
	4.5	7.5	15.0	25.0	35.0	45.0
N	1.024E-10	4.512E-11	1.499E-11	6.634E-12	3.864E-12	2.538E-12
NNE	6.187E-11	2.717E-11	8.936E-12	1.079E-11	1.877E-11	2.331E-11
NE	6.504E-11	2.852E-11	9.333E-12	1.922E-11	7.686E-12	4.762E-12
ENE	1.851E-10	8.191E-11	2.723E-11	2.589E-11	1.390E-11	8.613E-12
E	2.345E-10	1.038E-10	3.439E-11	2.443E-11	1.312E-11	8.128E-12
ESE	1.949E-10	9.097E-11	2.905E-11	1.009E-10	9.057E-12	5.613E-12
SE	1.804E-10	7.805E-11	2.518E-11	1.564E-11	3.646E-11	5.691E-11
SSE	1.212E-10	5.228E-11	1.700E-11	7.764E-12	1.078E-11	3.148E-12
S	1.203E-10	5.162E-11	1.675E-11	7.661E-12	2.389E-11	3.375E-12
SSW	1.581E-10	6.827E-11	2.174E-11	2.120E-11	3.021E-11	5.082E-12
SW	8.713E-11	3.976E-11	1.252E-11	5.266E-12	3.020E-12	2.782E-12
WSW	2.175E-11	9.548E-12	3.137E-12	1.362E-12	7.678E-13	5.268E-13
W	2.089E-11	9.176E-12	3.018E-12	1.312E-12	7.520E-13	4.906E-13
WNW	5.988E-11	2.631E-11	8.665E-12	3.775E-12	2.168E-12	1.417E-12
NW	1.181E-10	5.197E-11	1.720E-11	7.561E-12	4.378E-12	2.873E-12
NNW	1.014E-10	4.475E-11	1.490E-11	6.628E-12	3.876E-12	2.556E-12

TABLE C-9

SECTOR AVERAGE DISPERSION VALUES FOR REACTOR VENT DETERMINED
FROM GRAZING METEOROLOGICAL DATA (May-Oct., 1985 To 1992)

Sector Average Concentration X/Q (sec/m³)

SEGMENT BOUNDARIES IN MILES

<u>Direction</u>	0.5	0.75	1.0	1.5	2.5	3.5
N	6.872E-07	3.876E-07	2.760E-07	1.809E-07	1.070E-07	7.473E-08
NNE	2.784E-07	1.618E-07	1.187E-07	8.049E-08	4.922E-08	3.490E-08
NE	2.146E-07	1.293E-07	9.637E-08	6.593E-08	4.010E-08	2.814E-08
ENE	5.379E-07	3.161E-07	2.287E-07	1.517E-07	8.544E-08	5.754E-08
E	4.349E-07	2.511E-07	1.781E-07	1.161E-07	6.271E-08	4.151E-08
ESE	2.237E-07	1.316E-07	9.517E-08	6.077E-08	3.752E-08	2.507E-08
SE	1.404E-07	8.555E-08	6.434E-08	4.391E-08	2.761E-08	2.379E-08
SSE	8.466E-08	5.343E-08	4.251E-08	3.290E-08	2.625E-08	1.947E-08
S	1.138E-07	7.142E-08	5.844E-08	4.397E-08	3.334E-08	2.340E-08
SSW	1.195E-07	7.622E-08	6.418E-08	5.096E-08	3.474E-08	2.567E-08
SW	1.568E-07	1.021E-07	9.798E-08	7.350E-08	4.952E-08	3.388E-08
WSW	8.303E-08	5.439E-08	4.638E-08	4.813E-08	3.323E-08	2.418E-08
W	1.023E-07	6.109E-08	4.808E-08	3.752E-08	2.675E-08	2.039E-08
WNW	2.768E-07	1.563E-07	1.144E-07	8.024E-08	5.180E-08	3.796E-08
NW	4.819E-07	2.733E-07	1.974E-07	1.336E-07	8.207E-08	5.850E-08
NNW	5.836E-07	3.255E-07	2.311E-07	1.525E-07	9.119E-08	6.415E-08
	4.5	7.5	15.0	25.0	35.0	45.0
N	5.682E-08	3.229E-08	1.487E-08	8.630E-09	5.900E-09	5.432E-09
NNE	2.674E-08	1.527E-08	6.981E-09	6.259E-09	4.065E-09	2.955E-09
NE	2.133E-08	1.186E-08	5.653E-09	3.842E-09	2.467E-09	1.778E-09
ENE	4.249E-08	2.266E-08	1.191E-08	6.123E-09	3.960E-09	2.874E-09
E	3.039E-08	1.610E-08	8.670E-09	4.499E-09	2.939E-09	2.151E-09
ESE	1.846E-08	1.219E-08	5.018E-09	2.620E-09	1.719E-09	1.262E-09
SE	1.691E-08	8.600E-09	3.531E-09	1.859E-09	1.229E-09	9.077E-10
SSE	1.408E-08	7.122E-09	2.909E-09	1.533E-09	1.014E-09	7.489E-10
S	1.694E-08	8.538E-09	3.497E-09	1.849E-09	1.227E-09	9.083E-10
SSW	2.096E-08	1.036E-08	4.152E-09	2.119E-09	1.372E-09	9.979E-10
SW	2.774E-08	1.607E-08	6.287E-09	3.285E-09	2.100E-09	1.512E-09
WSW	1.858E-08	1.043E-08	5.006E-09	2.642E-09	1.930E-09	1.538E-09
W	1.628E-08	9.896E-09	4.778E-09	2.735E-09	1.885E-09	1.426E-09
WNW	2.983E-08	1.804E-08	8.977E-09	5.317E-09	3.751E-09	2.887E-09
NW	4.517E-08	2.656E-08	1.290E-08	7.554E-09	5.303E-09	4.069E-09
NNW	4.913E-08	2.849E-08	1.363E-08	7.907E-09	5.519E-09	4.218E-09

TABLE C-9 (CONTINUED)

SECTOR AVERAGE DEPOSITION VALUES FOR REACTOR VENT DETERMINED
FROM GRAZING METEOROLOGICAL DATA (May-Oct., 1985 To 1992)

(D/Q) Sector Average Deposition (1/m²)

SEGMENT BOUNDARIES IN MILES

<u>Direction</u>	0.5	0.75	1.0	1.5	2.5	3.5
N	5.293E-09	3.001E-09	1.993E-09	1.084E-09	4.833E-10	2.788E-10
NNE	2.213E-09	1.282E-09	8.672E-10	4.796E-10	2.178E-10	1.268E-10
NE	1.943E-09	1.129E-09	7.661E-10	4.253E-10	1.923E-10	1.114E-10
ENE	9.567E-09	5.374E-09	3.526E-09	1.908E-09	8.486E-10	4.910E-10
E	1.195E-08	6.594E-09	4.262E-09	2.273E-09	9.946E-10	5.705E-10
ESE	7.360E-09	4.098E-09	2.647E-09	1.400E-09	6.200E-10	3.559E-10
SE	4.567E-09	2.616E-09	1.713E-09	9.208E-10	4.141E-10	2.395E-10
SSE	2.349E-09	1.404E-09	9.335E-10	5.095E-10	2.374E-10	1.385E-10
S	3.680E-09	2.178E-09	1.449E-09	7.904E-10	3.660E-10	2.123E-10
SSW	2.552E-09	1.539E-09	1.065E-09	6.032E-10	2.835E-10	1.674E-10
SW	2.250E-09	1.407E-09	1.024E-09	5.859E-10	2.795E-10	1.655E-10
WSW	7.002E-10	4.587E-10	3.426E-10	2.133E-10	1.060E-10	6.420E-11
W	6.960E-10	4.315E-10	3.101E-10	1.811E-10	8.844E-11	5.324E-11
WNW	1.630E-09	9.674E-10	6.706E-10	3.802E-10	1.774E-10	1.045E-10
NW	3.128E-09	1.814E-09	1.232E-09	6.840E-10	3.116E-10	1.814E-10
NNW	4.161E-09	2.381E-09	1.595E-09	8.757E-10	3.947E-10	2.289E-10
	4.5	7.5	15.0	25.0	35.0	45.0
N	1.827E-10	7.623E-11	2.436E-11	1.057E-11	6.134E-12	5.692E-11
NNE	8.343E-11	3.499E-11	1.119E-11	2.150E-11	9.789E-12	5.547E-12
NE	7.311E-11	3.048E-11	9.592E-12	9.504E-12	5.097E-12	3.154E-12
ENE	3.225E-10	1.353E-10	1.156E-10	2.576E-11	1.382E-11	8.557E-12
E	3.727E-10	1.553E-10	7.770E-11	2.423E-11	1.300E-11	8.052E-12
ESE	2.326E-10	9.743E-11	4.546E-11	1.508E-11	7.942E-12	4.919E-12
SE	1.566E-10	6.774E-11	3.081E-11	1.184E-11	6.303E-12	3.709E-12
SSE	9.207E-11	4.261E-11	2.281E-11	1.017E-11	3.707E-12	2.214E-12
S	1.426E-10	6.463E-11	2.960E-11	1.496E-11	5.349E-12	3.211E-12
SSW	1.104E-10	4.819E-11	2.963E-11	1.059E-11	5.586E-12	2.816E-12
SW	1.109E-10	4.744E-11	3.118E-11	1.551E-11	7.818E-12	4.584E-12
WSW	4.303E-11	1.843E-11	5.936E-12	2.825E-12	2.461E-11	2.913E-12
W	3.556E-11	1.520E-11	4.937E-12	2.188E-12	1.280E-12	8.473E-13
WNW	6.913E-11	2.912E-11	9.300E-12	4.046E-12	2.335E-12	1.535E-12
NW	1.193E-10	4.998E-11	1.589E-11	6.865E-12	3.941E-12	2.584E-12
NNW	1.504E-10	6.293E-11	2.015E-11	8.774E-12	5.073E-12	3.346E-12

TABLE C-10

SECTOR AVERAGE DISPERSION VALUES FOR REFUEL FLOOR VENT
 DETERMINED FROM GRAZING METEOROLOGICAL DATA
 (May-Oct., 1985 To 1992)

Sector Average Concentration X/Q (sec/m³)

SEGMENT BOUNDARIES IN MILES

<u>Direction</u>	0.5	0.75	1.0	1.5	2.5	3.5
N	6.872E-07	3.876E-07	2.760E-07	1.809E-07	1.070E-07	7.473E-08
NNE	2.784E-07	1.618E-07	1.187E-07	8.049E-08	4.922E-08	3.490E-08
NE	2.146E-07	1.293E-07	9.637E-08	6.593E-08	4.010E-08	2.814E-08
ENE	5.379E-07	3.161E-07	2.287E-07	1.517E-07	8.544E-08	5.754E-08
E	4.349E-07	2.511E-07	1.781E-07	1.161E-07	6.271E-08	4.151E-08
ESE	2.237E-07	1.316E-07	9.517E-08	6.077E-08	3.752E-08	2.507E-08
SE	1.404E-07	8.555E-08	6.434E-08	4.391E-08	2.761E-08	2.379E-08
SSE	8.466E-08	5.343E-08	4.251E-08	3.290E-08	2.625E-08	1.947E-08
S	1.138E-07	7.142E-08	5.844E-08	4.397E-08	3.334E-08	2.340E-08
SSW	1.195E-07	7.622E-08	6.418E-08	5.096E-08	3.474E-08	2.567E-08
SW	1.568E-07	1.021E-07	9.798E-08	7.350E-08	4.952E-08	3.388E-08
WSW	8.303E-08	5.439E-08	4.638E-08	4.813E-08	3.323E-08	2.418E-08
W	1.023E-07	6.109E-08	4.808E-08	3.752E-08	2.675E-08	2.039E-08
WNW	2.768E-07	1.563E-07	1.144E-07	8.024E-08	5.180E-08	3.796E-08
NW	4.819E-07	2.733E-07	1.974E-07	1.336E-07	8.207E-08	5.850E-08
NNW	5.836E-07	3.255E-07	2.311E-07	1.525E-07	9.119E-08	6.415E-08
	4.5	7.5	15.0	25.0	35.0	45.0
N	5.682E-08	3.229E-08	1.487E-08	8.630E-09	5.900E-09	5.432E-09
NNE	2.674E-08	1.527E-08	6.981E-09	6.259E-09	4.065E-09	2.955E-09
NE	2.133E-08	1.186E-08	5.653E-09	3.842E-09	2.467E-09	1.778E-09
ENE	4.249E-08	2.266E-08	1.191E-08	6.123E-09	3.960E-09	2.874E-09
E	3.039E-08	1.610E-08	8.670E-09	4.499E-09	2.939E-09	2.151E-09
ESE	1.846E-08	1.219E-08	5.018E-09	2.620E-09	1.719E-09	1.262E-09
SE	1.691E-08	8.600E-09	3.531E-09	1.859E-09	1.229E-09	9.077E-10
SSE	1.408E-08	7.122E-09	2.909E-09	1.533E-09	1.014E-09	7.489E-10
S	1.694E-08	8.538E-09	3.497E-09	1.849E-09	1.227E-09	9.083E-10
SSW	2.096E-08	1.036E-08	4.152E-09	2.119E-09	1.372E-09	9.979E-10
SW	2.774E-08	1.607E-08	6.287E-09	3.285E-09	2.100E-09	1.512E-09
WSW	1.858E-08	1.043E-08	5.006E-09	2.642E-09	1.930E-09	1.538E-09
W	1.628E-08	9.896E-09	4.778E-09	2.735E-09	1.885E-09	1.426E-09
WNW	2.983E-08	1.804E-08	8.977E-09	5.317E-09	3.751E-09	2.887E-09
NW	4.517E-08	2.656E-08	1.290E-08	7.554E-09	5.303E-09	4.069E-09

NNW 4.913E-08 2.849E-08 1.363E-08 7.907E-09 5.519E-09 4.218E-09

TABLE C-10 (CONTINUED)

SECTOR AVERAGE DEPOSITION VALUES FOR REFUEL FLOOR VENT
 DETERMINED FROM GRAZING METEOROLOGICAL DATA
 (May-Oct., 1985 To 1992)

(D/Q) Sector Average Deposition (1/m²)

SEGMENT BOUNDARIES IN MILES

<u>Direction</u>	0.5	0.75	1.0	1.5	2.5	3.5
N	5.293E-09	3.001E-09	1.993E-09	1.084E-09	4.833E-10	2.788E-10
NNE	2.213E-09	1.282E-09	8.672E-10	4.796E-10	2.178E-10	1.268E-10
NE	1.943E-09	1.129E-09	7.661E-10	4.253E-10	1.923E-10	1.114E-10
ENE	9.567E-09	5.374E-09	3.526E-09	1.908E-09	8.486E-10	4.910E-10
E	1.195E-08	6.594E-09	4.262E-09	2.273E-09	9.946E-10	5.705E-10
ESE	7.360E-09	4.098E-09	2.647E-09	1.400E-09	6.200E-10	3.559E-10
SE	4.567E-09	2.616E-09	1.713E-09	9.208E-10	4.141E-10	2.395E-10
SSE	2.349E-09	1.404E-09	9.335E-10	5.095E-10	2.374E-10	1.385E-10
S	3.680E-09	2.178E-09	1.449E-09	7.904E-10	3.660E-10	2.123E-10
SSW	2.552E-09	1.539E-09	1.065E-09	6.032E-10	2.835E-10	1.674E-10
SW	2.250E-09	1.407E-09	1.024E-09	5.859E-10	2.795E-10	1.655E-10
WSW	7.002E-10	4.587E-10	3.426E-10	2.133E-10	1.060E-10	6.420E-11
W	6.960E-10	4.315E-10	3.101E-10	1.811E-10	8.844E-11	5.324E-11
WNW	1.630E-09	9.674E-10	6.706E-10	3.802E-10	1.774E-10	1.045E-10
NW	3.128E-09	1.814E-09	1.232E-09	6.840E-10	3.116E-10	1.814E-10
NNW	4.161E-09	2.381E-09	1.595E-09	8.757E-10	3.947E-10	2.289E-10
	4.5	7.5	15.0	25.0	35.0	45.0
N	1.827E-10	7.623E-11	2.436E-11	1.057E-11	6.134E-12	5.692E-11
NNE	8.343E-11	3.499E-11	1.119E-11	2.150E-11	9.789E-12	5.547E-12
NE	7.311E-11	3.048E-11	9.592E-12	9.504E-12	5.097E-12	3.154E-12
ENE	3.225E-10	1.353E-10	1.156E-10	2.576E-11	1.382E-11	8.557E-12
E	3.727E-10	1.553E-10	7.770E-11	2.423E-11	1.300E-11	8.052E-12
ESE	2.326E-10	9.743E-11	4.546E-11	1.508E-11	7.942E-12	4.919E-12
SE	1.566E-10	6.774E-11	3.081E-11	1.184E-11	6.303E-12	3.709E-12
SSE	9.207E-11	4.261E-11	2.281E-11	1.017E-11	3.707E-12	2.214E-12
S	1.426E-10	6.463E-11	2.960E-11	1.496E-11	5.349E-12	3.211E-12
SSW	1.104E-10	4.819E-11	2.963E-11	1.059E-11	5.586E-12	2.816E-12
SW	1.109E-10	4.744E-11	3.118E-11	1.551E-11	7.818E-12	4.584E-12
WSW	4.303E-11	1.843E-11	5.936E-12	2.825E-12	2.461E-11	2.913E-12
W	3.556E-11	1.520E-11	4.937E-12	2.188E-12	1.280E-12	8.473E-13
WNW	6.913E-11	2.912E-11	9.300E-12	4.046E-12	2.335E-12	1.535E-12
NW	1.193E-10	4.998E-11	1.589E-11	6.865E-12	3.941E-12	2.584E-12

NNW 1.504E-10 6.293E-11 2.015E-11 8.774E-12 5.073E-12 3.346E-12

TABLE C-11

SECTOR AVERAGE DISPERSION VALUES FOR TURBINE VENT DETERMINED
FROM GRAZING METEOROLOGICAL DATA (May-Oct., 1985 To 1992)

Sector Average Concentration X/Q (sec/m³)

SEGMENT BOUNDARIES IN MILES

<u>Direction</u>	0.5	0.75	1.0	1.5	2.5	3.5
N	5.709E-07	3.305E-07	2.412E-07	1.625E-07	9.818E-08	6.921E-08
NNE	2.285E-07	1.372E-07	1.037E-07	7.275E-08	4.562E-08	3.268E-08
NE	1.764E-07	1.102E-07	8.477E-08	6.015E-08	3.755E-08	2.661E-08
ENE	4.616E-07	2.776E-07	2.055E-07	1.405E-07	8.050E-08	5.457E-08
E	3.792E-07	2.246E-07	1.625E-07	1.091E-07	5.960E-08	3.964E-08
ESE	1.965E-07	1.194E-07	8.826E-08	5.753E-08	3.635E-08	2.434E-08
SE	1.272E-07	7.992E-08	6.120E-08	4.254E-08	2.712E-08	2.351E-08
SSE	7.646E-08	5.020E-08	4.085E-08	3.235E-08	2.618E-08	1.933E-08
S	1.036E-07	6.737E-08	5.658E-08	4.335E-08	3.322E-08	2.320E-08
SSW	1.046E-07	6.974E-08	6.111E-08	4.995E-08	3.438E-08	2.545E-08
SW	1.314E-07	9.022E-08	9.323E-08	7.163E-08	4.882E-08	3.339E-08
WSW	5.958E-08	4.293E-08	4.003E-08	4.609E-08	3.238E-08	2.363E-08
W	6.396E-08	4.183E-08	3.639E-08	3.164E-08	2.412E-08	1.880E-08
WNW	1.777E-07	1.075E-07	8.434E-08	6.407E-08	4.390E-08	3.301E-08
NW	3.558E-07	2.118E-07	1.598E-07	1.134E-07	7.213E-08	5.224E-08
NNW	4.537E-07	2.623E-07	1.924E-07	1.315E-07	8.085E-08	5.761E-08
	4.5	7.5	15.0	25.0	35.0	45.0
N	5.294E-08	3.037E-08	1.413E-08	8.267E-09	5.666E-09	5.296E-09
NNE	2.518E-08	1.451E-08	6.687E-09	6.127E-09	3.978E-09	2.891E-09
NE	2.028E-08	1.135E-08	5.477E-09	3.750E-09	2.407E-09	1.735E-09
ENE	4.044E-08	2.168E-08	1.158E-08	5.945E-09	3.845E-09	2.790E-09
E	2.910E-08	1.547E-08	8.448E-09	4.380E-09	2.862E-09	2.094E-09
ESE	1.794E-08	1.196E-08	4.909E-09	2.560E-09	1.680E-09	1.233E-09
SE	1.669E-08	8.467E-09	3.468E-09	1.826E-09	1.207E-09	8.915E-10
SSE	1.392E-08	7.028E-09	2.868E-09	1.511E-09	9.997E-10	7.383E-10
S	1.673E-08	8.418E-09	3.445E-09	1.821E-09	1.208E-09	8.947E-10
SSW	2.075E-08	1.023E-08	4.085E-09	2.083E-09	1.349E-09	9.812E-10
SW	2.742E-08	1.588E-08	6.199E-09	3.229E-09	2.064E-09	1.486E-09
WSW	1.818E-08	1.022E-08	4.932E-09	2.603E-09	1.905E-09	1.512E-09
W	1.518E-08	9.366E-09	4.578E-09	2.636E-09	1.821E-09	1.381E-09
WNW	2.633E-08	1.632E-08	8.318E-09	4.988E-09	3.541E-09	2.735E-09
NW	4.074E-08	2.438E-08	1.207E-08	7.141E-09	5.039E-09	3.879E-09
NNW	4.450E-08	2.620E-08	1.274E-08	7.463E-09	5.234E-09	4.013E-09

TABLE C-11 (CONTINUED)

SECTOR AVERAGE DEPOSITION VALUES FOR TURBINE VENT DETERMINED
FROM GRAZING METEOROLOGICAL DATA (May-Oct., 1985 To 1992)

(D/Q) Sector Average Deposition (1/m²)

SEGMENT BOUNDARIES IN MILES

<u>Direction</u>	0.5	0.75	1.0	1.5	2.5	3.5
N	4.847E-09	2.779E-09	1.860E-09	1.020E-09	4.566E-10	2.639E-10
NNE	2.032E-09	1.194E-09	8.146E-10	4.548E-10	2.075E-10	1.210E-10
NE	1.740E-09	1.030E-09	7.073E-10	3.972E-10	1.806E-10	1.049E-10
ENE	8.906E-09	5.042E-09	3.325E-09	1.812E-09	8.095E-10	4.694E-10
E	1.133E-08	6.299E-09	4.090E-09	2.199E-09	9.662E-10	5.554E-10
ESE	7.061E-09	3.955E-09	2.563E-09	1.364E-09	6.063E-10	3.486E-10
SE	4.447E-09	2.551E-09	1.671E-09	9.025E-10	4.067E-10	2.352E-10
SSE	2.328E-09	1.388E-09	9.215E-10	5.051E-10	2.350E-10	1.369E-10
S	3.634E-09	2.148E-09	1.428E-09	7.821E-10	3.617E-10	2.097E-10
SSW	2.496E-09	1.510E-09	1.047E-09	5.968E-10	2.803E-10	1.653E-10
SW	2.157E-09	1.362E-09	1.001E-09	5.766E-10	2.750E-10	1.628E-10
WSW	6.331E-10	4.276E-10	3.252E-10	2.063E-10	1.026E-10	6.218E-11
W	5.976E-10	3.834E-10	2.817E-10	1.680E-10	8.284E-11	5.007E-11
WNW	1.388E-09	8.480E-10	5.993E-10	3.462E-10	1.632E-10	9.657E-11
NW	2.777E-09	1.641E-09	1.128E-09	6.346E-10	2.909E-10	1.699E-10
NNW	3.765E-09	2.185E-09	1.477E-09	8.192E-10	3.712E-10	2.158E-10
	4.5	7.5	15.0	25.0	35.0	45.0
N	1.732E-10	7.236E-11	2.311E-11	1.013E-11	6.026E-12	8.848E-11
NNE	7.973E-11	3.347E-11	1.068E-11	2.103E-11	9.625E-12	5.470E-12
NE	6.896E-11	2.878E-11	9.085E-12	9.506E-12	5.098E-12	3.156E-12
ENE	3.089E-10	1.298E-10	1.140E-10	2.577E-11	1.382E-11	8.559E-12
E	3.636E-10	1.518E-10	7.743E-11	2.424E-11	1.300E-11	8.054E-12
ESE	2.282E-10	9.672E-11	4.575E-11	1.498E-11	7.946E-12	4.920E-12
SE	1.544E-10	6.793E-11	3.047E-11	1.174E-11	6.217E-12	3.655E-12
SSE	9.165E-11	4.352E-11	2.187E-11	9.446E-12	3.670E-12	2.215E-12
S	1.435E-10	6.606E-11	2.883E-11	1.384E-11	5.297E-12	3.212E-12
SSW	1.090E-10	4.835E-11	2.801E-11	1.041E-11	5.507E-12	2.816E-12
SW	1.090E-10	4.691E-11	3.601E-11	1.557E-11	7.813E-12	4.562E-12
WSW	4.171E-11	1.784E-11	5.729E-12	2.935E-12	3.639E-11	2.915E-12
W	3.353E-11	1.435E-11	4.643E-12	2.068E-12	1.217E-12	8.100E-13
WNW	6.407E-11	2.705E-11	8.612E-12	3.772E-12	2.196E-12	1.457E-12
NW	1.120E-10	4.697E-11	1.490E-11	6.476E-12	3.751E-12	2.485E-12
NNW	1.420E-10	5.952E-11	1.904E-11	8.344E-12	4.874E-12	3.254E-12

TABLE C-12

SECTOR AVERAGE DISPERSION VALUES FOR RADWASTE VENT DETERMINED
FROM GRAZING METEOROLOGICAL DATA (May-Oct., 1985 To 1992)

Sector Average Concentration X/Q (sec/m³)

SEGMENT BOUNDARIES IN MILES

<u>Direction</u>	0.5	0.75	1.0	1.5	2.5	3.5
N	1.033E-06	6.607E-07	4.934E-07	3.221E-07	1.851E-07	1.275E-07
NNE	4.455E-07	2.987E-07	2.285E-07	1.525E-07	8.827E-08	6.054E-08
NE	3.625E-07	2.468E-07	1.879E-07	1.232E-07	6.884E-08	4.598E-08
ENE	8.475E-07	5.272E-07	3.794E-07	2.416E-07	1.263E-07	8.178E-08
E	6.881E-07	4.030E-07	2.806E-07	1.778E-07	9.089E-08	5.854E-08
ESE	3.637E-07	2.260E-07	1.604E-07	9.717E-08	5.730E-08	3.661E-08
SE	2.507E-07	1.591E-07	1.137E-07	7.166E-08	4.147E-08	2.871E-08
SSE	1.528E-07	1.153E-07	8.631E-08	5.956E-08	3.778E-08	2.365E-08
S	2.033E-07	1.462E-07	1.136E-07	7.515E-08	4.517E-08	2.814E-08
SSW	2.465E-07	1.710E-07	1.378E-07	9.433E-08	5.423E-08	3.604E-08
SW	3.232E-07	2.419E-07	2.349E-07	1.473E-07	8.225E-08	5.213E-08
WSW	1.847E-07	1.571E-07	1.341E-07	1.183E-07	6.589E-08	4.363E-08
W	1.925E-07	1.496E-07	1.266E-07	9.400E-08	5.935E-08	4.234E-08
WNW	4.533E-07	3.100E-07	2.455E-07	1.732E-07	1.090E-07	7.925E-08
NW	7.620E-07	5.042E-07	3.862E-07	2.611E-07	1.583E-07	1.133E-07
NNW	8.836E-07	5.647E-07	4.242E-07	2.807E-07	1.666E-07	1.178E-07
	4.5	7.5	15.0	25.0	35.0	45.0
N	9.616E-08	5.366E-08	2.398E-08	1.359E-08	9.122E-09	7.874E-09
NNE	4.539E-08	2.496E-08	1.093E-08	7.546E-09	4.900E-09	3.562E-09
NE	3.379E-08	1.787E-08	8.096E-09	4.598E-09	2.952E-09	2.128E-09
ENE	5.900E-08	3.037E-08	1.395E-08	7.112E-09	4.597E-09	3.334E-09
E	4.216E-08	2.175E-08	1.009E-08	5.213E-09	3.404E-09	2.490E-09
ESE	2.622E-08	1.462E-08	5.848E-09	3.039E-09	1.992E-09	1.462E-09
SE	2.025E-08	1.013E-08	4.110E-09	2.159E-09	1.426E-09	1.053E-09
SSE	1.670E-08	8.369E-09	3.400E-09	1.788E-09	1.181E-09	8.713E-10
S	1.986E-08	9.951E-09	4.056E-09	2.139E-09	1.417E-09	1.048E-09
SSW	2.557E-08	1.246E-08	4.861E-09	2.477E-09	1.603E-09	1.166E-09
SW	3.986E-08	2.025E-08	7.746E-09	3.881E-09	2.481E-09	1.786E-09
WSW	3.183E-08	1.658E-08	7.380E-09	3.775E-09	2.571E-09	1.863E-09
W	3.249E-08	1.853E-08	8.383E-09	4.616E-09	3.108E-09	2.313E-09
WNW	6.191E-08	3.671E-08	1.744E-08	9.907E-09	6.795E-09	5.122E-09
NW	8.779E-08	5.149E-08	2.428E-08	1.376E-08	9.425E-09	7.099E-09
NNW	9.054E-08	5.244E-08	2.444E-08	1.376E-08	9.398E-09	7.065E-09

TABLE C-12 (CONTINUED)

SECTOR AVERAGE DEPOSITION VALUES FOR RADWASTE VENT DETERMINED
FROM GRAZING METEOROLOGICAL DATA (May-Oct., 1985 To 1992)

(D/Q) Sector Average Deposition (1/m²)

SEGMENT BOUNDARIES IN MILES

<u>Direction</u>	0.5	0.75	1.0	1.5	2.5	3.5
N	7.161E-09	3.910E-09	2.468E-09	1.281E-09	5.399E-10	3.016E-10
NNE	3.098E-09	1.725E-09	1.100E-09	5.785E-10	2.454E-10	1.375E-10
NE	2.767E-09	1.546E-09	9.859E-10	5.168E-10	2.179E-10	1.215E-10
ENE	1.236E-08	6.620E-09	4.148E-09	2.151E-09	9.130E-10	5.142E-10
E	1.471E-08	7.775E-09	4.841E-09	2.489E-09	1.051E-09	5.901E-10
ESE	8.980E-09	4.777E-09	2.975E-09	1.527E-09	6.496E-10	3.661E-10
SE	5.951E-09	3.176E-09	1.973E-09	1.018E-09	4.362E-10	3.758E-10
SSE	3.184E-09	1.734E-09	1.082E-09	5.670E-10	2.795E-10	2.748E-10
S	4.939E-09	2.682E-09	1.686E-09	8.791E-10	4.358E-10	3.566E-10
SSW	3.731E-09	2.062E-09	1.325E-09	7.054E-10	3.056E-10	2.065E-10
SW	3.491E-09	2.008E-09	1.354E-09	7.203E-10	3.108E-10	1.753E-10
WSW	1.216E-09	7.473E-10	5.065E-10	2.908E-10	1.262E-10	7.139E-11
W	1.108E-09	6.552E-10	4.355E-10	2.391E-10	1.045E-10	5.944E-11
WNW	2.417E-09	1.382E-09	8.957E-10	4.786E-10	2.049E-10	1.152E-10
NW	4.435E-09	2.485E-09	1.590E-09	8.377E-10	3.551E-10	1.988E-10
NNW	5.741E-09	3.164E-09	2.007E-09	1.049E-09	4.437E-10	2.484E-10
	4.5	7.5	15.0	25.0	35.0	45.0
N	1.944E-10	8.685E-11	1.650E-10	4.423E-10	5.252E-10	2.758E-11
NNE	8.880E-11	3.942E-11	7.098E-11	1.219E-11	6.530E-12	4.038E-12
NE	7.813E-11	3.424E-11	6.883E-11	9.492E-12	5.086E-12	3.146E-12
ENE	3.330E-10	1.437E-10	9.824E-11	2.573E-11	1.380E-11	8.541E-12
E	3.813E-10	1.608E-10	7.197E-11	2.421E-11	1.298E-11	8.039E-12
ESE	2.378E-10	1.543E-10	4.294E-11	1.480E-11	7.934E-12	4.911E-12
SE	2.575E-10	1.053E-10	2.854E-11	1.033E-11	5.540E-12	3.428E-12
SSE	1.909E-10	7.321E-11	1.969E-11	7.139E-12	3.573E-12	2.208E-12
S	2.295E-10	9.154E-11	2.687E-11	1.032E-11	5.181E-12	3.203E-12
SSW	2.750E-10	1.176E-10	2.497E-11	8.477E-12	4.541E-12	2.807E-12
SW	1.329E-10	1.642E-10	4.605E-11	1.041E-11	5.525E-12	3.393E-12
WSW	4.643E-11	2.156E-11	4.157E-11	4.604E-11	4.839E-12	1.971E-12
W	3.868E-11	1.646E-11	2.393E-11	8.590E-11	1.303E-10	1.365E-10
WNW	7.449E-11	3.222E-11	6.113E-11	2.097E-10	3.048E-10	3.120E-10
NW	1.282E-10	5.677E-11	1.156E-10	3.505E-10	4.802E-10	4.775E-10
NNW	1.602E-10	7.077E-11	1.317E-10	3.775E-10	5.051E-10	4.961E-10

TABLE C-13

SECTOR AVERAGE DISPERSION VALUES FOR THE STACK DETERMINED
FROM GRAZING METEOROLOGICAL DATA (May-Oct., 1985 To 1992)

Sector Average Concentration X/Q (sec/m³)

SEGMENT BOUNDARIES IN MILES

<u>Direction</u>	0.5	0.75	1.0	1.5	2.5	3.5
N	1.027E-08	1.097E-08	1.194E-08	1.411E-08	1.486E-08	1.339E-08
NNE	3.203E-09	4.104E-09	5.361E-09	7.740E-09	9.169E-09	8.589E-09
NE	1.541E-09	2.147E-09	3.601E-09	6.414E-09	8.365E-09	8.095E-09
ENE	2.136E-08	1.920E-08	2.080E-08	2.654E-08	2.643E-08	2.296E-08
E	2.418E-08	2.669E-08	2.929E-08	3.752E-08	3.256E-08	2.619E-08
ESE	2.565E-08	2.362E-08	2.317E-08	2.243E-08	2.257E-08	1.729E-08
SE	2.484E-08	1.862E-08	1.761E-08	1.750E-08	1.669E-08	1.992E-08
SSE	2.207E-08	1.569E-08	1.476E-08	1.572E-08	1.921E-08	1.773E-08
S	2.327E-08	1.668E-08	1.630E-08	1.732E-08	2.215E-08	1.961E-08
SSW	1.929E-08	1.592E-08	1.765E-08	2.163E-08	2.276E-08	2.047E-08
SW	7.525E-09	6.805E-09	1.138E-08	1.499E-08	1.706E-08	1.411E-08
WSW	1.477E-09	1.939E-09	2.783E-09	6.039E-09	6.782E-09	6.122E-09
W	1.621E-09	1.537E-09	2.124E-09	3.344E-09	4.143E-09	3.951E-09
WNW	3.121E-09	3.456E-09	4.222E-09	5.656E-09	6.317E-09	5.765E-09
NW	7.262E-09	7.526E-09	8.766E-09	1.127E-08	1.242E-08	1.130E-08
NNW	9.840E-09	1.035E-08	1.126E-08	1.325E-08	1.394E-08	1.259E-08
	4.5	7.5	15.0	25.0	35.0	45.0
N	1.166E-08	7.912E-09	4.057E-09	2.400E-09	1.651E-09	1.473E-09
NNE	7.654E-09	5.395E-09	2.899E-09	5.959E-09	3.873E-09	2.818E-09
NE	7.362E-09	5.385E-09	3.568E-09	7.949E-09	5.187E-09	3.784E-09
ENE	1.956E-08	1.284E-08	1.211E-08	9.552E-09	6.177E-09	4.480E-09
E	2.126E-08	1.291E-08	9.490E-09	6.183E-09	3.959E-09	2.853E-09
ESE	1.367E-08	1.137E-08	5.359E-09	3.641E-09	2.348E-09	1.702E-09
SE	1.483E-08	8.319E-09	3.902E-09	2.516E-09	1.633E-09	1.189E-09
SSE	1.426E-08	7.927E-09	3.472E-09	1.969E-09	1.445E-09	1.052E-09
S	1.720E-08	9.169E-09	3.894E-09	2.170E-09	1.617E-09	1.178E-09
SSW	2.008E-08	1.080E-08	5.377E-09	3.251E-09	2.089E-09	1.510E-09
SW	1.368E-08	1.015E-08	4.452E-09	3.488E-09	2.294E-09	1.730E-09
WSW	5.337E-09	3.643E-09	2.196E-09	1.283E-09	1.101E-09	1.497E-09
W	3.568E-09	2.588E-09	1.451E-09	8.966E-10	6.449E-10	5.031E-10
WNW	5.053E-09	3.461E-09	1.805E-09	1.063E-09	7.440E-10	5.702E-10
NW	9.881E-09	6.705E-09	3.423E-09	1.972E-09	1.356E-09	1.024E-09
NNW	1.100E-08	7.528E-09	3.920E-09	2.292E-09	1.590E-09	1.208E-09

TABLE C-13 (CONTINUED)

SECTOR AVERAGE DISPERSION VALUES FOR THE STACK DETERMINED
FROM GRAZING METEOROLOGICAL DATA (May-Oct., 1985 To 1992)

Sector Average Finite Cloud Gamma X/Q (sec/m³)

SEGMENT BOUNDARIES IN MILES

<u>Direction</u>	0.5	0.75	1.0	1.5	2.5	3.5
N	1.158E-07	8.009E-08	6.198E-08	4.338E-08	2.763E-08	2.031E-08
NNE	8.837E-08	6.084E-08	4.707E-08	3.305E-08	2.119E-08	1.565E-08
NE	1.004E-07	6.872E-08	5.300E-08	3.714E-08	2.383E-08	1.764E-08
ENE	1.844E-07	1.268E-07	9.832E-08	7.168E-08	4.551E-08	3.328E-08
E	1.719E-07	1.199E-07	9.332E-08	7.016E-08	4.346E-08	3.109E-08
ESE	1.054E-07	7.510E-08	5.799E-08	3.997E-08	2.748E-08	1.939E-08
SE	7.518E-08	5.213E-08	4.029E-08	2.868E-08	1.954E-08	1.780E-08
SSE	6.310E-08	4.479E-08	3.474E-08	2.569E-08	1.995E-08	1.574E-08
S	6.769E-08	4.821E-08	3.859E-08	2.845E-08	2.262E-08	1.744E-08
SSW	9.202E-08	6.303E-08	5.095E-08	3.824E-08	2.660E-08	2.061E-08
SW	8.132E-08	5.613E-08	4.944E-08	3.503E-08	2.387E-08	1.725E-08
WSW	5.017E-08	3.457E-08	2.681E-08	2.139E-08	1.367E-08	1.004E-08
W	4.869E-08	3.326E-08	2.566E-08	1.797E-08	1.151E-08	8.521E-09
WNW	5.779E-08	3.977E-08	3.077E-08	2.159E-08	1.379E-08	1.015E-08
NW	9.748E-08	6.725E-08	5.218E-08	3.674E-08	2.357E-08	1.737E-08
NNW	1.133E-07	7.823E-08	6.053E-08	4.235E-08	2.696E-08	1.982E-08
	4.5	7.5	15.0	25.0	35.0	45.0
N	1.599E-08	9.594E-09	4.587E-09	2.642E-09	1.803E-09	1.510E-09
NNE	1.238E-08	7.517E-09	3.669E-09	3.858E-09	2.576E-09	1.909E-09
NE	1.400E-08	8.577E-09	4.739E-09	4.937E-09	3.317E-09	2.468E-09
ENE	2.608E-08	1.550E-08	1.048E-08	6.589E-09	4.365E-09	3.218E-09
E	2.393E-08	1.373E-08	8.069E-09	4.645E-09	3.035E-09	2.217E-09
ESE	1.480E-08	1.035E-08	4.652E-09	2.723E-09	1.792E-09	1.316E-09
SE	1.326E-08	7.323E-09	3.289E-09	1.896E-09	1.256E-09	9.271E-10
SSE	1.216E-08	6.698E-09	2.936E-09	1.621E-09	1.123E-09	8.295E-10
S	1.392E-08	7.524E-09	3.256E-09	1.785E-09	1.244E-09	9.190E-10
SSW	1.778E-08	9.626E-09	4.425E-09	2.476E-09	1.623E-09	1.189E-09
SW	1.478E-08	9.614E-09	4.201E-09	2.647E-09	1.750E-09	1.302E-09
WSW	7.897E-09	4.740E-09	2.495E-09	1.413E-09	1.085E-09	1.056E-09
W	6.758E-09	4.136E-09	2.051E-09	1.200E-09	8.395E-10	6.423E-10
WNW	8.007E-09	4.832E-09	2.340E-09	1.344E-09	9.281E-10	7.043E-10
NW	1.369E-08	8.224E-09	3.930E-09	2.224E-09	1.520E-09	1.143E-09
NNW	1.561E-08	9.393E-09	4.520E-09	2.573E-09	1.765E-09	1.331E-09

TABLE C-13 (CONTINUED)

SECTOR AVERAGE DEPOSITION VALUES FOR THE STACK DETERMINED
FROM GRAZING METEOROLOGICAL DATA (May-Oct., 1985 To 1992)

(D/Q) Sector Average Deposition (1/m²)

SEGMENT BOUNDARIES IN MILES

<u>Direction</u>	0.5	0.75	1.0	1.5	2.5	3.5
N	8.120E-10	6.726E-10	5.859E-10	3.891E-10	2.241E-10	1.437E-10
NNE	2.594E-10	2.425E-10	2.324E-10	1.666E-10	1.006E-10	6.537E-11
NE	1.367E-10	1.617E-10	1.778E-10	1.396E-10	8.856E-11	5.825E-11
ENE	2.061E-09	1.641E-09	1.373E-09	8.782E-10	4.932E-10	3.145E-10
E	2.344E-09	1.893E-09	1.611E-09	1.048E-09	5.954E-10	3.804E-10
ESE	1.916E-09	1.446E-09	1.148E-09	6.978E-10	3.772E-10	2.378E-10
SE	1.509E-09	1.111E-09	8.536E-10	5.001E-10	2.647E-10	1.788E-10
SSE	1.381E-09	9.953E-10	7.444E-10	4.225E-10	2.282E-10	1.451E-10
S	1.637E-09	1.173E-09	8.706E-10	4.899E-10	2.644E-10	1.664E-10
SSW	1.380E-09	1.068E-09	8.670E-10	5.385E-10	2.985E-10	1.946E-10
SW	4.653E-10	4.167E-10	3.854E-10	2.688E-10	1.598E-10	1.034E-10
WSW	8.735E-11	8.698E-11	8.685E-11	6.410E-11	3.936E-11	2.568E-11
W	8.824E-11	8.612E-11	8.467E-11	6.182E-11	3.773E-11	2.459E-11
WNW	2.513E-10	2.214E-10	2.025E-10	1.401E-10	8.281E-11	5.351E-11
NW	5.753E-10	4.944E-10	4.434E-10	3.018E-10	1.766E-10	1.138E-10
NNW	8.411E-10	6.830E-10	5.837E-10	3.811E-10	2.170E-10	1.388E-10
	4.5	7.5	15.0	25.0	35.0	45.0
N	9.813E-11	4.342E-11	1.458E-11	6.584E-12	3.899E-12	2.583E-12
NNE	4.471E-11	1.970E-11	6.541E-12	1.089E-11	2.064E-11	2.610E-11
NE	3.992E-11	1.753E-11	5.759E-12	2.237E-11	8.393E-12	5.198E-12
ENE	2.147E-10	9.530E-11	3.198E-11	3.184E-11	1.709E-11	1.059E-11
E	2.596E-10	1.151E-10	3.834E-11	2.707E-11	1.453E-11	9.002E-12
ESE	1.620E-10	7.545E-11	2.442E-11	1.053E-10	7.907E-12	4.897E-12
SE	1.206E-10	5.231E-11	1.711E-11	1.248E-11	3.737E-11	6.706E-11
SSE	9.856E-11	4.268E-11	1.416E-11	6.581E-12	1.193E-11	2.789E-12
S	1.136E-10	4.896E-11	1.630E-11	7.617E-12	2.812E-11	3.396E-12
SSW	1.379E-10	5.967E-11	1.916E-11	2.198E-11	3.347E-11	4.991E-12
SW	7.147E-11	3.262E-11	1.036E-11	4.400E-12	2.543E-12	2.759E-12
WSW	1.757E-11	7.730E-12	2.554E-12	1.121E-12	6.388E-13	4.550E-13
W	1.684E-11	7.414E-12	2.457E-12	1.084E-12	6.291E-13	4.130E-13
WNW	3.659E-11	1.616E-11	5.394E-12	2.412E-12	1.417E-12	9.362E-13
NW	7.779E-11	3.438E-11	1.151E-11	5.170E-12	3.048E-12	2.018E-12
NNW	9.472E-11	4.197E-11	1.413E-11	6.421E-12	3.821E-12	2.541E-12

TABLE C-14

CRITICAL RECEPTOR DISPERSION AND DEPOSITION PARAMETERS
FOR VENT AND ELEVATED RELEASES

<u>DISPERSION PARAMETER DESCRIPTION</u>	<u>RECEPTOR</u>
Annual Average X/Q - Total Body; Stack	Site Boundary
Annual Average X/Q - Skin; Stack	Site Boundary*
Annual Average X/Q - Gamma Air; Stack	Site Boundary
Annual Average X/Q - Beta Air; Stack	Site Boundary*
Annual Average X/Q - Dep. Inhal.; Stack	Resident
Annual Average D/Q - GPD; Stack	Resident
Grazing D/Q - SFV & FFV; Stack	Garden
Grazing D/Q - Cow; Stack	Milk Animal
Grazing D/Q - Goat; Stack	Milk Animal
Grazing D/Q - Meat; Stack	Meat Animal
Annual Average X/Q - Total Body; Vent	Site Boundary
Annual Average X/Q - Skin; Vent	Site Boundary
Annual Average X/Q - Gamma Air; Vent	Site Boundary
Annual Average X/Q - Beta Air; Vent	Site Boundary
Annual Average X/Q - Dep. Inhal.; Vent	Resident
Annual Average D/Q - GPD; Vent	Resident
Grazing D/Q - SFV & FFV; Vent	Garden
Grazing D/Q - Cow; Vent	Milk Animal
Grazing D/Q - Goat; Vent	Milk Animal
Grazing D/Q - Meat; Vent	Meat Animal

* The highest X/Q is located beyond the site boundary.

TABLE C-15

85TH PERCENTILE HOURLY PLUME CENTERLINE DISPERSION VALUES
AND ANNUAL SECTOR AVERAGE DISPERSION VALUES
FOR UNMONITORED GROUND LEVEL RELEASES DETERMINED
FROM ANNUAL AVERAGE METEOROLOGICAL DATA (1985-1992)
(FOR USE WITH SHORT TERM RELEASES)

Concentration X/Q (sec/m³)

<u>Direction</u>		<u>Site Boundary Distance (m)</u>	<u>Hourly Plume Cent. Conc. (X/Q) (sec/m³)</u>	<u>Annual Sector Ave. Conc. (X/Q) (sec/m³)</u>	<u>Slope m</u>
N	w	225	1.284E-03	3.496E-05	-0.3970
NNE	w	225	1.061E-03	1.775E-05	-0.4506
NE	w	354	4.704E-04	5.342E-06	-0.4933
ENE	w	563	1.650E-04	3.429E-06	-0.4267
E	l	950	4.960E-05	1.054E-06	-0.4243
ESE	l	1030	3.611E-05	5.862E-07	-0.4539
SE	l	1110	3.204E-05	4.168E-07	-0.4783
SSE	l	1754	2.213E-05	1.732E-07	-0.5343
S	l	2205	1.640E-05	1.363E-07	-0.5277
SSW	l	2269	2.610E-05	2.003E-07	-0.5365
SW	l	2382	3.489E-05	3.141E-07	-0.5189
WSW	w	1867	7.570E-05	4.141E-07	-0.5737
W	w	644	3.338E-04	2.683E-06	-0.5314
WNW	w	370	8.355E-04	1.389E-05	-0.4513
NW	w	306	9.082E-04	2.596E-05	-0.3916
NNW	w	241	1.395E-03	3.684E-05	-0.4003

(Refer to Section 4.4.3)

TABLE C-16

85TH PERCENTILE HOURLY PLUME CENTERLINE DEPOSITION VALUES
AND ANNUAL SECTOR AVERAGE DEPOSITION VALUES
FOR UNMONITORED GROUND LEVEL RELEASES DETERMINED
FROM ANNUAL AVERAGE METEOROLOGICAL DATA (1985-1992)
(FOR USE WITH SHORT TERM RELEASES)

Deposition (D/Q) (1/m²)

<u>Direction</u>		<u>Site Boundary Distance (m)</u>	<u>Hourly Plume Cent. (D/Q) (1/m²)</u>	<u>Annual Sector Ave. (D/Q) (1/m²)</u>	<u>Slope m</u>
N	w	225	3.819E-06	1.331E-07	-0.3698
NNE	w	225	3.549E-06	7.094E-08	-0.4310
NE	w	354	1.840E-06	3.000E-08	-0.4534
ENE	w	563	1.166E-06	3.235E-08	-0.3949
E	l	950	4.777E-07	1.352E-08	-0.3927
ESE	l	1030	3.797E-07	8.757E-09	-0.4152
SE	l	1110	3.096E-07	6.456E-09	-0.4263
SSE	l	1754	1.560E-07	1.852E-09	-0.4884
S	l	2205	1.083E-07	1.409E-09	-0.4783
SSW	l	2269	1.300E-07	1.371E-09	-0.5014
SW	l	2382	1.366E-07	1.507E-09	-0.4965
WSW	w	1867	2.155E-07	1.247E-09	-0.5676
W	w	644	1.008E-06	7.794E-09	-0.5356
WNW	w	370	2.080E-06	4.097E-08	-0.4326
NW	w	306	2.588E-06	8.546E-08	-0.3757
NNW	w	241	3.727E-06	1.139E-07	-0.3842

(Refer to Section 4.4.3)

TABLE C-17

85TH PERCENTILE HOURLY PLUME CENTERLINE DISPERSION VALUES
 FOR UNMONITORED GROUND LEVEL RELEASES DETERMINED
 FROM ANNUAL AVERAGE METEOROLOGICAL DATA (1985-1992)
 (FOR USE WITH SHORT TERM RELEASES)

Plume Centerline Concentration X/Q (sec/m³)

SEGMENT BOUNDARIES IN MILES

<u>Direction</u>	0.5	0.75	1.0	1.5	2.5	3.5
N	1.699E-04	1.076E-04	7.986E-05	4.929E-05	3.382E-05	2.338E-05
NNE	1.607E-04	1.046E-04	7.674E-05	4.790E-05	2.941E-05	2.237E-05
NE	1.443E-04	8.910E-05	6.364E-05	3.787E-05	2.353E-05	1.628E-05
ENE	9.691E-05	6.042E-05	4.300E-05	2.458E-05	1.431E-05	9.546E-06
E	6.170E-05	3.762E-05	2.673E-05	1.457E-05	8.488E-06	5.543E-06
ESE	4.999E-05	2.937E-05	2.013E-05	1.079E-05	5.958E-06	3.790E-06
SE	4.934E-05	2.856E-05	1.944E-05	1.003E-05	5.698E-06	3.529E-06
SSE	6.206E-05	3.660E-05	2.469E-05	1.349E-05	7.622E-06	4.850E-06
S	6.415E-05	3.732E-05	2.483E-05	1.356E-05	7.681E-06	4.949E-06
SSW	1.018E-04	5.889E-05	4.124E-05	2.228E-05	1.334E-05	9.017E-06
SW	1.254E-04	7.730E-05	5.343E-05	3.173E-05	1.959E-05	1.331E-05
WSW	1.937E-04	1.217E-04	9.179E-05	5.636E-05	3.565E-05	2.610E-05
W	2.334E-04	1.519E-04	1.131E-04	7.255E-05	4.837E-05	3.588E-05
WNW	2.266E-04	1.507E-04	1.154E-04	7.694E-05	4.867E-05	3.613E-05
NW	2.002E-04	1.305E-04	9.910E-05	6.428E-05	4.403E-05	3.137E-05
NNW	1.950E-04	1.251E-04	9.565E-05	6.064E-05	4.107E-05	3.028E-05
	4.5 Miles	7.5 Miles	15.0 Miles	25.0 Miles	35.0 Miles	45.0 Miles
N	1.787E-05	1.084E-05	5.123E-06	3.189E-06	2.506E-06	2.232E-06
NNE	1.640E-05	9.724E-06	4.242E-06	2.665E-06	2.197E-06	1.946E-06
NE	1.202E-05	6.775E-06	3.149E-06	2.240E-06	1.763E-06	1.658E-06
ENE	7.055E-06	3.816E-06	1.880E-06	1.244E-06	1.024E-06	9.608E-07
E	3.976E-06	2.256E-06	1.239E-06	8.773E-07	7.968E-07	7.410E-07
ESE	2.708E-06	1.508E-06	8.402E-07	6.951E-07	6.563E-07	6.136E-07
SE	2.529E-06	1.446E-06	9.104E-07	7.173E-07	6.712E-07	6.380E-07
SSE	3.487E-06	1.855E-06	1.336E-06	1.005E-06	9.152E-07	8.714E-07
S	3.617E-06	1.977E-06	1.347E-06	9.941E-07	8.840E-07	8.540E-07
SSW	6.567E-06	3.377E-06	1.965E-06	1.491E-06	1.158E-06	1.102E-06
SW	9.555E-06	5.304E-06	2.844E-06	2.096E-06	1.490E-06	1.505E-06
WSW	2.015E-05	1.144E-05	6.078E-06	3.816E-06	2.824E-06	2.563E-06
W	2.801E-05	1.656E-05	8.601E-06	5.208E-06	4.080E-06	3.717E-06
WNW	2.841E-05	1.784E-05	8.792E-06	5.268E-06	4.015E-06	3.663E-06
NW	2.484E-05	1.399E-05	7.019E-06	4.387E-06	3.446E-06	3.205E-06
NNW	2.416E-05	1.525E-05	7.180E-06	4.311E-06	3.235E-06	3.083E-06

TABLE C-18

SECTOR AVERAGE DISPERSION VALUES
 FOR UNMONITORED GROUND LEVEL RELEASES DETERMINED
 FROM ANNUAL AVERAGE METEOROLOGICAL DATA (1985-1992)
 (FOR USE WITH LONG TERM RELEASES)

Sector Average Concentration X/Q (sec/m³)

SEGMENT BOUNDARIES IN MILES

<u>Direction</u>	0.5	0.75	1.0	1.5	2.5	3.5
N	3.948E-06	2.078E-06	1.348E-06	7.608E-07	3.800E-07	2.415E-07
NNE	2.048E-06	1.091E-06	7.116E-07	3.995E-07	1.969E-07	1.241E-07
NE	1.427E-06	7.723E-07	5.060E-07	2.825E-07	1.373E-07	8.575E-08
ENE	1.985E-06	1.070E-06	6.992E-07	3.889E-07	1.884E-07	1.176E-07
E	1.375E-06	7.249E-07	4.692E-07	2.593E-07	1.254E-07	7.838E-08
ESE	8.717E-07	4.596E-07	2.977E-07	1.639E-07	7.877E-08	4.911E-08
SE	6.983E-07	3.671E-07	2.384E-07	1.315E-07	6.333E-08	3.958E-08
SSE	5.697E-07	3.018E-07	1.968E-07	1.089E-07	5.258E-08	3.289E-08
S	6.334E-07	3.339E-07	2.169E-07	1.195E-07	5.752E-08	3.595E-08
SSW	9.625E-07	5.148E-07	3.338E-07	1.828E-07	8.685E-08	5.362E-08
SW	1.601E-06	8.640E-07	5.612E-07	3.081E-07	1.465E-07	9.029E-08
WSW	1.457E-06	7.891E-07	5.157E-07	2.866E-07	1.385E-07	8.613E-08
W	1.881E-06	9.925E-07	6.461E-07	3.645E-07	1.815E-07	1.150E-07
WNW	3.757E-06	1.944E-06	1.254E-06	7.106E-07	3.593E-07	2.300E-07
NW	5.025E-06	2.605E-06	1.678E-06	9.490E-07	4.789E-07	3.063E-07
NNW	4.607E-06	2.382E-06	1.534E-06	8.699E-07	4.408E-07	2.826E-07
	4.5	7.5	15.0	25.0	35.0	45.0
N	1.726E-07	8.781E-08	3.565E-08	1.855E-08	1.212E-08	8.843E-09
NNE	8.811E-08	4.427E-08	1.769E-08	9.098E-09	5.901E-09	4.285E-09
NE	6.049E-08	2.998E-08	1.176E-08	5.962E-09	3.832E-09	2.764E-09
ENE	8.299E-08	4.122E-08	1.627E-08	8.305E-09	5.365E-09	3.887E-09
E	5.540E-08	2.769E-08	1.109E-08	5.734E-09	3.740E-09	2.731E-09
ESE	3.465E-08	1.728E-08	6.916E-09	3.581E-09	2.339E-09	1.711E-09
SE	2.799E-08	1.402E-08	5.659E-09	2.952E-09	1.939E-09	1.425E-09
SSE	2.326E-08	1.164E-08	4.686E-09	2.438E-09	1.598E-09	1.172E-09
S	2.541E-08	1.272E-08	5.133E-09	2.678E-09	1.759E-09	1.293E-09
SSW	3.755E-08	1.840E-08	7.166E-09	3.633E-09	2.341E-09	1.696E-09
SW	6.312E-08	3.078E-08	1.186E-08	5.954E-09	3.807E-09	2.741E-09
WSW	6.060E-08	2.988E-08	1.165E-08	5.884E-09	3.773E-09	2.718E-09
W	8.207E-08	4.159E-08	1.680E-08	8.704E-09	5.673E-09	4.133E-09
WNW	1.653E-07	8.495E-08	3.494E-08	1.834E-08	1.206E-08	8.836E-09
NW	2.199E-07	1.130E-07	4.643E-08	2.436E-08	1.601E-08	1.173E-08
NNW	2.033E-07	1.048E-07	4.324E-08	2.275E-08	1.498E-08	1.099E-08

TABLE C-19

85TH PERCENTILE HOURLY PLUME CENTERLINE DEPOSITION VALUES
 FOR UNMONITORED GROUND LEVEL RELEASES DETERMINED
 FROM ANNUAL AVERAGE METEOROLOGICAL DATA (1985-1992)
 (FOR USE WITH SHORT TERM RELEASES)

(D/Q) Plume Centerline Deposition (1/m²)

SEGMENT BOUNDARIES IN MILES

<u>Direction</u>	0.5	0.75	1.0	1.5	2.5	3.5
N	8.196E-07	4.879E-07	3.235E-07	1.745E-07	7.680E-08	4.389E-08
NNE	7.499E-07	4.421E-07	2.918E-07	1.568E-07	6.889E-08	3.933E-08
NE	7.015E-07	4.084E-07	2.680E-07	1.434E-07	6.279E-08	3.582E-08
ENE	7.513E-07	4.265E-07	2.758E-07	1.458E-07	6.348E-08	3.618E-08
E	6.000E-07	3.392E-07	2.198E-07	1.164E-07	5.095E-08	2.906E-08
ESE	5.379E-07	2.994E-07	1.925E-07	1.013E-07	4.402E-08	2.510E-08
SE	4.920E-07	2.729E-07	1.756E-07	9.248E-08	4.022E-08	2.294E-08
SSE	4.987E-07	2.787E-07	1.793E-07	9.390E-08	4.076E-08	2.322E-08
S	5.035E-07	2.780E-07	1.784E-07	9.367E-08	4.064E-08	2.315E-08
SSW	6.150E-07	3.456E-07	2.231E-07	1.178E-07	5.125E-08	2.924E-08
SW	6.826E-07	3.885E-07	2.522E-07	1.337E-07	5.831E-08	3.312E-08
WSW	7.002E-07	4.101E-07	2.698E-07	1.446E-07	6.339E-08	3.617E-08
W	7.821E-07	4.647E-07	3.077E-07	1.658E-07	7.294E-08	4.168E-08
WNW	8.673E-07	5.222E-07	3.480E-07	1.886E-07	8.325E-08	4.764E-08
NW	8.526E-07	5.116E-07	3.403E-07	1.841E-07	8.119E-08	4.643E-08
NNW	8.945E-07	5.382E-07	3.586E-07	1.943E-07	8.572E-08	4.903E-08
	4.5	7.5	15.0	25.0	35.0	45.0
N	2.868E-08	1.216E-08	4.258E-09	1.853E-09	1.097E-09	8.646E-10
NNE	2.569E-08	1.087E-08	3.874E-09	1.831E-09	1.092E-09	8.632E-10
NE	2.339E-08	9.896E-09	3.653E-09	1.815E-09	1.091E-09	8.661E-10
ENE	2.344E-08	9.104E-09	3.470E-09	1.779E-09	1.102E-09	8.689E-10
E	1.884E-08	8.362E-09	3.407E-09	1.768E-09	1.099E-09	8.723E-10
ESE	1.644E-08	7.454E-09	3.210E-09	1.772E-09	1.094E-09	8.726E-10
SE	1.522E-08	7.432E-09	3.238E-09	1.752E-09	1.098E-09	8.714E-10
SSE	1.524E-08	7.294E-09	3.216E-09	1.725E-09	1.093E-09	8.703E-10
S	1.518E-08	7.268E-09	3.248E-09	1.760E-09	1.092E-09	8.686E-10
SSW	1.909E-08	7.815E-09	3.324E-09	1.801E-09	1.089E-09	8.654E-10
SW	2.164E-08	8.873E-09	3.386E-09	1.767E-09	1.086E-09	8.625E-10
WSW	2.362E-08	1.002E-08	3.516E-09	1.747E-09	1.081E-09	8.607E-10
W	2.724E-08	1.156E-08	3.953E-09	1.818E-09	1.082E-09	8.582E-10
WNW	3.117E-08	1.325E-08	4.389E-09	1.856E-09	1.088E-09	8.598E-10
NW	3.035E-08	1.288E-08	4.349E-09	1.863E-09	1.091E-09	8.632E-10
NNW	3.206E-08	1.348E-08	4.593E-09	1.895E-09	1.094E-09	8.638E-10

TABLE C-20

SECTOR AVERAGE DEPOSITION VALUES
 FOR UNMONITORED GROUND LEVEL RELEASES DETERMINED
 FROM ANNUAL AVERAGE METEOROLOGICAL DATA (1985-1992)
 (FOR USE WITH LONG TERM RELEASES)

(D/Q) Sector Average Deposition (1/m²)

SEGMENT BOUNDARIES IN MILES

<u>Direction</u>	0.5	0.75	1.0	1.5	2.5	3.5
N	1.937E-08	9.969E-09	6.130E-09	3.059E-09	1.257E-09	6.930E-10
NNE	1.032E-08	5.308E-09	3.264E-09	1.629E-09	6.689E-10	3.688E-10
NE	8.393E-09	4.317E-09	2.654E-09	1.324E-09	5.436E-10	2.996E-10
ENE	1.845E-08	9.552E-09	5.899E-09	2.962E-09	1.227E-09	6.800E-10
E	1.764E-08	9.161E-09	5.670E-09	2.856E-09	1.187E-09	6.598E-10
ESE	1.294E-08	6.744E-09	4.184E-09	2.114E-09	8.826E-10	4.920E-10
SE	1.076E-08	5.627E-09	3.499E-09	1.774E-09	7.439E-10	4.158E-10
SSE	6.557E-09	3.433E-09	2.137E-09	1.085E-09	4.555E-10	2.548E-10
S	7.306E-09	3.827E-09	2.383E-09	1.210E-09	5.084E-10	2.845E-10
SSW	7.625E-09	3.959E-09	2.450E-09	1.234E-09	5.125E-10	2.848E-10
SW	9.231E-09	4.768E-09	2.940E-09	1.473E-09	6.079E-10	3.363E-10
WSW	5.073E-09	2.611E-09	1.606E-09	8.018E-10	3.294E-10	1.816E-10
W	5.456E-09	2.807E-09	1.725E-09	8.608E-10	3.534E-10	1.947E-10
WNW	1.224E-08	6.296E-09	3.870E-09	1.930E-09	7.922E-10	4.365E-10
NW	1.930E-08	9.928E-09	6.103E-09	3.044E-09	1.250E-09	6.888E-10
NNW	1.827E-08	9.403E-09	5.782E-09	2.886E-09	1.185E-09	6.535E-10
	4.5	7.5	15.0	25.0	35.0	45.0
N	4.420E-10	1.789E-10	5.648E-11	2.279E-11	1.219E-11	7.527E-12
NNE	2.352E-10	9.517E-11	3.004E-11	1.212E-11	6.481E-12	4.001E-12
NE	1.911E-10	7.733E-11	2.442E-11	9.857E-12	5.274E-12	3.258E-12
ENE	4.346E-10	1.760E-10	5.563E-11	2.248E-11	1.204E-11	7.449E-12
E	4.221E-10	1.709E-10	5.406E-11	2.186E-11	1.172E-11	7.255E-12
ESE	3.150E-10	1.276E-10	4.035E-11	1.632E-11	8.750E-12	5.416E-12
SE	2.665E-10	1.079E-10	3.412E-11	1.379E-11	7.393E-12	4.574E-12
SSE	1.634E-10	6.612E-11	2.089E-11	8.433E-12	4.514E-12	2.789E-12
S	1.824E-10	7.383E-11	2.332E-11	9.413E-12	5.038E-12	3.112E-12
SSW	1.821E-10	7.369E-11	2.327E-11	9.385E-12	5.020E-12	3.099E-12
SW	2.147E-10	8.686E-11	2.740E-11	1.104E-11	5.900E-12	3.639E-12
WSW	1.158E-10	4.682E-11	1.474E-11	5.924E-12	3.156E-12	1.941E-12
W	1.241E-10	5.017E-11	1.579E-11	6.346E-12	3.381E-12	2.079E-12
WNW	2.783E-10	1.126E-10	3.548E-11	1.428E-11	7.624E-12	4.697E-12
NW	4.392E-10	1.777E-10	5.606E-11	2.259E-11	1.207E-11	7.446E-12
NNW	4.168E-10	1.686E-10	5.321E-11	2.145E-11	1.147E-11	7.074E-12

TABLE C-21

85TH PERCENTILE HOURLY PLUME CENTERLINE DISPERSION VALUES
 FOR UNMONITORED GROUND LEVEL RELEASES DETERMINED
 FROM GRAZING METEOROLOGICAL DATA (1985-1992)
 (FOR USE WITH SHORT TERM RELEASES)

Plume Centerline Concentration X/Q (sec/m³)

SEGMENT BOUNDARIES IN MILES

<u>Direction</u>	0.5	0.75	1.0	1.5	2.5	3.5
N	2.035E-04	1.319E-04	9.688E-05	6.511E-05	4.473E-05	3.234E-05
NNE	1.879E-04	1.270E-04	9.123E-05	5.931E-05	3.831E-05	2.740E-05
NE	1.632E-04	1.030E-04	7.465E-05	4.782E-05	2.895E-05	1.998E-05
ENE	1.029E-04	6.414E-05	4.529E-05	2.778E-05	1.533E-05	1.037E-05
E	6.347E-05	3.871E-05	2.645E-05	1.643E-05	8.680E-06	5.704E-06
ESE	5.529E-05	3.284E-05	2.249E-05	1.344E-05	7.231E-06	4.554E-06
SE	5.878E-05	3.449E-05	2.322E-05	1.327E-05	7.155E-06	4.530E-06
SSE	7.662E-05	4.653E-05	3.199E-05	1.929E-05	1.017E-05	6.744E-06
S	6.387E-05	3.657E-05	2.530E-05	1.454E-05	7.813E-06	5.065E-06
SSW	1.002E-04	6.046E-05	4.342E-05	2.548E-05	1.416E-05	9.655E-06
SW	1.271E-04	7.949E-05	5.718E-05	3.660E-05	2.001E-05	1.420E-05
WSW	2.173E-04	1.416E-04	1.017E-04	7.040E-05	4.171E-05	3.095E-05
W	2.657E-04	1.695E-04	1.282E-04	8.955E-05	5.926E-05	4.564E-05
WNW	2.947E-04	1.962E-04	1.530E-04	1.115E-04	7.065E-05	5.353E-05
NW	2.589E-04	1.711E-04	1.294E-04	9.394E-05	5.940E-05	4.747E-05
NNW	2.240E-04	1.457E-04	1.122E-04	7.873E-05	5.217E-05	4.167E-05
	4.5	7.5	15.0	25.0	35.0	45.0
N	2.466E-05	1.477E-05	7.229E-06	4.548E-06	3.258E-06	2.939E-06
NNE	2.146E-05	1.237E-05	5.954E-06	3.551E-06	2.874E-06	2.555E-06
NE	1.480E-05	8.449E-06	4.107E-06	2.760E-06	2.172E-06	1.943E-06
ENE	7.723E-06	4.094E-06	2.113E-06	1.431E-06	1.194E-06	1.080E-06
E	4.203E-06	2.450E-06	1.520E-06	1.093E-06	9.532E-07	9.103E-07
ESE	3.277E-06	2.083E-06	1.212E-06	8.868E-07	9.226E-07	9.234E-07
SE	3.284E-06	2.108E-06	1.223E-06	9.083E-07	9.658E-07	9.015E-07
SSE	4.949E-06	3.255E-06	1.759E-06	1.451E-06	1.200E-06	1.125E-06
S	3.595E-06	2.290E-06	1.634E-06	1.226E-06	1.051E-06	9.739E-07
SSW	7.015E-06	3.692E-06	2.072E-06	1.640E-06	1.361E-06	1.212E-06
SW	1.059E-05	5.604E-06	2.972E-06	2.285E-06	1.926E-06	1.784E-06
WSW	2.380E-05	1.346E-05	6.594E-06	4.291E-06	3.372E-06	3.081E-06
W	3.488E-05	2.109E-05	1.008E-05	6.435E-06	5.014E-06	4.515E-06
WNW	4.291E-05	2.492E-05	1.284E-05	8.174E-06	5.922E-06	5.432E-06
NW	3.796E-05	2.309E-05	1.200E-05	7.419E-06	4.994E-06	4.573E-06
NNW	3.380E-05	2.018E-05	9.838E-06	5.947E-06	4.413E-06	4.003E-06

TABLE C-22

SECTOR AVERAGE DISPERSION VALUES
 FOR UNMONITORED GROUND LEVEL RELEASES DETERMINED
 FROM GRAZING METEOROLOGICAL DATA (1985-1992)
 (FOR USE WITH LONG TERM RELEASES)

Sector Average Concentration X/Q (sec/m³)

SEGMENT BOUNDARIES IN MILES

<u>Direction</u>	0.5	0.75	1.0	1.5	2.5	3.5
N	5.300E-06	2.743E-06	1.774E-06	1.010E-06	5.125E-07	3.291E-07
NNE	2.423E-06	1.273E-06	8.309E-07	4.714E-07	2.365E-07	1.507E-07
NE	1.607E-06	8.669E-07	5.697E-07	3.202E-07	1.572E-07	9.874E-08
ENE	2.342E-06	1.257E-06	8.224E-07	4.586E-07	2.232E-07	1.398E-07
E	1.650E-06	8.651E-07	5.604E-07	3.111E-07	1.517E-07	9.540E-08
ESE	9.686E-07	5.088E-07	3.309E-07	1.837E-07	8.941E-08	5.619E-08
SE	6.517E-07	3.422E-07	2.237E-07	1.250E-07	6.131E-08	3.878E-08
SSE	5.531E-07	2.919E-07	1.915E-07	1.072E-07	5.265E-08	3.332E-08
S	6.636E-07	3.486E-07	2.274E-07	1.262E-07	6.142E-08	3.870E-08
SSW	8.999E-07	4.813E-07	3.136E-07	1.731E-07	8.310E-08	5.169E-08
SW	1.540E-06	8.357E-07	5.447E-07	2.999E-07	1.430E-07	8.841E-08
WSW	1.549E-06	8.355E-07	5.452E-07	3.039E-07	1.479E-07	9.243E-08
W	2.100E-06	1.097E-06	7.138E-07	4.055E-07	2.043E-07	1.305E-07
WNW	4.454E-06	2.263E-06	1.452E-06	8.306E-07	4.280E-07	2.7awE-07
NW	6.109E-06	3.102E-06	1.987E-06	1.135E-06	5.847E-07	3.787E-07
NNW	5.849E-06	2.971E-06	1.903E-06	1.087E-06	5.593E-07	3.621E-07
	4.5	7.5	15.0	25.0	35.0	45.0
N	2.369E-07	1.223E-07	5.055E-08	2.663E-08	1.753E-08	1.286E-08
NNE	1.079E-07	5.507E-08	2.245E-08	1.171E-08	7.663E-09	5.598E-09
NE	6.998E-08	3.501E-08	1.389E-08	7.107E-09	4.592E-09	3.324E-09
ENE	9.892E-08	4.941E-08	1.967E-08	1.011E-08	6.559E-09	4.768E-09
E	6.774E-08	3.416E-08	1.385E-08	7.224E-09	4.739E-09	3.475E-09
ESE	3.988E-08	2.010E-08	8.165E-09	4.270E-09	2.807E-09	2.062E-09
SE	2.764E-08	1.405E-08	5.767E-09	3.044E-09	2.013E-09	1.486E-09
SSE	2.376E-08	1.207E-08	4.950E-09	2.609E-09	1.724E-09	1.272E-09
S	2.753E-08	1.395E-08	5.723E-09	3.022E-09	2.002E-09	1.480E-09
SSW	3.639E-08	1.802E-08	7.121E-09	3.649E-09	2.367E-09	1.723E-09
SW	6.194E-08	3.035E-08	1.178E-08	5.946E-09	3.814E-09	2.750E-09
WSW	6.527E-08	3.245E-08	1.279E-08	6.514E-09	4.200E-09	3.037E-09
W	9.357E-08	4.793E-08	1.962E-08	1.026E-08	6.727E-09	4.920E-09
WNW	2.008E-07	1.049E-07	4.398E-08	2.339E-08	1.550E-08	1.142E-08
NW	2.744E-07	1.433E-07	6.013E-08	3.200E-08	2.120E-08	1.563E-08
NNW	2.622E-07	1.369E-07	5.743E-08	3.056E-08	2.025E-08	1.493E-08

TABLE C-23

85TH PERCENTILE HOURLY PLUME CENTERLINE DEPOSITION VALUES
 FOR UNMONITORED GROUND LEVEL RELEASES DETERMINED
 FROM GRAZING METEOROLOGICAL DATA (1985-1992)
 (FOR USE WITH SHORT TERM RELEASES)

(D/Q) Sector Average Deposition (1/m²)

SEGMENT BOUNDARIES IN MILES

<u>Direction</u>	0.5	0.75	1.0	1.5	2.5	3.5
N	9.063E-07	5.471E-07	3.636E-07	1.966E-07	8.666E-08	4.952E-08
NNE	8.251E-07	4.868E-07	3.215E-07	1.728E-07	7.592E-08	4.334E-08
NE	7.357E-07	4.285E-07	2.771E-07	1.482E-07	6.503E-08	3.718E-08
ENE	7.139E-07	4.059E-07	2.633E-07	1.390E-07	6.056E-08	3.455E-08
E	5.942E-07	3.352E-07	2.174E-07	1.145E-07	4.986E-08	2.843E-08
ESE	5.161E-07	2.898E-07	1.872E-07	9.833E-08	4.282E-08	2.443E-08
SE	5.089E-07	2.831E-07	1.820E-07	9.577E-08	4.161E-08	2.372E-08
SSE	5.281E-07	2.921E-07	1.855E-07	9.735E-08	4.223E-08	2.406E-08
S	4.971E-07	2.780E-07	1.795E-07	9.481E-08	4.129E-08	2.356E-08
SSW	6.017E-07	3.342E-07	2.150E-07	1.132E-07	4.916E-08	2.802E-08
SW	6.735E-07	3.808E-07	2.459E-07	1.297E-07	5.629E-08	3.210E-08
WSW	7.454E-07	4.299E-07	2.812E-07	1.501E-07	6.569E-08	3.750E-08
W	8.255E-07	4.942E-07	3.284E-07	1.775E-07	7.813E-08	4.461E-08
WNW	9.768E-07	5.984E-07	4.019E-07	2.191E-07	9.694E-08	5.542E-08
NW	9.981E-07	6.144E-07	4.117E-07	2.241E-07	9.911E-08	5.667E-08
NNW	9.449E-07	5.713E-07	3.826E-07	2.082E-07	9.205E-08	5.265E-08
	4.5	7.5	15.0	25.0	35.0	45.0
N	3.236E-08	1.356E-08	4.621E-09	1.897E-09	1.098E-09	8.646E-10
NNE	2.831E-08	1.195E-08	4.113E-09	1.839E-09	1.092E-09	8.622E-10
NE	2.433E-08	1.035E-08	3.679E-09	1.802E-09	1.091E-09	8.636E-10
ENE	2.248E-08	8.997E-09	3.623E-09	1.798E-09	1.100E-09	8.672E-10
E	1.850E-08	8.152E-09	3.457E-09	1.792E-09	1.096E-09	8.705E-10
ESE	1.618E-08	7.794E-09	3.226E-09	1.746E-09	1.094E-09	8.718E-10
SE	1.571E-08	7.255E-09	3.160E-09	1.748E-09	1.091E-09	8.694E-10
SSE	1.606E-08	7.248E-09	3.154E-09	1.790E-09	1.087E-09	8.633E-10
S	1.556E-08	7.412E-09	3.201E-09	1.765E-09	1.089E-09	8.651E-10
SSW	1.833E-08	7.403E-09	3.328E-09	1.773E-09	1.086E-09	8.637E-10
SW	2.098E-08	8.312E-09	3.361E-09	1.789E-09	1.083E-09	8.606E-10
WSW	2.451E-08	1.061E-08	3.594E-09	1.728E-09	1.078E-09	8.604E-10
W	2.912E-08	1.229E-08	4.144E-09	1.869E-09	1.081E-09	8.576E-10
WNW	3.619E-08	1.527E-08	5.019E-09	1.940E-09	1.088E-09	8.569E-10
NW	3.702E-08	1.563E-08	4.880E-09	1.914E-09	1.092E-09	8.605E-10
NNW	3.440E-08	1.450E-08	4.799E-09	1.929E-09	1.096E-09	8.631E-10

TABLE C-24

SECTOR AVERAGE DEPOSITION VALUES
 FOR UNMONITORED GROUND LEVEL RELEASES DETERMINED
 FROM GRAZING METEOROLOGICAL DATA (1985-1992)
 (FOR USE WITH LONG TERM RELEASES)

(D/Q) Sector Average Deposition (1/m²)

SEGMENT BOUNDARIES IN MILES

<u>Direction</u>	0.5	0.75	1.0	1.5	2.5	3.5
N	2.265E-08	1.167E-08	7.177E-09	3.585E-09	1.474E-09	8.132E-10
NNE	1.028E-08	5.295E-09	3.258E-09	1.627E-09	6.691E-10	3.691E-10
NE	8.034E-09	4.134E-09	2.542E-09	1.269E-09	5.213E-10	2.874E-10
ENE	2.078E-08	1.079E-08	6.675E-09	3.361E-09	1.397E-09	7.762E-10
E	1.924E-08	1.002E-08	6.213E-09	3.138E-09	1.309E-09	7.293E-10
ESE	1.159E-08	6.054E-09	3.762E-09	1.906E-09	7.979E-10	4.456E-10
SE	7.983E-09	4.184E-09	2.605E-09	1.324E-09	5.563E-10	3.114E-10
SSE	5.124E-09	2.690E-09	1.677E-09	8.534E-10	3.593E-10	2.014E-10
S	7.383E-09	3.880E-09	2.421E-09	1.233E-09	5.198E-10	2.916E-10
SSW	6.769E-09	3.525E-09	2.186E-09	1.104E-09	4.602E-10	2.563E-10
SW	8.471E-09	4.384E-09	2.706E-09	1.358E-09	5.619E-10	3.113E-10
WSW	5.062E-09	2.608E-09	1.605E-09	8.019E-10	3.298E-10	1.820E-10
W	5.392E-09	2.777E-09	1.708E-09	8.529E-10	3.506E-10	1.933E-10
WNW	1.123E-08	5.780E-09	3.555E-09	1.774E-09	7.289E-10	4.019E-10
NW	1.792E-08	9.223E-09	5.671E-09	2.830E-09	1.162E-09	6.408E-10
NNW	1.976E-08	1.018E-08	6.260E-09	3.126E-09	1.285E-09	7.091E-10
	4.5	7.5	15.0	25.0	35.0	45.0
N	5.188E-10	2.099E-10	6.626E-11	2.672E-11	1.429E-11	8.820E-12
NNE	2.355E-10	9.527E-11	3.006E-11	1.212E-11	6.476E-12	3.995E-12
NE	1.833E-10	7.418E-11	2.341E-11	9.442E-12	5.048E-12	3.116E-12
ENE	4.965E-10	2.010E-10	6.352E-11	2.565E-11	1.374E-11	8.493E-12
E	4.669E-10	1.890E-10	5.976E-11	2.415E-11	1.294E-11	8.006E-12
ESE	2.855E-10	1.156E-10	3.653E-11	1.476E-11	7.905E-12	4.888E-12
SE	1.997E-10	8.083E-11	2.553E-11	1.031E-11	5.516E-12	3.408E-12
SSE	1.292E-10	5.225E-11	1.648E-11	6.643E-12	3.550E-12	2.189E-12
S	1.871E-10	7.570E-11	2.390E-11	9.637E-12	5.153E-12	3.181E-12
SSW	1.641E-10	6.637E-11	2.094E-11	8.442E-12	4.512E-12	2.783E-12
SW	1.988E-10	8.042E-11	2.536E-11	1.021E-11	5.453E-12	3.361E-12
WSW	1.161E-10	4.691E-11	1.476E-11	5.930E-12	3.158E-12	1.942E-12
W	1.233E-10	4.981E-11	1.567E-11	6.292E-12	3.349E-12	2.058E-12
WNW	2.562E-10	1.036E-10	3.262E-11	1.311E-11	6.990E-12	4.301E-12
NW	4.086E-10	1.652E-10	5.209E-11	2.097E-11	1.119E-11	6.894E-12
NNW	4.523E-10	1.830E-10	5.771E-11	2.325E-11	1.242E-11	7.660E-12

APPENDIX D

LIMITED ANALYSIS APPROACH

DOSE ASSESSMENT FOR LIQUID RADIOACTIVE EFFLUENTS

APPENDIX D

**LIMITED ANALYSIS APPROACH
DOSE ASSESSMENT FOR LIQUID RADIOACTIVE EFFLUENTS**

<u>TABLE</u>	<u>TITLE</u>	<u>PAGE</u>
D-1	Calculation of Total Ci/yr Releases for Liquids	D-5
D-2	Organ Doses For Liquid Releases	D-6
D-3	Dose Contribution to the Adult's Whole Body From the Freshwater Fish Pathway	D-8
D-4	Dose Contribution to the Teenager's Liver from the Freshwater Fish Pathway	D-9
D-5	Dose Contribution to the Adult's Whole Body from the Potable Water Pathway	D-10
D-6	Dose Contribution to the Teenager's Liver from the Potable Water Pathway	D-11
D-7	Dose Contribution to the Adult's Whole Body and to the Teenager's Liver from the Lake Shoreline Deposits Pathway	D-12
D-8	Dose Contribution to the Adult's Whole Body and to the Teenager's Liver from the Swimming and Boating Pathways	D-13
D-9	Calculation of Total Ci/yr Releases for Liquids (2002 through 2009)	D-14

LIMITED ANALYSIS APPROACH DOSE ASSESSMENT FOR LIQUID RADIOACTIVE EFFLUENTS

The radioactive liquid effluents for the years 1980 through 1987 (from the JAFNPP Semi-Annual Effluent release reports) were evaluated to determine the critical pathways, organs, age groups, and nuclides which contributed to environmental doses. The liquid release nuclide distribution used in this analysis is shown in Table D-1. This analysis was performed to develop a limited dose analysis for determination of liquid effluent environmental doses. Limiting the dose calculation to a few selected nuclides that contribute the majority of the dose, along with the application of an appropriate conservatism factor to compensate for variations in isotopic mixtures, provides a simplified method of determining compliance with the dose limits of Technical Specification 2.3.

Tables D-2 through D-8 show the results of this evaluation. Table D-2 presents the dose for 8 organs and 4 age groups from all available pathways. The adult's whole body and teenager's age groups (adult, teenager, child, and infant) and all organs (bone, liver, kidney, thyroid, lung, skin, and GI-LLI). The dominant pathway contribution to these doses is freshwater fish ingestion.

Table D-3 presents the percent of the adult's whole body dose contribution by the major radionuclides through the dominant pathway, ingestion of freshwater fish. Table D-4 presents the same data for the teenager's liver dose. The data in Tables D-3 and D-4 show that the fish pathway contributes at least 92% to the adult's whole body dose and at least 80.9% to the teenager's liver dose from all pathways considered. The data in the tables also show that during 1980-1987 the radionuclides Cs-134, Cs-137, Zn-65, Co-60, and Mn-54 contributed over 91% of the total dose to the whole body and over 80% of the total liver dose via the freshwater fish ingestion pathway.

The data in Tables D-5 and D-6 show that the potable water pathway contributed no more than 1% to the adult's whole body dose and no more than 0.5% to the teenager's liver dose. This pathway is necessary to demonstrate compliance with 10CFR50 as specified in Sections 4.2 and 4.3.1 of NUREG-0133. As mentioned in Appendix A, Table A-4.3, this pathway is considered for all required analysis.

Table D-7 shows that 17.9% of the teenager's dose to the liver in 1984 was from the lake shoreline deposits pathway. The lake shoreline pathway contributed 5.7% of the adult's whole body dose in 1984. This pathway contributed 9.3% of the teenager's liver dose in 1986 and 2.8% of the adult's whole body dose in 1986. The lake shoreline deposits pathway is second to the freshwater fish pathway when the concentrations of Cs-134, Cs-137, Zn-65, Co-60, and Mn-54 are low as in 1984 and 1986.

**LIMITED ANALYSIS APPROACH
DOSE ASSESSMENT FOR LIQUID RADIOACTIVE EFFLUENTS
(Continued)**

Table D-8 shows that the swimming and boating pathways, combined, contribute no more than 1.5% to the adult's whole body dose and no more than 0.8% to the teenager's liver dose from 1980 to 1987. The swimming and boating pathways are not used in the ODCM since their dose contributions are very small.

A conservatism factor of 0.8 is introduced into the equation (i.e., calculated doses using this approach should be divided by 0.8) to compensate for any unexpected variability in nuclide and pathway dose contribution. Therefore, the dose commitment to the adult's whole body and teenager's liver due to radioactive material in liquid effluents can be reasonably estimated by limiting the dose calculation to these 5 nuclides and the fish and potable water pathways, which cumulatively contribute the bulk of the total dose calculated by accounting for all nuclides and all pathways.

The radioactive liquid effluents have decreased dramatically over the years. Liquid effluent releases for the years 2002 through 2009 were reviewed. Table D-9 lists the radionuclide distribution and also lists the reduction factors per radionuclide as compared to Table D-1. The liquid effluent data from 1980-1987 is what Appendix D is currently based on. Table D-1 is based on the 1980-1987 effluent data and has 34 radionuclides compared to the updated Table D-9 which has only 12 radionuclides. The critical pathways and age groups presented in Appendix D are still valid based on the 2002-2009 effluent data (see ODCM verification document, Reference 6.13).

TABLE D-1
CALCULATION OF TOTAL Ci/yr RELEASES FOR LIQUIDS
(Based on Semi-Annual Effluent Release Reports for the Years 1980 through 1987)

ISOTOPE	1980	1981	1982	1983	1984	1985	1986	1987	AVERAGE Ci/yr
H-3	2.81E 00	4.11E 00	6.55E-01	2.72E 00	4.77E 00	4.20E 00	5.00E 00	2.48E 00	3.34E 00
Ag-110m	1.12E-04	2.21E-04	1.15E-05	9.49E-05	2.66E-05	5.34E-06	--	--	5.90E-05
Cu-64	3.42E-02	--	--	--	--	--	--	--	4.28E-03
Cs-134	7.30E-02	8.00E-02	5.47E-02	5.11E-02	2.19E-04	8.71E-03	6.68E-05	1.47E-03	3.37E-02
Cs-137	1.06E-01	1.26E-01	6.96E-02	7.77E-02	8.80E-04	1.27E-02	1.01E-03	6.65E-03	5.01E-02
I-131	2.77E-02	4.50E-02	9.05E-04	1.95E-03	4.73E-05	2.32E-05	--	--	9.45E-03
Ba/La-140	4.61E-04	1.12E-03	1.82E-03	4.49E-04	5.86E-04	5.55E-04	2.61E-06	2.58E-05	6.27E-04
Co-58	1.07E-01	2.08E-01	2.94E-02	2.49E-02	3.23E-03	6.82E-03	--	2.90E-03	4.78E-02
Co-60	8.03E-01	1.40E 00	3.66E-01	4.86E-01	3.99E 02	9.96E-02	1.56E-02	4.32E 02	4.07E-01
Fe-59	1.31E-02	1.10E-02	3.46E-03	4.40E-03	3.21E-04	2.79E-04	--	3.49E-04	4.11E-03
Zn-65	3.11E-02	4.57E-02	9.81E-03	5.27E-03	1.29E-03	6.14E-03	7.20E-04	4.67E-04	1.26E-02
Mn-54	2.10E-01	3.44E-01	6.76E-02	1.04E-01	1.02E-02	2.86E-02	7.30E-04	1.60E-02	9.76E-02
Cr-51	4.63E-02	4.79E-02	2.77E-03	2.83E-03	8.30E-04	1.51E-04	2.95E-05	--	1.26E-02
Sb-124	4.87E-03	3.83E-03	5.37E-04	7.62E-04	1.87E-05	--	--	1.27E-04	1.27E-03
Mo-99	1.41E-02	6.44E-04	1.22E-04	7.61E-04	--	2.32E-04	2.07E-06	--	1.98E-03
Tc-99m	1.81E-04	1.67E-03	3.17E-05	2.40E-04	1.38E-04	1.94E-05	3.10E-07	--	2.85E-04
Ce-141	1.72E-05	6.99E-05	3.83E-05	1.03E-04	1.23E-04	1.32E-04	1.53E-06	--	6.06E-05
Zr/Nb-95	2.14E-03	2.54E-04	5.50E-05	1.45E-04	1.74E-04	7.02E-05	1.20E-06*	--	3.55E-04
Ce-144	6.33E-05	6.58E-04	2.46E-05	5.68E-05	1.88E-05	6.87E-04	1.27E-04	--	2.04E-04
I-133	1.22E-03	5.35E-03	1.03E-03	2.16E-03	1.08E-04	9.72E-06	1.67E-06	--	1.23E-03
Na-24	1.79E-02	3.77E-02	1.70E-03	2.01E-03	2.02E-04	2.22E-05	--	2.78E-04	7.48E-03
As-76	2.46E-04	2.08E-04	8.67E-05	3.40E-06	2.89E-04	2.24E-05	--	--	1.07E-04
Np-239	2.24E-03	4.29E-02	1.88E-02	3.55E-03	2.02E-03	2.45E-04	--	--	8.72E-03
Xe-133	9.65E-03	3.98E-02	1.05E-02	6.81E-04	2.82E-03	5.29E-03	1.82E-04	4.51E-05	8.62E-03
Xe-135	3.28E-03	5.85E-02	1.01E-02	7.03E-04	3.31E-02	9.86E-03	6.67E-04	--	1.45E-02
Kr-85m	2.88E-04	7.28E-06	7.14E-05	3.52E-05	5.40E-05	--	--	--	5.70E-05
I-135	4.97E-05	2.47E-03	1.45E-04	6.20E-04	--	--	--	--	4.11E-04
Sr-89	--	--	5.76E-04	--	--	--	--	--	7.20E-05
Sr-90	3.47E-05	1.27E-04	1.88E-04	1.38E-04	--	--	--	--	6.10E-05
Fe-55	--	--	--	--	--	2.19E-03	--	6.78E-03	1.12E-03
Co-57	--	--	--	--	--	--	1.29E-05	--	1.61E-06
Zr-97	--	--	--	--	--	--	2.26E-04	--	2.83E-05
Nb-95m	--	--	--	--	--	--	4.32E-06	--	5.40E-07
W-187	--	--	--	--	--	--	--	3.42E-05	4.28E-06

TABLE D-2

ORGAN DOSES FOR LIQUID RELEASES (ALL PATHWAYS)

ADULT								
YEAR	SKIN (mrem)	BONE (mrem)	LIVER (mrem)	W. BODY (mrem)	THYROID (mrem)	KIDNEY (mrem)	LUNG (mrem)	GI-LLI (mrem)
1980	4.94E-03	7.82E-02	1.31E-01	5.58E-02	6.52E-03	4.67E-02	2.00E-02	1.50E-02
1981	8.05E-03	8.97E-02	1.48E-01	6.43E-02	1.05E-02	5.45E-02	2.44E-02	1.97E-02
1982	2.28E-03	5.17E-02	8.75E-02	3.71E-02	2.10E-03	3.03E-02	1.27E-02	5.67E-03
1983	2.92E-03	5.37E-02	8.86E-02	3.74E-02	2.74E-03	3.10E-02	1.34E-02	6.94E-03
1984	2.01E-04	6.08E-04	9.56E-04	4.94E-04	1.86E-04	4.64E-04	2.63E-04	6.44E-04
1985	6.46E-04	9.98E-03	1.68E-02	7.18E-03	5.79E-04	6.07E-03	2.55E-03	1.82E-03
1986	8.21E-05	5.31E-04	7.48E-04	3.29E-04	7.58E-05	3.17E-04	1.56E-04	1.71E-04
1987	7.35E-04	1.05E-02	1.54E-02	6.24E-03	6.57E-04	5.62E-03	2.54E-03	1.83E-03
TEENAGER								
YEAR	SKIN (mrem)	BONE (mrem)	LIVER (mrem)	W. BODY (mrem)	THYROID (mrem)	KIDNEY (mrem)	LUNG (mrem)	GI-LLI (mrem)
1980	4.94E-03	7.82E-02	1.31E-01	5.58E-02	6.52E-03	4.67E-02	2.00E-02	1.50E-02
1981	8.05E-03	8.97E-02	1.48E-01	6.43E-02	1.05E-02	5.45E-02	2.44E-02	1.97E-02
1982	2.28E-03	5.17E-02	8.75E-02	3.71E-02	2.10E-03	3.03E-02	1.27E-02	5.67E-03
1983	2.92E-03	5.37E-02	8.86E-02	3.74E-02	2.74E-03	3.10E-02	1.34E-02	6.94E-03
1984	2.01E-04	6.08E-04	9.56E-04	4.94E-04	1.86E-04	4.64E-04	2.63E-04	6.44E-04
1985	6.46E-04	9.98E-03	1.68E-02	7.18E-03	5.79E-04	6.07E-03	2.55E-03	1.82E-03
1986	8.21E-05	5.31E-04	7.48E-04	3.29E-04	7.58E-05	3.17E-04	1.56E-04	1.71E-04
1987	7.35E-04	1.05E-02	1.54E-02	6.24E-03	6.57E-04	5.62E-03	2.54E-03	1.83E-03

TABLE D-2 (Continued)

ORGAN DOSES FOR LIQUID RELEASES (ALL PATHWAYS)

CHILD								
YEAR	SKIN (mrem)	BONE (mrem)	LIVER (mrem)	W. BODY (mrem)	THYROID (mrem)	KIDNEY (mrem)	LUNG (mrem)	GI-LLI (mrem)
1980	1.03E-03	9.27E-02	1.12E-01	2.22E-02	3.64E-03	3.68E-02	1.34E-02	4.86E-03
1981	1.68E-03	1.04E-01	1.25E-01	2.56E-02	4.79E-03	4.16E-02	1.53E-02	5.95E-03
1982	4.77E-04	6.18E-02	7.48E-02	1.43E-02	5.58E-04	2.43E-02	8.87E-03	1.74E-03
1983	6.09E-04	6.39E-02	7.57E-02	1.43E-02	7.70E-04	2.46E-02	9.13E-03	2.12E-03
1984	4.20E-05	5.96E-04	7.16E-04	2.13E-04	4.76E-05	2.78E-04	1.09E-04	2.01E-04
1985	1.35E-04	1.17E-02	1.42E-02	2.89E-03	1.41E-04	4.75E-03	1.69E-03	5.58E-04
1986	1.72E-05	5.89E-04	6.16E-04	1.38E-04	1.81E-05	2.24E-04	8.23E-05	4.99E-05
1987	1.53E-04	1.24E-02	1.33E-02	2.42E-03	1.60E-04	4.40E-03	1.66E-03	5.55E-04
INFANT								
YEAR	SKIN (mrem)	BONE (mrem)	LIVER (mrem)	W. BODY (mrem)	THYROID (mrem)	KIDNEY (mrem)	LUNG (mrem)	GI-LLI (mrem)
1980	0	4.12E-04	5.60E-04	2.58E-04	1.16E-03	2.58E-04	1.93E-04	2.34E-04
1981	0	5.45E-04	7.24E-04	4.08E-04	1.84E-03	3.69E-04	2.95E-04	3.83E-04
1982	0	2.52E-04	3.26E-04	1.20E-04	1.01E-04	1.32E-04	9.22E-05	1.01E-04
1983	0	2.67E-04	3.54E-04	1.47E-04	1.59E-04	1.52E-04	1.12E-04	1.27E-04
1984	0	7.73E-06	1.38E-05	1.31E-05	1.16E-05	1.06E-05	1.01E-05	1.34E-05
1985	0	5.14E-05	7.43E-05	3.61E-05	2.38E-05	3.57E-05	2.78E-05	3.38E-05
1986	0	3.78E-06	8.99E-06	7.81E-06	6.50E-06	7.07E-06	6.70E-06	7.83E-06
1987	0	5.64E-05	7.85E-05	4.16E-05	2.78E-05	4.00E-05	3.28E-05	3.90E-05

TABLE D-3
DOSE CONTRIBUTION TO THE ADULT'S WHOLE BODY FROM THE
FRESHWATER FISH PATHWAY
(PERCENT)

ISOTOPE	1980	1981	1982	1983	1984	1985	1986	1987
Cs-134	52.7	50.3	56.5	52.2	25.2	52.1	9.2	26.8
Cs-137	45.2	46.8	42.4	46.8	59.7	44.9	82.5	71.5
Zn-65	1.3	1.7	0.6	0.3	8.5	2.1	5.7	0.5
Co-60	0.6	0.9	0.4	0.5	4.5	0.6	2.1	0.8
Mn-54	0.2	0.3	0.1	0.2	1.7	0.2	0.1	0.4
The percentage (%) of the whole body dose from five nuclides in the fish pathway	100	100	100	100	99.6	99.9	99.6	100
The percentage (%) of the total dose to the adult's whole body from the fish pathway	98.8	98.3	99.2	98.9	92.0	98.8	95.6	98.4
The percentage (%) of the total dose to the adult's whole body from the five nuclides in the fish pathway	98.8	98.3	99.2	98.9	91.6	98.7	95.2	98.4

TABLE D-4
DOSE CONTRIBUTION TO THE TEENAGER'S LIVER FROM THE
FRESHWATER FISH PATHWAY
(PERCENT)

ISOTOPE	1980	1981	1982	1983	1984	1985	1986	1987
Cs-134	46.2	43.8	50.2	45.9	20.0	45.5	7.3	22.0
Cs-137	50.8	52.2	48.4	52.9	60.9	50.2	83.5	75.5
Zn-65	2.0	2.5	0.9	0.5	11.9	3.3	8.0	0.7
Co-60	0.2	0.3	0.1	0.2	1.3	0.2	0.6	0.2
Mn-54	0.8	1.1	0.4	0.6	5.6	0.9	0.5	1.4
 The percentage (%) of the liver dose from five nuclides in the fish path- way	 100	 99.9	 100	 100	 99.7	 100	 99.9	 99.8
 The percentage (%) of the total dose to the teen's liver from the fish pathway	 96.5	 95.0	 97.6	 97.0	 80.9	 96.4	 89.9	 95.6
 The percentage (%) of the total dose to the teen's liver from the five nuclides in the fish pathway	 96.5	 94.9	 97.6	 97.0	 80.7	 96.4	 89.8	 95.4

TABLE D-5
DOSE CONTRIBUTION TO THE ADULT'S WHOLE BODY FROM THE
POTABLE WATER PATHWAY
(PERCENT)

ISOTOPE	1980	1981	1982	1983	1984*	1985	1986	1987
Cs-134	41.5	35.7	47.5	41.9	3.29	35.7	1.18	15.5
Cs-137	35.6	33.2	35.7	37.6	7.82	30.7	10.5	41.5
Zn-65	1.01	1.2	0.5	0.25	1.11	1.44	0.73	0.28
Co-60	17.8	24.4	12.4	15.5	23.4	15.9	10.8	17.8
Mn-54	0.86	1.1	0.4	0.61	1.10	0.84	0.09	1.22
The percentage (%) of the whole body dose from the nuclides from the potable water pathway	96.8	95.6	96.5	95.9	36.7	84.6	23.3	76.3
The percentage (%) the total dose to the adult's whole body from the potable water pathway	0.16	0.18	0.15	0.15	0.89	0.18	0.94	0.21
The percentage (%) of the total dose of the adult's whole body from the five nuclides in the potable water pathway	0.15	0.17	0.14	0.14	0.33	0.15	0.22	0.16

* Tritium was the major contributor to the potable water pathway for 1984.

TABLE D-6
DOSE CONTRIBUTION TO THE TEENAGER'S LIVER FROM THE
POTABLE WATER PATHWAY
(PERCENT)

ISOTOPE	1980	1981	1982	1983	1984*	1985	1986	1987
Cs-134	40.9	37.0	47.0	41.7	4.87	36.9	1.74	16.1
Cs-137	45.0	44.2	45.3	48.0	14.8	40.8	19.9	55.3
Zn-65	1.8	2.14	0.85	0.44	2.90	2.63	1.90	0.52
Co-60	6.43	9.25	4.49	5.66	12.7	6.03	5.8	6.77
Mn-54	3.5	4.76	1.73	2.54	6.77	3.62	0.57	5.24
The percentage (%) of the liver dose from the nuclides from the potable water pathway	97.6	97.4	99.4	98.3	42.0	90.0	29.9	83.9
The percentage (%) of the total dose to the teen's liver from the potable water pathway	0.12	0.13	0.12	0.12	0.38	0.14	0.44	0.15
The percentage (%) of the total dose to the teen's liver from the five nuclides in the potable water pathway	0.11	0.12	0.11	0.11	0.16	0.13	0.13	0.12

* Tritium was the major contributor to the potable water pathway for 1984

TABLE D-7

**DOSE CONTRIBUTION TO THE ADULT'S WHOLE BODY AND TEENAGER'S
LIVER FROM THE LAKE SHORELINE DEPOSITS PATHWAY**

1980	1981	1982	1983	1984	1985	1986	1987	
The percentage (%) of the total dose to the adult's whole body from the lake shoreline deposits pathway	0.83	1.22	0.56	0.72	5.68	0.85	2.79	1.12
Maximum percentage from 1980 to 1987 - 5.68%								
Average percentage from 1980 to 1987 - 1.72%								
The percentage (%) of the total dose to the teenager's liver from the lake shoreline deposits pathway	3.22	4.62	2.22	2.80	17.91	3.27	9.33	4.04
Maximum percentage from 1980 to 1987 -	17.9%							
Average percentage from 1980 to 1987 -	5.93%							

TABLE D-8

**DOSE CONTRIBUTION TO THE ADULT'S WHOLE BODY AND TEENAGER'S
LIVER FROM THE SWIMMING AND BOATING PATHWAYS**

1980	1981	1982	1983	1984	1985	1986	1987	
Percentage (%) of the total dose to the Adult's whole body from the swimming and boating pathways	0.21	0.31	0.13	0.17	1.39	0.20	0.62	0.27
Maximum percentage from 1980 to 1987 -	1.39%							
Average percentage from 1980 to 1987 -	0.41%							
Percentage (%) of the total dose to the teenager's liver from the swimming and boating pathways	0.14	0.21	0.09	0.12	0.78	0.14	0.37	0.18
Maximum percentage from 1980 to 1987 -	0.78%							
Average percentage from 1980 to 1987 -	0.25%							

TABLE D-9

CALCULATION OF TOTAL Ci/yr RELEASES FOR LIQUIDS

(Based on Semi-Annual Effluent Release Reports for the Years 2002 through 2009)

ISOTOPE	2002	2003	2004	2005	2006	2007	2008	2009	AVERAGE Ci/yr	*REDUCTION FACTOR
H-3	6.25E-01	2.76E-03	5.06E-03	1.01-E02	3.81E+00	1.27E-01	3.80+00	1.70E-03	1.05E+00	3.2
Cs-137	3.14E-05								3.93E-06	12748
Co-60	8.44E-04				1.59E-05				1.07E-04	3804
Fe-59	1.88E-04								2.35E-05	175
Zn-65	7.88E-05				3.83E-05				1.46E-05	863
Mn-54	9.76E-04				1.04E-04				1.35E-04	723
Tc-99m	5.47E-07								6.84E-08	4166
Xe-133						5.36E-04			6.70E-05	128
Xe-135							9.91E-05		1.24E-05	1169
Sr-89						5.05E-06			6.31E-07	114
Sr-90	2.74E-07				7.06E-06	5.44E-07			9.85E-07	62
Fe-55	6.32E-04				2.02E-04	1.17E-05			1.06E-04	41.9

* Average Value in ODCM ÷ updated Average Value. For example for H-3, 3.34 ÷ 1.05 = 3.2

APPENDIX E
TECHNICAL BASES FOR EFFECTIVE DOSE FACTORS

APPENDIX E
TECHNICAL BASES FOR EFFECTIVE DOSE FACTORS

<u>TABLE</u>	<u>TITLE</u>	<u>PAGE</u>
E-1	Effective Dose Factors for Noble Gases - Whole Body Effective Dose (K_{eff})	E-6
E-2	Effective Dose Factors for Noble Gases - Air Doses (M_{eff}) and (N_{eff})	E-8
E-3	Effective Dose Factors for Noble Gases - Skin Effective Dose ($L + 1.1 M_{\text{eff}}$) and (L_{eff})	E-9
E-4	Tables of Source Terms Used for Development of Effective Dose Transfer Factors (Elevated Release)	E-10
E-5	Tables of Source Terms Used for Development of Effective Dose Transfer Factors (Vent Release)	E-11
E-6	Radionuclide Distribution of Vent and Elevated Releases	E-12

TECHNICAL BASES FOR EFFECTIVE DOSE FACTORS

The evaluation of doses due to releases of radioactive material to the atmosphere can be simplified by the use of effective dose transfer factors instead of using dose factors which are radionuclide specific. These effective factors, which are based on the typical radionuclide distribution in the releases, can be applied to the total radioactivity released to approximate the dose in the environment, i.e., instead of having to sum the isotopic distribution multiplied by the isotope specific dose factor, only a single multiplication (K_{eff} , L_{eff} , M_{eff} or N_{eff}) times the total quantity of radioactive material released, would be needed. This approach provides a reasonable estimate of the actual dose while eliminating the need for a detailed calculating technique.

Determination of Effective Dose Factors

The effective dose transfer factors are based on past operating data. The radioactive effluent distribution for the past years can be used to derive single effective factors by the following equations.

$$K_{\text{eff}} = \sum_{i=1}^n K_i \cdot f_i$$

E-1

Where:

K_{eff} = the effective whole body dose factor due to gamma emissions from all noble gases released.

K_i = the whole body dose factor due to gamma emissions from each noble gas radionuclide 'i' released.

f_i = the fractional abundance of noble gas radionuclide 'i' is of the total noble gas radionuclides.

A K_{eff} is calculated for elevated releases and also for vent releases.

$$L_{\text{eff}} = \sum_{i=1}^n L_i \cdot f_i$$

Where:

L_{eff} = the effective skin dose factor due to beta emissions from all noble gases released.

**TECHNICAL BASES FOR EFFECTIVE DOSE FACTORS
(Continued)**

L_i = the skin dose factor due to the beta emissions from each noble gas radionuclide 'i' released.

For ease of calculation, L_{eff} is calculated for elevated releases and $(L + 1.1M)_{eff}$ is calculated for vent releases.

$$(L + 1.1M)_{eff} = \sum_{i=1}^n (L_i + 1.1M_i) \cdot f_i$$

E-2

Where:

$(L + 1.1M)_{eff}$ = the effective skin dose factor due to beta and gamma emissions from all noble gases released from the vents.

$(L_i + 1.1M_i)$ = the skin dose factor due to beta and gamma emissions from each noble gas radionuclide 'i' released from the vents.

$$M_{eff} = \sum_{i=1}^n M_i \cdot f_i$$

E-3

Where:

M_{eff} = the effective air dose factor due to gamma emissions from all noble gases released.

M_i = the air dose factor due to gamma emissions from each noble gas radionuclide 'i' released.

A M_{eff} is calculated for elevated releases and also for vent releases.

**TECHNICAL BASES FOR EFFECTIVE DOSE FACTORS
(Continued)**

E-4

$$N_{\text{eff}} = \sum_{i=1}^n N_i \cdot f_i$$

Where:

N_{eff} = the effective air dose factor due to beta emissions from all noble gases released.

N_i = the air dose factor due to beta emissions from each noble gas radionuclide 'i' released.

A N_{eff} is calculated for elevated releases and also for vent releases.

To determine the appropriate effective factors to be used and to evaluate the degree of variability, the atmospheric radioactive effluents for the years 1985 through 1991 have been evaluated. Tables E-1, E-2, and E-3 present the results of this evaluation.

To compensate for any unusual variability in the radionuclide distribution, 3 sigma was added to the average K_{eff} , M_{eff} , N_{eff} , L_{eff} , and $(L + 1.1 M)_{\text{eff}}$ values. This added conservatism provides additional assurance that the evolution of doses by the use of a single effective factor will normally overestimate actual doses in the environment, and any underestimation will be of insignificant magnitude.

TABLE E-1
EFFECTIVE DOSE FACTORS FOR NOBLE GASES -
WHOLE BODY EFFECTIVE DOSE

[K_{eff}]

VENT RELEASE
[mrem/sec per μCi/m³]

YEAR	Whole Body Effective Dose Factor K _{eff}
1985	4.32E-05
1986	1.42E-04
1987	4.34E-05
1988	1.08E-04
1989	1.64E-04
1990	8.80E-05
1991	6.03E-05
mean ± σ	9.27E-05 ± 4.78E-05
mean + 3σ	2.36E-04

NOTE: The years 1985 through 1991 were selected as representative of historical noble gas releases from the vents. Calculated K_{eff} values based on the 1985 through 1991 data produce a more conservative result providing inclusion (bounding) of K_{eff} values that may be encountered if a fuel failure occurs. An evaluation of current vent release data (i.e. 1999 through 2003) resulted in non-conservative K_{eff} values.

TABLE E-1 (continued)
EFFECTIVE DOSE FACTORS FOR NOBLE GASES -
WHOLE BODY EFFECTIVE DOSE

[K_{eff}]

ELEVATED STACK RELEASE

[mrem/sec per $\mu\text{Ci}/\text{m}^3$]

YEAR	Whole Body Effective Dose Factor K _{eff}
1999	2.34E-04
2000	2.29E-04
2001	2.41E-04
2002	2.11E-04
2003	2.47E-04
mean $\pm \sigma$	2.32E-04 \pm 1.38E-05
mean + 3 σ	2.73E-04

TABLE E-2
EFFECTIVE DOSE FACTORS FOR NOBLE GASES -
AIR DOSE
[M_{eff} & N_{eff}]

YEAR	VENT RELEASE		ELEVATED RELEASE	
	[mrad/sec per $\mu\text{Ci}/\text{m}^3$]		[mrad/sec per $\mu\text{Ci}/\text{m}^3$]	
	Gamma-Air Effective Dose Factor M _{eff}	Beta-Air Effective Dose Factor N _{eff}	Gamma-Air Effective Dose Factor M _{eff}	Beta-Air Effective Dose Factor N _{eff}
1985	4.57E-05	6.78E-05	2.06E-04	1.26E-04
1986	1.49E-04	1.14E-04	2.28E-04	1.30E-04
1987	4.66E-05	5.21E-05	1.13E-04	6.58E-05
1988	1.13E-04	7.25E-05	1.17E-04	7.49E-05
1989	1.71E-04	7.30E-05	1.81E-04	1.52E-04
1990	9.29E-05	8.87E-05	1.25E-04	1.39E-04
1991	6.41E-05	6.30E-05	1.31E-04	9.02E-05
mean $\pm \sigma$	9.75E-05	7.59E-05	1.57E-04	1.11E-04
	\pm 4.95E-05	\pm 2.01E-05	\pm 4.70E-05	\pm 3.37E-05
mean + 3σ	2.46E-04	1.36E-04	2.98E-04	2.12E-04

TABLE E-3
EFFECTIVE DOSE FACTORS FOR NOBLE GASES -
SKIN EFFECTIVE DOSE

YEAR	VENT RELEASE [mrem/sec per $\mu\text{Ci}/\text{m}^3$]	ELEVATED RELEASE [mrem/sec per $\mu\text{Ci}/\text{m}^3$]
	Total Skin Effective Dose Factor (L + 1.1M) _{eff}	Skin Effective Dose Factor L _{eff}
1985	9.87E-05	1.09E-04
1986	2.37E-04	1.13E-04
1987	8.44E-05	4.57E-05
1988	1.77E-04	5.51E-05
1989	2.43E-04	1.34E-04
1990	1.58E-04	1.20E-04
1991	1.04E-04	7.08E-05
mean $\pm \sigma$	1.57E-04 \pm 6.54E-05	9.25E-05 \pm 3.47E-05
mean +3 σ	3.54E-04	1.97E-04

TABLE E-4

TABLES OF SOURCE TERMS USED FOR DEVELOPMENT OF EFFECTIVE DOSE
TRANSFER FACTORS

(Based on Semi-Annual Effluent Release Reports for the years 1985-1991 and 1999-2003)

ELEVATED RELEASE (Curies)

<u>RADIONUCLIDE</u>	<u>1985</u>	<u>1986</u>	<u>1987</u>	<u>1988</u>	<u>1989</u>	<u>1990</u>	<u>1991</u>
Ar-41	4.34E+01	3.65E+01	6.90E+01	1.34E+01	1.73E+-1	3.86E+-1	1.57E+01
Kr-83m	--	--	--	--	--	--	--
Kr-85m	3.47E+02	7.48E+01	6.6E+02	3.85E+02	1.28E+01	7.78E+01	1.94E+02
Kr-85	--	--	--	--	--	--	--
Kr-87	1.57E+03	2.15E+02	8.39E+01	1.59E+02	9.26E+00	3.85E+01	7.30E+01
Kr-88	1.13E+03	3.32E+02	4.60E+02	5.18E+02	2.20E+01	1.17E+02	2.99E+02
Kr-89	--	--	--	--	--	--	--
Kr-90	--	--	--	--	--	--	--
Xe-131m	8.51E+02	7.79E+00	2.30E+00	--	7.41E+00	1.88E+01	1.16E+02
Xe-133m	--	9.92E+00	2.73E-01	5.88E+00	--	3.38E+00	5.23E+00
Xe-133	2.77E+02	1.01E+02	1.63E+03	1.13E+03	7.17E+00	2.97E+02	4.74E+02
Xe-135m	1.76E+03	2.03E+02	9.13E+01	3.69E+01	6.09E+00	2.99E+01	2.38E+01
Xe-135	2.22E+03	3.34E+02	2.35E+02	1.00E+03	2.49E+01	1.40E+02	4.00E+02
Xe-137	--	3.86E+01	--	--	2.40E+01	1.87E+02	7.22E+01
Xe-138	5.59E+03	7.45E+02	2.26E+02	1.53E+01	2.04E+01	1.01E+02	7.55E+01
TOTAL	1.38E+04	2.10E+03	3.47E+03	3.27E+03	1.51E+02	1.05E+03	1.75E+03

<u>RADIONUCLIDE</u>	<u>1999</u>	<u>2000</u>	<u>2001</u>	<u>2002</u>	<u>2003</u>
Ar-41	1.95E+01	2.46E+01	2.51E+01	2.16E+01	1.38E+01
Kr-83m	--	--	--	--	--
Kr-85m	2.23E+00	3.79E+00	3.63E+00	8.59E+00	3.50E+00
Kr-85	--	--	--	--	--
Kr-87	1.24E+01	9.18E+00	5.53E-01	1.66E+01	4.99E-01
Kr-88	8.56E+00	5.80E+00	1.09E+00	1.97E+01	2.61E+00
Kr-89	--	--	--	--	--
Kr-90	--	--	--	--	--
Xe-131m	--	--	--	--	--
Xe-133m	--	--	--	--	--
Xe-133	5.17E-02	1.09E+00	1.55E+00	3.75E+00	7.60E-01
Xe-135m	9.99E+00	7.54E+00	4.09E-01	2.44E+00	2.21E-01
Xe-135	1.13E-01	8.58E+00	5.06E-01	2.67E+01	4.44E-01
Xe-137	5.36E-01	--	--	1.61E-01	--
Xe-138	3.35E+01	2.35E+01	1.16E+00	7.98E+00	8.14E-01
TOTAL	9.81E+01	8.41E+01	3.40E+01	1.08E+02	2.26E+01

TABLE E-5

TABLES OF SOURCE TERMS USED FOR DEVELOPMENT OF EFFECTIVE DOSE
TRANSFER FACTORS
(Based on Semi-Annual Effluent Release Reports for the years 1985 through 1991)

VENT RELEASE (Curles)

RADIONUCLIDE	1985	1986	1987	1988
Ar-41		--	--	-- --
Kr-83m		--	--	-- --
Kr-85m	--	3.35E+01	6.42E+01	3.14E+01
Kr-85	4.36E+02	-- --	--	
Kr-87	8.95E+00	4.61E+01	1.38E+01	7.78E+00
Kr-88	1.45E+01	7.25E+01	4.81E+01	4.13E+01
Kr-89	--	--	--	--
Kr-90	--	--	--	--
Xe-131m	1.44E+02	1.24E+02	1.19E+01	1.26E+01
Xe-133m	2.81E+01	4.65E+01	4.37E+02	5.33E+01
Xe-133	6.29E+01	4.91E+01	5.06E+02	2.75E+02
Xe-135m	9.66E+00	1.33E+01	3.39E+01	1.48E+01
Xe-135	1.68E+02	3.54E+01	1.31E+02	5.14E+01
Xe-137	--	3.10E+01	--	--
Xe-138	7.27E+01	1.06E+02	3.18E+01	1.35E+02
TOTAL	9.44E+02	5.57E+02	1.28E+03	6.23E+02

RADIONUCLIDE	1989	1990	1991
Ar-41	3.35E-01	9.02E-01	4.70E-01
Kr-83m	--	--	--
Kr-85m	7.08E+01	1.77E+01	1.74E+01
Kr-85	--	--	--
Kr-87	3.68E+00	1.13E+01	3.72E+00
Kr-88	1.01E+02	1.36E+01	1.63E+01
Kr-89	--	--	--
Kr-90	--	--	--
Xe-131m	5.57E+01	1.67E+01	1.11E+02
Xe-133m	5.05E+01	8.95E+01	1.70E+01
Xe-133	403E+01	5.54E+01	7.19E+01
Xe-135m	1.53E+01	8.81E+00	1.35E+01
Xe-135	2.62E+01	3.27E+01	2.39E+01
Xe-137	--	1.11E+01	7.85E+00
Xe-138	4.42E+01	4.57E+01	1.74E+01
TOTAL	4.08E+02	3.04E+02	3.01E+02

TABLE E-6
RADIONUCLIDE DISTRIBUTION OF VENT AND ELEVATED RELEASES
 (Based on Semi-Annual Effluent Release Reports for the years 1985 through 1991)
FRACTION OF TOTAL VENT RELEASE

RADIONUCLIDE	1985	1986	1987	1988	1989	1990	1991
Ar-41	--	--	--	--	8.21E-04	2.97E-03	1.57E-03
Kr-83m	--	--	--	--	--	--	--
Kr-85m	--	6.01E-02	5.03E-02	5.04E-02	1.73E-01	5.83E-02	5.80E-02
Kr-85	4.62E-01	--	--	--	--	--	--
Kr-87	9.48E-03	8.27E-02	1.08E-02	1.25E-02	9.02E-03	3.73E-02	1.24E-02
Kr-88	1.53E-02	1.30E-01	3.76E-02	6.63E-02	2.48E-01	4.48E-02	5.43E-02
Kr-89	--	--	--	--	--	--	--
Kr-90	--	--	--	--	--	--	--
Xe-131m	1.52E-02	2.23E-01	9.32E-03	2.02E-02	1.36E-01	5.51E-02	3.70E-01
Xe-133m	2.97E-02	8.34E-02	3.42E-01	8.56E-02	1.24E-01	2.95E-01	5.67E-02
Xe-133	6.66E-02	8.80E-02	3.96E-01	4.42E-01	9.87E-02	1.82E-01	2.39E-01
Xe-135m	1.02E-02	2.39E-02	2.65E-02	2.37E-02	3.74E-02	2.90E-02	4.49E-02
Xe-135	1.78E-01	6.35E-02	1.02E-01	8.26E-02	6.42E-02	1.08E-01	7.97E-02
Xe-137	--	5.56E-02	--	--	--	3.65E-02	2.61E-02
Xe-138	7.70E-02	1.89E-01	2.49E-02	2.17E-01	1.08E-01	1.51E-01	5.78E-02

FRACTION OF TOTAL ELEVATED RELEASE

RADIONUCLIDE	1985	1986	1987	1988	1989	1990	1991
Ar-41	3.15E-03	1.74E-02	1.99E-02	4.09E-03	1.14E-01	3.52E-02	8.97E-03
Kr-83m	--	--	--	--	--	--	--
Kr-85m	2.52E-02	3.56E-02	1.92E-01	1.18E-01	8.45E-02	7.44E-02	1.11E-01
Kr-85	--	--	--	--	--	--	--
Kr-87	1.14E-01	1.03E-01	2.42E-02	4.85E-02	6.12E-02	3.68E-02	4.17E-02
Kr-88	8.17E-02	1.58E-01	1.33E-01	1.58E-01	1.45E-01	1.12E-01	1.71E-01
Kr-89	--	--	--	--	--	--	--
Kr-90	--	--	--	--	--	--	--
Xe-131m	6.18E-02	3.71E-03	6.64E-04	--	4.90E-02	1.79E-02	6.62E-02
Xe-133m	--	4.73E-03	7.88E-05	1.80E-03	--	3.23E-03	2.99E-03
Xe-133	2.01E-02	4.83E-02	4.71E-01	3.47E-01	4.74E-02	2.84E-01	2.71E-01
Xe-135m	1.27E-01	9.68E-02	2.63E-02	1.13E-02	4.03E-02	2.86E-02	1.36E-02
Xe-135	1.61E-01	1.59E-01	6.78E-02	3.06E-01	1.65E-01	1.33E-01	2.28E-01
Xe-137	--	1.84E-02	--	--	1.59E-01	1.79E-01	4.13E-02
Xe-138	4.06E-01	3.55E-01	6.51E-02	4.67E-03	1.35E-01	9.62E-02	4.32E-02

RADIONUCLIDE	1999	2000	2001	2002	2003
Ar-41	1.99E-01	2.92E-01	7.38E-01	2.01E-01	6.09E-01
Kr-83m	--	--	--	--	--
Kr-85m	2.27E-02	4.51E-02	1.07E-01	7.99E-02	1.54E-01
Kr-85	--	--	--	--	--
Kr-87	1.26E-01	1.09E-01	1.63E-02	1.55E-01	2.20E-02
Kr-88	8.73E-02	6.91E-02	3.20E-02	1.83E-01	1.16E-01
Kr-89	--	--	--	--	--
Kr-90	--	--	--	--	--
Xe-131m	--	--	--	--	--
Xe-133m	--	--	--	--	--
Xe-133	5.00E-04	1.29E-02	4.57E-02	3.49E-02	3.36E-02
Xe-135m	1.02E-01	8.98E-02	1.20E-02	2.27E-02	9.78E-03
Xe-135	1.16E-01	1.02E-01	1.49E-02	2.48E-01	1.96E-02
Xe-137	5.50E-03	--	--	1.50E-03	--
Xe-138	3.42E-01	2.79E-01	3.41E-02	7.42E-02	3.60E-02

APPENDIX F

EFFLUENT MONITOR SAMPLING LOCATIONS AND DESCRIPTIONS

APPENDIX F

EFFLUENT MONITOR SAMPLING LOCATIONS AND DESCRIPTIONS

<u>TABLE</u>	<u>TITLE</u>	<u>PAGE</u>
F-1	Atmospheric Gaseous Release Point Data	F-3
F-2	Effluent Monitoring System Data	F-4

<u>FIGURE</u>	<u>TITLE</u>	<u>PAGE</u>
F-1	Gaseous Release Points Building Elevations	F-6
F-2	Gaseous Release Points Plant Yard Layout	F-7
F-3	Liquid Release Point	F-8
F-4	Gaseous Effluent Release Paths	F-9
F-5	Liquid Effluent Release Paths	F-10
F-6	Solid Radwaste Treatment System	F-11
F-7	Standby Gas Treatment System	F-12

TABLE F-1

JAMES A. FITZPATRICK NUCLEAR POWER PLANT
OFFSITE DOSE CALCULATION MANUAL (ODCM)

ATMOSPHERIC GASEOUS RELEASE POINT DATA

RELEASE POINT	STACK	REACTOR* BUILDING	TURBINE BUILDING	RADWASTE BUILDING	REFUEL* FLOOR
Height Above Grade (feet)	385	172	172	111	172
Release Mode	Elevated	Roof Top Vent	Roof Top Vent	Roof Top Vent	Roof Top Vent
Effluent Source	Turbine Gland Seal Condenser Gases Mechanical Vacuum Pump Exhaust Steam Jet Air Ejector Exhaust	Secondary and Auxiliary Building Exhaust Ventilation	Turbine Building Exhaust Ventilation	Waste Disposal Building Ventilation	Refuel Floor Exhaust Ventilation

* The Refuel Floor and Reactor Building vent is a combined release point.

**TABLE F-2
JAMES A. FITZPATRICK NUCLEAR POWER PLANT
OFFSITE DOSE CALCULATION MANUAL (ODCM)**

EFFLUENT MONITORING SYSTEM DATA

MONITOR DESCRIPTION	SAMPLING LOCATION	DETECTION TYPE	RANGE	CONTROL FUNCTIONS	ALARM SETPOINT USED	REFERENCE CALIBRATION SOURCE
Main steam line monitor	Located near the main steam lines downstream of the outboard MSIV's in the steam tunnel	4-gamma sensitive ion chambers	10^0 - 10^6 mR/hr	Closure of main steam line drain motor operated valves, mechanical vacuum pump line isolation valve, recirculation loop sample valves, and initiates a trip of the mechanical vacuum pump.	Yes	Victoreen Cs ¹³⁷ gamma dose rate source
Off-gas radiation monitoring system	Turbine 252' west	2-gamma sensitive ion chambers	10^0 - 10^6 mR/hr	Initiate closure of off-gas system isolation valves	Yes	Gas sample counted on Ge(Li)
Off-gas pipe (Stack) monitor	Stack	Scintillation detectors	10^{-1} - 10^6 cps	Indicate and record rate of release of radioactive material to the environment	Yes	Gas vent marinelli counted on Ge(Li)
Process liquid radiation monitors	Rad Waste - RW 272' Service H ₂ O Heater Bay 252'	Scintillation detectors	10^{-1} - 10^6 cps	Monitor for leaks of closed systems. Monitor normal release of radioactive material to the environment	Yes	Representative liquid sample counted on Ge(Li)

**TABLE F-2
(Continued)**

EFFLUENT MONITORING SYSTEM DATA

MONITOR DESCRIPTION	SAMPLING LOCATION	DETECTION TYPE	RANGE	CONTROL FUNCTIONS	ALARM SETPOINT USED	REFERENCE CALIBRATION SOURCE
Plant stack & vent noble gas monitors	Turbine - MG Set 300' Reactor - RX 344' Refuel - RX 369' Radwaste - TB 300' Stack	GM Detectors	10^1 - 10^6 CPM	Provide isolation of potentially contaminated systems	Yes	Gas marinelli counted on Ge(Li)
		Scintillation Detector	10^{-1} - 10^6 CPS			
Drywell continuous air monitor	Reactor 300' south side	Scintillation detectors	10^{-1} - 10^6 CPM	Monitor airborne radioactivity in Drywell during normal operation	Yes	Gas marinelli counted on Ge(Li)
Containment high range monitors	Drywell penetrations X110C and X100D	2-ion chamber detectors	10^0 - 10^8 R/hr	Accident control and initiates isolation	Yes	Victoreen Cs-137 gamma dose rate source
High range effluent monitors	Stack, Turbine Radwaste	2-ion chamber detectors	10^{-1} - 10^7 mR/hr	Accident control and initiates isolation	Yes	Victoreen Cs-137 gamma dose rate source

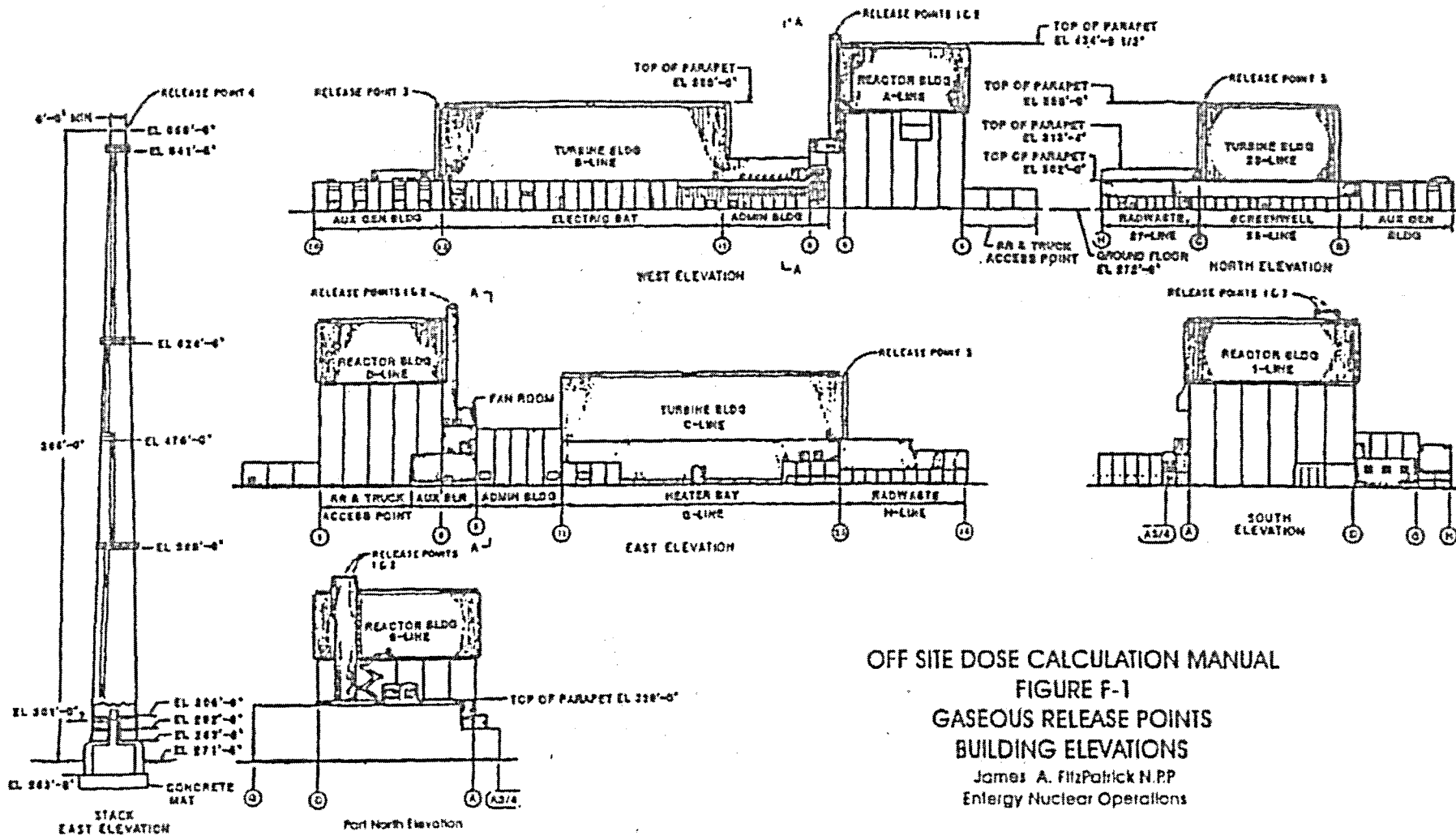

OFF SITE DOSE CALCULATION MANUAL

FIGURE F-1

GASEOUS RELEASE POINTS
BUILDING ELEVATIONS

James A. FitzPatrick N.P.P
Entergy Nuclear Operations

OFF-SITE DOSE CALCULATION MANUAL
FIGURE F-2 GASEOUS RELEASE POINTS
J. A. FITZPATRICK NPP
ENERGY NUCLEAR NORTH EAST

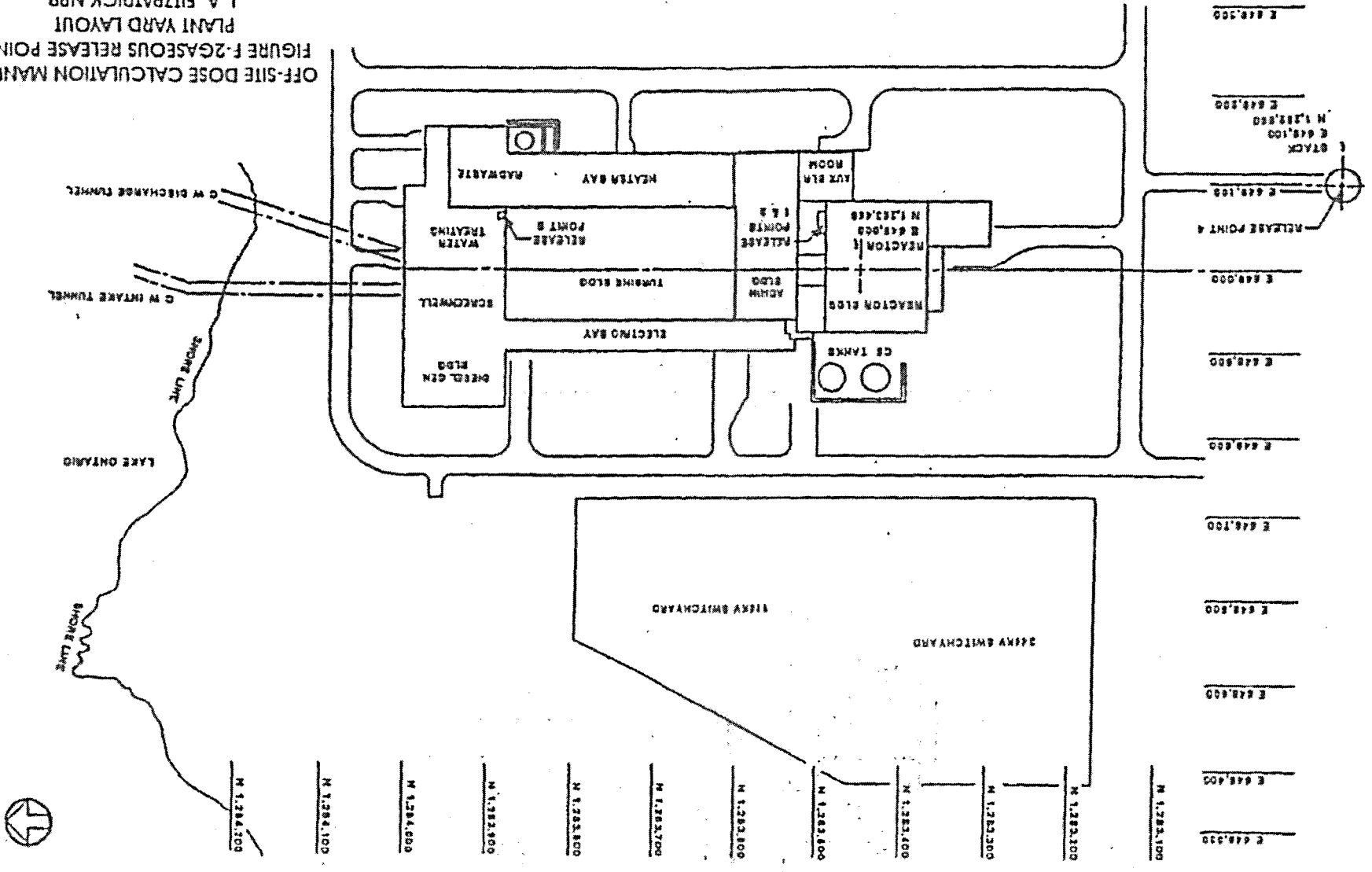

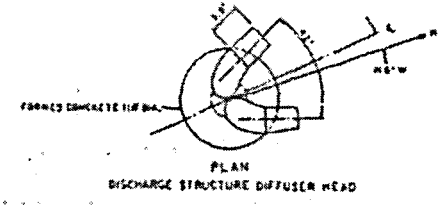
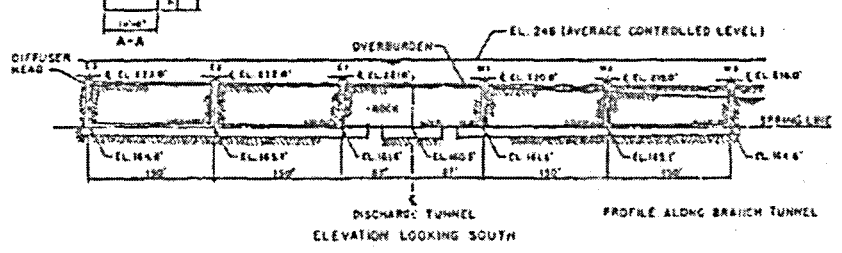
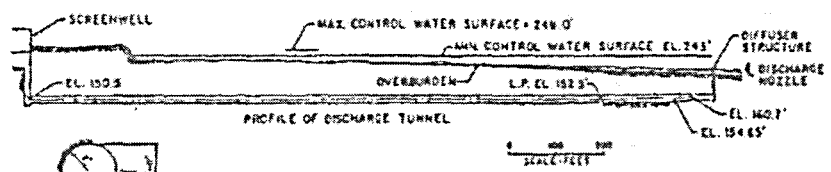
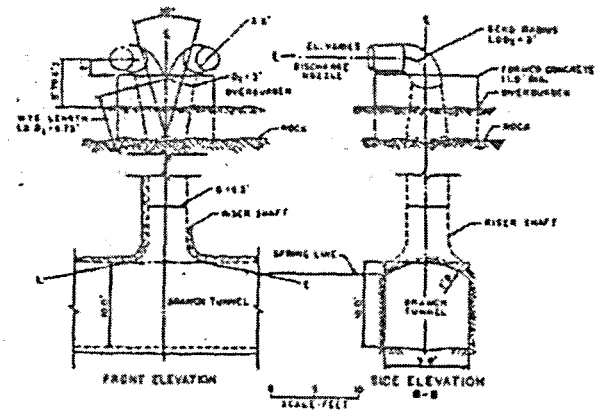
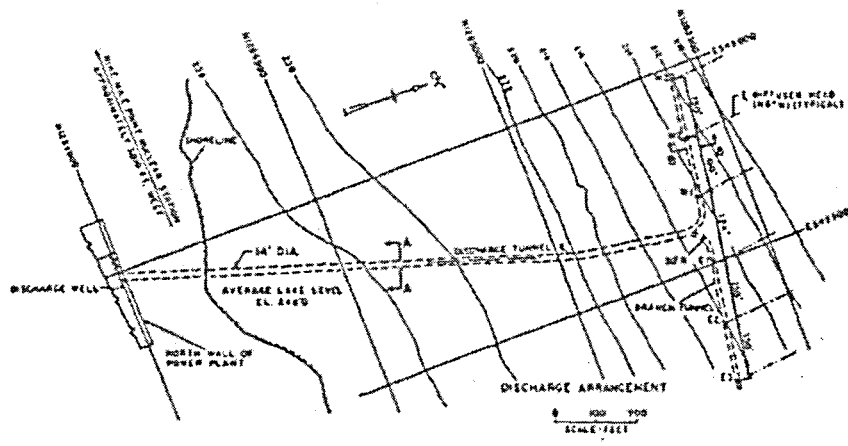

NOTE:
ALL ELEVATIONS BASED ON UNITED STATES LAKE SURVEY 1933 DATUM.

FIGURE F - 3
OFF-SITE DOSE CALCULATION MANUAL
LIQUID EFFLUENT RELEASE POINTS
DISCHARGE TUNNEL PLAN & PROFILE
J. A. FITZPATRICK N.P.P. ENTERGY NUCLEAR

FIGURE F-4

**JAMES A. FITZPATRICK NUCLEAR POWER PLANT
OFFSITE DOSE CALCULATION MANUAL (ODCM)
GASEOUS EFFLUENT RELEASE PATHS**

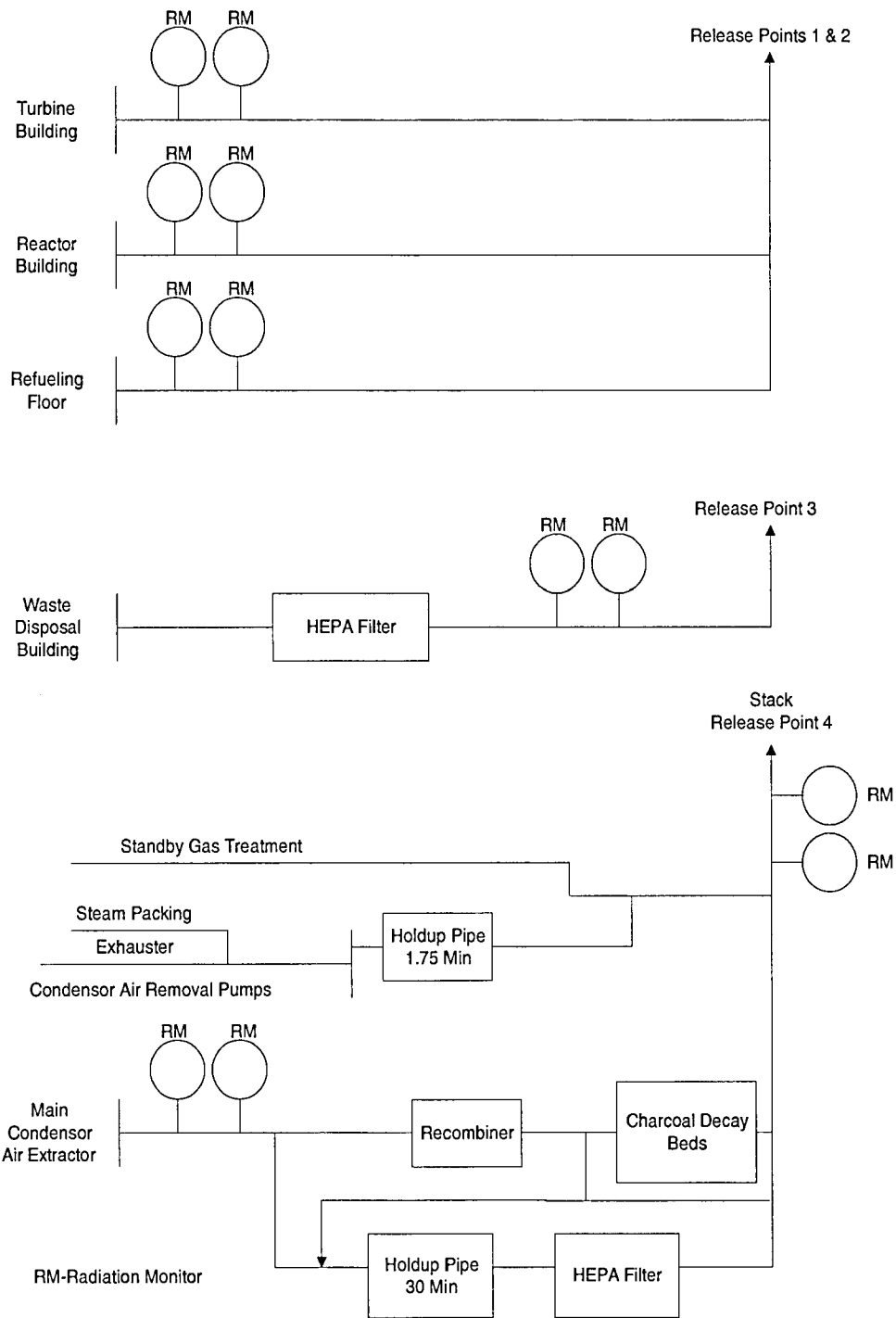
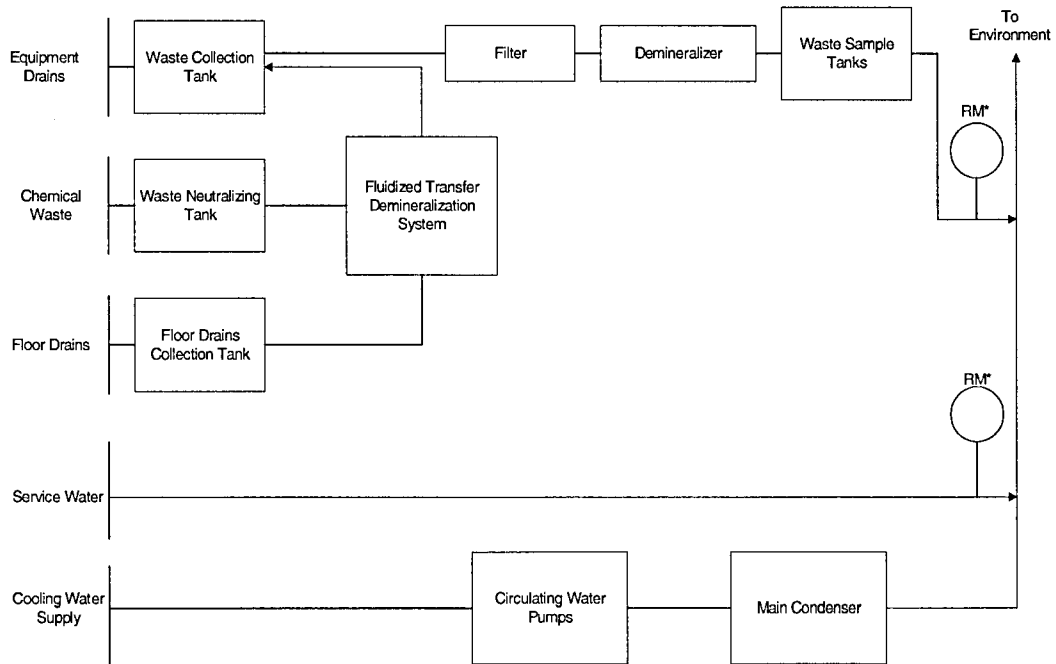

FIGURE F-5

JAMES A. FITZPATRICK NUCLEAR POWER PLANT
OFFSITE DOSE CALCULATION MANUAL (ODCM)
LIQUID EFFLUENT RELEASE PATHS



*RM-Radiation Monitor

POTENTIAL LIQUID EFFLUENT PATHS

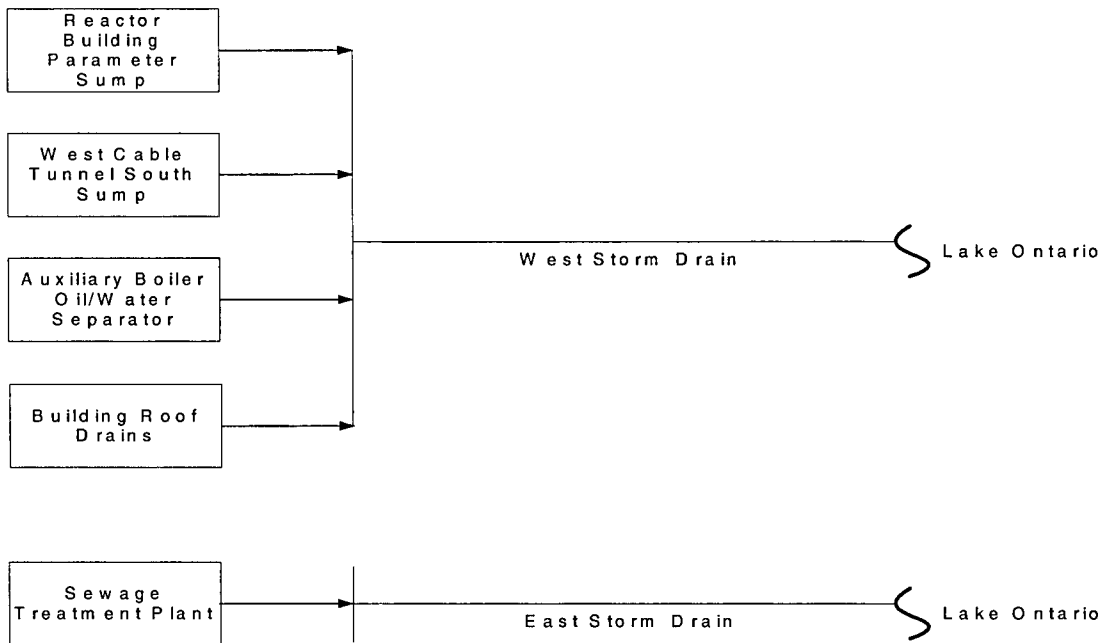

FIGURE F-6

JAMES A. FITZPATRICK NUCLEAR POWER PLANT
OFFSITE DOSE CALCULATION MANUAL (ODCM)
SOLID RADWASTE TREATMENT SYSTEM

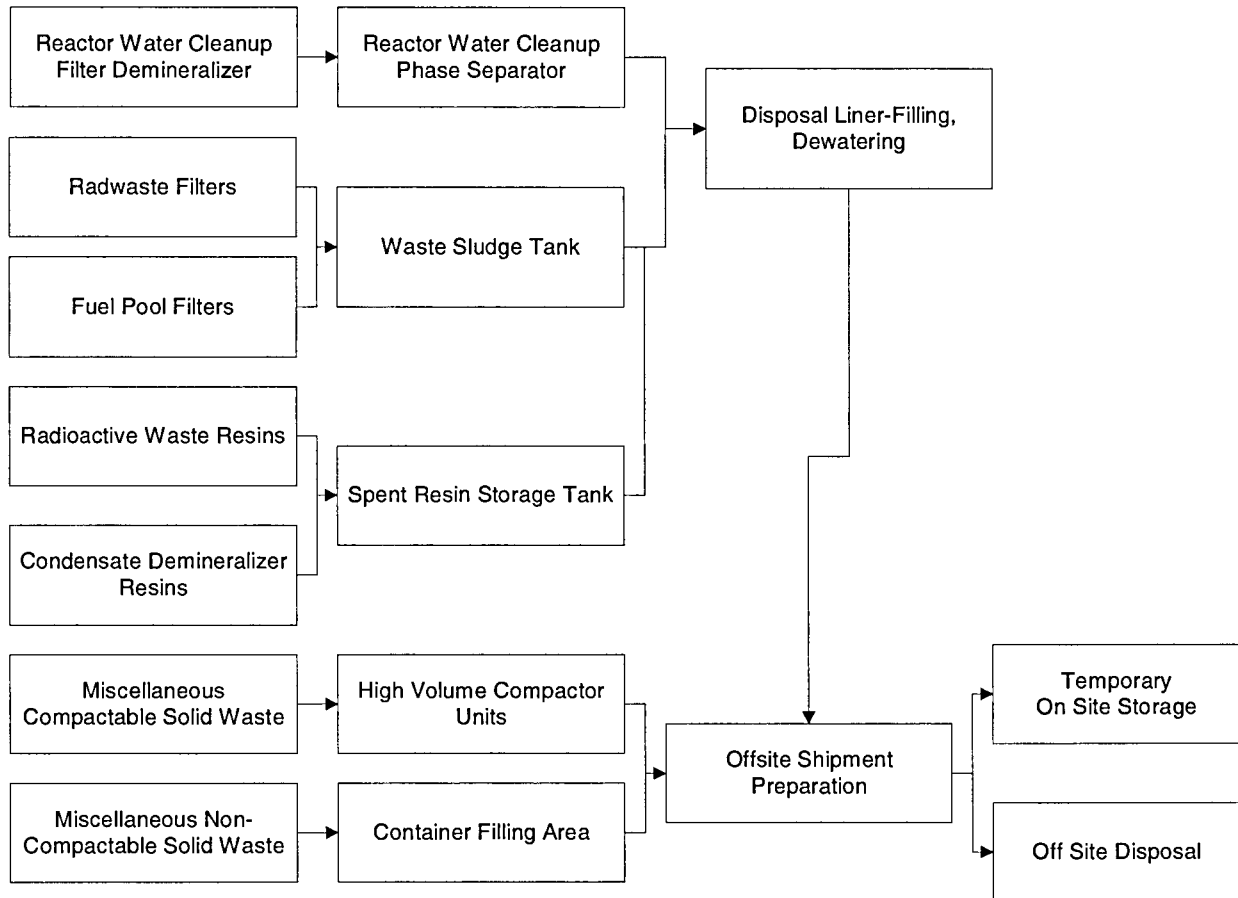
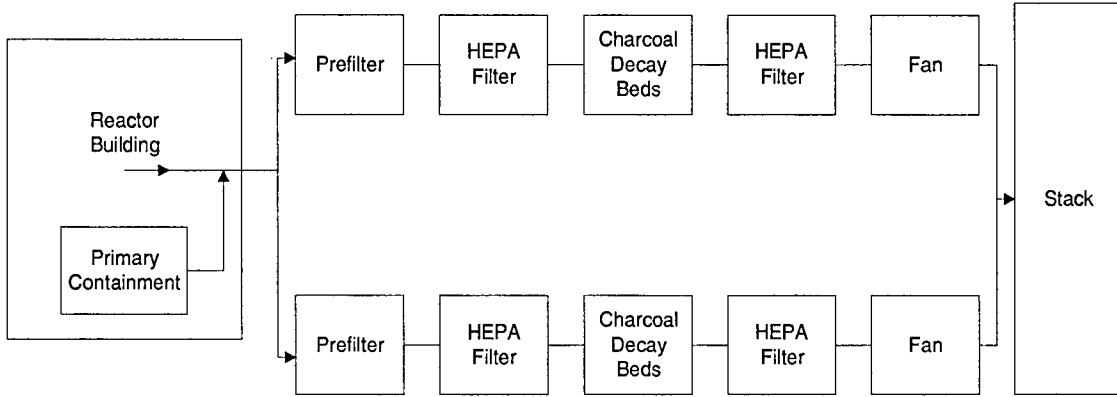

FIGURE F-7

JAMES A. FITZPATRICK NUCLEAR POWER PLANT
OFFSITE DOSE CALCULATION MANUAL (ODCM)

STANDBY GAS TREATMENT SYSTEM



APPENDIX G
UNRESTRICTED AREA MAP

APPENDIX G
UNRESTRICTED AREA MAP

<u>FIGURE</u>	<u>TITLE</u>	<u>PAGE</u>
G-1	JAFNPP Site Boundary Map	G-3

FIGURE G-1

JAMES A. FITZPATRICK NUCLEAR POWER PLANT

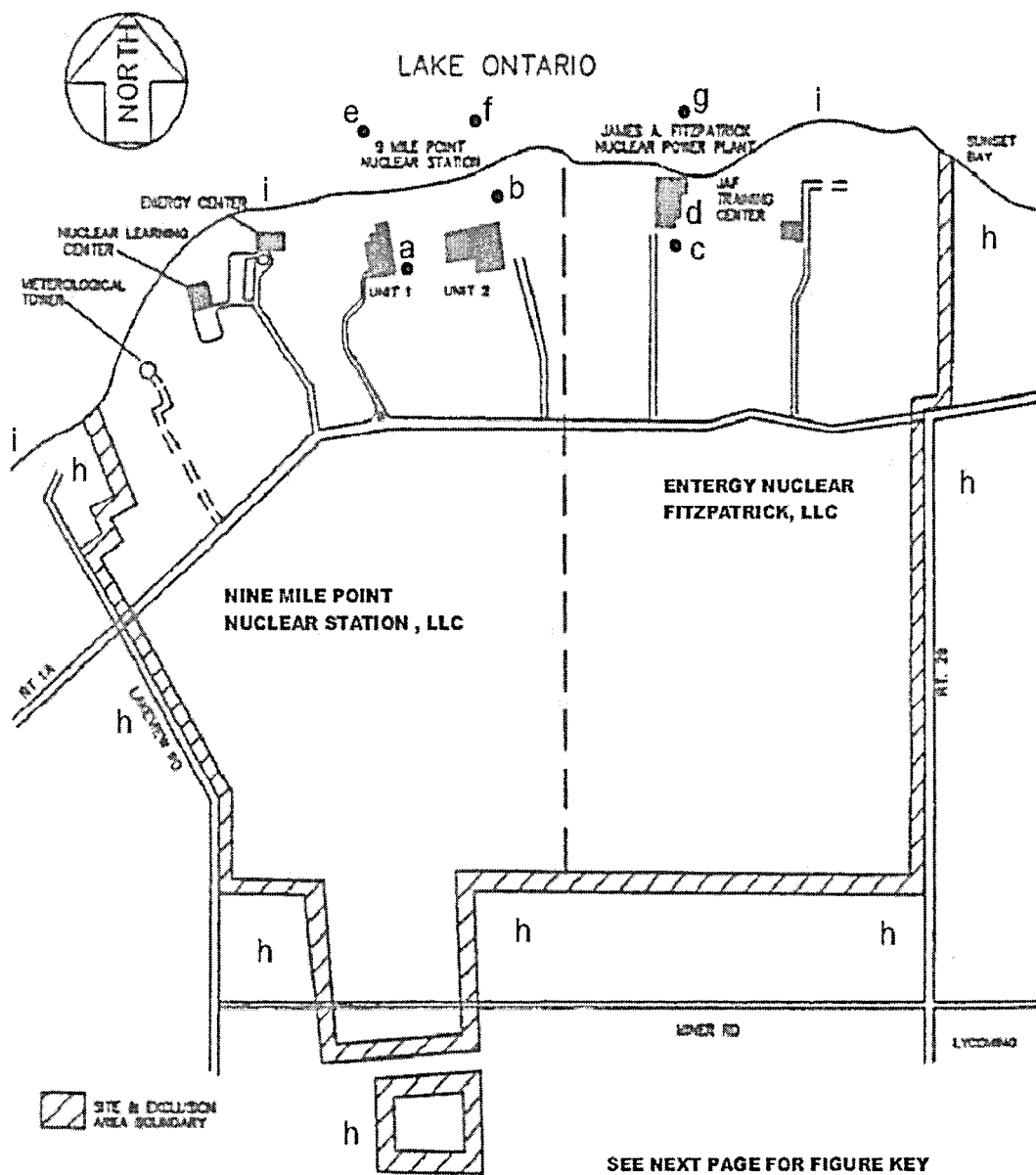

OFFSITE DOSE CALCULATION MANUAL (ODCM)
JAFNPP SITE BOUNDARY MAP

NOTES TO FIGURE G-1

- (a) NMP1 stack (height is 350 feet)
- (b) NMP2 stack (height is 430 feet)
- (c) JAFNPP stack (height is 385 feet)
- (d) Building vents
- (e) NMP1 radioactive liquid discharge (Lake Ontario, bottom)
- (f) NMP2 radioactive liquid discharge (Lake Ontario, bottom)
- (g) JAFNPP radioactive liquid discharge (Lake Ontario, bottom)
- (h) Site boundary
- (i) Lake Ontario shoreline

Additional Information:

- NMP2 reactor building vent is located 187 feet above ground level
- JAFNPP reactor and turbine building vents are located 173 feet above ground level
- JAFNPP radwaste building vent is 112 feet above ground level

APPENDIX H
ENVIRONMENTAL SAMPLE LOCATIONS

APPENDIX H

ENVIRONMENTAL SAMPLE LOCATIONS

<u>TABLE</u>	<u>TITLE</u>	<u>PAGE</u>
H-1	Radiological Environmental Monitoring Sampling Locations	H- 5
H-2	Liquid Effluent Pathway - Water Intake Points Description and Pumpage	H-15

<u>FIGURE</u>	<u>TITLE</u>	<u>PAGE</u>
H-1	Off-Site Environmental Sample Location Map	H-11
H-2	Off-Site Environmental Sample Location Map	H-12
H-3	On-Site Environmental Sample Location Map	H-13
H-4	On-Site Environmental ISFSI TLD Locations	H-14
H-5	Liquid Effluent Pathway - Water Intake Points	H-16

RADIOLOGICAL ENVIRONMENTAL SAMPLING LOCATIONS

1.0 RADIOLOGICAL ENVIRONMENTAL MONITORING PROGRAM

1.1 Sampling Stations/Locations

The current sampling locations are specified on Table H-1 and Figures H-1, H-2 and H-3. The Radiological Environmental Monitoring Program is a joint effort between the the owners and operators of the Nine Mile Point Unit 1, Nine Mile Point Unit 2 and the James A. FitzPatrick Nuclear Power Plant, respectively. Sampling locations are chosen on the basis of historical average dispersion or deposition parameters from the three units.

The average dispersion and deposition parameters for the three reactors have been calculated for a five (5) year period, 1978 through 1982 (Reference 6.11 C.T. Main Data). Ingestion sample location evaluations are based on calculations performed by C.T. Main as this report contains grazing season X/Q and D/Q calculations for each of the seven release points in use at the JAF/NMP site. Milk animal locations are evaluated using grazing season D/Qs with the grazing season defined as (April to December). The April through December grazing season is used to coincide with the April through December milk sampling period required by Part 1 (REC) Specifications. The deposition factor is evaluated at the census locations for each of seven release points (NMP 1 stack, NMP 2 stack, NMP 2 vent, JAF stack, JAF TB vent, JAF RW vent, and JAF RB vent). An arithmetic average of all release points is calculated and used in the evaluation. If it is determined that a milk sampling location exists at a location that yields a significantly higher (e.g. 50%) calculated D/Q rate, the new milk sampling location will be added to the monitoring program within 30 days. If a new location is added, the old location that yields the lowest calculated D/Q may be dropped from the program after October 31 of that year.

1.2 Interlaboratory Comparison Program

Analyses shall be performed on samples containing known quantities of radioactive material that are supplied as part of a Commission approved or sponsored Interlaboratory Comparison Program. Sample analysis shall be only for those media, (e.g. air, milk, water, etc.), that are included in the Nine Mile Point Environmental Monitoring Program and for which cross check samples are routinely available. The Quality Control sample results shall be reported in the Annual Radiological Environmental Operating Report so that the Commission staff may evaluate the results.

Specific sample media analyzed as part of the JAF Cross Check Program include the following:

- gamma emitters in air particulate filters
- I-131 in milk
- gamma emitters in milk
- gamma emitters in water
- tritium in water
- gamma emitters in soil/sediment
- I-131 in air particulate cartridges

The availability, schedule and subsequent analysis of cross check samples are subject to change as a result of administrative changes within the JAF sampling program and commercial availability of such samples.

1.3 Thermoluminescent Dosimeters Used for Environmental Measurements

Thermoluminescent Dosimeters (TLDs) are placed in an inner ring of stations in the general area of the site boundary, and in an outer ring in the 4 to 5 mile range from the site. There are 16 land based sectors in the inner ring and 8 land based sectors in the outer ring. TLDs are also placed in special interest areas such as population centers, nearby residences, schools, Independent Spent Fuel Storage Installation (ISFSI), and control locations.

1.4 Independent Spent Fuel Storage Installation (ISFSI) Environmental Monitoring Program

The radiological environmental monitoring program implemented at the site pursuant to JAF Technical Specifications Appendix B, contains program elements that satisfy the intent of 10 CFR 72.44(d)(2) and Certificate of Compliance No. 1014 Appendix A, Technical Specifications for the Hi-Storm 100 Cask System, Amendment 0.

TABLE H-1

RADIOLOGICAL ENVIRONMENTAL MONITORING SAMPLING LOCATIONS

TYPE OF SAMPLE	MAP* LOCATION (FIGURE NO.)	COLLECTION SITE	LOCATION⁺
Radioiodine and Particulates (air)	R1 (H-2)	Nine Mile Point Road North	1.8 mi @ 92° E
Radioiodine and Particulates (air)	R2 (H-3)	Co. Rt. 29 & Lake Road	1.1 mi @ 107° ESE
Radioiodine and Particulates (air)	R3 (H-3)	Co. Rt. 29	1.4 mi @ 133° SE
Radioiodine and Particulates (air)	R4 (H-3)	Village of Lycoming, NY	1.8 mi @ 145° SE
Radioiodine and Particulates (air)	R5 (H-2)	Montario Point Road	16.2 mi @ 42° NE
Direct Radiation (TLD)	75 (H-3)	North Fence, NMP-2	0.1 mi @ 354° N
Direct Radiation (TLD)	76 (H-3)	North Fence, NMP-2	0.1 mi @ 25° NNE
Direct Radiation (TLD)	77 (H-3)	North Fence, NMP-2	0.2 mi @ 36° NE
Direct Radiation (TLD)	23 (H-3)	North Shoreline Area (H-ONSITE Station)	0.8 mi @ 73° ENE
Direct Radiation (TLD)	78 (H-3)	East Boundary, JAFNPP	1.0 mi @ 85° E
Direct Radiation (TLD)	79 (H-3)	Co. Rt. 29	1.2 mi @ 120° ESE
Direct Radiation (TLD)	80 (H-3)	Co. Rt. 29	1.5 mi @ 136° SE
Direct Radiation (TLD)	81 (H-3)	Miner Road	1.6 mi @ 159° SSE
Direct Radiation (TLD)	82 (H-3)	Miner Road	1.6 mi @ 180° S
Direct Radiation (TLD)	83 (H-3)	Lakeview Road	1.2 mi @ 203° SSW
Direct Radiation (TLD)	84 (H-2)	Lakeview Road	1.1 mi @ 226° SW

* See Figures H-1, H-2, H-3 and H-4 for map locations

+ Based on 9 Mile Point Unit 2 Reactor Centerline. Distance and direction determined using Global Positioning System (GPS) readings.

TABLE H-1 (Continued)

RADIOLOGICAL ENVIRONMENTAL MONITORING SAMPLING LOCATIONS

TYPE OF SAMPLE	MAP* LOCATION (FIGURE NO.)	COLLECTION SITE	LOCATION⁺
Direct Radiation (TLD)	7 (H-3)	Site Meteorological Tower (G ONSITE Station)	0.7 mi @ 245° WSW
Direct Radiation (TLD)	18 (H-3)	Energy Information Center	0.4 mi @ 268° W
Direct Radiation (TLD)	85 (H-3)	North Fence, NMP-1	0.2 mi @ 292° WNW
Direct Radiation (TLD)	86 (H-3)	North Fence, NMP-1	0.1 mi @ 311° NW
Direct Radiation (TLD)	87 (H-3)	North Fence, NMP-1	0.1 mi @ 333° NNW
Direct Radiation (TLD)	88 (H-2)	Hickory Grove Road	4.5 mi @ 97° E
Direct Radiation (TLD)	89 (H-2)	Leavitt Road	4.3 mi @ 112° ESE
Direct Radiation (TLD)	90 (H-2)	Rt. 104 and Keefe Road	4.2 mi @ 135° SE
Direct Radiation (TLD)	91 (H-2)	Co. Rt. 51A	4.9 mi @ 157° SSE
Direct Radiation (TLD)	92 (H-2)	Maiden Lane Road	4.4 mi @ 183° S
Direct Radiation (TLD)	93 (H-2)	Co. Rt. 53	4.4 mi @ 206° SSW
Direct Radiation (TLD)	94 (H-2)	Co. Rt. 1 and Kocher Road	4.4 mi @ 224° SW
Direct Radiation (TLD)	95 (H-2)	Lake Shore, Alcan West Access Road	3.7 mi @ 239° WSW
Direct Radiation (TLD)	49 (H-2)	Phoenix, NY-Control	19.7 mi @ 168° SSE
Direct Radiation (TLD)	14 (H-2)	SW Oswego-Control	12.5 mi @ 227° SW
Direct Radiation (TLD)	96 (H-2)	Creamery Road	3.6 mi @ 199° SSW
Direct Radiation (TLD)	58 (H-2)	Alcan Aluminum, Rt. 1A	3.0 mi @ 222° SW
Direct Radiation (TLD)	97 (H-2)	Co. Rt. 29	1.8 mi @ 145° SE
Direct Radiation (TLD)	56 (H-2)	New Haven Elem. School	5.2 mi @ 124° SE

* See Figures H-1, H-2, H-3 and H-4 for map locations

+ Based on 9 Mile Point Unit 2 Reactor Centerline. Distance and direction determined using Global Positioning System (GPS) readings.

TABLE H-1 (Continued)

RADIOLOGICAL ENVIRONMENTAL MONITORING SAMPLING LOCATIONS

TYPE OF SAMPLE	MAP* LOCATION (FIGURE NO.)	COLLECTION SITE	LOCATION⁺
Direct Radiation (TLD)	15 (H-2)	West Site Boundary, Bible Camp	0.9 mi @ 240° WSW
Direct Radiation (TLD)	8 (H-2)	Montario Point Road (R5 OFFSITE Station-Control)	16.2 mi @ 42° NE
Surface Water	W8 (H-1)	NRG Steam Station Inlet Canal	7.6 mi @ 237° WSW
Surface Water	W3 (H-1)	JAFNPP Inlet Canal	0.6 mi @ 53° NE
Shoreline Sediment	05 (H-1)	Sunset Bay Shoreline	1.2 mi @ 84° E
Shoreline Sediment	06 (H-1)	Langs Beach-Control	4.8 mi @ 232° SW
Fish	F2 (H-1)	Nine Mile Point Transect	0.4 mi @ 290° WNW
Fish	F3 (H-1)	FitzPatrick Transect	0.8 mi @ 62° ENE
Fish	F0 (H-1)	Oswego Transect	5.9 mi @ 237° SW
Milk	77 (H-1)	Milk Location #77-Control Summerville	16.0 mi @ 190° S
Food Products ** (Broad Leaf Vegetation)	01 (H-1)	Garden - Cary	1.4 mi @ 84° E

* See Figures H-1, H-2, H-3 and H-4 for map locations

** Food product samples need not be samples from each locations listed. Two onsite samples will be collected from the location with the highest calculated average D/Q value from which edible or non-edible broad leaf vegetation is available. One control sample will be collected at a location listed from which edible or non-edible broad leaf vegetation is available.

+ Based on 9 Mile Point Unit 2 Reactor Centerline. Distance and direction determined using Global Positioning System (GPS) readings.

TABLE H-1 (Continued)

RADIOLOGICAL ENVIRONMENTAL MONITORING SAMPLING LOCATIONS

TYPE OF SAMPLE	MAP* LOCATION (FIGURE NO.)	COLLECTION SITE	LOCATION⁺
Food Products ** (Broad Leaf Vegetation)	79 (H-1)	Garden - Nerewski	1.5 mi @ 84° E
Food Products ** (Broad Leaf Vegetation)	48 (H-1)	Garden - Kronenbitter	1.5 mi @ 83° E
Food Products ** (Broad Leaf Vegetation)	133 (H-1)	Garden - Culeton	1.6 mi @ 83° E
Food Products ** (Broad Leaf Vegetation)	77 (H-1)	Garden - Vitullo	1.9 mi @ 101° E
Food Products ** (Broad Leaf Vegetation)	55 (H-1)	Garden - Woolson	1.9 mi @ 132° SE
Food Products ** (Broad Leaf Vegetation)	57 (H-1)	Garden - Parkhurst, G.	1.8 mi @ 126° SE
Food Products ** (Broad Leaf Vegetation)	422 (H-1)	Garden - Parkhurst, C.	2.0 mi @ 112° ESE
Food Products ** (Broad Leaf Vegetation)	132 (H-1)	Garden - Barton	2.0 mi @ 110° ESE
Food Products ** (Broad Leaf Vegetation)	142 (H-1)	Garden - Hall NM #49	1.7 mi @ 143° SE

* See Figures H-1, H-2, H-3 and H-4 for map locations

** Food product samples need not be samples from each locations listed. Two onsite samples will be collected from the location with the highest calculated average D/Q value from which edible or non-edible broad leaf vegetation is available. One control sample will be collected at a location listed from which edible or non-edible broad leaf vegetation is available.

+ Based on 9 Mile Point Unit 2 Reactor Centerline. Distance and direction determined using Global Positioning System (GPS) readings.

TABLE H-1 (Continued)

RADIOLOGICAL ENVIRONMENTAL MONITORING SAMPLING LOCATIONS

TYPE OF SAMPLE	MAP* LOCATION (FIGURE NO.)	COLLECTION SITE	LOCATION⁺
Food Products ** (Broad Leaf Vegetation)	143 (H-1)	Garden - Whaley, P. NM #54 1/2	1.6 mi @ 138° SE
Food Products ** (Broad Leaf Vegetation)	144 (H-1)	Garden - Whaley, C.	1.6 mi @ 139° SE
Food Products ** (Broad Leaf Vegetation)	425 (H-1)	Garden - Barsuch	1.8 mi @ 144° SE
Food Products ** (Broad Leaf Vegetation)	426 (H-1)	Garden - Larroca	1.8 mi @ 145° SE
Food Products ** (Broad Leaf Vegetation)	C2 (H-1)	Control - Flack	15.4 mi @ 222° SW
Food Products ** (Broad Leaf Vegetation)	240 (H-1)	Garden - Walcott	1.9 mi @ 96° E
Food Products ** (Broad Leaf Vegetation)	260 (H-1)	Garden - Battles	1.7 mi @ 98° E
Food Products ** (Broad Leaf Vegetation)	290 (H-1)	Garden - Lee, R.	1.8 mi @ 98° E
Food Products ** (Broad Leaf Vegetation)	274 (H-1)	Garden - Oldenberg	1.4 mi @ 106° ESE
Food Products ** (Broad Leaf Vegetation)	343 (H-1)	Garden - Fredette/Sheldon	1.8 mi @ 88° E
Food Products** (Broad Leaf Vegetation)	484 (H-1)	Garden - O'Connor	1.4 mi @ 132°SE

* See Figures H-1, H-2, H-3 and H-4 for map locations

** Food product samples need not be samples from each locations listed. Two onsite samples will be collected from the location with the highest calculated average D/Q value from which edible or non-edible broad leaf vegetation is available. One control sample will be collected at a location listed from which edible or non-edible broad leaf vegetation is available.

+ Based on 9 Mile Point Unit 2 Reactor Centerline. Distance and direction determined using Global Positioning System (GPS) readings.

TABLE H-1 (Continued)

RADIOLOGICAL ENVIRONMENTAL MONITORING SAMPLING LOCATIONS

TYPE OF SAMPLE	MAP* LOCATION (FIGURE NO.)	COLLECTION SITE	LOCATION
Direct Radiation	I-1 (H-4)	ISFSI ⁺⁺	West Fence, South
Direct Radiation	I-2 (H-4)	ISFSI ⁺⁺	West Fence, Center
Direct Radiation	I-3 (H-4)	ISFSI ⁺⁺	West Fence, North
Direct Radiation	I-4 (H-4)	ISFSI ⁺⁺	North Fence, West
Direct Radiation	I-5 (H-4)	ISFSI ⁺⁺	North Fence, Center
Direct Radiation	I-6 (H-4)	ISFSI ⁺⁺	North Fence, East
Direct Radiation	I-7 (H-4)	ISFSI ⁺⁺	East Fence, North
Direct Radiation	I-8 (H-4)	ISFSI ⁺⁺	East Fence, Center
Direct Radiation	I-9 (H-4)	ISFSI ⁺⁺	East Fence, South
Direct Radiation	I-10 (H-4)	ISFSI ⁺⁺	South Fence, East
Direct Radiation	I-11 (H-4)	ISFSI ⁺⁺	South Fence, Center
Direct Radiation	I-12 (H-4)	ISFSI ⁺⁺	South Fence, West

* See Figures H-1, H-2, H-3 and H-4 for map locations

++ Independent Spent Fuel Storage Installation

DEPARTMENT OF PUBLIC WORKS
 MAP OF
OSWEGO COUNTY
 New York

SCALE OF MILES

FIGURE H-1 ODCM
 OFF-SITE ENVIRONMENTAL
 SAMPLING LOCATIONS

KEY:

- FISH
- FOOD PRODUCT
- SHORELINE SEDIMENT
- SURFACE WATER
- MLK

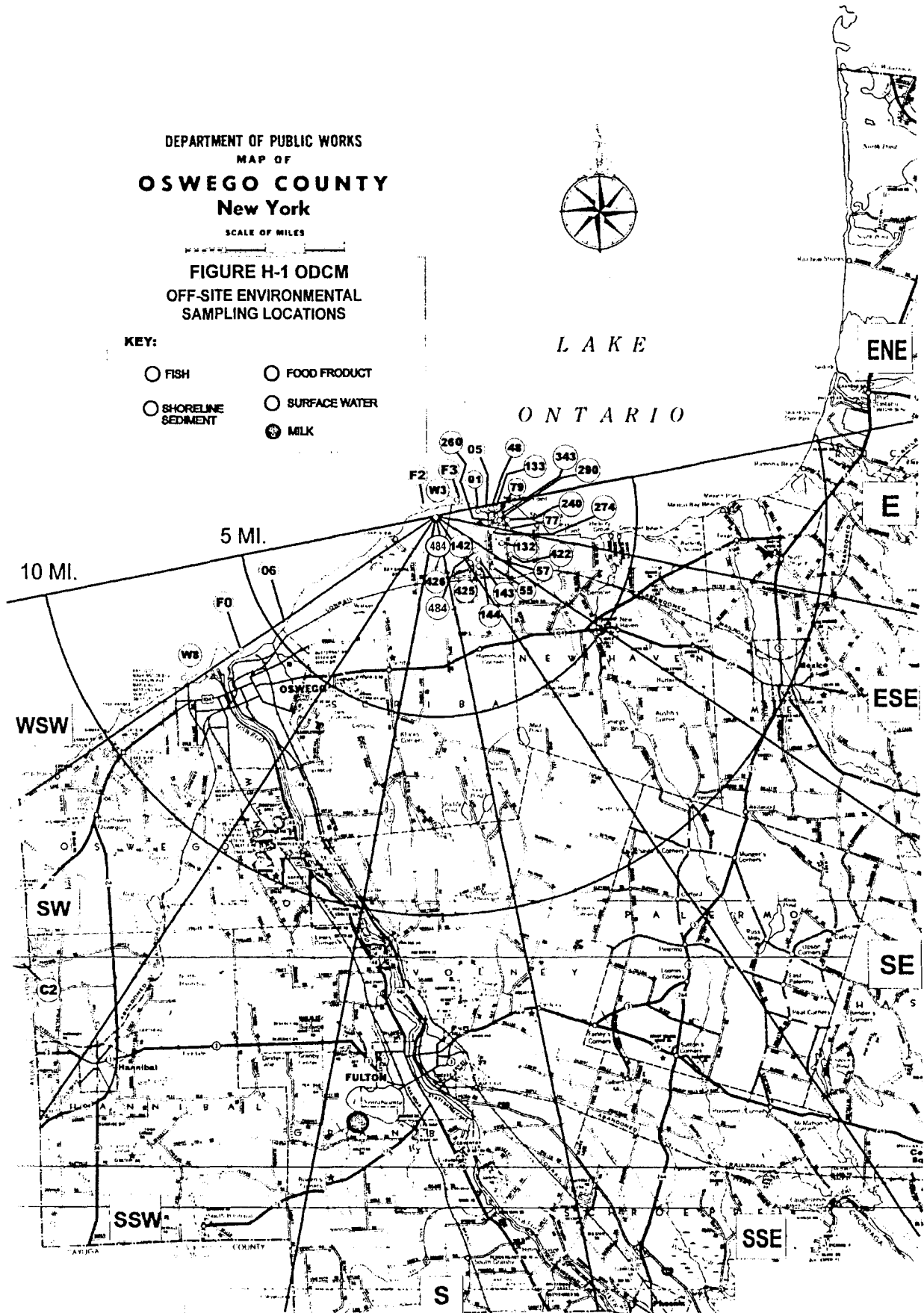
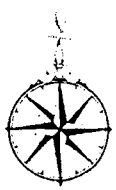

FIGURE H-2
OFF-SITE ENVIRONMENTAL STATION
AND TLD LOCATIONS

KEY

- ENVIRONMENTAL STATION
- TLD LOCATION



Oswego County
 New York

LAKE
 ONTARIO

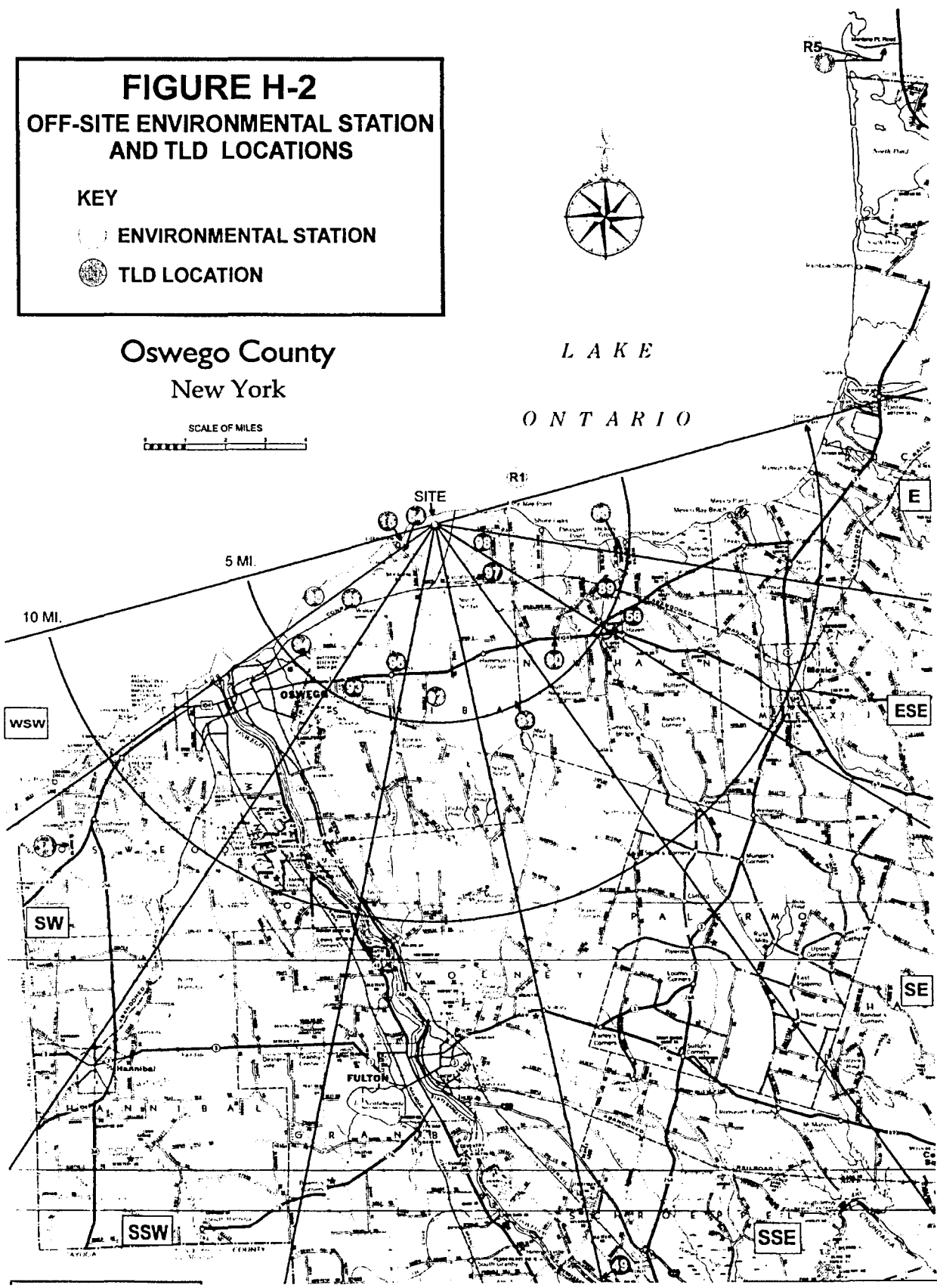
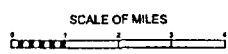

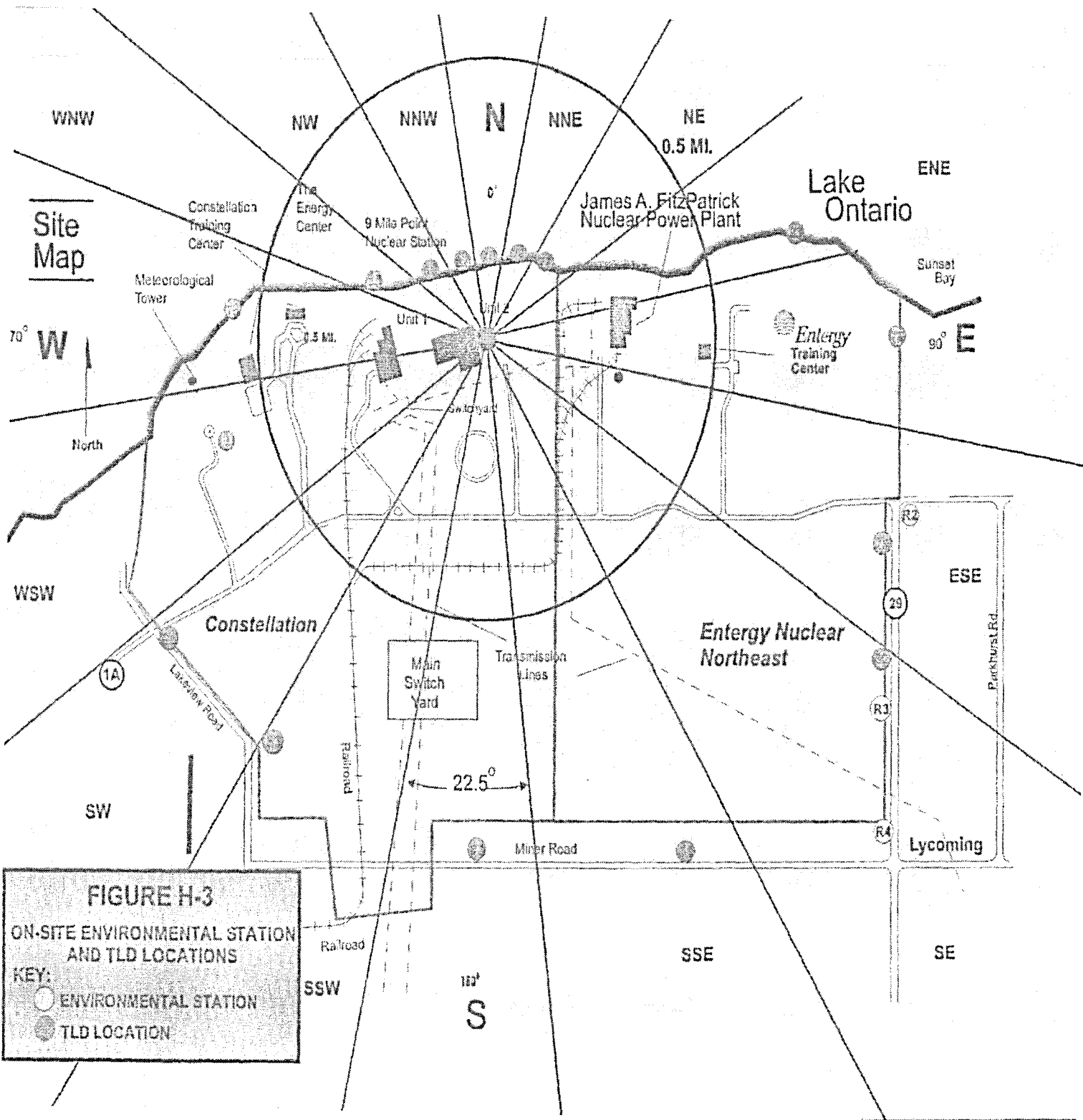
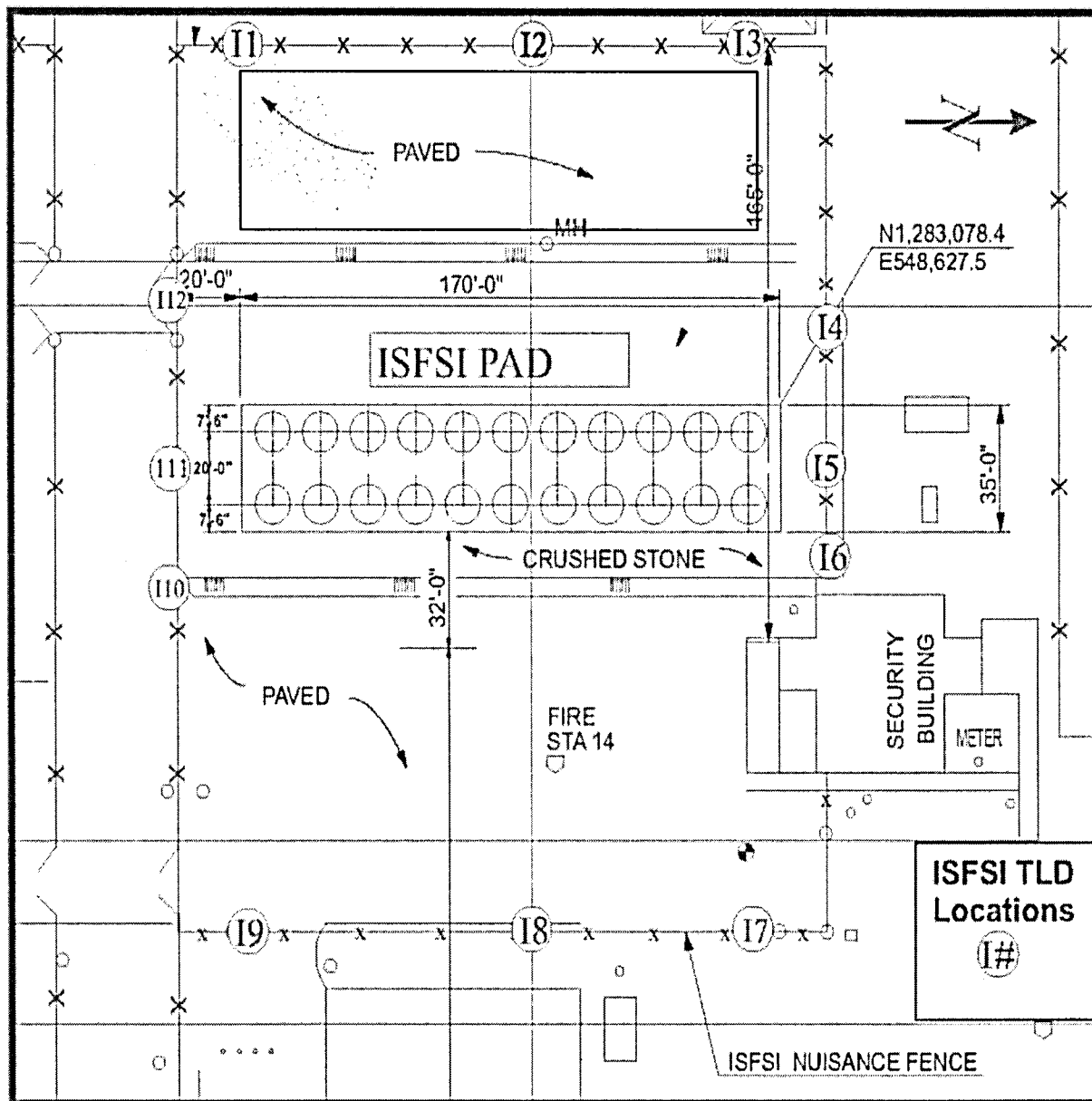

FIGURE H-4

JAMES A. FITZPATRICK NUCLEAR POWER PLANT
OFFSITE DOSE CALCULATION MANUAL (ODCM)
ON-SITE ENVIRONMENTAL ISFSI TLD LOCATIONS



**TABLE H-2
LIQUID EFFLUENT PATHWAY - WATER INTAKE POINTS
DESCRIPTION AND PUMPAGE**

<u>Location of Water Intake*</u>	<u>Average Water Pumpage</u> Millions of Gallons Per Day
1. At a point between Dennison Creek and Bear Creek at a site north of the intersection of lake and Knickerbocker Roads	0.80
2. At Pultneyville	1.0
3. At a point north of the village of Sodus near the intersection of Shore Road and an extension of Maple Avenue	1.0
4. In Sodus Point Village on Lake Road	0.133
5. At east of Port Bay	0.095
6. In the western part of the City of Oswego between Sixth and Sheldon Avenues and north of West Schuyler Street	20.0
7. At east of the Village of Sackets Harbor	0.30
8. In Sawmill Bay at a location on Independence Point approximately 0.5 miles south of Chaumont Village's southerly limit	0.04
9. Cape Vincent	0.246
10. Township of Pittsburg (Milton)	0.015
11. Township of Pittsburg (Glen Lawrence)	0.015
12. City of Kingston (2 intakes)	9.72
13. Township of Kingston (Pt. Pleasant)	0.705
14. Township of Kingston (Queen's Acres)	0.037
15. Township of Ernestown (Amherstview)	0.270
16. Village of Bath	0.150
17. Town of Picton	0.679

* See Figure H-5 for Map Locations

FIGURE H-5

JAMES A. FITZPATRICK NUCLEAR POWER PLANT

OFFSITE DOSE CALCULATION MANUAL (ODCM)

LIQUID EFFLUENT PATHWAY - WATER INTAKE POINTS

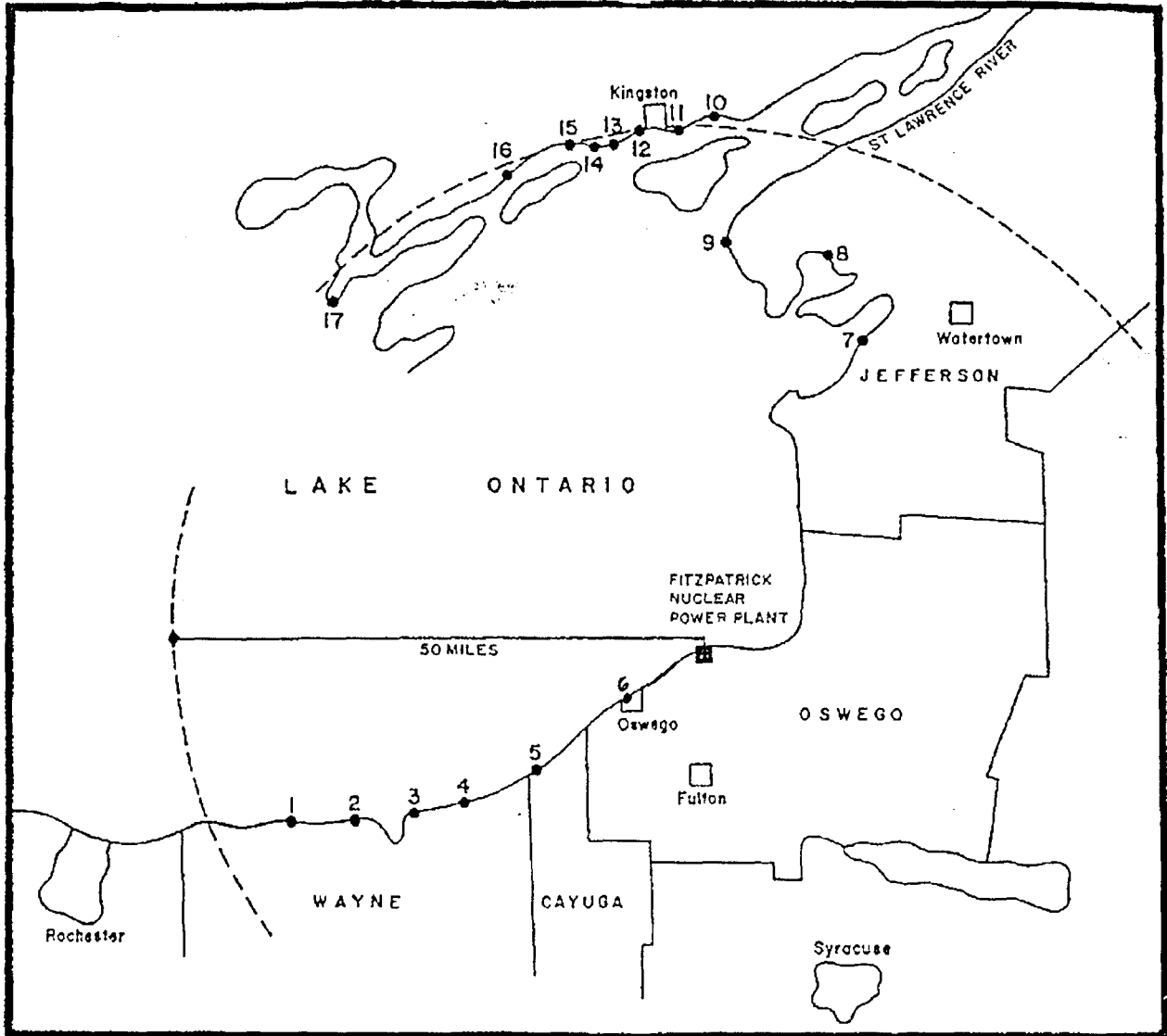

APPENDIX I
ODCM SUMMARY TABLES

APPENDIX I
ODCM SUMMARY TABLES

<u>TABLE</u>	<u>TITLE</u>	<u>PAGE</u>
I-1	Radioactive Effluent Release Limits Summary Table	I-3
I-2	ODCM Summary	I-4

TABLE I-1

RADIOACTIVE EFFLUENT RELEASE LIMITS - SUMMARY TABLE

DOSE/DOSE COMMITMENT	PATH/ SOURCE	MONTHLY PERIOD (1)			CALENDAR QUARTER			CALENDAR YEAR		
		WHOLE BODY (MREM)	SKIN (MRAD)	ANY ORGAN (MREM)	WHOLE BODY (MREM)	SKIN (MRAD)	ANY ORGAN (MREM)	WHOLE BODY (MREM)	SKIN (MRAD)	ANY ORGAN (MREM)
Member of the Public	Plant Liquid (2) Effluents	0.06	None	0.2	1.5	None	5	3	None	10
Member of the Public	Plant Gaseous (2) Effluents	None	None	None	5*	10*	7.5	10*	20*	15
At or Beyond Site Boundary	Plant Gaseous (3) Effluents	None	None	None	None	None	None	500	3000	1500
Member of the Public	Uranium (4) Fuel Cycle (Site)	None	None	None	None	None	None	25	None	25 (5)

(1) Equipment operability requirements for projected exposures. Refer to Specifications 2.4 (Liquid) and 3.6 (Gaseous).

(2) Plant Liquid and Gaseous release limitations in accordance with Appendix I to 10 CFR 50. Refer to Part 1, Specifications 2.3 (Liquids), 3.3 (Noble Gases) and 3.4 (Iodines and Particulates).

(3) Plant Gaseous release limitations in accordance with dose limits of 10 CFR 20.1001-20.2402. Refer to dose limits of Part 1, Specification 3.2.

(4) Site Gaseous release limitations in accordance with 40 CFR 190. Refer to Specification 5.0.

(5) Limits to any organ except the thyroid which shall be limited to 75 mrem.

* mrad, air dose.

TABLE I-2
ODCM SUMMARY

EFFLUENT PATHWAY	PURPOSE OF CALCULATION	FREQUENCY OF CALCULATION	REGULATORY REQUIREMENT	Part 1 (REC) REQUIREMENT	CORRESPONDING LIMITING VALUES	Part 2 (ODCM) SECTION	ODCM EQUATION NUMBER	INPUT DATA REQUIREMENTS	REPORTING REQUIREMENTS	MISCELLANEOUS
Liquid	Fraction of ECLs, F_L	Each batch release	10 times 10CFR20 Appendix B, Table 2, Column 2	Section 2.2	ECLs or for noble gases $2 \times 10^{-4} \mu\text{Ci/ml}$	Section 3.2.2	3-1	. Discharge structure exit flow . Waste tank release rate . Sample concentrations	Release Permit	
Liquid	Minimum required dilution factor f_2/f_1 min.	Each batch release	10 times 10CFR20 Appendix B, Table 2, Column 2	Section 2.2	ECLs or for dissolved noble gases $2 \times 10^{-4} \mu\text{Ci/ml}$	Section 3.2.3	3-2	. Sample concentrations	Release Permit	
Liquid	Determination of effluent monitor set-points	Each batch release	10 times 10CFR20 Appendix B, Table 2, Column 2	Section 2.1.2.c.1	FL less than or equal to 1 when calculating minimum dilution flow	Section 3.3.2	3-3	. FL . Sample concentrations	Input to operations	
Liquid	Annual Dose Assessment	Calendar year	USNRC Regulatory Guide 1.21	Section 6.0	N/A	Section 3.4.1	3.4a 3-4b	. Site specific dose commitment factors . Previous year's release volumes and curies . Site specific dilution & ingestion	Annual Radiological Effluent Report	
Liquid	Monthly Dose Assessment	Calendar month	10CFR50 Appendix I	Section 2.3	Whole Body dose - 1.5 mrem/qtr, 3 mrem/yr Organ dose - 5 mrem/qtr, 10 mrem/yr	Section 3.4.2	3-5a 3-5b	. Composite dose . Duration of release . Curies released . Volume of dilution	N/A	May use limited analysis approach of ODCM Section 3.4.2

TABLE I-2 (Continued)

ODCM SUMMARY

EFFLUENT PATHWAY	PURPOSE OF CALCULATION	FREQUENCY OF CALCULATION	REGULATORY REQUIREMENT	Part 1 (REC) REQUIREMENT	CORRESPONDING LIMITING VALUES	Part 1 (ODCM) SECTION	ODCM EQUATION NUMBER	INPUT DATA REQUIREMENTS	REPORTING REQUIREMENTS	MISCELLANEOUS
Liquid	Dose projection determination of need to operate liquid radwaste systems	Prior to release of unrestricted liquid effluents	N/A	Section 2.4	Whole body dose - 0.06 mrem/month Organ dose - .2 mrem/month	Section 3.5	N/A	. Number of batch releases, previous month . Projected number of releases current month	If non-compliance, 30-day NRC report	
Gaseous	Determining instantaneous noble gas release rates	Calendar week	10CFR20.105	Section 3.2.1.c.1.a	Whole body dose - 500 mrem/yr Skin dose - 3000 mrem/yr	Section 4.3.1	4-1 to 4-6	. Highest annual average X/Q for vent and elevated releases . Total body, skin, and air dose factors . Noble gas release rate ($\mu\text{Ci}/\text{sec}$) . Effective dose transfer factor for vent releases, fraction of release rate limit	N/A	May use a limited analysis approach of ODCM Section 4.3.1 to determine noble gas release rate limits

TABLE I-2 (Continued)

ODCM SUMMARY

EFFLUENT PATHWAY	PURPOSE OF CALCULATION	FREQUENCY OF CALCULATION	REGULATORY REQUIREMENT	Part 1 (REC) REQUIREMENT	CORRESPONDING LIMITING VALUES	Part 2 (ODCM) SECTION	ODCM EQUATION NUMBER	INPUT DATA REQUIREMENTS	REPORTING REQUIREMENTS	MISCELLANEOUS
Gaseous	Determination of effluent monitor set-points	Calendar month or upon major operational transients (i.e., power level changes and failed fuel)	10CFR20.105	Section 3.1 and 3.2.1.c.1.a	Elevated Release - 3.0×10^5 $\mu\text{Ci}/\text{sec}$ Vent release - 7.515×10^4 $\mu\text{Ci}/\text{sec}$	Section 4.3.2	N/A	. Maximum Volume release source . Calibration curve ($\mu\text{Ci}/\text{cc}$ vs CPM) for specified effluent monitor For ground level releases, fraction of release rate limit allocated to specified release point	Input to Operations	
Gaseous	Determining radioiodine, Tritium and 8 day particulate instantaneous release rates	Calendar week	10CFR20.105	Section 3.2.1.c.1.b	1500 mrem/yr. any organ	Section 4.3.3	4-9 4-10	. Long-term sector average concentration X/Q (Appendix C) . Long-term relative deposition value (Appendix C) . Dose factors for applicable environmental pathways (Table B-4 through B-6) Iodine, Tritium and 8-day particulate release rate ($\mu\text{Ci}/\text{sec}$)	N/A	

TABLE I-2 (Continued)

ODCM SUMMARY

EFFLUENT PATHWAY	PURPOSE OF CALCULATION	FREQUENCY OF CALCULATION	REGULATORY REQUIREMENT	Part 1 (REC) REQUIREMENT	CORRESPONDING LIMITING VALUES	Part 2 (ODCM) SECTION	ODCM EQUATION NUMBER	INPUT DATA REQUIREMENTS	REPORTING REQUIREMENTS	MISCELLANEOUS
Gaseous	Annual Dose Assessment	Calendar Year	USNRC Regulatory Guide 1.21	Section 6.1	N/A	Section 4.4.1	4-11 to 4-19	. Previous year's annual average D/Q and X/Q . Activity released ($\mu\text{Ci}/\text{yr}$) for the previous year from vent and elevated releases	Annual Radioactive Effluent Report	
Gaseous	Monthly Dose Assessment - Gamma air Dose - Beta air Dose	Calendar Month	10CFR50, Appendix I	Section 3.3.2.c.1	Gamma air Dose - 5 mrad/qtr 10 mrad/yr Beta air Dose - 10 mrad/qtr 20 mrad/yr	Section 4.4.2	4-20 4-23	. Gamma Air Dose factors, M . Beta Air Dose factor, N . Highest annual average X/Q for vent and elevated releases . Noble Gas curies released during the month		
Gaseous	Monthly Dose - radioiodine tritium and 8-day particulate	Calendar Month	10CFR50, Appendix I	Section 3.4.2.c.1	Any Organ - 7.5 mrem/qtr 15 mrem/yr	Section 4.4.2	4-24 to 4-27		N/A	May use limited analysis approach of ODCM Section 4.4.2.c

TABLE I-2 (Continued)

ODCM SUMMARY

EFFLUENT PATHWAY	PURPOSE OF CALCULATION	FREQUENCY OF CALCULATION	REGULATORY REQUIREMENT	Part 1 (REC) REQUIREMENT	CORRESPONDING LIMITING VALUES	Part 2 (ODCM) SECTION	ODCM EQUATION NUMBER	INPUT DATA REQUIREMENTS	REPORTING REQUIREMENTS	MISCELLANEOUS
Gaseous	Dose Projection Determination of need to operate off gas treatment system	Prior to release of unprocessed gaseous effluents	N/A	Section 3.5	0.2 mrad gamma 0.4 mrad beta 0.3 mrem organ	Section 4.5	4-20 4-31	. Gamma and Beta air dose and particulate, iodine, and tritium organ dose during the quarter to date . Number of days the plant is projected to be operational during the coming month	If non-compliance, 30 day NRC report	May use a limited analysis approach of ODCM Section 4.5.2
Liquid	Demonstrate compliance with annual fuel/cycle dose commitment limits	Calendar year if liquid releases exceed 3 mrem, total body, or 10 mrem, any organ	40CFR190	Section 4.1.1.c.1 (except thyroid) - 25 mrem/yr thyroid - 75 mrem/yr	Whole Body or any organ	Section 5.2	3-4	. Actual dilution ingestion factors (fish and potable water) . Radiological Environmental Monitoring Program Results		

TABLE I-2 (Continued)

ODCM SUMMARY

EFFLUENT PATHWAY	PURPOSE OF CALCULATION	FREQUENCY OF CALCULATION	REGULATORY REQUIREMENT	Part 1 (REC) REQUIREMENT	CORRESPONDING LIMITING VALUES	Part 2 (ODCM) SECTION	ODCM EQUATION NUMBER	INPUT DATA REQUIREMENTS	REPORTING REQUIREMENTS	MISCELLANEOUS
Gaseous	Demonstrate compliance with annual fuel cycle dose commitment limits	Calendar year, if gaseous releases exceed 10 mrad gamma air dose, 15 mrem thyroid or any organ	40CFR190	Section 4.1.1.c.1 (except thyroid) - 25 mrem/yr. thyroid - 75 mrem/yr.	Whole Body or any organ	Section 5.3	Equation Section 4-4	Current data, including: actual location of real individuals, meteorological conditions, and consumption of food (e.g. milk, meat, and vegetation)	30 day NRC Report	Substitute the total body dose factor (Ki) for the gamma air dose factor (Mi)
Direct Radiation	Demonstrate compliance with annual fuel/cycle dose commitment limits	Calendar year, if liquids or gases exceed dose limits indicated above	40CFR190	Section 4.1.1.c.1	Whole Body - 25 mrem/yr.	Section 5.4	N/A	. Shielding calculations . TLD results from environmental program		

JAFP-17-0037

Enclosure 3

Offsite Dose Calculation Manual Rev. 13 Part 1

ENTERGY NUCLEAR OPERATIONS, INC.
JAMES A. FITZPATRICK NUCLEAR POWER PLANT
DOCUMENTS AND VENDOR PROCEDURES

OFFSITE DOSE CALCULATION MANUAL
DVP-01.02
REV. 13

EFFECTIVE DATE: 5-9-16

*****	*****
* REFERENCE *	* QUALITY RELATED *
*****	*****
* TECHNICAL *	* OSRC *
*****	*****

REVISION SUMMARY SHEET

REV

CHANGE AND REASON FOR CHANGE

13

1. Part 1 Updated the Revision History of the
Page 2 ODCM. This is an editorial change.
Section 1.2

2. Part 1 Added time lines and guidance for
Page 39 actions to address loss of both SJAE
Section 3.6.1 radiation monitors. This increases the
accuracy of the ODCM.

3. Part 1 Added the guidance of sampling or
Page 40 temporary radiation monitor installation
Section 3.6.3 prior to entering TS 3.7.5 into the
Bases. This change increases the
accuracy of the ODCM.

PART I – RADIOLOGICAL EFFLUENT CONTROLS (REC)

TABLE OF CONTENTS

1.0 INTRODUCTION 2

2.0 LIQUID EFFLUENTS..... 7

2.2 CONCENTRATION OF LIQUID EFFLUENTS 11

3.0 GASEOUS EFFLUENTS 20

4.0 TOTAL DOSE..... 42

5.0 RADIOLOGICAL ENVIRONMENTAL MONITORING 47

**7.0 MAJOR MODIFICATIONS TO RADIOACTIVE LIQUID, GASEOUS, AND SOLID WASTE
TREATMENT SYSTEMS* 63**

8.0 PURGING OF THE PRIMARY CONTAINMENT..... 64

1.0 INTRODUCTION

1.1 Purpose

This Radioactive Effluent Controls Program (REC) was added to the Offsite Dose Calculation Manual (ODCM) in response to NRC Generic Letter 89-01. The program intent is to conform with 10 CFR 50.36a for the control of radioactive effluents and for maintaining the doses to members of the public "as low as is reasonably achievable." Generic Letter 89-01 described the NRC's determination that the Radiological Effluent Technical Specifications (RETS) should be simplified to improve Technical Specifications (TS) by implementing programmatic controls into the TS and procedural details into the ODCM.

1.2 Document Revision Overview

This is Revision 13 of the ODCM under the procedure designation of DVP-01.02. There were 9 revisions under the previous procedure designation of CDP-15. This revision constitutes the 22nd revision of the ODCM since its inception as Rev. 0 of CDP-15.

1.3 Definitions

A. Channel Calibration

See Technical Specifications.

B. Channel Check

See Technical Specifications.

C. Channel Functional Test

See Technical Specifications.

D. Dose Equivalent I-131

Dose Equivalent I-131 shall be that concentration of I-131 (microcurie/gram) that alone would produce the same thyroid dose as the quantity and isotopic mixture of I-131, I-132, I-133, I-134 and I-135 actually present. The thyroid dose conversion factors used for this calculation shall be those listed in International Commission on Radiological Protection Publication 30 (ICRP-30), "Limits for Intake by Workers", or in NRC Regulatory Guide 1.109, Revision 1, October 1977.

E. Independent Spent Fuel Storage Installation (ISFSI) Controlled Area

The JAFNPP ISFSI is defined to be the same area as the JAFNPP Exclusion Area, which is the combined JAFNPP and Nine Mile Point Nuclear Station (NMPNS) reactor site area. The boundary of the JAFNPP exclusion area traces the perimeter of the combined JAFNPP - NMPNS reactor sites. (See Figure 4.1-1, Site Boundary Map).

F. Logic System Functional Test

See Technical Specifications.

G. Member(s) of the Public

Member(s) of the Public includes all persons who are not occupationally associated with the facilities on the Entergy/Exelon Nuclear site. This category does not include employees of the utilities, its contractors or vendors. Also excluded from this category are persons who enter the site to service equipment or to make deliveries. This category does include persons who use portions of the site for recreational, occupational, or other purposes not associated with the plants.

H. Mode

See Technical Specifications.

I. Offgas Treatment System

The Offgas Treatment System is the system designed and installed to: reduce radioactive gaseous effluents by collecting primary coolant system offgases from the main condenser; and, providing for delay of the offgas for the purpose of reducing the total radioactivity prior to release to the environment.

J. Offsite Dose Calculation Manual

The ODCM describes the methodology and parameters to be used in the calculation of the offsite doses resulting from radioactive gaseous and liquid effluents, in the calculation of gaseous and liquid effluents monitoring alarm and trip setpoints, and in the conduct of the radiological environmental monitoring program.

The ODCM shall also contain the radioactive effluent controls and radiological environmental monitoring activities and descriptions of the information that should be included in the Annual Radiological Environment Operating and Radioactive Effluent Release reports required by Technical Specifications 5.6.2 and 5.6.3.

K. Operable - Operability

See Technical Specifications.

L. Process Control Program (PCP)

The PCP is a document which identifies the current formulas, sampling methods, analyses, tests, and determinations used to control the processing and packaging of solid radioactive wastes. The PCP controls these activities in such a way as to assure compliance with 10 CFR 20, 10 CFR 61, 10 CFR 71, and other applicable regulatory requirements governing the disposal of the radioactive waste.

M. Rated Thermal Power

See Rated Thermal Power, Technical Specifications.

N. Site Boundary

The Site Boundary is that line beyond which the land is not owned, leased, or otherwise controlled by Entergy and Exelon Nuclear. Refer to Figure 4.1-1 for the map of the Site Boundary with regard to liquid and gaseous releases.

O. Solidification

Solidification is the conversion of wet wastes into a form that meets shipping and burial ground requirements.

P. Source Check

A Source Check is the qualitative assessment of channel response when the channel sensor is exposed to a source of increased radioactivity.

Q. Surveillance Frequency Notations/Intervals

The Surveillance Frequency Notations/Intervals used in these specifications are defined as follows:

Notifications	Intervals	Frequency
D	Daily	At least once per 24 hours
W	Weekly	At least once per 7 days
M	Monthly	At least once per 31 days
Q	Quarterly	At least once per 92 days (3 months)
SA	Semiannually	At least once per 184 days
A	Annually or Yearly	At least once per 366 days
18M	18 Months	At least once per 18 months (550 days)
R	Operating Cycle	At least once per 24 months(731 days)

R. Treatment

Any process which effectively reduces the amount of radioactive material released to the environment. This includes such processes as filtration, evaporation/ condensation, settling/decanting, and solidification.

S. Unrestricted Area

An Unrestricted Area shall be any area at or beyond the Site Boundary where access is neither limited nor controlled by Entergy for purposes of protecting individuals against undue risk from exposure to radiation and radioactive materials, or any area within the Site Boundary used for residential quarters or for industrial, commercial, institutional, and/or recreational purposes

The definition of Unrestricted Area used in implementing the radiological effluent and radiological environmental monitoring controls has been expanded over that in 10 CFR 20.1003. The Unrestricted Area boundary may coincide with the exclusion (fenced) area boundary, as defined in 10 CFR 100.3(a), but the Unrestricted Area does not include areas over water bodies. The concept of Unrestricted Areas, established at or beyond the Site Boundary, is utilized in the Limiting Conditions for Operation to keep levels of radioactive materials in liquid and gaseous effluents as low as is reasonably achievable, pursuant to 10 CFR 50.36a.

1.4 Rules for Limiting Condition for Operation and Surveillance Requirements

The provisions of Technical Specifications LCO 3.0.5 are applicable to Part 1, Radioactive Effluent Controls Program, Limiting Conditions for Operation.

The provisions of Technical Specification SR 3.0.2 and SR 3.0.3 are applicable to the Part 1, Radioactive Effluent Controls Program Surveillance Frequency.

2.0 LIQUID EFFLUENTS

2.1 Liquid Effluent Monitors

2.1.1 Limiting Conditions For Operation

a. Applicability

Applies to the instrumentation required for monitoring radioactive liquid effluent discharges to the environment as specified in Table 2.1-1.

b. Objective

To ensure that radioactive liquid effluent discharges are properly monitored and recorded during release.

c. Specifications

1. The limiting conditions for operation of the instruments that monitor radioactive liquid effluents are given in Table 2.1-1. With a radioactive liquid effluent monitoring instrumentation channel alarm/trip set point less conservative than required by the ODCM (Part 2, Section 3.3), without delay suspend the release of radioactive liquid effluents monitored by the affected channel, or declare the channel inoperable, or change the set point so it is acceptably conservative.
2. With less than the minimum number of radioactive liquid effluent monitoring instrumentation channels operable, take the action shown in Table 2.1-1. Take corrective actions to return the instruments to operable status within 30 days and, if unsuccessful, explain in the next Radioactive Effluent Release Report why the inoperability was not corrected in a timely manner.

2.1.2 Surveillance Requirements

a. Applicability

Applies to the instrumentation for monitoring radioactive liquid effluent discharges.

b. Objective

To ensure that instrumentation required for radioactive liquid effluent discharges are maintained and calibrated.

c. Specifications

1. The alarm/trip set points of these channels shall be determined and adjusted in accordance with the methodology and parameters in the ODCM (Part 2, Section 3.3).
2. The surveillance requirements for the radioactive liquid effluent monitoring instrumentation is shown on Table 2.1-2.

2.1.3 Bases

The radioactive liquid effluent instrumentation is provided to monitor and control the releases of radioactive materials in liquid effluents during planned or unplanned releases. The alarm/trip set points for these instruments shall be calculated in accordance with methods in the ODCM (Part 2, Section 3.3) to ensure that the alarm/trip will occur prior to exceeding Part 1, Section 2.2.1.c.1 limits. The operability and use of this instrumentation is consistent with the requirements of 10 CFR 50, Appendix A, General Design Criteria 60, 63, and 64.

TABLE 2.1-1

RADIOACTIVE LIQUID EFFLUENT MONITORING INSTRUMENTATION

Instrument	Minimum Channels Operable	Action
Gross radioactivity monitors providing alarm and automatic termination of release Liquid radwaste effluent line	1	(a)
Gross beta or gamma radioactivity monitors providing alarm but not providing automatic termination of release Service water system effluent line	1	(b)
Flow rate measurement devices Liquid radwaste effluent line	1	(c)

NOTES FOR TABLE 2.1-1

- (a) With the number of operable channels less than the required minimum number, effluent releases may continue provided that prior to initiating a release:
 1. Two independent samples are analyzed;
 2. Two technically qualified members of the facility staff verify the discharge line valving;

Otherwise, suspend release of radioactive effluents via this pathway.

- (b) With the number of operable channels less than the required minimum number, effluent releases in this pathway may continue provided that, at least once per 12 hours, grab samples are collected and analyzed for principal gamma emitters at a limit of detection of at least 5×10^{-7} microcuries/ml. The principal gamma emitters for which the LLD specification applies exclusively are described in Note (c) to Table 2.2-1.
- (c) With the number of operable channels less than the required minimum number, effluent releases via this pathway may continue provided the flow rate is estimated at least once per four hours during actual releases. Pump curves or tank level decreases generated in situ may be used to estimate flow.

TABLE 2.1-2

MINIMUM TEST AND CALIBRATION FREQUENCY
FOR RADIATION MONITORING SYSTEMS^(a)

Instrument Channels	Channel Check(b)	Channel Functional Test(g)	Channel Calibration (g)	Logic System Functional Test (f)
Liquid Radwaste Discharge Monitor/ Isolation (c)(d)(e)(f)	Daily When Discharging	---	Quarterly	Once per 24 months
Liquid Radwaste Discharge Radioactivity Recorder(d)	Daily	Quarterly	Once per 18 months	---
Liquid Radwaste Discharge Flow Rate Measuring Devices(d)	Daily	Quarterly	Once per 18 months	---
Normal Service Water Effluent	Daily	---	Quarterly	---

NOTES FOR TABLE 2.1-2

- (a) Functional tests, calibrations and Channel Checks need not be performed when these instruments are not required to be operable or are tripped.
- (b) Channel Checks shall be performed at least once per day during these periods when the instruments are required to be operable.
- (c) A Source Check shall be performed prior to each release.
- (d) Liquid radwaste effluent line instrumentation surveillance requirements need not be performed when the instruments are not required as the result of the discharge path not being utilized.
- (e) An instrument Channel Calibration shall be performed with known radioactive sources standardized on plant equipment which has been calibrated with NIST traceable standards.
- (f) Simulated automatic actuation shall be performed once per 24 months. Simulated automatic action means applying a simulated signal to the sensor to actuate the circuit.
- (g) A successful test of the required contact(s) of a channel relay may be performed by the verification of the change of state of a single contact of the relay. This clarifies what is an acceptable Channel Functional Test of a relay. This is acceptable because all of the other required contacts of the relay are verified by other Technical Specifications and non-Technical Specification tests at least once per refueling interval with the applicable extension.

2.2 Concentration of Liquid Effluents

2.2.1 Limiting Conditions For Operation

a. Applicability

Applies to the concentration of radioactive materials in liquid effluents.

b. Objective

To ensure that the concentrations of radioactive materials in liquid effluents are kept to acceptable levels.

c. Specifications

1. The concentration of radioactive materials released from the plant to the Unrestricted Areas shall be limited to ten times the concentration values specified in 10 CFR 20, Appendix B, Table 2, Column 2 for radionuclides other than dissolved or entrained noble gases. For dissolved or entrained noble gases, the concentration shall be limited to $2 \times 10^{-4} \mu\text{Ci/ml}$ total activity.
2. With the concentration of radioactive material released from the plant to Unrestricted Areas exceeding the above limits, restore the concentration to within the above limits or terminate the release.

2.2.2 Surveillance Requirements

a. Applicability

Applies to the analysis of radioactive liquid wastes from the plant through a liquid pathway to an Unrestricted Area.

b. Objective

To ensure that analyses are performed and concentration determined for radioactive liquid releases.

c. Specifications

1. Radioactive liquid wastes shall be sampled and analyzed according to the sampling and analyses program of Table 2.2-1.

2. The results of the radioactivity analyses shall be used in accordance with the methods in the ODCM (Part 2, Section 3.2) to ensure that the concentrations at the point of release are maintained within the limits of Section 2.2.1.

2.2.3 Bases

This specification is provided to ensure that the concentration of radioactive materials released in liquid waste effluents from the site to Unrestricted Areas will be less than ten times the concentration values specified in 10 CFR 20, Appendix B, Table 2, Column 2 for radionuclides other than dissolved or entrained noble gases. This limitation provides additional assurance that the levels of radioactive materials in bodies of water outside the site will not result in exposure above (1) the design objectives of 10 CFR 50, Appendix I, Section II.A, to a Member(s) of the Public and (2) the limits of 10 CFR 20.1301 to the population. The concentration limit for dissolved or entrained noble gases is based on Xe-135 as the controlling radioisotope and its MPC in air (submersion) was converted to an equivalent concentration in water using methods described in ICRP Publication 2.

TABLE 2.2-1

RADIOACTIVE LIQUID WASTE SAMPLING AND ANALYSIS PROGRAM

Liquid Release Type	Sampling Frequency	Minimum Analysis Frequency	Type of Activity Analysis	Lower Limit of Detection (LLD) ^(a) (μCi/ml)
Batch Waste Release Tanks ^(b)	Prior to each batch	Each batch	Principal gamma emitters ^(c)	5×10^{-7}
			I-131	1×10^{-6}
	One batch per month	Monthly	Dissolved and entrained gases (gamma emitters)	1×10^{-5}
	Prior to each batch	Quarterly composite ^(d)	H-3	1×10^{-5}
			Gross alpha	1×10^{-7}
	Prior to each batch	Quarterly composite ^(d)	Sr-89, Sr-90	5×10^{-8}
			Fe-55	1×10^{-5}
	Continuous Releases ^(e)	Continuous ^(f)	Weekly composite ^(f)	Principle Gamma Emitters ^(c)
I-131				1×10^{-6}
Monthly grab sample		Monthly	Dissolved and entrained gases (gamma emitters)	1×10^{-5}
Continuous ^(f)		Monthly composite ^(f)	H-3	1×10^{-5}
			Gross alpha	1×10^{-7}
Continuous ^(f)		Quarterly composite ^(f)	Sr-89, Sr-90	5×10^{-8}
			Fe-55	1×10^{-5}

See notes next page

NOTES FOR TABLE 2.2-1

- (a) The LLD (Lower Limit of Detection) is defined, for the purpose of these specifications, as the smallest concentration of radioactive material in a sample that will yield a net count (above system background) that will be detected with 95% probability and with only 5% probability of falsely concluding that a blank observation represents a "real" signal.

For a particular measurement system (which may include radiochemical separation):

$$LLD = \frac{4.66 s_b}{E \cdot V \cdot 2.22 \times 10^6 \cdot Y \cdot \exp(-\lambda \Delta t)}$$

Where:

LLD is the a priori lower limit of detection, as defined above (in microCuries per unit mass or volume);

s_b is the standard deviation of the background counting rate or of the counting rate of a blank sample, as appropriate (in counts per minute);

E is the counting efficiency (in counts per disintegration);

V is the sample size (in units of mass or volume);

2.22×10^6 is the number of disintegrations per minute per microCurie;

Y is the fractional radiochemical yield (when applicable);

λ is the radioactive decay constant for the particular radionuclide; and

Δt for plant effluents is the elapsed time between the midpoint of sample collection and time of counting.

Typical values of E, V, Y, and Δt should be used in the calculations.

It should be recognized that the LLD is defined as an a priori (before the fact) limit representing the capability of a measurement system and not as an a posteriori (after the fact) limit for a particular measurement.

- (b) A batch release is the discharge of liquid waste of a discrete volume. Prior to sampling for analyses, each batch shall be isolated, and then mixed to assure representative sampling.

-
- (c) The principal gamma emitters for which the LLD specification applies exclusively are the following radionuclides: Mn-54, Fe-59, Co-58, Co-60, Zn-65, Mo-99, Cs-134, and Cs-137. This list does not mean that only these nuclides are to be detected and reported. Other peaks that are measurable and identifiable, together with the above nuclides, shall also be identified and reported in the Radioactive Effluent Release Report. The LLD for Mo-99, Ce-141, and Ce-144 is 5×10^{-5} .
 - (d) A composite sample is one in which the quantity of liquid sampled is proportional to the quantity of liquid waste discharged and in which the method of sampling employed results in a specimen that is representative of the liquids released.
 - (e) A continuous release is the discharge of liquid wastes of a non-discrete volume, e.g., from a volume of a system that has an input flow during the continuous release.
 - (f) To be representative of the quantities and concentrations of radioactive materials in liquid effluents, samples shall be collected continuously in proportion to the rate of flow of the effluent stream. Prior to analyses, all samples taken for the composite shall be thoroughly mixed in order for the composite sample to be representative of the effluent release.

2.3 Dose From Liquid Effluents

2.3.1 Limiting Conditions For Operation

a. Applicability

Applies to radiation doses from liquid effluents containing radioactive materials.

b. Objective

To ensure that the dose limitations of 10 CFR 50, Appendix I for liquids are met.

c. Specifications

1. The dose to a Member(s) of the Public from radioactive materials released from the plant in liquid effluents to Unrestricted Areas shall be limited as follows:
 - a. During any calendar quarter, limited to less than or equal to 1.5 mrem to the whole body and to less than or equal to 5 mrem to any organ; and,
 - b. During any calendar year, limited to less than or equal to 3 mrem to the whole body and to less than or equal to 10 mrem to any organ.
2. With the calculated dose from the release of radioactive materials in liquid effluents exceeding any of the above limits, the following shall be done:
 - a. Identify the causes for such release rates;
 - b. Define and initiate a program of corrective action; and
 - c. Prepare and submit a report to the NRC within 30 days.

2.3.2 Surveillance Requirements

a. Applicability

Applies to the calculation of the radiation dose from liquid effluents containing radioactive materials.

b. **Objective**

To ensure that the radiation dose from radioactive liquid effluents is determined.

c. **Specifications**

1. Cumulative dose contributions from liquid effluents shall be determined in accordance with the ODCM (Part 2, Section 3.4) at least monthly for the current calendar quarter and current calendar year.

2.3.3 **Bases**

This specification is provided to ensure that the requirements of 10 CFR 50, Appendix I, Section II.A, III.A and IV.A are met. The specification ensures that the guides set forth in 10 CFR 50, Appendix I, Section II.A are met. The specification provides the required operating flexibility and, at the same time, implements the guides set forth in 10 CFR 50, Appendix I, Section IV.A, to assure that the releases of radioactive material in liquid effluents will be kept "as low as is reasonably achievable."

2.4 Liquid Radioactive Waste Treatment System Operations

2.4.1 Limiting Conditions For Operation

a. Applicability

Applies to the operability of radioactive liquid processing equipment.

b. Objective

To ensure liquid radwaste treatment system(s) are operated to prevent exceeding the dose limits of Part 1, Section 2.3.1.c.1.

c. Specifications

1. The liquid radioactive waste treatment system shall be used when the projected dose from untreated liquid releases, over a 31 day period, to a Member(s) of the Public would exceed:
 - a. 0.06 mrem to the whole body; or,
 - b. 0.2 mrem to any organ.
2. With radioactive liquid waste being discharged without treatment and in excess of the above limits, prepare and submit to the Commission within 30 days a report that includes the following information:
 - a. Explanation if liquid radwaste was being discharged without treatment; and if so:
 - b. Identification of any inoperable equipment or subsystems and the reason for the inoperability;
 - c. Action(s) taken to restore the inoperable equipment to operable status; and
 - d. Summary description of action(s) taken to prevent a recurrence.

2.4.2 Surveillance Requirements

a. Applicability

Dose projections apply to liquid effluents released to Unrestricted Areas.

b. Objective

To ensure that action levels to require operation of waste treatment systems are determined.

c. Specifications

1. Doses to individuals in Unrestricted Areas due to liquid releases shall be projected at least monthly in accordance with the ODCM (Part 2, Section 3.5).

2.4.3 Bases

The requirement that the appropriate portions of this system be used when specified provides assurance that the releases of radioactive materials in liquid effluents will be kept "as low as is reasonably achievable". This specification assures that the requirements of 10 CFR 50.36a, 10 CFR 50, Appendix A, General Design Criterion 60, and design objective of 10 CFR 50, Appendix I, Section II.D are met. The specified limits governing the use of appropriate portions of the liquid radwaste treatment system were specified as a suitable fraction of the dose design objectives set forth in 10 CFR 50, Appendix I, Section II.A, for liquid effluents.

3.0 GASEOUS EFFLUENTS

3.1 Gaseous Effluent Monitors

3.1.1 Limiting Conditions For Operation

a. Applicability

Applies to the instrumentation required for monitoring the radioactive gaseous effluent pathways to the environment.

b. Objective

To ensure that radioactive gaseous effluent discharges are properly monitored and recorded during release.

c. Specifications

1. Radioactive gaseous wastes released to the environment via the below listed pathways shall be monitored and recorded during release from the respective pathway.
 - a. Main stack exhaust
 - b. Refuel floor exhaust
 - c. Reactor building exhaust
 - d. Turbine building exhaust
 - e. Radwaste building exhaust
2. Each pathway listed above shall also be sampled for iodine and particulate radioactivity on a continuous basis during release from the respective pathway.
3. If Sections 3.1.1.c.1 and 3.1.1.c.2 above, cannot be met, effluent releases may continue via the respective pathway provided gaseous grab samples are collected in the case of a monitor out of service or auxiliary samplers are used in case a particulate and iodine sampler is out of service:
 - a. Return the instrument to operable status within 30 days; or
 - b. Provide an explanation in the next Radioactive Release Report as to why the inoperability was not corrected within 30 days.

4. Alarm/Trip Setpoints are determined in accordance with Part 2, Section 4.3.2 to ensure the limits of Section 3.2.1 are not exceeded. With a radioactive gaseous effluent monitoring instrumentation channel alarm/trip setpoint less conservative than required by the above control:
 - a. Without delay, suspend the release of radioactive gaseous effluents monitored by the affected channel; or
 - b. Declare the channel inoperable; or
 - c. Change the setpoint so it is acceptably conservative.

3.1.2 Surveillance Requirements

a. Applicability

Applies to instrumentation listed in Section 3.1.1.c.1 and analyses of gaseous effluent releases.

b. Objective

To ensure that instrumentation required for gaseous effluent releases is maintained and calibrated and the radioactivity of gaseous releases is determined.

c. Specifications

1. Operation of the gaseous effluent monitors and recorders shall be verified by performing instrument surveillance as specified on Table 3.1-2.
2. The iodine cartridge and the particulate filter for each pathway listed in Section 3.1.1.c.1 shall be changed out at least weekly.
3. Grab samples, when required, shall be collected at least once per 12 hours and analyzed within 24 hours of collection. Auxiliary samplers shall run continuously and be changed out at least weekly.

3.1.3 Bases

The radioactive gaseous effluent instrumentation is provided to monitor and control the releases of radioactive materials in gaseous effluents during planned or unplanned releases. The alarm/trip set points for these instruments shall be calculated in accordance with methods in the ODCM to ensure that the alarm/trip will occur prior to exceeding the limits of Part 1, Section 3.2.1.c.1.

The operability and use of this instrumentation is consistent with the requirements of 10 CFR 50, Appendix A, General Design Criteria 60, 63 and 64.

Refer to Technical Specification Bases 3.3.6.2 for references pertaining to surveillance and allowable outage times for selected monitors listed on Table 3.1-1 and Table 3.1-2.

TABLE 3.1-1
RADIATION MONITORING SYSTEMS

Minimum No. of Operable Instrument Channels per Trip System	Function	Alarm/Trip Level Setting	Total No. of Instrument Channels Provided by Design	Action
1	Main Stack Exhaust Monitors	(b)	2	(f)
1(a)(h)	Refuel Area Exhaust Monitors(c)	(i)	2	(f)(g)
1(a)(h)	Reactor Building Area Exhaust Monitors(c)	(i)	2	(f)(g)
1(a)(h)	Turbine Building Exhaust Monitors	(b)	2	(f)
1(a)(h)	Radwaste Building Exhaust Monitors	(b)	2	(f)

NOTES FOR TABLE 3.1-1

- (a) A channel may be placed in an inoperable status for up to six hours during periods of required surveillance without placing the Trip System in the tripped condition provided the other OPERABLE channel is monitoring that Trip Function, that is, trip capability is maintained.
- (b) Alarm/Trip level setting is in accordance with the methods and procedures of the ODCM (Part 2, Section 4.3.2). These alarm/trip level settings are set to ensure the limits in Specification 3.2.1.c.1 are not exceeded.
- (c) Operability includes alarm.
- (d) Deleted
- (e) Deleted
- (f) Refer to Specification 3.1.1.c.3 and 3.1.1.c.4.
- (g) Refer to Technical Specification 3.3.6.2 for additional Required Actions.
- (h) An inoperable channel need not be placed in the tripped condition where this would cause the Trip to occur. In these cases, the inoperable channel shall be restored to operable status within 24 hours, or the indicated action shall be taken.
- (i) The allowable values are specified in Technical Specification Table 3.3.6.2-1.

TABLE 3.1-2

MINIMUM TEST AND CALIBRATION FREQUENCY FOR
RADIATION MONITORING SYSTEMS(a)

Instrument Channels	Channel Check(b)	Channel Calibration(d)	Logic System Functional Test (c)
Main Stack Exhaust Monitors and Recorders	Daily	Quarterly	---
Refuel Area Exhaust Monitors and Recorders	Daily	Quarterly	---
Reactor Building Area Exhaust Monitors, Recorders and Isolation	Daily	Quarterly	R
Turbine Building Exhaust Monitors and Recorders	Daily	Quarterly	---
Radwaste Building Exhaust Monitors and Recorders	Daily	Quarterly	---
SBGT Actuation	---	---	R

NOTES FOR TABLE 3.1-2

- (a) Channel Calibrations and Channel Checks need not be performed when these instruments are not required to be operable or are tripped.
- (b) Channel Checks shall be performed at least once per day during these periods when the instruments are required to be operable.
- (c) Simulated automatic actuation shall be performed once per 24 months. Simulated automatic actuation means applying a simulated signal to the sensor to actuate the circuit.
- (d) A successful test of the required contact(s) of a channel relay may be performed by the verification of the change of state of a single contact of the relay. This clarifies what is an acceptable Channel Functional Test of a relay. This is acceptable because all of the other required contacts of the relay are verified by other Technical Specification and non-Technical Specification tests at least once per refueling interval with the applicable extension.

**TABLE 3.1-3
RADIATION AND EFFLUENT FLOW INSTRUMENTATION**

Instrument Channels	Minimum No. of Operable Channels	Applicability	Action
Main Stack Exhaust			
1. Noble Gas Monitor ^(a)	1	Note (b)	
2. Iodine & Particulate Sampler ^(a)	1	Note(b)	
3. Discharge Flow Rate Monitor	1	Note (b)	Note (c)
Refuel Floor Exhaust			
1. Noble Gas Monitor	1	Note (b)	
2. Iodine & Particulate Sampler	1	Note (b)	
3. Discharge Flow Rate Monitor	1	Note (b)	Note (c)
Reactor Building Exhaust			
1. Noble Gas Monitor ^(a)	1	Note (b)	
2. Iodine & Particulate Sampler ^(a)	1	Note (b)	
3. Discharge Flow Rate Monitor	1	Note (b)	Note (c)
Turbine Building Exhaust			
1. Noble Gas Monitor	1	Note (b)	
2. Iodine & Particulate Sampler	1	Note (b)	
3. Discharge Flow Rate Monitor	1	Note (b)	Note (c)
Radwaste Building Exhaust			
1. Noble Gas Monitor	1	Note (b)	
2. Iodine & Particulate Sampler	1	Note (b)	
3. Discharge Flow Rate Monitor	1	Note (b)	Note (c)

(a) The same instrument is used for the monitor and sampler

(b) All modes

(c) With the number of channels OPERABLE less than the required by the minimum channels operable requirement, effluent releases via this pathway may continue provided the design flow rate is used for all effluent release calculations.

TABLE 3.1-4

MINIMUM TEST AND CALIBRATION FREQUENCY FOR RADIATION MONITORING
EFFLUENT FLOW INSTRUMENTATION

Instrument Channels	Calibration ^(b)	Calibration
Main Stack Exhaust		
1. Noble Gas Monitor ^(a)	Q	R
2. Iodine & Particulate Sampler ^(a)	Q	R
3. Discharge Flow Rate Monitor	----	R
Refuel Floor Exhaust		
1. Noble Gas Monitor	----	R
2. Iodine & Particulate Sampler	Q	R
3. Discharge Flow Rate Monitor	----	R
Reactor Building Exhaust		
1. Noble Gas Monitor ^(a)	Q	R
2. Iodine & Particulate Sampler ^(a)	Q	R
3. Discharge Flow Rate Monitor	----	R
Turbine Building Exhaust		
1. Noble Gas Monitor	----	R
2. Iodine & Particulate Sampler	Q	R
3. Discharge Flow Rate Monitor	----	R
Radwaste Building Exhaust		
1. Noble Gas Monitor	----	R
2. Iodine & Particulate Sampler	Q	R
3. Discharge Flow Rate Monitor	----	R

^(a) The same instrument is used for the monitor and sampler.

^(b) This calibration consists of verifying the flowrate with an independent calibrated instrument and adjusting flowrate as necessary.

3.2 Gaseous Dose Rates

3.2.1 Limiting Conditions For Operation

a. Applicability

Applies to the radiation dose rate from radioactive material in gaseous effluents from the plant.

b. Objective

To ensure that the dose rates at or beyond the Site Boundary from gaseous effluents do not exceed the annual dose limits of 10 CFR 20 for Unrestricted Areas.

c. Specifications

1. The dose rate at or beyond the Site Boundary due to radioactive materials released from the plant in gaseous effluents shall be limited as follows:
 - a. ≤ 500 mrem/year to the whole body and ≤ 3000 mrem/year to the skin from noble gases; and,
 - b. ≤ 1500 mrem/year to any organ from Iodine-131, Iodine-133, Tritium and for radioactive materials in particulate form with half-lives greater than 8 days (inhalation pathway only).
2. With the dose rates exceeding the above limits, without delay restore the release rate to within the above limits.

3.2.2 Surveillance Requirements

a. Applicability

Applies to the calculation of the dose rates from radioactive materials in gaseous effluents from the plant.

b. Objective

To ensure that appropriate calculations are performed to determine the dose rates from gaseous effluents from the plant.

c. Specifications

1. The dose rate due to noble gases in gaseous effluents shall be determined to be continuously within the limits of Section 3.2.1.c.1, in accordance with the methods and procedures of the ODCM (Part 2, Section 4.3.1).
2. The dose rate due to Iodine-131, Iodine-133, Tritium and radionuclides in particulate form with half-lives greater than 8 days in gaseous effluents, shall be determined to be within the above limits in accordance with the methods and procedures of the ODCM (Part 2, Section 4.3.3). This will be done by obtaining representative samples and performing analyses in accordance with the sampling and analyses program specified in Table 3.2-1.

3.2.3 Bases

This specification provides reasonable assurance that radioactive material discharged in gaseous effluents will not result in the exposure of a Member(s) of the Public in an Unrestricted Area, either at or beyond the Site Boundary in excess of the design objectives of Appendix I to 10CFR50. This specification is provided to ensure that gaseous effluents from the plant will be appropriately controlled. It provides operational flexibility for releasing gaseous effluents to satisfy the Section II.A and II.C design objectives of Appendix I to 10CFR50. The specified limits restrict, at all times, the corresponding gamma and beta dose rates above background to an individual at or beyond the exclusion area boundary to ≤ 500 mrem/year to the whole body or to ≤ 3000 mrem/year to the skin. These limits also restrict the corresponding thyroid dose rate above background to a child via the inhalation pathway to ≤ 1500 mrem/year.

TABLE 3.2-1
RADIOACTIVE GASEOUS WASTE SAMPLING AND ANALYSIS PROGRAM

Gaseous Release Type	Sampling Frequency	Minimum Analysis Frequency	Type of Activity Analysis	Lower Limit of Detection (LLD) ^(a) (μCi/ml)
Main Stack Refuel Floor Vent Reactor Building Vent Turbine Building Vent Radwaste Building Vent	Monthly Grab Sample ^(d)	Monthly Noble Gases ^(b)	Principal Gamma Emitters ^(b)	1 x 10 ⁻⁴
	Quarterly Grab Sample	Quarterly	H-3	1 x 10 ⁻⁶
	Continuous ^(c)	Weekly Charcoal Sample ^(e)	I-131	1 x 10 ⁻¹²
			I-133	None
	Continuous ^(c)	Weekly Particulate Sample ^(e)	Principal Gamma Emitters ^(b)	1 x 10 ⁻¹¹
			(I-131, I-133, others)	None
	Continuous ^(c)	1 Wk/Mo Particulate Sample	Gross Alpha	1 x 10 ⁻¹¹
	Continuous ^(c)	4 Wk/Qr Composite Particulate Sample	Sr-89, Sr-90	1 x 10 ⁻¹¹
Continuous ^(c)	Noble Gas Monitor	Noble Gases Gross Beta or Gamma	1 x 10 ⁻⁵	
Incinerated Oil ^(f)	Prior to Each Batch ^(g)	Each Batch ^(g)	Principal Gamma Emitters ^(b)	5 x 10 ⁻⁷
			I-131	1 x 10 ⁻⁶

See notes next page

NOTES FOR TABLE 3.2-1

- (a) The LLD is defined, for purpose of these specifications, as the smallest concentration of radioactive material in a sample that will yield a net count (above system background) that will be detected with 95% probability and with only 5% probability of falsely concluding that a blank observation represents a "real" signal.

For a particular measurement system (which may include radiochemical separation):

$$LLD = \frac{4.66 s_b}{E \cdot V \cdot 2.22 \cdot 10^6 \cdot Y \cdot \exp(-\lambda \Delta t)}$$

Where:

LLD is the a priori lower limit of detection, as defined above (in microcuries per unit mass or volume);

s_b is the standard deviation of the background counting rate or of the counting rate of a blank sample, as appropriate (in counts per minute);

E is the counting efficiency (in counts per disintegration);

V is the sample size (in units of mass or volume);

2.22×10^6 is the number of disintegrations per minute per microcurie;

Y is the fractional radiochemical yield (when applicable);

λ is the radioactive decay constant for the particular radionuclide; and

Δt for plant effluents is the elapsed time between the midpoint of sample collection and time of counting.

Typical values of E, V, Y, and Δt should be used in the calculations.

It should be recognized that the LLD is defined as an a priori (before the fact) limit representing the capability of a measurement system and not as an a posteriori (after the fact) limit for a particular measurement.

- (b) The principal gamma emitters for which the LLD specification applies exclusively are the following radionuclides: Kr-87, Kr-88, Xe-133, Xe-133m, Xe-135, Xe-135m, and Xe-138 for gaseous emissions; and, Mn-54, Fe-59, Co-58, Co-60, Zn-65, Mo-99, Cs-134, and Cs-137 for particulate emissions. This list does not mean that only these nuclides are to be detected and reported. Other peaks that are measurable and identifiable, together with the above nuclides, shall also be identified and reported in the Radioactive Effluent Release Report. The LLD for Mo-99, Ce-141, and Ce-144 is 5×10^{-11} . For oil samples, Table 2.2-1, Note (c) applies.
- (c) The ratio of the sample flow rate to the sampled stream flow rate shall be known for the time period covered by each dose or dose rate calculation made in accordance with Specifications. This determination shall be made using design flow rates if flow meters are not provided or are inoperable.
- (d) Main stack gaseous sampling and analysis shall also be performed following shutdown, startup, or a thermal power change exceeding 20% of Rated Thermal Power in one hour.
1. This requirement applies only if:
 - Analysis shows that the Dose Equivalent I-131 concentration in the primary coolant has increased more than a factor of 3; and
 - The noble gas monitor shows that effluent activity has increased more than a factor of 3; and
 - Corrections for increases due to changes in thermal power level have been made in both cases.
- (e) Main stack iodine and particulate sampling shall also be performed daily following each shutdown, startup or thermal power change exceeding 20% of Rated Thermal Power in one hour.
1. Daily sampling is not required for thermal power changes if the offgas charcoal filters are in service.
 2. In addition, this requirement applies only if:
 - Analysis shows that the Dose Equivalent I-131 concentration in the primary coolant has increased more than a factor of 3; and
 - The noble gas monitor shows that effluent activity has increased more than a factor of 3; and
 - Corrections for increases due to changes in thermal power level have been made in both cases.
 3. Daily sampling shall be performed until two consecutive samples show no increase in concentration but not to exceed 7 consecutive days.
 4. LLDs may be increased by a factor of 10 for analysis of daily samples.
 5. Analysis of daily and weekly samples shall be completed within 48 hours of changing.
- (f) Incinerated oil may be discharged via points other than the main stack and building vents (i.e., auxiliary boiler). Release shall be accounted for based on pre-release grab sample data.

- (g) Samples of incinerated oil releases shall be collected from and representative of filtered oil in liquid form. Whenever oil samples cannot be filtered such as No. 6 bunker fuel oil, raw oil samples shall be collected and analyzed.

3.3 Air Dose, Noble Gases

3.3.1 Limiting Conditions For Operation

a. Applicability

Applies to the air dose due to noble gases released from the plant.

b. Objective

To ensure that the noble gas dose limitations of 10 CFR 50, Appendix I, are met.

c. Specifications

1. The air dose to areas at or beyond the Site Boundary from noble gases released from the plant in gaseous effluents shall be limited:
 - a. During any calendar quarter, to less than or equal to 5 mrad from gamma radiation, and less than or equal to 10 mrad from beta radiation; and,
 - b. During any calendar year, to less than or equal to 10 mrad from gamma radiation and less than or equal to 20 mrad from beta radiation.
2. With the calculated air dose from radioactive noble gases in gaseous effluents exceeding any of the above limits, prepare and submit to the Commission, within 30 days, a report that:
 - a. Identifies the cause(s) for exceeding the limit(s); and
 - b. Defines the corrective actions that have been taken to reduce the releases; and
 - c. Identifies the proposed corrective actions to be taken to ensure that subsequent releases will be in compliance with the above limits.

3.3.2 Surveillance Requirements

a. Applicability

Applies to the calculation of the air dose due to noble gas effluent.

b. Objective

To ensure that appropriate calculations are performed to determine the air dose from noble gas effluents.

c. Specifications

1. Cumulative air dose contributions for noble gases shall be calculated at least monthly in accordance with the ODCM (Part 2, Section 4.4.2) for the current calendar quarter and the current calendar year.

3.3.3 Bases

This specification is provided to assure that the requirements of 10 CFR 50, Appendix I, Section II.B, III.A and IV.A are met. This specification implements the guides set forth in Appendix I, Section II.B. The specification provides the required operating flexibility and, at the same time, implements the guides set forth in Appendix I, Section IV.A, to assure that the releases of radioactive material in gaseous effluents will be kept "as low as is reasonably achievable."

3.4 Dose Due to Iodine-131, Iodine-133, Tritium and Radionuclides in Particulate Form

3.4.1 Limiting Conditions For Operation

a. Applicability

Applies to the cumulative dose from Iodine-131, Iodine-133, Tritium, and radionuclides in particulate form with half-lives greater than 8 days in gaseous effluents.

b. Objective

To ensure that the dose limitations of 10 CFR 50, Appendix I, are met.

c. Specifications

1. The dose to a Member(s) of the Public at or beyond the Site Boundary from Iodine-131, Iodine-133, Tritium, and radionuclides in particulate form with half-lives greater than 8 days released from the plant in gaseous effluents shall be limited:
 - a. During any calendar quarter to less than or equal to 7.5 mrem to any organ; and,
 - b. During any calendar year to less than or equal to 15 mrem to any organ.
 - c. Less than 0.1% of the limits of Specifications 3.4.1.c.1.a and 3.4.1.c.1.b as a result of burning contaminated oil.
2. With the calculated dose from the release of Iodine-131, Iodine-133, Tritium, and radionuclides in particulate form with half-lives greater than 8 days, in gaseous effluents exceeding any of the above limits, prepare and submit to the Commission within 30 days a report that:
 - a. Identifies the cause(s) for exceeding the limit; and
 - b. Defines the corrective actions that have been taken to reduce the releases; and
 - c. Identifies the proposed corrective actions to be taken to ensure that subsequent releases will be in compliance with the above limits.

3.4.2 Surveillance Requirements

a. Applicability

Applies to the calculation of the dose due to Iodine-131, Iodine-133, Tritium, and radionuclides in particulate form with half-lives greater than 8 days in gaseous effluents.

b. Objective

To ensure that appropriate calculations are performed to determine the dose from Iodine-131, Iodine-133, Tritium, and radionuclides in particulate form with half-lives greater than 8 days.

c. Specifications

1. Cumulative dose contributions shall be calculated at least monthly in accordance with the ODCM (Part 2, Section 4.4.2.c) for the current calendar quarter and the current calendar year.

3.4.3 Bases

This specification is provided to assure that the requirements of 10 CFR 50, Appendix I, Section II.C, III.A and IV.A are met. This specification implements the guides set forth in Appendix I, Section II.C. The specification provides the required operating flexibility and, at the same time, implements the guides set forth in Appendix I, Section IV.A, to assure that the releases of radioactive materials in gaseous effluents will be kept "as low as is reasonably achievable."

3.5 Offgas Treatment System

3.5.1 Limiting Conditions For Operation

a. **Applicability**

Applies to the system installed for reduction of radioactive materials in gaseous waste prior to discharge.

b. **Objective**

To minimize concentration of radioactive materials released from the site.

c. **Specifications**

1. The Offgas Treatment System shall be used to reduce the concentration of radioactive materials in gaseous effluents prior to release from the plant within 24 hours after the start-up of the second turbine driven feedwater pump.
2. The offgas charcoal beds shall be used, when Offgas Treatment System operation is required and the projected doses over a 31 day period due to gaseous effluent releases to a Member(s) of the Public at or beyond the site boundary would exceed:
 - a. 0.2 mrad for gamma radiation; or
 - b. 0.4 mrad for beta radiation; or
 - c. 0.3 mrem to any organ
3. With gaseous effluent from the main condenser being discharged without use of the charcoal beds for greater than seven days when treatment is required, and projected doses are in excess of the above limits, prepare and submit to the Commission, within 30 days, a Special Report that includes the following information:
 - a. Explanation of why gaseous effluent is being discharged without charcoal bed treatment, identification of any inoperable equipment or subsystems, and the reason for the inoperability.
 - b. Action(s) taken to restore the inoperable equipment to operable status; and
 - c. Summary description of action(s) taken to prevent a recurrence.

3.5.2 Surveillance Requirements

a. Applicability

Applies to the calculation of the radiation dose from gaseous effluents containing radioactive materials.

b. Objective

To ensure that treatment of gaseous wastes by the offgas system is implemented when required.

c. Specifications

1. If the charcoal beds are not in service when the Offgas Treatment System is required, doses due to gaseous releases from the site shall be projected at least monthly in accordance with the ODCM (Part 2, Section 4.5).

3.5.3 Bases

This specification is provided to ensure that the system will be available for use when required to reduce projected doses due to gaseous releases. This specification assures that the requirements of 10 CFR 50.36a, 10 CFR 50, Appendix A, General Design Criterion 60, and design objective in 10 CFR 50, Appendix I, Section II.D are met. The specified limits governing the use of appropriate portions of the systems are specified as a suitable fraction of the guide values set forth in 10 CFR 50, Appendix I, Sections II.B and II.C, for gaseous effluents.

The requirement for Offgas Treatment System operability provides assurance that the release of radioactive materials in gaseous waste will be kept "as low as is reasonably achievable." Operability of the system is based upon start-up of the second turbine driven feedwater pump. This is due to the fact that excess air in-leakages in the main condenser as a result of operating only one turbine driven feedwater pump will exceed Offgas Treatment System limitations and consequently render the system inoperable. Start-up of the second turbine driven feedwater pump will decrease air in-leakages and assure Offgas Treatment System availability.

3.6 Main Condenser Steam Jet Air Ejector Radiation Monitors

3.6.1 Limiting Conditions For Operation

a. Applicability

Applies to the instrumentation required for monitoring the main condenser offgas steam jet air ejector (SJAE) radiation when the reactor is in Mode 1, and Mode 2 or 3 with any main steam line not isolated and SJAE is in operation.

b. Objective

To ensure that the SJAE release rates are maintained at a level compatible for further treatment and release.

c. Specifications

Except as specified in 1. and 2. below, both SJAE system radiation monitors shall be operable with a trip level setting of $\leq 500,000$ $\mu\text{Ci}/\text{sec}$. The trip time delay setting for closure of the SJAE isolation valve shall be ≤ 15 minutes.

1. A channel may be placed in an inoperable status for up to six hours during periods of required surveillance without placing the Trip System in the tripped condition provided the other operable channel is monitoring that Trip Function. Otherwise, in the event that one of the two SJAE radiation monitors is made or found to be inoperable, continued operation is permissible provided that the inoperable monitor is tripped.
2. Upon the loss of both SJAE system radiation monitors, either:
 - a. Monitor radiation levels at the SJAE within 6 hours
OR
 - b. Sample SJAE system daily to ensure the release rate is $\leq 500,000$ $\mu\text{Ci}/\text{sec}$
OR
 - c. Enter Tech Spec 3.7.5, Main Condenser Steam Jet Air Ejector (SJAE) Offgas

3.6.2 Surveillance Requirements

a. Applicability

Applies to the instrumentation required for monitoring the main condenser offgas steam jet air ejector (SJAE) radiation when the reactor is in Mode 1, and Mode 2 or 3 with any main steam line not isolated and SJAE is in operation.

b. Objective

To ensure that the SJAE release rates are properly monitored.

c. Specifications

Operation of the SJAE radioactive offgas monitors shall be verified by performing instrument surveillance as specified on Table 3.6-1.

3.6.3 Bases

This specification is provided to assure that remedial action is taken to limit the noble gas release rate at the SJAE. The requirement provides reasonable assurance that the amount of noble gas that must be treated and/or released is controlled to a level that prevents exceeding the limits specified in Part 1, Section 3.2.1.

Two air ejector offgas monitors are provided and when their trip point is reached; cause an isolation of the air ejector offgas line. Isolation is initiated when one instrument reaches its high-high trip point and the other has a high-high trip, an inoperative trip or a downscale trip. There is a 15 minute delay before the air ejector offgas isolation valve is closed. This delay is accounted for by the 30 minute holdup time of the offgas before it is released to the stack. Both instruments are required for an isolation of the air ejector offgas line but the instruments are so designed that any instrument failure gives a downscale or inoperative alarm.

Upon the loss of both SJAE system radiation monitors, installation of temporary monitoring or daily sampling at the SJAE is acceptable. These actions provide regular monitoring of the system radiation levels. If temporary monitoring is not installed or daily sampling is not performed, TS 3.7.5 is entered since the ability to monitor radiation levels (gross gamma activity rate of noble gases) is lost.

Table 3.6-1
 MINIMUM TEST AND CALIBRATION FREQUENCY FOR
 RADIATION MONITORING SYSTEMS ^(a)

Instrument Channels	Channel Check (b)	Channel Calibration (e)(f)	Logic System Functional Test (c)(d)
SJAE Radiation Monitors/Offgas Line Isolation	Daily	Quarterly	Once per 24 months

- a. Channel Calibrations and Channel Checks need not be performed when these instruments are not required to be operable or are tripped.
- b. Channel Checks shall be performed at least once per day during these periods when the instruments are required to be operable.
- c. Simulated automatic actuation shall be performed once every 24 months. Simulated automatic actuation means applying a simulated signal to the sensor to actuate the circuit.
- d. The Logic System Functional Test shall include a calibration of time delay relay necessary for proper functioning of the trip system.
- e. The radiation sensors are excluded from the quarterly calibration. The radiation sensors shall be calibrated every 24 month
- f. A successful test of the required contact(s) of a channel relay may be performed by the verification of the change of state of a single contact of the relay. This clarifies what is an acceptable Channel Functional Test of a relay. This is acceptable because all of the other required contacts of the relay are verified by other Technical Specifications and non-Technical Specification tests at least once per refueling interval with the applicable extension.

4.0 TOTAL DOSE

4.1 Gaseous Effluent Monitors

4.1.1 Limiting Conditions For Operation

a. Applicability

Applies to radiation dose from releases of radioactivity and radiation from uranium fuel cycle sources.

b. Objective

1. To assure that the requirements of 40 CFR 190 are met.
2. To assure that the requirements of 10 CFR 72.104 are met in accordance with Section 3.2.3, Required Action A.2, Certificate of Compliance 1014, Appendix A, Technical Specifications for the Hi-Storm 100 Cask System.

c. Specifications

1. The dose or dose commitment to any Member(s) of the Public, due to releases of radioactivity and radiation, from uranium fuel cycle sources shall be limited as follows:
 - a. Less than or equal to 25 mrem/year to the whole body; and,
 - b. Less than or equal to 25 mrem/year to any organ except the thyroid which shall be limited to less than or equal to 75 mrem/year.

2. With the calculated doses from the release of radioactive materials in liquid or gaseous effluents exceeding twice the limits of Section 2.3.1.c.1, 3.3.1.c.1, 3.4.1.c.1.a or 3.4.1.c.1.b, calculations shall be made including an estimate of direct radiation contributions to determine whether the limits of Section 4.1.1.c.1 have been exceeded. If this is the case, a report defining corrective actions to be taken to reduce subsequent releases to levels within limits, along with a schedule for achieving conformance, shall be prepared and submitted to the Commission within 30 days. This report, as defined in 10 CFR 20.2203(c), shall include estimates of the radiation exposure (dose) to a Member(s) of the Public from uranium fuel cycle sources, including all effluent pathways and direct radiation, for the calendar year that includes the release(s) covered by this report. It shall also describe levels of radiation and concentration of radioactive material involved, and the cause of the exposure levels or concentrations. If the estimated dose(s) exceed(s) the above limits, and if the release condition resulting in violation of 40 CFR 190 and 10 CFR 72.104(a) has not already been corrected, the report shall include a request for variance in accordance with the provisions of 40 CFR 190 and 10 CFR 72. Submittal of the report is considered a timely request, and a variance is granted until staff action on the request is complete.

4.1.2 Surveillance Requirements

a. Applicability

Applies to the calculation of total dose due to releases of radioactivity and radiation from uranium fuel cycle sources.

b. Objective

To ensure that appropriate calculations are performed to determine total dose to a Member(s) of the Public.

c. Specifications

1. Dose Calculations: Cumulative dose contributions from liquid and gaseous effluents shall be determined in accordance with Sections 2.3.2.c.1, 3.3.2.c.1, and 3.4.2.c.1 and in accordance with the ODCM (Part 2, Section 5.0).
2. Cumulative dose contributions from direct radiation from the reactor units and from radwaste storage tanks shall be determined in accordance with the methodology and parameters in the ODCM (Part 2, Section 5.4). This requirement is applicable only under conditions set forth in Section 4.1.1.c.2.

4.1.3 Bases

This specification is provided to meet the dose limitations of 40 CFR 190 and 10 CFR 72.104(a). This specification requires the preparation and submittal of a report whenever the calculated dose from plant radioactive effluents exceed twice the design objective doses of 10 CFR 50, Appendix I. The report will describe a course of action that should result in the limitation of the annual dose to a Member(s) of the Public to within the limits of 40 CFR 190 and 10 CFR 72.104(a). For the purpose of the report, it may be assumed the dose commitment to the Member(s) of the Public from other uranium fuel cycle sources is negligible. However, dose contributions from other nuclear fuel cycle facilities at the same site or within a radius of 5 miles must be considered. If the dose to any Member(s) of the Public is estimated to exceed the requirements of 40 CFR 190 or 10 CFR 72.104(a), the report, with a request for variance (provided the release conditions resulting in a violation of 40 CFR 190 or 10 CFR 72.104(a) have not already been corrected), shall be submitted in accordance with provisions of 40 CFR 190.11 and 10 CFR 20.2203(c). This request is considered a timely request and fulfills the requirements of 40 CFR 190 and 10 CFR 72 until NRC staff action is completed. The variance only relates to the limits of 40 CFR 190 or 10 CFR 72.104(a) and does not apply in any way to the requirements for dose limitation addressed in Specifications 2.0 and 3.0. An individual is not considered a Member(s) of the Public during any period in which he/she is engaged in carrying out any operation that is part of the nuclear fuel cycle.

FIGURE 4.1-1
SITE BOUNDARY MAP

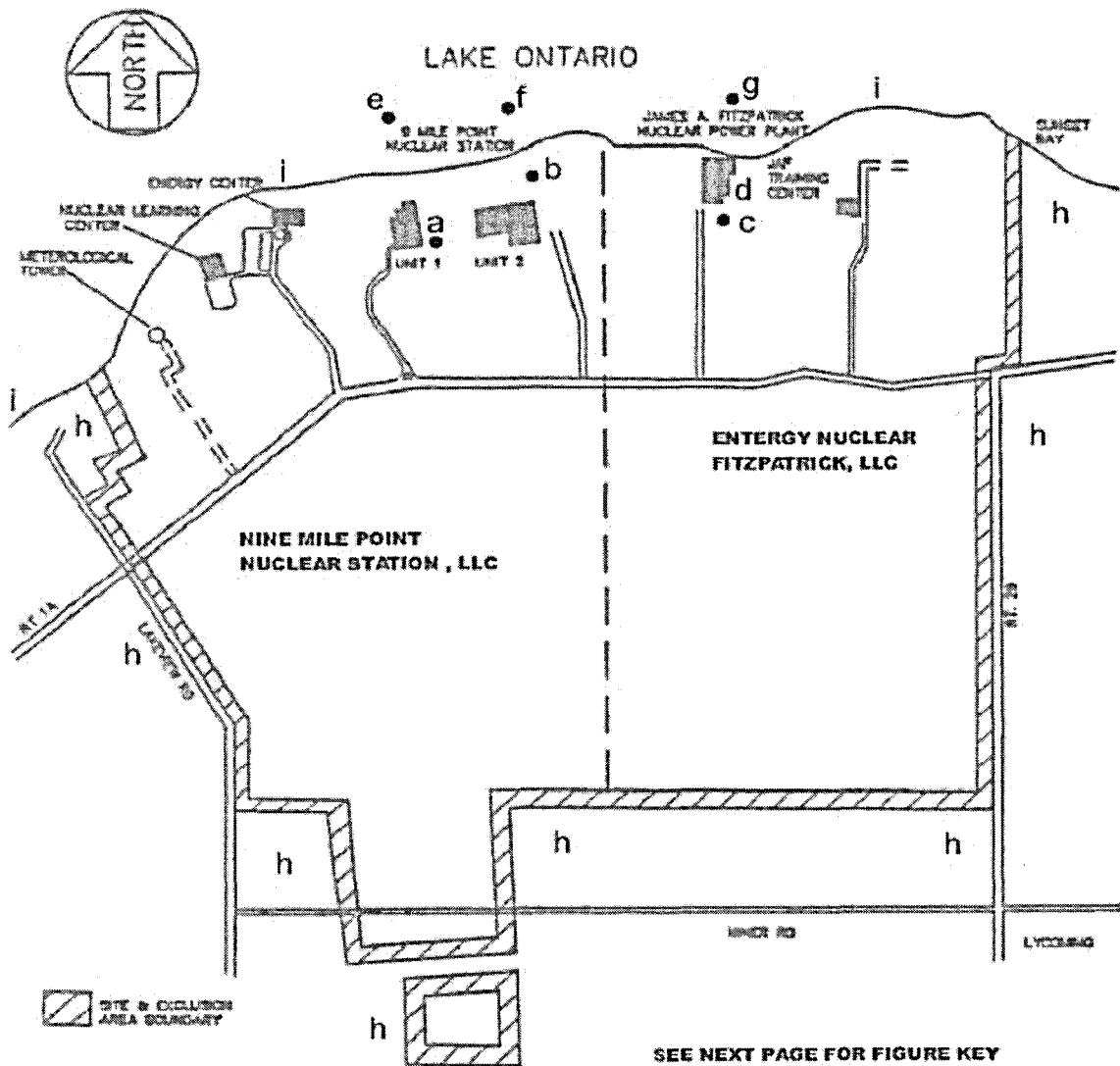

NOTES TO FIGURE 4.1-1

- (a) NMP1 stack (height is 350 feet)
- (b) NMP2 stack (height is 430 feet)
- (c) JAFNPP stack (height is 385 feet)
- (d) Building vents
- (e) NMP1 radioactive liquid discharge (Lake Ontario, bottom)
- (f) NMP2 radioactive liquid discharge (Lake Ontario, bottom)
- (g) JAFNPP radioactive liquid discharge (Lake Ontario, bottom)
- (h) Site Boundary
- (i) Lake Ontario shoreline

Additional Information:

- NMP2 reactor building vent is located 187 feet above ground level
- JAFNPP reactor and turbine building vents are located 173 feet above ground level
- JAFNPP radwaste building vent is 112 feet above ground level

5.0 RADIOLOGICAL ENVIRONMENTAL MONITORING

5.1 Monitoring Program

5.1.1 Limiting Conditions For Operation

a. Applicability

At all times.

b. Objective

To evaluate the effects of plant operation on the environs and to verify the effectiveness of the controls on radioactive material.

c. Specifications

1. With the radiological environmental monitoring program not being conducted as specified in Table 5.1-1, prepare and submit to the Commission, in the Annual Radiological Environmental Operating Report, a description of the reasons for not conducting the program as required and the plans for preventing a recurrence.

(Deviations are permitted from the required sampling schedule if samples are unobtainable due to hazardous conditions, seasonal unavailability, theft, uncooperative residents, or to malfunction of automatic sampling equipment. If the latter, efforts shall be made to complete corrective action prior to the end of the next sampling period.)

2. With the level of radioactivity (as the result of plant effluents) in an environmental sampling medium at a specified location exceeding the reporting levels of Table 5.1-2 when averaged over any calendar quarter, prepare and submit to the Commission a report within thirty (30) days from the end of the affected calendar quarter or within thirty (30) days from the time it is determined that a reporting level has been exceeded. This report shall identify the cause(s) for exceeding the limits(s) and define the corrective action(s) to be taken to reduce radioactive effluents so that the calculated annual dose to a Member(s) of the Public is less than the calendar year limits of Specifications 2.3.1.c.1.b, 3.3.1.c.1.b, and 3.4.1.c.1.b. When more than one of the radionuclides in Table 5.1-2 are detected in the sampling medium, this report shall be submitted if:

$$\frac{\text{concentration (1)}}{\text{reporting level (1)}} + \frac{\text{concentration (2)}}{\text{reporting level (2)}} + \dots \geq 1.0$$

When radionuclides other than those in Table 5.1-2 are detected and are the result of plant effluents, this report shall be submitted if the calculated annual dose to an individual is equal to or greater than the calendar year limits of Specifications 2.3.1.c.1.b, 3.3.1.c.1.b, and 3.4.1.c.1.b.

This report is not required if the measured level of radioactivity was not the result of plant effluents; however, in such an event, the condition shall be reported and described in the Annual Radiological Environmental Operating Report.

3. With milk or fresh leafy vegetable samples unavailable from one or more of the sample locations required by Table 5.1-1, locations for obtaining replacement samples shall be identified and added to the radiological environmental monitoring program within 30 days. The specific locations from which samples were unavailable may then be deleted from the monitoring program. The cause of the unavailability of samples and the new location(s) for obtaining replacement samples shall be identified in the next Radioactive Effluent Release Report. Also included in the report shall be a revised figure(s) and table for the ODCM reflecting the new location(s).

5.1.2 Surveillance Requirements

The radiological environmental monitoring samples shall be collected, pursuant to Table 5.1-1, from the locations given in the table and figure(s) in the ODCM (Appendix H) and shall be analyzed pursuant to the requirements of Table 5.1-1, and the detection capabilities required by Table 5.1-3.

5.1.3 Bases

The radiological environmental monitoring program required by this specification provides measurements of radiation and of radioactive materials in those exposure pathways and for those radionuclides that lead to the highest potential radiation exposures to members of the public resulting from station operation. This monitoring program ensures that 10 CFR 50, Appendix I, Section IV.B.2 is met. It thereby supplements the radiological effluent monitoring program by verifying that the measurable concentrations of radioactive materials and levels of radiation are not higher than expected, based on the effluent measurements and the modeling of the environmental exposure pathways. The initial specified monitoring program will be effective for at least the first three years of commercial operation. Following this period, program changes may be initiated based on operational experience.

The required detection capabilities for environmental sample analyses are tabulated in terms of the Lower Limit of Detection (LLDs). The LLDs required by Table 5.1-3 are considered optimum for routine environmental measurements in industrial laboratories. It should be recognized that the LLD is defined as an a priori (before the fact) limit representing the capability of a measurement system. The LLD is not an a posteriori (after the fact) limit for a particular measurement.

**TABLE 5.1-1
OPERATIONAL RADIOLOGICAL ENVIRONMENTAL MONITORING PROGRAM**

Exposure Pathway and/or Sample	Number of Samples ^(a) and Locations	Sampling and Collection Frequency ^(a)	Type and Frequency of Analysis
<u>AIRBORNE</u>			
Radioiodine and Particulates	<p>Samples from 5 locations:</p> <ul style="list-style-type: none"> a. 3 samples from offsite locations in different sectors of the highest calculated site average D/Q (based on all licensed site reactors) b. 1 sample from the vicinity of a community having the highest calculated site average D/Q (based on all licensed site reactors) c. 1 sample from a control location 9 to 20 miles distant and in the least prevalent wind direction^(d) 	<p>Continuous sample operation with sample collection weekly or as required by dust loading, whichever is more frequent</p>	<p><u>Radioiodine Canisters:</u> Analyze weekly for I-131</p> <p><u>Particulate Samples:</u> Gross beta radioactivity following filter change^(b), composite (by location) for gamma isotopic^(c) quarterly (as a minimum)</p>
Direct Radiation ^(e)	<p>32 stations with two or more dosimeters placed as follows:</p> <ul style="list-style-type: none"> a. An inner ring of stations in the general area of the Site Boundary b. An outer ring in the 4 to 5 mile range from the site with a station in each of the land based sectors. There are 16 land based sectors in the inner ring and 8 land based sectors in the outer ring c. The balance of the stations (8) are placed in special interest areas such as population centers, nearby residences, schools, and in 2 or 3 areas to serve as control stations 	<p>Quarterly</p>	<p>Gamma dose monthly or quarterly</p>

See notes following table

TABLE 5.1-1 (continued)
 OPERATIONAL RADIOLOGICAL ENVIRONMENTAL MONITORING PROGRAM

Exposure Pathway and/or Sample	Number of Samples ^(a) and Locations	Sampling and Collection Frequency ^(a)	Type and Frequency of Analysis
<u>WATERBORNE</u>			
Surface ^(f)	a. 1 sample upstream ^(d) b. 1 sample from the site's most downstream cooling water intake	Composite sample over one month period ^(g)	Gamma isotopic analysis monthly. Composite for Tritium analysis quarterly ^(c)
Sediment from Shoreline	1 sample from a downstream area with existing or potential recreational value	Twice per year	Gamma isotopic analysis semi-annually ^(c)
<u>INGESTION</u>			
Milk	a. Samples from milch animals in 3 locations within 3.5 miles distant having the highest calculated site average D/Q. If there are none, then 1 sample from milch animals in each of 3 areas 3.5 to 5.0 miles distant having the highest calculated site average D/Q (based on all licensed site reactors) ^(h) b. 1 sample from milch animals at a control location (9 to 20 miles distant and in a less prevalent wind direction) ^(d)	Twice per month, April through December (samples will be collected in January through March if I-131 is detected in November and December of the preceding year)	Gamma isotopic and I-131 analysis twice per month when milch animals are on pasture (April through December); monthly (January through March), if required ^(c)

See notes following table

TABLE 5.1-1 (continued)
OPERATIONAL RADIOLOGICAL ENVIRONMENTAL MONITORING PROGRAM

Exposure Pathway and/or Sample	Number of Samples ^(a) and Locations	Sampling and Collection Frequency ^(a)	Type and Frequency of Analysis
Fish	a. 1 sample of 2 commercially or recreationally important species in the vicinity of a site discharge point b. 1 sample of 2 species (same as in a. above or of a species with similar feeding habits) from an area at least 5 miles distant from the site ^(d)	Twice per year	Gamma isotopic ^(c) analysis of edible portions
Food Products	a. In lieu of the garden census as specified in Part 1, Section 5.2, samples of at least 3 different kinds of broad leaf vegetation (such as vegetables) grown nearest each of two different offsite locations of highest predicted site average D/Q (Based on all licensed site Reactors) One (1) sample of each of the similar broad leaf vegetation grown at least 9.3 miles distant in a least prevalent wind direction sector ^(d)	Once during harvest season	Gamma isotopic ^(c) analysis of edible portions. (Isotopic to include I-131)

See notes following table

NOTES FOR TABLE 5.1-1

- (a) It is recognized that, at times, it may not be possible or practical to obtain samples of the media of choice at the most desired location or time. In these instances suitable alternative media and locations may be chosen for the particular pathway in question. Actual locations (distance and directions) from the site shall be provided in the Annual Radiological Environmental Operating Report. Calculated site averaged D/Q values and meteorological parameters are based on historical data (specified in the ODCM) for all licensed site reactors.
- (b) Particulate sample filters should be analyzed for gross beta 24 hours or more after sampling to allow for radon and thoron daughter decay. If gross beta activity in air particulate samples is greater than 10 times a historical yearly mean of control samples, gamma isotopic analysis shall be performed on the individual samples.
- (c) Gamma isotopic analysis means the identification and quantification of gamma emitting radionuclides that may be attributable to the effluents from the plant.
- (d) The purpose of these samples is to obtain background information. If it is not practical to establish control locations in accordance with the distance and wind direction criteria, other sites which provide valid background data may be substituted.
- (e) One or more instruments, such as a pressurized ion chamber, for measuring and recording dose rate continuously may be used in place of, or in addition to, integrating dosimeters. For the purpose of this table, a thermoluminescent dosimeter may be considered to be one phosphor and two or more phosphors in a packet may be considered as two or more dosimeters. Film badges shall not be used for measuring direct radiation.
- (f) The "upstream sample" shall be taken at a distance beyond significant influence of the discharge. The "downstream sample" shall be taken in an area beyond, but near, the mixing zone, if practical.
- (g) Composite samples should be collected with equipment (or equivalent) which is capable of collecting an aliquot at time intervals which are very short (e.g., hourly) relative to the compositing period (e.g., monthly) in order to ensure that a representative sample is obtained.
- (h) A milk sampling location, as required in Table 5.1-1 is defined as a location having at least 10 milking cows present at a designated milk sample location. It has been found from past experience, and as a result of conferring with local farmers, that a minimum of 10 milking cows is necessary to guarantee an adequate supply of milk twice per month for analytical purposes. Locations with less than 10 milking cows are usually utilized for breeding purposes which eliminates a stable supply of milk for samples as a result of suckling calves and periods when the adult animals are dry. In the event that 3 milk sample locations cannot meet the requirement for 10 milking cows, then a sample location having less than 10 milking cows can be used if an adequate supply of milk can reasonably and reliably be obtained based on communications with the farmer.

TABLE 5.1-2

**REPORTING LEVELS
FOR RADIOACTIVITY CONCENTRATIONS IN ENVIRONMENTAL SAMPLES**

Analysis	Water (pCi/l)	Airborne Particulate or Gases (pCi/m ³)	Fish (pCi/kg, wet)	Milk (pCi/l)	Food Products (pCi/kg, wet)
H-3	30,000 ^(a)				
Mn-54	1,000		30,000		
Fe-59	400		10,000		
Co-58	1,000		30,000		
Co-60	300		10,000		
Zn-65	300		20,000		
Zr/Nb-95	400				
I-131	20 ^(a)	0.9		3	100
Cs-134	30	10	1,000	60	1,000
Cs-137	50	20	2,000	70	2,000
Ba/La-140	200			300	

- (a) No drinking water pathway exists at the James A. FitzPatrick/Nine Mile Point sites under normal operating conditions due to the distance and direction of the nearest drinking water intake. Therefore, value of 30,000 pCi/liter is used for tritium and 20 pCi/liter is used for I-131.

TABLE 5.1-3

DETECTION CAPABILITIES
FOR ENVIRONMENTAL SAMPLE ANALYSIS^(a)

LOWER LIMIT OF DETECTION (LLD)^(b)

Analysis	Water (pCi/l)	Airborne Particulate or Gases (pCi/m ³)	Fish (pCi/kg, wet)	Milk (pCi/l)	Food Products (pCi/kg, wet)	Sediment (pCi/kg, dry)
Gross Beta	4	0.01				
H-3	3,000 ^(c)					
Mn-54	15		130			
Fe-59	30		260			
Co-58,60	15		130			
Zn-65	30		260			
Zr/Nb-95	15					
I-131	15 ^(c)	0.07		1	60	
Cs-134	15	0.05	130	15	60	150
Cs-137	18	0.06	150	18	80	180
Ba/La-140	15			15		

NOTES FOR TABLE 5.1-3

- (a) The LLD is the smallest concentration of radioactive material in a sample that will be detected with 95% probability and with 5% probability of falsely concluding that a blank observation represents a "real" signal.

For a particular measurement system (which may include radiochemical separation),

$$LLD = \frac{4.66 s_b}{E \cdot V \cdot 2.22 \cdot Y \cdot \exp(-\lambda \Delta t)}$$

Where:

LLD is the a priori lower limit of detection, as defined above (in picoCurie per unit mass or volume);

s_b is the standard deviation of the background counting rate or of the counting rate of a blank sample, as appropriate (in counts per minute);

E is the counting efficiency (in counts per transformation);

V is the sample size (in units of mass or volume);

2.22 is the number of transformations per minute per picoCurie;

Y is the fractional radiochemical yield (when applicable);

λ is the radioactive decay constant for the particular radionuclide;

Δt is the elapsed time between sample collection (or end of the sample collection period) and time of counting.

Typical values of E, V, Y, and Δt should be used in the calculations.

- (b) It should be recognized that the LLD is defined as an a priori (before the fact) limit representing the capability of a measurement system and not as an a posteriori (after the fact) limit for a particular measurement. Analyses shall be performed in such a manner that the stated LLDs will be achieved under routine conditions. Occasionally background fluctuations, unavoidable small sample sizes, the presence of interfering nuclides, or other uncontrollable circumstances may render these LLDs unachievable. In such cases, the contributing factors shall be identified and described in the Annual Radiological Environmental Operating Report.
- (c) No drinking water pathway exists at the James A. FitzPatrick/ Nine Mile Point sites under normal operating conditions due to the direction and distance of the nearest drinking water intake. Therefore, an LLD value of 15 pCi/liter is used for I-131 and 3,000 pCi/liter is used for tritium.

5.2 Land Use Census Program

5.2.1 Limiting Conditions For Operation

a. Applicability

At all times.

b. Objective

To identify locations of milch animals and gardens of greater than 50 square meters within 5 miles of the site.

c. Specifications

1. A land use census shall be conducted and shall identify the locations of all milch animals, the nearest residence, and all gardens¹ of greater than 50 square meters producing fresh leafy vegetables, in each of the 16 meteorological sectors within a distance of 5 miles from the site.⁽¹⁾
2. With a land use census identifying a milch animal in a location(s) which represents a calculated D/Q value greater than the values currently being used in calculating Surveillance Requirement 3.4.2.c.1, identify the new location(s) in the next Radioactive Effluent Release Report.
3. With the land use census identifying a milch animal location(s) that represents a calculated D/Q (via the same exposure pathway) 50% greater than at a location from which samples are currently being obtained in accordance with Table 5.1-1, add the new location(s) to the radiological environmental monitoring program within 30 days. The sampling location(s), excluding the control station location, having the lowest calculated D/Q (via the same exposure pathway) may be deleted from this monitoring program after October 31 of the year in which this land use census is conducted. Identify the new location(s) in the next Radioactive Effluent Release Report and include the additions in the ODCM.

⁽¹⁾ Broad leaf vegetation sampling may be performed in lieu of the garden census as specified in Table 5.1-1.

5.2.2 Surveillance Requirements

The land use census shall be conducted during the growing season at least once per 12 months using the information that will provide the best results, such as by a door-to-door survey, aerial survey, or by consulting local agriculture authorities, etc. The results of the land use census shall be included in the Annual Radiological Environmental Operating Report.

5.2.3 Bases

This specification is provided to ensure that changes in the use of areas at and beyond the Site Boundary are identified and that modifications to the monitoring program are made if required by the results of this census. The best survey information, such as that from door-to-door surveys, aerial surveys, consultations with local agricultural authorities, etc., shall be used. This census satisfies the requirements of 10 CFR 50, Appendix I, Section IV.B.3. Restricting the census to gardens of greater than 50 m² provides assurance that significant exposure pathways via leafy vegetables will be identified and monitored since a garden of this size is the minimum required to produce the quantity (26 kg/year) of leafy vegetables assumed in Regulatory Guide 1.109, Revision 1, October 1977, for consumption by a child. To determine this minimum garden size, the following assumptions were made: (1) 20% of the garden was used for growing broad leaf vegetation (i.e., similar to lettuce and cabbage), and, (2) a vegetable yield of 2 kg/m². In lieu of the garden census the significance of the garden exposure pathway can be evaluated by the sampling of green leafy vegetables as specified in Table 5.1-1.

5.3 Interlaboratory Comparison Program

5.3.1 Limiting Conditions For Operation

a. **Applicability**

At all times.

b. **Objective**

To provide quality control of environmental sample analyses.

c. **Specifications**

1. Analyses shall be performed on radioactive materials supplied as part of an Interlaboratory Comparison Program. Participation in this program shall include all media for which samples are routinely collected and for which intercomparison samples are available.
2. With analyses not being performed as required above, report the corrective actions taken to prevent a recurrence in the Annual Radiological Environmental Operating Report.

5.3.2 Surveillance Requirements

A summary of the results obtained as part of the above required Interlaboratory Comparison Program shall be included in the Annual Radiological Environmental Operating Report.

5.3.3 Bases

The requirement for participation in an Interlaboratory Comparison Program is provided to ensure that independent checks on the precision and accuracy of the measurements of radioactive material in the environmental sample matrices are performed as part of the quality assurance program for environmental monitoring in order to demonstrate that the results are valid for the purposes of 10 CFR 50, Appendix I, Section IV.B.2.

6.0 REPORTS

6.1 Annual Radiological Environmental Operating Report

The Annual Radiological Environmental Operating Report covering the operation of the plant during the previous calendar year shall be submitted by May 15 of each year.

The report shall include summaries, interpretations, and analyses of trends of the results of the Radiological Environmental Monitoring Program for the reporting period. The material provided shall be consistent with the objectives outlined in the Offsite Dose Calculation Manual (ODCM), and in 10 CFR 50, Appendix I, Sections IV.B.2, IV.B.3, and IV.C. The report shall include a comparison with preoperational studies, operational controls (as appropriate), and environmental surveillance reports from the previous five years, and an assessment of the observed impacts of the plant operation on the environment. The reports shall also include the results of the Land Use Census required by Specification 5.2.

The report shall include the results of analyses of all radiological environmental samples and of all environmental radiation measurements taken during the period at the locations specified in Table 5.1-1, as well as summarized and tabulated results of these analyses and measurements in the format of the table in the Radiological Assessment Branch Technical Position, Revision 1, November 1979. In the event that some individual results are not available for inclusion with the report, the report shall be submitted noting and explaining the reasons for the missing results. This missing data shall be submitted in a supplementary report as soon as possible.

The report shall also include the following: A summary description of the Radiological Environmental Monitoring Program; at least two legible maps (one map shall cover stations near the Site Boundary; a second shall include the more distant stations) covering all sampling locations and keyed to a table giving distances and directions from the centerline of one reactor; the results of participation in the Interlaboratory Comparison Program required by Specification 5.3, and discussion of all analyses in which the LLDs required by Table 5.1-3 were not routinely achievable.

6.2 Radioactive Effluent Release Report

The Radioactive Effluent Release Report covering the operation of the plant during the previous year shall be submitted prior to May 1 of each year in accordance with 10 CFR 50.36a.

- 6.2.1 The report shall include a summary of the quantities of radioactive liquid and gaseous effluents and solid waste released from the plant. The material provided shall be consistent with the objectives outlined in the ODCM (Part 2) and Process Control Program and in conformance with 10 CFR 50.36a and 10 CFR 50, Appendix I, Section IV.B.1. The summary can be provided using as guidance Regulatory Guide 1.21, Revision 1, June 1974, "Measuring, Evaluating, and Reporting Radioactivity in Solid Wastes and Releases of Radioactive Materials in Liquid and Gaseous Effluents from Light-Water-Cooled Nuclear Power Plant", with data summarized on a quarterly basis following the format of Appendix B thereof.
- 6.2.2 The report may include an annual summary of meteorological data collected over the previous year. If the meteorological data is not included, ENO shall retain it on file and provide it to the US Nuclear Regulatory Commission upon request. This same report shall include an assessment of the radiation doses due to the radioactive liquid and gaseous effluents released from the plant during the previous calendar year to the public. All assumptions used in making these assessments (i.e., specific activity, exposure time and location) shall be included in these reports. The assessment of radiation doses shall be performed in accordance with the ODCM.
- 6.2.3 The report shall include any change to the PCP or the ODCM made during the reporting period, as well as a listing of new locations for dose calculations and/or environmental monitoring identified by the land use census pursuant to Specification 5.2.
- 6.2.4 The report shall also include an assessment of radiation doses to the likely most exposed Member(s) of the Public from reactor releases and other nearby uranium fuel cycle sources (including doses from primary effluent pathways and direct radiation) during the previous calendar year, to show conformance with 40 CFR 190, Environmental Radiation Protection Standards for Nuclear Power Operations. This assessment of radiation doses is performed in accordance with the ODCM.
- 6.2.5 The report shall include the following information for each class of solid waste (defined by 10 CFR 61) shipped offsite during the report period:
- a. Container volume;
 - b. Total curie quantity (specify whether determined by measurement or estimate);
 - c. Principal radionuclides (specify whether determined by measurement or estimate);
 - d. Source of waste and processing employed (e.g., dewatered spent resin, compacted dry waste, evaporator bottoms);
 - e. Type of container (e.g., LSA, Type A, Large Quantity), and,
 - f. Solidification agent or absorbent (e.g., cement, Dow media, etc.)

-
- 6.2.6 The report shall include a list and description of unplanned releases, to Unrestricted Areas of radioactive materials in gaseous and liquid effluents made during the reporting period.
- 6.2.7 The report shall contain the cause for unavailability of any environmental sample required by Table 5.1-1 and shall identify the locations for obtaining replacement samples. This shall also include a revised figure(s) and table for the ODCM reflecting the new location(s). Refer to Section 5.1.1.c.3.
- 6.2.8 The report shall contain new locations identified in the land use census in accordance with Sections 5.2.1.c.2 or 5.2.1.c.3.
- 6.2.9 The report shall contain the events leading to the conditions which resulted in exceeding the radioactivity limits for the specified outdoor liquid radwaste tanks specified in the Technical Requirements Manual, TRM 3.7.E.
- 6.2.10 The report shall contain details of any major modifications to Radioactive Liquid, Gaseous, and Solid Waste Treatment Systems as discussed in Section 7.0.

7.0 MAJOR MODIFICATIONS TO RADIOACTIVE LIQUID, GASEOUS, AND SOLID WASTE TREATMENT SYSTEMS*

Major modifications to radioactive waste systems (liquid, gaseous, and solid):

1. Shall be reported to the Commission in the Radioactive Effluent Release Report for the period in which the modification is completed and made operational. The discussion of each modification shall contain:
 - a. A summary of the evaluation that led to the determination that the modification could be made in accordance with 10 CFR 50.59,
 - b. Sufficient information to support the reason for the modification without benefit of additional or supplemental information; and
 - c. A description of the equipment, components, and processes involved and the interfaces with other plant systems.
 2. The following evaluations shall be reported to the Commission in the Radioactive Effluent Release Report, where such evaluations are required to be performed in order to assure compliance with the requirements of 10 CFR 50.59.
 - a. An evaluation of the modifications, which show the predicted releases of radioactive materials in liquid and gaseous effluents and/or quantity of solid waste that differ from those previously predicted in the license application and amendments thereto.
 - b. An evaluation of the modification, which shows expected maximum exposure to individuals in the Unrestricted Area and to the general population that differ from those previously estimated in the license application and amendments thereto; and
 - c. A comparison of the predicted release of radioactive materials, in liquid and gaseous effluents and in solid waste, to the actual releases for the period prior to when the modifications are to be made.
- (*) Entergy Nuclear Operations, Inc. may elect to submit the information called for in this Specification as part of the annual 10 CFR 50.59 Safety Evaluation Report.

8.0 PURGING OF THE PRIMARY CONTAINMENT

8.1 Limiting Conditions for Operation

a. Applicability

Applies to the purging operations of the primary containment purge system.

b. Objective

To ensure that the primary containment is purged through the Standby Gas Treatment System.

c. Specifications

1. The containment shall be purged through the Standby Gas Treatment System whenever the primary containment is required to be Operable per the Technical Specifications (TS). If this requirement cannot be met, then purging shall be discontinued without delay.
2. With the requirements of Part 1, Section 8.1.c.1 not met, enter the applicable TS LCO Conditions and Required Actions.

8.2 Bases

Limitations on purging the containment are established to maintain releases as low as reasonably achievable.

The TS provide the appropriate actions and restrictions if the requirements above are not met. The inability to purge through the Standby Gas Treatment System could be caused by a number of reasons, and thus, various TS 3.6 Sections could apply. The applicable TS LCO Conditions and Required Actions will be entered as required.

Last Page of Part I

DVP-01.02

PART 2 - OFFSITE DOSE CALCULATION MANUAL*

TABLE OF CONTENTS

1.0	INTRODUCTION.....	2
2.0	DEFINITIONS	3
3.0	LIQUID EFFLUENT METHODOLOGY	7
4.0	GASEOUS EFFLUENT METHODOLOGY.....	30
5.0	40 CFR 190 AND 10 CFR 72.104(a) DOSE EVALUATION	76
6.0	REFERENCES.....	79

1.0 INTRODUCTION

1.1 Purpose

This manual provides the methodology to calculate radiation doses to individuals in the vicinity of the James A. FitzPatrick Nuclear Power Plant. It also provides methodology for calculating effluent monitor set points and allowable release rates to ensure compliance with Technical Specifications 5.5.1 and 5.5.4, James A. FitzPatrick Nuclear Power Plant, Docket Number 50-333, and 10 CFR 20 1001-20.2402 release criteria.

1.2 Methodologies and Parameters

The ODCM follows the methodology and models suggested by the "Guidance Manual For Preparation of Radiological Effluent Technical Specifications for Nuclear Power Plants" (NUREG-0133 October 1978) and "Calculation of Annual Doses to Man from Routine Releases of Reactor Effluents for the Purpose of Evaluating Compliance with 10 CFR 50, Appendix I" (Regulatory Guide 1.109, Revision 1 dated October 1977). Simplifying assumptions have been made and justified where applicable to provide a more workable document for implementing programmatic controls in the Technical Specifications 5.5.1 and 5.5.4, as well as the procedural details of Part 1 of this document. Alternate calculating methods to those presented here may be used provided the general methodology is similar, well documented and the results are more precise. Additionally, as available, the most up-to-date revision of the Regulatory Guide 1.109 dose conversion factors and site specific environmental transfer factors may be substituted for those currently included and used in this document.

1.3 Document Revision Overview

This is Revision 12 of the ODCM under the procedure designation of DVP-01.02. There were 9 revisions under the previous procedure designation of CDP-15. This revision constitutes the 21st revision of the ODCM since its inception as Rev. 0 of CDP-15.

2.0 DEFINITIONS

Age Groups	Infants, children, teens and adults are age groups evaluated by this ODCM.
Beta	A beta particle (electron)
Beta Dose	The dose component to skin dose due to beta emitting radionuclides in air.
cc	Cubic Centimeter
Ci	Curie. A unit of radioactivity equal to $3.7E+10$ disintegrations per second. See also microCurie (μCi).
C_i	Concentration of a nuclide in the release source. Units of $\mu\text{Ci}/\text{cc}$ or $\mu\text{Ci}/\text{ml}$.
CFR	Code of Federal Regulations
Dose	A measure of the radiation energy deposited per unit mass (in mrem or mrad), that the organ or the individual receives from exposure to radioactive effluents dispersed in the environment.

Dose Commitment

The total dose delivered to the organ or whole body over a 50 year period resulting from uptake of radioactive material.

Dose Factor Normally, a factor that converts the effect of ingesting or inhaling radioactive material into the body, to dose to a specific organ. Body elimination, radioactive decay, and organ uptake are some of the factors that determine a dose factor for a given nuclide.

Dose Pathway

A specific path that radioactive material physically travels through in the environment prior to exposing an individual to its emitted radiation. The grass/cow/milk food chain is a dose pathway.

Dose Rate	The dose received per unit time.
(d/q)	The short-term atmospheric deposition factor (m^{-2}) for ground-level releases and a specified release duration.
$\overline{(D/Q)}$	A long term relative deposition coefficient. A factor with units of $1/m^2$ which describes the deposition of particulate matter from a plume at a point downrange from the source. It can be thought of as the part of the cloud that will fall out and deposit over one square meter of ground.
ECL	The Effluent Concentration Limit (ECL) is equal to 10 times the effluent concentration values listed in 10 CFR 20, Appendix B, Table 2, Column 2.
Gamma	A gamma photon
Gamma Dose	The dose component to skin or whole body dose due to gamma-emitting radionuclides in air.
Ground Plane	Radioactive material deposited uniformly over the ground emits radiation that produces an exposure pathway when an individual is present in the area. It is assumed that an adult receives the same exposure as an infant, regardless of the physical height differences. Only the whole body and skin is considered for the purpose of the ODCM.
H-3	Hydrogen-3, or tritium. An isotope of hydrogen that is a low-energy beta emitter.
I&8DP	Radioiodines and particulates with half-lives greater than eight days (includes H-3 where applicable).
LLD	Lower Limit of Detection. The smallest concentration of radioactive material in a sample that will yield a net count, above system background, that will be detected with 95 percent probability and with only 5 percent probability of falsely concluding that a blank observation represents a "real" signal.
LCO	Limiting Conditions for Operation in Part 1
m^3	Cubic meters
m^2	Square meters

Nuclide	An atomic nucleus that contains a specified number of protons and neutrons. Nuclide (i) signifies a specific nuclide under consideration (e.g., 1st, 2nd, 3rd, etc.). If nuclide (i) is I-131, then the M_i (dose factor) under consideration should be M_{I-131} , for example.
Organ	For the purpose of the ODCM, either the bone, liver, thyroid, kidney, lung, GI-LLI, skin or the W. Body (Whole body). W. Body is considered an organ for consistency with the ODCM nomenclature.
\dot{Q}_i	\dot{Q}_i (dotted) denotes a release rate in Ci/sec or μ Ci/sec for nuclide (i).
Q_i	Denotes Ci of nuclide (i) released over a specified time interval.
Receptor	The individual receiving radiation exposure from effluent releases at JAFNPP at a given location, or who ingests food products contained with trace amounts of radioactive materials. A receptor can receive dose from one or more dose pathways.

Release Source

A subsystem, tank, vent or stack where radioactive material can be released independently of other radioactive release points.

Restricted Area

An area access to which is limited by Entergy for the purpose of protecting individuals against risks from exposure to radiation and radioactive materials.

μ Ci	MicroCuries. 1 Ci = $1E+6$ μ Curies. The μ Ci is the standard unit of radioactivity for all dose calculations in the JAFNPP ODCM.
(x/q)	The short-term atmospheric deposition factor (sec/m^3) for ground-level releases and a specified release duration.
$\overline{(X/Q)}$	A long term relative atmospheric dispersion coefficient. It describes the physical dispersion characteristics of a semi-infinite cloud of noble gases as the cloud travels downwind from the release point.
$\overline{(X/Q)}_r$	Long term finite cloud atmospheric dispersion parameter for computation of external gamma radiation exposures (sec/m^3). (By definition, the gamma (X/Q) is the equivalent relative concentration of radioactivity in a semi-infinite cloud that would yield the same radiation exposure as a finite cloud aloft; it accounts for the actual plume dimensions and elevation above the receptor, and gamma radiation spectra.)

Unrestricted Area

An unrestricted area shall be any area at or beyond the site boundary where access is neither limited nor controlled by Entergy for purposes of protecting individuals against undue risk from exposure to radiation and radioactive materials, or any area within the site boundary used for residential quarters or for industrial, commercial, institutional, and/or recreational purposes.

Vent Building ventilation air exhausts via roof top ducts.

(X/W) The annual average relative concentration (sec/m^3) for a given liquid pathway (potable water or fish ingestion) for a specified release duration.

3.0 LIQUID EFFLUENT METHODOLOGY

3.1 Applicable Site Characteristics

The JAFNPP Final Safety Analysis Report (FSAR) contains the official description of the site characteristics. The description that follows is a brief summary for dose calculation purposes.

The James A. FitzPatrick Nuclear Power Plant is located on the eastern portion of the Nine Mile Point promontory on Lake Ontario in Oswego County, NY. The site is approximately seven miles northeast of the City of Oswego. Radioactive liquid releases normally enter Lake Ontario where the Circulating Water Discharge Tunnel terminates on the lake bottom approximately 1,400 feet from the shoreline.

3.2 10 CFR 20, ECL Limits-Determination of the Fraction (F_L) of Release Limits and Minimum Required Dilution

3.2.1 Requirements

In accordance with Part 1, Section 2.2.1.c.1, the concentration of liquid radioactive material released to unrestricted areas (Appendix G) shall not exceed 10 times the concentrations specified in 10 CFR 20, Appendix B, Table 2, Column 2 for radionuclides other than dissolved or entrained noble gases. Concentration of radionuclides in liquid waste is determined by sampling and analyses in accordance with Part 1, Radiological Effluent Controls, Section 2.2.

In accordance with Part 1, Radiological Effluent Controls, Section 2.2 for dissolved or entrained noble gases, the concentration shall be limited to $2E-4$ $\mu\text{Ci/ml}$.

3.2.2 Methodology

This section presents the calculating method to be used for determining F_L , the fraction of Part 1, Section 2.2.1.c.1 limits, of release concentrations of liquid radioactive effluents.

This method addresses the calculation for a specific release source. Administrative controls are applied to assure that the summation of F_L values for each release source does not exceed the Part 1, Section 2.2.1.c.1 limit. Normally, all potentially radioactive liquid effluents are released to the unrestricted area through a single monitored release path as indicated in Appendix F. However, the service water system presents a potential release point for radioactive liquid effluents. To assure the combined releases do not exceed Part 1, Section 2.2.1.c.1 effluent concentration limits (ECLs), the alarm set point, as determined in Section 3.3 includes a conservatism factor of 0.5.

The basic equation which determines the fraction (F_L) of the ECL is:

Eq. 3-1

$$F_L = \left[\frac{f_1}{f_2} \right] \times \sum_{i=1}^n \left[\frac{C_i}{ECL_i} \right]$$

Where:

- F_L = The fraction of ECLs resulting from the release source being discharged (dimensionless)
- f_1 = The undiluted release rate of the release source as measured at the liquid effluent monitor location, in gpm.
- f_2 = The discharge structure exit flow in gpm. (Summation of circulating water pump and service water pump discharge flow; minus the flow redirected for tempering)
- C_i = Each undiluted concentration of nuclide (i) in $\mu\text{Ci/ml}$ (includes both gamma and beta emitters)
- ECL_i = The ECL for nuclide (i) in $\mu\text{Ci/ml}$. The ECL_i is equal to 10 times the corresponding effluent concentration value listed in 10 CFR 20, Appendix B, Table 2, Column 2.

Using this approach, the fraction of the ECL is determined using a nuclide-by-nuclide evaluation.

3.2.3 Calculating Process for Determining f_2/f_1

The following section provides a procedure for determining the minimum required dilution factor (f_2/f_1) to ensure that $F_L \leq 1$ during the actual release. With $F_L \leq 1$, the minimum required dilution factor can be expressed as:

Eq. 3-2

$$\left(\frac{f_2}{f_1}\right)_{\min} = \sum_{i=1}^n \frac{C_i}{ECL_i}$$

- a. Obtain (C_i), the undiluted assay value of nuclide (i), in $\mu\text{Ci/ml}$.
- b. From Appendix A, Table A-1, obtain the corresponding ECL_i for nuclide (i) in $\mu\text{Ci/ml}$. The ECL_i is equal to 10 times the corresponding effluent concentration value listed in 10 CFR 20, Appendix B, Table 2, Column 2.
- c. Divide C_i by ECL_i .
- d. Repeat steps b and c above for each nuclide and sum the totals.
- e. Enter only the total Gamma activity and the minimum required dilution factor $(f_2/f_1)_{\min}$ on the liquid release permit.

3.3 Determination of Setpoints for Radioactive Liquid Effluent Monitors

3.3.1 Requirements

Part 1, Section 2.1.1.c.1 requires that the radioactive liquid effluent monitor be operable and set to initiate an alarm and/or trip in the event that the limits of Part 1, Section 2.2.1.c.1 are approached. The alarm and/or trip setpoints shall be determined and adjusted by the methodology which follows. The setpoint values should be applied above normal background levels.

The alarm setpoint for the liquid effluent radiation monitor is derived from the ECLs applied at the unrestricted area boundary where the discharge tunnel flows into Lake Ontario.

An Implementation Plan as defined in AP-02.04 shall be initiated and included in any ODCM revision whenever the methodology for calculating liquid setpoints is changed and the change in methodology results in a new calculated setpoint.

3.3.2 Methodology

The alarm setpoints do not consider dilution, dispersion, or decay of radioactive material beyond the unrestricted area boundary (i.e., the alarm setpoints are based on a concentration limit at the end of the discharge tunnel).

3.3.3 Radwaste Liquid Effluent Monitor

- a. A sample of each batch of liquid radwaste is analyzed for I-131 and other principal gamma emitters prior to release. The fraction F_L of 10 CFR 20, ECLs, and the minimum required dilution factor to achieve $F_L = 1$ is determined in accordance with the preceding section for the activity to be released. For cases other than minimum dilution calculation, $F_L < 0.5$.
- b. A conservative alarm and/or trip setpoint ($\mu\text{Ci}/\text{ml}$) is determined in accordance with the following equation:

Eq. 3-3

$$S = 0.5 \times \frac{C_g}{F_L}$$

Where:

- S = The alarm and/or trip set point above background corresponding to the limiting concentration of undiluted liquid effluent ($\mu\text{Ci}/\text{ml}$).
- 0.5 = Conservatism factor to account for releases from multiple points, and to allow for nuclides not detected by the monitor.

C_g = Total undiluted concentration of gamma emitters in $\mu\text{Ci/ml}$ as determined in the laboratory.

F_L = The fraction of the Part 1, Section 2.2.1.c.1, ECLs for unrestricted areas resulting from the release source being discharged.

3.3.3.1 Calculating Process

The following section provides a procedure for determining the radwaste liquid effluent monitor set point. Typical parameter values are used for illustration.

- Determine the undiluted gamma concentrations from laboratory analysis of the liquid effluent sample. For the purpose of this example, assume only Co-60 is present at a concentration of $3.0\text{E-}05 \mu\text{Ci/ml}$.
- Determine the beta activity from the most recent composite results (C_b). For the purposes of this example, assume only H-3 is present at a concentration of $2.2\text{E-}02 \mu\text{Ci/ml}$.
- Determine f_2 from pump curves and current plant operating configuration. A typical value is $3.78\text{E+}5 \text{ gpm}$.
- Determine the minimum required dilution factor in accordance with equation 3-2.

$$\left[\frac{f_2}{f_1} \right]_{\min} = \sum_{i=1}^n \frac{C_i}{(ECL)_i}$$

For this example, ECL values for Cobalt-60 and Tritium are obtained from Appendix A, Table A-1 (ECLs):

$$\left[\frac{f_2}{f_1} \right]_{\min} = \frac{3\text{E-}05}{3\text{E-}05} + \frac{2.2\text{E-}02}{1\text{E-}2}$$

$$\left[\frac{f_2}{f_1} \right]_{\min} = 3.2$$

- Determine or calculate the required f_1 at the liquid effluent monitor location. A typical value is 100 gpm .

- f. A typical value of the dilution factor from current plant operating conditions is:

$(3.78\text{E}+5 \text{ gpm})/100 \text{ gpm} = 3,780$, which is >3.2 . Therefore the release can be made at the current release rates and concentrations maintained within the 10 CFR 20 Part 1, Section 2.2.1.c.1 ECLs.

- g. Determine F_L , the fraction of 10 CFR 20 ECLs resulting from the release source being discharged at a dilution factor of 3,780, in accordance with equation 3-1.

$$F_L = \left[\frac{f_1}{f_2} \right] \times \sum_{i=1}^n \frac{C_i}{(ECL)_i}$$

$$= (100/3.78\text{E}+5) \times 3.2 \text{ (from 3.3.3.1.d)}$$

$$= (2.65\text{E}-4) \times 3.2$$

$$= 8.47\text{E}-4$$

- h. The liquid effluent monitor setpoint, S in $\mu\text{Ci/ml}$, from equation 3-3 is:

Eq. 3-3a

$$S = 0.5 \times \frac{C_g}{F_L}$$

$$= 0.5 \times [(3\text{E}-5)/(8.47\text{E}-4)]$$

$$= 1.77\text{E}-2$$

- i. Appropriate calibration factors are applied to this limiting concentration determined in step 3.3.3.g to determine an effluent monitor alarm potentiometer set point.

3.3.4 Service Water Liquid Effluent Monitor

- a. A conservative alarm setpoint (cps) for the service water liquid effluent monitor is determined in accordance with the following methodology:

$$DF = \frac{f_2}{f_1} \quad \text{Eq. 3-3b}$$

Where:

- DF = dilution factor resulting from the flow rate in the discharge structure divided by the undiluted release rate of the effluent release source.
- f_1 = the undiluted release rate of the effluent source measured at the service water liquid effluent monitor (gpm).
- f_2 = the discharge structure flow rate in gpm (summation of circulating water pumps and service water pumps discharge flows; minus the flow redirected for tempering).

$$SP = \frac{0.5 \times ECL_w \times DF}{Eff} + Bkg \quad \text{Eq. 3-3c}$$

Where:

- SP = set point of liquid effluent monitor in cps.
- 0.5 = conservatism factor to account for releases from multiple points or a reduction in the DF value due to changes in discharge canal flow, and to allow for nuclides not detected by the monitor.
- C_g = Total undiluted concentration of gamma emitters in $\mu\text{Ci/ml}$

$$= \frac{C_g}{n \sum_{i=1} \left[\frac{C_i}{ECL_i} \right]}$$

- ECL_w = weighted ECL for historical nuclide mix (See Section 3.3.4.b)
- Eff = efficiency of the liquid effluent monitor in $\mu\text{Ci/ml/cps}$.
- Bkg = normal monitor background (cps).

- b. Those nuclides present in previous batch releases from the liquid radwaste effluent system, nuclides present in historical Radioactive Effluent Release Reports or those nuclides present in the service water system may be used to calculate the ECL_w value. Other values for ECL_w may be used based on plant conditions (i.e. in the event of known leakage into the RBCLC system).

3.4 Dose Determination for Radioactive Liquid Effluents

3.4.1 Annual Dose Assessment-Radioactive Effluent Release Report Submittal

a. Requirements

Technical Specification 5.6.3 requires a Radioactive Effluent Release Report to be submitted that includes an assessment of the radiation doses to the public due to the radioactive liquid and gaseous effluents released from the unit during the previous calendar year. The dose assessment required by this report is due prior to May 1 of each year in accordance with 10 CFR 50.36a.

b. Methodology

This section provides the methodology to calculate the doses to all age groups and organs from all radionuclides identified in the liquid effluents. The method is based on the methodology suggested by NUREG-0133, October 1978, Sections 4.3 and 4.3.1 and Regulatory Guide 1.109. The determination of viable liquid dose pathways is described in Appendix A, Table A-4.3. The site-related dose factors for all viable pathways are listed in Appendix A, Tables A-2 and A-3. Table A-3 dose factors are compiled by age groups, for all organs and radionuclides common to a Boiling Water Reactor (BWR).

The following equation provides for a dose calculation to the whole body or any organ for a given age group based on actual release conditions during a calendar year for radioactive liquid releases. The equation for $D_{i\tau}$ is to be summed over all i nuclides:

$$D_{i\tau} = \frac{A_{i\tau} \Delta t_1 Q_{il}}{(DF)_i} \quad \text{Eq. 3-4a}$$

$$D_{\tau} = \sum_{i=1}^n D_{i\tau} \quad \text{Eq. 3-4b}$$

Where:

- D_{τ} = Total dose commitment for organ τ of an age group.
- $D_{i\tau}$ = Dose commitment in mrem received by organ τ of age group (to be specified) resulting from releases during time interval Δt_1 for nuclide (i).
- $A_{i\tau}$ = The site-related dose commitment factor to the whole body or any organ τ for each identified radionuclide (i). The $A_{i\tau}$ values listed in Appendix A, Tables A-2 and A-3 are site specific, in mrem/hr per $\mu\text{Ci/ml}$. Dose commitment factors are compiled by age groups, for organs and radionuclides common to a BWR environment. The derivation of $A_{i\tau}$ values is described in Appendix A, Table A-4.1.

- Δt_1 = The number of hours in the calendar year.
- Q_{i1} = The total quantity of nuclide (i) released during the time period Δt_1 , in μCi .
- $(DF)_1$ = The total volume of dilution released during Δt_1 (i.e., summation of circulating water pump and service water pump discharge flow; minus the flow redirected for tempering).

By entering the appropriate annual parameter values onto a form similar to that shown in Table 3.4.2, whole body or organ doses may be calculated as outlined in step 3.4.2.c.

In addition, more realistic assumptions may be made concerning the dilution and ingestion of fish and potable water by individuals who live and fish in the area.

3.4.2 **Monthly Dose Assessment - Verification of Compliance with 10 CFR 50, Appendix I Limits**

a. **Requirements**

Part 1, Section 2.3.2 requires an assessment to be performed at least once every month in any quarter in which radioactive effluent is discharged, to verify that radioactive liquid effluents from the plant do not result in a cumulative dose in excess of 1.5 mrem to the whole body and 5 mrem to any organ in a calendar quarter, and to verify that radioactive liquid effluents from the plant do not result in a cumulative dose in excess of 3.0 mrem to the whole body and 10 mrem to any organ during a calendar year.

b. **Methodology**

This section presents the calculating method to be used for the 10 CFR 50 Appendix I compliance verification. The method is based on the models suggested by NUREG-0133 October 1978 Sections 4.3 and 4.3.1 and Regulatory Guide 1.109.

1. General Approach

The general approach used is similar to that described for use in calculations for the Annual Dose Assessment Report. The liquid effluent dose pathways considered are fresh water fish, potable water and lake shoreline deposits (Appendix D). These pathways need to be considered for verifying compliance with the requirements specified above.

Site-specific dose factors for the fresh water fish, potable water and shoreline pathways are provided in Appendix A, Tables A-2 and A-3.

For JAFNPP, both the adult and teenager are normally the most limiting age groups (Appendix D), but the dose for child and infant may also be calculated by this method using the appropriate dose factors from Appendix A, Table A-3.

The following equation is used to determine a dose to the whole body or any organ for a given age group based on actual release conditions during a specified time interval for radioactive liquid releases. The equation for $D_{i\tau}$ is to be summed over all i nuclides:

$$D_{i\tau} = \frac{A_{i\tau} \Delta t_1 Q_{i1}}{(DF)_{i1}} \quad \text{Eq. 3-5a}$$

$$D_{\tau} = \sum_{i=1}^n D_{i\tau} \quad \text{Eq. 3-5b}$$

Where:

- D_{τ} = Dose commitment for organ τ of an age group.
- $D_{i\tau}$ = Dose commitment in mrem received by organ τ of age group (to be specified) from release time interval Δt_1 for nuclide (i).
- $A_{i\tau}$ = The dose factor for the fresh water fish, potable water lake shoreline deposits pathways for nuclide (i) for organ τ of age group (to be specified). (Appendix A, Tables A-2 and A-3 for $A_{i\tau f}$, $A_{i\tau w}$ and $A_{i\tau sh}$).
- Δt_1 = The number of hours in the reporting period.
- Q_{i1} = The total quantity of nuclide (i) released during the time period Δt_1 in μCi .
- $(DF)_{i1}$ = The total volume of dilution released during Δt_1 (i.e., the summation of circulating water pumps and service water pumps discharge volumes; minus the volume redirected for tempering).

2. Limited Analysis Approach

Based on the radionuclide distribution typical in radioactive effluents at JAFNPP, the calculated dose to individuals are dominated by the radionuclides, Cs-134, Cs-137, Zn-65, Mn-54 and Co-60. From 1980 through 1987, these nuclides, in the fresh water fish and potable water pathways, contributed at least 92 percent of the adult's whole body dose and at least 81 percent of the teenager's liver dose, which is the critical organ. Liquid effluent for the years 2002 through 2009 were also reviewed. Liquid releases have decreased dramatically as compared to 1980 – 1987. H-3 liquid releases have decreased; however, not as dramatically as the other nuclides and is added to this list. Therefore, the dose commitment due to radioactivity in liquid effluents may be reasonably evaluated by limiting the dose calculating process to these six radionuclides for the adult's whole body and the teenager's liver dose.

To allow for any unexpected variability in the radionuclide distribution, a conservatism factor of 0.8 is introduced into the equation. After calculating the dose based on these six nuclides, the cumulative dose should therefore be divided by 0.8. (Refer to Appendix D for a detailed evaluation and explanation of this limited analysis approach).

If the limited analysis approach is used, the calculation should be limited to the adult's whole body dose and teenager's liver dose from the fish and potable water pathways. Only the five previously specified nuclides need be evaluated.

3. Approach Selection Criteria

The limited analysis approach fully satisfies the requirements and can thus be used for routine releases. The more general approach may be used for more refined calculations for routine releases.

For non-routine releases, i.e., other than through the discharge canal, Section 3.4.3 is to be used.

c. Calculating Method

The methodology that follows is a step-by-step breakdown to calculate doses based on equation 3-5a. If the limited analysis approach is used, the calculation should be limited to the adult whole body dose and teenager's liver dose from the fish and potable water pathways. Only the five previously specified radionuclides need to be evaluated for the limited approach.

NOTE: Table 3.4.2 provides a convenient form for compiling the dose accounting information.

1. Determine (Δt_1) the number of hours of the reporting period.
2. Obtain $(DF)_1$ for the time period Δt_1 for the release source(s) of interest. DF_1 is the total volume of dilution, (i.e. the circulating water flow multiplied by the time) in milliliters.

3. Obtain Q_{i1} (μCi) for nuclide (i) for the time period Δt_1 .
4. Obtain $A_{i\tau}$ from the appropriate Liquid Dose Factor Table: Appendix A, Table A-2 for the fish and potable water pathways; Appendix A, Table A-3 for all other pathways.
5. Solve for Dose (i)

$$D_{i\tau} = \frac{A_{i\tau} \times \Delta t_1 \times Q_{i1}}{(DF)_{i\tau}} \quad \text{Eq. 3-6a}$$

6. Repeat steps 3 through 5 above for each nuclide reported and each organ required. If the limited analysis method is used, limit the radionuclides to H-3, Co-60, Mn-54, Zn-65, Cs-134 and Cs-137 and determine the adult's whole body dose and the teenager's liver dose.
7. Sum the $D_{i\tau}$ values to obtain the total dose. If the limited analysis method is being used, divide the cumulative dose by a conservatism factor of 0.8 to account for any unexpected variability in radionuclide distribution and any contribution from the lake shoreline deposits pathway.

$$D_{\tau} = \frac{\sum_{i=1}^n D_{i\tau}}{(0.8^*)} \quad \text{Eq. 3-6b}$$

* When limited analysis method is used

TABLE 3.4.2
FISH PATHWAY

Time/Date Start: _____ Time/Date Stop: _____ Δt_1 hours

Total Dilution Volume (DF)₁: _____ mls

Age Group: _____ Organ: _____ Dose Factor Table No. _____

Nuclide (i)	Q _{i1}	A _{it}	Dose (i) mrem
H-3			
Mn-54			
Co-60			
Zn-65			
Cs-134			
Cs-137			
Others:			
Total Dose $\tau =$			mrem
Eq. 3-6a If based on limited analysis, divided by 0.8			mrem

3.4.3 **Dose Assessment - Methodology For Liquid Releases Through the Storm Drain**

This section provides the methodology to calculate the doses to all age groups and organs from liquid releases other than routine releases through the discharge canal, such as releases via the storm drain.

a. **Requirements**

Non-routine liquid releases, when they occur, are to be added into the Radioactive Effluent Release Report(s) and the annual dose assessment report (Section 3.4.1) and the verification of compliance with 10 CFR 50 Appendix I regulatory guidelines (Section 3.4.2). The following are the Technical Specification requirements for non-routine liquid releases, other than through the discharge canal.

Technical Specification 5.6.3 requires a Radioactive Effluent Release Report to be submitted prior to May 1 of each year in accordance with 10 CFR 50.36a that includes an assessment of the radiation doses to the public due to the radioactive liquid and gaseous effluents released from the unit during the previous calendar year.

Part 1, Section 2.3.2.c requires an assessment to be performed at least once every month in any quarter in which radioactive effluent is discharged, to verify that radioactive liquid effluents from the plant do not result in a cumulative dose in excess of 1.5 mrem to the whole body and 5 mrem to any organ in a calendar quarter, and to verify that radioactive liquid effluents from the plant do not result in a cumulative dose in excess of 3.0 mrem to the whole body and 10 mrem to any organ during a calendar year.

b. **Methodology**

Exposure pathways of interest are the ingestion of contaminated fish and drinking of contaminated water. Exposure from shoreline deposits following non-routine releases was determined to be insignificant and has been excluded from this section.

The model used accommodates (in a single unified approach) releases ranging from instantaneous (slug) to continuous (steady-state).

The method of analysis selected for dilution of the released radioactivity in the lake makes use of the continuous-release model in Regulatory Guide 1.113, adapted to provide annual average concentrations for releases of shorter duration (including instantaneous). The model assumes an exposure interval of one year, regardless of the duration of the release.

For the fish-ingestion pathway, the fish is assumed to be adjacent to the release point for the duration of the release, and then to follow the radioactive plume for an overall exposure interval of one year. For the potable water pathway, the water supply is at 8.5 miles west of the plant (Oswego water intake), and is assumed to be continuously contaminated as a result of frequent current reversals.

The following equations present the annual dose due to the potable water and freshwater fish pathways for any given release, regardless of the release duration. These doses are to be assigned to an appropriate reporting interval (e.g., quarter) during which the release occurred.

Potable Water Pathway

Eq. 3-7a

$$D_{i\tau} = K_a \times U_f \times DF_{i\tau} \times C_i \times \dot{q} \times (X/W) \times \Delta t$$

$$D_\tau = \sum_{i=1}^n D_{i\tau}$$

Eq. 3-7b

Where:

- D_τ = Dose commitment for organ τ of an age group (mrem).
- $D_{i\tau}$ = Dose commitment received by organ τ of an age group (to be specified) for nuclide i (mrem).
- K_a = Is the unit conversion factor, 1.0E+09 (ml-pCi per liter- μ Ci).
- U_f = Is the water consumption rate for the age group of interest.

Adult:	730 liters/yr
Teen:	510 liters/yr
Child:	510 liters/yr
Infant:	330 liters/yr
- $DF_{i\tau}$ = Dose conversion factor (mrem per pCi ingested) for radionuclide i , for organ τ and age group of interest, from Tables E-11 through E-14 of Regulatory Guide 1.109.
- C_i = The average activity concentration of nuclide i in the effluent at the release point into the lake (μ Ci/ml).

- \dot{q} = The volumetric discharge rate of the effluent (m³/sec). \dot{q} is equal to the total volume of contaminated liquid release (m³) divided by the duration of the release.
- (X/W) = The annual average relative concentration (sec/m³) for the potable water pathway, as shown in Table 3.4.3 for a list of release durations. Release durations were selected to accommodate a change of no more than 20% between consecutive X/Ws.
- Δt = The exposure period which is one year (yr).

Freshwater Fish Pathway

$$D_{i\tau} = K_a \times U_f \times BF_i \times DF_{i\tau} \times C_i \times \dot{q} \times (X/W) \times \Delta t$$

Eq. 3-8a

$$D_\tau = \sum_{i=1}^n D_{i\tau}$$

Eq. 3-8b

Where:

- D_τ = Dose commitment of organ τ of an age group (mrem).
- $D_{i\tau}$ = Dose commitment received by organ τ of an age group (to be specified) for nuclide i (mrem).
- K_a = Is the unit conversion factor, 1.0E+09 (ml-pCi per liter- μ Ci).
- U_f = Is the freshwater fish consumption rate for the age group of interest, as follows:
- Adult: 21 (kg/yr)
 Teen: 16 (kg/yr)
 Child: 6.9 (kg/yr)
- BF_i = The bioaccumulation factor for radionuclide i , in freshwater fish (pCi/kg per pCi/liter), from Table A-1 of Regulatory Guide 1.109.

- DF_{ir} = Dose conversion factor (mrem per pCi ingested) for radionuclide i, for organ and age group of interest, from Tables E-11 through E-14 of Regulatory Guide 1.109.
- C_i = The average activity concentration of nuclide i in the effluent ($\mu\text{Ci/ml}$) at the release point into the lake.
- q = The volumetric discharge rate of the effluent (m^3/sec).
 q is equal to the total volume of contaminated liquid released (m^3) divided by the duration of the release.
- (X/W) = The annual average relative concentration (sec/m^3) for the fish ingestion pathway, as shown in Table 3.4.3 for a list of release durations. Release durations were selected to accommodate a change of no more than 20% between consecutive X/Ws.
- Δt = The exposure period which is one year (yr).

TABLE 3.4.3

RELEASE INTERVAL VERSUS ANNUAL AVERAGE CONCENTRATION (X/W)

Release Duration (days)	(X/W) (sec/m ³)	
	Fish Ingestion	Potable Water
0.0	3.49E-04*	1.84E-04*
> 0.0 - 0.5	3.89E-04	1.88E-04
> 0.5 - 1.0	4.28E-04	1.92E-04
> 1.0 - 1.5	4.68E-04	1.96E-04
> 1.5 - 2.5	5.47E-04	2.04E-04
> 2.5 - 3.5	6.26E-04	2.12E-04
> 3.5 - 5.0	7.44E-04	2.25E-04
> 5.0 - 6.5	8.62E-04	2.37E-04
> 6.5 - 8.5	1.02E-03	2.54E-04
> 8.5 - 11.0	1.22E-03	2.75E-04
> 11.0 - 13.5	1.41E-03	2.95E-04
> 13.5 - 17.0	1.69E-03	3.24E-04
> 17.0 - 21.0	2.01E-03	3.57E-04
> 21.0 - 25.5	2.36E-03	3.95E-04
> 25.5 - 31.0	2.80E-03	4.40E-04
> 31.0 - 38.0	3.35E-03	4.98E-04
> 38.0 - 46.0	3.98E-03	5.64E-04
> 46.0 - 56.0	4.77E-03	6.47E-04
> 56.0 - 68.0	5.71E-03	7.46E-04
> 68.0 - 82.0	6.82E-03	8.61E-04
> 82.0 - 99.0	8.16E-03	1.00E-03
> 99.0 - 119.5	9.77E-03	1.17E-03
> 119.5 - 144.0	1.17E-02	1.37E-03
> 144.0 - 173.5	1.40E-02	1.62E-03
> 173.5 - 209.0	1.68E-02	1.91E-03
> 209.0 - 251.5	2.02E-02	2.25E-03
> 251.5 - 302.5	2.42E-02	2.67E-03
> 302.5 - 365.0	2.90E-02**	3.13E-03**

* Instantaneous release (for reference)

** Continuous release

3.5 Dose Projections - Determination of Need to Operate Liquid Radwaste Treatment System

3.5.1 Requirements

Part 1, Section 2.4.1.c requires that appropriate subsystems of the liquid radwaste treatment system be used to reduce radioactive material in untreated liquid effluents when the projected monthly dose due to liquid releases to unrestricted areas, averaged over 31 days, would exceed 0.06 mrem to the whole body or 0.2 mrem to any organ. Doses are to be projected at least once per month.

3.5.2 Calculating Methodology

The method is based on whole body dose and limiting organ dose (liver) as calculated for the Monthly Dose Assessment. The adult is normally the limiting age group to be used for the dose projection to the whole body. The teen is normally the limiting age group to be used for the dose projection to the liver. Other age groups and/or limiting organs may be used if previous dose calculations indicate that the adult and teen are not the limiting age groups and the liver is not the limiting organ.

The following calculating methodology is provided for performing this dose projection.

a. Monthly Dose Projection

Each month the expected dose to man shall be projected. Projections shall be based on historical or prior month dose/Curie and historical or prior month concentration conversion factors. The historical factors are calculated from historical release data for both a refuel outage year and a non-refuel outage year. The current historical factors are on file within the Chemistry Department.

1. Each month make an estimate of the volume of liquid radwaste to be discharged during that month. The following variables should be considered in estimating radwaste volumes to be released:
 - (a) Projected plant operational status (run, shutdown, refuel, etc.).
 - (b) Status of radwaste treatment equipment. Equipment which is inoperable, such as the waste concentrator, should be factored into the source term or volume of liquid waste to be discharged from the plant.
 - (c) Additional factors indicating that actual liquid releases could differ significantly in the next month.
 - (d) Historical liquid waste discharge volumes.

2. Determine which dose/Ci and Ci/gal conversion factors should be used. Historical conversion factors can be used. Prior month conversion factors may be used if they are more representative of current release conditions. In the event that there was no release of liquid radwaste during the prior month, then the historical conversion factors can be used if liquid releases are expected during the projection month.
 - (a) The prior month dose/Ci conversion factors are calculated by obtaining the results of the prior month adult whole body and teen liver dose calculation.
 - (b) Divide the doses by the total number of Curies released from the plant during this same time period. This calculation yields a dose per Curie conversion factor for the adult whole body and teen liver for the most recent prior calendar month.
 - (c) The prior month Ci/gal concentration factor is calculated by obtaining the total number of Curies released from the plant during the prior month. Divide the Curie total by the total number of gallons of waste discharged during this same time period. This calculation yields the Ci/gal concentration conversion factor for the most recent month.
3. Multiply the estimated volume of liquid radwaste to be discharged, by the historical or prior month dose/Ci and Ci/gal conversion factors. This calculation yields a dose estimate to the adult whole body and teen liver for the projected month.
 - (a) Adult Whole Body Dose

$$TD_{tb} = T_v \times C_g \times D_{ctb}$$

- (b) Teen Liver Dose

$$TD_l = T_v \times C_g \times D_{cl}$$

Where:

T_v = Total volume of radwaste to be discharged during the month in gallons (estimated)

C_g = Curies per gallon conversion factor (historical or prior month)

D_{ctb} = Dose per Curies adult whole body (historical or prior month) in mrem

TD_{tb} = Total dose for adult whole body in mrem

D_{cl} = Dose per Curies teen liver (historical or prior month) in mrem

TD_1 = Total dose for teen liver in mrem

If the calculated doses are greater than 0.06 mrem to the whole body or 0.2 mrem to the liver, the appropriate subsystems of the liquid radwaste system shall be used to reduce the radioactivity levels prior to release.

b. Batch Dose Projections

The projected dose due to release of each batch can be made prior to the release of the batch. The projection of the dose related to each batch allows for an accurate method of estimating the dose from each batch prior to release and confirms the need to operate the subsystems of the radwaste system. The projection of dose based on each batch release helps to eliminate any inaccuracies as a result of using historical or estimated values in the monthly projection. The use of this dose projection on a batch release basis is not required by the technical specification and is used at the discretion of the Chemistry/Environmental Management.

The method is based on whole body dose and limiting organ dose (liver) as calculated in step 3.4.2. The adult is the limiting age group for projecting dose to the whole body and the teen is the limiting age group for projecting dose to the liver.

The following calculating methodology is provided for performing this dose projection:

1. Obtain the latest result of the monthly calculation of the adult whole body and teen liver dose (step 3.4.2).
2. Divide the doses by the total number of Curies released from the plant during the month. This yields a dose per Curie conversion factor for the adult whole body and teen liver for the most recent calendar month.
3. Maintain a running total of the Curies released during the past 30 days. Add to this the Curie content of the current batch to be released (31 day total).

4. Multiply the 31 day total from step (3), above by the dose per Curie conversion factors calculated in step (2), above. This yields the 31 day, whole body and liver doses projected for the release of the current batch.
5. If the calculated doses are greater than 0.06 mrem to the whole body or 0.2 mrem to the liver, the appropriate subsystems of the liquid radwaste system shall be used to reduce the radioactivity levels prior to release.

c. Continuous Liquid Release Dose Projections

Each month that a continuous liquid release is in progress, or is anticipated, the expected dose to man can be projected. The projection shall be based on historical, prior month or current dose/Curie and nuclide concentration (Curie/gallon) conversion factors. The historical conversion factors are calculated from prior releases. The prior month conversion factors are calculated from the prior month continuous liquid releases if such releases occurred. Current conversion factors are calculated from samples obtained at or near the beginning of the dose projection month.

1. Determine which dose/Ci and Ci/gal conversion factors should be used. Historical conversion factors can be used. Prior month or current conversion factors should be used if they are more representative of current release conditions.
 - (a) The current month Ci/gal concentration is calculated by using current sample results for radionuclide concentration and converting the results to Ci/gal.
 - (b) The current month estimated Curies released is calculated by multiplying the concentration by the known or expected flow rates for the effluent pathway times the period of release.
 - (c) Using the dose assessment methodology specified in section 3.4, calculate the adult whole body and teen liver doses using known or estimated flow rates and dilution factors.
 - (d) Divide the doses calculated in section (c) above by the estimated number of Curies to be released. This calculation yields a dose per Curie conversion factor for the current release parameters.
 - (e) The prior month dose/Ci conversion factors are calculated by obtaining the results of the prior month adult whole body and teen liver dose calculations.
 - (f) Divide the doses by the total number of Curies released from the plant via continuous releases during this same time period. This calculation yields a dose per Curie conversion factor for the adult whole body and teen liver for the most recent prior calendar month.

- (g) The prior month Ci/gal concentration factor is calculated by obtaining the total number of Curies released from the plant via continuous releases during the prior month. Divide the Curie total by the total number of gallons of waste discharged during this same time period. This calculation yields the Ci/gal concentration conversion factor for the most recent month.
2. Multiply the estimated volume of continuous liquid effluent to be discharged by the historical, prior month or current dose/Ci and Ci/gal conversion factors. This calculation yields dose estimates to the adult whole body and teen liver for the projected month.

(a) Adult Whole Body Dose $TD_{tb} = T_v \times C_g \times D_{ctb}$

(b) Teen Liver Dose $TD_l = T_v \times C_g \times D_{cl}$

Where:

T_v = Total volume of radwaste to be discharged during the month in gallons (estimated)

C_g = Curies per gallon conversion factor (historical, prior month, or current)

D_{ctb} = Dose per Curies adult whole body (historical, prior month, or current) in mrem

TD_{tb} = Total dose for adult whole body in mrem

D_{cl} = Dose per Curie teen liver (historical, prior month, or current) in mrem

TD_l = Total dose for teen liver in mrem

If the calculated doses are greater than 0.06 mrem to the whole body or 0.2 mrem to the liver or other critical organ, efforts should be made to reduce the effluent release rate or concentration.

d. Total Liquid Release Dose Projections

Doses from continuous releases, when they occur, should be added to doses from batch releases to ensure that the limits, 0.06 mrem to the whole body or 0.2 mrem to any organ, are not exceeded.

4.0 GASEOUS EFFLUENT METHODOLOGY

4.1 Gaseous Waste Streams

James A. FitzPatrick Nuclear Power Plant (JAFNPP) discharges gaseous effluents through a stack, and discharges ventilation air from the reactor building, turbine building, radwaste building, and refuel floor through separately monitored vent release points. There are three vent release locations. The refuel floor and reactor building vent is a combined release point. Normal gaseous effluent streams, and effluent discharge points are tabulated in Appendix F, Table F-1.

For the purpose of estimating offsite radionuclide concentrations and radiation doses, radionuclide concentrations are first measured in gaseous effluents and ventilation air exhausted from the plant. Part 1, Radiological Effluent Controls, Table 3.2-1 identifies the specific radionuclides in gaseous discharges for which sampling and analysis is done.

4.2 Data Requirements for Gaseous Effluent Calculations

Dose calculations to demonstrate compliance with Part 1, Sections 3.2, 3.3 and 3.4 are normally performed using historical meteorological data and receptor location(s). Historical meteorological data for use in performing dose calculations are provided in Appendix C. Dose calculations to show conformance with Part 1 dose limits may be performed using real meteorological data, real receptor locations, and sector wind frequency distribution if desired.

Historical meteorological data factors are calculated and used in dose calculations for the Radioactive Effluent Release Report. The report shall be submitted prior to May 1 of each year in accordance with 10 CFR 50.36a. Historical information and conservative receptor assumptions, are also used for ease of Part 1, Limiting Conditions for Operation (LCO) dose limit calculations. JAFNPP uses an elevated release model for stack discharges and mixed mode model for reactor, turbine, radwaste and refuel floor vents. Those radionuclides that appear in the gaseous effluent dose factor tables are representative of BWR isotopes that may be considered in dose calculations.

The historical meteorological data and associated dispersion factors (X/Q , D/Q) are found in Appendix C. The dispersion factors used for receptor dose calculations are calculated based on site meteorological data and plant specific release point parameters.

4.3 Instantaneous Release Rate and Set Point Determination

4.3.1 Determining Instantaneous Noble Gas Release Rates

a. Requirements

Part 1, Radiological Effluent Controls, Section 3.2.1.c limit the instantaneous dose rate from noble gases in airborne releases from the plant to ≤ 500 mrem/yr - whole body, and $\leq 3,000$ mrem/yr - skin.

The results of the sampling and analysis program of Part 1, Radiological Effluent Controls, Table 3.2-1 are used to demonstrate compliance with these limits.

b. Methodology

The instantaneous dose rates to the whole body and skin from noble gases are evaluated to determine gaseous effluent release rates and alarm and/or trip set points.

The following calculating method is provided for determining the instantaneous dose rates to the whole body and skin from noble gases in all monitored airborne release paths from JAFNPP. Conservatism factors in the instantaneous release rate equations are adequate to account for simultaneous releases from the NMP stack and vent. JAFNPP discharges gaseous effluents through a stack, and ventilation air from the reactor building, turbine building, radwaste building, and refuel floor through monitored vent release points.

The calculating methods are in accordance with NUREG-0133, October 1978, Section 5.1 and 5.2.

The equations for computing instantaneous dose rates are:

Whole Body Dose Rate

Vent

Eq. 4-1a

$$DR_{TB} = \sum_{i=1}^n K_i x(\overline{X/Q}) x \dot{Q}_i$$

Elevated Stack

Eq. 4-1b

$$DR_{TB} = \sum_{i=1}^n K_i x(\overline{X/Q})_y x \dot{Q}_i$$

The equations for DR_{TB} are to be summed over all vent and elevated stack release sources.

Skin Dose Rate**Vent**

$$DR_{SKIN} = \sum_{i=1}^n [L_i + 1.1 M_i](\overline{X/Q})_y x \dot{Q}_i$$

Eq. 4-2a

Elevated Stack

$$DR_{SKIN} = \sum_{i=1}^n [L_i(\overline{X/Q}) + 1.1 M_i(\overline{X/Q})_y] x \dot{Q}_i$$

Eq. 4-2b

Where:

- DR_{TB} = Whole body dose rate from noble gases in airborne releases, in mrem/sec.
- DR_{SKIN} = Skin dose rate from noble gases in airborne releases in mrem/sec.
- K_i = The whole body dose factor due to gamma emissions for each noble gas nuclide (i) reported in the release source, in mrem-m³/μCi-sec.
- L_i = The skin dose factor due to beta emissions for each noble gas nuclide (i) reported in the assay of the release source in mrem-m³/μCi-sec.
- M_i = The air dose factor due to gamma emissions for each noble gas nuclide (i) reported in the assay of the release source. The constant 1.1 converts 'mrad' to 'mrem' since the units of M_i are in: (mrad-m³/μCi-sec)

- $\overline{(X/Q)}$ = For vent or elevated stack releases, the highest annual average, concentration X/Q , calculated using long term historic meteorological data, for any land sector, at or beyond the site boundary, in sec/m^3 (Appendix C, Table C-1).
- $\overline{(X/Q)}_y$ = For elevated stack releases, the highest annual average, finite cloud X/Q , calculated using long term historic meteorological data, for any land sector, at or beyond the site boundary, in sec/m^3 (Appendix C, Table C-2).
- \dot{Q}_i = The release rate of noble gas nuclide (i) from the release source of interest, in $\mu\text{Ci}/\text{sec}$.

The equations for DR_{SKIN} are to be summed over all vent and elevated stack release sources.

1. Limited Analysis Approach - Instantaneous Noble Gas Release Rate

The above methodology can be simplified to provide for a rapid determination of cumulative noble gas release limits based on the requirements specified above. For ease of calculation and without unduly reducing the conservatism of the calculations, all releases may be treated as if discharged from two release points, an elevated stack and the reactor vent. The reactor vent is used to represent the combined discharge of the reactor building, turbine building, radwaste building, and refuel floor vents. Beginning with equations 4-1a and 4-1b, the simplification proceeds as follows.

From an evaluation of past releases, an effective whole body dose factor (K_{eff}) can be derived. This dose factor is, in effect, a weighted average whole body dose factor (i.e., weighted by the radionuclide distribution typical of past operation). See Appendix E for a detailed explanation and evaluation of K_{eff} . The value of K_{eff} has been derived from the radioactive noble gas effluents for the years 1985 through 1991 for the plant vents and the years 1999 through 2003 for the elevated stack release sources.

To compensate for any unusual variability in the radionuclide distribution, 3 sigma was added to the average K_{eff} values and are as follows:

$$\begin{aligned} K_{\text{eff}} &= 9.27\text{E-}5 + 3\sigma \\ &= 9.27\text{E-}5 + (3 \times 4.78\text{E-}5) \\ &= 2.36\text{E-}4 \text{ (mrem-}\text{m}^3\text{)} / (\mu\text{Ci-sec}) \end{aligned}$$

(Vent Releases based on 1985 through 1991 Vent Release Data)

$$\begin{aligned}
K_{\text{eff}} &= 2.32\text{E-}4 + 3\sigma \\
&= 2.32\text{E-}4 + (3 \times 1.38\text{E-}5) \\
&= 2.73\text{E-}4 \text{ (mrem-m}^3/\mu\text{Ci-sec)} \\
&\text{(Stack Releases)}
\end{aligned}$$

Either of these values, as appropriate, may be used in conjunction with the total noble gas release rate ($3Q_i$) to verify that the instantaneous dose rate is within the allowable limits. The simplified dose equations are as follows:

Vent

$$DR_{TB} = K_{\text{eff}} \times (\overline{X/Q}) \times \sum_{i=1}^n \dot{Q}_i \quad \text{Eq. 4-3a}$$

Elevated Stack

$$DR_{TB} = K_{\text{eff}} \times (\overline{X/Q})_y \times \sum_{i=1}^n \dot{Q}_i \quad \text{Eq. 4-3b}$$

Where:

- DR_{TB} = Whole body dose rate from noble gases in airborne releases, in mrem/sec.
- $(\overline{X/Q})$ = For vent releases, the highest annual average reactor vent concentration X/Q , calculated using long term historic meteorological data, for any land sector, at or beyond the site boundary, in sec/m^3 . (Appendix C, Table C-1)
- $(\overline{X/Q})_y$ = For elevated stack releases, the highest annual average finite cloud X/Q , calculated using long term historic meteorological data, for any land sector, at or beyond the site boundary, in sec/m^3 . (Appendix C, Table C-2)
- $\sum_{i=1}^n \dot{Q}_i$ = The total release rate of all noble gas nuclides from the release source of interest, in $\mu\text{Ci/sec}$.

A single cumulative (or gross) noble gas release rate limit for elevated stack releases (Q stack) and vent releases (Q vent) may be derived by combining equations 4-3a and 4-3b.

$$DR_{TB} = [K_{eff} (vent) \times (\overline{X/Q}) \times \dot{Q} (vent)] + [K_{eff} (stack) \times (\overline{X/Q})_y \times \dot{Q} (stack)] \quad \text{Eq. 4-4a}$$

These limits may be determined by taking the highest calculated annual average $(\overline{X/Q})_y$, for elevated stack releases and the highest calculated annual average reactor vent $(\overline{X/Q})$ for vent releases, at any of the land based sectors, at or beyond the site boundary. From Appendix C, Tables C-1 and C-2, these values are:

$$(\overline{X/Q})_y = 1.16E-7 \frac{\text{sec}}{\text{m}^3} \text{ (Stack Releases)}$$

$$(\overline{X/Q}) = 3.58E-7 \frac{\text{sec}}{\text{m}^3} \text{ (Reactor Vent Releases)}$$

Also, the Part 1 dose limit of Section 3.2.1.c.1.a is $DR_{TB} = 500 \text{ mrem/yr} = 1.585E-5 \text{ mrem/sec}$. Q (stack) was selected by requiring the stack not to yield a dose in excess of 300 mrem/yr or $9.51E-6 \text{ mrem/sec}$.

$$\dot{Q} (stack) = \frac{DR_{TB} (stack)}{[K_{eff} (stack) \times (\overline{X/Q})_y]} \quad \text{Eq. 4-4b}$$

Substituting the preceding values into equation 4-4b, $Q(stack) = 3.003E+5 \mu\text{Ci/sec}$ which was rounded to $3.0E+5 \mu\text{Ci/sec}$. Q(stack) was then substituted into equation 4-4a and solved for Q(vent). Therefore, the following are the cumulative (or gross) noble gas release rate limits:

Elevated Stack Release Rate Limit	= 3.00E+5 $\mu\text{Ci/sec}$
Vent Release Rate Limit	= 7.515E+4 $\mu\text{Ci/sec}$

As long as the noble gas release rates do not exceed these values (3.00E+5 $\mu\text{Ci}/\text{sec}$ for elevated stack releases and 7.515E+4 $\mu\text{Ci}/\text{sec}$ for vent releases), no additional dose rate calculations are needed to verify compliance with the instantaneous release rate limits of Part 1, Radiological Effluent Controls, Section 3.2.1.c.

2. **General Approach - Whole Body and Skin Nuclide Specific Instantaneous Release Rate Calculations**

The methods described herein may be used for more refined calculations or used if the actual releases exceed the values of:

Elevated Stack Release = 3.00E+5 $\mu\text{Ci}/\text{sec}$

Vent Release = 7.515E+4 $\mu\text{Ci}/\text{sec}$

Whole Body Dose Rate Vent

$$DR_{TB} = \sum_{i=1}^n K_i \times (\overline{X/Q}) \times \dot{Q}_i \quad \text{Eq. 4-5a}$$

The equation for DR_{TB} is to be summed over all vent release sources.

Eq. 4-5b

Elevated Stack

$$DR_{TB} = \sum_{i=1}^n K_i \times (\overline{X/Q})_{\gamma} \times \dot{Q}_i$$

Where:

DR_{TB} = Dose rate to the whole body due to gamma emissions from all noble gas nuclides, mrem/sec.

K_i = The whole body dose factor due to gamma emissions from noble gas radionuclide (i), in mrem-m³/ $\mu\text{Ci}\cdot\text{sec}$ (see Appendix B, Table B-1).

$(\overline{X/Q})$ = For vent releases, the highest annual average concentration X/Q , calculated using long term historic meteorological data, for any land sector, at or beyond the site boundary, in sec/m^3 (Appendix C, Table C-1).

$(\overline{X/Q})_y$ = For elevated stack releases, the highest annual average finite cloud $\overline{X/Q}$, calculated using long term historic meteorological data, for any land sector, at or beyond the site boundary, in sec/m^3 (Appendix C, Table C-2).

Stack $(\overline{X/Q})_y$ = $1.16\text{E-}7 \text{ sec}/\text{m}$;

Vent $(\overline{X/Q})$ = $3.58\text{E-}7 \text{ sec}/\text{m}$;

\dot{Q}_i = Release rate of the i th nuclide from the release source of interest, in $\mu\text{Ci}/\text{sec}$.

Skin Dose Rate

Vent

$$DR_{SKIN} = \sum_{i=1}^n [L_i + 1.1 M_i] (\overline{X/Q}) x \dot{Q}_i \quad \text{Eq. 4-6a}$$

The equation for DR_{SKIN} is to be summed over all vent release sources.

Elevated Stack

$$DR_{SKIN} = \sum_{i=1}^n [L_i (\overline{X/Q}) + 1.1 M_i (\overline{X/Q})_y] x \dot{Q}_i \quad \text{Eq. 4-6b}$$

Where:

DR_{SKIN} = Dose rate to skin due to beta and gamma radiation from all noble gas nuclides (mrem/ sec).

L_i = The skin dose factor due to beta emissions from noble gas nuclide (i), in $\text{mrem m}^3/\mu\text{Ci-sec}$ (Appendix B, Table B-1).

M_i = The air dose factor due to gamma emissions from noble gas nuclide (i), in $\text{mrad m}^3/\mu\text{Ci-sec}$ (Appendix B, Table B-2).

1.1 = Conversion factor for M_i from mrad to mrem.

$\overline{X/Q}$ = For vent or elevated stack releases, the highest annual average concentration X/Q , calculated using long term historic meteorological data, for any land sector, at or beyond the site boundary, in sec/m^3 (Appendix C, Table C-1).

$(\overline{X/Q})_y$ = For elevated stack releases, the highest annual average finite cloud X/Q , calculated using long term meteorological data, for any land sector, at or beyond the site boundary, in sec/m^3 (Appendix C, Table C-2).

Q_i = Release rate of the i^{th} nuclide from the release source of interest in $\mu\text{Ci}/\text{sec}$.

c. Calculating Process

The following outline provides a step-by-step explanation of how the whole body and skin dose rates are calculated on a nuclide-by-nuclide basis to evaluate compliance with Part 1, Radiological Effluent Controls, Section 3.2. This method is used for more refined calculations or if the actual releases exceed the value specified in the Limited Analysis Approach - Instantaneous Noble Gas Release Rate.

1. For a vent, the X/Q value = _____ sec/m ; and _____ is the most limiting land sector at or beyond the site boundary.

For an elevated stack release, the $(\overline{X/Q})$ value = _____ sec/m ; and _____ is the most limiting land sector at or beyond the site boundary and the $(\overline{X/Q})_y$ value = _____ sec/m ; and _____ is the most limiting land sector at or beyond the site boundary.

2. Enter the release rate in ft^3/min of the release source and convert it to cc/sec ;

$$= \left(\frac{\quad}{\text{min}} \right) \text{ft}^3 \times \frac{2.8317\text{E}+4 \text{ cc}}{\text{ft}^3} \times \frac{\text{min}}{60 \text{ sec}}$$

$$= \quad \text{cc}/\text{sec} \quad \text{volume release rate}$$

- Determine \dot{Q}_i for nuclide (i) by obtaining the $\mu\text{Ci}/\text{cc}$ assay value of the release source and multiplying it by the release rate computed in the previous steps.

$$\dot{Q}_i = \left(\frac{\quad}{\text{cc}} \right) \mu\text{Ci} \times \frac{\left(\quad \right) \text{cc}}{\text{sec}}$$

$$\dot{Q}_i = \text{_____} \mu\text{Ci}/\text{sec for nuclide (i)}$$

- To evaluate the whole body dose rate, obtain the K_i value for nuclide (i) from Appendix B, Table B-2.
- Solve for DR_{TBI} :

Vent

$$DR_{\text{TBI}} = K_i \times \left(\overline{X/Q} \right) \times \dot{Q}_i = \frac{\text{mrem} - \text{m}^3}{\mu\text{Ci} - \text{sec}} \times \frac{\text{sec}}{\text{m}^3} \times \frac{\mu\text{Ci}}{\text{sec}}$$

Elevated Stack

$$DR_{\text{TBI}} = K_i \times \left(\overline{X/Q} \right) \times \dot{Q}_i = \frac{\text{mrem} - \text{m}^3}{\mu\text{Ci} - \text{sec}} \times \frac{\text{sec}}{\text{m}^3} \times \frac{\mu\text{Ci}}{\text{sec}}$$

DR_{TBI} = Whole body dose rate from nuclide (i) for the specified release source in mrem/sec

- To evaluate the skin dose rate obtain the L_i and M_i values from Appendix B Table B-2 for nuclide (i).
- Solve for $DR_{\text{SKIN } i}$:

Vent

$$DR_{\text{SKIN } i} = \left[L_i + 1.1 M_i \right] \left(\overline{X/Q} \right) \times \dot{Q}_i$$

Elevated Stack

$$DR_{SKIN i} = \left[L_i(\overline{X/Q}) + 1.1 M_i(\overline{X/Q})_y \right] x \dot{Q}_i$$

$DR_{SKIN i}$ = Skin dose rate from nuclide (i) for the specified release source, in mrem/sec

8. Repeat steps 1 through 7 above for each noble gas nuclide (i) reported in the assay of the release source.
9. The dose rate to the whole body from radioactive noble gas gamma radiation from the specified release source is:

$$DR_{TB} = \sum_{i=1}^n DR_{TBi}$$

10. The dose rate to the skin due to noble gas radiation from the specified release source is:

$$DR_{SKIN} = \sum_{i=1}^n DR_{SKIN i}$$

The dose rate contribution of this release source shall be added to all other gaseous release sources that are in progress at the time of interest.

Part 1, Radiological Effluent Controls, Section 3.2.1.c.1.a requires the following:

$$DR_{TB} \leq 500 \text{ mrem/yr (1.585E-5 mrem/sec)}$$

$$DR_{SKIN} \leq 3,000 \text{ mrem/yr (9.513E-5 mrem/sec)}$$

Where:

DR_{TB} = The sum of the whole body dose rate contributions (mrem/sec) from all noble gas nuclides from all concurrent releases.

DR_{SKIN} = The sum of skin dose rate contributions (mrem/sec) from all noble gas nuclides from all concurrent releases.

4.3.2 Setpoint Determination

a. Requirements

To comply with Part 1, Specification 3.2.1.c.1.a, the alarm/trip setpoints are established to ensure that the Noble gas releases do not exceed the appropriate cumulative (or gross) Noble gas release rate limit specified in Limited Analysis Approach - Instantaneous Noble Gas Release Rate.

An Implementation Plan as defined in AP-02.04 shall be initiated and included in any ODCM revision whenever the methodology for calculating gaseous setpoints or gaseous monitor k-factors are changed and the change to the methodology or k-factors results in a new calculated setpoint.

If the stack setpoint limit is changed in the ODCM, an Exempt Setpoint Installation Notification (Attachment 6 of MCM-8A) shall be forwarded to the Setpoint Coordinator.

b. Methodology

This section describes the methodology for determining alarm/trip setpoints for the stack and vent gaseous release pathways. To allow for multiple sources of releases from different or common release points, the allowable operating setpoints will be administratively controlled to allocate a percentage of the total allowable release to each of the release sources. The cumulative Noble gas release rate limit for the stack (elevated) release is $3.0E+5$ $\mu\text{Ci}/\text{sec}$. The individual release rate limits for the other gaseous release points (assumed to be vent releases), are based upon an allocated percentage of the cumulative vent release rate limit ($7.515E+4$ $\mu\text{Ci}/\text{sec}$).

The sum of the four vent release points cannot exceed $7.515E+4$ $\mu\text{Ci}/\text{sec}$. The setpoint release rates for the vents follow.

<u>Release Point</u>	<u>Setpoint Release Rate ($\mu\text{Ci}/\text{sec}$)</u>	<u>K-factor ($\mu\text{Ci}/(\text{sec-cpm})$)</u>	<u>Nominal Setpoint Value (cpm)</u>
Turbine Building	46,500	0.62	75,000
Reactor Building	10,800	0.36	30,000*
Refuel Floor	12,000	0.40	30,000
Radwaste Building	5,700	0.19	30,000

* Maximum allowable value by Technical Specification table 3.3.6.2-1 is $\leq 24,800$ cpm. Nominal setpoint value is the bases for the maximum allowable value.

The K-factors for the vents were calculated by multiplying the calculated efficiency for Kr-85, $1.11E-8 \mu\text{Ci}/(\text{cc-cpm})$ derived from the manufacturer's sensitivity equation, by the flow rate for the release point.

<u>Release Point</u>	<u>Flow rate* (cfm)</u>	<u>K factor (μCi)/(sec-cpm)</u>
Turbine Building	118,000	0.62
Reactor Building	68,000	0.36
Refuel Floor	77,000	0.40
Radwaste Building	36,000	0.19

* Reference 6.20

Stack monitor K-factors are reviewed on a periodic basis. A conservative factor of 1.2 $\mu\text{Ci}/(\text{sec-cps})$ was selected taking into account potential worst case conditions of standby gas treatment in service. The alarm/setpoint value for the stack was calculated by dividing the setpoint release rate by the K-factor. The setpoint limit for the stack follows.

	<u>Setpoint Release Rate ($\mu\text{Ci}/\text{sec}$)</u>	<u>K-factor (μCi)/(sec-cps)</u>	<u>Nominal Setpoint Value (cps)</u>
Stack	300,000	1.2	250,000

The whole body dose is more limiting than the calculated skin dose. Therefore, the skin dose rate calculations are not required if the simplified dose rate calculation is used (i.e., using K_{eff} to determine release rate limits).

The calculating processes of step 4.3.1.c are to be used if the actual releases of noble gases exceed the predetermined limits of $3.0E+5 \mu\text{Ci}/\text{sec}$ for elevated stack releases or $7.515E+4 \mu\text{Ci}/\text{sec}$ for vent releases.

Under these conditions, a nuclide-by-nuclide evaluation is required to evaluate compliance with the dose rate limits of Part 1, Section 3.2.1.c.1.a.

4.3.3 Determining the Radioiodine, Tritium, and Eight Day Particulate Instantaneous Release Rates

a. Requirements

Part 1, Radiological Effluent Controls, Section 3.2.1.c.1.b limits the instantaneous dose rate from I-131, I-133, tritium, and particulate with half-lives greater than eight days released from the plant to $\leq 1,500$ mrem/yr to any organ, from the inhalation pathway only.

b. Methodology

The following calculating method is provided for determining the dose rate from radioiodines, tritium, and particulate. It is based on NUREG-0133, October 1978, Sections 5.2.1 and 5.2.1.1.

Actual concentrations of Iodine-131, Iodine-133, and radionuclides in particulate form with half-life greater than 8 days released from the plant in gaseous effluents shall be determined using gamma isotopic analysis. Tritium and strontium are determined by offsite analysis. Sampling and analysis shall be performed in accordance with frequency specified in Table 3.2-1 of Part 1, Radiological Effluents Controls.

The limiting age groups are the child and teen, and the limiting organ is the thyroid, per Table B-6.5, Appendix B. Based on an analysis of doses to various organs and age groups for the inhalation pathway, the child and teen were verified as being the controlling age groups and the thyroid as being the limiting organ. This pathway is the only one that need be considered for instantaneous releases. The long term sector average concentration (X/Q) values are based on historical meteorological data. Dose factors for nuclides listed in Appendix B, Table B-3 will be used.

Inhalation Pathway

The equation for $DR_{I\&8DP_\tau}$ is to be summed over all release sources (s).

Eq. 4-9

$$DR_{I\&8DP_\tau} = \sum_{s=1}^m \sum_{i=1}^n P_{ir} x (\overline{X/Q})_s x \dot{Q}_{is}$$

Where:

- τ = The organ of interest (thyroid) for the age group of interest.
- \dot{Q}_{is} = Total release rate of nuclide (i), ($\mu\text{Ci}/\text{sec}$) for each release source (s).
- $DR_{I\&8DP_\tau}$ = Total dose rate to the thyroid of the limiting age group from iodines, tritium, and eight day particulate via the inhalation pathway (mrem/yr) for all release points p.
- $\overline{(X/Q)}_s$ = The long term sector average concentration X/Q value based on historical meteorological data in (sec/m^3) for release sources (Appendix C).
- $P_{i\tau}$ = The dose factor for the inhalation pathway in (mrem/yr per $\mu\text{Ci}/\text{m}^3$) for nuclide (i) (Appendix B, Table B-3). The derivation of P_i values is given in Appendix B, Table B-6.1.
- m = The number of release sources of interest.

The maximum allowable release rate of all radioiodines, tritium, and particulate, summed together, is determined by the following relationship:

$$\dot{Q}_i = \sum_{s=1}^m \left[\frac{(FRAC)_s DR_{Thyroid}}{(\overline{X/Q})_s P_{i(Thyroid)}} \right] \times 0.8$$

Eq. 4-10

Where:

- $DR_{Thyroid}$ = Dose rate to the thyroid from the inhalation pathway set equal to Part 1, Radiological Effluent Controls, Section 3.2.1.c.1.b limit of $\leq 1,500$ mrem/year.
- $P_{i(Thyroid)}$ = The dose factor of I-131 for the inhalation pathway, $1.62\text{E}+7$ mrem/yr per $\mu\text{Ci}/\text{m}^3$ (Appendix B, Table B-3).
- $\overline{(X/Q)}_s$ = The long term sector average concentration X/Q value for any land sector value based on historical meteorological data in (sec/m^3) for release sources (Appendix C).

- \dot{Q}_I = Maximum allowable release rate of all radioiodines, tritium, and particulate summed together in $\mu\text{Ci}/\text{sec}$.
- $(\text{FRAC})_s$ = Fraction of 1500 mrem/yr limit allocated to release source s , such that $\sum (\text{Frac})_s = 1.0$.
- 0.8 = A conservatism factor.

4.4 Dose Determination for Radioactive Gaseous Effluents

This section addresses the methodologies for calculating the offsite radiation exposures (to all age groups and organs) from radionuclides in the gaseous effluents for the following:

- (a) Long-term (routine) releases - Annual dose assessment for inclusion in the Radioactive Effluent Release Report (Sec. 4.4.1),
- (b) Long-term (routine) releases - Verification of compliance with 10 CFR 50 Appendix I (Sec. 4.4.2), and
- (c) Short term releases (Sec. 4.4.3).

As described in NUREG-0133 (Ref. 6.2, Sec. 3.3), gaseous releases are characterized as "long" or "short" term depending on the frequency and duration of the releases. This characterization forms the basis for more accurate offsite dose assessments by matching the releases with more appropriate atmospheric dispersion and decay conditions.

Long-term gaseous releases refer to releases that are generally continuous and stable, with small fractional variations. Short-term releases, on the other hand, are intermittent or infrequent, with a defined total cumulative duration of 500 hours or less during a calendar year, and no more than 150 hours per quarter; they also include anticipated non-routine operational occurrences.

Offsite radiation doses from short-term releases [item (c) above], when they occur, are to be incorporated into both the annual dose assessment [item (a)] and the verification of compliance with regulatory guidelines [item (b)]. However, routine releases from JAF are essentially all long term and are continuously monitored by stack and vent effluent radiation monitors. Therefore, short-term releases at JAF are considered to be only unmonitored non-routine releases and are not applicable for definition of the alarm/trip setpoints for the stack and vent effluent monitors. In addition, in line with NUREG-0133, short-term releases are not used in assessing compliance with the Part 1, Section 3.2.1.c release limits as discussed in Section 4.3 of the ODCM.

4.4.1 Annual Dose Assessment - Radioactive Effluent Release Report Submittal

a. Requirements

Technical Specification 5.6.3 requires a Radioactive Effluent Release Report be submitted prior to May 1 of each year covering the operation of the plant during the previous year. The report shall include a summary of the quantities of radioactive liquid and gaseous effluents and solid waste released from the plant. The material provided shall be consistent with the objectives outlined in Part 1, Section 6.2.

b. Methodology

This section provides the methodology to calculate the doses to all age groups and organs from radionuclides identified in the gaseous effluents.

The method is based on the methodology suggested by NUREG-0133, October 1978, Sections 5.3 and 5.3.1. The determination of viable gaseous dose pathways is described in Appendix B, Table B-6.4. The site related dose factors for viable pathways are listed in Appendix B. Dose factors are compiled by age groups, for organs and radionuclides common to a BWR environment. Normally calculated annual long term historical atmospheric dispersion factors are used to perform the annual dose assessment. Actual meteorological data and sector wind frequency distributions for the year of interest may be used in lieu of the annual long term historical factors.

The following equations provide for a dose calculation to the whole body or any organ for a given age group based on actual releases during a specific time interval for radioactive gaseous release sources:

1. Annual Air Dose Due to Noble Gases

Vent

Eq. 4-11a

$$D_{\text{Gamma-Air}} = \sum_{i=1}^n M_i \times (\overline{X/Q}) \times Q_i$$

Elevated Stack

Eq. 4-11b

$$D_{\text{Gamma-Air}} = \sum_{i=1}^n M_i \times (\overline{X/Q})_y \times Q_i$$

Where:

$D_{\text{Gamma-Air}}$ = The gamma air dose from radioactive noble gases, in mrad.

M_i = The gamma air dose factor for radioactive noble gas nuclide 'i', in mrad-m³/μCi-sec (Appendix B, Table B-2).

$(\overline{X/Q})$ = The long term historical atmospheric dispersion factors for vent releases (annual average) for the location of interest. Actual meteorological data and sector wind frequency distributions may be used to determine annual X/Q for the year of interest in sec/m³.

$(\overline{X/Q})_y$ = The long term historical atmospheric dispersion factor for elevated stack releases (annual average) for the location of interest based on the finite cloud methodology. Actual meteorological data and sector wind frequency distributions may be used to determine annual X/Q for the year of interest in sec/m³.

Q_i = The number of μCi of nuclide 'i' released during the year of interest from the release source of interest.

The equations for $D_{\text{Gamma-Air}}$ are to be summed over all vent and elevated stack release sources.

Eq.4-12

$$D_{\text{Beta-Air}} = \sum_{i=1}^n N_i \times (\overline{X/Q}) \times Q_i$$

Where:

$D_{\text{Beta-Air}}$ = Beta air dose from radioactive noble gases in mrad.

N_i = The beta air dose factor for radioactive noble gas nuclide (i) in $\text{mrad}\cdot\text{m}^3/\mu\text{Ci}\cdot\text{sec}$ (see Appendix B, Table B-2).

$(\overline{X/Q})$ = The long term historical atmospheric dispersion factors for vent or elevated stack releases (annual average) for the location of interest. Actual meteorological data and sector wind frequency distributions may be used to determine annual X/Q for the year of interest in sec/m^3 .

Q_i = The number of μCi of nuclide 'i' released during the year of interest from the release source of interest.

The equations for $D_{\text{Beta-Air}}$ are to be summed over all vent and elevated stack release sources.

2. Annual Whole body Dose Due to Noble Gases

Vent

$$D_{TB} = \sum_{i=1}^n K_i \times (\overline{X/Q}) \times Q_i \quad \text{Eq. 4-12a}$$

Elevated Stack

Eq. 4-12b

$$D_{TB} = \sum_{i=1}^n K_i \times (\overline{X/Q}) \times Q_i$$

Where:

D_{TB} = Whole body dose from noble gases in airborne releases, in mrem.

K_i = The whole body dose factor due to gamma emissions for each noble gas nuclide (i) reported in the release source, in $\text{mrem}\cdot\text{m}^3/\mu\text{Ci}\cdot\text{sec}$ (Appendix B, Table B-1).

$(\overline{X/Q})$ = The long term historical atmospheric dispersion factors for vent or elevated stack releases (annual average) for the location of interest. Actual meteorological data and sector wind frequency distributions may be used to determine annual X/Q for the year of interest in sec/m^3 .

$(\overline{X/Q})_y$ = The long term historical atmospheric dispersion factor for elevated stack releases (annual average) for the location of interest based on the finite cloud methodology. Actual meteorological data and sector wind frequency distributions may be used to determine annual X/Q for the year of interest in sec/m³.

Q_i = The number of microCuries for each noble gas nuclide (i) released during the year of interest from the release source of interest.

The equations for D_{TB} are to be summed over all vent and elevated stack release sources.

3. Annual Total Skin Dose Due to Noble Gases

Vent Eq. 4-12c

$$D_{SKIN} = \sum_{i=1}^n [L_i + 1.1 M_i] (\overline{X/Q})_y x Q_i$$

Elevated Stack Eq. 4-12d

$$D_{SKIN} = \sum_{i=1}^n [L_i (\overline{X/Q})_y + 1.1 M_i (\overline{X/Q})_y] x Q_i$$

Where:

D_{SKIN} = Skin dose from noble gases in airborne releases in mrem.

L_i = The skin dose factor due to beta emissions for each noble gas nuclide (i) reported in the assay of the release source in mrem-m³/μCi-sec (Appendix B, Table B-1).

M_i = The air dose factor due to gamma emissions for each noble gas nuclide (i) reported in the assay of the release source. The constant 1.1 converts 'mrad' to 'mrem' since the units of M_i are in mrad-m³/μCi-sec (Appendix B, Table B-2).

- $\overline{(X/Q)}$ = The long term historical atmospheric dispersion factors for vent or elevated stack releases (annual average) for the location of interest. Actual meteorological data and sector wind frequency distributions may be used to determine annual X/Q for the year of interest in sec/m³.
- $\overline{(X/Q)}_r$ = The long term historical atmospheric dispersion factor for elevated stack releases (annual average) for the location of interest based on the finite cloud methodology. Actual meteorological data and sector wind frequency distributions may be used to determine annual X/Q for the year of interest in sec/m³.
- Q_i = The number of microCuries for each noble gas nuclide (i) released during the year of interest from the release source of interest.

The equations for D_{SKIN} are to be summed over all vent and elevated stack release sources.

4. Annual Dose Due to Radioiodines, Tritium, and Eight Day Particulate

Inhalation Pathways

Eq. 4-13

$$(D_{I\&8DP})_r = (3.17E-8) \sum_{i=1}^n R_i \times \overline{(X/Q)} \times Q_i$$

Ground Plane Deposition Pathway

Eq. 4-14

$$(D_{I\&8DP})_r = (3.17E-8) \sum_{i=1}^n R_i \times \overline{(D/Q)} \times Q_i$$

Cow's Milk Pathway

Eq. 4-15

$$(D_{I\&8DP})_{\tau} = (3.17E-8) \sum_{i=1}^n R_{i\tau} x (\overline{D/Q}) x Q_i$$

Goat's Milk Pathway

Eq. 4-16

$$(D_{I\&8DP})_{\tau} = (3.17E-8) \sum_{i=1}^n R_{i\tau} x (\overline{D/Q}) x Q_i$$

Meats

Eq. 4-17

$$(D_{I\&8DP})_{\tau} = (3.17E-8) \sum_{i=1}^n R_{i\tau} x (\overline{D/Q}) x Q_i$$

Vegetation

Eq. 4-18

$$(D_{I\&8DP})_{\tau} = (3.17E-8) \sum_{i=1}^n R_{i\tau} x (\overline{D/Q}) x Q_i$$

For tritium, the dose is calculated by substituting

$\overline{X/Q}$ for $(\overline{D/Q})$ and $R_{H-3\tau}$ for $R_{i\tau}$ in equations 4-15 to 4-18.

Total Annual Dose From Release Source of Interest

$$D_{\tau} = \sum_{z=1}^p (D_{I\&8DP})_{\tau z} \quad \text{Eq. 4-19a}$$

Total Annual Dose

Eq. 4-19b

$$D_{\tau} = \sum_{s=1}^m (D_{\tau s})$$

Where:

- τ = The organ of interest for the age group of interest.
- s = The release source of interest.
- z = Pathway of interest.
- p = The number of pathways of interest.
- m = Number of release sources of interest.
- $(D_{I\&8DP})_{\tau}$ = Annual dose to the organ τ for the age group of interest from iodines, tritium, and eight day particulate via the pathway of interest in (mrem).
- $3.17E-8$ = The inverse of the number of seconds per year in (years/sec).
- $D_{\tau s}$ = Total annual dose to organ τ from all applicable pathways for the age group of interest and for the release source of interest in (mrem).
- D_{τ} = Total annual dose to organ τ from all applicable pathways for the age group of interest and for all release sources of interest in (mrem).
- Q_i = The number of μCi of nuclide 'i' released during the year of interest from the release source of interest.
- $R_{i\tau}$ = The dose factor for nuclide (i) for organ τ for the pathway specified, units vary with pathway. The derivation of $R_{i\tau}$ values is given in Appendix B, Table B-6.2.

$(\overline{D/Q})$ = The long term historical annual average relative deposition values for elevated stack or vent releases for the ground plane deposition pathway. For the meat, cow, goat, and vegetable pathways, the long term historical grazing average deposition values for elevated stack and vent releases are used (Appendix C). A factor with units of m^2 which describes the deposition of particulate matter from a plume at a point downrange from the source. Actual meteorological data and sector wind frequency distribution may be used to determine annual average D/Q for the year of interest. D/Q is not used to calculate doses associated with H-3 releases.

$(\overline{X/Q})$ = The long term historical annual average atmospheric dispersion factors for vent or elevated stack releases for the location of interest (Appendix C). Actual meteorological data and sector wind frequency distributions may be used to determine annual X/Q for the year of interest in sec/m^3 . The X/Q is used to determine doses for H-3 releases.

4.4.2 **Monthly Dose Assessment - Verification of Compliance with 10 CFR 50, Appendix I**

a. **Determining the Gamma Air Dose for Radioactive Noble Gas Release Source(s)**

1. **Requirement**

Part 1, Radiological Effluent Controls, Section 3.3.2.c.1 limits the air dose from gamma radiation due to noble gases released from the plant in the gaseous effluent ≤ 10 mrad during any calendar year, and ≤ 5 mrad in any calendar quarter.

Part 1, Section 3.3.2.c.1, requires that cumulative air dose contributions from noble gases be calculated at least monthly for the current calendar quarter and current calendar year.

2. Methodology

The following calculational method is provided for determining the noble gas gamma air dose and is based on NUREG-0133 October 1978 Section 5.3.1. The dose calculation is independent of age group. The equation may be used for Part 1, Section 3.3.2.c.1 dose calculations, the dose calculation for the annual report, or for projecting dose, provided that the appropriate value of (X/Q) is used. The equation for gamma air dose is:

Vent Eq. 4-20a

$$D_{\text{Gamma-Air}} = \sum_{i=1}^n M_i \times (\overline{X/Q}) \times Q_i$$

Elevated Stack Eq. 4-20b

$$D_{\text{Gamma-Air}} = \sum_{i=1}^n M_i \times (\overline{X/Q})_y \times Q_i$$

Where:

- $D_{\text{Gamma-Air}}$ = The gamma air dose from radioactive noble gases in mrad.
- M_i = The gamma air dose factor for radioactive noble gas nuclide 'i', in mrad-m³/μCi-sec (Appendix B, Table B-2).
- $(\overline{X/Q})$ = The highest long term annual average atmospheric dispersion factors for vent releases for any land sector, in sec/m³ (Appendix C, Table C-1).
- $(\overline{X/Q})_y$ = The highest long term annual average atmospheric dispersion factor for elevated stack releases for any land sector based on the finite cloud methodology, in sec/m³ (Appendix C, Table C-2).
- Q_i = The number of μCi of nuclide 'i' released (or projected to be released) during the dose calculation exposure period (e.g., month, quarter, or year) from the release source of interest.

The equations for $D_{\text{Gamma-Air}}$ are to be summed over all vent and elevated stack release sources.

(a) **Limited Analysis Approach**

The following limited analysis approach may be used to establish monthly release objectives ($\mu\text{Ci}/\text{month}$) that will ensure compliance with 10 CFR 50, Appendix I gamma dose limits.

From an evaluation of past releases, a single effective gamma air dose factor (M_{eff}) has been derived, which is representative of the radionuclide abundances and corresponding dose contributions typical of past operation. (Appendix E has a detailed explanation and evaluation of M_{eff}). The value of M_{eff} has been derived from the radioactive noble gas effluents for the years 1985 through 1991.

To compensate for any unusual variability in the radionuclide distribution, 3 sigma was added to the average M_{eff} value, and are as follows.

$$\begin{aligned}M_{\text{eff}} &= 9.75\text{E-}5 + 3\sigma \\ &= 9.75\text{E-}5 + (3 \times 4.95\text{E-}5) \\ &= 2.46\text{E-}4 \text{ (mrad-m}^3\text{)/}(\mu\text{Ci-sec)} \\ &\quad \text{(vent release)}\end{aligned}$$

$$\begin{aligned}M_{\text{eff}} &= 1.57\text{E-}4 + 3\sigma \\ &= 1.57\text{E-}4 + (3 \times 4.70\text{E-}5) \\ &= 2.98\text{E-}4 \text{ (mrad-m}^3\text{)/}(\mu\text{Ci-sec)} \\ &\quad \text{(stack release)}\end{aligned}$$

The effective gamma air dose factor may be used in conjunction with the total noble gas release to simplify the dose evaluation and to verify that the cumulative gamma air dose is within the equivalence of the limits of Part 1, Radiological Effluent Controls, Section 3.3.1.c.1.

Equations 4-20a and 4-20b can be used to establish monthly release objectives. Combining equations 4-20a and 4-20b yields the following:

$$D_{Gamma-air} = [M_{eff}(vent) \times (\overline{X/Q}) \times Q(vent)] + [M_{eff}(stack) \times (\overline{X/Q})_y \times Q(stack)] \quad \text{Eq. 4-21}$$

Part 1, Radiological Effluent Controls, Section 3.3.2.c states that the doses must be evaluated once per month. The yearly dose limit is 10 mrad, which corresponds to a monthly allotment of 0.83 mrad. 0.83 mrad can be substituted into equation 4-21 for $D_{Gamma-air}$. The highest calculated annual average

$(\overline{X/Q})_y$, $1.16E-7 \text{ sec/m}^3$, for elevated stack releases and the highest calculated annual average reactor vent (X/Q) , $3.58E-7 \text{ sec/m}^3$, for vent releases, can be substituted into equation 4-21. $Q(stack)$ and $Q(vent)$ were selected so that the technical specifications limit of 10 mrad/yr or 0.83 mrad/month would not be exceeded. In addition, $Q(stack)$ was selected by requiring the stack not to exceed 60% of 0.83 mrad/month.

$$Q(stack) = \frac{D_{Gamma-air}(stack)}{[M_{eff}(stack) \times (\overline{X/Q})_y]} \quad \text{Eq. 4-22}$$

Substituting the preceding values into equation 4-22, yields $Q(stack) = 1.44E10 \text{ } \mu\text{Ci/month}$. $Q(stack)$ was then substituted into equation 4-21 and solved for $Q(vent)$. Therefore, the following are the cumulative noble gas monthly release objectives.

$$Q(\text{vent release}) = 3.77E+9 \text{ } \mu\text{Ci/month}$$

$$Q(\text{elevated stack release}) = 1.44E+10 \text{ } \mu\text{Ci/month}$$

As long as these values are not exceeded during any month, compliance with the quarterly and annual noble gas release limits of Part 1, Radiological Effluent Controls, Section 3.3.1.c.1 is demonstrated. When the limited approach method is used, the calculations of 4.4.2.a(2) must be performed monthly at a minimum.

The gamma air dose limit does not cause the beta air dose limit to be exceeded when the limited analysis approach of this section is used.

b. Determining the Beta Air Dose for Radioactive Noble Gas Release Sources

The beta air dose calculations of this step are required to be performed when the radionuclide specific dose analysis of Gamma Air Dose is performed. The radionuclide specific dose analysis is performed at least monthly in accordance with Part 1, Section 3.3.2.c.1.

1. Requirement

Part 1, Radiological Effluent Controls, Section 3.3.1.c.1 limits the air dose from beta radiation, due to noble gases released from the plant in the gaseous effluents, to less than or equal to 20 mrad during any calendar year and less than or equal to 10 mrad in any calendar quarter.

Part 1, Section 3.3.2.c.1 requires that cumulative air dose contributions from noble gases released from the plant be calculated at least monthly for the current calendar quarter and current calendar year.

When the nuclide specific dose calculation is used to evaluate compliance with the gamma air dose limits, the beta air dose shall be evaluated on a nuclide specific basis using the methodology presented below.

2. Methodology

The following calculating method is provided for determining the beta air dose and is based on NUREG-0133, October 1978, Section 5.3.1. The dose calculation is independent of any age group. The equation may be used for dose calculations for Part 1, Section 3.3.2.c.1, Radiological Effluent Release Reports, or for projecting dose, provided that the appropriate value of (X/Q) is used.

The equation for beta air dose is:

$$D_{\text{Beta-Air}} = \sum_{i=1}^n N_i \times (\overline{X/Q}) \times Q_i \quad \text{Eq. 4-23}$$

Where:

- $D_{\text{Beta-Air}}$ = Beta air dose from radioactive noble gases in (mrad).
- N_i = The beta air dose factor for radioactive noble gas nuclide 'i' in mrad-m³/μCi-sec (Appendix B, Table B-2).
- $(\overline{X/Q})$ = For vent or elevated stack releases, the highest annual average, X/Q, calculated using long term historic meteorological data, for any land sector, at or beyond the site boundary, in sec/m³ (Appendix C).
- Q_i = The number of μCi of nuclide 'i' released (or projected to be released) during the dose calculation exposure period from the release source of interest.

The equation for $D_{\text{Beta-Air}}$ is to be summed over all release sources.

c. **Determining the Radioiodine, Tritium, and Eight Day Particulate Dose to any Organ from Cumulative Releases**

1. **Requirement**

Part 1, Radiological Effluent Controls, Section 3.4.1.c limits the dose to the whole body or any organ resulting from the release of radioiodines, tritium, and particulate with half-lives greater than eight days released from the plant to less than 7.5 mrem/quarter and less than 15 mrem/yr to any organ.

Part 1, Section 3.4.2.c requires that cumulative dose contributions be calculated at least monthly for the current calendar quarter and current calendar year.

2. Methodology

The following calculating method is provided for determining the organ dose due to releases of radioiodines (I-131, I-133), tritium, and particulate with half-lives greater than 8 days. It is based on NUREG-0133, October 1978, Section 5.3.1. The equations can be used for any age group provided that the appropriate dose factors are used and the total dose reflects only those pathways that are applicable to the age group and the receptor location. The deposition factor, (D/Q), represents the rate of fallout from the cloud that affects a square meter of ground at various distances from the site. The total dose to an organ can then be determined by summing the pathways that apply to the receptor in the sector. The equations are:

Inhalation Pathway Eq. 4-24

$$(D_{I\&8DP})_r = (3.17E-8) \sum_{i=1}^n R_{i_r} x (\overline{X/Q}) x Q_i$$

Ground Plane Pathway Eq. 4-25

$$(D_{I\&8DP})_r = (3.17E-8) \sum_{i=1}^n R_{i_r} x (\overline{D/Q}) x Q_i$$

Cow's Milk Pathway Eq. 4-26a

$$(D_{I\&8DP})_r = (3.17E-8) \sum_{i=1}^n R_{i_r} x (\overline{D/Q}) x Q_i$$

Goat's Milk Pathway Eq. 4-26b

$$(D_{I\&8DP})_r = (3.17E-8) \sum_{i=1}^n R_{i_r} x (\overline{D/Q}) x Q_i$$

Meats

Eq. 4-26c

$$(D_{I\&8DP})_{\tau} = (3.17E-8) \sum_{i=1}^n R_{i\tau} x (\overline{D/Q}) x Q_i$$

Vegetation

Eq. 4-26d

$$(D_{I\&8DP})_{\tau} = (3.17E-8) \sum_{i=1}^n R_{i\tau} x (\overline{D/Q}) x Q_i$$

For tritium, the dose is calculated by substituting $\overline{X/Q}$ for $(\overline{D/Q})$ and $R_{H-3\tau}$ in $R_{i\tau}$ equations 4-26a to 4-26d.

Total Dose From a Release Source for Applicable Pathways

$$D_{\tau} = \sum_{z=1}^p (D_{I\&8DP})_z$$

Eq. 4-27a

Total Annual Dose From All Release Sources of Interest

Eq. 4-27b

$$D_{\tau} = \sum_{s=1}^m (D_{\tau})_s$$

Where:

- τ = The organ of interest in a specified age group.
- s = The release source of interest.
- z = The pathway of interest.
- p = The number of pathways of interest.

- m = The number of release sources of interest.
- $(D_{I\&8DP})_{\tau}$ = Dose in mrem to the organ τ of a specified age group from radioiodines, tritium, and 8 day particulate due to a particular pathway.
- $D_{\tau s}$ = Total dose to organ τ from all applicable pathways for a specified age group for the release source of interest in (mrem).
- D_{τ} = Total dose to organ τ from all applicable pathways for a specified age group and for all release sources of interest in (mrem).
- $3.17E-8$ = The inverse of the number of seconds per year in (years/sec).
- $R_{i\tau}$ = The dose factor for nuclide (i) organ τ of the specified age group. The units are either mrem- m^3 /yr- μ Ci for pathways using (X/Q), or mrem- m^2 -sec/yr- μ Ci for pathways using (D/Q) (Appendix B, Tables B-4 and B-5).
- $(\overline{X/Q})$ = The concentration (X/Q) value for a specific location where the receptor is located. The units are (sec/ m^3) (Appendix C). The X/Q is used to determine doses for H-3 releases.
- $(\overline{D/Q})$ = The deposition value for a specific location where the receptor is located. The units are m^2 (Appendix C). D/Q is not used to calculate doses associated with H-3 releases.
- Q_i = The number of μ Ci of nuclide (i) released (or projected to be released) during the dose calculation exposure period from the release source of interest.

(a) **Limited Analysis Approach**

Based on an analysis of doses to all organs and age groups from all monitored atmospheric release pathways, the milk and vegetation pathways have been identified as being the most significant pathways. The infant's thyroid (milk pathway) and child's thyroid (vegetation pathway) have been identified as being the limiting age groups and organ. These pathways contribute the majority of the total dose received by the infant and child thyroid. The radioiodines and tritium contribute essentially all of the dose via the milk and vegetation pathways. Therefore, it is possible to demonstrate compliance with the dose limit Part 1, Radiological Effluent Controls, Section 3.4.1.c.1 for radioiodines, tritium, and particulate with half-lives greater than 8 days by evaluating only the infant and child thyroid dose due to radioiodines and tritium in the milk and vegetation pathways.

The calculating method to be used includes a conservatism factor of 0.5 which assures that the calculated dose is always greater than or equal to the actual dose despite possible atypical distributions of radionuclides in the gaseous effluent. The following equations are used to calculate the doses from the milk and vegetation pathways.

$$D_{mlk-inf} = \frac{3.17E-8}{0.5} \left[\left(\overline{D/Q} \right)_s \sum_{iodines} R_{mlk-Child} \times Q_{is} \right] + \left[\left(\overline{X/Q} \right)_s \times R_{mlk-Child H-3T} \times Q_{H-3S} \right]$$

Eq. 4-28a

$$D_{veg-inf} = \frac{3.17E-8}{0.5} \left[\left(\overline{D/Q} \right)_s \sum_{iodines} R_{veg-Child} \times Q_{is} \right] + \left[\left(\overline{X/Q} \right)_s \times R_{veg-Child H-3T} \times Q_{H-3S} \right]$$

Eq. 4-28b

$$D_{\tau} = \sum_{s=1}^m D_{\tau s} \quad \text{Eq. 4-28c}$$

Select the equation (i.e., either 4-28a or 4-28b) that yields the highest dose. Substitute that equation into 4-28c for $D_{\tau s}$ and solve for D_{τ} .

Where:

- $R_{\text{mlk-inf } i\tau}$ = The dose factor for iodine nuclide (i), organ τ (thyroid), of the specified age group (infant) for the milk pathway. The units are either $\text{mrem}\cdot\text{m}^3/\text{yr}\cdot\mu\text{Ci}$ for pathways using (X/Q), or $\text{mrem}\cdot\text{m}^2\cdot\text{sec}/\text{yr}\cdot\mu\text{Ci}$ for pathways using (D/Q). (See Appendix B).
- $R_{\text{mlk-inf H-3}\tau}$ = The dose factor for iodine nuclide (tritium), organ τ (thyroid), of the specified age group (infant) for the milk pathway. The units are either $\text{mrem}\cdot\text{m}^3/\text{yr}\cdot\mu\text{Ci}$ for pathways using (X/Q), or $\text{mrem}\cdot\text{m}^2\cdot\text{sec}/\text{yr}\cdot\mu\text{Ci}$ for pathways using (D/Q). (See Appendix B).
- $R_{\text{veg-chd } i\tau}$ = The dose factor for iodine nuclide (i), organ τ (thyroid), of the specified age group (child) for the vegetation pathway. The units are either $\text{mrem}\cdot\text{m}^3/\text{yr}\cdot\mu\text{Ci}$ for pathways using (X/Q), or $\text{mrem}\cdot\text{m}^2\cdot\text{sec}/\text{yr}\cdot\mu\text{Ci}$ for pathways using (D/Q). (See Appendix B).
- $R_{\text{veg-H-3 } \tau}$ = The dose factor for iodine nuclide (tritium), organ τ (thyroid), of the specified age group (infant) for the milk pathway. The units are either $\text{mrem}\cdot\text{m}^3/\text{yr}\cdot\mu\text{Ci}$ for pathways using (X/Q), or $\text{mrem}\cdot\text{m}^2\cdot\text{sec}/\text{yr}\cdot\mu\text{Ci}$ for pathways using (D/Q). (See Appendix B).
- $D_{\text{mlk-inf } \tau s}$ = Dose in mrem to the infant's thyroid due to radioiodines and H-3 in the milk pathway for the release source of interest.
- $D_{\text{veg-chd } \tau s}$ = Dose in mrem to the child's thyroid due to radioiodines and H-3 in the vegetation pathway for the release source of interest.
- $D_{\tau s}$ = Dose in mrem to the most limiting age group's thyroid, from all pathways.
- D_{τ} = Total dose in mrem to the most limiting age group's thyroid, from all pathways for all release sources of interest.
- s = The release source of interest.

- m = The number of release sources of interest.
- Q_{is} = For elevated stack releases, Q_{is} is the total number of microCuries of nuclide i released from the stack during the dose calculation exposure period. For vent releases, Q_{is} is the total number of microCuries of nuclide i released from the four vents during the dose calculation period.
- Q_{H-3s} = For elevated stack releases, Q_{H-3s} is the total number of microCuries of nuclide tritium released from the stack during the dose calculation exposure period. For vent releases, Q_{H-3s} is the total number of microCuries of nuclide tritium released from the four vents during the dose calculation period.
- $\overline{D/Q_s}$ = The deposition value for a specific location where the receptor is located in (m^{-2}). For elevated stack releases the grazing season D/Q for the stack will be used. For vent releases, the grazing season D/Q for the reactor vent will be used.
- $\overline{X/Q_s}$ = The concentration (X/Q) value for a specific location where the receptor is located. The units are sec/m^3 . The grazing season X/Q is used to determine doses for H-3 releases. For elevated stack releases the grazing season X/Q for the stack will be used. For vent releases, the grazing season X/Q for the reactor vent will be used.

(b) **Approach Selection Criteria**

The limited analysis approach may be used for long-term (routine) releases to demonstrate compliance with the dose limit of Part 1, Radiological Effluent Controls, Sections 3.4.1.c.1.a and 3.4.1.c.1.b (7.5 mrem/qtr and 15 mrem/yr) for radioiodines, tritium, and particulate.

However, for the dose assessment included in the Radioactive Effluent Release Report, doses will be evaluated for designated age groups and organs via designated pathways from radioiodines, tritium, and particulates measured in the gaseous effluents according to sampling and analyses required by Part 1, Section 3.4.2.c.1.

4.4.3 Short Term Releases

As described in the introductory part to Sec. 4.4 (and in NUREG-0133), short-term releases are intermittent or infrequent, with a defined total cumulative duration of 500 hours or less during a calendar year, and no more than 150 hours per quarter. Radiological impact assessment models for short-term releases may make use of the long-term atmospheric dispersion factors (as described in Sections 4.4.1 and 4.4.2) if it can be demonstrated that past short-term releases were sufficiently random in both time of day and duration to be represented by the annual average dispersion conditions. Otherwise, use should be made of the short-term dose equations, as described below.

a. Requirements

Short-term releases, when they occur, are to be incorporated into the Radioactive Effluent Release Report(s) and the annual dose assessment report (Section 4.4.1) and the verification of compliance with 10 CFR 50 Appendix I, regulatory guidelines (Section 4.4.2). The following are the Technical Specification requirements for short-term releases.

Technical Specification 5.6.3 requires a Radioactive Effluent Release Report covering the operation of the unit during the previous year, be submitted prior to May 1 of each year in accordance with 10 CFR 50.36a. Part 1, Section 6.2 also requires that this report includes an assessment of the radiation doses to the public due to the radioactive liquid and gaseous effluents released from the unit during the previous calendar year.

Part 1, Section 3.3.1.c.1 limits the air dose from gamma radiation due to noble gases released from the plant in the gaseous effluent to ≤ 10 mrad during any calendar year, and ≤ 5 mrad in any calendar quarter.

Part 2, Section 3.3.2.c, requires that cumulative air dose contributions from noble gases be calculated at least monthly for the current calendar quarter and current calendar year.

b. Methodology

Routine releases via the main stack and vents are continuous. The methodology described below for short-term releases is thus for non-routine unmonitored ground-level releases.

The equations for offsite radiation exposures resulting from short-term releases are similar to those provided for vent releases in Sections 4.4.1 and 4.4.2. They are as follows:

1. **Air Dose Due to Noble Gases**

$$D_{Short\ Gamma-Air} = \sum_{i=1}^n M_i x(x/q) x q_i \quad \text{Eq. 4-29}$$

$$D_{Short\ Beta-Air} = \sum_{i=1}^n N_i x(x/q) x q_i \quad \text{Eq. 4-30}$$

Where:

q_i = The overall total activity (μCi) of radionuclide "i" released (or projected to be released) during the dose calculation exposure period (month, quarter, or year, as applicable) from a selected vent or unmonitored path, as a result of short-term releases.

(x/q) = The short term atmospheric dispersion factor (sec/m^3) for ground-level releases and the receptor of interest, defined as (from NUREG-0324):

$$(x/q) = (x/q)_{\text{Hourly PC}} \quad (t \leq 2 \text{ hr})$$

$$(x/q) = (x/q)_{\text{Hourly PC}} \times t^m \quad (2 < t \leq 500 \text{ hr})$$

$$(x/q) = (X/Q)_{\text{Annual SA}} \quad (t > 500 \text{ hr})$$

Where:

$$m = \frac{\log [(X/Q)_{\text{Annual SA}} / (x/q)_{\text{Hourly PC}}]}{\log (8760)}$$

t = release duration (hrs) (or the total sum of frequent short-term release durations) during the dose calculation exposure period

(Note: The limits $2 < t \leq 500$ are for annual analysis; for quarterly analysis, they are $2 < t \leq 150$)

$(X/Q)_{\text{Annual SA}}$ = long-term sector average (SA) atmospheric dispersion factor (sec/m^3) for ground level releases and the selected receptor, for distances out to 45 miles [from Table C-15 for the site boundary, Table C-18 for annual (all-season) meteorology, and Table C-22 for grazing-season meteorology]

$(x/q)_{\text{Hourly PC}}$ = short-term 85th percentile hourly plume centerline (PC) atmospheric dispersion factor (sec/m^3) for ground-level releases and the selected receptor [from Table C-15 for the site boundary, Table C-17 for annual meteorology, and Table C-21 for grazing-season meteorology]

All other parameters have been defined in Section 4.4.1.b.(1).

Short-term gamma air doses are to be added to the long term gamma air doses. Combining equations 4-11a, 4-11b, (or 4-20a, 4-20b for quarterly) and 4-29 results in the following:

$$D_{\text{Total Gamma-Air}} = D_{\text{Gamma-Air}}(\text{STACK}) + D_{\text{Gamma-Air}}(\text{Vents})$$

Eq. 4-31

$$+ D_{\text{Short Gamma-Air}}(\text{Unmonitored Non-routine Releases})$$

Short-term beta air doses are to be added to the long term beta air doses. Combining equations 4-12 (or 4-23 for quarterly) and 4-30 results in the following:

$$D_{\text{Total Beta-Air}} = D_{\text{Beta-Air}}$$

Eq. 4-32

$$+ D_{\text{Short Beta-Air}}(\text{Unmonitored Non-routine Releases})$$

2. Annual Whole Body Dose and Skin Dose Due to Noble Gases

The equations for whole body dose and skin dose which follow may be used in the preparation of the Radioactive Effluent Release Report (described above in Section 4.4.1). They are not applicable for the verification of compliance with 10 CFR 50, Appendix I (Section 4.4.2).

$$D_{short TB} = K_i x (x/q) x q_i \quad \text{Eq. 4-32a}$$

$$D_{short skin} = [L_i + 1.1 M_i] x (x/q) x q_i \quad \text{Eq. 4-32b}$$

All parameters in Equations 4-32a and 4-32b are as previously defined in Sections 4.4.1.b(2) and 4.4.1.b(3).

Short-term whole body and skin doses are to be added to the corresponding doses from long-term releases. Combining Equations 4-12a, 4-12b and 4-32a yields the following equation for the total TB dose:

$$D_{Total TB} = D_{TB} (STACK) + D_{TB} (Vents) + D_{Short TB} (Unmonitored Non - routine Releases) \quad \text{Eq. 4-32c}$$

Similarly, combining Equations 4-12c, 4-12d and 4-32b for the skin, yields:

$$D_{Total Skin} = D_{Skin} (STACK) + D_{Skin} (Vents) + D_{Short Skin} (Unmonitored Non - routine Releases) \quad \text{Eq. 4-32d}$$

3. Dose Due to Radioiodines, Tritium, and Eight Day Particulates

Inhalation Pathway

$$(D_{Short I \& 8DPT})_r = (3.17E - 8) \sum_{i=1}^n R_{i_r} x (x/q) x q_i \quad \text{Eq. 4-33}$$

All parameters have been defined previously. Short-term doses from the inhalation pathway are to be added to the corresponding long term doses from the same pathway. Combining equations 4-13 (or 4-24 for quarterly) and 4-33 results in the following:

$$[D_{Total I \& DPT}]_{\tau} = [D_{I \& DPT}]_{\tau} + [D_{Short I \& DPT}]_{\tau} (\text{Unmonitored Non-routine Releases})$$

Eq. 4-34

Ground Plane Deposition Pathway

$$(D_{Short I \& DPT})_{\tau} = (3.17E-8) \sum_{i=1}^n R_i \times (d/q) \times q_i$$

Eq. 4-35

Where:

(d/q) = The short term deposition factor (1/m²) for ground-level releases and the receptor of interest, defined as:

(d/q) = (d/q)_{Hourly PC} (t ≤ 2 hr)

(d/q) = (d/q)_{Hourly PC} × t^m (2 < t ≤ 500 hr)

(d/q) = (D/Q)_{Annual SA} (t > 500 hr)

Where:

$$m = \frac{\log [(D/Q)_{Annual SA} / (d/q)_{Hourly PC}]}{\log (8760)}$$

t = release duration (hrs) (or the total sum of frequent short-term release durations) during the dose calculation exposure period (Note: the limits 2 < t ≤ 500 are for annual analysis; for quarterly analysis, they are 2 < t ≤ 150)

(D/Q)_{Annual SA} = long-term sector average (SA) deposition (1/m²) for ground level releases and the selected receptor, for distances out to 45 miles [from Table C-16 for the site boundary, Table C-20 for annual (all-season) meteorology, and Table C-24 for grazing-season meteorology]

$(d/q)_{\text{Hourly PC}}$ = short-term 85th percentile hourly plume centerline (PC) deposition factor ($1/m^2$) for ground-level releases and the selected receptor [from Table C-16 for the site boundary, Table C-19 for annual meteorology, and Table C-23 for grazing-season meteorology]

All other parameters have been defined in Section 4.4.1.b (4).

Short-term doses from the ground plane pathway are to be added to the corresponding long term doses from the same pathway. Combining equations 4-14 (or 4-25 for quarterly) with 4-35 results in the following:

$$[D_{\text{Total I\&8DPT}}]_r = [D_{\text{I\&8DPT}}]_r + [D_{\text{Short I\&8DPT}}]_r (\text{Unmonitored Non - routine Releases}) \quad \text{Eq. 4-36}$$

Cow's Milk Pathway

$$(D_{\text{Short I\&8DPT}})_r = (3.17E-8) \sum_{i=1}^n R_{i_r} \times (d/q) \times q_i \quad \text{Eq. 4-37}$$

All parameters have been defined previously. Short-term doses from the cow's milk pathway are to be added to the corresponding long term doses from the same pathway. Combining equations 4-15 (or 4-26a for quarterly) with 4-37 results in the following:

$$[D_{\text{Total I\&8DPT}}]_r = [D_{\text{I\&8DPT}}]_r + [D_{\text{Short I\&8DPT}}]_r (\text{Unmonitored Non - routine Releases}) \quad \text{Eq. 4-38}$$

Goat's Milk Pathway

$$(D_{Short\ I\ \&\ DPT})_r = (3.17E-8) \sum_{i=1}^n R_i \cdot x(d/q) \cdot x q_i \quad \text{Eq. 4-39}$$

All parameters have been defined previously. Short-term doses from the goat's milk pathway are to be added to the corresponding long term doses from the same pathway. Combining equations 4-16 (or 4-26b for quarterly) with 4-39 results in the following:

$$\begin{aligned} [D_{Total\ I\ \&\ DPT}]_r &= [D_{I\ \&\ DPT}]_r \\ &+ [D_{Short\ I\ \&\ DPT}]_r \text{ (Unmonitored Non - routine Releases)} \end{aligned} \quad \text{Eq. 4-40}$$

$$(D_{Short\ I\ \&\ DPT})_r = (3.17E-8) \sum_{i=1}^n R_i \cdot x(d/q) \cdot x q_i \quad \text{Eq. 4-41}$$

Meats

All parameters have been defined previously. Short-term doses from the meat pathway are to be added to the corresponding long term doses from the same pathway. Combining equations 4-17 (or 4-26c for quarterly) with 4-41 results in the following:

$$\begin{aligned} [D_{Total\ I\ \&\ DPT}]_r &= [D_{I\ \&\ DPT}]_r \\ &+ [D_{Short\ I\ \&\ DPT}]_r \text{ (Unmonitored Non - routine Releases)} \end{aligned} \quad \text{Eq. 4-42}$$

Vegetation

$$(D_{Short\ I\ \&\ 8DPT})_{\tau} = (3.17E-8) \sum_{i=1}^n R_{i\tau} x (d/q) x q_i \quad \text{Eq. 4-43}$$

All parameters have been defined previously. Short-term doses from the vegetation pathway are to be added to the corresponding long term doses from the same pathway. Combining equations 4-18 (or 4-26d for quarterly) with 4-43 results in the following:

$$[D_{Total\ I\ \&\ 8DPT}]_{\tau} = [D_{I\ \&\ 8DPT}]_{\tau} + [D_{Short\ I\ \&\ 8DPT}]_{\tau} (\text{Unmonitored Non-routine Releases}) \quad \text{Eq. 4-44}$$

For tritium, the dose is calculated by substituting x/q for d/q, and $R_{H-3\tau}$ for $R_{i\tau}$ in Equations 4-37, 4-39, 4-41, and 4-43.

Total Annual Dose From Release Point of Interest

$$D_{Short\tau} = \sum_{z=1}^P (D_{Short\ i\ \&\ 8DP})_{\tau z} \quad \text{Eq. 4-45}$$

Short-term doses from unmonitored non-routine releases are to be added to the corresponding long term doses from the stack and vents. Combining Equations 4-19b (or 4-27b for quarterly) and 4-45, results in the following:

Total Annual Dose

$$D_{Total\tau} = D_{\tau} + D_{Short\tau} \quad \text{Eq. 4-46}$$

4.5 Dose Projections - Determination of Need to Operate Offgas Radwaste Treatment System

4.5.1 Requirement

Part 1, Section 3.5.2.c requires that doses to gaseous releases from the site be projected at least monthly if the charcoal beds are not in service when offgas treatment system operation is required.

4.5.2 Methodology

The following calculational method is provided for determining the projected doses.

$$PD_{\gamma} = \frac{31}{X} \times D_{\gamma} \times 1.2 \quad \text{Eq. 4-47}$$

$$PD_{\beta} = \frac{31}{X} \times D_{\beta} \times 1.2 \quad \text{Eq. 4-48}$$

$$PD_{I\&P} = \frac{31}{X} \times D_{I\&P} \times 1.2 \quad \text{Eq. 4-49}$$

Where:

PD_{γ} = Projected air dose due to noble gas gamma radiation during the current month (mrad) from all routine effluent pathways

PD_{β} = Projected air dose due to noble gas beta radiation during the current month (mrad) from all routine effluent pathways

$PD_{I\&P}$ = Projected dose to any organ due to Tritium, Iodine-131, Iodine-133 and particulates with half-lives greater than 8 days (mrem)

31 = Time period for projection (days)

X = Number of days to date during sample period used to project the doses

- D_{γ} = Air dose due to noble gas gamma radiation corresponding to the time period X (mrad)
- D_{β} = Air dose due to noble gas beta radiation corresponding to the time period X (mrad)
- $D_{I\&P}$ = Organ dose due to Iodines, Tritium and Particulates corresponding to the time period X (mrem)
- 1.2 = Conservatism factor to provide a margin for changes in mixture and operational line up, etc.

A formal dose projection would be based on the most appropriate results of the monthly calculations of the gamma air dose, the beta air dose, and the organ dose due to Tritium, Iodines and particulates with half-lives greater than 8 days. The doses calculated will be divided by the number of days in the sample period determined to be most appropriate for projecting doses. An appropriate period to base projection on should reflect similar radioactive release rates effective at the time of the projection. The per-day doses will be multiplied by 31 days, i.e., the time period for projection. The product is the projected dose for the coming 31 day period. Its value may be adjusted to account for any changes in operating conditions that could significantly alter the actual releases, such as failed fuel.

The calculated projected doses, PD_{γ} , PD_{β} , and $PD_{I\&P}$ will be compared to the following Part 1, Radiological Effluent Controls, Section 3.5.1.c.2 limits:

0.2 mrad for gamma radiation,

0.4 mrad for beta radiation, or

0.3 mrem to any organ.

If any doses exceed the above limits, the offgas charcoal beds will be used whenever the operation of the offgas treatment system is required during the projected time period.

a. Limited Analysis Approach and Selection Criteria

A simpler approach, a linear extrapolation of the most recent three-month dose for the coming month, could be used as long as the limits of Part 1, Radiological Effluent Controls, Section 3.5.1.c.2 are not reached, and that releases of radioactive material have not changed significantly during the time period used for projection.

5.0 40 CFR 190 AND 10 CFR 72.104(a) DOSE EVALUATION

Part 1, Radiological Effluent Controls, Section 4.1.1.c requires that the annual (calendar year) dose or dose commitment to any member of the public from uranium fuel cycle sources be limited to ≤ 25 mrem to the whole body or any organ (except the thyroid which is limited to ≤ 75 mrem). Compliance with the dose limits of 40 CFR 190 will be deemed to demonstrate compliance with the 100 mrem/yr limits of 10 CFR 20.1301 (a) (1).

5.1 Evaluation Bases

Dose evaluation to demonstrate compliance with the 40 CFR 190 and 10 CFR 72.104(a) dose limits need only be performed if the quarterly or annual doses calculated in steps 3.4.1, 3.4.2, 4.4.1, 4.4.2, and 4.4.3 exceed twice the dose limits of Part 1, Radiological Effluent Controls, Sections 2.3, 3.3 or 3.4 respectively. Quarterly doses exceeding 3 mrem to the whole body (liquid releases), 10 mrem to any organ (liquid releases), 10 mrad equivalent gamma air dose, 20 mrad equivalent beta air dose, or 15 mrem to the thyroid or any organ from radioiodines and particulates (atmospheric releases) and annual doses exceeding 6 mrem to the whole body (liquid releases), 20 mrem to any organ (liquid releases), 20 mrad equivalent gamma air dose, 40 mrad equivalent beta air dose, or 30 mrem to the thyroid or any organ from radioiodines and particulate (atmospheric releases) would require 40 CFR 190 and 10 CFR 72.104(a) evaluation. The dose evaluation includes dose contributions to a maximally exposed real individual from the calendar quarter in which the quarterly or annual limits were exceeded in addition to plant offsite dose contributions during the balance of the current calendar year.

40 CFR 190 and 10 CFR 72.104(a) dose assessments, when required, will be made using actual meteorological data and frequency distribution data for the year covered by the evaluation.

For purposes of the evaluation, if required, it may be assumed that the dose commitment to the maximally exposed real individual from other uranium fuel cycle sources is negligible. However, doses from JAFNPP will be added to the doses to the maximum exposed individual at Nine Mile Point Unit 1 and Unit 2, or to the nuclear fuel cycle facilities within a radius 8 km of the site.

As part of the Radiological Environmental Monitoring Program (REMP), JAF and Niagara Mohawk jointly support a TLD program that monitors the doses on and off-site. The environmental TLDs measure the direct gamma radiation from the sites; contributions from JAF, Nine Mile Units 1 and 2. The TLD results are presented annually in the JAF Radiological Environmental Operating Report (AREOR).

JAF and Niagara Mohawk issue Radioactive Effluent Release Reports. The dose contributions from effluents from the plant can be found in these reports.

JAF also reports annually to the commission, in accordance with 10 CFR 72.4 and 72.44(d)(3), the quantity of each of the principal radionuclides released to the environment in liquid and gaseous effluents during the previous 12 months of operation, and such other information as may be required by the commission to estimate maximum potential radiation dose commitment to the public resulting from effluent releases (Per JAF AP-03.04).

5.2 Doses From Liquid Releases

For the evaluation of doses to real individuals from liquid releases, the same calculating method as employed for Liquid Effluents Annual Dose Assessment will be used. However, more realistic assumptions and any current field data or updated estimates may be used, if available, concerning the dilution and ingestion of fish and potable water by individuals who live and fish in the area. Also, the results of the Radiological Environmental Monitoring Program will be included in determining more refined estimates of doses to real individuals by providing data on actual measured levels of plant-related radionuclides in the environment.

5.3 Doses From Atmospheric Releases

For the evaluation of doses to real individuals from the atmospheric releases, the same calculating methods as employed for Gaseous Effluent Annual Dose Assessment will be used except that the gamma and beta air doses are not calculated. Otherwise the same calculating sequence applies. However, any current field data or updated estimates may be used, if available, concerning the actual location of real individuals, the meteorological conditions, and the consumption of food (e.g., milk, meat and vegetation). Data obtained from the latest land use census Part 1, Section 5.2 should be used to determine locations for evaluating doses. Also, the results of the Radiological Environmental Monitoring Program will be included in determining more refined dose estimates to real individuals by providing data on actual measured levels of radioactivity and radiation at locations of interest.

5.4 Doses From Direct Radiation

Because 40 CFR 190 and 10 CFR 72.104(a) requirements include consideration of the offsite dose contribution from direct radiation, an estimate must be provided in the evaluation.

The direct radiation dose contribution from turbine shine (N-16) under hydrogen water chemistry conditions was evaluated to determine the need for additional shielding. Site boundary doses at the land based sectors of the site are less than 1 mrem/yr from this source.

The Interim Radioactive Waste Storage Facility (IRWSF) was evaluated for doses to the site boundary from a fully loaded facility in JAF-CALC-RAD-00030, Rev. 1. The calculation shows the site boundary gamma dose for the land based sectors of the site from the contained sources within the Interim Waste Storage Facility to be less than 1 mrem/yr.

The Independent Spent Fuel Storage Installation (ISFSI) was evaluated for doses to the site boundary from a Phase I configuration and cask storage source term. The Phase I ISFSI is loaded with 22 storage casks in a 11 x 2 array. Each cask is loaded with 68 spent fuel bundles. Calculations in JAF-CALC-SFS-03344, Rev. 0 and JAF-CALC-SFS-04025, Rev. 2 demonstrate that the site boundary gamma dose for the closest land based sector of the site is less than 1 mrem/hr from a fully loaded Phase I configuration.

Turbine shine, a fully loaded IRWSF, and the Phase I loaded ISFSI are the major contributors to direct radiation exposure at the site boundary. New sources will be analyzed on a case by case basis.

5.5 Doses to Members of the Public due to On-Site Activities

Members of the public are occasionally granted access to areas within the site boundary. Exposure to these members of the public due to liquid releases while on-site is highly unlikely and is not considered. Therefore, only exposure due to gaseous releases and direct radiation are considered. TLD and periodic area survey information is used to ensure that the dose and dose rates to such members of the public are within the limits of 10 CFR 1301 (a)(1).

6.0 REFERENCES

- 6.1 Regulatory Guide 1.109, Rev. 1, October 1977
- 6.2 NUREG-0133, October 1978
- 6.3 EN-AD-103, Document Control and Records Management Programs, Revision 03, April 29, 2005
- 6.4 Technical Specifications
- 6.5 James A. FitzPatrick Nuclear Power Plant, Docket 50-333, Compliance with 10 CFR 50, Appendix I
- 6.6 Final Environmental Impact Statement Related to Operation of James A. FitzPatrick Nuclear Power Plant, New York Power Authority; Docket No. 50-333, March 1973
- 6.7 Environmental Report, Operating License Stage, James A. FitzPatrick Plant, New York Power Authority, May 1971
 - 6.7.1 Supplement Environmental Report, Operating License Stage, November 1971
 - 6.7.2 Supplement #2 Environmental Report, Benefit/Cost Analysis, May 1972
 - 6.7.3 Supplement #3 Environmental Report, Answers to Atomic Energy Commission Questions, August 1982
- 6.8 Final Safety Analysis Report, James A. FitzPatrick Plant, New York Power Authority, Docket No. 50-333, Operating License No. DPR-59
- 6.9 New York Power Authority, Internal Memorandum from D. Dunning to G. Re, September 20, 1988
- 6.10 New York Power Authority, Corporate Radiological Engineering Calculation No. JAF-CALC-RAD-00025, Revision 1, Atmospheric Dispersion and Deposition Parameters for Routine Releases (1995)
- 6.11 CHAS. T. Main, Inc. X/Q and D/Q Tables for Nine Mile Point Unit 1, Nine Mile Point Unit 2 and James A. FitzPatrick Nuclear Power Plant, November 1985 (Contain 5 years of meteorological data, 1978 through 1982)
- 6.12 Idaho National Engineering Laboratory Technical Evaluation Report (TER) of the JAF ODCM for the NRC (EGG-PHY-8153, July 1988)

- 6.13 New York Power Authority Corporate Radiological Engineering Calculation Number JAF-CALC-RAD-00010, Revision 0, Verification Document for Radiological Effluent Controls and Offsite Dose Calculation Manual (Date Pending)
- 6.14 New York Power Authority Corporate Radiological Engineering Calculation Number JAF-CALC-RAD-00029, Aquatic Dispersion and Dose Assessment Methodology for Non-Routine Releases (1995)
- 6.15 Entergy Nuclear FitzPatrick, LLC and Entergy Nuclear Operations, Inc., James A. FitzPatrick Independent Spent Fuel Storage Installation JAF-CALC-SFS-03346, Rev. 0, Dose Rates in the Vicinity of the Hi-Storm Storage Cask and Phase I ISFSI
- 6.16 Entergy Nuclear FitzPatrick, LLC and Entergy Nuclear Operations, Inc., James A. FitzPatrick Independent Spent Fuel Storage Installation JAF-CALC-SFS-04025, Rev. 1, Confinement Analysis and Compliance with Applicable Regulations for the Phase I ISFSI
- 6.17 Entergy Nuclear FitzPatrick, LLC and Entergy Nuclear Operations, Inc., James A. FitzPatrick Independent Spent Fuel Storage Installation, 10 CFR 72.212 Evaluation Report
- 6.18 AP-03.04, Information Reporting Requirements, Revision 12
- 6.19 Certificate of Compliance No. 1014, Appendix A. Technical Specifications for the Hi-Storm 100 Cask System, Amendments 1 and 2
- 6.20 JAF-ICD-RBC-04561, Interface Control Document, Offsite Dose Manual Effluent Airflows, 04/23/03, Rev. 0
- 6.21 EPRI, Estimation of Carbon-14 in Nuclear Power Gaseous Effluents, December 2010
- 6.22 Entergy Echelon Nuclear Engineering, BWR Input Parameters for Determining Carbon-14 in Gaseous Effluent, NEAD-NS-11/006, Rev. 0

APPENDIX A
LIQUID DOSE CALCULATION DATA

APPENDIX A

LIQUID DOSE CALCULATION DATA

TABLE	TITLE	PAGE
A-1	Effluent Concentration Limits for Water in Unrestricted Areas	A-3
A-2	Dose Factors, Limited Analysis Approach	A-4
A-3	Dose Factors, All Remaining Pathways	A-9
A-4	Dose Factor Derivation	A-18

**TABLE A-1
EFFLUENT CONCENTRATION LIMITS FOR WATER IN UNRESTRICTED AREAS**

NUCLIDE¹	ECL (μCi/ml)	NUCLIDE¹	ECL(μCi/ml)
H-3	1.000E-02	Ru-103	3.000E-04
Be-7	6.000E-03	Ru-105	7.000E-04
Na-24	5.000E-04	Ru-106	3.000E-05
P-32	9.000E-05	Cd-109	6.000E-05
K-40	4.000E-05	Ag-110m	6.000E-05
Cr-51	5.000E-03	Sn-113	3.000E-04
Mn-54	3.000E-04	In-113m	7.000E-03
Mn-56	7.000E-04	Sb-122	1.000E-04
Fe-55	1.000E-03	Sb-124	7.000E-05
Fe-59	1.000E-04	Sb-125	3.000E-04
Co-57	6.000E-04	Te-123M	9.000E-05
Co-58	2.000E-04	Te-125m	2.000E-04
Co-60	3.000E-05	Te-127	1.000E-03
Ni-63	1.000E-03	Te-127m	9.000E-05
Ni-65	1.000E-03	Te-129m	7.000E-05
Cu-64	2.000E-03	Te-129	4.000E-03
Zn-65	5.000E-05	Te-131m	8.000E-05
Zn-69	8.000E-03	Te-131	8.000E-04
Zn-69m	6.000E-04	Te-132	9.000E-05
As-76	1.000E-04	Te-134	3.000E-03
Br-82	4.000E-04	I-130	2.000E-04
Br-83	9.000E-03	I-131	1.000E-05
Br-84	4.000E-03	I-132	1.000E-03
Br-85	1.000E-05	I-133	7.000E-05
Rb-86	7.000E-05	I-134	4.000E-03
Rb-88	4.000E-03	I-135	3.000E-04
Rb-89	9.000E-03	Cs-134	9.000E-06
Sr-85	4.000E-04	Cs-136	6.000E-05
Sr-89	8.000E-05	Cs-137	1.000E-05
Sr-90	5.000E-06	Cs-138	4.000E-03
Sr-91	2.000E-04	Ba-133	2.000E-04
Sr-92	4.000E-04	Ba-139	2.000E-03
Y-88	1.000E-04	Ba-140	8.000E-05
Y-90	7.000E-05	Ba-141	3.000E-03
Y-91m	2.000E-02	Ba-142	7.000E-03
Y-91	8.000E-05	La-140	9.000E-05
Y-92	4.000E-04	La-142	1.000E-03
Y-93	2.000E-04	Ce-139	7.000E-04
Zr-95	2.000E-04	Ce-141	3.000E-04
Zr-97	9.000E-05	Ce-143	2.000E-04
Nb-94	1.000E-04	Ce-144	3.000E-05
Nb-95	3.000E-04	Pr-143	2.000E-04
Nb-95m	3.000E-04	Pr-144	6.000E-03
Nb-97	3.000E-03	Nd-147	2.000E-04
Mo-99	2.000E-04	W-187	3.000E-04
Tc-99m	1.000E-02	Np-239	2.000E-04
Tc-101	2.000E-02		

(1) All ECL values are taken from 10 times 10CFR20 EC values.

TABLE A-2 DOSE
CONVERSION FACTORS FOR LIQUID DISCHARGES

<u>Limited Analysis Approach</u>	<u>PAGE</u>
Freshwater Fish (A_{itf}) - Adult	A-5
Potable Water (A_{itw}) - Adult	A-6
Freshwater Fish (A_{itf}) - Teenager	A-7
Potable Water (A_{itw}) - Teenager	A-8

TABLE A-2
A_{iff} VALUES - FRESHWATER FISH - ADULT
(mrem/hr per μ Ci/ml)

NUCLIDE	BONE	LIVER	THYROID	KIDNEY	LUNG	GI-LLI	SKIN	T. BODY
H-3	0	1.89E-02	1.89E-02	1.89E-02	1.89E-02	1.89E-02	0	1.89E-02
Na-24	3.39E 01	3.39E 01	3.39E 01	3.39E 01	3.39E 01	3.39E 01	0	3.39E 01
Cr-51	0	0	6.34E-02	2.34E-02	1.41E-01	2.67E 01	0	1.06E-01
Mn-54	0	3.65E 02	0	1.09E 02	0	1.12E 03	0	6.96E 01
Fe-55	5.49E 01	3.79E 01	0	0	2.11E 01	2.17E 01	0	8.84E 00
Fe-59	8.66E 01	2.03E 02	0	0	5.69E 01	6.78E 02	0	7.80E 01
Co-57	0	1.74E 00	0	0	0	4.43E 01	0	2.90E 00
Co-58	0	7.43E 00	0	0	0	1.51E 02	0	1.67E 01
Co-60	0	2.13E 01	0	0	0	4.01E 02	0	4.71E 01
Cu-64	0	8.31E-01	0	2.09E 00	0	7.08E 01	0	3.90E-01
Zn-65	1.93E 03	6.14E 03	0	4.11E 03	0	3.87E 03	0	2.78E 03
Sr-89	1.84E 03	0	0	0	0	2.96E 02	0	5.29E 01
Sr-90	4.54E 04	0	0	0	0	1.31E 03	0	1.11E 04
Nb-95	3.72E 01	2.07E 01	0	2.05E 01	0	1.26E 05	0	1.11E 01
Zr-95	2.00E-02	6.42E-03	0	1.01E-02	0	2.03E 01	0	4.35E-03
As-76	0	9.46E-01	0	1.78E 00	0	2.29E 03	0	9.04E-01
Nb-95m	3.27E 01	2.07E 01	0	2.05E 01	0	1.26E 05	0	1.11E 01
Zr-97	1.11E-03	2.23E-04	0	3.37E-04	0	6.91E 01	0	1.02E-04
Mo-99	0	8.60E 00	0	1.95E 01	0	1.99E 01	0	1.64E 00
Tc-99m	7.39E-04	2.09E-03	0	3.17E-02	1.02E-03	1.24E 00	0	2.66E-02
Ag-110m	7.34E-02	6.79E-02	0	1.34E-01	0	2.77E 01	0	4.03E-02
Sb-124	5.59E-01	1.05E-02	1.35E-03	0	4.35E-01	1.59E 01	0	2.21E-01
I-131	1.24E 01	1.78E 01	5.84E 03	3.05E+01	0	4.70E 00	0	1.02E 01
I-133	4.25E 00	7.39E 00	1.09E 03	1.29E 01	0	6.64E 00	0	2.25E 00
I-135	1.33E 00	3.47E 00	2.29E 02	5.57E 00	0	3.92E 00	0	1.28E 00
Cs-134	2.48E 04	5.91E 04	0	1.91E 04	6.34E 03	1.03E 03	0	4.83E 04
Cs-137	3.18E 04	4.35E 04	0	1.48E 04	4.91E 03	8.42E 02	0	2.85E 04
Ba-140	1.62E 01	2.03E-02	0	6.92E-03	1.17E-02	3.34E 01	0	1.06E 00
La-140	1.25E-02	6.28E-03	0	0	0	4.61E 02	0	1.66E-03
Ce-141	1.87E-03	1.26E-03	0	5.87E-04	0	4.83E 00	0	1.43E-04
Ce-144	9.74E-02	4.07E-02	0	2.41E-02	0	3.29E 01	0	5.23E-03
W-187	2.47E 01	2.06E 01	0	0	0	6.75E 03	0	7.21E 00
Np-239	2.37E-03	2.33E-04	0	7.28E-04	0	4.79E 01	0	1.29E-04

TABLE A-2
A_{itf} VALUES - POTABLE WATER - ADULT
(mrem/hr per μCi/ml)

NUCLIDE	BONE	LIVER	THYROID	KIDNEY	LUNG	GI-LLI	SKIN	T. BODY
H-3	0	5.29E-02	5.29E-02	5.29E-02	5.29E-02	5.29E-02	0	5.29E-02
Cr-51	0	0	8.02E-04	2.96E-04	1.78E-03	3.37E-01	0	1.34E-03
Mn-54	0	2.30E 00	0	6.86E-01	0	7.06E 00	0	4.39E-01
Fe-55	1.39E 00	9.58E-01	0	0	5.35E-01	5.50E-01	0	2.23E-01
Fe-59	2.19E 00	5.14E 00	0	0	1.44E 00	1.71E+01	0	1.97E 00
Co-57	0	8.83E-02	0	0	0	2.24E 00	0	1.47E-01
Co-58	0	3.76E-01	0	0	0	7.62E 00	0	8.42E-01
Co-60	0	1.08E 00	0	0	0	2.03E 01	0	2.38E 00
Zn-65	2.44E 00	7.77E 00	0	5.19E 00	0	4.89E 00	0	3.51E 00
Sr-89	1.55E 02	0	0	0	0	2.49E 01	0	4.45E 00
Sr-90	3.82E 03	0	0	0	0	1.10E 02	0	9.38E 02
Zr-95	1.53E-02	4.92E-03	0	7.72E-03	0	1.56E 01	0	3.33E-03
Zr-97	8.47E-04	1.71E-04	0	2.58E-04	0	5.29E 01	0	7.82E-05
Nb-95	3.14E-03	1.75E-03	0	1.72E-03	0	1.06E 01	0	9.38E-04
Mo-99	0	2.17E 00	0	4.92E 00	0	5.04E 00	0	4.13E-01
Ag-110m	8.07E-02	7.46E-02	0	1.47E-01	0	3.05E 01	0	4.43E-02
Sb-124	1.41E 00	2.67E-02	3.42E-03	0	1.10E 00	4.01E 01	0	5.59E-01
I-131	2.10E 00	3.00E 00	9.83E 02	5.14E 00	0	7.92E-01	0	1.72E 00
I-133	7.16E-01	1.25E 00	1.83E 02	2.17E 00	0	1.12E 00	0	3.79E-01
I-135	2.23E-01	5.85E-01	3.86E 01	9.38E-01	0	6.61E-01	0	2.16E-01
Cs-134	3.14E 01	7.46E 01	0	2.42E 01	8.02E 00	1.31E 00	0	6.10E 01
Cs-137	4.02E 01	5.49E 01	0	1.87E 01	6.20E 00	1.06E 00	0	3.61E 01
Ba-140	1.02E 01	1.29E-02	0	4.37E-03	7.36E-03	2.11E 01	0	6.71E-01
La-140	1.26E-03	6.35E-04	0	0	0	4.66E 01	0	1.68E-04
Ce-141	4.72E-03	3.19E-03	0	1.48E-03	0	1.22E 01	0	3.62E-04
Ce-144	2.46E-01	1.03E-01	0	6.10E-02	0	8.32E 01	0	1.32E-02
Na-24	8.57E-01	8.57E-01	8.57E-01	8.57E-01	8.57E-01	8.57E-01	0	8.57E-01
Cu-64	0	4.20E-02	0	1.06E-01	0	3.58E 00	0	1.97E-02
W-187	5.19E-02	4.34E-02	0	0	0	1.42E 01	0	1.51E-02
Np-239	6.00E-04	5.90E-05	0	1.84E-04	0	1.21E 01	0	3.25E-05
Tc-99m	1.25E-04	3.52E-04	0	5.35E-03	1.72E-04	2.08E-01	0	4.48E-03
As-76	0	2.39E-02	0	4.50E-02	0	5.80E 01	0	2.28E-02
Nb-95m	3.14E-03	1.75E-03	0	1.72E-03	0	1.06E 01	0	9.38E-04

TABLE A-2
A_{itw} VALUES - FRESHWATER FISH - TEENAGER
(mrem/hr per μ Ci/ml)

NUCLIDE	BONE	LIVER	THYROID	KIDNEY	LUNG	GI-LLI	SKIN	T. BODY
H-3	0	1.45E-02	1.45E-02	1.45E-02	1.45E-02	1.45E-02	0	1.45E-02
Na-24	3.50E 01	3.50E 01	3.50E 01	3.50E 01	3.50E 01	3.50E 01	0	3.50E 01
Cr-51	0	0	6.08E-02	2.40E-02	1.56E-01	1.84E 01	0	1.09E-01
Mn-54	0	3.59E 02	0	1.07E 02	0	7.35E 02	0	7.11E 01
Fe-55	5.75E 01	4.07E 01	0	0	2.58E 01	1.76E 01	0	9.50E 00
Fe-59	8.92E 01	2.08E 02	0	0	6.57E 01	4.92E 02	0	8.04E 01
Co-57	0	1.81E 00	0	0	0	3.37E 01	0	3.03E 00
Co-58	0	7.39E 00	0	0	0	1.02E 02	0	1.70E 01
Co-60	0	2.14E 01	0	0	0	2.78E 02	0	4.81E 01
Cu-64	0	8.74E-01	0	2.21E 00	0	6.78E 01	0	4.11E-01
Zn-65	1.75E 03	6.08E 03	0	3.89E 03	0	2.57E 03	0	2.84E 03
Sr-89	2.01E 03	0	0	0	0	2.39E 02	0	5.75E 01
Sr-90	3.78E 04	0	0	0	0	1.06E 03	0	9.35E 03
Nb-95	3.75E 01	2.08E 01	0	2.02E 01	0	8.89E 04	0	1.14E 01
Zr-95	2.07E-02	6.52E-03	0	9.58E-03	0	1.50E 01	0	4.48E-03
As-76	0	1.02E 00	0	1.93E 00	0	1.96E 03	0	9.83E-01
Nb-95m	3.75E 01	2.08E 01	0	2.02E 01	0	8.89E 04	0	1.14E 01
Zr-97	1.19E-03	2.35E-04	0	3.57E-04	0	6.37E 01	0	1.08E-04
Mo-99	0	9.17E 00	0	2.10E 01	0	1.64E 01	0	1.75E 00
Tc-99m	7.57E-04	2.11E-03	0	3.15E-02	1.17E-03	1.39E 00	0	2.74E-02
Ag-110m	7.17E-02	6.78E-02	0	1.29E-01	0	1.91E 01	0	4.13E-02
Sb-124	5.88E-01	1.08E-02	1.33E-03	0	5.14E-01	1.19E 01	0	2.29E-01
I-131	1.33E 01	1.87E 01	5.45E 03	3.21E 01	0	3.69E 00	0	1.00E 01
I-133	4.58E 00	7.77E 00	1.09E 03	1.36E 01	0	5.88E 00	0	2.37E 00
I-135	1.39E 00	3.58E 00	2.30E 02	5.56E 00	0	3.97E 00	0	1.33E 00
Cs-134	2.54E 04	5.99E 04	0	1.90E 04	7.27E 03	7.45E 02	0	2.78E 04
Cs-137	3.40E 04	4.53E 04	0	1.54E 04	5.99E 03	6.44E 02	0	1.58E 04
Ba-140	1.73E 01	2.12E-02	0	7.17E-03	1.42E-02	2.66E 01	0	1.11E 00
La-140	1.32E-02	6.50E-03	0	0	0	3.73E 02	0	1.73E-03
Ce-141	2.02E-03	1.35E-03	0	6.35E-04	0	3.86E 00	0	1.55E-04
Ce-144	1.06E-01	4.38E-02	0	2.61E-02	0	2.66E 01	0	5.68E-03
W-187	2.66E 01	2.17E 01	0	0	0	5.87E 03	0	7.61E 00
Np-239	2.68E-03	2.52E-04	0	7.92E-04	0	4.06E 01	0	1.40E-04

TABLE A-2
A_{itw} VALUES - POTABLE WATER - TEENAGER
(mrem/hr per μ Ci/ml)

NUCLIDE	BONE	LIVER	THYROID	KIDNEY	LUNG	GI-LLI	SKIN	T. BODY
H-3	0	3.73E-02	3.73E-02	3.73E-02	3.73E-02	3.73E-02	0	3.73E-02
Cr-51	0	0	7.05E-04	2.78E-04	1.81E-03	2.13E-01	0	1.27E-03
Mn-54	0	2.08E 00	0	6.20E-01	0	4.26E 00	0	4.12E-01
Fe-55	1.33E 00	9.44E-01	0	0	5.99E-01	4.09E-01	0	2.20E-01
Fe-59	2.07E 00	4.83E 00	0	0	1.52E 00	1.14E 01	0	1.86E 00
Co-57	0	8.39E-02	0	0	0	1.56E 00	0	1.41E-01
Co-58	0	3.42E-01	0	0	0	4.72E 00	0	7.89E-01
Co-60	0	9.90E-01	0	0	0	1.29E 01	0	2.23E 00
Zn-65	2.03E 00	7.05E 00	0	4.51E 00	0	2.98E 00	0	3.29E 00
Sr-89	1.55E 02	0	0	0	0	1.85E 01	0	4.44E 00
Sr-90	2.92E 03	0	0	0	0	8.21E 01	0	7.22E 02
Zr-95	1.45E-02	4.58E-03	0	6.73E-03	0	1.06E 01	0	3.15E-03
Zr-97	8.35E-04	1.65E-04	0	2.51E-04	0	4.47E 01	0	7.61E-05
Nb-95	2.90E-03	1.61E-03	0	1.56E-03	0	6.87E 00	0	8.84E-04
Mo-99	0	2.12E 00	0	4.86E 00	0	3.81E 00	0	4.05E-01
Ag-110m	7.22E-02	6.84E-02	0	1.30E-01	0	1.92E 01	0	4.16E-02
Sb-124	1.36E 00	2.51E-02	3.09E-03	0	1.19E 00	2.75E 01	0	5.32E-01
I-131	2.06E 00	2.89E 00	8.42E 02	4.97E 00	0	5.71E-01	0	1.55E 00
I-133	7.08E-01	1.20E 00	1.67E 02	2.11E 00	0	9.09E-01	0	3.66E-01
I-135	2.15E-01	5.53E-01	3.56E 01	8.74E-01	0	6.13E-01	0	2.05E-01
Cs-134	2.95E 01	6.94E 01	0	2.21E 01	8.42E 00	8.63E-01	0	3.22E 01
Cs-137	3.95E 01	5.25E 01	0	1.79E 01	6.94E 00	7.47E-01	0	1.83E 01
Ba-140	1.00E 01	1.23E-02	0	4.16E-03	8.25E-03	1.54E 01	0	6.54E-01
La-140	1.23E-03	6.03E-04	0	0	0	3.46E 01	0	1.60E-04
Ce-141	4.69E-03	3.13E-03	0	1.47E-03	0	8.95E 00	0	3.59E-04
Ce-144	2.45E-01	1.01E-01	0	6.06E-02	0	6.17E 01	0	1.31E-02
Na-24	8.60E-01	8.60E-01	8.60E-01	8.60E-01	8.60E-01	8.60E-01	0	8.60E-01
Cu-64	0	4.05E-02	0	1.03E-01	0	3.14E 00	0	1.91E-02
W-187	5.14E-02	4.19E-02	0	0	0	1.13E 01	0	1.47E-02
Np-239	6.20E-04	5.85E-05	0	1.84E-04	0	9.41E 00	0	3.25E-05
Tc-99m	1.17E-04	3.26E-04	0	4.86E-03	1.81E-04	2.14E-01	0	4.23E-03
As-76	0	2.36E-02	0	4.48E-02	0	4.55E 01	0	2.28E-02
Nb-95m	2.90E-03	1.61E-03	0	1.56E-03	0	6.87E 00	0	8.84E-04

TABLE A-3

DOSE CONVERSION FACTORS FOR LIQUID DISCHARGES

All Remaining Pathways	Page
Lake Shoreline Deposits (A_{itsh}) - Adult	A-10
Lake Shoreline Deposits (A_{itsh}) - Teenager	A-11
Potable Water (A_{itw}) - Child	A-12
Freshwater Fish (A_{itf}) - Child	A-13
Lake Shoreline Deposits (A_{itsh}) - Child	A-14
Potable Water (A_{itw}) - Infant	A-15
Freshwater Fish (A_{itf}) - Infant	A-16
Lake Shoreline Deposits (A_{itsh}) - Infant	A-17

TABLE A-3
A_{itsh} VALUES - LAKE SHORELINE DEPOSITS - ADULT
(mrem/hr per μ Ci/ml)

NUCLIDE	BONE	LIVER	THYROID	KIDNEY	LUNG	GI-LLI	SKIN	T. BODY
H-3	0	0	0	0	0	0	0	0
Na-24	3.56E-02	3.56E-02	3.56E-02	3.56E-02	3.56E-02	3.56E-02	4.13E-02	3.56E-02
Cr-51	1.38E-02	1.38E-02	1.38E-02	1.38E-02	1.38E-02	1.38E-02	1.64E-02	1.38E-02
Mn-54	4.13E 00	4.13E 00	4.13E 00	4.13E 00	4.13E 00	4.13E 00	4.85E 00	4.13E 00
Fe-55	0	0	0	0	0	0	0	0
Fe-59	8.13E-01	8.13E-01	8.13E-01	8.13E-01	8.13E-01	8.13E-01	9.55E-01	8.13E-01
Co-57	5.62E-02	5.62E-02	5.62E-02	5.62E-02	5.62E-02	5.62E-02	6.18E-01	5.62E-02
Co-58	1.13E 00	1.13E 00	1.13E 00	1.13E 00	1.13E 00	1.13E 00	1.32E 00	1.13E 00
Co-60	6.42E 01	6.42E 01	6.42E 01	6.42E 01	6.42E 01	6.42E 01	7.55E 01	6.42E 01
Cu-64	1.81E-03	1.81E-03	1.81E-03	1.81E-03	1.81E-03	1.81E-03	2.05E-03	1.81E-03
Zn-65	2.23E 00	2.23E 00	2.23E 00	2.23E 00	2.23E 00	2.23E 00	2.56E 00	2.23E 00
Sr-89	6.46E-05	6.46E-05	6.46E-05	6.46E-05	6.46E-05	6.46E-05	7.5 E-05	6.46E-05
Sr-90	0	0	0	0	0	0	0	0
Nb-95	4.08E-01	4.08E-01	4.08E-01	4.08E-01	4.08E-01	4.08E-01	4.80E-01	4.08E-01
Zr-95	7.30E-01	7.30E-01	7.30E-01	7.30E-01	7.30E 01	7.30E-01	8.46E-01	7.30E-01
As-76	1.14E-02	1.14E-02	1.14E-02	1.14E-02	1.14E-02	1.14E-02	3.96E-01	1.14E-02
Nb-95m	5.85E-03	5.85E-03	5.85E-03	5.85E-03	5.85E-03	5.85E-03	3.67E-02	5.85E-03
Zr-97	8.78E-03	8.78E-03	8.78E-03	8.78E-03	8.78E-03	8.78E-03	1.02E-02	8.78E-03
Mo-99	1.19E-02	1.19E-02	1.19E-02	1.19E-02	1.19E-02	1.19E-02	1.38E-02	1.19E-02
Tc-99m	5.47E-04	5.47E-04	5.47E-04	5.47E-04	5.47E-04	5.47E-04	6.27E-04	5.47E-04
Ag-110m	1.03E 01	1.03E 01	1.03E 01	1.03E 01	1.03E 01	1.03E 01	1.20E 01	1.03E 01
Sb-124	1.78E 00	1.78E 00	1.78E 00	1.78E 00	1.78E 00	1.78E 00	2.06E 00	1.78E 00
I-131	5.13E-02	5.13E-02	5.13E-02	5.13E-02	5.13E-02	5.13E-02	6.23E-02	5.13E-02
I-133	7.34E-03	7.34E-03	7.34E-03	7.34E-03	7.34E-03	7.34E-03	8.93E-03	7.34E-03
I-135	7.66E-03	7.66E-03	7.66E-03	7.66E-03	7.66E 03	7.66E-03	8.94E-03	7.66E-03
Cs-134	2.05E 01	2.05E 01	2.05E 01	2.05E 01	2.05E 01	2.05E 01	2.39E 01	2.05E 01
Cs-137	3.07E 01	3.07E 01	3.07E 01	3.07E 01	3.07E 01	3.07E 01	3.58E 01	3.07E 01
Ba-140	6.13E-02	6.13E-02	6.13E-02	6.13E-02	6.13E-02	6.13E-02	7.00E-02	6.13E-02
La-140	5.81E-02	5.81E-02	5.81E-02	5.81E-02	5.81E-02	5.81E-02	6.58E-02	5.81E-02
Ce-141	4.08E-02	4.08E-02	4.08E-02	4.08E-02	4.08E-02	4.08E-02	4.59E-02	4.08E-02
Ce-144	2.07E-01	2.07E-01	2.07E-01	2.07E-01	2.07E-01	2.07E-01	2.39E-01	2.07E-01
W-187	7.07E-03	7.07E-03	7.07E-03	7.07E-03	7.07E-03	7.07E-03	8.21E-03	7.07E-03
Np-239	5.20E-03	5.20E-03	5.20E-03	5.20E 03	5.20E-03	5.20E-03	6.02E-03	5.20E-03

TABLE A-3 (Continued)
Aitsh VALUES - LAKE SHORELINE DEPOSITS - TEENAGER
(mrem/hr per μ Ci/ml)

NUCLIDE	BONE	LIVER	THYROID	KIDNEY	LUNG	GI-LLI	SKIN	T. BODY
H-3	0	0	0	0	0	0	0	0
Na-24	1.98E-01	1.98E-01	1.98E-01	1.98E-01	1.98E-01	1.98E-01	2.31E-01	1.98E-01
Cr-51	7.76E-02	7.76E-02	7.76E-02	7.76E-02	7.76E-02	7.76E-02	9.17E-02	7.76E-02
Mn-54	2.31E 01	2.31E 01	2.31E 01	2.31E 01	2.31E 01	2.31E 01	2.71E 01	2.31E 01
Fe-55	0	0	0	0	0	0	0	0
Fe-59	4.54E 00	4.54E 00	4.54E 00	4.54E 00	4.54E 00	4.54E 00	5.34E 00	4.54E 00
Co-57	3.14E 00	3.14E 00	3.14E 00	3.14E 00	3.14E 00	3.14E 00	3.45E 00	3.14E 00
Co-58	6.31E 00	6.31E 00	6.31E 00	6.31E 00	6.31E 00	6.31E 00	7.39E 00	6.31E 00
Co-60	3.58E 02	3.58E 02	3.58E 02	3.58E 02	3.58E 02	3.58E 02	4.21E 02	3.58E 02
Cu-64	1.01E-02	1.01E-02	1.01E-02	1.01E-02	1.01E-02	1.01E-02	1.14E-02	1.01E-02
Zn-65	1.24E 01	1.24E 01	1.24E 01	1.24E 01	1.24E 01	1.24E 01	1.43E 01	1.24E 01
Sr-89	3.61E-04	3.61E-04	3.61E-04	3.61E-04	3.61E-04	3.61E-04	4.18E-04	3.61E-04
Sr-90	0	0	0	0	0	0	0	0
Nb-95	2.28E 00	2.28E 00	2.28E 00	2.28E 00	2.28E 00	2.28E 00	2.68E 00	2.28E 00
Zr-95	4.07E 00	4.07E 00	4.07E 00	4.07E 00	4.07E 00	4.07E 00	4.72E 00	4.07E 00
As-76	6.38E-02	6.38E-02	6.38E-02	6.38E-02	6.38E-02	6.38E-02	2.21E 00	6.38E-02
Nb-95m	3.27E-02	3.27E-02	3.27E-02	3.27E-02	3.27E-02	3.27E-02	2.05E 01	3.27E-02
Zr-97	4.90E-02	4.90E-02	4.90E-02	4.90E-02	4.90E-02	4.90E-02	5.70E-02	4.90E-02
Mo-99	6.65E-02	6.65E-02	6.65E-02	6.65E-02	6.65E-02	6.65E-02	7.70E-02	6.65E-02
Tc-99m	3.05E-03	3.05E-03	3.05E-03	3.05E-03	3.05E-03	3.05E-03	3.50E-03	3.05E-03
Ag-110m	5.73E 01	5.73E 01	5.73E 01	5.73E 01	5.73E 01	5.73E 01	6.68E 01	5.73E 01
Sb-124	9.96E 00	9.96E 00	9.96E 00	9.96E 00	9.96E 00	9.96E 00	1.15E 01	9.96E 00
I-131	2.87E-01	2.87E-01	2.87E-01	2.87E-01	2.87E-01	2.87E-01	3.48E-01	2.87E-01
I-133	4.09E-02	4.09E-02	4.09E-02	4.09E-02	4.09E-02	4.09E-02	4.98E-02	4.09E-02
I-135	4.28E-02	4.28E-02	4.28E-02	4.28E-02	4.28E-02	4.28E-02	4.99E-02	4.28E-02
Cs-134	1.14E 02	1.14E 02	1.14E 02	1.14E 02	1.14E 02	1.14E 02	1.33E 02	1.14E 02
Cs-137	1.71E 02	1.71E 02	1.71E 02	1.71E 02	1.71E 02	1.71E 02	2.00E 02	1.71E 02
Ba-140	3.42E-01	3.42E-01	3.42E-01	3.42E-01	3.42E 01	3.42E-01	3.91E-01	3.42E-01
La-140	3.24E-01	3.24E-01	3.24E-01	3.24E-01	3.24E-01	3.24E-01	3.67E-01	3.24E-01
Ce-141	2.28E-01	2.28E-01	2.28E-01	2.28E-01	2.28E-01	2.28E-01	2.56E-01	2.28E-01
Ce-144	1.16E 00	1.16E 00	1.16E 00	1.16E 00	1.16E 00	1.16E 00	1.34E 00	1.16E 00
W-187	3.95E-02	3.95E-02	3.95E-02	3.95E-02	3.95E-02	3.95E-02	4.58E-02	3.95E-02
Np-239	2.90E-02	2.90E-02	2.90E-02	2.90E-02	2.90E-02	2.90E-02	3.36E-02	2.90E-02

TABLE A-3 (Continued)
A_{itw} VALUES - POTABLE WATER - CHILD
(mrem/hr per μ Ci/ml)

NUCLIDE	BONE	LIVER	THYROID	KIDNEY	LUNG	GI-LLI	SKIN	T. BODY
H-3	0	7.15E-02	7.15E-02	7.15E-02	7.15E-02	7.15E-02	0	7.15E-02
Cr-51	0	0	1.74E-03	4.76E-04	3.18E-03	1.66E-01	0	3.14E-03
Mn-54	0	3.77E 00	0	1.06E 00	0	3.16E 00	0	1.00E 00
Fe-55	4.05E 00	2.15E 00	0	0	1.22E 00	3.98E-01	0	6.66E-01
Fe-59	5.81E 00	9.41E 00	0	0	2.73E 00	9.79E 00	0	4.69E 00
Co-57	0	1.74E-01	0	0	0	1.42E 00	0	3.52E-01
Co-58	0	6.34E-01	0	0	0	3.70E 00	0	1.94E 00
Co-60	0	1.86E 00	0	0	0	1.03E 01	0	5.49E 00
Zn-65	4.83E 00	1.29E 01	0	8.10E 00	0	2.26E 00	0	7.99E 00
Sr-89	4.65E 02	0	0	0	0	1.80E 01	0	1.33E 01
Sr-90	5.99E 03	0	0	0	0	8.07E 01	0	1.52E 03
Zr-95	4.09E-02	8.99E-03	0	1.29E-02	0	9.37E 00	0	7.99E-03
Zr-97	2.46E-03	3.56E-04	0	5.11E-04	0	5.39E 01	0	2.10E-04
Nb-95	7.93E-03	3.09E-03	0	2.90E-03	0	5.71E 00	0	2.21E-03
Mo-99	0	4.69E 00	0	1.00E 01	0	3.88E 00	0	1.16E 00
Ag-110m	1.90E-01	1.28E-01	0	2.39E-01	0	1.52E 01	0	1.02E-01
Sb-124	3.91E 00	5.07E-02	8.63E-03	0	2.17E 00	2.45E 01	0	1.37E 00
I-131	6.06E 00	6.10E 00	2.01E 03	1.00E 01	0	5.43E-01	0	3.46E 00
I-133	2.09E 00	2.58E 00	4.79E 02	4.30E 00	0	1.04E 00	0	9.76E-01
I-135	6.17E-01	1.11E 00	9.83E 01	1.70E 00	0	8.46E-01	0	5.25E-01
Cs-134	8.25E 01	1.35E 02	0	4.19E 01	1.50E 01	7.29E-01	0	2.85E 01
Cs-137	1.15E 02	1.10E 02	0	3.59E 01	1.29E 01	6.91E-01	0	1.63E 01
Ba-140	2.93E 01	2.57E-02	0	8.35E-03	1.53E-02	1.48E 01	0	1.71E 00
La-140	3.56E-03	1.24E-03	0	0	0	3.47E 01	0	4.19E-04
Ce-141	1.40E-02	6.98E-03	0	3.06E-03	0	8.70E 00	0	1.03E-03
Ce-144	7.33E-01	2.30E-01	0	1.27E-01	0	5.99E 01	0	3.91E-02
Na-24	2.04E 00	2.04E 00	2.04E 00	2.04E 00	2.04E 00	2.04E 00	0	2.04E 00
Cu-64	0	8.63E-02	0	2.09E-01	0	4.05E 00	0	5.21E-02
W-187	1.51E-01	8.95E-02	0	0	0	1.26E 01	0	4.02E-02
Np-239	1.85E-03	1.33E-04	0	3.84E-04	0	9.83E 00	0	9.34E-05
Tc-99m	3.25E-04	6.38E-04	0	9.27E-03	3.24E-04	3.63E-01	0	1.06E-02
As-76	0	5.36E-02	0	9.44E-02	0	5.43E 01	0	6.80E-02
Nb-95m	7.93E-03	3.09E-03	0	2.90E-03	0	5.71E 00	0	2.21E-03

TABLE A-3 (Continued)
A_{itw} VALUES - FRESHWATER FISH - CHILD
(mrem/hr per μ Ci/ml)

NUCLIDE	BONE	LIVER	THYROID	KIDNEY	LUNG	GI-LLI	SKIN	T. BODY
H-3	0	1.19E-02	1.19E-02	1.19E-02	1.19E-02	1.19E-02	0	1.19E-02
Na-24	3.80E 01	3.80E 01	3.80E 01	3.80E 01	3.80E 01	3.80E 01	0	3.80E 01
Cr-51	0	0	6.48E-02	1.77E-02	1.18E-01	6.19E 00	0	1.17E-01
Mn-54	0	2.81E 02	0	7.87E 01	0	2.35E 02	0	7.47E 01
Fe-55	7.54E 01	4.00E 01	0	0	2.26E 01	7.41E 00	0	1.24E 01
Fe-59	1.08E 02	1.75E 02	0	0	5.07E 01	1.82E 02	0	8.72E 01
Co-57	0	1.62E 00	0	0	0	1.32E 01	0	3.27E 00
Co-58	0	5.90E 00	0	0	0	3.44E 01	0	1.81E 01
Co-60	0	1.73E 01	0	0	0	9.60E 01	0	5.11E 01
Cu-64	0	8.03E-01	0	1.94E 00	0	3.77E 01	0	4.85E-01
Zn-65	1.80E 03	4.79E 03	0	3.02E 03	0	8.40E 02	0	2.98E 03
Sr-89	2.60E 03	0	0	0	0	1.00E 02	0	7.41E 01
Sr-90	3.34E 04	0	0	0	0	4.50E 02	0	8.48E 03
Nb-95	4.42E 01	1.72E 01	0	1.62E 01	0	3.19E 04	0	1.23E 01
Zr-95	2.51E-02	5.52E-03	0	7.90E-03	0	5.75E 00	0	4.91E-03
As-76	0	9.96E-01	0	1.76E 00	0	1.01E 03	0	1.27E 00
Nb-95m	4.42E 01	1.72E 01	0	1.62E 01	0	3.19E 04	0	1.23E 01
Zr-97	1.51E-03	2.18E-04	0	3.14E-04	0	3.31E 01	0	1.29E-04
Mo-99	0	8.72E 00	0	1.86E 01	0	1.86E 01	0	2.16E 00
Tc-99m	9.08E-04	1.78E-03	0	2.59E-02	9.04E-04	1.01E 00	0	2.95E-02
Ag-110m	8.13E-02	5.49E-02	0	1.02E-01	0	6.53E 00	0	4.39E-02
Sb-124	7.28E-01	9.44E-03	1.61E-04	0	4.04E-01	4.55E 00	0	2.55E-01
I-131	1.69E 01	1.70E 01	5.62E 03	2.79E 01	0	1.51E 00	0	9.67E 00
I-133	5.82E 00	7.20E 00	1.34E 03	1.20E 01	0	2.90E 00	0	2.72E 00
I-135	1.72E 00	3.10E 00	2.74E 02	4.75E 00	0	2.63E 00	0	1.47E 00
Cs-134	3.07E 04	5.03E 04	0	1.56E 04	5.60E 03	2.71E 02	0	1.06E 04
Cs-137	4.29E 04	4.10E 04	0	1.34E 04	4.81E 03	2.57E 02	0	6.06E 03
Ba-140	2.18E 01	1.19E-02	0	6.21E-03	1.14E-02	1.10E 01	0	1.27E 00
La-140	1.66E-02	5.78E-03	0	0	0	1.61E 02	0	1.95E-03
Ce-141	2.60E-03	1.30E-03	0	5.69E-04	0	1.62E 00	0	1.93E-04
Ce-144	1.36E-01	4.27E-02	0	2.37E-02	0	1.11E 01	0	7.28E-03
W-187	3.37E 01	2.00E 01	0	0	0	2.81E 03	0	8.97E 00
Np-239	3.44E-03	2.47E-04	0	7.14E-04	0	1.83E 01	0	1.74E-04

TABLE A-3 (Continued)
A_{itsh} VALUES - LAKE SHORELINE DEPOSITS - CHILD
(mrem/hr per μ Ci/ml)

NUCLIDE	BONE	LIVER	THYROID	KIDNEY	LUNG	GI-LLI	SKIN	T. BODY
H-3	0	0	0	0	0	0	0	0
Na-24	4.15E-02	4.15E-02	4.15E-02	4.15E-02	4.15E-02	4.15E-02	4.82E-02	4.15E-02
Cr-51	1.62E-02	1.62E-02	1.62E-02	1.62E-02	1.62E-02	1.62E-02	1.92E-02	1.62E-02
Mn-54	4.82E 00	4.82E 00	4.82E 00	4.82E 00	4.82E 00	4.82E 00	5.66E 00	4.82E 00
Fe-55	0	0	0	0	0	0	0	0
Fe-59	9.49E-01	9.49E-01	9.49E-01	9.49E-01	9.49E-01	9.49E-01	1.11E 00	9.49E-01
Co-57	6.56E-01	6.56E-01	6.56E-01	6.56E-01	6.56E-01	6.56E-01	7.21E-01	6.56E-01
Co-58	1.31E 00	1.31E 00	1.31E 00	1.31E 00	1.31E 00	1.31E 00	1.54E 00	1.31E 00
Co-60	7.49E 01	7.49E 01	7.49E 01	7.49E 01	7.49E 01	7.49E 01	8.81E 01	7.49E 01
Cu-64	2.11E-03	2.11E-03	2.11E-03	2.11E-03	2.11E-03	2.11E-03	2.40E-03	2.11E-03
Zn-65	2.60E 00	2.60E 00	2.60E 00	2.60E 00	2.60E 00	2.60E 00	2.99E 00	2.60E 00
Sr-89	7.54E-05	7.54E-05	7.54E-05	7.54E-05	7.54E-05	7.54E-05	8.75E-05	7.54E-05
Sr-90	0	0	0	0	0	0	0	0
Nb-95	4.76E-01	4.76E-01	4.76E-01	4.76E-01	4.76E-01	4.76E-01	5.60E-01	4.76E-01
Zr-95	8.51E-01	8.51E-01	8.51E-01	8.51E-01	8.51E-01	8.51E-01	9.87E-01	8.51E-01
As-76	1.33E-02	1.33E-02	1.33E-02	1.33E-02	1.33E-02	1.33E-02	4.62E-01	1.33E-02
Nb-95m	6.83E-03	6.83E-03	6.83E-03	6.83E-03	6.83E-03	6.83E-03	4.28E-02	6.83E-03
Zr-97	1.02E-02	1.02E-02	1.02E-02	1.02E-02	1.02E-02	1.02E-02	1.19E-02	1.02E-02
Mo-99	1.39E-02	1.39E-02	1.39E-02	1.39E-02	1.39E-02	1.39E-02	1.61E-02	1.39E-02
Tc-99m	6.38E-04	6.38E-04	6.38E-04	6.38E-04	6.38E-04	6.38E-04	7.31E-04	6.38E-04
Ag-110m	1.20E 01	1.20E 01	1.20E 01	1.20E 01	1.20E 01	1.20E 01	1.39E 01	1.20E 01
Sb-124	2.08E 00	2.08E 00	2.08E 00	2.08E 00	2.08E 00	2.08E 00	2.40E 00	2.08E 00
I-131	5.98E-02	5.98E-02	5.98E-02	5.98E-02	5.98E-02	5.98E-02	7.27E-02	5.98E-02
I-133	8.56E-03	8.56E-03	8.56E-03	8.56E-03	8.56E-03	8.56E-03	1.04E-02	8.56E-03
I-135	8.94E-03	8.94E-03	8.94E-03	8.94E-03	8.94E-03	8.94E-03	1.04E-02	8.94E-03
Cs-134	2.39E 01	2.39E 01	2.39E 01	2.39E 01	2.39E 01	2.39E 01	2.79E 01	2.39E 01
Cs-137	3.58E 01	3.58E 01	3.58E 01	3.58E 01	3.58E 01	3.58E 01	4.18E 01	3.58E 01
Ba-140	7.15E-02	7.15E-02	7.15E-02	7.15E-02	7.15E-02	7.15E-02	8.17E-02	7.15E-02
La-140	6.78E-02	6.78E-02	6.78E-02	6.78E-02	6.78E-02	6.78E-02	7.68E-02	6.78E-02
Ce-141	4.75E-02	4.75E-02	4.75E-02	4.75E-02	4.75E-02	4.75E-02	5.36E-02	4.75E-02
Ce-144	2.42E-01	2.42E-01	2.42E-01	2.42E-01	2.42E-01	2.42E-01	2.79E-01	2.42E-01
W-187	8.25E-03	8.25E-03	8.25E-03	8.25E-03	8.25E-03	8.25E-03	9.57E-03	8.25E-03
Np-239	6.06E-03	6.06E-03	6.06E-03	6.06E-03	6.06E-03	6.06E-03	7.02E-03	6.06E-03

TABLE A-3 (Continued)
A_{itw} VALUES - POTABLE WATER - INFANT
(mrem/hr per μ Ci/ml)

NUCLIDE	BONE	LIVER	THYROID	KIDNEY	LUNG	GI-LLI	SKIN	T. BODY
H-3	0	7.02E-02	7.02E-02	7.02E-02	7.02E-02	7.02E-02	0	7.02E-02
Cr-51	0	0	2.10E-03	4.58E-04	4.08E-03	9.37E-02	0	3.21E-03
Mn-54	0	4.54E 00	0	1.01E 00	0	1.67E 00	0	1.03E 00
Fe-55	3.17E 00	2.05E 00	0	0	1.00E 00	2.60E-01	0	5.47E-01
Fe-59	7.02E 00	1.23E 01	0	0	3.63E 00	5.86E 00	0	4.83E 00
Co-57	0	2.62E-01	0	0	0	8.94E-01	0	4.26E-01
Co-58	0	8.21E-01	0	0	0	2.04E 00	0	2.05E 00
Co-60	0	2.46E 00	0	0	0	5.86E 00	0	5.81E 00
Zn-65	4.20E 00	1.43E 01	0	6.98E 00	0	1.22E 01	0	6.63E 00
Sr-89	5.72E 02	0	0	0	0	1.18E 01	0	1.64E 01
Sr-90	4.22E 03	0	0	0	0	5.27E 01	0	1.07E 03
Zr-95	4.70E-02	1.14E-02	0	1.23E-02	0	5.70E 00	0	8.12E-03
Zr-97	3.37E-03	5.79E-04	0	5.84E-04	0	3.69E 01	0	2.64E-04
Nb-95	9.58E-03	3.94E-03	0	2.83E-03	0	3.33E 00	0	2.28E-03
Mo-99	0	7.75E 00	0	1.16E 01	0	2.55E 00	0	1.51E 00
Ag-110m	2.27E-01	1.66E-01	0	2.37E-01	0	8.59E 00	0	1.09E-01
Sb-124	4.88E 00	7.18E-02	1.29E-02	0	3.05E 00	1.50E 01	0	1.51E 00
I-131	8.19E 00	9.64E 00	3.17E 03	1.13E 01	0	3.44E-01	0	4.24E 00
I-133	2.85E 00	4.15E 00	7.54E 02	4.88E 00	0	7.02E-01	0	1.21E 00
I-135	8.30E-01	1.65E 00	1.47E 02	1.84E 00	0	5.97E-01	0	6.02E-01
Cs-134	8.60E 01	1.60E 02	0	4.13E 01	1.69E 01	4.35E-01	0	1.62E 01
Cs-137	1.19E 02	1.39E 02	0	3.74E 01	1.51E 01	4.35E-01	0	9.87E 00
Ba-140	3.89E 01	3.90E-02	0	9.26E-03	2.39E-02	9.58E 00	0	2.01E 00
La-140	4.81E-03	1.90E-03	0	0	0	2.23E 01	0	4.87E-04
Ce-141	1.79E-02	1.09E-02	0	3.37E-03	0	5.65E 00	0	1.28E-03
Ce-144	6.79E-01	2.78E-01	0	1.12E-01	0	3.89E 01	0	3.81E-02
Na-24	2.30E 00	2.30E 00	2.30E 00	2.30E 00	2.30E 00	2.30E 00	0	2.30E 00
Cu-64	0	1.39E-01	0	2.35E-01	0	2.85E 00	0	6.43E-02
W-187	2.06E-01	1.43E-01	0	0	0	8.41E 00	0	4.95E-02
Np-239	2.53E-03	2.26E-04	0	4.51E-04	0	6.54E 00	0	1.28E-04
Tc-99m	4.38E-04	9.03E-04	0	9.71E-03	4.72E-04	2.62E-01	0	1.16E-02
As-76	0	9.14E-02	0	1.11E-01	0	3.65E 01	0	9.33E-02
Nb-95m	9.58E-03	3.94E-03	0	2.83E-03	0	3.33E 00	0	2.28E-03

TABLE A-3 (Continued)
A_{if} VALUES - FRESHWATER FISH - INFANT
(mrem/hr per μ Ci/ml)

NUCLIDE	BONE	LIVER	THYROID	KIDNEY	LUNG	GI-LLI	SKIN	T. BODY
H-3	0	0	0	0	0	0	0	0
Na-24	0	0	0	0	0	0	0	0
Cr-51	0	0	0	0	0	0	0	0
Mn-54	0	0	0	0	0	0	0	0
Fe-55	0	0	0	0	0	0	0	0
Fe-59	0	0	0	0	0	0	0	0
Co-57	0	0	0	0	0	0	0	0
Co-58	0	0	0	0	0	0	0	0
Co-60	0	0	0	0	0	0	0	0
Cu-64	0	0	0	0	0	0	0	0
Zn-65	0	0	0	0	0	0	0	0
Sr-89	0	0	0	0	0	0	0	0
Sr-90	0	0	0	0	0	0	0	0
Nb-95	0	0	0	0	0	0	0	0
Zr-95	0	0	0	0	0	0	0	0
As-76	0	0	0	0	0	0	0	0
Nb-95m	0	0	0	0	0	0	0	0
Zr-97	0	0	0	0	0	0	0	0
Mo-99	0	0	0	0	0	0	0	0
Tc-99m	0	0	0	0	0	0	0	0
Ag-110m	0	0	0	0	0	0	0	0
Sb-124	0	0	0	0	0	0	0	0
I-131	0	0	0	0	0	0	0	0
I-133	0	0	0	0	0	0	0	0
I-135	0	0	0	0	0	0	0	0
Cs-134	0	0	0	0	0	0	0	0
Cs-137	0	0	0	0	0	0	0	0
Ba-140	0	0	0	0	0	0	0	0
La-140	0	0	0	0	0	0	0	0
Ce-141	0	0	0	0	0	0	0	0
Ce-144	0	0	0	0	0	0	0	0
W-187	0	0	0	0	0	0	0	0
Np-239	0	0	0	0	0	0	0	0

TABLE A-3 (Continued)
A_{Itsh} VALUES - LAKE SHORELINE DEPOSITS - INFANT
(mrem/hr per μ Ci/ml)

NUCLIDE	BONE	LIVER	THYROID	KIDNEY	LUNG	GI-LLI	SKIN	T. BODY
H-3	0	0	0	0	0	0	0	0
Na-24	0	0	0	0	0	0	0	0
Cr-51	0	0	0	0	0	0	0	0
Mn-54	0	0	0	0	0	0	0	0
Fe-55	0	0	0	0	0	0	0	0
Fe-59	0	0	0	0	0	0	0	0
Co-57	0	0	0	0	0	0	0	0
Co-58	0	0	0	0	0	0	0	0
Co-60	0	0	0	0	0	0	0	0
Cu-64	0	0	0	0	0	0	0	0
Zn-65	0	0	0	0	0	0	0	0
Sr-89	0	0	0	0	0	0	0	0
Sr-90	0	0	0	0	0	0	0	0
Nb-95	0	0	0	0	0	0	0	0
Zr-95	0	0	0	0	0	0	0	0
As-76	0	0	0	0	0	0	0	0
Nb-95m	0	0	0	0	0	0	0	0
Zr-97	0	0	0	0	0	0	0	0
Mo-99	0	0	0	0	0	0	0	0
Tc-99m	0	0	0	0	0	0	0	0
Ag-110m	0	0	0	0	0	0	0	0
Sb-124	0	0	0	0	0	0	0	0
I-131	0	0	0	0	0	0	0	0
I-133	0	0	0	0	0	0	0	0
I-135	0	0	0	0	0	0	0	0
Cs-134	0	0	0	0	0	0	0	0
Cs-137	0	0	0	0	0	0	0	0
Ba-140	0	0	0	0	0	0	0	0
La-140	0	0	0	0	0	0	0	0
Ce-141	0	0	0	0	0	0	0	0
Ce-144	0	0	0	0	0	0	0	0
W-187	0	0	0	0	0	0	0	0
Np-239	0	0	0	0	0	0	0	0

TABLE A-4

DERIVATION OF LIQUID DOSE FACTORS

Table	Title	Page
A-4.1	Dose Factor (A_{it}) Derivation	A-19
A-4.2	Parameters for the Liquid Effluent Pathway	A-22
A-4.3	Justification for Liquid Pathways Used to Assess Dose to Man	A-24

TABLE A-4.1

LIQUID DOSE FACTOR (A_{it}) DERIVATION

For purposes of calculating the dose contribution to organs of various receptor age groups, a composite dose factor, A_{it} , may be used for each radionuclide i . The composite dose factor, A_{it} , is the sum of the freshwater fish, A_{itf} , potable water, A_{itw} , and shoreline deposits pathway, A_{itsh} , dose factors. A_{it} embodies pathway transfer parameters (e.g., bioaccumulation factors), pathway usage factors, organ dose conversion factors, and dilution factors between the release point and assumed point of exposure pathway. The composite dose factor may be expressed as:

$$A_{it} = (K_o(U_w / D_w) + K_o U_f B F_i / D_f) D F_i + (K S U B o Z W T_i U_{sh} / D_{sh}) (1 - e^{-\lambda_i T_b}) D E$$

(A-4.1)

Where:

- A_{it} = is the composite dose parameter for the total body or organ of an age group for radionuclide, i , for all appropriate pathways, mrem/hr per μ Ci/ml.
- K_o = is a unit conversion factor, $1.14E5$ yr-pCi-ml per μ Ci-hr-l (NUREG-0133).
- U_w = water consumption rate for age group of interest (Table A-4.2).
- U_f = freshwater fish consumption rate for age group of interest (Table A-4.2).
- U_{sh} = duration of time an individual is located on the beach (Table A-4.2).
- D_w = dilution factor which reflects the dilution from the point of release to the nearest potable water intake (Table A-4.2).
- D_f = dilution factor which reflects the dilution from the point of release to the nearest point assumed for the freshwater fish catch (Table A-4.2).
- D_{sh} = dilution factor which reflects the dilution from the point of release to the nearest point assumed for shoreline deposit (Table A-4.2).
- $B F_i$ = bioaccumulation factor for radionuclide i , in freshwater fish, pCi/kg per pCi/l, from Table A-1 of Regulatory Guide 1.109.
- T_i = is the radiological half-life of radionuclide, i , in days.
- λ_i = is the radiological decay constant for radionuclide, i , in sec^{-1} .
- W = is the shoreline width factor (Table A-4.2).
- T_b = the period of time for which sediment or soil is exposed to the contaminated water (Table A-4.2).

- K_c = assumed transfer constant from water to sediment, in liters/kg per hr as defined in Z.
- M_s = mass of sediment, in kg/m² of surface as defined in Z.
- Z = $K_c \times M_s \times (24/.693)$, in l per m²-day (Table A-4.2).
- DF_i = dose conversion factor for radionuclide, i, for organ and age group of interest. Used to calculate the radiation dose from an intake of a radionuclide, mrem/pCi (Regulatory Guide 1.109, Tables E-11 to E-14).
- DE_i = dose conversion factor for radionuclide, i, for organ and age group of interest. Used to calculate the radiation dose from an external exposure of a radionuclide, mrem/hr per pCi/m² (Regulatory Guide 1.109, Table E-6).

Example Calculation:

I. Potable Water

The potable water pathway dose factor, A_{itw} , is calculated from Equation A-4.1 by setting the usage factors for freshwater fish and shoreline deposits equal to zero. Equation A-4.1 reduces to the following:

$$A_{itw} = K_o (U_w / D_w) DF_i$$

For Co-60, the total body dose factor for an adult due to the ingestion of potable water is:

$$DF_i = 4.72E-06 \text{ mrem/pCi}$$

$$U_w = 730 \text{ liters/yr}$$

$$D_w = 165$$

$$K_o = 1.14E5 \text{ yr-pCi-ml per } \mu\text{Ci-hr-l}$$

These values yield an A_{itw} factor of 2.38 mrem/hr per $\mu\text{Ci/ml}$ as listed in Table A-2 of this appendix.

II. Freshwater Fish

The freshwater fish pathway dose factor, A_{itf} , is calculated from Equation A-4.1 by setting the usage factors for potable water and shoreline deposits equal to zero.

$$A_{itf} = K_o (U_f BF_i / D_f) DF_i$$

Equation A-4.1 reduces to the following:

For Co-60, the total body dose factor for an adult due to the ingestion of freshwater fish is:

$$DF_i = 4.72E-06 \text{ mrem/pCi}$$

$$U_f = 21 \text{ kg/yr}$$

$$D_f = 12$$

$$BF_i = 50 \text{ pCi/kg per pCi/l}$$

$$K_o = 1.14E5 \text{ yr-pCi-ml per } \mu\text{Ci-hr-l}$$

These values yield an A_{itf} factor of 47.1 mrem/hr per $\mu\text{Ci/ml}$ as listed in Table A-2 of this appendix.

III. Lake Shoreline Deposits

The shoreline deposits pathway dose factor, A_{itsh} , is calculated from Equation A-4.1 by setting the usage factors for potable water and freshwater fish equal to zero. Equation

$$A_{itsh} = (K_o Z W T_i U_{sh} / D_{sh}) (1 - e^{-\lambda_i T_b}) DE_i$$

A-4.1 reduces to the following:

For Co-60, the total body dose factor for an adult from shoreline deposits is:

$$U_{sh} = 12 \text{ hrs/yr}$$

$$D_{sh} = 18$$

$$W = 0.30$$

$$T_i = 1.92E3 \text{ days}$$

$$T_b = 15 \text{ years or } 4.73E8 \text{ sec}$$

$$K_o = 1.14E5 \text{ yr-pCi-ml per } \mu\text{Ci-hr-l}$$

$$Z = 100 \text{ l per m}^2\text{-day}$$

$$\lambda_i = 4.2E-9 \text{ sec}^{-1}$$

$$DE_i = 1.70E-8 \text{ mrem/hr per pCi/m}^2 \text{ (Regulatory Guide 1.109, Table E-6)}$$

These values will yield an A_{itsh} factor of 64.2 mrem/hr per $\mu\text{Ci/ml}$ as listed in Table A-3 of this appendix.

TABLE A-4.2

PARAMETER FOR THE LIQUID EFFLUENT PATHWAY

PARAMETER	VALUE	REFERENCE	TABLE
U_w (liters/yr)-Potable Water/			
- infant	330	R.G. 1.109	E-5
- child	510	R.G. 1.109	E-5
- teen	510	R.G. 1.109	E-5
- adult	730	R.G. 1.109	E-5
U_f (kg/yr)-Freshwater Fish/			
- infant	0	R.G. 1.109	E-5
- child	6.9	R.G. 1.109	E-5
- teen	16	R.G. 1.109	E-5
- adult	21	R.G. 1.109	E-5
U_{sh} (hr/yr)-Lake Shoreline Deposits/			
- infant	0	R.G. 1.109	E-5
- child	14	R.G. 1.109	E-5
- teen	67	R.G. 1.109	E-5
- adult	12	R.G. 1.109	E-5
BF_i (pCi/kg per pCi/l)- Freshwater Fish	Each Radionuclide	R.G. 1.109	A-1
D_w (dimensionless)-Potable Water	165	Site Specific (JAF FSAR Fig. 16.1-19)	
D_f (dimensionless)-Freshwater Fish	12	Site Specific (JAF FSAR Fig. 16.1-19)	
D_{sh} (dimensionless)-Lake Shoreline Deposits	18	Site Specific (JAF FSAR Fig. 16.1-19)	

TABLE A-4.2 (Continued)

PARAMETER FOR THE LIQUID EFFLUENT PATHWAY

PARAMETER	VALUE	REFERENCE	TABLE
DF _i Potable Water/Freshwater Fish (mrem/pCi)	Each Radionuclide	R.G. 1.109	E-11 to E-14
DE _i Lake Shoreline Deposits (mrem/hr per pCi/m ²)	Each Radionuclide	R.G. 1.109	E-6
Z (l per m ² -day)-Lake Shoreline Deposits	100	R.G. 1.109	pg-14
W (dimensionless)-Lake Shoreline Deposits	0.3	R.G. 1.109	A-2
T _b (sec)-Lake Shoreline Deposits	4.73E8	R.G. 1.109	E-15
* Transit Time (hours)-Potable Water	31	Site Specific (Based on a current speed of 0.4 ft./sec JAF FSAR Fig. 16.1-19)	
* Transit Time (hours)-Freshwater Fish Consumption	0	Site Specific (JAF FSAR Fig. 16.1-19)	
* Transit Time (hours)-Lake Shoreline Deposits	2.9	Site Specific (JAF FSAR Fig. 16.1-19)	

* Location of maximally exposed individual for potable water is Oswego, 8.5 miles west of JAF discharge. Location of maximally exposed individual for freshwater fish consumption is the JAF discharge vicinity. Location of maximally exposed individual for lake shoreline deposits is Sunset Bay, 0.8 miles east of JAF discharge.

TABLE A-4.3

JUSTIFICATION FOR LIQUID PATHWAYS USED TO ASSESS DOSE TO MAN

PATHWAY	JUSTIFICATION FOR OMISSION OR INCLUSION
1. POTABLE WATER	This pathway is considered for all required analysis.
2. FRESHWATER FISH	This pathway is considered for all required analysis.
3. FRESHWATER SHELL	This pathway was not considered for the annual dose calculations and the 40CFR190 dose analysis. Reference 6.9 states that direct ingestion of aquatic invertebrates from Lake Ontario is not a common practice.
4. FRESHWATER PLANTS	No known pathway exists for the J.A. FitzPatrick plant and none is included in the dose analysis of References 6.5 through 6.8. Regulatory Guide 1.109, Appendix E, Section 2, page 1.109-36, states "Ingestion of aquatic plant material is not normally assumed."
5. SALTWATER FISH	Not applicable to a freshwater site.
6. SALTWATER SHELL FISH	Not applicable to a freshwater site.
7. SALTWATER PLANTS	Not applicable to a freshwater site.
8. DISCHARGE CANAL SHORELINE	This pathway is not applicable since the J.A. FitzPatrick Plant discharges through a tunnel to a diffuser offshore.
9. RIVER SHORELINE DEPOSITS	Not applicable to a Great Lake site.
10. LAKE SHORELINE DEPOSITS	This pathway is not necessary to demonstrate compliance with 10CFR20 and 10CFR50 as specified in Sections 4.2, and 4.3.1 of NUREG-0133. This pathway is considered for the annual dose calculations, the 40CFR190 dose analysis, and Section 3.4.2.b (1).
11. OCEAN SHORELINE DEPOSITS	Not applicable to a Great Lake Site.

TABLE A-4.3 (Continued)

JUSTIFICATION FOR LIQUID PATHWAYS USED TO ASSESS DOSE TO MAN

PATHWAY	JUSTIFICATION FOR OMISSION OR INCLUSION
12. TIDAL BASIN DEPOSITS	Not applicable to a Great Lake site.
13. SWIMMING	This pathway is not necessary to demonstrate compliance with 10CFR20 and 10CFR50 as specified in Sections 4.2, and 4.3.1 of NUREG-0133. This pathway is not used in the ODCM since its dose contribution is very small (Appendix D, Table D-8).
14. BOATING	This pathway is not necessary to demonstrate compliance with 10CFR20 and 10CFR50 as specified in Sections 4.2, and 4.3.1 of NUREG-0133. This pathway is not used in the ODCM since its dose contribution is very small (See Appendix D, Table D-8).
15. STORED FRUITS AND VEGETABLES	There are two possible methods of establishing this pathway; by using water from the lake for irrigation or using well water for irrigation, which may have become contaminated through discharges to the lake. References 6.6 and 6.7 document that a limited irrigation pathway exists; however, Reference 6.5 states that recent surveys indicate that the irrigation pathways discussed in the other documents no longer use lake water for irrigation. Since Reference 6.5 is the most recent document it is concluded that the irrigation pathway does not exist and need not be considered in any dose analysis. References 6.5 through 6.8 state that the possibility of groundwater contamination is extremely remote and no impact on groundwater is expected.
16. FRESH FRUITS AND VEGETABLES	This pathway need not be considered. See justification for pathway 15.
17. MEAT (CONTAMINATED FORAGE)	This pathway need not be considered. See justification for pathway 15.

TABLE A-4.3 (Continued)

JUSTIFICATION FOR LIQUID PATHWAYS USED TO ASSESS DOSE TO MAN

PATHWAY	JUSTIFICATION FOR OMISSION OR INCLUSION
18. MEAT (CONTAMINATED FEED)	This pathway need not be considered. See Justification for pathway 15.
19. MEAT (CONTAMINATED WATER)	This pathway is not necessary to demonstrate compliance with 10CFR20 and 10CFR50 as specified in Section 4.2 and 4.3.1 of NUREG-0133. The dose calculations shown in References 6.5 through 6.8 do not consider this pathway as a part of the analysis; hence, it is concluded that this pathway is insignificant and need not be considered for annual and 40CFR190 dose calculations.
20. COWS MILK (CONTAMINATED FORAGE)	This pathway need not be considered. See justification for pathway 15.
21. COWS MILK (CONTAMINATED FEED)	This pathway need not be considered. See justification for pathway 15.
22. COWS MILK (CONTAMINATED WATER)	This pathway need not be considered. See justification for pathway 19.
23. GOATS MILK (CONTAMINATED FORAGE)	This pathway need not be considered. See justification for pathway 15.
24. GOATS MILK (CONTAMINATED FEED)	This pathway need not be considered. See justification for pathway 15.
25. GOATS MILK (CONTAMINATED WATER)	This pathway need not be considered. See justification for pathway 19.

APPENDIX B

GASEOUS DOSE CALCULATION DATA

APPENDIX B
GASEOUS DOSE CALCULATION DATA

TABLE	TITLE	PAGE
B-1	Noble Gas Data Transfer Factors (K_i , L_i)	B-3
B-2	Air Dose Transfer Factors (M_i , N_i)	B-4
B-3	Inhalation Environmental Pathway Dose Conversion Factors (P_i) - Limiting Age Groups - Instantaneous	B-5
B-4	Limited Analysis Approach - Limiting Age Groups and Pathways - Gaseous Discharge Environmental Pathway Dose Conversion Factors (R_i)	B-7
B-5	Environmental Pathway Dose Conversion Factors (R_i) for All Remaining Pathways	B-10
B-6	Derivation of Gaseous Dose Factors	B-30
B-7	Quantification and Reporting of C-14 in JAF Releases	B-47

TABLE B-1

TRANSFER FACTORS FOR MAXIMUM DOSE TO A
PERSON OFFSITE DUE TO RADIOACTIVE NOBLE GASES

Dose Transfer Factors

RADIONUCLIDE	<u>GAMMA</u> K_i	<u>BETA</u> L_i	<u>GAMMA + BETA</u> $(L + 1.1 M) i$
	$\frac{\text{mrem}}{\mu\text{Ci sec/m}^3}$	$\frac{\text{mrem}}{\mu\text{Ci sec/m}^3}$	$\frac{\text{mrem}}{\mu\text{Ci sec/m}^3}$
Kr-83m	2.4E-9	--	6.7E-7
Kr-85m	3.7E-5	4.6E-5	8.9E-5
Kr-85	5.1E-7	4.2E-5	4.3E-5
Kr-87	1.9E-4	3.1E-4	5.3E-4
Kr-88	4.7E-4	7.5E-5	6.0E-4
Kr-89	5.3E-4	3.2E-4	9.3E-4
Kr-90	4.9E-4	2.3E-4	8.0E-4
Xe-131m	2.9E-6	1.5E-5	2.0E-5
Xe-133m	8.0E-6	3.1E-5	4.2E-5
Xe-133	9.3E-6	9.7E-6	2.2E-5
Xe-135m	9.9E-5	2.3E-5	1.4E-4
Xe-135	5.7E-5	5.9E-5	1.3E-4
Xe-137	4.5E-5	3.9E-4	4.4E-4
Xe-138	2.8E-4	1.3E-4	4.5E-4
Ar-41	2.8E-4	8.5E-5	4.0E-4

Ref: Regulatory Guide 1.109, Revision 1, Table B-1.

TABLE B-2

TRANSFER FACTORS FOR MAXIMUM OFFSITE AIR DOSE

Air Dose Transfer Factors

RADIONUCLIDE	GAMMA	BETA
	M_i	N_i
	$\frac{\text{mrad}}{\mu\text{Ci sec/m}^3}$	$\frac{\text{mrad}}{\mu\text{Ci sec/m}^3}$
Kr-83m	6.1E-7	9.1E-6
Kr-85m	3.9E-5	6.2E-5
Kr-85	5.4E-7	6.2E-5
Kr-87	2.0E-4	3.3E-4
Kr-88	4.8E-4	9.3E-5
Kr-89	5.5E-4	3.4E-4
Kr-90	5.2E-4	2.5E-4
Xe-131m	4.9E-6	3.5E-5
Xe-133m	1.0E-5	4.7E-5
Xe-133	1.1E-5	3.3E-5
Xe-135m	1.1E-4	2.3E-5
Xe-135	6.1E-5	7.8E-5
Xe-137	4.8E-5	4.0E-4
Xe-138	2.9E-4	1.5E-4
Ar-41	2.9E-4	1.0E-4

Ref: Regulatory Guide 1.109, Revision 1, Table B-1.

TABLE B-3

P_i VALUES - INHALATION - CHILD
$$\frac{\text{mrem/yr}}{\mu\text{Ci/m}^3}$$

NUCLIDE	BONE	LIVER	THYROID	KIDNEY	LUNG	GI-LLI	SKIN	T. BODY
H-3	0	1.12E 03	1.12E 03	1.12E 03	1.12E 03	1.12E 03	0	1.12E 03
Cr-51	0	0	8.55E 01	2.43E 01	1.70E 04	1.08E 03	0	1.54E 02
Mn-54	0	4.29E 04	0	1.00E 04	1.58E 06	2.29E 04	0	9.51E 03
Fe-55	4.74E 04	2.52E 04	0	0	1.11E 05	2.87E 03	0	7.77E 03
Fe-59	2.07E 04	3.34E 04	0	0	1.27E 06	7.07E 04	0	1.67E 04
Co-57	0	9.03E 02	0	0	5.07E 05	1.32E 04	0	1.07E 03
Co-58	0	1.77E 03	0	0	1.11E 06	3.44E 04	0	3.16E 03
Co-60	0	1.31E 04	0	0	7.07E 06	9.62E 04	0	2.26E 04
Zn-65	4.26E 04	1.13E 05	0	7.14E 04	9.95E 05	1.63E 04	0	7.03E 04
Sr-89	5.99E 05	0	0	0	2.16E 06	1.67E 05	0	1.72E 04
Sr-90	1.01E 08	0	0	0	1.48E 07	3.43E 05	0	6.44E 06
Zr-95	1.90E 05	4.18E 04	0	5.96E 04	2.23E 06	6.11E 04	0	3.70E 04
Nb-95	2.35E 04	9.18E 03	0	8.62E 03	6.14E 05	3.70E 04	0	6.55E 03
Mo-99	0	1.72E 02	0	3.92E 02	1.35E 05	1.27E 05	0	4.25E 01
Ag-110m	1.69E 04	1.14E 04	0	2.12E 04	5.48E 06	1.00E 05	0	9.14E 03
Sb-124	5.74E 04	7.40E 02	1.26E 02	0	3.24E 06	1.64E 05	0	2.00E 04
I-131	4.81E 04	4.81E 04	1.62E 07	7.88E 04	0	2.84E 03	0	2.73E 04
I-133	1.66E 04	2.03E 04	3.85E 06	3.38E 04	0	5.48E 03	0	7.70E 03
I-135	4.92E 03	8.73E 03	7.92E 05	1.34E 04	0	4.44E 03	0	4.14E 03
Cs-134	6.51E 05	1.01E 06	0	3.30E 05	1.21E 05	3.85E 03	0	2.25E 05
Cs-136	6.51E 04	1.71E 05	0	9.55E 04	1.45E 04	4.18E 03	0	1.16E 05
Cs-137	9.07E 05	8.25E 05	0	2.82E 05	1.04E 05	3.62E 03	0	1.28E 05
Ba-140	7.40E 04	6.48E 01	0	2.11E 01	1.74E 06	1.02E 05	0	4.33E 03
La-140	6.44E 02	2.25E 02	0	0	1.83E 05	2.26E 05	0	7.55E 01
Ce-141	3.92E 04	1.95E 04	0	8.55E 03	5.44E 05	5.66E 04	0	2.90E 03
Ce-144	6.77E 06	2.12E 06	0	1.17E 06	1.20E 07	3.89E 05	0	3.61E 05

TABLE B-3 (Continued)

P_i VALUES - INHALATION - TEEN
$$\frac{\text{mrem/yr}}{\mu\text{Ci/m}^3}$$

NUCLIDE	BONE	LIVER	THYROID	KIDNEY	LUNG	GI-LLI	SKIN	T. BODY
H-3	0	1.27E 03	1.27E 03	1.27E 03	1.27E 03	1.27E 03	0	1.27E 03
Cr-51	0	0	7.50E 01	3.07E 01	2.10E 04	3.00E 03	0	1.35E 02
Mn-54	0	5.11E 04	0	1.27E 04	1.98E 06	6.68E 04	0	8.40E 03
Fe-55	3.34E 04	2.38E 04	0	0	1.24E 05	6.39E 03	0	5.54E 03
Fe-59	1.59E 04	3.70E 04	0	0	1.53E 06	1.78E 05	0	1.43E 04
Co-57	0	9.44E 02	0	0	5.86E 05	3.14E 04	0	9.20E 02
Co-58	0	2.07E 03	0	0	1.34E 06	9.52E 04	0	2.78E 03
Co-60	0	1.51E 04	0	0	8.72E 06	2.59E 05	0	1.98E 04
Zn-65	3.86E 04	1.34E 05	0	8.64E 04	1.24E 06	4.66E 04	0	6.24E 04
Sr-89	4.34E 05	0	0	0	2.42E 06	3.71E 05	0	1.25E 04
Sr-90	1.08E 08	0	0	0	1.65E 07	7.65E 05	0	6.68E 06
Zr-95	1.46E 05	4.58E 04	0	6.74E 04	2.69E 06	1.49E 05	0	3.15E 04
Nb-95	1.86E 04	1.03E 04	0	1.00E 04	7.51E 05	9.68E 04	0	5.66E 03
Mo-99	0	1.69E 02	0	4.11E 02	1.54E 05	2.69E 05	0	3.22E 01
Ag-110m	1.38E 04	1.31E 04	0	2.50E 04	6.75E 06	2.73E 05	0	7.99E 03
Sb-124	4.30E 04	7.94E 02	9.76E 01	0	3.85E 06	3.98E 05	0	1.68E 04
I-131	3.54E 04	4.91E 04	1.46E 07	8.40E 04	0	6.49E 03	0	2.64E 04
I-133	1.22E 04	2.05E 04	2.92E 06	3.59E 04	0	1.03E 04	0	6.22E 03
I-135	3.70E 03	9.44E 03	6.21E 05	1.49E 04	0	6.95E 03	0	3.49E 03
Cs-134	5.02E 05	1.13E 06	0	3.75E 05	1.46E 05	9.76E 03	0	5.49E 05
Cs-136	5.15E 04	1.94E 05	0	1.10E 05	1.78E 04	1.09E 04	0	1.37E 05
Cs-137	6.70E 05	8.48E 05	0	3.04E 05	1.21E 05	8.48E 03	0	3.11E 05
Ba-140	5.47E 04	6.70E 01	0	2.28E 01	2.03E 06	2.29E 05	0	3.52E 03
La-140	4.79E 02	2.36E 02	0	0	2.14E 05	4.87E 05	0	6.26E 01
Ce-141	2.84E 04	1.90E 04	0	8.88E 03	6.14E 05	1.26E 05	0	2.17E 03
Ce-144	4.89E 06	2.02E 06	0	1.21E 06	1.34E 07	8.64E 05	0	2.62E 05

TABLE B-4

R_i VALUES - COW MILK - INFANT
 $\frac{\text{m}^2\text{-mrem/yr}}{\mu\text{Ci/sec}}$

NUCLIDE	BONE	LIVER	THYROID	KIDNEY	LUNG	GI-LLI	SKIN	T. BODY
H-3*	0	2.38E 03	2.38E 03	2.38E 03	2.38E 03	2.38E 03	0	2.38E 03
Cr-51	0	0	5.45E 04	1.19E 04	1.06E 05	2.43E 06	0	8.35E 04
Mn-54	0	2.51E 07	0	5.56E 06	0	9.22E 06	0	5.69E 06
Fe-55	8.98E 07	5.80E 07	0	0	2.83E 07	7.36E 06	0	1.55E 07
Fe-59	1.22E 08	2.13E 08	0	0	6.29E 07	1.02E 08	0	8.39E 07
Co-57	0	5.72E 06	0	0	0	1.95E 07	0	9.30E 06
Co-58	0	1.39E 07	0	0	0	3.46E 07	0	3.47E 07
Co-60	0	5.90E 07	0	0	0	1.40E 08	0	1.39E 08
Zn-65	3.53E 09	1.21E 10	0	5.87E 09	0	1.02E 10	0	5.58E 09
Sr-89	6.93E 09	0	0	0	0	1.42E 08	0	1.99E 08
Sr-90	8.19E 10	0	0	0	0	1.02E 09	0	2.09E 10
Zr-95	3.85E 03	9.39E 02	0	1.01E 03	0	4.68E 05	0	6.66E 02
Nb-95	3.14E 05	1.29E 05	0	9.27E 04	0	1.09E 08	0	7.48E 04
Mo-99	0	1.04E 08	0	1.55E 08	0	3.42E 07	0	2.02E 07
Ag-110m	2.46E 08	1.79E 08	0	2.56E 08	0	9.30E 09	0	1.19E 08
Sb-124	1.18E 08	1.73E 06	3.13E 05	0	7.37E 07	3.63E 08	0	3.65E 07
I-131	1.36E 09	1.60E 09	5.27E 11	1.87E 09	0	5.72E 07	0	7.05E 08
I-133	1.84E 07	2.67E 07	4.86E 09	3.14E 07	0	4.52E 06	0	7.83E 06
I-135	5.65E 04	1.12E 05	1.01E 07	1.25E 05	0	4.07E 04	0	4.10E 04
Cs-134	2.41E 10	4.50E 10	0	1.16E 10	4.75E 09	1.22E 08	0	4.54E 09
Cs-136	9.91E 08	2.91E 09	0	1.16E 09	2.37E 08	4.42E 07	0	1.09E 09
Cs-137	3.47E 10	4.06E 10	0	1.09E 10	4.41E 09	1.27E 08	0	2.88E 09
Ba-140	1.21E 08	1.21E 05	0	2.87E 04	7.42E 04	2.97E 07	0	6.23E 06
La-140	2.03E 01	8.01E 00	0	0	0	9.41E 04	0	2.06E 00
Ce-141	2.28E 04	1.39E 04	0	4.29E 03	0	7.18E 06	0	1.64E 03
Ce-144	1.49E 06	6.10E 05	0	2.46E 05	0	8.55E 07	0	8.35E 04

* $\frac{\text{mrem/yr}}{\mu\text{Ci/m}^3}$

TABLE B-4 (Continued)

R_i VALUES - GOAT MILK - INFANT
$$\frac{\text{m}^2\text{-mrem/yr}}{\mu\text{Ci/sec}}$$

NUCLIDE	BONE	LIVER	THYROID	KIDNEY	LUNG	GI-LLI	SKIN	T. BODY
H-3*	0	4.86E 03	4.86E 03	4.86E 03	4.86E 03	4.86E 03	0	4.86E 03
Cr-51	0	0	6.54E 03	1.43E 03	1.27E 04	2.92E 05	0	1.00E 04
Mn-54	0	3.01E 06	0	6.67E 05	0	1.11E 06	0	6.82E 05
Fe-55	1.17E 06	7.54E 05	0	0	3.69E 05	9.57E 04	0	2.01E 05
Fe-59	1.58E 06	2.77E 06	0	0	8.18E 05	1.32E 06	0	1.09E 06
Co-57	0	6.86E 05	0	0	0	2.34E 06	0	1.12E 06
Co-58	0	1.67E 06	0	0	0	4.15E 06	0	4.16E 06
Co-60	0	7.08E 06	0	0	0	1.69E 07	0	1.67E 07
Zn-65	4.23E 08	1.45E 09	0	7.04E 08	0	1.23E 09	0	6.70E 08
Sr-89	1.46E 10	0	0	0	0	2.99E 08	0	4.17E 08
Sr-90	1.72E 11	0	0	0	0	2.15E 09	0	4.38E 10
Zr-95	4.63E 02	1.13E 02	0	1.21E 02	0	5.61E 04	0	7.99E 01
Nb-95	3.77E 04	1.55E 04	0	1.11E 04	0	1.31E 07	0	8.97E 03
Mo-99	0	1.25E 07	0	1.86E 07	0	4.10E 06	0	2.43E 06
Ag-110m	2.95E 07	2.15E 07	0	3.08E 07	0	1.12E 09	0	1.42E 07
Sb-124	1.41E 07	2.08E 05	3.75E 04	0	8.85E 06	4.36E 07	0	4.38E 06
I-131	1.63E 09	1.92E 09	6.32E 11	2.25E 09	0	6.86E 07	0	8.45E 08
I-133	2.20E 07	3.21E 07	5.84E 09	3.77E 07	0	5.43E 06	0	9.40E 06
I-135	6.78E 04	1.35E 05	1.21E 07	1.50E 05	0	4.88E 04	0	4.92E 04
Cs-134	7.24E 10	1.35E 11	0	3.47E 10	1.42E 10	3.67E 08	0	1.36E 10
Cs-136	2.97E 09	8.74E 09	0	3.48E 09	7.12E 08	1.33E 08	0	3.26E 09
Cs-137	1.04E 11	1.22E 11	0	3.27E 10	1.32E 10	3.81E 08	0	8.63E 09
Ba-140	1.45E 07	1.45E 04	0	3.44E 03	8.91E 03	3.56E 06	0	7.47E 05
La-140	2.44E 00	9.61E-01	0	0	0	1.13E 04	0	2.47E-01
Ce-141	2.73E 03	1.67E 03	0	5.14E 02	0	8.62E 05	0	1.96E 02
Ce-144	1.79E 05	7.32E 04	0	2.96E 04	0	1.03E 07	0	1.00E 04

* $\frac{\text{mrem/yr}}{\mu\text{Ci/m}^3}$

TABLE B-4 (Continued)

R_i VALUES - VEGETATION - CHILD
 $\frac{\text{m}^2\text{-mrem/yr}}{\mu\text{Ci/sec}}$

NUCLIDE	BONE	LIVER	THYROID	KIDNEY	LUNG	GI-LLI	SKIN	T. BODY
H-3*	0	4.01E 03	4.01E 03	4.01E 03	4.01E 03	4.01E 03	0	4.01E 03
Cr-51	0	0	6.49E 04	1.77E 04	1.18E 05	6.20E 06	0	1.17E 05
Mn-54	0	6.65E 08	0	1.86E 08	0	5.58E 08	0	1.77E 08
Fe-55	8.01E 08	4.25E 08	0	0	2.40E 08	7.87E 07	0	1.32E 08
Fe-59	3.97E 08	6.42E 08	0	0	1.86E 08	6.69E 08	0	3.20E 08
Co-57	0	2.98E 07	0	0	0	2.44E 08	0	6.04E 07
Co-58	0	6.45E 07	0	0	0	3.76E 08	0	1.97E 08
Co-60	0	3.78E 08	0	0	0	2.10E 09	0	1.12E 09
Zn-65	8.12E 08	2.16E 09	0	1.36E 09	0	3.80E 08	0	1.35E 09
Sr-89	3.59E 10	0	0	0	0	1.39E 09	0	1.03E 09
Sr-90	1.24E 12	0	0	0	0	1.67E 10	0	3.15E 11
Zr-95	3.86E 06	8.50E 05	0	1.22E 06	0	8.86E 08	0	7.56E 05
Nb-95	4.10E 05	1.60E 05	0	1.50E 05	0	2.95E 08	0	1.14E 05
Mo-99	0	7.70E 06	0	1.64E 07	0	6.37E 06	0	1.91E 06
Ag-110m	3.21E 07	2.17E 07	0	4.04E 07	0	2.58E 09	0	1.74E 07
Sb-124	3.52E 08	4.57E 06	7.78E 05	0	1.95E 08	2.20E 09	0	1.23E 08
I-131	1.43E 08	1.44E 08	4.75E 10	2.36E 08	0	1.28E 07	0	8.17E 07
I-133	3.56E 06	4.41E 06	8.19E 08	7.34E 06	0	1.78E 06	0	1.67E 06
I-135	6.28E 04	1.13E 05	1.00E 07	1.73E 05	0	8.61E 04	0	5.34E 04
Cs-134	1.60E 10	2.63E 10	0	8.16E 09	2.93E 09	1.42E 08	0	5.55E 09
Cs-136	8.23E 07	2.26E 08	0	1.21E 08	1.80E 07	7.95E 06	0	1.46E 08
Cs-137	2.39E 10	2.29E 10	0	7.46E 09	2.68E 09	1.43E 08	0	3.38E 09
Ba-140	2.77E 08	2.43E 05	0	7.90E 04	1.45E 05	1.40E 08	0	1.62E 07
La-140	3.25E 03	1.14E 03	0	0	0	3.17E 07	0	3.83E 02
Ce-141	6.56E 05	3.27E 05	0	1.43E 05	0	4.08E 08	0	4.85E 04
Ce-144	1.27E 08	3.98E 07	0	2.21E 07	0	1.04E 10	0	6.78E 06

* $\frac{\text{mrem/yr}}{\mu\text{Ci/m}^3}$

TABLE B-5

R_i VALUES - GROUND PLANE - ADULT
 $\frac{m^2 \cdot mrem/yr}{\mu Ci/sec}$

NUCLIDE	BONE	LIVER	THYROID	KIDNEY	LUNG	GI-LLI	SKIN	T. BODY
H-3	0	0	0	0	0	0	0	0
Cr-51	4.65E 06	4.65E 06	4.65E 06	4.65E 06	4.65E 06	4.65E 06	5.50E 06	4.65E 06
Mn-54	1.38E 09	1.38E 09	1.38E 09	1.38E 09	1.38E 09	1.38E 09	1.62E 09	1.38E 09
Fe-55	0	0	0	0	0	0	0	0
Fe-59	2.73E 08	2.73E 08	2.73E 08	2.73E 08	2.73E 08	2.73E 08	3.20E 08	2.73E 08
Co-57	1.88E 08	1.88E 08	1.88E 08	1.88E 08	1.88E 08	1.88E 08	2.07E 08	1.88E 08
Co-58	3.80E 08	3.80E 08	3.80E 08	3.80E 08	3.80E 08	3.80E 08	4.45E 08	3.80E 08
Co-60	2.15E 10	2.15E 10	2.15E 10	2.15E 10	2.15E 10	2.15E 10	2.53E 10	2.15E 10
Zn-65	7.46E 08	7.46E 08	7.46E 08	7.46E 08	7.46E 08	7.46E 08	8.57E 08	7.46E 08
Sr-89	2.16E 04	2.16E 04	2.16E 04	2.16E 04	2.16E 04	2.16E 04	2.51E 04	2.16E 04
Sr-90	0	0	0	0	0	0	0	0
Zr-95	2.45E 08	2.45E 08	2.45E 08	2.45E 08	2.45E 08	2.45E 08	2.85E 08	2.45E 08
Nb-95	1.37E 08	1.37E 08	1.37E 08	1.37E 08	1.37E 08	1.37E 08	1.61E 08	1.37E 08
Mo-99	3.99E 06	3.99E 06	3.99E 06	3.99E 06	3.99E 06	3.99E 06	4.62E 06	3.99E 06
Ag-110m	3.45E 09	3.45E 09	3.45E 09	3.45E 09	3.45E 09	3.45E 09	4.02E 09	3.45E 09
Sb-124	5.99E 08	5.99E 08	5.99E 08	5.99E 08	5.99E 08	5.99E 08	6.92E 08	5.99E 08
I-131	1.72E 07	1.72E 07	1.72E 07	1.72E 07	1.72E 07	1.72E 07	2.09E 07	1.72E 07
I-133	2.46E 06	2.46E 06	2.46E 06	2.46E 06	2.46E 06	2.46E 06	3.00E 06	2.46E 06
I-135	2.53E 06	2.53E 06	2.53E 06	2.53E 06	2.53E 06	2.53E 06	2.95E 06	2.53E 06
Cs-134	6.90E 09	6.90E 09	6.90E 09	6.90E 09	6.90E 09	6.90E 09	8.05E 09	6.90E 09
Cs-136	1.51E 08	1.51E 08	1.51E 08	1.51E 08	1.51E 08	1.51E 08	1.71E 08	1.51E 08
Cs-137	1.03E 10	1.03E 10	1.03E 10	1.03E 10	1.03E 10	1.03E 10	1.20E 10	1.03E 10
Ba-140	2.05E 07	2.05E 07	2.05E 07	2.05E 07	2.05E 07	2.05E 07	2.35E 07	2.05E 07
La-140	1.92E 07	1.92E 07	1.92E 07	1.92E 07	1.92E 07	1.92E 07	2.18E 07	1.92E 07
Ce-141	1.37E 07	1.37E 07	1.37E 07	1.37E 07	1.37E 07	1.37E 07	1.54E 07	1.37E 07
Ce-144	6.96E 07	6.96E 07	6.96E 07	6.96E 07	6.96E 07	6.96E 07	8.05E 07	6.96E 07

TABLE B-5 (Continued)

R_i VALUES - INHALATION - ADULT
$$\frac{\text{mrem/yr}}{\mu\text{Ci/m}^3}$$

NUCLIDE	BONE	LIVER	THYROID	KIDNEY	LUNG	GI-LLI	SKIN	T. BODY
H-3	0	1.26E 03	1.26E 03	1.26E 03	1.26E 03	1.26E 03	0	1.26E 03
Cr-51	0	0	5.95E 01	2.28E 01	1.44E 04	3.32E 03	0	1.00E 02
Mn-54	0	3.96E 04	0	9.84E 03	1.40E 06	7.74E 04	0	6.30E 03
Fe-55	2.46E 04	1.70E 04	0	0	7.21E 04	6.03E 03	0	3.94E 03
Fe-59	1.18E 04	2.78E 04	0	0	1.02E 06	1.88E 05	0	1.06E 04
Co-57	0	6.92E 02	0	0	3.69E 05	3.14E 04	0	6.71E 02
Co-58	0	1.58E 03	0	0	9.28E 05	1.06E 05	0	2.07E 03
Co-60	0	1.15E 04	0	0	5.97E 06	2.85E 05	0	1.48E 04
Zn-65	3.24E 04	1.03E 05	0	6.90E 04	8.64E 05	5.34E 04	0	4.66E 04
Sr-89	3.04E 05	0	0	0	1.40E 06	3.50E 05	0	8.72E 03
Sr-90	9.92E 07	0	0	0	9.60E 06	7.22E 05	0	6.10E 06
Zr-95	1.07E 05	3.44E 04	0	5.42E 04	1.77E 06	1.50E 05	0	2.33E 04
Nb-95	1.41E 04	7.82E 03	0	7.74E 03	5.05E 05	1.04E 05	0	4.21E 03
Mo-99	0	1.21E 02	0	2.91E 02	9.12E 04	2.48E 05	0	2.30E 01
Ag-110m	1.08E 04	1.00E 04	0	1.97E 04	4.63E 06	3.02E 05	0	5.94E 03
Sb-124	3.12E 04	5.89E 02	7.55E 01	0	2.48E 06	4.06E 05	0	1.24E 04
I-131	2.52E 04	3.58E 04	1.19E 07	6.13E 04	0	6.28E 03	0	2.05E 04
I-133	8.64E 03	1.48E 04	2.15E 06	2.58E 04	0	8.88E 03	0	4.52E 03
I-135	2.68E 03	6.98E 03	4.48E 05	1.11E 04	0	5.25E 03	0	2.57E 03
Cs-134	3.73E 05	8.48E 05	0	2.87E 05	9.76E 04	1.04E 04	0	7.28E 05
Cs-136	3.90E 04	1.46E 05	0	8.56E 04	1.20E 04	1.17E 04	0	1.10E 05
Cs-137	4.78E 05	6.21E 05	0	2.22E 05	7.52E 04	8.40E 03	0	4.28E 05
Ba-140	3.90E 04	4.90E 01	0	1.67E 01	1.27E 06	2.18E 05	0	2.57E 03
La-140	3.44E 02	1.74E 02	0	0	1.36E 05	4.58E 05	0	4.58E 01
Ce-141	1.99E 04	1.35E 04	0	6.26E 03	3.62E 05	1.20E 05	0	1.53E 03
Ce-144	3.43E 06	1.43E 06	0	8.48E 05	7.78E 06	8.16E 05	0	1.84E 05

TABLE B-5 (Continued)

R_i VALUES - VEGETATION - ADULT
 $\frac{\text{m}^2\text{-mrem/yr}}{\mu\text{Ci/sec}}$

NUCLIDE	BONE	LIVER	THYROID	KIDNEY	LUNG	GI-LLI	SKIN	T. BODY
H-3*	0	2.25E 03	2.25E 03	2.25E 03	2.25E 03	2.25E 03	0	2.25E 03
Cr-51	0	0	2.77E 04	1.02E 04	6.15E 04	1.17E 07	0	4.64E 04
Mn-54	0	3.13E 08	0	9.31E 07	0	9.58E 08	0	5.97E 07
Fe-55	2.10E 08	1.45E 08	0	0	8.08E 07	8.31E 07	0	3.38E 07
Fe-59	1.26E 08	2.96E 08	0	0	8.27E 07	9.87E 08	0	1.13E 08
Co-57	0	1.17E 07	0	0	0	2.97E 08	0	1.94E 07
Co-58	0	3.08E 07	0	0	0	6.24E 08	0	6.90E 07
Co-60	0	1.67E 08	0	0	0	3.14E 09	0	3.69E 08
Zn-65	3.17E 08	1.01E 09	0	6.75E 08	0	6.36E 08	0	4.56E 08
Sr-89	9.95E 09	0	0	0	0	1.60E 09	0	2.86E 08
Sr-90	6.05E 11	0	0	0	0	1.75E 10	0	1.48E 11
Zr-95	1.18E 06	3.77E 05	0	5.92E 05	0	1.20E 09	0	2.55E 05
Nb-95	1.42E 05	7.91E 04	0	7.82E 04	0	4.80E 08	0	4.25E 04
Mo-99	0	6.14E 06	0	1.39E 07	0	1.42E 07	0	1.17E 06
Ag-110m	1.05E 07	9.75E 06	0	1.92E 07	0	3.98E 09	0	5.79E 06
Sb-124	1.04E 08	1.96E 06	2.52E 05	0	8.08E 07	2.94E 09	0	4.12E 07
I-131	8.07E 07	1.15E 08	3.78E 10	1.98E 08	0	3.05E 07	0	6.62E 07
I-133	2.10E 06	3.66E 06	5.38E 08	6.39E 06	0	3.29E 06	0	1.12E 06
I-135	3.91E 04	1.02E 05	6.75E 06	1.64E 05	0	1.16E 05	0	3.78E 04
Cs-134	4.67E 09	1.11E 10	0	3.60E 09	1.19E 09	1.94E 08	0	9.08E 09
Cs-136	4.26E 07	1.68E 08	0	9.37E 07	1.28E 07	1.91E 07	0	1.21E 08
Cs-137	6.36E 09	8.70E 09	0	2.95E 09	9.81E 08	1.68E 08	0	5.70E 09
Ba-140	1.29E 08	1.61E 05	0	5.49E 04	9.25E 04	2.65E 08	0	8.42E 06
La-140	1.98E 03	9.99E 02	0	0	0	7.33E 07	0	2.64E 02
Ce-141	1.97E 05	1.33E 05	0	6.19E 04	0	5.09E 08	0	1.51E 04
Ce-144	3.29E 07	1.38E 07	0	8.16E 06	0	1.11E 10	0	1.77E 06

* $\frac{\text{mrem/yr}}{\mu\text{Ci/m}^3}$

TABLE B-5 (Continued)

R_i VALUES - COW MEAT - ADULT

$$\frac{m^2 \cdot mrem/yr}{\mu Ci/sec}$$

NUCLIDE	BONE	LIVER	THYROID	KIDNEY	LUNG	GI-LLI	SKIN	T. BODY
H-3*	0	3.24E 02	3.24E 02	3.24E 02	3.24E 02	3.24E 02	0	3.24E 02
Cr-51	0	0	2.18E 03	8.04E 02	4.84E 03	9.18E 05	0	3.65E 03
Mn-54	0	5.90E 06	0	1.76E 06	0	1.81E 07	0	1.13E 06
Fe-55	1.95E 08	1.35E 08	0	0	7.51E 07	7.72E 07	0	3.14E 07
Fe-59	1.44E 08	3.39E 08	0	0	9.46E 07	1.13E 09	0	1.30E 08
Co-57	0	3.60E 06	0	0	0	9.14E 07	0	5.99E 06
Co-58	0	1.04E 07	0	0	0	2.12E 08	0	2.34E 07
Co-60	0	5.03E 07	0	0	0	9.46E 08	0	1.11E 08
Zn-65	2.26E 08	7.19E 08	0	4.8 1E 08	0	4.53E 08	0	3.25E 08
Sr-89	1.66E 08	0	0	0	0	2.66E 07	0	4.76E 06
Sr-90	8.38E 09	0	0	0	0	2.42E 08	0	2.06E 09
Zr-95	1.06E 06	3.40E 05	0	5.34E 05	0	1.08E 09	0	2.30E 05
Nb-95	1.22E 06	6.76E 05	0	6.68E 05	0	4.10E 09	0	3.64E 05
Mo-99	0	4.96E 04	0	1.12E 05	0	1.15E 05	0	9.44E 03
Ag-110m	4.25E 06	3.94E 06	0	7.74E 06	0	1.61E 09	0	2.34E 06
Sb-124	1.11E 07	2.10E 05	2.70E 04	0	8.67E 06	3.16E 08	0	4.41E 06
I-131	5.37E 06	7.68E 06	2.52E 09	1.32E 07	0	2.03E 06	0	4.40E 06
I-133	1.99E-01	3.46E-01	5.09E 01	6.04E-01	0	3.11E-01	0	1.05E-01
I-135	2.33E-17	6.10E-17	4.02E-15	9.77E-17	0	6.88E-17	0	2.25E-17
Cs-134	4.35E 08	1.03E 09	0	3.35E 08	1.11E 08	1.81E 07	0	8.46E 08
Cs-136	6.04E 06	2.38E 07	0	1.33E 07	1.82E 06	2.71E 06	0	1.72E 07
Cs-137	5.88E 08	8.04E 08	0	2.73E 08	9.07E 07	1.56E 07	0	5.27E 08
Ba-140	1.44E 07	1.81E 04	0	6.16E 03	1.04E 04	2.97E 07	0	9.44E 05
La-140	1.88E-02	9.48E-03	0	0	0	6.96E 02	0	2.50E-03
Ce-141	7.38E 03	4.99E 03	0	2.32E 03	0	1.91E 07	0	5.66E 02
Ce-144	9.34E 05	3.90E 05	0	2.32E 05	0	3.16E 08	0	5.01E 04

* $\frac{mrem/yr}{\mu Ci/m^3}$

TABLE B-5 (Continued)

R_i VALUES - COW MILK - ADULT
 $\frac{\text{m}^2\text{-mrem/yr}}{\mu\text{Ci/sec}}$

NUCLIDE	BONE	LIVER	THYROID	KIDNEY	LUNG	GI-LLI	SKIN	T. BODY
H-3*	0	7.63E 02	7.63E 02	7.63E 02	7.63E 02	7.63E 02	0	7.63E 02
Cr-51	0	0	8.85E 03	3.26E 03	1.96E 04	3.72E 06	0	1.48E 04
Mn-54	0	5.41E 06	0	1.61E 06	0	1.66E 07	0	1.03E 06
Fe-55	1.67E 07	1.15E 07	0	0	6.43E 06	6.61E 06	0	2.69E 06
Fe-59	1.61E 07	3.79E 07	0	0	1.06E 07	1.26E 08	0	1.45E 07
Co-57	0	8.18E 05	0	0	0	2.07E 07	0	1.36E 06
Co-58	0	2.70E 06	0	0	0	5.47E 07	0	6.05E 06
Co-60	0	1.10E 07	0	0	0	2.06E 08	0	2.42E 07
Zn-65	8.72E 08	2.77E 09	0	1.86E 09	0	1.75E 09	0	1.25E 09
Sr-89	7.99E 08	0	0	0	0	1.28E 08	0	2.29E 07
Sr-90	3.15E 10	0	0	0	0	9.11E 08	0	7.74E 09
Zr-95	5.34E 02	1.71E 02	0	2.69E 02	0	5.43E 05	0	1.16E 02
Nb-95	4.37E 04	2.43E 04	0	2.40E 04	0	1.48E 08	0	1.31E 04
Mo-99	0	1.24E 07	0	2.80E 07	0	2.87E 07	0	2.35E 06
Ag-110m	3.71E 07	3.43E 07	0	6.74E 07	0	1.40E 10	0	2.04E 07
Sb-124	1.45E 07	2.73E 05	3.51E 04	0	1.13E 07	4.11E 08	0	5.74E 06
I-131	1.48E 08	2.12E 08	6.94E 10	3.63E 08	0	5.59E 07	0	1.21E 08
I-133	1.96E 06	3.41E 06	5.01E 08	5.95E 06	0	3.06E 06	0	1.04E 06
I-135	6.46E 03	1.69E 04	1.12E 06	2.71E 04	0	1.91E 04	0	6.24E 03
Cs-134	3.74E 09	8.89E 09	0	2.88E 09	9.55E 08	1.56E 08	0	7.27E 09
Cs-136	1.32E 08	5.21E 08	0	2.90E 08	3.97E 07	5.92E 07	0	3.75E 08
Cs-137	4.98E 09	6.80E 09	0	2.31E 09	7.68E 08	1.32E 08	0	4.46E 09
Ba-140	1.35E 07	1.69E 04	0	5.76E 03	9.69E 03	2.78E 07	0	8.83E 05
La-140	2.26E 00	1.14E 00	0	0	0	8.37E 04	0	3.01E-01
Ce-141	2.55E 03	1.72E 03	0	8.00E 02	0	6.58E 06	0	1.95E 02
Ce-144	2.29E 05	9.58E 04	0	5.68E 04	0	7.75E 07	0	1.23E 04

* $\frac{\text{mrem/yr}}{\mu\text{Ci/m}^3}$

TABLE B-5 (Continued)

R_i VALUES - GOAT MILK - ADULT
 $\frac{\text{m}^2\text{-mrem/yr}}{\mu\text{Ci/sec}}$

NUCLIDE	BONE	LIVER	THYROID	KIDNEY	LUNG	GI-LLI	SKIN	T. BODY
H-3*	0	1.56E 03	1.56E 03	1.56E 03	1.56E 03	1.56E 03	0	1.56E 03
Cr-51	0	0	1.06E 03	3.91E 02	2.36E 03	4.47E 05	0	1.78E 03
Mn-54	0	6.49E 05	0	1.93E 05	0	1.99E 06	0	1.24E 05
Fe-55	2.17E 05	1.50E 05	0	0	8.36E 04	8.60E 04	0	3.49E 04
Fe-59	2.10E 05	4.93E 05	0	0	1.38E 05	1.64E 06	0	1.89E 05
Co-57	0	9.81E 04	0	0	0	2.49E 06	0	1.63E 05
Co-58	0	3.24E 05	0	0	0	6.57E 06	0	7.27E 05
Co-60	0	1.32E 06	0	0	0	2.48E 07	0	2.91E 06
Zn-65	1.05E 08	3.33E 08	0	2.23E 08	0	2.10E 08	0	1.50E 08
Sr-89	1.68E 09	0	0	0	0	2.69E 08	0	4.81E 07
Sr-90	6.62E 10	0	0	0	0	1.91E 09	0	1.63E 10
Zr-95	6.41E 01	2.06E 01	0	3.23E 01	0	6.52E 04	0	1.39E 01
Nb-95	5.24E 03	2.92E 03	0	2.88E 03	0	1.77E 07	0	1.57E 03
Mo-99	0	1.48E 06	0	3.36E 06	0	3.44E 06	0	2.82E 05
Ag-110m	4.45E 06	4.11E 06	0	8.09E 06	0	1.68E 09	0	2.44E 06
Sb-124	1.74E 06	3.28E 04	4.21E 03	0	1.35E 06	4.93E 07	0	6.89E 05
I-131	1.78E 08	2.54E 08	8.33E 10	4.36E 08	0	6.70E 07	0	1.46E 08
I-133	2.35E 06	4.09E 06	6.01E 08	7.14E 06	0	3.68E 06	0	1.25E 06
I-135	7.75E 03	2.03E 04	1.34E 06	3.25E 04	0	2.29E 04	0	7.49E 03
Cs-134	1.12E 10	2.67E 10	0	8.64E 09	2.87E 09	4.67E 08	0	2.18E 10
Cs-136	3.96E 08	1.56E 09	0	8.70E 08	1.19E 08	1.78E 08	0	1.13E 09
Cs-137	1.49E 10	2.04E 10	0	6.93E 09	2.30E 09	3.95E 08	0	1.34E 10
Ba-140	1.62E 06	2.03E 03	0	6.91E 02	1.16E 03	3.33E 06	0	1.06E 05
La-140	2.71E-01	1.37E-01	0	0	0	1.00E 04	0	3.61E-02
Ce-141	3.06E 02	2.07E 02	0	9.60E 01	0	7.90E 05	0	2.34E 01
Ce-144	2.75E 04	1.15E 04	0	6.82E 03	0	9.30E 06	0	1.48E 03

* $\frac{\text{mrem/yr}}{\mu\text{Ci/m}^3}$

TABLE B-5 (Continued)

R_i VALUES - GROUND PLANE - TEEN
 $\frac{\text{m}^2\text{-mrem/yr}}{\mu\text{Ci/sec}}$

NUCLIDE	BONE	LIVER	THYROID	KIDNEY	LUNG	GI-LLI	SKIN	T. BODY
H-3	0	0	0	0	0	0	0	0
Cr-51	4.65E 06	4.65E 06	4.65E 06	4.65E 06	4.65E 06	4.65E 06	5.50E 06	4.65E 06
Mn-54	1.38E 09	1.38E 09	1.38E 09	1.38E 09	1.38E 09	1.38E 09	1.62E 09	1.38E 09
Fe-55	0	0	0	0	0	0	0	0
Fe-59	2.73E 08	2.73E 08	2.73E 08	2.73E 08	2.73E 08	2.73E 08	3.20E 08	2.73E 08
Co-57	1.88E 08	1.88E 08	1.88E 08	1.88E 08	1.88E 08	1.88E 08	2.07E 08	1.88E 08
Co-58	3.80E 08	3.80E 08	3.80E 08	3.80E 08	3.80E 08	3.80E 08	4.45E 08	3.80E 08
Co-60	2.15E 10	2.15E 10	2.15E 10	2.15E 10	2.15E 10	2.15E 10	2.53E 10	2.15E 10
Zn-65	7.46E 08	7.46E 08	7.46E 08	7.46E 08	7.46E 08	7.46E 08	8.57E 08	7.46E 08
Sr-89	2.16E 04	2.16E 04	2.16E 04	2.16E 04	2.16E 04	2.16E 04	2.51E 04	2.16E 04
Sr-90	0	0	0	0	0	0	0	0
Zr-95	2.45E 08	2.45E 08	2.45E 08	2.45E 08	2.45E 08	2.45E 08	2.85E 08	2.45E 08
Nb-95	1.37E 08	1.37E 08	1.37E 08	1.37E 08	1.37E 08	1.37E 08	1.61E 08	1.37E 08
Mo-99	3.99E 06	3.99E 06	3.99E 06	3.99E 06	3.99E 06	3.99E 06	4.62E 06	3.99E 06
Ag-110m	3.45E 09	3.45E 09	3.45E 09	3.45E 09	3.45E 09	3.45E 09	4.02E 09	3.45E 09
Sb-124	5.99E 08	5.99E 08	5.99E 08	5.99E 08	5.99E 08	5.99E 08	6.92E 08	5.99E 08
I-131	1.72E 07	1.72E 07	1.72E 07	1.72E 07	1.72E 07	1.72E 07	2.09E 07	1.72E 07
I-133	2.46E 06	2.46E 06	2.46E 06	2.46E 06	2.46E 06	2.46E 06	3.00E 06	2.46E 06
I-135	2.53E 06	2.53E 06	2.53E 06	2.53E 06	2.53E 06	2.53E 06	2.95E 06	2.53E 06
Cs-134	6.90E 09	6.90E 09	6.90E 09	6.90E 09	6.90E 09	6.90E 09	8.05E 09	6.90E 09
Cs-136	1.51E 08	1.51E 08	1.51E 08	1.51E 08	1.51E 08	1.51E 08	1.71E 08	1.51E 08
Cs-137	1.03E 10	1.03E 10	1.03E 10	1.03E 10	1.03E 10	1.03E 10	1.20E 10	1.03E 10
Ba-140	2.05E 07	2.05E 07	2.05E 07	2.05E 07	2.05E 07	2.05E 07	2.35E 07	2.05E 07
La-140	1.92E 07	1.92E 07	1.92E 07	1.92E 07	1.92E 07	1.92E 07	2.18E 07	1.92E 07
Ce-141	1.37E 07	1.37E 07	1.37E 07	1.37E 07	1.37E 07	1.37E 07	1.54E 07	1.37E 07
Ce-144	6.96E 07	6.96E 07	6.96E 07	6.96E 07	6.96E 07	6.96E 07	8.05E 07	6.96E 07

TABLE B-5 (Continued)

R_i VALUES - INHALATION - TEEN
$$\frac{\text{mrem/yr}}{\mu\text{Ci/m}^3}$$

NUCLIDE	BONE	LIVER	THYROID	KIDNEY	LUNG	GI-LLI	SKIN	T. BODY
H-3	0	1.27E 03	1.27E 03	1.27E 03	1.27E 03	1.27E 03	0	1.27E 03
Cr-51	0	0	7.50E 01	3.07E 01	2.10E 04	3.00E 03	0	1.35E 02
Mn-54	0	5.11E 04	0	1.27E 04	1.98E 06	6.68E 04	0	8.40E 03
Fe-55	3.34E 04	2.38E 04	0	0	1.24E 05	6.39E 03	0	5.54E 03
Fe-59	1.59E 04	3.70E 04	0	0	1.53E 06	1.78E 05	0	1.43E 04
Co-57	0	9.44E 02	0	0	5.86E 05	3.14E 04	0	9.20E 02
Co-58	0	2.07E 03	0	0	1.34E 06	9.52E 04	0	2.78E 03
Co-60	0	1.51E 04	0	0	8.72E 06	2.59E 05	0	1.98E 04
Zn-65	3.86E 04	1.34E 05	0	8.64E 04	1.24E 06	4.66E 04	0	6.24E 04
Sr-89	4.34E 05	0	0	0	2.42E 06	3.71E 05	0	1.25E 04
Sr-90	1.08E 08	0	0	0	1.65E 07	7.65E 05	0	6.68E 06
Zr-95	1.46E 05	4.58E 04	0	6.74E 04	2.69E 06	1.49E 05	0	3.15E 04
Nb-95	1.86E 04	1.03E 04	0	1.00E 04	7.51E 05	9.68E 04	0	5.66E 03
Mo-99	0	1.69E 02	0	4.11E 02	1.54E 05	2.69E 05	0	3.22E 01
Ag-110m	1.38E 04	1.31E 04	0	2.50E 04	6.75E 06	2.73E 05	0	7.99E 03
Sb-124	4.30E 04	7.94E 02	9.76E 01	0	3.85E 06	3.98E 05	0	1.68E 04
I-131	3.54E 04	4.91E 04	1.46E 07	8.40E 04	0	6.49E 03	0	2.64E 04
I-133	1.22E 04	2.05E 04	2.92E 06	3.59E 04	0	1.03E 04	0	6.22E 03
I-135	3.70E 03	9.44E 03	6.21E 05	1.49E 04	0	6.95E 03	0	3.49E 03
Cs-134	5.02E 05	1.13E 06	0	3.75E 05	1.46E 05	9.76E 03	0	5.49E 05
Cs-136	5.15E 04	1.94E 05	0	1.10E 05	1.78E 04	1.09E 04	0	1.37E 05
Cs-137	6.70E 05	8.48E 05	0	3.04E 05	1.21E 05	8.48E 03	0	3.11E 05
Ba-140	5.47E 04	6.70E 01	0	2.28E 01	2.03E 06	2.29E 05	0	3.52E 03
La-140	4.79E 02	2.36E 02	0	0	2.14E 05	4.87E 05	0	6.26E 01
Ce-141	2.84E 04	1.90E 04	0	8.88E 03	6.14E 05	1.26E 05	0	2.17E 03
Ce-144	4.89E 06	2.02E 06	0	1.21E 06	1.34E 07	8.64E 05	0	2.62E 05

TABLE B-5 (Continued)

R_i VALUES - VEGETATION - TEEN $\frac{\text{m}^2\text{-mrem/yr}}{\mu\text{Ci/sec}}$ $\mu\text{Ci/sec}$

NUCLIDE	BONE	LIVER	THYROID	KIDNEY	LUNG	GI-LLI	SKIN	T. BODY
H-3*	0	2.59E 03	2.59E 03	2.59E 03	2.59E 03	2.59E 03	0	2.59E 03
Cr-51	0	0	3.42E 04	1.35E 04	8.79E 04	1.03E 07	0	6.16E 04
Mn-54	0	4.54E 08	0	1.36E 08	0	9.32E 08	0	9.01E 07
Fe-55	3.26E 08	2.31E 08	0	0	1.47E 08	1.00E 08	0	5.39E 07
Fe-59	1.79E 08	4.18E 08	0	0	1.32E 08	9.89E 08	0	1.61E 08
Co-57	0	1.79E 07	0	0	0	3.34E 08	0	3.00E 07
Co-58	0	4.37E 07	0	0	0	6.02E 08	0	1.01E 08
Co-60	0	2.49E 08	0	0	0	3.24E 09	0	5.60E 08
Zn-65	4.24E 08	1.47E 09	0	9.41E 08	0	6.23E 08	0	6.86E 08
Sr-89	1.51E 10	0	0	0	0	1.80E 09	0	4.33E 08
Sr-90	7.51E 11	0	0	0	0	2.11E 10	0	1.85E 11
Zr-95	1.72E 06	5.44E 05	0	7.99E 05	0	1.26E 09	0	3.74E 05
Nb-95	1.92E 05	1.07E 05	0	1.03E 05	0	4.56E 08	0	5.86E 04
Mo-99	0	5.64E 06	0	1.29E 07	0	1.01E 07	0	1.08E 06
Ag-110m	1.52E 07	1.44E 07	0	2.74E 07	0	4.03E 09	0	8.73E 06
Sb-124	1.55E 08	2.85E 06	3.51E 05	0	1.35E 08	3.12E 09	0	6.03E 07
I-131	7.68E 07	1.08E 08	3.14E 10	1.85E 08	0	2.13E 07	0	5.78E 07
I-133	1.95E 06	3.32E 06	4.63E 08	5.81E 06	0	2.51E 06	0	1.01E 06
I-135	3.53E 04	9.10E 04	5.85E 06	1.44E 05	0	1.01E 05	0	3.37E 04
Cs-134	7.10E 09	1.67E 10	0	5.31E 09	2.03E 09	2.08E 08	0	7.76E 09
Cs-136	4.37E 07	1.72E 08	0	9.36E 07	1.48E 07	1.38E 07	0	1.15E 08
Cs-137	1.01E 10	1.35E 10	0	4.59E 09	1.78E 09	1.92E 08	0	4.69E 09
Ba-140	1.38E 08	1.69E 05	0	5.74E 04	1.14E 05	2.13E 08	0	8.91E 06
La-140	1.81E 03	8.89E 02	0	0	0	5.11E 07	0	2.37E 02
Ce-141	2.83E 05	1.89E 05	0	8.89E 04	0	5.40E 08	0	2.17E 04
Ce-144	5.27E 07	2.18E 07	0	1.30E 07	0	1.33E 10	0	2.83E 06

* $\frac{\text{mrem/yr}}{\mu\text{Ci/m}^3}$

TABLE B-5 (Continued)

R_i VALUES - COW MEAT - TEEN
 $\frac{\text{m}^2\text{-mrem/yr}}{\mu\text{Ci/sec}}$

NUCLIDE	BONE	LIVER	THYROID	KIDNEY	LUNG	GI-LLI	SKIN	T. BODY
H-3*	0	1.93E 02	1.93E 02	1.93E 02	1.93E 02	1.93E 02	0	1.93E 02
Cr-51	0	0	1.62E 03	6.39E 02	4.17E 03	4.90E 05	0	2.92E 03
Mn-54	0	4.50E 06	0	1.34E 06	0	9.42E 06	0	8.93E 05
Fe-55	1.58E 08	1.12E 08	0	0	7.12E 07	4.86E 07	0	2.62E 07
Fe-59	1.15E 08	2.69E 08	0	0	8.48E 07	6.36E 08	0	1.04E 08
Co-57	0	2.89E 06	0	0	0	5.40E 07	0	4.85E 06
Co-58	0	8.06E 06	0	0	0	1.11E 08	0	1.86E 07
Co-60	0	3.91E 07	0	0	0	5.09E 08	0	8.80E 07
Zn-65	1.59E 08	5.52E 08	0	3.53E 08	0	2.34E 08	0	2.58E 08
Sr-89	1.40E 08	0	0	0	0	1.67E 07	0	4.01E 06
Sr-90	5.42E 09	0	0	0	0	1.52E 08	0	1.34E 09
Zr-95	8.50E 05	2.68E 05	0	3.94E 05	0	6.19E 08	0	1.84E 05
Nb-95	9.49E 05	5.27E 05	0	5.11E 05	0	2.25E 09	0	2.90E 05
Mo-99	0	4.10E 04	0	9.39E 04	0	7.35E 04	0	7.83E 03
Ag-110m	3.22E 06	3.05E 06	0	5.81E 06	0	8.56E 08	0	1.85E 06
Sb-124	9.09E 06	1.68E 05	2.06E 04	0	7.94E 06	1.83E 08	0	3.55E 06
I-131	4.46E 06	6.24E 06	1.82E 09	1.08E 07	0	1.24E 06	0	3.35E 06
I-133	1.66E-01	2.82E-01	3.94E 01	4.95E-01	0	2.14E-01	0	8.61E-02
I-135	1.89E-17	4.88E-17	3.14E-15	7.70E-17	0	5.40E-17	0	1.81E-17
Cs-134	3.46E 08	8.14E 08	0	2.59E 08	9.87E 07	1.01E 07	0	3.78E 08
Cs-136	4.71E 06	1.85E 07	0	1.01E 07	1.59E 06	1.49E 06	0	1.24E 07
Cs-137	4.88E 08	6.49E 08	0	2.21E 08	8.59E 07	9.24E 06	0	2.26E 08
Ba-140	1.19E 07	1.46E 04	0	4.95E 03	9.82E 03	1.84E 07	0	7.68E 05
La-140	1.55E-02	7.60E-03	0	0	0	4.36E 02	0	2.02E-03
Ce-141	6.20E 03	4.14E 03	0	1.95E 03	0	1.18E 07	0	4.75E 02
Ce-144	7.87E 05	3.26E 05	0	1.94E 05	0	1.98E 08	0	4.23E 04

* $\frac{\text{mrem/yr}}{\mu\text{Ci/m}^3}$

TABLE B-5 (Continued)

R_i VALUES - COW MILK - TEEN
 $\frac{\text{m}^2\text{-mrem/yr}}{\mu\text{Ci/sec}}$

NUCLIDE	BONE	LIVER	THYROID	KIDNEY	LUNG	GI-LLI	SKIN	T. BODY
H-3*	0	9.94E 02	9.94E 02	9.94E 02	9.94E 02	9.94E 02	0	9.94E 02
Cr-51	0	0	1.44E 04	5.67E 03	3.69E 04	4.34E 06	0	2.59E 04
Mn-54	0	9.02E 06	0	2.69E 06	0	1.85E 07	0	1.79E 06
Fe-55	2.96E 07	2.10E 07	0	0	1.33E 07	9.08E 06	0	4.89E 06
Fe-59	2.81E 07	6.57E 07	0	0	2.07E 07	1.55E 08	0	2.54E 07
Co-57	0	1.43E 06	0	0	0	2.68E 07	0	2.41E 06
Co-58	0	4.55E 06	0	0	0	6.27E 07	0	1.05E 07
Co-60	0	1.86E 07	0	0	0	2.42E 08	0	4.19E 07
Zn-65	1.34E 09	4.65E 09	0	2.97E 09	0	1.97E 09	0	2.17E 09
Sr-89	1.47E 09	0	0	0	0	1.75E 08	0	4.22E 07
Sr-90	4.46E 10	0	0	0	0	1.25E 09	0	1.10E 10
Zr-95	9.34E 02	2.95E 02	0	4.33E 02	0	6.80E 05	0	2.03E 02
Nb-95	7.45E 04	4.13E 04	0	4.01E 04	0	1.77E 08	0	2.28E 04
Mo-99	0	2.23E 07	0	5.11E 07	0	4.00E 07	0	4.26E 06
Ag-110m	6.13E 07	5.80E 07	0	1.11E 08	0	1.63E 10	0	3.53E 07
Sb-124	2.58E 07	4.76E 05	5.86E 04	0	2.25E 07	5.20E 08	0	1.01E 07
I-131	2.69E 08	3.76E 08	1.10E 11	6.47E 08	0	7.44E 07	0	2.02E 08
I-133	3.58E 06	6.07E 06	8.48E 08	1.06E 07	0	4.59E 06	0	1.85E 06
I-135	1.15E 04	2.95E 04	1.90E 06	4.66E 04	0	3.27E 04	0	1.09E 04
Cs-134	6.49E 09	1.53E 10	0	4.85E 09	1.85E 09	1.90E 08	0	7.09E 09
Cs-136	2.25E 08	8.84E 08	0	4.81E 08	7.59E 07	7.12E 07	0	5.94E 08
Cs-137	9.02E 09	1.20E 10	0	4.08E 09	1.59E 09	1.71E 08	0	4.18E 09
Ba-140	2.43E 07	2.98E 04	0	1.01E 04	2.00E 04	3.75E 07	0	1.57E 06
La-140	4.06E 00	2.00E 00	0	0	0	1.15E 05	0	5.31E-01
Ce-141	4.67E 03	3.12E 03	0	1.47E 03	0	8.91E 06	0	3.58E 02
Ce-144	4.22E 05	1.74E 05	0	1.04E 05	0	1.06E 08	0	2.27E 04

* $\frac{\text{mrem/yr}}{\mu\text{Ci/m}^3}$

TABLE B-5 (Continued)

R_i VALUES - GOAT MILK - TEEN

$$\frac{\text{m}^2\text{-mrem/yr}}{\mu\text{Ci/sec}}$$

NUCLIDE	BONE	LIVER	THYROID	KIDNEY	LUNG	GI-LLI	SKIN	T. BODY
H-3*	0	2.03E 03	2.03E 03	2.03E 03	2.03E 03	2.03E 03	0	2.03E 03
Cr-51	0	0	1.72E 03	6.80E 02	4.43E 03	5.21E 05	0	3.10E 03
Mn-54	0	1.08E 06	0	3.23E 05	0	2.22E 06	0	2.15E 05
Fe-55	3.85E 05	2.73E 05	0	0	1.73E 05	1.18E 05	0	6.36E 04
Fe-59	3.66E 05	8.54E 05	0	0	2.69E 05	2.02E 06	0	3.30E 05
Co-57	0	1.72E 05	0	0	0	3.21E 06	0	2.89E 05
Co-58	0	5.46E 05	0	0	0	7.52E 06	0	1.26E 06
Co-60	0	2.23E 06	0	0	0	2.91E 07	0	5.03E 06
Zn-65	1.61E 08	5.58E 08	0	3.57E 08	0	2.36E 08	0	2.60E 08
Sr-89	3.09E 09	0	0	0	0	3.68E 08	0	8.85E 07
Sr-90	9.36E 10	0	0	0	0	2.63E 09	0	2.31E 10
Zr-95	1.12E 02	3.54E 01	0	5.20E 01	0	8.16E 04	0	2.43E 01
Nb-95	8.94E 03	4.96E 03	0	4.81E 03	0	2.12E 07	0	2.73E 03
Mo-99	0	2.68E 06	0	6.13E 06	0	4.80E 06	0	5.11E 05
Ag-110m	7.35E 06	6.96E 06	0	1.33E 07	0	1.95E 09	0	4.23E 06
Sb-124	3.10E 06	5.71E 04	7.03E 03	0	2.71E 06	6.24E 07	0	1.21E 06
I-131	3.22E 08	4.51E 08	1.32E 11	7.77E 08	0	8.93E 07	0	2.42E 08
I-133	4.30E 06	7.29E 06	1.02E 09	1.28E 07	0	5.51E 06	0	2.22E 06
I-135	1.38E 04	3.54E 04	2.28E 06	5.60E 04	0	3.93E 04	0	1.31E 04
Cs-134	1.95E 10	4.58E 10	0	1.46E 10	5.56E 09	5.70E 08	0	2.13E 10
Cs-136	6.74E 08	2.65E 09	0	1.44E 09	2.28E 08	2.13E 08	0	1.78E 09
Cs-137	2.71E 10	3.60E 10	0	1.23E 10	4.76E 09	5.12E 08	0	1.25E 10
Ba-140	2.92E 06	3.58E 03	0	1.21E 03	2.41E 03	4.50E 06	0	1.88E 05
La-140	4.87E-01	2.40E-01	0	0	0	1.38E 04	0	6.37E-02
Ce-141	5.60E 02	3.74E 02	0	1.76E 02	0	1.07E 06	0	4.30E 01
Ce-144	5.06E 04	2.09E 04	0	1.25E 04	0	1.27E 07	0	2.72E 03

* $\frac{\text{mrem/yr}}{\mu\text{Ci/m}^3}$

TABLE B-5 (Continued)

R_i VALUES - GROUND PLANE - CHILD
$$\frac{\text{m}^2\text{-mrem/yr}}{\mu\text{Ci/sec}}$$

NUCLIDE	BONE	LIVER	THYROID	KIDNEY	LUNG	GI-LLI	SKIN	T. BODY
H-3	0	0	0	0	0	0	0	0
Cr-51	4.65E 06	4.65E 06	4.65E 06	4.65E 06	4.65E 06	4.65E 06	5.50E 06	4.65E 06
Mn-54	1.38E 09	1.38E 09	1.38E 09	1.38E 09	1.38E 09	1.38E 09	1.62E 09	1.38E 09
Fe-55	0	0	0	0	0	0	0	0
Fe-59	2.73E 08	2.73E 08	2.73E 08	2.73E 08	2.73E 08	2.73E 08	3.20E 08	2.73E 08
Co-57	1.88E 08	1.88E 08	1.88E 08	1.88E 08	1.88E 08	1.88E 08	2.07E 08	1.88E 08
Co-58	3.80E 08	3.80E 08	3.80E 08	3.80E 08	3.80E 08	3.80E 08	4.45E 08	3.80E 08
Co-60	2.15E 10	2.15E 10	2.15E 10	2.15E 10	2.15E 10	2.15E 10	2.53E 10	2.15E 10
Zn-65	7.46E 08	7.46E 08	7.46E 08	7.46E 08	7.46E 08	7.46E 08	8.57E 08	7.46E 08
Sr-89	2.16E 04	2.16E 04	2.16E 04	2.16E 04	2.16E 04	2.16E 04	2.51E 04	2.16E 04
Sr-90	0	0	0	0	0	0	0	0
Zr-95	2.45E 08	2.45E 08	2.45E 08	2.45E 08	2.45E 08	2.45E 08	2.85E 08	2.45E 08
Nb-95	1.37E 08	1.37E 08	1.37E 08	1.37E 08	1.37E 08	1.37E 08	1.61E 08	1.37E 08
Mo-99	3.99E 06	3.99E 06	3.99E 06	3.99E 06	3.99E 06	3.99E 06	4.62E 06	3.99E 06
Ag-110m	3.45E 09	3.45E 09	3.45E 09	3.45E 09	3.45E 09	3.45E 09	4.02E 09	3.45E 09
Sb-124	5.99E 08	5.99E 08	5.99E 08	5.99E 08	5.99E 08	5.99E 08	6.92E 08	5.99E 08
I-131	1.72E 07	1.72E 07	1.72E 07	1.72E 07	1.72E 07	1.72E 07	2.09E 07	1.72E 07
I-133	2.46E 06	2.46E 06	2.46E 06	2.46E 06	2.46E 06	2.46E 06	3.00E 06	2.46E 06
I-135	2.53E 06	2.53E 06	2.53E 06	2.53E 06	2.53E 06	2.53E 06	2.95E 06	2.53E 06
Cs-134	6.90E 09	6.90E 09	6.90E 09	6.90E 09	6.90E 09	6.90E 09	8.05E 09	6.90E 09
Cs-136	1.51E 08	1.51E 08	1.51E 08	1.51E 08	1.51E 08	1.51E 08	1.71E 08	1.51E 08
Cs-137	1.03E 10	1.03E 10	1.03E 10	1.03E 10	1.03E 10	1.03E 10	1.20E 10	1.03E 10
Ba-140	2.05E 07	2.05E 07	2.05E 07	2.05E 07	2.05E 07	2.05E 07	2.35E 07	2.05E 07
La-140	1.92E 07	1.92E 07	1.92E 07	1.92E 07	1.92E 07	1.92E 07	2.18E 07	1.92E 07
Ce-141	1.37E 07	1.37E 07	1.37E 07	1.37E 07	1.37E 07	1.37E 07	1.54E 07	1.37E 07
Ce-144	6.96E 07	6.96E 07	6.96E 07	6.96E 07	6.96E 07	6.96E 07	8.05E 07	6.96E 07

TABLE B-5 (Continued)

R_i VALUES - INHALATION - CHILD
$$\frac{\text{mrem/yr}}{\mu\text{Ci/m}^3}$$

NUCLIDE	BONE	LIVER	THYROID	KIDNEY	LUNG	GI-LLI	SKIN	T. BODY
H-3	0	1.12E 03	1.12E 03	1.12E 03	1.12E 03	1.12E 03	0	1.12E 03
Cr-51	0	0	8.55E 01	2.43E 01	1.70E 04	1.08E 03	0	1.54E 02
Mn-54	0	4.29E 04	0	1.00E 04	1.58E 06	2.29E 04	0	9.51E 03
Fe-55	4.74E 04	2.52E 04	0	0	1.11E 05	2.87E 03	0	7.77E 03
Fe-59	2.07E 04	3.34E 04	0	0	1.27E 06	7.07E 04	0	1.67E 04
Co-57	0	9.03E 02	0	0	5.07E 05	1.32E 04	0	1.07E 03
Co-58	0	1.77E 03	0	0	1.11E 06	3.44E 04	0	3.16E 03
Co-60	0	1.31E 04	0	0	7.07E 06	9.62E 04	0	2.26E 04
Zn-65	4.26E 04	1.13E 05	0	7.14E 04	9.95E 05	1.63E 04	0	7.03E 04
Sr-89	5.99E 05	0	0	0	2.16E 06	1.67E 05	0	1.72E 04
Sr-90	1.01E 08	0	0	0	1.48E 07	3.43E 05	0	6.44E 06
Zr-95	1.90E 05	4.18E 04	0	5.96E 04	2.23E 06	6.11E 04	0	3.70E 04
Nb-95	2.35E 04	9.18E 03	0	8.62E 03	6.14E 05	3.70E 04	0	6.55E 03
Mo-99	0	1.72E 02	0	3.92E 02	1.35E 05	1.27E 05	0	4.25E 01
Ag-110m	1.69E 04	1.14E 04	0	2.12E 04	5.48E 06	1.00E 05	0	9.14E 03
Sb-124	5.74E 04	7.40E 02	1.26E 02	0	3.24E 06	1.64E 05	0	2.00E 04
I-131	4.81E 04	4.81E 04	1.62E 07	7.88E 04	0	2.84E 03	0	2.73E 04
I-133	1.66E 04	2.03E 04	3.85E 06	3.38E 04	0	5.48E 03	0	7.70E 03
I-135	4.92E 03	8.73E 03	7.92E 05	1.34E 04	0	4.44E 03	0	4.14E 03
Cs-134	6.51E 05	1.01E 06	0	3.30E 05	1.21E 05	3.85E 03	0	2.25E 05
Cs-136	6.51E 04	1.71E 05	0	9.55E 04	1.45E 04	4.18E 03	0	1.16E 05
Cs-137	9.07E 05	8.25E 05	0	2.82E 05	1.04E 05	3.62E 03	0	1.28E 05
Ba-140	7.40E 04	6.48E 01	0	2.11E 01	1.74E 06	1.02E 05	0	4.33E 03
La-140	6.44E 02	2.25E 02	0	0	1.83E 05	2.26E 05	0	7.55E 01
Ce-141	3.92E 04	1.95E 04	0	8.55E 03	5.44E 05	5.66E 04	0	2.90E 03
Ce-144	6.77E 06	2.12E 06	0	1.17E 06	1.20E 07	3.89E 05	0	3.61E 05

TABLE B-5 (Continued)

R_i VALUES - COW MEAT - CHILD
 $\frac{\text{m}^2\text{-mrem/yr}}{\mu\text{Ci/sec}}$

NUCLIDE	BONE	LIVER	THYROID	KIDNEY	LUNG	GI-LLI	SKIN	T. BODY
H-3*	0	2.33E 02	2.33E 02	2.33E 02	2.33E 02	2.33E 02	0	2.33E 02
Cr-51	0	0	2.53E 03	6.90E 02	4.61E 03	2.41E 05	0	4.55E 03
Mn-54	0	5.15E 06	0	1.44E 06	0	4.32E 06	0	1.37E 06
Fe-55	3.04E 08	1.61E 08	0	0	9.11E 07	2.98E 07	0	4.99E 07
Fe-59	2.04E 08	3.30E 08	0	0	9.58E 07	3.44E 08	0	1.65E 08
Co-57	0	3.78E 06	0	0	0	3.10E 07	0	7.66E 06
Co-58	0	9.41E 06	0	0	0	5.49E 07	0	2.88E 07
Co-60	0	4.64E 07	0	0	0	2.57E 08	0	1.37E 08
Zn-65	2.39E 08	6.35E 08	0	4.00E 08	0	1.12E 08	0	3.95E 08
Sr-89	2.65E 08	0	0	0	0	1.03E 07	0	7.57E 06
Sr-90	7.01E 09	0	0	0	0	9.44E 07	0	1.78E 09
Zr-95	1.51E 06	3.32E 05	0	4.75E 05	0	3.46E 08	0	2.95E 05
Nb-95	1.64E 06	6.38E 05	0	6.00E 05	0	1.18E 09	0	4.56E 05
Mo-99	0	5.71E 04	0	1.22E 05	0	4.72E 04	0	1.41E 04
Ag-110m	5.34E 06	3.61E 06	0	6.72E 06	0	4.29E 08	0	2.88E 06
Sb-124	1.65E 07	2.13E 05	3.63E 04	0	9.13E 06	1.03E 08	0	5.77E 06
I-131	8.27E 06	8.32E 06	2.75E 09	1.37E 07	0	7.41E 05	0	4.73E 06
I-133	3.09E-01	3.82E-01	7.10E 01	6.37E-01	0	1.54E-01	0	1.45E-01
I-135	3.43E-17	6.17E-17	5.46E-15	9.46E-17	0	4.70E-17	0	2.92E-17
Cs-134	6.10E 08	1.00E 09	0	3.10E 08	1.11E 08	5.39E 06	0	2.11E 08
Cs-136	8.12E 06	2.23E 07	0	1.19E 07	1.77E 06	7.85E 05	0	1.45E 07
Cs-137	8.99E 08	8.60E 08	0	2.80E 08	1.01E 08	5.39E 06	0	1.27E 08
Ba-140	2.20E 07	1.93E 04	0	6.27E 03	1.15E 04	1.11E 07	0	1.28E 06
La-140	2.83E-02	9.90E-03	0	0	0	2.76E 02	0	3.34E-03
Ce-141	1.17E 04	5.82E 03	0	2.55E 03	0	7.26E 06	0	8.64E 02
Ce-144	1.48E 06	4.65E 05	0	2.57E 05	0	1.21E 08	0	7.92E 04

* $\frac{\text{mrem/yr}}{\mu\text{Ci/m}^3}$

TABLE B-5 (Continued)

R_i VALUES - COW MILK - CHILD

$$\frac{\text{m}^2\text{-mrem/yr}}{\mu\text{Ci/sec}}$$

NUCLIDE	BONE	LIVER	THYROID	KIDNEY	LUNG	GI-LLI	SKIN	T. BODY
H-3*	0	1.57E 03	1.57E 03	1.57E 03	1.57E 03	1.57E 03	0	1.57E 03
Cr-51	0	0	2.93E 04	8.00E 03	5.34E 04	2.80E 06	0	5.27E 04
Mn-54	0	1.35E 07	0	3.78E 06	0	1.13E 07	0	3.59E 06
Fe-55	7.43E 07	3.94E 07	0	0	2.23E 07	7.30E 06	0	1.22E 07
Fe-59	6.53E 07	1.06E 08	0	0	3.06E 07	1.10E 08	0	5.26E 07
Co-57	0	2.45E 06	0	0	0	2.01E 07	0	4.96E 06
Co-58	0	6.95E 06	0	0	0	4.05E 07	0	2.13E 07
Co-60	0	2.89E 07	0	0	0	1.60E 08	0	8.52E 07
Zn-65	2.63E 09	7.00E 09	0	4.41E 09	0	1.23E 09	0	4.35E 09
Sr-89	3.64E 09	0	0	0	0	1.41E 08	0	1.04E 08
Sr-90	7.53E 10	0	0	0	0	1.01E 09	0	1.91E 10
Zr-95	2.17E 03	4.77E 02	0	6.83E 02	0	4.98E 05	0	4.25E 02
Nb-95	1.68E 05	6.55E 04	0	6.15E 04	0	1.21E 08	0	4.68E 04
Mo-99	0	4.06E 07	0	8.67E 07	0	3.36E 07	0	1.00E 07
Ag-110m	1.33E 08	8.98E 07	0	1.67E 08	0	1.07E 10	0	7.18E 07
Sb-124	6.11E 07	7.92E 05	1.35E 05	0	3.39E 07	3.82E 08	0	2.14E 07
I-131	6.52E 08	6.55E 08	2.17E 11	1.08E 09	0	5.83E 07	0	3.72E 08
I-133	8.70E 06	1.08E 07	2.00E 09	1.79E 07	0	4.33E 06	0	4.07E 06
I-135	2.72E 04	4.89E 04	4.33E 06	7.49E 04	0	3.72E 04	0	2.31E 04
Cs-134	1.50E 10	2.46E 10	0	7.61E 09	2.73E 09	1.32E 08	0	5.18E 09
Cs-136	5.07E 08	1.39E 09	0	7.42E 08	1.11E 08	4.90E 07	0	9.02E 08
Cs-137	2.17E 10	2.08E 10	0	6.78E 09	2.44E 09	1.30E 08	0	3.07E 09
Ba-140	5.87E 07	5.15E 04	0	1.68E 04	3.07E 04	2.98E 07	0	3.43E 06
La-140	9.73E 00	3.40E 00	0	0	0	9.48E 04	0	1.15E 00
Ce-141	1.15E 04	5.73E 03	0	2.51E 03	0	7.15E 06	0	8.51E 02
Ce-144	1.04E 06	3.26E 05	0	1.80E 05	0	8.50E 07	0	5.55E 04

* $\frac{\text{mrem/yr}}{\mu\text{Ci/m}^3}$

TABLE B-5 (Continued)

R_i VALUES - GOAT MILK - CHILD
$$\frac{\text{m}^2\text{-mrem/yr}}{\mu\text{Ci/sec}}$$

NUCLIDE	BONE	LIVER	THYROID	KIDNEY	LUNG	GI-LLI	SKIN	T. BODY
H-3*	0	3.20E 03	3.20E 03	3.20E 03	3.20E 03	3.20E 03	0	3.20E 03
Cr-51	0	0	3.51E 03	9.60E 02	6.41E 03	3.36E 05	0	6.33E 03
Mn-54	0	1.62E 06	0	4.54E 05	0	1.36E 06	0	4.31E 05
Fe-55	9.65E 05	5.12E 05	0	0	2.90E 05	9.49E 04	0	1.59E 05
Fe-59	8.48E 05	1.37E 06	0	0	3.98E 05	1.43E 06	0	6.84E 05
Co-57	0	2.94E 05	0	0	0	2.41E 06	0	5.96E 05
Co-58	0	8.34E 05	0	0	0	4.86E 06	0	2.55E 06
Co-60	0	3.47E 06	0	0	0	1.92E 07	0	1.02E 07
Zn-65	3.15E 08	8.40E 08	0	5.29E 08	0	1.47E 08	0	5.22E 08
Sr-89	7.65E 09	0	0	0	0	2.96E 08	0	2.19E 08
Sr-90	1.58E 11	0	0	0	0	2.13E 09	0	4.01E 10
Zr-95	2.60E 02	5.73E 01	0	8.20E 01	0	5.97E 04	0	5.10E 01
Nb-95	2.02E 04	7.86E 03	0	7.39E 03	0	1.45E 07	0	5.62E 03
Mo-99	0	4.87E 06	0	1.04E 07	0	4.03E 06	0	1.21E 06
Ag-110m	1.59E 07	1.08E 07	0	2.01E 07	0	1.28E 09	0	8.61E 06
Sb-124	7.33E 06	9.15E 04	1.62E 04	0	4.07E 06	4.58E 07	0	2.57E 06
I-131	7.82E 08	7.86E 08	2.60E 11	1.29E 09	0	7.00E 07	0	4.47E 08
I-133	1.04E 07	1.29E 07	2.40E 09	2.15E 07	0	5.20E 06	0	4.88E 06
I-135	3.26E 04	5.87E 04	5.19E 06	8.99E 04	0	4.47E 04	0	2.77E 04
Cs-134	4.49E 10	7.37E 10	0	2.28E 10	8.19E 09	3.97E 08	0	1.55E 10
Cs-136	1.52E 09	4.18E 09	0	2.23E 09	3.32E 08	1.47E 08	0	2.71E 09
Cs-137	6.52E 10	6.24E 10	0	2.03E 10	7.32E 09	3.91E 08	0	9.21E 09
Ba-140	7.05E 06	6.17E 03	0	2.01E 03	3.68E 03	3.57E 06	0	4.11E 05
La-140	1.17E 00	4.08E-01	0	0	0	1.14E 04	0	1.38E-01
Ce-141	1.38E 03	6.88E 02	0	3.02E 02	0	8.58E 05	0	1.02E 02
Ce-144	1.25E 05	3.91E 04	0	2.14E 04	0	1.02E 07	0	6.66E 03

* $\frac{\text{mrem/yr}}{\mu\text{Ci/m}^3}$

TABLE B-5 (Continued)

R_i VALUES - GROUND PLANE - INFANT
 $\frac{\text{m}^2\text{-mrem/yr}}{\mu\text{Ci/sec}}$

NUCLIDE	BONE	LIVER	THYROID	KIDNEY	LUNG	GI-LLI	SKIN	T. BODY
H-3	0	0	0	0	0	0	0	0
Cr-51	4.65E 06	4.65E 06	4.65E 06	4.65E 06	4.65E 06	4.65E 06	5.50E 06	4.65E 06
Mn-54	1.38E 09	1.38E 09	1.38E 09	1.38E 09	1.38E 09	1.38E 09	1.62E 09	1.38E 09
Fe-55	0	0	0	0	0	0	0	0
Fe-59	2.73E 08	2.73E 08	2.73E 08	2.73E 08	2.73E 08	2.73E 08	3.20E 08	2.73E 08
Co-57	1.88E 08	1.88E 08	1.88E 08	1.88E 08	1.88E 08	1.88E 08	2.07E 08	1.88E 08
Co-58	3.80E 08	3.80E 08	3.80E 08	3.80E 08	3.80E 08	3.80E 08	4.45E 08	3.80E 08
Co-60	2.15E 10	2.15E 10	2.15E 10	2.15E 10	2.15E 10	2.15E 10	2.53E 10	2.15E 10
Zn-65	7.46E 08	7.46E 08	7.46E 08	7.46E 08	7.46E 08	7.46E 08	8.57E 08	7.46E 08
Sr-89	2.16E 04	2.16E 04	2.16E 04	2.16E 04	2.16E 04	2.16E 04	2.51E 04	2.16E 04
Sr-90	0	0	0	0	0	0	0	0
Zr-95	2.45E 08	2.45E 08	2.45E 08	2.45E 08	2.45E 08	2.45E 08	2.85E 08	2.45E 08
Nb-95	1.37E 08	1.37E 08	1.37E 08	1.37E 08	1.37E 08	1.37E 08	1.61E 08	1.37E 08
Mo-99	3.99E 06	3.99E 06	3.99E 06	3.99E 06	3.99E 06	3.99E 06	4.62E 06	3.99E 06
Ag-110m	3.45E 09	3.45E 09	3.45E 09	3.45E 09	3.45E 09	3.45E 09	4.02E 09	3.45E 09
Sb-124	5.99E 08	5.99E 08	5.99E 08	5.99E 08	5.99E 08	5.99E 08	6.92E 08	5.99E 08
I-131	1.72E 07	1.72E 07	1.72E 07	1.72E 07	1.72E 07	1.72E 07	2.09E 07	1.72E 07
I-133	2.46E 06	2.46E 06	2.46E 06	2.46E 06	2.46E 06	2.46E 06	3.00E 06	2.46E 06
I-135	2.53E 06	2.53E 06	2.53E 06	2.53E 06	2.53E 06	2.53E 06	2.95E 06	2.53E 06
Cs-134	6.90E 09	6.90E 09	6.90E 09	6.90E 09	6.90E 09	6.90E 09	8.05E 09	6.90E 09
Cs-136	1.51E 08	1.51E 08	1.51E 08	1.51E 08	1.51E 08	1.51E 08	1.71E 08	1.51E 08
Cs-137	1.03E 10	1.03E 10	1.03E 10	1.03E 10	1.03E 10	1.03E 10	1.20E 10	1.03E 10
Ba-140	2.05E 07	2.05E 07	2.05E 07	2.05E 07	2.05E 07	2.05E 07	2.35E 07	2.05E 07
La-140	1.92E 07	1.92E 07	1.92E 07	1.92E 07	1.92E 07	1.92E 07	2.18E 07	1.92E 07
Ce-141	1.37E 07	1.37E 07	1.37E 07	1.37E 07	1.37E 07	1.37E 07	1.54E 07	1.37E 07
Ce-144	6.96E 07	6.96E 07	6.96E 07	6.96E 07	6.96E 07	6.96E 07	8.05E 07	6.96E 07

TABLE B-5 (Continued)

R_i VALUES - INHALATION - INFANT
$$\frac{\text{mrem/yr}}{\mu\text{Ci/m}^3}$$

NUCLIDE	BONE	LIVER	THYROID	KIDNEY	LUNG	GI-LLI	SKIN	T. BODY
H-3	0	6.47E 02	6.47E 02	6.47E 02	6.47E 02	6.47E 02	0	6.47E 02
Cr-51	0	0	5.75E 01	1.32E 01	1.28E 04	3.57E 02	0	8.95E 01
Mn-54	0	2.53E 04	0	4.98E 03	1.00E 06	7.06E 03	0	4.98E 03
Fe-55	1.97E 04	1.17E 04	0	0	8.69E 04	1.09E 03	0	3.33E 03
Fe-59	1.36E 04	2.35E 04	0	0	1.02E 06	2.48E 04	0	9.48E 03
Co-57	0	6.51E 02	0	0	3.79E 05	4.86E 03	0	6.41E 02
Co-58	0	1.22E 03	0	0	7.77E 05	1.11E 04	0	1.82E 03
Co-60	0	8.02E 03	0	0	4.51E 06	3.19E 04	0	1.18E 04
Zn-65	1.93E 04	6.26E 04	0	3.25E 04	6.47E 05	5.14E 04	0	3.11E 04
Sr-89	3.98E 05	0	0	0	2.03E 06	6.40E 04	0	1.14E 04
Sr-90	4.09E 07	0	0	0	1.12E 07	1.31E 05	0	2.59E 06
Zr-95	1.15E 05	2.79E 04	0	3.11E 04	1.75E 06	2.17E 04	0	2.03E 04
Nb-95	1.57E 04	6.43E 03	0	4.72E 03	4.79E 05	1.27E 04	0	3.78E 03
Mo-99	0	1.65E 02	0	2.65E 02	1.35E 05	4.87E 04	0	3.23E 01
Ag-110m	9.98E 03	7.22E 03	0	1.09E 04	3.67E 06	3.30E 04	0	5.00E 03
Sb-124	3.79E 04	5.56E 02	1.00E 02	0	2.65E 06	5.91E 04	0	1.20E 04
I-131	3.79E 04	4.44E 04	1.48E 07	5.18E 04	0	1.06E 03	0	1.96E 04
I-133	1.32E 04	1.92E 04	3.56E 06	2.24E 04	0	2.16E 03	0	5.60E 03
I-135	3.86E 03	7.60E 03	6.96E 05	8.47E 03	0	1.83E 03	0	2.77E 03
Cs-134	3.96E 05	7.03E 05	0	1.90E 05	7.97E 04	1.33E 03	0	7.45E 04
Cs-136	4.83E 04	1.35E 05	0	5.64E 04	1.18E 04	1.43E 03	0	5.29E 04
Cs-137	5.49E 05	6.12E 05	0	1.72E 05	7.13E 04	1.33E 03	0	4.55E 04
Ba-140	5.60E 04	5.60E 01	0	1.34E 01	1.60E 06	3.84E 04	0	2.90E 03
La-140	5.05E 02	2.00E 02	0	0	1.68E 05	8.48E 04	0	5.15E 01
Ce-141	2.77E 04	1.67E 04	0	5.25E 03	5.17E 05	2.16E 04	0	1.99E 03
Ce-144	3.19E 06	1.21E 06	0	5.38E 05	9.84E 06	1.48E 05	0	1.76E 05

TABLE B-5 (Continued)

R_i VALUES - VEGETATION - INFANT
 AND
 R_i VALUES - COW MEAT - INFANT
 $\frac{m^2 \cdot mrem/yr}{\mu Ci/sec}$

NUCLIDE	BONE	LIVER	THYROID	KIDNEY	LUNG	GI-LLI	SKIN	T. BODY
H-3*	0	0	0	0	0	0	0	0
Cr-51	0	0	0	0	0	0	0	0
Mn-54	0	0	0	0	0	0	0	0
Fe-55	0	0	0	0	0	0	0	0
Fe-59	0	0	0	0	0	0	0	0
Co-57	0	0	0	0	0	0	0	0
Co-58	0	0	0	0	0	0	0	0
Co-60	0	0	0	0	0	0	0	0
Zn-65	0	0	0	0	0	0	0	0
Sr-89	0	0	0	0	0	0	0	0
Sr-90	0	0	0	0	0	0	0	0
Zr-95	0	0	0	0	0	0	0	0
Nb-95	0	0	0	0	0	0	0	0
Mo-99	0	0	0	0	0	0	0	0
Ag-110m	0	0	0	0	0	0	0	0
Sb-124	0	0	0	0	0	0	0	0
I-131	0	0	0	0	0	0	0	0
I-133	0	0	0	0	0	0	0	0
I-135	0	0	0	0	0	0	0	0
Cs-134	0	0	0	0	0	0	0	0
Cs-136	0	0	0	0	0	0	0	0
Cs-137	0	0	0	0	0	0	0	0
Ba-140	0	0	0	0	0	0	0	0
La-140	0	0	0	0	0	0	0	0
Ce-141	0	0	0	0	0	0	0	0
Ce-144	0	0	0	0	0	0	0	0

* $\frac{mrem/yr}{\mu Ci/m^3}$

TABLE B-6
DERIVATION OF GASEOUS DOSE FACTORS

TABLE	TITLE	PAGE
B-6.1	Derivation of (P _i) Values	B-31
B-6.2	Derivation of Gaseous Dose Factors (R _i)	B-32
B-6.3	Parameters for the Gaseous Effluent Pathway	B-41
B-6.4	Justification for Gaseous Pathways Used to Assess Dose	B-44
B-6.5	Organ Doses for Gaseous Releases - Inhalation Pathway	B-46

TABLE B-6.1

DERIVATION OF (P_i) VALUES

The pathway dose factor, P_i, for radioiodines, tritium, and 8-day particulates includes transport parameters of the ith nuclide, the receptor usage rate of the pathway media, and the appropriate dose conversion factor. For the inhalation pathway, the value of P_i is calculated as follows:

$$P_i = K' (BR) DFA_i \text{ (mrem/yr per } \mu\text{Ci/ m}^3 \text{)}$$

Where:

- K' = a constant of unit conversion, 10⁶ pCi/μCi.
- (BR) = the breathing rate of the age group, in m³/yr (Table E-5 of Regulatory Guide 1.109).
- DFA_i = the maximum organ inhalation dose factor for the appropriate age group for the ith radionuclide, in mrem/pCi (Tables E-7 to E-10 of Regulatory Guide 1.109).

Example Calculation:

For the I-131 child thyroid dose factor for exposure from inhalation:

$$DFA_i = 4.39\text{E-}03 \text{ mrem/pCi}$$

$$BR = 3700 \text{ m}^3/\text{yr}$$

These values will yield a P_i factor of 1.62E7 mrem/yr per μCi/m³ as listed in Table B-3 of this appendix.

TABLE B-6.2

DERIVATION OF GASEOUS DOSE FACTORS (R_i)

The pathway dose factor R_i for radioiodines, tritium, and 8 day particulates include transport parameters of the i th nuclide, the receptor usage rate of the pathway media, and the appropriate dose conversion factor. In developing the R_i values, separate expressions are written for each of the potential pathways.

I. INHALATION

For the inhalation pathway, the value of R_i is calculated as follows:

$$R_i = K' (BR)_a (DFA_i)_a \text{ (mrem/yr per } \mu\text{Ci/ m}^3 \text{)}$$

Where:

- K' = a constant of unit conversion, 10^6 pCi/ μ Ci.
- $(BR)_a$ = the breathing rate of the receptor of age group (a) in m^3/yr (Table B-6.3).
- $(DFA_i)_a$ = the organ inhalation dose factor for the receptor of age group (a) for the i th radionuclide, in mrem/pCi (Tables E-7 to E-10 of Regulatory Guide 1.109).

Example Calculation:

For the Co-60 child whole body dose factor from exposure due to inhalation:

$$(DFA_i)_a = 6.12\text{E-}6 \text{ mrem/pCi}$$

$$(BR)_a = 3700 \text{ m}^3/\text{yr}$$

These values yield a R_i factor of $2.26\text{E}4$ mrem/yr per $\mu\text{Ci}/\text{m}^3$ as listed in Table B-5 of this appendix.

II. GROUND PLANE

For the ground plane pathway, the value of R_i is calculated as follows:

$$R_i = K' K'' (SF) DFG_i \left[(1 - e^{-\lambda_i t}) / \lambda_i \right]$$

$$\text{(m}^2 \text{ - mrem / yr per } \mu\text{Ci / sec)}$$

TABLE B-6.2 (Continued)

DERIVATION OF GASEOUS DOSE FACTORS (R_i)

Where:

- K' = a constant of unit conversion, 10⁶ pCi/μCi.
- K" = a constant of unit conversion, 8760 hr/yr.
- λ_i = the decay constant for the ith radionuclide, sec⁻¹.
- t = the exposure time, 4.73E8 sec (Table B-6.3).
- DFG_i = the ground plane dose conversion factor for the ith radionuclide, mrem/hr per pCi/m². (See Table E-6 of Regulatory Guide 1.109).
- SF = the shielding factor, 0.7, dimensionless (Table B-6.3).

Example Calculation:

For the Co-60 child whole body dose factor from exposure due to the ground plane:

- λ_i = 4.20E-9 sec⁻¹
- DFG_i = 1.70E-8 mrem/hr per pCi/m²

These values yield a R_i factor of 2.15E10 m²-mrem/yr per μCi/sec as listed in Table B-5 of this appendix.

III. VEGETATION

A. Radioiodines And Eight Day Particulates

For the vegetation pathway, R_i, is calculated as follows:

$$R_i = K' \frac{(r)}{Y_v(\lambda_i + \lambda_w)} (DFL_i)_a \left[U_a^L f_L e^{-\lambda_i t_L} + U_a^S f_g e^{-\lambda_i t_h} \right]$$

(m² - mrem / yr per μCi / sec)

Where:

- K' = a Constant of unit conversion, 10⁶ pCi/μCi.
- U_a^L = the consumption rate of fresh leafy vegetation by the receptor in age group (a), in kg/yr (Table B-6.3).

TABLE B-6.2 (Continued)

DERIVATION OF GASEOUS DOSE FACTORS (R_i)

U_a^s	=	the consumption rate of stored vegetation by the receptor in age group (a), in kg/yr (Table B-6.3).
f_L	=	the fraction of the annual intake of fresh leafy vegetation grown locally (Table B-6.3).
f_g	=	the fraction of the annual intake of stored vegetation grown locally (Table B-6.3).
t_L	=	the average time between harvest of leafy vegetation and its consumption, in seconds (Table B-6.3).
t_h	=	the average time between harvest of stored vegetation and its consumption, in seconds (Table B-6.3).
Y_v	=	the vegetation areal density, in kg/m ² (Table B-6.3).
r	=	fraction of deposited activity retained on vegetation (Table B-6.3).
λ_i	=	the decay constant for the i th radionuclide, in sec ⁻¹ .
λ_w	=	the decay constant for removal of activity on leaf and plant surfaces by weathering, 5.73E-7 sec ⁻¹ (corresponding to a 14 day half-life).
$(DFL_i)_a$	=	the maximum organ ingestion dose factor for the i th radionuclide for the receptor in age group (a), in mrem/pCi (Tables E-11 to E-14 of Regulatory Guide 1.109).

Example Calculation:

For the Co-60 child whole body dose factor from exposure due to ingestion of vegetation:

U_a^t	=	26 kg/yr
U_a^s	=	520 kg/yr
f_L	=	1
f_g	=	0.76
t_L	=	8.6E4 sec
t_h	=	5.18E6 sec
Y_v	=	2 kg/m ²
r	=	0.2

TABLE B-6.2 (Continued)

DERIVATION OF GASEOUS DOSE FACTORS (R_i)

$$\begin{aligned} \lambda_i &= 4.2\text{E-}9 \text{ sec}^{-1} \\ \lambda_w &= 5.73\text{E-}7 \text{ sec}^{-1} \\ (\text{DFL}_i)_a &= 1.56\text{E-}5 \text{ mrem/pCi} \end{aligned}$$

These values yield an R_i factor of $1.12\text{E}9 \text{ m}^2\text{-mrem/yr}$ per $\mu\text{Ci/sec}$ as listed in Table B-4 of this appendix.

B. Tritium

The concentration of tritium in vegetation is based on the airborne concentration rather than the deposition. R_i is calculated as follows:

$$R_i = K' K''' (U_a^L f_L + U_a^s f_g) (\text{DFL}_i)_a [0.75 (0.5 / H)]$$

(mrem / yr per $\mu\text{Ci} / \text{m}^3$)

Where:

- K' = unit conversion constant, $10^6 \text{ pCi}/\mu\text{Ci}$.
- K''' = unit conversion constant, 10^3 gm/kg .
- 0.75 = the fraction of vegetation which is water (NUREG-0133).
- 0.50 = the ratio of the specific activity of the vegetation that is water to the atmospheric water (NUREG-0133).
- H = absolute atmospheric humidity, in gm/m^3 (Table B-6.3).

All other parameters are as previously defined above.

TABLE B-6.2 (Continued)

DERIVATION OF GASEOUS DOSE FACTORS (R_i)

Example Calculation

For the H-3 child whole body dose factor from exposure due to ingestion of vegetation:

$$\begin{aligned}
 U_a^L &= 26 \text{ kg/yr} \\
 U_a^S &= 520 \text{ kg/yr} \\
 f_L &= 1 \\
 f_g &= 0.76 \\
 (DFL_i)_a &= 2.03E-7 \text{ mrem/pCi} \\
 H &= 8 \text{ gm/m}^3 \text{ (NUREG-0133)}
 \end{aligned}$$

These values yield a R_i factor of 4.01E3 mrem/yr per $\mu\text{Ci/m}^3$ as listed in Table B-4 of this appendix.

IV. MEAT

A. Radioiodines And Eight Day Particulates

$$R_i = K \cdot \frac{Q_F(U_{ap})}{(\lambda_i + \lambda_w)} F_f(r) (DFL_i)_a \left[\frac{f_p f_s}{Y_p} + \frac{(1 - f_p f_s) e^{-\lambda_i t_h}}{Y_s} \right] e^{-\lambda_i t_f}$$

(m^2 - mrem / yr per μCi / sec)

Where:

- U_{ap} = the receptor's meat consumption rate for age (a), in kg/yr (Table B-6.3).
- F_f = the stable element transfer coefficients, in days/kg (Table E-1 of Regulatory Guide 1.109).
- t_f = the transport time from pasture to receptor, in sec (Table B-6.3).
- t_h = the transport time from crop field to receptor, in sec (Table B-6.3).

TABLE B-6.2 (Continued)

DERIVATION OF GASEOUS DOSE FACTORS (R_i)

- f_p = fraction of the year that the cow is on pasture (Table B-6.3).
 f_s = fraction of the cow feed that is pasture grass while the cow is on pasture (Table B-6.3).
 Q_f = the cow's consumption rate, in kg/day (wet weight). See Table B-6.3.

All other parameters were defined previously.

Example Calculation:

For the Co-60 child whole body dose factor from exposure due to ingestion of meat:

- U_{ap} = 41 kg/yr
 F_f = $1.3E-2$ days/kg
 t_h = $7.78E6$ sec
 t_f = $1.73E6$ sec
 f_p = $6/12 = 0.5$
 f_s = 1
 $(DFL_i)_a$ = $1.56E-5$ mrem/pCi
 Y_p = 0.7 kg/m²
 Y_s = 2.0 kg/m²
 Q_F = 50 kg/day

These values yield a R_i factor of $1.37E8$ m²-mrem/yr per μ Ci/sec as listed in Table B-5 of this appendix.

TABLE B-6.2 (Continued)

DERIVATION OF GASEOUS DOSE FACTORS (R_i)

B. Tritium

The concentration of tritium in meat is based on the airborne concentration rather than the deposition. R_i is calculated as follows:

$$R_i = K' K'' F_f Q_F U_{ap} (DFL_i)_a [0.75 (0.5 / H)]$$

(mrem / yr per μCi / m³)

Example Calculation:

All parameters have been defined in the previous sections for the H-3 child whole body dose factor from exposure due to ingestion of meat. Substituting values into the preceding equation, results in a R_i factor of 2.33E2 mrem/yr per μCi/m³ as listed in Table B-5 of this appendix.

V. COW'S MILK

A. Radioiodines and Eight Day Particulates

For the cow's milk pathway, R_i is calculated as follows:

$$R_i = K' \frac{Q_F (U_{ap})}{(\lambda_i + \lambda_w)} F_m (r) (DFL_i)_a \left[\frac{f_p f_s}{Y_p} + \frac{(1 - f_p f_s) e^{-\lambda_i t_f}}{Y_s} \right] e^{-\lambda_i t_f}$$

(m² - mrem / yr per μCi / sec)

Where:

- U_{ap} = the receptor's milk consumption rate for age (a), in liters/yr (Table B-6.3).
- t_f = the transport time from pasture to cow, to milk, to receptor in sec (Table B-6.3).
- F_m = the stable element transfer coefficients, in days/liter (from Regulatory Guide 1.109, Table E-1).

All other parameters were defined previously.

TABLE B-6.2 (Continued)

DERIVATION OF GASEOUS DOSE FACTORS (R_i)

Example Calculation:

For the Co-60 child whole body dose factor from exposure due to ingestion of cow's milk:

$$t_f = 1.73E5 \text{ sec}$$

$$U_{ap} = 330 \text{ l/yr}$$

$$F_m = 1.0E-3 \text{ days/l}$$

These values yield a R_i factor of $8.52E7 \text{ m}^2\text{-mrem/yr per } \mu\text{Ci/sec}$ as listed in Table B-5 of this appendix.

B. Tritium

The concentration of tritium in cow's milk is based on the airborne concentration rather than the deposition. R_i is calculated as follows:

$$R_i = K' K''' F_m Q_F U_{ap} (DFL_i)_a [0.75 (0.5/H)]$$

$$(\text{mrem / year per } \mu\text{Ci / m}^3)$$

Example Calculation:

All parameters have been defined in the previous sections for the H-3 child whole body dose factor from exposure due to ingestion of cow's milk. Substituting values into the preceding equation, results in a R_i factor of $1.57E3 \text{ mrem/yr per } \mu\text{Ci/m}^3$ as listed in Table B-5 of this appendix.

VI. GOAT'S MILK

A. Radioiodines and Eight Day Particulates

For the goat's milk pathway, R_i is calculated as follows:

$$R_i = K' \frac{Q_F (U_{ap})}{(\lambda_i + \lambda_w)} F_m (r) (DFL_i)_a \left[\frac{f_p f_s}{Y_p} + \frac{(1 - f_p f_s) e^{-\lambda_i t_h}}{Y_s} \right] e^{-\lambda_i t_f}$$

$$(\text{m}^2\text{-mrem / yr per } \mu\text{Ci / sec})$$

TABLE B-6.2 (Continued)

DERIVATION OF GASEOUS DOSE FACTORS (R_i)

Where:

- t_f = the transport time from pasture to goat, to milk, to receptor in sec (Table B-6.3).
- F_m = the stable element transfer coefficients. For the radionuclide in question, use Table E-2 of Regulatory Guide 1.109. If the radionuclide is not listed in Table E-2, use Table E-1 (i.e., the same value used for the cow's milk pathway).

All other parameters were defined previously.

Example Calculation:

For the Co-60 child whole body dose factor from exposure due to ingestion of goat's milk:

- Q_F = 6 kg/day (wet weight)
- F_m = 1.0E-3 days/l
- t_f = 1.73E5 sec

These values yield a R_i factor of 1.02E7 m²-mrem/yr per μCi/sec as listed in Table B-5 of this appendix.

B. Tritium

The concentration of tritium in goat's milk is based on the airborne concentration rather than the deposition. R_i is calculated as follows:

$$R_i = K' K''' F_m Q_F U_{ap} (DFL_i)_a [0.75 (0.5 / H)]$$

(mrem / yr per μCi / m³)

Example Calculation:

All parameters have been defined in the previous sections for the H-3 child whole body dose factor from exposure due to ingestion of goat's milk. Substituting values into the preceding equation, result in a R_i factor of 3.20E3 mrem/yr per μCi/m³ as listed in Table B-5 of this appendix.

TABLE B-6.3

PARAMETER FOR THE GASEOUS EFFLUENT PATHWAY

PARAMETERS	VALUE	REFERENCE	TABLE
U _{ap} (liters/yr)-cow's milk/			
-infant	330	R.G.1.109	E-5
-child	330	R.G.1.109	E-5
-teen	400	R.G.1.109	E-5
-adult	310	R.G.1.109	E-5
U _{ap} (liters/yr)-goat's milk/			
-infant	330	R.G.1.109	E-5
-child	330	R.G.1.109	E-5
-teen	400	R.G.1.109	E-5
-adult	310	R.G.1.109	E-5
U _a ^L (kg/yr)-vegetation/			
-infant	0	R.G.1.109	E-5
-child	26	R.G.1.109	E-5
-teen	42	R.G.1.109	E-5
-adult	64	R.G.1.109	E-5
U _a ^S (kg/yr)-vegetation/			
-infant	0	R.G.1.109	E-5
-child	520	R.G.1.109	E-5
-teen	630	R.G.1.109	E-5
-adult	520	R.G.1.109	E-5
U _{ap} (kg/yr)-meat/			
-infant	0	R.G.1.109	E-5
-child	41	R.G.1.109	E-5
-teen	65	R.G.1.109	E-5
-adult	110	R.G.1.109	E-5
(BR) _a (m ³ /yr)-inhalation/			
-infant	1400	R.G.1.109	E-5
-child	3700	R.G.1.109	E-5
-teen	8000	R.G.1.109	E-5
-adult	8000	R.G.1.109	E-5

TABLE B-6.3 (Continued)

PARAMETER FOR THE GASEOUS EFFLUENT PATHWAY

PARAMETERS	VALUE	REFERENCE	TABLE
r (dimensionless)	1.0 for Radioiodine	R.G. 1.109	E-15
	0.2 for Particulates	R.G. 1.109	E-15
fl (dimensionless)	1.0	R.G. 1.109	E-15
fg (dimensionless)	0.76	R.G. 1.109	E-15
tL (sec)-vegetation	8.6E4	R.G. 1.109	E-15
th (sec)-vegetation	5.18E6	R.G. 1.109	E-15
(DFAi)a (mrem/pCi)- inhalation	Each Radionuclide	R.G. 1.109	E-7 to E-10
DFGi (mrem/hr per pCi/m ²) ground plane	Each Radionuclide	R.G. 1.109	E-6
SF (dimensionless)	0.7	R.G. 1.109	E-15
t (sec)-ground plane	4.73E8	R.G. 1.109	E-15
QF (kg/day)-cow milk	50	R.G. 1.109	E-3
QF (kg/day)-goat milk	6	R.G. 1.109	E-3
Yp (kg/m ²)	0.7	R.G. 1.109	E-15
Ys (kg/m ²)	2.0	R.G. 1.109	E-15
(DFLi)a (mrem/pCi)- meat/milk/vegetation	Each Radionuclide	R.G. 1.109	E-11 to E-14
λw (sec ⁻¹)	5.73E-7	R.G. 1.109	E-15
tf (sec)-cow milk/ goat milk	1.73E5	R.G. 1.109	E-15
th (sec)-cow milk/ goat milk	7.78E6	R.G. 1.109	E-15
Yv (kg/m ²)	2.0	R.G. 1.109	E-15

TABLE B-6.3 (Continued)

PARAMETER FOR THE GASEOUS EFFLUENT PATHWAY

PARAMETERS	VALUE	REFERENCE	TABLE
fp (dimensionless)	0.5	site specific	
fs (dimensionless)	1.0	NUREG-0133	page 33
Fm (days/liter)	Each Radionuclide	R. G. 1.109	E-1
Ff (days/kg)	Each Stable Element	R.G. 1.109	E-1
tf (sec)-meat	1.73E6	R.G. 1.109	E-15
th (sec)-meat	7.78E6	R.G. 1.109	E-15
H (gm/m3)	8.0	NUREG-0133	page 34

TABLE B-6.4

JUSTIFICATION FOR GASEOUS PATHWAYS USED TO ASSESS
DOSE AT THE J. A. FITZPATRICK NUCLEAR POWER PLANT

PATHWAY	JUSTIFICATION FOR USAGE
1. NOBLE GAS EXPOSURE (GAMMA)	
a. Whole body	This pathway is used in the ODCM to calculate dose rates only. This pathway is required by Part 1 (REC) and NUREG-0133.
b. Gamma Air	This pathway is used in the ODCM. This pathway is required by Part 1 (REC) and NUREG-0133.
2. NOBLE GAS EXPOSURE (BETA)	
a. Skin	This pathway is used in the ODCM to calculate dose rates only. This pathway is required by Part 1 (REC) and NUREG-0133.
b. Beta Air	This pathway is used in the ODCM. This pathway is required by Part 1 (REC) and NUREG-0133.
3. GROUND PLANE DEPOSITION	This pathway is used in the ODCM to calculate dose only. It is not used to calculate dose rates. This pathway is required for use in dose calculation by Part 1 (REC). Part 1 (REC) does not require it to be used for dose rate calculations.
4. INHALATION	This pathway is used in the ODCM to calculate dose and dose rates. This pathway is required for use in dose and dose rate calculations by the Part 1 (REC) and NUREG-0133.
5. VEGETATION	This pathway is used in the ODCM to calculate dose only. It is not used to calculate dose rates. This pathway is required for use in dose calculations by NUREG-0133. Part 1 (REC) and NUREG-0133 do not require it to be used for dose rate calculations. The calculation of dose factors for stored fruit and vegetables and fresh is combined in one equation in both the ODCM and NUREG-0133.

TABLE B-6.4 (Continued)

JUSTIFICATION FOR GASEOUS PATHWAYS USED TO ASSESS
DOSE AT THE J. A. FITZPATRICK NUCLEAR POWER PLANT

<u>PATHWAY</u>	<u>JUSTIFICATION FOR USAGE</u>
6. MEAT	This pathway is used in the ODCM to calculate dose only. It is not used to calculate dose rates. This pathway is required for use in dose calculations by NUREG-0133. Part 1 (REC) does not require it to be used for dose rate calculations. The calculation of dose factors for Meat Contaminated Feed and Meat Contaminated Forage is combined in one equation in both the ODCM and NUREG-0133.
7. COW'S MILK	This pathway is used in the ODCM to calculate dose only. It is not used to calculate dose rates. This pathway is required for use in dose calculations by NUREG-0133. Part 1 (REC) does not require it to be used for dose rate calculations. The calculation of dose factors for Milk Contaminated Feed and Milk Contaminated Forage is combined in one equation in both the ODCM and NUREG-0133.
8. GOAT'S MILK	This pathway is used in the ODCM to calculate dose only. It is not used to calculate dose rates. This pathway is required for use in dose calculations by NUREG-0133. Part 1 (REC) and NUREG-0133 do not require it to be used for dose rate calculations. The calculation of dose factors for Milk Contaminated Feed and Milk Contaminated Forage is combined in one equation in both the ODCM and NUREG-0133.

**TABLE B-6.5
ORGAN DOSES FOR GASEOUS RELEASES (INHALATION PATHWAYS)***

ADULT							
YEAR	BONE (mrem)	LIVER (mrem)	THYROID (mrem)	KIDNEY (mrem)	LUNG (mrem)	GI-LLI (mrem)	T. BODY (mrem)
1997	1.89E-07	7.25E-04	7.34E-04	7.25E-04	7.27E-04	7.25E-04	7.25E-04
1996	5.06E-07	1.88E-04	2.84E-04	1.89E-04	1.91E-04	1.88E-04	1.88E-04
1995	7.91E-07	5.34E-05	1.51E-04	5.37E-05	5.65E-05	5.34E-05	5.28E-05
1994	7.63E-07	6.17E-05	2.53E-04	6.23E-05	7.46E-05	6.19E-05	6.10E-05
1993	1.05E-06	6.07E-05	1.32E-04	6.07E-05	8.13E-05	6.11E-05	6.00E-05
TEEN							
YEAR	BONE (mrem)	LIVER (mrem)	THYROID (mrem)	KIDNEY (mrem)	LUNG (mrem)	GI-LLI (mrem)	T. BODY (mrem)
1997	2.68E-07	7.31E-04	7.42E-04	7.31E-04	7.34E-04	7.31E-04	7.31E-04
1996	7.11E-07	1.91E-04	3.15E-04	1.91E-04	1.95E-04	1.90E-04	1.90E-04
1995	7.04E-07	5.40E-05	1.84E-04	5.46E-05	5.91E-05	5.40E-05	5.33E-05
1994	1.07E-06	6.26E-05	3.09E-04	6.35E-05	8.17E-05	6.24E-05	6.16E-05
1993	6.56E-07	6.16E-05	1.55E-04	6.16E-05	9.21E-05	6.15E-05	6.06E-05
CHILD							
YEAR	BONE (mrem)	LIVER (mrem)	THYROID (mrem)	KIDNEY (mrem)	LUNG (mrem)	GI-LLI (mrem)	T. BODY (mrem)
1997	3.67E-07	6.44E-04	6.59E-04	6.44E-04	6.47E-04	6.44E-04	6.44E-04
1996	9.69E-07	1.68E-04	3.20E-04	1.68E-04	1.71E-04	1.67E-04	1.67E-04
1995	1.53E-06	4.78E-05	2.08E-04	4.82E-05	5.19E-05	4.72E-05	4.71E-05
1994	1.44E-06	5.53E-05	3.52E-04	5.61E-05	7.07E-05	5.44E-05	5.45E-05
1993	1.96E-06	5.44E-05	1.72E-04	5.43E-05	7.92E-05	5.36E-05	5.36E-05
INFANT							
YEAR	BONE (mrem)	LIVER (mrem)	THYROID (mrem)	KIDNEY (mrem)	LUNG (mrem)	GI-LLI (mrem)	T. BODY (mrem)
1997	2.50E-07	3.72E-04	3.85E-04	3.72E-04	3.74E-04	3.72E-04	3.72E-04
1996	7.13E-07	9.71E-05	2.37E-04	9.72E-05	9.96E-05	9.66E-05	9.68E-05
1995	9.91E-07	2.79E-05	1.74E-04	2.79E-05	3.09E-05	2.72E-05	2.72E-05
1994	1.09E-06	3.25E-05	3.04E-04	3.26E-05	4.22E-05	3.13E-05	3.15E-05
1993	1.12E-06	3.16E-05	1.39E-04	3.14E-05	4.80E-05	3.10E-05	3.09E-05

* The critical organ is the thyroid for the years 1993 to 1997.
The critical age group is the teen for 1997 and the child for 1993 to 1996

TABLE B-7
QUANTIFICATION AND REPORTING OF C-14 IN JAF RELEASES

QUANTIFICATION AND REPORTING OF C-14 IN JAF RELEASES

In 2009, the NRC informed the nuclear power industry that it would require the industry to report releases of radioactive Carbon-14 in gaseous effluents beginning with the Annual Radioactive Effluent Release Report for calendar year 2010. In order to support this industry-wide effort, EPRI began to establish a standard methodology for estimating Carbon-14 (^{14}C) production in power plants, in addition to equations to estimate gaseous releases and chemical forms. EPRI published these standard methodologies in EPRI Technical Report 1021106, "Estimation of Carbon-14 in Nuclear Power Plant Gaseous Effluents". This report was used as the basis for estimating C-14 production rates and release activity for the James A. FitzPatrick NPP for 2010.

Carbon-14 Production Rate

The ^{14}C production rate from the $^{17}\text{O}(n,\alpha)^{14}\text{C}$ reaction is calculated using the equation in Section 3.2.2.1 from EPRI Report 1021106, modified for the two energy group flux distribution as follows:

$$\text{Production Rate } (\mu\text{Ci/sec} - \text{kg}) = \frac{N * [\sigma_{th} * \phi_{th} + \sigma_{if} * \phi_{if}] * 1\text{E-24} * \lambda}{3.7\text{E4}}$$

where:

- N = 1.27E22 atoms $^{17}\text{O}/\text{kg H}_2\text{O}$
- σ_{th} = "effective" thermal cross-section, b
- ϕ_{th} = thermal neutron flux, n/cm²-sec
- σ_{if} = "effective" intermediate+fast cross-section, b
- ϕ_{if} = intermediate+fast neutron flux, n/cm²-sec
- 1.0E-24 = conversion factor, 1.0E-24 cm²/b
- λ = ^{14}C decay constant, 3.833E-12/sec
- 3.7E4 = conversion factor, 3.7E4 d/sec- μCi

Combining common constants in the equation, the formula is simplified as follows:

$$(1.27\text{E}+22 * 1\text{E-24} * 3.833\text{E-12}) \div 3.7\text{E4} = 1.316\text{E-18}$$

$$\text{Production Rate } (\mu\text{Ci/sec} - \text{kg}) = 1.316\text{E-}18 * [\sigma_{\text{th}} * \phi_{\text{th}} + \sigma_{\text{if}} * \phi_{\text{if}}]$$

In accordance with EPRI Report 1021106, the production of ^{14}C from the $^{14}\text{N}(n,p)^{14}\text{C}$ contributes less than 0.1% to the total production, and is considered to be insignificant and negligible.

Neutron flux data for the James A. FitzPatrick (JAF) Station's reactor were derived in calculation NEAD-NS-11/006 performed by Entergy Echelon Nuclear Engineering. Flux data for the beginning-of-cycle, mid-cycle, and end-of-cycle periods in the moderator and bypass regions are presented in Table 2-1 of the Calculation Package. The JAF-specific neutron flux data in units of $\text{n/cm}^2\text{-sec}$ are as follows:

Period of Cycle	Moderator Region		Bypass Region	
	Thermal	Intermed+Fast	Thermal	Intermed+Fast
BOC	2.964E+13	1.962E+14	5.825E+13	1.810E+14
MOC	3.125E+13	2.028E+14	6.142E+13	1.871E+14
EOC	3.423E+13	2.062E+14	6.728E+13	1.901E+14

Effective neutron cross-section data for the $^{17}\text{O}(n,\alpha)^{14}\text{C}$ reaction in the two energy groups and regions of the reactor in a BWR are provided in Table 3-5 in EPRI Report 1021106. Data for the two neutron energy groups used in the JAF model are as follows:

Neutron Group	Effective Cross-Section - barns	
	Moderator	Bypass
Thermal	1.325E-01	1.386E-01
Intermediate+Fast	4.58E-02	4.32E-02

Combining the JAF-specific data in accordance with Section 3.3.2.1 of EPRI Report 1021106 yields the following ^{14}C production rates in units of $\mu\text{Ci/sec-kg}$:

$$\text{BOC, Thermal, Moderator: } 1.316\text{E-}18 * 2.964\text{E+}13 * 0.1325 = 5.168\text{E-}6$$

$$\text{BOC, I+F, Moderator: } 1.316\text{E-}18 * 1.962\text{E+}14 * 0.0458 = 1.183\text{E-}5$$

$$\text{BOC Moderator Subtotal: } (5.168\text{E-}6 + 1.183\text{E-}5) = 1.699\text{E-}5 \mu\text{Ci/sec-kg}$$

$$\text{MOC, Thermal, Moderator: } 1.316\text{E-}18 * 3.125\text{E+}13 * 0.1325 = 5.449\text{E-}6$$

$$\text{MOC, I+F, Moderator: } 1.316\text{E-}18 * 2.028\text{E+}14 * 0.0458 = 1.222\text{E-}5$$

$$\text{MOC Moderator Subtotal: } (5.449\text{E-}6 + 1.222\text{E-}5) = 1.767\text{E-}5 \mu\text{Ci/sec-kg}$$

$$\text{EOC, Thermal, Moderator: } 1.316\text{E-}18 * 3.423\text{E+}13 * 0.1325 = 5.969\text{E-}6$$

$$\text{EOC, I+F, Moderator: } 1.316\text{E-}18 * 2.062\text{E+}14 * 0.0458 = 1.243\text{E-}5$$

EOC Moderator Subtotal: $(5.969E-6 + 1.243E-5) = 1.840E-5$ uCi/sec-kg
Moderator Average: $(1.699E-5 + 1.767E-5 + 1.840E-5) \div 3 = 1.769E-5$ uCi/sec-kg
BOC,Thermal, Bypass: $1.316E-18 * 5.825E+13 * 0.1386 = 1.062E-5$
BOC, I+F, Bypass: $1.316E-18 * 1.810E+14 * 0.0432 = 1.029E-05$
BOC Bypass Subtotal: $(1.062E-5 + 1.029E-05) = 2.091E-5$ uCi/sec-kg
MOC,Thermal, Bypass: $1.316E-18 * 6.142E+13 * 0.1386 = 1.120E-5$
MOC, I+F, Bypass: $1.316E-18 * 1.871E+14 * 0.0432 = 1.064E-5$
MOC Bypass Subtotal: $(1.120E-5 + 1.064E-5) = 2.184E-5$ uCi/sec-kg
EOC,Thermal, Bypass: $1.316E-18 * 6.728E+13 * 0.1386 = 1.227E-5$
EOC, I+F, Bypass: $1.316E-18 * 1.901E+14 * 0.0432 = 1.081E-5$
EOC Bypass Subtotal: $(1.227E-5 + 1.081E-05) = 2.308E-5$ uCi/sec-kg
Bypass Average: $(2.091E-5 + 2.184E-5 + 2.308E-5) \div 3 = 2.194E-5$ uCi/sec-kg

The final set of parameters required to calculate the carbon-14 production is the mass of coolant in each region of the reactor. These data are provided in Table 2-2 of calculation NEAD-NS-11/006 and are as follows:

Moderator Region: 11005.9 kg

Bypass Region: 6931.6 kg

Multiplying the JAF-specific ¹⁴C production rates by the coolant masses in accordance with Sections 3.3.3 and 3.3.4 from EPRI Report 1021106 yields the following:

Moderator: $1.769E-5$ uCi/sec-kg * 11005.9 kg = $1.947E-1$ uCi/sec

Bypass: $2.194E-5$ uCi/sec-kg * 6931.6 kg = $1.521E-1$ uCi/sec

Combined: $(1.947E-1 + 1.521E-1) = 3.468E-1$ uCi/sec

JAF- Curies of C-14 Released per Effective Full-Power Year:

Curies Produced per Full-Power Year (FPY):

$$3.468\text{E-}1 \text{ uCi/sec} * 3600 \text{ sec/hr} * 24 \text{ hr/d} * 365.25 \text{ d/yr} * 1\text{E-}6 \text{ Ci/uCi} = 10.9 \text{ Ci/FPY}$$

Applying a correction factor for effective full power days (EFPD, Obtained from Corporate Reactor Engineering) provides actual curies for each year. For example, JAF's EFPD for 2010 was 316, the factor would be 316/365 or 0.87.

Information presented in EPRI Report 1021106 indicates that approximately 95% to 99% of all Carbon-14 produced in a BWR reactor vessel is released as a gaseous effluent. For conservative purposes, 99% of all C-14 produced in the reactor is assumed to be released as gaseous effluents.

For 2010, this would result in a release rate of:

$$10.9 \text{ Ci/FPY} * 0.87 * 0.99 \text{ release fraction} = 9.4 \text{ Ci of C-14/EFPY}$$

Carbon-14 Dose Pathways Resulting from Gaseous Effluents

The following assumptions and equations can be used for estimating C-14 doses from gaseous effluents. Examples are presented for calculating doses to the child from the inhalation and vegetation (ingestion) pathways. Regulatory Guide 1.109 methodology is used.

1. Assumptions

- a. Q_{C14} = gaseous effluent C-14 release rate, Ci/yr.
($10.9 \text{ Ci/FPY} * \text{EFPD}_{\text{Fraction}} * 0.99 \text{ release fraction}$)
- b. Q = C-14 gaseous release rate that is carbon dioxide, Ci/yr.
($10.9 \text{ Ci/FPY} * \text{EFPD}_{\text{Fraction}} * 0.99 \text{ release fraction} * 0.95 \{95\% \text{ as } \text{CO}_2\}$)
- c. p = ratio of C-14 releases to total release time = 1 (very conservative)
- d. X/Q @ Primary Receptor
- e. Fraction of total plant mass that is natural carbon = 0.11 (RG 1.109, C-8)
- f. Concentration (g/m^3) of natural carbon = 0.16 (RG 1.109, C-8)
- g. Child dose at the Primary Receptor is most limiting
- h. Dose Factors used from Reg Guide 1.109

Note: Values for c, e, and f are conservative and offered by RG 1.109. Better (site specific) data is being evaluated at JAF and throughout the industry for application in the future.

2. Vegetative Pathway Calculation from Reg Guide (see RG 1.109, equation C-8)

$$C_{14}^V \text{ pCi/kg} = 3.17E7 \{(\text{pCi-g-yr})/(\text{Ci-kg-sec})\} * p * Q * X/Q * (0.11/0.16)$$

3. Child Ingestion (uses 95% of total C-14 released, or just the CO₂ portion)

$$\text{Dose}_{C-14} = DF * [u^v f_g + u^l] * C_{14}^V \text{ pCi/kg}$$

$$\text{Where: } DF = 1.21E-5 \text{ mrem/pCi Bone Child [RG 1.109, E-13]}$$

$$2.42E-6 \text{ mrem/pCi TB Child [RG 1.109, E-13]}$$

$$u^v = 520 \text{ kg/yr \{child; } u^l = 26 \text{ kg/yr [usage factors, RG 1.109, E-5]\}}$$

$$f_g = 0.76 \text{ [fraction of produce ingested in garden of interest, E-15]}$$

4. Child Inhalation (uses all released C-14, not just CO₂)

$$\text{Dose}_{C-14} = BR * C_{14}^a \text{ pCi/m}^3 * DFI$$

$$\text{Where: } C_{14}^a \text{ pCi/m}^3 = 3.17E+4 (\text{pCi-yr})/(\text{Ci-sec}) * (Q_{C14}) * (X/Q)$$

$$BR_{\text{child}} = 3700 \text{ m}^3/\text{yr};$$

$$DFI = 9.70E-6 \text{ mrem/pCi}_{\text{Child Bone}}$$

$$DFI = 1.82E-6 \text{ mrem/pCi}_{\text{Child TB}}$$

APPENDIX C
METEOROLOGICAL INDEX

APPENDIX C

METEOROLOGICAL INDEX

The atmospheric dispersion and deposition tables presented in this Appendix were prepared using 8 years' worth of hourly meteorological data (at 10 m and 61 m above grade) collected on site by Niagara Mohawk during the period 1985 through 1992. The tables include the following:

- (a) Long-term annual average concentration (X/Q)s, finite-cloud gamma (X/Q)s, and (D/Q)s for the main stack, the four building vents, and unmonitored ground-level releases (site boundary and offsite receptors) [Tables C-1 through C-8, C-18, and C-20],
- (b) Long-term grazing season concentration (X/Q)s and (D/Q)s for the main stack, the four building vents, and unmonitored ground-level releases (offsite receptors excluding the site boundary) [Tables C-9 through C-13, C-22 and C-24],
- (c) Short-term 85th percentile hourly plume centerline concentration (X/Q)s and (D/Q)s for unmonitored ground-level releases, based on year-round meteorological data (site boundary and offsite receptors) [Tables C-15, C-16, C-17 and C-19],
- (d) Short-term 85th percentile hourly plume centerline concentration (X/Q)s and (D/Q)s for unmonitored ground-level releases, based on meteorological data for the grazing season (offsite receptors excluding the site boundary) [Tables C-21 and C-23],
- (e) Critical receptor long-term dispersion and deposition parameters for vent and elevated releases, year-round and grazing season averages [Table C-14].

The receptors of interest include the site boundary (SB) and various offsite locations in each sector at distances out to 45 miles. Note the following:

- (1) The long-term annual average concentration (X/Q)s and finite-cloud gamma (X/Q)s which were based on the sector-average model, are for use in assessing the air doses (gamma and beta), total body and skin dose, and doses due to inhalation from the various release points. The long-term annual average (D/Q)s are for assessing the radiation exposures due to ground plane deposition of radioactivity.
- (2) The long-term grazing season concentration (X/Q)s and (D/Q)s are for use in assessing the radiation exposures for the ingestion pathway. Based on census data, the grazing season was taken to be six months (May through October).

- (3) The 85th percentile hourly concentration (X/Q)s and (D/Q)s were based on the plume-centerline model and are for use in conjunction with short-term releases, as described in Section 4.4.3 of the ODCM. The selected percentile (85%) is applicable for the assessment of intermittent releases; it implies that the probability of exceeding the calculated hourly dispersion and deposition values is only 15%.
- (4) The dispersion and deposition parameters for the stack were based on the "elevated plume" model (with plume rise effects, and terrain features, but without building wake effects), and the meteorological data collected on the 61-m elevation of the meteorological tower. The dispersion and deposition parameters for the building vents (reactor building, refuel floor, turbine building, and radwaste building) were based on the "mixed-mode" release (with plume rise and building wake effects), and the data collected on the 10-m elevation of the tower. Unmonitored ground-level releases made use for the "ground release" model (with building wake effects, but without plume rise) and the meteorological data collected on the 10-m elevation of the tower.
- (5) For vent releases and unmonitored ground-level releases, the equations for gamma air dose, total body dose, and the gamma portion of skin dose make use of the concentration (X/Q) (i.e., the semi-infinite cloud model). For stack releases, on the other hand, the equations for the said exposures make use of the finite-cloud gamma (X/Q). By definition, the gamma (X/Q) is the equivalent relative concentration of radioactivity in a semi-infinite cloud that would yield the same radiation exposure as a finite cloud aloft; it accounts for the actual plume dimensions, elevation above the receptor, and gamma radiation spectra.

Complete details on the definition of the dispersion and deposition values presented in this appendix may be found in Reference 6.10.

APPENDIX C

METEOROLOGICAL DATA

<u>TABLE</u>	<u>TITLE</u>	<u>PAGE</u>
C-1	Concentration X/Q Values for Site Boundary Determined From Annual Average Meteorological Data	C-7
C-2	Finite Cloud Gamma X/Q Values for Site Boundary Determined From Annual Average Meteorological Data	C-8
C-3	Deposition D/Q Values for Site Boundary Determined From Annual Average Meteorological Data	C-9
C-4	Sector Average Dispersion And Deposition Values For Reactor Vent Determined From Annual Average Meteorological Data	C-10
C-5	Sector Average Dispersion And Deposition Values For Refuel Floor Vent Determined From Annual Average Meteorological Data	C-12
C-6	Sector Average Dispersion And Deposition Values For Turbine Vent Determined From Annual Average Meteorological Data	C-14
C-7	Sector Average Dispersion And Deposition Values For Radwaste Vent Determined From Annual Average Meteorological Data	C-16
C-8	Sector Average Dispersion And Deposition Values For The Stack Determined From Annual Average Meteorological Data	C-18
C-9	Sector Average Dispersion And Deposition Values For Reactor Vent Determined From Grazing Meteorological Data	C-21
C-10	Sector Average Dispersion And Deposition Values For Refuel Floor Vent Determined From Grazing Meteorological Data	C-23
C-11	Sector Average Dispersion And Deposition Values For Turbine Vent Determined From Grazing Meteorological Data	C-25
C-12	Sector Average Dispersion And Deposition Values For Radwaste Vent Determined From Grazing Meteorological Data	C-27
C-13	Sector Average Dispersion And Deposition Values For The Stack Determined From Grazing Meteorological Data	C-29

APPENDIX C

METEOROLOGICAL DATA (CONTINUED)

<u>TABLE</u>	<u>TITLE</u>	<u>PAGE</u>
C-14	Critical Receptor Dispersion And Deposition Parameters For Vent And Elevated Releases	C-32
C-15	85th Percentile Hourly Plume Centerline Dispersion Values and Annual Sector Average Dispersion Values For Unmonitored Ground Level Releases Determined From Annual Average Meteorological Data (1985-1992) (For Use With Short Term Releases)	C-33
C-16	85th Percentile Hourly Plume Centerline Deposition Values and Annual Sector Average Deposition Values For Unmonitored Ground Level Releases Determined From Annual Average Meteorological Data (1985-1992) (For Use With Short Term Releases)	C-34
C-17	85th Percentile Hourly Plume Centerline Dispersion Values For Unmonitored Ground Level Releases Determined From Annual Average Meteorological Data (1985-1992) (For Use With Short Term Releases)	C-35
C-18	Sector Average Dispersion Values For Unmonitored Ground Level Releases Determined From Annual Average Meteorological Data (1985-1992) (For Use With Long Term Releases)	C-36
C-19	85th Percentile Hourly Plume Centerline Deposition Values For Unmonitored Ground Level Releases Determined From Annual Average Meteorological Data (1985-1992) (For Use With Short Term Releases)	C-37
C-20	Sector Average Deposition Values For Unmonitored Ground Level Releases Determined From Annual Average Meteorological Data (1985-1992) (For Use With Long Term Releases)	C-38
C-21	85th Percentile Hourly Plume Centerline Dispersion Values For Unmonitored Ground Level Releases Determined From Grazing Meteorological Data (1985-1992) (For Use With Short Term Releases)	C-39

APPENDIX C

METEOROLOGICAL DATA (CONTINUED)

<u>TABLE</u>	<u>TITLE</u>	<u>PAGE</u>
C-22	Sector Average Dispersion Values For Unmonitored Ground Level Releases Determined From Grazing Meteorological Data (1985-1992) (For Use With Long Term Releases)	C-40
C-23	85th Percentile Hourly Plume Centerline Deposition Values For Unmonitored Ground Level Releases Determined From Grazing Meteorological Data (1985-1992) (For Use With Short Term Releases)	C-41
C-24	Sector Average Deposition Values For Unmonitored Ground Level Releases Determined From Grazing Meteorological Data (1985-1992) (For Use With Long Term Releases)	C-42

TABLE C-1

**CONCENTRATION X/Q VALUES FOR SITE BOUNDARY DETERMINED
FROM ANNUAL AVERAGE METEROLOGICAL DATA (1985 To 1992)**

Sector Average Concentration X/Q

(sec/m³)

Direction	Distance (m)	Stack	Turbine Building Vent	Refuel Floor Vent	Radwaste Building Vent	Reactor Building Vent	Unmonitored Ground Level Release	
N	w	225	1.05E-10	3.81E-06	4.65E-06	5.75E-06	4.65E-06	3.50E-05
NNE	w	225	3.58E-11	1.68E-06	2.05E-06	2.60E-06	2.05E-06	1.78E-05
NE	w	354	7.52E-10	6.53E-07	8.02E-07	1.12E-06	8.02E-07	5.34E-06
ENE	w	563	1.51E-08	7.82E-07	9.21E-07	1.35E-06	9.21E-07	3.43E-06
E	l	950	1.64E-08	3.19E-07	3.58E-07	5.39E-07	3.58E-07	1.05E-06
ESE	l	1030	1.78E-08	1.78E-07	1.97E-07	3.02E-07	1.97E-07	5.86E-07
SE	l	1110	1.94E-08	1.22E-07	1.33E-07	2.28E-07	1.33E-07	4.17E-07
SSE	l	1754	1.57E-08	4.74E-08	4.94E-08	9.17E-08	4.94E-08	1.73E-07
S	l	2205	1.79E-08	4.71E-08	4.80E-08	8.30E-08	4.80E-08	1.36E-07
SSW	l	2269	2.19E-08	6.11E-08	6.25E-08	1.14E-07	6.25E-08	2.00E-07
SW	l	2382	1.64E-08	7.97E-08	8.17E-08	1.60E-07	8.17E-08	3.14E-07
WSW	w	1867	3.55E-09	4.08E-08	4.52E-08	1.23E-07	4.52E-08	4.14E-07
W	w	644	1.33E-09	9.17E-08	1.43E-07	2.48E-07	1.43E-07	2.68E-06
WNW	w	370	1.87E-09	6.82E-07	9.99E-07	1.37E-06	9.99E-07	1.39E-05
NW	w	306	2.50E-09	1.77E-06	2.37E-06	3.09E-06	2.37E-06	2.60E-05
NNW	w	241	3.96E-10	2.98E-06	3.85E-06	4.81E-06	3.85E-06	3.68E-05

l = land

w = water

TABLE C-2

FINITE CLOUD GAMMA X/Q VALUES FOR SITE BOUNDARY DETERMINED
FROM ANNUAL AVERAGE METEROLOGICAL DATA (1985 To 1992)

Finite Cloud Gamma X/Q

(sec/m³)

<u>Direction</u>		<u>Distance</u> (m)	<u>Stack</u>
N	w	225	1.32E-07
NNE	w	225	1.06E-07
NE	w	354	1.12E-07
ENE	w	563	1.82E-07
E	1	950	1.16E-07
ESE	1	1030	7.71E-08
SE	1	1110	6.23E-08
SSE	1	1754	3.34E-08
S	1	2205	3.02E-08
SSW	1	2269	3.89E-08
SW	1	2382	3.45E-08
WSW	w	1867	2.20E-08
W	w	644	5.43E-08
WNW	w	370	8.40E-08
NW	w	306	1.38E-07
NNW	w	241	1.38E-07

1 = land

w = water

TABLE C-3

DEPOSITION D/Q VALUES FOR SITE BOUNDARY DETERMINED FROM
ANNUAL AVERAGE METEOROLOGICAL DATA (1985 To 1992)

(D/Q) Sector Average Deposition (1/m²)

SEGMENT BOUNDARIES IN MILES

Direction	Distance (m)	Stack	Turbine Building Vent	Refuel Floor Vent	Radwaste Building Vent	Reactor Building Vent	Unmonitored Ground Level Release	
N	w	225	2.95E-10	2.27E-08	2.65E-08	3.63E-08	2.65E-08	1.33E-07
NNE	w	225	9.26E-11	1.02E-08	1.18E-08	1.65E-08	1.18E-08	7.09E-08
NE	w	354	9.30E-11	6.21E-09	7.30E-09	1.05E-08	7.30E-09	3.00E-08
ENE	w	563	1.65E-09	1.40E-08	1.55E-08	2.00E-08	1.55E-08	3.23E-08
E	l	950	1.73E-09	9.03E-09	9.49E-09	1.11E-08	9.49E-09	1.35E-08
ESE	l	1030	1.70E-09	6.22E-09	6.49E-09	7.43E-09	6.49E-09	8.76E-09
SE	l	1110	1.61E-09	4.37E-09	4.54E-09	5.42E-09	4.54E-09	6.46E-09
SSE	l	1754	7.57E-10	1.16E-09	1.19E-09	1.39E-09	1.19E-09	1.85E-09
S	l	2205	5.52E-10	9.15E-10	9.31E-10	1.06E-09	9.31E-10	1.41E-09
SSW	l	2269	6.50E-10	7.66E-10	7.76E-10	9.33E-10	7.76E-10	1.37E-09
SW	l	2382	3.23E-10	7.01E-10	7.09E-10	9.00E-10	7.09E-10	1.51E-09
WSW	w	1867	9.10E-11	2.97E-10	3.08E-10	4.68E-10	3.08E-10	1.25E-09
W	w	644	7.43E-11	7.58E-10	9.15E-10	1.59E-09	9.15E-10	7.79E-09
WNW	w	370	1.89E-10	4.56E-09	5.56E-09	8.40E-09	5.56E-09	4.10E-08
NW	w	306	4.28E-10	1.22E-08	1.45E-08	2.08E-08	1.45E-08	8.55E-08
NNW	w	241	3.63E-10	1.71E-08	2.03E-08	2.80E-08	2.03E-08	1.14E-07

l = land

w = water

TABLE C-4

SECTOR AVERAGE DISPERSION VALUES FOR REACTOR VENT DETERMINED
FROM ANNUAL AVERAGE METEOROLOGICAL DATA (1985 To 1992)

Sector Average Concentration X/Q (sec/m³)

SEGMENT BOUNDARIES IN MILES

<u>Direction</u>	0.5	0.75	1.0	1.5	2.5	3.5
N	5.667E-07	3.319E-07	2.409E-07	1.596E-07	9.380E-08	6.472E-08
NNE	2.600E-07	1.591E-07	1.198E-07	8.235E-08	4.960E-08	3.446E-08
NE	2.296E-07	1.410E-07	1.048E-07	7.034E-08	4.129E-08	2.830E-08
ENE	5.479E-07	3.185E-07	2.260E-07	1.452E-07	7.962E-08	5.287E-08
E	4.528E-07	2.601E-07	1.808E-07	1.132E-07	5.918E-08	3.843E-08
ESE	2.804E-07	1.631E-07	1.142E-07	6.935E-08	3.941E-08	2.559E-08
SE	1.991E-07	1.204E-07	8.715E-08	5.609E-08	3.276E-08	2.602E-08
SSE	1.071E-07	6.936E-08	5.348E-08	3.911E-08	2.835E-08	2.013E-08
S	1.150E-07	7.388E-08	5.963E-08	4.379E-08	3.218E-08	2.223E-08
SSW	1.388E-07	9.086E-08	7.603E-08	5.888E-08	3.860E-08	2.786E-08
SW	1.688E-07	1.129E-07	1.094E-07	8.073E-08	5.290E-08	3.576E-08
WSW	8.263E-08	5.551E-08	4.795E-08	4.949E-08	3.369E-08	2.430E-08
W	1.040E-07	6.463E-08	5.213E-08	4.115E-08	2.881E-08	2.151E-08
WNW	2.926E-07	1.754E-07	1.326E-07	9.420E-08	5.955E-08	4.260E-08
NW	5.036E-07	3.005E-07	2.226E-07	1.520E-07	9.183E-08	6.416E-08
NNW	5.247E-07	3.041E-07	2.202E-07	1.468E-07	8.737E-08	6.082E-08
	4.5	7.5	15.0	25.0	35.0	45.0
N	4.865E-08	2.687E-08	1.186E-08	6.640E-09	4.458E-09	3.915E-09
NNE	2.595E-08	1.428E-08	6.212E-09	4.945E-09	3.183E-09	2.299E-09
NE	2.110E-08	1.138E-08	5.166E-09	3.338E-09	2.130E-09	1.530E-09
ENE	3.870E-08	2.034E-08	1.024E-08	5.223E-09	3.362E-09	2.430E-09
E	2.779E-08	1.440E-08	7.309E-09	3.751E-09	2.434E-09	1.772E-09
ESE	1.849E-08	1.133E-08	4.571E-09	2.357E-09	1.535E-09	1.121E-09
SE	1.833E-08	9.165E-09	3.693E-09	1.922E-09	1.261E-09	9.270E-10
SSE	1.438E-08	7.159E-09	2.869E-09	1.492E-09	9.784E-10	7.185E-10
S	1.595E-08	7.922E-09	3.182E-09	1.659E-09	1.091E-09	8.025E-10
SSW	2.231E-08	1.089E-08	4.278E-09	2.156E-09	1.385E-09	1.002E-09
SW	2.896E-08	1.667E-08	6.450E-09	3.357E-09	2.135E-09	1.532E-09
WSW	1.856E-08	1.029E-08	4.799E-09	2.500E-09	1.783E-09	1.393E-09
W	1.690E-08	9.922E-09	4.586E-09	2.552E-09	1.729E-09	1.294E-09
WNW	3.276E-08	1.885E-08	8.746E-09	4.942E-09	3.391E-09	2.562E-09
NW	4.862E-08	2.733E-08	1.241E-08	6.932E-09	4.729E-09	3.560E-09
NNW	4.607E-08	2.596E-08	1.186E-08	6.657E-09	4.554E-09	3.433E-09

TABLE C-4 (CONTINUED)

SECTOR AVERAGE DEPOSITION VALUES FOR REACTOR VENT DETERMINED
FROM ANNUAL AVERAGE METEOROLOGICAL DATA (1985 To 1992)

(D/Q) Sector Average Deposition (1/m²)

SEGMENT BOUNDARIES IN MILES

<u>Direction</u>	0.5	0.75	1.0	1.5	2.5	3.5
N	4.951E-09	2.856E-09	1.927E-09	1.065E-09	4.777E-10	2.756E-10
NNE	2.348E-09	1.421E-09	9.951E-10	5.692E-10	2.619E-10	1.528E-10
NE	2.456E-09	1.458E-09	1.004E-09	5.654E-10	2.556E-10	1.477E-10
ENE	9.540E-09	5.276E-09	3.429E-09	1.835E-09	8.030E-10	4.595E-10
E	1.212E-08	6.587E-09	4.219E-09	2.224E-09	9.594E-10	5.450E-10
ESE	9.330E-09	5.097E-09	3.260E-09	1.707E-09	7.428E-10	4.219E-10
SE	7.165E-09	3.997E-09	2.587E-09	1.378E-09	6.078E-10	3.473E-10
SSE	3.529E-09	2.047E-09	1.348E-09	7.357E-10	3.353E-10	1.926E-10
S	3.791E-09	2.219E-09	1.477E-09	8.098E-10	3.723E-10	2.142E-10
SSW	2.906E-09	1.760E-09	1.231E-09	7.082E-10	3.322E-10	1.950E-10
SW	2.421E-09	1.564E-09	1.185E-09	6.960E-10	3.340E-10	1.972E-10
WSW	6.780E-10	4.656E-10	3.626E-10	2.368E-10	1.188E-10	7.206E-11
W	7.119E-10	4.615E-10	3.455E-10	2.100E-10	1.041E-10	6.282E-11
WNW	2.129E-09	1.329E-09	9.567E-10	5.617E-10	2.648E-10	1.561E-10
NW	4.192E-09	2.500E-09	1.735E-09	9.847E-10	4.514E-10	2.629E-10
NNW	4.251E-09	2.462E-09	1.669E-09	9.270E-10	4.186E-10	2.423E-10
	4.5	7.5	15.0	25.0	35.0	45.0
N	1.805E-10	7.499E-11	2.350E-11	1.000E-11	5.731E-12	5.309E-11
NNE	1.006E-10	4.197E-11	1.303E-11	1.958E-11	9.064E-12	5.188E-12
NE	9.681E-11	4.014E-11	1.237E-11	9.909E-12	5.316E-12	3.291E-12
ENE	2.998E-10	1.245E-10	9.570E-11	2.256E-11	1.210E-11	7.496E-12
E	3.539E-10	1.462E-10	6.692E-11	2.192E-11	1.176E-11	7.287E-12
ESE	2.738E-10	1.133E-10	4.636E-11	1.651E-11	8.777E-12	5.439E-12
SE	2.252E-10	9.507E-11	3.796E-11	1.493E-11	7.928E-12	4.765E-12
SSE	1.266E-10	5.635E-11	2.578E-11	1.172E-11	4.605E-12	2.811E-12
S	1.434E-10	6.420E-11	2.776E-11	1.370E-11	5.149E-12	3.137E-12
SSW	1.279E-10	5.527E-11	3.074E-11	1.119E-11	5.882E-12	3.129E-12
SW	1.318E-10	5.575E-11	3.290E-11	1.541E-11	7.800E-12	4.596E-12
WSW	4.828E-11	2.055E-11	6.450E-12	2.997E-12	2.323E-11	2.807E-12
W	4.194E-11	1.780E-11	5.615E-12	2.418E-12	1.384E-12	9.038E-13
WNW	1.032E-10	4.323E-11	1.338E-11	5.670E-12	3.207E-12	2.082E-12
NW	1.730E-10	7.212E-11	2.246E-11	9.534E-12	5.405E-12	3.520E-12
NNW	1.590E-10	6.621E-11	2.081E-11	8.887E-12	5.062E-12	3.309E-12

TABLE C-5

SECTOR AVERAGE DISPERSION VALUES FOR REFUEL FLOOR VENT
DETERMINED FROM ANNUAL AVERAGE METEOROLOGICAL DATA
(1985 To 1992)

Sector Average Concentration X/Q (sec/m³)

SEGMENT BOUNDARIES IN MILES

<u>Direction</u>	0.5	0.75	1.0	1.5	2.5	3.5
N	5.667E-07	3.319E-07	2.409E-07	1.596E-07	9.380E-08	6.472E-08
NNE	2.600E-07	1.591E-07	1.198E-07	8.235E-08	4.960E-08	3.446E-08
NE	2.296E-07	1.410E-07	1.048E-07	7.034E-08	4.129E-08	2.830E-08
ENE	5.479E-07	3.185E-07	2.260E-07	1.452E-07	7.962E-08	5.287E-08
E	4.528E-07	2.601E-07	1.808E-07	1.132E-07	5.918E-08	3.843E-08
ESE	2.804E-07	1.631E-07	1.142E-07	6.935E-08	3.941E-08	2.559E-08
SE	1.991E-07	1.204E-07	8.715E-08	5.609E-08	3.276E-08	2.602E-08
SSE	1.071E-07	6.936E-08	5.348E-08	3.911E-08	2.835E-08	2.013E-08
S	1.150E-07	7.388E-08	5.963E-08	4.379E-08	3.218E-08	2.223E-08
SSW	1.388E-07	9.086E-08	7.603E-08	5.888E-08	3.860E-08	2.786E-08
SW	1.688E-07	1.129E-07	1.094E-07	8.073E-08	5.290E-08	3.576E-08
WSW	8.263E-08	5.551E-08	4.795E-08	4.949E-08	3.369E-08	2.430E-08
W	1.040E-07	6.463E-08	5.213E-08	4.115E-08	2.881E-08	2.151E-08
WNW	2.926E-07	1.754E-07	1.326E-07	9.420E-08	5.955E-08	4.260E-08
NW	5.036E-07	3.005E-07	2.226E-07	1.520E-07	9.183E-08	6.416E-08
NNW	5.247E-07	3.041E-07	2.202E-07	1.468E-07	8.737E-08	6.082E-08
	4.5	7.5	15.0	25.0	35.0	45.0
N	4.865E-08	2.687E-08	1.186E-08	6.640E-09	4.458E-09	3.915E-09
NNE	2.595E-08	1.428E-08	6.212E-09	4.945E-09	3.183E-09	2.299E-09
NE	2.110E-08	1.138E-08	5.166E-09	3.338E-09	2.130E-09	1.530E-09
ENE	3.870E-08	2.034E-08	1.024E-08	5.223E-09	3.362E-09	2.430E-09
E	2.779E-08	1.440E-08	7.309E-09	3.751E-09	2.434E-09	1.772E-09
ESE	1.849E-08	1.133E-08	4.571E-09	2.357E-09	1.535E-09	1.121E-09
SE	1.833E-08	9.165E-09	3.693E-09	1.922E-09	1.261E-09	9.270E-10
SSE	1.438E-08	7.159E-09	2.869E-09	1.492E-09	9.784E-10	7.185E-10
S	1.595E-08	7.922E-09	3.182E-09	1.659E-09	1.091E-09	8.025E-10
SSW	2.231E-08	1.089E-08	4.278E-09	2.156E-09	1.385E-09	1.002E-09
SW	2.896E-08	1.667E-08	6.450E-09	3.357E-09	2.135E-09	1.532E-09
WSW	1.856E-08	1.029E-08	4.799E-09	2.500E-09	1.783E-09	1.393E-09
W	1.690E-08	9.922E-09	4.586E-09	2.552E-09	1.729E-09	1.294E-09
WNW	3.276E-08	1.885E-08	8.746E-09	4.942E-09	3.391E-09	2.562E-09
NW	4.862E-08	2.733E-08	1.241E-08	6.932E-09	4.729E-09	3.560E-09
NNW	4.607E-08	2.596E-08	1.186E-08	6.657E-09	4.554E-09	3.433E-09

TABLE C-5 (CONTINUED)

SECTOR AVERAGE DEPOSITION VALUES FOR REFUEL FLOOR VENT
 DETERMINED FROM ANNUAL AVERAGE METEOROLOGICAL DATA
 (1985 To 1992)

(D/Q) Sector Average Deposition (1/m²)

SEGMENT BOUNDARIES IN MILES

<u>Direction</u>	0.5	0.75	1.0	1.5	2.5	3.5
N	4.951E-09	2.856E-09	1.927E-09	1.065E-09	4.777E-10	2.756E-10
NNE	2.348E-09	1.421E-09	9.951E-10	5.692E-10	2.619E-10	1.528E-10
NE	2.456E-09	1.458E-09	1.004E-09	5.654E-10	2.556E-10	1.477E-10
ENE	9.540E-09	5.276E-09	3.429E-09	1.835E-09	8.030E-10	4.595E-10
E	1.212E-08	6.587E-09	4.219E-09	2.224E-09	9.594E-10	5.450E-10
ESE	9.330E-09	5.097E-09	3.260E-09	1.707E-09	7.428E-10	4.219E-10
SE	7.165E-09	3.997E-09	2.587E-09	1.378E-09	6.078E-10	3.473E-10
SSE	3.529E-09	2.047E-09	1.348E-09	7.357E-10	3.353E-10	1.926E-10
S	3.791E-09	2.219E-09	1.477E-09	8.098E-10	3.723E-10	2.142E-10
SSW	2.906E-09	1.760E-09	1.231E-09	7.082E-10	3.322E-10	1.950E-10
SW	2.421E-09	1.564E-09	1.185E-09	6.960E-10	3.340E-10	1.972E-10
WSW	6.780E-10	4.656E-10	3.626E-10	2.368E-10	1.188E-10	7.206E-11
W	7.119E-10	4.615E-10	3.455E-10	2.100E-10	1.041E-10	6.282E-11
WNW	2.129E-09	1.329E-09	9.567E-10	5.617E-10	2.648E-10	1.561E-10
NW	4.192E-09	2.500E-09	1.735E-09	9.847E-10	4.514E-10	2.629E-10
NNW	4.251E-09	2.462E-09	1.669E-09	9.270E-10	4.186E-10	2.423E-10
	4.5	7.5	15.0	25.0	35.0	45.0
N	1.805E-10	7.499E-11	2.350E-11	1.000E-11	5.731E-12	5.309E-11
NNE	1.006E-10	4.197E-11	1.303E-11	1.958E-11	9.064E-12	5.188E-12
NE	9.681E-11	4.014E-11	1.237E-11	9.909E-12	5.316E-12	3.291E-12
ENE	2.998E-10	1.245E-10	9.570E-11	2.256E-11	1.210E-11	7.496E-12
E	3.539E-10	1.462E-10	6.692E-11	2.192E-11	1.176E-11	7.287E-12
ESE	2.738E-10	1.133E-10	4.636E-11	1.651E-11	8.777E-12	5.439E-12
SE	2.252E-10	9.507E-11	3.796E-11	1.493E-11	7.928E-12	4.765E-12
SSE	1.266E-10	5.635E-11	2.578E-11	1.172E-11	4.605E-12	2.811E-12
S	1.434E-10	6.420E-11	2.776E-11	1.370E-11	5.149E-12	3.137E-12
SSW	1.279E-10	5.527E-11	3.074E-11	1.119E-11	5.882E-12	3.129E-12
SW	1.318E-10	5.575E-11	3.290E-11	1.541E-11	7.800E-12	4.596E-12
WSW	4.828E-11	2.055E-11	6.450E-12	2.997E-12	2.323E-11	2.807E-12
W	4.194E-11	1.780E-11	5.615E-12	2.418E-12	1.384E-12	9.038E-13
WNW	1.032E-10	4.323E-11	1.338E-11	5.670E-12	3.207E-12	2.082E-12
NW	1.730E-10	7.212E-11	2.246E-11	9.534E-12	5.405E-12	3.520E-12
NNW	1.590E-10	6.621E-11	2.081E-11	8.887E-12	5.062E-12	3.309E-12

TABLE C-6

SECTOR AVERAGE DISPERSION VALUES FOR TURBINE VENT DETERMINED
FROM ANNUAL AVERAGE METEOROLOGICAL DATA (1985 To 1992)

Sector Average Concentration X/Q (sec/m³)

SEGMENT BOUNDARIES IN MILES

<u>Direction</u>	0.5	0.75	1.0	1.5	2.5	3.5
N	4.745E-07	2.863E-07	2.135E-07	1.455E-07	8.729E-08	6.072E-08
NNE	2.185E-07	1.391E-07	1.080E-07	7.646E-08	4.692E-08	3.283E-08
NE	1.908E-07	1.216E-07	9.320E-08	6.460E-08	3.878E-08	2.680E-08
ENE	4.685E-07	2.784E-07	2.016E-07	1.333E-07	7.437E-08	4.972E-08
E	4.004E-07	2.349E-07	1.660E-07	1.065E-07	5.619E-08	3.664E-08
ESE	2.495E-07	1.493E-07	1.063E-07	6.567E-08	3.806E-08	2.477E-08
SE	1.786E-07	1.116E-07	8.218E-08	5.383E-08	3.190E-08	2.554E-08
SSE	9.585E-08	6.492E-08	5.110E-08	3.820E-08	2.809E-08	1.988E-08
S	1.034E-07	6.930E-08	5.745E-08	4.300E-08	3.197E-08	2.199E-08
SSW	1.215E-07	8.350E-08	7.256E-08	5.767E-08	3.815E-08	2.758E-08
SW	1.416E-07	1.007E-07	1.047E-07	7.883E-08	5.215E-08	3.523E-08
WSW	5.908E-08	4.428E-08	4.183E-08	4.757E-08	3.288E-08	2.378E-08
W	6.826E-08	4.692E-08	4.159E-08	3.599E-08	2.653E-08	2.013E-08
WNW	2.087E-07	1.345E-07	1.079E-07	8.132E-08	5.342E-08	3.877E-08
NW	3.914E-07	2.458E-07	1.897E-07	1.349E-07	8.370E-08	5.909E-08
NNW	4.173E-07	2.514E-07	1.883E-07	1.300E-07	7.933E-08	5.580E-08
	4.5	7.5	15.0	25.0	35.0	45.0
N	4.584E-08	2.550E-08	1.134E-08	6.384E-09	4.294E-09	3.815E-09
NNE	2.481E-08	1.372E-08	5.996E-09	4.845E-09	3.117E-09	2.252E-09
NE	2.007E-08	1.089E-08	4.994E-09	3.250E-09	2.074E-09	1.489E-09
ENE	3.653E-08	1.930E-08	9.903E-09	5.042E-09	3.245E-09	2.346E-09
E	2.656E-08	1.381E-08	7.100E-09	3.641E-09	2.362E-09	1.720E-09
ESE	1.792E-08	1.108E-08	4.459E-09	2.297E-09	1.496E-09	1.093E-09
SE	1.797E-08	8.964E-09	3.605E-09	1.875E-09	1.230E-09	9.044E-10
SSE	1.416E-08	7.035E-09	2.816E-09	1.463E-09	9.598E-10	7.048E-10
S	1.571E-08	7.792E-09	3.126E-09	1.629E-09	1.071E-09	7.880E-10
SSW	2.205E-08	1.074E-08	4.204E-09	2.118E-09	1.360E-09	9.842E-10
SW	2.862E-08	1.648E-08	6.362E-09	3.300E-09	2.098E-09	1.506E-09
WSW	1.817E-08	1.008E-08	4.723E-09	2.459E-09	1.757E-09	1.368E-09
W	1.593E-08	9.451E-09	4.406E-09	2.462E-09	1.672E-09	1.253E-09
WNW	3.006E-08	1.752E-08	8.236E-09	4.686E-09	3.228E-09	2.445E-09
NW	4.505E-08	2.558E-08	1.174E-08	6.598E-09	4.516E-09	3.407E-09
NNW	4.254E-08	2.422E-08	1.119E-08	6.323E-09	4.340E-09	3.279E-09

TABLE C-6 (CONTINUED)

SECTOR AVERAGE DEPOSITION VALUES FOR TURBINE VENT DETERMINED
FROM ANNUAL AVERAGE METEOROLOGICAL DATA (1985 To 1992)

(D/Q) Sector Average Deposition (1/m²)

SEGMENT BOUNDARIES IN MILES

<u>Direction</u>	0.5	0.75	1.0	1.5	2.5	3.5
N	4.471E-09	2.622E-09	1.788E-09	9.981E-10	4.499E-10	2.601E-10
NNE	2.162E-09	1.335E-09	9.453E-10	5.462E-10	2.521E-10	1.472E-10
NE	2.186E-09	1.329E-09	9.286E-10	5.298E-10	2.409E-10	1.395E-10
ENE	8.763E-09	4.896E-09	3.204E-09	1.729E-09	7.605E-10	4.363E-10
E	1.148E-08	6.289E-09	4.047E-09	2.149E-09	9.307E-10	5.299E-10
ESE	8.909E-09	4.906E-09	3.151E-09	1.660E-09	7.258E-10	4.130E-10
SE	6.876E-09	3.858E-09	2.503E-09	1.341E-09	5.937E-10	3.397E-10
SSE	3.429E-09	1.995E-09	1.315E-09	7.210E-10	3.289E-10	1.890E-10
S	3.698E-09	2.171E-09	1.447E-09	7.965E-10	3.662E-10	2.108E-10
SSW	2.822E-09	1.722E-09	1.209E-09	6.997E-10	3.281E-10	1.923E-10
SW	2.314E-09	1.520E-09	1.164E-09	6.882E-10	3.299E-10	1.945E-10
WSW	6.070E-10	4.358E-10	3.469E-10	2.310E-10	1.159E-10	7.021E-11
W	6.082E-10	4.138E-10	3.183E-10	1.977E-10	9.874E-11	5.972E-11
WNW	1.870E-09	1.209E-09	8.870E-10	5.293E-10	2.511E-10	1.483E-10
NW	3.749E-09	2.290E-09	1.611E-09	9.262E-10	4.269E-10	2.492E-10
NNW	3.807E-09	2.246E-09	1.540E-09	8.652E-10	3.928E-10	2.280E-10
	4.5	7.5	15.0	25.0	35.0	45.0
N	1.706E-10	7.094E-11	2.218E-11	9.588E-12	5.736E-12	8.525E-11
NNE	9.706E-11	4.050E-11	1.253E-11	1.916E-11	8.919E-12	5.122E-12
NE	9.157E-11	3.799E-11	1.175E-11	9.911E-12	5.318E-12	3.292E-12
ENE	2.851E-10	1.186E-10	9.504E-11	2.256E-11	1.211E-11	7.499E-12
E	3.447E-10	1.427E-10	6.735E-11	2.192E-11	1.177E-11	7.290E-12
ESE	2.684E-10	1.124E-10	4.674E-11	1.645E-11	8.781E-12	5.440E-12
SE	2.212E-10	9.493E-11	3.784E-11	1.485E-11	7.867E-12	4.731E-12
SSE	1.257E-10	5.742E-11	2.530E-11	1.104E-11	4.586E-12	2.812E-12
S	1.444E-10	6.569E-11	2.721E-11	1.289E-11	5.120E-12	3.138E-12
SSW	1.262E-10	5.539E-11	2.941E-11	1.103E-11	5.812E-12	3.129E-12
SW	1.299E-10	5.523E-11	3.711E-11	1.548E-11	7.792E-12	4.577E-12
WSW	4.707E-11	2.001E-11	6.249E-12	3.103E-12	3.395E-11	2.790E-12
W	3.996E-11	1.697E-11	5.314E-12	2.295E-12	1.321E-12	8.690E-13
WNW	9.827E-11	4.117E-11	1.267E-11	5.391E-12	3.075E-12	2.019E-12
NW	1.642E-10	6.851E-11	2.125E-11	9.075E-12	5.220E-12	3.464E-12
NNW	1.498E-10	6.246E-11	1.958E-11	8.426E-12	4.885E-12	3.267E-12

TABLE C-7

**SECTOR AVERAGE DISPERSION VALUES FOR RADWASTE VENT DETERMINED
FROM ANNUAL AVERAGE METEOROLOGICAL DATA (1985 To 1992)**

Sector Average Concentration X/Q (sec/m³)

SEGMENT BOUNDARIES IN MILES

<u>Direction</u>	0.5	0.75	1.0	1.5	2.5	3.5
N	9.289E-07	6.007E-07	4.440E-07	2.832E-07	1.567E-07	1.052E-07
NNE	4.668E-07	3.155E-07	2.371E-07	1.529E-07	8.435E-08	5.617E-08
NE	4.087E-07	2.683E-07	1.978E-07	1.247E-07	6.698E-08	4.381E-08
ENE	8.420E-07	5.096E-07	3.592E-07	2.227E-07	1.142E-07	7.324E-08
E	6.787E-07	3.900E-07	2.660E-07	1.626E-07	8.118E-08	5.158E-08
ESE	4.270E-07	2.525E-07	1.727E-07	1.002E-07	5.512E-08	3.467E-08
SE	3.397E-07	2.050E-07	1.413E-07	8.476E-08	4.607E-08	3.077E-08
SSE	1.996E-07	1.413E-07	1.017E-07	6.620E-08	3.908E-08	2.419E-08
S	2.112E-07	1.498E-07	1.138E-07	7.360E-08	4.310E-08	2.660E-08
SSW	2.970E-07	2.024E-07	1.587E-07	1.052E-07	5.857E-08	3.831E-08
SW	3.696E-07	2.716E-07	2.542E-07	1.569E-07	8.631E-08	5.441E-08
WSW	1.939E-07	1.634E-07	1.376E-07	1.185E-07	6.500E-08	4.262E-08
W	2.088E-07	1.643E-07	1.369E-07	9.847E-08	5.958E-08	4.143E-08
WNW	5.250E-07	3.657E-07	2.845E-07	1.925E-07	1.135E-07	7.900E-08
NW	8.757E-07	5.846E-07	4.402E-07	2.869E-07	1.634E-07	1.120E-07
NNW	8.560E-07	5.557E-07	4.144E-07	2.685E-07	1.531E-07	1.051E-07
	4.5	7.5	15.0	25.0	35.0	45.0
N	7.785E-08	4.199E-08	1.805E-08	9.939E-09	6.584E-09	5.508E-09
NNE	4.127E-08	2.189E-08	9.195E-09	5.947E-09	3.828E-09	2.766E-09
NE	3.177E-08	1.642E-08	7.167E-09	3.976E-09	2.538E-09	1.823E-09
ENE	5.250E-08	2.670E-08	1.191E-08	6.030E-09	3.879E-09	2.803E-09
E	3.681E-08	1.868E-08	8.370E-09	4.283E-09	2.778E-09	2.022E-09
ESE	2.458E-08	1.326E-08	5.225E-09	2.684E-09	1.747E-09	1.276E-09
SE	2.154E-08	1.063E-08	4.246E-09	2.205E-09	1.446E-09	1.062E-09
SSE	1.695E-08	8.373E-09	3.340E-09	1.733E-09	1.136E-09	8.335E-10
S	1.865E-08	9.222E-09	3.690E-09	1.920E-09	1.261E-09	9.272E-10
SSW	2.696E-08	1.300E-08	4.993E-09	2.515E-09	1.615E-09	1.168E-09
SW	4.155E-08	2.103E-08	7.964E-09	3.960E-09	2.520E-09	1.809E-09
WSW	3.087E-08	1.587E-08	6.862E-09	3.473E-09	2.331E-09	1.681E-09
W	3.125E-08	1.729E-08	7.572E-09	4.088E-09	2.722E-09	2.012E-09
WNW	5.992E-08	3.374E-08	1.518E-08	8.361E-09	5.637E-09	4.201E-09
NW	8.418E-08	4.678E-08	2.083E-08	1.141E-08	7.675E-09	5.711E-09
NNW	7.914E-08	4.414E-08	1.974E-08	1.085E-08	7.307E-09	5.443E-09

TABLE C-7 (CONTINUED)

SECTOR AVERAGE DEPOSITION VALUES FOR RADWASTE VENT DETERMINED
FROM ANNUAL AVERAGE METEOROLOGICAL DATA (1985 To 1992)

(D/Q) Sector Average Deposition (1/m²)

SEGMENT BOUNDARIES IN MILES

<u>Direction</u>	0.5	0.75	1.0	1.5	2.5	3.5
N	7.139E-09	3.957E-09	2.509E-09	1.308E-09	5.489E-10	3.053E-10
NNE	3.697E-09	2.120E-09	1.363E-09	7.217E-10	3.046E-10	1.697E-10
NE	3.738E-09	2.100E-09	1.337E-09	6.993E-10	2.930E-10	1.625E-10
ENE	1.197E-08	6.395E-09	3.998E-09	2.058E-09	8.649E-10	4.834E-10
E	1.429E-08	7.542E-09	4.691E-09	2.400E-09	1.006E-09	5.616E-10
ESE	1.088E-08	5.771E-09	3.590E-09	1.833E-09	7.733E-10	4.331E-10
SE	8.853E-09	4.728E-09	2.941E-09	1.510E-09	6.410E-10	4.709E-10
SSE	4.668E-09	2.551E-09	1.593E-09	8.277E-10	3.887E-10	3.189E-10
S	5.074E-09	2.781E-09	1.752E-09	9.121E-10	4.447E-10	3.448E-10
SSW	4.395E-09	2.459E-09	1.585E-09	8.439E-10	3.627E-10	2.380E-10
SW	4.104E-09	2.423E-09	1.653E-09	8.807E-10	3.772E-10	2.107E-10
WSW	1.314E-09	8.355E-10	5.716E-10	3.315E-10	1.429E-10	8.030E-11
W	1.257E-09	7.732E-10	5.198E-10	2.877E-10	1.248E-10	7.047E-11
WNW	3.526E-09	2.077E-09	1.355E-09	7.280E-10	3.094E-10	1.727E-10
NW	6.440E-09	3.665E-09	2.353E-09	1.242E-09	5.239E-10	2.917E-10
NNW	6.161E-09	3.436E-09	2.187E-09	1.144E-09	4.817E-10	2.683E-10
	4.5	7.5	15.0	25.0	35.0	45.0
N	1.960E-10	8.595E-11	1.329E-10	3.272E-10	3.824E-10	2.186E-11
NNE	1.089E-10	4.740E-11	6.689E-11	1.218E-11	6.526E-12	4.037E-12
NE	1.040E-10	4.433E-11	5.931E-11	9.899E-12	5.306E-12	3.283E-12
ENE	3.114E-10	1.326E-10	8.260E-11	2.254E-11	1.209E-11	7.484E-12
E	3.613E-10	1.508E-10	6.296E-11	2.190E-11	1.175E-11	7.278E-12
ESE	2.795E-10	1.565E-10	4.490E-11	1.635E-11	8.770E-12	5.432E-12
SE	3.152E-10	1.283E-10	3.658E-11	1.382E-11	7.413E-12	4.590E-12
SSE	2.167E-10	8.427E-11	2.362E-11	8.810E-12	4.534E-12	2.805E-12
S	2.195E-10	8.754E-11	2.582E-11	9.909E-12	5.060E-12	3.130E-12
SSW	2.885E-10	1.221E-10	2.685E-11	9.418E-12	5.047E-12	3.122E-12
SW	1.536E-10	1.603E-10	4.503E-11	1.117E-11	5.944E-12	3.669E-12
WSW	5.191E-11	2.346E-11	3.839E-11	4.126E-11	4.659E-12	1.963E-12
W	4.561E-11	1.917E-11	2.377E-11	8.037E-11	1.204E-10	1.255E-10
WNW	1.110E-10	4.715E-11	6.492E-11	1.955E-10	2.750E-10	2.777E-10
NW	1.873E-10	8.094E-11	1.173E-10	3.145E-10	4.176E-10	4.099E-10
NNW	1.725E-10	7.523E-11	1.182E-10	3.151E-10	4.133E-10	4.025E-10

TABLE C-8

**SECTOR AVERAGE DISPERSION VALUES FOR THE STACK DETERMINED
FROM ANNUAL AVERAGE METEOROLOGICAL DATA (1985 To 1992)**

Sector Average Concentration X/Q (sec/m³)

SEGMENT BOUNDARIES IN MILES

<u>Direction</u>	0.5	0.75	1.0	1.5	2.5	3.5
N	6.304E-09	7.537E-09	9.600E-09	1.382E-08	1.504E-08	1.366E-08
NNE	2.263E-09	3.378E-09	5.419E-09	9.466E-09	1.092E-08	1.011E-08
NE	1.092E-09	2.089E-09	4.269E-09	8.509E-09	1.005E-08	9.366E-09
ENE	1.260E-08	1.222E-08	1.454E-08	2.100E-08	2.117E-08	1.845E-08
E	1.547E-08	1.816E-08	2.136E-08	2.978E-08	2.655E-08	2.150E-08
ESE	1.888E-08	1.914E-08	2.056E-08	2.174E-08	2.283E-08	1.737E-08
SE	2.187E-08	1.933E-08	1.993E-08	2.243E-08	2.028E-08	2.229E-08
SSE	1.833E-08	1.560E-08	1.566E-08	1.731E-08	2.077E-08	1.817E-08
S	1.747E-08	1.440E-08	1.540E-08	1.730E-08	2.211E-08	1.900E-08
SSW	1.689E-08	1.479E-08	1.724E-08	2.180E-08	2.270E-08	1.996E-08
SW	6.866E-09	6.874E-09	1.247E-08	1.675E-08	1.789E-08	1.442E-08
WSW	1.163E-09	1.723E-09	2.811E-09	6.821E-09	7.244E-09	6.414E-09
W	1.151E-09	1.393E-09	2.274E-09	4.102E-09	4.796E-09	4.483E-09
WNW	2.266E-09	3.077E-09	4.890E-09	8.276E-09	9.171E-09	8.262E-09
NW	5.561E-09	6.833E-09	9.696E-09	1.511E-08	1.648E-08	1.481E-08
NNW	6.602E-09	7.476E-09	9.456E-09	1.365E-08	1.498E-08	1.370E-08
	4.5	7.5	15.0	25.0	35.0	45.0
N	1.190E-08	7.990E-09	4.005E-09	2.317E-09	1.572E-09	1.348E-09
NNE	8.882E-09	6.046E-09	3.081E-09	4.716E-09	3.041E-09	2.200E-09
NE	8.270E-09	5.697E-09	3.376E-09	5.591E-09	3.622E-09	2.629E-09
ENE	1.569E-08	1.021E-08	8.735E-09	6.410E-09	4.121E-09	2.977E-09
E	1.748E-08	1.059E-08	7.444E-09	4.667E-09	2.974E-09	2.137E-09
ESE	1.362E-08	1.066E-08	4.756E-09	3.000E-09	1.917E-09	1.381E-09
SE	1.624E-08	8.678E-09	3.802E-09	2.282E-09	1.464E-09	1.059E-09
SSE	1.421E-08	7.626E-09	3.217E-09	1.770E-09	1.263E-09	9.154E-10
S	1.632E-08	8.545E-09	3.558E-09	1.953E-09	1.440E-09	1.045E-09
SSW	1.910E-08	1.011E-08	4.845E-09	2.835E-09	1.813E-09	1.306E-09
SW	1.354E-08	9.554E-09	4.078E-09	2.987E-09	1.946E-09	1.454E-09
WSW	5.511E-09	3.659E-09	2.100E-09	1.197E-09	9.790E-10	1.201E-09
W	3.977E-09	2.773E-09	1.472E-09	8.742E-10	6.133E-10	4.701E-10
WNW	7.135E-09	4.716E-09	2.335E-09	1.322E-09	9.004E-10	6.765E-10
NW	1.277E-08	8.409E-09	4.115E-09	2.298E-09	1.548E-09	1.152E-09
NNW	1.198E-08	8.121E-09	4.120E-09	2.355E-09	1.608E-09	1.207E-09

TABLE C-8 (CONTINUED)

SECTOR AVERAGE DISPERSION VALUES FOR THE STACK DETERMINED
FROM ANNUAL AVERAGE METEOROLOGICAL DATA (1985 To 1992)

Sector Average Finite Cloud Gamma X/Q (sec/m³)

SEGMENT BOUNDARIES IN MILES

<u>Direction</u>	0.5	0.75	1.0	1.6	2.5	3.5
N	1.056E-07	7.326E-08	5.707E-08	4.048E-08	2.615E-08	1.930E-08
NNE	8.423E-08	5.830E-08	4.543E-08	3.233E-08	2.100E-08	1.554E-08
NE	8.669E-08	5.979E-08	4.651E-08	3.304E-08	2.144E-08	1.588E-08
ENE	1.359E-07	9.388E-08	7.314E-08	5.381E-08	3.443E-08	2.522E-08
E	1.345E-07	9.409E-08	7.352E-08	5.582E-08	3.486E-08	2.500E-08
ESE	9.666E-08	6.962E-08	5.419E-08	3.785E-08	2.627E-08	1.849E-08
SE	8.156E-08	5.786E-08	4.497E-08	3.227E-08	2.186E-08	1.919E-08
SSE	6.370E-08	4.642E-08	3.607E-08	2.673E-08	2.041E-08	1.573E-08
S	6.367E-08	4.638E-08	3.736E-08	2.774E-08	2.192E-08	1.668E-08
SSW	8.747E-08	6.029E-08	4.886E-08	3.679E-08	2.549E-08	1.958E-08
SW	7.805E-08	5.421E-08	4.798E-08	3.412E-08	2.313E-08	1.662E-08
WSW	4.633E-08	3.206E-08	2.498E-08	2.009E-08	1.289E-08	9.455E-09
W	4.390E-08	3.020E-08	2.344E-08	1.660E-08	1.074E-08	7.954E-09
WNW	6.518E-08	4.519E-08	3.531E-08	2.520E-08	1.636E-08	1.207E-08
NW	1.075E-07	7.471E-08	5.846E-08	4.177E-08	2.713E-08	2.002E-08
NNW	1.090E-07	7.544E-08	5.873E-08	4.163E-08	2.689E-08	1.987E-08
	4.5	7.5	15.0	25.0	35.0	45.0
N	1.520E-08	9.085E-09	4.282E-09	2.428E-09	1.640E-09	1.343E-09
NNE	1.228E-08	7.377E-09	3.510E-09	3.242E-09	2.140E-09	1.574E-09
NE	1.255E-08	7.577E-09	3.990E-09	3.674E-09	2.441E-09	1.803E-09
ENE	1.975E-08	1.168E-08	7.533E-09	4.588E-09	3.017E-09	2.213E-09
E	1.925E-08	1.103E-08	6.332E-09	3.583E-09	2.329E-09	1.695E-09
ESE	1.405E-08	9.511E-09	4.144E-09	2.339E-09	1.522E-09	1.110E-09
SE	1.411E-08	7.582E-09	3.268E-09	1.809E-09	1.181E-09	8.637E-10
SSE	1.197E-08	6.451E-09	2.751E-09	1.485E-09	1.011E-09	7.413E-10
S	1.317E-08	7.027E-09	2.988E-09	1.616E-09	1.116E-09	8.202E-10
SSW	1.669E-08	8.946E-09	4.025E-09	2.212E-09	1.441E-09	1.051E-09
SW	1.405E-08	8.902E-09	3.815E-09	2.323E-09	1.522E-09	1.125E-09
WSW	7.417E-09	4.409E-09	2.259E-09	1.259E-09	9.433E-10	8.792E-10
W	6.295E-09	3.815E-09	1.849E-09	1.061E-09	7.318E-10	5.545E-10
WNW	9.503E-09	5.659E-09	2.658E-09	1.485E-09	1.006E-09	7.536E-10
NW	1.574E-08	9.343E-09	4.349E-09	2.405E-09	1.617E-09	1.203E-09
NNW	1.567E-08	9.395E-09	4.454E-09	2.499E-09	1.696E-09	1.269E-09

TABLE C-8 (CONTINUED)

SECTOR AVERAGE DEPOSITION VALUES FOR THE STACK DETERMINED
FROM ANNUAL AVERAGE METEOROLOGICAL DATA (1985 To 1992)

(D/Q) Sector Average Deposition ($1/m^2$)

SEGMENT BOUNDARIES IN MILES

<u>Direction</u>	0.5	0.75	1.0	1.5	2.5	3.5
N	5.867E-10	5.512E-10	5.298E-10	3.807E-10	2.303E-10	1.496E-10
NNE	2.220E-10	2.564E-10	2.787E-10	2.173E-10	1.374E-10	9.029E-11
NE	1.569E-10	2.254E-10	2.692E-10	2.210E-10	1.434E-10	9.484E-11
ENE	1.440E-09	1.219E-09	1.078E-09	7.247E-10	4.209E-10	2.708E-10
E	1.868E-09	1.566E-09	1.378E-09	9.226E-10	5.343E-10	3.433E-10
ESE	1.970E-09	1.546E-09	1.277E-09	8.070E-10	4.493E-10	2.857E-10
SE	2.009E-09	1.513E-09	1.195E-09	7.215E-10	3.920E-10	2.675E-10
SSE	1.472E-09	1.088E-09	8.401E-10	4.952E-10	2.782E-10	1.783E-10
S	1.432E-09	1.062E-09	8.226E-10	4.864E-10	2.765E-10	1.758E-10
SSW	1.448E-09	1.145E-09	9.499E-10	6.029E-10	3.398E-10	2.227E-10
SW	4.816E-10	4.577E-10	4.424E-10	3.191E-10	1.934E-10	1.258E-10
WSW	7.953E-11	9.105E-11	9.852E-11	7.657E-11	4.834E-11	3.175E-11
W	7.596E-11	8.732E-11	9.453E-11	7.349E-11	4.641E-11	3.049E-11
WNW	2.259E-10	2.548E-10	2.733E-10	2.114E-10	1.331E-10	8.739E-11
NW	5.672E-10	5.729E-10	5.770E-10	4.285E-10	2.640E-10	1.724E-10
NNW	6.313E-10	5.755E-10	5.408E-10	3.820E-10	2.288E-10	1.483E-10
	4.5	7.5	15.0	25.0	35.0	45.0
N	1.024E-10	4.512E-11	1.499E-11	6.634E-12	3.864E-12	2.538E-12
NNE	6.187E-11	2.717E-11	8.936E-12	1.079E-11	1.877E-11	2.331E-11
NE	6.504E-11	2.852E-11	9.333E-12	1.922E-11	7.686E-12	4.762E-12
ENE	1.851E-10	8.191E-11	2.723E-11	2.589E-11	1.390E-11	8.613E-12
E	2.345E-10	1.038E-10	3.439E-11	2.443E-11	1.312E-11	8.128E-12
ESE	1.949E-10	9.097E-11	2.905E-11	1.009E-10	9.057E-12	5.613E-12
SE	1.804E-10	7.805E-11	2.518E-11	1.564E-11	3.646E-11	5.691E-11
SSE	1.212E-10	5.228E-11	1.700E-11	7.764E-12	1.078E-11	3.148E-12
S	1.203E-10	5.162E-11	1.675E-11	7.661E-12	2.389E-11	3.375E-12
SSW	1.581E-10	6.827E-11	2.174E-11	2.120E-11	3.021E-11	5.082E-12
SW	8.713E-11	3.976E-11	1.252E-11	5.266E-12	3.020E-12	2.782E-12
WSW	2.175E-11	9.548E-12	3.137E-12	1.362E-12	7.678E-13	5.268E-13
W	2.089E-11	9.176E-12	3.018E-12	1.312E-12	7.520E-13	4.906E-13
WNW	5.988E-11	2.631E-11	8.665E-12	3.775E-12	2.168E-12	1.417E-12
NW	1.181E-10	5.197E-11	1.720E-11	7.561E-12	4.378E-12	2.873E-12
NNW	1.014E-10	4.475E-11	1.490E-11	6.628E-12	3.876E-12	2.556E-12

TABLE C-9

**SECTOR AVERAGE DISPERSION VALUES FOR REACTOR VENT DETERMINED
FROM GRAZING METEOROLOGICAL DATA (May-Oct., 1985 To 1992)**

Sector Average Concentration X/Q (sec/m³)

SEGMENT BOUNDARIES IN MILES

<u>Direction</u>	0.5	0.75	1.0	1.5	2.5	3.5
N	6.872E-07	3.876E-07	2.760E-07	1.809E-07	1.070E-07	7.473E-08
NNE	2.784E-07	1.618E-07	1.187E-07	8.049E-08	4.922E-08	3.490E-08
NE	2.146E-07	1.293E-07	9.637E-08	6.593E-08	4.010E-08	2.814E-08
ENE	5.379E-07	3.161E-07	2.287E-07	1.517E-07	8.544E-08	5.754E-08
E	4.349E-07	2.511E-07	1.781E-07	1.161E-07	6.271E-08	4.151E-08
ESE	2.237E-07	1.316E-07	9.517E-08	6.077E-08	3.752E-08	2.507E-08
SE	1.404E-07	8.555E-08	6.434E-08	4.391E-08	2.761E-08	2.379E-08
SSE	8.466E-08	5.343E-08	4.251E-08	3.290E-08	2.625E-08	1.947E-08
S	1.138E-07	7.142E-08	5.844E-08	4.397E-08	3.334E-08	2.340E-08
SSW	1.195E-07	7.622E-08	6.418E-08	5.096E-08	3.474E-08	2.567E-08
SW	1.568E-07	1.021E-07	9.798E-08	7.350E-08	4.952E-08	3.388E-08
WSW	8.303E-08	5.439E-08	4.638E-08	4.813E-08	3.323E-08	2.418E-08
W	1.023E-07	6.109E-08	4.808E-08	3.752E-08	2.675E-08	2.039E-08
WNW	2.768E-07	1.563E-07	1.144E-07	8.024E-08	5.180E-08	3.796E-08
NW	4.819E-07	2.733E-07	1.974E-07	1.336E-07	8.207E-08	5.850E-08
NNW	5.836E-07	3.255E-07	2.311E-07	1.525E-07	9.119E-08	6.415E-08
	4.5	7.5	15.0	25.0	35.0	45.0
N	5.682E-08	3.229E-08	1.487E-08	8.630E-09	5.900E-09	5.432E-09
NNE	2.674E-08	1.527E-08	6.981E-09	6.259E-09	4.065E-09	2.955E-09
NE	2.133E-08	1.186E-08	5.653E-09	3.842E-09	2.467E-09	1.778E-09
ENE	4.249E-08	2.266E-08	1.191E-08	6.123E-09	3.960E-09	2.874E-09
E	3.039E-08	1.610E-08	8.670E-09	4.499E-09	2.939E-09	2.151E-09
ESE	1.846E-08	1.219E-08	5.018E-09	2.620E-09	1.719E-09	1.262E-09
SE	1.691E-08	8.600E-09	3.531E-09	1.859E-09	1.229E-09	9.077E-10
SSE	1.408E-08	7.122E-09	2.909E-09	1.533E-09	1.014E-09	7.489E-10
S	1.694E-08	8.538E-09	3.497E-09	1.849E-09	1.227E-09	9.083E-10
SSW	2.096E-08	1.036E-08	4.152E-09	2.119E-09	1.372E-09	9.979E-10
SW	2.774E-08	1.607E-08	6.287E-09	3.285E-09	2.100E-09	1.512E-09
WSW	1.858E-08	1.043E-08	5.006E-09	2.642E-09	1.930E-09	1.538E-09
W	1.628E-08	9.896E-09	4.778E-09	2.735E-09	1.885E-09	1.426E-09
WNW	2.983E-08	1.804E-08	8.977E-09	5.317E-09	3.751E-09	2.887E-09
NW	4.517E-08	2.656E-08	1.290E-08	7.554E-09	5.303E-09	4.069E-09
NNW	4.913E-08	2.849E-08	1.363E-08	7.907E-09	5.519E-09	4.218E-09

TABLE C-9 (CONTINUED)

SECTOR AVERAGE DEPOSITION VALUES FOR REACTOR VENT DETERMINED
FROM GRAZING METEOROLOGICAL DATA (May-Oct., 1985 To 1992)

(D/Q) Sector Average Deposition ($1/m^2$)

SEGMENT BOUNDARIES IN MILES

<u>Direction</u>	0.5	0.75	1.0	1.5	2.5	3.5
N	5.293E-09	3.001E-09	1.993E-09	1.084E-09	4.833E-10	2.788E-10
NNE	2.213E-09	1.282E-09	8.672E-10	4.796E-10	2.178E-10	1.268E-10
NE	1.943E-09	1.129E-09	7.661E-10	4.253E-10	1.923E-10	1.114E-10
ENE	9.567E-09	5.374E-09	3.526E-09	1.908E-09	8.486E-10	4.910E-10
E	1.195E-08	6.594E-09	4.262E-09	2.273E-09	9.946E-10	5.705E-10
ESE	7.360E-09	4.098E-09	2.647E-09	1.400E-09	6.200E-10	3.559E-10
SE	4.567E-09	2.616E-09	1.713E-09	9.208E-10	4.141E-10	2.395E-10
SSE	2.349E-09	1.404E-09	9.335E-10	5.095E-10	2.374E-10	1.385E-10
S	3.680E-09	2.178E-09	1.449E-09	7.904E-10	3.660E-10	2.123E-10
SSW	2.552E-09	1.539E-09	1.065E-09	6.032E-10	2.835E-10	1.674E-10
SW	2.250E-09	1.407E-09	1.024E-09	5.859E-10	2.795E-10	1.655E-10
WSW	7.002E-10	4.587E-10	3.426E-10	2.133E-10	1.060E-10	6.420E-11
W	6.960E-10	4.315E-10	3.101E-10	1.811E-10	8.844E-11	5.324E-11
WNW	1.630E-09	9.674E-10	6.706E-10	3.802E-10	1.774E-10	1.045E-10
NW	3.128E-09	1.814E-09	1.232E-09	6.840E-10	3.116E-10	1.814E-10
NNW	4.161E-09	2.381E-09	1.595E-09	8.757E-10	3.947E-10	2.289E-10
	4.5	7.5	15.0	25.0	35.0	45.0
N	1.827E-10	7.623E-11	2.436E-11	1.057E-11	6.134E-12	5.692E-11
NNE	8.343E-11	3.499E-11	1.119E-11	2.150E-11	9.789E-12	5.547E-12
NE	7.311E-11	3.048E-11	9.592E-12	9.504E-12	5.097E-12	3.154E-12
ENE	3.225E-10	1.353E-10	1.156E-10	2.576E-11	1.382E-11	8.557E-12
E	3.727E-10	1.553E-10	7.770E-11	2.423E-11	1.300E-11	8.052E-12
ESE	2.326E-10	9.743E-11	4.546E-11	1.508E-11	7.942E-12	4.919E-12
SE	1.566E-10	6.774E-11	3.081E-11	1.184E-11	6.303E-12	3.709E-12
SSE	9.207E-11	4.261E-11	2.281E-11	1.017E-11	3.707E-12	2.214E-12
S	1.426E-10	6.463E-11	2.960E-11	1.496E-11	5.349E-12	3.211E-12
SSW	1.104E-10	4.819E-11	2.963E-11	1.059E-11	5.586E-12	2.816E-12
SW	1.109E-10	4.744E-11	3.118E-11	1.551E-11	7.818E-12	4.584E-12
WSW	4.303E-11	1.843E-11	5.936E-12	2.825E-12	2.461E-11	2.913E-12
W	3.556E-11	1.520E-11	4.937E-12	2.188E-12	1.280E-12	8.473E-13
WNW	6.913E-11	2.912E-11	9.300E-12	4.046E-12	2.335E-12	1.535E-12
NW	1.193E-10	4.998E-11	1.589E-11	6.865E-12	3.941E-12	2.584E-12
NNW	1.504E-10	6.293E-11	2.015E-11	8.774E-12	5.073E-12	3.346E-12

TABLE C-10

SECTOR AVERAGE DISPERSION VALUES FOR REFUEL FLOOR VENT
 DETERMINED FROM GRAZING METEOROLOGICAL DATA
 (May-Oct., 1985 To 1992)

Sector Average Concentration X/Q (sec/m³)

SEGMENT BOUNDARIES IN MILES

<u>Direction</u>	0.5	0.75	1.0	1.5	2.5	3.5
N	6.872E-07	3.876E-07	2.760E-07	1.809E-07	1.070E-07	7.473E-08
NNE	2.784E-07	1.618E-07	1.187E-07	8.049E-08	4.922E-08	3.490E-08
NE	2.146E-07	1.293E-07	9.637E-08	6.593E-08	4.010E-08	2.814E-08
ENE	5.379E-07	3.161E-07	2.287E-07	1.517E-07	8.544E-08	5.754E-08
E	4.349E-07	2.511E-07	1.781E-07	1.161E-07	6.271E-08	4.151E-08
ESE	2.237E-07	1.316E-07	9.517E-08	6.077E-08	3.752E-08	2.507E-08
SE	1.404E-07	8.555E-08	6.434E-08	4.391E-08	2.761E-08	2.379E-08
SSE	8.466E-08	5.343E-08	4.251E-08	3.290E-08	2.625E-08	1.947E-08
S	1.138E-07	7.142E-08	5.844E-08	4.397E-08	3.334E-08	2.340E-08
SSW	1.195E-07	7.622E-08	6.418E-08	5.096E-08	3.474E-08	2.567E-08
SW	1.568E-07	1.021E-07	9.798E-08	7.350E-08	4.952E-08	3.388E-08
WSW	8.303E-08	5.439E-08	4.638E-08	4.813E-08	3.323E-08	2.418E-08
W	1.023E-07	6.109E-08	4.808E-08	3.752E-08	2.675E-08	2.039E-08
WNW	2.768E-07	1.563E-07	1.144E-07	8.024E-08	5.180E-08	3.796E-08
NW	4.819E-07	2.733E-07	1.974E-07	1.336E-07	8.207E-08	5.850E-08
NNW	5.836E-07	3.255E-07	2.311E-07	1.525E-07	9.119E-08	6.415E-08
	4.5	7.5	15.0	25.0	35.0	45.0
N	5.682E-08	3.229E-08	1.487E-08	8.630E-09	5.900E-09	5.432E-09
NNE	2.674E-08	1.527E-08	6.981E-09	6.259E-09	4.065E-09	2.955E-09
NE	2.133E-08	1.186E-08	5.653E-09	3.842E-09	2.467E-09	1.778E-09
ENE	4.249E-08	2.266E-08	1.191E-08	6.123E-09	3.960E-09	2.874E-09
E	3.039E-08	1.610E-08	8.670E-09	4.499E-09	2.939E-09	2.151E-09
ESE	1.846E-08	1.219E-08	5.018E-09	2.620E-09	1.719E-09	1.262E-09
SE	1.691E-08	8.600E-09	3.531E-09	1.859E-09	1.229E-09	9.077E-10
SSE	1.408E-08	7.122E-09	2.909E-09	1.533E-09	1.014E-09	7.489E-10
S	1.694E-08	8.538E-09	3.497E-09	1.849E-09	1.227E-09	9.083E-10
SSW	2.096E-08	1.036E-08	4.152E-09	2.119E-09	1.372E-09	9.979E-10
SW	2.774E-08	1.607E-08	6.287E-09	3.285E-09	2.100E-09	1.512E-09
WSW	1.858E-08	1.043E-08	5.006E-09	2.642E-09	1.930E-09	1.538E-09
W	1.628E-08	9.896E-09	4.778E-09	2.735E-09	1.885E-09	1.426E-09
WNW	2.983E-08	1.804E-08	8.977E-09	5.317E-09	3.751E-09	2.887E-09
NW	4.517E-08	2.656E-08	1.290E-08	7.554E-09	5.303E-09	4.069E-09
NNW	4.913E-08	2.849E-08	1.363E-08	7.907E-09	5.519E-09	4.218E-09

TABLE C-10 (CONTINUED)

SECTOR AVERAGE DEPOSITION VALUES FOR REFUEL FLOOR VENT
DETERMINED FROM GRAZING METEOROLOGICAL DATA
(May-Oct., 1985 To 1992)

(D/Q) Sector Average Deposition (1/m²)

SEGMENT BOUNDARIES IN MILES

<u>Direction</u>	0.5	0.75	1.0	1.5	2.5	3.5
N	5.293E-09	3.001E-09	1.993E-09	1.084E-09	4.833E-10	2.788E-10
NNE	2.213E-09	1.282E-09	8.672E-10	4.796E-10	2.178E-10	1.268E-10
NE	1.943E-09	1.129E-09	7.661E-10	4.253E-10	1.923E-10	1.114E-10
ENE	9.567E-09	5.374E-09	3.526E-09	1.908E-09	8.486E-10	4.910E-10
E	1.195E-08	6.594E-09	4.262E-09	2.273E-09	9.946E-10	5.705E-10
ESE	7.360E-09	4.098E-09	2.647E-09	1.400E-09	6.200E-10	3.559E-10
SE	4.567E-09	2.616E-09	1.713E-09	9.208E-10	4.141E-10	2.395E-10
SSE	2.349E-09	1.404E-09	9.335E-10	5.095E-10	2.374E-10	1.385E-10
S	3.680E-09	2.178E-09	1.449E-09	7.904E-10	3.660E-10	2.123E-10
SSW	2.552E-09	1.539E-09	1.065E-09	6.032E-10	2.835E-10	1.674E-10
SW	2.250E-09	1.407E-09	1.024E-09	5.859E-10	2.795E-10	1.655E-10
WSW	7.002E-10	4.587E-10	3.426E-10	2.133E-10	1.060E-10	6.420E-11
W	6.960E-10	4.315E-10	3.101E-10	1.811E-10	8.844E-11	5.324E-11
WNW	1.630E-09	9.674E-10	6.706E-10	3.802E-10	1.774E-10	1.045E-10
NW	3.128E-09	1.814E-09	1.232E-09	6.840E-10	3.116E-10	1.814E-10
NNW	4.161E-09	2.381E-09	1.595E-09	8.757E-10	3.947E-10	2.289E-10
	4.5	7.5	15.0	25.0	35.0	45.0
N	1.827E-10	7.623E-11	2.436E-11	1.057E-11	6.134E-12	5.692E-11
NNE	8.343E-11	3.499E-11	1.119E-11	2.150E-11	9.789E-12	5.547E-12
NE	7.311E-11	3.048E-11	9.592E-12	9.504E-12	5.097E-12	3.154E-12
ENE	3.225E-10	1.353E-10	1.156E-10	2.576E-11	1.382E-11	8.557E-12
E	3.727E-10	1.553E-10	7.770E-11	2.423E-11	1.300E-11	8.052E-12
ESE	2.326E-10	9.743E-11	4.546E-11	1.508E-11	7.942E-12	4.919E-12
SE	1.566E-10	6.774E-11	3.081E-11	1.184E-11	6.303E-12	3.709E-12
SSE	9.207E-11	4.261E-11	2.281E-11	1.017E-11	3.707E-12	2.214E-12
S	1.426E-10	6.463E-11	2.960E-11	1.496E-11	5.349E-12	3.211E-12
SSW	1.104E-10	4.819E-11	2.963E-11	1.059E-11	5.586E-12	2.816E-12
SW	1.109E-10	4.744E-11	3.118E-11	1.551E-11	7.818E-12	4.584E-12
WSW	4.303E-11	1.843E-11	5.936E-12	2.825E-12	2.461E-11	2.913E-12
W	3.556E-11	1.520E-11	4.937E-12	2.188E-12	1.280E-12	8.473E-13
WNW	6.913E-11	2.912E-11	9.300E-12	4.046E-12	2.335E-12	1.535E-12
NW	1.193E-10	4.998E-11	1.589E-11	6.865E-12	3.941E-12	2.584E-12
NNW	1.504E-10	6.293E-11	2.015E-11	8.774E-12	5.073E-12	3.346E-12

TABLE C-11

SECTOR AVERAGE DISPERSION VALUES FOR TURBINE VENT DETERMINED
FROM GRAZING METEOROLOGICAL DATA (May-Oct., 1985 To 1992)

Sector Average Concentration X/Q (sec/m³)

SEGMENT BOUNDARIES IN MILES

<u>Direction</u>	0.5	0.75	1.0	1.5	2.5	3.5
N	5.709E-07	3.305E-07	2.412E-07	1.625E-07	9.818E-08	6.921E-08
NNE	2.285E-07	1.372E-07	1.037E-07	7.275E-08	4.562E-08	3.268E-08
NE	1.764E-07	1.102E-07	8.477E-08	6.015E-08	3.755E-08	2.661E-08
ENE	4.616E-07	2.776E-07	2.055E-07	1.405E-07	8.050E-08	5.457E-08
E	3.792E-07	2.246E-07	1.625E-07	1.091E-07	5.960E-08	3.964E-08
ESE	1.965E-07	1.194E-07	8.826E-08	5.753E-08	3.635E-08	2.434E-08
SE	1.272E-07	7.992E-08	6.120E-08	4.254E-08	2.712E-08	2.351E-08
SSE	7.646E-08	5.020E-08	4.085E-08	3.235E-08	2.618E-08	1.933E-08
S	1.036E-07	6.737E-08	5.658E-08	4.335E-08	3.322E-08	2.320E-08
SSW	1.046E-07	6.974E-08	6.111E-08	4.995E-08	3.438E-08	2.545E-08
SW	1.314E-07	9.022E-08	9.323E-08	7.163E-08	4.882E-08	3.339E-08
WSW	5.958E-08	4.293E-08	4.003E-08	4.609E-08	3.238E-08	2.363E-08
W	6.396E-08	4.183E-08	3.639E-08	3.164E-08	2.412E-08	1.880E-08
WNW	1.777E-07	1.075E-07	8.434E-08	6.407E-08	4.390E-08	3.301E-08
NW	3.558E-07	2.118E-07	1.598E-07	1.134E-07	7.213E-08	5.224E-08
NNW	4.537E-07	2.623E-07	1.924E-07	1.315E-07	8.085E-08	5.761E-08
	4.5	7.5	15.0	25.0	35.0	45.0
N	5.294E-08	3.037E-08	1.413E-08	8.267E-09	5.666E-09	5.296E-09
NNE	2.518E-08	1.451E-08	6.687E-09	6.127E-09	3.978E-09	2.891E-09
NE	2.028E-08	1.135E-08	5.477E-09	3.750E-09	2.407E-09	1.735E-09
ENE	4.044E-08	2.168E-08	1.158E-08	5.945E-09	3.845E-09	2.790E-09
E	2.910E-08	1.547E-08	8.448E-09	4.380E-09	2.862E-09	2.094E-09
ESE	1.794E-08	1.196E-08	4.909E-09	2.560E-09	1.680E-09	1.233E-09
SE	1.669E-08	8.467E-09	3.468E-09	1.826E-09	1.207E-09	8.915E-10
SSE	1.392E-08	7.028E-09	2.868E-09	1.511E-09	9.997E-10	7.383E-10
S	1.673E-08	8.418E-09	3.445E-09	1.821E-09	1.208E-09	8.947E-10
SSW	2.075E-08	1.023E-08	4.085E-09	2.083E-09	1.349E-09	9.812E-10
SW	2.742E-08	1.588E-08	6.199E-09	3.229E-09	2.064E-09	1.486E-09
WSW	1.818E-08	1.022E-08	4.932E-09	2.603E-09	1.905E-09	1.512E-09
W	1.518E-08	9.366E-09	4.578E-09	2.636E-09	1.821E-09	1.381E-09
WNW	2.633E-08	1.632E-08	8.318E-09	4.988E-09	3.541E-09	2.735E-09
NW	4.074E-08	2.438E-08	1.207E-08	7.141E-09	5.039E-09	3.879E-09
NNW	4.450E-08	2.620E-08	1.274E-08	7.463E-09	5.234E-09	4.013E-09

TABLE C-11 (CONTINUED)

SECTOR AVERAGE DEPOSITION VALUES FOR TURBINE VENT DETERMINED
FROM GRAZING METEOROLOGICAL DATA (May-Oct., 1985 To 1992)

(D/Q) Sector Average Deposition (1/m²)

SEGMENT BOUNDARIES IN MILES

<u>Direction</u>	0.5	0.75	1.0	1.5	2.5	3.5
N	4.847E-09	2.779E-09	1.860E-09	1.020E-09	4.566E-10	2.639E-10
NNE	2.032E-09	1.194E-09	8.146E-10	4.548E-10	2.075E-10	1.210E-10
NE	1.740E-09	1.030E-09	7.073E-10	3.972E-10	1.806E-10	1.049E-10
ENE	8.906E-09	5.042E-09	3.325E-09	1.812E-09	8.095E-10	4.694E-10
E	1.133E-08	6.299E-09	4.090E-09	2.199E-09	9.662E-10	5.554E-10
ESE	7.061E-09	3.955E-09	2.563E-09	1.364E-09	6.063E-10	3.486E-10
SE	4.447E-09	2.551E-09	1.671E-09	9.025E-10	4.067E-10	2.352E-10
SSE	2.328E-09	1.388E-09	9.215E-10	5.051E-10	2.350E-10	1.369E-10
S	3.634E-09	2.148E-09	1.428E-09	7.821E-10	3.617E-10	2.097E-10
SSW	2.496E-09	1.510E-09	1.047E-09	5.968E-10	2.803E-10	1.653E-10
SW	2.157E-09	1.362E-09	1.001E-09	5.766E-10	2.750E-10	1.628E-10
WSW	6.331E-10	4.276E-10	3.252E-10	2.063E-10	1.026E-10	6.218E-11
W	5.976E-10	3.834E-10	2.817E-10	1.680E-10	8.284E-11	5.007E-11
WNW	1.388E-09	8.480E-10	5.993E-10	3.462E-10	1.632E-10	9.657E-11
NW	2.777E-09	1.641E-09	1.128E-09	6.346E-10	2.909E-10	1.699E-10
NNW	3.765E-09	2.185E-09	1.477E-09	8.192E-10	3.712E-10	2.158E-10
	4.5	7.5	15.0	25.0	35.0	45.0
N	1.732E-10	7.236E-11	2.311E-11	1.013E-11	6.026E-12	8.848E-11
NNE	7.973E-11	3.347E-11	1.068E-11	2.103E-11	9.625E-12	5.470E-12
NE	6.896E-11	2.878E-11	9.085E-12	9.506E-12	5.098E-12	3.156E-12
ENE	3.089E-10	1.298E-10	1.140E-10	2.577E-11	1.382E-11	8.559E-12
E	3.636E-10	1.518E-10	7.743E-11	2.424E-11	1.300E-11	8.054E-12
ESE	2.282E-10	9.672E-11	4.575E-11	1.498E-11	7.946E-12	4.920E-12
SE	1.544E-10	6.793E-11	3.047E-11	1.174E-11	6.217E-12	3.655E-12
SSE	9.165E-11	4.352E-11	2.187E-11	9.446E-12	3.670E-12	2.215E-12
S	1.435E-10	6.606E-11	2.883E-11	1.384E-11	5.297E-12	3.212E-12
SSW	1.090E-10	4.835E-11	2.801E-11	1.041E-11	5.507E-12	2.816E-12
SW	1.090E-10	4.691E-11	3.601E-11	1.557E-11	7.813E-12	4.562E-12
WSW	4.171E-11	1.784E-11	5.729E-12	2.935E-12	3.639E-11	2.915E-12
W	3.353E-11	1.435E-11	4.643E-12	2.068E-12	1.217E-12	8.100E-13
WNW	6.407E-11	2.705E-11	8.612E-12	3.772E-12	2.196E-12	1.457E-12
NW	1.120E-10	4.697E-11	1.490E-11	6.476E-12	3.751E-12	2.485E-12
NNW	1.420E-10	5.952E-11	1.904E-11	8.344E-12	4.874E-12	3.254E-12

TABLE C-12

SECTOR AVERAGE DISPERSION VALUES FOR RADWASTE VENT DETERMINED
FROM GRAZING METEOROLOGICAL DATA (May-Oct., 1985 To 1992)

Sector Average Concentration X/Q (sec/m³)

SEGMENT BOUNDARIES IN MILES

<u>Direction</u>	0.5	0.75	1.0	1.5	2.5	3.5
N	1.033E-06	6.607E-07	4.934E-07	3.221E-07	1.851E-07	1.275E-07
NNE	4.455E-07	2.987E-07	2.285E-07	1.525E-07	8.827E-08	6.054E-08
NE	3.625E-07	2.468E-07	1.879E-07	1.232E-07	6.884E-08	4.598E-08
ENE	8.475E-07	5.272E-07	3.794E-07	2.416E-07	1.263E-07	8.178E-08
E	6.881E-07	4.030E-07	2.806E-07	1.778E-07	9.089E-08	5.854E-08
ESE	3.637E-07	2.260E-07	1.604E-07	9.717E-08	5.730E-08	3.661E-08
SE	2.507E-07	1.591E-07	1.137E-07	7.166E-08	4.147E-08	2.871E-08
SSE	1.528E-07	1.153E-07	8.631E-08	5.956E-08	3.778E-08	2.365E-08
S	2.033E-07	1.462E-07	1.136E-07	7.515E-08	4.517E-08	2.814E-08
SSW	2.465E-07	1.710E-07	1.378E-07	9.433E-08	5.423E-08	3.604E-08
SW	3.232E-07	2.419E-07	2.349E-07	1.473E-07	8.225E-08	5.213E-08
WSW	1.847E-07	1.571E-07	1.341E-07	1.183E-07	6.589E-08	4.363E-08
W	1.925E-07	1.496E-07	1.266E-07	9.400E-08	5.935E-08	4.234E-08
WNW	4.533E-07	3.100E-07	2.455E-07	1.732E-07	1.090E-07	7.925E-08
NW	7.620E-07	5.042E-07	3.862E-07	2.611E-07	1.583E-07	1.133E-07
NNW	8.836E-07	5.647E-07	4.242E-07	2.807E-07	1.666E-07	1.178E-07
	4.5	7.5	15.0	25.0	35.0	45.0
N	9.616E-08	5.366E-08	2.398E-08	1.359E-08	9.122E-09	7.874E-09
NNE	4.539E-08	2.496E-08	1.093E-08	7.546E-09	4.900E-09	3.562E-09
NE	3.379E-08	1.787E-08	8.096E-09	4.598E-09	2.952E-09	2.128E-09
ENE	5.900E-08	3.037E-08	1.395E-08	7.112E-09	4.597E-09	3.334E-09
E	4.216E-08	2.175E-08	1.009E-08	5.213E-09	3.404E-09	2.490E-09
ESE	2.622E-08	1.462E-08	5.848E-09	3.039E-09	1.992E-09	1.462E-09
SE	2.025E-08	1.013E-08	4.110E-09	2.159E-09	1.426E-09	1.053E-09
SSE	1.670E-08	8.369E-09	3.400E-09	1.788E-09	1.181E-09	8.713E-10
S	1.986E-08	9.951E-09	4.056E-09	2.139E-09	1.417E-09	1.048E-09
SSW	2.557E-08	1.246E-08	4.861E-09	2.477E-09	1.603E-09	1.166E-09
SW	3.986E-08	2.025E-08	7.746E-09	3.881E-09	2.481E-09	1.786E-09
WSW	3.183E-08	1.658E-08	7.380E-09	3.775E-09	2.571E-09	1.863E-09
W	3.249E-08	1.853E-08	8.383E-09	4.616E-09	3.108E-09	2.313E-09
WNW	6.191E-08	3.671E-08	1.744E-08	9.907E-09	6.795E-09	5.122E-09
NW	8.779E-08	5.149E-08	2.428E-08	1.376E-08	9.425E-09	7.099E-09
NNW	9.054E-08	5.244E-08	2.444E-08	1.376E-08	9.398E-09	7.065E-09

TABLE C-12 (CONTINUED)

SECTOR AVERAGE DEPOSITION VALUES FOR RADWASTE VENT DETERMINED
FROM GRAZING METEOROLOGICAL DATA (May-Oct., 1985 To 1992)

(D/Q) Sector Average Deposition (1/m²)

SEGMENT BOUNDARIES IN MILES

<u>Direction</u>	0.5	0.75	1.0	1.5	2.5	3.5
N	7.161E-09	3.910E-09	2.468E-09	1.281E-09	5.399E-10	3.016E-10
NNE	3.098E-09	1.725E-09	1.100E-09	5.785E-10	2.454E-10	1.375E-10
NE	2.767E-09	1.546E-09	9.859E-10	5.168E-10	2.179E-10	1.215E-10
ENE	1.236E-08	6.620E-09	4.148E-09	2.151E-09	9.130E-10	5.142E-10
E	1.471E-08	7.775E-09	4.841E-09	2.489E-09	1.051E-09	5.901E-10
ESE	8.980E-09	4.777E-09	2.975E-09	1.527E-09	6.496E-10	3.661E-10
SE	5.951E-09	3.176E-09	1.973E-09	1.018E-09	4.362E-10	3.758E-10
SSE	3.184E-09	1.734E-09	1.082E-09	5.670E-10	2.795E-10	2.748E-10
S	4.939E-09	2.682E-09	1.686E-09	8.791E-10	4.358E-10	3.566E-10
SSW	3.731E-09	2.062E-09	1.325E-09	7.054E-10	3.056E-10	2.065E-10
SW	3.491E-09	2.008E-09	1.354E-09	7.203E-10	3.108E-10	1.753E-10
WSW	1.216E-09	7.473E-10	5.065E-10	2.908E-10	1.262E-10	7.139E-11
W	1.108E-09	6.552E-10	4.355E-10	2.391E-10	1.045E-10	5.944E-11
WNW	2.417E-09	1.382E-09	8.957E-10	4.786E-10	2.049E-10	1.152E-10
NW	4.435E-09	2.485E-09	1.590E-09	8.377E-10	3.551E-10	1.988E-10
NNW	5.741E-09	3.164E-09	2.007E-09	1.049E-09	4.437E-10	2.484E-10
	4.5	7.5	15.0	25.0	35.0	45.0
N	1.944E-10	8.685E-11	1.650E-10	4.423E-10	5.252E-10	2.758E-11
NNE	8.880E-11	3.942E-11	7.098E-11	1.219E-11	6.530E-12	4.038E-12
NE	7.813E-11	3.424E-11	6.883E-11	9.492E-12	5.086E-12	3.146E-12
ENE	3.330E-10	1.437E-10	9.824E-11	2.573E-11	1.380E-11	8.541E-12
E	3.813E-10	1.608E-10	7.197E-11	2.421E-11	1.298E-11	8.039E-12
ESE	2.378E-10	1.543E-10	4.294E-11	1.480E-11	7.934E-12	4.911E-12
SE	2.575E-10	1.053E-10	2.854E-11	1.033E-11	5.540E-12	3.428E-12
SSE	1.909E-10	7.321E-11	1.969E-11	7.139E-12	3.573E-12	2.208E-12
S	2.295E-10	9.154E-11	2.687E-11	1.032E-11	5.181E-12	3.203E-12
SSW	2.750E-10	1.176E-10	2.497E-11	8.477E-12	4.541E-12	2.807E-12
SW	1.329E-10	1.642E-10	4.605E-11	1.041E-11	5.525E-12	3.393E-12
WSW	4.643E-11	2.156E-11	4.157E-11	4.604E-11	4.839E-12	1.971E-12
W	3.868E-11	1.646E-11	2.393E-11	8.590E-11	1.303E-10	1.365E-10
WNW	7.449E-11	3.222E-11	6.113E-11	2.097E-10	3.048E-10	3.120E-10
NW	1.282E-10	5.677E-11	1.156E-10	3.505E-10	4.802E-10	4.775E-10
NNW	1.602E-10	7.077E-11	1.317E-10	3.775E-10	5.051E-10	4.961E-10

TABLE C-13

SECTOR AVERAGE DISPERSION VALUES FOR THE STACK DETERMINED
FROM GRAZING METEOROLOGICAL DATA (May-Oct., 1985 To 1992)

Sector Average Concentration X/Q (sec/m³)

SEGMENT BOUNDARIES IN MILES

<u>Direction</u>	0.5	0.75	1.0	1.5	2.5	3.5
N	1.027E-08	1.097E-08	1.194E-08	1.411E-08	1.486E-08	1.339E-08
NNE	3.203E-09	4.104E-09	5.361E-09	7.740E-09	9.169E-09	8.589E-09
NE	1.541E-09	2.147E-09	3.601E-09	6.414E-09	8.365E-09	8.095E-09
ENE	2.136E-08	1.920E-08	2.080E-08	2.654E-08	2.643E-08	2.296E-08
E	2.418E-08	2.669E-08	2.929E-08	3.752E-08	3.256E-08	2.619E-08
ESE	2.565E-08	2.362E-08	2.317E-08	2.243E-08	2.257E-08	1.729E-08
SE	2.484E-08	1.862E-08	1.761E-08	1.750E-08	1.669E-08	1.992E-08
SSE	2.207E-08	1.569E-08	1.476E-08	1.572E-08	1.921E-08	1.773E-08
S	2.327E-08	1.668E-08	1.630E-08	1.732E-08	2.215E-08	1.961E-08
SSW	1.929E-08	1.592E-08	1.765E-08	2.163E-08	2.276E-08	2.047E-08
SW	7.525E-09	6.805E-09	1.138E-08	1.499E-08	1.706E-08	1.411E-08
WSW	1.477E-09	1.939E-09	2.783E-09	6.039E-09	6.782E-09	6.122E-09
W	1.621E-09	1.537E-09	2.124E-09	3.344E-09	4.143E-09	3.951E-09
WNW	3.121E-09	3.456E-09	4.222E-09	5.656E-09	6.317E-09	5.765E-09
NW	7.262E-09	7.526E-09	8.766E-09	1.127E-08	1.242E-08	1.130E-08
NNW	9.840E-09	1.035E-08	1.126E-08	1.325E-08	1.394E-08	1.259E-08
	4.5	7.5	15.0	25.0	35.0	45.0
N	1.166E-08	7.912E-09	4.057E-09	2.400E-09	1.651E-09	1.473E-09
NNE	7.654E-09	5.395E-09	2.899E-09	5.959E-09	3.873E-09	2.818E-09
NE	7.362E-09	5.385E-09	3.568E-09	7.949E-09	5.187E-09	3.784E-09
ENE	1.956E-08	1.284E-08	1.211E-08	9.552E-09	6.177E-09	4.480E-09
E	2.126E-08	1.291E-08	9.490E-09	6.183E-09	3.959E-09	2.853E-09
ESE	1.367E-08	1.137E-08	5.359E-09	3.641E-09	2.348E-09	1.702E-09
SE	1.483E-08	8.319E-09	3.902E-09	2.516E-09	1.633E-09	1.189E-09
SSE	1.426E-08	7.927E-09	3.472E-09	1.969E-09	1.445E-09	1.052E-09
S	1.720E-08	9.169E-09	3.894E-09	2.170E-09	1.617E-09	1.178E-09
SSW	2.008E-08	1.080E-08	5.377E-09	3.251E-09	2.089E-09	1.510E-09
SW	1.368E-08	1.015E-08	4.452E-09	3.488E-09	2.294E-09	1.730E-09
WSW	5.337E-09	3.643E-09	2.196E-09	1.283E-09	1.101E-09	1.497E-09
W	3.568E-09	2.588E-09	1.451E-09	8.966E-10	6.449E-10	5.031E-10
WNW	5.053E-09	3.461E-09	1.805E-09	1.063E-09	7.440E-10	5.702E-10
NW	9.881E-09	6.705E-09	3.423E-09	1.972E-09	1.356E-09	1.024E-09
NNW	1.100E-08	7.528E-09	3.920E-09	2.292E-09	1.590E-09	1.208E-09

TABLE C-13 (CONTINUED)

SECTOR AVERAGE DISPERSION VALUES FOR THE STACK DETERMINED
FROM GRAZING METEOROLOGICAL DATA (May-Oct., 1985 To 1992)

Sector Average Finite Cloud Gamma X/Q (sec/m³)

SEGMENT BOUNDARIES IN MILES

<u>Direction</u>	0.5	0.75	1.0	1.5	2.5	3.5
N	1.158E-07	8.009E-08	6.198E-08	4.338E-08	2.763E-08	2.031E-08
NNE	8.837E-08	6.084E-08	4.707E-08	3.305E-08	2.119E-08	1.565E-08
NE	1.004E-07	6.872E-08	5.300E-08	3.714E-08	2.383E-08	1.764E-08
ENE	1.844E-07	1.268E-07	9.832E-08	7.168E-08	4.551E-08	3.328E-08
E	1.719E-07	1.199E-07	9.332E-08	7.016E-08	4.346E-08	3.109E-08
ESE	1.054E-07	7.510E-08	5.799E-08	3.997E-08	2.748E-08	1.939E-08
SE	7.518E-08	5.213E-08	4.029E-08	2.868E-08	1.954E-08	1.780E-08
SSE	6.310E-08	4.479E-08	3.474E-08	2.569E-08	1.995E-08	1.574E-08
S	6.769E-08	4.821E-08	3.859E-08	2.845E-08	2.262E-08	1.744E-08
SSW	9.202E-08	6.303E-08	5.095E-08	3.824E-08	2.660E-08	2.061E-08
SW	8.132E-08	5.613E-08	4.944E-08	3.503E-08	2.387E-08	1.725E-08
WSW	5.017E-08	3.457E-08	2.681E-08	2.139E-08	1.367E-08	1.004E-08
W	4.869E-08	3.326E-08	2.566E-08	1.797E-08	1.151E-08	8.521E-09
WNW	5.779E-08	3.977E-08	3.077E-08	2.159E-08	1.379E-08	1.015E-08
NW	9.748E-08	6.725E-08	5.218E-08	3.674E-08	2.357E-08	1.737E-08
NNW	1.133E-07	7.823E-08	6.053E-08	4.235E-08	2.696E-08	1.982E-08
	4.5	7.5	15.0	25.0	35.0	45.0
N	1.599E-08	9.594E-09	4.587E-09	2.642E-09	1.803E-09	1.510E-09
NNE	1.238E-08	7.517E-09	3.669E-09	3.858E-09	2.576E-09	1.909E-09
NE	1.400E-08	8.577E-09	4.739E-09	4.937E-09	3.317E-09	2.468E-09
ENE	2.608E-08	1.550E-08	1.048E-08	6.589E-09	4.365E-09	3.218E-09
E	2.393E-08	1.373E-08	8.069E-09	4.645E-09	3.035E-09	2.217E-09
ESE	1.480E-08	1.035E-08	4.652E-09	2.723E-09	1.792E-09	1.316E-09
SE	1.326E-08	7.323E-09	3.289E-09	1.896E-09	1.256E-09	9.271E-10
SSE	1.216E-08	6.698E-09	2.936E-09	1.621E-09	1.123E-09	8.295E-10
S	1.392E-08	7.524E-09	3.256E-09	1.785E-09	1.244E-09	9.190E-10
SSW	1.778E-08	9.626E-09	4.425E-09	2.476E-09	1.623E-09	1.189E-09
SW	1.478E-08	9.614E-09	4.201E-09	2.647E-09	1.750E-09	1.302E-09
WSW	7.897E-09	4.740E-09	2.495E-09	1.413E-09	1.085E-09	1.056E-09
W	6.758E-09	4.136E-09	2.051E-09	1.200E-09	8.395E-10	6.423E-10
WNW	8.007E-09	4.832E-09	2.340E-09	1.344E-09	9.281E-10	7.043E-10
NW	1.369E-08	8.224E-09	3.930E-09	2.224E-09	1.520E-09	1.143E-09
NNW	1.561E-08	9.393E-09	4.520E-09	2.573E-09	1.765E-09	1.331E-09

TABLE C-13 (CONTINUED)

SECTOR AVERAGE DEPOSITION VALUES FOR THE STACK DETERMINED
FROM GRAZING METEOROLOGICAL DATA (May-Oct., 1985 To 1992)

(D/Q) Sector Average Deposition (1/m²)

SEGMENT BOUNDARIES IN MILES

<u>Direction</u>	0.5	0.75	1.0	1.5	2.5	3.5
N	8.120E-10	6.726E-10	5.859E-10	3.891E-10	2.241E-10	1.437E-10
NNE	2.594E-10	2.425E-10	2.324E-10	1.666E-10	1.006E-10	6.537E-11
NE	1.367E-10	1.617E-10	1.778E-10	1.396E-10	8.856E-11	5.825E-11
ENE	2.061E-09	1.641E-09	1.373E-09	8.782E-10	4.932E-10	3.145E-10
E	2.344E-09	1.893E-09	1.611E-09	1.048E-09	5.954E-10	3.804E-10
ESE	1.916E-09	1.446E-09	1.148E-09	6.978E-10	3.772E-10	2.378E-10
SE	1.509E-09	1.111E-09	8.536E-10	5.001E-10	2.647E-10	1.788E-10
SSE	1.381E-09	9.953E-10	7.444E-10	4.225E-10	2.282E-10	1.451E-10
S	1.637E-09	1.173E-09	8.706E-10	4.899E-10	2.644E-10	1.664E-10
SSW	1.380E-09	1.068E-09	8.670E-10	5.385E-10	2.985E-10	1.946E-10
SW	4.653E-10	4.167E-10	3.854E-10	2.688E-10	1.598E-10	1.034E-10
WSW	8.735E-11	8.698E-11	8.685E-11	6.410E-11	3.936E-11	2.568E-11
W	8.824E-11	8.612E-11	8.467E-11	6.182E-11	3.773E-11	2.459E-11
WNW	2.513E-10	2.214E-10	2.025E-10	1.401E-10	8.281E-11	5.351E-11
NW	5.753E-10	4.944E-10	4.434E-10	3.018E-10	1.766E-10	1.138E-10
NNW	8.411E-10	6.830E-10	5.837E-10	3.811E-10	2.170E-10	1.388E-10
	4.5	7.5	15.0	25.0	35.0	45.0
N	9.813E-11	4.342E-11	1.458E-11	6.584E-12	3.899E-12	2.583E-12
NNE	4.471E-11	1.970E-11	6.541E-12	1.089E-11	2.064E-11	2.610E-11
NE	3.992E-11	1.753E-11	5.759E-12	2.237E-11	8.393E-12	5.198E-12
ENE	2.147E-10	9.530E-11	3.198E-11	3.184E-11	1.709E-11	1.059E-11
E	2.596E-10	1.151E-10	3.834E-11	2.707E-11	1.453E-11	9.002E-12
ESE	1.620E-10	7.545E-11	2.442E-11	1.053E-10	7.907E-12	4.897E-12
SE	1.206E-10	5.231E-11	1.711E-11	1.248E-11	3.737E-11	6.706E-11
SSE	9.856E-11	4.268E-11	1.416E-11	6.581E-12	1.193E-11	2.789E-12
S	1.136E-10	4.896E-11	1.630E-11	7.617E-12	2.812E-11	3.396E-12
SSW	1.379E-10	5.967E-11	1.916E-11	2.198E-11	3.347E-11	4.991E-12
SW	7.147E-11	3.262E-11	1.036E-11	4.400E-12	2.543E-12	2.759E-12
WSW	1.757E-11	7.730E-12	2.554E-12	1.121E-12	6.388E-13	4.550E-13
W	1.684E-11	7.414E-12	2.457E-12	1.084E-12	6.291E-13	4.130E-13
WNW	3.659E-11	1.616E-11	5.394E-12	2.412E-12	1.417E-12	9.362E-13
NW	7.779E-11	3.438E-11	1.151E-11	5.170E-12	3.048E-12	2.018E-12
NNW	9.472E-11	4.197E-11	1.413E-11	6.421E-12	3.821E-12	2.541E-12

TABLE C-14

CRITICAL RECEPTOR DISPERSION AND DEPOSITION PARAMETERS
FOR VENT AND ELEVATED RELEASES

<u>DISPERSION PARAMETER DESCRIPTION</u>	<u>RECEPTOR</u>
Annual Average X/Q - Total Body; Stack	Site Boundary
Annual Average X/Q - Skin; Stack	Site Boundary*
Annual Average X/Q - Gamma Air; Stack	Site Boundary
Annual Average X/Q - Beta Air; Stack	Site Boundary*
Annual Average X/Q - Dep. Inhal.; Stack	Resident
Annual Average D/Q - GPD; Stack	Resident
Grazing D/Q - SFV & FFV; Stack	Garden
Grazing D/Q - Cow; Stack	Milk Animal
Grazing D/Q - Goat; Stack	Milk Animal
Grazing D/Q - Meat; Stack	Meat Animal
Annual Average X/Q - Total Body; Vent	Site Boundary
Annual Average X/Q - Skin; Vent	Site Boundary
Annual Average X/Q - Gamma Air; Vent	Site Boundary
Annual Average X/Q - Beta Air; Vent	Site Boundary
Annual Average X/Q - Dep. Inhal.; Vent	Resident
Annual Average D/Q - GPD; Vent	Resident
Grazing D/Q - SFV & FFV; Vent	Garden
Grazing D/Q - Cow; Vent	Milk Animal
Grazing D/Q - Goat; Vent	Milk Animal
Grazing D/Q - Meat; Vent	Meat Animal

* The highest X/Q is located beyond the site boundary.

TABLE C-15

**85TH PERCENTILE HOURLY PLUME CENTERLINE DISPERSION VALUES
AND ANNUAL SECTOR AVERAGE DISPERSION VALUES
FOR UNMONITORED GROUND LEVEL RELEASES DETERMINED
FROM ANNUAL AVERAGE METEOROLOGICAL DATA (1985-1992)
(FOR USE WITH SHORT TERM RELEASES)**

Concentration X/Q (sec/m³)

<u>Direction</u>		<u>Site Boundary Distance (m)</u>	<u>Hourly Plume Cent. Conc. (X/Q) (sec/m³)</u>	<u>Annual Sector Ave. Conc. (X/Q) (sec/m³)</u>	<u>Slope m</u>
N	w	225	1.284E-03	3.496E-05	-0.3970
NNE	w	225	1.061E-03	1.775E-05	-0.4506
NE	w	354	4.704E-04	5.342E-06	-0.4933
ENE	w	563	1.650E-04	3.429E-06	-0.4267
E	l	950	4.960E-05	1.054E-06	-0.4243
ESE	l	1030	3.611E-05	5.862E-07	-0.4539
SE	l	1110	3.204E-05	4.168E-07	-0.4783
SSE	l	1754	2.213E-05	1.732E-07	-0.5343
S	l	2205	1.640E-05	1.363E-07	-0.5277
SSW	l	2269	2.610E-05	2.003E-07	-0.5365
SW	l	2382	3.489E-05	3.141E-07	-0.5189
WSW	w	1867	7.570E-05	4.141E-07	-0.5737
W	w	644	3.338E-04	2.683E-06	-0.5314
WNW	w	370	8.355E-04	1.389E-05	-0.4513
NW	w	306	9.082E-04	2.596E-05	-0.3916
NNW	w	241	1.395E-03	3.684E-05	-0.4003

(Refer to Section 4.4.3)

TABLE C-16

**85TH PERCENTILE HOURLY PLUME CENTERLINE DEPOSITION VALUES
AND ANNUAL SECTOR AVERAGE DEPOSITION VALUES
FOR UNMONITORED GROUND LEVEL RELEASES DETERMINED
FROM ANNUAL AVERAGE METEOROLOGICAL DATA (1985-1992)
(FOR USE WITH SHORT TERM RELEASES)**

Deposition (D/Q) (1/m²)

<u>Direction</u>		<u>Site Boundary Distance (m)</u>	<u>Hourly Plume Cent. (D/Q) (1/m²)</u>	<u>Annual Sector Ave. (D/Q) (1/m²)</u>	<u>Slope m</u>
N	w	225	3.819E-06	1.331E-07	-0.3698
NNE	w	225	3.549E-06	7.094E-08	-0.4310
NE	w	354	1.840E-06	3.000E-08	-0.4534
ENE	w	563	1.166E-06	3.235E-08	-0.3949
E	l	950	4.777E-07	1.352E-08	-0.3927
ESE	l	1030	3.797E-07	8.757E-09	-0.4152
SE	l	1110	3.096E-07	6.456E-09	-0.4263
SSE	l	1754	1.560E-07	1.852E-09	-0.4884
S	l	2205	1.083E-07	1.409E-09	-0.4783
SSW	l	2269	1.300E-07	1.371E-09	-0.5014
SW	l	2382	1.366E-07	1.507E-09	-0.4965
WSW	w	1867	2.155E-07	1.247E-09	-0.5676
W	w	644	1.008E-06	7.794E-09	-0.5356
WNW	w	370	2.080E-06	4.097E-08	-0.4326
NW	w	306	2.588E-06	8.546E-08	-0.3757
NNW	w	241	3.727E-06	1.139E-07	-0.3842

(Refer to Section 4.4.3)

TABLE C-17

85TH PERCENTILE HOURLY PLUME CENTERLINE DISPERSION VALUES
 FOR UNMONITORED GROUND LEVEL RELEASES DETERMINED
 FROM ANNUAL AVERAGE METEOROLOGICAL DATA (1985-1992)
 (FOR USE WITH SHORT TERM RELEASES)

Plume Centerline Concentration X/Q (sec/m³)

SEGMENT BOUNDARIES IN MILES

<u>Direction</u>	0.5	0.75	1.0	1.5	2.5	3.5
N	1.699E-04	1.076E-04	7.986E-05	4.929E-05	3.382E-05	2.338E-05
NNE	1.607E-04	1.046E-04	7.674E-05	4.790E-05	2.941E-05	2.237E-05
NE	1.443E-04	8.910E-05	6.364E-05	3.787E-05	2.353E-05	1.628E-05
ENE	9.691E-05	6.042E-05	4.300E-05	2.458E-05	1.431E-05	9.546E-06
E	6.170E-05	3.762E-05	2.673E-05	1.457E-05	8.488E-06	5.543E-06
ESE	4.999E-05	2.937E-05	2.013E-05	1.079E-05	5.958E-06	3.790E-06
SE	4.934E-05	2.856E-05	1.944E-05	1.003E-05	5.698E-06	3.529E-06
SSE	6.206E-05	3.660E-05	2.469E-05	1.349E-05	7.622E-06	4.850E-06
S	6.415E-05	3.732E-05	2.483E-05	1.356E-05	7.681E-06	4.949E-06
SSW	1.018E-04	5.889E-05	4.124E-05	2.228E-05	1.334E-05	9.017E-06
SW	1.254E-04	7.730E-05	5.343E-05	3.173E-05	1.959E-05	1.331E-05
WSW	1.937E-04	1.217E-04	9.179E-05	5.636E-05	3.565E-05	2.610E-05
W	2.334E-04	1.519E-04	1.131E-04	7.255E-05	4.837E-05	3.588E-05
WNW	2.266E-04	1.507E-04	1.154E-04	7.694E-05	4.867E-05	3.613E-05
NW	2.002E-04	1.305E-04	9.910E-05	6.428E-05	4.403E-05	3.137E-05
NNW	1.950E-04	1.251E-04	9.565E-05	6.064E-05	4.107E-05	3.028E-05
	4.5 Miles	7.5 Miles	15.0 Miles	25.0 Miles	35.0 Miles	45.0 Miles
N	1.787E-05	1.084E-05	5.123E-06	3.189E-06	2.506E-06	2.232E-06
NNE	1.640E-05	9.724E-06	4.242E-06	2.665E-06	2.197E-06	1.946E-06
NE	1.202E-05	6.775E-06	3.149E-06	2.240E-06	1.763E-06	1.658E-06
ENE	7.055E-06	3.816E-06	1.880E-06	1.244E-06	1.024E-06	9.608E-07
E	3.976E-06	2.256E-06	1.239E-06	8.773E-07	7.968E-07	7.410E-07
ESE	2.708E-06	1.508E-06	8.402E-07	6.951E-07	6.563E-07	6.136E-07
SE	2.529E-06	1.446E-06	9.104E-07	7.173E-07	6.712E-07	6.380E-07
SSE	3.487E-06	1.855E-06	1.336E-06	1.005E-06	9.152E-07	8.714E-07
S	3.617E-06	1.977E-06	1.347E-06	9.941E-07	8.840E-07	8.540E-07
SSW	6.567E-06	3.377E-06	1.965E-06	1.491E-06	1.158E-06	1.102E-06
SW	9.555E-06	5.304E-06	2.844E-06	2.096E-06	1.490E-06	1.505E-06
WSW	2.015E-05	1.144E-05	6.078E-06	3.816E-06	2.824E-06	2.563E-06
W	2.801E-05	1.656E-05	8.601E-06	5.208E-06	4.080E-06	3.717E-06
WNW	2.841E-05	1.784E-05	8.792E-06	5.268E-06	4.015E-06	3.663E-06
NW	2.484E-05	1.399E-05	7.019E-06	4.387E-06	3.446E-06	3.205E-06
NNW	2.416E-05	1.525E-05	7.180E-06	4.311E-06	3.235E-06	3.083E-06

TABLE C-18

**SECTOR AVERAGE DISPERSION VALUES
FOR UNMONITORED GROUND LEVEL RELEASES DETERMINED
FROM ANNUAL AVERAGE METEOROLOGICAL DATA (1985-1992)
(FOR USE WITH LONG TERM RELEASES)**

Sector Average Concentration X/Q (sec/m³)

SEGMENT BOUNDARIES IN MILES

<u>Direction</u>	0.5	0.75	1.0	1.5	2.5	3.5
N	3.948E-06	2.078E-06	1.348E-06	7.608E-07	3.800E-07	2.415E-07
NNE	2.048E-06	1.091E-06	7.116E-07	3.995E-07	1.969E-07	1.241E-07
NE	1.427E-06	7.723E-07	5.060E-07	2.825E-07	1.373E-07	8.575E-08
ENE	1.985E-06	1.070E-06	6.992E-07	3.889E-07	1.884E-07	1.176E-07
E	1.375E-06	7.249E-07	4.692E-07	2.593E-07	1.254E-07	7.838E-08
ESE	8.717E-07	4.596E-07	2.977E-07	1.639E-07	7.877E-08	4.911E-08
SE	6.983E-07	3.671E-07	2.384E-07	1.315E-07	6.333E-08	3.958E-08
SSE	5.697E-07	3.018E-07	1.968E-07	1.089E-07	5.258E-08	3.289E-08
S	6.334E-07	3.339E-07	2.169E-07	1.195E-07	5.752E-08	3.595E-08
SSW	9.625E-07	5.148E-07	3.338E-07	1.828E-07	8.685E-08	5.362E-08
SW	1.601E-06	8.640E-07	5.612E-07	3.081E-07	1.465E-07	9.029E-08
WSW	1.457E-06	7.891E-07	5.157E-07	2.866E-07	1.385E-07	8.613E-08
W	1.881E-06	9.925E-07	6.461E-07	3.645E-07	1.815E-07	1.150E-07
WNW	3.757E-06	1.944E-06	1.254E-06	7.106E-07	3.593E-07	2.300E-07
NW	5.025E-06	2.605E-06	1.678E-06	9.490E-07	4.789E-07	3.063E-07
NNW	4.607E-06	2.382E-06	1.534E-06	8.699E-07	4.408E-07	2.826E-07
	4.5	7.5	15.0	25.0	35.0	45.0
N	1.726E-07	8.781E-08	3.565E-08	1.855E-08	1.212E-08	8.843E-09
NNE	8.811E-08	4.427E-08	1.769E-08	9.098E-09	5.901E-09	4.285E-09
NE	6.049E-08	2.998E-08	1.176E-08	5.962E-09	3.832E-09	2.764E-09
ENE	8.299E-08	4.122E-08	1.627E-08	8.305E-09	5.365E-09	3.887E-09
E	5.540E-08	2.769E-08	1.109E-08	5.734E-09	3.740E-09	2.731E-09
ESE	3.465E-08	1.728E-08	6.916E-09	3.581E-09	2.339E-09	1.711E-09
SE	2.799E-08	1.402E-08	5.659E-09	2.952E-09	1.939E-09	1.425E-09
SSE	2.326E-08	1.164E-08	4.686E-09	2.438E-09	1.598E-09	1.172E-09
S	2.541E-08	1.272E-08	5.133E-09	2.678E-09	1.759E-09	1.293E-09
SSW	3.755E-08	1.840E-08	7.166E-09	3.633E-09	2.341E-09	1.696E-09
SW	6.312E-08	3.078E-08	1.186E-08	5.954E-09	3.807E-09	2.741E-09
WSW	6.060E-08	2.988E-08	1.165E-08	5.884E-09	3.773E-09	2.718E-09
W	8.207E-08	4.159E-08	1.680E-08	8.704E-09	5.673E-09	4.133E-09
WNW	1.653E-07	8.495E-08	3.494E-08	1.834E-08	1.206E-08	8.836E-09
NW	2.199E-07	1.130E-07	4.643E-08	2.436E-08	1.601E-08	1.173E-08
NNW	2.033E-07	1.048E-07	4.324E-08	2.275E-08	1.498E-08	1.099E-08

TABLE C-19

**85TH PERCENTILE HOURLY PLUME CENTERLINE DEPOSITION VALUES
FOR UNMONITORED GROUND LEVEL RELEASES DETERMINED
FROM ANNUAL AVERAGE METEOROLOGICAL DATA (1985-1992)
(FOR USE WITH SHORT TERM RELEASES)**

(D/Q) Plume Centerline Deposition (1/m²)

SEGMENT BOUNDARIES IN MILES

<u>Direction</u>	0.5	0.75	1.0	1.5	2.5	3.5
N	8.196E-07	4.879E-07	3.235E-07	1.745E-07	7.680E-08	4.389E-08
NNE	7.499E-07	4.421E-07	2.918E-07	1.568E-07	6.889E-08	3.933E-08
NE	7.015E-07	4.084E-07	2.680E-07	1.434E-07	6.279E-08	3.582E-08
ENE	7.513E-07	4.265E-07	2.758E-07	1.458E-07	6.348E-08	3.618E-08
E	6.000E-07	3.392E-07	2.198E-07	1.164E-07	5.095E-08	2.906E-08
ESE	5.379E-07	2.994E-07	1.925E-07	1.013E-07	4.402E-08	2.510E-08
SE	4.920E-07	2.729E-07	1.756E-07	9.248E-08	4.022E-08	2.294E-08
SSE	4.987E-07	2.787E-07	1.793E-07	9.390E-08	4.076E-08	2.322E-08
S	5.035E-07	2.780E-07	1.784E-07	9.367E-08	4.064E-08	2.315E-08
SSW	6.150E-07	3.456E-07	2.231E-07	1.178E-07	5.125E-08	2.924E-08
SW	6.826E-07	3.885E-07	2.522E-07	1.337E-07	5.831E-08	3.312E-08
WSW	7.002E-07	4.101E-07	2.698E-07	1.446E-07	6.339E-08	3.617E-08
W	7.821E-07	4.647E-07	3.077E-07	1.658E-07	7.294E-08	4.168E-08
WNW	8.673E-07	5.222E-07	3.480E-07	1.886E-07	8.325E-08	4.764E-08
NW	8.526E-07	5.116E-07	3.403E-07	1.841E-07	8.119E-08	4.643E-08
NNW	8.945E-07	5.382E-07	3.586E-07	1.943E-07	8.572E-08	4.903E-08
	4.5	7.5	15.0	25.0	35.0	45.0
N	2.868E-08	1.216E-08	4.258E-09	1.853E-09	1.097E-09	8.646E-10
NNE	2.569E-08	1.087E-08	3.874E-09	1.831E-09	1.092E-09	8.632E-10
NE	2.339E-08	9.896E-09	3.653E-09	1.815E-09	1.091E-09	8.661E-10
ENE	2.344E-08	9.104E-09	3.470E-09	1.779E-09	1.102E-09	8.689E-10
E	1.884E-08	8.362E-09	3.407E-09	1.768E-09	1.099E-09	8.723E-10
ESE	1.644E-08	7.454E-09	3.210E-09	1.772E-09	1.094E-09	8.726E-10
SE	1.522E-08	7.432E-09	3.238E-09	1.752E-09	1.098E-09	8.714E-10
SSE	1.524E-08	7.294E-09	3.216E-09	1.725E-09	1.093E-09	8.703E-10
S	1.518E-08	7.268E-09	3.248E-09	1.760E-09	1.092E-09	8.686E-10
SSW	1.909E-08	7.815E-09	3.324E-09	1.801E-09	1.089E-09	8.654E-10
SW	2.164E-08	8.873E-09	3.386E-09	1.767E-09	1.086E-09	8.625E-10
WSW	2.362E-08	1.002E-08	3.516E-09	1.747E-09	1.081E-09	8.607E-10
W	2.724E-08	1.156E-08	3.953E-09	1.818E-09	1.082E-09	8.582E-10
WNW	3.117E-08	1.325E-08	4.389E-09	1.856E-09	1.088E-09	8.598E-10
NW	3.035E-08	1.288E-08	4.349E-09	1.863E-09	1.091E-09	8.632E-10
NNW	3.206E-08	1.348E-08	4.593E-09	1.895E-09	1.094E-09	8.638E-10

TABLE C-20

**SECTOR AVERAGE DEPOSITION VALUES
FOR UNMONITORED GROUND LEVEL RELEASES DETERMINED
FROM ANNUAL AVERAGE METEOROLOGICAL DATA (1985-1992)
(FOR USE WITH LONG TERM RELEASES)**

(D/Q) Sector Average Deposition ($1/m^2$)

SEGMENT BOUNDARIES IN MILES

<u>Direction</u>	0.5	0.75	1.0	1.5	2.5	3.5
N	1.937E-08	9.969E-09	6.130E-09	3.059E-09	1.257E-09	6.930E-10
NNE	1.032E-08	5.308E-09	3.264E-09	1.629E-09	6.689E-10	3.688E-10
NE	8.393E-09	4.317E-09	2.654E-09	1.324E-09	5.436E-10	2.996E-10
ENE	1.845E-08	9.552E-09	5.899E-09	2.962E-09	1.227E-09	6.800E-10
E	1.764E-08	9.161E-09	5.670E-09	2.856E-09	1.187E-09	6.598E-10
ESE	1.294E-08	6.744E-09	4.184E-09	2.114E-09	8.826E-10	4.920E-10
SE	1.076E-08	5.627E-09	3.499E-09	1.774E-09	7.439E-10	4.158E-10
SSE	6.557E-09	3.433E-09	2.137E-09	1.085E-09	4.555E-10	2.548E-10
S	7.306E-09	3.827E-09	2.383E-09	1.210E-09	5.084E-10	2.845E-10
SSW	7.625E-09	3.959E-09	2.450E-09	1.234E-09	5.125E-10	2.848E-10
SW	9.231E-09	4.768E-09	2.940E-09	1.473E-09	6.079E-10	3.363E-10
WSW	5.073E-09	2.611E-09	1.606E-09	8.018E-10	3.294E-10	1.816E-10
W	5.456E-09	2.807E-09	1.725E-09	8.608E-10	3.534E-10	1.947E-10
WNW	1.224E-08	6.296E-09	3.870E-09	1.930E-09	7.922E-10	4.365E-10
NW	1.930E-08	9.928E-09	6.103E-09	3.044E-09	1.250E-09	6.888E-10
NNW	1.827E-08	9.403E-09	5.782E-09	2.886E-09	1.185E-09	6.535E-10
	4.5	7.5	15.0	25.0	35.0	45.0
N	4.420E-10	1.789E-10	5.648E-11	2.279E-11	1.219E-11	7.527E-12
NNE	2.352E-10	9.517E-11	3.004E-11	1.212E-11	6.481E-12	4.001E-12
NE	1.911E-10	7.733E-11	2.442E-11	9.857E-12	5.274E-12	3.258E-12
ENE	4.346E-10	1.760E-10	5.563E-11	2.248E-11	1.204E-11	7.449E-12
E	4.221E-10	1.709E-10	5.406E-11	2.186E-11	1.172E-11	7.255E-12
ESE	3.150E-10	1.276E-10	4.035E-11	1.632E-11	8.750E-12	5.416E-12
SE	2.665E-10	1.079E-10	3.412E-11	1.379E-11	7.393E-12	4.574E-12
SSE	1.634E-10	6.612E-11	2.089E-11	8.433E-12	4.514E-12	2.789E-12
S	1.824E-10	7.383E-11	2.332E-11	9.413E-12	5.038E-12	3.112E-12
SSW	1.821E-10	7.369E-11	2.327E-11	9.385E-12	5.020E-12	3.099E-12
SW	2.147E-10	8.686E-11	2.740E-11	1.104E-11	5.900E-12	3.639E-12
WSW	1.158E-10	4.682E-11	1.474E-11	5.924E-12	3.156E-12	1.941E-12
W	1.241E-10	5.017E-11	1.579E-11	6.346E-12	3.381E-12	2.079E-12
WNW	2.783E-10	1.126E-10	3.548E-11	1.428E-11	7.624E-12	4.697E-12
NW	4.392E-10	1.777E-10	5.606E-11	2.259E-11	1.207E-11	7.446E-12
NNW	4.168E-10	1.686E-10	5.321E-11	2.145E-11	1.147E-11	7.074E-12

TABLE C-21

85TH PERCENTILE HOURLY PLUME CENTERLINE DISPERSION VALUES
 FOR UNMONITORED GROUND LEVEL RELEASES DETERMINED
 FROM GRAZING METEOROLOGICAL DATA (1985-1992)
 (FOR USE WITH SHORT TERM RELEASES)

Plume Centerline Concentration X/Q (sec/m³)

SEGMENT BOUNDARIES IN MILES

<u>Direction</u>	0.5	0.75	1.0	1.5	2.5	3.5
N	2.035E-04	1.319E-04	9.688E-05	6.511E-05	4.473E-05	3.234E-05
NNE	1.879E-04	1.270E-04	9.123E-05	5.931E-05	3.831E-05	2.740E-05
NE	1.632E-04	1.030E-04	7.465E-05	4.782E-05	2.895E-05	1.998E-05
ENE	1.029E-04	6.414E-05	4.529E-05	2.778E-05	1.533E-05	1.037E-05
E	6.347E-05	3.871E-05	2.645E-05	1.643E-05	8.680E-06	5.704E-06
ESE	5.529E-05	3.284E-05	2.249E-05	1.344E-05	7.231E-06	4.554E-06
SE	5.878E-05	3.449E-05	2.322E-05	1.327E-05	7.155E-06	4.530E-06
SSE	7.662E-05	4.653E-05	3.199E-05	1.929E-05	1.017E-05	6.744E-06
S	6.387E-05	3.657E-05	2.530E-05	1.454E-05	7.813E-06	5.065E-06
SSW	1.002E-04	6.046E-05	4.342E-05	2.548E-05	1.416E-05	9.655E-06
SW	1.271E-04	7.949E-05	5.718E-05	3.660E-05	2.001E-05	1.420E-05
WSW	2.173E-04	1.416E-04	1.017E-04	7.040E-05	4.171E-05	3.095E-05
W	2.657E-04	1.695E-04	1.282E-04	8.955E-05	5.926E-05	4.564E-05
WNW	2.947E-04	1.962E-04	1.530E-04	1.115E-04	7.065E-05	5.353E-05
NW	2.589E-04	1.711E-04	1.294E-04	9.394E-05	5.940E-05	4.747E-05
NNW	2.240E-04	1.457E-04	1.122E-04	7.873E-05	5.217E-05	4.167E-05
	4.5	7.5	15.0	25.0	35.0	45.0
N	2.466E-05	1.477E-05	7.229E-06	4.548E-06	3.258E-06	2.939E-06
NNE	2.146E-05	1.237E-05	5.954E-06	3.551E-06	2.874E-06	2.555E-06
NE	1.480E-05	8.449E-06	4.107E-06	2.760E-06	2.172E-06	1.943E-06
ENE	7.723E-06	4.094E-06	2.113E-06	1.431E-06	1.194E-06	1.080E-06
E	4.203E-06	2.450E-06	1.520E-06	1.093E-06	9.532E-07	9.103E-07
ESE	3.277E-06	2.083E-06	1.212E-06	8.868E-07	9.226E-07	9.234E-07
SE	3.284E-06	2.108E-06	1.223E-06	9.083E-07	9.658E-07	9.015E-07
SSE	4.949E-06	3.255E-06	1.759E-06	1.451E-06	1.200E-06	1.125E-06
S	3.595E-06	2.290E-06	1.634E-06	1.226E-06	1.051E-06	9.739E-07
SSW	7.015E-06	3.692E-06	2.072E-06	1.640E-06	1.361E-06	1.212E-06
SW	1.059E-05	5.604E-06	2.972E-06	2.285E-06	1.926E-06	1.784E-06
WSW	2.380E-05	1.346E-05	6.594E-06	4.291E-06	3.372E-06	3.081E-06
W	3.488E-05	2.109E-05	1.008E-05	6.435E-06	5.014E-06	4.515E-06
WNW	4.291E-05	2.492E-05	1.284E-05	8.174E-06	5.922E-06	5.432E-06
NW	3.796E-05	2.309E-05	1.200E-05	7.419E-06	4.994E-06	4.573E-06
NNW	3.380E-05	2.018E-05	9.838E-06	5.947E-06	4.413E-06	4.003E-06

TABLE C-22

**SECTOR AVERAGE DISPERSION VALUES
FOR UNMONITORED GROUND LEVEL RELEASES DETERMINED
FROM GRAZING METEOROLOGICAL DATA (1985-1992)
(FOR USE WITH LONG TERM RELEASES)**

Sector Average Concentration X/Q (sec/m³)

SEGMENT BOUNDARIES IN MILES

<u>Direction</u>	0.5	0.75	1.0	1.5	2.5	3.5
N	5.300E-06	2.743E-06	1.774E-06	1.010E-06	5.125E-07	3.291E-07
NNE	2.423E-06	1.273E-06	8.309E-07	4.714E-07	2.365E-07	1.507E-07
NE	1.607E-06	8.669E-07	5.697E-07	3.202E-07	1.572E-07	9.874E-08
ENE	2.342E-06	1.257E-06	8.224E-07	4.586E-07	2.232E-07	1.398E-07
E	1.650E-06	8.651E-07	5.604E-07	3.111E-07	1.517E-07	9.540E-08
ESE	9.686E-07	5.088E-07	3.309E-07	1.837E-07	8.941E-08	5.619E-08
SE	6.517E-07	3.422E-07	2.237E-07	1.250E-07	6.131E-08	3.878E-08
SSE	5.531E-07	2.919E-07	1.915E-07	1.072E-07	5.265E-08	3.332E-08
S	6.636E-07	3.486E-07	2.274E-07	1.262E-07	6.142E-08	3.870E-08
SSW	8.999E-07	4.813E-07	3.136E-07	1.731E-07	8.310E-08	5.169E-08
SW	1.540E-06	8.357E-07	5.447E-07	2.999E-07	1.430E-07	8.841E-08
WSW	1.549E-06	8.355E-07	5.452E-07	3.039E-07	1.479E-07	9.243E-08
W	2.100E-06	1.097E-06	7.138E-07	4.055E-07	2.043E-07	1.305E-07
WNW	4.454E-06	2.263E-06	1.452E-06	8.306E-07	4.280E-07	2.7awE-07
NW	6.109E-06	3.102E-06	1.987E-06	1.135E-06	5.847E-07	3.787E-07
NNW	5.849E-06	2.971E-06	1.903E-06	1.087E-06	5.593E-07	3.621E-07
	4.5	7.5	15.0	25.0	35.0	45.0
N	2.369E-07	1.223E-07	5.055E-08	2.663E-08	1.753E-08	1.286E-08
NNE	1.079E-07	5.507E-08	2.245E-08	1.171E-08	7.663E-09	5.598E-09
NE	6.998E-08	3.501E-08	1.389E-08	7.107E-09	4.592E-09	3.324E-09
ENE	9.892E-08	4.941E-08	1.967E-08	1.011E-08	6.559E-09	4.768E-09
E	6.774E-08	3.416E-08	1.385E-08	7.224E-09	4.739E-09	3.475E-09
ESE	3.988E-08	2.010E-08	8.165E-09	4.270E-09	2.807E-09	2.062E-09
SE	2.764E-08	1.405E-08	5.767E-09	3.044E-09	2.013E-09	1.486E-09
SSE	2.376E-08	1.207E-08	4.950E-09	2.609E-09	1.724E-09	1.272E-09
S	2.753E-08	1.395E-08	5.723E-09	3.022E-09	2.002E-09	1.480E-09
SSW	3.639E-08	1.802E-08	7.121E-09	3.649E-09	2.367E-09	1.723E-09
SW	6.194E-08	3.035E-08	1.178E-08	5.946E-09	3.814E-09	2.750E-09
WSW	6.527E-08	3.245E-08	1.279E-08	6.514E-09	4.200E-09	3.037E-09
W	9.357E-08	4.793E-08	1.962E-08	1.026E-08	6.727E-09	4.920E-09
WNW	2.008E-07	1.049E-07	4.398E-08	2.339E-08	1.550E-08	1.142E-08
NW	2.744E-07	1.433E-07	6.013E-08	3.200E-08	2.120E-08	1.563E-08
NNW	2.622E-07	1.369E-07	5.743E-08	3.056E-08	2.025E-08	1.493E-08

TABLE C-23

85TH PERCENTILE HOURLY PLUME CENTERLINE DEPOSITION VALUES
 FOR UNMONITORED GROUND LEVEL RELEASES DETERMINED
 FROM GRAZING METEOROLOGICAL DATA (1985-1992)
 (FOR USE WITH SHORT TERM RELEASES)

(D/Q) Sector Average Deposition (1/m²)

SEGMENT BOUNDARIES IN MILES

<u>Direction</u>	0.5	0.75	1.0	1.5	2.5	3.5
N	9.063E-07	5.471E-07	3.636E-07	1.966E-07	8.666E-08	4.952E-08
NNE	8.251E-07	4.868E-07	3.215E-07	1.728E-07	7.592E-08	4.334E-08
NE	7.357E-07	4.285E-07	2.771E-07	1.482E-07	6.503E-08	3.718E-08
ENE	7.139E-07	4.059E-07	2.633E-07	1.390E-07	6.056E-08	3.455E-08
E	5.942E-07	3.352E-07	2.174E-07	1.145E-07	4.986E-08	2.843E-08
ESE	5.161E-07	2.898E-07	1.872E-07	9.833E-08	4.282E-08	2.443E-08
SE	5.089E-07	2.831E-07	1.820E-07	9.577E-08	4.161E-08	2.372E-08
SSE	5.281E-07	2.921E-07	1.855E-07	9.735E-08	4.223E-08	2.406E-08
S	4.971E-07	2.780E-07	1.795E-07	9.481E-08	4.129E-08	2.356E-08
SSW	6.017E-07	3.342E-07	2.150E-07	1.132E-07	4.916E-08	2.802E-08
SW	6.735E-07	3.808E-07	2.459E-07	1.297E-07	5.629E-08	3.210E-08
WSW	7.454E-07	4.299E-07	2.812E-07	1.501E-07	6.569E-08	3.750E-08
W	8.255E-07	4.942E-07	3.284E-07	1.775E-07	7.813E-08	4.461E-08
WNW	9.768E-07	5.984E-07	4.019E-07	2.191E-07	9.694E-08	5.542E-08
NW	9.981E-07	6.144E-07	4.117E-07	2.241E-07	9.911E-08	5.667E-08
NNW	9.449E-07	5.713E-07	3.826E-07	2.082E-07	9.205E-08	5.265E-08
	4.5	7.5	15.0	25.0	35.0	45.0
N	3.236E-08	1.356E-08	4.621E-09	1.897E-09	1.098E-09	8.646E-10
NNE	2.831E-08	1.195E-08	4.113E-09	1.839E-09	1.092E-09	8.622E-10
NE	2.433E-08	1.035E-08	3.679E-09	1.802E-09	1.091E-09	8.636E-10
ENE	2.248E-08	8.997E-09	3.623E-09	1.798E-09	1.100E-09	8.672E-10
E	1.850E-08	8.152E-09	3.457E-09	1.792E-09	1.096E-09	8.705E-10
ESE	1.618E-08	7.794E-09	3.226E-09	1.746E-09	1.094E-09	8.718E-10
SE	1.571E-08	7.255E-09	3.160E-09	1.748E-09	1.091E-09	8.694E-10
SSE	1.606E-08	7.248E-09	3.154E-09	1.790E-09	1.087E-09	8.633E-10
S	1.556E-08	7.412E-09	3.201E-09	1.765E-09	1.089E-09	8.651E-10
SSW	1.833E-08	7.403E-09	3.328E-09	1.773E-09	1.086E-09	8.637E-10
SW	2.098E-08	8.312E-09	3.361E-09	1.789E-09	1.083E-09	8.606E-10
WSW	2.451E-08	1.061E-08	3.594E-09	1.728E-09	1.078E-09	8.604E-10
W	2.912E-08	1.229E-08	4.144E-09	1.869E-09	1.081E-09	8.576E-10
WNW	3.619E-08	1.527E-08	5.019E-09	1.940E-09	1.088E-09	8.569E-10
NW	3.702E-08	1.563E-08	4.880E-09	1.914E-09	1.092E-09	8.605E-10
NNW	3.440E-08	1.450E-08	4.799E-09	1.929E-09	1.096E-09	8.631E-10

TABLE C-24

**SECTOR AVERAGE DEPOSITION VALUES
FOR UNMONITORED GROUND LEVEL RELEASES DETERMINED
FROM GRAZING METEOROLOGICAL DATA (1985-1992)
(FOR USE WITH LONG TERM RELEASES)**

(D/Q) Sector Average Deposition ($1/m^2$)

SEGMENT BOUNDARIES IN MILES

<u>Direction</u>	0.5	0.75	1.0	1.5	2.5	3.5
N	2.265E-08	1.167E-08	7.177E-09	3.585E-09	1.474E-09	8.132E-10
NNE	1.028E-08	5.295E-09	3.258E-09	1.627E-09	6.691E-10	3.691E-10
NE	8.034E-09	4.134E-09	2.542E-09	1.269E-09	5.213E-10	2.874E-10
ENE	2.078E-08	1.079E-08	6.675E-09	3.361E-09	1.397E-09	7.762E-10
E	1.924E-08	1.002E-08	6.213E-09	3.138E-09	1.309E-09	7.293E-10
ESE	1.159E-08	6.054E-09	3.762E-09	1.906E-09	7.979E-10	4.456E-10
SE	7.983E-09	4.184E-09	2.605E-09	1.324E-09	5.563E-10	3.114E-10
SSE	5.124E-09	2.690E-09	1.677E-09	8.534E-10	3.593E-10	2.014E-10
S	7.383E-09	3.880E-09	2.421E-09	1.233E-09	5.198E-10	2.916E-10
SSW	6.769E-09	3.525E-09	2.186E-09	1.104E-09	4.602E-10	2.563E-10
SW	8.471E-09	4.384E-09	2.706E-09	1.358E-09	5.619E-10	3.113E-10
WSW	5.062E-09	2.608E-09	1.605E-09	8.019E-10	3.298E-10	1.820E-10
W	5.392E-09	2.777E-09	1.708E-09	8.529E-10	3.506E-10	1.933E-10
WNW	1.123E-08	5.780E-09	3.555E-09	1.774E-09	7.289E-10	4.019E-10
NW	1.792E-08	9.223E-09	5.671E-09	2.830E-09	1.162E-09	6.408E-10
NNW	1.976E-08	1.018E-08	6.260E-09	3.126E-09	1.285E-09	7.091E-10
	4.5	7.5	15.0	25.0	35.0	45.0
N	5.188E-10	2.099E-10	6.626E-11	2.672E-11	1.429E-11	8.820E-12
NNE	2.355E-10	9.527E-11	3.006E-11	1.212E-11	6.476E-12	3.995E-12
NE	1.833E-10	7.418E-11	2.341E-11	9.442E-12	5.048E-12	3.116E-12
ENE	4.965E-10	2.010E-10	6.352E-11	2.565E-11	1.374E-11	8.493E-12
E	4.669E-10	1.890E-10	5.976E-11	2.415E-11	1.294E-11	8.006E-12
ESE	2.855E-10	1.156E-10	3.653E-11	1.476E-11	7.905E-12	4.888E-12
SE	1.997E-10	8.083E-11	2.553E-11	1.031E-11	5.516E-12	3.408E-12
SSE	1.292E-10	5.225E-11	1.648E-11	6.643E-12	3.550E-12	2.189E-12
S	1.871E-10	7.570E-11	2.390E-11	9.637E-12	5.153E-12	3.181E-12
SSW	1.641E-10	6.637E-11	2.094E-11	8.442E-12	4.512E-12	2.783E-12
SW	1.988E-10	8.042E-11	2.536E-11	1.021E-11	5.453E-12	3.361E-12
WSW	1.161E-10	4.691E-11	1.476E-11	5.930E-12	3.158E-12	1.942E-12
W	1.233E-10	4.981E-11	1.567E-11	6.292E-12	3.349E-12	2.058E-12
WNW	2.562E-10	1.036E-10	3.262E-11	1.311E-11	6.990E-12	4.301E-12
NW	4.086E-10	1.652E-10	5.209E-11	2.097E-11	1.119E-11	6.894E-12
NNW	4.523E-10	1.830E-10	5.771E-11	2.325E-11	1.242E-11	7.660E-12

APPENDIX D

LIMITED ANALYSIS APPROACH

DOSE ASSESSMENT FOR LIQUID RADIOACTIVE EFFLUENTS

APPENDIX D

LIMITED ANALYSIS APPROACH DOSE ASSESSMENT FOR LIQUID RADIOACTIVE EFFLUENTS

<u>TABLE</u>	<u>TITLE</u>	<u>PAGE</u>
D-1	Calculation of Total Ci/yr Releases for Liquids	D-5
D-2	Organ Doses For Liquid Releases	D-6
D-3	Dose Contribution to the Adult's Whole Body From the Freshwater Fish Pathway	D-8
D-4	Dose Contribution to the Teenager's Liver from the Freshwater Fish Pathway	D-9
D-5	Dose Contribution to the Adult's Whole Body from the Potable Water Pathway	D-10
D-6	Dose Contribution to the Teenager's Liver from the Potable Water Pathway	D-11
D-7	Dose Contribution to the Adult's Whole Body and to the Teenager's Liver from the Lake Shoreline Deposits Pathway	D-12
D-8	Dose Contribution to the Adult's Whole Body and to the Teenager's Liver from the Swimming and Boating Pathways	D-13
D-9	Calculation of Total Ci/yr Releases for Liquids (2002 through 2009)	D-14

LIMITED ANALYSIS APPROACH DOSE ASSESSMENT FOR LIQUID RADIOACTIVE EFFLUENTS

The radioactive liquid effluents for the years 1980 through 1987 (from the JAFNPP Semi-Annual Effluent release reports) were evaluated to determine the critical pathways, organs, age groups, and nuclides which contributed to environmental doses. The liquid release nuclide distribution used in this analysis is shown in Table D-1. This analysis was performed to develop a limited dose analysis for determination of liquid effluent environmental doses. Limiting the dose calculation to a few selected nuclides that contribute the majority of the dose, along with the application of an appropriate conservatism factor to compensate for variations in isotopic mixtures, provides a simplified method of determining compliance with the dose limits of Technical Specification 2.3.

Tables D-2 through D-8 show the results of this evaluation. Table D-2 presents the dose for 8 organs and 4 age groups from all available pathways. The adult's whole body and teenager's age groups (adult, teenager, child, and infant) and all organs (bone, liver, kidney, thyroid, lung, skin, and GI-LLI). The dominant pathway contribution to these doses is freshwater fish ingestion. Table D-3 presents the percent of the adult's whole body dose contribution by the major radionuclides through the dominant pathway, ingestion of freshwater fish. Table D-4 presents the same data for the teenager's liver dose. The data in Tables D-3 and D-4 show that the fish pathway contributes at least 92% to the adult's whole body dose and at least 80.9% to the teenager's liver dose from all pathways considered. The data in the tables also show that during 1980-1987 the radionuclides Cs-134, Cs-137, Zn-65, Co-60, and Mn-54 contributed over 91% of the total dose to the whole body and over 80% of the total liver dose via the freshwater fish ingestion pathway.

The data in Tables D-5 and D-6 show that the potable water pathway contributed no more than 1% to the adult's whole body dose and no more than 0.5% to the teenager's liver dose. This pathway is necessary to demonstrate compliance with 10CFR50 as specified in Sections 4.2 and 4.3.1 of NUREG-0133. As mentioned in Appendix A, Table A-4.3, this pathway is considered for all required analysis.

Table D-7 shows that 17.9% of the teenager's dose to the liver in 1984 was from the lake shoreline deposits pathway. The lake shoreline pathway contributed 5.7% of the adult's whole body dose in 1984. This pathway contributed 9.3% of the teenager's liver dose in 1986 and 2.8% of the adult's whole body dose in 1986. The lake shoreline deposits pathway is second to the freshwater fish pathway when the concentrations of Cs-134, Cs-137, Zn-65, Co-60, and Mn-54 are low as in 1984 and 1986.

**LIMITED ANALYSIS APPROACH
DOSE ASSESSMENT FOR LIQUID RADIOACTIVE EFFLUENTS
(Continued)**

Table D-8 shows that the swimming and boating pathways, combined, contribute no more than 1.5% to the adult's whole body dose and no more than 0.8% to the teenager's liver dose from 1980 to 1987. The swimming and boating pathways are not used in the ODCM since their dose contributions are very small.

A conservatism factor of 0.8 is introduced into the equation (i.e., calculated doses using this approach should be divided by 0.8) to compensate for any unexpected variability in nuclide and pathway dose contribution. Therefore, the dose commitment to the adult's whole body and teenager's liver due to radioactive material in liquid effluents can be reasonably estimated by limiting the dose calculation to these 5 nuclides and the fish and potable water pathways, which cumulatively contribute the bulk of the total dose calculated by accounting for all nuclides and all pathways.

The radioactive liquid effluents have decreased dramatically over the years. Liquid effluent releases for the years 2002 through 2009 were reviewed. Table D-9 lists the radionuclide distribution and also lists the reduction factors per radionuclide as compared to Table D-1. The liquid effluent data from 1980-1987 is what Appendix D is currently based on. Table D-1 is based on the 1980-1987 effluent data and has 34 radionuclides compared to the updated Table D-9 which has only 12 radionuclides. The critical pathways and age groups presented in Appendix D are still valid based on the 2002-2009 effluent data (see ODCM verification document, Reference 6.13).

TABLE D-1
CALCULATION OF TOTAL Ci/yr RELEASES FOR LIQUIDS
(Based on Semi-Annual Effluent Release Reports for the Years 1980 through 1987)

ISOTOPE	1980	1981	1982	1983	1984	1985	1986	1987	AVERAGE Ci/yr
H-3	2.81E 00	4.11E 00	6.55E-01	2.72E 00	4.77E 00	4.20E 00	5.00E 00	2.48E 00	3.34E 00
Ag-110m	1.12E-04	2.21E-04	1.15E-05	9.49E-05	2.66E-05	5.34E-06	--	--	5.90E-05
Cu-64	3.42E-02	--	--	--	--	--	--	--	4.28E-03
Cs-134	7.30E-02	8.00E-02	5.47E-02	5.11E-02	2.19E-04	8.71E-03	6.68E-05	1.47E-03	3.37E-02
Cs-137	1.06E-01	1.26E-01	6.96E-02	7.77E-02	8.80E-04	1.27E-02	1.01E-03	6.65E-03	5.01E-02
I-131	2.77E-02	4.50E-02	9.05E-04	1.95E-03	4.73E-05	2.32E-05	--	--	9.45E-03
Ba/La-140	4.61E-04	1.12E-03	1.82E-03	4.49E-04	5.86E-04	5.55E-04	2.61E-06	2.58E-05	6.27E-04
Co-58	1.07E-01	2.08E-01	2.94E-02	2.49E-02	3.23E-03	6.82E-03	--	2.90E-03	4.78E-02
Co-60	8.03E-01	1.40E 00	3.66E-01	4.86E-01	3.99E 02	9.96E-02	1.56E-02	4.32E 02	4.07E-01
Fe-59	1.31E-02	1.10E-02	3.46E-03	4.40E-03	3.21E-04	2.79E-04	--	3.49E-04	4.11E-03
Zn-65	3.11E-02	4.57E-02	9.81E-03	5.27E-03	1.29E-03	6.14E-03	7.20E-04	4.67E-04	1.26E-02
Mn-54	2.10E-01	3.44E-01	6.76E-02	1.04E-01	1.02E-02	2.86E-02	7.30E-04	1.60E-02	9.76E-02
Cr-51	4.63E-02	4.79E-02	2.77E-03	2.83E-03	8.30E-04	1.51E-04	2.95E-05	--	1.26E-02
Sb-124	4.87E-03	3.83E-03	5.37E-04	7.62E-04	1.87E-05	--	--	1.27E-04	1.27E-03
Mo-99	1.41E-02	6.44E-04	1.22E-04	7.61E-04	--	2.32E-04	2.07E-06	--	1.98E-03
Tc-99m	1.81E-04	1.67E-03	3.17E-05	2.40E-04	1.38E-04	1.94E-05	3.10E-07	--	2.85E-04
Ce-141	1.72E-05	6.99E-05	3.83E-05	1.03E-04	1.23E-04	1.32E-04	1.53E-06	--	6.06E-05
Zr/Nb-95	2.14E-03	2.54E-04	5.50E-05	1.45E-04	1.74E-04	7.02E-05	1.20E-06*	--	3.55E-04
Ce-144	6.33E-05	6.58E-04	2.46E-05	5.68E-05	1.88E-05	6.87E-04	1.27E-04	--	2.04E-04
I-133	1.22E-03	5.35E-03	1.03E-03	2.16E-03	1.08E-04	9.72E-06	1.67E-06	--	1.23E-03
Na-24	1.79E-02	3.77E-02	1.70E-03	2.01E-03	2.02E-04	2.22E-05	--	2.78E-04	7.48E-03
As-76	2.46E-04	2.08E-04	8.67E-05	3.40E-06	2.89E-04	2.24E-05	--	--	1.07E-04
Np-239	2.24E-03	4.29E-02	1.88E-02	3.55E-03	2.02E-03	2.45E-04	--	--	8.72E-03
Xe-133	9.65E-03	3.98E-02	1.05E-02	6.81E-04	2.82E-03	5.29E-03	1.82E-04	4.51E-05	8.62E-03
Xe-135	3.28E-03	5.85E-02	1.01E-02	7.03E-04	3.31E-02	9.86E-03	6.67E-04	--	1.45E-02
Kr-85m	2.88E-04	7.28E-06	7.14E-05	3.52E-05	5.40E-05	--	--	--	5.70E-05
I-135	4.97E-05	2.47E-03	1.45E-04	6.20E-04	--	--	--	--	4.11E-04
Sr-89	--	--	5.76E-04	--	--	--	--	--	7.20E-05
Sr-90	3.47E-05	1.27E-04	1.88E-04	1.38E-04	--	--	--	--	6.10E-05
Fe-55	--	--	--	--	--	2.19E-03	--	6.78E-03	1.12E-03
Co-57	--	--	--	--	--	--	1.29E-05	--	1.61E-06
Zr-97	--	--	--	--	--	--	2.26E-04	--	2.83E-05
Nb-95m	--	--	--	--	--	--	4.32E-06	--	5.40E-07
W-187	--	--	--	--	--	--	--	3.42E-05	4.28E-06

TABLE D-2

ORGAN DOSES FOR LIQUID RELEASES (ALL PATHWAYS)

ADULT								
YEAR	SKIN (mrem)	BONE (mrem)	LIVER (mrem)	W. BODY (mrem)	THYROID (mrem)	KIDNEY (mrem)	LUNG (mrem)	GI-LLI (mrem)
1980	4.94E-03	7.82E-02	1.31E-01	5.58E-02	6.52E-03	4.67E-02	2.00E-02	1.50E-02
1981	8.05E-03	8.97E-02	1.48E-01	6.43E-02	1.05E-02	5.45E-02	2.44E-02	1.97E-02
1982	2.28E-03	5.17E-02	8.75E-02	3.71E-02	2.10E-03	3.03E-02	1.27E-02	5.67E-03
1983	2.92E-03	5.37E-02	8.86E-02	3.74E-02	2.74E-03	3.10E-02	1.34E-02	6.94E-03
1984	2.01E-04	6.08E-04	9.56E-04	4.94E-04	1.86E-04	4.64E-04	2.63E-04	6.44E-04
1985	6.46E-04	9.98E-03	1.68E-02	7.18E-03	5.79E-04	6.07E-03	2.55E-03	1.82E-03
1986	8.21E-05	5.31E-04	7.48E-04	3.29E-04	7.58E-05	3.17E-04	1.56E-04	1.71E-04
1987	7.35E-04	1.05E-02	1.54E-02	6.24E-03	6.57E-04	5.62E-03	2.54E-03	1.83E-03
TEENAGER								
YEAR	SKIN (mrem)	BONE (mrem)	LIVER (mrem)	W. BODY (mrem)	THYROID (mrem)	KIDNEY (mrem)	LUNG (mrem)	GI-LLI (mrem)
1980	4.94E-03	7.82E-02	1.31E-01	5.58E-02	6.52E-03	4.67E-02	2.00E-02	1.50E-02
1981	8.05E-03	8.97E-02	1.48E-01	6.43E-02	1.05E-02	5.45E-02	2.44E-02	1.97E-02
1982	2.28E-03	5.17E-02	8.75E-02	3.71E-02	2.10E-03	3.03E-02	1.27E-02	5.67E-03
1983	2.92E-03	5.37E-02	8.86E-02	3.74E-02	2.74E-03	3.10E-02	1.34E-02	6.94E-03
1984	2.01E-04	6.08E-04	9.56E-04	4.94E-04	1.86E-04	4.64E-04	2.63E-04	6.44E-04
1985	6.46E-04	9.98E-03	1.68E-02	7.18E-03	5.79E-04	6.07E-03	2.55E-03	1.82E-03
1986	8.21E-05	5.31E-04	7.48E-04	3.29E-04	7.58E-05	3.17E-04	1.56E-04	1.71E-04
1987	7.35E-04	1.05E-02	1.54E-02	6.24E-03	6.57E-04	5.62E-03	2.54E-03	1.83E-03

TABLE D-2 (Continued)

ORGAN DOSES FOR LIQUID RELEASES (ALL PATHWAYS)

CHILD								
YEAR	SKIN (mrem)	BONE (mrem)	LIVER (mrem)	W. BODY (mrem)	THYROID (mrem)	KIDNEY (mrem)	LUNG (mrem)	GI-LLI (mrem)
1980	1.03E-03	9.27E-02	1.12E-01	2.22E-02	3.64E-03	3.68E-02	1.34E-02	4.86E-03
1981	1.68E-03	1.04E-01	1.25E-01	2.56E-02	4.79E-03	4.16E-02	1.53E-02	5.95E-03
1982	4.77E-04	6.18E-02	7.48E-02	1.43E-02	5.58E-04	2.43E-02	8.87E-03	1.74E-03
1983	6.09E-04	6.39E-02	7.57E-02	1.43E-02	7.70E-04	2.46E-02	9.13E-03	2.12E-03
1984	4.20E-05	5.96E-04	7.16E-04	2.13E-04	4.76E-05	2.78E-04	1.09E-04	2.01E-04
1985	1.35E-04	1.17E-02	1.42E-02	2.89E-03	1.41E-04	4.75E-03	1.69E-03	5.58E-04
1986	1.72E-05	5.89E-04	6.16E-04	1.38E-04	1.81E-05	2.24E-04	8.23E-05	4.99E-05
1987	1.53E-04	1.24E-02	1.33E-02	2.42E-03	1.60E-04	4.40E-03	1.66E-03	5.55E-04
INFANT								
YEAR	SKIN (mrem)	BONE (mrem)	LIVER (mrem)	W. BODY (mrem)	THYROID (mrem)	KIDNEY (mrem)	LUNG (mrem)	GI-LLI (mrem)
1980	0	4.12E-04	5.60E-04	2.58E-04	1.16E-03	2.58E-04	1.93E-04	2.34E-04
1981	0	5.45E-04	7.24E-04	4.08E-04	1.84E-03	3.69E-04	2.95E-04	3.83E-04
1982	0	2.52E-04	3.26E-04	1.20E-04	1.01E-04	1.32E-04	9.22E-05	1.01E-04
1983	0	2.67E-04	3.54E-04	1.47E-04	1.59E-04	1.52E-04	1.12E-04	1.27E-04
1984	0	7.73E-06	1.38E-05	1.31E-05	1.16E-05	1.06E-05	1.01E-05	1.34E-05
1985	0	5.14E-05	7.43E-05	3.61E-05	2.38E-05	3.57E-05	2.78E-05	3.38E-05
1986	0	3.78E-06	8.99E-06	7.81E-06	6.50E-06	7.07E-06	6.70E-06	7.83E-06
1987	0	5.64E-05	7.85E-05	4.16E-05	2.78E-05	4.00E-05	3.28E-05	3.90E-05

TABLE D-3
DOSE CONTRIBUTION TO THE ADULT'S WHOLE BODY FROM THE
FRESHWATER FISH PATHWAY
(PERCENT)

ISOTOPE	1980	1981	1982	1983	1984	1985	1986	1987
Cs-134	52.7	50.3	56.5	52.2	25.2	52.1	9.2	26.8
Cs-137	45.2	46.8	42.4	46.8	59.7	44.9	82.5	71.5
Zn-65	1.3	1.7	0.6	0.3	8.5	2.1	5.7	0.5
Co-60	0.6	0.9	0.4	0.5	4.5	0.6	2.1	0.8
Mn-54	0.2	0.3	0.1	0.2	1.7	0.2	0.1	0.4
The percentage (%) of the whole body dose from five nuclides in the fish pathway	100	100	100	100	99.6	99.9	99.6	100
The percentage (%) of the total dose to the adult's whole body from the fish pathway	98.8	98.3	99.2	98.9	92.0	98.8	95.6	98.4
The percentage (%) of the total dose to the adult's whole body from the five nuclides in the fish pathway	98.8	98.3	99.2	98.9	91.6	98.7	95.2	98.4

TABLE D-4
DOSE CONTRIBUTION TO THE TEENAGER'S LIVER FROM THE
FRESHWATER FISH PATHWAY
(PERCENT)

ISOTOPE	1980	1981	1982	1983	1984	1985	1986	1987
Cs-134	46.2	43.8	50.2	45.9	20.0	45.5	7.3	22.0
Cs-137	50.8	52.2	48.4	52.9	60.9	50.2	83.5	75.5
Zn-65	2.0	2.5	0.9	0.5	11.9	3.3	8.0	0.7
Co-60	0.2	0.3	0.1	0.2	1.3	0.2	0.6	0.2
Mn-54	0.8	1.1	0.4	0.6	5.6	0.9	0.5	1.4
The percentage (%) of the liver dose from five nuclides in the fish path- way	100	99.9	100	100	99.7	100	99.9	99.8
The percentage (%) of the total dose to the teen's liver from the fish pathway	96.5	95.0	97.6	97.0	80.9	96.4	89.9	95.6
The percentage (%) of the total dose to the teen's liver from the five nuclides in the fish pathway	96.5	94.9	97.6	97.0	80.7	96.4	89.8	95.4

TABLE D-5
DOSE CONTRIBUTION TO THE ADULT'S WHOLE BODY FROM THE
POTABLE WATER PATHWAY
(PERCENT)

ISOTOPE	1980	1981	1982	1983	1984*	1985	1986	1987
Cs-134	41.5	35.7	47.5	41.9	3.29	35.7	1.18	15.5
Cs-137	35.6	33.2	35.7	37.6	7.82	30.7	10.5	41.5
Zn-65	1.01	1.2	0.5	0.25	1.11	1.44	0.73	0.28
Co-60	17.8	24.4	12.4	15.5	23.4	15.9	10.8	17.8
Mn-54	0.86	1.1	0.4	0.61	1.10	0.84	0.09	1.22
 The percentage (%) of the whole body dose from the nuclides from the potable water pathway	 96.8	 95.6	 96.5	 95.9	 36.7	 84.6	 23.3	 76.3
 The percentage (%) the total dose to the adult's whole body from the potable water pathway	 0.16	 0.18	 0.15	 0.15	 0.89	 0.18	 0.94	 0.21
 The percentage (%) of the total dose of the adult's whole body from the five nuclides in the potable water pathway	 0.15	 0.17	 0.14	 0.14	 0.33	 0.15	 0.22	 0.16

* Tritium was the major contributor to the potable water pathway for 1984.

TABLE D-6
DOSE CONTRIBUTION TO THE TEENAGER'S LIVER FROM THE
POTABLE WATER PATHWAY
(PERCENT)

ISOTOPE	1980	1981	1982	1983	1984*	1985	1986	1987
Cs-134	40.9	37.0	47.0	41.7	4.87	36.9	1.74	16.1
Cs-137	45.0	44.2	45.3	48.0	14.8	40.8	19.9	55.3
Zn-65	1.8	2.14	0.85	0.44	2.90	2.63	1.90	0.52
Co-60	6.43	9.25	4.49	5.66	12.7	6.03	5.8	6.77
Mn-54	3.5	4.76	1.73	2.54	6.77	3.62	0.57	5.24
The percentage (%) of the liver dose from the nuclides from the potable water pathway	97.6	97.4	99.4	98.3	42.0	90.0	29.9	83.9
The percentage (%) of the total dose to the teen's liver from the potable water pathway	0.12	0.13	0.12	0.12	0.38	0.14	0.44	0.15
The percentage (%) of the total dose to the teen's liver from the five nuclides in the potable water pathway	0.11	0.12	0.11	0.11	0.16	0.13	0.13	0.12

* Tritium was the major contributor to the potable water pathway for 1984

TABLE D-7

**DOSE CONTRIBUTION TO THE ADULT'S WHOLE BODY AND TEENAGER'S
LIVER FROM THE LAKE SHORELINE DEPOSITS PATHWAY**

1980	1981	1982	1983	1984	1985	1986	1987	
The percentage (%) of the total dose to the adult's whole body from the lake shoreline deposits pathway	0.83	1.22	0.56	0.72	5.68	0.85	2.79	1.12
Maximum percentage from 1980 to 1987 - 5.68%								
Average percentage from 1980 to 1987 - 1.72%								
The percentage (%) of the total dose to the teenager's liver from the lake shoreline deposits pathway	3.22	4.62	2.22	2.80	17.91	3.27	9.33	4.04
Maximum percentage from 1980 to 1987 -	17.9%							
Average percentage from 1980 to 1987 -	5.93%							

TABLE D-8

DOSE CONTRIBUTION TO THE ADULT'S WHOLE BODY AND TEENAGER'S
LIVER FROM THE SWIMMING AND BOATING PATHWAYS

1980	1981	1982	1983	1984	1985	1986	1987	
Percentage (%) of the total dose to the Adult's whole body from the swimming and boating pathways	0.21	0.31	0.13	0.17	1.39	0.20	0.62	0.27
Maximum percentage from 1980 to 1987 -	1.39%							
Average percentage from 1980 to 1987 -	0.41%							
Percentage (%) of the total dose to the teenager's liver from the swimming and boating pathways	0.14	0.21	0.09	0.12	0.78	0.14	0.37	0.18
Maximum percentage from 1980 to 1987 -	0.78%							
Average percentage from 1980 to 1987 -	0.25%							

TABLE D-9

CALCULATION OF TOTAL Ci/yr RELEASES FOR LIQUIDS

(Based on Semi-Annual Effluent Release Reports for the Years 2002 through 2009)

ISOTOPE	2002	2003	2004	2005	2006	2007	2008	2009	AVERAGE Ci/yr	*REDUCTION FACTOR
H-3	6.25E-01	2.76E-03	5.06E-03	1.01-E02	3.81E+00	1.27E-01	3.80+00	1.70E-03	1.05E+00	3.2
Cs-137	3.14E-05								3.93E-06	12748
Co-60	8.44E-04				1.59E-05				1.07E-04	3804
Fe-59	1.88E-04								2.35E-05	175
Zn-65	7.88E-05				3.83E-05				1.46E-05	863
Mn-54	9.76E-04				1.04E-04				1.35E-04	723
Tc-99m	5.47E-07								6.84E-08	4166
Xe-133						5.36E-04			6.70E-05	128
Xe-135							9.91E-05		1.24E-05	1169
Sr-89						5.05E-06			6.31E-07	114
Sr-90	2.74E-07				7.06E-06	5.44E-07			9.85E-07	62
Fe-55	6.32E-04				2.02E-04	1.17E-05			1.06E-04	41.9

* Average Value in ODCM ÷ updated Average Value. For example for H-3, 3.34 ÷ 1.05 = 3.2

APPENDIX E
TECHNICAL BASES FOR EFFECTIVE DOSE FACTORS

APPENDIX E

TECHNICAL BASES FOR EFFECTIVE DOSE FACTORS

<u>TABLE</u>	<u>TITLE</u>	<u>PAGE</u>
E-1	Effective Dose Factors for Noble Gases - Whole Body Effective Dose (K_{eff})	E-6
E-2	Effective Dose Factors for Noble Gases - Air Doses (M_{eff}) and (N_{eff})	E-8
E-3	Effective Dose Factors for Noble Gases - Skin Effective Dose ($(L + 1.1 M)_{\text{eff}}$ and (L_{eff})	E-9
E-4	Tables of Source Terms Used for Development of Effective Dose Transfer Factors (Elevated Release)	E-10
E-5	Tables of Source Terms Used for Development of Effective Dose Transfer Factors (Vent Release)	E-11
E-6	Radionuclide Distribution of Vent and Elevated Releases	E-12

TECHNICAL BASES FOR EFFECTIVE DOSE FACTORS

The evaluation of doses due to releases of radioactive material to the atmosphere can be simplified by the use of effective dose transfer factors instead of using dose factors which are radionuclide specific. These effective factors, which are based on the typical radionuclide distribution in the releases, can be applied to the total radioactivity released to approximate the dose in the environment, i.e., instead of having to sum the isotopic distribution multiplied by the isotope specific dose factor, only a single multiplication (K_{eff} , L_{eff} , M_{eff} or N_{eff}) times the total quantity of radioactive material released, would be needed. This approach provides a reasonable estimate of the actual dose while eliminating the need for a detailed calculating technique.

Determination of Effective Dose Factors

The effective dose transfer factors are based on past operating data. The radioactive effluent distribution for the past years can be used to derive single effective factors by the following equations.

$$K_{\text{eff}} = \sum_{i=1}^n K_i \cdot f_i$$

E-1

Where:

K_{eff} = the effective whole body dose factor due to gamma emissions from all noble gases released.

K_i = the whole body dose factor due to gamma emissions from each noble gas radionuclide 'i' released.

f_i = the fractional abundance of noble gas radionuclide 'i' is of the total noble gas radionuclides.

A K_{eff} is calculated for elevated releases and also for vent releases.

$$L_{\text{eff}} = \sum_{i=1}^n L_i \cdot f_i$$

Where:

L_{eff} = the effective skin dose factor due to beta emissions from all noble gases released.

**TECHNICAL BASES FOR EFFECTIVE DOSE FACTORS
(Continued)**

L_i = the skin dose factor due to the beta emissions from each noble gas radionuclide 'i' released.

For ease of calculation, L_{eff} is calculated for elevated releases and $(L + 1.1M)_{\text{eff}}$ is calculated for vent releases.

$$(L + 1.1M)_{\text{eff}} = \sum_{i=1}^n (L_i + 1.1M_i) \cdot f_i$$

E-2

Where:

$(L + 1.1M)_{\text{eff}}$ = the effective skin dose factor due to beta and gamma emissions from all noble gases released from the vents.

$(L_i + 1.1M_i)$ = the skin dose factor due to beta and gamma emissions from each noble gas radionuclide 'i' released from the vents.

$$M_{\text{eff}} = \sum_{i=1}^n M_i \cdot f_i$$

E-3

Where:

M_{eff} = the effective air dose factor due to gamma emissions from all noble gases released.

M_i = the air dose factor due to gamma emissions from each noble gas radionuclide 'i' released.

A M_{eff} is calculated for elevated releases and also for vent releases.

**TECHNICAL BASES FOR EFFECTIVE DOSE FACTORS
(Continued)**

E-4

$$N_{\text{eff}} = \sum_{i=1}^n N_i \cdot f_i$$

Where:

N_{eff} = the effective air dose factor due to beta emissions from all noble gases released.

N_i = the air dose factor due to beta emissions from each noble gas radionuclide "i" released.

A N_{eff} is calculated for elevated releases and also for vent releases.

To determine the appropriate effective factors to be used and to evaluate the degree of variability, the atmospheric radioactive effluents for the years 1985 through 1991 have been evaluated. Tables E-1, E-2, and E-3 present the results of this evaluation.

To compensate for any unusual variability in the radionuclide distribution, 3 sigma was added to the average K_{eff} , M_{eff} , N_{eff} , L_{eff} , and $(L + 1.1 M)_{\text{eff}}$ values. This added conservatism provides additional assurance that the evolution of doses by the use of a single effective factor will normally overestimate actual doses in the environment, and any underestimation will be of insignificant magnitude.

TABLE E-1
EFFECTIVE DOSE FACTORS FOR NOBLE GASES -
WHOLE BODY EFFECTIVE DOSE

[K_{eff}]	
VENT RELEASE	
[mrem/sec per $\mu\text{Ci}/\text{m}^3$]	
YEAR	Whole Body Effective Dose Factor K _{eff}
1985	4.32E-05
1986	1.42E-04
1987	4.34E-05
1988	1.08E-04
1989	1.64E-04
1990	8.80E-05
1991	6.03E-05
mean $\pm \sigma$	9.27E-05 \pm 4.78E-05
mean + 3σ	2.36E-04

NOTE: The years 1985 through 1991 were selected as representative of historical noble gas releases from the vents. Calculated K_{eff} values based on the 1985 through 1991 data produce a more conservative result providing inclusion (bounding) of K_{eff} values that may be encountered if a fuel failure occurs. An evaluation of current vent release data (i.e. 1999 through 2003) resulted in non-conservative K_{eff} values.

TABLE E-1 (continued)
EFFECTIVE DOSE FACTORS FOR NOBLE GASES -
WHOLE BODY EFFECTIVE DOSE

[K_{eff}]

ELEVATED STACK RELEASE

[mrem/sec per $\mu\text{Ci}/\text{m}^3$]

YEAR	Whole Body Effective Dose Factor K _{eff}
1999	2.34E-04
2000	2.29E-04
2001	2.41E-04
2002	2.11E-04
2003	2.47E-04
mean $\pm \sigma$	2.32E-04 \pm 1.38E-05
mean + 3σ	2.73E-04

TABLE E-2
EFFECTIVE DOSE FACTORS FOR NOBLE GASES -

AIR DOSE

[M_{eff} & N_{eff}]

YEAR	VENT RELEASE		ELEVATED RELEASE	
	[mrad/sec per $\mu\text{Ci}/\text{m}^3$]		[mrad/sec per $\mu\text{Ci}/\text{m}^3$]	
	Gamma-Air Effective Dose Factor M _{eff}	Beta-Air Effective Dose Factor N _{eff}	Gamma-Air Effective Dose Factor M _{eff}	Beta-Air Effective Dose Factor N _{eff}
1985	4.57E-05	6.78E-05	2.06E-04	1.26E-04
1986	1.49E-04	1.14E-04	2.28E-04	1.30E-04
1987	4.66E-05	5.21E-05	1.13E-04	6.58E-05
1988	1.13E-04	7.25E-05	1.17E-04	7.49E-05
1989	1.71E-04	7.30E-05	1.81E-04	1.52E-04
1990	9.29E-05	8.87E-05	1.25E-04	1.39E-04
1991	6.41E-05	6.30E-05	1.31E-04	9.02E-05
mean $\pm \sigma$	9.75E-05	7.59E-05	1.57E-04	1.11E-04
	\pm 4.95E-05	\pm 2.01E-05	\pm 4.70E-05	\pm 3.37E-05
mean + 3 σ	2.46E-04	1.36E-04	2.98E-04	2.12E-04

TABLE E-3
EFFECTIVE DOSE FACTORS FOR NOBLE GASES -
SKIN EFFECTIVE DOSE

YEAR	VENT RELEASE [mrem/sec per $\mu\text{Ci}/\text{m}^3$]	ELEVATED RELEASE [mrem/sec per $\mu\text{Ci}/\text{m}^3$]
	Total Skin Effective Dose Factor (L + 1.1M) _{eff}	Skin Effective Dose Factor L _{eff}
1985	9.87E-05	1.09E-04
1986	2.37E-04	1.13E-04
1987	8.44E-05	4.57E-05
1988	1.77E-04	5.51E-05
1989	2.43E-04	1.34E-04
1990	1.58E-04	1.20E-04
1991	1.04E-04	7.08E-05
mean $\pm \sigma$	1.57E-04 \pm 6.54E-05	9.25E-05 \pm 3.47E-05
mean +3 σ	3.54E-04	1.97E-04

TABLE E-4

**TABLES OF SOURCE TERMS USED FOR DEVELOPMENT OF EFFECTIVE DOSE
TRANSFER FACTORS**
(Based on Semi-Annual Effluent Release Reports for the years 1985-1991 and 1999-2003)

ELEVATED RELEASE (Curies)

RADIONUCLIDE	1985	1986	1987	1988	1989	1990	1991
Ar-41	4.34E+01	3.65E+01	6.90E+01	1.34E+01	1.73E+01	3.86E+01	1.57E+01
Kr-83m	--	--	--	--	--	--	--
Kr-85m	3.47E+02	7.48E+01	6.6E+02	3.85E+02	1.28E+01	7.78E+01	1.94E+02
Kr-85	--	--	--	--	--	--	--
Kr-87	1.57E+03	2.15E+02	8.39E+01	1.59E+02	9.26E+00	3.85E+01	7.30E+01
Kr-88	1.13E+03	3.32E+02	4.60E+02	5.18E+02	2.20E+01	1.17E+02	2.99E+02
Kr-89	--	--	--	--	--	--	--
Kr-90	--	--	--	--	--	--	--
Xe-131m	8.51E+02	7.79E+00	2.30E+00	--	7.41E+00	1.88E+01	1.16E+02
Xe-133m	--	9.92E+00	2.73E-01	5.88E+00	--	3.38E+00	5.23E+00
Xe-133	2.77E+02	1.01E+02	1.63E+03	1.13E+03	7.17E+00	2.97E+02	4.74E+02
Xe-135m	1.76E+03	2.03E+02	9.13E+01	3.69E+01	6.09E+00	2.99E+01	2.38E+01
Xe-135	2.22E+03	3.34E+02	2.35E+02	1.00E+03	2.49E+01	1.40E+02	4.00E+02
Xe-137	--	3.86E+01	--	--	2.40E+01	1.87E+02	7.22E+01
Xe-138	5.59E+03	7.45E+02	2.26E+02	1.53E+01	2.04E+01	1.01E+02	7.55E+01
TOTAL	1.38E+04	2.10E+03	3.47E+03	3.27E+03	1.51E+02	1.05E+03	1.75E+03

RADIONUCLIDE	1999	2000	2001	2002	2003
Ar-41	1.95E+01	2.46E+01	2.51E+01	2.16E+01	1.38E+01
Kr-83m	--	--	--	--	--
Kr-85m	2.23E+00	3.79E+00	3.63E+00	8.59E+00	3.50E+00
Kr-85	--	--	--	--	--
Kr-87	1.24E+01	9.18E+00	5.53E-01	1.66E+01	4.99E-01
Kr-88	8.56E+00	5.80E+00	1.09E+00	1.97E+01	2.61E+00
Kr-89	--	--	--	--	--
Kr-90	--	--	--	--	--
Xe-131m	--	--	--	--	--
Xe-133m	--	--	--	--	--
Xe-133	5.17E-02	1.09E+00	1.55E+00	3.75E+00	7.60E-01
Xe-135m	9.99E+00	7.54E+00	4.09E-01	2.44E+00	2.21E-01
Xe-135	1.13E-01	8.58E+00	5.06E-01	2.67E+01	4.44E-01
Xe-137	5.36E-01	--	--	1.61E-01	--
Xe-138	3.35E+01	2.35E+01	1.16E+00	7.98E+00	8.14E-01
TOTAL	9.81E+01	8.41E+01	3.40E+01	1.08E+02	2.26E+01

TABLE E-5

TABLES OF SOURCE TERMS USED FOR DEVELOPMENT OF EFFECTIVE DOSE
TRANSFER FACTORS
(Based on Semi-Annual Effluent Release Reports for the years 1985 through 1991)

VENT RELEASE (Curies)				
RADIONUCLIDE	1985	1986	1987	1988
Ar-41		--	--	-- --
Kr-83m		--	--	-- --
Kr-85m	--	3.35E+01	6.42E+01	3.14E+01
Kr-85	4.36E+02	-- --	--	
Kr-87	8.95E+00	4.61E+01	1.38E+01	7.78E+00
Kr-88	1.45E+01	7.25E+01	4.81E+01	4.13E+01
Kr-89	--	--	--	--
Kr-90	--	--	--	--
Xe-131m	1.44E+02	1.24E+02	1.19E+01	1.26E+01
Xe-133m	2.81E+01	4.65E+01	4.37E+02	5.33E+01
Xe-133	6.29E+01	4.91E+01	5.06E+02	2.75E+02
Xe-135m	9.66E+00	1.33E+01	3.39E+01	1.48E+01
Xe-135	1.68E+02	3.54E+01	1.31E+02	5.14E+01
Xe-137	--	3.10E+01	--	--
Xe-138	7.27E+01	1.06E+02	3.18E+01	1.35E+02
TOTAL	9.44E+02	5.57E+02	1.28E+03	6.23E+02
RADIONUCLIDE	1989	1990	1991	
Ar-41	3.35E-01	9.02E-01	4.70E-01	
Kr-83m	--	--	--	
Kr-85m	7.08E+01	1.77E+01	1.74E+01	
Kr-85	--	--	--	
Kr-87	3.68E+00	1.13E+01	3.72E+00	
Kr-88	1.01E+02	1.36E+01	1.63E+01	
Kr-89	--	--	--	
Kr-90	--	--	--	
Xe-131m	5.57E+01	1.67E+01	1.11E+02	
Xe-133m	5.05E+01	8.95E+01	1.70E+01	
Xe-133	403E+01	5.54E+01	7.19E+01	
Xe-135m	1.53E+01	8.81E+00	1.35E+01	
Xe-135	2.62E+01	3.27E+01	2.39E+01	
Xe-137	--	1.11E+01	7.85E+00	
Xe-138	4.42E+01	4.57E+01	1.74E+01	
TOTAL	4.08E+02	3.04E+02	3.01E+02	

TABLE E-6
RADIONUCLIDE DISTRIBUTION OF VENT AND ELEVATED RELEASES
 (Based on Semi-Annual Effluent Release Reports for the years 1985 through 1991)
FRACTION OF TOTAL VENT RELEASE

RADIONUCLIDE	1985	1986	1987	1988	1989	1990	1991
Ar-41	--	--	--	--	8.21E-04	2.97E-03	1.57E-03
Kr-83m	--	--	--	--	--	--	--
Kr-85m	--	6.01E-02	5.03E-02	5.04E-02	1.73E-01	5.83E-02	5.80E-02
Kr-85	4.62E-01	--	--	--	--	--	--
Kr-87	9.48E-03	8.27E-02	1.08E-02	1.25E-02	9.02E-03	3.73E-02	1.24E-02
Kr-88	1.53E-02	1.30E-01	3.76E-02	6.63E-02	2.48E-01	4.48E-02	5.43E-02
Kr-89	--	--	--	--	--	--	--
Kr-90	--	--	--	--	--	--	--
Xe-131m	1.52E-02	2.23E-01	9.32E-03	2.02E-02	1.36E-01	5.51E-02	3.70E-01
Xe-133m	2.97E-02	8.34E-02	3.42E-01	8.56E-02	1.24E-01	2.95E-01	5.67E-02
Xe-133	6.66E-02	8.80E-02	3.96E-01	4.42E-01	9.87E-02	1.82E-01	2.39E-01
Xe-135m	1.02E-02	2.39E-02	2.65E-02	2.37E-02	3.74E-02	2.90E-02	4.49E-02
Xe-135	1.78E-01	6.35E-02	1.02E-01	8.26E-02	6.42E-02	1.08E-01	7.97E-02
Xe-137	--	5.56E-02	--	--	--	3.65E-02	2.61E-02
Xe-138	7.70E-02	1.89E-01	2.49E-02	2.17E-01	1.08E-01	1.51E-01	5.78E-02

FRACTION OF TOTAL ELEVATED RELEASE

RADIONUCLIDE	1985	1986	1987	1988	1989	1990	1991
Ar-41	3.15E-03	1.74E-02	1.99E-02	4.09E-03	1.14E-01	3.52E-02	8.97E-03
Kr-83m	--	--	--	--	--	--	--
Kr-85m	2.52E-02	3.56E-02	1.92E-01	1.18E-01	8.45E-02	7.44E-02	1.11E-01
Kr-85	--	--	--	--	--	--	--
Kr-87	1.14E-01	1.03E-01	2.42E-02	4.85E-02	6.12E-02	3.68E-02	4.17E-02
Kr-88	8.17E-02	1.58E-01	1.33E-01	1.58E-01	1.45E-01	1.12E-01	1.71E-01
Kr-89	--	--	--	--	--	--	--
Kr-90	--	--	--	--	--	--	--
Xe-131m	6.18E-02	3.71E-03	6.64E-04	--	4.90E-02	1.79E-02	6.62E-02
Xe-133m	--	4.73E-03	7.88E-05	1.80E-03	--	3.23E-03	2.99E-03
Xe-133	2.01E-02	4.83E-02	4.71E-01	3.47E-01	4.74E-02	2.84E-01	2.71E-01
Xe-135m	1.27E-01	9.68E-02	2.63E-02	1.13E-02	4.03E-02	2.86E-02	1.36E-02
Xe-135	1.61E-01	1.59E-01	6.78E-02	3.06E-01	1.65E-01	1.33E-01	2.28E-01
Xe-137	--	1.84E-02	--	--	1.59E-01	1.79E-01	4.13E-02
Xe-138	4.06E-01	3.55E-01	6.51E-02	4.67E-03	1.35E-01	9.62E-02	4.32E-02

RADIONUCLIDE	1999	2000	2001	2002	2003
Ar-41	1.99E-01	2.92E-01	7.38E-01	2.01E-01	6.09E-01
Kr-83m	--	--	--	--	--
Kr-85m	2.27E-02	4.51E-02	1.07E-01	7.99E-02	1.54E-01
Kr-85	--	--	--	--	--
Kr-87	1.26E-01	1.09E-01	1.63E-02	1.55E-01	2.20E-02
Kr-88	8.73E-02	6.91E-02	3.20E-02	1.83E-01	1.16E-01
Kr-89	--	--	--	--	--
Kr-90	--	--	--	--	--
Xe-131m	--	--	--	--	--
Xe-133m	--	--	--	--	--
Xe-133	5.00E-04	1.29E-02	4.57E-02	3.49E-02	3.36E-02
Xe-135m	1.02E-01	8.98E-02	1.20E-02	2.27E-02	9.78E-03
Xe-135	1.16E-01	1.02E-01	1.49E-02	2.48E-01	1.96E-02
Xe-137	5.50E-03	--	--	1.50E-03	--
Xe-138	3.42E-01	2.79E-01	3.41E-02	7.42E-02	3.60E-02

APPENDIX F

EFFLUENT MONITOR SAMPLING LOCATIONS AND DESCRIPTIONS

APPENDIX F

EFFLUENT MONITOR SAMPLING LOCATIONS AND DESCRIPTIONS

<u>TABLE</u>	<u>TITLE</u>	<u>PAGE</u>
F-1	Atmospheric Gaseous Release Point Data	F-3
F-2	Effluent Monitoring System Data	F-4

<u>FIGURE</u>	<u>TITLE</u>	<u>PAGE</u>
F-1	Gaseous Release Points Building Elevations	F-6
F-2	Gaseous Release Points Plant Yard Layout	F-7
F-3	Liquid Release Point	F-8
F-4	Gaseous Effluent Release Paths	F-9
F-5	Liquid Effluent Release Paths	F-10
F-6	Solid Radwaste Treatment System	F-11
F-7	Standby Gas Treatment System	F-12

TABLE F-1

JAMES A. FITZPATRICK NUCLEAR POWER PLANT
OFFSITE DOSE CALCULATION MANUAL (ODCM)

ATMOSPHERIC GASEOUS RELEASE POINT DATA

RELEASE POINT	STACK	REACTOR* BUILDING	TURBINE BUILDING	RADWASTE BUILDING	REFUEL* FLOOR
Height Above Grade (feet)	385	172	172	111	172
Release Mode	Elevated	Roof Top Vent	Roof Top Vent	Roof Top Vent	Roof Top Vent
Effluent Source	Turbine Gland Seal Condenser Gases Mechanical Vacuum Pump Exhaust Steam Jet Air Ejector Exhaust	Secondary and Auxiliary Building Exhaust Ventilation	Turbine Building Exhaust Ventilation	Waste Disposal Building Ventilation	Refuel Floor Exhaust Ventilation

* The Refuel Floor and Reactor Building vent is a combined release point.

TABLE F-2
JAMES A. FITZPATRICK NUCLEAR POWER PLANT
OFFSITE DOSE CALCULATION MANUAL (ODCM)

EFFLUENT MONITORING SYSTEM DATA

MONITOR DESCRIPTION	SAMPLING LOCATION	DETECTION TYPE	RANGE	CONTROL FUNCTIONS	ALARM SETPOINT USED	REFERENCE CALIBRATION SOURCE
Main steam line monitor	Located near the main steam lines downstream of the outboard MSIV's in the steam tunnel	4-gamma sensitive ion chambers	10^0 - 10^6 mR/hr	Closure of main steam line drain motor operated valves, mechanical vacuum pump line isolation valve, recirculation loop sample valves, and initiates a trip of the mechanical vacuum pump.	Yes	Victoreen Cs ¹³⁷ gamma dose rate source
Off-gas radiation monitoring system	Turbine 252' west	2-gamma sensitive ion chambers	10^0 - 10^6 mR/hr	Initiate closure of off-gas system isolation valves	Yes	Gas sample counted on Ge(Li)
Off-gas pipe (Stack) monitor	Stack	Scintillation detectors	10^{-1} - 10^6 cps	Indicate and record rate of release of radioactive material to the environment	Yes	Gas vent marinelli counted on Ge(Li)
Process liquid radiation monitors	Rad Waste - RW 272' Service H ₂ O Heater Bay 252'	Scintillation detectors	10^{-1} - 10^6 cps	Monitor for leaks of closed systems. Monitor normal release of radioactive material to the environment	Yes	Representative liquid sample counted on Ge(Li)

**TABLE F-2
(Continued)**

EFFLUENT MONITORING SYSTEM DATA

MONITOR DESCRIPTION	SAMPLING LOCATION	DETECTION TYPE	RANGE	CONTROL FUNCTIONS	ALARM SETPOINT USED	REFERENCE CALIBRATION SOURCE
Plant stack & vent noble gas monitors	Turbine - MG Set 300' Reactor - RX 344' Refuel - RX 369' Radwaste - TB 300' Stack	GM Detectors	10^1 - 10^6 CPM	Provide isolation of potentially contaminated systems	Yes	Gas marinelli counted on Ge(Li)
		Scintillation Detector	10^{-1} - 10^6 CPS			
Drywell continuous air monitor	Reactor 300' south side	Scintillation detectors	10^{-1} - 10^6 CPM	Monitor airborne radioactivity in Drywell during normal operation	Yes	Gas marinelli counted on Ge(Li)
Containment high range monitors	Drywell penetrations X110C and X100D	2-ion chamber detectors	10^0 - 10^8 R/hr	Accident control and initiates isolation	Yes	Victoreen Cs-137 gamma dose rate source
High range effluent monitors	Stack, Turbine Radwaste	2-ion chamber detectors	10^{-1} - 10^7 mR/hr	Accident control and initiates isolation	Yes	Victoreen Cs-137 gamma dose rate source

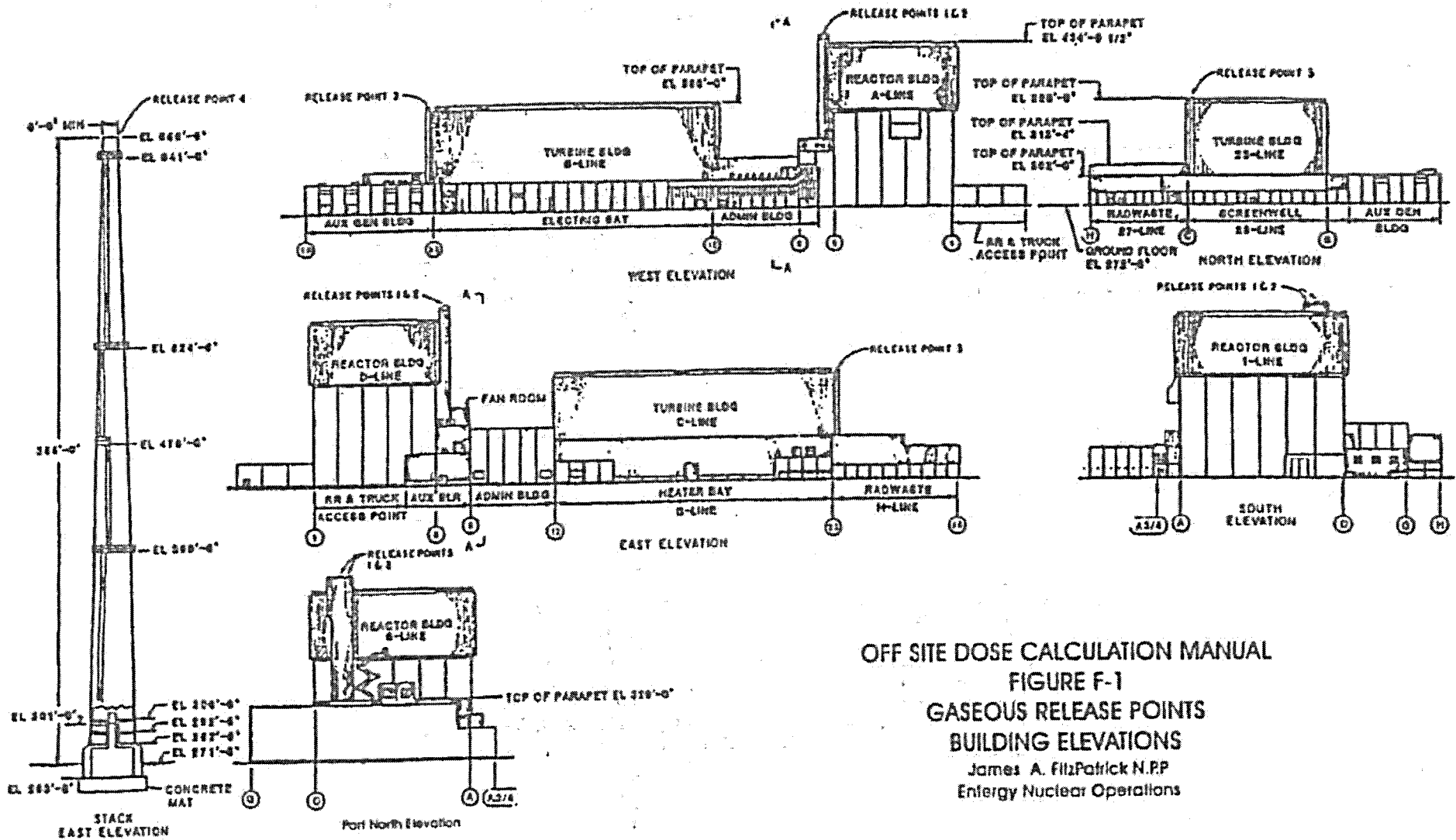

OFF SITE DOSE CALCULATION MANUAL
 FIGURE F-1
 GASEOUS RELEASE POINTS
 BUILDING ELEVATIONS
 James A. FitzPatrick N.P.P
 Entergy Nuclear Operations

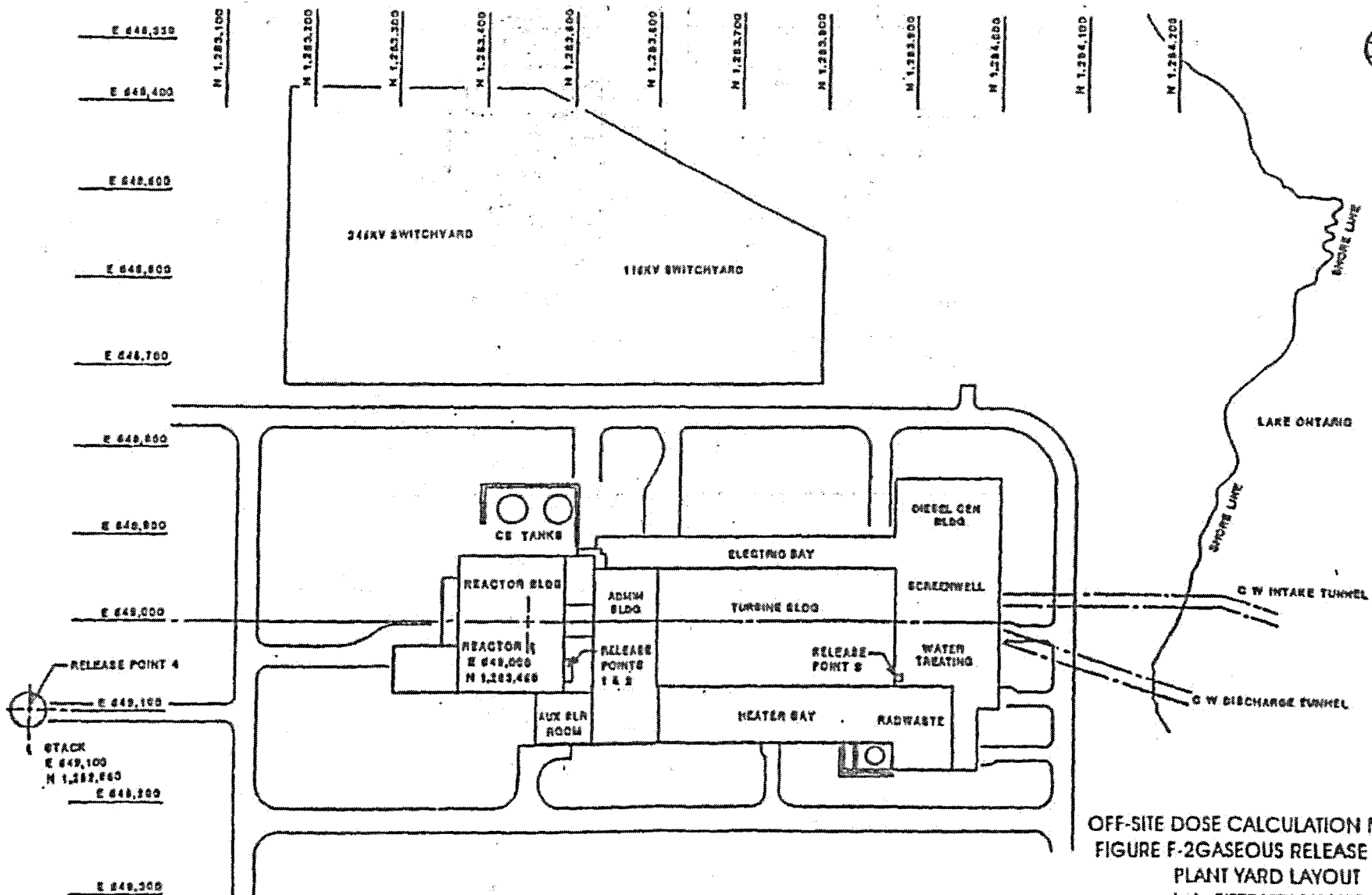

OFF-SITE DOSE CALCULATION MANUAL
 FIGURE F-2 GASEOUS RELEASE POINTS
 PLANT YARD LAYOUT
 J. A. FITZPATRICK NPP
 ENERGY NUCLEAR NORTHEAST

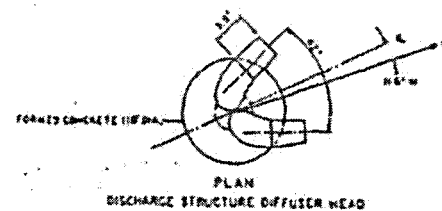
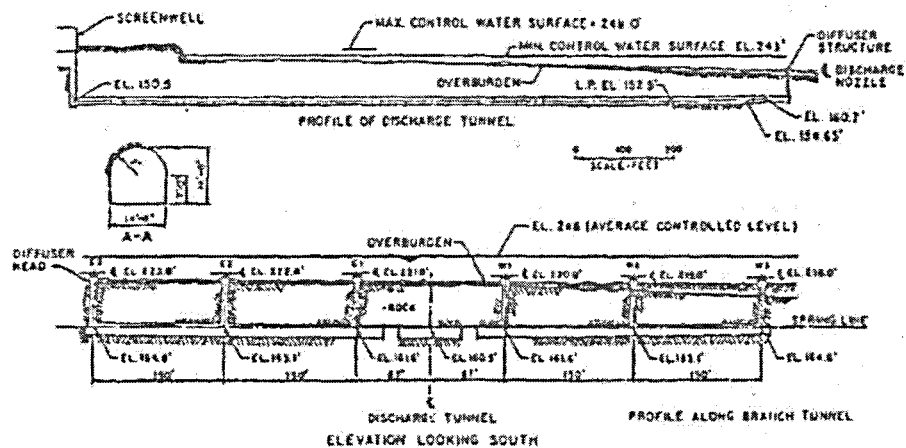
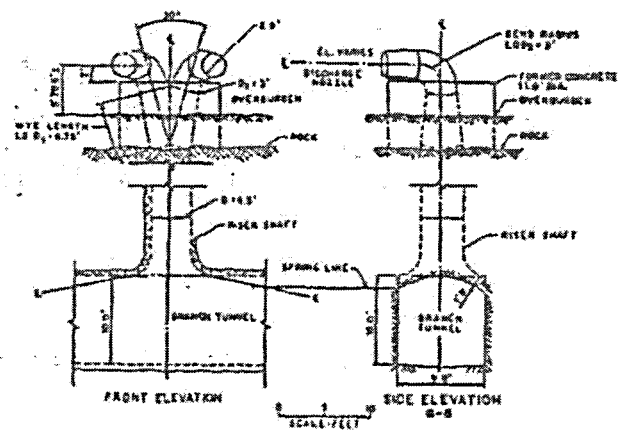
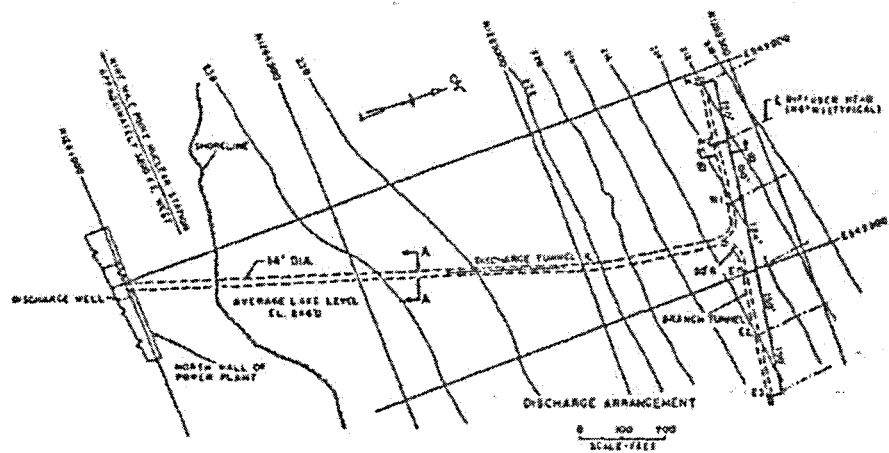

NOTE:
ALL ELEVATIONS BASED ON UNITED STATES LAKE SURVEY 1933 DATUM.

FIGURE F - 3
OFF-SITE DOSE CALCULATION MANUAL
LIQUID EFFLUENT RELEASE POINTS
DISCHARGE TUNNEL PLAN & PROFILE
J. A. FITZPATRICK N.P.P. ENTERGY NUCLEAR

FIGURE F-4

JAMES A. FITZPATRICK NUCLEAR POWER PLANT
OFFSITE DOSE CALCULATION MANUAL (ODCM)
GASEOUS EFFLUENT RELEASE PATHS

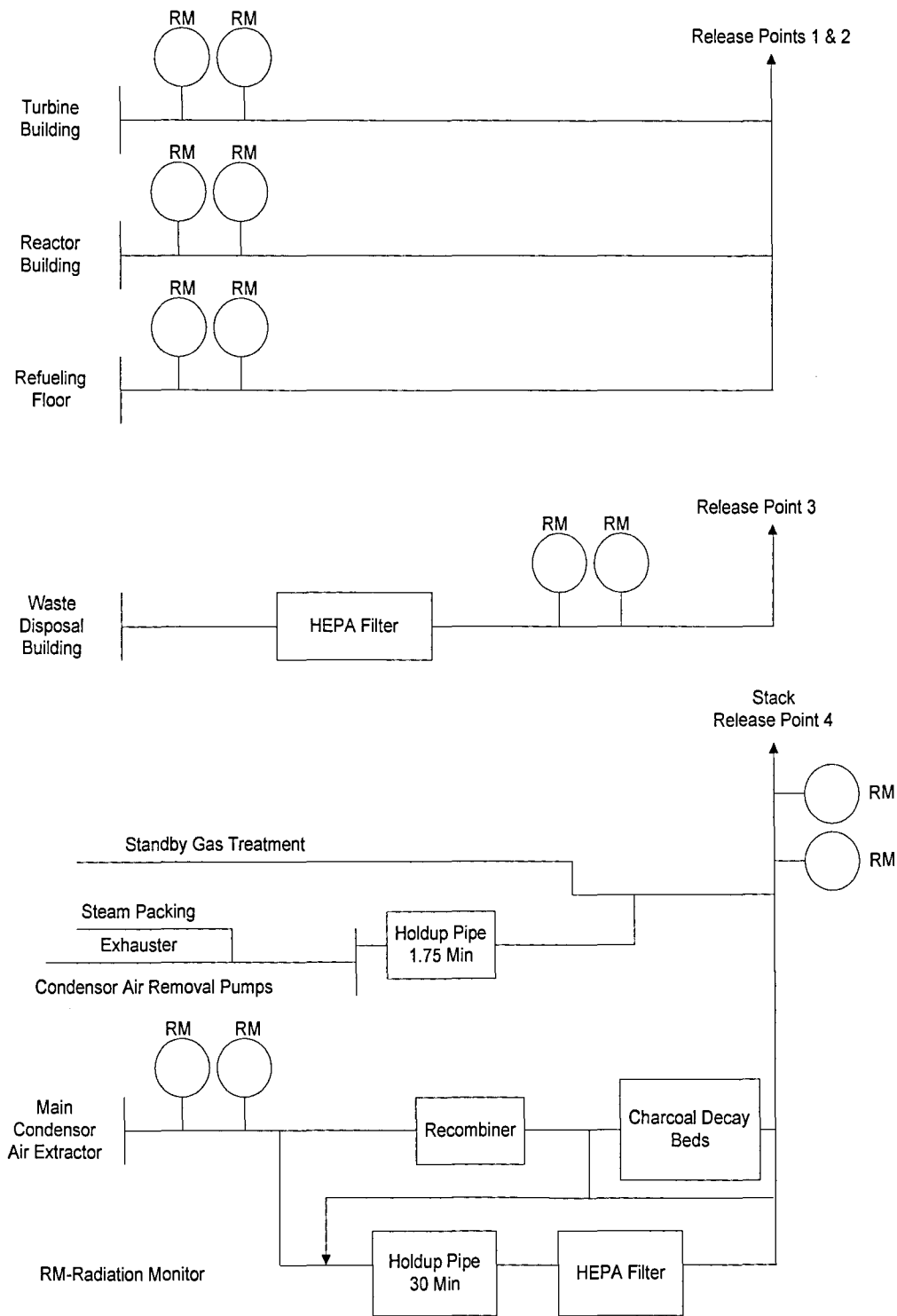
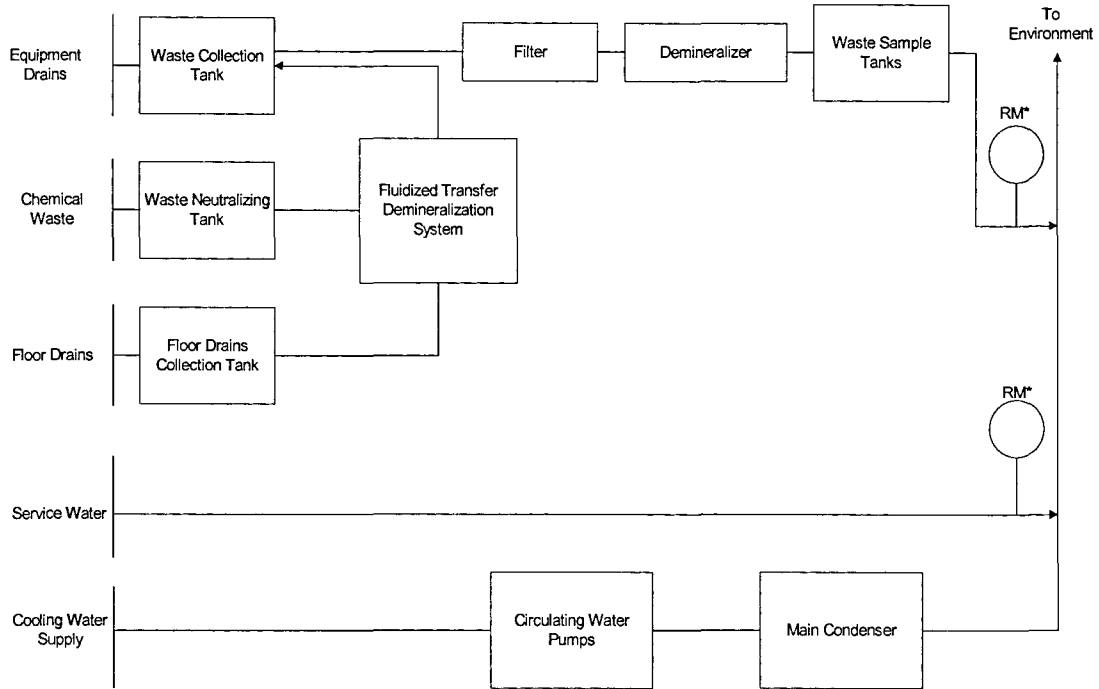

FIGURE F-5

JAMES A. FITZPATRICK NUCLEAR POWER PLANT
 OFFSITE DOSE CALCULATION MANUAL (ODCM)
 LIQUID EFFLUENT RELEASE PATHS



*RM-Radiation Monitor

POTENTIAL LIQUID EFFLUENT PATHS

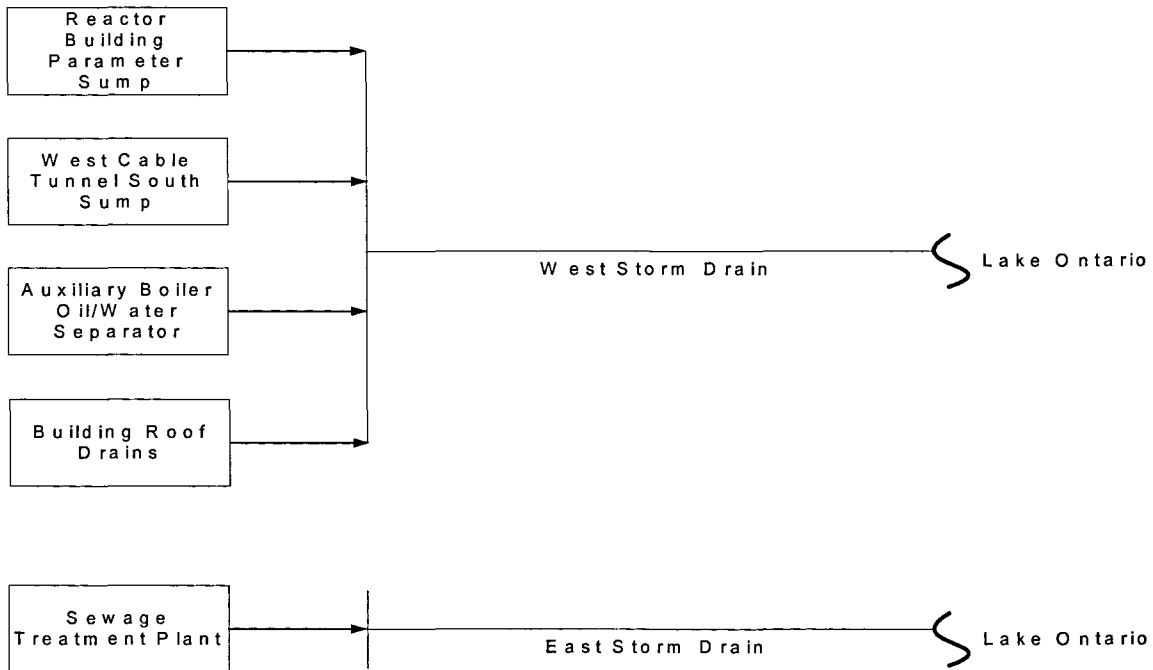

FIGURE F-6

JAMES A. FITZPATRICK NUCLEAR POWER PLANT
OFFSITE DOSE CALCULATION MANUAL (ODCM)
SOLID RADWASTE TREATMENT SYSTEM

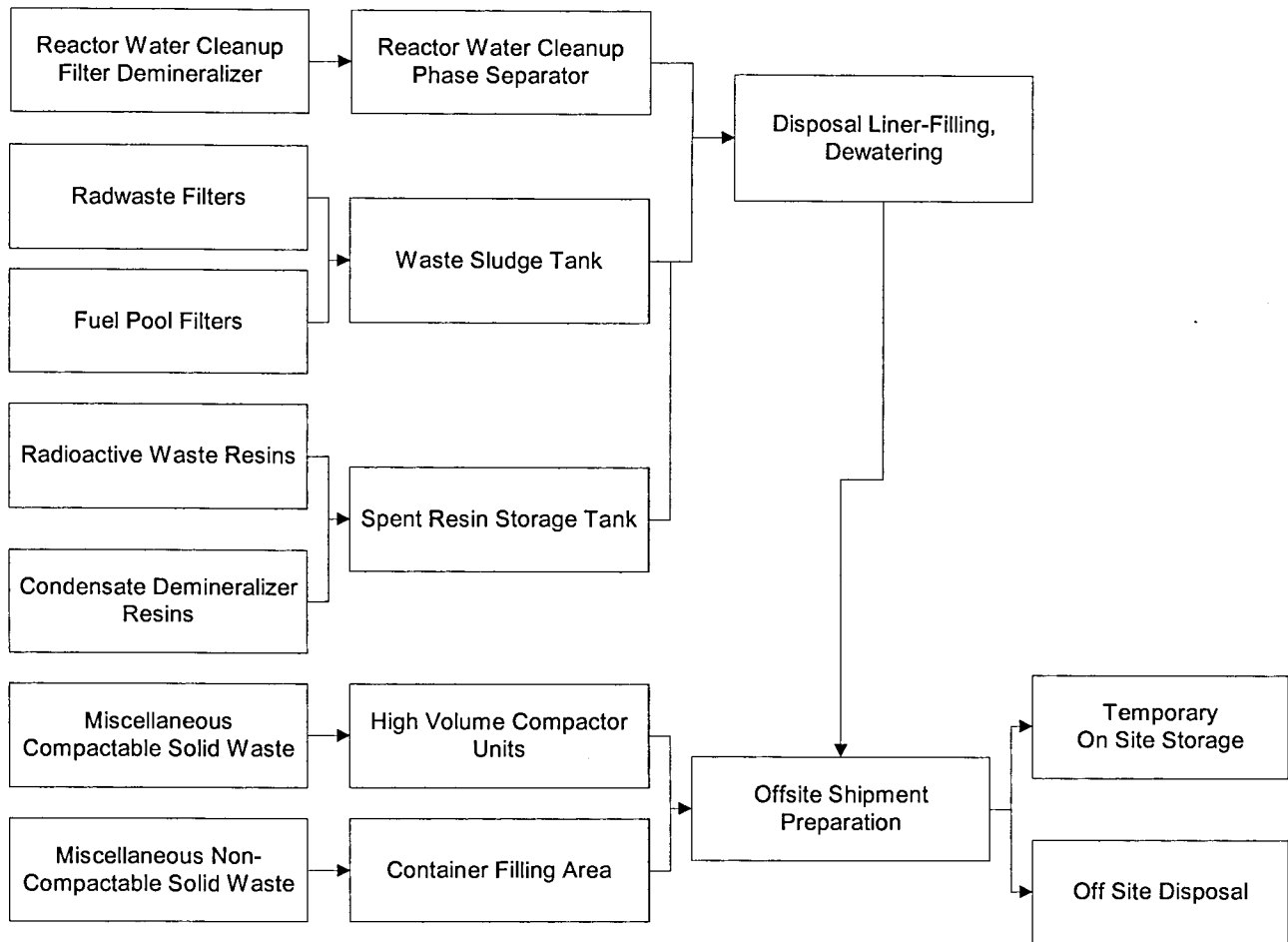
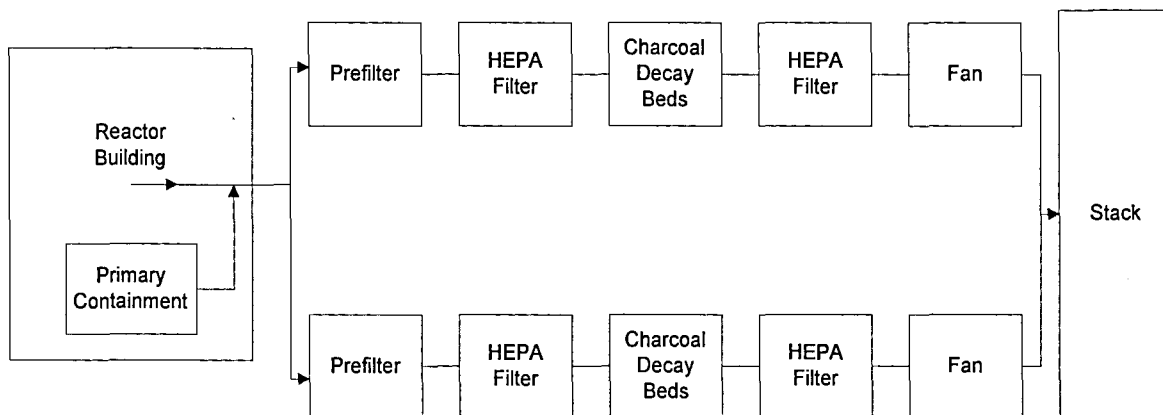

FIGURE F-7

JAMES A. FITZPATRICK NUCLEAR POWER PLANT
OFFSITE DOSE CALCULATION MANUAL (ODCM)

STANDBY GAS TREATMENT SYSTEM



APPENDIX G
UNRESTRICTED AREA MAP

APPENDIX G
UNRESTRICTED AREA MAP

<u>FIGURE</u>	<u>TITLE</u>	<u>PAGE</u>
G-1	JAFNPP Site Boundary Map	G-3

FIGURE G-1

JAMES A. FITZPATRICK NUCLEAR POWER PLANT
OFFSITE DOSE CALCULATION MANUAL (ODCM)
JAFNPP SITE BOUNDARY MAP

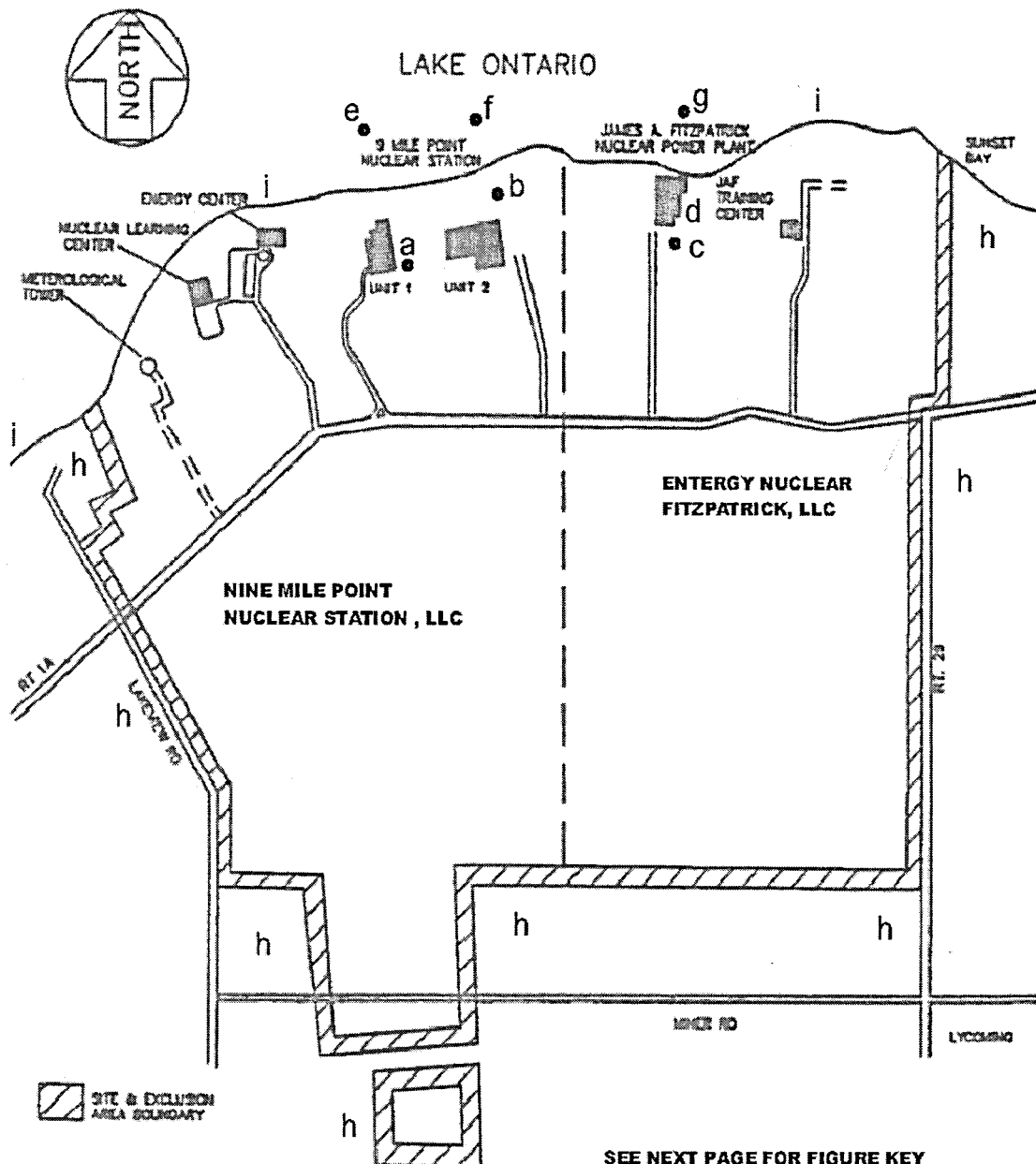

NOTES TO FIGURE G-1

- (a) NMP1 stack (height is 350 feet)
- (b) NMP2 stack (height is 430 feet)
- (c) JAFNPP stack (height is 385 feet)
- (d) Building vents
- (e) NMP1 radioactive liquid discharge (Lake Ontario, bottom)
- (f) NMP2 radioactive liquid discharge (Lake Ontario, bottom)
- (g) JAFNPP radioactive liquid discharge (Lake Ontario, bottom)
- (h) Site boundary
- (i) Lake Ontario shoreline

Additional Information:

- NMP2 reactor building vent is located 187 feet above ground level
- JAFNPP reactor and turbine building vents are located 173 feet above ground level
- JAFNPP radwaste building vent is 112 feet above ground level

APPENDIX H
ENVIRONMENTAL SAMPLE LOCATIONS

APPENDIX H

ENVIRONMENTAL SAMPLE LOCATIONS

<u>TABLE</u>	<u>TITLE</u>	<u>PAGE</u>
H-1	Radiological Environmental Monitoring Sampling Locations	H- 5
H-2	Liquid Effluent Pathway - Water Intake Points Description and Pumpage	H-15

<u>FIGURE</u>	<u>TITLE</u>	<u>PAGE</u>
H-1	Off-Site Environmental Sample Location Map	H-11
H-2	Off-Site Environmental Sample Location Map	H-12
H-3	On-Site Environmental Sample Location Map	H-13
H-4	On-Site Environmental ISFSI TLD Locations	H-14
H-5	Liquid Effluent Pathway - Water Intake Points	H-16

RADIOLOGICAL ENVIRONMENTAL SAMPLING LOCATIONS

1.0 RADIOLOGICAL ENVIRONMENTAL MONITORING PROGRAM

1.1 Sampling Stations/Locations

The current sampling locations are specified on Table H-1 and Figures H-1, H-2 and H-3. The Radiological Environmental Monitoring Program is a joint effort between the Niagara Mohawk Power Corporation and Entergy Nuclear Northeast, Entergy Nuclear Operations, Inc., the owners and operators of the Nine Mile Point Unit 1, Nine Mile Point Unit 2 and the James A. FitzPatrick Nuclear Power Plant, respectively. Sampling locations are chosen on the basis of historical average dispersion or deposition parameters from the three units.

The average dispersion and deposition parameters for the three reactors have been calculated for a five (5) year period, 1978 through 1982 (Reference 6.11 C.T. Main Data). Ingestion sample location evaluations are based on calculations performed by C.T. Main as this report contains grazing season X/Q and D/Q calculations for each of the seven release points in use at the JAF/NMP site. Milk animal locations are evaluated using grazing season D/Qs with the grazing season defined as (April to December). The April through December grazing season is used to coincide with the April through December milk sampling period required by Part 1 (REC) Specifications. The deposition factor is evaluated at the census locations for each of seven release points (NMP 1 stack, NMP 2 stack, NMP 2 vent, JAF stack, JAF TB vent, JAF RW vent, and JAF RB vent). An arithmetic average of all release points is calculated and used in the evaluation. If it is determined that a milk sampling location exists at a location that yields a significantly higher (e.g. 50%) calculated D/Q rate, the new milk sampling location will be added to the monitoring program within 30 days. If a new location is added, the old location that yields the lowest calculated D/Q may be dropped from the program after October 31 of that year.

1.2 Interlaboratory Comparison Program

Analyses shall be performed on samples containing known quantities of radioactive material that are supplied as part of a Commission approved or sponsored Interlaboratory Comparison Program. Sample analysis shall be only for those media, (e.g. air, milk, water, etc.), that are included in the Nine Mile Point Environmental Monitoring Program and for which cross check samples are routinely available. The Quality Control sample results shall be reported in the Annual Radiological Environmental Operating Report so that the Commission staff may evaluate the results.

Specific sample media analyzed as part of the JAF Cross Check Program include the following:

- gamma emitters in air particulate filters
- I-131 in milk
- gamma emitters in milk
- gamma emitters in water
- tritium in water
- gamma emitters in soil/sediment
- I-131 in air particulate cartridges

The availability, schedule and subsequent analysis of cross check samples are subject to change as a result of administrative changes within the JAF sampling program and commercial availability of such samples.

1.3 Thermoluminescent Dosimeters Used for Environmental Measurements

Thermoluminescent Dosimeters (TLDs) are placed in an inner ring of stations in the general area of the site boundary, and in an outer ring in the 4 to 5 mile range from the site. There are 16 land based sectors in the inner ring and 8 land based sectors in the outer ring. TLDs are also placed in special interest areas such as population centers, nearby residences, schools, Independent Spent Fuel Storage Installation (ISFSI), and control locations.

1.4 Independent Spent Fuel Storage Installation (ISFSI) Environmental Monitoring Program

The radiological environmental monitoring program implemented at the site pursuant to JAF Technical Specifications Appendix B, contains program elements that satisfy the intent of 10 CFR 72.44(d)(2) and Certificate of Compliance No. 1014 Appendix A, Technical Specifications for the Hi-Storm 100 Cask System, Amendment 0.

TABLE H-1

RADIOLOGICAL ENVIRONMENTAL MONITORING SAMPLING LOCATIONS

TYPE OF SAMPLE	MAP* LOCATION (FIGURE NO.)	COLLECTION SITE	LOCATION⁺
Radioiodine and Particulates (air)	R1 (H-2)	Nine Mile Point Road North	1.8 mi @ 92° E
Radioiodine and Particulates (air)	R2 (H-3)	Co. Rt. 29 & Lake Road	1.1 mi @ 107° ESE
Radioiodine and Particulates (air)	R3 (H-3)	Co. Rt. 29	1.4 mi @ 133° SE
Radioiodine and Particulates (air)	R4 (H-3)	Village of Lycoming, NY	1.8 mi @ 145° SE
Radioiodine and Particulates (air)	R5 (H-2)	Montario Point Road	16.2 mi @ 42° NE
Direct Radiation (TLD)	75 (H-3)	North Fence, NMP-2	0.1 mi @ 354° N
Direct Radiation (TLD)	76 (H-3)	North Fence, NMP-2	0.1 mi @ 25° NNE
Direct Radiation (TLD)	77 (H-3)	North Fence, NMP-2	0.2 mi @ 36° NE
Direct Radiation (TLD)	23 (H-3)	North Shoreline Area (H-ONSITE Station)	0.8 mi @ 73° ENE
Direct Radiation (TLD)	78 (H-3)	East Boundary, JAFNPP	1.0 mi @ 85° E
Direct Radiation (TLD)	79 (H-3)	Co. Rt. 29	1.2 mi @ 120° ESE
Direct Radiation (TLD)	80 (H-3)	Co. Rt. 29	1.5 mi @ 136° SE
Direct Radiation (TLD)	81 (H-3)	Miner Road	1.6 mi @ 159° SSE
Direct Radiation (TLD)	82 (H-3)	Miner Road	1.6 mi @ 180° S
Direct Radiation (TLD)	83 (H-3)	Lakeview Road	1.2 mi @ 203° SSW
Direct Radiation (TLD)	84 (H-2)	Lakeview Road	1.1 mi @ 226° SW

* See Figures H-1, H-2, H-3 and H-4 for map locations

+ Based on 9 Mile Point Unit 2 Reactor Centerline. Distance and direction determined using Global Positioning System (GPS) readings.

TABLE H-1 (Continued)

RADIOLOGICAL ENVIRONMENTAL MONITORING SAMPLING LOCATIONS

TYPE OF SAMPLE	MAP* LOCATION (FIGURE NO.)	COLLECTION SITE	LOCATION ⁺
Direct Radiation (TLD)	7 (H-3)	Site Meteorological Tower (G ONSITE Station)	0.7 mi @ 245° WSW
Direct Radiation (TLD)	18 (H-3)	Energy Information Center	0.4 mi @ 268° W
Direct Radiation (TLD)	85 (H-3)	North Fence, NMP-1	0.2 mi @ 292° WNW
Direct Radiation (TLD)	86 (H-3)	North Fence, NMP-1	0.1 mi @ 311° NW
Direct Radiation (TLD)	87 (H-3)	North Fence, NMP-1	0.1 mi @ 333° NNW
Direct Radiation (TLD)	88 (H-2)	Hickory Grove Road	4.5 mi @ 97° E
Direct Radiation (TLD)	89 (H-2)	Leavitt Road	4.3 mi @ 112° ESE
Direct Radiation (TLD)	90 (H-2)	Rt. 104 and Keefe Road	4.2 mi @ 135° SE
Direct Radiation (TLD)	91 (H-2)	Co. Rt. 51A	4.9 mi @ 157° SSE
Direct Radiation (TLD)	92 (H-2)	Maiden Lane Road	4.4 mi @ 183° S
Direct Radiation (TLD)	93 (H-2)	Co. Rt. 53	4.4 mi @ 206° SSW
Direct Radiation (TLD)	94 (H-2)	Co. Rt. 1 and Kocher Road	4.4 mi @ 224° SW
Direct Radiation (TLD)	95 (H-2)	Lake Shore, Alcan West Access Road	3.7 mi @ 239° WSW
Direct Radiation (TLD)	49 (H-2)	Phoenix, NY-Control	19.7 mi @ 168° SSE
Direct Radiation (TLD)	14 (H-2)	SW Oswego-Control	12.5 mi @ 227° SW
Direct Radiation (TLD)	96 (H-2)	Creamery Road	3.6 mi @ 199° SSW
Direct Radiation (TLD)	58 (H-2)	Alcan Aluminum, Rt. 1A	3.0 mi @ 222° SW
Direct Radiation (TLD)	97 (H-2)	Co. Rt. 29	1.8 mi @ 145° SE
Direct Radiation (TLD)	56 (H-2)	New Haven Elem. School	5.2 mi @ 124° SE

* See Figures H-1, H-2, H-3 and H-4 for map locations

+ Based on 9 Mile Point Unit 2 Reactor Centerline. Distance and direction determined using Global Positioning System (GPS) readings.

TABLE H-1 (Continued)

RADIOLOGICAL ENVIRONMENTAL MONITORING SAMPLING LOCATIONS

TYPE OF SAMPLE	MAP* LOCATION (FIGURE NO.)	COLLECTION SITE	LOCATION⁺
Direct Radiation (TLD)	15 (H-2)	West Site Boundary, Bible Camp	0.9 mi @ 240° WSW
Direct Radiation (TLD)	8 (H-2)	Montario Point Road (R5 OFFSITE Station-Control)	16.2 mi @ 42° NE
Surface Water	W8 (H-1)	NRG Steam Station Inlet Canal	7.6 mi @ 237° WSW
Surface Water	W3 (H-1)	JAFNPP Inlet Canal	0.6 mi @ 53° NE
Shoreline Sediment	05 (H-1)	Sunset Bay Shoreline	1.2 mi @ 84° E
Shoreline Sediment	06 (H-1)	Langs Beach-Control	4.8 mi @ 232° SW
Fish	F2 (H-1)	Nine Mile Point Transect	0.4 mi @ 290° WNW
Fish	F3 (H-1)	FitzPatrick Transect	0.8 mi @ 62° ENE
Fish	F0 (H-1)	Oswego Transect	5.9 mi @ 237° SW
Milk	77 (H-1)	Milk Location #77-Control Summerville	16.0 mi @ 190° S
Food Products ** (Broad Leaf Vegetation)	01 (H-1)	Garden - Cary	1.4 mi @ 84° E

* See Figures H-1, H-2, H-3 and H-4 for map locations

** Food product samples need not be samples from each locations listed. Two onsite samples will be collected from the location with the highest calculated average D/Q value from which edible or non-edible broad leaf vegetation is available. One control sample will be collected at a location listed from which edible or non-edible broad leaf vegetation is available.

+ Based on 9 Mile Point Unit 2 Reactor Centerline. Distance and direction determined using Global Positioning System (GPS) readings.

TABLE H-1 (Continued)

RADIOLOGICAL ENVIRONMENTAL MONITORING SAMPLING LOCATIONS

TYPE OF SAMPLE	MAP* LOCATION (FIGURE NO.)	COLLECTION SITE	LOCATION⁺
Food Products ** (Broad Leaf Vegetation)	79 (H-1)	Garden - Nerewski	1.5 mi @ 84° E
Food Products ** (Broad Leaf Vegetation)	48 (H-1)	Garden - Kronenbitter	1.5 mi @ 83° E
Food Products ** (Broad Leaf Vegetation)	133 (H-1)	Garden - Culeton	1.6 mi @ 83° E
Food Products ** (Broad Leaf Vegetation)	77 (H-1)	Garden - Vitullo	1.9 mi @ 101° E
Food Products ** (Broad Leaf Vegetation)	55 (H-1)	Garden - Woolson	1.9 mi @ 132° SE
Food Products ** (Broad Leaf Vegetation)	57 (H-1)	Garden - Parkhurst, G.	1.8 mi @ 126° SE
Food Products ** (Broad Leaf Vegetation)	422 (H-1)	Garden - Parkhurst, C.	2.0 mi @ 112° ESE
Food Products ** (Broad Leaf Vegetation)	132 (H-1)	Garden - Barton	2.0 mi @ 110° ESE
Food Products ** (Broad Leaf Vegetation)	142 (H-1)	Garden - Hall NM #49	1.7 mi @ 143° SE

* See Figures H-1, H-2, H-3 and H-4 for map locations

** Food product samples need not be samples from each locations listed. Two onsite samples will be collected from the location with the highest calculated average D/Q value from which edible or non-edible broad leaf vegetation is available. One control sample will be collected at a location listed from which edible or non-edible broad leaf vegetation is available.

+ Based on 9 Mile Point Unit 2 Reactor Centerline. Distance and direction determined using Global Positioning System (GPS) readings.

TABLE H-1 (Continued)

RADIOLOGICAL ENVIRONMENTAL MONITORING SAMPLING LOCATIONS

TYPE OF SAMPLE	MAP* LOCATION (FIGURE NO.)	COLLECTION SITE	LOCATION⁺
Food Products ** (Broad Leaf Vegetation)	143 (H-1)	Garden - Whaley, P. NM #54 1/2	1.6 mi @ 138° SE
Food Products ** (Broad Leaf Vegetation)	144 (H-1)	Garden - Whaley, C.	1.6 mi @ 139° SE
Food Products ** (Broad Leaf Vegetation)	425 (H-1)	Garden - Barsuch	1.8 mi @ 144° SE
Food Products ** (Broad Leaf Vegetation)	426 (H-1)	Garden - Larroca	1.8 mi @ 145° SE
Food Products ** (Broad Leaf Vegetation)	C2 (H-1)	Control - Flack	15.4 mi @ 222° SW
Food Products ** (Broad Leaf Vegetation)	240 (H-1)	Garden - Walcott	1.9 mi @ 96° E
Food Products ** (Broad Leaf Vegetation)	260 (H-1)	Garden - Battles	1.7 mi @ 98° E
Food Products ** (Broad Leaf Vegetation)	290 (H-1)	Garden - Lee, R.	1.8 mi @ 98° E
Food Products ** (Broad Leaf Vegetation)	274 (H-1)	Garden - Oldenberg	1.4 mi @ 106° ESE
Food Products ** (Broad Leaf Vegetation)	343 (H-1)	Garden - Fredette/Sheldon	1.8 mi @ 88° E
Food Products** (Broad Leaf Vegetation)	484 (H-1)	Garden - O'Connor	1.4 mi @ 132°SE

* See Figures H-1, H-2, H-3 and H-4 for map locations

** Food product samples need not be samples from each locations listed. Two onsite samples will be collected from the location with the highest calculated average D/Q value from which edible or non-edible broad leaf vegetation is available. One control sample will be collected at a location listed from which edible or non-edible broad leaf vegetation is available.

+ Based on 9 Mile Point Unit 2 Reactor Centerline. Distance and direction determined using Global Positioning System (GPS) readings.

TABLE H-1 (Continued)

RADIOLOGICAL ENVIRONMENTAL MONITORING SAMPLING LOCATIONS

TYPE OF SAMPLE	MAP* LOCATION (FIGURE NO.)	COLLECTION SITE	LOCATION
Direct Radiation	I-1 (H-4)	ISFSI ⁺⁺	West Fence, South
Direct Radiation	I-2 (H-4)	ISFSI ⁺⁺	West Fence, Center
Direct Radiation	I-3 (H-4)	ISFSI ⁺⁺	West Fence, North
Direct Radiation	I-4 (H-4)	ISFSI ⁺⁺	North Fence, West
Direct Radiation	I-5 (H-4)	ISFSI ⁺⁺	North Fence, Center
Direct Radiation	I-6 (H-4)	ISFSI ⁺⁺	North Fence, East
Direct Radiation	I-7 (H-4)	ISFSI ⁺⁺	East Fence, North
Direct Radiation	I-8 (H-4)	ISFSI ⁺⁺	East Fence, Center
Direct Radiation	I-9 (H-4)	ISFSI ⁺⁺	East Fence, South
Direct Radiation	I-10 (H-4)	ISFSI ⁺⁺	South Fence, East
Direct Radiation	I-11 (H-4)	ISFSI ⁺⁺	South Fence, Center
Direct Radiation	I-12 (H-4)	ISFSI ⁺⁺	South Fence, West

* See Figures H-1, H-2, H-3 and H-4 for map locations

++ Independent Spent Fuel Storage Installation

DEPARTMENT OF PUBLIC WORKS
 MAP OF
OSWEGO COUNTY
 New York

SCALE OF MILES

FIGURE H-1 ODCM
 OFF-SITE ENVIRONMENTAL
 SAMPLING LOCATIONS

KEY:

- FISH
- FOOD PRODUCT
- SHORELINE SEDIMENT
- SURFACE WATER
- MILK

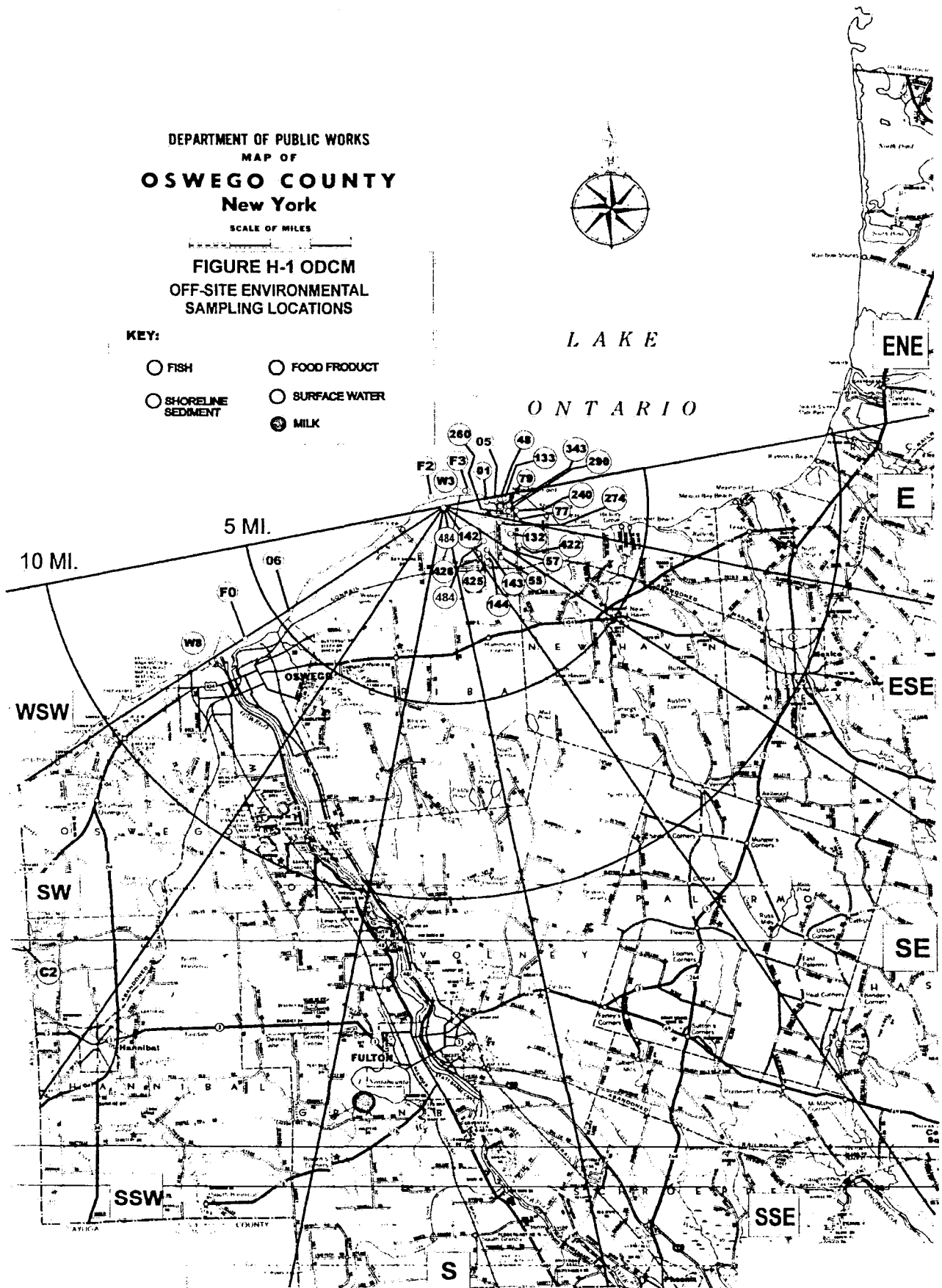
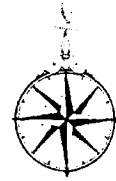

FIGURE H-2
OFF-SITE ENVIRONMENTAL STATION
AND TLD LOCATIONS

KEY

- ENVIRONMENTAL STATION
- TLD LOCATION



Oswego County
 New York

L A K E
 O N T A R I O

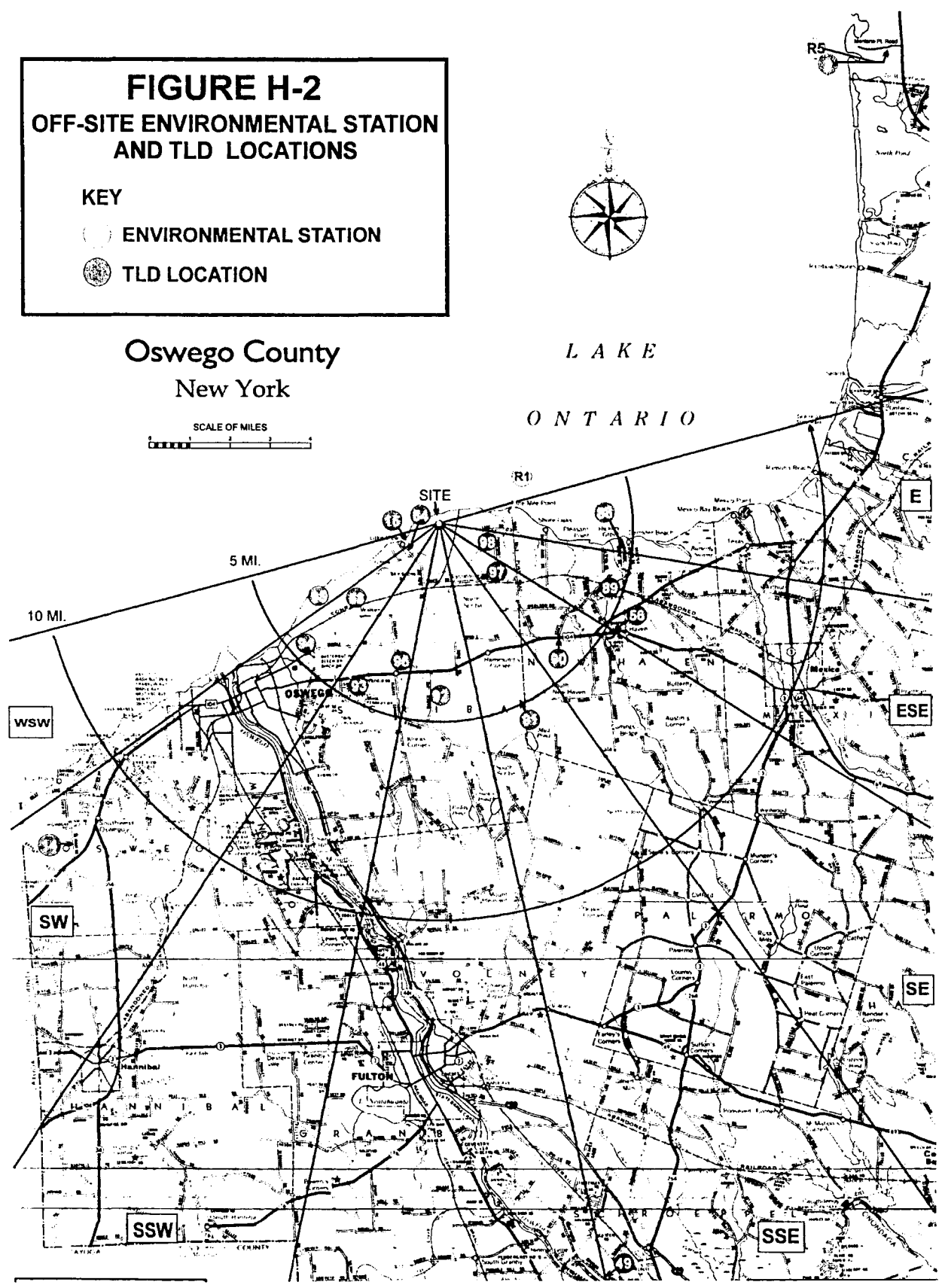
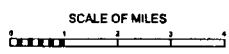

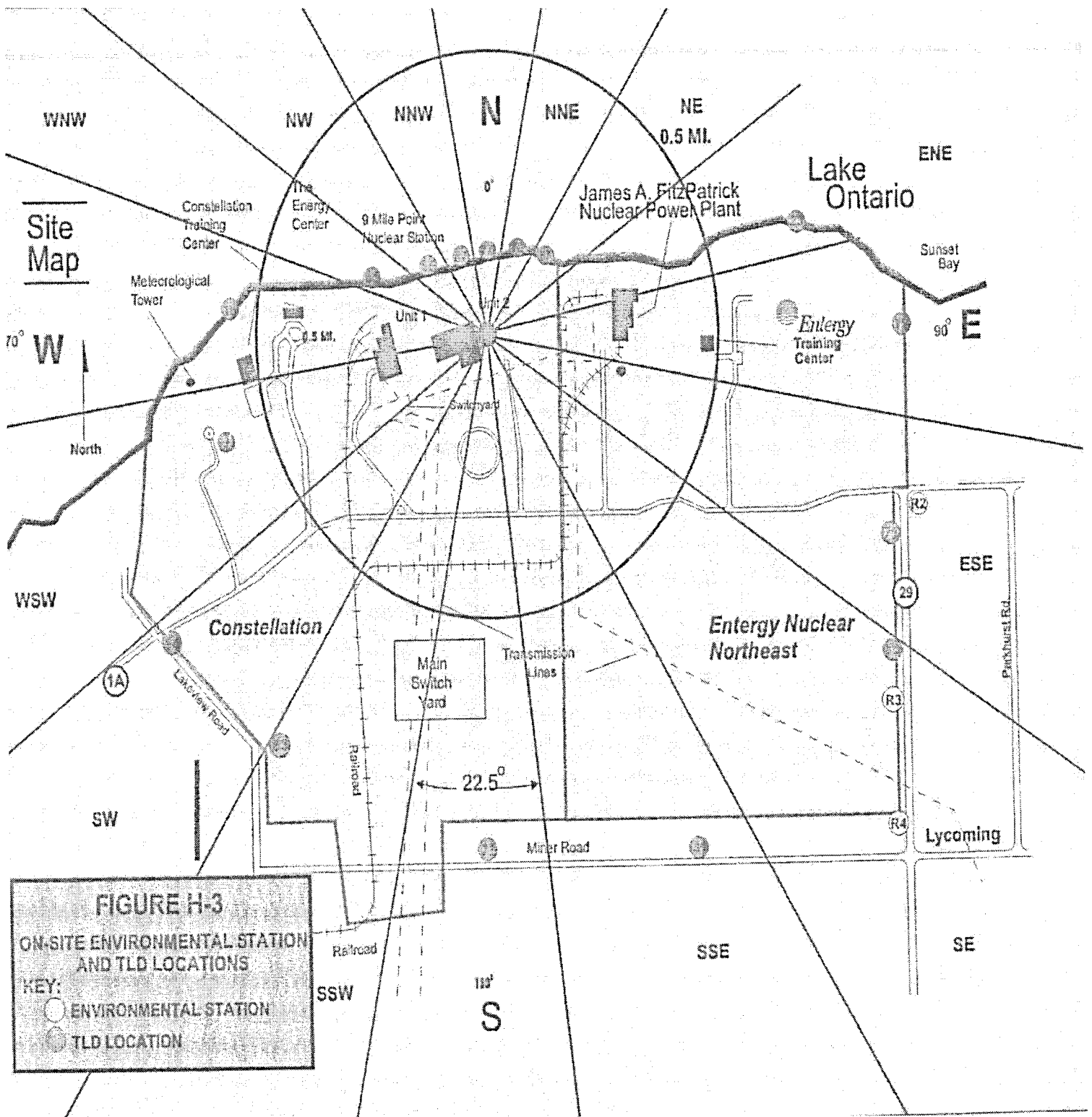
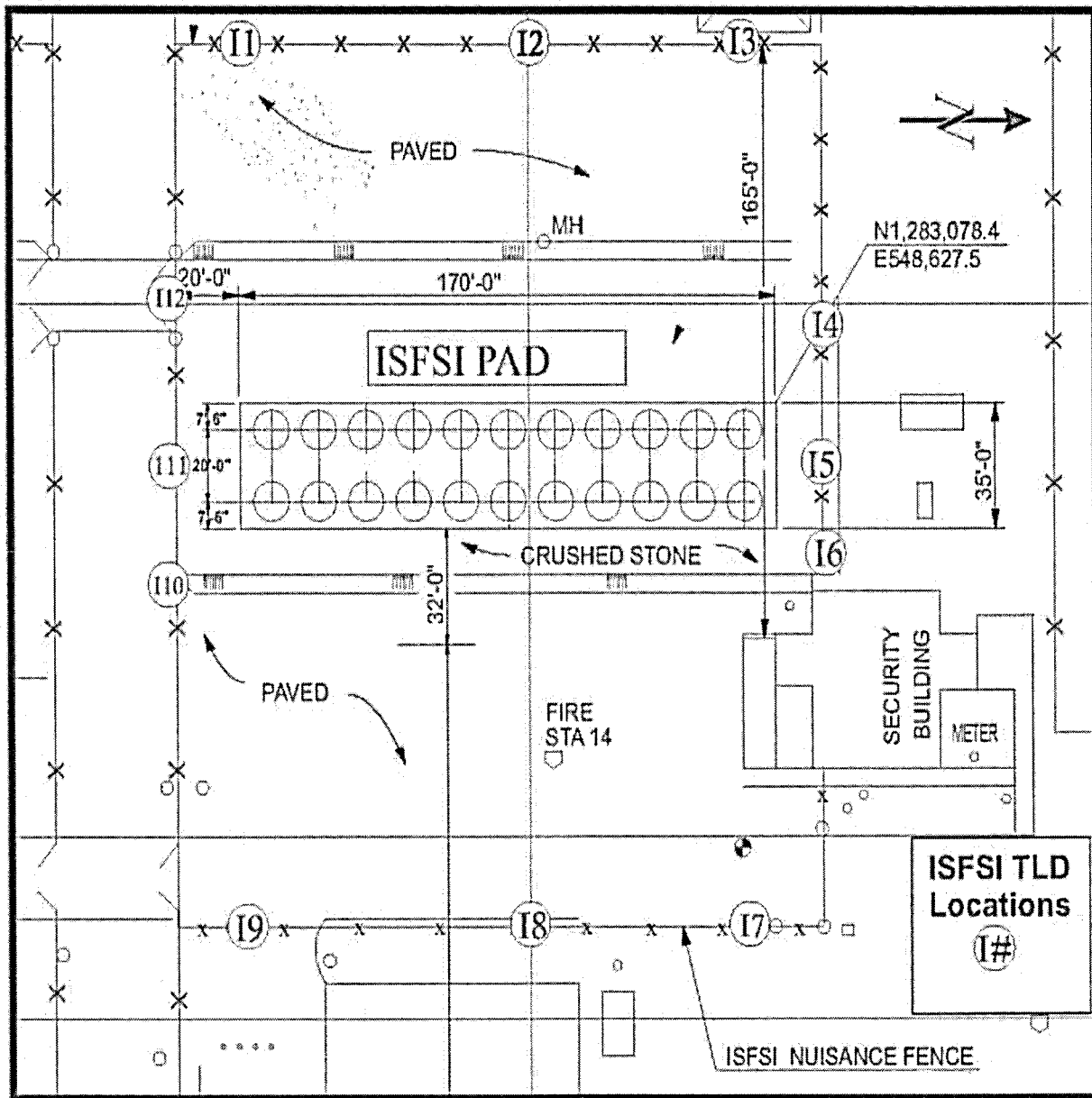

FIGURE H-3
ON-SITE ENVIRONMENTAL STATION
AND TLD LOCATIONS
KEY:
 ○ ENVIRONMENTAL STATION
 ● TLD LOCATION

FIGURE H-4

JAMES A. FITZPATRICK NUCLEAR POWER PLANT
OFFSITE DOSE CALCULATION MANUAL (ODCM)
ON-SITE ENVIRONMENTAL ISFSI TLD LOCATIONS



**TABLE H-2
LIQUID EFFLUENT PATHWAY - WATER INTAKE POINTS
DESCRIPTION AND PUMPAGE**

<u>Location of Water Intake*</u>	<u>Average Water Pumpage</u> Millions of Gallons Per Day
1. At a point between Dennison Creek and Bear Creak at a site north of the intersection of lake and Knickerbocker Roads	0.80
2. At Pultneyville	1.0
3. At a point north of the village of Sodus near the intersection of Shore Road and an extension of Maple Avenue	1.0
4. In Sodus Point Village on Lake Road	0.133
5. At east of Port Bay	0.095
6. In the western part of the City of Oswego between Sixth and Sheldon Avenues and north of West Schuyler Street	20.0
7. At east of the Village of Sackets Harbor	0.30
8. In Sawmill Bay at a location on Independence Point approximately 0.5 miles south of Chaumont Village's southerly limit	0.04
9. Cape Vincent	0.246
10. Township of Pittsburg (Milton)	0.015
11. Township of Pittsburg (Glen Lawrence)	0.015
12. City of Kingston (2 intakes)	9.72
13. Township of Kingston (Pt. Pleasant)	0.705
14. Township of Kingston (Queen's Acres)	0.037
15. Township of Ernestown (Amherstview)	0.270
16. Village of Bath	0.150
17. Town of Picton	0.679

* See Figure H-5 for Map Locations

FIGURE H-5

JAMES A. FITZPATRICK NUCLEAR POWER PLANT

OFFSITE DOSE CALCULATION MANUAL (ODCM)

LIQUID EFFLUENT PATHWAY - WATER INTAKE POINTS

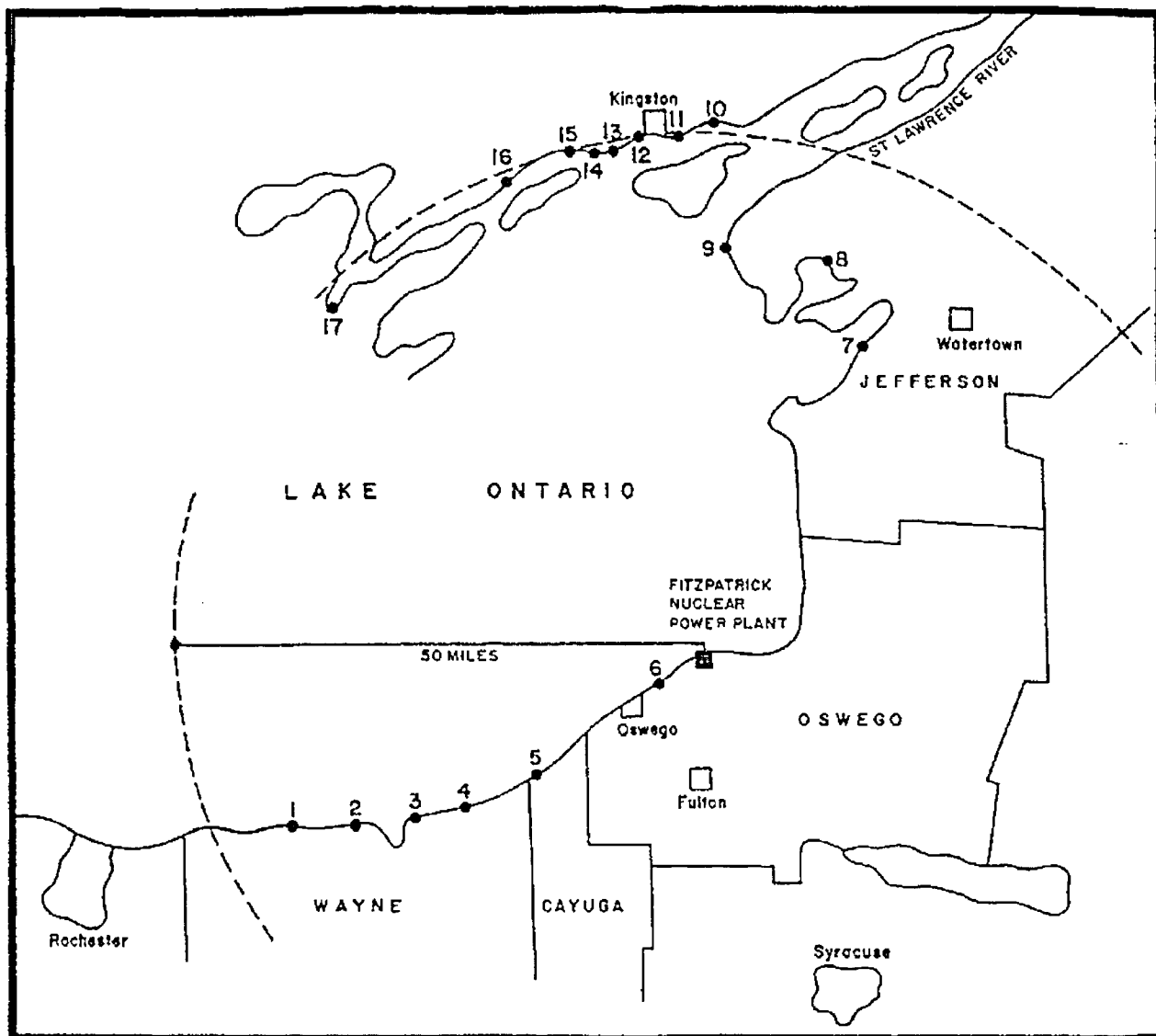

APPENDIX I
ODCM SUMMARY TABLES

APPENDIX I

ODCM SUMMARY TABLES

<u>TABLE</u>	<u>TITLE</u>	<u>PAGE</u>
I-1	Radioactive Effluent Release Limits Summary Table	I-3
I-2	ODCM Summary	I-4

TABLE I-1

RADIOACTIVE EFFLUENT RELEASE LIMITS - SUMMARY TABLE

DOSE/DOSE COMMITMENT	PATH/ SOURCE	MONTHLY PERIOD (1)			CALENDAR QUARTER			CALENDAR YEAR		
		WHOLE BODY (MREM)	SKIN (MRAD)	ANY ORGAN (MREM)	WHOLE BODY (MREM)	SKIN (MRAD)	ANY ORGAN (MREM)	WHOLE BODY (MREM)	SKIN (MRAD)	ANY ORGAN (MREM)
Member of the Public	Plant Liquid (2) Effluents	0.06	None	0.2	1.5	None	5	3	None	10
Member of the Public	Plant Gaseous (2) Effluents	None	None	None	5*	10*	7.5	10*	20*	15
At or Beyond Site Boundary	Plant Gaseous (3) Effluents	None	None	None	None	None	None	500	3000	1500
Member of the Public	Uranium (4) Fuel Cycle (Site)	None	None	None	None	None	None	25	None	25 (5)

(1) Equipment operability requirements for projected exposures. Refer to Specifications 2.4 (Liquid) and 3.6 (Gaseous).

(2) Plant Liquid and Gaseous release limitations in accordance with Appendix I to 10 CFR 50. Refer to Part 1, Specifications 2.3 (Liquids), 3.3 (Noble Gases) and 3.4 (Iodines and Particulates).

(3) Plant Gaseous release limitations in accordance with dose limits of 10 CFR 20.1001-20.2402. Refer to dose limits of Part 1, Specification 3.2.

(4) Site Gaseous release limitations in accordance with 40 CFR 190. Refer to Specification 5.0.

(5) Limits to any organ except the thyroid which shall be limited to 75 mrem.

* mrad, air dose.

TABLE I-2
ODCM SUMMARY

EFFLUENT PATHWAY	PURPOSE OF CALCULATION	FREQUENCY OF CALCULATION	REGULATORY REQUIREMENT	Part 1 (REC) REQUIREMENT	CORRESPONDING LIMITING VALUES	Part 2 (ODCM) SECTION	ODCM EQUATION NUMBER	INPUT DATA REQUIREMENTS	REPORTING REQUIREMENTS	MISCELLANEOUS
Liquid	Fraction of ECLs, F_L	Each batch release	10 times 10CFR20 Appendix B, Table 2, Column 2	Section 2.2	ECLs or for noble gases $2 \times 10^{-4} \mu\text{Ci/ml}$	Section 3.2.2	3-1	<ul style="list-style-type: none"> . Discharge structure exit flow . Waste tank release rate . Sample concentrations 	Release Permit	
Liquid	Minimum required dilution factor f_2/f_1 min.	Each batch release	10 times 10CFR20 Appendix B, Table 2, Column 2	Section 2.2	ECLs or for dissolved noble gases $2 \times 10^{-4} \mu\text{Ci/ml}$	Section 3.2.3	3-2	<ul style="list-style-type: none"> . Sample concentrations 	Release Permit	
Liquid	Determination of effluent monitor set-points	Each batch release	10 times 10CFR20 Appendix B, Table 2, Column 2	Section 2.1.2.c.1	FL less than or equal to 1 when calculating minimum dilution flow	Section 3.3.2	3-3	<ul style="list-style-type: none"> . FL . Sample concentrations 	Input to operations	
Liquid	Annual Dose Assessment	Calendar year	USNRC Regulatory Guide 1.21	Section 6.0	N/A	Section 3.4.1	3.4a 3-4b	<ul style="list-style-type: none"> . Site specific dose commitment factors . Previous year's release volumes and curies . Site specific dilution & ingestion 	Annual Radiological Effluent Report	
Liquid	Monthly Dose Assessment	Calendar month	10CFR50 Appendix I	Section 2.3	Whole Body dose - 1.5 mrem/qtr, 3 mrem/yr Organ dose - 5 mrem/qtr, 10 mrem/yr	Section 3.4.2	3-5a 3-5b	<ul style="list-style-type: none"> . Composite dose . Duration of release . Curies released . Volume of dilution 	N/A	May use limited analysis approach of ODCM Section 3.4.2

TABLE I-2 (Continued)

ODCM SUMMARY

EFFLUENT PATHWAY	PURPOSE OF CALCULATION	FREQUENCY OF CALCULATION	REGULATORY REQUIREMENT	Part 1 (REC) REQUIREMENT	CORRESPONDING LIMITING VALUES	Part 1 (ODCM) SECTION	ODCM EQUATION NUMBER	INPUT DATA REQUIREMENTS	REPORTING REQUIREMENTS	MISCELLANEOUS
Liquid	Dose projection determination of need to operate liquid radwaste systems	Prior to release of unrestricted liquid effluents	N/A	Section 2.4	Whole body dose - 0.06 mrem/month Organ dose - .2 mrem/month	Section 3.5	N/A	Number of batch releases, previous month Projected number of releases current month	If non-compliance, 30-day NRC report	
Gaseous	Determining instantaneous noble gas release rates	Calendar week	10CFR20.105	Section 3.2.1.c.1.a	Whole body dose - 500 mrem/yr Skin dose - 3000 mrem/yr	Section 4.3.1	4-1 to 4-6	Highest annual average X/Q for vent and elevated releases Total body, skin, and air dose factors Noble gas release rate ($\mu\text{Ci}/\text{sec}$) Effective dose transfer factor for vent releases, fraction of release rate limit	N/A	May use a limited analysis approach of ODCM Section 4.3.1 to determine noble gas release rate limits

TABLE I-2 (Continued)

ODCM SUMMARY

EFFLUENT PATHWAY	PURPOSE OF CALCULATION	FREQUENCY OF CALCULATION	REGULATORY REQUIREMENT	Part 1 (REC) REQUIREMENT	CORRESPONDING LIMITING VALUES	Part 2 (ODCM) SECTION	ODCM EQUATION NUMBER	INPUT DATA REQUIREMENTS	REPORTING REQUIREMENTS	MISCELLANEOUS
Gaseous	Determination of effluent monitor set-points	Calendar month or upon major operational transients (i.e., power level changes and failed fuel)	10CFR20.105	Section 3.1 and 3.2.1.c.1.a	Elevated Release - 3.0×10^5 μ Ci/sec Vent release - 6.98×10^4 μ Ci/sec	Section 4.3.2	N/A	<ul style="list-style-type: none"> . Maximum Volume release source . Calibration curve (μCi/cc vs CPM) for specified effluent monitor For ground level releases, fraction of release rate limit allocated to specified release point 	Input to Operations	
Gaseous	Determining radioiodine, Tritium and 8 day particulate instantaneous release rates	Calendar week	10CFR20.105	Section 3.2.1.c.1.b	1500 mrem/yr. any organ	Section 4.3.3	4-9 4-10	<ul style="list-style-type: none"> . Long-term sector average concentration X/Q (Appendix C) . Long-term relative deposition value (Appendix C) . Dose factors for applicable environmental pathways (Table B-4 through B-6) Iodine, Tritium and 8-day particulate release rate (μCi/sec) 	N/A	

TABLE I-2 (Continued)

ODCM SUMMARY

EFFLUENT PATHWAY	PURPOSE OF CALCULATION	FREQUENCY OF CALCULATION	REGULATORY REQUIREMENT	Part 1 (REC) REQUIREMENT	CORRESPONDING LIMITING VALUES	Part 2 (ODCM) SECTION	ODCM EQUATION NUMBER	INPUT DATA REQUIREMENTS	REPORTING REQUIREMENTS	MISCELLANEOUS
Gaseous	Annual Dose Assessment	Calendar Year	USNRC Regulatory Guide 1.21	Section 6.1	N/A	Section 4.4.1	4-11 to 4-19	<ul style="list-style-type: none"> . Previous year's annual average D/Q and X/Q . Activity released ($\mu\text{Ci}/\text{yr}$) for the previous year from vent and elevated releases 	Annual Radioactive Effluent Report	
Gaseous	Monthly Dose Assessment - Gamma air Dose - Beta air Dose	Calendar Month	10CFR50, Appendix I	Section 3.3.2.c.1	Gamma air Dose - 5 mrad/qtr 10 mrad/yr Beta air Dose - 10 mrad/qtr 20 mrad/yr	Section 4.4.2	4-20 4-23	<ul style="list-style-type: none"> . Gamma Air Dose factors, M . Beta Air Dose factor, N . Highest annual average X/Q for vent and elevated releases . Noble Gas curies released during the month 		
Gaseous	Monthly Dose - radioiodine tritium and 8-day particulate	Calendar Month	10CFR50, Appendix I	Section 3.4.2.c.1	Any Organ - 7.5 mrem/qtr 15 mrem/yr	Section 4.4.2	4-24 to 4-27		N/A	May use limited analysis approach of ODCM Section 4.4.2.c

TABLE I-2 (Continued)

ODCM SUMMARY

EFFLUENT PATHWAY	PURPOSE OF CALCULATION	FREQUENCY OF CALCULATION	REGULATORY REQUIREMENT	Part 1 (REC) REQUIREMENT	CORRESPONDING LIMITING VALUES	Part 2 (ODCM) SECTION	ODCM EQUATION NUMBER	INPUT DATA REQUIREMENTS	REPORTING REQUIREMENTS	MISCELLANEOUS
Gaseous	Dose Projection Determination of need to operate off gas treatment system	Prior to release of unprocessed gaseous effluents	N/A	Section 3.5	0.2 mrad gamma 0.4 mrad beta 0.3 mrem organ	Section 4.5	4-20 4-31	Gamma and Beta air dose and particulate, iodine, and tritium organ dose during the quarter to date Number of days the plant is projected to be operational during the coming month	If non-compliance, 30 day NRC report	May use a limited analysis approach of ODCM Section 4.5.2
Liquid	Demonstrate compliance with annual fuel/cycle dose commitment limits	Calendar year if liquid releases exceed 3 mrem, total body, or 10 mrem, any organ	40CFR190	Section 4.1.1.c.1 (except thyroid) - 25 mrem/yr thyroid - 75 mrem/yr	Whole Body or any organ	Section 5.2	3-4	Actual dilution ingestion factors (fish and potable water) Radiological Environmental Monitoring Program Results		

TABLE I-2 (Continued)

ODCM SUMMARY

EFFLUENT PATHWAY	PURPOSE OF CALCULATION	FREQUENCY OF CALCULATION	REGULATORY REQUIREMENT	Part 1 (REC) REQUIREMENT	CORRESPONDING LIMITING VALUES	Part 2 (ODCM) SECTION	ODCM EQUATION NUMBER	INPUT DATA REQUIREMENTS	REPORTING REQUIREMENTS	MISCELLANEOUS
Gaseous	Demonstrate compliance with annual fuel cycle dose commitment limits	Calendar year, if gaseous releases exceed 10 mrad gamma air dose, 15 mrem thyroid or any organ	40CFR190	Section 4.1.1.c.1 (except thyroid) - 25 mrem/yr. thyroid - 75 mrem/yr.	Whole Body or any organ	Section 5.3	Equation Section 4-4	Current data, including: actual location of real individuals, meteorological conditions, and consumption of food (e.g. milk, meat, and vegetation)	30 day NRC Report	Substitute the total body dose factor (Ki) for the gamma air dose factor (Mi)
Direct Radiation	Demonstrate compliance with annual fuel/cycle dose commitment limits	Calendar year, if liquids or gases exceed dose limits indicated above	40CFR190	Section 4.1.1.c.1	Whole Body - 25 mrem/yr.	Section 5.4	N/A	<ul style="list-style-type: none"> . Shielding calculations . TLD results from environmental program 		