

Official Transcript of Proceedings
NUCLEAR REGULATORY COMMISSION

Title: Advisory Committee on Reactor Safeguards
 APR1400 Subcommittee

Docket Number: N/A

Location: Rockville, Maryland

Date: March 21, 2017

Work Order No.: NRC-2954

Pages 1-255

NEAL R. GROSS AND CO., INC.
Court Reporters and Transcribers
1323 Rhode Island Avenue, N.W.
Washington, D.C. 20005
(202) 234-4433

1
2
3
4
5
6
7
8
9
10
11
12
13
14
15
16
17
18
19
20
21
22
23

DISCLAIMER

UNITED STATES NUCLEAR REGULATORY COMMISSION'S
ADVISORY COMMITTEE ON REACTOR SAFEGUARDS

The contents of this transcript of the proceeding of the United States Nuclear Regulatory Commission Advisory Committee on Reactor Safeguards, as reported herein, is a record of the discussions recorded at the meeting.

This transcript has not been reviewed, corrected, and edited, and it may contain inaccuracies.

UNITED STATES OF AMERICA
NUCLEAR REGULATORY COMMISSION

+ + + + +

ADVISORY COMMITTEE ON REACTOR SAFEGUARDS (ACRS)

+ + + + +

APR1400 SUBCOMMITTEE

+ + + + +

TUESDAY,

MARCH 21, 2017

+ + + + +

ROCKVILLE, MARYLAND

+ + + + +

The Subcommittee met at the Nuclear Regulatory Commission, Two White Flint North, Room T2B1, 11545 Rockville Pike, at 1:00 p.m., Matthew W. Sunseri, Chairman, presiding.

COMMITTEE MEMBERS:

MATTHEW W. SUNSERI, Chairman

RONALD G. BALLINGER, Member

MICHAEL L. CORRADINI, Member

WALTER L. KIRCHNER, Member

DANA A. POWERS, Member

JOY REMPE, Member

GORDON R. SKILLMAN, Member

NEAL R. GROSS

COURT REPORTERS AND TRANSCRIBERS
1323 RHODE ISLAND AVE., N.W.
WASHINGTON, D.C. 20005-3701

JOHN W. STETKAR, Member

DESIGNATED FEDERAL OFFICIAL:

DEREK WIDMAYER

ALSO PRESENT:

TONY AHN, KHNP

SURINDER ARORA, NRO

JOE ASHCRAFT, NRO

CLINT ASHLEY, NRO

DAN BARSS, NSIR

JOHN BUDZYNSKI, NRO

NAN CHIEN, NRO

HYOUNG DOO CHOI, KHNP

JEFF CIOCCO, NRO

JOSEPH DEMARSHALL, NRO

JAMES GILMER, NRO

ANNE-MARIE GRADY, NRO

RAJ GOEL, NRO

JEONG GEUN HA, KHNP

SYED HAIDER, NRO

CRAIG HARBUCK, NRO

MICHELLE HART, NRO

ALFRED HATHAWAY, RES

JUN HEO, KHNP

NEAL R. GROSS

COURT REPORTERS AND TRANSCRIBERS
1323 RHODE ISLAND AVE., N.W.
WASHINGTON, D.C. 20005-3701

SEKHWAN HUR, KEPCO E&C
SUNG JI HYUN, KHNP
INYOUNG IM, KHNP & KEPCO
DIANE JACKSON, NRO
HYEOK JEONG, KEPCO E&C
DEOGJA KANG, KEPCO E&C
REBECCA KAY, NRO
JUNGHO KIM, KHNP
TAE HAN KIM, KEPCO E&C
ALEX KLEIN, NRR
CHANG JAE LEE, KEPCO
DONGSU LEE, KEPCO E&C
JAIHO LEE, KHNP & KEPCO
JEONGHYEONG LEE, KEPCO E&C
SANGWON LEE, KHNP & KEPCO
SAMUEL LEE, NRO
DAE HEON LIM, KEPCO E&C
SHANLAI LU, NRO
TIM LUPOLD, NRO
GREGORY MAKAR, NRO
STEVE MANNON, AECOM
MICHAEL MCCOPPIN, NRO
JILL MONAHAN, Westinghouse
KEN MOTT, NRO

NEAL R. GROSS

COURT REPORTERS AND TRANSCRIBERS

1323 RHODE ISLAND AVE., N.W.

WASHINGTON, D.C. 20005-3701

(202) 234-4433

(202) 234-4433

SEONCHANG MUN, KEPCO E&C

DOOHWAN OH, KEPCO E&C

HUNGU OH, KEPCO E&C

JIYONG OH, KHNP

JIHWANG, PARK, KEPCO E&C

SEOK JEONG PARK, KEPCO E&C

ERIC PAUL, ERI

MARIE A. POHIDA, NRO

SHEILA RAY, NRR

JAMES ROSS, AECOM

CAYETANO SANTOS, NRO

JASON SCHAPEROW, NRO

JEONG HWAN SEO, KEPCO E&C

JONG TAE SEO, KEPCO E&C

ROB SISK, Westinghouse

SWAGATA SOM, NRR

JIM STRNISHA, NRO

ED STUTZCAGE, NRO

SUNGHYUN TAK, KEPCO E&C

MATT THOMAS, NRO

THEODORE TJADER, NRO

JESSICA UMANA, NRO

ANDREA D. VEIL, Executive Director, ACRS

HANRY WAGAGE, NRO

NEAL R. GROSS

COURT REPORTERS AND TRANSCRIBERS

1323 RHODE ISLAND AVE., N.W.

WASHINGTON, D.C. 20005-3701

(202) 234-4433

(202) 234-4433

DAVE WAGNER, KHNP

WILLIAM WARD, NSIR

DAN WIDREVITZ, NRO

JAIHWA YOON, KEPCO E&C

T A B L E O F C O N T E N T S

OPENING REMARKS/OBJECTIVES:

Matt Sunseri, ACRS Chairman.....6

STAFF OPENING REMARKS:

Jeff Ciocco, Program Director, NRO.....10

Michael McCoppin, Branch Chief.....10

CHAPTER 13:

Robert Sisk, Westinghouse.....11

APR-1400 CONDUCT OF OPERATION:

JaiHo Lee, KHNP & KEPCO.....11

NRC STAFF APR-1400 REVIEW:

William Ward, NSIR (13.1/13.4).....15/28

Surinder Arora, DCIP (13.2).....17

Eddie Robinson, NSIR (13.3).....20

Joe DeMarshall, DCIP (13.5).....28/100

CHAPTER 16:

TECHNICAL SPECIFICATIONS:

SangWon Lee, KHNP & KEPCO.....37

NRC STAFF CHAPTER 16 TECH SPEC PRESENTATION:

NEAL R. GROSS

COURT REPORTERS AND TRANSCRIBERS

1323 RHODE ISLAND AVE., N.W.

WASHINGTON, D.C. 20005-3701

(202) 234-4433

(202) 234-4433

Jessica Umana, NRO.....	61
Bob Tjader, NRO.....	61/156
Craig Harbuck, NRO.....	81
Joe Ashcraft, NRO.....	145
COMMITTEE DISCUSSION/QUESTIONS:.....	157

P R O C E E D I N G S

1:00 p.m.

CHAIRMAN SUNSERI: All right. It's 1:00.

The meeting will now come to order. This is a meeting of the APR-1400 Subcommittee of the Advisory Committee on Reactor Safeguards.

I am Matt Sunseri, Chairman of today's APR-1400 Subcommittee meeting. ACRS Members in attendance are: Gordon Skillman, Dr. Dana Powers will be joining us in about five minutes, Michael Corradini, Ron Ballinger, John Stetkar and Joy Rempe.

Chris Brown is our Designated Federal Official for this meeting.

The purpose of today's meeting is for the Subcommittee to receive briefings from Korea Electric Power Corporation and Korea Hydro and Nuclear Power Company, Ltd., KHNP, regarding their design certification application and the NRC staff regarding their safety evaluation report with open items

NEAL R. GROSS

COURT REPORTERS AND TRANSCRIBERS

1323 RHODE ISLAND AVE., N.W.

(202) 234-4433

WASHINGTON, D.C. 20005-3701

(202) 234-4433

specific to Chapter 6, Engineered Safety Features, Chapter 13, Conduct of Operations, and Chapter 16, Technical Specifications.

The ACRS was established by statute and is governed by the Federal Advisory Committee Act. This means that the Committee can only speak through its published letter reports. We hold meetings to gather information to support our deliberations.

Interested parties who wish to provide comments can contact our office requesting time once the meeting announcement is published in the Federal Register.

That said, we also set aside 10 minutes for comments from members of the public attending or listening to our meetings. Written comments are also welcomed.

The ACRS section of the U.S. NRC public website provides our charter, bylaws, letter reports and full transcripts of all Full and Subcommittee meetings, including slides presented at the meeting.

The rules for participation in today's meeting were announced in the Federal Register on Tuesday, March 8, 2017. The meeting was announced as an open/closed to public meeting. This meant that the

NEAL R. GROSS

COURT REPORTERS AND TRANSCRIBERS

1323 RHODE ISLAND AVE., N.W.

WASHINGTON, D.C. 20005-3701

(202) 234-4433

(202) 234-4433

Chairman can close the meeting as needed to protect information proprietary to KHNP or its vendors.

No request for making a statement to the Subcommittee has been received from the public.

A transcript of the meeting is being kept and will be made available as stated in the Federal Register notice. Therefore, I would request that participants in this meeting use the microphones located throughout the meeting room when addressing the Subcommittee.

Participants should first identify themselves and speak with sufficient clarity and volume so they can be readily heard.

We have a bridge line established for members of the public to listen in. The bridge number and password were published in the agenda posted on the NRC public website.

To minimize disturbance the public line will be kept in a listen-only mode. The public will have an opportunity to make a statement or provide comments at a designated time towards the end of this meeting.

I would request now that meeting attendees and participants silence your cell phones and other

NEAL R. GROSS

COURT REPORTERS AND TRANSCRIBERS

1323 RHODE ISLAND AVE., N.W.

WASHINGTON, D.C. 20005-3701

(202) 234-4433

(202) 234-4433

electronic devices.

All the chapters that we will be reviewing in the next few days are important and I want to make sure that we distribute our time appropriately. In particular, Chapter 13 defers many of the activities to the COL applicant.

We will be mainly looking in to see that these assignments are appropriate and have only allotted two hours for this chapter.

Chapter 16 describes the technical specifications that have been developed in accordance with NUREG-1432 following the standard technical specifications design. Although nearly 1,000 pages in volume, we have devoted six hours to this chapter. Since the technical specifications follow the technical -- the standard technical specification content, perhaps we could best spend our time -- less time on the standard items and allow more time for treatment of the plant differences, such as the 4 trains of the Emergency Core Cooling and Pilot Operated Safety Release Valves.

That leaves us with eight hours for Chapter 6. This chapter will likely be the most technically challenging for us in this series of

NEAL R. GROSS

COURT REPORTERS AND TRANSCRIBERS

1323 RHODE ISLAND AVE., N.W.

WASHINGTON, D.C. 20005-3701

(202) 234-4433

(202) 234-4433

chapters. Therefore, I ask that we get through Chapters 13 and 16 as efficiently as possible and perhaps even pick up time that can be applied to Chapter 6.

The schedule, as published, has footnotes giving us the flexibility to move up some items.

In summary, we want to maximize our time in Chapter 6 and we will use the footnote schedule of flexibility to do this.

Okay. With those opening remarks, I now invite Jeff Ciocco, NRO Project Manager, to introduce the presenters and start the briefing.

MR. CIOCCO: Thank you, Mr. Chairman, and thanks for having us. My name is Jeff Ciocco. I'm the lead project manager for the APR-1400, Standard Design Certification. Staff stands ready to present and defend our safety evaluations for Chapter 6, 13 and 16 and we will introduce our own specific speakers whenever staff gets up there.

Thank you for having us. I'm going to turn it over to my Branch Chief, Michael McCoppin.

MR. MCCOPPIN: Thanks, Jeff. Mike McCoppin, the Licensing Branch II Chief in the Office of New Reactors. I would also like to acknowledge all

NEAL R. GROSS

COURT REPORTERS AND TRANSCRIBERS

1323 RHODE ISLAND AVE., N.W.

WASHINGTON, D.C. 20005-3701

(202) 234-4433

(202) 234-4433

the efforts up to this point for all the stakeholders involved today.

In addition, I would also like to thank the ACRS for being so flexible in scheduling and in some cases receiving the staff's safety evaluations less than the 30 days needed for their review, in some cases. This flexibility has helped to keep the project on track and not slip to Phase 3, 4 and 5 milestones. So we -- thanks, thank you for your flexibility.

CHAIRMAN SUNSERI: Okay. Thank you for that. Now, we are ready to start the presentation. Chapter 13, Rob?

MR. SISK: Thank you, Chairman. This is Rob Sisk, Westinghouse, representing the APR-1400 design certification application. And as before, we appreciate the opportunity to present these chapters to the ACRS. And I will not belabor the point, but turn it over to JaiHo Lee to present Chapter 13.

MR. J. LEE: Thank you for introducing me. Good afternoon, everyone. My name is JaiHo Lee. I am responsible for Chapter 13 at KHNP Central Research Institute.

Today I am going to talk about DCD Chapter

NEAL R. GROSS

COURT REPORTERS AND TRANSCRIBERS

1323 RHODE ISLAND AVE., N.W.

WASHINGTON, D.C. 20005-3701

(202) 234-4433

(202) 234-4433

13, Conduct of Operation for APR-1400.

First of all, I am pleased to have this opportunity to present the APR-1400 Conduct of Operation to the ACRS Members. Even I think all of the Members may have reviewed the DCD Chapter 13 and the related chapters, this could be a good chance to enhance much more understanding of the APR-1400 design.

In this time, however, Chapter 13.6, Physical Security Design Features, will not be presented because it included many of security-related information and safeguard information.

Now, I'm going to move on to the next slide then. This is a slide that -- this slide shows the content of the presentation is sorted in the same order as the DCD Chapter 13.

After a brief overview of the Chapter 13, I will introduce each section of Chapter 13. And then I will talk about open items and current status. Finally, I will give a summary for this presentation.

As we all know, Chapter 13 of the DCD Tier II consists of seven sections relating to conduct of operation. Most of the sections consist of the COL items and their process.

NEAL R. GROSS

COURT REPORTERS AND TRANSCRIBERS

1323 RHODE ISLAND AVE., N.W.

WASHINGTON, D.C. 20005-3701

(202) 234-4433

(202) 234-4433

Section 13.1 addresses COL items for management, technical support, operating organization and qualification of a nuclear power plant personnel over the APR-1400.

Section 13.2 introduces the COL information for plant staff training.

Section 13.3 provides us the COL information items for emergency plan content.

Section 13.4 and 13.5 provide the COL items for operation approval and implementation and the COL items for administrative and operating procedures respectively.

As I mentioned earlier, Section 13.6 is physical security design features of APR-1400 will not be presented at this time.

And then Section 13.7 describes the COL information for fitness-for-duty program.

For the review of APR-1400 Chapter 13 Conduct of Operation, KHNP submitted a DCD T01 and T02 Chapter 13. There is no topical or technical report submitted on Chapter 13 excluding 13.6, Physical Security.

This slide shows the overview of Section 13.1. The Section 13.1 provides the COL applicant

NEAL R. GROSS

COURT REPORTERS AND TRANSCRIBERS

1323 RHODE ISLAND AVE., N.W.

WASHINGTON, D.C. 20005-3701

(202) 234-4433

(202) 234-4433

responsibilities for organizational structure of the applicant.

Section 13.1.1, Management and Technical Support Organization consist of a design, construction, operating responsibilities, organizational arrangement and qualifications.

And then Section 13.1.2, Operating Organization, include plant organization, plant personnel responsibilities and authorities and operating shift crew.

Finally, Section 13.1.3, Qualifications of Nuclear Power Plant, includes qualification requirements and qualification of plant personnel.

This slide shows the overview of a Section 13.2 and Section 13.3.

The Section 13.2 describes the COL applicant's development of a training program.

Section 13.3 provides the design features to support the emergency planning, including technical support center.

Section 13.4 describes the COL applicant's development of the Operational Program Implementation.

Section 13.5 describes the COL applicant's responsibilities for developing the administrative

NEAL R. GROSS

COURT REPORTERS AND TRANSCRIBERS

1323 RHODE ISLAND AVE., N.W.

WASHINGTON, D.C. 20005-3701

(202) 234-4433

(202) 234-4433

approaches for operating and maintenance procedures.

In Section 13.7, the development of the Fitness-For-Duty Program is the responsibility of the COL applicant.

There are no open items in Chapter 13 so far.

Here is the summary:

Chapter 13 provides the information relating to the preparation and the plans for design construction and operation of the APR-1400 Plans. This chapter describes the COL information items to be addressed by the COL applicant.

Thank you for listening.

CHAIRMAN SUNSERI: Thank you. So, Members, any comments or questions on Chapter 13 from the HMD? All right. So we're ready to move on to the staff's presentation. I think you all set a record for that, so appreciate your timeliness.

Okay. Is staff ready? So I'll turn it over to whoever wants to kick it off.

MR. WARD: Good afternoon. Thank you. My name is Bill Ward. I'm the Project Manager for Chapter 13 and this is the staff presentation on KHNP's APR-1400 Chapter 13 Review.

NEAL R. GROSS

COURT REPORTERS AND TRANSCRIBERS

1323 RHODE ISLAND AVE., N.W.

WASHINGTON, D.C. 20005-3701

(202) 234-4433

(202) 234-4433

Performing the review, we have from the Human Performance Operator Licensing, an ITAAC Branch, Surinder Arora and Joe DeMarshall. Everybody has got their tags up. Okay. And from NSIR, from the Reactor Licensing Branch of NSIR was Eddie Robinson.

And what sections were reviewed are presented below. In actuality, even though I'm listed for 13.1, I'm presenting it, but I didn't review 13.1.

The reviewer retired and so I'm going to present it to the best of my ability, but I didn't do the review.

13.4 is not really anything. In 13.4, we just kind of write a section to fill in for 13.4. So I wrote that section. And the other three sections were reviewed by Surinder, Eddie and Joe.

So we will get started with the summary. You just saw this with the KHNP presentation. They had seven sections here. We have five listed. The reason is Sections 13.6 and 13.7 related to Physical Security and Fitness-For-Duty. We don't review in the ACRS meetings, so we just list the five sections here and that's what we will be presenting.

Okay. Section 13.1. The intent of this section is to provide the assurance that the applicant has the COL items for corporate level management and

NEAL R. GROSS

COURT REPORTERS AND TRANSCRIBERS

1323 RHODE ISLAND AVE., N.W.

WASHINGTON, D.C. 20005-3701

(202) 234-4433

(202) 234-4433

technical support organizations. The purpose is to make sure the COL applicant will have the necessary managerial and technical resources to support the plant staff and construction, operation, maintenance in the event of emergency.

In this case, they had 11 COL items. The COL items were in the same manner as what other applicants have provided. They did cover all of the requirements in the TMI guidance in the regulations. And staff found no problem with the 11 COL items.

There were no RAIs issued. And so the conclusion is that the necessary COL items were provided to ensure that the COL applicant will have the organization required.

Any question on 13.1? Okay.

13.2?

MR. ARORA: Good afternoon to everyone in the room and those on the bridge line. My name is Surinder Arora and I'm a member of the Human Performance Operator Licensing, an ITAAC Branch in the Division of Construction Inspection and Operational Programs abbreviated as DCIP.

I'm here today to present 13 DCD --

CHAIRMAN SUNSERI: Can you turn your mic

NEAL R. GROSS

COURT REPORTERS AND TRANSCRIBERS

1323 RHODE ISLAND AVE., N.W.

WASHINGTON, D.C. 20005-3701

(202) 234-4433

(202) 234-4433

on? The green light on.

MR. ARORA: Oh, it was off. I'm sorry.
Should I continue from here or go back?

MR. WARD: Please, continue from there.

MR. ARORA: Okay. I'm here today to present KHNP Design Certification SE for Chapter 13, section 13.2 related to training of the plant personnel.

I inherited this section from one of my branch-mates who retired from the Commission last year. It could be the same person that Bill got 13.1 from.

As stated right here in the presentation this morning to the Committee, just before us, the combined license applicant is responsible for developing the description, content and schedule of the site-specific training programs for the licensed and non-licensed plant staff.

The information directing the COL applicant to do this is captured in five COL information items listed in KHNP Design Certification Application.

Since the training program details will be submitted by the COL applicant letter, the staff's

NEAL R. GROSS

COURT REPORTERS AND TRANSCRIBERS

1323 RHODE ISLAND AVE., N.W.

WASHINGTON, D.C. 20005-3701

(202) 234-4433

(202) 234-4433

review of the portion of the DC application was to confirm that the COL information items clearly and adequately convey the requirements to the COL applicant.

In reviewing the COL information items in the DCD, the staff found that two information items, numbers 13.2.3 and 13.2.4 failed to clearly commit to NEI 06-13A, which is the NRC-approved Industry Guidance that was developed by NEI.

In this two COL information items, KHNP had stated that the training programs for licensed and non-licensed plant staff will be provided by the COL applicant in accordance with NUREG-0800.

An RAI was issued to KHNP to obtain clarification on this difference in their application.

In response, KHNP corrected the wording previously given to us in the DC and they revised the COL information items in question.

In the RAI response, KHNP also provided a markup of the revision to the FSAR, which was reviewed by the staff and found acceptable.

In the current version of the SE, a confirmatory item has been created to verify the changes in the next version of the DC application when

NEAL R. GROSS

COURT REPORTERS AND TRANSCRIBERS

1323 RHODE ISLAND AVE., N.W.

WASHINGTON, D.C. 20005-3701

(202) 234-4433

(202) 234-4433

submitted. Except for this verification and closure of the confirmatory item, there are no open issues and the applicant's approach to developing the training programs for their plant staff is considered acceptable.

MR. WARD: Any questions?

CHAIRMAN SUNSERI: Okay. Thank you.

MR. ARORA: Thank you.

CHAIRMAN SUNSERI: Okay. Next.

MR. WARD: And for 13.3, Emergency Planning, we have Mr. Robinson.

MR. ROBINSON: All right. Well, let me first begin by saying good afternoon to the ACRS staff, NRC staff and those member of the public who are perhaps calling in to the bridge line. My name is Edward Robinson. I'm an --

CHAIRMAN SUNSERI: Is your mic on?

MR. ROBINSON: It's -- maybe I'll just get a little bit closer.

CHAIRMAN SUNSERI: Okay.

MR. ROBINSON: Is that better? Okay. I'm an EP Specialist in the Reactor Licensing Branch within the Office of NSIR. I have primary review responsibility for SER Section 13.3 titled Emergency

NEAL R. GROSS

COURT REPORTERS AND TRANSCRIBERS

1323 RHODE ISLAND AVE., N.W.

WASHINGTON, D.C. 20005-3701

(202) 234-4433

(202) 234-4433

Planning of the submitted APR-1400 Design Certification document.

With that being said, there are no open items associated with DCD Section 13.3 and as a result, the staff is not expecting any additional emergency planning-related information to be incorporated into a future revision of the DCD.

The staff's evaluation of the APR-1400 DCD application submittal concluded that the proposed size and location of the TSC was acceptable. The staff found that the TSC size and location descriptions provided by the applicant were in conformance with the guidance set forth in our SRP NUREG-0800 and, therefore consistent with the requirements set forth in 10 CFR 5047(b)(8) in subsection (4)(E)(8) of Appendix E to 10 CFR Part 50.

In part, the applicant stated that the TSC contains a floor space of at least 1875 square feet, which provided for a work space of, approximately, 75 square feet for each of the 25 personnel. 20 of which would be licensee personnel, in addition to 5 NRC personnel.

In addition to that, they go on to explain that the TSC has size and has space for data system

NEAL R. GROSS

COURT REPORTERS AND TRANSCRIBERS

1323 RHODE ISLAND AVE., N.W.

WASHINGTON, D.C. 20005-3701

(202) 234-4433

(202) 234-4433

equipment and document storage. The applicant also went on to explain in their application that the TSC is located near the main control room within the auxiliary building and also is a distance of about -- not to exceed 2 minutes walking distance between the two facilities.

NUREG-0800 identifies --

MEMBER SKILLMAN: Eddie, let me ask a question on that --

MR. ROBINSON: Yes, sure.

MEMBER SKILLMAN: -- point.

MR. ROBINSON: Okay.

MEMBER SKILLMAN: I understand the proximity is about 2 minutes from the control room to the TSC?

MR. ROBINSON: Yes, uh-huh.

MEMBER SKILLMAN: What attention did you give to the manner by which an individual gets from the control room to the TSC? How many doors, stairs, convoluted passageways does an individual need to proceed through in order to get from one to the other?

MR. ROBINSON: As far as testing, what that actually is, you know, we -- our guidance set forth in 06-96, I guess, basically says that they have

NEAL R. GROSS

COURT REPORTERS AND TRANSCRIBERS

1323 RHODE ISLAND AVE., N.W.

WASHINGTON, D.C. 20005-3701

(202) 234-4433

(202) 234-4433

to commit to having a 2 minute piece. They provided some figures, but as far as doors, etcetera, are concerned, how that kind of encompasses in to whether that two minute is actually part of that, that's probably more -- I don't know if I want to say that's -- I don't want to deflect the question, but I'm not sure if that's more for KHNP to kind of lay out that, but they didn't go into detail as far as like the number of doors or size.

They actually just said in their application hey, it's going to be 2 minutes walking distance. So when we look at that and it's on a docket, we look at 06-96 and see what they committed to and say that's in conformance with our guidance. So we didn't go into detail as far as breaking that down, the number of stairs.

MEMBER SKILLMAN: Okay. I thought I saw a diagram in the DCD and it's just right next door to the control room, isn't it? Like two doors and a flight of stairs, I think.

MR. ROBINSON: Yeah, within the auxiliary building. They provided a figure, but it's -- they provided a generic figure that shows that it is next door, but I couldn't tell from that whether there were

NEAL R. GROSS

COURT REPORTERS AND TRANSCRIBERS

1323 RHODE ISLAND AVE., N.W.

WASHINGTON, D.C. 20005-3701

(202) 234-4433

(202) 234-4433

stairs or on a second floor or what have you either.

MEMBER SKILLMAN: Okay.

MR. ROBINSON: NUREG-0800 identifies various emergency planning and reviewer interface areas as well. SER Section interface areas in which the staff verify various capabilities are addressed include SE Section 6.4, which provides information regarding the protection of the main control room personnel during emergency.

SER Section 7.5, which provides information related to TSC data retrieval capabilities, such as safety parameter displays or SPDS and emergency response data system or ERDS is provided in SER Section 7.5.

SE Section 9.3.2, which provides information pertaining to the PAS System or the Post-Accident Sampling System is at 9.3.2.

SE Section 9.4.1 provides the staff's determination of the acceptability of the TSC HVAC system and that it functions in a manner comparable to that of the main control room ventilation system.

SE Section 9.5.2, which discusses voice and data communications equipment.

SE Section 12.3, which provides the

NEAL R. GROSS

COURT REPORTERS AND TRANSCRIBERS

1323 RHODE ISLAND AVE., N.W.

WASHINGTON, D.C. 20005-3701

(202) 234-4433

(202) 234-4433

staff's determination on the acceptability of an on-site decontamination facilities provided by the applicant.

And finally, SE Section 15.3, which contains information related to the TSC radiological habitability, GDC-19.

The main reason why I wanted to highlight the SRP interface area is because I wanted to make sure that the ACRS staff and also members of the public understand that there is EP components addressed in these other sections and the staff is doing its due diligence to interact, engage with these sections to see what their -- what KHNP is talking about as far as it relates to the emergency planning and we are working together.

The next slide, please. In general, programmatic aspects of emergency planning and preparedness are the responsibility of the COL applicant that references the certified standard design. However, the applicant may, but is not required to, identify such programmatic responsibility as COL action or information items.

Within the APR-1400 Design Certification, the applicant provided five COL information items that

NEAL R. GROSS

COURT REPORTERS AND TRANSCRIBERS

1323 RHODE ISLAND AVE., N.W.

WASHINGTON, D.C. 20005-3701

(202) 234-4433

(202) 234-4433

are related to EP and that are to be addressed by those COL applicants who choose to represent the design. Those are as follows:

Develop interfaces of design features with site-specific designs and site parameters.

Develop a comprehensive emergency plan as a separate document.

Develop an emergency classification and action level scheme or EAL scheme.

Develop a multi-unit site interface plan dependent upon the location of the new reactor on or near an operating reactor site with an existing emergency plan.

And develop an emergency planning ITAAC.

Upon the staff's review of Section 13.3 of the DCD, it was determined that the information provided by the applicant met the criteria as set forth in NUREG-0800 and the regulations and, therefore, it was determined in the staff's evaluation report that the information that KHNP provided was acceptable.

CHAIRMAN SUNSERI: Okay. Thank you. And you know, just reflecting on my previous interjection on that TSC discussion, I guess I should have paused a

NEAL R. GROSS

COURT REPORTERS AND TRANSCRIBERS

1323 RHODE ISLAND AVE., N.W.

WASHINGTON, D.C. 20005-3701

(202) 234-4433

(202) 234-4433

second to give KHNP a chance to maybe answer that question. So I'll just visit that.

Does anybody want to comment? If not, that's fine. But, you know, if anybody wants to comment on the accessibility of the TSC from the control room?

MR. J. OH: Yes. This is Andy Oh, the Washington Office. Since there is -- TSC is located next door to the MCR. And you shut the door, pass through the MCR to the TSC is three doors. So it's going to take -- actual instance is very short, so 10 second is enough to move to the MCR to the TSC, I think.

MEMBER STETKAR: I'll observe that the 10 seconds is an awfully short time. I can't get to that door in 10 seconds. I'm old.

MEMBER SKILLMAN: Thank you, Andy. The reason I asked the question --

MEMBER STETKAR: Honestly, don't make statements that you can't support in terms of timing.

MR. J. OH: Um-hum.

MEMBER STETKAR: You create many, many problems for yourself by just making glib statements, so you cannot go through three doors in 10 seconds.

NEAL R. GROSS

COURT REPORTERS AND TRANSCRIBERS
1323 RHODE ISLAND AVE., N.W.

MEMBER SKILLMAN: I raised the question because in real experience, having the proximity from the control room to the tech support center and having easy passage between the two is a critical asset.

Now, we have been involved in other campaigns where the TSC has been moved some distance, but I can tell you from firsthand experience, what makes the emergency functions successful is when the shift supervisor or the shift manager and the tech support center coordinator can see each other and talk eyeball-to-eyeball. And that cannot happen if it's two stairs and three doors and two different buildings.

If -- as Andy said, it's just a matter of several doors and a very short distance, then that is a setup for success, but I would opine that if it's a long distance and if there is a hassle getting from one to the other, when you really need the tech support center as the brain of the control room, then that distance and the difficulty is a problem.

MR. ROBINSON: Thank you.

MR. WARD: Thanks. I would like to add that in Chapter 18 we also asked about the accessibility in the various other rooms that they

NEAL R. GROSS

COURT REPORTERS AND TRANSCRIBERS

1323 RHODE ISLAND AVE., N.W.

WASHINGTON, D.C. 20005-3701

(202) 234-4433

(202) 234-4433

have to get to in certain circumstances. And I don't want to misstate any of those, but I know we asked about those and, for example, one was, you know, 5 minutes to be able to get there and it was much further away than the TSC.

MR. ROBINSON: Thank you.

CHAIRMAN SUNSERI: And I would like to also have the record reflect that Member Walt Kirchner has joined us. Thanks, Walt. All right. Let's see, next section?

MR. WARD: Next is 13.4. This one, there really isn't much there except for what we added for a SECY paper a few years ago. The SRM now requires that the operational programs be identified per the SECY paper and the requirement here is that they have to provide COL items to pass that on to the COL applicant.

And in this case, KHNP provided two COL items to pass on the requirements of SECY 05 and that's a typo there, it should be 0197. And the second one for leakage monitor and prevention program per NUREG-0737, which is the PMI Action Plan requirements.

So both of those were in there, those were

NEAL R. GROSS

COURT REPORTERS AND TRANSCRIBERS

1323 RHODE ISLAND AVE., N.W.

WASHINGTON, D.C. 20005-3701

(202) 234-4433

(202) 234-4433

satisfactory. And the requirements were passed on, so we found this section satisfactory.

13.5?

MR. DEMARSHALL: Good afternoon. My name is Joe DeMarshall and unlike a couple of my colleagues, I'm the creator and grade on 13.5.

The background I've been with the NRC for 9 years, qualified reactor inspector and operator of licensing, chief examiner, and with PSEG Nuclear for about 18 years prior to that. I was a licensed SRO and IC system engineer.

Prior to that, I was Nuclear Navy six years, RO, enlisted, submarines.

CHAIRMAN SUNSERI: Joe, could you just maybe pull your microphone a little closer to you?

MR. DEMARSHALL: Sure.

CHAIRMAN SUNSERI: Thanks.

MR. DEMARSHALL: Is that -- is everybody able to hear that? Okay.

Scope to review. Plant procedures encompass pretty much three categories: Administrative procedures; operating and emergency operating procedures and maintenance and other operating procedures for safety-related activities.

NEAL R. GROSS

COURT REPORTERS AND TRANSCRIBERS

1323 RHODE ISLAND AVE., N.W.

WASHINGTON, D.C. 20005-3701

(202) 234-4433

(202) 234-4433

And the other operating activities, these will be types of activities that are not procedurally covered under the -- either the operating or the emergency operating procedure programs. Things that-- examples of those would be op surveillances like monthly diesel surveillances, weekly control rod exercise and those types of activities.

Okay. Development of detailed procedures is beyond the scope of the DC application. That responsibility resides with the COL applicant representing the design.

The COL information items pertaining to procedure descriptions and procedure program development/implementation are identified by the DC applicant.

Okay. Generic technical guidelines, otherwise referred to as the emergency operating guidelines, they are used by the COL applicants to develop their Plant-Specific Technical Guidelines or PSTGs from which their EOPs will be developed.

Preparation of the APR-1400 EOGs and submittal to the NRC for review is the responsibility of the DC applicant. And they are TMI action items, IC-1 and they are also SRP acceptance criteria for

NEAL R. GROSS

COURT REPORTERS AND TRANSCRIBERS

1323 RHODE ISLAND AVE., N.W.

WASHINGTON, D.C. 20005-3701

(202) 234-4433

(202) 234-4433

this Chapter 13.5. That would be chapter -- or SRP 13.5.2.1.

Okay. Next slide, please. Okay. Scope of the review continuing. So the staff evaluated DC application for acceptability of COL information items pertaining to the description of plant procedures. The acceptability of COL information items pertaining to establishment of a program with development and implementation of plant procedures. And lastly the technical adequacy of the APR-1400 EOGs and determination of their acceptability for use as a basis for development of COL applicant PSTGs.

I had no findings, no open issues for 13.5.

I would like to note that staff found two out of seven COL information items in Chapter 13.5 to be acceptable, originally.

There are many five COL information items require modifications that have been sufficiently resolved through the RAI process and have been identified as confirmatory items in Revision 1 of the DCD. And for the most part, those were clarifying items that needed to be resolved. So nothing major to note there.

NEAL R. GROSS

COURT REPORTERS AND TRANSCRIBERS

1323 RHODE ISLAND AVE., N.W.

WASHINGTON, D.C. 20005-3701

(202) 234-4433

(202) 234-4433

Okay. Next slide. Okay. Lastly, staff finds that the APR-1400 EOGs are technically adequate and acceptable for use in development of COL applicant PSTGs on the basis that the EOGs are based on the combustion engineering owners group GTGs, set 152, which have been previously reviewed and approved by the staff.

The EOGs retain structural format and event mitigation strategies of set 152 specifically referring to a structural format where you have standard post-trip actions, Optimal Recovery Guidelines, Function Recovery Guidelines and diagnostic actions.

The EOGs have been modified to reflect the APR-1400 specific design features. APR-1400 specific design features had been incorporated into the transient analyses for events categorized in the Optimal Recovery Guidelines of the APR-1400 EOGs.

And lastly, transient analysis results provided in APR-1400 Technical Report entitled "Best Estimate Analysis for the Operation of Transients in Accidents for APR-1400 Emergency Operating Guidelines," have been reviewed by the Reactor Systems Nuclear Performance and Code Branch as part of a

NEAL R. GROSS

COURT REPORTERS AND TRANSCRIBERS

1323 RHODE ISLAND AVE., N.W.

WASHINGTON, D.C. 20005-3701

(202) 234-4433

(202) 234-4433

Chapter 15 review and interface support activity and found to be acceptable for use in the development of the APR-1400 EOGs.

And that's all I have. Any questions?

MEMBER SKILLMAN: I do. On safety evaluations. It's on page 31 of the safety evaluation, statements made APR-1400 specific design features have been incorporated into the analysis for the operational transient in accidents that were used for the EOGs. Then it provides a list:

Reactor trip, LOCA, steam generator tube rupture, main steam line break, loss of all feedwater LOOP and station blackout. Where is the ATWS addressed? Maybe ATWS is categorized differently and it's not on that list, but I would have thought ATWS would have been on that list.

MR. DEMARSHALL: Okay. I can tell you that with respect to combustion engineering, GTGs, this is -- this list of events is what is specified. I don't recall seeing ATWS, that may be the case, but what I would like to do, if possible, I do have a Chapter 13 Interface, the gentleman here he may or may not be able to answer that.

MEMBER STETKAR: But remember ATWS is not

NEAL R. GROSS

COURT REPORTERS AND TRANSCRIBERS

1323 RHODE ISLAND AVE., N.W.

WASHINGTON, D.C. 20005-3701

(202) 234-4433

(202) 234-4433

a design basis accident. It's a special event.

MR. DEMARSHALL: It's --

MEMBER STETKAR: But it's typically covered in the emergency operating procedures.

MR. DEMARSHALL: John Budzynski, John, do you have any input on it?

MR. BUDZYNSKI: Yeah, I wanted to --

CHAIRMAN SUNSERI: Microphone.

MR. BUDZYNSKI: Yes, my name is John Budzynski. And all I did was review the report that was given to me. I didn't look at ATWS event at all.

I can go back and take a look at it and get back with you on this.

MEMBER SKILLMAN: Thank you. Okay. I'll follow-up with this. Thank you.

MR. BUDZYNSKI: Sure.

MR. DEMARSHALL: Did you have any input?

MEMBER CORRADINI: Can we hear from the licensee? I'm kind of curious.

MR. DEMARSHALL: Yeah.

CHAIRMAN SUNSERI: Just -- okay. It looks like they are huddling here. We will give them a chance to think it out.

MR. DEMARSHALL: The only -- I would like

NEAL R. GROSS

COURT REPORTERS AND TRANSCRIBERS

1323 RHODE ISLAND AVE., N.W.

WASHINGTON, D.C. 20005-3701

(202) 234-4433

(202) 234-4433

to offer -- I would have to follow-up and check on this, but with respect to the ATWS, I would think that that would probably be recovered under -- covered under the Functional Recovery Guidelines possibly in the radioactivity control.

Just a thought, but I'm thinking that's where it is going to be. And I will -- but I will follow-up with that as well. And let you know.

MEMBER SKILLMAN: Thank you.

CHAIRMAN SUNSERI: Okay. Well, we have a KHNP representative now.

MR. J.T. SEO: Yeah. My name is Jong Tae Seo from KEPCO E&C. I am involved in the developing of EOG APR-1400. So let me clarify on the ATWS teachers. Our EPG -- EOG consider optimal recovery and function recovery guidelines and ATWS, is by definition, is a failure or reactor trip. So it's covered in the functional recovery guidelines.

So you know, in a sense ATWS is covered by the functional recovery guidelines, that's what is said. You know, the optimal guide -- or recovery guideline includes only the reactor trips, simple reactor trips, that's what the current -- the APR-1400 uses. Is that clear, sir?

NEAL R. GROSS

COURT REPORTERS AND TRANSCRIBERS

1323 RHODE ISLAND AVE., N.W.

WASHINGTON, D.C. 20005-3701

(202) 234-4433

(202) 234-4433

MEMBER SKILLMAN: Yes, it's clear, but it would seem to me to -- that it should also cover reactor not trips.

MR. J.T. SEO: Yes, if reactor not trips, it has been covered as in the functional recovery guidelines where the safety function is recovered. Now, it's safety functions are recovered in the functional recovery guidelines by, you know, safety function -- by safety functions. So that covers ATWS. That's the concept of the EOGs.

MEMBER SKILLMAN: I understand your words.

MR. J.T. SEO: Yes.

MEMBER SKILLMAN: Thank you.

MR. J.T. SEO: Thank you.

CHAIRMAN SUNSERI: Okay. Anything else from staff?

MR. WARD: That's all we have. Thank you.

MEMBER REMPE: Okay. So is this the way the NRC organizes the operating guidelines? Do we have that same structure, so that ATWS could be covered in the same manner or how would this NRC catch it is I guess I'm curious now?

If this were just generically any application, where would you cover the --

NEAL R. GROSS

COURT REPORTERS AND TRANSCRIBERS

1323 RHODE ISLAND AVE., N.W.

WASHINGTON, D.C. 20005-3701

(202) 234-4433

(202) 234-4433

MR. DEMARSHALL: Well, what I would offer is that since this design is based on combustion engineering GTGs, combustion engineering has that standard format, the standard post-trip actions, diagnostic actions. It has the ultimate recovery guidelines which are the major events listed here, which doesn't list the ATWS, like steam generator tube rupture, excessive steam demand, those type events.

And then the Functional Recovery Guidelines would cover those were there -- would cover that type of activity. I'm going to follow-up with that, but that's where it would be.

MEMBER REMPE: I would be curious just, if you would --

MR. DEMARSHALL: Yes.

MEMBER REMPE: -- write something down and send it to Christopher and let us see it. Okay?

MR. DEMARSHALL: Sure.

MEMBER REMPE: Thank you.

MR. DEMARSHALL: Absolutely.

CHAIRMAN SUNSERI: Any other questions? All right. Well, thank you for that review.

So it looks like we are ahead of schedule here. If we could get the KHNP Chapter 16 group up

NEAL R. GROSS

COURT REPORTERS AND TRANSCRIBERS

1323 RHODE ISLAND AVE., N.W.

WASHINGTON, D.C. 20005-3701

(202) 234-4433

(202) 234-4433

and I suppose I will put the staff on notice that we will be ahead of schedule here, so if we can have the staff presentation ready for this afternoon, later this afternoon, that would be appreciated.

All right. It looks like the transition is complete. Rob, you have your team ready?

MR. SISK: Thank you very much and yes, I'll introduce.

SangWon Lee to lead us through the Chapter 16 discussion.

MR. SANGWON LEE: Yes.

MR. SISK: Please.

MR. SANGWON LEE: With that, ladies and gentlemen, my name is SangWon Lee and I work for Korea Hydro Nuclear Power Corporation. I'm very appreciative to have a presentation in front of the Honorable ACRS Members.

At this time, I would like to talk about the technical specifications.

This is the contents. After short overview, I will talk about the main deviation between the Standard Tech Spec and the APR-1400 Tech Spec and some technical issue will be explained and I will finalize it with the summary.

NEAL R. GROSS

COURT REPORTERS AND TRANSCRIBERS

1323 RHODE ISLAND AVE., N.W.

WASHINGTON, D.C. 20005-3701

(202) 234-4433

(202) 234-4433

Basically, APR-1400 Technical Specifications were developed based on the NUREG-1432 Rev. 4 dated 2012, standard tech spec for a formerly combustion engineering plant. And we do not apply the risk-informed technical specification, so the different design compared to the conventional C Plan to the APR-1400 was reviewed for applicability of the NUREG-1432 to APR-1400.

As a result, we are submit the technical report on the deviation between NUREG to APR-1400 dated 2015, December. And some of the applicability of the updated TSTF report was reviewed and so then it's implemented in the APR-1400 Tech Spec.

This slide shows the section overview of the Chapter 16.

Section 1 describe the use and applications.

And Section 2, safety limits.

And Section 3 include the limiting condition for operation and surveillance requirement for nine major subsection.

And Section 4 has design features.

And Section 5 has administrative controls.

I will now talk about the sections a little more

NEAL R. GROSS

COURT REPORTERS AND TRANSCRIBERS

1323 RHODE ISLAND AVE., N.W.

WASHINGTON, D.C. 20005-3701

(202) 234-4433

(202) 234-4433

detailed in the next slide.

In Section 3.1, Reactivity Control Systems, include the shutdown margin and reactivity balance and MTC and CEA insertion limits and special test exception.

And Section 3.2 include the linear heat rate and the radial peaking factors.

And Section 3.3, Instrumentation, include the RPS instrumentation and CEACs and Engineered Safety Features Actuation System Instrumentation, and EDG, and some containment purge isolation actuation, etcetera.

Section 3.4, RCS, include the RCS Loops and pressurizer and the Pressurizer Pilot Operated Safety Relief Values and Reactor Coolant Gas Vent System.

And Section 3.5, ECCS, include the SIT and SIS and IRWST.

Section 3.6, Containment Systems, has containment air locks, and containment isolation valves and containment spray system.

And Section 3.7, Plant Systems, has mainstream safety claves and auxiliary feedwater system and CCWS and Essential Service Water System and

NEAL R. GROSS

COURT REPORTERS AND TRANSCRIBERS

1323 RHODE ISLAND AVE., N.W.

WASHINGTON, D.C. 20005-3701

(202) 234-4433

(202) 234-4433

Control Room HVAC System, etcetera.

And Section 3.8, Electrical Power Systems, include the AC power and DC power and the supporting systems.

Section 3.9, Refueling Operations, has the Boron concentration, containment penetration and Shutdown Cooling System.

From this slide, I will briefly describe the main deviation between the standard tech spec and our design. I have five items on this slide.

The first one is ICS system. Basically, formerly CE Plant has the spring loaded pilot pressurized safety valve, PORV, but we used the pilot operated safety and relief valves and related deviation is 3.4.10.

POSRV has different characteristics on the valve opening time and valve position and verification and setpoint, etcetera. So these kind of characteristics is incorporated into the 3.4.10. And also, there are no PORV in APR-1400, so it -- that item was deleted.

This is the schematics of the POSRV. I will skip this slide.

The second thing is the Safety Injection

NEAL R. GROSS

COURT REPORTERS AND TRANSCRIBERS

1323 RHODE ISLAND AVE., N.W.

WASHINGTON, D.C. 20005-3701

(202) 234-4433

(202) 234-4433

System. NUREG-1432 is basically 2 trains of high pressure safety injection and 2 trains low pressure safety injection with 2 EDG meaning a 2 train system.

In APR-1400, we used 4 safety injection train and no LPSI and 4 EDG is applied. So there are some differences between the NUREG-1432, so we change the Section 3.5.2 and 3.5.3, required number of OPERABLE Trains for normal operation and 4 SI trains should be operable. And in shutdown case, we need the 2 diagonal safety injection trains should be OPERABLE.

It is applied in that limited condition for operation for APR-1400.

This is the schematics. Also schematics, for the safety injection system.

The third one is In-Containment Refueling Water Storage Tanks.

MEMBER CORRADINI: I'm sorry?

MR. SANGWON LEE: Yes?

MEMBER CORRADINI: Can we just go back? I want to make sure I understand what you meant by diagonal. So you mean that one in -- you have to have a combination of one or three and two or four? Is that what you mean by diagonal? I'm sorry, I am not sure.

NEAL R. GROSS

COURT REPORTERS AND TRANSCRIBERS

1323 RHODE ISLAND AVE., N.W.

WASHINGTON, D.C. 20005-3701

(202) 234-4433

(202) 234-4433

MR. SANGWON LEE: Yes, please.

MR. IM: My name is InYoung Im from KHNP.

It's true that 1 & 3 is that diagonal and 2 & 4 is diagonal.

MEMBER CORRADINI: Okay. Thank you.

CHAIRMAN SUNSERI: So I had a follow-up question on that. I mean, how does it -- how -- I mean, I see the picture here, but can you clearly delineate that on the chart? I mean, you know, by identifying the diagonal loops with each other? I mean, you know, otherwise it's kind of the operator knowledge, right, from knowing how the plant is built?

MR. IM: I'm sorry, I don't have the drawings right now, so maybe we can give it, the drawings, to you.

CHAIRMAN SUNSERI: No, I understand that.

I mean, you know, from a construction of the tech specs, it would seem clear if it said Loops 1 and 3 versus diagonal loops. I mean, but wouldn't that make more sense?

MR. SANGWON LEE: We have diagonal, we have put diagonal of the reactor vessel, hot rack and cold rack, but right now we don't prepare that, so we will give that figure. The base concept is that the

NEAL R. GROSS

COURT REPORTERS AND TRANSCRIBERS

1323 RHODE ISLAND AVE., N.W.

WASHINGTON, D.C. 20005-3701

(202) 234-4433

(202) 234-4433

location for the -- to prevent the bypass was something like that. We have high-gentle (phonetic) cut of the injection is preferable, so that is what the meaning of this issue.

MR. IM: Yeah, depending on what the technical specification diagonal, using the diagonal terminologies is different than naming 1 & 3 or 2 & 4. It is the longest setpoints that we used the diagonal.

CHAIRMAN SUNSERI: Yeah, so I understand that and we understand how the plant is constructed. I think just from a legalistic perspective, you know, we try to eliminate the, you know, uncertainty or, you know, lack of clarity, if you will, in the legal tech spec document, because we train the operators to follow that thing pretty rigorously, right? And so they don't have to think if it says 1 & 3, to be honest, I mean, you know? John, did you have a question or comment?

MEMBER STETKAR: It's just I didn't look at that in particular. I know I have had to craft a little matrix for myself, but it's basically a two division plant regardless of trains and stuff like that.

NEAL R. GROSS

COURT REPORTERS AND TRANSCRIBERS

1323 RHODE ISLAND AVE., N.W.

WASHINGTON, D.C. 20005-3701

(202) 234-4433

(202) 234-4433

Division 1 is mostly stuff that is given a label of 1 & 3 or A & C and some other labels.

Division 2 is given labels of 2 & 4, B & D or that kind of stuff.

So if you think of it that way, it all sorts -- kind of sorts itself out. Although I admit that I had put together a matrix, because sometimes there are 1As and 2As and 1Bs and 2Bs and that kind of stuff.

CHAIRMAN SUNSERI: Yeah, that's my experience, too.

MEMBER STETKAR: If I were operating the plant, I would probably know it, but --

CHAIRMAN SUNSERI: Well, wait. I think you are illustrating my point here.

MEMBER STETKAR: Yes.

CHAIRMAN SUNSERI: Because my experience in the plant is that it generally follows that kind of convention, but there always seems to be some exception in practice and you don't want the operators to have to figure that out, right? So being very explicit in the document is often helpful.

MEMBER STETKAR: Right.

CHAIRMAN SUNSERI: Walt, you had a

NEAL R. GROSS

COURT REPORTERS AND TRANSCRIBERS

1323 RHODE ISLAND AVE., N.W.

WASHINGTON, D.C. 20005-3701

(202) 234-4433

(202) 234-4433

question or comment?

MEMBER KIRCHNER: No, no.

MEMBER SKILLMAN: I would like to make a comment. I would find the requirement, as you have shown, in technical specifications to be very difficult. What if you are not able to have two diagonal trains and you must be in shutdown?

CHAIRMAN SUNSERI: It's limiting the --

MEMBER SKILLMAN: You're going to shutdown anyway. You're just going to shutdown in violation of your tech specs.

MR. IM: For the Large-Break LOCA --

MEMBER SKILLMAN: Pardon?

MR. IM: For the Large-Break LOCA, we need the minimum two diagonal trains.

MEMBER SKILLMAN: And if you don't have them? You are going to shutdown anyway.

MR. IM: In the test, it means that if there is only one diagonal, then if that train is -- then no mitigation possible. So we have to shutdown.

MEMBER SKILLMAN: Yes.

MEMBER STETKAR: Well --

MR. IM: But in case one set of diagonal train is available, then we have some allowable time

NEAL R. GROSS

COURT REPORTERS AND TRANSCRIBERS

1323 RHODE ISLAND AVE., N.W.

WASHINGTON, D.C. 20005-3701

(202) 234-4433

(202) 234-4433

allowing time to repair. If you cannot repair, then we have to shut the plant down.

MEMBER SKILLMAN: But I think -- just a minute. I understand the design objective. You want to go across the core on the down-comer, right? That's what you are trying to do.

MR. IM: Yes.

MEMBER SKILLMAN: I understand that. But if the conditions are such that you cannot achieve that, you cannot meet your tech specs, you are going to shutdown anyway.

MR. IM: Yes.

MEMBER SKILLMAN: So the way the tech spec is written can be a problem for your operators. That's a preferred mode. But if you do not have cross-core, you're probably going to shutdown anyway.

MR. IM: Yes, if you cannot repair.

MEMBER SKILLMAN: Correct. All I'm saying is at least from my years of dealing with technical specifications, the way this is worded, the English wording, is a preference. But if you cannot meet it, you are going to shutdown anyway. So it's really two out of four. I would just offer you to think about or suggest you might want to think about that. If you

NEAL R. GROSS

COURT REPORTERS AND TRANSCRIBERS

1323 RHODE ISLAND AVE., N.W.

WASHINGTON, D.C. 20005-3701

(202) 234-4433

(202) 234-4433

can't meet the diagonal requirement that is in the technical specifications, you are probably going to be in mode -- you are going to go from MODE 1 to probably MODE 3. You are going to drop through 2 and probably be in MODE 3.

MEMBER STETKAR: Let me try something, because as I said, I haven't read this, so let me ask KHNP, who authored this thing, if I have SI Pump 1 inoperable, I must restore that pump within 72 hours. Is that correct? Yes or no?

MR. IM: Yes.

MEMBER STETKAR: Okay. If I have SI Pumps 1 and 2 inoperable, can I stay in that condition for 72 hours?

MR. IM: No.

MEMBER STETKAR: Okay. If I have SI Pumps 1 and 3 inoperable, can I stay in that condition for 72 hours?

MR. IM: Right.

MEMBER STETKAR: Okay. You should be very explicit in the tech specs to tell the operators that. That's --

MR. IM: Yes.

MEMBER STETKAR: I sort of knew that the

NEAL R. GROSS

COURT REPORTERS AND TRANSCRIBERS

1323 RHODE ISLAND AVE., N.W.

WASHINGTON, D.C. 20005-3701

(202) 234-4433

(202) 234-4433

way -- but that's why I -- the way I understand the plant, but that's why I asked you those specific questions. Typical operators might not get it from this tech spec.

MEMBER CORRADINI: So your point is a matrix of what --

MEMBER STETKAR: You can have up to two pumps out simultaneously for 72 hours provided they are in the same division. The way I characterize things.

MEMBER SKILLMAN: They have got to be the correct two pumps, right?

MEMBER STETKAR: Yeah. It can't -- it can be 1 & 3 or 2 & 4.

MEMBER SKILLMAN: 2 & 4, right.

MEMBER STETKAR: But not the other four combinations of --

MEMBER SKILLMAN: That's why I suggest the way this is written can be misleading. And if it's worded properly, like John says, then I think that the specification can be enacted capably.

MR. IM: Okay.

MEMBER SKILLMAN: Okay. Thank you.

MR. SANGWON LEE: Okay. I will continue.

NEAL R. GROSS

COURT REPORTERS AND TRANSCRIBERS

1323 RHODE ISLAND AVE., N.W.

WASHINGTON, D.C. 20005-3701

(202) 234-4433

(202) 234-4433

In-Containment Refueling Water Storage Tank, in NUREG-1432 has applicability of MODES 1, 2, 3 and 4. And APR-1400 we expand the applicable MODE to 5 and 6 with RCS level is within 130 feet.

So the Section 3.5.4 is changing to use this expanded mode.

MEMBER CORRADINI: Okay. I'm sorry. Can you try that one more time?

MR. SANGWON LEE: We expand the in-containment refueling water storage tanks if available within MODES 1, 2, 3 and 4 and 5, 6 compared to the NUREG use the 1, 2, 3, 4 already.

MEMBER CORRADINI: And you did that how? That's what I didn't understand. I understood that you extended it, but I didn't understand how. What changed? I'm sorry.

MR. IM: Let me add something. So the standard tech spec just describes up to MODE 4. But during our evaluation, the shutdown risk evaluation, we need SI for a longer period of shutdown. So we added to LCO 3.5.3 to include more -- up to more than 6 at such level.

MEMBER CORRADINI: Okay.

MR. IM: So IRWST is the source of the

NEAL R. GROSS

COURT REPORTERS AND TRANSCRIBERS

1323 RHODE ISLAND AVE., N.W.

WASHINGTON, D.C. 20005-3701

(202) 234-4433

(202) 234-4433

safety injection pump, so IRWST applicability is extended at that point.

MEMBER CORRADINI: Extends to those modes?

MR. IM: Yes, yes.

MEMBER CORRADINI: Gotcha. All right.

Thank you.

MEMBER STETKAR: It basically applies during all modes until you flood-up the refueling cavity.

MR. IM: Right, right.

MEMBER STETKAR: Okay.

MR. IM: Yes.

MEMBER STETKAR: Which the standard tech specs, by the way, should have figured out, but nobody ever looks at shutdown stuff. I got that on the record.

MR. SANGWON LEE: Yes, I'll continue. An aux feedwater system, NUREG-1432 has a 3 train, two motor-driven pumps and one turbine-driven pump and it has a cross-tie between the trains. And APR-1400, we used the 4 train to, two motor-driven pumps and two turbine-driven pumps. And each division has one water-driven pump and one turbine-driven pump, but, however, we don't have any cross-tie after the

NEAL R. GROSS

COURT REPORTERS AND TRANSCRIBERS

1323 RHODE ISLAND AVE., N.W.

WASHINGTON, D.C. 20005-3701

(202) 234-4433

(202) 234-4433

discharge of the pumps. So the design is different to the NUREG-1432. So we change it.

One of the issues that the turbine-driven aux feedwater pump train inoperable due to the inoperable steam supply is deleted. It's not applicable in APR-1400, so -- and we change the three aux feedwater pumps to two aux feedwater division. Meaning four pumps. So the design process in the APR-1400 catch that. Also, condensed storage tanks is changing to the two aux feedwater storage tanks.

And this slide shows the schematics of the APR-1400 aux feedwater system.

Finally, Electrical Power System.

MEMBER STETKAR: Just backup.

MR. SANGWON LEE: Yes.

MEMBER STETKAR: I have to admit I'm not familiar with the standard tech specs, but what's the subtlety under Condition A where the turbine-driven aux feedwater train inoperability due to a steam supply was deleted? How is that different in APR-1400 compared to some other pressurized water reactor that has turbine-driven aux feedwater pumps?

MR. SANGWON LEE: Basically, conventional CE plant, the -- one turbine-driven aux feedwater is

NEAL R. GROSS

COURT REPORTERS AND TRANSCRIBERS

1323 RHODE ISLAND AVE., N.W.

WASHINGTON, D.C. 20005-3701

(202) 234-4433

(202) 234-4433

available and they use the --

MEMBER STETKAR: Okay.

MR. SANGWON LEE: Yeah.

MEMBER STETKAR: Okay. Thank you. I've got it.

MR. SANGWON LEE: Yes.

MEMBER STETKAR: Thank you.

MR. SANGWON LEE: Finally, the Electric Power System. NUREG-1432 has 2 train concept. And APR-1400 four EDG for two division concept. So the concept is different, so we applied these differences into the related 3.8.1 and 3.8.2.

This is the schematics of the electric system. So the design process explained in previous slide and right now, I will talk about the several technical issues that we perceive.

We think about is the:

One thing is aux feedwater system that I mentioned in the previous slide. So the issues is that no provision for the aux feedwater train for one steam generator supply feedwater to the other steam generator, because there is no cross-tie. So that issue is we have some responses and the NRC staff is reviewing the submitted responses.

NEAL R. GROSS

COURT REPORTERS AND TRANSCRIBERS

1323 RHODE ISLAND AVE., N.W.

WASHINGTON, D.C. 20005-3701

(202) 234-4433

(202) 234-4433

MEMBER CORRADINI: So just to make sure I understand what you are saying, is that back to your graphic on 14, there is no eventual cross-tie to feed both generators from either division?

MR. SANGWON LEE: Yeah.

MEMBER CORRADINI: That's your point?

MR. SANGWON LEE: Yeah.

MEMBER CORRADINI: Okay. Thank you.

MEMBER KIRCHNER: All right. I would just -- maybe it's quibbling with words, but I would not describe this design as a 4 train system. If you go back to Slide 11, you can see that for the SI systems they are unique individual systems. They have a common sump in the IRWST, but they are separate.

Whereas, if you look at this, a single failure where the lines join or where they take suction, takes two trains as you are calling out of service.

So it's -- I'm not quibbling with the design, but just perhaps the description. I don't think it really is truly a 4 train system, because you could have a single failure somewhere in that system, a break in a pipe, the venturi is clogged, whatever, take out two lines.

NEAL R. GROSS

COURT REPORTERS AND TRANSCRIBERS

1323 RHODE ISLAND AVE., N.W.

WASHINGTON, D.C. 20005-3701

(202) 234-4433

(202) 234-4433

MEMBER CORRADINI: Yeah, it's maybe mincing words, but --

MR. SANGWON LEE: So we basically -- these are concept in some cases compared to the train concept.

MEMBER STETKAR: When we get into more of the design, you will find more of this, because the safety injection pumps system looks like a 4, I'll call it, train system. And in fact, one pump is powered from each diesel. But when you look at electric power supplies, you will find that it becomes a little more strange.

It's easier to think of the plant as a two division plant with each division having two trains of equipment in that division.

MEMBER CORRADINI: But the end --

MEMBER STETKAR: And that helps a little bit for the jargon.

MEMBER CORRADINI: But the -- I think Walt's point, I think, is a fair point. With the independence or dependence within a division differs whether on SI or aux feed.

MEMBER STETKAR: That's absolutely -- or electric power or -- yes, it's absolutely correct.

NEAL R. GROSS

COURT REPORTERS AND TRANSCRIBERS

1323 RHODE ISLAND AVE., N.W.

WASHINGTON, D.C. 20005-3701

(202) 234-4433

(202) 234-4433

MEMBER KIRCHNER: And I was just looking at plumbing, not --

MEMBER STETKAR: Yeah, no, just --

MEMBER KIRCHNER: -- the electric. Okay. It's -- yeah, I'll be quiet.

MR. SANGWON LEE: All right. So the aux feedwater train is under reviewing by the NRC.

And the second one is Boron Mixing issue. Basically, this is the type of technical issues we assume complete RCS mixing assumption when ICP is idle and we have some computation of fully dynamics categories and -- on that point.

So the -- you see the validity of that is issues interpreting. But on the other hand, in Chapter 16, the -- to prevent unborated water source to the RCS, some isolation valve is -- should be managed in Chapter 16 as one of the issues.

So this issue is still under discussion with the NRC.

The next one is the surveillance requirement.

CHAIRMAN SUNSERI: Just a second.

MEMBER CORRADINI: I just want to make sure I understand. So the issue is the simulation to

NEAL R. GROSS

COURT REPORTERS AND TRANSCRIBERS

1323 RHODE ISLAND AVE., N.W.

WASHINGTON, D.C. 20005-3701

(202) 234-4433

(202) 234-4433

show resolution of the mixing? What's the issue exactly in reviewing your analysis?

MR. SANGWON LEE: Chapter 15, in Chapter 15.

MEMBER CORRADINI: Okay. So we will back to it.

MR. SANGWON LEE: Yeah.

MEMBER CORRADINI: Okay. All right. Fine. That's what I was hoping you would say.

MR. SANGWON LEE: Okay. The surveillance requirements for Boron-10 atom percent or SIT and IRWST is that if the boron recycling is used, the Boron-10, atom percent of the Boron-10, should be specified in the technical specification.

But our operating experience and the calculation shows that just a very -- it's not significant. Meaning, so we in -- our response is under reviewing on that.

So yeah. Finally, the Applicability Mode is that the -- when a steam generator is relied on heat removal, that footnote should be applied to the Mode 4 applicability of the AFAS on steam generator level low. So we reviewing on that and the response will be provided.

NEAL R. GROSS

COURT REPORTERS AND TRANSCRIBERS

1323 RHODE ISLAND AVE., N.W.

WASHINGTON, D.C. 20005-3701

(202) 234-4433

(202) 234-4433

Yes?

MEMBER CORRADINI: I'm not a tech spec expert. Can you explain that a little more for me? Help me, please. Can you kind of just expand upon the issue? I don't appreciate the issue other than there is an issue between you and the staff.

MR. IM: This is -- I'm not related to this section, but that's -- but there is a question that the AFAS function in the tech spec is -- has been described up to Mode 3. And some of the AFAS function should be used manually at lower modes. So that kind of issue is --

MEMBER CORRADINI: So you are extending the operation into modes that aren't, my understanding, in the tech spec? Is that what I'm hearing? I want to make sure that I understand completely. We will come back to it, I'm sure, but that's just --

COURT REPORTER: Microphone.

MEMBER SKILLMAN: Mike, what they have done is they have extended that from hot standby, that's Mode 3, to hot shutdown, that is Mode 4.

MEMBER CORRADINI: Okay.

MEMBER SKILLMAN: Mode 5 is cold shutdown.

NEAL R. GROSS

COURT REPORTERS AND TRANSCRIBERS

1323 RHODE ISLAND AVE., N.W.

WASHINGTON, D.C. 20005-3701

(202) 234-4433

(202) 234-4433

And 6 is refueling. One is power on.

COURT REPORTER: Microphone.

MEMBER CORRADINI: Yes, you're as bad as I am then.

MEMBER SKILLMAN: Yes. 1 is power on. 2 is start up. 3 is hot standby. And 4 is hot shutdown.

MEMBER CORRADINI: But --

MEMBER SKILLMAN: So what they have done is they have extended down into hot shutdown.

MEMBER CORRADINI: But -- yeah, okay. That I got. But I thought your explanation was historically or normally, you wouldn't see this in the tech spec or is it just required because of the uniqueness of this design? That's what I'm trying to understand.

MR. IM: Yeah, as I said about the SI system extension, the mode extension, so the original STS is not concerned about the lower mode of operation.

MEMBER CORRADINI: Okay. All right. So it goes back to Member Stetkar's --

MR. IM: Yeah.

MEMBER CORRADINI: -- happy that you have

NEAL R. GROSS

COURT REPORTERS AND TRANSCRIBERS

1323 RHODE ISLAND AVE., N.W.

WASHINGTON, D.C. 20005-3701

(202) 234-4433

(202) 234-4433

actually considered it into the lower modes.

MR. IM: Right.

MEMBER CORRADINI: Thank you.

MEMBER STETKAR: For the record, yes, I am.

MEMBER CORRADINI: Yes, you are what?

MEMBER STETKAR: Happy that they extended it into the lower modes.

MEMBER CORRADINI: Just start with happy.

MEMBER STETKAR: I'm never happy without a qualifier.

MR. SANGWON LEE: All right. Final slide.

APR-1400 technical specifications is developed based on the standard tech spec of formerly CE plant. And differences between the APR-1400 and the standard tech spec are reviewed and some of feature is reflected, including RCS and safety injection system, IRWST and aux feedwater system and electric power system.

So current status is we have 5 RAIs under preparation for Boron mixing and COL item, etcetera, but except despite all of the responses was submitted to the NRC and under review process. Thank you.

CHAIRMAN SUNSERI: All right. Thanks. Go ahead.

NEAL R. GROSS

COURT REPORTERS AND TRANSCRIBERS

1323 RHODE ISLAND AVE., N.W.

WASHINGTON, D.C. 20005-3701

(202) 234-4433

(202) 234-4433

MEMBER STETKAR: What I had pleaded and the staff may cover these, what RAI deals with the PRA regarding the tech specs?

MS. MONAHAN: Hello. It's Jill Monahan from Westinghouse. That issue is actually related to the applicability in LCO-3.0.9. And it's a little bit of risk-informed, but it's not.

COURT REPORTER: Can you speak up a little bit, please? A little louder, please.

MS. MONAHAN: I'm sorry. That issue is related to the applicability of LCO-3.0.9.

MEMBER STETKAR: Okay. Thank you.

CHAIRMAN SUNSERI: Any other Members? All right. Well, thank you very much.

All right. So we are at the end of today's agenda, but if the staff is ready, we would like to pick up tomorrow's discussion. You guys are ready? All right. So we will have the staff come up and we will take a little bit of transition time here and we will hear their Chapter 16 presentation.

I think that for -- this is on the schedule for like four hours, so we will take a break sometime in about an hour into it.

MEMBER STETKAR: Four hours? All right.

NEAL R. GROSS

COURT REPORTERS AND TRANSCRIBERS

1323 RHODE ISLAND AVE., N.W.

WASHINGTON, D.C. 20005-3701

(202) 234-4433

(202) 234-4433

We are --

CHAIRMAN SUNSERI: Actually tomorrow.

MEMBER STETKAR: Are you going to run this?

MS. UMANA: Yes, I am. I'll take care of this for you.

(Whereupon, the above-entitled matter went off the record at 2:20 p.m. and resumed at 2:22 p.m.)

CHAIRMAN SUNSERI: Are you ready?

MS. UMANA: Yeah. We have an exciting presentation for Chapter 16.

CHAIRMAN SUNSERI: Tech specs are always exciting for operators.

MS. UMANA: And they really are. Well, I'm Jessica Umana. I'm the Chapter PM for the tech specs and the tech staff that did the, I guess, bulk of the review is Craig Harbuck and Bob Tjader. I'm going to move on because this is a pretty substantial effort and so I think it's worth a few seconds to appreciate the number of staff involved in the review of Chapter 16, the tech specs.

Okay. So today you will hear the staff's overview on DCD Chapter 16. You will also hear about the technical topics that were covered in the staff

NEAL R. GROSS

COURT REPORTERS AND TRANSCRIBERS

1323 RHODE ISLAND AVE., N.W.

WASHINGTON, D.C. 20005-3701

(202) 234-4433

(202) 234-4433

review and the status summary of the review.

So with that, I will now turn it over to Bob Tjader, so he can start off with the first bullet there in the outline, which is an overview of Chapter 16.

MR. TJADER: Okay. Good afternoon. I'm Bob Tjader. The first slide is --

CHAIRMAN SUNSERI: Microphone, please.

MEMBER CORRADINI: Green light on.

MR. TJADER: There we go. Okay. Bob Tjader, Tech Spec Branch. The first slide is, which we passed already, just an outline of what we are going to present today. And we've got slides and information on all of these topics.

So we can go to the next slide, Slide 5. In the next few slides we will present all of the sections of the tech specs and the RAIs that are listed, the numbers there without the prefix 16 is omitted, for each of them.

Open RAI questions and sub-questions are listed for each tech spec subsection to highlight review areas for which our review is not yet complete.

Blue indicates sections and subsections with open issues.

NEAL R. GROSS

COURT REPORTERS AND TRANSCRIBERS

1323 RHODE ISLAND AVE., N.W.

WASHINGTON, D.C. 20005-3701

(202) 234-4433

(202) 234-4433

Underlining indicates RAI questions affecting multiple requirements.

RAI questions colored red remain open, pending editorial changes.

RAI questions colored black involve technical issues pending resolution.

At the top of DC -- at the top of the slide are four general RAI questions.

1642 is the application of LCO selection criteria in 5036. Basically, they are the four criteria listed in the -- in 5036 and our RAI requests how they applied that. And we are waiting response to that.

1643 is disposition of STS-approved generic changes. That is what we call travelers or TSTF changes and how they address those TSTF changes to the standard, that's the standard -- CE Standard 1432. And the RAI addresses the correction of certain deviation report errors.

1644 is identification of COL Action Items.

1645 replaces DCD Tier 2 with FSAR in Bases references, basically an editorial-type change.

Other ones listed on the pages for

NEAL R. GROSS

COURT REPORTERS AND TRANSCRIBERS

1323 RHODE ISLAND AVE., N.W.

WASHINGTON, D.C. 20005-3701

(202) 234-4433

(202) 234-4433

definition is the use of the word division in the definition of operability. Basically, they have added the word definition. We just want a description of -- or a discussion of that.

Regarding LCO 3.0.4, they have not adopted the risk-informed tech spec change, TSTF-359 for LCO 3.0.4.

For the most part, they have not adopted risk-informed tech spec changes. However, in the next two specs, as you referred to in the questions to the applicant, they have adopted two. They have adopted LCO 3.0.8, risk-informed action requirements for snubbers and 3.0.9 risk-informed action requirements for barriers.

And basically, the open item for 3.0.9 is referenced as, basically, we need the generic risk evaluation justifying the application of 3.0.9 for the plant.

MEMBER CORRADINI: So can I ask a learning question?

MR. TJADER: Sure.

MEMBER CORRADINI: So can an applicant pick and choose what is risk-informed and what is not?

And what the -- in other words, if they can get down

NEAL R. GROSS

COURT REPORTERS AND TRANSCRIBERS

1323 RHODE ISLAND AVE., N.W.

WASHINGTON, D.C. 20005-3701

(202) 234-4433

(202) 234-4433

to these sorts of limited -- LCO limited condition of operation and then decide I want this one risk-informed, I want this one deterministic?

MR. TJADER: Well, the risk-informed tech specs generally fall under different categories, different initiatives. Okay. And the initiatives they stand alone sort of. So Initiative 2 would be a missed surveillance. They haven't adopted that for whatever reason.

MEMBER CORRADINI: So you go by these categories as to what they would adopt?

MR. TJADER: These initiatives and what they can or cannot adopt. Now, there are certain very involved initiatives like Initiative 4B, we call it, is risk-informed completion times. And they can be applied to various specs throughout. And if they were, they haven't adopted it, but if they were, they could presumably say I want to apply it to these systems, but not those.

MEMBER CORRADINI: Oh.

MR. TJADER: It would depend very much on the quality and the applicability of their PRA and how their PRA applies to the plant.

MEMBER CORRADINI: Okay. Well, I guess I

NEAL R. GROSS

COURT REPORTERS AND TRANSCRIBERS

1323 RHODE ISLAND AVE., N.W.

WASHINGTON, D.C. 20005-3701

(202) 234-4433

(202) 234-4433

wasn't aware, because I haven't done enough homework apparently, that indeed these tech specs are being characterized as at least partially risk-informed. So given the fact that you have characterized them that way, what is the staff doing?

MR. TJADER: Well, they are very partially risk-informed.

MEMBER CORRADINI: That doesn't make any difference, as we have just established that they can partially risk-inform them. And you established on the record that the quality of the PRA should be commensurate to support those risk-informed decisions.

So my question to the staff is what is the staff doing in their review of the PRA, now a review not an audit, to confirm that for the risk-informed applications in this design certification, the PRA has adequate scope and technical quality and has had an independent PRA review done according to the quality attributes in Regulatory Guide 1.200 to support that risk-informed application.

MR. TJADER: Well --

MEMBER CORRADINI: You may not be able to answer that, but --

MR. TJADER: -- I --

NEAL R. GROSS

COURT REPORTERS AND TRANSCRIBERS

1323 RHODE ISLAND AVE., N.W.

WASHINGTON, D.C. 20005-3701

(202) 234-4433

(202) 234-4433

MEMBER CORRADINI: -- I hope the staff can.

MR. TJADER: Well, the PR -- well, let me answer it this way. The PRA Branch is responsible for reviewing the PRA. And they are reviewing the PRA.

MEMBER CORRADINI: They are auditing the PRA.

MR. TJADER: Yes. Now, let me say this. With regard to the partial application of risk-informed tech specs, okay, the PRA quality and its evaluation with respect to tech specs would be very important and significant if it were applied to some initiatives, particularly 4B, Risk-Informed Completion Times, or 5B, Surround Circuits and Control Program, it will be very important because they would be applying it basically real-time and applying it to the systems that are there.

In 3.0.8 and 3.0.9, these risk evaluations were asking for our risk evaluations that would be applicable to the -- to this application regardless of the mode that the plant is in and they would not have to revise anything in the process.

In other words, they are evaluating whether or not the time that you can be in the

NEAL R. GROSS

COURT REPORTERS AND TRANSCRIBERS

1323 RHODE ISLAND AVE., N.W.

WASHINGTON, D.C. 20005-3701

(202) 234-4433

(202) 234-4433

condition or you can have inoperable barriers, the time that is applied there is appropriate for the plant.

MEMBER CORRADINI: Bob, what's a barrier?

MR. TJADER: A barrier would be a door.

MEMBER CORRADINI: A fire be a barrier?

MR. TJADER: Yeah. A door, fire barrier, yeah.

MEMBER STETKAR: So now my PRA for internal fires and internal flooding must have adequate technical scope and detail and quality to support the conclusions that they have identified and evaluated the appropriate barriers from a risk perspective. Is that true?

MR. TJADER: That's true. Now --

MEMBER STETKAR: Okay. So now I need to look in pretty dog-gone good detail at the internal fire and flooding models.

MR. TJADER: Yeah, I'll have to defer to the --

MEMBER STETKAR: Okay.

MR. TJADER: -- PRA Branch. Now --

MEMBER STETKAR: I'll ask the PRA folks--

MR. TJADER: I'll give them a heads-up.

NEAL R. GROSS

COURT REPORTERS AND TRANSCRIBERS

1323 RHODE ISLAND AVE., N.W.

WASHINGTON, D.C. 20005-3701

(202) 234-4433

(202) 234-4433

MEMBER STETKAR: -- to say let's do that.

MR. TJADER: It's a similar type application in 3.0.8 with snubbers where they -- where the risk assessment is for the plant as a whole. And they have reviewed that, so I know they are doing it.

MEMBER STETKAR: Okay.

MR. TJADER: So okay.

MEMBER STETKAR: I wasn't aware that they were, so that was the reason I kind of got interested.

MR. TJADER: I'll give them a heads-up.

MS. UMANA: Well, I would request to see if Marie Pohida can come down.

MEMBER STETKAR: And when I say this is a difference, the reason that I'm interested just for the record, is that the level of review that the staff performs for that type of risk-informed application is much different from the level of the review that the staff has performed for any other design certification that at least the ACRS has looked at.

This would be the first design certification that I'm familiar with that has used the notion of risk-informed technical specifications.

One other applicant came close, and I won't name it, at the design certification stage,

NEAL R. GROSS

COURT REPORTERS AND TRANSCRIBERS

1323 RHODE ISLAND AVE., N.W.

WASHINGTON, D.C. 20005-3701

(202) 234-4433

(202) 234-4433

backed off and said no, we will just use standard tech specs and the COL applicant, in that case, was going to take off the gauntlet of risk-informed technical specifications and it didn't -- it never came to fruition. And I'll just stop here.

So this would be the first one that, at least I believe, we have seen that has anything to do with the notion of risk-informed technical specifications and the implications on the quality of the PRA, the scope of the PRA and the level of the staff's review of those elements of the PRA to support those particular applications.

MR. TJADER: Well, I don't want to belabor it.

MEMBER STETKAR: That's --

MR. TJADER: But I'll just say that the other initiatives do require, for instance, a similar application for -- that we do for the maintenance rule where you do an assessed risk, you know. And that would require a quality PRA and we do that for, you know, the other initiatives.

For this, this is a review done of the plant and its design and does not need to be reviewed in various modes. In other words, it's done for the

NEAL R. GROSS

COURT REPORTERS AND TRANSCRIBERS
1323 RHODE ISLAND AVE., N.W.

plant and --

MEMBER STETKAR: I don't understand that, because if I do a fire risk assessment during full power operation, the implications of having an open barrier, a door, may be different from the implications of having the same door open during shutdown modes, because the likelihood of a fire may be different and the consequences of that fire may be different. Just in the same two functional areas in the plant.

So if I'm doing a risk-informed approach to how long I can have that door open --

MR. TJADER: Well, they take conservative assumptions in performing it.

MR. KLEIN: Excuse me.

MEMBER STETKAR: I'll let it slide. We will let the PRA people.

MR. KLEIN: Excuse me. My name is Alex Klein. I'm the NRR Technical Specifications Branch Chief. Hi, John, how are you?

MEMBER STETKAR: Hi, Alex. We haven't talked in a long time.

MR. KLEIN: No, we have not. But we understand the question that you asked. I'll ask

NEAL R. GROSS

COURT REPORTERS AND TRANSCRIBERS

1323 RHODE ISLAND AVE., N.W.

WASHINGTON, D.C. 20005-3701

(202) 234-4433

(202) 234-4433

Jessica to, you know, as the PM for this effort, bring the question back to the appropriate staff and PRA to, you know, respond to the questions that the ACRS is asking you.

MS. UMANA: Yeah, and I'm trying to get some of the PRA folks down here, since you have two hours with us.

MR. KLEIN: That's what I mean.

MS. UMANA: They will drop in at some point.

MEMBER STETKAR: We don't want to go into -- we will have ample time in the Subcommittee meeting in April to actually go over the whole PRA. We have a day and a half or something like that scheduled for the PRA itself. It's just that at least I wasn't expecting to talk to the staff, the PRA staff in the context of a "risk-informed" application.

I was, you know, planning to question the PRA staff on their review of what is in Chapter 19 and any audits of the PRA that have been done to support that review.

MR. KLEIN: This is just a heads-up like Bob said.

CHAIRMAN SUNSERI: All right. Thanks.

NEAL R. GROSS

COURT REPORTERS AND TRANSCRIBERS

1323 RHODE ISLAND AVE., N.W.

WASHINGTON, D.C. 20005-3701

(202) 234-4433

(202) 234-4433

Joy, do you have a question?

MEMBER REMPE: I sure do. I apologize, because I had to step out for a phonecall, but I'm real confused because before I left, KHNP had on Slide 3 that the tech -- the risk-informed tech specifications are not applied. Now, suddenly I come back and I thought I heard you guys saying you were doing some sort of risk-informed --

MR. TJADER: Yeah, well, what I said was is that they have, in essence, not applied in accepting two LCOs.

MEMBER REMPE: Okay.

MR. TJADER: 3.0.8 and 3.0.9. And I'm -- and we have -- one of our open items is that we requested the risk assessment associated with applying 3.0.9 for unavailable barriers.

MEMBER REMPE: so I missed the part that they have --

MR. TJADER: In 2 they have applied to LCOs, they have used initiative, it's Initiative 7 --

MEMBER REMPE: Okay.

MR. TJADER: -- of the risk-informed initiatives. And as I said, it's not an on-line application of the PRA, but we will have the PRA

NEAL R. GROSS

COURT REPORTERS AND TRANSCRIBERS

1323 RHODE ISLAND AVE., N.W.

WASHINGTON, D.C. 20005-3701

(202) 234-4433

(202) 234-4433

Branch.

MEMBER REMPE: Okay. I appreciate it. Again, I was gone is why I was confused, I guess.

MR. TJADER: Okay.

MEMBER REMPE: Thank you.

MR. TJADER: Okay. Page 6. RAI Question 16171, initially the applicant had proposed two separate shutdown margin LCOs. And we -- in response to our questioning, they changed it back to one LCO, which caused the renumbering of the LCOs in Section 3.1 and they need to verify the correction to the references. So we need to verify that they have correctly renumbered the LCOs and references.

Subsections 3.1.8 and 3.1.12 and new specifications related to boron dilution and will be discussed later.

RAI footnote noted that RAI questions affecting tech specs originated during the review of other DCD chapters, which one would expect.

Okay. Slide 7. 16137 is to be discussed later. It's a correlation of Tech Spec Section 3.3 Surveillance Requirements and Instrumentation Testing described in DCD Chapter 7.

The control element assembly calculator is

NEAL R. GROSS

COURT REPORTERS AND TRANSCRIBERS

1323 RHODE ISLAND AVE., N.W.

WASHINGTON, D.C. 20005-3701

(202) 234-4433

(202) 234-4433

the CX-LCO-3.3.3, actions are to be discussed later in section -- with 16013.

Tech Spec 3.3.6 issues mostly related to clarifying scope of testing for ESF logic, such as priority logic, SFAS, EPS and manual.

Open item 16115.1 concerns using channel and division synonymously for ESF actuation logic functions.

115.2 concerns completion of staff review of information provided in RAI response regarding the arrangements of balance of plant, ESF and ESF components in each ESF, CCS, SFAS, actuation logic division into groups and subgroups.

3.3.11 --

CHAIRMAN SUNSERI: Hold on. Just a second. So that one right there, does that touch on the conversation that we had with the applicant about diagonal or, you know --

MR. TJADER: Well, that comes in with the safety injection system. And there may be someone in the electrical area, but no, I don't believe it does.

CHAIRMAN SUNSERI: But when we are talking about the logic of the trains "trains" I mean?

MR. HARBUCK: I can -- this has to do with

NEAL R. GROSS

COURT REPORTERS AND TRANSCRIBERS

1323 RHODE ISLAND AVE., N.W.

WASHINGTON, D.C. 20005-3701

(202) 234-4433

(202) 234-4433

-- this has to -- my name is Craig Harbuck. Okay. This has to do with the surveillance testing and how they staggered the testing, so that only certain groups or sets of components get actuated. And the problem is that we haven't been able to figure out which component has which group label.

MEMBER CHU: Okay.

MR. HARBUCK: I mean, it's a bookkeeping--

CHAIRMAN SUNSERI: All right. Thank you.

MR. HARBUCK: Okay.

MR. TJADER: And then 3.3.1, Post Action Monitoring, otherwise known as Accident Monitoring and Instrumentation. And 3.3.14 will be discussed later.

Slide 8. Shutdown Risk Mitigation is a significant issue in Section 3.4. And as you know, to their credit, they have addressed shutdown more rigorously than the standard has.

16149.2C, reduced RCS inventory on loss of shutdown cooling. Any questions?

MR. HARBUCK: Actions on losses.

MR. TJADER: Actions on losses. Certainly. I'm sorry.

16149.2K, RCS loops not filled definition. They have applied new definitions and things which we

NEAL R. GROSS

COURT REPORTERS AND TRANSCRIBERS

1323 RHODE ISLAND AVE., N.W.

WASHINGTON, D.C. 20005-3701

(202) 234-4433

(202) 234-4433

are working through, some of which were retained, some of which we have gotten rid of.

MR. HARBUCK: So this isn't a definition as a defined term. It's just understanding how they demarcate loops filled and loops not filled in MODE 5.

MR. TJADER: All right. Open item 1623 reflects having not received formal response to most of the 24 sub-questions of RAI 119, 79, 76. Question 1623.

Okay. 3.4.16, spec 3.4.16, RCGV, RCS vent arrangements are unique to APR-1400. The vents gas from both pressurized and reactor vessel closure head to the IRWST.

16152.6 verifying applicable LCO selection criteria, basis cells Criterion 3, RCGV function is not credited in the steam generator tube rupture analysis. So we are questioning just basically which application of the criteria they are using.

Okay. Slide 9. 1617 is a confirmatory item.

MR. HARBUCK: This is mislabeled. It shouldn't be listed here.

MR. TJADER: Okay. As is 46.

MR. HARBUCK: And 46.

NEAL R. GROSS

COURT REPORTERS AND TRANSCRIBERS

1323 RHODE ISLAND AVE., N.W.

WASHINGTON, D.C. 20005-3701

(202) 234-4433

(202) 234-4433

MR. TJADER: 46, yeah. 3.5.3, Shutdown Risk Mitigation. Manual safety injection change required when reactor vessel level is below the flange.

16149, response is still in evaluation by the staff.

6.3-10, Boron Recycling Issue. Reactor systems is reviewing that.

3.6.6, Containment Spray System is used for containment cooling. Containment spray pump may serve as a shutdown cooling pump in the same electrical division on MODES 4, 5 and 6. Shutdown cooling pump may serve as a containment stray pump in the same electrical division in MODES 1, 2 and 3.

Spec 3.6.7, Containment Closure Requirements in reduced inventory conditions in MODES 5 and 6 are discussed later.

Slide 10. The staff had issues with 3.7.5, Auxiliary Feedwater System and 3.7.11, Control Room Ventilation System. Both are discussed later.

Slide 11. Electrical System Spec 3.1.8 for clarifying implementation of cross-train check action requirements and 3.8.1 for inoperable EDGs.

3.9.5, MODE 6 Reduced Inventory Risk

NEAL R. GROSS

COURT REPORTERS AND TRANSCRIBERS

1323 RHODE ISLAND AVE., N.W.

WASHINGTON, D.C. 20005-3701

(202) 234-4433

(202) 234-4433

Mitigation and 3.9.7 is a new specification related to Boron dilution and will be discussed later.

Slide 12. Our instrumentation control and reactor systems are reviewing setpoint methodology, technical reports to be referenced in the setpoint control program in program 5.5.19, the Setpoint Control Program that's in progress.

Slide 13. Defined Terms. Operability, as I mentioned already, they need to justify the use of the word division and their change of the word operability.

MODE. Their MODES use cold leg temperature versus average temperature. Their analysis uses cold leg temperature. We are reviewing that.

MR. HARBUCK: Do you know --

MR. TJADER: But we have reviewed it and accepted it. Okay.

MR. HARBUCK: But there is other issues.

MR. TJADER: Okay. As I said, some of the definitions they have proposed we are reviewing. Some of them we had determined aren't really necessary.

MID-LOOP is one that they proposed. So far we haven't found a reason that we really need to

NEAL R. GROSS

COURT REPORTERS AND TRANSCRIBERS

1323 RHODE ISLAND AVE., N.W.

WASHINGTON, D.C. 20005-3701

(202) 234-4433

(202) 234-4433

get rid of it. But the question is is it really needed?

And in their shutdown mitigation, addressing shutdown mitigation, they deal in the specs throughout with various RCS elevations. Just quickly 112 feet and 3.3 inches at the top of the fuel 117 feet 4 inches are at minimum level for shutdown cooling system operation. 119 feet at the top of a hot leg, 124 feet 8/34 and it's the top of a 12 inch internal diameter DVI nozzle. 127 feet 1/4 inch, 3 feet below the top of the reactor flange, 130 feet 1/3 inch is the top of the reactor flange.

Well, I mean, these are just --

MEMBER CORRADINI: Just slow down.

MR. TJADER: 136, 10 and 1/4 inch is the bottom of the pressurizer. 153 feet and 1/4 inch, 23 feet above the top of the reactor vessel flange, 122 feet 4.2 inches on top of steam generator tube. So some of those things are referenced in some of those specs.

MEMBER CORRADINI: So I want to make sure, you are disposing of them quickly, so I term most of these definitional and just clarification rather than technical.

NEAL R. GROSS

COURT REPORTERS AND TRANSCRIBERS

1323 RHODE ISLAND AVE., N.W.

WASHINGTON, D.C. 20005-3701

(202) 234-4433

(202) 234-4433

MR. TJADER: Right.

MEMBER CORRADINI: Okay. Fine.

CHAIRMAN SUNSERI: So on some of these critical, I'll call them dimensions and I won't label them, but are there going to be ITAACs or something to verify these at the end or how --

MR. TJADER: Well, not related to specs. They may be in other systems ITAACs related to them.

MR. HARBUCK: Well, certainly these elevations are referenced to some point and for purposes of discussing the technical specification and establishing applicability requirements based on level, elevation is the way they have denoted these particular points.

And so we just thought we would mention what the key ones were that come into play just for familiarity with a follow-on discussion.

CHAIRMAN SUNSERI: Yeah, I mean, my experience is that's not uncommon, but what was -- your imperative though is the validation of that point, elevation to the physical plant, right?

MR. TJADER: I'm sure there is an ITAAC in the system.

CHAIRMAN SUNSERI: Okay.

NEAL R. GROSS

COURT REPORTERS AND TRANSCRIBERS

1323 RHODE ISLAND AVE., N.W.

WASHINGTON, D.C. 20005-3701

(202) 234-4433

(202) 234-4433

MR. TJADER: The system engineers have and things like that.

CHAIRMAN SUNSERI: Yes. And as Mike said, you all are going to fast-track. I neglected to ask a question earlier on. The setpoint methodology, is there a significant departure in what they are proposing for the setpoint methodology or is it just you have some questions?

MR. HARBUCK: We will be -- I'll just be discussing that briefly, but, yeah, there is a couple of issues that I'm aware of. If anyone from the I&C Group is here when we get to that slide, perhaps they can chime in with more detail.

CHAIRMAN SUNSERI: More to come though later?

MR. HARBUCK: Yes.

CHAIRMAN SUNSERI: Okay. All right. I'll hold off.

MR. HARBUCK: Yes. And that was part of the overview just to sort of give an idea of the scope and depth to the issues that we have and which sections are affected.

MR. TJADER: And now some of the technical issues, Craig will be addressing in the next few

NEAL R. GROSS

COURT REPORTERS AND TRANSCRIBERS

1323 RHODE ISLAND AVE., N.W.

WASHINGTON, D.C. 20005-3701

(202) 234-4433

(202) 234-4433

slides and I'll turn it over to him starting with requirements to mitigate shutdown risk.

MR. HARBUCK: Okay. All right. So Slide No. 14. My understanding is that the -- this shutdown evaluation report, although not specifically docketed with the application, has been incorporated as requested by the staff in the portions of Chapter 19 where some of the risk insights in that report were cited by the applicant in the analyses. That's as close as I can get to describing what is this -- that report.

But the other side of it is that a lot of their requirements were informed by that analysis. So I wanted to mention it. But I did not review the report in any great depth. I just simply have taken that as a basis for some of the requirements they have propose and it's what I have listed here and their applicabilities.

These LCOs all have the provisions that are related to shutdown risk mitigation.

Just to note, the applicant agreed to increase the applicability of the new LCO 3.6.7 on containment penetrations. Originally, they had proposed it to be applicable when you were at 3 feet

NEAL R. GROSS

COURT REPORTERS AND TRANSCRIBERS

1323 RHODE ISLAND AVE., N.W.

WASHINGTON, D.C. 20005-3701

(202) 234-4433

(202) 234-4433

below the reactor vessel flange, both in MODE 5 and in MODE 6. But now it is more in line with LCO 3.4.8 and 3.9.5, which also deal with shutdown cooling requirements and actions, in case you lose them.

Okay. Next slide. Some requirements to mitigate shutdown risk. Staff has an issue with the appropriate action requirements to increase the reactor vessel level from the low water level condition in case shutdown cooling is lost for more than a short time, i.e., before you start boiling the water in the reactor vessel.

So to clarify what has been proposed by the applicant in this regard, we have outlined how the operability requirements increase as reactor vessel level is decreased.

And so as I go through this list, bear in mind that if something was applicable in a broader sense, it continues to be applicable in the lower levels. So we are adding requirements as we go down, not removing any necessarily.

MEMBER KIRCHNER: Craig?

MR. HARBUCK: Yes.

MEMBER KIRCHNER: Just a question of clarification. I was struck by the 1/4 inch, 127 feet

NEAL R. GROSS

COURT REPORTERS AND TRANSCRIBERS

1323 RHODE ISLAND AVE., N.W.

WASHINGTON, D.C. 20005-3701

(202) 234-4433

(202) 234-4433

and 1/4 inch.

MR. HARBUCK: Based at the top of the reactor vessel flange is 130 feet and a 1/4 inch.

MEMBER KIRCHNER: Uh-huh.

MR. HARBUCK: And you know, actually I use centimeters and millimeters, I think, but --

MEMBER KIRCHNER: Uh-huh.

MR. HARBUCK: -- so I don't know what they started with, if they started with feet and inches or did they start with metric and then convert and how closely are they tied together.

MEMBER KIRCHNER: Well, it just begs the question during inspection are you within that quarter inch. That's -- is there some uncertainty, some latitude? I have got the vessel filled 127 feet.

MR. HARBUCK: That's a matter for the Chapter 13 folks and their operating procedures, I would think.

MEMBER KIRCHNER: Okay. And do you have level indications that --

MR. HARBUCK: Well, that has three --

MEMBER KIRCHNER: -- actually went through that?

MR. HARBUCK: -- different kinds of level

NEAL R. GROSS

COURT REPORTERS AND TRANSCRIBERS

1323 RHODE ISLAND AVE., N.W.

WASHINGTON, D.C. 20005-3701

(202) 234-4433

(202) 234-4433

indications for the reactor.

MEMBER KIRCHNER: Yes. It's a wide range and then --

MR. HARBUCK: Yes, and then a narrow range. And then they have got a special sonic kind of measurement when they are down to MID-LOOP situation.

MEMBER KIRCHNER: Yes.

MR. HARBUCK: Reading that in percent.

MEMBER KIRCHNER: Just beam it off the reflector off the water surface.

MR. HARBUCK: So it's -- I don't know how it works.

MEMBER KIRCHNER: All right.

MR. HARBUCK: But that's what I have been told when we had a meeting with them over a year ago, we were enlightened to that fact. But there is nothing automatic that takes place other than alarms, so those --

MEMBER CORRADINI: So you are going to go through these, but remind me, so MODE 5 is cold shutdown?

MR. HARBUCK: Yes, MODE 5 is less than 210 degrees on the cold leg temperature.

MEMBER CORRADINI: And pressure could

NEAL R. GROSS

COURT REPORTERS AND TRANSCRIBERS

1323 RHODE ISLAND AVE., N.W.

WASHINGTON, D.C. 20005-3701

(202) 234-4433

(202) 234-4433

vary?

MR. HARBUCK: Pressure could be whatever is allowed by the limited curve for that temperature.

MEMBER CORRADINI: Okay.

MR. HARBUCK: And you could have a steam generator above or it could be, you know, open to the atmosphere.

MEMBER CORRADINI: It could.

MR. HARBUCK: And level in the reactor vessel could be all the way down to the middle of the hot leg. You would still be in MODE 5.

MEMBER CORRADINI: All right. Thank you.

MR. HARBUCK: So it's -- okay. Okay. So let's go down this. The operability requirements:

In MODE 5, safety injection requires to manually initiated trains. And this is the control for operating each pump, I guess, is what is required.

You don't need any of the automatic instrumentation to initiate it or you don't even need the system level switches according to what the applicant has told me.

So as long as you have the ability to start the pumps or get them going, then you are satisfying their operability requirements. And again, they require that they be diagonally-oriented with

NEAL R. GROSS

COURT REPORTERS AND TRANSCRIBERS

1323 RHODE ISLAND AVE., N.W.

WASHINGTON, D.C. 20005-3701

(202) 234-4433

(202) 234-4433

respect to the reactor vessel, I guess over a concern of a break in a -- I don't know, it may be more that is necessary, but that's what they require.

Okay. In MODE 5 with Loops filled, you also require shutdown cooling, but just one train and either one -- and it's also one train and one train has got to be in operation and you either have to have another train available operable or you have to have both steam generators with 25 percent level on the secondary side.

MEMBER STETKAR: Subcommittee Members, there are only two pumps. So in this case, train is train or division or whatever, so shutdown cooling.

MR. HARBUCK: Right. Okay.

MEMBER STETKAR: This says you have to have one shutdown cooling --

MR. HARBUCK: Which is not to say --

MEMBER STETKAR: -- loop operating and either the other one operable or level in both steam generators.

MR. HARBUCK: Okay.

MEMBER CORRADINI: But shutdown cooling is this -- this is more, I mean, to clarify what I think is happening. There is no low pressure SI which would

NEAL R. GROSS

COURT REPORTERS AND TRANSCRIBERS

1323 RHODE ISLAND AVE., N.W.

WASHINGTON, D.C. 20005-3701

(202) 234-4433

(202) 234-4433

have been where RHR --

MEMBER STETKAR: Right.

MEMBER CORRADINI: -- the output in the RHR world it would be both shutdown cooling and low pressure injection, a separate system.

MR. HARBUCK: That's right.

MEMBER CORRADINI: Okay. Fine.

MR. HARBUCK: That's right.

MEMBER CORRADINI: Thank you.

CHAIRMAN SUNSERI: Although you might be able to use a containment spray pump for shutdown cooling in this phase, right?

MR. HARBUCK: Well, that has been designed into the system to be able to interchange these two pumps for the -- for each other's role as long as it's in the same electrical division, because that's where the pipes are lined up to valve them back in or out.

CHAIRMAN SUNSERI: That's -- glad you said division rather than train.

MR. HARBUCK: Okay.

MEMBER STETKAR: Shutdown cooling comes off one diesel and the spray cool comes off the other diesel.

MEMBER CORRADINI: It sounds like a simple

NEAL R. GROSS

COURT REPORTERS AND TRANSCRIBERS

1323 RHODE ISLAND AVE., N.W.

WASHINGTON, D.C. 20005-3701

(202) 234-4433

(202) 234-4433

plan until you look at it.

MR. HARBUCK: Okay. So let's see, so if you are in MODE 5, but your loops aren't filled, and this is something they are not sure what that exactly means, but your level is still above this 127 foot 1/4 inch level, which we referred to based on Generic Letter 8817, we referred to it as reduced RCS inventory.

What the significance of that is, I'm not an expert on. And at that particular -- so above 127 feet if the loop is not filled, you are required to have two trains of shutdown cooling with one train in operation and then there is no use of the steam generators as your heat sinks here.

And then also containment closure is required, that means the equipment hatch has to be bolted up, at least four bolts. The one door in the airlock closed. And most other penetrations isolated in some way, especially those having direct connection between the outside atmosphere and the containment or capable of being isolated by an operable containment isolation system.

They have a special system for the purge valves, for the containment system purge valves. They

NEAL R. GROSS

COURT REPORTERS AND TRANSCRIBERS

1323 RHODE ISLAND AVE., N.W.

WASHINGTON, D.C. 20005-3701

(202) 234-4433

(202) 234-4433

will automatically close on a high radiation signal from monitors inside containment.

Okay. Now, if you are above the top of the hot leg, you have drained down some, an additional requirement is that you have a containment spray pump is required and that pump has to be associated with the shutdown cooling division that is in operation.

Okay. And then if you are in that loop, you must have been shutdown for more than 96 hours and cold leg temperature must be less than 135 degrees to satisfy analysis assumptions, I guess, for loss of shutdown cooling in that condition.

Okay. Next, we have outlined the action requirements for not meeting these operability requirements as reactor vessel levels decrease.

So in all of MODE 5, if you lose one or both of your required diagonal trains, manual trains of the safety injection, the actions essentially just tell you, besides, you know, restore to operating -- operable status, they tell you to reduce cold leg temperature down to 135.

And then if the loops are filled, and you have no shutdown cooling operable or in operation, the actions require you to initiate action to either

NEAL R. GROSS

COURT REPORTERS AND TRANSCRIBERS

1323 RHODE ISLAND AVE., N.W.

WASHINGTON, D.C. 20005-3701

(202) 234-4433

(202) 234-4433

restore the shutdown cooling flow or to initiate a secondary heat removal, these are using the steam generators.

If the loops are not filled, but level is between the reduced inventory level of 127 feet or the reactor vessel flange of 130 feet, with both SI trains inoperable or one or both of them inoperable, actions also require you to initiate action to raise level to 130.

The -- and with no shutdown cooling train operable or in operation, the actions require immediately initiating the action to restore the train to operable status and in operation.

In MODE 5 with loops not filled, but with level between the top of the hot leg and the reduced inventory level, 3 feet below the flange --

MR. TJADER: Slide 17.

MR. HARBUCK: Yes, Slide 17. With no shutdown cooling train operable or in operation, actions also require you to initiate action to restore level to 127 feet.

And with required containment spray pump inoperable, because now below 127, you are required to have this extra containment spray pump, they give you

NEAL R. GROSS

COURT REPORTERS AND TRANSCRIBERS

1323 RHODE ISLAND AVE., N.W.

WASHINGTON, D.C. 20005-3701

(202) 234-4433

(202) 234-4433

48 hours to restore it. And if you don't get it back, then you have got to raise the level back up to 127 within six hours and that then takes away the requirement for the spray pump.

MEMBER KIRCHNER: Craig?

MR. HARBUCK: Yes?

MEMBER KIRCHNER: A clarification question.

MR. HARBUCK: Okay.

MEMBER KIRCHNER: The last bullet on page 16 and the first one on 17.

MR. HARBUCK: Okay.

MEMBER KIRCHNER: It's almost like thou shalt not do that. How do you get there? I mean, isn't it by default? The default logic, to me, is to keep the level at 127 feet or 130 and just I'm trying to think through how you got yourself in that position --

MR. HARBUCK: No.

MEMBER KIRCHNER: -- where you immediately have to take action.

MR. HARBUCK: Well, the -- we had some discussion with the applicant about this and they rightly pointed out that the Generic Letter 8817

NEAL R. GROSS

COURT REPORTERS AND TRANSCRIBERS

1323 RHODE ISLAND AVE., N.W.

WASHINGTON, D.C. 20005-3701

(202) 234-4433

(202) 234-4433

advises that you immediately initiate action to restore your shutdown cooling in case you lose it.

MEMBER KIRCHNER: Okay.

MR. HARBUCK: And based on that, the tech specs have protected the standard, too. In some places they say immediately initiate action to restore knowing that if you don't restore it, then you are eventually going to be in your emergency operating procedures and perhaps having to rely on your safety injection pumps that you now require to be operable.

MEMBER KIRCHNER: Okay.

MR. HARBUCK: So the tech specs don't get you out of things too much. They just offer you sometime, some remedial actions to minimize the, you know, risk, I guess, while you are trying to fix it. And if you can't fix it, then you shut down.

MEMBER KIRCHNER: Yeah. It seems to me though the simpler thing would be just say thou shalt not be below X elevation, 117. Pick a number, 127.

MR. HARBUCK: Right. But there is certain elevations that take place during refueling outages that are required to take the level down to the middle of the hot leg.

MEMBER KIRCHNER: More connecting.

NEAL R. GROSS

COURT REPORTERS AND TRANSCRIBERS

1323 RHODE ISLAND AVE., N.W.

WASHINGTON, D.C. 20005-3701

(202) 234-4433

(202) 234-4433

MR. HARBUCK: Yeah. And so the situation -- these are not, you know, long-term conditions.

MEMBER KIRCHNER: Right.

MR. HARBUCK: But when they do occur, it's important to be extra careful because you can boil -- start boiling pretty quickly in that time after shutdown.

MEMBER CORRADINI: Is it fair to say this is a lot more complete than you have seen in the past?

MR. HARBUCK: This is the first time we have really seen anyone try to establish a good set of requirements for shutdown for a PWR. I think other than the AP-1000 is a different story. Okay. They had passive systems and so they -- it was more of a natural fit and it evolved from the AP-600, which was just like the SYSTEM 80+ back in the mid-90s when shutdown risk was an issue or shutdown requirements was being -- even being considered to have a rule for it.

And somehow a lot of that never made it into the Standard Tech Specs.

MEMBER CORRADINI: Okay.

MR. HARBUCK: But we have been trying to get these requirements and we are gratified to see

NEAL R. GROSS

COURT REPORTERS AND TRANSCRIBERS

1323 RHODE ISLAND AVE., N.W.

WASHINGTON, D.C. 20005-3701

(202) 234-4433

(202) 234-4433

that they have proposed a comprehensive set of requirements here.

MEMBER CORRADINI: Is it fair to say that the staff is generally pleased with this? It sounds like it.

MR. HARBUCK: For the most part. But as usual, we are always trying to make sure we don't forego some --

MEMBER CORRADINI: Yes.

MR. HARBUCK: -- additional margin if it's there and doesn't cause a significant burden.

And so let me finish this point and then I'll make a point about that.

Okay. We are on Slide 17. And I think we were down, let's see, yeah, I was making the point about the containment spray pump. If you got to restore it back, otherwise, you raise the level up to where it's not required. And then if you are in the-- if the level is down in the hot leg, which is then the action or the additional action requirements include-- well, if you are less than 96 hours, somehow you got yourself in MID-LOOP, get out of it or if the temperature is too high, you reduce the temperature.

And so that's pretty much it.

NEAL R. GROSS

COURT REPORTERS AND TRANSCRIBERS

1323 RHODE ISLAND AVE., N.W.

WASHINGTON, D.C. 20005-3701

(202) 234-4433

(202) 234-4433

Now, the question I have on this particular scenario or listed requirements is when you have lost all your shutdown cooling and you are below 127 feet and you are told to raise the level up to 127 feet, I don't know exactly what the reason is for that being significant. Why not another 3 feet? You have already done about 8 or 9 feet if you had started out in the MID-LOOP situation.

So to me, it just didn't seem to be a good argument against raising level higher. The argument for it is that well, that's the level that is identified in the reg or the --

MEMBER CORRADINI: Generic?

MR. HARBUCK: -- Generic Letter. And so we are still -- we are going to have a discussion about that and with the assistance of the PRA Branch and try to come to a good understanding of what -- is 127 the best place to go or would 130 be better?

There are other actions where it tells you to go to that Level II, but the situation may be slightly different and it may not be so much of an issue. The issue though is where -- is when you are below 127 -- well, I'll just say this.

If you are in the maintenance activity in

NEAL R. GROSS

COURT REPORTERS AND TRANSCRIBERS

1323 RHODE ISLAND AVE., N.W.

WASHINGTON, D.C. 20005-3701

(202) 234-4433

(202) 234-4433

MID-LOOP and you have people inside the steam generator and all of a sudden you are faced with a loss of shutdown cooling and you want to restore inventory to provide yourself some additional water to extend how long before you start boiling, you have got to go through some maintenance activities to close -- to get people out, close things up and what have you and if you have to go to all that trouble and then you raise the level up to 127, what's the big deal of going another 3 feet? That's sort of how we look at it.

And that's -- I think I beat that horse to death. All right. Slide No. 18. Now, as you can imagine --

MEMBER KIRCHNER: But since you did --

MR. HARBUCK: Okay.

MEMBER KIRCHNER: -- I can jump back in and I'm just thinking of the logic diagram for all this. And I'm thinking isn't there a simpler way to set these limits? I know --

MR. HARBUCK: Well, you know, what --

MEMBER KIRCHNER: -- I appreciate the complications.

MR. HARBUCK: -- it has been -- it is not

NEAL R. GROSS

COURT REPORTERS AND TRANSCRIBERS

1323 RHODE ISLAND AVE., N.W.

WASHINGTON, D.C. 20005-3701

(202) 234-4433

(202) 234-4433

that easy to try to get your head around all these different LCOs and these different action requirements. And so we have -- we are pretty comfortable with the way things are set up at the moment, other than this one issue about, you know, what is the appropriate action if you really have lost your shutdown cooling.

MEMBER KIRCHNER: Don't forget that 1/4 of an inch.

MR. HARBUCK: Well, that's -- well, the 130 feet omits the quarter of an inch.

MEMBER KIRCHNER: Okay.

MR. HARBUCK: So it makes it easy. Okay.

Let's see, now as you can imagine, a discussion of this -- like this listing the operability requirements and the actions if level keeps going -- you know, at just different lower levels could be had in MODE 6 and it comes up with similar conclusions.

So we find these actions to be reasonable and the requirements to be consistent with the Generic Letter. So kudos to the applicant for that.

Now, I mentioned briefly earlier in the overview, but I'll discuss it a little bit more now. And this slide here is we are trying to clarify what

NEAL R. GROSS

COURT REPORTERS AND TRANSCRIBERS

1323 RHODE ISLAND AVE., N.W.

WASHINGTON, D.C. 20005-3701

(202) 234-4433

(202) 234-4433

constitutes a loop filled versus loops not filled. So you know when you are in the -- when LCO 3.4.7 and 3.4.8 and 3.6.7 apply, and so this is associated with open item No. 149.2K.

Now, the applicant considers the capability to use the secondary heat sink to be the determining factor in this distinction between these two conditions. But my RCS level or whether the reactor coolant pressure boundary is intact, which by that I mean are your manlife flanges are still installed.

As long as the steam generator tubes are full and steam generator secondary side is greater than 25 percent wide range, that is you have the ability to use the secondary heat sink, even though you may have drained part of the RCS down, the applicant apparently believes that they could -- they would consider themselves to still be in Spec 3.4.7.

Now, how could that be accomplished? I'm told that one way would be to pressurize the system using a gas as you are draining down. I'm not real familiar with the procedures for the activities necessary for changing level when you are coming out, going into a refueling outage, but this is my

NEAL R. GROSS

COURT REPORTERS AND TRANSCRIBERS

1323 RHODE ISLAND AVE., N.W.

WASHINGTON, D.C. 20005-3701

(202) 234-4433

(202) 234-4433

understanding.

And I'm happy to entertain the -- any comments that the applicant may wish to add, at this time, to clarify this situation. But we need to -- along with the PRA Group, which is principally concerned with the shutdown risk issue that we get all on the same page and in the Bases have a clear description for these specifications, have a clear description of what is loops filled and loops not filled.

Now, the standard tech specs is not different in this regard in terms of not really clarifying what it means. I suppose it's just part of the, you know, trade knowledge of operating a pressurized water reactor.

But in this case, since I'm a little confused about the answer they gave us, I want to nail it down and perhaps this is an opportunity for improvement in the standard itself. So if nothing else more on that, then we will go on to the next topic.

CHAIRMAN SUNSERI: So we are at the end of a section here and before we start on that new one, let's take a break here.

NEAL R. GROSS

COURT REPORTERS AND TRANSCRIBERS

1323 RHODE ISLAND AVE., N.W.

WASHINGTON, D.C. 20005-3701

(202) 234-4433

(202) 234-4433

MR. HARBUCK: All right.

CHAIRMAN SUNSERI: And we will break until 3:30 and then we will reconvene. Okay?

MR. HARBUCK: Okay.

CHAIRMAN SUNSERI: Thank you.

MR. HARBUCK: Thank you.

(Whereupon, the above-entitled matter went off the record at 3:12 p.m. and resumed at 3:30 p.m.)

CHAIRMAN SUNSERI: All right. We are going to reconvene, it's 3:30. Just a little break in the flow here though. In our previous session, we had a question on the anticipated transient without scram in the procedure interface, so we do have the technical reviewer here. Is that correct, Bill?

MR. WARD: That's correct.

CHAIRMAN SUNSERI: All right, Bill. So we would like to interject that into the discussion now, so we can have that conversation and/or at least person back to their other activity. So, Bill, it's up to you.

MR. DEMARSHALL: Yes, no, this is Joe DeMarshall. We spoke earlier and he heard the question from Mr. Skillman, Ms. Rempe about ATWS and how we reviewed it. And so we went back and did some

NEAL R. GROSS

COURT REPORTERS AND TRANSCRIBERS

1323 RHODE ISLAND AVE., N.W.

WASHINGTON, D.C. 20005-3701

(202) 234-4433

(202) 234-4433

research and he is going to give you a little bit more information it.

CHAIRMAN SUNSERI: Okay. All right.

MR. DEMARSHALL: I am going to thank the ACRS for allowing me the opportunity to close this out today. The EOGs for APR-1400 are, once again, based on the combustion engineering EOGs. The ATWS, to cut to the chase, is covered in the Functional Recovery Guidelines procedures of the EOGs for APR-1400.

The way that the APR-1400 EOGs work, the same way that the combustion engineering EOGs work is -- in the case of an ATWS, that -- we are talking about reactivity control. Okay. So reactivity control is a safety function.

And the first things that get checked in the EOGs for these -- for combustion engineering in APR-1400, they do what they call standard post-trip actions. And what standard post-trip actions are, they prioritize safety functions against acceptance criteria.

So they -- in this case, ATWS, reactivity control, there are acceptance criteria for that safety function. So any time that the acceptance criteria aren't met or a contingency action is required within

NEAL R. GROSS

COURT REPORTERS AND TRANSCRIBERS

1323 RHODE ISLAND AVE., N.W.

WASHINGTON, D.C. 20005-3701

(202) 234-4433

(202) 234-4433

the standard post-trip actions, it immediately kicks you out to, what is called, a diagnostic action where it is -- which are another aspect of the EOGs.

Okay. I have got on paper here the diagnostic actions are basically a flow chart. And I'm just going to go down -- here it says is reactivity control safety function met? The answer is no. It says go to the FRGs. So you bypass the ORGs, which was the question before, why didn't the ATWS show up in the ORGs? And those are event-specific design basis events.

The way that -- once you get into the FRGs, there is what are called reactor -- I'm sorry, risk assessment trees. And they are broken down into legs. They are basically another flow chart. Prior legs, each one they are called success paths. And the way you work them, I know everybody can't see this, but you work them left to right, okay?

There is three different categories for reactivity control. The first success path is CEA insertion. Okay. If that doesn't work, then you move over to the right and you borate with CVCS charging system. If that doesn't work, then your third success point as you borate with safety injection system from

NEAL R. GROSS

COURT REPORTERS AND TRANSCRIBERS

1323 RHODE ISLAND AVE., N.W.

WASHINGTON, D.C. 20005-3701

(202) 234-4433

(202) 234-4433

the in-containment refueling water storage tank. And the other option there is you can also borate using the shutdown cooling pumps with the suction from the in-containment refueling storage tank.

So this is all covered as it -- same as covered in the combustion engineering EOGs. I have all the paper here. I can leave that with somebody if they would like to see that.

MEMBER SKILLMAN: Let me respond as follows: The origin of my question came from my review of the safety evaluation Section 13.5.4.2. And in that section, the -- you explain the EOGs, the FRGs and then this statement is made. "The FRGs event diagnosis is not possible or ORG action is not sufficient. Addresses the safety functions of:

Reactivity control, maintenance of vital auxiliaries, that's vital AC and DC, RCS inventory control, RCS pressure control, RCS and core heat removal, containment isolation, containment temperature and pressure control, and containment combustion -- combustible gas control."

MR. DEMARSHALL: Sure.

MEMBER SKILLMAN: Then there is a series of bulleted items that leads to the statement that I

NEAL R. GROSS

COURT REPORTERS AND TRANSCRIBERS

1323 RHODE ISLAND AVE., N.W.

WASHINGTON, D.C. 20005-3701

(202) 234-4433

(202) 234-4433

spoke of earlier. And that statement is "APR-1400 specific design features incorporated into the analysis for the operational trains and accidents that were used for the EOGs." That contains a list. And that list contains:

Reactor trip LOCA, steam generator tube rupture, main steam line break, loss of all feedwater loop, SPO. And it just seemed given the preamble for reactivity control, ATWS should have been included.

So I have no doubt that ATWS has been addressed.

MR. DEMARSHALL: Right.

MEMBER SKILLMAN: But in the safety evaluation it seemed to me the way the text was provided, ATWS would have been included in that list.

So my concern is not that this has been orphaned somehow. That's not what I'm saying.

What I'm saying is the safety evaluation, at least in my estimation, didn't pin that down as firmly as you have in your explanation, Joe.

MR. DEMARSHALL: Okay. Um-hum.

MEMBER SKILLMAN: That's all I was trying to communicate.

MR. DEMARSHALL: Could I just take a quick

NEAL R. GROSS

COURT REPORTERS AND TRANSCRIBERS

1323 RHODE ISLAND AVE., N.W.

WASHINGTON, D.C. 20005-3701

(202) 234-4433

(202) 234-4433

second? Do you have that in front of you right now?

MEMBER SKILLMAN: I absolutely do. Actually, it's in the safety evaluation. And it is Section 13.5.4.2.

MR. DEMARSHALL: Okay.

MEMBER SKILLMAN: I'm going down and here is the description of what all those key functions are, which I am very well-aware of.

MR. DEMARSHALL: Okay.

MEMBER SKILLMAN: 50 years of this.

MR. DEMARSHALL: I understand.

MEMBER SKILLMAN: And I'm saying okay, here is a list and here is the --

CHAIRMAN SUNSERI: So, you know, let me interject here. I think we probably have understood where the requirement --

MR. DEMARSHALL: Sure.

CHAIRMAN SUNSERI: -- and you are interested in maybe making any changes or editing the safety evaluation, I would ask you to maybe get with Mr./Member Skillman after the meeting and, you know, maybe --

MR. WARD: Well, I would propose we just carry-on in Phase 5.

NEAL R. GROSS

COURT REPORTERS AND TRANSCRIBERS

1323 RHODE ISLAND AVE., N.W.

WASHINGTON, D.C. 20005-3701

(202) 234-4433

(202) 234-4433

MEMBER SKILLMAN: Marking your list and we'll pick it up as we go.

MR. WARD: Yeah.

MEMBER SKILLMAN: Is where I would be.

MR. WARD: Okay. So we will just carry it forward and make sure it is corrected in the next round.

MEMBER SKILLMAN: All right. Okay. I just wanted to make sure I understood.

MR. WARD: Did you have another question?

MEMBER REMPE: I appreciate the clarification. Thank you.

MR. WARD: Okay.

CHAIRMAN SUNSERI: Thank you.

MR. WARD: Thank you.

CHAIRMAN SUNSERI: Thank you that was very responsive to the question, so we appreciate that.

MS. UMANA: Also --

CHAIRMAN SUNSERI: All right.

MS. UMANA: -- I'm sorry. I have a member from the PRA Branch here if you want to go back and loop around to Mr. Stetkar's question earlier. Are you interested in doing so or should we --

CHAIRMAN SUNSERI: Sure, sure.

NEAL R. GROSS

COURT REPORTERS AND TRANSCRIBERS

1323 RHODE ISLAND AVE., N.W.

WASHINGTON, D.C. 20005-3701

(202) 234-4433

(202) 234-4433

MS. UMANA: Okay. It's Marie Pohida.

MS. POHIDA: Good afternoon.

CHAIRMAN SUNSERI: Good afternoon.

MS. POHIDA: I wasn't party to the discussion, so I'm brave.

MEMBER STETKAR: Yeah, hi, Marie. Let me give you the quick thing. I wasn't aware, because I hadn't read everything. What we heard this afternoon was the phrase part of the technical specifications for the certified design are risk-informed.

MS. POHIDA: Risk-informed? Okay.

MEMBER STETKAR: It's what we heard.

MS. POHIDA: Okay.

MEMBER STETKAR: That might require some clarification. In particular, two parts, one is requirements for pipe snubbers.

MS. POHIDA: Um-hum.

MEMBER STETKAR: The other part, which might be more relevant, is the requirement for barrier integrity. Fire barriers and flooding barriers. And so my question was well if, indeed, the LCOs in the certified design technical specifications for barrier integrity are risk-informed, meaning the times are somehow derived from the fire and flooding analyses.

NEAL R. GROSS

COURT REPORTERS AND TRANSCRIBERS

1323 RHODE ISLAND AVE., N.W.

WASHINGTON, D.C. 20005-3701

(202) 234-4433

(202) 234-4433

MS. POHIDA: Yes.

MEMBER STETKAR: How is the staff reviewing the internal fire and flooding analyses to confirm that, indeed, the PRA satisfies all of the quality attributes, Reg Guide 1.200 and so on, as you would do for, let's say, any other risk-informed application, whether that is, you know --

MS. POHIDA: Your tech specs in 4B.

MEMBER STETKAR: Tech spec or, you know, any of the other --

MS. POHIDA: Yes, I understand.

MEMBER STETKAR: -- initiatives, you know.

MS. POHIDA: Right.

MEMBER STETKAR: NFP-805.

MS. POHIDA: Yes.

MEMBER STETKAR: Sorry I had to say that, but --

MS. POHIDA: I understand.

MEMBER STETKAR: -- so the question is -- and I wasn't aware that there was something called risk-informed tech specs on this design, so everything that I have looked at in terms of Chapter 19 has been under sort of the normal Chapter 19.

MS. POHIDA: Yeah.

NEAL R. GROSS

COURT REPORTERS AND TRANSCRIBERS

1323 RHODE ISLAND AVE., N.W.

WASHINGTON, D.C. 20005-3701

(202) 234-4433

(202) 234-4433

MEMBER STETKAR: The staff is reviewing Chapter 19 and doing selective audits of the PRA to support that level of review.

MS. POHIDA: I can --

MEMBER STETKAR: So now I'll ask you. What are you doing in terms of reviewing the PRA for risk-informed tech spec application?

MEMBER SKILLMAN: And before you just jump in, identify yourself and who you are with.

MS. POHIDA: Oh, thank you. I'm Marie Pohida with the PRA Group at NRO.

Okay. First of all, my review was directed toward the shutdown PRA.

MEMBER STETKAR: Okay.

MS. POHIDA: So I cannot address the snubber issues and the fire barrier integrity issues. I will take that back to my supervisor.

MEMBER STETKAR: But in principle, I mean, the example I brought up, the fire barrier integrity issues do extend to the shutdown PRA --

MS. POHIDA: Yes.

MEMBER STETKAR: -- because there is a fire -- there -- to my knowledge, that if it isn't -- doesn't exist now, there will be a fire analysis for

NEAL R. GROSS

COURT REPORTERS AND TRANSCRIBERS

1323 RHODE ISLAND AVE., N.W.

WASHINGTON, D.C. 20005-3701

(202) 234-4433

(202) 234-4433

shutdown modes.

MS. POHIDA: And there was a fire analysis done for shutdown.

MEMBER STETKAR: Yes.

MS. POHIDA: Yes.

MEMBER STETKAR: And therefore, if I use the analogy of that door over there --

MS. POHIDA: Um-hum.

MEMBER STETKAR: -- the allowed time that that door may be inoperable could differ in principle during full power versus shutdown --

MS. POHIDA: Absolutely.

MEMBER STETKAR: -- because of the fire frequencies and each compartment can be different and the consequences of a fire in each compartment can be different. So therefore, in principle, there might be a different allowed unavailability time during full power versus shutdown based on the risk information.

Now, I'll just leave it there, but did you review the shutdown PRA fire analysis from the perspective of does it satisfy the quality attributes of Reg Guide 1.200 that it would need to satisfy for risk-informed technical specification?

MS. POHIDA: I --

NEAL R. GROSS

COURT REPORTERS AND TRANSCRIBERS

1323 RHODE ISLAND AVE., N.W.

WASHINGTON, D.C. 20005-3701

(202) 234-4433

(202) 234-4433

MEMBER STETKAR: Because that's a much different kind of review.

MS. POHIDA: Oh, I understand. I understand. And the PRA that needs -- the quality of the PRA that is needed to meet that goal is --

MEMBER STETKAR: Is --

MS. POHIDA: -- different than what is -- we typically review for design certification purposes.

MEMBER STETKAR: Correct.

MS. POHIDA: Okay. I understand the thrust of your question.

MEMBER STETKAR: Okay. You don't need to answer it necessarily today, but --

MS. POHIDA: I'll take that back.

MEMBER STETKAR: -- it is going to come back when we talk about Chapter 19.

MS. POHIDA: Okay.

MEMBER STETKAR: Unless there is miscommunication. Unless there is two loose -- let me start this again. The record can show that I'm stammering.

Unless the terminology that has been used by either the applicant or the staff or both is not very well-phrased in terms of the use of the term

NEAL R. GROSS

COURT REPORTERS AND TRANSCRIBERS

1323 RHODE ISLAND AVE., N.W.

WASHINGTON, D.C. 20005-3701

(202) 234-4433

(202) 234-4433

risk-informed.

MS. POHIDA: Yes, because risk-informed has a certain --

MEMBER STETKAR: Yes.

MS. POHIDA: -- connotation associated with it. Okay. I looked at the shutdown PRA for internal events, Level 1 and Level 2. I will take that back to the shutdown fire reviewer.

MEMBER STETKAR: Okay.

MS. POHIDA: Okay. I thought the question that was going to be directed toward me is with respect to tech specs review for shutdown internal events, is -- what we did is we looked at key insights from the PRA. And given we have Criterion 4, 5036, that says, you know, proposed LCOs should be considered for SSCs that are important to operating experience or PRA, that's how the shutdown tech specs were reviewed.

MEMBER STETKAR: That's --

MS. POHIDA: In that context.

MEMBER STETKAR: Yes.

MS. POHIDA: Okay.

MEMBER STETKAR: Yes. And from what I have read of Chapter 19, I can see that directional --

NEAL R. GROSS

COURT REPORTERS AND TRANSCRIBERS

1323 RHODE ISLAND AVE., N.W.

WASHINGTON, D.C. 20005-3701

(202) 234-4433

(202) 234-4433

MS. POHIDA: Yes.

MEMBER STETKAR: -- input.

MS. POHIDA: Right.

MEMBER STETKAR: And indeed, I can see -- yes, that directional input.

MS. POHIDA: Okay.

MEMBER STETKAR: But not the reverse where the PRA has been used to justify, you know, whatever it is 30 days or whatever is in the tech specs.

MS. POHIDA: For the -- yeah, I'll take it back to my supervisor and the reviewer for the word -- the use of the word informed, because that has an --

MEMBER STETKAR: That may affect though the tech specs reviewers --

MS. POHIDA: -- additional connotation.

MEMBER STETKAR: -- because they are --

CHAIRMAN SUNSERI: We are hanging on that.

MS. POHIDA: Okay.

MEMBER STETKAR: I'll talk to you tomorrow.

MS. POHIDA: Okay.

MEMBER STETKAR: But I just wanted to make sure that I hadn't misunderstood things, because I certainly would look at the PRA and its review

NEAL R. GROSS

COURT REPORTERS AND TRANSCRIBERS

1323 RHODE ISLAND AVE., N.W.

WASHINGTON, D.C. 20005-3701

(202) 234-4433

(202) 234-4433

differently if I knew it was being used for a risk-informed application as, I think, we normally understand that terminology.

MS. POHIDA: Okay. I understand.

MEMBER STETKAR: All right.

MS. POHIDA: All right. Thank you.

CHAIRMAN SUNSERI: Are we good?

MEMBER STETKAR: Thanks. Thanks, Marie.

CHAIRMAN SUNSERI: Yes, thanks.

MR. HARBUCK: Thanks for your response to this to our -- to their question there.

MS. POHIDA: Oh, it's my pleasure.

CHAIRMAN SUNSERI: All right. So let's get back into the Chapter 16 review. Just Craig, Bob, we're ready, back to you guys.

MR. HARBUCK: Okay. So we were done with the mitigating shutdown risk discussion and we will move on to requirements to preclude or mitigate inadvertent reactor coolant boron dilution.

Well, in addition to the neutron flux monitoring function in MODES 3, 4 and 5 of Standard Tech Spec 3.1. -- 3.3.13B and in MODE 6 of Standard Tech Spec 3.9.2, which have been retained in the APR-1400 specifications, the genetic tech specs include

NEAL R. GROSS

COURT REPORTERS AND TRANSCRIBERS

1323 RHODE ISLAND AVE., N.W.

WASHINGTON, D.C. 20005-3701

(202) 234-4433

(202) 234-4433

new specifications related to boron concentration.

3.3.14, the boron dilution alarms is meant to alert operators of a possible dilution event in MODES 3, 4 and 5. And sort of inherent in that is that you still have forced flow. There is flow in the reactor coolant system of some type.

MEMBER SKILLMAN: Craig, I would like to ask you. How has this issue been handled in the past?

I think I recall locking valves into --

MR. HARBUCK: Correct.

MEMBER SKILLMAN: -- on the B&W side making purification.

MR. HARBUCK: Yes, that is --

MEMBER SKILLMAN: We had chain and lock.

MR. HARBUCK: Yeah, that is certainly part of the solution. But every -- not everyone does the same thing. And some of it, I suppose, depends upon what you have analyzed for or demonstrated.

There is guidance which, I think in the SRP, talks about how much time you could allow an operator once they become aware of the ongoing event to take action to terminate it.

MEMBER SKILLMAN: But how has it been handled in the past? That's my real question.

NEAL R. GROSS

COURT REPORTERS AND TRANSCRIBERS

1323 RHODE ISLAND AVE., N.W.

WASHINGTON, D.C. 20005-3701

(202) 234-4433

(202) 234-4433

MR. HARBUCK: In what sense?

MEMBER SKILLMAN: I mean, well, this is not a new item.

MR. HARBUCK: No.

MEMBER SKILLMAN: Anybody who runs BWR knows if you have a charging pump that is drawing water from say a demineralized water tank or you have -- when your -- when the head is off and you are below, you know, atmospheric pressure or 25, 30 psi, a demineralized water pump that might be doing a backfeed into a portion of CVT, chemical and volume control or making purification, you can get this long slow unrecognized de-boration.

And if the water temperatures are great enough, you can get stratification. I have this coming from really -- from a really cold source and all of a sudden you say you know what, I'm -- I've got a neutron count I don't understand.

So I mean, this is not something that is new by any means. So my question is how has this been handled in the past? Well, what has been the prevention for inadvertent blind --

MR. HARBUCK: Well, am I -- I mean, I suppose what you mean is what has been done in terms

NEAL R. GROSS

COURT REPORTERS AND TRANSCRIBERS

1323 RHODE ISLAND AVE., N.W.

WASHINGTON, D.C. 20005-3701

(202) 234-4433

(202) 234-4433

of provisions in the standard --

MEMBER SKILLMAN: Tech specs.

MR. HARBUCK: -- tech specs?

MEMBER SKILLMAN: Well, like you say it's an open item.

MR. HARBUCK: And the ones that are -- those three requirements right there are what has been depended upon, but it's not a uniform -- but in terms of individual plants that are operating, they may have a variety of variation. You know, there may be variations for that. I'm not familiar with all of the different ways, but --

MEMBER CORRADINI: Can I -- I'm trying to understand your answer, sir. Are you saying that you are still trying to get the information to understand how they deal with the four things or what they have suggested?

MR. HARBUCK: Um, they --

MEMBER CORRADINI: I'm not understanding.

MR. HARBUCK: I bring up the issue because they have added additional requirements over what we normally see.

MEMBER CORRADINI: Okay.

MR. HARBUCK: And there are some aspects

NEAL R. GROSS

COURT REPORTERS AND TRANSCRIBERS

1323 RHODE ISLAND AVE., N.W.

WASHINGTON, D.C. 20005-3701

(202) 234-4433

(202) 234-4433

in their responses that are a bit -- maybe need to be clarified, but there is also an open item from -- and it was mentioned earlier in the applicant's presentation about concern over mixing and it was part of the analysis or what, I'm not sure.

But essentially, they proposed, in terms of that issue, Specification 3.1.12 to require:

If you don't have any forced circulation, your reactor coolant pumps are idle;

That you would close off your de-mineralized water source, so that you wouldn't be able to do that to have an event.

I don't know if that -- I think what is going on here is a balance between either mitigating the event or preventing it. And as you still have this boron dilution alarm system that is going to be there if you still have forced flow in the shutdown modes, but in case you don't, then the analysis -- I'm not sure what the issue was, but the -- what I think is on the table, this by the way 3 -- this Specification 3.1.12 is sort of a draft. It still hasn't been formally submitted yet. Is that right? We have been talking about it with the Reactor Systems Branch.

NEAL R. GROSS

COURT REPORTERS AND TRANSCRIBERS

1323 RHODE ISLAND AVE., N.W.

WASHINGTON, D.C. 20005-3701

(202) 234-4433

(202) 234-4433

I'm presenting it here as if it's -- this is what the solution is going to be. We have looked at the draft. It seems to be fine. And this is a way of addressing the issue.

MEMBER SKILLMAN: Well, I guess the reason I'm raising the subject, Craig, is it seems as though this is a new and open item. And I could understand it's an open item for this design certification, but it certainly is not a new item.

MR. HARBUCK: No. I think, let's see, what did I do with it? Okay. Yeah, I think when I saw new requirements, I mean this is stuff that we don't normally see in the standard. I mean, it's not in the Standard Tech Spec 1432. Those four LCOs are not there.

And so it's not that LCOs similar to those have not been used, have not been included in other plant tech specs in the past. It's just that they are not in 1432 in the CE standard. That's really all I mean by new for requirements.

MR. SAM LEE: Craig?

MR. HARBUCK: Yes, Sam?

MR. SAM LEE: I have a question.

MR. HARBUCK: Go ahead. Yes, come on up.

NEAL R. GROSS

COURT REPORTERS AND TRANSCRIBERS

1323 RHODE ISLAND AVE., N.W.

WASHINGTON, D.C. 20005-3701

(202) 234-4433

(202) 234-4433

MR. SAM LEE: Yeah, my name is Sam Lee.
Oh, it's on?

CHAIRMAN SUNSERI: Yes.

MR. SAM LEE: My name is Sam Lee. I'm a tech spec reviewer for the section that have this issue raised.

Basically, the issue is relating to we are mixing in the mode at ICP-120, so the chapter, the 15 -- the Chapter 15 that do the boron dilution, traditionally they rely on the auto -- the operator action to terminate it, depend on the alarm coming in either through the instrumentation, the new -- the nuclear instrumentation that provide the alarm.

And then the operator will respond to it.

So the time -- there is a time element in there that that operator will need to have at the time that they receive the alarm to the time they do termination.

So traditionally, there is a horizontal resistance that during the shutdown situation that rely on shutdown cooling consistent among the new RCP running, they still have an initial -- there is a well-mixing within the RCS system. And then the controller, the control room operator will receive the alarm through the instrumentation alarm only. And

NEAL R. GROSS

COURT REPORTERS AND TRANSCRIBERS

1323 RHODE ISLAND AVE., N.W.

WASHINGTON, D.C. 20005-3701

(202) 234-4433

(202) 234-4433

they have enough time to terminate it.

For KHNP, the analysis assumed that the operator will have a certain time to terminate it. So the question from the staff saying that, okay, is the system -- is the SCS been well-mixed just using the shutdown cooling water? And I believe the answer from the applicant was no.

So they cannot use the operator action to terminate it based on the alarm only. Say alarm from the system that provide alarm from the boron dilution alarm or the instrument, the nuclear instrumentation that provide in the -- provide through the instrumentation.

So for KHNP, the issue was the volume is not well-mixed, so you cannot create it, the alarm. You cannot say that you received the alarm, because there is some assumption the alarm -- the assumption the alarm to provide the indication was -- had to be well-mixed.

The analyst have to prove that it was well-mixed. And KHNP came back and I don't believe that they said that they can do that.

MEMBER STETKAR: If you were to look at a currently operating combustion engineering power plant

NEAL R. GROSS

COURT REPORTERS AND TRANSCRIBERS

1323 RHODE ISLAND AVE., N.W.

WASHINGTON, D.C. 20005-3701

(202) 234-4433

(202) 234-4433

in the United States today during shutdown when the reactor coolant pumps are not running, would you have the same question? That's a yes or no question. I don't need an explanation.

MR. SAM LEE: I cannot speak for the specific plan, because the specific plan will have an analysis to provide it there within RCP running, the RCS is well-mixed. This was a plant-to-plant design. For KHNP, they cannot provide analysis that was well-mixed.

MEMBER STETKAR: Okay. Thank you.

MR. SAM LEE: So it's not a new issue. It's just KHNP in this case that the credit they use in the Chapter 15 is not support their conclusion.

MR. HARBUCK: Okay. Just one last point on this. The Specification 3.1.8 is there in case despite your having isolated -- be in MID-LOOP operation and your isolation somehow doesn't work and you get an inadvertent dilution, this LCO limits the charging flow rate to that which an analysis that has been done or a documented Chapter 15 shows that the flow rate is what the analysis is showing, 150 gallons per minute.

So that's the purpose of 3.1.8. It -- and

NEAL R. GROSS

COURT REPORTERS AND TRANSCRIBERS

1323 RHODE ISLAND AVE., N.W.

WASHINGTON, D.C. 20005-3701

(202) 234-4433

(202) 234-4433

we viewed it as beneficial from an operating experience perspective. Okay.

The next topic is the Reactor Trip System and ESFAS Surveillance Requirements. Now, when you look at the tech specs, we see a number of defense surveillances for instrumentation. These don't really change whether you have analog or digital portions of our system, of your instrumentation system.

And so it's important to know the description of the testing in the DCD how these defined surveillances correlate in each -- in which -- and the pieces of each of the instruments loops, you know, what comes under each kind of test.

And so we made a stab at doing that ourselves, but really couldn't complete it. So we asked the applicant to do it for us. And they provided a response. And we are still looking at that, but there were a number of things which we are still reviewing.

We've got -- we need to make sure we get buy-in from the I&C Group, which has looked at it, but we need to close the loop on that.

I didn't go into any discussion about what some of these tests in the DCD are versus what tests

NEAL R. GROSS

COURT REPORTERS AND TRANSCRIBERS

1323 RHODE ISLAND AVE., N.W.

WASHINGTON, D.C. 20005-3701

(202) 234-4433

(202) 234-4433

correspond to tech specs, but that list has been provided and we are pretty well-satisfied with it. Then again, we are still looking at it and may need some additional clarification.

Let's see, okay, continuing on on Slide 21, this is something that was brought up earlier. We have ESF components grouped into subgroups and there is this note in the surveillance requirement 3.3.6.2, which is the ESFAS actuation logic test. And this is the -- the quotation is "Subgroup of Actuation Logic channel A, C and B, D shall be tested on a staggered basis."

This note does not exist in the standard tech specs. And I'm not real sure how to read that note. The basis describing the note doesn't help much either. So we asked them to give us a list of their actuated components, what they are powered from, what train they are in, which division of the actuation logic governs their initiation. And also what's the-- what are the subgroup designations?

You know, what is the numbering scheme you have or labeling scheme you have? And that, too, was, I believe, provided except that I haven't been able to figure out how to read it yet and have been too busy

NEAL R. GROSS

COURT REPORTERS AND TRANSCRIBERS

1323 RHODE ISLAND AVE., N.W.

WASHINGTON, D.C. 20005-3701

(202) 234-4433

(202) 234-4433

to talk to them about it. But we will get to the bottom of that and that's really all the issue is here, just to make sure that we understand what the design is.

And as -- and this information also helps us to do some checks to make sure that what they are claiming about the redundancy independence and what have you is valid.

MEMBER SKILLMAN: Craig, I'm going to ask you, you just basically communicated you are aware of this information. You really haven't been able to get to the bottom of it, but you have written a safety evaluation. Am I missing something?

MR. HARBUCK: I don't have -- there are aspects of this which still need to be looked at and clarified, but --

MEMBER SKILLMAN: Are the open items identified in the safety evaluation?

MR. HARBUCK: Well, this is open. These are open items, yes.

MEMBER SKILLMAN: Are they identified in the safety evaluation?

MR. HARBUCK: Yes, yes.

MEMBER SKILLMAN: Okay. All right.

NEAL R. GROSS

COURT REPORTERS AND TRANSCRIBERS

1323 RHODE ISLAND AVE., N.W.

WASHINGTON, D.C. 20005-3701

(202) 234-4433

(202) 234-4433

MR. HARBUCK: I mean, I list the open items right there on the slide. So okay.

All right. So we'll go on from that to another issue which I thought was -- might be of some interest and it raises an interesting situation in terms of how tech specs work.

And back 10, 15 years ago, Palo Verde upgraded the Core Protection Calculator or their Core Element Assembly Calculator position indicators to instead of having just two of these computers, having two per channel. So for a total of 8. And I guess the thinking is that if you have failures within the circuitry or the internal modules of these, it would only affect one channel most likely.

It didn't prevent the issue if you had a rod position indicating going bad that it would affect some of your rod -- affect multiple CEACs since each rod only has two position indicators on it, so you have two to work with. But it does afford a little bit more reliability in the system, more fault tolerance, I guess.

So they changed the action requirements when they did this in the tech specs to allow you to take a different action than what had previously been

NEAL R. GROSS

COURT REPORTERS AND TRANSCRIBERS

1323 RHODE ISLAND AVE., N.W.

WASHINGTON, D.C. 20005-3701

(202) 234-4433

(202) 234-4433

authorized, which is basically manually do what the CEAC was doing, which was to take a look at what your actual relative positions in your various rod groups were and determine what penalty factors needed to be inserted and do that manually.

As a simplification, it was proposed and accepted by the staff that you could say well, instead of -- if only one CPC channel is affected, instead of doing these other actions, recommend that you declare the CPC inoperable, thereby invoking the actions of the LPD and linear power density and the DNBR trips in Specification 3.3.1, which allows you to place an inoperable channel in trip or bypass. The thinking is you would put it in bypass still retaining a 2 out of 3 fault tolerant logic scheme in your combustion logic.

As -- and so that would be a little bit of a less burden. And because likelihood of affecting just one channel now increased because the CEAC may be able to affect fail and affect only one channel.

The question that arises is if other CEACs fail in other channels, now if it's in the same channel, you could -- it's still only going to be affecting one of the instrumentation channels for that

NEAL R. GROSS

COURT REPORTERS AND TRANSCRIBERS

1323 RHODE ISLAND AVE., N.W.

WASHINGTON, D.C. 20005-3701

(202) 234-4433

(202) 234-4433

-- for those trip functions and, therefore, you are still in the 2 out of the three on those trips.

But if it affects more than two, then maybe it's not such a good idea to go to the other LCO. Well, I got to thinking if you had taken that option to go to 3.3.1 and you are operating with one-- with your LPD and DNBR channel in bypass, and then another CPC channel is affected in some manner, it could be advantageous to say well, technically, the CPC is still operable even though the CEAC was inoperable.

I only declared it inoperable because it was sort of a convenience, but since I'm still operable, I'm going to say nope, CPC is operable and I'll do the manual actions that were prescribed by them. And so there are some questions about -- and these actions all, for the most part, allow you to operate with one or two CEACs inoperable indefinitely because they are -- that's just how it works.

If you do these other measures of manually checking your shutdown margin, manually checking your rod positions and that sort of things, then it enables you to keep operating. So I raised this issue to the applicant. I raised it to my colleagues. I talked to

NEAL R. GROSS

COURT REPORTERS AND TRANSCRIBERS

1323 RHODE ISLAND AVE., N.W.

WASHINGTON, D.C. 20005-3701

(202) 234-4433

(202) 234-4433

people about it who may have an opinion and haven't quite come to a real conclusion about tech spec mechanics, but in this particular case just from a, you know, practical standpoint, it seems that we have come to some understanding that if the situation were to arise at more than two CPCs or more than one CPC channel is impacted by CEAC inoperability, that most likely you would stick with the previously-prescribed actions and not take advantage of this other one.

However, every situation is different and, you know, you would have to decide on a case-by-case basis. But we don't have any issues with the action requirements themselves and we have this issue open because I would like that this will be appropriate for the Bases to explain who is deemed appropriate to do one path of action as opposed to the other instead of doing the -- what has been done in the past. So that's what that issue is about.

And I have nothing more to add. If you have any questions?

MEMBER SKILLMAN: Okay.

MR. HARBUCK: The next topic is -- revisits one of the items that was mentioned by the applicant earlier on the Auxiliary Feedwater System.

NEAL R. GROSS

COURT REPORTERS AND TRANSCRIBERS

1323 RHODE ISLAND AVE., N.W.

WASHINGTON, D.C. 20005-3701

(202) 234-4433

(202) 234-4433

And I sort of -- I mean, in some respects you could think of the auxiliary feedwater system like you think about shutdown cooling. It's -- there is to train or two divisions. And one division will do, but having a piece of one division, but with the wrong steam generator is not going to help you.

And so I got to thinking well what is the appropriate -- and I'm not going to read the slide here that outlines the design, but you know, what would be the appropriate action requirements? And there was a question about well, the standard allows you to have seven days if one of your two steam supplies to your single AFW pump turbine is inoperable and that's true, but, in that design, you also are able to feed either steam generator.

And so I was involved in the actual generic change to the standard. It was TSTF, I think it was either, 3.12 or 4.12. I can't remember. But where it was seen as a small likelihood that you would ever get in the situation where you failed the steam supply in one steam generator and, therefore, you lost your -- well, okay, let me back up.

Okay. So you are in the action statement and now you have a fault of the steam generator that

NEAL R. GROSS

COURT REPORTERS AND TRANSCRIBERS

1323 RHODE ISLAND AVE., N.W.

WASHINGTON, D.C. 20005-3701

(202) 234-4433

(202) 234-4433

is supplying the remaining steam supply to your pump.

So now you have lost your AFW pump. Are you on the right slide? Okay.

Okay. Here we go, Slide 24. And now the -- and so if you have a motor-driven pump that can feed its respective steam generator, then you are still capable of surviving the loss. And so you say-- but not an additional loss, so you basically have lost redundancy.

Well, the bottom line is that the situation in the standard doesn't really apply here, because it doesn't really matter what the mode of power is. The steam generator that is being fed by the turbine pump is the one that supplied the steam and that's the only place that gets it.

Okay? So we don't think the seven day completion time that is in the standard would apply in this case and we think that 72 hours would be appropriate for having this one pump inoperable and the one associated with one steam generator or one division or having one pump out in each division, that also results in the worst case scenario. It results in still having the ability to feed the remaining steam generator.

NEAL R. GROSS

COURT REPORTERS AND TRANSCRIBERS

1323 RHODE ISLAND AVE., N.W.

WASHINGTON, D.C. 20005-3701

(202) 234-4433

(202) 234-4433

If you have both pumps out in -- that feed one -- feed the same steam generator, however, the event could render you having no secondary heat sink, so we are questioning whether 72 hours is appropriate for that situation or whether there should be a shorter time and we still need to engage with the applicant further on that particular issue. And so those are the items that are listed there.

I would also like to bring up and if we still have available to look at -- I think there was an AFW drawing provided in the applicant's presentation. And so you will see on that drawing that it appears that you possibly could go backwards and these are like condensate storage tank fillers to the pump. You could use that line somehow to feed one train from the other trains or divisions tank. But there are some check valves in there, I believe, that are going to interfere with that and so I'm not sure that the assertion that you could, you know, switch off these two tanks for either train is correct.

And I'm not sure that cross-connecting the two tanks would -- under -- as you can see from the line down to the left of that drawing, I'm not sure that that's going to help you that much anyway,

NEAL R. GROSS

COURT REPORTERS AND TRANSCRIBERS

1323 RHODE ISLAND AVE., N.W.

WASHINGTON, D.C. 20005-3701

(202) 234-4433

(202) 234-4433

because the two tanks would then maintain the same level. At some point, it becomes a question as to whether you will be able to fulfill the function.

And that's really what that issue is about. Oh, I think we have someone from the -- who wants to say something from the KHNP.

MR. J.H. SEO: Thanks for the honor to speak in -- I work in the KEPCO Engineering Construction Division for Mechanical Engineering. And I am responsible --

MR. HARBUCK: Your name?

MR. J.H. SEO: -- engineering for aux feedwater system.

MR. HARBUCK: Okay.

MR. J.H. SEO: My name is Jeong Hwan Seo. Jeong Hwan Seo. But shortly you can say J, J. Seo.

MR. HARBUCK: All right.

MR. J.H. SEO: And what -- my comment. I have two comments.

MR. HARBUCK: All right.

MR. J.H. SEO: The first one is about the aux storage -- aux feedwater storage tank. You mentioned something about the check valves, but we don't have check valves. Exactly speaking, we have

NEAL R. GROSS

COURT REPORTERS AND TRANSCRIBERS

1323 RHODE ISLAND AVE., N.W.

WASHINGTON, D.C. 20005-3701

(202) 234-4433

(202) 234-4433

developed number 1162 and 1163, I guess, if my memory is correct. We have those two lots closed valves. So if you manually open those, you can connect -- you can back up the aux feedwater source from one tank to another tank. So there --

MR. HARBUCK: Are those -- is that the --

MR. J.H. SEO: -- is no check valves. That's my first comment.

MR. HARBUCK: Is that the -- it becomes sight line?

MR. J.H. SEO: For the -- we don't have -- we have condensate storage tank, but it is another backup. In our APR-1400 design, aux feedwater storage tank is another safety design storage tank. And condensate storage tank is non-safety, but we can provide the backups to water for the aux feedwater storage tank.

MR. HARBUCK: Okay. Well, I was just noticing that it was the supply from each of the tanks to each of the divisions that is connected to the line from the condensate storage tank and that line is the one you would use to supply the opposite division. Am I correct on that? Or are you saying you are relying on the cross-connect between the lower portions of the

NEAL R. GROSS

COURT REPORTERS AND TRANSCRIBERS

1323 RHODE ISLAND AVE., N.W.

WASHINGTON, D.C. 20005-3701

(202) 234-4433

(202) 234-4433

tanks that have this couple of manual dials in that line. Is that what you are referring to?

MR. J.H. SEO: Exactly.

MR. HARBUCK: Yeah, well, that's the question I might -- we are not sure that that connection would solve the issue. Okay?

MR. J.H. SEO: Okay. We look forward to have discussion with the staff for that.

MR. HARBUCK: Thank you.

MR. J.H. SEO: Yes.

MR. HARBUCK: Thank you for that. Okay. Let's see, is there anything I left out?

MEMBER KIRCHNER: Just to clarify, so the previous standard tech specs required -- specified the 72 hour interval to correct this. And so assuming they convince you of this cross-connecting and there is no issues that you then one can go to, what, are they proposing seven days?

MR. HARBUCK: Yeah, they are proposing to have seven days. And I mean one reason for that would be you would -- you have had mitigating action to line up the other tank or another source. And that would be part of the reason for being able to allow that. And so once we are convinced that that can be done, I

NEAL R. GROSS

COURT REPORTERS AND TRANSCRIBERS

1323 RHODE ISLAND AVE., N.W.

WASHINGTON, D.C. 20005-3701

(202) 234-4433

(202) 234-4433

suppose we would be able to consider the seven days.

MEMBER KIRCHNER: Okay. Thank you.

MR. HARBUCK: Yes.

MEMBER SKILLMAN: Craig, let me ask this.

MR. HARBUCK: Okay.

MEMBER SKILLMAN: I'm skimming through tech specs right now, the APR-1400 Tech Specs. And the wording of your first bullet, I'm asking you to verify that it's accurate, that first bullet communicates that it is the seven day completion time to restore the steam supply. I believe the spec was for the aux feed system.

And here is how I get there. I believe this tech spec has been around for ages and was based on the early experience operators were having with Worthingtons and with Terry Turbines. And the seven day was the same as the diesel engine and that was to give time to repair.

MR. HARBUCK: Okay.

MEMBER SKILLMAN: And so now if it's really a steam system, I'm looking for it right now, then I'm off-base. But if it was for the whole system, then I would ask whether or not KHNP has bought into the idea of giving up the seven days?

NEAL R. GROSS

COURT REPORTERS AND TRANSCRIBERS

1323 RHODE ISLAND AVE., N.W.

WASHINGTON, D.C. 20005-3701

(202) 234-4433

(202) 234-4433

Because that seven days can prevent a shutdown if you have got to do a repair.

And so the duration of out of service needs to be acceptable in terms of risk. But if the purpose of the time clock is to enable repair, then three working days is really short, because you might have to get parts.

MEMBER KIRCHNER: Because turbines take longer to repair?

MEMBER STETKAR: How many turbine-driven auxiliary feedwater pumps did the standard combustion engineering technical specifications have? How many?

MR. HARBUCK: One.

MEMBER STETKAR: Okay. How many does this one have?

MR. HARBUCK: Two.

MEMBER STETKAR: So the design is different. So therefore there is no reason to believe that a single one, you know, should be considered the same way in this design as it was in that other design, a completely irrelevant plant.

For each steam generator, this plant has one turbine-driven pump and one motor-driven pump for each of its two steam generators. In the standard

NEAL R. GROSS

COURT REPORTERS AND TRANSCRIBERS

1323 RHODE ISLAND AVE., N.W.

WASHINGTON, D.C. 20005-3701

(202) 234-4433

(202) 234-4433

design, the plant had three total pumps: One motor-driven to each steam generator and a turbine-driven that was shared between the two. It's a completely different design. You might as well pick up, you know, a BWR set of tech specs.

Forcing these tech specs to somehow emulate a different design is irrelevant. It might be relevant for areas where the designs look the same, but it isn't relevant for areas where they don't. So you know, and that works both ways, by the way.

MEMBER SKILLMAN: John, I understand your words, but I'm not aligned with you. If the purpose for the tech spec is to enable a repair, then the tech spec has to stand on that basis.

MEMBER STETKAR: My philosophy is the purpose of the tech spec is to minimize risk.

MEMBER SKILLMAN: I concur with that.

MEMBER STETKAR: Okay.

MEMBER SKILLMAN: Yes.

MEMBER STETKAR: That's not to facilitate a repair. If I wanted to facilitate a repair, I would have 300 days in there and still -- our tech specs at Zion allowed one pump in our component cooling water system that was shared between both units, five pumps

NEAL R. GROSS

COURT REPORTERS AND TRANSCRIBERS

1323 RHODE ISLAND AVE., N.W.

WASHINGTON, D.C. 20005-3701

(202) 234-4433

(202) 234-4433

total, to be out of service indefinitely.

One pump when I was there, I can say this now, was out of service for 15 months. We didn't violate the law. It wasn't very safe. But so you have to be careful.

MEMBER SKILLMAN: But that's dandy. But what I'm saying is if the purpose for this tech spec is to enable a repair and that repair is acceptable in risk space, then the seven days might be the right number, that's all I'm saying.

MR. HARBUCK: Yeah, and I think what John is saying --

MEMBER STETKAR: That's independent from the inoperable steam supply.

MEMBER SKILLMAN: Right. But we have to be careful that we are not comparing apples and oranges.

MEMBER STETKAR: And the steam supply is different though because in the other design I have two steam supplies to one turbine. So if I take out one steam supply, that turbine is still operable.

MEMBER SKILLMAN: Got that.

MEMBER STETKAR: In this place, if I take out a steam supply, I'm minus -- I don't have a

NEAL R. GROSS

COURT REPORTERS AND TRANSCRIBERS

1323 RHODE ISLAND AVE., N.W.

WASHINGTON, D.C. 20005-3701

(202) 234-4433

(202) 234-4433

turbine. It doesn't make any difference.

MEMBER SKILLMAN: It depends on what the emphasis is on the syllable.

MR. HARBUCK: Right.

MEMBER SKILLMAN: That's the only point I'm making.

MR. HARBUCK: Okay. I understand what you are saying and I think risk can be applied to try and find a basis for relaxing these action requirements. But until we have that, we are going to go with the standard times for loss of redundancy and loss of function.

MEMBER STETKAR: Well, but the key is what's loss of redundancy? Because in the standard design, I have lost a diversity and a redundancy if I lose the one and only one turbine-driven pump.

In this plant, I have lost one-half of redundancy and one-half of diversity, if you will, if I lose one turbine-driven pump.

MR. HARBUCK: Yeah, I'm not familiar with the --

MEMBER STETKAR: The -- but just think -- backup to the functional, forget risk assessment and things like that.

NEAL R. GROSS

COURT REPORTERS AND TRANSCRIBERS

1323 RHODE ISLAND AVE., N.W.

WASHINGTON, D.C. 20005-3701

(202) 234-4433

(202) 234-4433

MR. HARBUCK: Okay.

MEMBER STETKAR: I'm losing a different concept of diversity and redundancy when I take away either one motor-driven pump or one turbine-driven pump in this plant in the APR-1400 compared to the standard design just functional redundancy or diversity, however you want to characterize those things, if I took away one motor-driven pump or one turbine-driven pump in the other design.

So in that sense, you know, in my mind you need to think about those things a little bit differently.

CHAIRMAN SUNSERI: All right. I think we have got this one. Let's move on.

MR. HARBUCK: I think you understand that one. Let me make sure. Okay. Control Room Habitability System or Heating, Ventilation, Air Conditioning System basically has two divisions. Did we have a drawing of that system in this last presentation? I know there is one in the Chapter 6 presentation.

MR. TJADER: I don't think so.

MR. HARBUCK: If -- is it possible to pull that up? It would surely make the discussion easier

NEAL R. GROSS

COURT REPORTERS AND TRANSCRIBERS

1323 RHODE ISLAND AVE., N.W.

WASHINGTON, D.C. 20005-3701

(202) 234-4433

(202) 234-4433

to understand.

MS. UMANA: Chapter 6?

MR. HARBUCK: Yeah.

MS. UMANA: Ours or --

MR. HARBUCK: The applicant's application has a diagram of the control room. There we go. We should be on that one. There we are.

CHAIRMAN SUNSERI: Now the question is can you see it?

MR. HARBUCK: Okay. So this is discussing how the system works. First, in order to understand what the questions are we have posed, you will notice at the top of the drawing there is two separate outside air intake structures and in those are your control and emergency ventilation actuation system radiation monitors. And then there is a couple of dampers and then you have your flow paths going down to a set of isolation valves. And that's your normal ventilation flow path. It does straight to your air handling units, which do your humidity and temperature and cooling controls.

And the air cleaning units, which are at the bottom of the drawing, play no role during normal ventilation. But in the event that the radiation

NEAL R. GROSS

COURT REPORTERS AND TRANSCRIBERS

1323 RHODE ISLAND AVE., N.W.

WASHINGTON, D.C. 20005-3701

(202) 234-4433

(202) 234-4433

signal has actuated, the intake with the lower radiation signal will realign and but it will end up feeding to the -- whichever air handling unit, there is four of them, two in each division, whichever air handling unit was currently operating the associated fan in that divisions air cleaning unit will start.

And then the valves, the dampers will open and then you will have the flow path that involves feeding air through the filtration after it comes out of the control room as well as going -- and then going back to whichever air handling unit and back to the control room.

And so but you have four different diesels supporting these fans. And so we talk about having two trains or two fan trains in each division, but there is act -- there is two fan trains for the air handling units. There is two fan trains for the emergency ventilation filtration.

Okay. And then at the bottom you have an exhaust fan and some valves for smoke and then there is another one for something else. But I think that pretty well tells you how the system works.

So if on the CREVAS signal if something went wrong with the operating air handling unit or its

NEAL R. GROSS

COURT REPORTERS AND TRANSCRIBERS

1323 RHODE ISLAND AVE., N.W.

WASHINGTON, D.C. 20005-3701

(202) 234-4433

(202) 234-4433

associated air cleaning unit, the system is set up with an interlock so that the other division would then start. There would be a designated pair, you know, the air handling unit, air cleanup unit pair at that fan train would then start.

And so my question was whether that requirement for the other train to start should be a requirement for operability for that train because if your single failure in your event was the operating train, then you would want to be able to rely on the other one to start.

Well, the argument comes back from the applicant well, the operators will have time to manually do that, but then I have to ask the question well, in the ground rules for doing accident analysis and responding to events, how long is the operator not credited to take any manual actions after an event and does it apply in this case?

I don't know the answer to most of these questions. I know what I would like to think, so this is the issue that we have to nail down with the applicant and with the support of the Containment Ventilation Branch.

Any questions about that? Okay. Okay.

NEAL R. GROSS

COURT REPORTERS AND TRANSCRIBERS

1323 RHODE ISLAND AVE., N.W.

WASHINGTON, D.C. 20005-3701

(202) 234-4433

(202) 234-4433

You know, just one other thing that is in the side. There are two essential chilled water divisions required by an LCO and each division supports one of these divisions. But so you don't have separate water sources to provide the cooling for the air handling units to keep the air temperature down. So you don't really have completely independent trains in your divisions.

All right. The next topic is one that comes up every design cert and it presents some challenges and that is the accident monitoring instrumentation, which is what is referred to, but normally we hear it's labeled Post-Accident Monitoring, PAM, but in this design they use the phrase AMI, so we will do that.

And essentially, there was a split report for which LCO should and shouldn't be in the tech specs way back when in '88 or '87 time frame. Maybe it was '88, right, Bob?

MR. TJADER: Yes.

MR. HARBUCK: And in there is a discussion of what tech spec should have concerning post-accident monitoring instruments. And although we have changed slightly the letter designations of what these

NEAL R. GROSS

COURT REPORTERS AND TRANSCRIBERS

1323 RHODE ISLAND AVE., N.W.

WASHINGTON, D.C. 20005-3701

(202) 234-4433

(202) 234-4433

instruments are, the old labeling and the new labeling means that the new labeling Type A, B and C variables are supposed to be in the tech specs.

And the evaluation of that is as stated. If it's a Type A variable it's one that is relied on by an operator to perform manual actions that are credited in the transient safety analysis.

The Type B and C variables are needed by the operator to implement the emergency procedures and be able to properly monitor what is going on with the plant.

So then it falls down on us that we need to look at the EPGs or I guess they call them something different here. AO -- EOGs, is that what they call them? I don't know. But so we are dependent upon the Instrumentation and Control Branch at NRO to satisfy themselves that they have adequately identified the variables that need to be labeled Type B and C and in conjunction with the -- maybe also for Type B and C with Reactor Systems Branch and looking at the accident analysis, look at what needs to be Type A variables.

And the list that they end up with in Section 75 of the DCD needs to be the tech spec list

NEAL R. GROSS

COURT REPORTERS AND TRANSCRIBERS

1323 RHODE ISLAND AVE., N.W.

WASHINGTON, D.C. 20005-3701

(202) 234-4433

(202) 234-4433

that is required by the LCO needs to be consistent with that. Meaning they need -- they should be the same list. Right now, they are not.

So we are happy to write that this is an okay spec as soon as they give us the list that they say is okay, but until then it's an open issue.

All right. Setpoint Methodology for Limiting Safety System Settings. There are three documents listed on Slide 27 which have to do with various aspects of the determined setpoints for the given set of reactor trip and ESFAS functions and also ESFAS functions which are characterized as balance of plant ESF functions.

And so we have had an ongoing audit of the setpoint methodologies. And if Joe Ashcraft would like to say something about that just to fill in the gap here, I would appreciate it. What the status is and what we are going to do moving forward.

MR. ASHCRAFT: This is Joe Ashcraft, NRO, I&C staff. So earlier there was a question maybe as far as the methodology or I can just give you a status of what is going on.

So I'm not the original reviewer of the setpoint methodology. There was another member and he

NEAL R. GROSS

COURT REPORTERS AND TRANSCRIBERS

1323 RHODE ISLAND AVE., N.W.

WASHINGTON, D.C. 20005-3701

(202) 234-4433

(202) 234-4433

had written several RAIs which are still open. So at this time, we are resolving with KHNP some of the issues.

MEMBER STETKAR: Is that setpoint methodology in the context of Chapter 7 or this stuff?

MR. ASHCRAFT: Well, so the setpoint methodology -- well, so they have a CPC methodology, setpoint methodology and then they also have an uncertainty methodology which more or less is not even a methodology. It's Part 2 of 6704.

But essentially, yes, the setpoint methodology is tied to Chapter 7.

MEMBER STETKAR: Yes, okay, okay.

MR. ASHCRAFT: But it does feed into --

MEMBER STETKAR: Oh, sure, yes.

MR. ASHCRAFT: -- the Setpoint Control Program. So at this time, actually, I had raised some issues and we are resolving them, at this time, with KHNP. And I would like to say everything is going to be rosy, but we will get there.

And the CPC methodology there was one RAI that was open and I think we have established a path forward, so that one is fine or should be fine once we get the revised.

NEAL R. GROSS

COURT REPORTERS AND TRANSCRIBERS

1323 RHODE ISLAND AVE., N.W.

WASHINGTON, D.C. 20005-3701

(202) 234-4433

(202) 234-4433

MR. HARBUCK: Joe, could you elaborate at all whether my short list of key issues is correct? Can you see that?

MR. ASHCRAFT: Okay. Yeah, I was -- okay. So looking at your short list here, the first one, I'm going to say that is still an open item. I thought I had it resolved with some of my questions in their answer, but while I was sitting here listening to some of this other stuff, I started looking back so that -- what is considered AV and what the margin is from AV, in my mind, is still an open item.

The statistics for combined uncertainties, that really points to that, I guess it's the second bullet which is the uncertainty methodology, which is effectively Part 2 of 6704. The NRC doesn't endorse that, therefore, you know, we are not really reviewing that.

But I'll say I don't think there will probably be any issues, because it seems to be in line with Part 2, but it's just not something that we consider as part of the setpoint methodology. So when it -- and it talk -- so the methodology that we are reviewing will talk about how they combined statistics for combined uncertainties, whether it be statistical

NEAL R. GROSS

COURT REPORTERS AND TRANSCRIBERS

1323 RHODE ISLAND AVE., N.W.

WASHINGTON, D.C. 20005-3701

(202) 234-4433

(202) 234-4433

or bias or whatever.

But then this other document that we are not reviewing would be in more detail how they would do it for each individual uncertainty area.

So and every plant, I mean, they pretty much all follow this Part 2, but like I said the NRC never endorsed that. It's an industry practice, recommended practice is what they call it, so it's not really a standard.

MR. HARBUCK: And that's the off-site standard for 2002 that's listed here.

MR. ASHCRAFT: Well --

MR. HARBUCK: Or is that even listed? I must have listed it somewhere.

MR. ASHCRAFT: Well, so -- well, I don't think so. So their methodology --

MR. HARBUCK: No, I might not of.

MR. ASHCRAFT: -- and what we look at, so Reg Guide 1.105, Rev. 3, endorses 6704 Part 1, 1994 version. And we don't endorse the Part 2. And I believe that is what they point to.

MR. HARBUCK: Okay. All right.

MR. ASHCRAFT: So, yeah, yes, it's being resolved.

NEAL R. GROSS

COURT REPORTERS AND TRANSCRIBERS

1323 RHODE ISLAND AVE., N.W.

WASHINGTON, D.C. 20005-3701

(202) 234-4433

(202) 234-4433

MEMBER SKILLMAN: Thank you.

MR. HARBUCK: Thanks, Joe. Okay. Now, we are going to go to the final list of technical topics termed general issues. And the first one is perhaps the biggest issue we have and that is -- not the first I'm sorry. I jumped the gun, that's the next page, so retract that.

COL action items in the tech specs, the generic tech specs in the regulations and in the appendices, they call out the fact that there is portions of the tech specs which are site-specific that could not -- that were not within the scope of information that you had or required for the design cert, but you needed for getting the COL issued. And this is called COL action items.

And because they all have to be completed in order to issue the tech specs with the license, it's important that we clearly identify what they all are and if any of them require any special guidance on completing them or whether they can just be avoided altogether, that -- you know, we need to make sure that information is contained within the guidance discussions in the DCD, either in the form of a reviewer's notes or additional material up in the

NEAL R. GROSS

COURT REPORTERS AND TRANSCRIBERS

1323 RHODE ISLAND AVE., N.W.

WASHINGTON, D.C. 20005-3701

(202) 234-4433

(202) 234-4433

introduction part of Chapter 16.

And we haven't completed defining what this action item list is, but that's what this item is about. And once we have it, then it will make it easier for COL applicants to know what they have to do to complete the tech specs.

The -- okay. So I think we mentioned the Tech Spec Task Force traveler changes and in one case where they did not adopt one. Well, there is a lot of changes that occurred to earlier versions of NUREG-1432 which are in Revision 4 of that document, but which are not being adopted by the applicant.

So for that part of our review, we have to go back and look at what the tech specs were a couple -- three revisions ago sometimes. And then there has been since 1432, Rev. 4, was issued in 2012, there has been a number of significant travelers approved since then and some of those are proposed for incorporation in the generic tech specs.

We want to make sure we have a complete accounting, so that in the future when we go to create a standard tech spec for this or whether a COL applicant wants to change their tech specs, they understand what is considered to have been

NEAL R. GROSS

COURT REPORTERS AND TRANSCRIBERS

1323 RHODE ISLAND AVE., N.W.

WASHINGTON, D.C. 20005-3701

(202) 234-4433

(202) 234-4433

incorporated and what is not. And we have no confusion about that thereby helping to maintain standardization.

Administrative changes. I think it is fair to say that nearly every page of the Chapter 16 had either editorial or technical or other types of errors and it has been quite a challenge to try and get these all addressed. And we are still working on it.

The open items that are mentioned there, each one represents a dozen or more individual questions, some of which address specific issues and some of which address issues that are deemed global in nature. And many of them encompass all the rest of the list there of:

Correction of grammatical and typographical errors.

Replacement of inapplicable content that has been taken from the Bases of the standard tech specs, but didn't really apply to the requirements that APR-1400 was proposing.

Addition of missing content to the Bases. Typical, this would be not providing a rationale for completion time or surveillance frequencies or not

NEAL R. GROSS

COURT REPORTERS AND TRANSCRIBERS

1323 RHODE ISLAND AVE., N.W.

WASHINGTON, D.C. 20005-3701

(202) 234-4433

(202) 234-4433

having a discussion that explains some key aspect of the system or its function.

Clarification of submitted content in the Bases.

Conformance to STS style, punctuation, phrasing and formatting conventions.

And then the resolution of inconsistencies, both within the Chapter 16 and with other chapters of the DCD.

So we will -- this will be sort of the tail end of closing this review out is verifying that all -- that these types of issues have been addressed satisfactorily. So it's not really that they are open so much as it's just a rather large confirmatory item where we haven't identified every place that needs fixing.

Okay. So here we are. The biggest issue on the next slide, next slide, please, the application of the 10 CFR 50.36 LCO Selection Criteria. In past design certification reviews, the applicants have typically, to varying degrees, done some type of systematic assessment of their design and accident analysis against the criteria to validate their LCO selection.

NEAL R. GROSS

COURT REPORTERS AND TRANSCRIBERS

1323 RHODE ISLAND AVE., N.W.

WASHINGTON, D.C. 20005-3701

(202) 234-4433

(202) 234-4433

And it's out understanding that the applicant has not done that, but they have relied on what was in the CE standard. And as you may have noticed, they have added additional requirements and additional LCOs that you don't find in the standard, but it's not entirely clear if they have done a comprehensive check and if there is not something out there that ought to be considered for incorporation, either into an existing LCO, the scope of it or a whole new specification.

We have identified some examples so that maybe they could be considered for inclusion in tech specs because in the accident analysis when they talk about the secrets of events, you will find that the reactor tripped at some point for most of these events and they don't always take the function that is in the tech spec explicitly as the trip that takes you down, because it may be more conservative to assume one of these auxiliary trips or another trip.

The core protection calculator, in particular, in Table 7.2-4 in addition to listing all the reactor trip functions, it lists a set of CPC auxiliary trips which come out of the CPCs and they have their own trip settings. They are not the same

NEAL R. GROSS

COURT REPORTERS AND TRANSCRIBERS

1323 RHODE ISLAND AVE., N.W.

WASHINGTON, D.C. 20005-3701

(202) 234-4433

(202) 234-4433

as the corresponding LCOs stated functions, but a lot of times they are fairly duplicative, but there are some unique trips in the CPC auxiliary trip functions.

And so we decided a couple of examples here. Let's see, we list the RPS variable over-power trip function and the CPC variable over-power trip function. Based on the discussion referenced here, it appears that one would need to include both in the tech specs.

The one above it does not have anything to do with the chart -- the CPC auxiliary trips, but as I -- as we mentioned before, there is limitations in the charging system when you are low pressure for limiting the flow because of Boron dilution event analysis assumptions.

And normally the flow from -- to the charging system is through these bypass valves and you get flow that is related to the pump curve or the centrifugal charging pumps where the water is going. But in low shutdown, low-pressure conditions, these bypass valves can be closed, which diverts flow through these flow restricting orifices. And depending upon how many you close, whether you close one or two of the valves, you can either limit flow to

NEAL R. GROSS

COURT REPORTERS AND TRANSCRIBERS

1323 RHODE ISLAND AVE., N.W.

WASHINGTON, D.C. 20005-3701

(202) 234-4433

(202) 234-4433

180 gallons per minute or 150 gallons per minute.

There is actually a setpoint that measures the flow and if it exceeds some value above 180, it will cause one of these valves to close. And since that seems to be protecting an assumption of an analysis. It sounds like a candidate for an LCO or -- you know, so I -- so we mentioned that one.

Let's see, okay, so I think that pretty well makes the point. We need to discuss with the applicant about the examples we have cited. We have reported those in the SER and if there are any other ones.

Right now though, it looks like something that can be resolved, but it has to be resolved in order for us to find it, that the tech specs meet 50.36.

And the last thing we will mention is the deviation report. They had originally provided deviation report not as part of the application, but just as something to show how requirement-by-requirement the generic tech specs differed from the NUREG-1432.

The report only covers the specifications. It doesn't cover the Bases. And we know that there

NEAL R. GROSS

COURT REPORTERS AND TRANSCRIBERS

1323 RHODE ISLAND AVE., N.W.

WASHINGTON, D.C. 20005-3701

(202) 234-4433

(202) 234-4433

were some inconsistencies in this report and some of our open items dealt with trying to resolve those inconsistencies and that resulted in some changes in the deviation report, some of which we are still tracking as issues.

16-43 is the open item that we are -- that is covering that.

So having a deviation report is not a sufficient measure to say I have effectively analyzed against the criteria in 50.36 and I satisfy -- I don't believe you can do -- that alone will give you the basis for making that statement.

So but as part of our review, we are going to make sure that the report is at least -- is consistent and accurate. But it's not a requirement in and of itself to support the review of the tech specs. We could do the review without it.

We asked that they docket it, which they did, to facilitate our review, because it then enabled us to better understand what the differences were from their perspective and what their rationale for those differences were as opposed to identify differences and asking them a question about it if it wasn't obvious what their basis for the difference was.

NEAL R. GROSS

COURT REPORTERS AND TRANSCRIBERS

1323 RHODE ISLAND AVE., N.W.

WASHINGTON, D.C. 20005-3701

(202) 234-4433

(202) 234-4433

Okay. Okay. I'm going to -- that concludes what I was going to say and Bob is going to close with kind of a conclusion, a summary of --

MR. TJADER: A brief summary.

MR. HARBUCK: -- yeah. And that's the last slide.

MR. TJADER: A brief summary. Now, we have reviewed the APR-1400 Generic Tech Specs. We have written the safety evaluation with open items. Listed there are the open items we have covered and -- they are listed there. And we are willing to resolve the open items with the assistance of our Technical Branches. And that concludes the presentation.

CHAIRMAN SUNSERI: All right. Good. Any questions from the Members before we move on?

MEMBER KIRCHNER: Just may I go back, Matt, to the auxiliary feedwater system? Assuming, Craig, that you convince yourself that the 4 trains or 2 divisions, however it is characterized, have the redundancy you are looking for, then what would you expect them to do to show that 70 -- not 72, seven days is a justifiable window to restore the function of one of those trains without going to PRA techniques and so on?

NEAL R. GROSS

COURT REPORTERS AND TRANSCRIBERS

1323 RHODE ISLAND AVE., N.W.

WASHINGTON, D.C. 20005-3701

(202) 234-4433

(202) 234-4433

MR. HARBUCK: I guess, yeah, you know in general, one strategy for trying to get a bit longer on your repair time for an inoperable component or train would be to propose --

MEMBER KIRCHNER: But let's assume that the window is not based on repair time or the delivery of a turbine from off-shore to the plant or whatever or putting in a new steam supply line, that the basis for the window has some analysis or evaluation, as you said in your penultimate slide, of the safety window that you are working with, rather than the repair window.

Do you see what I'm asking? It's a little bit different. Don't ask the question how long does it take to repair. It could take more than seven days if the instrument is unavailable.

MR. HARBUCK: Well, one anecdote I can tell you is a case where you have a utility that at one time had a seven day ALT for a diesel generator. They, using I suppose to some extent risk-based arguments, were able to obtain a -- double that time and yet, recently the -- that diesel deliverable system failed to provide adequate flow to one of the bearings and the diesel suffered damage that required

NEAL R. GROSS

COURT REPORTERS AND TRANSCRIBERS

1323 RHODE ISLAND AVE., N.W.

WASHINGTON, D.C. 20005-3701

(202) 234-4433

(202) 234-4433

more than two weeks to repair it.

And so no matter how much you think the additional time is going to -- it probably will enable you to recover without having to first shutdown the plant, it doesn't guarantee it.

And so -- but if you are interested in increasing repair time, and when I say repair time what I mean is the completion time to restore the equipment to operable status, one strategy would be to propose remedial actions that provide some measure of additional assurance that should an event occur, that would -- you would -- that would require that broken train, that the remedial actions, whatever they were, will somehow help you to mitigate that.

In other words, it may not be the full response you are expecting. That sort of argument can be used and we see that in a number of places in the tech specs, particularly where if there is some indication that is not there, but you can get that indication often enough by doing a manual measurement, then the tech specs will allow you to continue for a time, if not indefinitely, doing that.

So there are strategies for trying to get longer allowed outage times besides just appealing to

NEAL R. GROSS

COURT REPORTERS AND TRANSCRIBERS

1323 RHODE ISLAND AVE., N.W.

WASHINGTON, D.C. 20005-3701

(202) 234-4433

(202) 234-4433

risk arguments.

MR. TJADER: You can use BRA, but I think that the reason for questioning the seven days was a lack of redundancy. And it seems to me that if this condensate, this line from the condensate storage tank would act as a cross-connect and restore that redundancy and provide adequate flow, that could be considered for restoring it to what is typically the completion time of seven days. And we can certainly--

MR. HARBUCK: Well, right.

CHAIRMAN SUNSERI: So I mean we could probably go into a lot of detail on this. In summary though is you have the question on the table. You are working with the applicant. You are going to resolve it one way or the other, right? Whether it goes short or longer or whatever, right?

MR. TJADER: That's right.

CHAIRMAN SUNSERI: Okay. John, you had a question?

MEMBER STETKAR: Yeah, I did. Because I was looking at this and I think that I certainly haven't studied the tech specs and I haven't studied the Bases for them. But I'm really confused and I hope that the staff and the applicant work this out,

NEAL R. GROSS

COURT REPORTERS AND TRANSCRIBERS

1323 RHODE ISLAND AVE., N.W.

WASHINGTON, D.C. 20005-3701

(202) 234-4433

(202) 234-4433

because when I read the Aux Feedwater Tech Specs, the seven day thing that we have been talking about, specifically says "One turbine-driven aux feedwater train inoperable due to associated inoperable steam supply."

MR. HARBUCK: Yeah.

MEMBER STETKAR: The next one.

MR. HARBUCK: Okay.

MEMBER STETKAR: Let me finish.

MR. HARBUCK: Okay.

MEMBER STETKAR: The next one says "One AFW train inoperable in MODE 1, 2 or 3 for reasons other than that condition."

The first one gives me seven days. The second one gives me 72 hours. I'm sorry, my turbine only has one steam supply, so this could very well be the problem with KHNP just trying to force fit something into tech specs that doesn't apply to their design.

CHAIRMAN SUNSERI: Right.

MEMBER STETKAR: And the staff then reacting to that sort of force fit in a strange way.

CHAIRMAN SUNSERI: Yeah, because that --

MEMBER STETKAR: It just doesn't make any

NEAL R. GROSS

COURT REPORTERS AND TRANSCRIBERS

1323 RHODE ISLAND AVE., N.W.

WASHINGTON, D.C. 20005-3701

(202) 234-4433

(202) 234-4433

sense.

(Simultaneous speaking.)

CHAIRMAN SUNSERI: Right. Because the way that reads is for a plant that --

MEMBER STETKAR: I can --

CHAIRMAN SUNSERI: -- has two supplies --

MEMBER STETKAR: Right. I can isolate the steam supply to my turbine, plug it, break it, whatever and I can sit there for seven days with that.

But if, for example, the pump or valve or something like that, I can only sit there for 72 hours. It just --

CHAIRMAN SUNSERI: Yeah.

MEMBER STETKAR: -- this does not make any logical sense whatsoever to me.

CHAIRMAN SUNSERI: Right.

MEMBER STETKAR: And I can understand, you know, this dialogue, but I -- all I said is I hope they work it out, because trying to speculate any sound reason why this thing is written that way doesn't -- just doesn't compute.

CHAIRMAN SUNSERI: Yeah. Well, in addition to the question that was already asked by the staff, I think we have brought sufficient focus to it

NEAL R. GROSS

COURT REPORTERS AND TRANSCRIBERS

1323 RHODE ISLAND AVE., N.W.

WASHINGTON, D.C. 20005-3701

(202) 234-4433

(202) 234-4433

to, you know, tell you that it's an important issue you need to resolve.

MEMBER STETKAR: You know, I get it in the design where we have two steam supplies to one turbine where one steam supply can be out for seven days and the turbine itself can be out for 72 hours.

CHAIRMAN SUNSERI: Um-hum.

MEMBER STETKAR: That I get.

CHAIRMAN SUNSERI: Right.

MEMBER STETKAR: But that's not what the document really says.

CHAIRMAN SUNSERI: Yes. Yeah, it's a conundrum. All right. So --

MEMBER REMPE: Actually, I have a question, too. I'm back on this risk informing the tech specs. Could we hear from the applicant on their opinion of whether their technical specifications like LCO 3.0.8 are really risk-informed? Because I'm reading their Chapter 16 on page 332 out of 989 and it has here a statement about "The risk assessment may not be quantified, but may be a qualitative awareness of the vulnerability of systems and components when one or more snubbers are not able to perform their associated support function."

NEAL R. GROSS

COURT REPORTERS AND TRANSCRIBERS

1323 RHODE ISLAND AVE., N.W.

WASHINGTON, D.C. 20005-3701

(202) 234-4433

(202) 234-4433

And I'm wondering if they consider this technical specification risk-informed? I know the staff said they did, right? But is that what the applicant believes also?

CHAIRMAN SUNSERI: Well, they said part -- the staff said partially risk-informed.

MEMBER REMPE: Partially, yeah. The staff said that, but what does the applicant believe? Is it partially risk-informed or is it just a qualitative awareness?

CHAIRMAN SUNSERI: SangWon Lee, anybody want to take that one on?

MEMBER REMPE: Because I'm just still puzzled why their Slide 3 said we are not risk-informed. And did they ever say it was?

MR. SANGWON LEE: Basically, we, as I mentioned, do not consider the risk-informed tech spec, but in the small portion of that, such as a snubber and some barriers, we think that we can apply that kind of things based on some reference documents, such as NUREG, on something like this.

So we would like to try to do that, but I'm not sure, at this time, it is sufficient or not. We will discuss in details on that issue.

NEAL R. GROSS

COURT REPORTERS AND TRANSCRIBERS
1323 RHODE ISLAND AVE., N.W.

MEMBER REMPE: Thank you.

MR. J. OH: This is Andy Oh, KHNP, Washington Office, again. For our tech spec, it's not risk-informed. But we can say is that 3.0.8 and 3.0.9 is not risk-informed. Risk -- one of a kind of risk initiative can be applied at that. Our rationale to apply that is that's already in, the document is NEI 04-08 per -- allowance for the non-technical specification barrier degradation on a support system operability.

And also, because that barrier can be less than the -- not the total source of the risk PRA model, because it -- that's out of the initiated event per the loss of coolant accident, high energy line break and feedwater line break, such a thing is very small.

Initiating event frequency is very small.

That's our rationale that we can apply that risk initiated thing can be implemented through our tech spec.

But the other thing is we don't apply any risk-informed tech spec including ALT extension or, you know, RMSP -- RMSF SSCO or something. That's our position.

NEAL R. GROSS

COURT REPORTERS AND TRANSCRIBERS

1323 RHODE ISLAND AVE., N.W.

WASHINGTON, D.C. 20005-3701

(202) 234-4433

(202) 234-4433

MEMBER REMPE: Thank you.

CHAIRMAN SUNSERI: In the middle, if you could state your name?

MR. SANGWON LEE: SangWon Lee. SangWon Lee from KHNP.

MEMBER REMPE: Thank you.

CHAIRMAN SUNSERI: Okay. Any other questions? So we are going to turn to the room now and see if there is anybody in the room that cares to make a statement. Anybody in the room care to make a statement?

All right. No one there. So we are going to open the phone line to see if there is any member of the public that would care to make a statement or comment.

OPERATOR: The phone line is open.

CHAIRMAN SUNSERI: If there is anybody on the phone line, please, this is your opportunity to make a comment or provide a statement. All right. There is none. So we are going to close the phone line.

And we will close here with Member comments. So we will start with Joy. Do you have any comments?

NEAL R. GROSS

COURT REPORTERS AND TRANSCRIBERS

1323 RHODE ISLAND AVE., N.W.

WASHINGTON, D.C. 20005-3701

(202) 234-4433

(202) 234-4433

MEMBER REMPE: Nope. Thanks to everyone for their presentations and their hard work and no other comments.

CHAIRMAN SUNSERI: Walt?

MEMBER KIRCHNER: No comments. Thank you all.

CHAIRMAN SUNSERI: John?

MEMBER STETKAR: Nothing more. Thank you.

CHAIRMAN SUNSERI: Ron?

MEMBER BALLINGER: Nothing more. Thank you.

CHAIRMAN SUNSERI: Mike?

MEMBER CORRADINI: Nothing more. Thank you.

CHAIRMAN SUNSERI: Dana?

MEMBER POWERS: I think Dick will make my comment.

CHAIRMAN SUNSERI: Dick?

MEMBER SKILLMAN: To the staff and to the KHNP Team, thank you. And I have no further comments. Thank you.

CHAIRMAN SUNSERI: Yeah, and I would like to extend my compliments to both the applicant and the staff today for getting through these topics in a very

NEAL R. GROSS

COURT REPORTERS AND TRANSCRIBERS

1323 RHODE ISLAND AVE., N.W.

WASHINGTON, D.C. 20005-3701

(202) 234-4433

(202) 234-4433

timely manner. Tech specs, as we have said, is a 1,000 page document. I think we got through it with a good discussion. We understand where everything is on this.

So we are going to recess for the evening.

Tomorrow morning we will resume presentations starting at 8:30 in this room with KHNP beginning on Chapter 6.

So at that time -- at this time, we are in recess until tomorrow morning, 8:30.

(Whereupon, the above-entitled meeting recessed at 5:07 p.m.)

NEAL R. GROSS

COURT REPORTERS AND TRANSCRIBERS

1323 RHODE ISLAND AVE., N.W.

WASHINGTON, D.C. 20005-3701

(202) 234-4433

(202) 234-4433

NEAL R. GROSS

COURT REPORTERS AND TRANSCRIBERS

1323 RHODE ISLAND AVE., N.W.

WASHINGTON, D.C. 20005-3701

(202) 234-4433

(202) 234-4433

APR1400 DCA

Chapter 13: Conduct of Operation

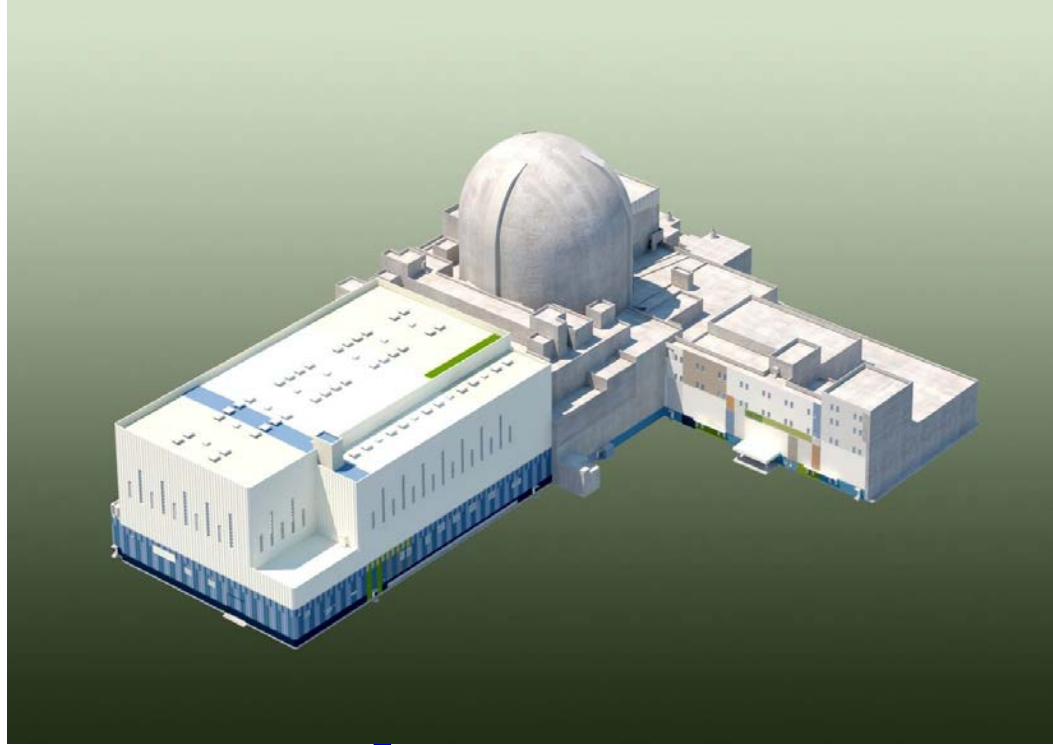

KEPCO/KHNP

March 21, 2016

ACRS Meeting (Mar. 21, 2017)

Contents

- **Overview of Chapter 13**
 - **Section Overview**
- **Section Summary (Conduct of Operation)**
- **Open items & Current Status**
- **Summary**
- **Attachments**
 - **List of COL Items**
 - **Acronym**

Overview of Chapter 13

● Section Overview

Section	Major Contents	Remark
13.1 Organizational Structure of the Applicant	COL items for management, technical support, operating organization and qualification of NPP personnel	COL
13.2 Training	COL items for plant staff training	COL
13.3 Emergency Planning	COL items for emergency plan content	COL
13.4 Operational Program Implementation	COL items for Operational Program Implementation	COL
13.5 Plant Procedures	COL items for administrative and operating procedures	COL
13.6 Physical Security	SRI and SGI	N.A.(SGI)
13.7 Fitness for Duty	COL items for fitness-for-duty program	COL

ACRS Meeting (Mar.21, 2017)

Overview of Chapter 13

- List of Submitted Documents

Document No.	Title	Revision	Type	ADAMS Accession No.
APR1400-K-X-FS-14002 -P & NP	APR1400 Design Control Document Tier 2: Chapter 13 Conduct of Operations	0	DCD	ML15006A052
APR1400-K-X-IT-14001 -P & NP	APR1400 Design Control Document Tier 1	0	DCD	ML15006A039

Conduct of Operation

- **13.1 Organizational Structure of the Applicant**
 - **13.1.1 Management and Technical Support Organization**
 - ◆ Design, Construction, and Operating Responsibilities
 - ◆ Organizational Arrangement
 - ◆ Qualifications
 - **13.1.2 Operating Organization**
 - ◆ Plant Organization
 - ◆ Plant Personnel Responsibilities and Authorities
 - ◆ Operating Shift Crews
 - **13.1.3 Qualifications of Nuclear Power Plant**
 - ◆ Qualification Requirements
 - ◆ Qualification of Plant Personnel

Conduct of Operation

● 13.2 Training

➤ 13.2.1 Plant Staff Training Program

- ◆ Program Description
- ◆ Coordination with Preparational Tests and Fuel Loading

➤ 13.2.2 Applicable Nuclear Regulatory Commission Documents

● 13.3 Emergency Planning

➤ 13.3.1 COLA and Emergency Plan Content

➤ 13.3.2 Emergency Plan Considerations for Multi-Unit Sites

➤ 13.3.3 Emergency Planning ITAAC

Conduct of Operation

- **13.4 Operational Program Implementation**
 - **13.4.1 Combined License Information**

- **13.5 Plant Procedures**
 - **13.5.1 Administrative Procedures**
 - ◆ Administrative Procedures - General
 - **13.5.2 Operating and Maintenance Procedures**
 - ◆ Operating and Emergency Operating Procedures
 - ◆ Maintenance and Other Operating Procedures

- **13.7 Fitness for Duty**
 - **13.7.1 Combined License Information**

Open Items & Current Status

- There are no open items.

Summary

- Chapter 13 provides information relating to conduct of operations of APR1400 plant.
- This chapter describes the COL information items to be addressed by the COL applicant.

Attachment : List of COL Items for Ch. 13 (1/6)

COL No.	Description
COL 13.1(1)	The COL applicant is to provide a description of the corporate or home office organization, its functions and responsibilities, and the number and the qualifications of personnel. The COL applicant is to be directed to activities such as the facility design, design review, design approval, construction management, testing, and operation of the plant.
COL 13.1(2)	The COL applicant is to develop a description of experience in the design, construction, and operation of nuclear power plants and experience in activities of similar scope and complexity.
COL 13.1(3)	The COL applicant is to describe its management, engineering, and technical support organizations. The description includes organizational charts for the current headquarters and engineering structure and any planned modifications and additions to those organizations to reflect the added functional responsibilities with the nuclear power plant.
COL 13.1(4)	The COL applicant is to develop a description of the organizational arrangement. The description is to include organizational charts reflecting the current headquarters and engineering structure and any planned modifications and additions to reflect the added functional responsibilities associated with the addition of the nuclear plant to the applicant's power generation capacity. The description shows how these responsibilities are delegated and assigned or expected to be assigned to each of the working or performance-level organizational units identified to implement these responsibilities. The description includes organizational charts reflecting the current corporate structure and the working- or performance-level organizational units that provide technical support for the operation.
COL 13.1(5)	The COL applicant is to develop the description of the general qualifications in terms of educational background and experience for positions or classes of positions described in the organizational arrangement.
COL 13.1(6)	The COL applicant is to develop a description of the structure, functions, and responsibilities of the onsite organization established to operate and maintain the plant.

Attachment : List of COL Items for Ch. 13 (2/6)

COL No.	Description
COL 13.1(7)	The COL applicant is to provide an organizational chart showing the title of each position, minimum number of persons to be assigned to duplicate positions, number of operating shift crews, and positions that require reactor operator and senior reactor operator licenses.
COL 13.1(8)	The COL applicant is to provide organizational information such as the functions, responsibilities, and authorities of the plant position. The COL applicant is to develop a description of the line of succession of authority and responsibility for overall station operation in the event of unexpected temporary contingencies, and the delegation of authority.
COL 13.1(9)	The COL applicant is to develop a description of the position titles, applicable operator licensing requirements for each, and the minimum numbers of personnel planned for each shift for all combinations of units proposed to be at the station in either operating or cold shutdown mode. The COL applicant is also to develop the description of shift crew staffing plans unique to refueling operations.
COL 13.1(10)	The COL applicant is to provide a description of the education, training, and experience requirements for each management, operating, technical, and maintenance position in the operating organization.
COL 13.1(11)	The COL applicant is to provide the qualification requirements of the initial appointees to plant positions for key plant managerial and supervisory personnel through the shift supervisory level.
COL 13.2(1)	The COL applicant is to develop the description and schedule of the training program for licensed reactor operators and non-licensed plant staff.
COL 13.2(2)	The COL applicant is to develop the site-specific training program by using NEI 06-13A as the template for the basic structure and content.
COL 13.2(3)	The COL applicant is to provide a licensed plant staff training program in accordance with NEI 06-13A.

Attachment : List of COL Items for Ch. 13 (3/6)

COL No.	Description
COL 13.2(4)	The COL applicant is to provide a non-licensed plant staff training program in accordance with NEI 06-13A.
COL 13.2(5)	The COL applicant is to develop training programs. The programs are to include a chart that shows the schedule of each part of the training program for each functional group of employees in the organization in relation to the schedule for preoperational testing, expected fuel loading, and expected time for examinations prior to plant criticality for licensed operators.
COL 13.2(6)	The COL applicant is to determine the extent of the NRC guidance that is applicable to the facility training program or the justification of exceptions.
COL 13.3(1)	The COL applicant is to develop the interfaces of design features with site-specific designs and site parameters.
COL 13.3(2)	The COL applicant is to develop a comprehensive emergency plan. The plan is developed as a physically separate document and includes copies of letters of agreement (or other certifications) from state and local governmental agencies with emergency planning responsibilities.
COL 13.3(3)	The COL applicant is to address an emergency classification and action level scheme as required by 10 CFR 50.47(b)(4).
COL 13.3(4)	The COL applicant is to develop the security-related aspects of an emergency plan.
COL 13.3(5)	The COL applicant is to develop a multi-unit site interface plan depending on the location of the new reactor on or near an operating reactor site with an existing emergency plan.
COL 13.3(6)	The COL applicant is to develop emergency planning inspections, tests, analyses, and acceptance criteria.

Attachment : List of COL Items for Ch. 13 (4/6)

COL No.	Description
COL 13.4(1)	The COL applicant is to develop operational programs and provide schedules for implementation of the programs, as defined in SECY-05-0197. The COL applicant is to provide commitments for the implementation of operational programs that are required by regulation. In some instances, the programs may be implemented in phases, where practical, and the applicant is to include the phased implementation milestones.
COL 13.4(2)	The COL applicant is responsible for developing a leakage monitoring and prevention program for the systems, as specified in Subsection 5.5.2 in Chapter 16, Technical Specifications. The leakage monitoring and prevention program is to provide suitable methods and acceptance criteria as defined in NUREG-0737, Item III.D.1.1.
COL 13.4(3)	The COL applicant is to develop an implementation plan for an inspection and monitoring program of the cladding material integrity of SG channel heads. The COL applicant is to provide a commitment for the implementation plan of the inspection and monitoring program.
COL 13.5(1)	The COL applicant is to describe the administrative and operating procedures. Administrative procedures provide for administrative control over safety-related activities for the operation of the facility. Operating procedures are used to ensure that routine operating, off-normal, and emergency activities are conducted in a safe manner. The COL applicant is to provide a description of the nature, content, and development process for the administrative and operating procedures, including preliminary schedules for preparation and target dates for completion (Reference 1 through 3).
COL 13.5(2)	The COL applicant is to provide a program for developing and implementing administrative procedures.

ACRS Meeting (Mar. 21, 2017)

Attachment : List of COL Items for Ch. 13 (5/6)

COL No.	Description
COL 13.5(3)	The COL applicant is to describe the different classifications of procedures the operators use in the MCR and locally in the plant for plant operations. The COL applicant is to describe the operating procedures that will be used by the operating organization (plant staff) to ensure that routine operating, off-normal, and emergency activities are conducted in a safe manner. The COL applicant is to identify the group within the operating organization responsible for maintaining the procedures and describe the general format and content of the different classifications.
COL 13.5(4)	The COL applicant is to provide a program for developing and implementing operating procedures.
COL 13.5(5)	The COL applicant is to provide a program for developing and implementing emergency operating procedures.
COL 13.5(6)	The COL applicant is to describe the procedures that provide coverage for other safety-related plant operating activities (i.e., operating activities not procedurally covered under the operating or emergency operating procedure programs), including related maintenance activities. The COL applicant is to provide a description of the nature, content, and development process for the maintenance and other operating procedures, including preliminary schedules for preparation and target dates for completion. In addition, the COL applicant is to describe how these procedures are classified, describe the general format and content of the various classifications, and identify the group(s) within the operating organization responsible for performing and maintaining the procedures.
COL 13.5(7)	The COL applicant is to provide a program for developing and implementing procedures that provide coverage for other safety-related plant operating activities (i.e., operating activities not procedurally covered under the operating or emergency operating procedure programs), including related maintenance activities.

Attachment : List of COL Items for Ch. 13 (6/6)

COL No.	Description
COL 13.5(8)	The COL applicant is to provide a program for developing shutdown procedure including the installation and removal order of the pressurizer manway and the nozzle dam.
COL 13.6(1)	The COL applicant is to develop a physical security plan, training and qualification plan, and safeguards contingency plan. The COL applicant is to address site-specific information related to the physical security, contingency, and guard training and qualification plans. These documents are categorized as SGI and are withheld from public disclosure pursuant to 10 CFR 73.21. The COL applicant is to address site-specific physical security ITAACs as applicable.
COL 13.6(2)	The COL applicant is to develop an access authorization program that meets the requirements of 10 CFR 73.56, and conformance with the requirement is to be specified in the physical security plan.
COL 13.6(3)	The COL applicant is to develop a cyber security plan and implementation program in accordance with 10 CFR 73.54. The plan document is categorized as SGI and is to be withheld from public disclosure pursuant to 10 CFR 2.390(d)(1).
COL 13.7(1)	The COL applicant is to develop the description of the fitness-for-duty programs during construction and for the operating plant.

Attachment : Acronyms

- **CFR** : Code of Federal Regulations
- **COL** : combined license
- **CRE** : control room envelope
- **EOF** : emergency operation facility
- **ERDS** : emergency response data system
- **HVAC** : heating, ventilation, and air conditioning
- **ITAAC** : inspections, tests, analyses, and acceptance criteria
- **MCR** : main control room
- **OSC** : operational support center
- **RG** : Regulatory Guide
- **SGI** : security safeguards information
- **SPDS** : safety parameter display system
- **SRI** : security-related information
- **SRP** : Standard Review Plan
- **TSC** : technical support center



Presentation to the ACRS Subcommittee

**Korea Hydro & Nuclear Power Co., Ltd (KHNP)
APR1400 Design Certification Application Review**

Safety Evaluation with Open Items: Chapter 13

CONDUCT OF OPERATIONS

MARCH 21, 2017

Staff Review Team

- ◆ **Human Performance, Operator Licensing, & ITAAC Branch**

 - Surinder Arora

 - Joe DeMarshall

- ◆ **Reactor Licensing Branch**

 - Eddie Robinson

- **Staff Presenters**

 - ◆ William Ward – DCD Sections 13.1, 13.4

 - ◆ Surinder Arora – DCD Section 13.2

 - ◆ Eddie Robinson – DCD Section 13.3

 - ◆ Joe DeMarshall – DCD Section 13.5

- **Project Managers**

 - ◆ Jeff Ciocco – Lead Project Manager

 - ◆ William Ward – Chapter 13 Project Manager

Overview of Design Certification Application, Chapter 13

SRP Section/Application Section	
13.1	Organizational Structure of the Applicant – contains COL items which require the COL applicant to develop the management and tech support organizational structure including design, construction, operating, and maintenance responsibilities. This includes the qualification requirements such as education, training, and experience for each position.
13.2	Training – contains COL items which require the COL applicant to develop the description and schedule of the training program for licensed reactor operators and non-licensed plant staff.
13.3	Emergency Planning (EP) – describes the design features, facilities, functions, and eqpt. necessary for EP and requires the COL applicant to develop the site-specific design.
13.4	Operational Program Implementation – contains COL items which require the COL applicant referencing this design to develop operational programs consistent with SRM-SECY-05-0197.
13.5	Plant Procedures – contains COL items which require the COL applicant to briefly describe the admin & operating procedures for all operational modes, and a schedule for preparing the procedures.

Technical Topics

Section 13.1 – Organizational Structure



Scope of Review

- The purpose of this section is to provide assurance that the applicant has established acceptable COL Information Items pertaining to the corporate-level management and technical support organizations necessary for the safe construction and operation of this design, including training and qualification requirements. That is, the COL applicant will have the necessary managerial and technical resources to support the plant staff in construction, operation, maintenance, and in the event of an emergency.

Technical Challenges

- None.

Finding

- Eleven COL information items are provided, COL 13.1(1) through 13.1(11). Staff found that the COL information items appropriately identified and sufficiently addressed the required information without the need for additional items.

Conclusion

- The staff has reviewed DCD Tier 2, Section 13.1, “Organizational Structure of the Applicant,” and determined that this approach to describing the corporate-level management and technical support organization, and the onsite operating organization, is acceptable to meet all applicable requirements.

Technical Topics

Section 13.2 – Training



Scope of Review

- The purpose of this section is to provide assurance that the applicant analyses job performance to design, develop, implement, and evaluate licensed and non-licensed staff training programs.
- The applicant establishes and maintains a staff of adequate size, ability & technical competence to operate and maintain the facility and to protect public health and safety.

Technical Challenges

- None. The applicant has provided COL information items stating that the COL applicant is responsible for developing the site-specific training programs for the plant staff.

Findings

- COL information items COL 13.2(3) and COL 13.2(4) pertaining to training programs for licensed and non-licensed staff, initially stated that these programs will be in accordance with NUREG-800, Sections 13.2.1.I.3 and 13.2.2.I.3, respectively. In response to the staff's RAI, references to the NUREG-800 sections were changed to NEI 06-13A.
- Except for the verification of the confirmatory item 13.02.01 in new revision to FSAR, there are no open issues.

Conclusion

- The staff has reviewed DCD Tier 2, Section 13.2, "Training," and determined that applicant's approach to describing, developing, and documenting the training programs is acceptable.

Technical Topics

Section 13.3 – Emergency Planning



- No Open Items
- DCD satisfies TSC size and location
- SRP Interface Areas
 - ♦ Protection of MCR personnel during an emergency is addressed in SE Section 6.4
 - ♦ TSC data retrieval capabilities is addressed in SE Section 7.5
 - ♦ Post Accident Sampling System is addressed in SE Section 9.3.2
 - ♦ TSC HVAC is addressed in SE Section 9.4.1
 - ♦ TSC Voice and Data Communications Equipment is addressed in SE Section 9.5.2
 - ♦ Onsite Decontamination Facilities is addressed in SE Section 12.3
 - ♦ TSC dose analysis is addressed in SE Section 15.0.3

Technical Topics

Section 13.3 – Emergency Planning (continued)



- 5 COL Information Items
 - ♦ Develop interfaces of design features with site-specific designs and site parameters.
 - ♦ Develop a comprehensive emergency plan as a physically separate document.
 - ♦ Develop an emergency classification and action level scheme.
 - ♦ Develop a multi-unit site interface plan depending on the location of the new reactor on, or near, an operating reactor site with an existing emergency plan.
 - ♦ Develop emergency planning ITAAC.

Technical Topics

Section 13.4 – Operational Programs



Scope of Review

- SRM-SECY-05-0197 (February 22, 2006) approved an approach for Operational Programs which relieved the DC applicant of the burden of describing operational programs which only the COL applicant could describe. As a result, NRC guidance states that the DCD should include a COL Information Item(s) directing the COL applicant to develop operational programs in accordance with SECY-05-0197.
- NRC staff reviews the application for the required COL Information Item(s).

Technical Challenges

- None.

Findings

- The applicant provided COL information items COL 13.4(1) and COL 13.4(2) stating that the COL applicant is responsible for developing the operational programs in accordance with SECY-05-1997 and a leakage monitoring and prevention program in accordance with NUREG-0737, "Clarification of TMI Action Plan Requirements," Item III.D.1.1.

Conclusion

- The staff has reviewed DCD Tier 2, Section 13.4, "Operational Programs," and determined that the COL Information Items the applicant provided are appropriate and acceptable.

Technical Topics

Section 13.5 – Plant Procedures



Scope of Review

- Plant Procedures encompass:
 - ♦ Administrative Procedures
 - ♦ Operating and Emergency Operating Procedures (EOPs)
 - ♦ Maintenance and Other Operating Procedures for safety-related activities
- Development of detailed procedures is beyond the scope of the DC application.
 - ♦ Responsibility resides with the COL applicant referencing the design.
 - ♦ COL information items pertaining to procedure descriptions, and procedure program development / implementation, are identified by the DC applicant.
- Generic Technical Guidelines (GTGs); otherwise referred to as the Emergency Operating Guidelines (EOGs)
 - ♦ Used by COL applicants to develop their Plant-Specific Technical Guidelines (P-STGs), from which their EOPs will be developed.
 - ♦ Preparation of the APR1400 EOGs and submittal to the NRC for review is the responsibility of the DC applicant.

Technical Topics

Section 13.5 – Plant Procedures



Scope of Review (cont'd)

- Staff evaluated the DC application for:
 - ♦ Acceptability of COL information items pertaining to descriptions of plant procedures.
 - ♦ Acceptability of COL information items pertaining to establishment of a program for development and implementation of plant procedures.
 - ♦ Technical adequacy of the APR 1400 EOGs, **AND** Determination of their acceptability for use as a basis for development of COL applicant P-STGs.

Findings

- No open item issues.
- The staff found 2 out of 7 COL information items in Chapter 13.5 to be acceptable. The remaining 5 COL information items require modifications that have been sufficiently resolved through the RAI process and have been identified as Confirmatory Items in Revision 1 of the DCD.

Technical Topics

Section 13.5 – Plant Procedures



Findings (cont'd)

- The staff finds that the APR1400 EOGs are technically adequate and acceptable for use in development of the COL applicant P-STGs on the basis that:
 - ♦ The EOGs are based on the Combustion Engineering Owners' Group GTGs (CEN-152), which have been previously reviewed and approved by the staff,
 - ♦ The EOGs retain the structural format and event mitigation strategies of CEN-152,
 - ♦ The EOGs have been modified to reflect the APR1400 specific design features,
 - ♦ APR1400 specific design features have been incorporated into the transient analyses for events categorized in the Optimal Recovery Guidelines of the APR1400 EOGs, and
 - ♦ Transient analyses results provided in APR1400 technical report KEPCO E&C/ND/TR/11-005, "**Best Estimate Analyses for the Operational Transients and Accidents for APR1400 Emergency Operating Guidelines,**" have been reviewed by the Reactor Systems, Nuclear Performance, and Code Review Branch (SRSB) (Chapter 15 Review Interface Support) and found to be acceptable for use in the development of the APR1400 EOGs.

APR1400 DCA

Chapter 16: Technical Specification

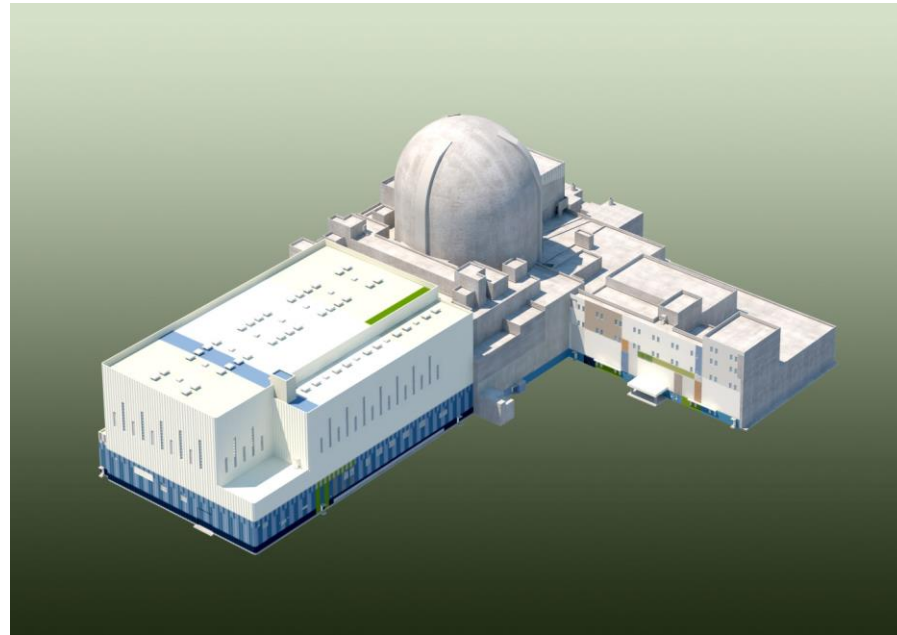

KEPCO/KHNP
March 21-22, 2017

Contents

- 1 Overview of Chapter 16
- 2 Main Deviations between STS and APR1400 TS
- 3 Technical Issues
- 4 Summary

Overview of Chapter 16

- ❑ **APR1400 Technical Specifications were developed based on NUREG-1432 Rev. 04 ('12. 04), “Standard Technical Specifications – Combustion Engineering Plants”**

- ❑ **Risk-Informed TS are not applied**

- ❑ **Different design feature of APR1400 were reviewed for applicability of NUREG-1432 to APR1400**
 - Technical Report submitted , “Deviation Report between NUREG-1432 Rev.4 and APR1400 TS” ('15.12, APR1400-K-O-NR-14001-NP, Rev.1,ML15338A328)
 - Applicability of updated TSTF reviewed

Overview of Chapter 16

□ Section Overview

Section	Contents	Presenter
1.0	USE AND APPLICATIONS	SANG WON LEE
2.0	SAFETY LIMITS	
3.0	LIMITING CONDITION FOR OPERATION (LCO) APPLICABILITY SUREVEILLANCE REQUIREMENT (SR) APPLICABILITY	
3.1	REACTIVITY CONTROL SYSTEMS	
3.2	POWER DISTRIBUTION LIMITS	
3.3	INSTRUMENTATION	
3.4	REACTOR COOLANT SYSTEM (RCS)	
3.5	EMERGENCY CORE COOLING SYSTEM (ECCS)	
3.6	CONTAINMENT SYSTEMS	
3.7	PLANT SYSTEMS	
3.8	ELECTRICAL POWER SYSTEMS	
3.9	REFUELING OPERATIONS	
4.0	DESIGN FEATURES	
5.0	ADMINISTRATIVE CONTROLS	

Overview of Chapter 16

❑ Section 3.1 REACTIVITY CONTROL SYSTEMS

- Shutdown Margin (SDM)
- Reactivity Balance
- Moderator Temperature Coefficient (MTC)
- Shutdown Control Element Assembly (CEA) Insertion Limits
- Special Test Exception (STE), etc.

❑ Section 3.2 POWER DISTRIBUTION LIMITS

- Linear Heat Rate (LHR)
- Planar Radial Peaking Factors, etc.

❑ Section 3.3 INSTRUMENTATION

- Reactor Protection System (RPS) Instrumentation
- Control Element Assembly Calculators (CEACs)
- Engineered Safety Features Actuation System (ESFAS) Instrumentation
- Emergency Diesel Generator (EDG) – Loss of Voltage Start (LOVS)
- Containment Purge Isolation Actuation Signal (CPIAS)
- Fuel Handling Area Emergency Ventilation Actuation Signal (FHEVAS)
- Remote Shutdown Display and Control, etc.

Overview of Chapter 16

❑ Section 3.4 REACTOR COOLANT SYSTEM (RCS)

- RCS Loops – Mode 1 to 5
- Pressurizer
- Pressurizer Pilot Operated Safety Relief Valves (POSRVs)
- Reactor Coolant Gas Vent (RCGV) Function, etc.

❑ Section 3.5 EMERGENCY CORE COOLING SYSTEM (ECCS)

- Safety Injection Tanks (SITs)
- Safety Injection System (SIS)
- In-Containment Refueling Water Storage Tank (IRWST), etc.

❑ Section 3.6 CONTAINMENT SYSTEMS

- Containment Air Locks
- Containment Isolation Valves
- Containment Spray System, etc.

Overview of Chapter 16

❑ Section 3.7 PLANT SYSTEMS

- Main Steam Safety Claves (MSSVs)
- Auxiliary Feedwater System (AFWS)
- Component Cooling Water System (CCWS)
- Essential Service Water System (ESWS)
- Control Room HVAC System (CRHS)
- Auxiliary Building Controlled Area Emergency Exhaust System (ABCAEES)
- Fuel Handling Area Emergency Exhaust System (FHAEEES), etc.

❑ Section 3.8 ELECTRICAL POWER SYSTEMS

- AC Sources
- DC Sources
- Diesel Fuel Oil, Lube Oil, and Starting Air, etc.

❑ Section 3.9 REFUELING OPERATIONS

- Boron Concentration
- Containment Penetration
- Shutdown Cooling System (SCS) and Coolant Circulation, etc.

Main Deviations (1/9)

□ Reactor Coolant System

- NUREG-1432 : PSV + PORV
- APR1400 : 4 Pilot Operated Safety Relief Valves (POSRVs)
- Related Deviation : 3.4.10
 - Section 3.4.10 : POSRVs.
 - Incorporated a POSRV instead of PSV.
 - Surveillance Requirements for subcomponents
 - Opening setpoints of spring loaded pilot valve
 - Opening time of main valve
 - Valve position verification
 - Operability test of main, pilot valves and isolation valves
 - No PORV in APR1400 design.

Main Deviations (2/9)

✓ POSRV

- Main Valve (1)
- Spring Loaded Pilot Valve (SLPV)
 - Automatic actuation for overpressure protection
 - Motor operated isolation valve
 - Normally open
 - Power removed
 - Closed in case of SLPV stuck open
- Manual isolation valve
 - Isolation for SLPV test and maintenance
 - Locked open
- Motor Operated Pilot Valve (2)
 - Manual actuation for rapid depressurization
 - Two valves installed in series
 - Normally closed
 - Power removed

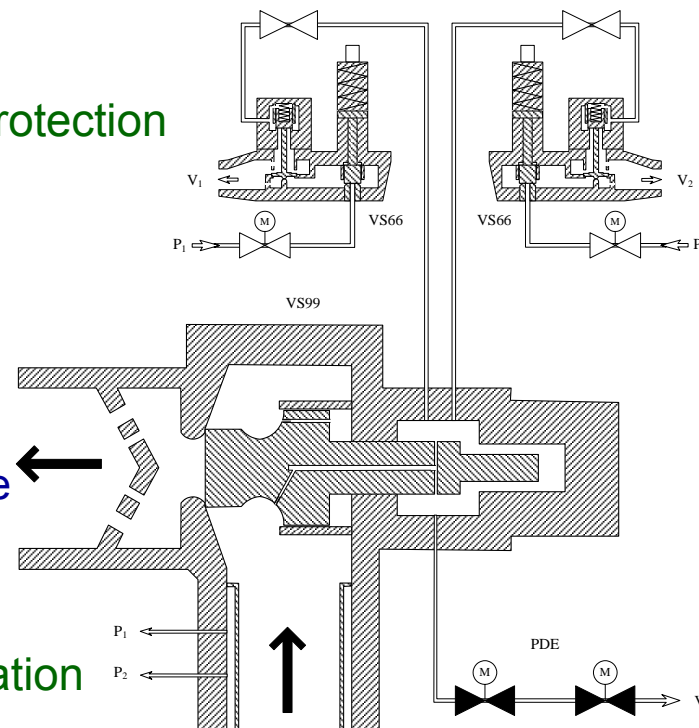

VS99 : Main Valve
 VS66 : Spring Loaded Pilot Valve
 PDE : Motor Operated Pilot Valves
 M : Motor Operated Valve
 V₁ : Pilot Discharge
 P₁ : Impulse Line

Main Deviations (3/9)

□ Safety Injection System

- NUREG-1432 : 2 trains of HPSI and LPSI, 2 EDG
- APR1400 : 4 SI trains, no LPSI, 4 EDG
- Related Deviation
 - Section 3.5.2, 3.5.3 : SIS
 - Required number of OPERABLE Trains: 4 SI trains for operating and 2 diagonal SI trains for shutdown

Main Deviations (4/9)

✓ APR1400 : 4 SI trains, no LPSI, 4 EDG

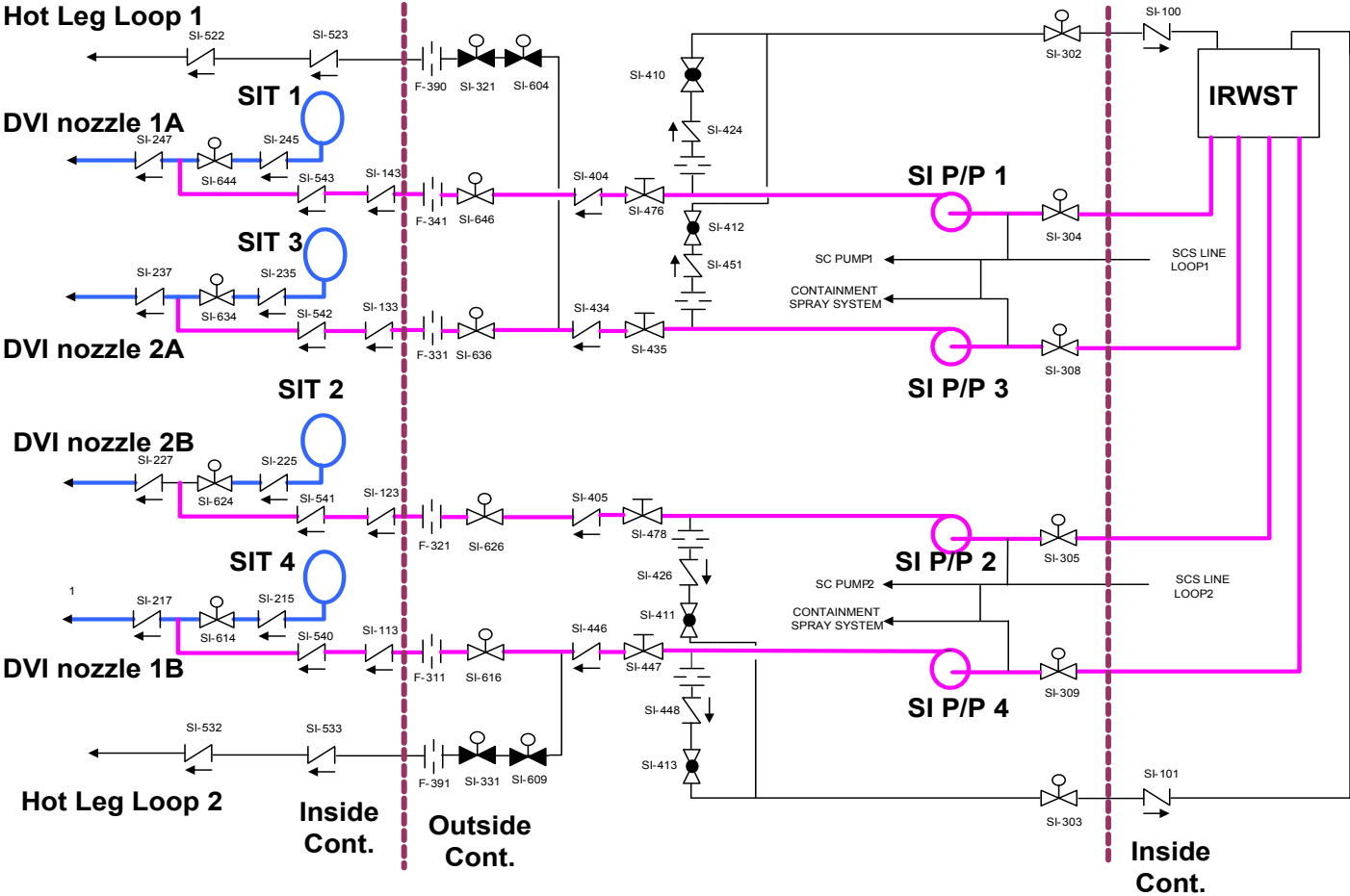

ACRS Meeting (March 21-22, 2017)

Main Deviations (5/9)

□ In-Containment Refueling Water Storage Tank

- NUREG-1432 : Applicability → MODES 1, 2, 3, and 4
- APR1400 : Applicability → MODES 1, 2, 3, 4, and 5,
MODE 6 with RCS level < 39.7 m
(130 ft 0 in)
- Related Deviation
 - Section 3.5.4 : In-Containment Refueling Water Storage Tank (IRWST)
 - IRWST is the water source of SIS during an accident and the applicable modes for SIS are extended to the modes specified in LCO 3.5.3.
 - Therefore, applicable modes for the IRWST are extended for providing water to SIS.

Main Deviations (6/9)

□ AF system

- NUREG-1432 :
3 train, two (2) motor driven pump + one (1) turbine driven pump
- APR1400 :
4 train, two (2) motor driven pump + two (2) turbine driven pump
- Related Deviation
 - Section 3.7.5 : AFWs
 - Condition A. Turbine driven AFW train inoperable due to one inoperable steam supply...(NUREG-1432) → Deleted
 - [Three AFW] → [Two auxiliary feedwater (AFW) divisions, each with one motor driven train and one turbine driven] train shall be operable
 - Section 3.7.6 : AFWST
 - [The CST] → [Two AFWST] shall be operable

Main Deviations (7/9)

✓ AF system

- APR1400 : AF System consists of 100 % x 2 motor-driven pumps, 100 % x 2 turbine-driven pumps, 100 % x 2 auxiliary feedwater storage tanks (AFWSTs), valves, venturis, and instrumentation

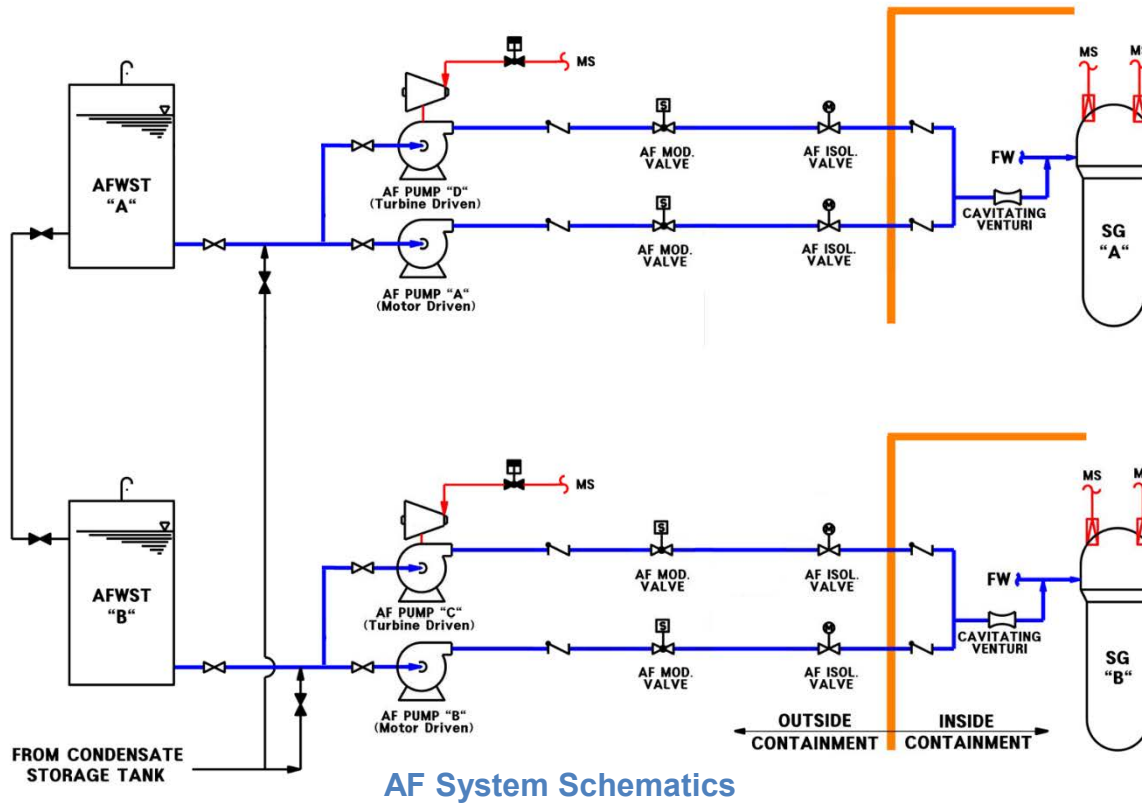

ACRS Meeting (March 21-22, 2017)

AF System Schematics

Main Deviations (8/9)

□ Electrical Power System

- NUREG-1432 : Two EDGs for two trains
(One EDG per each train)
- APR1400 : Four EDGs for two Divisions
(A pair of EDGs per each division)
- Related Deviation
 - Section 3.8.1 / 3.8.2 : AC sources – operating / shutdown
 - One EDG inoperable CONDITION in the Standard Technical Specifications (STS), NUREG-1432, Rev.4 is replaced with one or two EDG(s) in one division inoperable CONDITION in the APR1400 TS.
 - The term "Train A" and "Train B" used in the STS is replaced by "Division I" and "Division II". Between divisions, independence and redundancy are maintained.

Main Deviations (9/9)

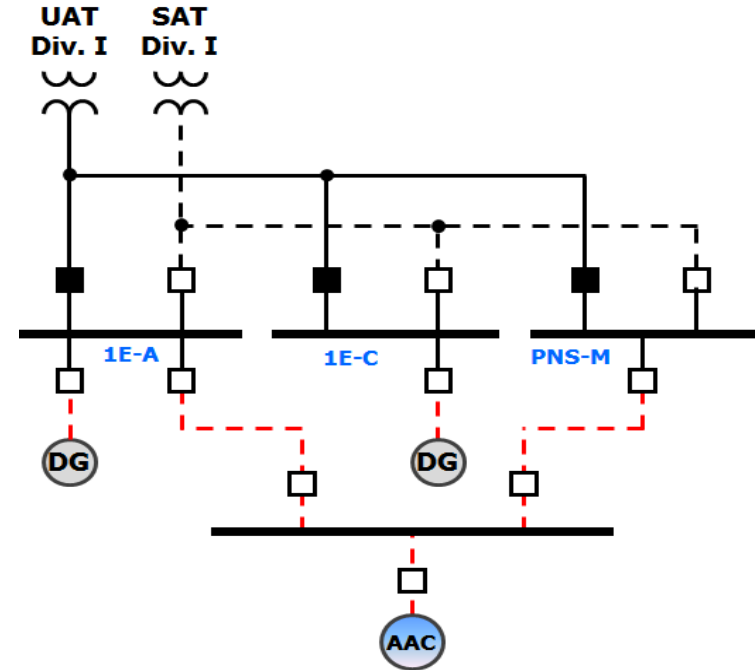
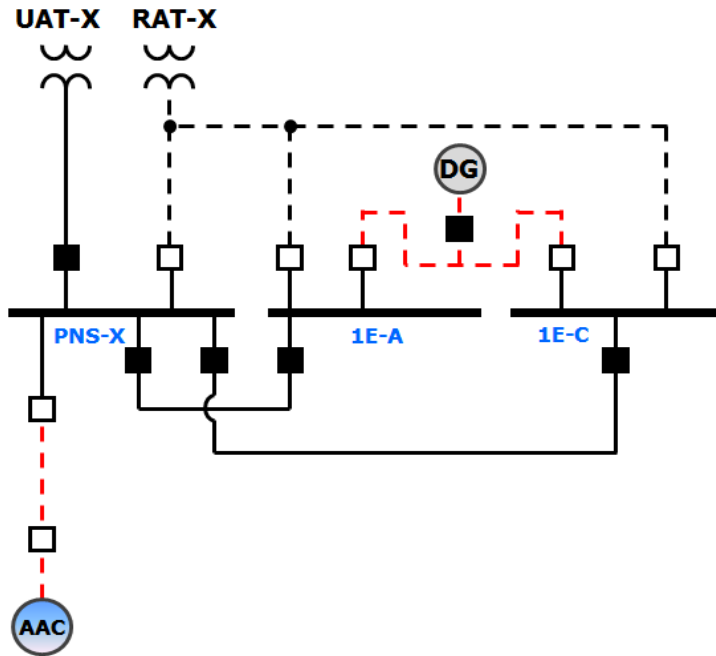

System 80+

- Two EDGs for two Trains (One EDG per each train)
- PPS I&II is supplied from UAT&RAT through PNS bus
- Additional direct connection from RAT to safety buses

APR 1400

- Four EDGs for two Divisions (A pair of EDGs per each division)
- PPS I (from UAT) and PPS II (from SAT) are directly supplied

Technical Issues (1/4)

□ AFWS Trains (RAI 498-8595, Q 16-154.1b thru 1g)

- **Issue** : No provision for the AFWS trains for one SG to supply feedwater to the other SG. One faulted SG with a loss of offsite power, and a single failure that disables one AFWS train associated with the un-faulted SG, only one AFWS train will remain available to perform the safety function
- **Response** : LCO 3.7.5 and Note is revised according to staff's recommendations. Detail comments on LCO Condition, Required Action and Completion Time was reviewed and the corresponding response was submitted to NRC.
- **Status (Plan)** : NRC staff is reviewing the submitted response.

Technical Issues (2/4)

□ Boron Mixing (RAI 17-7917, Q 15.04.06-1)

- **Issue** : Complete RCS mixing assumption
- **Response** : The CFX code has been used to determine the degree of the lower plenum mixing
- **Status (Plan)** : Adding new LCO to close the unborated water source isolation valve. Follow-up request of additional information was issued related to the isolation valve and pipe design, etc. There is no current conclusion and it is still under discussion with NRC

Technical Issues (3/4)

□ Surveillance Requirements for B-10 atom percent for SIT and IRWST (RAI 496-8630, Q 06-03)

- **Issue** : If boron recycling is used, surveillance requirement for atomic percent of B-10 should be specified in the Technical Specifications.
- **Response** :
 - Boron recycling is described in DCD section 9.3.4.
 - Operating experience shows that reduction of B-10 a/o is not significant (19.8->19.6) for 15 years. (0.02 a/o for 18 months)
 - The amount of reduction is equivalent to 4 ppm of boron concentration for 18 months. (4 ppm = 4000 ppm x 0.02 /19.8)
- **Status (Plan)** : Response is under review.

Technical Issues (4/4)

□ Applicability Mode (RAI 498-8595, Q 16-153)

- **Issue** : Table 3.3.5-1, Footnote (d) which states “When a steam generator is relied upon heat removal” should be applied to the Mode 4 Applicability of the AFAS on SG level – Low.
- **Response** :
 - The Applicability of AFAS and CIAS functions in Table 3.3.5-1 will be extended to Mode 4 so that all ESFAS functions include applicable Modes 1, 2, 3, and 4.
 - This approach of APR 1400 TS is more conservative than the STS that states only Modes 1, 2, and 3 for all ESFAS functions.
 - Footnote (d) “When a steam generator is relied upon heat removal” will be applied to the Mode 4 Applicability of the AFAS.
- **Status (Plan)** : Response will be provided.

Summary

- ❑ **APR1400 Technical Specifications are the same as the STS of NUREG-1432 in most respects**
- ❑ **Differences between APR1400 TS and STS are the unique APR1400 design features related to**
 - Reactor Coolant System
 - Safety Injection System
 - In-containment Refueling Water Storage Tank
 - Auxiliary Feedwater System
 - Electrical Power System
- ❑ **Current Status**
 - 5 RAIs are under preparation
 - ✓ Boron mixing, Table of Chap. 16 COL items, PRA, 2 editorial
 - All other responses were submitted

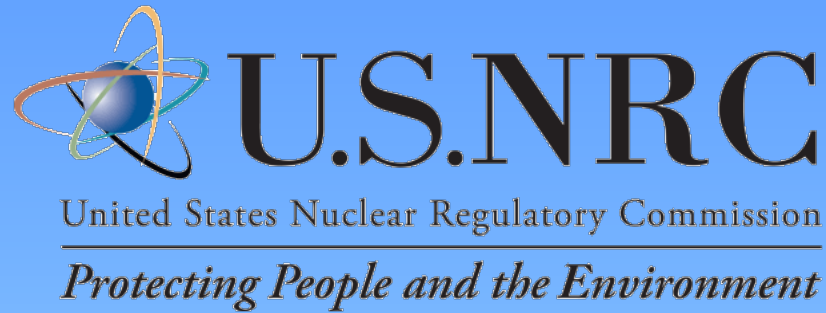

Presentation to the ACRS Subcommittee

**Korea Hydro Nuclear Power Co., Ltd (KHNP)
APR1400 Design Certification Application Review**

Safety Evaluation with Open Items: Chapter 16

GENERIC TECHNICAL SPECIFICATIONS AND BASES

MARCH 21-22, 2017

- **Technical Staff Presenters**
 - ◆ Craig Harbuck
 - ◆ Bob Tjader

- **Project Managers**
 - ◆ Jeff Ciocco – Lead Project Manager
 - ◆ Jessica Umaña – Chapter 16 Project Manager

Staff Review Team

- ◆ **Primary Reviewers**

- ◆ **Technical Specifications Branch*** Craig Harbuck, Bob Tjader
- ◆ **Plant Systems Branch** Rick Scully, Hien Le

- **Secondary Reviewers**

- ◆ **Containment and Ventilation Branch** Nan Chien, Raj Goel,
 Anne-Marie Grady, Syed Haider, Boyce Travis
- ◆ **Mechanical Engineering Branch** Tuan Le, James Strnisha
- ◆ **Radiation Protection and Accident Consequences Branch** ... Michelle Hart
- ◆ **Reactor Systems, Nuclear Performance, and Code Review Branch**
 Matt Thomas, Carl Thurston, Alexandra Burja
- ◆ **Instrumentation, Controls, and Electrical Engineering Branch**
 Joe Ashcraft, Ken Mott, Jack Zhao
- ◆ **Plant Systems Branch** Angelo Stubbs
- ◆ **Probabilistic Risk Assessment Branch** Marie Pohida
- ◆ **Electrical Engineering Branch**** Swagata Som
- ◆ **Materials & Chemical Engineering Branch** Greg Makar

* Center of expertise NRR/DSS/STSB

** Center of expertise NRR/DE/EEEB

- **Outline**

- ◆ Overview of Chapter 16 (Bob Tjader)
- ◆ Technical Topics (Craig Harbuck)
 - Defined Terms
 - Requirements to Mitigate Shutdown Risk
 - Requirements to Preclude or Mitigate Inadvertent Reactor Coolant Boron Dilution
 - Reactor Trip System and ESFAS Surveillance Requirements
 - Control Element Assembly Calculator (CEAC) and Core Protection Calculator (CPC) Action Requirements
 - Auxiliary Feedwater (AFW) System
 - Control Room HVAC System (CRHS)
 - Accident Monitoring Instrumentation
 - Setpoint Methodology for Limiting Safety System Settings
 - General Issues
- ◆ Review Status Summary (Bob Tjader)

Overview of Design Certification Application Chapter 16

DCD Chapter 16 42, 43, 44, 45, 8587, 8591, 8592

1.0 USE AND APPLICATION

1.1 Definitions 30

1.2 Logical Connectors

1.3 Completion Times

1.4 Frequency

Open Item Key:

Color red means editorial only.

Underline means issue affects multiple requirements.

2.0 SAFETY LIMITS (SLs)

2.1 SLs

2.1.1 Reactor Core SLs

2.1.2 RCS Pressure SL 58

2.2 SL Violations

3.0 LCO APPLICABILITY

LCO 3.0.1

LCO 3.0.2

LCO 3.0.3

LCO 3.0.4 STS Revision 2 version; TSTF-359

LCO 3.0.5

LCO 3.0.6

LCO 3.0.7

LCO 3.0.8

LCO 3.0.9 34, 44

Overview of Design Certification Application Chapter 16

3.0 SR APPLICABILITY

- SR 3.0.1
- SR 3.0.2
- SR 3.0.3
- SR 3.0.4

3.1 REACTIVITY CONTROL SYSTEMS

- 3.1.1 SHUTDOWN MARGIN (SDM) [171](#)
- 3.1.2 Reactivity Balance [60, 171](#)
- 3.1.3 Moderator Temperature Coefficient (MTC) [171](#)
- 3.1.4 Control Element Assembly (CEA) Alignment [44, 72.2, 171](#)
- 3.1.5 Shutdown CEA Insertion Limits [171](#)
- 3.1.6 Regulating CEA Insertion Limits [171](#)
- 3.1.7 Part Strength CEA Insertion Limits [74, 171](#)
- 3.1.8 Charging Flow [15.4.6-1, 15.4.6-7, 42, 139.1, 139.2, 139.3, 139.4, 139.5, 171](#)
- 3.1.9 Special Test Exception (STE) – SDM [171](#)
- 3.1.10 STE – MODES 1 and 2 [171](#)
- 3.1.11 STE – Reactivity Coefficient Testing [171](#)
- 3.1.12 Unborated Water Source Isolation Valve [15.4.6-1](#)

3.2 POWER DISTRIBUTION LIMITS

- 3.2.1 Linear Heat Rate (LHR)
- 3.2.2 Planar Radial Peaking Factors (F_{xy})
- 3.2.3 AZIMUTHAL POWER TILT (T_q)
- 3.2.4 Departure from Nucleate Boiling Ratio (DNBR) [125](#)
- 3.2.5 AXIAL SHAPE INDEX (ASI)

Overview of Design Certification Application Chapter 16

3.3 INSTRUMENTATION	<u>137.1</u>
3.3.1 Reactor Protection System (RPS) Instrumentation – Operating	<u>42</u> , 92, <u>137.1</u>
3.3.2 RPS Instrumentation - Shutdown	
3.3.3 Control Element Assembly Calculators (CEACs)	103.2
3.3.4 RPS Logic and Trip Initiation	
3.3.5 Engineered Safety Features Actuation System (ESFAS) Instrumentation	112.5 , 112.6 , 153.1 ,
3.3.6 ESFAS Logic and Manual Trip	112.4, 114.4, 115.1, 115.2, 115.3 , 116, 117.2, 117.3, 117.4 , 117.5 , 122.3a, 122.3b, 122.3c, 122.3d, 122.3e, 153.3
3.3.7 Emergency Diesel Generator (EDG) – Loss of Voltage Start (LOVS)	110.2, 110.4
3.3.8 Containment Purge Isolation Actuation Signal (CPIAS)	159
3.3.9 Control Room Emergency Ventilation Actuation Signal (CREVAS)	134.2 , 134.5, 134.6 , 134.7
3.3.10 Fuel Handling Area Emergency Ventilation Actuation Signal (FHEVAS)	135.4, 135.5, 135.8
3.3.11 Accident Monitoring Instrumentation (AMI)	7.5-1, 7.5-6, 123.1a, 123.1b,
3.3.12 Remote Shutdown Display and Control	7.4-8
3.3.13 Logarithmic Power Monitoring Channels	113.1, 15.4.6-7
3.3.14 Boron Dilution Alarms	15.4.6-1, 15.4.6-7, 113.1

Overview of Design Certification Application Chapter 16

3.4 REACTOR COOLANT SYSTEM (RCS)	23.24
3.4.1 RCS Pressure, Temperature, and Flow Limits	23.1, 23.2, 23.3, 23.5, 23.6
3.4.2 RCS Minimum Temperature for Criticality	23.7, 145.1
3.4.3 RCS Pressure and Temperature (P/T) Limits	
3.4.4 RCS Loops – MODES 1 and 2	
3.4.5 RCS Loops – MODE 3	23.8, 23.9
3.4.6 RCS Loops – MODE 4	23.10, 23.11, 23.12
3.4.7 RCS Loops – MODE 5 (Loops Filled)	23.13, 23.14, 23.15, 149.2K
3.4.8 RCS Loops – MODE 5 (Loops Not Filled)	140, 149.2C, 149.2K,
3.4.9 Pressurizer	
3.4.10 Pressurizer Pilot Operated Safety Relief Valves	23.19, 23.20a, 23.20b, 23.20c, 23.20d, 23.20e, 23.20f, 23.20g, 23.21
3.4.11 Low Temperature Overpressure Protection System	152.1b, 152.2a, 152.2b
3.4.12 RCS Operational LEAKAGE	15.0.3-2d
3.4.13 RCS Pressure Isolation Valve (PIV) Leakage	
3.4.14 RCS Leakage Detection Instrumentation	143.10
3.4.15 RCS Specific Activity	
3.4.16 Reactor Coolant Gas Vent (RCGV) Function	23.22a, 23.22b, 23.22d, 152.3, 152.4, 152.5, 152.6
3.4.17 Steam Generator Tube Integrity	

Overview of Design Certification Application Chapter 16

3.5 EMERGENCY CORE COOLING SYSTEM (ECCS)

3.5.1 Safety Injection Tanks (SITs)	6.3-10, 17, 46
3.5.2 Safety Injection System (SIS) – Operating	210
3.5.3 Safety Injection System (SIS) – Shutdown	149.2H, 149.2I
3.5.4 In-Containment Refueling Water Storage Tank (IRWST)	6.3-10, 149.2L
3.5.5 Trisodium Phosphate (TSP)	

3.6 CONTAINMENT SYSTEMS

3.6.1 Containment	
3.6.2 Containment Air Locks	
3.6.3 Containment Isolation Valves (CIVs)	
3.6.4 Containment Pressure	
3.6.5 Containment Air Temperature	
3.6.6 Containment Spray System	TSTF-523, 140.1, 140.2
3.6.7 Containment Penetrations – Shutdown Operations	25.4, 25.5, 149.1, 149.2G

Overview of Design Certification Application Chapter 16

3.7 PLANT SYSTEMS

3.7.1 Main Steam Safety Valves (MSSVs)	150.1
3.7.2 Main Steam Isolation Valves (MSIVs)	
3.7.3 Main Feedwater Isolation Valves (MFIVs)	
3.7.4 Main Steam Atmospheric Dump Valves (MSADVs)	
3.7.5 Auxiliary Feedwater System (AFWS)	150.2, 150.3, 154.1b, 154.1c, 154.1d, 154.1e, 154.1f, 154.1g
3.7.6 Auxiliary Feedwater Storage Tanks (AFWSTs)	154.4, 154.5, 154.6
3.7.7 Component Cooling Water System (CCWS)	
3.7.8 Essential Service Water System (ESWS)	
3.7.9 Ultimate Heat Sink (UHS)	<u>44</u>
3.7.10 Essential Chilled Water System (ECWS)	
3.7.11 Control Room HVAC System (CRHS)	24.12, 223.3b, 223.4a, 223.4b, 223.4c, 223.4e, 223.5b, 223.8, 223.12, 223.16, 223.17a, 223.17c, 223.17d
3.7.12 Auxiliary Building Controlled Area Emergency Exhaust System (ABCAEES)	
3.7.13 Fuel Handling Area Emergency Exhaust System (FHAEES)	
3.7.14 Spent Fuel Pool Water Level (SFPWL)	
3.7.15 Spent Fuel Pool Boron Concentration	
3.7.16 Spent Fuel Assembly Storage	
3.7.17 Secondary Specific Activity	

Overview of Design Certification Application Chapter 16

3.8 ELECTRICAL POWER SYSTEMS

3.8.1 AC Sources – Operating	106a, <u>141.1</u> , 141.2
3.8.2 AC Sources - Shutdown	
3.8.3 Diesel Fuel Oil, and Starting Air	
3.8.4 DC Sources – Operating	<u>141.1</u>
3.8.5 DC Sources – Shutdown	<u>141.1</u>
3.8.6 Battery Cell Parameters	<u>141.1</u>
3.8.7 Inverters - Operating	
3.8.8 Inverters – Shutdown	B 3.8.8 Applicability section
3.8.9 Distribution Systems – Operating	<u>141.1</u>
3.8.10 Distribution Systems – Shutdown	

3.9 REFUELING OPERATIONS

3.9.1 Boron Concentration	
3.9.2 Nuclear Instrumentation	
3.9.3 Containment Penetrations	
3.9.4 SCS and Coolant Circulation – High Water Level	
3.9.5 SCS and Coolant Circulation – Low Water Level	140.5, 149.2, 149.2M
3.9.6 Refueling Water Level	
3.9.7 Unborated Water Source Isolation Valve	15.4.6-1, 15.4.6-7
3.9.8 Decay Time	

Overview of Design Certification Application Chapter 16



4.0 DESIGN FEATURES 44

4.1 Site Location

4.2 Reactor Core

- 4.2.1 Fuel Assemblies
- 4.2.2 Control Rod Assemblies

4.3 Fuel Storage

- 4.3.1 Criticality
- 4.3.2 Drainage
- 4.3.3 Capacity

5.0 ADMINISTRATIVE CONTROLS

5.1 Responsibility

5.2 Organization

- 5.2.1 Onsite and Offsite Organizations
- 5.2.2 Unit Staff

5.3 Unit Staff Qualifications

5.4 Procedures

5.5 Programs and Manuals

- 5.5.1 Offsite Dose Calculation Manual
- 5.5.2 Primary Coolant Sources Outside Containment
- 5.5.3 Post-Accident Sampling
- 5.5.4 Radioactive Effluent Control Program
- 5.5.5 Component Cyclic or Transient Limit
- 5.5.6 Pre-Stressed Concrete Containment Tendon...
- 5.5.7 Reactor Coolant pump Flywheel Inspection ...
- 5.5.8 Inservice Testing Program
- 5.5.9 Steam Generator Program
- 5.5.10 Secondary Water Chemistry Program
- 5.5.11 Ventilation Filter Testing Program

5.5.12 Explosive Gas and Storage Tank Monitoring

5.5.13 Diesel Fuel Oil Testing Program

5.5.14 TS Bases Control Program

5.5.15 Safety Function Determination Program

5.5.16 Containment Leakage Rate Testing Program

5.5.17 Battery Monitoring and Maintenance Program

5.5.18 Control Room Envelope Habitability Program

5.5.19 Setpoint Control Program setpoint methodology

5.6 Reports

5.6.1 Annual Radiological Environmental Operating Report

5.6.2 Radiological Effluent Release Report

5.6.3 Core Operating Limits Report (COLR)

5.6.4 RCS Pressure and Temperature Limits Report (PTLR)

5.6.5 Accident Monitoring Report

5.6.6 Tendon Surveillance Report

5.6.7 Steam Generator Tube Inspection Report

5.7 High Radiation Area

Technical Topics

Defined Terms

- Revised definitions:
 - ♦ OPERABLE–OPERABILITY --- [Open Item 16-30](#)
 - ♦ MODE
 - ♦ CORE ALTERATIONS
- New definition: MID-LOOP --- [Open Item 16-139.5](#)
 - ♦ Reactor vessel (RV) level \leq 119 ft 1 in
 - ♦ \leq top of hot leg at junction to RV
 - ♦ \geq minimum level for SC train operation (117 ft 4 in)
- Withdrawn proposed definition: REDUCED RCS INVENTORY (Generic Letter 88-17, Loss of Decay Heat Removal)
 - ♦ RV level \leq 127 ft $\frac{1}{4}$ in
 - ♦ \geq 3 ft below top of RV flange (130 ft $\frac{1}{4}$ in)
 - ♦ KHNP uses the RG value of 3 ft below top of RV flange as being suitable for APR1400 RCS
 - ♦ Top of fuel assemblies is 112 ft 3.3 in

Technical Topics

Requirements to Mitigate Shutdown Risk

- Shutdown Evaluation Report (APR1400-E-N-NR-14005-P)
- **New requirements affect GTS Subsections:**
 - ♦ **3.1.8, Charging Flow --- Open Item**
MODE 5 with reactor vessel level ≤ 119 ft 1 in [hot leg level indication $\leq 100\%$].
 - ♦ **3.4.8, RCS Loops – MODE 5 (Loops Not Filled) --- Open Item**
 - ♦ **3.5.3, Safety Injection (SI) System -- Shutdown**
 - ♦ **3.5.4, In-Containment Refueling Water Storage Tank (IRWST)**
MODES 4 and 5,
MODE 6 with reactor vessel (RV) level $\frac{1}{4}$ inch below the top of the RV flange.
 - ♦ **3.6.7, Containment Penetrations – Shutdown Operations ***
MODE 5 with RCS loops not filled,
MODE 6 with water level < 23 ft above the top of the RV flange.
 - ♦ **3.9.3, Containment Penetrations**
During CORE ALTERATIONS,
During movement of irradiated fuel assemblies within containment.
 - ♦ **3.9.4, Shutdown Cooling System (SCS) and Coolant Circulation – High Water Level**
MODE 6 with water level ≥ 23 ft above the top of the RV flange
 - ♦ **3.9.5, SCS and Coolant Circulation – Low Water Level**
MODE 6 with water level < 23 ft above the top of the RV flange

* LCO 3.6.7 was initially proposed to only apply with RV level ≤ 127 ft $\frac{1}{4}$ in

Technical Topics

Requirements to Mitigate Shutdown Risk (continued) (2 of 5)

Applicability of operability and action requirements for shutdown cooling (SC) trains and safety injection (SI) trains in MODES 5 and 6 are tied to RCS water level and temperature, and time since reactor shutdown, to address concerns of GL 88-17

MODE 5 Operability Requirements:

- MODE 5: LCO 3.5.3 requires two operable diagonally oriented manually initiated SI trains and LCO 3.5.4 requires IRWST to be operable
- MODE 5 (Loops Filled): LCO 3.4.7 requires one operable SC train in operation and either another operable SC train, OR both steam generators with water level $\geq 25\%$ wide range
- MODE 5 (Loops Not Filled, RV level ≥ 127 ft $\frac{1}{4}$ in): LCO 3.4.8 requires two operable SC trains with one train in operation; LCO 3.6.7 requires containment closure and that the equipment hatch be closed before opening pressurizer manway
- MODE 5 (Loops Not Filled, RV level < 127 ft $\frac{1}{4}$ in): LCO 3.4.8 **also** requires an operable CS pump in the same electrical division as the running SC train

continued

Technical Topics

Requirements to Mitigate Shutdown Risk (continued) (3 of 5)

MODE 5 Operability Requirements (continued):

- MODE 5 (Loops Not Filled, RV level < 119 ft 1 in): LCO 3.4.8 **also** requires the reactor to have been shutdown for ≥ 96 hours and that cold leg temperature is $\leq 135^{\circ}\text{F}$ **before** entering (and while in) MID-LOOP condition; LCO 3.1.8 requires closure of the bypass valves for the charging flow restricting orifices to limit charging flow to ≤ 150 gpm

MODE 5 Action Requirements:

- MODE 5: LCO 3.5.3 and LCO 3.5.4 Actions include within 24 hours reducing RCS cold leg temperature to $< 135^{\circ}\text{F}$
- MODE 5 (Loops Filled): LCO 3.4.7 Actions include immediately initiating action to meet the LCO (restore core heat removal)
- MODE 5 (Loops Not Filled, 127 ft $\frac{1}{4}$ in < RV level < 130 ft 0 in): LCO 3.4.8 Actions include immediately initiating action to restore an SC train to operable status and operation; LCO 3.5.3 and LCO 3.5.4 Actions **also** include immediately initiating action to restore RCS level to > 130 ft 0 in

continued

Technical Topics

Requirements to Mitigate Shutdown Risk (continued) (4 of 5)

MODE 5 Action Requirements (continued):

- MODE 5 (Loops Not Filled, 119 ft 1 in < RV level \leq 127 ft 1/4 in): LCO 3.4.8 Actions require immediately initiating action to raise RCS level to > 127 ft 1/4 in – [Open Item 16-149.2C2 \(3.4.8 Required Action B.3\)](#)
- MODE 5 (Loops Not Filled, 119 ft 1 in < RV level \leq 127 ft 1/4 in): LCO 3.4.8 Actions **also** include that – unless the required CS pump is restored to operable status within 48 hours – RCS level be raised to > 127 ft 1/4 in within 6 hours; LCO 3.6.7 Actions include that – unless a containment penetration is restored to the required status within 4 hours – RCS level be raised to > 127 ft 1/4 in within 6 hours (Required Action B.1)
- MODE 5 (Loops Not Filled, 117 ft 4 in < RV level \leq 119 ft 1 in): LCO 3.4.8 Actions **also** require that if \leq 96 hours since reactor shutdown or core exit temperature is > 135°F (new Condition E), immediately initiating action to restore core exit temperature to \leq 135°F, and immediately initiating action to raise RCS level above MID-LOOP condition (> 119 ft 1 in)

continued

Technical Topics

Requirements to Mitigate Shutdown Risk (continued) (5 of 5)

A discussion of operability and action requirements in MODE 6 is similar, involving LCO 3.5.3, 3.5.4, 3.6.7, 3.9.3, 3.9.4, 3.9.5, and 3.9.6

- **3.4.7, 3.4.8, 3.6.7 Applicability -- Open Item 16-149.2K:**
 - Bases for Subsection 3.4.7 should describe unit configurations in MODE 5 covered by 'loops filled'
 - Bases for Subsections 3.4.8 and 3.6.7 should describe unit configurations in MODE 5 covered by 'loops not filled'
 - Status of pressurizer manway, steam generator manways, reactor coolant gas vent (RCGV) valves, and RCS level

Technical Topics

Requirements to Preclude or Mitigate Inadvertent Reactor Coolant Boron Dilution

- New requirements
 - ♦ 3.1.8, Charging Flow – **Open Item***
MODE 5 with reactor vessel level ≤ 119 ft 1 in [hot leg level indication $\leq 100\%$].
 - ♦ 3.1.12, Unborated Water Source Isolation Valve – **Open Item***
MODES 4 and 5 with all reactor coolant pumps (RCPs) idle.
 - ♦ 3.3.14, Boron Dilution Alarm System (BDAS) – **Open Item***
MODE 3 within 1 hour after neutron flux is within the startup range following a reactor shutdown,
MODES 4 and 5.
 - ♦ 3.9.7, Unborated Water Source Isolation Valve – **Open Item***
MODE 6
- Requirements derived from STS
 - ♦ 3.3.13, Logarithmic Power Monitoring Channels
MODES 3, 4, and 5 with the reactor trip circuit breakers (RTCBs) open or Control Element Assembly (CEA) Drive System not capable of CEA withdrawal.
 - ♦ 3.9.1, Boron Concentration (MODE 6)
 - ♦ 3.9.2, Nuclear Instrumentation (MODE 6)

* **Open Item 15.4.6-1** (RAI 17-7917)

Technical Topics

Reactor Trip System and ESFAS Surveillance Requirements

- Correlation of instrumentation SRs and Testing described by DCD Tier 2, and related I&C technical reports ([Open Item 16-137.1](#))
 - ◆ CHANNEL CALIBRATION
 - ◆ CHANNEL FUNCTIONAL TEST
 - ◆ ACTUATION LOGIC TEST
 - ◆ DCD Section 7.2 - Reactor Trip System
 - Section 7.2.2.5
 - Figure 7.2-11 RPS Testing Overlap
 - Figure 7.2-16 Manual Reactor Trip Initiation Diagram
 - ◆ DCD Section 7.3 - Engineered Safety Features Actuation System
 - Section 7.3.2.5
 - Figure 7.3-22, ESF-CCS Simplified Test Logic Diagram
 - Figure 7.3-24 ESF-CCS Actuation Test Logic Diagram

continued

Technical Topics

Reactor Trip System and ESFAS Surveillance Requirements (continued)

- ESFAS Actuation Logic Test of Subgroups of ESF components or trains ([Open Items 16-112.4, 16-122.3d](#) -- clarify term “subgroup” as used by SR 3.3.6.2 and surveillance column Note 2)
 - “2. Subgroup of Actuation Logic channel A, C and B, D shall be tested on a staggered basis.”
 - Need assistance from applicant understanding subgroup designators in provided list of ESF actuated components

Technical Topics

Control Element Assembly Calculator (CEAC) and Core Protection Calculator (CPC) Action Requirements

- Each CPC channel is supported by two dedicated CEACs (4 CPC channels, 8 CEACs)
- Action requirement preferences clarified in Bases
 - ♦ Declare affected CPC channel inoperable in 1 hour, and within 1 hour, place associated trip channel for reactor trip Functions (DNBR – Low, and LPD – High) in bypass per LCO 3.3.1 Required Action A.1
 - One CPC channel with one CEAC inoperable (Required Action A.1)
 - One CPC channel with both CEACs inoperable (Required Action B.1)
 - ♦ Else, take Required Action A.2 or B.2, as appropriate
 - Clarification needed – is it permissible to choose to exit Actions of LCO 3.3.1, and continue under LCO 3.3.3 Required Action A.2 or B.2, since each affected CPC channel is technically still operable --- [Open Item 16-103.2](#)

Technical Topics

Auxiliary Feedwater (AFW) System

- **AFW System Design**
 - ◆ Two AFW mechanical divisions
 - ◆ Each AFW system division has two diverse trains supplied by its own AFW Storage Tank (AFWST) to provide feedwater to one associated steam generator
 - ◆ The AFWST of one division cannot be directly aligned to supply pumps in the other division – [Open Item 16-154.5 \(Justify 7 days to restore one AFWST\)](#)
 - AFWST#1 and AFWST#2 may be manually connected using a pipe between the bottoms of both tanks
 - ◆ SG#1 provides steam to only the turbine driven pump in AFW division 1
SG#2 provides steam to only the turbine driven pump in AFW division 2
 - ◆ Class 1E ac electrical division I powers the motor driven pump in AFW division 1
Class 1E ac electrical division II powers the motor driven pump in AFW division 2

continued

Technical Topics

Auxiliary Feedwater (AFW) System (continued)

- **Open Items 16-154.1b, 1c, 1d, 1e, 1f, 1g**
 - ♦ (1b) The 7 day Completion Time to restore an inoperable steam supply to the one turbine driven pump of the STS-assumed AFW system design is not appropriate for one inoperable turbine driven pump in the APR1400 AFW system design
 - ♦ (1c) STS typically specify 72 hours to correct a loss of redundancy condition
 - One or both SGs with one AFW train inoperable for APR1400
 - ♦ (1d) The Condition of one SG with two AFW trains inoperable may warrant a Completion Time of < 72 hours to restore one train to operable status
 - ♦ (1e, 1f, 1g) are editorial changes to conform to STS phrasing conventions

Technical Topics

Control Room HVAC System (CRHS)

- Control Room HVAC System (CRHS) operability, action, and surveillance requirements
- Interlock to start the standby CRHS division air handling unit (AHU) and air cleaning unit (ACU) fans upon failure of the operating CRHS division after CREVAS actuation signal to initiate filtered ventilation
 - ♦ Should there be an LCO *explicitly* requiring this interlock to be operable, along with appropriate actions and surveillances? ([Open Item 16-223.4e](#))
 - ♦ When can operator manual action be credited after the start of an AOO or a DBA in the APR1400 safety analyses?
- Dependency of the two AHU fan trains in a division on a common division of the essential chilled water system ([Open Item 16-223.3b](#))

Technical Topics

Accident Monitoring Instrumentation

- Accident Monitoring Instrument (AMI) Functions
 - ♦ Types A, B, and C variable selection based on
 - Regulatory Guide 1.97, “Criteria for Accident Monitoring Instrumentation for Nuclear Power Plants,” Revision 4, June 2006, which endorses
 - IEEE Std. 497-2002, “IEEE Standard Criteria for Accident Monitoring Instrumentation for Nuclear Power Generating Stations,” 2002
 - ♦ Type A variable relied on by operator to perform manual actions credited in transient and safety analyses as described in DCD Tier 2
 - ♦ Type B and C variables needed by operator to implement emergency operating procedures (EOPs), which are derived from APR1400 Emergency Procedure Guidelines (EPGs)
- AMI Function list in GTS Table 3.3.11-1 must be consistent with the AMI variable list in DCD Section 7.5, Table 7.5-1
- Status of DCD Section 7.5 and EPG review by
 - ♦ Instrumentation, Controls, and Electrical Engineering Branch (ICE); and
 - ♦ Reactor Systems, Nuclear Performance, and Code Review Branch (SRSB)

Technical Topics

Setpoint Methodology for Limiting Safety System Settings

- Subsection 5.5.19, Setpoint Control Program, lists the staff-approved Setpoint Methodology related technical reports (TeR):
 - ♦ ARP1400-F-C-NR-14001P, Rev. 0, “CPC Setpoint Analysis Methodology for APR1400,” July 2014
 - ♦ APR1400-Z-J-NR-14004-P, Rev. 0, “Uncertainty Methodology and Application for Instrumentation,” November 2014
 - ♦ APR1400-Z-J-NR-14005-P, Rev. 0, “Setpoint Methodology for Plant Protection System,” November 2014
- TeR Audit in progress or just completed
 - ♦ Review status to be provided by ICE and SRSB
- Key issues
 - ♦ Selection of “margin” from the AV (draft NTSP, or LTSP) to calculate NTSP
 - ♦ Statistics for combining uncertainties

Technical Topics

General Issues

- Combined License (COL) action item determination –
[Open Item 16-44](#)
- Disposition of NRC-approved technical specifications task force (TSTF) traveler changes – [Open Item 16-43](#)
 - ♦ which have been incorporated in NUREG-1432 (digital), Revision 4; or
 - ♦ approved since issuance of NUREG-1432 (digital), Revision 4.
- Administrative Changes –
 - ♦ [Open Items 507-8587, 509 8591, and 508-8592](#)
 - ♦ Correction of grammatical and typographical errors
 - ♦ Replacement of inapplicable content taken from STS Bases
 - ♦ Addition of missing content to the Bases
 - ♦ Clarification of submitted content in the Bases
 - ♦ Conformance to STS style, punctuation, phrasing and formatting conventions
 - ♦ Resolution of inconsistencies, both within Chapter 16 and with the DCD



Technical Topics

General Issues (continued)

- Application of LCO selection criteria – **Open Item 16-42**
 - ♦ Systematic evaluation of design and safety analyses against the LCO selection criteria was not done
 - ♦ Core Protection Calculator (CPC) Auxiliary Trip Functions
 - ❑ DCD Tier 2, Table 7.2-4, RPS Design Inputs
 - ❑ Bases should explain whether operability and testing of CPC Auxiliary Trip Functions are required by GTS Subsection 3.3.1 as part of the reactor trip Functions of Low DNBR and High LPD in MODES 1 and 2
 - ♦ Charging flow Hi-Hi instrumentation (See 16-139.3; Subsection B 3.1.8)
 - Automatic closure of flow restriction orifice bypass valve to limit charging flow to 180 gpm
 - ♦ Based on ... DCD Tier 2, Section 15.4, and the applicant's response to RAI 340-8395, Question 15.4.8-5, it appears that the CPC VOPT Function, as well as the RPS VOPT Function, ought to be explicitly required by LCO 3.3.1 in Table 3.3.1-1.
- Deviation Report (Comparison of GTS and STS) – **Open Item 16-43**
 - ♦ Addresses Specifications only; Bases not included
 - ♦ Insufficient to conclude that proposed GTS satisfy 10 CFR 50.36(c)(2)(ii)



Chapter 16 Review Status SUMMARY

- The APR1400 Generic Technical Specifications are based upon the Digital CE Standard Technical Specifications; differences are a result of design differences with CE digital plant design considered in the STS and the applicant's applied operating experience
- A thorough review of the APR1400 GTS has been conducted resulting in a safety evaluation chapter that includes open items in the following areas:
 - New Definitions (i.e., MID-LOOP) resulting in numerous LCO differences and operational MODES based upon RCS cold leg versus average temperature)
 - Adequacy of RCS water level of 127 ft $\frac{1}{4}$ in, with loss of SC, but with SI operable
 - Requirements to prevent inadvertent reactor coolant boron dilution
 - I&C surveillance requirements & testing
 - ESFAS Actuation Logic of components/trains
 - AFW Required Actions & Completion Times appropriate to the APR1400 design
 - CRHS Required Actions and Surveillances
 - Accident monitoring instrumentation requirements
 - Application of LCO selection criteria, TSTF disposition & COL action items
 - Administrative and editorial differences
- Resolution of the Open Items will be accomplished with the assistance of the technical branches (i.e., ICE, SRSB, SPRA, SCVB, SPSB and EEEB)