



International Agreement Report

TRACE/RELAP5 Comparative Calculations For Double-Ended LBLOCA and SBO

Prepared by:

S. Iegan, A. Mazur,
Y. Vorobyov, O. Zhabin, S. Yanovskiy

State Nuclear Regulatory Inspectorate of Ukraine
And State Scientific and Technical Center
for Nuclear and Radiation Safety of Ukraine
9/11 Arsenalna str. Kyiv, Ukraine 01011

K. Tien, NRC Project Manager

**Division of Systems Analysis
Office of Nuclear Regulatory Research
U.S. Nuclear Regulatory Commission
Washington, DC 20555-0001**

Manuscript Completed: February 2016

Date Published: November 2016

Prepared as part of
The Agreement on Research Participation and Technical Exchange
Under the Thermal-Hydraulic Code Applications and Maintenance Program (CAMP)

**Published by
U.S. Nuclear Regulatory Commission**

AVAILABILITY OF REFERENCE MATERIALS IN NRC PUBLICATIONS

NRC Reference Material

As of November 1999, you may electronically access NUREG-series publications and other NRC records at the NRC's Public Electronic Reading Room at <http://www.nrc.gov/reading-rm.html>. Publicly released records include, to name a few, NUREG-series publications; *Federal Register* notices; applicant, licensee, and vendor documents and correspondence; NRC correspondence and internal memoranda; bulletins and information notices; inspection and investigative reports; licensee event reports; and Commission papers and their attachments.

NRC publications in the NUREG series, NRC regulations, and Title 10, "Energy," in the *Code of Federal Regulations* may also be purchased from one of these two sources.

1. The Superintendent of Documents

U.S. Government Publishing Office
Mail Stop SSOP
Washington, DC 20402-0001
Internet: <http://bookstore.gpo.gov>
Telephone: 1-866-512-1800
Fax: (202) 512-2104

2. The National Technical Information Service

5301 Shawnee Road
Alexandria, VA 22161-0002
<http://www.ntis.gov>
1-800-553-6847 or, locally, (703) 605-6000

A single copy of each NRC draft report for comment is available free, to the extent of supply, upon written request as follows:

U.S. Nuclear Regulatory Commission

Office of Administration
Publications Branch
Washington, DC 20555-0001
E-mail: distribution_resource@nrc.gov
Facsimile: (301) 415-2289

Some publications in the NUREG series that are posted at the NRC's Web site address <http://www.nrc.gov/reading-rm/doc-collections/nuregs> are updated periodically and may differ from the last printed version. Although references to material found on a Web site bear the date the material was accessed, the material available on the date cited may subsequently be removed from the site.

Non-NRC Reference Material

Documents available from public and special technical libraries include all open literature items, such as books, journal articles, transactions, *Federal Register* notices, Federal and State legislation, and congressional reports. Such documents as theses, dissertations, foreign reports and translations, and non-NRC conference proceedings may be purchased from their sponsoring organization.

Copies of industry codes and standards used in a substantive manner in the NRC regulatory process are maintained at—

The NRC Technical Library

Two White Flint North
11545 Rockville Pike
Rockville, MD 20852-2738

These standards are available in the library for reference use by the public. Codes and standards are usually copyrighted and may be purchased from the originating organization or, if they are American National Standards, from—

American National Standards Institute

11 West 42nd Street
New York, NY 10036-8002
<http://www.ansi.org>
(212) 642-4900

Legally binding regulatory requirements are stated only in laws; NRC regulations; licenses, including technical specifications; or orders, not in NUREG-series publications. The views expressed in contractor-prepared publications in this series are not necessarily those of the NRC.

The NUREG series comprises (1) technical and administrative reports and books prepared by the staff (NUREG-XXXX) or agency contractors (NUREG/CR-XXXX), (2) proceedings of conferences (NUREG/CP-XXXX), (3) reports resulting from international agreements (NUREG/IA-XXXX), (4) brochures (NUREG/BR-XXXX), and (5) compilations of legal decisions and orders of the Commission and Atomic and Safety Licensing Boards and of Directors' decisions under Section 2.206 of NRC's regulations (NUREG-0750).

DISCLAIMER: This report was prepared under an international cooperative agreement for the exchange of technical information. Neither the U.S. Government nor any agency thereof, nor any employee, makes any warranty, expressed or implied, or assumes any legal liability or responsibility for any third party's use, or the results of such use, of any information, apparatus, product or process disclosed in this publication, or represents that its use by such third party would not infringe privately owned rights.



International Agreement Report

TRACE/RELAP5 Comparative Calculations for Double-Ended LBLOCA and SBO

Prepared by:

S. Iegan, A. Mazur,
Y. Vorobyov, O. Zhabin, S. Yanovskiy

State Nuclear Regulatory Inspectorate of Ukraine
And State Scientific and Technical Center
for Nuclear and Radiation Safety of Ukraine
9/11 Arsenalna str. Kyiv, Ukraine 01011

K. Tien, NRC Project Manager

**Division of Systems Analysis
Office of Nuclear Regulatory Research
U.S. Nuclear Regulatory Commission
Washington, DC 20555-0001**

Manuscript Completed: February 2016

Date Published: November 2016

Prepared as part of
The Agreement on Research Participation and Technical Exchange
Under the Thermal-Hydraulic Code Applications and Maintenance Program (CAMP)

**Published by
U.S. Nuclear Regulatory Commission**

ABSTRACT

This report is developed by the State Nuclear Regulatory Inspectorate of Ukraine (SNRIU) and its technical support organization, the State Scientific and Technical Center for Nuclear and Radiation Safety of Ukraine (SSTC NRS), under Implementing Agreement On Thermal-Hydraulic Code Applications And Maintenance Between The United States Nuclear Regulatory Commission and State Nuclear Regulatory Inspectorate of Ukraine (signed in 2014) in accordance with Article III, Section C, of the Agreement.

The report provides description of quantitative analysis results of two initiating events for VVER-1000 reactor system with application of TRACE p4 and RELAP5/MOD3.2 codes. For these calculations RELAP5 input model for VVER-1000 was converted to TRACE code. The results obtained with both codes were compared to evaluate differences and to identify future needs for TRACE input deck enhancement.

CONTENTS

ABSTRACT	iii
LIST OF FIGURES	vii
LIST OF TABLES	viii
ABBREVIATIONS AND ACRONYMS	ix
1 INTRODUCTION	1-1
2 BRIEF DESCRIPTION OF TRACE MODEL FOR VVER-1000	2-1
2.1 Reactor	2-1
2.2 Main Coolant Piping	2-3
2.3 Pressurizer System	2-5
2.4 Steam Generator.....	2-6
2.5 Make-Up and Let-Down	2-8
2.6 Emergency Gas Removal System.....	2-8
2.7 Main Steam Lines.....	2-9
2.8 Main Steam Header	2-12
2.9 Main, Auxiliary and Emergency Feedwater Systems.....	2-13
2.10 Emergency Core Flooding System	2-14
2.11 High Pressure Injection System.....	2-15
2.12 Low Pressure Injection System.....	2-15
2.13 Safeguards and Control Systems Operation Logic	2-16
3 TRACE MODEL STEADY STATE CALCULATIONS	3-1
4 ANALYSIS RESULTS	4-1
4.1 Station Blackout.....	4-1
4.2 Double-Ended LB LOCA	4-7
5 DISCUSSION	5-1
5.1 SBO	5-1
5.2 LB LOCA.....	5-1
5.3 Future Plans.....	5-1
6 CONCLUSIONS	6-1
7 REFERENCES	7-1

LIST OF FIGURES

Figure 1	Nodalization Diagram of VVER-1000 (V-320).....	2-2
Figure 2	Nodalization Diagram of RCS Loop 1	2-3
Figure 3	Nodalization Diagram of RCS Loop 2	2-4
Figure 4	Nodalization Diagram of RCS Loop 3	2-4
Figure 5	Nodalization Diagram of RCS Loop 4, Connecting Pipe and Pressurizer	2-5
Figure 6	Nodalization Diagram of the Pressurizer Spray Line	2-6
Figure 7	Nodalization Diagram of SG Primary Side	2-6
Figure 8	Nodalization Diagram of SG Secondary Side	2-7
Figure 9	Nodalization Diagram of Makeup and Let-down	2-8
Figure 10	Nodalization Diagram of Emergency Gas Removal System	2-9
Figure 11	Nodalization Diagram of Steam Line No. 1, BRU-A and SG SRV	2-10
Figure 12	Nodalization Diagram of Steam Line No. 2, BRU-A and SG SRV	2-10
Figure 13	Nodalization Diagram of Steam Line No. 3, BRU-A and SG SRV	2-11
Figure 14	Nodalization Diagram of Steam Line No. 4, BRU-A and SG SRV	2-11
Figure 15	Nodalization Diagram of MSH and BRU-K	2-12
Figure 16	Nodalization Diagram of the Main and Auxiliary Feedwater Systems.....	2-13
Figure 17	Nodalization Diagram of the Emergency Feedwater System.....	2-13
Figure 18	Nodalization Diagram of the System of ECFS and LPIS Trains.....	2-14
Figure 19	Nodalization Diagram of HPIS Trains	2-15
Figure 20	Logical Diagram of HPIS Operation	2-17
Figure 21	Logical Diagram of LPIS Operation.....	2-18
Figure 22	Logical Diagram of Control and Protection System (Part 1	2-19
Figure 23	Logical Diagram of Control and Protection System (Part 2).....	2-20
Figure 24	Logical Diagram of Control and Protection System (Part 3).....	2-21
Figure 25	Logical Diagram of Control and Protection System (Part 4).....	2-22
Figure 26	Logical Diagram of PRZ Level Control by Makeup and Let-down.....	2-23
Figure 27	Logical Diagram of Make-up Pressure Difference Controller	2-24
Figure 28	Logical Diagram of MFW Flow Rate Controller (Part 1)	2-25
Figure 29	Logical Diagram of MFW Flow Rate Controller (Part 2)	2-26
Figure 30	Logical Diagram of SG Level Controller	2-27
Figure 31	Logical Diagram of BRU-A Controller	2-28
Figure 32	Logical Diagram of Turbine Control System	2-29
Figure 33	Reactor Power	4-3
Figure 34	Primary Pressure	4-3
Figure 35	SG Pressure	4-4
Figure 36	Pressurizer Coolant Level	4-4
Figure 37	Steam Generators Water Level.....	4-5
Figure 38	Cold Legs Temperature.....	4-5
Figure 39	Hot Legs Temperature.....	4-6
Figure 40	Max Cladding Temperature.....	4-6
Figure 41	Reactor Power (Fragment).....	4-9
Figure 42	Hot Channel Collapsed Level (Fragment).....	4-9
Figure 43	Hot Channel Mass Flow (Fragment)	4-10
Figure 44	Hot Channel Max Cladding Temperature	4-10
Figure 45	Hot Channel Max Fuel Temperature.....	4-11
Figure 46	RCS Pressure	4-11
Figure 47	HPIS Flow	4-12
Figure 48	LPIS Flow.....	4-12
Figure 49	HA Water Volume	4-13

Figure 50	Maximal Cladding Temperature	4-13
Figure 51	Hot Channel Collapsed Level	4-14

LIST OF TABLES

Table 1	Steady State Calculation Results	3-1
Table 2	Initial Conditions for SBO	4-1
Table 3	Timing of Main Events for SBO Calculation	4-2
Table 4	Initial Conditions for LBLOCA Calculation	4-7
Table 5	Timing of Main Events of LBLOCA Calculation.....	4-8

ABBREVIATIONS AND ACRONYMS

BRU-A	Steam Dump Valves to the Atmosphere
BRU-K	Steam Dump Valves to the Condenser
CAMP	Code Applications and Maintenance
ECFS	Emergency Core Flooding System
FA	Fuel Assembly
HA	Hydroaccumulator
HC	Hydraulic Component
HPIS	High Pressure Injection System
HS	Heat Structure
LB LOCA	Large Break Loss-of-Coolant Accident
LPIS	Low Pressure Injection System
MCP	Main Coolant Piping
MSH	Main Steam Header
MFW	Main Feedwater
PORVs	Pilot Operated Relief Valve
PRZ	Pressurizer
RCP	Reactor Coolant Pumps
RCS	Reactor Coolant System
SBO	Station Blackout
SG	Steam Generator
SNRIU	State Nuclear Regulatory Inspectorate of Ukraine
SSTC NRS	State Scientific and Technical Center for Nuclear and Radiation Safety
SRV	Steam Relief Valve
USNRC	United States Nuclear Regulatory Commission
VVER	Pressurized Water Reactor, Russian design

1 INTRODUCTION

At the end of 2014 the United States Nuclear Regulatory Commission (USNRC) and the State Nuclear Regulatory Inspectorate of Ukraine (SNRIU) signed Implementing Agreement On Thermal-Hydraulic Code Applications And Maintenance (CAMP). In accordance with Article III, Section C, of the Agreement, SNRIU shall submit to the USNRC the in-kind contribution reports providing the code assessment results or other activities results of equivalent value.

In the framework of the Agreement SNRIU and SSTC NRS obtained the state-of-the-art TRACE code which provides advanced capabilities for modeling thermal-hydraulic processes and components, control systems and allows coupling with PARCS neutron kinetics code. In 2015 SSTC NRS initiated activities on TRACE code application for evaluation of safety assessment results developed for Ukrainian NPPs. The existing SNRIU/SSTC NRS RELAP5 model for VVER-1000 was converted to TRACE code using Symbolic Nuclear Analysis Package (SNAP). The control systems operation logic was converted to TRACE model manually. RELAP and TRACE model descriptions are provided in [1, 2]. Brief description of TRACE model is provided in Section 2 to this report. Comparison of steady state results with nominal valves is provided in Section 3 .

After preparation of TRACE model and steady-state calculation the transient calculations were performed with application of RELAP5 and TRACE codes. The main objective of these calculations is initial evaluation of TRACE model developed in order to identify further steps for its improvement and qualification.

The initiating events analyzed are:

- Total loss of off-site and on-site power supply (total station blackout, SBO);
- Large break LOCA (850mm double-ended cold leg break) scenario with simultaneous loss of power.

2 BRIEF DESCRIPTION OF TRACE MODEL FOR VVER-1000

The TRACE model was developed by conversion of existing RELAP5 model for VVER-1000. The conversion was performed in two stages, namely:

- conversion of thermal hydraulic part of the model (hydraulic components and heat structures);
- conversion of logical part (control systems).

Conversion was performed with application of Symbolic Nuclear Analysis Package. Hydraulic elements obtained resulting from conversion almost do not require further manual correction and processing. Heat structures, which were connected to appropriate hydraulic components in RELAP model, and thermal and physical properties of constructional materials do not require correction as well.

However automatic conversion of control systems logic results in a number of errors and inconsistencies. Therefore, the safeguards and control systems logic were manually converted from RELAP deck to TRACE code.

Description of the main hydraulic components of TRACE model for VVER-1000 is provided below.

2.1 Reactor

Reactor model is 4-sectoral and has cross-links to simulate crossflows between the sectors. The area of inlet and outlet nozzles is divided into 8 equal parts modeling annular gaps between the core barrel and the reactor pressure vessel. This allows proper flow distribution in scenarios with partial number of reactor coolant pumps (RCP) in operation.

The core region is divided into 4 sectors (individual sector for each of 4 reactor coolant system loops) and modeled by hydraulic components (HC) 5029, 5032, 5030, 5031, 5033, 5034, 5035, 5036. Radial division of core region is not envisaged. Each sector has two channels: for "average" fuel assemblies (FA) and for "hot" fuel assembly.

Core bypasses are simplistically joined and presented by HC 5259, 5352 and 5271.

HC 5253, 5254, 5250, 5251, 5255, 5256, 5252 model downcomer parts at the cold legs nozzles region. HC 5245, 5246, 5002, 5003, 5247, 5248, 5004, 5001 model downcomer part below the RCS nozzles region. HC 5009, 5010, 5011, 5012 model a gap between reactor bottom and core barrel.

Lower plenum is modeled by HC 5020, 5017, 5019, 5018, 5016, 5015, 5014, 5013, 5021 5022 5023, 5024, 5025, 5026, 5027, 5028.

Upper plenum is modeled by a range of HC 5037, 5038, 5039, 5040, 5081, 5242, 5243, 5244, 5260, 5257.

Upper head is modeled by HC 5258. Reactor nodalization diagram is shown on figure below.

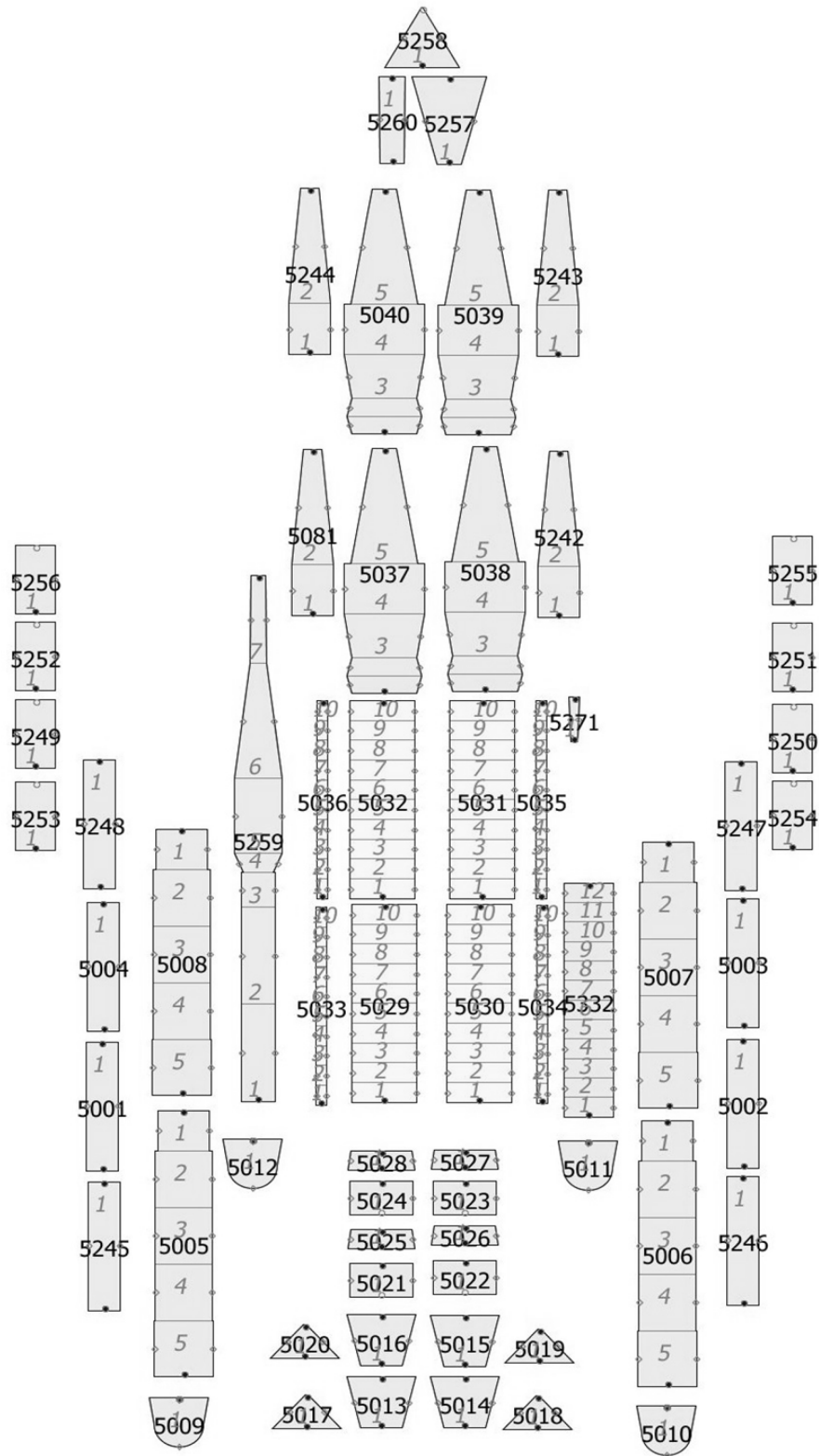

Figure 1 Nodalization Diagram of VVER-1000 (V-320)

HS in the core are modeled by “Fuel Rod” type and have cylindrical geometry reflecting FE geometry with the height of 354 cm. Eight heat structures were modeled in the core, and according to core division, each heat structure has an appropriate surface multiplier.

HS of the reactor pressure vessel models the heat transfer from the coolant through vessel wall to the environment.

HS of reactor internals such as core barrel and baffle model the heat exchange between components inside the reactor.

2.2 Main Coolant Piping

Main coolant piping (MCP) consists of four loops. Each loop has a cold and a hot leg. Nodalization diagrams of loops 1-4 are given on Figures 2 – 5.

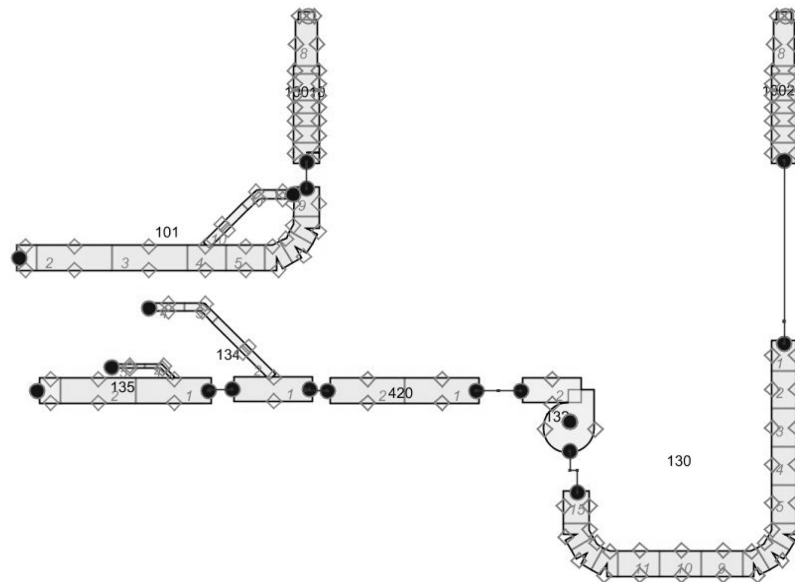

Figure 2 Nodalization Diagram of RCS Loop 1

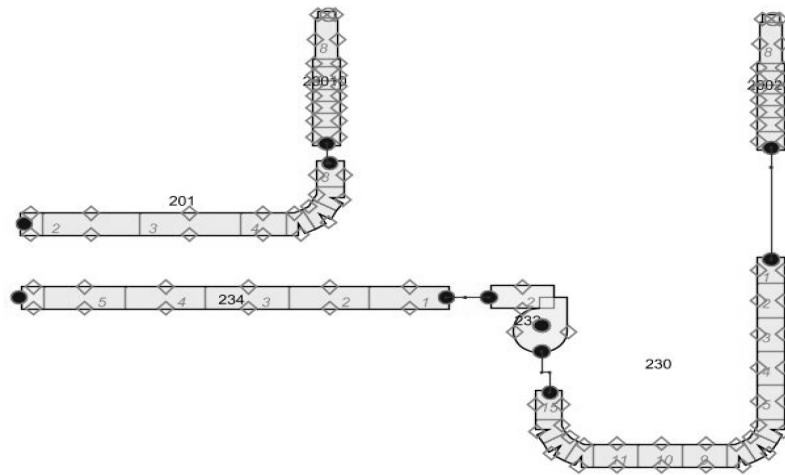

Figure 3 Nodalization Diagram of RCS Loop 2

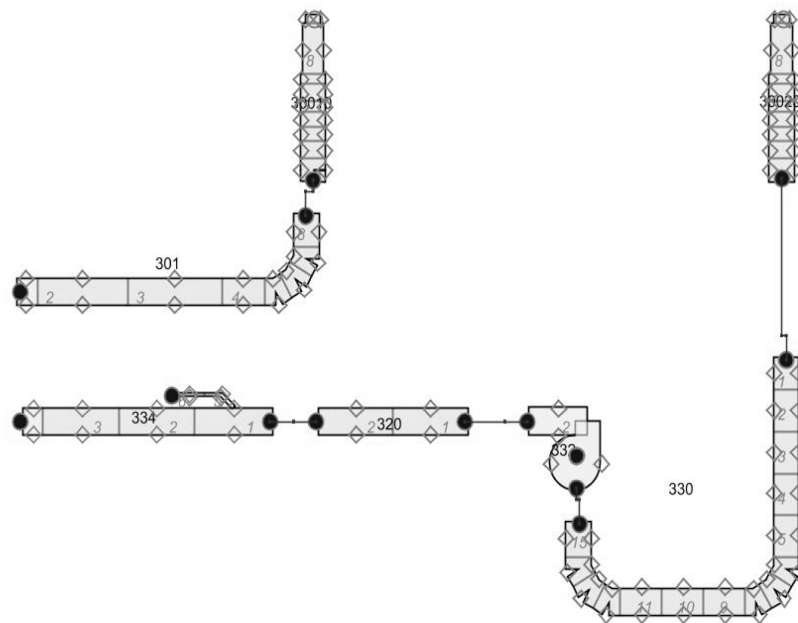

Figure 4 Nodalization Diagram of RCS Loop 3

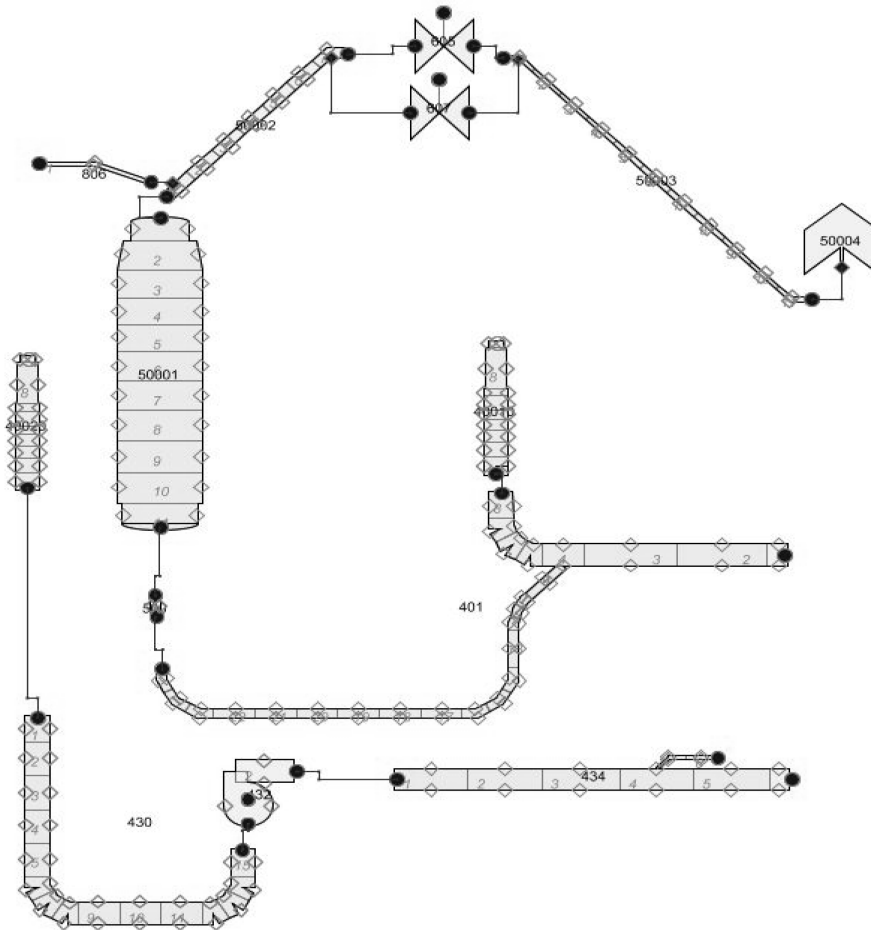

Figure 5 Nodalization Diagram of RCS Loop 4, Connecting Pipe and Pressurizer

2.3 Pressurizer System

Pressurizer (PRZ) model is implemented by PRIZER HC 50001. Steam discharge piping (PIPE HC 50002 and 50003) is connected to the pressurizer top part. HC 605, 607 (VALVE) model pressurizer pilot operated relief valves (PORVs) (control and the main PORVs, respectively). Pressurizer surge line is connected to RCS hot leg 4.

Pressurizer steam discharge includes three PORVs YP21,22,23S10. Valve operation algorithm is implemented according to opening/closure setpoints of the main and control PORVs. The setpoints are changed at station blackout after depletion of batteries to simulate spring-controlled PORV operation.

Nodalization diagram of the pressurizer system is provided in Figure 5 and Figure 6.

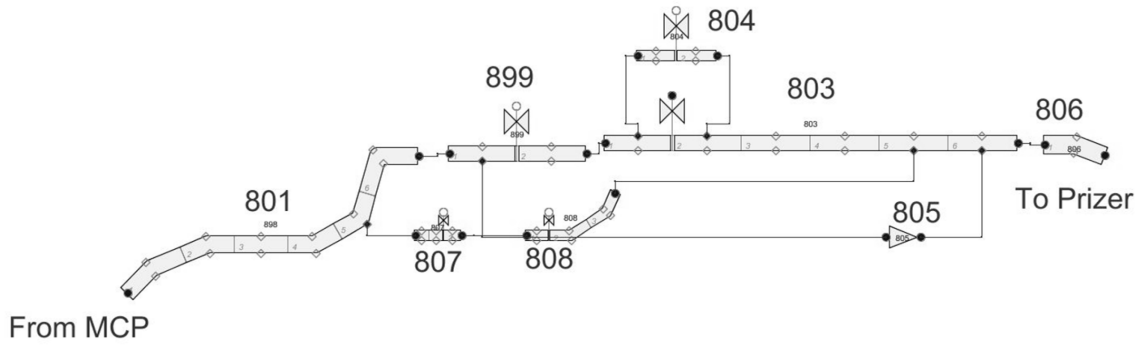

Figure 6 Nodalization Diagram of the Pressurizer Spray Line

2.4 Steam Generator

Nodalization diagram of steam generator (SG) primary side is given on Figure 7. SG primary side consists of two SG manifolds (cold and hot) and a tube bundle.

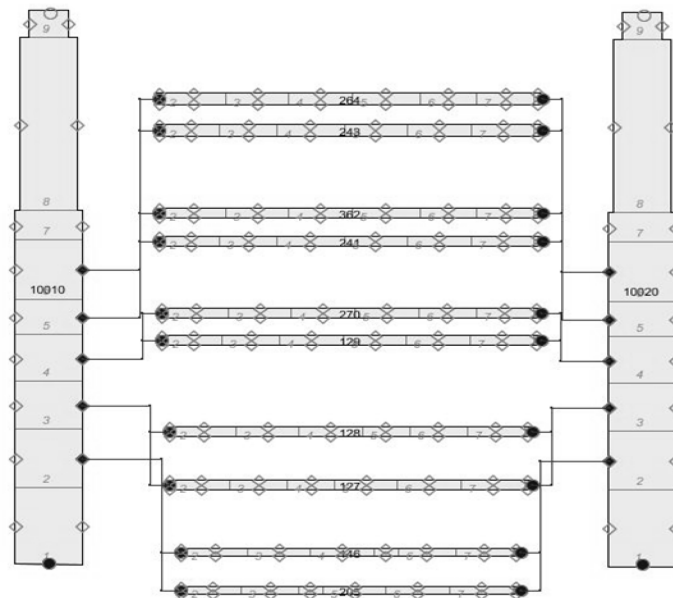

Figure 7 Nodalization Diagram of SG Primary Side

SG heat transfer surface consists of manifolds, 11000 tubes and tube support structures. Heat exchange U-shaped tubes are assembled into tube bundle and staggered with vertical spacing of 19 mm and horizontal spacing of 23 mm. Tubes are assembled in two U-shaped bundles, each bundle has three vertical corridors ensuring controlled hydrodynamics of circulating water.

Tube bundle model is implemented by PIPE hydraulic components. Resulting from the division diagram of SG secondary side, five layers of tube bundle are modeled; each of them has two U-shaped parts.

SG secondary side is modeled using quasi-3D approach. Such approximation was chosen for correct distribution of thermal load between SG secondary side volumes. Nodalization diagram of SG model is presented on Figure 8.

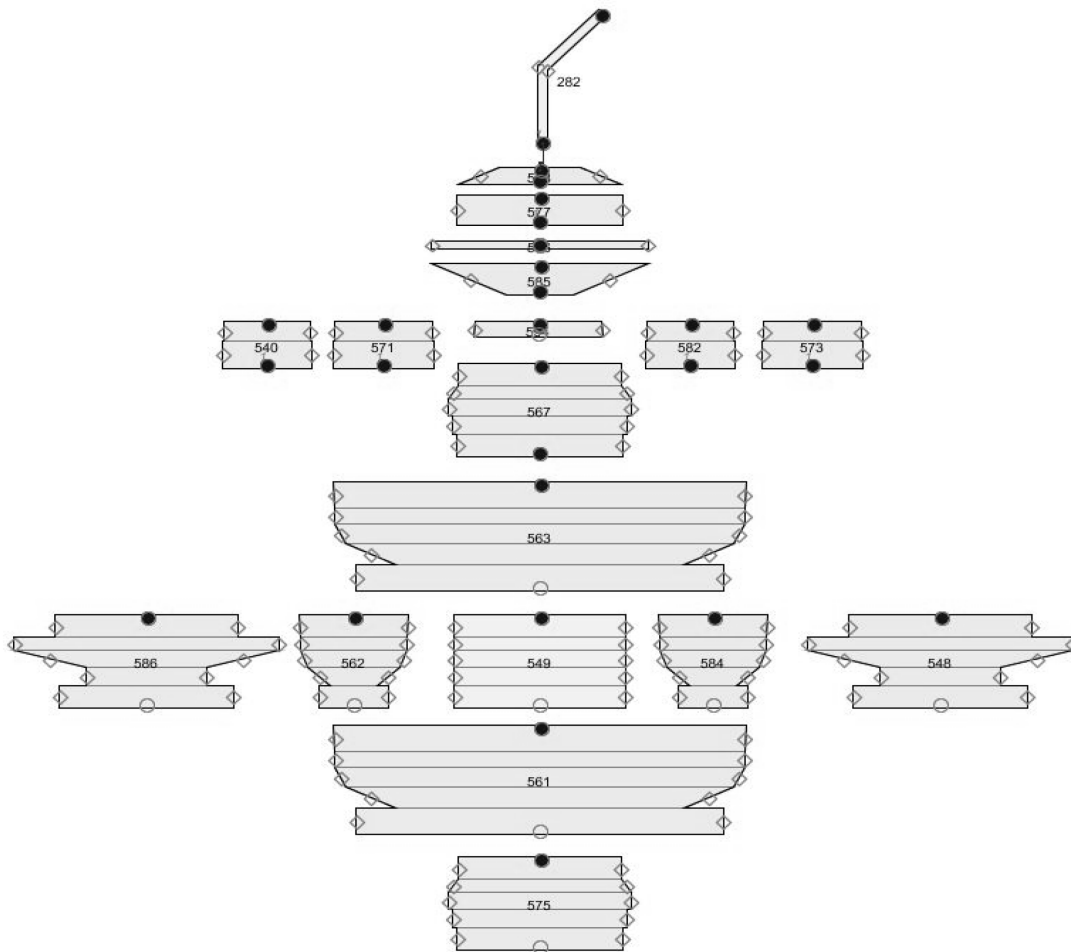

Figure 8 Nodalization Diagram of SG Secondary Side

HC 563,561 and HC 562,584 model SG secondary volumes of the tube bundle region corresponding to the straight and bended (U-shaped) parts of SG-tubes, respectively. HC 575, 567 (up to the 4th volume) model the secondary side volumes between SG tube bundle and SG vessel, and between external and internal tube bundle packs corresponding to the straight portions of SG tubes. 5th volume of these HC is somewhat smaller and is bounded by submerged perforated plate (SPP) side walls. HC 586,548 model similar SG secondary side volumes which correspond to the bended portion of SG tubes. HC 549 represents the central part of SG secondary side between SG tubes packs. HC 540, 571, 582, 573 model the secondary side volume between SPP side walls

and SG vessel. The steam volume of SG secondary side and of SG steam header are represented by HC 585, 596, 577, 568 and HC 282, respectively.

2.5 Make-Up and Let-Down

The make-up and let-down are modeled at a functional level. This system consists of two subsystems:

- makeup is connected to the cold legs in all four loops between SG cold manifold and RCP;
- let-down is connected to the cold legs of loop 2 and 3 downstream RCP outlet nozzle.

Makeup subsystem provides makeup water supply, and let-down ensures coolant removal from the primary system. Nodalization diagram of the makeup and let-down is given on Figure 9.

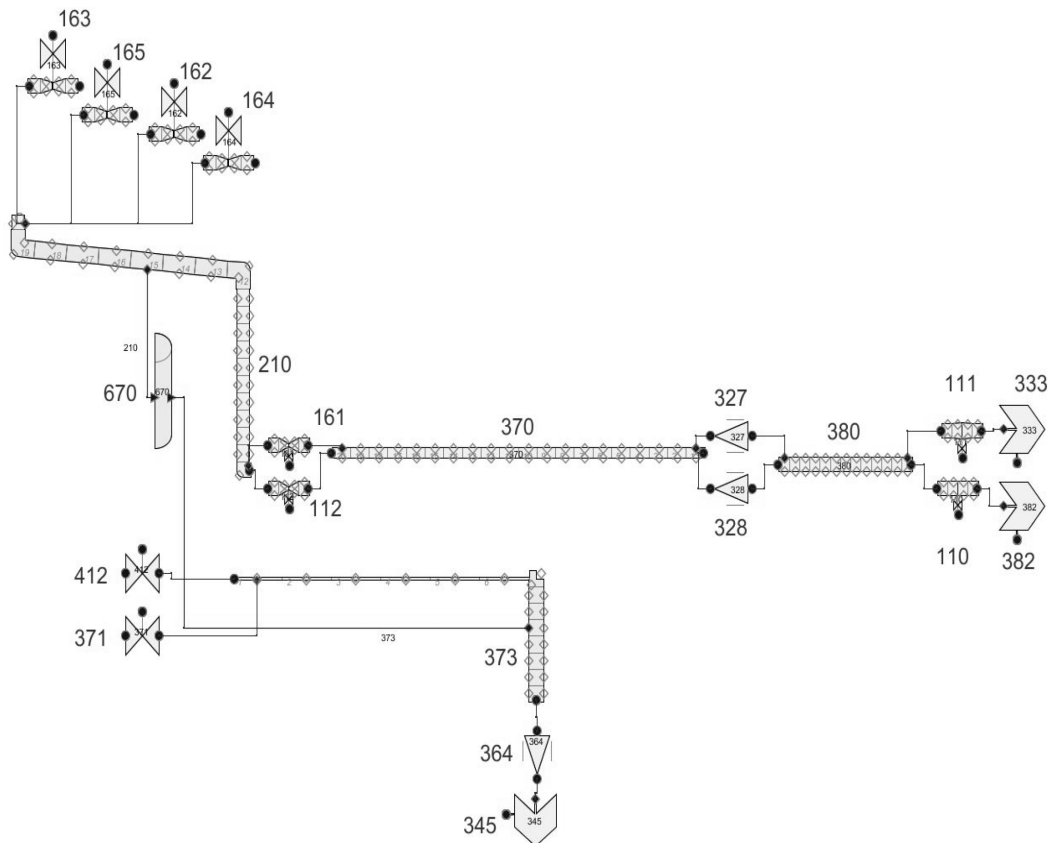

Figure 9 Nodalization Diagram of Makeup and Let-down

2.6 Emergency Gas Removal System

The emergency gas removal system is intended to remove steam-gas mixture from the primary system during accidents. The system consists of connecting pipes with cut-off valves installed, which connect reactor coolant system elements with bubbler tank.

Nodalization diagram of the emergency gas removal system is presented on Figure 10.

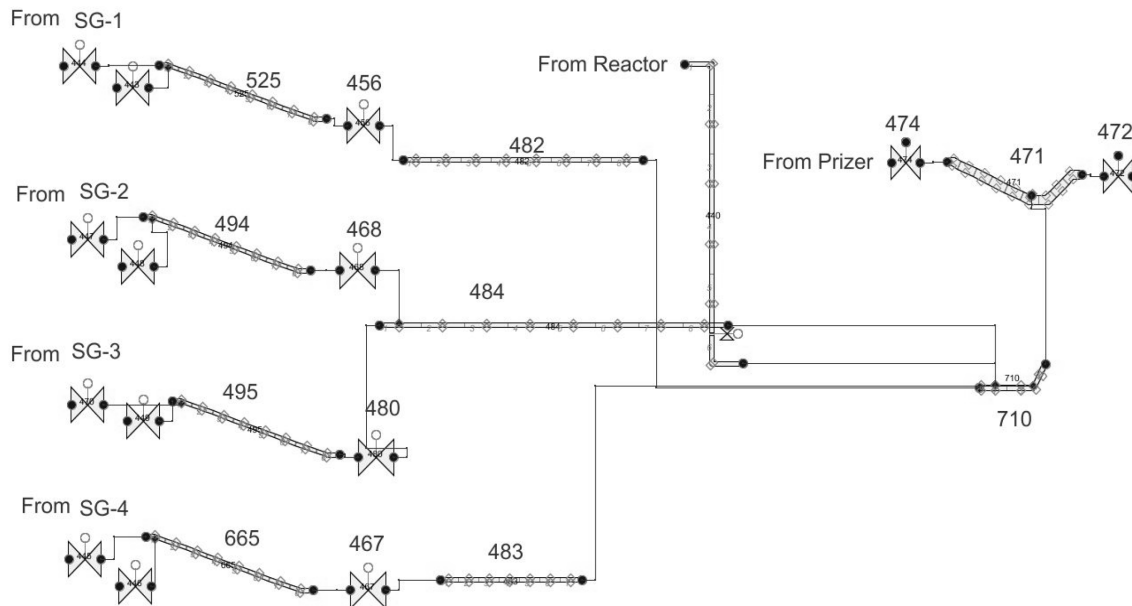

Figure 10 Nodalization Diagram of Emergency Gas Removal System

2.7 Main Steam Lines

Main steam lines system is designed to transfer saturated steam from SG to turbine high pressure cylinder. Each steam line model includes steam dump valves to the atmosphere (BRU-A), SG steam relief valves (SRV), main steam isolation valves, turbine stop and control valves.

Steam line model is implemented using PIPE HC (1-4)50, HC (1-4)57, TEE HC (1-4)51, HC (1-4)58, HC (1-4)53, VALVE HC (1-4)52, HC (1-4)54.

BRU-A is presented by VALVE HC (1-4)59, BREAK HC (1-4)60, which model atmospheric conditions. BRU-A flow rate is 900 t/h. Time for full opening/closure of BRU-A is 18 sec. SG SRV are modeled similarly to BRU-A. The model implements one control SG SRV and one double main SG SRV.

Turbine is modeled by boundary conditions for each steam line (downstream turbine stop valve) at functional level and presented by BREAK HC 574,635,576,587. Turbine stop valves are modeled by HC 566, 666, 756, 856 with identical boundary conditions.

Nodalization diagram of steam piping, BRU-A and SG SRV is shown on Figures 11–14.

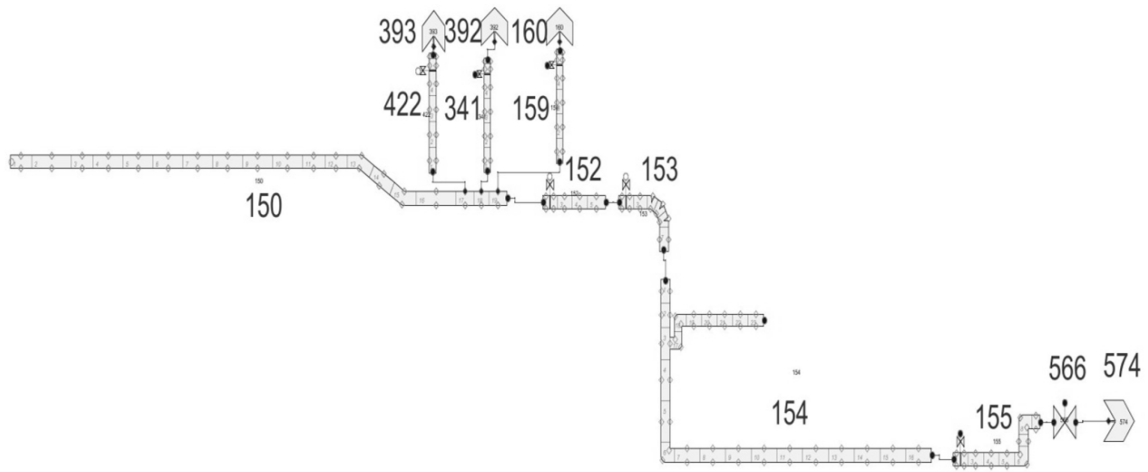

Figure 11 Nodalization Diagram of Steam Line No. 1, BRU-A and SG SRV

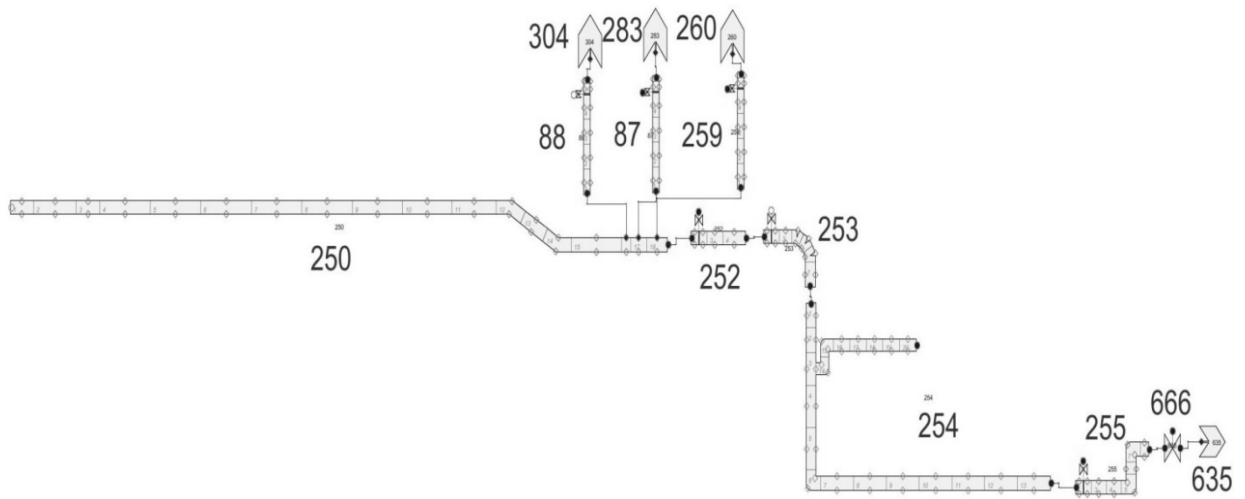

Figure 12 Nodalization Diagram of Steam Line No. 2, BRU-A and SG SRV

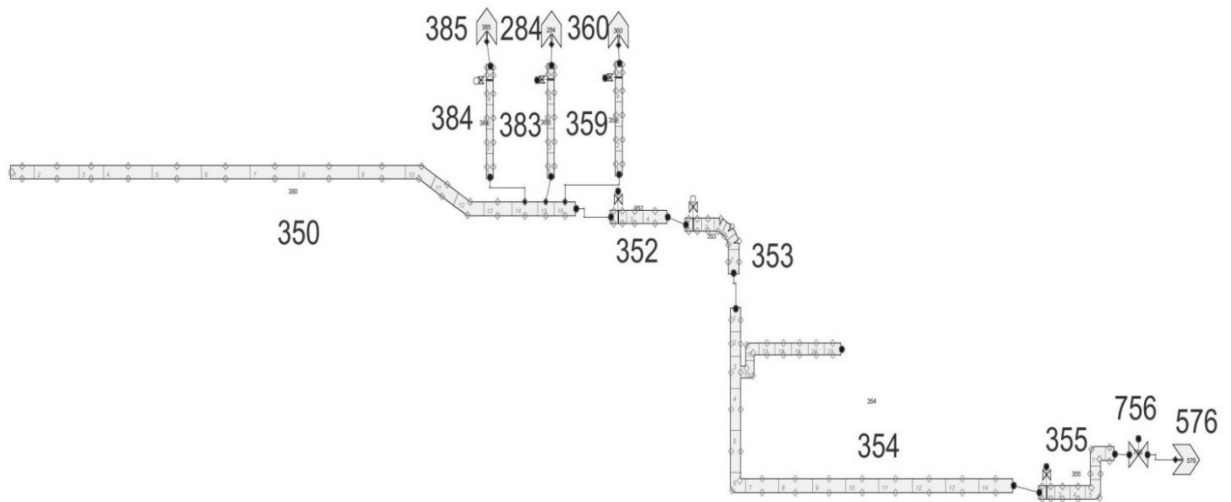

Figure 13 Nodalization Diagram of Steam Line No. 3, BRU-A and SG SRV

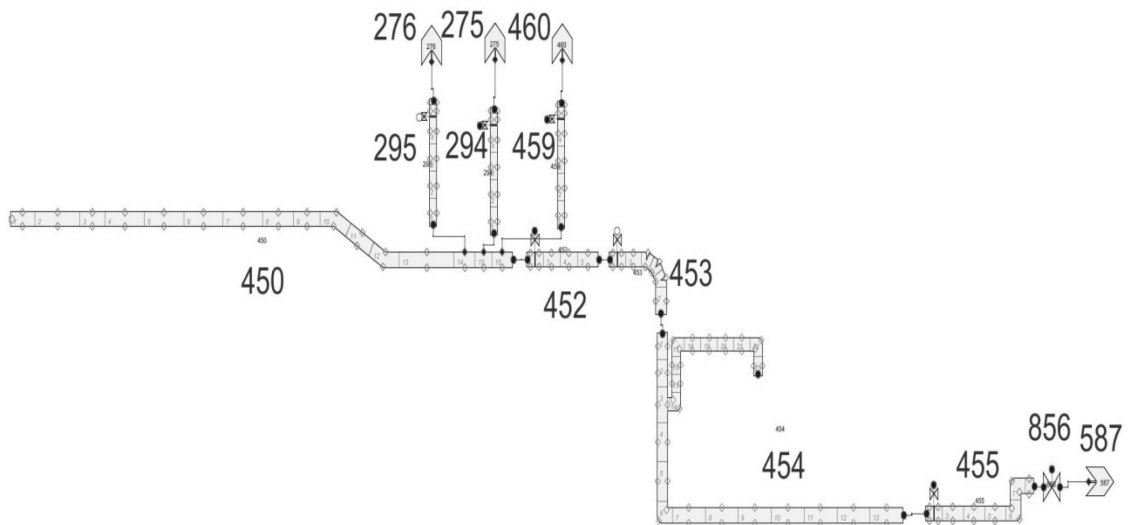

Figure 14 Nodalization Diagram of Steam Line No. 4, BRU-A and SG SRV

2.8 Main Steam Header

Main steam header (MSH) includes two semi-headers, connection lines between them and steam dump valves to the condenser (BRU-K).

MSH is modeled by PIPE HC500, 501.

TEE HC552, 556 model connection lines between two semi-headers. The connection are modeled as double components with appropriate equivalent hydraulic diameters assigned. VALVE HC553, 557 model BRU-K. One valve models two valves with equivalent cross section. BREAK HC554, 558 model turbine condenser. Nodalization diagram of MSH and BRU-K is presented in Figure 15.

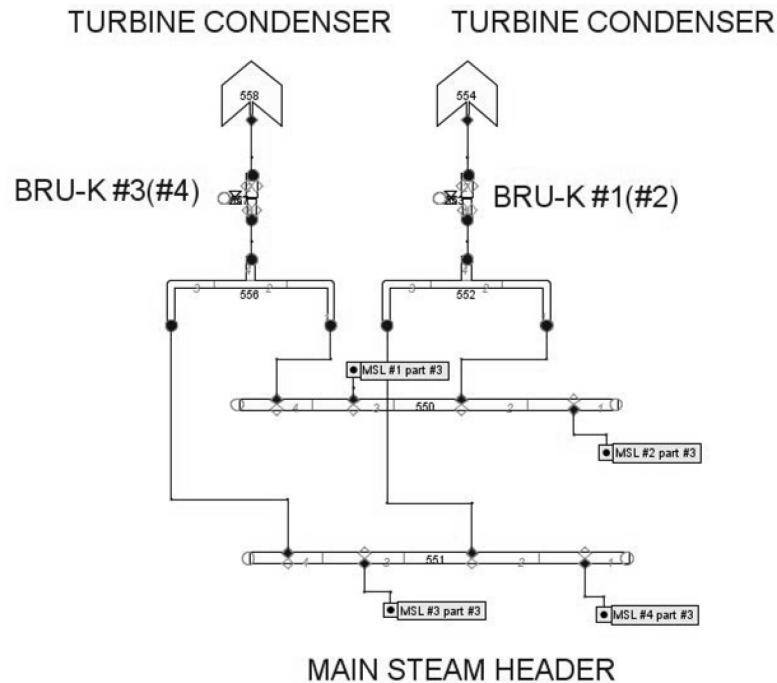

Figure 15 Nodalization Diagram of MSH and BRU-K

2.9 Main, Auxiliary and Emergency Feedwater Systems

The nodalization diagrams of the main, auxiliary and emergency feedwater systems are presented on Figure 16 and Figure 17.

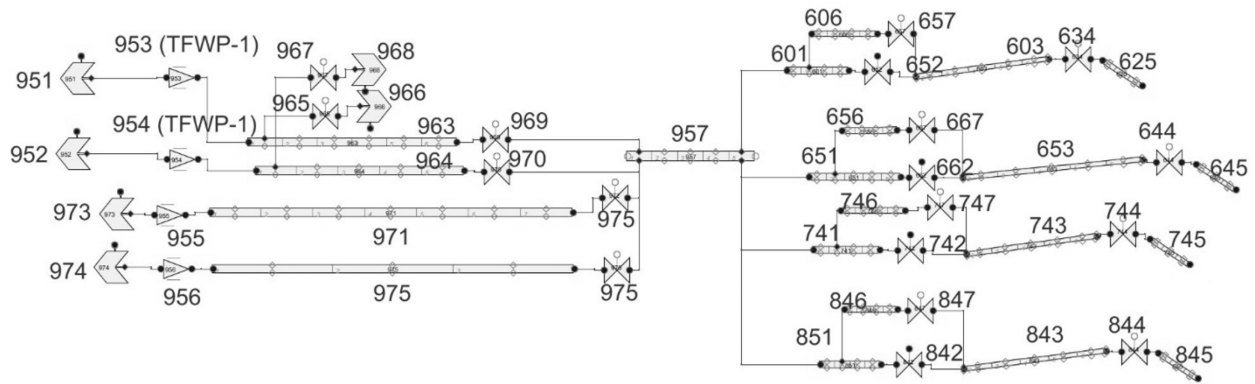

Figure 16 Nodalization Diagram of the Main and Auxiliary Feedwater Systems

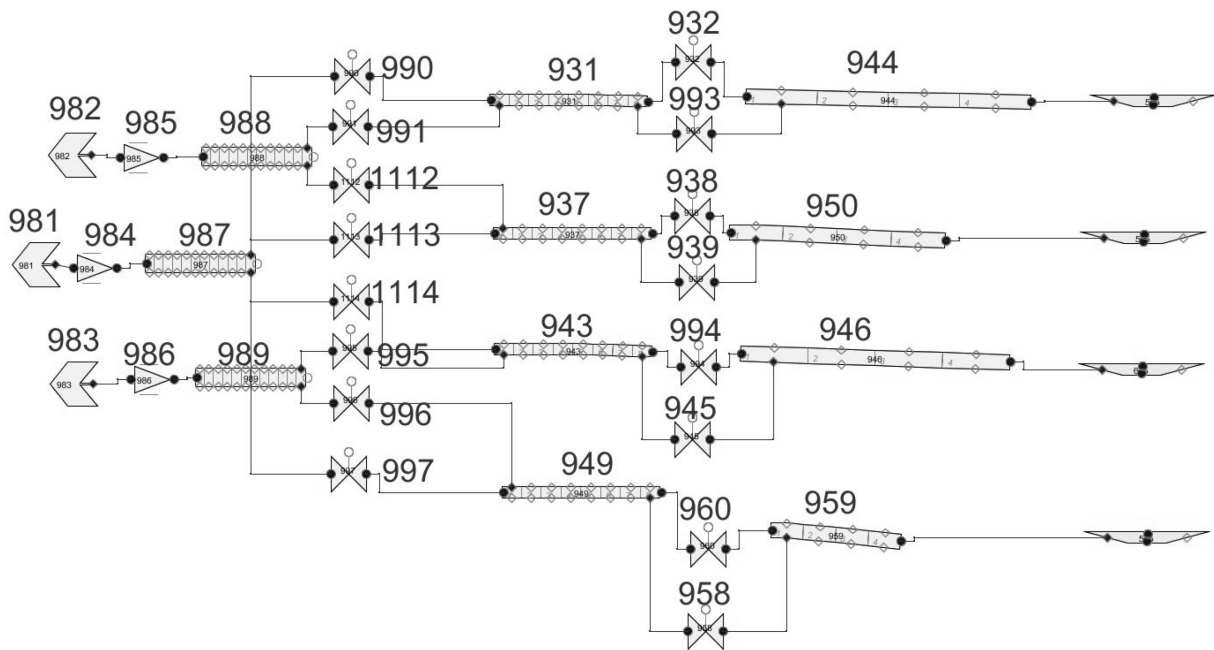

Figure 17 Nodalization Diagram of the Emergency Feedwater System

2.10 Emergency Core Flooding System

Emergency core flooding system (ECFS) consists of four independent functional groups, each of them includes:

- hydroaccumulator (HA);
- cut-off valve;
- connecting pipe.

Two functional groups supply boric acid solution to the reactor upper plenum, and other two groups supply it to the lower plenum. ECFS model is presented by PIPE HC610, 620, 630, 640 (option – Accumulator).

The nodalization diagram of ECFS and three LPIS trains is demonstrated on Figure 18.

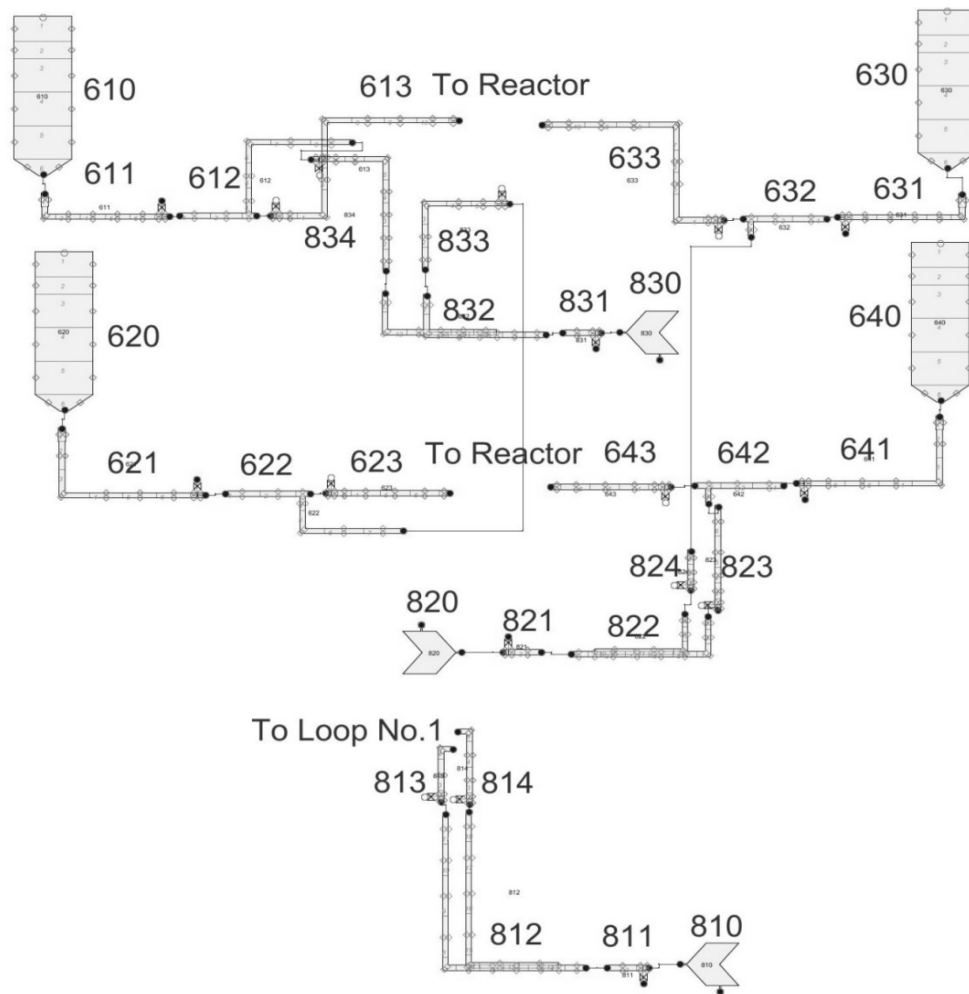

Figure 18 Nodalization Diagram of the System of ECFS and LPIS Trains

2.11 High Pressure Injection System

High Pressure Injection System (HPIS) includes two subsystems: high pressure injection system TQ13,23,33 and high pressure boron injection system TQ14,24,34.

TQ13,23,33 system model consists of three independent trains (TQ13, TQ23, TQ33), each train includes emergency storage tank of boric acid solution (TQ13B01, TQ23B01, TQ33B01), emergency boron injection pump (TQ13D01, TQ23D01, TQ33D01), piping, and valves.

TQ14,24,34 system model consists of three independent trains (TQ14, TQ24, TQ34), each train includes emergency storage tank of boric acid solution (TQ14B01, TQ24B01, TQ34B01), high pressure boron injection pump (TQ14D01, TQ24D01, TQ34D01), piping, and valves.

HPIS model is implemented at functional level by FILL HC 913, 914, 923, 924, 933, 934. Connecting pipes are modeled by VALVE components on which valves are modeled. Nodalization diagram of HPIS trains is presented on Figure 19. Logic diagram of HPIS operation is shown on Figure 20.

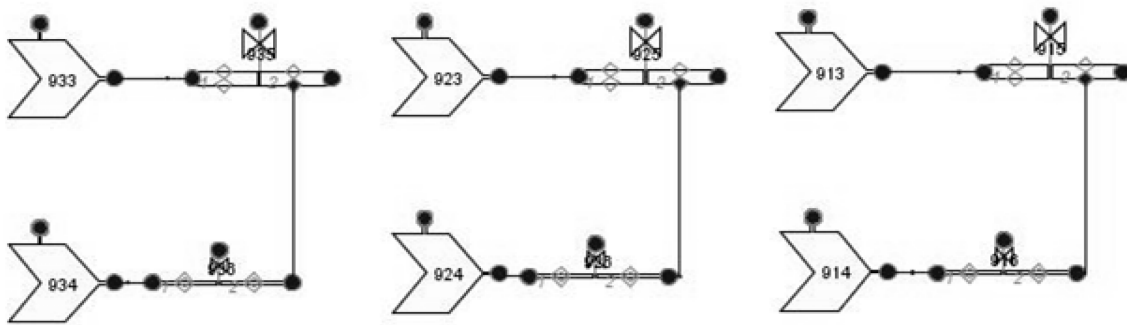

Figure 19 Nodalization Diagram of HPIS Trains

2.12 Low Pressure Injection System

Low Pressure Injection System (LPIS) performs both safety function (injection to the reactor coolant system and heat removal during the accidents) and normal operation function (namely, residual heat removal at low RCS pressures during normal plant shutdown) LPIS model consists of three independent trains (TQ12, TQ22, TQ32), each train is connected to sump tank (TQ10B01, TQ20B01, TQ30B01) and includes LPIS pump (TQ12D01, TQ22D01, TQ32D01), piping, and valves. Two trains are connected to HA–reactor connection lines to supply boric acid solution the reactor upper and lower plenum. TQ12 is connected to cold and hot legs of loop 1.

LPIS model is implemented at functional level and presented by TEE HC 6(1–4)2 (side connections), VALVE HA8(3,4) (4,5), FILL HC812, 822, 832. LPIS trains 2 and 3 are similar. Nodalization diagram of LPIS (TQ12,22,32) is presented on Figure 18. Logic diagram of LPIS operation is shown on Figure 21.

2.13 Safeguards and Control Systems Operation Logic

Figures 20–32 present logical diagrams for the main safeguards and control systems. The operation logic for the following systems and elements is provided:

- HPIS and LPIS;
- reactor control and protection system;
- PRZ level control;
- make-up pressure difference control;
- MFW flow rate controller;
- SG level controller;
- BRU-A controller;
- turbine control system.

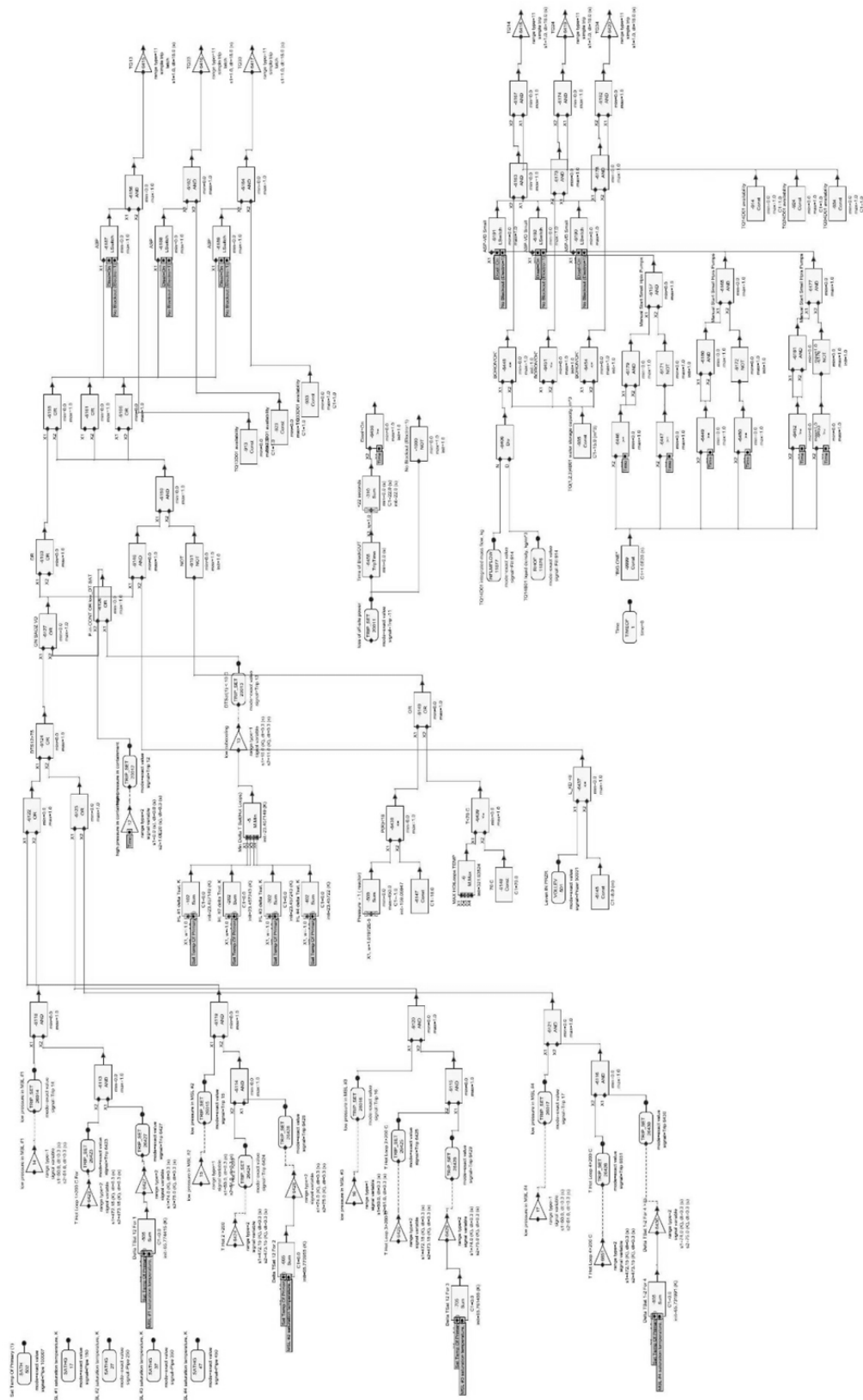

Figure 20 Logical Diagram of HPIS Operation

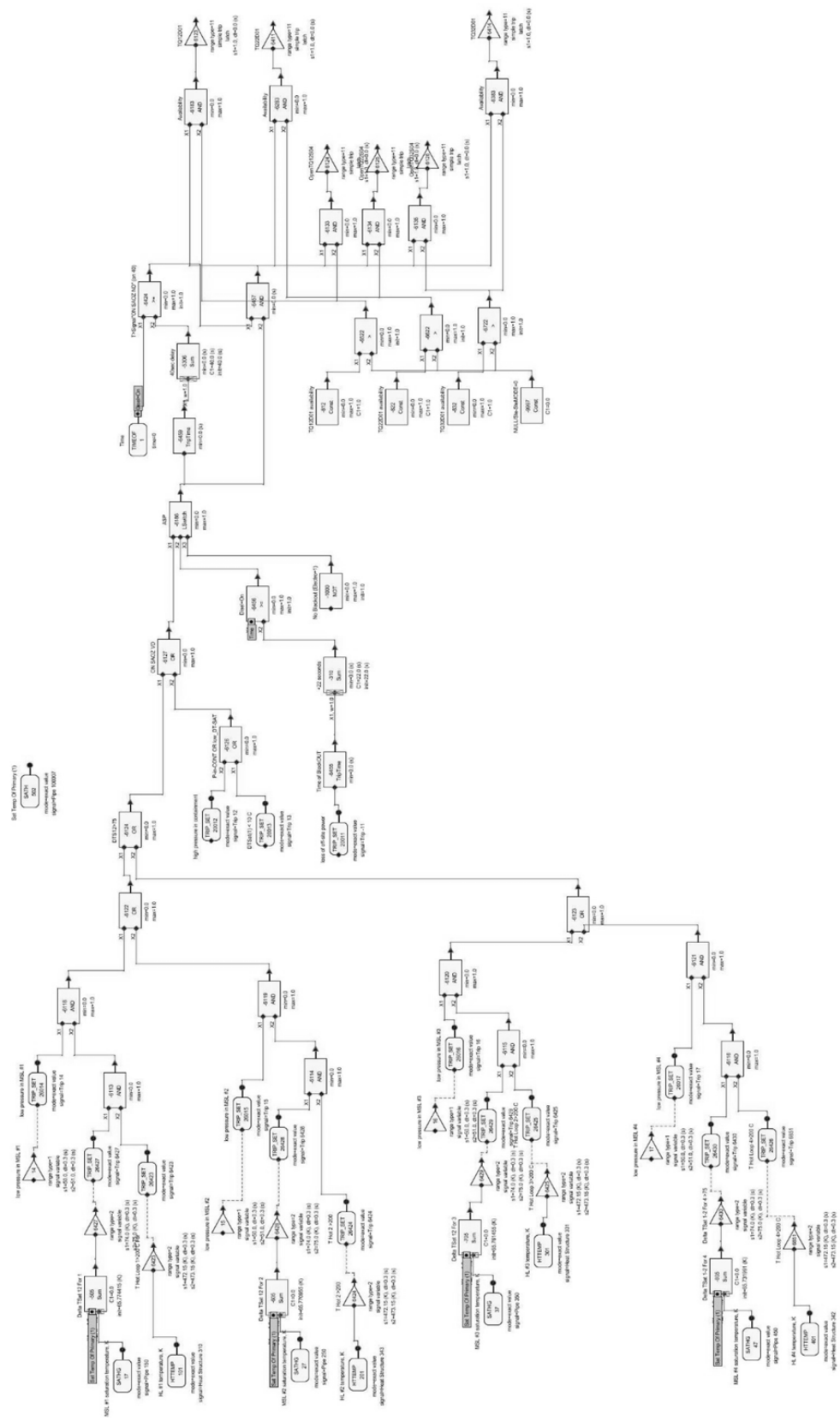

Figure 21 Logical Diagram of LPIS Operation

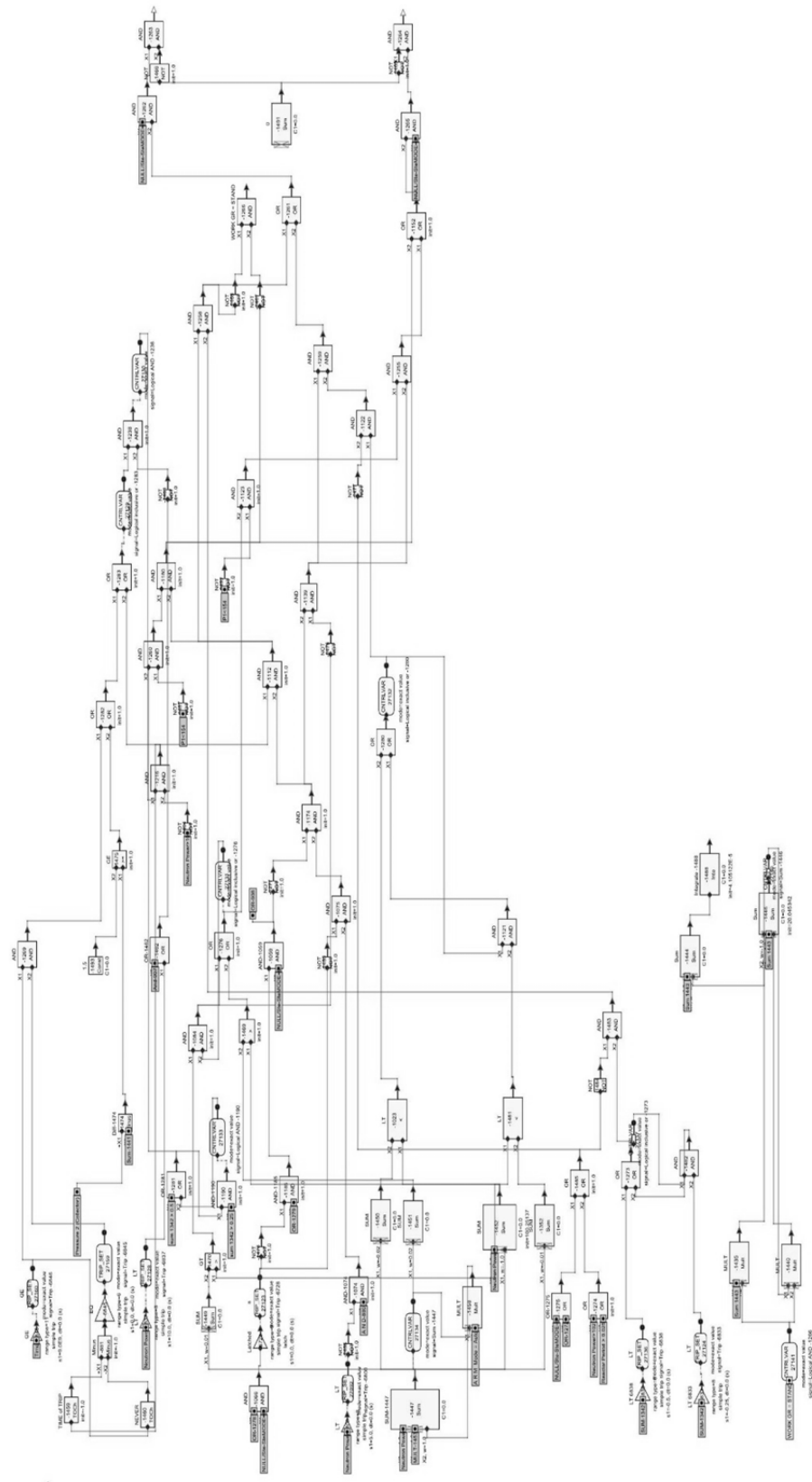

Figure 23 Logical Diagram of Control and Protection System (Part 2)

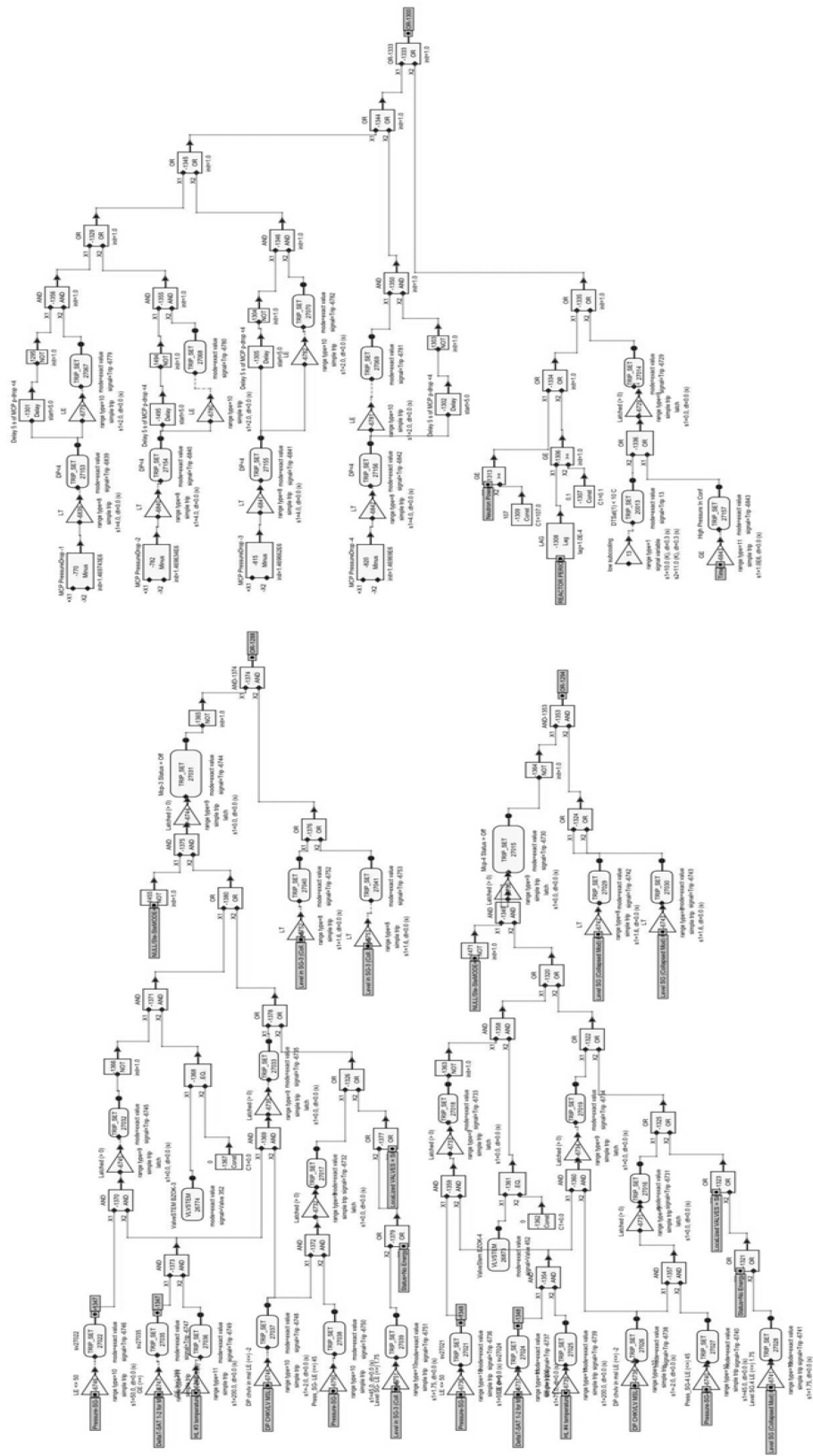

Figure 25 Logical Diagram of Control and Protection System (Part 4)

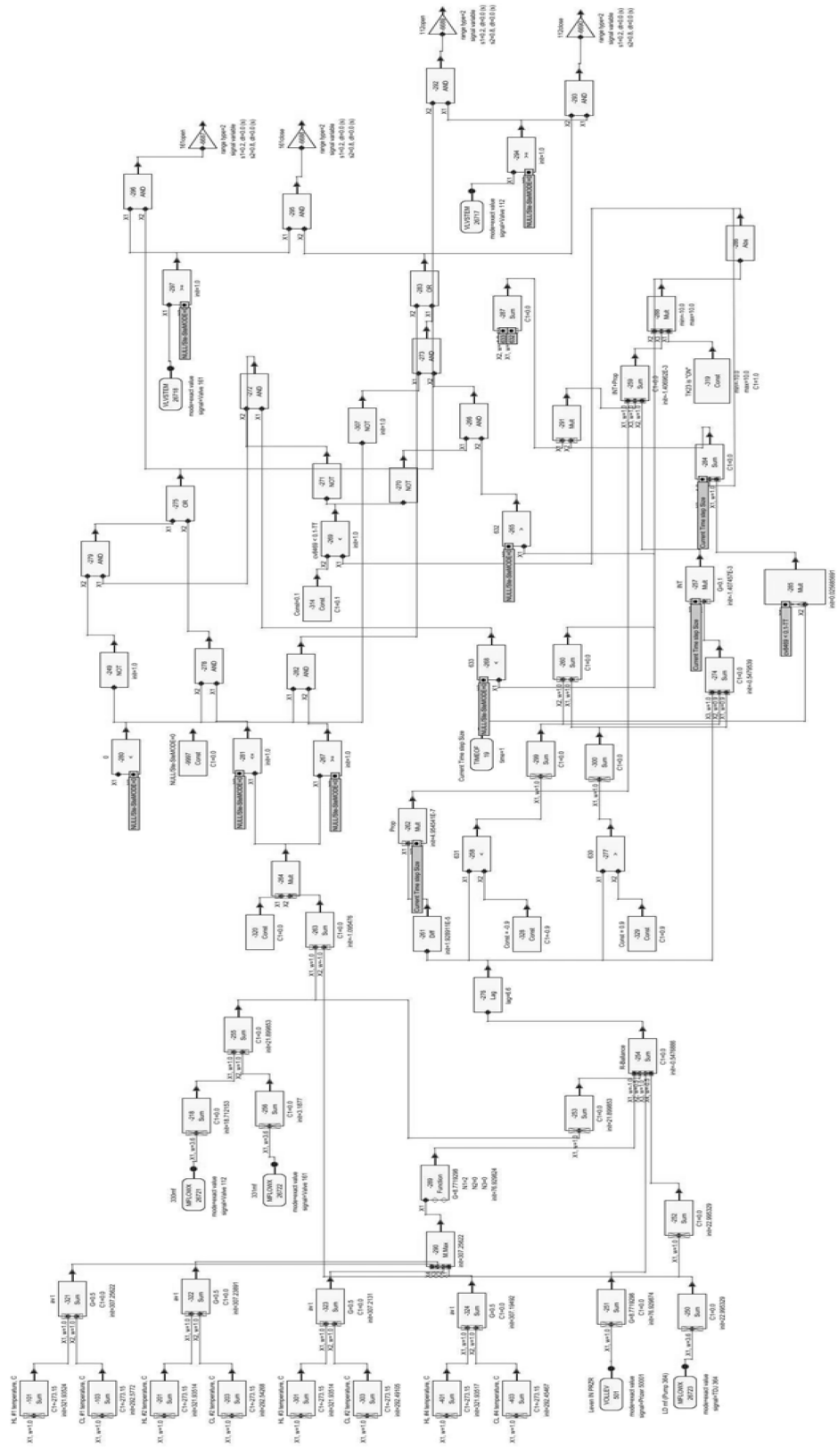

Figure 26 Logical Diagram of PRZ Level Control by Makeup and Let-down

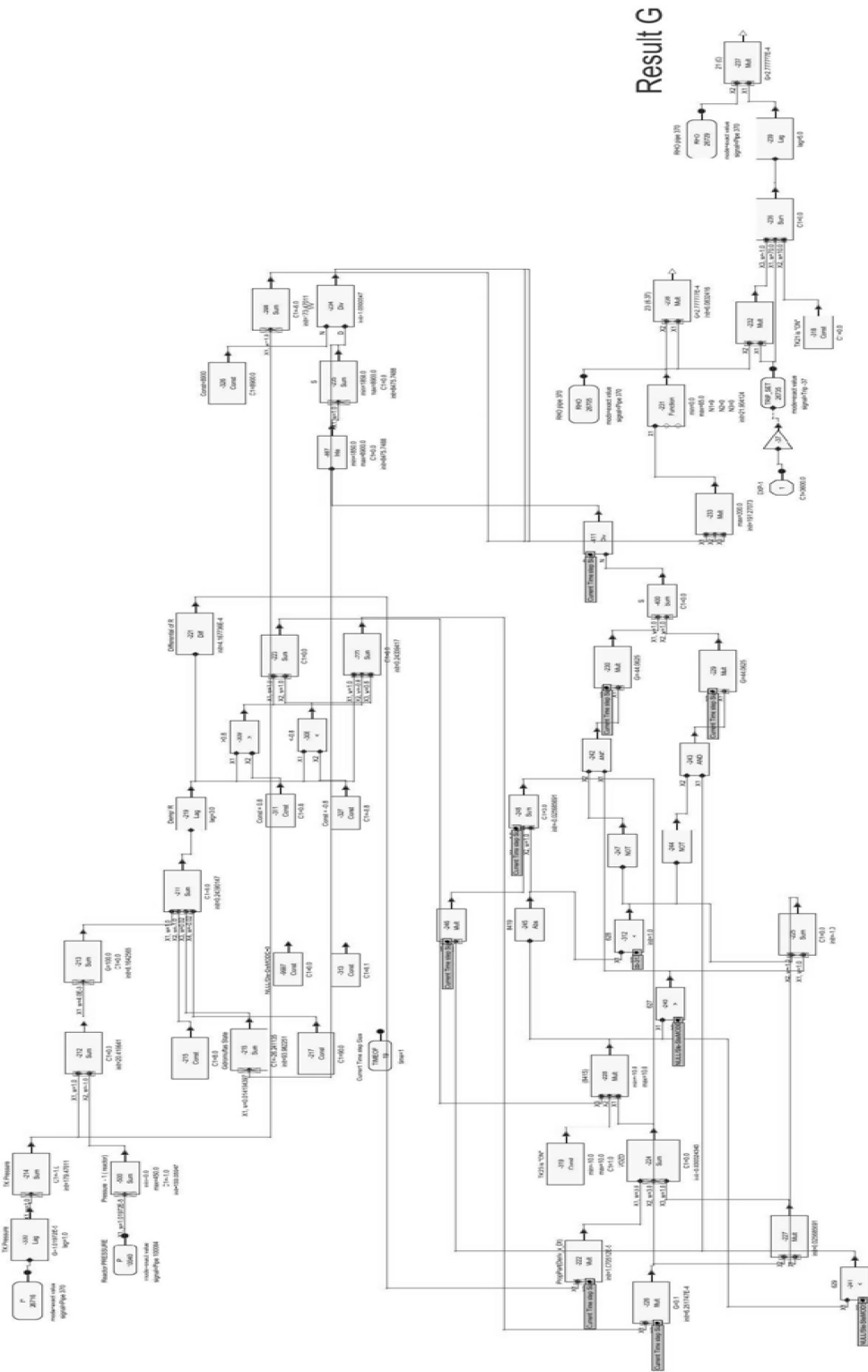

Figure 27 Logical Diagram of Make-up Pressure Difference Controller

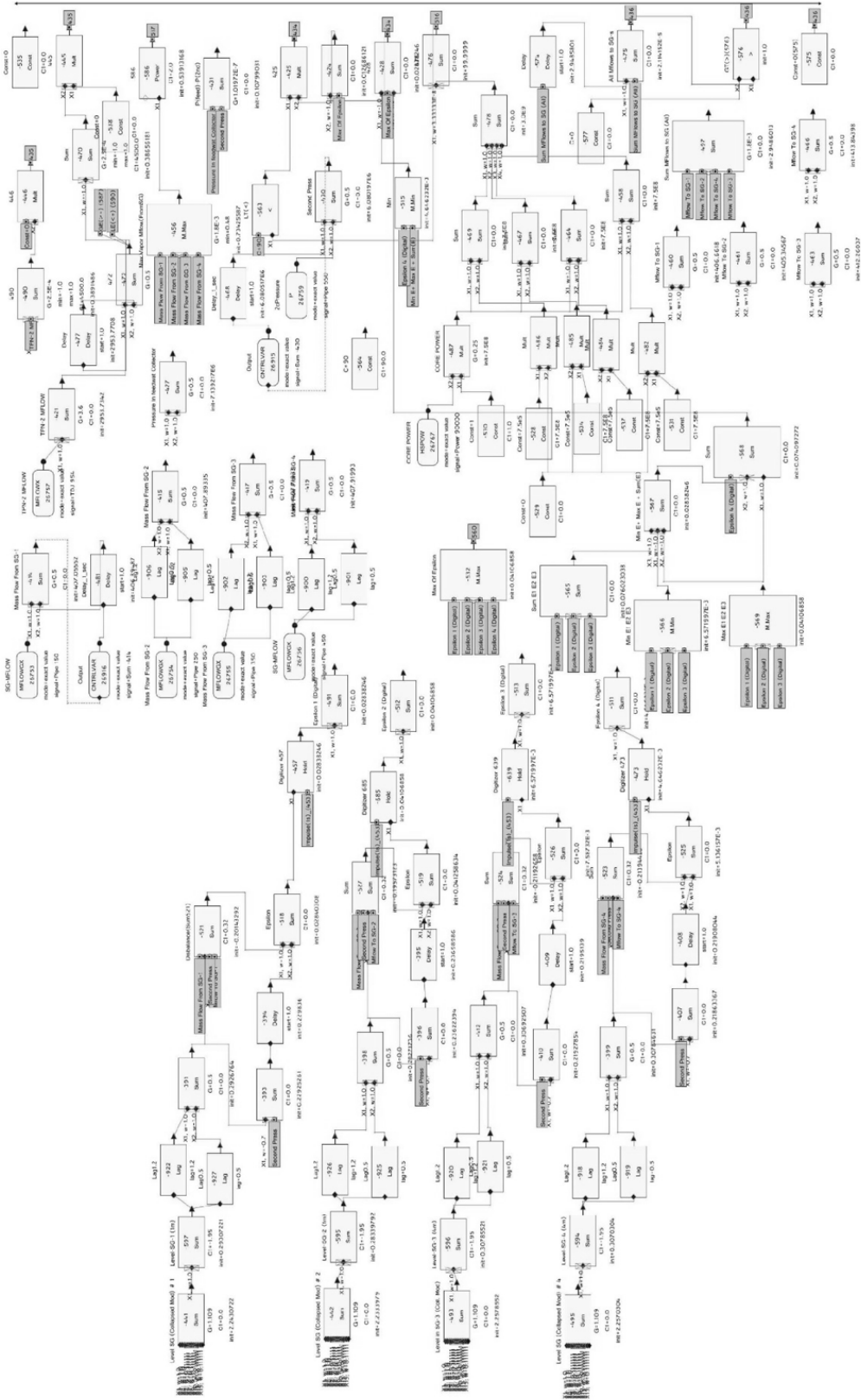

Figure 28 Logical Diagram of MFW Flow Rate Controller (Part 1)

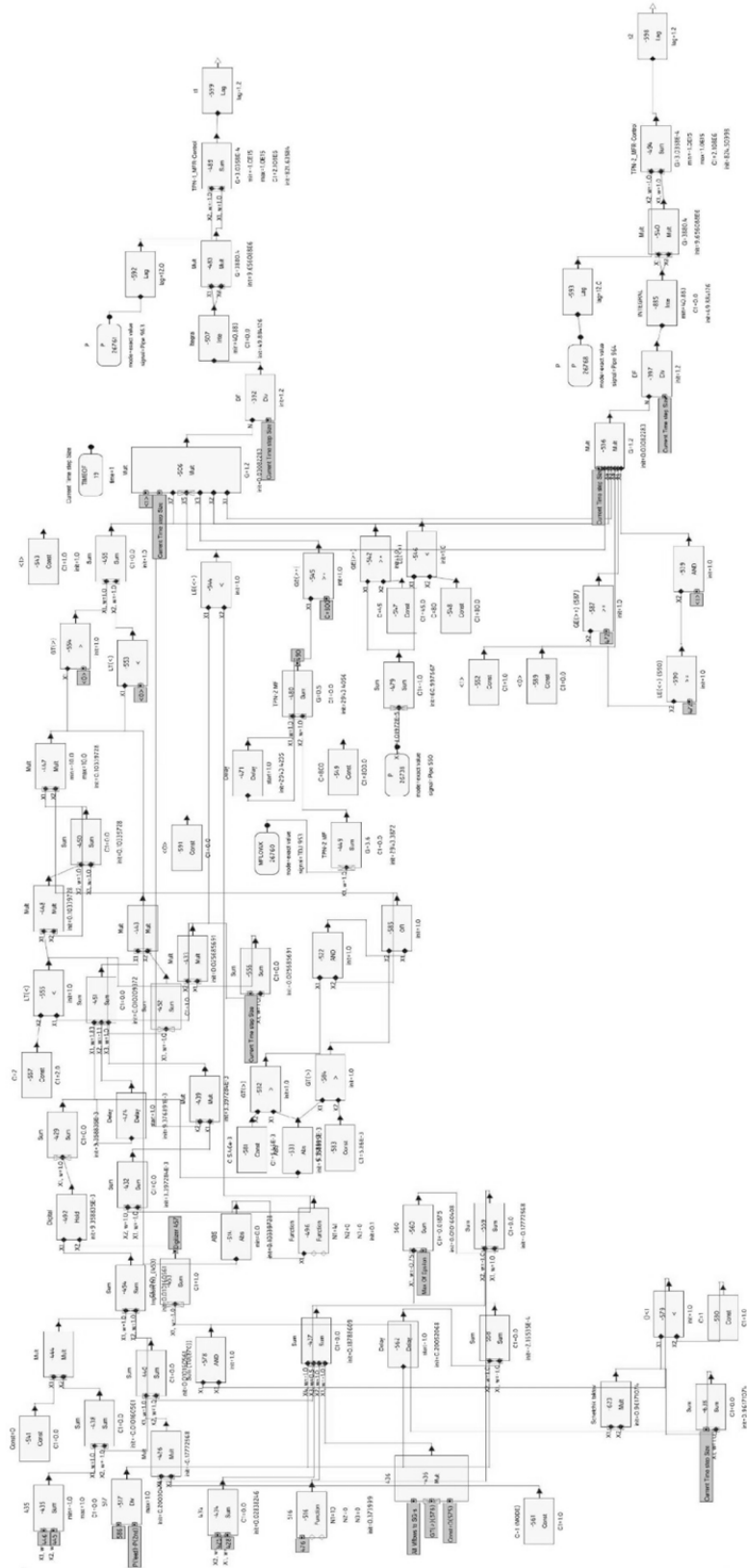

Figure 29 Logical Diagram of MFW Flow Rate Controller (Part 2)

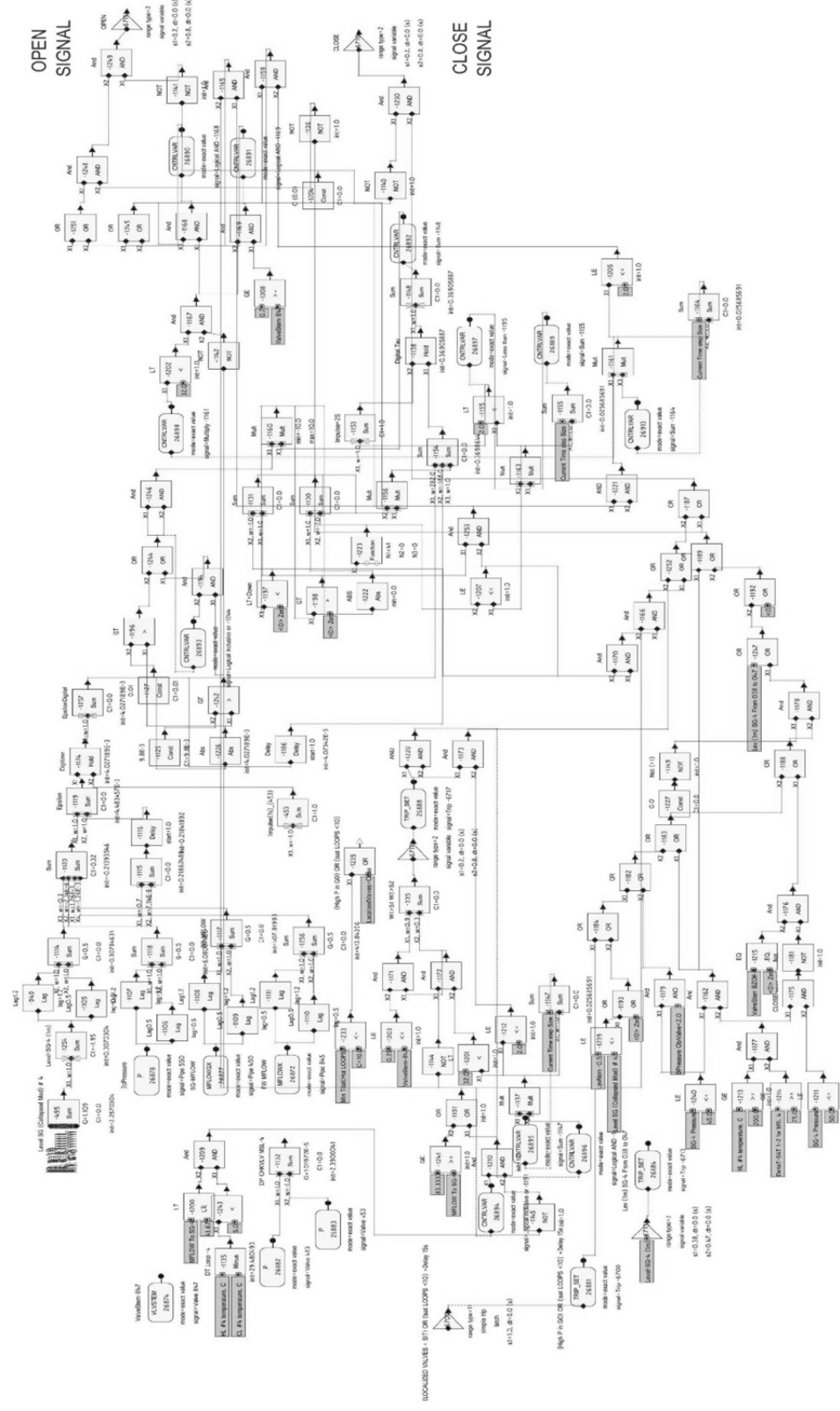

Figure 30 Logical Diagram of SG Level Controller

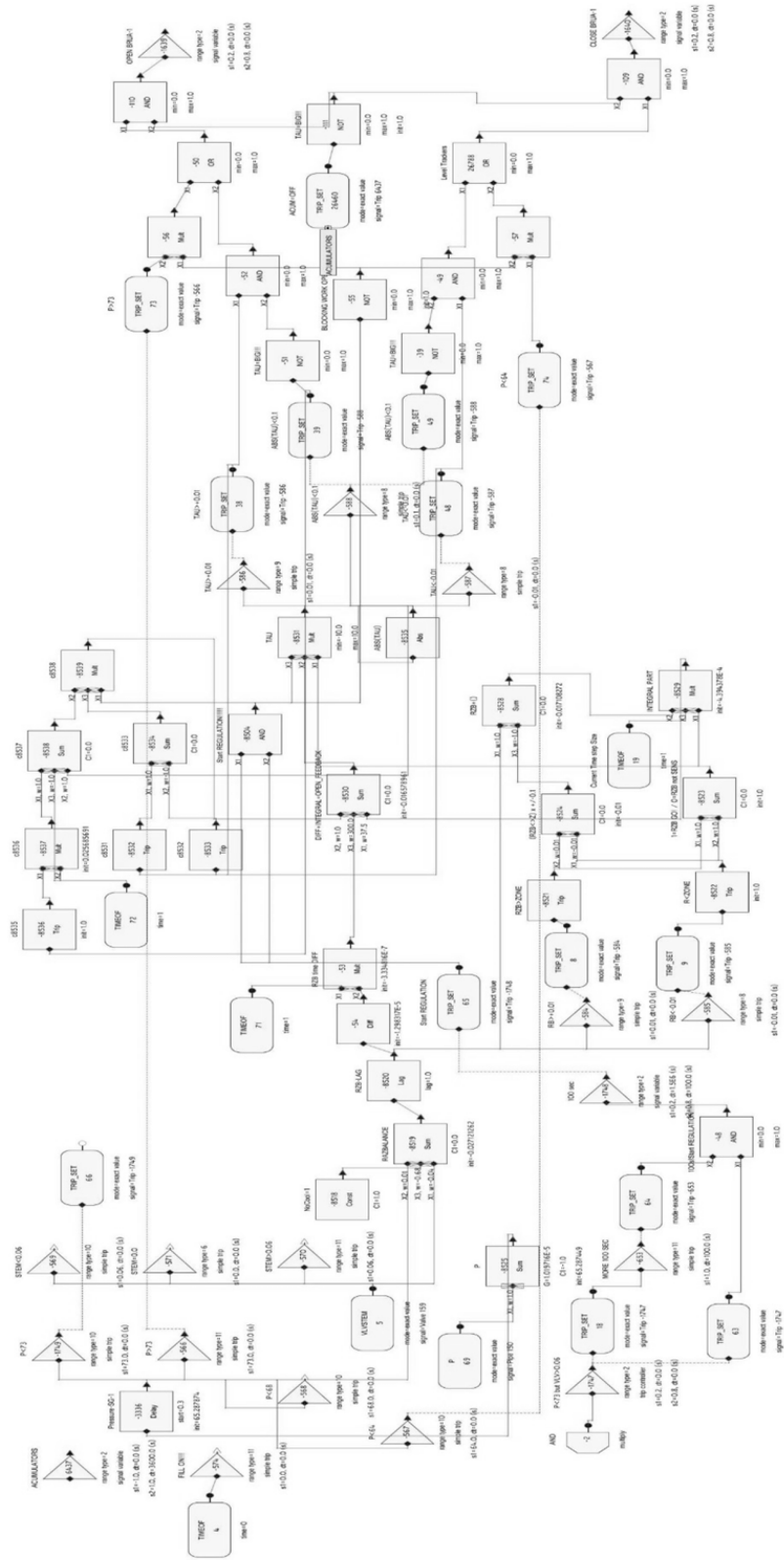

Figure 31 Logical Diagram of BRU-A Controller

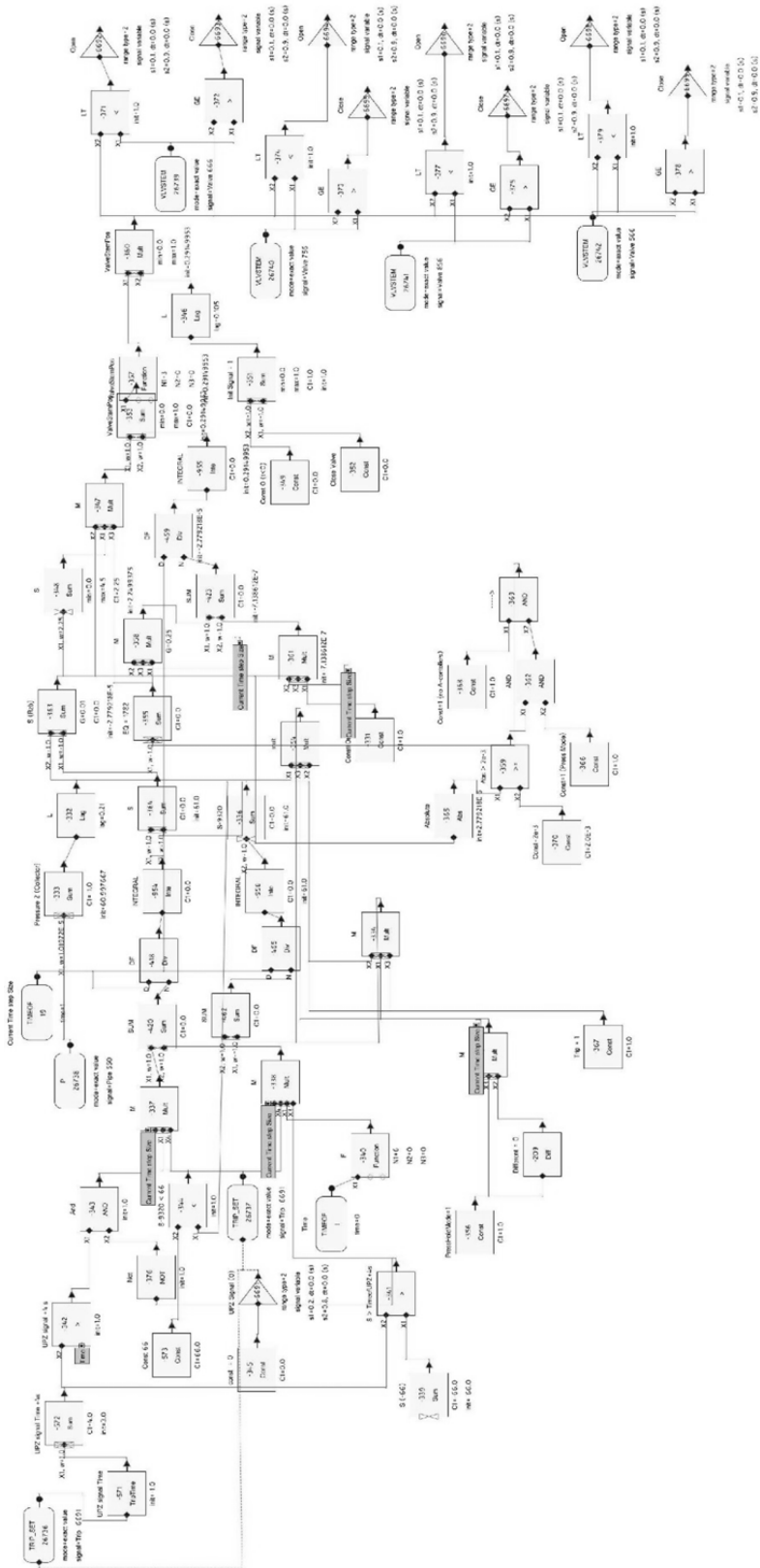

Figure 32 Logical Diagram of Turbine Control System

3 TRACE MODEL STEADY STATE CALCULATIONS

The results of TRACE model steady-state calculation for full power unit operation and correspondent nominal parameters are provided in table below.

Table 1 Steady State Calculation Results

Parameter	Dimension	Parameter value	
		Nominal value	Calculated value
Reactor thermal power	MW (%)	3000±120 (100±4%)	3000.0 (100%)
Reactor outlet pressure	kgf/cm ² (MPa)	160 ± 3 (15.7 ± 0.3)	159 (15.69)
Pressurizer level	m	8.770±0.15	8.77
Coolant flow rate through the reactor	m ³ /h	87500	85600
Coolant temperature at inlet to the reactor	°C	290	291.9
Coolant temperature at outlet from the reactor	°C	320	321.9
Coolant heat-up in the core	°C	30.3	30.0
Fuel cladding maximal temperature	°C	350	329.15
SG pressure	kgf/cm ² (MPa)	64 ± 2 (6.28 ± 0.2)	63.01
MSH pressure	kgf/cm ² (MPa)	61 ± 1 (6 ± 0.1)	61.03
Water level in SG (wide range level gauge)	m	2.25	2.20-2.27
Water level in SG (narrow range level gauge)	m	(0.27–0.32) ±0.015	0.312
Feedwater temperature	°C	220±5	220

Parameter	Dimension	Parameter value	
		Nominal value	Calculated value
SG steam flow rate	kg/sec	408.3 ± 16.7	408.0
SG total steam flow rate	t/h	5880 ± 240	5800
Water temperature in HA	°C	20–60	60
Water temperature in ECCS tanks (HPIS, LPIS)	°C	55–60	60

4 ANALYSIS RESULTS

4.1 Station Blackout

The calculation simulates total SBO scenario (i.e., loss of off-site and on-site power supply including a failure of emergency diesel generators) without operators recovery actions. The battery discharge time is assumed to be one hour (3600 sec.) after which the secondary side BRU-A are stuck in intermediate position. The feedwater control valves are assumed to stuck simultaneously with initiating event occurrence.

Initial conditions for SBO calculation are listed in Table 2 below.

Table 2 Initial Conditions for SBO

Parameter	RELAP5 Value	TRACE Value
Reactor Power	3000 (MWt)/ 100%	3000 (MWt)/ 100%
Pressure in primary circuit	159.1 (kgf/cm ²)	158.6 (kgf/cm ²)
Level in Pressurizer	8.70 (m)	8.72 (m)
Reactor Flow	84800 (m ³ /h)	84700 (m ³ /h)
Cold leg temperature	288°C	289°C
Hot leg temperature	320°C	321°C
Maximal fuel cladding temperature	355°C	357°C
Pressure in Steam Generators	62-63 (kgf/cm ²)	62-64 (kgf/cm ²)
Level in Steam Generators (1-m base)	0.274 (m)	0.300 (m)

After reactor scram and closure of turbine stop valves the steam dump from all SG begins via BRU-As operating in SG pressure maintenance mode. Condenser steam dump is not available because of loss of power. The decay heat is removed from reactor in natural circulation mode by evaporation of SGs water inventory. After decrease of SG level the primary to secondary circuit heat transfer degrades leading to an increase of RCS pressure with subsequent operation of PRZ PORVs powered from emergency power supply batteries. After batteries depletion (at 3600 sec.) PRZ PORVs operation is controlled by the spring setpoints which are slightly higher than normal ones.

By 4000 sec. the PRZ level reaches PRZ top due to primary coolant thermal expansion and boiling in the core. At 13000 sec. RELAP5 calculation shows initiation of cladding temperature increase which is temporarily interrupted by a drop due to loop seal clearance.

TRACE code gives later initiation time of cladding temperature increase (17000sec). Peak cladding temperature of a 1200°C is reached at about 26000 sec. that is 5000 sec. later than RELAP case.

The main events of the SBO calculations for RELAP5 and TRACE are listed in Table 3 below.

Table 3 Timing of Main Events for SBO Calculation

Event	Relap5 Timing [sec.]	TRACE Timing [sec.]
Loss of external power	0	0
BRU-As open	120	120
First PRZ PORV Opening	1050	1300
BRU-As stuck in intermediate position	3600	3600
Pressurizer is filled	4600	4550
SGs dry out	5900-7000	5900-7000
RELAP PCT is 1200°C	21000	-
End of TRACE calculation	-	25000

Plots with the results of RELAP5 and TRACE SBO calculations are given below.

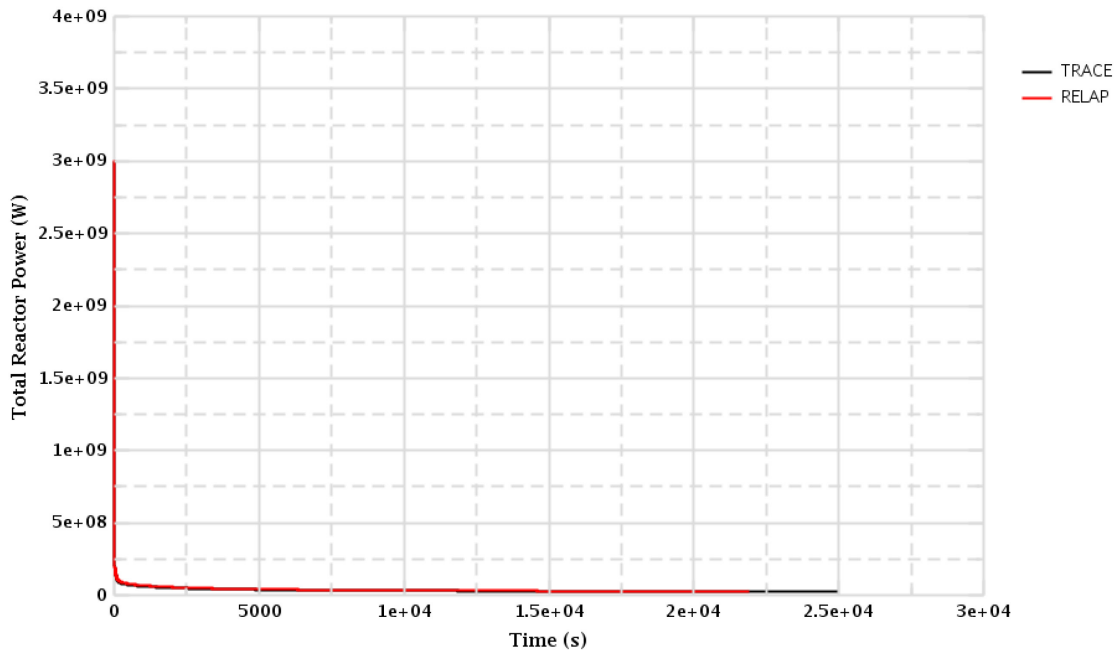

Figure 33 Reactor Power

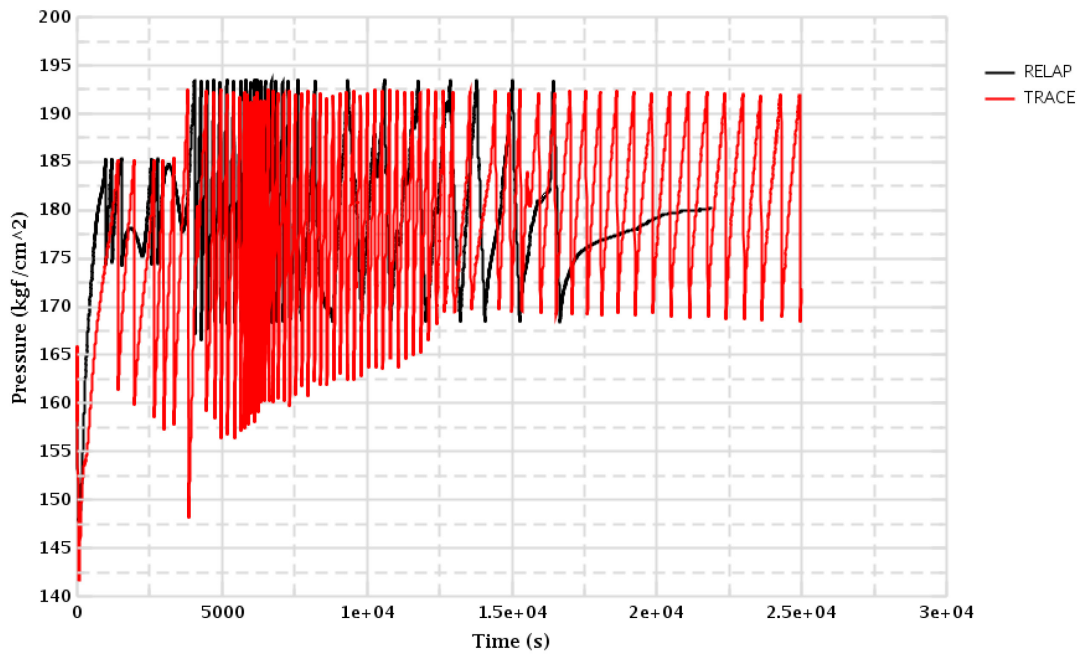

Figure 34 Primary Pressure

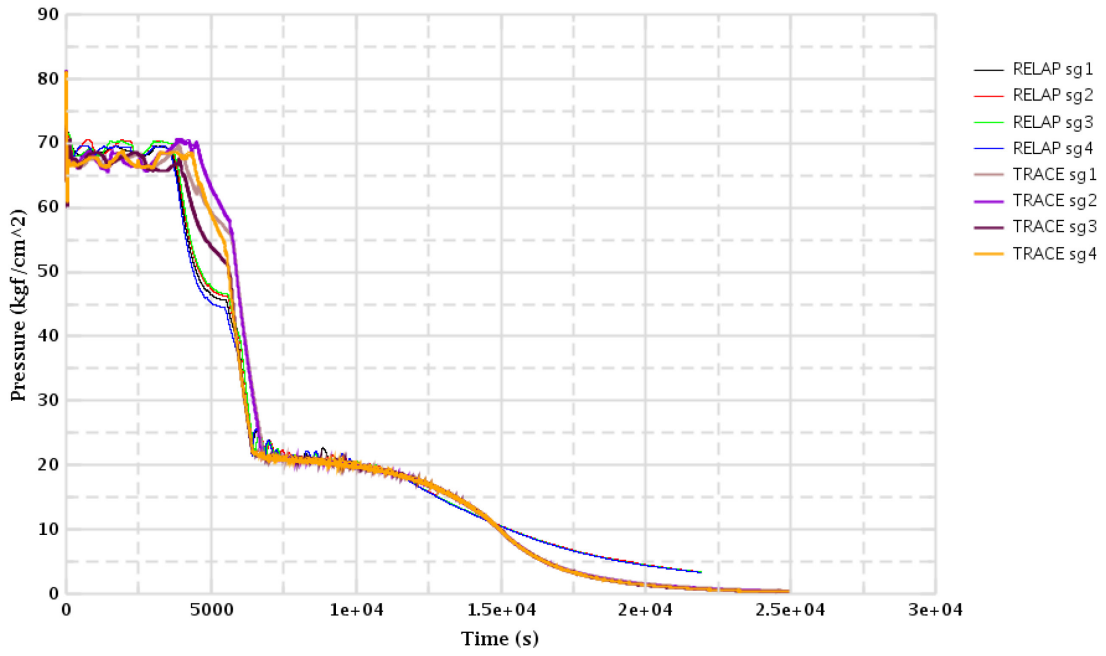

Figure 35 SG Pressure

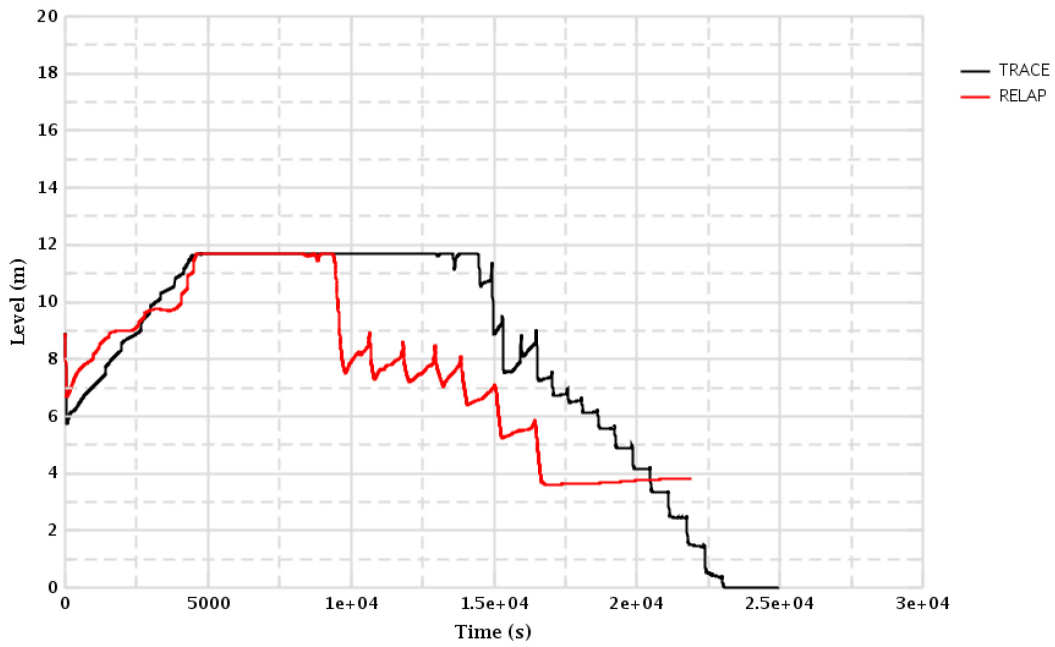

Figure 36 Pressurizer Coolant Level

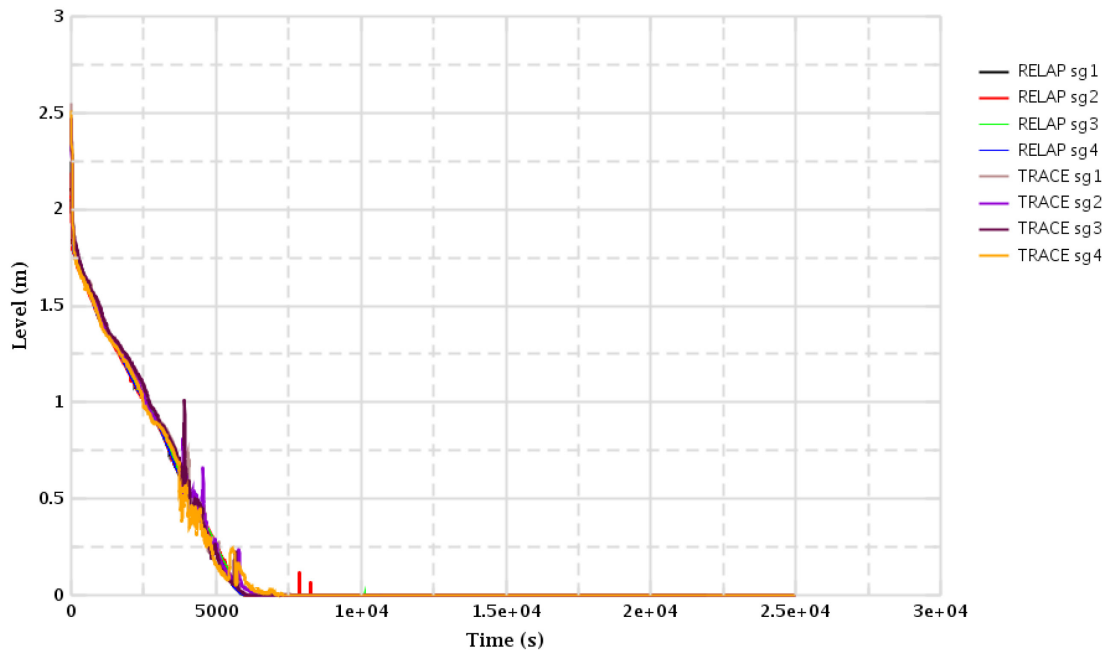

Figure 37 Steam Generators Water Level

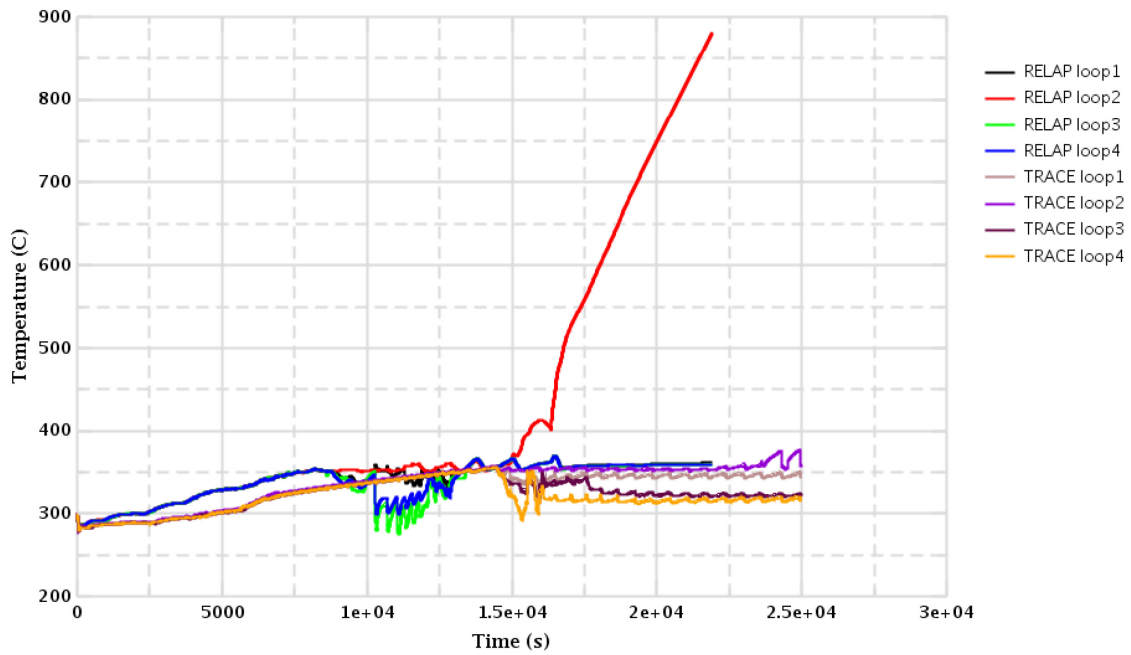

Figure 38 Cold Legs Temperature

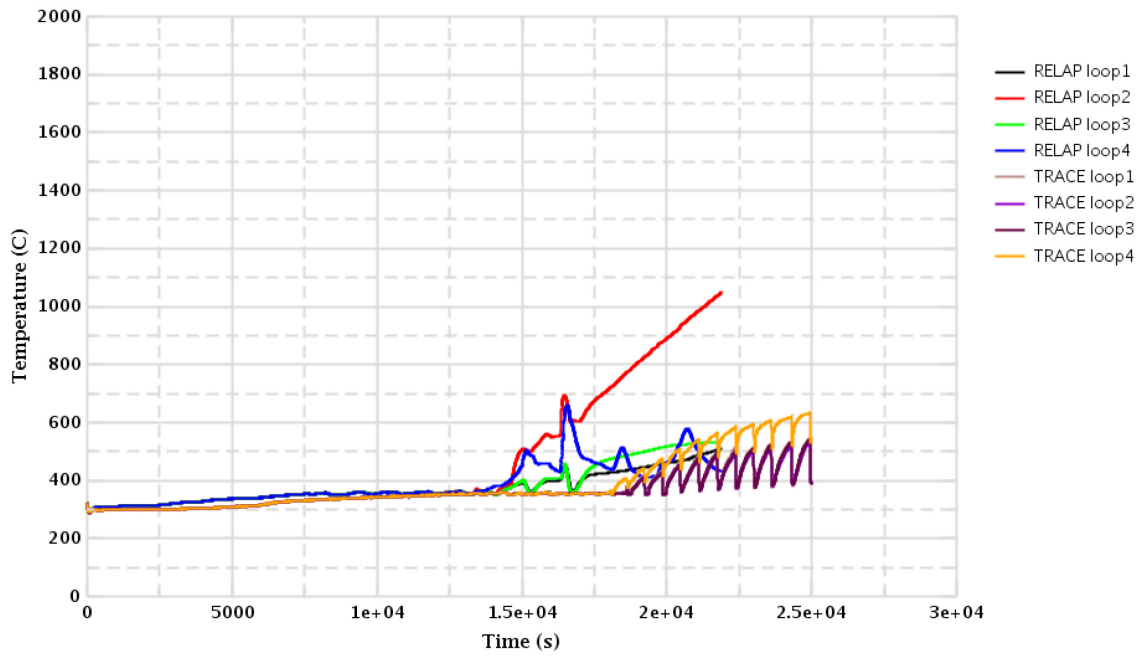

Figure 39 Hot Legs Temperature

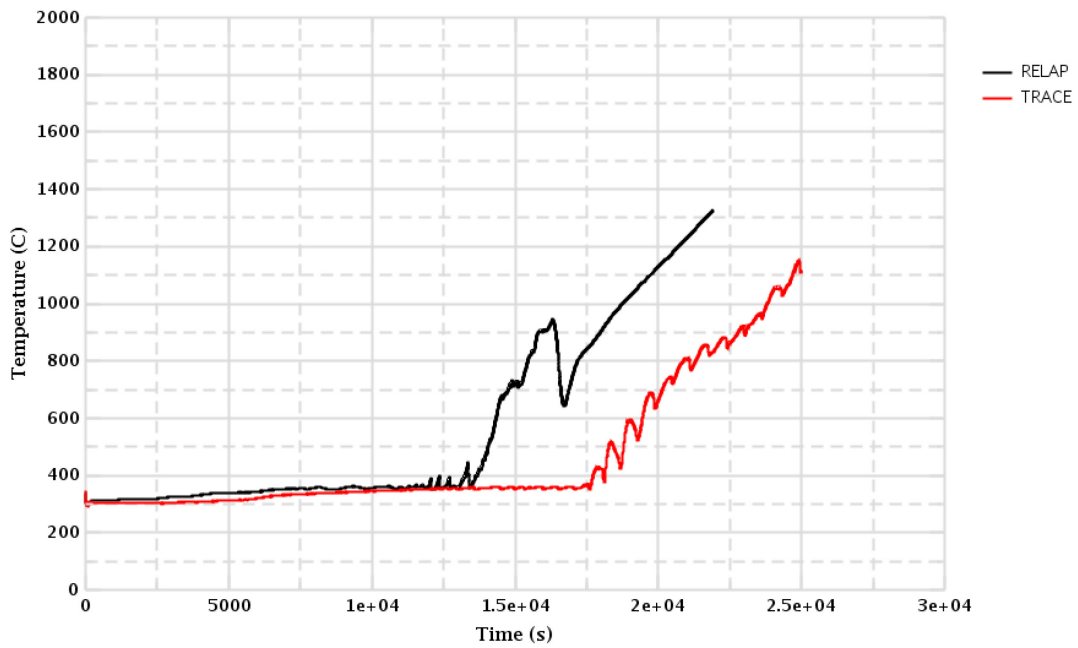

Figure 40 Max Cladding Temperature

4.2 Double-Ended LB LOCA

This analysis simulates the double ended guillotine break of the cold leg at the reactor inlet with simultaneous loss of power supply. Failure of one emergency diesel generator (DG) is postulated as the single failure.

Opening time of the break valves is equal to 0.001 sec. Initial reactor power is 104% and after reactor shutdown the decay heat is increased by 10%. The minimal reactor flow is assumed before initiating event occurrence. Postulated failures are failure of one HA connected to reactor downcomer, failure of one HPIS and LPIS trains. Axial core power profiles are symmetrical with peak value $K_z = 1.49$ and fuel pin peaking factor $K_r = 1.74$.

It is assumed conservatively that hot channel is isolated completely from the other core (for all 4 core sectors). Initial mass flow through hot channel during steady state is 96 kg/s (460 m³/h) in both RELAP and TRACE models. The reactor power in TRACE calculation is specified using a table from RELAP 5 model to get identical power decay after shutdown.

Initial conditions for LB LOCA calculation are listed in Table 4 below.

Table 4 Initial Conditions for LBLOCA Calculation

Parameter	RELAP 5 Value	TRACE Value
Core power	3120 (MW)/ 104%	3120 (MW)/ 104%
RCS pressure	159.0 (kgf/cm ²)	158.2 (kgf/cm ²)
Pressurizer level	8.70 (m)	8.77(m)
Vol. flow through reactor	80000 (m ³ /h)	80400 (m ³ /h)
Cold leg coolant temperature	290°C	292°C
Hot leg coolant temperature	323°C	324°C
Maximal fuel cladding temperature	351°C	348°C
Maximal fuel temperature (hot channel)	1967°C	1927°C
Secondary pressure	61 (kgf/cm ²)	61 (kgf/cm ²)
SG Level (narrow range gauge, 1-m base)	0.27 (m)	0.30 (m)
ECCS Temperature	90°C	90°C
Hot channel inlet mass flow	96 (kg/s)	96 (kg/s)

At 0 sec. of calculation the break is initiated. After the break the flow reversal occurs causing first cladding temperature rise. The temperature is decreased after HAs injection. After DGs start the ECCS trains start to inject borated water with 90°C temperature.

The second peak temperature at core reflood phase is reached at 315 sec. for RELAP 5 and at 355 sec. for TRACE calculation. After that because of continuous ECCS injection the temperature begins to decrease.

The main events of the RELAP5 and TRACE calculations of LBLOCA are listed in Table 5 below.

Table 5 Timing of Main Events of LBLOCA Calculation

Event	Relap 5 Timing [sec.]	TRACE Timing [sec.]	Comment
LOCA opens Loss of power supply	0	0	
Diesel generators start	18	18	
First cladding temperature peak	4.8	4.6	TRACE value 778°C RELAP value 980°C
Start of HPIS and LPIS injection	60	60	
Second cladding temperature peak	315	355	TRACE value 1127°C RELAP value 973°C
End of calculation	1000	1000	

Comparison plots for LB LOCA RELAP and TRACE calculations are shown below.

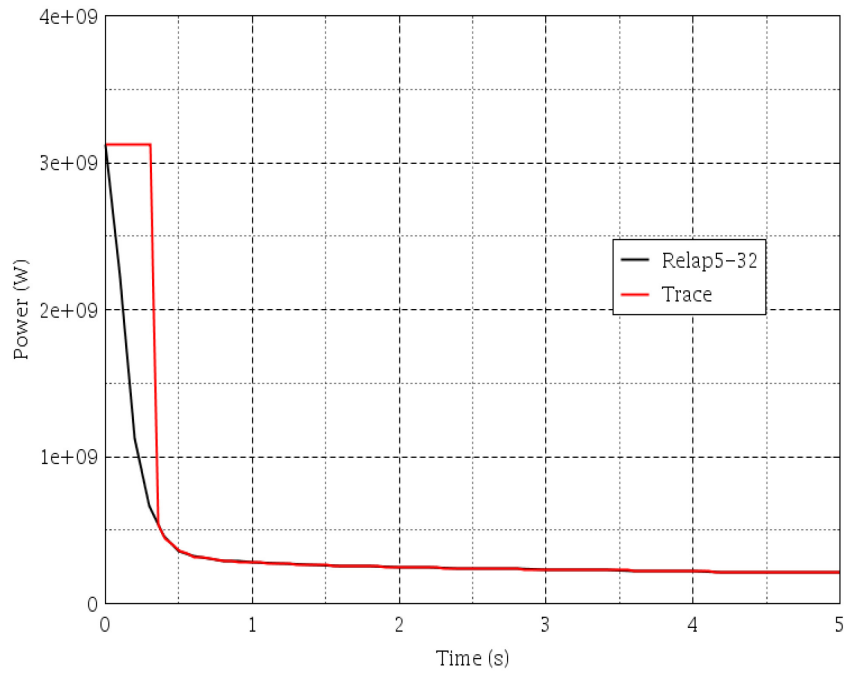

Figure 41 Reactor Power (Fragment)

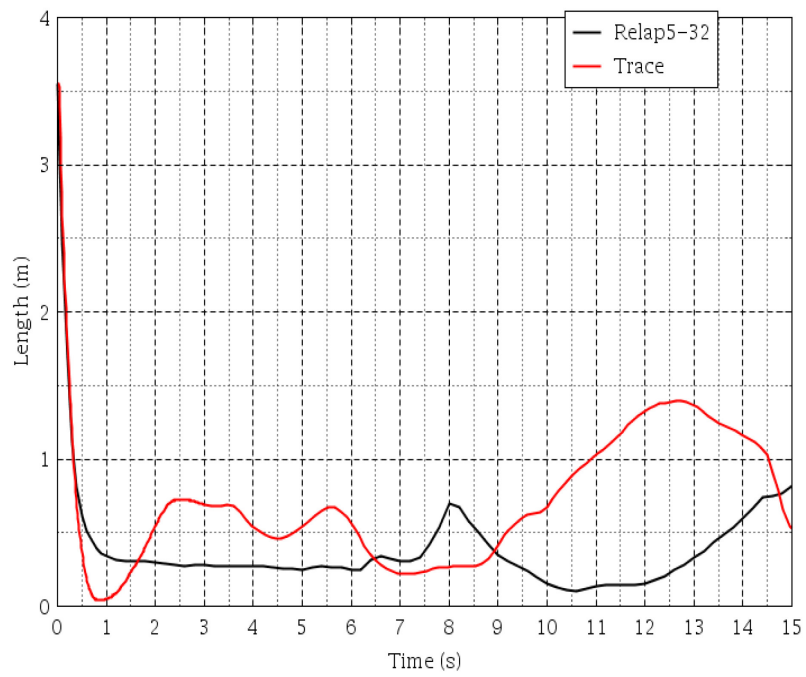

Figure 42 Hot Channel Collapsed Level (Fragment)

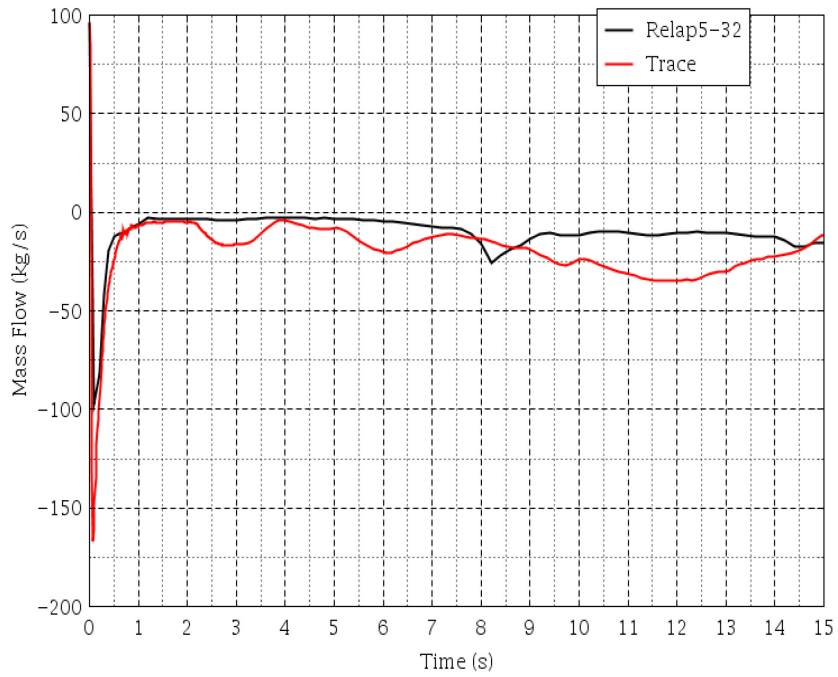

Figure 43 Hot Channel Mass Flow (Fragment)

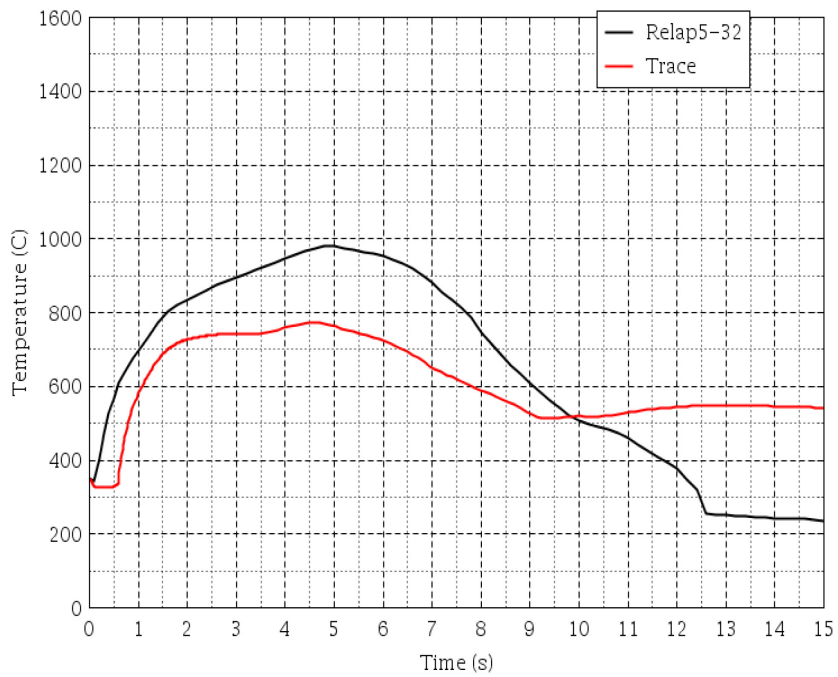

Figure 44 Hot Channel Max Cladding Temperature

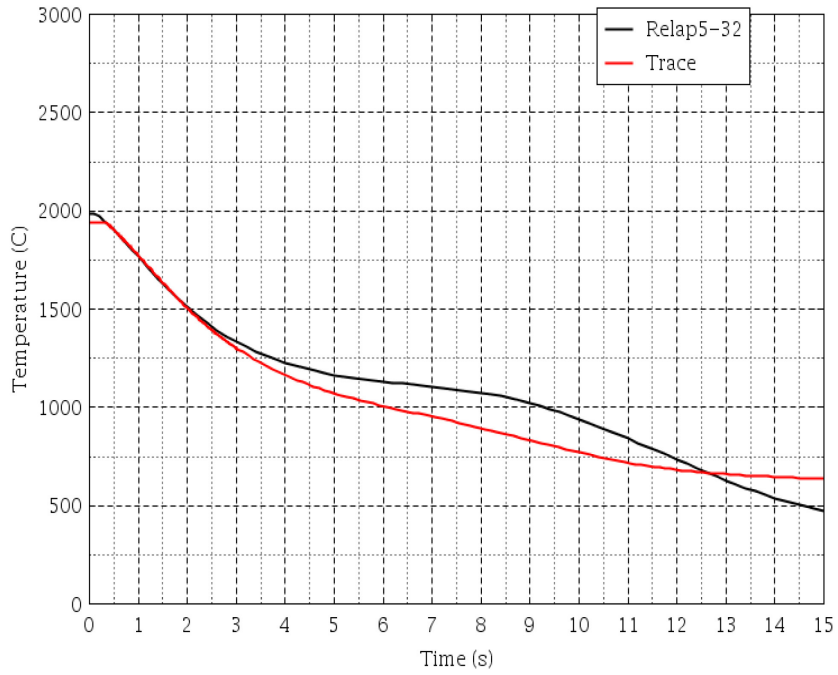

Figure 45 Hot Channel Max Fuel Temperature

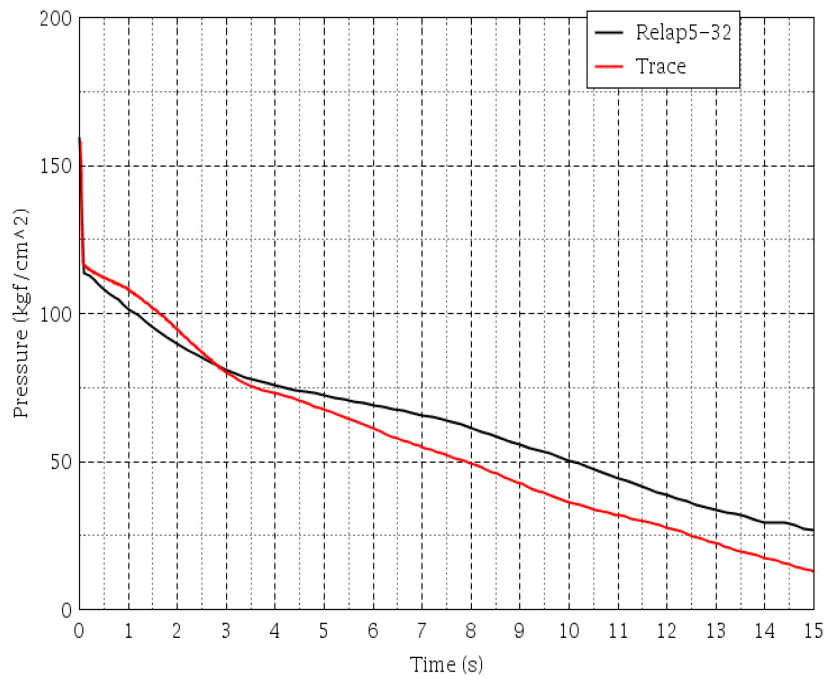

Figure 46 RCS Pressure

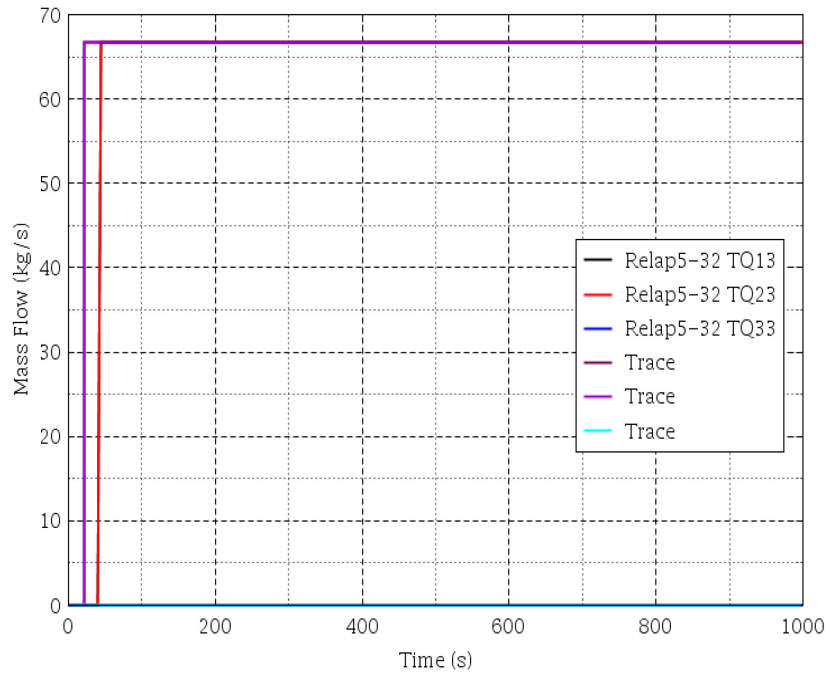

Figure 47 HPIS Flow

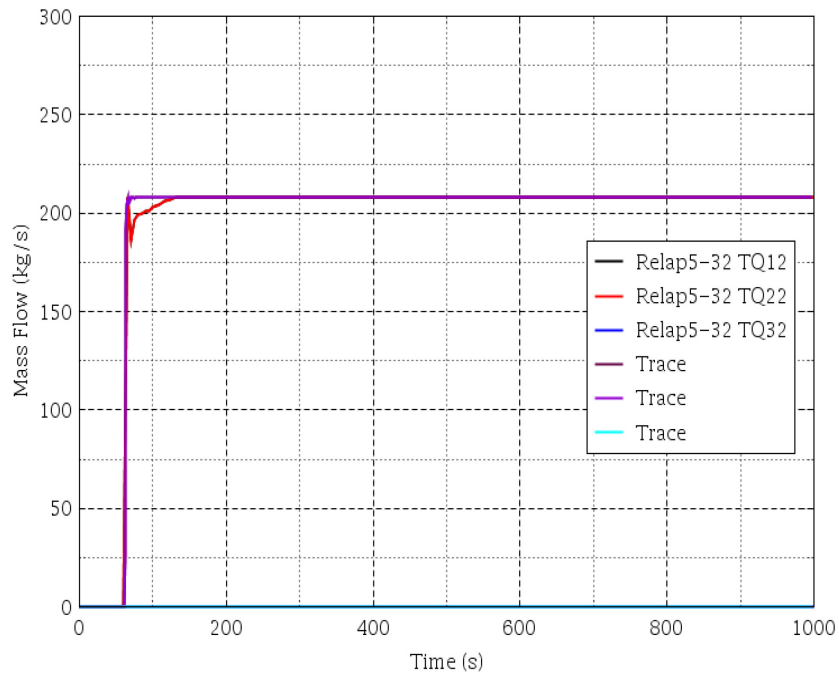

Figure 48 LPIS Flow

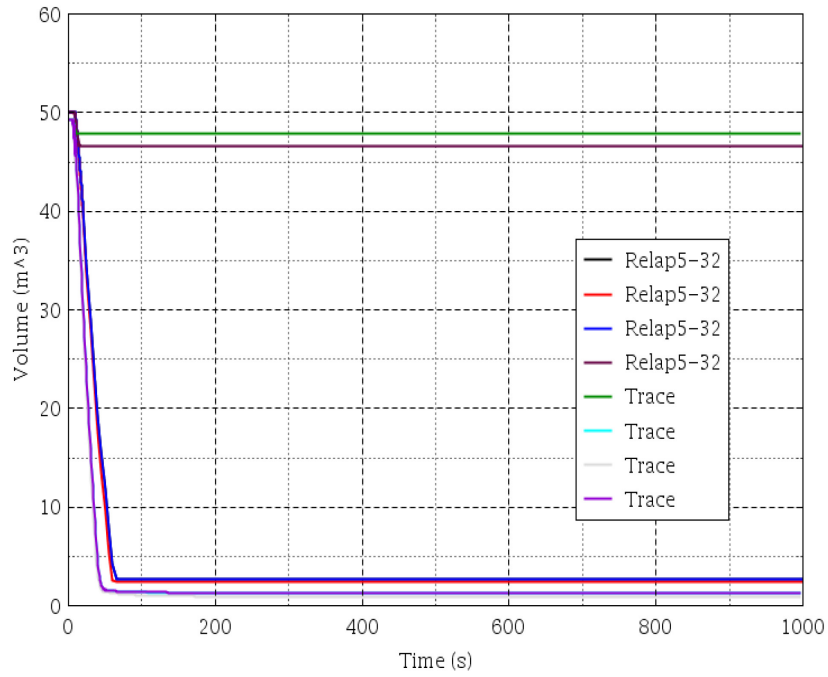

Figure 49 HA Water Volume

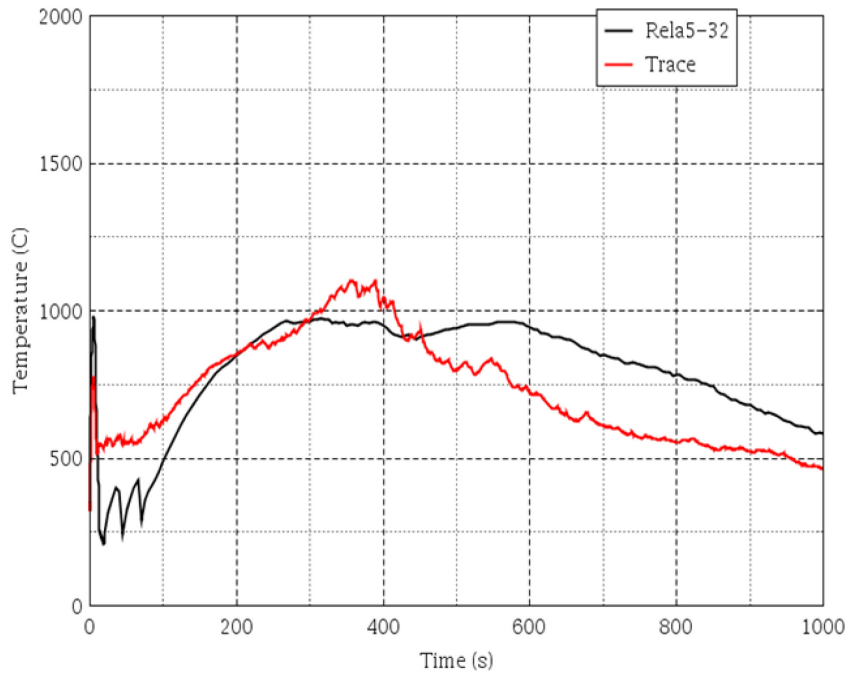

Figure 50 Maximal Cladding Temperature

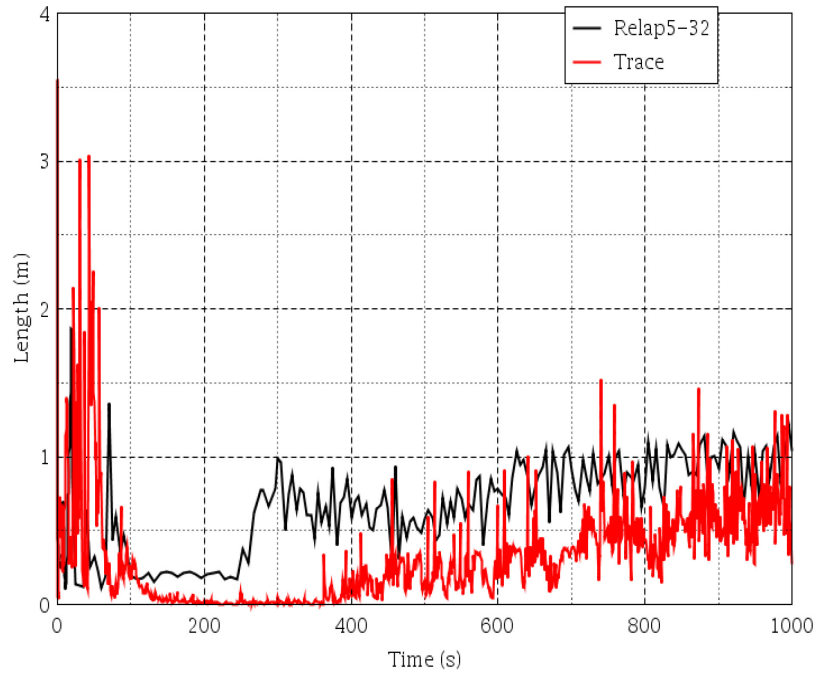

Figure 51 Hot Channel Collapsed Level

5 DISCUSSION

5.1 SBO

The results demonstrate that SG levels behavior in RELAP and TRACE calculations is in a good agreement so the heat transfer from primary to secondary is modeled adequately. But PRZ level increase timing is quite different that could be caused by difference in PRZ PORVs operation. Because of that the water release is also different that causes later core heat-up for the TRACE model. Other parameters seem to be in a good agreement.

Comparison of the results suggest that PRZ PORVs model for TRACE code requires more detailed evaluation in order to verify PORVs operation logic, discharge options, PRZ dome nodalization and other modeling options.

5.2 LB LOCA

Core flow reversal at the initial phase is clearly seen in both codes calculations. First cladding temperature peak in TRACE calculation is lower than the one predicted by RELAP. This can be caused by differences in heat transfer correlations. The ECCS flows and HA inventories are in good agreement because of nearly identical RCS pressure values after blowdown phase in both RELAP and TRACE calculations.

Second cladding peak temperature in TRACE calculation is higher because of lower coolant inventory in the reactor core. This suggests that the break discharge models and flow regimes during the reflood phase (especially droplet flows) should be checked. Timing of the max cladding temperatures is in good agreement for both codes.

5.3 Future Plans

Based on the results of initial TRACE model evaluation it can be concluded that the VVER-1000 model developed needs further improvement in the components/models and control logic simulation. Areas of further model improvement and qualification include:

- core modeling (hot channels, gap deformation);
- discharge models adjustment;
- improvement of reactor kinetics modeling;
- model verification
- model validation using actual NPP transient data.

Correspondent activities are foreseen in the framework of Task Order 17 under Basic Ordering Agreement #257586 between SSTC NRS and Brookhaven National Laboratory [3].

6 CONCLUSIONS

This report provides brief description of the results of comparative calculations performed for two accident scenarios with application of RELAP and TRACE VVER-1000 models. The initiating events analyzed include:

- Total loss of off-site and on-site power supply (total station blackout, SBO);
- Large break LOCA (850 mm double-ended cold leg break) scenario with simultaneous loss of power.

The comparison demonstrates good agreement between the results obtained with both codes but identified the need for further improvement of TRACE model developed. In particular, the model needs to be checked and improved in such areas as core modeling, systems performance characteristics and discharge model adjustment, reactor kinetics, etc. TRACE model qualification is foreseen to enable its further application in SNRIU/SSTC NRS regulatory activities on evaluation of safety assessments performed for Ukrainian NPPs.

7 REFERENCES

1. Development of the Multipurpose Thermal Hydraulic Model of NSSS with WWER-1000/320. Specification of the Main Components of the Model. R&D Report. Kyiv, SSTC NRS, 2010.
2. R&D Report. Support in Mastering the Computer Codes Obtained Within the 2014 CAMP and CSARP Agreements. Transfer of WWER-1000/320 Thermal Hydraulic Model Developed For RELAP5 Code Into TRACE Format, Kyiv, SSTC NRS, 2015.
3. Task Order 17 under BOA #257586 between the Brookhaven National Laboratory and the SSTC NRS, 2015.

BIBLIOGRAPHIC DATA SHEET

(See instructions on the reverse)

NUREG/IA-0475

2. TITLE AND SUBTITLE

TRACE/RELAP5 Comparative Calculations for Double-Ended LBLOCA and SBO

3. DATE REPORT PUBLISHED

MONTH

November

YEAR

2016

4. FIN OR GRANT NUMBER

5. AUTHOR(S)

S. Iegan, A. Mazur,
Y. Vorobyov, O. Zhabin, S. Yanovskiy

6. TYPE OF REPORT

Technical

7. PERIOD COVERED (Inclusive Dates)

8. PERFORMING ORGANIZATION - NAME AND ADDRESS (If NRC, provide Division, Office or Region, U. S. Nuclear Regulatory Commission, and mailing address; if contractor, provide name and mailing address.)

State Nuclear Regulatory Inspectorate of Ukraine
And State Scientific and Technical Center
9/11 Arsenalna str. Kyiv, Ukraine 01011

9. SPONSORING ORGANIZATION - NAME AND ADDRESS (If NRC, type "Same as above", if contractor, provide NRC Division, Office or Region, U. S. Nuclear Regulatory Commission, and mailing address.)

Division of Systems Analysis
Office of Nuclear Regulatory Research
U.S. Nuclear Regulatory Commission
Washington, DC 20555-0001

10. SUPPLEMENTARY NOTES

K. Tien, NRC Project Manager

11. ABSTRACT (200 words or less)

This report is developed by the State Nuclear Regulatory Inspectorate of Ukraine (SNRIU) and its technical support organization, the State Scientific and Technical Center for Nuclear and Radiation Safety of Ukraine (SSTC NRS), under Implementing Agreement On Thermal-Hydraulic Code Applications And Maintenance Between The United States Nuclear Regulatory Commission and State Nuclear Regulatory Inspectorate of Ukraine (signed in 2014) in accordance with Article III, Section C, of the Agreement.

The report provides description of quantitative analysis results of two initiating events for VVER-1000 reactor system with application of TRACE p4 and RELAP5/MOD3.2 codes. For these calculations RELAP5 input model for VVER-1000 was converted to TRACE code. The results obtained with both codes were compared to evaluate differences and to identify future needs for TRACE input deck enhancement.

12. KEY WORDS/DESCRIPTORS (List words or phrases that will assist researchers in locating the report.)

13. AVAILABILITY STATEMENT

unlimited

14. SECURITY CLASSIFICATION

(This Page)

unclassified

(This Report)

unclassified

15. NUMBER OF PAGES

16. PRICE



Federal Recycling Program



UNITED STATES
NUCLEAR REGULATORY COMMISSION
WASHINGTON, DC 20555-0001

OFFICIAL BUSINESS



NUREG/IA-0475

TRACE/RELAP5 Comparative Calculations for Double-Ended LBLUCA and SBO

November 2016