

George A. Lippard
Vice President, Nuclear Operations
(803) 345-4810

October 31, 2016
RC-16-0143



U. S. Nuclear Regulatory Commission
Document Control Desk
Washington, DC 20555-0001

Dear Sir / Madam:

Subject: VIRGIL C. SUMMER NUCLEAR STATION (VCSNS) UNIT 1
DOCKET NO. 50-395
OPERATING LICENSE NO. NPF-12
REPORT OF FULL COMPLIANCE AND FINAL INTEGRATED PLAN IN
RESPONSE TO MARCH 12, 2012, COMMISSION ORDER MODIFYING
LICENSES WITH REGARD TO REQUIREMENTS FOR MITIGATION
STRATEGIES FOR BEYOND-DESIGN-BASIS EXTERNAL EVENTS
(ORDER EA-12-049) FOR VIRGIL C. SUMMER NUCLEAR STATION UNIT 1

- References:
1. Nuclear Regulatory Commission (NRC) Order Number EA-12-049, *Issuance of Order to Modify Licenses with Regard to Requirements for Mitigation Strategies for Beyond-Design-Basis External Events*, dated March 12, 2012, Agencywide Documents Access and Management System (ADAMS) Accession Number ML12054A735
 2. NRC Interim Staff Guidance JLD-ISG-2012-01, *Compliance with Order EA-12-049, Order Modifying Licenses with Regard to Requirements for Mitigation Strategies for Beyond-Design-Basis External Events*, Revision 1, dated January 22, 2016, ADAMS Accession Number ML15357A163
 3. NEI 12-06, *Diverse and Flexible Coping Strategies (FLEX) Implementation Guide*, Revision 2, dated December 2015, ADAMS Accession Number ML16005A625
 4. SCE&G Letter, *Virgil C. Summer Nuclear Station (VCSNS) Unit 1 Initial Status Report in Response to March 12, 2012 Commission Order Modifying Licenses with Regard to Requirements for Mitigation Strategies for Beyond-Design-Basis External Events (Order Number EA-12-049)*, dated October 17, 2012, ADAMS Accession Number ML12296A252
 5. SCE&G Letter, *Virgil C. Summer, Unit 1, Overall Integrated Plan as Required by March 12, 2012 Commission Order Modifying Licenses with Regard to Requirements for Mitigation Strategies for Beyond-Design-Basis External Events (Order Number EA-12-049)*, dated February 28, 2013, ADAMS Accession Number ML13063A150

6. SCE&G Letter, *Virgil C. Summer, Unit 1, First Six-Month Status Report in Response to March 12, 2012 Commission Order Modifying Licenses with Regard to Requirements for Mitigation Strategies for Beyond-Design-Basis External Events (Order Number EA-12-049)*, dated August 28, 2013, ADAMS Accession Number ML13242A273
7. SCE&G Letter, *Virgil C. Summer, Unit 1, Second Six-Month Status Report in Response to March 12, 2012 Commission Order Modifying Licenses with Regard to Requirements for Mitigation Strategies for Beyond-Design-Basis External Events (Order Number EA-12-049)*, dated February 27, 2014, ADAMS Accession Number ML14063A203
8. SCE&G Letter, *Virgil C. Summer, Unit 1, Third Six-Month Status Report in Response to March 12, 2012 Commission Order Modifying Licenses with Regard to Requirements for Mitigation Strategies for Beyond-Design-Basis External Events (Order Number EA-12-049)*, dated August 28, 2014, ADAMS Accession Number ML14245A405
9. SCE&G Letter, *Virgil C. Summer, Unit 1, Fourth Six-Month Status Report in Response to March 12, 2012 Commission Order Modifying Licenses with Regard to Requirements for Mitigation Strategies for Beyond-Design-Basis External Events (Order Number EA-12-049)*, dated February 27, 2015, ADAMS Accession Number ML15062A007
10. SCE&G Letter, *Virgil C. Summer, Unit 1, Fifth Six-Month Status Report in Response to March 12, 2012 Commission Order Modifying Licenses with Regard to Requirements for Mitigation Strategies for Beyond-Design-Basis External Events (Order Number EA-12-049)*, dated August 24, 2015, ADAMS Accession Number ML15239A750
11. SCE&G Letter, *Virgil C. Summer, Unit 1, Sixth Six-Month Status Report in Response to March 12, 2012 Commission Order Modifying Licenses with Regard to Requirements for Mitigation Strategies for Beyond-Design-Basis External Events (Order Number EA-12-049)*, dated February 26, 2016, ADAMS Accession Number ML16061A005
12. SCE&G Letter, *Virgil C. Summer, Unit 1, Seventh Six-Month Status Report in Response to March 12, 2012 Commission Order Modifying Licenses with Regard to Requirements for Mitigation Strategies for Beyond-Design-Basis External Events (Order Number EA-12-049)*, dated August 29, 2016, ADAMS Accession Number ML16243A464
13. NRC letter, *Virgil C. Summer Nuclear Station, Unit 1 - Interim Staff Evaluation Relating to Overall Integrated Plan in Response to Order EA-12-049 (Mitigation Strategies)*, dated February 21, 2014, ADAMS Accession Number ML14034A339
14. NRC letter, *Virgil C. Summer Nuclear Station, Unit 1 - Report for the Onsite Audit Regarding Implementation of Mitigating Strategies and Reliable Spent Fuel Instrumentation Related to Orders EA-12-049 and EA-12-051*, dated September 16, 2015, ADAMS Accession Number ML15253A721

On March 12, 2012, the Nuclear Regulatory Commission (NRC) issued Order EA-12-049 (Reference 1) to South Carolina Electric & Gas Company (SCE&G). Reference 1 was immediately effective and directed SCE&G to develop, implement, and maintain guidance and strategies to maintain or restore core cooling, containment, and spent fuel pool cooling capabilities in the event of a beyond-design-basis external event. Specific requirements are outlined in Attachment 2 of Reference 1.

Reference 1 required submission of an initial status report 60 days following issuance of the final interim staff guidance (Reference 2) and an Overall Integrated Plan (OIP) pursuant to Section IV, Condition C. NRC Interim Staff Guidance JLD-ISG-2012-01 (Reference 2) endorses, with clarifications and exceptions identified, industry guidance document NEI 12-06, Revision 2 (Reference 3). Reference 4 provided the initial status report regarding mitigation strategies at the Virgil C. Summer Nuclear Station (VCSNS) Unit 1. Reference 5 provided the OIP for VCSNS Unit 1.

Reference 1 also required submission of a status report at six-month intervals following submittal of the OIP. References 6, 7, 8, 9, 10, 11, and 12 provided the first, second, third, fourth, fifth, sixth, and seventh six-month status reports, respectively, pursuant to Section IV, Condition C.2, of Reference 1 for VCSNS Unit 1.

The NRC issued an Interim Staff Evaluation (Reference 13) to VCSNS Unit 1. A response to each open and confirmatory item identified in Reference 13 was provided in Reference 11. With the exception of Confirmatory Item 3.2.1.2.A, all open and confirmatory items have been addressed and are considered closed as documented in the NRC Audit Report (Reference 14). Confirmatory Item 3.2.1.2.A, addressed in Reference 11, is considered complete pending NRC approval. Reference 14 identified two additional open items, Audit Question 12 and Additional Safety Evaluation Item 16. A response to the additional open items was also provided in Reference 11. These items have been addressed and are considered complete pending NRC approval.

The purpose of this letter is to provide the report of full compliance with Order EA-12-049 pursuant to Section IV, Condition C.3, of the order for VCSNS Unit 1 as of September 19, 2016. VCSNS Unit 1 has developed, implemented, and will maintain the guidance and strategies to maintain or restore core cooling, containment, and spent fuel pool cooling capabilities in the event of a beyond-design-basis external event.

Enclosure 1 provides a brief summary of the key elements associated with compliance to Order EA-12-049 for VCSNS Unit 1. It also includes an update to the milestone schedule that was initially submitted in the OIP and revised in subsequent status reports. Enclosure 2 provides the Final Integrated Plan (FIP) for VCSNS Unit 1.

The VCSNS Unit 1 FIP is based on NEI 12-06, Revision 2 with the exception of Appendix E, which was finalized after the validation process was completed. Other aspects of NEI 12-06, Revision 2, while not applicable to this Order, will be utilized for upcoming submittals (e.g., use of re-evaluated hazards, Appendix G and H) and rulemaking (e.g., references to NEI 13-06 and NEI 14-01).

This letter contains no new regulatory commitments. If you have any questions regarding this report, please contact Bruce L. Thompson at (803) 931-5042.

I certify under penalty of perjury that the foregoing is true and correct.

10/31/16
Executed on

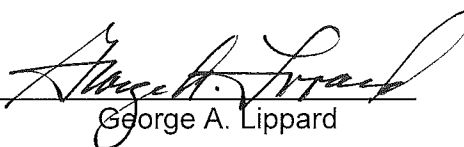
George A. Lippard

TS/GAL/wm

Enclosure 1: VCSNS Unit 1, Summary of Compliance Elements for Order EA-12-049

Enclosure 2: VCSNS Unit 1, Final Integrated Plan Document

c: K. B. Marsh
S. A. Byrne
J. B. Archie
N. S. Carns
J. H. Hamilton
S. M. Shealy
W. M. Cherry
C. Haney
S. A. Williams
M. O. Valentin
NRC Resident Inspector
NSRC
RTS (CR-12-01078)
File (815.07)
PRSF (RC-16-0143)

VIRGIL C. SUMMER NUCLEAR STATION (VCSNS) UNIT 1

ENCLOSURE 1

SUMMARY OF COMPLIANCE ELEMENTS FOR ORDER EA-12-049

The elements identified below for Virgil C. Summer Nuclear Station (VCSNS) Unit 1, as well as the Overall Integrated Plan (Reference 1), the six month status reports (References 2-8), and any additional docketed correspondence, demonstrate compliance with Order EA-12-049 (Reference 9). Of note, references identified in this enclosure are listed at the end of the enclosure.

Strategies – Complete

VCSNS Unit 1 strategies are in compliance with Order EA-12-049. All strategy related open items, confirmatory items, or audit questions/audit report items have been addressed and are considered complete.

Modifications – Complete

The modifications required to support the FLEX strategies for VCSNS Unit 1 have been fully implemented in accordance with the station design control process.

Equipment – Procured and Maintenance & Testing – Complete

The equipment required to implement the FLEX strategies is available for use at VCSNS Unit 1. The equipment has been procured in accordance with NEI 12-06, Sections 11.1 and 11.2, and has been initially tested/performance verified in accordance with NEI 12-06, Section 11.5.

Maintenance and testing will be conducted through the use of the VCSNS Unit 1 Preventative Maintenance program such that equipment reliability is achieved.

Protected Storage – Complete

The storage facilities required to implement the FLEX strategies for VCSNS Unit 1 have been completed and provide protection for the applicable site hazards. The equipment required to implement the FLEX strategies for VCSNS Unit 1 is stored in its protected configuration.

Procedures – Complete

FLEX Support Procedures (FSPs), for VCSNS Unit 1 have been developed, validated, and integrated with existing procedures. The FSPs and applicable existing procedures are effective and available for use in accordance with the site procedure control program.

Training – Complete

Training for VCSNS Unit 1 has been completed in accordance with an accepted training process as recommended in NEI 12-06, Section 11.6.

Staffing – Complete

The staffing study for VCSNS Unit 1 has been completed in accordance with 10CFR50.54(f), "Request for Information Pursuant to Title 10 of the Code of Federal Recommendations 2.1, 2.3, and 9.3, of the Near-Term Task Force review of Insights from the Fukushima Dai-ichi Accident," Recommendation 9.3, dated March 12, 2012 (Reference 10). The staffing study is documented in SCE&G letter, "Response to Request for Additional Information Regarding Phase 2 Staffing Submittals Associated with Near-Term Task Force Recommendation 9.3 Related to the Fukushima Dai-ichi Nuclear Power Plant Accident," dated June 16, 2015 [ML15169A090] (Reference 11).

National SAFER Response Centers – Complete

South Carolina Electric & Gas Company has established a contract with Pooled Equipment Inventory Company (PEICo) and has joined the Strategic Alliance for FLEX Emergency Response (SAFER) Team Equipment Committee for off-site facility coordination. We have validated that PEICo is ready to support VCSNS Unit 1 with Phase 3 equipment stored in the National SAFER Response Centers in accordance with the site specific SAFER Response Plan.

Validation and Verification – Complete

South Carolina Electric & Gas Company has completed performance of validation and verification to ensure the capability to implement FLEX strategies in accordance with industry developed guidance.

FLEX Program Document – Established

The VCSNS Unit 1 program document has been developed in accordance with the requirements of NEI 12-06. This document contains the FLEX strategies and their basis. It also provides references to the applicable site documentation.

Milestone Schedule

The following provides an update to the milestone schedule of the Overall Integrated Plan.

Milestone	Target Completion Date	Activity Status	Revised Target Completion Date
Submit 60 Day Status Report	Oct 2012	Complete	
Submit Overall Integrated Plan	Feb 2013	Complete	
Submit 6 Month Updates:			
Update 1	Aug 2013	Complete	
Update 2	Feb 2014	Complete	

Milestone	Target Completion Date	Activity Status	Revised Target Completion Date
Update 3	Aug 2014	Complete	
Update 4	Feb 2015	Complete	
Update 5	Aug 2015	Complete	
Update 6	Feb 2016	Complete	
Update 7	Aug 2016	Complete	
FLEX Strategy Evaluation	Aug 2013	Complete	
Walk-Throughs or Demonstrations	Aug 2015	Complete	
Perform Staffing Analysis	Jul 2014	Complete	
Modifications:			
Modifications Evaluation	Dec 2013	Complete	
Unit 1 Design Engineering Evaluation	Jan 2015	Complete	
Unit 1 Implementation Outage	Nov 2015	Complete	
Alternate EFW Modification	Jul 2016	Complete	
Storage:			
Design Storage Building	Jul 2014	Complete	
Storage Implementation	Jul 2015	Complete	
FLEX Equipment:			
Procure On-Site Equipment	Oct 2014	Complete	
Develop Strategies with RRC	Nov 2014	Complete	
Install Off-Site Delivery Station (if Necessary)	Aug 2013	Complete	
Procedures:			
PWROG issues NSSS-specific guidelines	May 2013	Complete	
Create Site-Specific FSPs	Feb 2014	Complete	
Create Maintenance Procedures	Oct 2014	Complete	

Milestone	Target Completion Date	Activity Status	Revised Target Completion Date
Training:			
Develop Training Plan	Jan 2015	Complete	
Training Complete	Jul 2015	Complete	
Unit 1 FLEX Implementation	Nov 2015	Complete	
Submit Completion Report	Jan 2016	Complete	Oct 2016

References

1. SCE&G Letter, *Virgil C. Summer, Unit 1, Overall Integrated Plan as Required by March 12, 2012 Commission Order Modifying Licenses with Regard to Requirements for Mitigation Strategies for Beyond-Design-Basis External Events (Order Number EA-12-049)*, dated February 28, 2013, ADAMS Accession Number ML13063A150
2. SCE&G Letter, *Virgil C. Summer, Unit 1, First Six-Month Status Report in Response to March 12, 2012 Commission Order Modifying Licenses with Regard to Requirements for Mitigation Strategies for Beyond-Design-Basis External Events (Order Number EA-12-049)*, dated August 28, 2013, ADAMS Accession Number ML13242A273
3. SCE&G Letter, *Virgil C. Summer, Unit 1, Second Six-Month Status Report in Response to March 12, 2012 Commission Order Modifying Licenses with Regard to Requirements for Mitigation Strategies for Beyond-Design-Basis External Events (Order Number EA-12-049)*, dated February 27, 2014, ADAMS Accession Number ML14063A203
4. SCE&G Letter, *Virgil C. Summer, Unit 1, Third Six-Month Status Report in Response to March 12, 2012 Commission Order Modifying Licenses with Regard to Requirements for Mitigation Strategies for Beyond-Design-Basis External Events (Order Number EA-12-049)*, dated August 28, 2014, ADAMS Accession Number ML14245A405
5. SCE&G Letter, *Virgil C. Summer, Unit 1, Fourth Six-Month Status Report in Response to March 12, 2012 Commission Order Modifying Licenses with Regard to Requirements for Mitigation Strategies for Beyond-Design-Basis External Events (Order Number EA-12-049)*, dated February 27, 2015, ADAMS Accession Number ML15062A007
6. SCE&G Letter, *Virgil C. Summer, Unit 1, Fifth Six-Month Status Report in Response to March 12, 2012 Commission Order Modifying Licenses with Regard to Requirements for Mitigation Strategies for Beyond-Design-Basis External Events (Order Number EA-12-049)*, dated August 24, 2015, ADAMS Accession Number ML15239A750
7. SCE&G Letter, *Virgil C. Summer, Unit 1, Sixth Six-Month Status Report in Response to March 12, 2012 Commission Order Modifying Licenses with Regard to Requirements for Mitigation Strategies for Beyond-Design-Basis External Events (Order Number EA-12-049)*, dated February 26, 2016, ADAMS Accession Number ML16061A005
8. SCE&G Letter, *Virgil C. Summer, Unit 1, Seventh Six-Month Status Report in Response to March 12, 2012 Commission Order Modifying Licenses with Regard to Requirements*

for Mitigation Strategies for Beyond-Design-Basis External Events (Order Number EA-12-049), dated August 29, 2016, ADAMS Accession Number ML16243A464

9. Nuclear Regulatory Commission (NRC) Order Number EA-12-049, *Issuance of Order to Modify Licenses with Regard to Requirements for Mitigation Strategies for Beyond-Design-Basis External Events*, dated March 12, 2012, ADAMS Accession Number ML12054A735
10. NRC Letter, *Request for Information Pursuant to Title 10 of the Code of Federal Regulations Recommendations 2.1, 2.3, and 9.3, of the Near-Term Task Force Review of Insights from the Fukushima Dai-ichi Accident*, dated March 12, 2012, ADAMS Accession Number ML12053A340
11. SCE&G Letter, "Response to Request for Additional Information Regarding Phase 2 Staffing Submittals Associated with Near-Term Task Force Recommendation 9.3 Related to the Fukushima Dai-ichi Nuclear Power Plant Accident," dated June 16, 2015 [ML15169A090]

Document Control Desk
CR-12-01078
RC-16-0143
Enclosure 2
Page 1 of 84

VIRGIL C. SUMMER NUCLEAR STATION (VCSNS) UNIT 1

ENCLOSURE 2

FINAL INTEGRATED PLAN DOCUMENT

**FINAL
INTEGRATED
PLAN
DOCUMENT**

**VIRGIL C. SUMMER
NUCLEAR STATION
UNIT 1**

October 2016

Table of Contents

1.	Background.....	5
2.	NRC Order 12-049 – Mitigation Strategies (FLEX).....	6
2.1	Baseline Assumptions	6
2.2	Strategies	8
2.3	Reactor Core Cooling and Heat Removal Strategy	9
2.3.1	Phase 1 Strategy.....	9
2.3.2	Phase 2 Strategy.....	12
2.3.3	Phase 3 Strategy.....	16
2.3.4	Systems, Structures, Components	17
2.3.5	FLEX Connections.....	19
2.3.6	Key Reactor Parameters	22
2.3.7	Thermal Hydraulic Analyses.....	22
2.3.8	Shutdown Margin Analysis	23
2.3.9	FLEX Pumps and Water Supplies.....	25
2.3.10	Electrical Analysis.....	27
2.4	Spent Fuel Pool Cooling/Inventory	27
2.4.1	Phase 1 Strategy.....	27
2.4.2	Phase 2 Strategy.....	28
2.4.3	Phase 3 Strategy.....	29
2.4.4	FLEX Connections and Ventilation	29
2.4.5	Key Spent Fuel Pool Parameters.....	30
2.4.6	Thermal-Hydraulic Analyses	30
2.4.7	FLEX Pump and Water Supplies	31
2.4.8	Electrical Analysis.....	32
2.5	Containment Integrity.....	32
2.5.1	Phase 1 Strategy.....	32

2.5.2	Phase 2 Strategy.....	33
2.5.3	Phase 3 Strategy.....	33
2.5.4	Structures, Systems, Components.....	34
2.5.5	FLEX Connections.....	34
2.5.6	Key Containment Parameters.....	35
2.5.7	Thermal-Hydraulic Analyses.....	35
2.5.8	Flex Pump and Water Supplies.....	35
2.5.9	Electrical Analysis.....	36
2.6	Characterization of External Hazards.....	36
2.6.1	Seismic.....	36
2.6.2	External Flooding.....	36
2.6.3	Severe Storms with High Wind.....	37
2.6.4	Snow, Ice, and Low Temperatures.....	37
2.6.5	Extreme High Temperatures.....	37
2.7	Protection of FLEX Equipment.....	38
2.8	Deployment of FLEX Equipment.....	39
2.8.1	Haul Paths.....	39
2.8.2	Accessibility.....	40
2.9	Deployment of strategies.....	41
2.9.1	EFW Makeup Strategies.....	41
2.9.2	RCS Inventory Strategies.....	42
2.9.3	Electrical Strategies.....	42
2.9.4	Fueling of Equipment.....	43
2.10	Offsite Resources.....	44
2.10.1	National SAFER Response Centers.....	44
2.10.2	Equipment List.....	45
2.11	Habitability and Equipment Operations.....	45
2.11.1	Ventilation.....	46
2.11.2	Plant Heating.....	47
2.12	Lighting.....	47
2.13	Communications.....	49

2.14	Secondary Water Sources	51
2.15	Shutdown and Refueling Analysis	51
2.16	Sequence of Events	53
2.17	Programmatic Elements	58
2.17.1	Overall Program Document	58
2.17.2	Procedural Guidance	59
2.17.3	Staffing	60
2.17.4	Training	61
2.17.5	Equipment List	62
2.17.6	Equipment Maintenance and Testing	62
3.	References	81

1. Background

In 2011, an earthquake-induced tsunami caused Beyond-Design-Basis (BDB) flooding at the Fukushima Dai-ichi Nuclear Power Station in Japan. The flooding caused the emergency power supplies and electrical distribution systems to be inoperable, resulting in an extended loss of alternating current (AC) power (ELAP) in five of the six units on the site. The ELAP led to (1) the loss of core cooling, (2) loss of spent fuel pool (SFP) cooling capabilities, and (3) a significant challenge to maintaining containment integrity. All direct current (DC) power was lost early in the event on Units 1 & 2 and after some period of time at the other units. Core damage occurred in three of the units along with a loss of containment integrity resulting in a release of radioactive material to the surrounding environment.

The US Nuclear Regulatory Commission (NRC) assembled a Near-Term Task Force (NTTF) to advise the Commission on actions the US nuclear industry should take to preclude core damage and a release of radioactive material after a natural disaster such as that seen at Fukushima. The NTTF report (Reference 1) contained many recommendations to fulfill this charter, including assessing extreme external event hazards and strengthening station capabilities for responding to beyond-design-basis external events (BDBEE).

Based on NTTF Recommendation 4.2, the NRC issued Order EA-12-049 (Reference 2) on March 12, 2012, to implement mitigation strategies for BDBEEs. The order provided the following requirements for strategies to mitigate BDBEEs:

Licensees shall develop, implement, and maintain guidance and strategies to maintain or restore core cooling, containment, and SFP cooling capabilities following a BDBEE.

These strategies must be capable of mitigating a simultaneous loss of all AC power and loss of normal access to the ultimate heat sink (UHS) and have adequate capacity to address challenges to core cooling, containment and SFP cooling capabilities at all units on a site subject to the Order.

Licensees must provide reasonable protection for the associated equipment from external events. Such protection must demonstrate that there is adequate capacity to address challenges to core cooling, containment, and SFP cooling capabilities at all units on a site subject to the Order.

Licensees must be capable of implementing the strategies in all modes.

Full compliance shall include procedures, guidance, training, and acquisition, staging or installing of equipment needed for the strategies.

The order specifies a three-phase approach for strategies to mitigate BDBEES:

Phase 1 - Initially cope relying on installed equipment and on-site resources.

Phase 2 - Transition from installed plant equipment to on-site BDB equipment.

Phase 3 - Obtain additional capability and redundancy from off-site equipment and resources until power, water, and coolant injection systems are restored or commissioned.

NRC Order EA-12-049 required licensees of operating reactors to submit an overall integrated plan (OIP), including a description of how compliance with these requirements would be achieved by February 28, 2013 (Reference 3). The Order also required licensees to complete implementation of the requirements no later than two refueling cycles after submittal of the OIP or December 31, 2016, whichever comes first.

The Nuclear Energy Institute (NEI) developed NEI 12-06 (Reference 4), which provides guidelines for nuclear stations to assess extreme external event hazards and implement the mitigation strategies specified in NRC Order EA-12-049. The NRC issued Interim Staff Guidance JLD-ISG-2012-01 (Reference 5), dated January 22, 2016, which endorsed NEI 12-06 with clarifications on determining baseline coping capability and equipment quality.

2. NRC Order 12-049 – Mitigation Strategies (FLEX)

2.1 Baseline Assumptions

The assumptions used for the evaluations of a Virgil C. Summer Nuclear Station (VCSNS) Unit 1, Extended Loss of AC Power / Loss of Ultimate Heat Sink (ELAP/LUHS) event and the development of diverse and flexible coping strategies (FLEX) are stated below. The following assumptions are consistent with those found in NEI 12-06, Section 3.2.1, *General Criteria and Baseline Assumptions*:

- A BDBEE occurs impacting VCSNS Unit 1.
- No specific initiating event is used. The initial condition is assumed to be a loss of off-site power (LOOP) with installed sources of emergency on-site AC power and station blackout (SBO) alternate AC power sources unavailable with no prospect for recovery.
- No additional accidents, events, or failures are assumed to occur immediately prior to or during the event, including security events.
- The reactor is initially operating at power, unless there are procedural requirements to shut down due to the impending event. The reactors have been operating at 100% power for the past 100 days.

- The reactor is successfully shut down when required (e.g., all rods inserted, no anticipated transient without scram). Steam release, to maintain decay heat removal upon shutdown, functions normally and reactor coolant system (RCS) overpressure protection valves respond normally, if required by plant conditions, and reseal.
- On-site staff is at site administrative minimum shift staffing levels. All personnel on-site are available to support site response.
- The reactor and supporting plant equipment are either operating within normal ranges for pressure, temperature and water level, or are available to operate, at the time of the event, consistent with the design and licensing basis.
- Cooling and makeup water inventories contained in systems or structures with designs that are robust with respect to seismic events, floods, and high winds and associated missiles are available. Permanent plant equipment that is contained in structures with designs that are robust with respect to seismic events, floods, and high winds and associated missiles, are available. The portion of the fire protection system that is robust with respect to seismic events, floods, and high winds and associated missiles is available as a water source.
- Normal access to the UHS is lost, but the water inventory in the UHS (i.e., Service Water (SW) pond) remains available and robust piping connecting the UHS to plant systems remains intact. The motive force for UHS flow (i.e., pumps) is assumed to be lost with no prospect for recovery.
- Fuel for BDB equipment stored in structures with designs that are robust with respect to seismic events, floods and high winds and associated missiles, remains available.
- Installed Class 1E electrical distribution systems, including inverters and battery chargers, remain available since they are protected.
- Reactor coolant inventory loss consists of unidentified leakage at the upper limit of the Technical Specification (TS), reactor coolant letdown flow (until isolated), and reactor coolant pump (RCP) seal leak-off at normal maximum rate.
- For the SFP, the heat load is assumed to be the maximum design basis heat load. In addition, inventory loss from sloshing during a seismic event does not preclude access to the pool area.

Additionally, key assumptions associated with implementation of FLEX Strategies are as follows:

- Additional staff resources are assumed to begin arriving on-site at hour 6, with the site fully staffed by 24 hours.
- This plan defines strategies capable of mitigating a simultaneous loss of all AC power and loss of normal access to the UHS resulting from a BDB event by providing adequate capability to maintain or restore core cooling, containment, and SFP cooling capabilities. Though specific strategies were developed, due to the inability to anticipate all possible scenarios, the strategies are also diverse and flexible to encompass a wide range of possible conditions. These pre-planned strategies developed to protect the public health and safety have been incorporated into the unit emergency operating procedures (EOPs) in accordance with established EOP change processes, and their impact to the design basis capabilities of the unit evaluated under 10 CFR 50.59.

The plant TSs contain the limiting conditions for normal unit operations to ensure that design safety features are available to respond to a design basis accident and direct the required actions to be taken when the limiting conditions are not met. The result of the BDB event may place the plant in a condition where it cannot comply with certain TSs and/or with its Security Plan, and, as such, may warrant invocation of Title 10 of the Code of Federal Regulations (10 CFR), Section 50.54(x) and/or Section 73.55(p).

2.2 Strategies

The objective of the FLEX Strategies is to establish an indefinite coping capability in order to 1) prevent damage to the fuel in the reactors, 2) maintain the containment function and 3) maintain cooling and prevent damage to fuel in the SFP using installed equipment, on-site portable equipment, and pre-staged off-site resources. This indefinite coping capability will address an ELAP (i.e., loss of off-site power, emergency diesel generators and any alternate AC source, but not the loss of AC power to buses fed by station batteries through inverters) with a simultaneous LUHS. This condition could arise following external events that are within the existing design basis with additional failures and conditions that could arise from a BDBEE.

The plant indefinite coping capability is attained through the implementation of pre-determined strategies (i.e., FLEX strategies) that are focused on maintaining or restoring key plant safety functions. The FLEX strategies are not tied to any specific damage state or mechanistic assessment of external events. Rather, the

strategies are developed to maintain the key plant safety functions based on the evaluation of plant response to the coincident ELAP/LUHS event. A safety function-based approach provides consistency with, and allows coordination with, existing plant EOPs. FLEX strategies are implemented in support of EOPs using FLEX Support Procedures (FSPs).

The strategies for coping with the plant conditions that result from an ELAP/LUHS event involve a three-phase approach:

Phase 1 – Initially cope by relying on installed plant equipment and on-site resources.

Phase 2 – Transition from installed plant equipment to on-site BDB equipment.

Phase 3 – Obtain additional capability and redundancy from off-site equipment and resources until power, water, and coolant injection systems are restored.

The duration of each phase is specific to the installed and portable equipment utilized for the particular FLEX strategy employed to mitigate the plant condition.

The strategies described below are capable of mitigating an ELAP/LHUS resulting from a BDBEE by providing adequate capability to maintain or restore core cooling, containment, and SFP cooling capabilities. Though specific strategies have been developed, due to the inability to anticipate all possible scenarios, the strategies are also diverse and flexible to encompass a wide range of possible conditions. These pre-planned strategies, developed to protect the health and safety of the public, are incorporated into VCSNS EOPs in accordance with established EOP change processes. The impact of the strategies on the design basis capabilities of the unit are evaluated under 10 CFR 50.59.

Within each section describing individual strategies, additional non credited strategies have been identified which could be used following a FLEX event. These “Defense in Depth Strategies” may also be used as compensatory measures if the credited strategies or equipment exceeds the allowable unavailability time. See Table 1, “Credited FLEX Strategies.”

2.3 Reactor Core Cooling and Heat Removal Strategy

2.3.1 Phase 1 Strategy

Following the occurrence of an ELAP event, the reactor will be tripped and the plant will initially stabilize at no-load RCS temperature and pressure conditions, with reactor decay heat removal via steam release to the atmosphere through the SG PORVs and/or the main steam safety valves.

Natural circulation of the RCS will develop to provide core cooling and the Turbine Driven Emergency Feedwater (TDEFW) pump will provide Emergency Feedwater (EFW) to the SGs to make-up for steam release.

Operators will respond to the event in accordance with EOPs to confirm RCS, secondary system, and containment conditions. A transition to EOP-6.0, *ECA-0.0 Loss of All ESF AC Power*, will be made upon the diagnosis of the total loss of AC power (Reference 6). This procedure directs isolation of RCS letdown pathways, confirmation of natural circulation cooling, verification of containment isolation, and establishment of electrical equipment alignment in preparation for eventual power restoration. The operators will verify or re-align EFW flow to all SGs, establish manual control of the SG PORVs, and initiate a controlled cooldown of the RCS to minimize inventory loss through the RCP seals. EOP-6.0 directs manual control of EFW flow to the SGs and manual control of the main steam PORVs to control steam release. Controlling steam release allows operators to control the RCS cooldown rate, as necessary.

The FLEX strategy for reactor core cooling and decay heat removal involves releasing steam from the steam generators (SGs) using the Power Operated Relief Valves (PORVs) and/or the main steam safety valves, and adding a corresponding amount of feedwater to the SGs. Initially, if the Condensate Storage Tank (CST) survives the event, the Turbine Driven Emergency Feedwater (TDEFW) pump will be aligned to take suction from the CST (Table 1, Item A). If the CST is not available following the event, a FLEX Alternate Emergency Feedwater (Alternate EFW) suction pump will transfer water from the UHS (i.e., SW pond) to the SGs, via the robust Service Water piping to the suction of the TDEFW pump (Reference 7). Operator actions to verify, re-align, and throttle EFW flow are required following an ELAP/LUHS event to prevent SG dryout and/or overflow.

A RCS cooldown will commence between 2 and 4 hours after an ELAP/LHUS event occurs as a result of a BDBEE.

DC bus load shedding will ensure battery life is extended to at least 15 hours total. FLEX generators will recharge the Class 1E station batteries prior to battery depletion.

Secondary

The Phase 1 strategy for reactor core cooling and heat removal involves use of installed plant equipment and water sources for EFW supply to the SGs. The TDEFW automatically starts on the LOOP condition, and does not require AC or DC electrical power to provide EFW to SGs. In the event that the TDEFW pump does not start on demand or the pump trips after starting, the operator will locally reset the turbine and the pump will be restarted. The EFW system is designed to provide flow from the TDEFW pump to all three SGs. For the first 1.5 hours of EFW supply, until manual operation is established, the EFW flowrate will be controlled from the main control room (MCR) by cycling the EFW feed valves. Subsequently, manual control of the flow rate from the TDEFW pump to the SGs will be performed locally at the flow control valves or the TDEFW pump speed governor in the Intermediate Building (IB). Initially, if the CST survives the BDBEE, the CST will be used as the EFW water source (Table 1 Item A). The CST is required to have a minimum contained volume of 179,850 gallons (per VCSNS TS 3.7.1.3). The TS 3.7.1.3 minimum CST level ensures that there are 154,062 “usable” gallons of water available to EFW. The CST will provide a suction source to the TDEFW pump providing RCS decay heat removal for a minimum of 8.4 hours, assuming a RCS cooldown of 75°F/hr commences between 2 and 4 hours into the event and the bounding cooldown is performed to 350°F. Considering normal levels, if the entire volume of the CST is available, inventory for feeding SGs will be available for greater than 60 hours. If the CST is not available following the event, permanently installed Alternate EFW Suction pumps in the SW pump house will be manually aligned to deliver approximately 500 gallons per minute (gpm) of water to the SW piping header (Table 1 Item B). The TDEFW will then take suction from the SW system and supply EFW to the SGs.

The Phase 1 strategy for reactor core cooling and heat removal relies upon Main Steam Code Safety Valves to release steam to the atmosphere. If instrument air is available, steam release from the SGs will be controlled remotely from the MCR using air-operated PORVs. In the event that instrument air is not available, steam release from the SGs will be controlled locally at the PORV hand wheels. In accordance with EOP-6.0, the first stage of the RCS cooldown will be initiated at a nominal rate of 75°F/hr to a SG pressure of 260 pound per square inch gauge (psig) minimum. The RCS cooldown reduces SG pressure to allow for eventual feedwater injection from a portable pump in the event that the TDEFW

pump becomes unavailable and the Motor Driven Emergency Feedwater (MDEFW) pumps remain unavailable.

RCS

The RCS will be cooled down and depressurized following the BDBEE. A cooldown will minimize the adverse effects of high temperature coolant on RCP shaft seal performance. In accordance with EOP-6.0, VCSNS will perform a two stage cooldown. During the first stage, the RCS will be cooled down and depressurized until SG pressure reaches approximately 260 psig, corresponding to a RCS core inlet temperature of about 409°F. This pressure, which is approximately 100 psig above the full injection point of the safety injection (SI) accumulators, will allow operators to isolate or vent the accumulators in order to prevent nitrogen from entering the RCS and disrupting natural circulation. During the second stage, the RCS will be cooled down and depressurized until RCS core inlet temperature reaches 350°F.

RCS isolation is verified to have occurred automatically, and RCS leakage is assumed to be through the RCP low leakage seals (See Section 2.3.7). In the absence of RCS inventory makeup, natural circulation is maintained until inventory losses from the seals lead to voiding in SG U-tubes, which is calculated to occur at 39.5 hours. Consequently RCS inventory control is not a Phase 1 concern.

Electrical/Instrumentation

The station Class 1E battery life is designed to be greater than 4 hours (with ultimate capacity calculated to be 5-6 hours). Strategies for providing power to the station batteries using Phase 2 portable power sources will begin immediately following the occurrence of an ELAP/LUHS. If the strategies cannot be successfully completed within 3 hours, load shedding of all non-essential AC and DC loads would commence and would be completed within 1 hour. With load stripping, the useable station Class 1E battery life is calculated to be 15 hours for the station batteries (Reference 8). Critical instrumentation is maintained throughout all phases.

2.3.2 Phase 2 Strategy

Secondary

The Phase 2 strategy for reactor core cooling and heat removal involves providing an indefinite supply of water for feeding the SGs. The TDEFW pump remains available to provide water to the SGs during Phase 2 as long as the SGs have sufficient pressure (i.e., pressure is greater than 100

psig) to drive the pump's terry turbine. When the TDEFW pump is no longer available (e.g., low steam pressure or other failure), other methods will be used to provide makeup to the SGs. One method involves repowering a MDEFW pump, either XPP-21A or XPP-21B, using two 7.2 kV, 1 MW combustion turbine generators (CTGs) (Table 1 Item C). The CTGs will energize a vital bus, XSW1DA or XSW1DB, so either MDEFW pump may be used to transfer water from the CST or Alternate EFW Suction source to all three SGs. Another method of supplying makeup to the SGs involves utilizing the FLEX (FX) SG feed pump which would take suction from either the CST or the discharge of the FX UHS pump system and deliver water to the SGs by means of flexible hose (Table 1 Item D). The discharge of the FX SG feed pump is directed to three connections, one for each SG, located downstream of the main feedwater isolation valves (MFIVs). Two routes exist for deploying hoses to these connections. One route is through a permanently installed header through the east IB penetration access area (referred to as the "east feed connection") and the other route is through the Auxiliary Building (AB) rollup door (referred to as the "west feed connection"). Figure 1 illustrates the strategies for feeding the SGs.

If the CST survives the event, the CST may be used to supply water to the SGs. The CST can be refilled from available water sources prior to depletion of its inventory. The order in which water sources will be used is based on the quality of the water. Assuming all potential sources survive the event, the order of preference is (1) Demineralized Water Storage Tank (DWST), (2) Filtered Water Storage Tank (FWST), (3) Monticello Reservoir, and (4) SW Pond. Figure 2 illustrates the strategies for providing makeup to the CST.

If the CST does not survive the event, the SW pond will serve as the initial water source for EFW. In this case, a FX alternate EFW suction pump may transfer water from the SW pond to suction of the TDEFW or MDEFW pump, which can continue to feed the SGs (Table 1 Items B and C). In addition, the FX SG feed pump, in combination with the FX UHS pump system can be aligned to supply water directly to the SGs, thereby bypassing the CST. The SW pond contains approximately 85 million gallons of usable water at the TS minimum water level and could supply water to the EFW for several weeks.

Defense-in-Depth Core Cooling Phase 2

A FX booster/transfer pump is capable of transferring water from the DWST (500,000 gallon capacity) and/or the FWST (100,000 gallon

capacity) to the CST, if the tanks are available following the event. The portable FX UHS pump systems are capable of transferring water from the SW pond or the Monticello Reservoir to the CST. When needed, a FX booster/transfer pump will be placed in series with the FX SG pump to meet design head requirements when using the west feed connection.

RCS

VCSNS has two diesel driven portable FX RCS makeup (FX RCS MU) pumps. The FX RCS MU pumps are stored in diverse locations, one in the Emergency Response Building (ERB) and one in the FLEX Storage Building (FSB). These pumps can be aligned to either the Refueling Water Storage Tank (RWST) or the Boric Acid Tanks (BATs) to provide adequate boration for the remainder of the event.

Permanent piping stub-outs allow the FX RCS MU pump to take suction from the RWST (minimum volume of 453,800 gallons) or the BATs (minimum volume of 14,000 gallons) using flexible hose. A high-pressure hose will be routed from the discharge of the FX RCS MU pump to either a connection point in the Safety Injection (SI) piping located in the Fuel Handling Building (FHB) (Table 1 Items E and F) or a connection point at the charging pump discharge hydro-test flange in the AB (Table 1 Items G and H) to provide RCS inventory makeup for the remainder of the ELAP event.

The requirements to provide RCS makeup/boration for ensuring shutdown margin are more immediate than the time required to prevent reflux cooling because RCS makeup is required within approximately 20 hours to ensure proper boron mixing. The Effective Multiplication Factor (K_{eff}) is calculated to be less than one (i.e., reactor is subcritical) at the RCS conditions described above for approximately 21 hours (See Section 2.3.8). RCS makeup and boron addition will be initiated by 20 hours to ensure natural circulation, reactivity control, and boron mixing is maintained.

The time at which boration is initiated varies according to RCS temperature, the pump used for injection, and the source of borated water (Reference 9).

Defense-in-Depth RCS Phase 2

Although not credited for FLEX, if the Alternate Seal Injection (ASI) pump survives the event and starts automatically, it will be allowed to remain running to ensure RCP seals receive cooling.

Electrical/Instrumentation

The Phase 2 strategy includes providing power for instruments used in monitoring key parameters. Two 7.2kV (1 MW) combustion turbine generators (CTGs) located in the Containment Access Ramp (CAR) will be used to provide power to the station battery chargers (Table 1 Item I). Alternatively, one of the 480V (80 kW) BDB DGs stored in either the ERB or FSB will be used to provide power to the station battery chargers or the station batteries (Table 1 Items J and K).

Two portable FLEX 7.2kV (1MW) CTGs will be used to provide power to the Class 1E ESF AC Distribution System and the Class 1E 125V DC Distribution System (Reference 10). The trailer mounted CTGs will be deployed outside the CAR, to allow for exhaust, while being connected by temporary cable to a terminal box located inside the CAR. Permanent cable will transfer power from this terminal box to one located within the IB. Temporary cable is used within the IB to connect the intermediate terminal box to those which are permanently connected to the 7.2kV switchgear buses (i.e., XSW1DA and/or XSW1DB). Power is then transferred from the buses to the station battery chargers via installed electrical distribution equipment. (Table 1 Item I)

Load shedding is performed if the strategies to extend DC power availability cannot be implemented within 3 hours of the event. In addition, the strategy to provide power to the station batteries or station battery chargers using BDB equipment will be employed. One method involves utilizing a 480V (80kW) DG and an AC distribution panel to supply AC power to the input of the station battery chargers (Table 1 Item J). The other method involves utilizing a 480V (80kW) DG and a portable battery charger to supply DC power to the output of the station battery chargers (Table 1 Item K). The BDB equipment is stored in diverse locations, one method is stored in the FSB and one method is stored in the ERB (Figure 3).

Defense-in-Depth Electrical Phase 2

An additional Phase 2 strategy involves using a 480V (300 kW) DG stored in either the Electrical Building (EB) or Auxiliary Electrical Building (AEB) to provide power to the station batteries (Figure 3).

Use of the installed 480V (300 kW) DG located in the EB or use of the 480V (300 kW) DG located in the AEB, is not a credited strategy but the DGs will be used if available (Reference 11). The DGs will automatically start and load on a loss of bus voltage. The distribution panel powered

from the DGs can be connected to two FLEX battery chargers located in the EB. The FLEX battery chargers provide power to disconnect devices located in the Control Building (CB). These disconnect devices will be connected to BDB connection receptacles in the CB using portable power cables. The BDB connection receptacles provide power to the plant distribution panels (i.e., DPN1HA2 and DPN1HB2) via pre-installed conduit. This connection allows power to be supplied to the station batteries and normal DC distribution system without use of the station battery chargers.

Passive Injection Isolation Phase 2

SI accumulators provide an immediate supply of borated water to the RCS as it is depressurized. However, volume injected by the SI accumulators is not credited for RCS boration, because VCS does not have wide range level indication available to determine total amount injected, therefore the required boration volume must be pumped in. The initial cooldown of the RCS is stopped at 260 psig, which is 100 psig above the expected conditions that would result in injection of the Nitrogen cover gas in the accumulators. This provides 100 psig of control margin to ensure the cooldown is stopped prior to the injection of nitrogen, which could disrupt natural circulation. Once the first stage of the cooldown is complete, action must be taken to either isolate the SI accumulators, or vent them. The preferred strategy to isolate the accumulators is to re-energize the motor operated isolation valves through normal ESF power distribution, using the CTGs (Table 1 Item L). An alternative strategy can be employed which energizes the motor operated isolation valves by connecting the power supply for the valve directly to the output of an 80kW FX Generator (Table 1 Item M).

Defense-in-Depth Passive Injection Isolation Phase 2

VCSNS also maintains two portable air compressors, one each in the ERB and FSB. In conjunction with a special adapter, stored in the B.5.b storage area of the ERB, maintenance personnel can restore air to the reactor building to facilitate venting of the nitrogen over-pressure gas in the accumulators.

2.3.3 Phase 3 Strategy

Secondary

The Phase 3 strategy for core cooling and decay heat removal includes continued use of the pumps which were credited in the Phase 2 strategy.

The National SAFER Response Center (NSRC) will provide backup pumps which will be used if needed. Additionally, the NSRC will provide a reverse osmosis/ion exchanger system to remove impurities from water supplies. FLEX procedures direct use of this equipment as soon as it arrives to improve water quality for feeding SGs.

RCS

RCS inventory and boration is adequately maintained by continuing the same strategy that was used during Phase 2. The water within the RWST and BATs will maintain RCS inventory for weeks due to low leakage seals. The portable diesel-driven FX RCS MU pump will provide indefinite coping given a long-term diesel fuel supply. Additionally, the NSRC will provide a mobile boration skid and reverse osmosis/ion exchanger system to supply long-term boration needs.

Electrical/Instrumentation

One 1 MW (480V) portable CTG will be provided by the NSRC to serve as a backup to the DGs located in the EB and AEB.

Two 1MW (4160V) portable CTGs will be provided by the NSRC to serve as a backup to the two portable FLEX 1MW CTGs. The two 1MW generators can be connected to a distribution panel, also provided by the NSRC, to either replace or supplement the FLEX CTGs. Connection to the plant requires the use of a 4160V to 7200V step-up transformer which is maintained onsite as FLEX equipment.

2.3.4 Systems, Structures, Components

2.3.4.1 Turbine Driven Emergency Feedwater Pump

The TDEFW pump will automatically start and will deliver EFW flow to all three SGs following an ELAP event. The TDEFW pump is safety-related, seismically qualified, and capable of providing the required system flow capacity. The air-operated, main steam to EFW pump turbine isolation valve supplies steam to the TDEFW pump turbine. This isolation valve is a normally closed valve that fails open on loss of air or power to ensure a steam supply to the turbine. The isolation valve receives an open signal on bus undervoltage to 1DA and 1DB or Lo-Lo SG level. This valve is equipped with an air accumulator to provide for remote closure if instrument air is not available. The speed of the turbine is regulated locally at the mechanical-hydraulic turbine governor. The TDEFW pump discharge flow control valves are normally open and fail open on a loss of

control power or upon a loss of control air to the actuator. Control air accumulators are supplied to maintain control air for the actuator. During an ELAP, procedures include instructions for manual operation of the TDEFW flow control valves in the event of a loss of air. The TDEFW pump is sized to provide more than the design basis EFW flow requirements and is located in a safety structure designed for protection for applicable design basis external events. The turbine oil cooler and the pump bearings are cooled by feedwater from the discharge side of the pump such that pump operation is independent of auxiliary plant cooling systems.

2.3.4.2 Motor Driven Emergency Feedwater Pumps

In the event that the TDEFW pump is not available, one of the two MDEFW pumps will be used to deliver EFW flow to all three SGs. Each MDEFW pump is safety-related, seismically qualified, and capable of providing the required system flow capacity. During an ELAP, procedures include instructions for local manual operation of the MDEFW pump discharge flow control valves. A MDEFW pump will be repowered using two CTGs to energize the vital Engineered Safety Features (ESF) buses, 1DA and 1DB.

2.3.4.3 Steam Generator Power Operated Relief Valves

During an ELAP/LUHS event, reactor core cooling and decay heat removal will be accomplished, for an indefinite time period, by opening and throttling the SG PORVs. If instrument air is available, the PORVs will be operated from the MCR. If instrument air is not available, local manual control of the PORVs will be performed through use of a hand wheel. The SG PORVs and the main steam piping upstream of the PORVs are safety-related, missile protected, and seismically qualified. The PORVs and upstream piping is housed within safety-related structures and is protected from all hazards.

2.3.4.4 Safety-Related Batteries

The safety-related batteries and associated DC distribution systems are located within safety-related structures designed to meet applicable design basis external hazards. The equipment will be used to power required key instrumentation and applicable DC components. Load shedding of non-essential equipment, completed within 4 hours of the occurrence of an ELAP/LUHS, provides an estimated total service time of approximately 15 hours of operations.

2.3.4.5 Condensate Storage Tank

The CST provides an EFW water source if it is available following the event. The CST volume is maintained greater than or equal to 179,850 gallons, per TS 3.7.1.3, to provide a minimum volume of 154,062 gallons to the EFW system. EFW suction is normally aligned to the CST.

2.3.4.6 Service Water Pond

The SW pond, a seismically qualified impoundment of a portion of Lake Monticello, serves as the UHS. At the minimum water level, 416.5 feet mean sea level, the SW pond contains approximately 85 million gallons of water. The portable FX UHS pump or the Alternate EFW pump system is capable of transferring water from the SW pond to the EFW system.

2.3.4.7 RWST

The RWST is a borated water source for RCS makeup. The tank is a stainless steel, safety-related, seismically qualified tank, but is not protected from missiles. The tank is located partially below grade level, just outside of the AB. During operations at power, the RWST borated volume is maintained greater than 453,800 gallons at a boron concentration between 2300 and 2500 ppm, per TS 3.5.4.

2.3.4.8 BAT

The BATs are borated water sources for RCS makeup. The stainless steel, safety-related, seismically qualified BATs are located in a structure that is protected from all hazards as applicable. During power operations, the combined borated volume of the BATs is maintained greater than 14,000 gallons at a boron concentration between 7000 and 7700 ppm.

2.3.5 FLEX Connections

The following subsections describe the FLEX related connection points for portable FLEX equipment.

2.3.5.1 Main Feedwater (FW) Connection

Flexible hose will be routed from the discharge of the portable FX SG feed pump to three main feed water line connections, one per steam generator, downstream of the MFIVs. The flexible hose can be routed to the connections, which are near the 436 foot elevation in the AB and IB, through either the east or the west penetration areas. The connection points are protected from all applicable hazards. The hydraulic analysis of the flow path from the FX SG feed pump connection to the primary FW

pump discharge connection has confirmed that applicable performance requirements are met.

2.3.5.2 Condensate Storage Tank Connections

A CST fill connection for a 2.5 inch hose exists on the CST. As part of the design, a 5 inch by 2.5 inch pipe adapter will be provided to allow a 5 inch FX hose to be connected. The pipe adapter will be stored with FLEX equipment. A FLEX connection is installed on the CST drain line to serve as a suction source for the FX SG Feed pump if the TDEFW pump is unavailable, but sources of makeup to the CST remain available (References 12 and 13). Both connections are protected from applicable hazards with the exception of the high wind hazard.

2.3.5.3 Service Water Connection

A 4 inch discharge connection is installed on the SW discharge crosstie header in the SW pump house. The piping connection includes piping, an isolation valve, a drain valve, and a hose connection. A FLEX hose will connect the FX alternate EFW suction pump discharge spool piece with the 4 inch discharge connection to deliver water from the SW pond to the suction of either the TDEFW or MDEFW pump (Reference 7). This connection is protected from all hazards.

2.3.5.4 Reactor Coolant System Connections

A 2 inch discharge connection is installed on 3 inch SI piping in the FHB. The modification includes a 2 inch pipe and two manual isolation ball valves. A high pressure hose will connect the discharge of the FX RCS makeup pump to the 2 inch pipe for delivery of water from the RWST or BATs to the RCS. The connection is protected from all applicable hazards.

The charging pump discharge hydro-test connection in the AB has been reconfigured to accommodate a 1.5 inch high pressure hose connection and a 3 inch low pressure fire hose connection. The hoses will deliver water from the discharge of the FX RCS makeup pump to the RCS. This connection allows water to be supplied to the RCS from the RWST or the BATs. The connection is protected from all applicable hazards.

2.3.5.5 Refueling Water Storage Tank Connection

A 4 inch RWST discharge connection is installed to allow operators to connect FLEX hoses. The connection includes 4 inch piping and a manual isolation ball valve to the 10 inch spent fuel return piping in the AB. Low pressure hoses connected to the 4 inch connection will provide RWST

water as a suction source for the FX RCS MU pump. The connection is protected from all applicable hazards.

2.3.5.6 Boric Acid Tanks Connection

A BAT discharge connection is installed to allow operators to connect FLEX hoses. The connection includes 2 inch piping and a manual isolation ball valve to the 3 inch BAT pump suction crosstie piping in the AB. Low pressure hoses connected at the 2 inch piping will provide BAT water, from either tank, as a suction source for the FX RCS MU pump. The connection is protected from all applicable hazards.

2.3.5.7 480V FLEX Diesel Generators Electrical Connection (Defense-in-Depth)

The 480V (300kW) FLEX Diesel Generators located in the EB and AEB can provide charging power to plant distribution panel DPN1HA2, by using portable cable. Plant distribution panel, DPN1HA2, can be powered by connecting a portable cable between the FLEX receptacle in the CB and disconnect fused switch device XDS0257. Similarly, plant distribution panel DPN1HB2 can be repowered by connecting a portable cable between the FLEX receptacle in the CB and disconnect fused switch device XDS0258.

2.3.5.8 FLEX Combustion Turbine Generator Electrical Connection

The FLEX 7.2kV (1MW) CTGs can provide power to the 7.2kV switchgear buses (XSW1DA and/or XSW1DB) by making multiple connections using temporary cable. The CTGs will be connected to GDS XBT0104 located in the CAR storage area using temporary cable. This box is seismically mounted and protected from flood, snow and ice, and operable within the outside temperature ranges specified by the site. A permanent circuit connects GDS XBT0104 to terminal box XBT0105. Temporary cable will be used to connect terminal box XBT0105 with terminals permanently connected to the 1DA and 1DB switchgear. Terminal box XBT0106 is used for 1DA connections, while terminal box XBT0107 is used for 1DB connections. Terminal boxes XBT0105, XBT0106, and XBT0107 are located on the 451 foot elevation of the IB and protected against all applicable hazards.

2.3.6 Key Reactor Parameters

Instrumentation is available to monitor the following key reactor parameters during all phases of the reactor core cooling and decay heat removal strategy:

- EFW Flowrate
- SG Water Level
- SG Pressure
- RCS Pressure
- RCS Temperature
- CST Level
- RWST Level
- BAT Level
- Reactor Vessel Level Indication System (RVLIS)
- Nuclear Instruments

Indicators for the instruments are located in the MCR. Instruments used to monitor the parameters listed above will be available after a required load stripping of the DC buses. In the unlikely event that the 120 VDC and 120 VAC vital bus infrastructure is damaged, alternate procedures for obtaining local indication of critical parameters is provided in FSP-7.0, *Loss of Vital Instrumentation or Control Power* (Reference 14).

Portable BDB equipment is supplied with the local instrumentation needed to operate the equipment. The use of these instruments is detailed in the associated FSPs. These procedures are based on inputs from the equipment suppliers, operations experience, and expected equipment function in an ELAP.

2.3.7 Thermal Hydraulic Analyses

2.3.7.1 Secondary Analysis

If the CST survives the BDBEE, an analysis concludes that for a RCS cooldown to 409°F, the CST minimum usable volume of 154,062 gallons for EFW would be available for approximately 9.7 hours (Reference 15). For a RCS cooldown to 350°F, the CST usable volume would be depleted in approximately 8.4 hours. FLEX strategies will be used to refill the CST, before it is depleted, using available water sources. Additional water

sources at VCSNS include the DWST, the FWST, the Monticello Reservoir, and the SW Pond. If available, water from the DWST and FWST can be pumped into the CST using the FX booster/transfer pump. Water from the Monticello Reservoir or SW Pond can be pumped into the CST (or directly into the SGs) using the FX UHS pump system. The additional volume of water would provide decay heat removal for several weeks. If the existing CST does not survive the BDBEE, the alternate EFW suction pump strategy would be implemented.

2.3.7.2 RCS Analysis

The model used for determination of RCS response was that used in the generic analysis in WCAP-17601 (Reference 16) and updated for Westinghouse 3 Loop Plants in WCAP-17792 (Reference 17). The Pressurized Water Reactor Owner's Group (PWROG) report, PWROG-14027-P (Reference 18), provides a method of adjusting the results from WCAP-17601 based on new information concerning RCP seal leakage.

VCSNS performed a site specific applicability review of the analysis and confirmed applicability to the station. Parameters used in the model were compared to VCSNS and the overall results were confirmed to be bounded by the model and inputs used in the WCAPs and associated analytical codes. The methodology in PWROG-14027-P was incorporated as VCSNS replaced the original Westinghouse RCP seals with Flowserve N-9000 seals.

Based on information from WCAP-17601 and WCAP-17792, reflux cooling is considered to be in progress when the one-hour centered moving average (CMA) of the flow quality at the top of the SG U-tube bend exceeds 0.1 in any one loop. An analysis concluded reflux cooling would begin in 39.5 hours if RCS makeup is not provided (Reference 19). Therefore, reflux cooling will be avoided, with considerable margin, with RCS inventory being controlled via the FX RCS MU pumps. Boration strategies require RCS inventory makeup be provided within 20 hours of initiation of the BDBEE.

2.3.8 Shutdown Margin Analysis

A shutdown margin analysis was performed and determined the reactivity shutdown margin (SDM) of at least 1% ($K_{eff} < 0.99$) is available up to 21 hours following the loss of power and a reactor trip from full power (Reference 9). However, due to xenon decay, additional core boron is needed in order to cooldown to the target SG temperature of 350°F.

Calculations show that injection of approximately 13000 gallons of 2300 ppm borated water from the RWST or 3626 gallons of 7000 ppm borated water from the BAT, using the FX RCS MU pump, will be adequate to meet shutdown reactivity requirements at the limiting end-of-cycle condition and a core inlet temperature as low as 350°F. This additional boron requirement will be met after 1 hour if RCS makeup is supplied from the BAT and after 3.6 hours if RCS makeup is supplied from the RWST. The makeup volume is accommodated by RCS volume shrink without venting the RCS.

The earliest time that additional boron is required is 21 hours after initiation of an ELAP event for cooldown to 350°F and 28 hours for cooldown to 409°F. The boration requirements bound the RCS inventory makeup requirements due to the installation of low leakage RCP seals.

The SDM calculation assumes a uniform boron mixing model. Boron mixing was identified as a generic concern by the NRC and was then addressed by the PWROG. The NRC endorsed the PWROG boron mixing position paper with the clarification that a one hour mixing time was adequate provided that the flow in all loops is greater than or equal to the corresponding single-phase natural circulation flow rate. For VCSNS, the time to reach the condition, where two-phase natural circulation flow is less than single-phase natural circulation flow, is calculated to be approximately 20.5 hours. Since the FX RCS MU Pump will be aligned prior to 20 hours into the event and the pump capacity of 60 gpm is well in excess of the maximum RCS leakage, the NRC clarification regarding single-phase flow has been addressed and a one hour mixing time is acceptable.

2.3.9 FLEX Pumps and Water Supplies

2.3.9.1 FX UHS Pump Systems

VCSNS has two FX UHS pump systems. Each FX UHS pump system consists of two 100% submersible hydraulic pumps and one diesel driven centrifugal booster pump. Each FX UHS pump system is stored on a FX UHS pump trailer; one system in the FSB and one system in the ERB. A FX UHS pump system is deployed by towing the FX UHS pump trailer with a Prinoth Panther T8 track vehicle which is also stored in the FLEX buildings. The track vehicle will deploy the pump system to the selected water source and place a submersible pump(s) in the water using the track vehicle's crane. Only one submersible pump is required to provide flow to the trailer mounted booster pump to obtain the design flow of 2500 gpm (300 psig). The submersible lift pump must be utilized when the UHS main pumps are taking suction from the SW Pond, due to the elevation difference. Direct draft may be utilized when the UHS main pumps are taking suction from Lake Monticello (Reference 20). To utilize direct draft, the elevation difference between UHS main pump suction and water source must be less than 14 feet (Reference 20).

The FX UHS pump system is used in multiple strategies including core cooling, SFP cooling, and containment cooling. The FX UHS pump system is sized to provide adequate flow to directly support simultaneously water supplies of 700 gpm to the FX booster/transfer pump, 120 gpm to the SFP, and 1500 gpm to the reactor building cooling units (RBCUs). A hydraulic analysis of the flow paths from each water source to the delivery locations has confirmed that applicable performance requirements are met (Reference 21).

2.3.9.2 FX SG Feed Pump

VCSNS has one FX SG feed pump which is stored in the FSB. The FX SG feed pump is a trailer-mounted, diesel-driven centrifugal pump with a design flow of 500 gpm (500 psig). The portable FX SG feed pump will be used to inject water into the SGs. The FX SG feed pump can take suction from the CST or other available tanks, the FX booster/transfer pump, or the FX UHS pump system. A hydraulic analysis has confirmed that the FX SG feed pump is sized to provide the minimum required SG injection flow rate to support reactor core cooling and decay heat removal (Reference 21).

2.3.9.3 FX Booster/Transfer Pumps (Defense-in-Depth)

VCSNS has two FX booster/transfer pumps, one stored in the FSB and one stored in the ERB. A FX booster/transfer pump will be used to transfer water from the DWST or FWST to the CST. The pumps can also provide additional head when placed in series with the FX SG feed pump or the FLEX UHS pumps. The portable, diesel-driven FX booster/transfer pumps have a minimum design flow of 800 gpm (Reference 22).

2.3.9.4 FX RCS MU Pumps

VCSNS has two FX RCS MU pumps, one stored in the FSB and one stored in the ERB. The *PWROG Core Cooling Position Paper* (Reference 23), issued in conjunction with WCAP 17601 (Reference 16), recommends that the required delivery pressure of the RCS injection pump be established at the saturation pressure of the reactor vessel head plus 100 pounds per square inch (psi) driving head to allow RCS injection. Following the formula in the position paper, the required delivery pressure for the RCS injection pumps at VCSNS is approximately 1886 psia. Accordingly, the FX RCS MU pumps are capable of delivering a flow of 60 gpm at a discharge pressure of up to 2000 psig (Reference 24). A hydraulic analysis of the FX RCS MU pump systems, associated hoses, and installed piping systems confirms that the minimum flow rate and head capabilities of the FX RCS MU pumps exceed the FLEX strategy requirements for maintaining RCS inventory (Reference 25). The two FX RCS MU pumps satisfy the N+1 requirement.

2.3.9.5 FX Alternate Emergency Feedwater Suction Pumps

VCSNS has two permanently installed FX Alternate EFW suction pumps. Both pumps are located in the SW pump house. The pumps are used to transfer water from the SW pond to the SW pump discharge crosstie header located in the SW pump house. Each pump can provide 15 feet absolute head pressure, at a rated flow of 500 gpm to prevent cavitation of the TDEFW pump and the MDEFW pumps. The pumps are powered from either of two 80 kw DGs stored in the FLEX Diesel Generator Building (FDG).

2.3.9.6 Monticello Reservoir

The Monticello Reservoir is a source of water for the SW pond. The SW pond is connected to the Monticello Reservoir by an interconnecting pipe. The interconnecting pipe is used to provide makeup from the Monticello

Reservoir to the SW pond in order to maintain operating levels in both heat sinks. See Section 2.14 for information related to water quality.

2.3.10 Electrical Analysis

The Class 1E battery duty cycle of 15 hours for VCSNS was calculated in accordance with the IEEE-485 methodology using manufacturer discharge test data applicable to the licensee's FLEX strategy as outlined in the NEI white paper on extended battery duty cycles (Reference 8). The Class 1E station batteries can be recharged using the 480V EB/AEB DGs, the 7.2kV CTGs, or the 80kW portable 480V DGs.

The two 7.2kV CTGs are 1 MW, three phase, 60Hz, trailer mounted generators. The CTGs are fueled from a 650 gallon (useable capacity) portable fuel trailer. The CTGs can provide power to the Class 1E DC buses via the 7.2kV switchgear buses 1DA and/or 1DB.

The portable 480V DGs stored in the FSB and ERB are 80 kW, three phase, 60Hz standby rating generators that are trailer-mounted with a 193 gallon diesel fuel tank built into the trailer. These portable 480V diesel generators can provide power to the station battery chargers or use a portable battery charger to energize the DC bus directly.

The two 480V DGs stored in the EB and AEB are 300kW, three phase, 60Hz generators. The AEB generator is portable, while the EB generator is permanently installed. The generators are fueled by a tank, in each respective building, containing a 19 hour supply of fuel. These pre-staged generators can provide power to the Class 1E DC buses via battery chargers located in the EB.

Additionally, portable 480V and 4kV generators are available from the NSRC for the Phase 3 strategy. These generators are considered redundant backups to the Phase 2 480V and 7.2kV generators. The 4kV NSRC DGs are able to power the 7.2kV switchgear through a portable 4kV-7.2kV step up transformer stored in the FSB.

2.4 Spent Fuel Pool Cooling/Inventory

The basic FLEX strategy for maintaining SFP cooling/inventory is to monitor SFP level and provide makeup water to the SFP sufficient to maintain adequate SFP level.

2.4.1 Phase 1 Strategy

The Phase 1 strategy for SFP cooling/inventory is to monitor the SFP level using instrumentation installed to meet the requirements of NRC Order

EA-12-051 (Reference 26). If no operator action is taken following a loss of SFP cooling at the maximum design heat load, analyses conclude the SFP will reach 212°F in approximately 21 hours (Reference 27) and boil off to a level 10 feet above the top of fuel in approximately 87 hours from initiation of the event (Reference 19).

2.4.2 Phase 2 Strategy

The Phase 2 strategy for SFP cooling/inventory is to initiate SFP makeup using one of the FX UHS pump systems from the SW pond or the Monticello Reservoir (Table 1 Item N). Make-up water to the SFP is not required to be borated per TS 5.6, Fuel Storage Design Features. The FX UHS pump systems, one stored in the ERB and the other stored in the FSB, are trailer mounted systems which will be deployed using one of two Prinoth Panther T8 track vehicles. The track vehicles are also stored in the FLEX buildings. Fire hoses will connect the discharge of the FLEX pumps to a permanent FLEX connection on the safety-related spent fuel cooling (SF) system. The FX connection is located in the safety-related Auxiliary Building (AB).

Alternate methods for providing SFP cooling/inventory involve routing hose from a fire pumper truck to the SFP deck where it can be pumped or sprayed (Table 1 Item O).

Spray monitors used for the SFP spray option are located in the FHB. The associated pumper trucks and hoses are located in diverse storage locations, one set in the ERB and one set in the FSB. The equipment used for the SFP spray option is the same as that required to comply with 10 CFR 50.54(hh)(2). The spray strategy is implemented in accordance with Beyond Design Basis Mitigating Guideline, BDMG-1.0, *Spent Fuel Pool Makeup and Spray Strategies* (Reference 28). Figure 4 provides a diagram of the SFP cooling/inventory strategy.

Defense-in-Depth Spent Fuel Pool Cooling/Inventory Phase 2 Strategy

The FX SG feed pump can provide SFP inventory from either the CST or a FX UHS pump system while supplying its core cooling function.

Additionally, if one CTG is in service, a Reactor Makeup Water Pump can be energized which can restore the plant's normal spent fuel pool makeup source. The Reactor Makeup Water Storage Tank (RMWST) is a seismically qualified tank containing 100,000 gallons of primary grade, demineralized water, adjacent to the RWST, which is normally used to

provide for evaporative losses from the SFP. The Reactor Makeup Water Pumps are seismically qualified, Class 1E pumps (Reference 29).

2.4.3 Phase 3 Strategy

The Phase 3 strategy for SFP cooling/inventory is a continuation of the Phase 2 strategy. Additional high capacity pumps will be provided by the NSRC to serve as backup to the on-site FLEX pumps. A water treatment skid, also provided by the NSRC, will be used to remove impurities in the water, as necessary.

2.4.4 FLEX Connections and Ventilation

2.4.4.1 Primary Connection

A seismically designed FLEX SFP makeup connection is installed on the existing safety-related SF system piping located on the 388 foot elevation of the AB. The new SFP makeup connection line is a 3 inch stainless steel line that tees into an existing 3 inch SF system line and continues to the 436 foot elevation of the AB where it accommodates a hose connection. The hose connection is located inside the AB, near the AB roll-up door at the 436 feet elevation. Hoses can be routed to the connection point from the east or north side of the plant. The connection and access routes are within structures protected from all hazards. The FLEX SFP makeup connection is sufficiently sized to allow a minimum flow of 120 gpm for SFP makeup.

2.4.4.2 Alternate Connection

The alternate strategy for providing makeup water to the SFP is to deliver water to the SFP with a FX Pumper Truck or FLEX pump by routing hoses to the SFP deck. From the SFP deck, the hose may be run directly over the side of the pool or to portable spray monitors. The spray strategy provides flow through portable spray monitors set up on the deck next to the SFP. The equipment used for the spray strategy is portable equipment that can be deployed from the various storage locations following a BDBEE.

2.4.4.3 Ventilation

Plant personnel will establish natural circulation by opening the railroad bay doors, located on the 436 foot elevation of the FHB, and at least 14 smoke detector access penetrations in the roof of the FHB. Outside air will enter the FHB through the railroad bay doors and vent through the roof

penetrations above the SFP. If additional ventilation is either desired or needed, destructive removal of translucent panels in the walls of the FHB may be performed (Reference 30).

2.4.5 Key Spent Fuel Pool Parameters

Instrumentation is available to monitor the SFP water level during all phases of the SFP cooling/inventory strategy.

The SFP water level is monitored by instrumentation that was installed in response to NRC Order EA-12-051, *Order Modifying Licenses with Regard to Reliable Spent Fuel Pool Level Instrumentation*.

2.4.6 Thermal-Hydraulic Analyses

As stated in the Phase 1 discussion, if no operator action is taken following a loss of SFP cooling at the maximum design heat load, analyses conclude the SFP will reach 212°F in approximately 21 hours and boil off to a level 10 feet above the top of fuel in approximately 87 hours. A separate analysis (Reference 19) determined SFP makeup would need to be provided at a flow rate of 93 gpm to replenish the water being boiled off. SFP makeup will begin 18 hours after event initiation at a flow rate of 120 gpm. The net gain in SFP level is calculated to be 2 inches per hour once makeup commences. The SFP cooling/inventory strategy provides adequate makeup to maintain an acceptable SFP level for shielding purposes.

2.4.7 FLEX Pump and Water Supplies

2.4.7.1 FX UHS Pump Systems

VCSNS has two redundant FX UHS pump systems. Each FX UHS pump system consists of two submersible hydraulic pumps and one diesel driven centrifugal booster pump. Each FX UHS pump system is stored on a FX UHS pump trailer, one system in the FSB and one system in the ERB. A FX UHS pump system is deployed by towing the FX UHS pump trailer with a Prinoth Panther T8 track vehicle which is also stored in the FLEX storage buildings. The track vehicle will deploy the pump system to the selected water source and place a submersible pump(s) in the water using the track vehicle's crane. Only one submersible pump is required to provide flow to the trailer mounted booster pump to obtain the design flow of 2500 gpm (300 psig).

The FX UHS pump system is used in multiple strategies including core cooling, SFP cooling, and containment cooling. The FX UHS pump system is sized to provide adequate flow to directly support simultaneously water supplies of 700 gpm to the FX booster/transfer pump, 120 gpm to the SFP, and 1500 gpm to the RBCUs. A hydraulic analysis of the flow paths from each water source to the delivery locations has confirmed that applicable performance requirements are met (Reference 21).

2.4.7.2 FX SG Feed Pump

VCSNS has one FX SG feed pump which is stored in the FSB. The FX SG feed pump is a trailer-mounted, diesel-driven centrifugal pump with a design flow of 500 gpm (500 psig). The portable FX SG feed pump will be used to provide water for the SFP. The FX SG feed pump can take suction from the CST or other available tanks, the FX booster/transfer pump, or the FX UHS pump system. A hydraulic analysis has confirmed that the FX SG feed pump is sized to provide the minimum required flow rate to support SFP makeup (Reference 21).

2.4.7.3 FX Pumper Trucks

VCSNS has two Fire Pumper Trucks (XFX100 and XFX101) capable of providing SFP makeup. XFX100 is equipped with a diesel driven Hale centrifugal pump with a design flow of 1750 gpm (at 150 psig). XFX101 is equipped with a diesel driven Hale centrifugal pump with a design flow of 2250 gpm (at 150 psig). A hydraulic analysis has confirmed that the FX

Pumper Trucks are appropriately sized to provide the minimum required flow rate to support SFP makeup (Reference 21 and Reference 31).

2.4.7.4 Monticello Reservoir

The Monticello Reservoir is a source of water for the SW pond. The SW pond is connected to the Monticello Reservoir by an interconnecting pipe, which is normally closed such that loss of Monticello Reservoir cannot drain the pond. The interconnecting pipe is used to provide makeup from the Monticello Reservoir to the SW pond in order to maintain operating levels in both heat sinks. See Section 2.14 for information related to water quality.

2.4.8 Electrical Analysis

The SFP will be monitored by instrumentation installed for Order EA-12-051. Both the primary and backup channels will be powered from dual selectable power supplies utilizing dedicated lithium ion batteries with backup batteries available for easy replacement.

The minimum expected battery life for each battery supply is 130 hours of continuous service (Reference 32). The battery systems will include provisions for battery replacement should the installed battery be non-functional following the event. Spare batteries will be readily available to maintain power to the system for the entire period of the FLEX response.

2.5 Containment Integrity

When an ELAP is initiated while VCSNS is in Modes 1-4, containment cooling can be lost for an extended period of time. A loss of containment cooling will cause containment temperature and pressure to slowly increase. An engineering model was developed to calculate containment pressure and temperature during an ELAP (Reference 33), assuming the RCS was cooled down and depressurized within the first 6 hours. The evaluation concluded that containment temperature and pressure will remain below containment design limits, and that key parameter instruments subject to the containment environment will remain functional for a minimum of 30 days. Therefore, actions to reduce containment temperature and pressure, and to ensure continued functionality of the instruments are not immediately required.

2.5.1 Phase 1 Strategy

The Phase 1 coping strategy for containment integrity involves verifying containment isolation per EOP-6.0, *ECA-0.0 Loss of All ESF AC Power*, and monitoring containment temperature and pressure using installed

instrumentation. MCR indication for containment pressure and containment temperature will be retained for the duration of the ELAP.

2.5.2 Phase 2 Strategy

The Phase 2 coping strategy for containment integrity is to continue monitoring containment temperature and pressure using installed instruments (Section 2.5.6). Phase 2 activities to repower installed instruments are required for continued monitoring of containment conditions.

Additionally, containment temperature and pressure will be reduced, if necessary, using a RBCU or Reactor Building (RB) spray. These methods are discussed in greater detail in the following section on Phase 3 strategies.

2.5.3 Phase 3 Strategy

The Phase 3 strategy for containment integrity involves reducing containment temperature and pressure, and ensuring continued functionality of instrumentation to monitor key parameters using existing plant systems, Phase 2 and/or Phase 3 FLEX equipment.

The Phase 3 coping strategy includes obtaining additional electrical capability and redundancy for on-site equipment until such time that normal power to the site can be restored. Two 1.1MW (480 V) portable CTGs will be provided by the NSRC. One NSRC generator can be used to reenergize a RBCU fan.

Containment temperature and pressure can be reduced using one of the options below.

Reactor Building Cooling Unit Option

The primary strategy is to provide cooling water to one RBCU in either train using a FX UHS pump system. Fire hose will connect the discharge of the FX UHS pump system to permanent pipe stub-outs on existing SW lines, which supply flow to the RBCUs. One RBCU fan can be repowered by one FLEX CTG via the 7.2 kV switchgear bus 1DA or 1DB (Reference 34). Alternately, the Phase 3 CTGs, supplied by the NSRC, can be used to power the fan motors. The associated fan will be placed in slow speed (Table 1 Items P and Q).

Defense-in-Depth Reactor Building Spray Option

An alternate strategy is to establish water spray within containment using the RB spray system. An existing 2.5 inch B.5.b connection on the 'B' RB spray header will be used to provide an alternate water supply to cool containment. Fire hose will connect the discharge of the FX UHS pump system to the existing B.5.b connection.

Figure 5 provides a diagram of the strategies to maintain containment integrity.

2.5.4 Structures, Systems, Components

2.5.4.1 Reactor Building Cooling Units

The RBCUs are part of the RB cooling system. RBCUs will receive cooling water from the SW system following a BDBEE. The cooling coils of the RBCUs use the cooling water to remove energy directly from the vapor region of the containment. The resulting cooled air is supplied to both upper and lower elevations of the RB.

2.5.4.2 Service Water Pond

The SW pond, a seismically qualified impoundment of a portion of Lake Monticello, serves as the UHS. The SW pond contains approximately 85 million gallons of water at elevation of 416.5 feet mean sea level. The portable FX UHS pump system is capable of transferring water from the SW pond to the RBCUs via SW supply lines. The FX UHS pump system can also be used to supply water to the RB spray system via a B.5.b connection.

2.5.4.3 Reactor Building Spray Headers and Nozzles

The RB spray headers and nozzles are part of the RB spray system which is used to remove thermal energy from containment. The spray system serves this function by spraying water into the containment atmosphere. Nozzles are located on the headers to provide an even distribution throughout the containment to provide maximum heat removal. The SW system will supply cooling water to the RB spray headers.

2.5.5 FLEX Connections

A 6 inch discharge connection is installed on the SW header piping, discharge side of the SW booster pumps, for each train of the RBCUs. The modification includes a 6 inch pipe and a manual isolation valve. A

hose will connect the discharge of the FX UHS pump system to the 6 inch pipe for delivery of water from either the SW pond or Monticello Reservoir to the RBCU. The RBCU 'A' connection is in the IB and the RBCU 'B' connection is in the AB. The connections are protected from all external hazards and only require access through safety related structures.

2.5.6 Key Containment Parameters

Instrumentation is available to monitor containment temperature and pressure during all phases of the containment integrity strategy.

2.5.7 Thermal-Hydraulic Analyses

Conservative evaluations have concluded that containment temperature and pressure will remain below containment design limits for a minimum of 30 days (Reference 33). Instruments, which monitor key parameters and are subject to the containment environment, are qualified to remain functional for a minimum of 45 days.

2.5.8 Flex Pump and Water Supplies

2.5.8.1 FX UHS Pump Systems

VCSNS has two FX UHS pump systems. Each FX UHS pump system consists of two submersible hydraulic pumps and one diesel driven centrifugal booster pump. Each FX UHS pump system is stored on a FX UHS pump trailer, one system in the FSB and one system in the ERB. A FX UHS pump system is deployed by towing the FX UHS pump trailer with one of two Prinoth Panther T8 track vehicle which is also stored in the FLEX storage buildings. The track vehicle will deploy the pump system to the selected water source and place a submersible pump(s) in the water using the track vehicle's crane. Only one submersible pump is required to provide flow to the trailer mounted booster pump to obtain the design flow of 2500 gpm (300 psig).

The FX UHS pump system is used in multiple strategies including core cooling, SFP cooling, and containment cooling. The FX UHS pump system is sized to provide adequate flow to directly support simultaneously water supplies of 700 gpm to the FX booster/transfer pump, 120 gpm to the SFP, and 1500 gpm to the RBCUs. A hydraulic analysis of the flow paths from each water source to the delivery locations has confirmed that applicable performance requirements are met.

2.5.8.2 Monticello Reservoir

The Monticello Reservoir is a source of water for the SW pond. The SW pond is connected to the Monticello Reservoir by an interconnecting pipe. The interconnecting pipe is used to provide makeup from the Monticello Reservoir to the SW pond in order to maintain operating levels in both heat sinks. See Section 2.14 for information related to water quality.

2.5.9 Electrical Analysis

The RBCU fan motors are 480V loads with breakers fed from the 7.2kV switchgear buses 1DA1 or 1DB1. RBCU fan motors will be repowered by the two FLEX 7.2kV CTGs via the switchgear buses. Alternately, the Phase 3 CTGs, supplied by the NSRC, will be used to energize the fans.

2.6 Characterization of External Hazards

2.6.1 Seismic

The VCSNS seismic hazard is considered to be the earthquake magnitude associated with the safe shutdown earthquake (SSE). Per FSAR Section 3.7.1, the maximum horizontal ground acceleration for the SSE is 0.15g at the competent rock foundation elevation and 0.25g for the soil foundation. For the operating basis earthquake (OBE), the maximum horizontal ground accelerations is 0.1g for rock foundation and 0.15g for soil foundation. The vertical component spectra used are two thirds of the horizontal components in all frequency ranges and occur simultaneously.

For FLEX strategies, the earthquake is assumed to occur without warning and result in damage to non-seismically designed structures and equipment. Non-seismic structures and equipment may fail in a manner that would prevent accomplishment of FLEX-related activities (e.g., normal access to plant equipment, functionality of non-seismic plant equipment, deployment of BDB equipment and restoration of normal plant services).

2.6.2 External Flooding

VCSNS is the equivalent of a dry site as defined in Regulatory Guide (RG) 1.102, *Flood Protection for Nuclear Power Plants* (Reference 35). The VCSNS site is susceptible to brief water build-up due to a local intense precipitation event. FLEX equipment is stored either within structures designed to protect the equipment from the flood elevations or above the flood elevation calculated by the site external flooding analysis. Local ponding onsite due to local intense precipitation (i.e. probable maximum

precipitation or PMP) event was a design consideration in selection of storage locations, equipment connections, and deployment routes.

2.6.3 Severe Storms with High Wind

Current plant design bases address the storm hazards of high winds, hurricanes, and tornados. FSAR, Section 3.3 states a wind velocity of 100 miles per hour (mph) is used for the analysis of Seismic Category I structures at VCSNS. The value represents the maximum wind velocity at the site for an altitude of 30 feet above grade and for a 100 year recurrence interval. Design parameters applicable to the design basis tornado include a rotational wind speed of 290 mph, a translational wind speed of 70 mph, and an atmospheric pressure drop of 3 psi at the rate of 2 psi/sec.

2.6.4 Snow, Ice, and Low Temperatures

VCSNS considered the effects of extreme low temperatures and weather conditions. Figure 8.2 of NEI 12-06 provides a visual representation of the potential for ice storms across the U.S. According to NEI 12-06, VCSNS is located within a region that may experience a severe ice storm, including catastrophic destruction of power lines and/or existence of extreme amounts of ice. FLEX equipment is stored in structures which meet either the plant design basis for snow, ice, cold conditions or the requirements of American Society of Civil Engineers (ASCE) 7-10 (Reference 36). Strategies for the deployment of FLEX equipment considers impedances associated with ice accumulation.

VCSNS is located at Latitude 34° 17' 54.1" North and Longitude 81° 18' 54.6" West. Per the guidance within NEI 12-06, sites located below the 35th parallel are not expected to experience significant snowfall which impacts the ability to deploy FLEX equipment. Therefore, the FLEX strategies screen out of the impedances caused by extreme snowfall. NEI 12-06 assumes the same basic trend applies to extreme low temperatures; hence, low temperature hazards are not applicable at VCSNS.

2.6.5 Extreme High Temperatures

VCSNS considered the effects of high temperatures. In the region around VCSNS, summer has approximately 50 days with temperatures of 90°F or above and 6 days with temperatures of 100°F or above. FLEX equipment is procured such that it is capable of functioning at the maximum design temperature for outdoor safety-related components. Per FSAR

Section 2.3.1, this maximum design temperature is 107°F. Mechanical cooling systems are provided for safety-related equipment which is located in areas susceptible to sustained high temperatures.

2.7 Protection of FLEX Equipment

Portable BDB equipment is stored in the ERB, FSB, and the CAR. These storage buildings are protected from all hazards listed in Section 2.6 with the exception of design basis tornado winds and missiles; therefore, separation is used to minimize the probability that a single event would damage all FLEX equipment. The ERB is located southwest of the RB and the FSB is located southeast of the RB (see Figure 6).

The seismic design criteria and loadings for the ERB were developed in accordance with ASCE 7-10 as an Essential Facility (Category IV), which is the most conservative and robust of the potential options. To ensure conformance with the NRC expectation that the ERB supports fulfillment of FLEX mitigating strategies, Design Calculation DC02490-004 Revision 1 (Reference 37), has been developed, in part, to analyze the ERB with respect to the SSE. The calculation evaluates the seismic lateral force resisting system (LFRS) components of the structure, in high bay location of the ERB where the equipment is to be stored. The conclusion of the calculation is that the seismic LFRS of the ERB is expected to withstand the SSE seismic forces and the ERB will remain accessible and will experience no catastrophic damage.

The seismic design criteria and loadings for the FSB were developed in accordance with ASCE 7-10 as an Essential Facility (Category IV), which is the most conservative of the potential options. To ensure conformance with the NRC expectation that the FSB supports fulfillment of FLEX mitigating strategies, Design Calculation DC02490-005 Revision 0 (Reference 38), has been developed, in part, to analyze the FSB with respect to the SSE. The FSB was designed to a wind speed in excess of the ASCE 7-10 wind speed requirements, in an attempt to demonstrate functionality during low intensity tornado events. Due to the increased wind speed used, the forces due to the design high wind of 188 mph bound the lateral SSE forces and therefore control the design of the lateral force resisting system design for the FLEX Storage Building (FSB). The conclusion of the calculation is that the seismic LFRS of the FSB is expected to withstand the SSE seismic forces and the FSB will remain accessible and will experience no catastrophic damage.

The CAR storage area is a part of the Intermediate Building East Penetration Area, and is a Safety Related/Seismic Category 1 concrete structure which is integral with the Intermediate Building structure. Therefore, the CAR concrete

structure was designed to withstand the SSE event. As part of the FLEX response, a metal panel curtain wall and roll-up door were added to the CAR area to enclose the access opening for the storage area and provide a suitable FLEX equipment storage area. Design Calculation DC03440-004 Revision 0 (Reference 39), was developed as part of the FLEX implementation to provide structural design of the enclosure wall and associated supports. The steel enclosure was designed for both the ASCE 7-10 wind and seismic loadings, and also the SSE loadings. Due to the light weight of the enclosure wall, the wind loadings controlled the design. In conclusion, the concrete and steel enclosures of the CAR Storage Area were both design to withstand the SSE event.

The Alternate EFW DG (XEG0140 and XEG0141), and supporting auxiliaries, are stored in the FLEX Diesel Generator Building (FDG) (Reference 40). The FDG is robust with respect to all applicable external hazards (Reference 40). The Alternative EFW pumps are located within the SWPH (Reference 41). The SWPH is a Safety Related, Seismically Category 1 structure and is robust with respect to all applicabe external hazards (Reference 41).

Large portable BDB equipment such as pumps and power supplies are secured, if required by analysis, inside the ERB, FSB, and CAR to protect them during a seismic event. The buildings have tie downs integrated into the floor slab for this purpose. These tie downs are used to secure any equipment that is not considered stable to ensure the stored BDB equipment remains protected from damage during a seismic event. Additionally, the fire protection system is seismically installed. The lighting, conduits, electrical and fire detection components are not seismically installed; they are considered insignificant and not able to damage BDB equipment.

Debris removal equipment is also stored inside the ERB and FSB in order to be reasonably protected from the applicable external events. The equipment is likely to remain functional and deployable to clear obstructions from the pathway between the BDB equipment's storage location and its deployment location(s).

Deployment of FLEX and debris removal equipment from the BDB storage buildings is not dependent on off-site power. All doors required to support FLEX strategy deployment are designed for manual operation.

2.8 Deployment of FLEX Equipment

2.8.1 Haul Paths

Preferred haul paths, over existing roads, have been identified and documented in the ERPs. Although haul paths are primarily over seismically prepared soil, diverse haul paths are utilized to address

liquefaction concerns on the west side of the VCSNS site. The haul paths were selected such that areas with trees, power lines, and narrow passages were avoided, when possible. However, high winds can cause debris from distant sources to interfere with planned haul paths. Debris removal equipment is stored in the FSB and the ERB. These diverse locations are separated by approximately 2,580 feet. The FSB will be the preferred source of FLEX equipment to support Phase 2 actions, subject to the availability of equipment following a BDBEE. The FSB is desired due to its proximity to vehicle access points in the protected area, and its position within the Owner Control Area (OCA). The haul paths from the FSB to final deployment locations are much more direct than the haul paths from the ERB. There are two designated routes from the ERB to final deployment locations, as well as multiple equipment access paths to these routes. Routes from the ERB to final deployment locations, which involve entering the southern and western entrances through the OCA barrier, will involve movement of security features. Figure 6 shows the haul paths from the FSB and the ERB to the various deployment locations.

2.8.2 Accessibility

Flex strategies may be challenged by 1) secured doors and gates, and 2) debris which blocks personnel or equipment access.

While the coping strategy to maintain site accessibility through doors and gates is part of the immediate activities required during Phase 1, it is applicable to all phases of FLEX coping strategies. Doors and gates serve a variety of barrier functions on-site. One primary function is security. The ability to open doors for ingress and egress, ventilation, or routing of temporary cables and/or hoses is necessary to implement the FLEX coping strategies. Operators have keys for emergency access to all areas required for equipment access and operator actions. Security has established a protocol to permit access to the OCA, protected area and internal locked areas under ELAP conditions.

Other barrier functions of doors and gates include fire, flood, radiation, ventilation, tornado, and high energy line break. As barriers, these doors and gates are typically administratively controlled to maintain their function as barriers during normal operations. Following an a BDBEE and subsequent ELAP event, FLEX coping strategies require the routing of hoses and cables to be run through various barriers in order to connect equipment to station fluid and electric systems. For this reason, certain gates and doors will be opened and remain open. This violation of normal

administrative controls is acknowledged and is acceptable during the implementation of FLEX coping strategies.

The deployment of onsite FLEX equipment, to implement Phase 2 and 3 strategies, requires pathways between the storage building(s) and various deployment locations be clear of debris resulting from a BDBEE. The stored FLEX equipment includes two track vehicles which are equipped with front end blades and articulating arms that can be used to move or remove debris from the needed travel paths. A Caterpillar wheel loader is also available to deal with more significant debris conditions. Phase 3 FLEX strategies involve receipt of equipment from offsite sources (e.g., NSRC) and receipt of various commodities such as fuel and supplies. Deliveries to the site will be by air or by ground transportation. Debris removal for the pathway between the site entrance and the NSRC receiving location and from the various plant access routes may be required. The same debris removal equipment used for on-site pathways will be used to support debris removal to facilitate road access to the site.

2.9 Deployment of strategies

2.9.1 EFW Makeup Strategies

The SW pond will remain available for any of the external hazards listed in Section 2.6 and provide a supply of water at least several weeks without makeup. Water from the reservoir can be used to refill the CST or it can be delivered to the portable FX SG feed pump by means of a FX UHS pump system.

If the CST survives the event, it will be used to provide water to the EFW. The CST will be supplied makeup water from various water sources by using a FX UHS pump system or a FX booster/transfer pump. If the DWST and FWST survive the event, they will be used to provide makeup to the CST. Alternately, the tanks can supply water directly to the EFW by using a FX booster/transfer pump and/or the FX SG feed pump.

If the CST does not survive the event, an alternate EFW strategy will be deployed. This strategy utilizes water from the SW pond and a FX Alt EFW suction pump which is installed in the SW pump house to provide water to the EFW system.

The portable pumps used for EFW makeup are stored in the ERB and FSB. With the exception of the FX SG feed pump, each storage building contains one of each type of pump. The FX SG feed pump is stored in the

FSB. Flexible hose, which is stored in the ERB, FSB, IB, AB and SW pump house, will be routed depending on the strategy being implemented.

The connections used in the EFW strategies are discussed in Section 2.3.5.

Figure 1 provides a diagram of the strategies available to feed the SGs. Figure 2 provides a diagram of the strategies to makeup to the CST. Figure 7 provides a diagram of the alternate EFW strategy available to feed the SGs.

2.9.2 RCS Inventory Strategies

A FX RCS MU pump will be used to provide makeup to the RCS from either the RWST or the BATs. Two FX RCS MU pumps are available; one is stored in the FSB and the other in the ERB.

The connections used in the RCS inventory strategies are discussed in Section 2.3.5.

Figure 8 provides a diagram of the strategies available to provide RCS makeup.

2.9.3 Electrical Strategies

The CTGs, which are stored on trailers within the CAR, will be moved outside the building to allow their air intake and exhaust to clear the storage structure. Cables required to connect the CTGs to the plant are stored on the 451 foot elevation of the IB adjacent to the CTG terminal boxes and locally at the CTGs. Neutral ground resistors (NGRs) are used to protect the CTGs from faulted loads. The NGRs, which are mounted on separate trailers, are deployed at their storage location near the CAR. The CTGs are protected from all external hazards except the high wind hazard.

The 480V (80kW) DGs will be deployed from their storage locations in the ERB and FSB. The DGs will be deployed to the Turbine Building roll up door or the AB roll up door. Cable trailers will also be deployed from their storage locations in the ERB or FSB. Cables will be routed from the deployed location to either the motor control centers or the station battery chargers depending on the function being provided.

The FLEX battery chargers are permanently mounted in the EB. Cables to connect the chargers to the plant are stored in the Relay Room inside the Control Building.

2.9.4 Fueling of Equipment

The FLEX strategies for maintenance and/or support of safety functions involve several elements, including the supply of fuel to necessary equipment (e.g., diesel powered generators, pumps, hauling vehicles and compressors). The general strategy for supplying fuel oil, to diesel driven portable equipment being utilized to cope with an ELAP/LUHS, is to draw fuel oil out of available diesel oil tanks located on the VCSNS site.

Fuel Oil Tanks

The credited sources of fuel oil for portable equipment are the underground DG fuel oil storage tanks (FOSTs). The two tanks contain approximately 50,000 gallons of diesel fuel each (number is based on plant logs) and are protected from all BDBEE hazards identified in Section 2.6. When fuel is needed, a fuel trailer and fuel transfer pump will be positioned on the ground above the DG FOST and its suction hose assembly will be inserted into the 3 inch pipe associated with the flame arrestor.

A second source for fuel oil will be the auxiliary boiler tank, if it remains available following a BDBEE. The fuel reserves in the auxiliary boiler tank, approximately 100,000 gallons of fuel, could be utilized to prolong the site capability before needing off-site fuel oil replenishment. Fuel is added to this tank from the same delivery tanker whose fuel is initially sampled and verified to meet plant TS requirements. Although the tank itself is not routinely sampled and monitored, when fuel is transferred to the operations group's fuel oil trailer, fuel from the auxiliary boiler tank is sampled and routinely verified to meet the same requirements as new fuel being added to the FOST. When the tank is utilized for FLEX, a suction hose will be connected to the 3 inch fitting situated at the northwest corner of the auxiliary boiler house and connected to the FLEX fuel transfer pump.

Additional tanks on the site serve as potential sources of fuel. The tanks can be used if they remain available following the BDBEE. On-site tanks include multiple fuel oil day tanks, the operations diesel fuel oil trailer, and the fleet maintenance underground tank.

Fuel Management Program

As FLEX equipment utilizes diesel fuel exclusively, a diesel fuel management program is used to ensure FLEX equipment will perform their required functions indefinitely. Fuel quality management

encompasses new fuel specification and testing, stored fuel monitoring and considerations applicable to the transfer of fuel. All of the considerations of fuel properties and quality management are appropriately incorporated in the FLEX program.

Fueling and Refueling of Equipment

FLEX support and transportation equipment (e.g., wheel loader and haul vehicles) will normally be maintained with sufficient fuel capacity to ensure their respective deployment functions. FLEX strategy mitigation equipment (e.g., UHS pumping systems pumps and SG Feed Pump) stored in either the ERB or the FSB will normally contain minimal fuel and thus require fueling prior to deployment and/or operation. The 1MW CTGs stored under the CAR do not have an integral fuel tank. The CTGs will be fueled by a dedicated Trans-Cube fuel trailer. This fuel trailer, having a nominal 792 gallon tank with 650 gallon refill, is maintained empty and will require initial fueling from the underground FOST via a portable transfer pump. Two additional Trans-Cube fuel trailers, with 792 gallon tanks, are stored onsite; one is stored in the ERB and the other one in the FSB. These fuel trailers will be used to add fuel to FLEX equipment prior to deployment from the storage locations, as necessary. Subsequently, the fuel trailers will be hauled by pickup trucks to deliver fuel from the FOSTs, or other sources, to the various deployed diesel driven equipment locations.

Consumption

Based on a fuel consumption study, (Reference 42) the amount of fuel consumed by major FLEX equipment over a seven day period was estimated to be 49,504 gallons. The estimate conservatively assumes full loading and continuous operation of most equipment. According to the fuel consumption estimate, the two FOSTs, which are protected from all BDBEE hazards, have adequate capacity to provide the on-site FLEX equipment with diesel fuel for approximately 14 days. This time period could be extended based upon utilization of the auxiliary boiler tank or other available tanks on-site. Arrangements with fuel supply vendors ensure availability of fuel from off-site resources prior to depletion of fuel on-site.

2.10 Offsite Resources

2.10.1 National SAFER Response Centers

The industry has established two regional response centers, designated as NSRCs, to support utilities during BDBEEs. SCE&G has established

contracts with the Pooled Equipment Inventory Company (PEICo) to participate in the process for support of the NSRCs, as required. Each NSRC will hold five sets of equipment, four of which will be able to be fully deployed when requested and the fifth set will have equipment in a maintenance cycle. In addition, on-site FLEX equipment hose and cable end fittings are standardized with the equipment supplied from the NSRC.

If a BDBEE and subsequent ELAP/LUHS condition occurs, equipment will be moved from one of the NSRCs to an interim staging area on-site. Communications will be established between the plant site and the Strategic Alliance for FLEX Emergency Response (SAFER) team via satellite phones and required equipment moved to the site as needed. If ground transportation from the NSRC to the site is available, the equipment will be transported directly from the NSRC to the interim staging area by truck. If ground transportation directly to the site is not available, the equipment will be flown to the SCE&G Aviation hanger at the Columbia Metropolitan Airport (CAE). From CAE, the equipment will be delivered to the site by truck if ground transportation is available between CAE and the site. If ground transportation from CAE to the site is not available, a truck will transport the equipment to the SCANA Corporate Campus and a helicopter will deliver the equipment to the interim staging area. The interim staging area for VCSNS is located near the FSB. The first equipment to arrive on-site will be delivered within 24 hours of the initial request. The order at which equipment is delivered is identified in the *SAFER Response Plan for Virgil C. Summer Nuclear Station* (Reference 43).

2.10.2 Equipment List

The equipment stored and maintained at the NSRC, which will be transported to VCSNS's local assembly area to support the response to a BDBEE, is listed in Table 2. Table 2 identifies the equipment that is specifically credited in the FLEX strategies for VCSNS and lists the equipment that will be available for backup/replacement should on-site equipment break down. Since all equipment will be delivered to the local assembly area, the time needed for the replacement of a failed component will be minimal.

2.11 Habitability and Equipment Operations

According to the guidance given in NEI 12-06, FLEX strategies must be capable of execution under the adverse conditions resulting from a BDBEE (e.g., a loss of ventilation and a loss of plant heating).

2.11.1 Ventilation

Following a BDBEE and subsequent ELAP at VCSNS, ventilation providing cooling to occupied areas and areas containing FLEX strategy equipment will be lost. The primary concern with regard to ventilation is the heat buildup which occurs with the loss of forced ventilation in areas that continue to have heat loads. An engineering evaluation was performed to identify a bounding scenario for time constraints and ventilation flow requirements (Reference 30). The resulting ventilation strategies ensure equipment operability and personnel habitability. The ventilation strategies for key areas are described below.

Main Control Room: temperatures are maintained in acceptable ranges by establishing natural circulation followed by forced ventilation in order to ensure habitability and equipment operations. Initially, building doors and duct access doors will be opened to create natural stack ventilation. Afterward, forced flow will be established using portable fans powered by a portable diesel generator. The MCR fan may be repowered and operated in the purge mode to add additional cooling.

Relay Room: temperatures are maintained in acceptable ranges by establishing natural circulation followed by forced ventilation in order to ensure equipment operations. Initially, building doors will be opened to establish a flow path from the relay room to the 483 foot elevation of the CB. Afterward, various access doors and building doors will be opened and forced flow will be established using portable fans powered by a portable diesel generator.

Turbine Driven Emergency Feedwater Pump Room: temperatures are maintained in acceptable ranges by establishing natural circulation to ensure equipment operations. Building doors will be opened to establish a flow path.

Motor Driven Emergency Feedwater Pump and Emergency Feedwater Control Valve Mezzanine Areas: temperatures are maintained in acceptable ranges by establishing forced ventilation in order to ensure habitability. Forced flow will be established using portable fans powered by a portable diesel generator. Portable ducting will be used, as needed.

PORV Areas: temperatures are maintained in acceptable ranges by establishing natural circulation in order to ensure habitability. Natural circulation will be established by opening doors, dampers, and pressure relief panels on the IB roof.

Battery Rooms and Battery Charger Rooms: temperatures are maintained in acceptable ranges by establishing both natural circulation and forced ventilation in order to ensure equipment operations. Building doors will be opened and portable exhaust fans will be used to establish flow. Also, ceiling openings in one of the charging room provides additional ventilation capabilities. The established flow path will allow hydrogen to be vented from the battery rooms.

Switchgear Rooms: temperatures are maintained in acceptable ranges by establishing natural circulation in order to ensure equipment operations.

Fuel Handling Building: temperatures are maintained in acceptable ranges by establishing natural circulation in order to ensure equipment operations. Natural circulation will be established by opening doors, and access penetrations in the roof.

Auxiliary Building: temperatures are maintained in acceptable ranges by establishing natural circulation in order to ensure habitability and equipment operations. Doors will be opened to create natural stack ventilation.

2.11.2 Plant Heating

Following a BDBEE and subsequent ELAP at VCSNS, plant heating to occupied areas and areas containing FLEX strategy equipment will be lost. An engineering evaluation was performed to identify any heating requirements needed to ensure equipment operability and personnel habitability (Reference 30). The evaluation concluded that there is no impact from extreme cold ambient conditions on plant areas containing FLEX equipment.

Areas within the FSB and ERB which contain FLEX equipment have infrared space heaters to maintain ambient conditions. The CTGs stored in the CAR are equipped with heaters. FLEX equipment is procured to function in extreme low temperatures expected at VCSNS.

2.12 Lighting

Plant lighting may not be available due to the ELAP and subsequent load shedding actions which extend battery life. Additionally, FLEX strategies may need to take place outdoors when natural light and plant lighting are not available. Installed emergency lighting within structures built to withstand the site design basis external events is initially available up to 8 hours following all BDBEE except the BDB seismic event. With the exception of MCR lighting, these lights are assumed to be unanalyzed for seismic conditions. The following sections describe the

lighting support strategy for deployment and/or operation of the equipment credited during the three phases of FLEX response.

Control Room Lighting

Lighting in the MCR is initially available following a BDBEE for all hazards described in Section 2.6. The seismically mounted emergency lighting in the MCR provides adequate light for up to 8 hours following a BDBEE. The FLEX strategy requires operators open breakers to the essential lighting panels, as part of the load shedding to extend to extend ESF battery life, if DC battery chargers are not re-energized by FLEX generators. If charging power is restored to the station batteries, prior to exhaustion of the emergency battery, DC powered lighting may be available in the MCR.

Technical Support Center Lighting

The primary TSC is located in the CB. If normal lighting in the CB is not available, area-wide lighting will be deployed to allow implementation of FLEX strategies. Electrical connections have been installed between a power pack in the CB and the DGs in the EB and the AEB. The power pack can be used to energize portable LED lights used to illuminate the TSC and MCR.

Debris Clearing Equipment and Other Vehicles

The Caterpillar wheel loader is outfitted with front and rear halogen work lights for night debris removal activities. The 2 Prinoth Panther T8 track vehicles are equipped with dual rear halogen lights and work area flood lights.

Phase 1 Equipment Lighting

Flashlights are part of the standard gear for operators and can be used for operations and surveillances occurring outside the MCR. In addition, although not credited, installed emergency lighting may be available up to 8 hours following event initiation for select areas throughout the site.

Phase 2 Equipment Lighting

Portable lighting towers are available to support equipment deployment. Also, various transporting vehicles have installed lighting equipment that may provide sufficient lighting for personnel to perform strategies. Lighting from lanterns or small battery powered area lights may be adequate for personnel making electrical or mechanical connections. Lighting towers, powered by DGs, may be used at staging areas. Personnel executing FSPs, specifically those which require connections to be made between FLEX equipment and permanent equipment, will be furnished with lanterns and lighting towers, as needed. In addition, large pumps and CTGs are equipped with local area lighting units.

Phase 3 Equipment Lighting

The Phase 3 delivery from the NSRC will include 3 light towers to support the unloading and staging of FLEX equipment. The 30 feet tall light towers will provide light coverage for 5 to 7 acres. Each tower has 4 lamps which are powered by a 30 kW DG.

Essential lighting, if available following the event, may be restored once the ESF bus becomes energized by FLEX equipment. Essential lighting is provided for access into the site buildings including the Turbine Building, AB, DG Building, IB, and CB.

2.13 Communications

The VCSNS communications systems and equipment are designed and installed to assure reliability of on-site and off-site communications in the event of a design basis accident scenario. However, in the event of an ELAP, limited communications systems functionality will be available.

A standard set of assumptions for a BDBEE, resulting in an ELAP, is identified in NEI 12-01, *Guideline for Assessing Beyond Design Basis Accident Response Staffing and Communications Capabilities* (Reference 44). As discussed in the requirements section, compliance with NEI 12-01 requires each licensee to maintain a minimum number of communication links, ensure that a method for notifying plant staff of an emergency is available, and provide a method for communicating to Emergency Response Organization (ERO) members that they need to report to their assigned duty station. The plant paging system is battery backed such that it can be used to notify plant personnel of an emergency. ERO personnel are trained to respond to their assigned emergency response facilities when notified of an event. If the BDBEE results in a loss of communications, ERO personnel are expected to gain awareness of the event through means such as direct observation, media reports, and/or word of mouth and report to their

assigned emergency response facility. This expectation is communicated during annually ERO training.

Portable Radios

If a BDBEE results in the loss of the normal plant communication systems, portable battery operated radios are used as the primary method for rapid on-site communication. There are two plant radio systems to facilitate radio communications, the plant radio system and the plant security radio system. The two radio systems function on a roaming concept in which a subscriber unit (e.g., handheld radio) automatically registers with the radio repeater system with the higher receive signal indication. If one system fails, the subscriber unit will automatically register with the other system. To allow both radio systems to communicate with each other, both systems transmit their radio communications to the New Nuclear Development (NND) radio tower. The NND radio tower is required to function for the plant radio system to function, but the security radio system is capable of functioning without the NND tower. The NND tower is both diesel backed with a 48 hour fuel supply and battery backed with 8 hours of battery power.

EOP-6.0, *ECA-0.0 Loss of All ESF AC Power*, directs operators to have Emergency Response Unit (ERU) staff conduct a communications assessment. If both the security radio system and NND radio towers have failed, personnel within the MCR will be unable to contact ERU staff via radio. Operations will have to contact ERU personnel via satellite phone and request ERU to deploy the portable communications tower. Once the portable radio tower is deployed, radio communications will resume except that communications may be unavailable below the AB 397 foot elevation. No time critical credited FLEX actions require communications occur below this elevation.

There are 16 radios, each with a spare battery, available in the MCR. The average battery life for the radios is slightly longer than 12 hours. In addition, there are 10 radio units and 10 battery chargers dedicated and maintained in the ERB for emergency response capability. The radios are provided with 10 battery replacements having a battery life of approximately 8 hours. The batteries will be recharged with the TSC power pack, a repowered 120VAC supply, or by energizing the battery chargers with a portable diesel generator.

Satellite Phones

There are 16 portable battery operated satellite phones located in various emergency response locations onsite. The satellite phones will facilitate on-site and off-site communications. The satellite phones have spare batteries and recharging stations which can be repowered with a portable diesel generator.

2.14 Secondary Water Sources

The Phase 2 strategy for supplying water to the SGs is based on the quality of water and survivability of the water source. Water from the CST will be utilized first, if it is available. Additionally, if the CST survives, water from the DWST and the FWST will be used to refill the CST prior to depletion. The DWST and FWST are not seismically qualified or protected against wind hazards, but normally contain more than 600,000 gallons of water. If the tanks are not available, the Monticello Reservoir would act as the water source. If none of the previously mentioned sources are available, the seismically qualified SW Pond (i.e., UHS) would be utilized. Water straining of pond water will be provided as part of the FLEX UHS pump system. Using water from the SW pond for feeding the SGs is part of the present licensing basis, FSAR Section 10.4.9.

Phase 3 equipment for VCSNS includes a portable water processing trailer. The water processing unit is capable of providing demineralized water for indefinite makeup to the SGs. Supply to the portable water processing trailer will come from the SW Pond.

Table 3 provides a list of credited water sources that may be used to provide cooling water to the SGs, their capacities, and an assessment of availability following the applicable hazards identified in Section 2.6.

2.15 Shutdown and Refueling Analysis

VCSNS will abide by the NEI position paper (Reference 45), entitled *Shutdown/Refueling Modes*, which addresses implementation of mitigating strategies during shutdown and refueling modes. The plant response to a loss of all AC power while on residual heat removal (RHR) is governed by AOP-304.4, *Loss of All ESF AC Power While Shutdown (Modes 5 and 6 and Defueled)* (Reference 46). This procedure directs entry into the FSPs as necessary for coping while in shutdown modes. Station Scheduling Procedure (SSP), SSP-4, *Outage Safety Review Guidelines* (Reference 47), directs plant staff to consider the use of FLEX equipment when developing contingency plans for high risk evolutions. SSP-2, *Planning and Scheduling of Outage Activities* (Reference 48), directs plant staff to configure the plant such that containment venting can be quickly established when the reactor coolant system is not intact. The BDB program maximizes the availability of FLEX equipment during shutdown/outage modes (e.g., ensures routine maintenance is not scheduled during these times).

FLEX mitigating strategies available during shutdown and refueling modes are described below.

Reactor Core Cooling and Heat Removal Strategy

RCS intact/SG intact: The reactor core cooling and heat removal strategies, discussed in Section 2.3, remain effective as long as the RCS is intact and the SGs are available for use.

RCS intact/SG not intact: If the RCS is intact but the SGs are not available to act as a heat sink, core heat removal will require a “feed and bleed” strategy. In this case, RCS makeup will be delivered by one of the following methods:

- Pre-staged FLEX pump taking suction from RWST
- Gravity drain from the RWST
- RHR system if electrical power is available

During Phase 3, a boration skid from the NSRC will be used in conjunction with FLEX pumps to supply borated water.

In addition, pressure in the RCS is controlled by opening the pressurizer PORVs or the reactor head vents.

RCS not intact (pressurizer manway removed): The same strategies outlined above for RCS intact/SGs not intact will be used with the exception of RCS pressure control. The pressurizer manway is an adequate hot leg vent.

RCS not intact (reactor vessel head removed, cavity below 23 feet): The same strategies outlined above for RCS not intact (pressurizer manway) will be used. The objective is to fill the cavity to 23 feet. If the RWST is in use at the time of the ELAP, it is possible sufficient inventory is not available to raise the cavity to 23 feet. RHR or SFP can be used to fill the cavity if AC power becomes available.

RCS not intact (reactor vessel head removed, cavity at 23 feet): The same strategies outlined above for RCS not intact (reactor vessel head removed, cavity below 23 feet) will be used with an additional option to open the fuel transfer gate valve from the SFP (i.e., connecting the SFP and the cavity). Makeup can be made with any available water source to preserve the available borated water supply as the RWST could be depleted from filling the cavity. The spent fuel pump or the RHR pump could provide makeup to the SFP if AC power becomes available.

Defueled: Reactor core cooling and heat removal is not required when defueled. Makeup to the SFP will be made using existing strategies for power operations. The time requirement for establishing SFP makeup will be based on heat load in the pool.

Spent Fuel Pool Cooling/Inventory

If an event occurs during a shutdown or refueling mode, depending on the plant configuration at the time, borated water sources should be allocated to the RCS.

The SFP makeup sources to be used for an event occurring during shutdown modes are listed below in order of preference.

- Reactor Make-up Water Storage Tank
- Condensate Storage Tank
- Demineralized Water Storage Tank
- Filtered Water Storage Tank
- Monticello Reservoir
- Service Water Pond

Containment Integrity

RCS intact/SG intact: The containment integrity strategies, discussed in Section 2.5, remain effective as long as the RCS is intact and the SGs are available for use. In this case, containment cooling is not required for a minimum of 30 days.

RCS intact/SG not intact: Containment pressure will be controlled by venting the RB. This is done by opening the integrated leak rate test vent line isolation valves. After the RB is vented, containment pressure and temperature can be reduced by using the RBCUs or the containment spray system.

RCS not intact (pressurizer manway removed): The pressurizer manway provides a vent path for the RCS. The same strategies outlined above in RCS intact/SG not intact will be used.

RCS not intact (reactor vessel head removed): The same strategies outlined above in RCS intact/SG not intact will be used.

Defueled: Containment maintenance is not required when defueled.

2.16 Sequence of Events

Table 4 below presents a Sequence of Events (SOE) timeline for an ELAP/LUHS event at VCSNS (Reference 49). Validation of each of the FLEX time constraint actions has been completed in accordance with the FLEX validation process document issued by NEI and includes consideration for staffing (Reference 50). The time to clear debris is assumed to be 2 hours. This time is considered to be reasonable based on site reviews and the location of the storage buildings.

Table 4: Sequence of Events Timeline

Action Item	Action	Time Constraint Y/N	Time Constraint (hours)	Remarks/Applicability
	Event Starts	N/A	--	Plant is at 100% Power
1	SBO Procedure (EOP 6.0) Entered	N	--	EOP-6.0 is direct entry procedure.
2	TDEFW starts, blowdown isolates	N	--	Automatic on Blackout, RCS temperature controlled by MS Safeties.
3	Isolate the RCS	N	--	Letdown isolates automatically if air is lost, otherwise this is performed from the CR.
4	Assess Status of EB Power	N	--	Preparatory actions to identify preferred method of re-charging Station Batteries.
5	Assess & Stage CTGs and Fuel Supply	N	--	Preparatory actions only, not connecting to plant equipment.
6	Assess deployment routes	N	--	Inside and outside protected area.
7	Assess Communication Systems, Deploy Portable Communication Tower if necessary	Y	T+4	Communication should be established early to coordinate FLEX response (should be performed before cooldown is commenced, at a minimum).
8	Isolate RCP Seals	N	--	RCP seal controlled bleed off (CBO) flow cannot be isolated (fails open). CBO flow redirected to PRT instead of VCT.
9	Align Alt EFW Suction	Y	T+1	Required only if CST is not available.
10	Isolate CST from the Main Condenser	N	--	Conserves inventory in CST.

Action Item	Action	Time Constraint Y/N	Time Constraint (hours)	Remarks/Applicability
11	Control Emergency Feed	Y	T+1.5	At full TDEFP flow, SGs take approx. 45 minutes to fill to 80% NR. Each EFW FCV has an air accumulator to allow closure for up to 3 hours.
12	Strip X Train DC Loads – Vent Main Generator Hydrogen	Y	T+2	Controlled vent allows securing ESOP and conservation of Non-1E DC Power. XBA1X Battery life is 2 hours.
13	Establish Relay Room Cooling (Natural Circulation)	Y	T+1	Prevent loss of control due to heatup of sensitive electronics.
14	Declare ELAP	Y	T+2	Crew is allowed two hours to determine if AC power can be recovered. By T=2, decision made by SS that an ELAP exists.
15	Contact NSRC	N	--	Notify NSRC to mobilize equipment for VCSNS.
16	Energize Station Batteries from EB Battery Chargers	Y	T+15	At least one battery charging strategy must be complete before Station Batteries are exhausted.
17	Energize Station Batteries from Station Battery Chargers, powered from CTGs	Y	T+15	At least one battery charging strategy must be complete before Station Batteries are exhausted.
18	Perform Cooldown ~ 75deg F/hr to ~260 psig steam pressure	Y	T+6	With low leakage RCP seals, immediate cooldown is not required, but cooldown will start at 2 to 4 hours, and be accomplished within 6 hours after the event.
19	Perform DC load stripping.	Y	T+4	Required to be completed within 4 hours of event start, if station batteries are not re-energized.

Action Item	Action	Time Constraint Y/N	Time Constraint (hours)	Remarks/Applicability
20	Establish TDEFP Room Cooling (Natural Circulation)	Y	T+4	To maintain equipment reliability.
21	Establish EFW FCV area Cooling (Natural Circulation)	Y	T+4	To maintain operator habitability.
22	Establish SG PORV Area Cooling (Natural Circulation)	Y	T+4	To maintain operator habitability.
23	Establish Battery Room Ventilation (Forced)	Y	T+77	77 hours after charging capability is restored, H2 concentration in battery room approaches 2%.
24	Establish Battery Charger Room Cooling (Natural Circulation)	Y	T+7	To maintain equipment reliability. Only required if CTGs used to re-energize Station Battery Chargers.
25	Establish ESF Switchgear 1DA/B Room Cooling	Y	T+10	To maintain equipment reliability and operator habitability. Only required if CTGs used to re-energize Station Battery Chargers.
26	Establish SF Pool Area Cooling (Natural Circulation)	Y	T+21	To maintain operator habitability.
27	Establish AB-463 North Area Cooling (Natural Circulation)	Y	T+14	To maintain equipment reliability and operator habitability.
28	Complete Walkdowns and Assessment of plant.	N	--	Assessment of plant damage should be complete by end of cooldown to prioritize subsequent actions.

Action Item	Action	Time Constraint Y/N	Time Constraint (hours)	Remarks/Applicability
29	Perform CST refill	Y	T+8.4	At T/S minimum volume, must either refill CST or go on alternate low pressure feed by T=8.4. CST inventory should last 64+ hours if at normal level.
30	Isolate or Vent SI Accumulators	N	--	Progression restraint – cannot cooldown further until isolation or venting performed.
31	Perform Low Pressure SG feed	Y	T+8.4	Required only if unable to fill CST, or other loss of emergency feed.
32	Refuel FLEX Equipment	Y	T+15	CTGs are first equipment that requires fuel.
33	Establish Control Room Cooling (Natural Circulation)	Y	--	To maintain operator habitability.
34	Establish Control Room Cooling (Forced)	Y	T+10	To maintain operator habitability.
35	Establish Relay Room Cooling (Forced)	Y	T+6	To maintain equipment reliability.
36	Boration	Y	T+28	Longest boration option requires 17.5 hours to inject. Boration must be accomplished by T+29 to maintain 409 deg F, assuming 1 hour for mixing. Boration must be complete by T=28.
37	Establish Long Term RCS Inventory Control	Y	T+39.5	Continue methods of RCS makeup established during boration. Time to reflux cooling is 39.5 hours and time to uncover core is 80.7 hours if RCS makeup is never achieved.

Action Item	Action	Time Constraint Y/N	Time Constraint (hours)	Remarks/Applicability
38	Establish RCS Letdown	N	T+24	If ASI survives or the RWST is chosen as the boration source, it's necessary to establish letdown to accommodate.
39	Depressurize SGs to 170 psig for Long Term Cooling	N	--	Long Term Cooling conditions (minimum SG pressure for continued operation of TDEFP) – RCS must be borated, Accumulators must be isolated.
40	Begin SF Pool makeup	Y	T+87	Time to boil in SFP conservatively estimated at 21 hours. At 2.06 in/hr boiloff, time to L2 (10ft above fuel) is 87 hours.
41	Improve Water Quality for long term SG Feed	N	--	NSRC Water Treatment equipment delivered to improve water quality if source is Lake or SW Pond.
42	Establish RB Cooling	N	T+30 days	RB cooling not required for > 30 days to prevent exceeding design temp/press limits but will be established when AC power is available.

2.17 Programmatic Elements

2.17.1 Overall Program Document

The Beyond Design Basis Program Manual for Virgil C. Summer, Unit 1 (Reference 51), provides a description of the Diverse and Flexible Coping Strategies (FLEX) Program. Key elements of the FLEX program include:

- Maintenance of the FSPs including any impacts on the interfacing procedures (e.g., EOPs, AOPs, BDMGs, SAMGs, etc.)
- Maintenance and testing of BDB equipment (e.g., emergency communications equipment, portable BDB equipment, BDB support equipment, and BDB support vehicles)

- Portable equipment deployment routes, staging areas, and connections to existing mechanical and electrical systems
- Validation of time critical operator actions
- The storage buildings (e.g., ERB and FSB) and the NSRC
- Hazards Considerations (e.g., flooding, seismic, high winds)
- Supporting evaluations, calculations and BDB series drawings
- Tracking of commitments and equipment unavailability
- Staffing, Training and Emergency Drills
- Configuration Management
- Program Maintenance

In addition, the program description includes a list of the FLEX basis documents that will be kept up to date for facility and procedure changes.

Existing design control procedures have been revised to ensure that changes to the plant design, physical plant layout, roads, buildings, and miscellaneous structures will not adversely impact the approved FLEX strategies. Changes for the FLEX strategies will be reviewed with respect to operations critical documents to ensure no adverse effect.

Future changes to the FLEX strategies may be made without prior NRC approval provided 1) the revised FLEX strategies meet the requirements of NEI 12-06, and 2) an engineering basis is documented that ensures that the change in FLEX strategies continues to ensure the key safety functions (i.e., core cooling, SFP cooling, and containment integrity) are met.

2.17.2 Procedural Guidance

The inability to predict actual plant conditions that require the use of FLEX equipment makes it impossible to provide specific procedural guidance. As such, the FSPs will provide guidance that can be employed for a variety of conditions. Clear criteria for entry into FSPs will ensure that FLEX strategies are not used inappropriately in lieu of existing procedures. When FLEX equipment is needed to supplement strategies within EOPs or Abnormal Operating Procedures (AOPs), the EOP or AOP, Severe Accident Management Guidelines (SAMGs), or Beyond Design Basis Mitigation Guidelines (BDMGs) will direct the entry into and exit from the appropriate FSP procedure.

FSPs have been developed in accordance with PWROG guidelines to provide available, pre-planned FLEX strategies for accomplishing specific tasks in the EOPs or AOPs. FSPs will be used to supplement, not replace, the existing procedure structure that establishes command and control for the event.

Procedural interfaces have been incorporated into EOP-6.0, ECA-0.0 Loss of All AC Power, to the extent necessary to include appropriate reference to FSPs and provide command and control for the ELAP. Additionally, procedural interfaces have been incorporated into the following AOPs to include appropriate reference to FSPs:

- AOP-123 series, Spent Fuel Pool
- AOP-304.4, Loss of All ESF AC Power while on RHR Cooling

FSP maintenance will be performed by the station's procedures group. In accordance with site administrative procedures, NEI 96-07, Revision 1, and NEI 97-04, Revision 1 are to be used to evaluate changes to procedures to determine the need for prior NRC approval. However, per the guidance and examples provided in NEI 96-07, changes to procedures (e.g., EOPs, AOPs, BDMGs, SAMGs, or FSPs) that perform actions in response to events that exceed a site's design basis should screen out. Therefore, procedure steps which recognize the BDB ELAP/LUHS has occurred and which direct actions to ensure core cooling, SFP cooling, or containment integrity should not require prior NRC approval.

FSPs will be reviewed and validated by the involved groups to the extent necessary to ensure the strategy is feasible. Validation may be accomplished via walk-throughs or drills of the guidelines.

2.17.3 Staffing

Using the methodology of NEI 12-01, *Guideline for Assessing Beyond Design Basis Accident Response Staffing and Communications Capabilities* (Reference 44), an assessment of the capability of the VCSNS on-shift staff and augmented ERO to respond to a BDBEE was performed. The assumptions for the NEI 12-01 Phase 2 scenario postulate that the BDBEE involves a large-scale external event that results in:

- an extended loss of AC power (ELAP)
- an extended loss of access to ultimate heat sink (UHS)
- impact on units (all units are in operation at the time of the event)

- impeded access to the units by off-site responders as follows:
 - 0 to 6 Hours Post Event – No site access.
 - 6 to 24 Hours Post Event – Limited site access. Individuals may access the site by walking, personal vehicle or via alternate transportation capabilities (e.g., private resource providers or public sector support).
 - 24+ Hours Post Event – Improved site access. Site access is restored to a near-normal status and/or augmented transportation resources are available to deliver equipment, supplies and large numbers of personnel.

A team of subject matter experts from Operations, Maintenance, Radiation Protection, Chemistry, Emergency Preparedness and industry consultants performed tabletop exercises in October 2014 and April 2015 to conduct the on-shift portion of the assessment. The participants reviewed the assumptions and applied existing procedural guidance, including applicable draft EOPs and FSPs for coping with a BDBEE using minimum on-shift staffing. Particular attention was given to the sequence and timing of each procedural step, its duration, and the on-shift individual performing the step to account for both the task and time motion analyses of NEI 10-05, *Assessment of On-Shift Emergency Response Organization Staffing and Capabilities* (Reference 52).

The on-shift ERO analysis concluded that the current VCSNS Unit 1 on-shift staffing present for the “no site access” 6-hour time period is sufficient to perform the EOP, FSP and emergency response tasks with additional shift personnel and training committed to for the implementation of FLEX.

The expanded ERO analysis concluded that the current VCSNS Unit 1 augmenting ERO is sufficient to fill positions for the expanded ERO functions. Thus, the ERO resources and capabilities necessary to implement transition phase coping strategies performed after the end of the “no site access” 6-hour time period exist in the current program.

2.17.4 Training

The training program at VCS has been revised to assure personnel proficiency in the mitigation of BDBEE is adequate and maintained. These programs and controls were developed and have been implemented in accordance with the Systematic Approach to Training (SAT) Process. Initial training has been provided and periodic training will be provided to site emergency response leaders on BDB emergency response strategies

and implementing guidelines. Personnel assigned to direct the execution of mitigation strategies for BDBEE have received the necessary training to ensure familiarity with the associated tasks, considering available job aids, instructions, and mitigating strategy time constraints.

Care has been taken to not give undue weight, in comparison with other training requirements, for operator training for BDBEE accident mitigation. The assessment of operator knowledge and skills in this area has been similarly weighted. Operator training does include use of equipment from the NSRC.

The ANSI/ANS 3.5, Nuclear Power Plant Simulators for use in Operator Training, certification of simulator fidelity is considered to be sufficient for the initial stages of the BDBEE scenario until the current capability of the simulator model is exceeded. Full scope simulator models will not be upgraded to accommodate FLEX training or drills.

Where appropriate, integrated FLEX drills will be organized on a team or crew basis and conducted periodically; with all time-sensitive actions to be evaluated over a period of not more than eight years. It is not required to connect and/or operate permanently installed equipment during these drills.

2.17.5 Equipment List

The portable equipment stored and maintained in the VCSNS FLEX storage locations, necessary for the implementation of the FLEX strategies in response to a BDBEE, is listed in Table 5. Table 5 identifies the location, applicable strategies, and performance criteria for major BDB equipment.

Table 6 lists the portable FLEX support equipment which is stored and maintained on site. Table 6 identifies the location and support function of this equipment.

2.17.6 Equipment Maintenance and Testing

NEI 12-06 provides guidance for the unavailability of equipment and connections that directly perform a FLEX mitigation strategy for core cooling, SFP cooling, and containment integrity. Allowed outage times are a function of the protection against site applicable hazards for the remaining available FLEX strategies. When a FLEX strategy is impaired due to equipment unavailability, the allowed outage time is reduced from 90 days to 45 days. Where VCSNS uses separation as a protection mechanism for the high wind hazard, allowed outage times for equipment

necessary to implement a FLEX strategy is 45 days. Equipment outage times will be managed as follows:

- The required FLEX equipment may be unavailable for 90 days provided that the site FLEX capability (N) is met. If the site FLEX (N) capability is met but not protected for all of the site's applicable hazards, then the allowed unavailability is reduced to 45 days.
- One of the connections to plant equipment required for FLEX strategies can be unavailable for 90 days provided the remaining connection remains available such that the site FLEX strategy is available.
- If FLEX equipment or connections become unavailable such that the site FLEX capability (N) is not maintained, initiate actions within 24 hours to restore the site FLEX capability (N) and implement compensatory measures (e.g., use of alternate suitable equipment or supplemental personnel) within 72 hours.

If FLEX equipment or connections to permanent plant equipment required for FLEX strategies are unavailable for greater than 45/90 days, restore the FLEX capability or implement compensatory measures (e.g., use of alternate suitable equipment or supplemental personnel) prior to exceedance of the 45/90 days (Reference 4).

Both channels of wide-range SFPLI have allowed outage times of 30 days due to the backup channel display being located outdoors.

Figure 1: Steam Generator Feed

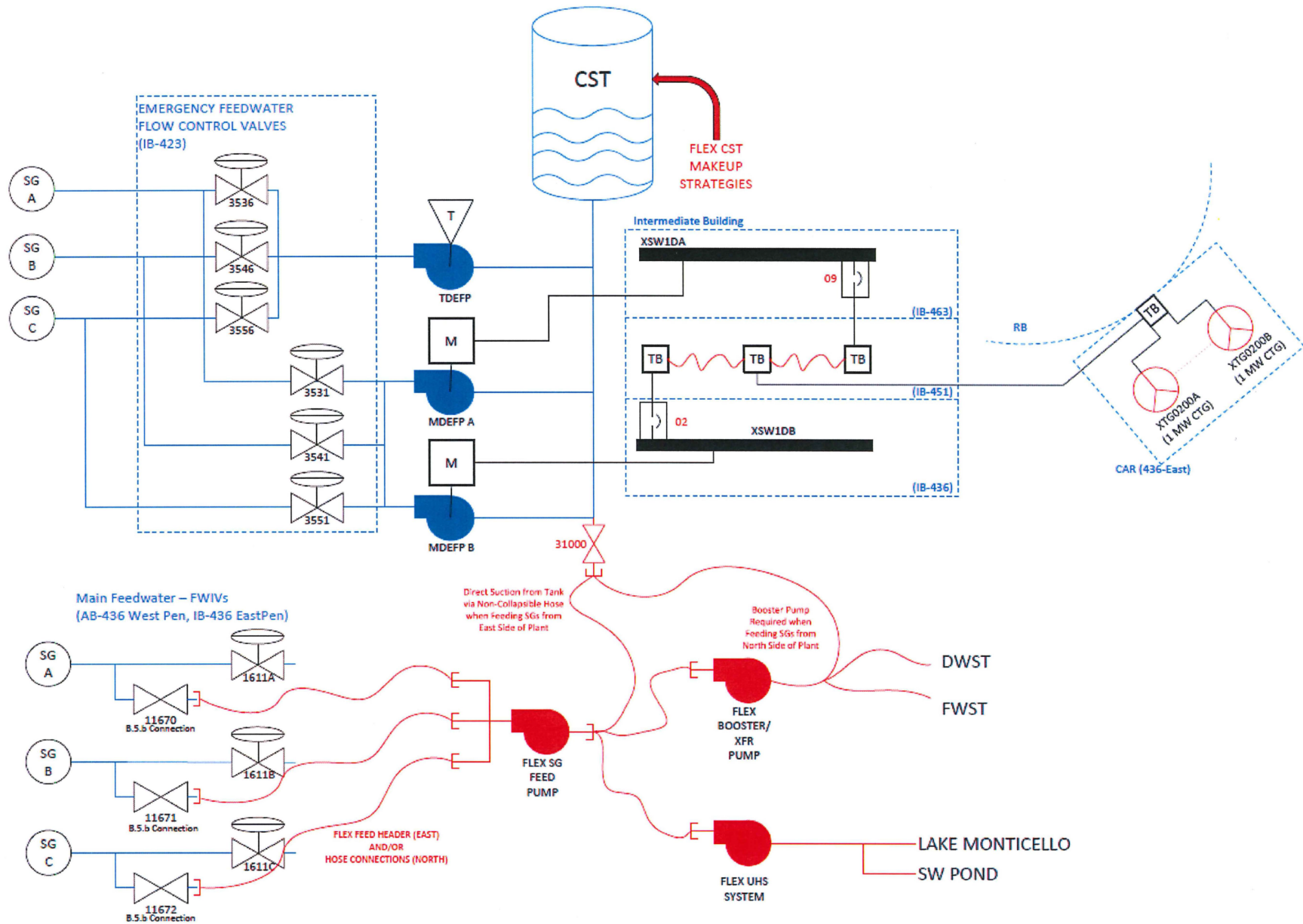

Figure 2: CONDENSATE STORAGE TANK MAKEUP

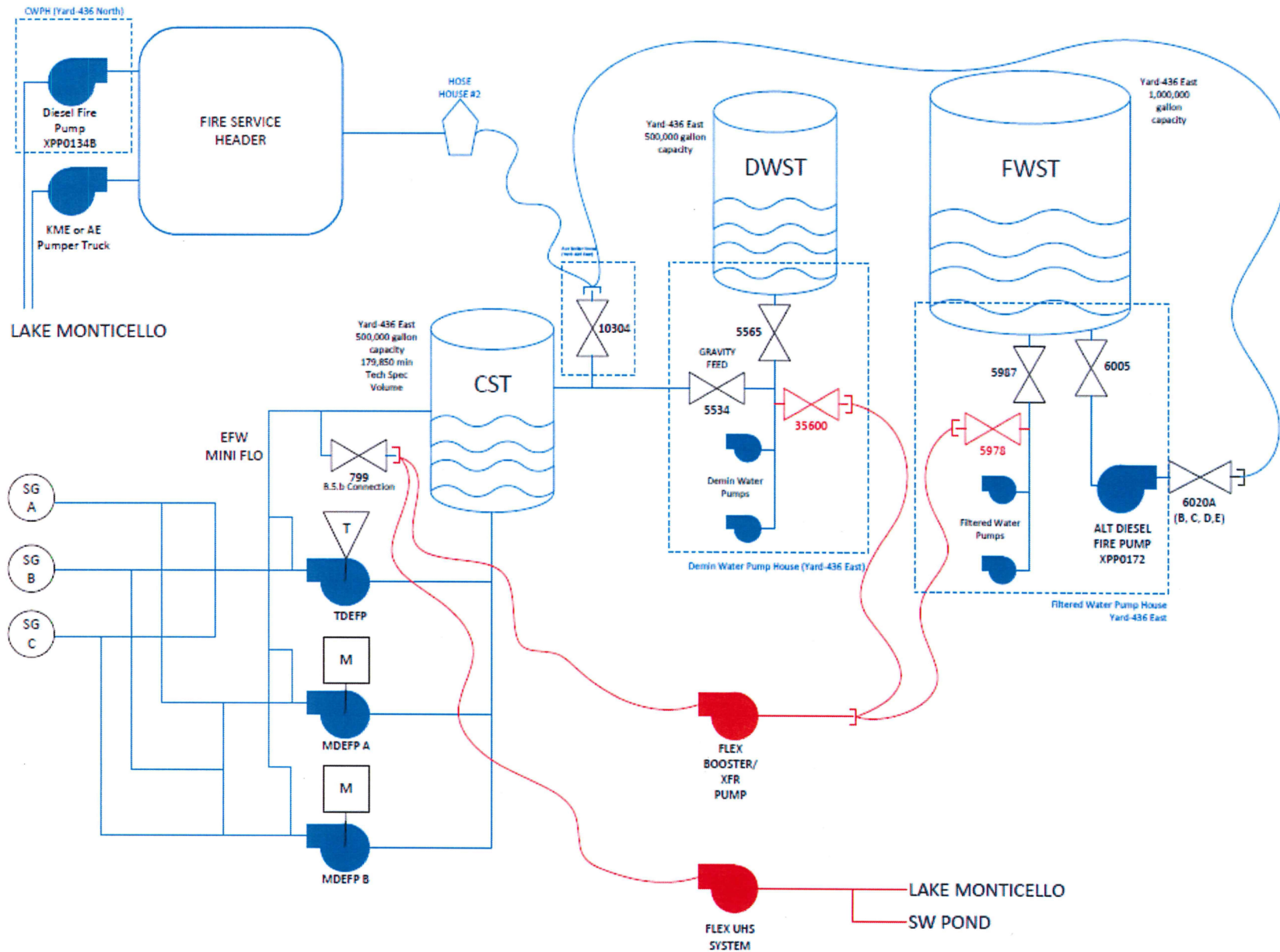
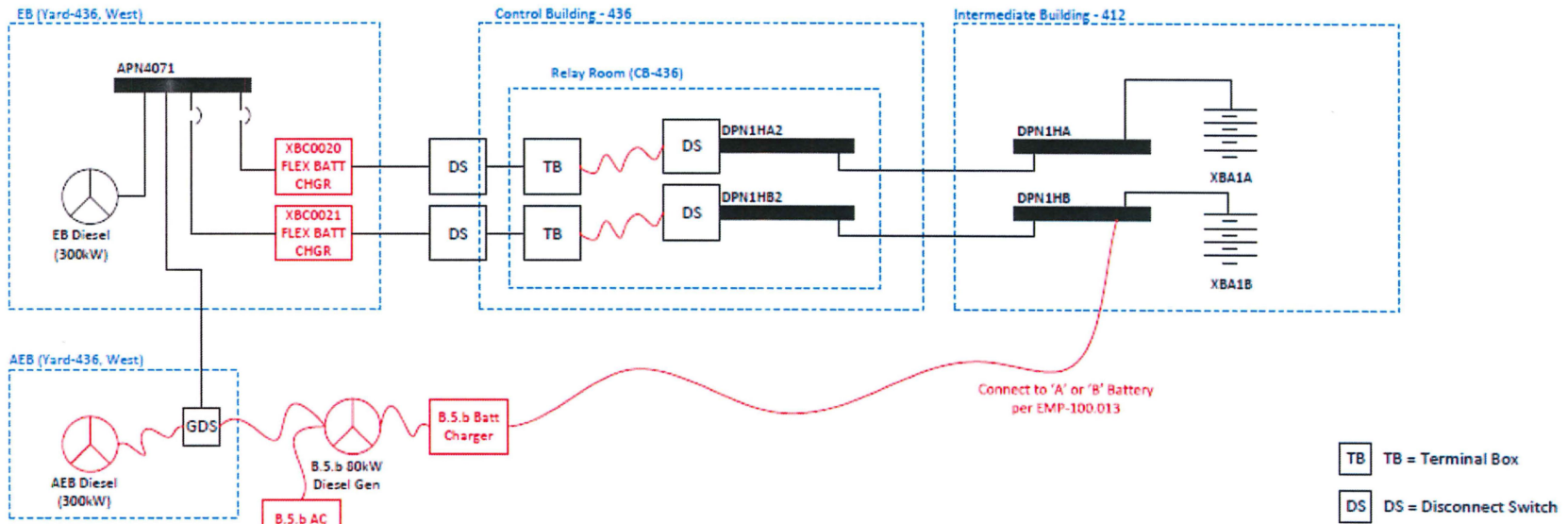

Figure 3: Restoration of DC Power (to Station Batteries)



RESTORATION OF AC POWER (to Station Battery Chargers)

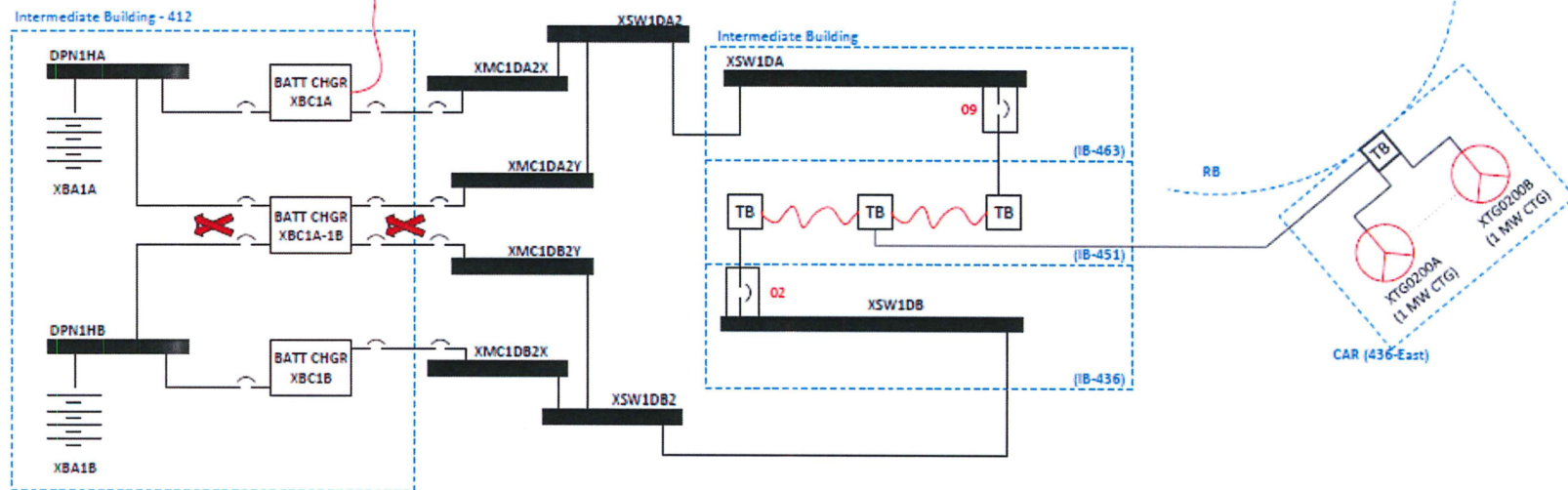
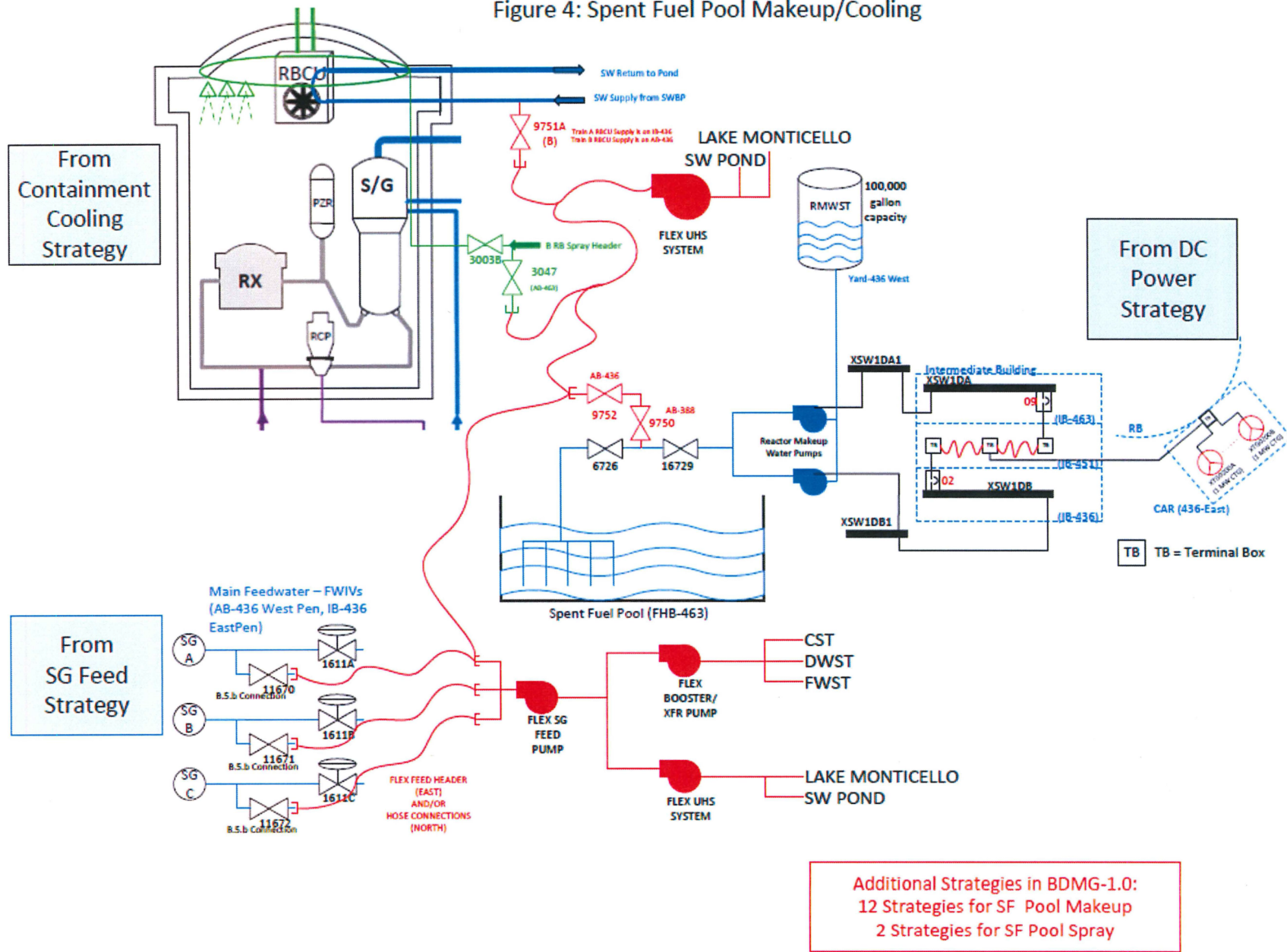

Figure 4: Spent Fuel Pool Makeup/Cooling



Additional Strategies in BDMG-1.0:
 12 Strategies for SF Pool Makeup
 2 Strategies for SF Pool Spray

Figure 5: Containment Integrity

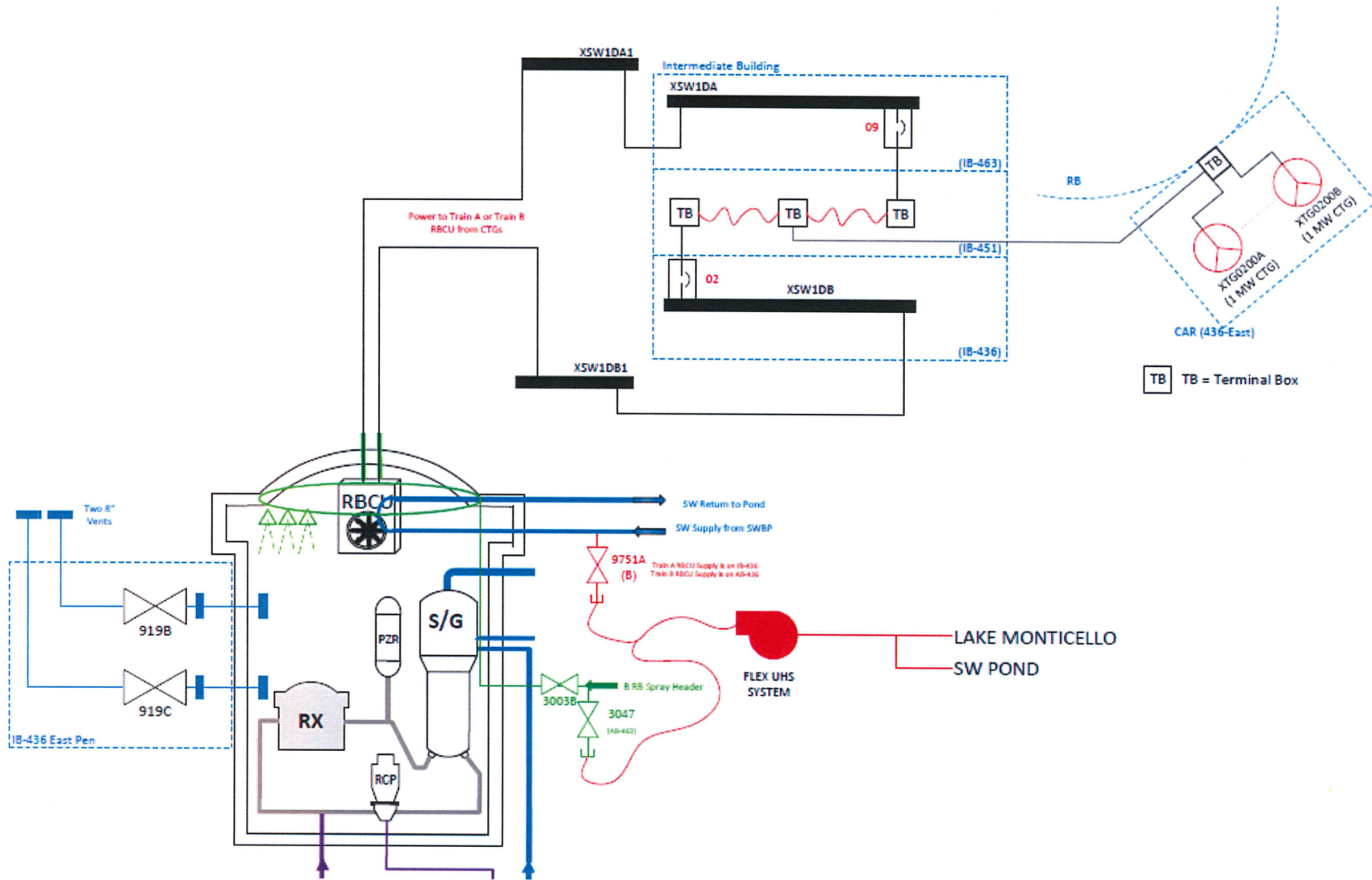

Figure 6: FLEX Storage Locations and Deployment Routes

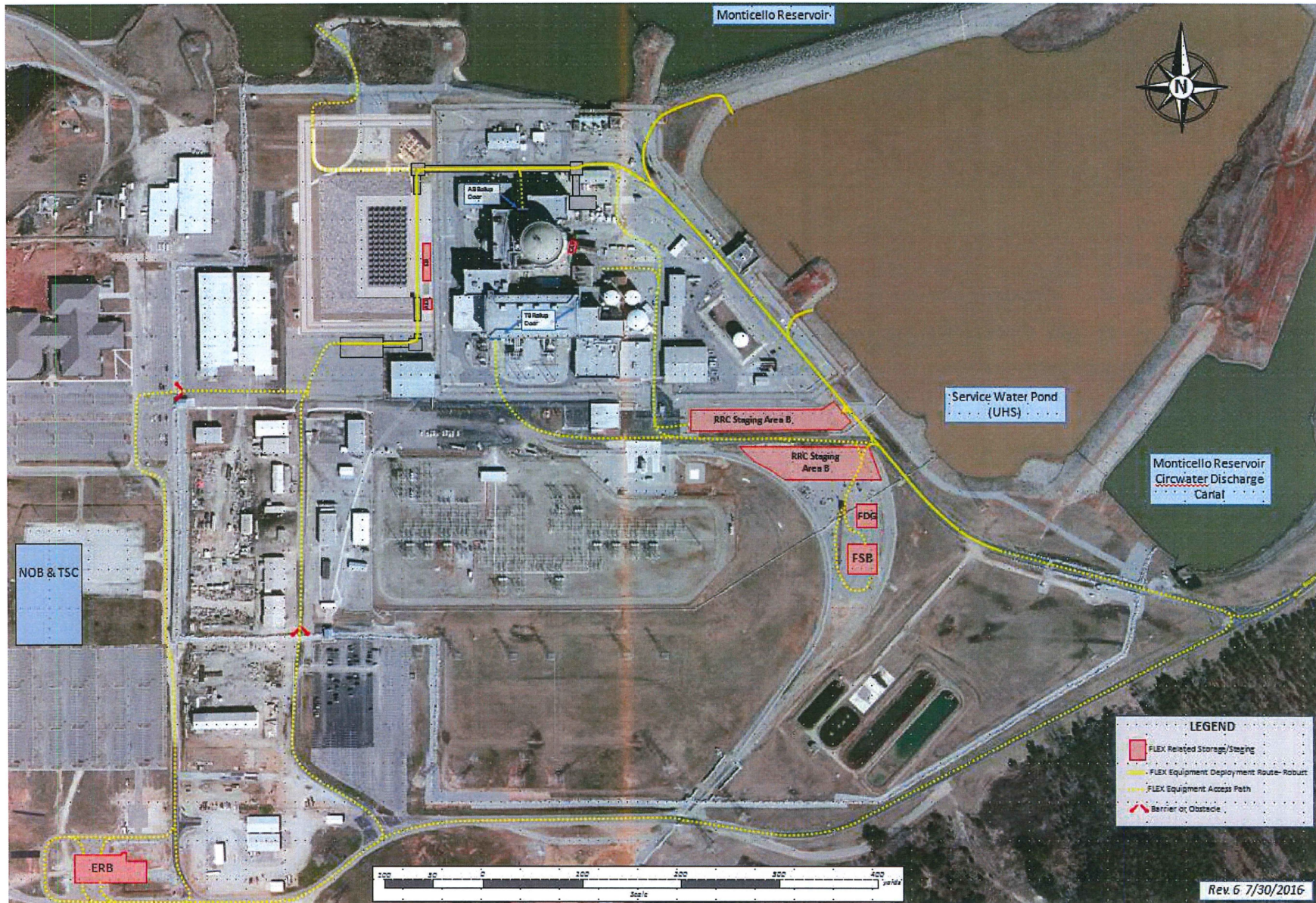

Figure 7: Alternate EFW Suction

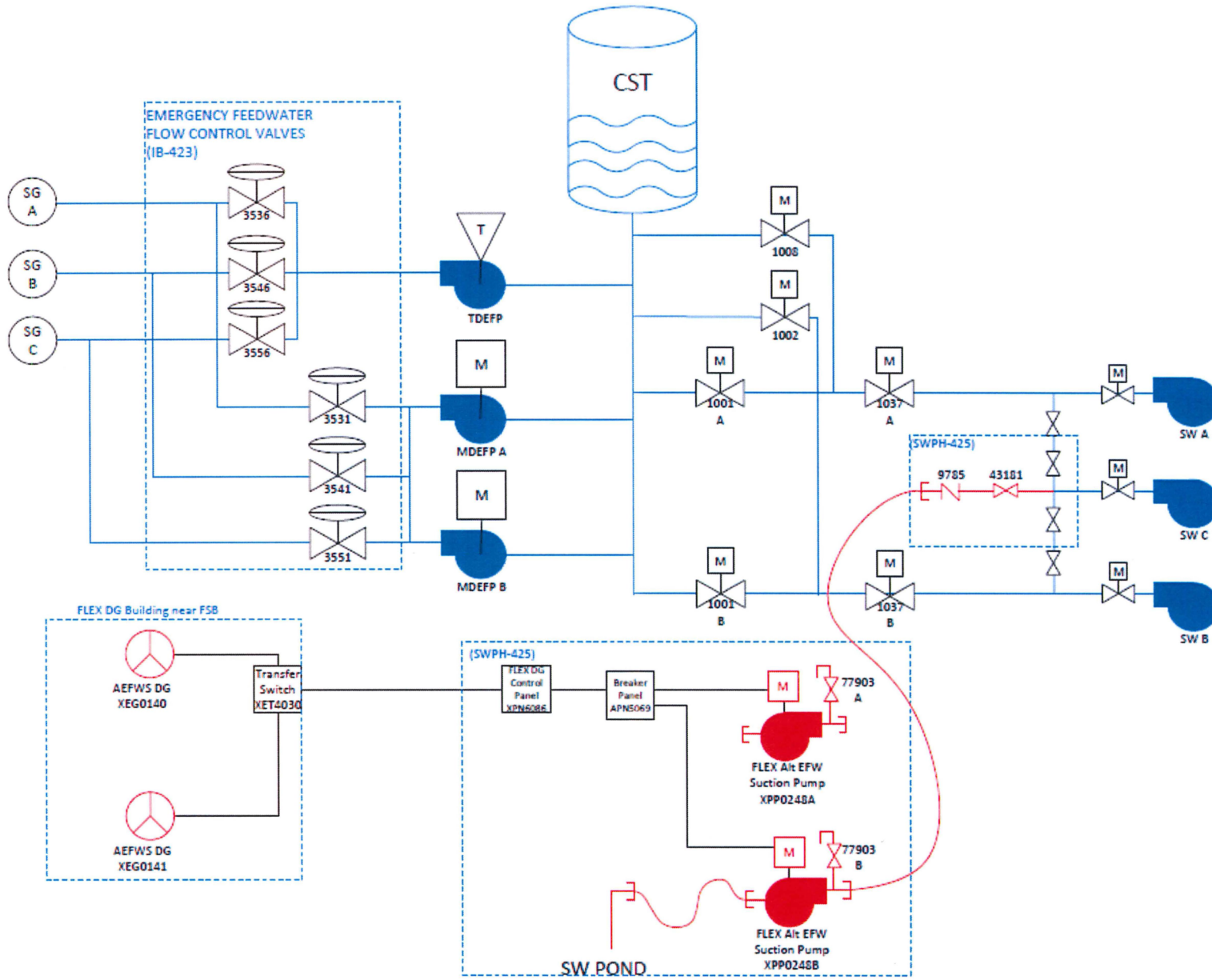

Figure 8: RCS Boration and Inventory Control

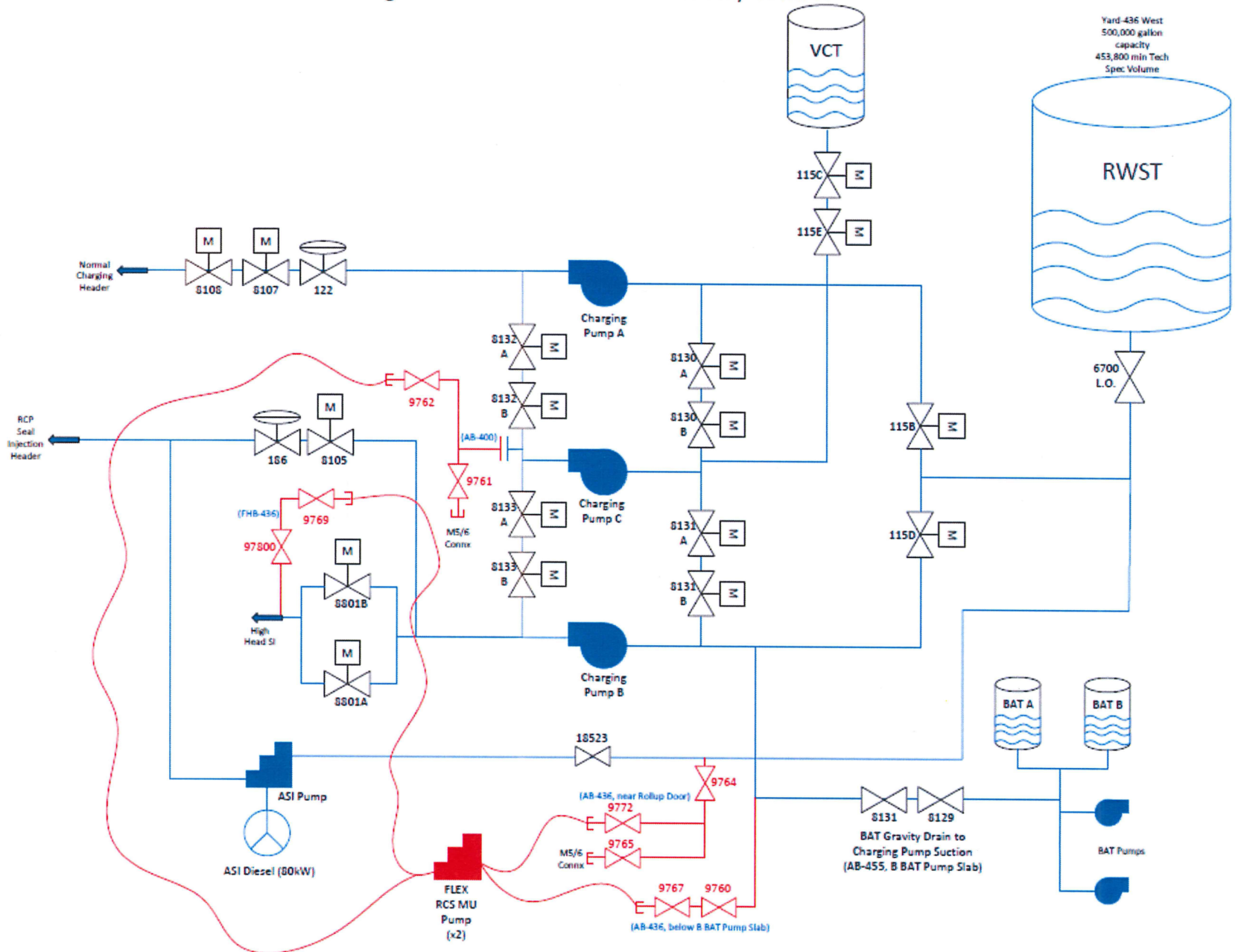

Table 1 – Credited FLEX Strategies						
Core Cooling (SG Feed)						
A	Phase 1 Strategy 1	Turbine Driven EFW	High Wind	Seismic	Temp.	Flood
		TDEFW Pump	Design Basis	Design Basis	Yes	Yes
		Suction Source - CST	Not Cred	Design Basis	Yes	Yes
B	Phase 1 Strategy 2	Turbine Driven EFW with Alternate EFW Suction Source	High Wind	Seismic	Temp.	Flood
		TDEFW Pump	Design Basis	Design Basis	Yes	Yes
		Suction Source - Alt EFW Suction Source Pumps XPP0248A/B and Generators XEG0140/141	Design Basis	Not Cred	Yes	Yes
C	Phase 2 Strategy 1	Feed SG with MDEFW energized from CTGs	High Wind	Seismic	Temp.	Flood
		Connection - XBT0104 , XBT0105, & XBT0106 or 107	Separation	Design Basis	Yes	Yes
		Required FX Equipment - (2) CTGs XTG0200A & B (CAR)	Separation	Design Basis	Yes	Yes
		Required FX Equipment - Fuel Tank and XFR Pump (Yard)	Separation	Design Basis	Yes	Yes
		Required FX Equipment - FX UHS Pump Sys	Separation	Design Basis	Yes	Yes
		Suction Source 1 - CST (makeup from SW Pond using FX UHS Pump Sys)	Not Cred	Design Basis	Yes	Yes
Suction Source 2 - Alt EFW Suction Source Pumps XPP0248A/B and Generators XEG0140/141	Design Basis	Not Cred	Yes	Yes		
D	Phase 2 Strategy 2	Feed SG with FX SG Feed Pump	High Wind	Seismic	Temp.	Flood
		Connection - XVG11670, XVG11671, XVG11672	Design Basis	Design Basis	Yes	Yes
		Required FX Equipment - FX SG Feed Pump XPP0237	Separation	ASCE 7-10	Yes	Yes
		Required FX Equip - FX UHS Pump Sys	Separation	ASCE 7-10	Yes	Yes
		Suction Source - SW Pond	Design Basis	Design Basis	Yes	Yes
Core Cooling (RCS Inventory & Boration Control)						
E	Phase 2 Strategy 1	BAT - FX RCS MU Pump - SI Injection Header	High Wind	Seismic	Temp.	Flood
		Suction Connection - XVA09760, XVA09767	Design Basis	Design Basis	Yes	Yes
		Discharge Connection - XVA97800, XVA09769	Design Basis	Design Basis	Yes	Yes
		Required FX Equipment - FX RCS MU Pump XPP0238A or B	Separation	ASCE 7-10	Yes	Yes
Suction Source - BAT	Design Basis	Design Basis	Yes	Yes		
F	Phase 2 Strategy 3	RWST - FX RCS MU Pump - SI Injection Header	High Wind	Seismic	Temp.	Flood
		Suction Connection - XVA09772, XVA09764	Design Basis	Design Basis	Yes	Yes
		Discharge Connection - XVA97800, XVA09769	Design Basis	Design Basis	Yes	Yes
		Required FX Equipment - FX RCS MU Pump XPP0238A or B	Separation	ASCE 7-10	Yes	Yes
Suction Source - RWST	Design Basis	Design Basis	Yes	Yes		

Table 1 – Credited FLEX Strategies						
Core Cooling (RCS Inventory & Boration Control) Continued						
G	Phase 2 Strategy 2	BAT - FX RCS MU Pump - CVCS	High Wind	Seismic	Temp.	Flood
		Suction Connection - XVA09760, XVA09767	Design Basis	Design Basis	Yes	Yes
		Discharge Connection - XVA09762	Design Basis	Design Basis	Yes	Yes
		Required FX Equipment - FX RCS MU Pump	Separation	ASCE 7-10	Yes	Yes
		Suction Source - BAT	Design Basis	Design Basis	Yes	Yes
H	Phase 2 Strategy 4	RWST - FX RCS MU Pump - CVCS	High Wind	Seismic	Temp.	Flood
		Suction Connection - XVA09772, XVA09764	Design Basis	Design Basis	Yes	Yes
		Discharge Connection - XVA09762	Design Basis	Design Basis	Yes	Yes
		Required FX Equipment - FX RCS MU Pump	Separation	ASCE 7-10	Yes	Yes
		Suction Source - RWST	Design Basis	Design Basis	Yes	Yes
DC Battery Charging – Supports ALL Strategies						
I	Phase 2 Strategy 1	Energize Station Battery Chargers with CTGs	High Wind	Seismic	Temp.	Flood
		Connection - XBT0104 , XBT0105, & XBT0106 or 107	Separation	Design Basis	Yes	Yes
		Required FX Equipment - (1) CTG XTG0200A or B (CAR)	Separation	Design Basis	Yes	Yes
		Required FX Equipment - Fuel Tank and XFR Pump (Yard)	Separation	Design Basis	Yes	Yes
J	Phase 2 Strategy 2	Energize Station Battery Chargers with Portable FX 80kW Gens (EMP100.016)	High Wind	Seismic	Temp.	Flood
		Connection - AC Input side of XBC1A, XBC1B or XBC1A-1B	Design Basis	Design Basis	Yes	Yes
		Required FX Equipment - 80kW FX Gens XEG0100, 107 or 108	Separation	ASCE 7-10	Yes	Yes
K	Phase 2 Strategy 3	Charge Station Batteries with Portable FX 80kW Gens (EMP100.013)	High Wind	Seismic	Temp.	Flood
		Connection - DC Output side of XBC1A-1B	Design Basis	Design Basis	Yes	Yes
		Required FX Equipment - 80kW FX Gens XEG0100, 107 or 108	Separation	ASCE 7-10	Yes	Yes
Core Cooling (Accumulator Isolation)						
L	Phase 2 Strategy 2	Energize Isolation Valves with CTGs	High Wind	Seismic	Temp.	Flood
		Connection - XBT0104 , XBT0105, XBT0106 & 107	Separation	Design Basis	Yes	Yes
		Required FX Equipment - (1) CTG XTG0200A or B (CAR)	Separation	Design Basis	Yes	Yes
		Required FX Equipment - Fuel Tank and XFR Pump (Yard)	Separation	Design Basis	Yes	Yes
M	Phase 2 Strategy 1	Energize Isolation Valves with Portable FX 80kW Gens	High Wind	Seismic	Temp.	Flood
		Connection - Load side of MCC (1DA2X, 1DB2Y)	Design Basis	Design Basis	Yes	Yes
		Required FX Equipment - 80kW FX Gens XEG0100, 107 or 108	Separation	Design Basis	Yes	Yes

Table 1 – Credited FLEX Strategies						
Spent Fuel Pool Cooling						
N	Phase 2 Strategy 1	FX UHS Pump to SFP Cooling Pipe Connection	High Wind	Seismic	Temp.	Flood
		Connection - XVA09750	Design Basis	Design Basis	Yes	Yes
		Required FX Equipment - FX UHS Pump Sys	Separation	Design Basis	Yes	Yes
		Suction Source - SW Pond	Design Basis	Design Basis	Yes	Yes
O	Phase 2 Strategy 2	B5b Pumper Truck to SFP floor Hose/Spray	High Wind	Seismic	Temp.	Flood
		Connection - SFP Floor	N/A	Design Basis	Yes	Yes
		Required FX Equipment - Pumper Truck XFX100 or 101	Separation	Design Basis	Yes	Yes
		Suction Source - Lake Monticello	Design Basis	Not Cred	Yes	Yes
Containment Cooling						
P	Phase 2 Strategy 1	Onsite FX Equipment to Power RBCU - A Train	High Wind	Seismic	Temp.	Flood
		Connection - XVA9751A	Design Basis	Design Basis	Yes	Yes
		Connection - XBT0104 , XBT0105, & XBT0106 or 107	Separation	Design Basis	Yes	Yes
		Required FX Equipment - (1) CTG XTG0200A or B (CAR)	Cred Phs 3	Design Basis	Yes	Yes
		Required FX Equipment - Fuel Tank and XFR Pump (Yard)	Cred Phs 3	Design Basis	Yes	Yes
		Required FX Equipment - FX UHS Pump Sys	Separation	ASCE 7-10	Yes	Yes
Q	Phase 2 Strategy 2	Onsite FX Equipment to Power RBCU - B Train	High Wind	Seismic	Temp.	Flood
		Connection - XVA9751B	Design Basis	Design Basis	Yes	Yes
		Connection - XBT0104 , XBT0105, & XBT0106 or 107	Separation	Design Basis	Yes	Yes
		Required FX Equipment - (1) CTG XTG0200A or B (CAR)	Cred Phs 3	Design Basis	Yes	Yes
		Required FX Equipment - Fuel Tank and XFR Pump (Yard)	Cred Phs 3	Design Basis	Yes	Yes
		Required FX Equipment - FX UHS Pump Sys	Separation	ASCE 7-10	Yes	Yes
		Suction Source - SW Pond	Design Basis	Design Basis	Yes	Yes
Legend						
Separation	FX Equipment required to implement this strategy is Separated in accordance with NEI 12-06 Section 7.3.1.1.c. This equipment resides in one of three locations - CAR, ERB or FSB. The ERB/FSB are ASCE-7-10 structures, separated from each other by approximately 2500 feet. The CAR is a seismic design basis structure, separated from the FSB by approximately 1300 feet, and separated from the ERB by approximately 2400 feet.					
Cred Phs 3	Onsite CTGs are not specifically protected against High Wind, but will be used if available. Otherwise, containment cooling is not required for up to 30 days. Offsite FLEX Equipment is credited for compliance.					

Table 2 – PWR Portable Equipment From NSRC

Equipment Quantity and Usage							Performance Criteria	
Portable Equipment	Quantity Provided	Core Cooling	SFP Cooling	Containment Cooling/ Integrity	Instrumentation	RCS Inventory		
Medium Voltage Generators	2	X		X	X	X	4.16 kV	1 MW
Low Voltage Generators	1			X	X	X	480VAC	1 MW
High Pressure Injection Pump	1					X	2000psi	60 GPM
S/G RPV Makeup Pump	1	X				X	500psi	500 GPM
Low Pressure / Medium Flow Pump	1		X	X			300psi	2500 GPM
Low Pressure / High Flow Pump	1	X	X	X		X	150psi	5000 GPM
Lighting Towers	3							440,000 Lu
Diesel Fuel Transfer	1	X	X	X	X	X		264 Gal

Table 2 – PWR Portable Equipment From NSRC

Equipment Quantity and Usage							Performance Criteria	
Portable Equipment	Quantity Provided	Core Cooling	SFP Cooling	Containment Cooling/ Integrity	Instrumentation	RCS Inventory		
Mobile Water Treatment	1	X	X			X	500 GPM	
Mobile Boration Skid	1					X	1000 Gal	

Table 3 –Credited Secondary Water Sources

Water Sources	Usable Volume (Gallons)	Applicable Hazard				Time Based on Decay Heat and Prompt Cool Down ¹
		Satisfies Seismic	Satisfies High Winds	Satisfies Low Temp	Satisfies High Temp	
Condensate Storage Tank (CST)	154,062	Y	N	Y	Y	8.4 hours
Service Water Pond	~85 Million	Y	Y	Y	Y	Many Weeks
Lake Monticello via FLEX Pump	Indefinite	N	Y	Y	Y	Indefinite

¹ Assuming RCS Cool Down to 350°F

Table 5 – PWR Portable Equipment Stored On-Site

Equipment ID	Description	Location	Credited Strategy							Performance Criteria
			SG Feed	RCS Makeup	SFP Cooling	Accum. Isolation	Battery Charging	Cont. Cooling	Alt EFW Suction	
XTG0200A XTG0200B	FX 7.2kV Turbine Generators	CAR	X			X	X	X		7.2kV 1 MW
XTK0201	FX Fuel Trailer	YARD	X			X	X	X		792 gallons
XOF0001	FX Fuel Oil Transfer Pump	CAR	X			X	X	X		85 gpm @ 50 psi
XPP0235A XPP0235B	FX UHS Pump Systems	FSB/ERB	X		X			X		2500 gpm @ 300 psi
XUV0006 XUV0007	FX Track Vehicles	FSB/ERB	X		X			X		-
XTR0003 XTR0004	FX Hose Trailers	FSB/ERB	X							-
XPP0237	FX SG Feed Pump	FSB	X							500 gpm @ 500 psi
XPP0238A XPP0238B	FX RCS Makeup Pumps	FSB/ERB		X						60 gpm @ 2000 psi
XEG0100 XEG0107 XEG0108	FX 80 kW Port Generators	FSB/ERB				X	X			480V 80 kW

Table 5 – PWR Portable Equipment Stored On-Site

Equipment ID	Description	Location	Credited Strategy							Performance Criteria
			SG Feed	RCS Makeup	SFP Cooling	Accum. Isolation	Battery Charging	Cont. Cooling	Alt EFW Suction	
XPN5926	FX Port Distr Panel	FSB				X	X			-
XTR0005 XTR0006	FX Cable Trailers	FSB/ERB				X	X			-
XPP0248A XPP0248B	FX Alt EFW Suction Pumps	SWPH							X	500 gpm @ 43 psi
XEG0140 XEG0141	FX Alt EFW Suction Generators	SWPH							X	480V 80 kW
XTK0202 XTK0203	FX Fuel Trailers	FSB/ERB	X	X	X	X	X	X	X	792 gallons
XOF0002 XOF0003	FX Fuel Oil Transfer Pumps	FSB/ERB	X	X	X	X	X	X	X	85 gpm @ 50 psi
ILI09780 ILI09781	FX SFPLI Indicators	AB/YARD			X					-
XFX100	FX Pumper Truck	FSB			X					1750 gpm a 150 psi
XFX101	FX Pumper Truck	ERB			X					2250 gpm @ 150 psi

Table 6 – PWR Portable Support Equipment Stored On-Site

Equipment ID	Description	Location	Support Equipment Function
XMT0001	FX Aluma Base Station and Repeater Tower	ERB	Communications
-	Twelve (12) Portable Satellite Phones	ERB	Communications
XWL0001	FX Wheel Loader	ERB	Debris Clearing
XUV0009 XUV0010	FX Haul Vehicles	-	Equipment Deployment
FLT0001 FLT0002	FX Diesel Lighting Tower	FSB/ERB	Lighting
-	Six (6) Pelican Lighting Sys	FSB/ERB	Lighting
-	Eight (8) LED Work Lights	ERB	Lighting
-	Four (4) Dual Head Light Arrays	ERB	Lighting
XEG0110-XEG0128	Nineteen (19) 5kW Gen-Sets	FSB/ERB	Ventilation/Lighting
XFN0210-XFN0217	Eight (8) 24" Fans	CB/AB/IB/FHB	Ventilation
XFN0222-XFN0225	Four (4) 20" Fans	IB	Ventilation
XFN0231-XFN0237	Seven (7) 24" Fans	FSB/ERB	Ventilation
XTR0001 XTR0002	FX Cargo Trailers	FSB/ERB	Ventilation
XPP0233 XPP0249	FX Portable Electric Sump Pumps	FSB/ERB	Water Removal

3. References

1. Nuclear Regulatory Commission (NRC), SECY-11-0093, *Near-Term Report and Recommendations for Agency Actions Following the Events in Japan*, dated July 21, 2011, Agencywide Documents Access and Management System (ADAMS) Accession Number ML11186A950
2. NRC Order Number EA-12-049, *Issuance of Order to Modify Licenses with Regard to Requirements for Mitigation Strategies for Beyond-Design-Basis External Events*, dated March 12, 2012, ADAMS Accession Number ML12054A735
3. VCSNS Technical Report, TR00080-002, Revision 0, *FLEX Overall Integrated Plan (OIP)*
4. NEI 12-06, *Diverse and Flexible Coping Strategies (FLEX) Implementation Guide*, Revision 2, dated December 2015, ADAMS Accession Number ML16005A625
5. NRC Interim Staff Guidance, JLD-ISG-2012-01, *Compliance with Order EA-12-049, Order Modifying Licenses with Regard to Requirements for Mitigation Strategies for Beyond-Design-Basis External Events*, Revision 1, dated January 22, 2016, ADAMS Accession Number ML15357A163
6. Emergency Operating Procedure, EOP-6.0, Revision 34, *ECA-0.0 Loss of All ESF AC Power*
7. FLEX Support Procedure, FSP-2.0, Revision 0, *Alternate EFW Suction Source*
8. VCSNS Calculation, DC08320-019, Revision 1, *EOP-6/DMG Ultimate Battery Life*
9. VCSNS Calculation, DC00080-003, Revision 2, *FLEX Boration Requirements*
10. VCSNS Calculation, DC08260-001, Revision 0, *FLEX East Strategy Electrical Calculations*
11. VCSNS Calculation, DC08260-002, Revision 0, *FLEX West Strategy Electrical Calculations*
12. FLEX Support Procedure, FSP-20.3.1, Revision 0, *Staging the FX SG Feed Pump Using the East Strategy (East Pen FLEX Header)*
13. FLEX Support Procedure, FSP20.3.2, Revision 0, *Staging the FX SG Feed Pump Using the West Strategy (AB Roll-up Door)*
14. FLEX Support Procedure, FSP-7.0, *Loss of Vital Instrumentation or Control Power*
15. VCSNS Calculation, DC00020-246, Revision 0, *Condensate Storage Tank Depletion Time- Response To INPO IER L1-11-4*
16. Westinghouse Electric Company, WCAP-17601, *Reactor Coolant System Response to the Extended Loss of AC Power Event for Westinghouse, Combustion Engineering and Babcox & Wilcox NSSS Designs*, dated August 2012
17. Westinghouse Electric Company, WCAP-17792, *Emergency Procedure Development Strategies for the Extended Loss of AC Power Event for all Domestic Pressurized Water Reactor Designs*, dated January 2014

18. Pressurized Water Reactor Owners Group, PWROG-14027-P, No. 1 Seal Flow Rate for Westinghouse Reactor Coolant Pumps Following Loss of All AC Power, Task 3: Evaluation of Revised Seal Flow Rate on Time to Enter Reflux Cooling and Time at which the Core Uncovers, dated April 2015
19. VCSNS Technical Report, TR00080-006, Revision 1, *FLEX Timeline Constraints Basis*
20. VCSNS Calculation, DC00080-007, Revision 1, *FX System Flow Model*
21. VCSNS Calculation, DC00080-001, Revision 2, *FLEX Flow Requirements for RBCU, S/G Feed, SFP Make-up and Tank Transfers*
22. Engineering Services Procurement Specification, SP-1007, Revision 1, *FX BSTR/XFER Pumps (XPP0236A and XPP0236B)*
23. PWROG, *PWROG Core Cooling Position Paper*, Revision 0, November, 2012, PA-PSC-0965
24. Engineering Services Procurement Specification, SP-1010, Revision 1, *FX RCS MU Pump (XPP0238)*
25. VCSNS Calculation, DC00080-009, Revision 1, *FX System Flow Model Analysis Case*
26. NRC Order Number EA-12-051, *Issuance of Order to Modify Licenses with Regard to Reliable Spent Fuel Pool Instrumentation*, dated March 12, 2012, ADAMS Accession Number ML12054A679
27. VCSNS Calculation, DC00020-244, Revision 0, *Spent Fuel Pool Time to Boil – Response to INPO IER L1-11-4*
28. Beyond Design Basis Mitigating Guideline, BDMG-1.0, Revision 2, *Spent Fuel Pool Makeup and Spray Strategies*
29. FLEX Support Procedure, FSP-11.0, Revision 0, *Alternate SFP Makeup and Cooling*
30. VCSNS Technical Report, TR00080-003, Revision 2, *FLEX Equipment Ventilation and Habitability Report*
31. VCSNS Calculation, DC00070-007, Revision 2, *SFP and Spray Strategies for BDBMG*
32. AREVA Letter, *Clarification of NRC Questions*, September 2, 2015
33. VCSNS Calculation, DC00080-010, Revision 1, *VCSNS ELAP Containment Response Due to RCS Inventory Loss*
34. FLEX Support Procedure, FSP-12.0, Revision 0, *Alternate Reactor Building Cooling*
35. Regulatory Guide 1.102, *Flood Protection for Nuclear Power Plants*, September 1976
36. ASCE 7-10, *Minimum Design Loads for Buildings and Other Structures*
37. VCSNS Calculation, DC02490-004, Revision 1, *Emergency Response Building Structural Calculations*
38. VCSNS Calculation, DC02490-005, Revision 0, *FLEX Storage Building Structural Calculations*

39. VCSNS Calculation, DC03440-004, Revision 0, *CAR Storage Area Enclosure Structural Design*
40. VCSNS Engineering Change Request (ECR), ECR 51012, *FLEX Alternate EFW Suction Source Diesel Generator Building*
41. VCSNS Engineering Change Request (ECR), ECR 51003B, *FLEX Alternate EFW Suction Source*
42. VCSNS Engineering Change Request (ECR), ECR 51000, *Development of New Plant System to Support FLEX Strategies (Fukushima)*
43. AREVA Document, Document Number 38-9238014-001, *SAFER Response Plan for Virgil C. Summer Nuclear Station*
44. NEI 12-01, *Guideline for Assessing Beyond Design Basis Accident Response Staffing and Communications Capabilities*, Revision 0, dated May 2012, ADAMS Accession Number ML12125A412
45. NEI 12-06 Guidance, *Shutdown / Refueling Modes*, Revision 0, dated September 2013, ADAMS Accession Number ML13269A087
46. Abnormal Operating Procedure, AOP-304.4, Revision 4, *ARG-4, Loss of All ESF AC Power While on RHR Cooling*
47. Station Scheduling Procedure, SSP-004, Revision 4C, *Outage Safety Review Guidelines*
48. Station Scheduling Procedure, SSP-002, Revision 6F, *Planning and Scheduling of Outage Activities*
49. VCSNS Technical Report, TR00080-002, Revision 2, *FLEX Overall Integrated Plan (OIP)*
50. VCSNS Technical Report, TR00080-007, Revision 1, *VCS Unit 1 FLEX Validation Document*
51. Beyond Design Basis Program Manual, Virgil C. Summer Nuclear Station
52. NEI 10-05, *Assessment of On-Shift Emergency Response Organization Staffing and Capabilities*, dated June 2011, ADAMS Accession Number ML111751698