



# Exelon Generation®

Order No. EA-13-109

RS-15-300

December 16, 2015

U.S. Nuclear Regulatory Commission  
ATTN: Document Control Desk  
Washington, DC 20555-0001

LaSalle County Station, Units 1 and 2  
Facility Operating License Nos. NPF-11 and NPF-18  
NRC Docket Nos. 50-373 and 50-374

Subject: Phase 1 (Updated) and Phase 2 Overall Integrated Plan in Response to June 6, 2013 Commission Order Modifying Licenses with Regard to Reliable Hardened Containment Vents Capable of Operation Under Severe Accident Conditions (Order Number EA-13-109)

References:

1. NRC Order Number EA-13-109, "Issuance of Order to Modify Licenses with Regard to Reliable Hardened Containment Vents Capable of Operation Under Severe Accident Conditions," dated June 6, 2013
2. NRC Interim Staff Guidance JLD-ISG-2015-01, "Compliance with Phase 2 Order EA-13-109, Order Modifying Licenses with Regard to Reliable Hardened Containment Vents Capable of Operation under Severe Accident Conditions", Revision 0, dated April 2015
3. NEI 13-02, "Industry Guidance for Compliance With Order EA-13-109, BWR Mark I & II Reliable Hardened Containment Vents Capable of Operation Under Severe Accident Conditions", Revision 1, dated April 2015
4. Exelon Generation Company, LLC's Answer to June 6, 2013, Commission Order Modifying Licenses with Regard to Reliable Hardened Containment Vents Capable of Operation Under Severe Accident Conditions (Order Number EA-13-109), dated June 26, 2013
5. Exelon Generation Company, LLC Phase 1 Overall Integrated Plan in Response to June 6, 2013 Commission Order Modifying Licenses with Regard to Reliable Hardened Containment Vents Capable of Operation Under Severe Accident Conditions (Order Number EA-13-109), dated June 30, 2014 (RS-14-059)
6. Exelon Generation Company, LLC First Six-Month Status Report Phase 1 Overall Integrated Plan in Response to June 6, 2013 Commission Order Modifying Licenses with Regard to Reliable Hardened Containment Vents Capable of Operation Under Severe Accident Conditions (Order Number EA-13-109), dated December 17, 2014 (RS-14-303)
7. Exelon Generation Company, LLC Second Six-Month Status Report Phase 1 Overall Integrated Plan in Response to June 6, 2013 Commission Order Modifying Licenses with Regard to Reliable Hardened Containment Vents Capable of Operation Under Severe Accident Conditions (Order Number EA-13-109), dated June 30, 2015 (RS-15-149)

A153  
NPD

8. NRC letter to Exelon Generation Company, LLC, LaSalle County Station, Units 1 and 2 – Interim Staff Evaluation Relating to Overall Integrated Plan in Response to Phase 1 of Order EA-13-109 (Severe Accident Capable Hardened Vents) (TAC Nos. MF4456 and MF4457), dated March 31, 2015

On June 6, 2013, the Nuclear Regulatory Commission (“NRC” or “Commission”) issued an order (Reference 1) to Exelon Generation Company, LLC (EGC). Reference 1 was immediately effective and directs EGC to require their BWRs with Mark I and Mark II containments to take certain actions to ensure that these facilities have a hardened containment vent system (HCVS) to remove decay heat from the containment, and maintain control of containment pressure within acceptable limits following events that result in loss of active containment heat removal capability while maintaining the capability to operate under severe accident (SA) conditions resulting from an Extended Loss of AC Power (ELAP). Specific requirements are outlined in Attachment 2 of Reference 1.

Reference 1 requires submission of an Overall Integrated Plan (OIP) by June 30, 2014 for Phase 1 of the Order, and an OIP by December 31, 2015 for Phase 2 of the Order. The interim staff guidance (Reference 2) provides direction regarding the content of the OIP for Phase 1 and Phase 2. Reference 2 endorses industry guidance document NEI 13-02, Revision 1 (Reference 3) with clarifications and exceptions identified in Reference 2. Reference 4 provided the EGC initial response regarding reliable hardened containment vents capable of operation under severe accident conditions. Reference 5 provided the LaSalle County Station, Units 1 and 2, Phase 1 OIP. References 6 and 7 provided the first and second six-month status reports pursuant to Section IV, Condition D.3 of Reference 1 for LaSalle County Station.

The purpose of this letter is to provide both the third six-month update for Phase 1 of the Order pursuant to Section IV, Condition D.3, of Reference 1, and the OIP for Phase 2 of the Order pursuant to Section IV, Condition D.2 of Reference 1, for LaSalle County Station, Units 1 and 2. The third six-month update for Phase 1 of the Order is incorporated into the HCVS Phase 1 and Phase 2 overall integrated plan document which provides a complete updated Phase 1 OIP, a list of the Phase 1 OIP open items, and addresses the NRC Interim Staff Evaluation open items for Phase 1 contained in Reference 8. Future six-month status reports will provide the updates for both Phase 1 and Phase 2 OIP implementation in a single status report.

Reference 3, Section 7.0 contains the specific reporting requirements for the Phase 1 and Phase 2 OIP. The information in the Enclosure provides the LaSalle County Station, Units 1 and 2 HCVS Phase 1 and Phase 2 OIP pursuant to Reference 2. The enclosed Phase 1 and Phase 2 OIP is based on conceptual design information. Final design details and associated procedure guidance, as well as any revisions to the information contained in the Enclosure, will be provided in the six-month Phase 1 and Phase 2 OIP updates required by Section IV, Condition D.3, of Reference 1.

This letter contains no new regulatory commitments. If you have any questions regarding this report, please contact David P. Helker at 610-765-5525.

U.S. Nuclear Regulatory Commission  
Integrated Plan Report to EA-13-109  
December 16, 2015  
Page 3

I declare under penalty of perjury that the foregoing is true and correct. Executed on the 16<sup>th</sup> day of December 2015.

Respectfully submitted,

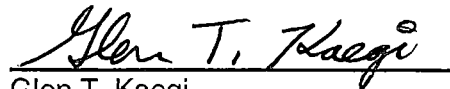

Glen T. Kaegi  
Director - Licensing & Regulatory Affairs  
Exelon Generation Company, LLC

Enclosure:

LaSalle County Station, Units 1 and 2, Overall Integrated Plan for Phase 1 and Phase 2  
Requirements for Reliable Hardened Containment Vent System (HCVS) Capable of  
Operation Under Severe Accident Conditions

cc: Director, Office of Nuclear Reactor Regulation  
NRC Regional Administrator - Region III  
NRC Senior Resident Inspector – LaSalle County Station  
NRC Project Manager, NRR – LaSalle County Station  
Mr. Charles H. Norton, NRR/JLD/PPSD/JOMB, NRC  
Mr. John P. Boska, NRR/JLD/JOMB, NRC  
Illinois Emergency Management Agency - Division of Nuclear Safety

**Enclosure 1**

**LaSalle County Station, Units 1 and 2**

**Overall Integrated Plan for Phase 1 and Phase 2 Requirements for Reliable Hardened  
Containment Vent System (HCVS) Capable of Operation Under Severe Accident Conditions**

(66 pages)



LaSalle County Station Units 1 and 2  
Overall Integrated Plan for Reliable Hardened Vents

**Table of Contents:**

**Introduction**

**Part 1: General Integrated Plan Elements and Assumptions**

**Part 2: Boundary Conditions for Wet Well Vent**

**Part 3: Boundary Conditions for EA-13-109, Option B.2**

**Part 3.1 Boundary Conditions for SAWA**

**Part 3.1A Boundary Conditions for SAWA/SAWM**

**Part 3.1B Boundary Conditions for SAWA/SADV**

**Part 4: Programmatic Controls, Training, Drills and Maintenance**

**Part 5: Implementation Schedule Milestones**

**Attachment 1: HCVS/SAWA Portable Equipment**

**Attachment 2A: Sequence of Events Timeline - HCVS**

**Attachment 2.1.A: Sequence of Events Timeline – SAWA / SAWM**

**Attachment 2.1.B: Sequence of Events Timeline – SADV**

**Attachment 2.1.C: SAWA / SAWM Plant-Specific Datum**

**Attachment 2.1.D: SAWM SAMG Approved Language**

**Attachment 3: Conceptual Sketches**

**Attachment 4: Failure Evaluation Table**

**Attachment 5: References**

**Attachment 6: Changes/Updates to this Overall Integrated Implementation Plan**

**Attachment 7: List of Overall Integrated Plan Open Items**

LaSalle County Station Units 1 and 2  
Overall Integrated Plan for Reliable Hardened Vents

## Introduction

In 1989, the NRC issued Generic Letter 89-16, "Installation of a Hardened Wetwell Vent," (Reference 2) to all licensees of Boiling Water Reactors (BWRs) with Mark I containments to encourage licensees to voluntarily install a hardened wetwell vent. In response, licensees installed a hardened vent pipe from the suppression pool to some point outside the secondary containment envelope (usually outside the reactor building). Some licensees also installed a hardened vent branch line from the drywell.

On March 19, 2013, the Nuclear Regulatory Commission (NRC) Commissioners directed the staff per Staff Requirements Memorandum (SRM) for SECY-12-0157 (Reference 26) to require licensees with Mark I and Mark II containments to "upgrade or replace the reliable hardened vents required by Order EA-12-050 with a containment venting system designed and installed to remain functional during severe accident conditions." In response, the NRC issued Order EA-13-109, *Issuance of Order to Modify Licenses with Regard to Reliable Hardened Containment Vents Capable of Operation under Severe Accidents*, June 6, 2013 (Reference 4). The Order (EA-13-109) requires that licensees of BWR facilities with Mark I and Mark II containment designs ensure that these facilities have a reliable hardened vent to remove decay heat from the containment, and maintain control of containment pressure within acceptable limits following events that result in the loss of active containment heat removal capability while maintaining the capability to operate under severe accident (SA) conditions resulting from an Extended Loss of AC Power (ELAP).

The Order requirements are applied in a phased approach where:

- "Phase 1 involves upgrading the venting capabilities from the containment wetwell to provide reliable, severe accident capable hardened vents to assist in preventing core damage and, if necessary, to provide venting capability during severe accident conditions." (Completed "no later than startup from the second refueling outage that begins after June 30, 2014, or June 30, 2018, whichever comes first.")
- "Phase 2 involves providing additional protections for severe accident conditions through installation of a reliable, severe accident capable drywell vent system or the development of a reliable containment venting strategy that makes it unlikely that a licensee would need to vent from the containment drywell during severe accident conditions." (Completed "no later than startup from the first refueling outage that begins after June 30, 2017, or June 30, 2019, whichever comes first.")

The NRC provided an acceptable approach for complying with Order EA-13-109 through Interim Staff Guidance (ISG) JLD-ISG-2013-02, issued in November 2013 (Reference 6), and JLD-ISG-2015-01, issued in April 2015 (Reference 31). These ISGs endorse the compliance approach presented in NEI 13-02 Revisions 0 and 1, *Compliance with Order EA-13-109, Severe Accident Reliable Hardened Containment Vents* (Reference 9 and 37), with clarifications. Except in those cases in which a licensee proposes an acceptable alternative method for complying with Order EA-13-109, the NRC staff will use the methods described in these ISGs to evaluate licensee compliance as presented in submittals required in Order EA-13-109.

The Order also requires submittal of an overall integrated plan which will provide a description of how the requirements of the Order will be achieved. This document provides the Overall Integrated Plan (OIP) for complying with Order EA-13-109 using the methods described in NEI 13-02 and endorsed by NRC

LaSalle County Station Units 1 and 2  
Overall Integrated Plan for Reliable Hardened Vents

JLD-ISG-2013-02 and JLD-ISG-2015-01. Six month progress reports will be provided consistent with the requirements of Order EA-13-109.

The submittals required are:

- OIP for Phase 1 of EA-13-109 was required to be submitted by Licensees to the NRC by June 30, 2014. The NRC requires periodic (6-month) updates for the HCVS actions being taken. The first update for Phase 1 was due December 2014, with the second due June 2015.
- OIP for Phase 2 of EA-13-109 is required to be submitted by Licensees to the NRC by December 31, 2015. It is expected the December 2015 six month update for Phase 1 will be combined with the Phase 2 OIP submittal by means of a combined Phase 1 and 2 OIP.
- Thereafter, the 6-month updates will be for both the Phase 1 and Phase 2 actions until complete, consistent with the requirements of Order EA-13-109.

**Note:** Per the Generic OIP, at the Licensee's option, the December 2015 six month update for Phase 1 may be independent of the Phase 2 OIP submittal, but will require separate six month updates for Phase 1 and 2 until each phase is in compliance. Exelon has not selected this option.

The LaSalle County Station (LSCS) venting actions for the EA-13-109, Phase 1 severe accident capable venting scenario can be summarized by the following:

- The Hardened Containment Vent System (HCVS) will be initiated via manual action from the Main Control Room (MCR) and/or from the Remote Operating Station (ROS) at the appropriate time based on procedural guidance in response to plant conditions from observed or derived symptoms. Once initiated, HCVS operation from the ROS is limited to the Order EA-13-109 Requirement 1.2.5. Specifically, in case the HCVS flow path valves or the Argon purge flow cannot be operated from the MCR, the ROS provides a back-up means of operating the valve(s) that does not require electrical power or control circuitry.
- The operators will utilize Containment Parameters of Pressure and Suppression Pool Level from the MCR instrumentation to monitor effectiveness of the venting actions.
- The vent operation will be monitored by HCVS valve position, temperature and effluent radiation levels.
- The HCVS motive force will be monitored and have the capacity to operate for 24 hours with installed equipment. Replenishment of the motive force will be by use of portable equipment prior to the installed motive force being exhausted.
- Venting actions will be capable of being maintained for a sustained period of up to 7 days.

The Phase 2 actions can be summarized as follows:

- Utilization of Severe Accident Water Addition (SAWA) to initially inject water into the Reactor Pressure Vessel (RPV). Although SAWA to the Drywell (DW) is an option, Exelon has selected SAWA injection to the RPV. Utilization of Severe Accident Water Management (SAWM) to control injection and Suppression Pool level to ensure the HCVS (Phase 1) wetwell vent (SAWV) will remain functional for the removal of decay heat from containment.

LaSalle County Station Units 1 and 2  
Overall Integrated Plan for Reliable Hardened Vents

- Ensure that the decay heat can be removed from the containment for seven (7) days using the HCVS or describe the alternate method(s) to remove decay heat from the containment from the time the HCVS is no longer functional until alternate means of decay heat removal are established that make it unlikely the drywell vent will be required for DW pressure control.
- The SAWA and SAWM actions will be manually activated and controlled from areas that are accessible during severe accident conditions.
- Parameters measured should be Drywell pressure, Suppression Pool level, SAWA flowrate and the HCVS parameters listed above.

**Note:** Although EA-13-109 Phase 2 allows selecting SAWA and a Severe Accident Capable Drywell Vent (SADV) strategy, Exelon has selected SAWA and SAWM.

## **Part 1: General Integrated Plan Elements and Assumptions**

### **Extent to which the guidance, JLD-ISG-2013-02, JLD-ISG-2015-01, and NEI 13-02, are being followed. Identify any deviations.**

*Include a description of any alternatives to the guidance. A technical justification and basis for the alternative needs to be provided. This will likely require a pre-meeting with the NRC to review the alternative.*

#### **Ref: JLD-ISG-2013-02 / JLD-ISG-2015-01**

Compliance will be attained for LSCS with no known deviations to the guidelines in JLD-ISG-2013-02, JLD-ISG-2015-01, and NEI 13-02 for each phase as follows:

- The Hardened Containment Vent System (HCVS) will be comprised of installed and portable equipment and operating guidance:
  - Severe Accident Wetwell Vent (SAWV) – Permanently installed vent from the Suppression Pool to the top of the Reactor Building.
  - Severe Accident Water Addition (SAWA) – A combination of permanently installed and portable equipment to provide a means to add water to the RPV following a severe accident and monitor system and plant conditions.
  - Severe Accident Water Management (SAWM) strategies and guidance for controlling the water addition to the RPV for the sustained operating period (Reference Attachment 2.1.D).
- Unit 2 Phase 1 (wetwell): Implemented by the startup from the second refueling outage that begins after June 30, 2014, or June 30, 2018, whichever comes first. Currently scheduled for 1Q2017.
- Unit 1 Phase 1 (wetwell): Implemented by the startup from the second refueling outage that begins after June 30, 2014, or June 30, 2018, whichever comes first. Currently scheduled for 1Q2018.
- Unit 1 Phase 2: (alternate strategy): Implemented by the startup from the first refueling outage that begins after June 30, 2017, or June 30, 2019, whichever comes first. Currently scheduled for 1Q2018.
- Unit 2 Phase 2 (alternate strategy): Implemented by the startup from the first refueling outage that begins after June 30, 2017, or June 30, 2019, whichever comes first. Currently scheduled for 1Q2019.

If deviations are identified at a later date, then the deviations will be communicated in a future 6-month update following identification.

### **State Applicable Extreme External Hazard from NEI 12-06, Section 4.0-9.0**

*List resultant determination of screened in hazards from the EA-12-049 Compliance.*

#### **Ref: NEI 13-02 Section 5.2.3 and D.1.2 / Reference 1**

The following extreme external hazards screen in for LSCS:

- Seismic; severe storms with high winds; snow, ice and extreme cold; and high temperatures.

The following extreme external hazards screen out for LSCS:

- External Flooding

## **Part 1: General Integrated Plan Elements and Assumptions**

### **Key Site assumptions to implement NEI 13-02 strategies.**

*Provide key assumptions associated with implementation of HCVS Phase 1 Strategies.*

**Ref: NEI 13-02, Revision 1, Section 2 and NEI 12-06, Revision 0**

Mark I/II Generic HCVS Related Assumptions:

Applicable EA-12-049 (Reference 3) assumptions:

- 049-1. Assumed initial plant conditions are as identified in NEI 12-06, §3.2.1.2, items 1 and 2 (Reference 8).
- 049-2. Assumed initial conditions are as identified in NEI 12-06, §3.2.1.3, items 1, 2, 4, 5, 6 and 8 (Reference 8).
- 049-3. Assumed reactor transient boundary conditions are as identified in NEI 12-06, §3.2.1.4, items 1, 2, 3 and 4 (Reference 8).
- 049-4. No additional events or failures are assumed to occur immediately prior to or during the event, including security events, except for the failure of Reactor Core Isolation Cooling (RCIC) or High Pressure Coolant Injection (HPCI) (Reference NEI 12-06, §3.2.1.3, item 9 [8]).
- 049-5. At time=0 the event is initiated and all rods insert and no other event beyond a common site ELAP is occurring at any or all of the units.
- 049-6. At time=1 hour (time sensitive at a time greater than 1 hour) an ELAP is declared and actions begin as defined in EA-12-049 compliance.
- 049-7. DC power and distribution can be credited for the duration determined per the EA-12-049 (FLEX) methodology for battery usage (greater than approximately 6 hours with a calculation limiting value of approximately 8 hrs.) (NEI 12-06, §3.2.1.3, item 8).
- 049-8. Deployment resources are assumed to begin arriving at hour 6 and fully staffed by 24 hours.
- 049-9. All activities associated with EA-12-049 (FLEX, [3]) that are not specific to implementation of the HCVS, including such items as debris removal, communication, notifications, Spent Fuel Pool (SFP) level and makeup, security response, opening doors for cooling, and initiating conditions for the events, can be credited as previously evaluated for FLEX. (Refer to assumption 109-2 below for clarity on SAWA.) (HCVS-FAQ-11 [34])

Applicable EA-13-109 (Reference 4) generic assumptions:

- 109-1. Site response activities associated with EA-13-109 actions are considered to have no access limitations associated with radiological conditions while Reactor Pressure Vessel (RPV) level is above 2/3 core height (core damage is not expected). This is further addressed in HCVS-FAQ-12 [35].
- 109-2. Portable equipment can supplement the installed equipment at or after 24 hours provided the portable equipment credited meets the criteria applicable to the HCVS. An example is use of FLEX portable compressed air supply equipment that is credited to recharge compressed gas lines for HCVS components after 24 hours. The FLEX portable air supply used must be demonstrated to meet the "SA Capable" criteria that are defined in NEI 13-02 Section 4.2.4.2 and Appendix D Section D.1.3 (Reference 9). This assumption does not apply to Phase 2 SAWA/SAWM because SAWA equipment needs to be connected and placed in service within 8 hours from the time of the loss of RPV injection (Reference HCVS-FAQ-12 [35]).
- 109-3. SFP Level is maintained with either on-site or off-site resources such that the SFP does not contribute to the

## **Part 1: General Integrated Plan Elements and Assumptions**

analyzed source term (Reference HCVS-FAQ-07 [18]).

- 109-4. Existing containment components design and testing values are governed by existing plant containment criteria (e.g., Appendix J) and are not subject to the testing criteria from NEI 13-02 (Reference HCVS-FAQ-05 [16] and NEI 13-02, §6.2.2 [9]).
- 109-5. Classical design basis evaluations and assumptions are not required when assessing the operation of the HCVS. The reason that this is not required is that the order postulates an unsuccessful mitigation of an event such that an ELAP progresses to a severe accident with ex-vessel core debris that classical design basis evaluations are intended to prevent (Reference NEI 13-02, §2.3.1 [9]).
- 109-6. HCVS manual actions require minimal operator steps and can be performed in the postulated thermal radiological environment at the location of the step(s) (e.g., load stripping, control switch manipulation, valving-in argon bottles) are acceptable to obtain HCVS venting dedicated functionality (Reference HCVS-FAQ-01 [12]). This assumption does not apply to Phase 2 SAWA/SAWM because SAWA equipment needs to be connected and placed in service within 8 hours from the time of the loss of RPV injection and will require more than minimal operator action. These actions are, however, similar to the current Phase 2 Staffing Assessment, and therefore the staffing assessment remains valid.
- 109-7. HCVS dedicated equipment is defined as vent process elements that are required for the HCVS to function in an ELAP event that progresses to core melt ex-vessel (Reference HCVS-FAQ-02 [13] and White Paper HCVS-WP-01 [21]). This assumption does not apply to Phase 2 SAWA/SAWM because SAWA equipment is not dedicated to HCVS but shared to support FLEX functions. This is further addressed in HCVS-FAQ-11 [34].
- 109-8. Use of MAAP Version 4 or higher provides adequate assurance of the plant conditions (e.g., RPV water level, temperatures, etc.) assumed for Order EA-13-109 [4] and SA HCVS operation (Reference FLEX MAAP Endorsement [29]). Additional analysis using RELAP5/MOD 3, GOTHIC, and MICROSIELD, etc., are acceptable methods for evaluating environmental conditions in other portions of the plant, provided that the specific version utilized is documented in the analysis. MAAP Version 5 was used to develop EPRI Technical Report 3002003301 to support drywell temperature response to SAWA under severe accident conditions.
- 109-9. NRC Published Accident evaluations (e.g., SOARCA, SECY-12-0157, NUREG 1465) as related to Order EA-13-109 conditions are acceptable as references (Reference NEI 13-02, §8 [9]).
- 109-10. Permanent modifications installed or planned per EA-12-049 are assumed implemented and may be credited for use in Order EA-13-109 response.
- 109-11. This Overall Integrated Plan is based on Emergency Operating Procedure (EOP) changes consistent with Emergency Procedures Guidelines/Severe Accident Guidelines (EPG/SAGs) Revision 3 as incorporated per the site's EOP/Severe Accident Procedure (SAP) procedure change process. This assumption does not apply to Phase 2 SAWM because SAWM is not part of revision 3 (Refer to Attachment 2.1.D for SAWM SAMG changes approved by the BWROG Emergency Procedures Committee.).
- 109-12. Under the postulated scenarios of Order EA-13-109 [4], the Main Control Room is adequately protected from excessive radiation dose as per General Design Criterion (GDC) 19 in 10CFR50 Appendix A and no further evaluation of its use as the preferred HCVS control location is required provided that the HCVS routing is a sufficient distance away from the MCR or is shielded to minimize impact to the MCR dose. In addition, adequate protective clothing and respiratory protection are available if required to address

## **Part 1: General Integrated Plan Elements and Assumptions**

contamination issues (Reference HCVS-FAQ-01 [12] and HCVS-FAQ-09 [20]).

- 109-13. The suppression pool/wetwell of a BWR Mark I/II containment is considered to be bounded by assuming a saturated environment for the duration of the event response because of the water/steam interactions.
- 109-14. RPV depressurization is directed by the EPGs in all cases prior to entry into the SAGs (Reference NEI 13-02 Rev 1 §I.1.3 [37]).
- 109-15. The Severe Accident impacts are assumed on one unit only due to the site compliance with NRC Order EA-12-049. However, each BWR Mk I and II, under the assumptions of NRC Order EA-13-109, ensures the capability to protect containment exists for each unit (Reference HCVS-FAQ-01 [12]). This is further addressed in HCVS-FAQ-10 [33].

### Plant Specific HCVS Related Assumptions/Characteristics:

- LSCS-1 EA-12-049 (FLEX) actions to restore power are sufficient to ensure continuous operation of non-dedicated containment instrumentation identified on Page 31 of the OIP.
- LSCS-2 Modifications that allow a FLEX generator to recharge the HCVS battery are assumed to have been installed such that a FLEX generator can be credited for HCVS operation at or beyond the initial 24-hour sustained operational period.
- LSCS-3 The rupture disk will be manually breached from the MCR if required for anticipatory venting during an ELAP.
- LSCS-4 The Plant layout of buildings and structures are depicted in Figures 3B and 3C. Note the Main Control Room is located in the Auxiliary Building. The Auxiliary Building is seismically qualified. The HCVS vent routing external to the Reactor Building is indicated on Figure 3C, and has both horizontal and vertical runs.
- LSCS-5 The HCVS external piping, located in its entirety more than 30 feet above ground level, consists solely of large bore (14-inches nominal diameter) piping and its piping supports, and the piping has less than 300 square feet of cross section. The HCVS external piping meets the reasonable protection requirements of HCVS-WP-04. The external structure used to support the HCVS piping is analyzed to the LSCS design basis tornado missiles to preclude a failure of the tower due to tornado winds and missiles, which could otherwise fall and damage safety related equipment (i.e., II/I).



## **Part 2: Boundary Conditions for Wetwell Vent**

**Provide a sequence of events and identify any time or environmental constraint required for success including the basis for the constraint.**

*HCVS Actions that have a time constraint to be successful should be identified with a technical basis and a justification provided that the time can reasonably be met (for example, action to open vent valves).*

*HCVS Actions that have an environmental constraint (e.g. actions in areas of High Thermal stress or High Dose areas) should be evaluated per guidance.*

*Describe in detail in this section the technical basis for the constraints identified on the sequence of events timeline attachment.*

*See attached sequence of events timeline (Attachment 2A).*

**Ref: EA-13-109, Section 1.1.1, 1.1.2, 1.1.3 / NEI 13-02, Section 4.2.5, 4.2.6. 6.1.1**

Exelon plans to install a WW flow path on each unit at LSCS that has two dedicated primary containment isolation valves and a downstream rupture disc that is routed totally separate from the other unit and with no interconnected systems except the common external support tower. The discharge from each unit is routed through a unit-specific pipe that discharges above the Reactor Building roof. Dedicated motive power (pressurized Argon gas) for HCVS valves will be unit-specific, and dedicated DC power (single battery rack and charger) for HCVS components will be common to both units, but not shared with any other function nor reliant on FLEX. Existing containment instrumentation (pressure and WW level) are not considered HCVS components and power will be maintained through the actions for EA-12-049 (FLEX).

The operation of the HCVS will be designed to minimize the reliance on operator actions in response to hazards listed in Part 1. Initial operator actions will be completed by trained plant personnel and will include the capability for remote-manual initiation from the HCVS control station. A list of the remote manual actions performed by plant personnel to open the HCVS vent path can be found in the following table (Table 2-1). A HCVS ELAP Failure Evaluation table, which shows alternate actions that can be performed, is included in Attachment 4.

LaSalle County Station Units 1 and 2  
Overall Integrated Plan for Reliable Hardened Vents

## **Part 2: Boundary Conditions for Wetwell Vent**

**Table 2-1 HCVS Remote Manual Actions**

Primary Action	Primary Location / Component	Notes
1. Energize the HCVS power supply to the HCVS components	MCR	This action is not required for operation at the ROS.
2. Isolate the HCVS leak-off path via three-way manual OR solenoid-operated valve (SOV)	ROS or MCR	This action is needed only once for initialization of the HCVS. Required step to prevent venting into the Reactor Building through the small leak-off path.
3. Open manual/SOV isolation valve on Argon motive gas supply	ROS or MCR	This action is needed only once for initialization of the HCVS.
4. Open manual/SOV isolation valve on Argon purge gas supply	ROS or MCR	This action is needed only once for initialization of the HCVS.
5. Breach the Rupture Disc by opening the Argon Purge Line for the specified amount of time	MCR	For severe accident conditions, containment pressure will be sufficient to breach the rupture disc and may be used as an alternate method of bursting the rupture disc.
6. Open Wetwell PCIVs	Key locked hand switches in the MCR panel	Alternate control via manual valves at the ROS.
7. Align generator to HCVS battery charger.	Near ROS	Prior to depletion of the HCVS battery supply, actions will be required to recharge the battery.
8. Replace Argon motive power bottles or align portable compressor	Air compressor will be located at the ROS.	Prior to depletion of the pneumatic sources, actions will be required to connect back-up sources at a time greater than 24 hours.

**ISE Open Item - 1:** Determine how HCVS DC Power and/or Motive Power will be disabled during normal operation to provide assurances against inadvertent operation, but to also minimize actions to enable operation following an ELAP.

Attachment 2A, Sequence of Events Timeline, was developed to identify required operator response times and potential environmental constraints. This timeline is based upon the following three sequences:

1. Sequence 1 is based upon the action response times developed for FLEX when utilizing anticipatory venting in a BDBEE without core damage.
2. Sequence 2 is based on SECY-12-0157 [26] long-term station blackout (LTSBO) (or ELAP) with a failure of RCIC after a black start where failure occurs because of subjectively assuming over injection.
3. Sequence 3 is based on NUREG-1935 (SOARCA [24]) results for a prolonged SBO (or ELAP) with

## **Part 2: Boundary Conditions for Wetwell Vent**

loss of RCIC case without black start.

The following is a discussion of time constraints identified in Attachment 2A for the 3 timeline sequences identified above:

- Within 5.4 Hours, initiate use of Hardened Containment Vent System (HCVS) per site procedures to maintain containment parameters below design limits and within the limits that allow continued use of RCIC - Reliable operation of HCVS will be met because HCVS meets the seismic requirements identified in NEI 13-02, will be powered by DC power from a dedicated power source, and HCVS valves are supplied with motive force from portable Argon bottles. HCVS controls and instrumentation will be DC powered. Valves will be operable from the HCVS control panel in the MCR, or at the ROS. DC power and motive gas will be available for 24 hours from dedicated permanent sources. Containment indications will be initially powered from existing IE Station battery and maintained by FLEX generators. Thus, initiation of the HCVS from the MCR or the Remote Operating Station within 5.4 hours is acceptable because the actions can be performed any time after declaration of an ELAP until the venting is needed at 5.4 hours for Beyond Design Basis External Events (BDBEE) venting. This action can also be performed for SA HCVS operation which occurs at a time further removed from an ELAP declaration as shown in Attachment 2.
- Within 24 hours, the permanently installed Argon bottles at the ROS for valve operation will be replaced, as required, to maintain sustained operation or alternatively a portable compressor will be connected at the ROS. This can be performed at any time prior to 24 hours to ensure adequate capacity is maintained; therefore, this time constraint is not limiting.
- Within 24 hours, the permanently installed Argon bottles at the ROS for vent purge will be replaced, as required, to maintain sustained operation. Note that Argon purging is required only if the event progresses to severe accident conditions.
- Within 24 hours, a portable generator will be installed and connected to recharge the dedicated HCVS power supply to maintain sustained operation. This can be performed any time prior to 24 hours; therefore, this time constraint is not limiting. Modifications will be implemented to facilitate the connections and operational actions required to supply power within 24 hours which is acceptable because the actions can be performed any time after declaration of an ELAP until the repowering is needed at greater than 24 hours.
- Current LSCS 1E battery durations are calculated to last 8 hours. FLEX DG will be staged beginning at approximately the 6-hour time frame (Reference FLEX OIP [1]). Within two (2) hours of staging, the FLEX DG will be in service. Thus, the FLEX DGs will be available to be placed in service at any point after 8 hours as required to supply power to containment parameters (containment pressure and WW level). A FLEX DG will be maintained in on-site FLEX storage buildings. The DG will be transferred and staged via haul routes and staging areas evaluated for impact from external hazards.

Discussion of radiological, temperature, other environmental constraints identified in Attachment 2A

- Actions to initiate HCVS operation are taken from the MCR or from the ROS in the BOP Auxiliary area. Both locations have significant shielding and/or physical separation from radiological sources. Non-radiological habitability for the MCR is being addressed as part of the LSCS FLEX response.
- Before the end of the initial 24-hour period, replenishment of the dedicated HCVS DC power and compressed gas (for motive power and vent purging) will occur at the ROS. The selection of the ROS

## **Part 2: Boundary Conditions for Wetwell Vent**

location will take into account the SA temperature and radiation condition to ensure access to the ROS is maintained. The design will allow replenishment with minimal actions.

**ISE Open Item - 4:** Confirm that the ROS will be in an accessible area following a SA.

### **Provide Details on the Vent characteristics**

#### **Vent Size and Basis (EA-13-109, Section 1.2.1 / NEI 13-02, Section 4.1.1)**

*What is the plants licensed power? Discuss any plans for possible increases in licensed power (e.g. MUR, EPU). What is the nominal diameter of the vent pipe in inches? Is the basis determined by venting at containment design pressure, PCPL, or some other criteria (e.g. anticipatory venting)?*

#### **Vent Capacity (EA-13-109, Section 1.2.1 / NEI 13-02, Section 4.1.1)**

*Indicate any exceptions to the 1% decay heat removal criteria, including reasons for the exception. Provide the heat capacity of the suppression pool in terms of time versus pressurization capacity, assuming suppression pool is the injection source.*

#### **Vent Path and Discharge (EA-13-109, Section 1.1.4, 1.2.2 / NEI 13-02, Section 4.1.3, 4.1.5 and Appendix F/G)**

*Provides a description of Vent path, release path, and impact of vent path on other vent element items.*

#### **Power and Pneumatic Supply Sources (EA-13-109, Section 1.2.5 & 1.2.6 / NEI 13-02, Section 4.2.3, 2.5, 4.2.2, 4.2.6, 6.1)**

*Provide a discussion of electrical power requirements, including a description of dedicated 24 hour power supply from permanently installed sources. Include a similar discussion as above for the valve motive force requirements. Indicate the area in the plant from where the installed/dedicated power and pneumatic supply sources are coming.*

*Indicate the areas where portable equipment will be staged after the 24 hour period, the dose fields in the area, and any shielding that would be necessary in that area.*

#### **Location of Control Panels (EA-13-109, Section 1.1.1, 1.1.2, 1.1.3, 1.1.4, 1.2.4, 1.2.5 / NEI 13-02, Section 4.1.3, 4.2.2, 4.2.3, 4.2.5, 4.2.6, 6.1.1. and Appendix F/G)**

*Indicate the location of the panels, and the dose fields in the area during severe accidents and any shielding that would be required in the area. This can be a qualitative assessment based on criteria in NEI 13-02.*

#### **Hydrogen (EA-13-109, Section 1.2.10, &1.2.11, and 1.2.12 / NEI 13-02, Section 2.3,2.4, 4.1.1, 4.1.6, 4.1.7, 5.1, & Appendix H)**

*State which approach or combination of approaches the plant will take to address the control of flammable gases, clearly demarcating the segments of vent system to which an approach applies.*

#### **Unintended Cross Flow of Vented Fluids (EA-13-109, Section 1.2.3, 1.2.12 / NEI 13-02, Section 4.1.2, 4.1.4, 4.1.6 and Appendix H)**

*Provide a description to eliminate/minimize unintended cross flow of vented fluids with emphasis on interfacing ventilation systems (e.g. SGTS). What design features are being included to limit leakage through interfacing valves or Appendix J type testing features?*

## **Part 2: Boundary Conditions for Wetwell Vent**

### **Prevention of Inadvertent Actuation (EA-13-109, Section 1.2.7/NEI 13-02, Section 4.2.1)**

*The HCVS shall include means to prevent inadvertent actuation.*

### **Component Qualifications (EA-13-109, Section 2.1 / NEI 13-02, Section 5.1)**

*State qualification criteria based on use of a combination of safety related and augmented quality dependent on the location, function and interconnected system requirements.*

### **Monitoring of HCVS (Order Elements 1.1.4, 1.2.8, 1.2.9/NEI 13-02, Section 4.1.3, 4.2.2, 4.2.4, and Appendix F/G)**

*Provide a description of instruments used to monitor HCVS operation and effluent. Power for an instrument will require the intrinsically safe equipment installed as part of the power sourcing.*

### **Component reliable and rugged performance (EA-13-109, Section 2.2 / NEI 13-02, Section 5.2, 5.3)**

*HCVS components including instrumentation should be designed, as a minimum, to meet the seismic design requirements of the plant.*

*Components including instrumentation that are not required to be seismically designed by the design basis of the plant should be designed for reliable and rugged performance that is capable of ensuring HCVS functionality following a seismic event. (Reference JLD-ISG-2012-01 and JLD-ISG-2012-03 for seismic details.)*

*The components including instrumentation external to a seismic category 1 (or equivalent building or enclosure should be designed to meet the external hazards that screen in for the plant as defined in guidance NEI 12-06 as endorsed by JLD-ISG-12-01 for Order EA-12-049.*

*Use of instruments and supporting components with known operating principles that are supplied by manufacturers with commercial quality assurance programs, such as ISO9001. The procurement specifications shall include the seismic requirements and/or instrument design requirements, and specify the need for commercial design standards and testing under seismic loadings consistent with design basis values at the instrument locations.*

*Demonstration of the seismic reliability of the instrumentation through methods that predict performance by analysis, qualification testing under simulated seismic conditions, a combination of testing and analysis, or the use of experience data. Guidance for these is based on sections 7, 8, 9, and 10 of IEEE Standard 344-2004, "IEEE Recommended Practice for Seismic Qualification of Class 1E Equipment for Nuclear Power Generating Stations," or a substantially similar industrial standard could be used.*

*Demonstration that the instrumentation is substantially similar in design to instrumentation that has been previously tested to seismic loading levels in accordance with the plant design basis at the location where the instrument is to be installed (g-levels and frequency ranges). Such testing and analysis should be similar to that performed for the plant licensing basis.*

## **Part 2: Boundary Conditions for Wetwell Vent**

### **Vent Size and Basis**

The HCVS wetwell path is designed for venting steam/energy at a nominal capacity of 1% of 4067 MWt at a drywell pressure of 45 psig accounting for downcomer submergence and assuming nominal suppression pool water level at the initial event conditions. Note: The thermal power assumes a power uprate of approximately 12.5% above the currently licensed thermal power of 3546 MWt. Although a power uprate is not planned for LSCS at this time, the HCVS wetwell path will be designed for the higher thermal power for any future uprates. This pressure is the lower of the containment design pressure and the PCPL value. The size of the wetwell portion of the HCVS will provide adequate capacity to meet or exceed the Order criteria.

### **Vent Capacity**

The 1% value at LSCS assumes that the suppression pool pressure suppression capacity is sufficient to absorb the decay heat generated during the first 3 hours. The vent would then be able to prevent containment pressure from increasing above the containment design pressure. As part of the detailed design, the duration of suppression pool decay heat absorption capability will be confirmed.

**ISE Open Item – 5:** Determine wetwell line size to meet 1% venting criteria and confirm suppression pool heat capacity.

### **Vent Path and Discharge**

The Phase 1 HCVS vent path at LSCS will consist of a WW vent on each unit. The WW vent lines will branch off of the existing DW/WW vacuum breaker piping (which is an extension of primary containment) and each will have two dedicated primary containment isolation valves (PCIVs) and a downstream rupture disc. The PCIVs will be installed outside the primary containment and as close to the primary containment as possible. The LaSalle Safety Evaluation Report (SER) NUREG-0519 (Reference 38), Section 6, Page 6-36, Item 4 states that an acceptable alternative to General Design Criteria (GDC) 55 and 56 is to have two PCIVs in series outside containment when the location of a valve inside containment would subject it to more severe environmental conditions (i.e., suppression pool dynamic loads), and it would not be easily accessible for inspection. Both of these conditions would be true in this case; therefore, locating both valves outside of containment is acceptable per the station's licensing bases.

The WW vent line is routed horizontally and vertically through the Reactor Building and then penetrates the Reactor Building wall. The WW line then is routed horizontally to a common support tower which supports both units' vertical runs of pipe up the Reactor Building wall to a point above the roof. There are no interconnected systems except the common support tower and there is no sharing of any flow path between the two units.

The HCVS discharge path will be routed to a point above any plant structure except for the LSCS vent stack. It is impractical to raise the HCVS above the vent stack, as the stack is twice the height of the Reactor Building [27]. The HCVS discharge point is just above that unit's Reactor Building and will follow the guidance of FAQ-HCVS-04 (Reference 15) such that the release point will vent high enough and away from emergency ventilation system intake and exhaust openings, main control room location, location of HCVS portable equipment, access routes required following an ELAP and BDBEE, and emergency response facilities to the extent reasonably possible; however, these must be considered in conjunction with other design criteria (e.g., flow capacity) and pipe routing limitations, to the degree practical. The current routing for LSCS is considered to be the best option considering all of the aforementioned items.

The current design for the external piping meets the reasonable tornado missile protection criteria of HCVS-

## **Part 2: Boundary Conditions for Wetwell Vent**

WP-04. The external piping consists solely of large bore piping and its supports, is more than 30 feet above ground level, and the pipe has less than 300 square feet of cross section.

### **Power and Pneumatic Supply Sources**

All electrical power required for operation of HCVS components will be from a dedicated HCVS DC battery source with permanently installed capacity for the first 24 hours and design provisions for recharging to maintain sustained operation. Motive (pneumatic) power to the HCVS valves is provided by a dedicated bank of Argon gas bottles with permanently installed capacity for the first 24 hours and design provisions for replacing bottles and/or connecting a portable compressor to maintain sustained operation. The initial stored motive air/gas will be designed for a minimum of 8 vent cycles for the HCVS valves for the first 24 hours (Reference 22). The 8 vent cycles is defined as initially opening all valves in the WW flow path, and then closing and reopening one of the valves in the flow path 7 times. The HCVS flow path valves are air-operated valves (AOVs) which are air-to-open and spring-to-close. Opening the valves from the HCVS control panel located in the MCR requires energizing DC-powered solenoid-operated valves (SOVs), which provide motive air/gas to the actuator. Additional analysis may be performed to reduce the number of vent cycles in the first 24 hours.

An assessment of temperature and radiological conditions will be performed to ensure that operating personnel can safely access and operate controls at the Remote Operating Station based on time constraints listed in Attachment 2.

All permanently installed HCVS equipment, including any connections required to supplement the HCVS operation during an ELAP (i.e., DC power and motive force [pressurized Argon/air]) will be located in areas reasonably protected from defined hazards listed in Part 1 of this report.

All valves required to open the flow path will be designed for remote manual operation following an ELAP, such that the primary means of valve manipulation does not rely on use of a handwheel, reach-rod or similar means that requires close proximity to the valve (Reference FAQ HCVS-03 [14]). The preferred method is opening the AOVs from the MCR through the control switch that energizes each AOV's associated motive gas supply SOV. The back-up method is from the ROS by repositioning manual valves which bypass the SOVs on the motive gas supply line: this allows opening and closing of a valve from the ROS without reliance on any electrical power or control circuit. Accessibility to the ROS will be verified during the detailed design phase.

Any supplemental connections will be pre-engineered to minimize man-power resources and address environmental concerns. Required portable equipment will be reasonably protected from screened in hazards listed in Part 1 of this OIP.

Access to the locations described above will not require temporary ladders or scaffolding.

### **Location of Control Panels**

The HCVS design allows initiating and then operating and monitoring the HCVS from the Main Control Room (MCR) and in addition, opening vent valve(s) from the ROS in case of a DC circuit failure. The tentative location for the ROS is the BOP Auxiliary area. The MCR location is protected from adverse natural phenomena and the normal control point for Plant Emergency Response actions. The ROS will be evaluated to ensure acceptable temperature and dose consequences. Note: Some components may not be directly located on the ROS, but are in the immediate area. Thus, reference to the ROS herein includes the equipment in the immediate area.

## **Part 2: Boundary Conditions for Wetwell Vent**

### **Hydrogen**

As required by EA-13-109, Section 1.2.11, the HCVS design will include an Argon purge system that will be connected just downstream of the second PCIV. It will be designed to prevent hydrogen detonation downstream of the second PCIV. The Argon purge system will have a switch in the MCR to open the purge supply SOV for the designated time, but the design also includes a manual bypass for the SOV for local operation at the ROS in case of a DC power or control circuit failure. The Argon purge will only be utilized following severe accident conditions when hydrogen is being vented. The installed capacity for the Argon purge system will be sized for a minimum of 8 purges within the first 24 hours of the ELAP (Reference 21). This number of vent cycles is the same value used for sizing the PCIV motive gas supply. The design will allow for Argon bottle replacement for continued operation past 24 hours.

The Argon purge system can also be used to breach the rupture disc for anticipatory venting during an ELAP in advance of containment pressure before reaching the rupture disc setpoint. The Argon pressure to the HCVS path is available at the ROS, which can be used to validate that the rupture disc was successfully breached for anticipatory venting. The MCR panel will include an indication of Argon bottle pressure to verify that the Argon purge system flow is occurring.

### **Unintended Cross Flow of Vented Fluids**

The HCVS uses dedicated PCIVs for containment isolation and a dedicated flow path that has neither any interconnected-systems nor sharing with the opposite unit's HCVS piping. The containment isolation valves are AOVs that are air-to-open and spring-to-close.

### **Prevention of Inadvertent Actuation**

EOP/EPG operating procedures provide clear guidance that the HCVS is not to be used to defeat containment integrity during any design basis transients or accidents. In addition, the HCVS will be designed to provide features to prevent inadvertent actuation due to a design error, equipment malfunction, or operator error such that any credited containment accident pressure (CAP) that would provide net positive suction head to the emergency core cooling system (ECCS) pumps will be available (inclusive of a design basis loss-of-coolant accident (DBLOCA)). However, the ECCS pumps will not have normal power available because of the starting boundary conditions of an ELAP. Note that LSCS does not credit CAP for its DBLOCA or FLEX strategies. Nevertheless, preventing inadvertent operation is addressed.

The features that prevent inadvertent actuation are two PCIVs in series and a downstream rupture disc. These valves are fail-closed AOVs (air-to-open, spring-to-close) that require energizing an SOV to allow the motive air/gas to open the valve. Each PCIV is controlled by its own key-locked switch. In addition, the DC power to the SOV and the motive gas supply will normally be disabled to prevent inadvertent operation.

### **Component Qualifications**

The HCVS components and components that interface with the HCVS are routed in or on seismically qualified structures.

HCVS components that are part of the containment pressure boundary will be safety-related. The containment system limits the leakage or release of radioactive materials to the environment to prevent offsite exposures from exceeding the guidelines of 10CFR100 during normal or design basis operations. Additionally, the closed PCIVs and downstream rupture disc serve as a boundary to prevent release of radioactive material. HCVS



## **Part 2: Boundary Conditions for Wetwell Vent**

components that are credited with maintaining the secondary containment boundary will be safety related. This includes the rupture disk and piping up to the reactor building penetration. HCVS components downstream of the secondary containment pressure boundary (i.e., downstream of the secondary containment penetration) will not be safety-related. The Argon purge piping is not credited with maintaining secondary containment and thus is not safety-related.

The HCVS components (SOVs and instrumentation) will be powered from a normally de-energized, dedicated power supply that will not be safety-related but will be considered Augmented Quality. However, if any HCVS electrical or controls component interfaces with Class IE power sources, it will be considered safety-related up to and including appropriate isolation devices such as fuses or breakers, as their failure could adversely impact containment isolation and/or a safety-related power source.

Newly installed piping and valves will be seismically qualified to ensure they are available to support HCVS operation. Electrical and controls components will be seismically qualified and will include the ability to handle harsh environmental conditions (although they will not be considered part of the site Environmental Qualification (EQ) program).

HCVS instrumentation performance (e.g., accuracy and precision) need not exceed that of similar plant installed equipment. Additionally, radiation monitoring instrumentation accuracy and range will be sufficient to determine a transition from no core damage to core damage. The HCVS instruments, including valve position indication, process instrumentation, radiation monitoring, and support system monitoring, will be qualified by using one or more of the three methods described in the ISG, which includes:

1. Purchase of instruments and supporting components with known operating principles from manufacturers with commercial quality assurance programs (e.g., ISO9001) where the procurement specifications include the applicable seismic requirements, design requirements, and applicable testing.
2. Demonstration of seismic reliability via methods that predict performance described in IEEE 344-2004.
3. Demonstration that instrumentation is substantially similar to the design of instrumentation previously qualified.

<b><u>Instrument</u></b>	<b><u>Qualification Method*</u></b>
HCVS Process Temperature	ISO9001 / IEEE 344-2004 / Demonstration
HCVS Process Radiation Monitor	ISO9001 / IEEE 344-2004 / Demonstration
HCVS Valve Position Indication	ISO9001 / IEEE 344-2004 / Demonstration
HCVS Pneumatic Supply Pressure	ISO9001 / IEEE 344-2004 / Demonstration
HCVS Electrical Power Supply Availability	ISO9001 / IEEE 344-2004 / Demonstration
HCVS Argon System Purge Pressure	ISO9001 / IEEE 344-2004 / Demonstration

\* The specific qualification method used for each required HCVS instrument will be reported in future 6-month status reports.

### **Monitoring of HCVS**

The LSCS wetwell HCVS will be capable of being remote-manually operated during sustained operations from a control panel located in the main control room (MCR) and will meet the requirements of Order element 1.2.4.

## **Part 2: Boundary Conditions for Wetwell Vent**

The MCR is a readily accessible location with no further evaluation required (Generic Assumption 109-12). Additionally, to meet the intent for a secondary control location of section 1.2.5 of the Order, a readily accessible Remote Operating Station (ROS) will be incorporated into the HCVS design as described in NEI 13-02, Section 4.2.2.1.2.1. The controls at the ROS location will be accessible and functional under a range of plant conditions, including severe accident conditions with due consideration to source term and dose impact on operator exposure, extended loss of AC power (ELAP), and inadequate containment cooling. An evaluation will be performed to determine accessibility to the location, habitability, staffing sufficiency, and communication capability with Vent-use decision makers.

The wetwell HCVS will include means to monitor the status of the vent system in the MCR and to monitor DC power, and Argon pressures at the ROS. The proposed design for the HCVS includes control switches in the MCR with valve position indication (open/close). The HCVS controls will meet the environmental and seismic requirements of the Order for the plant severe accident with an ELAP. The ability to open/close these valves multiple times during the event's first 24 hours will be provided by dedicated motive air/gas and DC power. Beyond the first 24 hours, the ability to maintain these valves open or closed will be maintained by replenishment of the motive air/gas and DC power at the ROS.

The wetwell HCVS will include indications for effluent temperature, valve position (open/close), and effluent radiation levels at the MCR. Other important information on the status of supporting systems (i.e., DC power source status, Argon pressure, and pneumatic supply pressure) will also be included in the design and located to support HCVS operation.

Other instrumentation that supports HCVS function will be provided in the MCR. This includes existing containment pressure and wetwell level indication. This instrumentation is not required to validate HCVS function and is therefore not powered from the dedicated HCVS batteries. However, these instruments are expected to be available since the FLEX DG supplies the station battery charger for these instruments and will be installed prior to depletion of the station batteries.

### **Component Reliable and Rugged Performance**

Unless otherwise required to be safety-related, Augmented Quality requirements will be applied to the components installed in response to this Order.

Non-safety related piping, electrical power supply, valve actuator pneumatic supply, and instrumentation (local and remote) components, will be designed/analyzed to conform to the requirements consistent with the applicable design codes (e.g., Non-safety, Seismic Category 1, B31.1) for the plant and to ensure functionality following a design basis earthquake.

Additional modifications required to meet the Order will provide reliability at the postulated vent pipe conditions (temperature and radiation levels). The instrumentation/power supplies/cables/connections (components) will be qualified for temperature, pressure, radiation level, total integrated radiation dose appropriate for that location (e.g., near the effluent vent pipe or at the HCVS ROS location).

Conduit design and/or cable trays will be installed to Seismic Category 1 criteria.

Both existing and new barriers will be used to provide a level of protection from externally generated missiles below 30 feet above ground level when permanent equipment is located outside of seismically qualified structures.

## **Part 2: Boundary Conditions for Wetwell Vent**

If the instruments are purchased as commercial-grade equipment, they will be qualified to operate under severe accident environment as required by NRC Order EA-13-109 and the guidance of NEI 13-02. These qualifications will be bounding conditions for LSCS.

For the HCVS instruments required after a potential seismic event, the following methods will be used to verify that the design and installation is reliable / rugged and thus capable of ensuring HCVS functionality following a seismic event. Applicable instruments are rated by the manufacturer (or otherwise tested) for seismic impact at levels commensurate with those of postulated severe accident event conditions in the area of instrument component use using one or more of the following methods:

- Substantial history of operational reliability in environments with significant vibration with a design envelope inclusive of the effects of seismic motion imparted to the instruments proposed at the location;
- Adequacy of seismic design and installation is demonstrated based on the guidance in Sections 7, 8, 9, and 10 of IEEE Standard 344-2004, IEEE Recommended Practice for Seismic Qualification of Class 1E Equipment for Nuclear Power Generating Stations, (Reference 28) or a similar industrial standard;
- Demonstration that proposed devices are substantially similar in design to models that have been previously tested for seismic effects in excess of the plant design basis at the location where the instrument is to be installed (g-levels and frequency ranges); or
- Demonstration of seismic qualification using seismic motion consistent with that of existing design basis loading at the installation location.

## **Part 2: Boundary Conditions for WW Vent – BDBEE Venting**

**Determine venting capability for BDBEE Venting, such as may be used in an ELAP scenario to mitigate core damage.**

Ref: EA-13-109, Section 1.1.4 / NEI 13-02, Section 2.2

### **First 24 Hour Coping Detail**

*Provide a general description of the venting actions for first 24 hours using installed equipment including station modifications that are proposed.*

Ref: EA-13-109, Section 1.2.6 / NEI 13-02, Section 2.5, 4.2.2

The operation of the HCVS will be designed to minimize reliance on operator actions for response to an ELAP and severe accident events. Immediate operator actions will be completed by qualified plant personnel from either the MCR or the HCVS ROS using remote-manual actions. The operator actions required to open a vent path are as described in Table 2-1.

Remote-manual is defined in this report as a non-automatic power operation of a component and does not require the operator to be at or in close proximity to the component. No other operator actions are required to initiate

## **Part 2: Boundary Conditions for WW Vent – BDBEE Venting**

venting under the guiding procedural protocol.

The HCVS will be designed to allow initiation, control, and monitoring of venting from the MCR. This location minimizes plant operators' exposure to adverse temperature and radiological conditions and is protected from hazards assumed in Part 1 of this report.

Permanently installed electrical power and motive air/gas capability will be available to support operation and monitoring of the HCVS for 24 hours.

### *System control:*

- i. Active: The PCIVs will be operated in accordance with EOPs/SOPs to control containment pressure. The HCVS will be designed for a minimum of 8 vent cycles under ELAP conditions over the first 24 hours following an ELAP (Reference 21). Controlled venting will be permitted in the revised EPGs and associated implementing EOPs.
- ii. Passive: Inadvertent actuation protection is provided by:

Key locked switches for the dedicated downstream PCIVs located in the Main Control Room and controlled by procedures

AND

Disabling the HCVS DC power to the SOV and disabling the motive power (pressurized Argon) for the dedicated PCIV except when required by procedures to initiate containment venting by a separate key locked switch

AND

A rupture disc downstream of the PCIVs. Note: the space between the PCIV and rupture disk is freely vented to the secondary containment, but this vent path is isolated prior to HCVS operation.

### **Greater Than 24 Hour Coping Detail**

*Provide a general description of the venting actions for greater than 24 hours using portable and installed equipment including station modifications that are proposed.*

**Ref: EA-13-109, Section 1.2.4 / NEI 13-02, Section 4.2.2**

Before the end of the 24 hours initial phase, available personnel will be able to connect supplemental air/gas for the motive gas and purge systems. Connections for supplementing electrical power and air/gas required for HCVS will be located in accessible areas with reasonable protection per NEI 12-06 that minimize personnel exposure to adverse conditions for HCVS initiation and operation. Connections will be pre-engineered quick disconnects, to the extent practical, to minimize manpower resources.

FLEX is credited solely to sustain power for a BDBEE ELAP to containment instruments used to monitor the containment (e.g., pressure and wetwell level). The response to NRC EA-12-049 will demonstrate the capability for FLEX efforts to maintain the power source.

These actions provide long term support for HCVS operation for the period beyond 24 hours to 7 days (sustained operation time period) because on-site and off-site personnel and resources will have access to the unit(s) to provide needed action and supplies.

### **Details:**

**Provide a brief description of Procedures / Guidelines:**

*Confirm that procedure/guidance exists or will be developed to support implementation.*

## **Part 2: Boundary Conditions for WW Vent – BDBEE Venting**

Primary Containment Control Flowchart will be provided to direct operations in protection and control of containment integrity, including use of the existing Hardened Containment Vent System.

These flowcharts are being revised as part of the EPG/SAGs revision 3 updates and associated EOP/SAP implementation. HCVS-specific procedure guidance will be developed and implemented to support HCVS implementation.

**ISE Open Item - 13:** Provide procedures for HCVS Operation.

### **Identify modifications:**

*List modifications and describe how they support the HCVS Actions.*

#### EA-12-049 Modifications

- At this time, no FLEX modifications have been identified that are specific to supporting HCVS.

#### EA-13-109 Modifications

- A modification will be required to install the Phase 1 (wetwell) vent path. The vent path will be routed outside the Reactor Building, horizontally from each unit to a common support tower, and then vertically up the outside of the Reactor Building wall. Since it goes outside of the Reactor Building, it will include provisions to ensure primary containment leakage during a design basis LOCA is properly processed within secondary containment. The wetwell vent path will include two PCIVs dedicated to this flow path with valve position indication (open/close) and remote-manual control only. There are no interposing systems, except for the shared support tower. There is no sharing of any flow paths with the opposite unit.
- A modification will be required to install the dedicated batteries needed to supply power to HCVS for the first 24 hours including capability for recharging from a charger at or before 24 hours. The batteries will be located at the ROS and shared between both units.
- A modification will be required to install the dedicated motive power (pressurized Argon gas) needed to open the HCVS valves for the first 24 hours including capability for replacing Argon bottles or connection of a portable compressor after 24 hours. The Argon bottles will be located at the ROS.
- A modification will be required to install the dedicated Argon purge system needed to prevent hydrogen detonation in the piping with sufficient installed capacity for the first 24 hours including capability for replacing Argon bottles or refilling from an Argon supply after 24 hours. The Argon bottles will be located at the ROS. Note that the Argon purge system is only required following severe accident conditions. It is not required if core damage is prevented.
- A modification will be required to add (a) HCVS flow path instrumentation consisting of temperature and effluent radiation in the MCR and (b) Motive power, Argon pressure and DC battery indication in the MCR and the ROS.
- A modification will be required to provide shielding from vent shine to maintain radiological conditions within the ERO guidance in locations where continuous actions are performed.

LaSalle County Station Units 1 and 2  
Overall Integrated Plan for Reliable Hardened Vents

**Part 2: Boundary Conditions for WW Vent – BDBEE Venting**

**Key Venting Parameters:**

*List instrumentation credited for this venting actions. Clearly indicate which of those already exist in the plant and what others will be newly installed (to comply with the vent order).*

Initiation, operation and monitoring of the HCVS venting will rely on the following key parameters and indicators which will be added as part of the HCVS modification.

<u>Key Parameter</u>	<u>Component Identifier</u>	<u>Indication Location</u>
HCVS Effluent temperature	TBD	MCR
HCVS Effluent radiation	TBD	MCR
HCVS valve position indication	TBD	MCR
HCVS DC Power Voltage/Conditions	TBD	ROS
HCVS Pneumatic supply pressure	TBD	ROS
HCVS Purge System pressure	TBD	MCR/ROS

Initiation, operation, and monitoring of the HCVS will rely on several existing MCR key parameters and indicators which are qualified or evaluated to Regulatory Guide 1.97 per the existing plant design (Reference NEI 13-02 Section 4.2.2.1.9 [9]):

<u>Key Parameter</u>	<u>Component Identifier</u>	<u>Indication Location</u>
Drywell pressure	1(2)PI-CM029	MCR
Wetwell level	1(2)LI-CM192	MCR
WW pressure	1(2)PI-CM056	MCR
WW water temperature	1(2)TI-CM037	MCR
Reactor pressure	1(2)C61-R011	Remote Shutdown Panel (RSP)

**Notes:** None

LaSalle County Station Units 1 and 2  
Overall Integrated Plan for Reliable Hardened Vents

**Part 2: Boundary Conditions for WW Vent – Severe Accident Venting**

**Determine venting capability for Severe Accident Venting, such as may be used in an ELAP scenario to mitigate core damage.**

**Ref: EA-13-109, Section 1.2.10 / NEI 13-02, Section 2.3**

**First 24 Hour Coping Detail**

*Provide a general description of the venting actions for first 24 hours using installed equipment including station modifications that are proposed.*

**Ref: EA-13-109, Section 1.2.6 / NEI 13-02, Section 2.5, 4.2.2**

The operation of the HCVS will be designed to minimize the reliance on operator actions for response to an ELAP and severe accident events. Severe accident event assumes that specific core cooling actions from the FLEX strategies identified in the response to Order EA-12-049 were not successfully initiated. Access to the reactor building will be restricted as determined by the RPV water level and core damage conditions. Immediate actions will be completed by Operators in the Main Control Room (MCR) and will include remote-manual actions. The ROS provides back-up capability to open HCVS valve(s) in case of a valve circuit or SOV failure. The operator actions required to open a vent path were previously listed in the BDBEE Venting Part 2 section of this report (Table 2-1).

Permanently installed power, Argon purge, and motive gas will be available to support operation and monitoring of the HCVS for 24 hours. Specifics are the same as for BDBEE Venting Part 2.

System control:

- i. Active: Same as for BDBEE Venting Part 2
- ii. Passive: Same as for BDBEE Venting Part 2

**Greater Than 24 Hour Coping Detail**

*Provide a general description of the venting actions for greater than 24 hours using portable and installed equipment including station modifications that are proposed.*

**Ref: EA-13-109, Section 1.2.4, 1.2.8 / NEI 13-02, Section 4.2.2**

Specifics are the same as for BDBEE Venting Part 2 with the clarification that Argon purge resupply is only necessary following severe accident conditions. Outside activities associated with the replenishment of bottles will be coordinated with vent cycling in order to minimize operator exposure due to vent operation.

These actions provide long term support for HCVS operation for the period beyond 24 hours to 7 days (sustained operation time period) because on-site and off-site personnel and resources will have access to the unit(s) to provide needed action and supplies.

**Details:**

**Provide a brief description of Procedures / Guidelines:**

*Confirm that procedure/guidance exists or will be developed to support implementation.*

The operation of the HCVS will be governed the same for SA conditions as for BDBEE conditions. Existing guidance in the SAMGs directs the plant staff to consider changing radiological conditions in a severe accident.

LaSalle County Station Units 1 and 2  
Overall Integrated Plan for Reliable Hardened Vents

**Part 2: Boundary Conditions for WW Vent – Severe Accident Venting**

**Identify modifications:**

*List modifications and describe how they support the HCVS Actions.*

Modifications are the same as for BDBEE Venting Part 2, including the addition of external shield walls as required to maintain radiological conditions within the ERO guidance in locations where continuous actions are performed.

**Key Venting Parameters:**

*List instrumentation credited for the HCVS Actions. Clearly indicate which of those already exist in the plant and what others will be newly installed (to comply with the vent order).*

Key venting parameters are the same as for BDBEE Venting Part 2.

**Notes:** None



LaSalle County Station Units 1 and 2  
Overall Integrated Plan for Reliable Hardened Vents

<b>Part 2: <u>Boundary Conditions for WW Vent</u> – Support Equipment Functions</b>
<b>Determine venting capability support functions needed</b>
<b>Ref: EA-13-109, Section 1.2.8, 1.2.9 / NEI 13-02, Section 2.5, 4.2.4, 6.1.2</b>
<b>BDBEE Venting</b>
<i>Provide a general description of the BDBEE Venting actions support functions. Identify methods and strategy(ies) utilized to achieve venting results.</i>
<b>Ref: EA-13-109, Section 1.2.9 / NEI 13-02, Section 2.5, 4.2.2, 4.2.4, 6.1.2</b>
All containment venting functions will be performed from the MCR or ROS.  Venting to prevent containment over pressurization will be maintained by permanently installed equipment. The HCVS dedicated DC power source, Argon purge gas, and dedicated motive force is adequate for the first 24 hours, but it can be replenished to support sustained operation.  Existing safety related station batteries will provide sufficient electrical power for MCR containment instrumentation for approximately 8 hours. Before station batteries are depleted, portable FLEX diesel generators, as detailed in the response to Order EA-12-049, will be credited to charge the station batteries and maintain DC bus voltage after 8 hours.
<b>Severe Accident Venting</b>
<i>Provide a general description of the Severe Accident Venting actions support functions. Identify methods and strategy(ies) utilized to achieve venting results.</i>
<b>Ref: EA-13-109, Section 1.2.8, 1.2.9 / NEI 13-02, Section 2.5, 4.2.2, 4.2.4, 6.1.2</b>
The same support functions that are used in the BDBEE scenario would be used for severe accident venting. The ROS (the location of the HCVS DC power source, Argon purge, and motive force) and the FLEX DG location will be evaluated to confirm accessibility under severe accident conditions.
<b>Details:</b>
<b>Provide a brief description of Procedures / Guidelines:</b> <i>Confirm that procedure/guidance exists or will be developed to support implementation.</i>
The operation of the HCVS will be governed the same for SA conditions as for BDBEE conditions. Existing guidance in the SAMG directs the plant staff to consider changes in radiological conditions in a severe accident.
<b>Identify modifications:</b> <i>List modifications and describe how they support the HCVS Actions.</i>
The same as for BDBEE Venting Part 2.
<b>Key Support Equipment Parameters:</b> <i>List instrumentation credited for the support equipment utilized in the venting operation. Clearly indicate which of those already exist in the plant and what others will be newly installed (to comply with the vent order).</i>
The same as for BDBEE Venting Part 2.
<b>Notes:</b> None

LaSalle County Station Units 1 and 2  
Overall Integrated Plan for Reliable Hardened Vents

**Part 2: Boundary Conditions for WW Vent – Venting Portable  
Equipment Deployment**

*Provide a general description of the venting actions using portable equipment including modifications that are proposed to maintain and/or support safety functions.*

**Ref: EA-13-109, Section 3.1 / NEI 13-02, Section 6.1.2, D.1.3.1**

Deployment pathways developed for compliance with Order EA-12-049 are acceptable without further evaluation needed except in areas around the Reactor Building or in the vicinity of the HCVS piping.

Before the end of the initial 24-hour period, replenishment of the HCVS dedicated DC power, Argon purge gas, and motive power (pressurized gas) will occur at the ROS. The selection of the ROS location will take into account the SA temperature and radiation condition to ensure access to the ROS is maintained. The design will allow replenishment with minimal actions.

**ISE Open Item - 4:** Confirm that the ROS will be in an area accessible following a SA.

**Details:**

**Provide a brief description of Procedures / Guidelines:**

*Confirm that procedure/guidance exists or will be developed to support implementation.*

Operation of the portable equipment is the same as for compliance with Order EA- 12-049; thus, they are acceptable without further evaluation with the exception that severe accident radiological conditions will be considered.

<b>Strategy</b>	<b>Modifications</b>	<b>Protection of connections</b>
Per compliance with Order EA-12-049 (FLEX)	N/A	Per compliance with Order EA-12-049 (FLEX)

**Notes:** None

## Part 3: Boundary Conditions for EA-13-109, Option 2

### General

*Licenses that use Option B.1 of EA-13-109 (SA Capable DW Vent without SAWA) must develop their own OIP. This template does not provide guidance for that option.*

*Licenses using Option B.2 of EA-13-109 (SAWA and SAWM or 545°F SADW Vent (SADV) with SAWA) may use this template for their OIP submittal. Both SAWM and SADV require the use of SAWA and may not be done independently. The HCVS actions under Part 2 apply to all of the following:*

*This Part is divided into the following sections:*

*3.1: Severe Accident Water Addition (SAWA)*

*3.1.A: Severe Accident Water Management (SAWM)*

*3.1.B: Severe Accident DW Vent (545 deg F)*

**Provide a sequence of events and identify any time constraint required for success including the basis for the time constraint.**

*SAWA and SAWM or SADV Actions supporting SA conditions that have a time constraint to be successful should be identified with a technical basis and a justification provided that the time can reasonably be met (for example, a walkthrough of deployment). Actions already identified under the HCVS part of this template need not be repeated here.*

*The time to establish the water addition capability into the RPV or DW should be less than 8 hours from the onset of the loss of all injection sources.*

- *Electrical generators satisfying the requirements of EA-12-049 may be credited for powering components and instrumentation needed to establish a flow path.*
- *Time Sensitive Actions (TSAs) for the purpose of SAWA are those actions needed to transport, connect and start portable equipment needed to provide SAWA flow or provide power to SAWA components in the flow path between the connection point and the RPV or drywell. Actions needed to establish power to SAWA instrumentation should also be included as TSAs.*

**Ref: NEI 13-02, Section 6.1.1.7.4.1, I.1.4, I.1.5**

The operation of the HCVS using SAWA and SAWM/SADV will be designed to minimize the reliance on operator actions in response to hazards listed in Part 1. Initial operator actions will be completed by plant personnel and will include the capability for remote-manual initiation from the MCR using control switches. In addition, HCVS valve operation, as required by EA-13-109 Requirement 1.2.5, may occur at the ROS.

Timelines (see attachments 2.1.A for SAWA/SAWM) were developed to identify required operator response times and actions. The timelines are an expansion of Attachment 2A and begin either as core damage occurs (SAWA) or after initial SAWA injection is established and as flowrate is adjusted for option B.2 (SAWM). The timelines do not assume the core is ex-vessel and the actions taken are appropriate for both in-vessel and ex-vessel core damage conditions.

LaSalle County Station Units 1 and 2  
Overall Integrated Plan for Reliable Hardened Vents

## Part 3: Boundary Conditions for EA-13-109, Option 2

### Part 3.1: Boundary Conditions for SAWA

**Table 3.1 – SAWA Manual Actions**

Primary Action	Primary Location/ Component	Notes
1. Establish HCVS capability in accordance with Part 2 of this OIP.	<ul style="list-style-type: none"> <li>■ MCR or ROS.</li> </ul>	<ul style="list-style-type: none"> <li>■ Applicable to SAWA/SAWM strategy.</li> </ul>
2. Connect FLEX (SAWA) pump discharge to injection piping.	<ul style="list-style-type: none"> <li>■ Ground level (710') by Reactor Building – connect hose from hard pipe (see step #3) outside the building to an Emergency Fuel Cooling (FC) pipe/riser in the building.</li> <li>■ Reactor Building 761' elevation – connect hose from the FC riser to the RHR system for RPV make-up.</li> </ul>	<ul style="list-style-type: none"> <li>■ Perform Reactor Building portions of deployment first.</li> </ul>
3. Connect FLEX (SAWA) pump to water source.	<ul style="list-style-type: none"> <li>■ At the pump deployment area, deploy the pump (including submersibles if required), connect suction hose to diesel driven pump, and connect pump discharge to underground pipe, as well as deploy remaining above ground hose from underground pipe to the FC pipe/riser.</li> </ul>	<ul style="list-style-type: none"> <li>■ From this location, the flow is via buried pipe and above ground hose to the Reactor Building (action #2, above). Present location for pump may require shielding from HCVS external piping.</li> </ul>
4. Power SAWA/HCVS components with EA-12-049 (FLEX) generator.	<ul style="list-style-type: none"> <li>■ At staging area on ground level by the Reactor Building.</li> </ul>	<ul style="list-style-type: none"> <li>■ Present location may require shielding from HCVS external piping. Alternate pad location being considered.</li> </ul>
5. Inject to RPV using FLEX (SAWA) pump (diesel).	<ul style="list-style-type: none"> <li>■ Requires energizing and opening one RHR/LPCI motor operated valve (MOV).</li> </ul>	<ul style="list-style-type: none"> <li>■ MOV will be powered from FLEX generator.</li> <li>■ Initial SAWA flow rate is 500 gpm.</li> </ul>
6. Monitor SAWA indications.	<ul style="list-style-type: none"> <li>■ MCR</li> </ul>	<ul style="list-style-type: none"> <li>■ Pump flow.</li> <li>■ MOV position indication.</li> </ul>
7. Use SAWM to maintain availability of the WW vent (Part 3.1.A).	<ul style="list-style-type: none"> <li>■ MCR</li> </ul>	<ul style="list-style-type: none"> <li>■ Monitor DW pressure and Suppression Pool level.</li> <li>■ Control SAWA flow via RHR/LPCI MOV.</li> </ul>

## Part 3: Boundary Conditions for EA-13-109, Option 2

### Discussion of timeline SAWA identified items

HCVS operations are discussed under Phase 1 of EA-13-109 (Part 2 of this OIP).

- 8 Hours – Establish electrical power and other EA-12-049 actions needed to support the strategies for EA-13-109, Phase 1 and Phase 2. Action being taken within the Reactor Building under EA-12-049 conditions after RPV level lowers to 2/3 core height must be evaluated for radiological conditions assuming permanent containment shielding remains intact. (HCVS-FAQ-12) All other actions required are assumed to be in-line with the FLEX timeline submitted in accordance with the EA-12-049 requirements.
- Less than 8 Hours – Initiate SAWA flow to the RPV. Having the HCVS in service will assist in minimizing the peak DW pressure during the initial cooling conditions provided by SAWA.

## Part 3.1: Boundary Conditions for SAWA

### Severe Accident Operation

*Determine operating requirements for SAWA, such as may be used in an ELAP scenario to mitigate core damage.*

**Ref: EA-13-109 Attachment 2, Section B.2.2, B.2.3 / NEI 13-02, Section I.1.6, I.1.4.4**

It is anticipated that SAWA will be used in Severe Accident Events based on presumed failure of injection systems or presumed failure of injection systems in a timely manner. This does not preclude the use of the SAWA system to supplement or replace the EA-12-049 injection systems if desired. SAWA will consist of both portable and installed equipment.

The motive force equipment needed to support the SAWA strategy shall be available prior to T=8 hours from the loss of injection (assumed at T=0).

The SAWA flow path includes methods to minimize exposure of personnel to radioactive liquids / gases and potentially flammable conditions by inclusion of backflow prevention. RHR LPCI injection mode has installed ECCS check valve qualified for accident scenarios to prevent reverse flow from the RPV.

### Description of SAWA actions for first 24 hours:

**Table 3.2 – SAWA Manual Actions Timeline**

Time	Action	Notes
T≤1 hour	<ul style="list-style-type: none"> <li>■ Declare ELAP Event.</li> </ul>	<ul style="list-style-type: none"> <li>■ All operator actions prior to this time include attempted recovery and load shedding.</li> </ul>
T=1-2 hours	<ul style="list-style-type: none"> <li>■ Connect SAWA hoses in Reactor Building (<i>Step 2 of Table 3.1</i>).</li> </ul>	<ul style="list-style-type: none"> <li>■ Evaluation required to confirm feasibility due to radiological conditions. (ISE Open Item 4)</li> </ul>
T=1-7 hours*	<ul style="list-style-type: none"> <li>■ Complete actions started at T&lt;1 hour (<i>Step 2 of Table 3.1</i>).</li> <li>■ Connect FLEX (SAWA) pump to water supply at intake structure (<i>Step 3 of Table 3.1</i>).</li> <li>■ Establish electrical power to HCVS and SAWA using</li> </ul>	<ul style="list-style-type: none"> <li>■ Evaluate core gap and early in vessel release impact to Reactor Building access for SAWA actions. It is assumed that Reactor Building access is</li> </ul>

LaSalle County Station Units 1 and 2  
Overall Integrated Plan for Reliable Hardened Vents

**Part 3: Boundary Conditions for EA-13-109, Option 2**

	EA-12-049 generator ( <i>Step 4 of Table 3.1</i> ). <ul style="list-style-type: none"> <li>■ Establish flow of 500 gpm to the RPV using SAWA systems (<i>Step 5 of Table 3.1</i>).</li> </ul>	limited due to the source term at this time unless otherwise noted. (Refer to HCVS-FAQ-12 for actions in T=1-7 hour timeframe.)
T≤8-12 hours	<ul style="list-style-type: none"> <li>■ Monitor and Maintain SAWA flow at 500 GPM for four hours (<i>Step 6 of Table 3.1</i>).</li> </ul>	<ul style="list-style-type: none"> <li>■ SAWA flow must commence by T=8 hours but should be done as soon as motive force is available.</li> </ul>
T≤12 hours	<ul style="list-style-type: none"> <li>■ Proceed to SAWM actions per Part 3.1.A (<i>Step 7 of Table 3.1</i>).</li> </ul>	<ul style="list-style-type: none"> <li>■ SAWA flow may be reduced to 100 GPM four hours following SAWA initiation.</li> </ul>

**\*The assumed times of T=1 hour to T=8 hours to establish the bounds of applicability of radiological evaluations have been reduced to T=1-7 hours in order to provide sufficient margin to inform operator action feasibility evaluations and will be further informed by emergency response dose assessment activities during an actual event. This accounts for the one hour gap between 7 and 8 hours in this timeline.**

**Greater Than 24 Hour Coping Detail**

*Provide a general description of the SAWA actions for greater than 24 hours using portable and installed equipment including station modifications that are proposed.*

**Ref: EA-13-109 Attachment 2, Section B.2.2, B.2.3/ NEI 13-02, Section 4.2.2.4.1.3.1, I.1.4,**

SAWA Operation is the same for the full period of sustained operation. If SAWM is employed, flow rates will be directed to preserve the availability of the HCVS wetwell vent (see 3.1.A).

**Details:**

**Details of Design Characteristics/Performance Specifications**

*SAWA shall be capable of providing an RPV injection rate of 500 gpm within 8 hours of a loss of all RPV injection following an ELAP/Severe Accident. SAWA shall meet the design characteristics of the HCVS with the exception of the dedicated 24 hour power source. Hydrogen mitigation is provided by backflow prevention for SAWA.*

**Ref: EA-13-109 Attachment 2, Section B.2.1, B.2.2, B.2.3/ NEI 13-02, Section I.1.4**

**Equipment Locations/Controls/Instrumentation**

LSCS has not performed a site specific evaluation to justify the use of a lower site unique initial SAWA flow rate. Consequently, LSCS will assume an initial flow rate of 500 gpm. This is based on the industry value of 500 gpm from Reference 37. This initial flow rate will be established within 8 hours of the loss of all RPV injection following an ELAP/Severe Accident and will be maintained for four hours before reduction to the wetwell vent preservation flow rate (Attachment 2.1.A).

The locations of the SAWA equipment and controls, as well as ingress and egress paths will be evaluated for the expected severe accident conditions (temperature, humidity, radiation) for the Sustained Operating period. Equipment will be evaluated to remain operational throughout the Sustained Operating period. Personnel exposure and temperature / humidity conditions for operation of SAWA equipment will not exceed the limits for ERO dose and plant safety guidelines for temperature and humidity.

The flow path will be from the FLEX (SAWA) pump suction at the UHS, to the ground level of the Reactor Building, through an FC pipe riser to the 761' elevation of the Reactor Building, through RHR/LPCI pipe, and then

### Part 3: Boundary Conditions for EA-13-109, Option 2

into the RPV. Hose connections are required (a) by the FLEX (SAWA) pump suction and discharge to connect to a buried pipe, (b) from the underground pipe to the connection at the Reactor Building ground level to connect to the FC pipe riser, and (c) at the 761' to connect the FC riser to the RHR/LPCI piping. This flow path requires opening an RHR/LPCI MOV. This valve will be energized from the FLEX diesel generator to allow remote-manual opening by 8 hours after the conditions for an ELAP are met. The flow control method is anticipated via manual control of the RHR/LPCI injection valves.

DW pressure and Suppression Pool level will be monitored and flow rate will be adjusted as required.

The FLEX (SAWA) pump suction source is a significant distance from the discharge of the HCVS pipe with new structural shielding between the HCVS pipe and the pump deployment location. Pump refueling will be accomplished during times when the vent is cycled closed in the same method as described in the EA-12-049 compliance documents. See mechanical and electrical sketches in attachments, plant layout sketches in the assumptions part and a list of actions elsewhere in this part.

Evaluations of actions outside the Reactor Building for projected SA conditions (radiation / temperature) indicate that personnel can complete the initial and support activities without exceeding the ERO-allowable dose for equipment operation or site safety standards (Reference HCVS-WP-02 [22]). This is accomplished by a combination of shielding (for continuously occupied areas) and coordinating the vent cycling operation. Evaluation of actions inside the Reactor Building for projected SA conditions (radiation/temperature) will be performed to determine that personnel can complete the initial and support activities without exceeding the ERO-allowable dose for equipment operation or site safety standards (Reference HCVS-FAQ-12 [35]).

Electrical equipment and instrumentation will be powered from the power sources noted in the table below with portable generators to maintain battery capacities during the Sustained Operating period. The indications include: (\* are minimum required instruments).

Parameter	Instrument	Location	Power Source / Notes
DW Pressure*	1/2PI-CM029	MCR	Division I battery via EA-12-049 generator and battery charger RG 1.97 qualified
Suppression Pool Level*	1/2LI-CM192	MCR	RG 1.97 qualified
SAWA Flow*	TBD	MCR	

The instrumentation and equipment being used for SAWA and supporting equipment has been evaluated to perform for the Sustained Operating period under the expected radiological and temperature conditions.

#### Equipment Protection

SAWA installed component and connections external to protected buildings will be protected against the screened-in hazards of EA-12-049 for the station. Portable equipment used for SAWA implementation will meet the protection requirements for storage in accordance with the criteria in NEI 12-06, Revision 0.

**Ref: EA-13-109 Attachment 2, Section B.2.2, B.2.3 / NEI 13-02, Section 5.1.1, 5.4.6, I.1.6**

**Part 3: Boundary Conditions for EA-13-109, Option 2**

**Provide a brief description of Procedures / Guidelines:**

*Confirm that procedure/guidance exists or will be developed to support implementation.*

**Ref: EA-13-109 Attachment 2, Section A.3.1, B.2.3 / NEI 13-02 Section 1.3, 6.1.2**

1. Connect FLEX (SAWA) pump discharge to RHR/LPCI piping.
2. Power SAWA/HCVS components with EA-12-049 (FLEX) generator using FSG.
3. Start FLEX (SAWA) pump to establish SAWA flow.
4. Adjust SAWA flow using SAWA flow indication to establish and maintain 500 gpm.

\*Where an FSG is referenced, it will be the same FSG reference with the same steps used for FLEX.

**Identify modifications:**

*List modifications and describe how they support the SAWA Actions.*

**Ref: EA-13-109 Attachment 2, Section B.2.2, / NEI 13-02, Section 4.2.4.4, 7.2.1.8, Appendix I**

The list of modifications, below, is limited to those required to upgrade EA-12-049 equipment to meet EA-13-109 Phase 2 requirements.

Electrical Modifications:

- MOV modifications required for flow control.

Mechanical Modifications:

- TBD

Instrument Modifications:

- SAWA Flow indication

**Phase 2 Open Item #2 – Verify Required Modifications to support SAWA/SAWM.**

**Component Qualifications:**

*State the qualification used for equipment supporting SAWA.*

**Ref: EA-13-109 Attachment 2, Section B.2.2, B.2.3 / NEI 13-02, Section I.1.6**

Permanently installed plant equipment shall meet the same qualifications as described in Part 2 of this OIP. Temporary/Portable equipment shall be qualified and stored to the same requirements as FLEX equipment as specified in NEI 12-06 Rev 0. SAWA components are not required to meet NEI 13-02, Table 2-1 design conditions.

**Notes:**

None

**Part 3.1.A: Boundary Conditions for SAWA/SAWM**

**Time periods for the maintaining SAWM actions such that the WW vent**



## Part 3: Boundary Conditions for EA-13-109, Option 2

*SAWM Actions supporting SA conditions that have a time constraint to be successful should be identified with a technical basis and a justification provided that the time can reasonably be met (for example, a walkthrough of deployment). Actions already identified under the HCVS part of this template need not be repeated here.*

*There are three time periods for the maintaining SAWM actions such that the WW vent remains available to remove decay heat from the containment:*

- *SAWM can be maintained for >7 days without the need for a drywell vent to maintain pressure below PCPL or containment design pressure, whichever is lower.*
  - *Under this approach, no detail concerning plant modifications or procedures is necessary with respect to how alternate containment heat removal will be provided.*
- *SAWM can be maintained for at least 72 hours, but less than 7 days before DW pressure reaches PCPL or design pressure, whichever is lower.*
  - *Under this approach, a functional description is required of how alternate containment heat removal might be established before DW pressure reaches PCPL or design pressure whichever is lower. Under this approach, physical plant modifications and detailed procedures are not necessary, but written descriptions of possible approaches for achieving alternate containment heat removal and pressure control will be provided.*
- *SAWM can be maintained for <72 hours SAWM strategy can be implemented but for less than 72 hours before DW pressure reaches PCPL or design pressure whichever is lower.*
  - *Under this approach, a functional description is required of how alternate containment heat removal might be established before DW pressure reaches PCPL or design pressure whichever is lower. Under this approach, physical plant modifications and detailed procedures are required to be implemented to insure achieving alternate containment heat removal and pressure control will be provided for the sustained operating period.*

**Ref: NEI 13-02 Appendix C.7**

SAWM can be maintained for >7 days without the need for a drywell vent to maintain pressure below PCPL.

### **Basis for SAWM time frame**

SAWM can be maintained >7 days:

LSCS has not performed a site specific evaluation to justify the use of a lower site unique initial SAWA flow rate. Consequently, LSCS will assume an initial flow rate of 500 gpm.

This initial flow rate will be established within 8 hours of the loss of all RPV injection following an ELAP/Severe Accident and will be maintained for four hours before reduction to the wetwell vent preservation flow rate.

Instrumentation relied upon for SAWM operations is Drywell Pressure, Suppression Pool level and SAWA flow. Except for SAWA flow, SAWM instruments are initially powered by station batteries and then by the FLEX (EA-12-049) generator, which is placed in-service prior to core breach. The DG will provide power throughout the Sustained Operation period (7 days). The SAWA flow instrument will be powered only by the DG as it is not required until after the DG has been placed in service.

Suppression Pool level indication is maintained throughout the Sustained Operation period, so the HCVS remains in-service. The time to reach the level at which the WW vent must be secured is >7days using SAWM flowrates (C.6.3, C.7.1.4.3).

Procedures will be developed that control the Suppression Pool level, while ensuring the DW pressure indicates the core is being cooled, whether in-vessel or ex-vessel. Procedures will dictate conditions during which SAWM

LaSalle County Station Units 1 and 2  
Overall Integrated Plan for Reliable Hardened Vents

**Part 3: Boundary Conditions for EA-13-109, Option 2**

flowrate should be adjusted (up or down) using suppression pool level and DW pressure as controlling parameters to remove the decay heat from the containment. (This is similar to the guidance currently provided in the BWROG SAMGs.) (C.7.1.4.3)

Attachment 2.1.A shows the timeline of events for SAWA / SAWM. (C.7.1.4.4)

**Table 3.1.B – SAWM Manual Actions**

Primary Action	Primary Location/ Component	Notes
1. Lower SAWA injection rate to control Suppression Pool Level and decay heat removal	MCR	<ul style="list-style-type: none"> <li>• Control to maintain containment and WW parameters to ensure WW vent remains functional.</li> <li>• 100 gpm minimum capability is maintained for greater than 7 days.</li> </ul>
2. Control SAWM flowrate for containment control/decay heat removal	Containment Instrument monitoring  SAWA flow at MCR	<ul style="list-style-type: none"> <li>• SAWM flowrate will be monitored using the following instruments:                             <ul style="list-style-type: none"> <li>– SAWA Flow</li> <li>– Suppression Pool Level</li> <li>– Drywell Pressure</li> </ul> </li> <li>• SAWM flowrate will be controlled using the RHR/LPCI MOV.</li> </ul>
3. Establish alternate decay heat removal	Various locations	SAWM strategy can preserve the wetwell vent path for >7 days.
4. Secure SAWA / SAWM	MCR or Pump	When alternate decay heat removal is established.

**SAWM Time Sensitive Actions**

Time Sensitive SAWM Actions:

12 Hours – Initiate actions to maintain the wetwell (WW) vent capability by lowering injection rate, while maintaining the cooling of the core debris (SAWM). Monitor SAWM critical parameters while ensuring the WW vent remains available.

**SAWM Severe Accident Operation**

*Determine operating requirements for SAWM, such as may be used in an ELAP scenario to mitigate core damage.*

**Ref: EA-13-109 Attachment 2, Section B.2.2, B.2.3 / NEI 13-02, Appendix C**

It is anticipated that SAWM will only be used in Severe Accident Events based on presumed failure of plant injection systems per direction by the plant SAMGs. Refer to Attachment 2.1.D for SAWM SAMG language additions.

## Part 3: Boundary Conditions for EA-13-109, Option 2

### First 24 Hour Coping Detail

*Provide a general description of the SAWM actions for first 24 hours using installed equipment including station modifications that are proposed.*

*Given the initial conditions for EA-13-109:*

- *BDBEE occurs with ELAP*
- *Failure of all injection systems, including steam-powered injection systems*

**Ref: EA-13-109, Section 1.2.6, Attachment 2, Section B.2.2, B.2.3 / NEI 13-02, Section 2.5, 4.2.2, Appendix C, Section C.7**

SAWA will be established as described as stated above. SAWM will use the installed instrumentation to monitor and adjust the flow from SAWA to control the pump discharge to deliver flowrates applicable to the SAWM strategy.

Once the SAWA initial flow rate has been established for 4 hours, the flow will be reduced while monitoring DW pressure and Suppression Pool level. SAWM flowrate can be lowered to maintain containment parameters and preserve the WW vent path. SAWM will be capable of injection for the period of Sustained Operation.

### Greater Than 24 Hour Coping Detail

*Provide a general description of the SAWM actions for greater than 24 hours using portable and installed equipment including station modifications that are proposed.*

**Ref: EA-13-109, Section 1.2.4, 1.2.8, Attachment 2, Section B.2.2, B.2.3 / NEI 13-02, Section 4.2.2, Appendix C, Section C.7**

SAWM can be maintained >7 days:

The SAWM flow strategy will be the same as the first 24 hours until 'alternate reliable containment heat removal and pressure control' is reestablished. SAWM flow strategy uses the SAWA flow path. No additional modifications are being made for SAWM.

### Details:

#### Details of Design Characteristics/Performance Specifications

**Ref: EA-13-109 Attachment 2, Section B.2.2, B.2.3 / NEI 13-02, Section Appendix C**

SAWM shall be capable of monitoring the containment parameters (DW pressure and Suppression Pool Level) to provide guidance on when injection rates shall be reduced, until alternate containment decay heat/pressure control is established. SAWA will be capable of injection for the period of Sustained Operation.

#### Equipment Locations/Controls/Instrumentation

*Describe location for SAWM monitoring and control.*

**Ref: EA-13-109 Attachment 2, Section B.2.2, B.2.3 / NEI 13-02, Appendix C, Section C.8, Appendix I**

The SAWM control location is the same as the SAWA control location. Indication of SAWM flow rate is provided in the MCR by a flow instrument qualified to operate under the expected environmental conditions.

LaSalle County Station Units 1 and 2  
Overall Integrated Plan for Reliable Hardened Vents

**Part 3: Boundary Conditions for EA-13-109, Option 2**

Injection flowrate is controlled by the RHR/LPCI MOV (see Table 3.1.B).

Suppression Pool level and DW pressure are read in the control room using indicators powered by the FLEX DG installed under EA-12-049. These indications are used to control SAWM flowrate to the RPV.

**Key Parameters:**

*List instrumentation credited for the SAWM Actions.*

Parameters used for SAWM are:

- Drywell Pressure
- Suppression Pool Level
- SAWM Flowrate

The Drywell pressure and Suppression Pool level instruments are qualified to RG 1.97 and are the same as listed in Part 2 of this OIP. The SAWM flow instrumentation will be qualified for the expected environmental conditions expected when needed.

Notes:

None

LaSalle County Station Units 1 and 2  
Overall Integrated Plan for Reliable Hardened Vents

<b>Part 3: Boundary Conditions for EA-13-109, Option 2</b>
<b>Part 3.1.B: Boundary Conditions for SAWA/SADV</b>
<b>Applicability of WW Design Considerations</b>
This section is not applicable to LSCS.
<b>Table 3.1.C – SADV Manual Actions</b>
<b>Timeline for SADV</b>
<b>Severe Accident Venting</b>
<b>First 24 Hour Coping Detail</b>
<b>Greater Than 24 Hour Coping Detail</b>
<b>Details:</b>

## **Part 4: Programmatic Controls, Training, Drills and Maintenance**

### **Identify how the programmatic controls will be met.**

*Provide a description of the programmatic controls equipment protection, storage and deployment and equipment quality addressing the impact of temperature and environment.*

**Ref: EA-13-109, Section 3.1, 3.20 / NEI 13-02, Section 6.1.2, 6.1.3, 6.2**

#### Program Controls:

The HCVS venting actions will include:

- Site procedures and programs are being developed in accordance with NEI 13-02 to address use and storage of portable equipment relative to the Severe Accident defined in NRC Order EA-13-109 and the hazards applicable to the site per Part 1 of this OIP.
- Routes for transporting portable equipment from storage location(s) to deployment areas will be developed as the response details are identified and finalized. The identified paths and deployment areas will be accessible when the HCVS is required to be functional including during Severe Accidents.

#### Procedures:

Procedures will be established for system operations when normal and backup power is available, and during ELAP conditions.

The HCVS and SAWA procedures will be developed and implemented following plant processes for initiating or revising procedures and contain the following details:

- appropriate conditions and criteria for use of the HCVS and SAWA
- when and how to place the HCVS and SAWA in operation
- location of system components
- instrumentation available
- normal and backup power supplies
- directions for sustained operation, including the storage and location of portable equipment (Reference NEI 13-02 [9])
- location of the remote control HCVS operating station (panel)
- training on operating the portable equipment
- testing of portable equipment

LSCS does not credit Containment Accident Pressure (CAP) for ECCS pump NPSH.

Provisions will be established for out-of-service requirements of the HCVS and compensatory measures that comply with the criteria from NEI 13-02 (Reference 9).

LSCS will establish provisions for out-of-service requirements of the HCVS and compensatory measures. The following provisions will be documented in the HCVS Program Document:

The provisions for out-of-service requirements for HCVS/SAWA are applicable in Modes 1, 2 and 3

- If for up to 90 consecutive days, the primary or alternate means of HCVS/SAWA operation are non-functional, no compensatory actions are necessary.

LaSalle County Station Units 1 and 2  
Overall Integrated Plan for Reliable Hardened Vents

**Part 4: Programmatic Controls, Training, Drills and Maintenance**

- If for up to 30 days, the primary and alternate means of HCVS/SAWA operation are non-functional, no compensatory actions are necessary.
- If the out of service times exceed 30 or 90 days as described above, the following actions will be performed through the site corrective action program:
  - Determine the cause(s) of the non-functionality,
  - Establish the actions to be taken and the schedule for restoring the system to functional status and to prevent recurrence,
  - Initiate action to implement appropriate compensatory actions, and
  - Restore full HCVS functionality at the earliest opportunity not to exceed one full operating cycle.

**Describe training plan**

*List training plans for affected organizations or describe the plan for training development.*

**Ref: EA-13-109, Section 3.2 / NEI 13-02, Section 6.1.3**

Personnel expected to perform direct execution of the HCVS/SAWA/SAWM actions will receive necessary training in the use of plant procedures for system operations when normal and backup power is available and during ELAP conditions. The training will be refreshed on a periodic basis and as any changes occur to the HCVS/SAWA/SAWM actions, systems or strategies. Training content and frequency will be established using the Systematic Approach to Training (SAT) process.

**Identify how the drills and exercise parameters will be met.**

*Alignment with NEI 13-06 and 14-01 as codified in NTTF Recommendation 8 and 9 rulemaking.*

*The Licensee should demonstrate use in drills, tabletops, or exercises for HCVS operation as follows:*

- *Hardened containment vent operation on normal power sources (no ELAP).*
- *During FLEX demonstrations (as required by EA-12-049): Hardened containment vent operation on backup power and from primary or alternate location during conditions of ELAP/loss of UHS with no core damage. System use is for containment heat removal AND containment pressure control.*
- *HCVS operation on backup power and from primary or alternate location during conditions of ELAP/loss of UHS with core damage. System use is for containment heat removal AND containment pressure control with potential for combustible gases (Demonstration may be in conjunction with SAG change).*
- *Operation for sustained period with SAWA and SAWM to provide decay heat removal and containment pressure control.*

**Ref: EA-13-109, Section 3.1 / NEI 13-02, Section 6.1.3**

LSCS will utilize the guidance provided in NEI 13-06 and 14-01 (References 10 and 11) for guidance related to drills, tabletops, or exercises for HCVS operation. In addition, LSCS will integrate these requirements with compliance to any rulemaking resulting from the NTTF Recommendations 8 and 9.

## **Part 4: Programmatic Controls, Training, Drills and Maintenance**

**Describe maintenance plan:**

- *The maintenance program should ensure that the HCVS/SAWA/SAWM equipment reliability is being achieved in a manner similar to that required for FLEX equipment. Standard industry templates (e.g., EPRI) and associated bases may be developed to define specific maintenance and testing.*
  - *Periodic testing and frequency should be determined based on equipment type and expected use (further details are provided in Part 6 of this document).*
  - *Testing should be done to verify design requirements and/or basis. The basis should be documented and deviations from vendor recommendations and applicable standards should be justified.*
  - *Preventive maintenance should be determined based on equipment type and expected use. The basis should be documented and deviations from vendor recommendations and applicable standards should be justified.*
  - *Existing work control processes may be used to control maintenance and testing.*
- *HCVS/SAWA permanent installed equipment should be maintained in a manner that is consistent with assuring that it performs its function when required.*
  - *HCVS/SAWA permanently installed equipment should be subject to maintenance and testing guidance provided to verify proper function.*
- *HCVS/SAWA non-installed equipment should be stored and maintained in a manner that is consistent with assuring that it does not degrade over long periods of storage and that it is accessible for periodic maintenance and testing.*

**Ref: EA-13-109, Section 1.2.13 / NEI 13-02, Section 5.4, 6.2**

LSCS will utilize the standard EPRI industry PM process (similar to the Preventive Maintenance Basis Database) for establishing the maintenance calibration and testing actions for HCVS/SAWA/SAWM components. The control program will include maintenance guidance, testing procedures and frequencies established based on type of equipment and considerations made within the EPRI guidelines.

LSCS will implement the following operation, testing and inspection requirements for the HCVS and SAWA to ensure reliable operation of the system.

**Table 4-1: Testing and Inspection Requirements**

Description	Frequency
Cycle the HCVS and installed SAWA valves <sup>1</sup> and the interfacing system valves not used to maintain containment integrity during Mode 1, 2 and 3. For HCVS valves, this test may be performed concurrently with the control logic test described below.	Once per every <sup>2</sup> operating cycle
Cycle the HCVS and installed SAWA check valves not used to maintain containment integrity during unit operations <sup>3</sup> .	Once per every other <sup>4</sup> operating cycle
Perform visual inspections and a walk down of HCVS and installed SAWA components.	Once per every other <sup>4</sup> operating cycle



LaSalle County Station Units 1 and 2  
Overall Integrated Plan for Reliable Hardened Vents

**Part 4: Programmatic Controls, Training, Drills and Maintenance**

Functionally test the HCVS radiation monitors.	Once per operating cycle
Leak test the HCVS.	(1) Prior to first declaring the system functional; (2) Once every three operating cycles thereafter; and (3) After restoration of any breach of system boundary within the buildings
Validate the HCVS operating procedures by conducting an open/close test of the HCVS control function from its control location and ensuring that all HCVS vent path and interfacing system valves <sup>5</sup> move to their proper (intended) positions.	Once per every other operating cycle

<sup>1</sup> Not required for HCVS and SAWA check valves.

<sup>2</sup> After two consecutive successful performances, the test frequency may be reduced to a maximum of once per every other operating cycle.

<sup>3</sup> Not required if integrity of check function (open and closed) is demonstrated by other plant testing requirements.

<sup>4</sup> After two consecutive successful performances, the test frequency may be reduced by one operating cycle to a maximum of once per every fourth operating cycle.

<sup>5</sup> Interfacing system boundary valves that are normally closed and fail closed under ELAP conditions (loss of power and/or air/gas) do not require control function testing under this part. Performing existing plant design basis function testing or system operation that reposition the valve(s) to the HCVS required position will meet this requirement without the need for additional testing.

**Notes:** None

LaSalle County Station Units 1 and 2  
Overall Integrated Plan for Reliable Hardened Vents

**Part 5: Milestone Schedule**

**Provide a milestone schedule. This schedule should include:**

- **Modifications timeline**
- **Procedure guidance development complete**
  - **HCVS Actions**
  - **Maintenance**
- **Storage plan (reasonable protection)**
- **Staffing analysis completion**
- **Long term use equipment acquisition timeline**
- **Training completion for the HCVS Actions**

*The dates specifically required by the order are obligated or committed dates. Other dates are planned dates subject to change. Updates will be provided in the periodic (six month) status reports.*

**Ref: EA-13-109, Section D.1, D.3 / NEI 13-02, Section 7.2.1**

The following milestone schedule is provided. The dates are planning dates subject to change as design and implementation details are developed. Any changes to the following target dates will be reflected in the subsequent 6-month status reports.

**Phase 1 Milestones:**

Milestone	Target Completion Date	Activity Status	Comments
Hold preliminary/conceptual design meeting	June 2014	Complete	
Submit Overall Integrated Implementation Plan	Jun 2014	Complete	
Submit 6 Month Status Report	Dec 2014	Complete	
Submit 6 Month Status Report	Jun 2015	Complete	
Submit 6 Month Status Report	Dec. 2015	Complete with this submittal	Simultaneous with Phase 2 OIP
U2 Design Engineering Complete	November 2016	Started	Design Engineering started in July 2014
U2 Maintenance and Operation Procedure Changes Developed, Training Complete	December 2016	Not Started	
U2 Implementation Outage	February 2017	Not Started	
U2 Procedure Changes Active, Walk-Through Demonstration/Functional Test	March 2017	Not Started	
U1 Design Engineering Complete	March 2017	Not Started	
U1 Maintenance and Operation Procedure Changes Developed, Training Complete	December 2017	Not Started	

LaSalle County Station Units 1 and 2  
Overall Integrated Plan for Reliable Hardened Vents

**Part 5: Milestone Schedule**

U1 Implementation Outage	February 2018	Not Started	
U1 Procedure Changes Active, Walk-Through Demonstration/Functional Test,	March 2018	Not Started	
Submit Completion Report	May 2018	Not started	

**Phase 2 Milestone Schedule:**

Phase 2 Milestone Schedule

Milestone	Target Completion Date	Activity Status	Comments
Submit Overall Integrated Implementation Plan	Dec 2015	Complete with this submittal	Simultaneous with Phase 1 Updated OIP
Hold preliminary/conceptual design meeting	June 2015	Complete	
Submit 6 Month Status Report	June 2016		
Submit 6 Month Status Report	Dec 2016		
Submit 6 Month Status Report	June 2017		
Submit 6 Month Status Report	Dec 2017		
Submit 6 Month Status Report	June 2018		
Submit 6 Month Status Report	Dec 2018		
U1 Design Engineering Complete	March 2017	Not Started	Simultaneous with Phase 1
U1 Maintenance and Operation Procedure Changes Developed, Training Complete	December 2017	Not Started	Simultaneous with Phase 1
U1 Implementation Outage	February 2018	Not Started	Simultaneous with Phase 1
U1 Procedure Changes Active, Walk-Through Demonstration/Functional Test, Design Engineering Complete	March 2018	Not Started	Simultaneous with Phase 1
U2 Design Engineering Complete	March 2018	Not Started	
U2 Maintenance and Operation Procedure Changes Developed, Training Complete	December 2018	Not Started	
U2 Implementation Outage	February 2019	Not Started	
U2 Procedure Changes Active, Walk-Through Demonstration/Functional Test, Design Engineering	March	Not	

LaSalle County Station Units 1 and 2  
Overall Integrated Plan for Reliable Hardened Vents

**Part 5: Milestone Schedule**

Complete	2019	Started	
Submit Completion Report	May 2019		
<b>Notes:</b> None			

LaSalle County Station Units 1 and 2  
Overall Integrated Plan for Reliable Hardened Vents

<b>Attachment 1: <u>HCVS/SAWA/SAWM Portable Equipment</u></b>				
<i>List portable equipment</i>	<i>BDBEE Venting</i>	<i>Severe Accident Venting</i>	<i>Performance Criteria</i>	<i>Maintenance / PM requirements</i>
Argon Cylinders	X	X	TBD	Check periodically for pressure, replace or replenish as needed
FLEX DG	X	X	500 KW 480 V	Per response to EA-12-049
FLEX (SAWA) Pump	X	X	1950 GPM @ 200 PSIG	Per response to EA-12-049
Portable Air Compressor (optional)	X	X	≈ 5 CFM	Per vendor manual

LaSalle County Station Units 1 and 2  
 Overall Integrated Plan for Reliable Hardened Vents

**Attachment 2A: Sequence of Events Timeline - HCVS**

**Attachment 2.1.A: Sequence of Events Timeline – SAWA / SAWM**

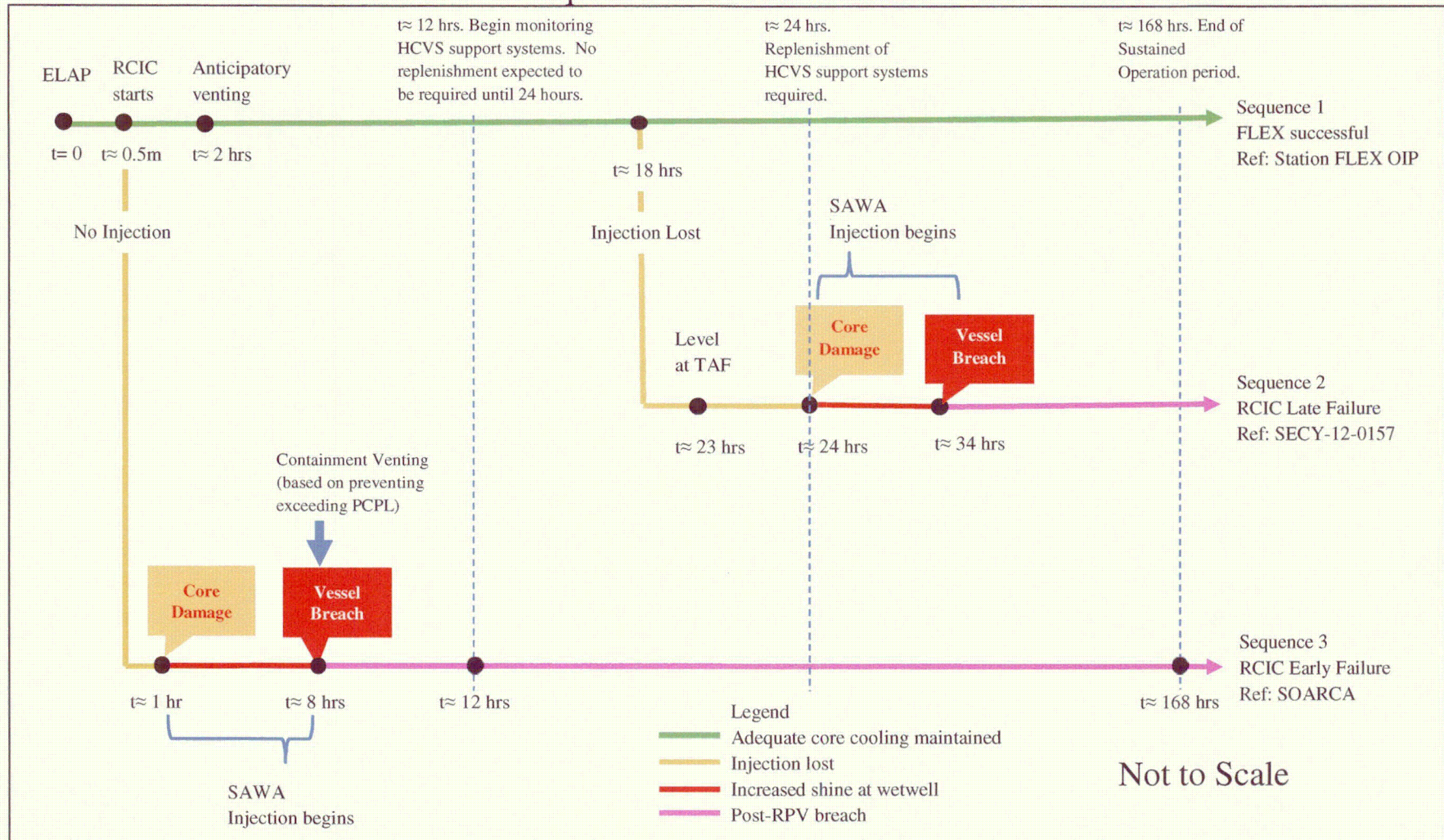



## SAWM Timeline

### Sustained Operation period

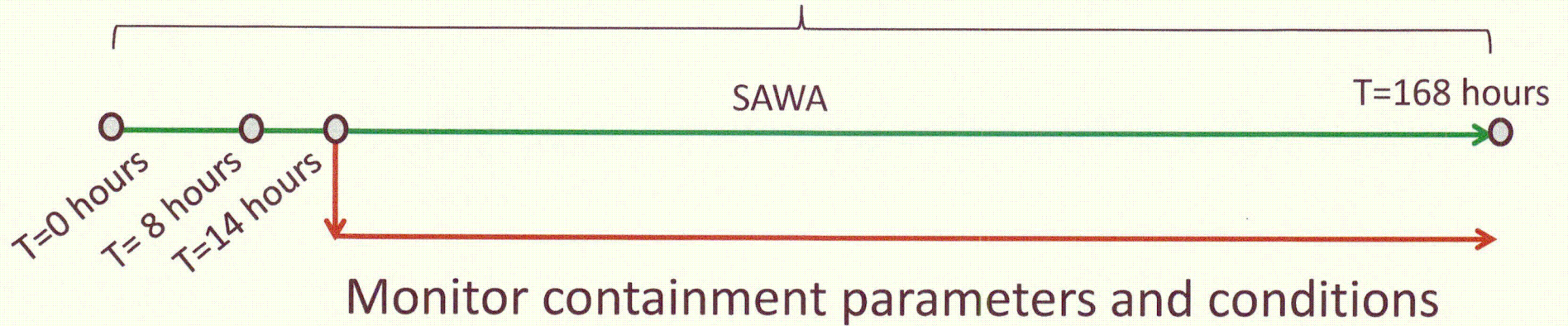

Time	Action
T = 0 hours	Start of ELAP
T ≤ 8 hours	Initiate SAWA flow at 500 gpm as soon as possible but no later than 8 hours
T ≤ 12 hours	Throttle SAWA flow to 100 gpm 4 hours after initiation of SAWA flow
T = 168 hours	End of Sustained Operation

LaSalle County Station Units 1 and 2  
Overall Integrated Plan for Reliable Hardened Vents  
Attachment 2.1.B: Sequence of Events Timeline – SADV

**Not applicable to LSCS**



LaSalle County Station Units 1 and 2  
 Overall Integrated Plan for Reliable Hardened Vents  
 Attachment 2.1.C: SAWA/SAWM Plant-Specific Datum

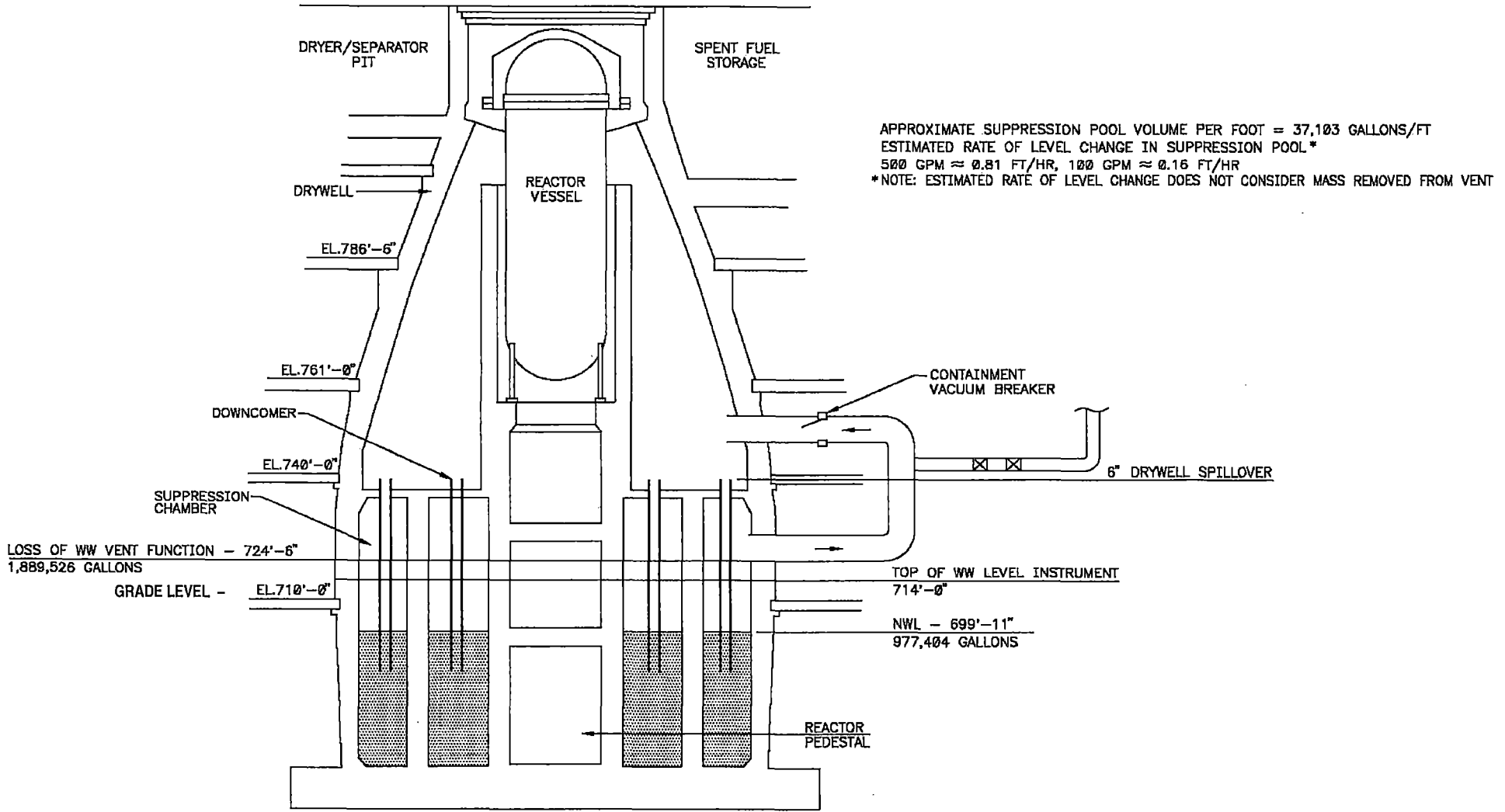

LASALLE PRIMARY CONTAINMENT OUTLINE

LaSalle County Station Units 1 and 2  
Overall Integrated Plan for Reliable Hardened Vents

Attachment 2.1.D: SAWM SAMG Approved Language

*The following general cautions, priorities and methods will be evaluated for plant specific applicability and incorporated as appropriate into the plant specific SAMGs using administrative procedures for EPG/SAG change control process and implementation. SAMGs are symptom based guidelines and therefore address a wide variety of possible plant conditions and capabilities while these changes are intended to accommodate those specific conditions assumed in Order EA-13-109. The changes will be made in a way that maintains the use of SAMGs in a symptom based mode while at the same time addressing those conditions that may exist under extended loss of AC power (ELAP) conditions with significant core damage including ex-vessel core debris.*

**Actual Approved Language that will be incorporated into site SAMG\***

**Cautions:**

- Addressing the possible plant response associated with adding water to hot core debris and the resulting pressurization of the primary containment by rapid steam generation.
- Addressing the plant impact that raising suppression pool water level above the elevation of the suppression chamber vent opening elevation will flood the suppression chamber vent path.

**Priorities:**

With significant core damage and RPV breach, SAMGs prioritize the preservation of primary containment integrity while limiting radioactivity releases as follows:

- Core debris in the primary containment is stabilized by water addition (SAWA).
- Primary containment pressure is controlled below the Primary Containment Pressure Limit (wetwell venting).
- Water addition is managed to preserve the Mark I/II suppression chamber vent paths, thereby retaining the benefits of suppression pool scrubbing and minimizing the likelihood of radioactivity and hydrogen release into the secondary containment (SAWM).

**Methods:**

Identify systems and capabilities to add water to the RPV or drywell, with the following generic guidance:

- Use controlled injection if possible.
- Inject into the RPV if possible.

Maintain injection from external sources of water as low as possible to preserve suppression chamber vent capability.

\* Actual language may vary by acceptable site procedure standards, but intent and structure should follow this guidance.

LaSalle County Station Units 1 and 2  
Overall Integrated Plan for Reliable Hardened Vents

Attachment 3: Conceptual Sketches

(Conceptual sketches, as necessary to indicate equipment which is installed or equipment hookups necessary for the strategies)

**Sketch 1A and 1B: Electrical Layout of System (*preliminary*)**

- Instrumentation Process Flow
- Electrical Connections

**Sketch 2A, 2B, and 2C: P&ID Layout of WW Vent, Pathways and Site Layout (*preliminary*)**

- Piping routing for vent path – WW Vent
  - Demarcate the valves (in the vent piping) between the currently existing and new ones
  - WW Vent Instrumentation Process Flow Diagram
  - Egress and Ingress Pathways to ROS, Battery Transfer Switch, DG Connections and Deployment location

**Sketch 3: P&ID Layout of SAWA, Pathways and Site Layout (*preliminary*)**

- Piping routing for SAWA path
  - SAWA instrumentation process paths.
  - SAWA connections .
  - Include a piping and instrumentation diagram of the vent system. Demarcate the valves (in the vent piping) between the currently existing and new ones.
  - Ingress and egress paths to and from control locations and manual action locations.
  - Site layout sketch to show locations of piping and associated components. This should include relative locations both horizontally and vertically.

LaSalle County Station Units 1 and 2  
Overall Integrated Plan for Reliable Hardened Vents

Sketch 1A: Electrical Layout of System - HCVS

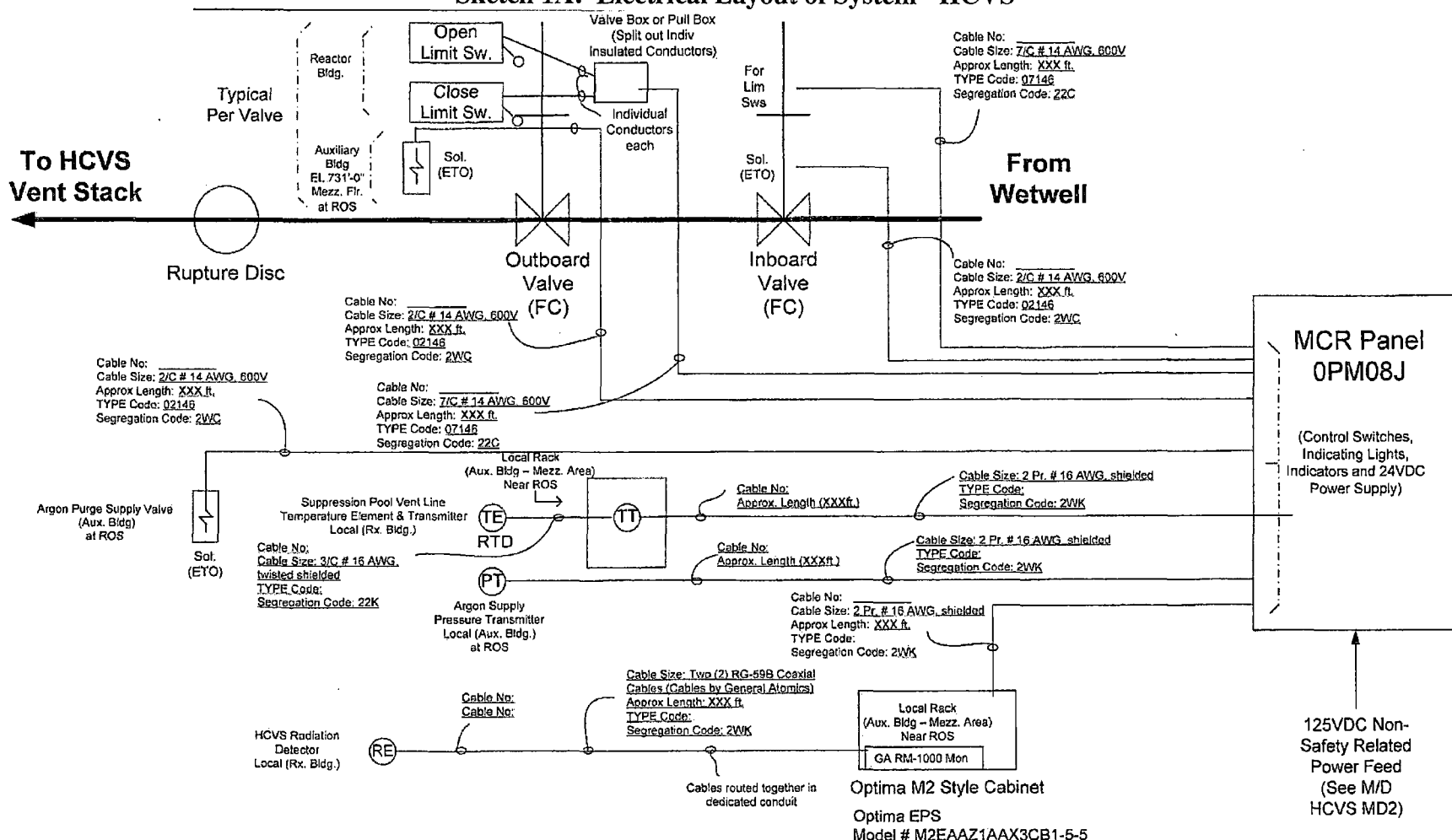

EC 392353 (10% Issue)

Notes:

- 1) Solenoids are ETO (Energize to Open) the valve. Each solenoid shall be controlled from a separate CR104P selector switch at Panel OPM08J.
- 2) The Limit Switches are at the valves in the Reactor Building; solenoids are at the locations shown above.

NOTES		REV
Quality Classification: Augmented Quality (AQ), Cables: NSR		1
Equipment Seismic Cat.: I		
SERVICE: HCVS Valve Control & Indication		
STATION: LaSalle Unit 2		

LaSalle County Station Units 1 and 2  
Overall Integrated Plan for Reliable Hardened Vents

Sketch 1B: Electrical Connections – HCVS and SAWA

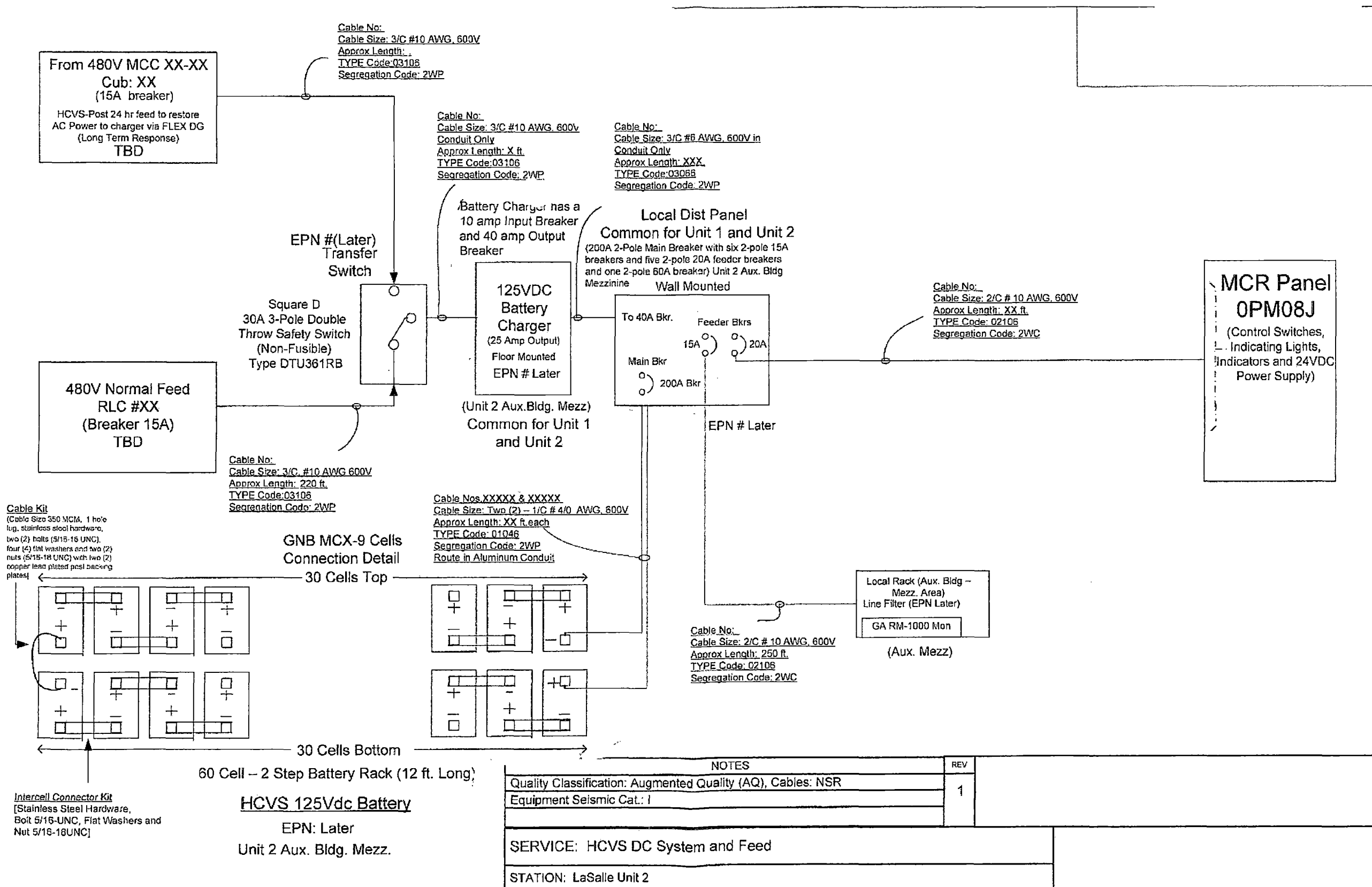

NOTES		REV
Quality Classification: Augmented Quality (AQ), Cables: NSR		1
Equipment Seismic Cat: I		
SERVICE: HCVS DC System and Feed		
STATION: LaSalle Unit 2		

LaSalle County Station Units 1 and 2  
Overall Integrated Plan for Reliable Hardened Vents

Sketch 2A: P&ID Sheet 1

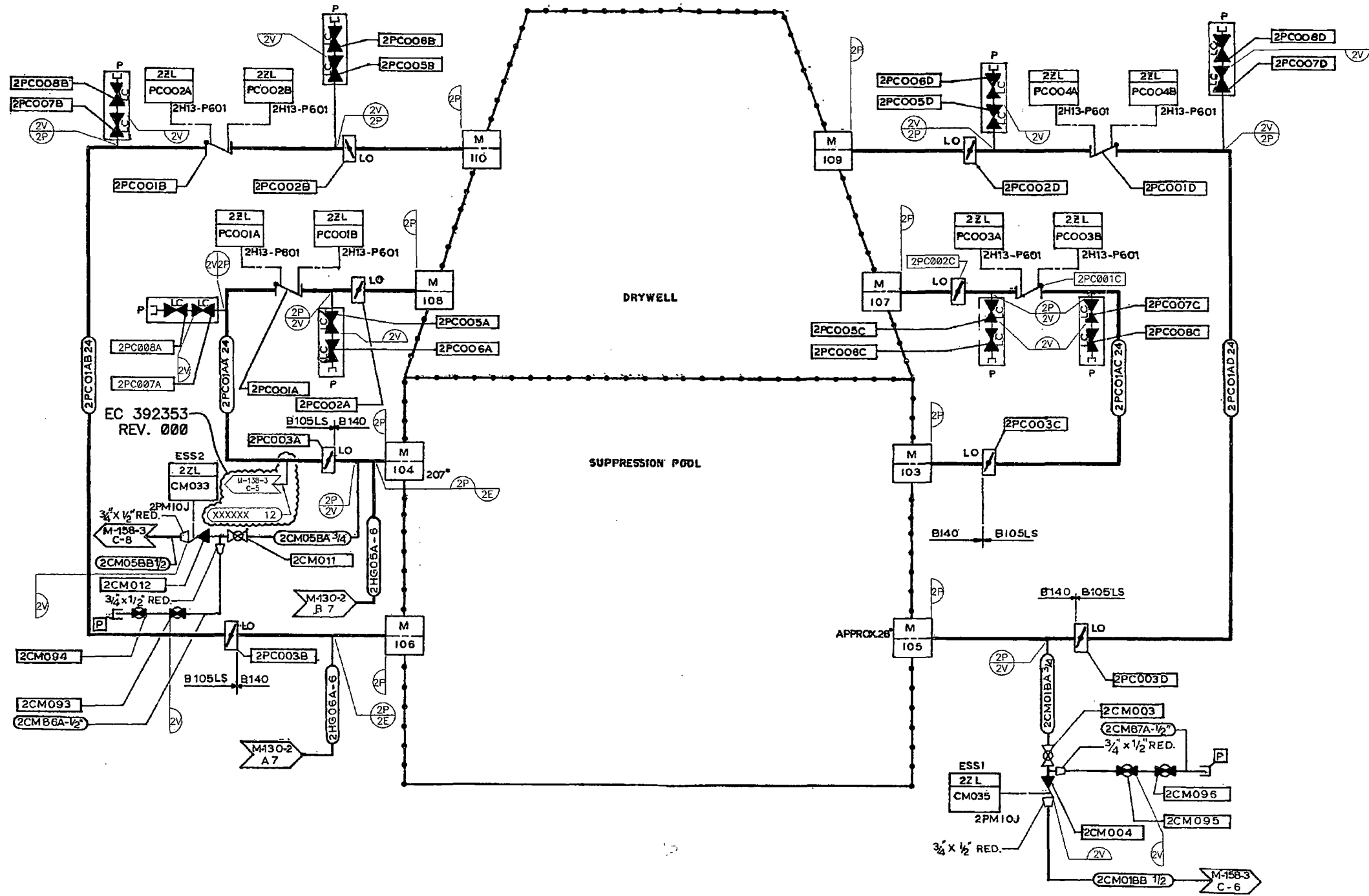

LaSalle County Station Units 1 and 2  
 Overall Integrated Plan for Reliable Hardened Vents  
 Sketch 2B: P&ID Sheet 2

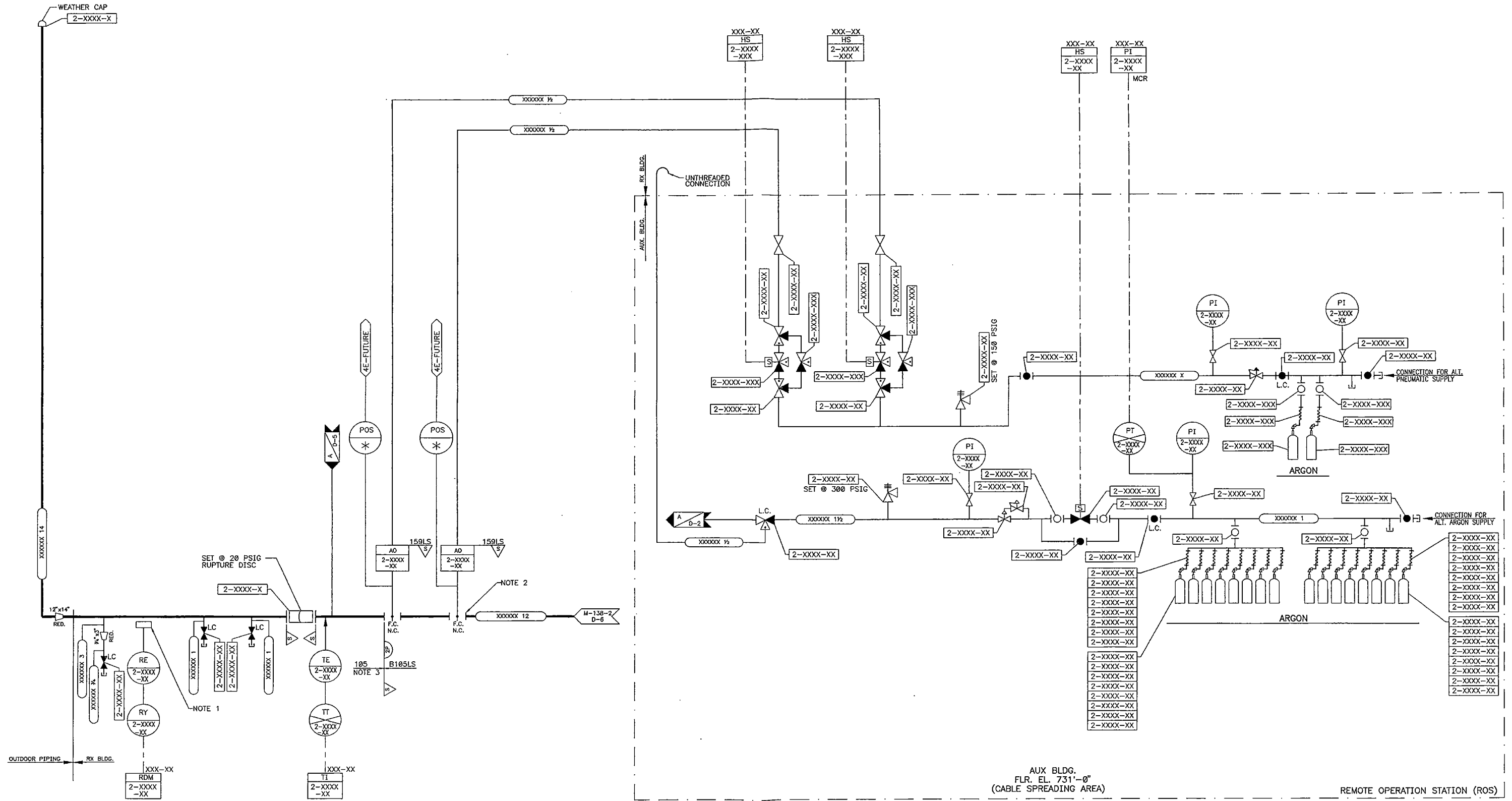



LaSalle County Station Units 1 and 2  
Overall Integrated Plan for Reliable Hardened Vents

Sketch 2C: Remote Operating Station

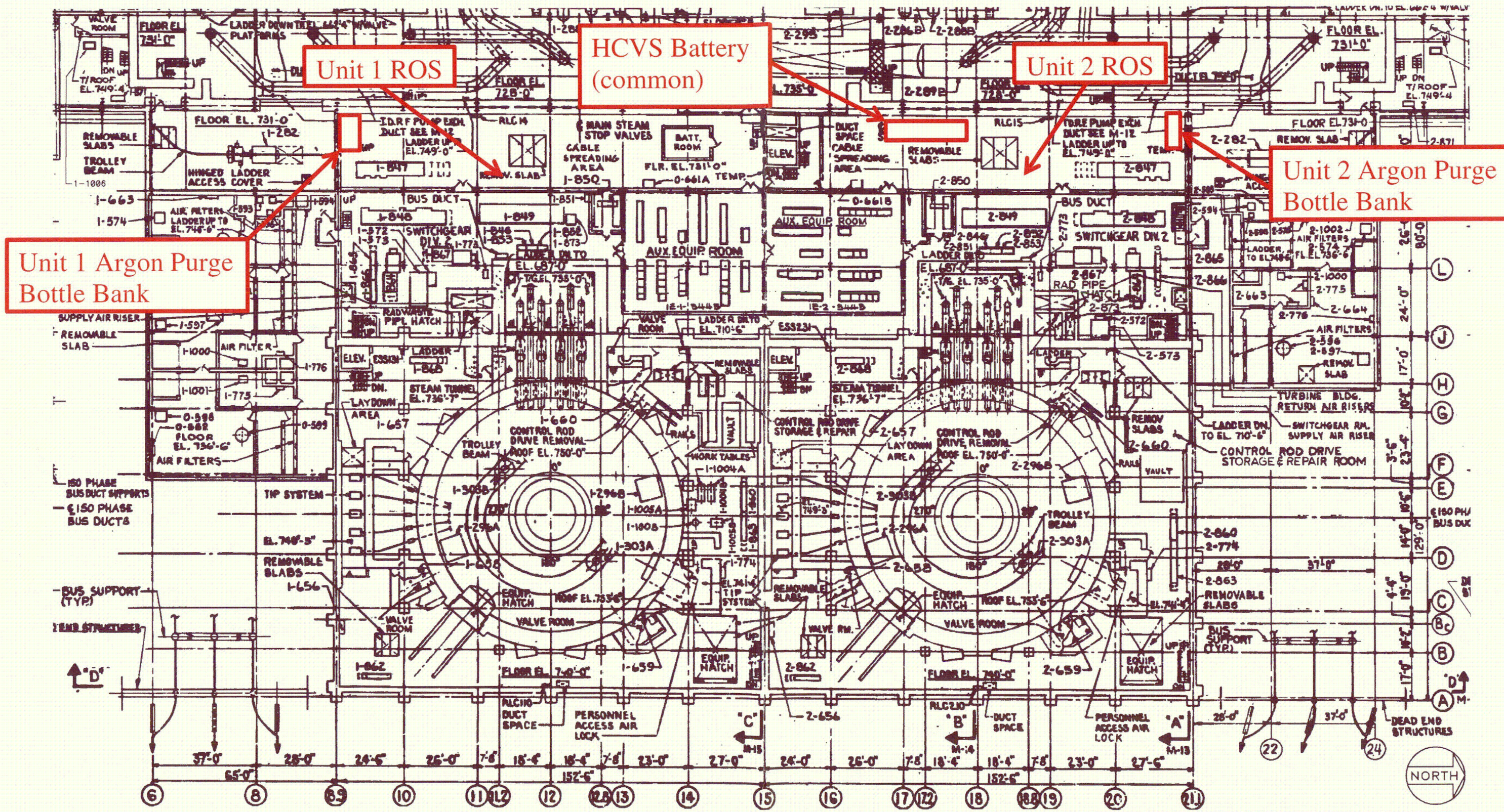



LaSalle County Station Units 1 and 2  
Overall Integrated Plan for Reliable Hardened Vents

Sketch 3A: P&ID Layout of SAWA  
(Note - Same as FLEX)

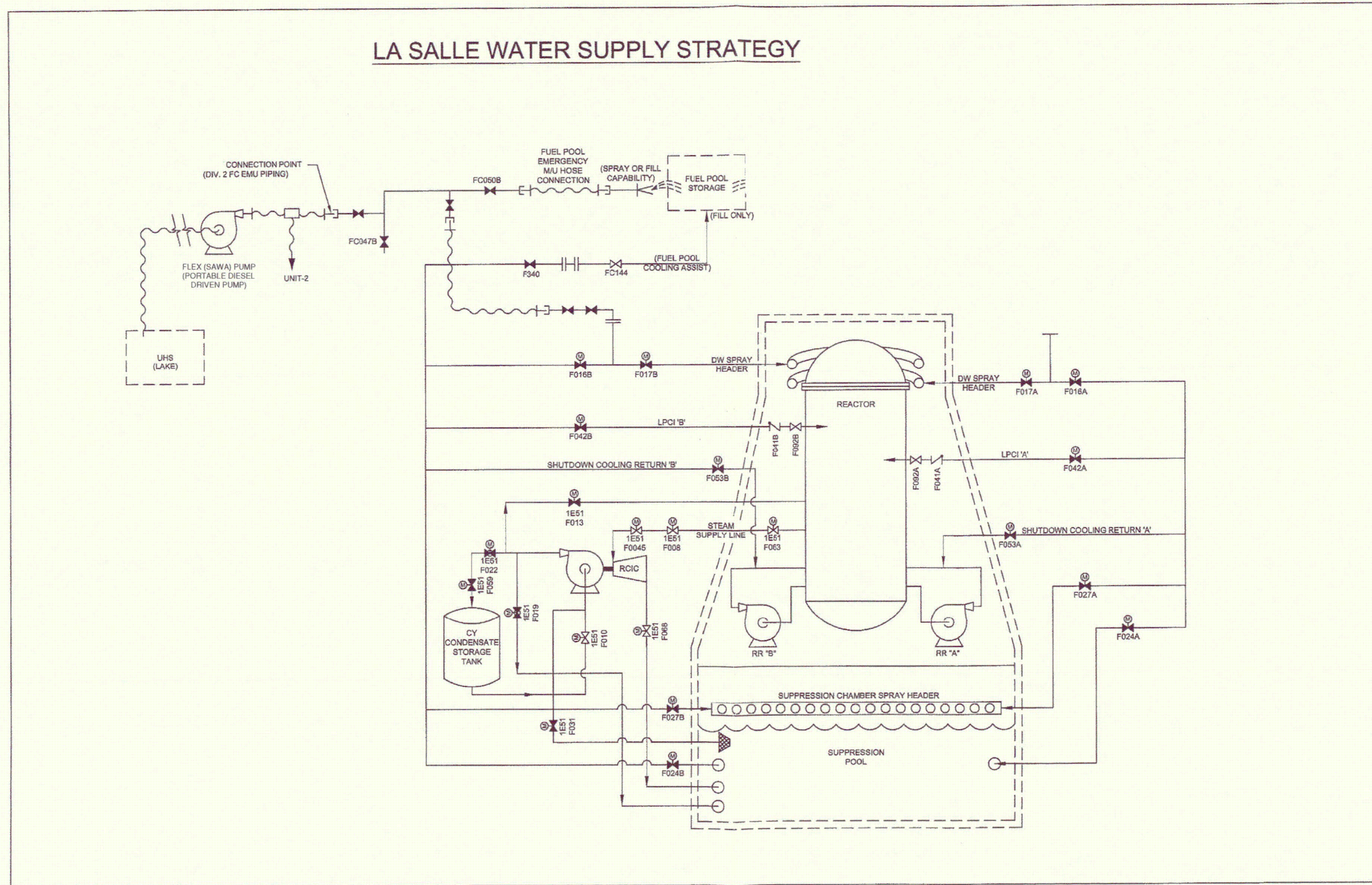



LaSalle County Station Units 1 and 2  
Overall Integrated Plan for Reliable Hardened Vents

Sketch 3B: Site Layout, Ingress and Egress Pathways (SAWA)  
SAWA External Hose Routing (same as FLEX)

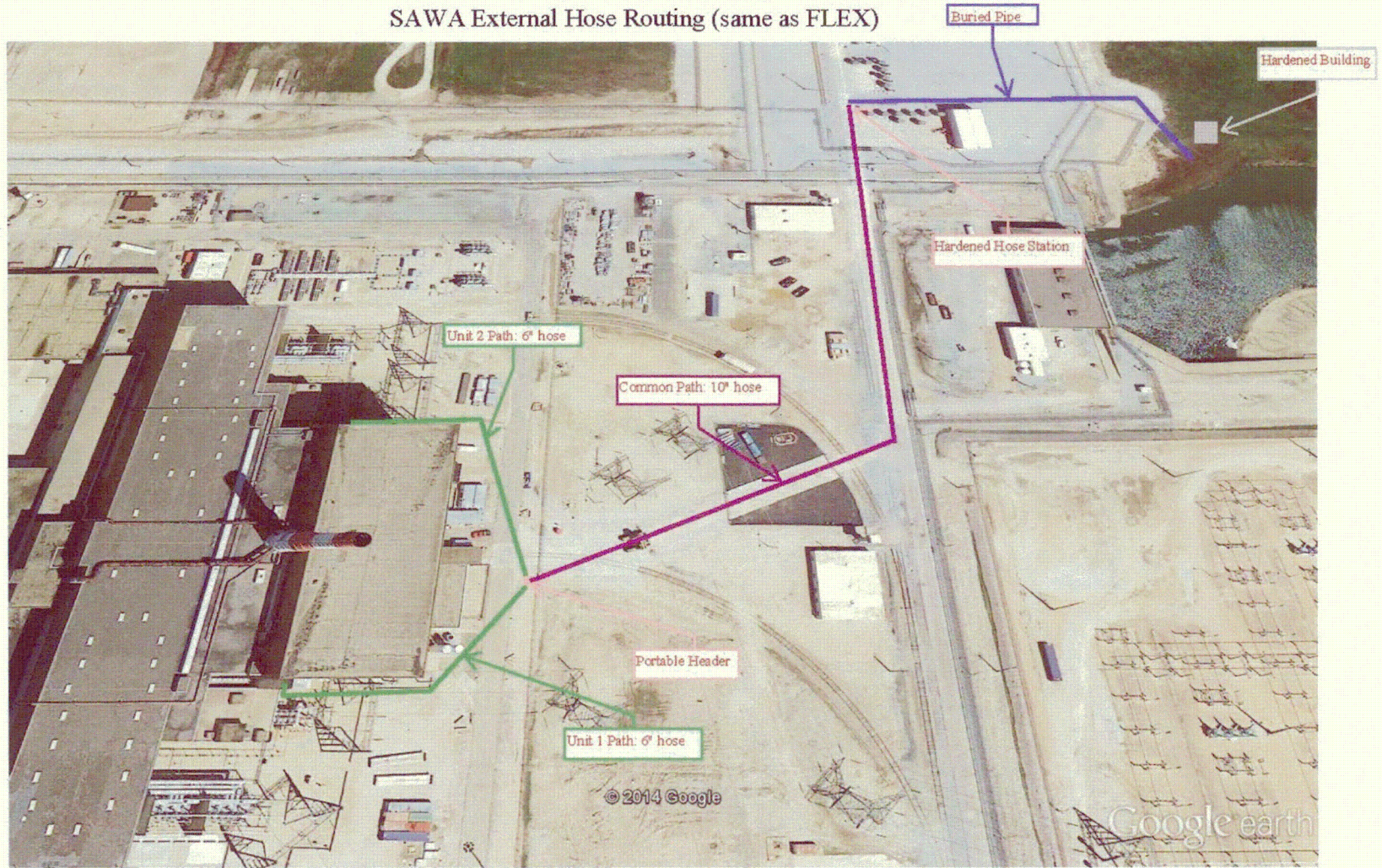

Note: The routing depicted in this sketch is for information only. The actual routing may change due to plant conditions.

Reference:  
Google Earth Pro Version 6.2.2.6613,  
Built on 4/11/2012, S&L Program  
Number 03.2.446-6.2, operated on  
Computer ZL7956



LaSalle County Station Units 1 and 2  
Overall Integrated Plan for Reliable Hardened Vents  
Sketch 3C: LSCS Reactor Building Elevation View

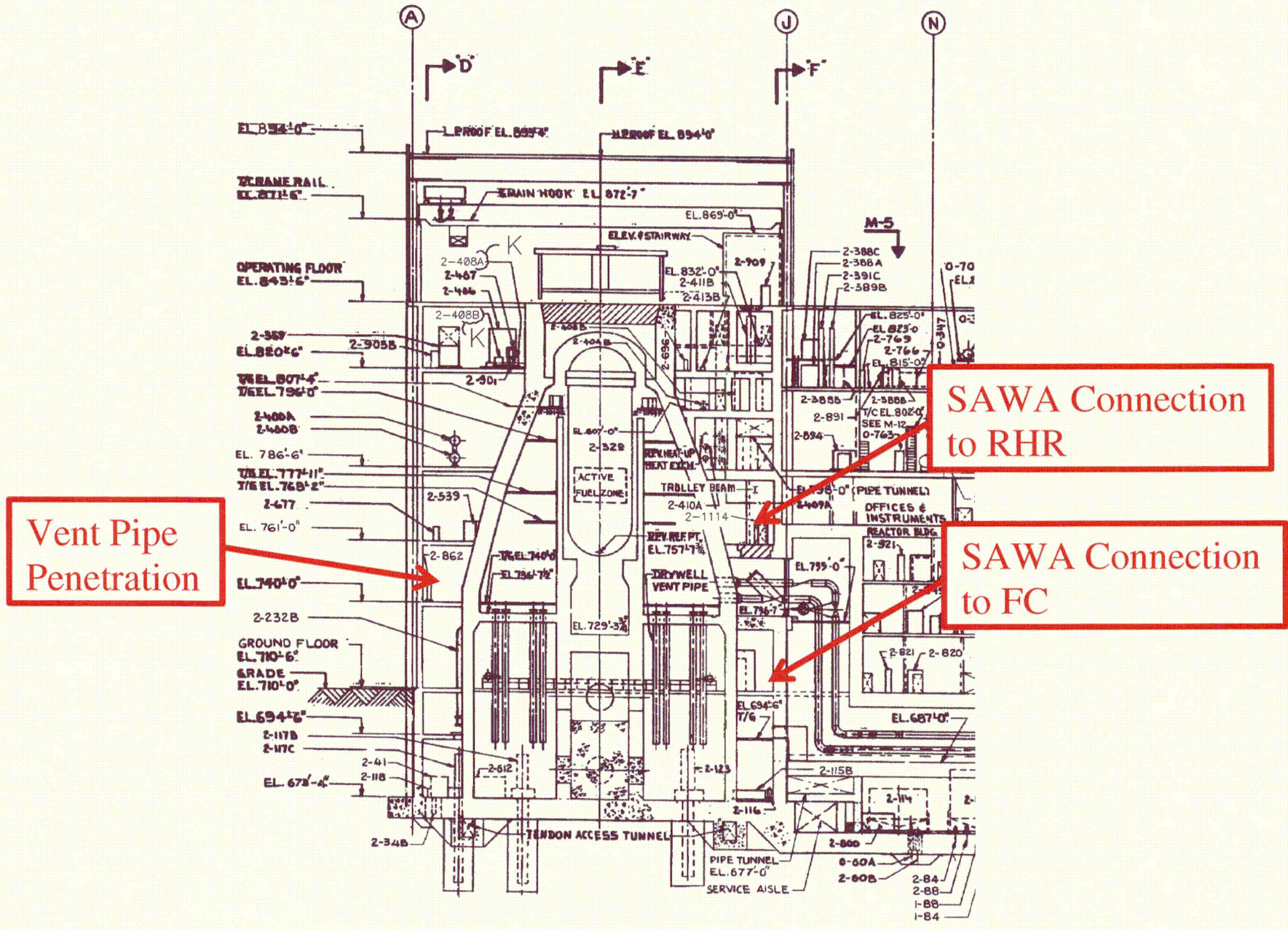

Vent Pipe Penetration

SAWA Connection to RHR

SAWA Connection to FC

LaSalle County Station Units 1 and 2  
Overall Integrated Plan for Reliable Hardened Vents

**Attachment 4: Failure Evaluation Table**

Table 4A: Wetwell HCVS Failure Evaluation Table

Functional Failure Mode	Failure Cause	Alternate Action	Failure with Alternate Action Prevents Containment Venting?
Fail to Vent (Open) on Demand	Valves fail to open/close due to loss of normal AC power/DC batteries.	None required – system SOVs utilize dedicated 24-hour power supply.	No
	Valves fail to open/close due to depletion of dedicated power supply.	Recharge system with provided portable generators.	No
	Valves fail to open/close due to complete loss of power supplies.	Manually operate backup pneumatic supply/vent lines at ROS.	No
	Valves fail to open/close due to loss of normal pneumatic supply.	No action needed. Valves are provided with dedicated motive force capable of 24-hour operation.	No
	Valves fail to open/close due to loss of alternate pneumatic supply (long term).	Replace bottles as needed and/or recharge with portable air compressors.	No
	Valve fails to open/close due to SOV failure.	Manually operate backup pneumatic supply/vent lines at ROS.	No
Fail to stop venting (Close) on demand	Not credible as there is not a common mode failure that would prevent the closure of at least 1 of the 2 valves needed for venting. Both valves designed to fail shut.	N/A	No
Spurious Opening	Not credible as key-locked switches prevent mispositioning of the HCVS PCIVs and additionally, DC power for the solenoid valve is normally de-energized.	N/A	No
Spurious Closure	Valves fail to remain open due to depletion of dedicated power supply.	Recharge system with provided portable generators.	No
	Valves fail to remain open due to complete loss of power supplies.	Manually operate backup pneumatic supply/vent lines at ROS.	No
	Valves fail to remain open due to loss of alternate pneumatic supply (long term).	Replace bottles as needed and/or recharge with portable air compressors.	No

LaSalle County Station Units 1 and 2  
Overall Integrated Plan for Reliable Hardened Vents

**Attachment 5: References**

1. Overall Integrated Plan for Mitigation Strategies for Beyond-Design-Basis External Events, dated February 28, 2013 (ML1306A421) for LSCS
2. Generic Letter 89-16, Installation of a Hardened Wetwell Vent, dated September 1, 1989
3. Order EA-12-049, Mitigation Strategies for Beyond-Design-Basis External Events, dated March 12, 2012
4. Order EA-13-109, Severe Accident Reliable Hardened Containment Vents, dated June 6, 2013
5. JLD-ISG-2012-01, Compliance with Order EA-12-049, Mitigation Strategies for Beyond-Design-Basis External Events, dated August 29, 2012
6. JLD-ISG-2013-02, Compliance with Order EA-13-109, Severe Accident Reliable Hardened Containment Vents, dated November 14, 2013
7. NRC Responses to Public Comments, Japan Lessons-Learned Project Directorate Interim Staff Guidance JLD-ISG-2012-02: Compliance with Order EA-12-050, Order Modifying Licenses with Regard to Reliable Hardened Containment Vents, ADAMS Accession No. ML12229A477, dated August 29, 2012
8. NEI 12-06, Diverse and Flexible Coping Strategies (FLEX) Implementation Guide, Rev. 0, dated August 2012
9. NEI 13-02, Industry Guidance for Compliance with Order EA-13-109, Rev. 0, dated November 2013
10. NEI 13-06, Enhancements to Emergency Response Capabilities for Beyond Design Basis Accidents and Events, Rev. 0, dated March 2014
11. NEI 14-01, Emergency Response Procedures and Guidelines for Extreme Events and Severe Accidents, Rev. 0, dated March 2014
12. NEI HCVS-FAQ-01, HCVS Primary and Alternate Controls and Monitoring Locations
13. NEI HCVS-FAQ-02, HCVS Dedicated Equipment
14. NEI HCVS-FAQ-03, HCVS Alternate Control Operating Mechanisms
15. NEI HCVS-FAQ-04, HCVS Release Point
16. NEI HCVS-FAQ-05, HCVS and SAWA Valve Testing
17. NEI HCVS-FAQ-06, HCVS FLEX and Generic Assumptions
18. NEI HCVS-FAQ-07, HCVS Source Term from SFP
19. NEI HCVS-FAQ-08, HCVS Instrument Qualification
20. NEI HCVS-FAQ-09, HCVS Toolbox Approach for Collateral Actions
21. NEI White Paper HCVS-WP-01, HCVS Dedicated and Permanently Installed Motive Force
22. NEI White Paper HCVS-WP-02, Sequences for HCVS Design and Method for Determining Radiological Dose from HCVS Piping
23. NEI White Paper HCVS-WP-03, Hydrogen/Carbon Monoxide Control Measures
24. NUREG-1935, State-of-the-Art Reactor Consequence Analysis (SOARCA)
25. NUREG/CR-7110, State-of-the-Art Reactor Consequence Analysis Project, Volume 1: Peach Bottom Integrated Analysis, Rev. 1
26. SECY-12-0157, Consideration of Additional Requirements for Containment Venting Systems for Boiling Water Reactors with Mark I and Mark II Containments, dated November 26, 2012
27. LSCS UFSAR, Updated Final Safety Analysis Report, Rev. 21
28. IEEE Standard 344-2004, IEEE Recommended Practice for Seismic Qualification of Class 1E Equipment for Nuclear Power Generating Stations
29. MAAP Endorsement Letter, dated October 3, 2013 (ML13275A318)
30. LS-MISC-017, MAAP Analysis to Support Initial FLEX Strategy, Rev. 2
31. JLD-ISG-2015-01, Compliance with Phase 2 of Order EA-13-109, Order Modifying Licenses with Regard to Reliable Hardened Containment Vents Capable of Operation under Severe Accident Conditions, dated April 2015
32. NEI White Paper HCVS-WP-04, Missile Evaluation for HCVS Components 30 Feet Above Grade, Rev. 0, dated August 17, 2015
33. NEI HCVS-FAQ-10, Severe Accident Multiple Unit Response
34. NEI HCVS-FAQ-11, Plant Response During a Severe Accident
35. NEI HCVS-FAQ-12, Radiological Evaluations on Plant Actions Prior to HCVS Initial Use
36. NEI HCVS-FAQ-13, Severe Accident Venting Actions Validation
37. NEI 13-02, Industry Guidance for Compliance with Order EA-13-109, Rev. 1, dated April 2015

LaSalle County Station Units 1 and 2  
Overall Integrated Plan for Reliable Hardened Vents

38.NUREG-0519, Safety Evaluation Report Related to the Operation of LaSalle County Station, Units 1 and 2, dated  
June 30, 1981



LaSalle County Station Units 1 and 2  
Overall Integrated Plan for Reliable Hardened Vents

**Attachment 6: Changes/Updates to this Overall Integrated Implementation Plan**

*This Overall Integrated Plan has been updated in format and content to encompass both Phase 1 and Phase 2 of Order EA-13-109. Any significant changes to this plan will be communicated to the NRC staff in the 6-Month Status Reports.*

LaSalle County Station Units 1 and 2  
Overall Integrated Plan for Reliable Hardened Vents

**Attachment 7: List of Overall Integrated Plan Open Items**

The following tables provide a summary of the open items documented in the Phase 1 Overall Integrated Plan or the Interim Staff Evaluation (ISE) and the status of each item.

<i>Open Item</i>	<i>Open Items from OIP</i>	<i>Status</i>
1	<i>Determine how Motive Power and/or HCVS Battery Power will be disabled during normal operation.</i>	<i>Deleted. Closed to ISE Open Item number 1.</i>
2	<i>Confirm that the Remote Operating Station (ROS) will be in an accessible area following a Severe Accident (SA).</i>	<i>Deleted. Closed to ISE Open Item number 4.</i>
3	<i>Determine wetwell line size to meet 1% venting criteria.</i>	<i>Deleted. Closed to ISE Open Item number 5.</i>
4	<i>Confirm suppression pool heat capacity.</i>	<i>Complete - See Reference 30. The MAAP analyses done for the LaSalle Station as part of the FLEX implementation demonstrate that containment venting can be delayed for greater than 3 hours from the start of the ELAP event.</i>
5	<i>Determine the approach for combustible gases.</i>	<i>Deleted. Closed to ISE Open Item number 9.</i>
6	<i>Provide procedures for HCVS Operation.</i>	<i>Deleted. Closed to ISE Open Item number 13.</i>
7	<i>Perform radiological evaluation for Phase 1 vent line impact on ERO response actions.</i>	<i>Not Started</i>

<i>Open Item</i>	<i>Interim Staff Evaluation (ISE) Open Items</i>	<i>Status</i>
1	<i>Make available for NRC staff audit documentation of a method to disable HCVS during normal operation to provide assurances against inadvertent operation that also minimizes actions to enable HCVS operation following an ELAP.</i>	<i>Not started</i>
2	<i>Make available for NRC staff audit the final sizing evaluation for HCVS batteries/battery charger including incorporation into FLEX DG loading calculation.</i>	<i>Not Started</i>
3	<i>Make available for NRC staff audit documentation of the HCVS argon pneumatic system design including sizing and location.</i>	<i>Not Started</i>



LaSalle County Station Units 1 and 2  
Overall Integrated Plan for Reliable Hardened Vents

4	<i>Make available for NRC staff audit an evaluation of temperature and radiological conditions to ensure that operating personnel can safely access and operate controls and support equipment.</i>	<i>Not Started</i>
5	<i>Make available for NRC staff audit analyses demonstrating that HCVS has the capacity to vent the steam/energy equivalent of one percent of licensed/rated thermal power (unless a lower value is justified), and that the suppression pool and the HCVS together are able to absorb and reject decay heat, such that following a reactor shutdown from full power containment pressure is restored and then maintained below the primary containment design pressure and the primary containment pressure limit.</i>	<i>Started. The MAAP analyses done for the LaSalle station as part of the FLEX implementation demonstrate that containment venting can be delayed for greater than 3 hours from the start of the ELAP event (See Reference 30).</i>
6	<i>Make available for NRC staff audit the seismic and tornado missile final design criteria for the HCVS stack.</i>	<i>Started. As discussed in the December 2015 OIP submittal, the LaSalle design complies with the reasonable tornado protection criteria of HCVS-WP-04.</i>
7	<i>Make available for NRC staff audit the descriptions of local conditions (temperature, radiation and humidity) anticipated during ELAP and severe accident for the components (valves, instrumentation, sensors, transmitters, indicators, electronics, control devices, etc.) required for HCVS venting including confirmation that the components are capable of performing their functions during ELAP and severe accident conditions.</i>	<i>Not Started</i>
8	<i>Make available for NRC staff audit documentation that demonstrates adequate communication between the remote HCVS operation locations and HCVS decision makers during ELAP and severe accident conditions.</i>	<i>Not Started</i>
9	<i>Provide a description of the final design of the HCVS to address hydrogen detonation and deflagration.</i>	<i>Started. As discussed in the December 2015 OIP submittal, the LaSalle design will use an Argon purge system to prevent the possibility of hydrogen detonation and deflagration.</i>
10	<i>Provide a description of the strategies for hydrogen control that minimizes the potential for hydrogen gas migration and ingress into the reactor building or other buildings.</i>	<i>Started. As discussed in the December 2015 OIP, the LSCS wetwell vent line for each unit has a dedicated HCVS flowpath from the wetwell penetration to the outside with no interconnected system. The discharge point meets the guidance of HCVS-FAQ-04.</i>
11	<i>Make available for NRC staff audit documentation of a seismic qualification evaluation of HCVS components.</i>	<i>Not Started</i>
12	<i>Make available for NRC staff audit descriptions of all instrumentation and controls (existing and planned) necessary to implement this order including qualification methods.</i>	<i>Not Started</i>
13	<i>Make available for NRC staff audit the procedures for HCVS operation.</i>	<i>Not Started</i>

LaSalle County Station Units 1 and 2  
Overall Integrated Plan for Reliable Hardened Vents

<b>Phase 2 Open Item</b>	<b>Action</b>	<b>Comment</b>
1	Evaluation required to confirm feasibility due to radiological conditions.	<i>Not Started</i>
2	Verify Required Modifications to support SAWA/SAWM.	<i>Not Started</i>