

Clinton Power Station  
8401 Power Road  
Clinton, IL 61727



U-604211  
April 16, 2015

10CFR50.36a

Document Control Desk  
U.S. Nuclear Regulatory Commission  
Washington, DC 20555

Clinton Power Station, Unit 1  
Facility Operating License No. NPF-62  
NRC Docket No. 50-461

Subject: Clinton Power Station 2014 Annual Radioactive Effluent Release Report

Exelon Generating Company, LLC (Exelon), Clinton Power Station is submitting the 2014 Annual Radioactive Effluent Release Report. This report is submitted in accordance with Technical Specification requirement 5.6.3, "Radioactive Effluent Release Report," and covers the period from January 1, 2014 through December 31, 2014.

There are no commitments contained in this letter.

Questions on this letter may be directed to Mr. Rick Bair, Chemistry Manager, at 217-937-3200.

Respectfully,

A handwritten signature in black ink, appearing to read "Mark M. Newcomer".

Mark M. Newcomer  
Site Vice President

dra/cas

cc: Regional Administrator – NRC Region III  
NRC Senior Resident Inspector – Clinton Power Station  
Office of Nuclear Facility Safety – Illinois Emergency Management Agency

4 E48  
NRR

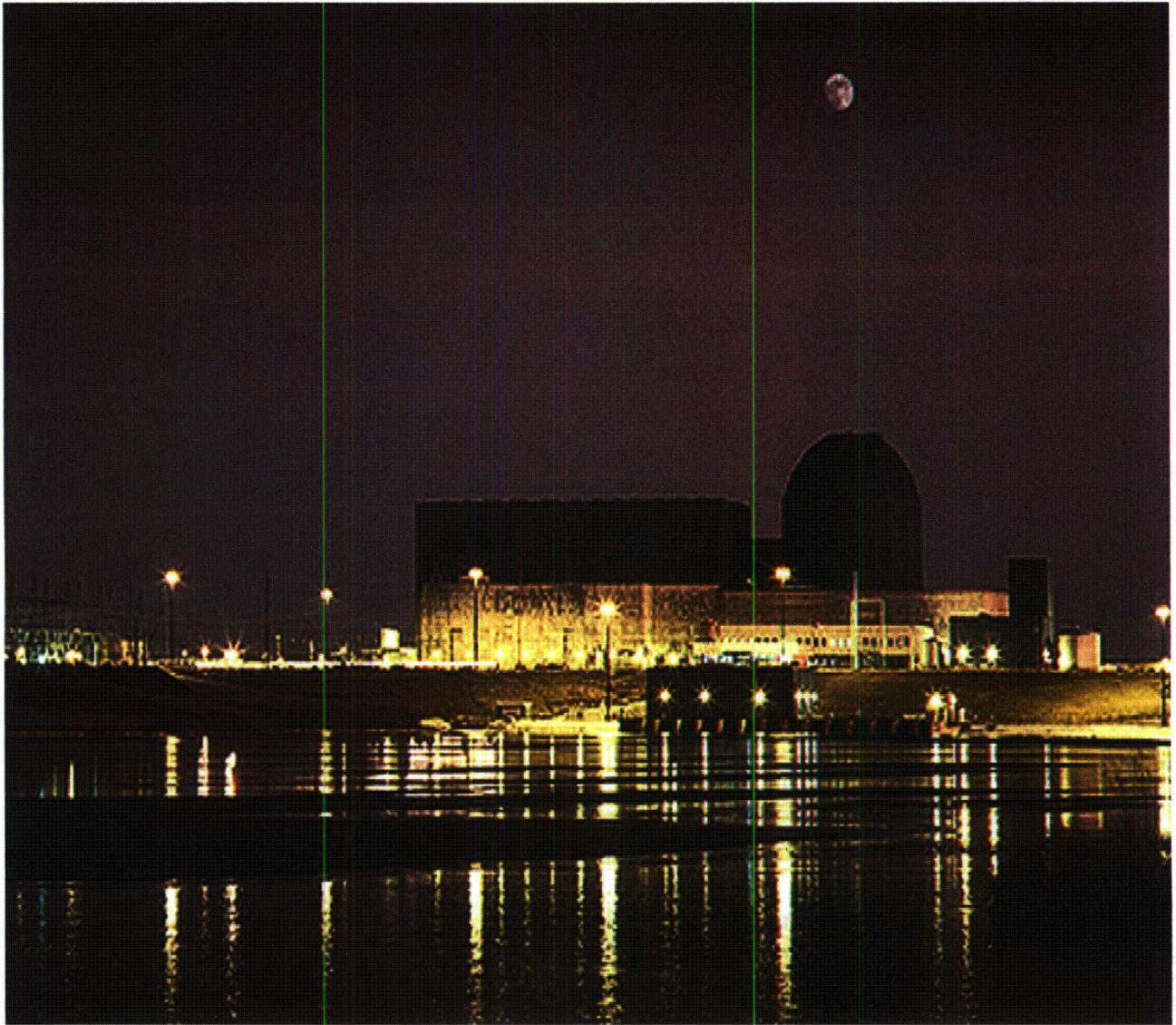

**Exelon**<sup>SM</sup>  
Nuclear

01 January 2014 – 31 December 2014

***ANNUAL RADIOACTIVE EFFLUENT RELEASE  
REPORT***

***CLINTON POWER STATION – DOCKET NUMBER 50-461***

Prepared by:

***Clinton Power Station***

## TABLE OF CONTENTS

SECTION	TITLE	PAGE
1	Executive Summary	5
2	Introduction	6
3	Supplemental Information	12
4	Radioactive Effluent Data	17
5	Solid Waste Disposal Information	27
6	Dose Measurements and Assessments	30
7	ODCM Operational Remedial Requirement Report	41
8	Meteorological Data and Dispersion Estimates	42
9	New Locations for Dose Calculation and / or Environmental Monitoring	102
10	Corrections to Data Reported in Previous Reports	105

## LIST OF TABLES

TABLE NUMBER	TITLE	PAGE
1	Gaseous Effluents – Summation of All Releases	17
	• 1A Air Doses Due to Gaseous Releases	18
	• 1B Doses to a Member of the Public Due to Radioiodines, Tritium and Particulates in Gaseous Releases	18
2	Gaseous Effluents – Nuclides Released	19
3	Radioactive Gaseous Waste LLD Values	20
4	Waterborne Effluents – Summation of All Releases	22
5	Waterborne Effluents – Nuclides Released	23
6	Radioactive Liquid Waste LLD Values	24
7	Solid Waste and Irradiated Fuel Shipments	28
8	Maximum Offsite Doses and Dose Commitments to Members of the Public In Each Sector	31
9	Calculated Doses to Members of the Public During Use of the Department of Natural Resources Recreation Area in the East-Southeast Sector within the CPS Site Boundary	34
10	Calculated Doses to Members of the Public During Use of the Road in the Southeast Sector within the CPS Site Boundary	35
11	Calculated Doses for the Residents in the South-Southeast Sector within the CPS Site Boundary	36
12	Calculated Doses for the Residents in the Southwest Sector within the CPS Site Boundary	37
13	Calculated Doses to Members of the Public During Use of the Agricultural Acreage in the South-Southwest Sector within the CPS Site Boundary	38
14	Calculated Doses for the Residents in the West-Southwest Sector within the CPS Site Boundary	39
15	Calculated Doses to Members of the Public During Use of Clinton Lake in the Northwest Sector within the CPS Site Boundary	40
16	Meteorological Data Availability	43
17	Classification of Atmospheric Stability	44
18	Joint Wind Frequency Distribution by Stability Class	45

## LIST OF FIGURES

FIGURE NUMBER	TITLE	PAGE
1	CPS Airborne Effluent Release Points	7
2	CPS Waterborne Effluents Release Pathway	8
3	Effluent Exposure Pathways	11
4	Areas Within the CPS Site Boundary Open to Members of the Public	33

## SECTION 1

### EXECUTIVE SUMMARY

The Annual Radioactive Effluent Release Report is a detailed description of gaseous and liquid radioactive effluents released from Clinton Power Station [CPS] and the resulting radiation doses for the period of 01 January 2014 through 31 December 2014. This report also includes a detailed meteorological section providing weather history of the surrounding area during this period. This information is used to calculate the offsite dose to our public.

The report also includes a summary of the amounts of radioactive material contained in solid waste that is packaged and shipped to a federally approved disposal / burial facility offsite. Additionally, this report notifies the U.S. Nuclear Regulatory Commission [NRC] staff of changes to CPS's Offsite Dose Calculation Manual [ODCM] and exceptions to the CPS effluent monitoring program that must be reported in accordance with ODCM Remedial Requirements 2.7.1.b and 3.9.2.b (Part I Section 3.1.1 Required Action G.1, Part I Section 3.2.1.1 Required Action F.1, and Part I Section 3.2.2.1 Required Action G.1 of revision 24, which was implemented January 2015).

The NRC requires that nuclear power facilities be designed, constructed, and operated in such a manner as to maintain radioactive effluent releases to unrestricted areas As Low As Reasonably Achievable [ALARA]. To ensure compliance with this criterion, the NRC has established limitations governing the release of radioactivity in effluents.

During 2014, CPS operations were well within these federally required limits. The maximum annual radiation dose delivered to the inhabitants of the area surrounding CPS - due to radioactivity released from the station - was 9.41E-02 [or 0.0941] mrem. The radiation dose to the public in the vicinity of CPS was calculated by using the concentration of radioactive nuclides from each gaseous effluent release coupled with historical weather conditions. The dose from CPS gaseous radioactive effluents was only a small fraction of the limit for the maximum exposed member of the public. There were no liquid effluent releases in 2014. As such, there was no dose received by the public from the liquid radioactive effluent pathway.

## SECTION 2

### INTRODUCTION

CPS is located in Harp Township, DeWitt County approximately six (6) miles east of the city of Clinton in east-central Illinois. CPS is a ~1,140 megawatt gross electrical power output boiling water reactor. Initial fuel load commenced in September of 1986 with initial criticality of the reactor occurring on 27 February 1987. Commercial operation commenced in April 1987 and the reactor reached 100% power for the first time on 15 September 1987.

CPS releases airborne effluents via two (2) gaseous effluent release points to the environment. They are the Common Station Heating, Ventilating, and Air Conditioning [HVAC] Vent and the Standby Gas Treatment System [SGTS] Vent [see Figure 1]. Each gaseous effluent release point is continuously monitored through a surveillance program of periodic sampling and analysis as specified in the ODCM.

CPS is licensed to release radioactive liquid effluents in a batch mode, however there were no radioactive liquid releases in 2014 at CPS. Each release would have been sampled and analyzed prior to release. Depending upon the amount of activity in a release, liquid effluents would vary from 10 to 300 gallons per minute [GPM]. This volume is then further combined with both Plant Service Water flow [a minimum of approximately 5,000 GPM] along with Plant Circulating Water flow [0 to 567,000 GPM] in the seal well, just prior to entering the 3.4 mile discharge flume into Lake Clinton [see Figure 2].

### **Processing and Monitoring**

CPS strictly controls effluents to ensure radioactivity released to the environment is maintained ALARA and does not exceed federal release limit criteria. Effluent controls include the operation of radiation monitoring systems within the plant as well as an offsite environmental analysis program. In-plant radiation monitoring systems are used to provide a continuous indication of radioactivity in effluent streams. Some are also used to collect particulate and radioiodine samples. Radioactive effluent related samples are analyzed in a controlled laboratory environment to identify the specific concentration of those radionuclides being released. Sampling and analysis provides for a more sensitive and precise method of determining effluent composition to complement the information provided by real-time radiation monitoring instruments.

Beyond the plant itself, a Radiological Environmental Monitoring Program [REMP] is maintained in accordance with Federal Regulations. The purpose of the REMP program is to assess the radiological impact on the environment due to the operation of CPS. Implicit in this charter is the license requirement to trend and assess radiation exposure rates and radioactivity concentrations that may contribute to dose to the public. The program consists of two phases; pre-operational and operational. During the pre-operational phase of the program, the baseline for the local radiation environment was established. The operational phase of the program includes the objective of making confirmatory measurements to verify that the in-plant controls for the release of radioactive material are functioning as designed. Assessment of the operational impact of CPS on the environment is based on data collected since initial criticality of the reactor.

Figure 1

CPS AIRBORNE EFFLUENT RELEASE POINTS

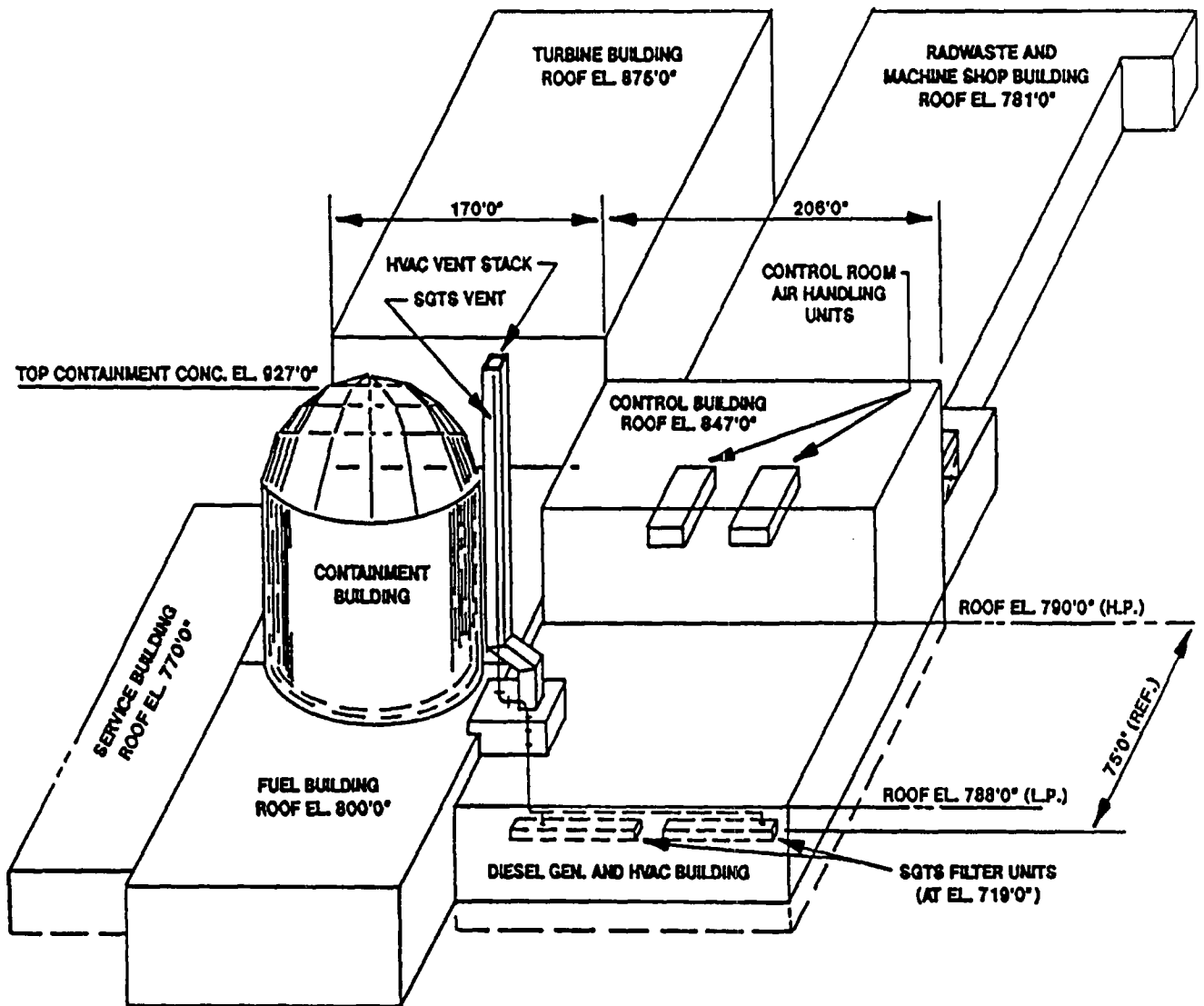

	<u>HVAC Exhaust Vent</u>	<u>SGTS Exhaust Vent</u>
Release Point Height (feet)	200	200
Building Height (feet)	190	190
Release Point Geometry	Duct	Pipe
Release Point Area (ft <sup>2</sup> )	120	2
Release Point Diameter (feet)	12*	1
Annual Average Flow Rate (ft <sup>3</sup> /sec)	2,738	73
Vertical Exit Velocity (feet/sec)	33	41

\* Effective  $2(A/\pi)^2$  diameter



Figure 2

CPS WATERBORNE EFFLUENTS RELEASE PATHWAY

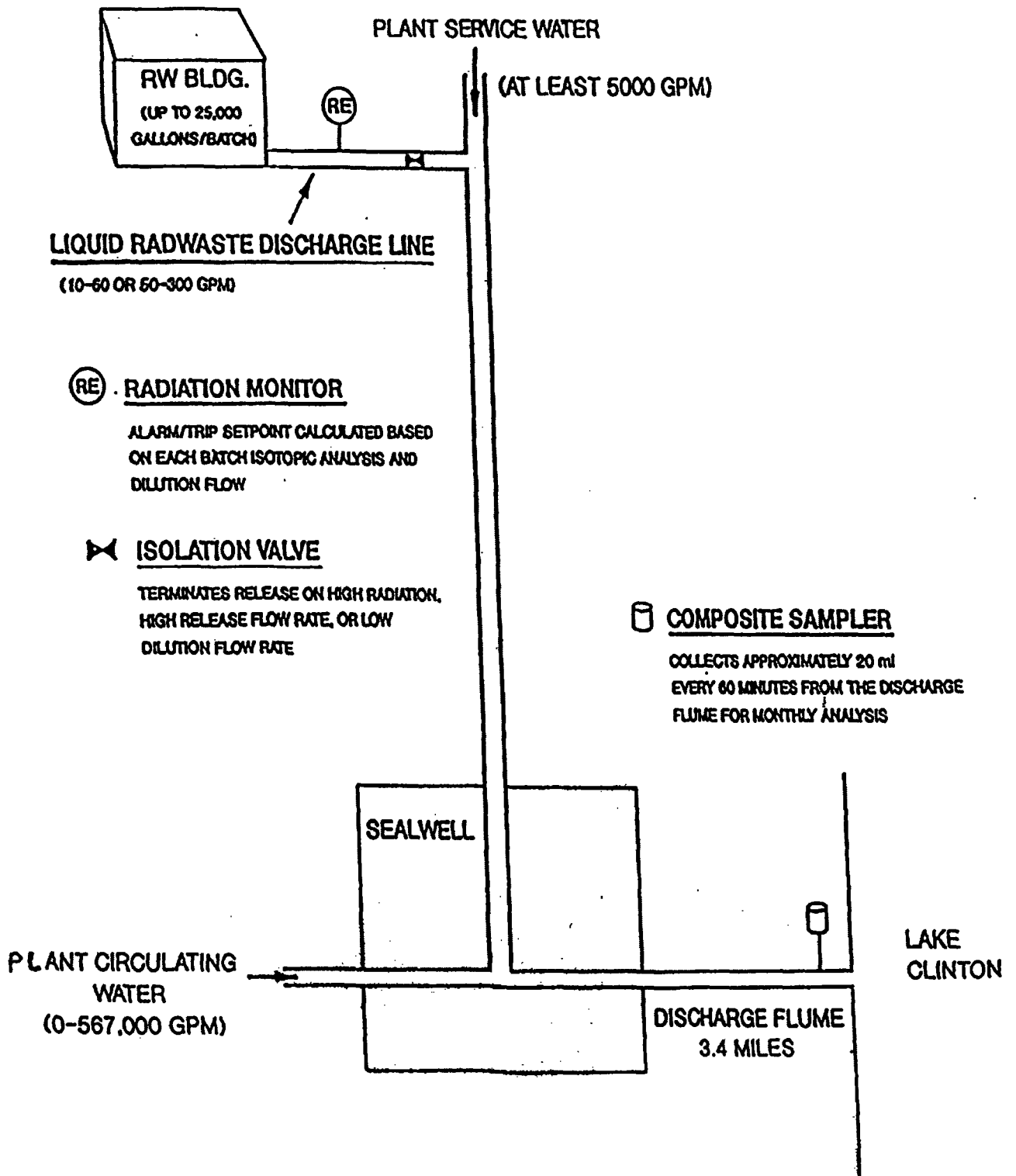

## **Exposure Pathways**

A radiological exposure pathway is the vehicle by which the public may become exposed to radioactivity released from nuclear facilities. The major pathways of concern are those that could cause the highest calculated radiation dose. These pathways are determined from the type and amount of radioactivity released, the environmental transport mechanism, and how the plant environs are used (i.e., residence, gardens, etc.). The environmental transport mechanism includes the historical meteorological characteristics of the area that are defined by wind speed and wind direction. This information is used to evaluate how the radionuclides will be distributed within the surrounding area. The most important factor in evaluating the exposure pathway is the use of the environment by the public living around CPS. Factors such as location of homes in the area, use of cattle for milk, and the growing of gardens for vegetable consumption are important considerations when evaluating exposure pathways. Figure 3 illustrates the effluent exposure pathways that were considered.

The radioactive gaseous effluent exposure pathways include direct radiation, deposition on plants and soil, and inhalation by animals and humans. The radioactive liquid effluent exposure pathways include fish consumption and direct exposure from Clinton Lake.

## **Dose Assessment**

Whole body radiation involves the exposure of all organs in the human body to ionizing radiation. Most naturally occurring background radiation exposures consist of whole body exposure although specific organs can receive radiation exposure from distinct radionuclides. These radionuclides enter the body through inhalation and ingestion and seek different organs depending on the nuclide. For example, radioactive iodine selectively concentrates in the thyroid, radioactive cesium collects in muscle and liver tissue, and radioactive strontium in mineralized bone.

The total dose to organs from a given radionuclide also depends on the amount of activity in the organ and the amount of time that the radionuclide remains in the body. Some radionuclides remain for very short periods of time due to their rapid radioactive decay and / or elimination rate from the body, while others may remain longer.

Radiation dose to the public in the area surrounding CPS is calculated for each release using historical weather conditions coupled with the concentrations of radioactive material present. The dose is calculated for all sixteen geographical sectors surrounding CPS and includes the location of the nearest residents, vegetable gardens producing broad leaf vegetables and dairy animals in all sectors. The calculated dose also uses the scientific concept of a "maximum exposed individual" and "standard man", and the maximum use factors for the environment, such as how much milk an average person consumes and how much air a person breathes in a year.

Section 6 contains more detailed information on dose to the public.

## **Gaseous Effluents**

Gaseous effluent radioactivity released from CPS is classified into two (2) categories. The first category is noble gases. The second category consists of I-131, I-133, H-3, C-14 and all radionuclides in particulate form with radioactive half-lives greater than eight (8) days. Noble gases - such as xenon and krypton - are biologically and chemically non-reactive. As such, these radionuclides – specifically Kr-85m , Xe-133 and Xe-135 – are the major contributors to external doses. Halogens I-131 and I-133, H-3, C-14 and radionuclides in particulate form with radioactive half-lives greater than eight (8) days are the major contributors to internal doses.

## **Liquid Effluents**

Liquid effluents may originate from two (2) sources at CPS. The first is effluent from the Radioactive Waste Treatment System. This water is demineralized prior to release. Samples are taken after the tank has been allowed to adequately recirculate. The second is from heat exchanger leaks found in closed cooling water systems that service radioactively contaminated systems. This would be considered an abnormal release. As a matter of station management commitment, CPS strives to be a zero (0) radioactive liquid release plant. The last liquid release occurred in September of 1992.

## **Solid Waste Shipments**

To reduce the radiation exposure to personnel and maintain the federally required ALARA concept, the NRC and the Department of Transportation [DOT] have established limits on the types of radioactive waste and the amount of radioactivity that may be packaged and shipped offsite for burial or disposal. To ensure that CPS is complying with these regulations, the types of waste and the radioactivity present are reported to the NRC.

FIGURE 3

EFFLUENT EXPOSURE PATHWAYS

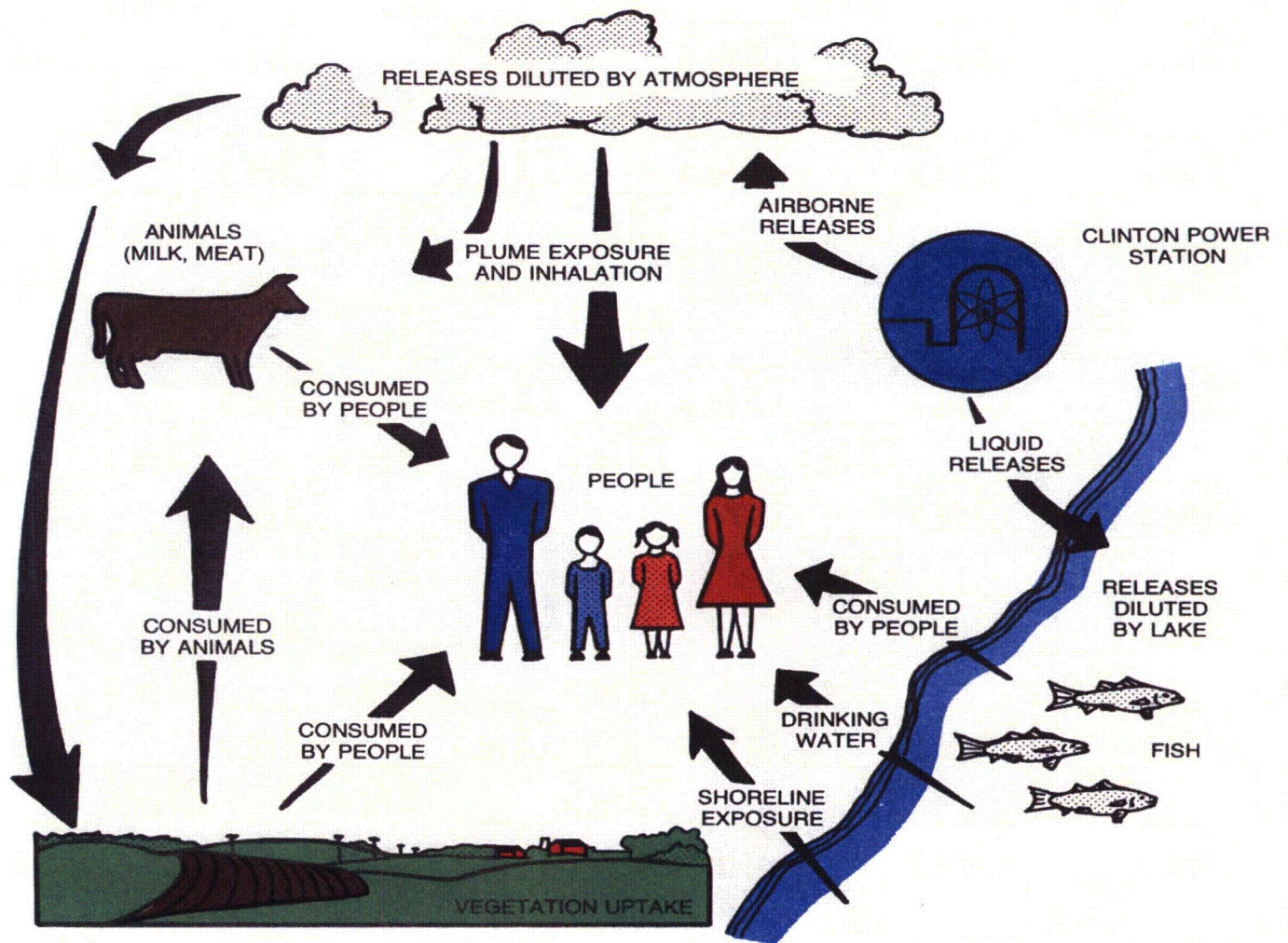

## SECTION 3

### SUPPLEMENTAL INFORMATION

#### I. REGULATORY LIMITS

The NRC requires nuclear power facilities to be designed, constructed and operated in such a way that the radioactivity in effluent releases to unrestricted areas are kept ALARA. To ensure these criteria are met, each license authorizing nuclear reactor operation includes the Offsite Dose Calculation Manual [ODCM] governing the release of radioactive effluents. The ODCM designates the limits for release of effluents, as well as the limits for doses to the general public from the release of radioactive liquids and gases. These limits are taken from Title 10 of the Code of Federal Regulations, Part 50, Appendix I (10CFR50 Appendix I), Title 10 of the Code of Federal Regulations, Part 20.1301 (10CFR20.1301) and Section 5.5.1 of our Station's Technical Specifications. Maintaining effluent releases within these operating limitations demonstrates compliance with ALARA principles. These limits are just a fraction of the dose limits established by the Environmental Protection Agency [EPA] found within Environmental Dose Standard Title 40, Code of Federal Regulations, Part 190 [40CFR190]. The EPA has established dose limits for members of the public in the vicinity of a nuclear power plant. These dose limits are:

- Less than or equal to 25 mrem per year to the total body.
- Less than or equal to 75 mrem per year to the thyroid.
- Less than or equal to 25 mrem per year to any other organ.

Specific limit information is given below.

#### A. Gaseous Effluents

1. The maximum permissible concentrations for gaseous effluents shall not exceed the values provided within Section 5.5.4.g of Station Technical Specifications. To ensure these concentrations are not exceeded, dose rates due to radioactive materials released in gaseous effluents from the site to areas at and beyond the site area boundary shall be limited to the following:
  - a. Noble gases
    - Less than or equal to 500 mrem/year to the total body.
    - Less than or equal to 3,000 mrem/year to the skin.
  - b. I-131, I-133, H-3, C-14, and all radionuclides in particulate form with radioactive half-lives greater than eight (8) days:
    - Less than or equal to 1,500 mrem/year to any organ.

2. In accordance with Title 10 of the Code of Federal Regulations, Part 50, Appendix I, (10CFR50 Appendix I) air dose due to noble gases released in gaseous effluents to areas at and beyond the site boundary shall be limited to the following:
  - a. Less than or equal to 5 mrad for gamma radiation and less than or equal to 10 mrad for beta radiation during any calendar quarter.
  - b. Less than or equal to 10 mrad for gamma radiation and less than or equal to 20 mrad for beta radiation during any calendar year.
3. In accordance with Title 10 of the Code of Federal Regulations, Part 50, Appendix I, (10CFR50 Appendix I), dose to a member of the public (from I-131, I-133, H-3, C-14, and all radionuclides in particulate form with radioactive half-lives greater than eight (8) days) in gaseous effluents released to areas at and beyond the site boundary shall be limited to the following values:
  - a. Less than or equal to 7.5 mrem to any organ, during any calendar quarter.
  - b. Less than or equal to 15 mrem to any organ, during any calendar year.

#### B. Liquid Effluents

1. The concentration of radioactive material released in liquid effluents to unrestricted areas shall be limited to the values provided within Section 5.5.4.b of Station Technical Specifications for radionuclides other than dissolved or entrained noble gases. For dissolved or entrained noble gases, the concentration shall be limited to 2.0E-04  $\mu\text{Ci/ml}$  total activity.
2. The dose or dose commitment to a member of the public from radioactive materials in liquid effluents released to unrestricted areas shall be limited to:
  - a. Less than or equal to 1.5 mrem to the total body and less than or equal to 5 mrem to any organ during any calendar quarter.
  - b. Less than or equal to 3 mrem to the total body and less than or equal to 10 mrem to any organ during any calendar year.

## **II. AVERAGE ENERGY**

The CPS ODCM limits the dose equivalent rates due to the release of fission and activation gases to less than or equal to 500 mrem per year to the total body and less than or equal to 3,000 mrem per year to the skin. These limits are based on dose calculations using actual isotopic concentrations from our effluent release streams and not based upon the gross count rate from our monitoring systems. Therefore, the average beta and gamma energies [E] for gaseous effluents as described in Regulatory Guide 1.21, "Measuring, Evaluating, and Reporting Radioactivity in Solid Wastes and Releases of Radioactive Materials in Liquid and Gaseous Effluents from Light-Water-Cooled Nuclear Power Plants", are not applicable.

### III. MEASUREMENT AND APPROXIMATIONS OF TOTAL RADIOACTIVITY

#### A. Fission and Activation Gases

Gas samples are collected weekly and are counted on a high purity germanium detector (HPGe) for principal gamma emitters. The HVAC and SGTS release points are continuously monitored and the average release flow rates for each release point are used to calculate the total activity released during a given time period.

#### B. Iodines

Iodine is continuously collected on a silver zeolite cartridge filter via an isokinetic sampling assembly from each release point. Filters are normally exchanged once per week and then analyzed on an HPGe system. The average flow rates for each release point are averaged over the duration of the sampling period and these results - along with specific isotopic concentrations - are then used to determine the total activity released during the time period in question.

#### C. Particulates

Particulates are continuously collected on a filter paper via an isokinetic sampling assembly on each release point. Filters are normally exchanged once per week and then analyzed on an HPGe system. The average flow rates for each release point are averaged over the duration of the sampling period and these results - along with specific isotopic concentrations - are then used to determine the total activity released during the time period in question.

#### D. Tritium

Tritium is collected by passing a known volume of the sample stream through a gas washer containing a known quantity of demineralized water. The collected samples are distilled and analyzed by liquid scintillation. The tritium released was calculated for each release point from the measured tritium concentration, the volume of the sample, the tritium collection efficiency, and the respective stack exhaust flow rates.

#### E. Gross Alpha

Gross alpha is analyzed routinely for the gaseous effluent pathway. Gross alpha is analyzed for the liquid effluent pathway when such effluent exists. Weekly gaseous particulate media is composited for offsite vendor analysis. Gross alpha activity greater than vendor LLD values is assigned to the applicable timeframe and gaseous volume released.

#### F. Carbon-14

Carbon-14 release values were estimated using the methodology included in the Electric Power Research Institute (EPRI) Technical Report 1021106, using the 2014 Clinton Power Station specific parameters of normalized Carbon-14 production rate of 5.049 Ci/GWt-yr, a gaseous release fraction of 0.99, a Carbon-14 carbon dioxide fraction of 0.95, a reactor power rating of 3473 MWt, and equivalent full power operation of 346.6 days.



## G. Liquid Effluents

Each tank of liquid radwaste is recirculated for at least two (2) tank volumes, sampled, and analyzed for principal gamma emitters prior to release. Each sample tank is recirculated for a sufficient amount of time prior to sampling, ensuring that a representative sample is obtained. Samples are then analyzed on an HPGe system and liquid release permits are generated based upon the values obtained from the isotopic analysis and the most recent values for H-3, gross alpha, Fe-55, Sr-89 and Sr-90. An aliquot based on release volume is saved and added to composite containers. The concentrations of composited isotopes and the volumes of the releases associated with these composites establish the proportional relationships that are then utilized for calculating the total activity released for these isotopes.

## H. Description of Error Estimates

Estimates of measurement and analytical error for gaseous and liquid effluents are calculated as follows:

$$E_T = \sqrt{[(E_1)^2 + (E_2)^2 + \dots + (E_n)^2]}$$

where:  $E_T$  = total percent error, and  
 $E_1 \dots E_N$  = percent error due to calibration standards, laboratory analysis, instruments, sample flow, etc.

## IV. ABNORMAL RELEASES

### A. Liquid

- |                                 |   |
|---------------------------------|---|
| 1. Number of Releases           | 0 |
| 2. Total Activity (Ci) Released | 0 |

### B. Gaseous

- |                                 |   |
|---------------------------------|---|
| 1. Number of Releases           | 0 |
| 2. Total Activity (Ci) Released | 0 |

## V. ODCM REVISIONS

There were no changes to the Offsite Dose Calculation Manual in 2014

## SECTION 4

### RADIOACTIVE EFFLUENT DATA

**TABLE 1**  
**GASEOUS EFFLUENTS - Summation Of All Releases**  
 Data Period: 01 January 2014 – 31 December 2014  
 Continuous Mixed Mode

	Units	Quarter 1	Quarter 2	Quarter 3	Quarter 4	Est. Total Error, %
<b>A. Fission &amp; Activation Gases</b>						
1. Total Release	Ci	2.18E+00	5.72E-01	1.14E+00	0.00E+00	30
2. Average release rate for period	μCi/sec	2.80E-01	7.28E-02	1.44E-01	0.00E+00	
3. Percent of ODCM Limit	%	*	*	*	*	
<b>B. Iodines</b>						
1. Total Iodine-131	Ci	3.55E-06	1.09E-06	1.76E-05	1.46E-05	31
2. Average release rate for period	μCi/sec	4.56E-07	1.39E-06	2.21E-06	1.84E-06	
3. Percent of ODCM Limit	%	*	*	*	*	
<b>C. Particulates</b>						
1. Particulates with half-lives >8 days	Ci	1.11E-05	3.34E-05	5.64E-05	1.10E-05	24
2. Average release rate for period	μCi/sec	1.43E-06	4.25E-06	7.10E-06	1.39E-06	
3. Percent of ODCM Limit	%	*	*	*	*	
4. Gross alpha radioactivity	Ci	0.00E+00	0.00E+00	0.00E+00	0.00E+00	
<b>D. Tritium</b>						
1. Total Release	Ci	5.84E+00	5.37E+00	5.61E+00	6.01E+00	21
2. Average release rate for period	μCi/sec	7.51E-01	6.84E-01	7.06E-01	7.56E-01	
3. Percent of ODCM Limit	%	*	*	*	*	
<b>E. Carbon-14</b>						
1. Total Release	Ci	3.79E+00	4.30E+00	4.37E+00	4.37E+00	
2. Average release Rate for period	μCi/sec	4.87E-01	5.47E-01	5.50E-01	5.50E-01	

\* Applicable limits are expressed in terms of dose. See Tables 1A and 1B of this report.

**TABLE 1A****Air Doses Due to Gaseous Releases****Doses per Quarter**

Type of Radiation	ODCM Limit	1 <sup>st</sup> Quarter	% of Limit	2 <sup>nd</sup> Quarter	% of Limit	3 <sup>rd</sup> Quarter	% of Limit	4 <sup>th</sup> Quarter	% of Limit
Gamma	5 mrad	9.07E-05	1.81E-03	2.38E-05	4.76E-04	4.75E-05	9.49E-04	0.00E+00	0.00E+00
Beta	10 mrad	3.20E-05	3.20E-04	8.39E-06	8.39E-05	1.67E-05	1.67E-04	0.00E+00	0.00E+00

**Doses per Year**

Type of Radiation	ODCM Limit	Year	% of Limit
Gamma	10 mrad	1.62E-04	1.62E-03
Beta	20 mrad	5.71E-05	2.85E-04

**TABLE 1B****Doses to a Member of the Public Due to Radioiodines, Noble Gases, Tritium, Carbon-14, and Particulates in Gaseous Releases****Doses per Quarter**

Type of Organ	ODCM Limit	Quarter 1	% of Limit	Quarter 2	% of Limit	Quarter 3	% of Limit	Quarter 4	% of Limit
Bone	7.5 mrem	2.12E-02	2.83E-01	2.40E-02	3.20E-01	2.44E-02	3.25E-01	2.44E-02	3.25E-01
Liver	7.5 mrem	4.35E-03	5.80E-02	4.93E-03	6.57E-02	5.01E-03	6.67E-02	5.01E-03	6.67E-02
TBody	7.5 mrem	4.35E-03	5.80E-02	4.93E-03	6.57E-02	5.00E-03	6.67E-02	5.01E-03	6.67E-02
Thyroid	7.5 mrem	4.35E-03	5.80E-02	4.93E-03	6.57E-02	5.01E-03	6.67E-02	5.01E-03	6.68E-02
Kidney	7.5 mrem	4.35E-03	5.80E-02	4.93E-03	6.57E-02	5.00E-03	6.67E-02	5.01E-03	6.67E-02
Lung	7.5 mrem	4.35E-03	5.80E-02	4.93E-03	6.57E-02	5.00E-03	6.67E-02	5.01E-03	6.67E-02
GI LLI	7.5 mrem	4.35E-03	5.80E-02	4.93E-03	6.57E-02	5.01E-03	6.68E-02	5.01E-03	6.68E-02

**Doses per Year**

Type of Organ	ODCM Limit	Year	% of Limit
Bone	15 mrem	9.41E-02	6.27E-01
Liver	15 mrem	1.93E-02	1.29E-01
TBody	15 mrem	1.93E-02	1.29E-01
Thyroid	15 mrem	1.93E-02	1.29E-01
Kidney	15 mrem	1.93E-02	1.29E-01
Lung	15 mrem	1.93E-02	1.29E-01
GI LLI	15 mrem	1.93E-02	1.29E-01

All dose calculations were performed using the methodology contained in the CPS ODCM.

**TABLE 2**  
**CLINTON POWER STATION**  
**GASEOUS EFFLUENTS - Nuclides Released**  
**YEAR: 2014**

Mixed Mode Release	X
Elevated Release	
Ground-Level Release	

Continuous Mode	X
Batch Mode	

	Units	Quarter 1 <sup>[2]</sup>	Quarter 2 <sup>[2]</sup>	Quarter 3 <sup>[2]</sup>	Quarter 4 <sup>[2]</sup>
<b>A. Fission Gases <sup>[1]</sup></b>					
Ar-41	Ci	2.18E+00	5.72E-01	1.14E+00	<LLD
Kr-87	Ci	<LLD	<LLD	<LLD	<LLD
Kr-88	Ci	<LLD	<LLD	<LLD	<LLD
Xe-133	Ci	<LLD	<LLD	<LLD	<LLD
Xe-133m	Ci	<LLD	<LLD	<LLD	<LLD
Xe-135	Ci	<LLD	<LLD	<LLD	<LLD
Xe-138	Ci	<LLD	<LLD	<LLD	<LLD
<b>Total for Period</b>	<b>Ci</b>	<b>2.18E+00</b>	<b>5.72E-01</b>	<b>1.14E+00</b>	<b>&lt;LLD</b>

<b>B. Iodines <sup>[1]</sup></b>					
I-131	Ci	3.55E-06	1.09E-05	1.76E-05	1.46E-05
I-133	Ci	<LLD	5.27E-05	6.33E-05	7.36E-06
I-135	Ci	<LLD	<LLD	<LLD	<LLD
<b>Total for Period</b>	<b>Ci</b>	<b>3.55E-06</b>	<b>6.36E-05</b>	<b>8.09E-005</b>	<b>2.20E-05</b>

<b>C. Particulates <sup>[1]</sup></b>					
Na-24	Ci	<LLD	<LLD	<LLD	1.22E-04
Cr-51	Ci	<LLD	<LLD	<LLD	<LLD
Mn-54	Ci	1.04E-05	3.34E-05	5.64E-05	1.10E-05
Co-58	Ci	7.06E-07	<LLD	<LLD	<LLD
Fe-59	Ci	<LLD	<LLD	<LLD	<LLD
Co-60	Ci	<LLD	<LLD	<LLD	<LLD
Zn-65	Ci	<LLD	<LLD	<LLD	<LLD
As-76	Ci	<LLD	<LLD	<LLD	1.13E-05
Sr-89	Ci	<LLD	<LLD	<LLD	<LLD
Sr-90	Ci	<LLD	<LLD	<LLD	<LLD
Y-91m	Ci	<LLD	<LLD	<LLD	3.73E-03
Mo-99	Ci	1.06E-06	1.95E-06	<LLD	<LLD
Tc-99m	Ci	1.63E-05	<LLD	<LLD	<LLD
Cs-134	Ci	<LLD	<LLD	<LLD	<LLD
Cs-137	Ci	<LLD	<LLD	<LLD	<LLD
Ce-141	Ci	<LLD	<LLD	<LLD	<LLD
Ce-144	Ci	<LLD	<LLD	<LLD	<LLD
<b>Gross Alpha</b>	<b>Ci</b>	<b>&lt;LLD</b>	<b>&lt;LLD</b>	<b>&lt;LLD</b>	<b>&lt;LLD</b>
<b>Total for Period</b>	<b>Ci</b>	<b>2.85E-05</b>	<b>3.54E-05</b>	<b>5.64E-05</b>	<b>3.87E-03</b>

<b>D. Tritium <sup>[1]</sup></b>					
<b>Total for Period</b>	<b>Ci</b>	<b>5.84E+00</b>	<b>5.37E+00</b>	<b>5.61E+00</b>	<b>6.01E+00</b>

<b>E. Carbon-14 <sup>[1]</sup></b>					
<b>Total for Period</b>	<b>Ci</b>	<b>3.79E+00</b>	<b>4.30E+00</b>	<b>4.37E+00</b>	<b>4.37E+00</b>

<sup>[1]</sup> Ten (10) times the values found in 10CFR20 Appendix B, Table 2, Column 1 are used for all Effluent Concentration Limit [ECL] calculations. For dissolved and entrained noble gases, the concentration is limited to 2.00E-04 µCi/cc total activity.

<sup>[2]</sup> The lower the value of the actual sample activity - with respect to background activity - the greater the counting error. Proportionally, large errors are reported for the various components of CPS gaseous effluents because of their consistent low sample activity.

ODCM required LLD values are listed in Table 6. All analyses met the required LLD's.

**TABLE 3****RADIOACTIVE GASEOUS WASTE LLD VALUES**

<b>TYPE OF ACTIVITY ANALYSIS</b>	<b>ODCM Required Lower Limit of Detection (LLD)<sup>a</sup> (μCi/cc)</b>
Principal Gamma Emitters, [Noble Gases] <sup>b,c</sup>	≤1.00E-04
H-3 <sup>c</sup>	≤1.00E-06
I-131 <sup>d</sup>	≤1.00E-12
I-133 <sup>d</sup>	≤1.00E-10
Principal Gamma Emitters, [Particulates] <sup>b,e</sup>	≤1.00E-11
Sr-89, Sr-90 <sup>f</sup>	≤1.00E-11
Gross Alpha <sup>f</sup>	≤1.00E-11

**Table 3 Notations**

<sup>a</sup>The Lower Limit of Detection (LLD) as defined for purposes of these specifications, as an "a priori" determination of the smallest concentration of radioactive material in a sample that will yield a net count - above system background - that will be detected with a 95% probability and with a low (5%) probability of incorrectly concluding that a blank observation represents a "real" signal.

For a particular measurement system, which may include radiochemical separation:

$$LLD = \frac{4.66 \cdot s_b}{E \cdot V \cdot 2.22 \times 10^6 \cdot Y \cdot e^{-\lambda \Delta t}}$$

### Table 3 Notations (continued)

Where:

LLD is the "a priori" lower limit of detection as defined above, as  $\mu\text{Ci}$  per unit mass or volume,

$s_b$  is the standard deviation of the background counting rate or of the counting rate of a blank sample as appropriate, in counts per minute (cpm),

E is the counting efficiency, in counts per disintegration,

V is the sample size in units of mass or volume,

$2.22\text{E}+06$  is the number of disintegrations per minute (dpm) per microcurie,

Y is the fractional radiochemical yield, when applicable,

$\lambda$  is the radioactive decay constant for the particular radionuclide ( $\text{sec}^{-1}$ ) and

$\Delta t$  for plant effluents is the elapsed time between the midpoint of sample collection and the time of counting (sec).

Typical values of E, V, Y, and  $\Delta t$  should be used in the calculation.

The LLD is defined as an *a priori* (before the fact) limit representing the capability of a measurement system and not as an *a posteriori* (after the fact) limit for a particular measurement.

<sup>b</sup>The principal gamma emitters for which the LLD specification applies include the following radionuclides: Kr-87, Kr-88, Xe-133, Xe-133m, Xe-135, and Xe-138 in noble gas releases and Mn-54, Fe-59, Co-58, Co-60, Zn-65, Mo-99, I-131, Cs-134, Cs-137, Ce-141, and Ce-144 in iodine and particulate releases. This list does not mean that only these nuclides are to be considered. Other gamma peaks that are identifiable - together with those of the above nuclides - shall also be analyzed and reported in the Radioactive Effluent Release Report.

<sup>c</sup>Weekly grab sample and analysis

<sup>d</sup>Continuous charcoal sample analyzed weekly

<sup>e</sup>Continuous particulate sample analyzed weekly

<sup>f</sup>Composite particulate sample analyzed monthly

**TABLE 4**

**WATERBORNE EFFLUENTS - Summation Of All Releases**  
 Data Period: 01 January 2014 through 31 December 2014

There were zero (0) liquid radwaste releases from CPS in 2014.

	Units	Quarter 1	Quarter 2	Quarter 3	Quarter 4	Est. Total Error, %
<b>A. Fission &amp; Activation Products</b>						
1. Total Release	Ci	0.00E+00	0.00E+00	0.00E+00	0.00E+00	N/A
2. Average diluted concentration during period	µCi/ml	0.00E+00	0.00E+00	0.00E+00	0.00E+00	
3. Percent of ODCM Limit	%	N/A	N/A	N/A	N/A	
<b>B. Tritium</b>						
1. Total Release	Ci	0.00E+00	0.00E+00	0.00E+00	0.00E+00	N/A
2. Average diluted concentration during period	µCi/ml	0.00E+00	0.00E+00	0.00E+00	0.00E+00	
3. Percent of ODCM Limit	%	N/A	N/A	N/A	N/A	
<b>C. Dissolved and Entrained Gases</b>						
1. Total Release	Ci	0.00E+00	0.00E+00	0.00E+00	0.00E+00	N/A
2. Average diluted concentration during period	µCi/ml	0.00E+00	0.00E+00	0.00E+00	0.00E+00	
3. Percent of ODCM Limit	%	N/A	N/A	N/A	N/A	
<b>D. Gross Alpha Radioactivity</b>						
Gross alpha radioactivity	Ci	0.00E+00	0.00E+00	0.00E+00	0.00E+00	N/A
<b>E. Volume of Waste Released (prior to Dilution)</b>						
Volume of Waste Released (prior to Dilution)	Liters	0.00E+00	0.00E+00	0.00E+00	0.00E+00	N/A
<b>F. Volume of dilution water used during period</b>						
Volume of dilution water used during period	Liters	0.00E+00	0.00E+00	0.00E+00	0.00E+00	N/A

**TABLE 5**

**WATERBORNE EFFLUENTS - Nuclides Released <sup>[1]</sup>**  
 Data Period: 01 January 2014 – 31 December 2014  
 All Modes

There were zero (0) liquid radwaste releases from CPS in 2014.

Continuous Mode		Batch Mode	X
-----------------	--	------------	---

Nuclide	Units	Quarter 1	Quarter 2	Quarter 3	Quarter 4
---------	-------	-----------	-----------	-----------	-----------

**A. Tritium**

H-3	Ci	0.00E+00	0.00E+00	0.00E+00	0.00E+00
-----	----	----------	----------	----------	----------

**B. Fission and Activation Products**

Sr-89	Ci	0.00E+00	0.00E+00	0.00E+00	0.00E+00
Sr-90	Ci	0.00E+00	0.00E+00	0.00E+00	0.00E+00
Cs-134	Ci	0.00E+00	0.00E+00	0.00E+00	0.00E+00
Cs-137	Ci	0.00E+00	0.00E+00	0.00E+00	0.00E+00
I-131	Ci	0.00E+00	0.00E+00	0.00E+00	0.00E+00
Co-58	Ci	0.00E+00	0.00E+00	0.00E+00	0.00E+00
Co-60	Ci	0.00E+00	0.00E+00	0.00E+00	0.00E+00
Fe-59	Ci	0.00E+00	0.00E+00	0.00E+00	0.00E+00
Zn-65	Ci	0.00E+00	0.00E+00	0.00E+00	0.00E+00
Mn-54	Ci	0.00E+00	0.00E+00	0.00E+00	0.00E+00
Cr-51	Ci	0.00E+00	0.00E+00	0.00E+00	0.00E+00
Zr/Nb-95	Ci	0.00E+00	0.00E+00	0.00E+00	0.00E+00
Mo-99	Ci	0.00E+00	0.00E+00	0.00E+00	0.00E+00
Tc-99m	Ci	0.00E+00	0.00E+00	0.00E+00	0.00E+00
Ba/La-140	Ci	0.00E+00	0.00E+00	0.00E+00	0.00E+00
Ce-141	Ci	0.00E+00	0.00E+00	0.00E+00	0.00E+00
Ce-144	Ci	0.00E+00	0.00E+00	0.00E+00	0.00E+00
Total	Ci	0.00E+00	0.00E+00	0.00E+00	0.00E+00

**C. Dissolved and Entrained Noble Gases**

Xe-133	Ci	0.00E+00	0.00E+00	0.00E+00	0.00E+00
Xe-135	Ci	0.00E+00	0.00E+00	0.00E+00	0.00E+00
Total	Ci	0.00E+00	0.00E+00	0.00E+00	0.00E+00

[1] A value corresponding to ten times the values found in 10CFR20 Appendix B, Table 2, Column 2 are used for all Effluent Concentration Limit (ECL) calculations. For dissolved and entrained noble gases, the concentration is limited to 2.00E-04 µCi/ml total activity.



**TABLE 6**  
**RADIOACTIVE LIQUID WASTE LLD VALUES**

TYPE OF ACTIVITY ANALYSIS	ODCM Required Lower Limit of Detection (LLD) <sup>a</sup> (μCi/ml)
Principal Gamma Emitters <sup>b</sup>	≤5.00E-07
I-131	≤1.00E-06
Dissolved and Entrained Gases (Gamma Emitters) <sup>c</sup>	≤1.00E-05
H-3	≤1.00E-05
Gross Alpha	≤1.00E-07
Sr-89, Sr-90	≤5.00E-08
Fe-55	≤1.00E-06

**Table 6 Notations**

<sup>a</sup>The Lower Limit of Detection (LLD) as defined for purposes of these specifications, as an "a priori" determination of the smallest concentration of radioactive material in a sample that will yield a net count - above system background - that will be detected with a 95% probability and with only a 5% probability of falsely concluding that a blank observation represents a "real" signal.

For a particular measurement system, which may include radiochemical separation:

$$LLD = \frac{4.66 \cdot s_b}{E \cdot V \cdot 2.22 \times 10^6 \cdot Y \cdot e^{-\lambda \Delta t}}$$

Where:

LLD is the "a priori" lower limit of detection as defined above, as μCi per unit mass or volume,

$s_b$  is the standard deviation of the background counting rate or of the counting rate of a blank sample as appropriate, in counts per minute (cpm),

### Table 6 Notations (continued)

E is the counting efficiency, as counts per disintegration,

V is the sample size in units of mass or volume,

2.22E+06 is the number of disintegrations per minute (dpm) per microcurie,

Y is the fractional radiochemical yield, when applicable,

$\lambda$  is the radioactive decay constant for the particular radionuclide ( $\text{sec}^{-1}$ ) and

$\Delta_t$  for plant effluents is the elapsed time between the midpoint of sample collection and the time of counting (sec).

Typical values of E, V, Y, and  $\lambda t$  should be used in the calculation.

The LLD is defined as an *a priori* (before the fact) limit representing the capability of a measurement system and not as an *a posteriori* (after the fact, MDA) limit for a particular measurement.

<sup>b</sup>The principal gamma emitters for which the LLD requirement applies include the following radionuclides: Mn<sup>54</sup>, Fe<sup>59</sup>, Co<sup>58</sup>, Co<sup>60</sup>, Zn<sup>65</sup>, Mo<sup>99</sup>, Cs<sup>134</sup>, Cs<sup>137</sup>, Ce<sup>141</sup>, and Ce<sup>144</sup> shall also be measured, but with an LLD of 5.0E-06. This list does not mean that only these nuclides are detected and reported. Other gamma peaks that are measurable - together with those of the above nuclides - shall also be analyzed and reported in the Radioactive Effluent Release Report.

<sup>c</sup>Dissolved and entrained gases are: Xe<sup>133</sup>, Xe<sup>135</sup>, Xe<sup>138</sup>, Kr<sup>85m</sup>, Kr<sup>87</sup> and Kr<sup>88</sup>.

## BATCH RELEASES

**There were zero (0) liquid radwaste releases from CPS in 2014.**

**A. Batch Liquid Releases: 2014**

- |   |     |
|---|-----|
| 1. Number of batch releases:                      | 0   |
| 2. Total time period for batch releases:          | N/A |
| 3. Maximum time period for batch release:         | N/A |
| 4. Average time period for batch release:         | N/A |
| 5. Minimum time period for batch release:         | N/A |
| 6. Average stream flow during periods of release: | N/A |
| 7. Total waste volume:                            | N/A |
| 8. Total dilution volume:                         | N/A |

**B. Batch Gaseous Releases: 2014**

- |   |     |
|---|-----|
| 1. Number of batch releases:              | 0   |
| 2. Total time period for batch releases:  | N/A |
| 3. Maximum time period for batch release: | N/A |
| 4. Average time period for batch release: | N/A |
| 5. Minimum time period for batch release: | N/A |

## SECTION 5

### SOLID WASTE DISPOSAL INFORMATION

During this reporting period – 01 January 2014 through 31 December 2014 - there were sixteen (16) radioactive waste shipments and zero (0) irradiated fuel shipments from CPS. In addition, the CPS ODCM requires reporting of the following information for solid waste shipped offsite during the above reporting period:

1. Container volume: Class A Waste: **1.12E+04** ft<sup>3</sup> / Class B Waste: **0.0** ft<sup>3</sup> / Class C Waste: **0.0** ft<sup>3</sup>

This total includes Dry Active Waste (DAW), resins, filter sludges and evaporator bottoms.

2. Total curie quantity: Class A Waste was **5.60E+02** curies and Class B Waste was **0.0** curies (determined by dose-to-curie and sample concentration methodology estimates) and Class C Waste was **0.0** curies in 2014.
3. Principal radionuclides: See A.2 for listing of measured radionuclides.
4. Source of waste and processing employed: Resins, filter sludges and evaporator bottoms dewatered, and non-compacted dry active waste.
5. Type of container: Type A, Type B and Strong Tight Container.
6. Solidification agent or absorbent: None.

**Table 7**

**SOLID WASTE AND IRRADIATED FUEL SHIPMENTS**

A. Solid Waste Shipped Offsite for Burial or Disposal: [**NOT** irradiated fuel]

1. Types of Waste

Types of Waste	Total Quantity (m <sup>3</sup> )	Total Activity (Ci)	Period	Est. Total Error, %
a. Spent resins, filter sludges, evaporator bottoms, etc.	2.00E+03	5.59E+02	Jan – Dec 2014	25
b. Dry compressible waste, contaminated equip, etc.	9.18E+03	8.31E-01	Jan – Dec 2014	25
c. Irradiated components, control rods, etc.	0.00E+00	0.00E+00	Jan – Dec 2014	25
d. Other	0.00E+00	0.00E+00	Jan – Dec 2014	25

2. Estimate of major nuclide composition (by type of waste)

Type of Waste	Major Nuclide Composition	%
a. Spent resins, filter sludges, evaporator bottoms, etc.	Mn-54	4.95
	Fe-55	78.96
	Co-60	13.72
	Ni-63	0.95
	Zn-65	0.51
	Other	0.91
	b. Dry compressible waste, contaminated equip, etc.	Mn-54
Fe-55		25.30
Co-60		28.06
Ni-63		.41
Zn-65		1.05
Other		0.50
c. Irradiated components, control rods, etc.	N/A	N/A
d. Other	N/A	N/A

**Table 7 (continued)**

**SOLID WASTE AND IRRADIATED FUEL SHIPMENTS [continued]**

**3. Solid Waste Disposition**

January - December 2014

Number of Shipments	Mode of Transportation	Destination
5	Hittman Transport	Clive Containerized Waste Facility
10	Hittman Transport	Energy Solutions/Bear Creek
1	Hittman Transport	ES-Barnwell Processing Facility

**B. Irradiated Fuel Shipments (Disposition)**

January - December 2014

Number of Shipments	Mode of Transportation	Destination
N/A	N/A	N/A

**C. Changes to the Process Control Program**

No changes were made to the Process Control Program during 2014

## SECTION 6

### DOSE MEASUREMENTS AND ASSESSMENTS

This section of the Annual Effluent Release Report provides the dose received by receptors around CPS from gaseous and liquid effluents. The dose to the receptor that would have received the highest dose in each sector (defined as the Critical Receptor for that sector) is listed within this report. This section also provides the dose to individuals who were inside the Site Boundary. This section also summarizes CPS's compliance with the requirements found within 40CFR190.

The assumptions used in determining dose values are as follows:

- All receptors within a five (5) mile radius are included in the Annual Land Use Census. This Annual Census determines what dose pathways are present as well as the distance of each receptor from the site.
- The annual average meteorological data for 2014 was used in conjunction with the Annual Land Use Census to determine the dose to each receptor within five (5) miles.
- The doses for each receptor from each sector were determined using methodologies given in the ODCM.
- The occupancy factor was taken into consideration by calculating the dose to individuals using areas inside the Site Boundary in non-residential areas. The occupancy factor is determined by dividing the number of hour[s] of occupancy per year (taken from the ODCM) and dividing that value by the total number of hour[s] per year.
- Dose to individuals using areas inside the Site Boundary (that are not residences) was calculated using the Ground Plane and Inhalation pathways.

**TABLE 8**

**MAXIMUM OFFSITE DOSES AND DOSE COMMITMENTS  
TO MEMBERS OF THE PUBLIC IN EACH SECTOR**  
Data Period: 01 January 2014 – 31 December 2014

This table illustrates the dose that a member from the public would most likely be exposed to from radioactive effluents in each sector from CPS. These values represent the maximum dose likely to expose a member of the public in each sector.

RECEPTOR INFORMATION					AIRBORNE EFFLUENT DOSE					WATERBORNE EFFLUENT DOSE (mrem) <sup>[1]</sup>	
					Iodine, Particulates, and Noble Gases (mrem)			Noble Gases (mrad)			
Sector	Distance (km)	Pathways	Organ	Age	Total Body	Skin	Organ	Gamma	Beta	Total Body	Organ
N	1.50	GP, I, M, V	B	A	1.93E-02	2.36E-04	9.41E-02	1.62E-04	5.71E-05	0.00E+00	0.00E+00
NNE	4.78	GP, I, V	B	A	7.05E-03	1.14E-04	3.42E-02	8.01E-05	2.82E-05		
NE	2.07	GP, I	B	A	2.72E-04	1.16E-04	7.61E-04	8.04E-05	2.84E-05		
ENE	4.59	GP, I, V	B	C	1.50E-02	6.41E-05	7.42E-02	4.51E-05	1.59E-05		
E	1.67	GP, I, V	B	A	8.62E-03	1.45E-04	4.17E-02	9.79E-05	3.45E-05		
ESE	5.30	GP, I, V	B	A	5.17E-03	8.39E-05	2.51E-02	5.87E-05	2.07E-05		
SE	4.44	GP, I	B	C	2.83E-04	8.40E-05	1.04E-03	5.87E-05	2.07E-05		
SSE	4.32	GP, I, V	B	C	2.08E-04	6.15E-05	7.61E-04	4.30E-05	1.52E-05		
S	6.60	GP, I, M, V	B	A	3.88E-03	4.62E-05	1.89E-02	3.26E-05	1.15E-05		
SSW	5.47	GP, I, M	B	A	9.59E-04	3.94E-05	4.56E-03	2.78E-05	9.79E-06		
SW	5.87	GP, I, V	B	C	1.33E-02	5.64E-05	6.57E-02	3.99E-05	1.41E-05		
WSW	5.53	GP, I, M, V	B	A	3.73E-03	4.42E-05	1.82E-02	3.13E-05	1.10E-05		
W	3.22	GP, I, V	B	A	2.96E-03	4.76E-05	1.43E-02	3.36E-05	1.19E-05		
WNW	2.75	GP, I, V	B	C	1.51E-02	6.41E-05	7.44E-02	4.52E-05	1.59E-05		
NW	4.51	GP, I, V	B	C	1.82E-02	7.70E-05	8.97E-02	5.45E-05	1.92E-05		
NNW	2.05	GP, I, M, V	B	A	1.26E-02	1.52E-04	6.15E-02	1.06E-04	3.73E-05		

**Key for Table 8**

GP = Ground Plane  
I = Inhalation  
M = Cows Meat

V = Vegetables  
B = Bone

A = Adult  
T = Teen  
I = Infant  
C = Child

[1] There were zero (0) liquid radwaste releases from CPS in 2014.

All doses were within all regulatory limits, including limits from 40CFR190.

All dose calculations were performed using the methodology contained in the CPS ODCM.



## COMPLIANCE WITH 40CFR190 REQUIREMENTS

Optically Stimulated Luminescent Dosimeters [OSLD] are stationed around CPS to measure the ambient gamma radiation field. Monitoring stations are placed near the site boundary and approximately five (5) miles from the reactor, in locations representing the sixteen (16) compass sectors. Other locations are chosen to measure the radiation field at places of special interest such as nearby residences, meeting places and population centers. Control sites are located further than ten (10) miles from the site, in areas that should not be affected by plant operations. The results from the TLDs are reported in the Annual Radiological Environmental Operating Report [AREOR]. The results from this effort indicated no excess dose to offsite areas.

Additionally, NUREG-0543, METHODS FOR DEMONSTRATING LWR COMPLIANCE WITH THE EPA URANIUM FUEL CYCLE STANDARD (40 CFR PART 190) states in section IV, "As long as a nuclear plant site operates at a level below the Appendix I reporting requirements, no extra analysis is required to demonstrate compliance with 40 CFR Part 190." The organ and whole body doses reported in Table 8 are determined using 10 CFR 50 Appendix I methodology. The doses reported are well below the limits of Appendix I.

### DOSE TO MEMBERS OF THE PUBLIC WITHIN THE SITE BOUNDARY

CPS ODCM section 7.2 (Part I, Section 6.2 of Revision 24) requires that the Radioactive Effluent Release Report include an assessment of the radiation doses from radioactive liquids and gaseous effluents to MEMBERS OF THE PUBLIC due to their activities inside the SITE BOUNDARY. Within the CPS site boundary there are seven areas that are open to members of the public as identified by CPS ODCM Table 3.4-4 (Part II, Table 5-3 of Revision 24) (see Figure 4):

- 
- The Department of Natural Resources Recreation Area at 1.287 kilometers (0.8 miles) in the ESE sector
  - A road at 0.495 kilometers (0.3 miles) in the SE sector
  - A residence at 2.736 kilometers (1.7 miles) in the SSE sector
  - A residence at 1.219 kilometers (0.8 miles) in the SW sector
  - Agricultural acreage at 1.372 kilometers (0.9 miles) in the SSW sector
  - A residence at 2.414 kilometers (1.5 miles) in the WSW sector
  - A portion of Clinton Lake at 0.335 kilometers (0.2 miles) in the NW sector
- 

At all of the above locations, the plume, inhalation and ground-plane exposure pathways are used for dose calculations. The 2014 Annual Land Use Census identified no other exposure pathways. All dose calculations were performed using the methodology contained in the CPS ODCM.

**FIGURE 4**

**AREAS WITHIN THE CPS SITE BOUNDARY OPEN  
TO MEMBERS OF THE  
PUBLIC**

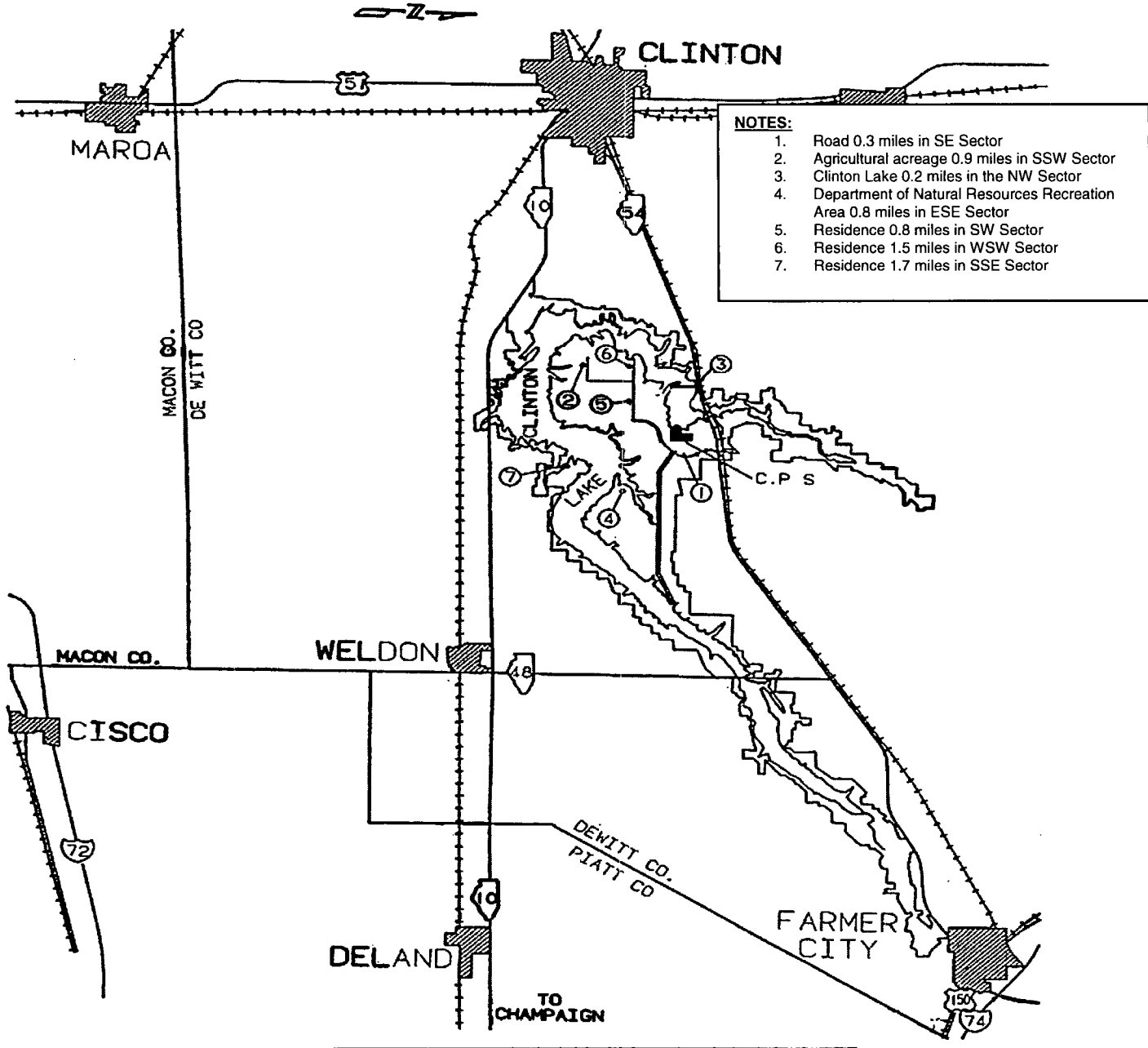

**TABLE 9**

**CALCULATED DOSES TO MEMBERS OF THE PUBLIC DURING USE OF THE  
DEPARTMENT OF NATURAL RESOURCES RECREATION AREA IN THE EAST-  
SOUTHEAST SECTOR WITHIN THE CPS SITE BOUNDARY**

Data Period: 01 January 2014 – 31 December 2014

DESCRIPTION	DOSE	UNITS
Total Body Dose Rate (Noble Gases)	4.21E-05	mrem/year
Skin Dose Rate (Noble Gases)	6.16E-05	mrem/year
Gamma Air Dose	4.42E-05	mrad
Beta Air Dose	1.56E-05	mrad
Total Body Dose	2.15E-04	mrem
Skin Dose <sup>[1]</sup>	6.56E-05	mrem

[1] DOSE includes the dose values resulting from the release of iodines, particulates (with half lives >8 days), noble gases, tritium, and carbon-14 in gaseous effluents.

Highest Organ Dose by Age Group:

Adult Bone	4.19E-04	mrem
Teen Bone	5.80E-04	mrem
Child Bone	7.83E-04	mrem
Infant Bone	5.90E-04	mrem

**TABLE 10**

**CALCULATED DOSES TO MEMBERS OF THE PUBLIC DURING USE OF THE ROAD  
IN THE SOUTHEAST SECTOR WITHIN THE CPS SITE BOUNDARY**

Data Period: 01 January 2014 – 31 December 2014

DESCRIPTION	DOSE	UNITS
Total Body Dose Rate (Noble Gases)	1.12E-05	mrem/year
Skin Dose Rate (Noble Gases)	1.64E-05	mrem/year
Gamma Air Dose	1.28E-05	mrads
Beta Air Dose	4.53E-06	mrads
Total Body Dose	6.26E-05	mrem
Skin Dose <sup>[1]</sup>	1.91E-05	mrem

[1] DOSE includes the dose values resulting from the release of iodines, particulates (with half lives >8 days), noble gases, tritium, and carbon-14 in gaseous effluents.

Highest Organ Dose by Age Group:

Adult Bone	1.22E-04	mrem
Teen Bone	1.69E-04	mrem
Child Bone	2.28E-04	mrem
Infant Bone	1.71E-04	mrem

**TABLE 11**

**CALCULATED DOSES FOR THE RESIDENTS IN THE SOUTH-SOUTHEAST SECTOR  
(2.736 kilometers) WITHIN THE CPS SITE BOUNDARY  
Data Period: 01 January 2014 – 31 December 2014**

DESCRIPTION	DOSE	UNITS
Total Body Dose Rate (Noble Gases)	5.49E-05	mrem/year
Skin Dose Rate (Noble Gases)	8.02E-05	mrem/year
Gamma Air Dose	5.79E-05	mrads
Beta Air Dose	2.04E-05	mrads
Total Body Dose	2.80E-04	mrem
Skin Dose <sup>[1]</sup>	8.36E-05	mrem

[1] DOSE includes the dose values resulting from the release of iodines, particulates (with half lives >8 days), noble gases, tritium, and carbon-14 in gaseous effluents.

**Highest Organ Dose by Age Group:**

Adult Bone	5.48E-04	mrem
Teen Bone	7.58E-04	mrem
Child Bone	1.02E-03	mrem
Infant Bone	7.72E-04	mrem

**TABLE 12**

**CALCULATED DOSES FOR THE RESIDENTS IN THE SOUTHWEST SECTOR (1.219 kilometers) WITHIN THE CPS SITE BOUNDARY**  
Data Period: 01 January 2014 – 31 December 2014

DESCRIPTION	DOSE	UNITS
Total Body Dose Rate (Noble Gases)	8.38E-05	mrem/year
Skin Dose Rate (Noble Gases)	1.22E-04	mrem/year
Gamma Air Dose	8.83E-05	mrads
Beta Air Dose	3.12E-05	mrads
Total Body Dose	4.29E-04	mrem
Skin Dose <sup>[1]</sup>	1.30E-04	mrem

[1] DOSE includes the dose values resulting from the release of iodines, particulates (with half lives >8 days), noble gases, tritium, and carbon-14 in gaseous effluents.

Highest Organ Dose by Age Group:

Adult Bone	8.38E-04	mrem
Teen Bone	1.16E-03	mrem
Child Bone	1.56E-03	mrem
Infant Bone	1.18E-03	mrem

**TABLE 13**

**CALCULATED DOSES TO MEMBERS OF THE PUBLIC DURING USE OF THE  
AGRICULTURAL ACREAGE IN THE SOUTH-SOUTHWEST SECTOR WITHIN THE  
CPS SITE BOUNDARY**

Data Period: 01 January 2014 – 31 December 2014

DESCRIPTION	DOSE	UNITS
Total Body Dose Rate (Noble Gases)	5.77E-06	mrem/year
Skin Dose Rate (Noble Gases)	8.43E-06	mrem/year
Gamma Air Dose	6.07E-06	mrads
Beta Air Dose	2.14E-06	mrads
Total Body Dose	2.95E-05	mrem
Skin Dose <sup>[1]</sup>	8.98E-06	mrem

[1] DOSE includes the dose values resulting from the release of iodines, particulates (with half lives >8 days), noble gases, tritium, and carbon-14 in gaseous effluents.

Highest Organ Dose by Age Group:

Adult Bone	5.76E-05	mrem
Teen Bone	7.96E-05	mrem
Child Bone	N/A <sup>[2]</sup>	mrem
Infant Bone	N/A <sup>[2]</sup>	mrem

[2] Dose calculated only for the age groups likely to be in the field.

**TABLE 14****CALCULATED DOSES FOR THE RESIDENTS IN THE WEST-SOUTHWEST SECTOR  
WITHIN THE CPS SITE BOUNDARY**

Data Period: 01 January 2014 – 31 December 2014

DESCRIPTION	DOSE	UNITS
Total Body Dose Rate (Noble Gases)	4.26E-05	mrem/year
Skin Dose Rate (Noble Gases)	6.22E-05	mrem/year
Gamma Air Dose	4.49E-05	mrads
Beta Air Dose	1.58E-05	mrads
Total Body Dose	2.17E-04	mrem
Skin Dose <sup>[1]</sup>	6.43E-05	mrem

[1] DOSE includes the dose values resulting from the release of iodines, particulates (with half lives >8 days), noble gases, tritium, and carbon-14 in gaseous effluents.

**Highest Organ Dose by Age Group:**

Adult Bone	4.24E-04	mrem
Teen Bone	5.87E-04	mrem
Child Bone	7.93E-04	mrem
Infant Bone	5.97E-04	mrem



**TABLE 15**

**CALCULATED DOSES TO MEMBERS OF THE PUBLIC DURING USE OF CLINTON LAKE IN THE NORTHWEST SECTOR WITHIN THE CPS SITE BOUNDARY**

Data Period: 01 January 2014 – 31 December 2014

DESCRIPTION	DOSE	UNITS
Total Body Dose Rate (Noble Gases)	9.38E-05	mrem/year
Skin Dose Rate (Noble Gases)	1.37E-04	mrem/year
Gamma Air Dose	9.81E-05	mrads
Beta Air Dose	3.46E-05	mrads
Total Body Dose	4.74E-04	mrem
Skin Dose <sup>[1]</sup>	1.42E-04	mrem

[1] DOSE includes the dose values resulting from the release of iodines, particulates (with half lives >8 days), noble gases, tritium, and carbon-14 in gaseous effluents.

Highest Organ Dose by Age Group:

Adult Bone	9.28E-04	mrem
Teen Bone	1.28E-03	mrem
Child Bone	1.74E-03	mrem
Infant Bone	1.31E-03	mrem

## SECTION 7

### ODCM OPERATIONAL REMEDIAL REQUIREMENT REPORTS

In accordance with CPS ODCM section[s] 2.7.1 and 3.9.2 (Part I Section 3.1.1 Required Action G.1, Part I Section 3.2.1.1 Required Action F.1, and Part I Section 3.2.2.1 Required Action G.1 of revision 24), INOPERABLE radioactive liquid and gaseous effluent monitoring instrumentation channels remaining in an INOPERABLE condition for greater than 30 days shall be reported in the Annual Radioactive Effluent Release Report.

During the course of 2014, there were two (2) instances when either a radioactive liquid or gaseous effluent instrumentation channel[s] was INOPERABLE for greater than any 30 day period. The events are documented below.

0UIX-PR051 channel 6, Station HVAC Effluent System Flow-Rate Measuring Device, was non-functional for greater than 30 days. 0UIX-PR051 was declared non-functional on March 3<sup>rd</sup>, 2014 at 01:51 and returned to service August 5<sup>th</sup>, 2014 at 10:28. All required remedial actions were carried out during this time. The extended inoperability was due to obsolescence of the associated transmitter 0FTVR500, which required an Engineering Change to provide a substitute replacement part.

1RIX-PR036, Plant Service Water Effluent Process Radiation Monitor, was non-functional for greater than 30 days. The monitor was declared non-functional on March 27<sup>th</sup>, 2014 at 15:42 due to communication failure with the Main Control Room, and was returned to service on December 4<sup>th</sup>, 2014 at 10:23. All required remedial actions were carried out during this time. The extended communication interruption was due to the necessity of developing an Engineering Change to route new communication cabling, as opposed to waiting until the next refueling outage to repair the existing communication equipment, which was inaccessible while the plant operated at power.

## SECTION 8

### METEOROLOGICAL DATA AND DISPERSION ESTIMATES

On 13 April 1972, the meteorological monitoring program commenced at the Clinton Power Station site. The meteorological system consists of a tower 199 feet high with two (2) levels of instrumentation at the 10-meter and 60-meter elevations. A combined cup and vane sensor measures wind direction and wind speed[s] at the 10-meter and 60-meter levels. An aspirated dual temperature sensor senses the temperatures at these levels. One-half of the dual sensors at each elevation are used for ambient temperature while the other half is used to provide a differential temperature between the 10-meter and 60-meter levels.

Meteorological monitoring instruments have been placed on the Clinton Power Station microwave tower at the 10-meter level to serve as a backup to the primary meteorological tower.

Clinton Power Station meteorological data is transmitted to the Main Control Room [MCR] via a dedicated communication link. Once the signals are received at the MCR, they are then converted to a 4 to 20 milliamp signal and fed individually to a microprocessor and chart recorders. The microprocessor is part of the Clinton Power Station Radiation Monitoring System [RMS]. Meteorological data is available via the microprocessors in the Main Control Room.

Dispersion modeling for effluents for normal operation of Clinton Power Station is a straight-line, sector-averaged Gaussian plume model designed to estimate average relative concentration at various receptor points. The model was developed in accordance with routine release analysis procedures specified in Regulatory Guide 1.111. For joint frequency input data, periods of calm are distributed in accordance with a directional distribution. For hourly input data, periods of calm are the previous hour's wind direction. Periods of calm are assigned a wind speed value of half the specified instrument threshold value. Reference Table 18 for more detailed information on meteorology and dispersion data.

**TABLE 16****METEOROLOGICAL DATA AVAILABILITY**

Data Period: 01 January 2014 – 31 December 2014

PARAMETER	PERCENT OF VALID PARAMETER HOURS (%)			
	Quarter 1	Quarter 2	Quarter 3	Quarter 4
1. Wind Speed				
a. 10-Meter sensor	99.7	99.8	100.0	99.8
b. 60 Meter sensor	97.5	99.9	100.0	99.8
2. Wind Direction				
a. 10-Meter sensor	99.9	99.9	100.0	99.8
b. 60 Meter sensor	99.9	97.5	100.0	99.8
3. Temperature				
a. 10-Meter sensor	99.9	99.8	100.0	99.9
b. 60 Meter sensor	99.9	99.8	100.0	99.9
c. Temperature Difference (10m-60m)	99.9	99.8	100.0	99.9
4. Percent of hours for which valid 10-meter Wind Speed, Wind Direction, and Delta Temperature were available	99.9	99.7	100.0	99.8
5. Percent of hours for which valid 60-meter Wind Speed, Wind Direction, and Delta Temperature were available	97.5	97.5	100.0	99.8

Clinton Power Station was able to achieve 99.7% Meteorological Recoverable Data for upper level joint frequency (speed, direction and delta T) and 99.9% Meteorological Recoverable Data from lower level joint frequency during 2014, exceeding the minimum criteria of 90% as delineated within Regulatory Guide 1.23.

**TABLE 17****CLASSIFICATION OF ATMOSPHERIC STABILITY**

Stability Classification	Pasquill Category	Defining Conditions
Extremely unstable	A	----- $<\Delta T \leq -1.042$
Moderately unstable	B	$-1.042 <\Delta T \leq -0.933$
Slightly unstable	C	$-0.933 <\Delta T \leq -0.823$
Neutral	D	$-0.823 <\Delta T \leq -0.274$
Slightly stable	E	$-0.274 <\Delta T \leq 0.823$
Moderately stable	F	$0.823 <\Delta T \leq 2.195$
Extremely stable	G	$2.195 <\Delta T \leq$ -----

---

$\Delta T$  = temperature difference in degrees Fahrenheit per 100 feet

**TABLE 18**

**JOINT WIND FREQUENCY DISTRIBUTION BY STABILITY CLASS**

Reporting Period: 01 January 2014 through 31 December 2014

The following table contains the joint wind frequency tables for CPS. The tables are segregated by sensor elevation and calendar quarter. All tabled values are in hours.

**TABLE 18 (continued)**

**JOINT WIND FREQUENCY DISTRIBUTION BY STABILITY CLASS**

Clinton Power Station

Period of Record: January - March 2014

Stability Class - Extremely Unstable - 60m-10m Delta-T (F)

Winds Measured at 10 Meters

Wind Direction	Wind Speed (in mph)						Total
	1-3	4-7	8-12	13-18	19-24	> 24	
N	0	0	3	5	0	0	8
NNE	0	1	0	0	0	0	1
NE	0	1	2	0	2	0	5
ENE	0	1	0	3	0	0	4
E	0	0	0	0	0	0	0
ESE	0	4	0	0	0	0	4
SE	0	3	1	2	0	0	6
SSE	0	8	2	7	1	0	18
S	0	2	16	2	0	0	20
SSW	0	0	6	0	0	0	6
SW	0	0	4	4	0	0	8
WSW	0	0	4	6	0	0	10
W	0	0	1	3	0	0	4
WNW	0	0	4	6	0	0	10
NW	0	4	5	0	2	0	11
NNW	0	0	11	1	0	0	12
Variable	0	0	0	0	0	0	0
Total	0	24	59	39	5	0	127

Hours of calm in this stability class: 0  
 Hours of missing wind measurements in this stability class: 0  
 Hours of missing stability measurements in all stability classes: 3

**TABLE 18 (continued)**

**JOINT WIND FREQUENCY DISTRIBUTION BY STABILITY CLASS**

Clinton Power Station

Period of Record: January - March 2014  
 Stability Class - Moderately Unstable - 60m-10m Delta-T (F)  
 Winds Measured at 10 Meters

Wind Direction	Wind Speed (in mph)						Total
	1-3	4-7	8-12	13-18	19-24	> 24	
N	0	0	2	4	0	0	6
NNE	0	0	3	1	0	0	4
NE	0	2	3	2	3	0	10
ENE	0	0	1	2	0	0	3
E	0	2	0	0	0	0	2
ESE	0	1	0	0	0	0	1
SE	0	0	0	0	0	0	0
SSE	0	1	1	1	0	0	3
S	0	1	1	2	0	0	4
SSW	0	2	1	0	0	0	3
SW	0	0	3	2	1	0	6
WSW	0	0	2	3	4	0	9
W	0	0	4	1	1	0	6
WNW	0	2	6	8	0	0	16
NW	0	3	4	4	1	0	12
NNW	0	0	7	1	0	0	8
Variable	0	0	0	0	0	0	0
Total	0	14	38	31	10	0	93

Hours of calm in this stability class: 0  
 Hours of missing wind measurements in this stability class: 0  
 Hours of missing stability measurements in all stability classes: 3



**TABLE 18 (continued)**

**JOINT WIND FREQUENCY DISTRIBUTION BY STABILITY CLASS**

Clinton Power Station

Period of Record: January - March 2014  
 Stability Class - Slightly Unstable - 60m-10m Delta-T (F)  
 Winds Measured at 10 Meters

Wind Direction	Wind Speed (in mph)						Total
	1-3	4-7	8-12	13-18	19-24	> 24	
N	0	1	11	5	0	0	17
NNE	0	1	5	3	0	0	9
NE	0	4	7	2	2	0	15
ENE	0	2	4	0	0	0	6
E	0	0	0	0	0	0	0
ESE	1	0	0	0	0	0	1
SE	0	4	1	0	0	0	5
SSE	0	0	3	0	0	0	3
S	0	1	5	7	0	0	13
SSW	1	0	6	4	2	0	13
SW	0	0	3	7	0	0	10
WSW	0	1	2	1	2	0	6
W	0	0	4	6	3	0	13
WNW	0	0	12	6	0	0	18
NW	0	6	7	4	0	0	17
NNW	0	0	7	7	0	0	14
Variable	0	0	0	0	0	0	0
Total	2	20	77	52	9	0	160

Hours of calm in this stability class: 0  
 Hours of missing wind measurements in this stability class: 0  
 Hours of missing stability measurements in all stability classes: 3

**TABLE 18 (continued)**

**JOINT WIND FREQUENCY DISTRIBUTION BY STABILITY CLASS**

Clinton Power Station

Period of Record: January - March 2014  
 Stability Class - Neutral - 60m-10m Delta-T (F)  
 Winds Measured at 10 Meters

Wind Direction	Wind Speed (in mph)						Total
	1-3	4-7	8-12	13-18	19-24	> 24	
N	0	13	35	37	10	0	95
NNE	1	15	15	19	4	1	55
NE	0	33	17	27	9	1	87
ENE	0	27	25	1	0	0	53
E	1	9	2	0	0	0	12
ESE	0	15	6	0	0	0	21
SE	1	16	12	4	0	0	33
SSE	2	28	54	18	0	0	102
S	0	12	29	31	4	0	76
SSW	0	17	24	31	9	2	83
SW	0	9	13	25	0	0	47
WSW	1	8	6	14	6	2	37
W	0	11	20	26	8	2	67
WNW	3	10	29	60	21	0	123
NW	0	14	53	34	19	5	125
NNW	0	23	48	18	5	1	95
Variable	0	0	0	0	0	0	0
Total	9	260	388	345	95	14	1111

Hours of calm in this stability class: 0  
 Hours of missing wind measurements in this stability class: 0  
 Hours of missing stability measurements in all stability classes: 3

**TABLE 18 (continued)**

**JOINT WIND FREQUENCY DISTRIBUTION BY STABILITY CLASS**

Clinton Power Station

Period of Record: January - March 2014  
 Stability Class - Slightly Stable - 60m-10m Delta-T (F)  
 Winds Measured at 10 Meters

Wind Direction	Wind Speed (in mph)						Total
	1-3	4-7	8-12	13-18	19-24	> 24	
N	3	10	2	0	0	0	15
NNE	4	6	0	0	0	0	10
NE	3	9	1	2	0	0	15
ENE	4	8	0	0	0	0	12
E	1	11	2	0	0	0	14
ESE	3	5	1	0	0	0	9
SE	2	20	4	0	0	0	26
SSE	2	15	20	3	0	0	40
S	1	11	40	18	0	0	70
SSW	1	9	32	15	0	0	57
SW	2	17	21	8	0	0	48
WSW	3	12	19	5	0	2	41
W	4	13	9	9	0	0	35
WNW	1	7	26	8	0	0	42
NW	4	11	30	4	2	1	52
NNW	3	14	2	0	0	1	20
Variable	0	0	0	0	0	0	0
Total	41	178	209	72	2	4	506

Hours of calm in this stability class: 0  
 Hours of missing wind measurements in this stability class: 0  
 Hours of missing stability measurements in all stability classes: 3

**TABLE 18 (continued)**

**JOINT WIND FREQUENCY DISTRIBUTION BY STABILITY CLASS**

Clinton Power Station

Period of Record: January - March 2014  
 Stability Class - Moderately Stable - 60m-10m Delta-T (F)  
 Winds Measured at 10 Meters

Wind Direction	Wind Speed (in mph)						Total
	1-3	4-7	8-12	13-18	19-24	> 24	
N	1	6	0	0	0	0	7
NNE	1	0	0	0	0	0	1
NE	3	9	0	0	0	0	12
ENE	3	1	0	0	0	0	4
E	0	3	0	0	0	0	3
ESE	1	5	0	0	0	0	6
SE	1	3	0	0	0	0	4
SSE	0	2	1	0	0	0	3
S	2	4	0	0	0	0	6
SSW	1	6	2	0	0	0	9
SW	3	4	2	0	0	0	9
WSW	1	8	1	0	0	0	10
W	1	11	0	1	0	0	13
WNW	2	7	4	0	0	0	13
NW	0	5	1	0	0	0	6
NNW	1	4	0	0	0	0	5
Variable	0	0	0	0	0	0	0
Total	21	78	11	1	0	0	111

Hours of calm in this stability class: 0  
 Hours of missing wind measurements in this stability class: 0  
 Hours of missing stability measurements in all stability classes: 3

**TABLE 18 (continued)**

**JOINT WIND FREQUENCY DISTRIBUTION BY STABILITY CLASS**

Clinton Power Station

Period of Record: January - March 2014

Stability Class - Extremely Stable - 60m-10m Delta-T (F)

Winds Measured at 10 Meters

Wind Direction	Wind Speed (in mph)						Total
	1-3	4-7	8-12	13-18	19-24	> 24	
N	0	1	0	0	0	0	1
NNE	0	1	0	0	0	0	1
NE	1	4	0	0	0	0	5
ENE	1	2	0	0	0	0	3
E	1	2	0	0	0	0	3
ESE	1	0	0	0	0	0	1
SE	2	2	0	0	0	0	4
SSE	0	3	1	0	0	0	4
S	0	7	0	0	0	0	7
SSW	2	2	0	0	0	0	4
SW	0	2	0	0	0	0	2
WSW	1	2	0	0	0	0	3
W	4	1	0	0	0	0	5
WNW	2	1	0	0	0	0	3
NW	0	3	0	0	0	0	3
NNW	0	0	0	0	0	0	0
Variable	0	0	0	0	0	0	0
Total	15	33	1	0	0	0	49

Hours of calm in this stability class: 0  
 Hours of missing wind measurements in this stability class: 0  
 Hours of missing stability measurements in all stability classes: 3

**TABLE 18 (continued)**

**JOINT WIND FREQUENCY DISTRIBUTION BY STABILITY CLASS**

Clinton Power Station

Period of Record: January - March 2014

Stability Class - Extremely Unstable - 60m-10m Delta-T (F)  
Winds Measured at 60 Meters

Wind Direction	Wind Speed (in mph)						Total
	1-3	4-7	8-12	13-18	19-24	> 24	
N	0	0	0	3	3	0	6
NNE	0	0	1	0	0	0	1
NE	0	1	1	0	0	2	4
ENE	0	0	1	0	4	0	5
E	0	0	0	0	0	0	0
ESE	0	4	2	0	0	0	6
SE	0	4	1	2	2	0	9
SSE	0	4	0	2	6	1	13
S	0	0	11	5	1	1	18
SSW	0	1	3	4	0	0	8
SW	0	0	2	5	1	0	8
WSW	0	0	2	7	1	0	10
W	0	0	0	3	1	0	4
WNW	0	0	4	1	6	0	11
NW	0	0	5	5	0	2	12
NNW	0	0	2	9	0	0	11
Variable	0	0	0	0	0	0	0
Total	0	14	35	46	25	6	126

Hours of calm in this stability class: 0  
Hours of missing wind measurements in this stability class: 1  
Hours of missing stability measurements in all stability classes: 3

**TABLE 18 (continued)**

**JOINT WIND FREQUENCY DISTRIBUTION BY STABILITY CLASS**

Clinton Power Station

Period of Record: January - March 2014

Stability Class - Moderately Unstable - 60m-10m Delta-T (F)

Winds Measured at 60 Meters

Wind Direction	Wind Speed (in mph)						Total
	1-3	4-7	8-12	13-18	19-24	> 24	
N	0	0	0	1	4	0	5
NNE	0	0	0	0	1	0	1
NE	0	2	5	1	0	4	12
ENE	0	0	0	0	3	0	3
E	0	1	2	0	0	0	3
ESE	0	1	0	0	0	0	1
SE	0	1	0	0	0	0	1
SSE	0	0	1	0	2	0	3
S	0	0	1	1	0	1	3
SSW	0	1	2	1	0	0	4
SW	0	1	1	1	1	1	5
WSW	0	0	0	2	2	5	9
W	0	0	1	4	0	1	6
WNW	0	0	4	6	6	0	16
NW	0	0	3	4	4	1	12
NNW	0	0	3	3	1	0	7
Variable	0	0	0	0	0	0	0
Total	0	7	23	24	24	13	91

Hours of calm in this stability class: 0  
 Hours of missing wind measurements in this stability class: 2  
 Hours of missing stability measurements in all stability classes: 3

**TABLE 18 (continued)**

**JOINT WIND FREQUENCY DISTRIBUTION BY STABILITY CLASS**

Clinton Power Station

Period of Record: January - March 2014

Stability Class - Slightly Unstable - 60m-10m Delta-T (F)

Winds Measured at 60 Meters

Wind Direction	Wind Speed (in mph)						Total
	1-3	4-7	8-12	13-18	19-24	> 24	
N	0	0	3	11	3	0	17
NNE	0	1	1	5	1	0	8
NE	0	0	7	4	0	3	14
ENE	0	0	3	3	1	0	7
E	0	0	0	0	0	0	0
ESE	0	0	0	0	0	0	0
SE	0	3	1	1	0	0	5
SSE	0	1	0	3	1	0	5
S	0	0	2	3	6	0	11
SSW	0	0	3	3	3	3	12
SW	0	0	1	3	4	2	10
WSW	0	0	1	2	1	2	6
W	0	0	0	9	2	4	15
WNW	0	0	2	9	5	0	16
NW	0	2	9	5	1	0	17
NNW	0	0	4	1	7	0	12
Variable	0	0	0	0	0	0	0
Total	0	7	37	62	35	14	155

Hours of calm in this stability class: 0

Hours of missing wind measurements in this stability class: 5

Hours of missing stability measurements in all stability classes: 3



**TABLE 18 (continued)**

**JOINT WIND FREQUENCY DISTRIBUTION BY STABILITY CLASS**

Clinton Power Station

Period of Record: January - March 2014

Stability Class - Neutral - 60m-10m Delta-T (F)

Winds Measured at 60 Meters

Wind Direction	Wind Speed (in mph)						Total
	1-3	4-7	8-12	13-18	19-24	> 24	
N	0	4	20	32	22	18	96
NNE	0	8	8	15	9	7	47
NE	0	6	19	8	20	15	68
ENE	0	2	27	25	8	6	68
E	0	3	7	6	1	0	17
ESE	1	0	10	7	2	0	20
SE	1	8	10	13	5	0	37
SSE	1	5	27	33	23	6	95
S	0	5	14	28	13	29	89
SSW	1	2	10	17	19	20	69
SW	0	8	11	12	19	4	54
WSW	0	5	3	5	12	12	37
W	1	5	10	15	23	13	67
WNW	1	1	10	20	50	33	115
NW	0	8	27	40	27	27	129
NNW	0	3	23	25	16	4	71
Variable	0	0	0	0	0	0	0
Total	6	73	236	301	269	194	1079

Hours of calm in this stability class: 0

Hours of missing wind measurements in this stability class: 32

Hours of missing stability measurements in all stability classes: 3

**TABLE 18 (continued)**

**JOINT WIND FREQUENCY DISTRIBUTION BY STABILITY CLASS**

Clinton Power Station

Period of Record: January - March 2014  
 Stability Class - Slightly Stable - 60m-10m Delta-T (F)  
 Winds Measured at 60 Meters

Wind Direction	Wind Speed (in mph)						Total
	1-3	4-7	8-12	13-18	19-24	> 24	
N	0	1	9	2	0	0	12
NNE	0	0	3	0	0	0	3
NE	2	3	3	0	1	2	11
ENE	3	6	6	2	0	0	17
E	1	2	7	8	0	0	18
ESE	0	3	5	1	1	0	10
SE	0	4	13	8	0	0	25
SSE	0	0	6	21	12	2	41
S	0	4	4	11	35	16	70
SSW	0	2	5	19	21	6	53
SW	0	1	7	21	16	1	46
WSW	0	1	4	15	15	2	37
W	0	1	9	12	9	2	33
WNW	1	3	7	26	15	1	53
NW	0	1	10	26	6	3	46
NNW	0	6	8	7	0	1	22
Variable	0	0	0	0	0	0	0
Total	7	38	106	179	131	36	497

Hours of calm in this stability class: 0  
 Hours of missing wind measurements in this stability class: 9  
 Hours of missing stability measurements in all stability classes: 3

**TABLE 18 (continued)**

**JOINT WIND FREQUENCY DISTRIBUTION BY STABILITY CLASS**

Clinton Power Station

Period of Record: January - March 2014

Stability Class - Moderately Stable - 60m-10m Delta-T (F)  
Winds Measured at 60 Meters

Wind Direction	Wind Speed (in mph)						Total
	1-3	4-7	8-12	13-18	19-24	> 24	
N	1	0	2	2	0	0	5
NNE	0	1	2	0	0	0	3
NE	0	1	4	0	0	0	5
ENE	0	0	3	2	0	0	5
E	0	1	3	1	0	0	5
ESE	0	3	4	1	0	0	8
SE	0	1	4	0	0	0	5
SSE	0	0	2	2	0	0	4
S	0	1	2	1	1	0	5
SSW	0	3	0	5	1	0	9
SW	0	0	0	6	0	0	6
WSW	0	0	1	3	2	0	6
W	0	3	5	9	0	1	18
WNW	0	1	3	2	0	0	6
NW	0	0	3	7	1	0	11
NNW	1	1	4	1	0	0	7
Variable	0	0	0	0	0	0	0
Total	2	16	42	42	5	1	108

Hours of calm in this stability class: 0  
 Hours of missing wind measurements in this stability class: 3  
 Hours of missing stability measurements in all stability classes: 3

**TABLE 18 (continued)**

**JOINT WIND FREQUENCY DISTRIBUTION BY STABILITY CLASS**

Clinton Power Station

Period of Record: January - March 2014

Stability Class - Extremely Stable - 60m-10m Delta-T (F)

Winds Measured at 60 Meters

Wind Direction	Wind Speed (in mph)						Total
	1-3	4-7	8-12	13-18	19-24	> 24	
N	0	0	0	0	0	0	0
NNE	0	2	1	0	0	0	3
NE	0	1	0	0	0	0	1
ENE	0	0	3	0	0	0	3
E	0	0	3	0	0	0	3
ESE	0	0	1	0	0	0	1
SE	0	0	4	0	0	0	4
SSE	1	0	1	2	0	0	4
S	0	0	0	2	1	0	3
SSW	0	3	0	3	0	0	6
SW	0	3	3	1	0	0	7
WSW	0	1	1	1	0	0	3
W	0	2	2	3	0	0	7
WNW	0	0	0	0	0	0	0
NW	0	0	1	0	0	0	1
NNW	0	0	3	0	0	0	3
Variable	0	0	0	0	0	0	0
Total	1	12	23	12	1	0	49

Hours of calm in this stability class: 0

Hours of missing wind measurements in this stability class: 0

Hours of missing stability measurements in all stability classes: 3

**TABLE 18 (continued)**

**JOINT WIND FREQUENCY DISTRIBUTION BY STABILITY CLASS**

Clinton Power Station

Period of Record: April - June 2014

Stability Class - Extremely Unstable - 60m-10m Delta-T (F)

Winds Measured at 10 Meters

Wind Direction	Wind Speed (in mph)						Total
	1-3	4-7	8-12	13-18	19-24	> 24	
N	0	0	6	1	0	0	7
NNE	0	0	2	0	0	0	2
NE	0	0	0	0	0	0	0
ENE	0	2	3	0	0	0	5
E	0	1	2	0	0	0	3
ESE	0	1	1	0	0	0	2
SE	0	4	4	1	0	0	9
SSE	0	1	0	7	0	0	8
S	0	0	4	2	0	0	6
SSW	0	1	3	3	0	0	7
SW	0	0	3	1	0	0	4
WSW	0	1	3	0	2	0	6
W	0	0	2	3	3	0	8
WNW	0	0	3	6	0	0	9
NW	0	2	7	7	0	0	16
NNW	0	1	2	4	0	0	7
Variable	0	0	0	0	0	0	0
Total	0	14	45	35	5	0	99

Hours of calm in this stability class: 0  
 Hours of missing wind measurements in this stability class: 1  
 Hours of missing stability measurements in all stability classes: 5

**TABLE 18 (continued)**

**JOINT WIND FREQUENCY DISTRIBUTION BY STABILITY CLASS**

Clinton Power Station

Period of Record: April - June 2014

Stability Class - Moderately Unstable - 60m-10m Delta-T (F)

Winds Measured at 10 Meters

Wind Direction	Wind Speed (in mph)						Total
	1-3	4-7	8-12	13-18	19-24	> 24	
N	0	1	3	0	0	0	4
NNE	0	0	0	0	0	0	0
NE	0	0	2	0	0	0	2
ENE	0	3	1	0	0	0	4
E	0	2	1	0	0	0	3
ESE	0	1	5	0	0	0	6
SE	0	5	1	0	0	0	6
SSE	0	3	5	5	0	0	13
S	0	5	4	1	0	0	10
SSW	0	2	5	2	2	0	11
SW	0	0	7	2	0	0	9
WSW	0	0	3	1	0	0	4
W	0	2	3	3	0	0	8
WNW	0	1	7	1	0	0	9
NW	0	4	2	2	0	0	8
NNW	0	4	3	0	0	0	7
Variable	0	0	0	0	0	0	0
Total	0	33	52	17	2	0	104

Hours of calm in this stability class: 0

Hours of missing wind measurements in this stability class: 0

Hours of missing stability measurements in all stability classes: 5

**TABLE 18 (continued)**

**JOINT WIND FREQUENCY DISTRIBUTION BY STABILITY CLASS**

Clinton Power Station

Period of Record: April - June 2014

Stability Class - Slightly Unstable - 60m-10m Delta-T (F)

Winds Measured at 10 Meters

Wind Direction	Wind Speed (in mph)						Total
	1-3	4-7	8-12	13-18	19-24	> 24	
N	0	4	4	2	0	0	10
NNE	0	2	1	0	0	0	3
NE	0	0	4	0	0	0	4
ENE	0	3	3	0	0	0	6
E	0	2	4	1	0	0	7
ESE	1	4	4	0	0	0	9
SE	0	7	2	1	0	0	10
SSE	0	6	4	4	0	0	14
S	0	11	14	1	0	0	26
SSW	0	4	11	2	1	0	18
SW	0	2	9	3	0	0	14
WSW	0	1	10	3	0	0	14
W	0	2	8	4	3	0	17
WNW	0	5	12	1	0	0	18
NW	0	9	2	0	0	0	11
NNW	0	1	0	0	0	0	1
Variable	0	0	0	0	0	0	0
Total	1	63	92	22	4	0	182

Hours of calm in this stability class: 0

Hours of missing wind measurements in this stability class: 0

Hours of missing stability measurements in all stability classes: 5

**TABLE 18 (continued)**

**JOINT WIND FREQUENCY DISTRIBUTION BY STABILITY CLASS**

Clinton Power Station

Period of Record: April - June 2014

Stability Class - Neutral - 60m-10m Delta-T (F)

Winds Measured at 10 Meters

Wind Direction	Wind Speed (in mph)						Total
	1-3	4-7	8-12	13-18	19-24	> 24	
N	3	7	10	6	0	0	26
NNE	0	9	12	1	2	0	24
NE	1	16	20	4	0	0	41
ENE	2	13	29	5	0	0	49
E	1	16	22	0	0	0	39
ESE	3	22	8	1	0	0	34
SE	2	28	16	3	0	0	49
SSE	6	34	28	15	0	0	83
S	2	17	53	19	1	0	92
SSW	1	18	42	39	6	0	106
SW	0	12	39	9	0	0	60
WSW	4	9	32	18	1	0	64
W	1	12	24	8	8	3	56
WNW	1	10	33	4	1	0	49
NW	2	12	28	8	0	0	50
NNW	1	13	26	12	0	0	52
Variable	0	0	0	0	0	0	0
Total	30	248	422	152	19	3	874

Hours of calm in this stability class: 1  
 Hours of missing wind measurements in this stability class: 0  
 Hours of missing stability measurements in all stability classes: 5



**TABLE 18 (continued)**

**JOINT WIND FREQUENCY DISTRIBUTION BY STABILITY CLASS**

Clinton Power Station

Period of Record: April - June 2014

Stability Class - Slightly Stable - 60m-10m Delta-T (F)

Winds Measured at 10 Meters

Wind Direction	Wind Speed (in mph)						Total
	1-3	4-7	8-12	13-18	19-24	> 24	
N	1	10	5	1	0	0	17
NNE	0	8	2	1	0	0	11
NE	0	28	16	0	0	0	44
ENE	5	17	11	0	0	0	33
E	9	16	8	0	0	0	33
ESE	15	38	6	1	0	0	60
SE	12	46	9	0	0	0	67
SSE	4	60	24	0	0	0	88
S	5	25	60	14	2	0	106
SSW	3	19	45	9	0	0	76
SW	7	22	25	2	0	0	56
WSW	13	17	7	1	0	0	38
W	5	7	6	1	0	0	19
WNW	5	13	7	0	0	0	25
NW	9	19	4	0	0	0	32
NNW	0	16	3	1	0	0	20
Variable	0	0	0	0	0	0	0
Total	93	361	238	31	2	0	725

Hours of calm in this stability class: 5  
 Hours of missing wind measurements in this stability class: 0  
 Hours of missing stability measurements in all stability classes: 5

**TABLE 18 (continued)**

**JOINT WIND FREQUENCY DISTRIBUTION BY STABILITY CLASS**

Clinton Power Station

Period of Record: April - June 2014

Stability Class - Moderately Stable - 60m-10m Delta-T (F)

Winds Measured at 10 Meters

Wind Direction	Wind Speed (in mph)						Total
	1-3	4-7	8-12	13-18	19-24	> 24	
N	0	2	0	0	0	0	2
NNE	4	0	0	0	0	0	4
NE	7	11	0	0	0	0	18
ENE	4	6	0	0	0	0	10
E	9	3	0	0	0	0	12
ESE	8	4	0	0	0	0	12
SE	8	4	1	0	0	0	13
SSE	0	4	0	0	0	0	4
S	1	9	1	0	0	0	11
SSW	0	2	0	0	0	0	2
SW	3	3	0	0	0	0	6
WSW	1	5	1	0	0	0	7
W	3	0	0	0	0	0	3
WNW	2	9	1	0	0	0	12
NW	2	15	0	0	0	0	17
NNW	0	5	1	0	0	0	6
Variable	0	0	0	0	0	0	0
Total	52	82	5	0	0	0	139

Hours of calm in this stability class: 1  
 Hours of missing wind measurements in this stability class: 0  
 Hours of missing stability measurements in all stability classes: 5

**TABLE 18 (continued)**

**JOINT WIND FREQUENCY DISTRIBUTION BY STABILITY CLASS**

Clinton Power Station

Period of Record: April - June 2014

Stability Class - Extremely Stable - 60m-10m Delta-T (F)

Winds Measured at 10 Meters

Wind Direction	Wind Speed (in mph)						Total
	1-3	4-7	8-12	13-18	19-24	> 24	
N	1	0	0	0	0	0	1
NNE	1	0	0	0	0	0	1
NE	3	8	0	0	0	0	11
ENE	4	1	0	0	0	0	5
E	3	0	0	0	0	0	3
ESE	0	0	0	0	0	0	0
SE	0	0	0	0	0	0	0
SSE	0	0	0	0	0	0	0
S	0	1	0	0	0	0	1
SSW	0	0	0	0	0	0	0
SW	0	0	0	0	0	0	0
WSW	1	0	0	0	0	0	1
W	6	0	0	0	0	0	6
WNW	4	1	0	0	0	0	5
NW	2	7	0	0	0	0	9
NNW	1	0	0	0	0	0	1
Variable	0	0	0	0	0	0	0
Total	26	18	0	0	0	0	44

Hours of calm in this stability class: 4  
 Hours of missing wind measurements in this stability class: 0  
 Hours of missing stability measurements in all stability classes: 5

**TABLE 18 (continued)**

**JOINT WIND FREQUENCY DISTRIBUTION BY STABILITY CLASS**

Clinton Power Station

Period of Record: April - June 2014

Stability Class - Extremely Unstable - 60m-10m Delta-T (F)  
Winds Measured at 60 Meters

Wind Direction	Wind Speed (in mph)						Total
	1-3	4-7	8-12	13-18	19-24	> 24	
N	0	0	1	5	1	0	7
NNE	0	0	0	1	0	0	1
NE	0	0	0	1	0	0	1
ENE	0	0	5	0	0	0	5
E	0	0	2	0	1	0	3
ESE	0	0	1	0	1	0	2
SE	0	1	7	0	1	0	9
SSE	0	1	0	0	3	4	8
S	0	0	1	2	2	1	6
SSW	0	0	2	4	2	0	8
SW	0	1	0	3	1	0	5
WSW	0	0	0	2	0	2	4
W	0	0	0	3	4	1	8
WNW	0	0	0	6	3	0	9
NW	0	0	2	9	3	0	14
NNW	0	0	4	5	1	0	10
Variable	0	0	0	0	0	0	0
Total	0	3	25	41	23	8	100

Hours of calm in this stability class: 0  
 Hours of missing wind measurements in this stability class: 0  
 Hours of missing stability measurements in all stability classes: 5

**TABLE 18 (continued)**

**JOINT WIND FREQUENCY DISTRIBUTION BY STABILITY CLASS**

Clinton Power Station

Period of Record: April - June 2014

Stability Class - Moderately Unstable - 60m-10m Delta-T (F)

Winds Measured at 60 Meters

Wind Direction	Wind Speed (in mph)						Total
	1-3	4-7	8-12	13-18	19-24	> 24	
N	0	1	1	2	0	0	4
NNE	0	0	0	0	0	0	0
NE	0	0	0	2	0	0	2
ENE	0	0	3	1	0	0	4
E	0	1	1	0	1	0	3
ESE	0	0	1	3	2	0	6
SE	0	1	4	0	1	0	6
SSE	0	1	3	5	4	1	14
S	0	5	3	2	1	0	11
SSW	0	0	3	2	2	2	9
SW	0	0	2	4	2	0	8
WSW	0	0	0	4	1	0	5
W	0	0	2	3	1	0	6
WNW	0	2	5	3	1	0	11
NW	0	2	3	1	2	0	8
NNW	0	4	0	3	0	0	7
Variable	0	0	0	0	0	0	0
Total	0	17	31	35	18	3	104

Hours of calm in this stability class: 0

Hours of missing wind measurements in this stability class: 0

Hours of missing stability measurements in all stability classes: 5

**TABLE 18 (continued)**

**JOINT WIND FREQUENCY DISTRIBUTION BY STABILITY CLASS**

Clinton Power Station

Period of Record: April - June 2014

Stability Class - Slightly Unstable - 60m-10m Delta-T (F)

Winds Measured at 60 Meters

Wind Direction	Wind Speed (in mph)						Total
	1-3	4-7	8-12	13-18	19-24	> 24	
N	0	2	3	4	1	0	10
NNE	0	1	0	1	0	0	2
NE	0	1	1	0	0	0	2
ENE	0	1	2	2	0	0	5
E	0	0	3	2	1	0	6
ESE	0	4	1	5	1	0	11
SE	0	5	3	0	1	0	9
SSE	0	4	2	4	4	0	14
S	0	7	4	11	4	0	26
SSW	0	2	7	7	1	1	18
SW	0	2	6	8	0	0	16
WSW	0	0	3	5	2	0	10
W	0	0	8	6	2	0	16
WNW	0	2	11	5	1	0	19
NW	0	3	6	2	0	0	11
NNW	0	0	1	0	0	0	1
Variable	0	0	0	0	0	0	0
Total	0	34	61	62	18	1	176

Hours of calm in this stability class: 0

Hours of missing wind measurements in this stability class: 6

Hours of missing stability measurements in all stability classes: 5

**TABLE 18 (continued)**

**JOINT WIND FREQUENCY DISTRIBUTION BY STABILITY CLASS**

Clinton Power Station

Period of Record: April - June 2014

Stability Class - Neutral - 60m-10m Delta-T (F)

Winds Measured at 60 Meters

Wind Direction	Wind Speed (in mph)						Total
	1-3	4-7	8-12	13-18	19-24	> 24	
N	0	4	5	11	4	0	24
NNE	1	2	8	11	0	3	25
NE	1	4	6	15	1	0	27
ENE	0	5	6	9	21	2	43
E	1	6	12	19	10	0	48
ESE	0	11	10	8	4	3	36
SE	2	16	17	15	5	0	55
SSE	2	12	16	23	13	8	74
S	1	9	14	32	36	11	103
SSW	0	5	14	30	33	13	95
SW	1	5	18	25	7	1	57
WSW	1	8	9	32	15	1	66
W	0	3	20	16	7	2	48
WNW	1	1	18	18	3	0	41
NW	0	3	13	27	5	0	48
NNW	0	2	13	26	10	0	51
Variable	0	0	0	0	0	0	0
Total	11	96	199	317	174	44	841

Hours of calm in this stability class: 1

Hours of missing wind measurements in this stability class: 33

Hours of missing stability measurements in all stability classes: 5

**TABLE 18 (continued)**

**JOINT WIND FREQUENCY DISTRIBUTION BY STABILITY CLASS**

Clinton Power Station

Period of Record: April - June 2014

Stability Class - Slightly Stable - 60m-10m Delta-T (F)

Winds Measured at 60 Meters

Wind Direction	Wind Speed (in mph)						Total
	1-3	4-7	8-12	13-18	19-24	> 24	
N	2	5	5	8	2	0	22
NNE	1	2	7	3	1	0	14
NE	1	3	12	9	3	0	28
ENE	0	1	8	21	11	0	41
E	0	0	4	13	4	0	21
ESE	0	11	16	21	2	0	50
SE	1	27	40	12	2	0	82
SSE	1	9	34	46	10	0	100
S	0	4	11	44	36	9	104
SSW	1	1	9	32	15	4	62
SW	0	8	19	23	8	0	58
WSW	3	4	10	12	1	0	30
W	2	5	12	8	2	0	29
WNW	1	9	10	9	0	0	29
NW	2	2	17	6	0	0	27
NNW	0	1	15	7	1	0	24
Variable	0	0	0	0	0	0	0
Total	15	92	229	274	98	13	721

Hours of calm in this stability class: 0  
 Hours of missing wind measurements in this stability class: 9  
 Hours of missing stability measurements in all stability classes: 5



**TABLE 18 (continued)**

**JOINT WIND FREQUENCY DISTRIBUTION BY STABILITY CLASS**

Clinton Power Station

Period of Record: April - June 2014

Stability Class - Moderately Stable - 60m-10m Delta-T (F)

Winds Measured at 60 Meters

Wind Direction	Wind Speed (in mph)						Total
	1-3	4-7	8-12	13-18	19-24	> 24	
N	0	3	1	2	0	0	6
NNE	0	0	1	0	0	0	1
NE	0	1	2	2	0	0	5
ENE	0	0	9	3	0	0	12
E	0	2	9	5	0	0	16
ESE	0	2	6	1	0	0	9
SE	0	4	12	2	0	0	18
SSE	0	2	6	0	0	0	8
S	0	1	0	10	0	0	11
SSW	0	1	1	2	0	0	4
SW	0	0	1	2	0	0	3
WSW	0	0	2	1	0	0	3
W	0	3	7	1	0	0	11
WNW	0	1	1	3	0	0	5
NW	0	1	5	10	0	0	16
NNW	0	0	5	6	0	0	11
Variable	0	0	0	0	0	0	0
Total	0	21	68	50	0	0	139

Hours of calm in this stability class: 0

Hours of missing wind measurements in this stability class: 1

Hours of missing stability measurements in all stability classes: 5

**TABLE 18 (continued)**

**JOINT WIND FREQUENCY DISTRIBUTION BY STABILITY CLASS**

Clinton Power Station

Period of Record: April - June 2014  
 Stability Class - Extremely Stable - 60m-10m Delta-T (F)  
 Winds Measured at 60 Meters

Wind Direction	Wind Speed (in mph)						Total
	1-3	4-7	8-12	13-18	19-24	> 24	
N	0	0	2	1	0	0	3
NNE	0	2	1	0	0	0	3
NE	0	0	0	0	0	0	0
ENE	0	3	1	2	0	0	6
E	0	1	5	2	0	0	8
ESE	0	0	3	1	0	0	4
SE	0	0	1	0	0	0	1
SSE	0	1	0	0	0	0	1
S	0	1	1	0	0	0	2
SSW	0	2	0	1	0	0	3
SW	0	0	0	0	0	0	0
WSW	1	0	0	0	0	0	1
W	0	0	1	0	0	0	1
WNW	0	0	1	0	0	0	1
NW	0	3	1	0	0	0	4
NNW	1	3	3	3	0	0	10
Variable	0	0	0	0	0	0	0
Total	2	16	20	10	0	0	48

Hours of calm in this stability class: 0  
 Hours of missing wind measurements in this stability class: 0  
 Hours of missing stability measurements in all stability classes: 5

**TABLE 18 (continued)**

**JOINT WIND FREQUENCY DISTRIBUTION BY STABILITY CLASS**

Clinton Power Station

Period of Record: July - September 2014

Stability Class - Extremely Unstable - 60m-10m Delta-T (F)  
Winds Measured at 10 Meters

Wind Direction	Wind Speed (in mph)						Total
	1-3	4-7	8-12	13-18	19-24	> 24	
N	0	1	0	0	0	0	1
NNE	0	0	3	3	0	0	6
NE	0	0	3	1	0	0	4
ENE	0	0	0	0	0	0	0
E	0	0	0	0	0	0	0
ESE	0	0	0	0	0	0	0
SE	0	0	0	0	0	0	0
SSE	0	0	0	0	0	0	0
S	0	0	0	0	0	0	0
SSW	0	1	0	0	0	0	1
SW	0	0	0	1	0	0	1
WSW	0	0	0	0	0	0	0
W	0	0	0	0	0	0	0
WNW	0	0	1	0	0	0	1
NW	0	0	6	1	0	0	7
NNW	0	0	4	0	0	0	4
Variable	0	0	0	0	0	0	0
Total	0	2	17	6	0	0	25

Hours of calm in this stability class: 0  
 Hours of missing wind measurements in this stability class: 0  
 Hours of missing stability measurements in all stability classes: 0

**TABLE 18 (continued)**

**JOINT WIND FREQUENCY DISTRIBUTION BY STABILITY CLASS**

Clinton Power Station

Period of Record: July - September 2014

Stability Class - Moderately Unstable - 60m-10m Delta-T (F)

Winds Measured at 10 Meters

Wind Direction	Wind Speed (in mph)						Total
	1-3	4-7	8-12	13-18	19-24	> 24	
N	0	3	3	0	0	0	6
NNE	0	1	3	2	0	0	6
NE	0	2	2	0	0	0	4
ENE	0	2	0	0	0	0	2
E	0	0	0	0	0	0	0
ESE	0	3	0	0	0	0	3
SE	0	1	0	0	0	0	1
SSE	0	1	2	0	0	0	3
S	0	6	2	0	0	0	8
SSW	0	2	2	0	0	0	4
SW	0	0	2	0	0	0	2
WSW	0	2	5	0	0	0	7
W	0	0	0	0	0	0	0
WNW	0	3	12	3	0	0	18
NW	0	3	6	5	0	0	14
NNW	0	4	4	0	0	0	8
Variable	0	0	0	0	0	0	0
Total	0	33	43	10	0	0	86

Hours of calm in this stability class: 0  
 Hours of missing wind measurements in this stability class: 0  
 Hours of missing stability measurements in all stability classes: 0

**TABLE 18 (continued)**

**JOINT WIND FREQUENCY DISTRIBUTION BY STABILITY CLASS**

Clinton Power Station

Period of Record: July - September 2014

Stability Class - Slightly Unstable - 60m-10m Delta-T (F)

Winds Measured at 10 Meters

Wind Direction	Wind Speed (in mph)						Total
	1-3	4-7	8-12	13-18	19-24	> 24	
N	0	6	6	0	0	0	12
NNE	0	6	3	0	0	0	9
NE	0	8	1	0	0	0	9
ENE	2	4	2	0	0	0	8
E	0	4	1	0	0	0	5
ESE	0	7	0	0	0	0	7
SE	0	8	0	0	0	0	8
SSE	0	6	3	0	0	0	9
S	0	14	4	0	0	0	18
SSW	0	10	8	0	0	0	18
SW	0	1	14	0	0	0	15
WSW	0	7	6	2	0	0	15
W	0	7	7	0	0	0	14
WNW	0	3	7	2	0	0	12
NW	0	10	8	0	0	0	18
NNW	0	6	1	1	0	0	8
Variable	0	0	0	0	0	0	0
Total	2	107	71	5	0	0	185

Hours of calm in this stability class: 0  
 Hours of missing wind measurements in this stability class: 0  
 Hours of missing stability measurements in all stability classes: 0

**TABLE 18 (continued)**

**JOINT WIND FREQUENCY DISTRIBUTION BY STABILITY CLASS**

Clinton Power Station

Period of Record: July - September 2014  
 Stability Class - Neutral - 60m-10m Delta-T (F)  
 Winds Measured at 10 Meters

Wind Direction	Wind Speed (in mph)						Total
	1-3	4-7	8-12	13-18	19-24	> 24	
N	0	27	30	1	0	0	58
NNE	2	35	17	1	0	0	55
NE	2	34	12	2	0	0	50
ENE	4	24	5	0	0	0	33
E	8	17	4	0	0	0	29
ESE	7	20	3	0	0	0	30
SE	15	46	3	0	0	0	64
SSE	9	25	13	0	0	0	47
S	11	34	14	0	0	0	59
SSW	4	28	43	6	0	0	81
SW	5	34	21	2	0	0	62
WSW	6	10	13	5	0	0	34
W	3	22	20	2	0	0	47
WNW	0	22	23	5	0	0	50
NW	1	16	19	2	0	0	38
NNW	4	18	4	1	0	0	27
Variable	0	0	0	0	0	0	0
Total	81	412	244	27	0	0	764

Hours of calm in this stability class: 0  
 Hours of missing wind measurements in this stability class: 0  
 Hours of missing stability measurements in all stability classes: 0

**TABLE 18 (continued)**

**JOINT WIND FREQUENCY DISTRIBUTION BY STABILITY CLASS**

Clinton Power Station

Period of Record: July - September 2014

Stability Class - Slightly Stable - 60m-10m Delta-T (F)

Winds Measured at 10 Meters

Wind Direction	Wind Speed (in mph)						Total
	1-3	4-7	8-12	13-18	19-24	> 24	
N	4	24	2	0	0	0	30
NNE	5	15	2	0	0	0	22
NE	6	28	1	0	0	0	35
ENE	5	28	1	0	0	0	34
E	9	28	3	0	0	0	40
ESE	6	41	0	0	0	0	47
SE	8	36	3	0	0	0	47
SSE	4	60	7	0	0	0	71
S	7	61	21	1	0	0	90
SSW	6	35	39	4	2	0	86
SW	5	16	26	1	0	0	48
WSW	6	15	6	1	0	0	28
W	9	21	9	1	0	0	40
WNW	6	27	17	0	0	0	50
NW	3	19	8	0	0	0	30
NNW	6	8	0	0	0	0	14
Variable	0	0	0	0	0	0	0
Total	95	462	145	8	2	0	712

Hours of calm in this stability class: 1  
 Hours of missing wind measurements in this stability class: 0  
 Hours of missing stability measurements in all stability classes: 0

**TABLE 18 (continued)**

**JOINT WIND FREQUENCY DISTRIBUTION BY STABILITY CLASS**

Clinton Power Station

Period of Record: July - September 2014  
 Stability Class - Moderately Stable - 60m-10m Delta-T (F)  
 Winds Measured at 10 Meters

Wind Direction	Wind Speed (in mph)						Total
	1-3	4-7	8-12	13-18	19-24	> 24	
N	5	6	0	0	0	0	11
NNE	4	5	0	0	0	0	9
NE	8	7	0	0	0	0	15
ENE	9	3	0	0	0	0	12
E	22	15	0	0	0	0	37
ESE	10	12	0	0	0	0	22
SE	5	1	0	0	0	0	6
SSE	4	12	0	0	0	0	16
S	7	4	2	0	0	0	13
SSW	5	7	2	0	0	0	14
SW	6	5	0	0	0	0	11
WSW	14	10	0	0	0	0	24
W	11	14	0	0	0	0	25
WNW	6	16	0	0	0	0	22
NW	9	0	0	0	0	0	9
NNW	8	0	0	0	0	0	8
Variable	0	0	0	0	0	0	0
Total	133	117	4	0	0	0	254

Hours of calm in this stability class: 9  
 Hours of missing wind measurements in this stability class: 0  
 Hours of missing stability measurements in all stability classes: 0



**TABLE 18 (continued)**

**JOINT WIND FREQUENCY DISTRIBUTION BY STABILITY CLASS**

Clinton Power Station

Period of Record: July - September 2014

Stability Class - Extremely Stable - 60m-10m Delta-T (F)

Winds Measured at 10 Meters

Wind Direction	Wind Speed (in mph)						Total
	1-3	4-7	8-12	13-18	19-24	> 24	
N	11	0	0	0	0	0	11
NNE	30	5	0	0	0	0	35
NE	42	22	0	0	0	0	64
ENE	11	2	0	0	0	0	13
E	3	1	0	0	0	0	4
ESE	2	0	0	0	0	0	2
SE	1	0	0	0	0	0	1
SSE	3	1	0	0	0	0	4
S	1	0	0	0	0	0	1
SSW	1	1	0	0	0	0	2
SW	2	0	0	0	0	0	2
WSW	1	0	0	0	0	0	1
W	4	0	0	0	0	0	4
WNW	8	3	0	0	0	0	11
NW	5	0	0	0	0	0	5
NNW	4	0	0	0	0	0	4
Variable	0	0	0	0	0	0	0
Total	129	35	0	0	0	0	164

Hours of calm in this stability class: 8  
 Hours of missing wind measurements in this stability class: 0  
 Hours of missing stability measurements in all stability classes: 0

**TABLE 18 (continued)**

**JOINT WIND FREQUENCY DISTRIBUTION BY STABILITY CLASS**

Clinton Power Station

Period of Record: July - September 2014  
 Stability Class - Extremely Unstable - 60m-10m Delta-T (F)  
 Winds Measured at 60 Meters

Wind Direction	Wind Speed (in mph)						Total
	1-3	4-7	8-12	13-18	19-24	> 24	
N	0	0	2	0	0	0	2
NNE	0	0	1	1	2	0	4
NE	0	0	1	2	1	0	4
ENE	0	0	1	0	0	0	1
E	0	0	0	0	0	0	0
ESE	0	0	0	0	0	0	0
SE	0	0	0	0	0	0	0
SSE	0	0	0	0	0	0	0
S	0	0	0	0	0	0	0
SSW	0	0	1	1	0	0	2
SW	0	0	0	0	0	0	0
WSW	0	0	0	0	0	0	0
W	0	0	0	0	0	0	0
WNW	0	0	0	1	0	0	1
NW	0	0	0	6	0	0	6
NNW	0	0	0	4	1	0	5
Variable	0	0	0	0	0	0	0
Total	0	0	6	15	4	0	25

Hours of calm in this stability class: 0  
 Hours of missing wind measurements in this stability class: 0  
 Hours of missing stability measurements in all stability classes: 0

**TABLE 18 (continued)**

**JOINT WIND FREQUENCY DISTRIBUTION BY STABILITY CLASS**

Clinton Power Station

Period of Record: July - September 2014

Stability Class - Moderately Unstable - 60m-10m Delta-T (F)

Winds Measured at 60 Meters

Wind Direction	Wind Speed (in mph)						Total
	1-3	4-7	8-12	13-18	19-24	> 24	
N	0	0	5	1	0	0	6
NNE	0	1	1	2	2	0	6
NE	0	1	2	1	0	0	4
ENE	0	1	1	0	0	0	2
E	0	0	0	0	0	0	0
ESE	0	1	1	0	0	0	2
SE	0	2	1	0	0	0	3
SSE	0	0	1	1	0	0	2
S	0	1	7	1	0	0	9
SSW	0	0	1	2	0	0	3
SW	0	0	1	0	0	0	1
WSW	0	0	5	3	0	0	8
W	0	0	0	0	0	0	0
WNW	0	0	7	4	3	0	14
NW	0	0	8	4	3	0	15
NNW	0	0	5	4	2	0	11
Variable	0	0	0	0	0	0	0
Total	0	7	46	23	10	0	86

Hours of calm in this stability class: 0  
 Hours of missing wind measurements in this stability class: 0  
 Hours of missing stability measurements in all stability classes: 0

**TABLE 18 (continued)**

**JOINT WIND FREQUENCY DISTRIBUTION BY STABILITY CLASS**

Clinton Power Station

Period of Record: July - September 2014  
 Stability Class - Slightly Unstable - 60m-10m Delta-T (F)  
 Winds Measured at 60 Meters

Wind Direction	Wind Speed (in mph)						Total
	1-3	4-7	8-12	13-18	19-24	> 24	
N	0	3	7	3	0	0	13
NNE	0	5	2	1	0	0	8
NE	0	5	4	1	0	0	10
ENE	0	5	2	2	0	0	9
E	0	4	0	1	0	0	5
ESE	0	4	3	0	0	0	7
SE	0	6	1	0	0	0	7
SSE	0	4	2	3	0	0	9
S	0	9	9	3	1	0	22
SSW	0	3	8	6	0	0	17
SW	0	1	6	5	0	0	12
WSW	0	2	7	4	1	0	14
W	0	6	2	4	0	0	12
WNW	0	1	3	6	1	0	11
NW	0	5	12	3	0	0	20
NNW	0	5	2	0	2	0	9
Variable	0	0	0	0	0	0	0
Total	0	68	70	42	5	0	185

Hours of calm in this stability class: 0  
 Hours of missing wind measurements in this stability class: 0  
 Hours of missing stability measurements in all stability classes: 0

**TABLE 18 (continued)**

**JOINT WIND FREQUENCY DISTRIBUTION BY STABILITY CLASS**

Clinton Power Station

Period of Record: July - September 2014

Stability Class - Neutral - 60m-10m Delta-T (F)  
Winds Measured at 60 Meters

Wind Direction	Wind Speed (in mph)						Total
	1-3	4-7	8-12	13-18	19-24	> 24	
N	1	8	34	17	2	0	62
NNE	0	19	21	7	2	0	49
NE	0	18	14	9	2	0	43
ENE	1	10	23	4	1	0	39
E	0	11	9	4	0	0	24
ESE	6	13	13	8	0	0	40
SE	6	36	21	1	0	0	64
SSE	5	15	19	11	0	0	50
S	3	16	24	14	4	1	62
SSW	0	11	25	31	7	0	74
SW	4	13	27	12	3	0	59
WSW	2	10	7	12	2	0	33
W	0	14	11	13	3	0	41
WNW	1	9	16	17	1	4	48
NW	1	5	16	20	2	0	44
NNW	1	7	18	5	1	0	32
Variable	0	0	0	0	0	0	0
Total	31	215	298	185	30	5	764

Hours of calm in this stability class: 0  
 Hours of missing wind measurements in this stability class: 0  
 Hours of missing stability measurements in all stability classes: 0

**TABLE 18 (continued)**

**JOINT WIND FREQUENCY DISTRIBUTION BY STABILITY CLASS**

Clinton Power Station

Period of Record: July - September 2014  
 Stability Class - Slightly Stable - 60m-10m Delta-T (F)  
 Winds Measured at 60 Meters

Wind Direction	Wind Speed (in mph)						Total
	1-3	4-7	8-12	13-18	19-24	> 24	
N	0	3	19	7	0	0	29
NNE	0	8	12	3	0	0	23
NE	0	8	12	7	0	0	27
ENE	0	3	18	11	0	0	32
E	0	6	8	17	0	0	31
ESE	0	4	26	18	0	0	48
SE	1	7	39	4	0	0	51
SSE	0	12	52	17	1	0	82
S	1	8	31	51	6	0	97
SSW	0	3	25	48	7	3	86
SW	0	9	12	31	3	0	55
WSW	0	7	7	9	1	0	24
W	0	2	12	11	3	0	28
WNW	1	3	16	21	2	0	43
NW	1	3	16	19	3	0	42
NNW	0	3	9	3	0	0	15
Variable	0	0	0	0	0	0	0
Total	4	89	314	277	26	3	713

Hours of calm in this stability class: 0  
 Hours of missing wind measurements in this stability class: 0  
 Hours of missing stability measurements in all stability classes: 0

**TABLE 18 (continued)**

**JOINT WIND FREQUENCY DISTRIBUTION BY STABILITY CLASS**

Clinton Power Station

Period of Record: July - September 2014

Stability Class - Moderately Stable - 60m-10m Delta-T (F)  
Winds Measured at 60 Meters

Wind Direction	Wind Speed (in mph)						Total
	1-3	4-7	8-12	13-18	19-24	> 24	
N	0	3	8	0	0	0	11
NNE	0	3	6	3	0	0	12
NE	0	2	2	3	0	0	7
ENE	0	2	7	2	0	0	11
E	0	1	6	1	0	0	8
ESE	0	3	21	4	0	0	28
SE	2	7	19	0	0	0	28
SSE	0	8	9	1	0	0	18
S	2	11	13	7	0	0	33
SSW	0	5	3	1	0	0	9
SW	1	3	9	2	0	0	15
WSW	0	6	4	4	0	0	14
W	2	4	9	12	0	0	27
WNW	1	4	11	0	0	0	16
NW	1	5	15	2	0	0	23
NNW	0	1	1	0	0	0	2
Variable	0	0	0	0	0	0	0
Total	9	68	143	42	0	0	262

Hours of calm in this stability class: 1  
Hours of missing wind measurements in this stability class: 0  
Hours of missing stability measurements in all stability classes: 0

**TABLE 18 (continued)**

**JOINT WIND FREQUENCY DISTRIBUTION BY STABILITY CLASS**

Clinton Power Station

Period of Record: July - September 2014  
 Stability Class - Extremely Stable - 60m-10m Delta-T (F)  
 Winds Measured at 60 Meters

Wind Direction	Wind Speed (in mph)						Total
	1-3	4-7	8-12	13-18	19-24	> 24	
N	0	2	1	0	0	0	3
NNE	0	5	5	1	0	0	11
NE	0	4	7	1	0	0	12
ENE	0	6	5	3	0	0	14
E	1	3	16	6	0	0	26
ESE	1	6	29	5	0	0	41
SE	3	7	1	0	0	0	11
SSE	1	7	5	0	0	0	13
S	1	6	2	0	0	0	9
SSW	1	3	0	0	0	0	4
SW	2	1	2	0	0	0	5
WSW	3	2	1	0	0	0	6
W	1	1	0	0	0	0	2
WNW	0	1	2	0	0	0	3
NW	0	2	7	0	0	0	9
NNW	0	0	2	0	0	0	2
Variable	0	0	0	0	0	0	0
Total	14	56	85	16	0	0	171

Hours of calm in this stability class: 1  
 Hours of missing wind measurements in this stability class: 0  
 Hours of missing stability measurements in all stability classes: 0



**TABLE 18 (continued)**

**JOINT WIND FREQUENCY DISTRIBUTION BY STABILITY CLASS**

Clinton Power Station

Period of Record: October - December 2014

Stability Class - Extremely Unstable - 60m-10m Delta-T (F)

Winds Measured at 10 Meters

Wind Direction	Wind Speed (in mph)						Total
	1-3	4-7	8-12	13-18	19-24	> 24	
N	0	0	1	0	0	0	1
NNE	0	0	5	2	0	0	7
NE	0	0	0	0	0	0	0
ENE	0	0	0	0	0	0	0
E	0	0	0	0	0	0	0
ESE	0	0	0	0	0	0	0
SE	0	0	2	0	0	0	2
SSE	0	0	0	0	0	0	0
S	0	0	1	0	0	0	1
SSW	0	0	0	0	0	0	0
SW	0	0	0	0	0	0	0
WSW	0	0	0	0	0	0	0
W	0	0	0	3	0	0	3
WNW	0	0	3	2	0	0	5
NW	0	0	0	0	0	0	0
NNW	0	0	0	0	0	0	0
Variable	0	0	0	0	0	0	0
Total	0	0	12	7	0	0	19

Hours of calm in this stability class: 0

Hours of missing wind measurements in this stability class: 0

Hours of missing stability measurements in all stability classes: 3

**TABLE 18 (continued)**

**JOINT WIND FREQUENCY DISTRIBUTION BY STABILITY CLASS**

Clinton Power Station

Period of Record: October - December 2014

Stability Class - Moderately Unstable - 60m-10m Delta-T (F)

Winds Measured at 10 Meters

Wind Direction	Wind Speed (in mph)						Total
	1-3	4-7	8-12	13-18	19-24	> 24	
N	0	0	4	1	0	0	5
NNE	0	0	2	0	0	0	2
NE	0	0	0	0	0	0	0
ENE	0	0	0	0	0	0	0
E	0	0	0	0	0	0	0
ESE	0	0	0	0	0	0	0
SE	0	4	1	0	0	0	5
SSE	0	1	2	0	0	0	3
S	0	2	3	0	0	0	5
SSW	0	3	3	1	0	0	7
SW	0	0	1	1	0	0	2
WSW	0	0	3	2	0	0	5
W	0	0	4	7	2	0	13
WNW	0	0	6	6	0	0	12
NW	0	0	2	0	0	0	2
NNW	0	0	3	0	0	0	3
Variable	0	0	0	0	0	0	0
Total	0	10	34	18	2	0	64

Hours of calm in this stability class: 0  
 Hours of missing wind measurements in this stability class: 0  
 Hours of missing stability measurements in all stability classes: 3

**TABLE 18 (continued)**

**JOINT WIND FREQUENCY DISTRIBUTION BY STABILITY CLASS**

Clinton Power Station

Period of Record: October - December 2014

Stability Class - Slightly Unstable - 60m-10m Delta-T (F)  
Winds Measured at 10 Meters

Wind Direction	Wind Speed (in mph)						Total
	1-3	4-7	8-12	13-18	19-24	> 24	
N	0	0	2	0	2	0	4
NNE	0	1	1	0	0	0	2
NE	0	0	0	0	0	0	0
ENE	0	2	0	0	0	0	2
E	0	1	0	0	0	0	1
ESE	0	2	0	0	0	0	2
SE	0	4	1	0	0	0	5
SSE	0	2	1	1	0	0	4
S	0	3	1	3	0	0	7
SSW	0	6	4	7	0	0	17
SW	0	1	5	0	0	0	6
WSW	0	0	2	1	0	0	3
W	0	0	4	5	4	0	13
WNW	0	0	11	5	3	0	19
NW	0	0	5	3	0	0	8
NNW	0	0	2	0	1	0	3
Variable	0	0	0	0	0	0	0
Total	0	22	39	25	10	0	96

Hours of calm in this stability class: 0  
 Hours of missing wind measurements in this stability class: 0  
 Hours of missing stability measurements in all stability classes: 3

**TABLE 18 (continued)**

**JOINT WIND FREQUENCY DISTRIBUTION BY STABILITY CLASS**

Clinton Power Station

Period of Record: October - December 2014  
 Stability Class - Neutral - 60m-10m Delta-T (F)  
 Winds Measured at 10 Meters

Wind Direction	Wind Speed (in mph)						Total
	1-3	4-7	8-12	13-18	19-24	> 24	
N	0	26	36	5	3	0	70
NNE	0	12	24	2	0	0	38
NE	1	17	15	0	0	0	33
ENE	0	22	0	0	0	0	22
E	4	11	2	0	0	0	17
ESE	4	24	6	0	0	0	34
SE	1	30	26	1	0	0	58
SSE	1	25	50	4	0	0	80
S	1	27	33	16	0	0	77
SSW	2	25	42	41	0	0	110
SW	3	23	26	7	0	0	59
WSW	5	16	20	17	5	0	63
W	5	11	39	46	10	0	111
WNW	5	17	78	70	9	0	179
NW	3	22	58	29	2	0	114
NNW	2	15	46	15	1	0	79
Variable	0	0	0	0	0	0	0
Total	37	323	501	253	30	0	1144

Hours of calm in this stability class: 0  
 Hours of missing wind measurements in this stability class: 1  
 Hours of missing stability measurements in all stability classes: 3

**TABLE 18 (continued)**

**JOINT WIND FREQUENCY DISTRIBUTION BY STABILITY CLASS**

Clinton Power Station

Period of Record: October - December 2014

Stability Class - Slightly Stable - 60m-10m Delta-T (F)

Winds Measured at 10 Meters

Wind Direction	Wind Speed (in mph)						Total
	1-3	4-7	8-12	13-18	19-24	> 24	
N	6	16	1	4	0	0	27
NNE	4	13	0	0	0	0	17
NE	8	26	2	0	0	0	36
ENE	3	9	0	0	0	0	12
E	1	18	1	0	0	0	20
ESE	6	28	1	0	0	0	35
SE	4	22	12	0	0	0	38
SSE	6	30	41	0	0	0	77
S	1	43	69	11	0	0	124
SSW	6	33	43	32	0	0	114
SW	3	15	18	2	0	0	38
WSW	5	12	24	0	0	0	41
W	2	16	24	4	0	0	46
WNW	5	15	25	4	0	0	49
NW	4	11	4	0	0	0	19
NNW	3	10	7	2	0	0	22
Variable	0	0	0	0	0	0	0
Total	67	317	272	59	0	0	715

Hours of calm in this stability class: 0  
 Hours of missing wind measurements in this stability class: 0  
 Hours of missing stability measurements in all stability classes: 3

**TABLE 18 (continued)**

**JOINT WIND FREQUENCY DISTRIBUTION BY STABILITY CLASS**

Clinton Power Station

Period of Record: October - December 2014  
 Stability Class - Moderately Stable - 60m-10m Delta-T (F)  
 Winds Measured at 10 Meters

Wind Direction	Wind Speed (in mph)						Total
	1-3	4-7	8-12	13-18	19-24	> 24	
N	7	2	0	0	0	0	9
NNE	7	8	0	0	0	0	15
NE	6	9	0	0	0	0	15
ENE	2	4	0	0	0	0	6
E	3	5	0	0	0	0	8
ESE	0	5	0	0	0	0	5
SE	0	6	0	0	0	0	6
SSE	0	0	1	0	0	0	1
S	3	1	0	0	0	0	4
SSW	1	6	2	0	0	0	9
SW	3	4	0	0	0	0	7
WSW	2	4	0	0	0	0	6
W	3	7	0	0	0	0	10
WNW	0	10	0	0	0	0	10
NW	3	8	0	0	0	0	11
NNW	4	3	0	0	0	0	7
Variable	0	0	0	0	0	0	0
Total	44	82	3	0	0	0	129

Hours of calm in this stability class: 1  
 Hours of missing wind measurements in this stability class: 0  
 Hours of missing stability measurements in all stability classes: 3

**TABLE 18 (continued)**

**JOINT WIND FREQUENCY DISTRIBUTION BY STABILITY CLASS**

Clinton Power Station

Period of Record: October - December 2014

Stability Class - Extremely Stable - 60m-10m Delta-T (F)

Winds Measured at 10 Meters

Wind Direction	Wind Speed (in mph)						Total
	1-3	4-7	8-12	13-18	19-24	> 24	
N	0	0	0	0	0	0	0
NNE	3	4	0	0	0	0	7
NE	1	8	0	0	0	0	9
ENE	0	0	0	0	0	0	0
E	1	0	0	0	0	0	1
ESE	0	0	0	0	0	0	0
SE	0	0	0	0	0	0	0
SSE	0	0	0	0	0	0	0
S	0	2	0	0	0	0	2
SSW	0	1	0	0	0	0	1
SW	2	0	0	0	0	0	2
WSW	0	0	0	0	0	0	0
W	3	0	0	0	0	0	3
WNW	2	0	0	0	0	0	2
NW	1	5	0	0	0	0	6
NNW	2	1	0	0	0	0	3
Variable	0	0	0	0	0	0	0
Total	15	21	0	0	0	0	36

Hours of calm in this stability class: 0

Hours of missing wind measurements in this stability class: 0

Hours of missing stability measurements in all stability classes: 3

**TABLE 18 (continued)**

**JOINT WIND FREQUENCY DISTRIBUTION BY STABILITY CLASS**

Clinton Power Station

Period of Record: October - December 2014  
 Stability Class - Extremely Unstable - 60m-10m Delta-T (F)  
 Winds Measured at 60 Meters

Wind Direction	Wind Speed (in mph)						Total
	1-3	4-7	8-12	13-18	19-24	> 24	
N	0	0	0	1	0	0	1
NNE	0	0	2	5	0	0	7
NE	0	0	0	0	0	0	0
ENE	0	0	0	0	0	0	0
E	0	0	0	0	0	0	0
ESE	0	0	0	0	0	0	0
SE	0	0	2	0	0	0	2
SSE	0	0	0	0	0	0	0
S	0	0	0	1	0	0	1
SSW	0	0	0	0	0	0	0
SW	0	0	0	0	0	0	0
WSW	0	0	0	0	0	0	0
W	0	0	0	0	3	0	3
WNW	0	0	0	3	1	0	4
NW	0	0	0	1	0	0	1
NNW	0	0	0	0	0	0	0
Variable	0	0	0	0	0	0	0
Total	0	0	4	11	4	0	19

Hours of calm in this stability class: 0  
 Hours of missing wind measurements in this stability class: 0  
 Hours of missing stability measurements in all stability classes: 3



**TABLE 18 (continued)**

**JOINT WIND FREQUENCY DISTRIBUTION BY STABILITY CLASS**

Clinton Power Station

Period of Record: October - December 2014

Stability Class - Moderately Unstable - 60m-10m Delta-T (F)

Winds Measured at 60 Meters

Wind Direction	Wind Speed (in mph)						Total
	1-3	4-7	8-12	13-18	19-24	> 24	
N	0	0	0	4	1	0	5
NNE	0	0	1	1	0	0	2
NE	0	0	0	0	0	0	0
ENE	0	0	0	0	0	0	0
E	0	0	0	0	0	0	0
ESE	0	0	0	0	0	0	0
SE	0	1	3	1	0	0	5
SSE	0	0	2	1	0	0	3
S	0	1	3	3	0	0	7
SSW	0	1	3	0	1	0	5
SW	0	0	0	2	0	0	2
WSW	0	0	0	4	1	0	5
W	0	0	3	2	6	2	13
WNW	0	0	2	7	2	0	11
NW	0	0	1	2	0	0	3
NNW	0	0	0	3	0	0	3
Variable	0	0	0	0	0	0	0
Total	0	3	18	30	11	2	64

Hours of calm in this stability class: 0

Hours of missing wind measurements in this stability class: 0

Hours of missing stability measurements in all stability classes: 3

**TABLE 18 (continued)**

**JOINT WIND FREQUENCY DISTRIBUTION BY STABILITY CLASS**

Clinton Power Station

Period of Record: October - December 2014  
 Stability Class - Slightly Unstable - 60m-10m Delta-T (F)  
 Winds Measured at 60 Meters

Wind Direction	Wind Speed (in mph)						Total
	1-3	4-7	8-12	13-18	19-24	> 24	
N	0	0	0	2	0	1	3
NNE	0	0	2	0	0	0	2
NE	0	0	0	0	0	0	0
ENE	0	0	2	0	0	0	2
E	0	0	1	0	0	0	1
ESE	0	0	2	0	0	0	2
SE	0	4	1	1	0	0	6
SSE	0	1	0	1	1	0	3
S	0	2	2	0	1	2	7
SSW	0	3	7	2	7	0	19
SW	0	0	4	1	0	0	5
WSW	0	0	1	1	0	0	2
W	0	0	2	3	3	4	12
WNW	0	0	4	9	4	4	21
NW	0	0	3	4	0	0	7
NNW	0	0	1	1	0	2	4
Variable	0	0	0	0	0	0	0
Total	0	10	32	25	16	13	96

Hours of calm in this stability class: 0  
 Hours of missing wind measurements in this stability class: 0  
 Hours of missing stability measurements in all stability classes: 3

**TABLE 18 (continued)**

**JOINT WIND FREQUENCY DISTRIBUTION BY STABILITY CLASS**

Clinton Power Station

Period of Record: October - December 2014

Stability Class - Neutral - 60m-10m Delta-T (F)

Winds Measured at 60 Meters

Wind Direction	Wind Speed (in mph)						Total
	1-3	4-7	8-12	13-18	19-24	> 24	
N	0	7	23	33	2	3	68
NNE	1	2	13	17	1	0	34
NE	0	5	7	16	0	0	28
ENE	0	3	20	4	0	0	27
E	1	4	7	5	0	0	17
ESE	1	6	17	8	0	0	32
SE	0	2	38	20	1	0	61
SSE	0	10	24	32	13	0	79
S	1	11	24	24	19	5	84
SSW	0	9	25	34	44	1	113
SW	0	6	27	12	7	0	52
WSW	3	10	7	18	15	7	60
W	2	8	13	37	32	12	104
WNW	0	14	22	64	50	26	176
NW	2	8	18	66	21	4	119
NNW	1	11	20	41	11	6	90
Variable	0	0	0	0	0	0	0
Total	12	116	305	431	216	64	1144

Hours of calm in this stability class: 0  
 Hours of missing wind measurements in this stability class: 1  
 Hours of missing stability measurements in all stability classes: 3

**TABLE 18 (continued)**

**JOINT WIND FREQUENCY DISTRIBUTION BY STABILITY CLASS**

Clinton Power Station

Period of Record: October - December 2014  
 Stability Class - Slightly Stable - 60m-10m Delta-T (F)  
 Winds Measured at 60 Meters

Wind Direction	Wind Speed (in mph)						Total
	1-3	4-7	8-12	13-18	19-24	> 24	
N	2	4	9	4	6	0	25
NNE	0	9	8	3	0	0	20
NE	0	4	8	18	0	0	30
ENE	1	0	7	6	0	0	14
E	0	3	5	8	0	0	16
ESE	1	3	7	10	0	0	21
SE	0	13	26	9	1	0	49
SSE	0	8	19	51	3	0	81
S	0	5	21	58	44	4	132
SSW	1	1	20	38	38	11	109
SW	0	5	6	23	4	0	38
WSW	1	2	4	28	1	0	36
W	0	7	3	32	4	0	46
WNW	1	3	10	31	7	0	52
NW	0	3	8	11	1	0	23
NNW	2	4	7	8	2	0	23
Variable	0	0	0	0	0	0	0
Total	9	74	168	338	111	15	715

Hours of calm in this stability class: 0  
 Hours of missing wind measurements in this stability class: 0  
 Hours of missing stability measurements in all stability classes: 3

**TABLE 18 (continued)**

**JOINT WIND FREQUENCY DISTRIBUTION BY STABILITY CLASS**

Clinton Power Station

Period of Record: October - December 2014

Stability Class - Moderately Stable - 60m-10m Delta-T (F)

Winds Measured at 60 Meters

Wind Direction	Wind Speed (in mph)						Total
	1-3	4-7	8-12	13-18	19-24	> 24	
N	0	1	1	2	0	0	4
NNE	0	7	7	1	0	0	15
NE	0	2	4	6	0	0	12
ENE	1	2	5	4	0	0	12
E	0	1	3	2	0	0	6
ESE	0	1	2	4	1	0	8
SE	0	2	6	0	0	0	8
SSE	0	3	1	0	0	0	4
S	1	2	1	0	1	0	5
SSW	0	1	1	4	0	0	6
SW	0	0	4	4	0	0	8
WSW	0	1	1	0	0	0	2
W	0	2	9	2	0	0	13
WNW	1	0	4	8	0	0	13
NW	0	2	2	3	0	0	7
NNW	0	2	3	2	0	0	7
Variable	0	0	0	0	0	0	0
Total	3	29	54	42	2	0	130

Hours of calm in this stability class: 0

Hours of missing wind measurements in this stability class: 0

Hours of missing stability measurements in all stability classes: 3

**TABLE 18 (continued)**

**JOINT WIND FREQUENCY DISTRIBUTION BY STABILITY CLASS**

Clinton Power Station

Period of Record: October - December 2014

Stability Class - Extremely Stable - 60m-10m Delta-T (F)

Winds Measured at 60 Meters

Wind Direction	Wind Speed (in mph)						Total
	1-3	4-7	8-12	13-18	19-24	> 24	
N	0	1	1	1	0	0	3
NNE	0	0	2	1	0	0	3
NE	0	0	2	3	0	0	5
ENE	0	0	2	3	0	0	5
E	0	0	3	0	0	0	3
ESE	0	0	0	0	0	0	0
SE	0	0	1	0	0	0	1
SSE	0	0	0	0	0	0	0
S	0	0	0	0	0	0	0
SSW	0	0	1	0	0	0	1
SW	0	1	0	0	0	0	1
WSW	0	0	1	0	0	0	1
W	0	1	0	0	0	0	1
WNW	0	1	2	0	0	0	3
NW	0	3	1	0	0	0	4
NNW	0	0	4	1	0	0	5
Variable	0	0	0	0	0	0	0
Total	0	7	20	9	0	0	36

Hours of calm in this stability class: 0  
 Hours of missing wind measurements in this stability class: 0  
 Hours of missing stability measurements in all stability classes: 3

## SECTION 9

### NEW LOCATIONS FOR DOSE CALCULATION AND / OR ENVIRONMENTAL MONITORING

The following is a summary of the 2014 Annual Land Use Census. It shows changes in locations for dose calculations and / or environmental monitoring identified by the Annual Land Use Census. The distance of the receptor is being listed in the report in lieu of the name of the resident. This is being done to maintain and respect the privacy of the residents.

#### 1.0 Nearest Residence

The nearest residents identified in each of the sixteen (16) sectors are shown below.

SECTOR	2014 RESIDENT (km)	AGE GROUP	2013 RESIDENT (km)	AGE GROUP
N	1.50	A	1.50	A
NNE	1.50	A	1.50	A
NE	2.07	A	2.07	A
ENE	2.86	A	2.86	C/A
E	1.67	A	1.67	A
ESE	5.14	A	5.14	A
SE	4.44	C/T/A	4.44	C/T/A
SSE	2.90	A	2.90	A
S	4.78	A	4.78	A
SSW	4.68	A	4.68	A
SW	1.17	A	1.17	A
WSW	3.62	A	3.62	A
W	1.95	C/T/A	1.95	C/T/A
WNW	2.63	A	2.63	A
NW	2.65	A	2.65	A
NNW	2.05	A	2.05	A

(I)nfant

(C)hild

(T)een

(A)dult

**SECTION 9 (continued)**

**2.0 Broadleaf Garden Census**

Ninety (90) gardens within a five (5) mile (8 km) radius were located in the sixteen (16) geographical sectors surrounding CPS. Twenty (20) gardens contained broad leaf vegetation. Although other crops were identified within these areas, they are not addressed as part of this report.

The nearest gardens greater than fifty (50) square-meters and producing broadleaf vegetation identified in each of the sixteen (16) geographical sectors are shown below.

SECTOR	2014 GARDENS (km)	AGE GROUPS	2013 GARDENS (km)	AGE GROUPS
N	1.50	A	1.50	A
NNE	4.78	A	4.78	A
NE	>8		6.98	A
ENE	2.86	A	2.86	C/A
E	1.67	A	1.67	A
ESE	5.30	A	5.14	A
SE	>8		7.10	C/A
SSE	>8	C/A	4.52	C/A
S	6.60	A	6.60	A
SSW	>8		>8	
SW	5.87	C/A	5.87	C/A
WSW	3.66	A	3.66	A
W	3.22	A	3.22	A
WNW	2.64	A	2.64	A
NW	4.51	I/C/T/A	4.70	C/A
NNW	2.05	A	2.05	A

(I)nfant

(C)hild

(T)een

(A)dult



## SECTION 9 (continued)

### 3.0 Milking Animal Census

Milking animals within the sixteen (16) geographical sectors were located within five (5) miles (8 km) surrounding CPS. These milking animals were either used for the nursing of their offspring or used for meat production for their own personal use and sold commercially. There were no residents that milked their animals for human consumption.

Milking animals were specifically identified for this report. Although other livestock were identified within these areas, they are not addressed as part of this report.

The nearest milking animals identified in each of the sixteen (16) geographical sectors are shown below.

SECTOR	2014 MILKING ANIMALS (km)	AGE GROUPS	2013 MILKING ANIMALS (km)	AGE GROUPS
N	1.50	A	1.50	A
NNE	3.76	A	4.78	T,A
NE	>8		>8	
ENE	6.63	A	6.63	A
E	>8		>8	
ESE	>8		>8	
SE	>8		>8	
SSE	>8		>8	
S	6.60	A	6.60	A
SSW	5.47	A	5.47	A
SW	>8		>8	
WSW	5.53	A	5.53	A
W	>8		>8	
WNW	>8		>8	
NW	>8		>8	
NNW	2.05	A	2.05	A

(I)nfant

(C)hild

(T)een

(A)dult

## **SECTION 10**

### **CORRECTIONS TO DATA REPORTED IN PREVIOUS REPORTS**

There were no administrative changes identified in 2014 against previously submitted Annual Radioactive Effluent Release Report[s] resulting in an errata data submittal to the Commission.

**OFFSITE DOSE CALCULATION MANUAL**  
**CLINTON POWER STATION**

## Change Matrix

The following table details the linkage between the Revision 23 (pre-ITS format) of the ODCM and the current revision (post-ITS format) of the ODCM regarding the re-numbering of the various sections. The purpose of this section is to permit a cross-reference from the old to new revision of the ODCM for procedures and surveillance tests. Changes to procedures to address the new numbering will occur as the procedures are revised on their normal revision process cycle. Because Revision 24 included a complete format change for ITS, no rev bars or change annotations were use in Rev. 24.

Revision 23 (old)	Rev. 23 page # _____ of 195	Current Revision
<b>Part I - Radiological Effluent Controls</b>		
1.0 General Information/Preface	12	Part I Section 1.0
1.1 Definitions	12	1.0 Definitions
1.2 General Operating Requirements	16	3/4.3.0
1.3 General Surveillance Requirements	17	3/4.4.0
2.3.1 Liquid Effluent Concentration Requirements	20	3/4.3.1
Table 2.3-1 Radioactive Liquid Waste Sampling and Analysis Program	21	Table 4.3.1-1
2.4.1 10CFR50, App. I, Dose Limits	31	3/4.3.2
2.5.1 Liquid Radwaste Treatment System	43	3/4.3.3
2.5.1.1 Liquid Effluent Dose Projections	44	4.3.3.1
2.7.1 Liquid Effluent Monitoring Instrumentation	45	3/4.1
Table 2.7-1 Radioactive Liquid Effluent Monitoring Instrumentation	46	Table 3.1-1
Table 2.7-2 Radioactive Liquid Effluent Monitoring Instrumentation Surveillance Requirements	50	Table 4.1-1
3.4.1 (Gaseous) Tech Spec Release Rate Limits	58	3/4.4.1
Table 3.4-1 Radioactive Gaseous Waste Sampling and Analysis Program	59	Table 4.4.1-1
3.5.1 Noble Gas Dose Limits	68	3/4.4.2
3.5.2 (Gaseous) Effluent Iodine, Tritium, Particulate Dose Limits	69	3/4.4.3
3.6.1 Gaseous Radwaste (Offgas Treatment) System	79	3/4.4.4
3.7.1 Ventilation Exhaust Treatment System	80	3/4.4.5
3.9.1 Offgas Radiation Monitoring Instrumentation	86	3/4.2.1
Table 3.9.1-1 Offgas Radiation Monitoring Instrumentation	87	Table 3.2-1
Table 3.9.1-2 Offgas Radiation Monitoring Instrumentation Surveillance Requirements	92	Table 4.2-1
3.9.2 Radioactive Gaseous Effluent Monitoring Instrumentation	93	3/4.2.2
Table 3.9.2-1 Radioactive Gaseous Effluent Monitoring Instrumentation	94	Table 3.2-2
Table 3.9.2-2 Radioactive Gaseous Effluent Monitoring Instrumentation Surveillance Requirements	98	Table 4.2-2
4.1 Total Dose	134	3/4.5

Revision 23 (old)	Rev. 23 page # of 195	Current Revision
5.1 REMP - Radiological Environmental Monitoring Program	137	3/4.6
Table 5.1-1 Radiological Environmental Monitoring Program	139	Table 4.6-1
Table 5.1-2 Reporting Levels for Radioactivity concentrations in Environmental Samples	152	Table 4.6-2
Table 5.1-3 Detection Levels for Environmental Sample Analysis	153	Table 4.6-3
5.2 REMP - Land Use Census	156	3/4.7
5.3 REMP - Interlab Comparison Program	158	3/4.8
6.0 Bases for Operation and Surveillance Requirements	163	5.0
6.1 General Operation and Surveillance Requirements	163	5.01
6.2 Monitoring Instrumentation	164	Liquid – 5.1, Gaseous – 5.2.1, 5.2.2
6.3.1 Liquid Effluents	166	5.3
6.3.2 Gaseous Effluents	169	5.4
6.3.3 Total Dose	173	5.5
6.4 REMP	174	5.6, 5.7, 5.8
7.0 Reporting Requirements	176	6.0
7.1 Annual Radioactive Environmental Operating Report (AREOR)	176	6.1
7.2 Radioactive Effluent Release Report (ARERR)	177	6.2
8.0 Adjustment of the CPS ODCM Methodology	182	5.02
<b>Part II - Methodology and Parameters</b>		
1.0 General Information/Preface	12	Part II Section 1.1
2.1 Liquid Effluents Introduction	19	4.1
2.3.2 Liquid Radwaste Discharge PRM Setpoints	24	2.1
2.3.3 Plant Service Water Effluent PRM Setpoints	29	2.2
2.3.4 Shutdown Service Water (SX) Effluent PRM Setpoints	30	2.3
2.3.5 Fuel Pool Heat Exchanger Service water Effluent PRM Setpoints	30	2.4
2.3.6 Component Cooling Water PRM Setpoints	31	2.5
2.4.2 10CFR50 App. I Dose Limits - Discussion	33	4.3
2.5.1.1 Liquid Effluent Dose Projection Calculations	44	4.3.1
2.5.1.2 Temporary Liquid Radwaste Hold-up Tanks	44	4.3.2
2.6 Doses From Other Significant Liquid Effluent Pathways	44	4.3
3.1 Gaseous Effluents Introduction	54	5.1
3.2.1 HVAC Stack Process Radiation Monitoring (PRM) System	55	3.1
3.2.2 SGTs Stack Process Radiation Monitoring (PRM) System	56	3.2
3.3.1 Pre-treatment Air Ejector Off-Gas Process Radiation Monitor (PRM)	56	3.3.1
3.3.2 Post-Treatment Air Ejector Off-Gas Process Radiation Monitor (PRM)	57	3.3.2

Revision 23 (old)	Rev. 23 page # _____ of 195	Current Revision
3.4.2 Dose Rate Due To Noble Gases	62	5.3
3.4.3 Dose Rate Due to Radioiodines, Particulates and Tritium	62	5.4
3.5.3 10CFR50 App. I Release Rate Limits - Noble Gas Air Dose Equations	70	5.5.1
3.5.4 10CFR50 App. I Release Rate Limits - Radioiodines, Particulate and Tritium Dose Equations	71	5.5.2
3.7.2 Gaseous Effluent Dose Projections Calculations	81	5.6
3.8.1 Gaseous Effluent PRM Total Body Dose Rate Setpoint	83	3.4.1
3.8.2 Gaseous Effluent PRM Skin Dose Rate Setpoint	85	3.4.2
5.0-1 REMP Locations Within 1 Mile of CPS	159	Figure 7-1
5.0-2 REMP Locations 1-2 Miles From CPS	160	Figure 7-2
5.0-3 REMP Locations 2-5 Miles From CPS	161	Figure 7-3
5.0-4 REMP Locations Greater Than 5 Miles From CPS	162	Figure 7-4
9.0 Atmospheric Transport and Dispersion Model	183	10.0

TABLE OF CONTENTS

SECTION	TITLE	PAGE
<b>PART I – RADIOLOGICAL EFFLUENT CONTROLS</b>		
1.0	Definition.....	2
2.0	Not Used.....	8
3/4	Controls and Surveillance Requirements.....	10
3/4.1	Radioactive Liquid Effluent Monitoring Instrumentation.....	12
3/4.2	Radioactive Gaseous Effluent Monitoring Instrumentation.....	20
3/4.2.1	Offgas Radiation Monitoring Instrumentation Controls.....	20
3/4.2.2	Radioactive Gaseous Effluent Monitoring Instrumentation Controls.....	27
3/4.3	Liquid Radwaste Effluents.....	34
3/4.3.1	Liquid Effluent Concentration.....	34
3/4.3.2	Dose From Liquid Effluents.....	38
3/4.3.3	Liquid Radwaste Treatment Systems.....	39
3/4.4	Radioactive Gaseous Effluents.....	40
3/4.4.1	Gaseous Effluent Dose Rates.....	40
3/4.4.2	Dose from Noble Gases.....	44
3/4.4.3	Dose from Iodine-131, Iodine-133, Tritium, and Radioactive Materials in Particulate Form.....	45
3/4.4.4	Gaseous Radwaste (Offgas) Treatment System.....	46
3/4.4.5	Ventilation Exhaust Treatment System.....	47
3/4.5	Total Dose.....	49
3/4.6	Radiological Environmental Monitoring Program.....	51
3/4.7	Land Use Census.....	69
3/4.8	Inter-Laboratory Comparison Program.....	72
3/4.9	Meteorological Monitoring Program.....	73
5.0	Bases.....	74
5.0.1	Controls and Surveillance Requirements.....	74
5.0.2	Adjustment of the CPS ODCM Methodology.....	74
5.1	Radioactive Liquid Effluent Monitoring Instrumentation.....	75
5.2	Radioactive Gaseous Effluent Monitoring Instrumentation.....	75
5.2.1	Offgas Radiation Monitoring Instrumentation.....	75
5.2.2	Radioactive Gaseous Effluent Monitoring Instrumentation.....	75
SECTION	TITLE	PAGE

PART I – RADIOLOGICAL EFFLUENT CONTROLS

5.3	Liquid Radwaste Effluents.....	75
5.3.1	Liquid Effluent Concentration.....	75
5.3.2	Dose from Liquid Effluents.....	76
5.3.3	Liquid Radwaste Treatment Systems .....	76
5.4	Radioactive Gaseous Effluents .....	77
5.4.1	Gaseous Effluent Dose Rates .....	77
5.4.2	Dose from Noble Gases .....	78
5.4.3	Dose from Iodine-131, Iodine-133, Tritium and Radioactive Materials in Particulate Form .....	78
5.4.4	Gaseous Radwaste Treatment (Off-Gas) System.....	79
5.4.5	Ventilation Exhaust Treatment System .....	79
5.5	Total Dose .....	80
5.6	Radiological Environmental Monitoring Program.....	81
5.7	Land Use Census .....	82
5.8	Interlaboratory Comparison Program .....	82
5.9	Meteorological Monitoring Program.....	82
6.0	Reporting Requirements .....	83
6.1	Annual Radiological Environmental Operating Report.....	83
6.2	Radioactive Effluent Release Report.....	83



SECTION	TITLE	PAGE
<b>PART II – OFFSITE DOSE CALCULATION MANUAL</b>		
1.0	General Information .....	88
1.1	Introduction .....	88
1.2	MCR ARPR LAN.....	88
2.0	Radioactive Liquid System Effluent Monitoring System.....	89
2.1	Liquid Radwaste Discharge Process Radiation Monitoring (PRM) Instrumentation .....	89
2.1.1	Liquid Radwaste Discharge PRM Setpoints .....	89
2.2	Plant Service Water Effluent PRM .....	92
2.2.1	Plant Service Water Effluent PRM Setpoints .....	92
2.3	Shutdown Service Water (SX) Effluent PRM.....	93
2.3.1	Shutdown Service Water (SX) Effluent PRM Setpoints .....	93
2.4	Fuel Pool Heat Exchanger Service Water Effluent PRM .....	93
2.4.1	Fuel Pool Heat Exchanger Service Water Effluent PRM Setpoints.....	93
2.5	Component Cooling Water PRM .....	94
2.5.1	Component Cooling Water PRM Setpoints.....	94
3.0	Radioactive Gaseous Effluent Monitoring System.....	99
3.1	HVAC Stack Process Radiation Monitoring (PRM) Instrumentation .....	99
3.2	SGTS Stack Process Radiation Monitoring (PRM) Instrumentation .....	99
3.3	Main Condenser Off-Gas Monitoring Instrumentation .....	100
3.3.1	Pre-Treatment Air Ejector Off-Gas Process Radiation Monitor (PRM) .....	100
3.3.2	Post-Treatment Air Ejector Off-Gas Process Radiation Monitor (PRM).....	100
3.4	Gaseous Effluent Monitor Setpoint Calculations .....	101
3.4.1	Total Body Dose Rate Setpoint .....	101
3.4.2	Skin Dose Rate Setpoint.....	102
4.0	Liquid Effluents .....	105
4.1	Introduction .....	105
4.2	10CFR20 Release Concentration Limits .....	105
4.3	10CFR50, Appendix I Dose Limits .....	105
4.4	Liquid Effluent Dose Projection Calculations .....	107
4.5	Temporary Liquid Radwaste Hold-Up Tanks.....	107

SECTION	TITLE	PAGE
PART II – OFFSITE DOSE CALCULATION MANUAL		
5.0	Radioactive Gaseous Effluents .....	114
5.1	Introduction .....	114
5.2	Technical Specification Release Rate Limits.....	115
5.3	Dose Rate Due To Noble Gases .....	115
5.4	Dose Rate due to Radioiodines, Particulates and Tritium.....	115
5.5	10CFR50, Appendix I Release Rate Limits .....	120
5.5.1	Noble Gas Air Dose Equations .....	120
5.5.2	Radioiodines, Particulates and Tritium Dose Equations.....	120
5.6	Gaseous Effluent Dose Projection Calculations .....	127
6.0	Total Dose .....	1663
7.0	Radiological Environmental Monitoring Program.....	1664
8.0	Land Use Census .....	16969
9.0	Interlaboratory Comparison Program .....	170
10.0	Atmospheric Transport and Dispersion Model.....	171
10.1	Introduction .....	171
10.2	Concurrent Meteorological Data Processing .....	171
10.2.1	Determinatino of Pasquill Stability Class .....	172
10.2.2	Calculation of Stack Height Wind Speed .....	172
10.2.3	Determination of Release Mode and the Entrainment Coefficient.....	174
10.2.4	Calculation of Vertical Standard Deviation.....	174
10.2.5	Calculation of the Building Wake Correction.....	174
10.2.6	Calculation of Momentum Plume Rise.....	175
10.2.7	Calculation of the Effective Plume Height.....	176
10.2.8	Determination of Affected Sectors .....	176
10.2.9	Calculation of Depletion and Deposition Factors .....	177
10.2.10	Ground Level X/Q, D2DPXQ, D1XQ, D/Q Analysis .....	180
10.2.11	Elevated X/Q, D2DPXQ, D1XQ, D/Q Analysis.....	181

SECTION	TITLE	PAGE
<b>PART I – RADIOLOGICAL EFFLUENT CONTROLS - TABLES</b>		
Table 1-1	Surveillance Frequency Notation .....	6
Table 3.1-1	Radioactive Liquid Effluent Monitoring Instrumentation .....	16
Table 4.1-1	Radioactive Liquid Effluent Monitoring Instrumentation Surveillance Requirements... ..	18
Table 3.2-1	Offgas Radiation Monitoring Instrumentation .....	24
Table 4.2-1	Offgas Radiation Monitoring Instrumentation Surveillance Requirements .....	26
Table 3.2-2	Radioactive Gaseous Effluent Monitoring Instrumentation .....	30
Table 4.2-2	Radioactive Gaseous Effluent Monitoring Instrumentation Surveillance Requirements .....	32
Table 4.3.1-1	Radioactive Liquid Waste Sampling and Analysis Program .....	36
Table 4.4.1-1	Radioactive Gaseous Waste Sampling and Analysis Program.....	41
Table 4.6-1	Radiological Environmental Monitoring Program.....	56
Table 4.6-2	Reporting Levels for Radioactivity Concentrations in Environmental Samples .....	66
Table 4.6-3	Detection Capabilities for Environmental Sample Analysis Lower Limit of Detection (LLD).....	67
<b>PART II – OFFSITE DOSE CALCULATION MANUAL - TABLES</b>		
Table 4-1	Adult Ingestion Dose Commitment Factors - $A_{ij}$ (mrem/hr per $\mu\text{Ci/ml}$ ) .....	109
Table 4-2	Bioaccumulation Factors - $BF_i$ (pCi/kg per pCi/liter) .....	111
Table 4-3	Adult Ingestion Dose Factors - $DF_i$ (mrem/pCi ingested) .....	112
Table 5-1	Dose Factors for Noble Gases and Daughters.....	117
Table 5-2	Inhalation Pathway Dose Rate Factors (Child) - $P_{ij}$ (mrem/yr per $\mu\text{Ci/m}^3$ ).....	118
Table 5-3	Location of Members of the Public within the CPS Site Boundary and their Associated Occupancy Factors.....	119
Table 5-4	Inhalation Dose Factors for Infant – $(DFA_i)_a$ (mrem per $\mu\text{Ci}$ inhaled).....	129
Table 5-5	Inhalation Dose Factors for Child – $(DFA_i)_a$ (mrem per $\mu\text{Ci}$ inhaled).....	130
Table 5-6	Inhalation Dose Factors for Teen – $(DFA_i)_a$ (mrem per $\mu\text{Ci}$ inhaled).....	131
Table 5-7	Inhalation Dose Factors for Adult – $(DFA_i)_a$ (mrem per $\mu\text{Ci}$ inhaled).....	132
Table 5-8	Ground Plane Dose Factors – $DFG_i$ (mrem/hr per $\mu\text{Ci/m}^2$ ).....	133
Table 5-9	Ingestion Dose Factors for Infant – $(DFL_i)_a$ (mrem per $\mu\text{Ci}$ ingested) .....	134
Table 5-10	Ingestion Dose Factors for Child – $(DFL_i)_a$ (mrem per $\mu\text{Ci}$ ingested) .....	135
Table 5-11	Ingestion Dose Factors for Teen – $(DFL_i)_a$ (mrem per $\mu\text{Ci}$ ingested) .....	136
Table 5-12	Ingestion Dose Factors for Adult – $(DFL_i)_a$ (mrem per $\mu\text{Ci}$ ingested) .....	137
Table 5-13	Input Parameters for Calculating $R^C_{aij}$ .....	138

SECTION	TITLE	PAGE
PART II – OFFSITE DOSE CALCULATION MANUAL - TABLES		
Table 5-14	Input Parameters for Calculating $R_{aij}^M$ .....	139
Table 5-15	Input Parameters for Calculating $R_{aij}^V$ .....	140
Table 5-16	Inhalation Pathway Factors - $R_{aij}^I$ (Infant) (mrem/yr per $\mu\text{Ci}/\text{m}^3$ ).....	141
Table 5-17	Inhalation Pathway Factors - $R_{aij}^I$ (Child) (mrem/yr per $\mu\text{Ci}/\text{m}^3$ ).....	142
Table 5-18	Inhalation Pathway Factors - $R_{aij}^I$ (Teen) (mrem/yr per $\mu\text{Ci}/\text{m}^3$ ).....	143
Table 5-19	Inhalation Pathway Factors - $R_{aij}^I$ (Adult) (mrem/yr per $\mu\text{Ci}/\text{m}^3$ ).....	144
Table 5-20	Cow Milk Pathway Factors - $R_{aij}^C$ (Infant) ( $\text{m}^2$ mrem/yr per $\mu\text{Ci}/\text{sec}$ ).....	145
Table 5-21	Cow Milk Pathway Factors - $R_{aij}^C$ (Child) ( $\text{m}^2$ mrem/yr per $\mu\text{Ci}/\text{sec}$ ).....	146
Table 5-22	Cow Milk Pathway Factors - $R_{aij}^C$ (Teen) ( $\text{m}^2$ mrem/yr per $\mu\text{Ci}/\text{sec}$ ).....	147
Table 5-23	Cow Milk Pathway Factors - $R_{aij}^C$ (Adult) ( $\text{m}^2$ mrem/yr per $\mu\text{Ci}/\text{sec}$ ).....	148
Table 5-24	Goat Milk Pathway Factors - $R_{aij}^C$ (Infant) ( $\text{m}^2$ mrem/yr per $\mu\text{Ci}/\text{sec}$ ).....	149
Table 5-25	Goat Milk Pathway Factors - $R_{aij}^C$ (Child) ( $\text{m}^2$ mrem/yr per $\mu\text{Ci}/\text{sec}$ ).....	150
Table 5-26	Goat Milk Pathway Factors - $R_{aij}^C$ (Teen) ( $\text{m}^2$ mrem/yr per $\mu\text{Ci}/\text{sec}$ ).....	151
Table 5-27	Goat Milk Pathway Factors - $R_{aij}^C$ (Adult) ( $\text{m}^2$ mrem/yr per $\mu\text{Ci}/\text{sec}$ ).....	152
Table 5-28	Meat Pathway Factors - $R_{aij}^M$ (Child) ( $\text{m}^2$ mrem/yr per $\mu\text{Ci}/\text{sec}$ ).....	153
Table 5-29	Meat Pathway Factors - $R_{aij}^M$ (Teen) ( $\text{m}^2$ mrem/yr per $\mu\text{Ci}/\text{sec}$ ).....	154
Table 5-30	Meat Pathway Factors - $R_{aij}^M$ (Adult) ( $\text{m}^2$ mrem/yr per $\mu\text{Ci}/\text{sec}$ ).....	155
Table 5-31	Vegetation Pathway Factors - $R_{aij}^V$ (Child) ( $\text{m}^2$ mrem/yr per $\mu\text{Ci}/\text{sec}$ ).....	156
Table 5-32	Vegetation Pathway Factors - $R_{aij}^V$ (Teen) ( $\text{m}^2$ mrem/yr per $\mu\text{Ci}/\text{sec}$ ).....	157
Table 5-33	Vegetation Pathway Factors - $R_{aij}^V$ (Adult) ( $\text{m}^2$ mrem/yr per $\mu\text{Ci}/\text{sec}$ ).....	158
Table 5-34	Ground Plane Pathway Factors - $R_i^G$ ( $\text{m}^2$ mrem/yr per $\mu\text{Ci}/\text{sec}$ ).....	159
Table 5-35	X/Q, D/Q at the Site Boundary 5-Year Average Values from 2008-2012 MET Data .....	160
Table 5-36	X/Q, D/Q at Specific Locations with the CPS Site Boundary 5-Year Average Values from 2008-2012 MET Data.....	161
Table 5-37	X/Q, D/Q at Residences and Air Samplers in Each Sector 5-year Average Values from 2008-2012 MET Data.....	162

<u>SECTION</u>	<u>TITLE</u>	<u>PAGE</u>
PART II – OFFSITE DOSE CALCULATION MANUAL - TABLES		
Table 10.2-1	$\sigma_z$ Values .....	174
Table 10.2-2	Wind Direction Table .....	176
Table 10.2-3	DPF-Depletion Factors from figures 2 through 5 of Regulatory Guide 1.111 .....	178
Table 10.2-4	DPSF-Deposition Factors from figures 6 through 9 of Regulatory Guide 1.111 .....	179
Table 10.2-5	Gaseous Effluent Release Point Characteristics .....	183

<u>SECTION</u>	<u>TITLE</u>	<u>PAGE</u>
<b>PART I – RADIOLOGICAL EFFLUENT CONTROLS - FIGURES</b>		
Figure 1-1	Unrestricted Area Boundary for Liquid Effluents.....	7
<b>PART II – OFFSITE DOSE CALCULATION MANUAL - FIGURES</b>		
Figure 2-1	Unrestricted Area Boundary for Liquid Effluents.....	95
Figure 2-2	Liquid Radwaste Treatment System .....	96
Figure 2-3	Shutdown and Fuel Pool Heat Exchanger Service Water Effluent Monitors .....	97
Figure 2-4	Solid Radwaste System Simplified Flow Diagram .....	98
Figure 3-1	Main Condenser Off-Gas Treatment System .....	104
Figure 4-1	Unrestricted Area Boundary for Liquid Effluents.....	108
Figure 5-1	CPS Site Boundary for Gaseous Effluents .....	128
Figure 7-1	REMP Locations within 1 Mile of CPS .....	165
Figure 7-2	REMP Locations 1-2 Miles from CPS .....	166
Figure 7-3	REMP Locations 2-5 Miles from CPS .....	167
Figure 7-4	REMP Locations Greater than 5 Miles from CPS.....	168

**OFFSITE DOSE CALCULATION MANUAL**  
**CLINTON POWER STATION**

**PART I – RADIOACTIVE EFFLUENT CONTROLS**  
**OFFSITE DOSE CALCULATION MANUAL**  
**CLINTON POWER STATION**



**OFFSITE DOSE CALCULATION MANUAL (ODCM)**1.0 **DEFINITIONS**

The following terms are defined so that uniform interpretation of this manual's requirements may be achieved. The defined terms appear in capitalized type and shall be applicable throughout this manual.

1.1 **ACTION**

**ACTION** shall be that part of a Control that prescribes remedial measures required under designated conditions.

1.2 **CHANNEL CALIBRATION**

A **CHANNEL CALIBRATION** shall be the adjustment, as necessary, of the channel output such that it responds within the necessary range and accuracy to known values of the parameter that the channel monitors. The Channel Calibration shall encompass the entire channel, including the required sensor, alarm, display and trip functions, and shall include the **CHANNEL FUNCTIONAL TEST**. Calibration of instrument channels with resistance temperature detector (RTD) or thermocouple sensors may consist of an in-place qualitative assessment of sensor behavior and normal calibration of the remaining adjustable devices in the channel. The **CHANNEL CALIBRATION** may be performed by means of any series of sequential, overlapping, or total channel steps so that the entire channel is calibrated.

1.3 **CHANNEL CHECK**

A **CHANNEL CHECK** shall be a qualitative assessment, by observation, of channel behavior during operation. This determination shall include, where possible, comparison of the channel indication and status to other indications or status derived from independent instrument channels measuring the same parameter.

1.4 **CHANNEL FUNCTIONAL TEST**

A **CHANNEL FUNCTIONAL TEST** shall be the injection of a simulated or actual signal into the channel as close to the sensor as practicable to verify Functionality, including required alarm, interlock, display, and trip functions, and channel failure trips. The **CHANNEL FUNCTIONAL TEST** may be performed by means of any series of sequential, overlapping, or total channel steps so that the entire channel is tested.

1.5 **DOSE EQUIVALENT I-131**

**DOSE EQUIVALENT I-131** shall be as defined in the Clinton Power Station Technical Specifications.

1.6 FREQUENCY NOTATION

The FREQUENCY NOTATION specified for the performance of surveillance requirements shall correspond to the intervals defined in TABLE 1-1.

1.7 FUNCTIONAL – FUNCTIONALITY

Functionality is an attribute of structures, systems, and components (SSCs) that is not controlled by Technical Specifications (TSs). An SSC is FUNCTIONAL or has FUNCTIONALITY when it is capable of performing its specified safety function, as set forth in the Current Licensing Basis. FUNCTIONALITY does not apply to specified safety functions, but does apply to the ability of non-TS SSCs to perform other specified functions that have a necessary support function.

1.8 GASEOUS RADWASTE TREATMENT SYSTEM

A GASEOUS RADWASTE TREATMENT SYSTEM is any system designed and installed to reduce radioactive gaseous effluents by collecting primary coolant system offgases from the main condenser evacuation system and providing for delay or holdup for the purpose of reducing the total radioactivity prior to release to the environment.

1.9 IMMEDIATELY

When IMMEDIATELY is used as a Completion Time, the Required ACTION should be pursued without delay and in a controlled manner.

1.10 MEMBER(S) OF THE PUBLIC

An individual in a controlled or unrestricted area. However, an individual is not a MEMBER OF THE PUBLIC during any period in which the individual receives an occupational dose.

1.11 MODE

A MODE shall correspond to any one inclusive combination of mode switch position, average reactor coolant temperature, and reactor vessel head closure bolt tensioning specified in Technical Specifications in Table 1.1-1 with fuel in the reactor vessel.

1.12 OFFSITE DOSE CALCULATION MANUAL (ODCM)

The OFFSITE DOSE CALCULATION MANUAL (ODCM) contains the methodology and parameters used in the calculation of offsite doses resulting from radioactive gaseous and liquid effluent, in the calculation of gaseous and liquid effluent monitoring Alarm/Trip Setpoints, and in the conduct of the Radiological Environmental Monitoring Program. The ODCM also contains (1) the Radiological Effluent Controls, (2) the Radiological Environmental Monitoring Program and (3) descriptions of the information that should be included in the Annual Radiological Environmental Operating and Annual Radioactive Effluent Release Reports.

1.13 PURGE – PURGING

PURGE or PURGING is the controlled process of discharging air or gas from a confinement to maintain temperature, pressure, humidity, concentration or other operating conditions in such a manner that replacement air or gas is required to purify the confinement.

1.14 SITE BOUNDARY

The SITE BOUNDARY shall be that line beyond which the land is neither owned, nor leased, nor otherwise controlled by the licensee. See FIGURE 1-1.

1.15 SOURCE CHECK

A SOURCE CHECK shall be the qualitative assessment of channel response when the channel sensor is exposed to a source of increased radioactivity.

1.16 UNRESTRICTED AREA

UNRESTRICTED AREA means an area, access to which is neither limited nor controlled by the licensee.

## 1.17 VENTILATION EXHAUST TREATMENT SYSTEM

A VENTILATION EXHAUST TREATMENT SYSTEM is any system designed and installed to reduce gaseous radioiodine or radioactive material in particulate form in effluents by passing ventilation or vent exhaust gases through charcoal adsorbers and/or HEPA filters for the purpose of removing iodine or particulates from the gaseous exhaust system prior to the release to the environment. Such a system is not considered to have any effect on noble gas effluents. Engineered Safety Feature (ESF) atmospheric cleanup systems are not considered to be VENTILATION EXHAUST TREATMENT SYSTEMS.

The following systems are designated VENTILATION EXHAUST TREATMENT SYSTEMS:

- 1) Machine Shop HVAC (VJ)
- 2) Laboratory HVAC (VL)
- 3) Drywell Purge (VQ)
- 4) Radwaste Bldg. HVAC (VW)

## 1.18 VENT – VENTING

VENTING is the controlled process of discharging air or gas from a confinement to maintain temperature, pressure, humidity, concentration or other operating conditions in such a manner that replacement air or gas is not provided. Vent used in a system name does not imply a VENTING process.

TABLE 1-1  
SURVEILLANCE FREQUENCY NOTATION

<u>Notation</u>	<u>Frequency</u>
S (Shiftly)	Once per 12 hours
D (Daily)	Once per 24 hours
W (Weekly)	Once per 7 days
B (Biweekly)	Once per 14 days
M (Monthly)	Once per 31 days
Q (Quarterly)	Once per 92 days
SA (Semi-Annually)	Once per 184 days
A (Annually)	Once per 366 days
R (Refueling Cycle)	Once per 18 months (550 days)
R24 (Refueling Cycle)	Once per 24 months (732 days)
S/U (Startup)	Prior to each reactor startup
P (Prior)	Completed prior to each release
N/A (NA)	Not applicable

NOTE: A FREQUENCY NOTATION for a composite sample describes the time period over which the sample is to be composited.

FIGURE 1-1  
UNRESTRICTED AREA BOUNDARY FOR LIQUID EFFLUENTS

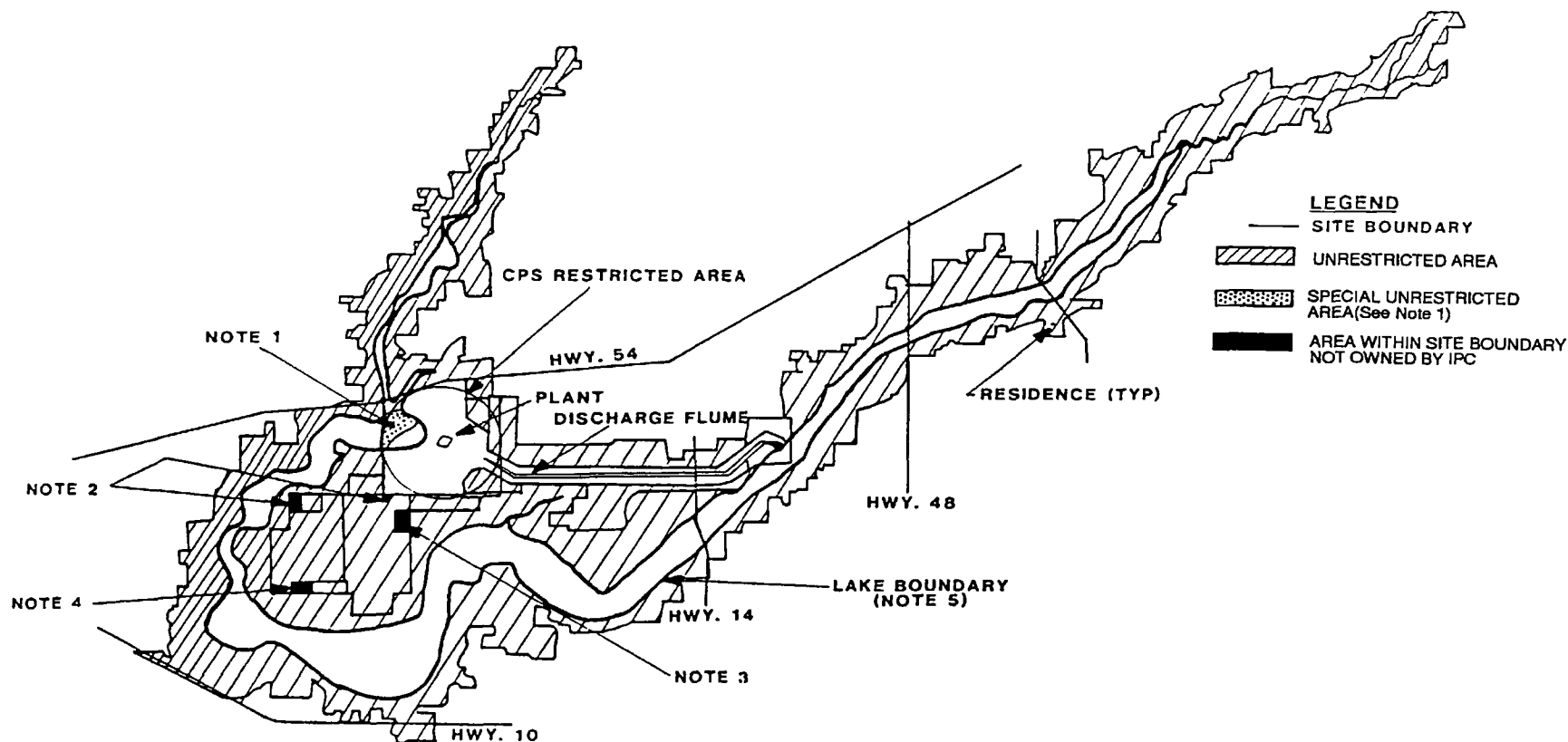

**NOTES**

1. The area in the lake between the buoys and the exclusion area boundary is unrestricted at this time. But will be controlled if plant effluent conditions warrant closure.
2. Land parcel not owned by Clinton Power Station, includes residences.
3. Land parcel not owned by Clinton Power Station, oil company pipeline pumping station.
4. Land parcel not owned by Clinton Power Station, agricultural use.
5. The lake shoreline is approximately 690 ft. Msl elevation line.

2.0 NOT USED

INTENTIONALLY BLANK



3/4 CONTROLS AND SURVEILLANCE REQUIREMENTS

3/4.0 APPLICABILITY

3.0 CONTROL

- 3.0.1 Compliance with the Controls contained in the succeeding controls is required during the OPERATIONAL MODES or other conditions specified herein, except that upon failure to meet the Control, the associated ACTION requirements shall be met.
- 3.0.2 Noncompliance with a control shall exist when the requirements of the Control and associated ACTION requirements are not met within the specified time intervals. If the Control is restored prior to expiration of the specified time intervals, completion of the ACTION requirements is not required.
- 3.0.3 Equipment removed from service or declared non-functional to comply with ACTION(s) may be returned to service under administrative control solely to perform testing required to demonstrate FUNCTIONALITY or the FUNCTIONALITY of other equipment. This is an exception to CONTROL 3.0.2 for the system returned to service under administrative control to perform the testing required to demonstrate FUNCTIONALITY.

4.0 SURVEILLANCE REQUIREMENTS

4.0.1 Surveillance Requirements shall be met during the OPERATIONAL MODES or other conditions specified for individual Controls unless otherwise stated in an individual Surveillance Requirement.

4.0.2 Each Surveillance Requirement shall be performed within the specified time interval with:

- a. A maximum allowable extension not to exceed 25% of the surveillance interval.
- b. For surveillance intervals specified as "once", the above interval extension does not apply.
- c. If an ACTION requires periodic performance on a "once per ..." basis, the above surveillance interval extension applies to each performance after the initial performance.

Exceptions to this Surveillance Requirement are stated in the individual Surveillance Requirements.

4.0.3 Failure to perform a Surveillance Requirement, whether such failure is experienced during the performance of the surveillance or between performances of the surveillance, within the allowed surveillance interval, defined by Specification 4.0.2, shall constitute noncompliance with the FUNCTIONALITY requirements for a Control. The time limits of the ACTION requirements are applicable at the time it is identified that a Surveillance Requirement has not been performed. The ACTION requirements may be delayed for up to 24 hours to permit the completion of the surveillance when the allowable outage time limits of the ACTION requirements are less than 24 hours. Surveillance Requirements do not have to be performed on non-functional equipment.

4.0.4 Entry into an OPERATIONAL MODE or other specified condition shall not be made unless the Surveillance Requirement(s) associated with the Control has been performed within the stated surveillance interval or as otherwise specified. This provision shall not prevent passage through or to OPERATIONAL MODES as required to comply with ACTION requirements. Exceptions to these requirements are stated in the individual controls.

3/4.1 RADIOACTIVE LIQUID EFFLUENT MONITORING INSTRUMENTATION

3.1 CONTROLS

3.1.1 The following conditions shall be met:

The radioactive liquid effluent monitoring instrumentation channels shown in TABLE 3.1-1 shall be FUNCTIONAL with their alarm/trip setpoints set to ensure the limits of 3.3.1 are not exceeded;

- a. The effluent monitoring instrument alarm/trip setpoints shall be determined and adjusted in accordance with the methodology and parameters described in the ODCM.

APPLICABILITY: At all times.

NOTE: Separate condition entry is allowed for each instrument.

**ACTIONS**

CONDITION	REQUIRED ACTION	COMPLETION TIME
A. Number of instrument channels FUNCTIONAL less than required by Table 3.1-1.	A.1 Enter the ACTION referenced in Table 3.1-1 for the instrument channel.	Immediately
B. Radioactive liquid effluent monitoring instrumentation channel alarm/trip setpoint less conservative than required.	B.1 Suspend the release of radioactive liquid effluents monitored by the affected channel.	Immediately
	<u>OR</u> B.2 Declare the affected instrument non-functional.	Immediately

CONDITION	REQUIRED ACTION	COMPLETION TIME
<p>C. As required by Action A.1 and referenced in Table 3.1-1.</p>	<p>C.1 Return the instrument to FUNCTIONAL status.</p> <p><u>AND</u></p> <p>C.2.1.1 Analyze at least two independent samples of tank's contents per 4.3.1.1.</p> <p><u>AND</u></p> <p>C.2.1.2 At least two technically qualified individuals independently verify the release rate calculations and discharge line valving.</p> <p><u>OR</u></p> <p>C.2.2 Suspend release of radioactive effluents via this pathway.</p>	<p>Within 30 days</p> <p>Prior to release</p> <p>Prior to release</p> <p>Immediately</p>
<p>D. As required by Action A.1 and referenced in Table 3.1-1.</p>	<p>D.1 Return the instrument to FUNCTIONAL status.</p> <p><u>AND</u></p> <p>D.2 Estimate tank liquid level.</p>	<p>30 days</p> <p>During all liquid additions to the tank.</p>

CONDITION	REQUIRED ACTION	COMPLETION TIME
<p>E. As required by Action A.1 and referenced in Table 3.1-1.</p>	<p>E.1 Return the instrument to FUNCTIONAL status.</p> <p><u>AND</u></p> <p>E.2.1 Perform CHANNEL CHECK using local monitor indication.</p> <p><u>OR</u></p> <p>E.2.2 Collect and analyze grab samples for radioactivity at an LLD of <math>\leq 5.00E-07</math> <math>\mu\text{Ci/ml}</math> for the Principal Gamma Emitters, an LLD of <math>\leq 5.00E-06</math> <math>\mu\text{Ci/ml}</math> for Ce-144, and an LLD of <math>\leq 1.00E-05</math> <math>\mu\text{Ci/ml}</math> for dissolved and entrained gases (gamma emitters only, see TABLE 3.1-1 Note (f)).</p>	<p>30 days</p> <p>Within 8 hours of declaring non-functional,</p> <p><u>AND</u></p> <p>Every 8 hours thereafter.</p> <p>Once per 12 hours</p>
<p>F. One or more flow measurement device channels non-functional.</p>	<p>F.1 Restore the channel to FUNCTIONAL status.</p> <p><u>AND</u></p> <p>-----NOTE-----</p> <ol style="list-style-type: none"> <li>1. Pump performance curves generated in place may be used to estimate flow.</li> <li>2. CW flow may also be estimated from the number of CW pumps in operation.</li> <li>3. All flows diverted from Plant Service Water must be taken into account when estimating dilution flow when Plant Service Water is the only dilution source.</li> </ol> <p>-----</p>	<p>30 days</p>

CONDITION	REQUIRED ACTION	COMPLETION TIME
	F.2 Estimate the effluent release flow rate via this pathway	Once per 4 hours during actual releases.
G. Radioactive liquid effluent monitoring instrumentation not returned to FUNCTIONAL status in the time specified in Conditions C, D, E or F.	G.1 Explain why the non-FUNCTIONALITY was not corrected in a timely manner in the next Radioactive Effluent Release Report.	As part of the next Radioactive Effluent Release Report submittal.

TABLE 3.1-1  
RADIOACTIVE LIQUID EFFLUENT MONITORING INSTRUMENTATION

INSTRUMENT	MINIMUM CHANNELS FUNCTIONAL(e)	ACTION	APPLICABILITY
1. Radioactive Monitors Providing Alarm and Automatic Termination of Release			
a. Liquid Radwaste Discharge Process Radiation Monitor 0RIX-RP040	1 (a)	C	(b)
2. Radioactivity Monitors Providing Alarm but Not Providing Automatic Termination of Release			
a. Plant Service Water Effluent Process Radiation Monitor 1RIX-RP036	1 (a)	E	(c)
b. Shutdown Service Water Effluent Process Radiation Monitor Div1:1RIX-PR038 Div2:1RIX-PRO39	1/Division* (a)	E	(c)
c. Fuel Pool Heat Exchanger Service Water Radiation Monitor trainA:1RIX-PR004 trainB:1RIX-PR005	1/On Service Heat Exchanger (a)	E	(c)
d. Component Cooling Water Process Radiation Monitor 1RIX-PRO37	1 (a)	E	(c)
3. Flow Rate Measurement Devices (OUIX-PRO52)			
a. Liquid Radwaste Effluent Line (Channel 1-low, Channel 2-high)	1	F	(b)
b. Plant Service Water Effluent Line (Ch 3)	1	F	(b)
c. Plant Circulation Water Line** (Ch 5)	1	F	(b)
4. Tank Level Indicating Devices			
a. Cycled Condensate Storage (meter indication at panel 1H23-P870 or computer point CY-BA401)	1	D	(d)
b. Reactor Core Isolation Cooling Storage (meter indication at panel 1H13-P862)	1	D	(d)

\* Division I and Division II only.

\*\* The plant circulation water (CW) flow rate measurement device is based upon the CW pump breaker position and an analog signal that specifies a preset flow rate.

TABLE NOTATION

- (a) Channel FUNCTIONALITY shall include the capability of the MCR ARPR LAN to provide the alarm status of the applicable radiation monitor channel(s).
- (b) Required only during radioactive discharge.
- (c) Any time system is in service.
- (d) During additions to the tank.
- (e) When a channel is placed in non-functional status solely for the performance of required surveillances (source checks, sampling) entry into the associated Required Action may be delayed for up to one hour.

SURVEILLANCE REQUIREMENTS

SURVEILLANCE REQUIREMENT	FREQUENCY
4.1.1 Perform SOURCE CHECK of radioactive liquid effluent monitoring instruments.	Per TABLE 4.1-1
4.1.2 Perform CHANNEL CHECK of radioactive liquid effluent monitoring instruments.	Per TABLE 4.1-1
4.1.3 Perform CHANNEL CALIBRATION of radioactive liquid effluent monitoring instruments.	Per TABLE 4.1-1
4.1.4 Perform CHANNEL FUNCTIONAL TEST of radioactive liquid effluent monitoring instruments.	Per TABLE 4.1-1



TABLE 4.1-1  
RADIOACTIVE LIQUID EFFLUENT MONITORING  
INSTRUMENTATION SURVEILLANCE REQUIREMENTS  
Page 1 of 2

INSTRUMENT	CHANNEL CHECK	SOURCE CHECK	CHANNEL CALIBRATION	CHANNEL FUNCTIONAL TEST
1. Radioactivity Monitors Providing Alarm and Automatic Termination of Release				
a. Liquid Radwaste Discharge Process Radiation Monitor Effluent Line	S (4,5)	P	R (3)	Q (1)
2. Radioactivity Monitors Providing Alarm but Not Providing Automatic Termination of Release				
a. Plant Service Water Effluent Process Radiation Monitor	S (5)	M	R (3)	Q (2)
b. Shutdown Service Water Effluent Process Radiation Monitor	S (5)	M	R (3)	Q (2)
c. Fuel Pool Heat Exchanger Service Water Radiation Monitor	S (5)	M	R (3)	Q (2)
d. Component Cooling Water Process Radiation Monitor	S (5)	M	R (3)	Q (2)
3. Flow Rate Measurement Devices				
a. Liquid Radwaste Effluent Line	S (4)	NA	R	Q
b. Plant Service Water Effluent Line	S (4)	NA	R	Q
c. Plant Circulation Water Line	S (4)	NA	NA	R
4. Tank Level Indicating Devices				
a. Cycled Condensate Storage	D*	NA	R	NA
b. Reactor Core Isolation Cooling	D*	NA	R	NA

\* During liquid additions to the tank.

TABLE 4.1-1  
RADIOACTIVE LIQUID EFFLUENT MONITORING  
INSTRUMENTATION SURVEILLANCE REQUIREMENTS  
Page 2 of 2

TABLE NOTATION

- (1) The CHANNEL FUNCTIONAL TEST shall also demonstrate that automatic isolation of this pathway occurs and that the MCR ARPR LAN provides annunciation and event display in response to each of the following conditions:
  1. Instrument indicates measured levels above the alarm/trip (HIGH) setpoint.
  2. Detector failure (LOW FAIL, HI FAIL).
  3. Sample flow failure (EXTERNAL FAIL).
  4. Instrument not set in normal operate mode (CALIBRATE, MAINTENANCE, or STANDBY.). A demonstration of automatic isolation of the release pathway is not applicable to this condition.
- (2) The CHANNEL FUNCTIONAL TEST shall also demonstrate that the MCR ARPR LAN responds with annunciation and event display to each of the following conditions:
  1. Instrument indicates measured levels above the alarm (HIGH) setpoint.
  2. Detector failure (LOW FAIL, HI FAIL).
  3. Sample flow failure (EXTERNAL FAIL).
  4. Instrument not set in normal operate mode (CALIBRATE, MAINTENANCE, or STANDBY.). A demonstration of automatic isolation of the release pathway is not applicable to this condition.
- (3) The initial CHANNEL CALIBRATION shall be performed using one or more of the reference standards certified by the National Institute of Standards and Technology (NIST) or using standards that have been obtained from suppliers that participate in measurement assurance activities with NIST. These standards shall permit calibrating the system over its intended range of energy and measurement range. For subsequent CHANNEL CALIBRATION, sources that have been related to the initial calibration shall be used.
- (4) CHANNEL CHECK shall consist of verifying indication of flow during periods of discharge. CHANNEL CHECKS are required when continuous, periodic, or batch releases are made.
- (5) The CHANNEL CHECK performed from the MCR ARPR LAN also verifies communication.

3/4.2 RADIOACTIVE GASEOUS EFFLUENT MONITORING INSTRUMENTATION

3/4.2.1 OFFGAS RADIATION MONITORING INSTRUMENTATION CONTROLS

3.2.1 CONTROLS

3.2.1.1 The following conditions shall be met:

- a. The offgas radiation monitoring instrumentation channels shown in TABLE 3.2-1 shall be FUNCTIONAL with alarm/trip setpoints within the specified limits.

APPLICABILITY: During operation of the main condenser air ejectors.

NOTE: Separate condition entry is allowed for each instrument.

ACTIONS

CONDITION	REQUIRED ACTION	COMPLETION TIME
A. Number of instrument channels FUNCTIONAL less than required by Table 3.2-1.	A.1 Enter the Action referenced in Table 3.2-1 for the instrument channel.	Immediately
B. Offgas radiation monitoring instrumentation channel alarm/trip setpoint exceeding the TABLE 3.2-1 value.	B.1 Suspend the release of radioactive gaseous effluents monitored by the affected channel.	Immediately
	<u>OR</u> B.2 Declare the affected channel non-functional.	Immediately

CONDITION	REQUIRED ACTION	COMPLETION TIME
<p>C. As required by Required Action A.1 and referenced in Table 3.2-1.</p>	<p>C.1 Return the instrument to FUNCTIONAL status</p> <p><u>AND</u></p>	<p>30 days</p>
	<p>C.2.1.1 Perform a CHANNEL CHECK using local monitor indication.</p> <p><u>AND</u></p> <p><u>AND</u></p> <p>-----NOTE----- This requirement is to provide sample indication to initiate Tech. Spec. Surveillance Requirement 3.7.5.1. -----</p>	<p>Within 8 hours</p> <p><u>AND</u></p> <p>Once per 8 hours thereafter.</p>
	<p>C.2.1.2 Locally check for TREND alarm.</p> <p><u>OR</u></p>	<p>Within 2 hours</p> <p><u>AND</u></p> <p>Once per 2 hours thereafter.</p>
	<p>C.2.2.1 Ensure the offgas treatment system is not bypassed (filtration system bypass is allowed during plant start-ups);</p> <p><u>AND</u></p> <p>-----NOTE----- The following step ensures compliance with Technical Specification Surveillance Requirement 3.7.5.1. -----</p> <p>C.2.2.2 Perform grab samples</p>	<p>Immediately</p>

CONDITION	REQUIRED ACTION	COMPLETION TIME
C. (continued)	<p>until the monitor is returned to FUNCTIONAL status.</p> <p><u>AND</u></p> <p>C.2.2.3 Perform noble gas gamma isotopic analysis</p>	<p>4 hours</p> <p><u>AND</u></p> <p>Once per 4 hours thereafter.</p> <p>Within 24 hours of sampling</p>
D. As required by Required Action A.1 and referenced in Table 3.2-1.	<p>D.1 Return the instrument to FUNCTIONAL status</p> <p><u>AND</u></p> <p>D.2.1 Perform a CHANNEL CHECK using local monitor indication.</p> <p><u>OR</u></p> <p>D.2.2.1 Perform grab samples until the monitor is returned to FUNCTIONAL status.</p> <p><u>AND</u></p> <p>D.2.2.2 Perform noble gas gamma isotopic analysis</p>	<p>Immediately</p> <p>Within 8 hours</p> <p><u>AND</u></p> <p>Once per 8 hours thereafter.</p> <p>8 hours</p> <p><u>AND</u></p> <p>Once per 8 hours thereafter</p> <p>Within 24 hours of sampling</p>
E. As required by Required Action A.1 and referenced in Table 3.2-1.	E.1 Estimate the flow rate via the applicable release pathways.	Once per 8 hours

CONDITION	REQUIRED ACTION	COMPLETION TIME
F. Instrumentation not returned to FUNCTIONAL status in the time specified in Conditions C or D.	F.1 Explain why the non-FUNCTIONALITY was not corrected in a timely manner in the next Radioactive Effluent Release Report.	As part of the next Radioactive Effluent Release Report submittal.

TABLE 3.2-1  
OFFGAS RADIATION MONITORING INSTRUMENTATION

INSTRUMENTATION	MINIMUM CHANNELS FUNCTIONAL <sup>e</sup>	ALARM/TRIP SETPOINT	Action
1. Pre-treatment Off-gas PRM - Noble Gas Activity Monitor 1RIX-PR034	1 <sup>d</sup>	$\leq 50 \mu\text{Ci/cc}^{\text{a,b}}$	C
2. Post-treatment Off-gas PRM 1RIX-PR035/41			
a. High-Range Noble Gas Activity Monitor Providing Alarm and Automatic Termination of Release (Ch. 7)	1 <sup>d</sup>	$\leq 7.06 \mu\text{Ci/cc}^{\text{c}}$	D
b. Effluent System Flow Rate Measuring Device 1N66-R620	1	NA	E
c. Sample Flow Rate Measuring Device (Ch 15)	1	NA	E

- a. Alarm only.
- b. Radioactivity concentration expected at the monitor location is a noble gas mix with a 2.9-minute decay.
- c. Radioactivity concentration expected at the monitor location is a noble gas mix released from the off-gas treatment system.
- d. Channel FUNCTIONALITY shall include the capability of the MCR ARPR LAN to provide the alarm status of the applicable radiation monitor channel(s).
- e. When a channel is placed in a non-functional status solely for the performance of required surveillances (source checks, sampling) entry into the associated Required Action may be delayed for up to one hour.

#### 4.2.1 SURVEILLANCE REQUIREMENTS

SURVEILLANCE REQUIREMENT	FREQUENCY
4.2.1.1 Perform SOURCE CHECK of radiation monitoring instrumentation channels.	Per TABLE 4.2-1
4.2.1.2 Perform CHANNEL CHECK of radiation monitoring instrumentation channels.	Per TABLE 4.2-1
4.2.1.3 Perform CHANNEL CALIBRATION of radiation monitoring instrumentation channels.	Per TABLE 4.2-1
4.2.1.4 Perform CHANNEL FUNCTIONAL TEST of radiation monitoring instrumentation channels.	Per TABLE 4.2-1



TABLE 4.2-1  
OFFGAS RADIATION MONITORING INSTRUMENTATION  
SURVEILLANCE REQUIREMENTS

INSTRUMENTATION	CHANNEL CHECK	SOURCE CHECK	CHANNEL FUNCTIONAL TEST	CHANNEL CALIBRATION
1. Pre-treatment Off-gas PRM - Noble Gas Activity Monitor 1RIX-PR034	S (3)	M	Q (1)	R (2)
2. Post-treatment Off-gas PRM 1RIX-PR035/41				
a. High-Range Noble Gas Activity Monitor Providing Alarm and Automatic Termination of Release (ch 7)	S (3)	W	Q (1)	R24 (2) <sup>a</sup>
b. Effluent System Flow-Rate Measuring Device 1N66-R620	D	NA	Q	R
c. Sample Flow Rate Measuring Device (ch 15)	S	NA	Q	R24

TABLE NOTATION

- a. Automatic isolation of valve 1N66-F060 shall be demonstrated during the CHANNEL CALIBRATION.
- (1) The CHANNEL FUNCTIONAL TEST shall also demonstrate that the MCR ARPR LAN responds with annunciation and event display to each of the following conditions:
  - 1. Instrument indicates measured levels above the alarm/trip (HIGH) setpoint.
  - 2. Detector failure (LOW FAIL, HI FAIL).
  - 3. Sample flow failure (EXTERNAL FAIL).
  - 4. Instrument not set in normal operate mode (CALIBRATE, MAINTENANCE, or STANDBY).
- (2) The initial CHANNEL CALIBRATION shall be performed using one or more of the reference standards certified by the National Institute of Standards and Technology (NIST) or using standards that have been obtained from suppliers that participate in measurement assurance activities with NIST. These standards shall permit calibrating the system over its intended energy range and measurement range. Subsequent CHANNEL CALIBRATION shall be performed using the initial radioactive standards or other standards of equivalent quality or radioactive sources that have been related to the initial calibration.
- (3) The CHANNEL CHECK shall also determine that channel communication is established to the MCR ARPR LAN. By system design, the Channel Check from the MCR ARPR LAN verifies communication.

3/4.2.2 RADIOACTIVE GASEOUS EFFLUENT MONITORING INSTRUMENTATION CONTROLS

3.2.2 CONTROLS

3.2.2.1 The following conditions shall be met:

- a. The radioactive gaseous effluent monitoring instrumentation channels shown in TABLE 3.2-2 shall be FUNCTIONAL with their alarm/trip setpoints set to ensure that the limits of 3.4.1 and Technical Specification 3.7.5 are not exceeded.
- b. The alarm/trip setpoints of these channels shall be determined and adjusted in accordance with the ODCM methodology and parameters.

APPLICABILITY: As shown in TABLE 3.2-2.

NOTE: Separate condition entry is allowed for each instrument.

ACTIONS

CONDITION	REQUIRED ACTION	COMPLETION TIME
A. Number of instrument channels FUNCTIONAL less than required by Table 3.2-2	A.1 Enter the Action referenced in Table 3.2-1 for the instrument channel	Immediately
B. Radioactive gaseous effluent monitoring instrumentation channel alarm/trip setpoint less conservative than required.	B.1 Suspend the release of radioactive gaseous effluents monitored by the affected channel.	Immediately
	<u>OR</u> B.2 Declare the channel non-functional	Immediately

CONDITION	REQUIRED ACTION	COMPLETION TIME
<p>C. As required by Action A.1 and referenced in Table 3.2-2</p>	<p>C.1 Restore instrumentation to FUNCTIONAL status.</p> <p><u>AND</u></p> <p>C.2.1 Perform a CHANNEL CHECK using local monitor indication.</p> <p><u>OR</u></p> <p>C.2.2.1 Obtain grab samples;</p> <p><u>AND</u></p> <p>C.2.2.2 Analyze grab samples for gross noble gas activity, and then releases via this pathway may continue.</p>	<p>30 days</p> <p>Within 8 hours</p> <p><u>AND</u></p> <p>Once per 8 hours thereafter</p> <p>Within 8 hours</p> <p><u>AND</u></p> <p>Once per 8 hours thereafter</p> <p>Within 24 hours of obtaining grab sample.</p>
<p>D. As required by Action A.1 and referenced in Table 3.2-2</p>	<p>D.1 Restore instrument to FUNCTIONAL status;</p> <p><u>AND</u></p> <p>D.2 Obtain samples per TABLE 4.4.1-1 with auxiliary sampling equipment, then releases via this pathway may continue.</p>	<p>30 days</p> <p>4 hours after channel declared non-functional,</p> <p><u>AND</u></p> <p>Continuously thereafter.</p>



TABLE 3.2-2  
RADIOACTIVE GASEOUS EFFLUENT MONITORING INSTRUMENTATION

INSTRUMENT	MINIMUM CHANNELS FUNCTIONAL (g)	APPLICABILITY	REQUIRED ACTION
1. Station HVAC Exhaust PRM 0RIX-PR001/2			
a. High-Range Noble Gas Activity Monitor (Ch 7)	1 <sup>(c)</sup>	a	C
b. Low-Range Noble Gas Activity Monitor (Ch 5)	1 <sup>(c)</sup>	a	C
c. Iodine Sampler <sup>(d)</sup>	1	a	D
d. Particulate Sampler <sup>(d)</sup>	1	a	D
e. Sample Flow-Rate Measuring Device (Ch 15)	1	a	C
2. Standby Gas Treatment System Exhaust PRM 0RIX-PR003/4			
a. High-Range Noble Gas Activity Monitor (Ch 9)	1 <sup>(c)</sup>	b	C
b. Low-Range Noble Gas Activity Monitor (Ch 6)	1 <sup>(c)</sup>	b	C
c. Iodine Sampler <sup>(d)</sup>	1	b	D
d. Particulate Sampler <sup>(d)</sup>	1	b	D
e. Sample Flow-Rate Measuring Device (Ch 15)	1	b	C
3. Station HVAC Exhaust AXM 0RIX-PR012			
a. High-Range Noble Gas Activity Monitor (Ch 3)	1	e	F
b. Intermediate-Range Noble Gas Activity Monitor (Ch 4)	1	e	F
c. Sample Flow-Rate Measuring Device 0FI-PR012B	1	e	F
4. Standby Gas Treatment System Exhaust AXM 0RIX-PR008			
a. High-Range Noble Gas Activity Monitor (Ch 3)	1	e	F
b. Intermediate-Range Noble Gas Activity Monitor (Ch 4)	1	e	F
c. Sample Flow-Rate Measuring Device 0FI-PR008B	1	e	F
5. Station HVAC Effluent System Flow-Rate Measuring Device 0UIX-PR051 Ch 6	1	a	E
6. SGTS Effluent System Flow-Rate Measuring Device 0UIX-PR051 Ch 1	1	f	E

- a. At all times.
- b. When standby gas treatment system is in standby or operation.
- c. Channel FUNCTIONALITY shall include the capability of the MCR ARPR LAN to provide the alarm status of the applicable radiation monitor channel(s).
- d. Filter media (particulate collection patch for particulates and charcoal cartridge for iodines) in place with an operating sample pump constitutes an functional iodine/particulate sampler.
- e. Modes 1, 2, and 3 only
- f. When Standby Gas Treatment System is in operation.
- g. When a channel is placed in a non-FUNCTIONAL status solely for the performance of required surveillances, entry into associated ACTION may be delayed for up to one hour.

4.2.2 SURVEILLANCE REQUIREMENTS

SURVEILLANCE REQUIREMENT	FREQUENCY
4.2.2.1 Perform SOURCE CHECK of radioactive gaseous effluent monitoring instrumentation channel.	Per TABLE 4.2-2
4.2.2.2 Perform CHANNEL CHECK of radioactive gaseous effluent monitoring instrumentation channel.	Per TABLE 4.2-2
4.2.2.3 Perform CHANNEL CALIBRATION of radioactive gaseous effluent monitoring instrumentation channel.	Per TABLE 4.2-2
4.2.2.4 Perform CHANNEL FUNCTIONAL TEST of radioactive gaseous effluent monitoring instrumentation channel.	Per TABLE 4.2-2

TABLE 4.2-2  
RADIOACTIVE GASEOUS EFFLUENT MONITORING  
INSTRUMENTATION SURVEILLANCE REQUIREMENTS  
Page 1 of 2

INSTRUMENT	CHANNEL CHECK	SOURCE CHECK	CHANNEL CALIBRATION	CHANNEL FUNCTIONAL TEST
1. Station HVAC Exhaust PRM 0R1X-PR001/2				
a. High-Range Noble Gas Activity Monitor (Ch 7)	S (3)	M	R (2)	Q (1)
b. Low-Range Noble Gas Activity Monitor (Ch 5)	S (3)	M	R (2)	Q (1)
c. Iodine Sampler	W	NA	NA	NA
d. Particulate Sampler	W	NA	NA	NA
e. Sample Flow-Rate Measuring Device (Ch 15)	S	NA	R	Q
2. Standby Gas Treatment System Exhaust PRM 0R1X-PR003/4				
a. High-Rang Noble Gas Activity Monitor (Ch 9)	S (3)	NA	R (2)	Q (1)
b. Low-Range Noble Gas Activity Monitor (Ch 6)	S (3)	M	R (2)	Q (1)
c. Iodine Sampler	W	NA	NA	NA
d. Particulate Sampler	W	NA	NA	NA
e. Sample Flow-Rate Measuring Device (Ch 15)	S	NA	R	Q
3. Station HVAC Exhaust AXM 0R1X-PR012				
a. High-Range Noble Gas Activity Monitor (Ch 3)	S (3)	M	R (2)	NA
b. Intermediate-Range Noble Gas Activity Monitor (Ch 4)	S (3)	M	R (2)	NA
c. Sample Flow-Rate Measuring Device 0F1-PR012B	*	NA	R	NA
4. Standby Gas Treatment System Exhaust AXM 0R1X-PR008				
a. High-Range Noble Gas Activity Monitor (Ch 3)	S (3)	M	R (2)	NA
b. Intermediate-Range Noble Gas Activity Monitor (Ch 4)	S (3)	M	R (2)	NA
c. Sample Flow-Rate Measuring Device 0F1-PR008B	*	NA	R	NA
d. Automatic Operation <sup>(4)</sup>	NA	NA	NA	NA
5. Station HVAC Effluent System Flow-Rate Measuring Device 0U1X-PR051, Ch 6	S	NA	R	Q
6. SGTS Effluent System Flow-Rate Measuring Device 0U1X-PR051, Ch 1	S	NA	R	Q
7. Inservice Calibrations on Station HVAC Exhaust and Standby Gas Treatment System Exhaust PRMs	NA	NA	A (a, b)	NA

\* Shiftly when in operation with the pump running.

TABLE 4.2-2  
RADIOACTIVE GASEOUS EFFLUENT MONITORING  
INSTRUMENTATION SURVEILLANCE REQUIREMENTS  
Page 2 of 2

TABLE NOTATION

- a. Per Regulatory Guide 1.21, compare the PRM readings with grab sample results for the noble gas and particulate/iodine channels. Modify the channel calibrations as necessary to ensure monitor readings are related to the concentration or release rates of nuclides in the monitored path.
- b. Not applicable if the activity in the sample stream is not high enough to provide a statistically relevant comparison.
- (1) The CHANNEL FUNCTIONAL TEST shall also demonstrate that the MCR ARPR LAN responds with annunciation and event display to each of the following conditions:
  - 1. Instrument indicates measured levels above the alarm (HIGH) setpoint.
  - 2. Detector failure (LOW FAIL, HI FAIL).
  - 3. Sample flow failure (EXTERNAL FAIL).
  - 4. Instrument not set in normal operate mode (CALIBRATE, MAINTENANCE, or STANDBY).
- (2) The initial CHANNEL CALIBRATION shall be performed using one or more of the reference standards certified by the National Institute of Standards and Technology (NIST) or using standards that have been obtained from suppliers that participate in measurement assurance activities with NIST. These standards shall permit calibrating the system over its intended range of energy and measurement range. Subsequent CHANNEL CALIBRATION shall be performed using the initial radioactive standards or other standards of equivalent quality or radioactive sources that have been related to the initial calibration.
- (3) The CHANNEL CHECK performed from the MCR ARPR LAN also verified communication.
- (4) Verify the SGTS AXM automatically starts upon initiation of DIV I SGTS and remains in service following shutdown of DIV I SGTS. Periodicity = 24 months.



3/4.3 LIQUID RADWASTE EFFLUENTS

3/4.3.1 LIQUID EFFLUENT CONCENTRATION

3.3.1 CONTROLS

3.3.1.1 The effluent concentration limit (ECL) of radioactive material released in liquid effluent to UNRESTRICTED AREAS (see FIGURE 1-1) shall be limited to:

- a. 10 times the concentrations specified in 10CFR20, Appendix B, Table 2, Column 2 for radionuclides other than dissolved or entrained noble gases; and
- b.  $2 \times 10^{-4}$   $\mu\text{Ci/ml}$  total activity concentration for all dissolved or entrained noble gases.

APPLICABILITY: During all releases via this pathway.

ACTIONS

CONDITION	REQUIRED ACTION	COMPLETION TIME
A. Concentration of radioactive material released in liquid effluents to UNRESTRICTED AREAS exceeding limits.	A.1 Restore the concentration to within limits.	Immediately

#### 4.3.1 SURVEILLANCE REQUIREMENTS

SURVEILLANCE	FREQUENCY
4.3.1.1 Obtain samples of radioactive liquid wastes and analyze per TABLE 4.3.1-1.	Per TABLE 4.3.1-1
4.3.1.2 Evaluate analysis results to ensure concentrations are within the limits of 3.3.1.1 using the calculational methods of the ODCM.	Per TABLE 4.3.1-1

TABLE 4.3.1-1  
RADIOACTIVE LIQUID WASTE SAMPLING AND ANALYSIS PROGRAM  
Page 1 of 2

LIQUID RELEASE TYPE	SAMPLING FREQUENCY	MINIMUM ANALYSIS FREQUENCY	TYPE OF ACTIVITY ANALYSIS	LOWER LIMIT OF DETECTION (LLD) <sup>(a)</sup> (μCi/ml)
A. Batch Waste Release Tanks <sup>(b)</sup>	P, Each Batch	P, Each Batch	Principal Gamma Emitters <sup>(c)</sup>	≤5x10 <sup>-7</sup>
			I-131	≤1x10 <sup>-6</sup>
	P One Batch/M	M	Dissolved & Entrained Gases (Gamma Emitters) <sup>(e)</sup>	≤1x10 <sup>-5</sup>
	P, Each Batch	Q Composite <sup>(d)</sup>	H-3	≤1x10 <sup>-5</sup>
			Fe-55	≤1x10 <sup>-6</sup>
			Sr-89, Sr-90	≤5x10 <sup>-8</sup>
			Gross Alpha	≤1x10 <sup>-7</sup>

NOTE: To comply with the above requirements, setpoints will be calculated to assure that Seal Well concentrations do not exceed CONTROL 3.3.1.

TABLE NOTATION

- a. The LLD is defined, for purposes of this surveillance, as the smallest concentration of radioactive material in a sample that will yield a net count above system background that will be detected with 95% probability with 5% probability of falsely concluding that a blank observation represents a "real" signal.

For a particular measurement system (which may include radiochemical separation):

$$LLD = \frac{4.66S_b}{[E \cdot V \cdot 2.22 \times 10^6 \cdot Y \cdot \exp(-\lambda \Delta t)]}$$

Where: LLD is the "a priori" lower limit of detection as defined above (as microcurie per unit mass or volume),  
 $S_b$  is the standard deviation of the background counting rate or of the counting rate of a blank sample as appropriate (as counts per minute),  
 E is the counting efficiency (as counts per disintegration),  
 V is the sample size (in units of mass or volume),  
 $2.22 \times 10^6$  is the number of disintegrations per minute per microcurie,  
 Y is the fractional radiochemical yield (when applicable),  
 $\lambda$  is the radioactive decay constant for the particular radionuclide (sec<sup>-1</sup>), and  
 $\Delta t$  is the elapsed time between midpoint of sample collection and the midpoint of the counting interval.  
 Typical values of E, V, Y and  $\Delta t$  should be used in the calculation.

TABLE 4.3.1-1  
RADIOACTIVE LIQUID WASTE SAMPLING AND ANALYSIS PROGRAM  
Page 2 of 2

TABLE NOTATION (Continued)

It should be recognized that the LLD is defined as an a priori (before the fact) limit representing the capability of a measurement system and not as an a posteriori (after the fact) limit for a particular measurement.

- b. A batch release is the discharge of liquid wastes of a discrete volume. Prior to sampling for analyses, the tank is isolated from all inputs and recirculated a minimum of two tank volumes at which time a sample is obtained for isotopic analysis.
- c. The principal gamma emitters are: Mn-54, Fe-59, Co-58, Co-60, Zn-65, Mo-99, Cs-134, Cs-137, and Ce-141. Ce-144 shall also be measured, but with an LLD of  $\leq 5.00E-06$   $\mu\text{Ci/ml}$ . All identified radionuclides shall be reported in the Radioactive Effluent Release Report pursuant to Technical Specification 5.6.3 in a format outlined in Regulatory Guide 1.21, Appendix B, Revision 1, June 1974.
- d. A composite sample is one in which the quantity of liquid sampled is proportional to the quantity of liquid waste discharged and in which the method of sampling employed results in a specimen that is representative of the liquids released.
- e. Dissolved and Entrained gases are: Xe-133, Xe-135, Xe-138, Kr-85m, Kr-87, and Kr-88.

3/4.3.2 DOSE FROM LIQUID EFFLUENTS

3.3.2 CONTROLS

3.3.2.1 The dose or dose commitment to a MEMBER OF THE PUBLIC from radioactive materials in liquid effluents released to UNRESTRICTED AREAS (see FIGURE 1-1) shall be limited to:

- a.  $\leq 1.5$  mrem to the total body and  $\leq 5$  mrem to any organ during any calendar quarter; and
- b.  $\leq 3.0$  mrem to the total body and  $\leq 10$  mrem to any organ during any calendar year, and

APPLICABILITY: At all times.

ACTIONS

CONDITION	REQUIRED ACTION	COMPLETION TIME
A. Calculated dose from the release of radioactive materials in liquid effluents exceeds any limits of 3.3.2.1.	A.1 Submit a Special Report to the NRC Regional Office Regional Administrator that identifies causes for exceeding limits, defines corrective actions that have been taken to reduce the releases and the proposed corrective actions to be taken to assure that subsequent releases will be in compliance with the limits.	30 days

4.3.2 SURVEILLANCE REQUIREMENTS

SURVEILLANCE REQUIREMENT	FREQUENCY
4.3.2.1 Determine cumulative dose contributions from liquid effluents for the current calendar quarter and current calendar year in accordance with the methodology and parameters described in the ODCM.	31 days

3/4.3.3 LIQUID RADWASTE TREATMENT SYSTEMS

3.3.3 CONTROLS

3.3.3.1 The Liquid Radwaste Treatment System shall:

- a. Be FUNCTIONAL.
- b. Be used (appropriate system portions) to reduce the radioactive materials in liquid wastes prior to their discharge when the projected doses due to the liquid effluents to UNRESTRICTED AREAS (see FIGURE 1-1) would exceed 0.06 mrem to the total body or 0.2 mrem to any organ in a 31-day period.

APPLICABILITY: At all times.

ACTIONS

CONDITION	REQUIRED ACTION	COMPLETION TIME
A. Liquid waste is being discharged without treatment, in excess of the limits of 3.3.3.1, and any portion of the liquid radwaste treatment system not in operation	A.1 Submit a Special Report to the NRC Regional Office Regional Administrator that includes an explanation of why liquid radwaste was being discharged without treatment, non-functional equipment or subsystem identification and reason, action(s) taken to restore the non-functional equipment to FUNCTIONAL status, and a summary description of the action(s) taken to prevent recurrence.	30 days

4.3.3 SURVEILLANCE REQUIREMENTS

SURVEILLANCE REQUIREMENT	FREQUENCY
4.3.3.1 Determine projected doses due to liquid releases to UNRESTRICTED AREAS in accordance with the methodology and parameters described in the ODCM.	31 days
4.3.3.2 Demonstrate Liquid Radwaste Treatment System FUNCTIONALITY by meeting the requirements of Controls 3.3.1 and 3.3.2	N/A

3/4.4 RADIOACTIVE GASEOUS EFFLUENTS

3/4.4.1 GASEOUS EFFLUENT DOSE RATES

3.4.1 CONTROLS

3.4.1.1 The dose rate due to radioactive materials released in gaseous effluents from the site to areas at and beyond the SITE BOUNDARY (see FIGURE 1-1) shall be limited to the following:

- a. For noble gases,  $\leq 500$  mrem/year to the total body and  $\leq 3000$  mrem/year to the skin; and
- b. For iodine-131, iodine-133, tritium, and all radionuclides in particulate form with half-lives  $> 8$  days,  $\leq 1500$  mrem/year to any organ.

APPLICABILITY: At all times.

ACTIONS

CONDITION	REQUIRED ACTION	COMPLETION TIME
A. Dose rates exceeding any limits of 3.4.1.1.	A.1 Restore the release rate to within the limits.	Immediately

4.4.1 SURVEILLANCE REQUIREMENTS

SURVEILLANCE REQUIREMENT	FREQUENCY
4.4.1.1 Determine the dose rate due to noble gases in gaseous effluents is within the limits of 3.4.1.1.a in accordance with the methodology and parameters of the ODCM by obtaining and analyzing representative samples.	In accordance with sampling and analysis program specified in TABLE 4.4.1-1
4.4.1.2 Determine the dose rate due to iodine-131, iodine-133, tritium, and all radionuclides in particulate form with half-lives $> 8$ days in gaseous effluents is within the limits of 3.4.1.1.b in accordance with the methods and procedures of the ODCM by obtaining representative samples and performing analysis.	In accordance with sampling and analysis program specified in TABLE 4.4.1-1

TABLE 4.4.1-1  
RADIOACTIVE GASEOUS WASTE SAMPLING AND ANALYSIS PROGRAM  
Page 1 of 3

Gaseous Release Type	Sampling Frequency	Analysis Frequency	Type of Activity Analysis	Lower Limit of Detection LLD <sup>a</sup> (μCi/cc)
<b>A. Station HVAC Exhaust</b>				
1. Noble Gas and Tritium Release	W <sup>2</sup> Grab - upon initiation of flow without delay in a controlled manner	W <sup>2</sup>	Principal Gamma Emitters <sup>1</sup>	≤1.00E-04
			H-3	≤1.00E-06
2. Iodines Release	Continuous <sup>3</sup>	W <sup>4</sup>	I-131	≤1.00E-12
			I-133	≤1.00E-10
3. Particulates Release	Continuous <sup>3</sup>	W <sup>4</sup>	Principal Gamma Emitters <sup>1</sup>	≤1.00E-11
		M Composite	Gross Alpha Activity	≤1.00E-11
		Q Composite	Sr-89, Sr-90 Activity	≤1.00E-11
<b>B. Standby Gas Treatment System Exhaust, when flow exists</b>				
1. Noble Gas and Tritium Release	Each Release Grab - upon initiation of flow without delay in a controlled manner.	Each Release	Principal Gamma Emitters <sup>1</sup>	≤1.00E-04
			H-3	≤1.00E-06
2. Iodines Release	Continuous <sup>3</sup> when VG system flow exists	W <sup>4</sup>	I-131	≤1.00E-12
			I-133	≤1.00E-10
3. Particulates Release	Continuous <sup>3</sup> when VG system flow exists	W <sup>4</sup>	Principal Gamma Emitters <sup>1</sup>	≤1.00E-11
		M Composite	Gross Alpha Activity	≤1.00E-11
		Q Composite	Sr-89, Sr-90 Activity	≤1.00E-11
<b>C Drywell Purge and High Volume Containment Ventilation, modes 4 and 5 only <sup>5,6</sup></b>				
1. Noble Gas and Tritium Release	Grab - upon initiation of flow without delay in a controlled manner	Each Release	Principal Gamma Emitters <sup>1</sup>	≤1.00E-04
			H-3	≤1.00E-06
<b>D. Mechanical Vacuum Pump <sup>5,6</sup></b>				
1. Noble Gas and Tritium Release	Grab - upon initiation of flow without delay in a controlled manner	Each Release	Principal Gamma Emitters <sup>1</sup>	≤1.00E-04
			H-3	≤1.00E-06



TABLE 4.4.1-1  
RADIOACTIVE GASEOUS WASTE SAMPLING AND ANALYSIS PROGRAM  
Page 2 of 3

TABLE NOTATION

- a. The LLD is defined, for purposes of these specifications, as the smallest concentration of radioactive material in a sample that will yield a net count, above system background, that will be detected with 95% probability with only 5% probability of falsely concluding that a blank observation represents a "real" signal.  
For a particular measurement system, which may include radiochemical separation:

$$LLD = \frac{4.66S_b}{[E \cdot V \cdot 2.22 \times 10^6 \cdot Y \cdot \exp(-\lambda \Delta t)]}$$

Where: LLD is the "a priori" lower limit of detection as defined above, as microcuries per unit mass or volume,  
 $S_b$  is the standard deviation of the background counting rate or of the counting rate of a blank sample as appropriate, as counts per minute,  $S_b = \sqrt{\frac{R_{bkg}}{t}}$   
 $R_{bkg}$  = background count rate  
 $t$  = the background count time  
 $E$  is the counting efficiency, as counts per disintegration,  
 $V$  is the sample size in units of mass or volume,  
 $2.22E06$  is the number of disintegrations per minute per microcurie,  
 $Y$  is the fractional radiochemical yield, when applicable,  
 $\lambda$  is the radioactive decay constant for the particular radionuclide ( $\text{sec}^{-1}$ ) and  $\Delta t$  for plant effluents is the elapsed time between the midpoint of sample collection and the midpoint of the counting interval (sec).  
 Typical values of  $E$ ,  $V$ ,  $Y$ , and  $\Delta t$  should be used in the calculation.  
 It should be recognized that the LLD is defined as an a priori (before the fact) limit representing the capability of a measurement system and not as an a posteriori (after the fact) limit for a particular measurement.

TABLE 4.4.1-1  
RADIOACTIVE GASEOUS WASTE SAMPLING AND ANALYSIS PROGRAM  
Page 3 of 3

TABLE NOTATION

1. The principal gamma emitters are: Kr-87, Kr-88, Xe-133, Xe-133m, Xe-135, and Xe-138 in noble gas releases and Mn-54, Fe-59, Co-58, Co-60, Zn-65, Mo-99, I-131, Cs-134, Cs-137, Ce-141 and Ce-144 in iodine and particulate releases. Other gamma peaks that are identifiable, together with those of the above nuclides, shall be analyzed and reported in the Radioactive Effluent Release Report pursuant to Technical Specification 5.6.3 in the format outlined in Regulatory Guide 1.21, Appendix B, Revision 1, June 1974.
2. Sampling and analysis shall also be performed without delay in a controlled manner following shutdown, startup, or a THERMAL POWER change exceeding 15% of RATED THERMAL POWER within a 1-hour period.
3. The ratio of the sample flow rate to the sampled stream flow rate shall be known for the time period covered by each dose or dose rate calculation made in accordance with Section 3/4.4.
4. Samples shall be changed at least once per 7 days and analysis shall be completed within 48 hours after changing, or after removal from sampler. Sampling shall also be performed at least once per 24 hours for at least 7 days following each shutdown, startup, or THERMAL POWER change exceeding 15% of RATED THERMAL POWER in 1-hour period and analyses shall be completed within 48 hours of changing. When samples collected for 24 hours or less are analyzed, the corresponding LLDs may be increased by a factor of 10. Twenty-four (24) hour sampling requirements do apply if: (1) analysis shows that the DOSE EQUIVALENT I-131 concentration in the primary coolant has increased more than a factor of 3, and (2) the noble gas monitor on the applicable PRM (HVAC or SGTS) shows that effluent activity has increased more than a factor of 3.
5. Samples are taken from the in-service HVAC PRM.
6. Iodines and Particulates released from these discharges are accounted for in the weekly samples taken in accordance with items A2 and A3 in TABLE 4.4.1-1.

3/4.4.2 DOSE FROM NOBLE GASES

3.4.2 CONTROLS

3.4.2.1 The air dose due to noble gases released in gaseous effluents, from each reactor unit, to areas at and beyond the SITE BOUNDARY (see FIGURE 1-1) shall be limited to the following:

- a. For gamma radiation,  $\leq 5$  mrad during any calendar quarter;
- b. For beta radiation,  $\leq 10$  mrad during any calendar quarter;
- c. For gamma radiation,  $\leq 10$  mrad during any calendar year; and
- d. For beta radiation,  $\leq 20$  mrad during any calendar year.

APPLICABILITY: At all times.

ACTIONS

CONDITION	REQUIRED ACTION	COMPLETION TIME
A. Calculated air dose from radioactive noble gases in gaseous effluents exceeding any of the limits of 3.4.2.1	A.1 Submit a Special Report to the NRC Regional Office Regional Administrator that identifies causes for exceeding limits, defines corrective actions that have been taken to reduce the releases, and proposed corrective actions to be taken to assure that subsequent releases will be in compliance with the limits.	30 days

4.4.2 SURVEILLANCE REQUIREMENTS

SURVEILLANCE REQUIREMENT	FREQUENCY
4.4.2.1 Determine cumulative dose contributions for noble gases for the current calendar quarter and current calendar year in accordance with the methodology and parameters described in the ODCM.	31 days

3/4.4.3 DOSE FROM IODINE -131, IODINE -133, TRITIUM, AND RADIOACTIVE MATERIALS IN PARTICULATE FORM

3.4.3 CONTROLS

3.4.3.1 The dose to a MEMBER OF THE PUBLIC from iodine-131, iodine-133, tritium and all radionuclides in particulate form with half-lives > 8 days in gaseous effluents released to areas at and beyond the SITE BOUNDARY (FIGURE 1-1) shall be limited to the following:

- a. ≤ 7.5 mrem to any organ during any calendar quarter; and
- b. ≤ 15 mrem to any organ during any calendar year.

APPLICABILITY: At all times.

ACTIONS

CONDITION	REQUIRED ACTION	COMPLETION TIME
A. Calculated dose from the release of iodine-131, iodine-133, tritium and radionuclides in particulate form, with half-lives > 8 days in gaseous effluents exceeding any of the limits of 3.4.3.1	A.1 Submit a Special Report to the NRC Regional Office Regional Administrator that identifies causes for exceeding limits, defines corrective actions that have been taken to reduce the releases, and proposed corrective actions to assure that subsequent releases will be in compliance with the limits.	30 days

4.4.3 SURVEILLANCE REQUIREMENTS

SURVEILLANCE REQUIREMENT	FREQUENCY
4.4.3.1 Determine cumulative dose contributions for the current calendar quarter and calendar year for iodine-131, iodine-133, tritium, and radionuclides in particulate form with half-lives greater than 8 days in accordance with the methodology and parameters in the ODCM.	31 days

3/4.4.4 GASEOUS RADWASTE (OFFGAS) TREATMENT SYSTEM

3.4.4 CONTROLS

3.4.4.1 The GASEOUS RADWASTE (Offgas) TREATMENT SYSTEM shall be in operation.

APPLICABILITY: Whenever the main condenser steam jet air ejector (SJAE) system is in operation.

ACTIONS

CONDITION	REQUIRED ACTION	COMPLETION TIME
A. Gaseous radwaste from the main condenser air ejector system being discharged without treatment for more than 7 days.	A.1 Submit a Special Report to the NRC Regional Office Regional Administrator that includes non-functional equipment or subsystem identification and non-functionality reason, actions taken to restore the non-functional equipment to FUNCTIONAL status, and summary description of actions taken to prevent a recurrence.	30 days

4.4.4 SURVEILLANCE REQUIREMENTS

SURVEILLANCE REQUIREMENT	FREQUENCY
-----NOTE-----	
When placing the Offgas Treatment System in the charcoal bypass mode, the alarm setpoints for the Station HVAC Exhaust and the Post-Treatment Offgas radiation monitors may be calculated to account for the increased fractions of short-lived noble gases. The noble gas release fractions shall be based either on actual measured values or on design basis noble gas concentration fractions (30-minute delay) in the primary coolant offgas.	
4.4.4.1 Verify the GASEOUS RADWASTE (Offgas) TREATMENT SYSTEM is in operation when the main condenser air ejector system is in use.	12 hours

3/4.4.5 VENTILATION EXHAUST TREATMENT SYSTEM

3.4.5 CONTROLS

3.4.5.1 The appropriate portions of the VENTILATION EXHAUST TREATMENT SYSTEM (VETS) shall:

- a. Be FUNCTIONAL
- b. Be used to reduce the radioactive materials in gaseous waste prior to their discharge when the projected doses due to gaseous effluent releases at and beyond the SITE BOUNDARY (see FIGURE 1-1) would exceed 0.3 mrem to any organ in a 31-day period.

APPLICABILITY: At all times, other than when the VETS is undergoing routine maintenance.

ACTIONS

CONDITION	REQUIRED ACTION	COMPLETION TIME
A. Gaseous waste being discharged without treatment and in excess of the limit of 3.4.5.1.	A.1 Submit a Special Report to the NRC Regional Office Regional Administrator that includes an explanation of why gaseous radwaste was being discharged without treatment, non-functional equipment or subsystem identification and non-functionality reason, actions taken to restore the non-functional equipment to FUNCTIONAL status, and summary description of actions taken to prevent a recurrence.	30 days

#### 4.4.5 SURVEILLANCE REQUIREMENTS

SURVEILLANCE REQUIREMENT	FREQUENCY
4.4.5.1 Determine projected doses due to gaseous releases to UNRESTRICTED AREAS in accordance with the ODCM methodology when the VETS is not in use.	31 days
4.4.5.2 Demonstrate the Ventilation Exhaust Treatment System FUNCTIONALITY by meeting the requirements of Controls 3.4.1, 3.4.2, and 3.4.3.	N/A

3/4.5 TOTAL DOSE

3.5 CONTROLS – Total Dose

3.5.1 The annual (calendar year) dose or dose commitment to any MEMBER OF THE PUBLIC due to releases of radioactivity, radiation from uranium fuel cycle, and ISFSI sources shall be limited to

- a.  $\leq 25$  mrem to the total body;
- b.  $\leq 75$  mrem to the thyroid, or
- c.  $\leq 25$  mrem to any other organ.

APPLICABILITY: At all times.

ACTIONS

CONDITION	REQUIRED ACTION	COMPLETION TIME
A. Calculated doses from the release of radioactive materials in liquid or gaseous effluents exceeding twice the limits of 3.3.2.1, 3.4.2.1, or 3.4.3.1.	A.1 Determine if the limits of 3.5.1 have been exceeded via calculation, including direct radiation contributions from the reactor unit and outside storage tanks.	Immediately
B. Dose limits of 3.5.1 items a, b or c has been exceeded.	B.1 Submit a Special Report to the NRC Regional Office Regional Administrator, as defined in 10CFR20.2203(4), that defines the corrective action to be taken to reduce subsequent releases to prevent recurrence of exceeding the limits and includes the schedule for achieving conformance with the limits, estimates of each individual's dose, the levels of radiation and concentrations of radioactive material involved, the cause of the elevated exposures, dose rates, or concentrations, ALARA constraints, generally applicable environmental standards, and associated license conditions.	30 days



## 4.5.1 SURVEILLANCE REQUIREMENTS

SURVEILLANCE REQUIREMENT	FREQUENCY
4.5.1.1 Determine cumulative dose contributions from liquid and gaseous effluents in accordance with the methodology and parameters described or specified in the ODCM (see note below)	Under conditions as specified in 3.5.1 ACTIONS A or B
4.5.1.2 Determine cumulative dose contributions from direct radiation from the reactor, from radwaste storage tanks, and ISFSI in accordance with the methodology and parameters described or specified in the ODCM (see note below).	Under conditions as specified in 3.5.1 ACTIONS A or B.

NOTE: The total body and organ doses resulting from liquid effluents will be summed with the doses resulting from gaseous effluents (including non-noble gases) and the doses to the maximum exposed individual from other operations of the uranium fuel cycle. The effluent doses will be based upon releases from CPS during the previous three quarters and from the quarter in which the 3.5.1 Control requirement was exceeded.

3/4.6 RADIOLOGICAL ENVIRONMENTAL MONITORING PROGRAM

3.6 CONTROLS

3.6.1 The Radiological Environmental Monitoring Program (REMP) shall be conducted as specified in Table 4.6-1.

APPLICABILITY: At all times.

ACTIONS

CONDITION	REQUIRED ACTION	COMPLETION TIME
A. REMP not being conducted as specified in Table 4.6-1.	A.1 Prepare and submit to the NRC, in the Annual Radiological Environmental Operating Report required by Technical Specification 5.6.2, a description of the reasons for not conducting the program as required and the plans for preventing a recurrence.	Submittal of next Annual Radiological Environmental Operating Report

CONDITION	REQUIRED ACTION	COMPLETION TIME
<p>B. Level of radioactivity in an environmental sampling medium exceeds the reporting levels of TABLE 4.6-2 when averaged over any calendar quarter.</p> <p><u>OR</u></p> <p>More than one radionuclide in TABLE 4.6-2 is detected in the sampling medium,</p> <p style="text-align: center;"><u>AND</u></p> $\frac{C_1}{RL_1} + \frac{C_2}{RL_2} + \dots \geq 1.0$ <p>Where: C = concentration RL = reporting level.</p> <p><u>OR</u></p> <p>Radionuclides other than those in Table 4.6-2 are detected,</p> <p style="text-align: center;"><u>AND</u></p> <p>The potential annual dose to a MEMBER OF THE PUBLIC is greater than or equal to the calendar year limits of 3.3.2, 3.4.2, or 3.4.3</p> <p><u>AND</u></p> <p><u>Is the result of plant effluents.</u></p>	<p>B.1 Submit a Special Report to the NRC Regional Office Regional Administrator that identifies the cause(s) for exceeding the limits and defines the corrective actions to be taken to reduce radioactive effluents so that the potential annual dose to a MEMBER OF THE PUBLIC is less than the calendar year reporting level of 3.3.2, 3.4.2, or 3.4.3. The methodology and parameters used to estimate the potential annual dose to a MEMBER OF THE PUBLIC shall be indicated in this report.</p>	<p>Within 30 days</p>

CONDITION	REQUIRED ACTION	COMPLETION TIME
<p>C. Level of radioactivity in an environmental sampling medium exceeds the reporting levels of TABLE 4.6-2 when averaged over any calendar quarter.</p> <p><u>OR</u></p> <p>More than one radionuclide in TABLE 4.6-2 is detected in the sampling medium,</p> <p><u>AND</u></p> $\frac{C_1}{RL_1} + \frac{C_2}{RL_2} + \dots \geq 1.0$ <p>where; C = concentration RL = reporting level.</p> <p><u>OR</u></p> <p>Radionuclides other than those in Table 4.6-2 are detected,</p> <p><u>AND</u></p> <p>The potential annual dose to a MEMBER OF THE PUBLIC is greater than or equal to the calendar year limits of 3.3.2, 3.4.2, or 3.4.3</p> <p><u>AND</u></p> <p><u>Is NOT the result of plant effluents.</u></p>	<p>C.1 Describe the condition in the Annual Radiological Environmental Operation Report.</p>	<p>As part of the next Annual Radiological Environmental Operating Report.</p>

CONDITION	REQUIRED ACTION	COMPLETION TIME
<p>D. Milk or fresh, leafy vegetation samples from one or more of the sample locations required by Table 4.6-1 unavailable.</p>	<p>D.1 Identify locations for obtaining replacement samples and add them to the REMP.</p> <p><u>AND</u></p>	<p>30 days</p>
	<p>D.2 Delete the specific locations from which samples were unavailable from the REMP.</p> <p><u>AND</u></p>	<p>30 days</p>
	<p>D.3 Pursuant to Technical Specification 5.5.1, identify the cause of the sample unavailability, identify the new location(s) for obtaining samples, and include revised figures and tables for the ODCM reflecting the new location(s) in the next Annual Radiological Environmental Operating Report.</p>	<p>As part of the next Annual Radiological Environmental Operating Report</p>

#### 4.6 SURVEILLANCE REQUIREMENTS

SURVEILLANCE REQUIREMENT	FREQUENCY
4.6.1 Collect REMP samples pursuant to Table 4.6-1 from the specific locations given in Table 4.6-1 and ODCM Figures 6-1 through 6-4 and analyze per Table 4.6-1 to the detection capabilities required by Table 4.6-3.	In accordance Table 4.6-1.

TABLE 4.6-1  
RADIOLOGICAL ENVIRONMENTAL MONITORING PROGRAM  
Page 1 of 10

EXPOSURE PATHWAY AND/OR SAMPLE	NUMBER OF REPRESENTATIVE SAMPLES AND SAMPLE LOCATIONS <sup>a</sup>	SAMPLING AND COLLECTION FREQUENCY	TYPE AND FREQUENCY OF ANALYSIS																																																			
1. DIRECT RADIATION <sup>b</sup>	40 routine monitoring stations either with two or more dosimeters or with one instrument for measuring and recording dose rate continuously, placed as follows:  (1) an inner ring of stations, one in each meteorological sector in the general area of the SITE BOUNDARY;	Quarterly	Gamma dose quarterly																																																			
	<table border="1"> <thead> <tr> <th data-bbox="569 629 741 707">SECTOR</th> <th data-bbox="741 629 913 707">CODE</th> <th data-bbox="913 629 1199 707">DISTANCE from station (miles)</th> </tr> </thead> <tbody> <tr><td>N</td><td>CL-36</td><td>0.6</td></tr> <tr><td>NNE</td><td>CL-5</td><td>0.7</td></tr> <tr><td>NE</td><td>CL-22</td><td>0.6</td></tr> <tr><td>ENE</td><td>CL-23</td><td>0.5</td></tr> <tr><td>E</td><td>CL-24</td><td>0.5</td></tr> <tr><td>ESE</td><td>CL-42</td><td>2.8</td></tr> <tr><td>SE</td><td>CL-43</td><td>2.8</td></tr> <tr><td>SSE</td><td>CL-44</td><td>2.3</td></tr> <tr><td>S</td><td>CL-45</td><td>2.8</td></tr> <tr><td>SSW</td><td>CL-46</td><td>2.8</td></tr> <tr><td>SW</td><td>CL-47</td><td>3.3</td></tr> <tr><td>WSW</td><td>CL-48</td><td>2.3</td></tr> <tr><td>W</td><td>CL-1</td><td>1.8</td></tr> <tr><td>WNW</td><td>CL-34</td><td>0.8</td></tr> <tr><td>NW</td><td>CL-35</td><td>0.7</td></tr> <tr><td>NNW</td><td>CL-63</td><td>1.3</td></tr> </tbody> </table>	SECTOR	CODE	DISTANCE from station (miles)	N	CL-36	0.6	NNE	CL-5	0.7	NE	CL-22	0.6	ENE	CL-23	0.5	E	CL-24	0.5	ESE	CL-42	2.8	SE	CL-43	2.8	SSE	CL-44	2.3	S	CL-45	2.8	SSW	CL-46	2.8	SW	CL-47	3.3	WSW	CL-48	2.3	W	CL-1	1.8	WNW	CL-34	0.8	NW	CL-35	0.7	NNW	CL-63	1.3		
SECTOR	CODE	DISTANCE from station (miles)																																																				
N	CL-36	0.6																																																				
NNE	CL-5	0.7																																																				
NE	CL-22	0.6																																																				
ENE	CL-23	0.5																																																				
E	CL-24	0.5																																																				
ESE	CL-42	2.8																																																				
SE	CL-43	2.8																																																				
SSE	CL-44	2.3																																																				
S	CL-45	2.8																																																				
SSW	CL-46	2.8																																																				
SW	CL-47	3.3																																																				
WSW	CL-48	2.3																																																				
W	CL-1	1.8																																																				
WNW	CL-34	0.8																																																				
NW	CL-35	0.7																																																				
NNW	CL-63	1.3																																																				

TABLE 4.6-1  
RADIOLOGICAL ENVIRONMENTAL MONITORING PROGRAM  
Page 2 of 10

EXPOSURE PATHWAY AND/OR SAMPLE	NUMBER OF REPRESENTATIVE SAMPLES AND SAMPLE LOCATIONS <sup>a</sup>	SAMPLING AND COLLECTION FREQUENCY	TYPE AND FREQUENCY OF ANALYSIS
1. DIRECT RADIATION <sup>b</sup> (continued)	(2) an outer ring of stations, one in each meteorological sector in the 6 to 8 km (3.7 miles to 5.0 miles) range from the site;		

SECTOR	CODE	DISTANCE from station (miles)
N	CL-76	4.6
NNE	CL-77	4.5
NE	CL-78	4.8
ENE	CL-79	4.5
E	CL-53	4.3
ESE	CL-54	4.6
SE	CL-55	4.1
SSE	CL-56	4.1
S	CL-57	4.6
SSW	CL-58	4.3
SW	CL-60	4.5
WSW	CL-61	4.5
W	CL-80	4.1
WNW	CL-81	4.5
NW	CL-51	4.4
NNW	CL-52	4.3



TABLE 4.6-1  
RADIOLOGICAL ENVIRONMENTAL MONITORING PROGRAM  
Page 3 of 10

EXPOSURE PATHWAY AND/OR SAMPLE	NUMBER OF REPRESENTATIVE SAMPLES AND SAMPLE LOCATIONS <sup>a</sup>	SAMPLING AND COLLECTION FREQUENCY	TYPE AND FREQUENCY OF ANALYSIS
1. DIRECT RADIATION <sup>b</sup> (continued)	(3) the balance of the stations to be placed in special interest areas such as population centers, nearby residences, schools, and in 1 or 2 areas to serve as control stations.		

SECTOR	CODE	DISTANCE from station (miles)
N	CL-37	3.4
N	CL-75	0.9
ENE	CL-65	2.6
E	CL-41	2.4
S (control)	CL-11	16
W	CL-49	3.5
W	CL-74	1.9
WNW	CL-64	2.1

TABLE 4.6-1  
RADIOLOGICAL ENVIRONMENTAL MONITORING PROGRAM  
Page 4 of 10

EXPOSURE PATHWAY AND/OR SAMPLE	NUMBER OF REPRESENTATIVE SAMPLES AND SAMPLE LOCATIONS <sup>a</sup>	SAMPLING AND COLLECTION FREQUENCY	TYPE AND FREQUENCY OF ANALYSIS
2. AIRBORNE			
Radioiodine and Particulates	<p>Samples from 5 locations:</p> <p>a. 3 samples from close to the 3 SITE BOUNDARY locations in different sectors of the highest calculated annual average ground-level D/Q.</p>	Continuous sampler operations with sample collection weekly, or more frequently if required by dust loading.	<p><u>Radioiodine Canister</u>: I-131 analysis weekly.</p> <p><u>Particulate Sampler</u>: Gross beta radioactivity analysis following filter change<sup>d</sup>; Gamma isotopic analysis<sup>e</sup> of composite (by location) quarterly.</p>

SECTOR	CODE	DISTANCE from station (miles)
NNE	CL-2	0.7
NE	CL-3	0.7
N	CL-15	0.9

b. 1 sample from the vicinity of a community having the highest calculated annual average ground-level D/Q.		
---	--	--

SECTOR	CODE	DISTANCE from station (miles)
E	CL-8	2.2

TABLE 4.6-1  
RADIOLOGICAL ENVIRONMENTAL MONITORING PROGRAM  
Page 5 of 10

EXPOSURE PATHWAY AND/OR SAMPLE	NUMBER OF REPRESENTATIVE SAMPLES AND SAMPLE LOCATIONS <sup>a</sup>	SAMPLING AND COLLECTION FREQUENCY	TYPE AND FREQUENCY OF ANALYSIS
2. AIRBORNE			
(continued)	c. 1 sample from a control location, as for example 15-30 km (9.3 miles to 18.6 miles) distant and in the least prevalent wind direction <sup>c</sup> .		

SECTOR	CODE	DISTANCE from station (miles)
S (control)	CL-11	16

3. WATERBORNE			
a. Surface <sup>f</sup>	1 sample upstream 1 sample downstream	Composite sample over 1 month period <sup>g</sup>	Gamma isotopic analysis <sup>e</sup> monthly. Composite for tritium analysis quarterly.

SECTOR	CODE	DISTANCE from station (miles)
ENE (upstream)	CL-91	6.1
SE (downstream)	CL-90	0.4

TABLE 4.6-1  
RADIOLOGICAL ENVIRONMENTAL MONITORING PROGRAM  
Page 6 of 10

EXPOSURE PATHWAY AND/OR SAMPLE	NUMBER OF REPRESENTATIVE SAMPLES AND SAMPLE LOCATIONS <sup>a</sup>			SAMPLING AND COLLECTION FREQUENCY	TYPE AND FREQUENCY OF ANALYSIS
3. WATERBORNE (continued)					
b. Ground	Samples from 1 or 2 sources, only if likely to be affected <sup>h</sup> .			Quarterly	Gamma isotopic <sup>e</sup> and tritium analysis quarterly.
	SECTOR	CODE	DISTANCE from station (miles)		
	E	CL-12	1.6*		
	ESE	CL-7D	2.3		
	*Sample location is in pump station distant from well. Well located 1.0 mile S of plant on the edge of the lake.				
c. Drinking	1 sample of each of 1 to 3 of the nearest water supplies that could be affected by its discharge.*  *No municipal or public drinking water supplies are taken from Clinton Lake or downstream for 200 miles. Drinking water for Clinton Power Station is supplied by Clinton Lake.			Composite sample over 2-week period <sup>g</sup> when I-131 analysis is performed, monthly composite otherwise.	I-131 analysis on each composite when the dose calculated for the consumption of the water is greater than 1 mrem per year <sup>l</sup> . Composite for gross beta and gamma isotopic analyses <sup>e</sup> monthly. Composite for tritium analysis quarterly.
	SECTOR	CODE	DISTANCE from station (miles)		
	WNW	CL-14	within Service Building		
	1 sample from a control location**				
	**No control location necessary				

TABLE 4.6-1  
RADIOLOGICAL ENVIRONMENTAL MONITORING PROGRAM  
Page 7 of 10

EXPOSURE PATHWAY AND/OR SAMPLE	NUMBER OF REPRESENTATIVE SAMPLES AND SAMPLE LOCATIONS <sup>a</sup>	SAMPLING AND COLLECTION FREQUENCY	TYPE AND FREQUENCY OF ANALYSIS						
3. WATERBORNE (continued)									
d. Sediment from shoreline	1 sample from downstream area with existing or potential recreational value.	Semiannually	Gamma isotopic analysis <sup>e</sup> semiannually.						
	<table border="1"> <thead> <tr> <th>SECTOR</th> <th>CODE</th> <th>DISTANCE from station (miles)</th> </tr> </thead> <tbody> <tr> <td>SE</td> <td>CL-7B</td> <td>2.1</td> </tr> </tbody> </table>	SECTOR	CODE	DISTANCE from station (miles)	SE	CL-7B	2.1		
SECTOR	CODE	DISTANCE from station (miles)							
SE	CL-7B	2.1							
4. INGESTION									
a. Milk	Samples from milking animals in 3 locations within 5-km distance having the highest dose potential. If there are none, 1 sample from milking animals in each of 3 areas between 5 to 8 km distant where doses are calculated to be in greater than 1 mrem per year <sup>k</sup> . *	Semimonthly when animals are on pasture, monthly at other times	Gamma isotopic <sup>e</sup> and I-131 analysis semimonthly when animals are on pasture; monthly at other times.						
*This sample requirement is checked annually as part of the annual land use survey.									

TABLE 4.6-1  
RADIOLOGICAL ENVIRONMENTAL MONITORING PROGRAM  
Page 8 of 10

EXPOSURE PATHWAY AND/OR SAMPLE	NUMBER OF REPRESENTATIVE SAMPLES AND SAMPLE LOCATIONS <sup>a</sup>			SAMPLING AND COLLECTION FREQUENCY	TYPE AND FREQUENCY OF ANALYSIS
4. INGESTION (continued)					
a. Milk (continued)	1 sample from milking animals at a control location, 15-30 km (9.3 miles to 18.6 miles) distant and in the least prevalent wind direction <sup>(c)</sup> .				
	SECTOR	CODE	DISTANCE from station (miles)		
	WSW (control)	CL-116	14		
b. Fish and Invertebrates	1 sample each of 3 important species (such as bass, crappie, carp, or bluegill) in vicinity of plant discharge area.			Sample in season, or semiannually if they are not seasonal	Gamma isotopic analysis <sup>e</sup> on edible portions.
	SECTOR	CODE	DISTANCE from station (miles)		
	E	CL-19	3.4		
	1 sample of same species in areas not influenced by plant discharge.				
	SECTOR	CODE	DISTANCE from station (miles)		
	S (control)	CL-105	50		

TABLE 4.6-1  
RADIOLOGICAL ENVIRONMENTAL MONITORING PROGRAM  
Page 9 of 10

EXPOSURE PATHWAY AND/OR SAMPLE	NUMBER OF REPRESENTATIVE SAMPLES AND SAMPLE LOCATIONS <sup>a</sup>	SAMPLING AND COLLECTION FREQUENCY	TYPE AND FREQUENCY OF ANALYSIS												
4. INGESTION (continued)															
c. Food Products	1 sample of each principal class of food products from any area that is irrigated by water in which liquid plant wastes have been discharged.*	At time of harvest <sup>j</sup>	Gamma isotopic analysis <sup>e</sup> on edible portion.												
*No known usage of Salt Creek water for irrigation in DeWitt, Logan, Menard, or Cass Counties. This information is checked annually as part of the land use survey.															
	Samples of 3 different kinds of broad leaf vegetation (such as lettuce, cabbage, and Swiss chard) grown nearest each of two different offsite locations of highest predicted annual average ground-level D/Q if milk sampling is not performed.	Monthly during growing season.	Gamma isotopic <sup>e</sup> and I-131 analysis.												
	<table border="1"> <thead> <tr> <th>SECTOR</th> <th>CODE</th> <th>DISTANCE from station (miles)</th> </tr> </thead> <tbody> <tr> <td>NE</td> <td>CL-115</td> <td>0.7</td> </tr> <tr> <td>N</td> <td>CL-117</td> <td>0.9</td> </tr> <tr> <td>NNE</td> <td>CL-118</td> <td>0.7</td> </tr> </tbody> </table>	SECTOR	CODE	DISTANCE from station (miles)	NE	CL-115	0.7	N	CL-117	0.9	NNE	CL-118	0.7		
SECTOR	CODE	DISTANCE from station (miles)													
NE	CL-115	0.7													
N	CL-117	0.9													
NNE	CL-118	0.7													
	1 sample of each of the similar broad leaf vegetation grown 15-30 km (9.3 miles to 18.6 miles) distant in the least prevalent wind direction <sup>(c)</sup> if milk sampling is not performed.	Monthly during growing season	Gamma isotopic <sup>e</sup> and I-131												
	<table border="1"> <thead> <tr> <th>SECTOR</th> <th>CODE</th> <th>DISTANCE from station (miles)</th> </tr> </thead> <tbody> <tr> <td>SSE (Control)</td> <td>CL-114</td> <td>12.5</td> </tr> </tbody> </table>	SECTOR	CODE	DISTANCE from station (miles)	SSE (Control)	CL-114	12.5								
SECTOR	CODE	DISTANCE from station (miles)													
SSE (Control)	CL-114	12.5													

TABLE 4.6-1  
RADIOLOGICAL ENVIRONMENTAL MONITORING PROGRAM  
Page 10 of 10  
TABLE NOTATIONS

- a. Refer to NUREG-0133, "Preparation of Radiological Effluent Technical Specifications for Nuclear Power Plants," October 1978, and to Radiological Assessment Branch Technical Position, Revision 1, November 1979. Deviations are permitted from the required sampling schedule if specimens are unobtainable due to hazardous conditions, seasonal unavailability, malfunction of automatic sampling equipment and other legitimate reasons. If specimens are unobtainable due to sampling equipment malfunction, every effort shall be made to complete corrective action prior to the end of the next sampling period. All deviations from the sampling schedule shall be documented in the Annual Radiological Environmental Operating Report pursuant to Technical Specification 5.6.2. It is recognized that, at times, it may not be possible or practicable to continue to obtain samples of the media of choice at the most desired location or time. In these instances suitable alternative media and locations may be chosen for the particular pathway in question and appropriate substitutions made within 30 days in the radiological environmental monitoring program given in the ODCM. Pursuant to Technical Specification 5.5.1, identify the cause of the unavailability of samples for that pathway and identify the new location(s) for obtaining replacement samples in the next annual Radiological Environmental Operating Report and also include in the report a revised figure(s) and table for the ODCM reflecting the new location(s).
- b. One or more instruments, such as a pressurized ion chamber, for measuring and recording dose rate continuously may be used in place of, or in addition to, integrating dosimeters. For the purposes of this table, a dosimeter is considered one detection instrument; two or more detection instruments in a packet are considered as two or more dosimeters. Film badges shall not be used as dosimeters for measuring direct radiation. The 40 stations is not an absolute number. The number of direct radiation monitoring stations may be reduced according to geographical limitations; e.g., at an ocean site, some sectors will be over water so that the number of dosimeters may be reduced accordingly. The frequency of analysis or readout for dosimeter systems will depend upon the characteristics of the specific system used and should be selected to obtain optimum dose information with minimal fading.
- c. The purpose of this sample is to obtain background information. If it is not practical to establish control locations in accordance with the distance and wind direction criteria, other sites that provide valid background data may be substituted.
- d. Airborne particulate sample filters shall be analyzed for gross beta radioactivity 24 hours or more after sampling to allow for radon and thoron daughter decay. If gross beta activity in air particulate samples is greater than ten times the yearly mean of control samples, gamma isotopic analysis shall be performed on the individual samples.
- e. Gamma isotopic analysis means the identification and quantification of gamma-emitting radionuclides that may be attributable to the effluents from the facility.
- f. The "upstream sample" shall be taken at a distance beyond significant influence of the discharge. The "downstream" sample shall be taken in an area beyond but near the mixing zone. "Upstream" samples in an estuary must be taken far enough upstream to be beyond the plant influence.
- g. A composite sample is one in which the quantity (aliquot) of liquid sampled is proportional to the quantity of flowing liquid (or time) and in which the method of sampling employed results in a specimen that is representative of the liquid flow. In this program composite sample aliquots shall be collected at time intervals that are very short (e.g., hourly) relative to the compositing period (e.g., monthly) in order to assure obtaining a representative sample.
- h. Groundwater samples shall be taken when this source is tapped for drinking or irrigation purposes in areas where the hydraulic gradient or recharge properties are suitable for contamination.
- i. The dose shall be calculated for the maximum organ and age group, using the methodology and parameters in the ODCM.
- j. If harvest occurs more than once a year, sampling shall be performed during each discrete harvest. If harvest occurs continuously, sampling shall be monthly. Attention shall be paid to including samples of tuberous and root food products.
- k. The dose shall be calculated for the maximum organ and age group, using the methodology and parameters in the ODCM.
- l. Where access to green leafy vegetables from private gardens is not possible, non-edible plants with similar leaf characteristics from the same vicinity may be substituted.



TABLE 4.6-2  
REPORTING LEVELS FOR RADIOACTIVITY CONCENTRATIONS IN ENVIRONMENTAL SAMPLES

ANALYSIS	WATER (pCi/l)	AIRBORNE PARTICULATE OR GASES (pCi/m <sup>3</sup> )	FISH (pCi/kg, wet)	MILK (pCi/l)	FOOD PRODUCTS (pCi/kg, wet)
H-3	20,000*				
Mn-54	1,000		30,000		
Fe-59	400		10,000		
Co-58	1,000		30,000		
Co-60	300		10,000		
Zn-65	300		20,000		
Zr-Nb-95	400***				
I-131	2**	0.9		3	100
Cs-134	30	10	1,000	60	1,000
Cs-137	50	20	2,000	70	2,000
Ba-La-140	200***			300	

\* For drinking water samples. This is 40CFR Part 141 value. If no drinking water pathway exists, a value of 30,000 pCi/l may be used.

\*\* If no drinking water pathway exists, a value of 20 pCi/l may be used.

\*\*\* Total for parent and daughter.

TABLE 4.6-3  
DETECTION CAPABILITIES FOR ENVIRONMENTAL SAMPLE ANALYSIS<sup>a</sup>  
LOWER LIMIT OF DETECTION (LLD)<sup>b,c</sup>  
Page 1 of 2

ANALYSIS	WATER (pCi/l)	AIRBORNE PARTICULATE OR GAS (pCi/m <sup>3</sup> )	FISH (pCi/kg, wet)	MILK (pCi/l)	FOOD PRODUCTS (pCi/kg, wet)	SEDIMENT (pCi/kg, dry)
Gross beta	4	0.01				
H-3	2000*					
Mn-54	15		130			
Fe-59	30		260			
Co-58,60	15		130			
Zn-65	30		260			
Zr-95	30					
Nb-95	15					
I-131	1**	0.07		1	60	
Cs-134	15	0.05	130	15	60	150
Cs-137	18	0.06	150	18	80	180
Ba-140	60			60		
La-140	15			15		

\* If no drinking water pathway exists, a value of 3000 pCi/l may be used.

\*\* If no drinking water pathway exists, a value of 15 pCi/l may be used.

TABLE 4.6-3  
DETECTION CAPABILITIES FOR ENVIRONMENTAL SAMPLE ANALYSIS<sup>a</sup>  
LOWER LIMIT OF DETECTION (LLD)<sup>b,c</sup>  
Page 2 of 2

TABLE NOTATIONS

- a. This list does not mean that only these nuclides are to be considered. Other peaks that are identifiable, together with those of the above nuclides, shall also be analyzed and reported in the Annual Radiological Environmental Operating Report pursuant to Technical Specification 5.6.2.
- b. Required detection capabilities for dosimeters used for environmental measurements shall be in accordance with the recommendations of Regulatory Guide 4.13, Rev. 1, July 1977.
- c. The LLD is defined, for purposes of these specifications, as the smallest concentration of radioactive material in a sample that will yield a net count, above system background, that will be detected with 95% probability with only 5% probability of falsely concluding that a blank observation represents a "real" signal.

For a particular measurement system, which may include radiochemical separation:

$$LLD = \frac{4.66S_b}{E \cdot V \cdot 2.22 \cdot Y \cdot e^{(-\lambda\Delta t)}}$$

- Where:
- LLD is the "a priori" lower limit of detection as defined above, as picocuries per unit mass or volume,
  - S<sub>b</sub> is the standard deviation of the background counting rate or of the counting rate of a blank sample as appropriate, as counts per minute,
  - E is the counting efficiency, as counts per disintegration,
  - V is the sample size in units of mass or volume,
  - 2.22 is the number of disintegrations per minute per picocurie,
  - Y is the fractional radiochemical yield, when applicable,
  - λ is the radioactive decay constant for the particular radionuclide (sec<sup>-1</sup>), and
  - Δt for environmental samples is the elapsed time between sample collection, or end of the sample collection period, and time of counting (sec).
- Typical values of E, V, Y, and Δt should be used in the calculation.

It should be recognized that the LLD is defined as an a priori (before the fact) limit representing the capability of a measurement system and not as an a posteriori (after the fact) limit for a particular measurement. Analyses shall be performed in such a manner that the stated LLDs will be achieved under routine conditions. Occasionally background fluctuations, unavoidable small sample sizes, the presence of interfering nuclides, or other uncontrollable circumstances may render these LLDs unachievable. In such cases, the contributing factors shall be identified and described in the Annual Radiological Environmental Operating Report pursuant to Technical Specification 5.6.2.

3/4.7 LAND USE CENSUS

3.7 CONTROLS

3.7.1 A Land Use Census shall be conducted and shall identify within a distance of 8 km (5 miles) the location in each of the 16 meteorological sectors of the nearest milk animal, the nearest residence, the nearest garden<sup>(1)</sup> of greater than 50m<sup>2</sup> (500 ft<sup>2</sup>) producing broad leaf vegetation. The Land Use Census shall also identify within a distance of 5 km (3.1 miles) for elevated or mixed-mode releases, as defined in Regulatory Guide 1.111, the locations in each of the 16 meteorological sectors of all milk animals and all gardens of greater than 50m<sup>2</sup> producing broad leaf vegetation. The land use census will also identify the nearest resident to the ISFSI.

Broad leaf vegetation sampling of at least three different kinds of vegetation may be performed at the SITE BOUNDARY in each of two different sectors with the highest predicted D/Qs in lieu of the garden census. Requirements for broad leaf sampling in Table 4.6-1 Item 4.c shall be followed, including analysis of control samples.

APPLICABILITY: At all times.

ACTIONS

CONDITION	REQUIRED ACTION	COMPLETION TIME
A. Land use census identifies a location that yields a calculated dose or dose commitment that is greater than the values currently being calculated in 0.1.	A.1 Identify the new location(s) in the Radioactive Effluent Release Report pursuant to Technical Specification 5.6.3.	As part of the next Radioactive Effluent Release Report



#### 4.7 SURVEILLANCE REQUIREMENTS

SURVEILLANCE REQUIREMENT	FREQUENCY
4.7.1 Conduct the land use census during the growing season using that information that will provide the best results, such as by a door-to-door survey, aerial survey, or by consulting local agriculture authorities.	12 months
4.7.2 Include the Land Use Census results in the annual Radiological Environmental Operating Report pursuant to Technical Specification 5.6.2.	As part of the next annual Radiological Environmental Operating Report.

3/4.8 INTER-LABORATORY COMPARISON PROGRAM

3.8 CONTROLS

3.8.1 Analyses shall be performed on radioactive materials supplied as part of an Interlaboratory Comparison Program that corresponds to samples required by Table 4.6-1.

APPLICABILITY: At all times.

ACTIONS

CONDITION	REQUIRED ACTION	COMPLETION TIME
A. Analyses of 3.8.1 not being performed.	A.1 Report corrective actions taken to prevent a recurrence to the NRC in the Annual Radiological Environmental Operating Report pursuant to Technical Specification 5.6.2.	As part of next Annual Radiological Environmental Operating Report.

4.8 SURVEILLANCE REQUIREMENTS

SURVEILLANCE REQUIREMENT	FREQUENCY
4.8.1 Include a summary of the Interlaboratory Comparison Program results obtained in the Annual Radiological Environmental Operating Report pursuant to Technical Specification 5.6.2.	As part of next Annual Radiological Environmental Operating Report.

3/4.9 METEOROLOGICAL MONITORING PROGRAM (NOT USED)



5.0 BASES

5.0.1 Control and Surveillance Requirements (3/4.0)

The requirements of 3.0 and 4.0 provide general requirements applicable to each of the Controls and Surveillance Requirements specified within 3.1 through 3.8.

5.0.1.1 The requirement of 3.0.1 is provided to emphasize when each Control is applicable and when the associated ACTION should be met.

5.0.1.2 Item 3.0.2 and related items define those conditions necessary to constitute compliance with the terms of an individual Control and associated ACTION.

5.0.1.3 The requirement of 4.0.1 provides that surveillance activities, necessary to ensure the Controls are met, will be performed during the conditions for which the Controls are applicable. Some surveillance activities may be required to be performed without regard to the applicable conditions specified in the associated Control.

5.0.1.4 The provisions of 4.0.2 provide allowable tolerances for performing surveillance activities beyond those specified in the nominal surveillance interval. These tolerances are necessary to provide operational flexibility because of scheduling and performance considerations. The phrase "at least" associated with a surveillance frequency does not negate this allowable tolerance; instead, it permits the more frequent performance of surveillance activities.

The tolerance values, taken either individually or consecutively over three test intervals, are sufficiently restrictive to ensure that the reliability associated with the surveillance activity is not significantly degraded beyond that obtained from the nominal specified interval.

5.0.1.5 The provisions of 4.0.3 set forth the criteria for determination of compliance with the FUNCTIONALITY requirements of the Controls. Under these criteria, equipment, systems, or components are assumed to be FUNCTIONAL if the associated surveillance activities have been satisfactorily performed within the specified time interval. Nothing in this provision is to be construed as defining equipment, systems or components FUNCTIONAL, when such items are found or known to be non-functional although still meeting the Surveillance Requirements.

5.0.2 Adjustment of the CPS ODCM Methodology

Consistent with the NRC Commissioners' opinion on 10CFR50 Appendix I dated April 30, 1975; CPS will use environmental monitoring data to improve dose calculational models and to request CPS ODCM changes on the basis of such operating experience data. Such adjustments are recognized as being especially important for the radioiodine-milk pathway where conservative regulatory guide assumptions have been made. By using environmental monitoring data, uncertainties associated with plume behavior, radioiodine chemical form, deposition and retention of forages, and milk consumption patterns may be circumvented or reduced.

## 5.1 RADIOACTIVE LIQUID EFFLUENT MONITORING INSTRUMENTATION (3/4.1)

The radioactive liquid effluent instrumentation is provided to monitor and control, as applicable, the releases of radioactive materials in liquid effluents during actual or potential releases of liquid effluents. The alarm/trip setpoints for these instruments shall be calculated and adjusted in accordance with the methodology and parameters in this manual to ensure that the alarm/trip will occur prior to exceeding the limits of 10CFR Part 20. The FUNCTIONALITY and use of this instrumentation is consistent with the requirements of General Design Criteria 60, 63 and 64 of Appendix A to 10CFR Part 50.

## 5.2 RADIOACTIVE GASEOUS EFFLUENT MONITORING INSTRUMENTATION (3/4.2)

### 5.2.1 Offgas Radiation Monitoring Instrumentation (3/4.2.1)

The FUNCTIONALITY of the radiation monitoring instrumentation ensures that; (1) the radiation levels are continually measured in the areas served by the individual channels; (2) the alarm or automatic action is initiated when the radiation level trip setpoint is exceeded; and (3) sufficient information is available on selected plant parameters to monitor and assess these variables following an accident. This capability is consistent with 10CFR Part 50, Appendix A, General Design Criteria 19, 60, 61, 63 and 64.

### 5.2.2 Radioactive Gaseous Effluent Monitoring Instrumentation (3/4.2.2)

The radioactive gaseous effluent instrumentation is provided to monitor and control, as applicable, the release of radioactive materials in gaseous effluents during actual or potential releases of gaseous effluents. The alarm/trip setpoints for these instruments shall be calculated and adjusted in accordance with the methodology and parameters in this manual to ensure that the alarm/trip will occur prior to exceeding the limits of 10CFR Part 20. The FUNCTIONALITY and use of this instrumentation is consistent with the requirements of General Design Criteria 60, 63 and 64 of Appendix A to 10CFR Part 50. The sensitivity of any noble gas activity monitors used to show compliance with the gaseous effluent release requirements of 3.4.2 shall be such that concentrations as low as  $1 \times 10^{-6}$   $\mu\text{Ci/ml}$  are measurable.

## 5.3 LIQUID RADWASTE EFFLUENTS (3/4.3)

### 5.3.1 Liquid Effluent Concentration (3/4.3.1)

This requirement is provided to ensure that the concentration of radioactive materials released in liquid waste effluents to UNRESTRICTED AREAS will be less than ten times the concentration levels specified in 10CFR Part 20, Appendix B, Table 2, Column 2. This limitation provides additional assurance that the levels of radioactive materials in bodies of water in UNRESTRICTED AREAS will result in exposures within (1) the Section II.A design objectives of Appendix I, 10CFR Part 50, to a MEMBER OF THE PUBLIC and (2) the limits of 10CFR Part 20.1301 to the population. The concentration limit for dissolved or entrained noble gases is based

upon the assumption that Xe-135 is the controlling radioisotope and its ECL in air (submersion) was converted to an equivalent concentration in water using the methods described in International Commission on Radiological Protection (ICRP) Publication 2.

This requirement applies to the release of radioactive materials in liquid effluents from the site.

The required detection capabilities for radioactive materials in liquid waste samples are tabulated in terms of the lower limits of detection (LLDs). Detailed discussion of the LLD, and other detection limits can be found in Currie, L. A., "Lower Limit of Detection: Definition and Elaboration of a Proposed Position for Radiological Effluent and Environmental Measurements," NUREG/CR-4007 (September 1984), and in the HASL Procedures Manual, HASL-300.

### 5.3.2 Dose from Liquid Effluents (3/4.3.2)

This requirement is provided to implement the requirements of Sections II.A, III.A and IV.A of Appendix I, 10CFR Part 50. The Control implements the guides set forth in Section II.A of Appendix I. The quarterly limits specified in the CONTROLS represent one-half of the annual design objective of Section II.A of 10CFR50, Appendix I. The ACTION statements provide the required operating flexibility and at the same time implement the guides set forth in Section IV.A of Appendix I to assure that the releases of radioactive material in liquid effluents to UNRESTRICTED AREAS will be kept "as low as is reasonably achievable." Also, for fresh water sites with drinking water supplies that can be potentially affected by plant operations, there is reasonable assurance that the operation of the facility will not result in radionuclide concentrations in the finished drinking water that are in excess of the requirements of 40CFR Part 141. The dose calculation methodology and parameters in this manual implement the requirements in Section III.A of Appendix I that conformance with the guides of Appendix I be shown by calculational procedures based on models and data, such that the actual exposure of a MEMBER OF THE PUBLIC through appropriate pathways is unlikely to be substantially underestimated. The equations specified in this manual for calculating the doses due to the actual release rates of radioactive materials in liquid effluents are consistent with the methodology provided in Regulatory Guide 1.109, "Calculation of Annual Doses to Man from Routine Releases of Reactor Effluents for the Purpose of Evaluating Compliance with 10CFR Part 50, Appendix I," Revision 1, October 1977 and Regulatory Guide 1.113, "Estimating Aquatic Dispersion of Effluents from Accidental and Routine Reactor Releases for the Purpose of Implementing Appendix I," April 1977.

This requirement applies to the release of radioactive materials in liquid effluents from the one reactor unit on the site.

### 5.3.3 Liquid Radwaste Treatment Systems (3/4.3.3)

The FUNCTIONALITY of the liquid radwaste treatment system ensures that this system will be available for use whenever liquid effluents require treatment prior to

release to the environment. The requirement that the appropriate portions of this system be used when specified, provides assurance that the releases of radioactive materials in liquid effluents will be kept "as low as is reasonably achievable." This specification implements the requirements of 10CFR Part 50.36a, General Design Criterion 60 of Appendix A to 10CFR Part 50 and the design objective given in Section II.D of appendix I to 10CFR Part 50. The specified limits governing the use of appropriate portions of the liquid radwaste treatment system were specified as a suitable fraction of the dose design objectives set forth in Section II.A of Appendix I, 10CFR Part 50, for liquid effluents.

This requirement applies to the release of radioactive materials in liquid effluents from the one reactor unit on the site.

#### 5.4 RADIOACTIVE GASEOUS EFFLUENTS (3/4.4)

##### 5.4.1 Gaseous Effluent Dose Rates (3/4.4.1)

This requirement is provided to ensure that the dose at any time at and beyond the SITE BOUNDARY from gaseous effluents from all units on the site will be within the annual dose limits of 10CFR Part 20 to UNRESTRICTED AREAS. The annual dose limits are the doses associated with the concentrations of 10CFR Part 20, Appendix B, Table 2, Column 1. These limits provide reasonable assurance that radioactive material discharged in gaseous effluents will not result in the exposure of a MEMBER OF THE PUBLIC in an UNRESTRICTED AREA, either within or outside the SITE BOUNDARY, to annual average concentrations exceeding the limits specified in Appendix B, Table 2 of 10CFR Part 20. For MEMBERS OF THE PUBLIC who may at times be within the SITE BOUNDARY, the occupancy of that MEMBER OF THE PUBLIC will usually be sufficiently low to compensate for any increase in the atmospheric diffusion factor above that for the SITE BOUNDARY. Examples of such MEMBERS OF THE PUBLIC, with the appropriate occupancy factors, shall be given in this manual. Doses for such MEMBERS OF THE PUBLIC are provided in the Radioactive Effluent Release Report. The specified release rate limits restrict, at all times, the corresponding gamma and beta dose rates above background to a MEMBER OF THE PUBLIC, at or beyond the SITE BOUNDARY, to less than or equal to 500 mrem/year to the whole body or to less than or equal to 3000 mrem/year to the skin. These release rate limits also restrict, at all times, the corresponding thyroid dose rate above background to a child via the inhalation pathway to less than or equal to 1500 mrem/year.

This requirement applies to the release of radioactive materials in gaseous effluents from the one reactor unit on the site.

The required detection capabilities for radioactive materials in gaseous waste samples are tabulated in terms of the lower limits of detection (LLDs). Detailed discussion of the LLD, and other detection limits can be found in Currie, L. A., "Lower Limit of Detection: Definition and Elaboration of a Proposed Position for Radiological Effluent and Environmental Measurements," NUREG/CR-4007 (September 1984), and in the HASL Procedures Manual, HASL-300.

#### 5.4.2 Dose from Noble Gases (3/4.4.2)

This requirement is provided to implement the requirements of Sections II.B, III.A and IV.A of Appendix I, 10CFR Part 50. The Control implements the guides set forth in Section II.B of Appendix I. The ACTION statements provide the required operating flexibility and at the same time implement the guides set forth in Section IV.A of Appendix I to assure that the releases of radioactive material in gaseous effluents to UNRESTRICTED AREAS will be kept "as low as is reasonably achievable." The Surveillance Requirements implement the requirements in Section III.A of Appendix I that conformance with the guides of Appendix I be shown by calculational procedures based on models and data such that the actual exposure of a MEMBER OF THE PUBLIC through appropriate pathways is unlikely to be substantially underestimated. The dose calculation methodology and parameters established in this manual for calculating the doses due to the actual release rates for radioactive noble gases in gaseous effluents are consistent with the methodology provided in Regulatory Guide 1.109, "Calculation of Annual Doses to Man from Routine Releases of Reactor Effluents for the Purpose of Evaluating Compliance with 10CFR Part 50, Appendix I," Revision 1, October 1977 and Regulatory Guide 1.111, "Methods for Estimating Atmospheric Transport and Dispersion of Gaseous Effluents in Routine Releases from Light-Water Cooled Reactors" Revision 1, July 1977.

This requirement applies to the release of radioactive materials in gaseous effluents from the site.

#### 5.4.3 Dose from Iodine-131, Iodine-133, Tritium and Radioactive Materials in Particulate Form (3/4.4.3)

This requirement is provided to implement the requirements of Sections II.C, III.A and IV.A of Appendix I, 10CFR Part 50. The Control are the guides set forth in Section II.C of Appendix I. The ACTION statements provide the required operating flexibility and at the same time implement the guides set forth in Section IV.A of Appendix I to assure that the releases of radioactive material in gaseous effluents to UNRESTRICTED AREAS will be kept "as low as is reasonably achievable." The calculational methods specified in the Surveillance Requirements implement the requirements in Section III.A of Appendix I that conformance with the guides of Appendix I be shown by calculational procedures based on models and data, such that the actual exposure of a MEMBER OF THE PUBLIC through appropriate pathways is unlikely to be substantially underestimated. The calculational methodology and parameters for calculating the doses due to the actual release rates of the subject materials are consistent with the methodology provided in Regulatory Guide 1.109, "Calculation of Annual Doses to Man from Routine Releases of Reactor Effluents for the Purpose of Evaluating Compliance with 10CFR Part 50, Appendix I," Revision 1, October 1977 and Regulatory Guide 1.111, "Methods for Estimating Atmospheric Transport and Dispersion of Gaseous Effluents in Routine Releases from Light-Water Cooled Reactors" Revision 1, July 1977. These equations also provide for determining the actual doses based upon the annual average atmospheric conditions. The release rate specifications for iodine-131, tritium, and radionuclides in particulate form with half-lives greater than 8 days

are dependent upon the existing radionuclide pathways to man in the areas at and beyond the SITE BOUNDARY. The pathways that were examined in the development of these calculations were: (1) individual inhalation of airborne radionuclides, (2) deposition of radionuclides onto green leafy vegetation with subsequent consumption by man, (3) deposition onto grassy areas where milk animals and meat producing animals graze with consumption of the milk and meat by man, and (4) deposition on the ground with subsequent exposure of man.

This requirement applies to the release of radioactive materials in gaseous effluents from one reactor unit on the site.

#### 5.4.4 Gaseous Radwaste Treatment (Off-Gas) System (3/4.4.4)

The FUNCTIONALITY of the WASTE GAS HOLDUP SYSTEM ensures that the system will be available for use whenever gaseous effluents require treatment prior to release to the environment. The requirement that the appropriate portions of the system be used, when specified, provides reasonable assurance that the releases of radioactive materials in gaseous effluents will be kept "as low as reasonably achievable." This requirement implements the requirements of 10CFR Part 50.36a, General Design Criterion 60 of Appendix A to 10CFR Part 50 and the design objectives given in Section II.D of Appendix I to 10CFR Part 50. The specified limits governing the use of appropriate portions of the systems were specified as a suitable fraction of the dose design objectives set forth in Section II.B and II.C of Appendix I, 10CFR Part 50, for gaseous effluents.

This requirement applies to the release of radioactive materials in gaseous effluents from the one reactor unit on the site.

#### 5.4.5 Ventilation Exhaust Treatment System (3/4.4.5)

The FUNCTIONALITY of the VENTILATION EXHAUST TREATMENT SYSTEM ensures that the system will be available for use whenever gaseous effluents require treatment prior to release to the environment. The requirement that the appropriate portions of the system be used, when specified, provides reasonable assurance that the releases of radioactive materials in gaseous effluents will be kept "as low as reasonably achievable." This requirement implements the requirements of 10CFR Part 50.36a, General Design Criterion 60 of Appendix A to 10CFR Part 50 and the design objectives given in Section II.D of Appendix I to 10CFR Part 50. The specified limits governing the use of appropriate portions of the systems were specified as a suitable fraction of the dose design objectives set forth in Section II.B and II.C of Appendix I, 10CFR Part 50, for gaseous effluents.

This requirement applies to the release of radioactive materials in gaseous effluents from the one reactor unit on the site.

#### 5.5 TOTAL DOSE (3/4.5)

This requirement is provided to meet the dose limitations of 40CFR Part 190 that have been incorporated into 10CFR20.1301, as well as the dose limitations specific

to Independent Spent Fuel Storage Installation (ISFSI) operations in accordance with 10CFR72.104. Over the long term, as more storage modules containing dry shielded canisters of spent fuel are placed on the ISFSI pad, it is expected that ISFSI operations will become the prominent contributor to dose limits in this section. ISFSI dose contribution is in the form of direct radiation as no liquid or gas releases are expected to occur from the ISFSI canisters. The CPS 10CFR72.212 Report prepared in accordance with 10CFR72 requirements assumes a certain array of storage modules exists on the pad. The dose contribution from this array of casks combination with historical uranium fuel cycle operations prior to ISFSI operations was analyzed to be within 40CFR190 and 10CFR72.104 limits, and is documented in Holtec Report No. HI-2135750, Site Boundary Dose Rate Calculations for HI-STORM FW System for Clinton Power Station. The requirement that dose limits of 10CFR72.104 apply to "any real individual" is controlled for ISFSI activities in the ISFSI 72.212 report. Therefore, for the purposes of analyzing dose from the ISFSI, the member of the public as defined in 40CFR190 is the same as the "real individual" identified in the 72.212 report

Dose monitoring requirements of 40CFR190 and 10CFR72.104 may be met through direct measurement (i.e., field dosimeters), determined from survey measurements, or calculated from shielding codes. CPS determines the 40CFR190 dose by the use of field dosimeters maintained and reported on as part of the Radiological Environmental Monitoring Program (REMP). The requirement requires the preparation and submittal of a Special Report whenever the calculated doses from plant generated radioactive effluents and direct radiation exceed 25 mrem to the total body or any organ, except the thyroid, which shall be limited to less than or equal to 75 mrem. For sites containing up to 4 reactors, it is highly unlikely that the resultant dose to a MEMBER OF THE PUBLIC will exceed the dose limits of 40CFR Part 190 if the individual reactors remain within twice the dose design objectives of Appendix I, and if direct radiation doses from the reactor units and outside storage tanks are kept small. The Special Report will describe a course of action that should result in the limitation of the annual dose to a MEMBER OF THE PUBLIC to within the 40CFR Part 190 or 10CFR72.104 limits. For the purposes of the Special Report, it may be assumed that the dose commitment to the MEMBER OF THE PUBLIC from other uranium fuel cycles sources is negligible, with the exception that dose contributions from other nuclear fuel cycle facilities at the same site or within a radius of 8 km must be considered. If the dose to any MEMBER OF THE PUBLIC is estimated to exceed the requirements of 40CFR Part 190 or 10CFR72.104, the Special Report with a request for a variance (provided the release conditions resulting in violation of 40CFR Part 190 or 10CFR72.104 have not already been corrected), in accordance with the provisions of 40CFR Part 190.11, 10CFR72.104 and 10CFR Part 20.2203, is considered to be a timely request and fulfills the requirements of 40CFR Part 190 or 10CFR72.104 until NRC staff action is completed. The variance only relates to the limits of 40CFR Part 190 or 10CFR72.104, and does not apply in any way to the other requirements for dose limitation of 10CFR Part 20, as addressed in 3.3.1 and 3.4.1. An individual is not considered a MEMBER OF THE PUBLIC during any period in which he/she is engaged in carrying out any operation that is part of the nuclear fuel cycle.

The radiological environmental monitoring program required by this requirement provides representative measurements of radiation and of radioactive materials in those exposure pathways and for those radionuclides that lead to the highest potential radiation exposures of MEMBERS OF THE PUBLIC resulting from the station operation. This monitoring program implements Section IV.B.2 of Appendix I to 10CFR Part 50 and thereby supplements the radiological effluent monitoring program by verifying that the measurable concentrations of radioactive materials and levels of radiation are not higher than expected on the basis of the effluent measurements and the modeling of the environmental exposure pathways. Guidance for this monitoring program is provided by the Radiological Assessment Branch Technical Position on Environmental Monitoring, Revision 1, November 1979. The initially specified monitoring program will be effective for at least the first three years of commercial operation. Following this period, program changes may be initiated based on operational experience.

The required detection capabilities for environmental sample analyses are tabulated in terms of the lower limits of detection (LLDs). The LLDs required by TABLE 4.6-3 are considered optimum for routine environmental measurements in industrial laboratories. It should be recognized that the LLD is defined as an a priori (before the fact) limit representing the capability of a measurement system and not as an a posteriori (after the fact) limit for a particular measurement.

Detailed discussion of the LLD, and other detection limits, can be found in Currie, L. A., "Lower Limit of Detection: Definition and Elaboration of a Proposed Position for Radiological Effluent and Environmental Measurements," NUREG/CR-4007 (September 1984), and in the HASL Procedures Manual, HASL-300.

#### 5.7 LAND USE CENSUS (3/4.7)

This requirement is provided to ensure that changes in the use of areas at and beyond the SITE BOUNDARY are identified and that modifications to the radiological environmental monitoring program are made if required by the results of this census. The land use census shall be performed using the best information available (e.g., a door-to-door survey, from aerial surveys, questionnaire, or from consulting with local agricultural authorities). This census satisfies the requirements of Section IV.B.3 of Appendix I to 10CFR Part 50. Restricting the census to gardens of greater than 50 m<sup>2</sup> provides assurance that significant exposure pathways via leafy vegetables will be identified and monitored since a garden of this size is the minimum required to produce the quantity (26 kg/year) of leafy vegetables assumed in Regulatory Guide 1.109 for consumption by a child. To determine this minimum garden size, the following assumptions were made: (1) 20% of the garden was used for growing broad leaf vegetation (i.e., similar to lettuce and cabbage) and (2) a vegetation yield of 2 kg/m<sup>2</sup>.

#### 5.8 INTERLABORATORY COMPARISON PROGRAM (3/4.8)

The requirement for participation in an Interlaboratory Comparison Program is provided to ensure that independent checks on the precision and accuracy of the



measurements of radioactive material in environmental sample matrices are performed as part of the quality assurance program for environmental monitoring in order to demonstrate that the results are valid for the purposes of Section IV.B.2 of Appendix I to 10CFR Part 50.

5.9 METEOROLOGICAL MONITORING PROGRAM (3/4.9 NOT USED)

6.0 REPORTING REQUIREMENTS

6.1 ANNUAL RADIOLOGICAL ENVIRONMENTAL OPERATING REPORT

6.1.1 Routine Radiological Environmental Operating Reports covering the operation of the unit during the previous calendar year shall be submitted by May 1 of each year pursuant to Technical Specification 5.6.2.

6.1.2 The Annual Radiological Environmental Operating Reports shall include the following information:

6.1.2.1 Summaries, interpretations, and an analysis of trends of the results of the radiological environmental surveillance activities for the report period, including a comparison with preoperational studies, with operational controls as appropriate, and with previous environmental surveillance reports, and an assessment of the observed impacts of the plant operation on the environment.

6.1.2.2 The results of land use censuses required by 3.7.

6.1.2.3 Results of analysis of all radiological environmental samples and of all environmental radiation measurements taken during the period pursuant to the locations specified in the Tables and Figures in this manual, as well as summarized and tabulated results of these analyses and measurements in the format of the table in the Radiological Assessment Branch Technical Position, Revision 1, November 1979. In the event that some individual results are not available for inclusion with the report, the report shall be submitted noting and explaining the reasons for the missing results. The missing data shall be submitted as soon as possible in a supplementary report.

6.1.2.4 A summary description of the radiological environmental monitoring program.

6.1.2.5 At least two legible maps covering all sample locations keyed to a table giving distances and directions from the HVAC stack. One map shall cover stations near the SITE BOUNDARY and a second map shall include the more distant stations.

6.1.2.6 The results of licensee participation in the Interlaboratory Comparison Program, required by 3.8.

6.1.2.7 Discussion of all deviations from the sampling schedule of Table 4.6-1.

6.1.2.8 Discussion of all analysis in which the LLD required by TABLE 4.6-3 was not achievable.

6.2 RADIOACTIVE EFFLUENT RELEASE REPORT

6.2.1 Routine Radioactive Effluent Release Reports covering the operations of the unit during the previous calendar year of operation shall be submitted by May 1 of each year pursuant to Technical Specification 5.6.3.

6.2.2 The Radioactive Effluent Release Report shall include the following information:

6.2.2.1 A summary of the quantities of radioactive liquid and gaseous effluents and solid waste released from the unit as outlined in Regulatory Guide 1.21, "Measuring, Evaluating, and Reporting Radioactivity in Solid Wastes and Releases of Radioactive Materials in Liquid and Gaseous Effluents from Light-Water-Cooled Nuclear Power Plants, Revision 1, June 1974, with data summarized on a quarterly basis following the format of Appendix B thereof. For solid wastes, the format for Table 3 in Appendix B shall be supplemented with 3 additional categories: class of solid wastes (as defined by 10CFR Part 61), type of container (e.g., LSA, Type A, Type B, Large Quantity), and SOLIDIFICATION agent or absorbent (e.g., cement, urea formaldehyde).

6.2.2.2 The following information for each class of solid waste (as defined by 10CFR Part 61) shipped offsite during the report period:

- a. Total container volume,
- b. Total curie quantity (specify whether determined by measurement or estimate),
- c. Principal radionuclides (specify whether determined by measurement or estimate),
- d. Source of waste and processing employed (e.g., dewatered spent resin, compacted dry waste, evaporator bottoms).

6.2.2.3 A list and description of unplanned releases from the site to UNRESTRICTED AREAS of radioactive materials in gaseous and liquid effluents made during the reporting period.

6.2.2.4 A listing of new locations for dose calculations and/or environmental monitoring identified by the land use census pursuant to 3.7.

6.2.2.5 Changes to the ODCM pursuant to Technical Specification 5.5.1.

6.2.2.6 Major changes to radioactive liquid, gaseous, and solid waste treatment systems. Licensees may choose to submit the information called for in this requirement as part of its annual USAR update. Changes described by this requirement shall become effective upon review by the Plant Operations Review Committee (PORC). The discussion of each change shall contain.

- a. A summary of the evaluation that led to the determination that the change could be made in accordance with 10CFR Part 50.59.
- b. Sufficient detailed information to totally support the reason for the change without benefit of additional or supplemental information;

- c. A detailed description of the equipment, components and processes involved and the interfaces with other plant systems;
- d. An evaluation of the change, which shows the predicted releases of radioactive materials in liquid and gaseous effluents and/or quantity of solid waste that differ from those previously predicted in the license application and amendments thereto;
- e. An evaluation of the change, which shows the expected minimum exposures to a MEMBER OF THE PUBLIC in the UNRESTRICTED AREA and to the general population that differ from those previously estimated in the license application and amendments thereto;
- f. A comparison of the predicted releases of radioactive materials, in liquid and gaseous effluents and in solid waste, to the actual releases for the period prior to when the changes are to be made;
- g. An estimate of the exposure to plant operating personnel as a result of the change; and
- h. Documentation of the fact that the change was reviewed and found acceptable by the PORC.

6.2.2.7 An annual summary of hourly meteorological data collected over the previous year. This annual summary may be either in the form of an hour-by-hour listing on magnetic tape of wind speed, wind direction, atmospheric stability, and precipitation (if measured), or in the form of joint frequency distributions of wind speed, wind direction, and atmospheric stability.

6.2.2.8 An assessment of the radiation doses due to the radioactive liquid and gaseous effluents released from the unit or station during the previous calendar year. Beta and gamma air dose due to the release of noble gas in gaseous effluents is calculated at the CPS site boundary in each of the 16 geographical directions surrounding CPS. Dose due to the release of radioactive iodines and particulates in gaseous effluents is calculated at the critical receptor location in each of the 16 geographical sectors surrounding CPS to a distance of 5 miles. Dose summaries based on these calculations are provided in the Radioactive Effluent Release Report.

6.2.2.9 An assessment of the radiation doses from radioactive liquid and gaseous effluents to MEMBERS OF THE PUBLIC due to their activities inside the SITE BOUNDARY (FIGURE 1-1) during the report period.

NOTE: All assumptions used in making the following assessments, i.e., specific activity, exposure time and location, shall be included in these reports. Annual average meteorological conditions or meteorological conditions concurrent with the time of release of radioactive materials in gaseous effluents, as determined by sampling frequency and measurements, may be used for determining the gaseous pathway doses. The assessment of radiation doses shall be performed in accordance with the methodology and parameters in this manual.

- 6.2.2.10 An assessment of radiation doses to the likely most exposed MEMBER OF THE PUBLIC from reactor releases and other nearby uranium fuel cycle sources, including doses from primary effluent pathways and direct radiation, for the previous calendar year to show conformance with 40CFR Part 190, Environmental Radiation Protection Standards for Nuclear Power Operation and 10CFR72.104, Criteria for radioactive materials in effluents and direct radiation from an ISFSI or MPS.

Acceptable methods for calculating the dose contribution from liquid and gaseous effluents are given in Regulatory Guide 1.109, Rev. 1, October 1977.

**PART II – METHODOLOGY AND PARAMETERS**

**OFFSITE DOSE CALCULATION MANUAL**

**CLINTON POWER STATION**

1.0 GENERAL INFORMATION

1.1 INTRODUCTION

The Clinton Power Station OFFSITE DOSE CALCULATION MANUAL (CPS-ODCM) provides the methodologies and parameters to be used by Clinton Power Station to assure compliance with the radioactive effluent dose limitations stated in 10CFR20, 10CFR50 Appendix A (General Design Criteria 60 and 64), 10CFR50 Appendix I, 40CFR190, and 10CFR72.

The CPS-ODCM was prepared based on guidance provided in NUREG-0133, Preparation of Radiological Effluent Technical Specifications for Nuclear Power Plants (October 1978), and NUREG-0473, Radiological Effluent Technical Specifications for Boiling Water Reactors (Draft 7, to Revision 3). This manual along with station procedures will be used by CPS personnel to demonstrate compliance with the above referenced Federal Regulations.

Changes to the CPS-ODCM shall be provided in the Radioactive Effluent Release Report.

1.2 MCR ARPR LAN

The MCR ARPR LAN is the means whereby data is transmitted from the ARPR monitors to the central collection equipment. ARPR monitor instrumentation consists of 0RM34J AR/PR Monitor on 1CX16J and 0RM32J AR/PR Monitor on 1H13-P864.

The communication requirements for the MCR ARPR LAN will be satisfied if communication is verified at either the 1CC16J terminal or the 1H13-P864 terminal with either terminal being designated as the Master Terminal.

2.0 RADIOACTIVE LIQUID SYSTEM EFFLUENT MONITORING SYSTEM

2.1 LIQUID RADWASTE DISCHARGE PROCESS RADIATION MONITORING (PRM) INSTRUMENTATION

This monitoring subsystem measures liquid radwaste effluent radioactivity prior to the effluent joining plant service water and circulating water dilution streams. A high radioactivity signal from this gamma scintillation detector automatically terminates the liquid radwaste effluent release. The liquid radwaste effluent flow, variable from 10-60 GPM or 50-300 GPM, combines with Plant Service Water flow (minimum flow approximately 2000 GPM during plant shutdown periods depending on system loads) and Plant Circulating Water flow (0-567,000 GPM) in the Seal Well prior to entering the 3.4-mile discharge flume to Lake Clinton (see Figure 2-1).

2.1.1 Liquid Radwaste Discharge PRM Setpoints

To comply with Part I RECS Sections 3.1.1 and 3.3.1, the alarm/trip setpoints for liquid effluent monitors and flow measurement devices are set to assure that the following equation is satisfied:

$$cf/(F + f) \leq ECL \tag{2-1}$$

- Where: ECL = the Effluent Concentration Limit (Part I RECS Section 3.3.1) implementing 10 times the effluent concentration limit of 10CFR20, Appendix B, Table 2, Column 2 and corresponding to the specific mix of radionuclides in the effluent stream being considered, in  $\mu\text{Ci/ml}$ . For dissolved or entrained noble gases, the concentration is limited to  $2.00\text{E-}04 \mu\text{Ci/ml}$ .
- c = the setpoint, in  $\mu\text{Ci/ml}$ , of the radioactivity monitor measuring the radioactivity concentration in the effluent line prior to dilution and subsequent release; the setpoint is inversely proportional to the volumetric flow of the effluent line and proportional to the volumetric flow of the dilution stream(s) plus the effluent stream.
- F = the dilution water flow setpoints as determined at the Seal Well, in volume per unit time
- f = the liquid radwaste discharge flow setpoint as determined at the liquid radwaste discharge PRM location, in volume per unit time (same units as F)

The available dilution water flow (F) should be constant for a given release, and the liquid radwaste tank discharge flow (f) and monitor setpoint (c) are set to meet the condition of equation (2-1) for a given effluent concentration (ECL). The method by which this is accomplished is illustrated in sections 2.1.1.1 through 2.1.1.5.



### 2.1.1.1 Liquid Radwaste Tank Isotopic Concentration

The isotopic concentration for a liquid radwaste tank to be discharged is obtained from the sum of the measured concentrations as determined by the analyses required in Part I RECS Table 4.3.1-1:

$$\sum_i C_i = \sum_g C_g + \sum_a C_a + \sum_s C_s + C_T + C_{Fe}, \mu\text{Ci/ml} \quad (2-2)$$

- Where:
- $\sum_g C_g$  = The sum of concentrations  $C_g$  of each measured gamma emitter g (including I-131) observed by gamma spectroscopy of the waste sample,  $\mu\text{Ci/ml}$ .
  - $\sum_a C_a$  = The sum of concentrations  $C_a$  of alpha emitters (a) in liquid radwaste as measured in the most current QUARTERLY composite discharge tank sample,  $\mu\text{Ci/ml}$ .
  - $\sum_s C_s$  = The sum of concentrations  $C_s$  of Sr-89/Sr-90 in liquid radwaste as observed in the most current QUARTERLY composite discharge tank sample,  $\mu\text{Ci/ml}$ .
  - $C_T$  = The measured concentration of H-3 in liquid radwaste as determined from analysis of the most current QUARTERLY composite discharge tank sample,  $\mu\text{Ci/ml}$ .
  - $C_{Fe}$  = The measured concentration of Fe-55 in liquid radwaste as observed in the most current QUARTERLY composite discharge tank sample,  $\mu\text{Ci/ml}$ .

### 2.1.1.2 Dilution Factor Calculation

The measured radionuclide concentrations are used to calculate a DILUTION FACTOR (DF) which is equivalent to the ratio of total dilution flow rate to liquid radwaste tank effluent flow rate required to assure that the limiting concentrations specified in Part I RECS Section 3.3.1 are met at the point of discharge to the unrestricted area.

$$D_{req,g} = \frac{\sum_{i=g} \frac{C_i}{ECL_i}}{f \cdot R_{max}}$$

$$D_{req,ng} = \frac{\sum_{i=ng} \frac{C_i}{ECL_i}}{f \cdot R_{max}}$$

$$D_{req} = D_{req,g} + D_{req,ng} \quad (2-3)$$

- Where:
- $D_{req,g}$  = Required dilution factor for gamma emitters
  - $D_{req,ng}$  = Required dilution factor for non-gamma emitters
  - $ECL_i$  = Effluent concentration limit of nuclide i in  $\mu\text{Ci/ml}$  equal to 10

times the values in 10CFR20 Appendix B, Table 2, Column 2 for radionuclides other than dissolved or entrained noble gases. For dissolved or entrained noble gases, the concentration is limited to 2.00E-04  $\mu\text{Ci/ml}$ .

- f = Release point safety factor.  
 $R_{\text{max}}$  = The maximum ECL ratio from the release point setpoint definition.  
 $C_i$  = The concentration of nuclide i in  $\mu\text{Ci/ml}$ .  
 SF = The conservative SAFETY FACTOR, if used, normally applied to compensate for statistical fluctuations and measurement errors, dimensionless.

### 2.1.1.3 Effluent Flow Rate

The maximum permissible liquid radwaste tank effluent flow rate,  $R_{\text{cwmax}}$ , is calculated by the following equation:

$$R_{\text{cwmax}} = \frac{F_{\text{avail}} + (f_{\text{alloc}} \cdot F_{\text{waste}})}{D_{\text{req}}}, \text{ volume/time} \quad (2-4)$$

- Where:  $R_{\text{cwmax}}$  = Maximum waste flow rate  
 $F_{\text{avail}}$  = Minimum expected dilution water flow rate (Circulating and/or Service Water systems), volume/time  
 $f_{\text{alloc}}$  = 0.9 = Flow rate correction factor to provide a 10% margin for variations in flow rates, dimensionless  
 $F_{\text{waste}}$  = Maximum expected liquid radwaste tank effluent flow rate, volume/time  
 $D_{\text{req}}$  = The DILUTION FACTOR calculated by equation (2), dimensionless

Equation (2) is valid only for  $DF \geq 1$ ; for  $DF < 1$ , the liquid radwaste tank effluent concentration meets the limits of Part I RECS Section 3.3.1 without dilution and therefore  $R_{\text{cwmax}}$  may assume any value not to exceed discharge pump capacity.

### 2.1.1.4 Liquid Radwaste Discharge PRM Setpoint

The liquid radwaste discharge PRM setpoint may now be specified based on the values of  $\sum_j C_j$  (Eq. 2-2) and  $R_{\text{cwmax}}$  (Eq. 2) which were determined to provide compliance with the concentration limits of Part I RECS Section 3.3.1. The monitor response is primarily a gamma response and the actual setpoint is therefore based on  $\sum_g C_g$  (Eq. 2-2). The monitor setpoint, in counts per minute (cpm), which corresponds to the particular setpoint concentration,  $S_{\text{max}}$ , is determined based on monitor calibration data or operational data which correlates monitor response to sample analyses associated with the actual liquid radwaste discharged. The use of operational data is considered valid only if the integrity of the laboratory methods of determination are proven more accurate than the monitor data.

The set point concentration,  $S_{max}$ , is obtained by the following equations:

$$S_{adj} = \frac{R_{cw\ max}}{F_{waste}} \quad (2-5)$$

$$S_{max} = S_{adj} * \sum_g C_g \quad (2-6)$$

Where:  $F_{waste}$  = The actual liquid radwaste effluent flow rate, volume/time

$R_{cw\ max}$  and  $F_{waste}$  are defined in section 2.1.1.3.

If  $S_{adj} \geq 1$ , the value obtained for  $S_{max}$  is used to determine the monitor setpoint above background, cpm, from either of the two methods described above. In the case where  $S_{adj} < 1$ , no release may be made using the existing discharge parameter values ( $R_{cw\ max}$ ,  $F_{waste}$ ).

The setpoint concentration is conservative, even if  $R_{cw\ max}$  is attainable, since the calculated flow rate contains the SAFETY FACTOR, dilution flow rate and liquid radwaste tank effluent flow rate margins.

#### 2.1.1.5 Spurious Alarm Prevention

To prevent spurious alarms, revise the Plant Service Water Effluent PRM setpoint to coincide with the setpoint concentration,  $S_{max}$ , calculated by equation (2-). This setpoint is valid only during periods of actual liquid radwaste discharges.

## 2.2 PLANT SERVICE WATER EFFLUENT PRM

### 2.2.1 Plant Service Water Effluent PRM Setpoints

Plant service water effluent continuously releases to the Seal Well where it mixes with circulating water effluent (if present) prior to entering Lake Clinton via the 3.4-mile discharge flume. Anytime water is flowing through the Plant Service Water System, then radioactive effluent monitoring is required. To ensure that Plant Service Water intersystem leakage has not occurred, quarterly Service Water effluent grab samples will be obtained anytime water is flowing through the Plant Service Water System and analyzed to determine the identity and quantity of principal gamma-emitting radionuclides and tritium. In addition, a quarterly composite of positive grab samples will be analyzed to determine the quantity of Sr-89, Sr-90, Fe-55 and gross alpha species released. The analytical Lower Limit of Detection (LLD) for these analyses are specified in Part I RECS Table 4.3-1.

If the quarterly grab sample analysis indicates the presence of contamination above background, PRM setpoints will be established following section 2.1 methodology as follows:

- 2.2.1.1 Perform section 2.1.1.2, solving equation (2) for DF using the appropriate values in the concentration term from the grab sample analysis.

- 2.2.1.2 A modified dilution factor,  $DF_m$ , must be determined so that available dilution flows may be apportioned among simultaneous discharge pathways. The modified dilution factor is defined as:

$$DF_m = DF/F_A \quad (2-7)$$

Where:  $F_A$  = Is an administrative allocation factor which may be assigned any value between 0 and 1 under the condition that

$$\sum_n (F_A)_n \leq 1 \quad (2-8)$$

Where:  $n$  = The number of liquid discharge pathways for which  $DF \geq 1$  and which are planned for simultaneous release. For simplicity,  $F_A$  may be assigned the value  $1/n$ . Calculate  $R_{cwm\max}$  in equation (2) by substituting the value of  $DF_m$  for  $D_{req}$  and perform the calculation specified in section 2.1.1.4 to determine flow rate and PRM setpoints.

## 2.3 SHUTDOWN SERVICE WATER (SX) EFFLUENT PRM

### 2.3.1 Shutdown Service Water (SX) Effluent RPM Setpoints

Shutdown Service Water, when initiated, is a potential continuous radioactive discharge pathway to the Ultimate Heat Sink (UHS) (see Figure 2-2). SX effluent sampling, analysis and setpoint establishment will be performed as discussed for the Plant Service Water system in Section 2.2.

## 2.4 FUEL POOL HEAT EXCHANGER SERVICE WATER EFFLUENT PRM

### 2.4.1 Fuel Pool Heat Exchanger Service Water Effluent PRM Setpoints

The Fuel Pool Heat Exchanger Service Water is normally supplied by the Component Cooling Water (CCW) system (a closed loop system). The Component Cooling Water system rejects heat loads to the Plant Service Water system where radiation from intersystem leakage would be detected as described in section 2.2. Fuel Pool Heat Exchanger Service Water cooling may also be provided from the Safe Shutdown Service Water System (SX), which is not a closed system. Effluent from the SX system is considered a potential radioactive discharge pathway when SX replaces Component Cooling Water as the heat sink for the Fuel Pool heat exchangers. Samples are collected from the Component Cooling Water system on a quarterly basis and analyzed as discussed in section 2.2. This sample allows Component Cooling Water to be analyzed prior to placing the Fuel Pool Heat Exchanger in the SX Cooling mode. This will account for a potential radioactive release to the Ultimate Heat Sink via SX. Discharge monitoring will be performed any time a Fuel Pool Cooling heat exchanger is in service (FC water is flowing through the heat exchanger) AND the heat sink for the FC heat exchanger is being

provided by SX. The analysis results may then be used to establish Fuel Pool Heat Exchanger Service Water PRM and flow rate setpoints following Section 2.2.1.1 and 2.2.1.2 methodology.

Any releases of radioactivity to the environment from the Plant Service Water (except during liquid radwaste discharges), Shutdown Service Water or Fuel Pool Heat Exchanger Service Water Systems are considered abnormal events. Such events will be accounted for as unplanned releases in the Radioactive Effluent Release Report.

## 2.5 COMPONENT COOLING WATER PRM

### 2.5.1 Component Cooling Water PRM Setpoints

The Component Cooling water system is a potential continuous radioactive discharge pathway to the Service Water system due to the Component Cooling water system generally operating at a higher pressure and the potential for heat exchanger tube leaks. Component Cooling provides cooling to components and heat exchangers that carry radioactive fluids or are in areas that could result in radioactive contamination if the components are damaged. Except for the sampling requirement described in 2.4, sampling on this system is done on an as needed basis. The PRM setpoints are established using the methodology in Section 2.22.

FIGURE 2-1  
UNRESTRICTED AREA BOUNDARY FOR LIQUID EFFLUENTS

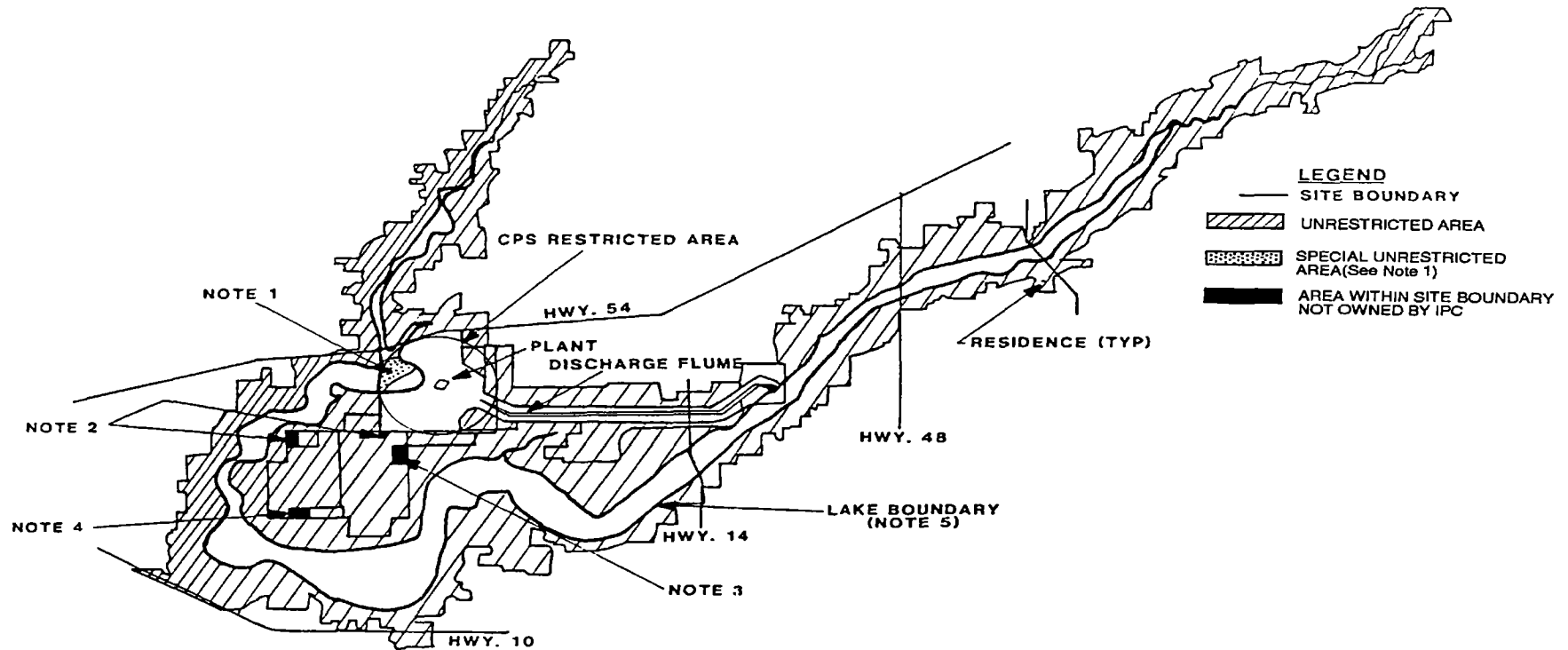

NOTES

1. The Area in the Lake Between the Buoys and the Exclusion Area Boundary Is Unrestricted at this Time. But Will Be Controlled if Plant Effluent Conditions Warrant Closure.
2. Land Parcel Not Owned by Clinton Power Station, Includes Residences.
3. Land Parcel Not Owned by Clinton Power Station, Oil Company Pipeline Pumping Station.
4. Land Parcel Not Owned by Clinton Power Station, Agricultural Use.
5. The Lake Shoreline Is Approximately 690 ft. Msl Elevation Line.

FIGURE 2-2  
LIQUID RADWASTE TREATMENT SYSTEM

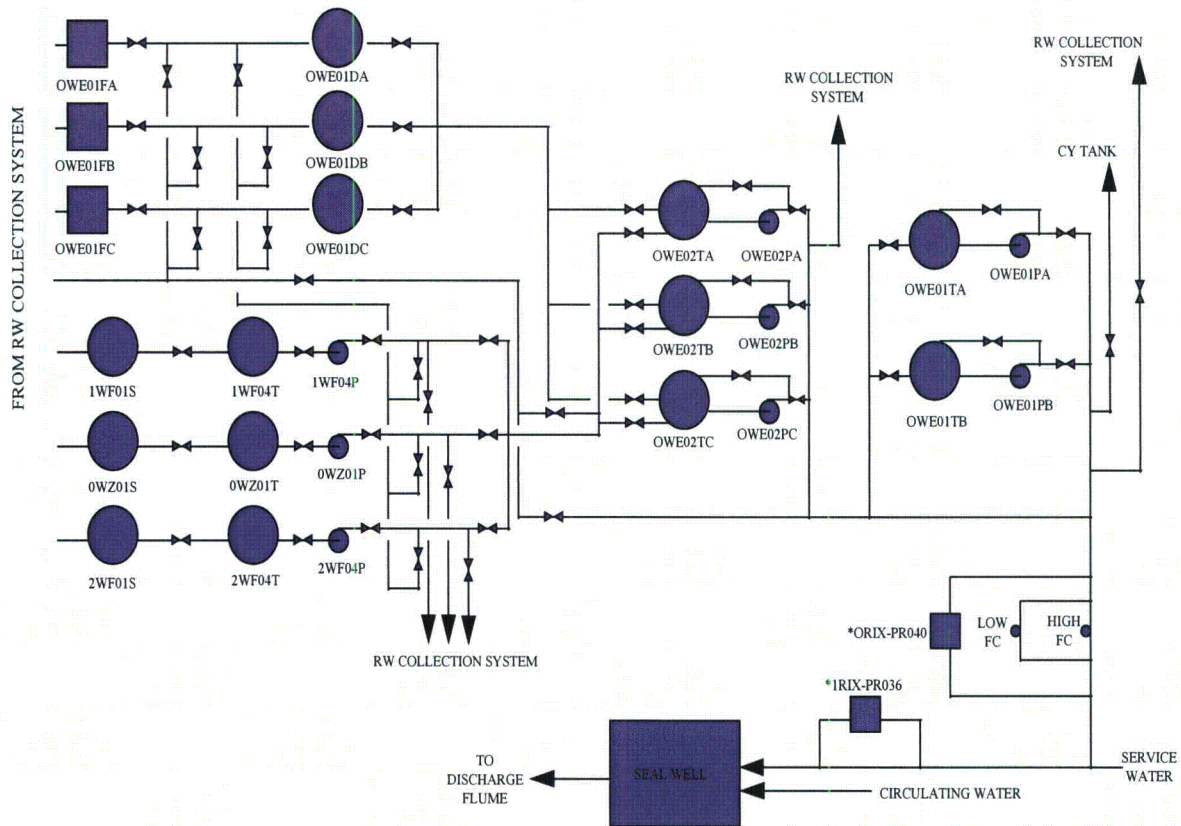

\*Monitors required by Part I RECS Section 3.1.1

1WF01S Floor Drain Evaporator	0WZ01P Chem. Wst. Evap. Tank Pump	2WF04T Floor Drain Evaporator Tank	OWE02PA, B, and C Waste Samp. Tk Pumps
2WF01S Floor Drain Evaporator	OWE01FA, B, and C Waste Filters	0WZ01T Chem. Waste Evaporator Tank	OWE01TA and B Excess Water Tanks
0WZ01S Chemical Waste Evaporator	OWE01DA, B, and C Waste Demins	1WF04P Flr. Drn. Evap. Tank Pump	OWE01PA and B Excess Water Tank Pumps
1WF04T Floor Drain Evaporator Tank	OWE02TA, B, and C Waste Sample Tks.	2WF04P Flr. Drn. Evap. Tank Pump	1PR036 Service Water PRM
			0PR040 Liquid RW Discharge PRM

FIGURE 2-3  
SHUTDOWN AND FUEL POOL HEAT EXCHANGER SERVICE WATER  
EFFLUENT MONITORS

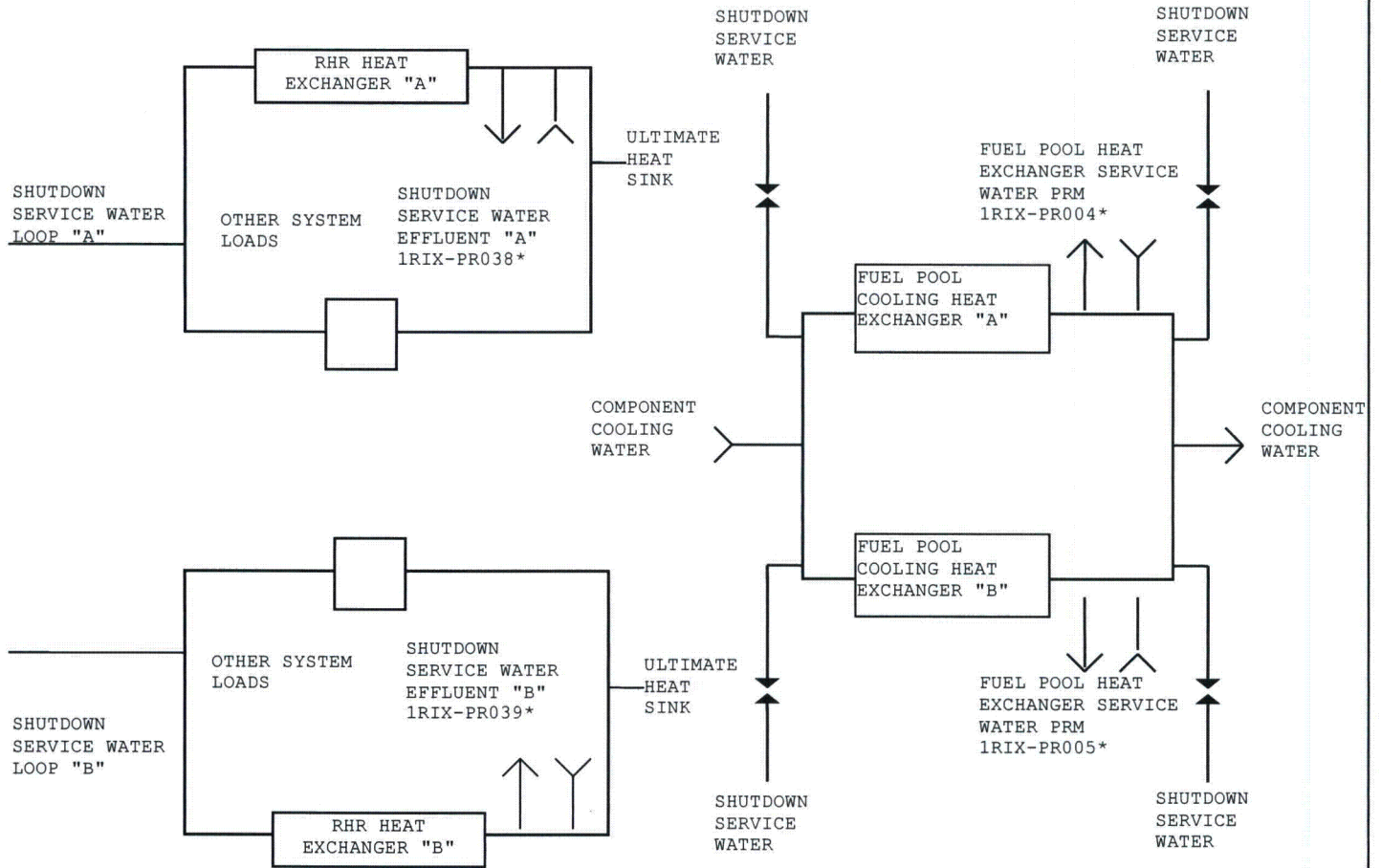

NORMAL COOLING SUPPLY - COMPONENT COOLING WATER  
EMERGENCY COOLING SUPPLY - SHUTDOWN SERVICE WATER

\*Monitors required by Part I RECS Section 3.1.1

1RIX-PR038 Shutdown Service Water Effluent "A"	1RIX-PR005 Fuel Pool Heat Exchanger Service Water PRM
1RIX-PR039 Shutdown Service Water Effluent "B"	1RIX-PR004 Fuel Pool Heat Exchanger Service Water PRM
1RDX-PR037 Component Cooling Water	



FIGURE 2-4  
SOLID RADWASTE SYSTEM  
SIMPLIFIED FLOW DIAGRAM

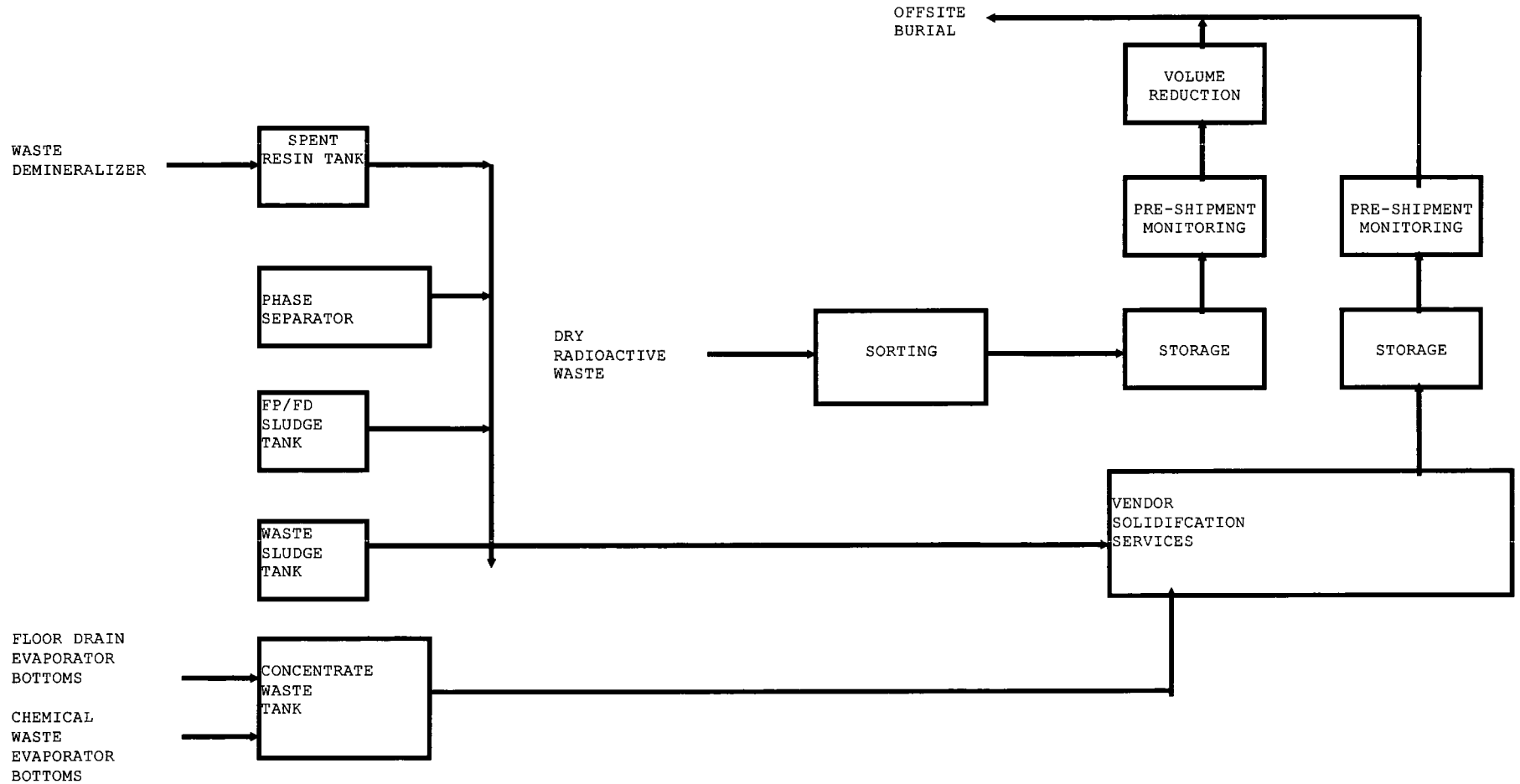

### 3.0 RADIOACTIVE GASEOUS EFFLUENT MONITORING SYSTEM

#### 3.1 HVAC STACK PROCESS RADIATION MONITORING (PRM) INSTRUMENTATION

The HVAC Stack inputs are monitored for radioactivity prior to discharge to the environment by the HVAC Stack PRM. The PRM detector configuration provides effluent monitoring using nine (9) channels as follows:

- a. Beta scintillator for particulates
- b. Alpha surface barrier detector to account for the radon/thoron contribution to the beta particulate measurement
- c. Gamma scintillator for iodine
- d. Iodine background subtraction
- e. Beta scintillator for low range noble gas
- f. Energy-compensated Geiger-Mueller (G-M) detector for high range noble gas
- g. Energy-compensated G-M detector for gamma area subtraction
- h. Sample pressure indication at the HVAC PRM
- i. Sample flow rate indication at the HVAC PRM

This monitor has one control function. Upon detection of activity that exceeds the high alarm setpoint on any channel, a failure of any channel (low or high), loss of AC power to the monitor, or flow failure the HVAC Accident Range PRM (ORIX-PR012) automatically transfers from a "STANDBY" condition to in service. Also, an annunciator alarms in the Main Control Room where proper response actions will be initiated in accordance with CPS procedures.

#### 3.2 SGTS STACK PROCESS RADIATION MONITORING (PRM) INSTRUMENTATION

As is discussed in Part II ODCM Section 5.1, the SGTS is used to reduce post-accident concentrations of radioactivity in the primary and secondary containment via filter trains. The SGTS Stack PRM monitors the gaseous effluent of the filter trains at the SGTS Stack prior to release to the environment. The PRM detector configuration utilizes nine (9) channels as follows:

- a. Beta scintillator for particulates
- b. Gamma scintillator for iodine
- c. Iodine background subtraction

- d. Beta scintillator for low range noble gas
- e. Energy-compensated G-M detector for intermediate range noble gas
- f. Energy-compensated G-M detector for gamma area subtraction
- g. Alpha surface barrier detector to account for the radon/thoron contribution to the beta particulate measurement
- h. Sample pressure indication at the SGTS PRM
- i. Sample flow-rate indication at the SGTS PRM

This monitor has no control function but annunciates in the Main Control Room where proper response actions will be initiated in accordance with CPS procedures.

### 3.3 MAIN CONDENSER OFF-GAS MONITORING INSTRUMENTATION

#### 3.3.1 Pre-Treatment Air Ejector Off-Gas Process Radiation Monitor (PRM)

The Pre-Treatment Off-Gas PRM monitors hydrogen recombiner effluent for gross noble gas radioactivity. This effluent is then routed to the charcoal adsorbers for eventual release to the environment via the station HVAC Stack (see Figure 3-1). The PRM detector configuration consists of a single energy-compensated G-M detector mounted in a gas volume.

The monitor has no control function but annunciates in the Main Control Room where proper response actions will be initiated in accordance with CPS procedures.

#### 3.3.2 Post-Treatment Air Ejector Off-Gas Process Radiation Monitor (PRM)

The Post-Treatment Off-Gas PRM monitors the gaseous radioactivity at upstream, intermediate or downstream sections of the charcoal adsorber beds prior to the effluent entering the station HVAC Stack for release to the environment (see Figure 3-1). The PRM detector configuration is as described for the HVAC Stack PRM System (3.1).

The monitor has two control functions. Upon detection of noble gas activity in excess of the ALERT setpoint, the charcoal adsorber bypass valves shut (if in the charcoal bypass mode) and the off-gas is routed through the adsorbers.

Should noble gas activity exceed the HIGH setpoint, or upon PRM failure, the off-gas system is automatically isolated from the HVAC Stack and a reactor scram may occur if loss of condenser vacuum occurs.

The Main Condenser Off-Gas Treatment System is shown in Figure 3-1.

### 3.4 GASEOUS EFFLUENT MONITOR SETPOINT CALCULATIONS

Gaseous effluent Process Radiation Monitor (PRM) alarm setpoints shall be calculated to ensure that the instantaneous dose rate in unrestricted areas due to noble gases released do not exceed 500 mrem/year to the total body and 3000 mrem/year to the skin. The initial setpoints were calculated using the BWR/GALE code radionuclide mix obtained for CPS; when the actual radionuclide mix can be determined, it will be used for setpoint calculations. The PRM setpoints are based on the instantaneous noble gas dose rates and are applied at the point of which the effluent enters an unrestricted area.

Due to PRM limitations, non-noble gas setpoints will not be implemented to demonstrate compliance with Part I RECS Section 3.4.1(b). Compliance with the organ dose rate limitation is demonstrated during performance of sampling and analysis activities required by Part I RECS Table 4.4.1-1.

Both total body and skin dose setpoints will be calculated and the more restrictive limit applied to the respective PRM. The actual setpoint used may be lower than the restrictive limit since the two release points will be partitioned such that their sum does not exceed 100 percent of the restrictive limit. The percentages used to partition the release points could vary at plant discretion to accommodate plant operational conditions. In no case will the combined releases due to variations in the PRM setpoints result in effluent limits being exceeded.

#### 3.4.1 Total Body Dose Rate Setpoint

The fraction of the total gaseous radioactivity in each gaseous effluent release path  $j$  for each noble gas radionuclide  $i$  shall be determined using the following relationship:

$$f_{ij} = C_{ij}/(\sum_i C_{ij}), \text{ dimensionless} \quad (3-1)$$

Where:  $C_{ij}$  = The measured concentration of identified noble gas radionuclide  $i$  in gaseous effluent release path  $j$ ,  $\mu\text{Ci/cc}$

The maximum acceptable release rate of all noble gases in release path  $j$  to comply with Part I RECS Section 3.4.1 is calculated by using the equation:

$$Q_{Tj} = \frac{500 \cdot F_j}{[(X/Q)_j \cdot \sum_i (K_i f_{ij})]}, \mu\text{Ci/sec} \quad (3-2)$$

Where:  $Q_{Tj}$  = The maximum acceptable release rate of all noble gases in release path  $j$ ,  $\mu\text{Ci/sec}$   
 $F_j$  = Total dose rate allocation factor assigned to release path  $j$  (varying between 0.0 and 1.0), dimensionless  
 500 = Total body dose rate limit specified in Part I RECS Section

- 3.4.1.1(a), mrem/year
- $\overline{(X/Q)}_j$  = The highest calculated average relative concentration of release path j at the site boundary
- $K_i$  = The total body dose factor due to gamma emissions of noble gas radionuclide i as listed in Table B-1 of Regulatory Guide 1.109 and Part II ODCM Table 5-1 of this manual, mrem/yr per  $\mu\text{Ci}/\text{m}^3$
- $f_{ij}$  = The fraction as defined by equation (3-1), dimensionless

The total maximum acceptable concentration setpoint of noble gas radionuclides in release path j is calculated using the following equation:

$$C_{Tj} = Q_{Tj} / R_j, \mu\text{Ci}/\text{cc} \quad (3-3)$$

- Where:  $C_{Tj}$  = The total maximum acceptable concentration setpoint of all noble gases in release path j,  $\mu\text{Ci}/\text{cc}$
- $Q_{Tj}$  = The maximum acceptable release rate of all noble gases in release path j determined from equation (3 - 4),  $\mu\text{Ci}/\text{sec}$
- $R_j$  = The effluent release rate of release point j,  $\text{cc}/\text{sec}$

### 3.4.2 Skin Dose Rate Setpoint

To ensure compliance with the Part I RECS Section 3.4.1(a) skin dose rate limit, PRM setpoints shall be calculated using the methodology presented in Section 3.4.1 and by substituting the following equation for equation (3-1):

$$Q_{sj} = \frac{3000 \cdot F_j}{[\overline{(X/Q)}_j \cdot \sum_i (L_i + 1.1M_i) \cdot f_{ij}]}, \mu\text{Ci}/\text{sec} \quad (3-4)$$

- Where:  $Q_{sj}$  = The maximum acceptable release rate of all noble gases in release path j,  $\mu\text{Ci}/\text{sec}$
- $F_j$  = Total dose rate allocation factor assigned to release path j (varying between 0.0 and 1.0), dimensionless
- 3000 = Skin dose rate limit specified in Part I RECS Section 3.4.1.1(a), mrem/year
- $\overline{(X/Q)}_j$  = The highest calculated average relative concentration of release path j at the site boundary
- $L_i$  = The skin dose factor due to gamma emissions for each identified noble gas radionuclide i, mrem/yr per  $\mu\text{Ci}/\text{m}^3$ , as listed in Part II ODCM Table 5-1 of this manual.
- 1.1 = An air dose to skin dose equivalent conversion factor, mrem/mrad

- $M_i$  = The air dose factor due to gamma emissions for each identified noble gas radionuclide  $i$ , mrad/yr per  $\mu\text{Ci}/\text{m}^3$ , as listed in Part II ODCM Table 5-1 of this manual
- $f_{ij}$  = The fraction defined by equation (3-1)

The calculated total body and skin maximum acceptable concentration setpoints are compared and the more restrictive setpoint used. A safety factor may also be applied to the concentration setpoint calculated by equation (3-2) to compensate for statistical fluctuations and measurement errors.

FIGURE 3-1  
MAIN CONDENSER OFF-GAS TREATMENT SYSTEM

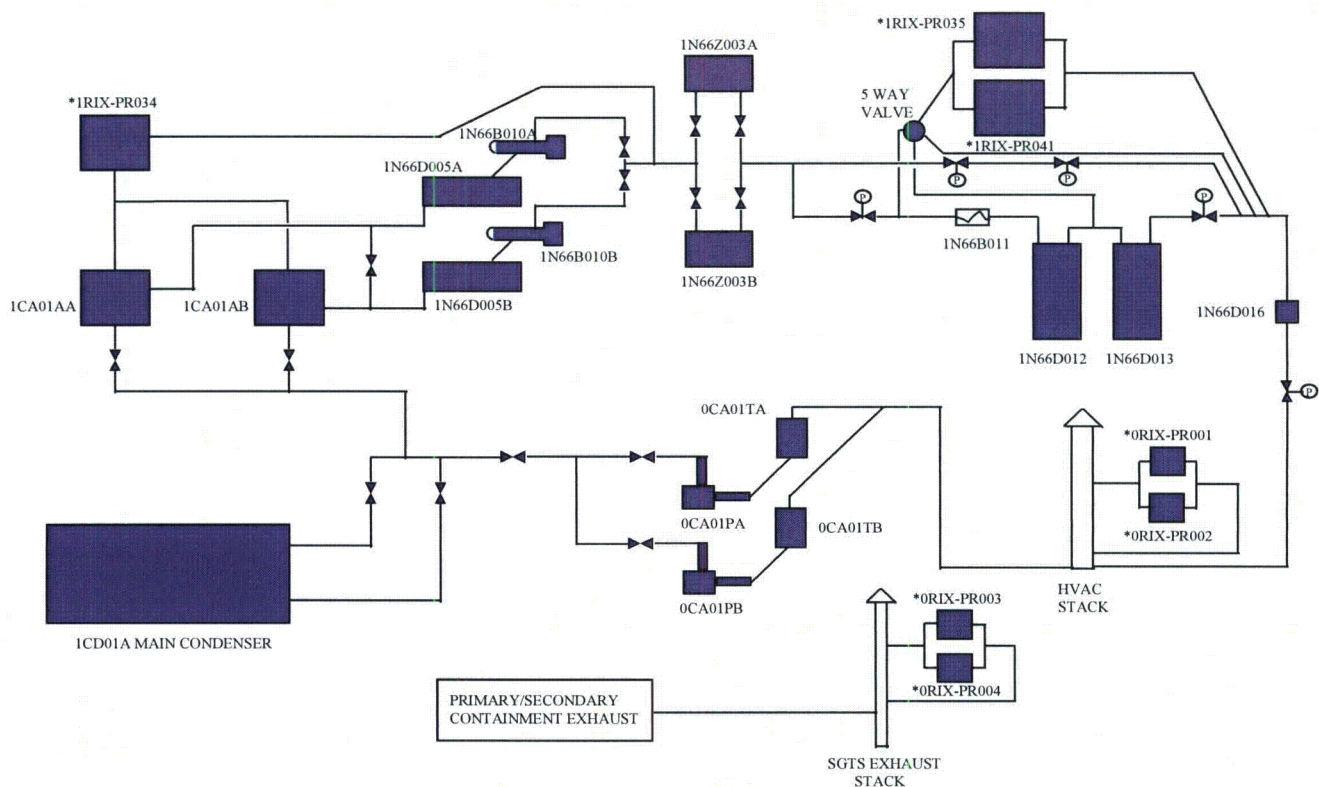

\*Monitors required by Part I RECS Sections 3.2.1 and 3.2.2

1CD01A Main Condenser	0CA01TA CV Separator Tank A	1N66B010B Cooler Condenser B	1N66D013 Charcoal Adsorber	1RIX-PR035 Off-Gas Post Treatment PRM
1CA01AA Steam Jet Air Ejector A	0CA01TB CV Separator Tank B	1N66Z003A Dessicant Dryer A	1N66D016 HEPA Filter	1RIX-PR041 Off-Gas Post Treatment PRM
1CA01AB Steam Jet Air Ejector B	1N66D005A Recombiner A	1N66Z003B Dessicant Dryer B	0RIX-PR001 HVAC Stack PRM #1	0RIX-PR003 Standby Gas Treatment PRM
0CA01PA Condenser Vacuum (CV) Pump A	1N66D005B Recombiner B	1N66B011 Gas Cooler	0RIX-PR002 HVAC Stack PRM #2	0RIX-PR004 Standby Gas Treatment PRM
0CA01PB CV Pump B	1N66B010A Cooler Condenser A	1N66D012 Charcoal Adsorber	1RIX-PR034 Off-Gas Pretreatment PRM	

## 4.0 LIQUID EFFLUENTS

### 4.1 INTRODUCTION

Liquid radwaste effluent released from CPS will meet ten times the 10CFR20 concentration limits at the point of discharge to the unrestricted area shown in FIGURE 4-1. This design and operation objective will be achieved at all times. Actual discharges of liquid radwaste effluent will normally occur on a batch basis and the average concentration at the point of discharge will be only a small percentage of the allowed limits. Refer to Clinton USAR Section 11.5 for a description of radiation monitoring, sampling and effluent control systems.

Cumulative quarterly dose contributions due to radioactive effluents released to the unrestricted area will be determined once every 31 days using NUREG-0133 and Regulatory Guide 1.109 methodology and parameters during periods when liquid effluent activity exceeds the Lower Limit of Detection (LLD) values.

### 4.2 10CFR20 RELEASE CONCENTRATION LIMITS

The Operation and Surveillance Requirements pertaining to discharge of liquid radwaste effluent to the unrestricted area are specified in RECS 3/4.3.1.

### 4.3 10CFR50, APPENDIX I DOSE LIMITS

The Operation and Surveillance Requirements concerning 10CFR50, Appendix I Release Limits are specified in section RECS 3/4.3.2.

This section is based upon the aquatic food and potable water exposure pathways only. Other exposure pathways, namely shoreline deposits and irrigated crops, may arise at Clinton Power Station and will be included in the section 4.3 dose contribution if they are likely to provide a significant contribution to the total dose. A pathway is considered significant if a conservative evaluation yields an additional dose increment greater than or equal to 10 percent of the total from all other existing pathways. Methods for calculating doses from other potentially significant liquid effluent pathways are presented in Appendix A to Regulatory Guide 1.109.

When the land use census or environmental monitoring information determine that other significant liquid effluent pathways are present, the Regulatory Guide 1.109 Appendix A equations and parameters will be used in lieu of site-specific data to determine a pathway's significance.



The dose contribution to the maximum exposed individual from all radionuclides identified in liquid effluents released to the unrestricted area is calculated as follows:

$$D_j = A_{ij} \sum_{s,t} \Delta t_s \cdot C_{is} \cdot F_{sr}, \text{ mrem} \quad (4-1)$$

- Where:
- $D_j$  = The cumulative calendar quarter or yearly dose to any organ j from liquid effluent for the total release period, mrem
  - $\Delta t_s$  = The length of time, s, over which  $C_{is}$  and  $F_{sr}$  are averaged for liquid releases, hours
  - = Liquid Radwaste Tank Volume/Liquid Radwaste Discharge Flow Rate
  - $C_{is}$  = The average concentration of nuclide i for time period s in undiluted liquid effluent during release period  $\Delta t_s$  for any liquid release,  $\mu\text{Ci/ml}$
  - $F_{sr}$  = The near field average dilution factor for receptor r during any liquid effluent release, dimensionless. Defined as the ratio of the average undiluted liquid radwaste flow during the release, to the product of the average flow from the discharge structure (during the reporting period, i.e., quarter or year) to the unrestricted receiving water and Z
  - =  $\frac{\text{Average Undiluted Liquid Waste Flow}}{(\text{Average Discharge Structure Flow})Z}$  (4-1)
  - Z = The applicable dilution factor for Lake Clinton, dimensionless
  - = 1.0
  - $A_{ij}$  = The composite ingestion dose commitment factor for the total body or critical organ j of an ADULT for radionuclide i, mrem/hr per  $\mu\text{Ci/ml}$
  - =  $K_o[(U_w/D_w) + (U_f BF_i)] DF_i$  (4-2)

- Where:
- $K_o$  = A units conversion factor,  $1.14E+05 \text{ pCi}\cdot\text{ml}\cdot\text{yr}/\mu\text{Ci}\cdot\text{liter}\cdot\text{hr}$   
=  $(1.00E+06 \text{ pCi}/\mu\text{Ci})(1.00E+03 \text{ ml/liter})/8760 \text{ hr/yr}$
  - $U_w$  = Annual water consumption by the maximum adult, liter/yr
  - $D_w$  = Dilution factor from the near field area to the nearest potable water intake, 1.0
  - $U_f$  = Adult fish consumption rate, 21 kg/yr (Table E-5 of Regulatory Guide 1.109)
  - $BF_i$  = Bioaccumulation factor for radionuclide i in fish, pCi/kg per pCi/liter (TABLE 4-2 taken from Table A-1 of Regulatory Guide 1.109)
  - $DF_i$  = Adult ingestion dose conversion factor for radionuclide i, total body or critical organ, mrem/pCi (TABLE 4-3 taken from Table E-11 of Regulatory Guide 1.109)

TABLE 4-1 contains values for  $A_{ij}$  as calculated by equation (4-2).

#### 4.4 LIQUID EFFLUENT DOSE PROJECTION CALCULATIONS

The 31 day projected dose shall be calculated using the following equation:

$$D_{pj} = (D_j * p) + D_{aj} \quad (4-3)$$

- Where:
- $D_{pj}$  = The 31 day projected dose by organ j.
  - $D_j$  = Total dose (mrem) for all valid release points for the release period (usually quarter) by organ j.
  - $P$  = The projection factor which is the results of 31 divided by the number of days from the start of the quarter to the end of the release.
  - $D_{aj}$  = Additional anticipated dose for gaseous release by organ j and quarter of release.

#### 4.5 TEMPORARY LIQUID RADWASTE HOLD-UP TANKS

The use of temporary liquid radwaste hold-up tanks may occur at CPS. To comply with Operational Requirements Manual (ORM) 2.4.4, the curie limit for liquid radwaste stored in such tanks may be calculated using the methodology presented in Appendix B of NUREG-0133 (BWR-RATAFR code), but limited to less than or equal to 10 curies, excluding tritium and dissolved or entrained noble gases.

FIGURE 4-1

UNRESTRICTED AREA BOUNDARY FOR LIQUID EFFLUENTS

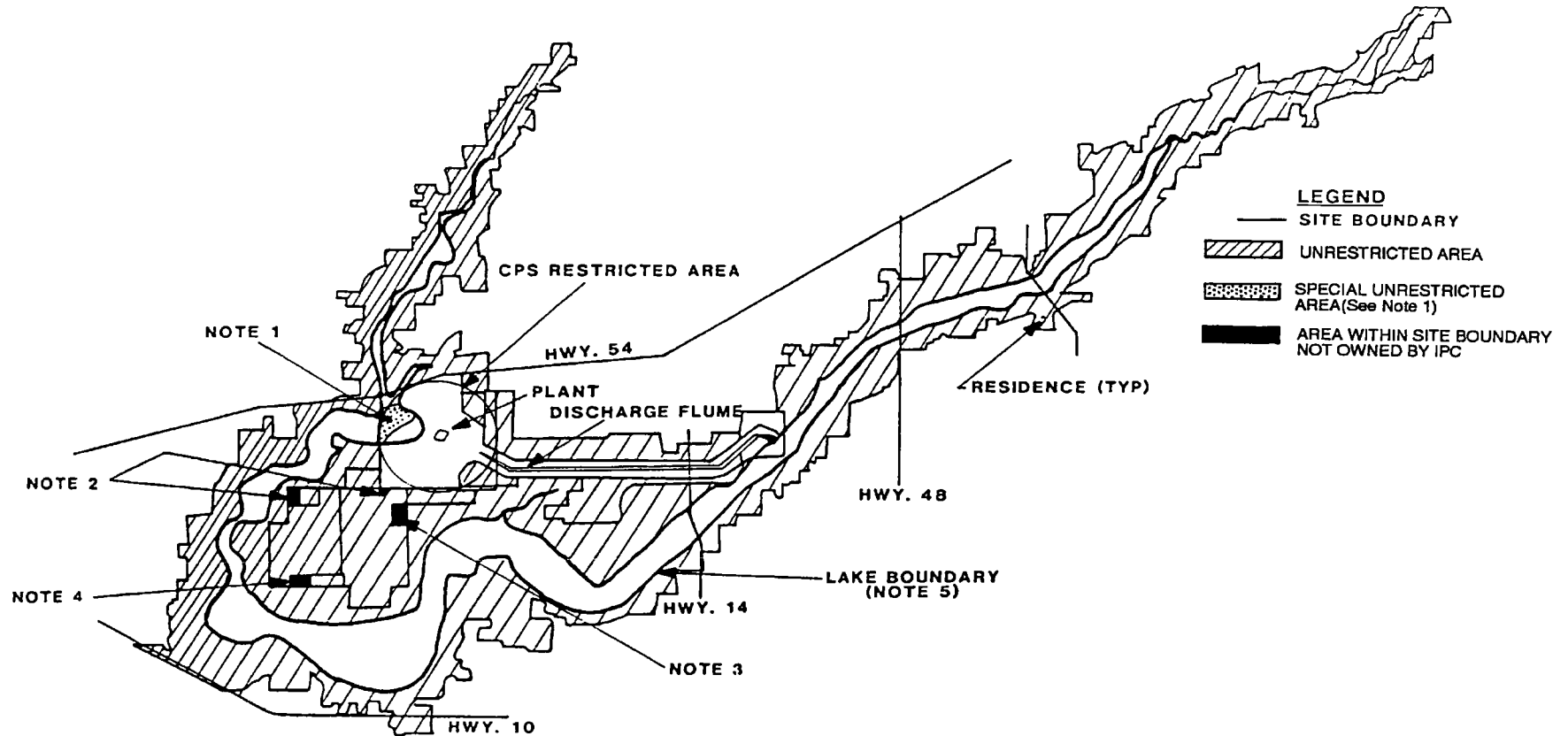

NOTES

1. The Area in the Lake Between the Buoys and the Exclusion Area Boundary Is Unrestricted at this Time. But Will Be Controlled if Plant Effluent Conditions Warrant Closure.
2. Land Parcel Not Owned by Clinton Power Station, Includes Residences.
3. Land Parcel Not Owned by Clinton Power Station, Oil Company Pipeline Pumping Station.
4. Land Parcel Not Owned by Clinton Power Station, Agricultural Use.
5. The Lake Shoreline Is Approximately 690 ft. Msl Elevation Line.

TABLE 4-1  
ADULT INGESTION DOSE COMMITMENT FACTORS - A<sub>ij</sub>  
(mrem/hr per  $\mu\text{Ci/ml}$ )  
Page 1 of 2

ISOTOPE	BONE	LIVER	T.BODY	THYROID	KIDNEY	LUNG	GI-LLI
H-3	NO DATA	2.26E-01	2.26E-01	2.26E-01	2.26E-01	2.26E-01	2.26E-01
C-14	3.12E+04	6.24E+03	6.24E+03	6.24E+03	6.24E+03	6.24E+03	6.24E+03
NA-24	4.06E+02	4.06E+02	4.06E+02	4.06E+02	4.06E+02	4.06E+02	4.06E+02
P-32	1.39E+06	8.62E+04	5.36E+04	NO DATA	NO DATA	NO DATA	1.56E+05
CR-51	NO DATA	NO DATA	1.27E+00	7.60E-01	2.80E-01	1.68E+00	3.20E+02
MN-54	NO DATA	4.37E+03	8.34E+02	NO DATA	1.30E+03	NO DATA	1.34E+04
MN-56	NO DATA	1.10E+02	1.95E+01	NO DATA	1.40E+02	NO DATA	3.51E+03
FE-55	6.57E+02	4.54E+02	1.06E+02	NO DATA	NO DATA	2.53E+02	2.60E+02
FE-59	1.04E+03	2.44E+03	9.34E+02	NO DATA	NO DATA	6.81E+02	8.13E+03
CO-58	NO DATA	8.90E+01	2.00E+02	NO DATA	NO DATA	NO DATA	1.80E+03
CO-60	NO DATA	2.56E+02	5.64E+02	NO DATA	NO DATA	NO DATA	4.80E+03
NI-63	3.11E+04	2.15E+03	1.04E+03	NO DATA	NO DATA	NO DATA	4.49E+02
NI-65	1.26E+02	1.64E+01	7.48E+00	NO DATA	NO DATA	NO DATA	4.16E+02
CU-64	NO DATA	9.97E+00	4.67E+00	NO DATA	2.51E+01	NO DATA	8.48E+02
ZN-65	2.31E+04	7.36E+04	3.33E+04	NO DATA	4.92E+04	NO DATA	4.64E+04
ZN-69	4.92E+01	9.42E+01	6.55E+00	NO DATA	6.12E+01	NO DATA	1.41E+01
BR-83	NO DATA	NO DATA	4.03E+01	NO DATA	NO DATA	NO DATA	5.81E+01
BR-84	NO DATA	NO DATA	5.23E+01	NO DATA	NO DATA	NO DATA	4.10E-04
BR-85	NO DATA	NO DATA	2.15E+00	NO DATA	NO DATA	NO DATA	LT 1E-15*
RB-86	NO DATA	1.01E+05	4.70E+04	NO DATA	NO DATA	NO DATA	1.99E+04
RB-88	NO DATA	2.89E+02	1.53E+02	NO DATA	NO DATA	NO DATA	4.00E-09
RB-89	NO DATA	1.92E+02	1.35E+02	NO DATA	NO DATA	NO DATA	1.11E-11
SR-89	2.21E+04	NO DATA	6.34E+02	NO DATA	NO DATA	NO DATA	3.54E+03
SR-90	5.43E+05	NO DATA	1.33E+05	NO DATA	NO DATA	NO DATA	1.57E+04
SR-91	4.06E+02	NO DATA	1.64E+01	NO DATA	NO DATA	NO DATA	1.94E+03
SR-92	1.54E+02	NO DATA	6.67E+00	NO DATA	NO DATA	NO DATA	3.05E+03
Y-90	5.75E-01	NO DATA	1.54E-02	NO DATA	NO DATA	NO DATA	6.10E+03
Y-91m	5.43E-03	NO DATA	2.10E-04	NO DATA	NO DATA	NO DATA	1.60E-02
Y-91	8.42E+00	NO DATA	2.25E-01	NO DATA	NO DATA	NO DATA	4.64E+03
Y-92	5.05E-02	NO DATA	1.48E-03	NO DATA	NO DATA	NO DATA	8.84E+02
Y-93	1.60E-01	NO DATA	4.42E-03	NO DATA	NO DATA	NO DATA	5.08E+03
ZR-95	2.40E-01	7.69E-02	5.20E-02	NO DATA	1.21E-01	NO DATA	2.44E+02
ZR-97	1.32E-02	2.67E-03	1.22E-03	NO DATA	4.04E-03	NO DATA	8.28E+02
NB-95	4.46E+02	2.48E+02	1.33E+02	NO DATA	2.45E+02	NO DATA	1.51E+06
MO-99	NO DATA	1.03E+02	1.96E+01	NO DATA	2.33E+02	NO DATA	2.39E+02
TC-99m	8.86E-03	2.50E-02	3.19E-01	NO DATA	3.80E-01	1.23E-02	1.48E+01
TC-101	9.11E-03	1.31E-02	1.29E-01	NO DATA	2.36E-01	6.70E-03	3.94E-14
RU-103	4.42E+00	NO DATA	1.90E+00	NO DATA	1.69E+01	NO DATA	5.16E+02
RU-105	3.68E-01	NO DATA	1.45E-01	NO DATA	4.76E+00	NO DATA	2.25E+02
RU-106	6.57E+01	NO DATA	8.32E+00	NO DATA	1.27E+02	NO DATA	4.25E+03
AG-110m	NO DATA	NO DATA	NO DATA	NO DATA	NO DATA	NO DATA	NO DATA
TE-125m	2.57E+03	9.28E+02	3.43E+02	7.70E+02	1.04E+04	NO DATA	1.02E+04
TE-127m	6.47E+03	2.31E+03	7.89E+02	1.65E+03	2.63E+04	NO DATA	2.17E+04
TE-127	1.05E+02	3.77E+01	2.28E+01	7.79E+01	4.28E+02	NO DATA	8.30E+03
TE-129m	1.10E+04	4.10E+03	1.74E+03	3.78E+03	4.59E+04	NO DATA	5.54E+04
TE-129	3.00E+01	1.13E+01	7.31E+00	2.30E+01	1.26E+02	NO DATA	2.26E+01
TE-131m	1.65E+03	8.09E+02	6.74E+02	1.28E+03	8.19E+03	NO DATA	8.03E+04
TE-131	1.88E+01	7.87E+00	5.95E+00	1.55E+01	8.25E+01	NO DATA	2.67E+00

TABLE 4-1  
 ADULT INGESTION DOSE COMMITMENT FACTORS - A<sub>ij</sub>  
 (mrem/hr per  $\mu\text{Ci/ml}$ )  
 Page 2 of 2

ISOTOPE	BONE	LIVER	T.BODY	THYROID	KIDNEY	LUNG	GI-LLI
TE-132	2.41E+03	1.56E+03	1.46E+03	1.72E+03	1.50E+04	NO DATA	7.37E+04
I-130	2.71E+01	7.99E+01	3.15E+01	6.78E+03	1.25E+02	NO DATA	6.88E+01
I-131	1.49E+02	2.13E+02	1.22E+02	6.99E+04	3.66E+02	NO DATA	5.63E+01
I-132	7.28E+00	1.95E+01	6.81E+00	6.81E+02	3.10E+01	NO DATA	3.66E+00
I-133	5.09E+01	8.85E+01	2.70E+01	1.30E+04	1.54E+02	NO DATA	7.96E+01
I-134	3.80E+00	1.03E+01	3.69E+00	1.79E+02	1.64E+01	NO DATA	9.00E-03
I-135	1.59E+01	4.16E+01	1.53E+01	2.74E+03	6.67E+01	NO DATA	4.70E+01
CS-134	2.97E+05	7.07E+05	5.78E+05	NO DATA	2.29E+05	7.60E+04	1.24E+04
CS-136	3.11E+04	1.23E+05	8.84E+04	NO DATA	6.84E+04	9.37E+03	1.40E+04
CS-137	3.81E+05	5.21E+05	3.41E+05	NO DATA	1.77E+05	5.88E+04	1.01E+04
CS-138	2.64E+02	5.21E+02	2.58E+02	NO DATA	3.83E+02	3.78E+01	2.22E-03
BA-139	9.29E-01	6.60E-04	2.72E-02	NO DATA	6.18E-04	3.75E-04	1.65E+00
BA-140	1.94E+02	2.44E-01	1.27E+01	NO DATA	8.29E-02	1.40E-01	4.00E+02
BA-141	4.50E-01	3.40E-04	1.52E-02	NO DATA	3.16E-04	1.93E-04	2.12E-10
BA-142	2.04E-01	2.09E-04	1.28E-02	NO DATA	1.77E-04	1.18E-04	2.89E-19
LA-140	1.49E-01	7.53E-02	1.99E-02	NO DATA	NO DATA	NO DATA	5.53E+03
LA-142	7.65E-03	3.48E-03	8.66E-04	NO DATA	NO DATA	NO DATA	2.54E+01
CE-141	2.24E-02	1.51E-02	1.72E-03	NO DATA	7.03E-03	NO DATA	5.78E+01
CE-143	3.94E-03	2.92E+00	3.23E-04	NO DATA	1.28E-03	NO DATA	1.09E+02
CE-144	1.17E+00	4.88E-01	6.26E-02	NO DATA	2.89E-01	NO DATA	3.94E+02
PR-143	5.50E-01	2.20E-01	2.72E-02	NO DATA	1.27E-01	NO DATA	2.41E+03
PR-144	1.80E-03	7.47E-04	9.14E-05	NO DATA	4.21E-04	NO DATA	2.59E-10
ND-147	3.76E-01	4.34E-01	2.60E-02	NO DATA	2.54E-01	NO DATA	2.08E+03
W-187	2.95E+02	2.47E+02	8.63E+01	NO DATA	NO DATA	NO DATA	8.09E+04
NP-239	2.84E-02	2.80E-03	1.54E-03	NO DATA	8.72E-03	NO DATA	5.74E+02

\* Less than 1.00E-15

TABLE 4-2  
BIOACCUMULATION FACTORS - BF<sub>i</sub>  
(pCi/kg per pCi/liter)

ELEMENT	FRESHWATER FISH
H	9.00E-01
C	4.60E+03
Na	1.00E+02
P	1.00E+05
Cr	2.00E+02
Mn	4.00E+02
Fe	1.00E+02
Co	5.00E+01
Ni	1.00E+02
Cu	5.00E+01
Zn	2.00E+03
Br	4.20E+02
Rb	2.00E+03
Sr	3.00E+01
Y	2.50E+01
Zr	3.30E+00
Nb	3.00E+04
Mo	1.00E+01
Tc	1.50E+01
Ru	1.00E+01
Rh	1.00E+01
Te	4.00E+02
I	1.50E+01
Cs	2.00E+03
Ba	4.00E+00
La	2.50E+01
Ce	1.00E+00
Pr	2.50E+01
Nd	2.50E+01
W	1.20E+03
Np	1.00E+01

TABLE 4-3  
ADULT INGESTION DOSE FACTORS -DF<sub>i</sub>  
(mrem/pCi ingested)  
Page 1 of 2

ISOTOPE	BONE	LIVER	T.BODY	THYROID	KIDNEY	LUNG	GI-LLI
H-3	NO DATA	1.05E-07	1.05E-07	1.05E-07	1.05E-07	1.05E-07	1.05E-07
C-14	2.84E-06	5.68E-07	5.68E-07	5.68E-07	5.68E-07	5.68E-07	5.68E-07
NA-24	1.70E-06	1.70E-06	1.70E-06	1.70E-06	1.70E-06	1.70E-06	1.70E-06
P-32	1.93E-04	1.20E-05	7.46E-06	NO DATA	NO DATA	NO DATA	2.17E-05
CR-51	NO DATA	NO DATA	2.66E-09	1.59E-09	5.86E-10	3.53E-09	6.69E-07
MN-54	NO DATA	4.57E-06	8.72E-07	NO DATA	1.36E-06	NO DATA	1.40E-05
MN-56	NO DATA	1.15E-07	2.04E-08	NO DATA	1.46E-07	NO DATA	3.67E-06
FE-55	2.75E-06	1.90E-06	4.43E-07	NO DATA	NO DATA	1.06E-06	1.09E-06
FE-59	4.34E-06	1.02E-05	3.91E-06	NO DATA	NO DATA	2.85E-06	3.40E-05
CO-58	NO DATA	7.45E-07	1.67E-06	NO DATA	NO DATA	NO DATA	1.51E-05
CO-60	NO DATA	2.14E-06	4.72E-06	NO DATA	NO DATA	NO DATA	4.02E-05
NI-63	1.30E-04	9.01E-06	4.36E-06	NO DATA	NO DATA	NO DATA	1.88E-06
NI-65	5.28E-07	6.86E-08	3.13E-08	NO DATA	NO DATA	NO DATA	1.74E-06
CU-64	NO DATA	8.33E-08	3.91E-08	NO DATA	2.10E-07	NO DATA	7.10E-06
ZN-65	4.84E-06	1.54E-05	6.96E-06	NO DATA	1.03E-05	NO DATA	9.70E-06
ZN-69	1.03E-08	1.97E-08	1.37E-09	NO DATA	1.28E-08	NO DATA	2.96E-09
BR-83	NO DATA	NO DATA	4.02E-08	NO DATA	NO DATA	NO DATA	5.79E-08
BR-84	NO DATA	NO DATA	5.21E-08	NO DATA	NO DATA	NO DATA	4.09E-13
BR-85	NO DATA	NO DATA	2.14E-09	NO DATA	NO DATA	NO DATA	LT 1E-24*
RB-86	NO DATA	2.11E-05	9.83E-06	NO DATA	NO DATA	NO DATA	4.16E-06
RB-88	NO DATA	6.05E-08	3.21E-08	NO DATA	NO DATA	NO DATA	8.36E-19
RB-89	NO DATA	4.01E-08	2.82E-08	NO DATA	NO DATA	NO DATA	2.33E-21
SR-89	3.08E-04	NO DATA	8.84E-06	NO DATA	NO DATA	NO DATA	4.94E-05
SR-90	7.58E-03	NO DATA	1.86E-03	NO DATA	NO DATA	NO DATA	2.19E-04
SR-91	5.67E-06	NO DATA	2.29E-07	NO DATA	NO DATA	NO DATA	2.70E-05
SR-92	2.15E-06	NO DATA	9.30E-08	NO DATA	NO DATA	NO DATA	4.26E-05
Y-90	9.62E-09	NO DATA	2.58E-10	NO DATA	NO DATA	NO DATA	1.02E-04
Y-91m	9.09E-11	NO DATA	3.52E-12	NO DATA	NO DATA	NO DATA	2.67E-10
Y-91	1.41E-07	NO DATA	3.77E-09	NO DATA	NO DATA	NO DATA	7.76E-05
Y-92	8.45E-10	NO DATA	2.47E-11	NO DATA	NO DATA	NO DATA	1.48E-05
Y-93	2.68E-09	NO DATA	7.40E-11	NO DATA	NO DATA	NO DATA	8.50E-05
ZR-95	3.04E-08	9.75E-09	6.60E-09	NO DATA	1.53E-08	NO DATA	3.09E-05
ZR-97	1.68E-09	3.39E-10	1.55E-10	NO DATA	5.12E-10	NO DATA	1.05E-04
NB-95	6.22E-09	3.46E-09	1.86E-09	NO DATA	3.42E-09	NO DATA	2.10E-05
MO-99	NO DATA	4.31E-06	8.20E-07	NO DATA	9.76E-06	NO DATA	9.99E-06
TC-99m	2.47E-10	6.98E-10	8.89E-09	NO DATA	1.06E-08	3.42E-10	4.13E-07
TC-101	2.54E-10	3.66E-10	3.59E-09	NO DATA	6.59E-09	1.87E-10	1.10E-21
RU-103	1.85E-07	NO DATA	7.97E-08	NO DATA	7.06E-07	NO DATA	2.16E-05
RU-105	1.54E-08	NO DATA	6.08E-09	NO DATA	1.99E-07	NO DATA	9.42E-06
RU-106	2.75E-06	NO DATA	3.48E-07	NO DATA	5.31E-06	NO DATA	1.78E-04
AG-110m	1.60E-07	1.48E-07	8.79E-08	NO DATA	2.91E-07	NO DATA	6.04E-05
TE-125m	2.68E-06	9.71E-07	3.59E-07	8.06E-07	1.09E-05	NO DATA	1.07E-05
TE-127m	6.77E-06	2.42E-06	8.25E-07	1.73E-06	2.75E-05	NO DATA	2.27E-05
TE-127	1.10E-07	3.95E-08	2.38E-08	8.15E-08	4.48E-07	NO DATA	8.68E-06
TE-129m	1.15E-05	4.29E-06	1.82E-06	3.95E-06	4.80E-05	NO DATA	5.79E-05
TE-129	3.14E-08	1.18E-08	7.65E-09	2.41E-08	1.32E-07	NO DATA	2.37E-08
TE-131m	1.73E-06	8.46E-07	7.05E-07	1.34E-06	8.57E-06	NO DATA	8.40E-05
TE-131	1.97E-08	8.23E-09	6.22E-09	1.62E-08	8.63E-08	NO DATA	2.79E-09

TABLE 4-3  
ADULT INGESTION DOSE FACTORS - DF<sub>i</sub>  
(mrem/pCi ingested)  
Page 2 of 2

ISOTOPE	BONE	LIVER	T.BODY	THYROID	KIDNEY	LUNG	GI-LLI
TE-132	2.52E-06	1.63E-06	1.53E-06	1.80E-06	1.57E-05	NO DATA	7.71E-05
I-130	7.56E-07	2.23E-06	8.80E-07	1.89E-04	3.48E-06	NO DATA	1.92E-06
I-131	4.16E-06	5.95E-06	3.41E-06	1.95E-03	1.02E-05	NO DATA	1.57E-06
I-132	2.03E-07	5.43E-07	1.90E-07	1.90E-05	8.65E-07	NO DATA	1.02E-07
I-133	1.42E-06	2.47E-06	7.53E-07	3.63E-04	4.31E-06	NO DATA	2.22E-06
I-134	1.06E-07	2.88E-07	1.03E-07	4.99E-06	4.58E-07	NO DATA	2.51E-10
I-135	4.43E-07	1.16E-06	4.28E-07	7.65E-05	1.86E-06	NO DATA	1.31E-06
CS-134	6.22E-05	1.48E-04	1.21E-04	NO DATA	4.79E-05	1.59E-05	2.59E-06
CS-136	6.51E-06	2.57E-05	1.85E-05	NO DATA	1.43E-05	1.96E-06	2.92E-06
CS-137	7.97E-05	1.09E-04	7.14E-05	NO DATA	3.70E-05	1.23E-05	2.11E-06
CS-138	5.52E-08	1.09E-07	5.40E-08	NO DATA	8.01E-08	7.91E-09	4.65E-13
BA-139	9.70E-08	6.91E-11	2.84E-09	NO DATA	6.46E-11	3.92E-11	1.72E-07
BA-140	2.03E-05	2.55E-08	1.33E-06	NO DATA	8.67E-09	1.46E-08	4.18E-05
BA-141	4.71E-08	3.56E-11	1.59E-09	NO DATA	3.31E-11	2.02E-11	2.22E-17
BA-142	2.13E-08	2.19E-11	1.34E-09	NO DATA	1.85E-11	1.24E-11	3.00E-26
LA-140	2.50E-09	1.26E-09	3.33E-10	NO DATA	NO DATA	NO DATA	9.25E-05
LA-142	1.28E-10	5.82E-11	1.45E-11	NO DATA	NO DATA	NO DATA	4.25E-07
CE-141	9.36E-09	6.33E-09	7.18E-10	NO DATA	2.94E-09	NO DATA	2.42E-05
CE-143	1.65E-09	1.22E-06	1.35E-10	NO DATA	5.37E-10	NO DATA	4.56E-05
CE-144	4.88E-07	2.04E-07	2.62E-08	NO DATA	1.21E-07	NO DATA	1.65E-04
PR-143	9.20E-09	3.69E-09	4.56E-10	NO DATA	2.13E-09	NO DATA	4.03E-05
PR-144	3.01E-11	1.25E-11	1.53E-12	NO DATA	7.05E-12	NO DATA	4.33E-18
ND-147	6.29E-09	7.27E-09	4.35E-10	NO DATA	4.25E-09	NO DATA	3.49E-05
W-187	1.03E-07	8.61E-08	3.01E-08	NO DATA	NO DATA	NO DATA	2.82E-05
NP-239	1.19E-09	1.17E-10	6.45E-11	NO DATA	3.65E-10	NO DATA	2.40E-05

\* Less than 1.00E-24



## 5.0 RADIOACTIVE GASEOUS EFFLUENTS

### 5.1 INTRODUCTION

Gaseous effluents from CPS are released on both a batch and continuous basis. Gaseous effluents are normally discharged on a long-term basis. High volume Continuous Containment Purge and mechanical vacuum pump discharge may be considered short-term releases.

There are two gaseous effluent release points to the environment: the Common Station HVAC Stack and the Standby Gas Treatment System (SGTS) Stack. The height of these stacks is such that all gaseous effluents are treated as mixed-mode releases. The SGTS is an Engineered Safety Feature filter system utilized following an accident to reduce iodine and particulate activity in gases leaking from the primary containment and which are potentially present in the secondary containment. The Common Station HVAC Stack ("HVAC Stack") receives process and ventilation exhaust from the following inputs:

- a. Continuous Containment Purge (CCP)
- b. Containment Building Ventilation
- c. Turbine Building Ventilation
- d. Radwaste Building Ventilation
- e. Auxiliary Building Ventilation
- f. Fuel Building Ventilation
- g. Auxiliary Building Refrigerant Purge
- h. Laboratory Ventilation System
- i. Counting/Equipment Decon Rooms Ventilation
- j. Steam Packing Exhauster
- k. Mechanical Vacuum Pump
- l. Drywell Purge

The effluent exiting the SGTS stack is monitored at the SGTS stack and the combined inputs to the HVAC stack are monitored at the HVAC stack. All inputs to the HVAC Stack, with the exception of input numbers g through j, can be monitored prior to entering the stack.

FIGURE 5-1 delineates the CPS site boundary for implementation of gaseous effluent 10CFR20 and 10CFR50, Appendix I Release Rate Limits.

## 5.2 TECHNICAL SPECIFICATION RELEASE RATE LIMITS

The Operation and Surveillance Requirements concerning Technical Specification Release Rate Limits are specified in Part I RECS Section 3/4.4.1. Dose Rate calculations for ensuring compliance with these limits are discussed in Sections 5.3 and 5.4, below.

## 5.3 DOSE RATE DUE TO NOBLE GASES

In order to comply with Part I RECS Section 3.4.1.1.(a), the dose rate at or beyond the site boundary due to noble gases shall be calculated as follows:

$$D_t = \sum_i K_i * shf * \sum_v [(X/Q)_{vr} * Q_{iv}] \quad (5-1)$$

= total body dose rate at time of release, mrem/year

$$D_s = \sum_i shf * (L_i + 1.1M_i) * \sum_v [(X/Q)_{vr} * Q_{iv}] \quad (5-2)$$

= skin dose rate at time of release, mrem/year

The terms in the above equations are defined in section 5.4.

## 5.4 DOSE RATE DUE TO RADIOIODINES, PARTICULATES AND TRITIUM

In order to comply with Part I RECS Section 3.4.1.1(b), organ dose rates due to radioiodines (I-131, I-133), particulates with half-lives > 8 days and tritium shall be calculated as follows:

$$D_j = \sum [P_{ij} * Q_{ivm} * (X/Q)_v] \quad (5-3)$$

= organ dose rate at time of release, mrem/yr

The terms used in equations (5-1) through (5-3) are defined as follows:

- $K_i$  = The total body dose factor due to gamma emissions for each identified noble gas radionuclide  $i$ , mrem/yr per  $\mu\text{Ci}/\text{m}^3$  from TABLE 5-1
- $L_i$  = The skin dose factor due to beta emissions for each identified noble gas radionuclide  $i$ , mrem/yr per  $\mu\text{Ci}/\text{m}^3$  from TABLE 5-1
- $M_i$  = The air dose factor due to gamma emissions for each identified noble gas radionuclide  $i$ , mrad/yr per  $\mu\text{Ci}/\text{m}^3$  (1.1 mrem/mrad converts air dose to skin dose) from TABLE 5-1
- $Shf$  = Noble gas shielding factor, which is set to 1
- $P_{ij}$  = The dose factor for non-noble gas radionuclide  $i$  and organ  $j$  which includes pathway transport parameters, receptor usage factors and the dosimetry of the exposure. The dose factors for the inhalation, mrem/yr per  $\mu\text{Ci}/\text{m}^3$ , pathway are listed in TABLE 5-2 (CHILD). Dose factors are based on NUREG-0133, Section 5.2.1.1 assumptions unless otherwise stated.

- $Q_{iv}$  = The release rate of noble gas radionuclide  $i$  in gaseous effluent from mixed-mode release points,  $\mu\text{Ci}/\text{sec}$
- $Q_{ivm}$  = The release rate of non-noble gas radionuclide  $i$  in gaseous effluent from mixed-mode release points,  $\mu\text{Ci}/\text{sec}$
- $(X/Q)_{vr}$  = The highest value of the annual atmospheric dispersion factor from release point  $v$  at the site boundary, for all sectors,  $(\text{sec}/\text{m}^3)$ .
- $(X/Q)_v$  = The highest calculated average relative concentration  $(X/Q)$  for any area at or beyond the site boundary from mixed-mode release point  $v$ ,  $\text{sec}/\text{m}^3$ .

$D_j$  is calculated for each of six organs and the total body; the maximum  $D_j$  value is then used to determine compliance with Part I RECS Section 3.4.1.1(b).

The factors  $K_j$ ,  $L_j$ , and  $M_j$  relate the radionuclide airborne concentrations to various dose rates assuming a semi-infinite cloud. These factors are listed in TABLE 5-1 and were obtained from Table B-1 of Regulatory Guide 1.109 after multiplying the values by the conversion  $10^6 \text{ pCi}/\mu\text{Ci}$ .

10CFR20 organ dose rate calculations are limited to the inhalation pathway only. Part I RECS Section 3.4.1.1(a) is applicable to the unrestricted area location characterized by the  $(X/Q)_v$  value that results in the maximum total body or skin dose commitment. Should the total body and skin locations differ, the selected location shall be that which minimizes allowable release rates.

There are unrestricted areas within the CPS site boundary that are utilized by members of the public for residences, farming, recreation and camping. These areas are identified in TABLE 5-3. TABLE 5-3 will be revised to remain consistent with the most recent land use census.

TABLE 5-1  
DOSE FACTORS FOR NOBLE GASES AND DAUGHTERS\*

Radionuclide	Total Body Dose Factor, K <sub>i</sub>	Skin Dose Factor, L <sub>i</sub>	Gamma Air Dose Factor, M <sub>i</sub>	Beta Air Dose Factor, N <sub>i</sub>
	(mrem/yr per μCi/m <sup>3</sup> )	(mrem/yr per μCi/m <sup>3</sup> )	(mrad/yr per μCi/m <sup>3</sup> )	(mrad/yr per μCi/m <sup>3</sup> )
Kr-85m	1.17E+03	1.46E+03	1.23E+03	1.97E+03
Kr-85	1.61E+01	1.34E+03	1.72E+01	1.95E+03
Kr-87	5.92E+03	9.73E+03	6.17E+03	1.03E+04
Kr-88	1.47E+04	2.37E+03	1.52E+04	2.93E+03
Kr-89	1.66E+04	1.01E+04	1.73E+04	1.06E+04
Kr-90	1.56E+04	7.29E+03	1.63E+04	7.83E+03
Xe-131m	9.15E+01	4.76E+02	1.56E+02	1.11E+03
Xe-133m	2.51E+02	9.94E+02	3.27E+02	1.48E+03
Xe-133	2.94E+02	3.06E+02	3.53E+02	1.05E+03
Xe-135m	3.12E+03	7.11E+02	3.36E+03	7.39E+02
Xe-135	1.81E+03	1.86E+03	1.92E+03	2.46E+03
Xe-137	1.42E+03	1.22E+04	1.51E+03	1.27E+04
Xe-138	8.83E+03	4.13E+03	9.21E+03	4.75E+03
Ar-41	8.84E+03	2.69E+03	9.30E+03	3.28E+03

\* The listed dose factors are for radionuclides that may be detected in gaseous effluents.

TABLE 5-2  
INHALATION PATHWAY DOSE RATE FACTORS (CHILD) - P<sub>ij</sub>  
(mrem/yr per  $\mu\text{Ci}/\text{m}^3$ )

ORGAN ISOTOPE	BONE	LIVER	T.BODY	THYROID	KIDNEY	LUNG	GI-LLI
H-3	NO DATA	1.12E+03	1.12E+03	1.12E+03	1.12E+03	1.12E+03	1.12E+03
P-32	2.60E+06	1.14E+05	9.88E+04	NO DATA	NO DATA	NO DATA	4.22E+04
CR-51	NO DATA	NO DATA	1.54E+02	8.55E+01	2.43+01	1.70E+04	1.08E+03
MN-54	NO DATA	4.29E+04	9.51E+03	NO DATA	1.00E+04	1.58E+06	2.29E+04
FE-55	4.74E+04	2.52E+04	7.77E+03	NO DATA	NO DATA	1.11E+05	2.87E+03
FE-59	2.07E+04	3.34E+04	1.67E+04	NO DATA	NO DATA	1.27E+06	7.07E+04
CO-58	NO DATA	1.77E+03	3.16E+03	NO DATA	NO DATA	1.11E+06	3.44E+04
CO-60	NO DATA	1.31E+04	2.26E+04	NO DATA	NO DATA	7.07E+06	9.62E+04
NI-63	8.21E+05	4.63E+04	2.80E+04	NO DATA	NO DATA	2.75E+05	6.33E+03
ZN-65	4.26E+04	1.13E+05	7.03E+04	NO DATA	7.14E+04	9.95E+05	1.63E+04
RB-86	NO DATA	1.98E+05	1.14E+05	NO DATA	NO DATA	NO DATA	7.99E+03
SR-89	5.99E+05	NO DATA	1.72E+04	NO DATA	NO DATA	2.16E+06	1.67E+05
SR-90	1.01E+08	NO DATA	6.49E+06	NO DATA	NO DATA	1.48E+07	3.43E+05
Y-90	4.11E+03	NO DATA	1.11E+02	NO DATA	NO DATA	2.62E+05	2.68E+05
Y-91	9.14E+05	NO DATA	2.44E+04	NO DATA	NO DATA	2.63+06	1.84E+05
ZR-95	1.90E+05	4.18E+04	3.70E+04	NO DATA	5.96E+04	2.23E+06	6.11E+04
NB-95	2.35E+04	9.18E+03	6.55E+03	NO DATA	8.62E+03	6.14E+05	3.70E+04
MO-99	NO DATA	1.72E+02	4.26E+01	NO DATA	3.92E+02	1.35E+05	1.27E+05
TC-99m	1.78E-03	3.48E-03	5.77E-02	NO DATA	5.07E-02	9.51E+02	4.81E+03
RU-103	2.79E+03	NO DATA	1.07E+03	NO DATA	7.03E+03	6.62E+05	4.48E+04
RU-106	1.36E+05	NO DATA	1.69E+04	NO DATA	1.84E+05	1.43E+07	4.29E+05
AG-110m	1.69E+04	1.14E+04	9.14E+03	NO DATA	2.12E+04	5.48E+06	1.00E+05
TE-125m	6.73E+04	2.33E+03	9.14E+02	1.92E+03	NO DATA	4.77E+05	3.38E+04
TE-127m	2.49E+04	8.56E+03	3.03E+03	6.07E+03	6.36E+04	1.48E+06	7.14E+04
TE-129m	1.92E+04	6.85E+03	3.04E+03	6.33E+03	5.03E+04	1.76E+06	1.82E+05
I-130	8.18E+03	1.64E+04	8.44E+03	1.85E+06	2.45E+04	NO DATA	5.11E+03
I-131	4.81E+04	4.81E+04	2.73E+04	1.62E+07	7.88E+04	NO DATA	2.84E+03
I-132	2.12E+03	4.07E+03	1.88E+03	1.94E+05	6.25E+03	NO DATA	3.20E+03
I-133	1.66E+04	2.03E+04	7.70E+03	3.85E+06	3.38E+04	NO DATA	5.48E+03
I-134	1.17E+03	2.16E+03	9.95E+02	5.07E+04	3.30E+03	NO DATA	9.55E+02
I-135	4.92E+03	8.73E+03	4.14E+03	7.92E+05	1.34E+04	NO DATA	4.44E+03
CS-134	6.51E+05	1.01E+06	2.25E+05	NO DATA	3.30E+05	1.21E+05	3.84E+03
CS-136	6.51E+04	1.71E+05	1.16E+05	NO DATA	9.55E+04	1.45E+04	4.18E+03
CS-137	9.07E+05	8.25E+05	1.28E+05	NO DATA	2.82E+05	1.04E+05	3.62E+03
BA-140	7.40E+04	6.48E+01	4.33E+03	NO DATA	2.11E+01	1.74E+06	1.02E+05
CE-141	3.92E+04	1.95E+04	2.90E+03	NO DATA	8.55E+03	5.44E+05	5.66E+04
CE-144	6.77E+06	2.12E+06	3.62E+05	NO DATA	1.17E+06	1.20E+07	3.89E+05
PR-143	1.85E+04	5.55E+03	9.14E+02	NO DATA	3.00E+03	4.33E+05	9.73E+04
ND-147	1.08E+04	8.73E+03	6.81E+02	NO DATA	4.81E+03	3.28E+05	8.21E+04
C-14	3.59E+04	6.73E+03	6.73E+03	6.73E+03	6.73E+03	6.73E+03	6.73E+03

TABLE 5-3  
LOCATION OF MEMBERS OF THE PUBLIC WITHIN THE CPS SITE BOUNDARY  
AND THEIR ASSOCIATED OCCUPANCY FACTORS\*

Location	Distance (mile/meter)	Sector	Occupancy (hrs/yr)
Road	0.3/495	SE	243 <sup>(1)</sup>
Agricultural Acreage <sup>(2)</sup>	0.9/1372	SSW	966 <sup>(3)</sup>
Clinton Lake	0.2/335	NW	2208 <sup>(4)</sup>
Department of Conservation Recreation Area	0.8/1287	ESE	2208 <sup>(5)</sup>
Residence	0.8/1219	SW	8760
Residence	1.5/2414	WSW	8760
Residence	1.7/2736	SSE	8760

- (1) Assumes travel on road for forty minutes per day.
  - (2) Maximum farm acreage (276) within site boundary.
  - (3) Assumes 3.5 hours in field per acre farmed.
  - (4) Assumes continuous occupation on Clinton Lake for the months of June, July, and August.
  - (5) Assumes continuous occupation on Department of Conservation camping areas for the months of June, July, and August.
- \* Doses for such MEMBERS OF THE PUBLIC are provided in the Radioactive Effluent Release Report as given in Part I RECS Section 5.4.

5.5 10CFR50, APPENDIX I RELEASE RATE LIMITS

The Operation and Surveillance Requirements concerning 10CFR50 (Appendix I) Release Rate Limits are specified in Part I RECS Section 3/4.4.2 and 3/4.4.3. Dose calculations for ensuring compliance with these limits are discussed in Sections 5.5.1 and 5.5.2 below.

5.5.1 Noble Gas Air Dose Equations

The air dose at or beyond the site boundary (see Figure 5-1) due to noble gases released in gaseous effluent will be determined using the following equations.

During any calendar quarter or calendar year, for gamma radiation:

$$D_{\gamma} = 3.17E-08 * \sum_i [ M_i * (X/Q)_V * Q_{iV} ] \quad (5-4)$$

During any calendar quarter or calendar year, for beta radiation:

$$D_{\beta} = 3.17E-08 * \sum_i [ N_i * (X/Q)_V * Q_{iV} ] \quad (5-5)$$

- Where:
- $M_i$  = The gamma air dose factor for each identified noble gas radionuclide  $i$ , mrad/year per  $\mu\text{Ci}/\text{m}^3$  ( $M_i$  values are listed in TABLE 5-1).
  - $N_i$  = The beta air dose factor for each identified noble gas radionuclide  $i$ , mrad/year per  $\mu\text{Ci}/\text{m}^3$  ( $N_i$  values are listed in TABLE 5-1).
  - $(X/Q)_V$  = The highest calculated average relative concentration from mixed-mode release points for areas at or beyond the site boundary,  $\text{sec}/\text{m}^3$ .
  - $Q_{iV}$  = The total release of noble gas radionuclide  $i$  for long-term releases from mixed-mode release points,  $\mu\text{Ci}$ . Releases shall be cumulative over the calendar quarter or year, as appropriate.
  - $3.17E-08$  = The inverse of the number of seconds in a year.

Part I RECS Section 3.4.2 noble gas dose calculations are evaluated at the site boundary location where maximum air doses prevail. Should the beta and gamma locations differ, the selected location shall be that which minimizes allowable release rates due to the gamma component.

5.5.2 Radioiodines, Particulates and Tritium Dose Equations

The dose to an individual at or beyond the site boundary due to radioiodines (I-131, I-133), tritium and particulates with half-lives > 8 days, will be determined using the following equation:

For any calendar quarter or calendar year,

$$D_j = 3.17E-08 * f_0 * \sum_i [R_{ija}^p * W_{pv} * Q_{iv}] \quad (5-6)$$

- Where:
- $Q_{iv}$  = The releases of radionuclide i (I-131, I-133, tritium and particulates with half-lives greater than 8 days) for releases from vent v for mixed-mode releases,  $\mu\text{Ci}$ . Releases shall be cumulative over the calendar quarter or year, as appropriate.
  - $W_{pv}$  = The annual average dispersion parameter for estimating the dose to an individual as appropriate to pathway p and release point v, at a controlling location, for mixed-mode releases.
    - =  $(X/Q)_m$ ,  $\text{sec}/\text{m}^3$ , for the inhalation pathway at the location of the critical receptor.
    - =  $(D/Q)_m$ ,  $\text{m}^{-2}$ , for the food and ground plane pathways at the location of the critical receptor.
  - 3.17E-08 = The inverse of the number of seconds in a year.
  - $R_{ija}^p$  = The dose factor for each identified radionuclide i, pathway (p), organ (j), and age group (a),  $\text{m}^2\text{-mrem}/\text{year}$  per  $\mu\text{Ci}/\text{sec}$  or  $\text{mrem}/\text{year}$  per  $\mu\text{Ci}/\text{m}^3$ .
  - $f_0$  = Occupancy factor which is set to 1

Part I RECS Section 3.4.3 is applicable to the location at or beyond the site boundary where the combination of existing pathways and receptor age groups indicates the maximum potential exposure. The inhalation and ground plane exposure pathways exist at all locations; other pathways exist as determined by the most current land use census.

#### 5.5.2.1 Dose Factor For Radionuclide i ( $R_{ija}^p$ )

The  $R_{ija}^p$  values used to calculate  $D_j$  in equation (5-6) are determined separately for each of the potential exposure pathways, namely:

- a. Inhalation (I)
- b. Ground Plane Contamination (G)
- c. Grass-Cow/Goat-Milk (C)
- d. Grass-Cow-Meat (M)
- e. Vegetation (V)



The  $R_{ija}^P$  parameter is independent of the duration of gaseous releases and is calculated using the methodology discussed in the remainder of this section.

(a) Calculation of the Inhalation Pathway Factor,  $R_{ija}^I$

$$R_{ija}^I = K'(BR)_a(DFA_{ij})_a, \text{ mrem/year per } \mu\text{Ci/m}^3 \quad (5-7)$$

Where:  $K'$  = A units conversion constant,  $10^6$  pCi/ $\mu$ Ci  
 $(BR)_a$  = The breathing rate of the receptor age group (a),  $\text{m}^3/\text{year}$   
 = 1400 (infant)  
 = 3700 (child)  
 = 8000 (teen and adult)

Values for  $(BR)_a$  are obtained from NUREG-0133, pg. 32

$(DFA_{ij})_a$  = The organ inhalation dose factor for receptor of age group (a) for radionuclide i, and organ j, mrem/pCi. Values for  $(DFA_{ij})_a$  were obtained from Tables E-7 through E-10 of Regulatory Guide 1.109 and are presented in TABLE 5-4 through TABLE 5-7 of this manual.

(b) Calculation of the Ground Plane Pathway Factor,  $R_{ija}^G$

$$R_{ija}^G = K'K''(SF)(DFG_{ij})[(1-e^{-\lambda_i t})/\lambda_i], \text{ m}^2\text{-mrem/year per } \mu\text{Ci/sec} \quad (5-8)$$

Where:  $K'$  = A units conversion constant,  $10^6$  pCi/ $\mu$ Ci  
 $K''$  = A units conversion constant, 8760 hour/year  
 $SF$  = The shielding factor, dimensionless  
 = 0.7 as suggested in Table E-15 of Regulatory Guide 1.109  
 $DFG_{ij}$  = The ground plane dose conversion factor for radionuclide i, mrem/hour per pCi/ $\text{m}^2$ . Values for  $DFG_{ij}$  were obtained from Table E-6 of Regulatory Guide 1.109 and are presented in TABLE 5-8 of this manual.  
 $\lambda_i$  = The decay constant for radionuclide i,  $\text{sec}^{-1}$   
 $t$  = The exposure time, sec  
 =  $6.31\text{E}+08$  sec (20 years)

(c) Calculation of the Grass-Cow/Goat-Milk Pathway Factor,  $R_{ija}^c$

$$R_{ija}^c = K' \left[ \frac{Q_f (U_{ap})}{(\lambda_i + \lambda_w)} \right] F_m(r) (DFL_{ij})_a \cdot \left[ \frac{f_p f_s}{Y_p} + \frac{(1 - f_p f_s) (e^{-\lambda_i t_h})}{Y_s} \right] \cdot e^{(-\lambda_i t_h)}, \text{ m}^2\text{-mrem/yr per } \mu\text{Ci/sec} \quad (5-9)$$

- Where:
- $K'$  = A units conversion constant,  $10^6$  pCi/ $\mu$ Ci
  - $Q_f$  = The cow/goat feed consumption rate, kg(wet)/day
  - $U_{ap}$  = The receptor's milk consumption rate for age group (a), liters/year
  - $Y_p$  = The agricultural productivity by unit area of pasture feed grass, kg/m<sup>2</sup>
  - $Y_s$  = The agricultural productivity by unit area of stored feed, kg/m<sup>2</sup>
  - $F_{mi}$  = The stable element transfer coefficient for nuclide i in milk, days/liter. These values are from Tables E-1 and E-2 of Regulatory Guide 1.109.
  - $r$  = Fraction of deposited activity retained on feed grass, dimensionless
  - $(DFL_{ij})_a$  = The organ ingestion dose factor for radionuclide i and the receptor in age group (a), mrem/pCi. Values for  $(DFL_{ij})_a$  were obtained from Tables E-11 through E-14 of Regulatory Guide 1.109 and are presented in TABLE 5-9 through TABLE 5-12 of this manual.
  - $\lambda_i$  = The decay constant for radionuclide i, sec<sup>-1</sup>
  - $\lambda_w$  = The decay constant for removal of activity on leaf and plant surfaces by weathering, sec<sup>-1</sup>  
=  $5.73\text{E-}07$  sec<sup>-1</sup> (corresponding to a 14-day half-life)
  - $t_f$  = The transport time from pasture to animal, to milk, to receptor, sec
  - $t_h$  = The transport time from pasture to harvest, to animal, sec
  - $f_p$  = Fraction of the year that the cow/goat is on pasture, dimensionless
  - $f_s$  = Fraction of the cow/goat feed that is pasture grass while the cow/goat is on pasture, dimensionless

The input parameters for calculating  $R_{ija}^c$  are listed in TABLE 5-13.

### Tritium

The concentration of tritium in milk is based on its airborne concentration rather than the deposition.

$$R^C_T = K'K''F_m Q_F U_{ap}(DFL_{ij})_a * 0.75(0.5/H), \text{ mrem/yr per } \mu\text{Ci/m}^3 \quad (5-10)$$

- Where:
- K'' = A units conversion constant, 10<sup>3</sup> gm/kg
  - H = The absolute atmospheric humidity  
= 8 gm/m<sup>3</sup> (NUREG-0133, p. 34)
  - 0.75 = The fraction of total feed that is water, dimensionless
  - 0.5 = The ratio of the specific activity of the feed grass water to the atmospheric water, dimensionless

The other parameters are as defined in the calculation of R<sup>C</sup><sub>ija</sub>

### Carbon-14

The concentration of carbon-14 in milk is based on its airborne concentration rather than the deposition.

$$R^C_{c-14} = K' K'' p F_m Q_F (DFL_{ij})_a [0.11/0.16], \text{ mrem/yr per } \mu\text{Ci/m}^3 \quad (5-11)$$

- Where:
- p = The fractional equilibrium ration (4400 hrs/8760 hrs). The ratio of the total annual release time for (C-14) atmospheric releases to the total annual time during photosynthesis occurs (taken to be 4400 hrs), under the condition that the value of p should never exceed unity. For continuous C-14 releases, p is taken to be unity.
  - 0.11 = The fraction of total plant mass that is natural carbon, dimensionless.
  - 0.16 = The concentration of natural carbon in the atmosphere, [gm/m<sup>3</sup>].

The other parameters are as defined in the calculation of R<sup>C</sup><sub>ija</sub>.

(d) Calculation of the Grass-Cow-Meat Pathway Factor,  $R^{M_{ija}}$

$$R^{M_{ija}} = \left[ \frac{K' Q_f (U_{ap})}{(\lambda_i + \lambda_w)} \right] F_f(r) (DFL_{ij})_a \cdot \left[ \frac{f_p f_s}{Y_p} + \frac{(1 - f_p f_s)(e^{-\lambda t_h})}{Y_s} \right] \cdot e^{(-\lambda t_s)}, \text{ m}^2\text{-mrem/yr per } \mu\text{Ci/sec} \quad (5-11)$$

- Where:
- $K'$  = A units conversion constant,  $10^6$  pCi/ $\mu$ Ci
  - $U_{ap}$  = The receptor's meat consumption rate for age group (a), kg/year
  - $F_f$  = The stable element transfer coefficient, days/kg
  - $t_s$  = The transport time from pasture to animal to slaughter of meat animal to receptor, seconds
  - $t_h$  = The transport time from crop field to harvest to animal, seconds
  - $(DFL_{ij})_a$  = The organ ingestion dose factor for radionuclide i and the receptor in age group (a), mrem per pCi. Values are tabulated in TABLE 5-9 through TABLE 5-12 of this manual.

The input parameters necessary for calculating  $R^{M_{ija}}$  are listed in TABLE 5-14. All other terms are as defined for equations (5-9) and (5-10).

Tritium

The concentration of tritium in meat is based on its airborne concentration rather than the deposition.

$$R^{M_T} = K' K'' F_f Q_F U_{ap} (DFL_{ij})_a [0.75(0.5/H)], \text{ mrem/yr per } \mu\text{Ci/m}^3 \quad (5-12)$$

The terms in equation (5-12) are as defined in equations (5-10) and (5-11).

Carbon-14

The concentration of carbon-14 in meat is based on its airborne concentration rather than the deposition.

$$R^{M_{c-14}} = K' K'' F_m Q_F (DFL_{ij})_a [0.11/0.16], \text{ mrem/yr per } \mu\text{Ci/m}^3 \quad (5-14)$$

The terms in equation (5-14) are as defined in equation (5-10), (5-11), and (5-12).

(e) Calculation of the Vegetation Pathway Factor,  $R_{ipj}^V$

$$R_{ipj}^V = K' \left[ \frac{(r)}{(Y_v (\lambda_i + \lambda_w))} \right] \cdot (DFL_{ij})_a \cdot [U_a^L f_L (e^{-\lambda_i t_L}) + U_a^S f_g (e^{-\lambda_i t_h})], \text{ m}^2\text{-mrem/yr per } \mu\text{Ci/sec} \quad (5-13)$$

- Where:
- $K'$  = A units conversion constant,  $10^6$  pCi/ $\mu$ Ci
  - $U_a^L$  = The consumption rate of fresh leafy vegetation by the receptor in age group (a), kg/year
  - $U_a^S$  = The consumption rate of stored vegetation by the receptor in age group (a), kg/yr
  - $f_L$  = The fraction of the annual intake of fresh leafy vegetation grown locally, dimensionless
  - $f_g$  = The fraction of the annual intake of stored vegetation grown locally, dimensionless
  - $t_L$  = The average time between harvest of leafy vegetation and its consumption, seconds
  - $t_h$  = The average time between harvest of stored vegetation and its consumption, seconds
  - $Y_v$  = the vegetation area density, kg/m<sup>2</sup>
  - $(DFL_{ij})_a$  = The organ ingestion dose factor for organ j, radionuclide I, and the receptor in age group (a), mrem per pCi. Values are tabulated in TABLE 5-9 through TABLE 5-12 of this manual.

The input parameters necessary for calculating  $R_{ipj}^V$  are listed in TABLE 5-15. All other terms are as defined for equations ( m<sup>2</sup>-mrem/yr per  $\mu$ Ci/sec(5-9) and (5-).

Tritium

The concentration of tritium in vegetation is based on its airborne concentration rather than the deposition.

$$R_{VT}^V = K'K''(U_a^L f_L + U_a^S f_g)(DFL_{ij})_a [0.75(0.5/H)], \text{ mrem/yr per } \mu\text{Ci/m}^3 \quad (5-14)$$

The terms in equation (5-) are as defined in equations (5-10) and (5-).

Carbon-14

The concentration of carbon-14 in vegation is based on its airborne concentration rather than the deposition.

$$R^{C-14} = K' K'' p F_m Q_F (DFL_{ij})_a [0.11/0.16], \text{ mrem/yr per } \mu\text{Ci/m}^3 \quad (5-17)$$

The terms in equation (5-17) are as defined in equations (5-10), (5-11), and (5-15).

The pathway dose rate factors by age group are listed in TABLE 5-16 through TABLE 5-34.

5.6 GASEOUS EFFLUENT DOSE PROJECTION CALCULATIONS

The 31 day projected dose shall be calculated using the following equation

$$D_{pj} = (D_j * p) + D_{aj} \quad (5-15)$$

- Where:
- $D_{pj}$  = the 31 day projected dose by organ j.
  - $D_j$  = sum of dose for all valid release points for the release period (usually quarter) by organ j.
  - $p$  = the projection factor which is the results of 31 divided by the number of days from the start of the quarter to the end of the release.
  - $D_{aj}$  = additional anticipated dose for gaseous release by organ j and quarter of release.

FIGURE 5-1  
CPS SITE BOUNDARY FOR GASEOUS EFFLUENTS

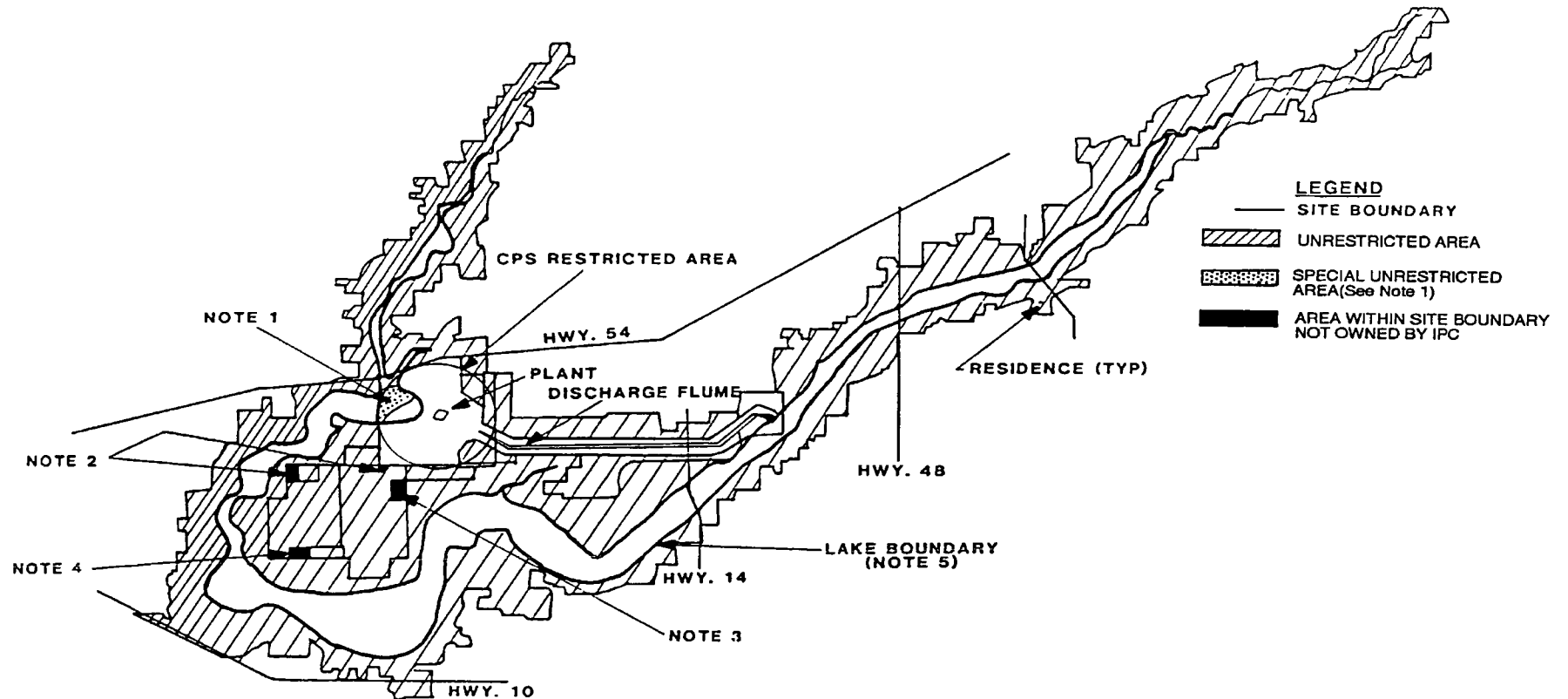

**NOTES**

1. The area in the lake between the buoys and the exclusion area boundary is unrestricted at this time. But will be controlled if plant effluent conditions warrant closure.
2. Land parcel not owned by Clinton Power Station, includes residences.
3. Land parcel not owned by Clinton Power Station, oil company pipeline pumping station.
4. Land parcel not owned by Clinton Power Station, agricultural use.
5. The lake shoreline is approximately 690 ft. MSL elevation line.

TABLE 5-4  
INHALATION DOSE FACTORS FOR INFANT - (DFA<sub>i</sub>)<sub>a</sub>  
(mrem per  $\mu$ Ci inhaled)

NUCLIDE	BONE	LIVER	T.BODY	THYROID	KIDNEY	LUNG	GI-LLI
H-3	NO DATA	4.62E-07	4.62E-07	4.62E-07	4.62E-07	4.62E-07	4.62E-07
C-14	1.89E-05	3.79E-06	3.79E-06	3.79E-06	3.79E-06	3.79E-06	3.79E-06
P-32	1.45E-03	8.03E-05	5.53E-05	NO DATA	NO DATA	NO DATA	1.15E-05
CR-51	NO DATA	NO DATA	6.39E-08	4.11E-08	9.45E-09	9.17E-06	2.55E-07
MN-54	NO DATA	1.81E-05	3.56E-06	NO DATA	3.56E-06	7.14E-04	5.04E-06
FE-55	1.41E-05	8.39E-06	2.38E-06	NO DATA	NO DATA	6.21E-05	7.82E-07
FE-59	9.69E-06	1.68E-05	6.77E-06	NO DATA	NO DATA	7.25E-04	1.77E-05
CO-58	NO DATA	8.71E-07	1.30E-06	NO DATA	NO DATA	5.55E-04	7.95E-06
CO-60	NO DATA	5.73E-06	8.41E-06	NO DATA	NO DATA	3.22E-03	2.28E-05
NI-63	2.42E-04	1.46E-05	8.29E-06	NO DATA	NO DATA	1.49E-04	1.73E-06
ZN-65	1.38E-05	4.47E-05	2.22E-05	NO DATA	2.32E-05	4.62E-04	3.67E-05
RB-86	NO DATA	1.36E-04	6.30E-05	NO DATA	NO DATA	NO DATA	2.17E-06
SR-89	2.84E-04	NO DATA	8.15E-06	NO DATA	NO DATA	1.45E-03	4.57E-05
SR-90	2.92E-02	NO DATA	1.85E-03	NO DATA	NO DATA	8.03E-03	9.36E-05
Y-90	2.35E-06	NO DATA	6.30E-08	NO DATA	NO DATA	1.92E-04	7.43E-05
Y-91	4.20E-04	NO DATA	1.12E-05	NO DATA	NO DATA	1.75E-03	5.02E-05
ZR-95	8.24E-05	1.99E-05	1.45E-05	NO DATA	2.22E-05	1.25E-03	1.55E-05
NB-95	1.12E-05	4.59E-06	2.70E-06	NO DATA	3.37E-06	3.42E-04	9.05E-06
MO-99	NO DATA	1.18E-07	2.31E-08	NO DATA	1.89E-07	9.63E-05	3.48E-05
TC-99m	9.98E-13	2.06E-12	2.66E-11	NO DATA	2.22E-11	5.79E-07	1.45E-06
RU-103	1.44E-06	NO DATA	4.85E-07	NO DATA	3.03E-06	3.94E-04	1.15E-05
RU-106	6.20E-05	NO DATA	7.70E-06	NO DATA	7.61E-05	8.26E-03	1.17E-04
AG-110m	7.13E-06	5.16E-06	3.57E-06	NO DATA	7.80E-06	2.62E-03	2.36E-05
TE-125m	3.40E-06	1.42E-06	4.70E-07	1.16E-06	NO DATA	3.19E-04	9.22E-06
TE-127m	1.19E-05	4.93E-06	1.48E-06	3.48E-06	2.68E-05	9.37E-04	1.95E-05
TE-129m	1.01E-05	4.35E-06	1.59E-06	3.91E-06	2.27E-05	1.20E-03	4.93E-05
I-130	4.54E-06	9.91E-06	3.98E-06	1.14E-03	1.09E-05	NO DATA	1.42E-06
I-131	2.71E-05	3.17E-05	1.40E-05	1.06E-02	3.70E-05	NO DATA	7.56E-07
I-132	1.21E-06	2.53E-06	8.99E-07	1.21E-04	2.82E-06	NO DATA	1.36E-06
I-133	9.46E-06	1.37E-05	4.00E-06	2.54E-03	1.60E-05	NO DATA	1.54E-06
I-134	6.58E-07	1.34E-06	4.75E-07	3.18E-05	1.49E-06	NO DATA	9.21E-07
I-135	2.76E-06	5.43E-06	1.98E-06	4.97E-04	6.05E-06	NO DATA	1.31E-06
CS-134	2.83E-04	5.02E-04	5.32E-05	NO DATA	1.36E-04	5.69E-05	9.53E-07
CS-136	3.45E-05	9.61E-05	3.78E-05	NO DATA	4.03E-05	8.40E-06	1.02E-06
CS-137	3.92E-04	4.37E-04	3.25E-05	NO DATA	1.23E-04	5.09E-05	9.53E-07
BA-140	4.00E-05	4.00E-08	2.07E-06	NO DATA	9.59E-09	1.14E-03	2.74E-05
CE-141	1.98E-05	1.19E-05	1.42E-06	NO DATA	3.75E-06	3.69E-04	1.54E-05
CE-144	2.28E-03	8.65E-04	1.26E-04	NO DATA	3.84E-04	7.03E-03	1.06E-04
PR-143	1.00E-05	3.74E-06	4.99E-07	NO DATA	1.41E-06	3.09E-04	2.66E-05
ND-147	5.67E-06	5.81E-06	3.57E-07	NO DATA	2.25E-06	2.30E-04	2.23E-05



TABLE 5-5  
INHALATION DOSE FACTORS FOR CHILD - (DFA<sub>i</sub>)<sub>a</sub>  
(mrem per  $\mu$ Ci inhaled)

NUCLIDE	BONE	LIVER	T.BODY	THYROID	KIDNEY	LUNG	GI-LLI
H-3	NO DATA	3.04E-07	3.04E-07	3.04E-07	3.04E-07	3.04E-07	3.04E-07
C-14	9.7E-06	1.82E-06	1.82E-06	1.82E-06	1.82E-06	1.82E-06	1.82E-06
P-32	7.04E-04	3.09E-05	2.67E-05	NO DATA	NO DATA	NO DATA	1.14E-05
CR-51	NO DATA	NO DATA	4.17E-08	2.31E-08	6.57E-09	4.59E-06	2.93E-07
MN-54	NO DATA	1.16E-05	2.57E-06	NO DATA	2.71E-06	4.26E-04	6.19E-06
FE-55	1.28E-05	6.80E-06	2.10E-06	NO DATA	NO DATA	3.00E-05	7.75E-07
FE-59	5.59E-06	9.04E-06	4.51E-06	NO DATA	NO DATA	3.43E-04	1.91E-05
CO-58	NO DATA	4.79E-07	8.55E-07	NO DATA	NO DATA	2.99E-04	9.29E-06
CO-60	NO DATA	3.55E-06	6.12E-06	NO DATA	NO DATA	1.91E-03	2.60E-05
NI-63	2.22E-04	1.25E-05	7.56E-06	NO DATA	NO DATA	7.43E-05	1.71E-06
ZN-65	1.15E-05	3.06E-05	1.90E-05	NO DATA	1.93E-05	2.69E-04	4.41E-06
RB-86	NO DATA	5.36E-05	3.09E-05	NO DATA	NO DATA	NO DATA	2.16E-06
SR-89	1.62E-04	NO DATA	4.66E-06	NO DATA	NO DATA	5.83E-04	4.52E-05
SR-90	2.73E-02	NO DATA	1.74E-03	NO DATA	NO DATA	3.99E-03	9.28E-05
Y-90	1.11E-06	NO DATA	2.99E-08	NO DATA	NO DATA	7.07E-05	7.24E-05
Y-91	2.47E-04	NO DATA	6.59E-06	NO DATA	NO DATA	7.10E-04	4.97E-05
ZR-95	5.13E-05	1.13E-05	1.00E-05	NO DATA	1.61E-05	6.03E-04	1.65E-05
NB-95	6.35E-06	2.48E-06	1.77E-06	NO DATA	2.33E-06	1.66E-04	1.00E-05
MO-99	NO DATA	4.66E-08	1.15E-08	NO DATA	1.06E-07	3.66E-05	3.42E-05
TC-99m	4.81E-13	9.41E-13	1.56E-11	NO DATA	1.37E-11	2.57E-07	1.30E-06
RU-103	7.55E-07	NO DATA	2.90E-07	NO DATA	1.90E-06	1.79E-04	1.21E-05
RU-106	3.68E-05	NO DATA	4.57E-06	NO DATA	4.97E-05	3.87E-03	1.16E-04
AG-110m	4.56E-06	3.08E-06	2.47E-06	NO DATA	5.74E-06	1.48E-03	2.71E-05
TE-125m	1.82E-06	6.29E-07	2.47E-07	5.20E-07	NO DATA	1.29E-04	9.13E-06
TE-127m	6.72E-06	2.31E-06	8.18E-07	1.64E-06	1.72E-05	4.00E-04	1.93E-05
TE-129m	5.19E-06	1.85E-06	8.22E-07	1.71E-06	1.36E-05	4.76E-04	4.91E-05
I-130	2.21E-06	4.43E-06	2.28E-06	4.99E-04	6.61E-06	NO DATA	1.38E-06
I-131	1.30E-05	1.30E-05	7.37E-06	4.39E-03	2.13E-05	NO DATA	7.68E-07
I-132	5.72E-07	1.10E-06	5.07E-07	5.23E-05	1.69E-06	NO DATA	8.65E-07
I-133	4.48E-06	5.49E-06	2.08E-06	1.04E-03	9.13E-06	NO DATA	1.48E-06
I-134	3.17E-07	5.84E-07	2.69E-07	1.37E-05	8.92E-07	NO DATA	2.58E-07
I-135	1.33E-06	2.36E-06	1.12E-06	2.14E-04	3.62E-06	NO DATA	1.20E-06
CS-134	1.76E-04	2.74E-04	6.07E-05	NO DATA	8.93E-05	3.27E-05	1.04E-06
CS-136	1.76E-05	4.62E-05	3.14E-05	NO DATA	2.58E-05	3.93E-06	1.13E-06
CS-137	2.45E-04	2.23E-04	3.47E-05	NO DATA	7.63E-05	2.81E-05	9.78E-07
BA-140	2.00E-05	1.75E-08	1.17E-06	NO DATA	5.71E-09	4.71E-04	2.75E-05
CE-141	1.06E-05	5.28E-06	7.83E-07	NO DATA	2.31E-06	1.47E-04	1.53E-05
CE-144	1.83E-03	5.72E-04	9.77E-05	NO DATA	3.17E-04	3.23E-03	1.05E-04
PR-143	4.99E-06	1.50E-06	2.47E-07	NO DATA	8.11E-07	1.17E-04	2.63E-05
ND-147	2.92E-06	2.36E-06	1.84E-07	NO DATA	1.30E-06	8.87E-05	2.22E-05

TABLE 5-6  
 INHALATION DOSE FACTORS FOR TEEN - (DFA<sub>i</sub>)<sub>a</sub>  
 (mrem per  $\mu$ Ci inhaled)

NUCLIDE	BONE	LIVER	T.BODY	THYROID	KIDNEY	LUNG	GI-LLI
H-3	NO DATA	1.59E-07	1.59E-07	1.59E-07	1.59E-07	1.59E-07	1.59E-07
C-14	3.25E-06	6.09E-07	6.09E-07	6.09E-07	6.09E-07	6.09E-07	6.09E-07
P-32	2.36E-04	1.37E-05	8.95E-06	NO DATA	NO DATA	NO DATA	1.16E-05
CR-51	NO DATA	NO DATA	1.69E-08	9.37E-09	3.84E-09	2.62E-06	3.75E-07
MN-54	NO DATA	6.39E-06	1.05E-06	NO DATA	1.59E-06	2.48E-04	8.35E-06
FE-55	4.18E-06	2.98E-06	6.93E-07	NO DATA	NO DATA	1.55E-05	7.99E-07
FE-59	1.99E-06	4.62E-06	1.79E-06	NO DATA	NO DATA	1.91E-04	2.23E-05
CO-58	NO DATA	2.59E-07	3.47E-07	NO DATA	NO DATA	1.68E-04	1.19E-05
CO-60	NO DATA	1.89E-06	2.48E-06	NO DATA	NO DATA	1.09E-03	3.24E-05
NI-63	7.25E-05	5.43E-06	2.47E-06	NO DATA	NO DATA	3.84E-05	1.77E-06
ZN-65	4.82E-06	1.67E-05	7.80E-06	NO DATA	1.08E-05	1.55E-04	5.83E-06
RB-86	NO DATA	2.38E-05	1.05E-05	NO DATA	NO DATA	NO DATA	2.21E-06
SR-89	5.43E-05	NO DATA	1.56E-06	NO DATA	NO DATA	3.02E-04	4.64E-05
SR-90	1.35E-02	NO DATA	8.35E-04	NO DATA	NO DATA	2.06E-03	9.56E-05
Y-90	3.73E-07	NO DATA	1.00E-08	NO DATA	NO DATA	3.66E-05	6.99E-05
Y-91	8.26E-05	NO DATA	2.21E-06	NO DATA	NO DATA	3.67E-04	5.11E-05
ZR-95	1.82E-05	5.73E-06	3.94E-06	NO DATA	8.42E-06	3.36E-04	1.86E-05
NB-95	2.32E-06	1.29E-06	7.08E-07	NO DATA	1.25E-06	9.39E-05	1.21E-05
MO-99	NO DATA	2.11E-08	4.03E-09	NO DATA	5.14E-08	1.92E-05	3.36E-05
TC-99m	1.73E-13	4.83E-13	6.24E-12	NO DATA	7.20E-12	1.44E-07	7.66E-07
RU-103	2.63E-07	NO DATA	1.12E-07	NO DATA	9.29E-07	9.79E-05	1.36E-05
RU-106	1.23E-05	NO DATA	1.55E-06	NO DATA	2.38E-05	2.01E-03	1.20E-04
AG-110m	1.73E-06	1.64E-06	9.99E-07	NO DATA	3.13E-06	8.44E-04	3.41E-05
TE-125m	6.10E-07	2.80E-07	8.34E-08	1.75E-07	NO DATA	6.70E-05	9.38E-06
TE-127m	2.25E-06	1.02E-06	2.73E-07	5.48E-07	8.17E-06	2.07E-04	1.99E-05
TE-129m	1.74E-06	8.23E-07	2.81E-07	5.72E-07	6.49E-06	2.47E-04	5.06E-05
I-130	7.80E-07	2.24E-06	8.96E-07	1.86E-04	3.44E-06	NO DATA	1.14E-06
I-131	4.43E-06	6.14E-06	3.30E-06	1.83E-03	1.05E-05	NO DATA	8.11E-07
I-132	1.99E-07	5.47E-07	1.97E-07	1.89E-05	8.65E-07	NO DATA	1.59E-07
I-133	1.52E-06	2.56E-06	7.78E-07	3.65E-04	4.49E-06	NO DATA	1.29E-06
I-134	1.11E-07	2.90E-07	1.05E-07	4.94E-06	4.58E-07	NO DATA	2.55E-09
I-135	4.62E-07	1.18E-06	4.36E-07	7.76E-05	1.86E-06	NO DATA	8.69E-07
CS-134	6.28E-05	1.41E-04	6.86E-05	NO DATA	4.69E-05	1.83E-05	1.22E-06
CS-136	6.44E-06	2.42E-05	1.71E-05	NO DATA	1.38E-05	2.22E-06	1.36E-06
CS-137	8.38E-05	1.06E-04	3.89E-05	NO DATA	3.80E-05	1.51E-05	1.06E-06
BA-140	6.84E-06	8.38E-09	4.40E-07	NO DATA	2.85E-09	2.54E-04	2.86E-05
CE-141	3.55E-06	2.37E-06	2.71E-07	NO DATA	1.11E-06	7.67E-05	1.58E-05
CE-144	6.11E-04	2.53E-04	3.28E-05	NO DATA	1.51E-04	1.67E-03	1.08E-04
PR-143	1.67E-06	6.64E-07	8.28E-08	NO DATA	3.86E-07	6.04E-05	2.67E-05
ND-147	9.83E-07	1.07E-06	6.41E-08	NO DATA	6.28E-07	4.65E-05	2.28E-05

TABLE 5-7  
INHALATION DOSE FACTORS FOR ADULT - (DFA<sub>i</sub>)<sub>a</sub>  
(mrem per μCi inhaled)

NUCLIDE	BONE	LIVER	T.BODY	THYROID	KIDNEY	LUNG	GI-LLI
H-3	NO DATA	1.58E-07	1.58E-07	1.58E-07	1.58E-07	1.58E-07	1.58E-07
C-14	2.27E-06	4.26E-07	4.26E-07	4.26E-07	4.26E-07	4.26E-07	4.26E-07
P-32	1.65E-04	9.64E-06	6.26E-06	NO DATA	NO DATA	NO DATA	1.08E-05
CR-51	NO DATA	NO DATA	1.25E-08	7.44E-09	2.85E-09	1.80E-06	4.15E-07
MN-54	NO DATA	4.95E-06	7.87E-07	NO DATA	1.23E-06	1.75E-04	9.67E-06
FE-55	3.07E-06	2.12E-06	4.93E-07	NO DATA	NO DATA	9.01E-06	7.54E-07
FE-59	1.47E-06	3.47E-06	1.32E-06	NO DATA	NO DATA	1.27E-04	2.35E-05
CO-58	NO DATA	1.98E-07	2.59E-07	NO DATA	NO DATA	1.16E-04	1.33E-05
CO-60	NO DATA	1.44E-06	1.85E-06	NO DATA	NO DATA	7.46E-04	3.56E-05
NI-63	5.40E-05	3.93E-06	1.81E-06	NO DATA	NO DATA	2.23E-05	1.67E-06
ZN-65	4.05E-06	1.29E-05	5.82E-06	NO DATA	8.62E-06	1.08E-04	6.68E-06
RB-86	NO DATA	1.69E-05	7.37E-06	NO DATA	NO DATA	NO DATA	2.08E-06
SR-89	3.80E-05	NO DATA	1.09E-06	NO DATA	NO DATA	1.75E-04	4.37E-05
SR-90	1.24E-02	NO DATA	7.62E-04	NO DATA	NO DATA	1.20E-03	9.02E-05
Y-90	2.61E-07	NO DATA	7.01E-09	NO DATA	NO DATA	2.12E-05	6.32E-05
Y-91	5.78E-05	NO DATA	1.55E-06	NO DATA	NO DATA	2.13E-04	4.81E-05
ZR-95	1.34E-05	4.30E-06	2.91E-06	NO DATA	6.77E-06	2.21E-04	1.88E-05
NB-95	1.76E-06	9.77E-07	5.26E-07	NO DATA	9.67E-07	6.31E-05	1.30E-05
MO-99	NO DATA	1.51E-08	2.87E-09	NO DATA	3.64E-08	1.14E-05	3.10E-05
TC-99m	1.29E-13	3.64E-13	4.63E-12	NO DATA	5.52E-12	9.55E-08	5.20E-07
RU-103	1.91E-07	NO DATA	8.23E-08	NO DATA	7.29E-07	6.31E-05	1.38E-05
RU-106	8.64E-06	NO DATA	1.09E-06	NO DATA	1.67E-05	1.17E-03	1.14E-04
AG-110m	1.35E-06	1.25E-06	7.43E-07	NO DATA	2.46E-06	5.79E-04	3.78E-05
TE-125m	4.27E-07	1.98E-07	5.84E-08	1.31E-07	1.55E-06	3.92E-05	8.83E-06
TE-127m	1.58E-06	7.21E-07	1.96E-07	4.11E-07	5.72E-06	1.20E-04	1.87E-05
TE-129m	1.22E-06	5.84E-07	1.98E-07	4.30E-07	4.57E-06	1.45E-04	4.79E-05
I-130	5.72E-07	1.68E-06	6.60E-07	1.42E-04	2.61E-06	NO DATA	9.61E-07
I-131	3.15E-06	4.47E-06	2.56E-06	1.49E-03	7.66E-06	NO DATA	7.85E-07
I-132	1.45E-07	4.07E-07	1.45E-07	1.43E-05	6.48E-07	NO DATA	5.08E-08
I-133	1.08E-06	1.85E-06	5.65E-07	2.69E-04	3.23E-06	NO DATA	1.11E-06
I-134	8.05E-08	2.16E-07	7.69E-08	3.73E-06	3.44E-07	NO DATA	1.26E-10
I-135	3.35E-07	8.73E-07	3.21E-07	5.60E-05	1.39E-06	NO DATA	6.56E-07
CS-134	4.66E-05	1.06E-04	9.10E-05	NO DATA	3.59E-05	1.22E-05	1.30E-06
CS-136	4.88E-06	1.83E-05	1.38E-05	NO DATA	1.07E-05	1.50E-06	1.46E-06
CS-137	5.98E-05	7.76E-05	5.35E-05	NO DATA	2.78E-05	9.40E-06	1.05E-06
BA-140	4.88E-06	6.13E-09	3.21E-07	NO DATA	2.09E-09	1.59E-04	2.73E-05
CE-141	2.49E-06	1.69E-06	1.91E-07	NO DATA	7.83E-07	4.52E-05	1.50E-05
CE-144	4.29E-04	1.79E-04	2.30E-05	NO DATA	1.06E-04	9.72E-04	1.02E-04
PR-143	1.17E-06	4.69E-07	5.80E-08	NO DATA	2.70E-07	3.51E-05	2.50E-05
ND-147	6.59E-07	7.62E-07	4.56E-08	NO DATA	4.45E-07	2.76E-05	2.16E-05

TABLE 5-8  
GROUND PLANE DOSE FACTORS - DFG<sub>i</sub>  
(mrem/hr per  $\mu\text{Ci}/\text{m}^2$ )

ELEMENT	TOTAL BODY	SKIN
H-3	0.0	0.0
C-14	0.0	0.0
P-32	0.0	0.0
Cr-51	2.20E-10	2.60E-10
Mn-54	5.80E-09	6.80E-09
Fe-55	0.0	0.0
Fe-59	8.00E-09	9.40E-09
Co-58	7.00E-09	8.20E-09
Co-60	1.70E-08	2.00E-08
Ni-63	0.0	0.0
Zn-65	4.00E-09	4.60E-09
Rb-86	6.30E-10	7.20E-10
Sr-89	5.60E-13	6.50E-13
Y-90	2.20E-12	2.60E-12
Y-91	2.40E-11	2.70E-11
Zr-95	5.00E-09	5.80E-09
Nb-95	5.10E-09	6.00E-09
Mo-99	1.90E-09	2.20E-09
Tc-99m	9.60E-10	1.10E-09
Ru-103	3.60E-09	4.20E-09
Ru-106	1.50E-09	1.80E-09
Ag-110m	1.80E-08	2.10E-08
Te-125m	3.50E-11	4.80E-11
Te-127m	1.10E-12	1.30E-12
Te-129m	7.70E-10	9.00E-10
I-130	1.40E-08	1.70E-08
I-131	2.80E-09	3.40E-09
I-132	1.70E-08	2.00E-08
I-133	3.70E-09	4.50E-09
I-134	1.60E-08	1.90E-08
I-135	1.20E-08	1.40E-08
Cs-134	1.20E-08	1.40E-08
Cs-136	1.50E-08	1.70E-08
Cs-137	4.20E-09	4.90E-09
Ba-140	2.10E-09	2.40E-09
Ce-141	5.50E-10	6.20E-10
Ce-144	3.20E-10	3.70E-10
Pr-143	0.0	0.0
Nd-147	1.00E-09	1.20E-09
C-14	0.0	0.0

TABLE 5-9  
INGESTION DOSE FACTORS FOR INFANT - (DFL<sub>i</sub>)<sub>a</sub>  
(mrem per  $\mu$ Ci ingested)

NUCLIDE	BONE	LIVER	T.BODY	THYROID	KIDNEY	LUNG	GI-LLI
H-3	NO DATA	3.08E-07	3.08E-07	3.08E-07	3.08E-07	3.08E-07	3.08E-07
C-14	2.37E-05	5.06E-06	5.06E-06	5.06E-06	5.06E-06	5.06E-06	5.06E-06
P-32	1.70E-03	1.00E-04	6.59E-05	NO DATA	NO DATA	NO DATA	2.30E-05
CR-51	NO DATA	NO DATA	1.41E-08	9.20E-09	2.01E-09	1.79E-08	4.11E-07
MN-54	NO DATA	1.99E-05	4.51E-06	NO DATA	4.41E-06	NO DATA	7.31E-06
FE-55	1.39E-05	8.98E-06	2.40E-06	NO DATA	NO DATA	4.39E-06	1.14E-06
FE-59	3.08E-05	5.38E-05	2.12E-05	NO DATA	NO DATA	1.59E-05	2.57E-05
CO-58	NO DATA	3.60E-06	8.98E-06	NO DATA	NO DATA	NO DATA	8.97E-06
CO-60	NO DATA	1.08E-05	2.55E-05	NO DATA	NO DATA	NO DATA	2.57E-05
NI-63	6.34E-04	3.92E-05	2.20E-05	NO DATA	NO DATA	NO DATA	1.95E-06
ZN-65	1.84E-05	6.31E-05	2.91E-05	NO DATA	3.06E-05	NO DATA	5.33E-05
RB-86	NO DATA	1.70E-04	8.40E-05	NO DATA	NO DATA	NO DATA	4.34E-06
SR-89	2.51E-03	NO DATA	7.20E-05	NO DATA	NO DATA	NO DATA	5.16E-05
SR-90	1.85E-02	NO DATA	4.71E-03	NO DATA	NO DATA	NO DATA	2.31E-04
Y-90	8.69E-08	NO DATA	2.33E-09	NO DATA	NO DATA	NO DATA	1.20E-04
Y-91	1.13E-06	NO DATA	3.01E-08	NO DATA	NO DATA	NO DATA	8.10E-05
ZR-95	2.06E-07	5.02E-08	3.56E-08	NO DATA	5.41E-08	NO DATA	2.50E-05
NB-95	4.20E-08	1.73E-08	1.00E-08	NO DATA	1.24E-08	NO DATA	1.46E-05
MO-99	NO DATA	3.40E-05	6.63E-06	NO DATA	5.08E-05	NO DATA	1.12E-05
TC-99m	1.92E-09	3.96E-09	5.10E-08	NO DATA	4.26E-08	2.07E-09	1.15E-06
RU-103	1.48E-06	NO DATA	4.95E-07	NO DATA	3.08E-06	NO DATA	1.80E-05
RU-106	2.41E-05	NO DATA	3.01E-06	NO DATA	2.85E-05	NO DATA	1.83E-04
AG-110m	9.96E-07	7.27E-07	4.81E-07	NO DATA	1.04E-06	NO DATA	3.77E-05
TE-125m	2.33E-05	7.79E-06	3.15E-06	7.84E-06	NO DATA	NO DATA	1.11E-05
TE-127m	5.85E-05	1.94E-05	7.08E-06	1.69E-05	1.44E-04	NO DATA	2.36E-05
TE-129m	1.00E-04	3.43E-05	1.54E-05	3.84E-05	2.50E-04	NO DATA	5.97E-05
I-130	6.00E-06	1.32E-05	5.30E-06	1.48E-03	1.45E-05	NO DATA	2.83E-06
I-131	3.59E-05	4.23E-05	1.86E-05	1.39E-02	4.94E-05	NO DATA	1.51E-06
I-132	1.66E-06	3.37E-06	1.20E-06	1.58E-04	3.76E-06	NO DATA	2.73E-06
I-133	1.25E-05	1.82E-05	5.33E-06	3.31E-03	2.14E-05	NO DATA	3.08E-06
I-134	8.69E-07	1.78E-06	6.33E-07	4.15E-05	1.99E-06	NO DATA	1.84E-06
I-135	3.64E-06	7.24E-06	2.64E-06	6.49E-04	8.07E-06	NO DATA	2.62E-06
CS-134	3.77E-04	7.03E-04	7.10E-05	NO DATA	1.81E-04	7.42E-05	1.91E-06
CS-136	4.59E-05	1.35E-04	5.04E-05	NO DATA	5.38E-05	1.10E-05	2.05E-06
CS-137	5.22E-04	6.11E-04	4.33E-05	NO DATA	1.64E-04	6.64E-05	1.91E-06
BA-140	1.71E-04	1.71E-07	8.81E-06	NO DATA	4.06E-08	1.05E-07	4.20E-05
CE-141	7.87E-08	4.80E-08	5.65E-09	NO DATA	1.48E-08	NO DATA	2.48E-05
CE-144	2.98E-06	1.22E-06	1.67E-07	NO DATA	4.93E-07	NO DATA	1.71E-04
PR-143	8.13E-08	3.04E-08	4.03E-09	NO DATA	1.13E-08	NO DATA	4.29E-05
ND-147	5.53E-08	5.68E-08	3.48E-09	NO DATA	2.19E-08	NO DATA	3.60E-05

TABLE 5-10  
INGESTION DOSE FACTORS FOR CHILD - (DFL<sub>i</sub>)<sub>a</sub>  
(mrem per μCi ingested)

NUCLIDE	BONE	LIVER	T.BODY	THYROID	KIDNEY	LUNG	GI-LLI
H-3	NO DATA	2.03E-07	2.03E-07	2.03E-07	2.03E-07	2.03E-07	2.03E-07
C-14	1.21E-05	2.42E-06	2.42E-06	2.42E-06	2.42E-06	2.42E-06	2.42E-06
P-32	8.25E-04	3.86E-05	3.18E-05	NO DATA	NO DATA	NO DATA	2.28E-05
CR-51	NO DATA	NO DATA	8.90E-09	4.94E-09	1.35E-09	9.02E-09	4.72E-07
MN-54	NO DATA	1.07E-05	2.85E-06	NO DATA	3.00E-06	NO DATA	8.98E-06
FE-55	1.15E-05	6.10E-06	1.89E-06	NO DATA	NO DATA	3.45E-06	1.13E-06
FE-59	1.65E-05	2.67E-05	1.33E-05	NO DATA	NO DATA	7.74E-06	2.78E-05
CO-58	NO DATA	1.80E-06	5.51E-06	NO DATA	NO DATA	NO DATA	1.05E-05
CO-60	NO DATA	5.29E-06	1.56E-05	NO DATA	NO DATA	NO DATA	2.93E-05
NI-63	5.38E-04	2.88E-05	1.83E-05	NO DATA	NO DATA	NO DATA	1.94E-06
ZN-65	1.37E-05	3.65E-05	2.27E-05	NO DATA	2.30E-05	NO DATA	6.41E-06
RB-86	NO DATA	6.70E-05	4.12E-05	NO DATA	NO DATA	NO DATA	4.31E-06
SR-89	1.32E-03	NO DATA	3.77E-05	NO DATA	NO DATA	NO DATA	5.11E-05
SR-90	1.70E-02	NO DATA	4.31E-03	NO DATA	NO DATA	NO DATA	2.29E-04
Y-90	4.11E-08	NO DATA	1.10E-09	NO DATA	NO DATA	NO DATA	1.17E-04
Y-91	6.02E-07	NO DATA	1.61E-08	NO DATA	NO DATA	NO DATA	8.02E-05
ZR-95	1.16E-07	2.55E-08	2.27E-08	NO DATA	3.65E-08	NO DATA	2.66E-05
NB-95	2.25E-08	8.76E-09	6.26E-09	NO DATA	8.23E-09	NO DATA	1.62E-05
MO-99	NO DATA	1.33E-05	3.29E-06	NO DATA	2.84E-05	NO DATA	1.10E-05
TC-99m	9.23E-10	1.81E-09	3.00E-08	NO DATA	2.63E-08	9.19E-10	1.03E-06
RU-103	7.31E-07	NO DATA	2.81E-07	NO DATA	1.84E-06	NO DATA	1.89E-05
RU-106	1.17E-05	NO DATA	1.46E-06	NO DATA	1.58E-05	NO DATA	1.82E-04
AG-110m	5.39E-07	3.64E-07	2.91E-07	NO DATA	6.78E-07	NO DATA	4.33E-05
TE-125m	1.14E-05	3.09E-06	1.52E-06	3.20E-06	NO DATA	NO DATA	1.10E-05
TE-127m	2.89E-05	7.78E-06	3.43E-06	6.91E-06	8.24E-05	NO DATA	2.34E-05
TE-129m	4.87E-05	1.36E-05	7.56E-06	1.57E-05	1.43E-04	NO DATA	5.94E-05
I-130	2.92E-06	5.90E-06	3.04E-06	6.50E-04	8.82E-06	NO DATA	2.76E-06
I-131	1.72E-05	1.73E-05	9.83E-06	5.72E-03	2.84E-05	NO DATA	1.54E-06
I-132	8.00E-07	1.47E-06	6.76E-07	6.82E-05	2.25E-06	NO DATA	1.73E-06
I-133	5.92E-06	7.32E-06	2.77E-06	1.36E-03	1.22E-05	NO DATA	2.95E-06
I-134	4.19E-07	7.78E-07	3.58E-07	1.79E-05	1.19E-06	NO DATA	5.16E-07
I-135	1.75E-06	3.15E-06	1.49E-06	2.79E-04	4.83E-06	NO DATA	2.40E-06
CS-134	2.34E-04	3.84E-04	8.10E-05	NO DATA	1.19E-04	4.27E-05	2.07E-06
CS-136	2.35E-05	6.46E-05	4.18E-05	NO DATA	3.44E-05	5.13E-06	2.27E-06
CS-137	3.27E-04	3.13E-04	4.62E-05	NO DATA	1.02E-04	3.67E-05	1.96E-06
BA-140	8.31E-05	7.28E-08	4.85E-06	NO DATA	2.37E-08	4.34E-08	4.21E-05
CE-141	8.97E-08	1.98E-08	2.94E-09	NO DATA	8.68E-09	NO DATA	2.47E-05
CE-144	2.08E-06	6.52E-07	1.11E-07	NO DATA	3.61E-07	NO DATA	1.70E-04
PR-143	3.93E-08	1.18E-08	1.95E-09	NO DATA	6.39E-09	NO DATA	4.24E-05
ND-147	2.79E-08	2.26E-08	1.75E-09	NO DATA	1.24E-08	NO DATA	3.58E-05

TABLE 5-11  
INGESTION DOSE FACTORS FOR TEEN - (DFL)<sub>i</sub><sub>a</sub>  
(mrem per  $\mu$ Ci ingested)

NUCLIDE	BONE	LIVER	T.BODY	THYROID	KIDNEY	LUNG	GI-LLI
H-3	NO DATA	1.06E-07	1.06E-07	1.06E-07	1.06E-07	1.06E-07	1.06E-07
C-14	4.06E-06	8.12E-07	8.12E-07	8.12E-07	8.12E-07	8.12E-07	8.12E-07
P-32	2.76E-04	1.71E-05	1.07E-05	NO DATA	NO DATA	NO DATA	2.32E-05
CR-51	NO DATA	NO DATA	3.60E-09	2.00E-09	7.89E-10	5.14E-09	6.05E-07
MN-54	NO DATA	5.90E-06	1.17E-06	NO DATA	1.76E-06	NO DATA	1.21E-05
FE-55	3.78E-06	2.68E-06	6.25E-07	NO DATA	NO DATA	1.70E-06	1.16E-06
FE-59	5.87E-06	1.37E-05	5.29E-06	NO DATA	NO DATA	4.32E-06	3.24E-05
CO-58	NO DATA	9.72E-07	2.24E-06	NO DATA	NO DATA	NO DATA	1.34E-05
CO-60	NO DATA	2.81E-06	6.33E-06	NO DATA	NO DATA	NO DATA	3.66E-05
NI-63	1.77E-04	1.25E-05	6.00E-06	NO DATA	NO DATA	NO DATA	1.99E-06
ZN-65	5.76E-06	2.00E-05	9.33E-06	NO DATA	1.28E-05	NO DATA	8.47E-06
RB-86	NO DATA	2.98E-05	1.40E-05	NO DATA	NO DATA	NO DATA	4.41E-06
SR-89	4.40E-04	NO DATA	1.26E-05	NO DATA	NO DATA	NO DATA	5.24E-05
SR-90	8.30E-03	NO DATA	2.05E-03	NO DATA	NO DATA	NO DATA	2.33E-04
Y-90	1.37E-08	NO DATA	3.69E-10	NO DATA	NO DATA	NO DATA	1.13E-04
Y-91	2.01E-07	NO DATA	5.39E-09	NO DATA	NO DATA	NO DATA	8.24E-05
ZR-95	4.12E-08	1.30E-08	8.94E-09	NO DATA	1.91E-08	NO DATA	3.00E-05
NB-95	8.22E-09	4.56E-09	2.51E-09	NO DATA	4.42E-09	NO DATA	1.95E-05
MO-99	NO DATA	6.03E-06	1.15E-06	NO DATA	1.38E-05	NO DATA	1.08E-05
TC-99m	3.32E-10	9.26E-10	1.20E-08	NO DATA	1.38E-08	5.14E-10	6.08E-07
RU-103	2.55E-07	NO DATA	1.09E-07	NO DATA	8.99E-07	NO DATA	2.13E-05
RU-106	3.92E-06	NO DATA	4.94E-07	NO DATA	7.56E-06	NO DATA	1.88E-04
AG-110m	2.05E-07	1.94E-07	1.18E-07	NO DATA	3.70E-07	NO DATA	5.45E-05
TE-125m	3.83E-06	1.38E-06	5.12E-07	1.07E-06	NO DATA	NO DATA	1.13E-05
TE-127m	9.67E-06	3.43E-06	1.15E-06	2.30E-06	3.92E-05	NO DATA	2.41E-05
TE-129m	1.63E-05	6.05E-06	2.58E-06	5.26E-06	6.82E-05	NO DATA	6.12E-05
I-130	1.03E-06	2.98E-06	1.19E-06	2.43E-04	4.59E-06	NO DATA	2.29E-06
I-131	5.85E-06	8.19E-06	4.40E-06	2.39E-03	1.41E-05	NO DATA	1.62E-06
I-132	2.79E-07	7.30E-07	2.62E-07	2.46E-05	1.15E-06	NO DATA	3.18E-07
I-133	2.01E-06	3.41E-06	1.04E-06	4.76E-04	5.98E-06	NO DATA	2.58E-06
I-134	1.46E-07	3.87E-07	1.39E-07	6.45E-06	6.10E-07	NO DATA	5.10E-09
I-135	6.10E-07	1.57E-06	5.82E-07	1.01E-04	2.48E-06	NO DATA	1.74E-06
CS-134	8.37E-05	1.97E-04	9.14E-05	NO DATA	6.26E-05	2.39E-05	2.45E-06
CS-136	8.59E-06	3.38E-05	2.27E-05	NO DATA	1.84E-05	2.90E-06	2.72E-06
CS-137	1.12E-04	1.49E-04	5.19E-05	NO DATA	5.07E-05	1.97E-05	2.12E-06
BA-140	2.84E-05	3.48E-08	1.83E-06	NO DATA	1.18E-08	2.34E-08	4.38E-05
CE-141	1.33E-08	8.88E-09	1.02E-09	NO DATA	4.18E-09	NO DATA	2.54E-05
CE-144	6.96E-07	2.88E-07	3.74E-08	NO DATA	1.72E-07	NO DATA	1.75E-04
PR-143	1.31E-08	5.23E-09	6.52E-10	NO DATA	3.04E-09	NO DATA	4.31E-05
ND-147	9.38E-09	1.02E-08	6.11E-10	NO DATA	5.99E-09	NO DATA	3.68E-05

TABLE 5-12  
 INGESTION DOSE FACTORS FOR ADULT - (DFL<sub>i</sub>)<sub>a</sub>  
 (mrem per  $\mu$ Ci ingested)

NUCLIDE	BONE	LIVER	T.BODY	THYROID	KIDNEY	LUNG	GI-LLI
H-3	NO DATA	1.05E-07	1.05E-07	1.05E-07	1.05E-07	1.05E-07	1.05E-07
C-14	2.84E-06	5.68E-07	5.68E-07	5.68E-07	5.68E-07	5.68E-07	5.68E-07
P-32	1.93E-04	1.20E-05	7.46E-06	NO DATA	NO DATA	NO DATA	2.17E-05
CR-51	NO DATA	NO DATA	2.66E-09	1.59E-09	5.86E-10	3.53E-09	6.69E-07
MN-54	NO DATA	4.57E-06	8.72E-07	NO DATA	1.36E-06	NO DATA	1.40E-05
FE-55	2.75E-06	1.90E-06	4.43E-07	NO DATA	NO DATA	1.06E-06	1.09E-06
FE-59	4.34E-06	1.02E-05	3.91E-06	NO DATA	NO DATA	2.85E-06	3.40E-05
CO-58	NO DATA	7.45E-07	1.67E-06	NO DATA	NO DATA	NO DATA	1.51E-05
CO-60	NO DATA	2.14E-06	4.72E-06	NO DATA	NO DATA	NO DATA	4.02E-05
NI-63	1.30E-04	9.01E-06	4.36E-06	NO DATA	NO DATA	NO DATA	1.88E-06
ZN-65	4.84E-06	1.54E-05	6.96E-06	NO DATA	1.03E-05	NO DATA	9.70E-06
RB-86	NO DATA	2.11E-05	9.83E-06	NO DATA	NO DATA	NO DATA	4.16E-06
SR-89	3.08E-04	NO DATA	8.84E-06	NO DATA	NO DATA	NO DATA	4.94E-05
SR-90	7.58E-03	NO DATA	1.86E-03	NO DATA	NO DATA	NO DATA	2.19E-04
Y-90	9.62E-09	NO DATA	2.58E-10	NO DATA	NO DATA	NO DATA	1.02E-04
Y-91	1.41E-07	NO DATA	3.77E-09	NO DATA	NO DATA	NO DATA	7.76E-05
ZR-95	3.04E-08	9.75E-09	6.60E-09	NO DATA	1.53E-08	NO DATA	3.09E-05
NB-95	6.22E-09	3.46E-09	1.86E-09	NO DATA	3.42E-09	NO DATA	2.10E-05
MO-99	NO DATA	4.31E-06	8.20E-07	NO DATA	9.76E-06	NO DATA	9.99E-06
TC-99m	2.47E-10	6.98E-10	8.89E-09	NO DATA	1.06E-08	3.42E-10	4.13E-07
RU-103	1.85E-07	NO DATA	7.97E-08	NO DATA	7.06E-07	NO DATA	2.16E-05
RU-106	2.75E-06	NO DATA	3.48E-07	NO DATA	5.31E-06	NO DATA	1.78E-04
AG-110m	1.60E-07	1.48E-07	8.79E-08	NO DATA	2.91E-07	NO DATA	6.04E-05
TE-125m	2.68E-06	9.71E-07	3.59E-07	8.06E-07	1.09E-05	NO DATA	1.07E-05
TE-127m	6.77E-06	2.42E-06	8.25E-07	1.73E-06	2.75E-05	NO DATA	2.27E-05
TE-129m	1.15E-05	4.29E-06	1.82E-06	3.95E-06	4.80E-05	NO DATA	5.79E-05
I-130	7.56E-07	2.23E-06	8.80E-07	1.89E-04	3.48E-06	NO DATA	1.92E-06
I-131	4.16E-06	5.95E-06	3.41E-06	1.95E-03	1.02E-05	NO DATA	1.57E-06
I-132	2.03E-07	5.43E-07	1.90E-07	1.90E-05	8.65E-07	NO DATA	1.02E-07
I-133	1.42E-06	2.47E-06	7.53E-07	3.63E-04	4.31E-06	NO DATA	2.22E-06
I-134	1.06E-07	2.88E-07	1.03E-07	4.99E-06	4.58E-07	NO DATA	2.51E-10
I-135	4.43E-07	1.16E-06	4.28E-07	7.65E-05	1.86E-06	NO DATA	1.31E-06
CS-134	6.22E-05	1.48E-04	1.21E-04	NO DATA	4.79E-05	1.59E-05	2.59E-06
CS-136	6.51E-06	2.57E-05	1.85E-05	NO DATA	1.43E-05	1.96E-06	2.92E-06
CS-137	7.97E-05	1.09E-04	7.14E-05	NO DATA	3.70E-05	1.23E-05	2.11E-06
BA-140	2.03E-05	2.55E-08	1.33E-06	NO DATA	8.67E-09	1.46E-08	4.18E-05
CE-141	9.36E-09	6.33E-09	7.18E-10	NO DATA	2.94E-09	NO DATA	2.42E-05
CE-144	4.88E-07	2.04E-07	2.62E-08	NO DATA	1.21E-07	NO DATA	1.65E-04
PR-143	9.20E-09	3.69E-09	4.56E-10	NO DATA	2.13E-09	NO DATA	4.03E-05
ND-147	6.29E-09	7.27E-09	4.35E-10	NO DATA	4.25E-09	NO DATA	3.49E-05



TABLE 5-13

INPUT PARAMETERS FOR CALCULATING  $R_{aij}^C$

Parameter	Value	Table*
$Q_F$ (kg/day)	50 for cow 6 for goat	E-3
$U_{ap}$ (liters/yr) - Infant	330	E-5
- Child	330	E-5
- Teen	400	E-5
- Adult	310	E-5
$Y_p$ (kg/m <sup>2</sup> )	0.7	E-15
$Y_s$ (kg/m <sup>2</sup> )	2.0	E-15
$F_m$ (days/liter)	Each stable element for cow Each stable element for goat	E-1 E-2
$r$ (dimensionless)	1.0 for radioiodine 0.2 for particulates	E-15 E-15
$t_f$ (seconds)	1.73E+05(2 days)	E-15
$t_h$ (seconds)	7.78E+06(90 days)	E-15
$f_s$ (dimensionless)	1.0 for cow 1.0 for goat	NUREG -0133 Section 5.3.1.3
$f_p$ (dimensionless)	1.0 for cow 1.0 for goat	NUREG -0133 Section 5.3.1.3

\* of Regulatory Guide 1.109 unless otherwise stated

TABLE 5-14  
INPUT PARAMETERS FOR CALCULATING  $R_{aj}^M$

Parameter	Value	Table*
U <sub>ap</sub> (liters/yr) - Infant	0	E-5
- Child	41	E-5
- Teen	65	E-5
- Adult	110	E-5
F <sub>f</sub> (days/kg)	Each stable element	E-1
t <sub>s</sub> (seconds)	1.73E+06 (20 days)	E-15
t <sub>h</sub> (seconds)	7.78E+06 (90 days)	E-15
Y <sub>p</sub> (kg/m <sup>2</sup> )	0.7	E-15
Y <sub>s</sub> (kg/m <sup>2</sup> )	2.0	E-15
r(dimensionless)	1.0 for radioiodine 0.2 for particulates	E-15 E-15
Q <sub>f</sub> (kg/day)	50	E-3

\* of Regulatory Guide 1.109

TABLE 5-15  
INPUT PARAMETERS FOR CALCULATING  $R_{aj}^V$

Parameter	Value	Table*
$U_a^L$ (kg/yr) - Infant	0	E-5
- Child	26	E-5
- Teen	42	E-5
- Adult	64	E-5
$U_a^S$ (kg/yr) - Infant	0	E-5
- Child	520	E-5
- Teen	630	E-5
- Adult	520	E-5
$f_L$ (dimensionless)	1.0	E-15
$f_g$ (dimensionless)	0.76	E-15
$t_L$ (seconds)	8.60E+04 (1 day)	E-15
$t_h$ (seconds)	5.18E+06 (60 days)	E-15
$Y_v$ (kg/m <sup>2</sup> )	2.0	E-15

\* of Regulatory Guide 1.109

TABLE 5-16  
INHALATION PATHWAY FACTORS -  $R_{aj}^I$  (INFANT)  
(mrem/yr per  $\mu\text{Ci}/\text{m}^3$ )

ORGAN: ISOTOPE	BONE	LIVER	T.BODY	THYROID	KIDNEY	LUNG	GI-LLI
H-3	NO DATA	6.47E+02	6.47E+02	6.47E+02	6.47E+02	6.47E+02	6.47E+02
C-14	2.65E+04	5.31E+03	5.31E+03	5.31E+03	5.31E+03	5.31E+03	5.31E+03
P-32	2.03E+06	1.12E+05	7.74E+04	NO DATA	NO DATA	NO DATA	1.61E+04
CR-51	NO DATA	NO DATA	8.95E+01	5.75E+01	1.32E+01	1.28E+04	3.57E+02
MN-54	NO DATA	2.53E+04	4.98E+03	NO DATA	4.98E+03	1.00E+06	7.06E+03
FE-55	1.97E+04	1.17E+04	3.33E+03	NO DATA	NO DATA	8.69E+04	1.09E+03
FE-59	1.36E+04	2.35E+04	9.48E+03	NO DATA	NO DATA	1.02E+06	2.48E+04
CO-58	NO DATA	1.22E+03	1.82E+03	NO DATA	NO DATA	7.77E+05	1.11E+04
CO-60	NO DATA	8.02E+03	1.18E+04	NO DATA	NO DATA	4.51E+06	3.19E+04
NI-63	3.39E+05	2.04E+04	1.16E+04	NO DATA	NO DATA	2.09E+05	2.42E+03
ZN-65	1.93E+04	6.26E+04	3.11E+04	NO DATA	3.25E+04	6.47E+05	5.14E+04
RB-86	NO DATA	1.90E+05	8.82E+04	NO DATA	NO DATA	NO DATA	3.04E+03
SR-89	3.98E+05	NO DATA	1.14E+04	NO DATA	NO DATA	2.03E+06	6.40E+04
SR-90	4.09E+07	NO DATA	2.59E+06	NO DATA	NO DATA	1.12E+07	1.31E+05
Y-90	3.29E+03	NO DATA	8.82E+01	NO DATA	NO DATA	2.69E+05	1.04E+05
Y-91	5.88E+05	NO DATA	1.57E+04	NO DATA	NO DATA	2.45E+06	7.03E+04
ZR-95	1.15E+05	2.79E+04	2.03E+04	NO DATA	3.11E+04	1.75E+06	2.17E+04
NB-95	1.57E+04	6.43E+03	3.78E+03	NO DATA	4.72E+03	4.79E+05	1.27E+04
MO-99	NO DATA	1.65E+02	3.23E+01	NO DATA	2.65E+02	1.35E+05	4.87E+04
TC-99m	1.40E-03	2.88E-03	3.72E-02	NO DATA	3.11E-02	8.11E+02	2.03E+03
RU-103	2.02E+03	NO DATA	6.79E+02	NO DATA	4.24E+03	5.52E+05	1.61E+04
RU-106	8.68E+04	NO DATA	1.09E+04	NO DATA	1.07E+05	1.16E+07	1.64E+05
AG-110m	9.98E+03	7.22E+03	5.00E+03	NO DATA	1.09E+04	3.67E+06	3.30E+04
TE-125m	4.76E+03	1.99E+03	6.58E+02	1.62E+03	NO DATA	4.47E+05	1.29E+04
TE-127m	1.67E+04	6.90E+03	2.07E+03	4.87E+03	3.75E+04	1.31E+06	2.73E+04
TE-129m	1.41E+04	6.09E+03	2.23E+03	5.47E+03	3.18E+04	1.68E+06	6.90E+04
I-130	6.39E+03	1.39E+04	5.57E+03	1.60E+06	1.53E+04	NO DATA	1.99E+03
I-131	3.79E+04	4.44E+04	1.96E+04	1.48E+07	5.18E+04	NO DATA	1.06E+03
I-132	1.69E+03	3.54E+03	1.26E+03	1.69E+05	3.95E+03	NO DATA	1.90E+03
I-133	1.32E+04	1.92E+04	5.60E+03	3.56E+06	2.24E+04	NO DATA	2.16E+03
I-134	9.21E+02	1.88E+03	6.65E+02	4.45E+04	2.09E+03	NO DATA	1.29E+03
I-135	3.86E+03	7.60E+03	2.77E+03	6.96E+05	8.47E+03	NO DATA	1.83E+03
CS-134	3.96E+05	7.03E+05	7.45E+04	NO DATA	1.90E+05	7.97E+04	1.33E+03
CS-136	4.83E+04	1.35E+05	5.29E+04	NO DATA	5.64E+04	1.18E+04	1.43E+03
CS-137	5.49E+05	6.12E+05	4.55E+04	NO DATA	1.72E+05	7.13E+04	1.33E+03
BA-140	5.60E+04	5.60E+01	2.90E+03	NO DATA	1.34E+01	1.60E+06	3.84E+04
CE-141	2.77E+04	1.67E+04	1.99E+03	NO DATA	5.25E+03	5.17E+05	2.16E+04
CE-144	3.19E+06	1.21E+06	1.76E+05	NO DATA	5.38E+05	9.84E+06	1.48E+05
PR-143	1.40E+04	5.24E+03	6.99E+02	NO DATA	1.97E+03	4.33E+05	3.72E+04
ND-147	7.94E+03	8.13E+03	5.00E+02	NO DATA	3.15E+03	3.22E+05	3.12E+04

TABLE 5-17  
INHALATION PATHWAY FACTORS -  $R_{aj}^1$  (CHILD)  
(mrem/yr per  $\mu\text{Ci}/\text{m}^3$ )

ORGAN: ISOTOPE	BONE	LIVER	T.BODY	THYROID	KIDNEY	LUNG	GI-LLI
H-3	NO DATA	1.12E+03	1.12E+03	1.12E+03	1.12E+03	1.12E+03	1.12E+03
C-14	3.59E+04	6.73E+03	6.73E+03	6.73E+03	6.73E+03	6.73E+03	6.73E+03
P-32	2.60E+06	1.14E+05	9.87E+04	NO DATA	NO DATA	NO DATA	4.21E+04
CR-51	NO DATA	NO DATA	1.54E+02	8.54E+01	2.43E+01	1.70E+04	1.08E+03
MN-54	NO DATA	4.29E+04	9.51E+03	NO DATA	1.00E+04	1.58E+06	2.29E+04
FE-55	4.74E+04	2.52E+04	7.77E+03	NO DATA	NO DATA	1.11E+05	2.87E+03
FE-59	2.07E+04	3.34E+04	1.67E+04	NO DATA	NO DATA	1.27E+06	7.07E+04
CO-58	NO DATA	1.77E+03	3.16E+03	NO DATA	NO DATA	1.11E+06	3.44E+04
CO-60	NO DATA	1.31E+04	2.26E+04	NO DATA	NO DATA	7.07E+06	9.62E+04
NI-63	8.21E+05	4.63E+04	2.80E+04	NO DATA	NO DATA	2.75E+05	6.33E+03
ZN-65	4.26E+04	1.13E+05	7.03E+04	NO DATA	7.14E+04	9.95E+05	1.63E+04
RB-86	NO DATA	1.98E+05	1.14E+05	NO DATA	NO DATA	NO DATA	7.99E+03
SR-89	5.99E+05	NO DATA	1.72E+04	NO DATA	NO DATA	2.16E+06	1.67E+05
SR-90	1.01E+08	NO DATA	6.44E+06	NO DATA	NO DATA	1.48E+07	3.43E+05
Y-90	4.11E+03	NO DATA	1.11E+02	NO DATA	NO DATA	2.62E+05	2.66E+05
Y-91	9.14E+05	NO DATA	2.44E+04	NO DATA	NO DATA	2.63E+06	1.84E+05
ZR-95	1.90E+05	4.18E+04	3.70E+04	NO DATA	5.96E+04	2.23E+06	6.11E+04
NB-95	2.35E+04	9.18E+03	6.55E+03	NO DATA	8.62E+03	6.14E+05	3.70E+04
MO-99	NO DATA	1.72E+02	4.26E+01	NO DATA	3.92E+02	1.35E+05	1.27E+05
TC-99m	1.78E-03	3.48E-03	5.77E-02	NO DATA	5.07E-02	9.51E+02	4.81E+03
RU-103	2.79E+03	NO DATA	1.07E+03	NO DATA	7.03E+03	6.62E+05	4.48E+04
RU-106	1.36E+05	NO DATA	1.69E+04	NO DATA	1.84E+05	1.43E+07	4.29E+05
AG-110m	1.69E+04	1.14E+04	9.14E+03	NO DATA	2.12E+04	5.48E+06	1.00E+05
TE-125m	6.73E+03	2.33E+03	9.14E+02	1.92E+03	NO DATA	4.77E+05	3.38E+04
TE-127m	2.49E+04	8.55E+03	3.02E+03	6.07E+03	6.36E+04	1.48E+06	7.14E+04
TE-129m	1.92E+04	6.85E+03	3.04E+03	6.33E+03	5.03E+04	1.76E+06	1.82E+05
I-130	8.18E+03	1.64E+04	8.44E+03	1.85E+06	2.45E+04	NO DATA	5.11E+03
I-131	4.81E+04	4.81E+04	2.73E+04	1.62E+07	7.88E+04	NO DATA	2.84E+03
I-132	2.12E+03	4.07E+03	1.88E+03	1.94E+05	6.25E+03	NO DATA	3.20E+03
I-133	1.66E+04	2.03E+04	7.70E+03	3.85E+06	3.38E+04	NO DATA	5.48E+03
I-134	1.17E+03	2.16E+03	9.95E+02	5.07E+04	3.30E+03	NO DATA	9.54E+02
I-135	4.92E+03	8.73E+03	4.14E+03	7.92E+05	1.34E+04	NO DATA	4.44E+03
CS-134	6.51E+05	1.01E+06	2.25E+05	NO DATA	3.30E+05	1.21E+05	3.85E+03
CS-136	6.51E+04	1.71E+05	1.16E+05	NO DATA	9.55E+04	1.45E+04	4.18E+03
CS-137	9.70E+05	8.25E+05	1.28E+05	NO DATA	2.82E+05	1.04E+05	3.62E+03
BA-140	7.40E+04	6.48E+01	4.33E+03	NO DATA	2.11E+01	1.74E+06	1.02E+05
CE-141	3.92E+04	1.95E+05	2.90E+03	NO DATA	8.55E+03	5.44E+05	5.66E+04
CE-144	6.77E+06	2.12E+06	3.61E+05	NO DATA	1.17E+06	1.20E+07	3.89E+05
PR-143	1.85E+04	5.55E+03	9.14E+02	NO DATA	3.00E+03	4.33E+05	9.73E+04
ND-147	1.08E+04	8.73E+03	6.81E+02	NO DATA	4.81E+03	3.28E+05	8.21E+04

TABLE 5-18  
INHALATION PATHWAY FACTORS -  $R_{ajj}^1$  (TEEN)  
(mrem/yr per  $\mu\text{Ci}/\text{m}^3$ )

ORGAN: ISOTOPE	BONE	LIVER	T.BODY	THYROID	KIDNEY	LUNG	GI-LLI
H-3	NO DATA	1.27E+03	1.27E+03	1.27E+03	1.27E+03	1.27E+03	1.27E+03
C-14	2.60E+04	4.87E+03	4.87E+03	4.87E+03	4.87E+03	4.87E+03	4.87E+03
P-32	1.89E+06	1.10E+05	7.16E+04	NO DATA	NO DATA	NO DATA	9.28E+04
CR-51	NO DATA	NO DATA	1.35E+02	7.50E+01	3.07E+01	2.10E+04	3.00E+03
MN-54	NO DATA	5.11E+04	8.40E+03	NO DATA	1.27E+04	1.98E+06	6.68E+04
FE-55	3.34E+04	2.38E+04	5.54E+03	NO DATA	NO DATA	1.24E+05	6.39E+03
FE-59	1.59E+04	3.70E+04	1.43E+04	NO DATA	NO DATA	1.53E+06	1.78E+05
CO-58	NO DATA	2.07E+03	2.78E+03	NO DATA	NO DATA	1.34E+06	9.52E+04
CO-60	NO DATA	1.51E+04	1.98E+04	NO DATA	NO DATA	8.72E+06	2.59E+05
NI-63	5.80E+05	4.34E+04	1.98E+04	NO DATA	NO DATA	3.07E+05	1.42E+04
ZN-65	3.86E+04	1.34E+05	6.24E+04	NO DATA	8.64E+04	1.24E+06	4.66E+04
RB-86	NO DATA	1.90E+05	8.40E+04	NO DATA	NO DATA	NO DATA	1.77E+04
SR-89	4.34E+05	NO DATA	1.25E+04	NO DATA	NO DATA	2.42E+06	3.71E+05
SR-90	1.08E+08	NO DATA	6.68E+06	NO DATA	NO DATA	1.65E+07	7.65E+05
Y-90	2.98E+03	NO DATA	8.00E+01	NO DATA	NO DATA	2.93E+05	5.59E+05
Y-91	6.61E+05	NO DATA	1.77E+04	NO DATA	NO DATA	2.94E+06	4.09E+05
ZR-95	1.46E+05	4.58E+04	3.15E+04	NO DATA	6.74E+04	2.69E+06	1.49E+05
NB-95	1.86E+04	1.03E+04	5.66E+03	NO DATA	1.00E+04	7.51E+05	9.68E+04
MO-99	NO DATA	1.69E+02	3.22E+01	NO DATA	4.11E+02	1.54E+05	2.69E+05
TC-99m	1.38E-03	3.86E-03	4.99E-02	NO DATA	5.76E-02	1.15E+03	6.13E+03
RU-103	2.10E+03	NO DATA	8.96E+02	NO DATA	7.43E+03	7.83E+05	1.09E+05
RU-106	9.84E+04	NO DATA	1.24E+04	NO DATA	1.90E+05	1.61E+07	9.60E+05
AG-110m	1.38E+04	1.31E+04	7.99E+03	NO DATA	2.50E+04	6.75E+06	2.73E+05
TE-125m	4.88E+03	2.24E+03	6.67E+02	1.40E+03	NO DATA	5.36E+05	7.50E+04
TE-127m	1.80E+04	8.16E+03	2.18E+03	4.38E+03	6.54E+04	1.66E+06	1.59E+05
TE-129m	1.39E+04	6.58E+03	2.25E+03	4.58E+03	5.19E+04	1.98E+06	4.05E+05
I-130	6.24E+03	1.78E+04	7.17E+03	1.49E+06	2.75E+04	NO DATA	9.12E+03
I-131	3.54E+04	4.91E+04	2.64E+04	1.46E+07	8.40E+04	NO DATA	6.49E+03
I-132	1.59E+03	4.38E+03	1.58E+03	1.51E+05	6.92E+03	NO DATA	1.27E+03
I-133	1.22E+04	2.05E+04	6.22E+03	2.92E+06	3.59E+04	NO DATA	1.03E+04
I-134	8.88E+02	2.32E+03	8.40E+02	3.95E+04	3.66E+03	NO DATA	2.04E+01
I-135	3.70E+03	9.44E+03	3.49E+03	6.21E+05	1.49E+04	NO DATA	6.95E+03
CS-134	5.02E+05	1.12E+06	5.49E+05	NO DATA	3.75E+05	1.46E+05	9.76E+03
CS-136	5.15E+04	1.94E+05	1.37E+05	NO DATA	1.10E+05	1.78E+04	1.09E+04
CS-137	6.70E+05	8.48E+05	3.11E+05	NO DATA	3.04E+05	1.21E+05	8.48E+03
BA-140	5.47E+04	6.70E+01	3.52E+03	NO DATA	2.28E+01	2.03E+06	2.29E+05
CE-141	2.84E+04	1.90E+04	2.17E+03	NO DATA	8.88E+03	6.14E+05	1.26E+05
CE-144	4.89E+06	2.02E+06	2.62E+05	NO DATA	1.21E+06	1.34E+07	8.64E+05
PR-143	1.34E+04	5.31E+03	6.62E+02	NO DATA	3.09E+03	4.83E+05	2.14E+05
ND-147	7.86E+03	8.56E+03	5.13E+02	NO DATA	5.02E+03	3.72E+05	1.82E+05

TABLE 5-19  
INHALATION PATHWAY FACTORS -  $R_{aj}^I$  (ADULT)  
(mrem/yr per  $\mu\text{Ci}/\text{m}^3$ )

ORGAN: ISOTOPE	BONE	LIVER	T.BODY	THYROID	KIDNEY	LUNG	GI-LLI
H-3	NO DATA	1.26E+03	1.26E+03	1.26E+03	1.26E+03	1.26E+03	1.26E+03
C-14	1.82E+04	3.41E+03	3.41E+03	3.41E+03	3.41E+03	3.41E+03	3.41E+03
P-32	1.32E+06	7.71E+04	5.01E+04	NO DATA	NO DATA	NO DATA	8.64E+04
CR-51	NO DATA	NO DATA	1.00E+02	5.95E+01	2.28E+01	1.44E+04	3.32E+03
MN-54	NO DATA	3.96E+04	6.30E+03	NO DATA	9.84E+03	1.40E+06	7.74E+04
FE-55	2.46E+04	1.70E+04	3.94E+03	NO DATA	NO DATA	7.21E+04	6.03E+03
FE-59	1.18E+04	2.78E+04	1.06E+04	NO DATA	NO DATA	1.02E+06	1.88E+05
CO-58	NO DATA	1.58E+03	2.07E+03	NO DATA	NO DATA	9.28E+05	1.06E+05
CO-60	NO DATA	1.15E+04	1.48E+04	NO DATA	NO DATA	5.97E+06	2.85E+05
NI-63	4.32E+05	3.14E+04	1.45E+04	NO DATA	NO DATA	1.78E+05	1.34E+04
ZN-65	3.24E+04	1.03E+05	4.66E+04	NO DATA	6.90E+04	8.64E+05	5.34E+04
RB-86	NO DATA	1.35E+05	5.90E+04	NO DATA	NO DATA	NO DATA	1.66E+04
SR-89	3.04E+05	NO DATA	8.72E+03	NO DATA	NO DATA	1.40E+06	3.50E+05
SR-90	9.92E+07	NO DATA	6.10E+06	NO DATA	NO DATA	9.60E+06	7.22E+05
Y-90	2.09E+03	NO DATA	5.61E+01	NO DATA	NO DATA	1.70E+05	5.06E+05
Y-91	4.62E+05	NO DATA	1.24E+04	NO DATA	NO DATA	1.70E+06	3.85E+05
ZR-95	1.07E+05	3.44E+04	2.33E+04	NO DATA	5.42E+04	1.77E+06	1.50E+05
NB-95	1.41E+04	7.82E+03	4.21E+03	NO DATA	7.74E+03	5.05E+05	1.04E+05
MO-99	NO DATA	1.21E+02	2.30E+01	NO DATA	2.91E+02	9.12E+04	2.48E+05
TC-99m	1.03E-03	2.91E-03	3.70E-02	NO DATA	4.42E-02	7.64E+02	4.16E+03
RU-103	1.53E+03	NO DATA	6.58E+02	NO DATA	5.83E+03	5.05E+05	1.10E+05
RU-106	6.91E+04	NO DATA	8.72E+03	NO DATA	1.34E+05	9.36E+06	9.12E+05
AG-110m	1.08E+04	1.00E+04	5.94E+03	NO DATA	1.97E+04	4.63E+06	3.02E+05
TE-125m	3.42E+03	1.58E+03	4.67E+02	1.05E+03	1.24E+04	3.14E+05	7.06E+04
TE-127m	1.26E+04	5.77E+03	1.57E+03	3.29E+03	4.58E+04	9.60E+05	1.50E+05
TE-129m	9.76E+03	4.67E+03	1.58E+03	3.44E+03	3.66E+04	1.16E+06	3.83E+05
I-130	4.58E+03	1.34E+04	5.28E+03	1.14E+06	2.09E+04	NO DATA	7.69E+03
I-131	2.52E+04	3.58E+04	2.05E+04	1.19E+07	6.13E+04	NO DATA	6.28E+03
I-132	1.16E+03	3.26E+03	1.16E+03	1.14E+05	5.18E+03	NO DATA	4.06E+02
I-133	8.64E+03	1.48E+04	4.52E+03	2.15E+06	2.58E+04	NO DATA	8.88E+03
I-134	6.44E+02	1.73E+03	6.15E+02	2.98E+04	2.75E+03	NO DATA	1.01E+00
I-135	2.68E+03	6.98E+03	2.57E+03	4.48E+05	1.11E+04	NO DATA	5.25E+03
CS-134	3.73E+05	8.48E+05	7.28E+05	NO DATA	2.87E+05	9.76E+04	1.04E+04
CS-136	3.90E+04	1.46E+05	1.10E+05	NO DATA	8.56E+04	1.20E+04	1.17E+04
CS-137	4.78E+05	6.21E+05	4.28E+05	NO DATA	2.22E+05	7.52E+04	8.40E+03
BA-140	3.90E+04	4.90E+01	2.57E+03	NO DATA	1.67E+01	1.27E+06	2.18E+05
CE-141	1.99E+04	1.35E+04	1.53E+03	NO DATA	6.26E+03	3.62E+05	1.20E+05
CE-144	3.43E+06	1.43E+06	1.84E+05	NO DATA	8.48E+05	7.78E+06	8.16E+05
PR-143	9.36E+03	3.75E+03	4.64E+02	NO DATA	2.16E+03	2.81E+05	2.00E+05
ND-147	5.27E+03	6.10E+03	3.65E+02	NO DATA	3.56E+03	2.21E+05	1.73E+05

TABLE 5-20  
COW MILK PATHWAY FACTORS -  $R_{aij}^C$  (INFANT)  
( $m^2rem/yr$  per  $\mu Ci/sec$ )

ORGAN: ISOTOPE	BONE	LIVER	T.BODY	THYROID	KIDNEY	LUNG	GI-LLI
H-3	NO DATA	2.38E+03*	2.38E+03*	2.38E+03*	2.38E+03*	2.38E+03*	2.38E+03*
C-14	3.23E+06	6.89E+05	6.89E+05	6.89E+05	6.89E+05	6.89E+05	6.89E+05
P-32	1.60E+11	9.41E+09	6.20E+09	NO DATA	NO DATA	NO DATA	2.16E+09
CR-51	NO DATA	NO DATA	1.61E+05	1.05E+05	2.29E+04	2.04E+05	4.69E+06
MN-54	NO DATA	3.90E+07	8.84E+06	NO DATA	8.64E+06	NO DATA	1.43E+07
FE-55	1.35E+08	8.72E+07	2.33E+07	NO DATA	NO DATA	4.26E+07	1.11E+07
FE-59	2.25E+08	3.92E+08	1.55E+08	NO DATA	NO DATA	1.16E+08	1.87E+08
CO-58	NO DATA	2.43E+07	6.06E+07	NO DATA	NO DATA	NO DATA	6.05E+07
CO-60	NO DATA	8.82E+07	2.08E+08	NO DATA	NO DATA	NO DATA	2.10E+08
NI-63	3.50E+10	2.16E+09	1.21E+09	NO DATA	NO DATA	NO DATA	1.08E+08
ZN-65	5.55E+09	1.91E+10	8.78E+09	NO DATA	9.23E+09	NO DATA	1.61E+10
RB-86	NO DATA	2.23E+10	1.10E+10	NO DATA	NO DATA	NO DATA	5.70E+08
SR-89	1.26E+10	NO DATA	3.61E+08	NO DATA	NO DATA	NO DATA	2.59E+08
SR-90	1.22E+11	NO DATA	3.10E+10	NO DATA	NO DATA	NO DATA	1.52E+09
Y-90	6.83E+02	NO DATA	1.83E+01	NO DATA	NO DATA	NO DATA	9.43E+05
Y-91	7.33E+04	NO DATA	1.95E+03	NO DATA	NO DATA	NO DATA	5.26E+06
ZR-95	6.82E+03	1.66E+03	1.18E+03	NO DATA	1.79E+03	NO DATA	8.28E+05
NB-95	5.93E+05	2.44E+05	1.41E+05	NO DATA	1.75E+05	NO DATA	2.06E+08
MO-99	NO DATA	2.07E+08	4.04E+07	NO DATA	3.10E+08	NO DATA	6.83E+07
TC-99m	2.75E+01	5.66E+01	7.29E+02	NO DATA	6.09E+02	2.96E+01	1.64E+04
RU-103	8.67E+03	NO DATA	2.92E+03	NO DATA	1.81E+04	NO DATA	1.06E+05
RU-106	1.91E+05	NO DATA	2.38E+04	NO DATA	2.26E+05	NO DATA	1.45E+06
AG-110m	3.85E+08	2.81E+08	1.86E+08	NO DATA	4.02E+08	NO DATA	1.46E+10
TE-125m	1.51E+08	5.05E+07	2.04E+07	5.08E+07	NO DATA	NO DATA	7.19E+07
TE-127m	4.22E+08	1.40E+08	5.10E+07	1.22E+08	1.04E+09	NO DATA	1.70E+08
TE-129m	5.56E+08	1.91E+08	8.56E+07	2.14E+08	1.39E+09	NO DATA	3.32E+08
I-130	3.53E+06	7.76E+06	3.12E+06	8.70E+08	8.53E+06	NO DATA	1.66E+06
I-131	2.71E+09	3.19E+09	1.40E+09	1.05E+12	3.73E+09	NO DATA	1.14E+08
I-132	1.43E+00	2.90E+00	1.03E+00	1.36E+02	3.24E+00	NO DATA	2.35E+00
I-133	3.63E+07	5.28E+07	1.55E+07	9.60E+09	6.21E+07	NO DATA	8.93E+06
I-134	1.64E-11	3.36E-11	1.20E-11	7.86E-10	3.76E-11	NO DATA	3.48E-11
I-135	1.13E+05	2.24E+05	8.18E+04	2.01E+07	2.50E+05	NO DATA	8.12E+04
CS-134	3.65E+10	6.81E+10	6.88E+09	NO DATA	1.75E+10	7.19E+09	1.85E+08
CS-136	1.97E+09	5.81E+09	2.17E+09	NO DATA	2.31E+09	4.73E+08	8.82E+07
CS-137	5.15E+10	6.03E+10	4.27E+09	NO DATA	1.62E+10	6.44E+09	1.89E+08
BA-140	2.45E+08	2.45E+05	1.26E+07	NO DATA	5.72E+04	1.50E+05	5.92E+07
CE-141	4.34E+04	2.65E+04	3.12E+03	NO DATA	8.17E+03	NO DATA	1.37E+07
CE-144	2.34E+06	9.56E+05	1.31E+05	NO DATA	3.87E+05	NO DATA	1.34E+08
PR-143	1.49E+03	5.56E+02	7.37E+01	NO DATA	2.07E+02	NO DATA	7.85E+05
ND-147	8.79E+02	9.03E+02	5.53E+01	NO DATA	3.48E+02	NO DATA	5.72E+05

\*mrem/yr per  $\mu Ci/m^3$



TABLE 5-21  
COW MILK PATHWAY FACTORS -  $R_{ajj}^C$  (CHILD)  
( $m^2mrem/yr$  per  $\mu Ci/sec$ )

ORGAN: ISOTOPE	BONE	LIVER	T.BODY	THYROID	KIDNEY	LUNG	GI-LLI
H-3	NO DATA	1.57E+03*	1.57E+03*	1.57E+03*	1.57E+03*	1.57E+03*	1.57E+03*
C-14	1.65E+06	3.29E+05	3.29E+05	3.29E+05	3.29E+05	3.29E+05	3.29E+05
P-32	7.79E+10	3.64E+09	3.00E+09	NO DATA	NO DATA	NO DATA	2.15E+09
CR-51	NO DATA	NO DATA	1.01E+05	5.63E+04	1.54E+04	1.03E+05	5.38E+06
MN-54	NO DATA	2.10E+07	5.59E+06	NO DATA	5.88E+06	NO DATA	1.76E+07
FE-55	1.12E+08	5.94E+07	1.84E+07	NO DATA	NO DATA	3.36E+07	1.10E+07
FE-59	1.20E+08	1.95E+08	9.71E+07	NO DATA	NO DATA	5.65E+07	2.03E+08
CO-58	NO DATA	1.21E+07	3.71E+07	NO DATA	NO DATA	NO DATA	7.08E+07
CO-60	NO DATA	4.32E+07	1.27E+08	NO DATA	NO DATA	NO DATA	2.39E+08
NI-63	2.97E+10	1.59E+09	1.01E+09	NO DATA	NO DATA	NO DATA	1.07E+08
ZN-65	4.13E+09	1.10E+10	6.83E+09	NO DATA	6.92E+09	NO DATA	1.93E+09
RB-86	NO DATA	8.78E+09	5.40E+09	NO DATA	NO DATA	NO DATA	5.65E+08
SR-89	6.63E+09	NO DATA	1.89E+08	NO DATA	NO DATA	NO DATA	2.57E+08
SR-90	1.12E+11	NO DATA	2.84E+10	NO DATA	NO DATA	NO DATA	1.51E+09
Y-90	3.23E+02	NO DATA	8.65E+00	NO DATA	NO DATA	NO DATA	9.20E+05
Y-91	3.90E+04	NO DATA	1.04E+03	NO DATA	NO DATA	NO DATA	5.20E+06
ZR-95	3.84E+03	8.44E+02	7.51E+02	NO DATA	1.21E+03	NO DATA	8.80E+05
NB-95	3.18E+05	1.24E+05	8.84E+04	NO DATA	1.16E+05	NO DATA	2.29E+08
MO-99	NO DATA	8.15E+07	2.02E+07	NO DATA	1.74E+08	NO DATA	6.74E+07
TC-99m	1.32E+01	2.58E+01	4.28E+02	NO DATA	3.75E+02	1.31E+01	1.47E+04
RU-103	4.29E+03	NO DATA	1.65E+03	NO DATA	1.08E+04	NO DATA	1.11E+05
RU-106	9.25E+04	NO DATA	1.15E+04	NO DATA	1.25E+05	NO DATA	1.44E+06
AG-110m	2.09E+08	1.41E+08	1.13E+08	NO DATA	2.63E+08	NO DATA	1.68E+10
TE-125m	7.39E+07	2.00E+07	9.85E+07	2.07E+07	NO DATA	NO DATA	7.13E+07
TE-127m	2.08E+08	5.61E+07	2.47E+07	4.98E+07	5.94E+08	NO DATA	1.69E+08
TE-129m	2.71E+08	7.58E+07	4.21E+07	8.74E+07	7.97E+08	NO DATA	3.31E+08
I-130	1.72E+06	3.47E+06	1.79E+06	3.82E+08	5.19E+06	NO DATA	1.62E+06
I-131	1.30E+09	1.31E+09	7.44E+08	4.33E+11	2.15E+09	NO DATA	1.17E+08
I-132	6.91E-01	1.27E+00	5.84E-01	5.89E+01	1.94E+00	NO DATA	1.49E+00
I-133	1.72E+07	2.12E+07	8.03E+06	3.94E+09	3.54E+07	NO DATA	8.56E+06
I-134	7.92E-12	1.47E-11	6.77E-12	3.38E-10	2.25E-11	NO DATA	9.75E-12
I-135	5.43E+04	9.77E+04	4.62E+04	8.56E+06	1.50E+05	NO DATA	7.44E+04
CS-134	2.27E+10	3.72E+10	7.85E+09	NO DATA	1.15E+10	4.14E+09	2.01E+08
CS-136	1.01E+09	2.78E+09	1.80E+09	NO DATA	1.48E+09	2.21E+08	9.76E+07
CS-137	3.23E+10	3.09E+10	4.56E+09	NO DATA	1.01E+10	3.63E+09	1.94E+08
BA-140	1.18E+08	1.03E+05	6.84E+06	NO DATA	3.37E+04	6.12E+04	5.94E+07
CE-141	2.19E+04	1.09E+04	1.62E+03	NO DATA	4.78E+03	NO DATA	1.36E+07
CE-144	1.63E+06	5.10E+05	8.68E+04	NO DATA	2.82E+05	NO DATA	1.33E+08
PR-143	7.19E+02	2.16E+02	3.57E+01	NO DATA	1.17E+02	NO DATA	7.76E+05
ND-147	4.44E+02	3.59E+02	2.78E+01	NO DATA	1.97E+02	NO DATA	5.69E+05

\* $mrem/yr$  per  $\mu Ci/m^3$

TABLE 5-22

COW MILK PATHWAY FACTORS -  $R_{aij}^C$  (TEEN)  
( $m^2$ mrem/yr per  $\mu$ Ci)

ORGAN: ISOTOPE	BONE	LIVER	T.BODY	THYROID	KIDNEY	LUNG	GI-LLI
H-3	NO DATA	9.92E+02*	9.92E+02*	9.92E+02*	9.92E+02*	9.92E+02*	9.92E+02*
C-14	6.70E+05	1.34E+05	1.34E+05	1.34E+05	1.34E+05	1.34E+05	1.34E+05
P-32	3.15E+10	1.95E+09	1.22E+09	NO DATA	NO DATA	NO DATA	2.64E+09
CR-51	NO DATA	NO DATA	5.00E+04	2.78E+04	1.10E+04	7.14E+04	8.41E+06
MN-54	NO DATA	1.40E+07	2.78E+06	NO DATA	4.19E+06	NO DATA	2.88E+07
FE-55	4.46E+07	3.16E+07	7.38E+06	NO DATA	NO DATA	2.01E+07	1.37E+07
FE-59	5.18E+07	1.21E+08	4.67E+07	NO DATA	NO DATA	3.81E+07	2.68E+08
CO-58	NO DATA	7.98E+06	1.84E+07	NO DATA	NO DATA	NO DATA	1.10E+08
CO-60	NO DATA	2.78E+07	6.26E+07	NO DATA	NO DATA	NO DATA	3.62E+08
NI-63	1.18E+10	8.34E+08	4.00E+08	NO DATA	NO DATA	NO DATA	1.33E+08
ZN-65	2.11E+09	7.32E+09	3.41E+09	NO DATA	4.68E+09	NO DATA	3.10E+09
RB-86	NO DATA	4.74E+09	2.23E+09	NO DATA	NO DATA	NO DATA	7.01E+08
SR-89	2.68E+09	NO DATA	7.67E+07	NO DATA	NO DATA	NO DATA	3.19E+08
SR-90	6.62E+10	NO DATA	1.64E+10	NO DATA	NO DATA	NO DATA	1.86E+09
Y-90	1.31E+02	NO DATA	3.53E+00	NO DATA	NO DATA	NO DATA	1.08E+06
Y-91	1.58E+04	NO DATA	4.24E+02	NO DATA	NO DATA	NO DATA	6.48E+06
ZR-95	1.65E+03	5.20E+02	3.58E+02	NO DATA	7.65E+02	NO DATA	1.20E+06
NB-95	1.41E+05	7.81E+04	4.30E+04	NO DATA	7.57E+04	NO DATA	3.34E+08
MO-99	NO DATA	4.46E+07	8.50E+06	NO DATA	1.02E+08	NO DATA	7.98E+07
TC-99m	5.74E+00	1.60E+01	2.08E+02	NO DATA	2.39E+02	8.89E+00	1.05E+04
RU-103	1.81E+03	NO DATA	7.73E+02	NO DATA	6.37E+03	NO DATA	1.51E+05
RU-106	3.75E+04	NO DATA	4.73E+03	NO DATA	7.23E+04	NO DATA	1.80E+06
AG-110m	9.64E+07	9.12E+07	5.55E+07	NO DATA	1.74E+08	NO DATA	2.56E+10
TE-125m	3.01E+07	1.08E+07	4.02E+06	8.41E+06	NO DATA	NO DATA	8.88E+07
TE-127m	8.43E+07	2.99E+07	1.00E+07	2.01E+07	3.42E+08	NO DATA	2.10E+08
TE-129m	1.10E+08	4.09E+07	1.74E+07	3.56E+07	4.61E+08	NO DATA	4.14E+08
I-130	7.33E+05	2.12E+06	8.47E+05	1.73E+08	3.27E+06	NO DATA	1.63E+06
I-131	5.36E+08	7.50E+08	4.03E+08	2.19E+11	1.29E+09	NO DATA	1.48E+08
I-132	2.90E-01	7.59E-01	2.72E-01	2.56E+01	1.20E+00	NO DATA	3.31E-01
I-133	7.06E+06	1.20E+07	3.65E+06	1.67E+09	2.10E+07	NO DATA	9.06E+06
I-134	3.34E-12	8.86E-12	3.18E-12	1.48E-10	1.40E-11	NO DATA	1.17E-13
I-135	2.29E+04	5.90E+04	2.19E+04	3.80E+06	9.32E+04	NO DATA	6.54E+04
CS-134	9.79E+09	2.30E+10	1.07E+10	NO DATA	7.32E+09	2.80E+09	2.87E+08
CS-136	4.48E+08	1.76E+09	1.18E+09	NO DATA	9.59E+08	1.51E+08	1.42E+08
CS-137	1.33E+10	1.77E+10	6.18E+09	NO DATA	6.03E+09	2.34E+09	2.52E+08
BA-140	4.85E+07	5.95E+04	3.13E+06	NO DATA	2.02E+04	4.00E+04	7.49E+07
CE-141	8.88E+03	5.93E+03	6.81E+02	NO DATA	2.79E+03	NO DATA	1.70E+07
CE-144	6.61E+05	2.73E+05	3.55E+04	NO DATA	1.63E+05	NO DATA	1.66E+08
PR-143	2.91E+02	1.16E+02	1.45E+01	NO DATA	6.75E+01	NO DATA	9.57E+05
ND-147	1.81E+02	1.97E+02	1.18E+01	NO DATA	1.16E+02	NO DATA	7.10E+05

\*mrem/yr per  $\mu$ Ci/m<sup>3</sup>

TABLE 5-23  
COW MILK PATHWAY FACTORS -  $R_{aij}^C$  (ADULT)  
( $m^2mrem/yr$  per  $\mu Ci/sec$ )

ORGAN: ISOTOPE	BONE	LIVER	T.BODY	THYROID	KIDNEY	LUNG	GI-LLI
H-3	NO DATA	7.62E+02*	7.62E+02*	7.62E+02*	7.62E+02*	7.62E+02*	7.62E+02*
C-14	3.63E+05	7.26E+04	7.26E+04	7.26E+04	7.26E+04	7.26E+04	7.26E+04
P-32	1.71E+10	1.06E+09	6.61E+08	NO DATA	NO DATA	NO DATA	1.92E+09
CR-51	NO DATA	NO DATA	2.85E+04	1.70E+04	6.27E+03	3.78E+04	7.16E+06
MN-54	NO DATA	8.41E+06	1.60E+06	NO DATA	2.50E+06	NO DATA	2.58E+07
FE-55	2.51E+07	1.73E+07	4.04E+06	NO DATA	NO DATA	9.68E+06	9.95E+06
FE-59	2.97E+07	6.99E+07	2.68E+07	NO DATA	NO DATA	1.95E+07	2.33E+08
CO-58	NO DATA	4.72E+06	1.06E+07	NO DATA	NO DATA	NO DATA	9.57E+07
CO-60	NO DATA	1.64E+07	3.62E+07	NO DATA	NO DATA	NO DATA	3.08E+08
NI-63	6.73E+09	4.67E+08	2.26E+08	NO DATA	NO DATA	NO DATA	9.74E+07
ZN-65	1.37E+09	4.37E+09	1.98E+09	NO DATA	2.93E+09	NO DATA	2.75E+09
RB-86	NO DATA	2.60E+09	1.21E+09	NO DATA	NO DATA	NO DATA	5.12E+08
SR-89	1.45E+09	NO DATA	4.16E+07	NO DATA	NO DATA	NO DATA	2.33E+08
SR-90	4.68E+10	NO DATA	1.15E+10	NO DATA	NO DATA	NO DATA	1.35E+09
Y-90	7.10E+01	NO DATA	1.90E+00	NO DATA	NO DATA	NO DATA	7.53E+05
Y-91	8.60E+03	NO DATA	2.30E+02	NO DATA	NO DATA	NO DATA	4.73E+06
ZR-95	9.45E+02	3.03E+02	2.05E+02	NO DATA	4.76E+02	NO DATA	9.61E+05
NB-95	8.25E+04	4.59E+04	2.47E+04	NO DATA	4.54E+04	NO DATA	2.79E+08
MO-99	NO DATA	2.48E+07	4.72E+06	NO DATA	5.61E+07	NO DATA	5.74E+07
TC-99m	3.31E+00	9.35E+00	1.19E+02	NO DATA	1.42E+02	4.58E+00	5.53E+03
RU-103	1.02E+03	NO DATA	4.39E+02	NO DATA	3.89E+03	NO DATA	1.19E+05
RU-106	2.04E+04	NO DATA	2.58E+03	NO DATA	3.94E+04	NO DATA	1.32E+06
AG-110m	5.82E+07	5.39E+07	3.20E+07	NO DATA	1.06E+08	NO DATA	2.20E+10
TE-125m	1.63E+07	5.91E+06	2.19E+06	4.91E+06	6.64E+07	NO DATA	6.52E+07
TE-127m	4.58E+07	1.64E+07	5.58E+06	1.17E+07	1.86E+08	NO DATA	1.53E+08
TE-129m	6.01E+07	2.24E+07	9.52E+06	2.07E+07	2.51E+08	NO DATA	3.03E+08
I-130	4.16E+05	1.23E+06	4.84E+05	1.04E+08	1.91E+06	NO DATA	1.06E+06
I-131	2.97E+08	4.24E+08	2.43E+08	1.39E+11	7.27E+08	NO DATA	1.12E+08
I-132	1.65E-01	4.40E-01	1.54E-01	1.54E+01	7.02E-01	NO DATA	8.27E-02
I-133	3.86E+06	6.72E+06	2.05E+06	9.87E+08	1.17E+07	NO DATA	6.04E+06
I-134	1.89E-12	5.13E-12	1.83E-12	8.88E-11	8.15E-12	NO DATA	4.47E-15
I-135	1.29E+04	3.39E+04	1.25E+04	2.23E+06	5.43E+04	NO DATA	3.83E+04
CS-134	5.67E+09	1.35E+10	1.10E+10	NO DATA	4.37E+09	1.45E+09	2.36E+08
CS-136	2.64E+08	1.04E+09	7.49E+08	NO DATA	5.79E+08	7.94E+07	1.18E+08
CS-137	7.39E+09	1.01E+10	6.62E+09	NO DATA	3.43E+09	1.14E+09	1.96E+08
BA-140	2.72E+07	3.42E+04	1.78E-06	NO DATA	1.16E+04	1.96E+04	5.60E+07
CE-141	4.84E+03	3.27E+03	3.71E+02	NO DATA	1.52E+03	NO DATA	1.25E+07
CE-144	3.58E+05	1.50E+05	1.92E+04	NO DATA	8.87E+04	NO DATA	1.21E+08
PR-143	1.58E+02	6.35E+01	7.84E+00	NO DATA	3.66E+01	NO DATA	6.93E+05
ND-147	9.44E+01	1.09E+02	6.53E+00	NO DATA	6.38E+01	NO DATA	5.24E+05

\* $mrem/yr$  per  $\mu Ci/m^3$

TABLE 5-24  
 GOAT MILK PATHWAY FACTORS -  $R_{ajj}^C$  (INFANT)  
 ( $m^2rem/yr$  per  $\mu Ci/sec$ )

ORGAN: ISOTOPE	BONE	LIVER	T.BODY	THYROID	KIDNEY	LUNG	GI-LLI
H-3	NO DATA	4.86E+03*	4.86E+03*	4.86E+03*	4.86E+03*	4.86E+03*	4.86E+03*
C-14	3.23E+06	6.89E+05	6.89E+05	6.89E+05	6.89E+05	6.89E+05	6.89E+05
P-32	1.90E+11	1.12E+10	7.46E+09	NO DATA	NO DATA	NO DATA	2.58E+09
CR-51	NO DATA	NO DATA	1.93E+04	1.26E+04	2.75E+03	2.45E+04	5.63E+05
MN-54	NO DATA	4.68E+06	1.06E+06	NO DATA	1.04E+06	NO DATA	1.72E+06
FE-55	1.75E+06	1.13E+06	3.02E+05	NO DATA	NO DATA	5.53E+05	1.44E+05
FE-59	2.91E+06	5.08E+06	2.00E+06	NO DATA	NO DATA	1.50E+06	2.43E+06
CO-58	NO DATA	2.90E+06	7.24E+06	NO DATA	NO DATA	NO DATA	7.23E+06
CO-60	NO DATA	1.06E+07	2.49E+07	NO DATA	NO DATA	NO DATA	2.51E+07
NI-63	4.19E+09	2.59E+08	1.45E+08	NO DATA	NO DATA	NO DATA	1.29E+07
ZN-65	6.64E+08	2.28E+09	1.05E+09	NO DATA	1.10E+09	NO DATA	1.92E+09
RB-86	NO DATA	2.65E+09	1.31E+09	NO DATA	NO DATA	NO DATA	6.79E+07
SR-89	2.64E+10	NO DATA	7.56E+08	NO DATA	NO DATA	NO DATA	5.42E+08
SR-90	2.55E+11	NO DATA	6.50E+10	NO DATA	NO DATA	NO DATA	3.19E+09
Y-90	8.19E+01	NO DATA	2.19E+00	NO DATA	NO DATA	NO DATA	1.13E+05
Y-91	8.78E+03	NO DATA	2.34E+02	NO DATA	NO DATA	NO DATA	6.29E+05
ZR-95	8.16E+02	1.99E+02	1.41E+02	NO DATA	2.14E+02	NO DATA	9.90E+04
NB-95	7.12E+04	2.93E+04	1.69E+04	NO DATA	2.10E+04	NO DATA	2.47E+07
MO-99	NO DATA	2.48E+07	4.84E+06	NO DATA	3.71E+07	NO DATA	8.18E+06
TC-99m	3.26E+00	6.73E+00	8.67E+01	NO DATA	7.24E+01	3.52E+00	1.96E+03
RU-103	1.04E+03	NO DATA	3.47E+02	NO DATA	2.16E+03	NO DATA	1.26E+04
RU-106	2.28E+04	NO DATA	2.84E+03	NO DATA	2.69E+04	NO DATA	1.73E+05
AG-110m	4.62E+07	3.37E+07	2.23E+07	NO DATA	4.83E+07	NO DATA	1.75E+09
TE-125m	1.80E+07	6.02E+06	2.43E+06	6.06E+06	NO DATA	NO DATA	8.58E+06
TE-127m	5.04E+07	1.67E+07	6.10E+06	1.46E+07	1.24E+08	NO DATA	2.03E+07
TE-129m	6.68E+07	2.29E+07	1.03E+07	2.57E+07	1.67E+08	NO DATA	3.99E+07
I-130	4.22E+06	9.28E+06	3.73E+06	1.04E+09	1.02E+07	NO DATA	1.99E+06
I-131	3.25E+09	3.83E+09	1.69E+09	1.26E+12	4.48E+09	NO DATA	1.37E+08
I-132	1.73E+00	3.50E+00	1.25E+00	1.64E+02	3.91E+00	NO DATA	2.84E+00
I-133	4.34E+07	6.32E+07	1.85E+07	1.15E+10	7.43E+07	NO DATA	1.07E+07
I-134	1.97E-11	4.04E-11	1.44E-11	9.42E-10	4.52E-11	NO DATA	4.18E-11
I-135	1.36E+05	2.70E+05	9.85E+04	2.42E+07	3.01E+05	NO DATA	9.77E+04
CS-134	1.09E+11	2.04E+11	2.06E+10	NO DATA	5.25E+10	2.15E+10	5.54E+08
CS-136	5.92E+09	1.74E+10	6.50E+09	NO DATA	6.94E+09	1.42E+09	2.64E+08
CS-137	1.54E+11	1.80E+11	1.28E+10	NO DATA	4.84E+10	1.96E+10	5.63E+08
BA-140	2.87E+07	2.87E+04	1.48E+06	NO DATA	6.82E+03	1.76E+04	7.06E+06
CE-141	5.20E+03	3.17E+03	3.73E+02	NO DATA	9.78E+02	NO DATA	1.64E+06
CE-144	2.79E+05	1.14E+05	1.56E+04	NO DATA	4.61E+04	NO DATA	1.60E+07
PR-143	1.78E+02	6.66E+01	8.83E+00	NO DATA	2.47E+01	NO DATA	9.40E+04
ND-147	1.06E+02	1.08E+02	6.65E+00	NO DATA	4.18E+01	NO DATA	6.88E+04

\*mrem/yr per  $\mu Ci/m^3$

TABLE 5-25  
GOAT MILK PATHWAY FACTORS -  $R_{ajj}^C$  (CHILD)  
( $m^2mrem/yr$  per  $\mu Ci/sec$ )

ORGAN: ISOTOPE	BONE	LIVER	T.BODY	THYROID	KIDNEY	LUNG	GI-LLI
H-3	NO DATA	3.20E+03*	3.20E+03*	3.20E+03*	3.20E+03*	3.20E+03*	3.20E+03*
C-14	1.65E+06	3.29E+05	3.29E+05	3.29E+05	3.29E+05	3.29E+05	3.29E+05
P-32	9.32E+10	4.36E+09	3.59E+09	NO DATA	NO DATA	NO DATA	2.58E+09
CR-51	NO DATA	NO DATA	1.22E+04	6.77E+03	1.85E+03	1.24E+04	6.47E+05
MN-54	NO DATA	2.51E+06	6.70E+05	NO DATA	7.05E+05	NO DATA	2.11E+06
FE-55	1.45E+06	7.65E+05	2.38E+05	NO DATA	NO DATA	4.35E+05	1.42E+05
FE-59	1.55E+06	2.52E+06	1.25E+06	NO DATA	NO DATA	7.29E+05	2.62E+06
CO-58	NO DATA	1.46E+06	4.46E+06	NO DATA	NO DATA	NO DATA	8.49E+06
CO-60	NO DATA	5.16E+06	1.52E+07	NO DATA	NO DATA	NO DATA	2.86E+07
NI-63	3.55E+09	1.90E+08	1.21E+08	NO DATA	NO DATA	NO DATA	1.28E+07
ZN-65	4.96E+08	1.32E+09	8.22E+08	NO DATA	8.33E+08	NO DATA	2.32E+08
RB-86	NO DATA	1.05E+09	6.47E+08	NO DATA	NO DATA	NO DATA	6.77E+07
SR-89	1.39E+10	NO DATA	3.96E+08	NO DATA	NO DATA	NO DATA	5.37E+08
SR-90	2.35E+11	NO DATA	5.95E+10	NO DATA	NO DATA	NO DATA	3.16E+09
Y-90	3.86E+01	NO DATA	1.03E+00	NO DATA	NO DATA	NO DATA	1.10E+05
Y-91	4.67E+03	NO DATA	1.25E+02	NO DATA	NO DATA	NO DATA	6.22E+05
ZR-95	4.58E+02	1.01E+02	8.97E+01	NO DATA	1.44E+02	NO DATA	1.05E+05
NB-95	3.81E+04	1.48E+04	1.06E+04	NO DATA	1.39E+04	NO DATA	2.75E+07
MO-99	NO DATA	9.74E+06	2.41E+06	NO DATA	2.08E+07	NO DATA	8.05E+06
TC-99m	1.58E+00	3.10E+00	5.13E+01	NO DATA	4.50E+01	1.57E+00	1.76E+03
RU-103	5.10E+02	NO DATA	1.96E+02	NO DATA	1.28E+03	NO DATA	1.32E+04
RU-106	1.11E+04	NO DATA	1.38E+03	NO DATA	1.49E+04	NO DATA	1.72E+05
AG-110m	2.50E+07	1.69E+07	1.35E+07	NO DATA	3.15E+07	NO DATA	2.01E+09
TE-125m	8.84E+06	2.39E+06	1.18E+06	2.48E+06	NO DATA	NO DATA	8.53E+06
TE-127m	2.49E+07	6.71E+06	2.96E+06	5.96E+06	7.10E+07	NO DATA	2.02E+07
TE-129m	3.24E+07	9.06E+06	5.03E+06	1.05E+07	9.52E+07	NO DATA	3.96E+07
I-130	2.06E+06	4.17E+06	2.15E+06	4.59E+08	6.23E+06	NO DATA	1.95E+06
I-131	1.56E+09	1.57E+09	8.94E+08	5.20E+11	2.58E+09	NO DATA	1.40E+08
I-132	8.32E-01	1.52E+00	7.03E-01	7.09E+01	2.34E+00	NO DATA	1.80E+00
I-133	2.06E+07	2.55E+07	9.64E+06	4.73E+09	4.25E+07	NO DATA	1.03E+07
I-134	9.51E-12	1.77E-11	8.13E-12	4.06E-10	2.70E-11	NO DATA	1.17E-11
I-135	6.53E+04	1.17E+05	5.56E+04	1.04E+07	1.80E+05	NO DATA	8.95E+04
CS-134	6.76E+10	1.11E+11	2.34E+10	NO DATA	3.44E+10	1.23E+10	5.98E+08
CS-136	3.03E+09	8.33E+09	5.39E+09	NO DATA	4.44E+09	6.62E+08	2.93E+08
CS-137	9.65E+10	9.23E+10	1.36E+10	NO DATA	3.01E+10	1.08E+10	5.78E+08
BA-140	1.40E+07	1.22E+04	8.15E+05	NO DATA	3.98E+03	7.29E+03	7.07E+06
CE-141	2.62E+03	1.31E+03	1.94E+02	NO DATA	5.73E+02	NO DATA	1.63E+06
CE-144	1.94E+05	6.10E+04	1.04E+04	NO DATA	3.38E+04	NO DATA	1.59E+07
PR-143	8.61E+01	2.58E+01	4.27E+00	NO DATA	1.40E+01	NO DATA	9.29E+04
ND-147	5.33E+01	4.32E+01	3.34E+00	NO DATA	2.37E+01	NO DATA	6.84E+04

\* $mrem/yr$  per  $\mu Ci/m^3$

TABLE 5-26  
 GOAT MILK PATHWAY FACTORS -  $R_{aij}^C$  (TEEN)  
 ( $m^2mrem/yr$  per  $\mu Ci$ )

ORGAN: ISOTOPE	BONE	LIVER	T.BODY	THYROID	KIDNEY	LUNG	GI-LLI
H-3	NO DATA	2.02E+03*	2.02E+03*	2.02E+03*	2.02E+03*	2.02E+03*	2.02E+03*
C-14	6.70E+05	1.34E+05	1.34E+05	1.34E+05	1.34E+05	1.34E+05	1.34E+05
P-32	3.78E+10	2.34E+09	1.47E+09	NO DATA	NO DATA	NO DATA	3.18E+09
CR-51	NO DATA	NO DATA	5.94E+03	3.30E+03	1.30E+03	8.48E+03	9.98E+05
MN-54	NO DATA	1.68E+06	3.32E+05	NO DATA	5.00E+05	NO DATA	3.44E+06
FE-55	5.79E+05	4.11E+05	9.57E+04	NO DATA	NO DATA	2.60E+05	1.78E+05
FE-59	6.75E+05	1.58E+06	6.08E+05	NO DATA	NO DATA	4.97E+05	3.73E+06
CO-58	NO DATA	9.51E+05	2.19E+06	NO DATA	NO DATA	NO DATA	1.31E+07
CO-60	NO DATA	3.32E+06	7.47E+06	NO DATA	NO DATA	NO DATA	4.32E+07
NI-63	1.42E+09	1.00E+08	4.81E+07	NO DATA	NO DATA	NO DATA	1.60E+07
ZN-65	2.52E+08	8.76E+08	4.09E+08	NO DATA	5.61E+08	NO DATA	3.71E+08
RB-86	NO DATA	5.66E+08	2.66E+08	NO DATA	NO DATA	NO DATA	8.38E+07
SR-89	5.59E+09	NO DATA	1.60E+08	NO DATA	NO DATA	NO DATA	6.65E+08
SR-90	1.38E+11	NO DATA	3.40E+10	NO DATA	NO DATA	NO DATA	3.87E+09
Y-90	1.56E+01	NO DATA	4.21E-01	NO DATA	NO DATA	NO DATA	1.29E+05
Y-91	1.89E+03	NO DATA	5.07E+01	NO DATA	NO DATA	NO DATA	7.75E+05
ZR-95	1.98E+02	6.24E+01	4.29E+01	NO DATA	9.17E+01	NO DATA	1.44E+05
NB-95	1.69E+04	9.37E+03	5.16E+03	NO DATA	9.08E+03	NO DATA	4.01E+07
MO-99	NO DATA	5.33E+06	1.02E+06	NO DATA	1.22E+07	NO DATA	9.55E+06
TC-99m	6.87E-01	1.92E+00	2.48E+01	NO DATA	2.86E+01	1.06E+00	1.26E+03
RU-103	2.17E+02	NO DATA	9.27E+01	NO DATA	7.64E+02	NO DATA	1.81E+04
RU-106	4.47E+03	NO DATA	5.63E+02	NO DATA	8.62E+03	NO DATA	2.14E+05
AG-110m	1.15E+07	1.09E+07	6.62E+06	NO DATA	2.08E+07	NO DATA	3.06E+09
TE-125m	3.59E+06	1.29E+06	4.80E+05	1.00E+06	NO DATA	NO DATA	1.06E+07
TE-127m	1.01E+07	3.57E+06	1.20E+06	2.39E+06	4.08E+07	NO DATA	2.51E+07
TE-129m	1.32E+07	4.89E+06	2.08E+06	4.25E+06	5.51E+07	NO DATA	4.94E+07
I-130	8.82E+05	2.55E+06	1.02E+06	2.08E+08	3.93E+06	NO DATA	1.96E+06
I-131	6.44E+08	9.01E+08	4.84E+08	2.63E+11	1.55E+09	NO DATA	1.78E+08
I-132	3.52E-01	9.20E-01	3.30E-01	3.10E+01	1.45E+00	NO DATA	4.01E-01
I-133	8.48E+06	1.44E+07	4.39E+06	2.01E+09	2.52E+07	NO DATA	1.09E+07
I-134	4.03E-12	1.07E-11	3.84E-12	1.78E-10	1.68E-11	NO DATA	1.41E-13
I-135	2.75E+04	7.08E+04	2.62E+04	4.56E+06	1.12E+05	NO DATA	7.85E+04
CS-134	2.94E+10	6.91E+10	3.21E+10	NO DATA	2.20E+10	8.39E+09	8.60E+08
CS-136	1.34E+09	5.27E+09	3.54E+09	NO DATA	2.87E+09	4.52E+08	4.24E+08
CS-137	4.01E+10	5.33E+10	1.86E+10	NO DATA	1.82E+10	7.05E+09	7.59E+08
BA-140	5.82E+06	7.13E+03	3.75E+05	NO DATA	2.42E+03	4.80E+03	8.98E+06
CE-141	1.07E+03	7.12E+02	8.17E+01	NO DATA	3.35E+02	NO DATA	2.04E+06
CE-144	7.86E+04	3.25E+04	4.23E+03	NO DATA	1.94E+04	NO DATA	1.98E+07
PR-143	3.47E+01	1.39E+01	1.73E+00	NO DATA	8.06E+00	NO DATA	1.14E+05
ND-147	2.17E+01	2.36E+01	1.41E+00	NO DATA	1.38E+01	NO DATA	8.50E+04

\*mrem/yr per  $\mu Ci/m^3$

TABLE 5-27  
GOAT MILK PATHWAY FACTORS -  $R_{aij}^C$  (ADULT)  
( $m^2mrem/yr$  per  $\mu Ci/sec$ )

ORGAN: ISOTOPE	BONE	LIVER	T.BODY	THYROID	KIDNEY	LUNG	GI-LLI
H-3	NO DATA	1.55E+03*	1.55E+03*	1.55E+03*	1.55E+03*	1.55E+03*	1.55E+03*
C-14	3.63E+05	7.26E+04	7.26E+04	7.26E+04	7.26E+04	7.26E+04	7.26E+04
P-32	2.05E+10	1.27E+09	7.91E+08	NO DATA	NO DATA	NO DATA	2.30E+09
CR-51	NO DATA	NO DATA	3.43E+03	2.05E+03	7.56E+02	4.55E+03	8.63E+05
MN-54	NO DATA	1.01E+06	1.92E+05	NO DATA	2.99E+05	NO DATA	3.08E+06
FE-55	3.27E+05	2.26E+05	5.27E+04	NO DATA	NO DATA	1.26E+05	1.30E+05
FE-59	3.85E+05	9.06E+05	3.47E+05	NO DATA	NO DATA	2.53E+05	3.02E+06
CO-58	NO DATA	5.62E+05	1.26E+06	NO DATA	NO DATA	NO DATA	1.14E+07
CO-60	NO DATA	1.96E+06	4.33E+06	NO DATA	NO DATA	NO DATA	3.69E+07
NI-63	8.05E+08	5.58E+07	2.70E+07	NO DATA	NO DATA	NO DATA	1.16E+07
ZN-65	1.64E+08	5.22E+08	2.36E+08	NO DATA	3.49E+08	NO DATA	3.29E+08
RB-86	NO DATA	3.10E+08	1.45E+08	NO DATA	NO DATA	NO DATA	6.12E+07
SR-89	3.04E+09	NO DATA	8.73E+07	NO DATA	NO DATA	NO DATA	4.88E+08
SR-90	9.78E+10	NO DATA	2.40E+10	NO DATA	NO DATA	NO DATA	2.83E+09
Y-90	8.48E+00	NO DATA	2.28E-01	NO DATA	NO DATA	NO DATA	9.00E+04
Y-91	1.03E+03	NO DATA	2.75E+01	NO DATA	NO DATA	NO DATA	5.66E+05
ZR-95	1.13E+02	3.63E+01	2.46E+01	NO DATA	5.69E+01	NO DATA	1.15E+05
NB-95	9.90E+03	5.51E+03	2.96E+03	NO DATA	5.45E+03	NO DATA	3.34E+07
MO-99	NO DATA	2.96E+06	5.63E+05	NO DATA	6.71E+06	NO DATA	6.86E+06
TC-99m	3.95E-01	1.12E+00	1.42E+01	NO DATA	1.70E+01	5.47E-01	6.61E+02
RU-103	1.22E+02	NO DATA	5.24E+01	NO DATA	4.64E+02	NO DATA	1.42E+04
RU-106	2.44E+03	NO DATA	3.09E+02	NO DATA	4.72E+03	NO DATA	1.58E+05
AG-110m	6.96E+06	6.44E+06	3.82E+06	NO DATA	1.27E+07	NO DATA	2.63E+09
TE-125m	1.95E+06	7.07E+05	2.61E+05	5.87E+05	7.94E+06	NO DATA	7.79E+06
TE-127m	5.46E+06	1.95E+06	6.66E+05	1.40E+06	2.22E+07	NO DATA	2.83E+07
TE-129m	7.21E+06	2.69E+06	1.14E+06	2.48E+06	3.01E+07	NO DATA	3.63E+07
I-130	5.00E+05	1.47E+06	5.82E+05	1.25E+08	2.30E+06	NO DATA	1.27E+06
I-131	3.54E+08	5.06E+08	2.90E+08	1.66E+11	8.68E+08	NO DATA	1.34E+08
I-132	1.98E-01	5.29E-01	1.85E-01	1.85E+01	8.43E-01	NO DATA	9.93E-02
I-133	4.62E+06	8.03E+06	2.45E+06	1.18E+09	1.40E+07	NO DATA	7.22E+06
I-134	2.27E+12	6.16E-12	2.20E-12	1.07E-10	9.80E-12	NO DATA	5.37E-15
I-135	1.55E+04	4.06E+04	1.50E+04	2.68E+06	6.51E+04	NO DATA	4.59E+04
CS-134	1.69E+10	4.03E+10	3.29E+10	NO DATA	1.30E+10	4.32E+09	7.04E+08
CS-136	7.88E+08	3.11E+09	2.24E+09	NO DATA	1.73E+09	2.37E+08	3.53E+08
CS-137	2.21E+10	3.03E+10	1.98E+10	NO DATA	1.02E+10	3.41E+09	5.84E+08
BA-140	3.23E+06	4.05E+03	2.11E+05	NO DATA	1.38E+03	2.32E+03	6.65E+06
CE-141	5.80E+02	3.92E+02	4.45E+01	NO DATA	1.82E+02	NO DATA	1.50E+06
CE-144	4.29E+04	1.79E+04	2.30E+03	NO DATA	1.06E+04	NO DATA	1.45E+07
PR-143	1.89E+01	7.56E+00	9.35E-01	NO DATA	4.37E+00	NO DATA	8.26E+04
ND-147	1.13E+01	1.30E+01	7.79E-01	NO DATA	7.64E+00	NO DATA	6.25E+04

\* $mrem/yr$  per  $\mu Ci/m^3$

TABLE 5-28  
MEAT PATHWAY FACTORS -  $R_{ajj}^M$  (CHILD)  
( $m^2mrem/yr$  per  $\mu Ci/sec$ )

ORGAN: ISOTOPE	BONE	LIVER	T.BODY	THYROID	KIDNEY	LUNG	GI-LLI
H-3	NO DATA	2.33E+02*	2.33E+02*	2.33E+02*	2.33E+02*	2.33E+02*	2.33E+02*
C-14	5.29E+05	1.06E+05	1.06E+05	1.06E+05	1.06E+05	1.06E+05	1.06E+05
P-32	7.43E+09	3.47E+08	2.86E+08	NO DATA	NO DATA	NO DATA	2.05E+08
CR-51	NO DATA	NO DATA	8.78E+03	4.88E+03	1.33E+03	8.90E+03	4.66E+05
MN-54	NO DATA	8.03E+06	2.14E+06	NO DATA	2.25E+06	NO DATA	6.74E+06
FE-55	4.58E+08	2.43E+08	7.52E+07	NO DATA	NO DATA	1.37E+08	4.50E+07
FE-59	3.76E+08	6.09E+08	3.03E+08	NO DATA	NO DATA	1.76E+08	6.34E+08
CO-58	NO DATA	1.64E+07	5.03E+07	NO DATA	NO DATA	NO DATA	9.58E+07
CO-60	NO DATA	6.93E+07	2.04E+08	NO DATA	NO DATA	NO DATA	3.84E+08
NI-63	2.91E+10	1.56E+09	9.90E+08	NO DATA	NO DATA	NO DATA	1.05E+08
ZN-65	3.75E+08	1.00E+09	6.22E+08	NO DATA	6.30E+08	NO DATA	1.76E+08
RB-86	NO DATA	5.76E+08	3.54E+08	NO DATA	NO DATA	NO DATA	3.71E+07
SR-89	4.80E+08	NO DATA	1.37E+07	NO DATA	NO DATA	NO DATA	1.86E+07
SR-90	1.04E+10	NO DATA	2.64E+09	NO DATA	NO DATA	NO DATA	1.40E+08
Y-90	1.73E+02	NO DATA	4.62E+00	NO DATA	NO DATA	NO DATA	4.91E+05
Y-91	1.80E+06	NO DATA	4.81E+04	NO DATA	NO DATA	NO DATA	2.40E+08
ZR-95	2.67E+06	5.87E+05	5.22E+05	NO DATA	8.40E+05	NO DATA	6.12E+08
NB-95	3.10E+06	1.21E+06	8.61E+05	NO DATA	1.13E+06	NO DATA	2.23E+09
MO-99	NO DATA	1.14E+05	2.83E+04	NO DATA	2.44E+05	NO DATA	9.45E+04
TC-99m	6.01E-21	1.18E-20	1.95E-19	NO DATA	1.71E-19	5.98E-21	6.71E-18
RU-103	1.55E+08	NO DATA	5.96E+07	NO DATA	3.90E+08	NO DATA	4.01E+09
RU-106	4.43E+09	NO DATA	5.53E+08	NO DATA	5.99E+09	NO DATA	6.90E+10
AG-110m	8.41E+06	5.68E+06	4.54E+06	NO DATA	1.06E+07	NO DATA	6.75E+08
TE-125m	5.69E+08	1.54E+08	7.58E+07	1.60E+08	NO DATA	NO DATA	5.49E+08
TE-127m	1.77E+09	4.78E+08	2.11E+08	4.24E+08	5.06E+09	NO DATA	1.44E+09
TE-129m	1.79E+09	4.99E+08	2.77E+08	5.76E+08	5.25E+09	NO DATA	2.18E+09
I-130	2.91E-06	5.89E-06	3.03E-06	6.49E-04	8.80E-06	NO DATA	2.75E-06
I-131	1.65E+07	1.66E+07	9.46E+06	5.50E+09	2.73E+07	NO DATA	1.48E+06
I-132	1.05E-58	1.93E-58	8.86E-59	8.93E-57	2.95E-58	NO DATA	2.27E-58
I-133	5.75E-01	7.10E-01	2.69E-01	1.32E+02	1.18E+00	NO DATA	2.86E-01
I-134	0.00E+00	0.00E+00	0.00E+00	0.00E+00	0.00E+00	NO DATA	0.00E+00
I-135	6.86E-17	1.23E-16	5.83E-17	1.09E-14	1.89E-16	NO DATA	9.38E-17
CS-134	9.20E+08	1.51E+09	3.18E+08	NO DATA	4.68E+08	1.68E+08	8.14E+06
CS-136	1.62E+07	4.45E+07	2.88E+07	NO DATA	2.37E+07	3.53E+06	1.56E+06
CS-137	1.33E+09	1.27E+09	1.88E+08	NO DATA	4.15E+08	1.49E+08	7.98E+06
BA-140	4.38E+07	3.84E+04	2.56E+06	NO DATA	1.25E+04	2.29E+04	2.22E+07
CE-141	2.22E+04	1.11E+04	1.64E+03	NO DATA	4.85E+03	NO DATA	1.38E+07
CE-144	2.31E+06	7.24E+05	1.23E+05	NO DATA	4.01E+05	NO DATA	1.89E+08
PR-143	3.34E+04	1.00E+04	1.66E+03	NO DATA	5.43E+03	NO DATA	3.60E+07
ND-147	1.17E+04	9.47E+03	7.33E+02	NO DATA	5.20E+03	NO DATA	1.50E+07

\* $mrem/yr$  per  $\mu Ci/m^3$



TABLE 5-29  
MEAT PATHWAY FACTORS -  $R_{ajj}^M$  (TEEN)  
( $m^2mrem/yr$  per  $\mu Ci$ )

ORGAN: ISOTOPE	BONE	LIVER	T.BODY	THYROID	KIDNEY	LUNG	GI-LLI
H-3	NO DATA	1.93E+02*	1.93E+02*	1.93E+02*	1.93E+02*	1.93E+02*	1.93E+02*
C-14	2.81E+05	5.62E+04	5.62E+04	5.62E+04	5.62E+04	5.62E+04	5.62E+04
P-32	3.95E+09	2.45E+08	1.53E+08	NO DATA	NO DATA	NO DATA	3.32E+08
CR-51	NO DATA	NO DATA	5.65E+03	3.14E+03	1.24E+03	8.07E+03	9.50E+05
MN-54	NO DATA	7.02E+06	1.39E+06	NO DATA	2.09E+06	NO DATA	1.44E+07
FE-55	2.38E+08	1.69E+08	3.94E+07	NO DATA	NO DATA	1.07E+08	7.31E+07
FE-59	2.12E+08	4.95E+08	1.91E+08	NO DATA	NO DATA	1.56E+08	1.17E+09
CO-58	NO DATA	1.41E+07	3.25E+07	NO DATA	NO DATA	NO DATA	1.94E+08
CO-60	NO DATA	5.84E+07	1.32E+08	NO DATA	NO DATA	NO DATA	7.61E+08
NI-63	1.52E+10	1.07E+09	5.15E+08	NO DATA	NO DATA	NO DATA	1.71E+08
ZN-65	2.50E+08	8.69E+08	4.05E+08	NO DATA	5.56E+08	NO DATA	3.68E+08
RB-86	NO DATA	4.05E+08	1.90E+08	NO DATA	NO DATA	NO DATA	6.00E+07
SR-89	2.54E+08	NO DATA	7.27E+06	NO DATA	NO DATA	NO DATA	3.02E+07
SR-90	8.04E+09	NO DATA	1.99E+09	NO DATA	NO DATA	NO DATA	2.26E+08
Y-90	9.11E+01	NO DATA	2.45E+00	NO DATA	NO DATA	NO DATA	7.51E+05
Y-91	9.55E+05	NO DATA	2.56E+04	NO DATA	NO DATA	NO DATA	3.91E+08
ZR-95	1.50E+06	4.74E+05	3.25E+05	NO DATA	6.93E+05	NO DATA	1.09E+09
NB-95	1.79E+06	9.94E+05	5.47E+05	NO DATA	9.64E+05	NO DATA	4.25E+09
MO-99	NO DATA	8.20E+04	1.56E+04	NO DATA	1.88E+05	NO DATA	1.47E+05
TC-99m	3.42E-21	9.54E-21	1.24E-19	NO DATA	1.42E-19	5.29E-21	6.26E-18
RU-103	8.57E+07	NO DATA	3.66E+07	NO DATA	3.02E+08	NO DATA	7.16E+09
RU-106	2.36E+09	NO DATA	2.97E+08	NO DATA	4.54E+09	NO DATA	1.13E+11
AG-110m	5.04E+06	4.77E+06	2.90E+06	NO DATA	9.10E+06	NO DATA	1.34E+09
TE-125m	3.03E+08	1.09E+08	4.06E+07	8.47E+07	NO DATA	NO DATA	8.95E+08
TE-127m	9.40E+08	3.33E+08	1.12E+08	2.24E+08	3.81E+09	NO DATA	2.34E+09
TE-129m	9.49E+08	3.52E+08	1.50E+08	3.06E+08	3.97E+09	NO DATA	3.56E+09
I-130	1.63E-06	4.71E-06	1.88E-06	3.84E-04	7.25E-06	NO DATA	3.62E-06
I-131	8.89E+06	1.24E+07	6.69E+06	3.63E+09	2.14E+07	NO DATA	2.46E+06
I-132	5.78E-59	1.51E-58	5.42E-59	5.09E-57	2.38E-58	NO DATA	6.58E-59
I-133	3.09E-01	5.25E-01	1.60E-01	7.32E+01	9.20E+01	NO DATA	3.97E-01
I-134	0.00E+00	0.00E+00	0.00E+00	0.00E+00	0.00E+00	NO DATA	0.00E+00
I-135	3.79E-17	9.75E-17	3.61E-17	6.27E-15	1.54E-16	NO DATA	1.08E-16
CS-134	5.22E+08	1.23E+09	5.70E+08	NO DATA	3.91E+08	1.49E+08	1.53E+07
CS-136	9.36E+06	3.68E+07	2.47E+07	NO DATA	2.01E+07	3.16E+06	2.96E+06
CS-137	7.24E+08	9.63E+08	3.35E+08	NO DATA	3.28E+08	1.27E+08	1.37E+07
BA-140	2.37E+07	2.91E+04	1.53E+06	NO DATA	9.86E+03	1.96E+04	3.66E+07
CE-141	1.17E+04	7.83E+03	9.00E+02	NO DATA	3.69E+03	NO DATA	2.24E+07
CE-144	1.23E+06	5.10E+05	6.62E+04	NO DATA	3.04E+05	NO DATA	3.10E+08
PR-143	1.77E+04	7.06E+03	8.80E+02	NO DATA	4.10E+03	NO DATA	5.82E+07
ND-147	6.22E+03	6.76E+03	4.05E+02	NO DATA	3.97E+03	NO DATA	2.44E+07

\* $mrem/yr$  per  $\mu Ci/m^3$

TABLE 5-30  
MEAT PATHWAY FACTORS -  $R_{aij}^M$  (ADULT)  
( $m^2$ mrem/yr per  $\mu$ Ci/sec)

ORGAN: ISOTOPE	BONE	LIVER	T.BODY	THYROID	KIDNEY	LUNG	GI-LLI
H-3	NO DATA	3.24E+02*	3.24E+02*	3.24E+02*	3.24E+02*	3.24E+02*	3.24E+02*
C-14	3.33E+05	6.66E+04	6.66E+04	6.66E+04	6.66E+04	6.66E+04	6.66E+04
P-32	4.65E+09	2.89E+08	1.80E+08	NO DATA	NO DATA	NO DATA	5.23E+08
CR-51	NO DATA	NO DATA	7.05E+03	4.21E+03	1.55E+03	9.35E+03	1.77E+06
MN-54	NO DATA	9.19E+06	1.75E+06	NO DATA	2.73E+06	NO DATA	2.81E+07
FE-55	2.94E+08	2.03E+08	4.74E+07	NO DATA	NO DATA	1.13E+08	1.17E+08
FE-59	2.66E+08	6.24E+08	2.39E+08	NO DATA	NO DATA	1.74E+08	2.08E+09
CO-58	NO DATA	1.83E+07	4.09E+07	NO DATA	NO DATA	NO DATA	3.70E+08
CO-60	NO DATA	7.51E+07	1.66E+08	NO DATA	NO DATA	NO DATA	1.41E+09
NI-63	1.89E+10	1.31E+09	6.32E+08	NO DATA	NO DATA	NO DATA	2.73E+08
ZN-65	3.56E+08	1.13E+09	5.12E+08	NO DATA	7.57E+08	NO DATA	7.13E+08
RB-86	NO DATA	4.87E+08	2.27E+08	NO DATA	NO DATA	NO DATA	9.61E+07
SR-89	3.01E+08	NO DATA	8.64E+06	NO DATA	NO DATA	NO DATA	4.83E+07
SR-90	1.24E+10	NO DATA	3.05E+09	NO DATA	NO DATA	NO DATA	3.59E+08
Y-90	1.09E+02	NO DATA	2.92E+00	NO DATA	NO DATA	NO DATA	1.15E+06
Y-91	1.13E+06	NO DATA	3.03E+04	NO DATA	NO DATA	NO DATA	6.23E+08
ZR-95	1.87E+06	6.00E+05	4.06E+05	NO DATA	9.41E+05	NO DATA	1.90E+09
NB-95	2.30E+06	1.28E+06	6.86E+05	NO DATA	1.26E+06	NO DATA	7.75E+09
MO-99	NO DATA	9.91E+04	1.89E+04	NO DATA	2.24E+05	NO DATA	2.30E+05
TC-99m	4.32E-21	1.22E-20	1.56E-19	NO DATA	1.86E-19	5.99E-21	7.23E-18
RU-103	1.05E+08	NO DATA	4.53E+07	NO DATA	4.02E+08	NO DATA	1.23E+10
RU-106	2.81E+09	NO DATA	3.55E+08	NO DATA	5.42E+09	NO DATA	1.82E+11
AG-110m	6.67E+06	6.17E+06	3.67E+06	NO DATA	1.21E+07	NO DATA	2.52E+09
TE-125m	3.59E+08	1.30E+08	4.81E+07	1.08E+08	1.46E+09	NO DATA	1.43E+09
TE-127m	1.12E+09	3.99E+08	1.36E+08	2.85E+08	4.54E+09	NO DATA	3.75E+09
TE-129m	1.13E+09	4.22E+08	1.79E+08	3.89E+08	4.73E+09	NO DATA	5.70E+09
I-130	2.03E-06	5.98E-06	2.36E-06	5.07E-04	9.33E-06	NO DATA	5.15E-06
I-131	1.07E+07	1.54E+07	8.80E+06	5.03E+09	2.63E+07	NO DATA	4.05E+06
I-132	7.13E-59	1.91E-58	6.67E-59	6.67E-57	3.04E-58	NO DATA	3.58E-59
I-133	3.70E-01	6.43E-01	1.96E-01	9.45E+01	1.12E+00	NO DATA	5.78E-01
I-134	0.00E+00	0.00E+00	0.00E+00	0.00E+00	0.00E+00	NO DATA	0.00E+00
I-135	4.65E-17	1.22E-16	4.49E-17	8.03E-15	1.95E-16	NO DATA	1.38E-16
CS-134	6.53E+08	1.55E+09	1.27E+09	NO DATA	5.03E+08	1.67E+08	2.72E+07
CS-136	1.20E+07	4.75E+07	3.42E+07	NO DATA	2.65E+07	3.63E+06	5.40E+06
CS-137	8.69E+08	1.19E+09	7.78E+08	NO DATA	4.03E+08	1.34E+08	2.30E+07
BA-140	2.88E+07	3.62E+04	1.89E+06	NO DATA	1.23E+04	2.07E+04	5.94E+07
CE-141	1.39E+04	9.43E+03	1.07E+03	NO DATA	4.38E+03	NO DATA	3.61E+07
CE-144	1.46E+06	6.10E+05	7.83E+04	NO DATA	3.62E+05	NO DATA	4.93E+08
PR-143	2.09E+04	8.40E+03	1.04E+03	NO DATA	4.85E+03	NO DATA	9.17E+07
ND-147	7.04E+03	8.14E+03	4.87E+02	NO DATA	4.76E+03	NO DATA	3.91E+07

\*mrem/yr per  $\mu$ Ci/m<sup>3</sup>

TABLE 5-31  
VEGETATION PATHWAY FACTORS -  $R_{aj}^V$  (CHILD)  
( $m^2mrem/yr$  per  $\mu Ci/sec$ )

ORGAN: ISOTOPE	BONE	LIVER	T.BODY	THYROID	KIDNEY	LUNG	GI-LLI
H-3	NO DATA	4.01E+03*	4.01E+03*	4.01E+03*	4.01E+03*	4.01E+03*	4.01E+03*
C-14	3.50E+06	7.01E+05	7.01E+05	7.01E+05	7.01E+05	7.01E+05	7.01E+05
P-32	3.37E+09	1.57E+08	1.30E+08	NO DATA	NO DATA	NO DATA	9.30E+07
CR-51	NO DATA	NO DATA	1.17E+05	6.49E+04	1.77E+04	1.18E+05	6.20E+06
MN-54	NO DATA	6.64E+08	1.77E+08	NO DATA	1.86E+08	NO DATA	5.58E+08
FE-55	8.02E+08	4.25E+08	1.32E+08	NO DATA	NO DATA	2.40E+08	7.88E+07
FE-59	3.98E+08	6.43E+08	3.21E+08	NO DATA	NO DATA	1.87E+08	6.70E+08
CO-58	NO DATA	6.44E+07	1.97E+08	NO DATA	NO DATA	NO DATA	3.76E+08
CO-60	NO DATA	3.79E+08	1.12E+09	NO DATA	NO DATA	NO DATA	2.10E+09
NI-63	3.95E+10	2.11E+09	1.34E+09	NO DATA	NO DATA	NO DATA	1.42E+08
ZN-65	8.11E+08	2.16E+09	1.34E+09	NO DATA	1.36E+09	NO DATA	3.79E+08
RB-86	NO DATA	4.53E+08	2.79E+08	NO DATA	NO DATA	NO DATA	2.91E+07
SR-89	3.59E+10	NO DATA	1.03E+09	NO DATA	NO DATA	NO DATA	1.39E+09
SR-90	1.24E+12	NO DATA	3.14E+11	NO DATA	NO DATA	NO DATA	1.67E+10
Y-90	2.31E+04	NO DATA	6.18E+02	NO DATA	NO DATA	NO DATA	6.58E+07
Y-91	1.86E+07	NO DATA	4.97E+05	NO DATA	NO DATA	NO DATA	2.48E+09
ZR-95	3.86E+06	8.49E+05	7.56E+05	NO DATA	1.22E+06	NO DATA	8.86E+08
NB-95	4.10E+05	1.60E+05	1.14E+05	NO DATA	1.50E+05	NO DATA	2.95E+08
MO-99	NO DATA	7.67E+06	1.90E+06	NO DATA	1.64E+07	NO DATA	6.35E+06
TC-99m	4.70E+00	9.21E+00	1.53E+02	NO DATA	1.34E+02	4.68E+00	5.24E+03
RU-103	1.54E+07	NO DATA	5.90E+06	NO DATA	3.86E+07	NO DATA	3.97E+08
RU-106	7.45E+08	NO DATA	9.30E+07	NO DATA	1.01E+09	NO DATA	1.16E+10
AG-110m	3.21E+07	2.17E+07	1.73E+07	NO DATA	4.04E+07	NO DATA	2.58E+09
TE-125m	3.51E+08	9.52E+07	4.68E+07	9.86E+07	NO DATA	NO DATA	3.39E+08
TE-127m	1.32E+09	3.56E+08	1.57E+08	3.16E+08	3.77E+09	NO DATA	1.07E+09
TE-129m	8.43E+08	2.35E+08	1.31E+08	2.72E+08	2.47E+09	NO DATA	1.03E+09
I-130	6.10E+05	1.23E+06	6.35E+05	1.36E+08	1.84E+06	NO DATA	5.77E+05
I-131	1.43E+08	1.44E+08	8.16E+07	4.75E+10	2.36E+08	NO DATA	1.28E+07
I-132	9.20E+01	1.69E+02	7.77E+01	7.84E+03	2.59E+02	NO DATA	1.99E+02
I-133	3.53E+06	4.36E+06	1.65E+06	8.11E+08	7.27E+06	NO DATA	1.76E+06
I-134	1.50E-04	2.79E-04	1.28E-04	6.41E-03	4.26E-04	NO DATA	1.85E-04
I-135	6.28E+04	1.13E+05	5.34E+04	1.00E+07	1.73E+05	NO DATA	8.61E+04
CS-134	1.60E+10	2.63E+10	5.55E+09	NO DATA	8.15E+09	2.92E+09	1.42E+08
CS-136	8.23E+07	2.26E+08	1.46E+08	NO DATA	1.20E+08	1.80E+07	7.95E+06
CS-137	2.39E+10	2.29E+10	3.38E+09	NO DATA	7.46E+09	2.68E+09	1.43E+08
BA-140	2.77E+08	2.42E+05	1.62E+07	NO DATA	7.89E+04	1.45E+05	1.40E+08
CE-141	6.56E+05	3.27E+05	4.85E+04	NO DATA	1.43E+05	NO DATA	4.08E+08
CE-144	1.27E+08	3.99E+07	6.79E+06	NO DATA	2.21E+07	NO DATA	1.04E+10
PR-143	1.45E+05	4.37E+04	7.22E+03	NO DATA	2.36E+04	NO DATA	1.57E+08
ND-147	7.16E+04	5.80E+04	4.49E+03	NO DATA	3.18E+04	NO DATA	9.18E+07

\* $mrem/yr$  per  $\mu Ci/m^3$

TABLE 5-32  
VEGETATION PATHWAY FACTORS -  $R_{aj}^V$  (TEEN)  
( $m^2$ mrem/yr per  $\mu$ Ci/sec)

ORGAN: ISOTOPE	BONE	LIVER	T.BODY	THYROID	KIDNEY	LUNG	GI-LLI
H-3	NO DATA	2.59E+03*	2.59E+03*	2.59E+03*	2.59E+03*	2.59E+03*	2.59E+03*
C-14	1.45E+06	2.91E+05	2.91E+05	2.91E+05	2.91E+05	2.91E+05	2.91E+05
P-32	1.61E+09	9.97E+07	6.24E+07	NO DATA	NO DATA	NO DATA	1.35E+08
CR-51	NO DATA	NO DATA	6.12E+04	3.40E+04	1.34E+04	8.74E+04	1.03E+07
MN-54	NO DATA	4.54E+08	9.01E+07	NO DATA	1.36E+08	NO DATA	9.32E+08
FE-55	3.26E+08	2.31E+08	5.39E+07	NO DATA	NO DATA	1.46E+08	1.00E+08
FE-59	1.79E+08	4.18E+08	1.61E+08	NO DATA	NO DATA	1.32E+08	9.88E+08
CO-58	NO DATA	4.36E+07	1.01E+08	NO DATA	NO DATA	NO DATA	6.02E+08
CO-60	NO DATA	2.49E+08	5.60E+08	NO DATA	NO DATA	NO DATA	3.24E+09
NI-63	1.61E+10	1.14E+09	5.46E+08	NO DATA	NO DATA	NO DATA	1.81E+08
ZN-65	4.23E+08	1.47E+09	6.86E+08	NO DATA	9.41E+08	NO DATA	6.23E+08
RB-86	NO DATA	2.72E+08	1.28E+08	NO DATA	NO DATA	NO DATA	4.02E+07
SR-89	1.51E+10	NO DATA	4.32E+08	NO DATA	NO DATA	NO DATA	1.80E+09
SR-90	7.50E+11	NO DATA	1.85E+11	NO DATA	NO DATA	NO DATA	2.11E+10
Y-90	1.25E+04	NO DATA	3.37E+02	NO DATA	NO DATA	NO DATA	1.03E+08
Y-91	7.84E+06	NO DATA	2.10E+05	NO DATA	NO DATA	NO DATA	3.21E+09
ZR-95	1.73E+06	5.46E+05	3.75E+05	NO DATA	8.02E+05	NO DATA	1.26E+09
NB-95	1.92E+05	1.07E+05	5.86E+04	NO DATA	1.03E+05	NO DATA	4.56E+08
MO-99	NO DATA	5.64E+06	1.08E+06	NO DATA	1.29E+07	NO DATA	1.01E+07
TC-99m	2.73E+00	7.61E+00	9.86E+01	NO DATA	1.13E+02	4.23E+00	5.00E+03
RU-103	6.81E+06	NO DATA	2.91E+06	NO DATA	2.40E+07	NO DATA	5.69E+08
RU-106	3.09E+08	NO DATA	3.89E+07	NO DATA	5.95E+08	NO DATA	1.48E+10
AG-110m	1.51E+07	1.43E+07	8.72E+06	NO DATA	2.72E+07	NO DATA	4.03E+09
TE-125m	1.49E+08	5.35E+07	1.99E+07	4.15E+07	NO DATA	NO DATA	4.38E+08
TE-127m	5.52E+08	1.96E+08	6.57E+07	1.31E+08	2.24E+09	NO DATA	1.38E+09
TE-129m	3.60E+08	1.34E+08	5.70E+07	1.16E+08	1.51E+09	NO DATA	1.35E+09
I-130	3.50E+05	1.01E+06	4.05E+05	8.26E+07	1.56E+06	NO DATA	7.79E+05
I-131	7.66E+07	1.07E+08	5.76E+07	3.13E+10	1.85E+08	NO DATA	2.12E+07
I-132	5.19E+01	1.36E+02	4.87E+01	4.58E+03	2.14E+02	NO DATA	5.91E+01
I-133	1.93E+06	3.28E+06	1.00E+06	4.58E+08	5.75E+06	NO DATA	2.48E+06
I-134	8.44E-05	2.24E-04	8.03E-05	3.73E-03	3.53E-04	NO DATA	2.95E-06
I-135	3.53E+04	9.09E+04	3.37E+04	5.85E+06	1.44E+05	NO DATA	1.01E+05
CS-134	7.10E+09	1.67E+10	7.75E+09	NO DATA	5.31E+09	2.03E+09	2.08E+08
CS-136	4.37E+07	1.72E+08	1.16E+08	NO DATA	9.37E+07	1.48E+07	1.38E+07
CS-137	1.01E+10	1.35E+10	4.70E+09	NO DATA	4.59E+09	1.78E+09	1.92E+08
BA-140	1.38E+08	1.69E+05	8.89E+06	NO DATA	5.73E+04	1.14E+05	2.13E+08
CE-141	2.83E+05	1.89E+05	2.17E+04	NO DATA	8.90E+04	NO DATA	5.41E+08
CE-144	5.29E+07	2.19E+07	2.84E+06	NO DATA	1.31E+07	NO DATA	1.33E+10
PR-143	7.00E+04	2.79E+04	3.48E+03	NO DATA	1.62E+04	NO DATA	2.30E+08
ND-147	3.62E+04	3.94E+04	2.36E+03	NO DATA	2.31E+04	NO DATA	1.42E+08

\*mrem/yr per  $\mu$ Ci/m<sup>3</sup>

TABLE 5-33

VEGETATION PATHWAY FACTORS -  $R_{ajj}^V$  (ADULT)  
( $m^2 mrem/yr$  per  $\mu Ci/sec$ )

ORGAN: ISOTOPE	BONE	LIVER	T.BODY	THYROID	KIDNEY	LUNG	GI-LLI
H-3	NO DATA	2.26E+03*	2.26E+03*	2.26E+03*	2.26E+03*	2.26E+03*	2.26E+03*
C-14	8.97E+05	1.79E+05	1.79E+05	1.79E+05	1.79E+05	1.79E+05	1.79E+05
P-32	1.40E+09	8.70E+07	5.41E+07	NO DATA	NO DATA	NO DATA	1.57E+08
CR-51	NO DATA	NO DATA	4.60E+04	2.75E+04	1.01E+04	6.11E+04	1.16E+07
MN-54	NO DATA	3.13E+08	5.96E+07	NO DATA	9.30E+07	NO DATA	9.58E+08
FE-55	2.10E+08	1.45E+08	3.38E+07	NO DATA	NO DATA	8.10E+07	8.33E+07
FE-59	1.26E+08	2.96E+08	1.13E+08	NO DATA	NO DATA	8.27E+07	9.86E+08
CO-58	NO DATA	3.08E+07	6.90E+07	NO DATA	NO DATA	NO DATA	6.24E+08
CO-60	NO DATA	1.67E+08	3.69E+08	NO DATA	NO DATA	NO DATA	3.14E+09
NI-63	1.04E+10	7.21E+08	3.49E+08	NO DATA	NO DATA	NO DATA	1.50E+08
ZN-65	3.18E+08	1.01E+09	4.57E+08	NO DATA	6.76E+08	NO DATA	6.36E+08
RB-86	NO DATA	2.19E+08	1.02E+08	NO DATA	NO DATA	NO DATA	4.33E+07
SR-89	9.95E+09	NO DATA	2.86E+08	NO DATA	NO DATA	NO DATA	1.60E+09
SR-90	6.04E+11	NO DATA	1.48E+11	NO DATA	NO DATA	NO DATA	1.75E+10
Y-90	1.33E+04	NO DATA	3.56E+02	NO DATA	NO DATA	NO DATA	1.41E+08
Y-91	5.12E+06	NO DATA	1.37E+05	NO DATA	NO DATA	NO DATA	2.82E+09
ZR-95	1.18E+06	3.79E+05	2.56E+05	NO DATA	5.94E+05	NO DATA	1.20E+09
NB-95	1.42E+05	7.91E+04	4.25E+04	NO DATA	7.82E+04	NO DATA	4.80E+08
MO-99	NO DATA	6.12E+06	1.16E+06	NO DATA	1.39E+07	NO DATA	1.42E+07
TC-99m	3.09E+00	8.73E+00	1.11E+02	NO DATA	1.33E+02	4.28E+00	5.16E+03
RU-103	4.77E+06	NO DATA	2.06E+06	NO DATA	1.82E+07	NO DATA	5.57E+08
RU-106	1.93E+08	NO DATA	2.44E+07	NO DATA	3.73E+08	NO DATA	1.25E+10
AG-110m	1.05E+07	9.75E+06	5.79E+06	NO DATA	1.92E+07	NO DATA	3.98E+09
TE-125m	9.67E+07	3.51E+07	1.30E+07	2.91E+07	3.93E+08	NO DATA	3.86E+08
TE-127m	3.49E+08	1.25E+08	4.26E+07	8.93E+07	1.42E+09	NO DATA	1.17E+09
TE-129m	2.51E+08	9.35E+07	3.97E+07	8.61E+07	1.05E+09	NO DATA	1.26E+09
I-130	3.91E+05	1.15E+06	4.55E+05	9.77E+07	1.80E+06	NO DATA	9.93E+05
I-131	8.07E+07	1.15E+08	6.62E+07	3.78E+10	1.98E+08	NO DATA	3.05E+07
I-132	5.77E+01	1.54E+02	5.40E+01	5.40E+03	2.46E+02	NO DATA	2.90E+01
I-133	2.09E+06	3.63E+06	1.11E+06	5.34E+08	6.34E+06	NO DATA	3.26E+06
I-134	9.33E-05	2.53E-04	9.06E-05	4.39E-03	4.03E-04	NO DATA	2.12E-07
I-135	3.91E+04	1.02E+05	3.77E+04	6.75E+06	1.64E+05	NO DATA	1.16E+05
CS-134	4.67E+09	1.11E+10	9.08E+09	NO DATA	3.59E+09	1.19E+09	1.94E+08
CS-136	4.26E+07	1.68E+08	1.21E+08	NO DATA	9.35E+07	1.28E+07	1.91E+07
CS-137	6.36E+09	8.70E+09	5.70E+09	NO DATA	2.95E+09	9.82E+08	1.68E+08
BA-140	1.29E+08	1.62E+05	8.43E+06	NO DATA	5.50E+04	9.26E+04	2.65E+08
CE-141	1.97E+05	1.33E+05	1.51E+04	NO DATA	6.19E+04	NO DATA	5.09E+08
CE-144	3.28E+07	1.37E+07	1.76E+06	NO DATA	8.14E+06	NO DATA	1.11E+10
PR-143	6.26E+04	2.51E+04	3.10E+03	NO DATA	1.45E+04	NO DATA	2.74E+08
ND-147	3.33E+04	3.85E+04	2.31E+03	NO DATA	2.25E+04	NO DATA	1.85E+08

\* $mrem/yr$  per  $\mu Ci/m^3$

TABLE 5-34  
GROUND PLANE PATHWAY FACTORS -  $R_i^G$   
( $m^2mrem/yr$  per  $\mu Ci/sec$ )

ISOTOPE	TOTAL BODY	SKIN	ISOTOPE	TOTAL BODY	SKIN
H-3	0.00E+00	0.00E+00	I-134	4.46E+05	5.30E+05
C-14	0.00E+00	0.00E+00	Y-90	4.50E+03	5.31E+03
P-32	0.00E+00	0.00E+00	Y-91	1.07E+06	1.21E+06
CR-51	4.65E+06	5.50E+06	ZR-95	2.45E+08	2.85E+08
MN-54	1.38E+09	1.62E+09	NB-95	1.37E+08	1.61E+08
MO-99	3.99E+06	4.62E+06	TC-99m	1.84E+05	2.11E+05
FE-55	0.00E+00	0.00E+00	RU-103	1.08E+08	1.26E+08
FE-59	2.73E+08	3.20E+08	RU-106	4.22E+08	5.06E+08
CO-58	3.80E+08	4.45E+08	TE-127m	9.16E+04	1.08E+05
CO-60	2.32E+10	2.73E+10	I-131	1.72E+07	2.09E+07
NI-63	0.00E+00	0.00E+00	I-132	1.25E+06	1.47E+06
AG-110m	3.44E+09	4.01E+09	I-135	2.53E+06	2.95E+06
TE-125m	1.56E+06	2.13E+06	CS-134	6.87E+09	8.01E+09
ZN-65	7.48E+08	8.60E+08	CS-136	1.51E+08	1.71E+08
TE-129m	1.98E+07	2.31E+07	BA-140	2.05E+07	2.35E+07
RB-86	8.98E+06	1.03E+07	CE-141	1.37E+07	1.54E+07
I-130	5.50E+06	6.68E+06	CE-144	6.96E+07	8.05E+07
SR-89	2.16E+04	2.50E+04	PR-143	0.00E+00	0.00E+00
SR-90	NO DATA	NO DATA	ND-147	8.39E+06	1.01E+07
I-133	2.45E+06	2.98E+06			

TABLE 5-35  
X/Q, D/Q AT THE SITE BOUNDARY  
5-YEAR AVERAGE VALUES FROM 2008-2012 MET DATA

	Direction	Range (m)	No Decay Undepleted X/Q (sec/m <sup>3</sup> )	8 Day Decay Depleted X/Q (sec/m <sup>3</sup> )	D/Q (1/m <sup>2</sup> )
site boundary	E	1219	1.06E-07	9.73E-08	2.36E-09
site boundary	ENE	1219	7.93E-08	7.30E-08	1.58E-09
site boundary	ESE	4816	5.25E-08	4.83E-08	4.64E-10
site boundary	N	1400	1.57E-07	1.44E-07	2.65E-09
site boundary	NE	1097	1.09E-07	9.99E-08	2.01E-09
site boundary	NNE	1341	1.42E-07	1.30E-07	2.52E-09
site boundary	NNW	1585	9.44E-08	8.70E-08	1.25E-09
site boundary	NW	1463	6.11E-08	5.66E-08	9.30E-10
site boundary	S	3343	4.44E-08	4.16E-08	4.49E-10
site boundary	SE	3842	5.58E-08	5.17E-08	5.29E-10
site boundary	SSE	3353	3.99E-08	3.73E-08	3.80E-10
site boundary	SSW	4633	3.01E-08	2.80E-08	2.40E-10
site boundary	SW	5121	4.23E-08	3.95E-08	2.45E-10
site boundary	W	2256	3.45E-08	3.26E-08	3.53E-10
site boundary	WNW	1097	5.30E-08	4.90E-08	8.05E-10
site boundary	WSW	3414	3.42E-08	3.24E-08	2.59E-10

TABLE 5-36  
X/Q, D/Q AT SPECIFIC LOCATIONS WITHIN THE CPS SITE BOUNDARY  
5-YEAR AVERAGE VALUES FROM 2008-2012 MET DATA

	Direction	Range (m)	No Decay Undepleted X/Q (sec/m <sup>3</sup> )	8 Day Decay Depleted X/Q (sec/m <sup>3</sup> )	D/Q (1/m <sup>2</sup> )
Table 3.4-4	ESE	1287	1.46E-07	1.34E-07	3.19E-09
Table 3.4-4	NW	335	3.60E-07	3.45E-07	4.12E-09
Table 3.4-4	SE	495	3.87E-07	3.66E-07	7.47E-09
Table 3.4-4	SSE	2736	4.51E-08	4.22E-08	4.91E-10
Table 3.4-4	SSW	1372	6.87E-08	6.33E-08	1.37E-09
Table 3.4-4	SW	1219	9.96E-08	9.16E-08	1.66E-09
Table 3.4-4	WSW	2414	3.87E-08	3.65E-08	4.01E-10



TABLE 5-37  
X/Q, D/Q AT RESIDENCES IN EACH SECTOR  
5-YEAR AVERAGE VALUES FROM 2008-2012 MET DATA\*

	Direction	Range (m)	No Decay Undepleted X/Q (sec/m <sup>3</sup> )	8 Day Decay Depleted X/Q (sec/m <sup>3</sup> )	D/Q (1/m <sup>2</sup> )
residence	E	1670	7.97E-08	7.31E-08	1.54E-09
residence	ENE	2860	4.35E-08	4.05E-08	4.78E-10
residence	ESE	5140	4.95E-08	4.56E-08	4.19E-10
residence	N	1500	1.48E-07	1.35E-07	2.43E-09
residence	NE	6980	2.94E-08	2.74E-08	1.43E-10
residence	NNE	3760	6.88E-08	6.36E-08	5.71E-10
residence	NNW	2050	8.48E-08	7.89E-08	9.01E-10
residence	NW	4700	4.21E-08	4.00E-08	1.98E-10
residence	S	6600	2.60E-08	2.41E-08	1.64E-10
residence	SE	7100	3.25E-08	2.98E-08	2.04E-10
residence	SSE	4520	3.21E-08	2.99E-08	2.51E-10
residence	SSW	4680	2.99E-08	2.78E-08	2.37E-10
residence	SW	5870	3.83E-08	3.57E-08	1.99E-10
residence	W	3220	3.24E-08	3.08E-08	2.27E-10
residence	WNW	2640	4.28E-08	4.07E-08	3.16E-10
residence	WSW	5530	2.60E-08	2.46E-08	1.32E-10

\*The residence identified in each sector was that household having the highest dose commitment as identified by the 2013 Annual Land Use Census.

6.0 TOTAL DOSE

The annual (calendar year) dose or dose commitment to any MEMBER OF THE PUBLIC due to releases of radioactivity and to radiation from uranium fuel cycle sources shall be limited to less than or equal to 25 mrem to the total body or any organ, except the thyroid, which shall be limited to less than or equal to 75 mrem. Total dose requirements are further discussed in Part I RECS Section 3/4.5.

7.0 RADIOLOGICAL ENVIRONMENTAL MONITORING PROGRAM

The primary requirements for the Clinton Power Station Radiological Environmental Monitoring Program (REMP) are set forth in Part I RECS Table 4.6-1 and shown by location in Figure 7-1 through Figure 7-4. In addition to the required sampling program, CPS will perform supplemental periodic and long-term sampling analyses in order to better monitor environmental exposure pathways. These samples will not be listed in this manual.

FIGURE 7-1  
REMP LOCATIONS WITHIN 1 MILE OF CPS

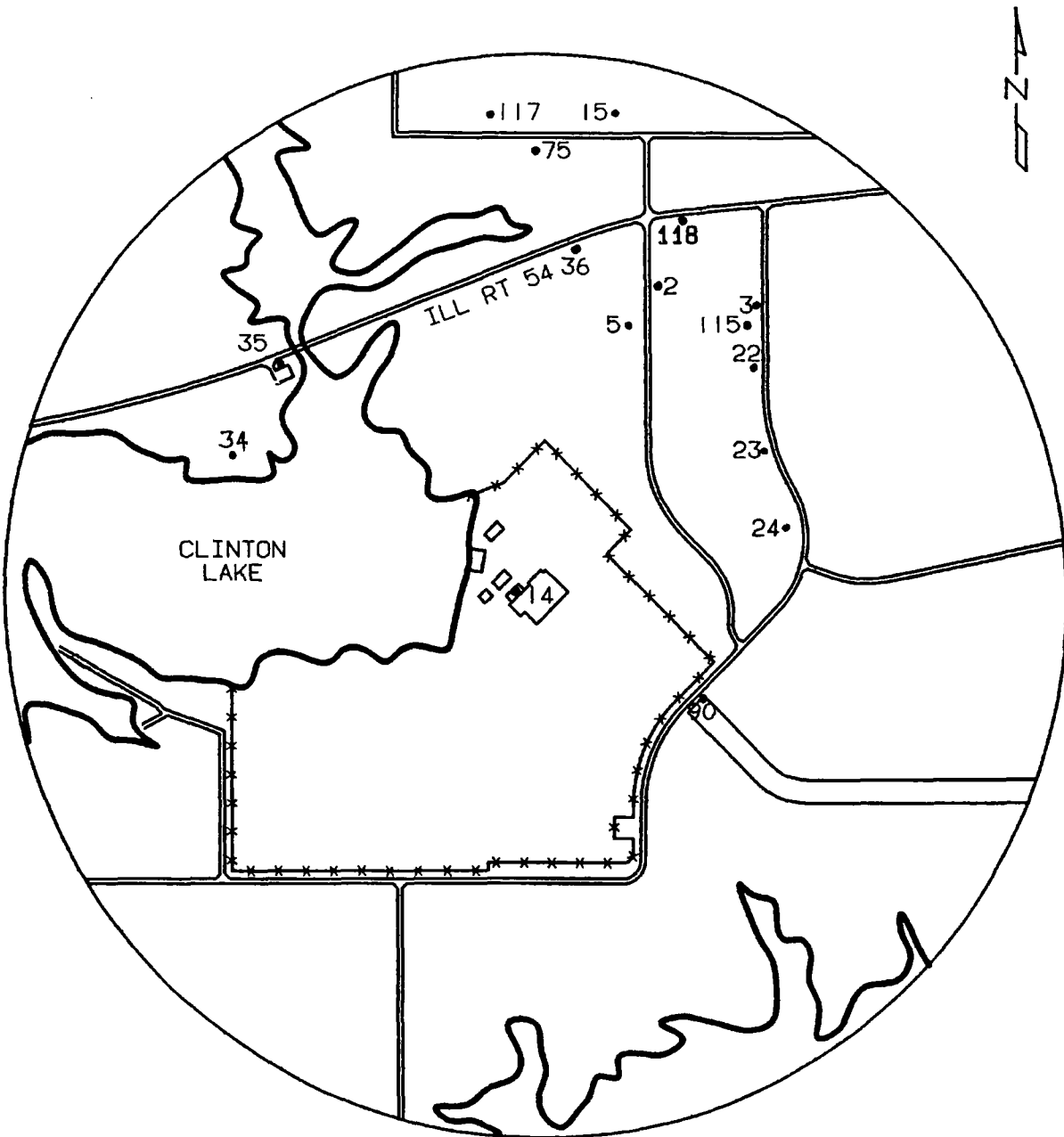

FIGURE 7-2  
REMP LOCATIONS 1-2 MILES FROM CPS

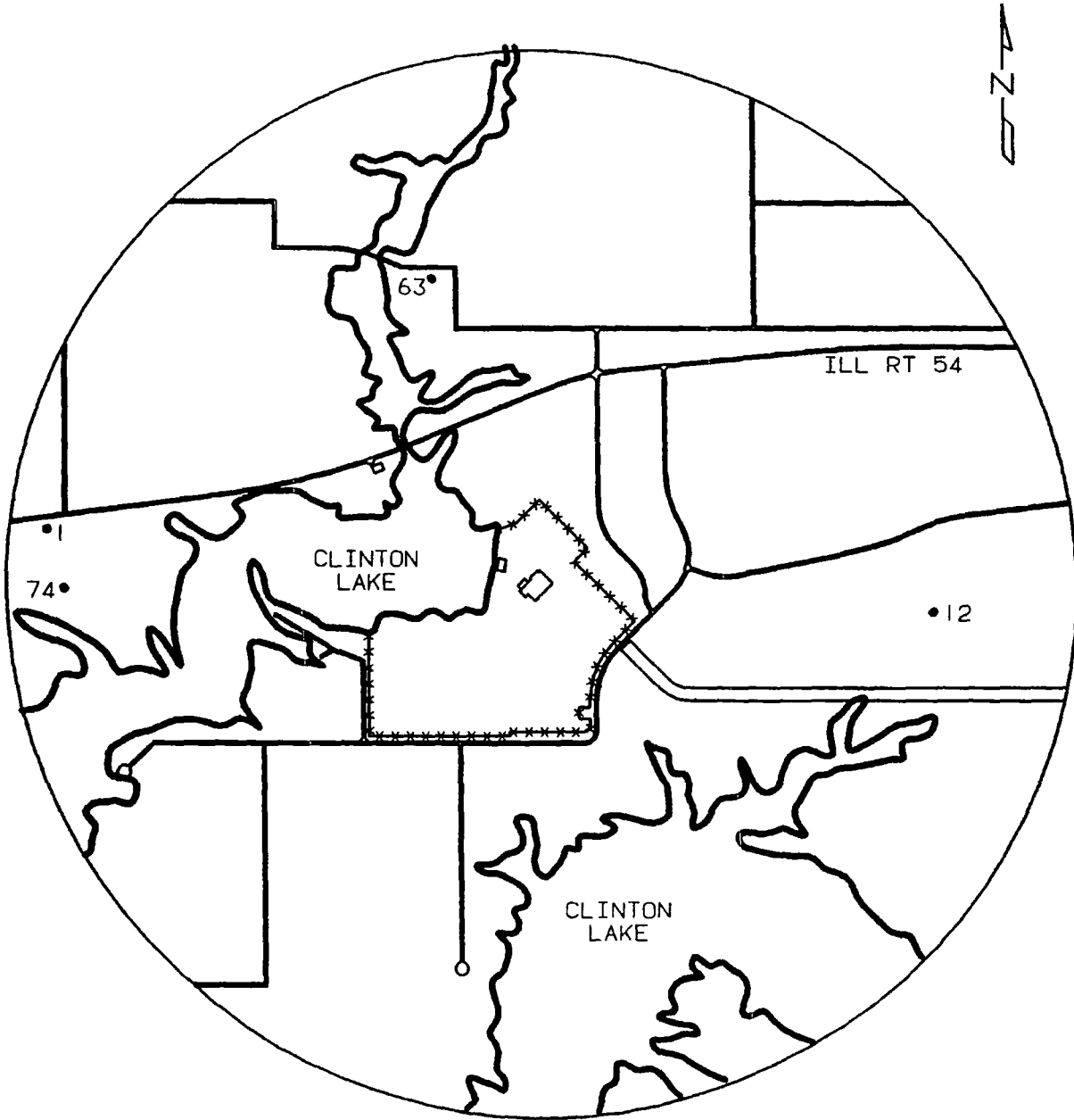
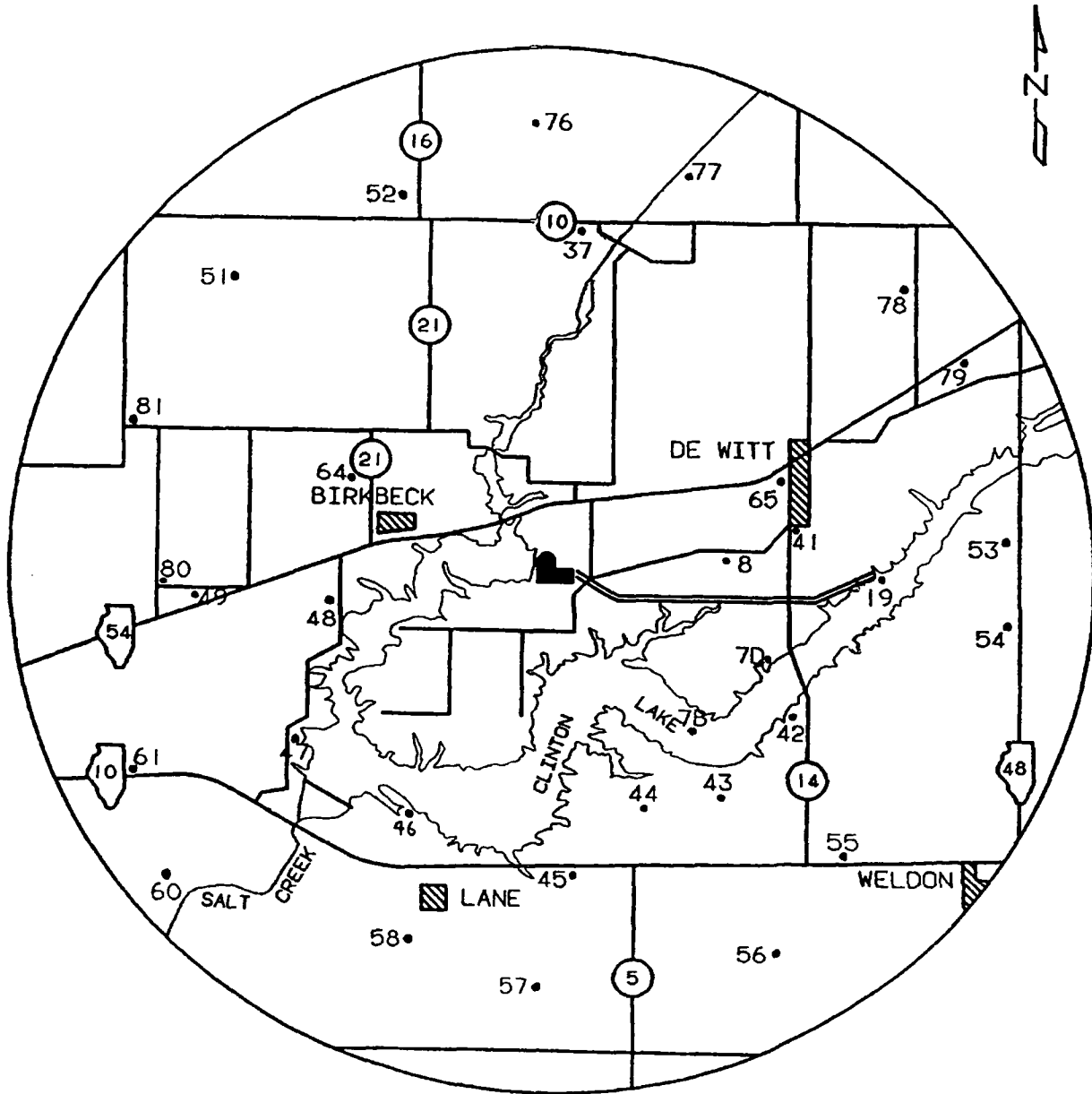

FIGURE 7-3  
REMP LOCATIONS 2-5 MILES FROM CPS





8.0 LAND USE CENSUS

A land use census shall be conducted and shall identify within a distance of 8 km (5 miles) the location in each of the 16 meteorological sectors of the nearest milk animal, the nearest residence and the nearest garden\* of greater than 50 m<sup>2</sup> (500 ft<sup>2</sup>) producing broad leaf vegetation. For elevated or mixed-mode releases as defined in Regulatory Guide 1.111, Revision 1, July 1977, the land use census shall also identify within a distance of 5 km (3 miles) the location in each of the 16 meteorological sectors of all milk animals and all gardens of greater than 50 m<sup>2</sup> producing broad leaf vegetation. This requirement is further discussed in Part I RECS Section 3/4.7.



9.0 INTERLABORATORY COMPARISON PROGRAM

All analyses for CPS Radiological Environmental Monitoring Program are performed by a corporate approved contractor laboratory. The contractor laboratory takes part in an interlaboratory comparison (cross-check) program. This is a program operated by agencies/laboratories which supply environmental-type samples (e.g., milk or water) containing concentrations of radionuclides known to the issuing laboratory but not to the participant laboratory. The purpose of such a program is to provide an independent check on the contractor laboratory's analytical procedures and to alert it to any possible problems.

Any issues identified through the interlaboratory comparison program are investigated by the contractor laboratory. The results of the investigation and the corrective actions are reported in the Annual Radiological Environmental Operating Report.

Operation and Surveillance Requirements for the Interlaboratory Comparison Program are prescribed in Part I RECS Section 3/4.8.

## 10.0 ATMOSPHERIC TRANSPORT AND DISPERSION MODEL

### 10.1 INTRODUCTION

The atmospheric transport and dispersion model used by Clinton Power Station is a straight-line, sector- averaged Gaussian model designed to estimate average relative concentrations at various receptor points. The model was developed in accordance with routine release analysis procedures specified by Regulatory Guide 1.111 (Revision 1 July 1977), Section C.1.c "Constant Mean Wind Direction Models".

All meteorological and dose calculations prescribed in this manual are based on meteorological data concurrent with the time of release or the annual average values. Near-real time meteorological data processing is described in Section 10.2.

### 10.2 CONCURRENT METEOROLOGICAL DATA PROCESSING

Meteorological data is acquired and processed through a model which utilizes bi-level hourly meteorological tower data or single level joint frequency data to perform the required analysis. Three distinct release modes are treated: elevated, ground and mixed. A set of four output arrays are generated for each dose receptor location as follows:

- a. Relative undecayed, undepleted plume concentration (X/Q)
- b. Relative decayed and depleted radioiodine and particulate concentration (D2DPXQ) [8 day decay]
- c. Relative decayed noble gas concentration (D1XQ) [2.26 day decay]
- d. Relative particulate and radioiodine deposition (D/Q)

Since the Regulatory Guide 1.111 depletion and deposition curves are defined only within the range encompassing 100 to 200,000 meters, analysis results are not considered valid outside this range. The following sections describe the calculations performed by the transport and dispersion model for a one hour time interval.

10.2.1 Determination of Pasquill Stability Class

The Pasquill Stability Class is determined by categorizing the temperature gradient,  $\Delta T$ , into one of several ranges between -0.900 and 0.900 °C/meter according to the following equation:

$$\Delta T = (T_U - T_L)/(H_U - H_L), \text{ °C/meter} \quad (10-1)$$

Where:  $T_U$  = Meteorological (met) tower upper level temperature, °C  
 $T_L$  = Meteorological tower lower level temperature, °C  
 $H_U$  = Meteorological tower upper level instrumentation height  
= 60 meters  
 $H_L$  = Meteorological tower level instrumentation height  
= 10 meters

$\Delta T$  is then classified according to the following scheme:

Pasquill Stability	Defining Condition
A (Extremely Unstable)	$-0.900 < \Delta T \leq -0.019$
B	$-0.019 < \Delta T \leq -0.017$
C	$-0.017 < \Delta T \leq -0.015$
D (Neutral)	$-0.015 < \Delta T \leq -0.005$
E	$-0.005 < \Delta T \leq 0.015$
F	$0.015 < \Delta T \leq 0.040$
G (Extremely Stable)	$0.040 < \Delta T \leq 0.900$
Invalid	$\Delta T \leq -0.900$ or $\Delta T > 0.900$

10.2.2 Calculation of Stack Height Wind Speed

The wind speed at the release point (HVAC Exhaust Stack or Standby Gas Treatment System Exhaust Stack) height, STACWS, is calculated using the expressions:

$$\text{STACWS} = \text{WSP}_U (\text{STACKH}/\text{H}_U)^P, \text{ meter/sec} \quad (10-2)$$

Where:  $\text{WSP}_U$  = Upper met tower level wind speed, meter/sec  
 $\text{WSP}_L$  = Lower met tower level wind speed, meter/sec  
STACKH = Physical release point stack height

$P$  = Wind power law exponent, 0.25 for stabilities A, B, C; 0.33 for stability D; 0.5 for stabilities E, F, G, dimensionless. These coefficients come from The Recommended Guide for the Prediction of the Dispersion of Airborne Effluents, May 1968.

All other parameters are as defined for equation (10-1).

### 10.2.3 Determination of Release Mode and the Entrainment Coefficient

The mode of release can be elevated, ground or mixed; the latter being a combination of the first two. The mode of release, as well as an entrainment coefficient, TCORR, are determined from the stack height, STACH, building height, BLDGHT, stack exit velocity, EXITV, and wind speed at the stack height, STACWS.

For effluents exhausted from release points that are higher than twice the height of adjacent solid structures,

$$\text{STACKH} > 2 (\text{BLDGHT}), \text{TCORR} = 0.0 \quad (10-3)$$

the release is considered completely elevated and the entrainment coefficient is zero. For effluents released from points less than the height of adjacent solid structures, a ground-level release is assumed

$$\text{STACKH} < \text{BLDGHT}, \text{TCORR} = 1.0 \quad (10-4)$$

and the entrainment coefficient is unity. For effluents released from points or vents at the level of, or above, adjacent solid structures, but lower than elevated release points,

$$2(\text{BLDGHT}) > \text{STACKH} > \text{BLDGHT} \quad (10-5)$$

the release is treated as elevated, ground or mixed according to the following relationships:

$$\text{ELEVATED: } \text{TCORR} = 0.00 \text{ if } \text{EXITV} > 5(\text{STACWS}) \quad (10-6)$$

$$\text{GROUND: } \text{TCORR} = 1.0 \text{ if } \text{EXITV} < \text{STACWS} \quad (10-7)$$

$$\text{MIXED: } \text{TCORR} = 0.30 - 0.06(\text{EXITV}/\text{STACWS}) \text{ if } 5(\text{STACWS}) \geq \text{EXITV} > 1.5 (\text{STACWS}) \quad (10-8)$$

$$\text{TCORR} = 2.58 - 1.58(\text{EXITV}/\text{STACWS}) \text{ if } 1.5(\text{STACWS}) > \text{EXITV} > (\text{STACWS}) \quad (10-9)$$

In the mixed mode, the release is considered to occur as an elevated release 100 (1-TCORR) percent of the time and as a ground release 100 (TCORR) percent of the time. Each of these cases are then evaluated separately and the concentration X/Q calculated according to the fraction of the time each release occurs.

10.2.4 Calculation of Vertical Standard Deviation

The vertical plume spread (vertical standard deviation),  $\sigma_z$  is a function of the distance from the release point to the reception point for a given Pasquill stability class. The numerical value of  $\sigma_z$  is obtained by linear interpolation of the values in the following table which are taken from Regulatory Guide 1.145:

TABLE 10.2-1  
 $\sigma_z$  Values

Distance (meters)	Stability Class						
	A	B	C	D	E	F	G
200	31	21	15	10	6	4	3
500	120	55	34	19	13	8	5
1000	530	124	64	32	21	13	8
2000	1000	340	120	52	34	20	13
3000	1000	800	170	68	44	25	16
6000	1000	1000	300	110	71	35	23
10000	1000	1000	450	147	85	45	28
30000	1000	1000	1000	275	130	65	40
50000	1000	1000	1000	350	155	75	50
80000	1000	1000	1000	460	180	85	55

The values in this table are limited by the "mixing height lid" which is specified at 1000m.

10.2.5 Calculation of the Building Wake Correction

For ground-based and mixed-mode releases, an adjustment is made in the calculation of  $X/Q$  that takes into consideration initial mixing of the effluent plume within the building wake. This adjustment is an additional factor added in quadrature to the vertical plume spread equation (10-10):

$$\Sigma_z = [\sigma_z^2 + 0.5 (\text{BLDGHT})^2/\pi] \quad (10-10)$$

with the requirement that  $\Sigma_z$  is restricted to values

$$\Sigma_z \leq (3) (\sigma_z). \quad (10-11)$$

## 10.2.6 Calculation of Momentum Plume Rise

For elevated or mixed-mode releases only, the amount of plume rise due to the initial vertical momentum of the exhausted effluent,  $\Delta H$ , is calculated. For Pasquill stability classes A,B,C and D,  $\Delta H$  is calculated per section 10.2.6.1; for classes E,F and G, section 10.2.6.2 is used.

### 10.2.6.1 $\Delta H$ For Pasquill Class A,B,C and D

$\Delta H$  is calculated using both equations (10-12) and (10-13) and the minimum value is selected for use.

$$\Delta H_1 = 1.44(\text{STACD})(\text{EXITV}/\text{STACWS})^{2/3}(X/\text{STACD})^{1/3} \quad (10-12)$$

$$\Delta H_2 = 3.0(\text{STACD})(\text{EXITV}/\text{STACWS}), \text{ meter} \quad (10-13)$$

Where: STACD = Internal release point stack diameter  
 = 3.77 meters (HVAC Exhaust Stack)  
 = 0.44 meters (SGTS Exhaust Stack)  
 EXITV = Stack exit velocity, meter/second  
 X = Distance to specified receptor, meter

All other parameters are as defined previously.

### 10.2.6.2 $\Delta H$ For Pasquill Class E,F and G

$\Delta H$  is determined by selecting the minimum value calculated by equations (10-12) and (10-13) above and equations (10-14) and (10-15) below:

$$\Delta H_3 = 4.0[(0.5(\text{EXITV})(\text{STACD}))^2/S]^{1/3}, \text{ meter} \quad (10-14)$$

$$\Delta H_4 = 1.5[(0.5(\text{EXITV})(\text{STACD}))^2/\text{STACWS}]^{1/3}(S)^{-1/6}, \text{ meter} \quad (10-15)$$

Where: S = Restoring acceleration per unit vertical displacement for adiabatic motion,  $\text{sec}^{-2}$   
 =  $9.8 * T_z/(273+T_{\text{amb}})$   
 $T_z$  = 0.025 (E stability - default value)  
 $T_z$  = 0.05 (F stability - default value)  
 $T_z$  = 0.075 (G stability - default value)  
 $T_{\text{amb}}$  = Ambient air temperature ( $^{\circ}\text{C}$ ) [If temperature is missing, the default value will be used]

All other parameters are as defined in section 10.2.6.1.

10.2.7 Calculation of the Effective Plume Height

The effective plume height, H, is determined using section 10.2.6 results for the momentum plume rise, ΔH, and the terrain height, TERAİN:

$$H = \text{STACKH} + \Delta H - \text{TERAİN, meter} \quad (10-16)$$

Where: TERAİN = Difference between the plant base height above mean sea level (MSL) and the receptor point height above MSL, meter ≥0.0.

10.2.8 Determination of Affected Sectors

The wind direction for the hour determined which sector will be affected. Sectors are 22.5° arcs and are classified according to the following scheme:

TABLE 10.2-2  
WIND DIRECTION TABLE

Sector Number	Compass Direction	Wind Direction (WD)
1	N	0.0° ≤ WD < 11.25° or 348.75° ≤ WD ≤ 360.00°
2	NNE	11.25° ≤ WD < 33.75°
3	NE	33.75° ≤ WD < 56.25°
4	ENE	56.25° ≤ WD < 78.75°
5	E	78.75° ≤ WD < 101.25°
6	ESE	101.25° ≤ WD < 123.75°
7	SE	123.75° ≤ WD < 146.25°
8	SSE	146.25° ≤ WD < 168.75°
9	S	168.75° ≤ WD < 191.25°
10	SSW	191.25° ≤ WD < 213.75°
11	SW	213.75° ≤ WD < 236.25°
12	WSW	236.25° ≤ WD < 258.75°
13	W	258.75° ≤ WD < 281.25°
14	WNW	281.25° ≤ WD < 303.75°
15	NW	303.75° ≤ WD < 326.25°
16	NNW	326.25° ≤ WD < 348.75°

For elevated releases, the wind speed at the upper met tower level is used; ground releases use the speed of the wind at the lower met tower level. The wind direction is the same at both levels. During periods of calm wind, the wind speed is set at 0.5 meters/second the anemometer threshold value and assigned the direction measured for the hour.

#### 10.2.9 Calculation of Depletion and Deposition Factors

The depletion, DPF, and deposition, DPSF, factors are taken from the tables below which have been derived from curves found in Regulatory Guide 1.111. Both the DPF and DPSF values depend on the effective plume height, H, the stability class, S, and the distance, X, to the receptor.

The Regulatory Guide 1.111 curves represent plumes that are 100, 60, 30, and 0 (ground-level) meters above the ground. For plume heights and receptor distances other than those listed, the factors are interpolated from the tables. The model assumes that, after full plume rise is achieved, the plume cannot get higher from the ground. The derivation of these curves assumed no change in terrain height with downwind distance. Since topography does change with distance, as does the vertical distance between the plume centerline and the ground, use more than one depletion or deposition value as the plume travels away from the plant with distance.



TABLE 10.2-3  
DPF - DEPLETION FACTORS  
FROM FIGURES 2 THROUGH 5 OF REGULATORY GUIDE 1.111

Height of Release (m)	Pasquill Stability Class	Distance (meters)									
		200	500	1,000	2,000	3,000	6,000	10,000	30,000	50,000	80,000
Ground	All	0.970	0.936	0.900	0.860	0.832	0.770	0.714	0.590	0.517	0.440
30	A,B,C,	0.990	0.964	0.935	0.900	0.875	0.828	0.793	0.680	0.590	0.478
30	D	1.000	0.985	0.960	0.920	0.900	0.850	0.810	0.707	0.650	0.593
30	E,F,G	1.000	1.000	1.000	1.000	1.000	1.000	0.970	0.792	0.664	0.546
60	A,B,C	1.000	0.985	0.967	0.942	0.928	0.878	0.839	0.700	0.617	0.500
60	D	1.000	1.000	1.000	0.970	0.950	0.910	0.870	0.767	0.707	0.646
60	E,F,G	1.000	1.000	1.000	1.000	1.000	1.000	1.000	1.000	1.000	0.977
100	A,B,C	1.000	1.000	0.978	0.950	0.932	0.885	0.850	0.725	0.628	0.500
100	D	1.000	1.000	1.000	0.989	0.982	0.946	0.910	0.807	0.746	0.685
100	E,F,G	1.000	1.000	1.000	1.000	1.000	1.000	1.000	1.000	1.000	1.000

TABLE 10.2-4  
DPSF - DEPOSITION FACTORS  
FROM FIGURES 6 THROUGH 9 OF REGULATORY GUIDE 1.111 (m-1)\*

Height of Release (m)	Pasquill Stability Class	Distance (meters)									
		200	500	1,000	2,000	3,000	6,000	10,000	30,000	50,000	80,000
Ground	All	1.25E-04	8.00E-05	5.40E-05	3.20E-05	2.60E-05	1.50E-05	9.90E-06	4.50E-06	3.00E-06	2.00E-06
30	All	1.10E-04	8.00E-05	4.20E-05	2.40E-05	1.80E-05	1.10E-05	8.00E-06	4.80E-06	4.00E-06	3.50E-06
30	A,B,C,	5.50E-06	4.10E-06	4.80E-05	3.00E-05	2.40E-05	1.30E-05	8.00E-06	3.40E-06	2.30E-06	1.60E-06
30	D	1.00E-11	1.00E-10	1.00E-09	1.00E-08	1.00E-07	2.00E-06	6.30E-06	8.80E-06	5.30E-06	3.00E-06
60	E,F,G	1.80E-05	4.40E-05	3.80E-05	2.40E-05	1.80E-05	1.10E-05	8.20E-06	5.00E-06	4.20E-06	3.50E-06
60	A,B,C	2.80E-07	5.50E-06	1.60E-05	2.00E-05	1.80E-05	1.30E-05	8.90E-06	3.60E-06	2.50E-06	1.70E-06
60	D	1.00E-14	1.00E-13	1.00E-12	1.00E-11	1.00E-10	1.00E-09	1.00E-08	1.60E-08	2.00E-07	6.80E-07
100	E,F,G	4.00E-06	2.60E-05	3.30E-05	2.40E-05	1.70E-05	1.10E-05	8.10E-06	5.00E-06	4.50E-06	3.70E-06
100	A,B,C	1.00E-08	2.60E-07	2.50E-06	9.00E-06	1.10E-05	1.00E-05	7.50E-06	3.90E-06	2.80E-06	1.90E-06
100	D	1.00E-08	2.60E-07	2.50E-06	9.00E-06	1.10E-05	1.00E-05	7.50E-06	3.90E-06	2.80E-06	1.90E-06
100	E,F,G	1.00E-15	1.00E-15	1.00E-18	1.00E-15	1.00E-15	1.00E-15	1.00E-15	1.00E-15	1.00E-15	1.00E-15

## 10.2.10 Ground Level X/Q, D2DPXQ, D1XQ, D/Q Analysis

## 10.2.10.1 Undecayed, Undepleted Plume Relative Concentration, X/Q

The atmospheric concentration of effluent at ground level, normalized by the source term Q, is given by the following equation:

$$X/Q = 2.032(TCORR)/WSP_L(X)A_{\min}, \text{ sec/m}^3 \quad (10-17)$$

Where:  $A_{\min}$  = The lesser of the two values obtained by equations (10-10) and (10-11), meter<sub>«</sub>

2.032 = The constant  $(2/\pi)$  divided by the width in radians of a  $22.5^\circ$  sector (i.e.,  $\pi/8$ , dimensionless)

X = Distance between release point to receptor, meter

## 10.2.10.2 Decayed, Depleted Radioiodine and Particulate Relative Concentration, D2DPXQ

The decayed, depleted radioiodine concentration, D2DPXQ, is calculated in accordance with the following equation:

$$D2DPXQ = DPF(DC2)X/Q, \text{ sec/m}^3 \quad (10-18)$$

Where: DPF = The depletion factor calculated per section 10.2.9, dimensionless

DC2 = The radioiodine 8 day decay factor, dimensionless  
 $= \exp[-0.693(X)/t_{\ll}(WSP_L)]$   
 $= \exp[-0.693(X)/(8 \text{ day})(24 \text{ hr/day})(3600 \text{ sec/hr})(WSP_L)]$   
 $= \exp[-1.00E-06(X/WSP_L)]$

## 10.2.10.3 Decayed Noble Gas Plume Relative Concentration, D1XQ

The decayed noble gas plume relative concentration, D1XQ, is calculated in accordance with the following equation:

$$D1XQ = DC1 (X/Q), \text{ sec/m}^3 \quad (10-19)$$

Where: DC1 = The noble gas decay factor, dimensionless

$= \exp [-0.693(X)/t_{\ll}(WSP_L)]$   
 $= \exp [-0.693(X)/(2.26 \text{ day})(24 \text{ hr/day}) (3600 \text{ sec/hr})(WSP_L)]$   
 $= \exp [-3.55E-06 (X/WSP_L)]$

#### 10.2.10.4 Radioiodine and Particulate Relative Deposition, D/Q

The relative deposition for radioiodines and particulates, D/Q is calculated in accordance with the following equation:

$$D/Q = [DPSF(DC2)(TCORR)]/[(2\pi/16)X], m^{-2} \quad (10-20)$$

Where: DPSF = The deposition factor calculated per section 10.2.9,  $m^{-1}$

#### 10.2.11 Elevated X/Q, D2DPXQ, D1XQ, D/Q Analysis

##### 10.2.11.1 Undecayed, Undepleted Plume Relative Concentration, X/Q

The atmospheric concentration of effluent at elevated level, normalized by the source term Q, is given by the following equation:

$$X/Q = [2.032(1-TCORR)\exp[-0.5(H/\sigma_z)^2]]/[STACWS(X) \sigma_z], \text{ sec}/m^3 \quad (10-21)$$

Where: All parameters are as previously defined.

##### 10.2.11.2 Decayed, Depleted Radioiodine and Particulate Relative Concentration, D2DPXQ

The calculation of D2DPXQ for elevated releases follows section 10.2.10.2 methodology with the exception that the WSPL value used in the calculation of DC2 in equation (10-21) is replaced by the STACWS value and the equation (10-24) X/Q is used.

$$D2DPXQ = DPF(DC2)X/Q, \text{ sec}/m^3 \quad (10-22)$$

Where: DPF = The depletion factor calculated per section 10.2.9, dimensionless  
 DC2 = The radioiodine 8 day decay factor, dimensionless  
 =  $\exp[-0.693(X)/t_{\text{dc}}(\text{STACWS})]$   
 =  $\exp[-0.693(X)/(8 \text{ day})(24 \text{ hr/day})(3600 \text{ sec/hr}) (\text{STACWS})]$   
 =  $\exp[-1.00E-06(X/ \text{STACWS})]$

### 10.2.11.3 Decayed Noble Gas Plume Relative Concentration, D1XQ

The calculation of D1XQ for elevated releases follows section 10.2.10.3 methodology by substituting the equation (10-24) X/Q value into equation (10-22) and STACWS for WSPL in the calculation of DC1.

$$D1XQ = DC1 (X/Q), \text{ sec/m}^3 \quad (10-23)$$

Where: DC1 = The noble gas decay factor, dimensionless  
 =  $\exp [-0.693(X)/t_{\text{eff}}(\text{STACWS})]$   
 =  $\exp [-0.693(X)/(2.26 \text{ day})(24 \text{ hr/day} (3600 \text{ sec/hr})(\text{STACWS}))]$   
 =  $\exp [-3.55\text{E-}06 (X/\text{STACWS})]$

### 10.2.11.4 Radioiodine and Particulate Relative Deposition, D/Q

The calculation of D/Q for elevated releases follows section 10.2.10.4 methodology by substituting (1-TCORR) for the TCORR term in equation (10-23) and STACWS for WSPL in the calculation of DC2.

$$D/Q = [\text{DPSF}(1-\text{TCORR})]/[(2\pi/16)X], \text{ m}^{-2} \quad (10-24)$$

Where: DPSF = The deposition factor calculated per section 10.2.9,  $\text{m}^{-1}$

Table 10.2-5  
GASEOUS EFFLUENT RELEASE POINT CHARACTERISTICS

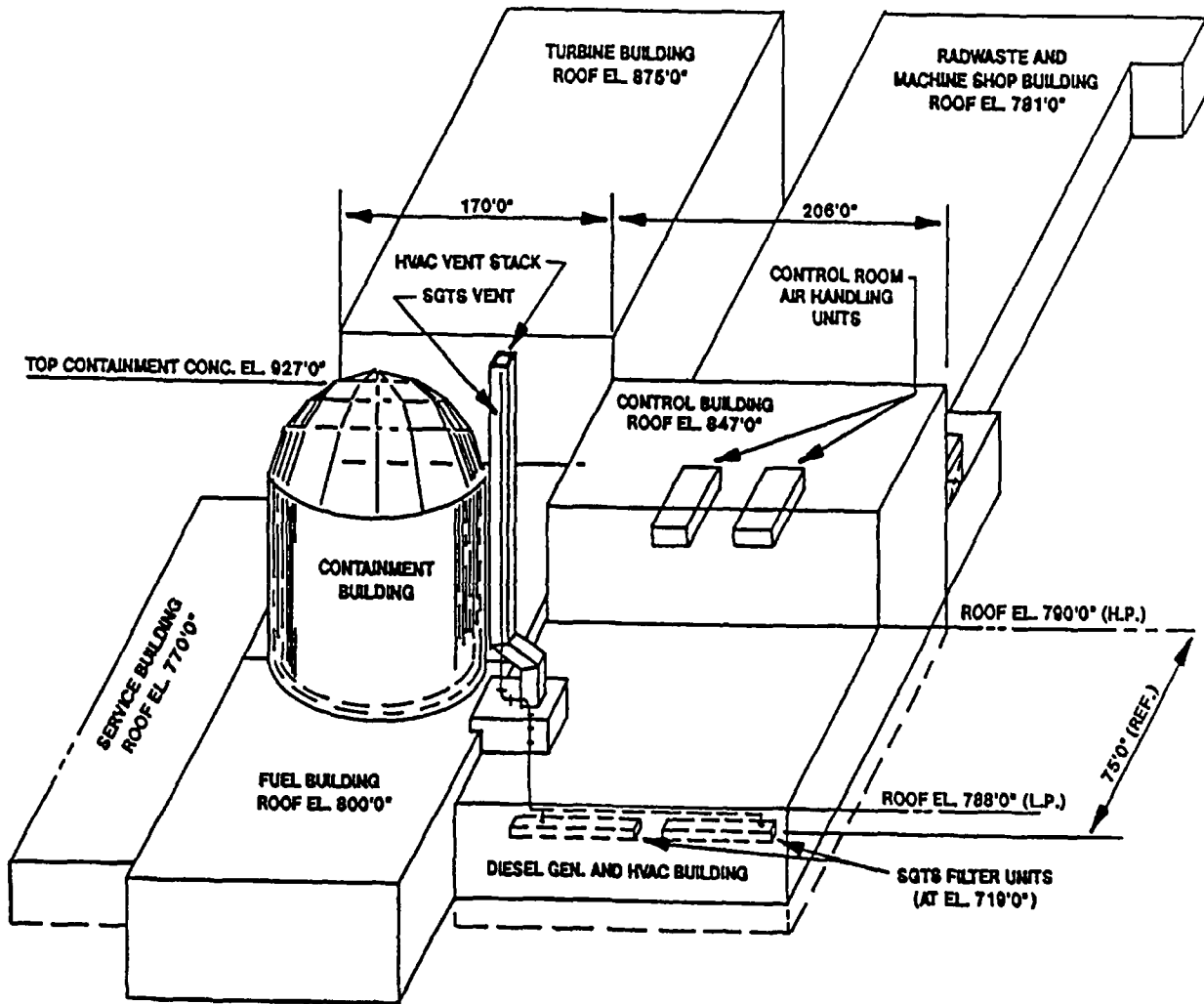

	<u>HVAC Exhaust Stack</u>	<u>SGTS Exhaust Stack</u>
Release Point Height (m)	61	61
Building Height (m)	58	58
Release Point Geometry	Duct	Pipe
Release Point Area (m <sup>2</sup> )	11.15	0.15
Release Point Diameter (m)	3.77*	0.44
Annual Average Flow Rate (m <sup>3</sup> /sec)	111.71	1.89
Vertical Exit Velocity (m/sec)	10.02	12.49

\* Effective  $2(A/\pi)$  diameter