



Order No. EA-13-109

RS-14-062

June 30, 2014

U.S. Nuclear Regulatory Commission
ATTN: Document Control Desk
Washington, DC 20555-0001

Peach Bottom Atomic Power Station, Units 2 and 3
Renewed Facility Operating License Nos. DPR-44 and DPR-56
NRC Docket Nos. 50-277 and 50-278

Subject: Phase 1 Overall Integrated Plan in Response to June 6, 2013 Commission Order Modifying Licenses with Regard to Reliable Hardened Containment Vents Capable of Operation Under Severe Accident Conditions (Order Number EA-13-109)

References:

1. NRC Order Number EA-13-109, "Issuance of Order to Modify Licenses with Regard to Reliable Hardened Containment Vents Capable of Operation Under Severe Accident Conditions," dated June 6, 2013
2. NRC Interim Staff Guidance JLD-ISG-2013-02, "Compliance with Order EA-13-109, Order Modifying Licenses with Regard to Reliable Hardened Containment Vents Capable of Operation under Severe Accident Conditions", Revision 0, dated November 14, 2013
3. Exelon Generation Company, LLC's Answer to June 6, 2013, Commission Order Modifying Licenses with Regard to Reliable Hardened Containment Vents Capable of Operation Under Severe Accident Conditions (Order Number EA-13-109), dated June 26, 2013
4. NEI 13-02, "Industry Guidance for Compliance With Order EA-13-109, BWR Mark I & II Reliable Hardened Containment Vents Capable of Operation Under Severe Accident Conditions", Revision 0, dated November 2013
5. NRC Generic Letter 89-16, Installation of a Hardened Wetwell Vent, dated September 1, 1989

On June 6, 2013, the Nuclear Regulatory Commission ("NRC" or "Commission") issued an order (Reference 1) to Exelon Generation Company, LLC (EGC). Reference 1 was immediately effective and directs EGC to require their BWRs with Mark I and Mark II containments to take certain actions to ensure that these facilities have a hardened containment vent system (HCVS) to remove decay heat from the containment, and maintain control of containment pressure within acceptable limits following events that result in loss of active containment heat removal capability while maintaining the capability to operate under severe accident (SA) conditions resulting from an Extended Loss of AC Power (ELAP). Specific requirements are outlined in Attachment 2 of Reference 1.

Reference 1 requires submission of an Overall Integrated Plan (OIP) by June 30, 2014 for Phase 1 of the Order. The interim staff guidance (Reference 2) was issued November 14, 2013, which provides direction regarding the content of this OIP. Reference 3 provided the EGC initial status report regarding reliable hardened containment vents capable of operation under severe accident

conditions. The purpose of this letter is to provide the OIP for Phase 1 of the Order pursuant to Section IV, Condition D.1, of Reference 1. This letter confirms EGC has received Reference 2 and has a Phase 1 OIP complying with the guidance for the purpose of ensuring the functionality of a HCVS to remove decay heat from the containment, and maintain control of containment pressure within acceptable limits following events that result in the loss of active containment heat removal capability while maintaining the capability to operate under SA conditions resulting from an ELAP as described in Attachment 2 of Reference 1.

Reference 4, Section 7.0 contains the specific reporting requirements for the OIP. The information in the Enclosure provides the Peach Bottom Atomic Power Station, Units 2 and 3 Phase 1 OIP pursuant to Reference 2. The enclosed OIP is based on conceptual design information. Final design details and associated procedure guidance, as well as any revisions to the information contained in the Enclosure, will be provided in the 6-month OIP updates required by Section IV, Condition D.3, of Reference 1.

For the purposes of compliance with Phase 1 of Order EA-13-109, Order Modifying Licenses with Regard to Reliable Hardened Containment Vents Capable of Operation Under Severe Accident Conditions, Peach Bottom Atomic Power Station, Units 2 and 3 plans to install a severe accident capable wetwell vent.

Compliance with the requirements of Reference 1 will supersede any and all actions or commitments associated with Reference 5. Any actions or commitments made relative to Reference 5 are rescinded and not binding by submittal of the Reference 1 Phase 1 OIP via this letter.

This letter contains no new regulatory commitments. If you have any questions regarding this report, please contact David P. Helker at 610-765-5525.

I declare under penalty of perjury that the foregoing is true and correct. Executed on the 30th day of June 2014.

Respectfully submitted,

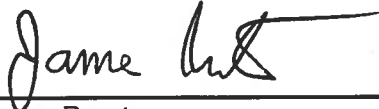

James Barstow
Director - Licensing & Regulatory Affairs
Exelon Generation Company, LLC

Enclosure:

1. Peach Bottom Atomic Power Station, Units 2 and 3, Overall Integrated Plan for Phase 1 Requirements for Reliable Hardened Containment Vent System (HCVS) Capable of Operation Under Severe Accident Conditions

cc: Director, Office of Nuclear Reactor Regulation
NRC Regional Administrator - Region I
NRC Senior Resident Inspector – Peach Bottom Atomic Power Station
NRC Project Manager, NRR – Peach Bottom Atomic Power Station
Mr. William D. Reckley, NRR/JLD/PSB, NRC
Mr. Rajender Auluck, NRR/JLD/PSB, NRC
Director, Bureau of Radiation Protection – Pennsylvania Department of Environmental
Resources
S. T. Gray, State of Maryland
R. R. Janati, Chief, Division of Nuclear Safety, Pennsylvania Department of Environmental
Protection, Bureau of Radiation Protection

Enclosure 1

Peach Bottom Atomic Power Station, Units 2 and 3

**Overall Integrated Plan for Phase 1 Requirements for Reliable Hardened Containment
Vent System (HCVS) Capable of Operation Under Severe Accident Conditions**

(45 pages)

Peach Bottom Atomic Power Station, Units 2 and 3 Overall Integrated Plan for Phase 1 Requirements for
Reliable Hardened Containment Vent System (HCVS) Capable of Operation Under Severe Accident
Conditions

Table of Contents:

Introduction:

Part 1:	<u>General Integrated Plan Elements and Assumptions</u>
Part 2:	<u>Boundary Conditions for Wet Well Vent</u>
Part 3:	<u>Boundary Conditions for Dry Well Vent</u>
Part 4:	<u>Programmatic Controls, Training, Drills and Maintenance</u>
Part 5:	<u>Milestones Schedule</u>
Attachment 1:	<u>HCVS Portable Equipment</u>
Attachment 2:	<u>Sequence of Events Timeline</u>
Attachment 3:	<u>Conceptual Sketches</u>
Attachment 4:	<u>Failure Evaluation Table</u>
Attachment 5:	<u>References</u>
Attachment 6:	<u>Changes/Updates to this Overall Integrated Implementation Plan</u>
Attachment 7:	<u>List of Overall Integrated Plan Open Items</u>

Peach Bottom Atomic Power Station, Units 2 and 3 Overall Integrated Plan for Phase 1 Requirements for Reliable Hardened Containment Vent System (HCVS) Capable of Operation Under Severe Accident Conditions

Introduction

In 1989, the NRC issued Generic Letter 89-16, "Installation of a Hardened Wetwell Vent," to all licensees of BWRs with Mark I containments to encourage licensees to voluntarily install a hardened wetwell vent. In response, licensees installed a hardened vent pipe from the wetwell to some point outside the secondary containment envelope (usually outside the reactor building). Some licensees also installed a hardened vent branch line from the drywell.

On March 19, 2013, the Nuclear Regulatory Commission (NRC) Commissioners directed the staff per Staff Requirements Memorandum (SRM) for SECY-12-0157 to require licensees with Mark I and Mark II containments to "upgrade or replace the reliable hardened vents required by Order EA-12-050 with a containment venting system designed and installed to remain functional during severe accident conditions." In response, the NRC issued Order EA-13-109, *Issuance of Order to Modify Licenses with Regard to Reliable Hardened Containment Vents Capable of Operation Under Severe Accidents*, June 6, 2013. The Order (EA-13-109) requires that licensees of BWR facilities with Mark I and Mark II containment designs ensure that these facilities have a reliable hardened vent to remove decay heat from the containment, and maintain control of containment pressure within acceptable limits following events that result in the loss of active containment heat removal capability while maintaining the capability to operate under severe accident (SA) conditions resulting from an Extended Loss of AC Power (ELAP).

The Order requirements are applied in a phased approach where:

- "Phase 1 involves upgrading the venting capabilities from the containment wetwell to provide reliable, severe accident capable hardened vents to assist in preventing core damage and, if necessary, to provide venting capability during severe accident conditions." (Completed "no later than startup from the second refueling outage that begins after June 30, 2014, or June 30, 2018, whichever comes first.")
- "Phase 2 involves providing additional protections for severe accident conditions through installation of a reliable, severe accident capable drywell vent system or the development of a reliable containment venting strategy that makes it unlikely that a licensee would need to vent from the containment drywell during severe accident conditions." (Completed "no later than startup from the first refueling outage that begins after June 30, 2017, or June 30, 2019, whichever comes first.")

The NRC provided an acceptable approach for complying with Order EA-13-109 through Interim Staff Guidance (JLD-ISG-2013-02) issued in November 2013. The ISG endorses the compliance approach presented in NEI 13-02 Revision 0, *Compliance with Order EA-13-109, Severe Accident Reliable Hardened Containment Vents*, with clarifications.

Peach Bottom Atomic Power Station, Units 2 and 3 Overall Integrated Plan for Phase 1 Requirements for Reliable Hardened Containment Vent System (HCVS) Capable of Operation Under Severe Accident Conditions

Except in those cases in which a licensee proposes an acceptable alternative method for complying with Order EA-13-109, the NRC staff will use the methods described in this ISG (NEI 13-02) to evaluate licensee compliance as presented in submittals required in Order EA-13-109.

The Order also requires submittal of an overall integrated plan which will provide a description of how the requirements of the Order will be achieved. This document provides the Overall Integrated Plan (OIP) for complying with Order EA-13-109 using the methods described in NEI 13-02 and endorsed by NRC JLD-ISG-2013-02. Six month progress reports will be provided consistent with the requirements of Order EA-13-109.

Peach Bottom venting actions for the EA-13-109 SA capable venting scenario can be summarized by the following:

- The HCVS will be initiated via manual action from the Main Control Room (MCR) or Remote Operating Station (ROS) at the appropriate time based on procedural guidance in response to plant conditions from observed or derived symptoms.
- The vent will utilize Containment Parameters of Pressure and Wetwell (WW) Water Level from the MCR instrumentation to monitor effectiveness of the venting actions.
- The vent operation will be monitored by HCVS valve position, temperature, pressure and effluent radiation levels.
- The HCVS motive force will be monitored and have the capacity to operate for 24 hours with installed equipment. Replenishment of the motive force will be by use of portable equipment once the installed motive force is exhausted.
- Venting actions will be capable of being maintained for a sustained period of up to 7 days or a shorter time if justified.

Peach Bottom Atomic Power Station, Units 2 and 3 Overall Integrated Plan for Phase 1 Requirements for Reliable Hardened Containment Vent System (HCVS) Capable of Operation Under Severe Accident Conditions

Part 1: General Integrated Plan Elements and Assumptions

Extent to which the guidance, JLD-ISG-2013-02 and NEI 13-02, are being followed. Identify any deviations

Include a description of any alternatives to the guidance. A technical justification and basis for the alternative needs to be provided. This will likely require a pre-meeting with the NRC to review the alternative

Ref: JLD-ISG-2013-02

Compliance will be attained for Peach Bottom Atomic Power Station (PBAPS) to the guidelines in JLD-ISG-2013-02 and NEI 13-02 for each phase as follows:

- Unit 2 Phase 1 (wetwell): by the startup from the second refueling outage that begins after June 30, 2014, or June 30, 2018, whichever comes first. Currently scheduled for 4th Quarter 2016.
- Unit 3 Phase 1 (wetwell): by the startup from the second refueling outage that begins after June 30, 2014, or June 30, 2018, whichever comes first. Currently scheduled for 4th Quarter 2017.
- Unit 3 Phase 2: (drywell): by the startup from the first refueling outage that begins after June 30, 2017, or June 30, 2019, whichever comes first. Currently scheduled for 4th Quarter 2017.
- Unit 2 Phase 2 (drywell): by the startup from the first refueling outage that begins after June 30, 2017, or June 30, 2019, whichever comes first. Currently scheduled for 4th Quarter 2018.

The current design of the circuits for the in-board PCIV used in the torus vent pathway requires the installation of jumpers to by-pass the containment high drywell pressure isolation logic. The jumpers also bypass the reactor low level, Reactor Building (RB) and Refuel Floor vent exhaust hi-rad, and Main Stack hi-rad isolations. The use of jumpers may be retained in the design of the HCVS if it is determined that redesign of the safety-related logic is not feasible or is considered a less conservative approach with respect to compliance with design basis requirements. If the use of jumpers is retained, a technical justification and basis will be included in a future six month update.

If other deviations are identified at a later date, then the deviations will be communicated in a future 6 month update following identification.

State Applicable Extreme External Hazard from NEI 12-06, Section 4.0-9.0

List resultant determination of screened in hazards from the EA-12-049 Compliance

Ref: NEI 13-02 Section 5.2.3 and D.1.2

The following extreme external hazards screen-in for PBAPS

- Seismic; External Flooding; Severe Storms with High Winds; Snow, Ice and Extreme Cold; and High Temperature

The following extreme external hazards screen out for PBAPS

- None

Peach Bottom Atomic Power Station, Units 2 and 3 Overall Integrated Plan for Phase 1 Requirements for
Reliable Hardened Containment Vent System (HCVS) Capable of Operation Under Severe Accident
Conditions

Part 1: General Integrated Plan Elements and Assumptions

Key Site assumptions to implement NEI 13-02 HCVS Actions

Provide key assumptions associated with implementation of HCVS Phase 1 Actions

Ref: NEI 13-02 Section 1

Mark I/II Generic HCVS Related Assumptions:

Applicable EA-12-049 assumptions:

- 049-1. Assumed initial plant conditions are as identified in NEI 12-06 section 3.2.1.2 items 1 and 2
- 049-2. Assumed initial conditions are as identified in NEI 12-06 section 3.2.1.3 items 1, 2, 4, 5, 6 and 8
- 049-3. Assumed reactor transient boundary conditions are as identified in NEI 12-06 section 3.2.1.4 items 1, 2, 3 and 4
- 049-4. No additional events or failures are assumed to occur immediately prior to or during the event, including security events. (NEI 12-06, section 3.2.1.3 item 9)
- 049-5. At Time = 0 the event is initiated and all rods insert and no other event beyond a common site ELAP is occurring at any or all of the units. (NEI 12-06, section 3.2.1.3 item 9 and 3.2.1.4 item 1-4)
- 049-6. At 60 minutes an ELAP is declared and actions begin as defined in EA-12-049 compliance.
- 049-7. DC power and distribution can be credited for the duration determined per the EA-12-049 (FLEX) methodology for battery usage, (at T= 5 hours with a calculation limiting value of 5.5 hrs.) (NEI 12-06, section 3.2.1.3 item 8)
- 049-8. Deployment resources are assumed to begin arriving at hour 6 and fully staffed by 24 hours; however, per the PBAPS FLEX OIP, normal staffing level is sufficient to provide the FLEX response.
- 049-9. All activities associated with plant specific EA-12-049 FLEX strategies that are not specific to implementation of the HCVS, including such items as debris removal, communication, notifications, SFP level makeup, security response, opening doors for cooling, and initiating conditions for the event, can be credited as previously evaluated for FLEX.

Applicable EA-13-109 generic assumptions:

- 109-1. Site response activities associated with EA-13-109 actions are considered to have no access limitations associated with radiological impacts while RPV level is above 2/3 core height (core damage is not expected).
- 109-2. Portable equipment can supplement the installed equipment after 24 hours provided the portable equipment credited meets the criteria applicable to the HCVS. The portable equipment (e.g., backup generator, backup compressor or N2 bottles) used to replenish HCVS components must be demonstrated to meet the "SA Capable" criteria that are defined in NEI 13-02 Section 4.2.4.2 and Appendix D Section D.1.3.
- 109-3. SFP Level is maintained such that the SFP does not contribute to the analyzed source term. (HCVS-FAQ-07)
- 109-4. Existing containment components design and testing values are governed by existing plant containment criteria (e.g., Appendix J) and are not subject to the testing criteria from NEI 13-02. (HCVS-FAQ-05 and NEI 13-02 section 6.2.2).

Peach Bottom Atomic Power Station, Units 2 and 3 Overall Integrated Plan for Phase 1 Requirements for Reliable Hardened Containment Vent System (HCVS) Capable of Operation Under Severe Accident Conditions

Part 1: General Integrated Plan Elements and Assumptions

- 109-5. Classical design basis evaluations and assumptions are not required when assessing the operation of the HCVS. The reason this is not required is that the order postulates an unsuccessful mitigation of an event such that an ELAP progresses to a severe accident with ex-vessel core debris which classical design basis evaluations are intended to prevent. (NEI 13-02 section 2.3.1).
- 109-6. HCVS manual actions that require minimal operator steps can be performed in the postulated thermal and radiological environment at the location of the step(s) (e.g., load stripping, control switch manipulation, valving-in nitrogen bottles) are acceptable to obtain HCVS venting dedicated functionality. (HCVS-FAQ-01)
- 109-7. HCVS dedicated equipment is defined as vent process elements that are required for the HCVS to function in an ELAP event that progresses to core melt ex-vessel. (HCVS-FAQ-02 and White Paper HCVS-WP-01)
- 109-8. Use of MAAP Version 4 or higher provides adequate assurance of the plant conditions (e.g., RPV water level, temperatures, etc.) assumed for Order EA-13-109 BDBEE and SA HCVS operation. (FLEX MAAP Endorsement ML13190A201) Additional analysis using RELAP5/MOD 3, GOthic, PCFLUD, LOCADOSE and SHIELD are acceptable methods for evaluating environmental conditions in areas of the plant provided the specific version utilized is documented in the analysis.
- 109-9. Utilization of NRC Published Accident evaluations (e.g., SOARCA, SECY-12-0157, and NUREG-1465), as related to Order EA-13-109 conditions, is acceptable as references. (NEI 13-02 section 8)
- 109-10. Permanent modifications installed per EA-12-049 are assumed implemented and may be credited for use in EA-13-109 Order response.
- 109-11. This Overall Integrated Plan is based on Emergency Operating Procedure changes consistent with EPG/SAGs Revision 3 as incorporated per the sites EOP/SAMG procedure change process.
- 109-12. Under the postulated scenarios of order EA-13-109 the Control Room is adequately protected from excessive radiation dose per General Design Criterion (GDC) 19 in 10CFR50 Appendix A and no further evaluation of its use as the preferred HCVS control location is required. (HCVS-FAQ-01) In addition, adequate protective clothing and respiratory protection is available if required to address contamination issues.

Plant Specific HCVS Related Assumptions/Characteristics:

PBAPS -1 EA-12-049 (FLEX) actions to restore power are sufficient to ensure continuous operation of non-dedicated containment instrumentation.

Peach Bottom Atomic Power Station, Units 2 and 3 Overall Integrated Plan for Phase 1 Requirements for Reliable Hardened Containment Vent System (HCVS) Capable of Operation Under Severe Accident Conditions

Part 2: Boundary Conditions for Wetwell Vent

Provide a sequence of events and identify any time or environmental constraint required for success including the basis for the constraint.

HCVS Actions that have a time constraint to be successful should be identified with a technical basis and a justification provided that the time can reasonably be met (for example, action to open vent valves).

HCVS Actions that have an environmental constraint (e.g. actions in areas of High Thermal stress or High Dose areas) should be evaluated per guidance.

Describe in detail in this section the technical basis for the constraints identified on the sequence of events timeline attachment.

See attached sequence of events timeline (Attachment 2)

Ref: EA-13-109 Section 1.1.1, 1.1.2, 1.1.3/ NEI 13-02 Section 4.2.5, 4.2.6. 6.1.1

The existing wetwell (WW) HCVS at each PBAPS unit has a containment penetration that is shared with the Standby Gas Treatment System (SGTS). The upstream primary containment isolation valve (PCIV) is common to the HCVS and the SGTS flow paths. Each system has a dedicated downstream PCIV. Each unit has a HCVS flow path that is totally separate from the other unit and with no interconnected systems downstream of the PCIVs. The vent pipe from each unit is routed separately and discharges above the unit’s Reactor Building roof.

The PCIVs have DC powered solenoid valves and have back-up motive air from the Safety Grade Instrument Gas (SGIG). Although the power to the DC solenoid valves will be maintained by the FLEX Diesel Generator (DG) implemented for EA-12-049, each unit will add dedicated DC power for HCVS components that is not shared with any other function and that does not rely on FLEX, with the clarification that existing containment instrumentation (pressure and WW level) are not considered HCVS components and power will be maintained through the actions for EA-12-049.

The operation of the HCVS will be designed to minimize the reliance on operator actions in response to hazards listed in Part 1. Immediate operator actions will be completed by plant personnel and will include the capability for remote-manual initiation from the HCVS control station. A list of the remote manual actions performed by plant personnel to open the HCVS vent path can be found in the following table (2-1). A HCVS Extended Loss of AC Power (ELAP) Failure Evaluation table, which shows alternate actions that can be performed, is included in Attachment 4.

Table 2-1 HCVS Remote Manual Actions

Primary Action	Primary Location / Component	Notes
1. Over-ride the containment isolation signal and open the WW PCIVs	MCR and CSR	The existing PCIVs have SGIG for back-up motive air and have DC powered solenoid valves (SV’s) powered from the safety related DC bus.

**Peach Bottom Atomic Power Station, Units 2 and 3 Overall Integrated Plan for Phase 1 Requirements for
Reliable Hardened Containment Vent System (HCVS) Capable of Operation Under Severe Accident
Conditions**

Part 2: Boundary Conditions for Wetwell Vent

2. For anticipatory venting, open the secondary containment barrier.	TBD	Currently PBAPS uses a rupture disc with a 30 psig setting for the secondary containment barrier. PBAPS will either provide a means to rupture this disc or replace the disc with a power operated valve.
3. Verify that the FLEX DG continues to maintain power to the Station Battery	TBD	If the station battery power is not maintained by the FLEX DG, energize the solenoid valve from the HCVS battery.
4. Align portable generator to HCVS battery charger.	ROS	Prior to depletion of the HCVS battery supply, actions will be required to recharge the battery.
5. Monitor motive air pressure (SGIG pressure)	MCR	SGIG availability is anticipated for the 7 day duration.

A timeline was developed to identify required operator response times and potential environmental constraints. This timeline is based upon the following three cases:

1. Case 1 is based upon the action response times developed for FLEX when utilizing anticipatory venting in a BDBEE without core damage.
2. Case 2 is based on a SECY-12-0157 long term station blackout (LTSBO) (or ELAP) with failure of Reactor Core Isolation Cooling (RCIC) after a black start where failure occurs because of subjectively assuming over injection.
3. Case 3 is based on NUREG-1935 (SOARCA) results for a Short-Term SBO – Unmitigated Response (without RCIC Blackstart).

Discussion of time constraints identified in Attachment 2 for the 3 timeline cases identified above

- Within 4.8 hours, initiate use of HCVS per site procedures to maintain containment parameters below design limits and within the limits that allow continued use of RCIC. Reliable operation of HCVS will be met because HCVS meets the seismic requirements identified in NEI 13-02, will be powered by DC power from Station 1E battery backed up by a dedicated power source, and HCVS valves are supplied with motive force from the SGIG. HCVS instrumentation and controls will be DC powered. Valves will be operable from the HCVS control panel in the MCR, or from the ROS. DC power and motive air will be available for 24 hours from permanent sources. Containment pressure and WW indication will be initially powered from existing 1E Station battery and maintained by FLEX generators. Thus initiation of the HCVS from the MCR or the ROS within 4.8 hours is acceptable because the actions can be performed any time after declaration of an ELAP until the venting is needed at 4.8 hours for BDBEE venting. This action can also be performed for SA HCVS operation which occurs at a time further removed from an ELAP declaration as shown in Attachment 2.
- The SGIG can provide motive power (pressurized N2 gas) for the seven day sustained period.

Part 2: Boundary Conditions for Wetwell Vent

- Within 24 hours, a portable generator can be installed and connected to recharge the dedicated HCVS power supply to maintain sustained operation. Modifications will be implemented to facilitate the connections and operational actions required to supply power well before 24 hours, which is acceptable because the actions can be performed any time after declaration of an ELAP until the repowering is needed at greater than 24 hours.
- Current PBAPS 1E battery durations are calculated to last 5.5 hours. FLEX DG will be staged and providing power to Safety Related 1E equipment within 5 hours. Thus the FLEX DGs will be available to be placed in service at any point after 5 hours as required to supply power to containment parameters (containment pressure and WW level) and to the SVs for the HCVS PCIVs. A FLEX DG will be maintained in on-site FLEX storage buildings. The FLEX DG will be transferred via haul routes to staging areas evaluated for impact from external hazards.
- There are no site specific actions that are time critical for HCVS initiation. Only two actions are time critical for FLEX response implementation: begin setup of the FLEX generator (at 60 minutes), and line up the FLEX pump (at 6 hours). Neither is time critical for HCVS initiation.

Discussion of radiological and temperature constraints identified in Attachment 2

- Actions to initiate HCVS operation are taken from the MCR or from the ROS. The MCR has significant shielding and physical separation from radiological sources. Non-radiological habitability for the MCR is being addressed as part of the PBAPS FLEX response.
- Before the end of the initial 24-hour period, replenishment of the HCVS dedicated DC power will occur at the ROS. The selection of the ROS location will take into account the SA temperature and radiation conditions to ensure access to the ROS is maintained. The design will allow replenishment with minimal actions.

Open Item 1: Confirm that the ROS will be in an accessible area following a SA.

Provide Details on the Vent characteristics

Vent Size and Basis (EA-13-109 Section 1.2.1 / NEI 13-02 Section 4.1.1)

What is the plants licensed power? Discuss any plans for possible increases in licensed power (e.g. MUR, EPU). What is the nominal diameter of the vent pipe in inches? Is the basis determined by venting at containment design pressure, Primary Containment Pressure Limit (PCPL), or some other criteria (e.g. anticipatory venting)?

Vent Capacity (EA-13-109 Section 1.2.1 / NEI 13-02 Section 4.1.1)

Indicate any exceptions to the 1% decay heat removal criteria, including reasons for the exception. Provide the heat capacity of the suppression pool in terms of time versus pressurization capacity.

Vent Path and Discharge (EA-13-109 Section 1.1.4, 1.2.2/ NEI 13-02 Section 4.1.3, 4.1.5 and Appendix F/G)

Provides a description of vent path, release path, and impact of vent path on other vent element

Part 2: Boundary Conditions for Wetwell Vent

items.

Power and Pneumatic Supply Sources (EA-13-109 Section 1.2.5 & 1.2.6 / NEI 13-02 Section 4.2.3, 2.5, 4.2.2, 4.2.6, 6.1)

Provide a discussion of electrical power requirements, including a description of dedicated 24 hour power supply from permanently installed sources. Include a similar discussion as above for the valve motive force requirements. Indicate the area in the plant from where the installed/dedicated power and pneumatic supply sources are coming.

Indicate the areas where portable equipment will be staged after the 24 hour period, the dose fields in the area, and any shielding that would be necessary in that area. Any shielding that would be provided in those areas.

Location of Control Panels (EA-13-109 Section 1.1.1, 1.1.2, 1.1.3, 1.1.4, 1.2.4, 1.2.5 / NEI 13-02 Section 4.1.3, 4.2.2, 4.2.3, 4.2.5, 4.2.6, 6.1.1 and Appendix F/G)

Indicate the location of the panels, and the dose fields in the area during severe accidents and any shielding that would be required in the area. This can be a qualitative assessment based on criteria in NEI 13-02.

Hydrogen (EA-13-109 Section 1.2.10, 1.2.11, 1.2.12 / NEI 13-02 Section 2.3.2.4, 4.1.1, 4.1.6, 4.1.7, 5.1, & Appendix H)

State which approach or combination of approaches the plant will take to address the control of flammable gases, clearly demarcating the segments of vent system to which an approach applies.

Unintended Cross Flow of Vented Fluids (EA-13-109 Section 1.2.3, 1.2.12 / NEI 13-02 Section 4.1.2, 4.1.4, 4.1.6 and Appendix H)

Provide a description to eliminate/minimize unintended cross flow of vented fluids with emphasis on interfacing ventilation systems (e.g. SGTS). What design features are being included to limit leakage through interfacing valves or Appendix J type testing features?

Prevention of Inadvertent Actuation (EA-13-109 Section 1.2.7/NEI 13-02 Section 4.2.1)

The HCVS shall include means to prevent inadvertent actuation.

Component Qualifications (EA-13-109 Section 2.1 / NEI 13-02 Section 5.1, 5.3)

State qualification criteria based on use of a combination of safety related and augmented quality dependent on the location, function and interconnected system requirements.

Monitoring of HCVS (Order Elements 1.1.4, 1.2.8, 1.2.9/NEI 13-02 4.1.3, 4.2.2, 4.2.4, and Appendix F/G)

Provides a description of instruments used to monitor HCVS operation and effluent. Power for an instrument will require the intrinsically safe equipment installed as part of the power sourcing.

Component reliable and rugged performance (EA-13-109 Section 2.2 / NEI 13-02 Section 5.2, 5.3)

HCVS components including instrumentation should be designed, as a minimum, to meet the seismic design requirements of the plant.

Part 2: Boundary Conditions for Wetwell Vent

Components including instrumentation that are not required to be seismically designed by the design basis of the plant should be designed for reliable and rugged performance that is capable of ensuring HCVS functionality following a seismic event.

The components including instrumentation external to a seismic category 1 (or equivalent building or enclosure should be designed to meet the external hazards that screen-in for the plant as defined in guidance NEI 12-06 as endorsed by JLD-ISG-12-01 for Order EA-12-049.

Use of instruments and supporting components with known operating principles that are supplied by manufacturers with commercial quality assurance programs, such as ISO9001. The procurement specifications shall include the seismic requirements and/or instrument design requirements, and specify the need for commercial design standards and testing under seismic loadings consistent with design basis values at the instrument locations.

Demonstration of the seismic reliability of the instrumentation through methods that predict performance by analysis, qualification testing under simulated seismic conditions, a combination of testing and analysis, or the use of experience data. Guidance for these is based on IEEE Standard 344, "IEEE Recommended Practice for Seismic Qualification of Class 1E Equipment for Nuclear Power Generating Stations," or a substantially similar industrial standard.

Demonstration that the instrumentation is substantially similar in design to instrumentation that has been previously tested to seismic loading levels in accordance with the plant design basis at the location where the instrument is to be installed (g-levels and frequency ranges). Such testing and analysis should be similar to that performed for the plant licensing basis.

Vent Size and Basis

The HCVS WW vent path was designed for venting steam/energy at a nominal capacity of 1% of 3293 MWt thermal power at a pressure of 60 psig. The original PBAPS WW vents were oversized for these nominal conditions, and had sufficient margin for previous PBAPS Stretch Power Uprate (to 3458 MWt in 1994/1995) and Measurement Uncertainty Recapture (MUR) Power Uprate (to 3514 MWt in 2002). PBAPS Calculation PM-0546 demonstrates adequacy for current station power rating of 3514 MWt at a PCPL rating of 60 psig, with flow margins of 42% on Unit 2 and 45% on Unit 3.

PM-0546 tabulates flow for a variety of pressures between 10 psig and 60 psig, which encompasses the design pressure rating of 56 psig. PM-0546 concludes that at torus pressures of 20 psig or greater, the vent flow exceeds flow required to assure depressurization. PBAPS Extended Power Uprate (EPU), to be implemented in 2014 and 2015, will raise thermal power to 3951 MWt, an increase of approximately 12.4%. Calculation PM-0546 appears to have sufficient margin, which will be validated per EPU ECRs 10-00409, 10-00478, and/or 13-00243.

The nominal diameter of the WW penetration piping is 18-inches until the branch line for the HCVS, which is 16-inches nominal diameter.

Vent Capacity

The PBAPS WW pressure suppression capacity is sufficient to absorb the decay heat generated beyond the first 8 to 10 hours, by which time decay heat is well below 1% thermal power. The vent is

Peach Bottom Atomic Power Station, Units 2 and 3 Overall Integrated Plan for Phase 1 Requirements for
Reliable Hardened Containment Vent System (HCVS) Capable of Operation Under Severe Accident
Conditions

Part 2: Boundary Conditions for Wetwell Vent

not needed in this initial period to prevent containment pressure from increasing above the containment design pressure. PBAPS has used the Modular Accident Analysis Program (MAAP) to support its FLEX /HCVS strategy. PB-MISC-010 lists three cases applicable to the 16" WW vents at PBAPS:

Case 1: RPV rapid cooldown to 500 psig then 80° F/hr cooldown with SRVs to 125 psig; WW vent opened when torus pressure exceeds 60 psig.

Case 7: RPV 80° F/hr cooldown with SRVs to 125 psig starting at t = 20 min; WW vent opened when torus pressure exceeds 60 psig.

Case 10: RPV 80° F/hr cooldown with SRVs to 200 psig starting at t = 20 min; WW vent opened when torus temperature exceeds 200° F.

For the three cases, Case 7 is bounding for containment pressure. There is sufficient capacity such that the WW vent can remain closed for greater than 10 hours and containment pressure would still not exceed containment design pressure.

PBAPS Calculation PM-0428, Primary Containment Conditions during Station Blackout, makes assumptions that are slightly different from the MAAP runs, but its conclusion is similar: containment pressure is approximately 44 psig after 8 hours, lower than containment design pressure of 56 psig. The calculation result is very comparable to the MAAP pressure value graph at T = 8 hours.

PBAPS Vendor Document G-080-VC-314, PBAPS Units 2 and 3 - GE SIL 636 Evaluation Project - Containment Response During SBO Event, results in a peak containment airspace pressure of 46 psig during an 8 hour coping period, which is comparable to both the PM-0546 and the MAAP runs.

The three independent analytical methods yield similar results, and affirm that suppression pool capacity is sufficient to absorb decay heat generated during the first three hours.

Vent Path and Discharge

The current PBAPS HCVS vent path consists of a WW vent on each unit. The flow path starting at the second PCIV is dedicated to the HCVS and there is no sharing of any component with the other unit. The only interconnected system is the SGTS which is isolated by a PCIV. The WW vent is routed horizontally above the top of the torus, exits the torus room roof (secondary containment) at 135', and then runs vertically on the outside of the RB to a point above the top of the RB. The vertical run is on the west side of the RB.

The HCVS discharge point is above any building in the PBAPS protected area. The RB roof parapet is 294'. The HCVS discharge point is at 300'. The only higher structure in the protected area is the RB ventilation exhaust discharge point at 305', on the east side of the RB, approximately 150 feet away (east-west). The RB ventilation exhaust fans will not be powered during an ELAP; however, chimney effect would preclude an inward pressure gradient. The HCVS release point is away from Control Room ventilation system intake, which is below 177'. The PBAPS Main Stack is at a higher elevation, but it not in the PBAPS protected area. The HCVS discharge does not adversely impact any ventilation intake or exhaust openings, MCR location, location of HCVS portable equipment,

Part 2: Boundary Conditions for Wetwell Vent

access routes required following an ELAP and BDBEE, or emergency response facilities.

The following is provided for information purposes regarding the layout of the plant. On each unit, the HCVS vent vertically runs up the RB west side, which faces a steeply rising slope of exposed bedrock. The slope width encompasses both RBs in the North-South direction. The slope base begins at approximately elevation 135' and 70 feet west of the RB. At approximately elevation 200' and 100 feet west of the RB, the slope becomes more gradual, to approximately elevation 240' and 200 feet west of the RB; and then even more gradual to elevation 270' and 300 feet west of the RB. Above this elevation, the slope continues an even more gradual ascent. On top of the slope, to the north, is PBAPS's north transmission substation. The top of the slope, including the substation, is an Owner Controlled Area. There is no other industrial facility or residence in this area. The protected area and substation are procedurally controlled against potential severe weather missiles. If forecasts are for hurricanes, or severe storms with winds in excess of 40 mph, or tornado warnings issued for the immediate area; then trailers and staged equipment are removed from the protected area and substations, and any trailers not removed are tied down.

The RB is a Seismic Category I structure, which provides its own wind and missile protection for the portion of the WW vent inside the RB. Peach Bottom has reviewed the portion of the WW vent outside of the RB per the guidance of NEI 12-06 as endorsed by JLD-ISG-12-001 for Order EA-12-049, and concluded that reasonable protection from tornado wind and tornado missiles is provided. The existing piping, external to the RB is designed for tornado wind speed of 300 mph vs. FLEX Overall Integrated Plan peak tornado wind speed of 165 mph. Therefore, tornado wind loading is not a concern.

For tornado missiles, per NEI 12-06 section 7.3, tornados travel from the West or West Southwesterly direction. NEI 12-06 section 7.3 requires either 1) tornado missile protection for a single FLEX Equipment Storage Building; or 2) multiple (diverse) unprotected FLEX Equipment Storage Buildings that are axially separated in the North-South direction. The PBAPS DG Building is a Seismic Category I structure, protected against tornado missiles. The PBAPS DG Building and the WW vents are axially separated in the North-South direction, by a distance of approximately 300 feet for the U2 WW vent and 600 feet for the U3 WW vent. The corridor between the RB and the bedrock slope is approximately 70 feet wide in the due north-south direction.

The reasonable protection guidance of NEI 12-06, afforded by this North-South separation, is applicable to the tornado missile-protected DG Building and the WW vents. Per NEI 12-06 guidance, it is unreasonable that tornado missiles could impact an unprotected FLEX Storage Building and then travel north-south to impact a second FLEX Storage Building. By similarity, it is unreasonable that tornado missiles could impact the protected DG Building to initiate the ELAP, and then travel due north to impact a seismically supported WW vent. Therefore, the existing PBAPS WW vents are partially within a Seismic Category I structure and otherwise are reasonably protected against potential tornado missiles.

Power and Pneumatic Supply Sources

The electrical circuit for the existing HCVS PCIVs is powered from the Station 1E battery that will be maintained by the FLEX generator. Electrical power required for operation of HCVS components

Part 2: Boundary Conditions for Wetwell Vent

will be from a dedicated HCVS DC battery source with permanently installed capacity for the first 24 hours and design provisions for recharging to maintain sustained operation. The design will allow repowering this circuit from the HCVS in the unlikely case that the FLEX generator fails to maintain the Station 1E battery charged.

Motive (pneumatic) power to the HCVS valves will be provided by the SGIG. This is an existing safety grade system located within a Seismic Class I structure. The initial stored motive power will allow for a minimum of 12 vent cycles for the HCVS valves for the first 24 hours. The 12 vent cycles is defined as initially opening all valves in the WW flow path, and then shutting and reopening one of the valves in the flow paths 11 times. PBAPS Calculation PM-0375 shows the SGIG tank has sufficient supply to meet HCVS opening and closing cycles.

1. The HCVS flow path valves are air-operated valves (AOV) with air-to-open and spring-to-shut. Opening the valves from the HCVS control panel located in the MCR requires energizing DC powered SVs and Instrument Air or SGIG pneumatic supply.
2. An assessment of temperature and radiological conditions will be performed to ensure that operating personnel can safely access and operate controls at the ROS based on time constraints listed in Attachment 2.
3. All permanently installed HCVS equipment, including any connections required to supplement the HCVS operation during an ELAP (i.e., DC power and motive force [pressurized N₂]) will be located in areas reasonably protected from defined hazards listed in Part 1 of this report.
4. All valves required to open the flow path will be designed for remote manual operation following an ELAP, such that the primary means of valve manipulation does not rely on use of a handwheel, reach-rod or similar means that requires close proximity to the valve (FAQ HCVS-03). The preferred method is opening from the MCR through the control switch that energizes the AOVs' SVs. The back-up method is from the ROS by repositioning valves on the pneumatic line; this allows opening and closing of a valve from the ROS without reliance on any electrical power or control circuit. Accessibility to the ROS will be verified during the detailed design.
5. Any supplemental connections will be pre-engineered to minimize man-power resources and address environmental concerns. Required portable equipment will be reasonably protected from screened in hazards listed in Part 1 of this OIP.
6. Access to the locations described above will not require temporary ladders or scaffolding.

Open item 1: Confirm the ROS will be in an accessible area following a SA.

Location of Control Panels

The HCVS design allows initiating and then operating and monitoring the HCVS from the MCR and in addition, opening valves from the ROS in case of a DC circuit failure. The tentative location for the

Part 2: Boundary Conditions for Wetwell Vent

ROS is the Cooling Water Equipment Room on RB elevation 116' (Unit 2 Room 105 and Unit 3 Room 162). The MCR location is protected from adverse natural phenomena and the normal control point for Plant Emergency Response actions. The ROS will be evaluated to ensure acceptable temperature and dose consequences.

Open Item 1: Confirm that the ROS will be in an accessible area following a SA.

Hydrogen

As is required by EA-13-109, Section 1.2.11, the HCVS must be designed such that it is able to either provide assurance that oxygen cannot enter and mix with flammable gas in the HCVS (so as to form a combustible gas mixture), or it must be able to accommodate the dynamic loading resulting from a combustible gas detonation. Several configurations are available which will support the former (e.g., purge, mechanical isolation from outside air, etc.) or the latter (design of potentially affected portions of the system to withstand a detonation relative to pipe stress and support structures).

PBAPS will determine the approach or combination of approaches the plant will take to address the combustible gas mixture. PBAPS intends to follow the guidance in HCVS-WP-03, Hydrogen/CO Control Measures.

Open Item 4: Determine the design approach for combustible gas.

Unintended Cross Flow of Vented Fluids

Although the existing wetwell HCVS at each Peach Bottom unit has a containment penetration that is shared with the SGTS, the SGTS is isolated by its PCIV. The HCVS flow path does not have any other connected systems and does not share any flow path with the opposite unit. The discharge from each unit is routed above each unit's RB roof. The HCVS discharge points, from unit to unit, are separated by approximately 300 feet in the North-South direction.

Prevention of Inadvertent Actuation

EOP/ERG operating procedures provide clear guidance that the HCVS is not to be used to defeat containment integrity during any design basis transient or accident. In addition, the HCVS is designed to provide features to prevent inadvertent actuation due to a design error, equipment malfunction, or operator error such that any credited containment accident pressure (CAP) that would provide net positive suction head to the emergency core cooling system (ECCS) pumps will be available, inclusive of a design basis loss-of-coolant accident (DBLOCA). However the ECCS pumps will not have power available because of the starting boundary conditions of an ELAP. Note that PBAPS currently does credit CAP for operation of Residual Heat Removal (RHR) and Core Spray (CS) pumps during a variety of events, which are bounded by a DBLOCA. However, post-EPU modifications, CAP credit for RHR and CS will be completely eliminated. There is no CAP credit for operation of the HPCI or the RCIC pumps. However, PB procedure T-102 sheet 3 provides RCIC pump NPSH limits at elevated torus temperature and pressure.

Part 2: Boundary Conditions for Wetwell Vent

The features that prevent inadvertent actuation are two PCIVs in series, procedural controls, key-lock switches, and circuits with fuses removed. In addition, a downstream rupture disc exists in the current configuration, and is provided to maintain secondary containment under design basis events. PBAPS is evaluating the option of retaining the rupture disc or replacing it with a Secondary Containment Isolation Valve (SCIV). The downstream PCIV and the rupture disc/SCIV are dedicated to the HCVS. All PCIVs and the SCIV are fail-shut AOVs. They are air to open, spring to shut AOVs that require energizing a SV to allow the motive air to open the valve. Current PBAPS design features and procedural controls that prevent inadvertent venting will be maintained. Similar design features (and procedural controls) will be incorporated at the ROS to prevent inadvertent venting from that location.

Component Qualifications

HCVS components up to the secondary containment pressure boundary are safety-related. The containment system limits the leakage or release of radioactive materials to the environment to prevent offsite exposures from exceeding the guidelines of 10CFR100. During normal or design basis operations, secondary containment is the pressure boundary to prevent release of radioactive material. HCVS components outside of the RB secondary containment pressure boundary (i.e., outside the RB) are not required to be safety-related.

Except for the existing PCIVs, the other HCVS components will be powered from a normally de-energized, dedicated power supply that will not be safety-related but will be Augmented Quality. However, any HCVS electrical or controls component that interfaces with Class 1E power sources will be considered safety-related up to and including appropriate isolation devices such as fuses or breakers, as their failure could adversely impact a safety-related power source. Electrical and controls components will have the ability to handle harsh environmental conditions, although they will not be considered part of the site Environmental Qualification (EQ) program. Unless otherwise required to be safety-related, Augmented Quality requirements will be applied to the components installed in response to this Order.

HCVS instrumentation performance (e.g., accuracy and precision) need not exceed that of similar plant installed equipment. Additionally, radiation monitoring instrumentation accuracy and range will be sufficient to confirm flow of radionuclides through the HCVS. The HCVS instruments, including valve position indication, process instrumentation, radiation monitoring, and support system monitoring, will be qualified by using one or more of the three methods described in the ISG, which include:

1. Purchase of instruments and supporting components with known operating principles from manufacturers with commercial quality assurance programs (e.g., ISO9001) where the procurement specifications include the applicable seismic requirements, design requirements, and applicable testing.
2. Demonstration of seismic reliability via methods that predict performance described in IEEE 344-2004
3. Demonstration that instrumentation is substantially similar to the design of instrumentation previously qualified.

Peach Bottom Atomic Power Station, Units 2 and 3 Overall Integrated Plan for Phase 1 Requirements for Reliable Hardened Containment Vent System (HCVS) Capable of Operation Under Severe Accident Conditions

Part 2: Boundary Conditions for Wetwell Vent

<u>Instrument</u>	<u>Qualification Method*</u>
HCVS Process Temperature	ISO9001 / IEEE 344-2004 / Demonstration
HCVS Process Pressure	ISO9001 / IEEE 344-2004 / Demonstration
HCVS Process Radiation Monitor	ISO9001 / IEEE 344-2004 / Demonstration
HCVS Process Valve Position	ISO9001 / IEEE 344-2004 / Demonstration
HCVS Pneumatic Supply Pressure	ISO9001 / IEEE 344-2004 / Demonstration
HCVS Electrical Power Supply Availability	ISO9001 / IEEE 344-2004 / Demonstration

* The specific qualification method used for each required HCVS instrument will be reported in future 6 month status reports.

Monitoring of HCVS

The PBAPS WW HCVS will be capable of being remote-manually operated during sustained operations from a control panel located in the MCR and will meet the requirements of Order element 1.2.4. The MCR is a readily accessible location with no further evaluation required. Additionally, to meet the intent for a secondary control location of section 1.2.5 of the Order, a readily accessible ROS will also be incorporated into the HCVS design as described in NEI 13-02 section 4.2.2.1.2.1. The controls and indications at the ROS location will be accessible and functional under a range of plant conditions, including SA conditions with due consideration to source term and dose impact on operator exposure, ELAP, and inadequate containment cooling. An evaluation will be performed to determine accessibility to the location, habitability, staffing sufficiency, and communication capability with Vent-use decision makers.

The WW HCVS will include means to monitor the status of the vent system in the MCR and to monitor DC power and N2 pressure at the MCR or ROS. The existing design for the HCVS includes control switches in the MCR with valve position indication. The new HCVS controls will meet the environmental and seismic requirements of the Order for the SA with an ELAP. The ability to open/close these valves multiple times during the event's first 24 hours will be provided by the SGIG and DC power. Beyond the first 24 hours, the ability to maintain these valves open or closed will be maintained by sustaining the motive air and DC power.

The WW HCVS will include indications for vent pipe pressure, valve position, temperature, and effluent radiation levels at the MCR. Other important information on the status of supporting systems (i.e., DC power source status and pneumatic supply pressure) will also be included in the design and located to support HCVS operation.

The design will rely on existing containment pressure and WW level indication in the MCR to monitor containment parameters. This monitoring instrumentation provides the indication from the MCR as per Requirement 1.2.4. This instrumentation is not required to validate HCVS function and is therefore not powered from the dedicated HCVS batteries. However, these instruments are expected to be available since the FLEX DG supplies the station battery charger for these instruments and will

Part 2: Boundary Conditions for Wetwell Vent

be installed prior to depletion of the station batteries.

Component reliable and rugged performance

The HCVS components and components that interface with the HCVS are routed in seismically qualified structures. Newly installed piping and valves will be seismically qualified to handle the forces associated with the PBAPS Safe Shutdown Earthquake (SSE) back to their isolation boundaries. New electrical and controls components will be seismically qualified.

The HCVS downstream of the second containment isolation valve, including piping and supports, electrical power supply, valve actuator pneumatic supply, and instrumentation (local and remote) components, will be designed/analyzed to conform to the requirements consistent with the applicable design codes (e.g., Non-safety, Seismic Category 1, B31.1) for the plant and to ensure functionality following a design basis earthquake.

Additional modifications required to meet the Order will provide reliability at the postulated vent pipe conditions (temperature, pressure, and radiation levels). The instrumentation/power supplies/cables/connections (components) will be qualified for temperature, pressure, radiation level, total integrated radiation dose appropriate for that location (e.g., near the effluent vent pipe or at the HCVS ROS location).

Conduit and cable trays will be installed to the applicable Seismic Class 1 criteria.

If the instruments are purchased as commercial-grade equipment, they will be qualified to operate in the SA environment as required by NRC Order EA-13-109 and the guidance of NEI 13-02. The equipment will be qualified seismically, environmentally (IEEE 323-1974), and for electro-magnetic compatibility.

For the dedicated HCVS instruments required after a potential seismic event, the following methods will be used to verify that the design and installation is reliable / rugged and thus capable of ensuring HCVS functionality following a seismic event. Applicable instruments are rated by the manufacturer (or otherwise tested) for seismic impact at levels commensurate with those of postulated SA conditions in the area of instrument component use using one or more of the following methods:

- demonstration of seismic motion will be consistent with that of existing design basis loads at the installed location;
- substantial history of operational reliability in environments with significant vibration with a design envelope inclusive of the effects of seismic motion imparted to the instruments proposed at the location;
- adequacy of seismic design and installation is demonstrated based on the guidance in IEEE Standard 344, *IEEE Recommended Practice for Seismic Qualification of Class 1E Equipment for Nuclear Power Generating Stations*, or a substantially similar industrial standard;
- demonstration that proposed devices are substantially similar in design to models that have been previously tested for seismic effects in excess of the plant design basis at the location where the instrument is to be installed (g-levels and frequency ranges); or

Peach Bottom Atomic Power Station, Units 2 and 3 Overall Integrated Plan for Phase 1 Requirements for
Reliable Hardened Containment Vent System (HCVS) Capable of Operation Under Severe Accident
Conditions

Part 2: Boundary Conditions for Wetwell Vent

- seismic qualification using seismic motion consistent with that of existing design basis loading at the installation location.

Peach Bottom Atomic Power Station, Units 2 and 3 Overall Integrated Plan for Phase 1 Requirements for Reliable Hardened Containment Vent System (HCVS) Capable of Operation Under Severe Accident Conditions

Part 2: Boundary Conditions for WW Vent: BDBEE Venting

Determine venting capability for BDBEE Venting, such as may be used in an ELAP scenario to mitigate core damage.

Ref: EA-13-109 Section 1.1.4 / NEI 13-02 Section 2.2

First 24 Hour Coping Detail

Provide a general description of the venting actions for first 24 hours using installed equipment including station modifications that are proposed.

Ref: EA-13-109 Section 1.2.6 / NEI 13-02 Section 2.5, 4.2.2

The operation of the HCVS will be designed to minimize the reliance on operator actions for response to an ELAP and BDBEE hazards identified in Part 1 of this OIP. Immediate operator actions can be completed by Operators from the HCVS control stations, and include remote-manual initiation. The operator actions required to open a vent path are as described in Table 2-1.

Remote-manual is defined in this report as a non-automatic power operation of a component that does not require the operator to be at or in close proximity to the component. No other operator actions are required to initiate venting under the guiding procedural protocol.

The HCVS will be designed to allow initiation, control, and monitoring of venting from the MCR. This location minimizes plant operators' exposure to adverse temperature and radiological conditions and is protected from hazards assumed in Part 1 of this report.

Permanently installed and dedicated power capability will be available to support operation and monitoring of the HCVS for the first 24 hours.

System control:

- i. Active: The HCVS will be procedurally operated to control containment pressure. The HCVS will be designed for 12 vent cycles under ELAP conditions over the first 24 hours following an ELAP. Controlled venting will be permitted under new and revised guidelines and/or procedures.
- ii. Passive: Inadvertent actuation protection is provided by:
 - A key lock switch for the dedicated downstream PCIV located in the MCR, locked controls at the ROS, and controlled by procedures, AND
 - Disabling the HCVS DC power to the SV and disabling the motive power (pressurized N2) for the dedicated PCIV except when required by procedures to initiate containment venting.

Peach Bottom Atomic Power Station, Units 2 and 3 Overall Integrated Plan for Phase 1 Requirements for
 Reliable Hardened Containment Vent System (HCVS) Capable of Operation Under Severe Accident
 Conditions

Part 2: Boundary Conditions for WW Vent: BDBEE Venting

Greater Than 24 Hour Coping Detail

Provide a general description of the venting actions for greater than 24 hours using portable and installed equipment including station modifications that are proposed

Ref: EA-13-109 Section 1.2.4, 1.2.8 / NEI 13-02 Section 4.2.2

Before the end of the 24 hours initial phase, available personnel will be able to sustain HCVS operation. Connections for supplementing electrical power required for HCVS will be located in accessible areas with reasonable protection per NEI 12-06 that minimize personnel exposure to adverse conditions for HCVS initiation and operation. Connections will be pre-engineered quick disconnects to minimize manpower resources.

FLEX is credited to sustain power for a BDBEE ELAP to containment instruments used to monitor the containment (e.g., pressure and WW level). It will also provide the preferred power to the PCIV circuit. The response to NRC Order EA-12-049 will demonstrate the capability for FLEX efforts to maintain the power source. The dedicated HCVS power source will be available as a back-up.

These actions provide long term support for HCVS operation for the period beyond 24 hours to 7 days (sustained operation time period) because on-site and off-site personnel and resources will have access to the units to provide needed action and supplies.

Details:

Provide a brief description of Procedures / Guidelines:

Confirm that procedure/guidance exists or will be developed to support implementation

New and revised Primary Containment Control guidelines and procedures will be provided to direct operations in protection and control of containment integrity, including use of the HCVS.

Open Item 2: – Provide guidelines and procedures for HCVS Operation.

Identify modifications

List modifications and describe how they support the HCVS Actions

EA-12-049 Modifications

- EA-12-049 modifications are addressed in the OIP for that order. No additional FLEX modifications have been identified to support HCVS.

EA-13-109 Modifications

- PBAPS AR A1893549 is a Unit 2 WW ECR placeholder scheduled for P2R21 (4th Quarter 2016). AR A1943379 is for Unit 2 WW pre-outage activities.
- PBAPS AR A1893548 is a Unit 3 WW ECR placeholder scheduled for P3R21 (4th Quarter

Peach Bottom Atomic Power Station, Units 2 and 3 Overall Integrated Plan for Phase 1 Requirements for Reliable Hardened Containment Vent System (HCVS) Capable of Operation Under Severe Accident Conditions

Part 2: Boundary Conditions for WW Vent: BDBEE Venting

2017). AR A1943377 is for Unit 3 WW pre-outage activities.

- The PBAPS HCVS modifications are in Request for Proposal phase with Exelon’s Engineers-of-Choice at the time of this OIP. The RFP requests modifications to comply with NRC Order EA-13-109 and NEI Guidance 13-02. Proposal evaluations and modifications include:
 - Existing WW vent and components for ability to function under SA Conditions.
 - Options of keeping the existing rupture disc and modifying the vent to allow anticipatory venting below the rupture disc set pressure; or replacing the rupture disc with a SCIV.
 - A 24-hour dedicated HCVS power supply with quick connects for a temporary generator.
 - Quick connects for a portable compressor or N2 bottles.
 - A ROS with devices to prevent inadvertent actuation.
 - A backup pneumatic supply to directly and manually open the PCIVs and SCIV, and purge the vent line.
 - HCVS flow path instrumentation consisting of pressure and temperature in the MCR or ROS, and motive power and DC battery indication in the MCR or ROS.
 - The existing design already has a DC powered radiation monitor dedicated to the HCVS flow path, which will be evaluated for adequacy of range and re-powered from Division 1.

Key Venting Parameters:

List instrumentation credited for this venting actions. Clearly indicate which of those already exist in the plant and what others will be newly installed (to comply with the vent order).

Initiation, operation and monitoring of the HCVS venting will rely on the following key parameters and indicators which will be added as part of the HCVS modification:

Key Parameter	Component Identifier	Indication Location
HCVS Effluent temperature	TBD	MCR
HCVS Effluent radiation	Unit 3: RIS-90291 Unit 2: RIS-80291	MCR – 30C010 MCR – 20C010
HCVS pressure indication	TBD	MCR/ROS
HCVS valve position indication	TBD	MCR/ROS
HCVS DC Power Voltage/Conditions	TBD	MCR/ROS
SGIG pneumatic supply pressure	TBD	MCR/ROS

Initiation, operation and monitoring of the HCVS system will rely on several existing MCR key parameters and indicators which are qualified or evaluated to Regulatory Guide 1.97 per the existing plant design:

Key Parameter	Component Identifier	Indication Location
Drywell pressure	Unit 3: PR/TR-5805 Unit 2: PR/TR-4805	MCR – 30C003 MCR – 20C003

Peach Bottom Atomic Power Station, Units 2 and 3 Overall Integrated Plan for Phase 1 Requirements for Reliable Hardened Containment Vent System (HCVS) Capable of Operation Under Severe Accident Conditions

Part 2: Boundary Conditions for WW Vent: BDBEE Venting

Torus Water Level	Unit 3: LI-9027 and LI-9123A (wide range) Unit 2: LI-8027 and LI-8123A (wide range)	MCR – 30C003 MCR – 20C003
-------------------	--	------------------------------

HCVS indications for HCVS valve position indication, HCVS pneumatic supply pressure, HCVS effluent temperature, and HCVS system pressure will be installed in the MCR to comply with EA-13-109.

Notes:

- 1) HCVS effluent radiation instruments RIS-90291 and RIS-80291; drywell pressure instruments PR/TR-5805 and PR/TR-4805; and torus water level instruments LI-9027, LI-9123A, LI-8027, and LI-8123A already exist. All other instruments will be new. RIS-90291 and RIS-80291 need power supplies modified from Division 2 to Division 1, such that FLEX generator will provide backup power.
- 2) SGIG pneumatic hi-low pressure alarm in the MCR, PS-9702 and PS-8702 already exist, but are powered from Division 2. This is not a stand-alone instrument like the radiation instrument. It is part of an array of SGIG instruments, all powered by Division 2. At this time it is expected that a new instrument will be required.

Part 2: Boundary Conditions for WW Vent: Severe Accident Venting

Determine venting capability for Severe Accident Venting, such as may be used in an ELAP scenario to mitigate core damage.

Ref: EA-13-109 Section 1.2.10 / NEI 13-02 Section 2.3

First 24 Hour Coping Detail

Provide a general description of the venting actions for first 24 hours using installed equipment including station modifications that are proposed.

Ref: EA-13-109 Section 1.2.6 / NEI 13-02 Section 2.5, 4.2.2

The operation of the HCVS will be designed to minimize the reliance on operator actions for response to an ELAP and SA. SA assumes that specific core cooling actions from the FLEX strategies identified in the response to Order EA-12-049 were not successfully initiated. Access to portions of the RB, including the torus room, will be restricted as determined by the RPV water level and core damage conditions. Immediate actions will be completed by Operators in the MCR and will include remote-manual actions. The ROS provides back-up capability to open HCVS valves in case of a valve circuit or SV failure. The operator actions required to open a vent path were previously listed in the BDBEE Venting Part 2 section of this report (Table 2-1).

Permanently installed power and motive air/gas capability will be available to support operation and monitoring of the HCVS for 24 hours. Specifics are the same as for BDBEE Venting Part 2.

Peach Bottom Atomic Power Station, Units 2 and 3 Overall Integrated Plan for Phase 1 Requirements for Reliable Hardened Containment Vent System (HCVS) Capable of Operation Under Severe Accident Conditions

Part 2: <u>Boundary Conditions for WW Vent</u>: Severe Accident Venting
System control: <ul style="list-style-type: none"> i. Active: Same as for Part 2 BDBEE Venting ii. Passive: Same as for Part 2 BDBEE Venting
<p>Greater Than 24 Hour Coping Detail <i>Provide a general description of the venting actions for greater than 24 hours using portable and installed equipment including station modifications that are proposed.</i></p> <p>Ref: EA-13-109 Section 1.2.4, 1.2.8 / NEI 13-02 Section 4.2.2</p>
<p>Specifics are the same as for Part 2 BDBEE Venting. PBAPS FLEX strategy assumes the ability to cope for as long as required (in FLEX Phase 2, reliance on on-site portable equipment) using FLEX equipment.</p> <p>Open item 1: Confirm the ROS will be in an accessible area following a SA. These actions provide long term support for HCVS operation for the period beyond 24 hours to 7 days (sustained operation time period) because on-site and off-site personnel and resources will have access to the units to provide needed action and supplies.</p>
Details:
<p>Provide a brief description of Procedures / Guidelines: <i>Confirm that procedure/guidance exists or will be developed to support implementation.</i></p>
<p>The operation of the HCVS will be governed the same for SA conditions as for BDBEE conditions. Existing guidance in the SAMGs directs the plant staff to consider changing radiological conditions in a SA.</p>
<p>Identify modifications: <i>List modifications and describe how they support the HCVS Actions.</i></p>
<p>The same as for Part 2 BDBEE Venting.</p>
<p>Key Venting Parameters: <i>List instrumentation credited for the HCVS Actions. Clearly indicate which of those already exist in the plant and what others will be newly installed (to comply with the vent order)</i></p>
<p>The same as for Part 2 BDBEE Venting.</p>
<p>Notes: None</p>

Peach Bottom Atomic Power Station, Units 2 and 3 Overall Integrated Plan for Phase 1 Requirements for Reliable Hardened Containment Vent System (HCVS) Capable of Operation Under Severe Accident Conditions

Part 2: Boundary Conditions for WW Vent: HCVS Support Equipment Functions

Determine venting capability support functions needed

Ref: EA-13-109 Section 1.2.8, 1.2.9/NEI 13-02 Section 2.5, 4.2.4, 6.1.2

BDBEE Venting

Provide a general description of the BDBEE Venting actions support functions. Identify methods and strategy to achieve venting results.

Ref: EA-13-109 Section 1.2.9 / NEI 13-02 Section 2.5, 4.2.2, 4.2.4, 6.1.2

All containment venting functions will be performed from the MCR or ROS.

Venting to prevent containment over-pressurization will be maintained by permanently installed equipment. The HCVS dedicated DC power source is adequate for the first 24 hours, but it can be replenished to support sustained operation.

Existing safety related station batteries will provide sufficient electrical power for MCR containment instrumentation and the existing PCIV circuits for greater than 5.5 hours. Before station batteries are depleted, portable FLEX diesel generators, as detailed in the response to Order EA-12-049, will be credited to charge the station batteries and maintain DC bus voltage after 5.0 hours.

Severe Accident Venting

Provide a general description of the Severe Accident Venting actions support functions. Identify methods and strategy to achieve venting results.

Ref: EA-13-109 Section 1.2.8, 1.2.9 / NEI 13-02 Section 2.5, 4.2.2, 4.2.4, 6.1.2

The same support functions that are used in the BDBEE scenario would be used for SA venting. The ROS (the location of the HCVS DC power source and motive force) will be evaluated to confirm accessibility under SA conditions.

Details:

Provide a brief description of Procedures / Guidelines:

Confirm that procedure/guidance exists or will be developed to support implementation.

All the HCVS equipment for the first 24 hours is permanently installed. The key portable HCVS item is the HCVS portable generator needed to sustain operation after 24 hours. Also, the FLEX DGs will be credited to maintain existing containment instrumentation. This portable equipment will be staged in position for the duration of the event.

Identify modifications:

List modifications and describe how they support the HCVS Actions.

Peach Bottom Atomic Power Station, Units 2 and 3 Overall Integrated Plan for Phase 1 Requirements for
Reliable Hardened Containment Vent System (HCVS) Capable of Operation Under Severe Accident
Conditions

Part 2: <u>Boundary Conditions for WW Vent:</u> HCVS Support Equipment Functions
The same as for Part 2 BDBEE Venting
Key Support Equipment Parameters: <i>List instrumentation credited for the support equipment utilized in the venting operation. Clearly indicate which of those already exist in the plant and what others will be newly installed (to comply with the vent order)</i>
The same as for Part 2 BDBEE Venting.
Notes:

Peach Bottom Atomic Power Station, Units 2 and 3 Overall Integrated Plan for Phase 1 Requirements for
 Reliable Hardened Containment Vent System (HCVS) Capable of Operation Under Severe Accident
 Conditions

Part 2: Boundary Conditions for WW Vent: HCVS Venting Portable Equipment Deployment

Provide a general description of the venting actions using portable equipment including modifications that are proposed to maintain and/or support safety functions.

Ref: EA-13-109 Section 3.1 / NEI 13-02 Section 6.1.2, D.1.3.1

Deployment pathways developed for compliance with Order EA-12-049 are acceptable without further evaluation needed except in areas around the RB or in the vicinity of the HCVS piping.

Before the end of the initial 24-hour period, replenishment of the HCVS dedicated DC power will occur at the ROS. The selection of the ROS location will take into account the SA temperature and radiation condition to ensure access to the ROS is maintained. The design will allow replenishment with minimal actions.

Details:

Provide a brief description of Procedures / Guidelines:

Confirm that procedure/guidance exists or will be developed to support implementation.

Operation of the portable equipment is the same as for compliance with Order EA-12-049; thus, they are acceptable without further evaluation.

HCVS Actions	Modifications	Protection of connections
<i>Identify Actions including how the equipment will be deployed to the point of use.</i>	<i>Identify modifications</i>	<i>Identify how the connection is protected</i>
Per compliance with Order EA-12-049 (FLEX)	N/A	Per compliance with Order EA-12-049 (FLEX)

Notes:

Peach Bottom Atomic Power Station, Units 2 and 3 Overall Integrated Plan for Phase 1 Requirements for Reliable Hardened Containment Vent System (HCVS) Capable of Operation Under Severe Accident Conditions

Part 3: Boundary Conditions for Drywell Vent

Provide a sequence of events and identify any time constraint required for success including the basis for the time constraint.

HCVS Actions that have a time constraint to be successful should be identified with a technical basis and a justification provided that the time can reasonably be met (for example, a walk-through of deployment).

Describe in detail in this section the technical basis for the time constraint identified on the sequence of events timeline Attachment 2B

See attached sequence of events timeline (Attachment 2B).

Ref: EA-13-109 Section X.X.X / NEI 13-02 Section X.X.x

This section will be completed with the Phase 2 OIP submittal by December 31, 2015.

Severe Accident Venting

Determine venting capability for Severe Accident Venting, such as may be used in an ELAP scenario to mitigate core damage.

Ref: EA-13-109 Section X.X.X / NEI 13-02 Section X.X.x

First 24 Hour Coping Detail

Provide a general description of the venting actions for first 24 hours using installed equipment including station modifications that are proposed.

Ref: EA-13-109 Section X.X.X / NEI 13-02 Section X.X.x

This section will be completed with the Phase 2 OIP submittal by December 31, 2015.

Greater Than 24 Hour Coping Detail

Provide a general description of the venting actions for greater than 24 hours using portable and installed equipment including station modifications that are proposed.

Ref: EA-13-109 Section X.X.X / NEI 13-02 Section X.X.x

This section will be completed with the Phase 2 OIP submittal by December 31, 2015.

Details:

Provide a brief description of Procedures / Guidelines:

Confirm that procedure/guidance exists or will be developed to support implementation.

This section will be completed with the Phase 2 OIP submittal by December 31, 2015.

Peach Bottom Atomic Power Station, Units 2 and 3 Overall Integrated Plan for Phase 1 Requirements for
Reliable Hardened Containment Vent System (HCVS) Capable of Operation Under Severe Accident
Conditions

Part 3: Boundary Conditions for Drywell Vent

Identify modifications:

List modifications and describe how they support the HCVS Actions.

This section will be completed with the Phase 2 OIP submittal by December 31, 2015.

Key Venting Parameters:

List instrumentation credited for the venting HCVS Actions.

This section will be completed with the Phase 2 OIP submittal by December 31, 2015.

Notes:

Peach Bottom Atomic Power Station, Units 2 and 3 Overall Integrated Plan for Phase 1 Requirements for Reliable Hardened Containment Vent System (HCVS) Capable of Operation Under Severe Accident Conditions

Part 4: Programmatic Controls, Training, Drills and Maintenance

Identify how the programmatic controls will be met.

Provide a description of the programmatic controls equipment protection, storage and deployment and equipment quality addressing the impact of temperature and environment

Ref: EA-13-109 Section 3.1, 3.2 / NEI 13-02 Section 6.1.2, 6.1.3, 6.2

Program Controls:

The HCVS venting actions will include:

- Site procedures and programs are being developed in accordance with NEI 12-06 and 13-02 to address use and storage of portable equipment relative to the SA defined in NRC Order EA-13-109 and the hazards applicable to the site per Part 1 of this OIP.
- Routes for transporting portable equipment from storage location(s) to deployment areas will be developed as the response details are identified and finalized. The identified paths and deployment areas will be accessible during all modes of operation and during a SA.

Procedures:

Procedures will be established for system operations when normal and backup power is available, and during ELAP conditions.

The HCVS procedures will be developed and implemented following the plant's process for initiating or revising procedures and contain the following details:

- appropriate conditions and criteria for use of the HCVS
- when and how to place the HCVS in operation,
- the location of system components,
- instrumentation available,
- normal and backup power supplies,
- directions for sustained operation, including the storage location of portable equipment,
- operating the portable equipment, and
- testing of portable equipment

PBAPS currently does credit CAP for its Residual Heat Removal (RHR) and Core Spray (CS) pumps for a variety of events, bounded by a DBLOCA. However, post-EPU modifications implementation, CAP credit for RHR and CS will be completely eliminated. There is no CAP credit for operation of the HPCI or the RCIC pumps. However, PB procedure T-102 sheet 3 provides RCIC pump NPSH limits at elevated torus temperature and pressure.

PBAPS will establish provisions for out-of-service requirements of the HCVS and compensatory measures. The following provisions will be documented in a PBAPS specific controlling document.

The provisions for out-of-service requirements for HCVS functionality are applicable in Modes 1, 2 and 3.

- If for up to 90 consecutive days, the primary or alternate means of HCVS operation are non-functional, no compensatory actions are necessary.

Part 4: Programmatic Controls, Training, Drills and Maintenance

- If for up to 30 days, the primary and alternate means of HCVS operation are non-functional, no compensatory actions are necessary.
- If the out of service times exceed 30 or 90 days as described above, the following actions will be performed:
 - The condition will be entered into the corrective action system,
 - The HCVS functionality will be restored in a manner consistent with plant procedures,
 - A cause assessment will be performed to prevent future loss of function for similar causes,
 - Initiate action to implement appropriate compensatory actions.

Open Item 3: Identify Site Specific Controlling Document for HCVS out of service and compensatory measures.

Describe training plan

List training plans for affected organizations or describe the plan for training development.

Ref: EA-13-109 Section 3.2 / NEI 13-02 Section 6.1.3

Personnel expected to perform direct execution of the HCVS will receive necessary training in the use of plant procedures for system operations when normal and backup power is available and during ELAP conditions. The training will be refreshed on a periodic basis and as any changes occur to the HCVS. Training content and frequency will be established using the Systematic Approach to Training (SAT) process.

Identify how the drills and exercise parameters will be met.

Alignment with NEI 13-06 and 14-01 as codified in NTF Recommendation 8 and 9 rulemaking.

The Licensee should demonstrate use of the HCVS system in drills, tabletops, or exercises as follows:

- *Hardened containment vent operation on normal power sources (no ELAP).*
- *During FLEX demonstrations: HCVS operation on backup power and from primary or alternate location during conditions of ELAP/loss of UHS with no core damage. System use is for containment heat removal AND containment pressure control.*
- *HCVS operation on backup power and from primary or alternate location during conditions of ELAP/loss of UHS with core damage. System use is for containment heat removal AND containment pressure control with potential for combustible gases (Demonstration may be in conjunction with SAG change).*

Ref: EA-13-109 Section 3.1 / NEI 13-02 Section 6.1.3

Peach Bottom Atomic Power Station, Units 2 and 3 Overall Integrated Plan for Phase 1 Requirements for Reliable Hardened Containment Vent System (HCVS) Capable of Operation Under Severe Accident Conditions

Part 4: Programmatic Controls, Training, Drills and Maintenance

PBAPS will utilize the guidance provided in NEI 13-06 and 14-01 for guidance related to drills, tabletops, or exercises for HCVS operation. In addition, PBAPS will integrate these requirements with compliance to any rulemaking resulting from the NTF Recommendations 8 and 9.

Describe maintenance plan:

- *The HCVS maintenance program should ensure that the HCVS equipment reliability is being achieved in a manner similar to that required for FLEX equipment. Standard industry templates (e.g., EPRI) and associated bases may be developed to define specific maintenance and testing.*
 - *Periodic testing and frequency should be determined based on equipment type, expected use and manufacturer's recommendations.*
 - *Testing should be done to verify design requirements and/or basis. The basis should be documented and deviations from vendor recommendations and applicable standards should be justified.*
 - *Preventive maintenance should be determined based on equipment type and expected use. The basis should be documented and deviations from vendor recommendations and applicable standards should be justified.*
 - *Existing work control processes may be used to control maintenance and testing.*
- *HCVS permanent installed equipment should be maintained in a manner that is consistent with assuring that it performs its function when required.*
 - *HCVS permanently installed equipment should be subject to maintenance and testing guidance provided to verify proper function.*
- *HCVS non-installed equipment should be stored and maintained in a manner that is consistent with assuring that it does not degrade over long periods of storage and that it is accessible for periodic maintenance and testing.*

Ref: EA-13-109 Section 1.2.13 / NEI 13-02 Section 5.4, 6.2

PBAPS will utilize the standard EPRI industry PM process (similar to the Preventive Maintenance Basis Database) for establishing the maintenance calibration and testing actions for HCVS components. The control program will include maintenance guidance, testing procedures and frequencies established based on type of equipment and considerations made within the EPRI guidelines.

PBAPS will implement the following operation, testing and inspection requirements for the HCVS to ensure reliable operation of the system.

Table 4-1: Testing and Inspection Requirements

Description	Frequency
Cycle the HCVS valves and the interfacing system valves not used to maintain containment integrity during operations.	Once per operating cycle
Perform visual inspections and a walk down of HCVS components	Once per operating cycle

Peach Bottom Atomic Power Station, Units 2 and 3 Overall Integrated Plan for Phase 1 Requirements for
 Reliable Hardened Containment Vent System (HCVS) Capable of Operation Under Severe Accident
 Conditions

Part 4: Programmatic Controls, Training, Drills and Maintenance

Test and calibrate the HCVS radiation monitors.	Once per operating cycle
Leak test the HCVS.	(1) Prior to first declaring the system functional; (2) Once every three operating cycles thereafter; and (3) After restoration of any breach of system boundary within the buildings
Validate the HCVS operating procedures by conducting an open/close test of the HCVS control logic from its control panel and ensuring that all interfacing system valves move to their proper (intended) positions.	Once per every other operating cycle

Notes:

Peach Bottom Atomic Power Station, Units 2 and 3 Overall Integrated Plan for Phase 1 Requirements for Reliable Hardened Containment Vent System (HCVS) Capable of Operation Under Severe Accident Conditions

Part 5: Milestone Schedule

Provide a milestone schedule.

This schedule should include:

- *Modifications timeline*
- *Procedure guidance development complete*
 - *HCVS Actions*
 - *Maintenance*
- *Storage plan (reasonable protection)*
- *Staffing analysis completion*
- *Long term use equipment acquisition timeline*
- *Training completion for the HCVS Actions*

The dates specifically required by the order are obligated or committed dates. Other dates are planned dates subject to change. Updates will be provided in the periodic (six month) status reports.

Ref: EA-13-109 Section D.1, D.3 / NEI 13-02 Section 7.2.1

The following milestone schedule is provided. The dates are planning dates subject to change as design and implementation details are developed. Any changes to the following target dates will be reflected in the subsequent 6 month status reports.

Milestone	Target Completion Date	Activity Status	Comments { <u>Include date changes in this column</u> }
Hold preliminary / conceptual design meeting	Apr. 2014	Complete	
Submit Overall Integrated Implementation Plan	Jun. 2014	Complete	Complete with this submittal
Submit 6 Month Status Report	Dec. 2014		
Submit 6 Month Status Report	Jun. 2015		
U2 Design Engineering for WW Vent - Approved	Sep. 2015		
Submit 6 Month Status Report	Dec. 2015		Simultaneous with Phase 2 OIP
Submit 6 Month Status Report	Jun. 2016		
U3 Design Engineering for WW and Phase 2 - Approved	Sep. 2016		
U2 WW Operations Procedure Changes Developed	Sep. 2016		
U2 WW Specific Maintenance Procedure Developed	Sep. 2016		
U2 WW Training Complete	Sep. 2016		
U2 WW Implementation Outage	Nov. 2016		
U2 WW Procedure Changes Active	Nov. 2016		
U2 WW Walk Through Demonstration/Functional Test	Nov. 2016		
Submit 6 Month Status Report	Dec. 2016		
Submit 6 Month Status Report	Jun. 2017		
U2 Design Engineering for Phase 2 - Approved	Sep. 2017		

Peach Bottom Atomic Power Station, Units 2 and 3 Overall Integrated Plan for Phase 1 Requirements for
 Reliable Hardened Containment Vent System (HCVS) Capable of Operation Under Severe Accident
 Conditions

Part 5: <u>Milestone Schedule</u>			
U3 Operations Procedure Changes Developed	Sep. 2017		
U3 Specific Maintenance Procedure Developed	Sep. 2017		
U3 Training Complete	Sep. 2017		
U3 Implementation Outage	Oct. 2017		
U3 Procedure Changes Active	Oct. 2017		
U3 Walk Through Demonstration/Functional Test	Oct. 2017		
Submit 6 Month Status Report	Dec. 2017		
Submit 6 Month Status Report	Jun. 2018		
U2 Phase 2 Operations Procedure Changes Developed	Sep. 2018		
U2 Phase 2 Specific Maintenance Procedure Developed	Sep. 2018		
U2 Phase 2 Training Complete	Sep, 2018		
U2 Phase 2 Implementation Outage	Oct. 2018		
U2 Phase 2 Procedure Changes Active	Oct. 2018		
U2 Phase 2 Walk Through Demonstration/Functional Test	Oct. 2018		
Submit Completion Report	Dec. 2018		

Peach Bottom Atomic Power Station, Units 2 and 3 Overall Integrated Plan for Phase 1 Requirements for Reliable Hardened Containment Vent System (HCVS) Capable of Operation Under Severe Accident Conditions

Attachment 1: HCVS Portable Equipment

<i>List portable equipment</i>	<i>BDBEE Venting</i>	<i>Severe Accident Venting</i>	<i>Performance Criteria</i>	<i>Maintenance / PM requirements</i>
Portable HCVS battery charger and/or generator	X	X	TBD	Test periodically for performance
Portable HCVS air compressor	X	X	TBD	Test periodically for performance

Peach Bottom Atomic Power Station, Units 2 and 3 Overall Integrated Plan for Phase 1 Requirements for Reliable Hardened Containment Vent System (HCVS) Capable of Operation Under Severe Accident Conditions

Attachment 2: Sequence of Events Timeline

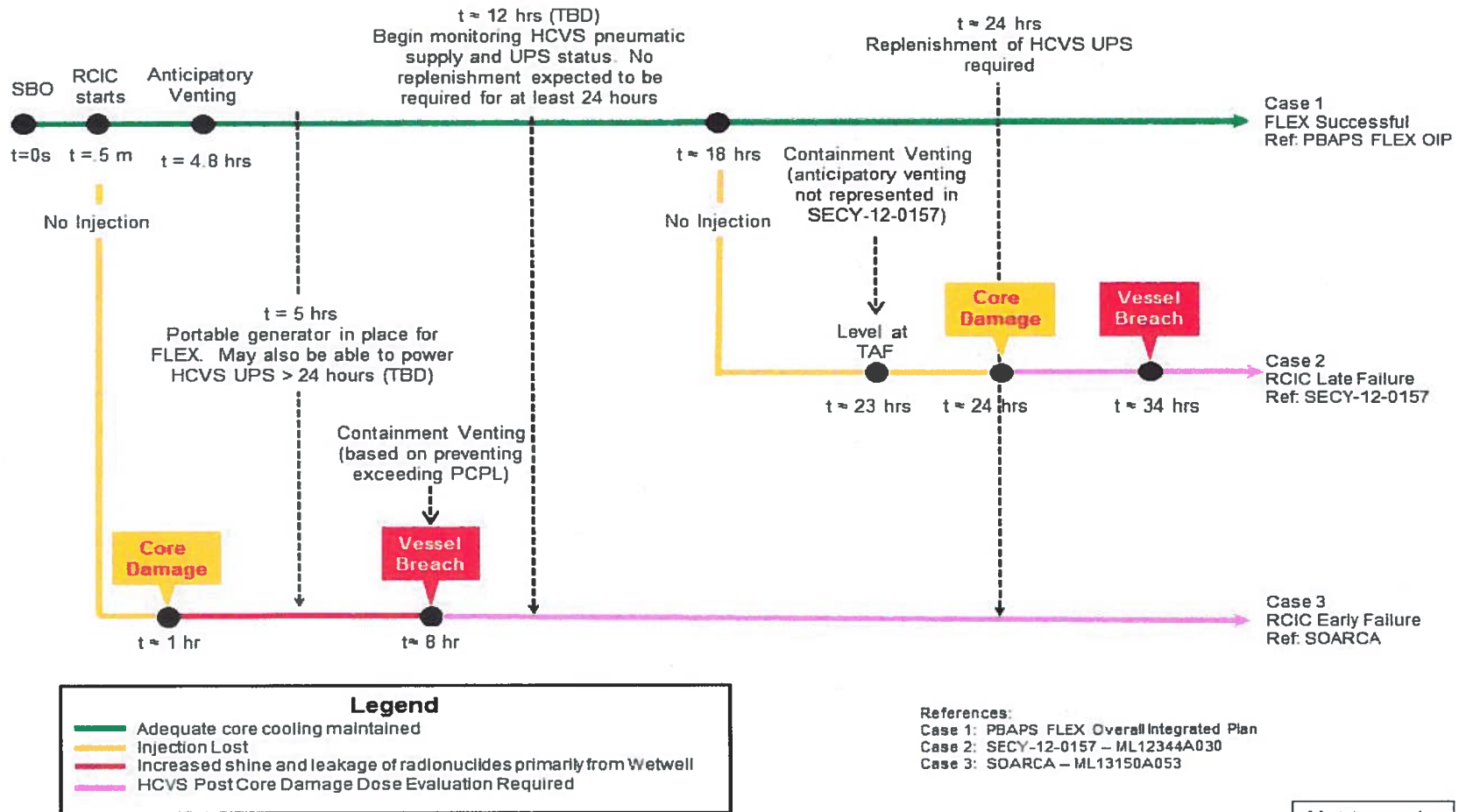

Attachment 3: Conceptual Sketches

(Conceptual sketches, as necessary to indicate equipment which is installed or equipment hookups necessary for the HCVS Actions)

- Plant layout with egress and ingress pathways
- Piping routing for vent path
- Instrumentation Process Flow
- Electrical Connections
- Include a piping and instrumentation diagram of the vent system. Demarcate the valves (in the vent piping) between the currently existing and new ones.

Sketch 1: Electrical Layout of System (*preliminary*)

Sketch 2: P&ID Layout of HCVS (*preliminary*)

- Piping routing for vent path
- Demarcate the valves (in the vent piping) between the currently existing and new ones
- HCVS Instrumentation Process Flow Diagram
-

Sketch 3: Plant Layout (*later*)

- Egress and Ingress Pathways to ROS, Battery Transfer Switch, DG Connections and Deployment location
- Site layout sketch to show location/routing of HCVS piping and associated components. This should include relative locations both horizontally and vertically

Peach Bottom Atomic Power Station, Units 2 and 3 Overall Integrated Plan for Phase 1 Requirements for Reliable Hardened Containment Vent System (HCVS) Capable of Operation Under Severe Accident Conditions

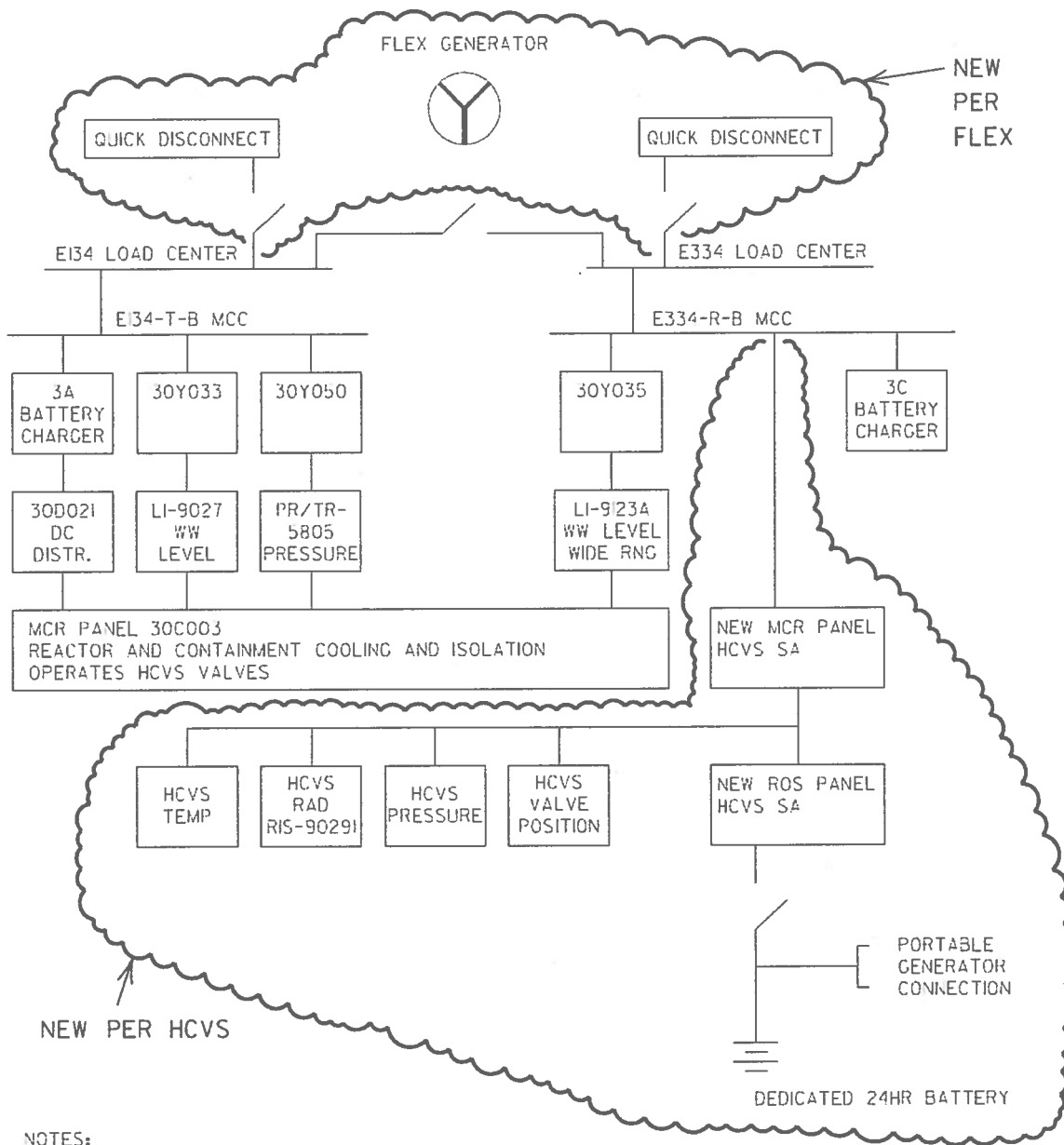

NOTES:

- 1) ONE (1) FLEX GENERATOR PER UNIT
- 2) RELOCATE RIS-9029I FROM DIVISION 2 POWER SUPPLY TO DIVISION 1

**Sketch 1: Electrical Layout of System (preliminary)
Unit 3, Unit 2 similar**

Peach Bottom Atomic Power Station, Units 2 and 3 Overall Integrated Plan for Phase 1 Requirements for Reliable Hardened Containment Vent System (HCVS) Capable of Operation Under Severe Accident Conditions

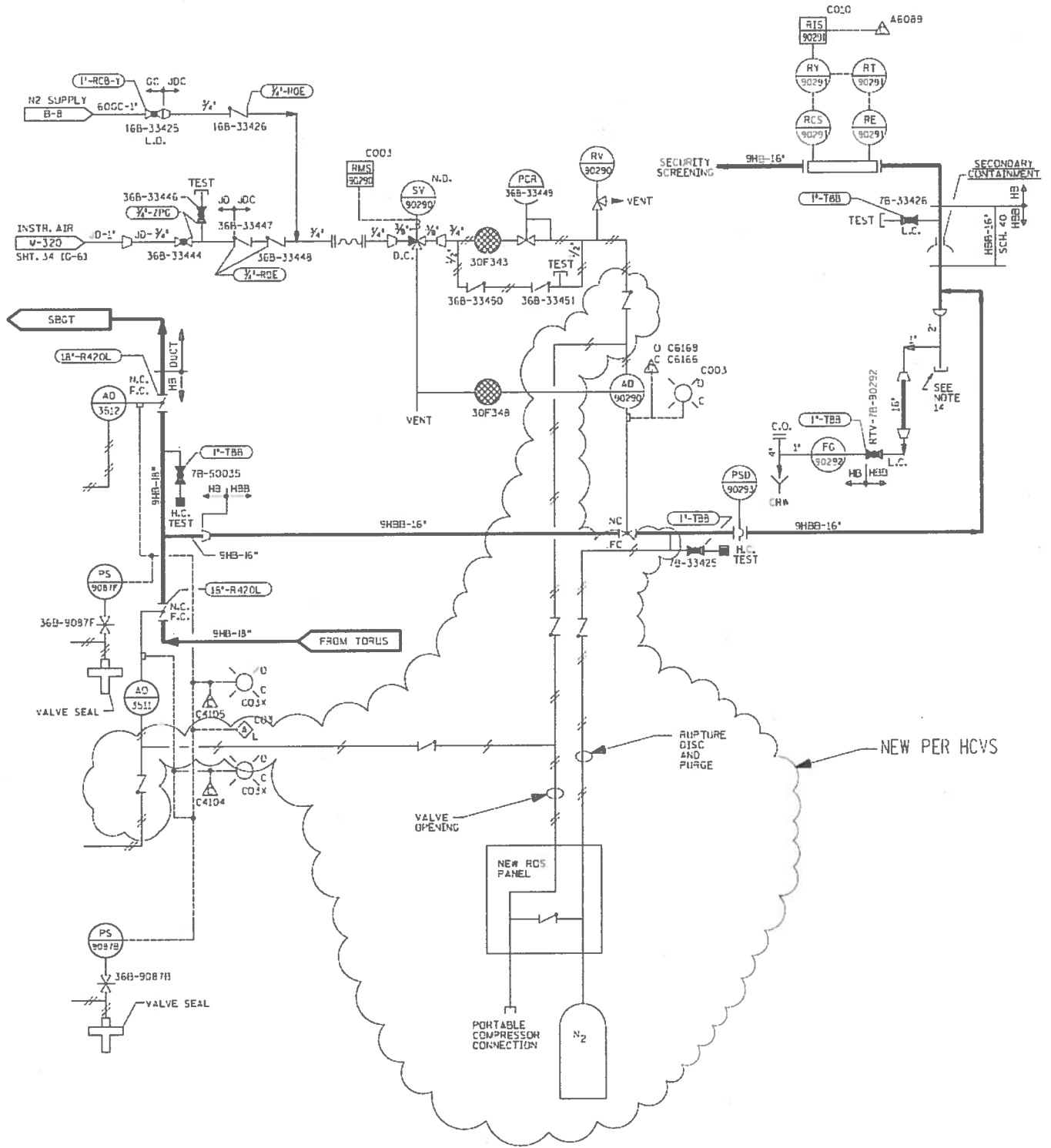

Sketch 2: P&ID of HCVS (preliminary)
Unit 3, Unit 2 similar

Attachment 4: Failure Evaluation Table

Table 4A: Wet Well HCVS Failure Evaluation Table

Functional Failure Mode	Failure Cause	Alternate Action	Failure with Alternate Action Impact on Containment Venting?
Failure of Vent to Open on Demand	ELAP event (loss of all AC)	No action needed, DC power and motive force is supplied from dedicated HCVS supply	No
Failure of Vent to Open on Demand	Valves fail to open/close due to complete loss of HCVS batteries (long term)	Recharge HCVS batteries with portable provided generator, considering SA conditions	No
Failure of Vent to Open on Demand	Valves fail to open/close due to loss of pneumatic air supply (long term)	Replace bottles as needed or connect portable compressor	No
Failure of Vent to Open on Demand	Valves fail to open/close due to SOV failure and/or circuit failure	Open the affected valve at the ROS which is independent of the electrical circuit.	No

Attachment 5: References

1. Generic Letter 89-16, Installation of a Hardened Wetwell Vent, dated September 1, 1989
2. Order EA-12-049, Mitigation Strategies for Beyond-Design-Basis External Events, dated March 12, 2012
3. Order EA-12-050, Reliable Hardened Containment Vents, dated March 12, 2012
4. Order EA-12-051, Reliable SFP Level Instrumentation, dated March 12, 2012
5. Order EA-13-109, Severe Accident Reliable Hardened Containment Vents, dated June 6, 2013
6. JLD-ISG-2012-01, Compliance with Order EA-12-049, Mitigation Strategies for Beyond-Design-Basis External Events, dated August 29, 2012
7. JLD-ISG-2012-02, Compliance with Order EA-12-050, Reliable Hardened Containment Vents, dated August 29, 2012
8. JLD-ISG-2013-02, Compliance with Order EA-13-109, Severe Accident Reliable Hardened Containment Vents, dated November 14, 2013
9. NRC Responses to Public Comments, Japan Lessons-Learned Project Directorate Interim Staff Guidance JLD-ISG-2012-02: Compliance with Order EA-12-050, Order Modifying Licenses with Regard to Reliable Hardened Containment Vents, ADAMS Accession No. ML12229A477, dated August 29, 2012
10. NEI 12-06, Diverse and Flexible Coping Strategies (FLEX) Implementation Guide, Revision 1, dated August 2012
11. NEI 13-02, Industry Guidance for Compliance with Order EA-13-109, Revision 0, Dated November 2013
12. NEI 13-06, Enhancements to Emergency Response Capabilities for Beyond Design Basis Accidents and Events, Revision 0, dated March 2014
13. NEI 14-01, Emergency Response Procedures and Guidelines for Extreme Events and Severe Accidents, Revision 0, dated March 2014
14. NEI FAQ HCVS-01, HCVS Primary Controls and Alternate Controls and Monitoring Locations
15. NEI FAQ HCVS-02, HCVS Dedicated Equipment
16. NEI FAQ HCVS-03, HCVS Alternate Control Operating Mechanisms
17. NEI FAQ HCVS-04, HCVS Release Point
18. NEI FAQ HCVS-05, HCVS Control and 'Boundary Valves'
19. NEI FAQ HCVS-06, FLEX Assumptions/HCVS Generic Assumptions
20. NEI FAQ HCVS-07, Consideration of Release from Spent Fuel Pool Anomalies
21. NEI FAQ HCVS-08, HCVS Instrument Qualifications
22. NEI FAQ HCVS-09, Use of Toolbox Actions for Personnel
23. NEI White Paper HCVS-WP-01, HCVS Dedicated Power and Motive Force
24. NEI White Paper HCVS-WP-02, HCVS Cyclic Operations Approach
25. NEI White Paper HCVS-WP-03, Hydrogen/CO Control Measures

Peach Bottom Atomic Power Station, Units 2 and 3 Overall Integrated Plan for Phase 1 Requirements for Reliable Hardened Containment Vent System (HCVS) Capable of Operation Under Severe Accident Conditions

26. NEI White Paper HCVS-WP-04, FLEX/HCVS Interactions
27. IEEE Standard 344-2004, IEEE Recommended Practice for Seismic Qualification of Class 1E Equipment for Nuclear Power *Generating Stations*,
28. PBAPS EA-12-049 (FLEX) Overall Integrated Implementation Plan, Rev 0, February 2013
29. PBAPS EA-12-050 (HCVS) Overall Integrated Implementation Plan, Rev 0, February 2013
30. PBAPS EA-12-051 (SFP LI) Overall Integrated Implementation Plan, Rev 0, February 2013
31. Memorandum to R.W. Borchardt , dated May 19, 2013, Subject "Staff Requirements – SECY-12-0157- Consideration of Additional Requirements for Containment Venting systems for Boiling Water Reactors with Mark I and Mark II Containments"
32. PBAPS Procedure T-200J-2, Containment Venting via the Torus Hardened Vent, Revision 2
33. PBAPS Procedure T-200J-3, Containment Venting via the Torus Hardened Vent, Revision 2
34. PBAPS PB-MISC-010, MAAP Analysis to support Initial FLEX Strategy, Revision 0
35. PBAPS Calculation PM-0428, Primary Containment Conditions during Station Blackout, Revision 1
36. PBAPS G-080-VC-314, PB SIL 636 – Containment Response During SBO Event, Revision 0
37. PBAPS SDOC A-9-7, Plasteel Insulated Siding North, West Elevation Reactor Building, Revision 5
38. PBAPS Calc PM-0531, Pipe Stress for Torus Vent from Torus Room Roof to RB Roof, Revision 1
39. PBAPS SDOC A-9-15(16), Air Exhaust Stack Exterior Elevations, Unit 2(3) Reactor Building, Revision 3
40. PB SDOC A-45, Louver Schedule and Details, Revision 6
41. OP-AA-108-111-1001, Preparation for Severe Weather, Revision 13
42. PBAPS Calculation PM-0375, Limiting Demand for the CAD System and the SGIG System, Revision 5
43. PBAPS Calculation PM-0531, Pipe Stress Calculation for Torus Hardened Vent from Torus Room Roof, Revision 1
44. PBAPS Procedure T-102 sheet 3, Primary Containment Control, Revision 13
45. PBAPS Procedure T-200-2, Primary Containment Venting, Revision 12
46. PBAPS Procedure T-200-3, Primary Containment Venting, Revision 14

Attachment 6: Changes/Updates to this Overall Integrated Implementation Plan

Any significant changes to this plan will be communicated to the NRC staff in the 6 Month Status Reports

Attachment 7: List of Overall Integrated Plan Open Items

Open Item	Action	Comment
1	Confirm that the ROS will be in an accessible area following a SA	Confirmatory action
2	Provide procedures for HCVS Operation.	Procedure development
3	Identify Site Specific Controlling Document for HCVS out of service and compensatory measures	Procedure development
4	Determine the design approach for combustible gas	Design approach