



102-06670-DCM/MAM
February 28, 2013

DWIGHT C. MIMS
Senior Vice President, Nuclear
Regulatory & Oversight

Palo Verde
Nuclear Generating Station
P.O. Box 52034
Phoenix, AZ 85072
Mail Station 7605
Tel 623 393 5403

U.S. Nuclear Regulatory Commission
ATTN: Document Control Desk
11555 Rockville Pike
Rockville, MD 20852

- References:
1. NRC Order Number EA-12-049, *Order Modifying Licenses with Regard to Requirements for Mitigation Strategies for Beyond-Design-Basis External Events*, dated March 12, 2012
 2. NRC Interim Staff Guidance JLD-ISG-2012-01, *Compliance with Order EA-12-049, Order Modifying Licenses with Regard to Requirements for Mitigation Strategies for Beyond-Design-Basis External Events*, Revision 0, dated August 29, 2012
 3. NEI 12-06, *Diverse and Flexible Coping Strategies (FLEX) Implementation Guide*, Revision 0, dated August 21, 2012
 4. APS Letter 102-06614, *Initial Status Report in Response to March 12, 2012 Commission Order Modifying Licenses with Regard to Requirements for Mitigation Strategies for Beyond-Design-Basis External Events (Order Number EA-12-049)*, dated October 29, 2012

Dear Sirs:

Subject: **Palo Verde Nuclear Generating Station (PVNGS)
Units 1, 2, and 3
Docket Nos. STN 50-528, 50-529, and 50-530
APS Overall Integrated Plan in Response to March 12, 2012
Commission Order Modifying Licenses with Regard to Requirements
for Mitigation Strategies for Beyond-Design-Basis External Events
(Order Number EA-12-049)**

On March 12, 2012, the Nuclear Regulatory Commission (NRC) issued an order (Reference 1) to Arizona Public Service Company (APS). Reference 1 was immediately effective and directs APS to develop, implement, and maintain guidance and strategies to maintain or restore core cooling, containment, and spent fuel pool cooling capabilities in the event of a beyond-design-basis external event. Specific requirements are outlined in Attachment 2 of Reference 1.

Reference 1 requires submission of an overall integrated plan by February 28, 2013. The NRC Interim Staff Guidance (ISG) (Reference 2) was issued August 29, 2012 which endorses industry guidance document NEI 12-06, Revision 0 (Reference 3) with clarifications and exceptions identified in Reference 2. Reference 3 provides direction regarding the content of this overall integrated plan.

ASB
MLK

ATTN: Document Control Desk
U.S. Nuclear Regulatory Commission
APS Integrated Plan for Mitigation Strategies for Beyond-Design-Basis External Events
Page 2

On October 29, 2012, APS provided the initial status report for PVNGS regarding mitigation strategies (Reference 4), as required by Reference 1.

The purpose of this letter is to provide an overall integrated plan pursuant to Section IV, Condition C.1, of Reference 1. This letter confirms APS has received Reference 2 and has an overall integrated plan developed in accordance with the guidance for defining and deploying strategies that will enhance the ability to cope with conditions resulting from beyond-design-basis external events.

The information in the enclosure provides the PVNGS Overall Integrated Plan for mitigation strategies that incorporates the guidance from Reference 3. The enclosed overall integrated plan is based on conceptual design information. Final design details and associated procedure guidance, as well as any revisions to the information contained in the Enclosure, will be provided in the 6-month updates required by Reference 1.

No commitments are being made to the NRC by this letter.

Should you have any questions concerning the content of this letter, please contact Mark McGhee, Operations Support Manager, Regulatory Affairs, at (623) 393-4972.

I declare under penalty of perjury that the foregoing is true and correct.

Executed on 2/28/13
(Date)

Sincerely,

A.C. Marino

Enclosure - APS Overall Integrated Plan in Response to March 12, 2012 Commission Order Modifying Licenses with Regard to Requirements for Mitigation Strategies for Beyond-Design-Basis External Events

DCM/MAM/DKE/hsc

cc:	E. J. Leeds,	NRC Director, Office of Nuclear Reactor Regulation
	E. E. Collins Jr.	NRC Region IV Regional Administrator
	J. K. Rankin	NRC NRR Project Manager
	M. A. Brown	NRC Senior Resident Inspector for PVNGS
	J. A. Kratchman	NRR/JLD/PMB, NRC
	E. E. Bowman	NRR/DPR/PGCB, NRC

ENCLOSURE 1

**APS Overall Integrated Plan in Response to March 12, 2012
Commission Order Modifying Licenses with Regard to
Requirements for Mitigation Strategies for
Beyond-Design-Basis External Events**

Table of Contents

EXECUTIVE SUMMARY 3

REFERENCES 5

ACRONYMS 7

GENERAL INTEGRATED PLAN ELEMENTS 10

 MAINTAIN CORE COOLING AND HEAT REMOVAL 23

 MAINTAIN RCS INVENTORY CONTROL 32

 STORAGE / PROTECTION OF EQUIPMENT: 36

 MAINTAIN CONTAINMENT 40

 MAINTAIN SPENT FUEL POOL COOLING 44

 SAFETY FUNCTIONS SUPPORT 50

PHASE 2 AND PHASE 3 EQUIPMENT OVERVIEW TABLES 63

 TABLE A - PWR PORTABLE EQUIPMENT PHASE 2 64

 TABLE B - PWR PORTABLE EQUIPMENT PHASE 3 65

 TABLE C - PHASE 3 RESPONSE EQUIPMENT/COMMODITIES 66

OPEN ITEMS 67

ATTACHMENTS

 ATTACHMENT 1A - SEQUENCE OF EVENTS TIMELINE FOR MODES 1 - 4 68

 ATTACHMENT 1B – NSSS SIGNIFICANT REFERENCE ANALYSIS DEVIATION TABLE 74

 ATTACHMENT 2 – MILESTONE SCHEDULE 76

 ATTACHMENT 3 - CONCEPTUAL SKETCHES (FIGURES) 77

 FIGURE 3-1: PVNGS POWER BLOCK DEPLOYMENT PATHS 78

 FIGURE 3-2: FLEX EQUIPMENT STAGING AREAS 79

 REACTOR CORE COOLING AND HEAT REMOVAL 80

 FIGURE 3-3: SG MAKEUP PRIMARY CONNECTION 81

 FIGURE 3-4: SG MAKEUP ALTERNATE CONNECTION 82

 FIGURE 3-5: SG MAKEUP 83

 REACTOR CORE COOLING AND HEAT REMOVAL 84

 FIGURE 3-6: RCS PRIMARY MAKEUP CONNECTIONS 85

 FIGURE 3-7: RCS ALTERNATE MAKEUP CONNECTIONS 86

 FIGURE 3-8: PRIMARY RCS MAKEUP STRATEGY 87

 FIGURE 3-9: ALTERNATE RCS MAKEUP STRATEGY 88

 REACTOR CORE COOLING AND HEAT REMOVAL 89

 FIGURE 3-10: ALTERNATE RCS MAKEUP STRATEGY FOR MODES 5 AND 6 90

 SFP MAKEUP 91

 FIGURE 3-11: SFP MAKEUP PRIMARY CONNECTION 92

 FIGURE 3-12: SFP MAKEUP ALTERNATE CONNECTION 93

 FIGURE 3-13: CST MAKEUP CONNECTION MODIFICATION WITH NEW VALVES 94

 NON-BORATED WATER SOURCE MAKEUP 95

 FIGURE 3-14: DELETED 96

 FIGURE 3-15: CST MAKEUP PUMPING FROM THE RESERVOIRS 97

ELECTRICAL	98
FIGURE 3-16: PRIM CONNECTION LOC FOR THE FLEX GENERATORS (TRAIN A).....	99
FIGURE 3-17: DEPLOYMENT ROUTE FOR 480V AND 4.16KV GENERATORS	100
FIGURE 3-18: SEVEN-DAY UNDERGROUND DIESEL FUEL TANKS	100
FIGURE 3-19: PRIM CONNECTION FOR THE FLEX GENERATORS (TRAIN A)	101
FIGURE 3-20: SINGLE-LINE FOR PRIMARY CONNECTION TO L31.....	102
FIGURE 3-21: SINGLE-LINE FOR PRIMARY CONNECTION TO L33.....	103
FIGURE 3-22: SINGLE-LINE FOR PRIMARY CONNECTION TO L35.....	104
FIGURE 3-23: ALT CONNECTION FOR THE FLEX GENERATORS (TRAIN B).....	105
FIGURE 3-24: ALT CONNECTION LOC FOR THE FLEX GENERATORS (TRAIN B).....	106
FIGURE 3-25: SINGLE-LINE FOR ALTE CONNECTION TO L32	107
FIGURE 3-26: SINGLE-LINE FOR FOR ALT CONNECTION TO L34	108
FIGURE 3-27: SINGLE-LINE FOR FOR ALT CONNECTION TO L36	109
FIGURE 3-28: DELETED.....	110
FIGURE 3-29: DELETED.....	110
FIGURE 3-30: DELETED.....	110
FIGURE 3-31: DELETED.....	110
FIGURE 3-32: PRIM CONNECTIONS FOR THE RCS FLEX PUMPS.....	111
FIGURE 3-33: PRIM ELECTRICAL CONNECTIONS FOR THE RCS FLEX PUMPS	112
FIGURE 3-34: PRIM LOCATION FOR JUNCTION BOX FOR RCS FLEX PUMPS	113
FIGURE 3-35: SINGLE-LINE FOR PRI CONNECTION TO FLEX RCS MAKEUP PUMPS.....	114
FIGURE 3-36: ALT RCS FLEX PUMPS CONNECTIONS	115
FIGURE 3-37: ALT SWITCH LOCATION – INSIDE WALL OF CHARGING PUMP ROOM E.....	116
FIGURE 3-38: ALT CHARGING PUMP ROOM E JUNCTION BOX LOC.....	116
FIGURE 3-39: PRIM 3MW, 4.16KV FLEX GENERATOR CONNECTION	117
FIGURE 3-40: NEW BREAKER PANEL LOC ON PBA-S03	118
FIGURE 3-41: ALTERNATE 3MW, FLEX GENERATOR CONNECTION	119

Executive Summary

On March 12, 2012, the Nuclear Regulatory Commission (NRC) issued Order EA-12-049 to all licensees requiring implementation of mitigation strategies for beyond-design-basis external events (BDBEE), as identified in Near-Term Task Force (NTTF) Recommendation 4.2. Order EA-12-049 requires submission of an overall integrated plan to the NRC by February 28, 2013. In order to assist the industry in responding to the NRC order, the Nuclear Energy Institute (NEI) developed guidance in report number 12-06, "Diverse and Flexible Coping Strategies (FLEX) Implementation Guide." NRC interim staff guidance (ISG) JLD-ISG-2012-01 endorses, with clarifications, the methodologies described in NEI 12-06.

This submittal describes the Palo Verde Nuclear Generating Station (PVNGS) Overall Integrated Plan, including key assumptions, implementing strategies, and operator action times for complying with the NRC order and implementing FLEX, as described by JLD-ISG-2012-01 and NEI 12-06. The PVNGS Overall Integrated Plan contains a description of the general elements of the plan, followed by a discussion of the safety functions that are identified in the order, which are core cooling, containment integrity, and spent fuel pool cooling.

The NRC order requires that the underlying strategies for coping with BDBEE involve a three-phase approach:

- **Phase 1:** Initially cope by relying on installed plant equipment.
- **Phase 2:** Transition from installed plant equipment to on-site FLEX equipment.
- **Phase 3:** Obtain additional capability and redundancy from off-site equipment to provide coping capability for an indefinite period of time.

These phases are discussed in the response in terms of how each phase addresses the identified safety functions. The first step of the FLEX strategy is establishment of the baseline coping capability to maintain or restore key plant safety functions under the conditions of an extended loss of alternating current (ac) power (ELAP) and loss of normal access to the ultimate heat sink (LUHS). These strategies are independent of a specific damage state or mechanistic assessment of external events. To meet the requirements of an overall integrated plan, the safety functions of core cooling, containment integrity, and spent fuel pool cooling need to be maintained indefinitely under these conditions. Using conservative operator action times and NEI 12-06 guidance, Arizona Public Service (APS) has determined that the long term coping and approach to shutdown cooling is achievable without loss of natural circulation flow. APS is also developing procedures and processes to address plant strategies for implementing the overall integrated plan.

Based on NEI 12-06 screening guidance, the two external hazards that are applicable to PVNGS are seismic and extreme heat. APS has evaluated the functional threats from each of these hazards and identified FLEX equipment and strategies that are expected to be effective in mitigating these events. Based on this evaluation, strategies that focus on the seismic hazard were selected, since extreme high temperatures for a prolonged duration and extreme drought are slowly progressing meteorological

APS Overall Integrated Plan in Response to March 12, 2012 Commission Order Modifying Licenses with Regard to Requirements for Mitigation Strategies for Beyond-Design-Basis External Events

events which can be adequately addressed by existing plant procedures that will ensure the plant is shut down, if required, and placed in a safe condition for these situations.

The information within this submittal is prepared solely to support beyond design bases operational procedures to mitigate the limiting external events applicable to PVNGS. It provides a description of the conceptual approach used by APS to implement the PVNGS Overall Integrated Plan.

References

1. NRC Order EA-12-049, "Issuance of Order to Modify Licenses with Regard to Requirements for Mitigation Strategies for Beyond-Design-Basis External Events," March 12, 2012. [Agencywide Documents Access and Management System (ADAMS) Accession Number ML12056A045]
2. NEI 12-06, Revision 0, "Diverse and Flexible Coping Strategies (FLEX) Implementation Guide," August 2012. [ADAMS Accession Number ML12221A205]
3. NRC Interim Staff Guidance JLD-ISG-2012-01, Revision 0, "Compliance with Order EA-12-049, Order Modifying Licenses with Regard to Requirements for Mitigation Strategies for Beyond-Design-Basis External Events," August 2012. [ADAMS Accession Number ML12229A174]
4. "Palo Verde Nuclear Generating Station Units 1, 2, and 3 Updated Final Safety Analysis Report (UFSAR)," Revision 16A, October 2011.
5. DAR-TDA-12-2, Revision 0, "Palo Verde Units 1, 2 & 3 Beyond Design Bases Event - Extended Loss of AC Power," December 6, 2012
6. NRC Final Safety Evaluation for Topical Report WCAP-15996-P, "Technical Description Manual for CENTS Code," TAC No. MB6982, November 24, 2004
7. CN-REA-12-36, Revision 0, "Palo Verde Units Best-Estimate Decay Heat for Extended Loss-of-AC Power," August 20, 2012
8. Letter PVNGS to US NRC, "Revised Station Blackout (SBO) Evaluation," PVNGS Letter No. 102-05370-CDM/TNW/RAB, October 28, 2005. (NRC reviewed document)
9. EPRI Report NP-6041-SL Revision 1, "A Methodology for Assessment of Nuclear Plant Seismic Margin", August 1991.
10. Letter, PVNGS to US NRC, "Response to NRC Request for Additional Information (RAI) Regarding Revised Station Blackout Evaluation," PVNGS Letter No. 102-05513-CE/SAB/DJS, June 9, 2006
11. Reference Deleted
12. PVNGS Study 13-NS-A108, Revision 0, "PVNGS Engineering Response to INPO IER 11-4 Recommendations 1, 2 and 3"
13. PVNGS Procedure 79IS-9ZZ07, "PVNGS Extended Loss of All Site AC Guideline." DRAFT.
14. WCAP-17601-P, Revision 1, "Reactor Coolant System Response to the Extended Loss of AC Power Event for Westinghouse, Combustion Engineering and Babcock & Wilcox NSSS Designs," January 2013
15. Westinghouse Report TR-FSE-13-6, Revision 0, "Palo Verde Nuclear Generating Station FLEX Integrated Plan," February 2013
16. PVNGS Emergency Operating Procedure 40EP-9EO08, Revision 18, "Blackout."
17. NEI 12-01, "Guideline for Assessing Beyond Design Basis Accident Response Staffing and Communications Capabilities," April 2012. [ADAMS Accession Number ML12110A204]
18. NRC Order EA-12-051, "Order Modifying Licenses with Regard to Reliable Spent Fuel Pool Instrumentation," issued March 12, 2012. [(ADAMS) Accession No. ML12056A044]
19. RWA-1213-001, Revision 0, "Palo Verde Turbine Driven AFW Pump Room Heat Up Analysis for an External Loss of AC Power
20. PVNGS Calculation TA-13-2001-005, Revision 1, "Loss of Shutdown Cooling Analyses for RCS Drain Operations and Nozzle Dam Installation," March 28, 2003
21. PVNGS Calculation 13-N001-0602-645-2, Revision 1, "Sulzer Bingham Pumps E12.5.387 Seal Flow and Leakage Report," November 8, 1996
22. LTR-PCSA-12-92 Revision 0, "Transmittal of Final PWROG Generic FLEX Support Guidelines and Interfaces (Controlling Procedure Interface and Recommended Instruments) from PA-PSC-0965," December 17, 2012.

APS Overall Integrated Plan in Response to March 12, 2012 Commission Order Modifying Licenses with Regard to Requirements for Mitigation Strategies for Beyond-Design-Basis External Events

23. Task Interface Agreement (TIA) 2004-04, "Acceptability of Proceduralized Departures from Technical Specifications (TSs) Requirements at the Surry Power Station," (TAC Nos. MC4331 and MC4332)," dated September 12, 2006. (Accession No. MLO60590273)
24. NEI 12-02, "Industry Guidance for Compliance with NRC Order EA-12-051, 'To Modify Licenses with Regard to Reliable Spent Fuel Pool Instrumentation'," Revision 1, August 2012.
25. NRC JLD-ISG-2012-03, "Compliance with Order EA-12-051, Reliable Spent Fuel Pool Instrumentation," Revision 0, August 29, 2012.

Acronyms

Acronym	Definition
AC	alternating current
ADV	atmospheric dump valve
AFW	auxiliary feedwater
APS	Arizona Public Service Company
BDBEE	beyond-design-basis external event
CENTS	Combustion Engineering Nuclear Transient Simulator
CET	core exit thermocouple
CFR	Code of Federal Regulations
CST	condensate storage tank
CT	condensate transfer system
CVCS	chemical and volume control system
DC	direct current
ECW	essential cooling water
ELAP	extended loss of all AC power
EOP	emergency operating procedure
EPRI	Electric Power Research Institute
EQ	environmentally qualified
ERO	emergency response organization
ESP	essential spray pond
FLEX	Diverse and Flexible Coping Strategies
FSG	FLEX support guideline
GOTHIC	Generation of Thermal-Hydraulic Information for Containments
HDPE	high density polyethylene
HPSI	high pressure safety injection
HVAC	heating, ventilation, and air conditioning
LPSI	low pressure safety injection
LUHS	loss of ultimate heat sink
MAAP	modular accident analysis program
MCC	motor control center
MSIV	main steam isolation valve

APS Overall Integrated Plan in Response to March 12, 2012 Commission Order Modifying Licenses with Regard to Requirements for Mitigation Strategies for Beyond-Design-Basis External Events

Acronym	Definition
MSSS	main steam support structure
MSSV	main steam safety valve
MV	medium voltage
NEI	Nuclear Energy Institute
NRC	Nuclear Regulatory Commission
NSSS	nuclear steam supply system
OBE	operating basis earthquake
PC	Spent fuel pool cooling system
PD	positive displacement
PMP	probable maximum precipitation
PVNGS	Palo Verde Nuclear Generating Station
PWR	pressurized water reactor
RCP	reactor coolant pump
RCS	reactor coolant system
RRC	Regional Response Center
RVLMS	reactor vessel level monitoring system
RWMT	reactor makeup water tank
RWT	refueling water tank
SAFER	Strategic Alliance for FLEX Emergency Response
SBO	station blackout
SBOG	station blackout generator
SDC	shutdown cooling
SDR	standard dimension ratio
SFP	spent fuel pool
SG	steam generator
SIT	safety injection tank
SSC	systems, structures and components
SSE	safe shutdown earthquake
TDAFWP	turbine driven auxiliary feedwater pump
UBC	universal building code
UFSAR	Updated Final Safety Analysis Report
UHS	ultimate heat sink

APS Overall Integrated Plan in Response to March 12, 2012 Commission Order Modifying Licenses with Regard to Requirements for Mitigation Strategies for Beyond-Design-Basis External Events

Acronym	Definition
US	United States
WR	wide range
WRF	water reclamation facility

General Integrated Plan Elements Palo Verde Nuclear Generating Station

Determine Applicable Extreme External Hazard

Ref: NEI 12-06 Section 4.0 - 9.0
JLD-ISG-2012-01 Section 1.0

Input the hazards applicable to the site; seismic, external flood, high winds, snow, ice, cold, high temps.

Describe how NEI 12-06 sections 4 – 9 were applied and the basis for why the plant screened out for certain hazards

General Integrated Plan Elements

Arizona Public Service Company (APS) has evaluated the Palo Verde Nuclear Generating Station (PVNGS) for external hazards based on the guidance in Nuclear Energy Institute (NEI) 12-06 (Reference 2) and determined that the Seismic and Extreme Heat hazards are applicable to PVNGS; and the External Flooding, High Wind and Extreme Cold hazards are not applicable to PVNGS. The basis for how the NEI 12-06 guidance was applied for each hazard is described below.

APS has evaluated the functional threats from each of these hazards and identified equipment and strategies that are expected to be effective in deployment of Diverse and Flexible Coping Strategies (FLEX) equipment and mitigation of these events. The FLEX equipment is being purchased commercial grade and storage locations will be established to provide appropriate protection from these hazards. PVNGS is also developing procedures and processes to address plant strategies for responding to these hazards.

Seismic:

Table 4-2 of the NEI 12-06 guidance requires that all plants consider the impact of a seismic event. As a result, the FLEX equipment will be protected from the current PVNGS seismic design basis event to ensure the equipment remains accessible and can be delivered to its deployed location(s). This assessment will include ensuring that storage locations and deployment routes meet the FLEX criteria.

As described in the PVNGS Updated Final Safety Analysis Report (UFSAR) (Reference 4), section 3.7, Seismic Design, the seismic criteria include two design basis earthquake spectra: Operating Basis Earthquake (OBE) and Safe Shutdown Earthquake (SSE). The site seismic design response spectra define the vibratory ground motion of the OBE and the SSE for rock-supported structures. The magnitude of the SSE and the OBE are 0.20g and 0.10g, respectively. For additional conservatism, the seismic analysis for Seismic Category I structures was performed using a 0.25g SSE and a 0.13g OBE. These values constitute the design basis for PVNGS.

General Integrated Plan Elements

External Flooding:

Access to Seismic Category I systems, structures and components (SSCs) at PVNGS is available above the elevation of the probable maximum flood level. The PVNGS site is susceptible to brief water buildup due to probable maximum precipitation (PMP); however, the PVNGS drainage system and grading plan is designed with sufficient capacity to prevent flooding of Seismic Category I structures (UFSAR, Section 2.4.2.2.2).

PVNGS is a dry site (UFSAR, Section 2.4.2.2) and does not rely on a permanently installed seawall or levee for flood protection. Therefore, PVNGS does not need to consider external flooding as a hazard defined in NEI 12-06 (Section 6.2.1).

High Wind:

Based upon the location of the site at 33°23'N and 112°52'W and the information provided in Figures 7-1 and 7-2 of NEI 12-06, PVNGS is not expected to experience winds exceeding 130 mph. Therefore, the high wind hazard is not applicable to PVNGS.

Extreme Cold:

The guidance of NEI 12-06 requires the consideration of the temperature ranges and weather conditions for each site with regard to the storage and deployment of the FLEX equipment. However, NEI 12-06 further clarifies that snow, ice and extreme cold are not expected at sites in Southern California, Arizona, the Gulf Coast, and Florida. Because the site is located in Arizona and below the 35th parallel (33°23'N and 112°52' W), the extreme cold hazard (which includes snow and ice) is not applicable to PVNGS.

Extreme Heat:

As stated in NEI 12-06, all sites are required to consider high temperatures in their characterization of site hazards. PVNGS addresses the effect of extreme heat on continued plant operation with current administrative controls if the temperature exceeds design basis values.

PVNGS may experience extreme high temperatures for a prolonged duration. However, the extreme drought and high temperature meteorological events progress slowly such that existing plant administrative and operational procedures are adequate to ensure that the plant is shut down and placed in a safe condition if the temperature of any SSCs exceed design basis limiting conditions.

The extreme heat event considered herein is a loss of AC power as a result of short duration high temperatures coincident with high electrical grid demands, resulting in a regional black out. During this type of event, the equipment conditions and water inventories at the station are expected to be within design limits such that no additional limitation on initial conditions/failures/abnormalities are expected.

General Integrated Plan Elements	
<p>Key Site assumptions to implement NEI 12-06 strategies</p> <p>Ref: NEI 12-06 Section 3.2.1</p>	<p><i>Provide key assumptions associated with implementation of FLEX Strategies:</i></p> <ul style="list-style-type: none"> • <i>Flood and seismic re-evaluations pursuant to the 10 CFR 50.54(f) letter of March 12, 2012 are not completed and therefore not assumed in this submittal.</i> • <i>Exceptions for the site security plan or other (license/site specific) requirements of 10CFR may be required.</i> • <i>Deployment resources are assumed to begin arriving at hour 6 and fully staffed by 24 hours.</i> • <i>Certain Technical Specifications cannot be complied with during FLEX implementation.</i>
<p>This plan defines strategies capable of mitigating a simultaneous loss of all alternating current (AC) power and loss of normal access to the ultimate heat sink resulting from a beyond-design-basis event by providing adequate capability to maintain or restore core cooling, containment, and SFP cooling capabilities at all units on the site. Though specific strategies are being developed, due to the inability to anticipate all possible scenarios, the strategies are also diverse and flexible to encompass a wide range of possible conditions. These pre-planned strategies, developed to protect the public health and safety, will be incorporated into the emergency operating procedures (EOP) in accordance with established EOP change processes, and their impact to the design basis capabilities of the unit evaluated under 10 CFR 50.59 (Reference 23). The plant Technical Specifications contain the limiting conditions for normal unit operations to ensure that design safety features are available to respond to a design basis accident and direct the required actions to be taken when the limiting conditions are not met. The result of the beyond-design-basis event may place the plant in a condition where it cannot comply with certain Technical Specifications and/or with its Security Plan, and, as such, may warrant invocation of 10 CFR 50.54(x) and/or 10 CFR 73.55(p).</p> <p>The PVNGS FLEX strategies are based upon a range of initial conditions and assumptions which are consistent with those detailed in NEI 12-06, Section 3.2.1. Analysis has been performed consistent with the recommendations contained within the Executive Summary of the Pressurized Water Reactors Owners Group (PWROG) Core Cooling Position Paper (Reference 22) and assumptions from that document are incorporated into the plant-specific analytical bases. Generic industry criteria and assumptions and site-specific assumptions to be used in establishing baseline coping capability are presented here:</p> <p>NEI 12-06 Assumptions</p> <p><u>Initial Plant Conditions:</u></p> <ol style="list-style-type: none"> 1. Prior to the event, the reactor has been operating at 100 percent rated thermal power for at least 100 days or has just been shut down from such a power history in advance of the postulated event. 2. At the time of the postulated event, the reactor and supporting systems are within normal operating ranges for pressure, temperature, and water level for the plant conditions. Plant equipment is either normally operating or available from the standby state as described in 	

General Integrated Plan Elements

the plant design and licensing basis.

Initial Conditions:

3. No specific initiating event is used. The initial condition is assumed to be a loss of offsite power (LOOP) at the plant site resulting from an external event that affects the offsite power system either throughout the grid or at the plant with no prospect for recovery of offsite power for an extended period. The LOOP is assumed to affect all units at a plant site.
4. Installed sources of emergency onsite AC power and station blackout (SBO) alternate AC power sources are not available and are not imminently recoverable.
5. Cooling and makeup water inventories contained in systems or structures with designs that are robust with respect to seismic events, floods, and high winds, and associated missiles are available.
6. Normal access to the ultimate heat sink (UHS) is lost, but the water inventory in the UHS remains available and robust piping connecting the UHS to plant systems remains intact. The motive force for UHS flow (i.e., pumps) is assumed to be lost with no prospect for recovery.
7. Fuel for FLEX equipment stored in structures with designs which are robust with respect to seismic events, floods and high winds and associated missiles, remains available.
8. Permanent plant equipment that is contained in structures with designs that are robust with respect to seismic events, floods, and high winds, and associated missiles, are available.
9. Other equipment, such as portable AC power sources, portable backup DC power supplies, spare batteries, and equipment credited for 50.54(hh)(2), may be used provided that it is reasonably protected from the applicable external hazards per Sections 5 through 9 and Section 11.3 of NEI 12-06 and has predetermined hookup strategies with appropriate procedures/guidance and the equipment is stored in a relatively close vicinity of the site.
10. Installed electrical distribution systems, including inverters and battery chargers, remain available provided they are protected consistent with current station design.
11. No additional events or single failures of SSCs are assumed to occur immediately prior to or during the event, including security events.
12. Reliance on the fire protection system ring header as a water source is acceptable only if the header meets the criteria to be considered robust with respect to seismic events, floods, and high winds, and associated missiles.

Reactor Transient Boundary Conditions:

13. Following the loss of all AC power, the reactor automatically trips and all rods are inserted.
14. The main steam system valves (such as main steam isolation valves, turbine stops, atmospheric dumps, etc.), necessary to maintain decay heat removal functions operate as designed.
15. Safety/relief valves or power operated relief valves initially operate in a normal manner if conditions in the reactor coolant system (RCS) so require. Normal valve reseating is also

General Integrated Plan Elements

assumed.

16. No independent failures, other than those causing the extended loss of all AC power (ELAP)/loss of UHS (LUHS) event, are assumed to occur in the course of the transient.

PWR Reactor Coolant Inventory Loss Assumptions:

17. Normal system leakage
18. Losses from letdown unless automatically isolated or until isolation is procedurally directed
19. Losses due to reactor coolant pump seal leakage (rate is dependent on RCP seal design)

Initial Spent Fuel Pool (SFP) Conditions:

20. All boundaries of the SFP are intact, including the liner, gates, transfer canals, etc.
21. Although sloshing may occur during a seismic event, the initial loss of SFP inventory does not preclude access to the refueling deck around the pool.
22. SFP cooling system is intact, including attached piping.
23. SFP heat load assumes the maximum design basis heat load for the site.

Containment Isolation Valves

24. It is assumed that the containment isolation actions delineated in current station blackout coping procedures are sufficient.

The following assumptions are specific to the PVNGS site:

25. Flood and seismic re-evaluations pursuant to the 10 CFR 50.54(f) letter of March 12, 2012 are not completed and therefore not assumed in this submittal. As the re-evaluations are completed, appropriate issues will be entered into the PVNGS corrective action program and addressed on a schedule commensurate with other licensing bases changes.
26. The following conditions exist:
 - a. Class 1E DC battery banks are available.
 - b. Class 1E AC and DC distribution system is available.
 - c. Initial operator response is the same as for a SBO event.
 - d. PVNGS staff will be able to identify an ELAP condition within one (1) hour of event initiation in order to initiate actions required to address the BDBEE.
 - e. Best estimate parameters and decay heat are used to establish operator action times.
 - f. No failure of any SSC, in addition to the components specified in Reference 2, is assumed.
27. The FLEX design hardened connections are protected against external hazards or are established at multiple and diverse locations. Connections will be designed to Seismic Category I or augmented seismic requirements. They will either be located in Seismic Category I structures or outside and above grade.
28. Deployment routes and staging areas are assessed for the impact of hazards.

General Integrated Plan Elements

- 29. Exceptions to the site security plan or other license/site specific requirements will be considered in the FLEX support guidelines (FSGs).
- 30. Required staffing levels will be determined consistent with guidance contained in NEI 12-06 for each of the site specific FLEX strategies. Assumed available staffing levels will be determined consistent with NEI 12-01 (Reference 17), as described below.
The event impedes site access as follows:
 - a. Post event time: 6 hours – No site access. This duration reflects the time necessary to clear roadway obstructions, use different travel routes, mobilize alternate transportation capabilities (e.g., private resource providers or public sector support, etc.)
 - b. Post event time: 6 to 24 hours – Limited site access. Individuals may access the site by walking, personal vehicle or via alternate transportation capabilities (e.g., private resource providers or public sector support).
 - c. Post event time: 24+ hours – Improved site access. Site access is restored to a near-normal status and/or augmented transportation resources are available to deliver equipment, supplies and large numbers of personnel.
- 31. FLEX equipment is stored with no fuel.
- 32. Fueling and deployment of FLEX components will be initiated prior to the need for any equipment.
- 33. Portable FLEX components will be procured commercially and will meet the design requirements established in pressurized water reactor (PWR) Portable Equipment Phase 2 and Portable Equipment Phase 3 tables contained herein.
- 34. PVNGS will install a Spent Fuel Pool Level Instrumentation System per NRC order EA-12-051 (Reference 18).
- 35. The onsite FLEX equipment required for Phase 2 will be stored at a storage location which is close enough to its FLEX function location to not impact the installation of the equipment to meet its Phase 2 function and will be deployed using the roads shown in Attachment 3, Figure 3-1.
- 36. RCS leakage through RCP seals will be lower than the maximum leakage at full RCS pressure. Operator actions are credited for cooling and depressurizing the RCS. As RCS pressure diminishes, so will the attendant leakage. RCP seal leakage rates are dependent on RCS pressure and will decrease with decreasing pressure (Reference 5).
- 37. Instrumentation on FLEX equipment will be used to confirm adequate performance of equipment functions.

<p>Extent to which the guidance, JLD-ISG-2012-01 and NEI 12-06, are being followed. Identify any deviations to JLD-</p>	<p><i>Include a description of any alternatives to the guidance, and provide a milestone schedule of planned action.</i></p>
--	--

General Integrated Plan Elements	
<p>ISG-2012-01 and NEI 12-06.</p> <p>Ref: JLD-ISG-2012-01 Ref: NEI 12-06 Section 13.1</p>	
<p>Based upon current plans, PVNGS does not expect to deviate from the guidelines provided in JLD-ISG-2012-01 and NEI 12-06. If, during ongoing planning and implementation activities, the need for a deviation is identified, the deviation will be communicated to the NRC in a future six month update.</p>	
General Integrated Plan Elements	
<p>Provide a sequence of events and identify any time constraint required for success including the technical basis for the time constraint</p> <p>Ref: NEI 12-06 Section 3.2.1.7 JLD-ISG-2012-01 Section 2.1</p>	<p><i>Strategies that have a time constraint to be successful should be identified with a technical basis and a justification provided that the time can reasonably be met (for example, a walkthrough of deployment).</i></p> <p><i>Describe in detail in this section the technical basis for the time constraint identified on the sequence of events timeline</i></p> <p><i>Attachment 1A</i></p> <p><i>See attached sequence of events timeline (Attachment 1A).</i></p> <p><i>Technical Basis Support information, see attached NSSS</i></p> <p><i>Significant Reference Analysis Deviation Table (Attachment 1B)</i></p>
<p>General:</p> <p>The sequence of events timeline and associated mitigating strategy time constraints have been identified for the PVNGS Mode 1 to Mode 4 FLEX strategies (Phase 1 through Phase 3). The actions specified for Mode 1 to Mode 4 conditions are bounding when compared to the Mode 5, Mode 6 and full core offload scenarios because the upper mode scenarios require the most personnel, actions, and time constraints. A table with the sequence of events timeline and a description of the related actions and time constraints is provided in Attachment 1A. The times identified to initiate each action in this section and in Attachment 1A are based on resource loading to allow completion of actions prior to their individual time constraints. Time sensitive completion times are included. General information related to how time constraints were determined is provided below:</p> <ol style="list-style-type: none"> 1. A plant specific thermal hydraulic evaluation of the PVNGS nuclear steam supply system (NSSS) response during the ELAP transient was performed using the Combustion Engineering Nuclear Transient Simulator (CENTS) computer code (Reference 5). The analysis methodology and assumptions of the plant specific evaluation are generally consistent with 	

General Integrated Plan Elements

- the similar generic analysis provided in WCAP-17601-P (Reference 14). In the evaluation, PVNGS identified some deviations between the two analysis methods. These deviations are noted in Attachment 1B.
2. CENTS is approved by the NRC for modeling of RCS natural circulation heat removal for single phase flow with vapor is present in the reactor vessel head and pressurizer (Reference 6). The FLEX strategy for PVNGS requires actions based on maintaining sufficient liquid inventory in the RCS such that vapor will be confined to these regions. This will be accomplished by performing an early plant cooldown to reduce RCS pressure and leakage and allow for injection from the Safety Injection Tanks (SITs). Subsequently, through alignment of Phase 2 FLEX equipment, RCS injection will be established prior to expansion of the vapor in the head or pressurizer into the hot leg. The required injection pressure at the RCS system boundary will be greater than the saturation pressure for the selected cooldown temperature.
 3. Containment integrity was reviewed using computer code modular accident analysis program (MAAP) 4.0.7. MAAP was used to model the containment response for 72 hours post event and containment pressure and temperature did not exceed 50 percent of containment design limits.
 4. A best estimate decay heat curve was developed using SCALE 6 ORIGEN-APR for use in NSSS modeling (Reference 7).
 5. Environmental conditions within the control room and safety related battery rooms were evaluated using methods and tools from NUMARC 87-000, PCFLUD (Bechtel software) or GOTHIC 8.0 (Electric Power Research Institute (EPRI) software).
 6. PVNGS is an alternate AC, 16 hour coping plant (10 CFR 50.63 and Regulatory Guide 1.55). Applicable portions of supporting analysis have been used in ELAP evaluations. The PVNGS submittal and NRC acceptance of the 16 hour coping analysis for station blackout are documented in Reference 8.

Discussion of time constraints identified in Attachment 1A

The discussion below describes those actions with time constraints listed in Attachment 1A.

Table Item 4 – SBOG Fails to Start: As defined by NEI 12-06, alternate AC sources are lost during the ELAP event. PVNGS SBO procedures require the operator to start the SBOG. It is assumed that the SBOG fails to start within one hour of the start of the event. This is an ELAP time constraint since the SBO procedure credits the SBOG being available within one hour.

Table Item 5 - Entry into ELAP: A time period of one hour is selected conservatively to ensure that ELAP entry conditions can be verified by control room staff and it is validated that alternate AC sources (i.e., two redundant trains of SBOGs) are not available. One hour is a reasonable assumption since the SBOGs have to be manually started and they are located at the water reclamation facility approximately one mile from the PVNGS Unit 1 control room (Reference 10).

It should be noted that during a multi-unit SBO event at PVNGS wherein the SBOGs function, it

General Integrated Plan Elements

would be necessary to select a unit(s) to place into ELAP because installed SBOG capacity will not support all units simultaneously. This knowledge would be available prior to attempting to start the SBOGs. Therefore, it would be expected that for at least one unit, ELAP could be declared earlier. The basis for selecting a unit to place into ELAP and procedural direction for that selection will be developed to ensure effective decision making by plant staff.

To ensure consistent performance, a simulator scenario will be developed to validate that the control room operators can recognize ELAP entry conditions within one hour.

Table Item 6 – Start Cooldown: Operations will promptly begin a cooldown following the declaration of ELAP. The cooldown will be performed at the normal cooldown rate of approximately 70°F/hour. Cooldown rate will affect the amount of condensate inventory required in this stage of the event. Cooldown and depressurization of the RCS will result in reduced loss of RCS inventory from RCP seal leakage.

During the event, RCS makeup to compensate for inventory loss from RCP seal leakage is provided from the SITs. Reduction of RCP seal leakage rates will prolong the time that SIT inventory will be available and extends the time until RCS makeup is required.

Table Item 7 – Complete DC Load Shed: DC load shed must be completed within 2 hours in order to achieve a battery coping time of 47 hours on battery bank B (Reference 16, Section 8.6). For Phase 1, PVNGS can cope on the installed DC batteries for up to 10 hours with no load shedding. If load shedding, as described in PVNGS Study 13-NS-A108 (Reference 12), is completed, the battery coping period is extended to 47 hours. This load shed strategy will preserve station batteries and provide additional time prior to needing to re-energize battery chargers.

Table Item 8 - Open TDAFWP Room Door for Ventilation: During an ELAP, the essential heating ventilation and air conditioning (HVAC) unit in the TDAFWP room is inoperable. However, the TDAFWP would be actuated automatically shortly after the initiation of the event. The system is powered by steam sources from each steam generator and from essential 120V AC power. This pump is bunkered at the 80 ft elevation (20 ft below ground elevation) in a water tight compartment. The TDAFWP room temperature would increase as a result of heat addition from multiple sources such as steam piping, turbine, and gland seal or other leakages and heat generated by the control panel. To ensure that the functionality of the TDAFWP is maintained for the duration of the event, a new analysis using the GOTHIC computer code was performed. The analysis results show that if the doors to the TDAFWP room are opened within 2 hours, the room temperature will remain below the control cabinet critical component acceptable temperature (Reference 19) so that the TDAFWP will continue to perform its function. Therefore, it is concluded that, to maintain temperature in the compartment for the duration of the event to a value at or below this limit, access doors to the TDAFWP room will need to be opened (Reference 19).

Table Item 9 – Open Control Room Doors: Block open doors to provide ventilation to maintain control room temperature. Reference 12, Section IX.3 provides a list of rooms reviewed (including

General Integrated Plan Elements

the control room) and predicted temperatures. Because load shed is to be completed within 2 hours, heat loads in the control room are minimal (only essential identified instrumentation is powered). It is predicted that long term control room temperature would approach outside air temperature, per design. The PVNGS FSG (Reference 13) will also include steps to open control room doors.

Table Item 12 – Complete Operator Assessment Walkdowns: PVNGS will include a post event operator assessment appendix for the FSGs. The operator assessment will evaluate and document the condition of plant SSCs after an ELAP event is declared. It is assumed that this assessment will take up to four (4) hours, depending on the local site conditions.

The walkdowns will also include operator actions to aid in mitigating the event. Two actions with time constraints have been identified. On the secondary side walkdowns, the condition of the condensate storage tank (CST) must be observed and selected valves must be closed. On the primary side walkdown, a vent path for the Fuel Building must be established before SFP boiling occurs. The vent path will be established by opening the fuel building rollup door.

Table Item 12 contains a reference to Open Item 2 (OI2) which will provide tracking of actions to complete development of the FSG. Existing site EOPs will be updated to direct use of the FSG during an ELAP. Additionally, a program and procedural control process is being implemented to meet the requirements of NEI 12-06, section 2.4 and section 11.

Table Item 12a – Establish a Fuel Building Vent Path: Fuel Building rollup door is manually opened prior to earliest predicted spent fuel pool time to boil (11.5 hours). This provides a large ventilation pathway to maintain Fuel Building accessibility to the alternate SFP makeup pump location.

Table Item 13 – ADV backup nitrogen exhausted: ADV backup nitrogen supply is sized for 16 hours. ADVs will require manual operation once backup nitrogen supply is depleted.

Table Item 14 – 500 kW 480V Generators Installed: Battery power is depleted if the generator is not available to power battery chargers (Reference 15, Section 8.6).

Table Item 16 - Install Reactor Coolant System (RCS) Makeup Pump: Action is required to maintain subcooled natural circulation and to prevent two phase natural circulation. Reference 5 (Case 2) shows that this action is required within 49 hours (Reference 15, Section 8.2).

Table Item 17 – Establish SFP makeup: SFP makeup is established prior to SFP inventory being depleted below 10 feet above the fuel (39 hours). This level was selected based on the guidance of NEI 12-02, Rev. 1, (Reference 24) and will maintain radiation levels at or below 2.5 mr/hr, as discussed in Reference 4, Section 9.1.4.3.4.

Table Item 18 – Condensate Storage Tank (CST) Empties- Switchover to Reactor Makeup Water Tank (RMWT) (Refueling Water Tank (RWT) (for high Seismic Event)): When the CST depletes, the TDAFWP suction path is realigned to RMWT.

General Integrated Plan Elements
Table Item 19 – Vent nitrogen from SITs: This action is dependent on SIT injection rate, not event time. Operator action will be to vent SIT nitrogen over pressure when SIT level reaches 10% to preclude injection of nitrogen into RCS.

General Integrated Plan Elements	
Identify how strategies will be deployed in all modes	<i>Describe how the strategies will be deployed in all modes.</i>
Ref: NEI 12-06 section 13.1.6	
<p>The FLEX strategies will be deployable in all Modes considering the following:</p> <ul style="list-style-type: none"> • PVNGS has not determined the location for FLEX equipment storage (OI1) • Figure 3-1 identifies proposed deployment paths for transportation of FLEX equipment to staging areas. • Figure 3-2 identifies proposed locations for staging areas available in all Modes. • Roads and staging areas are selected considering seismic and liquefaction phenomena (Reference 15). • The routes and paths will be maintained clear in all Modes by an administrative program. 	
<p>Provide a milestone schedule. This schedule should include:</p> <ul style="list-style-type: none"> • Modifications timeline <ul style="list-style-type: none"> ○ Phase 1 Modifications ○ Phase 2 Modifications ○ Phase 3 Modifications • Procedure guidance development complete <ul style="list-style-type: none"> ○ Strategies ○ Maintenance • Storage plan (reasonable protection) • Staffing analysis completion • FLEX equipment acquisition timeline • Training completion for the strategies • Regional Response Centers operational <p>Ref: NEI 12-06 Section 13.1</p>	<p>The dates specifically required by the order are obligated or committed dates. Other dates are planned dates subject to change. Updates will be provided in the periodic (six month) status reports.</p> <p>See Attachment 2 for the planned milestone schedule.</p>

General Integrated Plan Elements	
General Integrated Plan Elements	
<p>Identify how the programmatic controls will be met</p> <p>Ref: NEI 12-06 Section 11 JLD-ISG-2012-01 Section 6.0</p>	<p><i>Provide a description of the programmatic controls equipment protection, storage and deployment and equipment quality. See section 11 in NEI 12-06. Storage of equipment, 11.3, will be documented in later sections of this template and need not be included in this section.</i></p> <p><i>See section 6.0 of JLD-ISG-2012-01.</i></p>
<p>Programs and controls will be established to protect the equipment from applicable NEI 12-06 hazards. In addition, these programs will provide guidance to protect the staging location, deployment roads and pathways, and system connections for implementation of the FLEX strategies.</p> <p>Equipment associated with these strategies will be procured as commercial grade equipment. The storage, maintenance, testing, and configuration control of the equipment will be in accordance with NEI 12-06, Section 11.0. PVNGS will use the standard EPRI industry preventative maintenance template for establishing the maintenance and testing actions for FLEX components. The administrative program will include maintenance guidance, testing procedures and frequencies established based on type of equipment and considerations made within the EPRI templates.</p> <p>The unavailability of equipment and applicable connections that directly perform a FLEX mitigation strategy will be managed using plant equipment control guidelines developed in accordance with NEI 12-06, Section 11.5.</p> <p>The FLEX strategies and basis will be maintained in an overall program document. Existing plant configuration control procedures will be modified to ensure that changes to the plant design, physical plant layout, roads, buildings, and miscellaneous structures will not adversely impact the approved FLEX strategies in accordance with NEI 12-06, Section 11.8.</p> <p>The Phase 2 and 3 FLEX equipment for ELAP will have unique identification labels.</p>	
<p>Describe Training Plan</p>	<p><i>List training plans for affected organizations or describe the plan for training development</i></p>
<p>New training of emergency response organization (ERO) and plant personnel involved in the implementation of FLEX mitigation strategies will be performed in 2014, prior to the Unit 1 (lead unit) implementation. Licensed and non-licensed operator training will be performed as part of the normal operator training schedule. Programs and controls will be established to assure personnel proficiency in the mitigation of beyond-design-basis events is developed and maintained in accordance with NEI 12-06, Section 11.6.</p>	
<p>Describe Regional Response Center plan</p>	<p><i>Discussion in this section may include the following information and will be further developed as the Regional Response Center development is completed.</i></p>

General Integrated Plan Elements	
	<ul style="list-style-type: none"> • <i>Site-specific RRC plan</i> • <i>Identification of the primary and secondary RRC sites</i> • <i>Identification of any alternate equipment sites (i.e., another nearby site with compatible equipment that can be deployed)</i> • <i>Describe how delivery to the site is acceptable</i> • <i>Describe how all requirements in NEI 12-06 are identified</i>
<p>The industry will establish two (2) regional response centers (RRCs) to support utilities during beyond design basis events. Each RRC will hold five (5) sets of equipment, four (4) of which will be able to be fully deployed when requested, and the fifth set will have equipment in a maintenance cycle. Equipment will be moved from a RRC to a local offsite assembly area, established by the Strategic Alliance for FLEX Emergency Response (SAFER) team and the utility. Communications will be established between the affected nuclear site and the SAFER team and the required equipment will be moved to the site as needed. The first piece of critical safety function equipment, as established during development of the nuclear site’s playbook, will be delivered to the site within 24 hours of the initial request. PVNGS will execute and maintain a contract with the selected RRC vendor in accordance with the requirements of Section 12 of NEI 12-06.</p>	
<p>Notes: None</p>	

Maintain Core Cooling and Heat Removal

Determine Baseline coping capability with installed coping¹ modifications not including FLEX modifications, utilizing methods described in Table 3-2 of NEI 12-06:

- AFW/EFW
- Depressurize SG for Makeup with Portable Injection Source
- Sustained Source of Water

Ref: JLD-ISG-2012-01 Sections 2 and 3

Maintain Core Cooling and Heat Removal

PWR Installed Equipment Phase 1

Provide a general description of the coping strategies using installed equipment including station modifications that are proposed to maintain core cooling. Identify methods (AFW/EFW) and strategy(ies) utilized to achieve this coping time.

Core Cooling with Steam Generators Available (see Item 2 in Notes section)

No modifications or changes to PVNGS are needed to cope during Phase 1 of the ELAP event.

At the time of the postulated event, the reactor and supporting systems are within normal operating ranges for pressure, temperature, and water level for the plant conditions. At the initiating event, the automatic plant systems, with the exception of AC sources, will respond as designed (assumption 26). Operators will enter existing PVNGS SBO emergency operating procedures (EOPs) (existing EOPs will be revised to refer to the FSG). The EOPs will direct the operators to take actions to confirm several responses including control rod insertion, closure of the main steam isolation valves (MSIVs), automatic start and operation of the TDAFWP taking suction from the CST, and actuation of the main steam safety valves (MSSVs). The EOPs will also direct action to isolate or confirm isolation of any RCS leakage paths and to start the SBOGs. The ELAP procedures will be entered when the SBO generator is confirmed to be unavailable and it is confirmed that offsite power cannot be restored by either communication with the load dispatcher or visual verification of physical damage to site infrastructure. Once ELAP procedures are entered, operators will be directed to begin DC electrical load shedding. Operators will also be directed to initiate an RCS cooldown to a hot stand-by temperature of approximately 350 degrees Fahrenheit (Tcold) through operation of the Atmospheric Dump Valves (ADVs). Control of these valves is available in the control room and is supported by existing nitrogen supplies (Reference 4). The rate of the cooldown is

¹ Coping modifications consist of modifications installed to increase initial coping time, i.e. generators to preserve vital instruments or increase operating time on battery powered equipment.

Maintain Core Cooling and Heat Removal

PWR Installed Equipment Phase 1

within the capability of the plant. This cooldown will be incorporated into the PVNGS EOPs and site specific FSGs. Following cooldown, the SG pressure will be controlled at or above 135 psia to maintain the desired plant conditions.

The TDAFWP delivers CST inventory to the SGs and SG level is initially controlled within control bands of 35 to 85 percent narrow range (Reference 5). The system alignment will draw water from the CST initially and can be aligned following CST depletion to take suction from the RMWT via local manual operator action. This realignment uses existing piping and procedures.

The TDAFWP and CST (part of the tank volume, 300,000 gallons) are currently qualified for seismic events (UFSAR, Reference 4). Further evaluations of the seismic fragility of the CST and RMWT have demonstrated that their full volume of 550,000 gallons and 480,000 gallons, respectively, are seismically robust and can be credited to support coping during ELAP per the requirements of NEI 12-06 (see Item 1 in Notes section). The TDAFWP is capable of using both tanks as sources for SG makeup with installed piping allowing PVNGS to cope for 116 hours. The AFW usage for that time is 6,117,320 lbm or 762,677 gal (Reference 15). The secondary side walkdown contained in the FSG will confirm that the integrity of these tanks is maintained. Contingency actions to provide makeup water from the RWT can be taken.

PVNGS has identified that a loss of ventilation could adversely affect operation of the TDAFWP. Without ventilation, the TDAFWP room temperature will exceed 130°F within four (4) hours. PVNGS has determined that opening the access doors to the room within 2 hours will limit the temperature to a maximum of 130°F, thereby maintaining pump availability (Reference 19). The FSG will require operator action to open TDAFWP room doors within 2 hours.

The PVNGS strategy uses one train of ADVs initially in the event. The other train ADV solenoids are de-energized during load shed (Reference 13). The ADVs are operated using DC powered solenoids and N2 bottles. As long as there is sufficient N2, the valves will be operated from the control room. Once the N2 inventory has depleted, Reference 13 provides instructions to manually operate the valves.

Core Cooling with Steam Generators Not Available (see Item 2 in Notes section)

Core cooling is maintained through once through heat removal from the RCS via coolant boil-off. Inventory is maintained in the vessel by ensuring adequate RCS inventory makeup from the RWT via gravity feed. Gravity feed functions based on the RWT fluid height, line losses through the gravity flow path, and developed pressure within the RCS. During this event, a hot leg vent will have been established such that a release path is available to support once through cooling via boil-off. This action also results in the introduction of non-condensables into the RCS, which reduce or eliminate the ability to remove heat via the SGs. If a hot leg vent is not present, the SGs will be available for core heat removal. In Mode 5 conditions where SGs are available, the heat up and pressurization of the system following ELAP will establish natural circulation cooling consistent with the SG available strategies. Pressure is maintained sufficiently low in the RCS by ensuring that adequate venting is established prior to entering conditions

Maintain Core Cooling and Heat Removal	
PWR Installed Equipment Phase 1	
wherein SG cooling is not available as a part of shutdown risk management (Reference 20).	
Details:	
Provide a brief description of Procedures / Strategies / Guidelines	PVNGS Procedure 79IS-9ZZ07 (Reference 13), "PVNGS Extended Loss of All Site AC Guideline," is being developed to support this event.
Identify modifications	There are no modifications required for Phase 1.
Key Reactor Parameters	<p>The instrumentation expected to be required for PWRs in Mode 1 for core heat removal and inventory control in NEI 12-06, Section 3.2.1.10, are:</p> <ul style="list-style-type: none"> • SG Level/Pressure • RCS Pressure/Temperature • Containment Pressure <p>The list of instrumentation below will be powered by station batteries at the initiation of the event. When an ELAP is declared, DC electrical load shedding will begin. These instruments will be maintained. Once the onsite portable 480 V diesel generator is staged, batteries will be recharged to maintain a supply of power to this instrumentation (Reference 15).</p> <p>SG Level:</p> <ul style="list-style-type: none"> • Steam Generator Level (wide range (WR)) <p>SG Pressure:</p> <ul style="list-style-type: none"> • Steam Generator Pressure <p>RCS Temperature:</p> <ul style="list-style-type: none"> • Core Exit Thermocouples (CETs) • T_{hot}, T_{cold} (two Hot Leg and two Cold Leg on same loop) • Subcooling/Saturation Margin (RCS and CET) <p>RCS Pressure:</p> <ul style="list-style-type: none"> • RCS Pressure (WR) <p>Containment Pressure:</p> <ul style="list-style-type: none"> • Containment Building Pressure <p>(see Item 3 in Notes section)</p>

Maintain Core Cooling and Heat Removal	
PWR Installed Equipment Phase 1	
	<p>Mode 5 and 6 Instrumentation:</p> <p>RCS Temperature:</p> <ul style="list-style-type: none"> • Core Exit Thermocouples • T_{hot}, T_{cold} (two Hot Leg and two Cold Leg on same loop) • Subcooling/Saturation Margin (RCS and CET) <p>RCS Pressure:</p> <ul style="list-style-type: none"> • RCS Pressure (WR) <p>Containment Pressure:</p> <ul style="list-style-type: none"> • Containment Building Pressure <p>(see Item 3 in Notes section)</p> <p>PVNGS will develop procedures to read this instrumentation locally, where applicable, using a portable instrument, as required by Section 5.3.3 of NEI 12-06.</p>
<p>Notes:</p> <p>Item 1- Seismic fragility evaluations were performed using the guidance contained in EPRI NP-6041-SL (Reference 9). The total CST and RMWT volume is available to mitigate the event. Tanks and associated piping survive beyond design basis SSE level events. CST level instrumentation is intended to be powered such that level can be monitored from the control room. RMWT level will be read locally.</p> <p>Item 2- Core cooling strategies are provided for conditions when steam generators are available or when steam generators are not available but a sufficient RCS vent has been established to support core cooling. This assumption is consistent with the guidance of NEI 12-06. Per NEI 12-06, other configurations are not considered as these occur for short durations.</p> <p>Item 3- As a result of breaker alignments performed to energize required instrumentation listed above, the following additional Instrumentation is also available to the operator for monitoring:</p> <ul style="list-style-type: none"> • Safety Injection Tanks 2A and 2B Level and Pressure • Pressurizer Level • Reactor Vessel Level Monitoring System (RVLMS) • ADV Positions • TDAFWP flow to each SG (A-train power) • Condensate Storage Tank Level • Pressurizer Level 	

Maintain Core Cooling and Heat Removal

PWR Portable Equipment Phase 2

Provide a general description of the coping strategies using onsite portable equipment including station modifications that are proposed to maintain core cooling. Identify methods and strategy(ies) utilized to achieve this coping time.

Core Cooling with Steam Generators Available

At PVNGS, the Phase 1 core cooling strategy of SG injection from the TDAFWP taking suction from CST or RMWT can be maintained until these suction sources are exhausted or insufficient steam pressure is available at the TDAFWP turbine to support continued operation. Given the quantity of water available in the CST and RMWT, makeup to the CST is deferred until Phase 3. The transition into Phase 2 is therefore required once the operating conditions of the TDAFWP can no longer be maintained. As the event proceeds, the decay heat produced by the nuclear fuel will decrease, resulting in decreased heat transfer from the primary coolant to the SG and decreased steam flow from the SGs. Initially, ADVs will be closed to maintain SG pressure; however, eventually the steam flow required by the TDAFWP will exceed that being delivered by the SG and pressure will decrease, and as a result the steam output from the SG will decrease. Eventually, the steam output will not be sufficient to run the TDAFWP. Prior to loss of functionality of the TDAFWP, the FLEX SG makeup pump will be staged and placed in operation.

Phase 2 SG makeup to ensure core cooling will be provided by a portable diesel driven pump. This pump will take suction from the CST or RMWT, as the TDAFWP does in Phase 1. The FLEX suction connection provides the capability to take suction from either tank as a source of makeup to the SGs. The discharge will be into the AFW lines downstream of the containment isolation valves.

Core Cooling with Steam Generators Not Available

In Mode 5 and Mode 6 with SGs not available, the Phase 1 core cooling method will continue until the Phase 2 core cooling method is placed in service. Phase 2 core cooling is maintained with once through heat removal with makeup provided to the RCS via the FLEX pump with borated coolant. Sufficient coolant is provided to match boil-off rates. Flushing flow is initiated (flow rate is increased beyond the steaming rate) prior to reaching the boron precipitation limit. Per Westinghouse Report TR-FSE-13-6 (Reference 15), Section 5, a steaming rate of approximately 115 gpm is expected at 37 hours post-event for the Mode 5 condition. At this time, a total flushing flow rate of 127 gpm (steaming rate with a 10% factor added to preclude significant precipitation of boric acid in the vessel) would be established to ensure adequate boron flushing.

Details:

**vide a brief description of
cedures / Strategies /
elines**

PVNGS Procedure 79IS-9ZZ07 (Reference 13), "PVNGS Extended Loss of All Site AC Guideline," is being developed to support this event.

Maintain Core Cooling and Heat Removal	
PWR Portable Equipment Phase 2	
Identify modifications	<p>Primary and alternate SG FLEX pump discharge pipe will be installed from the SG FLEX pump staging area to the tie-in to the AFW system. Each line will include isolation valves and a standard connection for a SG FLEX pump to connect with hoses, as shown in Figures 3-3 and 3-4.</p> <p>A new suction connection will be installed. The new suction pipe will run from the B AFW pump room back to the SG FLEX pump staging area. The suction connection will tie into the B AFW pump suction line where it can access the inventory in both the CST and RMWT.</p> <p>For Mode 5 and Mode 6 with SGs not available, the primary and alternate RCS injection FLEX pump discharge pipe will be installed from the RCS injection FLEX pump staging area to the tie-in to the HPSI system. Each line will include isolation valves and a standard hose connection. The primary suction path will use the RWT drain line connection modification. The alternate suction path will use a charging pump suction line connection. See Figure 3-10.</p>
Key Reactor Parameters	Same as discussed in Phase 1.
Notes: Same as discussed in Phase 1.	
Storage / Protection of Equipment: Describe storage / protection plan or schedule to determine storage requirements	
Seismic	Storage is an open item (OI1). However, the FLEX storage building that will house the equipment for this function will be constructed to be seismically robust using, at a minimum, the requirements of American Society of Civil Engineers (ASCE) 7-10 (consistent with NEI 12-06, Section 5). Equipment inside the building will be restrained in such a way that it will not be damaged during a seismic event.
Flooding	The FLEX equipment storage building will be designed above flood level with adequate drainage.
Severe Storms with High Winds	The FLEX equipment storage building structure will be designed within Enhanced Fujita 3 requirements.
Snow, Ice, and Extreme Cold	The local universal building code will be applied.
High Temperatures	The FLEX equipment storage building will have adequate ventilation for high temperatures.

APS Overall Integrated Plan in Response to March 12, 2012 Commission Order Modifying Licenses with Regard to Requirements for Mitigation Strategies for Beyond-Design-Basis External Events

Maintain Core Cooling and Heat Removal		
PWR Portable Equipment Phase 2		
Deployment Conceptual Design		
(Conceptual Sketches provided in Attachment 3 figures)		
Strategy	Modifications	Protection of connections
<p>The storage location and structure have not been determined yet. Figure 3-1 identifies clear deployment paths onsite for the transportation of FLEX equipment. For this function, a clear deployment path is shown from the identified roads in the power block to the staging area north of the CST.</p>	<p>The modification for this function will include a new suction connection and two new discharge connections.</p> <p>The suction connection will be new 6" permanent piping run down the condensate pipe tunnel into the main steam support structure (MSSS) and tie into the B train AFW pump suction piping.</p> <p>The two discharge connections (primary and alternate) will be 3" piping run down the condensate pipe tunnel into the MSSS. The two discharge piping runs and the suction connection will be seismically qualified. Proposed pipe runs are shown in Figure 3-5.</p> <p>The primary and alternate RCS injection discharge pipe will be installed from pump staging area to the tie-in to the HPSI system. Each line will include isolation valves and a standard hose connection. Primary suction path will use the RWT drain line connection modification. Alternate suction path will use a charging pump suction line connection. See Figure 3-10.</p>	<p>Piping and valves for FLEX will be enclosed within a Seismic Category I structure. New FLEX piping shall be installed to meet necessary seismic requirements. Connections will be above the PVNGS flood level.</p> <p>The connection points for the suction and discharge will be outside the condensate transfer (CT) pump house and will be designed to withstand the applicable NEI 12-06 external hazards.</p> <p>Modifications are designed to Seismic Category I requirements. They will either be located in Seismic Category I structures or outside, above the ground. PVNGS is a dry site, but intends to keep connections off the ground to avoid the potential impacts of run-off or pooling from precipitation. The high wind and extreme cold hazards are not applicable to PVNGS. Extreme heat is not expected to affect the functionality of the connections.</p>
<p>Notes:</p> <p>None</p>		

Maintain Core Cooling and Heat Removal	
PWR Portable Equipment Phase 3	
<p><i>Provide a general description of the coping strategies using Phase 3 equipment including modifications that are proposed to maintain core cooling. Identify methods and strategy(ies) utilized to achieve this coping time.</i></p> <p><u>Core Cooling with Steam Generators Available and Steam Generators Not Available</u></p> <p>Phase 3 for PVNGS will include strategies for coolant makeup to support continuation of Phase 2 strategies. These strategies are applicable to all Modes with the exception of Mode 6 during full core offload. An ELAP occurring during full core offload will only require SFP cooling.</p> <p>Phase 2 strategies will continue; however, CST makeup will be required to ensure coolant is available for SG makeup. To transport water, temporary piping will be run to either the 45 acre or 85 acre reservoir, as shown on Figure 3-15. This piping will be stored onsite and deployment will begin during Phase 2. At the reservoir, a portable pump will be staged with a short length of suction hose run into the reservoir. Piping and valves connecting the two reservoirs can be aligned to allow simultaneous suction from both sources.</p> <p>Phase 3 equipment for PVNGS includes 4.16 kV generators. If required, these generators will provide capability to energize motor-driven AFW Pump train B. The 4.16 kV generator(s) will be delivered from the RRC.</p>	
Details:	
Provide a brief description of Procedures / Strategies / Guidelines	PVNGS Procedure 79IS-9ZZ07 (Reference 13), "PVNGS Extended Loss of All Site AC Guideline," is being developed to support this event.
Identify modifications	A refill connection will be installed on the CST drain line. This connection will modify an existing drain line from the CST. A new valve will be added on the existing line downstream of the drain line valve and the vertical over flow pipe. The connection point will be installed with a new valve off of the vertical pipe.
Key Reactor Parameters	Same as discussed in Phase 1.
Notes: Same as discussed in Phase 1.	
Storage / Protection of Equipment: Describe storage / protection plan or schedule to determine storage requirements	
Seismic	Same as discussed in Phase2.
Flooding	Same as discussed in Phase2.

Maintain Core Cooling and Heat Removal		
PWR Portable Equipment Phase 3		
Severe Storms with High Winds	Same as discussed in Phase2.	
Snow, Ice, and Extreme Cold	Same as discussed in Phase2.	
High Temperatures	Same as discussed in Phase2.	
Deployment Conceptual Design		
(Conceptual Sketches provided in Attachment 3 figures)		
Strategy	Modifications	Protection of connections
<p>Equipment will be transported from the Phase 3 offsite staging area (O13)</p> <p>The FLEX equipment storage location and structure have not been determined yet. Figure 3-1 identified clear deployment paths onsite for the transportation of FLEX equipment within the power block.</p>	<p>Refill connections to the CST at each unit are needed.</p> <p>A modification to the CST drain line will be installed to add two valves and a Storz connector to facilitate refilling of the CST. The current valve pit containing the drain line may need to be enlarged to accommodate the new valves as shown in Figure 3-13</p> <p>A modification to the RWT drain line will be installed to support refilling the tank. This modification is discussed in the RCS Inventory Control section.</p>	<p>The refill connection will be designed to withstand the applicable NEI 12-06 hazards. Other equipment will be portable.</p> <p>The connections will be designed to Seismic Category I requirements.</p>
Notes:		
None		

Maintain RCS Inventory Control

Determine Baseline coping capability with installed coping² modifications not including FLEX modifications, utilizing methods described in Table 3-2 of NEI 12-06:

- Low Leak RCP Seals or RCS makeup required
- All Plants Provide Means to Provide Borated RCS Makeup

Maintain RCS Inventory Control

PWR Installed Equipment Phase 1:

Provide a general description of the coping strategies using installed equipment including modifications that are proposed to maintain RCS inventory control. Identify methods (Low Leak RCP Seals and/or borated high pressure RCS makeup) and strategy(ies) utilized to achieve this coping time.

This section addresses RCS inventory control and subcriticality issues for conditions where steam generators are available. RCS inventory control and subcriticality issues for conditions where steam generators are not available are addressed in the maintain core cooling section of this report (See Item 1 in Notes section).

Two functions are lost during an ELAP which challenge the ability of the RCS to maintain inventory: inventory makeup and RCP seal cooling.

Without RCP seal cooling, the PVNGS RCP seals are expected to deteriorate such that a leak path develops from the RCS. A function of FLEX is to establish a means of RCS makeup; however, until that can be done, the system's ability to cope was analyzed (Reference 5).

Plant personnel will cool down the RCS to approximately 350°F as specified in the SBO EOP (Reference 16) and the FSGs (Reference 13). Cooling down and depressurizing the RCS allows the safety injection tanks (SITs) to inject. Also, at this time, a steam bubble will begin to form in the reactor vessel head.

PVNGS RCP seals are assumed to have a maximum leakage of 17 gpm per pump at normal operating pressure (Reference 21, Case 1). The assumed RCS leakage through the RCP seals is made up through injection of SIT inventory.

² Coping modifications consist of modifications installed to increase initial coping time, i.e. generators to preserve vital instruments or increase operating time on battery powered equipment.

Maintain RCS Inventory Control	
PWR Installed Equipment Phase 1:	
<p>From the beginning of the event, single phase natural circulation through the RCS will transfer heat to the SGs. After approximately 49 hours, SIT inventory will cease to makeup to the RCS. Shortly after this occurs, the single phase natural circulation will transition to two phase natural circulation. Prior to this transition, Phase 2 strategies will be deployed.</p> <p>During Phase 1, Borated RCS makeup is provided from the SITs. PVNGS control rod shutdown margin and borated water inventory in the RCS and SITs is sufficient to prevent recriticality of the core.</p>	
Details:	
Provide a brief description of Procedures / Strategies / Guidelines	PVNGS Procedure 79IS-9ZZ07 (Reference 13), "PVNGS Extended Loss of All Site AC Guideline," is being developed to support this event.
Identify modifications	Modifications are not required for Phase 1.
Key Reactor Parameters	<p>The instrumentation expected to be required for PWRs in Mode 1 for core heat removal and inventory control in NEI 12-06, Section 3.2.1.10, are:</p> <ul style="list-style-type: none"> • SG Level/Pressure • RCS Pressure/Temperature • Containment Pressure <p>The list of instrumentation below will be powered by station batteries at the initiation of the event. When an ELAP is declared, DC electrical load shedding will begin. These instruments will be maintained. Once the onsite portable 480 V diesel generator is staged, batteries will be recharged to maintain a supply of power to this instrumentation (Reference 15).</p> <p>SG Level:</p> <ul style="list-style-type: none"> • Steam Generator Level (wide range (WR)) <p>SG Pressure:</p> <ul style="list-style-type: none"> • Steam Generator Pressure <p>RCS Temperature:</p> <ul style="list-style-type: none"> • Core Exit Thermocouples (CETs) • T_{hot}, T_{cold} (two Hot Leg and two Cold Leg on same loop) • Subcooling/Saturation Margin (RCS and CET) <p>RCS Pressure:</p> <ul style="list-style-type: none"> • RCS Pressure (WR)

Maintain RCS Inventory Control	
PWR Installed Equipment Phase 1:	
	<p>Containment Pressure:</p> <ul style="list-style-type: none"> • Containment Building Pressure <p>(see Item 2 in Notes section)</p> <p>Mode 5 and 6 Instrumentation:</p> <p>RCS Temperature:</p> <ul style="list-style-type: none"> • Core Exit Thermocouples • T_{hot}, T_{cold} (two Hot Leg and two Cold Leg on same loop) • Subcooling/Saturation Margin (RCS and CET) <p>RCS Pressure:</p> <ul style="list-style-type: none"> • RCS Pressure (WR) <p>Containment Pressure:</p> <ul style="list-style-type: none"> • Containment Building Pressure <p>(see Item 2 in Notes section)</p> <p>PVNGS will develop procedures to read this instrumentation locally, where applicable, using a portable instrument, as required by Section 5.3.3 of NEI 12-06.</p>
<p>Notes:</p> <p>Item 1- Core cooling strategies are provided for conditions when steam generators are available or when steam generators are not available but a sufficient RCS vent has been established to support core cooling. This assumption is consistent with the guidance of NEI 12-06. Per NEI 12-06, other configurations are not considered as these occur for short durations.</p> <p>Item 2- As a result of breaker alignments performed to energize required instrumentation listed above, the following additional Instrumentation is also available to the operator for monitoring:</p> <ul style="list-style-type: none"> • Safety Injection Tanks 2A and 2B Level and Pressure • Pressurizer Level • Reactor Vessel Level Monitoring System (RVLMS) • ADV Positions • TDAFWP flow to each SG (A-train power) • Condensate Storage Tank Level • Pressurizer Level 	

Maintain RCS Inventory Control	
PWR Portable Equipment Phase 2:	
<p><i>Provide a general description of the coping strategies using onsite portable equipment including modifications that are proposed to maintain RCS inventory control. Identify methods (Low Leak RCP Seals and/or borated high pressure RCS makeup) and strategy(ies) utilized to achieve this coping time.</i></p> <p>This section addresses RCS inventory control and subcriticality issues for conditions where steam generators are available. RCS inventory control and subcriticality issues for conditions where steam generators are not available are addressed in the core cooling section of this report.</p> <p>The Phase 2 activities for RCS inventory control involve alignment of a pump to provide borated water for RCS makeup and to maintain RCS inventory; and are summarized in Reference 15, Section 8.2. Core reactivity is maintained by control rods and RCS boron inventory. PVNGS control rod shutdown margin and borated water inventory in the RCS and SITs are sufficient to prevent recriticality of the core.</p> <p>In Phase 1 the RCS credits makeup from the SITs for leakage and shrinkage due to cooldown. The transition to Phase 2 strategies is needed before the SIT inventory is completely depleted. Once RCS makeup has been established, SIT N₂ overpressure should be vented to prevent N₂ injection into the RCS.</p> <p>The preferred strategy will repower the installed charging pump once 480 VAC power is available. If the installed pump cannot be used, portable FLEX equipment will be deployed.</p> <p>The primary and alternate FLEX strategies will use an electric positive displacement (PD) pump and new piping connecting to the high pressure safety injection (HPSI) system. Suction will be from the RWT.</p> <p>The primary strategy will include staging a pump outside the west side of the Auxiliary Building. The RWT will be used as its primary suction source connecting to a drain valve at grade level off of the RWT. From below the staging area, in the essential pipe tunnel, hard piping will run into the Auxiliary Building and connect to the HPSI system as shown in Figure 3-8.</p> <p>The suggested pipe routing starts at the staging area in the plant west yard, penetrates the grade into the 88 ft pipe tunnel, and then heads east into the Auxiliary Building 88 ft pipe chase and heads for the west containment pipe wrap.</p> <p>The alternate connection point staging area will be located inside the rollup door on the east side of the Auxiliary Building on the 100 ft elevation. The connection will take suction from the RWT using chemical and volume control system (CVCS) piping. The discharge will be to the HPSI system. The alternate discharge piping will run from the staging area to the tie-in locations into the HPSI system as shown in Figure 3-9.</p>	
Details:	
Provide a brief description of Procedures / Strategies / Guidelines	PVNGS Procedure 79IS-9ZZ07 (Reference 13), "PVNGS Extended Loss of All Site AC Guideline," is being developed to support this event.

APS Overall Integrated Plan in Response to March 12, 2012 Commission Order Modifying Licenses with Regard to Requirements for Mitigation Strategies for Beyond-Design-Basis External Events

Maintain RCS Inventory Control		
PWR Portable Equipment Phase 2:		
Identify modifications	New piping will run from the tie in points in the HPSI system to the staging areas.	
Key Reactor Parameters	Same as discussed in Phase 1.	
Notes: Same as discussed in Phase 1.		
Storage / Protection of Equipment:		
Describe storage / protection plan or schedule to determine storage requirements		
Seismic	Storage is an open item (OI1). However, the FLEX storage building that will house equipment for this function will be constructed to be seismically robust using, at a minimum, the requirements of ASCE 7-10 (consistent with NEI 12-06, Section 5). Equipment inside the building will be restrained in such a way that it will not be damaged during a seismic event.	
Flooding	The FLEX equipment storage building will be designed above flood level with adequate drainage.	
Severe Storms with High Winds	The FLEX equipment storage building structure will be designed within Enhanced Fujita 3 requirements.	
Snow, Ice, and Extreme Cold	The local universal building code will be applied.	
High Temperatures	The FLEX equipment storage building will have adequate ventilation for high temperatures.	
Deployment Conceptual Modification		
(Conceptual Sketches provided in Attachment 3 figures)		
Strategy	Modifications	Protection of connections
The FLEX equipment storage location and structure have not been determined yet. Figure 3-1 identifies clear deployment paths onsite for the transportation of FLEX equipment. For this function, a clear deployment path is shown from the identified roads to the	The modified RWT drain line will include multiple quick connections to draw from the RWT for the primary strategy. The modified test connection in the CVCS will allow quick connection for the alternate strategy.	Piping and valves for FLEX will be enclosed within a Seismic Category I structure. New FLEX piping shall be installed to meet necessary seismic requirements. Connections will be above the PVNGS flood level. The connection points for the

Maintain RCS Inventory Control		
PWR Portable Equipment Phase 2:		
<p>power block to the primary staging area south of the RWT. The deployment path to the alternate staging location runs between the MSSS and the Turbine Building. Since the Turbine Building is not a seismically qualified building, access to this staging area may not be available during all events.</p>	<p>The primary and alternate discharge piping from the standard connections to the tie-in locations will be sized appropriately.</p> <p>These pipe runs will be seismically qualified and each will include isolation valves. See Figures 3-6 through 3-9.</p>	<p>suction and discharge will be designed to withstand the applicable NEI 12-06 external hazards.</p> <p>Modifications are designed to Seismic Category I requirements. They will either be located in Seismic Category I structures or outside, above the ground. PVNGS is a dry site, but intends to keep connections off the ground to avoid the potential impacts of run-off or pooling from precipitation. The high wind and extreme cold hazards are not applicable to PVNGS. Extreme heat is not expected to affect the functionality of the connections.</p> <p>The connection for the alternate strategy will be located within the Auxiliary Building, protected from the applicable NEI 12-06 hazards.</p>
<p>Notes:</p> <p style="padding-left: 40px;">None</p>		

Maintain RCS Inventory Control
PWR Portable Equipment Phase 3:
<p><i>Provide a general description of the coping strategies using phase 3 equipment including modifications that are proposed to maintain RCS inventory control. Identify methods (Low Leak RCP Seals and/or borated high pressure RCS makeup) and strategy(ies) utilized to achieve this coping time.</i></p> <p>This section addresses RCS inventory control and subcriticality issues for conditions where steam</p>

Maintain RCS Inventory Control		
PWR Portable Equipment Phase 3:		
generators are available. RCS inventory control and subcriticality issues for conditions where steam generators are not available are addressed in the maintain core cooling section of this report. RCS inventory is adequately maintained via the Phase 2 strategy.		
Details:		
Provide a brief description of Procedures / Strategies / Guidelines	PVNGS Procedure 79IS-9ZZ07, "PVNGS Extended Loss of All Site AC Guideline," is being developed to support this event.	
Identify modifications	Modifications are not required for Phase 3.	
Key Reactor Parameters	Same as discussed in Phase 1.	
Notes: Same as discussed in Phase 1.		
Storage / Protection of Equipment: Describe storage / protection plan or schedule to determine storage requirements		
Seismic	Same as discussed in Phase 2.	
Flooding	Same as discussed in Phase 2.	
Severe Storms with High Winds	Same as discussed in Phase 2.	
Snow, Ice, and Extreme Cold	Same as discussed in Phase 2.	
High Temperatures	Same as discussed in Phase 2.	
Deployment Conceptual Modification (Conceptual Sketches provided in Attachment 3 figures)		
Strategy	Modifications	Protection of connections
A backup to the Phase 2 equipment will be transported from the Phase 3 offsite staging area (O13). The FLEX equipment storage location and structure have not been determined yet. Figure 3-1	There are no additional mechanical modifications required beyond those identified in Phase 2. Required electrical modifications are discussed in the Safety Functions Support section.	No additional protection is required beyond what was identified in Phase 2.

APS Overall Integrated Plan in Response to March 12, 2012 Commission Order Modifying Licenses with Regard to Requirements for Mitigation Strategies for Beyond-Design-Basis External Events

Maintain RCS Inventory Control		
PWR Portable Equipment Phase 3:		
identified clear deployment paths onsite for the transportation of FLEX equipment within the power block. For this function, a deployment from a storage facility assumed within the power block will use these roads to transport equipment to the staging area.		
Notes: None		

Maintain Containment

Determine Baseline coping capability with installed coping³ modifications not including FLEX modifications, utilizing methods described in Table 3-2 of NEI 12-06:

- Containment Spray
- Hydrogen igniters (ice condenser containments only)

Maintain Containment

PWR Installed Equipment Phase 1:

Provide a general description of the coping strategies using installed equipment including modifications that are proposed to maintain containment. Identify methods (containment spray/Hydrogen igniter) and strategy(ies) utilized to achieve this coping time.

A containment evaluation has been performed based on the boundary conditions described in Section 2 of NEI 12-06. Containment integrity was reviewed using computer code MAAP 4.0.7. MAAP modeled the containment response for 72 hours post event and pressure and temperature remained less than one half of containment design limits (Reference 12).

Monitoring of containment conditions will still occur. FSGs will include containment monitoring during a FLEX event.

There are no Phase 1 actions required at this time that need to be addressed.

Additional strategies to maintain containment conditions during conditions outside those described in Section 2 of NEI 12-06 have not been determined (O14).

Details:

Provide a brief description of Procedures / Strategies / Guidelines	PVNGS Procedure 79IS-9ZZ07, "PVNGS Extended Loss of All Site AC Guideline," is being developed to support this event.
Identify modifications	Modifications are not required for Phase 1.
Key Containment Parameters	Containment Building Pressure PVNGS will develop procedures to read this instrumentation locally, where applicable, using a portable instrument, as required by Section

³ Coping modifications consist of modifications installed to increase initial coping time, i.e. generators to preserve vital instruments or increase operating time on battery powered equipment.

APS Overall Integrated Plan in Response to March 12, 2012 Commission Order Modifying Licenses with Regard to Requirements for Mitigation Strategies for Beyond-Design-Basis External Events

Maintain Containment	
PWR Installed Equipment Phase 1:	
	5.3.3 of NEI 12-06.
Notes: None	

Maintain Containment	
PWR Portable Equipment Phase 2:	
<p><i>Provide a general description of the coping strategies using onsite portable equipment including modifications that are proposed to maintain containment. Identify methods (containment spray/hydrogen igniters) and strategy(ies) utilized to achieve this coping time.</i></p> <p>A containment evaluation has been performed based on the boundary conditions described in Section 2 of NEI 12-06. Containment integrity was reviewed using computer code MAAP 4.0.7. MAAP modeled the containment response for 72 hours post event and pressure and temperature remained within one half of containment design limits (Reference 12).</p> <p>Monitoring of containment conditions will still occur. FSGs will include containment monitoring during a FLEX event.</p> <p>There are no Phase 2 actions required at this time that need to be addressed.</p> <p>Additional strategies to maintain containment conditions during conditions outside those described in Section 2 of NEI 12-06 have not been determined (OI4).</p>	
Details:	
Provide a brief description of Procedures / Strategies / Guidelines	PVNGS Procedure 79IS-9ZZ07 (Reference 13), "PVNGS Extended Loss of All Site AC Guideline," is being developed to support this event.
Identify modifications	Modifications are not required for Phase 2.
Key Containment Parameters	Same as discussed in Phase 1.
Notes: None	
Storage / Protection of Equipment: Describe storage / protection plan or schedule to determine storage requirements	

APS Overall Integrated Plan in Response to March 12, 2012 Commission Order Modifying Licenses with Regard to Requirements for Mitigation Strategies for Beyond-Design-Basis External Events

Maintain Containment		
PWR Portable Equipment Phase 2:		
Seismic	Not applicable	
Flooding	Not applicable	
Severe Storms with High Winds	Not applicable	
Snow, Ice, and Extreme Cold	Not applicable	
High Temperatures	Not applicable	
Deployment Conceptual Modification		
Strategy	Modifications	Protection of connections
N/A	N/A	N/A
Notes: None		

Maintain Containment		
PWR Portable Equipment Phase 3:		
<p><i>Provide a general description of the coping strategies using phase 3 equipment including modifications that are proposed to maintain containment. Identify methods (containment spray/hydrogen igniters) and strategy(ies) utilized to achieve this coping time.</i></p> <p>A containment evaluation has been performed based on the boundary conditions described in Section 2 of NEI 12-06. Containment integrity was reviewed using computer code MAAP 4.0.7. MAAP modeled the containment response for 72 hours post event and pressure and temperature remained within one half of containment design limits (Reference 12).</p> <p>Monitoring of containment conditions will still occur. FSGs will include containment monitoring during a FLEX event.</p> <p>There are no Phase 3 actions required at this time that need to be addressed.</p> <p>Additional strategies to maintain containment conditions during conditions outside those described in Section 2 of NEI 12-06 have not been determined (OI4).</p>		
Details:		
Provide a brief description of Procedures / Strategies / Guidelines	PVNGS Procedure 79IS-9ZZ07 (Reference 13), "PVNGS Extended Loss of All Site AC Guideline," is being developed to support this event.	
Identify modifications	Modifications are not required for Phase 3.	
Key Containment Parameters	Same as discussed in Phase 1.	
Notes:		
None		
Deployment Conceptual Modification		
Strategy	Modifications	Protection of connections
N/A	N/A	N/A
Notes:		
None		

Maintain Spent Fuel Pool Cooling

Determine Baseline coping capability with installed coping⁴ modifications not including FLEX modifications, utilizing methods described in Table 3-2 of NEI 12-06:

- Makeup with Portable Injection Source

Maintain Spent Fuel Pool Cooling

PWR Installed Equipment Phase 1

Provide a general description of the coping strategies using installed equipment including modifications that are proposed to maintain spent fuel pool cooling. Identify methods (makeup via portable injection source) and strategy(ies) utilized to achieve this coping time.

The PVNGS SFP conditions were analyzed for a number of postulated scenarios for the ELAP event. The scenario with ELAP following a seismic event (summarized in Reference 15) was found to be the limiting case due to higher SFP inventory losses. The event conditions considered that would affect time to boil are:

- SFP decay heat during Mode 1 to Mode 6 with core not off-loaded
- SFP decay heat following full core offload

The flow rates to makeup for SFP boil-off were determined using the decay heat load from the spent fuel assemblies in the SFP storage racks. There are two conditions analyzed for the SFP decay heat load: normal operation and the worst case scenario which is defined as a full core offload beginning 100 hours after shutdown plus 964 fuel assemblies from the 12 previous refueling cycles (Reference 4). Table 4.6.2-1 from Reference 4 shows the decay heat loads for the normal and worst case scenarios. The time to boil calculations are determined based on the site elevation and an assumed SFP coolant bulk temperature of 125 F (Reference 4). Additionally, the calculations assume loss of SFP inventory resulting from seismic sloshing, loss of non seismically qualified piping entering the pool and system leakage.

In a postulated ELAP, the required SFP makeup flow rate to match the boil-off for the Mode 1- 6 with core not off-loaded case is 27 gpm and the SFP makeup flow rate for the full core offload case is 100 gpm (Reference 15).

The inventory loss resulting from system leakage and pool gate seal leakage is estimated to be 31 gpm (assuming leakage through the fuel transfer canal gate and fuel transfer tube containment isolation valve

⁴ Coping modifications consist of modifications installed to increase initial coping time, i.e. generators to preserve vital instruments or increase operating time on battery powered equipment.

Maintain Spent Fuel Pool Cooling	
PWR Installed Equipment Phase 1	
<p>PC-V118). Therefore, SFP makeup flow rate requirement to maintain adequate SFP level (10 ft above the fuel) is 58 gpm for the Mode 1- 6 with core not off-loaded case and 131 gpm for the full core offload case. Diesel driven pumps will be used to deliver the required flow rate through monitor type nozzles to provide water to the spent fuel pool.</p> <p>In Phase 1, action is taken to open the Fuel Building rollup door to maintain accessibility to the alternate SFP makeup pump location which will be used in Phase 2.</p> <p>In the event of a postulated ELAP with maximum SFP heat loads due to a full core offload, the time to boil is reduced. The most conservative case time to boil is 3.3 hours after an ELAP. As a result of boiling, SFP level will reach 10 ft of water above the irradiated fuel assemblies in approximately 17 hours after the initiating event. Procedures will be established to support the SFP cooling safety function during events with full core offload conditions.</p> <p>Conservatively, for the Mode 1 to Mode 6 with core not off-loaded case, SFP boiling will occur approximately 11.5 hours after the initiating event. As a result of boiling, SFP level will reach 10 ft of water above the irradiated fuel assemblies in approximately 39 hours after the initiating event. Within 39 hours, Phase 2 actions should be initiated to provide makeup to the SFP.</p>	
Details:	
Provide a brief description of Procedures / Strategies / Guidelines	The FSGs will require that SFP level is monitored and will instruct plant personnel when to initiate Phase 2 coping. PVNGS Procedure 79IS-9ZZ07 (Reference 13), "PVNGS Extended Loss of All Site AC Guideline," is being developed to support this event.
Identify modifications	Modifications are not required for Phase 1.
Key SFP Parameter	Spent Fuel Pool Level per EA-12-051 (Reference 18) and NEI 12-06 PVNGS will develop procedures to read this instrumentation locally, where applicable, using a portable instrument, as required by Section 5.3.3 of NEI 12-06.
Notes:	
None	

Maintain Spent Fuel Pool Cooling

PWR Portable Equipment Phase 2:

Provide a general description of the coping strategies using onsite portable equipment including modifications that are proposed to maintain spent fuel pool cooling. Identify methods (makeup via portable injection source) and strategy(ies) utilized to achieve this coping time.

In a postulated ELAP, the required SFP makeup flow rate to match the boil-off for the Mode 1- 6 with core not off-loaded case is 27 gpm and the SFP makeup flow rate for the full core offload case is 100 gpm (Reference 15).

The inventory loss resulting from system leakage and pool gate seal leakage is estimated to be 31 gpm (assuming leakage through the fuel transfer canal gate and fuel transfer tube containment isolation valve PC-V118). Therefore, SFP makeup flow rate requirement to maintain adequate SFP level (10 ft above the fuel) is 58 gpm for the Mode 1- 6 with core not off-loaded case and 131 gpm for the full core offload case. Diesel driven pumps will be selected to deliver the required flow rate through monitor type nozzles to provide water to the spent fuel pool.

In the event of a postulated ELAP with maximum SFP heat loads due to a full core offload, the time to boil is reduced. The most conservative case time to boil is 3.3 hours after an ELAP. As a result of boiling, SPF level will reach 10 ft of water above the irradiated fuel assemblies in approximately 17 hours after the initiating event. Procedures will be established to support the SFP cooling safety function during events with full cool offload conditions.

Conservatively, for the Mode 1 to Mode 6 with core not off-loaded case, SFP boiling will occur approximately 11.5 hours after the initiating event. As a result of boiling, SPF level will reach 10 ft of water above the irradiated fuel assemblies in approximately 39 hours after the initiating event. Within 39 hours, Phase 2 actions should be initiated to provide makeup to the SFP.

Phase 2 actions will stage a FLEX pump outside the fuel building. In Mode 1 through Mode 4, the RWT will be used as the primary source for SFP makeup. In Modes 5 and 6 and during a full core offload, the CST will be used as the primary source for SFP makeup.

The FLEX pump discharge hose is routed to one of the two permanent SFP makeup connections. The primary connection is on the outside of the north wall of the fuel building. The alternate connection is just inside the rollup door to the fuel building.

Details:

Provide a brief description of Procedures / Strategies / Guidelines	PVNGS Procedure 79IS-9ZZ07 (Reference 13), "PVNGS Extended Loss of All Site AC Guideline," is being developed to support this event.
Identify modifications	Two new seismically qualified pipes will be installed from the pump staging

APS Overall Integrated Plan in Response to March 12, 2012 Commission Order Modifying Licenses with Regard to Requirements for Mitigation Strategies for Beyond-Design-Basis External Events

Maintain Spent Fuel Pool Cooling		
	area to a location above the 140 ft elevation of the Fuel Building. One valve on each discharge pipe will be included. The RWT and CST drain lines will each be modified to include a suction hose connection for the SFP makeup pump.	
Key SFP Parameter	Same as discussed in Phase 1.	
Notes: None		
Storage / Protection of Equipment: Describe storage / protection plan or schedule to determine storage requirements		
Seismic	Storage is an open item (OI1). However, the FLEX storage building that will house equipment for this function will be constructed to be seismically robust using, at a minimum, the requirements of ASCE 7-10 (consistent with NEI 12-06, Section 5). Equipment inside the building will be restrained in such a way that it will not be damaged during a seismic event.	
Flooding	The FLEX equipment storage building will be designed above flood level with adequate drainage.	
Severe Storms with High Winds	The FLEX equipment storage building structure will be designed within Enhanced Fujita 3 requirements.	
Snow, Ice, and Extreme Cold	The local universal building code will be applied.	
High Temperatures	The FLEX equipment storage building will have adequate ventilation for high temperatures.	
Deployment Conceptual Design (Conceptual Sketches provided in Attachment 3 figures)		
Strategy	Modifications	Protection of connections
The FLEX equipment storage location and structure have not been determined yet. Figure 3-1 identifies clear deployment paths onsite for the transportation of FLEX equipment. For this function, a clear deployment path is shown from the identified roads in the power block to the primary staging area northwest of the RWT and the alternate staging area inside the rollup door on the north side of the Fuel Building.	As shown in Figures 3-11 and 3-12, there are two new pipes to be installed. The first routes from the primary staging area to outside the north side of the Fuel Building up the outside wall to an elevation above the 140 ft elevation of the Fuel Building. The pipe will penetrate the wall to a location where it can spray from monitor nozzles into the SFP. The second pipe will run from the bay of the Fuel Building, along the inside of the north side of the Fuel	The new piping will be Seismic Category I. Connections will be above the PVNGS flood level. The primary discharge piping will be secured to a Seismic Category I building. The alternate discharge piping will be enclosed within a Seismic Category I building. The suction connections will be from the RWT or the CST depending on the Mode of operation when the event occurs.

Maintain Spent Fuel Pool Cooling		
	<p>Building wall up to a level above the 140 ft elevation of the Fuel Building. At that elevation, the pipe will run inside the north wall from the bay to north of the SFP and be directed to spray from monitor nozzles into the SFP.</p> <p>Each piping header will be equipped with a number of standard monitor nozzles to direct flow into the SFP area.</p>	
<p>Notes: None</p>		

Maintain Spent Fuel Pool Cooling		
PWR Portable Equipment Phase 3:		
<p><i>Provide a general description of the coping strategies using phase 3 equipment including modifications that are proposed to maintain spent fuel pool cooling. Identify methods (makeup via portable injection source) and strategy(ies) utilized to achieve this coping time.</i></p> <p>PVNGS will continue the Phase 2 strategies to provide makeup to the SFP in Phase 3.</p> <p>In Phase 3, makeup will be provided to the CST and RWT from the station reservoirs using a pipeline and pumps sized to match the decay heat.</p>		
Details:		
Provide a brief description of Procedures / Strategies / Guidelines	PVNGS Procedure 79IS-9ZZ07 (Reference 13), "PVNGS Extended Loss of All Site AC Guideline," is being developed to support this event.	
Identify modifications	Modifications are not required for Phase 3.	
Key SFP Parameter	Same as discussed in Phase 1.	
Notes: None		
Deployment Conceptual Design (Attachment 3 contains Conceptual Sketches)		
Strategy	Modifications	Protection of connections
Same as the Phase 2 strategy.	None.	Same as the Phase 2 strategy.
Notes: None		

Safety Functions Support

Determine Baseline coping capability with installed coping⁵ modifications not including FLEX modifications.

Safety Functions Support

PWR Installed Equipment Phase 1

Provide a general description of the coping strategies using installed equipment including station modifications that are proposed to maintain and/or support safety functions. Identify methods and strategy(ies) utilized to achieve coping times.

During Phase 1, PVNGS requires vital instrumentation power to cope with an ELAP and LUHS. Vital instrumentation is powered from the 125V DC Class 1E power system.

The 125V DC Class 1E power system (PK) batteries are lead-acid and consist of four Trains: A, B, C, and D. Each train consists of a battery charger, battery, DC bus, inverter, and respective vital loads.

The battery coping time with no load shedding is 13 hours. If load shedding, as described in Reference 12, is completed, the battery coping period is extended to 47 hours. Battery load shedding is to be completed within two hours after an ELAP.

PVNGS emergency lighting batteries will last up to 16 hours (Reference 12, Section V.2.1). Ventilation is not required during Phase 1, although doors may be propped open to alleviate high temperatures in the main control room and electrical equipment rooms. The temperature increase above ambient in the control building will be minimal since very few instruments are powered.

PVNGS emergency communications use the guidance of NEI 12-01, Rev. 0, (Reference 17). Two-way hand-held radios and sound powered phones will be used by in-plant teams. Satellite phones will be used by offsite radiological field assessment teams to support mitigation strategies.

Details:

Provide a brief description of Procedures / Strategies /

PVNGS Procedure 79IS-9ZZ07 (Reference 13), "PVNGS Extended Loss of All Site AC Guideline," is being developed to support this event.

⁵ Coping modifications consist of modifications installed to increase initial coping time, i.e. generators to preserve vital instruments or increase operating time on battery powered equipment.

APS Overall Integrated Plan in Response to March 12, 2012 Commission Order Modifying Licenses with Regard to Requirements for Mitigation Strategies for Beyond-Design-Basis External Events

Safety Functions Support	
PWR Installed Equipment Phase 1	
Guidelines	
Identify modifications	Modifications are not required for Phase 1.
Key Parameters	DC bus voltage is required to be monitored in order to ensure that the DC bus voltage remains above the minimum voltage.
Notes: None	

Safety Functions Support

PWR Portable Equipment Phase 2

Provide a general description of the coping strategies using onsite portable equipment including station modifications that are proposed to maintain and/or support safety functions. Identify methods and strategy(ies) utilized to achieve coping times.

The critical electrical equipment required during Phase 2 is vital instrumentation, battery chargers, FLEX RCS makeup pumps, installed charging pumps, ventilation, and lighting. Energizing these loads will be accomplished using two 480V FLEX generators connected to either train of the Class 1E 480V switchgear and alignment of the required equipment in that train. If required, portable generators with portable light stands or light strings will be used for lighting the control room.

Eight 500kW FLEX generators, as required for N+1, will be stored onsite. Twenty eight hours after the ELAP, two FLEX generators will be deployed to the staging area south of the diesel building (see Figures 3-16 and 3-18). Although the storage area is not yet determined, the expected deployment path is shown in Figure 3-17. FLEX generators will be trailer mounted for ease of deployment. A set of FLEX cables will be stored with each generator and will be either deployed on the generator trailer or on a separate cart. These cables provide a positive locking mechanism to ensure a tight waterproof connection. Phase rotation will be verified during installation.

Each FLEX generator will be grounded via a flexible cable to a ground test well which will provide an accessible ground in the staging area that will not affect traffic.

The FLEX generators will be connected to the Class 1E 480V load centers via FLEX connection junction boxes. Two boxes will be mounted on the south wall of the control building to support the primary connection. See Figure 3-19 for an overview of the primary strategy. Two boxes will be mounted on the east wall of the diesel building to support the alternate connection. See Figure 3-23 for an overview of the alternate strategy. Both 480V strategies will be designed to be available for BDBEE, as defined in Study 13-NS-A108.R000 (Reference 12), although Train B may have limited access after a seismic event due its close proximity to a non seismic structure.

The primary strategy is to repower the 480V Class 1E load centers on Train A (L31, L33, and L35, respective Figures 3-20, 3-21, and 3-22). Repowering these load centers will allow PVNGS to repower the vital battery chargers A and C, thus allowing for indefinite vital battery coping time. Prior to energizing the FLEX generators, breakers in load centers L31, L33 and L35 must be opened (approximately 30 breakers). Breakers in the motor control centers (MCCs) M31, M33, M35, M37 and M71 must be opened also (approximately 120 breakers). This will isolate loads so the FLEX generators do not fail because of overload. When the FLEX generators are running, then the 12 loads identified in Table 1 can be systematically energized. Guidance for aligning the system will be included in procedure 79IS-9ZZ07 (Reference 13), "PVNGS Extended Loss of All Site AC Guideline."

Safety Functions Support

PWR Portable Equipment Phase 2

If the installed charging pumps are not operational, the primary FLEX strategy for energizing the FLEX RCS pumps is to energize MCC M33 from load center L33 (Figure 3-35). The pumps will be connected to a FLEX junction box located outdoors near the RWT. Power will be provided from spare breakers in MCC M33.

The alternate strategy is to repower the 480V Class 1E load centers on Train B (L32, L34, and L36). Repowering these load centers will allow PVNGS to repower the vital battery chargers B and D, thus allowing for indefinite vital battery coping time. Prior to energizing the FLEX generators, breakers in load centers L32, L34 and L36 must be opened (approximately 30 breakers). Breakers in MCCs M32, M34, M36, and M72 also must be opened (approximately 90 breakers). This will isolate the affected loads so the FLEX generators do not fail because of overload. When the FLEX generators are running, then the loads identified in Table 1 below can be systematically energized. Guidance for aligning the system will be included in procedure 79IS-9ZZ07, "PVNGS Extended Loss of All Site AC Guideline."

If the installed charging pumps are not operational, the alternate FLEX strategy for energizing the FLEX RCS pump(s) is to energize the circuit feeding the swing charging pump 1M-CHE-PO1 located in the Auxiliary Building. This pump is fed from load center L36, breaker C2. A double throw switch to be installed in the circuit will redirect power to the FLEX pump(s) during an ELAP.

Table 1: Installed Loads Credited in Phase 2

Train A	Train B	Load
L31	L32	QBA/B-V01/2 (25kVA) Control Room Emergency Lighting
L31	L32	PKC/D-H13/H14 (58kVA) "C/D" Battery Charger
L31	L32	HJA/B-J01A/B (1hp) "A/B" Battery Room Exhaust Fan
L31	L32	HJA/B-J01B/A (1hp) "C/D" Battery Room Exhaust Fan
L33	L34	QFN-X04 (25kVA) In Plant Communication
L33	L34	HFA/B-J01 (40hp) Fuel and Auxiliary Building Air Recirculation
L35	L36	PKA/B-H11/12 (80/92kVA) "A/B" Battery Charger
L35	L36	CHE-PO1 (100hp) Swing Charging Pump "E" *
L35	L36	QBN-D91/D90 (160 kW) Essential Lighting Control Room, Auxiliary and Radwaste Building
L35	L36	HJA/B-F04 (125hp) Control Room Air Recirculation

* Charging pump A or B could also be used instead of the swing charging pump.

The 480V FLEX generators must be deployed and operational at T+34 hours. Deploying the FLEX generators from storage to the staging area, connecting the FLEX generators to the FLEX junction boxes, and aligning the system to the required loads will take four people roughly six hours. To ensure that 480V power is restored at T+34 hours, FLEX generator deployment will begin no later than T+24 hours. Since the battery coping with load shedding is 47 hours, and the battery chargers will be re-energized at T+34 hours, there are 13 hours of margin.

Safety Functions Support	
PWR Portable Equipment Phase 2	
<p>The FLEX generators will be stored onsite with no fuel. Once deployed to the staging area, the FLEX generators will be fueled with a gravity-fed hose from either of the two safety-related diesel day tanks located in the nearby diesel building. Each tank in the diesel building has a capacity of 1100 gallons and a Technical Specification minimum volume of 550 gallons. Each FLEX generator will be filled with 250 gallons using the 550 gallons from one tank and leaving the other full if the installed Class 1E generators are recovered. The FLEX generators will consume 36 gal/hr of fuel at 100 percent load; therefore, 250 gallons will last approximately 7 hours before refueling. Once the FLEX generators are running, the existing 480V 3hp diesel transfer pump will be available, allowing the day tanks to be refilled from the underground 7-day tanks. See Figure 3-18 for the location of the 7-day tanks.</p>	
Details:	
Provide a brief description of Procedures / Strategies / Guidelines	PVNGS Procedure 79IS-9ZZ07, "PVNGS Extended Loss of All Site AC Guideline," is being developed to support this event.
Identify modifications	<p>To facilitate FLEX generator connections, primary and alternate FLEX junction boxes must be installed and permanently connected to the 480V Class 1E load centers. To facilitate FLEX RCS makeup pump connections, primary and alternate FLEX junction boxes, double throw switches, cabling and conduit must be installed and permanently connected to the electrical system. General installation requirements are listed below with more detail for each connection location provided in the subsections following.</p> <p>General Installation Requirements:</p> <p>Modifications to Train A equipment that will support the FLEX strategies are marked up in red and modifications to Train B equipment that will support the FLEX strategies are marked up in green in the provided electrical figures.</p> <p>Phase rotation will be verified during installation.</p> <p>Permanent installations and terminations will be made in accordance with PVNGS standard procedures and specifications.</p> <p>Supports for conduit, junction boxes, and switches will be seismically mounted.</p> <p>The exact raceway layout, cable routes and equipment modifications will</p>

Safety Functions Support

PWR Portable Equipment Phase 2

be determined in the detailed design phase.

New breakers, switches, etc. will be labeled in accordance with PVNGS standard labeling requirements.

New breaker connections to the Train A and Train B load centers will be maintained in the open position during normal operation thus isolating the load centers from the FLEX connections.

A ground test well will be installed at the generator staging location to provide a quick access point to the station ground. The well will be installed so that the top is flush with grade to avoid causing tripping or traffic hazards. The general locations for ground test wells are shown in Figures 3-19 and 3-23. From each test well, a bare copper grounding conductor will be buried in earth and routed in opposite directions to the two nearest station grounding conductors. Ground system connections will be made in accordance with the station standard grounding procedures and specifications.

Primary 480V Connection Train A

To facilitate the primary FLEX generator connections to Train A, two junction boxes will be installed on the south wall of the control building as shown in Figure 3-16 and permanently connected to the 480V Class 1E load centers L31, L33, and L35, as shown in Figure 3-19.

Two junction boxes (JB1 associated with FLEX generator 1 and JB2 associated with FLEX generator 2) will be permanently installed on the south wall of the control building. These boxes are approximately 45 x 30 x 16 inches. Adequate space is available on the south wall of the control building as shown in Figure 3-16.

Load center L31 has a spare breaker in location D4. A new circuit will be installed from the spare breaker in L31 to JB1. The distance from JB1 to L31 is approximately 90 ft. See Figure 3-20 for a single-line diagram showing the electrical path from the FLEX generator to power the loads shown in Table 1.

Load center L33 has a spare breaker in location C4. A new circuit will be installed from the spare breaker in L33 to JB1. The distance from JB1 to

Safety Functions Support

PWR Portable Equipment Phase 2

L33 is approximately 70 ft. See Figure 3-21 for a single-line diagram showing the electrical path from the FLEX generator to power the loads shown in Table 1.

Load center L35 has a spare breaker in location D4 (B3 in Unit 2). A new circuit will be installed from the spare breaker in L35 to JB2. The distance from JB2 to L35 is approximately 50 ft. See Figure 3-22 for a single-line diagram showing the electrical path from the FLEX generator to power the loads shown in Table 1.

The new circuits will be installed in rigid steel conduit and routed through the south wall of the control building to the respective load centers. Refer to Figures 3-16 and 3-19 for the intended path of the cable/conduit routing along with an approximate location of the junction boxes and FLEX generators.

Alternate 480V Connection Train B

To facilitate the alternate FLEX generator connections to Train B, two junction boxes will be installed on the east wall of the diesel building and permanently connected to the 480V Class 1E load centers L32, L34, and L36, as shown in Figure 3-23.

Two junction boxes (JB3 associated with FLEX generator 1 and JB4 associated with FLEX generator 2) will be permanently installed on the east wall of the diesel building. These boxes are approximately 45 x 30 x 16 inches. Adequate space is available on the east wall of the diesel building as shown in Figure 3-24.

Load center L32 has a spare breaker in location D4. A new circuit will be installed from the spare breaker in L32 to JB3. The distance from JB3 to L32 is approximately 90 feet. See Figure 3-25 for a single-line diagram showing the electrical path from the FLEX generator to power the loads shown in Table 1.

Load center L34 has a spare breaker in location C4. A new circuit will be installed from the spare breaker in L34 to JB3. The distance from JB3 to L34 is approximately 70 ft. See Figure 3-26 for a single-line diagram showing the electrical path from the FLEX generator to power the loads

Safety Functions Support	
PWR Portable Equipment Phase 2	
	<p>shown in Table 1.</p> <p>Load center L36 has a spare breaker in location B3. A new circuit will be installed from the spare breaker in L36 to JB4. The distance from JB4 to L36 is approximately 50 ft. See Figure 3-27 for a single-line diagram showing the electrical path from the FLEX generator to power the loads shown in Table 1.</p> <p>The new circuits will be installed in rigid steel conduit and routed through the east wall of the control building to the respective load centers. Refer to Figures 3-23 and 3-24 for the intended path of the cable/conduit routing along with an approximate location of the junction boxes and FLEX generators.</p> <p>Primary and Alternate Power Supply for FLEX RCS Makeup Pumps</p> <p>One 50 hp motor driven FLEX RCS makeup pump is required to support the RCS makeup strategy. The required pump can be installed in either of two locations. The primary location is outside adjacent to the RWT (Figures 3-32 and 3-33) and the secondary location is on the 100' elevation of the auxiliary building (Figure 3-36).</p> <p>Each FLEX RCS makeup pump staging location will be provided with both a primary and alternate source of power via two new junction boxes with quick connect features for motor hookup. Power from the 480V FLEX generators described above will be provided to the new junction boxes at each location. One junction box will be supplied from Train A electrical distribution equipment and the other junction box supplied from Train B.</p> <p>Cable routing distances to the four pump junction boxes will be minimized through use of the MCCs nearest to each pump location, as shown in Figures 3-27 and 3-35.</p>
Key Parameters	DC bus voltage is required to be monitored in order to ensure that the DC bus voltage remains above the minimum voltage.
Storage / Protection of Equipment : Describe storage / protection plan or schedule to determine storage requirements	
Seismic	Storage is an open item (OI1). However, the FLEX storage building that will house equipment for this function will be constructed to be seismically robust using, at a minimum, the requirements of ASCE 7-10. Equipment inside the building will be restrained in such a way that it

APS Overall Integrated Plan in Response to March 12, 2012 Commission Order Modifying Licenses with Regard to Requirements for Mitigation Strategies for Beyond-Design-Basis External Events

Safety Functions Support		
PWR Portable Equipment Phase 2		
	will not be damaged during a seismic event.	
Flooding	The FLEX equipment storage building will be designed above flood level with adequate drainage.	
Severe Storms with High Winds	The FLEX equipment storage building structure will be designed within Enhanced Fujita 3 requirements.	
Snow, Ice, and Extreme Cold	The local universal building code will be applied.	
High Temperatures	The FLEX equipment storage building will have adequate ventilation for high temperatures.	
Deployment Conceptual Design (Attachment 3 contains Conceptual Sketches)		
Strategy	Modifications	Protection of connections
The FLEX equipment storage location and structure have not been determined yet. Figure 3-1 identifies clear deployment paths onsite for the transportation of FLEX equipment.	Modifications to support the primary and alternate strategies are described in the Phase 2 modification discussion above, as shown in Figures 3-32 through 3-38.	FLEX connection locations and equipment are protected from the applicable hazards in NEI 12-06. They will be designed to Seismic Category I requirements. They will either be located in Seismic Category I structures or outside, above the ground. PVNGS is a dry site, but intends to keep connections off the ground to avoid the potential impacts of run-off or pooling from precipitation. The high wind and extreme cold hazards are not applicable to PVNGS. Extreme heat is not expected to affect the functionality of the connections.
Notes: Refer to the modification discussion under the section for "Maintain Core Cooling and Heat Removal" on page 29.		

Safety Functions Support

PWR Portable Equipment Phase 3

Provide a general description of the coping strategies using phase 3 equipment including modifications that are proposed to maintain and/or support safety functions. Identify methods and strategy(ies) utilized to achieve coping times.

Early in the FLEX implementation, the site will notify the RRC and request equipment. The medium voltage (MV) 4.16kV FLEX generator is expected to arrive onsite between 24 and 72 hours into the ELAP. When the generator and enough personnel are available on site, one train of the Class 1E, 4.16kV switchgear will be energized.

The MV FLEX generator will be deployed to the same staging area as the 480V FLEX generators just south of the diesel building as shown in Figures 3-16 and 3-24. The deployment path is shown in Figure 3-17 and is the same path used for the 480V FLEX generators. Four mobile generator connection panels/junction boxes and four sets of FLEX cables (N+1) will be stored in the same location as the 480V equipment.

To allow generators from the RRC to be used at all sites in the region, the generator is supplied with bus bar connections. To make FLEX connections, the mobile generator connection panel/junction box will be placed near the generator and jumper cables installed from the generator bus bars to the mobile FLEX connection panel/junction box.

The FLEX cables provide a positive locking mechanism to ensure a tight waterproof connection. Phase rotation will be verified during installation. Using one conductor per phase instead of bundled cables reduces weight and eases deployment.

The MV FLEX generator will be connected to the Class 1E 4.16kV switchgear via an installed FLEX junction box mounted outside on either the west or east wall of the diesel building as shown in Figure 3-39 and Figure 3-41. Train A switchgear will be energized via a new breaker installed in a new section of Train A switchgear (see Figure 3-40) and Train B switchgear will be energized through an existing spare breaker.

The same ground test wells to be used for the 480V FLEX generator can also be used as an equipment ground for the 4.16kV FLEX generator. The approximate location of the ground test wells can be found on Figures 3-19 and 3-23.

The primary strategy to repower the 4.16kV system is to power the Class 1E switchgear on Train A (1E-PBA-S03). To align Train A and the MV FLEX generator, breakers must be opened on 1E-PBA-S03 (14 breakers)

This will isolate loads so the FLEX generator does not fail because of overload. After the FLEX generator is running, breaker S03U (new breaker) is closed to energize the 4.16kV bus. Then breakers S03F, S03M, and S03C are closed to energize pumps or systems

The alternate strategy to repower the 4.16kV system is to power the Class 1E switchgear on Train B (1E-PBB-S04). To align Train B and the MV FLEX generator, breakers must be opened on 1E-PBB-S04 (14

Safety Functions Support	
PWR Portable Equipment Phase 3	
<p>breakers).</p> <p>This will isolate loads so the FLEX generator does not fail because of overload. After the FLEX generator is running, breaker S04P is closed to energize the 4.16kV bus. Then breakers S04F, S04M, and S04C are closed to energize pumps and needed systems.</p> <p>New breaker connections to the 4.16kV Train A and Train B switchgear will be maintained in the open position during normal operation thus isolating the switchgear from the FLEX connections.</p> <p>Both MV strategies will be designed to be available for applicable NEI 12-06 BDBEES.</p> <p>The MV FLEX generator deployment is not time critical.</p>	
Details:	
Provide a brief description of Procedures / Strategies / Guidelines	PVNGS Procedure 79IS-9ZZ07 (Reference 13), "PVNGS Extended Loss of All Site AC Guideline," is being developed to support this event.
Identify modifications	<p>To facilitate MV FLEX generator connections, a seismic, Class 1E primary and alternate FLEX connection panel will be installed and permanently connected to the 4160V Class 1E switchgear.</p> <p>Train A switchgear S03 does not have a spare breaker so a new vertical section will be installed. The primary FLEX connection panel will be installed on the west wall of the diesel building. To accommodate the required connection, these panels will be approximately 72 x 38 x 24 inches. Adequate space is available on the west wall of the diesel building. Refer to figure 3-41.</p> <p>Train B switchgear S04 has a spare at S04P. The primary FLEX connection panel will be installed on the east wall of the diesel building. To accommodate the required connection, these panels will be approximately 72 x 38 x 24 inches. Adequate space is available on the west wall of the diesel building.</p> <p>Overcurrent protective relays in the spare cubicle provide adequate protective functions. New relays will be included with the vertical section to be added to S03. Relay settings will be calculated as part of the detailed design.</p>

Safety Functions Support		
PWR Portable Equipment Phase 3		
	<p>New circuits will be installed in the switchgear rooms from the switchgear to the FLEX connection panels. Each circuit will consist of three-phase conductors and one ground conductor. The raceway supports and FLEX connection panels will be seismically rated in accordance with PVNGS standard requirements.</p> <p>All terminations will be made in accordance with the station standard procedures and specifications. The exact routing of the cable tray will be completed during the detailed design phase.</p> <p>The ground test well installed for the 480V FLEX generator can support both FLEX generators; therefore no additional ground well will be installed.</p>	
Key Parameters	<p><i>List instrumentation credited or recovered for this coping evaluation.</i></p> <p>No instrumentation is required to support the electrical coping strategies.</p>	
Storage / Protection of Equipment : Describe storage / protection plan or schedule to determine storage requirements		
Seismic	Storage is an open item (OI1). However, the FLEX storage building that will house equipment for this function will be constructed to be seismically robust using, at a minimum, the requirements of ASCE 7-10. Equipment inside the building will be restrained in such a way that it will not be damaged during a seismic event.	
Flooding	The FLEX equipment storage building will be designed above flood level with adequate drainage.	
Severe Storms with High Winds	The FLEX equipment storage building structure will be designed within Enhanced Fujita 3 requirements.	
Snow, Ice, and Extreme Cold	The local universal building code will be applied.	
High Temperatures	The FLEX equipment storage building will have adequate ventilation for high temperatures.	
Deployment Conceptual Design (Attachment 3 contains Conceptual Sketches)		
Strategy	Modifications	Protection of connections
The FLEX equipment storage location and structure have not been determined yet. Figure 3-1 identifies clear deployment paths	Modifications to support the primary and alternate strategies as described above.	FLEX connection locations and equipment are protected from the applicable hazards in NEI 12-06. They will be designed to

Safety Functions Support		
PWR Portable Equipment Phase 3		
<p>onsite for the transportation of FLEX equipment.</p>		<p>Seismic Category I requirements and will either be located in Seismic Category I structures or outside, above the ground. PVNGS is a dry site, but intends to keep connections off the ground to not be impacted by the potential impacts of runoff or pooling from precipitation. The high wind and extreme cold hazards are not applicable to PVNGS. Extreme heat is not expected to affect the functionality of the connections.</p>
<p>Notes: None</p>		

Phase 2 and Phase 3 Equipment Overview Tables

Tables A, B, and C provide a summary overview of the types of and quantities of equipment needed to support the overall integrated plan. The content of these tables do not restrict or expand the previously discussed material. Some of the items in the tables are general considerations that PVNGS is evaluating and have not been discussed in the prior details.

Table A - PWR Portable Equipment Phase 2

Table B - PWR Portable Equipment Phase 3

Table C - Phase 3 Response Equipment/Commodities

Table A - PWR Portable Equipment Phase 2

<i>Use and (potential / flexibility) diverse uses</i>						<i>Performance Criteria</i>	<i>Maintenance</i>
<i>List portable equipment</i>	<i>Core</i>	<i>Containment</i>	<i>SFP</i>	<i>Instrumentation</i>	<i>Accessibility</i>		<i>Maintenance / PM requirements</i>
Four (4) self priming pumps	X		X			370 gpm, 500 psi	Will follow EPRI template requirements
Eight (8) 480 VAC Generators	X			X	X	500 kW	Will follow EPRI template requirements
Four (4) High Pressure RCS Makeup Pumps	X					30 gpm, 1525 psi	Will follow EPRI template requirements
Four (4) SFP Makeup Pumps			X			110 gpm, 20 psi	Will follow EPRI template requirements

Table B - PWR Portable Equipment Phase 3

<i>Use and (potential / flexibility) diverse uses</i>						<i>Performance Criteria</i>	<i>Notes</i>
<i>List portable equipment</i>	<i>Core</i>	<i>Containment</i>	<i>SFP</i>	<i>Instrumentation</i>	<i>Accessibility</i>		
Three (3) 4160 VAC Generator	X		X	X	X	5 MW	Portable 4160 VAC generator will power AFW Pump train B and will be used for recovery phase
High Pressure RCS Makeup Pumps	X					30 gpm, 1525 psia	Positive Displacement Pump, Portable AC motor driven skid mounted.
High Density Polyethylene (HDPE) Pipe	X	X	X			N/A	HDPE-12"- Standard Dimension Ratio (SDR) 17 40' Bundles Length = Approximately 3 miles
HDPE Pipe Fusion Welder	X	X	X			N/A	Fusion Machine (HDPE 10"-18")
Pumps to makeup to the CST from reservoirs	X		X			1200 gpm, 130 psig	

Table C - Phase 3 Response Equipment/Commodities	
Item	Notes*
Radiation Protection Equipment <ul style="list-style-type: none"> • Survey instruments • Dosimetry • Offsite monitoring/sampling 	
Commodities <ul style="list-style-type: none"> • Food • Potable water 	
Fuel Requirements <ul style="list-style-type: none"> • Diesel Fuel 	
Heavy Equipment <ul style="list-style-type: none"> • Transportation equipment • Debris clearing equipment 	

*APS expects to use these resources or similar resources provided by the RRC. Once the final RRC equipment list is available, APS will confirm the site needs are met.

Open Items

Open Item	Description	Affected Pages
OI1	A storage location for FLEX equipment needs to be selected.	20, 29, 40, 52, 62, 66
OI2	PVNGS FSG is currently a draft document and will need to be finalized. Existing site EOPs will need to be updated to direct use of the PVNGS Extended Loss of All Site AC Guideline during an ELAP. Additionally a program and procedural control process is under development and will be implemented to meet the requirement of NEI-12-06 .	15, 19
OI3	Structure, content, and details of the regional response center (RRC) playbook, and location of the offsite staging area will be determined.	24, 44
OI4	Additional strategies to maintain containment conditions during mode 5 and 6 ELAP will be evaluated.	45, 46, 48

Attachment 1A

Sequence of Events Timeline Mode 1-4

Table Item	Elapsed Time (hr)	Action	New ELAP Time Constraint Y/N	Time Constraint (hr)	Reference	Remarks / Applicability
	0	Event Starts				Plant at 100% power
1	0.001	Control Rods Insert	N		4	Part of current license and the normal plant response to a loss of offsite power is for the plant to trip and control rods to insert within 4 seconds (Reference 4, Section 3.9.4.1)
2	0.017	TDAFWP Starts	N		4	Part of current license and the normal plant response to a loss of offsite power for pump to start and to begin providing steam generator (SG) makeup for core cooling and heat removal.
3	0.25	SBO Procedures are Entered	N			Estimated time for operator to recognize SBO. Actions (Reference 16) are taken when both emergency diesel generators are not available following a loss of offsite power. SBO procedures instruct the operator to start the station blackout generators (SBOGs).
4	1	SBOG Fails to Start	Y	1	2	Fails as required by NEI 12-06. Must be acknowledged within time constraint to enter ELAP guidelines
5	1	Enter ELAP Guidelines	Y	1		Required as following actions are dependent on this action

APS Overall Integrated Plan in Response to March 12, 2012 Commission Order Modifying Licenses with Regard to Requirements for Mitigation Strategies for Beyond-Design-Basis External Events

Table Item	Elapsed Time (hr)	Action	New ELAP Time Constraint Y/N	Time Constraint (hr)	Reference	Remarks / Applicability
6	1	Start Cooldown	Y	1	5	Analytical basis assumes cooldown initiation time of 1 hour and cooldown rate of 70 degrees per hour.
7	2	Complete DC Load Shed	Y	2	16	DC load shed to be completed by this time. To ensure battery coping times / assumptions are met.
8	2	Open TDAFWP Room Door for Ventilation	Y	2	19	Required to maintain environmental conditions for equipment operation in TDAFWP room.
9	2	Open Control Room Doors for Ventilation	Y	2	12	Required to provide ventilation to maintain control room temperature.
10	3	SITs begin to inject	N		5	This response occurs as RCS depressurizes without operator action. Actual start of injection time may vary due to factors such as containment temperature, RCS leakage, initial SIT inventory and pressure.

APS Overall Integrated Plan in Response to March 12, 2012 Commission Order Modifying Licenses with Regard to Requirements for Mitigation Strategies for Beyond-Design-Basis External Events

Table Item	Elapsed Time (hr)	Action	New ELAP Time Constraint Y/N	Time Constraint (hr)	Reference	Remarks / Applicability
11	4	Operator completes cooldown, maintains SG pressure	N		5	<p>Analytical basis assumes cooldown initiation time of 1 hour and cooldown rate of 70 °F/hr. Operations will begin a cooldown at one hour at the normal cooldown rate of approximately 70°F/hr. The cooldown is expected to be completed within 4.11 hours of the initiation of the event. Cooldown / depressurization of the RCS will result in reduced loss of RCS inventory from RCP seal leakage.</p> <p>The RCS cooldown will stop at 350°F. This temperature was chosen to ensure that adequate steam supply pressure is available to operate the TDAFWP.</p>
12	4	Complete Operator Assessment Walkdowns	Y	4	O12	<p>Assessment of equipment status will be separated into Primary and Secondary side walkdowns. Specific tasks within the walkdowns have time constraints. Specifically, establishing Fuel Building venting (see Item 12a) and isolation of selected flowpaths from the CST.</p>

APS Overall Integrated Plan in Response to March 12, 2012 Commission Order Modifying Licenses with Regard to Requirements for Mitigation Strategies for Beyond-Design-Basis External Events

Table Item	Elapsed Time (hr)	Action	New ELAP Time Constraint Y/N	Time Constraint (hr)	Reference	Remarks / Applicability
12a	4	Establishing Fuel Building Vent Path	Y	11	16	Roll up door to the Fuel Building truck bay is opened prior to earliest predicted spent fuel pool time to boil. This action would provide ventilation to maintain accessibility to alternate SFP makeup pump location .
13	16	Begin Manually Operating ADVs	Y	16	4	ADV's must be manually operated once the N ₂ supply is depleted (UFSAR, Reference 4).
14	34	500 kW 480V Generators Installed	Y	39	15	Battery power will be depleted if the generator is not available to power chargers within 47 hours. These generators will recharge the batteries as well as power battery room ventilation, control room lighting and control room cooling. Generators are deployed such that diesel fueling is accomplished via gravity feed from the diesel day tanks. Long term fuel supply is ensured by repowering the diesel transfer pumps which fill the diesel day tanks from the diesel storage tanks.
15	35	Start Charging Pump	N		16	Use of an installed charging pump is the preferred RCS makeup strategy. If it is not available, the FLEX RCS makeup pump will be used.

APS Overall Integrated Plan in Response to March 12, 2012 Commission Order Modifying Licenses with Regard to Requirements for Mitigation Strategies for Beyond-Design-Basis External Events

Table Item	Elapsed Time (hr)	Action	New ELAP Time Constraint Y/N	Time Constraint (hr)	Reference	Remarks / Applicability
16	36	Install RCS Makeup Pump	Y	49	5	Required to maintain subcooled natural circulation and to prevent two phase natural circulation. SITs empty and the FLEX pump is needed for inventory makeup to the RCS.
17	39	Establish SFP Makeup	Y	39	16	Established prior to SFP inventory being depleted below 10 feet above the irradiate fuel seated in spent fuel pool storage rack.
18	42	CST Empties/ Switchover to RMWT	Y	45	16	When the CST depletes, TDAFWP suction is realigned to the RMWT.
19	*	Vent Nitrogen off SITs	N		5	*This action is dependent on SIT injection rate, not event time. Operator action will be to vent SIT N ₂ over pressure when SIT level reaches 10%.
20	48	Stage SG Makeup Pump	N		16	It is expected TDAFWP performance exceeds this duration; however, a backup SG makeup pump should be staged as soon as it is available.
21	72	Water from WRF to CSTs at each Unit	N		16	There are 116 hours of water available within the power block in the CST and RMWT or be in recovery phase.

APS Overall Integrated Plan in Response to March 12, 2012 Commission Order Modifying Licenses with Regard to Requirements for Mitigation Strategies for Beyond-Design-Basis External Events

Table Item	Elapsed Time (hr)	Action	New ELAP Time Constraint Y/N	Time Constraint (hr)	Reference	Remarks / Applicability
22	*	Diesel fuel deployment to support diesel SG makeup pump	N		16	A mechanism is established for transferring diesel fuel from the diesel day tanks to the SG makeup pump staging location to ensure a continuous supply of fuel. *Dependent on starting time of RCS makeup pump.
23	>72	Diesel SG Makeup Pump On/TDAFW Pump Off	N		16	This item is dependent on the steam available during the progression of the ELAP event.
24	72	4.16 kV Generator (from RRC) Installed	N		16	Estimated need time is based on phase 3, long-term plant mitigation strategy and recovery phase.

Attachment 1B

NSSS Significant Reference Analysis Deviation Table

APS has evaluated WCAP-17601 (Reference 14) considering PVNGS site-specific parameters and determined the conclusions of that document are applicable to PVNGS. APS has performed a plant specific analysis consistent with the recommendations of the core cooling position paper, provided as an attachment to LTR-PCSA-12-92 (Reference 22). The following deviations between the WCAP and plant specific analyses were identified as part of this evaluation and justification is provided based on the direction contained in NEI 12-06. No other deviations have been identified with respect to the PWROG recommendations for the FLEX program.

Item	Parameter of Interest	WCAP value (WCAP-17601-P)	WCAP Section	Plant applied value	Gap and discussion
1	Decay heat model	ANS 79 + 2σ	Section 4.2.1	Plant Specific Best Estimate Decay Heat Curve Developed [Noted Deviation]	Reference 5 utilized the decay heat curve documented in Reference 7. Use of best estimate decay heat values in the thermal hydraulic evaluation and for determination of plant water needs is a deviation from the WCAP but is consistent with NEI 12-06 and is justified by Reference 7.
2	RCP leakage (per RCP at NOP/NOT)	Determine site specific leak rates per Reference 5; 15 gpm applied generically	Section 4.4.2	17 gpm, Parametric study performed between 1 and 25 gpm [Noted Deviation]	Reference 15, Section 8.2; Reference 5, Table 5.2-2 identifies the PVNGS plant specific value and it is applied for the purpose of sizing FLEX equipment and determining timing. Reference 5 performed parametric cases to evaluate the sensitivity to this parameter. This value and approach are consistent with Reference 14 and represent an acceptable deviation to the generic approach.

APS Overall Integrated Plan in Response to March 12, 2012 Commission Order Modifying Licenses with Regard to Requirements for Mitigation Strategies for Beyond-Design-Basis External Events

Item	Parameter of interest	WCAP value (WCAP-17601-P)	WCAP Section	Plant applied value	Gap and discussion
3	Time initiating cool down	2 hours	Section 5.5.2.2.1	1 hour [Noted Deviation]	<p>Reference 15, Section 8.2. The cooldown start time deviates from the time assumed in the WCAP. Direction to begin the cooldown earlier is based on assumptions used in Reference 5 and guidance will be provided in the FSG. This approach helps minimize seal leakage and improves the plant response determined in Reference 5.</p> <p>This approach is consistent with Reference 14 and represents an acceptable deviation to the generic approach.</p>

Attachment 2 Milestone Schedule

The dates specifically required by the order are obligated or committed dates. Other dates are planned dates subject to change. Updates will be provided in the six month status reports.

Task	Feb-13	Mar-13	Apr-13	May-13	Jun-13	Jul-13	Aug-13	Sep-13	Oct-13	Nov-13	Dec-13	Jan-14	Feb-14	Mar-14	Apr-14	May-14	Jun-14	Jul-14	Aug-14	Sep-14	Oct-14	Nov-14	Dec-14	Jan-15	Feb-15	Mar-15	Apr-15	May-15	Jun-15	Jul-15	Aug-15	Sep-15	Oct-15	Nov-15	Dec-15				
6 Month Status Update																																							
Modifications																																							
Develop Strategies																																							
Implement Mods																																							
Unit 1, 2 and 3 Phase 1 Modifications																																							
Unit 1 Phase 2 Mods																																							
Unit 1 Phase 3 Mods																																							
Unit 2 Phase 2 Mods																																							
Unit 2 Phase 3 Mods																																							
Unit 3 Phase 2 Mods																																							
Unit 3 Phase 3 Mods																																							
Procedural Guidance																																							
Develop FSGs																																							
Create Maintenance Procedures																																							
Storage Plan																																							
Develop Storage Plan																																							
Fabricate Storage Facility (Open Item)																																							
Staffing Analysis																																							
Perform Staffing Analysis																																							
FLEX Equipment																																							
Equipment acquisition																																							
Training																																							
Develop Training Plan																																							
Implement Training																																							
Regional Response Center																																							
Regional Response Center (RCC) Operational																																							
Unit Implementation Schedule																																							
Unit 1 Implementation Outage (Full)																																							
Unit 2 final Implementation Outage																																							
Unit 3 final Implementation Outage																																							

Attachment 3 - Conceptual Sketches (Figures)

The figures in Attachment 3 are conceptual sketches and are intended to display current typical modification concepts and do not represent final design changes to implement the overall integrated plan required by the order. Significant changes to these concepts will be provided in semi-annual updates.

Color is relevant to the figures included within this appendix.

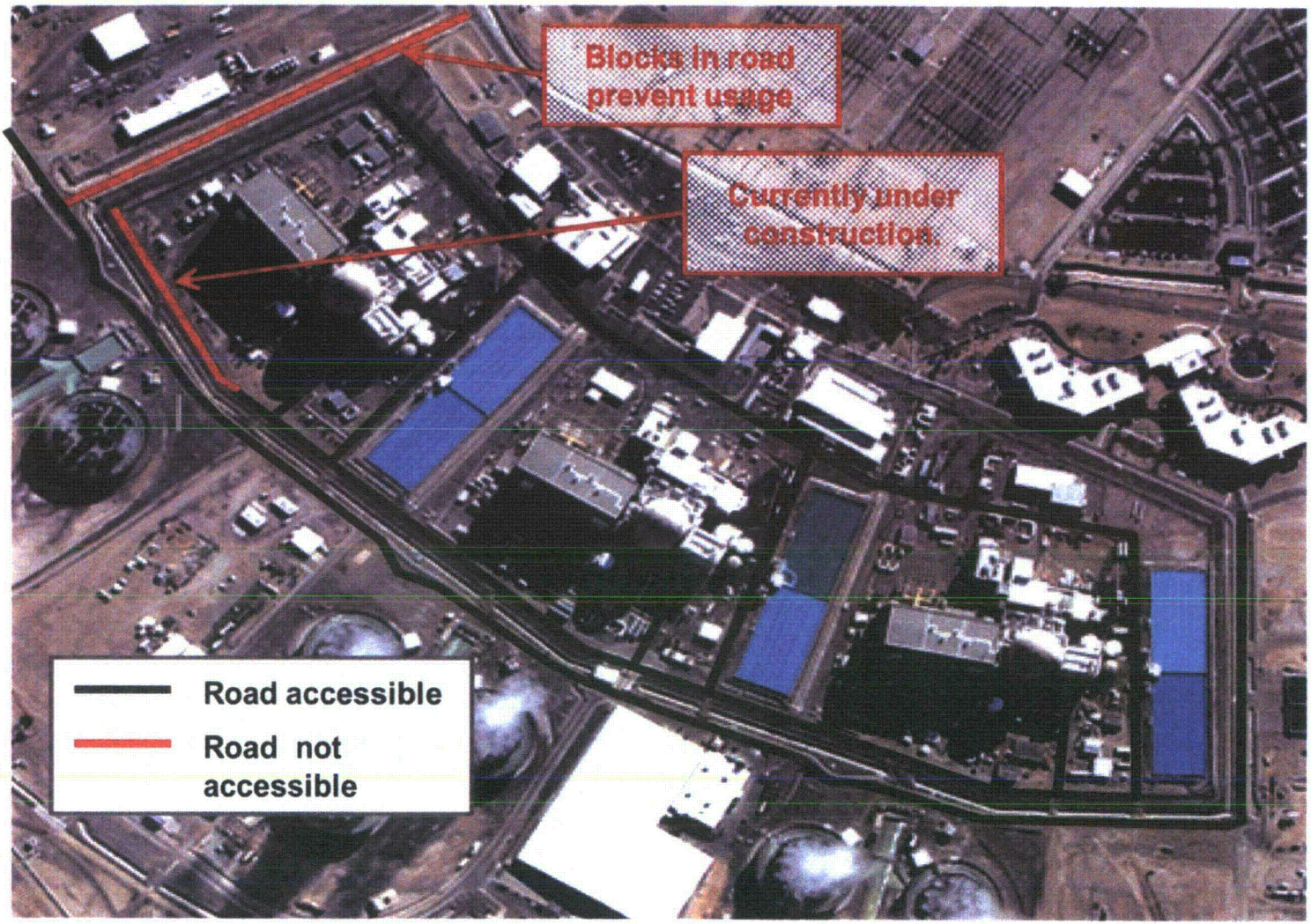

Figure 3-1: PVNGS Power Block Deployment Paths

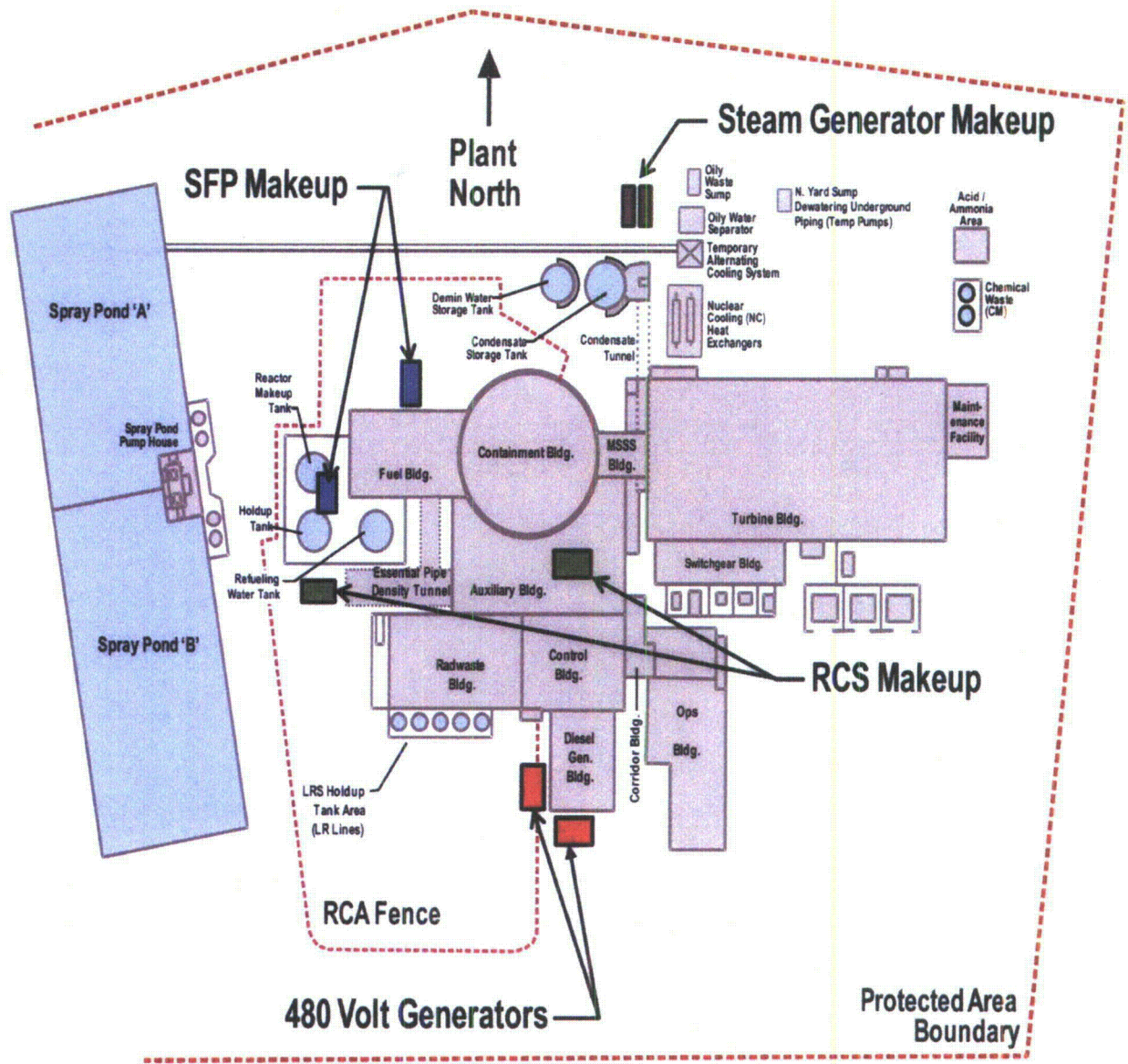

Figure 3-2: FLEX Equipment Staging Areas

Reactor Core Cooling and Heat Removal (SGs Available)

The figures in Attachment 3 are conceptual sketches and are intended to display current typical modification concepts and do not represent final design changes to implement the overall integrated plan required by the order. Significant changes to these concepts will be provided in semi-annual updates.

Color is relevant to the figures included within this appendix.

Figures in this section:

FIGURE 3-3: SG MAKEUP PRIMARY CONNECTION

FIGURE 3-4: SG MAKEUP ALTERNATE CONNECTION

FIGURE 3-5: SG MAKEUP

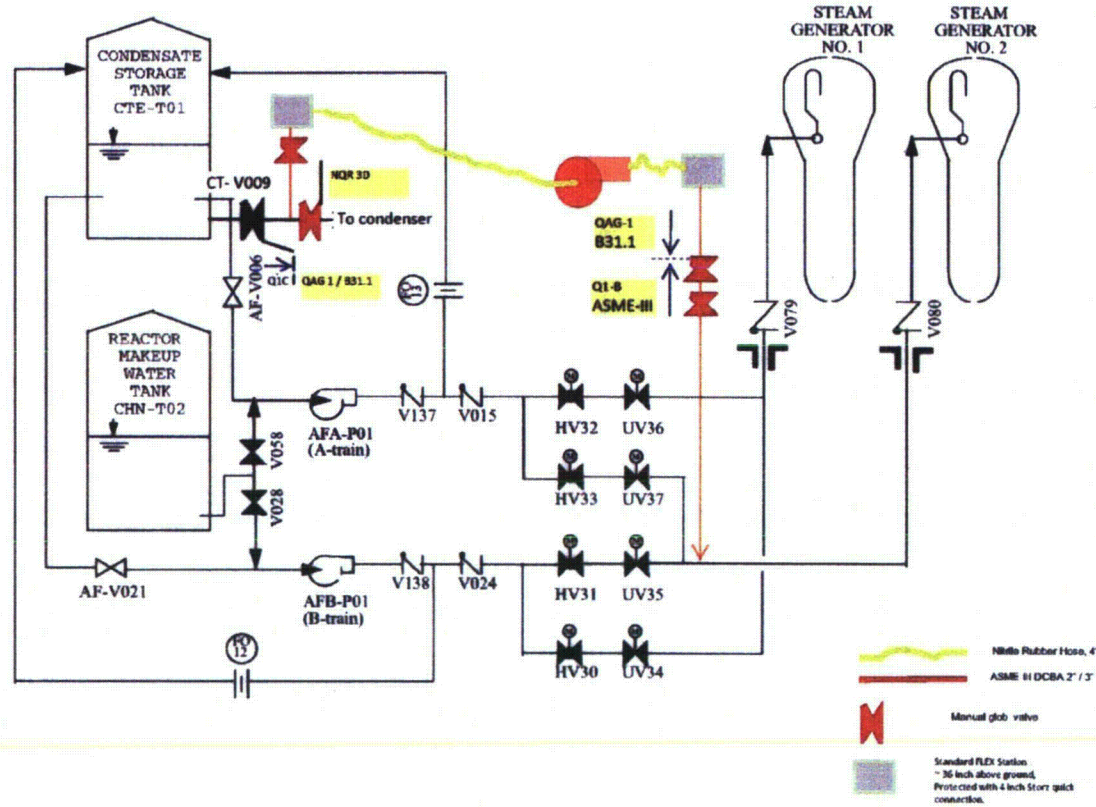

Figure 3-3: SG Makeup Primary Connection

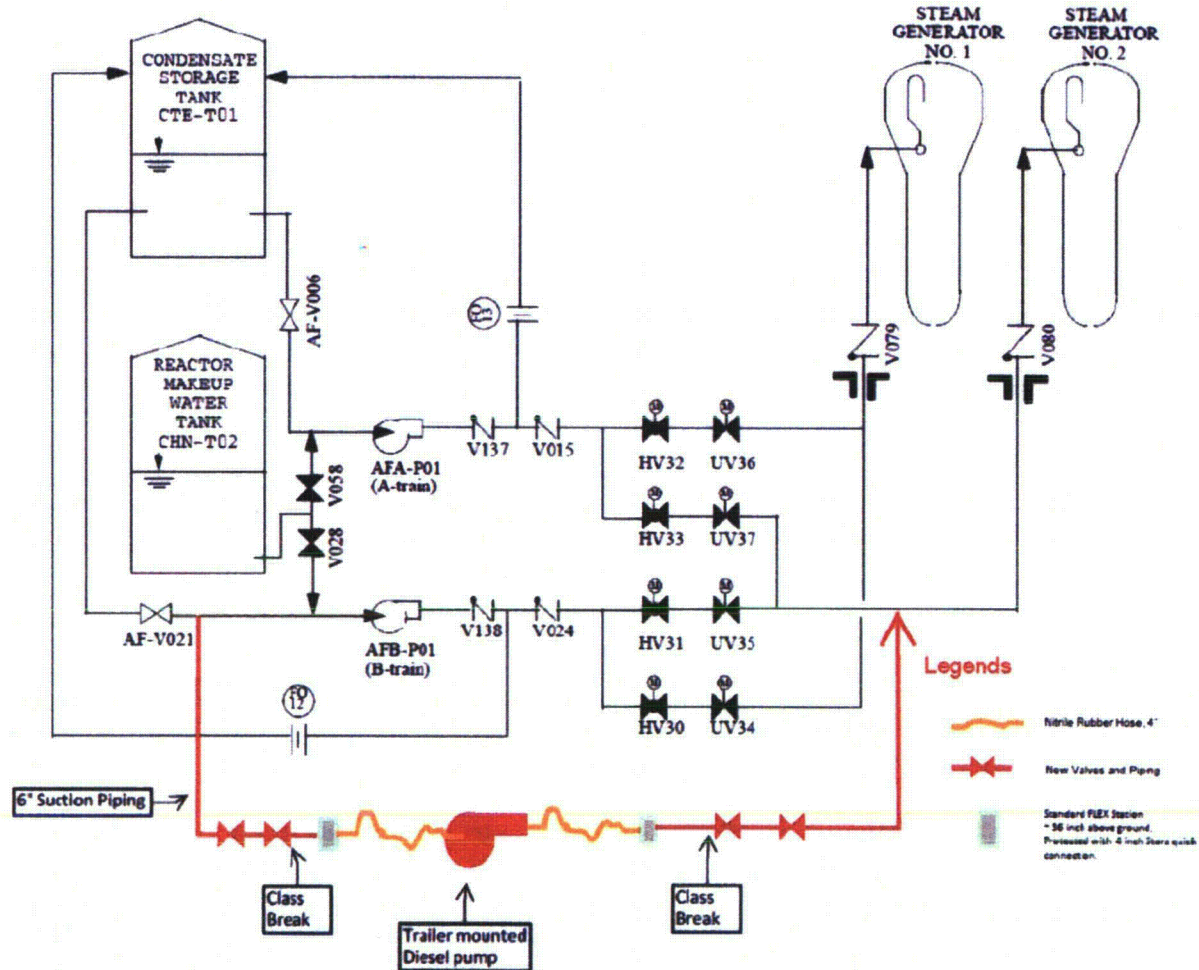

Figure 3-4: SG Makeup Alternate Connection

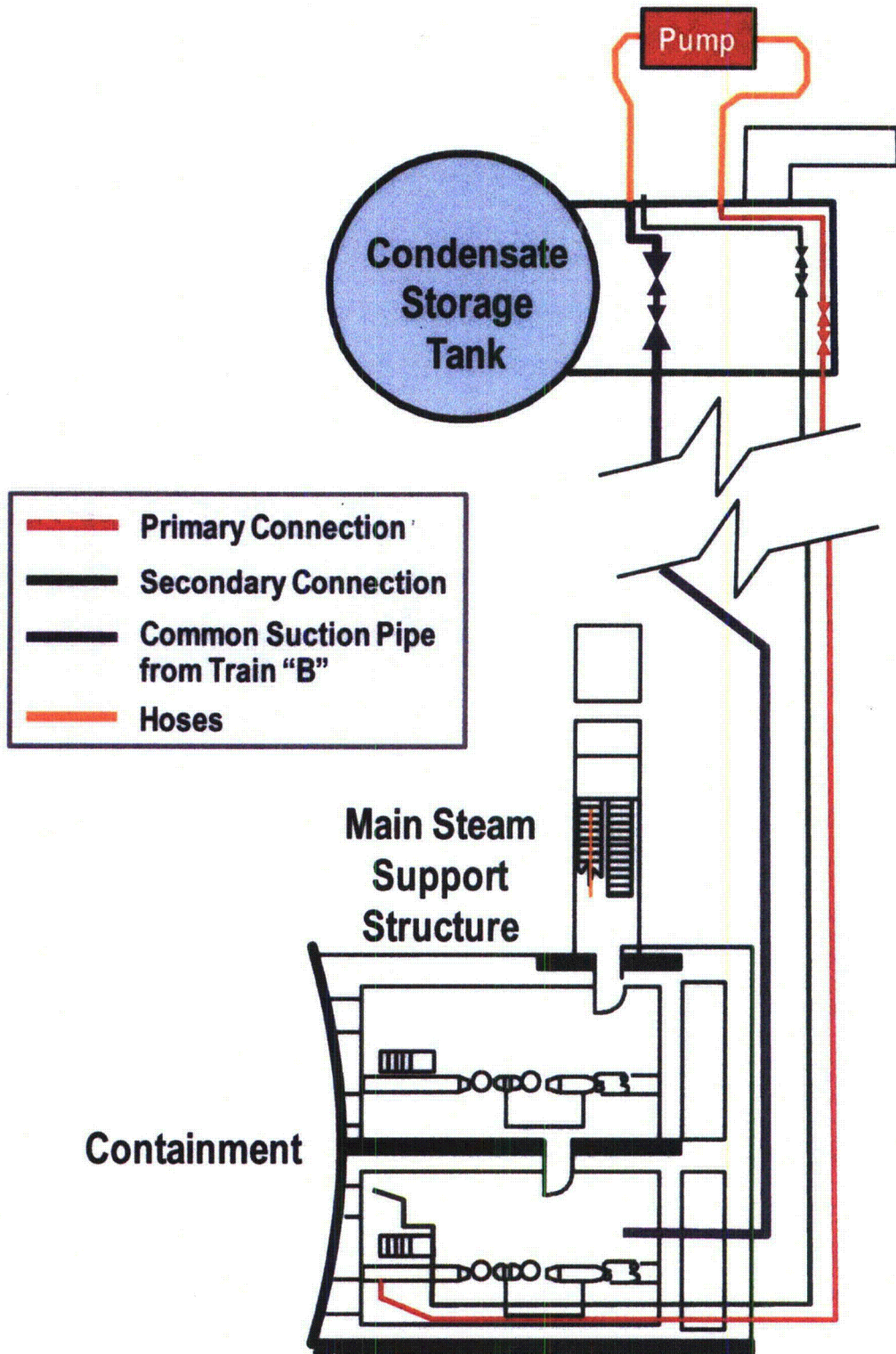

Figure 3-5: SG Makeup

RCS Inventory Control/Long-Term Subcriticality

The figures in Attachment 3 are conceptual sketches and are intended to display current typical modification concepts and do not represent final design changes to implement the overall integrated plan required by the order. Significant changes to these concepts will be provided in semi-annual updates.

Color is relevant to the figures included within this appendix.

Figures in this section:

- FIGURE 3-6: RCS PRIMARY MAKEUP CONNECTIONS
- FIGURE 3-7: RCS ALTERNATE MAKEUP CONNECTIONS
- FIGURE 3-8: PRIMARY RCS MAKEUP STRATEGY
- FIGURE 3-9: ALTERNATE RCS MAKEUP STRATEGY

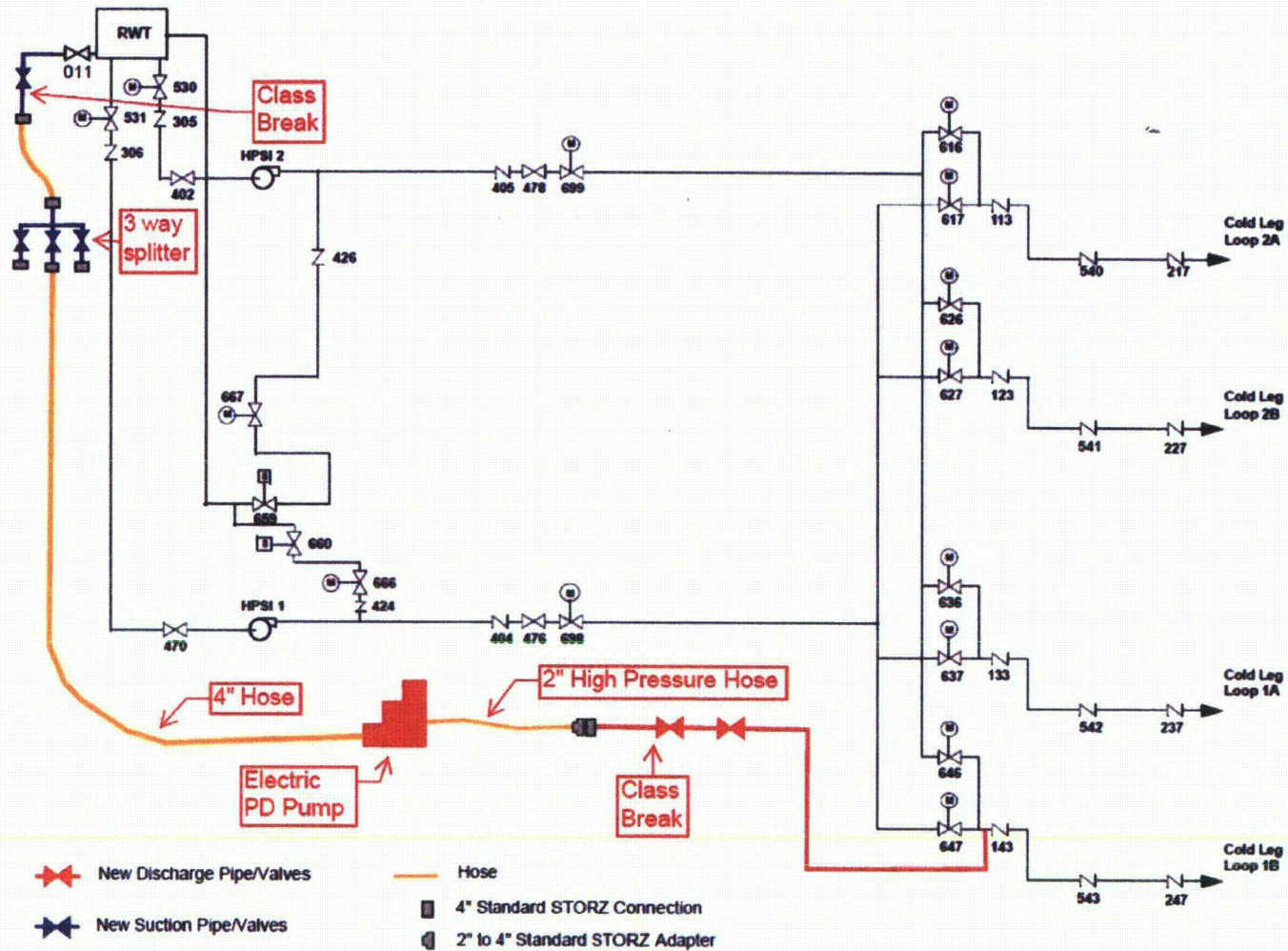

Figure 3-6: RCS Primary Makeup Connections

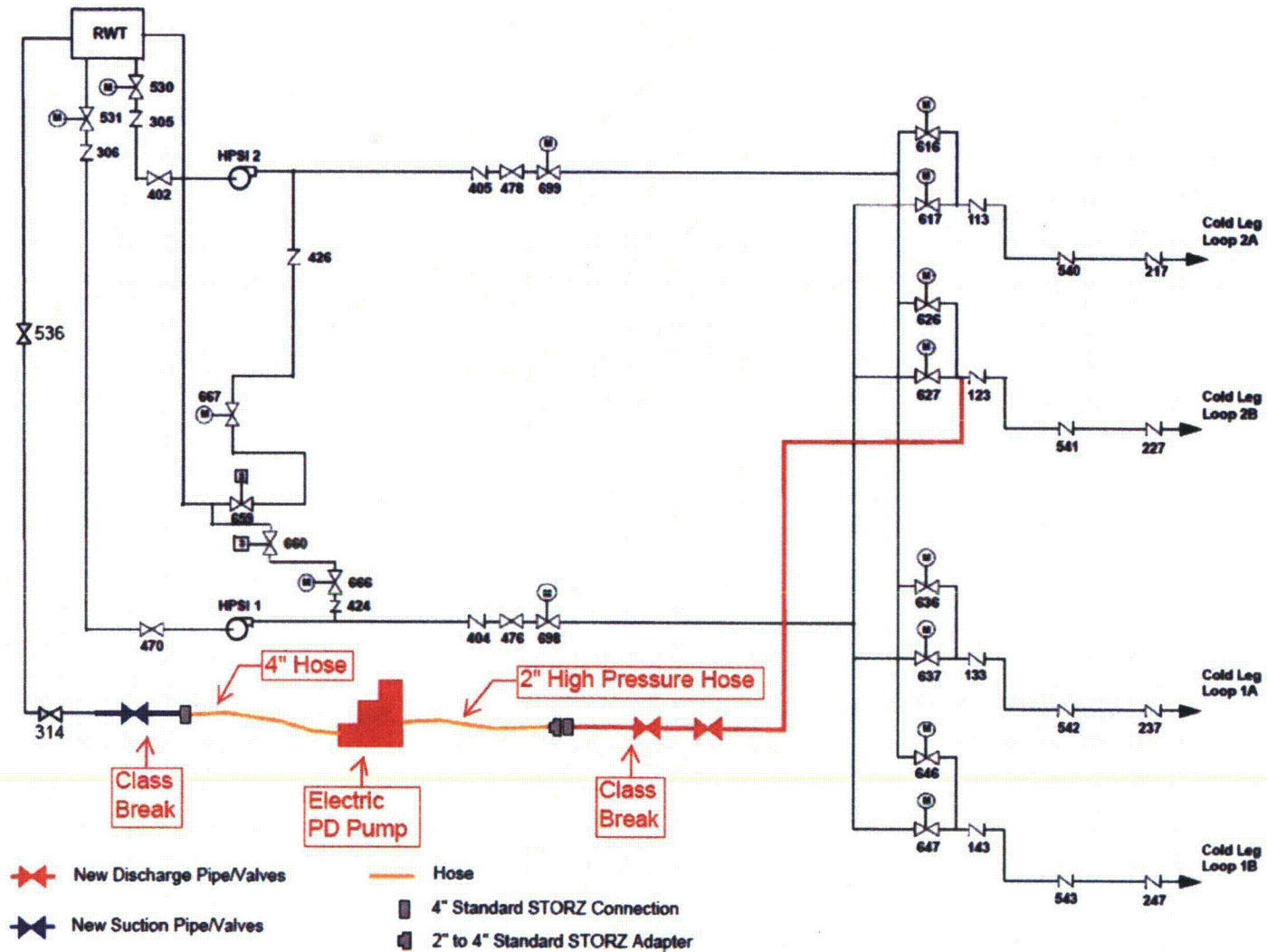

Figure 3-7: RCS Alternate Makeup Connections

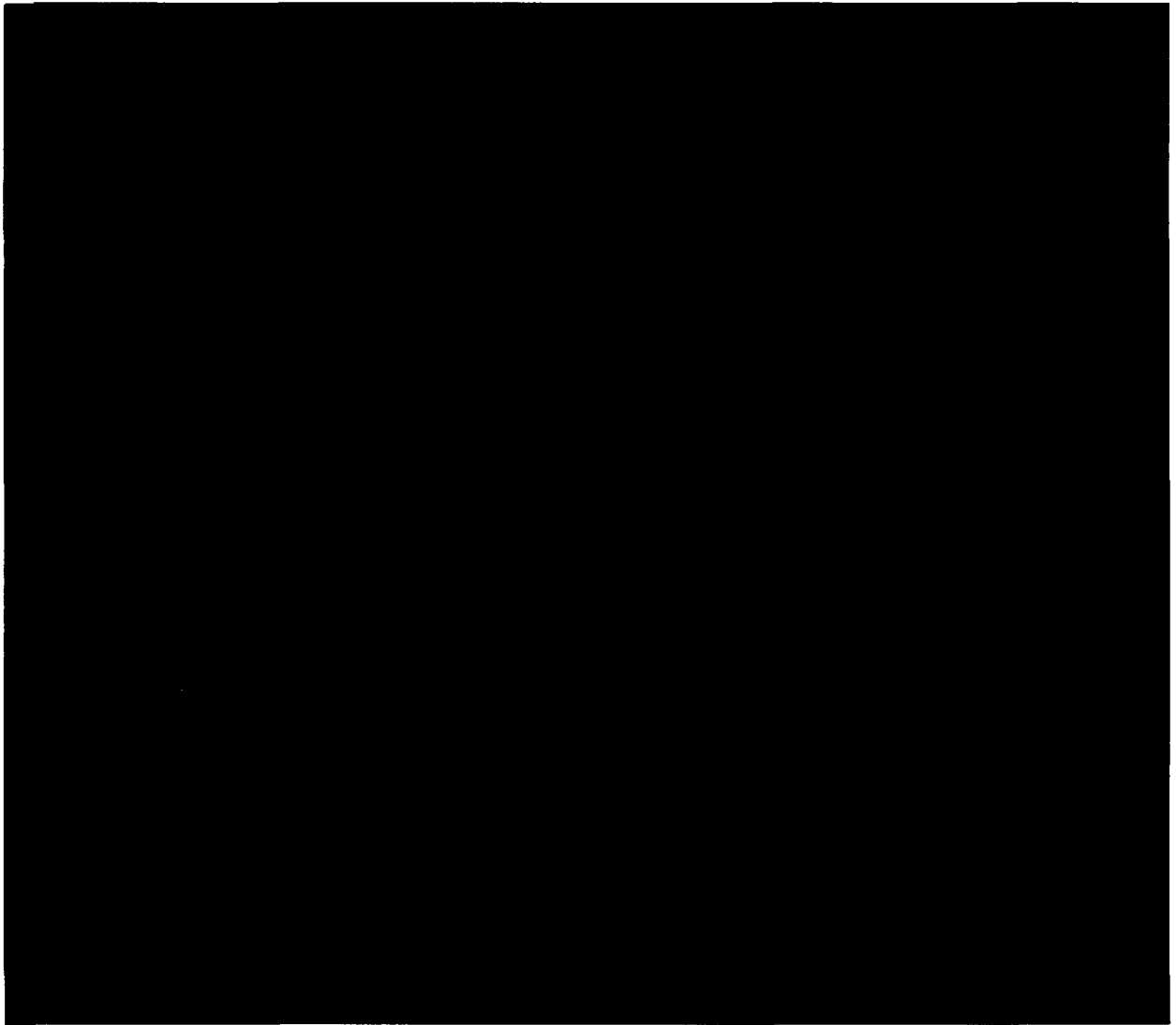

Figure 3-8: Primary RCS Makeup Strategy

Auxiliary Building 100-foot Elevation

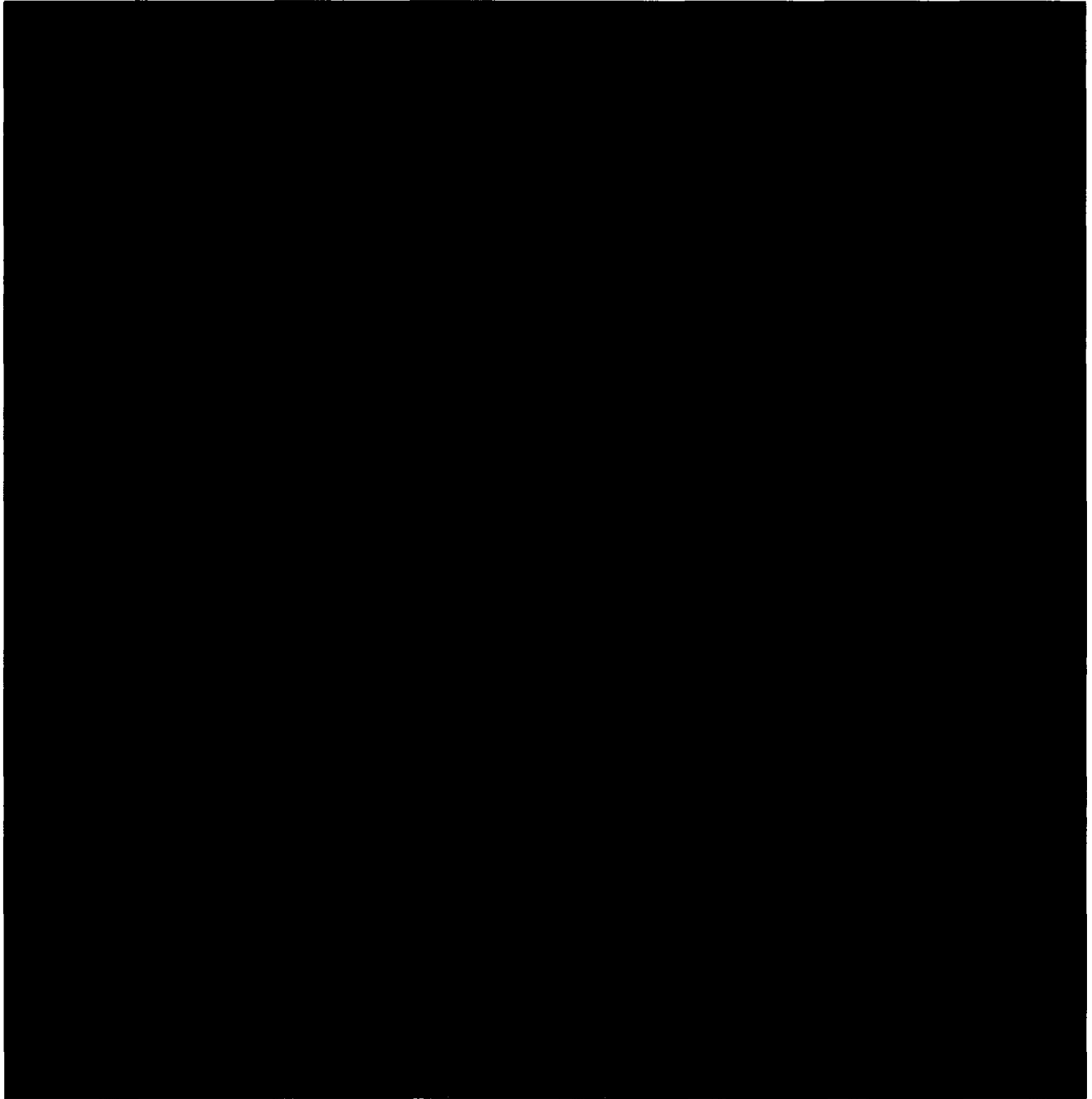

Figure 3-9: Alternate RCS Makeup Strategy

Reactor Core Cooling and Heat Removal (SGs Not Available)

The figures in Attachment 3 are conceptual sketches and are intended to display current typical modification concepts and do not represent final design changes to implement the overall integrated plan required by the order. Significant changes to these concepts will be provided in semi-annual updates.

Color is relevant to the figures included within this appendix.

Figures in this section:

FIGURE 3-10: ALTERNATE RCS MAKEUP STRATEGY MODES 5 AND 6

For Primary RCS makeup strategy for Modes 5 and 6, refer to Figure 3-8

Auxiliary Building 100-foot Elevation

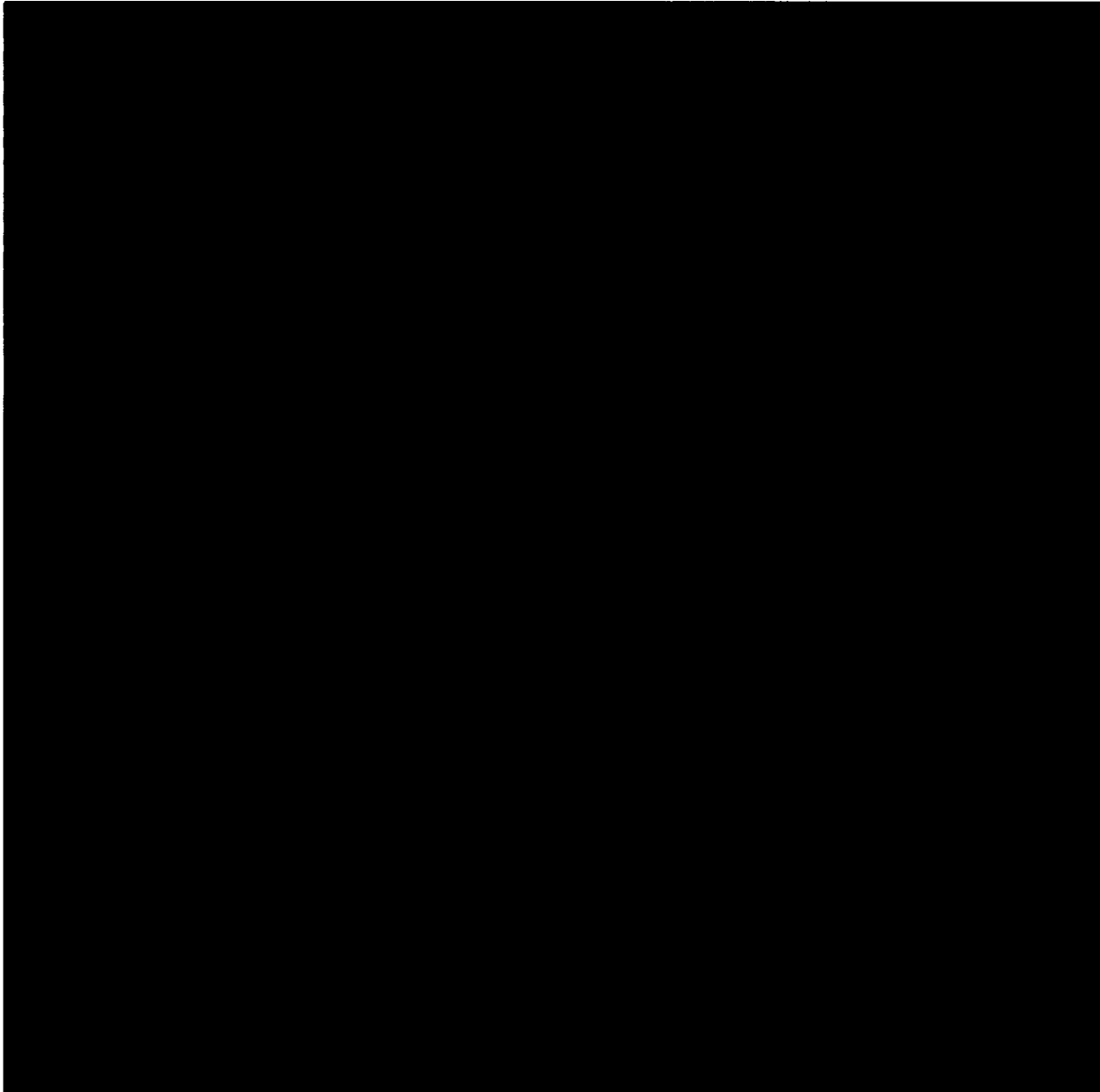

Figure 3-10: Alternate RCS Makeup Strategy for Modes 5 and 6

SFP Makeup

The figures in Attachment 3 are conceptual sketches and are intended to display current typical modification concepts and do not represent final design changes to implement the overall integrated plan required by the order. Significant changes to these concepts will be provided in semi-annual updates.

Color is relevant to the figures included within this appendix.

Figures in this section:

FIGURE 3-11: SFP MAKEUP PRIMARY CONNECTION

FIGURE 3-12: SFP MAKEUP ALTERNATE CONNECTION

FIGURE 3-13: CST MAKEUP CONNECTION MODIFICATION WITH NEW VALVES

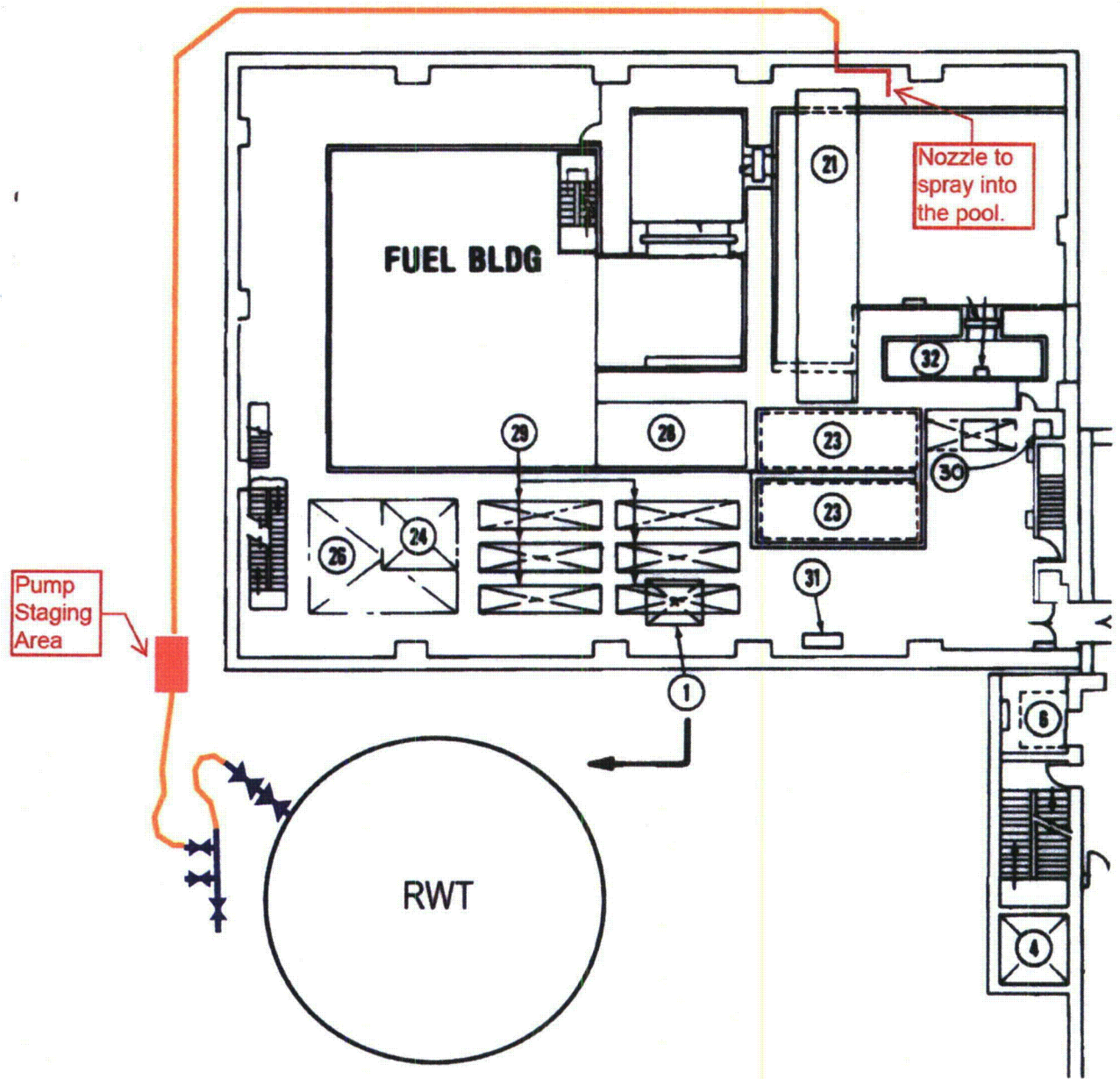

Figure 3-11: SFP Makeup Primary Connection

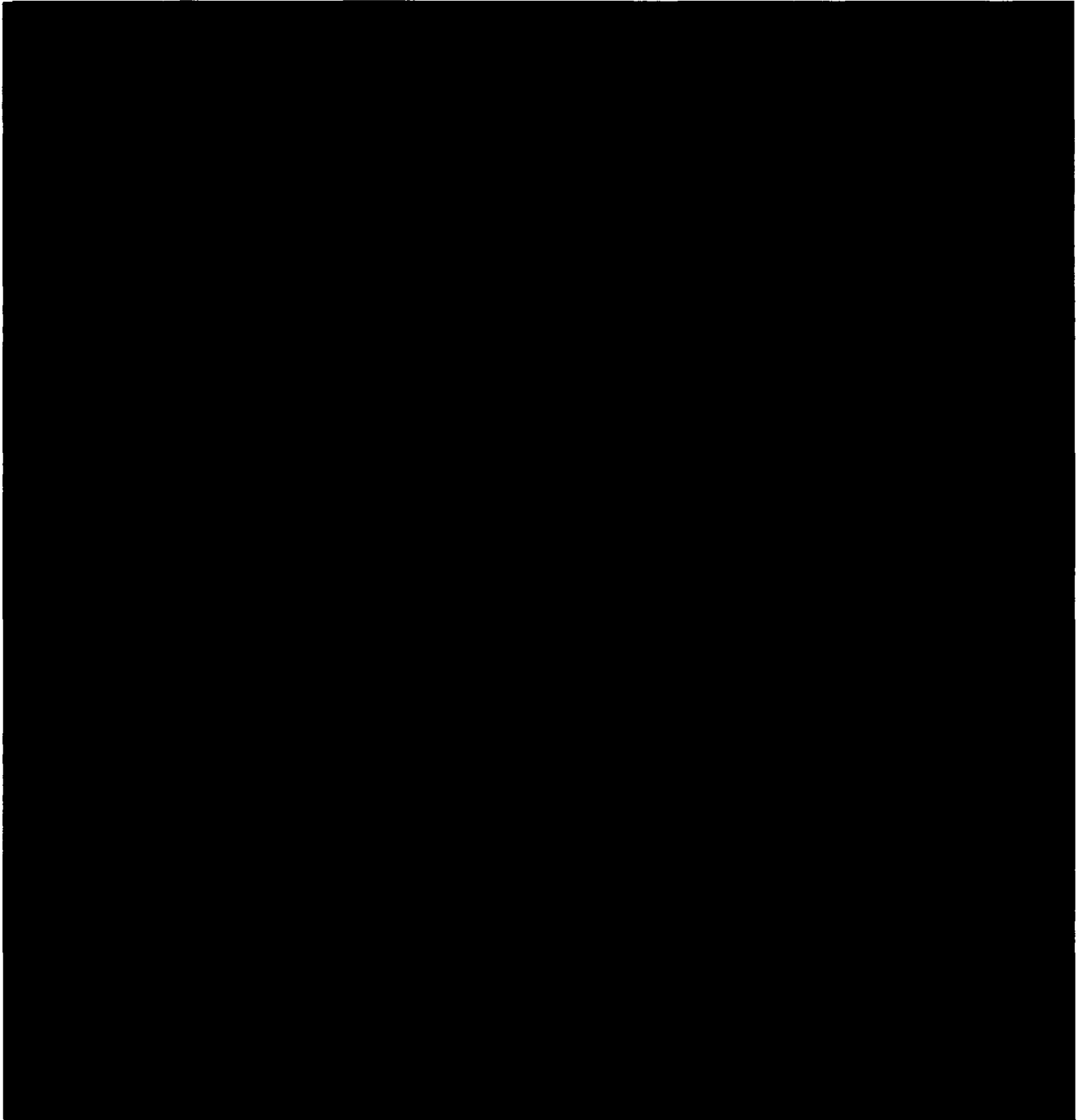

Figure 3-12: SFP Makeup Alternate Connection

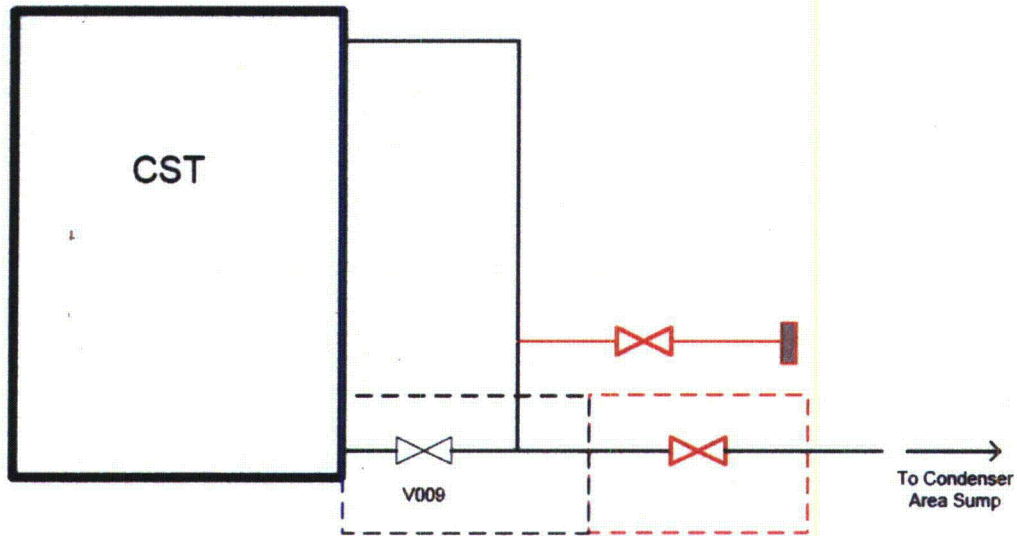

Figure 3-13: CST Makeup Connection Modification with New Valves
(Red indicates new valves, pipe and expansion of current valve enclosure.)

Non-Borated Water Source Makeup

The figures in Attachment 3 are conceptual sketches and are intended to display current typical modification concepts and do not represent final design changes to implement the overall integrated plan required by the order. Significant changes to these concepts will be provided in semi-annual updates.

Color is relevant to the figures included within this appendix.

Figures in this section:

FIGURE 3- 14: DELETED

FIGURE 3-15: CST MAKEUP PUMPING FROM THE RESERVOIRS

Figure 3- 14

DELETED



Figure 3-15: CST Makeup Pumping from the Reservoirs

Electrical

The figures in Attachment 3 are conceptual sketches and are intended to display current typical modification concepts and do not represent final design changes to implement the overall integrated plan required by the order. Significant changes to these concepts will be provided in semi-annual updates.

Color is relevant to the figures included within this appendix.

Figures in this section:

- FIGURE 3-16: PRIMARY LOCATION FOR FLEX GENERATORS
- FIGURE 3-17: DEPLOYMENT ROUTE FOR 480V AND 4.16KV GENERATORS
- FIGURE 3-18: SEVEN-DAY UNDERGROUND DIESEL FUEL TANKS
- FIGURE 3-19: PRIMARY CONNECTION FOR FLEX GENERATORS
- FIGURE 3-20: SINGLE-LINE FOR PRIMARY CONNECTION TO L31
- FIGURE 3-21: SINGLE-LINE FOR PRIMARY CONNECTION TO L33
- FIGURE 3-22: SINGLE-LINE FOR PRIMARY CONNECTION TO L35
- FIGURE 3-23: ALTERNATE CONNECTION FOR FLEX GENERATORS
- FIGURE 3-24: ALTERNATE CONNECTION LOCATION FLEX GENERATORS
- FIGURE 3-25: SINGLE-LINE FOR ALTERNATE CONNECTION TO L32
- FIGURE 3-26: SINGLE-LINE FOR ALTERNATE CONNECTION TO L34
- FIGURE 3-27: SINGLE-LINE FOR ALTERNATE CONNECTION TO L36
- FIGURE 3-28: DELETED
- FIGURE 3-29: DELETED
- FIGURE 3-30: DELETED
- FIGURE 3-31: DELETED
- FIGURE 3-32: PRIM ELECTRICAL CONNECTIONS FOR RCS FLEX PUMPS
- FIGURE 3-33: PRIM ELECTRICAL CONNECTIONS FOR RCS FLEX PUMPS
- FIGURE 3-34: PRIM LOCATION RCS FLEX PUMPS JUNCTION BOX
- FIGURE 3-35: SINGLE-LINE FOR CONNECTION TO FLEX RCS PUMPS
- FIGURE 3-36: ALTERNATE RCS FLEX PUMP CONNECTIONS
- FIGURE 3-37: ALTERNATE SWITCH LOCATION –CHARGING ROOM E
- FIGURE 3-38: ALTERNATE CHARGING ROOM E JUNCTION BOX LOCATION
- FIGURE 3-39: PRIMARY 4.16KV FLEX GENERATOR CONNECTION
- FIGURE 3-40: NEW BREAKER PANEL LOCATION ON PBA-S03
- FIGURE 3-41: ALTERNATE 4.16KV FLEX GENERATOR CONNECTION
- FIGURE 3-42: SINGLE LINE TRAIN A 4.16KV CONNECTION POINT
- FIGURE 3-43: SINGLE LINE TRAIN B 4.16KV CONNECTION POINT

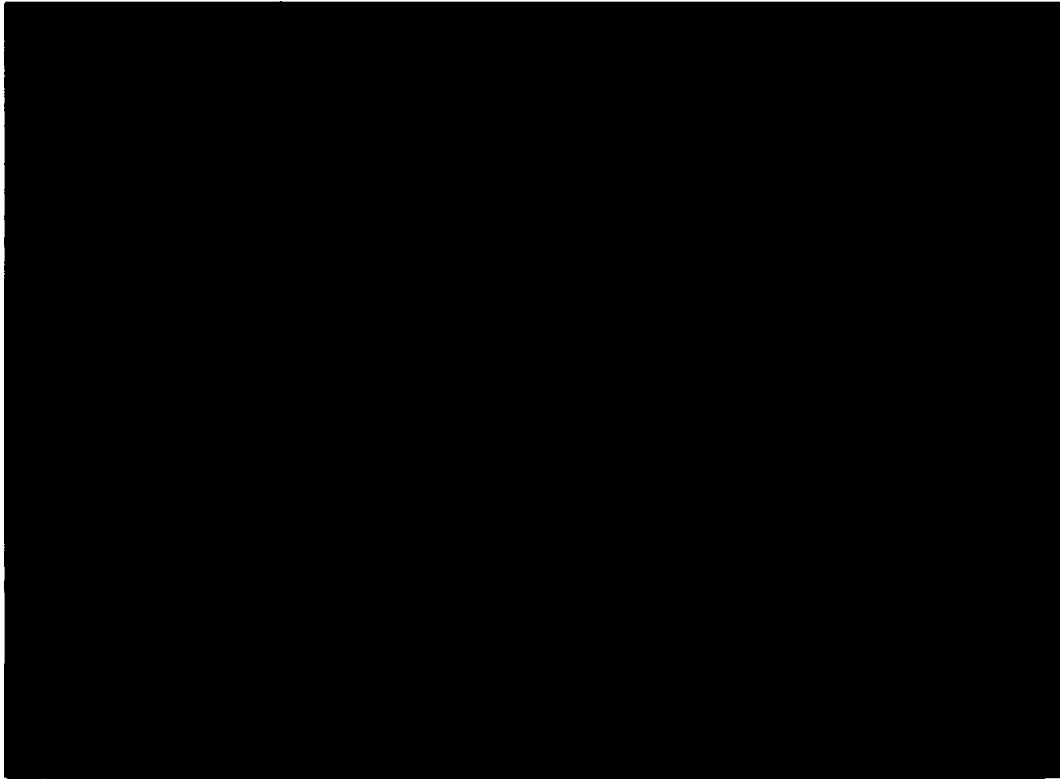

Figure 3-16– Primary Connection Location for the 480 V Train A FLEX Generators

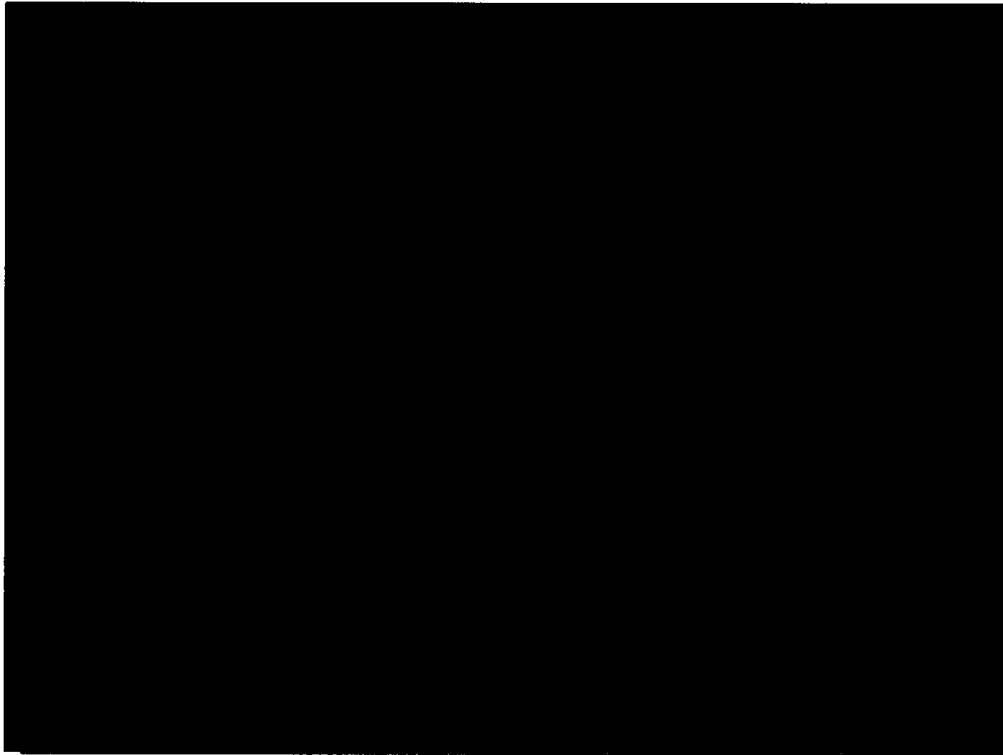

Figure 3-17: Deployment Route for 480V and 4.16kV Generators



Figure 3-18: Seven-day Underground Diesel Fuel Tanks

Control Building 100-foot Elevation

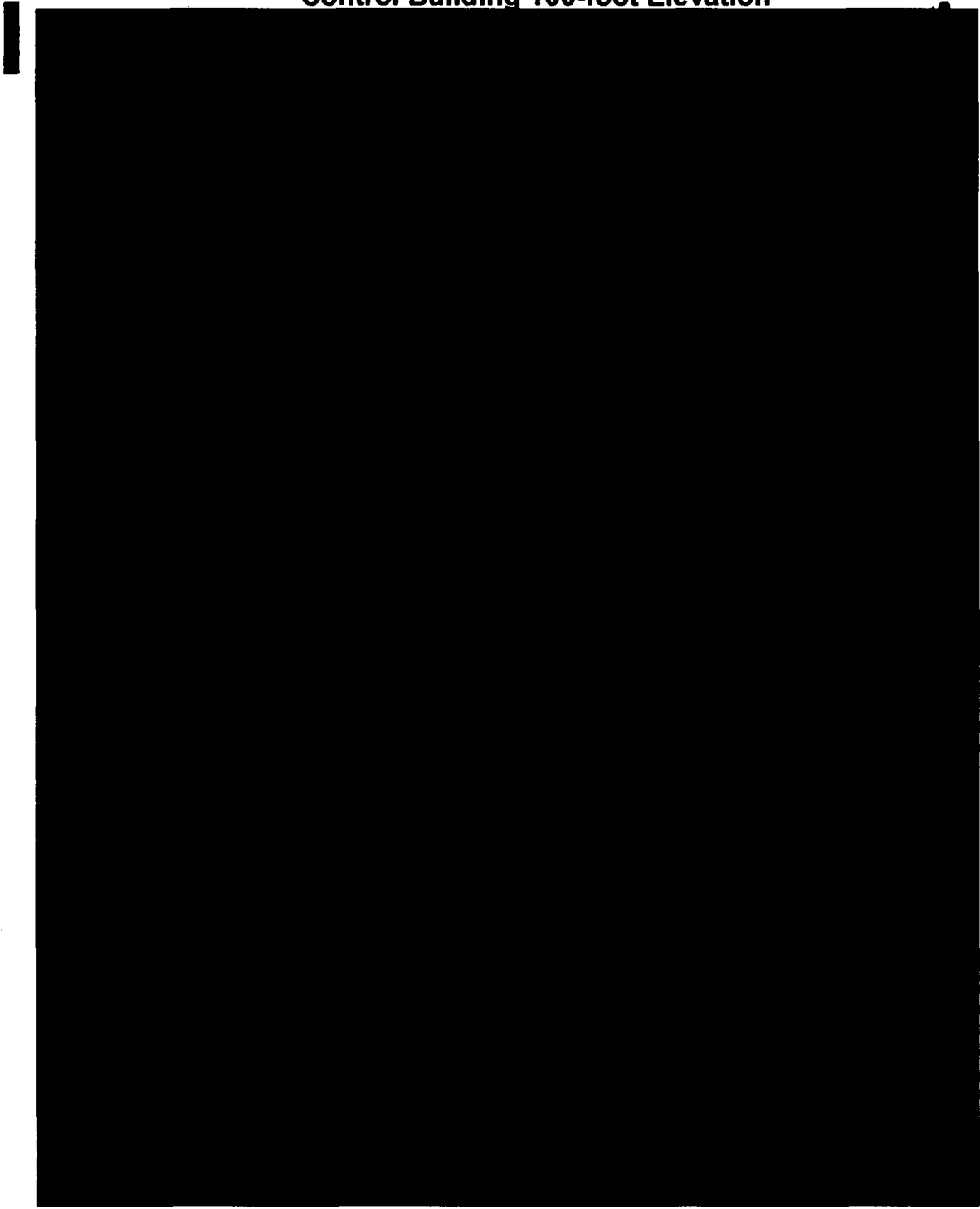

Figure 3-19: Primary Connection for the 480 V Train A FLEX Generators

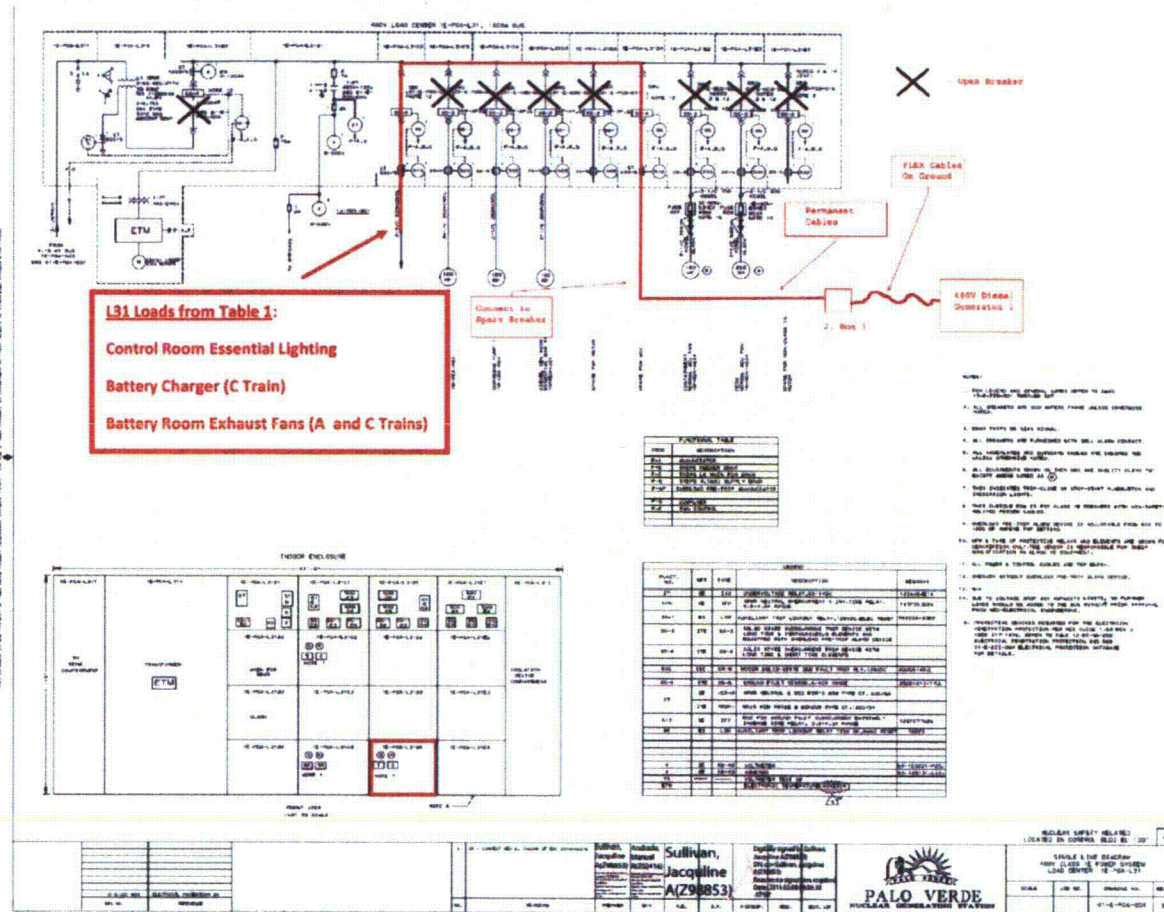

Figure 3-20: Single-Line for Primary Connection to Train A 480V Load Center L31

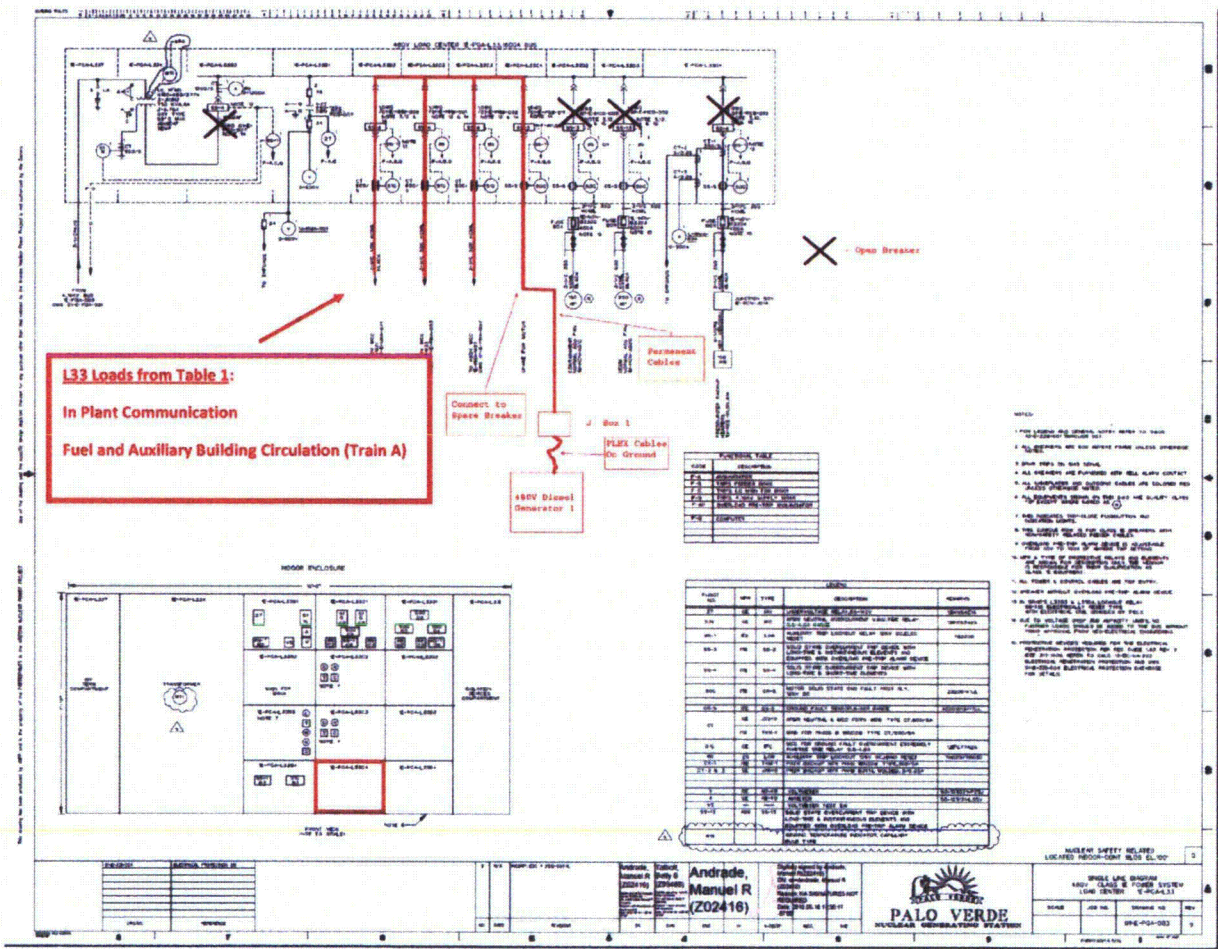

Figure 3-21: Single-Line for Primary Connection to Train A 480V Load Center L33

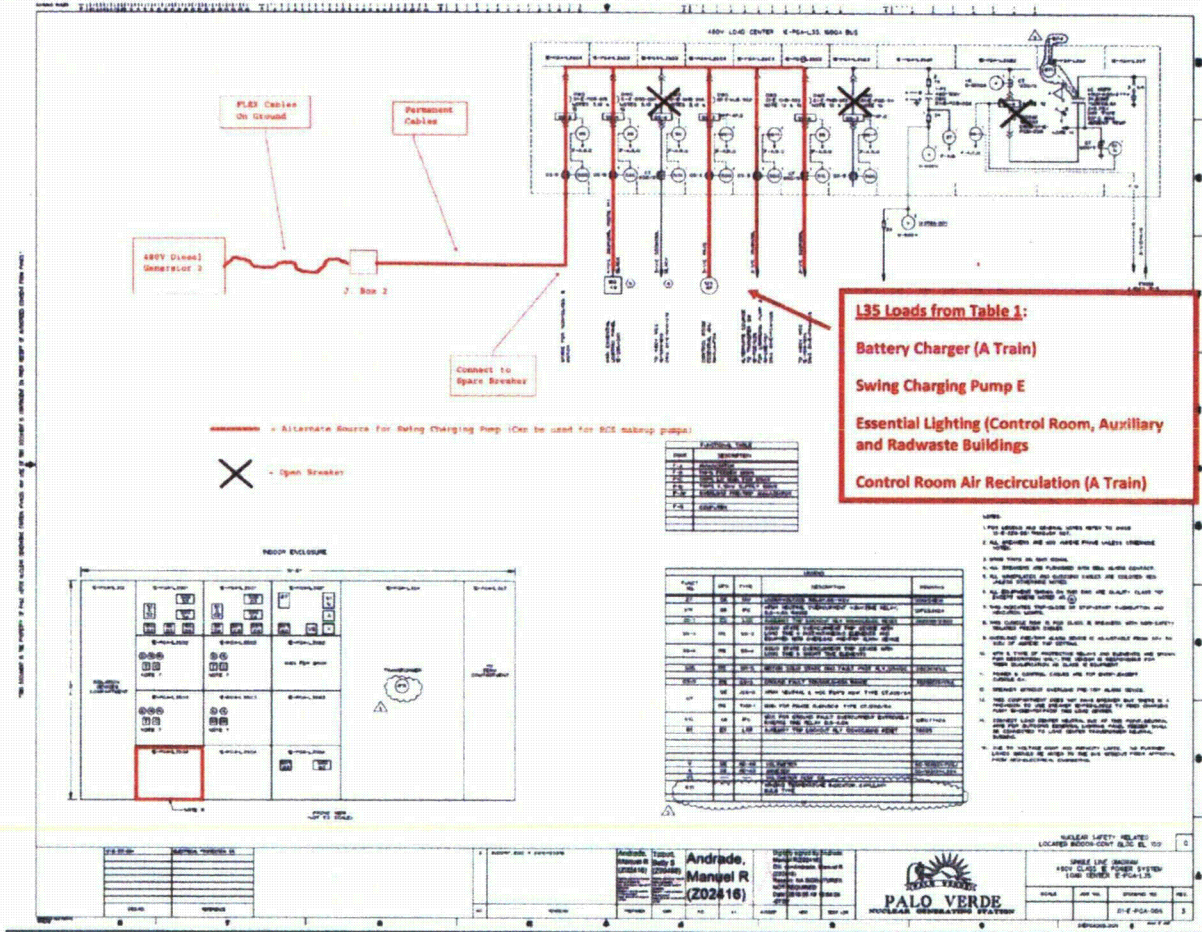

Figure 3-22: Single-Line for Primary Connection to Train A 480V Load Center L35

Control Building 100-foot Elevation

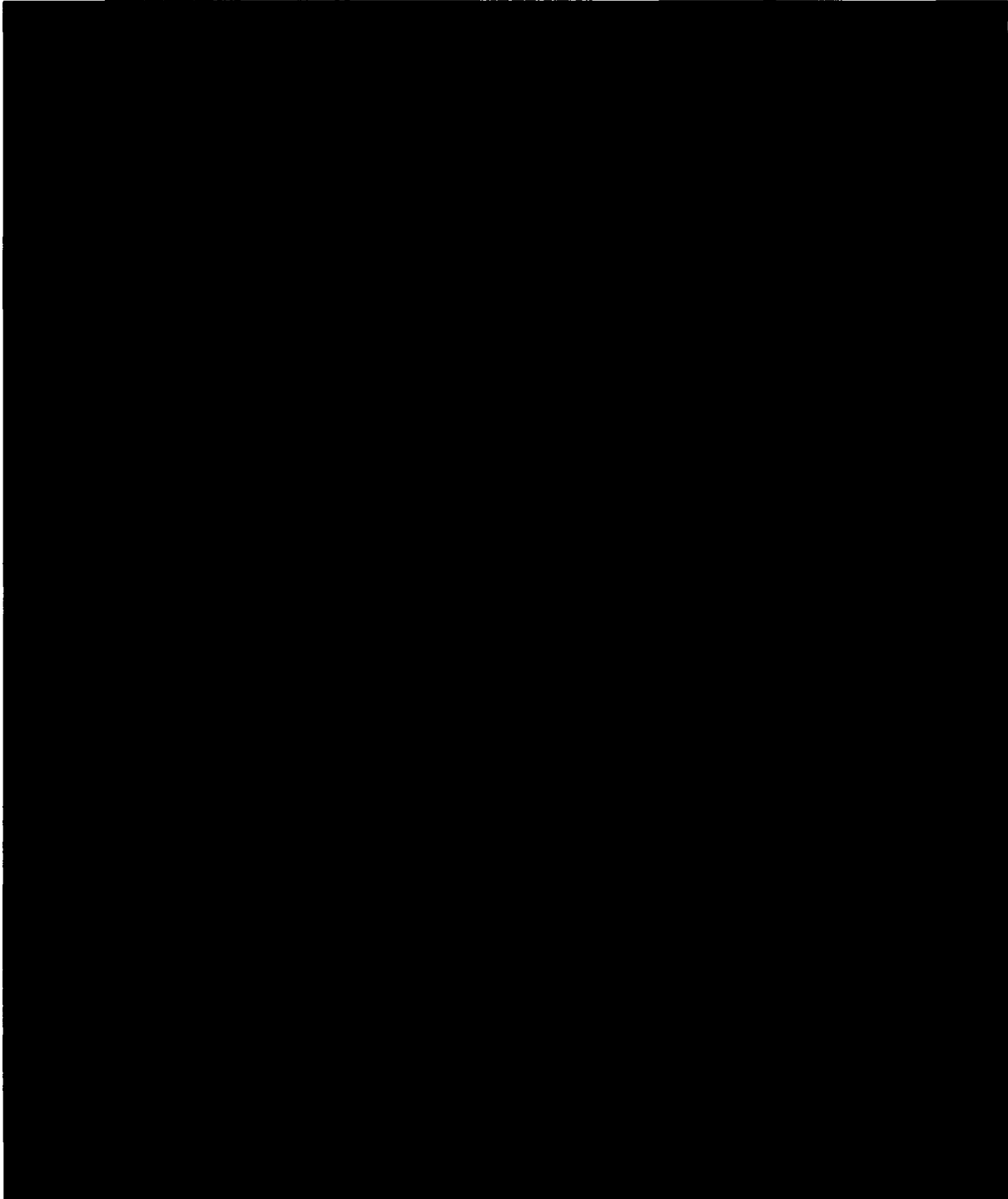

Figure 3-23: Alternate Connection for the 480 V Train B FLEX Generators

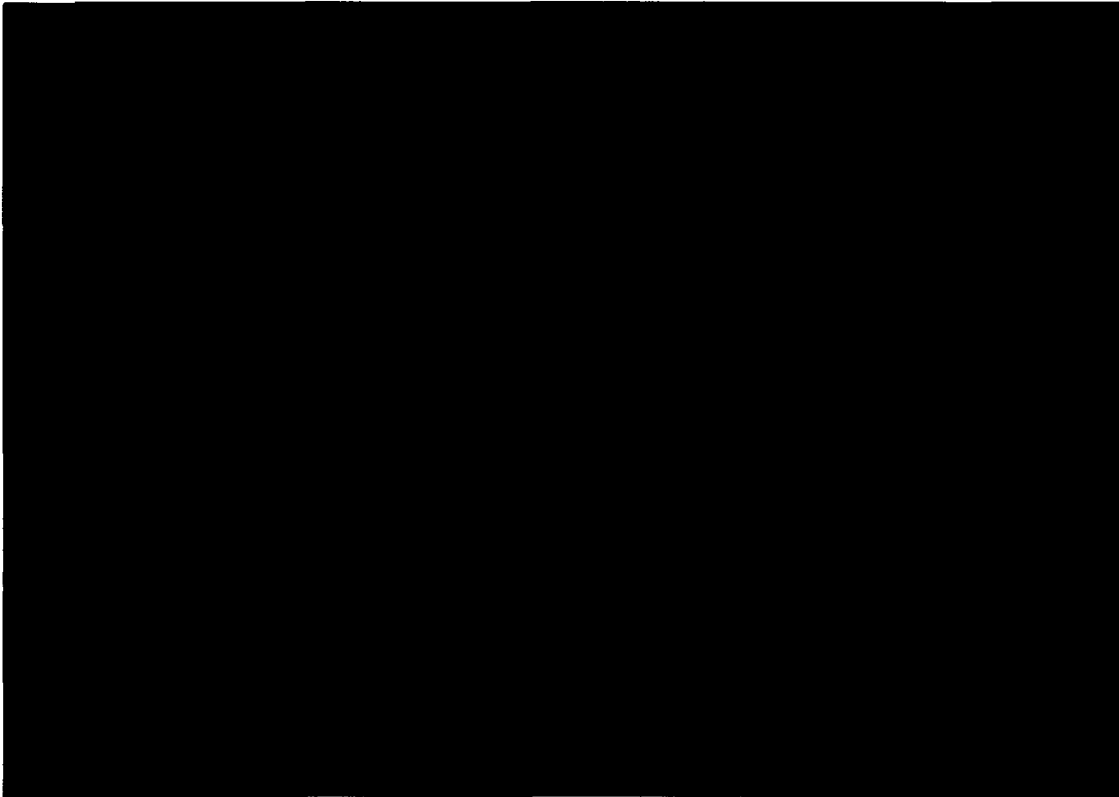

Figure 3-24: Alternate Connection Location for the 480 V Train B FLEX Generators

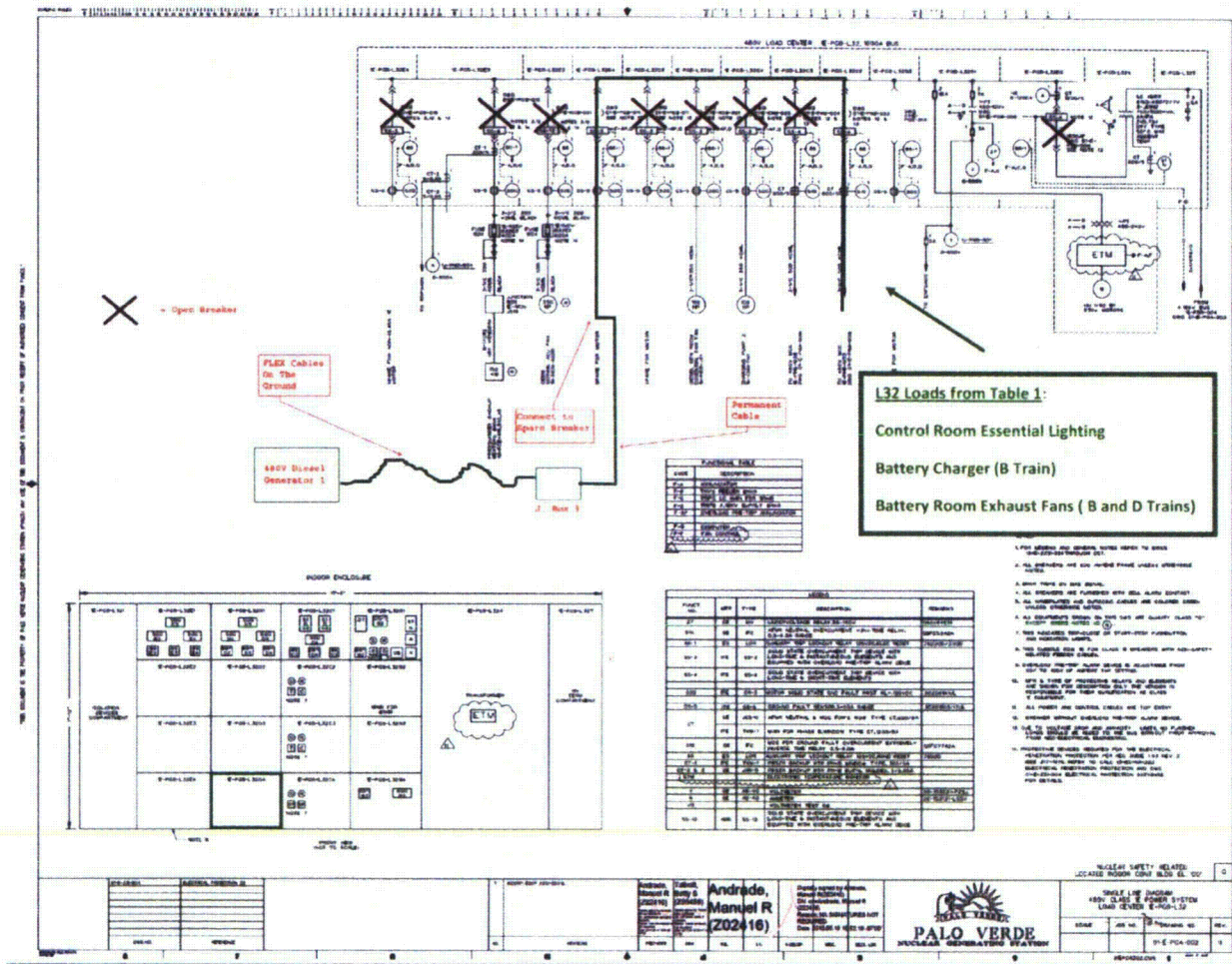

Figure 3-25: Single-Line for Alternate Connection to Train B 480V Load Center L32

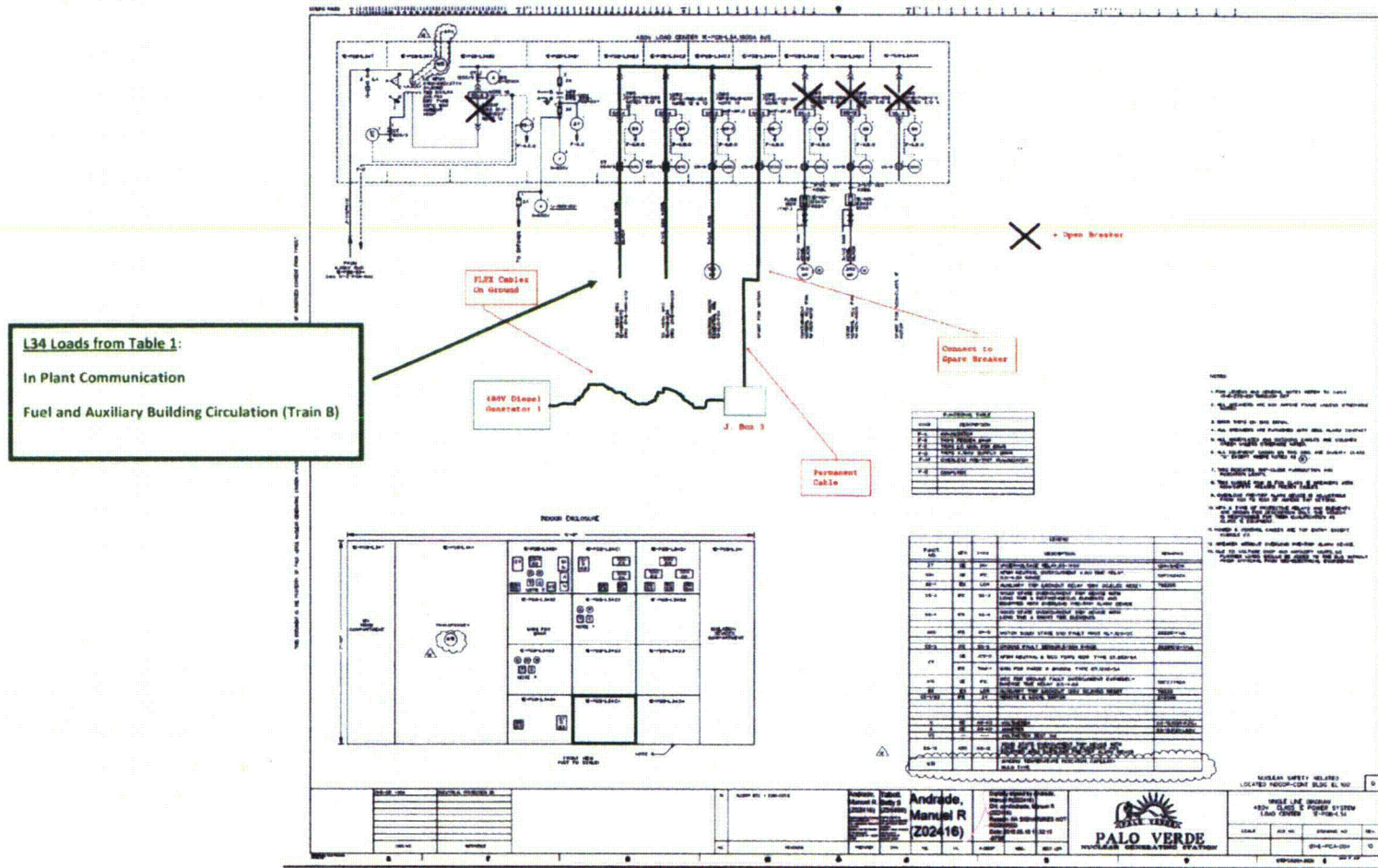

Figure 3-26: Single-Line for Alternate Connection to Train B 480V Load Center L34

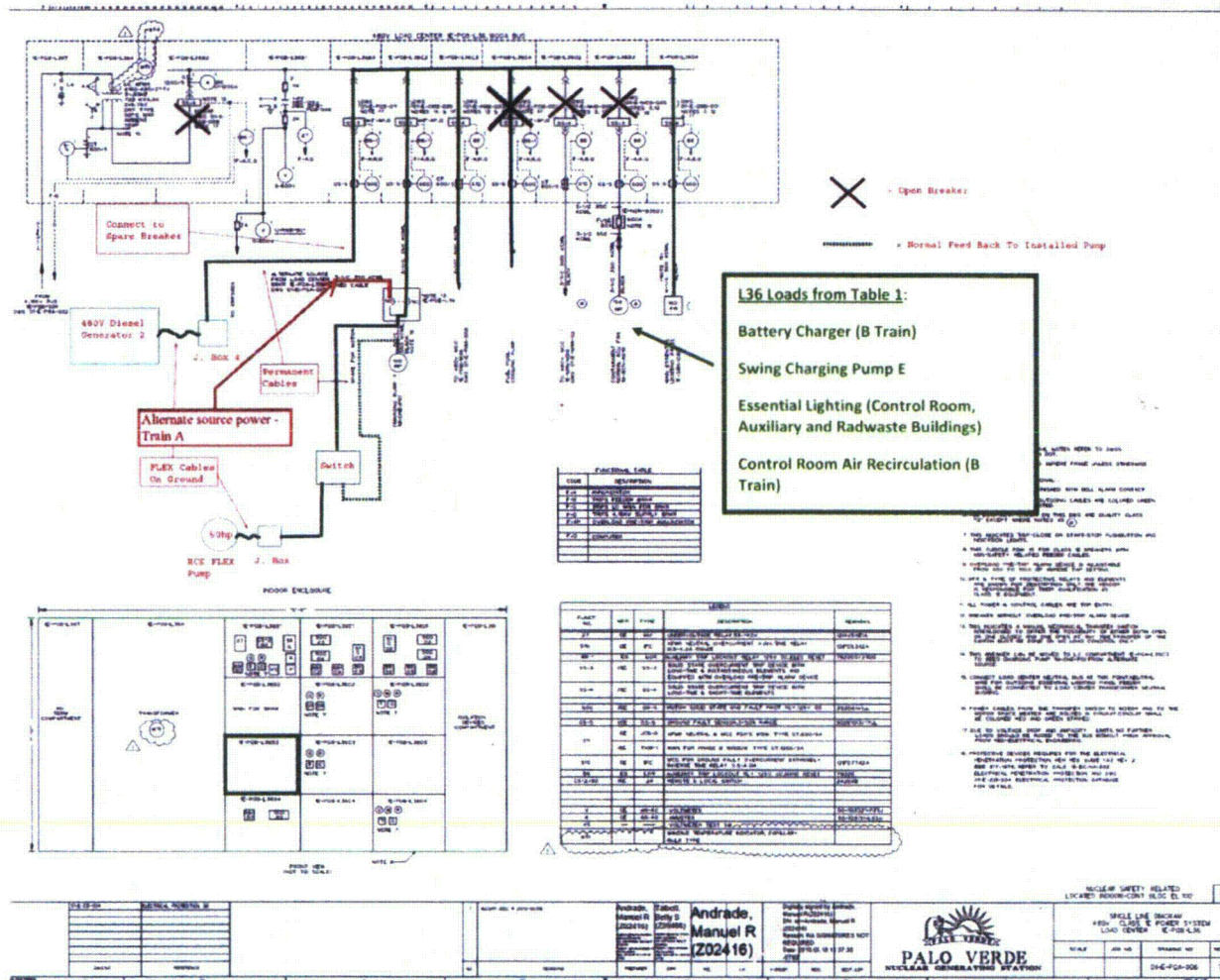

Figure 3-27: Single-Line for Alternate Connection to Train B 480V Load Center L36

Figure 3-28

DELETED

Figure 3-29

DELETED

Figure 3-30

DELETED

Figure 3-31

DELETED

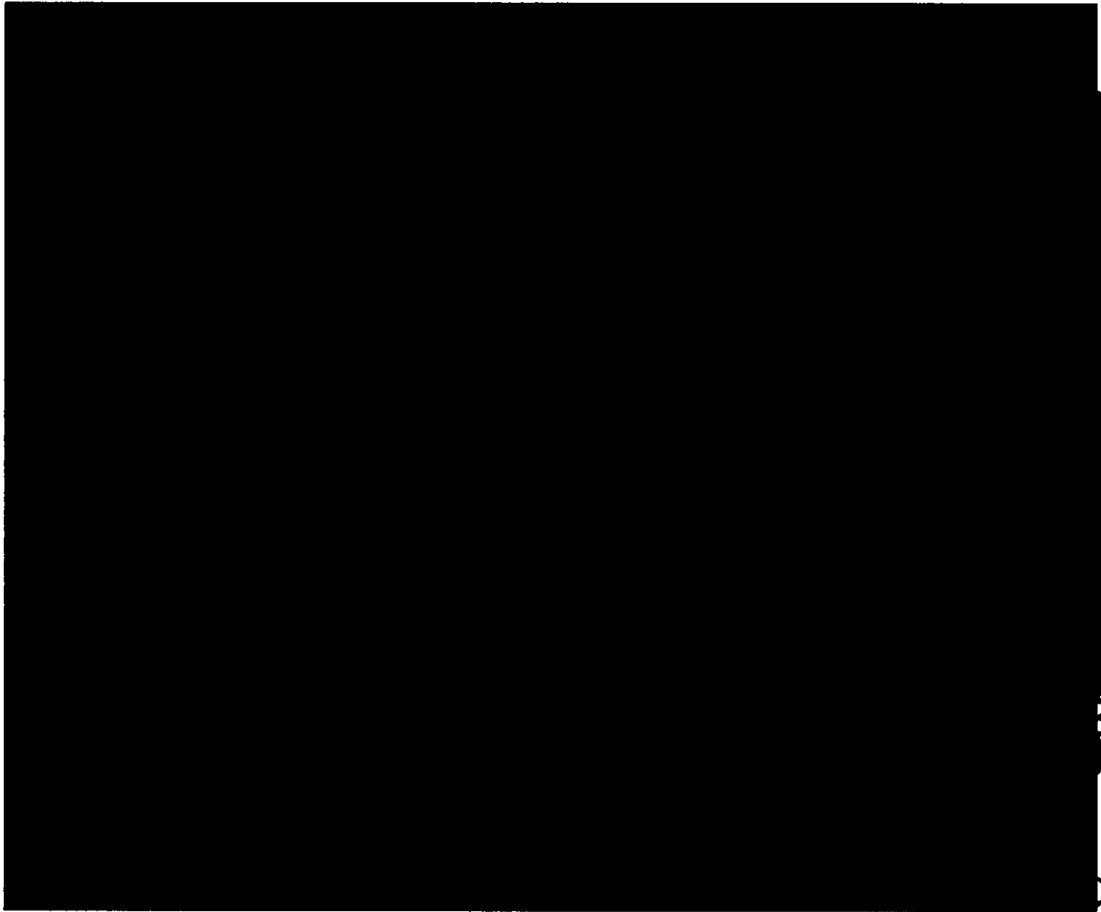

Figure 3-32: Primary Electrical Connections for the RCS FLEX Pumps for Train A

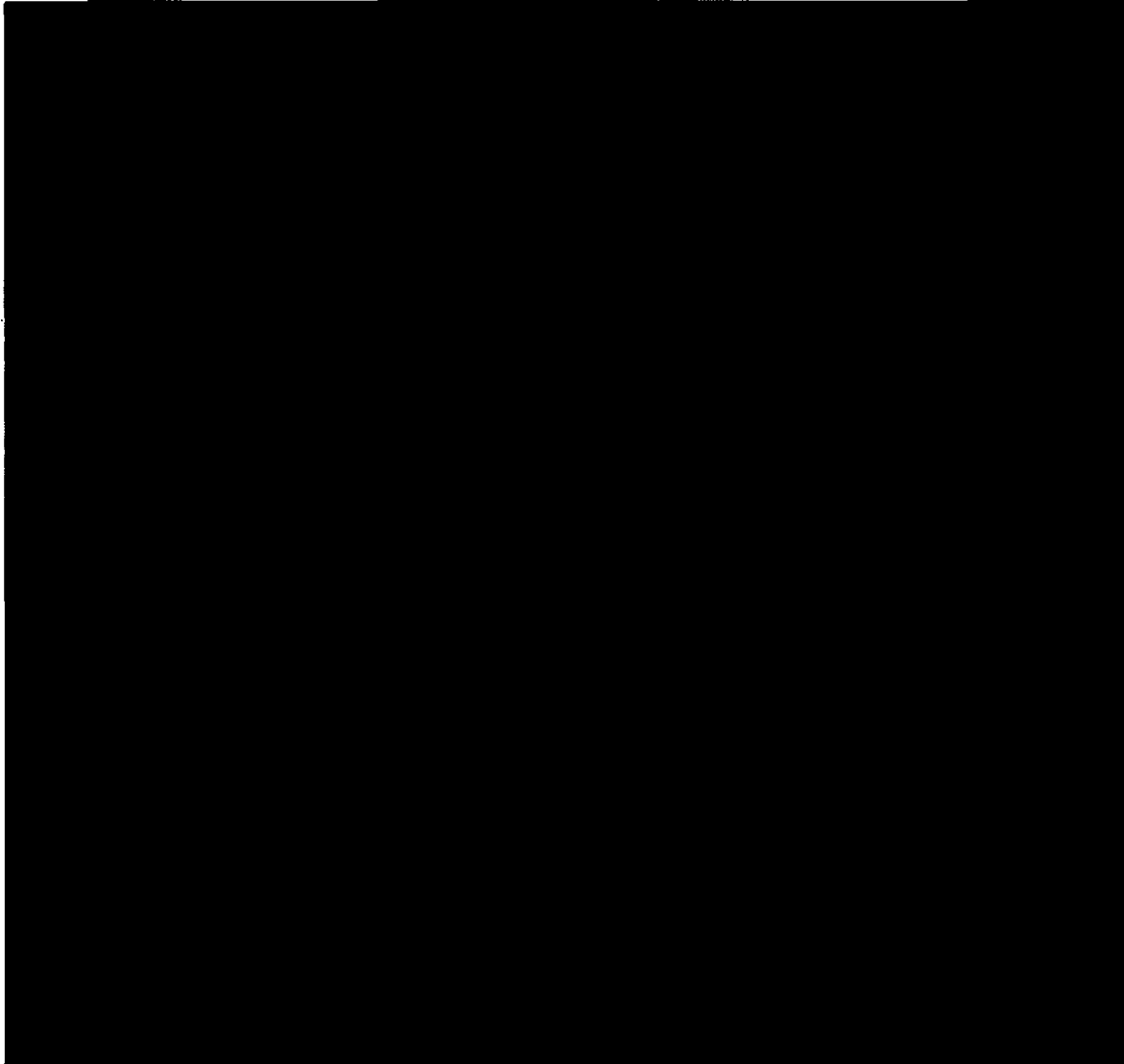

Figure 3-33: Primary Electrical Connections for the RCS FLEX Pumps for Train A



Figure 3-34: Primary Location for Junction Box near the RWT West of the Auxiliary Building for RCS FLEX Pumps –Train A

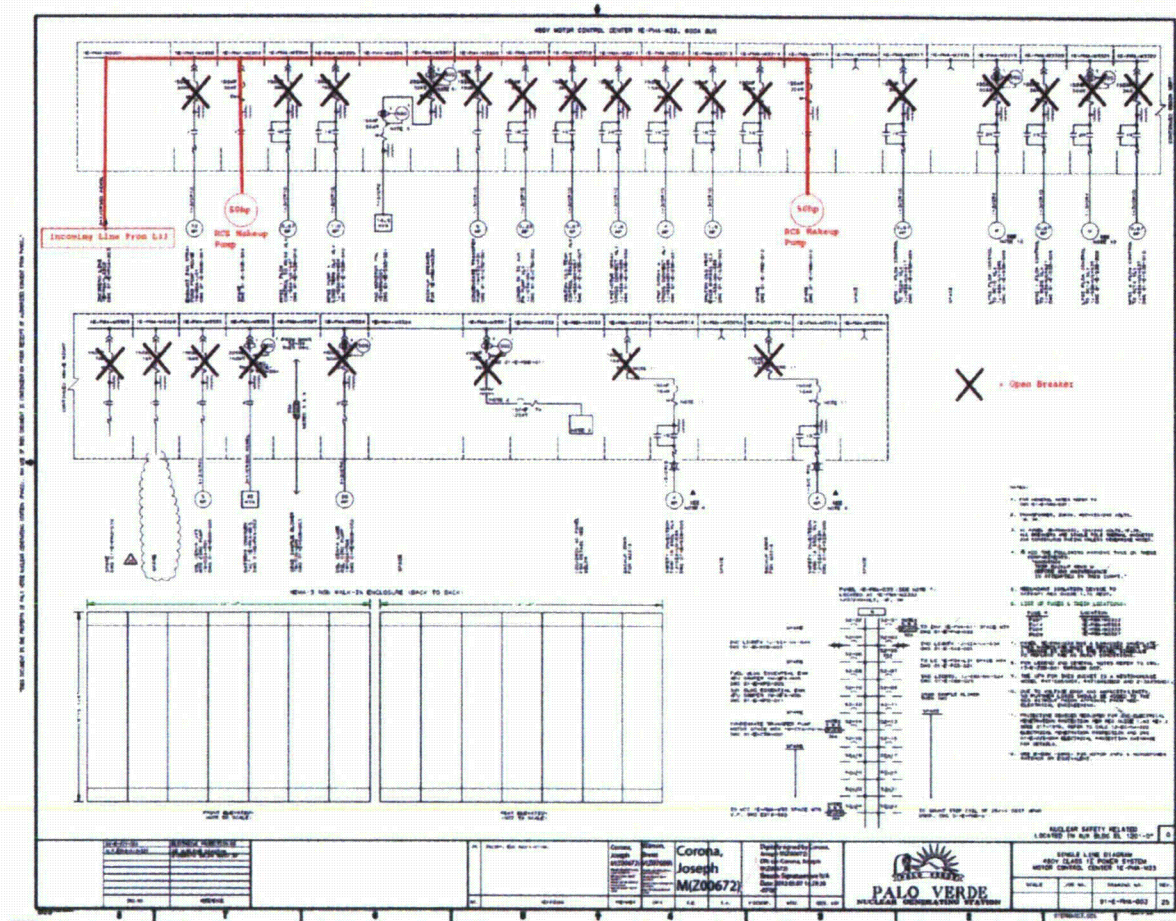

Figure 3-35: Single-Line for Primary Connection to Train A 480V MCC M33 FLEX RCS Makeup Pumps

Auxiliary Building 120-foot Elevation

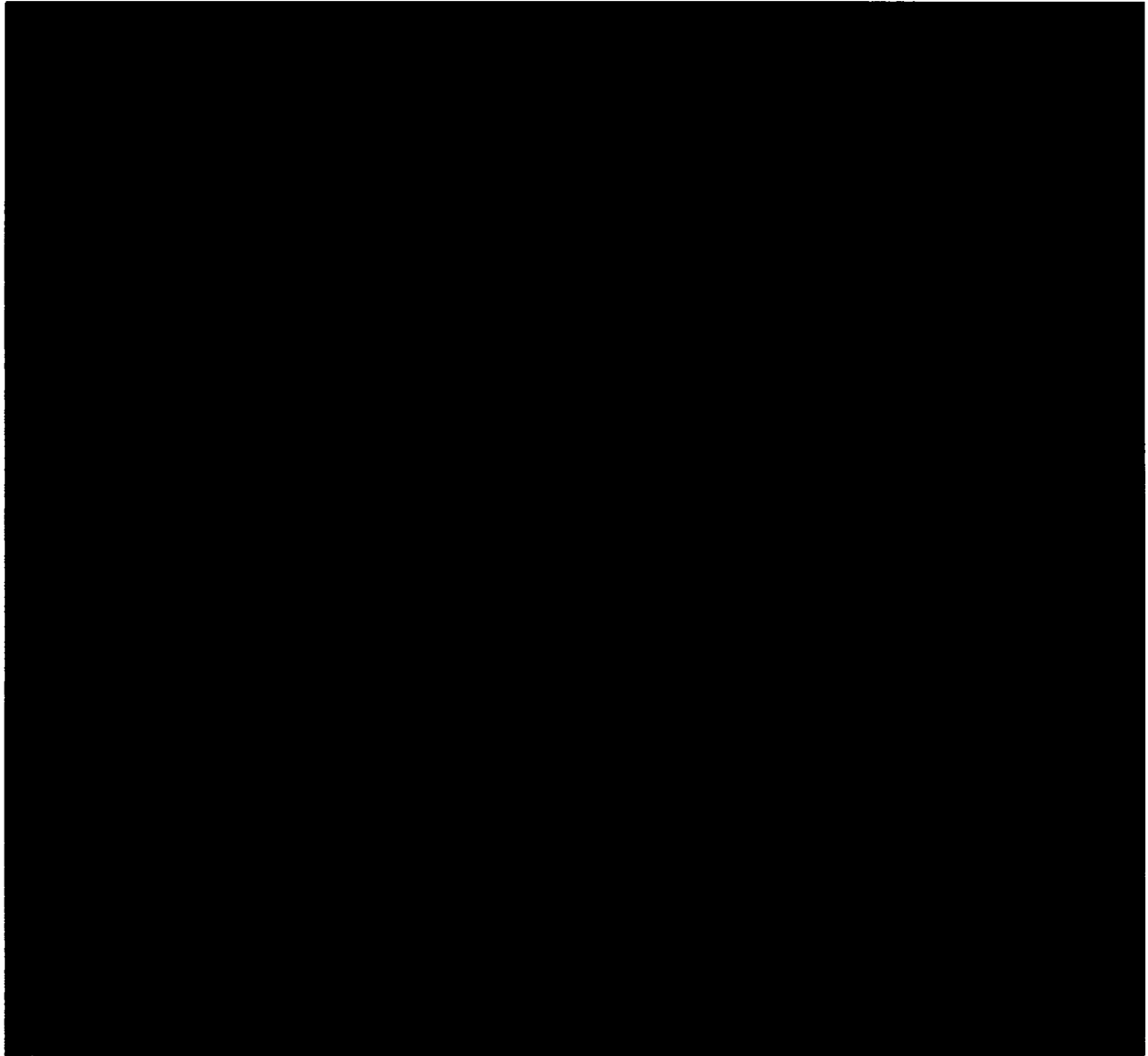

Figure 3-36: Alternate RCS FLEX Pumps Connections

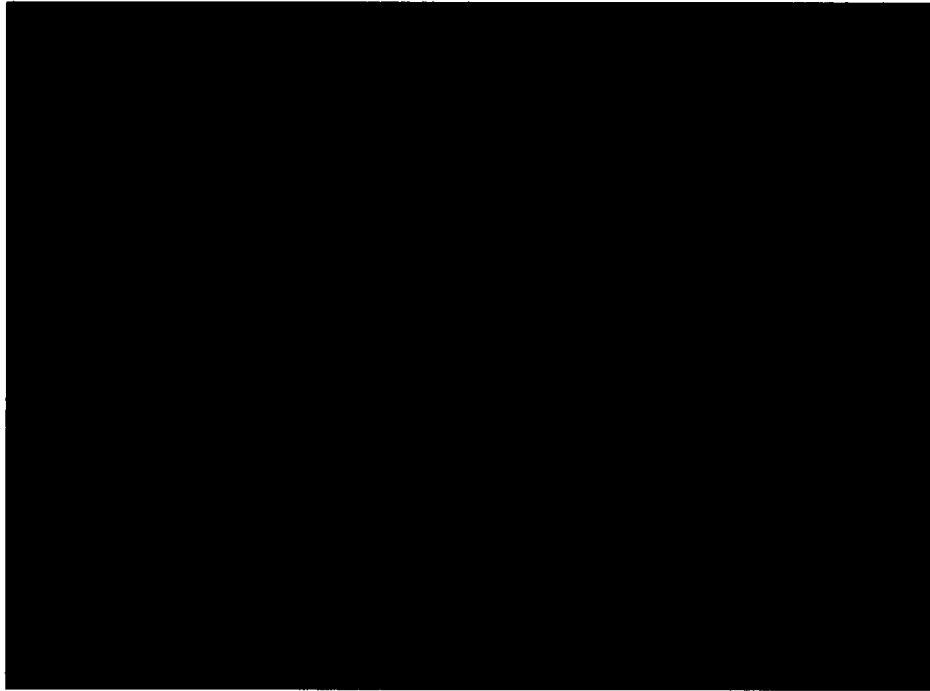

Figure 3-37: Alternate Switch Location –Inside Wall of Charging Pump Room E

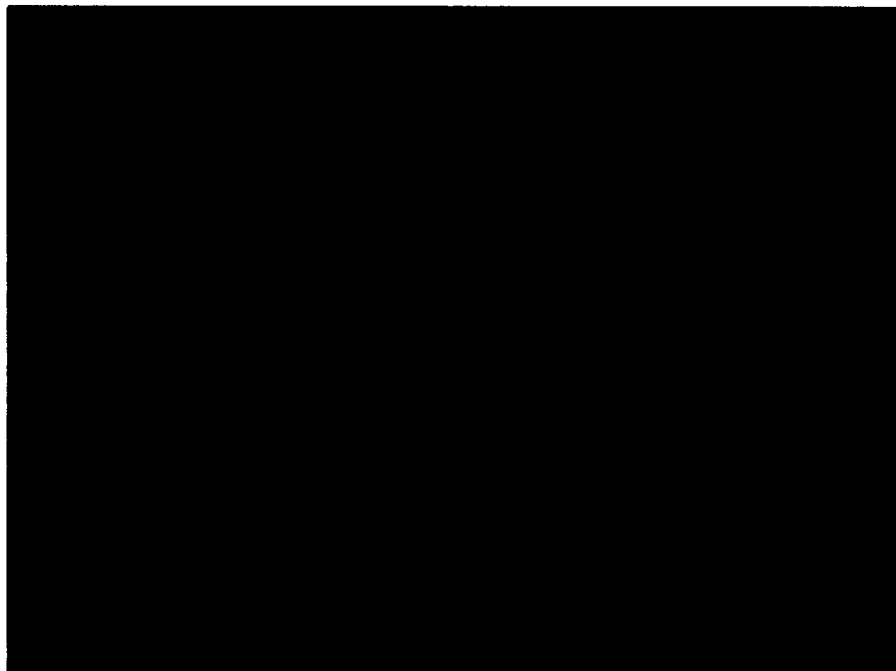

Figure 3-38: Alternate Charging Pump Room E Junction Box Location

Control Building 100-foot Elevation

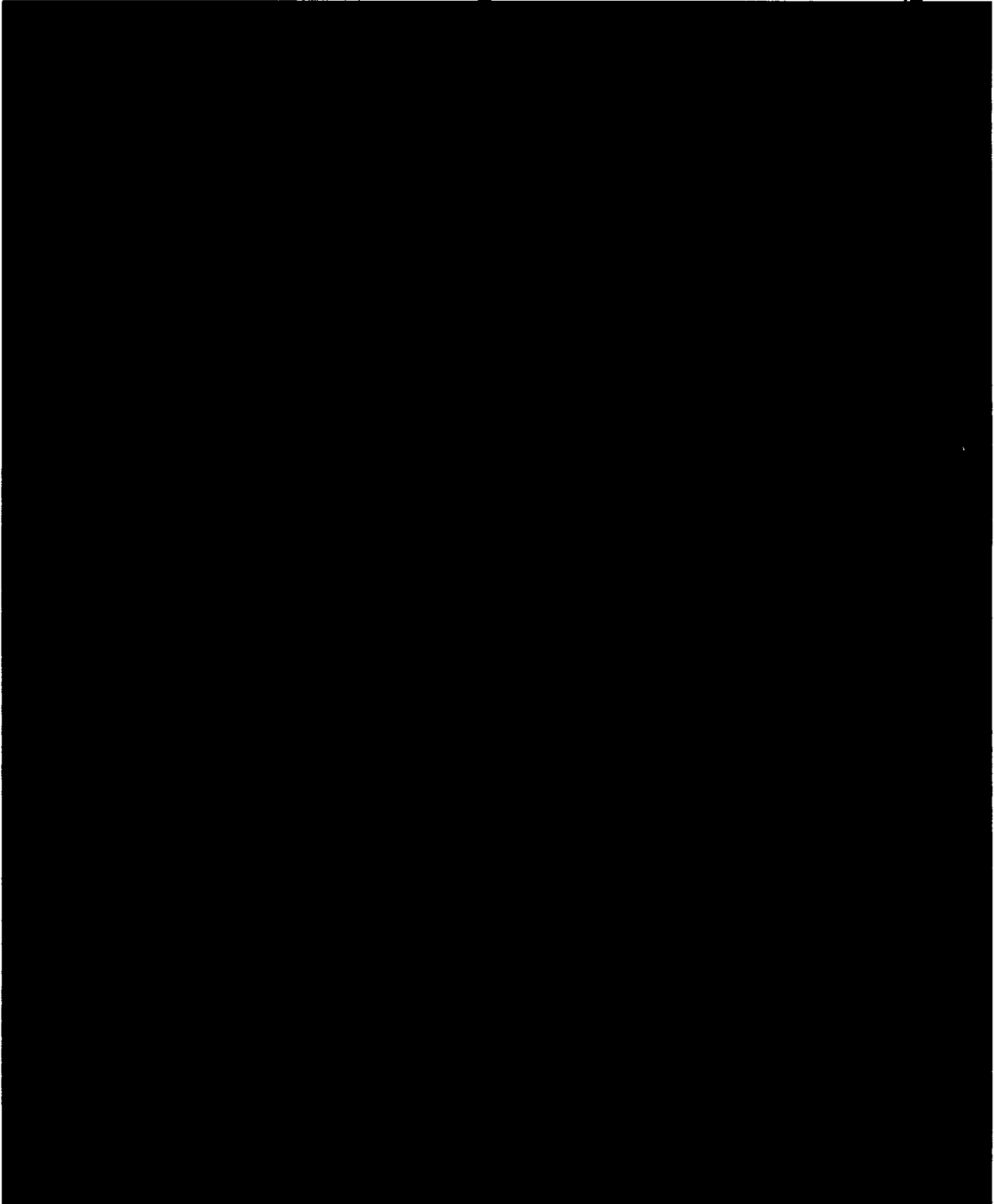

Figure 3-39: Primary 3MW, 4.16kV FLEX Generator Connection

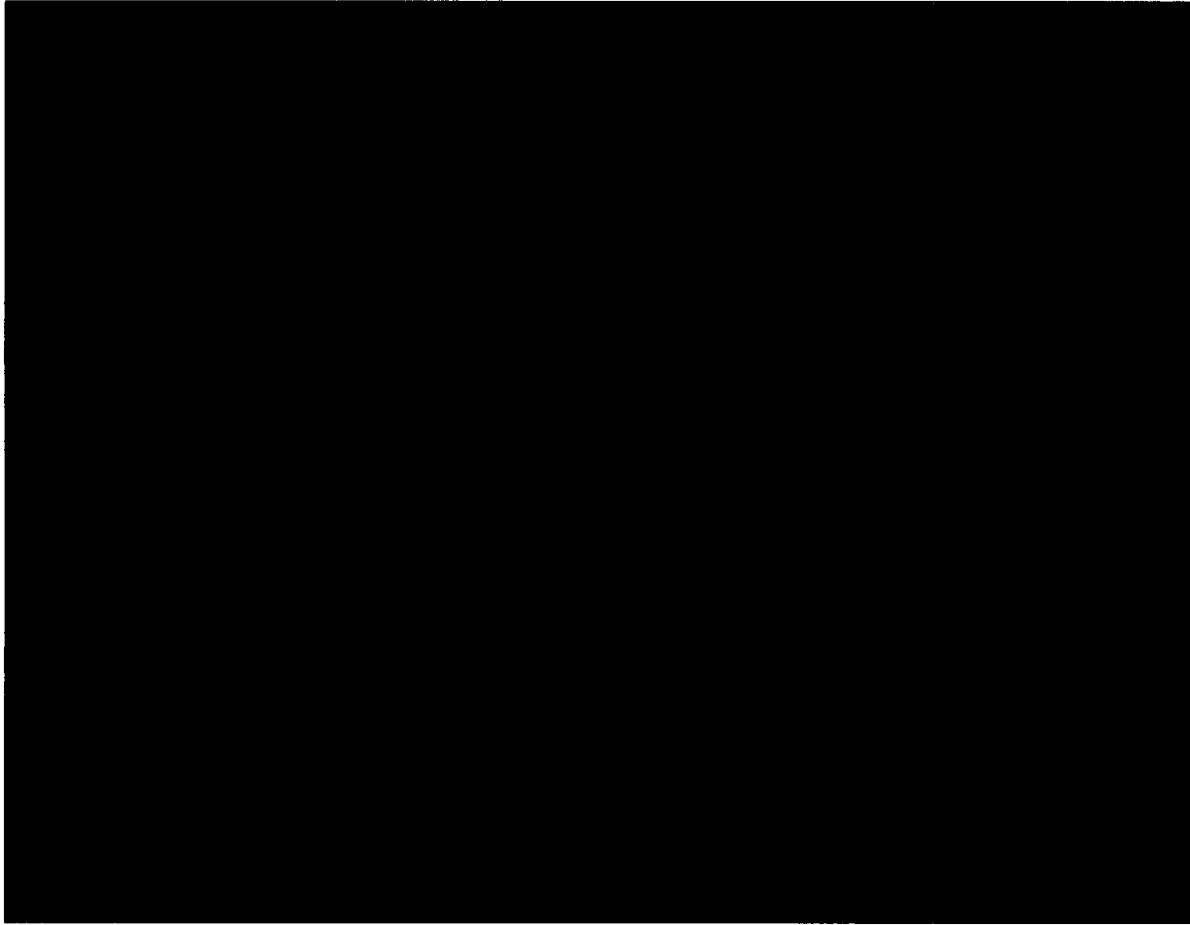

Figure 3-40: New Breaker Panel Location on PBA-S03

Control Building 100-foot Elevation

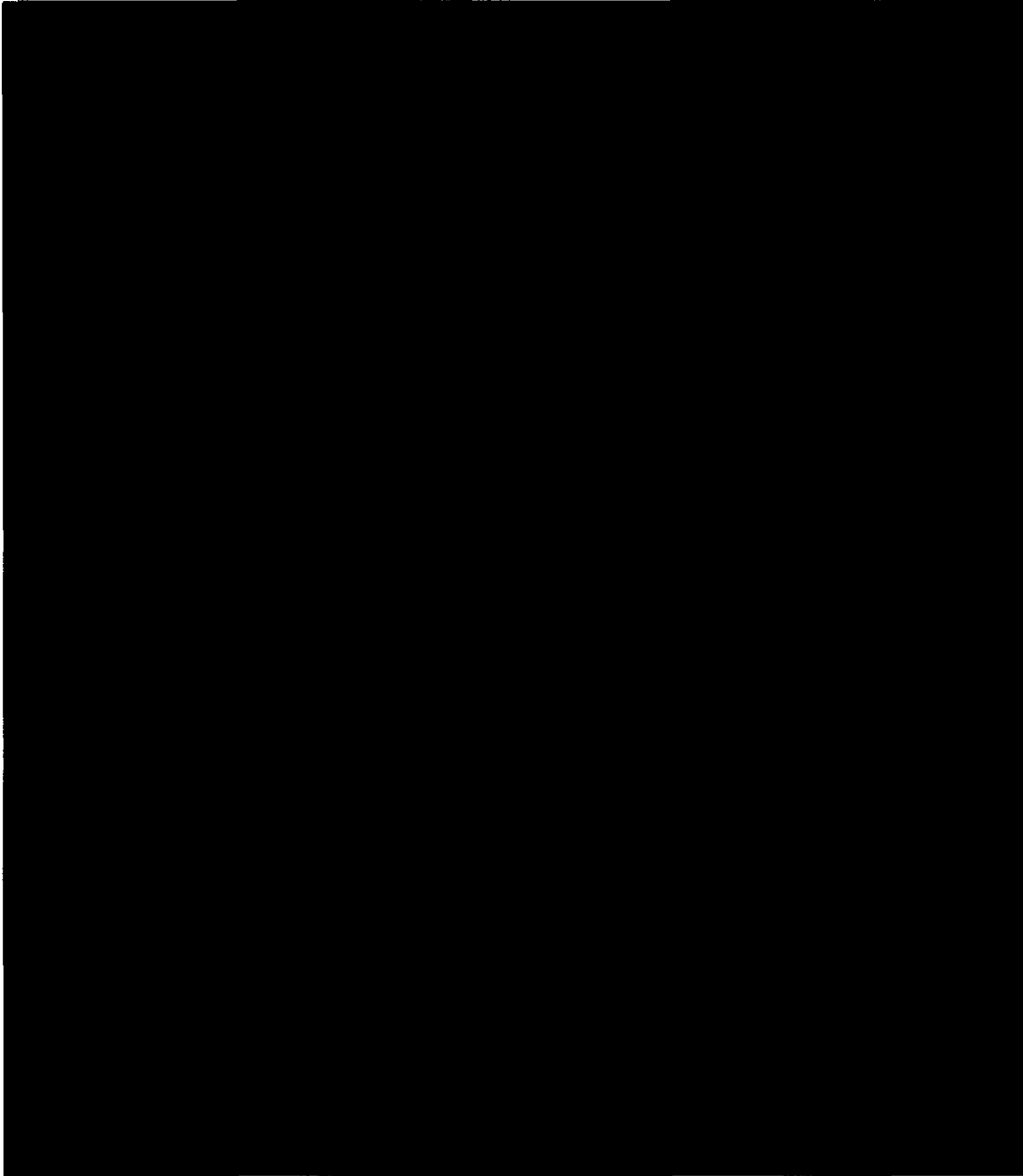

Figure 3-41: Alternate 3MW, FLEX Generator Connection