



South Texas Project Electric Generating Station P.O. Box 289 Wadsworth, Texas 77483

February 28, 2013  
NOC-AE-13002963  
10 CFR 50.4  
10 CFR 2.202

U.S. Nuclear Regulatory Commission  
ATTN: Document Control Desk  
Washington, D.C. 20555-0001

South Texas Project  
Units 1 & 2  
Docket Nos. STN 50-498, STN 50-499  
STPNOC Overall Integrated Plan in Response to March 12, 2012 Commission Order  
Modifying Licenses with Regard to Requirements for Mitigation Strategies  
For Beyond-Design-Basis External Events (Order Number EA-12-049)

- References:
1. NRC Order Number EA-12-049, Order Modifying Licenses with Regard to Requirements for Mitigation Strategies for Beyond-Design-Basis External Events dated March 12, 2012.
  2. NRC Interim Staff Guidance JLD-ISG-2012-01, "Compliance with Order EA-12-049, Order Modifying Licenses with Regard to Requirements for Mitigation Strategies for Beyond-Design-Basis External Events," Revision 0, dated August 29, 2012.
  3. NEI 12-06, "Diverse and Flexible Coping Strategies (FLEX) Implementation Guide," Revision 0, dated August, 2012.
  4. STPNOC Initial Status Report in Response to March 12, 2012, Commission Order Modifying Licenses with Regard to Requirements for Mitigation Strategies for Beyond-Design-Basis External Events (Order Number EA-12-049), dated October 24, 2012.

On March 12, 2012, the Nuclear Regulatory Commission (NRC) issued an order (Reference 1) to STP Nuclear Operating Company (STPNOC). Reference 1 was immediately effective and directs STPNOC to develop, implement, and maintain guidance and strategies to maintain or restore core cooling, containment, and spent fuel pool cooling capabilities in the event of a beyond-design-basis external event. Specific requirements are outlined in Attachment 2 of Reference 1.

Reference 1 requires submission of an Overall Integrated Plan by February 28, 2013. The NRC Interim Staff Guidance (ISG) (Reference 2) was issued August 29, 2012 which endorses industry guidance document NEI 12-06, Revision 0 (Reference 3) with clarifications and

STI 33654475

AISI  
NRR

exceptions identified in Reference 2. Reference 3 provides direction regarding the content of this Overall Integrated Plan.

Reference 4 provided the STPNOC initial status report regarding mitigation strategies, as required by Reference 1.

The purpose of this letter is to provide the Overall Integrated Plan pursuant to Section IV, Condition C.1, of Reference 1. This letter confirms STPNOC has received Reference 2 and has an Overall Integrated Plan developed in accordance with the guidance for defining and deploying strategies that will enhance the ability to cope with conditions resulting from beyond-design-basis external events.

The information in the enclosure provides the STPNOC Overall Integrated Plan (the STPNOC FLEX Integrated Plan) for mitigation strategies pursuant to Reference 3. The enclosed Integrated Plan is based on conceptual design information. Final design details and associated procedure guidance, as well as any revisions to the information contained in the Enclosure, will be provided in the 6-month Integrated Plan updates required by Reference 1.

This letter contains no new regulatory commitments.

If there are any questions regarding this letter, please contact Jim Morris at (361) 972-8652.

I declare under penalty of perjury that the foregoing is true and correct.

Executed on: 2/28/13

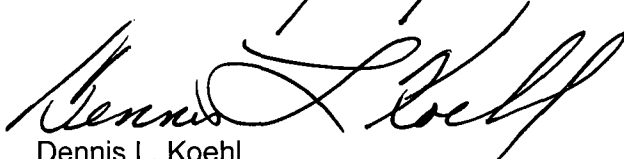

Dennis L. Koehl  
President and CEO / CNO

Enclosure: STPNOC FLEX Integrated Plan

jrm

cc:  
(paper copy)

(electronic copy)

Regional Administrator, Region IV  
U. S. Nuclear Regulatory Commission  
1600 East Lamar Boulevard  
Arlington, TX 76011-4511

A. H. Gutterman, Esquire  
Morgan, Lewis & Bockius LLP

Balwant K. Singal  
U. S. Nuclear Regulatory Commission

Balwant K. Singal  
Senior Project Manager  
U.S. Nuclear Regulatory Commission  
One White Flint North (MS 8 B1)  
11555 Rockville Pike  
Rockville, MD 20852

John Ragan  
Chris O'Hara  
Jim von Suskil  
NRG South Texas LP

Senior Resident Inspector  
U. S. Nuclear Regulatory Commission  
P. O. Box 289, Mail Code: MN116  
Wadsworth, TX 77483

Kevin Pollo  
Richard Pena  
City Public Service

C. M. Canady  
City of Austin  
Electric Utility Department  
721 Barton Springs Road  
Austin, TX 78704

Peter Nemeth  
Crain Caton & James, P.C.

C. Mele  
City of Austin

Eric Leeds  
Director, Office of Nuclear Reactor Regulation  
U.S. Nuclear Regulatory Commission  
One White Flint North (MS 13 H 16M)  
11555 Rockville Pike  
Rockville, MD 20852

Richard A. Ratliff  
Texas Department of State Health  
Services

Alice Rogers  
Texas Department of State Health  
Services

# ENCLOSURE

STPNOC FLEX Integrated Plan

# STPNOC FLEX Integrated Plan

## General Integrated Plan Elements (PWR)

### **A GENERAL OVERVIEW OF THE SOUTH TEXAS PROJECT UNITS 1 and 2 AND THE INTEGRATED PLAN**

In response to the events at the Fukushima Dai-ichi plants, the NRC issued Order EA-12-049 (“the Order”) which requires that US nuclear power plants provide an Implementation Plan for adding diverse and flexible mitigation strategies – or FLEX – that will increase defense-in-depth for beyond-design-basis external event (“BDBEE”) scenarios to address an Extended Loss of AC power (“ELAP”) and loss of normal access to the ultimate heat sink (“LUHS”) occurring simultaneously at all units on a site.

NEI worked with the NRC to develop NEI Report 12-06, Revision 0, “Diverse and Flexible Coping Strategies (“FLEX”) Implementation Guide” (“NEI 12-06”) which was endorsed as a means of complying with NRC Order EA-12-049, (with comments) by the NRC in Interim Staff Guidance Document JLD-ISG-2012-01, Revision 0.

The South Texas Project (STP) site is located in south-central Matagorda County west of the Colorado River, 8 miles north-northwest of the town of Matagorda and about 89 miles southwest of Houston. It consists of approximately 12,220 acres of land and includes areas being used for a plant, a railroad, and a cooling reservoir. The plant is located about 12 miles south-southwest of Bay City and about 13 miles east-northeast of Palacios between FM (farm-to-market road) 1095 and the Colorado River.

The station is composed of two units, each having an identical pressurized water reactor (PWR) Nuclear Steam Supply System (NSSS) and turbine generator (TG). The units are arranged using a "slide-along" concept which results in Unit 2 being similar to Unit 1, and 600 ft away.

The 7,000-acre Main Cooling Reservoir (MCR) is fully enclosed with an embankment; baffle dikes direct the flow of water. The station is located at the north end of the MCR with condenser cooling water being discharged into the western half of the MCR and returned to the power plant intake through the eastern half of the MCR.

Reactor Coolant System: High-pressure light water serves as the coolant, neutron moderator, reflector, and solvent for the neutron absorber. The Reactor Coolant System (RCS), comprised of four parallel loops (each with a Reactor Coolant Pump [RCP] and a steam generator [SG]), is used to transfer the heat generated in the core to the SGs using RCPs to circulate the water. RCS pressure is maintained by means of a pressurizer attached to the hot leg of one of the loops.

Spent Fuel Storage – Each unit of the STP includes its own separate spent fuel storage facilities. These facilities are located in both the Containment and the FHB. The spent fuel storage facilities are designed for the underwater storage of spent fuel assemblies and control rods after their removal from the reactor vessel. Spent fuel storage space is provided to accommodate about one-third of a core in the Containment fuel pool and approximately 10 cores in the spent fuel pool (SFP) located in the FHB. Shielding for the spent fuel storage arrangement is adequate to protect plant personnel from exposure to radiation during all phases of spent fuel handling and storage.

Reactor Containment - This structure provides a virtually leaktight barrier to prevent escape of fission products to the environment in the unlikely event of a loss of coolant accident (LOCA). The Reactor Containment is a post-tensioned concrete cylinder with a steel liner plate, hemispherical top, and flat bottom.

## STPNOC FLEX Integrated Plan

The overall dimensions of the Containment are:

- Inside Diameter – 150 ft
- Cylinder Height - 166 ft-3 in.
- Cylinder Wall thickness - 4 ft
- Liner thickness - 3/8 in.
- Foundation Mat thickness - 18 ft
- Mat liner thickness - 3/8 in.

Ref. UFSAR 1.2.2.3.1

The STP FLEX strategies will consist of both an on-site component using equipment stored at the plant site and an off-site component for the provision of additional materials and equipment for longer term response. By providing multiple means of power and water supply to support key safety functions, FLEX can mitigate the consequences of beyond-design-basis external events.

The underlying strategies for coping with these conditions involve a three-phase approach:

- 1) Initially cope by relying on installed plant equipment. (Phase 1)
- 2) Transition from installed plant equipment to on-site FLEX equipment. (Phase 2)
- 3) Obtain additional capability and redundancy from off-site equipment until power, water, and coolant injection systems are restored or commissioned. (Phase 3)

To the extent practical, analysis has been developed to support plant specific decision-making; however, additional analysis is forthcoming. Where there is a specific analysis or procedure or strategy that has yet to be completed or needs additional work, that item is annotated as such in this integrated plan as an open item. Much of the analysis done to support these strategies is in WCAP 17601 (Ref. 4).

STP has a unique challenge associated with one of the external hazards: the design basis flood. The maximum flood water level on a vertical face at the south end of the plant structures is El. 50.8 ft mean sea level (MSL), which is El. 22.8 ft above plant grade. This maximum elevation occurs during a quasi-steady-state condition after a breach of the MCR embankment and is based on an instantaneous removal of approximately 2,000 ft of the embankment opposite the power block structures. (Ref. UFSAR 3.4.1.1). As such, STP's strategies are quite different than most other utilities. Most plants can take credit for strategies and procedures established to meet 10CFR50.54(hh)(2) (B.5.b); however, because deployment of those strategies is on the ground, STP cannot. Equipment that is not required until phase 3 must be stored at its deployed location.

An overview of each phase from a general perspective follows so that the reader can be familiar with the overall flow of this integrated plan.

Because of the robust design of STP, the phase 1 coping lasts longer than the time it takes for offsite resources and equipment to arrive on site. Very little is credited for use in phase 2. However, because the design basis flood from the MCR breach would inundate the site for so long, equipment will be pre-deployed and strategies will be immediately implemented, regardless of how long phase 1 coping lasts.

### Core Cooling

Phase 1: When the Outside Design Basis External Event (ODBEE) occurs, the reactor automatically trips (all rods insert) and core cooling is provided automatically by means of the safety related turbine driven Auxiliary Feedwater pump (TDAFW). During an Extended Loss of AC Power (ELAP), the only pump

## STPNOC FLEX Integrated Plan

available to supply feedwater from the Auxiliary Feedwater Storage tank (AFWST) to the SG is the TDAFW pump. This pump uses steam from the SG as a motive force instead of electricity. Maintaining SG heat removal capability and thus, secondary inventory, is of paramount importance during the ELAP event. The demand for AFW is the greatest at the beginning of the event when decay heat is the largest and during the plant cooldown phase when sensible heat is being removed. This pump feeds the SG while operators cooldown and depressurize the RCS under natural circulation conditions (forced flow from the reactor coolant pumps has ceased due to the loss of AC power). This TDAFW pump will run until SG pressure drops below 100 psia. At that point, the pressure is not sufficient to run the pump without potentially damaging it. Analysis has shown that for a standard Westinghouse 4-loop plant, there is sufficient steam to run the TDAFW pump for a little over 5 days. STP's Auxiliary Feedwater Storage tank (AFWST) has a capacity of 525,000 gallons which has been calculated to be sufficient for RCS heat removal for approximately 44 hours (ref.5). So, the limiting factor for phase 1 coping for this safety function is AFWST inventory. Means to re-fill the AFWST to extend this time will be discussed later but the result of this general discussion is that phase 1 of core cooling lasts 44 hours.

Phase 2: The TDAFW pump should operate well into phase 3 and there will be adequate water in the AFWST to continue feeding the SGs and cooling the RCS until assistance from offsite arrives at STP.

Phase 3: Phase 3 is basically an extension of phase 2 coping; however, at some point there will be a need for a pump to replace the TDAFW pump when it can no longer run. A 480 volt power generator (diesel generator (DG) or combustion turbine generator (CTG) that runs on diesel fuel) will be pre-staged on top of a building above the DB flood event. Also pre-staged will be cabling and connectors to provide power to a FLEX SG feed pump pre-staged in a safety related building. This pump will have both a primary and an alternate connection point into the AFW system. Preliminary calculations have shown the roof can support the additional weight of the FLEX generator and enclosure; however, additional calculations are necessary. This is open item #13. The generator will provide power to this pump. The generator will be enclosed in a structure designed to protect against design basis external events as required by NEI 12-06.

As mentioned above, the ability to fill the AFWST is critical to continue cooling the core. STP has numerous tanks, concrete basins, condensate hotwells and a 7000 acre cooling reservoir to draw from (assuming the event was not the breach of the main reservoir). The AFWST has 2 connection points to fill it: one on top of the tank and one on ground level. Pumps and hoses will move water from at least one of these sources (depending on what sources survive the external event) to the AFWST at a sufficient rate to makeup to the AFWST more than is being used by the TDAFW pump. STP also has a gravity feed strategy to makeup to the AFWST. These will be discussed in detail. Operators will continue to makeup to the AFWST as needed and continue making up to the SGs as needed to remove decay heat from the reactor core. STP will receive equipment from the Regional Response Center (RRC) to help ensure the ability to cope long term.

### RCS Inventory

Phase 1 – The main consequence, for this safety function, of a loss of all AC power for Westinghouse NSSS designs is RCP seal leakage. Specifically, when cooling to the RCP seal packages is lost, water at high temperatures could force the leakage in the number one seal to become excessive. Without AC power to the Emergency Core Cooling System (ECCS), the RCS cannot tolerate this amount of mass loss for an extended time period and, at some point, inadequate core cooling will result. From the time an ODBEE occurs, WCAP 17601 shows that STP's reactor core will remain covered for at least 60 hours without any makeup to the RCS whatsoever. This is based on a 21 gallon per minute (gpm) leak from each seal package (ref WCAP 17601 section 4.2.2).

## STPNOC FLEX Integrated Plan

Phase 2 – The RCS cooldown and depressurization will complete in the early hours of phase 2 coping. SG pressure will be maintained such that the SI Accumulators will not inject their N<sub>2</sub> cover gas into the RCS.

Phase 3 – Phase 3 will again be an extension of phase 2 coping. Prior to reaching the 60 hour mark, RCS makeup will be required. Off site resources and equipment will have arrived at STP to assist in strategy implementation. STP again will use the 480V FLEX generator, pre-staged on the roof, to power the permanent plant CVCS Positive Displacement Pump (PDP) (preferred and primary connection point) or the FLEX RCS Fill pump (backup [N+1] and alternate connection point) for makeup to the RCS. The pump(s) will take their suction on the ~ 2500 ppm boron concentration Refueling Water Storage tank (RWST) and discharge into the RCS via Safety Injection or CVCS piping. The PDP can also take suction on the ~ 7000 ppm boron concentrated Boric Acid Storage Tanks (BATs).

Prior to the RWST water depleting, makeup to the tank will commence using the Reactor Makeup Water Storage tank (RMWST) and the Boric Acid tanks (BATS). The necessary pumps will be powered by the FLEX 480V generator.

### Containment

The GOTHIC Containment analysis revealed that RCB pressure remains below design pressure of 56 psig for over 90 days provided the core remains covered; therefore, there are no coping actions at this time. Open item #6 to complete analysis.

### Spent Fuel Pool Cooling

Phase 1 – NEI 12-06, section 3.2.1.2 assumes the plants are at 100% power for at least 100 days when this ELAP event occurs and that all systems are operating in their normal operating ranges. Using this assumption when this external event occurs, the pumps that normally move the Spent Fuel Pool (SFP) water through heat exchangers will secure due to the loss of power. The pool will gradually begin to heat up from the decay heat being transferred into the water from the spent fuel. STP calculated SFP heatup and boil-off based on conservative assumptions are as follows: assuming the event occurs after a 20 day refueling outage and also assuming an initial SFP water temperature of 160°F and a SFP heatup of 3.83 °F/hour, the pool will begin to boil in about 13 hours. The SFP boil-off rate is  $1.844 \times 10^4$  lbm/hour. Boil-off analysis shows that it will take over 96 hours for SFP level to reach the pre-determined level of 10 feet above the fuel assemblies. This is the level selected in NRC Order EA 12-51 as that level below which would limit SFP deck accessibility due to elevated radiation levels. SFP level would reach the top of the fuel assemblies in a total time from event initiation of approximately 144 hours. The timeline found later in this document is based on this assumption: trip from 100% power after at least 100 days of full power operation.

NEI 12-06, section 3.2.1.6 also discusses the SFP conditions and assumes the SFP heat load is the maximum design basis heat load for the site. Using this assumption when the event occurs, the pool would begin to boil in about 3 hours and would boil down to 10 feet above the fuel in about 25 hours. (Ref. 27 Case 7B on page 63) The FLEX SFP Fill pump will be sized to meet or exceed the makeup required for this heat load.

Phase 2 – No phase 2 strategy is required for filling the SFP.



## STPNOC FLEX Integrated Plan

Phase 3 - Phase 3 will again be an extension of phase 2 coping. The RRC will have provided equipment and people to assist in the SFP fill strategies. At some point, well before this 96 hour mark, makeup to the SFP will commence at a rate of at least 130.6 gpm to raise SFP water level. Two different pumps, N and N+1, powered from the FLEX 480V generator on top of the roof will provide more than adequate makeup in this event. The 480V RMW pump powered from C train electrical distribution or the FLEX SFP Fill pump with hoses stretched to the SFP deck to provide makeup to the pool. The RMW pump takes suction on the RMWST while the FLEX SFP Fill pump (N+1) takes suction on the RWST.

Another pump is available for SFP spray. It is a large capacity diesel driven pump that will be stored in its deployment location or will come from the RRC. This diesel driven pump will use an available water source, of which there are many. Prior to the RWST water depleting, makeup to the tank will commence using the Reactor Makeup Water Storage tank (RMWST) and the Boric Acid tanks (BATS).

The following is a list of FLEX equipment used in the phases 2 and 3 coping for all functions PER UNIT unless otherwise stated:

1. 480V, 500 kW, air-cooled generator that runs on diesel fuel
2. 480V load center/distribution panel
3. 480V FLEX SG feed pump rated at 400 psig at 300 gpm
4. 480V FLEX SG feed pump rated at 400 psig at 300 gpm for N+1
5. 480V Chemical and Volume Control system (CVCS) Positive Displacement Charging pump (permanent plant equipment) for RCS makeup
6. 480V FLEX RCS fill pump rated at 1500 psia at 40 gpm for N+1
7. 480V Reactor Makeup Water pump for SFP makeup (permanent plant equipment)
8. 480V FLEX SFP fill pump rated at 75 psig at 200 gpm for SFP makeup using hoses
9. Diesel driven pump rated at 1000 gpm at 175 psig for SFP spray for both units
10. Diesel driven pump rated at 1000 gpm at 175 psig for SFP spray for both units for N+1
11. Portable DC power with inverters to power 480V Motor Control Center (MCC) breakers for closing SI Accumulator discharge valves (Open item #1, battery is still in design phase)
12. Three 120V, 6500 watt diesel generators
13. One 120V fuel oil transfer pump for moving diesel fuel from the ESF DG Fuel Oil tanks to the FLEX generator fuel oil tank.
14. Two 120V water pumps for moving water around the site filling tanks, etc.
15. FLEX fuel oil tank (500 gallon)
16. Electrical cabling to each load
17. Hoses for connecting pumps to permanent plant piping and fuel oil transfer
18. Valves to separate hoses from permanent plant piping
19. Ventilation fans
20. An assortment of small items like light strings, radio batteries and chargers, satellite phones, batteries and chargers, small fuel cans, extension cords, etc.
21. Standard connections (electrical and mechanical) will be agreed upon and installed at STP.
22. Concrete enclosure to house the 480V FLEX DG, fuel tank and load center.
23. 4160V Diesel generator (2 MW) stored at the Regional Response Center (RRC).
24. FLUKE 705 loop calibrator
25. FLUKE 114 multimeter

### STORAGE

Because of the design basis flood (breach of the 7000 acre Main Cooling Reservoir) that all FLEX equipment must be protected from, STP will store FLEX equipment in most cases inside safety related

## STPNOC FLEX Integrated Plan

structures or inside a structure to be built on top of the MAB that will protect equipment much like safety related structures do. STP is still evaluating whether there will be a need for storage of other FLEX equipment outside the power block. (Open item #3.) If STP builds a storage facility to protect FLEX equipment, deployment routes will be evaluated and established for all external events. STP is evaluating storing FLEX equipment in the FHB truck bay. This would not require building a separate storage facility.

This overview was provided to help the reader review the different strategies, safety functions, phases and equipment such that the reader can better understand how STP intends to comply with this Order.

### **Determine Applicable Extreme External Hazard**

**Ref: NEI 12-06 section 4.0 -9.0**

**JLD-ISG-2012-01 section 1.0**

*Input the hazards applicable to the site; seismic, external flood, high winds, snow, ice, cold, high temps. Describe how NEI 12-06 sections 5 – 9 were applied and the basis for why the plant screened out for certain hazards.*

In response to the Order, STPEGS performed a FLEX hazards assessment for STP Units 1 and 2 (“STP 1 & 2”) to identify the BDB extreme external hazards which are applicable to the site from the following five classes of BDB external hazards defined in NEI 12-06, Section 2.2, using the processes in NEI 12-06, Sections 5 through 9):

- seismic events (NEI 12-06, Section 5)
- external flooding (NEI 12-06, Section 6)
- storms such as hurricanes, high winds, and tornadoes (NEI 12-06, Section 7)
- extreme snow, ice, and cold (NEI 12-06, Section 8)
- extreme heat (NEI 12-06, Section 9)

Following this assessment, each of the extreme external hazards found to be applicable was evaluated to determine the impact with regard to the following:

- Protection of FLEX equipment
- Deployment of FLEX equipment
- Procedural interfaces
- Utilization of off-site resources.

It is noted that other Tier 1 assessments, including those for seismic, flooding and staffing, are being completed in parallel with this FLEX assessment. The results of those assessments are being provided in their respective reports, and are not addressed in this Report, unless specifically stated.

### **DETERMINATION OF THE APPLICABLE BDB EXTREME EXTERNAL HAZARDS**

A key factor in assessing the impact of hazards on the plants is their location. As documented in the STPEGS Updated Final Safety Analysis Report (“UFSAR”), Section 1.2.1.1, the site is located in south-central Matagorda County, Texas, west of the Colorado River, which is about 8 miles north-northwest of the town of Matagorda, about 12 miles south-southwest of Bay City and about 89 miles

## STPNOC FLEX Integrated Plan

southwest of Houston, between FM (farm-to-market road) 1095 and the Colorado River.

Each unit utilizes a four-loop, pressurized water reactor (PWR) Nuclear Steam Supply System (NSSS) and supporting auxiliary systems designed by Westinghouse Electric Corporation. (UFSAR, Section 1.1).

### ASSESSMENT OF THE FIVE CLASSES OF BDB EXTREME EXTERNAL HAZARDS

The assessment of the impact of the five classes of hazards on the plants was performed in accordance with NEI 12-06, as detailed herein. The methodology for the determining the applicability and impact of each of the five classes of hazards identified in NEI 12-06, Section 2.2 is as defined below.

Although the purpose of this assessment is to identify the applicability of BDBEE, the design basis information for the respective hazard is provided for reference.

#### Seismic Events:

The assessment to determine the applicability of a BDB seismic event was completed in accordance with NEI 12-06, Section 5, "Assess Seismic Impact", which, in Section 5.2, requires that "All sites will address BDB seismic considerations in the implementation of FLEX strategies...", so a BDB seismic event must be considered applicable to the STP 1 and 2 site. Information on the current seismic design basis for STP 1 and 2 is presented in Section 2.5 of the UFSAR.

**Current Safe Shutdown Earthquake:** The current seismic design basis for the plant is discussed in UFSAR Section 2.5.2.6 and 2.5.2.7. The maximum vibratory ground acceleration associated with an intensity VI (modified Mercalli) is about 0.07g. Therefore, 0.1g is a conservative estimate of the Safe Shutdown Earthquake (SSE) acceleration at the site ground surface. (UFSAR Section 2.5.2.6.)

**Current Operating Basis Earthquake (OBE):** Based on the intensity/acceleration correlations shown in UFSAR Table 2.5.2-8, the maximum acceleration of an intensity V (modified Mercalli) earthquake is about 0.035g. This is a reasonable OBE. However, to comply with Appendix A of 10CFR100, the acceleration for the OBE is selected as 0.05g, one-half of the SSE (0.10g). (UFSAR Section 2.5.2.6.)

**Design Response Spectra:** As stated in UFSAR, Section 3.7, the peak accelerations associated with SSE and OBE have been established based on the seismicity evaluation described in Section 2.5. The expected peak horizontal acceleration at this site is less than 0.10g. The peak horizontal accelerations of 0.10g and 0.05g incorporated in the design response spectra for the SSE and OBE, respectively, comply with Appendix A, "Reactor Site Criteria," to 10CFR100. The ground acceleration as represented by the spectral acceleration at 33 Hz is 0.1g for both the horizontal and the vertical directions. At 50 Hz the vertical spectral acceleration is reduced to two-thirds of the horizontal acceleration.

#### External flooding

The assessment to determine the applicability of BDB external flooding hazards on the site was completed in accordance with NEI 12-06, Section 6, "Assess External Flooding Impact", which identifies the typical types of flooding that should be addressed, including:

- flooding from nearby rivers, lakes and reservoirs
- local intense precipitation
- high tides
- seiche
- hurricane and storm surge
- tsunami events

## STPNOC FLEX Integrated Plan

UFSAR Section 2.4, "Hydrologic Engineering", provides an assessment of the types flooding applicable to the site. It indicates that "The STP generating station is located in the floodplain of the estuarial portion of the lower Colorado River Basin, about 8 miles inland from Matagorda, Texas. As a result of the location, the site is subjected to hydrometeorological events peculiar to inland sites, as well as to coastal sites."

As a consequence, BDBEE flooding of all of the types identified above could potentially occur at the site and must be considered in assessing the flooding impact, although, in assessing the design basis impact, the UFSAR, Section 2.4, states that the "Potential effects of tsunamis, seiches, ice flooding, landslides, channel diversions, and low water are not critical."

Information on characterizing the flooding events is provided in NEI 12-06, Table 6-1, "Flood Warning and Persistence Considerations". For the STP 1 & 2 site. UFSAR Section 1.2.1.3 states that "Plant grade is 28 ft. mean sea level ("MSL") and the maximum water level that occurs during any flooding phenomenon is El. 50.8 ft. MSL." Flood level varies from El. 50.8 ft to El. 40.8 ft depending on the location throughout the plant site. UFSAR Section 2.4, "Hydrologic Engineering", addresses the design basis flooding events in the following sections:

Flooding from a Main Cooling Reservoir (MCR) Breach: UFSAR, Section 2.4.4 identifies the design basis flood which produces the maximum water level from flooding, as the "Postulated instantaneous removal of a section of the north embankment of the Main Cooling Reservoir (MCR)". UFSAR Section 2.4.4.1.1.3, "Postulated Failure of the South Texas Project Electric Generating Station Cooling Reservoir Embankment" provides an extensive discussion of this design basis hazard and Table 2.4.1, "Summary of Flood Analyses Results", Item 10, "Instantaneous removal of 2,000-ft-long (nominal) section of the north embankment of the Cooling Reservoir, assuming an initial water surface elevation of 50.5 ft." defines the "Maximum Flood Elevation at Plant as 50.8 ft. MSL."

Flooding from nearby rivers and lakes: UFSAR 2.4.3 and 2.4.4 discuss the design basis flooding which could occur from the nearby Colorado River, including the consequence of upstream dam failures and the impact of a probable maximum precipitation event on the rivers and site.

Local Intense Precipitation: UFSAR 2.4.2, 2.4.3 and 2.4.4 discuss the impact of a probable maximum precipitation (PMP) event on various flooding scenarios.

Table 2.4-1, "Summary of Flood Analyses Results" presents the results the flooding analyses and the maximum flooding level for postulated design basis flooding events and tabulates the resulting flood characteristics and flooding levels.

### Storms such as hurricanes, high winds, and tornadoes:

The assessment to determine the applicability of BDB storms such as hurricanes, high winds and tornados was completed in accordance with NEI 12-06, Section 7, "Assess Impact of Severe Storms with High Winds". As discussed in NEI 12-06, Section 7.2.1, the impact of high winds from these hazards is postulated to result in potential damage when the wind speeds reach a value of 130 mph or greater.

The assessment of individual storm hazards was assessed as follows:

Hurricanes: NEI 12-06, Section 7.2.1 indicates that Figure 7.1 may be used to determine whether sites should address hurricane wind hazards. Figure 7.1, "Contours of Peak-Gust Wind Speeds at 10-m Height in Flat Open Terrain, Annual Exceedance Probability of  $10^{-6}$ " shows that, for the location of STP Units 1 & 2, the applicable hurricane wind speed should for this exceedance probability is approximately 210 mph. Thus, the impact of high winds must be considered applicable for the STP 1 & 2 site.

## STPNOC FLEX Integrated Plan

The current STP 1 & 2 design basis information for hurricanes is provided in UFSAR, Section 2.3.1.2.6.

### High Winds:

The current meteorology for design basis wind speeds is discussed in UFSAR, Section 2.3.1.1. The design basis wind speeds for the site are defined in UFSAR, Section 3.3.1.1, which states “The design wind velocity selected for South Texas Project Electric Generating Station (STPEGS) is 125 mph.”

### Tornados:

NEI 12-06, Section 7.2.1 indicates that Figure 7.2 may be used to determine whether the site design basis wind speed for tornados is greater than 130 mph, which is the value above which damage will occur and above which the impact of tornados should be considered. For the plant latitude of Figure 7.2, “Recommended Tornado Design Wind Speeds for the  $10^{-6}$  / year Probability Level” shows that, for a latitude of  $28^{\circ}$  and longitude of approximately  $96^{\circ}$  longitude, the location of STP Units 1 & 2, wind speed is between 161mph and 174 mph or approximately 168 mph, so, the hazard from tornados must be considered for the STP 1 & 2 site.

The current meteorology for design basis tornados is discussed in UFSAR, Section 2.3.1.1. The design basis tornado wind speeds for the site are defined in UFSAR, Section 3.3.1.1, which states “However, it should be noted that the design tornado (see Section 3.3.2.1) parameters include winds with a tangential velocity of 290 mph and a translational velocity of 70 mph (maximum). For design calculations, the tornado wind loading is assumed to be 360 mph, almost three times the design wind velocity.

### Extreme snow, ice, and cold

The assessment to determine the applicability of BDB events from extreme snow, ice and cold was completed in accordance with NEI 12-06, Section 7, “Assess Impact of Severe Storms with High Winds”. The applicability of these hazards was assessed in accordance with Section 8, “Assess Impact of Snow, Ice and Extreme Cold”.

The applicability of these individual hazards was assessed in accordance is as follows:

Extreme Snow: The applicability was evaluated based on the requirements of NEI 12-06, Section 8.2.1, which indicates that sites on the Gulf Coast, including those below the  $35^{\text{th}}$  parallel, are unlikely to experience extreme snow. NEI 12-06, Figure 8.1, “Record 3-Day Snowfalls” shows that for the area of the STP 1 & 2 plants, although snow occurs, it does not reach extreme levels. On this basis, extreme snowfall is not considered to be an applicable hazard for STP 1 & 2 that would adversely impact equipment deployment.

UFSAR Table 2.3-4, “Site / Region Meteorological Extremes” provides information on the snowfall levels in the STP 1 & 2 area.

Extreme Ice: NEI 12-06, Figure 8.2, “Maximum Ice Storm Severity Maps shows that the area of STP 1 & 2 is in Ice Severity Level 3 (Yellow), “Low to medium damage to power lines and/or existence of considerable amount of ice”. Section 8.2.1 states that plants with this Ice Severity Level should consider the effects of ice storm impacts.

## STPNOC FLEX Integrated Plan

Extreme Cold: Per NEI 12-06, sites in southern California, Arizona, the Gulf Coast and Florida do not experience these conditions and only requires that “all other sites address FLEX deployment for these conditions”, so “extreme cold” is not considered an applicable hazard for the STP 1 & 2 site.

Extreme Heat: The assessment to determine the applicability of BDB extreme heat hazard was completed in accordance with NEI 12-06, Section 9, “Assess Impact of High Temperatures, which, in Section 9.2, states that “all sites must consider the impact of high temperatures”, so it is considered applicable for STP 1 & 2.

The current design basis for extreme heat is primarily based on the ability of the equipment to remain operational when subjected to extreme heat. This is discussed in the applicable sections of the UFSAR for the respective systems and equipment and, when appropriate is also addressed in plant procedures.

### DETERMINATION OF THE APPLICABLE BDB EXTREME EXTERNAL HAZARDS

The results of the assessment of the impact of these BDB hazards impact on the individual elements of the FLEX mitigation strategy, is discussed in each of the sections entitled “Storage/Protection of Equipment” later in this document

In conclusion, an assessment was conducted of the hazard classes identified in NEI Section 2.2 and this Implementation Plan defines the applicability of those hazards which must be considered applicable to STP 1 & 2 to provide diverse and flexible mitigation strategies that will increase defense-in-depth for beyond-design-basis external events (“BDBEE”) scenarios to address an Extended Loss of AC power (“ELAP”) and loss of normal access to the ultimate heat sink (“LUHS”) occurring simultaneously at all units on a site.

## STPNOC FLEX Integrated Plan

**Key Site assumptions to implement NEI 12-06 strategies.**

**Ref: NEI 12-06 section 3.2.1**

Provide key assumptions associated with implementation of FLEX Strategies:

1. Flood and seismic re-evaluations pursuant to the 10 CFR 50.54(f) letter of March 12, 2012 are not completed and therefore not assumed in this submittal. As the re-evaluations are completed, appropriate issues will be entered into the corrective action program and addressed on a schedule commensurate with other licensing bases changes. (Open item (OI) #19.)
2. The following conditions exist:
  - a. DC batteries are available.
  - b. AC and DC distribution system available.
  - c. Plant initial response is the same as SBO.
  - d. Entry to ELAP will be 10 minutes from loss of all AC if an alternate AC source does not restore power to one ESF bus.
  - e. Best estimate analysis and decay heat is used to establish operator time and action.
3. Based on NEI 12-06, deployment resources begin arriving at 6 hours after the event and are fully staffed by 24 hours.
4. Per NEI 12-06, Section 3.2.1.2, Initial Plant Conditions, prior to the event the plant has been operating at 100% power for at least 100 days.
5. Two Regional Resource Centers (RRCs) will be established by the nuclear industry to provide phase 3 equipment to nuclear sites within 24 hrs of requesting the equipment. The location of these RRCs is Memphis, Tennessee and Phoenix, Arizona.
6. Per NEI 12-06, Section 3.2 "Performance Attributes", "...installed equipment that is designed to be robust with respect to DBEE is assumed to be fully available."
7. Section 3.2.1.3 (6) "Initial Conditions", states "Permanent plant equipment that is contained in structures with designs that are robust with respect to seismic events, floods and high winds and associated missiles are available."
8. Section 3.2.1.3 (8) "Initial Conditions", states "Installed electrical distribution systems...remain available provided they are protected..."
9. Based on Section 3.2, all protected equipment, including the Turbine Driven Auxiliary Feed Water (TDAFW) pump will perform as designed, except those pieces assumed to be lost in the Order.
10. Emergency Operating Procedure changes will be made using approved guidance.
11. Additional analysis may be required that could affect some of the strategies discussed in this submittal.

## STPNOC FLEX Integrated Plan

12. STP assumes that the preliminary calculations performed to provide assurance that the 480V FLEX generator(s), fuel tank, auxiliary equipment and enclosure can be installed on the MAB roof will be validated by a detailed calculation.
13. STP assumes that the only external event that could potentially cause damage to the SFP liner is a seismic event.
14. As stated in the guidance: “Each plant has unique features and for this reason, the implementation of FLEX capabilities will be site-specific”. The unique features of STP Units 1 and 2 are:
  - a. The design basis flood level which adds over 20 ft of water to the site immediately. This forces STP to pre-stage almost all equipment at its deployment location.
  - b. Three completely independent, 100% capacity ESF diesel generators per unit, protected from all design basis external events.
  - c. The Auxiliary Feedwater Storage Tank (AFWST) is a safety related, seismically qualified tank of 525,000 gallons, providing 44 hours of feedwater inventory.
  - d. Using the assumptions in WCAP 17601, core uncover would not occur for at least 60 hours without any additional water added and reflux cooling does not begin until 33 hours into the event. Site specific analysis for reflux cooling is open item #2.
  - e. 125VDC power is available for instrumentation on 2 of the 4 channels for over 24 hours following a deep load shedding strategy. Another strategy reduces loads on selected buses even more, giving up to 47 hours on 1 channel. (Ref. 6)
  - f. The need for Spent Fuel Pool makeup is beyond 30 hours. (Ref. 2)

This robust design allows STP to cope for beyond 30 hours without the need for a FLEX Steam Generator (SG) feed pump or a FLEX Reactor Coolant System (RCS) feed pump. Thus, small 120V diesel generators are the only power necessary for the first 30+ hours of this event.

15. A “modification” is a change to a permanent plant system, structure or component.
16. Permanent plant equipment that is evaluated probabilistically for wind-driven missiles in accordance with the current design and license basis is assumed to remain available.
17. Assumptions are consistent with those detailed in NEI 12-06, Section 3.2.1.
18. RCP seal leakage is assumed to be 21gpm/RCP per WCAP 17601.
19. This plan defines strategies capable of mitigating a simultaneous loss of all alternating current (ac) power and loss of normal access to the ultimate heat sink resulting from a beyond-design-basis event by providing adequate capability to maintain or restore core cooling, containment, and SFP cooling capabilities at all units on a site. Though specific strategies are being developed, due to the inability to anticipate all possible scenarios, the strategies are also diverse and flexible to encompass a wide range of possible conditions. These pre-planned strategies developed to protect the public health and safety will be incorporated into the unit emergency operating procedures in accordance with established EOP change processes, and their impact to



## STPNOC FLEX Integrated Plan

the design basis capabilities of the unit evaluated under 10 CFR 50.59. The plant Technical Specifications contain the limiting conditions for normal unit operations to ensure that design safety features are available to respond to a design basis accident and direct the required actions to be taken when the limiting conditions are not met. The result of the beyond-design-basis event may place the plant in a condition where it cannot comply with certain Technical Specifications and/or with its Security Plan, and, as such, may warrant invocation of 10 CFR 50.54(x) and/or 10 CFR 73.55(p).

**Extent to which the guidance, JLD-ISG-2012-01 and NEI 12-06, are being followed. Identify any deviations to JLD-ISG-2012-01 and NEI 12-06.**

**Ref: JLD-ISG-2012-01  
NEI 12-06 13.1**

*Include a description of any alternatives to the guidance, and provide a milestone schedule of planned action.*

The primary objective of Order EA-12-049 and NEI guidance 12-06 is for nuclear plants to provide protective measures for an external event that is beyond design basis using portable equipment. Because the South Texas Project has a unique design basis flood (breach of the embankment of the 7000 acre above ground reservoir) that almost instantaneously floods the site with over 20 feet of water, STP proposes a strategy to pre-stage and protect a 480V air-cooled generator (DG or CTG) on the top of a roof of the power block. This new generator would not have the same vulnerabilities that each of the ESF DGs share (e.g. common cooling, design, construction and same building) and thus would offer significant additional protection. Pre-staged, protected equipment would then be powered to provide optimal coping in the event of a BDBEE that results in an Extended Loss of AC Power (ELAP) event. Although some portable equipment is used in these strategies, these pre-staged features will be used primarily to cope in all three response phases in lieu of extensive use of portable equipment.

This FLEX 480V DG/CTG will be protected from all design basis external events by, among other things, building an enclosure around it that would protect it from missiles. It will be able to power different pumps and other equipment by means of separate, independent connections.

In summary, crediting this FLEX equipment during all three phases of a BDBEE ELAP response provides an optimal recovery plan that relies very little on portable equipment deployment for the first 24 hours of the event.

Regarding Spent Fuel Pool spray capability, strategies exist to spray the pool as required by NEI 12-06 for all external outside design basis events. However, for a design basis flood, spray capability will not be available for approximately 72 hours (Ref.7) due to the flood waters at the site receding to ~ 1.5 ft at this time. A design basis flood will not cause a significant leak in the pool so the extended deployment time is acceptable.

Analysis of the boil off in the spent fuel pool shows that SFP make up is required prior to 96 hours following an ELAP event due to radiological habitability concerns on the refuel deck. (Ref.2) This supports the 72 hour delay caused by the flood waters. STP will still have other SFP fill strategies that

## STPNOC FLEX Integrated Plan

can be accomplished during a flood.

**Provide a sequence of events and identify any time constraint required for success including the technical basis for the time constraint.**

**Ref: NEI 12-06 section 3.2.1.7**  
**JLD-ISG-2012-01 section 2.1**

*Strategies that have a time constraint to be successful should be identified with a technical basis and a justification provided that the time can reasonably be met (for example, a walk through of deployment). Describe in detail in this section the technical basis for the time constraint identified on the sequence of events timeline Attachment 1A*

*See attached sequence of events timeline (Attachment 1A).*

1. Initial DC bus stripping within 30 minutes: STP has a site specific requirement to perform an initial stripping of DC loads which is require within 30 minute of the event to extend the DC battery life out to 4 hours. This action is part of the current procedure.
2. Emergency Communicator contacting the State and County within 15 min of declared event: As part of the Emergency Response Organization (ERO) duties a Plant Operator will obtain a satellite phone to contact with State and County within 15 minutes. Satellite phones are staged across the hallway from the Control Room in an emergency locker with extra batteries and batteries chargers. (Reference 0ERP01-ZV-SH01, Shift Manager and 0POP01-ZA-0001, Plant Operations Department Administrative Guidelines)
3. RO Communicate with NRC within 1 hour: As part of the Emergency Response Organization (ERO) duties a Reactor Operator will obtain a satellite phone to contact with NRC as soon as possible but always within 1 hour. Satellite phones are staged across the hallway from the Control Room in an emergency locker with extra batteries and batteries chargers. (Reference 0ERP01-ZV-SH01, Shift Manager and 0POP01-ZA-0001, Plant Operations Department Administrative Guidelines)
4. Control Room staff commences cooldown to < 550°F within 1 hour: Cooldown should commence within the hour to ensure RCS Tcolds are reduced to less than 550 °F. Cooldown is to protect the RCP seal package. WCAP-17601-P Rev. 0 Section 4.4.1.1 indicates RCP O-rings will remain intact for at least several hours at cold leg temperature of approximately 570 °F.
5. Perform deep DC load shedding per new FLEX Support Guidelines (FSG) within 2 hours of event: The deep stripping allows the required instrumentation and control capabilities to be extend beyond the initial 4 hours capacity if completed within 2 hours. (ref. 6) This will allow time to obtain flex equipment to restore battery charger and instrument bus.
6. Energize A and C train battery chargers within 12 hours: Restore battery charger prior to depleting the battery and losing the vital instrumentation. (ref 6) In the event that all manner of DC power is lost such that instrumentation is lost, procedures would direct operators to use a multimeter to get readings from QDPS until DC power could be restored.

*Technical Basis Support information, see attached NSSS Significant Reference Analysis Deviation*

## STPNOC FLEX Integrated Plan

### *Table (Attachment 1B)*

Site specific analysis will be required to determine if additional time constraints may exist. OI# 2,7,8

#### **Identify how strategies will be deployed in all modes.**

**Ref: NEI 12-06 section 13.1.6**

*Describe how the strategies will be deployed in all modifications.*

The plans/strategies discussed in this paper primarily reflect an initial condition of operating modes 1-4; however, deployment of FLEX equipment will be possible for all modes of operation. The 480V FLEX DG will be available to be started and fueled in all modes. The FLEX pumps will be available to fill the SGs, RCS and SFP in all modes. An administrative program will ensure the strategies can be implemented in all modes by maintaining the portable FLEX equipment available to be deployed during all modes.

During Mode 5 and 6 prior to flood up, the FLEX SFP Fill pump (rated at 200 gpm) will be directed to discharge into the Safety Injection piping which is connected to the RCS. Using this pump for the RCS makeup takes away one of the 3 makeup capabilities to the SFP; however, two makeup capabilities for the SFP remain. This should be acceptable for the short duration of this plant configuration. Additional strategies may be required and will be determined. (Open item #11.)

Mid-loop operations, if scheduled, are typically of short duration with respect to other operating conditions. While the likelihood of a BDBEE occurring during mid-loop operations is extremely remote, current procedures direct the operators to gravity feed the RCS from the RWST.

During refueling operations the water from the Refueling Water Storage Tank (RWST) is contained in the cavity above the reactor and in the refueling canal and the gate between the transfer canal and the Spent Fuel Pool (SFP) is typically open. By virtue of this additional water volume over the core, extended times to boil are expected. (Ref.8) Consequently, the strategy to provide gravity makeup flow from the RWST would not be applicable in this condition.

Very little equipment is stored away from the location it will be used because of the need to protect against the design basis flood. Additional equipment (needing to be deployed) is not needed for at least 72 hours. Because of this, STP is evaluating storing this equipment at the RRC. (Open item #3.)

Transportation strategies, if necessary, will be developed from the equipment storage/staging area to where the equipment is needed. An administrative program will be developed to ensure pathways remain clear or can be restored post event.

Identification of storage location and protection and creation of the administrative program are open items # 3 and # 4, respectively.

#### **Provide a milestone schedule. This schedule should include:**

- **Modification timeline**
  - **Phase 1 Modifications**
  - **Phase 2 Modifications**
  - **Phase 3 Modifications**
- **Procedure guidance development complete**

## STPNOC FLEX Integrated Plan

- **Strategies**
- **Maintenance**
- **Storage plan (reasonable protection)**
- **Staffing analysis completion**
- **FLEX equipment acquisition timeline**
- **Training completion for the strategies**
- **Regional Response Centers operational**

**Ref: NEI 12-06 section 13.1**

*The dates specifically required by the order are obligated or committed dates.*

*Other dates are planned dates and are subject to change.*

*Updates will be provided in the periodic (six month) status reports*

STP has revised the future outage dates for Unit 2 because of an extended forced outage that unit 2 is currently in. The second outage from this plan submittal is now scheduled for the Spring of 2015.

**See attached milestone schedule Attachment 2**

**Identify how the programmatic controls will be met.**

**Ref: NEI 12-06 section 11**  
**JLD-ISG-2012-01 section 6.0**

*Provide a description of the programmatic controls equipment protection, storage and deployment and equipment quality. See section 11 in NEI 12-06. Storage of equipment, 11.3, will be documented in later sections of this template and need not be included in this section.  
See section 6.0 of JLD-ISG-2012-01.*

Equipment associated with these strategies will be procured as commercial equipment with design, storage, maintenance, testing, and configuration control in accordance with NEI 12-06 Rev.0 Section 11.0.

The unavailability of equipment and applicable connections that directly performs a FLEX mitigation strategy will be managed using plant equipment control guidelines developed in accordance with NEI 12-06 Rev.0 Section 11.5.

Programs and controls will be established to assure personnel proficiency in the mitigation of beyond design-basis events is developed and maintained in accordance with NEI 12-06 Rev.0 Section 11.6.

The FLEX strategies and basis will be maintained in an overall program document. Existing plant configuration control procedures will be modified to ensure that changes to the plant design, physical plant layout, roads, buildings, and miscellaneous structures will not adversely impact the approved FLEX strategies in accordance with NEI 12-06 Rev.0 Section 11.8.

## STPNOC FLEX Integrated Plan

<b>Describe training plan</b>
<i>List training plans for affected organizations or describe the plan for training development</i> The Systematic Approach to Training (SAT) will be used to evaluate what training is required for station personnel based upon changes to plant equipment and procedures that result from implementation of the strategies described in this integrated plan. This training will be completed prior to final implementation of the requirements of this Order.
<b>Describe Regional Response Center plan</b>
The industry will establish two (2) Regional Response Centers (RRC) to support utilities during beyond design basis events. Each RRC will hold five (5) sets of equipment, four (4) of which will be able to be fully deployed when requested, the fifth set will have equipment in a maintenance cycle. Equipment will be moved from an RRC to a local Assembly Area, established by the Strategic Alliance for Flex Emergency Response (SAFER) team and the utility. Communications will be established between the affected nuclear site and the SAFER team and required equipment moved to the site as needed. First arriving equipment, as established during development of STP's agreed upon contractual plan of action (playbook), will be delivered to the site staging area within 24 hours from the initial request. The staging area has yet to be determined – open item #16. A contract has been executed and will be maintained in accordance with section 12 of NEI 12-06.

## STPNOC FLEX Integrated Plan

### Maintain Core Cooling and Heat Removal

Determine Baseline coping capability with installed coping<sup>1</sup> modifications not including FLEX modifications, utilizing methods described in Table 3-2 of NEI 12-06:

- AFWITHEFW
- Depressurize SG for Makeup with Portable Injection Source
- Sustained Source of Water

Ref: JLD-ISG-2012-01 section 2 and 3

### PWR Installed Equipment Phase 1

*Provide a general description of the coping strategies using installed equipment including station modifications that are proposed to maintain core cooling. Identify methods (AFW/EFW) and strategy (ies) utilized to achieve this coping time.*

On a loss of all AC power event, design basis or outside design basis, the reactor will automatically trip and the TDAFW will automatically start and feed the D Steam Generator (SG). (Ref. 21 UFSAR page 5 of Appendix 10A) Operators will manually align AFW flow to all four SGs per the Emergency Operating Procedures (Ref 13). Per WCAP 17601, the TDAFW will safely operate until steam pressure drops below 100 psia. (Ref 4 page 2-2) The length of time the TDAFW pump will run will be a function of decay heat but it should run for ~ 5 days given the assumptions in NEI 12-06. (Ref 4 section 5.1.3.1)

Operator actions will be directed by the Emergency Operating Procedures. STP takes no exception to WCAP 17601. Those assumptions, suggestions and analysis applicable to 4-loop Westinghouse PWRs will be utilized by STP. As described in reference 4, STP will initiate an operator controlled symmetric cooldown of the RCS at 2 hours following event initiation and RCS cooldown is terminated when SG pressure reaches 350 psig (RCS cold leg temperature of 425°F). The 350 psig SG pressure setpoint is to prevent injection of accumulator cover gas into the RCS. This particular process is currently applied via ECA-0.0 (Ref. 13) and WCAP 17601 demonstrate a bounding core uncover time of ~55 hours (60 hours for STP) and also the ability to maintain the reactor in a subcritical state. Maintaining secondary cooling is critical to the success of the PWR ELAP coping strategy as it becomes the ultimate heat sink. The primary method for supplying feedwater to the SGs during an ELAP is via the installed steam driven portion of the AFW system. This installed pump is sized to provide sufficient SG feedwater flow to remove decay heat post-reactor trip. The pump is also sized to remove energy stored in the RCS metal, water mass, and fuel while maintaining adequate SG inventory necessary to cooldown/depressurize the primary system to conditions that allow placing the Residual Heat Removal (RHR) system in service. Assuming the RHR system will not be available during an ELAP event due to the significant support system requirements, the SGs must remain available to remove decay heat for an indefinite period of time. In addition, during an ELAP event the installed steam driven portion of the AFW system is the single source for maintaining SG inventory. Therefore, an Alternate Low Pressure Feedwater Source FLEX Support Guideline (FSG) that implements another SG feed capability is being developed to maintain an adequate secondary heat sink.

Calculations have demonstrated that this ELAP event will not cause the TDAFW pump room to heatup beyond the TDAFW pump Environmental Qualification temperature limit of 170°F. Ref. 16.

## STPNOC FLEX Integrated Plan

The safety related Auxiliary Feed Water Storage Tank (AFWST) has sufficient capacity to provide water to the SGs for about 44 hrs (Ref.5) before needing to be refilled. No station modifications are proposed for phase 1 coping time; however, numerous procedure changes will be required. Vital instrumentation will be available to the operators during this event to ensure they feed and steam SGs properly. An extensive proceduralized load shedding process will be implemented to extend battery life to ensure these critical parameters can be monitored from the control rooms. This will be discussed in more detail in the “support” section of this integrated plan.

### Details:

#### **Provide a brief description of Procedures / Strategies / Guidelines**

*Confirm that procedure/guidance exists or will be developed to support implementation.*  
 Procedures will be developed to support this implementation. (Open item #9.) Strategies will be directed using Ref. 13 while, as needed, performing the activities of Flex Support Guidelines (FSGs).

#### **Identify modifications**

*List modifications and describe how they support coping time.*  
 No modifications will be necessary to cope for the specified times.

#### **Key Reactor Parameters**

*List instrumentation credited for this coping evaluation phase.*

For the Core Cooling safety function, the following parameters will be monitored:

SG Wide Range (WR) levels	SG pressures	AFW flow
RCS pressure	RCS Tcolds	AFWST level
Extended Range NIs	RCS Thots	CETs

#### **NOTE:**

STP has 4 class 1E batteries that supply power to 4 redundant instrument channels. A battery life coping study was done for STP in 2012 for the 125VDC Class 1E batteries. (Ref 6) Based on the results of this study, most of these vital parameters will be available in the control room for at least 24 hrs on two of the four instrumentation channels. Below are the results (rounded down) of this study:

- Channel I 12 hrs
- Channel II 29 hrs
- Channel III 25 hrs
- Channel IV 13 hrs

This is based on a significant amount of load being shed at or before 2 hours into the event. (Ref. 6)

## STPNOC FLEX Integrated Plan

### Maintain Core Cooling and Heat Removal

#### PWR Portable Equipment Phase 2

*Provide a general description of the coping strategies using on-site portable equipment including station modifications that are proposed to maintain core cooling. Identify methods and strategy (ies) utilized to achieve this coping time.*

Although the robust design of STP allows ample time for offsite resources to arrive prior to engaging in the core cooling strategy, STP personnel will start the 480V FLEX DG and power components as readily as possible in phase 2.

Thus, the components and strategies will be discussed here because STP will move to engage in them quickly to provide protection sooner than required. These are really phase 3 strategies, but will be implemented as soon as possible.

#### Details:

#### **Provide a brief description of Procedures / Strategies / Guidelines**

*Confirm that procedure/guidance exists or will be developed to support implementation with a description of the procedure / strategy / guideline.*

A 480V diesel generator (DG) will be staged and protected on the roof of the Mechanical Auxiliary Building (MAB). This DG will power a pre-staged SG feed pump located at the bottom level of the Isolation Valve Cubicle (IVC) to feed the SGs. It will take suction on the AFWST and be capable of discharging into all four SGs.

Procedures (FSGs) are being developed to direct operators in these strategies. (Open item #9.)

#### **Identify modifications**

*List modifications necessary for phase 2*

Pre-stage the FLEX SG feed pump capable of 400 psig/300 gpm (Ref.4) at the bottom of the IVC. Permanently install a "T" in the AFW suction line and a "T" in the AFW X-connect piping with manual isolation valves on each. Pre-install cable and conduit down to the bottom elevation of the IVC to power pump. Stage properly rated hoses for connecting to "Ts".

The following is generic for all strategies associated with key functions:

Pre-stage the 480V FLEX DG, fuel tank, cabling and conduits.

Pre-install cabling to areas near the buckets on selected Motor Control Centers (MCCs) to enable powering of battery chargers on A and C ESF DC buses for instrumentation considerations.

See conceptual drawing # 4

#### **Key Reactor Parameters**

*List instrumentation credited or recovered for this coping evaluation.*

SG WR levels	CETs
SG pressures	AFWST level
AFW flow	RCS Tcolds



## STPNOC FLEX Integrated Plan

<b>Maintain Core Cooling and Heat Removal</b>	
<b>PWR Portable Equipment Phase 2</b>	
RCS pressure RCS Thots	Extended Range NIs
<b>Storage / Protection of Equipment :</b> <b>Describe storage / protection plan or schedule to determine storage requirements</b>	
<b>Seismic</b>	
<i>List Protection or schedule to protect</i>	
Each pump and hose will be staged in a safety related structure. The diesel generator will be staged on the MAB roof and will be enclosed in a missile protected concrete structure. The components in this structure will be available following a seismic event, since they are housed in a seismically robust structure per NEI 12-06, Section 3.2.1.3 (6).	
<b>Flooding</b>	
Note: if stored below current flood level, then ensure procedures exist to move equipment prior to exceeding flood level.	
<i>List Protection or schedule to protect</i>	
The above mentioned DG will be located above the design basis flood elevation. Other equipment will be stored in safety related buildings.	
<b>Severe Storms with High Winds</b>	
<i>List Protection or schedule to protect</i>	
The enclosure will be designed to protect equipment from severe storms and high winds, the same as a safety-related structure. It will also provide protection from design basis missiles.	
<b>Snow, Ice, and Extreme Cold</b>	
<i>List Protection or schedule to protect</i>	
Components are to be protected inside enclosed structures, with freeze protection to be determined during design phase.	
<b>High Temperatures</b>	
<i>List Protection or schedule to protect</i>	
Components are to be protected inside enclosed structures, with heat protection measures to be determined during design phase.	

## STPNOC FLEX Integrated Plan

<b>Maintain Core Cooling and Heat Removal</b>		
<b>PWR Portable Equipment Phase 2</b>		
<b>Deployment Conceptual Design (Attachment 3 contains Conceptual Sketches)</b>		
<p>This FLEX equipment will, for the most part, be pre-staged in its deployed location. Some support equipment, specifically the 120V diesel generators will be moved a short distance to allow fumes to exhaust outdoors. Extension cords will be run from the small diesel generators to loads. Light strings and fans will be placed to support personnel and strategies. Hose sections will be connected to pumps and piping as necessary to support pump operations. Fuel will be collected in 5 gallon cans from the ESF DG FOSTs and taken to the small diesel generators as needed.</p>		
<b>Strategy</b>	<b>Modifications</b>	<b>Protection of connections</b>
<i>Identify Strategy including how the equipment will be deployed to the point of use.</i>	<i>Identify modifications</i>	<i>Identify how the connection is protected</i>
<p>Makeup to SGs:</p> <p>Connections will be made by on-shift maintenance and operations personnel to connect the hoses to the previously installed T's and FLEX SG feed pump. Once powered, pump will be locally started by operations personnel and manually aligned to feed all SGs per FSGs. (Open item #9.)</p>	<p>No modifications are necessary for the deployment of this equipment because the equipment will be stored at its deployment location. Modifications to the AFW piping will be required to support the strategy.</p>	<p>Connections are inside safety related building</p>
<p>ALL STRATEGIES RELY ON THE FOLLOWING DEPLOYMENT MEANS FOR THE 480V FLEX DG BY ON SHIFT PERSONNEL:</p> <ul style="list-style-type: none"> <li>• Fuel the 480V FLEX DG by moving the 120VAC diesel generator stored in the ESF DGB onto the catwalk.</li> <li>• Connect hoses staged in the storage building on top of the MAB and in the ESF DG building to the fuel oil transfer pump stored in an ESF DG building and to the fuel oil storage tank for the</li> </ul>	<p>No modifications are necessary for the deployment of this equipment.</p>	<p>Some connections are inside a protected structure but some will be made after the event.</p>

# STPNOC FLEX Integrated Plan

## Maintain Core Cooling and Heat Removal

### PWR Portable Equipment Phase 2

#### 480V FLEX DG.

- Connect an extension cord from the small DG to the fuel oil transfer pump.
- Add fuel to the 120 VAC DG, start the DG and fuel the tank for the 480V FLEX DG.
- When fuel level is adequate, start 480V FLEX DG.
- The specifics of this strategy will be captured in FSG procedures. (Open item # 9.)

**Notes:** Conceptual sketches for fuel oil fill are #s 2 and 3

## STPNOC FLEX Integrated Plan

### Maintain Core Cooling and Heat Removal

#### PWR Portable Equipment Phase 3

*Provide a general description of the coping strategies using phase 3 equipment including modifications that are proposed to maintain core cooling. Identify methods and strategy (ies) utilized to achieve this coping time.*

Phase 3 of this strategy will be a continuation of phase 2.

Depending on decay heat, the TDAFW pump will run, feeding the four SGs, for a period of time until decay heat no longer supports the pump running (i.e. running the pump could cause RCS cooldown below a pre-determined value). Prior to that point the FLEX 480V diesel generator will be started to provide power to the FLEX SG feed pump and other FLEX equipment. This will provide a means to fill the SGs as necessary. If it becomes necessary to manually operate the TDAFW pump, procedural direction is given in EOPs and the normal operating procedure for the AFW system to do such. (Ref. 22) A +1 SG Fill pump will be staged in the same location. An alternate injection path will be available for either pump.

With respect to filling the AFWST, procedural direction will be given to the operations staff to begin preparations to fill the AFWST at some pre-determined level. Depending on the type of external event that took place, different tanks, basins and reservoirs will or will not be available as a supply to fill the AFWST. The FSG will list each potential source of water in order of priority and equipment needed will be staged and protected. This is open item #9. A 120VAC pump powered from a 120VAC diesel generator will be used for most of these sources; however, for the design basis flood, a gravity feed source will be used. The Feedwater Dearator (DA) is located above the flood level and above the top of the AFWST. The DA will be intact and available on a design basis flood. The DA has numerous one inch vents and drains that can be coupled together to gravity feed into the top of the AFWST. Three one inch vents on the north side of the bottom of the tank are selected for use in this strategy. The DA's volume is 195,000 gals (ref. 26). This volume would be adequate until the flood waters recede (~72 hours) when makeup can begin with another source.

At some point during "indefinite" coping, STP can bring in a 4160V diesel generator from the RRC and power one of the three ESF buses at one of the ESF transformers on the low (4160V) side. This will power the selected ESF 4160V electrical bus. This will provide power to permanent plant equipment for lighting, battery chargers, pumps, valves, fans, etc. With respect to core cooling, an AFW pump (motor driven) would be powered.

#### Details:

#### **Provide a brief description of Procedures / Strategies / Guidelines**

*Confirm that procedure/guidance exists or will be developed to support implementation with a description of the procedure / strategy / guideline.*

Procedures will be developed to implement these strategies

## STPNOC FLEX Integrated Plan

<b>Maintain Core Cooling and Heat Removal</b>		
<b>PWR Portable Equipment Phase 3</b>		
<b>Identify modifications</b>		
<i>List modifications necessary for phase 3</i>		
<b>Key Reactor Parameters</b>		
<i>List instrumentation credited or recovered for this coping evaluation.</i>		
<ul style="list-style-type: none"> <li>• CETs</li> <li>• RCS WR pressure</li> <li>• RCS Tcolds</li> <li>• SG levels</li> <li>• SG pressures</li> <li>• AFW flow</li> <li>• AFWST level</li> <li>• Extended Range NIs</li> </ul>		
<b>Deployment Conceptual Design</b> (Attachment 3 contains Conceptual Sketches)		
<b>Strategy</b>	<b>Modifications</b>	<b>Protection of connections</b>
<i>Identify Strategy including how the equipment will be deployed to the point of use.</i>	<i>Identify modifications</i>	<i>Identify how the connection is protected</i>
As discussed previously, the AFWST should last for ~ 44 hours after which, additional water makeup will need to be provided to allow continued feeding of the SGs. (Ref. 5) Hoses will be run to an available water source such as from tank drain valves, inside basins and hotwells or inside reservoirs for suction and will be pumped by a 120V pump powered from a 120VAC diesel generator to the AFWST. Current procedural guidance offers numerous means to fill the AFWST but the equipment necessary is not protected. STP will protect the equipment required to support	Connections are still being assessed; some modifications may be required to support deployment of these pumps. This is open item #5.	Because there are a variety of water sources available, these connection points will not need to be protected. (Ref. Conceptual drawing #1 on AFWST fill sources.)

# STPNOC FLEX Integrated Plan

<b>Maintain Core Cooling and Heat Removal</b>		
<b>PWR Portable Equipment Phase 3</b>		
<p>these strategies. In the event of a flood, the earlier discussed gravity feed of the AFWST using the Feedwater DA will be preferred and should begin at about the 24 hour mark. Another means of AFWST makeup is using the RRC provided diesel driven pump taking suction on a basin or reservoir.</p>		

## STPNOC FLEX Integrated Plan

<b>Maintain RCS Inventory Control</b>
<p><b>Determine Baseline coping capability with installed coping<sup>2</sup> modifications not including FLEX modifications, utilizing methods described in Table 3-2 of NEI 12-06:</b></p> <ul style="list-style-type: none"> <li>• <b>Low Leak RCP Seals or RCS makeup required</b></li> <li>• <b>All Plants Provide Means to Provide Borated RCS Makeup</b></li> </ul>
<b>PWR Installed Equipment Phase 1:</b>
<p><i>Provide a general description of the coping strategies using installed equipment including modifications that are proposed to maintain core cooling. Identify methods (Low Leak RCP Seals and/or borated high pressure RCS makeup) and strategy (ies) utilized to achieve this coping time.</i></p> <p>WCAP 17601 shows, based on a 21 gpm RCP seal leak per RCP, that STP should have ~ 60 hrs from event initiation to the point where core uncover begins.</p> <p>No additional strategies are required for phase 1 coping.</p>
<b>Details:</b>
<p><b>Provide a brief description of Procedures / Strategies / Guidelines</b></p> <p><i>Confirm that procedure/guidance exists or will be developed to support implementation</i></p> <p>Procedures will be developed to implement these strategies.</p>
<p><b>Identify modifications</b></p> <p><i>List modifications</i></p> <p>None for inventory for Phase 1.</p>
<p><b>Key Reactor Parameters</b></p> <p><i>List instrumentation credited for this coping evaluation.</i></p> <ul style="list-style-type: none"> <li>• Pzr level</li> <li>• RVWL level</li> <li>• CETs</li> <li>• Extended Range NIs</li> <li>• RWST level</li> <li>• RCS WR Pressure</li> <li>• RCB WR sump level</li> </ul>

<sup>2</sup> Coping modifications consist of modifications installed to increase initial coping time, i.e. generators to preserve vital instruments or increase operating time on battery powered equipment.

## STPNOC FLEX Integrated Plan

### Maintain RCS Inventory Control

#### PWR Portable Equipment Phase 2:

*Provide a general description of the coping strategies using on-site portable equipment including modifications that are proposed to maintain core cooling. Identify methods (Low Leak RCP Seals and/or borated high pressure RCS makeup) and strategy (ies) utilized to achieve this coping time.*

Because of the robust design of STP, the strategies to makeup to the RCS are considered phase 3 coping strategies; however, because it would be prudent to immediately implement strategies to protect the core, these phase 3 strategies and equipment will be discussed here. Realistically, if an event occurred, plant personnel would not wait. Whatever they could do they would do, as quickly as possible, to protect the plant, the core and the public. Thus, these strategies will be discussed here.

#### Details:

#### Provide a brief description of Procedures / Strategies / Guidelines

*Confirm that procedure/guidance exists or will be developed to support implementation*

Procedures will be developed to implement these strategies. (Open item #9.) A 480V diesel generator will be staged and protected on the roof of the MAB. This DG will have its power run to various locations throughout the plant. For RCS makeup, the N pump is the CVCS PDP, which is permanent plant equipment. The N+1 pump will be staged at the -21' of the Fuel Handling Building (FHB) and will be tied into the Safety Injection (SI) systems. The suction line will be connected to the SI or CS piping for the FLEX pump to pull its suction from. The exact location of this connection is tracked with open item #17. The discharge of the FLEX RCS Fill pump will be attached to SI system discharge piping. It will get its suction from the Refueling Water Storage Tank (RWST) and discharge into the RCS via the SI piping.

#### Identify modifications

*List modifications*

Cable and conduit to power the CVCS PDP will be installed. T's and valves will be installed into the permanent plant systems for the +1 pump. System tie-ins are still being determined with open item #17. Cable and conduit would be installed down to the -21' FHB to power the FLEX RCS Fill pump. The 480V DG has been previously described.

#### Key Reactor Parameters

*List instrumentation credited or recovered for this coping evaluation.*

- Pzr level
- RVWL level
- CETs
- RWST level
- RCS WR Pressure
- RCB WR sump level



## STPNOC FLEX Integrated Plan

<b>Maintain RCS Inventory Control</b>
<b>PWR Portable Equipment Phase 2:</b>
<b>Storage / Protection of Equipment: Describe storage / protection plan or schedule to determine storage requirements</b>
<b>Seismic</b>  <i>List Protection or schedule to protect</i>  Each pump and hose will be staged in a safety related structure. The diesel generator will be pre-staged on the MAB roof and will be enclosed in a missile protected concrete building. The components in this building will withstand a seismic event.
<b>Flooding</b>  Note: if stored below current flood level, then ensure procedures exist to move equipment prior to exceeding flood level.  <i>List Protection or schedule to protect</i>  The above mentioned equipment will be located above the design basis flood elevation or in a safety related structure which is not susceptible to flooding.
<b>Severe Storms with High Winds</b>  <i>List Protection or schedule to protect</i>  The diesel generator will be pre-staged on the MAB roof and will be enclosed in a missile protected concrete building.
<b>Snow, Ice, and Extreme Cold</b>  <i>List Protection or schedule to protect</i>  Components are to be protected inside enclosed structures, with freeze protection to be determined during design phase.
<b>High Temperatures</b>  <i>List Protection or schedule to protect</i>  Components are to be protected inside enclosed structures, with heat protection to be determined during design phase.

## STPNOC FLEX Integrated Plan

<b>Deployment Conceptual Modifications (Attachment 3 contains Conceptual Sketches)</b>		
<b>Strategy</b>	<b>Modifications</b>	<b>Protection of connections</b>
<i>Identify Strategy including how the equipment will be deployed to the point of use.</i>	<i>Identify modifications</i>	<i>Identify how the connection is protected</i>
Once the 480V DG is running, power will be provided to the RCS fill pump (CVCS PDP) on the 10' of the MAB. The pump gets suction from the RWST or the BATs and, by manually operating valves, can discharge into the RCS.	No modifications will be required for the deployment of this equipment, except for that already discussed.	Inside a safety related building
<p><b>Notes:</b>                      Deployment of the +1 strategy will consist of attaching hoses to the installed piping and pre-staged pumps. Electrical power will be provided to the pumps (in conduit). The pre-staged diesel will be fueled by means of a small 120V diesel generator and pump, taking suction from one of the three ESF diesel fuel oil storage tanks.</p>		

## STPNOC FLEX Integrated Plan

### Maintain RCS Inventory Control

#### PWR Portable Equipment Phase 3:

*Provide a general description of the coping strategies using phase 3 equipment including modifications that are proposed to maintain core cooling. Identify methods (Low Leak RCP Seals and/or borated high pressure RCS makeup) and strategy (ies) utilized to achieve this coping time...*

Well before reaching the 60 hour mark where core uncover would occur without RCS makeup, RCS makeup using a pre-staged high pressure pump will commence at a rate of ~40 gpm at 1500 psia (Ref. 4). Site specific analysis is yet to be performed. Open items 7 and 8. This will alleviate the concern of a return to criticality from the cooldown and ensure the core remains covered throughout the duration of the event.

The preferred RCS Fill pump is the CVCS Positive Displacement pump (PDP), located on the 10' of the MAB. Cabling and conduit will be pre-installed to provide power to the pump from the FLEX 480V generator located on the roof of the MAB. No hoses or connections will be required for this strategy. The CVCS PDP can take suction on either the RWST or the BA Storage tanks and will discharge into the RCS using the CVCS system piping.

The +1 pre-staged FLEX RCS Fill pump will be located at the bottom elevation of the FHB, near the SI pumps. Cabling and conduit will be pre-installed to provide power to the FLEX pump from the FLEX 480V generator located on the roof of the MAB. Hoses and fittings to make connections to permanent plant piping will be stored in the same location in the FHB.

At some point during "indefinite" coping, STP can bring in a 4160V diesel generator from the RRC and power one of the three ESF buses at one of the ESF transformers on the low (4160V) side. This will power the selected ESF 4160V electrical bus. This will provide power to permanent plant equipment for lighting, battery chargers, pumps, valves, fans, etc. With respect to RCS inventory, a Safety Injection pump (motor driven) would be powered.

#### Details:

#### Provide a brief description of Procedures / Strategies / Guidelines

*Confirm that procedure/guidance exists or will be developed to support implementation*

Procedures will be developed to implement these strategies. Phase 3 will makeup to the RCS as necessary using the RWST or BATs. If desired, when time permits, makeup to the RWST using a Reactor Makeup Water Storage Tank (RMWST) pump and a Boric Acid (BA) Transfer pump (powered via the 480V diesel generator) is available. There will be ~ 450k gals available in the RWST and another 200k gals available from the RMWST and BA tanks. (Refs. 9-11) Once these are all depleted, the water level in containment will be sufficient to use the water in the emergency sumps to makeup to the RCS as necessary using the recirculation modification of operation by manually opening an isolation valve. There are other sources of water like the Recycle Holdup tanks that are available to fill the RWST as well.

## STPNOC FLEX Integrated Plan

<b>Maintain RCS Inventory Control</b>		
<b>PWR Portable Equipment Phase 3:</b>		
<b>Identify modifications</b>		
<i>List modifications</i>		
The previously described 480V FLEX DG modification to support powering permanent plant and FLEX equipment for indefinite coping.		
<b>Key Reactor Parameters</b>		
<i>List instrumentation credited or recovered for this coping evaluation.</i>		
<ul style="list-style-type: none"> <li>• CETs</li> <li>• RVWL</li> <li>• Pzr Level</li> <li>• Extended Range NIs</li> <li>• RCS WR Pressure</li> <li>• RCB WR sump level</li> </ul>		
<b>Deployment Conceptual Modifications (Attachment 3 contains Conceptual Sketches)</b>		
<b>Strategy</b>	<b>Modifications</b>	<b>Protection of connections</b>
<i>Identify Strategy including how the equipment will be deployed to the point of use.</i>	<i>Identify modifications</i>	<i>Identify how the connection is protected</i>
480V diesel generator. Manual hookups (electrical and fuel oil) will be necessary as described earlier.	Build pad on roof of MAB to support 480V DG. Have pre-run cabling down to FLEX equipment that is pre-staged such as the CVCS PDP and the FLEX RCS Fill pump.	Electrical connections are inside a robust building. Connections to the buses themselves are in a safety related building (EAB, MAB, FHB).

## STPNOC FLEX Integrated Plan

<b>Maintain Containment</b>
<p><b>Determine Baseline coping capability with installed coping<sup>3</sup> modifications not including FLEX modifications, utilizing methods described in Table 3-2 of NEI 12-06:</b></p> <ul style="list-style-type: none"> <li>• Containment Spray</li> <li>• Hydrogen igniters (ice condenser containments only)</li> </ul>
<b>PWR Installed Equipment Phase 1:</b>
<p><i>Provide a general description of the coping strategies using installed equipment including modifications that are proposed to maintain containment. Identify methods (containment spray/Hydrogen igniter) and strategy (ies) utilized to achieve this coping time.</i></p> <p>The GOTHIC Containment analysis revealed that RCB pressure stays below design pressure of 56 psig for over 90 days provided severe core damage is mitigated; therefore, there are no phase 1 actions required at this time that need to be addressed. This analysis is still being completed and is open item #6.</p>
<b>Details:</b>
<p><b>Provide a brief description of Procedures / Strategies / Guidelines</b></p> <p>N/A</p>
<p><b>Identify modifications</b></p> <p>N/A</p>
<p><b>Key Containment Parameters</b></p> <p>No instrumentation is necessary; however, the ability to monitor RCB pressure will be provided.</p>
<p><b>Notes:</b></p> <p>Containment analysis using GOTHIC 7.2b showed RCB pressure stays below design pressure of 56 psig for over 90 days. Ref. 1</p>

<sup>3</sup> Coping modifications consist of modifications installed to increase initial coping time, i.e. generators to preserve vital instruments or increase operating time on battery powered equipment.

## STPNOC FLEX Integrated Plan

<b>Maintain Containment</b>
<b>PWR Portable Equipment Phase 2:</b> NA – analysis shows this is not necessary
<p><i>Provide a general description of the coping strategies using on-site portable equipment including modifications that are proposed to maintain containment. Identify methods (containment spray/hydrogen igniters) and strategy (ies) utilized to achieve this coping time.</i></p> <p>The GOTHIC Containment analysis revealed that RCB pressure stays below design pressure of 56 psig for over 90 days; therefore, there are no phase 2 actions required at this time that need to be addressed.</p>
<b>Details:</b>
<p><b>Provide a brief description of Procedures / Strategies / Guidelines</b></p> <p><i>Confirm that procedure/guidance exists or will be developed to support implementation</i> NA</p>
<p><b>Identify modifications</b></p> <p><i>List modifications</i> None</p>
<p><b>Key Containment Parameters</b></p> <p><i>List instrumentation credited or recovered for this coping evaluation.</i></p> <p>Containment Pressure indication</p>
<b>Storage / Protection of Equipment:</b>
<b>Describe storage / protection plan or schedule to determine storage requirements</b>
<p><b>Seismic</b></p> <p><i>List how equipment is protected or schedule to protect</i> NA</p>
<p><b>Flooding</b></p> <p><i>List how equipment is protected or schedule to protect</i> NA</p>
<p><b>Severe Storms with High Winds</b></p> <p><i>List how equipment is protected or schedule to protect</i> NA</p>
<p><b>Snow, Ice, and Extreme Cold</b></p> <p><i>List how equipment is protected or schedule to protect</i></p>

## STPNOC FLEX Integrated Plan

<b>Maintain Containment</b>		
NA		
<b>High Temperatures</b>		
<i>List how equipment is protected or schedule to protect</i>		
NA		
<b>Deployment Conceptual Modification (Attachment 3 contains Conceptual Sketches)</b>		
<b>Strategy</b>	<b>Modifications</b>	<b>Protection of connections</b>
<i>Identify Strategy including how the equipment will be deployed to the point of use.</i>	<i>Identify modifications</i>	<i>Identify how the connection is protected</i>
NA	NA	
<b>Notes:</b>		

## STPNOC FLEX Integrated Plan

<b>Maintain Containment</b>		
<b>PWR Portable Equipment Phase 3:</b>		
<p><i>Provide a general description of the coping strategies using phase 3 equipment including modifications that are proposed to maintain containment. Identify methods (containment spray/hydrogen igniters) and strategy (ies) utilized to achieve this coping time.</i></p> <p>In the event that this event duration is prolonged greater than 90 days, some means of containment cooling may be required. STP will either power the Containment Spray pumps with restored off-site or on-site power, a 4160V generator or operate the Reactor Containment Fan Coolers. These strategies are part of the restoration phase and are not strategized in this integrated plan.</p>		
<b>Details:</b>		
<b>Provide a brief description of Procedures / Strategies / Guidelines</b>		
<i>Confirm that procedure/guidance exists or will be developed to support implementation</i>		
<b>Identify modifications</b>		
<i>List modifications</i>		
None		
<b>Key Containment Parameters</b>		
<i>List instrumentation credited or recovered for this coping evaluation.</i>		
Containment pressure		
<b>Deployment Conceptual Modification</b> <b>(Attachment 3 contains Conceptual Sketches)</b>		
<b>Strategy</b>	<b>Modifications</b>	<b>Protection of connections</b>
<i>Identify Strategy including how the equipment will be deployed to the point of use.</i>	<i>Identify modifications</i>	<i>Identify how the connection is protected</i>
<b>Notes:</b>		



## STPNOC FLEX Integrated Plan

<b>Maintain Spent Fuel Pool Cooling</b>
<p><b>Determine Baseline coping capability with installed coping<sup>4</sup> modifications not including FLEX modifications, utilizing methods described in Table 3-2 of NEI 12-06:</b></p> <ul style="list-style-type: none"> <li>• <b>Makeup with Portable Injection Source</b></li> </ul>
<b>PWR Installed Equipment Phase 1:</b>
<p><i>Provide a general description of the coping strategies using installed equipment including modifications that are proposed to maintain spent fuel pool cooling. Identify methods (makeup via portable injection source) and strategy (ies) utilized to achieve this coping time.</i></p> <p>During Phase 1, the SFP will gradually begin to heat up due to the loss of forced circulation cooling and temperature is expected to start boiling (if start of event SFP temperature is 160°F) at just over 13 hours. It is over 96 hours before level drops to a point where accessibility to the spent fuel pool deck will be limited due to unacceptable radiation levels (NEI 12-02 calls this level 2). Thus, there are no phase 1 actions required at this time that need to be addressed. (Ref. 2)</p> <p>NEI 12-06, section 3.2.1.6 also discusses the SFP conditions and assumes the SFP heat load is the maximum design basis heat load for the site. Using this assumption when the event occurs, the pool would begin to boil in about 3 hours and would boil down to 10 feet above the fuel in about 25 hours. (Ref. 27 Case 7B on page 63) The FLEX SFP Fill pump will be sized to meet or exceed the makeup required for this heat load.</p> <p>Regardless of which initial conditions are assumed, STP can makeup to the SFP prior to reaching what NEI 12-02 calls level 2 by at least one of the three methods of makeup:</p> <ul style="list-style-type: none"> <li>• Reactor Makeup Water pump using the normal SFP system</li> <li>• FLEX SFP Fill pump using hoses to the pool</li> <li>• Large diesel driven pump for SFP spray</li> </ul> <p>The SFP Fill pump is sized to be capable of exceeding boil-off rate for the boundary conditions in NEI 12-06, 3.2.1.6.</p> <p>The EOPs have procedural guidance in a loss of AC power event to periodically check SFP level so that makeup can commence when necessary. (Ref. 13)</p>
<b>Details:</b>
<p><b>Provide a brief description of Procedures / Strategies / Guidelines</b></p> <p>No coping actions are required for Phase 1.</p>
<p><b>Identify modifications</b></p> <p>No modifications are required for Phase 1</p>

<sup>4</sup> Coping modifications consist of modifications installed to increase initial coping time, i.e. generators to preserve vital instruments or increase operating time on battery powered equipment.

## STPNOC FLEX Integrated Plan

### **Key SFP Parameter**

Per EA 12-051, STP will install SFP level indication and have a remote readout available.

### **Notes:**

Spent Fuel Pool data shows that, without makeup, the SFP level will not lower to 10' above the fuel for over 96 hours. This is based on the event occurring immediately after a 20 day refueling outage. Ref. 2

## STPNOC FLEX Integrated Plan

<b>Maintain Spent Fuel Pool Cooling</b>
<b>PWR Portable Equipment Phase 2:</b>
<p><i>Provide a general description of the coping strategies using on-site portable equipment including modifications that are proposed to maintain spent fuel pool cooling. Identify methods (makeup via portable injection source) and strategy (ies) utilized to achieve this coping time.</i></p> <p>During Phase 2, operators will continue to monitor SFP level as called for in the EOPs using two protected level instruments installed per NEI 12-02. Analysis of the SFP heatup following a loss of power to the SFP Cooling pumps shows that the time for boiling to begin in the SFP will be no earlier than 13 hours and the time for SFP level to be at level 2 (10' above the fuel per NEI 12-02) will be no less than 96 hours. At ~ 144 hours, the fuel will become uncovered (level 3 per NEI 12-02). (Refs. 2 and 17)</p>
<b>Details:</b>
<p><b>Provide a brief description of Procedures / Strategies / Guidelines</b></p> <p><i>Confirm that procedure/guidance exists or will be developed to support implementation</i></p> <p>Procedures will be developed to support implementation. (Open item #9.)</p>
<p><b>Identify modifications</b></p> <p><i>List modifications</i></p> <p>Modifications are discussed in phase 3 coping strategies</p>
<p><b>Key SFP Parameter</b></p> <p>Per EA 12-051, STP will install SFP level indication and have a remote readout available.</p>
<b>Storage / Protection of Equipment:</b>
<b>Describe storage / protection plan or schedule to determine storage requirements</b>
<p><b>Seismic</b></p> <p><i>List how equipment is protected or schedule to protect</i></p> <p>Regardless of what phase is being discussed, each pump (the RMW pump, the FLEX SFP fill pump and the large capacity diesel driven pump), tools and hoses will be staged in a design basis building (safety related structure). The diesel generator will be pre-staged on the MAB roof and will be enclosed in a missile protected concrete building. The location is above the design basis flood elevation. The components in this building will withstand a seismic event.</p>

## STPNOC FLEX Integrated Plan

<b>Maintain Spent Fuel Pool Cooling</b>		
<b>Flooding</b>		
<i>List how equipment is protected or schedule to protect</i>		
All FLEX equipment is located in safety related structures or on the MAB roof in a robust enclosure above the flood level.		
<b>Severe Storms with High Winds</b>		
<i>List how equipment is protected or schedule to protect</i>		
All FLEX equipment is located in safety related structures or on the MAB roof in a robust structure that will prevent damage from severe storms with high winds or other high wind events.		
<b>Snow, Ice, and Extreme Cold</b>		
<i>List how equipment is protected or schedule to protect</i>		
Components are to be protected inside enclosed structures, with freeze protection to be determined during design phase.		
<b>Deployment Conceptual Design (Attachment 3 contains Conceptual Sketches)</b>		
<b>Strategy</b>	<b>Modifications</b>	<b>Protection of connections</b>
<i>Identify Strategy including how the equipment will be deployed to the point of use.</i>	<i>Identify modifications</i>	<i>Identify how the connection is protected</i>
<b>Notes:</b>		
Current procedural direction (Ref. 20) exists to ventilate the FHB in the event of elevated temperatures in the building. On-site personnel will block open various doors for the MAB and FHB, thus encouraging ventilation through natural circulation.		

## STPNOC FLEX Integrated Plan

### Maintain Spent Fuel Pool Cooling

#### PWR Portable Equipment Phase 3:

*Provide a general description of the coping strategies using phase 3 equipment including modifications that are proposed to maintain spent fuel pool cooling. Identify methods (makeup via portable injection source) and strategy (ies) utilized to achieve this coping time.*

With the loss of spent fuel pool water due to boiling, makeup will be required. There are three options for providing makeup to the SFP:

1. A Reactor Makeup Water (RMW) pump can make up to the SFP by opening one valve in the Fuel Handling Building and starting the RMW pump. This is proceduralized in Ref. 14 but will require power to be supplied to the pump via the FLEX DG. The 480V FLEX generator staged on the MAB roof would supply power to this pump using pre-installed cabling and, after the event, maintenance personnel will take the cabling to the 480V motor control center and connect power to the individual breaker that feeds this pump. Fairly early in the event (~ 12 hrs), this manual valve (FC-0048) shall be opened so that, if the operating deck of the SFP were to become inaccessible at some point later in the event, SFP fill could still be performed. The RMW pump will take suction on the RMWST.
2. A pre-staged FLEX SFP fill pump will be attached to the ECCS system in a manner still to be determined. This pump would then provide water to a hose line which would be run to the 68' elevation where it can feed water to the SFP. This would be similar to the existing strategy called for in Ref. 14, Attachment 5, albeit with a FLEX pump in place. The hoses that will be deployed to the SFP deck are already in location, protected in a safety related building (the FHB). This FLEX pump will take suction on the RWST.
3. Other large capacity (1000 gpm at 175 psig) diesel driven pumps are available to provide a high volume of water to the SFP using hoses as described already or using spray. These pumps may be stored / protected on site or at the RRC. (Open item #3.) These pumps can take suction on a variety of water sources in the plant area including the Main Cooling Reservoir and the Ultimate Heat Sink. This means of SFP makeup is already proceduralized in references 19 and 29.

At some point during "indefinite" coping, STP can bring in a 4160V diesel generator from the RRC and power one of the three ESF buses at one of the ESF transformers on the low (4160V) side. This will power the selected ESF 4160V electrical bus. This will provide power to permanent plant equipment for lighting, battery chargers, pumps, valves, fans, etc. With respect to Spent Fuel Pool inventory, another Reactor Makeup Water pump or a Safety Injection pump (motor driven) could be powered.

#### Details:

#### **Provide a brief description of Procedures / Strategies / Guidelines**

*Confirm that procedure/guidance exists or will be developed to support implementation*

Procedures will be developed to support implementation, Open item #9

## STPNOC FLEX Integrated Plan

<b>Maintain Spent Fuel Pool Cooling</b>		
<p><b>Identify modifications</b>  <i>List modifications</i></p> <p>Cabling will be installed from the FLEX 480V generator to the room where the normal feeder breaker for the RMW pump is located.</p> <p>The specifics of this modification are still being worked out; however, it will include installing cable and conduit to power the 480V FLEX SFP fill pump. This pump will be provided suction from the RWST and discharging into the pool via hoses that will be taken to the refueling floor. See conceptual dwg # 6.</p> <p>No modifications will be necessary for the large capacity diesel driven pumps as that strategy currently exists in ref. 18.</p> <p>All modifications to support the 480V DG plan to power up and deploy FLEX equipment have been discussed already.</p>		
<p><b>Key SFP Parameter</b></p> <p><i>Per EA 12-051</i>                      Spent Fuel Pool Level Indication</p>		
<b>Deployment Conceptual Design (Attachment 3 contains Conceptual Sketches)</b>		
<b>Strategy</b>	<b>Modifications</b>	<b>Protection of connections</b>
<i>Identify Strategy including how the equipment will be deployed to the point of use.</i>	<i>Identify modifications</i>	<i>Identify how the connection is protected</i>

## STPNOC FLEX Integrated Plan

<b>Maintain Spent Fuel Pool Cooling</b>		
<p>A means of makeup to the SFP would be using the RMW pump. This is would be powered by the FLEX generator. This is the easiest of all options.</p>	<p>480V DG and cabling which has already been described. This pump is on one of the 480V MCCs for C train and will be powered from the 480 FLEX generator.</p>	<p>Already described</p>
<p>Another means of makeup to the SF Pool is the FLEX SFP fill pump.</p>	<p>Modifications are required for:</p> <ul style="list-style-type: none"> <li>• Piping tie-ins into the SI or CS system for pump suction and discharge.</li> <li>• 480V power to the pump motor</li> </ul>	<p>Inside a safety related building</p>
<p>Spray will be provided using the high capacity diesel driven pumps that will be stored significantly apart from each other. One pump may provide spray for both units simultaneously. (Open item #20.)</p>	<p>Currently proceduralized in OPOP10-FC-0001 so no modifications will be required.</p>	<p>Connection is provided inside a safety related building. Storage locations are still under review. This is captured in open item #3.</p>

## STPNOC FLEX Integrated Plan

<b>Safety Functions Support</b>
<b>Determine Baseline coping capability with installed coping<sup>5</sup> modifications not including FLEX modifications.</b>
<b>PWR Installed Equipment Phase 1</b>
<p><i>Provide a general description of the coping strategies using installed equipment including station modifications that are proposed to maintain and/or support safety functions. Identify methods and strategy (ies) utilized to achieve coping times.</i></p> <p>Support equipment will be required for phase 1 as follows:</p> <ul style="list-style-type: none"> <li>• Concerning lighting, operators carry flashlights and DC lighting located throughout the plant will operate for at least 8 hours. Ref. UFSAR 9.5.3.2.3 “EMERGENCY DC LIGHTING SYSTEM</li> <li>• Concerning communications, each unit has two additional, portable satellite phones for communications with off-site agencies. This is necessary because the antennae for the current satellite phone may be damaged in the event. Other communications methods are sound powered headsets, line of sight radio use and use of runners.</li> <li>• Equipment heatup – calculations have shown that opening cabinet and room doors to critical equipment like the TDAFW pump, QDPS and the safety related 120VAC inverters will ensure equipment temperatures will remain low enough for equipment to function properly. Ref 12 and 16. Procedural direction will be given in the appropriate EOP and/or FSG to open doors as necessary. (Open item #9.)</li> </ul>
<b>Details:</b>
<p><b>Provide a brief description of Procedures / Strategies / Guidelines</b></p> <p><i>Confirm that procedure/guidance exists or will be developed to support implementation.</i></p> <p>Open item #9.</p>
<p><b>Identify modifications</b></p> <p><i>List modifications and describe how they support coping time.</i></p> <p>No modifications are required for support equipment in Phase 1.</p>
<p><b>Key Parameters</b></p> <p><i>List instrumentation credited for this coping evaluation phase.</i></p> <p>There is no additional instrumentation that has not already been discussed in each of the previous sections.</p>

<sup>5</sup> Coping modifications consist of modifications installed to increase initial coping time, i.e. generators to preserve vital instruments or increase operating time on battery powered equipment.



## STPNOC FLEX Integrated Plan

### Safety Functions Support

#### PWR Portable Equipment Phase 2

*Provide a general description of the coping strategies using on-site portable equipment including station modifications that are proposed to maintain and/or support safety functions. Identify methods and strategy (ies) utilized to achieve coping times.*

#### Details:

##### **Provide a brief description of Procedures / Strategies / Guidelines**

*Confirm that procedure/guidance exists or will be developed to support implementation with a description of the procedure / strategy / guideline.*

**Communications:** As previously discussed, each unit now has 2 portable satellite phones and additional batteries. Also each unit has been provided additional batteries and a charger for radio communications. These are stored in an Emergency Locker in a safety related building. 120V FLEX diesel generators will provide power to charge these batteries during the event. The communications assessment performed in 2012 revealed the potential need for two mobile satellite/cell communications systems that will need to be protected. These may be provided by the RRC. STP will meet the requirements of NEI 12-01, Section 4; however, specifics have not been determined yet. As they are identified, they will be incorporated and protection/storage strategies developed.

**Lighting:** Each operator has portable lighting on his person and additional headlamps will be stored in protected locations throughout the plant. Appendix R lighting should last at least 8 hrs. (Ref. 23) Additional lighting (e.g. Battle-lanterns) is located inside the power block. In the event that areas are discovered where additional lighting is desired, lighting strings are purchased and will be located in areas inside the power block. 120V FLEX diesel generators will provide power to these light strings.

**Ventilation:** 120V high volume fans are already strategically located in the EAB for use during loss of HVAC events. These fans would be used to move air for personnel and equipment. They would be powered from the 120V FLEX diesel generators.

**Instrumentation:** There will be 4 channels of redundant critical instrumentation for the first 12 hours of the event. (Ref. 6) After that 2 channels will be available for at least 24 hours for most vital instruments. Once the FLEX generator is started and powers the A and C safety related battery charges, at least 2 channels of instrumentation will be available for the duration of the event. Heatup calculations for the Qualified Display Parameter System (QDPS), a safety related, post TMI, micro-processor, cabinets and the class 1E inverters show that prior to 24 hours into the event, the room doors will need to be opened for ventilation. (Ref. 12) Following opening the room doors, the cabinets and inverters will not reach their high temperature limit for another 3 days. (Ref.12) By then forced ventilation will be established per the FSGs. In the unlikely event that all DC were to be lost or the ability to monitor parameters is lost in the control room, a procedure will be written to guide operators in monitoring critical parameters at the QDPS cabinets using a multimeter. (Open item #9.)

**Fuel Oil:** A 120V DG will be stored in one of the ESF Diesel Generator Buildings along with a pump that will pump fuel oil from one of the ESF DG Fuel Oil Storage Tanks to the FLEX DG fuel oil tank on top of the MAB roof. Approximately 300' of 1" hose will be staged to support this strategy. (Ref. 15) A 1" fuel oil chemical sampling line will be used for suction to this pump. 5 gallon fill cans will be used to fuel the 120V DG. It will be filled at either the previously mentioned chemical sampling line of one of the ESF DGs or using the small fuel oil transfer pump, whichever is easiest. See conceptual

## STPNOC FLEX Integrated Plan

<b>Safety Functions Support</b>
<b>PWR Portable Equipment Phase 2</b>
<p>drawings #2 and 3. STP has approximately 180,000 gallons of diesel fuel that is protected from external events. The 480V FLEX diesel generator will use approximately (TBD) gallons per hour at full load and the three 120V diesel generators will use 1 gal/hr each; thus, there will be enough fuel to last TBD days. (Open item # 15.) Other equipment that uses diesel fuel are the diesel driven pumps used in Phase 3 to fill tanks and spray the SFP if necessary.</p> <p><b>Storage:</b> Storage locations are to be determined. The primary challenge to storing any equipment outside the power block is how to protect against the design basis flood. The equipment that requires storage will most likely be the high capacity diesel driven pumps. STP is evaluating storing the diesel driven pumps inside the FHB truck bay where they would be protected from all events except flooding. They would be at their deployment location for SFP spray capability, which will not be required in the event of a flood, only a seismic event. (Open item #3.)</p>
<p><b>Identify modifications</b></p> <p><i>List modifications necessary for phase 2</i>  The modifications associated with the FLEX equipment have been previously described.</p>
<p><b>Key Parameters</b></p> <p><i>List instrumentation credited or recovered for this coping evaluation.</i>  Local fuel tank level for 480V FLEX diesel generator</p>
<p><b>Storage / Protection of Equipment :</b>  <b>Describe storage / protection plan or schedule to determine storage requirements</b></p>
<p><b>Seismic</b></p> <p><i>List how equipment is protected or schedule to protect</i></p> <p>All the above mentioned equipment will be stored inside safety related structures or inside the protected enclosure on the roof of the MAB.</p>
<p><b>Flooding</b></p> <p>Note: if stored below current flood level, then ensure procedures exist to move equipment prior to exceeding flood level.</p> <p><i>List how equipment is protected or schedule to protect</i></p> <p>All the above mentioned equipment will be stored inside safety related structures or inside the protected enclosure on the roof of the MAB.</p>
<p><b>Severe Storms with High Winds</b></p> <p><i>List how equipment is protected or schedule to protect</i></p>

## STPNOC FLEX Integrated Plan

<b>Safety Functions Support</b>		
<b>PWR Portable Equipment Phase 2</b>		
<p>All the above mentioned equipment will be stored inside safety related structures or inside the protected enclosure on the roof of the MAB.</p>		
<p><b>Snow, Ice, and Extreme Cold</b></p> <p><i>List how equipment is protected or schedule to protect</i></p> <p>All the above mentioned equipment will be stored inside safety related structures or inside the protected enclosure on the roof of the MAB.</p>		
<p><b>High Temperatures</b></p> <p><i>List how equipment is protected or schedule to protect</i></p> <p>All the above mentioned equipment will be stored inside safety related structures or inside the protected enclosure on the roof of the MAB.</p>		
<b>Deployment Conceptual Design (Attachment 3 contains Conceptual Sketches)</b>		
<b>Strategy</b>	<b>Modifications</b>	<b>Protection of connections</b>
<i>Identify Strategy including how the equipment will be deployed to the point of use.</i>	<i>Identify modifications</i>	<i>Identify how the connection is protected</i>
As discussed earlier, setup of 120V diesel generators, light strings, fans and the fuel oil transfer system will all need on-site personnel support.	No modifications will be required to support the deployment.	These connections do not need to be protected as they are assembled after the event, above the flood level, and inside or on top of safety related buildings.

## STPNOC FLEX Integrated Plan

<b>Safety Functions Support</b>
<b>PWR Portable Equipment Phase 3</b>
<p><i>Provide a general description of the coping strategies using phase 3 equipment including modifications that are proposed to maintain and/or support safety functions. Identify methods and strategy (ies) utilized to achieve coping times.</i></p> <p>No additional support equipment has been identified for Phase 3 that has not already been discussed in Phase 2.</p> <p>At some point during “indefinite” coping, STP can bring in a 4160V diesel generator from the RRC and power one of the three ESF buses at the ESF transformers on the low (4160V) side. This will power the selected ESF 4160V electrical bus. This will provide power to permanent plant equipment for lighting, battery chargers, pumps, valves, fans, etc. For a design basis flood from the MCR, this strategy would not be possible until after the flood waters recede (~ 72 hrs).</p>
<b>Details:</b>
<p><b>Provide a brief description of Procedures / Strategies / Guidelines</b></p> <p><i>Confirm that procedure/guidance exists or will be developed to support implementation with a description of the procedure / strategy / guideline.</i></p> <p><b>N+1:</b> STP recognizes that, because phase 1 coping of each of the four safety functions will last beyond the time required for offsite resources to arrive at the site, the need for “+1” equipment is debatable. However, because of where this equipment must be pre-staged, STP will have equipment to support the “+1” requirement. The N and +1 equipment for each of these primary strategies will be provided by permanent plant equipment (pumps) and FLEX pumps all powered by the 480V FLEX DG. There will be at least 2 pumps to makeup to each of the Safety Functions’ systems/components: SG feed, RCS fill and SFP fill.</p> <p>STP is still evaluating whether the backup 480V generator should be stored on the roof with the N generator or if it can be stored at the RRC and brought in before the 30 hour point is reached. If the event is not a flood, it may be more prudent to bring in a 4160V diesel generator as the backup power source and install it to an ESF transformer as described earlier. This is possible because current strategies can be implemented without the use of N equipment powered by the FLEX 480V DG for at least 30 hours. Open items #2, 3 and 10.</p>
<p><b>Identify modifications</b></p> <p><i>List modifications necessary for phase 3</i></p> <p>None</p>
<p><b>Key Parameters</b></p> <p><i>List instrumentation credited or recovered for this coping evaluation.</i></p>

STPNOC FLEX Integrated Plan

Safety Functions Support		
PWR Portable Equipment Phase 3		
Deployment Conceptual Design (Attachment 3 contains Conceptual Sketches)		
Strategy	Modifications	Protection of connections
<i>Identify Strategy including how the equipment will be deployed to the point of use.</i>	<i>Identify modifications</i>	<i>Identify how the connection is protected</i>
The 4160V FLEX DG would come from the RRC and be pulled into the plant using a vehicle. Electricians would open the transformer and connect cabling to energize the selected 4160V ESF bus.	No mods would be necessary	Connections to cables are not protected per se but the cabling is from underground and would be accessible under most external events. Debris removal equipment may be necessary for some events.

## STPNOC FLEX Integrated Plan

<b>PWR Portable Equipment Phase 2</b>							
<i>Use and (potential / flexibility) diverse uses</i>						<i>Performance Criteria</i>	<i>Maintenance</i>
<i>List portable equipment PER UNIT</i>	Core	Containment	SFP	Instrumentation	Accessibility, small battery charging, comms and fuel, etc		Maintenance / PM requirements
<b>(3) 120 VAC Generators</b>					X	<b>6500 W</b>	<b>Will follow EPRI template requirements</b>
<b>(2) portable satellite phones with additional batteries</b>					X		<b>Will follow EPRI template requirements</b>
<b>(8) additional sound powered phones with cables</b>					X		<b>Will follow EPRI template requirements</b>
<b>(3) Fluke 705 loop calibrator</b>				X			<b>Will follow EPRI template requirements</b>
<b>(3) Fluke 114 multimeter</b>				X			<b>Will follow EPRI template requirements</b>
<b>(6) Radio batteries and charger</b>					X		<b>Will follow EPRI template requirements</b>
<b>Headlamps</b>					X	<b># of which is TBD</b>	<b>Will follow EPRI template requirements</b>
<b>120V Fuel Oil Transfer pump</b>	X		X	X	X		<b>Will follow EPRI template requirements</b>
<b>Assortment of hoses and fittings</b>	X		X		X	<b>TBD</b>	<b>Will follow EPRI template requirements</b>
<b>5 gal fuel cans</b>	X		X	X	X	<b>3</b>	<b>Will follow EPRI template requirements</b>

## STPNOC FLEX Integrated Plan

<b>PWR Portable Equipment Phase 3 – although these are listed as Phase 3 most will need to be pre-deployed in their useful location due to the design basis flood from the main reservoir breach.</b>							
<i>Use and (potential / flexibility) diverse uses</i>						<i>Performance Criteria</i>	<i>Notes</i>
<i>List portable equipment PER UNIT</i>	Core	Containment	SFP	Instrumentation	Accessibility/ other		
<b>4160 VAC Generator</b>	<b>X</b>	<b>X</b>	<b>X</b>	<b>X</b>	<b>X</b>	<b>2 MW</b>	<b>4160 VAC generator could power at least one installed ESF bus from its respective ESF transformer. (from RRC)</b>
<b>Hi volume diesel driven pump</b>			<b>X</b>			<b>1000 gpm @ 175 psig</b>	<b>For SFP spray or fill function if necessary. Also could be used for makeup to AFWST from a variety of sources.</b>
<b>120VAC pumps</b>	<b>X</b>					<b>TBD</b>	<b>These pumps would be used to fill tanks, move water, etc.</b>
<b>Portable light towers</b>					<b>X</b>	<b>6 that use diesel fuel</b>	
<b>Remote cellular/satellite system</b>					<b>X</b>	<b>2</b>	
<b>Smaller capacity diesel driven pumps</b>	<b>X</b>		<b>X</b>			<b>4 pumps, 150 gpm</b>	
<b>Air compressors</b>	<b>X</b>	<b>X</b>	<b>X</b>			<b>3</b>	
<b>480 VAC Generator</b>	<b>X</b>		<b>X</b>	<b>X</b>		<b>500 kW</b>	
<b>High Pressure Pump for RCS fill</b>	<b>X</b>					<b>1500 psia and 40 gpm (site specific analysis may be required)</b>	
<b>SG Feed Pump</b>	<b>X</b>					<b>400 psig and 300 gpm (site specific analysis required – OI#7)</b>	

**STPNOC FLEX Integrated Plan**

<b>SFP Fill Pump</b>			<b>X</b>			<b>75 psig and 200 gpm</b>	
<b>tractor</b>	<b>X</b>						
<b>Fuel oil tanker truck for 4160V DG</b>	<b>X</b>						
<b>(3) Light strings</b>					<b>X</b>	<b>100' each</b>	
<b>(12) Ventilation fans and trunks</b>				<b>X</b>	<b>X</b>		



## STPNOC FLEX Integrated Plan

<b>Phase 3 Response Equipment/Commodities</b>	
<b>Item</b>	<b>Notes</b>
<b>Radiation Protection Equipment</b> <ul style="list-style-type: none"> <li>• Survey instruments</li> <li>• Dosimetry</li> <li>• Off-site monitoring/sampling</li> </ul>	
<b>Commodities</b> <ul style="list-style-type: none"> <li>• Food</li> <li>• Potable water</li> <li>• Portable toilets</li> </ul>	
<b>Fuel Requirements</b> <ul style="list-style-type: none"> <li>• Means of transporting tanker trucks of diesel fuel to the site</li> </ul>	<b>180k gals of protected fuel. 30 days into event, fuel preparations should begin to bring additional fuel on site.</b>
<b>Heavy Equipment</b> <ul style="list-style-type: none"> <li>• Transportation equipment</li> <li>• Debris clearing equipment</li> <li>• 480V diesel generator</li> </ul>	<b>Debris removal equipment will be stored at the RRC and will be brought to the site as necessary.</b>
<b>Additional items</b> <ul style="list-style-type: none"> <li>• 50 drums of boric acid</li> <li>• Portable air tanks for valve manipulations</li> </ul>	

# STPNOC FLEX Integrated Plan

## Attachment 1A

### Sequence of Events Timeline Mode 1-4

Action item	Elapsed Time (hr)	Action	New ELAP Time Constraint Y/N <sup>6</sup>	Time Constraint (hr)	Remarks / Applicability
	0	<b>Event Starts</b>	NA		Plant @100% power
1.	<1	Control Rods Insert	N		Part of current license
2.	<1	TDAFWP Starts	N		Part of current license
3.	<1	Rx Trip and EC00 Procedures are entered	N		
4.	<1	Operators attempt to start ESF DGs	N		STPNOC has three ESF diesel generators that are in a seismic and hazard protected building. The STPEGS SBO position credits any one of the three Standby Diesel Generators as the AAC source. Each SDG is periodically tested to demonstrate the capability to power the equipment credited for coping within ten minutes of SBO event initiation. (UFSAR 8.3.4) The EOP has a continuous action step to restore AC ESF power by energizing a Standby diesel generator. Since STPNOC is an alternate AC coping for SBO, if ESF Diesel Generator does not start and carry an ESF train, then STPNOC is beyond the SBO coping. (Reference UFSAR 8.3.4.4) No time is credited for attempting to manual starts an ESF Diesel Generator.
5.	<1	Transfer Station Blackout switches for SG PORVs	N		Current Step in the EOP. STPNOC site specific design on a loss of AC power to the SG PORV Hydraulic pump motor the SG PORV will fail closed. These STPNOC site specific switches will bypass the fail closed circuit and restore DC control power to the SG PORV controller which will allow SG PORV control from the Control Room. (Reference Design Change Package DCP# 08-9595-10 and -11 for Unit 1 and 2)
6.	1	Cross-connect AFW to all 4 SGs	N		Auxiliary Feedwater (AFW) will automatically align to the "D" SG. A current EOP step ensures adequate heat sink is being maintained. This step will distribute the AFW flow to the other SGs for a symmetrical cooldown. (Reference UFSAR 7.4.1.1)
7.	1	Initial stripping of DC loads per EC00	N	.5	STP has a site specific requirement to perform an initial stripping of DC loads which is require within 30 minute of the event to extend the DC battery life out to 4 hours. This action is part of the current procedure.
8.	1	Start Cooldown	N	1	Cooldown should commence within the hour to ensure RCS Tcolds are reduced to less than 550 °F. Cooldown is to protect the RCP seal package. Per WCAP-17601-P Rev. 0 Section 4.4.1.1, indicates RCP O-rings will remain intact for at least several hours at cold leg temperature of approximately 570 °F.

<sup>6</sup> Instructions: Provide justification if No or NA is selected in the remark column. If yes, include technical basis discussion as requires by NEI 12-06, Section 3.2.1.7.

## STPNOC FLEX Integrated Plan

Action item	Elapsed Time (hr)	Action	New ELAP Time Constraint Y/N <sup>6</sup>	Time Constraint (hr)	Remarks / Applicability
9.	1	On shift maintenance notified to prepare 480V FLEX DG and FLEX pumps for operation	N		This is an early support action for maintenance to start making the electrical connections needed to connect the pre-staged FLEX 480V diesel generator to FLEX equipment. Tools and hardware needed will be pre-staged to make all connections. New Flex guidance will be provided to support this early action. Pointer will be provided in the EOP to an FSG during an ELAP event.
10.	<2*	Initiate and complete DC Load Shed (deep per FSG)	Y	2	The deep stripping allows the required instrumentation and control capabilities to be extend beyond the initial 4 hours if completed within 2 hours. (ref. 6) This will allow time to obtain flex equipment to restore battery charger and instrument bus. New Flex Support Guideline (FSG) will be generated to support the deep loads stripping to extend battery life.
11.	2	Continue cooldown using SG PORVs from the Control Room conserving PORV strokes and feeding all SG with TDAFW pump (per OPOP05-EO-EC00, "Loss of All AC Power")	N		Cooling down to the target SG pressure per the current EOP requirements will extend into the second hour.
12.	2	Isolate all CIVs per OPOP05-EO-EC00, "Loss of All AC Power"	N		Current EOP step.
13.	2	Contact offsite RRC for equipment	N		Depending on the nature of the event, it could be very important to get equipment headed for STP as soon as possible. This would support longer term recovery actions as well. (Open item #9: Procedure would be required to provide guidance on how to contact the RRC and the type of equipment that will be needed.)
14.	2-3	SI Accumulators may begin to Inject	N		Site specific analysis is needed to determine if any accumulator volume will be injected into the RCS and a method to monitor accumulator level would be required. SI accumulator injection could occur as part of the SG depress/ RCS cooldown. (Open item #8: Site specific analysis to determine SI accumulator injection can be used to obtain adequate shutdown margin during cooldown to target temperature)
15.	3	2 operators begins preps to move fuel to the FLEX DG Day tank with 120V FLEX DG and pump	N		This is a support action to connect a portable pump power from a portable FLEX 120V Flex diesel to transfer fuel oil to the 480V diesel generator day tank. (Open item #9 associated with fuel oil strategy: (1) Modification for the installed day tank and any field connection; (2) Purchase FLEX equipment and hardware to support strategy; (3) Generate FSG procedure to implement strategy)

## STPNOC FLEX Integrated Plan

Action item	Elapsed Time (hr)	Action	New ELAP Time Constraint Y/N <sup>6</sup>	Time Constraint (hr)	Remarks / Applicability
16.	4	Operator completes cooldown, maintains SG pressure	N		The action depends on adequate RCS boron. Current EOP monitors for re-criticality and if startup rate is greater than zero then the EOP allows the RCS to heat-up. STP would plateau at a higher SG pressure and RCS temperature until adequate shutdown margin could be obtained. This action is a current EOP step to stabilize the plant prior to nitrogen injection from the SI Accumulator into the RCS. (Reference: 5Z010Z51003 setpoint O.8) (Open item #7: Site specific analysis will be performed to determine potential for re-criticality at the end of life.)
17.	4	Use FLEX Portable Power to CLOSE discharge isolation valves to SI accumulator to prevent N2 injecting per FSG. [Option to use the SI accumulator vents if discharge valves can not be closed]	N		Open item #1 Isolating the SI accumulator will ensure SI Accumulator nitrogen is not introduced into the RCS which could complicate the recovery. (Open item #9: Generate FSG procedure to implement this strategy)
18.	6	Maintenance and Operations continue preparing 480V FLEX equipment for power	N		This is a support action for placing the portable FLEX 480V diesel generator in service.
19.	6	Operator enters FHB to open FC-0048 to support SFP fill from RMW pump.	Y	<96	Analysis shows that SFP water level will not lower to 10 feet above the fuel for 96 hours. (Ref. 2)
20.	8*	500 kW 480V Generator started Add fuel to tank as necessary	Y	29	All battery power will be depleted if the generator is not available to power chargers within 29 hours. If the DG is not able to charge the batteries within this time, operators will have to use a multimeter to retrieve parameter readings from QDPS.
21.	8*	Energize "A" train battery charger and run continuously	Y	12 hrs 42 minutes	Restore battery prior to depleting this battery and losing instrumentation. (See ref 6). The battery charger will be energized by the FLEX diesel.
22.	8*	Energize "C" train battery charger and run continuously	Y	13 hrs 49 minutes	Restore battery prior to depleting this battery and losing instrumentation. (See ref 6). The battery charger will be energized by the FLEX diesel.

## STPNOC FLEX Integrated Plan

Action item	Elapsed Time (hr)	Action	New ELAP Time Constraint Y/N <sup>6</sup>	Time Constraint (hr)	Remarks / Applicability
23.	8	Deploy and start exhaust fans for battery rooms and run continuously	N		Support for the battery charger being placed in service and charging the battery for potential hydrogen buildup in the room. Battery exhaust fans will be energized by the FLEX diesel by means of 120V receptacles through permanent distribution network via the MCC. (Reference Dwg 00009EOPMAK#1 and #2 sheet 01)
24.	9	Energize lighting panels and 120V receptacles. Using 120V FLEX diesel generators and 480V DG, charge small batteries (satellite phones and radios) and provide supplemental light strings.	N		This will provide for safer travel paths and ensure long term communications. Appendix R lighting will last at least 8 hours.
25.	9-12*	Start CVCS PDP to fill RCS to 50% Pzr level	Y	60	This action would restore RCS inventory due to possible RCP seal leakage and support boration for additional shutdown margin. 50% is the normal pressurizer level to ensure the heaters are covered in the EOPs. (Reference 5Z010Z51003 setpoint D.7)
26.	9-12	Operators dispatched to evaluate FHB atmosphere	N		Depending on conditions, operators may elect to begin venting the FHB using current POP10 (EDMG) guidance.
27.	12	Start FLEX SG feed pump and secure TDAFW pump	Y	Depends on where plant is in life cycle	This action supports maintaining SG feed water supply using a motor driven SG feed pump if low steam line pressure condition occur which could prevent running the Turbine driven AFW pump or excess cooldown is being caused by the running the Turbine driven AFW pump.
28.	14	SFP Makeup from Reactor Makeup Pump	Y	16/96	Makeup to the SFP should commence prior to level lowering to level #1 per NEI 12-02 (16 hrs) and must commence prior to level lowering to level #2 (96 hrs).
29.	14	Begin preparations to fill the AFWST	Y	44	Calculation for tank deletion time shows 44 hours until depletion. (Ref. Calculation 25799-000-MOC-AF-00001 Rev. 0)
30.	16	Evaluate need to re-start RCS fill pump to re-fill RCS	N		Will periodically need to refill RCS
31.	24	Evaluate total plant status for recovery	N		Support long term recovery

STPNOC FLEX Integrated Plan

Action item	Elapsed Time (hr)	Action	New ELAP Time Constraint Y/N <sup>6</sup>	Time Constraint (hr)	Remarks / Applicability
32.	30	Receive equipment from RRC: <ul style="list-style-type: none"> <li>• Diesel driven pumps</li> <li>• 4160V DG</li> <li>• Debris moving equipment</li> <li>• tractor</li> </ul>	N		

\* Actions must be validated in field once FSGs are written.

## STPNOC FLEX Integrated Plan

### NSSS Significant Reference Analysis Deviation Table

Item	Parameter of interest	WCAP value (WCAP-17601-P August 2012 Revision 0)	WCAP page	Plant applied value	Gap and discussion
1	Start cooldown and SG depress rate/ RCS cooldown rate	2 hours at Nominal 75 F/hr cooldown rate to target RCS temperature	Page 4-14 Assumption 19 Section 4.2.2 Page 4-14 Assumption 3	Start within 1 hour and SG depress at max rate	Current EOP guidance for achieving target SG pressure
2	Core uncover	Approximately 55 hours	Section 5.2.1 Page 5-4 Section 5.3.1.3 Page 5-33	60.3 hours	WCAP-17601-P rev. 0 Table 5.3.1.7-1 page 5-35
3	RCS Makeup / Boration pump	40 gpm at 1500 psia	Section 3.1 Objective #5 Page 3-3, 3-4	TBD	Site specific analysis is required to determine these values. STP will verify CVCS PDP flowrate is sufficient.
4	Commence RCS boration	Near or beyond 24 hours for 3-loop and 4-loop plants	Section 5.8.1 Page 5-206	TBD	Site specific analysis is required to determine actual time.





## STPNOC FLEX Integrated Plan

### 480VAC FLEX DG LOAD LIST

EQUIPMENT	PWR Req	kW	4HR	8HR	10HR	12HR	14HR	18HR	24HR	30HR	36HR
RCS FLEX Pump (+1)	480VAC, 70 HP	50	0	0	0	0	0	0	0	0	0
AFW FLEX Pump	480VAC, 100 HP	70	0	0	0	70	70	70	70	70	70
AFW FLEX Pump (+1)	480VAC, 100 HP	70	0	0	0	0	0	0	0	0	0
SFP FLEX Pump (+1)	480VAC, 20 HP	15	0	0	0	0	0	0	0	0	0
Train A Battery Charger	480VAC, 75KW*	75	0	75	75	75	75	75	75	75	75
Train C Battery Charger	480VAC, 75KW*	75	0	75	75	75	75	75	75	75	75
Reactor Make-up Water Pump 1A**	480VAC, 50HP	37	0	0	0	37		37	37	37	37
CVCS PDP for RCS M/U pump	480V, 75 HP	56	56	56	0	0	0	56	56	56	56
Receptacles and Lighting Loads***	480VAC, 114KW	114	114	114	114	114	114	114	114	114	114
Misc. Loads ****	480VAC, 70kW	60	60	60	60	60	60	60	60	60	60
	FLEX DG Capacity, KW:	622	230	380	324	431	394	487	487	487	487
	Nearest Standard DG Size, KW:	500									

**NOTES:**

These times were used for the load calculation and do not reflect actual use times.

\* Per sec. 5.2 in STP Battery Coping Study 2011-11676-EAD, Rev. 0. Includes all Class 1E DC and 120V Vital AC loads.

\*\* Run for 2 hrs OR as needed @ 12HR, @ 18HR, @ 24HR, @ 30HR

\*\*\* 50% is energized lighting transformer sizes on STP drawing 9E569E03649#2, Rev. 25

\*\*\*\* Margin to accommodate some unspecified and/or intermittent loads (based on industry practice, a margin in the range of 10 to 15% is used)

**STPNOC FLEX Integrated Plan**

**ATTACHMENT 3**

**CONCEPTUAL DRAWINGS**

# STPNOC FLEX Integrated Plan

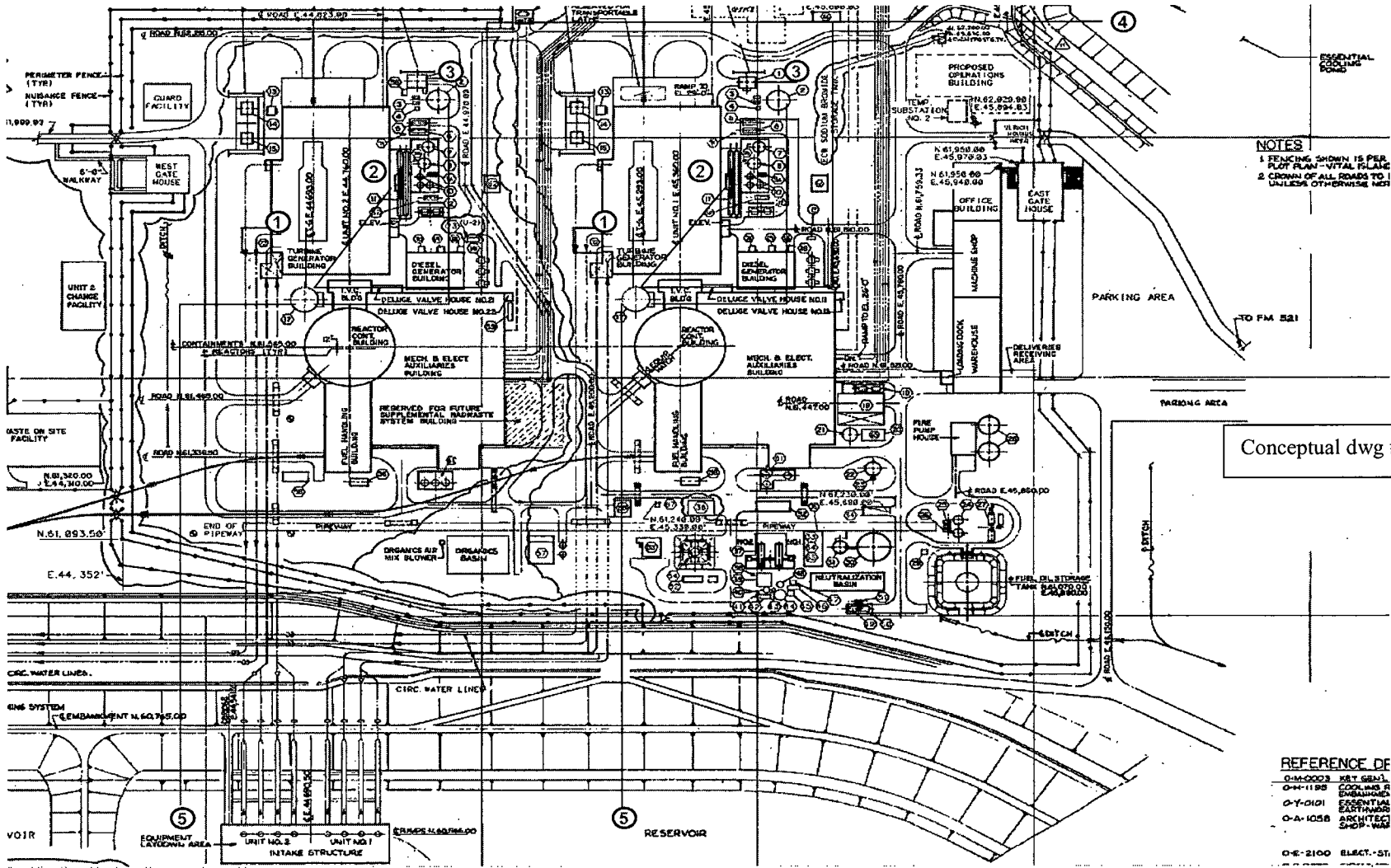

**NOTES**  
 1 FENCING SHOWN IS PER PLOT PLAN - VITAL ISLAND  
 2 CROWN OF ALL ROADS TO 1 UNLESS OTHERWISE NOTED

Conceptual dwg # 1

**REFERENCE DE**

O-M-0003	MET. GEN'L
O-M-1198	CONCRETE F. BUILDINGS
O-Y-0101	ESSENTIAL BUILDINGS
O-A-1058	ARCHITECT. SHOP - WAREHOUSE
O-E-2100	ELECT. - ST.

**Key to AFWST  
 Water Supply Routes**

- Routes are numbered in order of preference:
1. Condenser Hotwell \*; 2. Feedwater Deaerator Tank;
  3. Secondary Makeup Tank \*; 4. Essential Cooling Pond \*\*;
  5. Main Cooling Reservoir \*\*

\*Non-seismic, but may survive event, demineralized water source  
 \*\*Degraded water supplies, but most likely to survive event, even partially

# STPNOC FLEX Integrated Plan

Conceptual dwg # 2

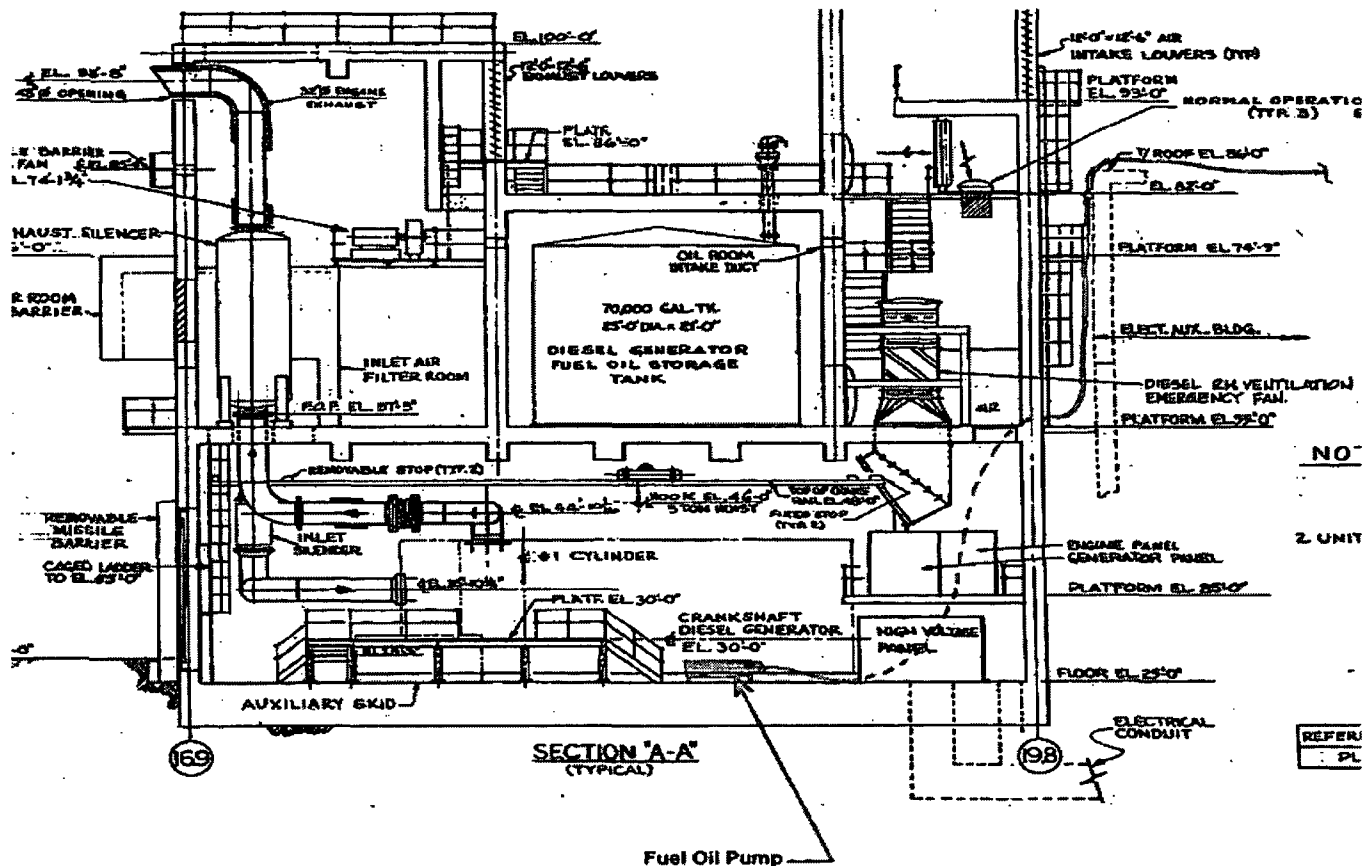

References  
 Drawing 6D019M0020, Rev. 8

## SECTION VIEW, FLEX DIESEL GENERATOR FUEL LINE DIESEL GENERATOR BUILDING

# STPNOC FLEX Integrated Plan

Conceptual dwg # 3

0020, Rev. 8  
 5032, Rev. 7  
 5037, Rev. 3  
 5033, Rev. 0  
 5038, Rev. 5  
 5042, Rev. 3  
 5043, Rev. 4

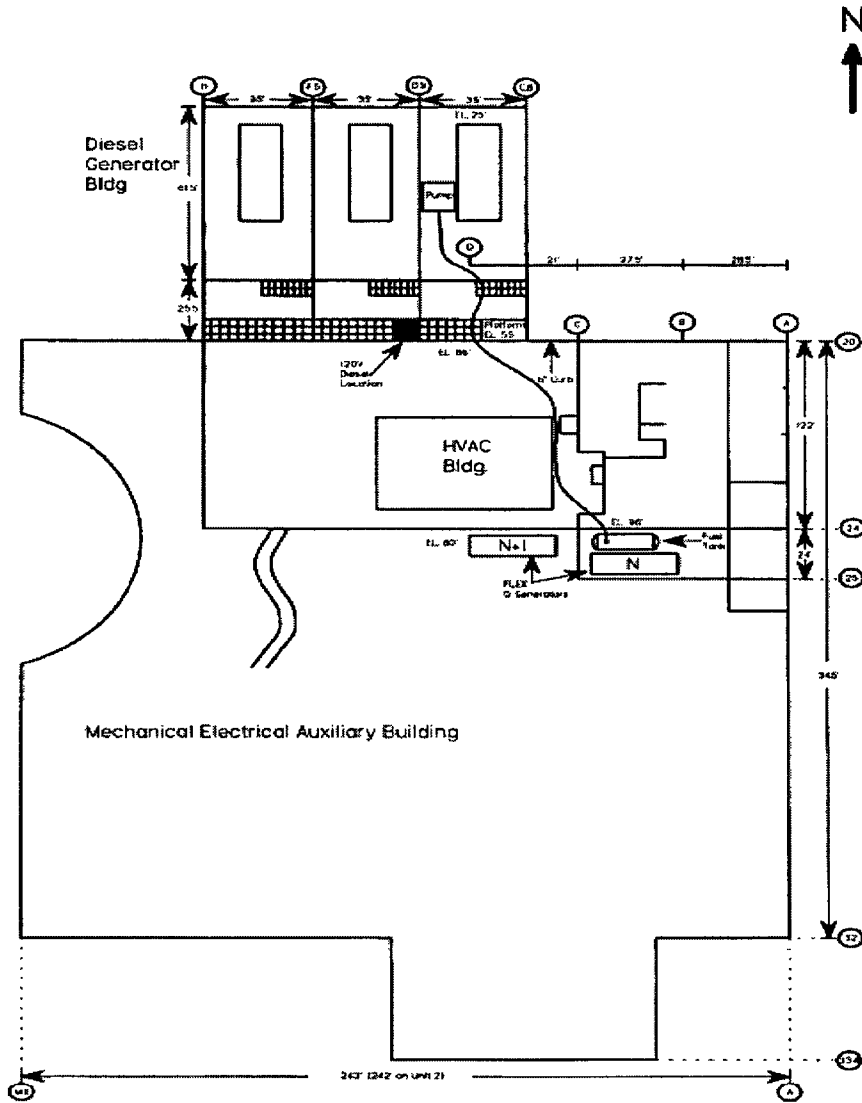

PLAN VIEW, FLEX DIESEL GENERATOR FUEL LINE

# STPNOC FLEX Integrated Plan

Conceptual dwg # 4

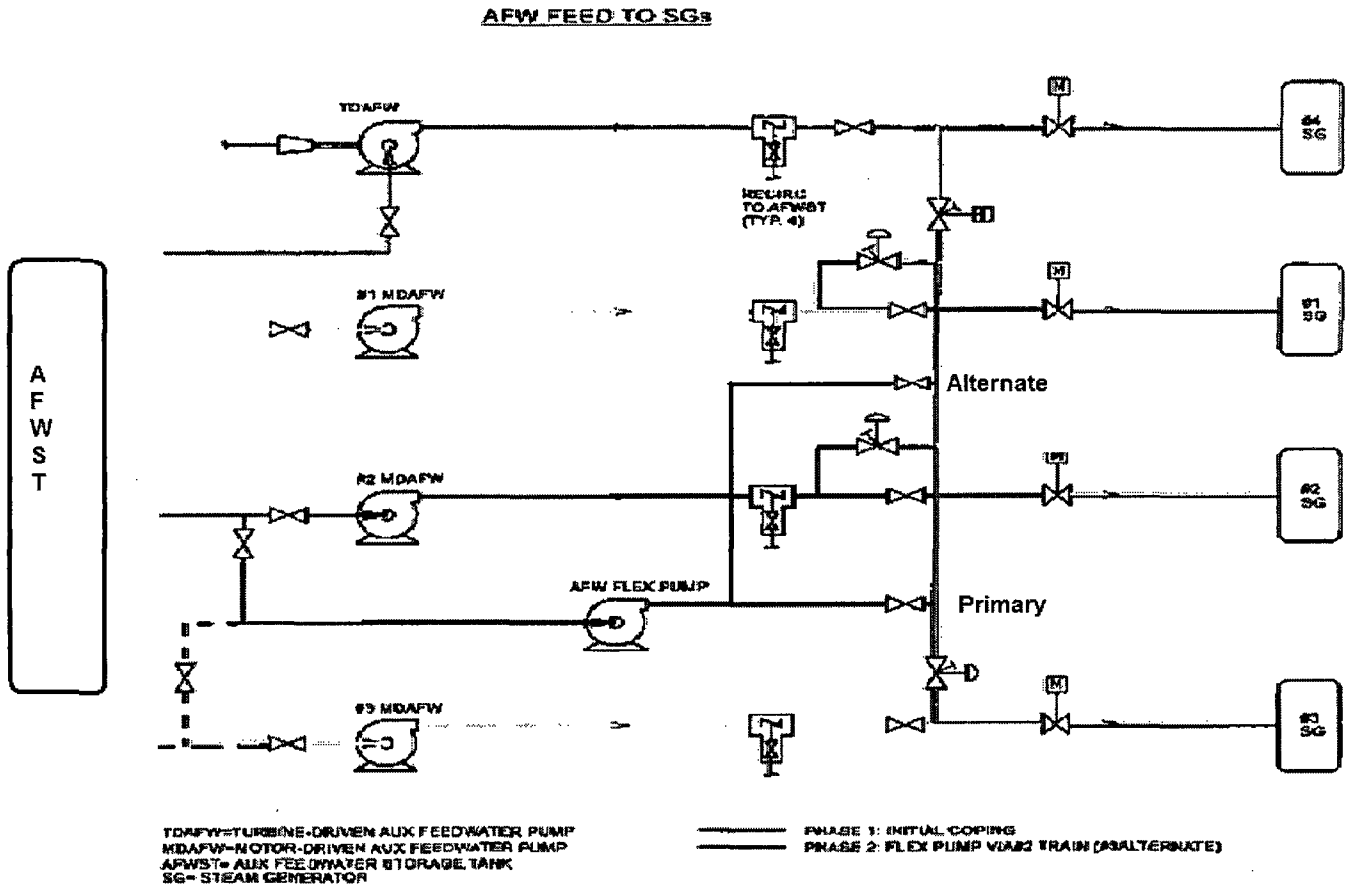

# STPNOC FLEX Integrated Plan

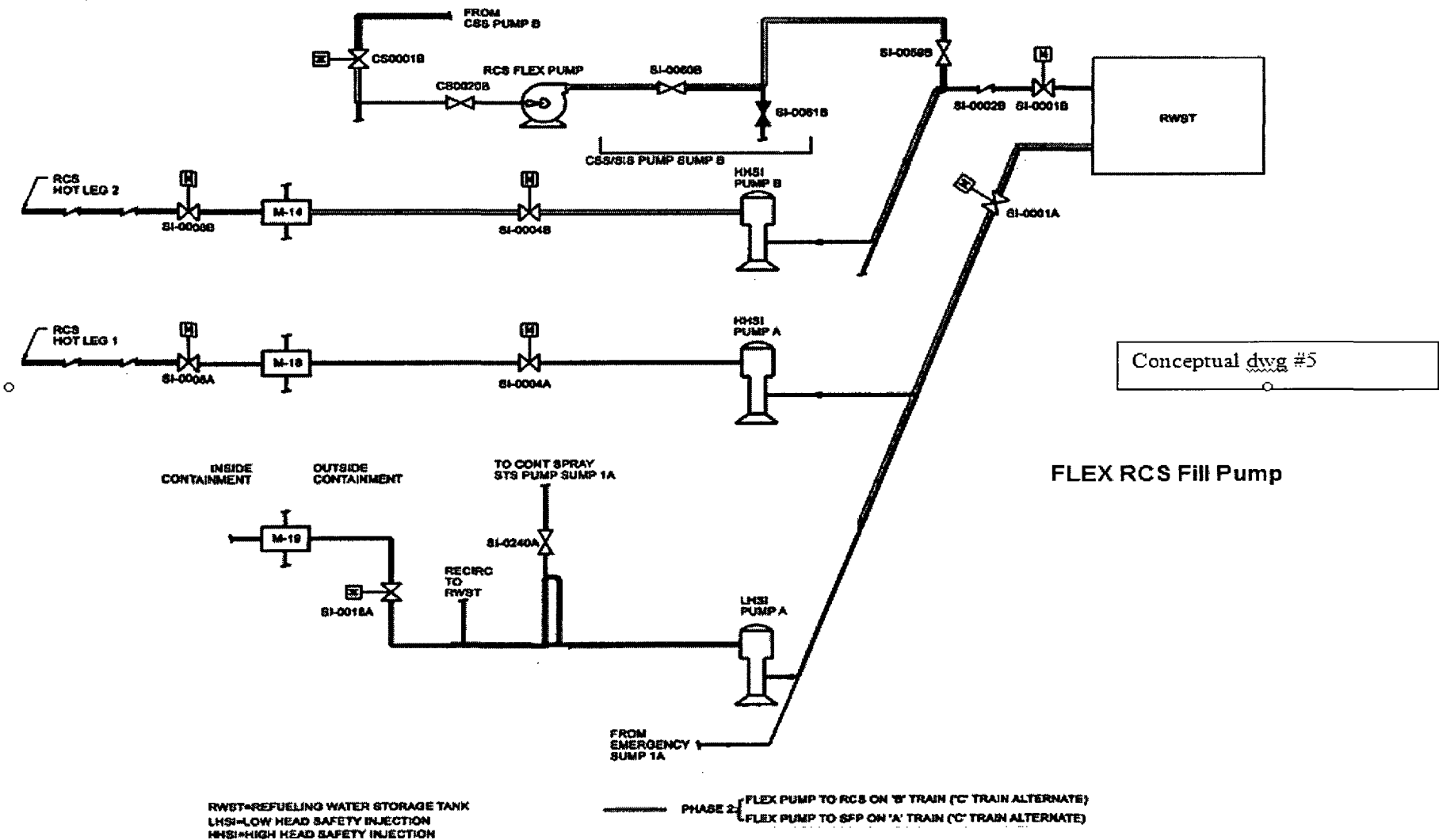

Conceptual dwg #5

FLEX RCS Fill Pump

# STPNOC FLEX Integrated Plan

Conceptual dwg # 6  
SFP FLEX pump

Figure M-5, RCS SFP Supply Lines

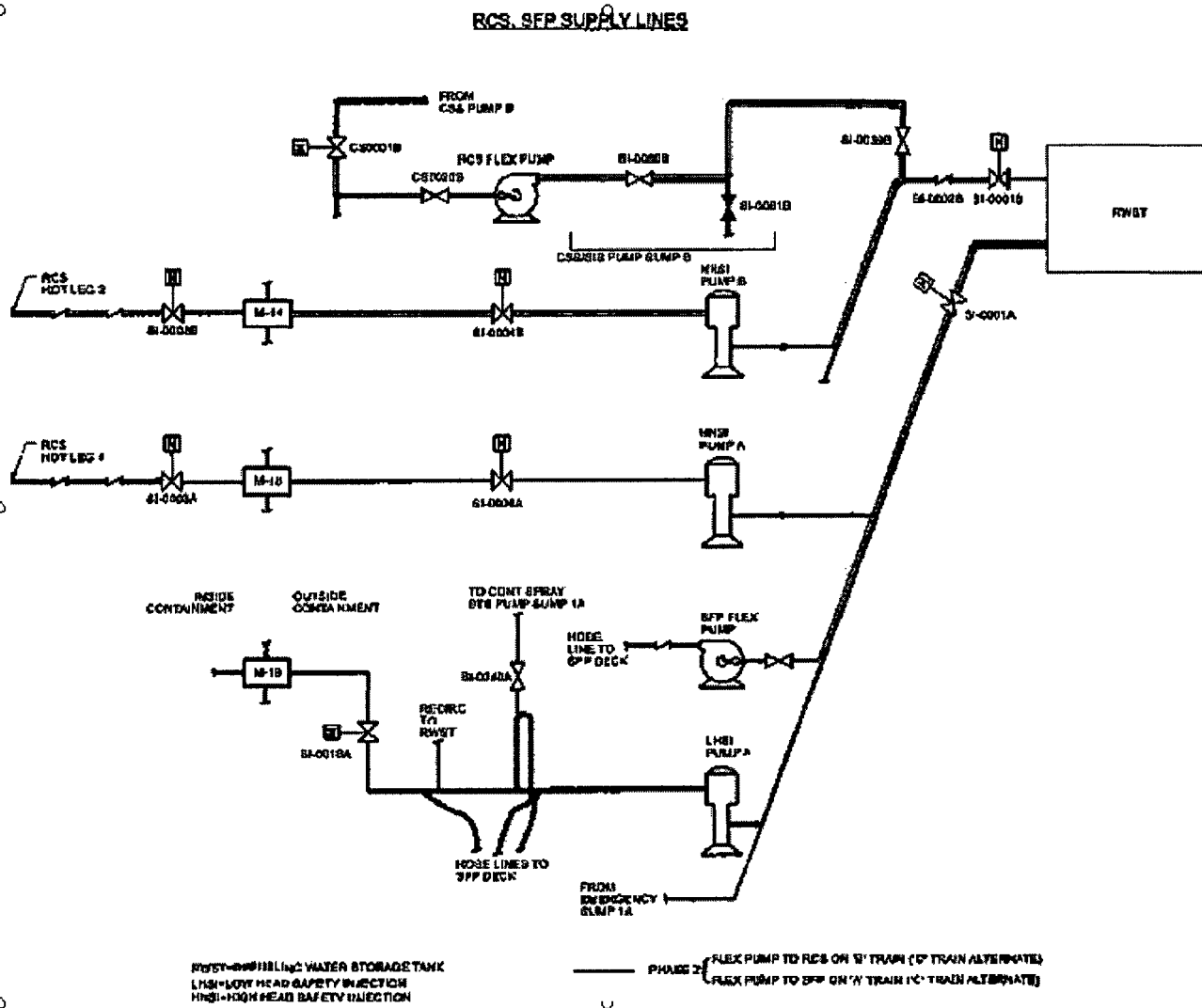



# STPNOC FLEX Integrated Plan

Conceptual dwg # 7

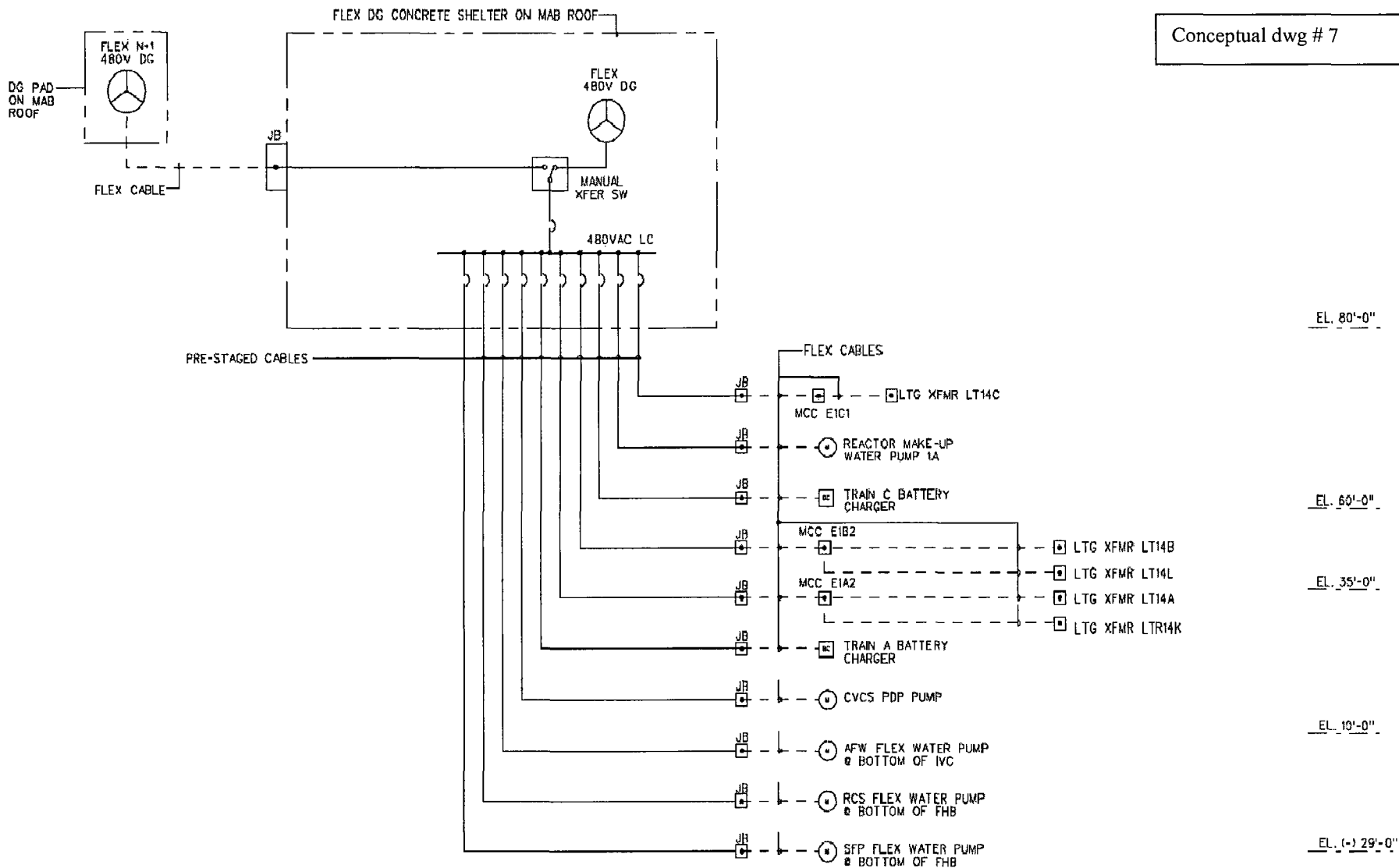

STPNOC FLEX Integrated Plan

Conceptual dwg #8

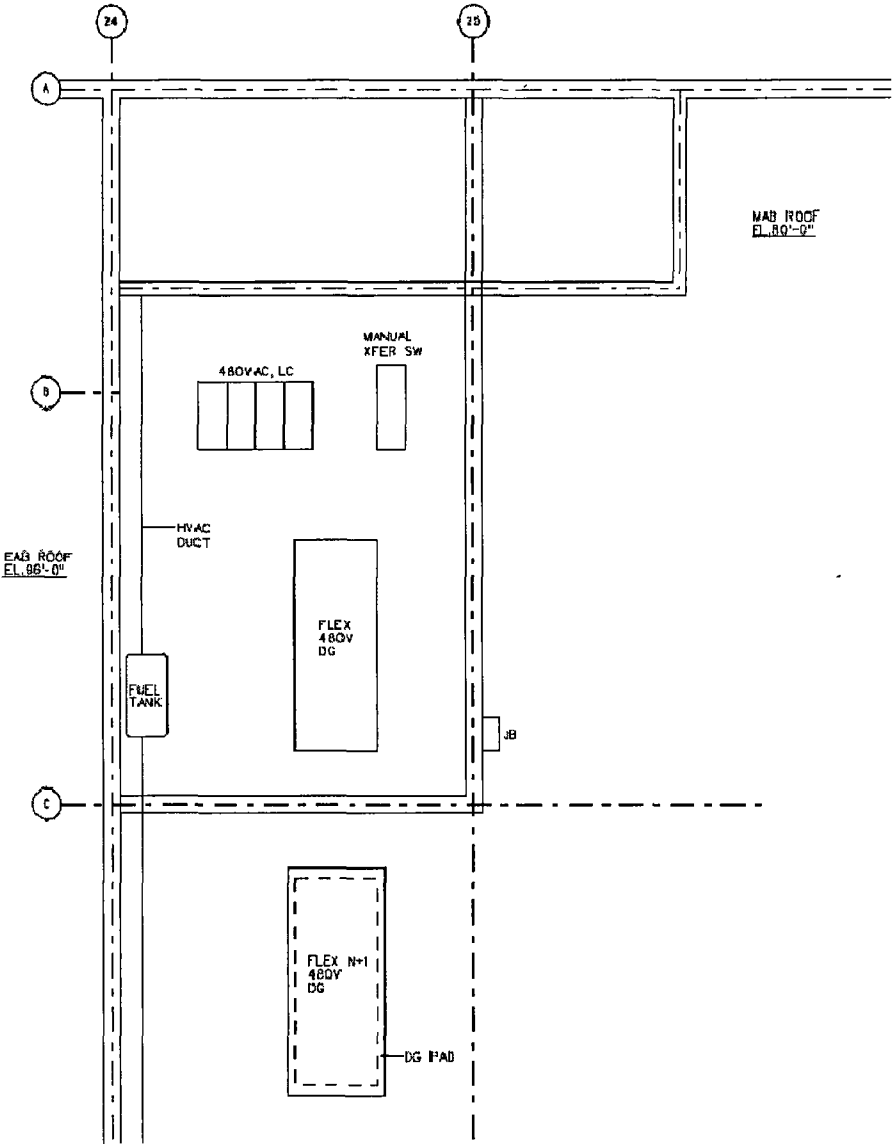

# STPNOC FLEX Integrated Plan

Conceptual dwg #9

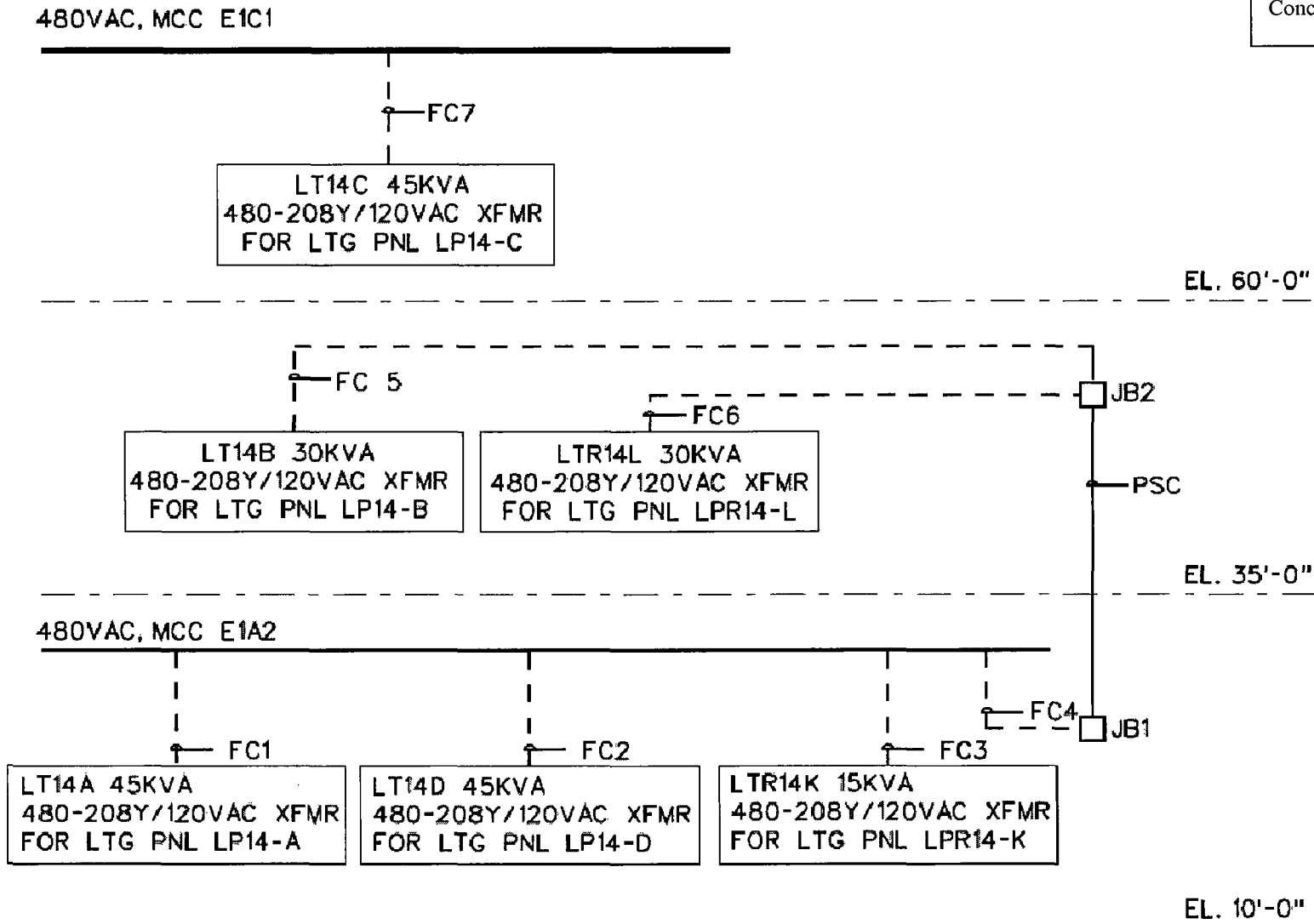

**FC** - FLEX CABLE (STORED ON SITE, INSTALLED DURING IMPLEMENTATION OF STP FLEX LIGHTING STRATEGY)  
**PSC** - PRE-STAGED CABLE (PERMANENTLY INSTALLED BETWEEN JB1 ON EL. 10'-0" AND JB2 ON EL. 35'-0")

## STPNOC FLEX Integrated Plan

### REFERENCES:

1. RCB Pressure/Temperature GOTHIC Run - Awaiting official calc to be approved. Open Item #6
2. CREE 11-12544-10 – Spent Fuel Pool Heatup CR Engineering Evaluation
3. PWROG Core Position Paper Rev. 0 November 2012
4. WCAP 17601 – RCS Response to the ELAP Event for Westinghouse, CE and B&W NSSS Designs
5. AFWST calc 25799-000-M0C-AF-00001, Rev. 0, “Confirmation of Auxiliary Feedwater Storage Tank (AFWST) Coping Time (STP FLEX)”.
6. 2011 Class 1E Battery Coping Study, Sargent and Lundy; STI# 33338842; DOC# 201111676EAD
7. South Texas Project Units 1 and 2 Flood Analysis, Atkins; STI# 33430176; DOC# 120021
8. 0POP03-ZG-0010, Refueling Operations, Rev. 61
9. P&ID 5N129F05013
10. P&ID 5R279F05033
11. P&ID 5R17905009
12. EAB Heatup analysis done by Zachry Nuclear Engineering 1/2013 (STI #33645430)
13. 0POP05-EO-EC00, Loss of All AC Power emergency operating procedure
14. 0POP04-FC-0001, Loss of Spent Fuel Pool Cooling
15. 25799-000-M0C-YA-00001, Rev. 0, “Miscellaneous Mechanical Items for STP FLEX Support”
16. TDAFW pump heatup calculation MC-06506 (STI-31767960)
17. NEI 12-02 Industry Guidance for Compliance with NRC Order EA-12-051, “To Modify Licenses with Regard to Reliable Spent Fuel Pool Instrumentation”
18. NEI 12-06
19. 0POP10-FC-0001, Spent Fuel Pool Damage Mitigation Strategies
20. 0POP10-FC-0002, Maximizing the SFP Heat Sink Coping Time Using Barn Door Ventilation
21. UFSAR sections 1.2, 2.0, 3.4 and Appendix 10A
22. 0POP02-AF-0001, Auxiliary Feedwater
23. STATION BLACK OUT (SBO) document, 5N049EB01118, Section 4.2.3.9. Page 4-22
24. RCS Draindown and Reflood Calc 98-RC-004 (31001828)
25. Westinghouse letter to HL&P ST-WS-HS-90096 RCS Volumes
26. P&ID 6S139F20009, Feedwater
27. NC-07106 Spent Fuel Pool Heatup Analysis for 18 Month Refueling Cycles Rev. 3
28. 0POP02-FO-0001, Fuel Oil Storage and Transfer, Rev 50 page 46. Max fill recommended 63,350 per ESF DG FOST.
29. 0POP10-FP-0001, Alternate Fire Protection System Operation

## STPNOC FLEX Integrated Plan

### Open Items are as follows:

- OI #1 – Portable DC power inverted to 480VAC still in design phase - STP needs further review to see if this strategy will be needed
- OI #2 – Site specific analysis on time to RCS Reflux cooling to ensure STP does not allow water level low enough to enter that stage of core cooling and provides minimum mission times to deploy RCS makeup pumps
- OI #3 – Storage locations, protection and transportation for large diesel driven pumps TBD
- OI #4 – Administrative program governing FLEX implementation to be developed
- OI #5 – Fill connections TBD
- OI #6 – Complete GOTHIC analysis of RCB pressure and temperature during/after event
- OI #7 – Site specific analysis on return to criticality temperature with attention given to:
  - SG FLEX feed pump sizing based on stabilizing at higher SG pressure
  - RCS inventory analysis at higher target SG pressure with higher extended RCP seal leakage
- OI #8 – Site specific analysis on target cooldown temperature for SI Accumulator injection or if any accumulator water will be utilized during the cooldown
- OI #9 – FLEX Support Guideline procedure work associated with:
  - Use of the RRC
  - Fuel oil strategy
  - Filling SFP
  - 125VDC plan (deep load shedding)
  - Connecting power to the electrical FLEX equipment (e.g. hookup to breakers)
  - FLEX implementing strategies
  - Filling AFWST
- OI #10 - Store backup 480V generator on roof or at RRC – TBD
- OI #11 – Site specific analysis required for modes 5 and 6 RCS fill rate for heat removal and boron flushing
- OI #12 – No longer applicable
- OI #13 - Provide calculation proving MAB can support additional weight of 480V FLEX generator(s), fuel tank, enclosure, etc.
- OI #14 – No longer applicable
- OI #15 – Calculation on how much fuel the FLEX DG will use and how long will our stored capacity last
- OI #16 – Determine where STP's staging area will be located - Travel paths will be determined when staging area is determined
- OI #17 – Determine where to make tie-ins into SI system for suction and discharge for RCS and SFP FLEX Fill pumps
- OI#18 – Determine instrumentation that will be specifically associated with the FLEX equipment (e.g. Fuel oil level for the FLEX DG fuel tank)
- OI#19 - As the flood and seismic re-evaluations are completed, appropriate issues will be entered into the corrective action program and addressed on a schedule commensurate with other licensing bases changes
- OI#20 – Analysis showing that one large diesel driven pump can provide SFP spray to both units SFPs simultaneously

NOTE: Further work on these strategies may determine that some of these OI's are not required or additional OI's are needed