



STEVEN D. CAPPS
Vice President
McGuire Nuclear Station

Duke Energy
MG01VP / 12700 Hagers Ferry Rd.
Huntersville, NC 28078

980-875-4805
980-875-4809 fax
Steven.Capps@duke-energy.com

February 28, 2013

10 CFR 50.4

U. S. Nuclear Regulatory Commission
ATTN: Document Control Desk
11555 Rockville Pike
Rockville, MD 20852

SUBJECT: Duke Energy Carolinas, LLC (Duke Energy)
McGuire Nuclear Station (MNS), Units 1 and 2
Docket Nos. 50-369 and 50-370
Renewed License Nos. NPF-9 and NPF-17
Response to March 12, 2012, Commission Order to Modify Licenses With
Regard To Requirements for Mitigation Strategies for Beyond Design Basis
External Events, EA-12-049

REFERENCES:

1. NRC Letter, E.J. Leeds (NRC) to All Power Reactor Licensees and Holders of Construction Permits in Active or Deferred Status, *Order to Modify Licenses With Regard To Requirements for Mitigation Strategies for Beyond Design Basis External Events, EA-12-049*, dated March 12, 2012, Accession No. ML12054A736
2. NRC Interim Staff Guidance JLD-ISG-2012-01, *Compliance with Order EA-12-049, Order Modifying Licenses with Regard to Requirements for Mitigation Strategies for Beyond-Design-Basis External Events, Revision 0*, dated August 29, 2012, Accession No. ML12229A174

On March 12, 2012, the Nuclear Regulatory Commission (NRC) issued an order (i.e., Reference 1) to Duke Energy. Reference 1 was immediately effective and directs Duke Energy to develop, implement, and maintain guidance and strategies to maintain or restore core cooling, containment, and spent fuel pool capabilities in the event of a beyond-design-basis external event-initiated Extended Loss of AC Power (ELAP). Specific requirements are outlined in Attachment 2 of Reference 1.

Reference 1 requires submission of an overall integrated plan, including a description of how compliance with the requirements described in Attachment 2 of Order EA-12-049 will be achieved, to the Commission for review by February 28, 2013, and subsequent submission of interim status reports at six-month intervals following submittal of the overall integrated plan. Pursuant to Section IV, Condition C.1 of Reference 1, Duke Energy hereby submits to the

A151
NRR

Commission for review the enclosed overall integrated plan for McGuire Nuclear Station (MNS), including a description of how compliance with the requirements described in Attachment 2 of Reference 1 will be achieved.

The Enclosure contains the current design information as of the writing of this letter, much of which is still preliminary, pending completion of on-going evaluations and analyses. As further design details and associated procedure guidance are finalized, supplemental information will be communicated to the Staff in the six-month status reports required by Reference 1.

This letter contains no new regulatory commitments.

If you have any questions or require additional information, please contact Michael K. Leisure at (980) 875-5171.

I declare under the penalty of perjury that the foregoing is true and correct. Executed on February 28, 2013.

Sincerely,

A handwritten signature in black ink, appearing to read "S.D. Capps", written in a cursive style.

Steven D. Capps

Enclosure

Overall Integrated Plan

xc:

V.M. McCree, Region II Administrator
U.S. Nuclear Regulatory Commission
Marquis One Tower
245 Peachtree Center Avenue NE, Suite 1200
Atlanta, Georgia 30303-1257

Eric J. Leeds, Director, Office of Nuclear Reactor Regulation
U.S. Nuclear Regulatory Commission
One White Flint North, Mailstop 13-H16M
11555 Rockville Pike
Rockville, MD 20852-2738

J.H. Thompson, Project Manager (MNS and CNS)
U.S. Nuclear Regulatory Commission
One White Flint North, Mailstop 8 G9A
11555 Rockville Pike
Rockville, MD 20852-2738

J. Zeiler
NRC Senior Resident Inspector
McGuire Nuclear Station

Document Control Desk
U.S. Nuclear Regulatory Commission
Washington, DC 20555-001

Justin Folkwein
American Nuclear Insurers
95 Glastonbury Blvd., Suite 300
Glastonbury, CT 06033-4453

United States Nuclear Regulatory Commission
February 28, 2013
Enclosure
Page 1

ENCLOSURE
OVERALL INTEGRATED PLAN:
MCGUIRE NUCLEAR STATION
DOCKET NOS. 50-369 and 50-370

General Integrated Plan Elements	
<p>Determine Applicable Extreme External Hazard</p> <p>Ref: NEI 12-06 section 4.0 -9.0 JLD-ISG-2012-01 section 1.0</p>	<p><i>Input the hazards applicable to the site; seismic, external flood, high winds, snow, ice, cold, high temps.</i></p> <p><i>Describe how NEI 12-06 sections 5 – 9 were applied and the basis for why the plant screened out for certain hazards.</i></p> <p><u>Seismic Hazard Assessment:</u></p> <p>The McGuire Nuclear Station (MNS) Updated Final Analysis Report (UFSAR) Section 3.1 (Reference 1) states that the Safe Shutdown Earthquake (SSE) is 0.15g acting horizontally and 0.10g acting vertically, and the Operating Basis Earthquake (OBE) is 0.08g acting horizontally and 0.0533g acting vertically. As discussed in UFSAR Section 2.5.4.8 (Reference 1), soils beneath the site are not considered susceptible to liquefaction. The seismic hazard applies to all sites as required by Nuclear Energy Institute (NEI) 12-06 (Reference 2).</p> <p><u>External Flood Hazard Assessment:</u></p> <p>As described in UFSAR Sections 2.4, 2.4.10, and 3.4 (Reference 1), MNS Seismic Category I structures are not susceptible to external flooding from the Probable Maximum Precipitation (PMP) or Probable Maximum Flood (PMF) events. The limiting site flooding event for MNS is the Probable Maximum Precipitation (PMP) event, which is of limited duration and water level. The external flood hazard is applicable for MNS.</p> <p><u>High Wind Hazard Assessment:</u></p> <p>As described in UFSAR Section 2.1.1 (Reference 1), the MNS site is located at latitude 35 degrees - 25 minutes - 59 seconds north and longitude 80 degrees - 56 minutes - 55 seconds west. The site is in northwestern Mecklenburg County, North Carolina, 17 miles north-northwest of Charlotte, North Carolina.</p> <p>According to NEI 12-06 Figures 7-1 and 7-2 (Reference 2), the location of MNS has a Peak-Gust Wind Speed of 150 miles per hour (mph) and a Recommended Tornado Design Wind Speed of 172 mph. Based on the potential for winds in excess of 130 mph, the MNS site is susceptible to damage from severe winds from a hurricane or tornado.</p>

General Integrated Plan Elements	
	<p>Therefore, the high wind hazard is applicable for MNS.</p> <p><u>Extreme Cold Hazard Assessment:</u></p> <p>MNS is located above the 35th parallel, and is therefore subject to low-to-significant snowfall accumulation and extreme low temperatures per NEI 12-06 Figure 8-1 (Reference 2). Based on NEI 12-06 Figure 8-2 (Reference 2), the MNS site location is also subject to the existence of large amounts of ice, and thus the potential for severe power line damage. Therefore, the extreme cold hazard is applicable for MNS.</p> <p><u>Extreme High Temperature Hazard Assessment:</u></p> <p>NEI 12-06, Section 9.2 (Reference 2) states that virtually every state in the lower 48 contiguous United States has experienced temperatures in excess of 110°F and many in excess of 120°F. In accordance with NEI 12-06 (Reference 2), all sites will address high temperatures. Therefore, the extreme high temperature hazard is applicable for MNS.</p> <p><u>Summary</u></p> <p>The applicable beyond-design-basis external events (BDBEE) for MNS include seismic, external flooding, storms with high winds, extreme cold (including snow and ice), and high temperature.</p>
<p>Key Site assumptions to implement NEI 12-06 strategies. Ref: NEI 12-06 section 3.2.1</p>	<p><i>Provide key assumptions associated with implementation of FLEX Strategies:</i></p> <p>Key assumptions associated with implementation of “Diverse and Flexible Mitigation Capability” (“FLEX”) strategies:</p> <ol style="list-style-type: none"> 1. The seismic and flood re-evaluations pursuant to the 10 CFR 50.54(f) letter of March 12, 2012 (Reference 3) do not result in changes to the current design basis. It is assumed that the external flooding and seismic reevaluation do not adversely impact the equipment that forms a part of the MNS FLEX strategy. Any changes to the seismic or flood design basis may require a

General Integrated Plan Elements

- change to the plans in the MNS response to Order EA-12-049 (Reference 4).
2. All installed alternating current (AC) power supplies (emergency on-site and station blackout alternate AC power sources as defined by 10 CFR 50.2) will be considered not available and not imminently recoverable.
 3. Systems, structures, and components (SSC) will be considered seismically robust if seismic requirements are imposed by licensing requirements.
 4. Where non-safety, non-seismically designed, permanently installed equipment is used for FLEX strategies, SSCs will be considered seismically robust by any of the following methods:
 - Seismic Qualification Utility Group (SQUG) methods.
 - Testing, analysis or experience-based methods are applied for the equipment class at design basis seismic levels.
 - High Confidence of a Low Probability of Failure (HCLPF) capacities are determined (e.g. Electric Power Research Institute (EPRI) NP-6041 Revision 1, (Reference 5)) to be conservative compared to the SSE.
 - Methodologies in EPRI 1019199, *Experience Based Seismic Verification Guidelines for Piping and Tubing Systems*, (Reference 6) can be successfully applied relative to the SSE.
 - Other industry recognized codes such as AWWA D100, *Welded Carbon Steel Tanks for Water Storage*, (Reference 7) are applied to demonstrate functionality at SSE level ground motion.
 5. Qualification of equipment that forms part of the FLEX strategy and personnel access for deployment of FLEX equipment assumes no core damage.
 6. For events with no advance warning, per NEI 12-06 Section 12.1 (Reference 2), on-site resources will be used to cope with the first two phases of the casualty for a minimum of the first 24 hours of the event. However, consistent with NEI 12-01 Section 3.4 and item 4 of Section 2.2 (Reference 8), Emergency Response Organization (ERO) personnel will become site resources as they arrive in Phase 2. ERO personnel are assumed to begin arriving at 6 hours and the site ERO will be staffed at 24 hours after the event.

General Integrated Plan Elements

7. Phase 3 resources (personnel and equipment) are assumed to start arriving within 24 hours of the request in accordance with the Regional Response Center (RRC) playbook. All resources from the RRC are assumed to be available within 72 hours of the request.
8. This plan defines strategies capable of mitigating a simultaneous loss of all alternating current power and loss of normal access to the ultimate heat sink resulting from a beyond-design-basis event by providing adequate capability to maintain or restore core cooling, containment, and Spent Fuel Pool (SFP) cooling capabilities at all units on a site. Though specific strategies are being developed, due to the inability to anticipate all possible scenarios, the strategies are also diverse and flexible to encompass a wide range of possible conditions. These pre-planned strategies developed to protect the public health and safety will be incorporated into the unit emergency operating procedures in accordance with established Emergency Operating Procedure (EOP) change processes, and their impact to the design basis capabilities of the unit evaluated under 10 CFR 50.59. The plant Technical Specifications contain the limiting conditions for normal unit operations to ensure that design safety features are available to respond to a design basis accident and direct the required actions to be taken when the limiting conditions are not met. The result of the beyond-design-basis event may place the plant in a condition where it cannot comply with certain Technical Specifications and/or with its Security Plan, and, as such, may warrant invocation of 10 CFR 50.54(x) and/or 10 CFR 73.55(p) (Reference 32).
9. The MNS nuclear service water intake and discharge headers from the Ultimate Heat Sink (UHS) can gravity feed the Turbine-Driven Auxiliary Feedwater (TDAFW) pumps. Additionally, the intake is approximately 40 feet under water. As such, loss of access to the UHS is assumed to result only from the loss of AC power to the motor operated valves that would normally automatically align this flow path. This is consistent with NEI 12-06, 3.2.1.3(4) (Reference 2) which states, "Normal access to the ultimate heat sink is lost, but the water inventory in the UHS remains available and robust piping connecting the UHS to plant systems remains intact". Two independent, full safety-related (i.e. robust) flow paths from the UHS to the TDAFW

General Integrated Plan Elements	
	pumps exist and could be locally aligned during an Extended Loss of AC Power (ELAP) event.
<p>Extent to which the guidance, JLD-ISG-2012-01 and NEI 12-06, are being followed. Identify any deviations to JLD-ISG-2012-01 and NEI 12-06.</p> <p>Ref: JLD-ISG-2012-01 NEI 12-06 13.1</p>	<p><i>Include a description of any alternatives to the guidance, and provide a milestone schedule of planned action.</i></p> <p>The MNS strategy has no known deviations to the guidance in NEI 12-06 (Reference 2) and JLD-ISG-2012-01 (Reference 9). If deviations are identified, the deviations will be communicated in a future six month update following identification.</p>
<p>Provide a sequence of events and identify any time constraint required for success including the technical basis for the time constraint.</p> <p>Ref: NEI 12-06 section 3.2.1.7 JLD-ISG-2012-01 section 2.1</p>	<p><i>Strategies that have a time constraint to be successful should be identified with a technical basis and a justification provided that the time can reasonably be met (for example, a walk-through of deployment).</i></p> <p><i>Describe in detail in this section the technical basis for the time constraint identified on the sequence of events timeline Attachment 1A.</i></p> <p><i>See attached sequence of events timeline (Attachment 1A)</i></p> <p><i>Technical Basis Support information, see attached NSSS Significant Reference Analysis Deviation Table (Attachment 1B)</i></p> <p>See Attachments 1A for the current sequence of events timeline. Note that the MNS FLEX strategy is evolving. A staffing Phase 2 study will be performed in accordance with NEI 12-01 (Reference 8) to verify that all actions can be taken in accordance with the timeline. Time constraints shown in Attachment 1A will be validated to be reasonable as the strategy is finalized. (OPEN ITEM 12) The current technical basis is as follows (Item Nos. refer to Attachment 1A):</p> <p><u>Item 3:</u> The TDAFW pump automatically aligns to condenser circulating water pipes if the Auxiliary Feedwater Storage Tank (CAST) is damaged by tornado. An engineering change will be implemented to align the TDAFW pump to the underground condenser circulating water pipes on low suction pressure. (OPEN ITEM 2)</p>

General Integrated Plan Elements

Item 5: The Extended Loss of AC Power (ELAP) event with Loss of the Ultimate Heat Sink (LUHS) and coincident external event is estimated to take one hour to diagnose based on a staffing study that was performed for INPO Event Report (IER) L1 11-4 (Reference 21).

Item 7: The control room doors must be opened at two hours to maintain acceptable control room temperatures. The time to open doors is based on the analysis performed in Reference 22.

Item 10: Non-critical loads must be disconnected within three hours to preserve the vital batteries. The time is based on an analysis performed in Reference 23.

Item 12: The spent fuel pool roll-up doors are opened in accordance with NEI 12-06 (Reference 2) to vent steam from the spent fuel pool building. The four hour response time is conservatively selected during refueling outages and subsequent to full core offloads to occur before the onset of boiling. The 15 hour time response is conservatively selected during normal operation to occur before the onset of boiling as well. In both cases, elevated dose rates would not occur until many hours later. Both response times are also consistent with the alignment of the diesel pumps to the spent fuel pools in item 11.

Item 14: Sources of water into the ground water sump in the vicinity of the TDAFW pump are isolated early in Phase 2 (8-12 hours) to improve margin to flooding of the auxiliary feedwater pump room. An analysis was performed in Reference 20 that indicates that flooding will not occur for at least 48 hours. This analysis will be revised to demonstrate that this time remains unaffected even if potential sources of water from Auxiliary Building or Turbine Building flooding are considered (OPEN ITEM 13). Phase 2 staffing studies will further be performed to validate the acceptability of the time-line (OPEN ITEM 12).

Item 15: Portable pumps are aligned from the refueling water storage tank (RWST) to the intermediate head safety injection (SI) or residual heat removal (RHR) systems to provide reactor coolant system (NC) makeup in about 8 to 12 hours. This time is chosen to correspond with the post trip, peak xenon concentration in the reactor and should provide ample

General Integrated Plan Elements

time to offset the positive reactivity that will occur due to the decay of xenon and cool down of the reactor coolant system. A calculation will be performed to demonstrate that sufficient negative reactivity can be added through use of a pump and a reactor coolant system vent path to achieve xenon free cool down in accordance with the Pressurized Water Reactor Owner's Group (PWROG) FLEX Support Guidelines (FSG) (Reference 13). (OPEN ITEM 14)

Item 16: Pre-staged portable ground water sump pumps and associated diesel generators are aligned to remove water in the sump inside the auxiliary feedwater pump room at 8 to 24 hours. The response time is chosen to provide additional margin to flooding. An analysis performed in Reference 20 indicates that flooding will not occur for at least 48 hours. This analysis will be revised to demonstrate that this time remains unaffected even if potential sources of water from Auxiliary Building or Turbine Building flooding are considered (OPEN ITEM 13).

Item 17: Use of portable fans or Heating, Ventilation, Air-Conditioning (HVAC) units may eventually be required to remove heat or hydrogen (in the case of the vital battery rooms). The response times of 8 to 24 hours are estimated based on existing analyses and engineering judgment. Calculations will be performed to determine room heatup and hydrogen accumulation rates in the vital battery room and heatup rates in the interior doghouses (OPEN ITEM 15 and OPEN ITEM 16).

Item 18: The cold leg accumulators will be isolated in 8 to 24 hours to prevent the injection of nitrogen from the accumulators before the reactor coolant system is cooled down and depressurized to the associated condition. The response time is based on engineering judgment and is largely driven by FSGs that cool down and makeup to the reactor coolant system.

Item 19: The vital batteries will conservatively be recharged in 8 to 24 hours. An analysis (Reference 23) indicates that vital battery capacity is greater than 24 hours. Future strategies will ensure that battery capability is extended to ensure batteries can be recharged prior to loss of Direct Current (DC) power in Phase 2.

General Integrated Plan Elements

Item 22: The existing Ultra High Frequency (UHF) communication system and satellite phone system battery capacity will be substantially increased by an engineering change. However, the batteries will eventually be depleted and will need to be recharged. A response time of 10-24 hours is chosen based on engineering judgment of what can be achieved by the engineering change. (OPEN ITEM 4)

Item 24: If the Auxiliary Feedwater Storage Tank (CAST) is unavailable, the TDAFW pump will automatically align to the underground condenser circulating water pipe headers with an engineering change. (OPEN ITEM 2) An option will also be provided to manually align to the UHS via the Nuclear Service Water System (RN). The UHS provides a nearly indefinite source of water to the TDAFW pump (although makeup to the UHS is addressed in Phase 3). An evaluation will be performed to determine how long raw water can be used to supply Steam Generators (SGs) without excessively affecting SG capability to remove heat and provide steam to the TDAFW pump. This will help determine when Phase 3 equipment may be needed to assist in providing cleaner water sources. (OPEN ITEM 17)

Item 26: Portable lighting will be put into place around 24 hours as resources become available. (OPEN ITEM 9)

Item 27: MNS will transition to Phase 3 using the Regional Response Center (RRC) playbook at around 24 hours.

Item 28: Methods will be initiated to circulate and cool air in lower containment subcompartments to prevent any adverse impact on critical instrumentation. The response time is based on engineering judgment and will be confirmed by analysis (OPEN ITEM 19).

Item 29: After 72 hours, the following will be performed or evaluated. The response time is based on containment analyses (Reference 24) that indicates containment will remain below the design pressure for over 72 hours.

- Instrument air will be isolated to containment
- Evaluate the need to align portable diesel pumps for containment spray
- Evaluate other containment cooling strategies.

General Integrated Plan Elements	
	<p>Attachment 1B provides a discussion of deviations relative to the Nuclear Steam Supply System (NSSS) significant reference analysis. The NSSS vendor for MNS is Westinghouse, and the applicable analysis is WCAP-17601-P (Reference 10). The WCAP provides a generic Reactor Coolant System (RCS) inventory coping time based on cooldown assumptions in the generic Station Blackout (SBO) Emergency Operating Procedure (EOP). The MNS EOPs provide the cooldown strategies consistent with the generic EOP and the WCAP, so the conclusions in the WCAP bound the MNS response. Hence, Attachment 1B is not applicable.</p>
<p>Identify how strategies will be deployed in all modes.</p> <p>Ref: NEI 12-06 section 13.1.6</p>	<p><i>Describe how the strategies will be deployed in all modes.</i></p> <p>Deployment routes will be established and are expected to be utilized to transport FLEX equipment to the deployment areas. The identified paths and deployment areas will be accessible during all modes of operation. This deployment strategy will be included within an administrative program in order to keep pathways clear or actions to clear the pathways. (OPEN ITEM 20)</p>
<p>Provide a milestone schedule. This schedule should include:</p> <ul style="list-style-type: none"> • Modifications timeline <ul style="list-style-type: none"> ○ Phase 1 Modifications ○ Phase 2 Modifications ○ Phase 3 Modifications • Procedure guidance development complete <ul style="list-style-type: none"> ○ Strategies ○ Maintenance • Storage plan (reasonable protection) • Staffing analysis completion • FLEX equipment acquisition timeline 	<p><i>The dates specifically required by the order are obligated or committed dates. Other dates are planned dates subject to change. Updates will be provided in the periodic (six month) status reports.</i></p> <p>See Attachment 2 for milestone details.</p>

General Integrated Plan Elements	
<ul style="list-style-type: none"> • Training completion for the strategies • Regional Response Centers operational <p>Ref: NEI 12-06 section 13.1</p>	
<p>Identify how the programmatic controls will be met.</p> <p>Ref: NEI 12-06 section 11 JLD-ISG-2012-01 section 6.0</p>	<p><i>Provide a description of the programmatic controls equipment protection, storage and deployment and equipment quality. See section 11 in NEI 12-06. Storage of equipment, 11.3, will be documented in later sections of this template and need not be included in this section. See section 6.0 of JLD-ISG-2012-01.</i></p> <p>MNS will implement programmatic controls in accordance with NEI 12-06 (Reference 2). Procedures and guidelines will be reviewed and revised and/or generated as required to address additional programmatic controls as a result of FLEX requirements. (OPEN ITEM 21)</p> <p>Equipment associated with FLEX mitigation strategies will be procured as commercial equipment with design, storage, maintenance, testing, and configuration control in accordance with NEI 12-06 Section 11.1 (Reference 2). (OPEN ITEM 22) Installed structures, systems and components (SSCs) pursuant to 10 CFR 50.63(a) will continue to meet augmented guidelines of Regulatory Guide (RG) 1.155, <i>Station Blackout</i> (Reference 11). (OPEN ITEM 23)</p> <p>The unavailability of equipment and applicable connections that directly perform a FLEX mitigation strategy will be managed using plant equipment control guidelines developed in accordance with NEI 12-06 Section 11.5 (Reference 2). (OPEN ITEM 24)</p> <p>Programs and processes will be established to ensure that personnel proficiency in the mitigation of beyond-design-basis events is developed and maintained in accordance with NEI 12-06 Section 11.6 (Reference 2). (OPEN ITEM 25)</p> <p>The FLEX strategies and basis will be maintained in overall FLEX basis documents. (OPEN ITEM 26) Existing plant configuration control documents will be modified to ensure</p>

General Integrated Plan Elements	
	<p>that changes to the plant design, physical plant layout, roads, buildings, and miscellaneous structures will not adversely impact the approved FLEX strategies in accordance with NEI 12-06 Section 11.8 (Reference 2). (OPEN ITEM 27)</p>
Describe training plan	<p><i>List training plans for affected organizations or describe the plan for training development</i></p> <p>Training will be initiated through the Systematic Approach to Training (SAT) process. Training will be developed and provided to all involved plant personnel based on any procedural changes or new procedures developed to address and identify FLEX activities. Applicable training will be completed prior to the implementation of FLEX. (OPEN ITEM 28)</p>
Describe Regional Response Center plan	<p><i>Discussion in this section may include the following information and will be further developed as the Regional Response Center development is completed.</i></p> <ul style="list-style-type: none"> • <i>Site-specific RRC plan</i> • <i>Identification of the primary and secondary RRC sites</i> • <i>Identification of any alternate equipment sites (i.e. another nearby site with compatible equipment that can be deployed)</i> • <i>Describe how delivery to the site is acceptable</i> • <i>Describe how all requirements in NEI 12-06 are identified</i> <p>The industry will establish two (2) Regional Response Centers (RRCs) to support utilities during beyond-design-basis events. (OPEN ITEM 29) Each RRC will hold five sets of equipment, four of which will be able to be fully deployed when requested. The fifth set will have equipment in a maintenance cycle. Equipment will be moved from an RRC to a local Assembly Area, established by the Strategic Alliance of FLEX Emergency Response (SAFER) team and the utility. Communications will be established between the affected nuclear site and the SAFER team, and required equipment moved to the site as needed. First arriving equipment, as established during development of the nuclear site's playbook, will be delivered to the site within 24 hours from the initial request. A contract has been signed between the site and</p>

General Integrated Plan Elements	
	the Pooled Equipment Inventory Company to provide Phase 3 services and equipment.
Notes:	

Maintain Core Cooling & Heat Removal

Determine Baseline coping capability with installed coping¹ modifications not including FLEX modifications, utilizing methods described in Table 3-2 of NEI 12-06:

- AFW/EFW
- Depressurize SG for Makeup with Portable Injection Source
- Sustained Source of Water

Ref: JLD-ISG-2012-01 section 2 and 3.

PWR Installed Equipment Phase 1

Provide a general description of the coping strategies using installed equipment including station modifications that are proposed to maintain core cooling. Identify methods (AFW/EFW) and strategy(ies) utilized to achieve this coping time.

Strategy with Steam Generators (S/Gs) Available:

In general, the Phase 1 strategy to maintain core cooling involves use of the turbine driven auxiliary feedwater pump (TDAFWP), feedwater control valves (FCVs) to all four steam generators and steam generator Power-Operated Relief Valves (PORVs) on all four steam generators to provide symmetric cooling to the reactor coolant system. Water is provided to the TDAFWP from one of two sources:

1. Seismic / Other Non Tornado/Hurricane ELAP Events:

Auxiliary Feedwater Storage Tank (CAST) - Analyses were performed to demonstrate that the elevated water storage tank is capable of withstanding the SSE (Reference 33) and the design basis wind load (Reference 18). The CAST contains approximately 300,000 gallons of demineralized water. The CASTs are normally aligned to the TDAFWPs and have sufficient volume to provide about 16 hours of cooling.

2. Tornado/Hurricane Force Wind ELAP Events:

Buried condenser circulating water pipe headers - These headers are capable of withstanding the design basis wind loading and the design basis tornado (by virtue of not being exposed), and contain at least a two day supply of raw water. Lake Norman inventory is connected to this piping and can provide an indefinite supply following a design basis tornado or a hurricane. These underground headers are currently normally isolated by valves that must be manually opened. A modification will be performed to provide actuators and logic that will automatically align this source of water to the TDAFWPs if the CAST suction source is lost. The modification will also provide a means for manually aligning this source of water if the CAST is initially available but later depleted after many hours of use. (OPEN ITEM 2)

¹ Coping modifications consist of modifications installed to increase initial coping time, i.e. generators to preserve vital instruments or increase operating time on battery powered equipment.

Maintain Core Cooling & Heat Removal

Additionally, the Nuclear Service Water intake / discharge headers can provide gravity flow to the TDAFWPs from the UHS via AC powered motor operated valves if manually aligned. These valves would normally open automatically on low pump suction pressure. However, since Order EA-12-049 requires that all AC power be assumed lost, these valves would have to be manually opened to supply water from the UHS to the TDAFWPs. As such, these valves could also be opened to supply water to the TDAFWPs once the CAST is depleted or if the buried condenser circulating water headers are depleted of water.

A modification will also be implemented to provide assured air to the TDAFWP flow control valves and the SG PORVs to allow these valves to be operated from the control room until a source of makeup air / power can be provided in Phase 2. The modification includes addition of several instrument air valves that can quickly be aligned manually at the beginning of the event to bypass several solenoid valves that would otherwise have to be reset or re-powered. (OPEN ITEM 1)

Strategy with Steam Generators (SGs) NOT Available:

There are no necessary actions to provide coping during Phase 1. Furthermore, MNS has no means of providing borated RCS makeup for Phase 1.

Details:

Provide a brief description of Procedures / Strategies / Guidelines	<p><i>Confirm that procedure/guidance exists or will be developed to support implementation.</i></p> <p>Site-specific procedures and/or FLEX Support Guidelines (FSGs) will be developed using industry guidance to address the criteria in NEI 12-06, Section 11.4 (Reference 2). (OPEN ITEM 9)</p>
Identify modifications	<p><i>List modifications and describe how they support coping time.</i></p> <p>The list of modifications and the method by which each one supports the overall mitigation strategy are captured in Attachment 4A.</p>
Key Reactor Parameters	<p><i>List instrumentation credited for this coping evaluation phase.</i></p> <p>Key reactor instrumentation needed to maintain core cooling and heat removal are as follows:</p> <ol style="list-style-type: none"> 1. Steam Generator (S/G) narrow-range levels 2. S/G steam pressures 3. TDAFW pump flows 4. Inadequate core cooling monitor (ICCM) including Reactor Vessel Level Instrumentation System (RVLIS), Incore thermocouples (T/Cs), Wide-range reactor coolant system (NC) pressure and subcooling margin, Reactor Coolant (NC) loop T_{HOT} 5. Pressurizer level

Maintain Core Cooling & Heat Removal

Notes:

Maintain Core Cooling & Heat Removal

PWR Portable Equipment Phase 2

Provide a general description of the coping strategies using on-site portable equipment including station modifications that are proposed to maintain core cooling. Identify methods and strategy(ies) utilized to achieve this coping time.

Steam Generators Available:

In general, the Phase 2 strategy to maintain core cooling involves continued use of the turbine driven auxiliary feedwater pump (TDAFWP), feedwater control valves (FCVs) to all four steam generators and steam generator PORVs on all four steam generators to provide symmetric cooling to the reactor coolant system. Water is provided to the TDAFWP from one of two sources:

1. Seismic / Other Non Tornado/Hurricane ELAP Events:

The CAST inventory will eventually be depleted at around 16 hours into the event. Phase 2 will then be implemented using one or more of the following approaches:

- Makeup to the CAST using a low pressure portable pump and the existing "Section B.5.b mitigating strategy" (Reference 12) procedure.
- If automatic TDAFWP suction alignment to the buried condenser circulating water piping headers has not already occurred, manually realign the TDAFWP suction to the:
 - Buried condenser circulating water piping headers which contain at least two days worth of cooling water.
 - or-
 - UHS by manually opening the AC motor operated nuclear service water (RN) valves
- Align low pressure portable pump(s) to deliver raw water makeup from the UHS to the steam generators. The primary SG feed connection is already available (a pre-existing connection installed pursuant to Section B.5.b mitigating strategy and can be used in conjunction with the low pressure portable pumps to provide makeup to all four SGs. This connection is located on top of the Auxiliary Building and is protected on the north and south sides from wind and missiles by surrounding structures. A modification will be implemented that will provide alternate SG feed connections in the interior and exterior doghouses that can supply makeup to all four SGs. These alternate SG feed connections will be fully protected against external events by virtue of being located within the Category I doghouse structures. (OPEN ITEM 5)

2. Tornado/Hurricane Force Wind ELAP Events:

The CAST is assumed to be unavailable, and Phase 1 coping relies on automatic alignment of the TDAFW suction to the buried condenser circulating water piping headers, which can provide at least two days of cooling water. Phase 2 will then be implemented using one or more of the following approaches:

Maintain Core Cooling & Heat Removal

PWR Portable Equipment Phase 2

- Manually realign the TDAFWP suction to the UHS by manually opening the AC motor operated nuclear service water (RN) valves
- Align low pressure portable pump(s) to deliver raw water makeup from the UHS to the SGs. The primary SG feed connection is already available (a pre-existing connection installed pursuant to the Section B.5.b mitigating strategy) and can be used in conjunction with the low pressure portable pumps to provide makeup to all four SGs. This connection is located on top of the Auxiliary Building and is protected on the north and south sides from wind and missiles by surrounding structures. A modification will be implemented that will provide alternate SG feed connections in the interior and exterior doghouses that can supply makeup to all four SGs. These alternate SG feed connections will be fully protected against external events by virtue of being located within the Category I doghouse structures. (OPEN ITEM 5)

MNS procedures will be written in accordance with PWROG generic FLEX Support Guidelines (FSGs)(Reference 13) for each of these options (OPEN ITEM 9). For use of the low pressure pump option, the SGs will be depressurized below the discharge pressure of the low pressure pump but above a pressure that would result in injection of nitrogen from the cold leg accumulators (~300 psig) into the reactor coolant system. The pumps will be specified and procured to provide enough flow (~300 gpm) to remove decay heat.

SG and reactor coolant system pressures will eventually decrease even further due to a decrease in decay heat. The Cold Leg Accumulator (CLA) valves will be re-powered and closed to prevent nitrogen from being injected into the reactor coolant system (OPEN ITEM 9).

Conceptual design sketches for the portable Steam Generator makeup scheme are provided in Attachment 4B.

TDAFWP FCV and SG PORV Air

The TDAFWP FCV and SG PORV assured air systems will eventually be depleted. Portable diesel air compressors will be provided to maintain an air supply to these valves. The assured air system(s) will be designed to provide at least 8 hours of air before portable compressed air needs to be provided.

Primary and alternate diesel air compressor connection points will be provided. (OPEN ITEM 1) The primary connection point will be seismically rugged, and located within the exterior doghouse, a Category I structure. The secondary connection point will be seismically rugged and designed to withstand tornado wind loads, and will be located at an accessible location on the Auxiliary Building roof. Conceptual design sketches for the portable air distribution scheme are provided in Attachment 3.

Steam Generators NOT Available:

See Phase 2 "*Shutdown Operation*" discussion under "Maintain RCS Inventory Control" section for

Maintain Core Cooling & Heat Removal	
PWR Portable Equipment Phase 2	
Mode 5/6 heat removal strategies.	
Details:	
Provide a brief description of Procedures / Strategies / Guidelines	<p><i>Confirm that procedure/guidance exists or will be developed to support implementation with a description of the procedure / strategy / guideline.</i></p> <p>Site-specific procedures and/or FSGs will be developed using industry guidance to address the criteria in NEI 12-06, Section 11.4 (Reference 2). (OPEN ITEM 9)</p>
Identify modifications	<p><i>List modifications necessary for phase 2</i></p> <p>The list of modifications and the method by which each one supports the overall mitigation strategy are captured in Attachment 4A.</p>
Key Reactor Parameters	<p><i>List instrumentation credited or recovered for this coping evaluation.</i></p> <p>Same as Phase 1</p>
Storage / Protection of Equipment :	
Describe storage / protection plan or schedule to determine storage requirements	
Seismic	<p><i>List how equipment is protected or schedule to protect</i></p> <p>Portable equipment will be stored directly in Category I structures in some cases to reduce the time to deploy the equipment. In most cases though, the equipment will be stored in one of three FLEX storage facilities (N+1 where N is the number of units). The FLEX storage facilities will be designed in accordance with ASCE 7-10, <i>Minimum Design Loads for Buildings and Other Structures</i> (Reference 14). (OPEN ITEM 30)</p>
Flooding Note: if stored below current flood level, then ensure procedures exist to move equipment prior to exceeding flood level.	<p><i>List how equipment is protected or schedule to protect</i></p> <p>MNS Seismic Category I structures are not susceptible to external flooding from the Probable Maximum Precipitation (PMP) or Probable Maximum Flood (PMF) events. The limiting site flooding event for MNS is the Probable Maximum Precipitation (PMP) event, which is of limited duration and water level. FLEX storage facilities will be located above any potential site flood level, and/or the effects of localized flooding will be evaluated in the FLEX facility design and equipment deployment. (OPEN ITEM 31)</p>

Maintain Core Cooling & Heat Removal		
PWR Portable Equipment Phase 2		
Severe Storms with High Winds	<p><i>List how equipment is protected or schedule to protect</i></p> <p>The Category I structures are designed to withstand design basis winds and tornados. The FLEX storage facilities will be designed in accordance with ASCE 7-10 (Reference 14), to withstand the maximum anticipated hurricane and tornado winds as outlined in NEI 12-06 (Reference 2). The FLEX buildings will be located in accordance with NEI 12-06 (Reference 2) Section 7.3.1 to prevent damage to more than one of the three facilities due to tornado missiles. (OPEN ITEM 30)</p> <p>Debris removal/remediation equipment and procedures will be provided to support FLEX equipment deployment. (OPEN ITEM 32)</p>	
Snow, Ice, and Extreme Cold	<p><i>List how equipment is protected or schedule to protect</i></p> <p>Snow and ice removal/remediation equipment and procedures will be provided to support FLEX equipment deployment. (OPEN ITEM 33)</p> <p>FLEX equipment will be capable of operation under extreme temperatures, and suitably maintained to ensure standby readiness. FLEX storage facilities will be designed to accommodate maximum snow and ice loading. (OPEN ITEM 34)</p> <p>MNS will evaluate the need to provide freeze protection for critical instrumentation and exposed FLEX connections. (OPEN ITEM 18)</p>	
High Temperatures	<p><i>List how equipment is protected or schedule to protect</i></p> <p>FLEX equipment will be capable of operation under extreme temperatures, and suitably maintained to ensure standby readiness. FLEX storage facilities will be vented to maintain acceptable temperature. (OPEN ITEM 34)</p>	
Deployment Conceptual Design (Attachment 3 contains Conceptual Sketches)		
Strategy	Modifications	Protection of connections
<i>Identify Strategy including how the equipment will be deployed to the point of use.</i>	<i>Identify modifications</i>	<i>Identify how the connection is protected</i>
Process Connections including Steam Generator Makeup	Process Connections (see Attachment 4A)	Steam Generator Makeup - The primary connection is located on top of the Auxiliary Building and is protected on the north and south sides from

Maintain Core Cooling & Heat Removal		
PWR Portable Equipment Phase 2		
		wind and missiles by surrounding structures. The alternate makeup connections will be protected inside the doghouses, a Category I structure (OPEN ITEM 5).
Instrument Air Process Connections	Assured Air to the TDAFWP FCVs and SG PORVs (see Attachment 4A)	Instrument Air - primary connection will be seismically rugged and protected inside the exterior doghouse, a Category I structure. Alternate connection will be rugged with respect to seismic and tornado wind, and located exterior to the Auxiliary Building. (OPEN ITEM 1)
Notes:		

Maintain Core Cooling & Heat Removal

PWR Portable Equipment Phase 3

Provide a general description of the coping strategies using phase 3 equipment including modifications that are proposed to maintain core cooling. Identify methods and strategy(ies) utilized to achieve this coping time.

Phase 3 will begin 24 hours after the event. At 24 hours personnel and equipment will begin being delivered to MNS in accordance with the Regional Response Center (RRC) play book. All equipment and personnel will be delivered according to the playbook within 72 hours of event start. Depending on extent of damage, Phase 3 equipment will be used to repower emergency buses and restore normal residual heat removal cooling.

Portable RRC equipment that will be required to provide long term recovery and stabilization of the plant is listed in the "PWR Portable Equipment Phase 3" table which follows.

Details:

Provide a brief description of Procedures / Strategies / Guidelines	<p><i>Confirm that procedure/guidance exists or will be developed to support implementation with a description of the procedure / strategy / guideline.</i></p> <p>Site-specific procedures and/or FSGs will be developed using industry guidance to address the criteria in NEI 12-06, Section 11.4 (Reference 2). (OPEN ITEM 9)</p>
Identify modifications	<p><i>List modifications necessary for phase 3</i></p> <p>There are no modifications needed to support Phase 3.</p>
Key Reactor Parameters	<p><i>List instrumentation credited or recovered for this coping evaluation.</i></p> <p>Same as Phase 1</p>

**Deployment Conceptual Design
 (Attachment 3 contains Conceptual Sketches)**

Strategy	Modifications	Protection of connections
<i>Identify Strategy including how the equipment will be deployed to the point of use.</i>	<i>Identify modifications</i>	<i>Identify how the connection is protected</i>
Phase 3 equipment is provided by the RRC (not stored onsite). Deployment strategies will be developed. (OPEN ITEM 20)	N/A	Connection points will be located in protected Category I structures.

Maintain Core Cooling & Heat Removal
PWR Portable Equipment Phase 3
Notes:

Maintain RCS Inventory Control	
<p>Determine Baseline coping capability with installed coping² modifications not including FLEX modifications, utilizing methods described in Table 3-2 of NEI 12-06:</p> <ul style="list-style-type: none"> • Low Leak RCP Seals or RCS makeup required • All Plants Provide Means to Provide Borated RCS Makeup 	
PWR Installed Equipment Phase 1:	
<p><i>Provide a general description of the coping strategies using installed equipment including modifications that are proposed to maintain core cooling. Identify methods (Low Leak RCP Seals and/or borated high pressure RCS makeup) and strategy(ies) utilized to achieve this coping time.</i></p> <p>MNS does not have low leakage Reactor Coolant Pump (RCP) shutdown seals installed, and does not have the capability for high pressure borated water injection into the Reactor Coolant System (RCS) for BDBEE.</p> <p>There is no MNS strategy required to maintain RCS inventory in Phase I, since core uncover does not occur for 55 hours according to the PWROG generic analysis (Reference 10) and 72 hours according to the MNS specific analysis (Reference 31).</p>	
Details:	
Provide a brief description of Procedures / Strategies / Guidelines	<p><i>Confirm that procedure/guidance exists or will be developed to support implementation</i></p> <p>Not applicable</p>
Identify modifications	<p><i>List modifications</i></p> <p>Not applicable</p>
Key Reactor Parameters	<p><i>List instrumentation credited for this coping evaluation.</i></p> <p>Key reactor instrumentation needed to maintain RCS inventory control are as follows:</p> <ol style="list-style-type: none"> 1. Inadequate core cooling monitor (ICCM) including Reactor Vessel Level Instrumentation System (RVLIS), Incore thermocouples (T/Cs), Wide-range NC system pressure and subcooling margin, Reactor Coolant (NC) loop T_{HOT} 2. Pressurizer level 3. Pressurizer PORV position indication 4. Wide-range (Gammametrics) neutron source range flux monitoring 5. Source Range Start-up Rate (SUR) monitor

² Coping modifications consist of modifications installed to increase initial coping time, i.e. generators to preserve vital instruments or increase operating time on battery powered equipment.

Maintain RCS Inventory Control

Notes:

Maintain RCS Inventory Control

PWR Portable Equipment Phase 2:

Provide a general description of the coping strategies using on-site portable equipment including modifications that are proposed to maintain core cooling. Identify methods (Low Leak RCP Seals and/or borated high pressure RCS makeup) and strategy(ies) utilized to achieve this coping time.

There are several portable equipment needs and methodologies that will be used in Phase 2 to maintain RCS inventory control as follows:

Reactor Makeup and Negative Reactivity Addition

Due to leakage past the reactor coolant pump seals, the core will eventually uncover if reactor makeup is not established. Additionally, shutdown margin will be reduced as a result of xenon decay and cooldown of the reactor coolant system. An analysis will be performed to determine required boration. (OPEN ITEM 14)

In order to compensate for the loss of inventory and ensure the reactor remains subcritical, the PWROG Core Cooling Position Paper (Reference 15) provides three options for reactor makeup:

1. High pressure pump (estimated to be greater than or equal to 1600 psig)
2. Low pressure pump (approximately 650 psig)
3. Passive Cold Leg Accumulator (CLA) injection

Normal Operation

The MNS will employ the first option listed (high pressure pump) for the RCS makeup method since it is simpler than the other approaches and can be implemented earlier in the event. Letdown will be established using the reactor head vent solenoid valves, if required. These valves are powered by vital DC.

The portable high pressure electric pump and associated hose will be staged in the Auxiliary Building to provide makeup to the reactor coolant system with borated water from the Refueling Water Storage Tank (RWST). The pump pressure and flow rate (>40 gpm @ >1600 psig) will be established in accordance with the PWROG Core Cooling Position Paper (Reference 15). Sufficient borated water will be added to maintain the core subcritical, at a xenon free condition, at 350°F.

A modification will be implemented (OPEN ITEM 5) to provide permanent process connections for the portable RCS makeup pump suction and discharge. Primary and alternate RCS makeup connections will be provided on the Intermediate Head Safety Injection (NI) discharge headers. The connections will provide diverse makeup paths (separate divisions), as either connection can be aligned to supply the cold legs or hot legs. An additional RWST process connection will be installed to provide a borated water suction supply to the portable RCS makeup pump.

Maintain RCS Inventory Control	
PWR Portable Equipment Phase 2:	
<i>Shutdown Operation</i>	
<p>For shutdown operations, MNS will employ the second option listed (low pressure pump) for the RCS makeup method. A second lower pressure, higher flow (~300 gpm @ <400 psig) electric pump will be provided to provide borated makeup to the reactor coolant system if the event were to occur during a refueling outage. The low pressure pump(s), associated fittings, and hoses will be stored in the FLEX storage facilities.</p> <p>Modifications will be implemented to provide permanent process connections for the portable RCS makeup pump. A primary RCS makeup connection will be provided on the Residual Heat Removal (ND) discharge header. (OPEN ITEM 5) The Residual Heat Removal connection will provide the ability to make-up to either the RCS cold legs or hot legs. The alternate RCS make-up connections will be provided on the Intermediate Head Safety Injection (NI) discharge headers, as described previously for normal operation. An additional RWST process connection (same as that described for normal operation) will be installed to provide a borated water suction supply to the portable RCS makeup pump.</p> <p>An evaluation will be performed to ensure that the 300 gpm pump is capable of adequate flow and pressure to support feed and bleed core cooling in typical Mode 5 and Mode 6 configurations. (OPEN ITEM 35)</p>	
Details:	
Provide a brief description of Procedures / Strategies / Guidelines	<p><i>Confirm that procedure/guidance exists or will be developed to support implementation</i></p> <p>Site-specific procedures and/or FSGs will be developed using industry guidance to address the criteria in NEI 12-06, Section 11.4 (Reference 2). (OPEN ITEM 9)</p>
Identify modifications	<p><i>List modifications</i></p> <p>See Attachment 4A.</p>
Key Reactor Parameters	<p><i>List instrumentation credited or recovered for this coping evaluation.</i></p> <p>Same as Phase 1</p>
Storage / Protection of Equipment:	
Describe storage / protection plan or schedule to determine storage requirements	
Seismic	<p><i>List how equipment is protected or schedule to protect</i></p> <p>Portable equipment will be stored directly in Category I structures in some cases to reduce the time to deploy the equipment. In most</p>

Maintain RCS Inventory Control	
PWR Portable Equipment Phase 2:	
	cases though, the equipment will be stored in one of three FLEX storage facilities (N+1 where N is the number of units). The FLEX storage facilities will be designed in accordance with ASCE 7-10 (Reference 14). (OPEN ITEM 30)
Flooding Note: if stored below current flood level, then ensure procedures exist to move equipment prior to exceeding flood level.	<i>List how equipment is protected or schedule to protect</i> MNS Seismic Category I structures are not susceptible to external flooding from the Probable Maximum Precipitation (PMP) or Probable Maximum Flood (PMF) events. The limiting site flooding event for MNS is the Probable Maximum Precipitation (PMP) event, which is of limited duration and water level. FLEX storage facilities will be located above any potential site flood level, and/or the effects of localized flooding will be evaluated in the FLEX facility design and equipment deployment. (OPEN ITEM 31)
Severe Storms with High Winds	<i>List how equipment is protected or schedule to protect</i> The Category I structures are designed to withstand design basis winds and tornados. The FLEX storage facilities will be designed in accordance with ASCE 7-10 (Reference 14), to withstand the maximum anticipated hurricane and tornado winds as outlined in NEI 12-06 (Reference 2). The FLEX buildings will be located in accordance with NEI 12-06 (Reference 2) Section 7.3.1 to prevent damage to more than one of the three facilities due to tornado missiles. (OPEN ITEM 30) Debris removal/remediation equipment and procedures will be provided to support FLEX equipment deployment. (OPEN ITEM 32)
Snow, Ice, and Extreme Cold	<i>List how equipment is protected or schedule to protect</i> Snow and ice removal/remediation equipment and procedures will be provided to support FLEX equipment deployment. (OPEN ITEM 33) FLEX equipment will be capable of operation under extreme temperatures, and suitably maintained to ensure standby readiness. FLEX storage facilities will be designed to accommodate maximum snow and ice loading. (OPEN ITEM 34) MNS will evaluate the need to provide freeze protection for critical instrumentation and exposed FLEX connections. (OPEN ITEM 18)

Maintain RCS Inventory Control		
PWR Portable Equipment Phase 2:		
High Temperatures	<i>List how equipment is protected or schedule to protect</i> FLEX equipment will be capable of operation under extreme temperatures, and suitably maintained to ensure standby readiness. FLEX storage facilities will be vented to maintain acceptable temperature. (OPEN ITEM 34)	
Deployment Conceptual Modification (Attachment 3 contains Conceptual Sketches)		
Strategy	Modifications	Protection of connections
<i>Identify Strategy including how the equipment will be deployed to the point of use.</i>	<i>Identify modifications</i>	<i>Identify how the connection is protected</i>
Process Connections including Reactor Makeup	Process Connections (see Attachment 4A)	Reactor Makeup- All reactor coolant system makeup connections (ND and NI headers) and the borated water supply connection to RWST are inside the Auxiliary Building, a Category I facility
FLEX Storage Facilities	FLEX Storage Facilities (see Attachment 4A)	N+1 FLEX Storage facilities will be built in accordance with ASCE 7-10 (Reference 14).
Notes:		

Maintain RCS Inventory Control		
PWR Portable Equipment Phase 3:		
<p><i>Provide a general description of the coping strategies using phase 3 equipment including modifications that are proposed to maintain core cooling. Identify methods (Low Leak RCP Seals and/or borated high pressure RCS makeup) and strategy(ies) utilized to achieve this coping time.</i></p> <p>Obtain additional solid boric acid from the RRC to replenish the RWST and maintain shutdown margin.</p>		
Details:		
Provide a brief description of Procedures / Strategies / Guidelines	<p><i>Confirm that procedure/guidance exists or will be developed to support implementation</i></p> <p>Site-specific procedures and/or FSGs will be developed using industry guidance to address the criteria in NEI 12-06, Section 11.4 (Reference 2). (OPEN ITEM 9)</p>	
Identify modifications	<p><i>List modifications</i></p> <p>None</p>	
Key Reactor Parameters	<p><i>List instrumentation credited or recovered for this coping evaluation.</i></p> <p>Same as Phase 1</p>	
Deployment Conceptual Modification (Attachment 3 contains Conceptual Sketches)		
Strategy	Modifications	Protection of connections
<i>Identify Strategy including how the equipment will be deployed to the point of use.</i>	<i>Identify modifications</i>	<i>Identify how the connection is protected</i>
Phase 3 equipment is provided by the RRC (not stored onsite). Deployment strategies will be developed. (OPEN ITEM 20)	N/A	Connection points will be located in protected in Category I structures.

Notes:

Maintain Containment

Determine Baseline coping capability with installed coping³ modifications not including FLEX modifications, utilizing methods described in Table 3-2 of NEI 12-06:

- **Containment Spray**
- **Hydrogen igniters (ice condenser containments only)**

PWR Installed Equipment Phase 1:

Provide a general description of the coping strategies using installed equipment including modifications that are proposed to maintain containment. Identify methods (containment spray/Hydrogen igniter) and strategy(ies) utilized to achieve this coping time.

The MNS Reactor Building includes a metal containment vessel and annulus region between the metal containment and a reinforced concrete enclosure. The containment vessel design pressure is 15 psig.

The MNS containment is initially passively cooled by an ice condenser. Steam leaving the primary system is cooled as it rises from lower containment, through the ice condenser and into upper containment. A containment analysis (Reference 24) was performed based on reactor coolant pump seal leakage that decreased with reactor coolant system pressure over time. The results of the analysis indicated that the design pressure in containment would not be exceeded prior to 72 hours. Although the function between leakage and time may change somewhat when the FSGs are implemented because action will be proactively taken to both restore reactor inventory and cool down and depressurize the reactor coolant system to limit leakage, containment pressure is still expected to remain below the design pressure for 72 hours.

Since the overall FLEX strategy is aimed at preventing core damage, the engineering change process will drive out an evaluation to prioritize operator actions associated with containment isolation as time allows. For example, the containment isolations to the Containment Ventilation Unit Condensate Drain Tank (VUCDT) will be closed first since this path connects containment atmosphere directly to the Auxiliary Building. (OPEN ITEM 36)

Details:

Provide a brief description of Procedures / Strategies / Guidelines	<i>Confirm that procedure/guidance exists or will be developed to support implementation</i>
	Not Applicable
Identify modifications	<i>List modifications</i>
	Not Applicable
Key Containment Parameters	<i>List instrumentation credited for this coping evaluation.</i>

³ Coping modifications consist of modifications installed to increase initial coping time, i.e. generators to preserve vital instruments or increase operating time on battery powered equipment.

Maintain Containment	
	1. Containment wide-range pressure
Notes:	

Maintain Containment

PWR Portable Equipment Phase 2:

Provide a general description of the coping strategies using on-site portable equipment including modifications that are proposed to maintain containment. Identify methods (containment spray/hydrogen igniters) and strategy(ies) utilized to achieve this coping time.

Primary Strategy

One train of hydrogen igniters will be re-powered and restored to service in Phase 2 using the portable power strategy described under Safety Support Function, Phase 2.

Containment Spray (CS) capability will be restored in accordance with PWROG generic FLEX Support Guidelines (Reference 13), if required. An analysis will be performed to validate that containment spray for temperature/pressure control is not required over the long term. If the long term containment analysis determines that containment temperature and/or pressure will reach unacceptable levels over the long term, connections installed for Section B.5.b containment spray mitigating strategies will be used with the portable diesel driven pumps to supply water from the UHS to the connections located in the Auxiliary building. (OPEN ITEM 37)

Additional analyses (Reference 34) verified that the annulus portion of the containment does not increase in pressure during the long term, since it passively relieves through the annulus HVAC system (VE) exhaust dampers.

Alternate Strategy

The opposite train of hydrogen igniters can be re-powered and restored to service in Phase 2 using the portable power strategy described under Safety Support Function, Phase 2.

If the long term containment analysis determines that containment temperature and/or pressure will reach unacceptable levels over the long term, a modification will be performed to add a connection leading to the 'A' containment spray header. (OPEN ITEM 5) A diesel-powered pump will be used to supply water from the UHS to the connection at the pressure and flow rate required to establish a spray field in containment.

Details:

Provide a brief description of Procedures / Strategies / Guidelines

Confirm that procedure/guidance exists or will be developed to support implementation

Site-specific procedures and/or FSGs will be developed using industry guidance to address the criteria in NEI 12-06, Section 11.4 (Reference 2). (OPEN ITEM 9)

Maintain Containment	
Identify modifications	<p><i>List modifications</i></p> <p>See Attachment 4A.</p>
Key Containment Parameters	<p><i>List instrumentation credited or recovered for this coping evaluation.</i></p> <p>Same as Phase 1</p>
Storage / Protection of Equipment: Describe storage / protection plan or schedule to determine storage requirements	
Seismic	<p><i>List how equipment is protected or schedule to protect</i></p> <p>Portable equipment will be stored directly in Category I structures in some cases to reduce the time to deploy the equipment. In most cases though, the equipment will be stored in one of three FLEX storage facilities (N+1 where N is the number of units). The FLEX storage facilities will be designed in accordance with ASCE 7-10 (Reference 14) to sustain a Safe Shutdown Earthquake (SSE). (OPEN ITEM 30)</p>
Flooding	<p><i>List how equipment is protected or schedule to protect</i></p> <p>MNS Seismic Category I structures are not susceptible to external flooding from the Probable Maximum Precipitation (PMP) or Probable Maximum Flood (PMF) events. The limiting site flooding event for MNS is the Probable Maximum Precipitation (PMP) event, which is of limited duration and water level. FLEX storage facilities will be located above any potential site flood level, and/or the effects of localized flooding will be evaluated in the FLEX facility design and equipment deployment. (OPEN ITEM 31)</p>
Severe Storms with High Winds	<p><i>List how equipment is protected or schedule to protect</i></p> <p>The Category I structures are designed to withstand design basis winds and tornados. The FLEX storage facilities will be designed in accordance with ASCE 7-10 (Reference 14), to withstand the maximum anticipated hurricane and tornado winds as outlined in NEI 12-06 (Reference 2). The FLEX buildings will be located in accordance with NEI 12-06 (Reference 2) Section 7.3.1 to prevent damage to more than one of the three facilities due to tornado missiles. (OPEN ITEM 30)</p> <p>Debris removal/remediation equipment and procedures will be provided to support FLEX equipment deployment. (OPEN ITEM 32)</p>

Maintain Containment		
Snow, Ice, and Extreme Cold	<p><i>List how equipment is protected or schedule to protect</i></p> <p>Snow and ice removal/remediation equipment and procedures will be provided to support FLEX equipment deployment. (OPEN ITEM 33)</p> <p>FLEX equipment will be capable of operation under extreme temperatures, and suitably maintained to ensure standby readiness. FLEX storage facilities will be designed to accommodate maximum snow and ice loading. (OPEN ITEM 34)</p> <p>MNS will evaluate the need to provide freeze protection for critical instrumentation and exposed FLEX connections. (OPEN ITEM 18)</p>	
High Temperatures	<p><i>List how equipment is protected or schedule to protect</i></p> <p>FLEX equipment will be capable of operation under extreme temperatures, and suitably maintained to ensure standby readiness. FLEX storage facilities will be vented to maintain acceptable temperature. (OPEN ITEM 34)</p>	
Deployment Conceptual Modification (Attachment 3 contains Conceptual Sketches)		
Strategy	Modifications	Protection of connections
<i>Identify Strategy including how the equipment will be deployed to the point of use.</i>	<i>Identify modifications</i>	<i>Identify how the connection is protected</i>
Process Connection for Containment Spray (NS) Capability	Process Connections (see Attachment 4A)	Containment Spray header process connections will be located inside a Category I facility.
FLEX Storage Facilities	FLEX Storage Facilities (see Attachment 4A)	N+1 FLEX Storage facilities will be built in accordance with ASCE 7-10 (Reference 14).
Notes:		

Maintain Containment		
PWR Portable Equipment Phase 3:		
<p><i>Provide a general description of the coping strategies using phase 3 equipment including modifications that are proposed to maintain containment. Identify methods (containment spray/hydrogen igniters) and strategy(ies) utilized to achieve this coping time.</i></p> <p>In addition to the portable equipment and actions outlined to maintain core cooling and heat removal in Phase 3, the following additional actions will be taken to maintain containment:</p> <ol style="list-style-type: none"> 1. Fans in containment that circulate air will be restored as required to cool the cubicle areas and to prevent the increase in temperature from having an adverse impact on essential instrumentation. The engineering change process will drive out an evaluation to determine the appropriate timing of these actions. (OPEN ITEM 19 and OPEN ITEM 38) 2. Evaluate other long term strategies for cooling containment such as circulating the air volume in the annulus. (OPEN ITEM 39) 		
Details:		
Provide a brief description of Procedures / Strategies / Guidelines	<p><i>Confirm that procedure/guidance exists or will be developed to support implementation</i></p> <p>Site-specific procedures and/or FSGs will be developed using industry guidance to address the criteria in NEI 12-06, Section 11.4 (Reference 2). (OPEN ITEM 9)</p>	
Identify modifications	<p><i>List modifications</i></p> <p>None</p>	
Key Containment Parameters	<p><i>List instrumentation credited or recovered for this coping evaluation.</i></p> <p>Same as Phase 1</p>	
Deployment Conceptual Modification (Attachment 3 contains Conceptual Sketches)		
Strategy	Modifications	Protection of connections
<i>Identify Strategy including how the equipment will be deployed to the point of use.</i>	<i>Identify modifications</i>	<i>Identify how the connection is protected</i>
Phase 3 equipment is provided by the RRC (not stored onsite). Deployment strategies will be developed. (OPEN ITEM 20)	N/A	Connection points will be located in protected Category I structures.

Maintain Containment

Notes:

Maintain Spent Fuel Pool Cooling	
Determine Baseline coping capability with installed coping⁴ modifications not including FLEX modifications, utilizing methods described in Table 3-2 of NEI 12-06:	
<ul style="list-style-type: none"> • Makeup with Portable Injection Source 	
PWR Installed Equipment Phase 1:	
<p><i>Provide a general description of the coping strategies using installed equipment including modifications that are proposed to maintain spent fuel pool cooling. Identify methods (makeup via portable injection source) and strategy(ies) utilized to achieve this coping time.</i></p> <p>A modification will install two separate wide-range level instruments in accordance with NEI 12-02 (Reference 19). (OPEN ITEM 3)</p> <p>During normal plant operation, the SFP will not reach the boiling point after an ELAP/LUHS event for at least 17 hours based on best estimate analysis (Reference 17). However, UFSAR Table 9-6 indicates that based on a normal operating design basis heat load of 20.8 MBTU/hr and an initial pool temperature of 140°F, the pool could begin boiling as early as 9.4 hours. UFSAR Table 9-6 also indicates that during a refueling outage, the SFP could begin boiling as early as 4.6 hours based on a design basis heat load of 42.2 MBTU/hr. Adequate SFP inventory exists to provide personnel shielding well beyond the time of boiling. Therefore, no coping strategies are required for Phase 1. However, in non-tornado events where the portion of the RWST above the missile shield cannot be damaged, the RWST can be aligned to the SFP to maintain inventory by gravity feed.</p>	
Details:	
Provide a brief description of Procedures / Strategies / Guidelines	<p><i>Confirm that procedure/guidance exists or will be developed to support implementation</i></p> <p>Site-specific procedures and/or FSGs will be developed using industry guidance to address the criteria in NEI 12-06, Section 11.4 (Reference 2). (OPEN ITEM 9)</p>
Identify modifications	<p><i>List modifications</i></p> <p>See Attachment 4A.</p>
Key SFP Parameter	<p><i>List instrumentation credited or recovered for this coping evaluation.</i></p> <p>SFP level instrumentation per NRC Order EA-12-051 (Reference 16)</p>
Notes:	

⁴ Coping modifications consist of modifications installed to increase initial coping time, i.e. generators to preserve vital instruments or increase operating time on battery powered equipment.

Maintain Spent Fuel Pool Cooling

PWR Portable Equipment Phase 2:

Provide a general description of the coping strategies using on-site portable equipment including modifications that are proposed to maintain spent fuel pool cooling. Identify methods (makeup via portable injection source) and strategy(ies) utilized to achieve this coping time.

Primary Connection

Makeup water will be provided from the UHS to the spent fuel pool using a high capacity diesel operated pump. Water will be sprayed into the pool above the operating deck using an existing Section B.5.b mitigating strategy spray nozzle (Reference 29).

Once SFP boiling begins, a steam release pathway must be established to minimize potential infiltration of steam into areas of the Auxiliary Building. The steam release pathway will be through the Fuel Building roll-up truck bay door.

Alternate Connection

Makeup water will be provided from the UHS to the SFP using a high-capacity diesel-operated pump. Water will be directed through a connection to the SFP cooling system located outside the Fuel Building and inside the Auxiliary Building. The connection is being added by a modification. (OPEN ITEM 5)

The MNS SFP has been analyzed for various boron dilution events to remain subcritical within established soluble boron concentration limits (as specified in References 35 and 36). Further evaluation will be performed to ensure predicted makeup water dilution rates in the Spent Fuel Pools for the coping strategies described herein are bounded. (OPEN ITEM 44)

Details:

Provide a brief description of Procedures / Strategies / Guidelines	<i>Confirm that procedure/guidance exists or will be developed to support implementation</i> Site-specific procedures and/or FSGs will be developed using industry guidance to address the criteria in NEI 12-06, Section 11.4 (Reference 2). (OPEN ITEM 9)
Identify modifications	<i>List modifications</i> See Attachment 4A.
Key SFP Parameter	<i>List instrumentation credited or recovered for this coping evaluation.</i> Same as Phase 1

Maintain Spent Fuel Pool Cooling	
Storage / Protection of Equipment: Describe storage / protection plan or schedule to determine storage requirements	
Seismic	<p><i>List how equipment is protected or schedule to protect</i></p> <p>Portable equipment will be stored directly in Category I structures in some cases to reduce the time to deploy the equipment. In most cases though, the equipment will be stored in one of three FLEX storage facilities (N+1 where N is the number of units). The FLEX storage facilities will be designed in accordance with ASCE 7-10 (Reference 14) to sustain a Safe Shutdown Earthquake (SSE). (OPEN ITEM 30)</p>
Flooding	<p><i>List how equipment is protected or schedule to protect</i></p> <p>MNS Seismic Category I structures are not susceptible to external flooding from the Probable Maximum Precipitation (PMP) or Probable Maximum Flood (PMF) events. The limiting site flooding event for MNS is the Probable Maximum Precipitation (PMP) event, which is of limited duration and water level. FLEX storage facilities will be located above any potential site flood level, and/or the effects of localized flooding will be evaluated in the FLEX facility design and equipment deployment. (OPEN ITEM 31)</p>
Severe Storms with High Winds	<p><i>List how equipment is protected or schedule to protect</i></p> <p>The Category I structures are designed to withstand design basis winds and tornados. The FLEX storage facilities will be designed in accordance with ASCE 7-10 (Reference 14), to withstand the maximum anticipated hurricane and tornado winds as outlined in NEI 12-06 (Reference 2). The FLEX buildings will be located in accordance with NEI 12-06 (Reference 2) Section 7.3.1 to prevent damage to more than one of the three facilities due to tornado missiles. (OPEN ITEM 30)</p> <p>Debris removal/remediation equipment and procedures will be provided to support FLEX equipment deployment. (OPEN ITEM 32)</p>
Snow, Ice, and Extreme Cold	<p><i>List how equipment is protected or schedule to protect</i></p> <p>Snow and ice removal/remediation equipment and procedures will be provided to support FLEX equipment deployment. (OPEN ITEM 33)</p> <p>FLEX equipment will be capable of operation under extreme temperatures, and suitably maintained to ensure standby readiness. FLEX storage facilities will be designed to accommodate maximum snow and ice loading. (OPEN ITEM 34)</p> <p>MNS will evaluate the need to provide freeze protection for critical</p>

Maintain Spent Fuel Pool Cooling		
	instrumentation and exposed FLEX connections. (OPEN ITEM 18)	
High Temperatures	<p><i>List how equipment is protected or schedule to protect</i></p> <p>FLEX equipment will be capable of operation under extreme temperatures, and suitably maintained to ensure standby readiness. FLEX storage facilities will be vented to maintain acceptable temperature. (OPEN ITEM 34)</p>	
Deployment Conceptual Design (Attachment 3 contains Conceptual Sketches)		
Strategy	Modifications	Protection of connections
<i>Identify Strategy including how the equipment will be deployed to the point of use.</i>	<i>Identify modifications</i>	<i>Identify how the connection is protected</i>
Add a connection to the SFP cooling system header outside the spent fuel pool building to ensure habitability for operators.	Process Connections (see Attachment 4A)	Connection will be located in the Auxiliary Building, a Category I structure
FLEX Storage Facilities	FLEX Storage Facilities (see Attachment 4A)	N+1 FLEX Storage facilities will be built in accordance with ASCE 7-10 (Reference 14).
Notes:		

Maintain Spent Fuel Pool Cooling

PWR Portable Equipment Phase 3:

Provide a general description of the coping strategies using phase 3 equipment including modifications that are proposed to maintain spent fuel pool cooling. Identify methods (makeup via portable injection source) and strategy(ies) utilized to achieve this coping time.

The Phase 3 strategy is a continuation of the Phase 2 strategy. Phase 3 equipment will be used to backup Phase 2 equipment in use to supply SFP makeup. Depending on extent of damage, Phase 3 equipment will be used to repower emergency buses and restore normal SFP cooling.

The McGuire SFP has been analyzed for various boron dilution events to remain subcritical within established soluble boron concentration limits (as specified in References 35 and 36). Further evaluation will be performed to ensure predicted makeup water dilution rates in the Spent Fuel Pools for the coping strategies described herein are bounded. (OPEN ITEM 44)

Details:

Provide a brief description of Procedures / Strategies / Guidelines	<i>Confirm that procedure/guidance exists or will be developed to support implementation</i> Site-specific procedures and/or FSGs will be developed using industry guidance to address the criteria in NEI 12-06, Section 11.4 (Reference 2). (OPEN ITEM 9)
Identify modifications	<i>List modifications</i> None
Key SFP Parameter	<i>List instrumentation credited or recovered for this coping evaluation</i> Same as Phase 1

**Deployment Conceptual Design
 (Attachment 3 contains Conceptual Sketches)**

Strategy	Modifications	Protection of connections
<i>Identify Strategy including how the equipment will be deployed to the point of use.</i>	<i>Identify modifications</i>	<i>Identify how the connection is protected</i>
Phase 3 equipment is provided by the RRC (not stored onsite). Deployment strategies will be developed. (OPEN ITEM 20)	N/A	Connection points will be located in protected Category I structures.

Maintain Spent Fuel Pool Cooling

Notes:

Safety Functions Support

Determine Baseline coping capability with installed coping⁵ modifications not including FLEX modifications.

PWR Installed Equipment Phase 1

Provide a general description of the coping strategies using installed equipment including station modifications that are proposed to maintain and/or support safety functions. Identify methods and strategy(ies) utilized to achieve coping times.

Essential Instrumentation and Vital I&C

A vital battery load reduction scheme has been developed that includes only those components and instrumentation that are essential to supporting the FLEX strategy. Instrumentation will be maintained consistent with PWROG recommendations (Reference 13).

Non-critical loads must be disconnected within three hours to preserve vital batteries. This strategy will ensure battery capability is extended to ensure batteries can be recharged in Phase 2, prior to loss of DC power (Reference 23). (OPEN ITEM 9)

The instrumentation and components that are required or desired to support the strategy are as follows:

- SG narrow-range levels
- SG steam pressures
- Auxiliary Feedwater flow to SGs
- TDAFW solenoid operated valves (SOVs)
- Wide-range (Gammametrics) neutron source range flux monitoring
- Inadequate core cooling monitor (ICCM) including
 - RVLIS
 - Incore T/Cs
 - Wide-range NC system pressure
 - Subcooling margin
 - NC loop T_{HOT}
- Pressurizer level
- Source Range Start-up Rate (SUR) monitor
- RWST level
- Containment wide-range pressure
- Containment sump wide-range level
- Containment high-range area radiation monitor
- Pressurizer PORV position indication
- 4160V Essential Auxiliary Power System Switchgear ETA/ETB breaker control and

⁵ Coping modifications consist of modifications installed to increase initial coping time, i.e. generators to preserve vital instruments or increase operating time on battery powered equipment.

Safety Functions Support

- relay power
- Battery voltage

These instruments will be used in the FSGs in accordance with the PWROG guidance (Reference 13). Setpoint uncertainty analyses will be developed in accordance with PWROG guidance (Reference 13). (OPEN ITEM 46)

HVAC

An analysis (Reference 22) was completed to demonstrate that adequate control room cooling would be available if action was taken to open various doors at around 2 hours after the event occurs. This action will be incorporated into procedures (OPEN ITEM 41).

Lighting

Hard hat LED lights have been procured to ensure operators can safely move through the plant during an ELAP. Diverse storage locations will be provided for the hard hat lighting. (OPEN ITEM 11)

Appendix R emergency battery-backed lighting is currently available in many areas where manual actions (eg. connecting hoses, power cables, or operating pumps or compressors) are required. The lighting is nominally rated for 8 hour capacity.

Communication

Enhancements to current communications systems and equipment used during an emergency event are being evaluated pursuant to the 10 CFR 50.54(f) letter of March 12, 2012 (Reference 3). The UHF system is relied upon for emergency communication between the control room and the field. The UHF radio communication system was seismically evaluated to assess the system seismic ruggedness (Reference 18). The UHF system cabinet anchorage and antennae mounting were determined to be seismically rugged. The UHF radio system is protected by Category I structures, with the exception of some outdoor antennas. Communication system enhancements are proposed as follows (OPEN ITEM 4):

- Secure the internal cabinet batteries
- Improve the UHF system ruggedness and reliability in the event of a tornado/wind missile
- Upgrade battery capacity from 4 hours to provide sufficient time for establishing a portable power supply to the system in Phase 2
- Provide additional Technical Support Center (TSC) antennae for portable satellite phones

Staffing

An ERO staffing analysis will be performed in accordance with NTTF Recommendation 9.3 and NEI 12-01, *Guideline for Assessing Beyond Design Basis Accident Response Staffing and Communications* (Reference 8), which will include ensuring adequate on-shift and augmented

Safety Functions Support	
staff are available to support, install, and operate FLEX mitigation strategy equipment. (OPEN ITEM 12)	
Details:	
Provide a brief description of Procedures / Strategies / Guidelines	<p><i>Confirm that procedure/guidance exists or will be developed to support implementation.</i></p> <p>Site-specific procedures and/or FSGs will be developed using industry guidance to address the criteria in NEI 12-06, Section 11.4 (Reference 2). (OPEN ITEM 9)</p>
Identify modifications	<p><i>List modifications and describe how they support coping time.</i></p> <p>See Attachment 4A.</p>
Key Parameters	<p><i>List instrumentation credited for this coping evaluation phase.</i></p> <p>Battery voltage read from the analog output of the battery charger</p>
Notes:	

Safety Functions Support

PWR Portable Equipment Phase 2

Provide a general description of the coping strategies using on-site portable equipment including station modifications that are proposed to maintain and/or support safety functions. Identify methods and strategy(ies) utilized to achieve coping times.

Generic Note: Need discussion on how to provide fuel for the DGs.

Essential Instrumentation and Vital I&E

The vital batteries will be recharged within the first 8 to 24 hours using the portable power scheme described below.

The key reactor parameters that must be monitored in Phase 1 are the same that must be monitored in Phase 2. However, the vital batteries will eventually be depleted if not re-charged.

In order to prevent or mitigate this inevitability:

1. Portable power distribution equipment will be used to re-power the vital batteries (OPEN ITEM 40), or
2. An alternate strategy to deploy portable generators and cables will be developed to directly reestablish power to the power supplies in the 7300 cabinets thereby re-powering the instrumentation loops (OPEN ITEM 40), or
3. An alternate strategy to utilize handheld instruments will be developed to tap into the instrument loops locally to monitor essential parameters (OPEN ITEM 40)

Heating, Ventilation and Air-Conditioning (HVAC)

HVAC analysis will be performed to demonstrate that the ambient room temperatures and hydrogen concentrations (vital battery rooms only) would remain acceptable in critical areas with no additional action. (OPEN ITEM 15)

Communication

Portable generators will be used to re-charge the UHF radio communication system batteries before depletion. Batteries will be replaced in hand held UHF radios as needed.

Portable Power Distribution

Portable power procedures will be developed in accordance with PWROG generic FLEX Support Guidelines (Reference 13). (OPEN ITEM 9) A portable power distribution scheme will be developed consistent with this guidance to recharge required equipment using portable diesel generators, transformers, power panels and cables. Equipment required to be re-powered by NEI 12-06 (Reference 2) include the vital batteries, the Cold Leg Accumulator (CLA) isolation valves, portable RCS reactor makeup pumps, and the hydrogen igniters.

Safety Functions Support

PWR Portable Equipment Phase 2

In accordance with NEI 12-06 (Reference 2), the portable power equipment will be connected using both a primary approach and an alternate approach. The primary approach will use permanently installed motor control center (MCC) buckets with external power connectors to provide power to specific components. Portable MCC buckets are used as an alternate strategy and connection to re-power the associated bus. (OPEN ITEM 6)

A portable battery pack with inverter is also being evaluated for use. The battery pack would be rapidly deployed for use to close the CLA motor-operated valves (MOVs) outside of containment penetration without reliance on the valve's limit or torque switches or the valve's relay circuitry. If successfully developed, this technology could also be used to open and close other MOVs inside containment. (OPEN ITEM 47)

Conceptual design sketches for the portable power distribution scheme are provided in Attachment 3.

Fuel Oil for Portable Equipment

Fuel oil will be provided from the buried emergency diesel generator (EDG) fuel oil tanks using portable fuel oil transfer pumps. The fuel oil will be stored in diesel fuel oil tanker trucks for delivery to portable equipment when required. A fuel oil evaluation will be performed to assess long-term FLEX equipment fuel oil requirements. (OPEN ITEM 42)

Staffing

An ERO staffing analysis will be performed in accordance with NTTF Recommendation 9.3 and NEI 12-01, *Guideline for Assessing Beyond Design Basis Accident Response Staffing and Communications* (Reference 8), which will include ensuring adequate on-shift and augmented staff are available to support, install, and operate FLEX mitigation strategy equipment. (OPEN ITEM 12)

Details:

<p>Provide a brief description of Procedures / Strategies / Guidelines</p>	<p><i>Confirm that procedure/guidance exists or will be developed to support implementation.</i></p> <p>Site-specific procedures and/or FSGs will be developed using industry guidance to address the criteria in NEI 12-06, Section 11.4 (Reference 2). (OPEN ITEM 9)</p>
<p>Identify modifications</p>	<p><i>List modifications and describe how they support coping time.</i></p> <p>See Attachment 4A.</p>

Safety Functions Support	
PWR Portable Equipment Phase 2	
Key Parameters	<p><i>List instrumentation credited for this coping evaluation phase.</i></p> <p>Same as Phase 1</p>
Storage / Protection of Equipment :	
Describe storage / protection plan or schedule to determine storage requirements	
Seismic	<p><i>List how equipment is protected or schedule to protect</i></p> <p>Portable equipment will be stored directly in Category I structures in some cases to reduce the time to deploy the equipment. In most cases though, the equipment will be stored in one of three FLEX storage facilities (N+1 where N is the number of units). The FLEX storage facilities will be designed in accordance with ASCE 7-10 (Reference 14) to sustain a Safe Shutdown Earthquake (SSE). (OPEN ITEM 30)</p>
<p>Flooding</p> <p>Note: if stored below current flood level, then ensure procedures exist to move equipment prior to exceeding flood level.</p>	<p><i>List how equipment is protected or schedule to protect</i></p> <p>MNS Seismic Category I structures are not susceptible to external flooding from the Probable Maximum Precipitation (PMP) or Probable Maximum Flood (PMF) events. The limiting site flooding event for MNS is the Probable Maximum Precipitation (PMP) event, which is of limited duration and water level. FLEX storage facilities will be located above any potential site flood level, and/or the effects of localized flooding will be evaluated in the FLEX facility design and equipment deployment. (OPEN ITEM 31)</p>
Severe Storms with High Winds	<p><i>List how equipment is protected or schedule to protect</i></p> <p>The Category I structures are designed to withstand design basis winds and tornados. The FLEX storage facilities will be designed in accordance with ASCE 7-10 (Reference 14), to withstand the maximum anticipated hurricane and tornado winds as outlined in NEI 12-06 (Reference 2). The FLEX buildings will be located in accordance with NEI 12-06 (Reference 2) Section 7.3.1 to prevent damage to more than one of the three facilities due to tornado missiles. (OPEN ITEM 30)</p> <p>Debris removal/remediation equipment and procedures will be provided to support FLEX equipment deployment. (OPEN ITEM 32)</p>

Safety Functions Support		
PWR Portable Equipment Phase 2		
Snow, Ice, and Extreme Cold	<p><i>List how equipment is protected or schedule to protect</i></p> <p>Snow and ice removal/remediation equipment and procedures will be provided to support FLEX equipment deployment. (OPEN ITEM 33)</p> <p>FLEX equipment will be capable of operation under extreme temperatures, and suitably maintained to ensure standby readiness. FLEX storage facilities will be designed to accommodate maximum snow and ice loading. (OPEN ITEM 34)</p> <p>MNS will evaluate the need to provide freeze protection for critical instrumentation and exposed FLEX connections. (OPEN ITEM 18)</p>	
High Temperatures	<p><i>List how equipment is protected or schedule to protect</i></p> <p>FLEX equipment will be capable of operation under extreme temperatures, and suitably maintained to ensure standby readiness. FLEX storage facilities will be vented to maintain acceptable temperature. (OPEN ITEM 34)</p>	
Deployment Conceptual Design (Attachment 3 contains Conceptual Sketches)		
Strategy	Modifications	Protection of connections
<i>Identify Strategy including how the equipment will be deployed to the point of use.</i>	<i>Identify modifications</i>	<i>Identify how the connection is protected</i>
Electrical Connections	Permanent Connections for Portable Electrical Equipment (see Attachment 4A)	Primary and alternate connection points will be located in protected Category I structures.
FLEX Storage Facilities	FLEX Storage Facilities (see Attachment 4A)	N+1 FLEX Storage facilities will be built in accordance with ASCE 7-10 (Reference 14).
Notes:		

Safety Functions Support		
PWR Portable Equipment Phase 3		
<p><i>Provide a general description of the coping strategies using phase 3 equipment including modifications that are proposed to maintain and/or support safety functions. Identify methods and strategy(ies) utilized to achieve coping times.</i></p> <p>Portable RRC equipment that will be required to provide long term recovery and stabilization of the plant is listed in the "PWR Portable Equipment Phase 3" table which follows.</p>		
Details:		
Provide a brief description of Procedures / Strategies / Guidelines	<p><i>Confirm that procedure/guidance exists or will be developed to support implementation.</i></p> <p>Site-specific procedures and/or FSGs will be developed using industry guidance to address the criteria in NEI 12-06, Section 11.4 (Reference 2). (OPEN ITEM 9)</p>	
Identify modifications	<p><i>List modifications and describe how they support coping time.</i></p> <p>None</p>	
Key Parameters	<p><i>List instrumentation credited for this coping evaluation phase.</i></p> <p>Same as Phase 1</p>	
Deployment Conceptual Design (Attachment 3 contains Conceptual Sketches)		
Strategy	Modifications	Protection of connections
<i>Identify Strategy including how the equipment will be deployed to the point of use.</i>	<i>Identify modifications</i>	<i>Identify how the connection is protected</i>
Phase 3 equipment is provided by the RRC (not stored onsite). Deployment strategies will be developed. (OPEN ITEM 20)	N/A	N/A
Notes:		

PWR Portable Equipment Phase 2							
<i>Use and (potential / flexibility) diverse uses</i>						<i>Performance Criteria</i>	<i>Maintenance</i>
<i>List portable equipment</i>	Core	Containment	SFP	Instrumentation	Accessibility		Maintenance / PM requirements
(5) Diesel pumps	X	X	X			(3) ≥1500 gpm @ 150 psig (at least one of which can also provide 300 gpm @ 400 psig) (2) 300 gpm @ 400 psig	Maintenance will be performed in accordance with the requirements of NEI 12-06, Section 11.5.
Fire hose with suitable connections	X	X	X			5 inch hose @ 300 psig working pressure 3 inch hose @ 400 psig working pressure	Maintenance will be performed in accordance with the requirements of NEI 12-06, Section 11.5.
High Pressure Hose and Pump Suction hose	X					~1 inch high pressure hose ~4 inch suction piping	Maintenance will be performed in accordance with the requirements of NEI 12-06, Section 11.5.
(3) High pressure electric positive displacement pumps	X					~40 gpm @ ≥1600 psig	Maintenance will be performed in accordance with the requirements of NEI 12-06, Section 11.5.

PWR Portable Equipment Phase 2							
<i>Use and (potential / flexibility) diverse uses</i>						<i>Performance Criteria</i>	<i>Maintenance</i>
<i>List portable equipment</i>	Core	Containment	SFP	Instrumentation	Accessibility		Maintenance / PM requirements
(3) Low pressure higher capacity electric centrifugal pumps	X					~300 gpm ≤400 psig	Maintenance will be performed in accordance with the requirements of NEI 12-06, Section 11.5.
(3) 12 VDC Fuel Transfer Pumps	X	X	X			~20 gpm @ 1 atm	Maintenance will be performed in accordance with the requirements of NEI 12-06, Section 11.5.
(2) Fuel Oil Storage Tanker Trucks	X	X	X				Maintenance will be performed in accordance with the requirements of NEI 12-06, Section 11.5.
(3) Diesel Air Compressors	X					~375 CFM @ ≥100 psig	Maintenance will be performed in accordance with the requirements of NEI 12-06, Section 11.5.
Air Compressor Hose	X						Maintenance will be performed in accordance with the requirements of NEI 12-06, Section 11.5.

PWR Portable Equipment Phase 2							
<i>Use and (potential / flexibility) diverse uses</i>						<i>Performance Criteria</i>	<i>Maintenance</i>
<i>List portable equipment</i>	Core	Containment	SFP	Instrumentation	Accessibility		Maintenance / PM requirements
(2) DGs	X	X		X		50 KVA 600 VAC	Maintenance will be performed in accordance with the requirements of NEI 12-06, Section 11.5.
(2) DGs	X	X		X		500 KVA 600 VAC	Maintenance will be performed in accordance with the requirements of NEI 12-06, Section 11.5.
(9) Power Distribution Panels and associated cabling	X	X		X		600 AMP 600 VAC	Maintenance will be performed in accordance with the requirements of NEI 12-06, Section 11.5.
(18) Portable Power Transformers	X	X		X		600/480/240/120 VAC 15KVA	Maintenance will be performed in accordance with the requirements of NEI 12-06, Section 11.5.
(36) Local Distribution Panels	X	X		X		12.5 KVA 120 VAC	Maintenance will be performed in accordance with the requirements of NEI 12-06, Section 11.5.

PWR Portable Equipment Phase 2							
<i>Use and (potential / flexibility) diverse uses</i>						<i>Performance Criteria</i>	<i>Maintenance</i>
<i>List portable equipment</i>	Core	Containment	SFP	Instrumentation	Accessibility		Maintenance / PM requirements
(2) Portable Battery Charger	X	X		X		200 AMP, 600VAC/125VDC	Maintenance will be performed in accordance with the requirements of NEI 12-06, Section 11.5.
(6) Portable Battery Charger	X	X		X		25 AMP, 600 VAC/125VDC	Maintenance will be performed in accordance with the requirements of NEI 12-06, Section 11.5.
(2) Trailer Mounted Power Transformer	X	X		X		600 KVA 600/480VAC	Maintenance will be performed in accordance with the requirements of NEI 12-06, Section 11.5.
(30) A/C Units	X			X		120 VAC, 11,000 BTU/hr	Maintenance will be performed in accordance with the requirements of NEI 12-06, Section 11.5.
(6) Fans	X			X		15 HP Variable Speed	Maintenance will be performed in accordance with the requirements of NEI 12-06, Section 11.5.

PWR Portable Equipment Phase 2							
<i>Use and (potential / flexibility) diverse uses</i>						<i>Performance Criteria</i>	<i>Maintenance</i>
<i>List portable equipment</i>	Core	Containment	SFP	Instrumentation	Accessibility		Maintenance / PM requirements
(21) Lighting Strings	X	X		X		100 W Equivalent Lamp	Maintenance will be performed in accordance with the requirements of NEI 12-06, Section 11.5.
(15) Transformers	X	X		X		600/120 VAC 2KVA	Maintenance will be performed in accordance with the requirements of NEI 12-06, Section 11.5.
(9) 9x12 Trailers	X	X		X		Used to store and deploy power equipment	Maintenance will be performed in accordance with the requirements of NEI 12-06, Section 11.5.
(2) Dewatering Pumps	X					~300 - 400 gpm. Used to mitigate potential AFW pump room flooding	Maintenance will be performed in accordance with the requirements of NEI 12-06, Section 11.5.

PWR Portable Equipment Phase 2							
<i>Use and (potential / flexibility) diverse uses</i>						<i>Performance Criteria</i>	<i>Maintenance</i>
<i>List portable equipment</i>	Core	Containment	SFP	Instrumentation	Accessibility		Maintenance / PM requirements
(2) Debris removal vehicles outside and adjacent to two of the three FLEX storage facilities					X		
Additional equipment such as chain saws and fuel					X		

PWR Portable Equipment Phase 3							
List portable equipment	Use and (potential / flexibility) diverse uses					Performance Criteria	Notes
	Core	Containment	SFP	Instrumentation	Accessibility		
(4) 2MW diesel generators	X	X	X	X		Parallel operation, 4.16KV	For restoring miscellaneous loads (HVAC systems, etc.)
(2) large mobile air compressors	X	X	X	X		~1200 SCFM @ 100 psig	
(2) low pressure diesel pumps	X					~3500 gpm @300 psig	For restoring UHS inventory
(2) mobile demineralizer units	X	X	X			~500 gpm	For restoring CAST and RWST levels
Batching tank and powdered boric acid	X		X			TBD	For restoring RWST boron concentration
(8) high capacity submersible sump pumps	X					~1500 gpm or greater	
(2) Diesel fuel tanker trucks (with diesel fuel)	X					Diesel fuel tanker trucks to deliver >12000 gallons of diesel fuel per day.(two tankers/day)	

PWR Portable Equipment Phase 3							
List portable equipment	Use and (potential / flexibility) diverse uses					Performance Criteria	Notes
	Core	Containment	SFP	Instrumentation	Accessibility		
Additional diesel pumps, generators, compressors, lighting, and other support equipment to act as spares to existing Phase 2 equipment stored on site	X						
Trained operators and procedures to operate RRC equipment	X	X	X	X		4 copies	Required by station directives
Food and beverage trucks	X	X	X	X		2 shifts for 7 days	

Phase 3 Response Equipment/Commodities	
Item	Notes
Radiation Protection Equipment <ul style="list-style-type: none">• Survey instruments• Dosimetry• Off-site monitoring/sampling	Analysis will be performed to determine radiation protection equipment requirements. (OPEN ITEM 45)
Commodities <ul style="list-style-type: none">• Food• Potable water• Sanitary Facilities	Analysis will be performed to determine commodities requirements. (OPEN ITEM 43)
Fuel Requirements <ul style="list-style-type: none">• Diesel Fuel• Gasoline, two-cycle oil	An evaluation will be performed to determine diesel fuel, gasoline and two-cycle oil requirements. (OPEN ITEM 42)
Heavy Equipment <ul style="list-style-type: none">• Transportation equipment• Debris clearing equipment	Transportation equipment will be provided to move the large skids/trailer-mounted equipment provided from off-site.

**Attachment 1A
 Sequence of Events Timeline**

Action item	Elapsed Time (hrs)	Action	ELAP New Time Constraint Y/N⁶	Remarks / Applicability
1	0	Event Starts	NA	Plant @100% power
2	0	TDAFW Pump Starts on Low-Low SG Level or Loss of Power to 4160V essential bus (blackout)	N	Existing automatic action per UFSAR Section 7.4.1.1 (Reference 1).
3	0	TDAFW Pump automatically aligns to condenser circulating water pipe headers if CAST is damaged by tornado	Y	
4	0.5 - 1	Take manual control of TDAFW FCVs	N	A plant modification will be implemented to ensure adequate manpower and resources. (OPEN ITEM 1) The time is based on Reference 25, Reference 26, and Reference 27.
5	1	Diagnose event	Y	
6	2	Isolate Reactor Coolant Pump seal return	N	See Reference 27.
7	2	Open control room doors	Y	
8	2	De-energize sequencer to prevent automatic cycling of breakers and resulting reduction in vital battery capacity	N	The sequencer must be de-energized at two hours to prevent cycling of breakers and the resulting reduction in vital battery capacity. The time is based on an analysis performed in Reference 23. See also Reference 27.
9	2	Initiate cooldown and depressurization of reactor coolant system	N	See Reference 27.
10	3	Disconnect non-critical loads to preserve vital batteries	Y	

⁶ Instructions: Provide justification if No or NA is selected in the remarks column
 If yes include technical basis discussion as required by NEI 12-06 section 3.2.1.7

Action item	Elapsed Time (hrs)	Action	ELAP New Time Constraint Y/N ⁶	Remarks / Applicability
11	4-15	Connect diesel driven pump to spent fuel pool cooling system above operating deck or in shielded location to refill pool	N	4 hrs selected for boiling subsequent to full core offload. 15 hrs selected for boiling subsequent to 21 day or greater outage. Section B.5.b mitigating strategy procedures already exist to align the diesel driven pumps to the pool in these time frames. See UFSAR Table 9-6 (Reference 1), Reference 17, Reference 27, Reference 28, and Reference 29.
12	4-15	Open Spent Fuel Pool Roll-up doors	Y	
13	6	Begin manual isolation of containment in accordance with prioritization scheme	NA	The overall FLEX strategy is developed to prevent fuel damage. As such, containment isolation will be performed but is not required to mitigate ELAP.
14	8-12	Secure isolable inputs of water into ground water sump beside TDAFW pump	Y	
15	8-12	Aligning pumps from RWST to NI or ND systems to provide NC makeup and boration (powered by portable generators)	Y	
16	8-24	Align pre-staged portable ground water sump pumps and associated diesel generators	Y	
17	8-24	Install portable fans and HVAC (powered by portable generators)	Y	
18	8-24	Isolate the cold leg accumulators (CLAs) (powered by portable generators, or other portable power supply)	Y	
19	8-24	Recharge vital batteries	Y	

Action item	Elapsed Time (hrs)	Action	ELAP New Time Constraint Y/N ⁶	Remarks / Applicability
20	8-48	Re-power hydrogen igniters (powered by portable generators)	NA	The FLEX Strategy maintains core cooling. This action is required by NEI 12-06 (Reference 2) as a contingency.
21	10	Align Diesel Driven Pump to Feed SGs (contingency)	NA	The FLEX strategy is developed to preserve and use the TDAFW pumps. As such, use of the portable pump is only performed as a contingency.
22	10-24	Recharge UHF communication system and satellite phone system (powered by portable generators)	Y	
23	15	Makeup to the CAST with the diesel pump from the UHS	N	CAST is eventually depleted around 16 hours. There are existing Section B.5.b mitigating strategy procedures. See Reference 28 and Reference 30.
24	15	Evaluate manually aligning Nuclear Service Water System (RN) from UHS to the TDAFW pump suction	Y	
25	15	Evaluate manually aligning TDAFW pump to Circulating Water header if not already automatically aligned or RN is not already manually aligned (contingency)	NA	This action can be performed as an alternative to filling the CAST with a portable pump as outlined in action item 23 above.
26	24	Provide portable lighting (beyond head and hand lamps) (powered by portable generators, self powered, or by other portable supply)	Y	
27	24	Begin Phase 3 using RRC playbook	Y	

Action item	Elapsed Time (hrs)	Action	ELAP New Time Constraint Y/N⁶	Remarks / Applicability
28	48	Initiate methods to circulate and cool air in lower containment subcompartments to prevent any adverse impact on critical instrumentation (equipment powered by portable generators)	Y	
29	72	Isolate instrument air to containment, evaluate the need to align portable diesel pumps for containment spray, and evaluate other containment cooling strategies	Y	

**Attachment 2
Milestone Schedule**

NOTE: The dates and sequences provided in this milestone schedule are best estimates based on information available at the time the schedule was developed and may change as designs are finalized and construction proceeds. Therefore, these dates and sequences are not considered to be regulatory commitments.

NOTE: In accordance with Order EA-12-049 (Reference 4), updates to the Overall Integrated Plan will be submitted on a six-month frequency.

Activity No.	Description	Unit 1 Schedule	Unit 2 Schedule
1	Complete Engineering Change Package and Plan Work Orders	03/20/2014	03/20/2015
2	Receive all portable FLEX equipment	05/20/2014	05/20/2015
3	Transmit results of Phase 2 staffing study	05/20/2014	05/20/2015
4	Complete all FSGs, AOPs, EOPs, OPs	06/20/2014	06/20/2015
5	Complete training for all FSGs, AOPs, EOPs, OPs	09/20/2014	09/20/2015
6	Complete all Maintenance Procedures	09/20/2014	09/20/2015
7	Begin Outage (1EOC23 for Unit 1 and 2EOC23 for Unit 2)	Fall 2014	Fall 2015
8	Storage Plan - Reasonable Protection Facilities Complete	Fall 2014	Fall 2014
9	Regional Response Center in place	10/19/2014	10/11/2015

Attachment 3
Conceptual Sketches for Portable Equipment

Drawing Description	Sheet
FLEX Air Compressor Process Connections for TDAFWP FCV and SG PORV Assured Air	1
FLEX Air Compressor Hose Route	2
Primary and Alternate AC Connection Points Train A Unit 1(2)	3
Primary and Alternate AC Connection Points Train B Unit 1(2)	4
Power Distribution Cable Routes	5 - 10
Power Distribution Panel (PDP) 1	11
Power Distribution Panel 2	12
Portable Pump Feed to SG	13
Portable Pump Alternate Feed to SG	14
Portable Pump Feed to Spent Fuel Pools (KF)	15
Portable Pump Feed For Containment Spray (NS)	16

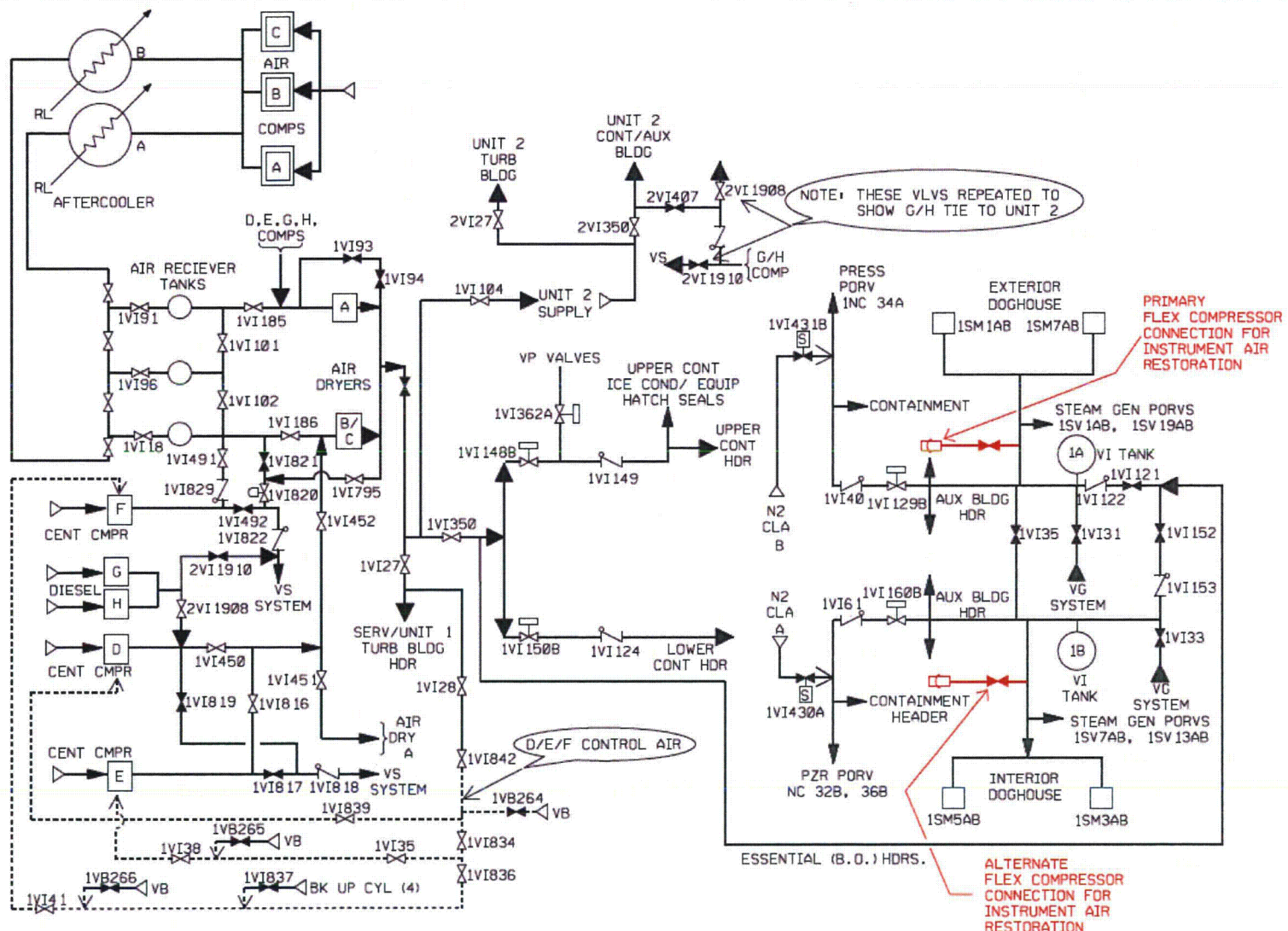

NOTE: THESE VLVS REPEATED TO SHOW G/H TIE TO UNIT 2

PRIMARY FLEX COMPRESSOR CONNECTION FOR INSTRUMENT AIR RESTORATION

ALTERNATE FLEX COMPRESSOR CONNECTION FOR INSTRUMENT AIR RESTORATION

INSTRUMENT AIR SYSTEM
 FLEX COMPRESSOR PROCESS CONNECTIONS
 (UNIT 1 SHOWN, UNIT 2 SIMILAR)

FLEX INSTRUMENT AIR COMPRESSOR
LOCATION AND HOSE ROUTES
(UNIT 1 SHOWN, UNIT 2 SIMILAR)

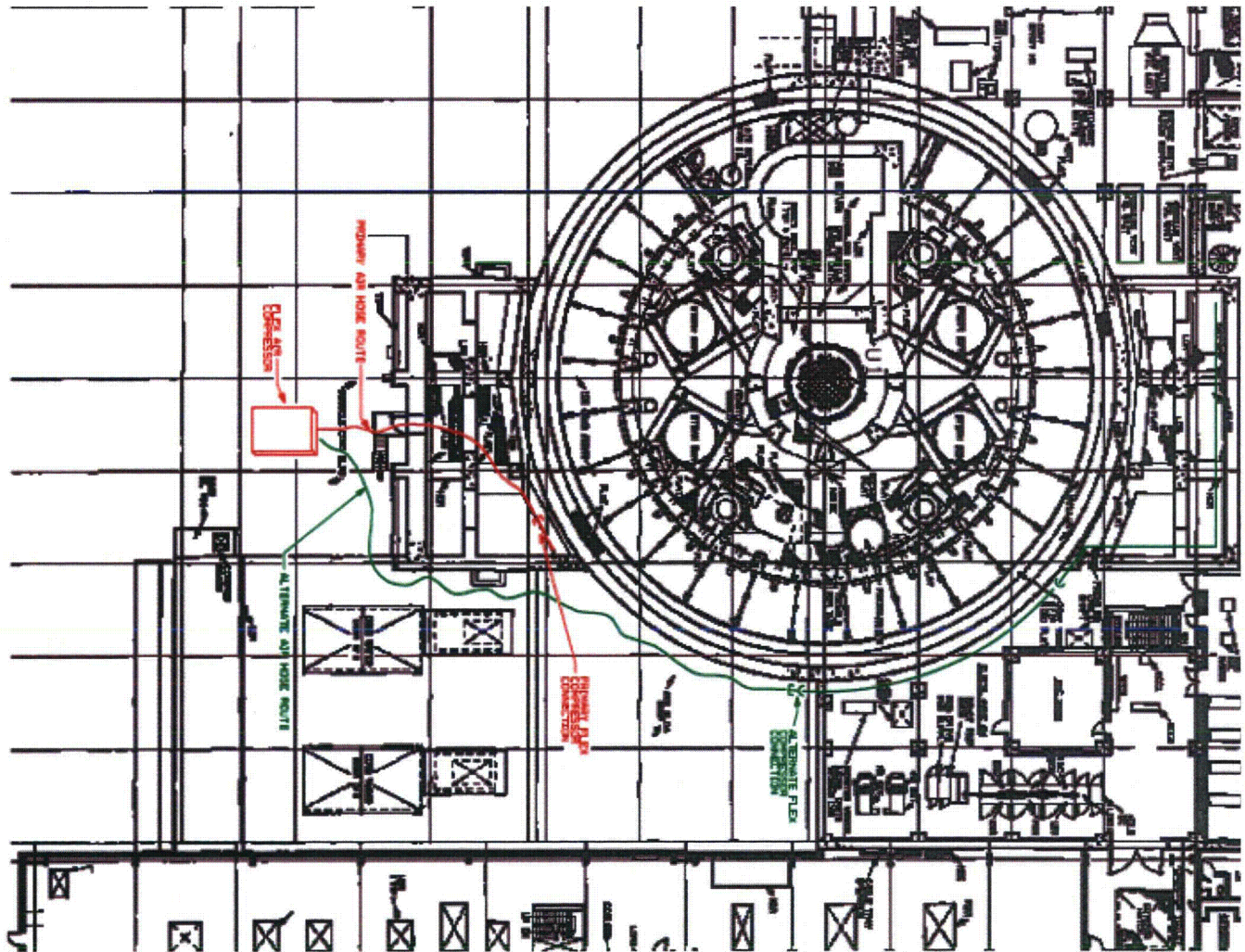

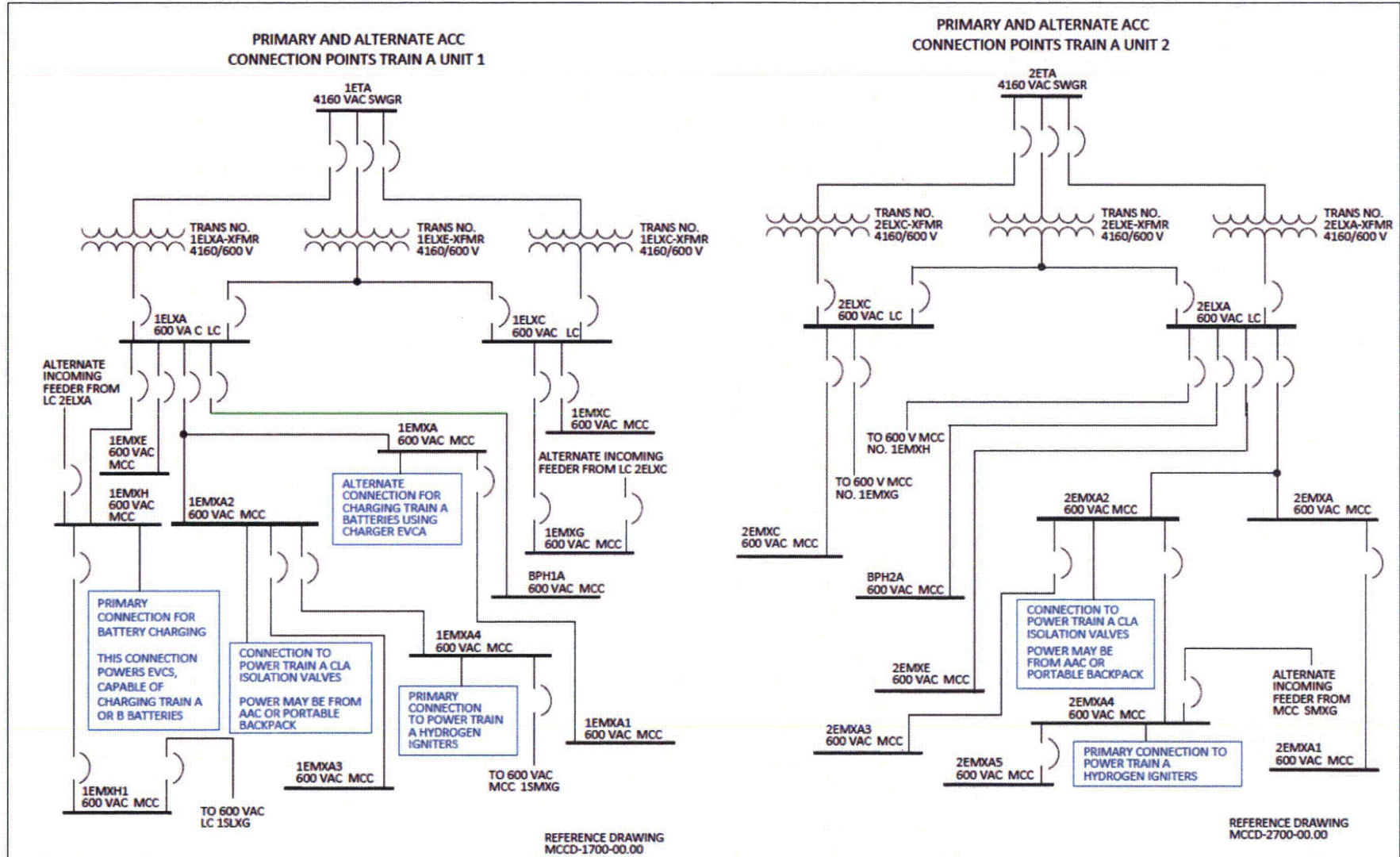

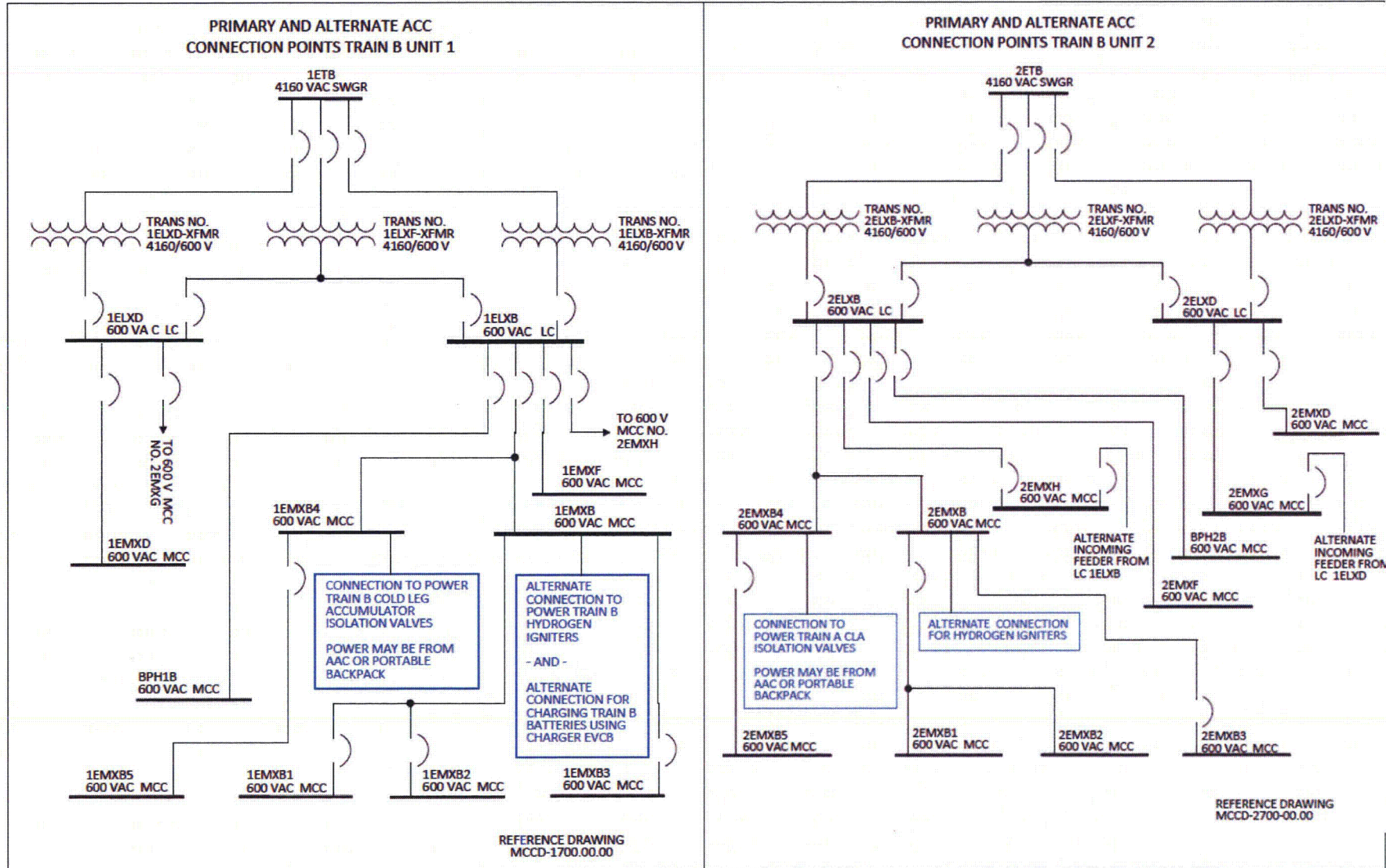

ALTERNATE AC POWER DISTRIBUTION SYSTEM
 GENERAL ARRANGEMENT DIAGRAM
 AUXILIARY BUILDING ELEVATION 760'-0"

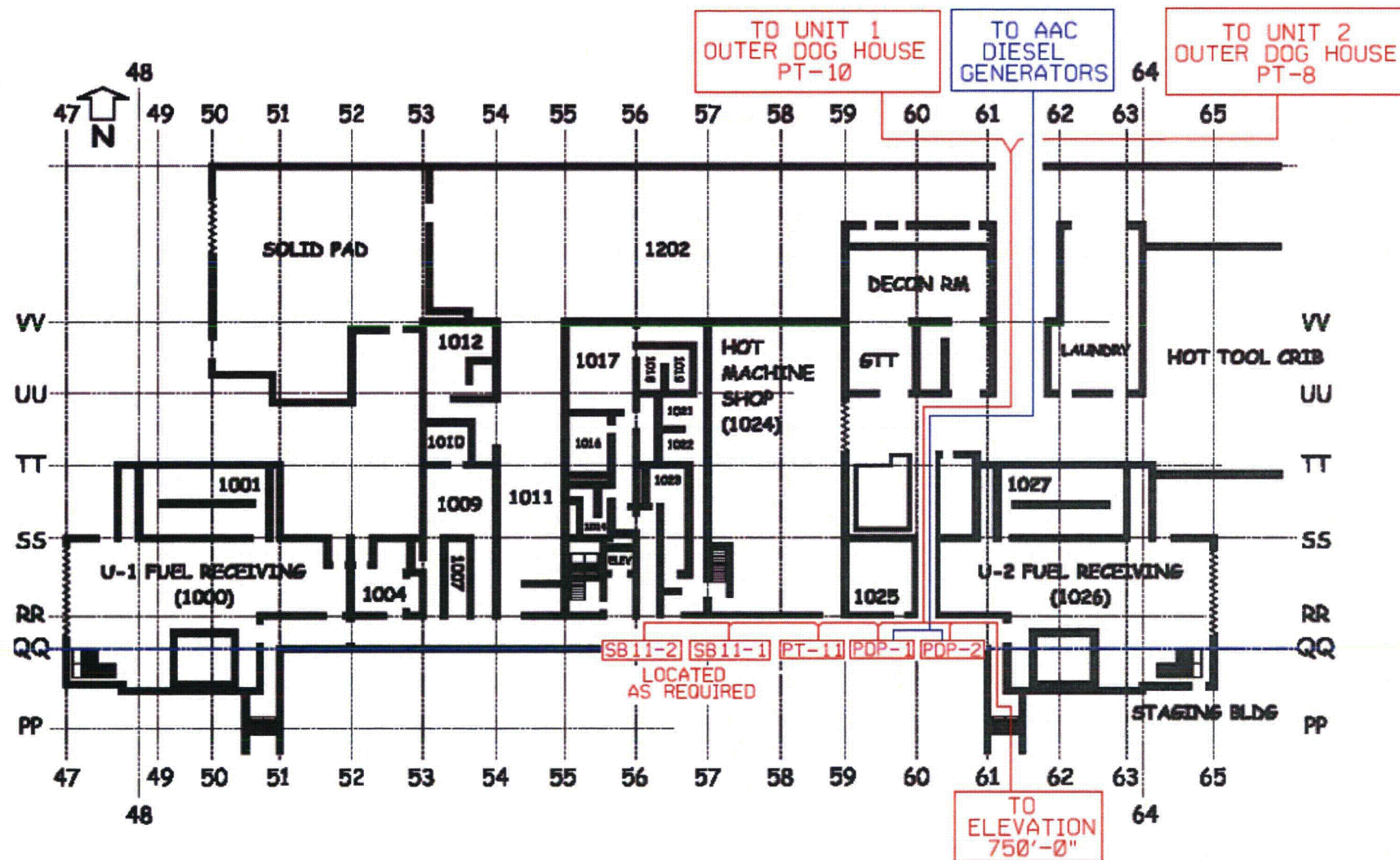

ALTERNATE AC POWER DISTRIBUTION SYSTEM
 GENERAL ARRANGEMENT DIAGRAM
 AUXILIARY BUILDING ELEVATION 750'-0"

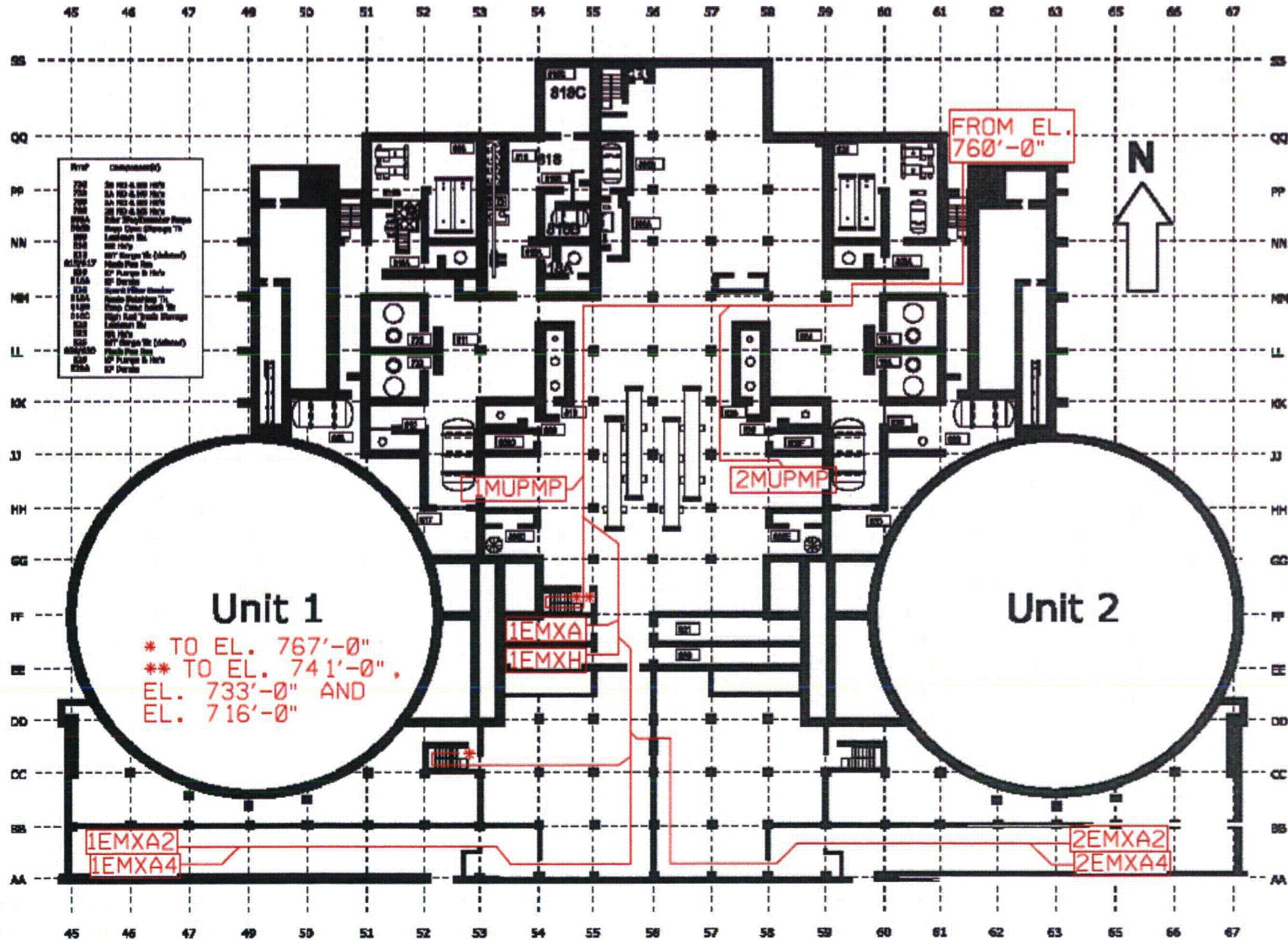

ALTERNATE AC POWER DISTRIBUTION SYSTEM
 GENERAL ARRANGEMENT DIAGRAM
 AUXILIARY BUILDING ELEVATION 733'-0"

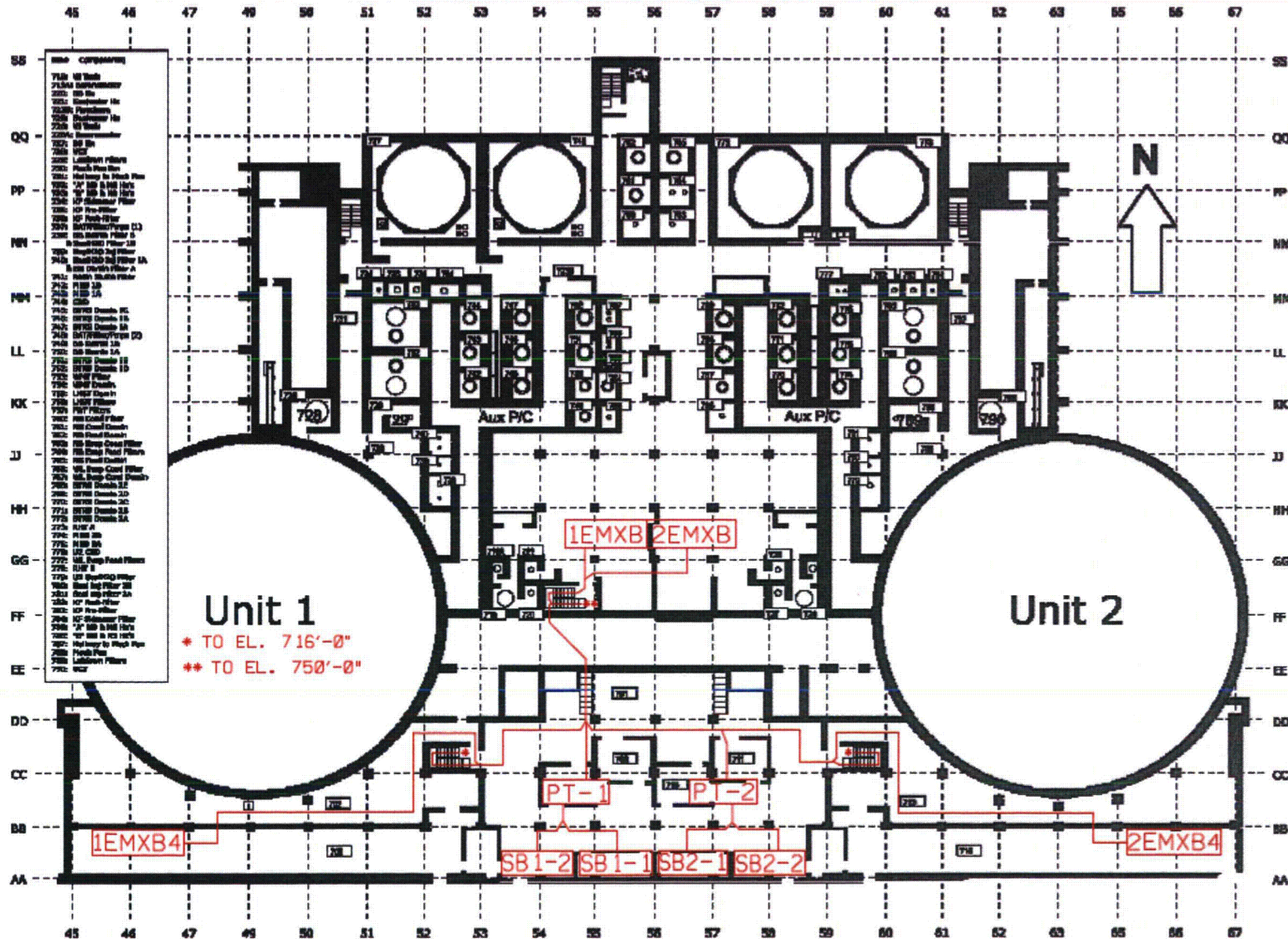

ALTERNATE AC POWER DISTRIBUTION SYSTEM
 GENERAL ARRANGEMENT DIAGRAM
 AUXILIARY BUILDING ELEVATION 7'16"-0"

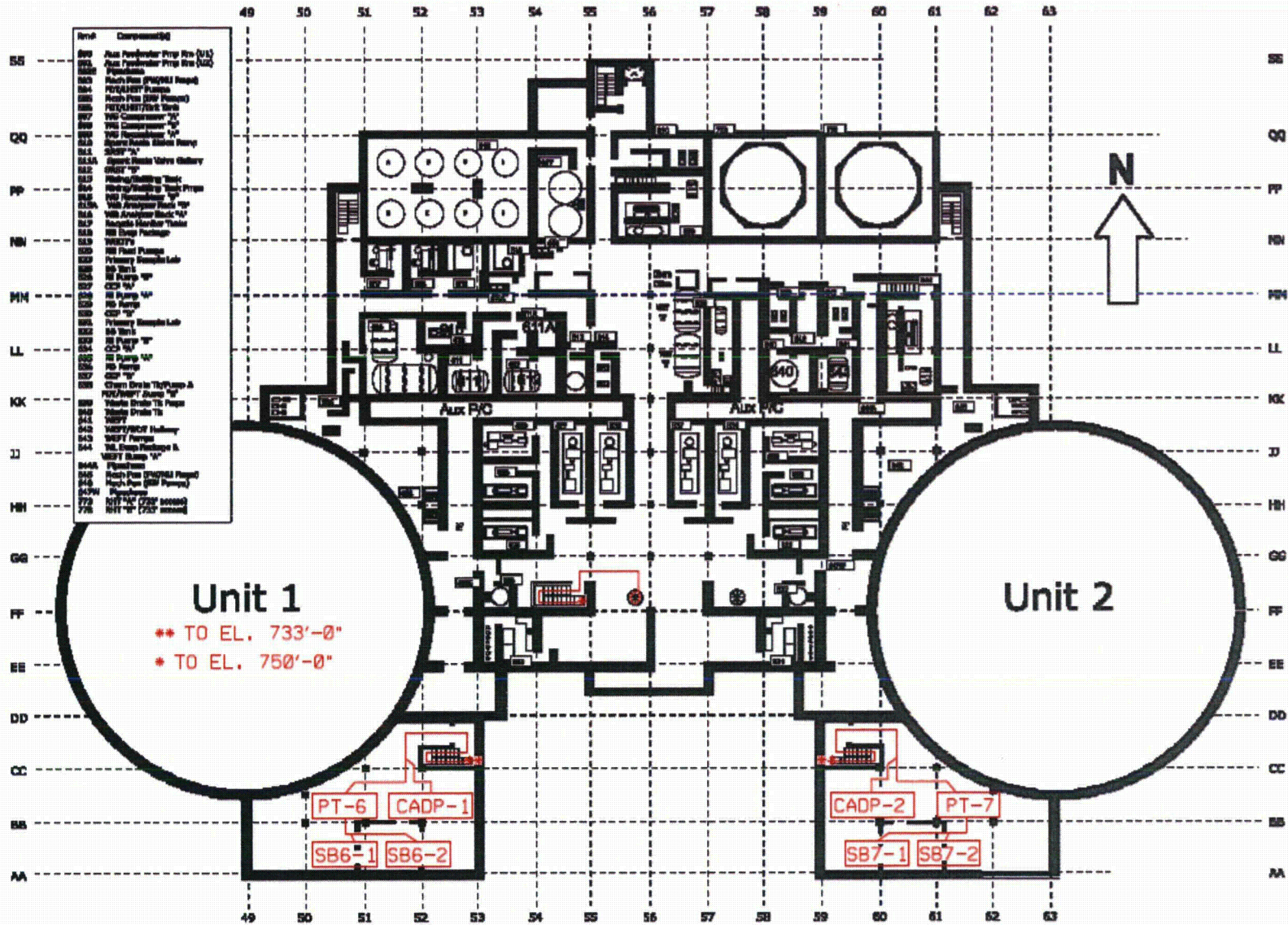

ALTERNATE AC POWER DISTRIBUTION SYSTEM
 GENERAL ARRANGEMENT DIAGRAM
 AUXILIARY BUILDING ELEVATION 695'-0"

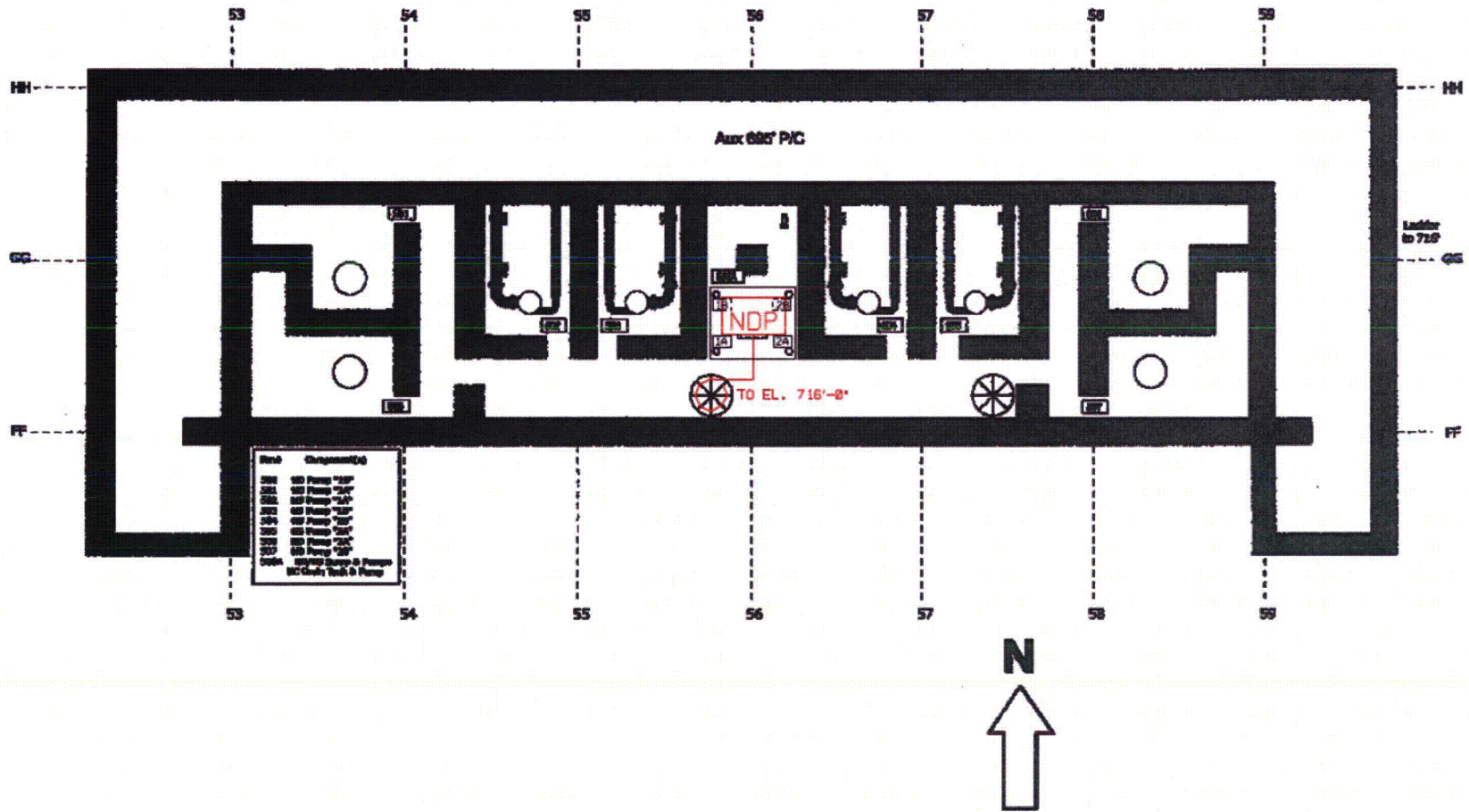

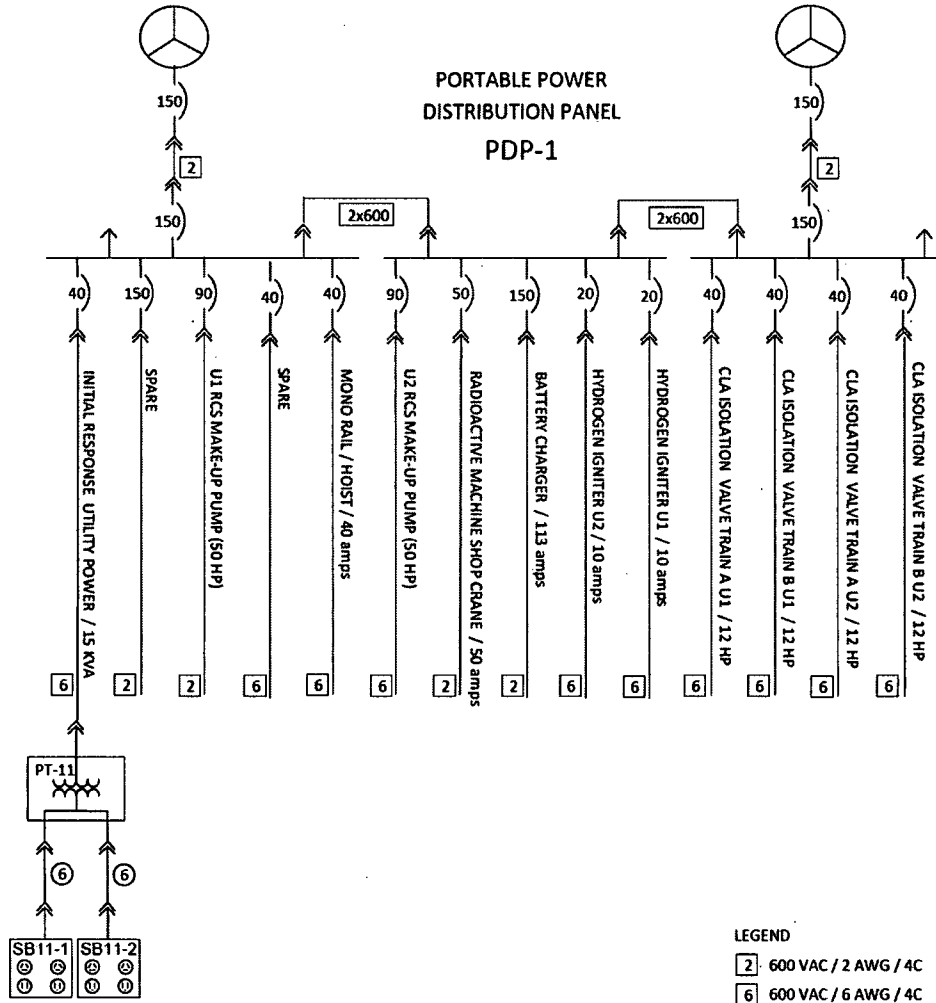

- LEGEND
- 2 600 VAC / 2 AWG / 4C
 - 6 600 VAC / 6 AWG / 4C
 - 6 240 VAC / 6 AWG / 4C
 - 2x600 600 VAC / 2 x 600 MCM
 - PDP-XX POWER DISTRIBUTION PANEL
 - PT-XX PORTABLE POWER TRANSFORMER
 - SBXX-XX LOCAL DISTRIBUTION PANEL (SPIDER BOX)

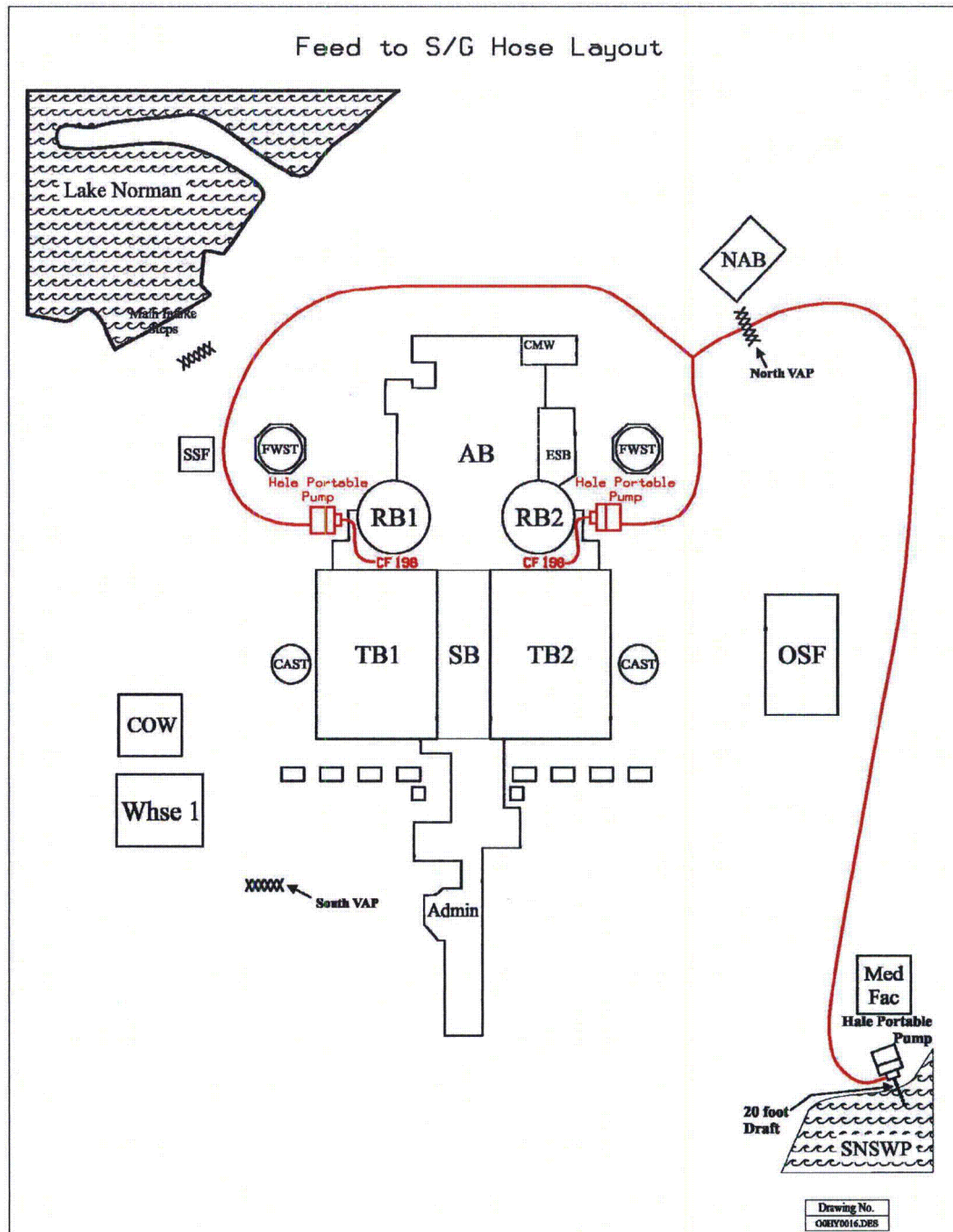

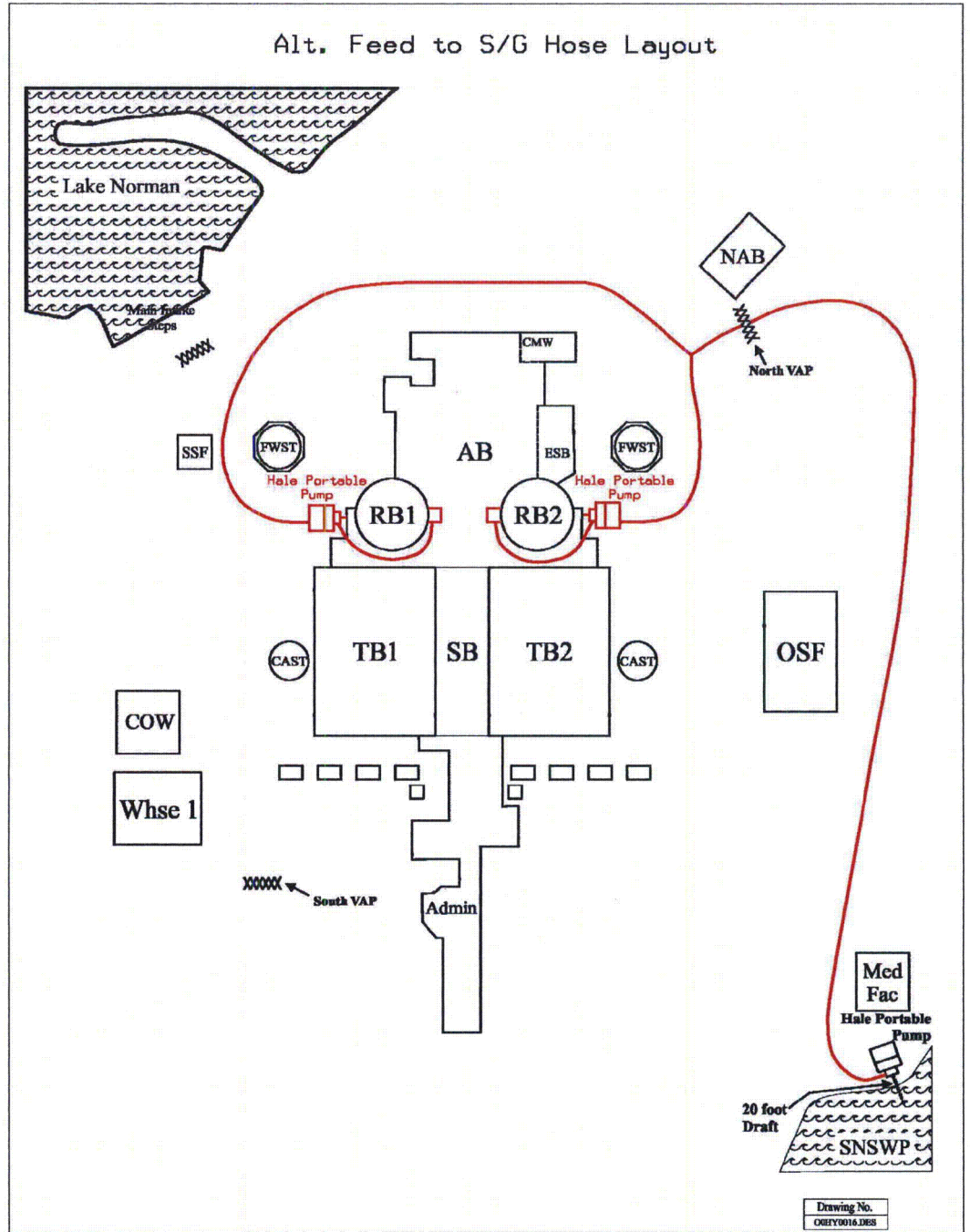

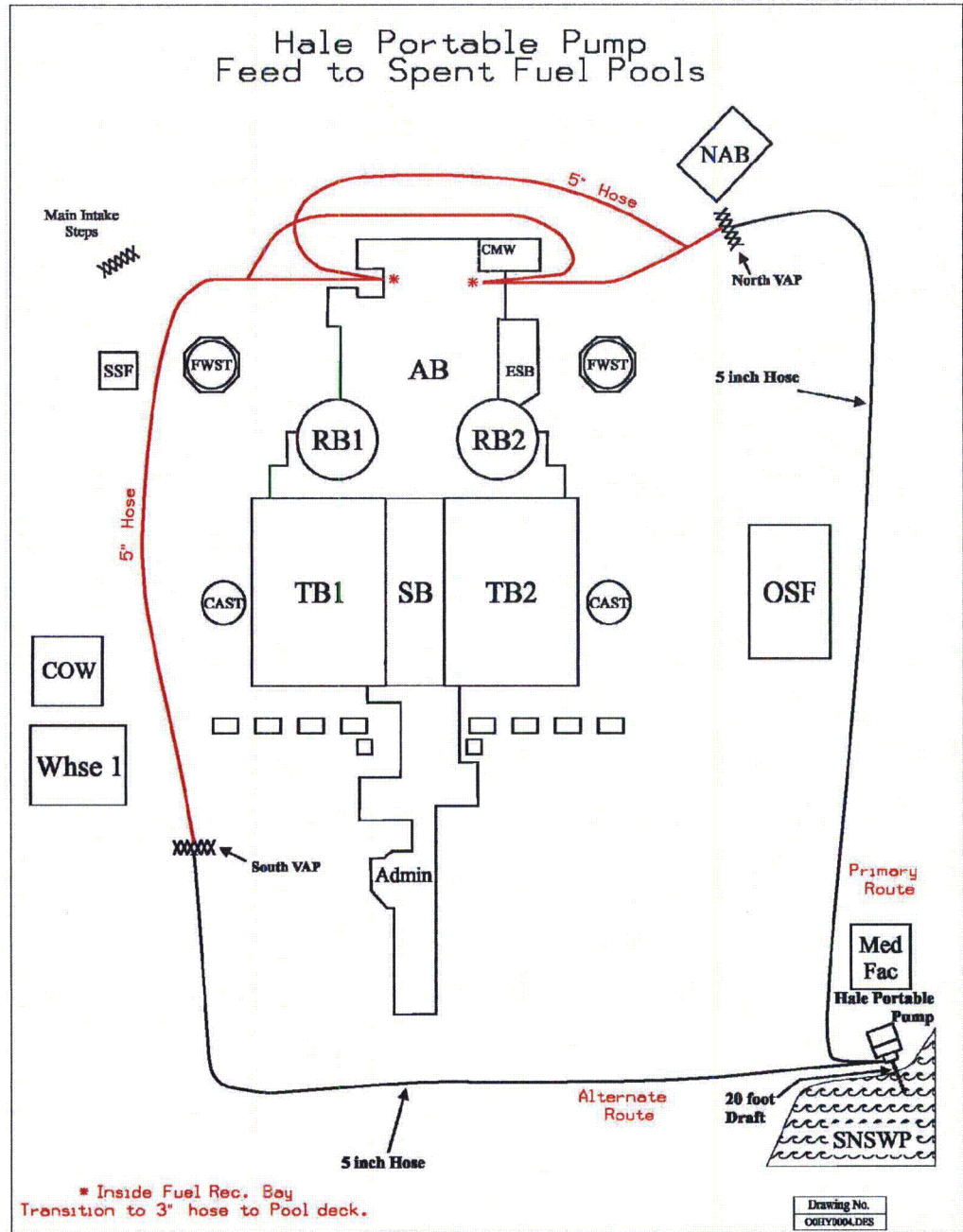

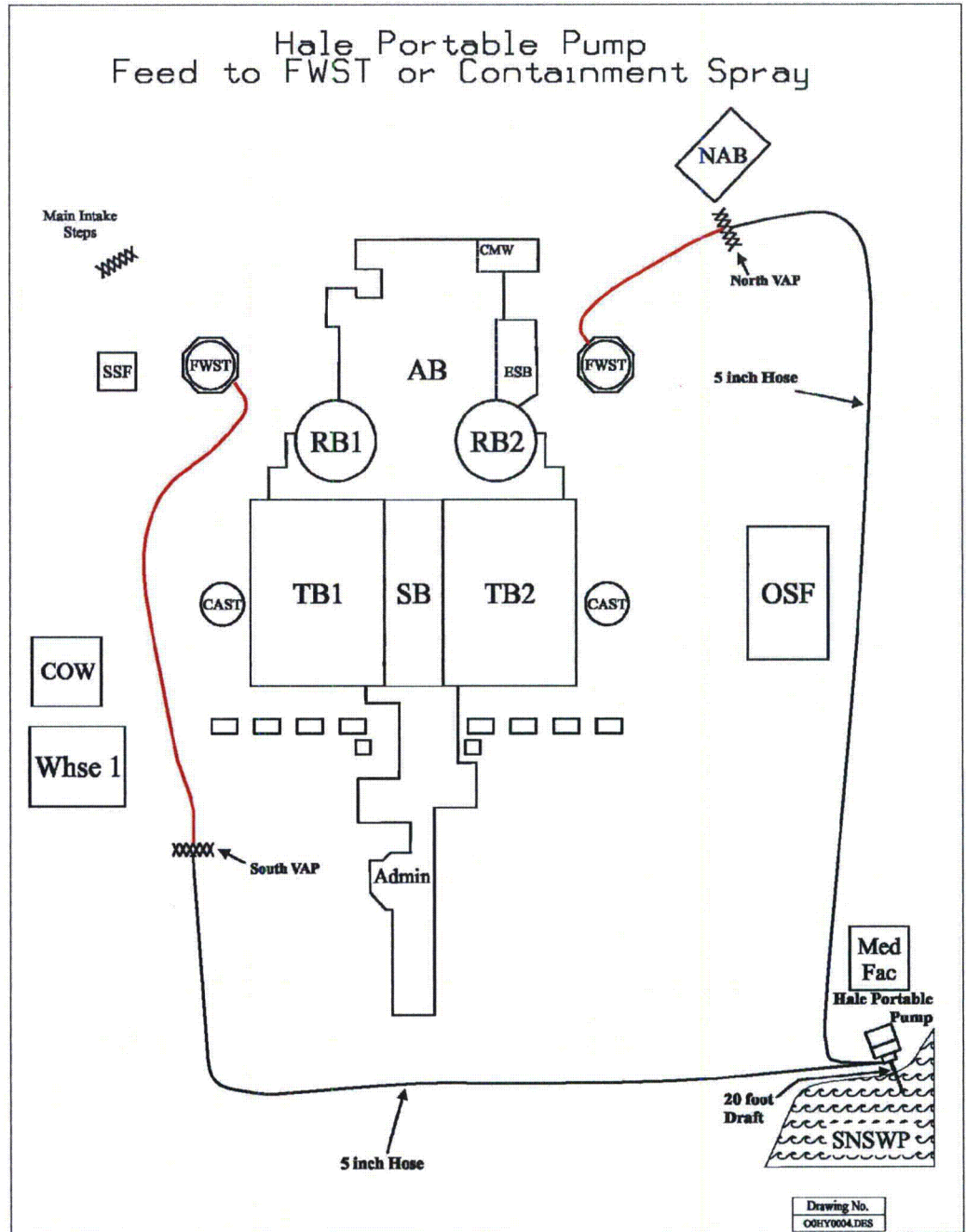

**Attachment 4A
 Engineering Changes**

Item No.	Description	Mitigation Function	Phase(s)
1	<p>(OPEN ITEM 1)</p> <p><u>Assured Air to the TDAFWP FCVs and SG PORVs</u></p> <p>Provides an assured air supply to both the TDAFW FCVs and the SG PORVs to promote better command and control from the control room and to reduce the number of operators needed to control secondary cooling. Also provides primary and alternate connection points for portable compressors.</p>	Core Cooling and Heat Removal	1, 2 and 3
2	<p>(OPEN ITEM 2)</p> <p><u>Assured Water Supply to the TDAFWPs</u></p> <p>Automatically aligns the underground condenser circulating water header to the TDAFWP in the event the Auxiliary Feedwater Storage Tank (CAST) is lost.</p> <p>Includes a Technical Specification change to raise the Nuclear Service Water (RN) to Auxiliary Feedwater low pressure signal that automatically aligns the AFW pumps to RN subsequent to a loss of the CAST. The setpoint change is needed to ensure the RN source is the preferred source and to prevent air ingress under certain scenarios.</p>	Core Cooling and Heat Removal	1, 2

Item No.	Description	Mitigation Function	Phase(s)
3	<p>(OPEN ITEM 3)</p> <p><u>SFP Wide-Range Level Instrumentation</u></p> <p>Installs two new Wide-Range SFP level instruments, which are electrically independent, battery backed, and spatially separated per NEI 12-02 (Reference 19).</p>	SFP Cooling	1, 2, 3
4	<p>(OPEN ITEM 4)</p> <p><u>UHF Communication System Upgrades</u></p> <p>Extends battery capacity for system through Phase 1 to allow sufficient time to re-charge batteries in Phase 2. Provide additional TSC satellite antennae. The modification scope will also improve the seismic ruggedness of the system and reliability in the event of tornado/wind missile.</p>	All	1, 2
5	<p>(OPEN ITEM 5)</p> <p><u>Process Connections</u></p> <p>Provides redundant process connections to provide steam generator (SG) makeup, reactor makeup and negative reactivity addition, spent fuel pool (SFP) cooling, and containment spray.</p>	Core Cooling and Heat Removal Inventory Control Containment Integrity SFP Cooling	2,3
6	<p>(OPEN ITEM 6)</p> <p><u>Permanent Connections for Portable Electrical Equipment</u></p> <p>NEI 12-06 requires that a primary and alternate method be provided to supply power to the vital batteries, the hydrogen igniters, the portable RCS</p>	Core Cooling and Heat Removal Containment Integrity Support Systems	2, 3

Item No.	Description	Mitigation Function	Phase(s)
	<p>reactor makeup pumps, and the cold leg accumulator MOVs. Permanently installed MCC buckets will be provided to provide the primary method for re-powering these components. The buckets will contain external power connections. Portable MCC buckets are used as an alternate strategy and connection to re-power the associated bus. The alternate strategy will provide defense-in-depth for the primary strategy.</p>		
7	<p>(OPEN ITEM 7)</p> <p><u>FLEX Storage Facilities</u></p> <p>Three FLEX storage facilities will be provided that are designed to ASCE 7-10 to withstand a Safe Shutdown Earthquake (SSE) and the maximum expected tornado and hurricane winds as outlined in NEI 12-06. The storage facilities will be located so that the most probable tornado paths will not affect the plant and more than one of facilities concurrently.</p>	All	2
8	<p>(OPEN ITEM 8)</p> <p><u>Submersible Ground Water Sump Pump</u></p> <p>Submersible sump pumps with permanent cable connections between the pumps and FLEX generator connection points at approximately grade level will be provided. All components will be located in a seismically robust facility.</p>	Core Cooling and Heat Removal	2, 3
9	<p>(OPEN ITEM 9)</p> <p><u>FLEX Strategy Implementation</u></p> <p>This engineering change will drive out the analysis necessary to:</p> <ul style="list-style-type: none"> • Support the overall FLEX strategy; document the overall FLEX strategy 	All	All

Item No.	Description	Mitigation Function	Phase(s)
	<ul style="list-style-type: none"> • Specify, procure and stage portable FLEX equipment • Generate the maintenance and operating procedures that support the portable FLEX equipment • Create the new and revised FSGs, EOPs, and other procedures to implement the strategy perform • Drive out the staffing studies and training needed to support these procedures • Portable lighting • Verify supporting analyses/calculations support current FLEX strategy, prior to implementation 		
10	<p>(OPEN ITEM 10)</p> <p><u>'B' RN to CA Pump Suction Re-route</u></p> <p>This engineering change involves a re-route of the 'B' emergency service water (RN) header supply to the Auxiliary Feedwater (CA) pumps from the discharge to the inlet side of the emergency diesel generator heat exchanger. This engineering change is necessary to ensure the RN system remains the source of water to the CA pumps for design basis events (e.g. not ELAP and LUHS). Under some limited conditions and scenarios for the current configuration, air might otherwise be inadvertently introduced into the CA pump suction.</p>	Core Cooling and Heat Removal	1, 2, 3
11	<p>(OPEN ITEM 11)</p> <p><u>Install Emergency Hardhat Light Storage Boxes and Hardhat Hooks</u></p> <p>This Engineering Change installs storage boxes at diverse locations for previously procured personnel hardhat lights.</p>	All	1, 2

Attachment 4B
Conceptual Engineering Change Sketches

Drawing Description	Sheet
TDAFWP FCV Assured Air Flow Diagram	1
SG PORV Assured Air Flow Diagram	2
Hale Pump Feedwater Connections Inside Doghouses	3
RWST Connection for Portable Reactor Makeup Pump Suction	4
ND Connection for Portable Reactor Makeup Pump Discharge	5
NI Connection for Portable Reactor Makeup Pump Discharge	6
NS Portable Pump Connection for "A" Containment Spray Header Discharge (typical both units)	7
Spent Fuel Pool Cooling Connection for Portable Hale Pump Discharge	8
WZ Pump Discharge Connections for Portable Submersible Ground Water Sump Pump Discharge	9 - 10
FLEX Equipment Storage Facility Site Plan	11

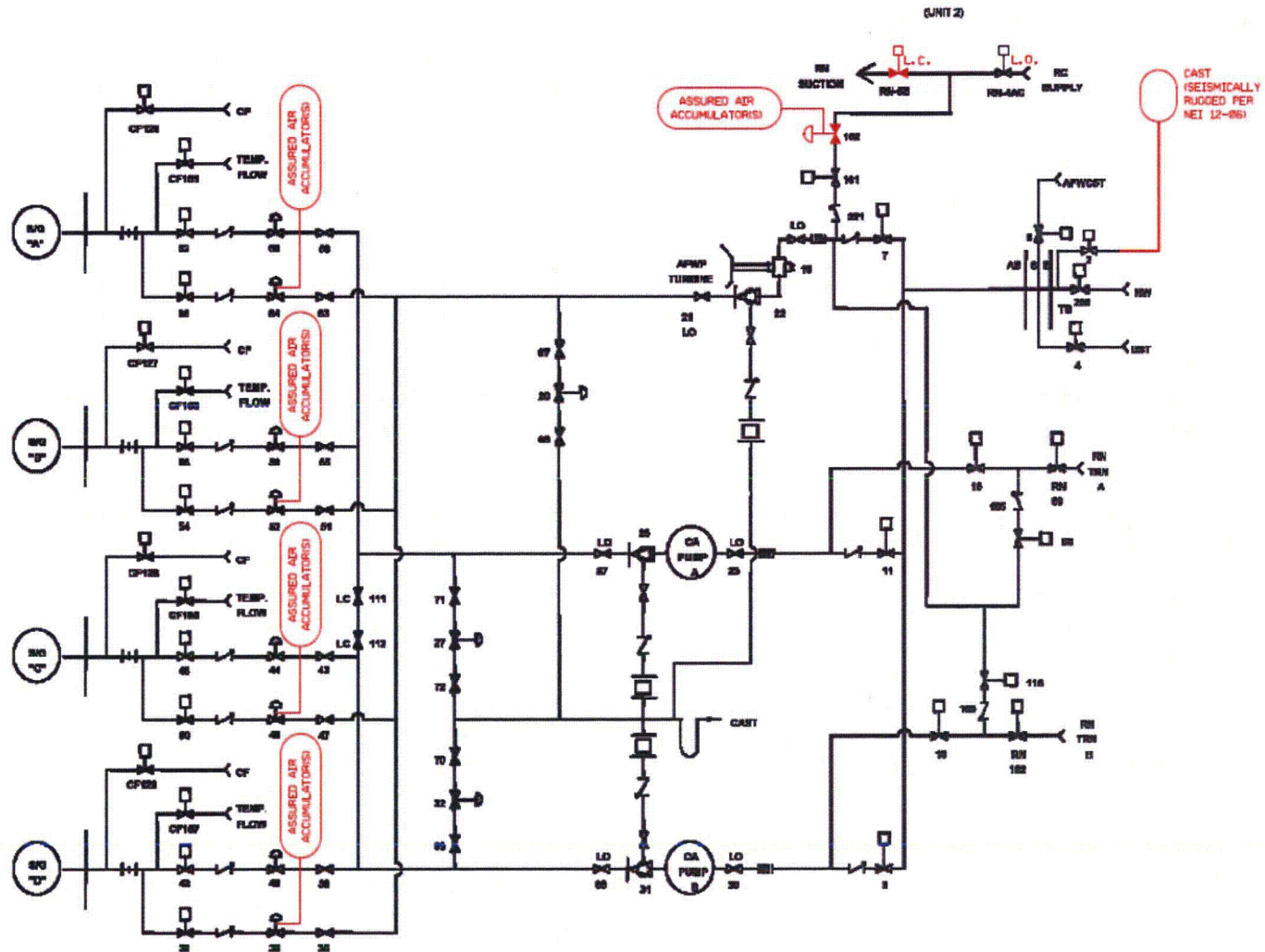

AUXILIARY FEEDWATER SYSTEM
TDAFW FLEX FLOW CONTROL AIR SUPPLY
AND FLEX ASSURED SUCTION
(UNIT 2 SHOWN. UNIT 1 SIMILAR)

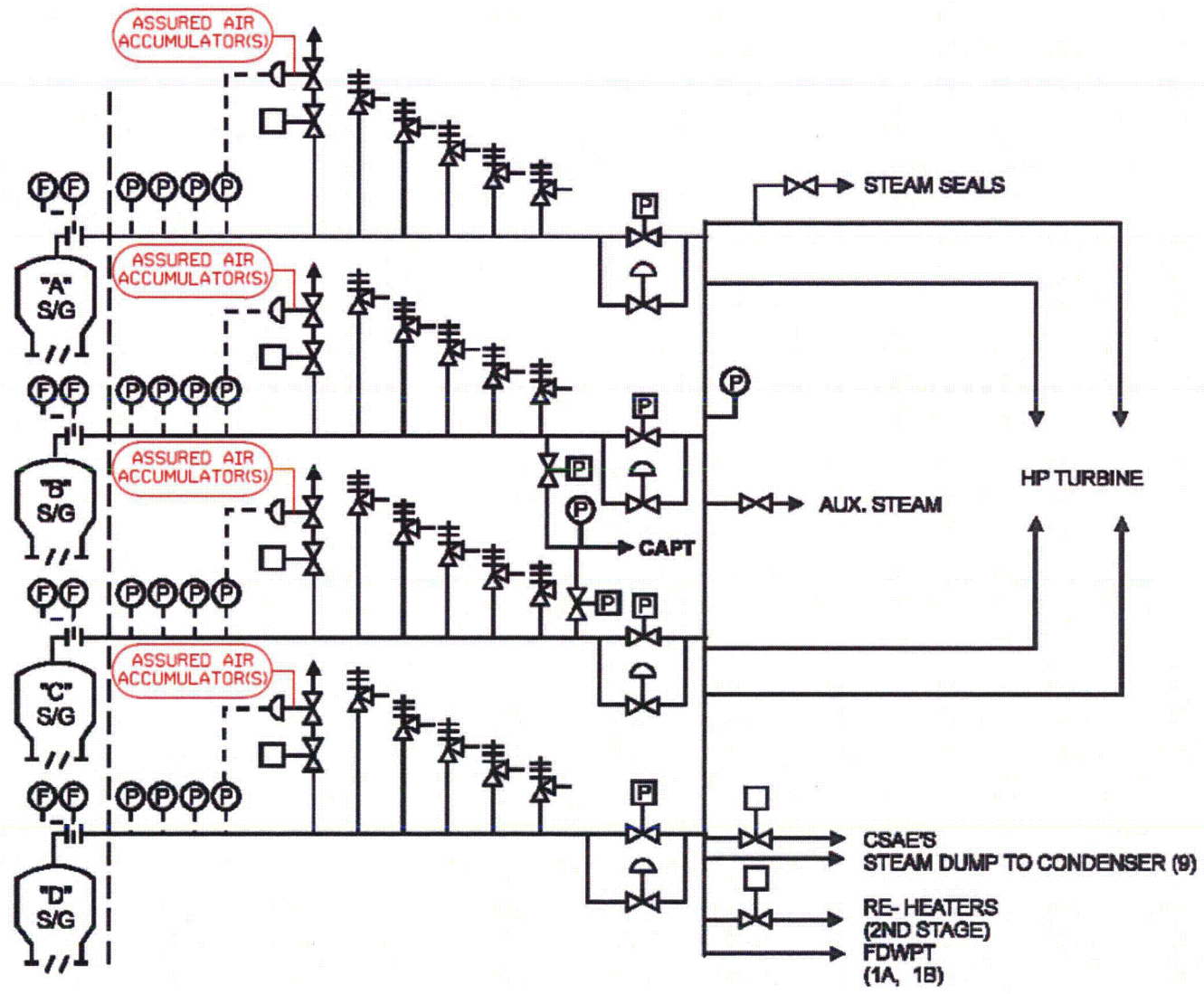

MAIN STEAM SYSTEM
FLEX S/G PORV AIR SUPPLY
(UNIT 1 SHOWN, UNIT 2 SIMILAR)

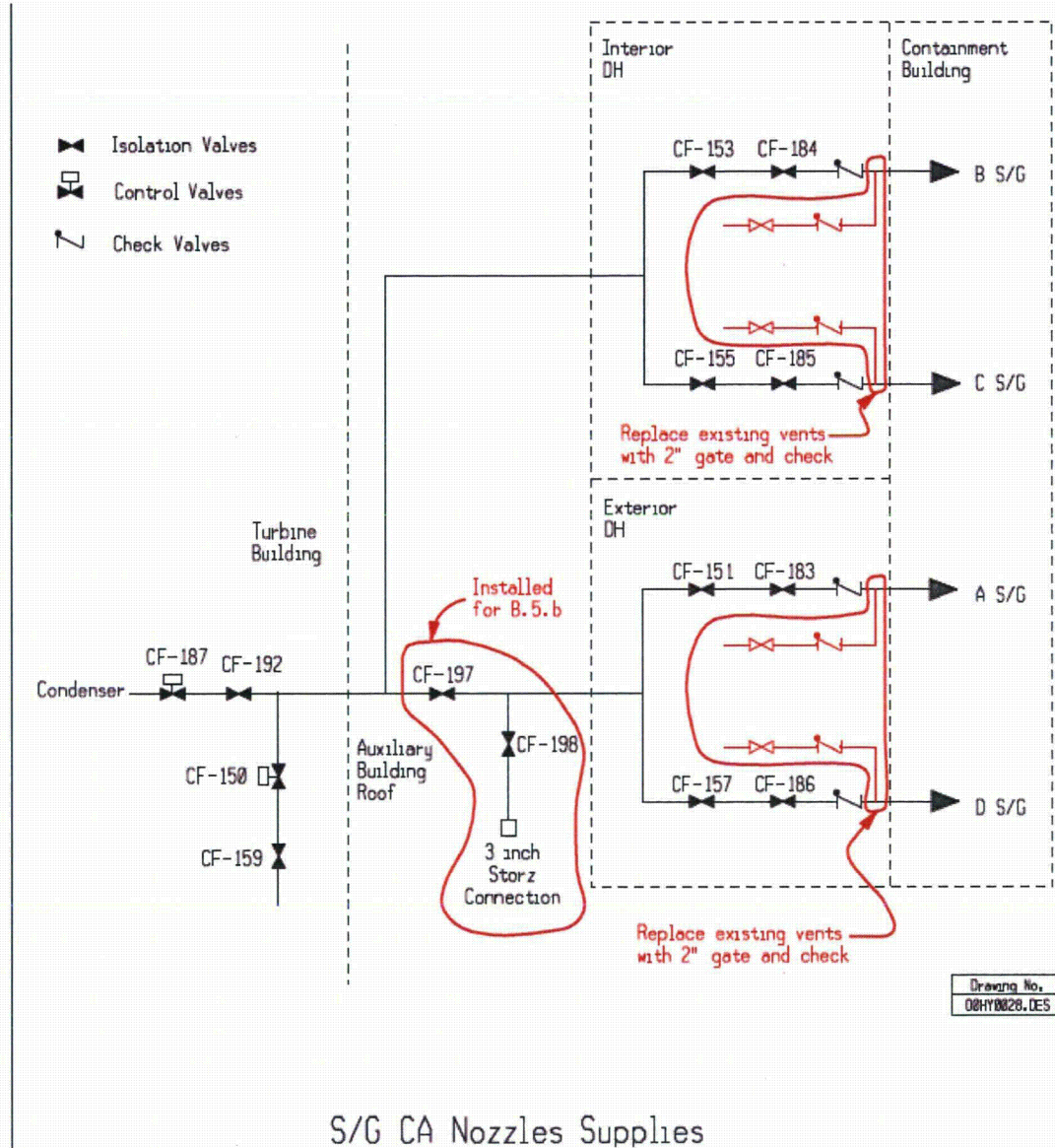

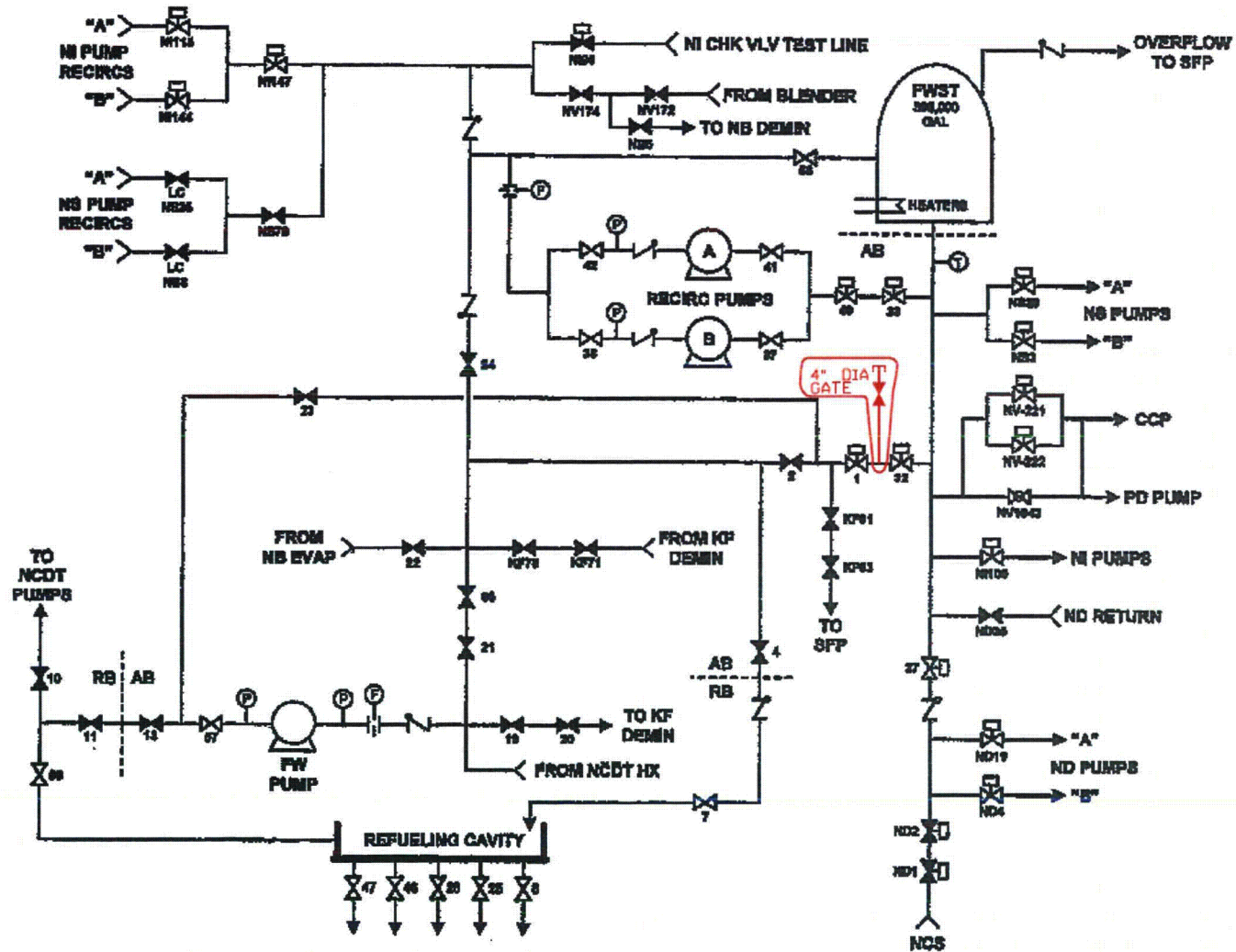

BORATED WATER SUPPLY

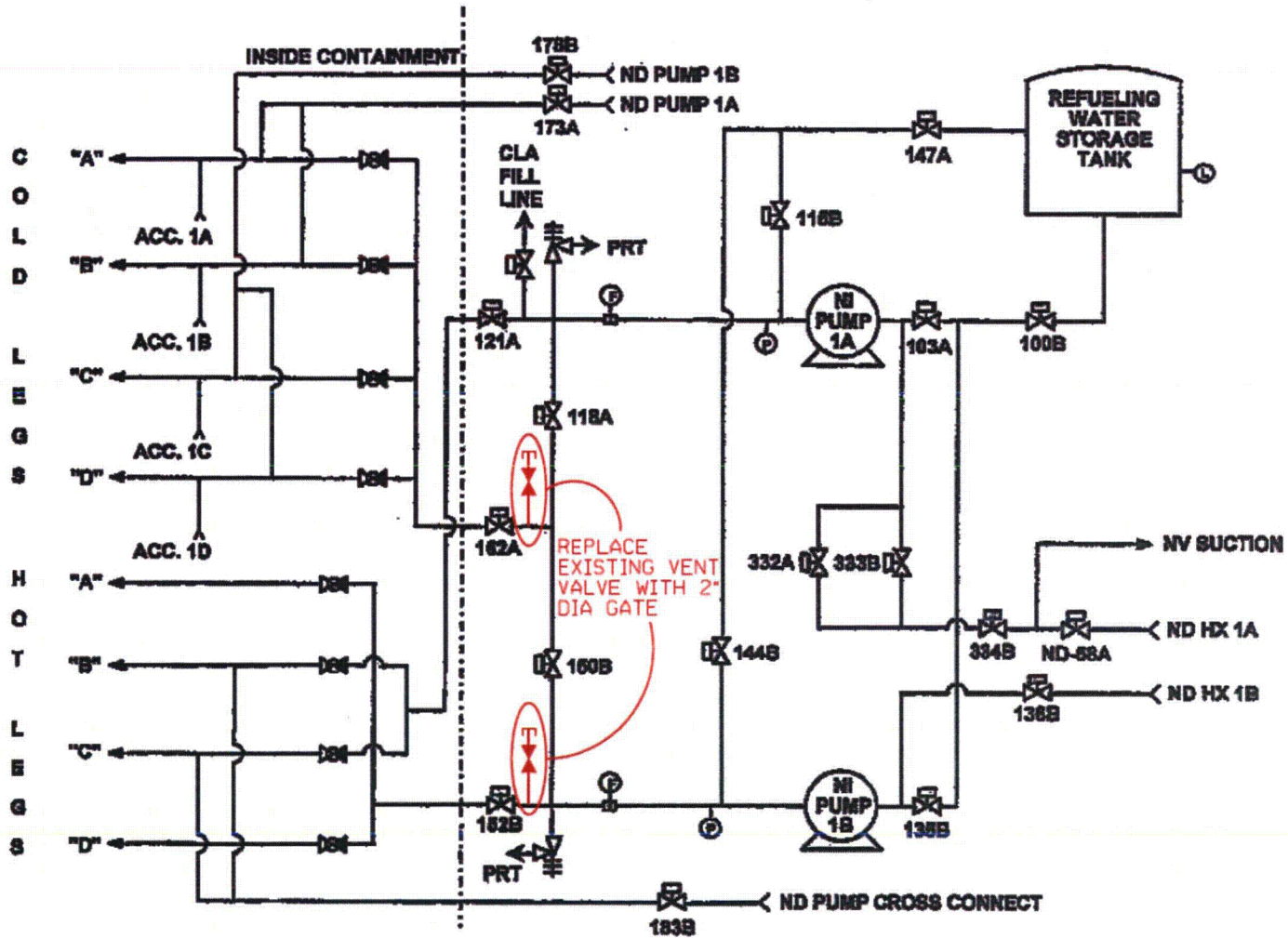

NC BORATION / MAKEUP / COOLING (B)

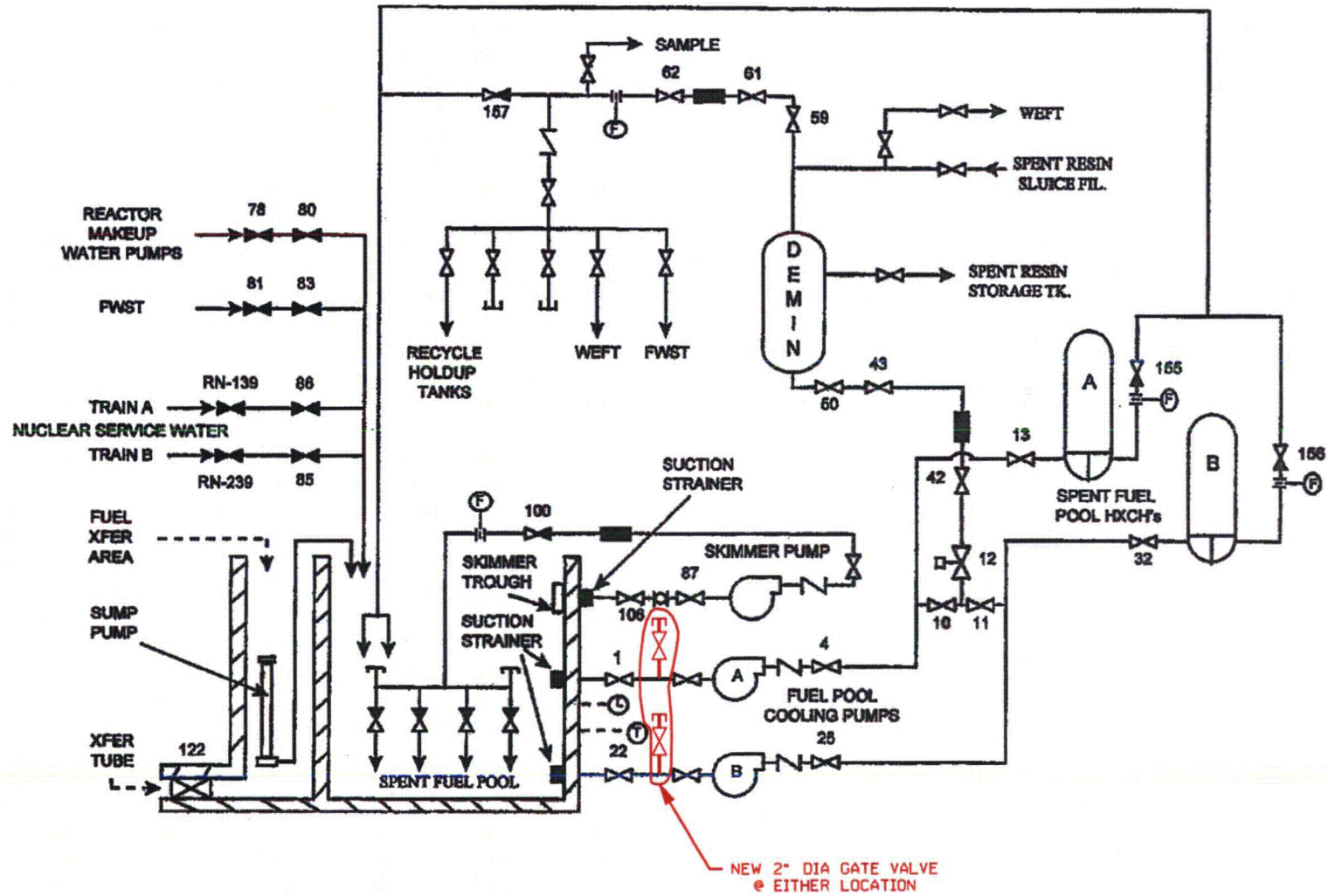

ALTERNATE SPENT FUEL POOL MAKEUP

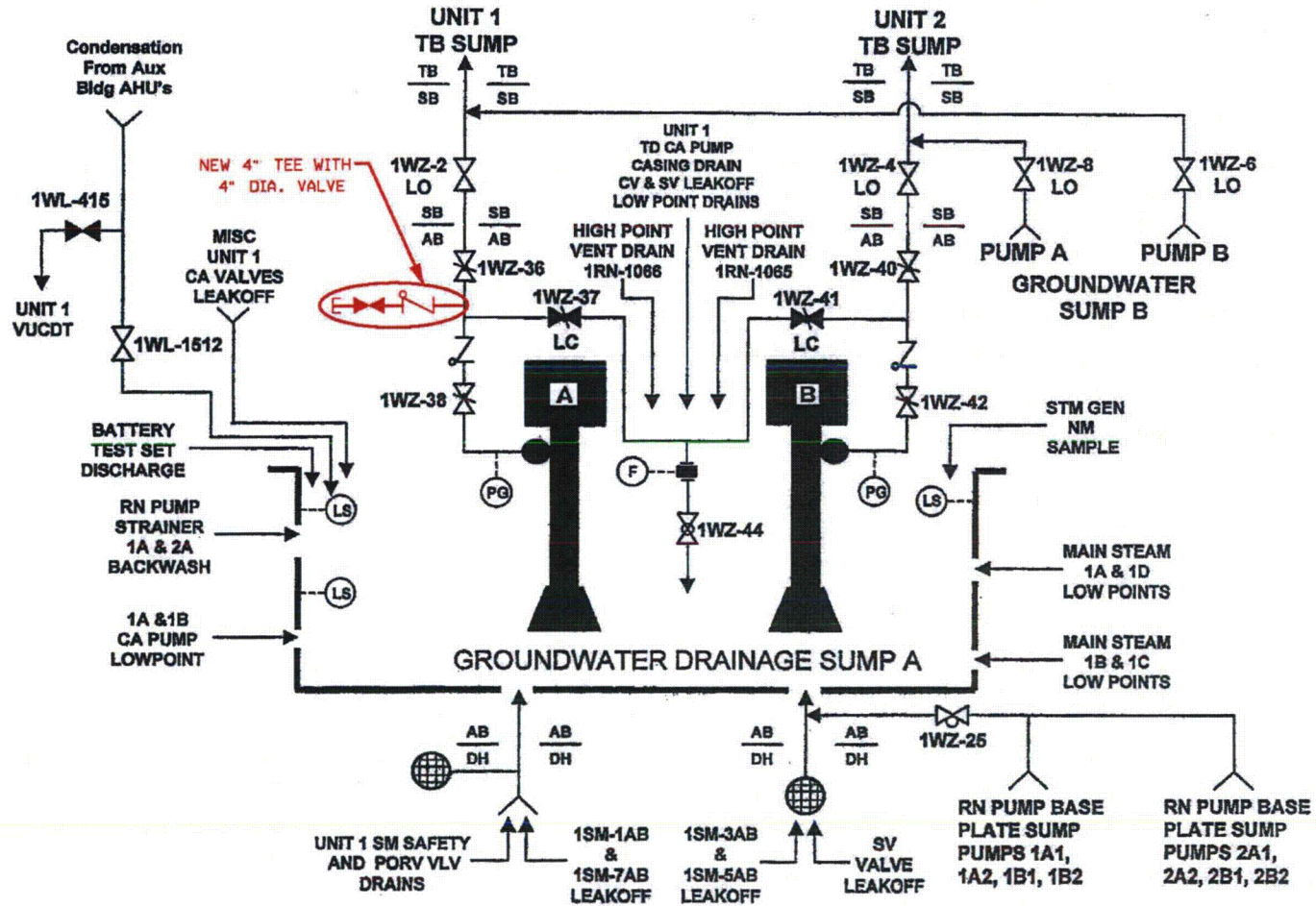

INTERNAL FLOOD MITIGATION
 CONNECTIONS UNIT 1

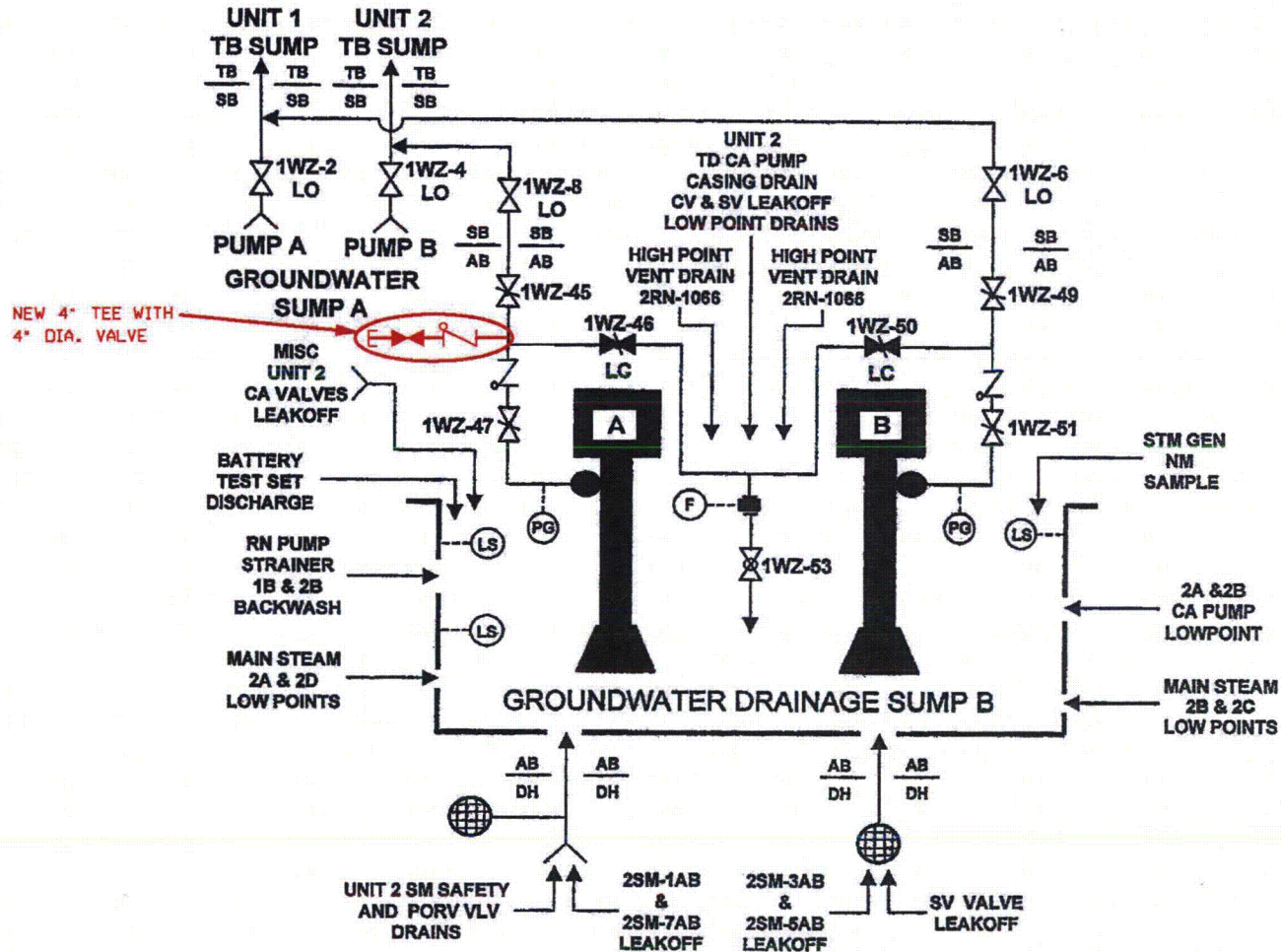

INTERNAL FLOOD MITIGATION
 CONNECTIONS UNIT 2

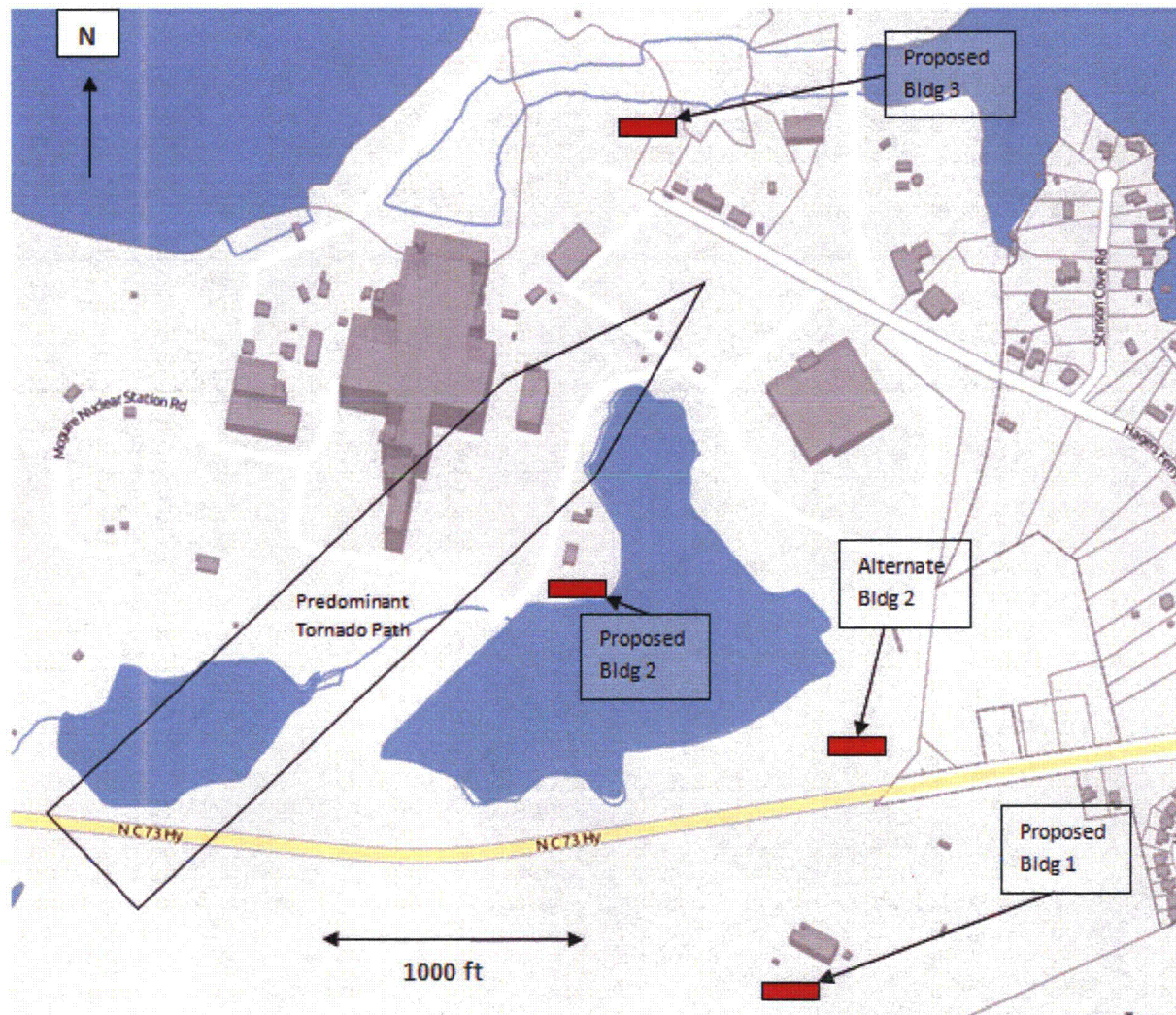

FLEX Equipment Storage Facility Site Plan

**Attachment 5
 List of References**

NOTE: *The following references are provided for information only. Their inclusion within this document does not incorporate them into the current licensing basis by reference nor does it imply intent to do so. References which have not been docketed are available onsite for NRC examination and inspection.*

Reference #	Document Title
1	McGuire Nuclear Station Updated Final Safety Analysis Report UFSAR <ul style="list-style-type: none"> • Section 2.1.1, <i>Site Location</i> • Section 2.4, <i>Hydrology</i> • Section 2.4.10, <i>Flooding Protection Requirements</i> • Section 2.5.4.8, <i>Liquefaction Potential</i> • Table 2-9, <i>McGuire Nuclear Station – Vicinity Climatology</i> • Section 3.1, <i>Conformance with General Design Criteria</i> • Section 3.4, <i>Water Level (Flood) Design</i> • Section 7.4.1.1, <i>Auxiliary Feedwater System</i> • Table 9-6, <i>Time to Boiling Following Loss of Forced Cooling Under Design Basis Conditions for McGuire Units 1 & 2 Spent Fuel Pools</i>
2	NEI 12-06, <i>Diverse and Flexible Coping Strategies (FLEX) Implementation Guide, Revision 0</i>
3	NRC Letter, <i>Request for Information Pursuant to Title 10 of the Code of Federal Regulations 50.54(f) Regarding Recommendations 2.1, 2.3, and 9.3, of the Near-Term Task Force Review of Insights from the Fukushima Dai-Ichi Accident</i> , dated March 12, 2012
4	NRC Order EA-12-049, <i>Issuance of Order to Modify Licenses with regard to Requirements for Mitigation Strategies for Beyond-Design-Basis Events</i> , dated March 12, 2012
5	EPRI NP-6041, <i>A Methodology for Assessment of Nuclear Power Plant Seismic Margins, Revision 1</i>
6	EPRI 1019199, <i>Experience Based Seismic Verification Guidelines for Piping and Tubing Systems</i>
7	AWWA D100, <i>Welded Carbon Steel Tanks for Water Storage</i>
8	NEI 12-01, <i>Guideline for Assessing Beyond Design Basis Accident Response Staffing and Communications Capabilities, Revision 0</i>
9	JLD-ISG-2012-01, <i>Compliance with Order EA-12-049, Order Modifying Licenses with Regard to Requirements for Mitigation Strategies for Beyond-Design-Basis External Events</i>
10	WCAP-17601-P, <i>Reactor Coolant System Response to ELAP for Westinghouse, Combustion Engineering and B&W</i> , August 2012
11	Regulatory Guide (RG) 1.155, <i>Station Blackout</i>
12	Section B.5.b of the Interim Compensatory Measures (ICM) Order, EA-02-026, dated February 25, 2002

Reference #	Document Title
13	PWR Owner's Group (PWROG) Project Authorization PA-PSC-0965 R0, <i>Emergency Response to Extended Station Blackout Events</i>
14	ASCE 7-10, <i>Minimum Design Loads for Buildings and Other Structures</i>
15	PWROG Core Cooling Position Paper, Revision 0, November 2012
16	NRC Order EA-12-051, <i>Issuance of Order to Modify Licenses with regard to Reliable Spent Fuel Pool Instrumentation</i> , dated March 12, 2012
17	Duke Energy Calculation MCC-1223.04-00-0012, <i>Critical Fuel Pool Level with Standby Makeup Pump Tanking Suction</i>
18	Duke Energy MCM 1151.00-0041.001, Revision 0, <i>Seismic Ruggedness and Tornado Wind Evaluation of Selected SSCs in Support of Response to INPO IER 11-4</i>
19	NEI 12-02, <i>Industry Guidance for Compliance with NRC Order EA-12-051, "To Modify Licenses with Regard to Reliable Spent Fuel Pool Instrumentation,"</i> Revision 1
20	Duke Energy Calculation MCC-1223.31-00-0012, <i>Determination of "A" and "B" WZ SUMP Flood-Out Times for SBO with SSF Unavailable</i>
21	Duke Energy Corrective Action Program PIP M-11-5722 Action 13, <i>Documentation of IER L1 11-04 Staffing Study</i>
22	Duke Energy Calculation MCC-1211.00-33-0011, <i>Analysis of YC Chiller Response Time to a Station Blackout (SBO) Event</i> , Revision 2, Addendum 1, <i>Control Room Heatup Analysis Subsequent to ELAP</i>
23	Duke Energy Calculation MCC-1381.05-00-0351, <i>U1/2, 125VDC Vital I&C Power System (EPL) Battery SBO Coping Time Estimate, (IER L1 11-4)</i>
24	Duke Energy Calculation DPC-1552.08-00-0268, <i>Extended Loss of AC Power - Ice Condenser Containment Response (IER L1 11-4)</i>
25	Duke Energy Procedure PT/0/A/4600/113, <i>Operator Time Critical Task Verification</i> , Encl. 13.13
26	Duke Energy Calculation DPC-1552.08-00-0255, <i>RSG SSF Station Blackout Analysis</i>
27	Duke Energy Procedure EP/1(2)/A/5000/ECA-0.0, <i>Loss of All AC Power</i>
28	Duke Energy Technical Support Center (TSC) Guidance Vol. 2, Enclosure 28, <i>CA Storage Tank (Water Tower) Makeup from RY or Hale Portable Pump</i> Enclosure 39, <i>Spent Fuel Pool Makeup From RY Hydrant or Hale Portable Pump</i>
29	Duke Energy Procedure AP/1(2)/A/5500/41, <i>Loss of Spent Fuel Pool Cooling or Damage</i>
30	Duke Energy Calculation MCC-1223.42-00-0037, <i>Evaluation of the Use of Non-Safety Water Sources for the Auxiliary Feedwater System, Attachment 15, CAST depletion time</i>
31	Duke Energy Calculation DPC-1535.00-00-0023, <i>Thermal Hydraulic Analyses in Support of IER L1 11-4 Extended Loss of AC</i>

Reference #	Document Title
32	Task Interface Agreement (TIA) 2004-04, <i>Acceptability of Proceduralized Departures from Technical Specifications (TSs) Requirements at the Surry Power Station</i> , (TAC Nos. MC4331 and MC4332)," dated September 12, 2006. (Accession No. ML060590273)
33	Duke Energy MCM 1151.00-0042.001, Rev. 0, <i>Seismic Ruggedness of Non-Safety-Related Auxiliary Feedwater System Suction Sources in Response to INPO IER 11-4</i>
34	Duke Energy Calculation DPC-1227.00-00-0024, <i>Annulus Conditions Following Station Blackout</i>
35	Duke Energy Calculation MCC-1201.28-00-0001, Revision 1, <i>Evaluation of Potential Boron Dilution Accidents for the McGuire Spent Fuel Pools</i>
36	MNS Technical Specification 3.7.14, <i>Spent Fuel Pool Boron Concentration</i> , and TS 3.7.14 Bases

**Attachment 6
 List of Open Items**

OPEN ITEM #	Open Item Description
1	<p>Implement plant modification: <u>Assured Air to the TDAFWP FCVs and SG PORVs</u></p> <p>Provides an assured air supply to both the TDAFW Pump FCVs and the SG PORVs to promote better command and control from the control room and to reduce the number of operators needed to control secondary cooling. Also provides primary and alternate connection points for diesel air compressors.</p>
2	<p>Implement plant modification: <u>Assured Water Supply to the TDAFWPs</u></p> <p>Automatically aligns the underground circulating water header to the TDAFWP in the event the Auxiliary Feedwater Storage Tank (CAST) is lost. Also includes a Technical Specification change to raise the Nuclear Service Water (RN) to Auxiliary Feedwater low pressure signal that automatically aligns the Auxiliary Feedwater pumps to RN subsequent to a loss of the CAST.</p>
3	<p>Implement plant modification: <u>SFP Wide-Range Level Instrumentation</u></p> <p>Installs two new Wide-Range SFP level instruments, which are electrically independent, battery backed, and spatially separated per NEI 12-02.</p>
4	<p>Implement plant modification: <u>UHF Communication System Upgrades</u></p> <p>Extends battery capacity for system through Phase 1 to allow sufficient time to re-charge batteries in Phase 2. Also provide additional TSC satellite antennae. The modification scope will also improve the seismic ruggedness of the system and reliability in the event of tornado/wind missile.</p>
5	<p>Implement plant modification: <u>Process Connections</u></p> <p>Provides redundant process connections to provide steam generator (SG) makeup, reactor makeup and negative reactivity addition, spent fuel pool (SFP) cooling, and containment spray.</p>

OPEN ITEM #	Open Item Description
6	<p>Implement plant modification: <u>Permanent Connections for Portable Electrical Equipment</u></p> <p>NEI 12-06 requires that a primary and alternate method be provided to supply power to the vital batteries, the hydrogen igniters, the portable RCS reactor makeup pumps, and the cold leg accumulator valves. Permanently installed MCC buckets will be provided to provide the primary method for re-powering these components. The buckets will contain external power connections. Portable MCC buckets are used as an alternate strategy and connection to re-power the associated bus. The alternate strategy will provide defense-in-depth for the primary strategy.</p>
7	<p>Implement plant modification: <u>FLEX Storage Facilities</u></p> <p>Three FLEX storage facilities will be provided that are designed to ASCE 7-10 to withstand a Safe Shutdown Earthquake (SSE) and the maximum expected tornado and hurricane winds as outlined in NEI 12-06. The storage facilities will be located so that the most probable tornado paths will not affect the plant and more than one of facilities concurrently.</p>
8	<p>Implement plant modification: <u>Submersible Ground Water Sump Pump</u></p> <p>Portable submersible sump pumps with permanent cable connections between the pumps and FLEX generator connection points at approximately grade level will be provided. All components will be located in a seismically robust facility.</p>
9	<p>Implement plant modification: <u>FLEX Strategy Implementation</u></p> <p>This engineering change will drive out the analysis necessary to:</p> <ul style="list-style-type: none"> • Support the overall FLEX strategy; document the overall FLEX strategy • Specify, procure and stage portable FLEX equipment • Generate the maintenance and operating procedures that support the portable FLEX equipment • Create the new and revised FSGs, EOPs, and other procedures to implement the strategy • Drive out the staffing studies and training needed to support these procedures • Portable lighting • Verify supporting analyses/calculations support current FLEX strategy, prior to implementation

OPEN ITEM #	Open Item Description
10	<p>Implement plant modification: <u>'B' RN to CA Pump Suction Re-route</u></p> <p>This engineering change involves a re-route of the 'B' emergency service water (RN) header supply to the auxiliary feedwater (CA) pumps from the outlet to the inlet side of the emergency diesel generator heat exchanger. This engineering change is necessary to ensure the RN system remains the source of water to the CA pumps for design basis events (e.g. not ELAP and LUHS). Under some limited conditions and scenarios for the current configuration, air might otherwise be inadvertently introduced into the CA pump suction.</p>
11	<p>Implement plant modification: <u>Install Emergency Hardhat Light Storage Boxes and Hardhat Hooks</u></p> <p>This Engineering Change installs storage boxes at diverse locations for previously procured personnel hardhat lights.</p>
12	<p>A staffing Phase 2 study will be performed in accordance with NEI 12-01 to verify that all actions can be taken in accordance with the timeline. Time constraints shown in Attachment 1A will be validated to be reasonable as the strategy is finalized.</p>
13	<p>An analysis was performed in Duke Energy Calculation MCC 1223.31-00-0012 (Reference 20) that indicates that flooding will not occur for at least 48 hours. This analysis will be revised to demonstrate that this time remains unaffected even if potential sources of water from Auxiliary Building or Turbine Building flooding are considered.</p>
14	<p>A calculation will be performed to demonstrate that sufficient negative reactivity can be added through use of a pump and a reactor coolant system vent path to achieve xenon free cool down in accordance with the PWROG FSG guidelines (Reference 13).</p>
15	<p>Complete vital battery area room heatup and hydrogen accumulation calculation to determine if portable fans or HVAC units may be required, and timeframe for deployment.</p>
16	<p>Complete a calculation to determine when elevated interior doghouse temperatures adversely impact the FLEX strategy and to evaluate methods for mitigation.</p>
17	<p>An evaluation will be performed to determine how long raw water can be used to supply SGs without excessively affecting SG capability to remove heat and provide steam to the TDAFW pump. This will help determine when Phase 3 equipment may be needed to assist in providing cleaner water sources.</p>
18	<p>MNS will evaluate the need to provide freeze protection for critical instrumentation and exposed FLEX connections.</p>
19	<p>Methods will be initiated to circulate and cool air in lower containment subcompartments to prevent any adverse impact on critical instrumentation. The response time is based on engineering judgment and will be confirmed by analysis.</p>

OPEN ITEM #	Open Item Description
20	Deployment routes will be established and are expected to be utilized to transport FLEX equipment to the deployment areas. The identified paths and deployment areas will be accessible during all modes of operation. This deployment strategy will be included within an administrative program in order to keep pathways clear or actions to clear the pathways.
21	MNS will implement programmatic controls in accordance with NEI 12-06 (Reference 2). Procedures and guidelines will be reviewed and revised and/or generated as required to address additional programmatic controls as a result of FLEX requirements.
22	Equipment associated with FLEX mitigation strategies will be procured as commercial equipment with design, storage, maintenance, testing, and configuration control in accordance with NEI 12-06 Section 11.1 (Reference 2).
23	Installed structures, systems and components pursuant to 10 CFR 50.63(a) will continue to meet augmented guidelines of Regulatory Guide (RG) 1.155, <i>Station Blackout</i> (Reference 11).
24	The unavailability of equipment and applicable connections that directly performs a FLEX mitigation strategy will be managed using plant equipment control guidelines developed in accordance with NEI 12-06 Section 11.5 (Reference 2).
25	Programs and processes will be established to ensure that personnel proficiency in the mitigation of beyond-design-basis events is developed and maintained in accordance with NEI 12-06 Section 11.6 (Reference 2).
26	The FLEX strategies and basis will be maintained in overall FLEX basis documents.
27	Existing plant configuration control documents will be modified to ensure that changes to the plant design, physical plant layout, roads, buildings, and miscellaneous structures will not adversely impact the approved FLEX strategies in accordance with NEI 12-06 Section 11.8 (Reference 2).
28	Training will be initiated through the Systematic Approach to Training (SAT) process. Training will be developed and provided to all involved plant personnel based on any procedural changes or new procedures developed to address and identify FLEX activities. Applicable training will be completed prior to the implementation of FLEX.
29	The industry will establish two Regional Response Centers (RRCs) to support utilities during beyond-design-basis events.

OPEN ITEM #	Open Item Description
30	The N+1 FLEX storage facilities will be designed in accordance with ASCE 7-10, <i>Minimum Design Loads for Buildings and Other Structures</i> (Reference 14). The FLEX storage facilities will be designed in accordance with ASCE 7-10 (Reference 14), to withstand the maximum anticipated hurricane and tornado winds as outlined in NEI 12-06 (Reference 2). The FLEX buildings will be located in accordance with NEI 12-06 (Reference 2) Section 7.3.1 to prevent damage to more than one of the three facilities due to tornado missiles.
31	FLEX storage facilities will be located above any potential site flood level, and/or the effects of localized flooding will be evaluated in the FLEX facility design and equipment deployment.
32	Debris removal/remediation equipment and procedures will be provided to support FLEX equipment deployment.
33	Snow and ice removal/remediation equipment and procedures will be provided to support FLEX equipment deployment.
34	FLEX equipment will be capable of operation under extreme temperatures, and suitably maintained to ensure standby readiness. FLEX storage facilities will be designed to accommodate maximum snow and ice loading. FLEX storage facilities will be vented to maintain acceptable temperature.
35	An evaluation will be performed to ensure that the 300 gpm pump is capable of adequate flow and pressure to support feed and bleed core cooling in typical Mode 5 and Mode 6 configurations.
36	Since the overall FLEX strategy is aimed at preventing core damage, the engineering change process will drive out an evaluation to prioritize operator actions associated with containment isolation as time allows. For example, the containment isolations to the Containment Ventilation Unit Condensate Drain Tank (VUCDT) will be closed first since this path connects containment atmosphere directly to the Auxiliary Building.
37	An analysis will be performed to validate that containment spray for temperature/pressure control is not required over the long term. If the long term containment analysis determines that containment temperature and/or pressure will reach unacceptable levels over the long term, connections installed for Section B.5.b containment spray mitigating strategies will be used with the portable diesel driven pumps to supply water from the UHS to the connections located in the Auxiliary Building.
38	Fans in containment that circulate air will be restored as required to cool the cubicle areas and to prevent the increase in temperature from having an adverse impact on essential instrumentation. The engineering change process will drive out an evaluation to determine the appropriate timing of these actions.
39	Evaluate other long term strategies for cooling containment such as circulating the air volume in the annulus.

OPEN ITEM #	Open Item Description
40	<p>In order to prevent or mitigate this inevitability:</p> <ol style="list-style-type: none"> 1. Portable power distribution equipment will be used to repower the vital batteries, or 2. An alternate strategy to deploy portable generators and cables will be developed to directly reestablish power to the power supplies in the 7300 cabinets thereby re-powering the instrumentation loops, or 3. An alternate strategy to utilize handheld instruments will be developed to tap into the instrument loops locally to monitor essential parameters.
41	<p>An analysis (Reference 22) was completed to demonstrate that adequate control room cooling would be available if action was taken to open various doors at around 2 hours after the event occurs. This action will be incorporated into procedures.</p>
42	<p>An evaluation will be performed to determine diesel fuel, gasoline and two-cycle oil requirements for Phase 1 and Phase 2 portable equipment.</p>
43	<p>Analysis will be performed to determine commodities requirements.</p>
44	<p>Evaluate SFP to ensure predicted makeup water dilution rates in the Spent Fuel Pools for the coping strategies described herein are bounded.</p>
45	<p>Analysis will be performed to determine radiation protection equipment requirements.</p>
46	<p>These instruments will be used in the FSGs in accordance with the PWROG guidance (Reference 13). Setpoint uncertainty analyses will be developed in accordance with PWROG guidance (Reference 13).</p>
47	<p>A portable battery pack with inverter is also being evaluated for use. The battery pack would be rapidly deployed for use to close the CLA motor-operated valves (MOVs) outside of containment penetration without reliance on the valve's limit or torque switches or the valve's relay circuitry.</p>