

Part 21 (PAR)

Event # 47630

Rep Org: GE HITACHI NUCLEAR ENERGY		Notification Date / Time: 02/01/2012 15:33 (EDT)	
Supplier: GE HITACHI NUCLEAR ENERGY		Event Date / Time: 02/01/2012 (EST)	
Last Modification: 06/06/2012			
Region: 1	Docket #:		
City: WILMINGTON	Agreement State:		Yes
County:	License #:		
State: NC			
NRC Notified by: DALE PORTER	Notifications:	WILLIAM COOK	R1DO
HQ Ops Officer: JOHN KNOKE		JONATHAN BARTLEY	R2DO
Emergency Class: NON EMERGENCY		JAMNES CAMERON	R3DO
10 CFR Section:		JEFF CLARK	R4DO
21.21(a)(2)	INTERIM EVAL OF DEVIATION	PART21 GROUP	

PART 21 REPORT - FAILURE OF CRD COLLET RETAINER TUBE/OUTER TUBE WELD

The following information was received via facsimile:

"During a recent refurbishment of a Control Rod Drive (CRD) performed by GE Hitachi Nuclear Energy (GEH) for a domestic customer a 360 degree failure of the collet retainer tube fillet weld was identified. This weld is part of the CRD 919D258G003 Cylinder, Tube and Flange (CTF) assembly. The collet retainer tube fillet weld was performed in 1983 and subsequently assembled into a Group 003 part number 919D258G003 CTF. This G003 CTF assembly was assembled into a CRD in 1995 and placed into service in 1996. GEH continues to investigate the cause(s) of the failed fillet weld. Once the cause of the fillet weld failure is determined, GEH will review the extent of condition of this failure as well as the consequences to determine if a reportable condition exists.

"There were no adverse effects on the CRD's operation observed due to this failure.

"This 60-day interim notification, in accordance with 10CFR Part 21.21(a)(2), will be sent to all BWR/2-6 plants that utilize CRDs equipped with either 919D258G002 or 919D258G003 CTF assemblies."

The affected plants are: Nine Mile Point 1-2, Fermi 2, Columbia, Grand Gulf, River Bend, Fitzpatrick, Pilgrim, Vermont Yankee, Clinton, Dresden 2-3, LaSalle 1-2, Limerick 1-2, Oyster Creek, Peach Bottom 2-3, Quad Cities 1-2, Perry 1, Duane Arnold, Cooper, Susquehanna 1-2, Brunswick 1-2, Hope Creek, Hatch 1 - 2, Browns Ferry 1-3, Monticello, and Millstone.

*** UPDATE FROM GE HITACHI VIA FAX AT 1259 EDT ON 6/6/12 ***

"GEH has completed the evaluation of this condition and has determined that the failure of Control Rod Drive collet

JEI9
NRR

Part 21 (PAR)
retainer tube fillet weld is not a Reportable Condition as defined by 10CFR Part 21."

Event # 47630

Notified R1DO (Cahill), R2DO (Widmann), R3DO (Passehl), R4DO (Gepford) and Part 21 Group (via email).



HITACHI

GE Hitachi Nuclear Energy

To: NRC Operations Center

Fax: 301-816-5151

From: Dale E. Porter, GE Hitachi Nuclear Energy

Fax: 910-819-4829

Date/Time: June 6, 2012 12:45 pm

Number of pages, including this one: 9

Comments:

**HITACHI****GE Hitachi Nuclear Energy**

June 6, 2012
MFN 12-006 R1

U.S. Nuclear Regulatory Commission
Attn: Document Control Desk
Washington, DC 20555-0001

Dale E. Porter

GE-Hitachi Nuclear Energy Americas LLC
Safety Evaluation Program Manager

3901 Castle Hayne Rd.,
Wilmington, NC 28401
USA

T 910 819-4491
Dale.Porter@GE.Com

**Subject: Part 21 60-Day Interim Report Notification - Closure:
Failure of CRD Collet Retainer Tube/Outer Tube Weld**

This letter provides information concerning an evaluation performed by GE Hitachi Nuclear Energy (GEH) regarding a failure of one Control Rod Drive (CRD) collet retainer tube fillet weld. GEH has completed the evaluation of this condition and has determined that the failure of Control Rod Drive (CRD) collet retainer tube fillet weld **is not a Reportable Condition** as defined by 10CFR Part 21. Please find attached a summary of the information obtained through the evaluation that supports this conclusion.

If you have any questions, please call me at (910) 819-4491.

Sincerely,

Dale E. Porter
Safety Evaluation Program Manager
GE-Hitachi Nuclear Energy Americas LLC

References:

1. Letter from Dale E. Porter (GEH) to Document Control Desk (US NRC), Subject: Part 21 60-Day Interim Report Notification: Failure of CRD Collet Retainer Tube/Outer Tube Weld, February 1, 2012, MFN 12-006 R0.

cc: S. S. Philpott, USNRC
S. J. Pannier, USNRC
O. Tabatabai-Yazdi, USNRC
J. F. Harrison, GEH
J. G. Head, GEH

MFN 12-006 R1

Page 2 of 2

P. L. Campbell, GEH Washington

A. A. Lingenfelter, GNF

PRC File

DRF Section No. 0000-0146-6794

MFN 12-006 R1

Page 1 of 5

Background

During a planned refurbishment of a Control Rod Drive (CRD) performed by GE Hitachi Nuclear Energy (GEH) for a domestic customer in December of 2011, a 360 degree failure of the collet retainer tube fillet weld was identified. This weld is part of the CRD 919D258G003 Cylinder, Tube and Flange (CTF) assembly. The function of this assembly is to react to the applied hydraulic loads so that the collet fingers can be retracted from the index tube and allow the CRD to be moved for control rod positioning or scram. The collet retainer tube fillet weld was fabricated in 1983 and subsequently assembled into a part number 919D258G003 CTF. This 919D258G003 CTF was assembled into a CRD in 1995 and placed into service in 1996. There was no adverse operational performance of this CRD reported.

GE Hitachi Nuclear Energy (GEH) provides CRD CTF assemblies to operating GEH BWRs (BWR/2-6). The CTF inspection recommendations are specified in SIL 139 and applicable supplements. Inspections primarily consist of dye penetrant examinations of all collet retainer tubes and their welds of the CTFs during normal CRD maintenance. All CTFs that exhibit any relevant linear indication in the collet retainer tube or their welds during refurbishment at GEH are rejected and removed from service. Since GEH began refurbishing CRD assemblies for domestic customers, approximately 2100 CTF assemblies (G002 and G003) have been dye penetrant tested. Of these a total of 11 CTF assemblies were rejected for linear indications related to this fillet weld prior to this most recent identified failure. These indications did not result in a complete weld failure or compromise CRD functionality.

In December of 2011, refurbishment of a CRD G003 CTF assembly revealed a 360 degree failure around the collet retainer tube fillet weld, and a complete separation, with a 0.15" axial displacement of the collet housing from the outer tube. This is the first occurrence of this type failure on any CTF assembly observed by GEH. It is noted that the subject CRD continued to perform normally, including scrambling, while in service.

Evaluation

The fillet weld design in question is applicable to all 919D258G002 and G003 Cylinder, Tube and Flange assemblies since the collet retainer tube material, configuration and fillet weld design are the same for both groups. This fillet weld is located on the Outer Tube Assembly and is part of the Cylinder, Tube and Flange (CTF) assembly of the CRD mechanism.

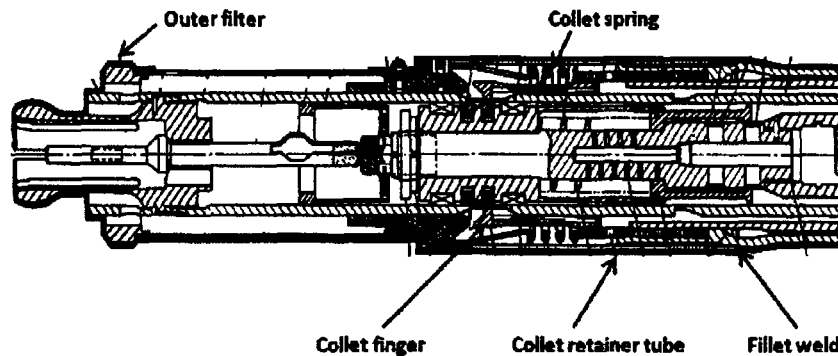

The G003 CTF containing the failed fillet weld was removed from service in 2011. The collet retainer tube axial displacement was observed to be 0.15 inches. The observed displacement is bounded by two dimensions for potential movement of the collet retainer tube:

1. Per drawing dimensions, after separation, the collet retainer tube could displace a nominal axial distance of ~1.3 inches, before the top of the CRD outer filter would stop against the bottom of the control rod guide tube base.
2. After separation, an axial displacement of ~1 inch would result in the collet spring, which is maintained in a compressed state per design requirements, returning to its free-length state. The collet spring in its free-length state would restrict the collet fingers from deflecting outward and clearing of the index tube notches.

CRD index tube movement would likely begin to be inhibited if the collet retainer tube was to separate and displace approximately 1 inch or more. This degree of separation could potentially result in a stuck control rod (no insert, withdraw or scram capability).

Additional occurrences of this failure are deemed to have a very low probability based on the following:

1. Since 1977, more than 5,000 G002 and G003 CTFs have been manufactured and many are approaching 30 years of service without observing a similar condition.
2. Approximately 2,100 G002 and G003 CTF assemblies have been dye penetrant inspected by GEH and this is the first identified failure of this type.
3. There were over 2,500 G002 and G003 CTF assemblies fabricated in the same period as this failed CTF and there have been no other 360 degree fillet weld failures identified.

In order to fully understand the consequence of a 360 fillet weld crack, testing was performed to determine if the inherent weld shrinkage and distortion due to the weld process is sufficient to prevent enough separation of the collet retainer tube and prevent a

MFN 12-006 R1

Page 3 of 5

substantial safety hazard. Testing was performed on four assemblies. Three assemblies were CTFs returned from service for refurbishment, and the fourth assembly was a full mock up sample fabricated at the GEH Wilmington facility. A push test process was developed to measure the force required to separate the collet retainer tube from the outer tube with the fillet weld no longer intact. This force was compared to the axial forces applied to the collet retainer tube during normal and transient operation.

After a review of all of the possible loading conditions for the fleet, it was concluded that the primary axial force applied to the fillet weld during normal and transient operation is associated with the CRD withdraw cycle. Therefore, in order for any CRD to continue to operate after a collet retainer tube fillet weld failure, the force applied during the withdraw cycle must be less than the force required to separate and displace the collet retainer tube \geq one inch from the outer tube.

Three of the four CTF assemblies tested were CTFs removed from service and rejected at GEH Wilmington during refurbishment. The first was the CTF containing the 360 degree cracked fillet weld. The other two were CTF assemblies with relevant circumferential indications identified by GEH while performing an LP inspection during CRD refurbishment.

The push tests for these three CTF assemblies were performed at the GEH Vallecitos facility. It was observed during the evaluation that the 360 degree cracked fillet weld was partially penetrated for most of the weld circumference, while the welds of the other two CTF assemblies were fully penetrated welds. One of the CTFs rejected for LP linear indications was confirmed to be cracked in the location of the LP indication, which was a 5 3/8" long indication. There was also galling observed on the contacting surfaces of the parts, attributed to the radial interference between the parts due to weld shrinkage and weld drop-through. In all cases the push-out force was more than two times greater than the forces applied to the CRD during normal and transient conditions.

The fourth assembly tested was a full mockup sample fabricated and tested at the GEH Wilmington facility. A weld process was developed to establish and evaluate worst case conditions. [Development samples were prepared in GEH Wilmington to simulate the 360 degree cracked fillet weld for the plant sample. This weld is considered the worst case weld fabricated because this is the only weld to have cracked 360 degrees. The weld was partially penetrated except for two one inch long opposing sections which were fully penetrated. The weld process developed in GEH Wilmington replicated these weld characteristics.] The sample parts representing the collet retainer tube and outer tube were prepared so that the fit-up between the parts was the largest clearance allowed by drawing. One full mockup sample was welded per this process and represents the fourth assembly tested. This was considered a conservative test representing bounding conditions.

During process development it was determined that galling is a significant contributor to the push-out force. This conclusion was reached based on comparing push-out force of

MFN 12-006 R1

Page 4 of 5

samples that included and did not include galling. Galling has been observed in the locations of full penetration and is due to shrinkage and weld drop-through. It has been concluded that galling will occur in the fully penetrated locations similar to the 360 degree weld failure assembly.

An additional contributor to push-out force is the presence of a circumferential relief groove ~0.15" wide that is machined (per the drawing) in the inner spacer tube; directly underneath the root of the weld joint. As the collet retainer tube wall-end shrinks during welding, the root of the weld shrinks into this groove; effectively keying the collet retainer tube into the spacer to limit its axial displacement.

If an unlikely complete weld failure occurs, then in order for the collet retainer tube to be capable of displacing axially (with respect to the inner spacer) greater than 0.15", then the weld-shrunk tube-end must stretch (expand) diametrically out of this groove. The force required for tube expansion causes increased friction at the interfacing surfaces and increases galling radial forces. This causes a corresponding increase in the push-out force required for tube displacement greater than 0.15". The push test found that the push-out force was more than two times greater than the forces applied to the CRD during normal and transient conditions.

Conclusion

Push tests performed on the four CTF assemblies indicate weld shrinkage combined with interface galling due to weld drop-through prevents an unacceptable separation displacement of the collet retainer tube and outer tube, even with worst-case collet retainer tube/outer tube fit-up and welding heat input. The fit-up of the collet retainer tube to the outer tube is held to tight diametrical tolerances, and has a minimal assembly pre-weld gap by drawing controls. Even if complete weld fracture occurs, collet retainer tube separation and displacement is well controlled and acceptably limited by the design dimensions and joint configuration.

Testing of CTF assemblies removed from service and a number of CTF weld mockups shows that there would be full collet functionality in the unlikely event that the weld would completely fracture, regardless of the detailed nature of the weld cracking mechanism.

It is noted that the weekly/monthly CRD surveillances performed at the plants would detect the loss of functionality in the unlikely event of a complete separation of the collet retainer tube. Such a loss of functionality has never been reported as being due to a cracked or failed CTF assembly fillet weld.

Even if a complete weld fracture occurs, collet retainer tube separation is well controlled and sufficiently limited by the design dimensions and joint configuration. Therefore, GEH

MFN 12-006 R1

Page 5 of 5

concludes that the condition of a 360 degree cracked collet retainer tube fillet weld does not result in a substantial safety hazard, nor cause a BWR to violate any plant technical specification limit. Therefore, PRC 11-69 **does not constitute a Reportable Condition** per 10CFR Part 21.

ABWR and ESBWR Design Certification Documentation Applicability

The issue described above has been reviewed for applicability to documentation associated with 10 CFR 52 and it has been determined that there is no effect on the technical information contained in either the ABWR certified design or the ESBWR design in certification.

MFN 12-006 R1

Page 1 of 1

Attachment 2
US Plants Potentially Affected

<u>Utility</u>	<u>Plant</u>
<u>X</u> Constellation Energy	Nine Mile Point 1-2
<u>X</u> Detroit Edison Co.	Fermi 2
<u>X</u> Energy Northwest	Columbia
<u>X</u> Entergy	Grand Gulf
<u>X</u> Entergy	River Bend
<u>X</u> Entergy	FitzPatrick
<u>X</u> Entergy	Pilgrim
<u>X</u> Entergy	Vermont Yankee
<u>X</u> Exelon	Clinton
<u>X</u> Exelon	Dresden 2-3
<u>X</u> Exelon	LaSalle 1-2
<u>X</u> Exelon	Limerick 1-2
<u>X</u> Exelon	Oyster Creek
<u>X</u> Exelon	Peach Bottom 2-3
<u>X</u> Exelon	Quad Cities 1-2
<u>X</u> FirstEnergy Nuclear Operating Co.	Perry 1
<u>X</u> Florida Power & Light	Duane Arnold
<u>X</u> Nebraska Public Power District	Cooper
<u>X</u> PPL Susquehanna LLC	Susquehanna 1-2
<u>X</u> Progress Energy	Brunswick 1-2
<u>X</u> PSEG Services Corp.	Hope Creek
<u>X</u> Southern Nuclear Operating Co.	Hatch 1 - 2
<u>X</u> Southern Nuclear Operating Co.	Pooled Equipment Inventory Co.
<u>X</u> Tennessee Valley Authority	Browns Ferry 1-3
<u>X</u> Xcel Energy	Monticello
<u>X</u> North East Utilities	Millstone