



# Fort Calhoun Station Public Meeting with the Nuclear Regulatory Commission



April 4, 2012



Fort Calhoun Station  
Vice President & Chief Nuclear Officer

# DAVID BANNISTER

## OPENING REMARKS



# Performance Initiatives



- Integrated Performance Improvement Plan
- Plant Status
- In-depth Reviews
- Look-Ahead



Fort Calhoun Station  
Recovery Manager

# **RON SHORT**

## **INTEGRATED PERFORMANCE IMPROVEMENT PLAN STATUS**

4/6/2012





# Integrated Performance Improvement Plan

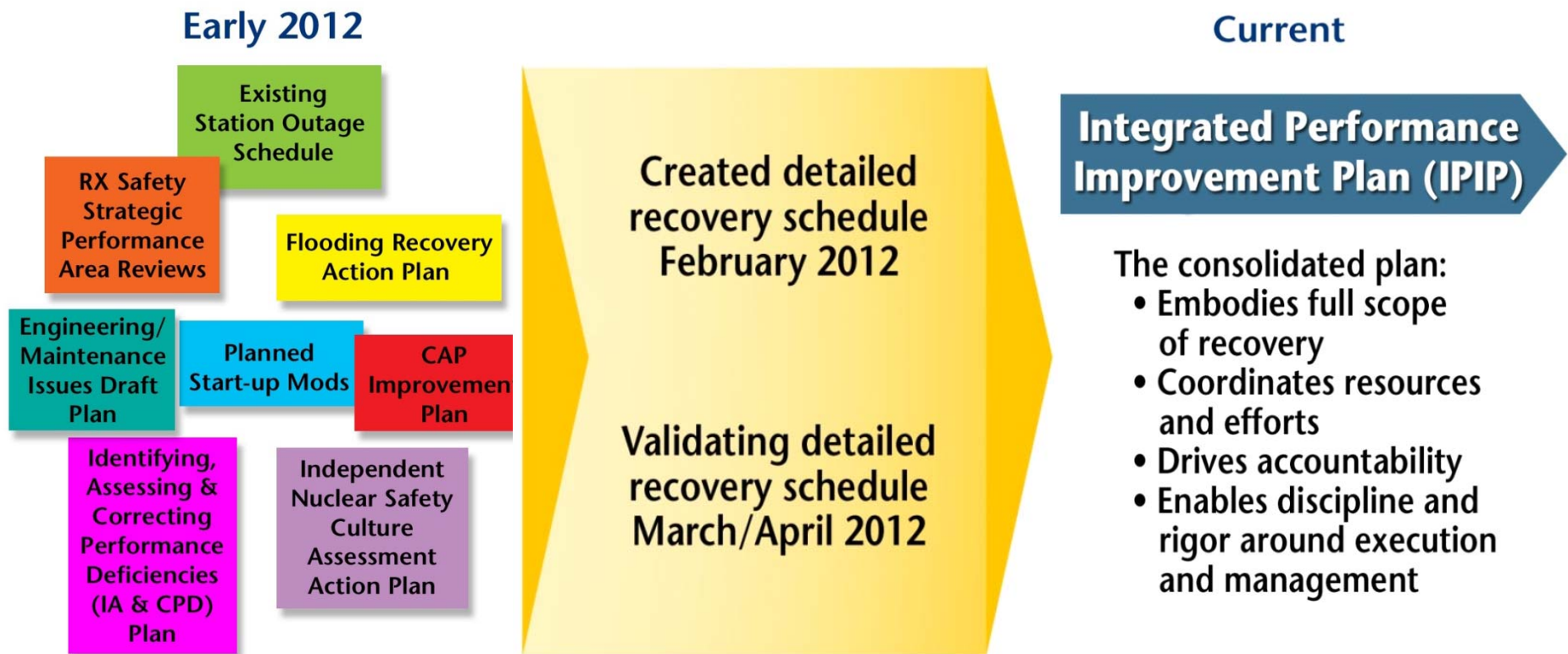



# Fort Calhoun Station Integrated Performance Improvement Plan



*Our History, Our Future*

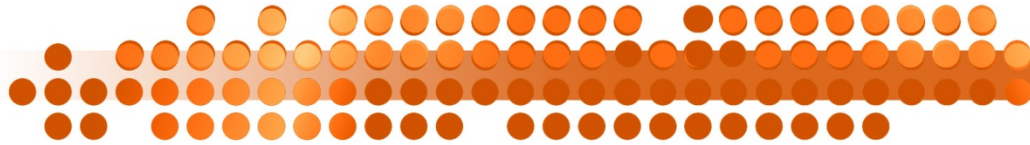

**Safety is  
our Top Priority**

**Identify and correct  
our performance issues**

**Return the station to service  
in a safe and cost effective way**



## Integrated Performance Improvement Plan

Systematic approach to performance improvement – four phases

Analysis

Evaluate significance and trends

Identify fundamental performance deficiencies

Implement corrective action



## Flooding Recovery Plan



- ☑ Flood damage repair complete
- ☑ Flooding lessons learned included in plant procedures
- ☑ Remaining issues added to IPIP

## Reactor Safety Review



- 4160/480 volt AC
- 125 volt DC/Emergency Batteries
- High Pressure Safety Injection



## Reactor Safety Review

- Selection based on nuclear safety significance
- Six key attributes addressed
  - Design
  - Equipment Performance
  - Configuration Control
  - Procedure Quality
  - Human Performance
  - Emergency Response Organization Readiness

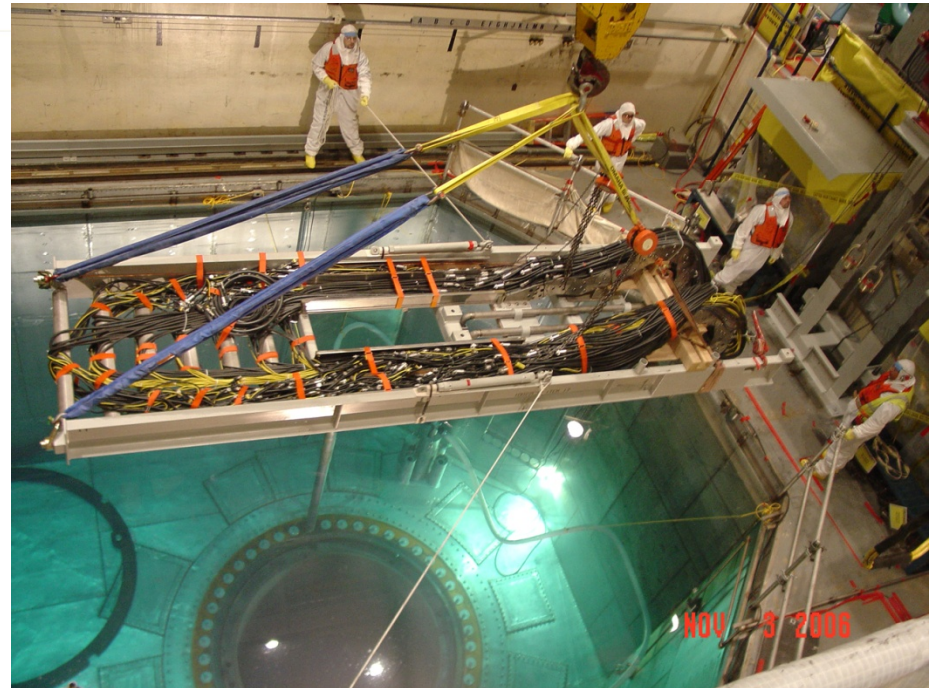

## Identifying and Correcting Performance Deficiencies

- Review of processes for finding and fixing problems
- Ten assessment areas
  - Audits and oversight
  - Historical Data Review and trending



## Nuclear Safety Culture Assessment

- Areas of focus:
  - Survey
  - Interviews: One-on-one and focus groups
  - Observations and document reviews
- Conducted by recognized experts
- Results discussed with NRC and at a future public meeting

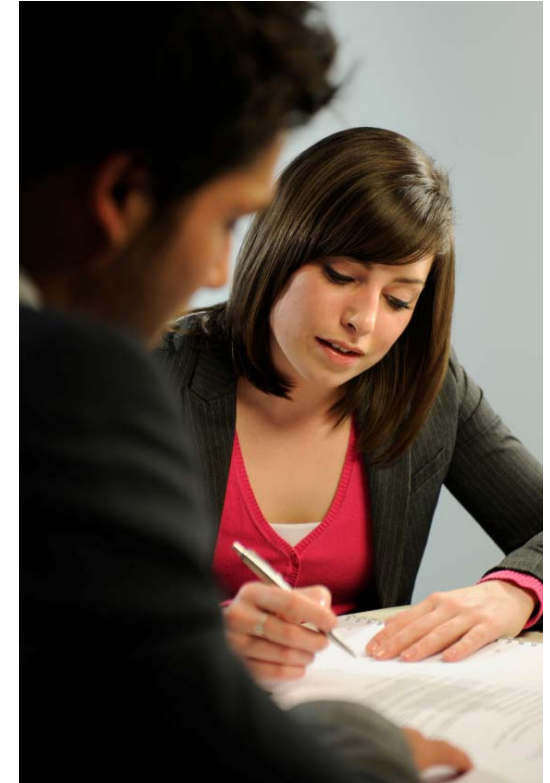



## Engineering/Maintenance Issues



- Scope - Resolution of design and program issues:
  - Vendor manuals
  - Equipment service life
  - Degraded/non-conforming conditions
  - Vendor design changes



# Summary

- Integrated Improvement plan established
- Staffing and resources in place
- Work has begun
- Progress is being made



Fort Calhoun Station  
Division Manager

# **WOODY GOODELL**

## **CORRECTIVE ACTION PROGRAM**



## Corrective Action Program

- Improved CAP culture
  - ☑ Key to Station improvement
  - ☑ Comprehensive program improvement
  - ☑ Training being completed



## Corrective Action Program



- Enhanced management involvement
- Reinforcing behaviors
- Multi-disciplinary screening team
- Established new positions

## Corrective Action Program



- Safety Culture Assessment will refine actions
- Behavioral changes take time
- Seeing improvements
- Future state



Fort Calhoun Station  
Plant Manager

# MIKE PROSPERO

## PLANT STATUS



June 2011



August 2011

August 2011



March 2012

*your energy partner*

**OPPD**  
Omaha Public Power District



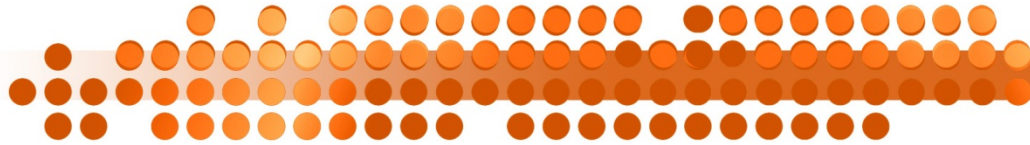

# Plant Status

June 2011



March 2012



Looking Down the Access Road towards the Plant



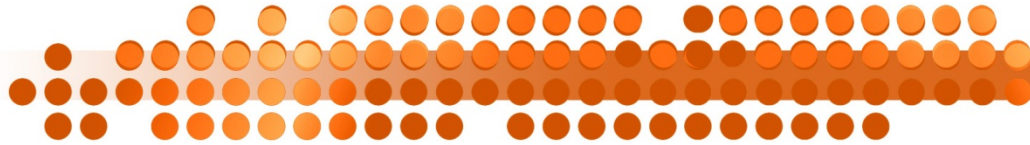

# Plant Status

June 2011



March 2012



View of Plant from Access Bridge

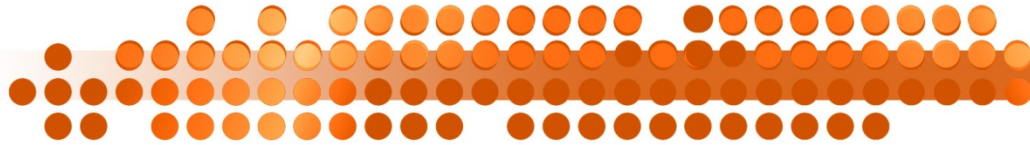

# Plant Status

June 2011



March 2012



Walkway Exiting the Plant



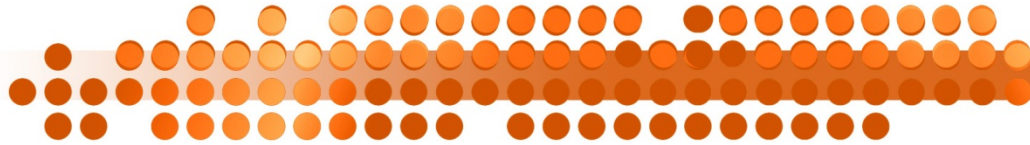

# Plant Status

June 2011



March 2012



View of River from Plant



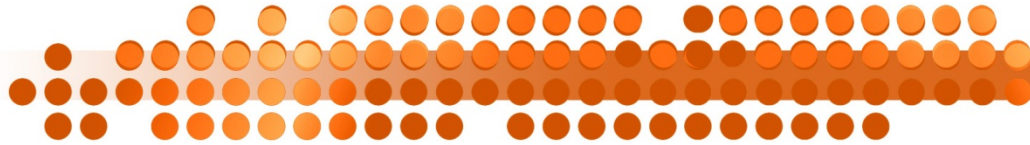

# Plant Status

## Flood Cleanup Activities

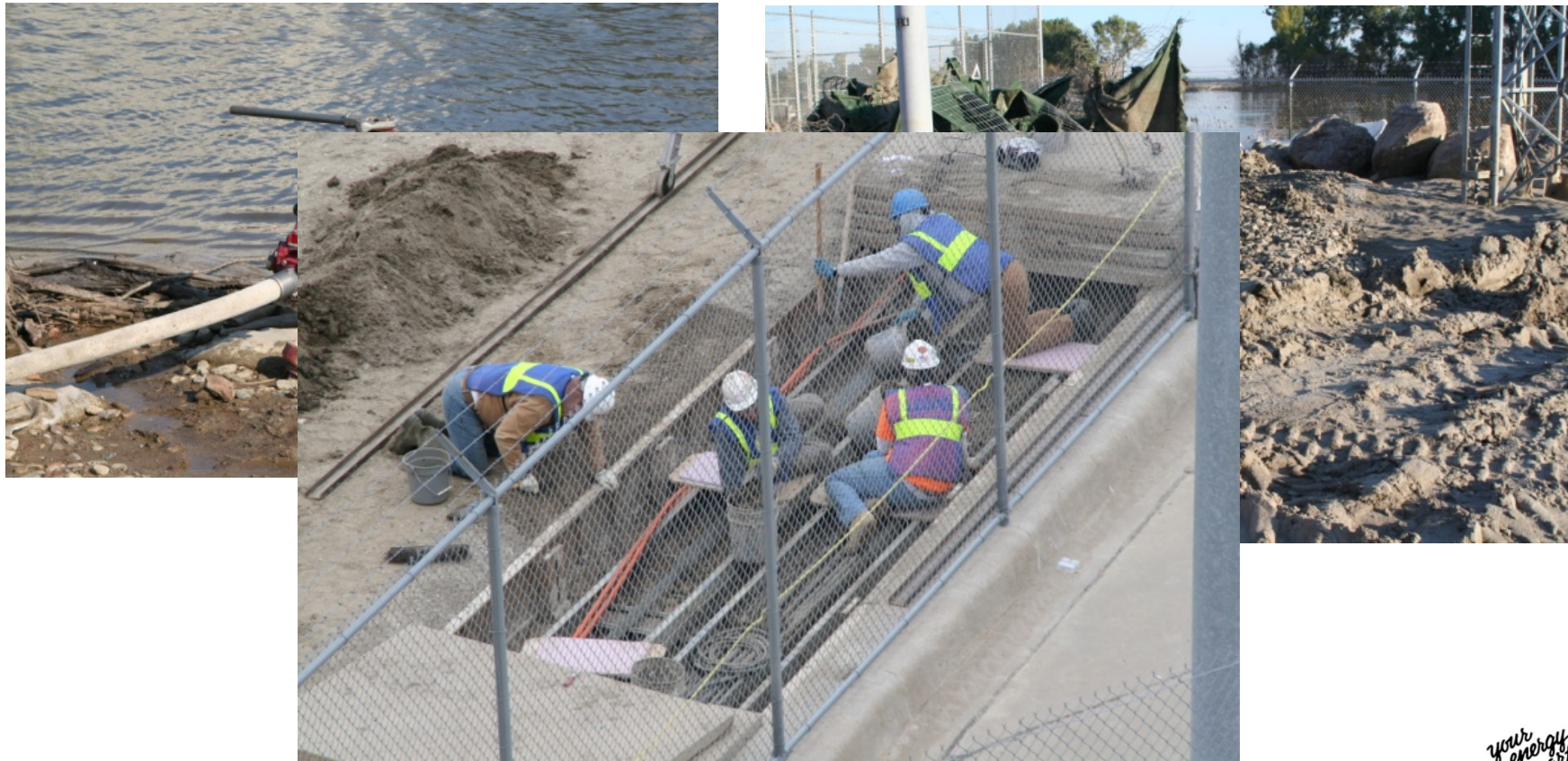

# Plant Status

- Plant in cold shutdown
- Safe condition
- Maintenance and testing activities in progress



4/6/2012



# Plant Status

- Meteorological Tower
  - Out of service due to flooding
  - Received weather information from other sources
  - Operational





# Plant Status



**Restored Switchgear 1B4A**

- Electrical equipment restoration
  - ✓ Fire damaged electrical equipment repaired
  - ✓ Tested
  - ✓ Re-energized
  - ✓ Returned to normal electrical alignment

# Lessons Learned

## Procedural Guidance Upgraded

### FORT CALHOUN STATION

- ☑ FCSG-63, “Establishing Incident Command” implemented
- ☑ FCSG-64, “External Flooding of Site” implemented

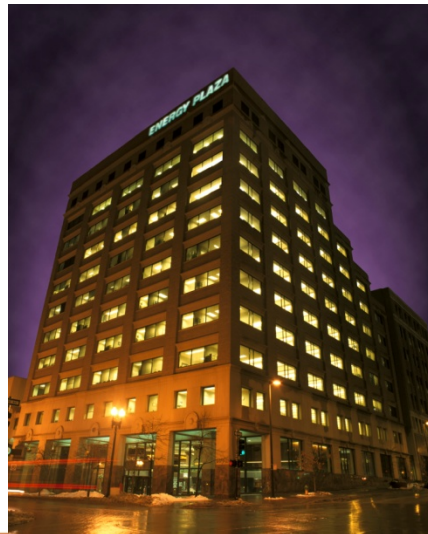
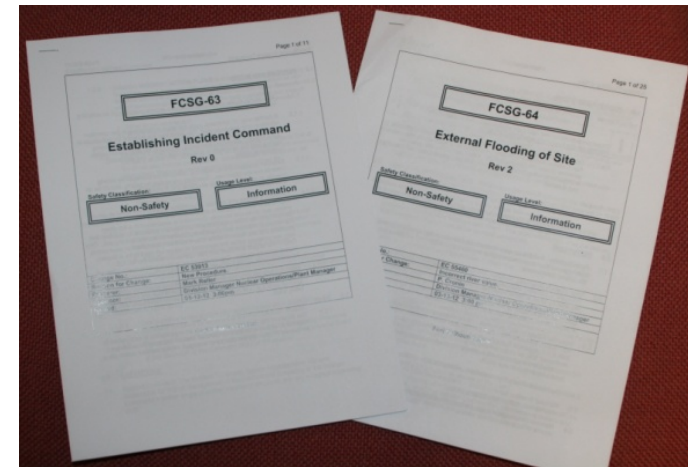

### OMAHA PUBLIC POWER DISTRICT

- ☑ Business Continuity Plan updated to incorporate lessons learned



# Lessons Learned

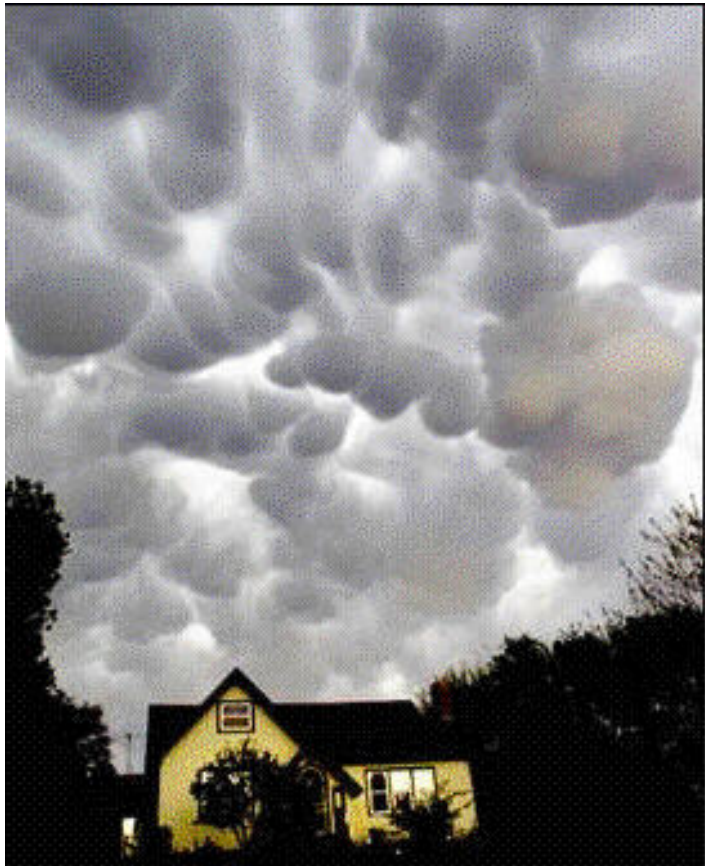

## Abnormal Operating Procedure Enhanced

- ☑ AOP-01, “Acts of Nature” updated with enhanced flooding actions.

# Lessons Learned



☑ EPIP-TSC-2, “Catastrophic Flooding Preparations” updated



# Lessons Learned

## AC Power Reliability Re-Evaluated based on Flooding Event Length

- ☑ New method to transfer diesel fuel during flooding



# Lessons Learned

## Building and Floor Penetrations Sealed and Certified

- ☑ Approximately 375 penetrations (electrical conduit, piping runs, etc.) were sealed and certified



# Lessons Learned

## Below-Ground Surveys Conducted

- No significant impacts identified to date

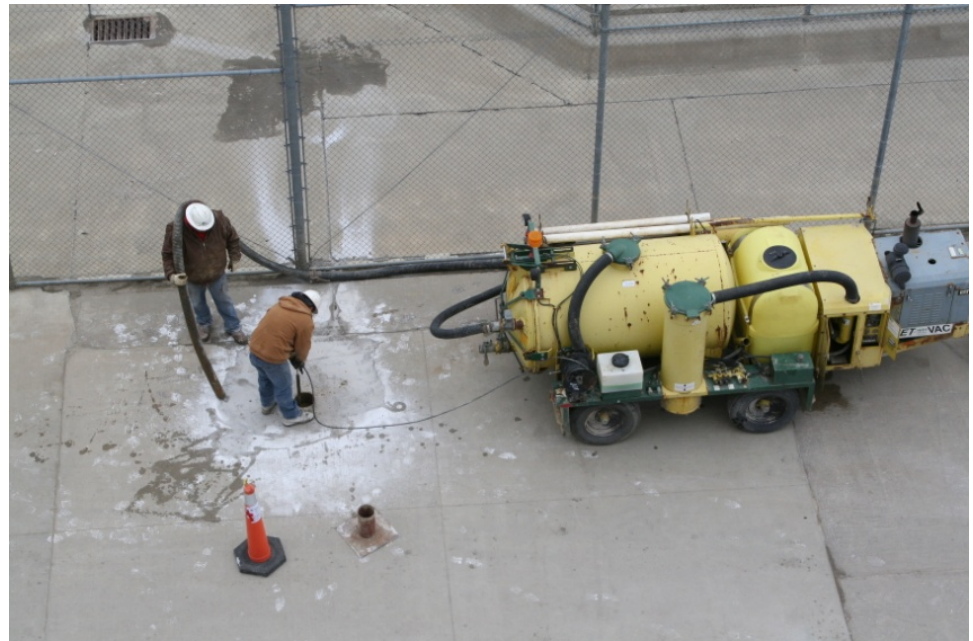



# Flood Readiness

## Intake structure

- Evaluating equipment classification
- Changed operating procedures
- Actions needed to protect the sluice gates and motor operated valves from river debris during a flood
- Interim compensatory measures

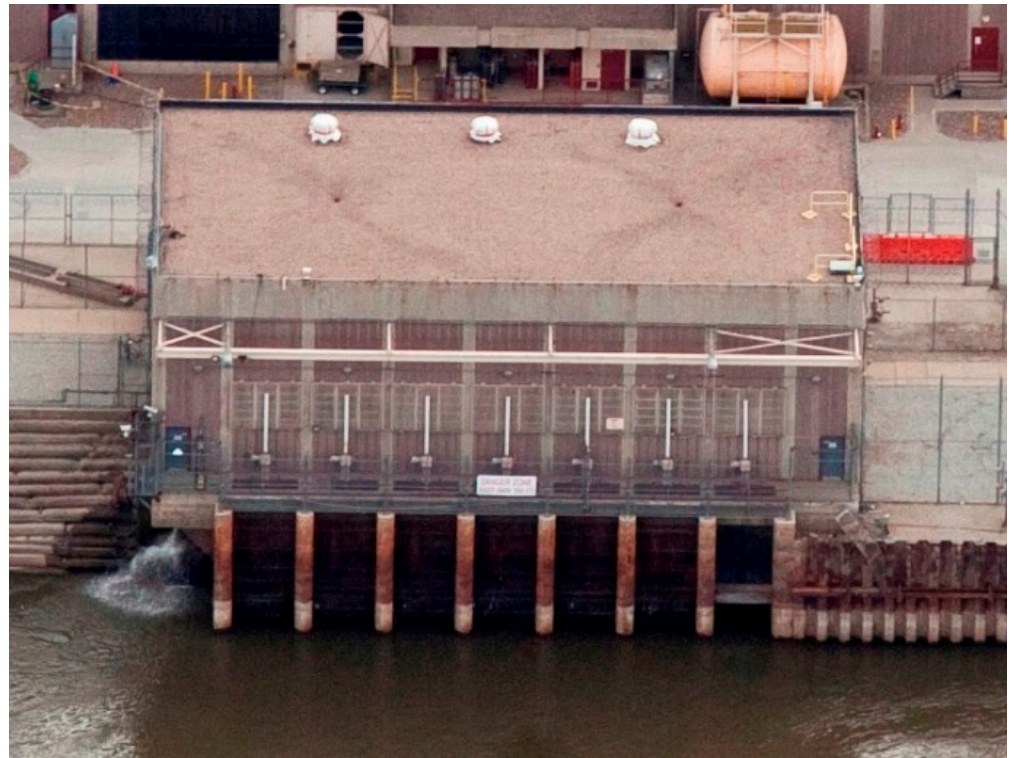



# Plant Status

## Public Warning Sirens

- 101 Sirens
- Several lost power during flood
  - Sirens operable
- Recent Siren Outage



# NRC Inspection Readiness

- Actions to improve inspection readiness
  - Detailed self-assessments



# NRC Inspection Readiness

- Actions to improve inspection readiness
  - Senior management led challenge boards



# NRC Inspection Readiness

- Triennial Fire Protection Inspection Conducted Last Week



- First of two weeks of inspection (will be back April 9<sup>th</sup>)
- Working on items identified





# NRC Inspection Readiness

- Emergency Planning Inspection Conducted Last Week

- Evaluated Exercise with States and Counties

“The Nuclear Regulatory Commission concluded that the overall Emergency Planning Organization performance continued to provide confidence in Fort Calhoun’s ability to implement the major elements of the emergency plan and protect the health and safety of the public.”

*Senior Inspector, NRC Region IV*



Fort Calhoun Station  
Division Manager Engineering

# **JOHN HERMAN**

## **ELECTRICAL FIRE**

# 480-Volt Load Center



4/6/2012



# 480-Volt Load Center

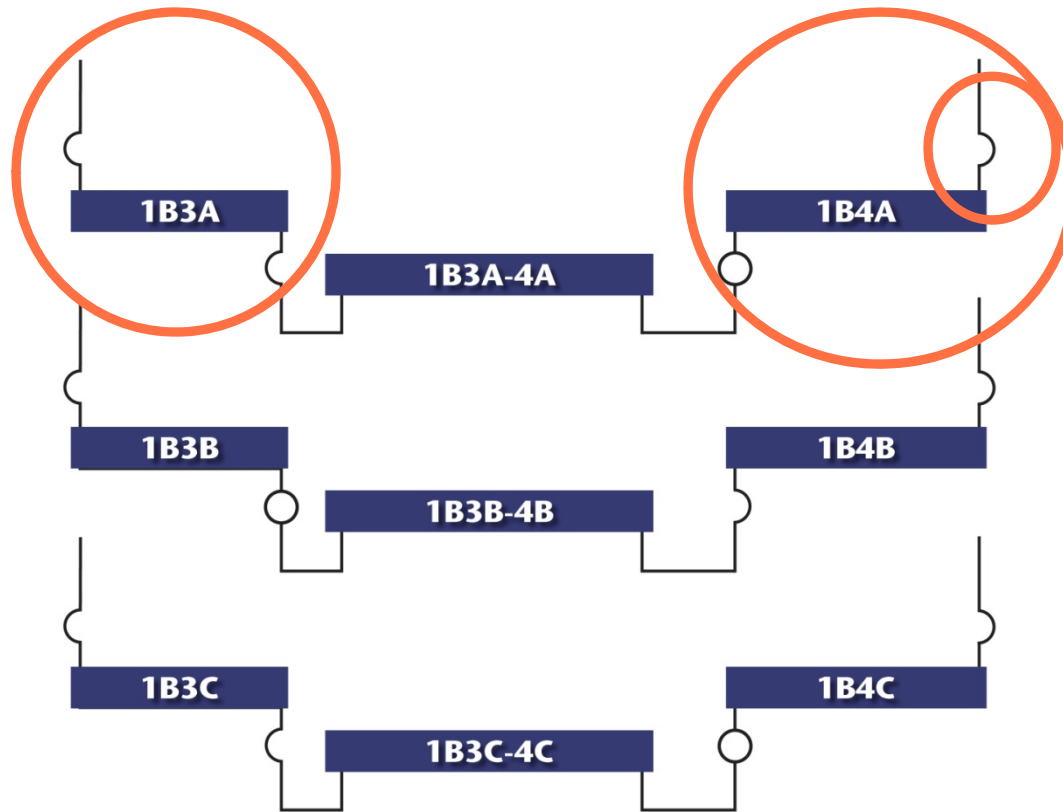

# Load Center with Breaker



4/6/2012



# Event

- June 7, 2011 – Electrical fault caused a fire in 480 volt load center 1B4A
  - Fire damage required complete replacement of load center 1B4A
  - No other load centers were damaged by the fire





# Event

- Soot from the fire caused supply breaker 1B3A to trip on over-current
  - Breaker was reset and power restored to 1B3A
  - There was no damage to load center 1B3A



# Priorities

- Safety
- Quality
- Timeliness

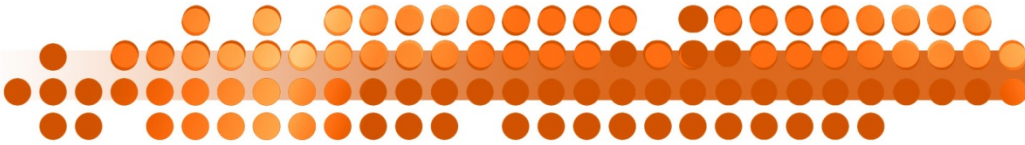

**Elevated Walkways  
to get around plant**



**Looking Down the Access  
Road towards the Plant**





# Response Activities

- Fire occurred on Tuesday, June 7, 2011
- A forensic engineering company was on-site to begin fire investigation by Friday
- Demolition work could not begin until fire investigation was complete

# Response Activities



**Due to flooding, materials to rebuild on-site had to be brought in via barge**

- Replacement electrical equipment had to be custom built to fit the existing equipment
- Two options considered:
  - Build the entire load center off-site
  - Rebuild in place one-site

# Response Activities

- Work had to be performed in series to ensure no more than one additional load center was removed at a time
- Engineering design package
- 1B3A root cause analysis







# Response Timeline

- 6/7/11 Fire event
- 6/10/11 Engineering work started
- 7/23/11 Demolition and reconstruction work started
- 8/29/11 Flood level below 1004' msl – site recovery started
- 9/12/11 Root cause analysis for fire completed
- 10/27/11 Reconstruction work finished
- 12/9/11 Extent of condition work completed
- 2/17/12 Engineering work completed
- 3/5/12 1B4A load center energized for testing



# Lessons Learned

- Following the fire, the Fort Calhoun Station:
  - Acted promptly to investigate the fire
  - Determined the cause
  - Began the engineering work
  - Procure new electrical equipment



# Lessons Learned

- Timely completion of EOC work
- Timely completion of design package
- Appropriate resources allocated





# Root Cause Analysis Terminology

- **Direct Cause** – the physical condition that created the failure
- **Root Cause** - the situation that allowed the physical condition to exist, if corrected would have prevented the event from occurring



# Root Cause Analysis Terminology

- **Contributing Cause** – increases the likeliness or severity of an occurrence
- **Extent of Condition** – describes other equipment that could have the same physical condition that led to the failure
- **Extent of Cause** – describes how the root cause could impact other equipment and processes

# Current Root Cause Analysis



Circuit Breaker Finger & Stab

Direct cause of the fire  
in load center 1B4A

- High resistance electrical connection failed

Direct cause of the  
1B3A breaker trip

- Overcurrent condition



# Bus-tie breaker and 1B3A supply breaker both tripped

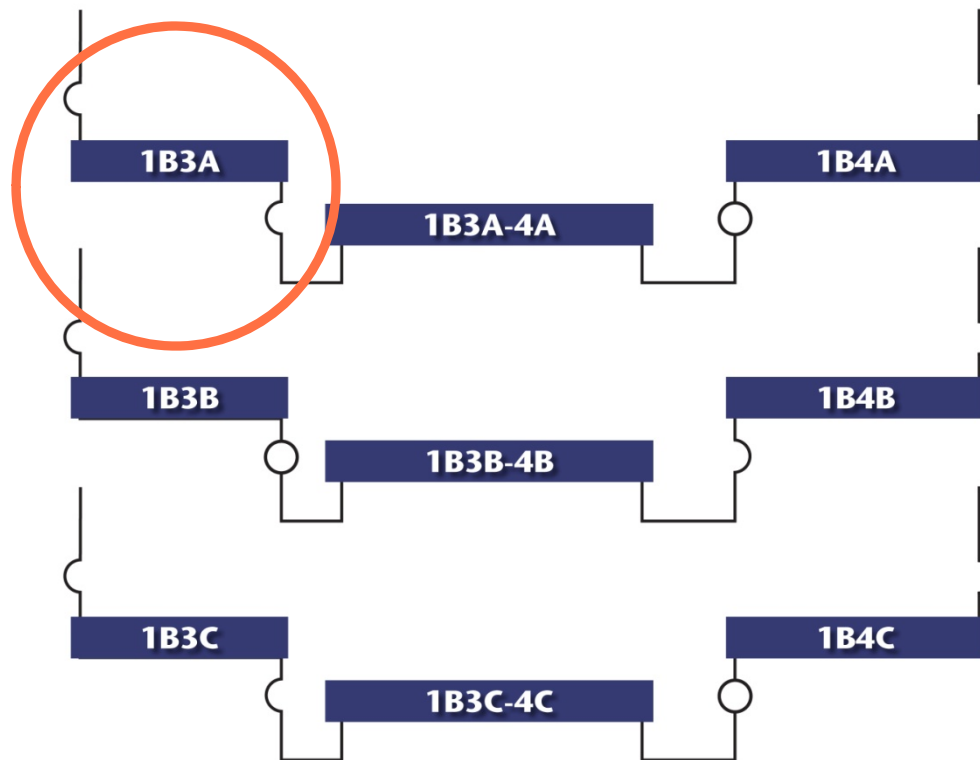

# 480-Volt Load Center



4/6/2012

# 1B3A Breaker

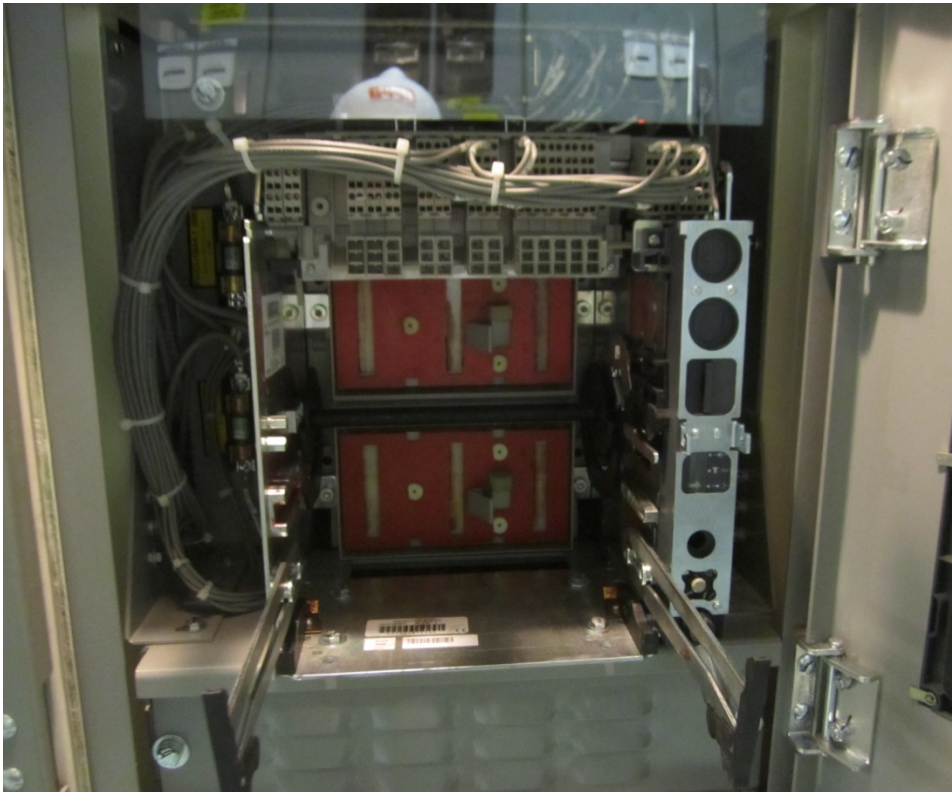

- The two breakers were removed from the plant and tested together at the testing facility



# 1B3A Breaker Jumper

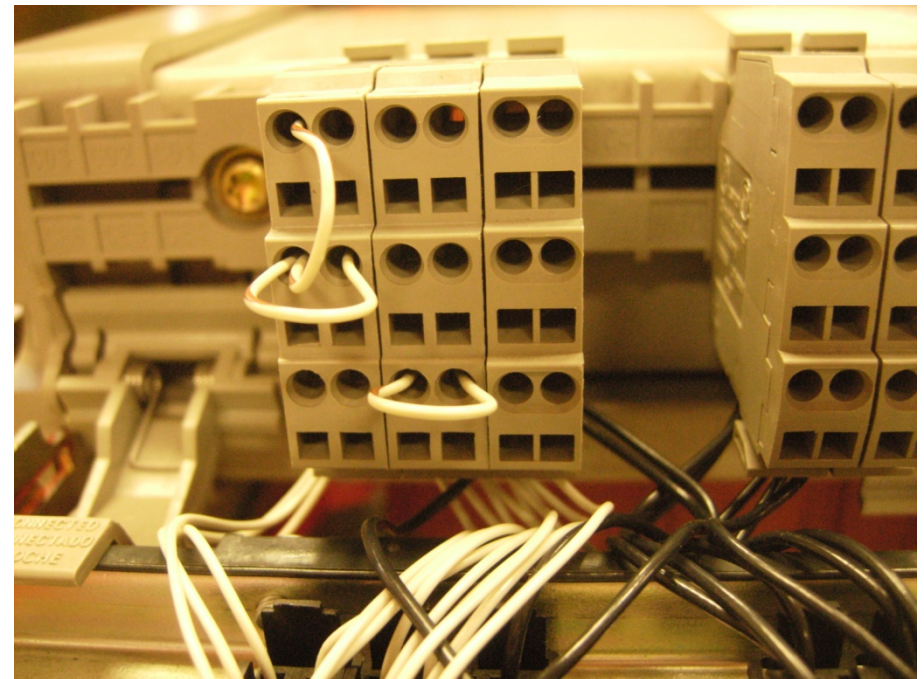
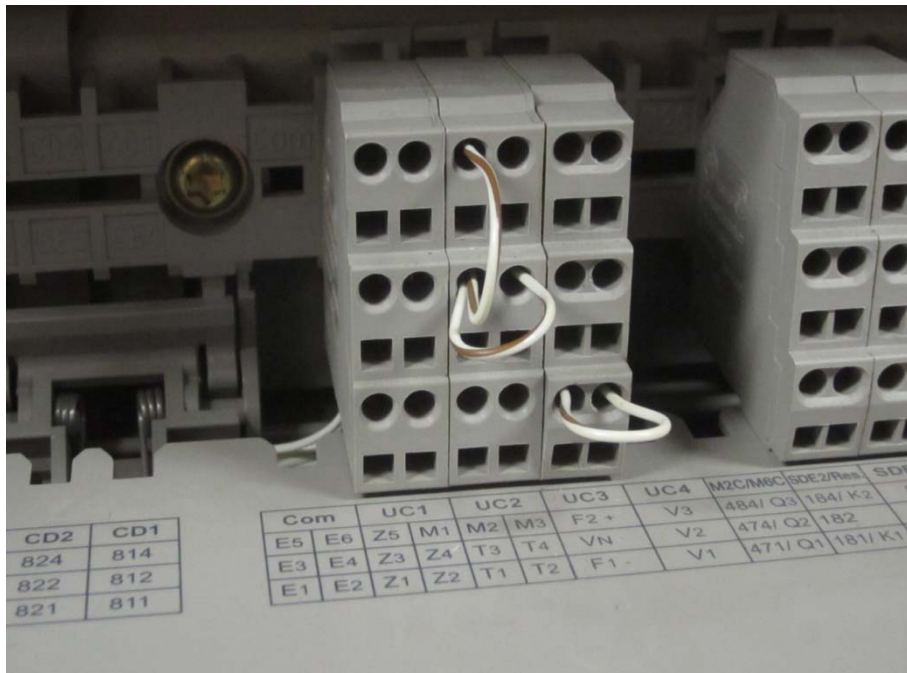



# 1B3A Breaker

- Design change procedures do not provide guidance to evaluate the impact of unused design features
- Training not provided on unique features of new equipment

# Corrective Actions

- Demolition and clean-up after the fire
- Fabrication and reconstruction of 1B4A
- Extent of condition investigations and repairs on other 480 VAC circuit breakers
- Remove hardened grease



# Corrective Actions



4/6/2012





# Corrective Actions

- ☑ Procedures were changed to include specific guidance on identifying critical characteristics
- ☑ Expanded the requirements for researching operating experience during design process
- ☑ More detailed instructions for cleaning breaker stabs



# Corrective Actions

- ☑ Review of in-progress modifications
- ☑ Review of previously completed modifications (in-progress)
- ☑ New thermography procedure for investigating unusual “odors”
- ☑ Quality audit of equipment supplier



# Corrective Actions

- ☑ Verified other jumpers installed correctly
- ☑ Identified other equipment supplied by same vendor

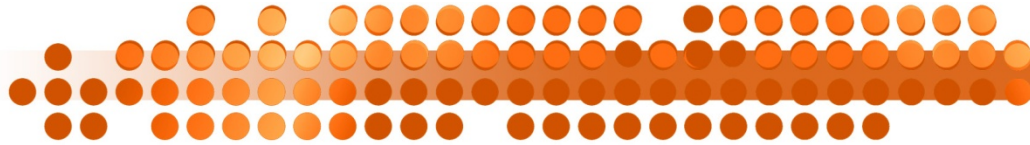

4/6/2012





Fort Calhoun Station

Vice President & Chief Nuclear Officer

# DAVID BANNISTER

## LOOK AHEAD AND CLOSING REMARKS