



International Agreement Report

Assessment of TRACE 4.160 and 5.0 against RCP Trip Transient in Almaraz I Nuclear Power Plant

Prepared by:

C. Queral*, A. Expósito*, G. Jiménez*, L. Valle*, and J. Carlos Martínez-Murillo**

*Universidad Politécnica de Madrid
Alenza 4. 28003 Madrid
Spain

**Almaraz-Trillo AIE
Avenida de Manoteras 46 Bis. 28050 Madrid
Spain

A. Calvo, NRC Project Manager

**Office of Nuclear Regulatory Research
U.S. Nuclear Regulatory Commission
Washington, DC 20555-0001**

July 2010

Prepared as part of
The Agreement on Research Participation and Technical Exchange
Under the Thermal-Hydraulic Code Applications and Maintenance Program (CAMP)

**Published by
U.S. Nuclear Regulatory Commission**

**AVAILABILITY OF REFERENCE MATERIALS
IN NRC PUBLICATIONS**

NRC Reference Material

As of November 1999, you may electronically access NUREG-series publications and other NRC records at NRC's Public Electronic Reading Room at <http://www.nrc.gov/reading-rm.html>. Publicly released records include, to name a few, NUREG-series publications; *Federal Register* notices; applicant, licensee, and vendor documents and correspondence; NRC correspondence and internal memoranda; bulletins and information notices; inspection and investigative reports; licensee event reports; and Commission papers and their attachments.

NRC publications in the NUREG series, NRC regulations, and *Title 10, Energy*, in the Code of *Federal Regulations* may also be purchased from one of these two sources.

1. The Superintendent of Documents
U.S. Government Printing Office
Mail Stop SSOP
Washington, DC 20402-0001
Internet: bookstore.gpo.gov
Telephone: 202-512-1800
Fax: 202-512-2250
2. The National Technical Information Service
Springfield, VA 22161-0002
www.ntis.gov
1-800-553-6847 or, locally, 703-605-6000

A single copy of each NRC draft report for comment is available free, to the extent of supply, upon written request as follows:

Address: U.S. Nuclear Regulatory Commission
Office of Administration
Reproduction and Mail Services Branch
Washington, DC 20555-0001

E-mail: DISTRIBUTION@nrc.gov
Facsimile: 301-415-2289

Some publications in the NUREG series that are posted at NRC's Web site address <http://www.nrc.gov/reading-rm/doc-collections/nuregs> are updated periodically and may differ from the last printed version. Although references to material found on a Web site bear the date the material was accessed, the material available on the date cited may subsequently be removed from the site.

Non-NRC Reference Material

Documents available from public and special technical libraries include all open literature items, such as books, journal articles, and transactions, *Federal Register* notices, Federal and State legislation, and congressional reports. Such documents as theses, dissertations, foreign reports and translations, and non-NRC conference proceedings may be purchased from their sponsoring organization.

Copies of industry codes and standards used in a substantive manner in the NRC regulatory process are maintained at—

The NRC Technical Library
Two White Flint North
11545 Rockville Pike
Rockville, MD 20852-2738

These standards are available in the library for reference use by the public. Codes and standards are usually copyrighted and may be purchased from the originating organization or, if they are American National Standards, from—

American National Standards Institute
11 West 42nd Street
New York, NY 10036-8002
www.ansi.org
212-642-4900

Legally binding regulatory requirements are stated only in laws; NRC regulations; licenses, including technical specifications; or orders, not in NUREG-series publications. The views expressed in contractor-prepared publications in this series are not necessarily those of the NRC.

The NUREG series comprises (1) technical and administrative reports and books prepared by the staff (NUREG-XXXX) or agency contractors (NUREG/CR-XXXX), (2) proceedings of conferences (NUREG/CP-XXXX), (3) reports resulting from international agreements (NUREG/IA-XXXX), (4) brochures (NUREG/BR-XXXX), and (5) compilations of legal decisions and orders of the Commission and Atomic and Safety Licensing Boards and of Directors' decisions under Section 2.206 of NRC's regulations (NUREG-0750).

DISCLAIMER: This report was prepared under an international cooperative agreement for the exchange of technical information. Neither the U.S. Government nor any agency thereof, nor any employee, makes any warranty, expressed or implied, or assumes any legal liability or responsibility for any third party's use, or the results of such use, of any information, apparatus, product or process disclosed in this publication, or represents that its use by such third party would not infringe privately owned rights.



International Agreement Report

Assessment of TRACE 4.160 and 5.0 against RCP Trip Transient in Almaraz I Nuclear Power Plant

Prepared by:

C. Queral*, A. Expósito*, G. Jiménez*, L. Valle*, and J. Carlos Martínez-Murillo**

*Universidad Politécnica de Madrid
Alenza 4. 28003 Madrid
Spain

**Almaraz-Trillo AIE
Avenida de Manóteras 46 Bis. 28050 Madrid
Spain

A. Calvo, NRC Project Manager

**Office of Nuclear Regulatory Research
U.S. Nuclear Regulatory Commission
Washington, DC 20555-0001**

July 2010

Prepared as part of
The Agreement on Research Participation and Technical Exchange
Under the Thermal-Hydraulic Code Applications and Maintenance Program (CAMP)

**Published by
U.S. Nuclear Regulatory Commission**

ABSTRACT

The Energy Systems Department of Universidad Politécnica de Madrid has developed a model of Almaraz NPP, Westinghouse three loops PWR design, for TRACE code in the framework of several projects sponsored by the Spanish Nuclear Regulatory Commission (CSN) and the Electric Energy Industry of Spain (UNESA). At present, a full power and a shutdown model are applied for sequences analysis. The model has been adjusted at several power rates and steady state results show good agreement with plant data. In order to check the whole model, a wide spectrum of transient simulations were performed, observing a good behavior. For partial fulfilment of the bilateral - agreement for cooperation in thermalhydraulic activities between the Consejo de Seguridad Nuclear of Spain (CSN) and the United States Nuclear Regulatory Commission (US-NRC), the simulation of single RCP trip transient that took place in Almaraz NPP on May 13 (2002) has been performed, comparing the results obtained with plant data. The data comparison was quite encouraging when TRACE version 4.160 is used. However, the results obtained using TRACE 5.0 were not satisfactory. Wrong predictions were obtained for the steam flow through the Steam Dump valves during the transient. Regardless of this problem, the work made allowed performing the first validation transient with the plant model. The simulations have been run in a Pentium IV 3.4 MHz under Windows XP and AMD Opteron Dual Core Processors 180 & 1222 under Debian Linux, both with 32 and 64 bits executables. This work has been sponsored by UNESA and Almaraz-Trillo AIE.

FOREWORD

This report represents one of the assessment/application calculations submitted in fulfillment of the bilateral agreement for cooperation in thermohydraulic activities between the Consejo de Seguridad Nuclear (CSN) and the US Nuclear Regulatory Commission (USNRC) in the form of Spanish contribution to the Code Assessment and Management Program (CAMP) of the USNRC, whose main purpose is the validation of TRACE code.

The CSN and UNESA (the association of the Spanish utilities), together with some relevant universities, have set up a coordinated framework (CAMP-Spain), whose main objectives are the fulfillment of the formal CAMP requirements and the improvement of the quality of the technical support groups that provide services to the Spanish utilities, the CSN, the research centers and the engineering companies.

This report is one of the Spanish utilities contribution to the above mentioned CAMP-Spain program and it has been reviewed by the AP-28 Project Coordination Committee for the submission to the CSN.

CONTENTS

	<u>Page</u>
Abstract	iii
Foreword	v
Executive Summary	xi
Abbreviations	xiii
1 Introduction	1-1
2 Description of the Almaraz I NPP	2-1
3 Description of Almaraz I NPP TRACE Model	3-1
4 Verification of Almaraz I NPP TRACE Model	4-1
5 Description of the One RCP Trip Transient	5-1
5.1 Evolution of Primary Parameters	5-1
5.2 Evolution of Secondary Parameters	5-6
6 Analysis of the Simulation Results with TRACE 4.160	6-1
6.1 Boundary Conditions	6-1
6.2 Results from the Simulation	6-4
7 Sensitivity Analysis with TRACE 4.160	7-1
8 Problems Found in the Simulation Using TRACE 5.0	8-1
9 Execution Statistics	9-1
10 Graphical Interface of the Almaraz I NPP TRACE Model	10-1
11 Conclusions	11-1
12 References	12-1
Appendix A. TRACE 5.0 Opening Valve Flow Problem Reported	A-1

Figures

	<u>Page</u>
1 Almaraz I NPP general scheme	2-1
2 Almaraz I NPP primary and secondary (from SGs to steam collector) schemes .	2-3
3 Almaraz I NPP secondary scheme from steam collector to high and low pressure turbines	2-4
4 Almaraz I NPP MFWS/AFWS scheme	2-5
5 Simplified nodalization of the Almaraz I NPP TRACE model	3-2
6 Vessel nodalization of Almaraz I NPP TRACE model	3-3
7 Transit time and cross area sections for primary loop 2. Nominal flow conditions.	3-4
8 Primary loops mass flow rates (plant data)	5-3
9 Averaged temperature (plant data)	5-3
10 Cold leg temperature. Loops 1, 2 and 3 (plant data)	5-4
11 Hot leg temperature. Loops 1, 2 and 3 (plant data)	5-4
12 Pressurizer pressure (plant data)	5-5
13 Pressurizer level (plant data)	5-5
14 Steam dump control in temperature mode with turbine trip	5-6
15 MFW mass flow rate - SG1, SG2 and SG3 (plant data)	5-7
16 Steam generators narrow range level (plant data)	5-7
17 Steam generators pressure (plant data)	5-8
18 MFW mass flow rates - SG1, SG2 and SG3 (plant data)	6-1
19 MFW temperature - SG1, SG2 and SG3 (plant data)	6-2
20 AFW mass flow rate - SG1 (plant data)	6-2
21 AFW mass flow rate - SG2 (plant data)	6-3
22 AFW mass flow rate - SG3 (plant data)	6-3
23 Loop 2 hot leg water temperature during the simulation of RCP trip transient .	6-8
24 Loop 2 mass flow during the simulation of RCP trip transient. TRACE 4.160 model	6-9
25 Loops 1 and 3 mass flows during the simulation of RCP trip transient. TRACE 4.160 model	6-9
26 Loop 2 temperatures during the simulation of RCP trip transient. TRACE 4.160 model	6-10

27	Loops 1 and 3 temperatures during the simulation of RCP trip transient. TRACE 4.160 model	6-10
28	Steam generators pressure during the simulation of RCP trip transient. TRACE 4.160 model	6-11
29	Steam generators narrow range calibrations	6-12
30	Steam generators narrow range levels during the simulation of RCP trip transient. TRACE 4.160 model	6-13
31	Pressurizer level during the simulation of RCP trip transient. TRACE 4.160 model	6-13
32	Pressurizer pressure during the simulation of RCP trip transient. TRACE 4.160 model	6-14
33	Pressure drops along primary system. TRACE 4.160 model	6-14
34	Improved nodalization of the steam dump system in SNAP	7-2
35	Loop 2 RCP angular velocity variation for nominal hydraulic torque reduction .	7-3
36	Hot leg 2 first peak temperature variation for nominal hydraulic torque reduction	7-3
37	Loop 2 mass flow rate variation for nominal hydraulic torque reduction	7-4
38	Loop 2 mass flows for different C_i par friction coefficients	7-4
39	RCP 2 angular velocities for different C_i par friction coefficients	7-5
40	Loop 2 hot leg higher temperature peak for different C_i par friction coefficients .	7-5
41	Loop 2 hot leg higher temperature peak variation for different nodalization schemes	7-6
42	Comparison of secondary pressure trends for RCP trip transient using TRACE 4.160 and 5.0	8-1
43	CPU time versus simulation time. TRACE versions 4.160 and 5.0 with Debian / AMD Opteron Dual Core Processor 180 system	9-1
44	SNAP animation mask for Almaraz I NPP model	10-1
45	CNA mask simulating RCP trip transient at 0, 292.5 and 759.6 s.	10-2
46	Valve opening for both code versions, TRACE 4.160 and 5.0	A-2
47	Mass flow rates with/without choked flow model on. TRACE 4.160 and 5.0 . . .	A-3
48	Mass flow rates for different valve aperture speeds. TRACE 4.160 and 5.0 . . .	A-3
49	Mass flow rates with choked flow model and different discharge coefficients. TRACE 4.160 and 5.0	A-4
50	Mass flow rates with/without choked flow model on. TRACE versions 4.160, 4.273, 5RC1 and 5.0	A-4

Tables

	<u>Page</u>
1 Main operating parameters of the Almaraz I NPP	2-2
2 Systems and controls actuated in the verification transients	4-2
3 Almaraz I NPP model steady states at different power levels	4-2
4 Time sequence for relevant events in the RCP trip validation transient	5-2
5 Comparison of steady state conditions of Almaraz I NPP plant and TRACE 4.160 model	6-7
6 Sequence events in the RCP trip validation transient	6-8

EXECUTIVE SUMMARY

A TRACE 4.160 simulation was conducted to assess code capability to predict RCP trip transient behavior in Almaraz I Nuclear Power Plant. In this transient, the RCP of the loop 2 (this loop has the pressurizer surge line connection) tripped and the reactor SCRAM is generated in a short time by the low flow in 1/3 loops coincident with permissive P8. After its demand, the reactor protection system starts the insertion of shutdown and control banks. After reactor SCRAM, primary temperatures decrease, leading to a decrease in pressurizer level and pressure. The turbine trip signal demands the turbine bypass opening. There are no reliable data about how the SD valves actuate during the transient, but it is clear that one or more valves did not fully close (because T_{avg} decreases below HZP value), so some assumptions had to be taken to reproduce the same plant behavior in secondary pressure.

The transient simulation was made using two versions of TRACE code, 4.160 and the last released, 5.0. Meanwhile the results obtained using TRACE 4.160 were accurate, TRACE 5.0 presented a non expected behavior in the calculation of mass flow rates during valve openings. This problem made unsuitable the transient simulation using this code version. Despite this problem, from the run statistics it was found that TRACE 5.0 is quite promising according to time execution. In fact, 5.0 version is 1.6 times faster than 4.160 version. Also, no significant differences were found between the results of different runs executed in Windows and Debian systems, and between 32 and 64 bits code versions.

ABBREVIATIONS

ACCS	Accumulators
AFWS	Auxiliary Feedwater System
BC	Boundary condition
CSN	Spanish Nuclear Regulatory Commission
CVCS	Chemical and Volume Control System
DSE-UPM	Departamento de Sistemas Energéticos - Universidad Politécnica de Madrid Department of Energy Systems - Technical University of Madrid
ECCS	Emergency Core Cooling System
F&B	Feed and Bleed
HPIS	High Pressure Injection System
LPIS	Low Pressure Injection System
MDP	Motor Driven Pump
MFWS	Main Feedwater System
MSIV	Main Steam Isolation Valve
MSLB	Main Steam Line Break
NPP	Nuclear Power Plant
PORV	Power Operated Relieve Valve
RCP	Reactor cooling Pump
RHRS	Residual Heat Removal System
RTD	Thermoresistance sensor
RV / SV	Relieve and Safety Valves
SD	Steam Dump
SG	Steam Generator
T	Temperature
TDP	Turbine Driven Pump
TLFW	Total Loss of Feedwater
UNESA	Electric Energy Industry of Spain

1 INTRODUCTION

Our group (DSE-UPM) began to work with RELAP5 code in 1997, [12]. Later, during the Consolidated Thermal-hydraulic Code project (1999-2002), DSE-UPM group performed the conversion of a RELAP5/MOD3 model of Almaraz I NPP to TRAC-M, [10]. This model was applied in the simulation of several nominal and shutdown transients. Finally, along 2005 the DSE-UPM group converted the TRAC-M model to the last code developed by the NRC, the TRACE code. The development of the Almaraz I NPP model for TRACE code has been framed within several national and international projects (CAMP, OECD/NEA SETH, OECD/NEA ROSA and OECD/NEA PKL-2) sponsored in Spain by Consejo de Seguridad Nuclear (CSN) and Electric Energy Industry of Spain (UNESA). In the Spanish national projects, one of the most important objectives is the maintenance and development of the Spanish NPP models with the thermal-hydraulic codes that were sponsored by NRC, such as RELAP5 and TRACE. Since 2005, a collaboration between Almaraz-Trillo AIE and our group is undergoing. The basic aim of this collaboration is the improvement of the Almaraz NPP model for TRACE code, and the work presented in this document is one of the activities made during last year, [5].

Almaraz NPP is owned by Iberdrola (53%), Endesa (36%) and Unión Fenosa (11%) located in Cáceres (Spain). This facility is a Westinghouse PWR with three loops and two turbines, high and low pressure turbines, in tandem compound. The nominal current power is 2739 MWt (year 2008), but it was 2686 MWt when the RCP trip transient took place (year 2002). Original Westinghouse steam generators, model D3, were replaced on 1996/7 with KWU Siemens steam generators model 61W/D3. These new steam generators do not have preheaters and the feedwater injects directly above the downcomer, through J-tubes.

Different transient simulations have been performed using the Almaraz I NPP model: several core power steady states, full power verification transients, simulations of loss of RHRS sequences in low power - shutdown plant configuration and a full power validation transient occurred in Almaraz I NPP. This document is mainly focused on the validation transient, related with the reactor trip induced by one RCP trip and the following steam dump partial malfunction, showing the results obtained.

The transient was initiated by an automatic trip of one RCP at about 100 % power in the Almaraz I NPP. In this transient, the RCP of the loop 2 (this loop has the pressurizer surge line connection) tripped and the reactor SCRAM is generated in a short time by the low flow in 1/3 loops coincident with permissive P8. After its demand, the reactor protection system starts the insertion of shutdown and control banks. After reactor SCRAM, primary temperatures decrease, leading to a decrease in pressurizer level and pressure, the minimum pressure value reached is 135.55 bar abs. The level decrease brings out a water mass flow discharge from the pressurizer to the hot leg of loop 2. During this discharge, the angular velocity of the tripped RCP is decreasing and then, the flow is inverted in loop 2.

In the secondary side, turbine trip signal demands the turbine bypass opening. There are no reliable data about how the steam dump valves actuated during the transient, but it is clear

that one or more valves did not fully close (because pressure behavior of steam generators and T_{avg} decreases below HZP value), so some assumptions had to be taken to reproduce the same plant behavior in secondary pressure.

This document presents:

- a brief description of the main design aspects of the Almaraz I NPP, section 2,
- a description of the relevant NPP TRACE model parts, section 3,
- a revision of the different transients run to model verification, section 4,
- the detailed description of the one RCP plant transient, section 5,
- the simulation results obtained using TRACE 4.160, section 6,
- an analysis of the different sensitivity tests carried out for this transient using TRACE 4.160, section 7,
- a description of the problems found during the transient simulation using TRACE 5.0, section 8, and
- a presentation of the Almaraz I NPP mask developed to perform simulations using SNAP animation capabilities, section 10.

This validation transient is the first of a series of validation transients which will be performed in the next future.

2 Description of the Almaraz I NPP

Almaraz NPP consists of two PWRs located in Cáceres (Spain) and it is owned by a consortium of three spanish utilities: Iberdrola (53%), Endesa (36%) and Unión Fenosa (11%). Commercial operation started in April 1.981 (Unit I) and in September 1.983 (Unit II). Each unit has a PWR Westinghouse with three loops and two turbines, high and low pressure turbines, in tandem compound. The nominal power is 2686 MWt and 977 MWe. It is equipped with three steam generators Siemens KWU 61W/D3. Reactor coolant pumps are type single stage, centrifugal model W-11011-A1 (93-D) designed by Westinghouse. The AFWs consists of one turbine driven pump and two motor driven pumps. More plant characteristics and plant schematic diagrams are shown in Table 1 and Figures 1 to 4.

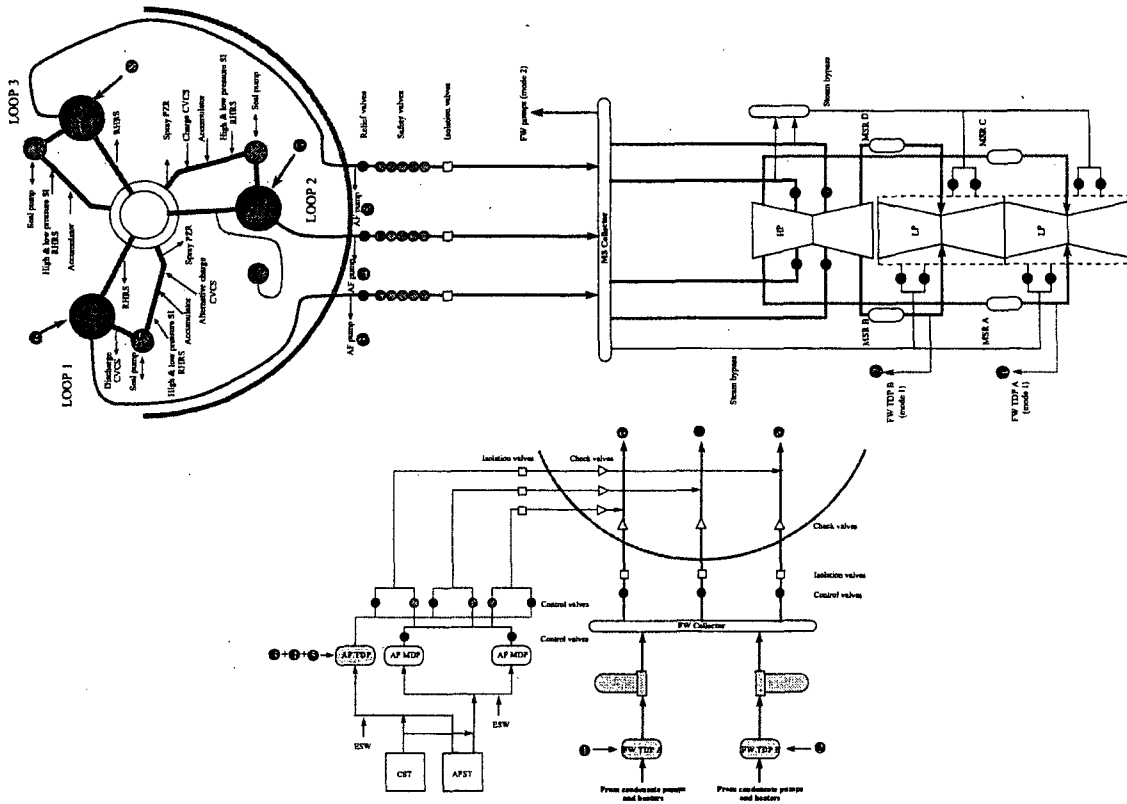

Figure 1: Almaraz I NPP general scheme

Table 1: Main operating parameters of the Almaraz I NPP

Description	Value
Thermal reactor power	2686 Mwt(*)
Fuel	UO ₂ + GdO ₂
Number of assemblies	157
Number of loops	3
Reactor operating pressure	155.017 bar
Coolant averaged temperature	
Zero load	564.9 K
100 %	580.8 K
Steam generators	Siemens KWU 61W/D3
Number of tubes (per SG)	5130
Total tube length (per SG)	108294.3 m
Tube inner diameter	17.96 mm
Tube material	INCOLOY 800
Pumps type	Centrifugal model W-11011-A1 (93-D)
Pump discharge head	86.26 m
Design flow rate	6.27 m ³ /s
Pump speed	155.509 rad/s
Primary volumes	
Vessel	100.81 m ³
Hot leg (x3)	3.18 m ³
Steam generator (x3)	32.28 m ³
Cross leg (x3)	3.6 m ³
Reactor coolant pump (x3)	4.02 m ³
Cold leg (x3)	3.23 m ³
Surge line	1.14 m ³
Pressurizer	39.64 m ³
Spray lines	0.45 m ³
TOTAL	280.97 m ³
Number of PZR relieve / safety valves	2 / 3
Number of PZR spray valves	2
Heaters capacity (proportional/backup)	(377 kW / 1023 kW)
Maximum spray flow	0.022 m ³ /s·valve
Steam mass flow rate at 100%	
SG1	489 kg/s
SG2	486 kg/s
SG3	500 kg/s

* At present (2008), plant power is 2739 MWt

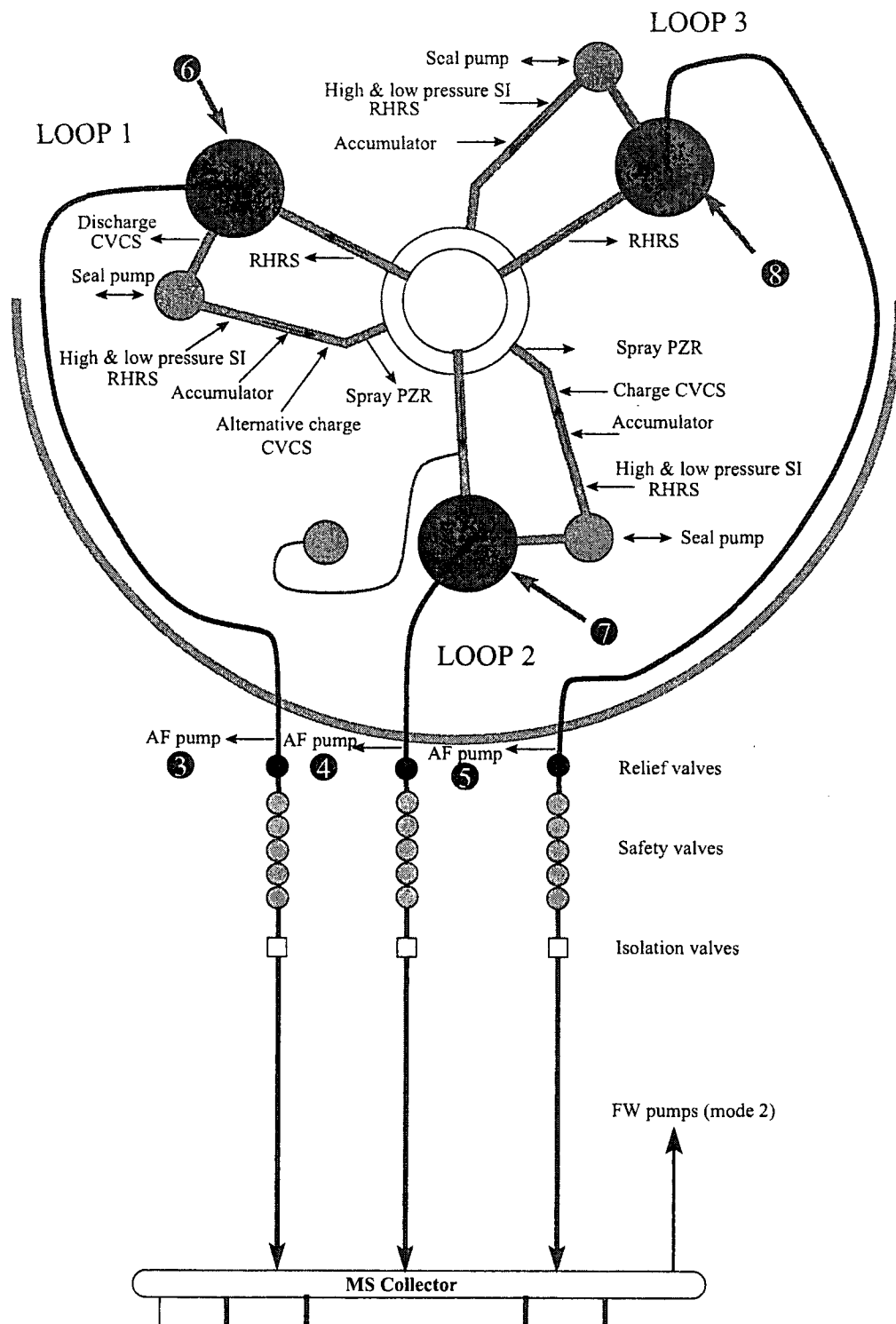

Figure 2: Almaraz I NPP primary and secondary (from SGs to steam collector) schemes

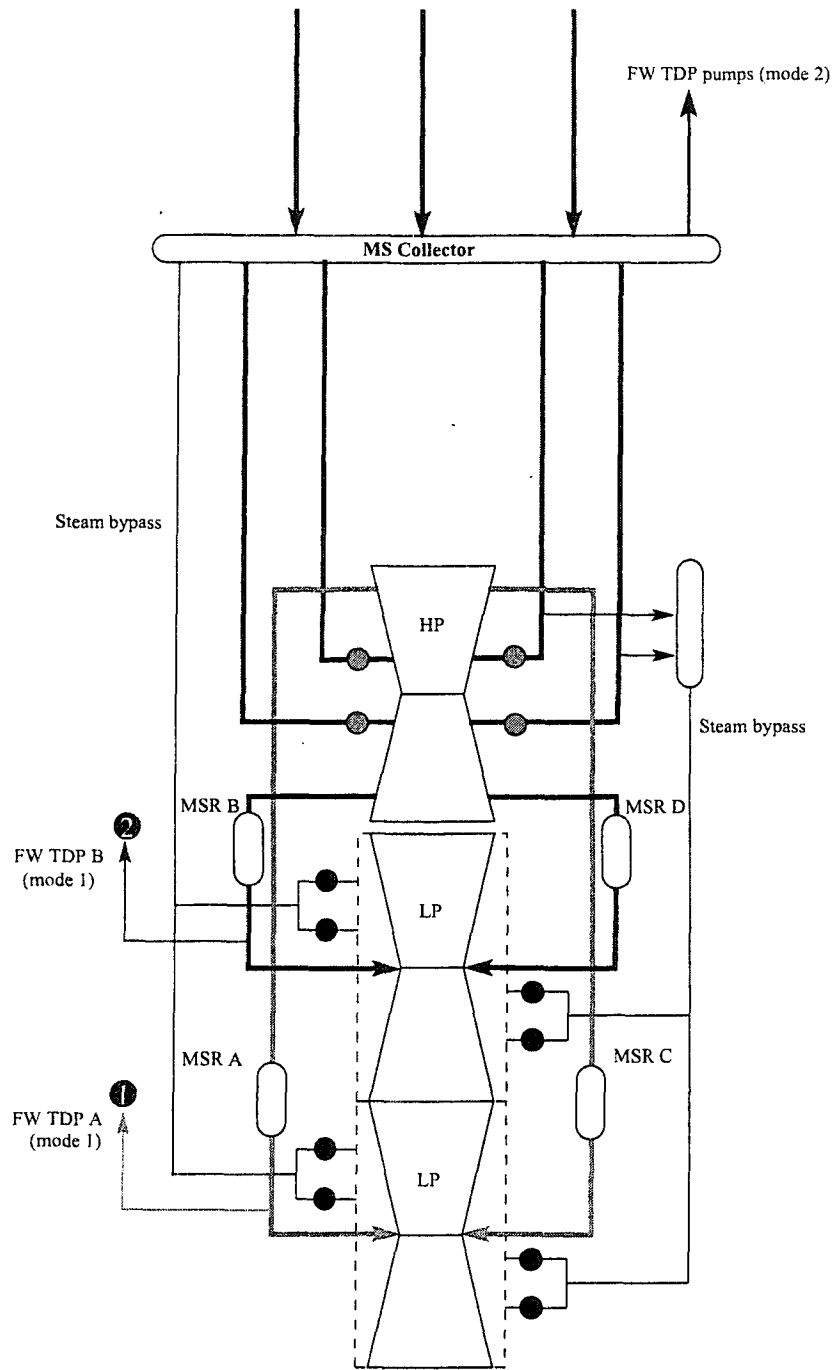

Figure 3: Almaraz I NPP secondary scheme from steam collector to high and low pressure turbines

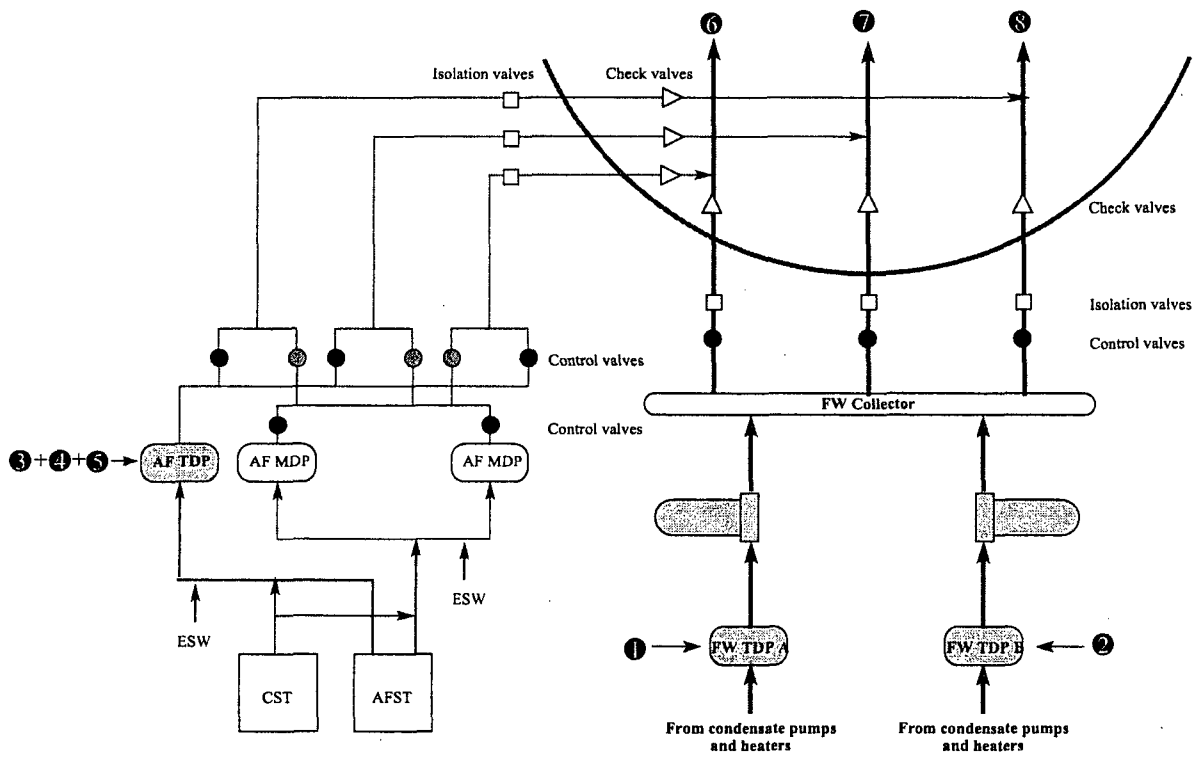

Figure 4: Almaraz I NPP MFWS/AFWS scheme

3 Description of Almaraz I NPP TRACE Model

Almaraz I NPP TRACE model (Westinghouse, three loops plant) is composed of 252 thermal-hydraulic components (1 VESSEL, 52 PIPE, 71 TEE, 41 VALVE, 3 PUMP, 20 FILL, 27 BREAK, 36 HEAT STRUCTURE and 1 POWER component), 685 signal variables, 1532 control blocks and 47 trips, Figure 5, [4, 11, 3, 9].

With regard to the primary circuit, the following components have been modelled:

- Reactor vessel, modelled by a VESSEL component with 24 axial levels, three azimuthal sectors and four radial sectors, which includes the core region, guide tubes, support columns, core bypass, and the bypass to vessel head via downcomer and guide tubes, Figure 6.
- Three loops, with its pumps, steam generators and pressurizer in loop 2 (containing heaters, relief/safety valves and pressurizer spray system).
- Chemical and Volume Control System (CVCS).
- High pressure safety injection system and accumulators.

In reference to the secondary circuit, the following components have been modelled:

- The steam lines up to the turbine stop valves, including the relief, safety and isolating valves.
- The steam dump system, including all the lines with the eight discharge valves to the condenser.
- FW and AFW systems. Feed water pumps coastdown, auxiliary feedwater mass flows and temperatures are included as boundary conditions.

The control systems and protection and engineering safeguards systems and signals that have been modelled are:

- Pressurizer level control: CVCS isolating discharge signal, CVCS charge flow and heaters.
- Pressurizer pressure control: including proportional and backup heaters, spray lines and PORVs.
- Steam generators level control system.
- Steam dump control.
- Turbine control.

- Protection and engineering safeguard system-signals: Emergency shutdown system (SCRAM); safety injection; pressurizer safety valves logic; auxiliary feedwater system activation; logic of relief, safety and isolating valves of steam lines; normal feedwater system isolation, turbine trip and pump trip.

Finally, a transit time and cross area sections figure for primary loop 2 is included to have a general idea about the model topology, Figure 7.

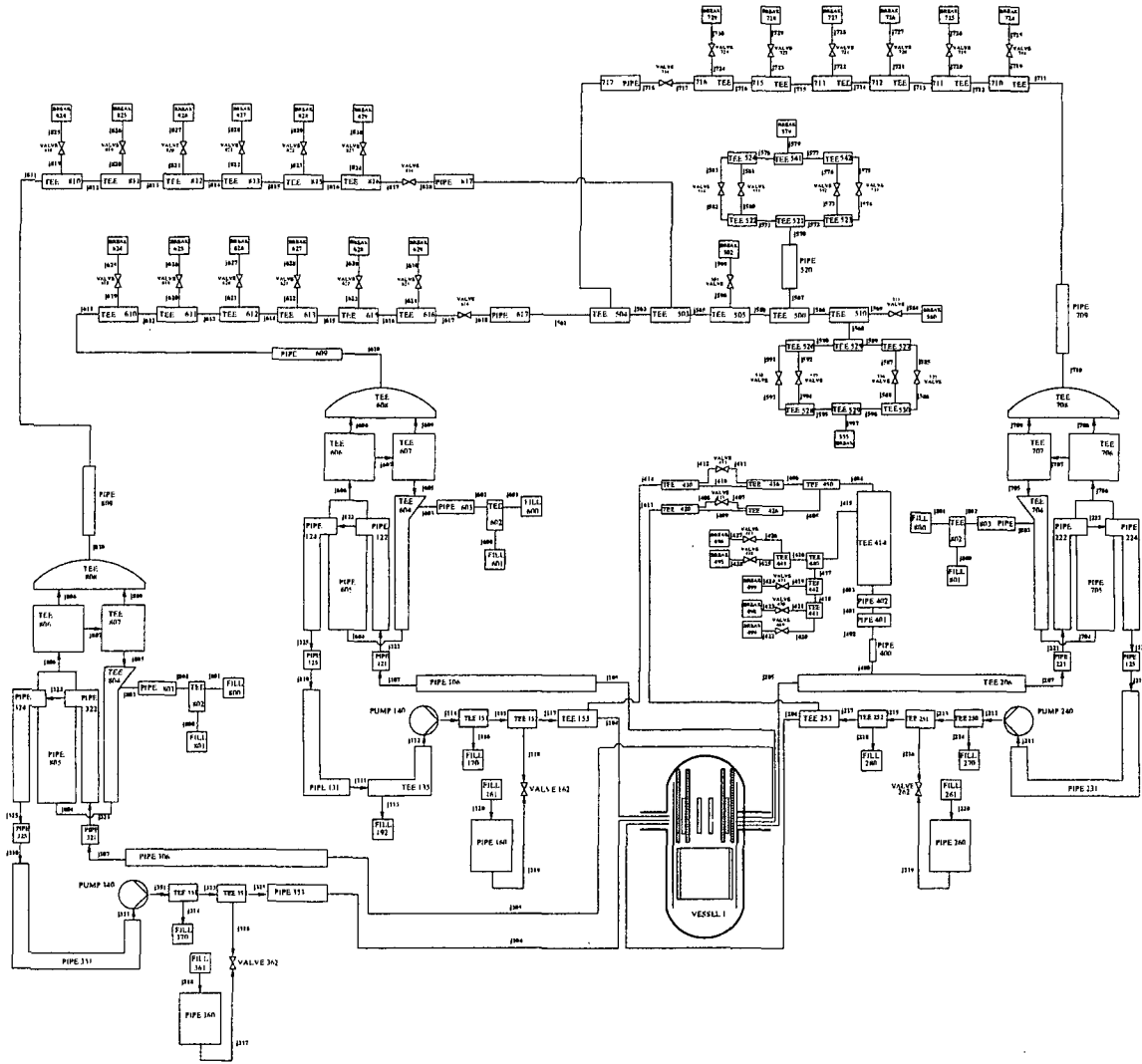

Figure 5: Simplified nodalization of the Almaraz I NPP TRACE model

HYDRODYNAMIC COMPONENTS

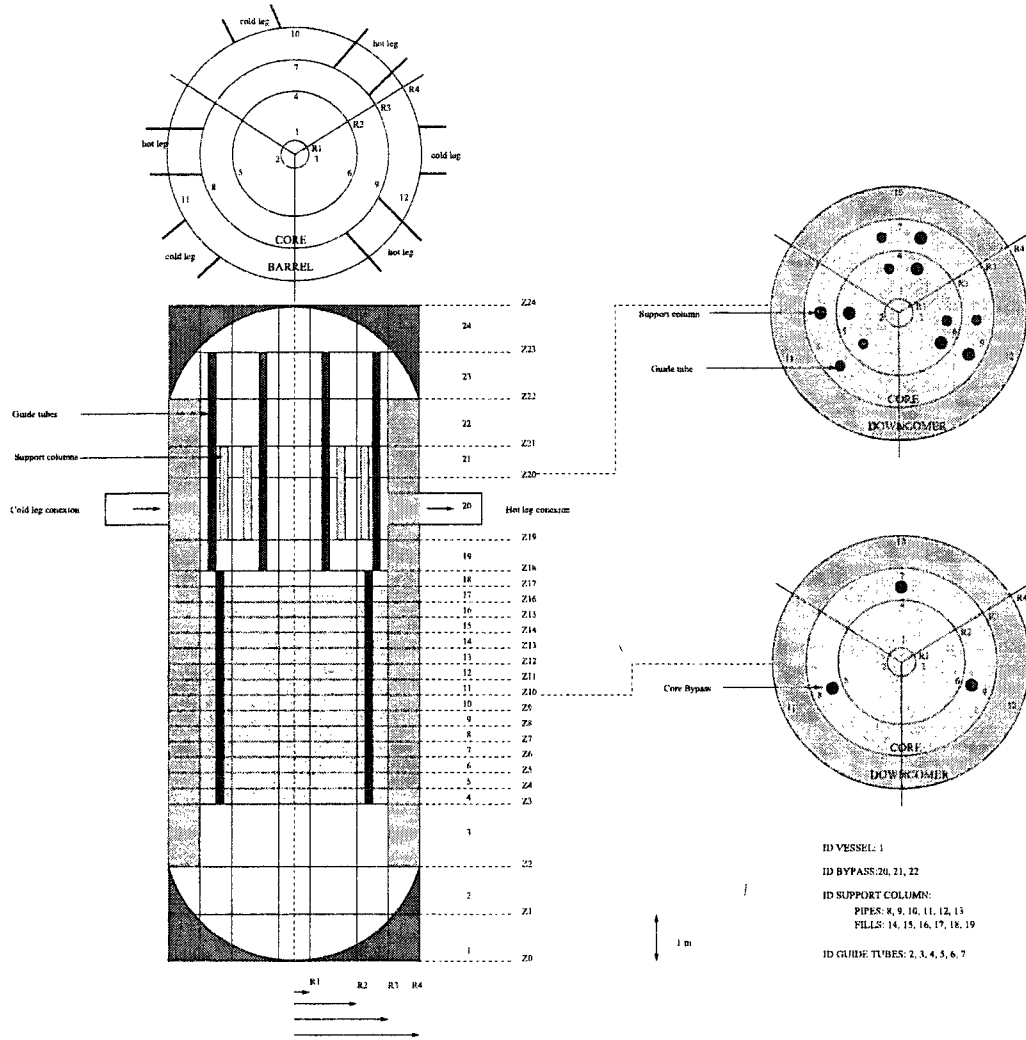

Figure 6: Vessel nodalization of Almaraz I NPP TRACE model

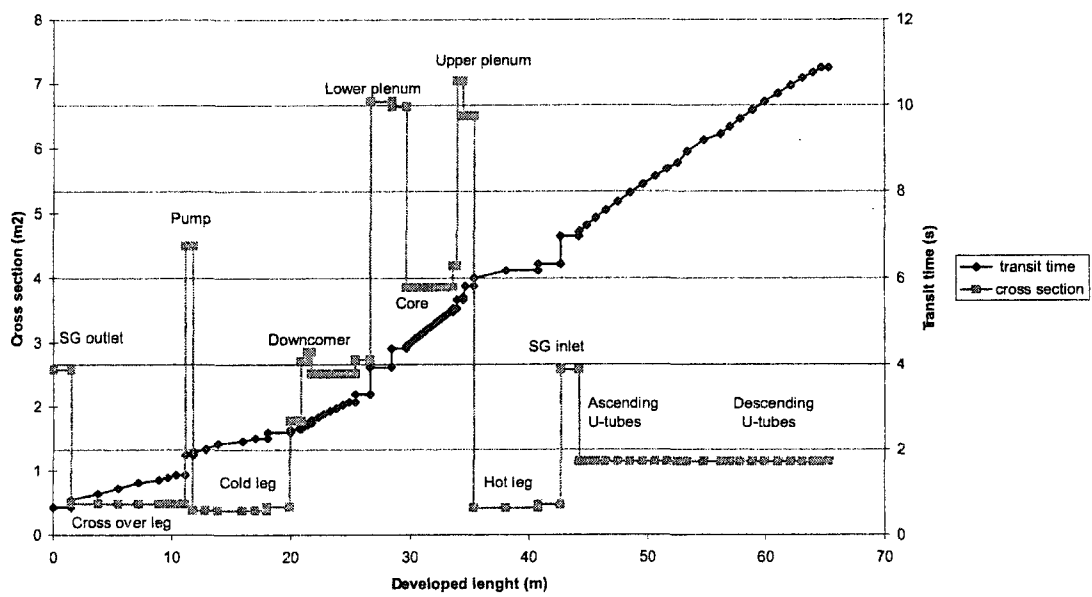

Figure 7: Transit time and cross area sections for primary loop 2. Nominal flow conditions.

4 Verification of Almaraz I NPP TRACE Model

Several simulations were performed with the model to assess its main parameters and systems. These simulations are classified in three groups.

First group consists of eight steady states at several power rates. In detail, steady state simulations for 100 %, 75%, 50%, 25%, 10%, 3%, 2% and 1% of nominal power were considered, and the results show a good agreement with the plant data for the main parameters (RCS temperatures and pressure and SG steam flow, dome pressure and recirculation ratio), [2]. Results of some important variables at different power levels such as primary average temperature, secondary pressure and secondary mass flow are included in Table 3.

The second group, a set of verification transients at full power, allowed to check all the systems and signals included in the model, Table 2:

- Turbine trip (TT).
- Turbine trip without steam dump (TT1).
- Turbine trip without SD or relief valves (TT2).
- Turbine trip without relief valves (TT3).
- Turbine trip without Auxiliary Feedwater (TT4).
- Opening of a Pressurizer PORV (OPP).
- Main Steam Line Break (MSLB).
- Total Loss of Feedwater (TLFW) - TLFW without AFWS and F&B.
- Total Loss of Feedwater (TLFW) - TLFW with AFWS.

The results of the simulations show that the behavior for the transients is the expected [2]. In general, good results were obtained for all the simulations, and they allowed improving the model, in particular SGs, SD and pressurizer models. Other transients like inadvertent injection of ECCS (ECCS), load rejection (LR) and trip of all RCPs (3RCP), are being performed in order to finish the verification of the plant model.

The third group, oriented to low power and shutdown plant conditions is composed of several simulations to analyse plant behavior during a loss of RHRS, considering different primary configurations and steam generators availability, [6]: closed primary system, [7]; two pressurizer PORVs open, [1]; pressurizer manway open, [1] and [8]; one or two PORVs open, [8]; and vessel vent valve open, [8].

The results of this work, performed in the framework of SETH and PKL-2 OCDE/NEA projects, allow improving available times for these sequences, proposing modifications to some abnormal operating procedures, [1] and [8].

Finally, with respect to future works, we also expect to perform SGTR and different LOCA simulations to analyze the plant behaviour and to compare with the phenomenology observed in the OECD/NEA ROSA and PKL experiments.

Table 2: Systems and controls actuated in the verification transients

System/control	TT	TT1	TT2	TT3	TT4	MSLB	OPP	3RCP	ECCS	TLFW	LR
PZR RV	NO	NO	NO	NO	NO	NO	NO	NO	YES	YES	YES
PZR Spray	NO	NO	NO	NO	NO	NO	NO	NO	YES	YES	YES
PZR Heat. Prop.	YES	YES	YES	YES	YES	YES	YES	YES	YES	YES	YES
PZR Heat. Back.	YES	YES	YES	YES	YES	YES	YES	YES	NO	NO	YES
PZR SV	NO	NO	NO	NO	NO	NO	NO	NO	YES	NO	NO
Lev. control	YES	YES	YES	YES	YES	NO	NO	YES	NO	YES	YES
Disch. isolat.	NO	NO	NO	NO	NO	YES	YES	NO	NO	NO	NO
Heaters activ.	NO	NO	NO	NO	NO	YES	YES	NO	NO	NO	NO
Heaters disact.	NO	NO	NO	NO	NO	YES	YES	NO	NO	NO	NO
Control rods	NO	NO	NO	NO	NO	NO	NO	NO	NO	NO	NO
ECCS HPIS	NO	NO	NO	NO	NO	YES	YES	NO	X	NO	NO
LPIS	NO	NO	NO	NO	NO	NO	NO	NO	NO	NO	NO
ACCS	NO	NO	NO	NO	NO	NO	NO	NO	NO	NO	NO
RCPs	NO	NO	NO	NO	NO	NO	NO	YES	NO	NO	NO
Turbine	X	X	X	X	X	YES	YES	YES	YES	YES	YES
Steam dump	YES	X	X	YES	YES	NO	YES	YES	YES	YES	YES
AFW	YES	YES	YES	YES	X	YES	YES	YES	YES	YES	YES
SGs RV	YES	YES	X	X	YES	YES	NO	NO	NO	NO	NO
SGs SV	NO	NO	YES	NO	NO	NO	NO	NO	NO	NO	NO
MSIV	NO	NO	NO	NO	NO	YES	NO	NO	NO	NO	NO

Table 3: Almaraz I NPP model steady states at different power levels

Power (%)	100%	75%	50%	25%	10%	3%	2%	1%
Steam flow (kg/s)								
TRACE	1488.24	1072.6	683.1	322.2	126.3	37.6	24.6	12.6
PLANT	1489.5	1072.8	683.1	323.4	126	37.8		
Primary flow per loop (kg/s)								
TRACE	4643	4648	4652	4654	4654	4654	4654	4652
PLANT	4650.4	4650.4	4650.4	4650.4	4650.4	4650.4	4650.4	4650.4
Average primary temp. (°C)								
TRACE	307.6	303.6	299.65	295.6	293.3	292.15	292.03	291.8
PLANT	307.63	303.64	299.6	295.6	293.3	292.8	292.05	291.9
Recirc. Ratio of SG								
TRACE	3.6	4.73	6.72	11.37	22.5	45.8	58.02	85.9
PLANT	3.64	5.12	7.91	15.352	33.564			
SG Dome Pressure (bar)								
TRACE	68.22	69.85	71.52	73.3	74.45	75.13	75.31	75.48
PLANT	68.3	69.5	70.5	72	73.5			

5 Description of the One RCP Trip Transient

First transient chosen for validation of TRACE model was the reactor trip induced by one RCP trip, which took place in May 2002.

Almaraz I NPP was operating in stable conditions, at 100% of nominal power (2686 MWt), supplying an electrical power of 972 MWe. The plant state was, Table 3:

- Reactor, turbine and main unit controls were in automatic mode.
- Control rods were also in automatic, with all control banks withdrawn 228 steps.
- Primary system boron concentration was 1409 ppm.
- Main operation parameters were within normal values for the power level in which the unit was operating.
- Electric grid configuration was normal, with the 6.3 kV 1A1, 1A2, 1A5 bars connected to the auxiliary transformer, and the 1A3 bar from 1A1, and 1A4 from the start up transformer (T1A2).

On May 13, 2002, at 12.59 pm, the RCP of loop 2 tripped generating a transient (events sequence is included in Table 4), which resulted in the reactor trip due to low flow signal in one loop. The reactor trip signal originated the opening of the two reactor trip switches (RTA and RTB) with the dropping of all control and shutdown rods, and the turbine trip signal. Due to the turbine trip signal all stop and control turbine valves were closed. Following plant behavior, considering the main plant parameters evolution, is described in detail in the following sections. It is remarkable that the plant data has a 0.5 s of time interval and some measurements were made in no IS units.

5.1 Evolution of Primary Parameters

RCP 2 trip led to reactor SCRAM. The mass flow started to decrease in loop 2 according with RCP coastdown, while the mass flow in the other loops tended to increase, Figure 8. During the final part of the RCP 2 coastdown, the mass flow in that loop is inverted. It is important to clarify that loop flow meters are not configured to measure inverted flows, and that is the reason why there are not reliable data in those conditions for the mass flow in that loop.

After reactor scram, averaged temperature decreased to 289.4 °C approximately, changing the trend when the operator close all MSIVs, recovering hot zero power value (291.7°C), Figure 9. Regarding cold leg temperatures, no change is shown respect its usual behavior during a normal reactor scram, Figure 10. On the other hand, hot leg temperatures decreased suddenly as expected until they reached hot zero power values, with a trend similar to the averaged temperature. In loop 2, it is shown that there is a slight difference in the hot leg

Table 4: Time sequence for relevant events in the RCP trip validation transient

Events	Time (s)
RCP loop 2 trip	282.0
Reactor SCRAM induced by low mass flow in loop 2 (90 % in 1/3)+ P8 (Q_{nom} 1 loop 4650.4 kg/s)	283.5
Turbine trip caused by reactor SCRAM	283.5
SD valves opening in turbine trip mode	284.5
Pressurizer pressure starts to decrease	285.5
Backup heaters switch on due to low pressure (155,5 kg/cm ² rel. = 153.45 bar)	286.0
Averaged temperature starts to decrease to 289.4 °C	286.5
Full insertion of the control and shutdown rods	289,5
AFWS turbo and motor driven pumps starting up caused by the low low narrow range level signal in the steam generators (17.6%)	292.5
MFW turbo driven pumps velocities start to decrease	294.5
MFW admission valves closing induced by SCRAM reactor signal coincident with low averaged temperature (295 °C)	305.0
Reverse flow in loop 2	307.0
Minimum temperature reached at the loop 2 hot leg	311.0
Averaged temperature equals hot zero averaged temperature (291.7 °C), and decreasing	404.5
Operators decide to close the main steam isolation valves to mitigate overcooling transient (MSIV bypass valves are open)	448.0
End of available plant data	840.0

temperature behavior during the SD cooling transients, due to PZR surge line discharge, Figure 11. Hot leg temperature had two peaks that appeared when the water mass flow discharged through the surge line, hotter than hot leg water, and the inverse flow from the steam generator mix and pass through RTD location (RTD are located between the vessel and the surge line connection).

After reactor SCRAM, pressurizer pressure decreased reaching a minimum value of 137.5 kg/cm² rel. Subsequently, the pressure recovered normal values due to the actuation of the pressure control, backup and proportional heaters, Figure 12.

When SCRAM took place, pressurizer level decreased to hot zero power level values, remaining around this value for all the transient, Figure 13. The primary cooling lead to a inventory contraction, decreasing the level to a minimum value of 14 %. As it was expected, reference level value was reached due to level control actuation on charge flow.

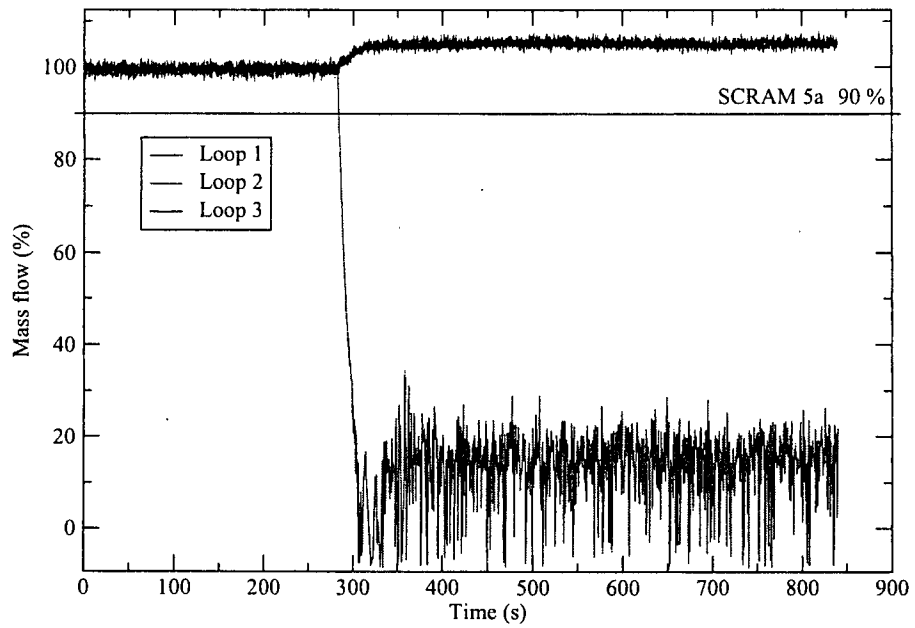

Figure 8: Primary loops mass flow rates (plant data)

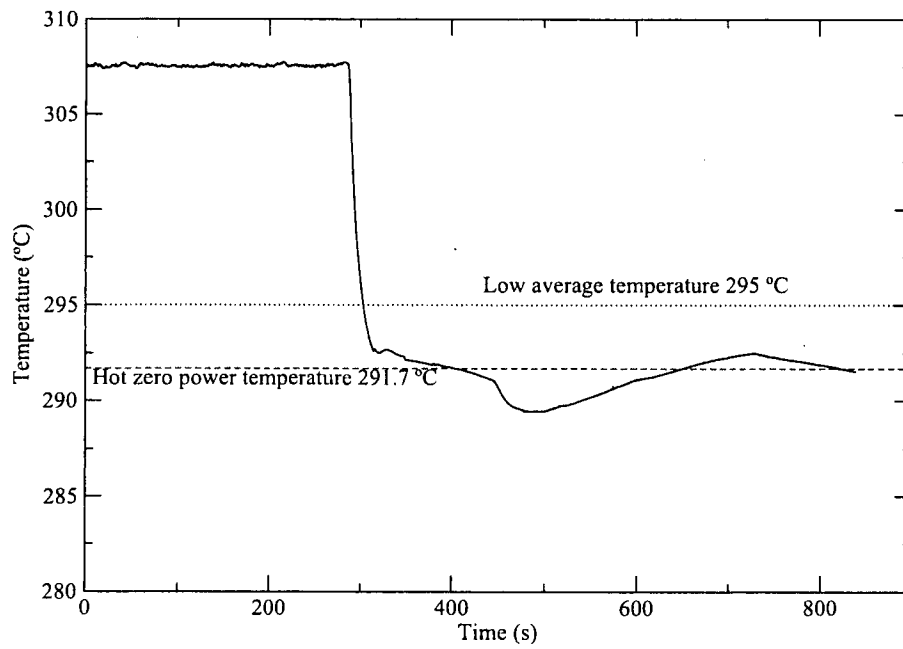

Figure 9: Averaged temperature (plant data)

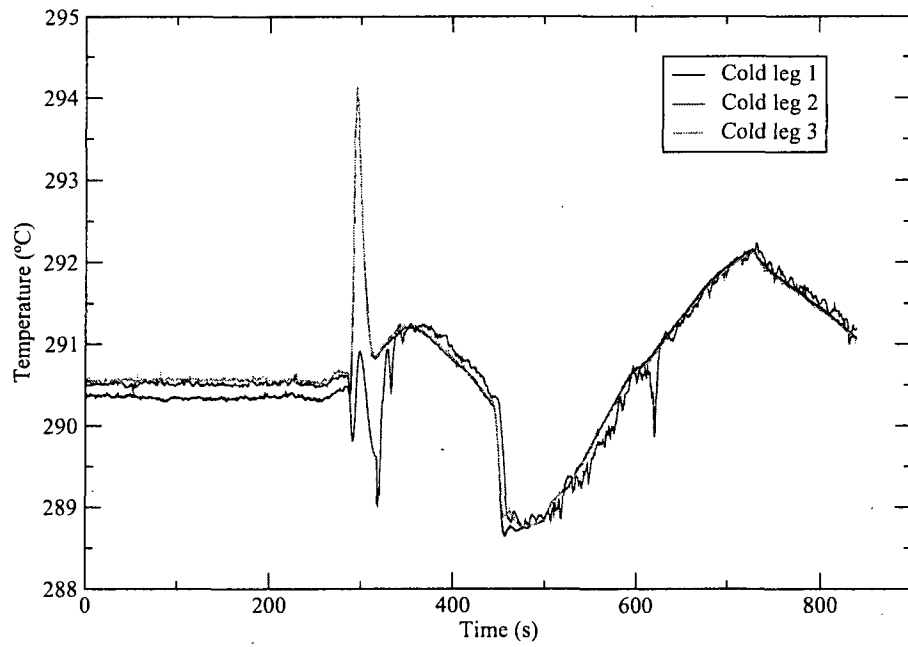

Figure 10: Cold leg temperature. Loops 1, 2 and 3 (plant data)

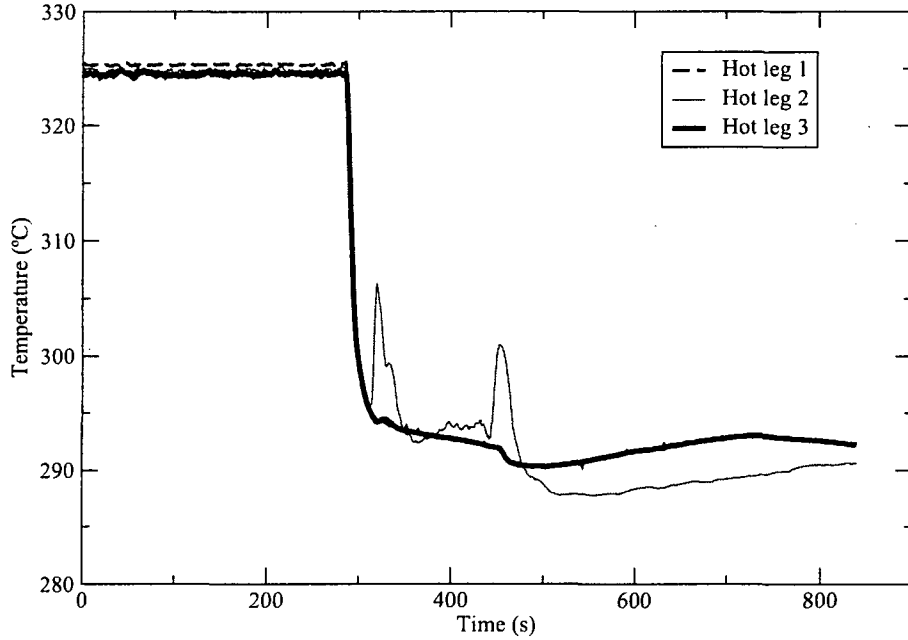

Figure 11: Hot leg temperature. Loops 1, 2 and 3 (plant data)

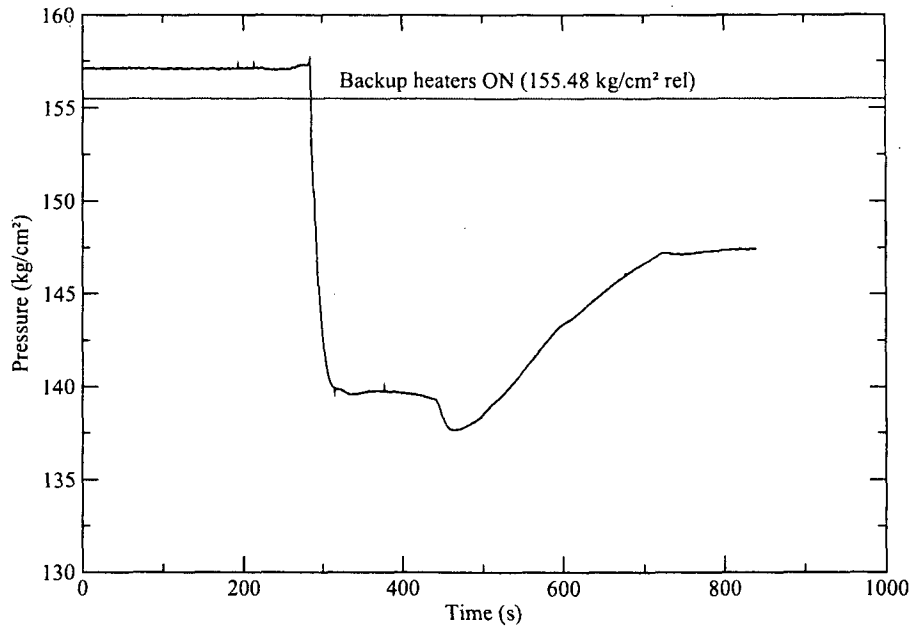

Figure 12: Pressurizer pressure (plant data)

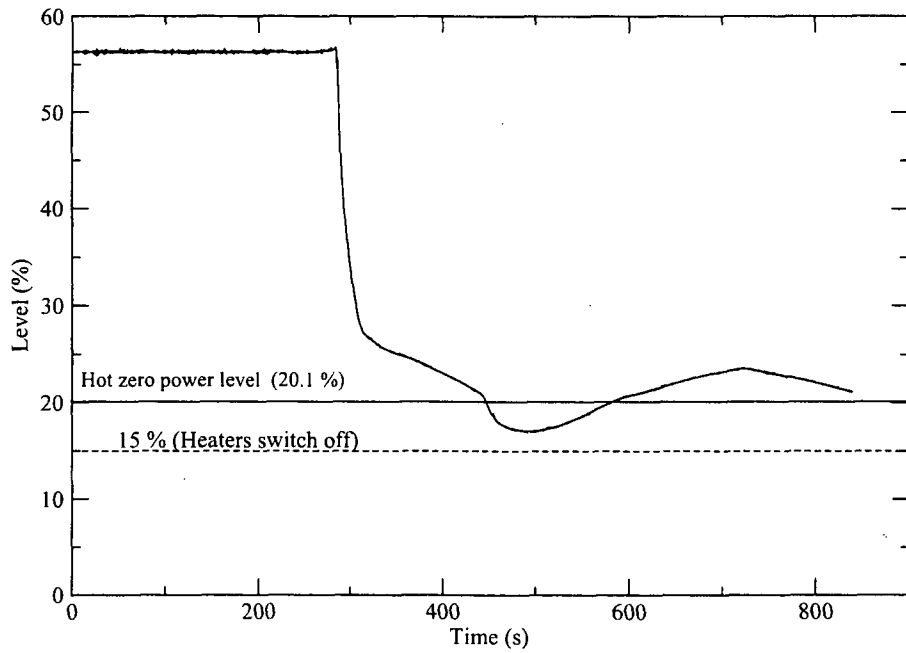

Figure 13: Pressurizer level (plant data)

5.2 Evolution of Secondary Parameters

Main Feedwater water mass flow rate to the three steam generators is reduced during the feedwater turbo driven pumps coastdown after its trip and, finally, the mass flow is canceled by the closing of the main feedwater isolation valves, Figure 15, induced by SCRAM reactor signal coincident with low averaged temperature (295 °C), Figure 9.

Narrow range levels decreased suddenly due to scram, reaching values of 6.5 %, 11% and 5% at the steam generators 1, 2 and 3 respectively, Figure 16. The starting up of AFWS turbo and motor driven pumps is caused by the low low narrow range level signal in the steam generators (17.6%), injecting to all SGs.

At the time of turbine trip and the consequent closing of the stop valves, there was an increase in the pressure of the steam generators, Figure 17, reaching maximum values at around atmospheric relief valves set point. After the initial maximum, pressure decreased showing the same trend than averaged temperature.

Some SD valves failures were induced from the secondary pressure and the Steam Dump behavior during the transient. This system actuated properly in the first part of the transient, but three valves (MS1-HV-4501/4504/4505) did not fully closed after the closure demand, Figure 14. Despite that averaged temperature was below its hot zero power value, the system was still discharging steam to the condenser. Also, secondary pressure measurement shows a strong evidence of a steam discharge equivalent to a SD bank capacity. As a result, operators decided to close the main steam isolation valves, remaining open the MSIV bypass valves, Figure 17.

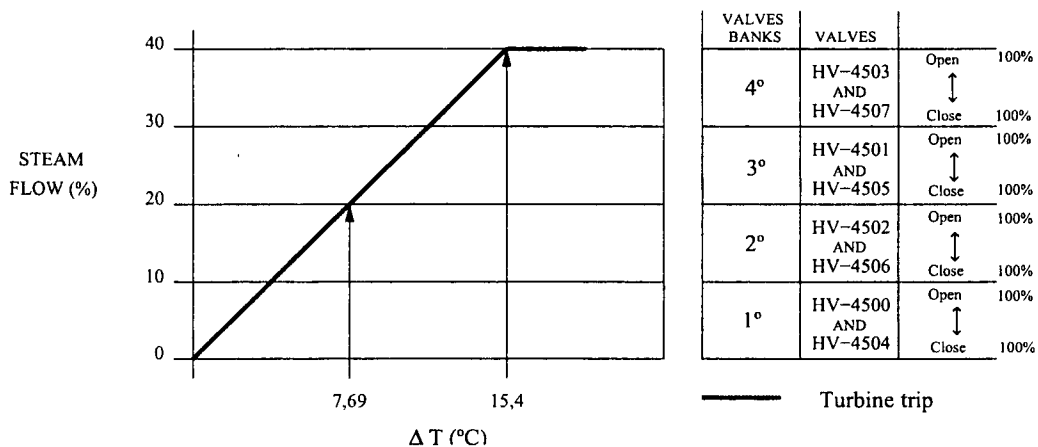

Figure 14: Steam dump control in temperature mode with turbine trip

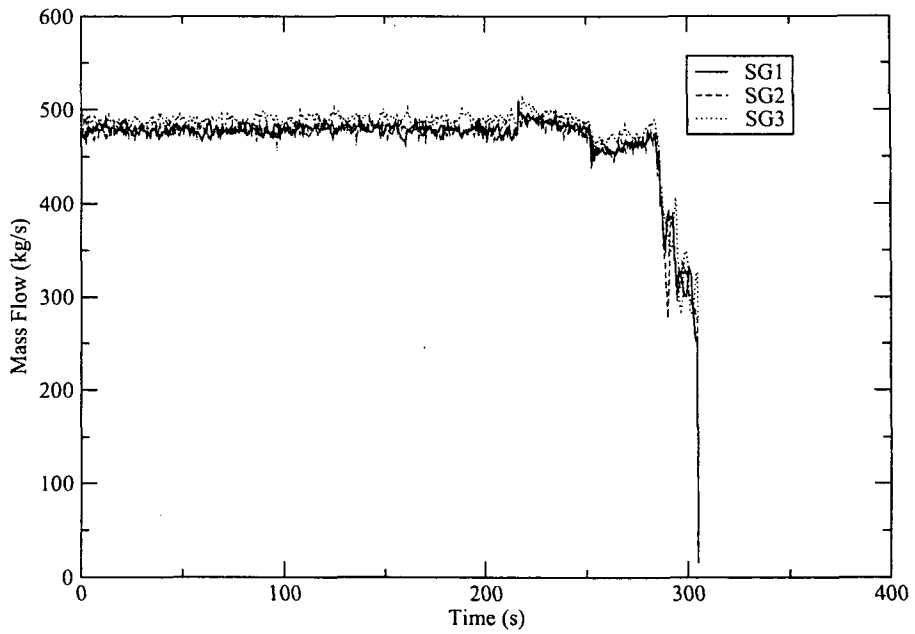

Figure 15: MFW mass flow rate - SG1, SG2 and SG3 (plant data)

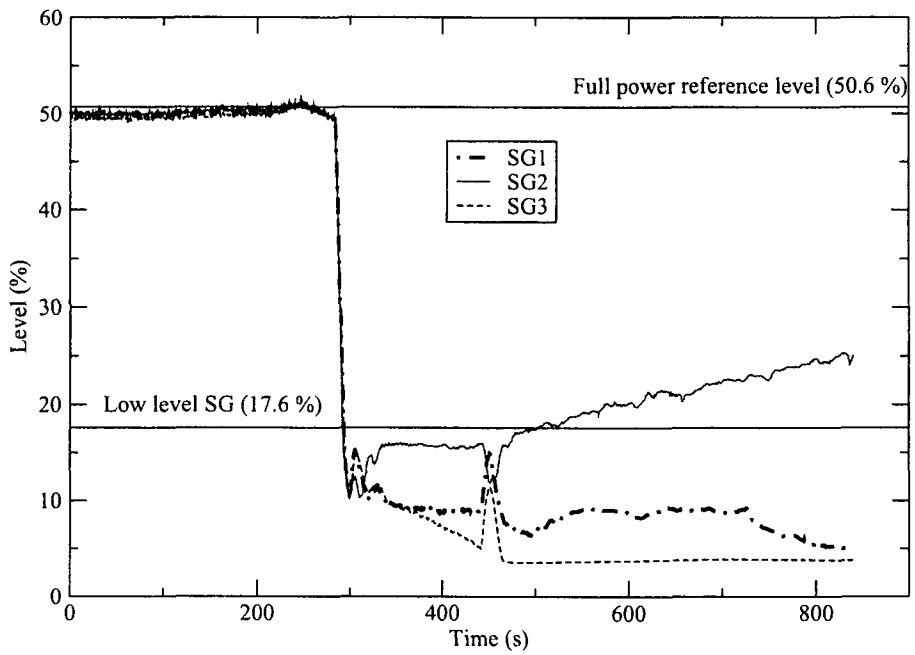

Figure 16: Steam generators narrow range level (plant data)

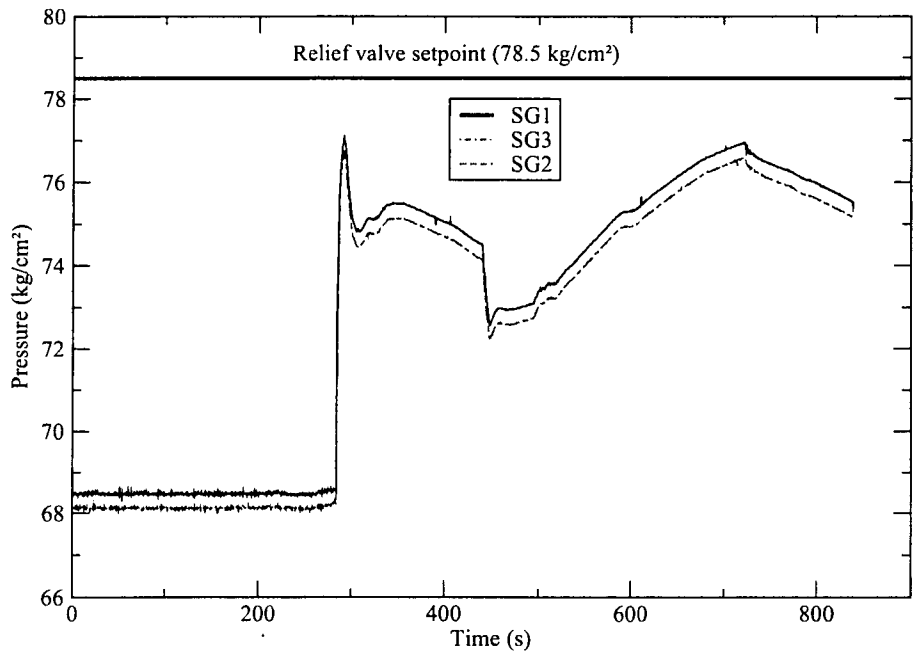

Figure 17: Steam generators pressure (plant data)

6 Analysis of the Simulation Results with TRACE 4.160

In this section an in-depth view of the boundary conditions considered for the transient simulation and the simulation results are presented.

6.1 Boundary Conditions

For the simulation, the following boundary conditions were considered:

- Steam generators main feedwater mass flow rates and temperatures, Figures 18 and 19, taken into account the MFW isolation and TDP coastdown.
- Steam generators auxiliary feedwater mass flow rates, Figures 20 and 22. Constant value of 25 °C was set for the inlet temperature.
- Adjustment of several steam dump valves to obtain secondary pressure trend. The valve areas were adjusted using trial and error method because there were not reliable plant data.

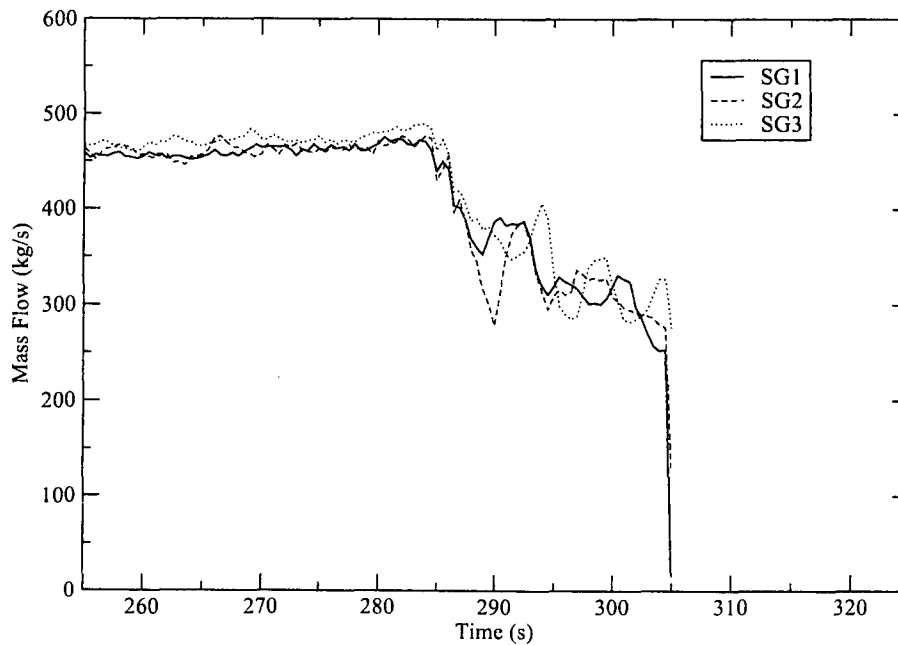

Figure 18: MFW mass flow rates - SG1, SG2 and SG3 (plant data)

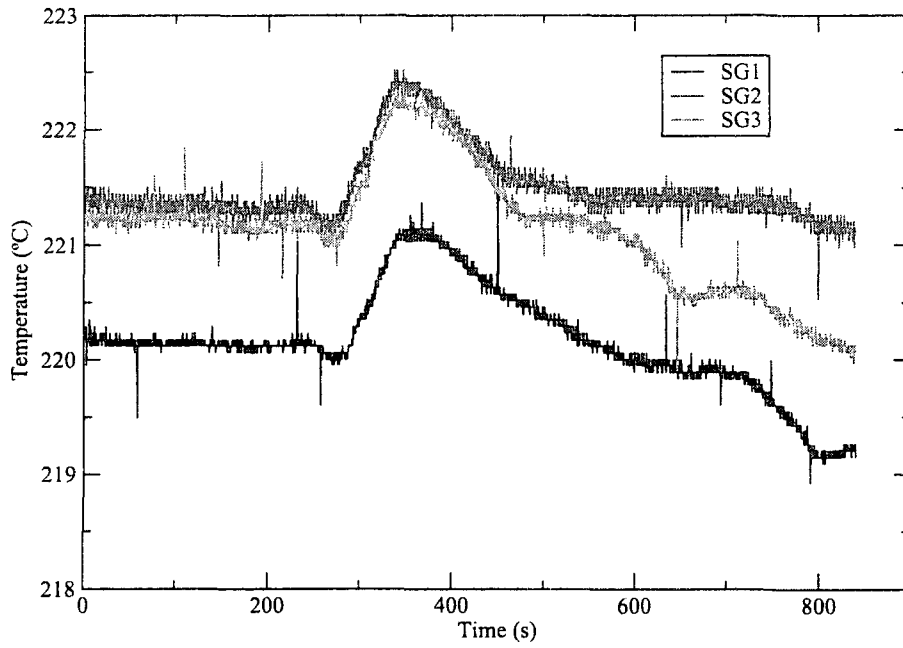

Figure 19: MFW temperature - SG1, SG2 and SG3 (plant data)

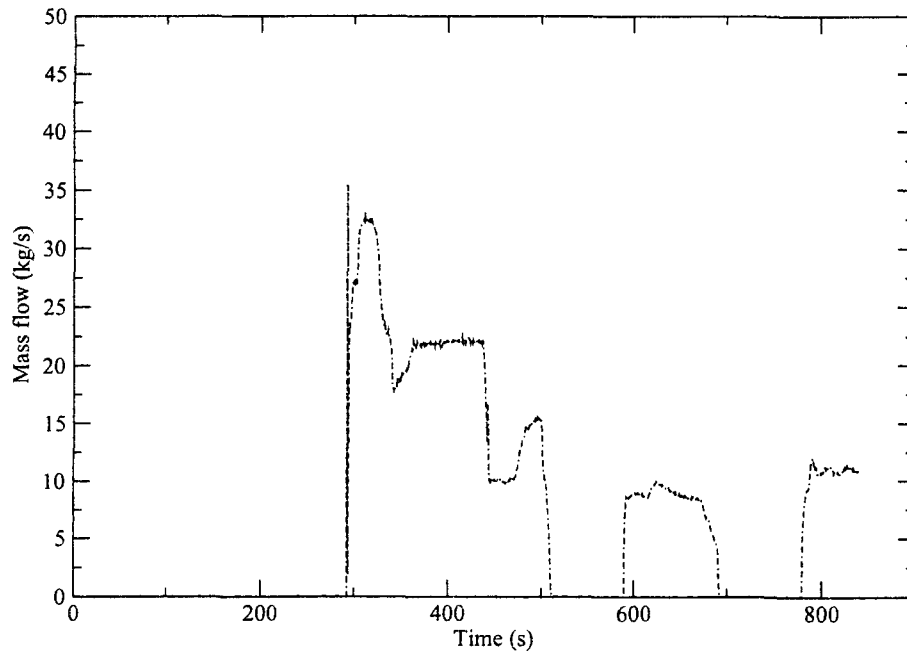

Figure 20: AFW mass flow rate - SG1 (plant data)

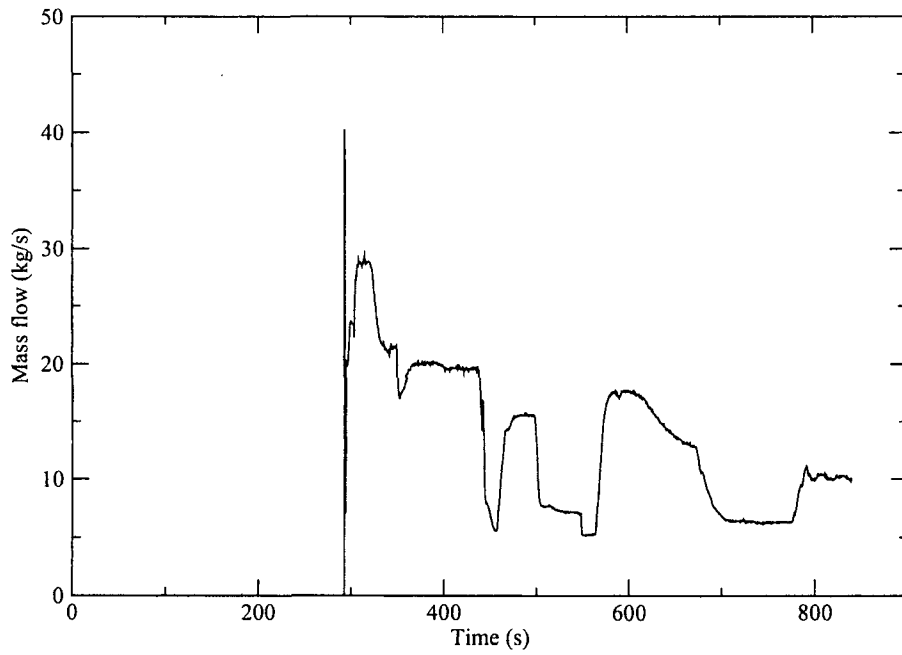

Figure 21: AFW mass flow rate - SG2 (plant data)

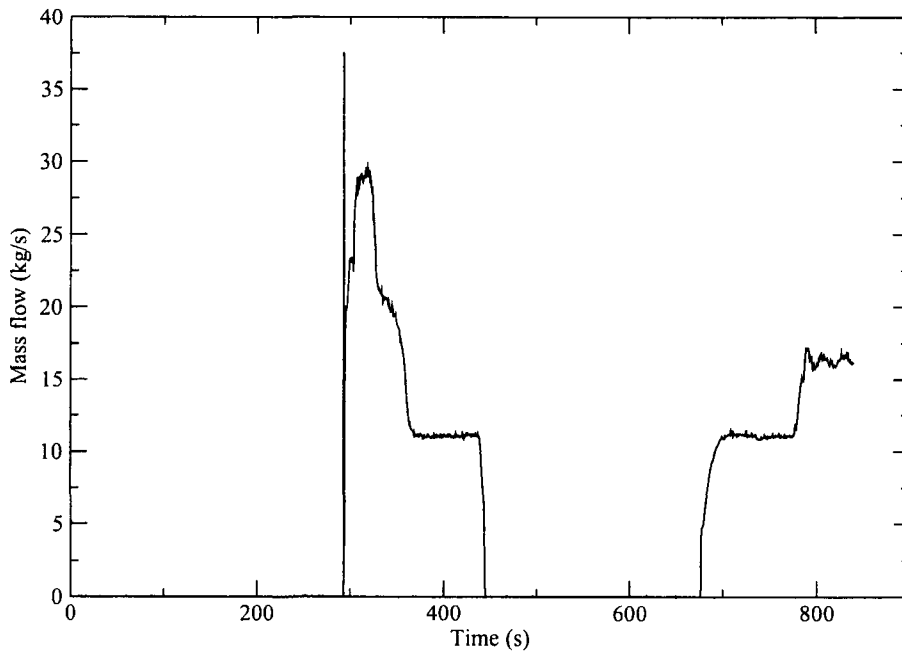

Figure 22: AFW mass flow rate - SG3 (plant data)

6.2 Results from the Simulation

The simulation was run from a steady state restart, Table 5, which shows a good agreement with plant data. A first group of simulations shown that was necessary to reproduce the pump coastdown and secondary pressures in a very detailed way. So, in order to separate the simulation of primary side from secondary side in a first stage, it was decided to simulate a group of transients with secondary pressure as boundary condition. Later, when coastdown was well adjusted, secondary pressure was also adjusted in the whole model without pressure boundary condition. The final results obtained in the simulation are detailed below.

The transient begins with a RCP trip in loop 2 at 282.0 s. This RCP trip generates a transient with three differentiated phases, Figure 23:

Phase 1. RCP coastdown in loop 2 from nominal mass flow to null mass flow. From $t = 282$ s to $t \approx 307$ s.

Phase 2. Reverse flow in loop 2 with $\omega > 0$. From $t \approx 307$ s to $t \approx 550$ s.

This phase begins when the flow in loop 2 is reversed, $t \approx 307$ s. This time was calculated in two ways:

1. Taking into account that loop 2 hot leg temperature starts to increase, $t \approx 307$ s, when the hot water from the pressurizer, mixed with the cold water from the steam generator, reaches the RTD location, Figure 26.

It must be remembered that RTD location is between pressure vessel hot leg outlet and the connection of PZR surge line with hot leg.

2. Also, this moment can be inferred from the extrapolation of the coastdown curve from plant data, Figure 24.

Both methods are affected by uncertainty. Hot leg temperature trend change has a transport delay, from surge line connection to RTD location, which could be corrected considering the flow velocity. Coastdown curve extrapolation supposed linear trend for the coastdown where no plant data is available. This last uncertainty is higher than the previous one.

The best way to determine this moment, is obtaining the time when loop 2 hot leg temperature starts to increase, $t \approx 307$ s.

Phase 3. Reverse flow in loop 2 with $\omega = 0$. From $t \approx 550$ s to $t \approx 840$ s.

It is clear that there is reverse flow because $T_{\text{hot-leg}} < T_{\text{cold-leg}}$, Figure 23.

As it was commented above this is one of the main variables that was necessary to adjust so, in order to obtain a good simulation of the RCP coastdown several changes and adjustments were performed in the model:

Phase 1. This phase was well reproduced adjusting **RCPs hydraulic and friction torques**, in order to obtain the right RCP coastdown in loop 2, Figure 24. This adjustment also gives good transient mass flows in loops 1 and 3, Figure 25.

Phase 2. This phase begins when the flow in loop 2 is reversed, $t \approx 307$ s.

In order to reproduce this coastdown phase it was observed in a sensitivity analysis that the behavior of hot leg temperature in loop 2 is more sensitive to pump parameters than mass flow in Phase 1. So, pump parameters values were tuned again in order to obtain good results in Phase 1 and 2 simultaneously. However, only first maximum temperature was well reproduced in Phase 2. The rest of hot leg temperature transient in loop 2 is quite difficult to reproduce because, in the sensitivity analysis, is observed that the results are quite sensitive to mesh size near the connection of surge line with hot leg. This sensitivity analysis is described in detail in the next section.

This adjustment gives good simulation results for the mass flows and temperatures in loops 1 and 3, Figures 25 and 27.

Phase 3. When loop 2 RCP is full stopped the mass flow rates in all loops do not depend on pump parameters so, these mass flows could be adjusted with **loop 2 reverse friction factor**, Figures 24 and 25.

In order to adjust these mass flows, it must be taken into account that there is no reliable plant data of mass flow in loop 2. The right way to adjust mass flow in loop 2 is to reproduce the temperature difference between hot leg/cold leg of loop 2 during this phase, Figures 26 and 27.

Referring to the other loops, a mass flow rate increase takes place due to flow redistribution, reaching a maximum value in accordance with plant data, Figure 25.

Due to the initial mass flow decrease a reactor SCRAM signal is generated in a short time by low flow in 1/3 loops. A few seconds later primary temperatures start to decrease, leading to a decrease in pressurizer level and pressure. This first stage of the transient is well simulated, Figures 26, 27, 31 and 32. The reactor SCRAM signal generates a turbine trip signal, which also demands the turbine bypass valves opening.

As mentioned earlier, some not fully closed SD valves led to an anomalous secondary pressure behavior, Figure 28, which led to a primary overcooling transient, Figure 9. In order to reproduce the **secondary pressure**, the steam dump model was adjusted supposing a bank (two valves) not fully closed. In detail:

- For the first part of the transient, until several SD valves remained not fully closed, the transient was simulated without additional considerations.

In this way, it was taken into account that the SD worked properly until $t \approx 325.0$ s.

- The second part of the pressure transient, from $t \approx 325.0$ s to $t \approx 440.0$ s, was adjusted with one bank stuck partially open, leading to primary overcooling during almost 115 seconds.
- After this time interval, $t > 440.0$ s, this bank is almost fully open, worsen the cooling transient.

At the beginning of this transient phase, $t \approx 440.0$ s, the operator isolated the steam lines, opening the MSIV bypass to allow cooling via SD. The simulation of these manual modifications had an important impact in the primary temperatures, whose simulation show a good behavior in this phase of the transient.

During the different simulations performed, the **SGs narrow range level** was always underestimated by 4% when compared with plant data. This deviation respect to plant data led to consider a 4% calibration offset. Three calibrations were tested to correct this problem, Figure 29:

1. Adding 4 % to the whole range (4% - 104%).
2. Adding 4 % to the origin keeping 100 % point (4% - 100%).
3. Adding 4 % to the origin keeping 50.6 % point, which corresponds to the narrow range level value for 100 % power (4% - 96%).

The best results were obtained using the last one, Figure 30.

Respect to the **pressure and level in the pressurizer**, the level trend is quite good compared with plant data, Figure 31. However, pressure tends to be higher during the transient and, at the final part, the overestimation is 2 bars above the plant pressure, Figure 32. This problem has not been solved, but several tests and sensitivity analyses have been performed to establish the cause of this behavior:

- Several pressurizer nodalizations were tested. Future work is going to be performed to include new pressurizer models, including 2D models for the pressurizer, in the full plant model to analyze the influence in the transient simulation.
- The spray mass flow behavior during the transient has been analyzed, including pressure differences between loops with and without pressurizer, Figure 33. This parameter has not strong influence in pressure trend in this transient.
- Different heaters models have been tested in order to quantify the response time in transient conditions. These models were a direct heat deposition in the fluid and several heat structure models. It was concluded that the response time of the heaters has not a strong influence on the pressure trend after reactor SCRAM.

In general, despite the primary pressure difference, it is observed that event simulation sequence match quite well with plan data, Table 6.

Table 5: Comparison of steady state conditions of Almaraz I NPP plant and TRACE 4.160 model

Items	Plant (loop w/wo PZR)	TRACE (loop w/wo PZR)
Core power	2696 MWt	2696 MWt
Primary loops		
Hot leg liq. temperature (K)		
Loop 1	598.5 K	597.3 K
Loop 2	597.9 K	596.8 K
Loop 3	597.6 K	597.4 K
Cold leg liq. temperature (K)		
Loop 1	563.5 K	563.0 K
Loop 2	563.7 K	563.0 K
Loop 3	563.7 K	563.1 K
Averaged temp. (K)		
Loop 1	581.0 K	580.2 K
Loop 2	580.8 K	579.9 K
Loop 3	580.7 K	580.2 K
Mass flow rate (kg/s per loop)		
Loop 1	100%	4615 kg/s
Loop 2	100%	4685 kg/s
Loop 3	100%	4634 kg/s
Pressurizer (PZR)		
Pressure	155.04 bar abs	155.04 bar
Liquid level (%)	56.3%	55.6%
Steam generators		
Secondary pressure (MPa)		
SG 1	67.8 bar abs	68.0 bar
SG 2	68.2 bar abs	67.9 bar
SG 3	67.6 bar abs	68.0 bar
Secondary liq. level (%)		
SG 1	50.2%	50.6%
SG 2	49.6%	50.6%
SG 3	49.6%	50.6%
Main feedwater mass flow rate (kg/s)		
SG 1	489 kg/s	492.3 kg/s
SG 2	486 kg/s	491.6 kg/s
SG 3	500 kg/s	494.4 kg/s

Table 6: Sequence events in the RCP trip validation transient

Events	Time (s)	
	Plant	Simulation
RCP #2 trip	282	282
SCRAM / Turbine trip signals	283.5	283.7
MFW isolation valve closing signal	284	284.0 (BC)
SD demand start	284.5	285
Backup heaters switch on	286	288.9
Demand signal for AFWS	292.5	292.5 (BC)
MFW TDP angular velocity decreases	294.5	294.5 (BC)
Inverse flow in loop 2	~ 307	305.8
Regulating bank (#1) stuck open	—	~ 325.0*
Bank stuck (#1) fails full open	—	~ 440.0*
MSIV manually actuated (MSIV bypass valves are opened)	448	448 (manual)
End of plant data	840	

* Events inferred from plant data trend of the secondary pressure

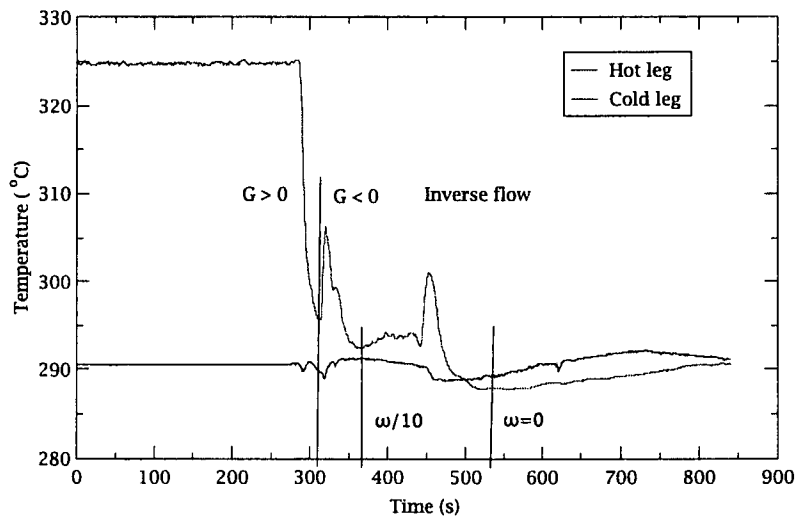

Figure 23: Loop 2 hot leg water temperature during the simulation of RCP trip transient

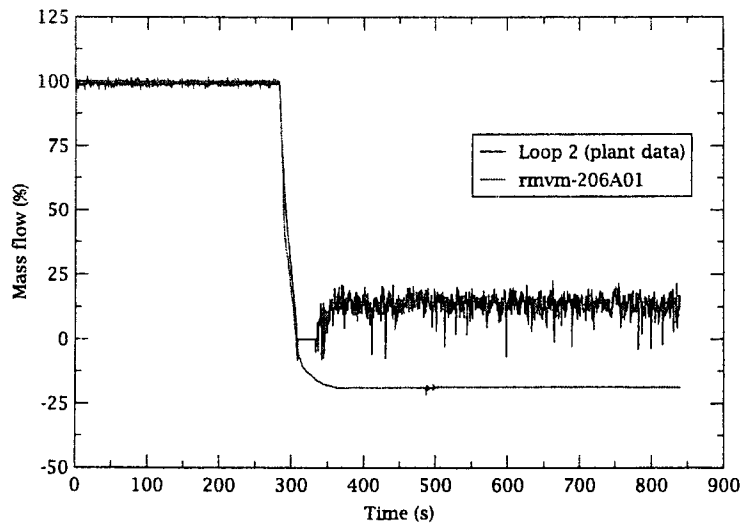

Figure 24: Loop 2 mass flow during the simulation of RCP trip transient. TRACE 4.160 model

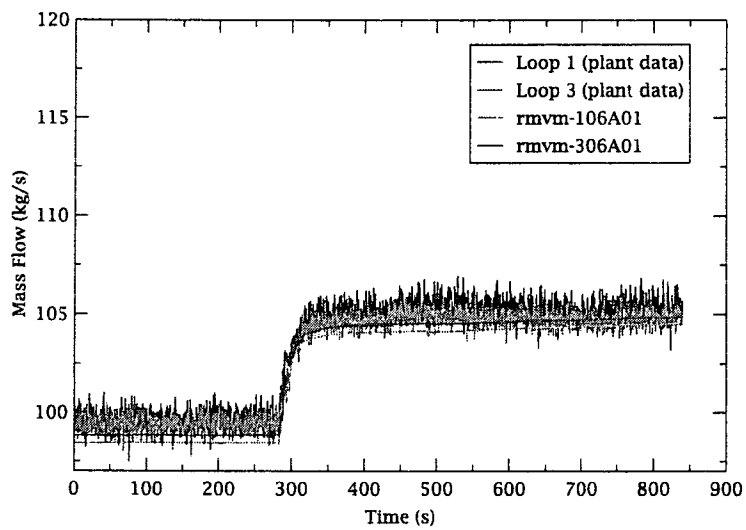

Figure 25: Loops 1 and 3 mass flows during the simulation of RCP trip transient. TRACE 4.160 model

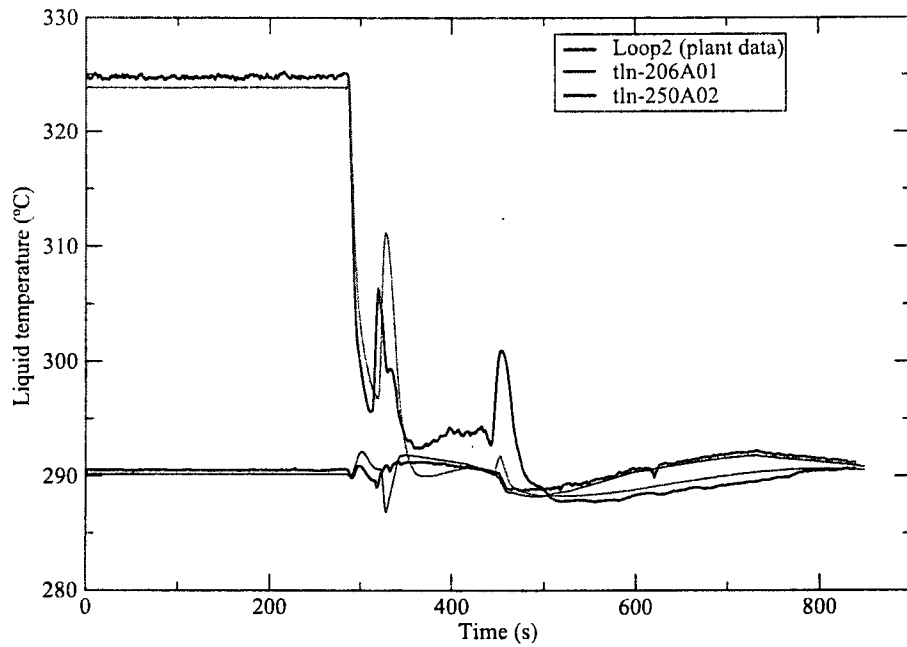

Figure 26: Loop 2 temperatures during the simulation of RCP trip transient. TRACE 4.160 model

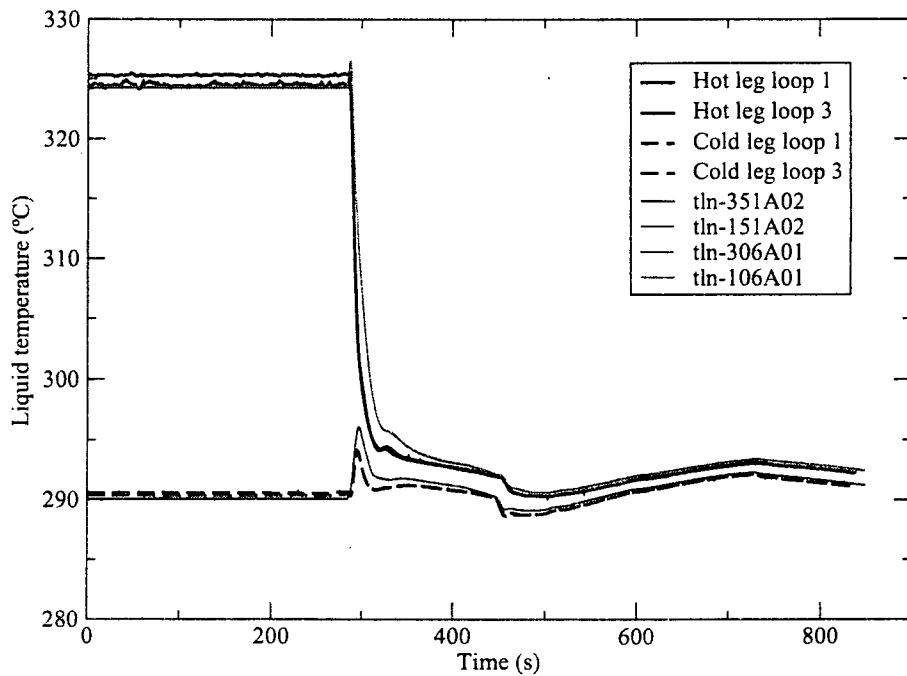

Figure 27: Loops 1 and 3 temperatures during the simulation of RCP trip transient. TRACE 4.160 model

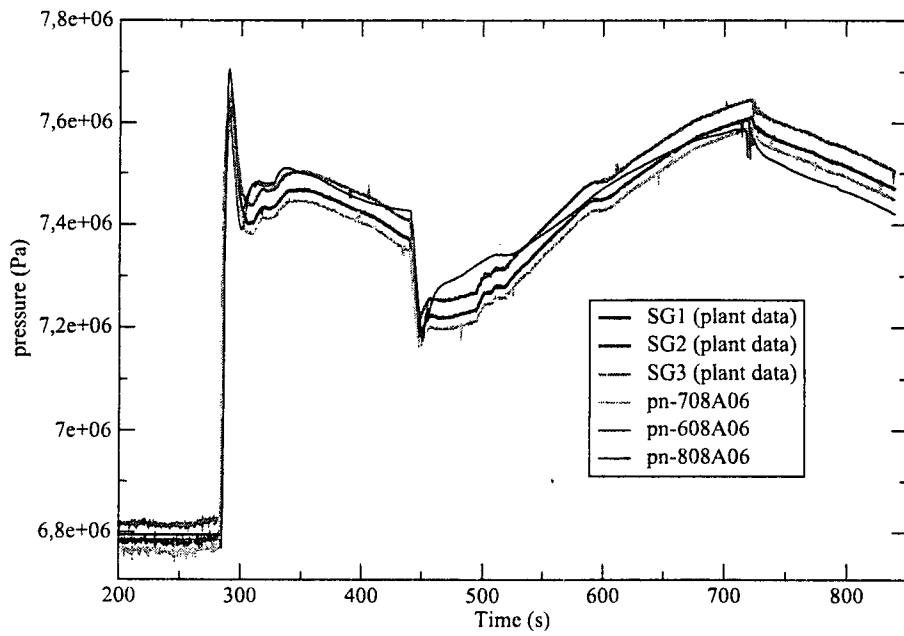

Figure 28: Steam generators pressure during the simulation of RCP trip transient. TRACE 4.160 model

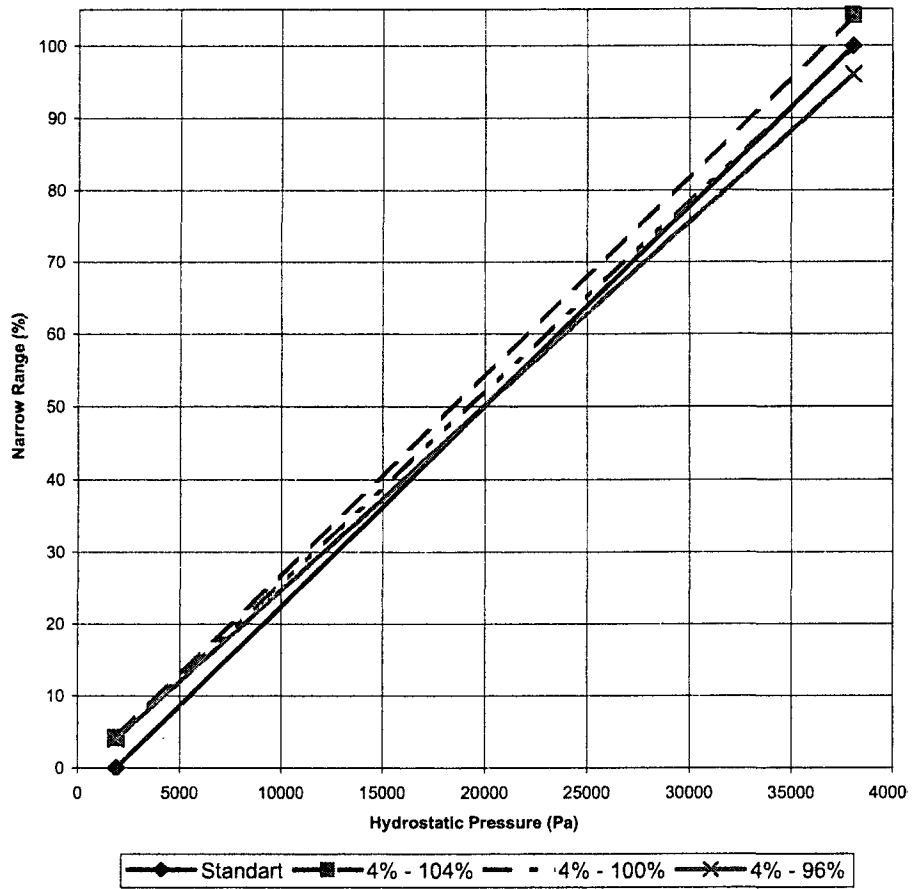

Figure 29: Steam generators narrow range calibrations

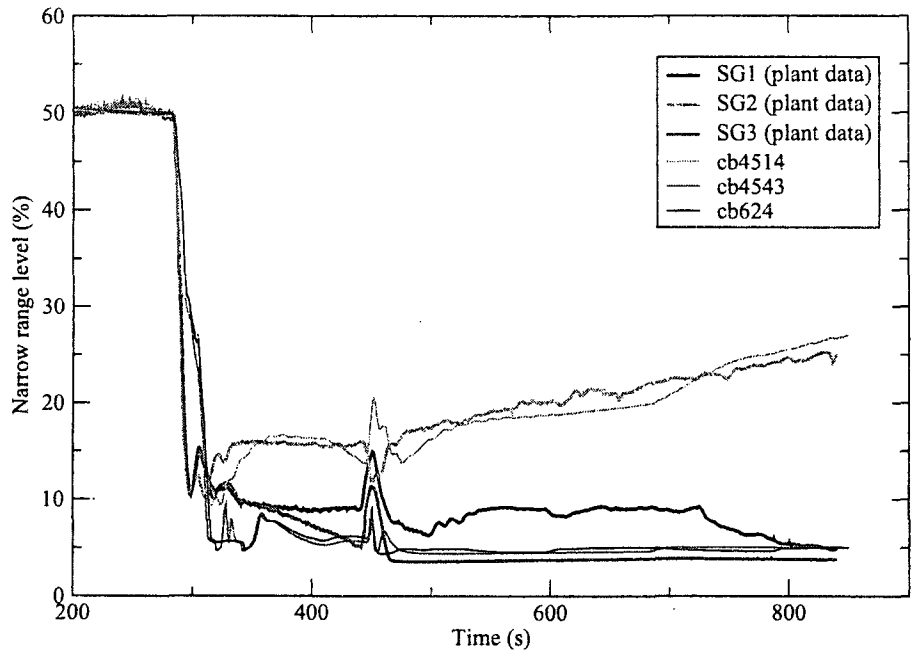

Figure 30: Steam generators narrow range levels during the simulation of RCP trip transient. TRACE 4.160 model

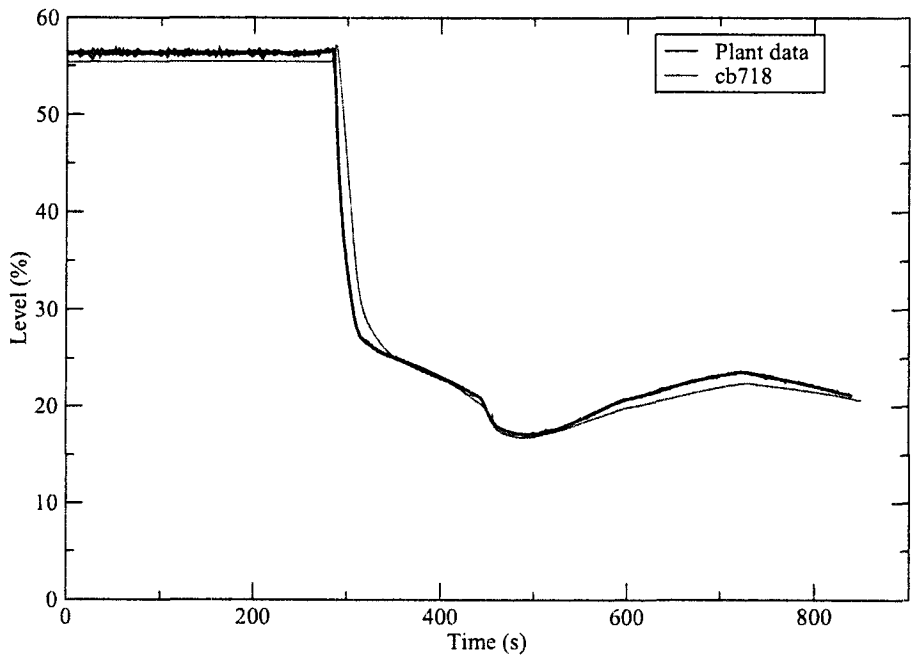

Figure 31: Pressurizer level during the simulation of RCP trip transient. TRACE 4.160 model

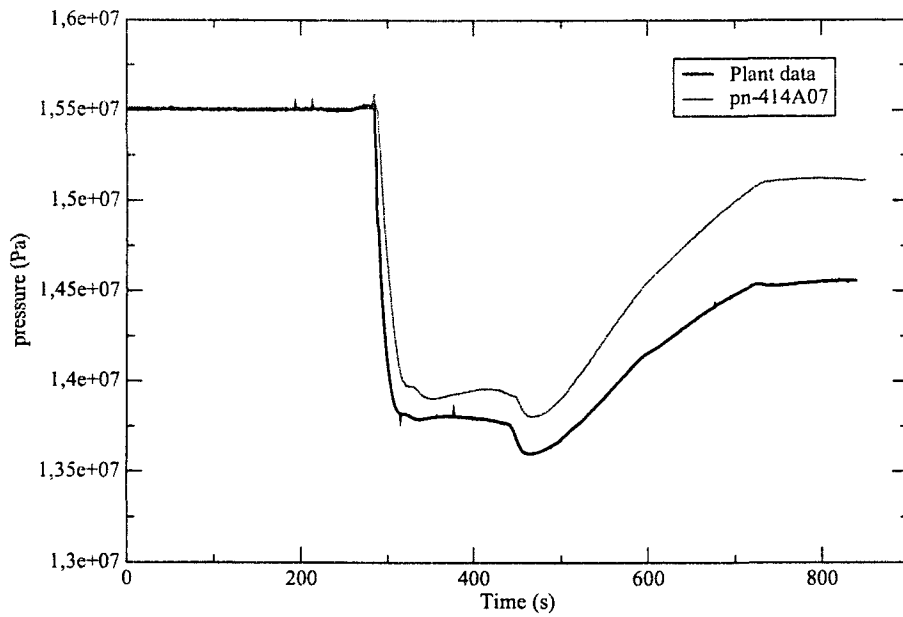

Figure 32: Pressurizer pressure during the simulation of RCP trip transient. TRACE 4.160 model

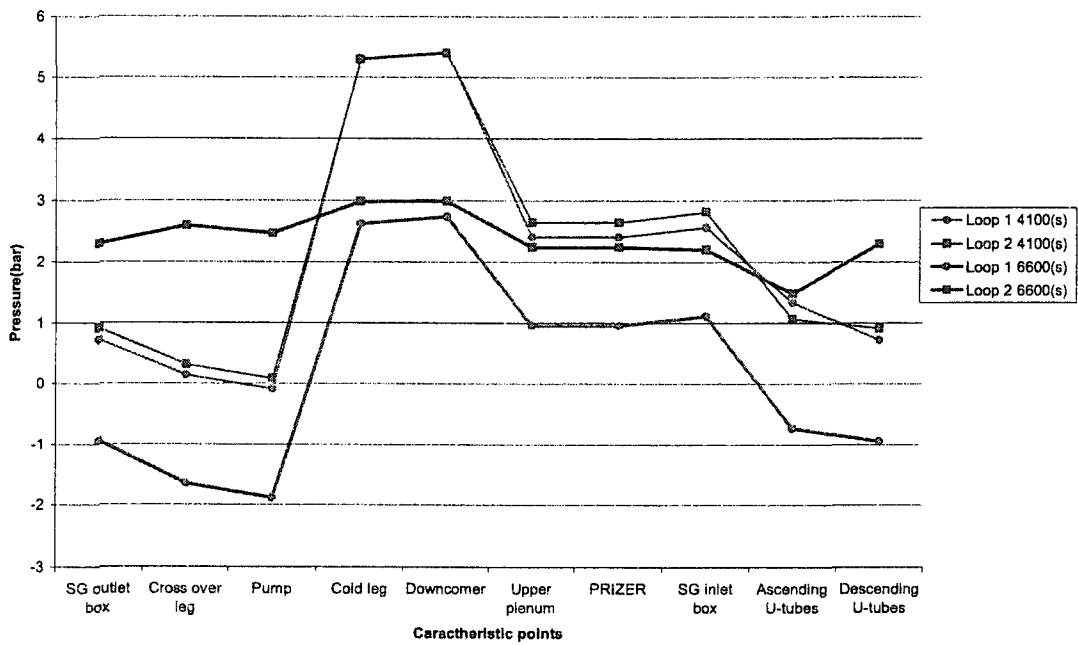

Figure 33: Pressure drops along primary system. TRACE 4.160 model

7 Sensitivity Analysis with TRACE 4.160

Several sensitivity tests were performed to analyze the impact in the plant main parameters:

- RCP model parameters: nominal hydraulic and friction torque constants.
- Nodalization of the hot leg at the pressurizer surge line connection.
- Measurements uncertainty in plant data.
- Simulation of the short term part of the transient (2-3 seconds) with no reactor SCRAM or no turbine trip signals.

RCP nominal hydraulic torque and friction torque constants

These parameters are important to adjust the time when the hot leg flow in loop 2 is inverted and the first peak in temperature appears, Figures 35 to 40. For the nominal hydraulic torque, a 30% reduction was necessary to obtain the higher hot leg temperature peak trend. Considering for each friction factor a value of $C_i=4000$ N·m, it was possible to obtain the peak trend for the friction factors C_2 and C_3 .

Also, the parameters of torque friction model for $\omega \leq \omega_0/10$ were made equal to the $\omega > \omega_0/10$ ones. It was noted that this assumption has no coastdown effect in this transient.

Nodalization of hot leg near the pressurizer surge line connection

The results show that due to TRACE numerical diffusion, the size of the nodalization in this part of the model has an important impact in the value and shape of the temperature peaks, Figure 41. Due to the nature of this transient (RCP trip), Courant number variation during the transient is within a large interval, so it is not possible to avoid the numerical diffusion during the whole transient changing the nodalization. Therefore, hot leg nodalization was not changed.

Measurements uncertainty in plant data

The sensitivity analyses on steam collector pressure, MFWS and AFWS mass flows and temperatures shown that plant behavior only presents a high sensitivity on MFW mass flow rate. Therefore, accurate boundary conditions for MFW mass flow rate was set obtaining a better simulation of steam generators narrow range levels.

Simulation of the short term part of the transient

Two tests were run, one with no reactor SCRAM and the other one with no turbine trip signals, to study the behavior of the pressure and level of the pressurizer during the short term part of the transient (2-3 seconds). The main objective of this analysis was to establish the dominant effects in the first seconds of the transient.

It can be remarked that during the validation process were obtained some results which led to some nodalization changes in parts of the model (steam lines, pressurizer, ...), Figure 34, and some adjustments were made (RCS loop reverse fiction factors, RCP coastdown, ...) getting improvements in the results. During this stage of the work, individual models were used to study its behavior during the transient. For example, SG, 3D vessel and pressurizer models were tested individually. Also, some tests were run with the secondary pressure as boundary condition in the steam line header for the whole plant model. Theses tests were useful to study separate effects in model parameters.

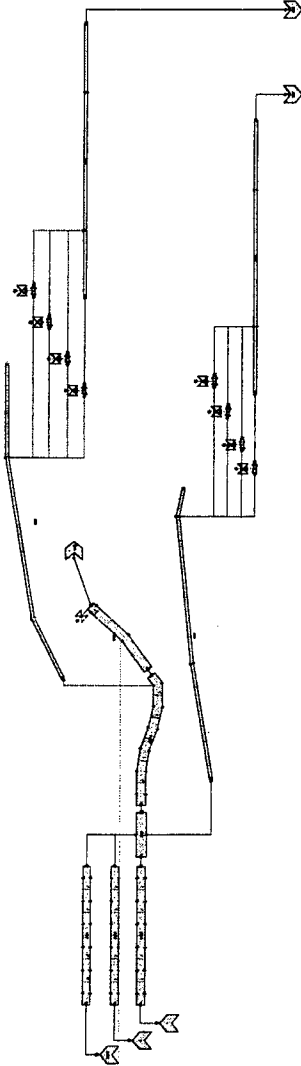

Figure 34: Improved nodalization of the steam dump system in SNAP

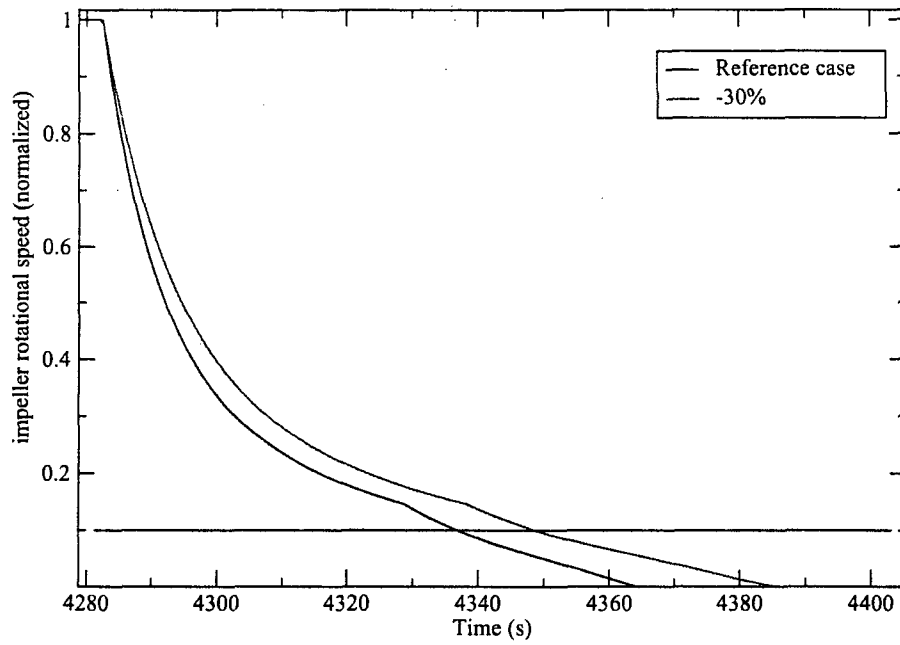

Figure 35: Loop 2 RCP angular velocity variation for nominal hydraulic torque reduction

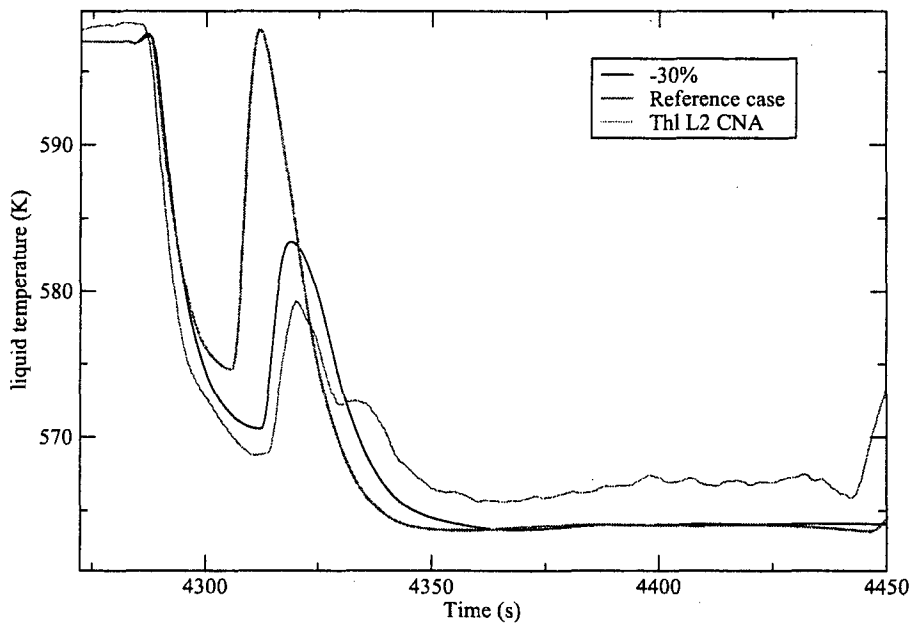

Figure 36: Hot leg 2 first peak temperature variation for nominal hydraulic torque reduction

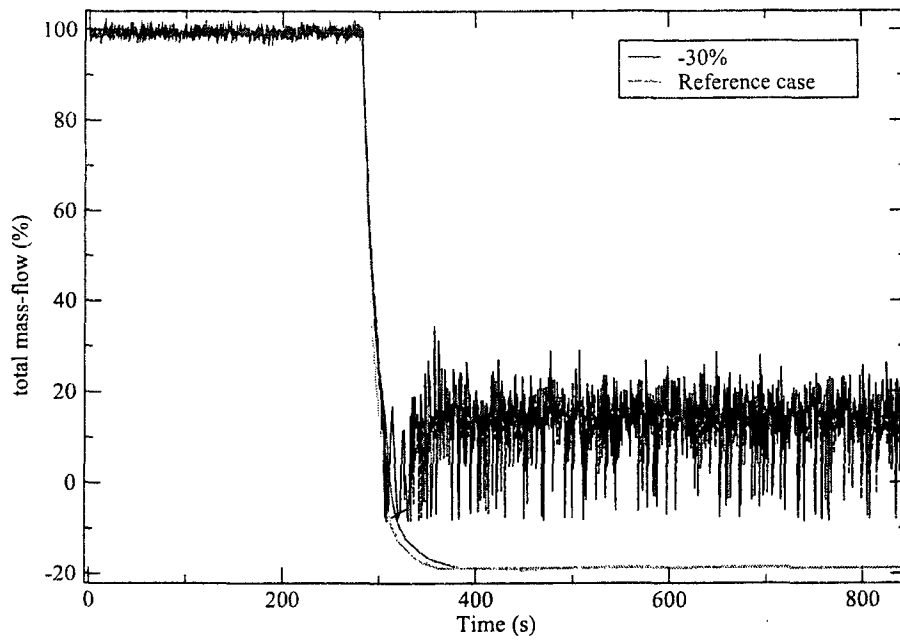

Figure 37: Loop 2 mass flow rate variation for nominal hydraulic torque reduction

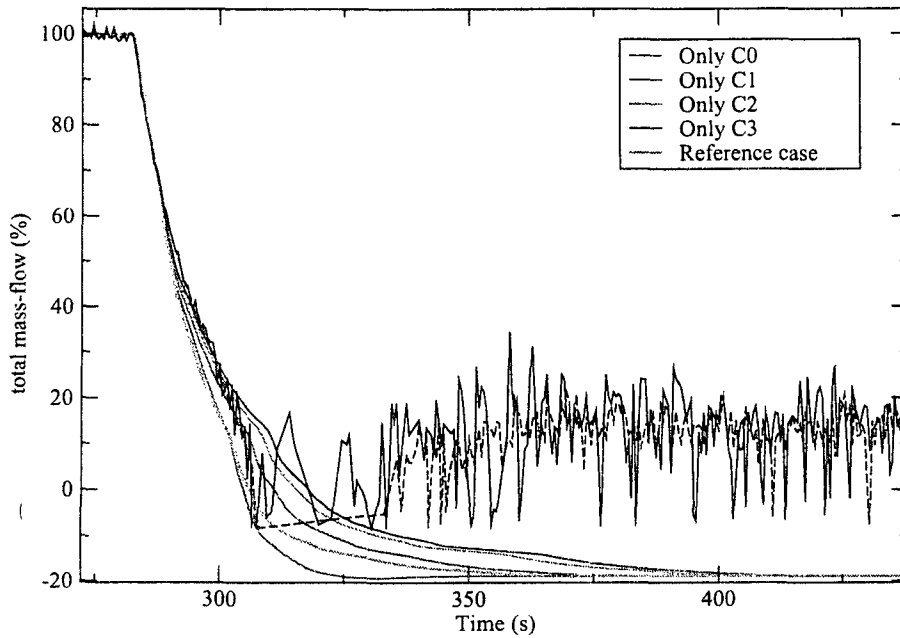

Figure 38: Loop 2 mass flows for different C_i par friction coefficients

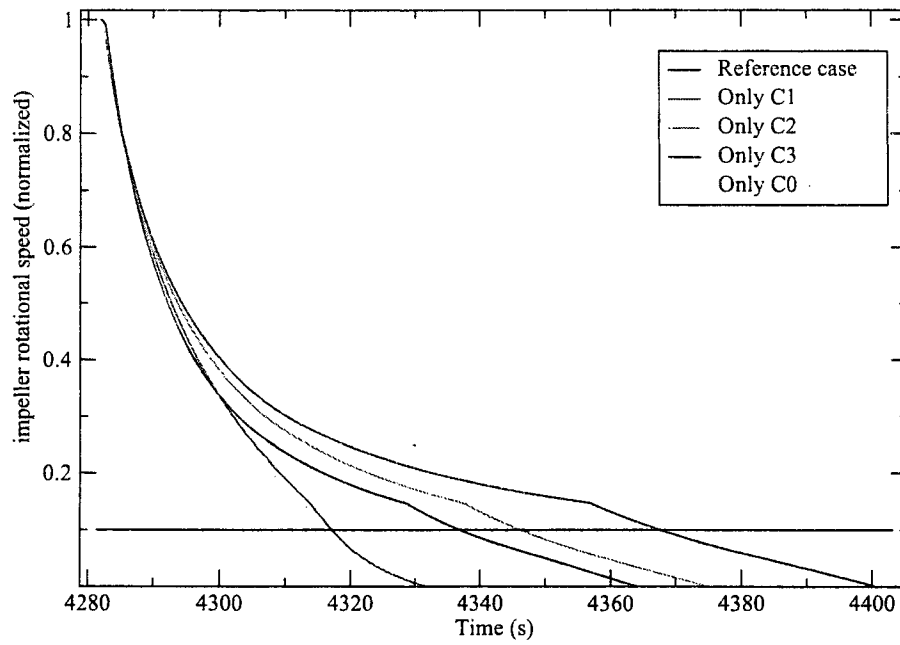

Figure 39: RCP 2 angular velocities for different C_i par friction coefficients

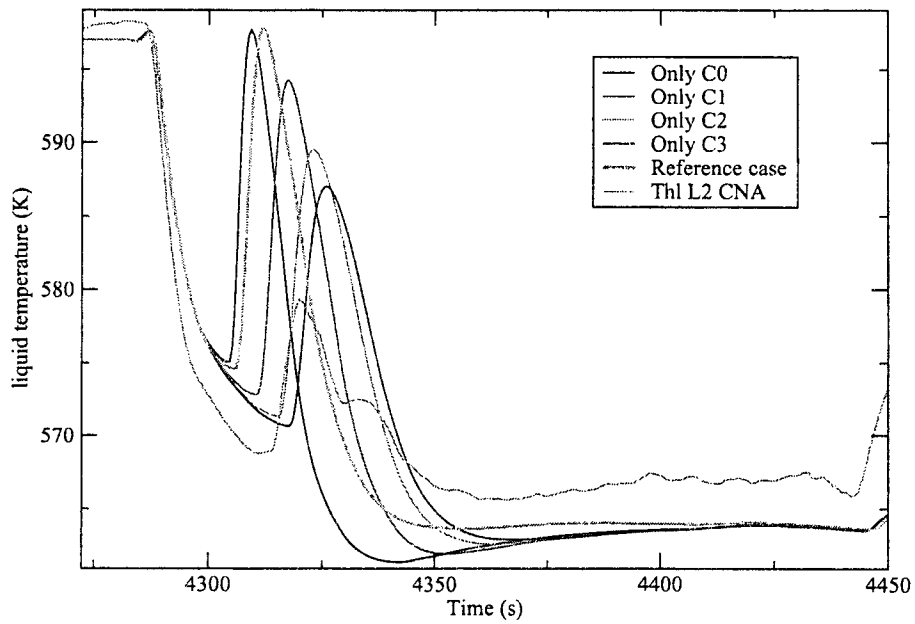

Figure 40: Loop 2 hot leg higher temperature peak for different C_i par friction coefficients

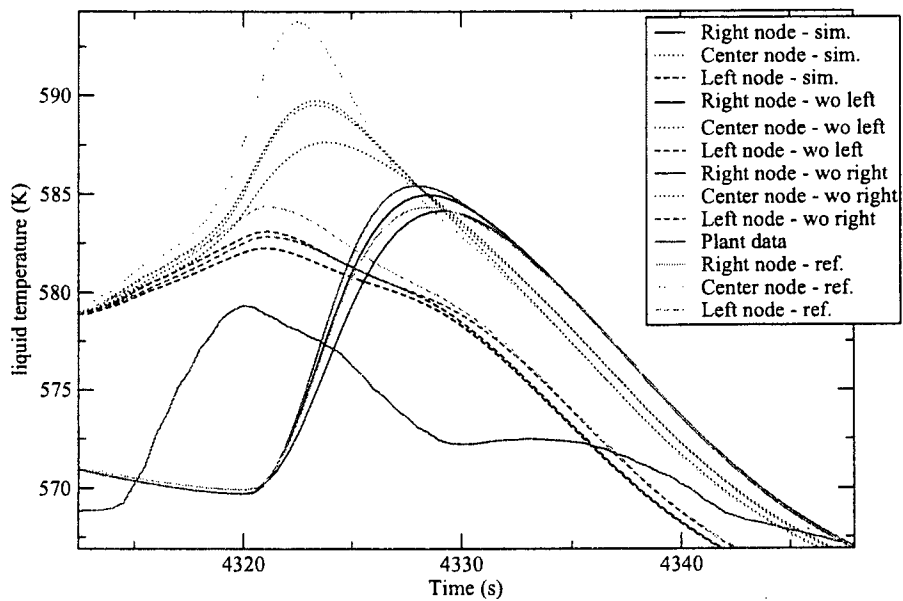

Figure 41: Loop 2 hot leg higher temperature peak variation for different nodalization schemes

8 Problems Found in the Simulation Using TRACE 5.0

During the works performed for the transient simulation a new version of TRACE was available, TRACE 5.0 (official release). However, when this version was used, an unexpected behavior in the calculation of the vapor mass flow during the opening of the steam dump valves was observed. In this case, the secondary pressure decrease due to steam dump bypass actuation is more accused, Figure 42.

In order to study this problem a small model "break-valve (2 nodes)-break" was run using several TRACE versions (TRACE 4.160, 4.273, 5RC1 and 5.0 RC3). The conclusions of this work are included in the appendix 6.2.

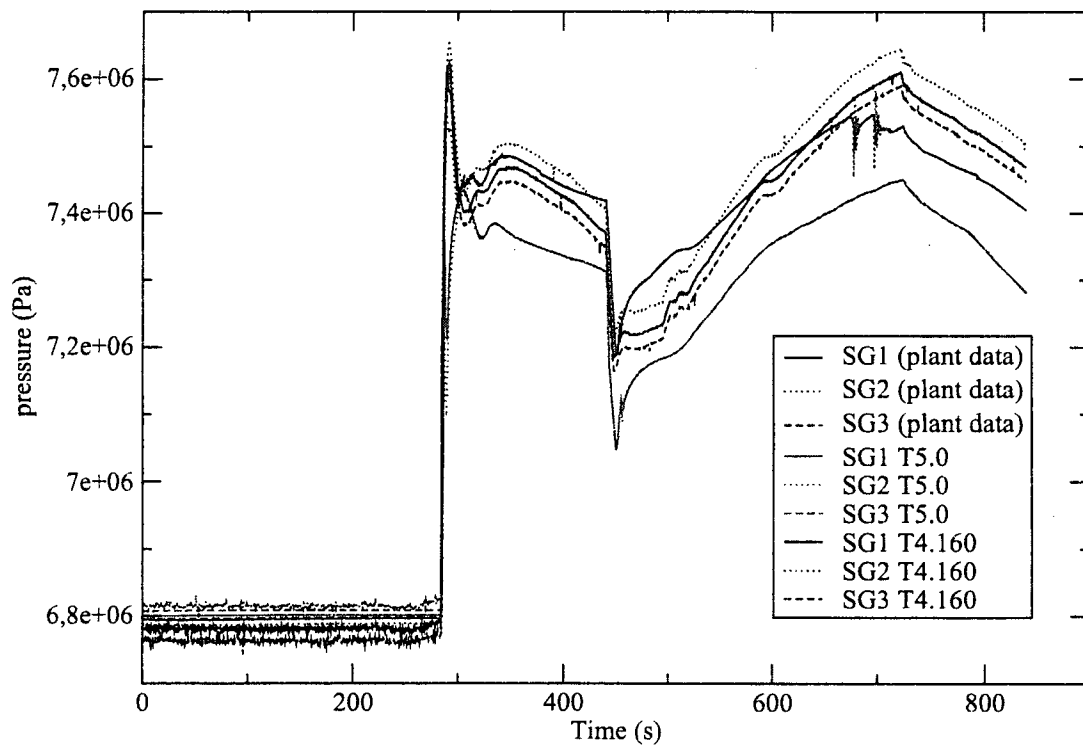

Figure 42: Comparison of secondary pressure trends for RCP trip transient using TRACE 4.160 and 5.0

9 Execution Statistics

The transient simulation was made using two versions of TRACE code, 4.160 and the last released, 5.0. Despite the problem described in section 8, related with the mass flow calculation during the few seconds after a valve opening, TRACE 5.0 is quite promising regarding time execution. In fact, 5.0 version is 1.6 more times faster than 4.160 version, Figure 43. Both codes have a slight calculation overload during turbine trip and steam dump demand, and manual MSIV closing.

The simulations have been run in Pentium IV 3.4 MHz under Windows XP and AMD Opteron Dual Core Processors 180 & 1222 under Debian, both with 32 and 64 bits pre-compiled executables provided by NRC. No significant differences were found between runs executed in Windows and Debian systems, and between 32 and 64 bits code versions.

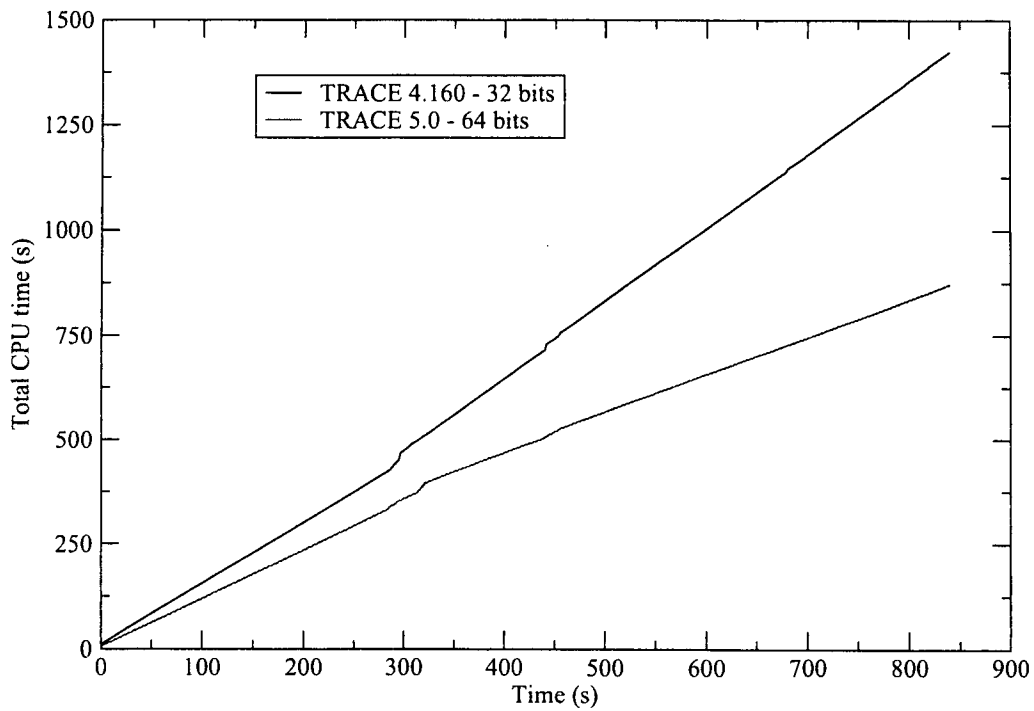

Figure 43: CPU time versus simulation time. TRACE versions 4.160 and 5.0 with Debian / AMD Opteron Dual Core Processor 180 system

10 Graphical Interface of the Almaraz I NPP TRACE Model

SNAP tool availability has supposed an advantage in the graphical representation of the results of the nuclear plants simulations. This application, developed with the sponsorship of Nuclear Regulatory Commission (NRC), is outlined as a good complement for the engineering analysis.

One of its main characteristics is the possibility of creation of masks in two dimensions for its use in the way of animation, allowing to the user to draw the part of the model that is considered of interest. This characteristic is complemented with the choice of chromatic ranges for the thermal-hydraulic components based on the variable of interest. In addition, it is possible to add online plotting of these variable while the transient is running in the animation mask.

Our previous works include several analysis of transients for isolated components, as well as the modelization of the whole Almaraz I NPP mask, useful for verification of this transient, Figure 44. To give an example, three snapshots of the simulation video are shown in Figure 45. The animation mask only works properly when using last versions of both programs, SNAP 26.6 and TRACE 5.0.

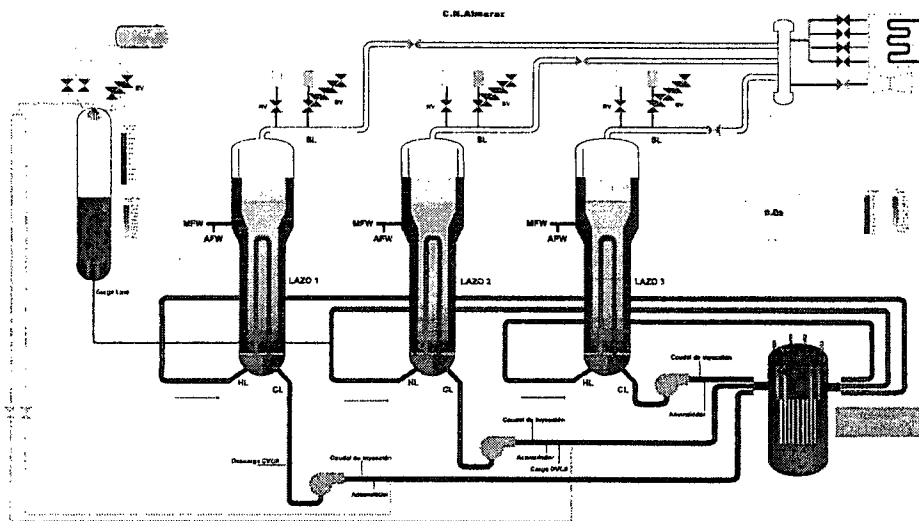

Figure 44: SNAP animation mask for Almaraz I NPP model

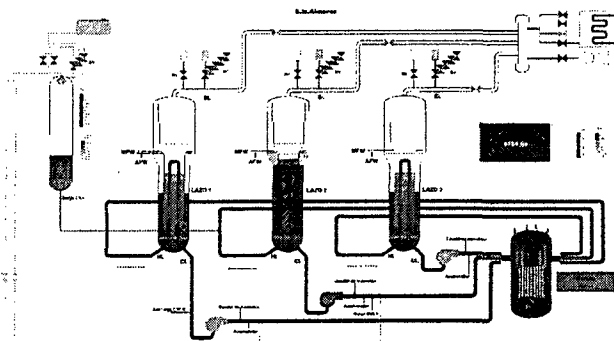
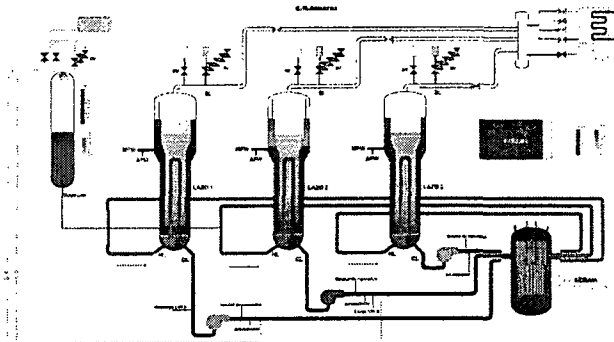
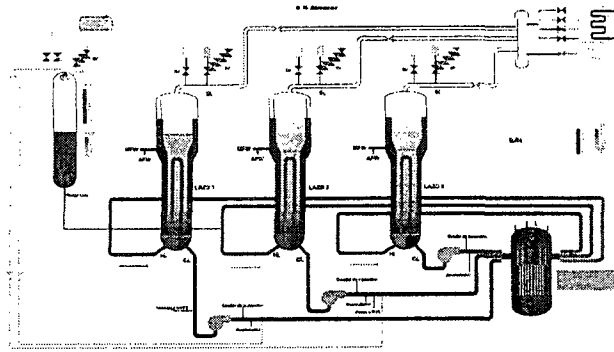

Figure 45: CNA mask simulating RCP trip transient at 0, 292.5 and 759.6 s.

11 CONCLUSIONS

The TRACE model developed for Almaraz I NPP has been verified considering a wide spectrum of conditions, being robust and showing good behavior. The results obtained in the simulation of a real transient corresponding to one RCP trip transient in Almaraz I NPP were in good agreement with plant data.

In this transient, the RCP of the loop 2 (this loop has the pressurizer surge line connection) tripped and the reactor SCRAM is generated in a short time by the low flow in 1/3 loops. After its demand, the reactor protection system starts the insertion of shutdown and control banks. After reactor SCRAM, primary temperatures decrease, leading to a decrease in pressurizer level and pressure. Turbine trip signal demands the turbine bypass opening. There are no reliable data about how the SD valves actuate during this transient, but it is clear that one or more valves did not fully closed (because T_{avg} decreases below HZP value), so some assumptions were taken to reproduce the same plant behavior in secondary pressure.

It was found that adequate reproduction of secondary pressure was specially challenging, and only it was achieved when assuming different steam discharges to the condenser.

The transient simulation was made using two versions of TRACE code, 4.160 and the last released, 5.0. Meanwhile the results obtained using TRACE 4.160 were accurate, TRACE 5.0 presented a non expected behavior in the calculation of mass flow rates during valve openings. These problems made unsuitable transient simulation using this code version. Despite this problem, from the run statistics it was found that TRACE 5.0 is quite promising regarding with time execution. In fact, 5.0 version is 1.6 more times faster than 4.160 version. Also, no significant differences were found between runs executed in Windows and Debian systems, and between 32 and 64 bits code versions.

More validation transients will be necessary to improve the quality of the model. In this way, it is expected that next years the validation process will go on with the simulation of new transients.

This work was supported by UNESA and Almaraz - Trillo AIE. Their support is gratefully acknowledged.

12 REFERENCES

- [1] I. González, C. Qeral, and A. Expósito. Phenomenology during the loss of residual heat removal system at midloop conditions with pressurizer PORVs open: Associated boron dilution. *Annals of Nuclear Energy*, 34(3):166, 2007.
- [2] I. González, C. Qeral, A. Expósito, and M. Novales. TRACE Model of Almaraz Nuclear Power Plant. In *Proc. Of the International Conference Nuclear Energy for New Europe*, Bled, Slovenia, 2005. Nuclear Society of Slovenia.
- [3] A. Lopez, C. Qeral, and I. Gallego. Conversion of Almaraz NPP Model from RELAP5 into TRAC-M. *Transactions of the American Nuclear Society*, 89:408, 2003.
- [4] J. Mulas, C. Qeral, I. Collazo, A. Concejal, N. Burbano, A. López, and I. Tarrega. Conversion of control systems, protection and engineering safeguard system-signals of Almaraz NPP model from RELAP5 into TRAC-M. In *Proc. Of the International Conference Nuclear Energy for New Europe*, Kranska Gora, Slovenia, 2002. Nuclear Society of Slovenia.
- [5] C. Qeral, A. Expósito, G. Jimenez, L. Valle, and Martinez-Murillo J. C. Verification and validation of Almaraz NPP TRACE model. In *Proc. Of the International Congress on Advances in Nuclear Power Plants*, Anaheim, California, USA, 2008. American Nuclear Society.
- [6] C. Qeral, I. González, and Expósito. Simulation of loss of RHRS sequences in the Almaraz NPP during midloop operation using TRACE code. In *Proc. Of the International Congress on Advances in Nuclear Power Plants*, Reno, USA, 2006. American Nuclear Society.
- [7] C. Qeral, I. González, and A. Expósito. Analysis of the cooling capability of steam generators during the loss of residual heat removal system at midloop operation with closed primary system. *Annals of Nuclear Energy*, 33(13):1112, 2006.
- [8] C. Qeral, I. González, and A. Expósito. Analysis of abnormal operation procedures in sequences of loss of the RHRS at midloop operation. *Annals of Nuclear Energy*, 35:1321–1334, 2008.
- [9] C. Qeral, I. González, A. Expósito, I. Gallego, and A. Concejal. Conversion of the steam generator model of Almaraz NPP from RELAP5/MOD3 into TRAC-M, TRAC-P and TRACE. In *Proc. of the Mathematics and Computation, Supercomputing, Reactor Physics and Nuclear and Biological Applications*, Avignon, France, 2005. American Nuclear Society.

- [10] C. Qeral, J. Mulas, I. Collazo, A. Concejal, and N. Burbano. Problems found in the conversion of Almaraz NPP model from RELAP5 into TRAC-M. Document sent to the NRC in April, 2003, DSE-UPM, 2002.
- [11] C. Qeral, J. Mulas, I. Collazo, A. Concejal, N. Burbano, I. Gallego, and A. López. Conversion of the Thermal Hydraulics Components of Almaraz NPP Model from RELAP5 into TRAC-M. In *Proc. Of the International Conference Nuclear Energy for New Europe*, Kranska Gora, Slovenia, 2002. Nuclear Society of Slovenia.
- [12] C. Qeral, J. Mulas, and C. G. de la Rúa. Analysis of the RELAP5/MOD3.2.2beta Critical Flow Models and Assessment Against Critical Flow Data From the Marviken Tests. NUREG/IA-0186, NRC, 2000.

Appendix A. TRACE 5.0 Opening Valve Flow Problem Reported

In this appendix it is described the problem that was found during the simulations of the transient with TRACE 5.0 (official release), see Section 8. Here it is shown the report text as it was sent to NRC: TRACEZilla Bug 370 "Unexpected behavior of critical flow model during the opening of a valve".

It has been noticed an unexpected behavior in the calculation of choked flow during the opening of the steam dump valves of a plant model using TRACE 5.0 (released in August 2007). We noticed this behavior because we were working with a previous version, TRACE 4.160, and the results fitted quite well with plant data.

A small model "break-valve (2 nodes)-break" was made and several tests were performed to study the problem. The reference model is a break with a constant pressure similar to pressure in NPP SGs at full power and the other break with 1 bar pressure (to simulate steam dump discharge conditions). The transient starts when the valve is opening, Figure 46. The tests carried out were:

- Behavior of mass flows with/without choked flow model with both code versions, Figure 47:
 1. With choked flow model off: same results for TRACE 5.0 and TRACE 4.160.
 2. With choked flow model on:
 - Phase 1): during the valve opening TRACE 5.0 calculates a mass flow 150 % higher than TRACE 4.160.
 - Phase 2): when the valve is opened at steady state conditions both codes calculate the same mass flow.
 - Phase 3) when the valve is closing both codes calculate the same mass flow.
- Comparison and sensitivity analysis between different models and parameters values:
 - It is remarkable, that TRACE 5.0 choked flow is higher than noncritical mass flow calculated during phase 1.
 - Comparison between mass flows with choked flow model "on" and with different aperture speeds, Figure 48: the mass flow overestimation is greater as faster the valve opens. Also, it is remarkable that TRACE 4.160 shows a similar overestimation behavior (with lower mass flow values) when the valve opens with very high velocities (aperture fraction from 0.0 to 1.0 in 0.1 ms).
 - Comparison between mass flows with choked flow model on and different values of discharge coefficients, Figure 49: the mass flow overestimation remains unaltered in phase 1 (the discharge coefficient doesn't affect its value), but the mass flow obtained for both code versions in phase 2 and 3, changes as expected.

- Platform execution: the results are the same in SUN and PC Linux and Windows platforms (Debian and Windows XP) using 32 and 64 bit precompiled executables of TRACE 5.0 and TRACE 4.160 supplied by NRC.

More tests were performed using another two TRACE versions, so the test has been performed for TRACE 5.0 official release, 5.0 RC1, 4.273 and 4.160 with and without choked flow model on, Figure 50. It seems that the problem is more important in the TRACE 5 versions (RC1 and 5.0 official). Additionally, it could be remarked that some differences have found in the results for RC1 and 5.0 official release. The tests run with choked flow model "off" show different maximum mass flow rates.

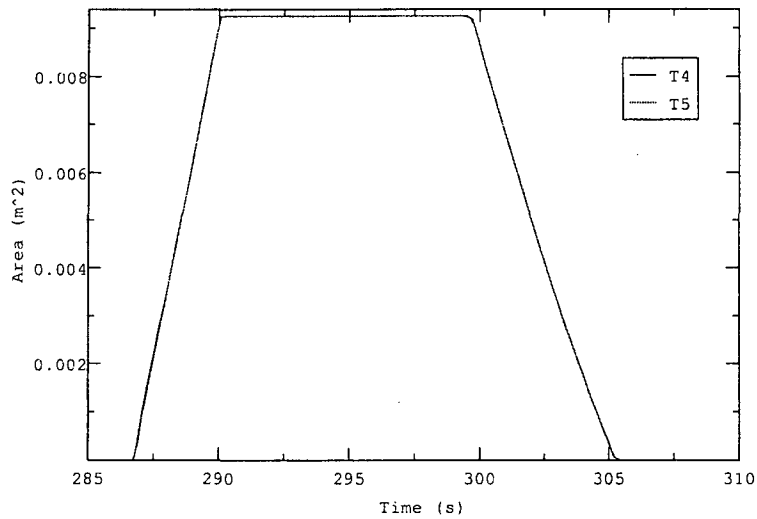

Figure 46: Valve opening for both code versions, TRACE 4.160 and 5.0

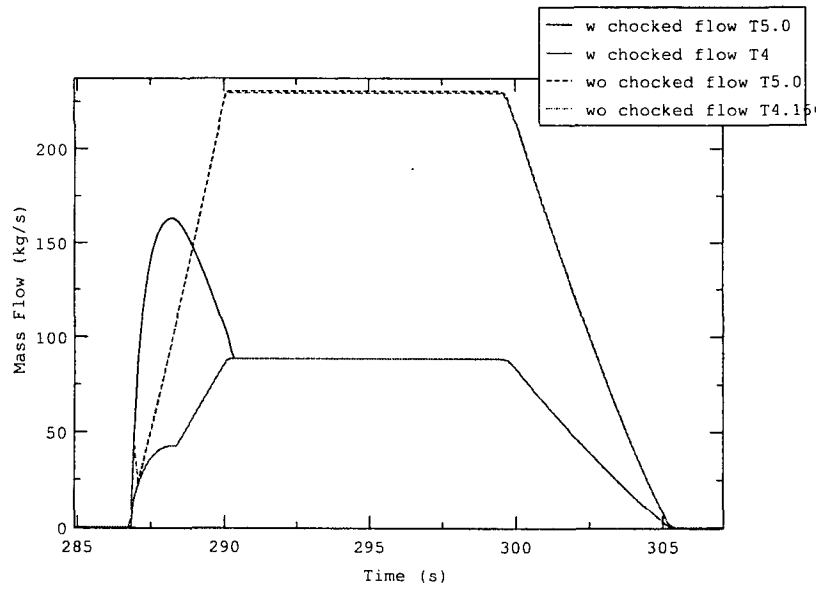

Figure 47: Mass flow rates with/without choaked flow model on. TRACE 4.160 and 5.0

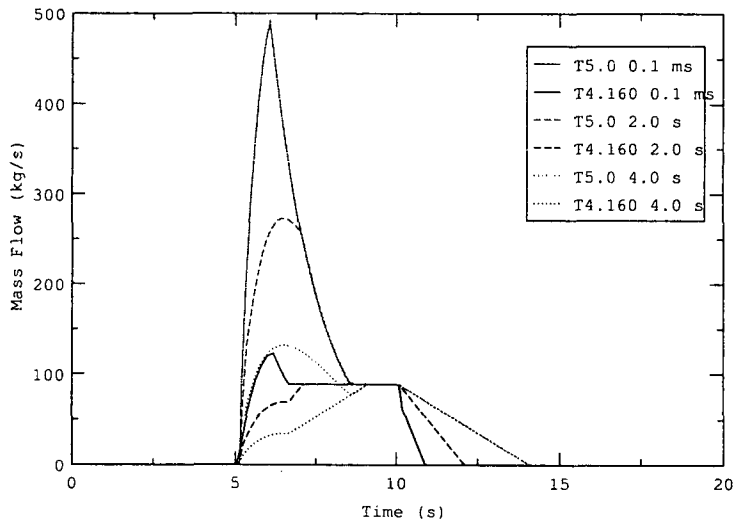

Figure 48: Mass flow rates for different valve aperture speeds. TRACE 4.160 and 5.0

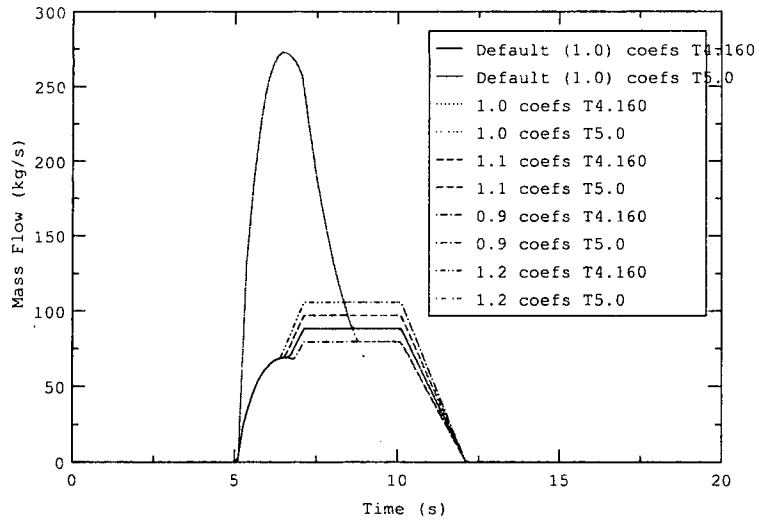

Figure 49: Mass flow rates with choked flow model and different discharge coefficients. TRACE 4.160 and 5.0

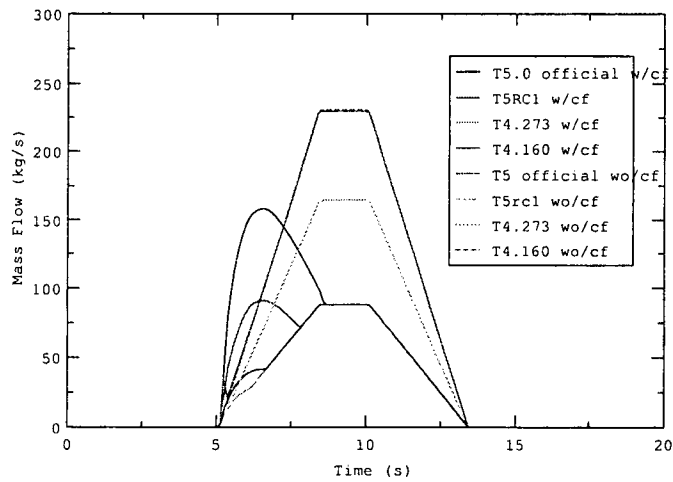

Figure 50: Mass flow rates with/without choked flow model on. TRACE versions 4.160, 4.273, 5RC1 and 5.0

<p>NRC FORM 335 (9-2004) NRCMD 3.7</p> <p style="text-align: center;">U.S. NUCLEAR REGULATORY COMMISSION</p> <p style="text-align: center;">BIBLIOGRAPHIC DATA SHEET <i>(See instructions on the reverse)</i></p>	<p>1. REPORT NUMBER (Assigned by NRC, Add Vol., Supp., Rev., and Addendum Numbers, if any.) NUREG/IA-0233</p>				
<p>2. TITLE AND SUBTITLE Assessment of TRACE 4.160 and 5.0 against RCP Trip Transient Almaraz I Nuclear Power Plant</p>	<p>3. DATE REPORT PUBLISHED</p> <table border="1"> <tr> <td>MONTH</td> <td>YEAR</td> </tr> <tr> <td>July</td> <td>2010</td> </tr> </table> <p>4. FIN OR GRANT NUMBER</p>	MONTH	YEAR	July	2010
MONTH	YEAR				
July	2010				
<p>5. AUTHOR(S) César Queral*, Antonio Expósito*, Gonzalo Jiménez*, Laura Valle* and Juan Carlos Martínez-Murillo**</p>	<p>6. TYPE OF REPORT Technical</p> <p>7. PERIOD COVERED <i>(Inclusive Dates)</i></p>				
<p>8. PERFORMING ORGANIZATION - NAME AND ADDRESS <i>(If NRC, provide Division, Office or Region, U.S. Nuclear Regulatory Commission, and mailing address; if contractor, provide name and mailing address.)</i></p> <table> <tr> <td>* Universidad Politécnica de Madrid Alenza 4. 28003 Madrid Spain</td> <td>** Almaraz-Trillo AIE Avenida de Manoteras 46 Bis. 28050 Madrid Spain</td> </tr> </table>		* Universidad Politécnica de Madrid Alenza 4. 28003 Madrid Spain	** Almaraz-Trillo AIE Avenida de Manoteras 46 Bis. 28050 Madrid Spain		
* Universidad Politécnica de Madrid Alenza 4. 28003 Madrid Spain	** Almaraz-Trillo AIE Avenida de Manoteras 46 Bis. 28050 Madrid Spain				
<p>9. SPONSORING ORGANIZATION - NAME AND ADDRESS <i>(If NRC, type "Same as above"; if contractor, provide NRC Division, Office or Region, U.S. Nuclear Regulatory Commission, and mailing address.)</i></p> <p>Division of Systems Analysis Office of Nuclear Regulatory Research U.S. Nuclear Regulatory Commission Washington, DC 20555-0001</p>					
<p>10. SUPPLEMENTARY NOTES A. Calvo, NRC Project Manager</p>					
<p>11. ABSTRACT <i>(200 words or less)</i></p> <p>The Energy Systems Department of Universidad Politecnica de Madrid has developed a model of Almaraz NPP, Westinghouse three loops PWR design, for TRACE code in the framework of several projects sponsored by the Spanish Nuclear Regulatory Commission (CSN) and the Electric Energy Industry of Spain (UNESA). At present, a full power and a shutdown model are applied for sequences analysis. The model has been adjusted at several power rates and steady state results show good agreement with plant data. In order to check the whole model, a wide spectrum of transient simulations were performed, observing a good behavior. For partial fulfillment of the bilateral - agreement for cooperation in thermal hydraulic activities between the Consejo de Seguridad Nuclear of Spain (CSN) and the United States Nuclear Regulatory Commission (US-NRC), the simulation of single RCP trip transient that took place in Almaraz NPP on May 13 (2002) has been performed, comparing the results obtained with plant data. The data comparison was quite encouraging when TRACE version 4.160 is used. However, the results obtained using TRACE 5.0 were not satisfactory. Wrong predictions were obtained for the steam flow through the Steam Dump valves during the transient. Regardless of this problem, the work made allowed performing the first validation transient with the plant model. The simulations have been run in a Pentium IV 3.4 MHz under Windows XP and AMD Opteron Dual Core Processors 180 & 1222 under Debian Linux, both with 32 and 64 bits executables. This work has been sponsored by UNESA and Almaraz-Trillo AIE.</p>					
<p>12. KEY WORDS/DESCRIPTORS <i>(List words or phrases that will assist researchers in locating the report.)</i></p> <p>Consejo de Seguridad Nuclear (CSN) Thermal-hydraulic CAMP-Spain program TRACE 4.160 simulation RCP trip transient behavior Almaraz I Nuclear Power Plant SCRAM Electric Energy Industry of Spain (UNESA) RELAP5 Westinghouse PWR</p>	<p>13. AVAILABILITY STATEMENT unlimited</p> <p>14. SECURITY CLASSIFICATION</p> <p><i>(This Page)</i> unclassified</p> <p><i>(This Report)</i> unclassified</p> <p>15. NUMBER OF PAGES</p> <p>16. PRICE</p>				



Federal Recycling Program



UNITED STATES
NUCLEAR REGULATORY COMMISSION
WASHINGTON, DC 20555-0001

OFFICIAL BUSINESS