

CONTENTS

	Page
1.2.4 Canister Receipt and Closure Facility	1.2.4-1
1.2.4.1 Canister Receipt and Closure Facility Description	1.2.4-1
1.2.4.2 Mechanical Handling System	1.2.4-9
1.2.4.3 Process Systems.	1.2.4-49
1.2.4.4 Canister Receipt and Closure Facility Heating, Ventilation, and Air-Conditioning Systems	1.2.4-53
1.2.4.5 General References	1.2.4-65

INTENTIONALLY LEFT BLANK

TABLES

	Page
1.2.4-1. Description of Non-ITS Mechanical Handling Structures, Systems, or Components Used in the CRCF, Which Are Also Used in Other Handling Facilities	1.2.4-69
1.2.4-2. CRCF-Specific Non-ITS Structures, Systems, and Components in the Mechanical Handling System	1.2.4-74
1.2.4-3. Summary-Level Description of Equipment and Personnel Shield Doors.	1.2.4-75
1.2.4-4. Preclosure Nuclear Safety Design Bases and their Relationship to Design Criteria for the CRCF	1.2.4-77
1.2.4-5. Handling Facilities Equipment Stands	1.2.4-95
1.2.4-6. Summary-Level Description of ITS Equipment Confinement Doors	1.2.4-97
1.2.4-7. CRCF ITS HVAC Exhaust Components and System Design Data	1.2.4-98
1.2.4-8. CRCF Indoor Design Temperatures	1.2.4-99
1.2.4-9. CRCF Non-ITS HVAC Supply Components and System Design Data.	1.2.4-100
1.2.4-10. CRCF Non-ITS HVAC Exhaust Components and System Design Data.	1.2.4-101
1.2.4-11. CRCF ITS HVAC Supply Components and System Design Data.	1.2.4-102

INTENTIONALLY LEFT BLANK

FIGURES

	Page
1.2.4-1. CRCF General Arrangement Legend	1.2.4-103
1.2.4-2. CRCF General Arrangement Ground Floor Plan	1.2.4-105
1.2.4-3. CRCF General Arrangement Second Floor Plan	1.2.4-107
1.2.4-4. CRCF General Arrangement Third Floor Plan.	1.2.4-109
1.2.4-5. CRCF General Arrangement Roof Plan	1.2.4-111
1.2.4-6. CRCF General Arrangement Section A	1.2.4-113
1.2.4-7. CRCF General Arrangement Section B	1.2.4-115
1.2.4-8. CRCF General Arrangement Section C	1.2.4-117
1.2.4-9. CRCF General Arrangement Section D	1.2.4-119
1.2.4-10. CRCF General Arrangement Section E	1.2.4-121
1.2.4-11. CRCF General Arrangement Section F	1.2.4-123
1.2.4-12. Major Waste Processing Functions in the CRCF	1.2.4-125
1.2.4-13. CRCF Operational Sequences and Material Flow Paths (Sheet 1 of 2).	1.2.4-127
1.2.4-13. CRCF Operational Sequences and Material Flow Paths (Sheet 2 of 2).	1.2.4-129
1.2.4-14. Waste Form Inventory Present within CRCF at Any One Time	1.2.4-131
1.2.4-15. Logic Diagram for a Typical Reversing Motor	1.2.4-133
1.2.4-16. Logic Diagram for a Typical Reversing Motor with Stop Command	1.2.4-135
1.2.4-17. Logic Diagram for a Typical Dual-Coil Solenoid Air-Operated Device.	1.2.4-137
1.2.4-18. Logic Diagram for a Typical Motor Drive with Auto Command.	1.2.4-139
1.2.4-19. Equipment Shield Door (Type 1) Mechanical Equipment Envelope	1.2.4-141
1.2.4-20. Equipment Shield Door Process and Instrumentation Diagram	1.2.4-143
1.2.4-21. Logic Diagram for Equipment Shield Door—Single (Types 1 and 4).	1.2.4-145
1.2.4-22. Cask Preparation Room Equipment Confinement Door East Mechanical Equipment Envelope	1.2.4-147
1.2.4-23. Nuclear Facilities Equipment Confinement Door Process and Instrumentation Diagram	1.2.4-149
1.2.4-24. Logic Diagram for Equipment Confinement Doors—Double	1.2.4-151
1.2.4-25. Cask Preparation Room Equipment Confinement Door South Mechanical Equipment Envelope	1.2.4-153
1.2.4-26. Cask Transfer Trolley Mechanical Equipment Envelope Plan and Elevations.	1.2.4-155
1.2.4-27. Cask Transfer Trolley Process and Instrumentation Diagram	1.2.4-157
1.2.4-28. Cask Handling Yoke Mechanical Equipment Envelope.	1.2.4-159
1.2.4-29. Cask Handling Yoke Process and Instrumentation Diagram	1.2.4-161
1.2.4-30. Logic Diagram for the Cask Handling Yoke	1.2.4-163
1.2.4-31. Cask Lid-Lifting Grapple Mechanical Equipment Envelope	1.2.4-165
1.2.4-32. Cask Lid-Lifting Grapple Process and Instrumentation Diagram	1.2.4-167

FIGURES (Continued)

	Page
1.2.4-33. Logic Diagram for the Cask Handling Crane Cask Lid-Lifting Grapple	1.2.4-169
1.2.4-34. CRCF Cask Handling Crane Mechanical Equipment Envelope	1.2.4-171
1.2.4-35. Cask Handling Crane Process and Instrumentation Diagram (Sheet 1 of 4).	1.2.4-173
1.2.4-35. Cask Handling Crane Process and Instrumentation Diagram (Sheet 2 of 4).	1.2.4-175
1.2.4-35. Cask Handling Crane Process and Instrumentation Diagram (Sheet 3 of 4).	1.2.4-177
1.2.4-35. Cask Handling Crane Process and Instrumentation Diagram (Sheet 4 of 4).	1.2.4-179
1.2.4-36. Logic Diagram for the Cask Handling Crane Main Hoist	1.2.4-181
1.2.4-37. Logic Diagram for the Cask Handling Crane Auxiliary Hoist	1.2.4-183
1.2.4-38. Dual-Purpose Canister Lid Adapter	1.2.4-185
1.2.4-39. Horizontal Lifting Beam Mechanical Equipment Envelope.	1.2.4-187
1.2.4-40. Nuclear Facilities Rail Cask Lid Adapter Mechanical Equipment Envelope	1.2.4-189
1.2.4-41. Cask Preparation Platform Mechanical Equipment Envelope (Sheet 1 of 2).	1.2.4-191
1.2.4-41. Cask Preparation Platform Mechanical Equipment Envelope (Sheet 2 of 2).	1.2.4-193
1.2.4-42. Impact Limiter Lifting Device Mechanical Equipment Envelope	1.2.4-195
1.2.4-43. Defense Waste Processing Facility/Idaho National Laboratory HLW Canister Grapple Mechanical Equipment Envelope.	1.2.4-197
1.2.4-44. Defense Waste Processing Facility/Idaho National Laboratory and West Valley Demonstration Project/Hanford HLW Canister Grapples Process and Instrumentation Diagram.	1.2.4-199
1.2.4-45. Defense Waste Processing Facility/Idaho National Laboratory and West Valley Demonstration Project/Hanford HLW Canister Grapples Logic Diagram.	1.2.4-201
1.2.4-46. West Valley Demonstration Project/Hanford HLW Canister Grapple Mechanical Equipment Envelope	1.2.4-203
1.2.4-47. Canister Transfer Machine Canister Grapple	1.2.4-205
1.2.4-48. Canister Transfer Machine Canister Grapple Process and Instrumentation Diagram	1.2.4-207
1.2.4-49. Logic Diagram for the Canister Transfer Machine Canister Grapple.	1.2.4-209
1.2.4-50. Canister Transfer Machine Mechanical Equipment Envelope	1.2.4-211
1.2.4-51. Canister Transfer Machine Process and Instrumentation Diagram (Sheet 1 of 3).	1.2.4-213
1.2.4-51. Canister Transfer Machine Process and Instrumentation Diagram (Sheet 2 of 3).	1.2.4-215
1.2.4-51. Canister Transfer Machine Process and Instrumentation Diagram (Sheet 3 of 3).	1.2.4-217
1.2.4-52. Logic Diagram for the Canister Transfer Machine Bridge.	1.2.4-219

FIGURES (Continued)

	Page
1.2.4-53. Logic Diagram for the Canister Transfer Machine Shield Skirt and Slide Gate.	1.2.4-221
1.2.4-54. Logic Diagram for the Canister Transfer Machine Shield Bell Trolley.	1.2.4-223
1.2.4-55. Logic Diagram for the Canister Transfer Machine Canister Hoist.	1.2.4-225
1.2.4-56. Logic Diagram for the Canister Transfer Machine Canister Hoist Trolley.	1.2.4-227
1.2.4-57. Port Slide Gate Mechanical Equipment Envelope	1.2.4-229
1.2.4-58. Slide Gate Process and Instrumentation Diagram	1.2.4-231
1.2.4-59. Logic Diagram for the Cask Port and Waste Package Slide Gate (Double)	1.2.4-233
1.2.4-60. TAD Canister Slide Gate Mechanical Equipment Envelope	1.2.4-235
1.2.4-61. Logic Diagram for the Cask Port Slide Gate (Single)	1.2.4-237
1.2.4-62. DOE Canister Slide Gate Mechanical Equipment Envelope	1.2.4-239
1.2.4-63. Hanford Multicanister Overpack Canister Grapple Mechanical Equipment Envelope.	1.2.4-241
1.2.4-64. Hanford Multicanister Overpack, 18-in., and 24-in. SNF Canister Grapples Process and Instrumentation Diagram.	1.2.4-243
1.2.4-65. Hanford Multicanister Overpack, 18-in., and 24-in. SNF Canister Grapples Logic Diagram.	1.2.4-245
1.2.4-66. SNF Canister Grapple, 18-in., Mechanical Equipment Envelope	1.2.4-247
1.2.4-67. SNF Canister Grapple, 24-in., Mechanical Equipment Envelope	1.2.4-249
1.2.4-68. DOE Canister Staging Rack Mechanical Equipment Envelope	1.2.4-251
1.2.4-69. TAD Canister Staging Rack Mechanical Equipment Envelope	1.2.4-253
1.2.4-70. Waste Package Closure Welds (Typical)	1.2.4-255
1.2.4-71. Waste Package Closure System Flow Diagram	1.2.4-257
1.2.4-72. Illustration of Waste Package Closure Area Operating Floor (Partial View)	1.2.4-259
1.2.4-73. Waste Package Closure Room Robotic Arms	1.2.4-261
1.2.4-74. Robotic Arms Mechanical Equipment Envelope	1.2.4-263
1.2.4-75. Welding End Effector	1.2.4-265
1.2.4-76. Waste Package Inerting System Piping and Instrumentation Diagram	1.2.4-267
1.2.4-77. CRCF Waste Package Closure Room Remote Handling System Mechanical Equipment Envelope	1.2.4-269
1.2.4-78. Waste Package Closure Room Crane Mechanical Equipment Envelope	1.2.4-271
1.2.4-79. Waste Package Closure Room Crane Mechanical Handling Process and Instrumentation Diagram	1.2.4-273
1.2.4-80. Closure Support Room Crane Mechanical Equipment Envelope.	1.2.4-275
1.2.4-81. Waste Package Closure Support Room Crane Process and Instrumentation Diagram	1.2.4-277
1.2.4-82. Nuclear Facilities Equipment Shield Door (Type 4) Mechanical Equipment Envelope.	1.2.4-279

FIGURES (Continued)

	Page
1.2.4-83. CRCF Waste Package Loadout Room Equipment Shield Door Logic Diagram	1.2.4-281
1.2.4-84. CRCF Waste Package Positioning Room Equipment Shield Door Logic Diagram	1.2.4-283
1.2.4-85. Waste Package Loadout Room Personnel Access and Shield Doors Mechanical Equipment Envelope	1.2.4-285
1.2.4-86. Waste Package Loadout Room Personnel Access and Shield Doors Process and Instrumentation Diagram	1.2.4-287
1.2.4-87. Personnel Access and Shield Door Logic Diagram	1.2.4-289
1.2.4-88. Waste Package Transfer Trolley Mechanical Equipment Envelope Plan and Elevations (Sheet 1 of 2)	1.2.4-291
1.2.4-88. Waste Package Transfer Trolley Mechanical Equipment Envelope Elevation and Detail (Sheet 2 of 2).	1.2.4-293
1.2.4-89. Waste Package Transfer Trolley Process and Instrumentation Diagram	1.2.4-295
1.2.4-90. Logic Diagram for the Waste Package Transfer Trolley	1.2.4-297
1.2.4-91. Waste Package Handling Crane Mechanical Equipment Envelope	1.2.4-299
1.2.4-92. Waste Package Handling Crane Process and Instrumentation Diagram	1.2.4-301
1.2.4-93. TEV Mechanical Onboard Position Switch and Stationary Actuating Bracket	1.2.4-303
1.2.4-94. Cask Cavity Gas Sampling System Piping and Instrumentation Diagram	1.2.4-305
1.2.4-95. CRCF Liquid Low-Level Waste Sampling and Sump Piping and Instrumentation Diagram	1.2.4-307
1.2.4-96. CRCF Confinement Zoning, Ground Floor	1.2.4-309
1.2.4-97. CRCF Confinement Zoning, Second Floor	1.2.4-311
1.2.4-98. CRCF Confinement Zoning, Third Floor	1.2.4-313
1.2.4-99. CRCF 1 Composite Ventilation Flow Diagram, Tertiary Confinement ITS Exhaust and Non-ITS HVAC Supply Subsystems	1.2.4-315
1.2.4-100. CRCF 1 ITS Confinement Areas Air Distribution System Ventilation and Instrumentation Diagram	1.2.4-317
1.2.4-101. CRCF 1 ITS Confinement Areas HEPA Exhaust System—Train A Ventilation and Instrumentation Diagram	1.2.4-319
1.2.4-102. CRCF 1 ITS Confinement Areas HEPA Exhaust System—Train B Ventilation and Instrumentation Diagram	1.2.4-321
1.2.4-103. CRCF and WHF ITS Confinement Areas HEPA Exhaust Fan (Trains A and B) Digital Logic Diagram	1.2.4-323
1.2.4-104. CRCF 1 Composite Ventilation Flow Diagram, Tertiary Confinement ITS HVAC Systems, Electrical and Battery Rooms.	1.2.4-325
1.2.4-105. CRCF 1 Confinement ITS Electrical Room HVAC System—Train A Ventilation and Instrumentation Diagram	1.2.4-327
1.2.4-106. CRCF 1 Confinement ITS Electrical Room HVAC System—Train B Ventilation and Instrumentation Diagram.	1.2.4-329

FIGURES (Continued)

	Page
1.2.4-107. CRCF 1 Confinement ITS Battery Room Exhaust System—Train A Ventilation and Instrumentation Diagram	1.2.4-331
1.2.4-108. CRCF 1 Confinement ITS Battery Room Exhaust System—Train B Ventilation and Instrumentation Diagram.	1.2.4-333
1.2.4-109. CRCF and WHF Confinement ITS Electrical Room Fan Coil Unit (Trains A and B) Digital Logic Diagram	1.2.4-335
1.2.4-110. CRCF and WHF Confinement ITS Electrical Room Fan Coil Unit (Trains A and B) Digital Logic Diagram	1.2.4-337
1.2.4-111. CRCF and WHF Confinement ITS Battery Room Exhaust Fan (Trains A and B) Digital Logic Diagram	1.2.4-339
1.2.4-112. CRCF 1 Cask Preparation Room HVAC Supply System Ventilation and Instrumentation Diagram	1.2.4-341
1.2.4-113. CRCF 1 Composite Ventilation Flow Diagram, Tertiary Confinement Non-ITS Exhaust and HVAC Supply Systems.	1.2.4-343
1.2.4-114. CRCF 1 Composite Ventilation Flow Diagram, Tertiary Confinement Ground Floor HVAC Systems	1.2.4-345
1.2.4-115. CRCF 1 Composite Ventilation Flow Diagram, Tertiary Confinement Non-ITS HVAC System Supply and Exhaust	1.2.4-347
1.2.4-116. CRCF 1 Confinement Waste Package Loadout Room HVAC Supply System Ventilation and Instrumentation Diagram	1.2.4-349
1.2.4-117. CRCF 1 Confinement Canister Transfer Room HVAC System Ventilation and Instrumentation Diagram	1.2.4-351
1.2.4-118. CRCF 1 Confinement Second Floor North HVAC Supply System Ventilation and Instrumentation Diagram	1.2.4-353
1.2.4-119. CRCF 1 Confinement Second Floor North Areas Air Distribution System Ventilation and Instrumentation Diagram	1.2.4-355
1.2.4-120. CRCF 1 Confinement Waste Package Closure Areas Air Distribution System Ventilation and Instrumentation Diagram	1.2.4-357
1.2.4-121. CRCF 1 Second Floor South HVAC Supply System Ventilation and Instrumentation Diagram	1.2.4-359
1.2.4-122. CRCF 1 Confinement Second Floor South Areas Air Distribution System Ventilation and Instrumentation Diagram	1.2.4-361
1.2.4-123. CRCF 1 Confinement Non-ITS HEPA Exhaust System—Second Floor Ventilation and Instrumentation Diagram.	1.2.4-363
1.2.4-124. CRCF Composite Ventilation Flow Diagram, Nonconfinement Non-ITS HVAC System, Support and Operations.	1.2.4-365
1.2.4-125. Nuclear Facilities Grapple Stand Mechanical Equipment Envelope	1.2.4-367
1.2.4-126. Equipment Stands Mechanical Equipment Envelope.	1.2.4-369
1.2.4-127. Mobile Access Platform Mechanical Equipment Envelope (Sheet 1 of 2).	1.2.4-371
1.2.4-127. Mobile Access Platform Mechanical Equipment Envelope (Sheet 2 of 2).	1.2.4-373
1.2.4-128. Mobile Access Platform Process and Instrumentation Diagram	1.2.4-375
1.2.4-129. Waste Package Pallet Yoke Mechanical Equipment Envelope	1.2.4-377

FIGURES (Continued)

	Page
1.2.4-130. Waste Package Pallet Yoke Process and Instrumentation Diagram	1.2.4-379
1.2.4-131. Waste Package Pallet Yoke Stand Mechanical Equipment Envelope	1.2.4-381
1.2.4-132. Canister Transfer Machine Maintenance Crane Mechanical Equipment Envelope	1.2.4-383
1.2.4-133. Canister Transfer Machine Maintenance Crane Process and Instrumentation Diagram	1.2.4-385
1.2.4-134. Cask Handling Yoke Stand Mechanical Equipment Envelope	1.2.4-387
1.2.4-135. Waste Package Shield Ring Lift Beam Mechanical Equipment Envelope	1.2.4-389
1.2.4-136. Waste Package Shield Ring Lift Beam Stand Mechanical Equipment Envelope	1.2.4-391
1.2.4-137. Waste Package Transfer Carriage Docking Station Mechanical Equipment Envelope Plan, Elevation, and Section.	1.2.4-393
1.2.4-138. Waste Package Transfer Carriage Docking Station Process and Instrumentation Diagram	1.2.4-395
1.2.4-139. Loadout Platforms Mechanical Equipment Envelope (Sheet 1 of 2)	1.2.4-397
1.2.4-139. Loadout Platforms Mechanical Equipment Envelope (Sheet 2 of 2)	1.2.4-399
1.2.4-140. Loadout Platform Process and Instrumentation Diagram.	1.2.4-401
1.2.4-141. Cask Tilting Frame Mechanical Equipment Envelope	1.2.4-403
1.2.4-142. Nuclear Facilities Truck Cask Lid Adapter Mechanical Equipment Envelope	1.2.4-405
1.2.4-143. Horizontal Cask Stand Mechanical Equipment Envelope	1.2.4-407
1.2.4-144. Horizontal Lifting Beam Stand Mechanical Equipment Envelope	1.2.4-409
1.2.4-145. CRCF, RF, and WHF Mobile Lift Mechanical Equipment Envelope	1.2.4-411
1.2.4-146. Nuclear Facilities Personnel Confinement Single Door Mechanical Equipment Envelope	1.2.4-413
1.2.4-147. CRCF Shield Window Mechanical Equipment Envelope Elevation and Sections	1.2.4-415

1.2.4 Canister Receipt and Closure Facility

[NUREG-1804, Section 2.1.1.2.3: AC 1, AC 2, AC 6; Section 2.1.1.6.3: AC 1, AC 2; Section 2.1.1.7.3.1: AC 1; Section 2.1.1.7.3.2: AC 1; Section 2.1.1.7.3.3(I): AC 1, AC 2, AC 4; HLWRS-ISG-02, Section 2.1.1.2.3: AC 2]

The design and operation of the Canister Receipt and Closure Facility (CRCF) and the systems within the facility are described in this section. There will be three identical CRCFs constructed in phases in the geologic repository operations area. Information specific to the generic features of structural design, mechanical handling design, and heating, ventilation, and air-conditioning (HVAC) design is provided in Sections 1.2.2.1, 1.2.2.2, and 1.2.2.3. Information related to the electrical power, controls and monitoring, fire protection, plant services, and waste management is provided in Sections 1.4.1 to 1.4.5, respectively. The methodologies for shielding and nuclear criticality design are addressed in Sections 1.10.3 and 1.14, respectively.

Important to safety (ITS) structures, systems, and components (SSCs) that are used in the handling facilities (including the CRCF) are described in detail in this section. Logic diagrams for ITS SSCs in the CRCF and other handling facilities are included in this section where the description of ITS equipment is provided. The non-ITS SSCs that are used in handling facilities (including the CRCF) and others that are specific to the CRCF are described in Tables 1.2.4-1 and 1.2.4-2.

1.2.4.1 Canister Receipt and Closure Facility Description

[NUREG-1804, Section 2.1.1.2.3: AC 1(2), (3), (4), AC 2, AC 6; Section 2.1.1.6.3: AC 1(2)(e), (2)(h), AC 2(2); Section 2.1.1.7.3.1: AC 1(1), (2), (3), (5), (6), (9); Section 2.1.1.7.3.2: AC 1(1), (2); Section 2.1.1.7.3.3(I): AC 1(1), AC 2(1),(2), (3), AC 4(1)]

1.2.4.1.1 Facility Description

The CRCF provides the facility as well as the necessary utilities and support systems to perform the following functions:

- Receive transportation casks containing waste forms in canisters such as transportation, aging, and disposal (TAD) canisters; high-level radioactive waste (HLW) canisters; dual-purpose canisters (DPCs); and U.S. Department of Energy (DOE) spent nuclear fuel (SNF) canisters. Naval SNF canisters are handled only in the Initial Handling Facility (IHF). The CRCF has the capability of handling rail and truck casks.
- Provide staging capability for DOE SNF canisters, HLW canisters, and TAD canisters.
- Receive loaded TAD canisters inside aging overpacks from the Aging Facility. Receive loaded TAD canisters from the Wet Handling Facility (WHF) in aging overpacks.
- Enable the movement of TAD canisters in aging overpacks between the CRCF, Receipt Facility (RF), WHF, and the Aging Facility.

- Prepare the transportation casks for unloading by removing impact limiters; inspecting, upending, and removing casks from their conveyances; gas sampling; and unbolting the cask lid(s).
- Transfer the contents of the transportation casks and aging overpacks into waste packages for emplacement.
- Transfer the TAD canisters and DPCs from transportation casks to aging overpacks for movement between handling facilities or into an aging overpack for movement to the Aging Facility.
- Replace the lid(s) on the unloaded transportation casks. The transportation casks are inspected, surveyed, and decontaminated prior to leaving the facility.
- Install the waste package inner lid on a loaded waste package (inner lid with integral shield plug for codisposal waste packages) and weld it closed; inspect and leak test the inner lid weld; evacuate the waste package inner vessel and backfill with helium; close and seal weld the purge port in the inner lid; inspect and leak test the purge port closure; install the waste package outer lid and weld it closed; nondestructively examine the outer lid weld; and stress mitigate the outer lid weld.
- Inspect the completed waste package for compliance to emplacement requirements.
- Position the completed waste package such that the transport and emplacement vehicle (TEV) can receive it.
- Conduct maintenance, radiological surveys, minor decontamination, and low-level radioactive waste collection, as required.
- Confine and control the radioactive waste sources during normal operations, off-normal operations, and event sequences.
- Control radiation exposure, temperature, and human access, prevent criticality, and mitigate identified hazards.
- Provide adequate shielding.
- Monitor the facility operations and performance to ensure the health and safety of workers and the public.
- Withstand natural phenomena and nearby military and industrial hazards.

The CRCF is an ITS surface structure located east of the North Portal of the repository. The CRCF is physically separated from other surface buildings to isolate it from interactions with the other facilities during a seismic event. The location of the CRCF relative to the other surface facilities is shown in [Figures 1.2.1-1](#) and [1.2.1-2](#). The CRCF is located such that it is protected from external

flooding as shown in [Figure 1.2.2-7](#). The distance of the geologic repository operations area facilities from the site boundary is shown in [Figure 1.1-1](#).

The CRCF is a reinforced concrete and steel frame structure made of noncombustible materials with interior and exterior shear walls, exterior concrete buttresses, concrete floor and roof slab diaphragms, and concrete mat foundation. The overall size of the CRCF is approximately 392 ft wide by 420 ft long and 100 ft high. The walls and floors are primarily constructed of reinforced concrete. Where not required for structural considerations, appurtenance area exterior walls are constructed of metal siding panels with insulation.

The foundation for the CRCF is a reinforced concrete mat foundation having the thickness necessary to adequately support the superstructure. The mat for the main CRCF reinforced concrete structure (i.e., the core building that is made up of 4-ft-thick concrete walls) is a 6-ft-thick mat, except in the waste package loadout room, where it is thicker to accommodate the operation of the waste package transfer trolley. The foundations are reinforced to resist forces determined for the design loads.

The CRCF main reinforced concrete structure and the structural steel vestibule are designed to withstand the design basis ground motion (DBGM)-2 seismic event. The loads associated with the various cask and canister handling equipment are supported from the CRCF interior walls and slabs and then transferred to the foundation. The cask transfer trolley, waste package transfer trolley, and the site transporter are supported directly by the basemat foundation for the CRCF building.

Ancillary areas of the facility that are not categorized as ITS are constructed using lighter concrete construction and insulated metal panels on steel framing that are attached to, but fall outside the footprint of, the main CRCF reinforced concrete structure. The mat foundations for the CRCF ancillary area non-ITS structures are reinforced concrete mats as necessary to adequately support the superstructures. There are also rooms and personnel corridors on the roof of the main CRCF structure that are non-ITS. The non-ITS portion of the CRCF will not compromise the integrity of the main CRCF ITS structure in a DBGM-2 event.

The general arrangement floor plans for the CRCF and the associated legend are shown in [Figures 1.2.4-1 to 1.2.4-4](#). A roof plan is shown in [Figure 1.2.4-5](#). Cross-sectional views of the facility are shown in [Figures 1.2.4-6 to 1.2.4-11](#). Room or area numbers corresponding to the figures are given in parentheses to aid in understanding the location where processes are performed or where major equipment is located. On the ground floor general arrangement ([Figure 1.2.4-2](#)), ITS and non-ITS portions of the facility are identified.

The CRCF is divided into areas for handling operations and areas to support these activities. Handling activities are performed in the following areas: transportation cask vestibule and site transporter vestibule (Rooms 1036 and 1027), cask preparation room (Room 1026), cask unloading rooms (Rooms 1023 and 1024), waste package positioning rooms (Rooms 1018 and 1019), waste package loadout room (Room 1015), canister transfer room (Room 2004), gas sampling room (Room 1034), waste package closure room (Room 2007), and facility operations room (Room 1013). The handling support areas include HVAC equipment rooms (Rooms 1003, 1004, 1009, 1010, 1011, 1030, 1031, 1032, 1035, 2001, 2005, 2008, and 2012), electrical rooms (Rooms 1007, 1008, and 1029), maintenance areas (Rooms 1012 and 1033), waste package closure

support rooms (Rooms 2003 and 2011), corridors and stairways, and facilities needed to support essential personnel.

The radiation/radiological monitoring system provides for monitoring of dose rates and airborne radioactivity levels throughout the CRCF as described in [Section 1.4.2](#). For airborne radioactivity monitoring, the system includes continuous air monitors and effluent monitors. The system includes area radiation monitors that measure gamma and neutron radiation levels. The system instruments include local alarms that provide audible and visible warnings if thresholds are exceeded. The system and alarms are monitored in the facility operations room and the Central Control Center.

The CRCF is designed to provide radiation protection to workers, the public, and the environment and to minimize occupational exposure in accordance with as low as is reasonably achievable dose principles. Features for minimization and control of radioactive contamination within the CRCF are incorporated into the design. Shielded work areas, as required, are incorporated into the design. [Section 1.10](#) addresses the design to reduce occupational doses. Interlocks on shield doors are provided to ensure that workers are not inadvertently exposed to high radiation.

Major mechanical handling equipment includes overhead bridge cranes, cask transfer trolleys, canister transfer machines, waste package transfer trolleys, and associated lifting fixtures and devices.

[Table 1.2.4-3](#) provides a summary description of the equipment and personnel shield doors used in the handling facilities. The five types of equipment shield doors are summarized below:

- Type 1: Single slide-type door with floor plates
- Type 2: Double slide-type door
- Type 3: Double swing (hinged) doors
- Type 4: Single slide-type door
- Type 5: Double slide-type door with floor plates.

An overview of the major areas in the CRCF is provided below.

1.2.4.1.1.1 Cask Receipt Area

1.2.4.1.1.1.1 Transportation Cask Vestibule and Annex (Rooms 1036 and 1036A)

The transportation cask vestibule and annex is a receiving area with direct rail and road access for the rail-based and truck-based transportation casks. It also provides environmental separation between the preparation area and the outside environment.

This area has direct rail and road access to handle transportation casks between the vestibule annex, transportation cask vestibule, and cask preparation room.

1.2.4.1.1.1.2 Site Transporter Vestibule (Room 1027)

The site transporter vestibule serves as a staging area for the site transporter with an aging overpack. It also provides environmental separation between the outside environment and inside the CRCF. This area provides direct site transporter access for the delivery and removal of aging overpacks.

1.2.4.1.1.2 Cask Preparation Room (Room 1026)

The purpose of the cask preparation room is to prepare the transportation cask and the aging overpack to be ready for canister transfer based on the requirements and needs of the individual cask types.

The cask preparation room is equipped with a 200-ton bridge crane. The crane is used to upend the transportation casks and place them into a cask transfer trolley. The cask transfer trolley is used to move casks on an air cushion into a cask unloading room. The crane rails for the cask handling crane are supported by corbels cast into the concrete walls.

1.2.4.1.1.3 Cask Unloading Rooms (Rooms 1023 and 1024)

The cask unloading rooms shield personnel in other rooms of the facility from radiation during canister transfer operations out of a transportation cask or into or out of an aging overpack. Once a cask transfer trolley positions a cask or a site transporter positions an aging overpack in the rooms, no other operations requiring personnel to be present are performed from inside the rooms.

1.2.4.1.1.4 Canister Transfer Room (Room 2004)

The canister transfer room connects with the cask unloading rooms (Rooms 1023 and 1024), waste package positioning rooms (Rooms 1018 and 1019), and canister staging areas (Rooms 1017, 1021, 1022, and 1025). The purpose of the transfer room is to transfer TAD canisters, HLW canisters, and DOE SNF canisters from the transportation cask or aging overpack to a waste package. The canister transfer room can also be used to transfer a dual-purpose canister (DPC) from a transportation cask to an aging overpack.

This area consists of two operating floors—the transfer room located on the second floor and the associated cask unloading rooms, waste package positioning rooms, and canister staging areas located on the ground floor immediately under the transfer room.

Two canister transfer machines move canisters from the cask unloading rooms to the waste package positioning rooms or canister staging areas.

1.2.4.1.1.5 Waste Package Positioning Rooms (Rooms 1018 and 1019)

The waste package positioning rooms shield personnel in other rooms of the facility from radiation during canister transfer operations into a waste package, installation of the inner lid with integral shield plug for codisposal waste packages, and during translation of the loaded waste package from the loading position to the closure position. The waste package transfer trolley operates inside the waste package positioning rooms.

1.2.4.1.1.6 Waste Package Closure Room (Room 2007)

The waste package closure room provides space for the closure operations, including welding, nondestructive examination, inerting, stress mitigation, and associated operations such as contamination surveys.

The waste package closure subsystem closes waste packages that have been loaded with TAD canisters, DOE SNF canisters, or HLW canisters.

1.2.4.1.1.7 Waste Package Loadout Room (Room 1015) and Waste Package Loadout Vestibule (Room 1014)

The purpose of the waste package loadout room and waste package loadout vestibule is to transfer a loaded waste package from the waste package transfer trolley to the TEV. The waste package loadout room shields personnel in other rooms of the facility during inspection of the waste package and transfer of the waste package to the TEV.

Equipment shield doors are provided between the waste package loadout room and waste package loadout vestibule. Shielded windows provide for viewing into the waste package loadout room and into the waste package closure room (Room 2007) from the second floor corridor (Room 2006J). The waste package loadout vestibule provides environmental separation between the waste package loadout room and the outdoors.

The waste package loadout room also receives empty waste packages and emplacement pallets and loads them into the waste package transfer trolley for subsequent movement to the waste package positioning rooms (Rooms 1018 and 1019).

1.2.4.1.2 Operational Processes

Figure 1.2.4-12 illustrates the major waste processing functions performed in the CRCF. Figure 1.2.4-13 shows the operational sequences and material flow through the CRCF. Figure 1.2.4-14 shows the waste form inventory present within the CRCF at any one time.

The major operational waste processing functions are summarized in the following sections.

1.2.4.1.2.1 Cask Handling

The site transporter vestibule receives a loaded aging overpack containing a TAD canister from the RF, WHF, or Aging Facility. The transportation cask vestibule receives transportation casks containing TAD canisters, DPCs, or canisters containing HLW or DOE SNF.

In the cask preparation room, the transportation cask impact limiters are removed and the lifting trunnions are installed, as required. The cask transfer trolley is configured with the appropriate pedestal for the transportation cask, which is upended and moved into the trolley. Once the transportation cask is secured to the cask transfer trolley, the trolley is moved under the cask preparation platform, the cask cavity is sampled and depressurized, and the transportation cask lid

bolts are removed. If the cask lid is not equipped with a lid-lifting fixture, a fixture is installed. The cask transfer trolley is then moved to the cask unloading room.

After an aging overpack is received in the cask preparation room, the aging overpack lid bolts are removed, and then the aging overpack is moved to the cask unloading room.

1.2.4.1.2.2 Canister Transfer

Canister transfer operations in the CRCF occur in the cask unloading rooms, canister transfer room, and the waste package positioning rooms. Canister transfer operations are performed in the canister transfer room using a canister transfer machine. Canister staging areas are provided for the staging of TAD canisters and canisters containing HLW and DOE SNF until the proper assortment of canisters and waste packages are in place for efficient loading of waste packages.

The canister transfer machine is moved to the cask port, the shield skirt is lowered, and the canister transfer machine slide gate and cask port slide gate are opened. The cask lid is removed. The canister guide sleeve is lowered (for TAD canisters and DPCs only). The TAD canister, DPC, or canister containing HLW or DOE SNF is lifted into the canister transfer machine, the canister guide sleeve is raised, and the canister transfer machine and cask port slide gates are closed. Once the slide gates are closed and the shield skirt is raised, the loaded canister transfer machine moves the TAD canisters or canisters containing HLW or DOE SNF to the waste package port. Once the shield skirt is lowered, the canister transfer machine and waste package transfer room slide gates are opened, the canister guide sleeve is lowered, and the canister is lowered into the waste package. Before the waste package is moved to the closure location within the waste package positioning room, an inner lid with integral shield plug is placed inside waste packages with DOE SNF and HLW canisters. The canister transfer machine transfers DPCs in a similar manner from a transportation cask located in one cask unloading room to an aging overpack in the adjacent cask unloading room.

1.2.4.1.2.3 Waste Package Closure

Waste package closure operations include welding waste package lids to the waste package, inerting the waste package inner vessel, mitigating the stress associated with the welding of the outer lid, and performing nondestructive examination of the waste package closure welds. Weld defects, if found, are repaired or reworked as necessary by the waste package closure system. The waste package remains on the ground floor of the CRCF during the closure process.

1.2.4.1.2.4 Waste Package Loadout

The waste package transfer trolley moves the loaded and sealed waste package from the waste package positioning room to the waste package loadout room, where the trolley engages the waste package transfer carriage docking station and is locked down. The waste package transfer trolley shielded enclosure is downended into the horizontal position.

The waste package transfer carriage, conveying the loaded waste package and emplacement pallet, is withdrawn from the waste package transfer trolley and is placed into position to be received by the TEV. In the CRCF and IHF, an electrified third rail is present to provide power to the TEV. The TEV lifting feature raises the waste package and emplacement pallet off of the waste package

transfer carriage. The TEV bottom shield plate is retracted and the doors are closed. The waste package is inspected for surface flaws as it travels between the waste package transfer trolley and the TEV. A contamination survey of the TEV exterior is performed, and the TEV is decontaminated, if necessary, prior to moving out of the CRCF.

The waste package loadout room equipment shield door is opened, and the TEV moves into the waste package loadout vestibule. The equipment shield door is closed, the exterior door is opened and the TEV moves out of the CRCF toward the North Portal and into the subsurface.

1.2.4.1.3 Safety Category Classification

The overall CRCF is classified as ITS, although some portions of the CRCF that do not contain ITS SSCs are classified as non-ITS (Figure 1.2.4-2). The ITS structure provides protection of SSCs from internal and external hazards. The CRCF is designed such that failures of portions, parts, subparts, or subsystems of non-ITS SSCs cannot adversely interact with an ITS SSC and prevent the safety function from being performed. The TEV rails in the waste package loadout room and the rails for the waste package transfer trolley in the CRCF are categorized as ITS.

1.2.4.1.4 Procedural Safety Controls to Prevent Event Sequences or Mitigate Their Effects

There are no procedural safety controls for the structural features of the CRCF.

1.2.4.1.5 Design Bases and Design Criteria

The nuclear safety design bases for ITS and important-to-waste-isolation (ITWI) SSCs and features are derived from the preclosure safety analysis presented in Sections 1.6 through 1.9 and the postclosure performance assessment presented in Sections 2.1 through 2.4. The nuclear safety design bases identify the safety functions to be performed and the controlling parameters with values or ranges of values that bound the design.

The quantitative assessment of event sequences, including the evaluation of component reliability and the effects of operator action, is developed in Section 1.7. SSCs or procedural safety controls appearing in an event sequence with a prevention or mitigation safety function are described in the applicable design section of the SAR.

Section 1.9 describes the methodology for safety classification of SSCs and features of the repository. The tables in Section 1.9 present the safety classification of the SSCs and features. These tables also list the preclosure and postclosure nuclear safety design bases for each structure, system, or major component.

To demonstrate the relationship between the nuclear safety design bases and the design criteria for the repository SSCs and features, the nuclear safety design bases are repeated in the appropriate SAR sections for each individual ITS or ITWI SSC or feature that performs a safety function. The design criteria are specific characteristics of the ITS and ITWI SSC or feature that are utilized to implement the assigned safety functions.

The nuclear safety design bases and their relationship to design criteria for the CRCF structure and ITS or ITWI SSCs contained within the CRCF are provided in [Table 1.2.4-4](#).

1.2.4.1.6 Design Methodologies

The design methodologies for the CRCF structure are in accordance with the codes and standards provided in [Section 1.2.2.1](#). The design methodologies for the TEV rails and rails for the waste package transfer trolley are in accordance with ASME NOG-1-2004.

1.2.4.1.7 Consistency of Materials with Design Methodologies

Materials of construction used in the design of the CRCF structure are in accordance with the codes and standards provided in [Section 1.2.2.1](#). Materials of construction used in the design of TEV rails and the rails for the waste package transfer trolley are in accordance with ASME NOG-1-2004.

1.2.4.1.8 Design Codes and Standards

The principal codes and standards applicable to the CRCF structure are provided in [Section 1.2.2.1](#). The TEV rails and the rails for the waste package transfer trolley are designed in accordance with ASME NOG-1-2004.

1.2.4.1.9 Design Load Combinations

The design load combinations for the CRCF structure are in accordance with codes and standards provided in [Section 1.2.2.1](#). These design load combinations are applicable to steel and reinforced concrete structures. The design load combinations for the TEV rails and the rails for the waste package transfer trolley are in accordance with ASME NOG-1-2004.

1.2.4.2 Mechanical Handling System

[NUREG-1804, Section 2.1.1.2.3: AC 1(2), (3), (4), AC 2, AC 6; Section 2.1.1.6.3: AC 1(2)(h), AC 2(2); Section 2.1.1.7.3.1: AC 1(1), (2), (3), (5), (6), (9); Section 2.1.1.7.3.2: AC 1(1), (2); Section 2.1.1.7.3.3(I): AC 1(1), AC 2(1), (2), (3), AC 4(1)]

The CRCF mechanical handling system consists of the following subsystems: cask handling, canister transfer, waste package closure, and waste package loadout. ITS SSCs in the mechanical handling system are designed as described in [Section 1.2.2.2](#). The non-ITS mechanical handling SSCs in the CRCF, which are used in handling facilities, are described in summary in [Table 1.2.4-1](#). The CRCF-specific non-ITS SSCs in the mechanical handling system are described in summary in [Table 1.2.4-2](#). The design bases and their relationship to design criteria for the CRCF are shown in [Table 1.2.4-4](#). The equipment stands for the handling facilities are listed in [Table 1.2.4-5](#). [Table 1.2.4-3](#) provides the summary-level description of Types 1 through 5 equipment shield doors and the personnel shield doors. [Table 1.2.4-6](#) provides the summary-level description of equipment confinement doors. The rated capacity of the ITS mechanical handling equipment is provided in [Tables 1.2.2-10](#) and [1.2.2-11](#).

Logic diagrams for ITS SSCs are shown where the description of ITS equipment is provided. Typical non-ITS logic diagrams, which show the interface with digital control and management information system (DCMIS)/programmable logic controller elements within selected ITS logic diagrams, are shown in [Figures 1.2.4-15 to 1.2.4-18](#).

1.2.4.2.1 Cask Handling Subsystem

1.2.4.2.1.1 Subsystem Description

The cask handling subsystem contains the cask preparation subsystem and the waste package preparation subsystem. These two systems prepare loaded transportation casks and aging overpacks and empty waste packages for loading and unloading operations.

1.2.4.2.1.1.1 Subsystem Functions

Cask Preparation Subsystem—The functions of the cask preparation subsystem are to:

- Receive loaded transportation casks by rail or truck
- Receive loaded aging overpacks by site transporter from the WHF, Aging Facility, or RF
- Prepare empty aging overpacks for canister transfer operations
- Prepare loaded transportation casks and aging overpacks for canister transfer operations
- Receive unloaded transportation casks after canister transfer operations and prepare transportation casks for leaving the CRCF
- Prepare unloaded aging overpacks for subsequent reuse.

Waste Package Preparation Subsystem—The functions of the waste package preparation subsystem are to:

- Receive empty waste packages and appurtenances
- Prepare empty waste packages for canister transfer operations.

1.2.4.2.1.1.2 Subsystem Location and Functional Arrangement

The cask preparation and waste package preparation subsystems are located in the transportation cask vestibule (Rooms 1036 and 1036A), site transporter vestibule (Room 1027), cask preparation room (Room 1026), cask unloading rooms (Rooms 1023 and 1024), waste package loadout vestibule (Room 1014), and waste package loadout room (Room 1015). These areas are shown in [Figures 1.2.4-2 and 1.2.4-3](#).

1.2.4.2.1.1.3 Subsystem and Components

1.2.4.2.1.1.3.1 Cask Preparation Subsystem

ITS SSCs in the CRCF cask preparation subsystem, which are similar to those used in other handling facilities, are described below.

Cask Unloading Room Equipment Shield Door (Type 1)—The cask unloading room equipment shield door provides equipment and personnel access to the cask unloading room. The cask unloading room equipment shield door is a single slide-open-type door. The door is operated by an electric motor turning a screw, which interacts with a door-mounted bracket. The door overlaps the aperture on the top, bottom, and both sides to preclude streaming. The weight of the door is supported by rollers under the bottom of the door, which run in a floor-recessed channel. The channel is covered with hinged plates to provide a level floor when the door is open. The plates are lifted up by a slide ramp, located on both ends of the door, as the door moves. The Type 1 equipment shield door is used in the IHF, CRCF, and WHF. Details of this equipment are shown in [Figures 1.2.4-19 and 1.2.4-20](#). The logic diagram for the equipment shield doors (Types 1 and 4) is shown in [Figure 1.2.4-21](#). The logic diagram applies to the CRCF, IHF, and WHF.

Operation of the equipment shield door is controlled from the facility operations room. A local emergency open button is provided. Indication of the door being fully opened and fully closed is provided to the facility operations room. The door is interlocked with the cask port slide gate, so that both cannot be opened at the same time during normal operations. The equipment shield doors for the cask unloading room also have a confinement function and are interlocked with the equipment confinement doors. The door also has an obstruction sensor that halts door travel and opens the door when an obstacle is detected in the pathway of the door.

Cask Preparation Room Equipment Confinement Doors (East)—The cask preparation room equipment confinement doors (east) provide equipment and personnel access to the cask preparation room. The two cask preparation room equipment confinement doors (east) are slide-open-type doors, each made up of two side-by-side door panels on the same rail. Each door is operated by an electric motor turning a screw, which interacts with a door-mounted bracket. The door overlaps the aperture on the top, bottom, and both sides to provide confinement. Sealing features are provided to limit air leakage. The weight of the door is supported by rollers under the bottom of the door, which run in a floor-recessed channel. Details of this equipment are shown in [Figures 1.2.4-22 and 1.2.4-23](#). The logic diagram for the equipment confinement doors are shown in [Figure 1.2.4-24](#). The logic diagram applies to the CRCF and RF.

Operation of the equipment confinement door is controlled from the facility operations room. Indication of the door being fully opened and fully closed is provided to the facility operations room. The door is interlocked with the cask unloading room equipment shield doors (north and south) so that they will not be open at the same time during normal operation. The door also has an obstruction sensor that halts door travel and opens the door when an obstacle is detected in the pathway of the door.

Cask Preparation Room Equipment Confinement Door (South)—The cask preparation room equipment confinement door (south) provides equipment and personnel access to the cask

preparation room. The cask preparation room equipment confinement door (south) is a slide-open-type door, made up of two side-by-side door panels on the same rail. Each door panel is operated by an electric motor turning a screw, which interacts with a door-mounted bracket. The door overlaps the aperture on the top, bottom, and both sides to provide confinement. Sealing features are provided to limit air leakage. The weight of the door is supported by rollers under the bottom of the door, which run in a floor-recessed channel. Details of this equipment are shown in [Figures 1.2.4-23](#) and [1.2.4-25](#). The logic diagram for the equipment confinement doors is shown in [Figure 1.2.4-24](#). The logic diagram applies to the CRCF and RF.

Operation of the confinement door is controlled from the facility operations room. Indication of the door being fully opened and fully closed is provided to the facility operations room. The door is interlocked with the cask unloading room equipment shield doors (north and south) so that they will not be open at the same time during normal operation. The door also has an obstruction sensor that halts door travel and opens the door when an obstacle is detected in the pathway of the door.

Cask Transfer Trolley—The cask transfer trolley is used in the CRCF, WHF, and RF to transfer the transportation casks between the cask preparation area and the cask unloading room. The cask transfer trolley is rated at 200 tons. The trolley consists of a steel platform and structural steel framework, with remotely operated restraint arms that are used for securing the transportation cask. The restraint arms are able to restrain the transportation cask in place during a DBGM-2 seismic event. Steel pedestals are used to position the cask at the correct location and height. The cask transfer trolley uses air film technology and is supported by multiple air-bearing modules during movement. Two pneumatically powered traction drive units are used to propel and steer the cask transfer trolley. The air supply throttle valve limits the speed of the cask transfer trolley to less than 2.5 mph. Shutoff valves in the air supply common header control the air supply to the air bearings and drive units. Air-bearing pressure is controlled by individual pressure regulators. When the cask transfer trolley movement is complete, air pressure is reduced, and the air supply is isolated, allowing the trolley to come to rest supported by landing pads on the bottom of the platform. The air supply is then disconnected. The cask transfer trolley fails safe on either loss of air or overpressurization.

Control and monitoring of the cask transfer trolley drive units and air bearings are local to the equipment and are powered by an onboard battery. The operator uses pendant controls to operate the trolley. The floor surface on which the cask transfer trolley operates is smooth so as to permit interruption-free trolley operation. For details of this equipment, refer to [Figures 1.2.4-26](#) and [1.2.4-27](#).

To handle the different sizes of casks, pedestals are used in the bottom of the cask transfer trolley. The pedestal is loaded into the cask transfer trolley using the cask handling crane and rigging. This equipment is used in the IHF, CRCF, RF, and WHF.

Cask Handling Yoke—The cask handling yoke is used for lifting operations for the transportation casks. The cask handling yoke is used to offload transportation casks from the conveyance, move the cask for receipt and transfer preparation operations, and return the emptied cask to the transportation system. Each transportation cask has a set of lifting trunnions that can be engaged by the cask handling yoke. The cask handling yoke has interchangeable arms that accommodate the various types of casks. The cask handling yoke has a lift capacity of 200 tons.

The cask handling yoke has two lifting arms, which connect to the trunnions on the transportation cask. The arm positions are adjustable to accommodate the various diameters of casks. The arms are adjusted by an electric motor mounted in the cask handling yoke, which receives power through an electric connection from the cask handling crane.

Sensors on the cask handling yoke provide the status of lifting arm engagement with the cask trunnions, lifting feature pin engagement with the crane hook, and lifting arm adjustment at end of travel. When not in use, the cask handling yoke rests in the cask handling yoke stand. The cask handling yoke is provided with remote and local control capabilities to engage or disengage the cask handling yoke arms. The cask handling yoke arms must be either fully engaged or disengaged to allow movement of the cask handling crane hoist. The cask handling yoke is used in the IHF, CRCF, WHF, and RF. For details of this equipment, refer to [Figures 1.2.4-28 and 1.2.4-29](#). [Figure 1.2.4-30](#) shows the logic diagram for the cask handling yoke in the IHF, CRCF, WHF, and RF.

Cask Lid-Lifting Grapples—Cask lid-lifting grapples are used in the CRCF and RF in conjunction with the cask handling crane to remove the lids of casks containing DPCs. The cask lid-lifting grapple has electric actuators with a mechanical safety feature that prevents grapple disengagement when a load is suspended from the grapple. The cask lid-lifting grapple has a capacity of 8 tons. The cask lid-lifting grapple is remotely operated. For details of this equipment, refer to [Figures 1.2.4-31 and 1.2.4-32](#). The logic diagram for the cask lid-lifting grapple is shown in [Figure 1.2.4-33](#).

Cask Handling Crane—The cask handling crane is used for heavy load lifts in the preparation area. The main function is movement of a transportation cask from a railcar into a cask transfer trolley. The cask handling crane operates in the cask preparation room. The cask handling crane is a top running double-girder type bridge crane with a top running trolley. The main hoist is rated at 200 tons with an auxiliary hoist rated at 20 tons. Due to the configuration of the crane in the facility, it is not possible for the cask handling crane to lift the bottom of a cask more than 30 ft above the floor.

The cask handling crane is equipped with double retention capability for lubricating oil at locations where there is a potential for leaked oil to enter a breached canister.

The cask handling bridge crane is a NOG-1, Type I crane (ASME NOG-1-2004) and is equipped with seismic restraint rail clamps to prevent derailment and dropping during a DBGM-2 event. [Figures 1.2.4-34 and 1.2.4-35](#) show details of the cask handling crane. The cask handling crane is used in the IHF, CRCF, RF, and WHF.

The following is a description of the control and monitoring instrumentation for the cask handling crane:

- **Cask Handling Crane Bridge**—The cask handling crane bridge is provided with both remote and local control capabilities to run the bridge in either direction along the cask preparation room runway. The speed of the bridge is limited to 20 ft/min. Both sides of the bridge are provided with a slowdown or stop switch for bridge approach to the building runway stop. The slowdown or stop switch initiates ramp down to zero speed prior to contact with the building stop.

- **Cask Handling Crane Hoist Trolley**—The cask handling crane hoist trolley is provided with both remote and local control capabilities to run the trolley in either direction along the bridge. The speed of the hoist trolley is limited to 20 ft/min. The trolley is provided with slowdown or stop switches for approaches to bridge stops. The slowdown or stop switches initiate ramp down to zero speed prior to contact with the bridge stops.
- **Cask Handling Crane Hoist**—The cask handling crane hoist is provided with both remote and local control capabilities to operate the hoist in either direction. The cask handling yoke must be either fully engaged or disengaged to allow movement of the hoist. A means is provided for resetting of the emergency drum brake and for jogging the brake for emergency load lowering. The logic diagram for the cask handling crane main hoist is shown in [Figure 1.2.4-36](#). The logic diagram for the cask handling crane auxiliary hoist is shown in [Figure 1.2.4-37](#). These logic diagrams are applicable only to the IHF, CRCF, and RF. The logic diagrams for the cask handling crane in the WHF are shown in [Section 1.2.5](#).

The following control system devices are provided for the safe operation of the cask handling hoist:

- **Operating Range Limit Switches**—The cask handling crane hoist is provided with first hoist lower and upper limit switches to limit the hook normal height operating range by stopping hoist movement and setting the hoist brakes. If the cask handling crane hoist exceeds this operating range, final hoist lower and upper limit switches are provided beyond the normal operating range limit switches for additional protection. Actuation of either of the two final limit switches will trip the power to the hoist and set the hoist holding brakes. Further hoisting or lowering is prevented until the operator can reactivate the hoist using local, key-operated switches and return the system to normal operating range, which can only occur through movement of the hoist in the direction opposite of the direction of travel that previously activated the limit switch. The final hoist lower and upper limit switches are both electrically and mechanically independent from the first hoist lower and upper limit switches.
- **Overspeed Switch**—The overspeed switch is designed to stop the hoisting operation and set the hoist holding and emergency brakes once an overspeed condition is reached. This condition can be manually reset by the operator locally through a key-operated switch.
- **Load Cell**—The cask handling crane hoist is provided with a grapple hoist load cell that is set below the grapple hoist capacity. Upon reaching the overload set limit, hoisting operation in the raising direction is prevented but allows the operator to lower the load.
- **Rope Misspool Sensor**—The cask handling crane hoist is provided with a grapple hoist misspooling sensor that trips the power to the hoist and sets the hoist holding brake. This condition can be manually reset by the operator locally through a key-operated switch.

- **Broken Rope Sensor**—The cask handling crane hoist is provided with a grapple hoist broken rope sensor that trips the power to the hoist and sets the hoist holding brake. This condition can be manually reset by the operator locally through a key-operated switch.
- **Hoist Dynamic Braking Resistors Temperature Monitor**—A high braking resistors temperature condition trips the hoist motor. The hoist motor is reset by a reset switch on the main electrical panel.

DPC Lid Adapter—This equipment is used in the CRCF, WHF, and RF. The function of the DPC lid adapter is to lift DPCs of various sizes. The DPC lid adapter has a capacity of 45 tons. The adapter has multiple mounting positions that accommodate the various DPCs. The lid adapter is configured to match the TAD canister lifting feature outline/interface. The equipment detail is shown in [Figure 1.2.4-38](#).

Horizontal Lifting Beam—This equipment is used to lift and transfer horizontal casks. The lifting beam has a capacity of 150 tons. For details of this equipment, refer to [Figure 1.2.4-39](#). The horizontal lifting beam is used in the CRCF, WHF, and RF.

Rail Cask Lid Adapter—The rail cask lid adapter is engaged by the canister transfer machine canister grapple to remove the lids of transportation casks. For details of this equipment, refer to [Figure 1.2.4-40](#). The rail cask lid adapter is used in the IHF, CRCF, WHF, and RF.

ITS SSCs that are unique to the CRCF cask preparation subsystem are described below:

Cask Preparation Platform—The main function is to provide personnel and tool access to the top of a cask while the cask is restrained in the cask transfer trolley and site transporter. The cask preparation platform consists of a mechanism that raises and lowers the platform above the cask transfer trolley and site transporter with an opening to accommodate access to the transportation casks and aging overpacks. The platform shield plate is mounted over the opening. This platform shield plate is retracted to gain access for retrieving cask lids or to add lid-lifting fixtures and is closed for bolting or unbolting operations.

[Figure 1.2.4-41](#) shows the cask preparation platform mechanical equipment envelope.

1.2.4.2.1.1.3.2 Waste Package Preparation Subsystem

The waste package handling crane is described in [Section 1.2.4.2](#) and is ITS. There are no other ITS SSCs in the waste package preparation subsystem, as the subsystem only handles empty waste packages.

1.2.4.2.1.2 Operational Processes

1.2.4.2.1.2.1 Cask Preparation Subsystem

The cask preparation subsystem is used to prepare loaded transportation casks and aging overpacks for canister transfer operations. The operational processes for the components in the cask preparation subsystem are described below.

A railcar or truck carrying a loaded transportation cask enters the transportation cask vestibule and the vestibule annex and the building exterior door is closed. Subsequently, the cask preparation room equipment confinement door is opened to allow the railcar or truck to enter the cask preparation room. The cask impact limiters and the cask tie-downs are removed using the cask handling crane, impact limiter lifting device (Figure 1.2.4-42), and the mobile access platform. If required, the trunnions are installed using common tools, standard rigging, the mobile access platform, and the cask handling crane. The cask lifting trunnions are then engaged with the cask handling yoke, and the cask is upended on the transportation skid using the cask handling crane.

Certain transportation casks cannot be upended on the transportation skid. Before the impact limiters can be removed from this cask, it must be removed from the conveyance. The cask tie-downs are removed. The cask is engaged by the horizontal lifting beam and lifted horizontally from the conveyance. The cask is moved to the cask stand. The impact limiters are then removed using standard rigging. The cask is then engaged again with the horizontal lifting beam and moved to the cask tilting frame. The cask is disengaged from the horizontal lifting beam and secured to the cask tilting frame. The cask is then engaged with the cask yoke and upended to the vertical orientation using the cask handling crane. The cask is then unsecured from the cask tilting frame to allow further handling.

Prior to moving the vertical cask to the cask transfer trolley, a cask pedestal is installed on the cask transfer trolley using the cask handling crane and standard rigging. With the transportation cask in the vertical orientation, the cask is placed in the cask transfer trolley using the cask handling crane. The cask is then secured in the trolley, and the cask yoke is disengaged from the cask. Once cask gas sampling and pressure equalizing of the cask internal and atmospheric pressures have taken place, the transportation cask lid bolts are removed.

For casks containing a TAD canister, a lid-lifting fixture is then placed on the cask lid using the cask handling crane and common tools. Some casks may have an integrated lifting fixture.

For casks containing a DPC, the cask lid is removed using the cask handling crane and the lid-lifting grapple. A lifting fixture is placed on the DPC with the cask handling crane and fastened to the DPC.

Once the transportation cask has been unloaded, the cask unloading room equipment shield door is opened, the cask transfer trolley containing the unloaded cask is moved out of the unloading room back into the preparation area, and the cask unloading room equipment shield door is closed. The cask is placed back into the conveyance, the impact limiters are then replaced, and the conveyance is moved out of the facility.

In some cases, a transportation cask will be received that contains commercial SNF that must be aged before it may be transferred to a waste package. In such cases, an unloaded aging overpack is brought in to the cask preparation area via the site transporter. The aging overpack lid bolts are removed using the cask preparation platform and common tools. The cask unloading room equipment shield door is opened, the site transporter containing the aging overpack is then moved into one of the cask unloading rooms, and the cask unloading room equipment shield door is closed.

Once the waste form has been transferred to the aging overpack by the canister transfer subsystem, the aging overpack is moved back to the cask preparation room via the site transporter. The aging

overpack lid bolts are then replaced, and the loaded aging overpack is sent to the Aging Facility via the site transporter.

TAD canisters may also be transferred out of the transportation cask, placed in an aging overpack in another facility, and sent to CRCF for transfer to a waste package. Additionally, waste forms that have been sent to the Aging Facility are returned to the CRCF for transfer to a waste package. The overall operational processes for the preparation and export of these loaded aging overpacks are the same.

The loaded aging overpack is received in the cask preparation area via the site transporter. The unloading room equipment shield door is opened, and the site transporter is moved into the unloading room and deactivated. The electrical supply is then disconnected, and the cable is retracted so that the cask unloading room equipment shield door can be closed. The unloading room equipment shield door is closed.

The aging overpack lid bolts will be removed using the cask preparation platform and common tools. The site transporter containing the aging overpack will then be moved into one of the cask unloading rooms.

Once the TAD canister has been transferred by the canister transfer subsystem to a waste package, the aging overpack is moved back to the cask preparation room via the site transporter. The aging overpack lid bolts are then replaced, and the empty aging overpack is moved out of the facility via the site transporter.

1.2.4.2.1.2.2 Waste Package Preparation Subsystem

The waste package preparation subsystem prepares empty waste packages for SNF and HLW transfer operations. The waste package handling crane is functionally a part of the waste package preparation subsystem, but it also performs a waste package loadout function. The waste package handling crane is described in [Section 1.2.4.2.4](#).

The waste package loadout room equipment shield door is opened, and an empty waste package and emplacement pallet are moved into the area along with the associated pedestal and shield ring. A waste package transfer trolley is present with its shield enclosure in the vertical position. The waste package transfer trolley pedestal is removed from the transfer truck and placed in the waste package transfer trolley shielded enclosure by using the waste package handling crane. The waste package pallet yoke is connected to the waste package handling crane hook and then lifted from the waste package pallet yoke stand by the crane.

The waste package transfer trolley shielded enclosure is rotated to the horizontal position and its transfer carriage is extended. The waste package assemblage is lifted by the waste package handling crane using the waste package pallet yoke, and then it is placed on the waste package transfer carriage (extended in the horizontal position). The waste package transfer carriage is retracted into the waste package transfer trolley shielded enclosure. Movement of the carriage is performed by the bracket and screw mechanism in the waste package transfer carriage docking station. The waste package transfer trolley shielded enclosure is opened into the vertical position by onboard drive motors.

The waste package handling yoke is placed in the waste package handling yoke stand by the waste package handling crane and uncoupled from the crane hook. The crane hook is then coupled to the waste package shield ring lift beam. The appropriate waste package shield ring is removed from the waste package shield ring stand and placed on the top of the waste package transfer trolley shielded enclosure, allowing the waste package to protrude from the top of the enclosure. Personnel on the loadout platforms perform final verification of the waste package position and orientation in the waste package transfer trolley.

After the waste package positioning room equipment shield door is opened, the waste package transfer trolley is unlocked from the waste package transfer carriage docking station and the waste package transfer trolley is moved to the waste package loading area of the waste package positioning room. The waste package positioning room equipment shield door is closed.

1.2.4.2.1.3 Safety Category Classification

The cask transfer trolley, cask handling crane, cask handling yoke, cask preparation platform, cask unloading room equipment shield door, equipment confinement doors, DPC lid adapter, horizontal lifting beam, rail cask lid adapter, and cask lid-lifting grapples in the cask preparation subsystem are categorized as ITS. The waste package handling crane is ITS and is described in [Section 1.2.4.2.4](#). No other components in the waste package preparation subsystem are ITS, because the waste packages do not contain any waste forms during preparation activities.

1.2.4.2.1.4 Procedural Safety Controls to Prevent Event Sequences or Mitigate Their Effects

The preclosure safety analysis identifies four procedural safety controls related to the operation of components in the cask handling subsystem of the CRCF. [Table 1.9-10](#) identifies the unique numbering of the preclosure procedural safety controls, as well as the associated facility or operations area, SSCs, and bases.

PSC-1—To limit the spurious movement of the cask transfer trolley potentially resulting in canister impacts, the cask preparation and canister transfer operating procedures will include a warning that deflation of the CRCF cask transfer trolley is an important procedural step in the preclosure safety analysis. The cask preparation and canister transfer operating procedures will require that the cask transfer trolley be on the floor of the CRCF with the air pallet feature deactivated during loading of the cask onto the trolley, cask preparation activities while the cask is on the trolley, and during canister loading and unloading activities. This requirement will be independently verified.

PSC-11—To ensure seismic stability of the transportation cask during cask preparation, the cask preparation operating procedure will include a warning that connection to the CRCF cask handling crane is an important procedural step in the preclosure safety analysis. The cask preparation operating procedure will require that a loaded transportation cask remain attached to the CRCF cask handling crane hoist and associated yoke until the cask is placed into the cask transfer trolley and the trolley's seismic restraints are properly engaged. The engagement of the seismic restraints will be independently verified prior to slacking the load on the CRCF cask handling crane.

PSC-12—To prevent the operator from attempting to remove the cask lid with the lid bolts still in place, the cask preparation operating procedure will include a warning that the removal of loaded transportation cask lid bolts is a procedural step important to the preclosure safety analysis. The cask preparation operating procedure will include a prerequisite to confirm lid bolt removal prior to movement of the cask from the CRCF cask preparation room (Room 1026) to the cask unloading rooms (Rooms 1023 and 1024). The removal of the bolts will be independently verified.

PSC-26—To ensure that confinement is in place whenever conducting operations with a potential for a drop involving a loaded cask, the cask preparation operating procedures will include a warning that the closure of the cask preparation room (Room 1026) equipment confinement doors is a procedural step important to the preclosure safety analysis. The cask preparation operating procedures will include a prerequisite to confirm that the cask preparation room equipment confinement doors are closed prior to operations with a potential for a drop involving a loaded cask. The closure of the doors will be independently verified.

1.2.4.2.1.5 Design Bases and Design Criteria

The nuclear safety design bases and design criteria for the cask handling subsystem in the CRCF are addressed in [Table 1.2.4-4](#).

1.2.4.2.1.6 Design Methodologies

The design methodologies for the ITS SSCs in the CRCF cask preparation subsystem that are similar to those in other handling facilities, including the cask transfer trolley, cask handling crane, cask handling yoke, cask preparation platform, DPC lid adapter, horizontal lifting beam, rail cask lid adapter, and cask lid-lifting grapples, are in accordance with codes and standards provided in [Section 1.2.2.2](#). The methodology used in the design of equipment shield doors and the equipment confinement doors is in accordance with Section Q1.2 of ANSI/AISC N690-1994.

1.2.4.2.1.7 Consistency of Materials with Design Methodologies

Materials of construction used in the design of ITS SSCs in the cask preparation subsystem that are similar to those in other handling facilities, including the cask transfer trolley, cask handling crane, cask handling yoke, cask preparation platform, DPC lid adapter, horizontal lifting beam, rail cask lid adapter, and cask lid-lifting grapples, are in accordance with codes and standards provided in [Section 1.2.2.2](#). Materials of construction used in the design of the equipment shield doors and the equipment confinement doors are in accordance with Section Q1.4 of ANSI/AISC N690-1994.

1.2.4.2.1.8 Design Codes and Standards

The principal codes and standards applicable to the cask handling subsystem are identified in [Table 1.2.2-12](#).

1.2.4.2.1.9 Design Load Combinations

The load combinations used in the analysis of ITS SSCs in the cask preparation subsystem that are similar to those in other handling facilities, including the cask transfer trolley, cask handling crane, cask handling yoke, cask preparation platform, DPC lid adapter, horizontal lifting beam, rail cask lid adapter, and cask lid-lifting grapples, are in accordance with the codes and standards provided in [Section 1.2.2.2](#). The design load combinations analyzed include normal conditions and event sequences and the effects of natural phenomena. The load combinations and applicable stress limit coefficients used in the design of the equipment shield doors and the equipment confinement doors are in accordance with Table Q1.5.7.1 of ANSI/AISC N690-1994.

1.2.4.2.2 Canister Transfer Subsystem

1.2.4.2.2.1 Subsystem Description

The canister transfer subsystem consists of SSCs that transfer canisters from transportation casks and aging overpacks into waste packages for delivery to the TEV. The canister transfer subsystem also transfers TAD canisters and DPCs from transportation casks to aging overpacks.

1.2.4.2.2.1.1 Subsystem Functions

The functions of the canister transfer subsystem are to:

- Transfer TAD canisters and HLW and DOE SNF canisters from transportation casks to waste packages
- Transfer TAD canisters and DPCs from transportation casks to aging overpacks
- Transfer TAD canisters from aging overpacks to waste packages
- Move waste packages to the waste package positioning room after loading.

1.2.4.2.2.1.2 Subsystem Location and Functional Arrangement

The canister transfer subsystem is located in the cask unloading rooms, canister transfer room, and the waste package positioning rooms. The cask unloading rooms and canister transfer room are also used to transfer canisters to aging overpacks for movement to the Aging Facility, WHF, and RF. These areas are shown in [Figures 1.2.4-2 and 1.2.4-3](#).

1.2.4.2.2.1.3 Subsystem and Components

ITS SSCs in the CRCF canister transfer subsystem that are similar to those used in other handling facilities are described below.

Defense Waste Processing Facility/Idaho National Laboratory HLW Canister Grapple—The Defense Waste Processing Facility/Idaho National Laboratory HLW canister grapple is used by the canister transfer machine to lift canisters from transportation casks and place them within waste

packages or into staging racks. This grapple uses three lifting jaws, equally spaced, to engage a canister. This grapple has a mechanical jaw actuation mechanism with a double setdown safety release feature. The grapple lifting feature interfaces with the canister transfer machine canister grapple. When not in use, this canister grapple rests in the stand located in the canister transfer machine maintenance area. The Defense Waste Processing Facility/Idaho National Laboratory HLW canister grapple has a lifting capacity of 5 tons. This grapple is used in the IHF and CRCF. [Figures 1.2.4-43](#) and [1.2.4-44](#) provide details of the equipment. The logic diagram for the Defense Waste Processing Facility/Idaho National Laboratory and West Valley Demonstration Project/Hanford HLW canister grapple is shown in [Figure 1.2.4-45](#). The logic diagram applies to the IHF and the CRCF.

West Valley Demonstration Project/Hanford HLW Canister Grapple—The West Valley Demonstration Project/Hanford HLW canister grapple is used by the canister transfer machine to lift HLW canisters from transportation casks and place them within waste packages or into staging racks. The grapple uses three lifting jaws, equally spaced, to clamp onto a canister. The West Valley Demonstration Project/Hanford HLW canister grapple has a lifting capacity of 10 tons. The grapple lifting feature interfaces with the canister transfer machine canister grapple. When not in use, the canister grapple rests in the canister grapple stand, located in the canister transfer machine maintenance area. The grapple has a mechanical jaw actuation mechanism with a double setdown safety release feature. Permanent pin connections are used to assemble the lift fixture, long reach extension, and grapple lift bail. For details of this equipment, refer to [Figure 1.2.4-46](#) for the mechanical equipment envelope and [Figure 1.2.4-44](#) for the process and instrumentation diagram. These grapples are used in the IHF and CRCF. The logic diagram for the Defense Waste Processing Facility/Idaho National Laboratory and West Valley Demonstration Project/Hanford HLW canister grapple is shown in [Figure 1.2.4-45](#). The logic diagram applies to the IHF and the CRCF.

Canister Transfer Machine Canister Grapple—The canister transfer machine canister grapple is used to lift lids from transportation casks and aging overpacks, interface with the HLW and DOE SNF grapples to lift HLW and DOE SNF canisters, and lift DPCs and TAD canisters during canister transfer operations.

The canister transfer machine canister grapple dimensional envelope has a 3-point lift equally spaced with 60° jaw engagement and a grapple capacity of 70 tons. The canister transfer machine canister grapple is provided with remote and local control capabilities to engage or disengage the canister grapple, canister, and lids. Raising or lowering the canister transfer machine canister grapple is possible only if the canister transfer machine canister grapple is either fully engaged or fully disengaged. The canister transfer machine canister grapple is normally connected to the canister transfer machine lower block assembly. [Figures 1.2.4-47](#) and [1.2.4-48](#) provide details of this equipment. The canister transfer machine grapples are used in the IHF, CRCF, WHF, and RF. The logic diagram for the canister transfer machine canister grapple is shown in [Figure 1.2.4-49](#). The logic diagram applies to the IHF, CRCF, WHF, and RF.

Canister Transfer Machine—The canister transfer machine transfers canisters from a transportation cask on a transfer trolley or an aging overpack on a site transporter to a waste package. The canister transfer machine has a rated capacity of 70 tons. The canister transfer machine also has the capability to transfer canisters to staging areas for temporary staging prior to

transfer of canisters to the waste package. The canister transfer machine is used in the IHF, CRCF, WHF, and RF. This ITS machine is a special-purpose overhead bridge crane with two trolleys. One trolley permanently supports a shield bell assembly, which is used to provide radiation shielding for the canister during transfer operations. The second trolley houses the hoisting machinery. The canister transfer machine, including loads, weighs approximately 400 to 500 tons, depending on which facility the canister transfer machine is in and where it is located in the facility. The CRCF is equipped with two canister transfer machines; the system is designed with anticollision features that allow both machines to operate at the same time. For details of this equipment, refer to [Figures 1.2.4-50 and 1.2.4-51](#).

The canister transfer machine operates in a semiautomated manner. Deliberate operator action is required to initiate machine movement, canister guide sleeve operation, hoist operation, and grapple engagement or disengagement. Coordinates for the transfer ports, lid staging areas, and other locations are preprogrammed, allowing the canister transfer machine to accurately position itself at the desired location in response to an operator command. Machine vision technology facilitates positioning of the machine for transfer operations between casks and waste packages.

The shield bell trolley supports a shield bell. The shield bell incorporates steel and borated polyethylene shielding to limit external dose rates to 100 mrem/hr on contact. The shield bell is sized to accept a loaded canister.

Within the shield bell is a canister guide sleeve that is lowered through the transfer room floor prior to lifting a TAD canister or a DPC from a transportation cask or aging overpack, and prior to lowering a TAD canister or DPC into a waste package or aging overpack. The function of this guide sleeve is to guide the canister into the cask, waste package, or aging overpack in the unlikely event of a canister drop to ensure a flat-bottom drop.

The shield bell trolley is able to move along the span of the bridge girders to position the shield bell over the floor openings in the canister transfer room. A motorized slide gate is provided at the bottom of the bell to provide bottom shielding for the canister once it is inside the shield bell. A motorized shield skirt is also provided to close any gap between the canister transfer machine bottom plate and the floor surface to prevent any lateral radiation shine during a canister transfer operation.

The canister transfer machine is equipped with double retention capability for lubricating oil at locations where there is a potential for leaked oil to enter a breached canister.

Due to the configuration of the canister transfer machine in the facility, it is not possible for the canister transfer machine to lift the bottom of a canister more than 45 ft above the cavity floor of the transportation cask, aging overpack, or waste package.

The following is a description of the control and monitoring instrumentation for the canister transfer machine:

- **Canister Transfer Machine Bridge**—The canister transfer machine bridge is provided with both remote and local control capabilities to run the bridge in either direction along the CRCF runway. The speed of the bridge is limited to 20 ft/min. In the CRCF, each

canister transfer machine is provided with anticollision features to prevent the two canister transfer machines from colliding. Each canister transfer machine is provided with a slowdown or stop switch for bridge approach to the building runway stop. The slowdown or stop switch initiates ramp down to zero speed prior to contact with the building stop. A hardwired interlock is provided to prevent the bridge from moving in either direction if the shield skirt is not raised. The logic diagram for the canister transfer machine bridge is shown in [Figure 1.2.4-52](#). The canister transfer machine logic diagrams apply to the CRCF, IHF, WHF, and RF.

- **Shield Skirt and Slide Gate**—The canister transfer machine shield skirt and slide gate are capable of being operated either remotely or locally. Hardwired interlocks are provided to prevent raising the shield skirt unless the slide gate is closed and opening the slide gate unless the shield skirt is lowered. The skirt anticollision device stops canister transfer machine travel in case an internal or external obstruction is encountered by the skirt. The shield skirt position limit switches are also interlocked with the canister transfer machine canister hoist and canister transfer machine bridge, shield bell, and canister hoist trolley drives. The canister transfer machine canister hoist drive does not operate unless the shield skirt is lowered. The shield skirt must be in the raised position to allow operation of the canister transfer machine bridge, shield bell, and canister hoist trolley drives. The power of the slide gate motor drive and torque switch settings limit the force that can be applied to a canister, guide sleeve, or hoist rope if the slide gate were to inadvertently close. Actuation of the torque switch trips the motor. The logic diagram for the canister transfer machine shield skirt and slide gate is shown in [Figure 1.2.4-53](#).
- **Shield Bell Trolley**—The shield bell trolley is provided with both remote and local control capabilities to run the trolley in either direction along the canister transfer machine bridge. The shield skirt must be raised to allow movement of the shield bell trolley. The trolley is provided with slowdown/stop switches for approaches to runway stops. The slowdown/stop switches initiate ramp down to zero speed prior to contact with the runway stops. The logic diagram for the canister transfer machine shield bell trolley is shown in [Figure 1.2.4-54](#).
- **Canister Hoist**—The canister hoist is provided with both remote and local control capabilities to operate the hoist in either direction. The shield skirt must be lowered and the grapple either fully engaged or disengaged to allow movement of the canister hoist. A means is provided for resetting of the emergency drum brake and for jogging the brake for emergency load lowering. The logic diagram for the canister transfer machine canister hoist is shown in [Figure 1.2.4-55](#).

The following control system devices are provided for the safe operation of the canister hoist:

- **Operating Range Limit**—The canister hoist is provided with first hoist lower and upper limit switches to limit the hook normal height operating range by stopping hoist movement and setting the hoist brakes. If the canister hoist exceeds this operating range, final hoist lower and upper limit switches are provided beyond the normal operating range limit switches for additional protection. Actuation of either of the two final limit switches will trip the power to the hoist and set the hoist holding brakes. Further hoisting or

lowering is prevented until the operator can reactivate the hoist using local key-operated switches and return the system to normal operating range, which happens only through movement of the hoist in the direction opposite of the direction of travel that previously activated the limit switch. The final hoist lower and upper limit switches are both electrically and mechanically independent from the first hoist lower and upper limit switches.

Two additional features are provided to limit the canister lift height that are independent of the two upper-limit switches. Hoist travel is stopped on receipt of a signal from a sensor that indicates when the load has cleared the canister transfer machine slide gate. The hoist adjustable speed drive also stops the hoist at a designated setpoint corresponding to a height lower than that of the first upper travel limit switch.

- **Overspeed Switch**—The overspeed switch is designed to stop the hoisting operation and set the hoist holding and emergency brakes once an overspeed condition is reached. This condition can be manually reset by the operator locally through a key-operated switch.
- **Load Cell**—The canister hoist is provided with a grapple hoist load cell that is set below the grapple hoist capacity. Upon reaching the overload set limit, hoisting operation in the raising direction is prevented but allows the operator to lower the load.
- **Rope Misspool Sensor**—The canister hoist is provided with a grapple hoist misspooling sensor that trips the power to the hoist and sets the hoist holding brake. This condition can be manually reset by the operator locally through a key-operated switch.
- **Broken Rope Sensor**—The canister hoist is provided with a grapple hoist broken rope sensor that trips the power to the hoist and sets the hoist holding brake. This condition can be manually reset by the operator locally through a key-operated switch.
- **Hoist Dynamic Braking Resistors Temperature Monitor**—A high braking resistors temperature condition trips the hoist motor.
- **Motor Winding Resistance Temperature Detectors**—A high motor winding temperature condition trips the hoist motor.

Canister Hoist Trolley—During normal operations, the canister hoist trolley is mechanically coupled to the shield bell trolley and both trolleys operate as a unit, using the shield bell trolley motor and controls. The speed of the trolleys is limited to 20 ft/min. However, the canister transfer machine design allows for the canister hoist and shield bell trolleys to operate independently, if required, such as for testing and maintenance.

To operate the canister hoist trolley independently of the shield bell trolley, the two trolleys must be mechanically decoupled and the shield skirt must be raised. The canister hoist trolley is provided with both remote and local control capabilities to run the trolley in either direction along the canister transfer machine bridge. The trolley is provided with slowdown/stop switches for approaches to runway stops. The slowdown/stop switches initiate ramp down to zero speed prior to contact with

the runway stops. The logic diagram for the canister transfer machine canister hoist trolley is shown in [Figure 1.2.4-56](#).

Cask Port Slide Gate—The cask port slide gate is located in the floor of the canister transfer room between the canister transfer room and the cask unloading room. The gate assembly consists of two opposing sliding shield gates mounted on heavy-duty bearing blocks and single-edge V-slides, a thick cover plate, two linear actuator drives (one for each gate), and a prefabricated fitted embed for proper fit-up of the assembly. A motor for each gate provides the motive power to move the gates.

The slide gates in the concrete floor and cover plate are flush and level to allow proper contact of the retractable shield skirt for the canister transfer machine. The cask port slide gates are made of steel. When closed, the cask port slide gates provide sufficient shielding to allow operators on the deck when loaded casks are located in the cask unloading room. The cask port slide gate incorporates steel and borated polyethylene shielding to limit external dose rates to 100 mrem/hr on contact.

Each cask port slide gate assembly is interlocked with position switches, which prevent the cask port slide gate from opening unless the canister transfer machine is in position over the cask port slide gate. Operation of the cask port slide gate is controlled from the facility operations room. The power of the slide gate motor drives and the torque switch settings limit the force that can be applied to a canister, guide sleeve, or hoist rope if the slide gate were to inadvertently close.

The design of each cask port slide gate incorporates a criticality prevention feature to prevent inadvertent placement of more than one DOE SNF canister in a waste container that lacks divider plates. An interlock is provided to prevent the cask port slide gate from opening when an aging overpack is present in the cask unloading room, unless the canister transfer machine is centered over the cask port. Since the position of the canister transfer machine hoist is fixed at the center of the machine, this interlock does not permit placement of multiple canisters in an aging overpack.

The cask port slide gates are provided with a facility operations room panel enable/disable switch to operate the cask port slide gates in either the open or close direction. The enable/disable switch must be in the enable position, equipment shield doors associated with the particular cask port slide gates must be fully closed, and the canister transfer machine skirt must be in place for canister removal to allow the gates to be opened. The cask port slide gates fully opened and fully closed limit switches are provided to limit the gate travel in the opening and closing directions, respectively. The cask port slide gates fully closed permissive signals are sent to the associated equipment shield door.

The cask port slide gate is used in the CRCF, IHF, WHF, and the RF. For details of this equipment, refer to [Figures 1.2.4-57](#) and [1.2.4-58](#). The logic diagram for the cask port slide gate (double) is shown in [Figure 1.2.4-59](#). This logic diagram applies to the CRCF, IHF, WHF, and RF.

Waste Package Port Slide Gate—The waste package port slide gate is located in the floor of the canister transfer room between the canister transfer room and the waste package loading area of the waste package positioning room. The gate assembly consists of two opposing sliding shield gates mounted on heavy-duty bearing blocks and single-edge V-slides, a thick cover plate, two linear actuator drives (one for each gate), and a prefabricated, fitted embed for proper fit-up of the

assembly. A motor for each gate provides the motive power to move the gate. The slide gates in the concrete floor and cover plate are flush and level to allow proper contact of the retractable shield skirt for the canister transfer machine. The waste package port slide gates are made of steel. When closed, the waste package port slide gates provide sufficient shielding to allow operators on the deck when loaded waste packages are located in the waste package loading area. The waste package port slide gate incorporates steel and borated polyethylene shielding to limit external dose rates to 100 mrem/hr on contact.

Each waste package port slide gate assembly is interlocked with position switches, which keep the slide gate from opening unless the canister transfer machine is in position over the waste package port slide gate. Operation of the gate is controlled from the facility operations room. The power of the slide gate motor drives and the torque switch settings limit the force that can be applied to a canister, guide sleeve, or hoist rope if the slide gate were to inadvertently close.

The design of each waste package port slide gate incorporates a criticality prevention feature to prevent inadvertent placement of more than one DOE SNF canister in a waste container that lacks divider plates. An interlock is provided to prevent the waste package port slide gate from opening when an TAD waste package is present below the waste package port, unless the canister transfer machine is centered over the waste package port. Since the position of the canister transfer machine hoist is fixed at the center of the machine, this interlock does not permit placement of multiple canisters in a TAD waste package.

The waste package port slide gates are provided with a facility operations room panel enable/disable switch to operate the waste package port slide gates in either the open or close direction. The enable/disable switch must be in the enable position, equipment shield doors associated with the particular slide gate must be fully closed, the waste package transfer trolley with shield ring must be in place below the port, and the canister transfer machine must be in place with the shield skirt lowered to allow the gate to be opened. The waste package port slide gates fully opened and fully closed limit switches are provided to limit the gate travel in the opening and closing directions, respectively. The waste package port slide gate fully closed permissive signals are sent to the associated equipment shield door and waste package transfer trolley.

The waste package port slide gates are used in the CRCF and IHF. For details of this equipment, refer to [Figures 1.2.4-57](#) and [1.2.4-58](#). The logic diagram for the waste package port slide gate is shown in [Figure 1.2.4-59](#).

ITS SSCs that are unique to the CRCF canister transfer subsystem are described below.

TAD Canister Slide Gate—The TAD canister slide gate is located in the floor of the canister transfer room between the canister transfer room and the canister staging area. The gate assembly consists of a single sliding shield gate mounted on heavy-duty bearing blocks and single-edge V-slides, a thick cover plate, a linear actuator, and a prefabricated fitted embed for proper fit-up of the assembly. A motor for the gate provides the motive power to the gate.

The slide gate in the concrete floor and cover plate are flush and level to allow proper contact of the retractable shield skirt for the canister transfer machine. The TAD canister slide gates are made from steel. When closed, the TAD canister slide gate provides sufficient shielding to allow operators on

the deck when canisters are located in the canister staging room. The TAD canister slide gate incorporates steel and borated polyethylene shielding to limit external dose rates to 100 mrem/hr on contact. Each TAD canister slide gate assembly is interlocked with position switches, which prevent the TAD canister port slide gate from opening unless the canister transfer machine is in position over the TAD canister port slide gate.

The design of each TAD canister slide gate incorporates a criticality prevention feature to prevent inadvertent placement of more than one DOE SNF canister in a location that was not designed for them. An interlock is provided to prevent the TAD canister slide gate from opening unless the canister transfer machine is centered over the port. Since the position of the canister transfer machine hoist is fixed at the center of the machine, this interlock does not permit placement of multiple canisters in a TAD canister staging rack.

Operation of the TAD canister port slide gate is controlled from the facility operations room. The power of the slide gate motor drive and the torque switch settings limit the force that can be applied to a canister or hoist rope if the slide gate were to inadvertently close. The TAD canister slide gates are provided with a facility operations room panel enable/disable switch to operate the TAD canister slide gates in either the open or close direction. The enable/disable switch must be in enable position and the canister transfer machine skirt must be in place for canister removal to allow the gate to be opened. The TAD canister slide gate fully opened and fully closed limit switches are provided to limit the gate travel in the opening and closing directions, respectively. For details of this equipment, refer to [Figures 1.2.4-58](#) and [1.2.4-60](#). [Figure 1.2.4-61](#) shows the CRCF slide gate (single) logic diagram.

DOE Canister Slide Gate—The DOE canister slide gate is located in the floor of the canister transfer room between the canister transfer room and the canister staging rooms. When closed, the DOE canister slide gate provides sufficient shielding to allow operators on the deck when loaded casks are located in the canister staging areas. The DOE canister slide gate incorporates steel shielding to limit external dose rates to 100 mrem/hr on contact.

The gate assembly consists of a single sliding shield gate mounted on heavy-duty bearing blocks and single-edge V-slides, a thick cover plate, a linear actuator, and a prefabricated fitted embed for proper fit-up of the assembly. A motor for the gate provides the motive power to the gate. The slide gate in the concrete floor and cover plate are flush and level to allow proper contact of the retractable shield skirt for the canister transfer machine. The DOE canister slide gates are made from steel. The DOE canister slide gates are provided with a facility operations room panel enable/disable switch to operate the DOE canister slide gates in either the open or close direction. The enable/disable switch must be in enable position and the canister transfer machine skirt must be in place for canister removal to allow the gate to be opened. For DOE canister slide gates, a common facility operations room control switch and an enable/disable switch for both the slide gate motors are provided. The DOE canister slide gates fully opened and fully closed limit switches are provided to limit the gate travel in the opening and closing directions, respectively. The power of the slide gate motor drive and the torque switch settings limit the force that can be applied to a canister or hoist rope if the slide gate were to inadvertently close on a canister. For details of this equipment, refer to [Figures 1.2.4-58](#) and [1.2.4-62](#). [Figure 1.2.4-61](#) shows the cask port slide gate (single) logic diagram for the CRCF.

Hanford Multicanister Overpack Canister Grapple—The Hanford multicanister overpack (MCO) canister grapple is used by the canister transfer machine to lift MCO canisters from transportation casks and place them within waste packages or into staging racks. The grapple uses three lifting jaws, equally spaced, to engage a canister. The grapple has a lifting capacity of 15 tons. The grapple lifting feature interfaces with the canister transfer machine canister grapple. When not in use, the Hanford MCO canister grapple rests in the canister grapple stand, located in the canister transfer machine maintenance area. The grapple has a pneumatic jaw actuation with a remotely operated fail-safe mechanical lock. Neither loss of air nor overpressurization causes the grapple jaws to disengage and drop the load. The Hanford MCO canister grapple is provided with remote and local control capabilities to engage or disengage the canisters. Raising or lowering the grapple is possible only if the grapple is either fully engaged or fully disengaged with the load. The Hanford MCO canister grapple is connected to the canister transfer machine canister grapple. The grapple with a suspended canister is prevented mechanically from unintentional canister disengagement. For details of this equipment, refer to [Figures 1.2.4-63](#) and [1.2.4-64](#). The logic diagram for the Hanford MCO canister grapples is shown in [Figure 1.2.4-65](#).

SNF Canister Grapple, 18-in.—The 18-in. SNF canister grapple is used by the canister transfer machine to lift DOE SNF canisters from transportation casks and place them within waste packages or into staging racks. The grapple uses three lifting jaws, equally spaced, to engage a canister. The grapple has a lifting capacity of 5 tons. The grapple lifting feature interfaces with the canister transfer machine canister grapple. When not in use, the grapple rests in the SNF canister grapple stand, located in the canister transfer machine maintenance area. The grapple has a pneumatic jaw actuation with a remotely operated fail-safe mechanical lock. Neither loss of air nor overpressurization causes the grapple jaws to disengage and drop the load. The grapple is provided with remote and local control capabilities to engage or disengage the canisters. Raising or lowering the grapple is possible only if the grapple is either fully engaged or disengaged with the load. The 18-in. SNF canister grapple is connected to the canister transfer machine grapple. The grapple with a suspended canister is prevented mechanically from unintentional canister disengagement. For details of this equipment, refer to [Figures 1.2.4-64](#) and [1.2.4-66](#). The logic diagram for the 18-in. SNF canister grapple is shown in [Figure 1.2.4-65](#).

SNF Canister Grapple, 24-in.—The 24-in. SNF canister grapple is used by the canister transfer machine to lift DOE SNF canisters from transportation casks and place them within waste packages or into staging racks. The 24-in. SNF canister grapple is also used to lift the waste package inner lid for the HLW waste packages. The grapple uses three lifting jaws, equally spaced, to clamp onto a canister. The grapple has a lifting capacity of 7 tons. The grapple lifting feature interfaces with the canister transfer machine SNF canister grapple. When not in use, the grapple rests in the canister grapple stand, located in the canister transfer machine maintenance area. The grapple has a pneumatic jaw actuation with a remotely operated fail-safe mechanical lock. Neither loss of air nor overpressurization causes the grapple jaws to disengage and drop the load. The grapple is provided with remote and local control capabilities to engage or disengage the canisters. Raising or lowering the 24-in. SNF canister grapple is possible only if the grapple is either fully engaged or disengaged with the load. The grapple is connected to the canister transfer machine grapple. The grapple with a suspended canister is prevented mechanically from unintentional canister disengagement. For details of this equipment, refer to [Figures 1.2.4-64](#) and [1.2.4-67](#). The logic diagram for the 24-in. SNF canister grapple is shown in [Figure 1.2.4-65](#).

DOE Canister Staging Racks—The DOE canister staging racks are steel structures that hold HLW and DOE SNF canisters for staging purposes in the CRCF. The total staging capacity of the rack assemblies is ten canisters. The location of the rack assemblies is shown in [Figure 1.2.4-2](#) (Rooms 1021 and 1025). The staging racks provide seismic support for the canisters and, in combination with pedestals for short canisters, supports the canister at an elevation that minimizes potential drop height. The DOE canisters are sufficiently spaced by the DOE canister staging racks to prevent criticality. A thermal barrier encloses the bottom and sides of the canisters to control canister temperatures during certain fire scenarios. The staging area is ventilated to remove decay heat. [Figure 1.2.4-68](#) shows the mechanical equipment envelope for the DOE canister staging racks, including the pedestals.

TAD Canister Staging Racks—The TAD canister staging racks are steel structures that hold TAD canisters for staging purposes in the CRCF. The total staging capacity of the rack assemblies is two canisters. The location of the rack assemblies is shown in [Figure 1.2.4-2](#) (Rooms 1017 and 1022). The staging racks provide seismic supports for the canisters at an elevation that minimizes potential drop height. The TAD canisters are sufficiently spaced by the TAD canister staging racks to prevent criticality. A thermal barrier encloses the bottom and sides of the canisters to control canister temperatures during certain fire scenarios. The staging area is ventilated to remove decay heat. [Figure 1.2.4-69](#) shows the mechanical equipment envelope for the TAD canister staging racks.

1.2.4.2.2.2 Operational Processes

The operational processes for components in the canister transfer subsystem are described below.

The canister transfer subsystem transfers canisters between loaded transportation casks, aging overpacks, and unloaded waste packages. The canister transfer subsystem transfers canisters positioned in the cask unloading room to waste packages in the waste package positioning room. The canister transfer subsystem can also transfer vertical DPCs from a cask in the unloading room to an aging overpack located in the other cask unloading room.

Once a loaded transportation cask or aging overpack is positioned under the cask port slide gate in the unloading room, the canister transfer machine is positioned over the cask port slide gate. The canister transfer machine shield skirt is then lowered. The canister transfer machine slide gate and the cask port slide gates are then opened.

For every type of cask, except those that contain DPCs, the appropriate grapple is lowered by the canister transfer machine hoist to engage the cask lid. The cask lid is then raised into the shield bell, the cask port slide gate and the canister transfer machine slide gate are closed, and the canister transfer machine shield skirt is raised. The canister transfer machine then moves to the lid staging area, and the lid is staged. The canister transfer machine then moves back to the position over the cask port slide gate. The canister transfer machine shield skirt is lowered, and the cask port slide gate and canister transfer machine slide gate are opened. If the cask contains a DPC, then the process of staging the lid is not necessary, as the lid has been removed in the cask preparation area.

The canister guide sleeve is lowered through the cask port (for TAD canisters and DPCs only). The grapple is lowered through the cask port to engage the canister. The canister is then raised into the

canister transfer machine shield bell. Once the canister is raised up into the canister transfer machine, the canister guide sleeve is raised, and the cask port slide gate and the canister transfer machine slide gate are closed. Once both gates are closed, the shield skirt is raised preparatory to placement of the canister.

At this point, there are three options for placement of the canister being handled:

1. If the TAD canister or DPC must be aged, it is loaded into an aging overpack for aging at the Aging Facility.

Prior to removing the canister from the transportation cask, an empty aging overpack is prepared to receive the canister. An empty aging overpack is brought with the site transporter to the position below the cask port in the empty cask unloading room. The canister transfer machine moves to the position over the cask port. The shield skirt is lowered and the canister transfer machine slide gate and the cask port slide gate are opened. The appropriate grapple is then lowered to engage the empty aging overpack lid. The empty aging overpack lid is raised into the canister transfer machine shield bell. The canister transfer machine slide gate and the cask port slide gate are closed and the skirt is raised. The canister transfer machine then moves to the lid staging area and stages the empty aging overpack lid.

The operations for removing the canister from the loaded transportation cask, as described above, are then performed. The canister transfer machine, with a canister, is moved to a position over the other cask port. The canister transfer machine shield skirt is lowered, and the cask port slide gate and the canister transfer machine slide gate are opened. The canister guide sleeve is lowered, and the canister is then lowered through the cask port and placed in the aging overpack. The grapple is then retracted by the canister transfer machine, the canister guide sleeve is raised, the canister transfer machine and cask port slide gates are closed, and the canister transfer machine shield skirt is raised. The canister transfer machine then moves to the lid staging area. The canister transfer machine picks up the aging overpack lid from the staging area and moves back to the position over the cask port. The canister transfer machine shield skirt is lowered, the cask port slide gate and the canister transfer machine slide gate are opened, and the aging overpack lid is replaced on the aging overpack.

A contamination survey of the canister is taken during the canister transfer operation to determine surface contamination levels and assess if they are within acceptable limits. If the surface contamination levels are not within acceptable limits, the canister is sent to the WHF for decontamination.

The loaded aging overpack is then moved out of the cask unloading room to the cask preparation area to be prepared to be moved by the site transporter to the aging pad.

2. If a canister cannot be directly placed in a waste package, it can be staged.

Staging areas are provided for TAD canisters, DOE SNF canisters, and HLW canisters. The canister transfer machine moves to the appropriate staging location. The canister

transfer machine shield skirt is lowered, the canister transfer machine slide gate is opened, the staging area slide gate is opened, and the canister is lowered into the staging position. Once the canister is in place, the grapple is retracted by the canister transfer machine, the slide gates are closed, and the canister transfer machine shield skirt is raised. The staged canister can be removed from the staging position for placement into a waste package at a later time. The canister is removed in the same manner as described above for removal of a canister from a transportation cask.

3. In the case where a canister does not need to be aged or staged, it can be directly loaded into a waste package.

Prior to loading the canister in the waste package, an empty waste package must be prepared to receive the canister and brought to the position below the waste package port by the waste package preparation subsystem.

If a codisposal waste package is to be loaded with DOE SNF (including MCOs) or HLW canisters, a waste package inner lid with integral shield plug is prestaged in the lid staging area. The lid is obtained from the maintenance access room by the canister transfer machine, via the maintenance access hatch, and placed in the lid staging area.

A canister is then removed from the transportation cask, aging overpack, or canister staging area as described above. The canister transfer machine moves to the position over the waste package port and the shield skirt is lowered. The waste package port and canister transfer machine slide gates are opened, the canister guide sleeve is lowered (for the TAD canister only), and the canister is lowered into the appropriate position in the waste package (depending on the type of canister being processed). Once the canister is in place, the grapple is retracted by the canister transfer machine, the canister guide sleeve is raised, the waste package port and canister transfer machine slide gates are closed, and the canister transfer machine shield skirt is raised. This placement process is repeated several times for codisposal waste packages that will be loaded with multiple canisters (DOE SNF or HLW canisters).

For codisposal waste packages, the waste package inner lid is placed on the waste package prior to the waste package being sent to the waste package closure subsystem. The canister transfer machine moves to the lid staging area, picks up the waste package inner lid, and moves back to the position over the waste package port. The canister transfer machine shield skirt is lowered, the canister transfer machine slide gate and waste package port slide gate are opened, and the waste package inner lid is placed on the waste package. The canister transfer machine and waste package port slide gates are closed, and the canister transfer machine shield skirt is raised. The waste package is moved to the position under the closure room via the waste package transfer trolley for closure operations.

1.2.4.2.2.3 Safety Category Classification

The following components of the canister transfer subsystem are classified as ITS:

- Canister transfer machine
- Canister transfer machine canister grapple
- Defense Waste Processing Facility/Idaho National Laboratory HLW canister grapple
- West Valley Demonstration Project/Hanford HLW canister grapple
- Hanford MCO canister grapple
- 18-in. SNF canister grapple
- 24-in. SNF canister grapple
- DPC lid adapter
- Cask port slide gate
- Waste package port slide gate
- DOE canister slide gate
- TAD canister slide gate
- DOE canister staging rack
- TAD canister staging rack.

1.2.4.2.2.4 Procedural Safety Controls to Prevent Event Sequences or Mitigate Their Effects

The preclosure safety analysis identifies two procedural safety controls related to the operation of components in the canister transfer subsystem of the CRCF. [Table 1.9-10](#) identifies the unique numbering of the preclosure procedural safety controls, as well as the associated facility or operations area, SSCs, and bases.

PSC-13—To limit the probability of personnel receiving direct radiation exposure during operations with the canister transfer machine, the canister transfer operating procedure will include a warning that workers entering the CRCF canister transfer area (Room 2004) could receive an inadvertent exposure if the canister transfer machine is away from a port with a waste form present and the slide gate open. The procedures will require an independent verification that the port slide gates are closed at the completion of a canister transfer operation.

PSC-14—To limit the probability that a loaded canister is not in a vertical orientation during transfer, the canister transfer operating procedure will include a warning that the lowering of the CRCF canister transfer machine guide sleeve prior to lifting or lowering a DPC or TAD canister is a procedural step important to the preclosure safety analysis. The canister transfer operating procedure will include a prerequisite to confirm guide sleeve lowering prior to lifting or lowering a DPC or TAD canister. The lowering of the guide sleeve will be independently verified.

1.2.4.2.2.5 Design Bases and Design Criteria

The nuclear safety design bases and design criteria for the canister transfer subsystem in the CRCF are addressed in [Table 1.2.4-4](#).

1.2.4.2.2.6 Design Methodologies

The design methodologies used in the design of ITS SSCs in the canister transfer subsystem that are similar to those in other handling facilities, including the canister transfer machine, grapples, and DPC lid adapter, are in accordance with codes and standards provided in [Section 1.2.2.2](#). The methodologies used in the design of the cask port, waste package port, DOE canister and TAD canister slide gates, and the DOE and TAD canister staging racks are in accordance with Section Q1.2 of ANSI/AISC N690-1994.

1.2.4.2.2.7 Consistency of Materials with Design Methodologies

Materials of construction used in the design of the ITS SSCs in the canister transfer subsystem that are similar to those in other handling facilities, including the canister transfer machine, grapples, and DPC lid adapter are in accordance with codes and standards provided in [Section 1.2.2.2](#).

Materials of construction used in the design of the cask port, waste package port, DOE canister and TAD canister slide gates, and DOE and TAD canister staging racks are in accordance with Section Q1.4 of ANSI/AISC N690-1994.

1.2.4.2.2.8 Design Codes and Standards

The principal codes and standards applicable to the canister transfer subsystem are identified in [Table 1.2.2-12](#).

1.2.4.2.2.9 Design Load and Combinations

The load combinations used in the design of ITS SSCs for the canister transfer subsystem that are similar to those in other handling facilities, including the canister transfer machine, grapple, and DPC lid adapter, are in accordance with codes and standards provided in [Section 1.2.2.2](#). The design load combinations analyzed include normal and event sequences and the effects of natural phenomena. The load combinations and applicable stress limit coefficients used in the design of the cask port, waste package port, DOE canister and TAD canister slide gates, and DOE and TAD canister staging racks are in accordance with Table Q1.5.7.1 of ANSI/AISC N690-1994.

1.2.4.2.3 Waste Package Closure Subsystem

The waste package closure subsystem performs the operations to complete the closure of the waste package. The waste package closure subsystem for the CRCF is the same as the waste package closure subsystem for the IHF, including the process and equipment in the waste package closure room and supporting areas, although the physical arrangement may vary between the IHF and CRCF. Because the waste package closure subsystems are the same, they are described only in this section.

The waste package closure subsystem in the CRCF closes waste packages that have been loaded with TAD canisters, DOE SNF canisters, or HLW canisters. The CRCF does not process any naval SNF canisters.

Waste package closure involves engaging and welding the inner lid spread ring, inerting the waste package with helium, setting and welding the outer lid to the outer corrosion barrier, performing leak testing on the inner vessel closure, performing nondestructive examination of welds, and conducting postweld stress mitigation on the outer lid closure weld. The top of the waste package with the components affected by the waste package closure subsystem and a representation of the typical closure design are shown in [Figure 1.2.4-70](#). The waste package closure system flow diagram is shown in [Figure 1.2.4-71](#). The physical location of the waste package closure subsystem in the CRCF (Room 2007) is shown in [Figure 1.2.4-3](#).

1.2.4.2.3.1 Subsystem Description

The waste package closure subsystem and its subsystems have been categorized as non-ITS except for a limited portion of the subsystem, including the bridge of the remote handling system, which is categorized as ITS in order to protect against structural collapse of the bridge due to a spectrum of seismic events. The basis for the non-ITS classification is that no event sequences take credit for this system for the prevention, reduction of frequency, or mitigation of an event sequence. Although this subsystem, except for the bridge of the remote handling system, is non-ITS, it is a crucial component of the operation and therefore is described in greater detail than other non-ITS subsystems. The weld process of the waste package closure subsystem is controlled as a special process by the Quality Assurance Program described in [Section 5.1](#). The activities performed by the system are controlled by approved procedures.

The principal components of the system include welding equipment; nondestructive examination equipment for visual, eddy current, and ultrasonic inspections of the welds and leak detection; stress mitigation equipment for treatment of the outer lid weld; inerting equipment; and associated robotic arms. Other equipment includes the spread ring expander tool, leak detection tools, cameras, and the remote handling system. The system performs its functions through remote operation of the system components.

The waste package closure subsystem uses a limited quantity of water after completion of welding the outer lid. Water is used for the ultrasonic inspection of the outer lid weld and the stress mitigation process. The design criteria for these applications require features to limit the quantity of water that can come into contact with the waste package. Because of the limited quantity of water in the waste package closure subsystem components and the inner and outer lids being installed before the water is used, introduction of this water into the waste package is not considered credible.

The capability of the waste package closure subsystem will be confirmed by demonstration testing of a full-scale prototype system. The prototype includes welding, nondestructive examinations, inerting, stress mitigation, material handling, and process controls subsystems. The objective of the waste package closure subsystem prototype program is to design, develop, and construct the complete system required to successfully close the waste package. An iterative process of revising and modifying the waste package closure subsystem prototype will be part of the design process. When prototype construction is finalized, a demonstration test of the closure operations will be performed on only the closure end of the waste package; thus, the mock-up will be full diameter but not full height as compared to the waste package. The purpose of the demonstration test is to verify that the individual subsystems and integrated system function in accordance with the design

requirements and to establish closure operations procedures. This program is coordinated with the waste package prototype fabrication program.

1.2.4.2.3.1.1 Subsystem Functions

The principal functions of the waste package closure subsystem are to:

- Perform a seal weld between the spread ring and the inner lid, the spread ring and the inner vessel, and the spread ring ends; perform a seal weld between the purge port cap and the inner lid; and perform a narrow groove weld between the outer lid and the outer corrosion barrier.
- Perform nondestructive examination of the welds to verify the integrity of the welds and repair any minor weld defects found.
- Purge and fill the waste package inner vessel with helium gas to inert the environment.
- Perform a leak detection test of the inner lid seals to ensure the integrity of the helium environment in the inner vessel.
- Perform stress mitigation of the outer lid groove closure weld to induce compressive residual stresses.

1.2.4.2.3.1.2 Subsystem Location and Functional Arrangement

The waste package remains on the ground floor of the CRCF during the closure process. The loaded waste package is moved on a trolley within the waste package positioning room from the loading position to the closure position below the closure room. Before the waste package and pallet assembly is loaded into the waste package transfer trolley, a pedestal is placed in the waste package transfer trolley so that when the waste package is upended, the top of the waste package is at a fixed elevation to accommodate the waste package closure subsystem. The top of the waste package is accessible from the closure room operating floor.

The closure room is located in a shielded area. There is one closure room with two sets of closure equipment in the CRCF. A large-diameter bearing and mounting plate assembly is bolted directly to the operating floor for each set of closure room equipment. The robotic arms are mounted to the rotating portion of the bearing and plate assembly. The robotic arms position the end effectors (using various tools and devices) to perform the welds and inspections. A remote handling system inside the closure room is used to position the closure lids and tools for inerting, leak detection, spread ring expansion, and stress mitigation. The waste package closure room crane runs the length of the closure room area. Near the closure room is a waste package closure support room that is mainly used for tool maintenance. The waste package closure operator workstations are located in the facility operations room in the CRCF.

Figure 1.2.4-72 shows a partial view of the closure room. Tools and devices are staged in specific storage locations to facilitate remote operation of the system. Figure 1.2.4-73 shows the waste

package closure room robotic arms. Figure 1.2.4-74 shows the robotic arms mechanical equipment envelope.

1.2.4.2.3.1.3 Subsystem and Components

Welding Subsystem—The gas tungsten arc welding process is used for waste package closure welds and weld repairs. Welding is performed in accordance with procedures qualified to the *2001 ASME Boiler and Pressure Vessel Code* (ASME 2001, Section IX), as noted below:

- The spread ring and purge port cap welds are two-pass seal welds.
- The outer lid weld is a multipass full-thickness groove weld.

Welding process procedures will be developed that identify the required welding parameters. The process procedures will:

- Identify the parameters necessary to consistently achieve acceptable welds
- State the control method for each weld parameter and the acceptable range of values.

Welding end effectors consisting of welding equipment attached to robotic arms are used to accomplish the welding. Each welding end effector includes the following:

- Welding torch
- Wire feed positioner
- Wire guide
- Automatic voltage control and oscillation axis
- Temperature sensor
- Seam tracker and laser profile measurement sensor
- Arc viewing cameras
- Tool interface device.

Figure 1.2.4-75 shows the welding end effector. The cooling air hose and shielding gas hose connections are on the welding torch and the closure room wall; the hoses are routed using a cable management chain.

For normal welding, two robotic arms with end effectors are utilized, each with a coverage of over 180° of arc. Separate sets of end effectors are used for welding and inspection. Additionally, a repair end effector is used to remove minor weld defects.

The welds are inspected in accordance with examination procedures developed using *2001 ASME Boiler and Pressure Vessel Code* (ASME 2001, Section V and Section III, Division 1, Subsection NC) as a guide, with modification as appropriate:

- Seal welds—visual inspection
- Groove welds—visual, eddy current, and ultrasonic inspection.

2001 ASME Boiler and Pressure Vessel Code, Section III, Subsection NC (ASME 2001), specifies liquid penetrant or magnetic particle techniques for surface inspection and repair groove inspection.

These techniques are manually performed and involve the use of special liquids or loose powders that produce additional waste streams, making them unsuitable for use in a high-radiation environment, remote operation, or elevated temperature applications. A further limitation is that magnetic particle testing is not applicable to Alloy 22 (UNS N06022), due to its lack of ferromagnetic character. The eddy current technique is used due its ability to perform the same task without using special liquids or powders, its suitability for the Alloy 22 material, and its adaptability to remote operations using robotic manipulators. Eddy current inspection is used to detect surface-breaking defects in the outer lid weld. Since *2001 ASME Boiler and Pressure Vessel Code*, Section V (ASME 2001), has no strictly applicable section for weld surface eddy current testing examination, the ultrasonic testing examination article (Section V, Article 4, Mandatory Appendices I and II, and Nonmandatory, Appendix E) and the “Eddy Current Examination of Tubular Products” (Section V, Article 8) of the ASME code is used as a guide to develop the detailed written procedure as is appropriate for the specific equipment and acceptance criteria. The specifics of the eddy current testing calibration processes will be defined to set the sensitivity of the equipment to detect defects greater than the acceptance criteria of 1/16 in. Calibrating the complete eddy current testing examination system will be performed at the beginning of each examination and confirmed at the end of data acquisition for the examination of the closure weld. A decrease in sensitivity of greater than 20% during confirmation of calibration requires that the prior examination be repeated with a recalibrated system (using Section V, Article 4 (ASME 2001) as a guideline).

2001 ASME Boiler and Pressure Vessel Code, Section III, Subsection NC (ASME 2001), permits radiographic or ultrasonic examination of the volume of a weld. Inspection is required for the entire volume of the outer lid weld with an acceptance criteria of 1/16 in. or less. Because of the waste package configuration, the outer weld of the waste package is not accessible to radiographic examination. The ultrasonic examination method, using water as a couplant film and as a coolant for the ultrasonic piezo-electric transducer, is therefore used for inspecting the volume of the outer lid weld. The calibration and calibration confirmation process of the ultrasonic testing will be completed per *2001 ASME Boiler and Pressure Vessel Code* (ASME 2001), Section V, Article 4, Mandatory Appendices I and II, and Nonmandatory, Appendix E, with the modification that the calibration block will be appropriate for the acceptance criteria. The general requirements in Article 4 of the ASME code are satisfied by calibrating and confirming calibration with the same electronics and probes (transducers and search units) used in the examination, using the calibration blocks that are located in the closure area, and deploying the probes to make the scans with the same robots.

An eddy current/ultrasonic inspection end effector is used for the outer lid groove weld inspection. This end effector includes the appropriate probes and transducers. The inspection end effector is in contact with the weld surface and automatically maintains alignment with weld seam. The inspection end effector is capable of meeting the requirement to detect weld defects of 1/16 in. or greater. This capability is demonstrated as part of the process qualification, and the end effector is checked with a calibration block.

2001 ASME Boiler and Pressure Vessel Code, Section V, Article 4, Mandatory Appendices I and II, and Nonmandatory, Appendix E (ASME 2001), has no strictly applicable section for visual testing using a laser profiling sensor. The visual testing hardware used to perform the inspection is a laser profiling sensor capable of detecting and measuring defects exceeding the acceptance criteria that

require geometric measurements of the outer lid groove weld and inner lid seal welds such as undercut or underfill. The sensor provides data to make quantitative determinations on the workmanship of the welds and immediately adjacent areas as it pertains to effectively applying subsequent nondestructive examination to the welds. The laser profiling sensor is on the welding end effector. The arc viewing cameras on the welding end effector or the video camera on the ultrasonic testing/eddy current testing end effector provide views of the tooling and weld joint to support full remote operation but are not designed to be appropriate for visual testing. Confirming the functionality and capability of detecting indications greater than the acceptance criteria of the visual testing system requires a method that determines that relative distance measures are within specification of the laser profiling sensor.

A weld dressing end effector is used for weld repairs. The defect is removed, resulting in an excavated cavity of a predetermined contour. The excavated cavity surface is inspected using the eddy current inspection end effector. Then the cavity is welded and inspected in accordance with the welding and inspection procedures.

Stress Mitigation Subsystem—The stress mitigation process for the outer lid closure weld is controlled plasticity burnishing. Controlled plasticity burnishing is a patented method of controlled burnishing to develop specifically tailored compressive residual stress with associated controlled amounts of cold work at the outer surface of the waste package outer lid closure weld. The basic tool consists of a ball that rolls across the surface of the weld. The pressure from the ball causes plastic deformation to occur resulting in a compressive state of stress after the ball passes. Water is used as a coolant for the controlled plasticity burnishing process. The design of the tool provides a seal around the processing ball and limits the quantity of water released to a very thin film on the ball surface. Any accumulation of water on the waste package, though not anticipated, quickly evaporates.

Inerting Subsystem—The inner vessel of the waste package is evacuated and backfilled with helium through a purge port on the inner lid. The inner vessel of the waste package is evacuated by the inerting system vacuum pump. The system is designed to draw a vacuum in the waste package to a maximum pressure of 3 torr. The exhaust is contained and vented to the HVAC subsystem. The helium is supplied by the service gas system. The helium is supplied to the inner vessel purge port. The inner vessel internal condition is maintained at a pressure of at least 2 psig, and the maximum quantity of oxidizing gases will be limited to a total of 1 g-mol. There is a pressure detector in the inlet line to the waste package that inputs vacuum and helium pressure to the system controller, which starts and stops the vacuum pump and opens and shuts valves as the waste package is taken through two vacuum and backfilling cycles. The inerting process is in accordance with the inerting process described in NUREG-1536 (NRC 1997), Sections 8.0 and V.1. The waste package inerting system piping and instrumentation diagram is shown in [Figure 1.2.4-76](#).

The purge port tool forms a seal over the purge port in the inner lid. The purge port tool retracts and reinserts the purge port plug during the inerting process. The purge port tool and the vacuum and helium hoses are positioned by the remote handling system. After the waste package inner vessel is backfilled by helium, both the spread ring welds and the purge port plug are leak tested in accordance with *2001 ASME Boiler and Pressure Vessel Code* (ASME 2001, Section V, Article 10, Appendix IX) to verify that no leakage can be detected that exceeds the rate of 10^{-6} std cm³/s. Leak

test tools are positioned by the remote handling system over the purge port and the seal weld at the spread ring.

Control and Data Management Subsystem—The control and data management subsystem controls operations in the closure room. It ensures reliability, accuracy, and consistency of welds through the use of self-monitoring devices and operator alarms. It coordinates the movement of equipment so that interferences are avoided. It permits remote operation of the welding, inspection, and inerting functions so the operator can remain outside of the shield walls and maintain as low as is reasonably achievable occupational exposures. The software for the subsystem is developed and tested in accordance with approved validation and verification procedures.

The control and data management subsystem operates at two control levels: (1) supervisory and (2) process and hardware. This supervisory control level of control gives supervisors oversight of closure operations at workstations and access to operational status reports. It provides at the workstations the status of interfacing facilities. It receives information from the workstations about the status of in-process waste package closures and directs the information to the DCMIS. The process and hardware control level gives individual operators control over closure room equipment. There are three types of process and hardware control workstations for each closure room:

- **Closure Room Material Handling Station**—Remote-controlled equipment moves material and tools around the closure room. This station controls those movements, waste package identification and verification, and material tracking.
- **Welding Control Station**—Oversees the welding operations and adjusts welding end effector parameters. The welding control station is operated automatically but under the supervision of an operator.
- **Inspection Station**—Operates the inspection end effector for placement and use of eddy current probes and ultrasonic probes. Provides the necessary data to assess the adequacy of the welds.

Closure Room Material Handling Subsystem—The closure room material handling subsystem moves materials and equipment into the closure room, moves materials and components within the closure room, and removes materials and components from the closure room for maintenance or replacement. The 15-ton and 5-ton cranes include bridge-to-rail and trolley-to-rail restraining devices to prevent bridge derailment during seismic events. The closure room cranes are designed to accommodate the weight of the anticipated loads, including the heaviest load and associated lifting devices or grapple, using the methods and practices of ASME NOG-1-2004 for a Type III crane.

The equipment associated with the non-ITS portions of the closure room material handling subsystem is described below:

- A remote handling system performs the majority of the closure room material handling operations. The remote handling system is a top-running, bridge-mounted,

electro-mechanical system with a trolley, telescoping vertical mast, and associated manipulator arm attached to the end of the mast. The waste package closure subsystem and its subsystems have been categorized as non-ITS except for the bridge of the remote handling system, which is categorized as ITS, in order to protect against structural collapse of the bridge due to a spectrum of seismic events. This 3-ton remote handling system travels the width and length of the closure room to move equipment and materials. It is indexed and programmed to obtain tools and lids from staging locations and position them on the waste package. It can also be used to handle other unplanned moves, if necessary. The CRCF waste package closure room remote handling system mechanical equipment envelope is shown in [Figure 1.2.4-77](#).

- A 15-ton closure room crane operates over the closure room for maintenance operations. This bridge crane is located above the remote handling system and runs on a separate set of rails. [Figure 1.2.4-78](#) shows the waste package closure room crane mechanical equipment envelope and [Figure 1.2.4-79](#) shows the waste package closure room crane mechanical handling process and instrumentation diagram.
- A 5-ton closure support room crane is provided for the closure support area adjacent to the closure room in the CRCF. This crane is used to handle and move heavy items, such as waste package lids, in the closure support area. [Figure 1.2.4-80](#) shows the closure support room crane mechanical equipment envelope and [Figure 1.2.4-81](#) shows the process and instrumentation diagram for the waste package closure support room crane.
- A closure transfer cart moves materials such as waste package lids and welding and inspection tools to and from the closure support room and the closure room. The closure transfer cart is a rigid platform that functions as a table. Single-flanged wheels are mounted to the base of the cart, which rides on rails in the floor. The closure transfer cart is driven by a linear synchronous motor system, magnetically coupled with the cart. The linear synchronous motor system has two parts: an array of fixed linear synchronous motors (electromagnet modules) that are placed in a trench in the floor and an associated permanent magnet array fixed to the bottom of the cart.

Details of the design of the bridge of the remote handling system, which is ITS, are presented below.

ITS Component Description—The bridge of the remote handling system constitutes the ITS portion of the waste package closure subsystem. The remote handling system bridge is designed in accordance with the applicable provisions of ASME NOG-1-2004, Type II crane for loads and accelerations associated with a DBGM-2 seismic event. There is sufficient margin in the design standard such that designing to a DBGM-2 seismic event ensures that the probability of collapse for more severe seismic events is acceptably low. The remote handling system bridge is required not to fall on the waste package.

Operational Processes—The 3-ton remote handling system travels the width and length of the closure room to move equipment and materials associated with the waste package closure process.

Safety Category Classification—The bridge portion of the remote handling system is ITS because it is relied on to reduce the probability of collapse due to a spectrum of seismic events.

Procedural Safety Controls to Prevent Event Sequences—There are no procedural safety controls associated with the bridge of the remote handling system.

Design Bases and Design Criteria—The nuclear safety design bases and design criteria for the bridge of the remote handling system in the CRCF are addressed in [Table 1.2.4-4](#).

Design Methodologies—The design methodologies for the design of the ITS bridge of the remote handling system are in accordance with ASME NOG-1-2004, Type II.

Consistency of Materials with Design Methodologies—Materials utilized for the structural aspects of the bridge of the remote handling system are in accordance with ASME NOG-1-2004, Type II.

Design Codes and Standards—The bridge of the remote handling system is designed in accordance with ASME NOG-1-2004, Type II.

Design Load and Combinations—The load combinations used in the design of the bridge of the remote handling system are in accordance with ASME NOG-1-2004, Type II.

1.2.4.2.3.2 Operational Processes

A loaded waste package is moved to beneath the opening in the closure room floor by the waste package transfer trolley. The waste package is positioned at the process height by the use of pedestals to ensure that it is at the correct height to be within the reach of the robotic arms.

On loss of power, the cranes stop operation and hold their loads. The robotic arms and end effectors are connected to a normal uninterruptible power supply so that welding operations can be shut down in a controlled manner. On restoration of normal power, manual operator action from the workstations is required to restart the processes.

The helium for the backfill of the inner vessel and the argon-helium blend shielding gas for the welding are supplied from the service gas subsystem. The welding torches are cooled using instrument air.

Since the waste packages are loaded with canistered waste, they are not expected to require decontamination. The closure weld joint and adjacent surfaces of the waste package are surveyed and decontaminated, if needed, prior to welding.

The control and data management subsystem interfaces with the DCMIS and the electrical power system. Remote readout of workstation displays is provided in the Central Control Center in the Central Control Center Facility.

The waste package closure subsystem equipment requires periodic adjustments, repairs, and replacements. Components and equipment are provided with features such as quick-release connections for cables and hoses and release handles or actuators to allow easy removal for maintenance. Maintenance takes place in the closure room and the closure support area.

Waste package closure welding, nondestructive examination, stress mitigation, and inerting are conducted in accordance with approved administrative controls. The processes for waste package closure welding, nondestructive examination, stress mitigation, and inerting will be developed in accordance with the codes and standards identified in [Section 1.2.4.2.3.3](#). The processes are monitored by qualified operators, and resulting process data are checked and verified as acceptable by qualified individuals.

Waste package closure welding, nondestructive examination, stress mitigation, and inerting normal operating procedures will specify, for example, the welding procedure specification, nondestructive examination procedure, qualification and proficiency requirements for operators and inspectors, and acceptance and independent verification records for critical process steps.

The following paragraphs present a description of the normal operational sequence.

Waste Package Transfer Trolley Delivers Waste Packages—The loaded waste package on the waste package transfer trolley is moved to the waste package closure station. The waste package is ready for closure.

Identify and Determine Position of Waste Package in Closure Room—The waste package, lids, purge port caps, spread rings, and other components have identifiers for traceability. The waste package and components are validated to ensure proper identity. The waste package closure subsystem detects and records the position and orientation of the waste package.

Place Inner Lid with Spread Ring—For the TAD waste packages, the waste package closure system places the inner lid with spread ring in the CRCF closure room. For DOE SNF and HLW waste packages, the canister transfer machine places the inner lid with integral shield plug in the waste package loading station prior to moving the waste package for closure within the positioning room.

Expand Spread Ring into Inner Vessel Spread Ring Groove—When in position beneath the opening in the closure room floor, the spread ring expander tool is used to expand the spread ring into the groove in the inner vessel, which holds the inner lid in place for welding.

Weld Spread Ring to Inner Lid and Inner Vessel—The spread ring is tack welded to the inner lid and inner vessel and then welded to the inner lid and inner vessel with a two-pass seal weld. The spread ring segment ends are then welded with a two-pass seal weld. The welds are visually inspected. Weld repair is performed, if required.

Evacuate and Backfill Waste Package with Helium—The inner vessel is evacuated through a purge port in the inner lid to remove interior oxidizing gases to the maximum extent practicable. The purge port plug arrives already threaded into the purge port and is partially retracted before operations begin. The vacuum is held for at least 30 minutes without any additional air removal to verify adequate moisture removal. After the waste package has held the vacuum for at least 30 minutes at a maximum of 3 torr, the waste package is backfilled and pressurized with helium to a pressure of at least 2 psig. After the waste package is pressurized, the inner vessel is evacuated for a second time to 3 torr, without a hold time, and again backfilled and pressurized with helium

to at least 2 psig. Once the evacuating and backfilling operations are complete, the purge port plug is fully seated in the purge port.

Helium Leak Test Welds at Spread Ring—The spread ring leak test tool is placed over the spread ring welds to be tested. The space between the spread ring and the leak test tool is evacuated and monitored for the presence of helium.

Helium Leak Test at Purge Port—A helium leak test of the purge port plug is performed. The purge port is covered by the purge port cap, which is then tack and seal welded. After the cap is attached, the tack and seal welds securing the cap are visually inspected. Weld repair is performed, if required.

Place Outer Lid and Weld to Outer Corrosion Barrier—The outer lid is put in place and tack welded to the outer corrosion barrier. The tack welds are visually inspected. The outer lid is then multipass groove welded to the outer corrosion barrier. After each weld pass, the weld is inspected using ultrasonic methods. After the final weld pass, the welds are inspected using visual, eddy current, and ultrasonic methods. Weld repair is performed, if required.

Stress Mitigate Outer Lid Weld—Controlled plasticity burnishing is performed on the final closure weld by inducing compressive stresses into the outer surface of the weld. After controlled plasticity burnishing is complete, the welds are again inspected using visual, eddy current, and ultrasonic methods. Weld repair is performed, if required; the stress mitigation is repeated; and the weld is reinspected.

1.2.4.2.3.3 Design Codes and Standards

The waste package closure subsystem-related welds, weld repairs, and inspections are performed in accordance with *2001 ASME Boiler and Pressure Vessel Code* (ASME 2001, Section II, Part C; Section III, Division I, Subsection NC; Section IX; Section V).

Waste package closure subsystem SSCs are designed using the methods and practices in the applicable sections of the codes and standards presented below:

- ANSI/AWS A5.32/A5.32M-97, *Specification for Welding Shielding Gases*
- ASME B30.20-2003, *Below-the-Hook Lifting Devices*
- NFPA 801, *Standard for Fire Protection for Facilities Handling Radioactive Materials*
- ASME NOG-1-2004, *Rules for Construction of Overhead and Gantry Cranes (Top Running Bridge, Multiple Girder)*.

The inerting of the waste package is performed in accordance with the applicable sections of NUREG-1536, *Standard Review Plan for Dry Cask Storage Systems* (NRC 1997).

1.2.4.2.4 Waste Package Loadout Subsystem

1.2.4.2.4.1 Subsystem Description

The waste package loadout subsystem consists of SSCs necessary to transport and orient the sealed waste packages for transfer to the TEV.

1.2.4.2.4.1.1 Subsystem Functions

The waste package loadout subsystem receives sealed waste packages after closure operations and prepares them for transfer to the emplacement and retrieval system.

1.2.4.2.4.1.2 Subsystem Location and Functional Arrangement

The loadout of sealed waste packages takes place in the waste package loadout room. The area where the waste package loadout operations take place is shown in [Figures 1.2.4-2](#) and [1.2.4-3](#).

1.2.4.2.4.1.3 Subsystem and Components

ITS SSCs in the CRCF waste package loadout subsystem, which are also used in the IHF, are listed below and described in this section.

Waste Package Loadout Room Equipment Shield Doors (Type 4)—The two waste package loadout room equipment shield doors provide equipment and personnel access to the waste package loadout room. Each waste package loadout room equipment shield door is a single panel, slide-type door, made up of two thick steel plates with neutron-absorbing material. Each door is operated by an electric motor turning a screw, which interacts with a door-mounted bracket. The door overlaps the aperture on the top, bottom, and both sides to prevent streaming. The weight of the door is supported by rollers under the bottom of the door, which run in a floor-recessed channel. The equipment shield doors are controlled from the facility operations room. A local emergency open button is provided. An interlock to a dedicated radiation monitor within the loadout area is provided to prevent the equipment shield door from opening during transfer of a waste package from the waste package transfer trolley to the TEV. The doors are also provided with obstruction sensors, such that they cannot close if the TEV, or other equipment, is in the way. For details of waste package loadout room equipment shield doors, refer to [Figures 1.2.4-20](#) and [1.2.4-82](#). The logic diagram for waste package loadout room equipment shield doors is shown in [Figure 1.2.4-83](#).

Waste Package Positioning Room Equipment Shield Doors (Type 4)—The waste package positioning room equipment shield doors provide equipment and personnel access to the waste package positioning rooms. The design of these equipment shield doors is the same as that of the waste package loadout room equipment shield doors described above.

The equipment shield doors are controlled from the facility operations room. A local emergency open button is provided. The equipment shield doors are interlocked with the waste package port slide gate, such that the doors cannot be opened unless the slide gate is in the closed position. The equipment shield doors are also interlocked with the waste package loadout room equipment shield

doors and waste package loadout room personnel shield doors such that the waste package positioning room equipment shield doors cannot open if any of the other doors are open. The doors are also provided with obstruction sensors, such that they cannot close if the waste package transfer trolley, or other equipment, is in the way of closing. For details of these equipment shield doors, refer to [Figures 1.2.4-20](#) and [1.2.4-82](#). The logic diagram for the waste package positioning room equipment shield doors is shown in [Figure 1.2.4-84](#).

Waste Package Loadout Room Personnel Shield Door—The personnel shield doors provide access from the waste package loadout room to personnel corridors or an HVAC room. The personnel shield doors are hinged on one side for a swing-open operation. Each door works in conjunction with a personnel access door that provides emergency egress, air seals, and/or secure entry features. The doors are larger than the door aperture on the top and both sides to prevent streaming. The gap on the bottom of the door is shielded by use of a riser plate mounted to the floor. Latches for the door keep the door closed during waste package processing or open when personnel are present within the loadout room. Sensors on the door latches provide indication to the facility operations room that the door is latched opened, latched closed, or ajar. The sensors also provide signals to lights on the outside of the associated personnel access door, providing indication that the personnel shield door is open or closed.

For each personnel access door there are two locked or encoded handswitches. One is local to the personnel access door, and the second is located in the facility operations room. Both switches must be operated to allow personnel entry to the waste package loadout room. Each personnel access door is also interlocked with a dedicated radiation monitor within the waste package loadout room to prevent the door from being opened during transfer of a waste package from the waste package transfer trolley to the TEV.

Latches and door positions are remotely indicated at the facility operations room. This equipment is used in the CRCF and IHF. For details of this equipment, refer to [Figures 1.2.4-85](#) and [1.2.4-86](#). The logic diagram for the personnel shield door is shown in [Figure 1.2.4-87](#).

Waste Package Transfer Trolley—The waste package transfer trolley is used to orient and transport a waste package for receipt of canisters, lid installation, and delivery to the TEV. The capacity of the waste package transfer trolley is 100 tons. The waste package transfer trolley consists of two main parts: the shielded enclosure and the waste package transfer trolley. The waste package transfer trolley is designed to handle the following waste packages and emplacement pallets: 21-PWR/44-BWR TAD, 5-DHLW/DOE Short Codisposal, 5-DHLW/DOE Long Codisposal, and the 2-MCO/2-DHLW waste packages; the emplacement pallet; and the short emplacement pallet.

The shielded enclosure provides shielding for the loaded waste package. Steel and borated polyethylene shielding is provided to limit external dose rates to 100 mrem/hr on contact. The enclosure encases the waste package and emplacement pallet assembly on all sides, with the exception of the top. The shield ring, which is placed on top in the vertical position, allows the waste package to protrude, which greatly reduces the radiation shine from the space between the waste package and the shielded enclosure, while accommodating the waste package closure process. The different-sized waste packages are maintained at the same top elevation to support the closure

process. Pedestals are used on the bottom of the vertical enclosure to elevate the waste packages to the required height.

The waste package transfer trolley bears the weight of the shielded enclosure by a support structure and shaft. The shaft on the support structure allows the enclosure to rotate the waste package at the docking station. The shielded enclosure is rotated by electric motor and gear assemblies (one on each side of the enclosure). The mechanical gears provide positive engagement at all times, preventing any slippage or other free movement of the shielded enclosure. The gear motors are hard-wire interlocked with the docking station lockdown mechanism such that the motors cannot actuate unless the waste package transfer trolley is docked. This prevents any rotation of the shielded enclosure unless it is at the docking station.

The waste package transfer trolley is provided with remote control capabilities to run the waste package transfer trolley between the waste package loadout room and the waste package positioning rooms and to rotate the enclosure to the vertical or horizontal orientation. The speed of the waste package transfer trolley is limited to 2.5 mph. In the forward or reverse direction, limit switches are provided to limit its travel. Forward and reverse range detectors are also provided to trip the waste package transfer trolley translational motor in case a limit switch fails, or if something is in the path of the trolley. The waste package transfer trolley is equipped with limit switches to limit the shielded enclosure rotational movement. The shielded enclosure is interlocked with the docking station locking mechanism such that the shielded enclosure cannot rotate unless the waste package transfer trolley is locked to the docking station. The waste package transfer trolley is interlocked with the carriage retrieval mechanism such that operation of the carriage retrieval mechanism automatically interrupts power to the trolley to prevent movement of the trolley during waste package transfer operations. The waste package transfer trolley is also interlocked with the waste package port slide gate such that opening of the slide gate interrupts power to the trolley to prevent movement of the trolley during canister transfer operations. This equipment is used in the CRCF and IHF only. For details of this equipment, refer to [Figures 1.2.4-88 to 1.2.4-89](#). The logic diagram for the waste package transfer trolley is shown in [Figure 1.2.4-90](#).

The waste package transfer trolley transports waste packages of varying lengths. The top of each waste package is positioned at a set height. To accommodate the various waste packages and maintain the top set height requirement, waste package pedestals are used within the waste package transfer trolley shielded enclosure. The pedestals are loaded into the waste package transfer trolley shielded enclosure by use of the waste package handling crane while the shielded enclosure is in the vertical position. Once loaded into the shielded enclosure, the pedestals are pinned into location using bolts through the shielded enclosure. The pedestals are stored in the Warehouse and Non-Nuclear Receipt Facility and brought in by truck when needed. This equipment is used in the CRCF and IHF.

Waste Package Handling Crane—The waste package handling crane, which is located in the waste package loadout room, is used to handle and lift empty waste packages and in waste package loadout preparation and recovery operations. The waste package handling bridge crane is a top running, double girder type crane with the top running trolley. The main hoist is rated at 100 tons with an auxiliary hook rated at 20 tons. The waste package handling crane does not lift any waste form. It is designed to not collapse. [Section 1.2.2.2](#) and [Table 1.2.2-12](#) provide further

details for ITS cranes. For details of this equipment, refer to [Figures 1.2.4-91](#) and [1.2.4-92](#). The waste package handling crane is used in the IHF and CRCF.

Waste Package Shield Ring—The waste package shield ring sits on top of the waste package transfer trolley shielded enclosure (while in the vertical position). The shield ring provides an opening for the top of the waste package to project through to accommodate the lid welding and nondestructive examination processes while providing shielding for the annular space between the waste package transfer trolley shielded enclosure and the loaded waste package. The shield ring also includes four trunnions on the sides to allow for remote removal by the waste package handling crane, using the waste package shield ring lift beam. When not in use, the waste package shield ring rests in the waste package shield ring stand. [Figure 1.2.4-88](#) shows the position of the waste package shield ring installed on the waste package transfer trolley.

There are no ITS SSCs that are unique to the CRCF waste package loadout subsystem.

1.2.4.2.4.2 Operational Processes

After an empty TEV has entered the waste package loadout vestibule and the exterior door has been closed, the waste package loadout room equipment shield door is opened, and the TEV is moved into the waste package loadout room. The waste package loadout room equipment shield door is then closed. The TEV opens its shield doors, extends its bottom shield, and lowers its lifting feature. As the TEV enters the loadout room, the hardwired, mechanically operated switch mounted on the TEV contacts the stationary actuating device mounted to the rails inside the waste package loadout room. Activating this switch allows the operator in the Central Control Center to unlock and open the TEV shielded enclosure doors ([Section 1.3.3.5](#)). The actuating bracket for the TEV mechanical onboard position switch is illustrated in [Figure 1.2.4-93](#).

Once the waste package is sealed and inspected, the waste package positioning room equipment shield door is opened, and the waste package transfer trolley, carrying a loaded waste package, is moved from the waste package positioning room. The waste package transfer trolley moves to the waste package transfer carriage docking station and is locked down. The waste package positioning room equipment shield door is closed. The waste package shield ring is removed by the waste package handling crane, using the waste package shield ring lift beam.

The waste package transfer trolley shielded enclosure is downended into the horizontal position. As the shielded enclosure is downended, the carriage makes contact with the transfer mechanism of the waste package transfer carriage docking station. The waste package transfer carriage, conveying the loaded waste package and emplacement pallet, is withdrawn by the retrieval mechanism from the waste package transfer trolley and is placed in position to be received by the TEV.

The TEV lifting feature raises the waste package and pallet off of the waste package transfer carriage. The TEV bottom shield is retracted and shield doors are closed. As the TEV exits the waste package loadout room, it again contacts the actuating bracket for the mechanical onboard position switch, which resets the TEV equipment shield door interlock to ensure the doors stay closed and locked during TEV travel to the emplacement drift. The waste package loadout room equipment shield door is opened, and the TEV moves into the waste package loadout vestibule.

The waste package loadout room equipment shield door is closed, the waste package loadout vestibule exterior door is opened, and the TEV moves out of the CRCF.

During the transfer of the sealed waste package from the waste package transfer trolley to the TEV, the waste package is inspected by qualified operators for unacceptable surface marring so that it meets the limits identified in [Section 1.5.2](#), and then is certified as suitable for emplacement by process control and/or inspection. To perform the inspection, cameras are mounted around the travel path perimeter of the waste package, allowing the operators to view the surface of the waste package as it travels between equipment. The cameras are of a high enough resolution to allow the operators to properly determine the acceptability of the waste package outer corrosion barrier prior to transport and emplacement of the waste package in the repository. The cameras are mounted such that the surface of the waste package can be viewed except the small surface area obscured by the emplacement pallet, which protects the waste package from surface marring in these areas.

1.2.4.2.4.3 Safety Category Classification

The waste package transfer trolley, waste package handling crane, waste package shield rings, waste package loadout room equipment shield doors, waste package positioning room equipment shield doors, and waste package loadout room personnel shield doors in the waste package loadout subsystem are categorized as ITS.

1.2.4.2.4.4 Procedural Safety Controls to Prevent Event Sequences or Mitigate Their Effects

The preclosure safety analysis identifies one procedural safety control related to the operation of components in the waste package loadout subsystem of the CRCF. [Table 1.9-10](#) identifies the unique numbering of the preclosure procedural safety controls, as well as the associated facility or operations area, SSCs, and bases.

PSC-3—To limit the probability of personnel receiving direct radiation exposure during the movement of a loaded waste package into the transport and emplacement vehicle, the waste package loading, closure, and loadout operating procedures will include warnings that movement of a loaded waste package could result in inadvertent personnel exposures if operators are present in the CRCF waste package positioning rooms (Rooms 1018 or 1019) or the waste package loadout room (Room 1015). The procedures will include prerequisites for movement of the loaded waste package to verify that the CRCF waste package positioning rooms and CRCF waste package loadout room are empty of personnel and that access to these potential radiation areas has been appropriately posted and controlled in accordance with the Operational Radiation Protection Program.

1.2.4.2.4.5 Design Bases and Design Criteria

The nuclear safety design bases and design criteria for the waste package loadout subsystem in the CRCF are addressed in [Table 1.2.4-4](#).

1.2.4.2.4.6 Design Methodologies

The design methodologies used in the design of ITS SSCs in the waste package loadout subsystem, including the waste package transfer trolley, waste package shield rings, and waste package handling crane, are in accordance with codes and standards provided in [Section 1.2.2.2](#). The methodologies used in the design of the equipment and personnel shield doors are in accordance with Section Q1.2 of ANSI/AISC N690-1994.

1.2.4.2.4.7 Consistency of Materials with Design Methodologies

Materials of construction used in the design of ITS SSCs in the CRCF waste package loadout subsystem, including the waste package transfer trolley, waste package shield rings, and waste package handling crane, are in accordance with codes and standards provided in [Section 1.2.2.2](#). Materials of construction used in the design of equipment and personnel shield doors are in accordance with Section Q1.4 of ANSI/AISC N690-1994.

1.2.4.2.4.8 Design Codes and Standards

The principal codes and standards applicable to the waste package loadout subsystem are identified in [Table 1.2.2-12](#).

1.2.4.2.4.9 Design Load and Combinations

The load combinations used in the analysis of ITS SSCs for the CRCF waste package loadout subsystem, including the waste package trolley, waste package shield rings, and waste package handling crane, are in accordance with codes and standards provided in [Section 1.2.2.2](#). The design load combinations analyzed include normal conditions and event sequences and the effects of natural phenomena. The load combinations and applicable stress limit coefficients used in the design of equipment and personnel shield doors are in accordance with Table Q1.5.7.1 of ANSI/AISC N690-1994.

1.2.4.3 Process Systems

[NUREG-1804, Section 2.1.1.2.3: AC 1(2), (3), (4), AC 2, AC 6]

1.2.4.3.1 Cask Cavity Gas Sampling Subsystem

1.2.4.3.1.1 Subsystem Description

The cask cavity gas sampling system samples the gas inside a loaded transportation cask before it is opened to obtain an indication of the condition of the waste inside. The presence of gaseous fission products or gases other than helium is indicative of off-normal conditions inside the cask. The cask cavity gas sampling system also vents the cask to the HVAC system to equalize pressure with the room prior to opening the cask. The cask cavity gas sampling systems in the IHF, RF, and WHF are functionally the same as the cask cavity gas sampling system in the CRCF. The CRCF cask cavity gas sampling piping and instrumentation diagram is shown in [Figure 1.2.4-94](#).

The cask cavity gas sampling subsystem is classified as non-ITS.

1.2.4.3.1.1.1 Subsystem Functions

The functions of the cask cavity gas sampling subsystem are to:

- Check the initial cask internal pressure
- Draw samples of the cask cavity blanket gas
- Analyze the cavity gas samples for composition and radionuclide concentration
- Vent the cask cavity blanket gas to the HVAC system
- Purge the gas sampling lines and equipment to prepare for the next cask blanket gas sampling.

1.2.4.3.1.1.2 Subsystem Location and Functional Arrangement

The majority of the CRCF cask cavity gas sampling subsystem is located in the gas sampling equipment room (Room 1034), which contains the analytical unit for speciation and quantification of radioactive and chemical compositions, and the sample recirculation vacuum pump. Local to the cask being sampled is the sampling manifold, containing the flexible-hose couplings, the radioactive particulate sampling unit, and the local vacuum-flask sampling port.

1.2.4.3.1.1.3 Components

The major components of the cask cavity gas sampling subsystem are described below:

- **Particulate Sampler**—This unit is located immediately downstream of the cask outlet and operates as a filter to protect downstream system components from the deposition of particulates, particularly radioactive particulates. Local radiation monitors are utilized to detect the presence of any radioactive particulate or contamination in the detector/filter.
- **Vacuum Pump**—The vacuum pump provides the motive force for recirculating gas from the cask and establishes the uniform gas composition before the sample is drawn off. The vacuum pump is protected from particulate accumulation by the upstream radioactive particulate sampler.
- **Portable Sample Vacuum Flask**—A portable sample vacuum flask may be used to manually collect a gas sample that can be taken to a gas-sampling lab. The sample port is located close to the gas return to the cask during recirculation flow.
- **Gas Sampling Package**—This package performs the radioactive and chemical speciation and quantification of the cask gas sample. The following components are included:
 - **Sample Gas Cooler**—The sample gas cooler removes heat from the sample stream to permit operation without damage to the analytical equipment.

- **Radioactive Gas Detection Unit**—The detection and measurement of radioactive gases, particularly ^{85}Kr , from the cask cavity gas sample are performed in an online stand-alone radioactive gas detection unit. This device performs gross beta/gamma activity measurements on the sample gas passing through a sample chamber.
- **Gas Chromatograph**—The gas chromatograph package includes a gas sampler and sample valve plus its dedicated computer. The gas chromatograph measures the concentrations of any gases, specifically N_2 , H_2 , O_2 , Ar , CO , and CO_2 , present in the grab sample down to a few parts per million and displays the results on a dedicated personal computer. A helium carrier stream is utilized.
- **Helium**—Helium carrier gas is used to carry the gas sample through the gas chromatograph. Helium is also used to purge the cask cavity and sample piping after sampling.

1.2.4.3.1.2 Operational Processes

The cask cavity gas sampling system piping is connected to the cask vent and drain nozzles by flexible hoses with quick-disconnect couplings at both ends. Small-diameter piping connects the gas sampling area with the gas sampling lab via a recirculation line that is intended to establish a representative gaseous sample before it is drawn off for analysis in the analytical instrumentation.

Immediately downstream of the cask gas outlet is a particulate radiation detector that also operates as a filter to protect downstream system components from the deposition of particulates, particularly radioactive particulates. The equipment located in the cask cavity gas sampling system recirculation line is capable of operation at cask temperature.

Once the representative cask atmosphere is established at the inlet to the analytical instrumentation, gas then flows through the sampling system, driven by the higher-than-ambient pressure in the cask cavity or by the circulating vacuum pump. Off-gas is vented to the HVAC system.

The initial pressure is an immediate indication of whether the cask seal integrity has been maintained, with low or no pressure indicative of a leak. The sample points for temperature and pressure are upstream of the gas sample cooler.

Gas leaving the cask enters an online particulate sampler. The online particulate sampler is a stand-alone device designed to perform online detection and measurement of the radioactive particulates in the sample gas. The sample gas enters the unit and passes through a filter that captures particulates present in the sample gas. The filters are made of a material that is free of gamma emitters and has intrinsic radioactive emissions lower than the detection limits. Used filters are disposed of as solid low-level radioactive waste.

From the online particulate sampler, the filtered gas sample enters the system recirculation vacuum pump and is subsequently returned to the cask.

When ready, a continuous gas sample is bled to the gas sampling package that speciates and quantifies radioactive and chemical gaseous constituents. This package consists of a sample gas

cooler and a standalone radioactive gas detection unit designed to detect and measure radioactive gases, particularly ^{85}Kr . A small sample of the gas stream leaving the online radioactive gas detection unit is fed to a gas chromatograph. The sample is carried through the gas chromatograph by a stream of helium carrier gas. The gas chromatograph measures the concentration of any N_2 , H_2 , O_2 , Ar, CO, and CO_2 . The gaseous effluent from the gas chromatograph is directed to the HVAC system.

After the gas sampling operation, the remaining cask blanket gas inventory can be purged and vented to the HVAC system, if needed.

Provisions for section cleanout of the sample line and the associated equipment are provided in applicable procedures.

1.2.4.3.1.3 Design Codes and Standards

The cask cavity gas sampling subsystem is designed using the methods and practices in the following codes and standards:

- ANSI/ANS-57.7-1988, *Design Criteria for an Independent Spent Fuel Storage Installation (Water Pool Type)*
- ANSI/ANS-57.9-1992, *Design Criteria for an Independent Spent Fuel Storage Installation (Dry Type)*.

1.2.4.3.2 Water Collection Subsystem

1.2.4.3.2.1 Subsystem Description

The water collection subsystem provides floor drains to collect small amounts of water that are discharged or leak from process SSCs and to control fire suppression water. Floor drains are provided in different confinement areas as needed and they are not interconnected. The sampling and sump piping for the water collection system for the CRCF is shown in [Figure 1.2.4-95](#). The system is classified as non-ITS.

1.2.4.3.2.2 Operational Processes

The water collection subsystem routinely collects potentially contaminated water in the sampling tank in the liquid low-level radioactive waste sump for the CRCF. The water in the sampling tank is sampled, and contaminated water is sent to the CRCF collection tank or sump. It is then transported by tanker truck to the Low-Level Waste Facility as described in [Section 1.4.5](#).

1.2.4.3.2.3 Design Codes and Standards

The water collection subsystem is designed using the methods and practices in NFPA 801, *Standard for Fire Protection for Facilities Handling Radioactive Materials*, and Regulatory Guide 1.143, *Design Guidance for Radioactive Waste Management Systems, Structures, and Components Installed in Light-Water-Cooled Nuclear Power Plants*, Table 1, excluding footnotes.

1.2.4.4 Canister Receipt and Closure Facility Heating, Ventilation, and Air-Conditioning Systems

[NUREG-1804, Section 2.1.1.2.3: AC 1(2), (3), (4), AC 2, AC 6; Section 2.1.1.6.3: AC 1(2)(a), (2)(d), (2)(h), (2)(j), (2)(l), AC 2(2); Section 2.1.1.7.3.1: AC 1(1), (2), (3), (5), (6), (9); Section 2.1.1.7.3.2: AC 1(1), (2); Section 2.1.1.7.3.3(I): AC 1(1), AC 2(1), (2), (3), AC 4(1)]

The CRCF HVAC system is designed to limit the release of radioactive airborne contaminants for the protection of the workers and public, condition air to support the operation of ITS SSCs, and maintain the indoor environmental conditions required for operations and for the health and safety of the facility workers.

The ventilation confinement zoning in the CRCF is based upon normal operations. The CRCF is expected to remain clean during normal operations, and airborne contamination is not expected. The confinement zoning for the CRCF is tertiary as defined in [Table 1.2.2-13](#).

The remaining portions of the facility where there is no potential for contamination are classified as a nonconfinement zone. [Figures 1.2.4-96](#) through [1.2.4-98](#) illustrate the confinement zoning for the CRCF.

Some of the areas within the tertiary confinement zone have a potential for contamination release from a dropped loaded canister. The confinement in these areas is ITS. The ITS confinement areas are the cask preparation area, canister staging areas, cask unloading rooms, and waste package positioning rooms. The exhaust subsystem SSCs serving the ITS confinement areas are ITS.

The removal of heat from the ITS electrical and battery rooms is an ITS function. The supply and exhaust to these rooms are classified as ITS in order to ensure the ITS electrical systems continue to perform their safety function.

During normal operations, the HVAC system operates to dissipate the heat gain from various sources to maintain the required room temperature for proper operation of equipment and personnel comfort. Air handling units and fan coil units are utilized to supply conditioned air to various areas and the supply air is then returned and/or exhausted. The air handling units and fan coil units are sized to dissipate the heat generated from lights, solar loads, and operating mechanical and electrical equipment, as well as the decay heat generated from waste forms present in the area served by the HVAC system.

Thermal evaluation of the CRCF unloading rooms (Rooms 1023 and 1024), positioning rooms (Rooms 1018 and 1019), and canister staging areas (Rooms 1017, 1021, 1022, and 1025) indicates that under off-normal conditions with no air flow for 30 days, the off-normal limits of the SNF cladding and the waste package outer corrosion barrier are not exceeded. This evaluation bounds the remaining rooms in the CRCF. The heat loads considered in this evaluation are 22 kW for commercial SNF canisters, 18 kW for waste packages, and 7.1 kW for 5-DHLW/DOE codisposal waste packages. The maximum thermal power for a HLW canister is 720 watts, therefore, the maximum thermal power for a HLW and DOE SNF waste package is less than 6 kW.

During normal operations, the SNF cladding in the commercial SNF canisters does not exceed the normal temperature limit of 400°C. During off-normal conditions with no air flow for 30 days, the SNF cladding in the commercial SNF canisters does not exceed the off-normal temperature limit of 570°C. The evaluations also show that under both normal and off-normal conditions with no air flow for 30 days, the HLW glass temperature does not exceed 400°C and the DOE SNF cladding temperature does not exceed the limit of 350°C. The HVAC system is designed to ensure that during normal operations, the normal limits for DOE canisters stated in [Section 1.5.1.3](#) are not exceeded during handling.

1.2.4.4.1 System Description

The CRCF HVAC system includes the following subsystems:

- ITS exhaust subsystem serving ITS tertiary confinement areas
- ITS HVAC subsystems serving the ITS electrical equipment and battery rooms
- Non-ITS HVAC supply subsystems serving ITS tertiary confinement areas
- Non-ITS HVAC supply and exhaust subsystems serving non-ITS tertiary confinement areas
- Non-ITS HVAC subsystem serving non-ITS nonconfinement areas.

Each subsystem is provided with the necessary distribution ductwork and accessories, electrical power, and instrumentation and controls to operate, control, monitor, alarm, provide status, and verify that the required function is met.

ITS Exhaust Subsystem Serving ITS Tertiary Confinement Areas—The ITS exhaust subsystem is provided for areas that have a potential for a drop and breach of a waste form, resulting in potential airborne contamination that requires mitigation during an event sequence. Air is exhausted from these areas through two stages of ITS exhaust high-efficiency particulate air (HEPA) filters. The ITS exhaust subsystem flow rate is greater than the make-up air flow rate ensuring that the air flow is into the confinement areas.

Each ITS exhaust HEPA filter train consists of three HEPA filter plenums with a bag-in/bag-out feature, demisters, prefilters, two stages of HEPA filters, and an exhaust fan with adjustable speed drive. The exhaust subsystem includes redundant ITS components, including ductwork. The HVAC supply subsystem components fail-safe on loss of power; for example, supply dampers close and supply fans stop running. ITS diesel generators provide ITS electric power to the exhaust fans. The ITS exhaust subsystem is provided with ITS instrumentation and controls to automatically start the stand-by fan should the running fan fail. Physical separation is provided so that damage to one train of exhaust equipment does not cause damage to the redundant train.

The ITS exhaust subsystem effluent is monitored for radioactivity downstream of the exhaust fans. Upon detection of high exhaust air radiation, a high radiation alarm is annunciated locally, at the facility operations room, and in the Central Control Center.

Figure 1.2.4-99 shows the composite ventilation flow diagram for the ITS exhaust subsystem. Figure 1.2.4-100 shows the ITS confinement areas air distribution system ventilation and instrumentation diagram. Figures 1.2.4-101 to 1.2.4-102 show the ventilation and instrumentation diagrams for the ITS confinement areas HEPA exhaust subsystem for Trains A and B. Figure 1.2.4-103 shows the ITS confinement areas exhaust subsystem HEPA exhaust fan (Trains A and B) logic diagram.

ITS HVAC Subsystems Serving the ITS Electrical Equipment and Battery Rooms—Each group of ITS electrical rooms and battery rooms (Train A and Train B) are served by redundant sets of HVAC supply and exhaust equipment. The supply air is conditioned using a split-type, direct expansion recirculating fan coil unit with a HEPA filter. This localized cooling ensures that ITS electrical power is not lost due to overheating in these areas. A remote condensing unit is provided for each fan coil unit. Air is continuously exhausted from each battery room to preclude accumulation of hydrogen generated by the batteries during charging. Hydrogen concentrations are maintained well below the lower explosive limit. A single stage HEPA filter is provided in each exhaust path. Figure 1.2.4-104 shows the composite ventilation flow diagram and Figures 1.2.4-105 to 1.2.4-108 show the ventilation and instrumentation diagrams for the ITS HVAC subsystems serving the ITS electrical equipment and battery rooms. Figures 1.2.4-109 and 1.2.4-110 show the CRCF and WHF confinement ITS electrical room fan coil unit (Trains A and B) logic diagram. Figure 1.2.4-111 shows the CRCF and WHF confinement ITS battery room exhaust fan (Trains A and B) logic diagram.

Non-ITS HVAC Supply Subsystems Serving the ITS Tertiary Confinement Areas—The ITS confinement areas are cooled by direct supply from non-ITS air handling units, including cascaded air from cooler adjacent spaces to maintain the temperature required for the equipment and for the personnel present during the process operation. The supply units consist of recirculating air handling units, each provided with prefilters and HEPA filters, heating and cooling coils, and a supply fan. Figure 1.2.4-99 shows the composite ventilation flow diagram and Figure 1.2.4-112 shows the ventilation and instrumentation diagram for the non-ITS HVAC supply subsystem serving the ITS tertiary confinement areas.

Non-ITS HVAC Supply and Exhaust Subsystems Serving the Non-ITS Tertiary Confinement Areas—The non-ITS confinement areas are served by recirculating supply air units and exhaust HEPA filter assemblies. There are four supply subsystems (each subsystem has one operating and one standby air handling unit) serving non-ITS confinement areas: one for the north first level, one for the south first level, one for the north second level, and one for the south second level. In addition, dedicated recirculating air supply units are also provided for the canister transfer room and for the waste package loadout room.

A portion of the air supplied to the non-ITS confinement areas is exhausted by the non-ITS exhaust HEPA assembly or cascaded to the ITS confinement areas in order to maintain the appropriate confinement, and the remaining air is returned to the air handling unit. The exhaust air for the non-ITS confinement areas is passed through a single stage of HEPA filters prior to discharging to the atmosphere. The exhaust system effluent is monitored for radioactivity downstream of the exhaust fans. Upon detection of high exhaust air radiation, a high radiation alarm is annunciated locally, at the facility operations room, and in the Central Control Center.

The normal power battery room is also provided with a separate exhaust that operates continuously with sufficient volume changes per hour to preclude accumulation of hydrogen generated by the batteries during charging such that it is below the lower level explosive limit. Air that is cascaded or supplied into the battery room is exhausted by means of a redundant one-stage exhaust HEPA filter unit and exhaust fan with spark-resistant construction and explosion-proof motors. This exhaust is also provided with a radioactivity monitor.

A separate non-ITS confinement HVAC subsystem also serves low-level radioactive waste and decontamination areas. Air that is cascaded or supplied into low-level radioactive waste and decontamination areas is never returned back to the system; it is exhausted instead by means of one-stage exhaust HEPA filter units. The exhaust system effluent is monitored for radioactivity downstream of the exhaust fans. Upon detection of high exhaust air radiation, a high radiation alarm is annunciated locally, at the facility operations room, and in the Central Control Center.

Figures 1.2.4-99 and 1.2.4-113 show the composite ventilation flow diagrams for the non-ITS exhaust and non-ITS supply subsystem. Figure 1.2.4-114 shows the composite ventilation flow diagram for the tertiary confinement, ground floor HVAC subsystem. Figure 1.2.4-115 shows the composite ventilation flow diagram for the tertiary confinement non-ITS HVAC subsystem supply and exhaust.

Figures 1.2.4-112 to 1.2.4-123 show the ventilation and instrumentation diagrams for the non-ITS HVAC supply and exhaust subsystems serving the non-ITS tertiary confinement areas.

Non-ITS HVAC Subsystem Serving Non-ITS Nonconfinement Areas—The non-ITS nonconfinement HVAC subsystem provides conditioned air for cooling, heating, and ventilation for the safety, health, and comfort of the personnel and maintains the environmental conditions suitable for the proper performance of SSCs in the noncontaminated areas of the CRCF.

The non-ITS, nonconfinement HVAC system is provided for areas such as offices, vestibules, and facility operations rooms that have no potential for contamination. The system provides pressure differentials that are slightly positive in the clean areas of the facilities relative to the ambient air pressure to minimize infiltration of unconditioned air and dust during the system operation. It is a recirculating HVAC system with no HEPA filter. The non-ITS air handling units are provided with economizers, and the supply air is either returned or exhausted depending on the temperature of the outside air relative to the inside room temperature.

In addition, dedicated non-ITS recirculating fan coil units are provided for the entrance and exit vestibules of the operating areas. The vestibules are classified as nonconfinement areas. Each supply unit is provided with prefilters and high-efficiency primary filters, heating and cooling coils, and a supply fan.

Figure 1.2.4-124 shows the composite ventilation flow diagram for the nonconfinement, non-ITS HVAC subsystem serving support and operations.

1.2.4.4.1.1 System Functions

The functions of the CRCF HVAC system are to:

- Maintain airflow from areas of lesser contamination potential to areas of greater contamination potential
- Maintain space temperatures within acceptable limits
- Remove potentially contaminated airborne particulate from the exhaust
- Provide a release point to the atmosphere via continuously monitored discharge.

1.2.4.4.1.2 System Location and Functional Arrangement

The location and arrangement of the HVAC supply and exhaust equipment are shown on [Figures 1.2.4-2](#) and [1.2.4-3](#). The area ventilation confinement zones are shown in [Figures 1.2.4-96](#) to [1.2.4-98](#).

- [Table 1.2.2-14](#) provides the HVAC system monitoring, status, and alarm functions.
- [Table 1.2.4-4](#) provides the HVAC design bases and their relationship to design criteria.
- [Table 1.2.4-7](#) provides the ITS HVAC exhaust components and system design data.
- [Table 1.2.4-8](#) provides the indoor design temperatures.
- [Table 1.2.4-9](#) provides the non-ITS HVAC supply components and system design data.
- [Table 1.2.4-10](#) provides the non-ITS HVAC exhaust components and system design data.
- [Table 1.2.4-11](#) provides the ITS HVAC supply components and system design data.

The redundant ITS exhaust subsystem components are located in separate rooms on the first level of the facility. The ITS fan coil units serving the ITS electrical rooms are located inside the rooms they serve while the condensing units are located in a missile-protected area outdoors. The ITS battery room exhaust trains are located in separate rooms on the first level. The non-ITS air handling units and non-ITS HEPA exhaust units serving the first level north and south non-ITS confinement areas, including corridors, are located in HVAC equipment rooms on the first level. The non-ITS air handling units and non-ITS HEPA exhaust units serving the second level north and south non-ITS confinement areas, including corridors, are located in HVAC equipment rooms on the second level. The dedicated air handling units serving the canister transfer room and the waste package loadout room are located inside the corresponding room they serve. The nonconfinement air handling unit is located in a ground floor HVAC equipment room adjacent to the nonconfinement areas.

1.2.4.4.1.3 Systems and Components

Major components in the CRCF HVAC system are described below.

ITS Exhaust HEPA Filter Plenums—The ITS exhaust HEPA filter plenums used to mitigate the consequences of a radioactive release consist of demisters, prefilters, and two stages of 99.97% efficiency HEPA filters. The HEPA filter plenum housings are made of continuously welded stainless steel, and include explosion-proof lights, filter test port sections, pressure gauges across

each filter section, and drain connections. The demisters in the HEPA filter plenum are used to protect the HEPA filters from damage or loss due to entrained moisture in the airstream. The prefilters are installed upstream of the first stage HEPA filter to remove large airborne particulates.

ITS Exhaust Fans—The ITS exhaust fans for the ITS exhaust HEPA filter plenums are heavy-duty, centrifugal-type fans with nonoverloading airfoil or backward-inclined blades. The fans are equipped with adjustable speed drives to provide adjustment in the system airflow to maintain the required air flows in the confinement areas and to compensate for filter dust loading.

ITS Fan Coil Units for ITS Electrical and Battery Rooms—Each fan coil unit consists of prefilters, HEPA filters, a supply fan, and direct expansion cooling coils. Each fan coil unit is provided with an ITS condensing unit. The fans for the fan coil units are heavy-duty, plenum or scroll-type centrifugal fans with nonoverloading airfoil or backward-inclined blades and are equipped with adjustable speed drives to provide adjustment in the airflow to compensate for filter loading.

Non-ITS Air Handling Units and Fan Coil Units for Confinement Areas—Each air handling unit or fan coil unit used for confinement areas consists of prefilters, HEPA filters, supply fan, heating coils, and cooling coils. The fans for the air handling units and fan coil units are heavy-duty plenum or scroll-type centrifugal fans with nonoverloading airfoil or backward-inclined blades. The air handling unit (but not the fan coil units) fans are equipped with adjustable speed drives to provide adjustment in the airflow to compensate for filter loading.

The outdoor air supply inlet is provided with bird screen and storm-type louvers or a rain hood for protection from the environmental elements.

Non-ITS Air Handling Units and Fan Coil Units for Nonconfinement Areas—Each air handling unit or fan coil unit for nonconfinement areas is a recirculating type unit consisting of prefilters, primary filters, heating coils, cooling coils, a supply fan, and a return/exhaust fan (for the air handling unit only). The fans for the air handling units and fan coil units are heavy-duty, plenum or scroll-type centrifugal fans with a nonoverloading airfoil or backward inclined blades. The air handling unit fans are also equipped with adjustable speed drives to provide adjustment in the airflow to compensate for filter loading.

Dampers—Parallel blade dampers are used for isolating systems or portions of a system. Opposed blade-type volume dampers are used to provide system balancing. Backdraft dampers are used to maintain the proper direction of air flow and prevent reversal of the air flow. ITS tornado dampers are provided in the ITS exhaust ductwork discharging to the atmosphere to prevent damage to the ITS SSCs in the exhaust system caused by rapid depressurization during a tornado event. Automatic isolation dampers with electric actuators are provided on the inlet and discharge side of the non-ITS supply air handling units to isolate the nonoperating units. These dampers are interlocked to open when the supply fan is energized and to close when the fan stops. Backdraft dampers are provided at the discharge of each HEPA exhaust unit to prevent backflow through the standby unit.

Ductwork—Ductwork classified as ITS is designed to maintain its confinement boundary during normal operation and during event sequences. Exhaust ducts from potentially contaminated areas

are made of stainless steel with welded construction to minimize duct leakage. The exhaust ducts are sized to maintain sufficient transport velocities to minimize particulate contaminants from settling out of the airstream.

Controls and Instrumentation—The HVAC system parameters are monitored and controlled by temperature, pressure, and flow instrumentation.

The automatic start of a standby train, in the event that the operating train fails, is incorporated into the hardwired logic signal to the ITS adjustable speed drive. No commands from the DCMIS, process requests, or operator actions can override the safety function of the ITS adjustable speed drive.

The design of the instrumentation and controls for the HVAC system is based on the following considerations:

- The supply air handling units are interlocked with the exhaust fans when applicable to prevent the air handling unit from operating until the exhaust fans are operating.
- The supply air handling units are provided with a supply air temperature sensor connected to a digital controller. The set points are set or are automatically reset by room conditions or operator choice based on actual building load.
- The fan airflow rate is maintained at its set point by using the adjustable speed drive controlled by a discharge duct flow controller with a duct-mounted flow sensor and transmitter.
- The negative pressure in selected confinement areas is normally maintained by using the exhaust fan adjustable speed drive controlled by a pressure differential controller with duct-mounted or room-located differential pressure sensors (or both) and transmitters.
- The reheat coils are controlled by individual temperature controllers with room-mounted temperature sensors and transmitters.

1.2.4.4.2 Operational Processes

ITS Exhaust Units during Normal Operation—The ITS confinement areas are normally maintained at a negative pressure relative to the atmosphere and rooms served by the non-ITS confinement system. This is accomplished by exhausting more air from the ITS confinement areas than the make-up supply resulting in cascaded air due to infiltration from outside air and from nonconfinement areas. The air is exhausted directly by the ITS exhaust fans through two stages of HEPA filters prior to discharging to the atmosphere. The ITS adjustable speed drive varies speed as required to maintain proper differential pressure relative to atmosphere. A duct-mounted differential pressure sensor and transmitter monitors the differential pressure of the main exhaust duct and sends a signal to the differential pressure controller to adjust the exhaust fan adjustable speed drive. A differential pressure sensor and transmitter also monitors the differential pressure of the ITS confinement areas directly and sends a signal to the DCMIS to annunciate an alarm in the event of abnormally high or low differential pressures.

Normal control of the ITS exhaust fan is through an adjustable speed drive receiving start/stop commands from the DCMIS as initiated by an operator from the facility operations room. Once started, the fan speed is controlled by the adjustable speed drive via an analog input from the DCMIS based on the differential pressure at the main exhaust duct. In the event that the analog input signal to the adjustable speed drive is lost or corrupted, the adjustable speed drive reverts to a predetermined set point that resides within the adjustable speed drive. The operating fan will shut down and the standby fan will automatically start via a hardwired logic interlock, if any of the following occurs: (1) low differential pressure across the operating fan coincident with low air flow (fan failure); (2) high differential pressure across the HEPA filter train; (3) low differential pressure across the HEPA filter train; (4) fan trip.

ITS Fan Coil Units during Normal Operation—ITS direct expansion fan coil units with remote ITS air-cooled condensing units are utilized to maintain space temperatures in each of the Train A or Train B ITS electrical and battery rooms. For added reliability, two fan coil units, each with an independent condensing unit, are provided for each ITS electrical and battery room. One fan coil unit is normally sufficient to maintain the unoccupied temperature criteria. However, the second fan coil unit starts when either of the following occurs: (1) low differential pressure across the operating fan coincident with low air flow (fan coil unit failure); (2) fan trip. If the operating fan coil unit cannot maintain the required room temperature (especially when there is an extended personnel presence and the room temperature has to be lowered for personnel comfort) then the standby unit is manually started. The exhaust fans for the battery room are interlocked with the fan coil units, preventing both fan coil units from operating unless both battery room exhaust fans are running (to preclude pressurizing the battery rooms). The operation of the refrigerant compressors in the condensing units is controlled by the signal from the temperature sensor/transmitter located in the electrical room or the battery room (whichever is higher) as determined by a signal selector. The battery room exhaust operates continuously with sufficient volume changes per hour to preclude accumulation of hydrogen. A redundant, explosion-proof exhaust HEPA assembly is provided for each battery room with the standby unit starting automatically when either of the following occurs: (1) low differential pressure across the operating fan coincident with low air flow (fan failure); (2) fan trip.

ITS Confinement Areas Air Supply Subsystems during Normal Operation—During normal operation, the temperature of the following ITS confinement areas is controlled as noted below:

- The cask preparation room is maintained at a maximum of 85°F by means of a dedicated recirculating air handling unit located in the second floor. Part of this air is cascaded to the cask unloading rooms to maintain a temperature that does not exceed 100°F in these rooms.
- The waste package loadout room is maintained at a maximum of 85°F by means of dedicated recirculating air handling units located inside the room. Part of this air is cascaded to the waste package positioning rooms and then to the cask unloading rooms to maintain these rooms at a temperature that does not exceed 100°F.
- The canister staging areas are supplied with conditioned air from the first level (south) recirculating air handling unit to maintain these areas at a temperature that does not exceed 100°F.

The dedicated air handling units serving each of the ITS confinement areas noted above operate continuously during normal operation and are interlocked to operate only if either of the ITS exhaust fans is operating. A room-mounted temperature sensor and transmitter provides the signal to modulate the cooling coil or heating coil control valve to maintain the proper temperature.

Normal control of the supply is through an adjustable speed drive receiving start/stop commands from the DCMIS as initiated by an operator from the facility operations room. Once started, the supply fan speed is controlled by the adjustable speed drive via an analog input from the DCMIS based on the airflow rate at the discharge duct.

Failure of the operating unit, as determined by the differential pressure switch across the fan, shuts down the operating fan, closes its associated inlet and discharge dampers, and starts the standby fan automatically.

Non-ITS Confinement Areas Supply and Exhaust Subsystems during Normal Operation—Conditioned air is delivered to the non-ITS confinement areas via the CRCF north and south air handling units. A portion of this air, including air infiltration from outdoors, is exhausted directly by the non-ITS exhaust fans through a single stage of HEPA filters. The battery room is maintained at a negative pressure relative to the electrical rooms and corridors by exhausting supply and infiltration air through a single stage of HEPA filters. The remaining non-ITS confinement areas' air is returned and mixes with makeup air and is cooled or heated prior to redistribution.

Fan coil units with chilled water for cooling and hot water for heating are provided in the non-ITS confinement utility room to maintain the required space temperature. Locally mounted thermostats provide the cooling or heating signals to modulate the control valves of the cooling or heating coils to maintain temperature set points. The standby fan coil unit starts upon failure of an operating fan coil unit. These units are non-ITS.

Normal control of the supply is through an adjustable speed drive receiving start/stop commands from the DCMIS as initiated by an operator from the facility operations room. The supply units are interlocked to start only when the associated exhaust fan is operating. Once started, the supply fan speed is controlled by the adjustable speed drive via an analog input from the DCMIS based on the airflow rate at the discharge duct.

Failure of the operating unit, as determined by the differential pressure switch across the fan, shuts down the operating fan, closes its associated inlet and discharge dampers, and starts the standby fan automatically.

Normal control of the non-ITS exhaust fan is through an adjustable speed drive receiving start/stop commands from the DCMIS as initiated by an operator from the facility operations room. A permissive interlock is provided to allow start of the corresponding supply units only when the exhaust fan is operating. Once started, the exhaust fan speed is controlled by the adjustable speed drive via an analog input from the DCMIS based on the differential pressure at the main exhaust duct or selected confinement rooms or both. In the event of failure of the operating exhaust fan, as determined by the low differential pressure signal from the differential pressure switch across the fan, the operating fan will trip, and the standby unit will automatically start via the DCMIS logic interlock.

The CRCF exhaust effluent is monitored for radioactivity downstream of the exhaust fans. Upon detection of high effluent radiation, a high radiation alarm is annunciated locally, at the facility operations room, and in the Central Control Center. As the HEPA filter loading increases, the pressure drop across the filters increases. To compensate for this increase in differential pressure, the fan adjustable speed drive is modulated accordingly. If the pressure drop across the HEPA filters reaches the high set point, a high differential pressure condition is alarmed.

Non-ITS Nonconfinement HVAC System during Normal Operation—The non-ITS air handling units with economizers supply conditioned air to nonconfinement areas. The return air from the room is either recirculated or exhausted depending on the temperature of the outside air relative to the inside room temperature.

Failure of the operating unit, as determined by the differential pressure switch across the fan, shuts down the operating fan and starts the standby fan automatically.

Motor speed and differential pressure across the fans are continuously monitored. In the event low differential pressure across the operating fan and/or low speed are detected, the fan automatically shuts down, closes its associated inlet and discharge dampers, and fan failure is annunciated. This will also trigger the automatic start of the standby fan.

Fan coil units with chilled water for cooling and hot water for heating operate to maintain space temperatures in the various vestibules. Locally mounted thermostats provide the cooling or heating signals to modulate the control valves of the cooling or heating coils to maintain temperature set points. The standby fan coil unit starts upon failure of an operating fan coil unit. These units are non-ITS.

Confinement Operation with Loss of Normal Power—In the event of loss of offsite power, the non-ITS equipment shuts down or moves to the fail position and the ITS exhaust fans stop running. During the period of time while the ITS diesel generators start and the ITS exhaust fans are loaded on the ITS electrical busses, the ITS confinement areas are effectively isolated and there is negligible driving force to disperse potential radioactive material. Once the ITS exhaust fans are running, filtration of exhaust air can continue.

Shutdown—Fans continuously run until manually stopped. Automatic shutdown occurs when low differential pressure across the operating fan coincident with low air flow is detected, and fan or fan coil unit failure is annunciated. The shutdown event automatically starts the standby fan or fan coil unit.

The inlet and discharge dampers automatically close on shutdown of their associated operating supply fan.

For planned maintenance and shutdown, the ventilation systems are taken out of service by shutting down the supply fans first before the exhaust fans. During normal operation, the shutdown sequence is the same as for removal from service.

Loss of Chilled Water or Hot Water—Upon loss of chilled or hot water to the air handling or fan coil units, the units continue to operate. Loss of chilled water or hot water does not impact the safety function of any ITS SSC.

Interlocks, Trips, and Alarms—Each supply and exhaust fan is interlocked with its corresponding discharge damper such that the damper opens upon fan start or closes upon fan stop. In the event the fan discharge damper does not fully open on receipt of a fan “start” signal, the fan automatically stops, fan failure is annunciated, and the standby fan is started.

The CRCF exhaust system provides the required interlock/permissive trip signal to start or stop the CRCF air handling units. The exhaust system must be operating for the corresponding air handling units to start and run. Complete failure of the exhaust system stops the operation of all the air handling supply units.

Each supply air handling unit is provided with a duct-mounted smoke detector located downstream of the filters to shut down the unit whenever smoke is detected in the air stream. An automatic electric motor-actuated smoke damper is also provided to automatically isolate the air handling unit when smoke is detected.

Interfaces—The plant cooling and heating system provides hot and chilled water to the air handling unit cooling and heating coils to condition the air for the different areas of the facility during normal operations. The HVAC fans and dampers interface with the electrical power system. Those ITS components of the HVAC system that require electricity to perform their intended safety function are connected to the ITS electrical power system. The electrical power supply serving the ITS HEPA exhaust fans and the ITS fan coil units and condensing units serving the ITS electrical rooms are provided from the ITS electrical buses. The DCMIS provides non-ITS HVAC controls. The ITS instrumentation and controls associated with the automatic startup of the standby ITS exhaust fan are controlled by hardwired logic and are not directly connected to the DCMIS.

The fire protection system interfaces with the HVAC system. In the event smoke is detected in the discharge duct, the duct-mounted smoke detector shuts off the affected supply fan. The exhaust fans will continue to operate. Fire suppression systems, including automatic and manual water deluge systems, are provided for the ITS exhaust HEPA filter plenums. [Section 1.4.3](#) provides details related to fire protection.

The radiation monitoring and alarm system provides continuous monitoring of radioactive contaminants in the exhaust air. The monitoring is accomplished by using a sampling system on the final discharge duct that takes representative samples to the radiation monitor in accordance with ANSI/HPS N13.1-1999.

The facility provides floor drains, curbs, ramps, and/or trenches in the HVAC equipment rooms to collect the fire suppression water or other system leakage. The low-level radioactive waste management system receives the potentially contaminated effluents from drains and spent filters from the exhaust filter plenums.

1.2.4.4.3 Safety Category Classification

Safety classification of HVAC systems is based upon whether credit is taken in the preclosure safety analysis for SSCs to mitigate the consequences of an event sequence. Portions of the confinement HVAC system that support the cooling of ITS electrical and controls equipment are classified as ITS. Portions of the confinement HVAC system that exhaust from areas with a potential for a breach are classified as ITS.

1.2.4.4.4 Procedural Safety Controls to Prevent Event Sequences or Mitigate Their Effects

The preclosure safety analysis identifies one procedural safety control related to the operation of components in the HVAC system of the CRCF. [Table 1.9-10](#) identifies the unique numbering of the preclosure procedural safety controls, as well as the associated facility or operations area, SSCs, and bases.

PSC-7—To limit the probability that the CRCF HVAC system fails to start upon demand, the CRCF operating procedures will identify the required status of the ITS confinement HVAC exhaust fans and the ITS supply and exhaust fans for the ITS electrical and battery rooms in the CRCF as a condition for commencing waste handling operations in the CRCF.

1.2.4.4.5 Design Bases and Design Criteria

The nuclear safety design bases and design criteria for the HVAC system in the CRCF are addressed in [Table 1.2.4-4](#).

1.2.4.4.6 Design Methodologies

The design methodologies used in the design of ITS SSCs in the CRCF HVAC systems are in accordance with codes and standards provided in [Section 1.2.2.3](#).

1.2.4.4.7 Consistency of Materials with Design Methodologies

Materials of construction used in the design of ITS SSCs in the CRCF HVAC systems are in accordance with codes and standards provided in [Section 1.2.2.3](#).

1.2.4.4.8 Design Codes and Standards

The principal codes and standards applicable to the ITS SSCs in the CRCF HVAC systems are provided in [Section 1.2.2.3](#).

Non-ITS SSCs in the CRCF HVAC systems are designed using the methods and practices in the following codes and standards:

- ANSI/AMCA 210-99, *Laboratory Methods of Testing Fans for Aerodynamic Performance Rating*
- *HVAC Duct Construction Standards—Metal and Flexible* (SMACNA 1995)
- ARI Std 410-2001, *Forced-Circulation Air-Cooling and Air-Heating Coils*
- ASME AG-1-2003, *Code on Nuclear Air and Gas Treatment*, including the 2004 addenda (ASME AG-1a-2004)
- UL 900, *Air Filter Units*
- Regulatory Guide 1.140, *Design, Inspection, and Testing Criteria for Air Filtration and Adsorption Units of Normal Atmosphere Cleanup Systems in Light-Water-Cooled Nuclear Power Plants*
- ANSI/HPS N13.1-1999, *American National Standard Sampling and Monitoring Releases of Airborne Radioactive Substances from the Stacks and Ducts of Nuclear Facilities*.

1.2.4.4.9 Design Load Combinations

The design load combinations used in the analysis of ITS SSCs for the CRCF HVAC system are in accordance with codes and standards provided in [Section 1.2.2.3](#).

1.2.4.5 General References

AISC (American Institute of Steel Construction) 1997. *Manual of Steel Construction, Allowable Stress Design*. 9th Edition, 2nd Revision, 2nd Impression. Chicago, Illinois: American Institute of Steel Construction. TIC: 240772.

ANSI N14.6-1993. *American National Standard for Radioactive Materials—Special Lifting Devices for Shipping Containers Weighing 10000 Pounds (4500 kg) or More*. New York, New York: American National Standards Institute. TIC: 236261.

ANSI/AISC N690-1994. *American National Standard Specification for the Design, Fabrication, and Erection of Steel Safety-Related Structures for Nuclear Facilities*. Chicago, Illinois: American Institute of Steel Construction. TIC: 252734.

ANSI/AMCA 210-99. 2000. *Laboratory Methods of Testing Fans for Aerodynamic Performance Rating*. Arlington Heights, Illinois: Air Movement and Control Association International. TIC: 249168.

ANSI/ANS-57.7-1988. *Design Criteria for an Independent Spent Fuel Storage Installation (Water Pool Type)*. La Grange Park, Illinois: American Nuclear Society. TIC: 238870.

ANSI/ANS-57.9-1992. *Design Criteria for an Independent Spent Fuel Storage Installation (Dry Type)*. La Grange Park, Illinois: American Nuclear Society. TIC: 3043.

ANSI/AWS A5.32/A5.32M-97. 1998. *Specification for Welding Shielding Gases*. Miami, Florida: American Welding Society. TIC: 253550.

ANSI/HPS N13.1-1999. *American National Standard Sampling and Monitoring Releases of Airborne Radioactive Substances from the Stacks and Ducts of Nuclear Facilities*. McLean, Virginia: Health Physics Society. TIC: 248835.

ARI Std 410-2001. 2002. *Forced-Circulation Air-Cooling and Air-Heating Coils*. Arlington, Virginia: Air-Conditioning and Refrigeration Institute. TIC: 254106.

ASME (American Society of Mechanical Engineers) 2001. *2001 ASME Boiler and Pressure Vessel Code*. New York, New York: American Society of Mechanical Engineers. TIC: 251425.

ASME AG-1-2003. *Code on Nuclear Air and Gas Treatment*, including the 2004 addenda (ASME AG-1a-2004). New York, New York: American Society of Mechanical Engineers. TIC: 258079; 258080.

ASME B30.20-2003. *Below-the-Hook Lifting Devices*. New York, New York: American Society of Mechanical Engineers. TIC: 256185.

ASME NOG-1-2004. 2005. *Rules for Construction of Overhead and Gantry Cranes (Top Running Bridge, Multiple Girder)*. New York, New York: American Society of Mechanical Engineers. TIC: 257672.

ASTM C 1572-04. 2004. *Standard Guide for Dry Lead Glass and Oil-Filled Lead Glass Radiation Shielding Window Components for Remotely Operated Facilities*. West Conshohocken, Pennsylvania: American Society for Testing and Materials. TIC: 256821.

NFPA 801. 2003. *Standard for Fire Protection for Facilities Handling Radioactive Materials*. 2003 Edition. Quincy, Massachusetts: National Fire Protection Association. TIC: 254811.

NRC (U.S. Nuclear Regulatory Commission) 1980. *Control of Heavy Loads at Nuclear Power Plants*. NUREG-0612. Washington, D.C.: U.S. Nuclear Regulatory Commission. TIC: 209017.

NRC 1997. *Standard Review Plan for Dry Cask Storage Systems*. NUREG-1536. Washington, D.C.: U.S. Nuclear Regulatory Commission. ACC: MOL.20010724.0307.

Regulatory Guide 1.140, Rev. 2. 2001. *Design, Inspection, and Testing Criteria for Air Filtration and Adsorption Units of Normal Atmosphere Cleanup Systems in Light-Water-Cooled Nuclear Power Plants*. Washington, D.C.: U.S. Nuclear Regulatory Commission. ACC: MOL.20050516.0416.

Regulatory Guide 1.143, Rev. 2. 2001. *Design Guidance for Radioactive Waste Management Systems, Structures, and Components Installed in Light-Water-Cooled Nuclear Power Plants*. Washington, D.C.: U.S. Nuclear Regulatory Commission. ACC: MOL.20050516.0258.

SMACNA (Sheet Metal and Air Conditioning Contractors' National Association) 1995. *HVAC Duct Construction Standards—Metal and Flexible*. 2nd Edition. Chantilly, Virginia: Sheet Metal and Air Conditioning Contractors' National Association. TIC: 232331.

UL 900. 2004. *Air Filter Units*. 7th Edition. Northbrook, Illinois: Underwriters Laboratories. TIC: 258760.

INTENTIONALLY LEFT BLANK

Table 1.2.4-1. Description of Non-ITS Mechanical Handling Structures, Systems, or Components Used in the CRCF, Which Are Also Used in Other Handling Facilities

Non-ITS Mechanical Handling SSCs in the CRCF, Which Are Also Used in Other Handling Facilities	Summary Description
Nuclear Facilities Grapple Stands	The nuclear facilities grapple stands provide a laydown area for grapples. This equipment is designed using the methods and practices provided in <i>Manual of Steel Construction, Allowable Stress Design</i> (AISC 1997). The mechanical equipment envelope for a typical grapple stand is shown in Figure 1.2.4-125 .
Equipment Stands	The equipment stands are used in the IHF, CRCF, WHF, and RF to store equipment when not in use. This equipment is designed using the methods and practices provided in <i>Manual of Steel Construction, Allowable Stress Design</i> (AISC 1997). Refer to Figure 1.2.4-126 and Table 1.2.4-5 .
Mobile Access Platform	The mobile access platform is used for personnel access with tools to the transportation cask while on conveyance for cask preparation around the railcar or truck. The mobile access platform is a steel structure located in the cask handling area. The platform provides four working levels for personnel to access the cask transfer trolley. The platform is split down the center to allow passage of the cask transfer trolley to the cask transfer room. The top two levels of the platform have articulating walkways between the two sections. Each level of the platform is accessed by stairs. The top level of the platform provides access to the canister transfer machine operating deck. This equipment is designed using the methods and practices provided in <i>Manual of Steel Construction, Allowable Stress Design</i> (AISC 1997). For details of this equipment, refer to Figures 1.2.4-127 and 1.2.4-128 . This equipment is used in the IHF, CRCF, WHF, and RF.
Waste Package Pallet Yoke	The waste package pallet yoke is located in the waste package loadout room and used by the waste package handling crane to lift and move the empty waste package and pallet assemblies in the waste package loadout room. The waste package pallet yoke has eight lifting arms. The four inner arms are for the shorter pallet and the four outer arms are for the longer pallet. The pallet yoke lifting arms have lifting lugs that rotate to engage the pallet for lifting operations. The pallet yoke, in concert with the waste package handling crane, delivers the waste package and pallet to the waste package transfer carriage. This equipment is designed using the methods and practices provided in ASME B30.20-2003 and <i>Manual of Steel Construction, Allowable Stress Design</i> (AISC 1997). For details of this equipment, refer to Figures 1.2.4-129 and 1.2.4-130 . This equipment is used in the IHF and CRCF.
Waste Package Pallet Yoke Stand	The waste package pallet yoke stand is a structural frame used to hold and store the waste package pallet yoke when not in use. The stand is normally stored in the Warehouse and Non-Nuclear Receipt Facility and is brought in by truck when the waste package pallet yoke is loaded into or out of the stand. This equipment is designed using the methods and practices provided in <i>Manual of Steel Construction, Allowable Stress Design</i> (AISC 1997). This equipment is shown in Figure 1.2.4-131 . This equipment is used in the IHF and CRCF.

Table 1.2.4-1. Description of Non-ITS Mechanical Handling Structures, Systems, or Components Used in the CRCF, Which Are Also Used in Other Handling Facilities (Continued)

Non-ITS Mechanical Handling SSCs in the CRCF, Which Are Also Used in Other Handling Facilities	Summary Description
Waste Package Closure Room Crane	The waste package closure room crane is located above the waste package closure room and the waste package closure support room for material handling and maintenance operations. The waste package closure room crane is a top running, double girder type crane with the main hoist rated at 15 tons. This equipment is designed using the methods and practices provided in ASME NOG-1-2004 for a Type III crane. For details of this equipment, refer to Figures 1.2.4-78 and 1.2.4-79 . This equipment is used in the IHF and CRCF.
Canister Transfer Machine Maintenance Crane	The canister transfer machine maintenance crane is an overhead crane rated at 15-ton capacity located in the canister transfer room. The canister transfer machine maintenance crane is mounted above the canister transfer machine. The crane lifts waste package shield plugs and supports canister transfer machine maintenance when required. The crane is also used to lift miscellaneous fixtures and items in support of canister transfer activities. This equipment is designed using the methods and practices provided in ASME NOG-1-2004 for a Type II crane. For details of this equipment, refer to Figures 1.2.4-132 and 1.2.4-133 . This equipment is used in the IHF, CRCF, WHF, and RF.
Impact Limiter Lifting Device	The function of the impact limiter lifting device is to minimize worker exposure due to installation time. Removable engineering structures fastened to either end of a transportation cask, certified by the U.S. Nuclear Regulatory Commission, reduce the structural loads on a cask body that would result from a severe transportation accident. Typical impact limiters are removed from the cask during handling or loading and are fastened in place on the cask prior to transportation. This equipment is designed using the methods and practices provided in ASME B30.20-2003 and <i>Manual of Steel Construction, Allowable Stress Design</i> (AISC 1997). For details of this equipment, refer to Figure 1.2.4-42 . This equipment is used in the IHF, CRCF, WHF, and RF.
Cask Handling Yoke Stand	The cask handling yoke stand is a structural frame used to hold and store the cask handling yoke when not in use. The stand is normally staged within the Warehouse and Non-Nuclear Receipt Facility and brought in by truck before the cask handling yoke is loaded into the stand. This equipment is designed using the methods and practices provided in <i>Manual of Steel Construction, Allowable Stress Design</i> (AISC 1997). For details of this equipment, refer to Figure 1.2.4-134 . This equipment is used in the CRCF, IHF, and RF.
Waste Package Shield Ring Lift Beam	The waste package shield ring lift beam is used to install and remove the waste package shield ring from the waste package transfer trolley while the shielded enclosure is in the vertical position. The beam is a framework with four bottom hooks that mate with the four trunnions on the side of each waste package shield ring. The beam is used in conjunction with the waste package handling crane. This equipment is designed using the methods and practices provided in <i>Manual of Steel Construction, Allowable Stress Design</i> (AISC 1997). For details of this equipment, refer to Figure 1.2.4-135 . This equipment is used in the IHF and CRCF.
Waste Package Shield Ring Lift Beam Stand	The waste package shield ring lift beam stand holds and stores the waste package shield ring lift beam when not in use. This equipment is designed using the methods and practices provided in the <i>Manual of Steel Construction, Allowable Stress Design</i> (AISC 1997). For details of this equipment, refer to Figure 1.2.4-136 . This equipment is used in the IHF and CRCF.

Table 1.2.4-1. Description of Non-ITS Mechanical Handling Structures, Systems, or Components Used in the CRCF, Which Are Also Used in Other Handling Facilities (Continued)

Non-ITS Mechanical Handling SSCs in the CRCF, Which Are Also Used in Other Handling Facilities	Summary Description
Waste Package Transfer Carriage Docking Station	<p>The waste package transfer carriage docking stations are located in the waste package loadout room. Each docking station provides an elevated surface for the waste package transfer carriage to transverse from the shielded enclosure of the waste package transfer trolley to the TEV.</p> <p>The waste package transfer carriage runs in a trough in the loadout dock. The depth of the trough is equal to the height of the carriage, delivering the waste package and pallet at floor level. This accommodates the lifting feature of the TEV. The carriage is pulled by a screw and bracket mechanism. The mechanism runs in a trench in the loadout dock. The bracket makes contact with the retrieval arm of the carriage as the shielded enclosure is rotated down into its horizontal position. As the screw turns, it moves the bracket along its length, thus pulling the carriage.</p> <p>Actuation of the mechanism automatically removes power from the waste package transfer trolley, preventing the trolley from any motion during transfer of a loaded waste package from the trolley to the TEV.</p> <p>The carriage transfer assembly is controlled from the facility operations room. Position indication of the carriage and motor amperage is provided to the operators in the facility operations room.</p> <p>A lockdown mechanism is located in the face of the docking station to interface with the waste package transfer trolley. The lockdown mechanism consists of two locking arms, which rotate up and down. The locking arms interface with corresponding brackets on the waste package transfer trolley. The locking arms are moved up and down by electric actuators. The arms are interlocked in the closed position until the waste package transfer trolley shielded enclosure is fully moved into the vertical position. The lockdown mechanism is controlled from the facility operations room. This equipment is designed using the methods and practices provided in <i>Manual of Steel Construction, Allowable Stress Design</i> (AISC 1997). For details of this equipment, refer to Figures 1.2.4-137 and 1.2.4-138. The waste package transfer carriage docking station is used in the IHF and CRCF.</p>
Waste Package Transfer Carriage	<p>The waste package transfer carriage works with the waste package transfer trolley and the waste package transfer carriage docking station to move unloaded waste packages into the trolley and loaded waste packages out of the trolley and into the TEV. The carriage is a steel plate with rollers on the bottom. A retrieval arm on the front of the carriage rests in a gap in the waste package transfer trolley shielded enclosure when riding in the trolley and interacts with the carriage transfer assembly of the waste package transfer carriage docking station. Cam followers on the bottom of the carriage interact with runners in the waste package transfer carriage docking station to guide the carriage as it travels in the docking station trench. This equipment is designed using the methods and practices provided in <i>Manual of Steel Construction, Allowable Stress Design</i> (AISC 1997). For details of this equipment, refer to Figure 1.2.4-138. The waste package transfer carriage is used in the IHF and CRCF.</p>

Table 1.2.4-1. Description of Non-ITS Mechanical Handling Structures, Systems, or Components Used in the CRCF, Which Are Also Used in Other Handling Facilities (Continued)

Non-ITS Mechanical Handling SSCs in the CRCF, Which Are Also Used in Other Handling Facilities	Summary Description
Loadout Platforms	The CRCF loadout platforms are steel structures located in the waste package loadout room. The platforms provide a single operating level for operators to access the top of the waste package transfer trolley shielded enclosure when the trolley shielded closure is in the vertical position. Sections of the platforms nearest the waste package transfer trolley are moveable to allow maintenance access to the gear mechanisms on the waste package transfer trolley by the waste package handling crane. This equipment is designed using the methods and practices provided in <i>Manual of Steel Construction, Allowable Stress Design</i> (AISC 1997). For details of this equipment, refer to Figures 1.2.4-139 and 1.2.4-140 . This equipment is used in the IHF and CRCF.
Process Opening Cover	The process opening cover is used to cover the opening in the waste package closure room when maintenance is being performed within the room. This equipment is designed using the methods and practices provided in <i>Manual of Steel Construction, Allowable Stress Design</i> (AISC 1997). The process opening cover is used in the IHF and CRCF.
Cask Tilting Frame	This equipment is only used with certain transportation casks. The cask tilting frame is used to upend certain transportation casks from a horizontal position to a vertical position. The cask tilting frame has the capacity to upend certain loaded rail cask and is pre-staged in the cask preparation area as required. The cask tilting frame rotates certain transportation casks, which are either loaded with a DPC or are unloaded. This equipment is designed using the methods and practices provided in <i>Manual of Steel Construction, Allowable Stress Design</i> (AISC 1997). For details of this equipment, refer to Figure 1.2.4-141 . The cask tilting frame is used in the CRCF, WHF, and RF.
Truck Cask Lid Adapter	The truck cask lid adapter is engaged by the canister transfer machine canister grapple to remove the lids of transportation casks. This equipment is designed using the methods and practices provided in ANSI N14.6-1993. For details of this equipment, refer to Figure 1.2.4-142 . Truck cask lid adapters are used in the IHF, CRCF, and WHF.
Horizontal Cask Stand	The cask stand is a structural steel frame used to support certain transportation casks while the impact limiters are removed or trunnions are installed. The cask stand is pre-staged in the cask preparation area as required. This equipment is designed using the methods and practices provided in <i>Manual of Steel Construction, Allowable Stress Design</i> (AISC 1997). For details of this equipment, refer to Figure 1.2.4-143 . This equipment is used by the CRCF, WHF, and RF.
Horizontal Lifting Beam Stand	The function of this equipment is to support, stage, and secure the horizontal lifting beam. This equipment is designed so that it can be handled with a forklift or overhead crane with standard rigging. This equipment is designed using the methods and practices provided in <i>Manual of Steel Construction, Allowable Stress Design</i> (AISC 1997). This equipment is shown in Figure 1.2.4-144 . This equipment is located in the cask preparation room and is shared by the CRCF, WHF, and RF.
Remote Handling System (except for bridge)	The equipment is described in Section 1.2.4.2.3 . For details of this equipment, see Figure 1.2.4-77 .

Table 1.2.4-1. Description of Non-ITS Mechanical Handling Structures, Systems, or Components Used in the CRCF, Which Are Also Used in Other Handling Facilities (Continued)

Non-ITS Mechanical Handling SSCs in the CRCF, Which Are Also Used in Other Handling Facilities	Summary Description
Mobile Lift	The mobile lift provides personnel access to casks on a railcar, horizontal cask stand, and tilt frame during cask operations. The mobile lift is electric powered and omnidirectional. This equipment is designed using the methods and practices provided in <i>Manual of Steel Construction, Allowable Stress Design</i> (AISC 1997). This equipment is shown in Figure 1.2.4-145 . This equipment is used in the cask preparation room for the CRCF, RF, and WHF.

Table 1.2.4-2. CRCF-Specific Non-ITS Structures, Systems, and Components in the Mechanical Handling System

CRCF-Specific Non-ITS SSCs in the Mechanical Handling System	Summary Description
Closure Transfer Cart	Section 1.2.4.2.3 provides the description of the closure transfer cart. This equipment is designed following the methods and practices in <i>Manual of Steel Construction, Allowable Stress Design</i> (AISC 1997). This equipment is used in the CRCF.
Waste Package Closure Support Room Crane	The closure support room crane is used for maintenance operations as an overhead crane at the north and south areas of the closure support room. This crane is also used for the movement of non-waste-associated materials within the closure support room. Controls and monitoring of the closure support room crane operation are local to the equipment. A retractable traveling pendant is provided for controlling the closure support room crane operation. The closure support room crane can be stopped and restored to normal operation using the pendant switches. This equipment is designed using the methods and practices provided in ASME NOG-1-2004 for a Type III crane. For details of this equipment, refer to Figures 1.2.4-78 through 1.2.4-80. This equipment is used in the CRCF.
Personnel Confinement Single Door	The personnel confinement single doors provide personnel access to various confinement areas. The personnel confinement single doors are hinged on one side for a swing-open operation. The doors are manually opened with an automatic close mechanism. The personnel confinement single doors are close fitting to provide confinement. The personnel confinement doors are not interlocked with other equipment. The personnel confinement doors, by virtue of their small size, cannot impair the ability of the HVAC system to perform its safety function and are classified as non-ITS. The opening and closing of the personnel confinement doors may cause small pressure fluctuations, but the air flow is in the correct direction. This equipment is used in the CRCF, WHF, and RF. This equipment is designed using the methods and practices provided in <i>Manual of Steel Construction, Allowable Stress Design</i> (AISC 1997). For details of this equipment, refer to Figure 1.2.4-146.
Shield Windows	The CRCF shield windows are designed for different sections of the facility and include the waste package loadout room observation shield windows, waste package closure room observation shield windows, and transfer room observation shield windows. The shield windows support facility operations and protect personnel from radiation. The shield windows are designed using the methods and practices of ASTM C 1572-04 2004. The CRCF shield window is shown in Figure 1.2.4-147.

Table 1.2.4-3. Summary-Level Description of Equipment and Personnel Shield Doors

Door Type	Facility	Room Name	Door Type						Door Description
			Single Slide	Dual Slide	Dual Hinged	Floor Plates	Shield Bar	Personnel	
1	CRCF	Cask Unloading Room—North	X			X			The Type 1 door is a single slide panel, and is operated by an electric motor turning a screw, which interacts with a door-mounted bracket. Hinged floor plates cover the door channel as the door moves open, to allow smooth transition for the cask transfer trolley as it travels through the doorway.
		Cask Unloading Room—South	X			X			
	IHF	Cask Unloading Room	X			X			
	WHF	Cask Unloading Room	X			X			
2	IHF	Waste Package Loadout Room		X					The Type 2 door has dual slide panels. Each door is operated by an electric motor turning a screw, which interacts with a door-mounted bracket.
	RF	Loading Room		X					
3	IHF	Waste Package Positioning Room			X (2 doors)		X (2 doors)		The Type 3 door has dual hinged panels, which swing open. Each door is operated by an electric motor. A shield bar on the face of each door is actuated when the door is closed to seal the gap on the bottom of the door to prevent radiation shine.

Table 1.2.4-3. Summary-Level Description of Equipment and Personnel Shield Doors (Continued)

Door Type	Facility	Room Name	Door Type						Door Description
			Single Slide	Dual Slide	Dual Hinged	Floor Plates	Shield Bar	Personnel	
4	CRCF	Waste Package Positioning Room—North	X						The Type 4 door is a single slide panel, and is operated by an electric motor turning a screw, which interacts with a door-mounted bracket.
		Waste Package Positioning Room—South	X						
		Waste Package Loadout Room	X (2 doors)						
	WHF	Site Transporter Vestibule	X						
5	RF	Cask Unloading Room		X		X			The Type 5 door has dual slide panels. Each door is operated by an electric motor turning a screw, which interacts with a door-mounted bracket. Hinged floor plates cover the door channel as the door moves open, to allow smooth transition for the cask transfer trolley as it travels through the doorway.
Personnel Doors	CRCF	Waste Package Loadout Room						X (3 doors)	The personnel shield doors are manually operated swing doors that allow personnel access to and from the waste package loadout rooms in CRCF and IHF.
	IHF	Waste Package Loadout Room						X (2 doors)	

Table 1.2.4-4. Preclosure Nuclear Safety Design Bases and their Relationship to Design Criteria for the CRCF

System or Facility (System Code)	Subsystem or Function (as Applicable)	Component	Nuclear Safety Design Bases		Design Criteria
			Safety Function	Controlling Parameters and Values	
Canister Receipt and Closure Facility (CR)	Canister Receipt and Closure Facility (CRCF)	Structure	Maintain building structural integrity to protect ITS SSCs inside the building from external events	CR.01. The mean frequency of building collapse due to winds less than or equal to 120 mph shall not exceed 1×10^{-6} per year.	Structure is required to be designed to meet the wind and ash loads described in Table 1.2.2-1 .
				CR.02. The mean frequency of building collapse due to volcanic ash fall less than or equal to a roof load of 21 lb/ft ² shall not exceed 1×10^{-6} per year.	Structure is required to be designed to meet the wind and ash loads described in Table 1.2.2-1 .
				CR.03. The CRCF shall be located such that there is a distance of at least one-half mile between the CRCF and the repository heliport.	The heliport is located at least 1/2 mi from any ITS structure.
			Protect against building collapse onto waste container	CR.04. The mean frequency of collapse of CRCF structure due to the spectrum of seismic events shall be less than or equal to 2×10^{-6} per year.	Fragility assessment of building collapse is performed to develop the fragility curve for the structure. Convolution of the structure fragility curve and seismic hazard curve (as described in Section 1.7) is performed to demonstrate compliance.
		Rails for the Transport and Emplacement Vehicle (TEV) (Inside the Waste Package Loadout Room)	Protect against derailment of the TEV during loading of a waste package	CR.05. The mean frequency of the TEV derailment due to failure of the TEV rail system (at the loadout station) due to the spectrum of seismic events shall be less than or equal to 1×10^{-4} per year.	The TEV is required to be designed in accordance with the requirements of ASME NOG-1-2004 for Type I cranes. The TEV and rails at the loadout station are required to be designed to prevent the TEV from derailing during a DBG-2 seismic event.

Table 1.2.4-4. Preclosure Nuclear Safety Design Bases and their Relationship to Design Criteria for the CRCF (Continued)

System or Facility (System Code)	Subsystem or Function (as Applicable)	Component	Nuclear Safety Design Bases		Design Criteria
			Safety Function	Controlling Parameters and Values	
Canister Receipt and Closure Facility (CR) (Continued)	Canister Receipt and Closure Facility (CRCF) (Continued)	Shield Doors (Including Anchorages) and Equipment Confinement Doors	Protect against direct exposure of personnel	CR.06. Equipment and personnel shield doors shall have a mean probability of inadvertent opening of less than or equal to 1×10^{-7} per waste container handled.	Equipment shield doors are required to be interlocked to prevent them from opening when associated equipment and personnel shield doors or transfer port slide gates that have a complementary shielding function are not closed. Equipment shield doors and personnel access doors associated with personnel shield doors at exits from the waste package loadout room are required to be interlocked with a radiation monitor to prevent inadvertent opening during waste package loadout operations.
			Preclude collapse onto waste containers	CR.07. An equipment shield door falling onto a waste container as a result of impact from a conveyance shall be precluded.	Equipment shield doors are required to be designed in accordance with the applicable provisions of ANSI/AISC N690-1994. Equipment shield doors are required to be designed to not collapse following an impact from a conveyance at its design speed.
			Mitigate the consequences of radionuclide release	CR.08. The mean probability that the HVAC system in the CRCF confinement areas becomes unavailable (during a 30-day mission time following a radionuclide release) due to the simultaneous opening of an equipment confinement door and a cask unloading room shield door shall be less than or equal to 3×10^{-7} .	Equipment confinement doors and equipment shield doors with a confinement function are required to be designed with interlocks to prevent them from opening when associated equipment doors that have a complementary confinement function are not closed
			Protect against equipment shield door collapse onto a waste container	CR.09. The mean frequency of collapse of equipment shield doors (including attachment of door to wall and frame anchorages) due to the spectrum of seismic event shall be less than or equal to 6×10^{-6} per year.	Equipment shield doors are required to be designed in accordance with the applicable provisions of ANSI/AISC N690-1994 for loads and accelerations associated with a DBGM-2 seismic event. Additional structural capacity is provided as required to demonstrate compliance.

Table 1.2.4-4. Preclosure Nuclear Safety Design Bases and their Relationship to Design Criteria for the CRCF (Continued)

System or Facility (System Code)	Subsystem or Function (as Applicable)	Component	Nuclear Safety Design Bases		Design Criteria
			Safety Function	Controlling Parameters and Values	
Canister Receipt and Closure Facility (CR) (Continued)	Canister Receipt and Closure Facility (CRCF) (Continued)	DOE Canister Slide Gates (060-HTC0-HTCH-00005/00006/00007/00008/00009)	Protect against dropping a canister due to a spurious closure of the slide gate	CR.HTC.01. The mean probability of a canister drop resulting from a spurious closure of the slide gate shall be less than or equal to 2×10^{-6} per transfer.	The slide gates are required to be power-limited such that the maximum slide gate closing force is insufficient to sever the hoisting ropes.
			Protect against direct exposure to personnel	CR.HTC.02. The mean probability of occurrence of an inadvertent opening of a slide gate shall be less than or equal to 4×10^{-9} per transfer.	Each slide gate is required to be interlocked to prevent it from opening unless a canister transfer machine is present above it with its shield skirt lowered.
			Preclude canister breach	CR.HTC.03. Closure of the slide gate shall be incapable of breaching a canister.	The slide gates are required to be power-limited such that the maximum slide gate closing force is insufficient to breach a canister.
		Cask Port Slide Gates (060-HTC0-HTCH-00001/00002)	Protect against dropping a canister due to a spurious closure of the slide gate	CR.HTC.04. The mean probability of a canister drop resulting from a spurious closure of the slide gate shall be less than or equal to 2×10^{-6} per transfer.	The slide gates are required to be power-limited such that the maximum slide gate closing force is insufficient to sever the hoisting ropes.
			Protect against direct exposure to personnel	CR.HTC.05. The mean probability of occurrence of an inadvertent opening of a slide gate shall be less than or equal to 4×10^{-9} per transfer.	Slide gates are required to be interlocked to prevent them from opening when associated equipment shield doors that have a complementary shielding function are not closed. Each slide gate is required to be interlocked to prevent it from opening unless a canister transfer machine is present above it with its shield skirt lowered.
			Preclude canister breach	CR.HTC.06. Closure of the slide gate shall be incapable of breaching a canister.	The slide gates are required to be power-limited such that the maximum slide gate closing force is insufficient to breach the canister.

Table 1.2.4-4. Preclosure Nuclear Safety Design Bases and their Relationship to Design Criteria for the CRCF (Continued)

System or Facility (System Code)	Subsystem or Function (as Applicable)	Component	Nuclear Safety Design Bases		Design Criteria
			Safety Function	Controlling Parameters and Values	
Canister Receipt and Closure Facility (CR) (Continued)	Canister Receipt and Closure Facility (CRCF) (Continued)	TAD Slide Gates (060-HTC0-HTCH-00010/00011)	Protect against dropping a canister due to a spurious closure of the slide gate	CR.HTC.07. The mean probability of a canister drop resulting from a spurious closure of the slide gate shall be less than or equal to 2×10^{-6} per transfer.	The slide gates are required to be power-limited such that the maximum slide gate closing force is insufficient to sever the hoisting ropes.
			Protect against direct exposure to personnel	CR.HTC.08. The mean probability of occurrence of an inadvertent opening of a slide gate shall be less than or equal to 4×10^{-9} per transfer.	Each slide gate is required to be interlocked to prevent it from opening unless a canister transfer machine is present above it with its shield skirt lowered.
			Preclude canister breach	CR.HTC.09. Closure of the slide gate shall be incapable of breaching a canister.	The slide gates are required to be power-limited such that the maximum slide gate closing force is insufficient to breach the canister.
		Waste Package Port Slide Gates (060-HTC0-HTCH-00003/00004)	Protect against dropping a canister due to a spurious closure of the slide gate	CR.HTC.10. The mean probability of a canister drop resulting from a spurious closure of the slide gate shall be less than or equal to 2×10^{-6} per transfer.	The slide gates are required to be power-limited such that the maximum slide gate closing force is insufficient to sever the hoisting ropes.
			Protect against direct exposure to personnel	CR.HTC.11. The mean probability of occurrence of an inadvertent opening of a slide gate shall be less than or equal to 4×10^{-9} per transfer.	Slide gates are required to be interlocked to prevent them from opening when associated equipment shield doors that have a complementary shielding function are not closed. Each slide gate is required to be interlocked to prevent it from opening unless a canister transfer machine is present above it with its shield skirt lowered.
			Preclude canister breach	CR.HTC.12. Closure of the slide gate shall be incapable of breaching a canister.	The slide gates are required to be power-limited such that the maximum slide gate closing force is insufficient to breach a canister.
			Preclude canister drop onto floor	CR.HTC.13. The waste package port slide gate shall be incapable of opening without a waste package transfer trolley with waste package in position to receive a canister.	The waste package port slide gate is required to be designed with an interlock to prevent opening of the waste package port slide gate when the waste package transfer trolley with waste package is not correctly positioned below the port.

Table 1.2.4-4. Preclosure Nuclear Safety Design Bases and their Relationship to Design Criteria for the CRCF (Continued)

System or Facility (System Code)	Subsystem or Function (as Applicable)	Component	Nuclear Safety Design Bases		Design Criteria
			Safety Function	Controlling Parameters and Values	
Canister Receipt and Closure Facility (CR) (Continued)	Canister Receipt and Closure Facility (CRCF) (Continued)	Cask Preparation Platform (060-HMH0-PLAT-00001)	Protect against platform collapse	CR.HMH.01. The mean frequency of collapse of the cask preparation platform due to the spectrum of seismic events shall be less than or equal to 3×10^{-6} per year.	The platform is required to be designed in accordance with the applicable provisions of ANSI/AISC N690-1994 for loads and accelerations associated with a DBGM-2 seismic event. Additional structural capacity is provided as required to demonstrate compliance.
			Protect against platform collapse or waste container breach due to an impact from the cask transfer trolley or site transporter	CR.HMH.02. The mean frequency of platform collapse or waste container breach from the impact of the cask transfer trolley or site transporter into the platform due to the spectrum of seismic events shall be less than or equal to 2×10^{-5} per year.	The platform is required to be designed in accordance with the applicable provisions of ANSI/AISC N690-1994 for loads and accelerations associated with a DBGM-2 seismic event. Additional structural capacity is provided as required to preclude platform collapse. Energy absorbing features are required as necessary to limit impact forces on the waste container.
Mechanical Handling System (H)	Cask Handling	Cask Handling Yoke (060-HM00-BEAM-00001)	Protect against drop	H.CR.HM.01. The cask handling yoke is an integral part of the load-bearing path. See cask handling crane requirements.	The special lifting device/adaptor is required to be designed in accordance with the requirements of ANSI N14.6-1993, as modified by NUREG-0612 (NRC 1980), Section 5.1.1(4). Special lifting devices are required to have an interlock to prevent special lifting device actuation if the special lifting device is not properly connected to the hoisting system and an interlock to prevent hoist motion if the special lifting device is not either fully engaged or fully disengaged. Special lifting devices/adapters are required to be designed for loads and accelerations associated with a DBGM-2 seismic event.
		Cask Handling Crane; 200-ton (060-HM00-CRN-00001)	Protect against drop	H.CR.HM.02. The mean probability of dropping a loaded cask from less than the two-block height resulting from the failure of a piece of equipment within the load path shall be less than or equal to 3×10^{-5} per transfer with the cask yoke or 1×10^{-4} per transfer with a sling.	The crane is required to be designed in accordance with the requirements of ASME NOG-1-2004 for Type I cranes.

Table 1.2.4-4. Preclosure Nuclear Safety Design Bases and their Relationship to Design Criteria for the CRCF (Continued)

System or Facility (System Code)	Subsystem or Function (as Applicable)	Component	Nuclear Safety Design Bases		Design Criteria
			Safety Function	Controlling Parameters and Values	
Mechanical Handling System (H) (Continued)	Cask Handling (Continued)	Cask Handling Crane; 200-ton (060-HM00-CRN-00001) (Continued)	Protect against drop	H.CR.HM.03. The mean probability of dropping a loaded cask from a two-block height resulting from the failure of a piece of equipment within the load-bearing path shall be less than or equal to 4×10^{-7} per transfer.	The crane is required to be designed in accordance with the requirements of ASME NOG-1-2004 for Type I cranes.
			Limit drop height	H.CR.HM.04. The two-block drop height shall not exceed 30 ft from bottom of shortest cask to the floor.	The crane, in conjunction with the special lifting device, is required to be designed such that the bottom of any cask cannot be more than 30 ft above the floor with the crane hoisting system in a two-block condition.
			Protect against drop of a load onto a cask	H.CR.HM.05. The mean probability of dropping a load onto a loaded cask or its contents shall be less than or equal to 4×10^{-5} per cask handled.	The crane is required to be designed in accordance with the requirements of ASME NOG-1-2004 for Type I cranes.
			Maintain moderator control	H.CR.HM.06. The mean probability of inadvertent introduction of an oil moderator into a canister shall be less than or equal to 9×10^{-5} over a 720-hour period following a radioactive release.	The crane is required to be designed in accordance with the requirements of ASME NOG-1-2004 for Type I cranes. The crane is required to have double retention capability on the areas of the crane where leaked lubricating oil could enter a breached canister.
			Limit speed	H.CR.HM.07. The speed of the trolley and bridge shall be limited to 20 ft/min.	The trolley and bridge are required to be designed to preclude speeds greater than 20 ft/min.
			Protect against crane collapse onto a waste container	H.CR.HM.08. The mean frequency of collapse of the cask handling crane due to the spectrum of seismic events shall be less than or equal to 8×10^{-6} per year.	The crane is required to be designed in accordance with the requirements of ASME NOG-1-2004 for Type I cranes, for loads and accelerations associated with a DBGM-2 seismic event. Additional structural capacity is provided as required to demonstrate compliance.

Table 1.2.4-4. Preclosure Nuclear Safety Design Bases and their Relationship to Design Criteria for the CRCF (Continued)

System or Facility (System Code)	Subsystem or Function (as Applicable)	Component	Nuclear Safety Design Bases		Design Criteria
			Safety Function	Controlling Parameters and Values	
Mechanical Handling System (H) (Continued)	Cask Handling (Continued)	Cask Handling Crane; 200-ton (060-HM00-CRN-00001) (Continued)	Protect against a cask or heavy object drop from the crane	H.CR.HM.09. The mean frequency of a hoist system failure of the cask handling crane due to the spectrum of seismic events shall be less than or equal to 2×10^{-5} per year.	The crane is required to be designed in accordance with the requirements of ASME NOG-1-2004 for Type I cranes, for loads and accelerations associated with a DBGM-2 seismic event.
		Cask Transfer Trolley and Pedestals Trolleys: (060-HM00-TRLY-00001/00002) Pedestals: (060-HM00-PED-00001/00002)	Limit speed	H.CR.HM.10. The speed of the cask transfer trolley shall be limited to 2.5 mph.	The cask transfer trolley is required to be designed to preclude speed greater than 2.5 mph.
			Protect against spurious movement	H.CR.HM.11. The mean probability of spurious movement of the cask transfer trolley while a canister is being lifted by the canister transfer machine shall be less than or equal to 1×10^{-9} per transfer.	The cask transfer trolley is required to be designed such that its pneumatic power supply must be disconnected for the cask unloading room equipment shield door to be closed.
			Protect against impact and inducing stresses on the waste container	H.CR.HM.12. The mean frequency of the sliding of the cask transfer trolley into a wall and inducing stresses that can breach the waste container due to the spectrum of seismic events shall be less than or equal to 1×10^{-6} per year.	Operating clearance and energy-absorbing features are required to be provided to minimize the likelihood of seismic-induced sliding impact and control impact loads as needed.
				H.CR.HM.13. The mean frequency of a rocking impact of the cask transfer trolley into a wall and inducing stresses that can breach the waste container due to the spectrum of seismic events shall be less than or equal to 1×10^{-6} per year.	Operating clearance and energy-absorbing features are required to be provided to minimize the likelihood of seismic-induced rocking impact and control impact loads as needed.

Table 1.2.4-4. Preclosure Nuclear Safety Design Bases and their Relationship to Design Criteria for the CRCF (Continued)

System or Facility (System Code)	Subsystem or Function (as Applicable)	Component	Nuclear Safety Design Bases		Design Criteria
			Safety Function	Controlling Parameters and Values	
Mechanical Handling System (H) (Continued)	Cask Handling/Cask Receipt	Horizontal Lifting Beam (200-HMC0-BEAM-00001) (shared with RF)	Protect against drop	H.CR.HMC.01 The horizontal lifting beam is an integral part of the load-bearing path. See cask handling crane requirements.	The special lifting device/adaptor is required to be designed in accordance with the requirements of ANSI N14.6-1993, as modified by NUREG-0612 (NRC 1980), Section 5.1.1(4). Special lifting devices/adapters are required to be designed for loads and accelerations associated with a DBGM-2 seismic event.
	Cask Handling/Cask Preparation	Cask Lid Lifting Grapples (060-HMH0-HEQ-00012)	Protect against drop of a load onto a canister	H.CR.HMH.01. The cask lid lifting grapple is an integral part of the load-bearing path. See cask handling crane requirements.	The special lifting device/adaptor is required to be designed in accordance with the requirements of ANSI N14.6-1993, as modified by NUREG-0612 (NRC 1980), Section 5.1.1(4). Special lifting devices are required to have an interlock to prevent special lifting device actuation if the special lifting device is not properly connected to the hoisting system and an interlock to prevent hoist motion if the special lifting device is not either fully engaged or fully disengaged. Special lifting devices/adapters are required to be designed for loads and accelerations associated with a DBGM-2 seismic event.
		DPC Lid Adapter (060-HMH0-HEQ-00005/00006)	Protect against drop of a DPC	H.CR.HMH.02. The DPC lid adapter is an integral part of the load-bearing path. See canister transfer machine requirements.	The special lifting device/adaptor is required to be designed in accordance with the requirements of ANSI N14.6-1993, as modified by NUREG-0612 (NRC 1980), Section 5.1.1(4). Special lifting devices/adapters are required to be designed for loads and accelerations associated with a DBGM-2 seismic event.

Table 1.2.4-4. Preclosure Nuclear Safety Design Bases and their Relationship to Design Criteria for the CRCF (Continued)

System or Facility (System Code)	Subsystem or Function (as Applicable)	Component	Nuclear Safety Design Bases		Design Criteria
			Safety Function	Controlling Parameters and Values	
Mechanical Handling System (H) (Continued)	Cask Handling/Cask Preparation (Continued)	Rail Cask Lid Adapters (060-HMH0-HEQ-00003/00004)	Protect against drop	H.CR.HMH.03. The rail cask lid adapter is an integral part of the load-bearing path. See cask handling crane requirements.	The special lifting device/adapter is required to be designed in accordance with the requirements of ANSI N14.6-1993, as modified by NUREG-0612 (NRC 1980), Section 5.1.1(4). Special lifting devices/adapters are required to be designed for loads and accelerations associated with a DBGM-2 seismic event.
	Cask Handling/Waste Package Preparation	Waste Package Handling Crane (060-HMP0-CRN-00001)	Protect against collapse of the waste package handling crane	H.CR.HMP.01. The mean frequency of collapse of the waste package handling crane due to the spectrum of seismic events shall be less than or equal to 8×10^{-6} per year.	The crane is required to be designed in accordance with the requirements of ASME NOG-1-2004 for Type II cranes, for loads and accelerations associated with a DBGM-2 seismic event. Additional structural capacity is provided as required to demonstrate compliance.
	Waste Transfer/Canister Transfer	Canister Transfer Machine (060-HTC0-FHM-00001/00002)	Protect against drop	H.CR.HTC.01. The mean probability of dropping a canister from below the two-block height due to the failure of a piece of equipment within the load-bearing path shall be less than or equal to 1×10^{-5} per transfer for each canister transfer machine.	The canister transfer machine is required to be designed in accordance with the requirements of ASME NOG-1-2004 for Type I cranes. The canister transfer machine is required to be designed with the following features: <ul style="list-style-type: none"> • Two hoist upper limit switches • A hoist adjustable speed drive that stops the hoist at setpoints that are independent from the hoist upper limit switches • A load cell overload limit that stops the hoist • A sensor to stop the hoist when the load clears the canister transfer machine slide gate.

Table 1.2.4-4. Preclosure Nuclear Safety Design Bases and their Relationship to Design Criteria for the CRCF (Continued)

System or Facility (System Code)	Subsystem or Function (as Applicable)	Component	Nuclear Safety Design Bases		Design Criteria
			Safety Function	Controlling Parameters and Values	
Mechanical Handling System (H) (Continued)	Waste Transfer/ Canister Transfer (Continued)	Canister Transfer Machine (060-HTC0-FHM-00001/00002) (Continued)	Protect against drop (Continued)	H.CR.HTC.02. The mean probability of drop of a canister from the two-block height due to the failure of a piece of equipment within the load-bearing path shall be less than or equal to 3×10^{-8} per transfer.	<p>The canister transfer machine is required to be designed in accordance with the requirements of ASME NOG-1-2004 for Type I cranes.</p> <p>The canister transfer machine is required to be designed with the following features:</p> <ul style="list-style-type: none"> • Two hoist upper limit switches • A hoist adjustable speed drive that stops the hoist at setpoints that are independent from the hoist upper limit switches • A load cell overload limit that stops the hoist • A sensor to stop the hoist when the load clears the canister transfer machine slide gate.
			Limit drop height	H.CR.HTC.03. The two-block height shall not exceed 45 ft from the bottom of a canister to the cavity floor of the cask, aging overpack, or waste package.	The canister transfer machine, in conjunction with the special lifting device(s), is required to be designed such that the bottom of any canister cannot be more than 45 ft above the cavity floor of the cask, aging overpack, or waste package with the canister transfer machine hoisting system in a two-block condition.
			Protect against drop of a load onto a canister	H.CR.HTC.04. The mean probability of dropping a load onto a canister shall be less than or equal to 1×10^{-5} per transfer.	<p>The canister transfer machine is required to be designed in accordance with the requirements of ASME NOG-1-2004 for Type I cranes.</p> <p>The canister transfer machine is required to be designed with the following features:</p> <ul style="list-style-type: none"> • Two hoist upper limit switches • A hoist adjustable speed drive that stops the hoist at setpoints that are independent from the hoist upper limit switches • A load cell overload limit that stops the hoist • A sensor to stop the hoist when the load clears the canister transfer machine slide gate.

Table 1.2.4-4. Preclosure Nuclear Safety Design Bases and their Relationship to Design Criteria for the CRCF (Continued)

System or Facility (System Code)	Subsystem or Function (as Applicable)	Component	Nuclear Safety Design Bases		Design Criteria
			Safety Function	Controlling Parameters and Values	
Mechanical Handling System (H) (Continued)	Waste Transfer/ Canister Transfer (Continued)	Canister Transfer Machine (060-HTC0-FHM-00001/00002) (Continued)	Protect against spurious movement	H.CR.HTC.05. The mean probability of a spurious movement of the canister transfer machine while a canister is being lifted or lowered shall be less than or equal to 7×10^{-9} per transfer for each canister transfer machine.	Interlocks are required to be provided to prevent operation of the canister transfer machine bridge and trolley drives unless the canister transfer machine shield skirt is raised, indicating that the canister is clear of the canister transfer machine slide gate. The circuit breakers that provide power to the adjustable speed drives for the bridge and trolley motors are required to have instantaneous over-current protection.
			Limit Speed	H.CR.HTC.06. The speed of the canister transfer machine trolley and bridge shall be limited to 20 ft/min.	The canister transfer machine is required to be designed with a maximum speed limit of the trolley and bridge of 20 ft/min.
			Preclude non-flat bottom drop of a DPC or TAD canister	H.CR.HTC.07. The canister transfer machine shall preclude non-flat-bottom drops of DPCs and TAD canisters.	The canister transfer machine shall be designed with guide features for DPCs and TAD canisters to preclude non-flat bottom drops.
			Protect against direct exposure to personnel	H.CR.HTC.08. The mean probability of inadvertent radiation streaming resulting from the inadvertent opening of the canister transfer machine slide gate, the inadvertent raising of the canister transfer machine shield skirt, or an inadvertent motion of the canister transfer machine away from an open port shall be less than or equal to 9×10^{-6} per transfer.	The canister transfer machine is required to be designed with the following features: <ul style="list-style-type: none"> • Shield skirt–hoist interlock (skirt must be down to permit hoist operation) • Shield skirt–canister transfer machine slide gate interlock (either skirt must be down or gate must be closed) • Shield skirt–port gate interlock (skirt must be down before port gate can be opened). • PSC-13 (Section 1.2.4.2.2.4) addresses closure of the port slide gates at the completion of a canister transfer operation.

Table 1.2.4-4. Preclosure Nuclear Safety Design Bases and their Relationship to Design Criteria for the CRCF (Continued)

System or Facility (System Code)	Subsystem or Function (as Applicable)	Component	Nuclear Safety Design Bases		Design Criteria
			Safety Function	Controlling Parameters and Values	
Mechanical Handling System (H) (Continued)	Waste Transfer/ Canister Transfer (Continued)	Canister Transfer Machine (060-HTC0-FHM-00001/00002) (Continued)	Maintain moderator control	H.CR.HTC.09. The mean probability of inadvertent introduction of an oil moderator into a canister shall be less than or equal to 9×10^{-5} over a 720-hour period following the breach of a canister.	The canister transfer machine is required to be designed in accordance with the requirements of ASME NOG-1-2004 for Type I cranes. The canister transfer machine is required to have double retention capability on areas of the crane where leaked lubricating oil could enter a breached waste canister.
			Preclude canister breach	H.CR.HTC.10. Closure of the canister transfer machine slide gate shall be incapable of breaching a canister.	The canister transfer machine slide gate is required to be power-limited such that the maximum slide gate closing force is insufficient to breach a canister.
			Maintain DOE SNF canister separation	H.CR.HTC.11. The conditional probability of inadvertent placement of more than four DOE standardized canisters in a TAD waste package, TAD staging rack, or aging overpack shall be less than or equal to 3×10^{-6} .	The slide gate is required to be designed with an interlock that allows a canister to be placed in an aging overpack, a TAD waste package, or TAD canister staging rack only if the canister transfer machine is centered with the receptacle.
			Protect against collapse of the canister transfer machine	H.CR.HTC.12. The mean frequency of collapse of the canister transfer machine due to the spectrum of seismic events shall be less than or equal to 1×10^{-5} per year.	The canister transfer machine is required to be designed in accordance with the requirements of ASME NOG-1-2004 for Type I cranes, for loads and accelerations associated with a DBGM-2 seismic event. Additional structural capacity is provided as required to demonstrate compliance.
			Protect against a canister or heavy object drop from the canister transfer machine	H.CR.HTC.13. The mean frequency of a hoist system failure of the canister transfer machine due to the spectrum of seismic events shall be less than or equal to 2×10^{-5} per year.	The canister transfer machine is required to be designed in accordance with the requirements of ASME NOG-1-2004 for Type I cranes, for loads and accelerations associated with a DBGM-2 seismic event.

Table 1.2.4-4. Preclosure Nuclear Safety Design Bases and their Relationship to Design Criteria for the CRCF (Continued)

System or Facility (System Code)	Subsystem or Function (as Applicable)	Component	Nuclear Safety Design Bases		Design Criteria
			Safety Function	Controlling Parameters and Values	
Mechanical Handling System (H) (Continued)	Waste Transfer/ Canister Transfer (Continued)	Canister Grapples (060-HTC0-HEQ-00003/00004/00005/00006/00007) Canister Transfer Machine Grapples (060-HTC0-HEQ-00001/00002)	Protect against drop	H.CR.HTC.14. The canister grapple is an integral part of the load-bearing path. See canister transfer machine requirements.	<p>The special lifting device/adaptor is required to be designed in accordance with the requirements of ANSI N14.6-1993, as modified by NUREG-0612 (NRC 1980), Section 5.1.1(4).</p> <p>The special lifting device is required to have mechanical features that prevent special lifting device disengagement when a load is suspended from the special lifting device.</p> <p>Electrically operated special lifting devices are required to have an interlock to prevent special lifting device actuation if the special lifting device is not properly connected to the hoisting system and an interlock to prevent hoist motion if the special lifting device is not either fully engaged or fully disengaged.</p> <p>For mechanically operated special lifting devices (HLW canisters only) an interlock is required to prevent hoist motion if the special lifting device is not properly connected to the hoisting system or if the special lifting device is not either fully engaged or fully disengaged.</p> <p>Special lifting devices/adapters are required to be designed for loads and accelerations associated with a DBGM-2 seismic event.</p>

Table 1.2.4-4. Preclosure Nuclear Safety Design Bases and their Relationship to Design Criteria for the CRCF (Continued)

System or Facility (System Code)	Subsystem or Function (as Applicable)	Component	Nuclear Safety Design Bases		Design Criteria
			Safety Function	Controlling Parameters and Values	
Mechanical Handling System (H) (Continued)	Waste Transfer/ Canister Transfer (Continued)	Canister Grapples (060-HTC0-HEQ-00003/00004/00005/00006/00007) Canister Transfer Machine Grapples (060-HTC0-HEQ-00001/00002) (Continued)	Protect against drop of a load onto a canister	H.CR.HTC.15. The canister grapple is an integral part of the load-bearing path. See canister transfer machine requirements.	<p>The special lifting device/adaptor is required to be designed in accordance with the requirements of ANSI N14.6-1993, as modified by NUREG-0612 (NRC 1980), Section 5.1.1(4).</p> <p>The special lifting device is required to have mechanical features that prevent special lifting device disengagement when a load is suspended from the special lifting device.</p> <p>Electrically operated special lifting devices are required to have an interlock to prevent special lifting device actuation if the special lifting device is not properly connected to the hoisting system and an interlock to prevent hoist motion if the special lifting device is not either fully engaged or fully disengaged.</p> <p>For mechanically operated special lifting devices (HLW canisters only) an interlock is required to prevent hoist motion if the special lifting device is not properly connected to the hoisting system or if the special lifting device is not either fully engaged or fully disengaged.</p> <p>Special lifting devices/adapters are required to be designed for loads and accelerations associated with a DBGM-2 seismic event.</p>
		TAD Staging Racks (and Thermal Barrier) (060-HTC0-RK-00011/00012)	Protect against a tipover/impact of a canister	H.CR.HTC.16. The mean frequency of collapse of the TAD staging racks due to the spectrum of seismic events shall be less than or equal to 2×10^{-6} per year.	The TAD canister staging racks are required to be designed in accordance with the applicable provisions of ANSI/AISC N690-1994 for loads and accelerations associated with a DBGM-2 seismic event. Additional structural capacity is provided as required to demonstrate compliance.

Table 1.2.4-4. Preclosure Nuclear Safety Design Bases and their Relationship to Design Criteria for the CRCF (Continued)

System or Facility (System Code)	Subsystem or Function (as Applicable)	Component	Nuclear Safety Design Bases		Design Criteria
			Safety Function	Controlling Parameters and Values	
Mechanical Handling System (H) (Continued)	Waste Transfer/ Canister Transfer (Continued)	TAD Staging Racks (and Thermal Barrier) (060-HTC0-RK-00011/00012) (Continued)	Protect against canister breach	H.CR.HTC.17. The mean conditional probability of breach of a TAD canister contained within a staging rack resulting from the spectrum of fires shall be less than or equal to 2×10^{-6} per fire event.	<p>The thermal barrier (around the staging racks) is required to be designed such that the thermal penetration meets the required reliability when evaluated against the spectrum of fires.</p> <p>The canister is required to be designed such that the fire-induced failure hazard meets the required reliability when evaluated against the spectrum of fires.</p> <p>(Note: preclosure safety analysis depends on the reliabilities of each component.)</p>
		DOE Canister Staging Racks (and Thermal Barrier) (060-HTC0-RK-00006/00007/00008/00009/00010)	Protect against a tipover/impact of a canister	H.CR.HTC.18. The mean frequency of collapse of the DOE canister staging racks (such that the spacing between the surface of adjacent DOE standardized canisters in a staging rack is less than 30 cm) due to the spectrum of seismic events shall be less than or equal to 2×10^{-6} per year.	The DOE canister staging racks are required to be designed in accordance with the applicable provisions of ANSI/AISC N690-1994 for loads and accelerations associated with a DBG-2 seismic event. Additional structural capacity is provided as required to demonstrate compliance.
			Protect against canister breach	H.CR.HTC.19. The mean conditional probability of breach of a DOE standardized canister contained within a staging rack resulting from the spectrum of fires shall be less than or equal to 2×10^{-6} per fire event.	<p>The thermal barrier (around the staging racks) is required to be designed such that the thermal penetration meets the required reliability when evaluated against the spectrum of fires.</p> <p>The standardized DOE SNF canister is required to be designed such that the fire-induced failure hazard meets the required reliability when evaluated against the spectrum of fires.</p> <p>(Note: preclosure safety analysis depends on the reliabilities of each component.)</p>

Table 1.2.4-4. Preclosure Nuclear Safety Design Bases and their Relationship to Design Criteria for the CRCF (Continued)

System or Facility (System Code)	Subsystem or Function (as Applicable)	Component	Nuclear Safety Design Bases		Design Criteria
			Safety Function	Controlling Parameters and Values	
Mechanical Handling System (H) (Continued)	Waste Package Closure	Remote Handling System Bridge (060-HWH0-HEQ-00003)	Protect against collapse of the remote handling bridge	H.CR.HWH.01. The mean frequency of collapse of the remote handling system bridge due to the spectrum of seismic events shall be less than or equal to 8×10^{-6} per year.	The remote handling system bridge is required to be designed in accordance with the requirements of ASME NOG-1-2004 for Type II cranes, for loads and accelerations associated with a DBGM-2 seismic event. Additional structural capacity is provided as required to demonstrate compliance.
	Waste Package Loadout	Waste Package Shield Rings (060-HL00-HEQ-00001/00002/00003)	Provide lateral and vertical stability to the waste package in the waste package transfer trolley	H.CR.HL.01. The mean frequency of the shield ring becoming displaced from the waste package transfer trolley due to the spectrum of seismic events shall be less than or equal to 2×10^{-5} per year.	The waste package transfer trolley, including the associated waste package shield rings, is required to be designed in accordance with the requirements of ASME NOG-1-2004 for Type I cranes, for loads and accelerations associated with a DBGM-2 seismic event.
		Waste Package Transfer Trolley (including Pedestals, Seismic Rail Restraints, and Rails) (Trolleys: 060-HL00-TRLY-00001/00002) (Pedestals: 060-HL00-PED-00001/00002/00003/00004/00005/00006/00007/00008)	Preclude rapid tilt-down	H.CR.HL.02. The waste package transfer trolley shall be incapable of rapid tilt-down.	The waste package transfer trolley is required to have two drive trains to rotate the shielded enclosure, either of which can support the enclosure. Power is required to be applied to rotate the shielded enclosure in either direction.
			Limit speed	H.CR.HL.03. The speed of the waste package transfer trolley shall be limited to 2.5 mph.	The waste package transfer trolley is required to be designed to preclude speed greater than 2.5 mph.
			Protect against spurious movement	H.CR.HL.04. The mean probability of spurious movement of the waste package transfer trolley while a canister is being lowered by the canister transfer machine shall be less than or equal to 1×10^{-9} per transfer.	An interlock is required to be provided to interrupt power to the waste package transfer trolley when the waste package port slide gate is opened.
			Protect against tipover of the waste package transfer trolley holding a loaded waste package	H.CR.HL.05. The mean frequency of tipover of the waste package transfer trolley due to the spectrum of seismic events shall be less than or equal to 2×10^{-6} per year.	The waste package transfer trolley is required to be designed in accordance with the requirements of ASME NOG-1-2004 for Type I cranes, for loads and accelerations associated with a DBGM-2 seismic event. The waste package transfer trolley is required to operate on seismically designed rails and have seismic restraints such that it will not tip over during a seismic event.

Table 1.2.4-4. Preclosure Nuclear Safety Design Bases and their Relationship to Design Criteria for the CRCF (Continued)

System or Facility (System Code)	Subsystem or Function (as Applicable)	Component	Nuclear Safety Design Bases		Design Criteria
			Safety Function	Controlling Parameters and Values	
Mechanical Handling System (H) (Continued)	Waste Package Loadout (Continued)	Waste Package Transfer Trolley (including Pedestals, Seismic Rail Restraints, and Rails) (Trolleys: 060-HL00-TRLY-00001/00002) (Pedestals: 060-HL00-PED-00001/00002/00003/00004/00005/00006/00007/00008) (Continued)	Protect against rocking (which induces an impact into a wall) of a waste package transfer trolley holding a loaded waste package	H.CR.HL.06. The mean frequency of rocking impact of the waste package transfer trolley into a wall due to the spectrum of seismic events shall be less than or equal to 2×10^{-5} per year.	The waste package transfer trolley is required to be designed in accordance with the requirements of ASME NOG-1-2004 for Type I cranes, for loads and accelerations associated with a DBGM-2 seismic event. The waste package transfer trolley is required to operate on seismically designed rails and have seismic restraints such that it will not have a rocking impact during a seismic event.
Surface Nuclear Confinement HVAC System (VC)	Surface Nuclear Confinement HVAC	Portions of the surface nuclear confinement HVAC system that exhaust from areas with a potential for a breach	Mitigate the consequences of radionuclide release	VC.CR.01. The mean probability that the HVAC system (including HEPA filtration of exhaust air from the CRCF confinement areas) becomes unavailable during a 30-day mission time following a radionuclide release shall be less than or equal to 4×10^{-2} . This parameter does not apply in the case of large fires, which may disable the HVAC system.	The HVAC subsystem that exhausts from areas where there is a potential for canister breach is required to be designed to have two full capacity independent trains with automatic start upon failure of the operating train.
		Portions of the surface nuclear confinement HVAC system that support the cooling of ITS electrical equipment and battery rooms	Support ITS electrical function	VC.CR.02. The mean conditional probability of failure of the portions of the surface nuclear confinement HVAC system that support the cooling of ITS electrical equipment and battery rooms in the CRCF shall be less than or equal to 2×10^{-2} per ITS electrical train over a period of 720 hours following a radionuclide release.	The HVAC subsystem that provides cooling for the ITS electrical equipment and battery rooms is required to be designed to have an independent train for the rooms associated with each of the two ITS electrical trains.

Table 1.2.4-4. Preclosure Nuclear Safety Design Bases and their Relationship to Design Criteria for the CRCF (Continued)

System or Facility (System Code)	Subsystem or Function (as Applicable)	Component	Nuclear Safety Design Bases		Design Criteria
			Safety Function	Controlling Parameters and Values	
Balance of Plant (SB)	Flood Protection	Flood Control Features	Protect ITS SSCs from external flooding events	SB.01. The site flood control features will be designed to the probable maximum flood.	The flood protection features are required to be located and sized to prevent the inundation of the ITS structures due to a flood associated with the probable maximum precipitation event.

NOTE: "Protect against" in this table means either "reduce the probability of" or "reduce the frequency of."

For casks, canisters, and associated handling equipment that were previously designed, the component design will be evaluated to confirm that the controlling parameters and values are met.

Seismic control values shown represent the integration of the probability distribution of SSC failure (i.e., the loss of safety function) with the seismic hazard curve.

The numbers appearing in parentheses in the third column are component numbers.

Facility Codes: CR: Canister Receipt and Closure Facility; SB: Balance of Plant.

System Codes: H: Mechanical Handling; HE: Emplacement and Retrieval/Drip Shield Installation.

Infrastructure System Codes: VC: Surface Nuclear Confinement HVAC.

Subsystem Codes: HL: Waste Package Loadout; HM: Cask Handling; HMC: Cask Receipt; HMH: Cask Preparation; HMP: Waste Package Preparation; HTC: Canister Transfer; HWH: Material Handling.

Table 1.2.4-5. Handling Facilities Equipment Stands

Equipment Stands	Facility	Location
TAD Canister Welding Machine Stand (Equipment Number: 050-HC00-RK-00001)	WHF	TAD Canister Closure Station
TAD Canister Closure Shield Ring Stand (Equipment Number: 050-HC00-RK-00002)	WHF	TAD Canister Closure Station
DPC Cutting Machine Stand (Equipment Number: 050-HD00-RK-00001)	WHF	DPC Cutting Station
DPC Cutting Shield Ring Stand (Equipment Number: 050-HD00-RK-00002)	WHF	DPC Cutting Station
DPC Adapter Plate Stand (Equipment Number: 050-HD00-RK-00003)	WHF	DPC Cutting Station
Shield Plug Lift Adapter Stand (Equipment Number: 050-HD00-RK-00004)	WHF	DPC Cutting Station
Lid Adapter Stand 1 (Equipment Number: 050-HM00-RK-00009)	WHF	Cask Preparation Area
Lid Adapter Stand 2 (Equipment Number: 050-HM00-RK-00010)	WHF	Cask Preparation Area
Waste Package Shield Ring Stand 1 (Equipment Number: 51A-HL00-RK-00002)	IHF	Waste Package Loadout Room
Waste Package Shield Ring Stand 2 (Equipment Number: 51A-HL00-RK-00003)	IHF	Waste Package Loadout Room
Naval Cask Lid Stand (Equipment Number: 51A-HMH0-RK-00002)	IHF	Cask Preparation Area
Naval Cask Restraint Plate Stand (Equipment Number: 51A-HMH0-RK-00004)	IHF	Cask Preparation Area
Truck Cask Lid Adapter Stand (Equipment Number: 51A-HMH0-RK-00005)	IHF	Cask Preparation Area
Rail Cask Lid Adapter Stand (Equipment Number: 51A-HMH0-RK-00006)	IHF	Cask Preparation Area
Naval Adapter Stand (Equipment Number: 51A-HTC0-RK-00001)	IHF	Cask Preparation Area
Transfer Staging Stand (Equipment Number: 51A-HTC0-RK-00005)	IHF	Canister Transfer Machine Maintenance Area
Process Opening Cover Stand (Equipment Number: 51A-HW00-RK-00001)	IHF	Waste Package Closure Support Room
Waste Package Lid Stand (Equipment Number: 51A-HW00-RK-00002)	IHF	Waste Package Closure Support Room
Cask Lid Stand (Equipment Number: 200-HMH0-RK-00004)	RF	Cask Preparation Room

Table 1.2.4-5. Handling Facilities Equipment Stands (Continued)

Equipment Stands	Facility	Location
DPC Lid Adapter Stand (Equipment Number: 200-HMH0-RK-00005)	RF	Cask Preparation Room
Waste Package Shield Ring Stand 1 (Equipment Number: 060-HL00-RK-00003)	CRCF	Waste Package Loadout Room
Waste Package Shield Ring Stand 2 (Equipment Number: 060-HL00-RK-00004)	CRCF	Waste Package Loadout Room
Cask Lid Stand (Equipment Number: 060-HMH0-RK-00002)	CRCF	Cask Preparation Room
Process Opening Cover Stand 1 (Equipment Number: 060-HW00-RK-00001)	CRCF	Waste Package Closure Support Room
Process Opening Cover Stand 2 (Equipment Number: 060-HW00-RK-00002)	CRCF	Waste Package Closure Support Room
Waste Package Lid Stand 1 (Equipment Number: 060-HW00-RK-00003)	CRCF	Waste Package Closure Support Room
Waste Package Lid Stand 2 (Equipment Number: 060-HW00-RK-00004)	CRCF	Waste Package Closure Support Room

NOTE: [Figure 1.2.4-126](#) provides the mechanical equipment envelope for a typical equipment stand.

Table 1.2.4-6. Summary-Level Description of ITS Equipment Confinement Doors

Door Name	Facility	Room/Area Name	Single Panel	Double Panel
WHF Cask Preparation Area Equipment Confinement Door	WHF	Cask Preparation Area	X	
CRCF 1 Cask Preparation Room Equipment Confinement Door South	CRCF	Cask Preparation Area		X
CRCF 1 Cask Preparation Room Equipment Confinement Door East 1	CRCF	Cask Preparation Area		X
CRCF 1 Cask Preparation Room Equipment Confinement Door East 2	CRCF	Cask Preparation Area		X

Table 1.2.4-7. CRCF ITS HVAC Exhaust Components and System Design Data

Subsystem/Components	Number of Units		Nominal Airflow Capacity cfm/unit	HEPA Filter Plenum Components (Number of Banks)		
	Operating	Standby		Demister	Prefilter	HEPA Filter
ITS Confinement Areas Exhaust HEPA Filter Plenum—Train A (Equipment Number: 060-VCT0-FLT-00009/00010/00011)	3	0	13,500	1	1	2
ITS Confinement Areas Exhaust Fan—Train A (Equipment Number: 060-VCT0-EXH-00009)	1	0	40,500	NA	NA	NA
ITS Confinement Areas Exhaust HEPA Filter Plenum—Train B (Equipment Number: 060-VCT0-FLT-00012/00013/00014)	0	3	13,500	1	1	2
ITS Confinement Areas Exhaust Fan—Train B (Equipment Number: 060-VCT0-EXH-00010)	0	1	40,500	NA	NA	NA
ITS Battery Room Train A Exhaust HEPA Filter Plenum (Equipment Number: 060-VCT0-FLT-00005/00006)	1	1	1,000	NA	1	1
ITS Battery Room Train A Exhaust Fan (Equipment Number: 060-VCT0-EXH-00005/00006)	1	1	1,000	NA	NA	NA
ITS Battery Room Train B Exhaust HEPA Filter Plenum (Equipment Number: 060-VCT0-FLT-00007/00008)	1	1	1,000	NA	1	1
ITS Battery Room Train B Exhaust Fan (Equipment Number: 060-VCT0-EXH-00007/00008)	1	1	1,000	NA	NA	NA

NOTE: Equipment numbers are shown in [Figures 1.2.4-99](#) and [1.2.4-104](#).
NA = not applicable.

Table 1.2.4-8. CRCF Indoor Design Temperatures

Area or Room	Maximum Summer Temperature (°F Dry Bulb)	Minimum Winter Temperature (°F Dry Bulb)
Cask Preparation Area	85 ^a	65
Waste Package Positioning Room	100 ^b	65
Cask Unloading Room	100 ^b	65
Canister Staging Rooms	100 ^b	65
HVAC Rooms	90 ^b	65
Utility Room	90 ^b	65
Low-Level Radioactive Waste Staging Room	90 ^b	65
Support Areas	76	70
Gas Sampling Room	90 ^b	65
Electrical Rooms	90 ^b	65
Battery Rooms	77	72
Corridors	85	65
Waste Package Loadout Room	85 ^a	65
Waste Package Closure Room	90 ^b	65
Closure Support Rooms	78	65
Closure Equipment Room	78	65
Canister Transfer Room	85 ^a	65
Maintenance/Operations Storage Room	85 ^a	65
Instrument and Electrical Shop	85 ^a	65
Elevator Lobby	85	65
Offices	75	70
Operations Rooms	75	70
Communications Room	75	70
Vestibules	90 ^a	65

NOTE: ^aThese areas are normally not occupied. However, these areas are designed to be at maximum of 85°F since there is expected extended occupancy during operation.

^bThese areas are normally not occupied and the temperature limits are based on the electrical equipment located in the space.

Table 1.2.4-9. CRCF Non-ITS HVAC Supply Components and System Design Data

Subsystem/Components	Number of Units		Nominal Airflow Capacity cfm/unit
	Operating	Standby	
Cask Preparation Area Recirculating Supply Air Handling Unit (Equipment Number: 060-VCT0-AHU-00005/00006)	1	1	24,000
1st Level (North) Confinement Areas Supply Air Handling Unit (Equipment Number: 060-VCT0-AHU-00009/00010)	1	1	24,000
1st Level (South) Confinement Areas Supply Air Handling Unit (Equipment Number: 060-VCT0-AHU-00011/00012)	1	1	24,000
2nd Level (North) Confinement Areas Supply Air Handling Unit (Equipment Number: 060-VCT0-AHU-00001/00002)	1	1	24,000
2nd Level (South) Confinement Areas Supply Air Handling Unit (Equipment Number: 060-VCT0-AHU-00007/00008)	1	1	24,000
Waste Package Loadout Room Recirculating Supply Air Handling Unit (Equipment Number: 060-VCT0-AHU-00013/00014)	1	1	20,000
Canister Transfer Room Recirculating Supply Air Handling Unit (Equipment Number: 060-VCT0-AHU-00003/00004)	1	1	30,000
Low-Level Radioactive Waste Staging Room and Miscellaneous Areas Supply Air Handling Unit (Equipment Number: 060-VCT0-AHU-00015/00016)	1	1	8,000
Utility Room (Tertiary Confinement)—Fan Coil Units (Equipment Number: 060-VCT0-FCU-00005/00006)	1	1	10,000
Nonconfinement Areas Supply Air Handling Unit (Equipment Number: 060-VN10-AHU-00001/00002)	1	1	18,000
Nonconfinement Areas Return Fan (Integral to 060-VN10-AHU-00001/00002)	1	1	18,000
Waste Package Loadout Vestibule (Nonconfinement)—Fan Coil Units (Equipment Number: 060-VN10-FCU-00001/00002)	1	1	8,000
Site Transporter Vestibule (Nonconfinement)—Fan Coil Units (Equipment Number: 060-VN10-FCU-00003/00004)	1	1	12,000
Transportation Cask Vestibule (Nonconfinement)—Fan Coil Units (Equipment Number: 060-VN10-FCU-00005/00006)	1	1	6,000
Transportation Cask Vestibule Annex (Nonconfinement)—Fan Coil Units (Equipment Number: 060-VN10-FCU-00007/00008)	1	1	6,000

NOTE: Equipment and equipment numbers are shown in [Figures 1.2.4-99, 1.2.4-113 to 1.2.4-115, and 1.2.4-124](#).

Table 1.2.4-10. CRCF Non-ITS HVAC Exhaust Components and System Design Data

Subsystem/Components	Number of Units		Nominal Airflow Capacity cfm/unit	HEPA Filter Plenum Components (No. of Banks)		
	Operating	Standby		Demister	Prefilter	HEPA Filter
1st Level Non-ITS HEPA Exhaust Filter Plenum (Equipment Number: 060-VCT0-FLT-00017/00018)	1	1	4,000	NA	1	1
1st Level Non-ITS Exhaust Fan (Equipment Number: 060-VCT0-EXH-00013/00014)	1	1	4,000	NA	NA	NA
2nd Level Non-ITS HEPA Exhaust Filter Plenum (Equipment Number: 060-VCT0-FLT-00003/00004)	1	1	12,000	NA	1	1
2nd Level Non-ITS Exhaust Fan (Equipment Number: 060-VCT0-EXH-00003/00004)	1	1	12,000	NA	NA	NA
Non-ITS Battery Room Exhaust HEPA Filter Plenum (Equipment Number: 060-VCT0-FLT-00001/00002)	1	1	1,000	NA	1	1
Non-ITS Battery Room Exhaust Fan (Equipment Number: 060-VCT0-EXH-00001/00002)	1	1	1,000	NA	NA	NA
Low-Level Radioactive Waste Staging Room and Miscellaneous Areas HEPA Exhaust Filter Plenum (Equipment Number: 060-VCT0-FLT-00015/00016)	1	1	8,000	NA	1	1
Low-Level Radioactive Waste Staging Room and Miscellaneous Areas Exhaust Fan (Equipment Number: 060-VCT0-EXH-00011/00012)	1	1	8,000	NA	NA	NA
Men's Restroom/Locker and Janitor Closet Exhaust Fan (Equipment Number: 060-VN10-EXH-00001)	1	NA	800	NA	NA	NA
Women's Restroom/Locker Exhaust Fan (Equipment Number: 060-VN10-EXH-00002)	1	NA	800	NA	NA	NA

NOTE: Equipment numbers are shown in [Figures 1.2.4-113 to 1.2.4-115](#) and [1.2.4-124](#).
NA = not applicable.

Table 1.2.4-11. CRCF ITS HVAC Supply Components and System Design Data

Subsystem/Components	Number of Units		Nominal Airflow Capacity
	Operating	Standby	
ITS Electrical Room Train A—Direct Expansion Fan Coil Units (Equipment Number: 060-VCT0-FCU-00001/00002)	1	1	6,000 cfm
ITS Electrical Room Train A—Condensing Units (Equipment Number: 060-VCT0-CDU-00001/00002)	1	1	20 tons
ITS Electrical Room Train B—Direct Expansion Fan Coil Units (Equipment Number: 060-VCT0-FCU-00003/00004)	1	1	6,000 cfm
ITS Electrical Room Train B—Condensing Units (Equipment Number: 060-VCT0-CDU-00003/00004)	1	1	20 tons

NOTE: Equipment numbers are shown in [Figure 1.2.4-104](#).

ROOM LEGEND
CANISTER RECEIPT AND CLOSURE FACILITY 1

GROUND FLOOR

- 1001 LOW-LEVEL RADIOACTIVE WASTE STAGING ROOM
- 1001A HVAC ROOM (LOW-LEVEL RADIOACTIVE WASTE SUPPLY)
- 1002 NORTH MAINTENANCE VESTIBULE
- 1002A PERSONNEL VESTIBULE
- 1003 HVAC ROOM (SUPPORT AREA SUPPLY)
- 1004 HVAC ROOM (NON-ITS LOW-LEVEL RADIOACTIVE WASTE AREAS HEPA EXHAUST)
- 1005A CORRIDOR
- 1005B CORRIDOR
- 1005C CORRIDOR
- 1005D CORRIDOR
- 1005E CORRIDOR
- 1005F CORRIDOR
- 1005G CORRIDOR
- 1005H CORRIDOR
- 1005J CORRIDOR
- 1006 UTILITY CHASE
- 1007 ELECTRICAL ROOM (NORMAL POWER)
- 1007A BATTERY ROOM (NORMAL POWER)
- 1008 ELECTRICAL ROOM (ITS TRAIN A)
- 1008A BATTERY ROOM (ITS TRAIN A)
- 1009 HVAC ROOM (ITS BATTERY ROOM HEPA EXHAUST TRAIN A)
- 1010 HVAC ROOM (NON-ITS SUPPLY)
- 1011 HVAC ROOM (ITS HEPA EXHAUST TRAIN A)
- 1012 MAINTENANCE ROOM (NORTH CTM)
- 1013 OPERATIONS ROOM
- 1013A OPERATIONS SUPERVISOR ROOM
- 1014 WASTE PACKAGE LOADOUT VESTIBULE
- 1015 WASTE PACKAGE LOADOUT ROOM
- 1016 UNASSIGNED
- 1017 CANISTER STAGING AREA #1
- 1018 WASTE PACKAGE POSITIONING ROOM (NORTH)
- 1019 WASTE PACKAGE POSITIONING ROOM (SOUTH)
- 1020 UNASSIGNED
- 1021 CANISTER STAGING AREA #2
- 1022 CANISTER STAGING AREA #3
- 1023 CASK UNLOADING ROOM (NORTH)
- 1024 CASK UNLOADING ROOM (SOUTH)
- 1025 CANISTER STAGING AREA #4
- 1026 CASK PREPARATION ROOM
- 1027 SITE TRANSPORTER VESTIBULE
- 1028 UTILITY ROOM
- 1029 ELECTRICAL ROOM (ITS TRAIN B)
- 1029A BATTERY ROOM (ITS TRAIN B)
- 1030 HVAC ROOM (ITS BATTERY ROOM HEPA EXHAUST TRAIN B)
- 1031 HVAC ROOM (NON-ITS SUPPLY)
- 1032 HVAC ROOM (ITS HEPA EXHAUST TRAIN B)
- 1033 MAINTENANCE ROOM (SOUTH CANISTER TRANSFER MACHINE)
- 1034 GAS SAMPLING ROOM
- 1035 HVAC ROOM (NON-ITS ROOM HEPA EXHAUST)
- 1036 TRANSPORTATION CASK VESTIBULE
- 1036A VESTIBULE ANNEX
- 1036B PERSONNEL VESTIBULE
- 1037 SOUTH MAINTENANCE VESTIBULE
- 1038 STAIR #1
- 1039 STAIR #2
- 1040 STAIR #3
- 1041 STAIR #4
- 1042 STAIR #5
- 1043 STAIR #6
- 1044 PERSONNEL ELEVATOR
- 1044A ELEVATOR MECHANICAL ROOM
- 1045 CORRIDOR
- 1046 ELEVATOR LOBBY
- 1047 FREIGHT ELEVATOR (NORTH)
- 1047A VESTIBULE
- 1048 ELEVATOR LOBBY
- 1049 FREIGHT ELEVATOR (SOUTH)
- 1049A VESTIBULE
- 1050 ELEVATOR LOBBY
- 1051 FIRE WATER RISER VALVE ROOM #1
- 1052 FIRE WATER RISER VALVE ROOM #2
- 1053 FIRE WATER RISER VALVE ROOM #3
- 1054 FIRE WATER RISER VALVE ROOM #4
- 1055 GAS STORAGE AREA

GROUND FLOOR SUPPORT AREA

- 1201 WOMENS LOCKER/SHOWER RESTROOM
- 1202 SECURITY POST
- 1203 RADIOLOGICAL PROTECTION STAFF WORK ROOM
- 1204 BRIEFING ROOM
- 1205 MENS LOCKER/SHOWER RESTROOM
- 1206 JANITOR CLOSET
- 1207 BREAK ROOM
- 1208 VENDING ROOM
- 1209 ENTRANCE LOBBY
- 1210 ENTRY/EXIT VESTIBULE
- 1211 RADIOLOGICAL PROTECTION LAB/SAMPLE PREPARATION ROOM
- 1212 DECOR ROOM
- 1213 VESTIBULE IN/OUT
- 1214 RADIOLOGICAL ACCESS CONTROL POINT
- 1215 RADIOLOGICAL PROTECTION LAB/COUNT ROOM
- 1216 RADIOLOGICAL PROTECTION INSTRUMENT ROOM
- 1217 RADIOLOGICAL ACCESS EXIT/PCM ROOM
- 1218 RADIOLOGICAL PROTECTION GEAR SUPPLY ROOM
- 1219 RADIOLOGICAL PROTECTION EQUIPMENT ROOM
- 1220 RESPIRATOR ROOM
- 1221 CHANGE ROOM 1
- 1222 CHANGE ROOM 2

SECOND FLOOR

- 2001 HVAC ROOM (NON-ITS HEPA EXHAUST AND NORTH AREAS SUPPLY)
- 2002 INSTRUMENT AND ELECTRICAL SHOP
- 2003 CLOSURE SUPPORT ROOM (NORTH)
- 2003A PERSONNEL ACCESS ROOM (NORTH)
- 2004 CANISTER TRANSFER ROOM
- 2005 HVAC ROOM (CASK PREP ROOM SUPPLY)
- 2005A COMMUNICATIONS ROOM
- 2006A CORRIDOR
- 2006B CORRIDOR
- 2006C NOT USED
- 2006D CORRIDOR
- 2006E CORRIDOR
- 2006F CORRIDOR
- 2006G CORRIDOR
- 2006H CORRIDOR
- 2006J CORRIDOR
- 2006K CORRIDOR
- 2006L UTILITY CHASE
- 2006M UTILITY CHASE
- 2007 WASTE PACKAGE CLOSURE ROOM
- 2007A CLOSURE EQUIPMENT ROOM (NORTH)
- 2007B CLOSURE EQUIPMENT ROOM (SOUTH)
- 2008 HVAC ROOM (SOUTH AREAS SUPPLY)
- 2009 NOT USED
- 2010 MAINTENANCE AND OPERATIONS STORAGE ROOM
- 2011 CLOSURE SUPPORT ROOM (SOUTH)
- 2011A PERSONNEL ACCESS ROOM (SOUTH)
- 2012 HVAC ROOM (NON-ITS HEPA EXHAUST)
- 2013 THRU NOT USED
- 2037 STAIR #1
- 2038 STAIR #2
- 2039 STAIR #3
- 2040 STAIR #4
- 2041 STAIR #5
- 2042 STAIR #6
- 2043 NOT USED
- 2044 CORRIDOR
- 2045 CORRIDOR
- 2045A STORAGE ROOM
- 2046 ELEVATOR LOBBY
- 2047 NOT USED
- 2048 ELEVATOR LOBBY
- 2049 NOT USED
- 2050 ELEVATOR LOBBY

THIRD FLOOR

- 3001 CORRIDOR
- 3002 CORRIDOR
- 3003 THRU NOT USED
- 3037 STAIR #1
- 3038 STAIR #2
- 3039 NOT USED
- 3040 NOT USED
- 3041 STAIR #4
- 3042 NOT USED
- 3043 NOT USED
- 3044 NOT USED
- 3045 CORRIDOR
- 3045A STORAGE ROOM
- 3046 ELEVATOR LOBBY
- 3047 NOT USED
- 3048 ELEVATOR LOBBY
- 3049 NOT USED
- 3050 ELEVATOR LOBBY

ROOF

- R001 PERSONNEL ELEVATOR MACHINE ROOM
- R002 FREIGHT ELEVATOR MACHINE ROOM (SOUTH)
- R003 FREIGHT ELEVATOR MACHINE ROOM (NORTH)
- R038 PERSONNEL ELEVATOR MACHINE ROOM STAIR
- R041 FREIGHT ELEVATOR MACHINE ROOM STAIR (SOUTH)
- R048A FREIGHT ELEVATOR MACHINE ROOM STAIR (NORTH)

PIT

- P001 LIQUID LOW-LEVEL RADIOACTIVE WASTE SUMP

DRAWING LEGEND

- GRID LINE
- CHECKERED PLATE
- FLOOR GRATING
- PARTITION WALL
- CONCRETE SECTION
- OVERHEAD CRANE HOOK APPROACH
- ROOM/AREA NUMBER
- GRADE SECTION
- BUILT UP ROOFING
- EYE WASH/SHOWER STATION
- METAL EXTERIOR PANEL SYSTEM
- CRUSH PAD
- RAISED COMPUTER FLOOR
- CONFINEMENT DOOR

00249DC_LA_1889b.ai

Figure 1.2.4-1. CRCF General Arrangement Legend

INTENTIONALLY LEFT BLANK

This figure has been designated Official Use Only under the Freedom of Information Act (5 U.S.C. 552), Exemption 2, Circumvention of Statute.

This figure is included in Appendix A and has been updated: Figures Designated as Official Use Only, as [Figure A-22](#).

NOTE: AO = aging overpack; HR = handrail; LC = load center; LLW = low-level radioactive waste; MCC = motor control center; WP = waste package; WPTT = waste package transfer trolley.

Figure 1.2.4-2. CRCF General Arrangement Ground Floor Plan

INTENTIONALLY LEFT BLANK

This figure has been designated Official Use Only under the Freedom of Information Act (5 U.S.C. 552), Exemption 2, Circumvention of Statute.

This figure is included in Appendix A and has been updated: Information Designated as Official Use Only, as [Figure A-23](#).

NOTE: MCC = motor control center; RHS = remote handling system; WP = waste package.

Figure 1.2.4-3. CRCF General Arrangement Second Floor Plan

INTENTIONALLY LEFT BLANK

This figure has been designated Official Use Only under the Freedom of Information Act (5 U.S.C. 552), Exemption 2, Circumvention of Statute.

This figure is included in Appendix A and has been updated: Information Designated as Official Use Only, as [Figure A-24](#).

NOTE: CTM = canister transfer machine.

Figure 1.2.4-4. CRCF General Arrangement Third Floor Plan

INTENTIONALLY LEFT BLANK

This figure has been designated Official Use Only under the Freedom of Information Act (5 U.S.C. 552), Exemption 2, Circumvention of Statute.

This figure is included in Appendix A: Information Designated as Official Use Only, as [Figure A-25](#).

NOTE: LLW = low-level radioactive waste.

Figure 1.2.4-5. CRCF General Arrangement Roof Plan

INTENTIONALLY LEFT BLANK

This figure has been designated Official Use Only under the Freedom of Information Act (5 U.S.C. 552), Exemption 2, Circumvention of Statute.

This figure is included in Appendix A: Information Designated as Official Use Only, as [Figure A-26](#).

NOTE: CTM = canister transfer machine; LC = load center; MCC = motor control center.

Figure 1.2.4-6. CRCF General Arrangement Section A

INTENTIONALLY LEFT BLANK

This figure has been designated Official Use Only under the Freedom of Information Act (5 U.S.C. 552), Exemption 2, Circumvention of Statute.

This figure is included in Appendix A: Information Designated as Official Use Only, as [Figure A-27](#).

NOTE: MCC = motor control center; WP = waste package.

Figure 1.2.4-7. CRCF General Arrangement Section B

INTENTIONALLY LEFT BLANK

This figure has been designated Official Use Only under the Freedom of Information Act (5 U.S.C. 552), Exemption 2, Circumvention of Statute.

This figure is included in Appendix A: Information Designated as Official Use Only, as [Figure A-28](#).

NOTE: LC = load center; MCC = motor control center; WP = waste package.

Figure 1.2.4-8. CRCF General Arrangement Section C

INTENTIONALLY LEFT BLANK

This figure has been designated Official Use Only under the Freedom of Information Act (5 U.S.C. 552), Exemption 2, Circumvention of Statute.

This figure is included in Appendix A: Information Designated as Official Use Only, as [Figure A-29](#).

NOTE: HR = handrail; LLW = low-level radioactive waste; WP = waste package.

Figure 1.2.4-9. CRCF General Arrangement Section D

INTENTIONALLY LEFT BLANK

This figure has been designated Official Use Only under the Freedom of Information Act (5 U.S.C. 552), Exemption 2, Circumvention of Statute.

This figure is included in Appendix A: Information Designated as Official Use Only, as [Figure A-30](#).

NOTE: CTM = canister transfer machine.

Figure 1.2.4-10. CRCF General Arrangement Section E

INTENTIONALLY LEFT BLANK

This figure has been designated Official Use Only under the Freedom of Information Act (5 U.S.C. 552), Exemption 2, Circumvention of Statute.

This figure is included in Appendix A: Information Designated as Official Use Only, as [Figure A-31](#).

Figure 1.2.4-11. CRCF General Arrangement Section F

INTENTIONALLY LEFT BLANK

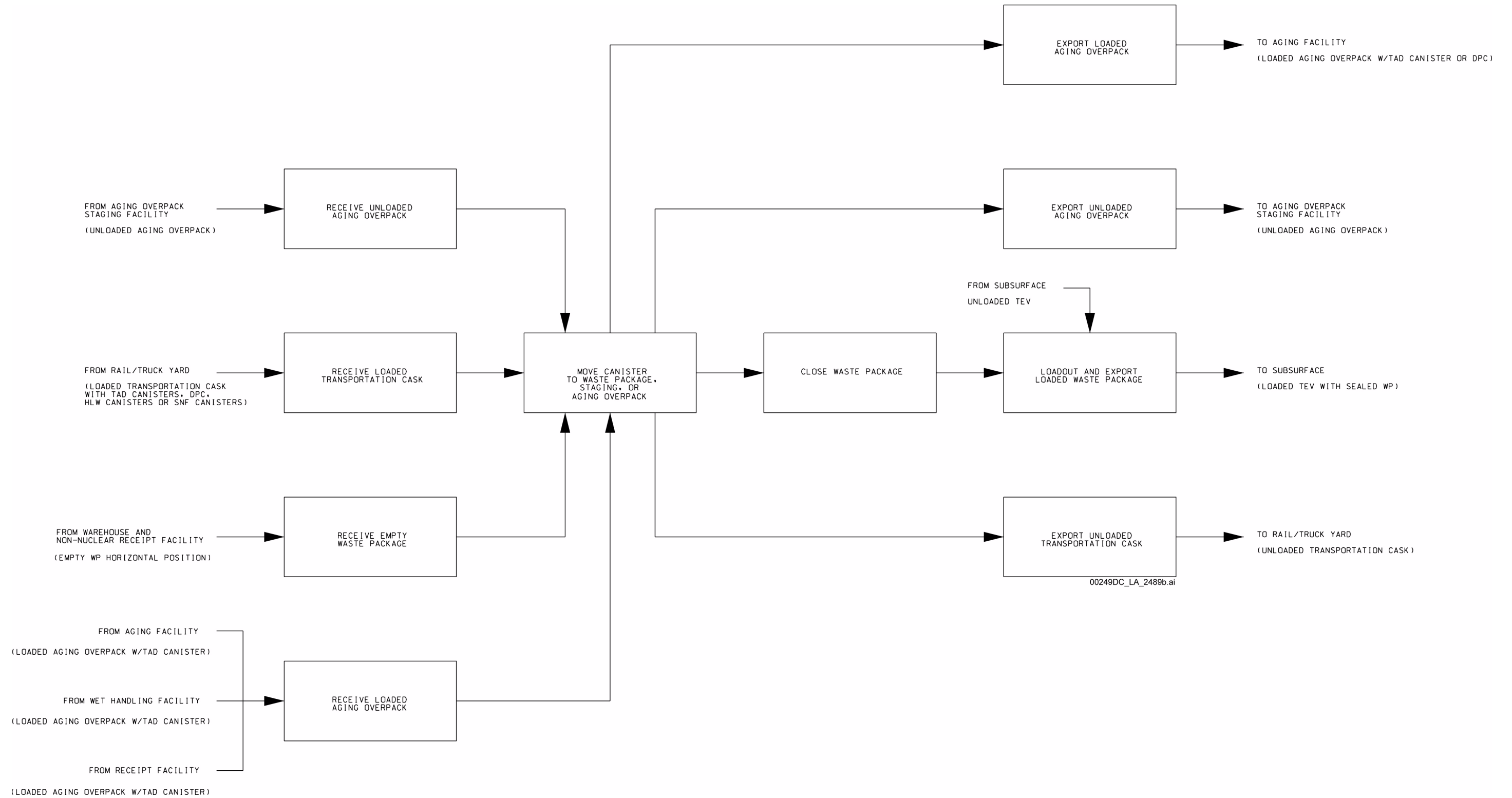

NOTE: WP = waste package.

Figure 1.2.4-12. Major Waste Processing Functions in the CRCF

INTENTIONALLY LEFT BLANK

This figure has been designated Official Use Only under the Freedom of Information Act (5 U.S.C. 552), Exemption 2, Circumvention of Statute.

This figure is included in Appendix A: Information Designated as Official Use Only, as [Figure A-32](#).

Figure 1.2.4-13. CRCF Operational Sequences and Material Flow Paths (Sheet 1 of 2)

INTENTIONALLY LEFT BLANK

This figure has been designated Official Use Only under the Freedom of Information Act (5 U.S.C. 552), Exemption 2, Circumvention of Statute.

This figure is included in Appendix A: Information Designated as Official Use Only, as [Figure A-32](#).

Figure 1.2.4-13. CRCF Operational Sequences and Material Flow Paths (Sheet 2 of 2)

INTENTIONALLY LEFT BLANK

This figure has been designated Official Use Only under the Freedom of Information Act (5 U.S.C. 552), Exemption 2, Circumvention of Statute.

This figure is included in Appendix A: Information Designated as Official Use Only, as [Figure A-33](#).

NOTE: This figure is an example representing the number of waste forms that could be present in the facility at any one time. It does not define limits on number of waste forms that may be present in specific areas of the facility.

Figure 1.2.4-14. Waste Form Inventory Present within CRCF at Any One Time

INTENTIONALLY LEFT BLANK

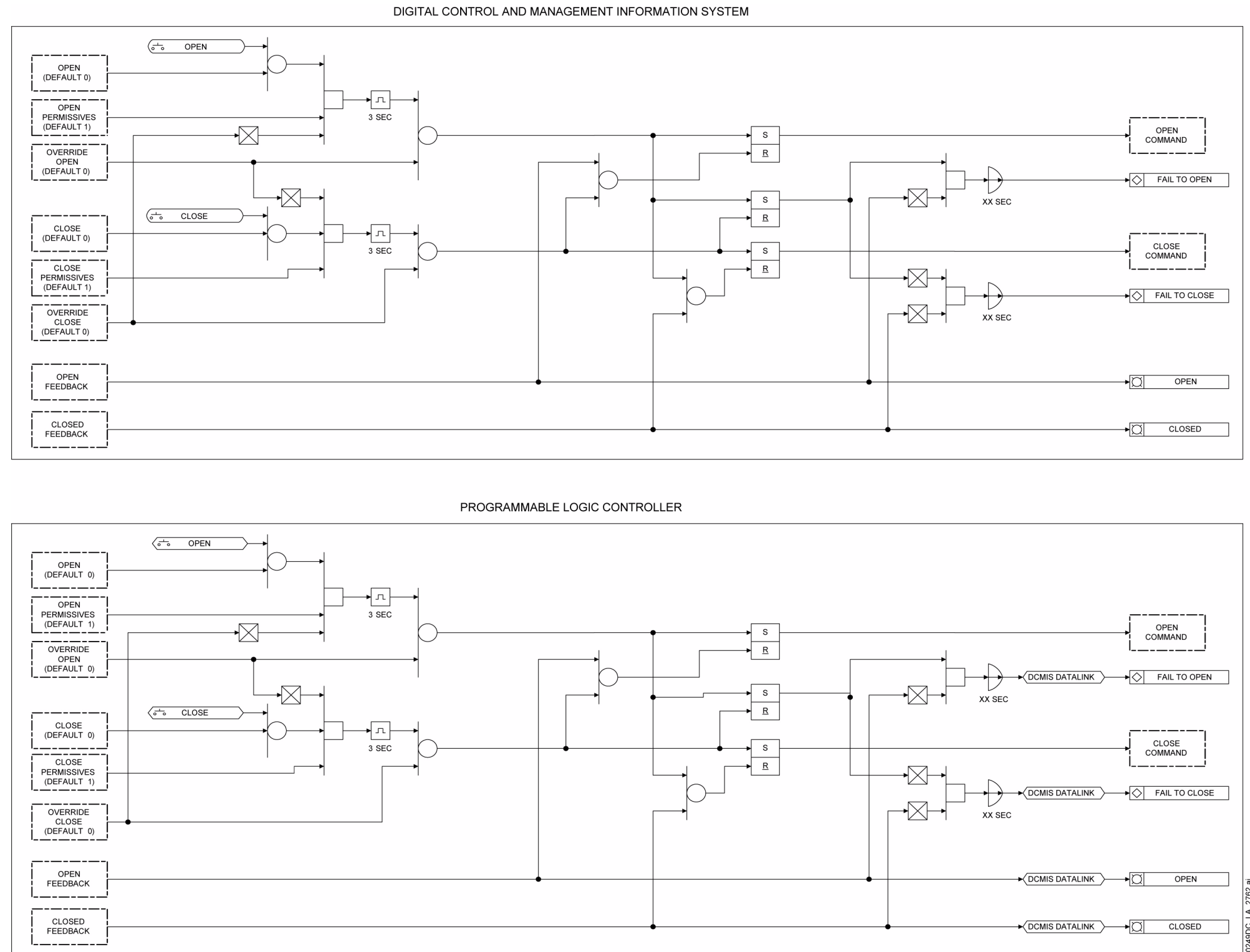

NOTE: Maintained output without stop-travel command, fully open/fully closed limit switches, and manual mode only.

Figure 1.2.4-15. Logic Diagram for a Typical Reversing Motor

INTENTIONALLY LEFT BLANK

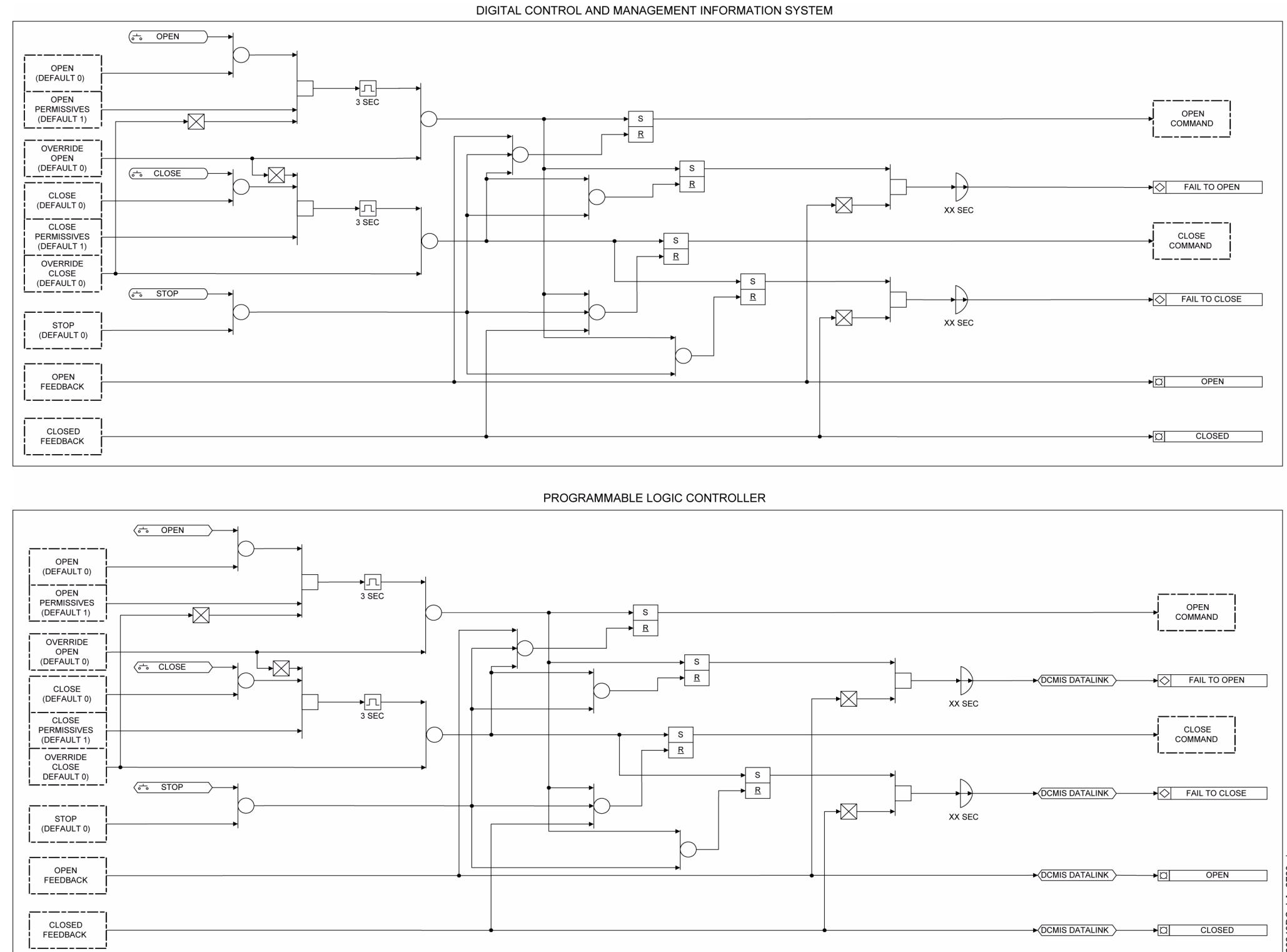

NOTE: Maintained output with stop-travel command, fully open/close limit switch, and manual mode only.

Figure 1.2.4-16. Logic Diagram for a Typical Reversing Motor with Stop Command

00249DC_LA_2763.ai

INTENTIONALLY LEFT BLANK

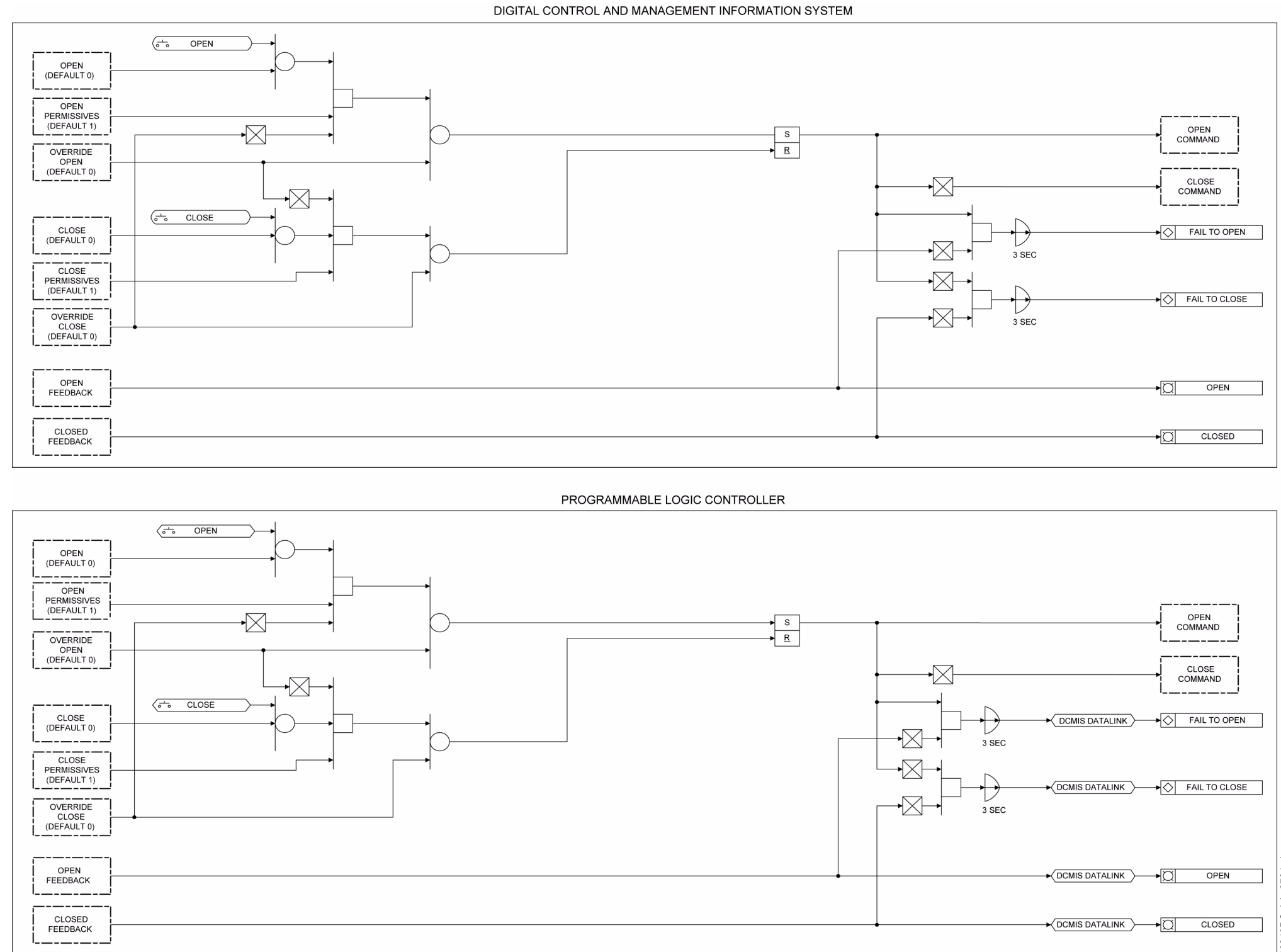
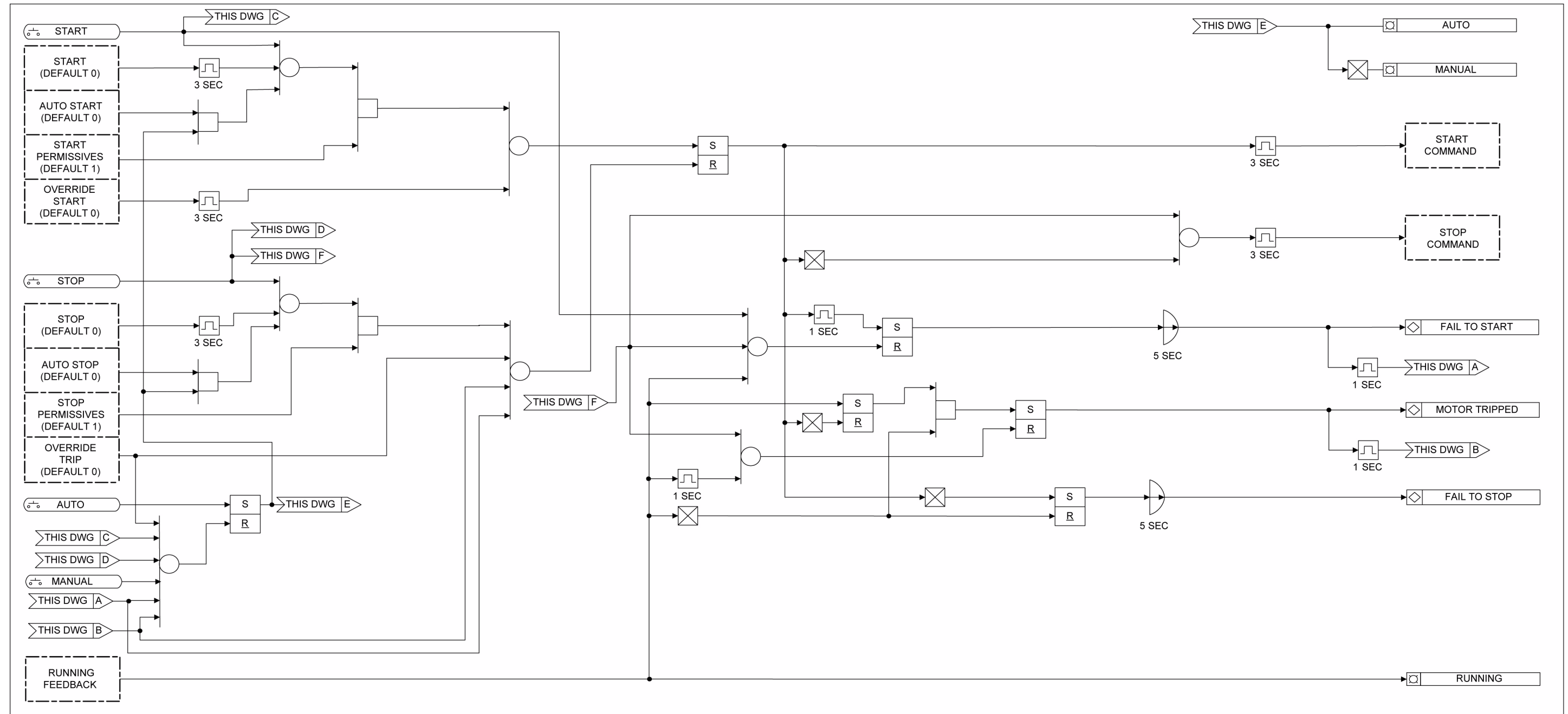

Figure 1.2.4-17. Logic Diagram for a Typical Dual-Coil Solenoid Air-Operated Device

00249DC_LA_2764.ai

INTENTIONALLY LEFT BLANK

DIGITAL CONTROL AND MANAGEMENT INFORMATION SYSTEM



00249DC_LA_2765.ai

NOTE: The typical motor drive with auto command has momentary output with auto/manual mode.

Figure 1.2.4-18. Logic Diagram for a Typical Motor Drive with Auto Command

INTENTIONALLY LEFT BLANK

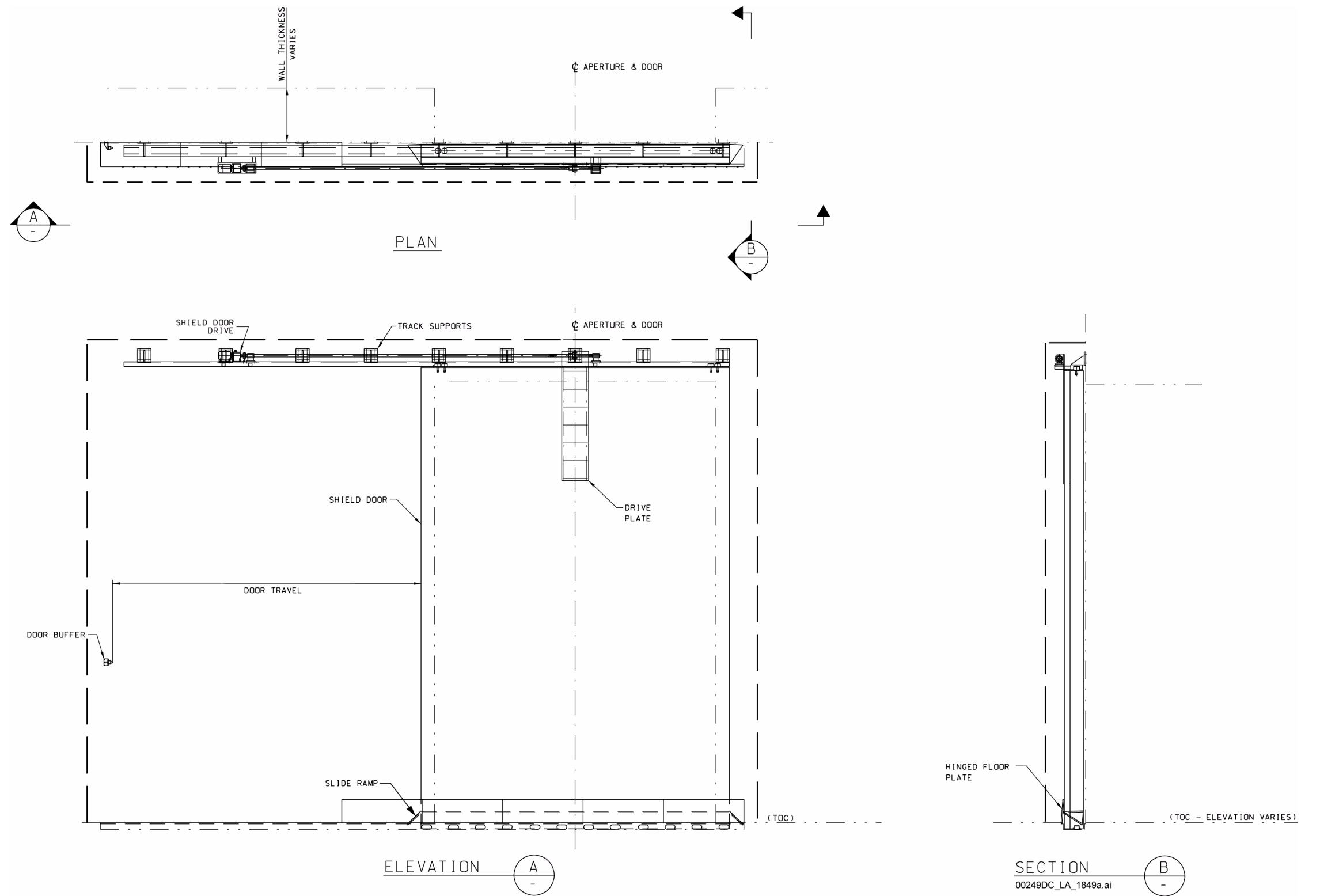

Equipment Number: 060-CR00-DR-00001/00002, CRCF cask unloading room, equipment shield door, north 1/south 2; 51A-IH00-DR-00001, IHF cask unloading room equipment shield door; WHF 050-WH00-DR-00003, cask unloading room equipment shield door.

Figure 1.2.4-19. Equipment Shield Door (Type 1) Mechanical Equipment Envelope

INTENTIONALLY LEFT BLANK

INSTRUMENTATION TABLE

FACILITY NAME	FACILITY AREA NO.	EQUIPMENT SHIELD DOOR EQUIPMENT NUMBER	INSTRUMENT SYSTEM CODE	OPEN/CLOSE HANDSWITCH	OPEN/CLOSED POSITION INDICATOR	ENABLE/DISABLE SWITCH	EMERGENCY OPEN SWITCH	EMERGENCY OPEN ALARM	OBSTRUCTION			DOOR LIMIT SWITCHES (SINGLE OR DOUBLE DOOR SYSTEM)				INTERFACING CONFINEMENT DOOR EQUIPMENT NUMBER	INTERFACING SLIDE GATE EQUIPMENT NUMBER	INTERFACING PERSONNEL SHIELD DOOR EQUIPMENT NUMBER	INTERFACING EQUIPMENT SHIELD DOOR EQUIPMENT NUMBER	INTERFACING RADIATION SWITCH	
									SENSOR	SWITCH	ALARM	DOOR OPEN LIMIT SWITCH	DOOR CLOSED LIMIT SWITCH	DOOR OPEN LIMIT SWITCH	DOOR CLOSED LIMIT SWITCH						
CANISTER RECEIPT AND CLOSURE FACILITY (CRCF)	060	060-CR00-DR-00001	HTCO	HS-2101	Z1-2101	HS-2102	HS-2103	HA-2103	YE-2104	YS-2104	YA-2104	ZSH-2101	ZSL-2101 (ITS)	N/A	N/A	060-CR00-DR-00010 060-CR00-DR-00011 060-CR00-DR-00012	060-HTCO-HTCH-00001	N/A	N/A	N/A	
		060-CR00-DR-00002	HTCO	HS-2201	Z1-2201	HS-2202	HS-2203	HS-2203	YE-2204	YS-2204	YA-2204	ZSH-2201	ZSL-2201 (ITS)	N/A	N/A	060-CR00-DR-00010 060-CR00-DR-00011 060-CR00-DR-00012	060-HTCO-HTCH-00002	N/A	N/A	N/A	
		060-CR00-DR-00003	HWOOD	HS-2101	Z1-2101	HS-2102	HS-2103	HA-2103	YE-2104	YS-2104	YA-2104	ZSH-2101	ZSL-2101 (ITS)	N/A	N/A	N/A	060-HTCO-HTCH-00003	060-CR00-DR-00007 060-CR00-DR-00008 060-CR00-DR-00009	060-CR00-DR-00005 060-CR00-DR-00006	N/A	
		060-CR00-DR-00004	HWOOD	HS-2201	Z1-2201	HS-2202	HS-2203	HA-2203	YE-2204	YS-2204	YA-2204	ZSH-2201	ZSL-2201 (ITS)	N/A	N/A	N/A	060-HTCO-HTCH-00004	060-CR00-DR-00007 060-CR00-DR-00008 060-CR00-DR-00009	060-CR00-DR-00005 060-CR00-DR-00006	N/A	
		060-CR00-DR-00005	HLOO	HS-2101	Z1-2101	HS-2102	HS-2103	HA-2103	YE-2104	YS-2104	YA-2104	ZSH-2101	ZSL-2101 (ITS)	N/A	N/A	N/A	N/A	N/A	060-CR00-DR-00007 060-CR00-DR-00008 060-CR00-DR-00009	060-CR00-DR-00004 060-CR00-DR-00004	RSH-0005-1 (ITS)
		060-CR00-DR-00006	HLOO	HS-2201	Z1-2201	HS-2202	HS-2203	HA-2203	YE-2204	YS-2204	YA-2204	ZSH-2201	ZSL-2201 (ITS)	N/A	N/A	N/A	N/A	N/A	060-CR00-DR-00007 060-CR00-DR-00008 060-CR00-DR-00009	060-CR00-DR-00003 060-CR00-DR-00004	RSH-0005-1 (ITS)
INITIAL HANDLING FACILITY (IHF)	51A	51A-IH00-DR-00001	HTCO	HS-2101	Z1-2101	HS-2102	HS-2103	HA-2103	YE-2104	YS-2104	YA-2104	ZSH-2101	ZSL-2101 (ITS)	N/A	N/A	N/A	51A-HTCO-HTCH-00001	N/A	N/A	N/A	
		51A-IH00-DR-00002	HWOOD	HS-2101	Z1-2101	HS-2102	HS-2103	HA-2103	YE-2104	YS-2104	YA-2104	ZSH-2101A	ZSL-2101A (ITS)	ZSH-2101B	ZSL-2101B (ITS)	N/A	51A-HTCO-HTCH-00002	N/A	N/A	N/A	
		51A-IH00-DR-00003	HWOOD	HS-2201	Z1-2201	HS-2202	HS-2203	HA-2203	YE-2204	YS-2204	YA-2204	ZSH-2201A	ZSL-2201A (ITS)	ZSH-2201B	ZSL-2201B (ITS)	N/A	N/A	51A-IH00-DR-00005 51A-IH00-DR-00006	51A-IH00-DR-00004	N/A	
RECEIPT FACILITY (RF)	200	200-RF00-DR-00001	HTCO	HS-2101	Z1-2101	HS-2102	HS-2103	HA-2103	YE-2104	YS-2104	YA-2104	ZSH-2101A	ZSL-2101A (ITS)	ZSH-2101B	ZSL-2101B (ITS)	200-RF00-DR-00003	200-HTCO-HTCH-00001	N/A	N/A	N/A	
		200-RF00-DR-00002	HTCO	HS-2201	Z1-2201	HS-2202	HS-2203	HA-2203	YE-2204	YS-2204	YA-2204	ZSH-2201A	ZSL-2201A (ITS)	ZSH-2201B	ZSL-2201B (ITS)	N/A	200-HTCO-HTCH-00002	N/A	N/A	N/A	
WET HANDLING FACILITY (WHF)	050	050-WH00-DR-00003	HTCO	HS-2101	Z1-2101	HS-2102	HS-2103	HA-2103	YE-2104	YS-2104	YA-2104	ZSH-2101	ZSL-2101 (ITS)	N/A	N/A	N/A	050-HTCO-HTCH-00002	N/A	N/A	N/A	
		050-WH00-DR-00004	HTCO	HS-2201	Z1-2201	HS-2202	HS-2203	HA-2203	YE-2204	YS-2204	YA-2204	ZSH-2201	ZSL-2201 (ITS)	N/A	N/A	N/A	050-HTCO-HTCH-00001	N/A	N/A	N/A	

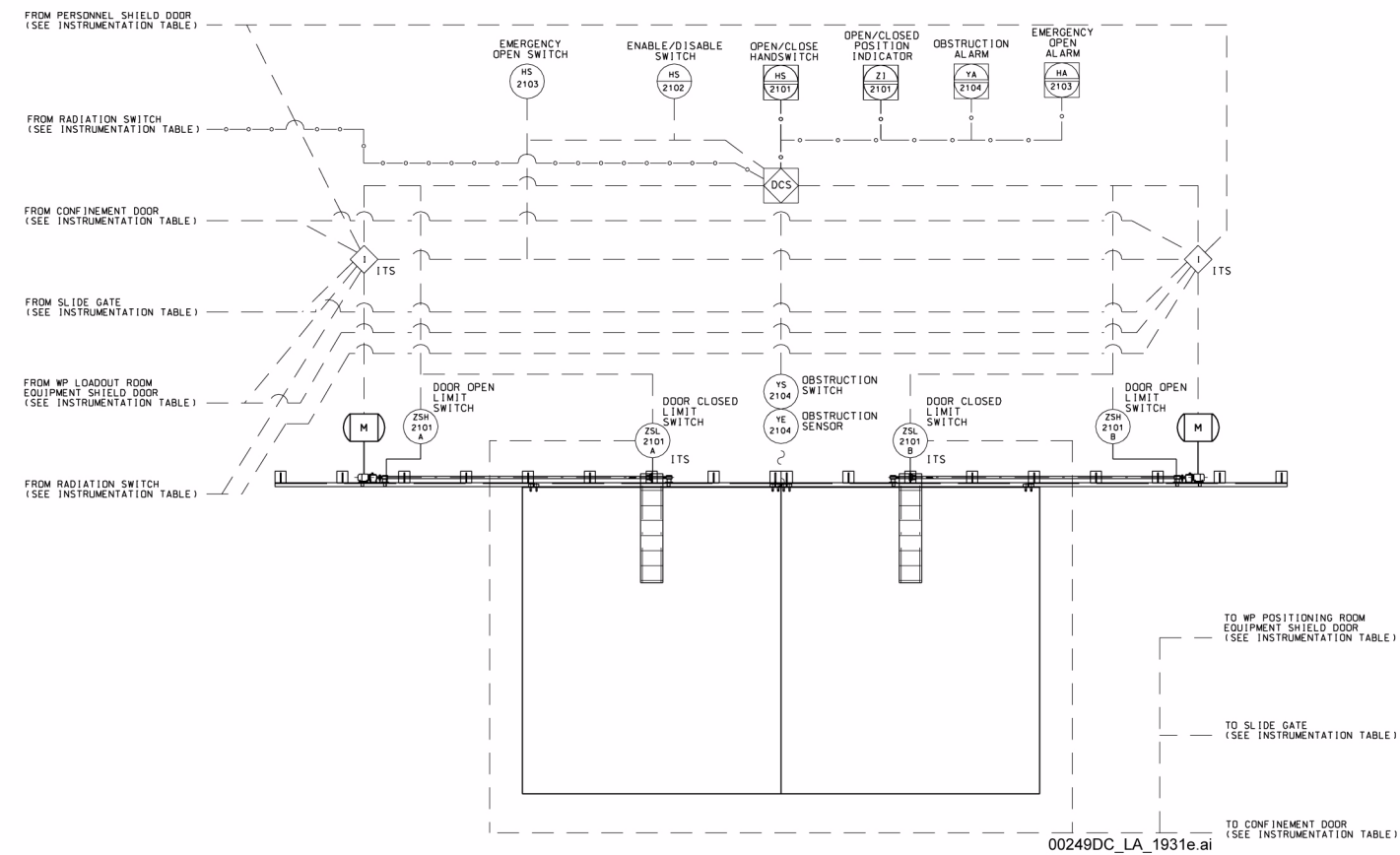

EQUIPMENT SHIELD DOOR INSTRUMENTATION

EXAMPLE DIAGRAM. SEE INSTRUMENTATION TABLE FOR APPLICABLE INSTRUMENTS AND INTERFACES. DOUBLE DOOR SYSTEM AS SHOWN. SINGLE DOOR SYSTEM SIMILAR.

NOTE: Instrumentation tag numbers are prefixed by "XXX-YYYY-" where XXX is the area code and YYYY is the system code.

Figure 1.2.4-20. Equipment Shield Door Process and Instrumentation Diagram

INTENTIONALLY LEFT BLANK

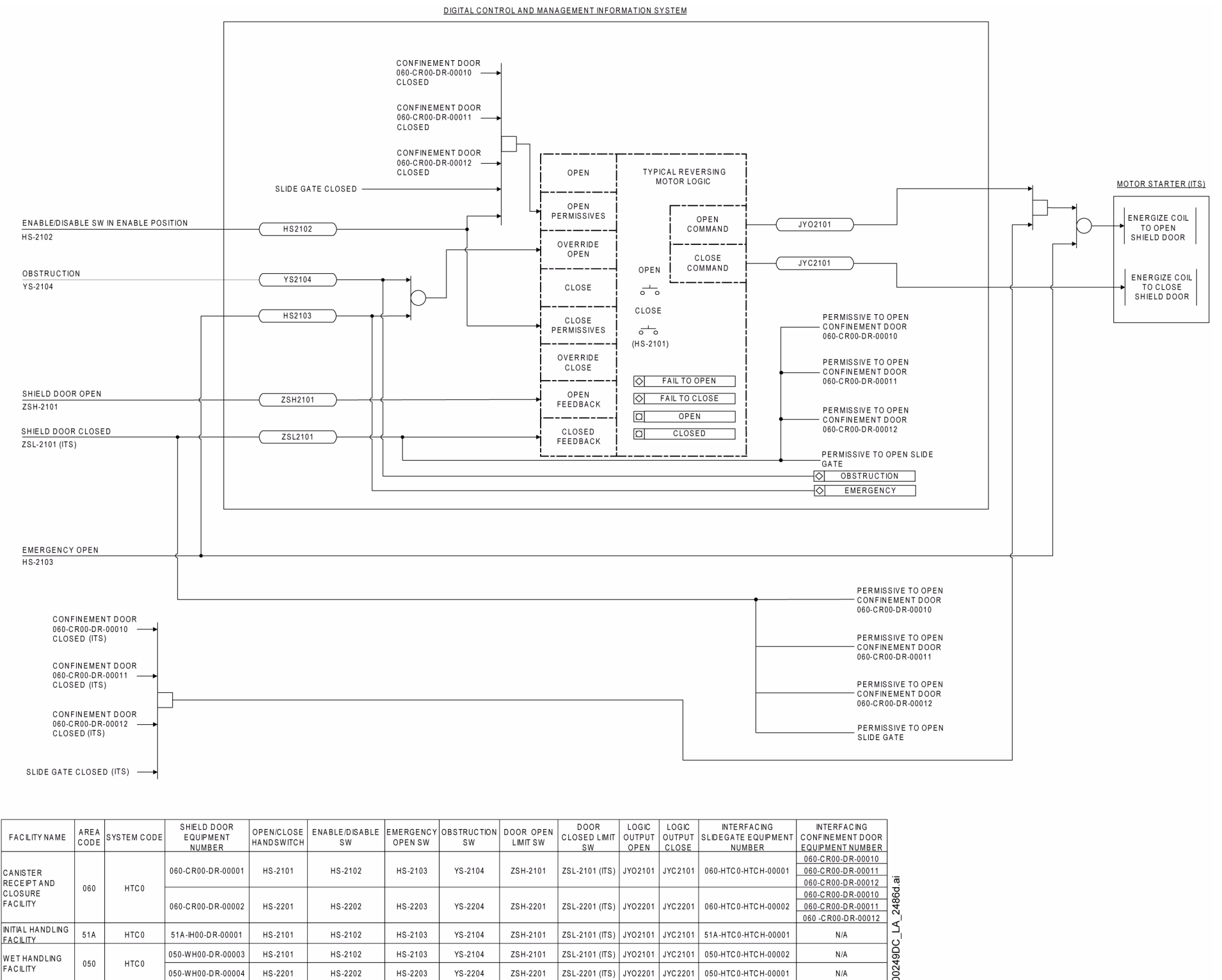

NOTE: ITS controls are identified by the letters "ITS" after the instrumentation tag number or control device identifier. The DCMIS is non-ITS and non-ITWI. Instrumentation tag numbers are prefixed by "XXX-YYYY-" and software tag numbers are prefixed by "XXXYYYYY," where XXX is the area code and YYYY is the system code.

Figure 1.2.4-21. Logic Diagram for Equipment Shield Door—Single (Types 1 and 4)

INTENTIONALLY LEFT BLANK

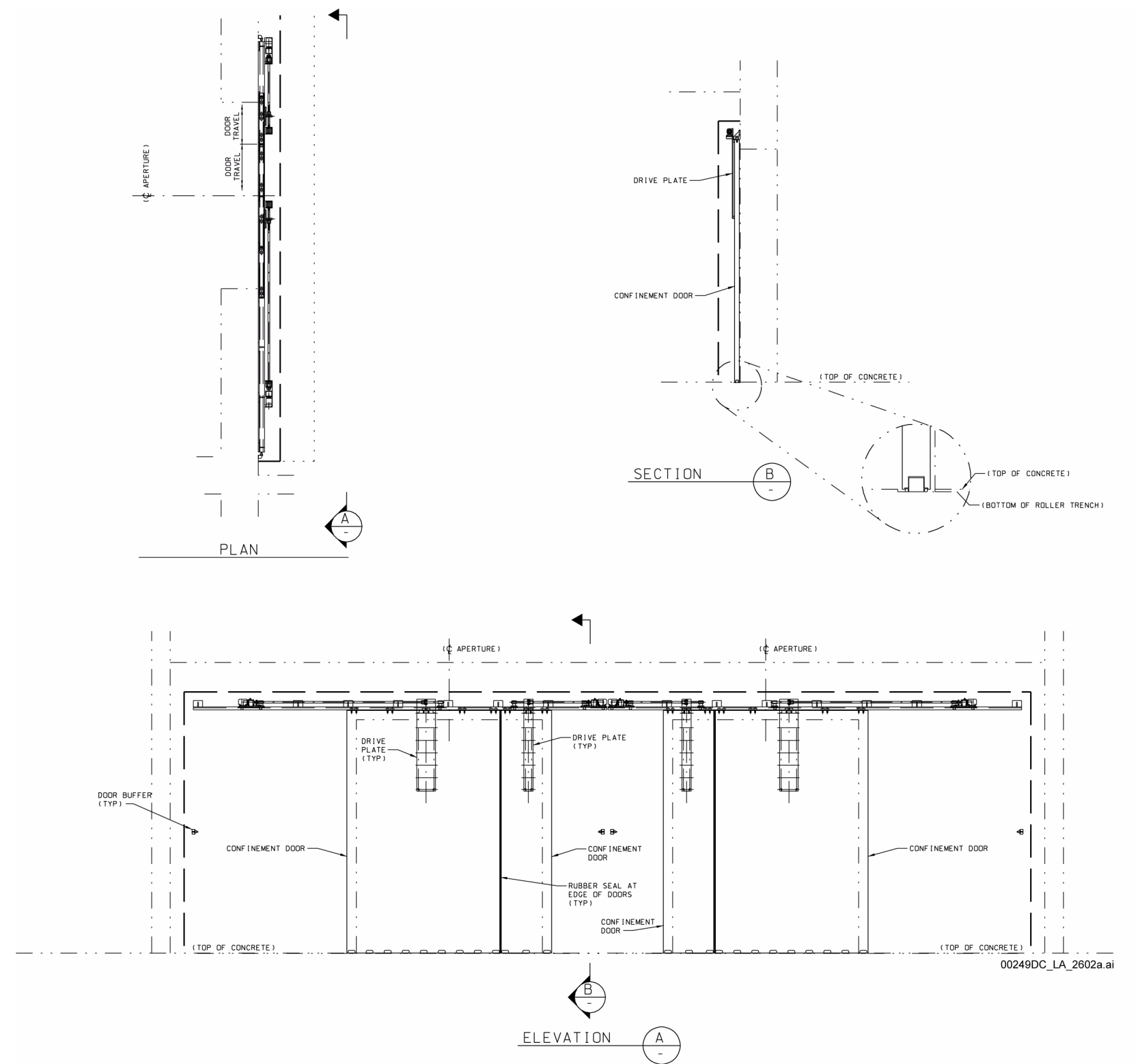

00249DC_LA_2602a.ai

Figure 1.2.4-22. Cask Preparation Room Equipment Confinement Door East Mechanical Equipment Envelope

Equipment Number: 060-CR00-DR-00011/00012.

INTENTIONALLY LEFT BLANK

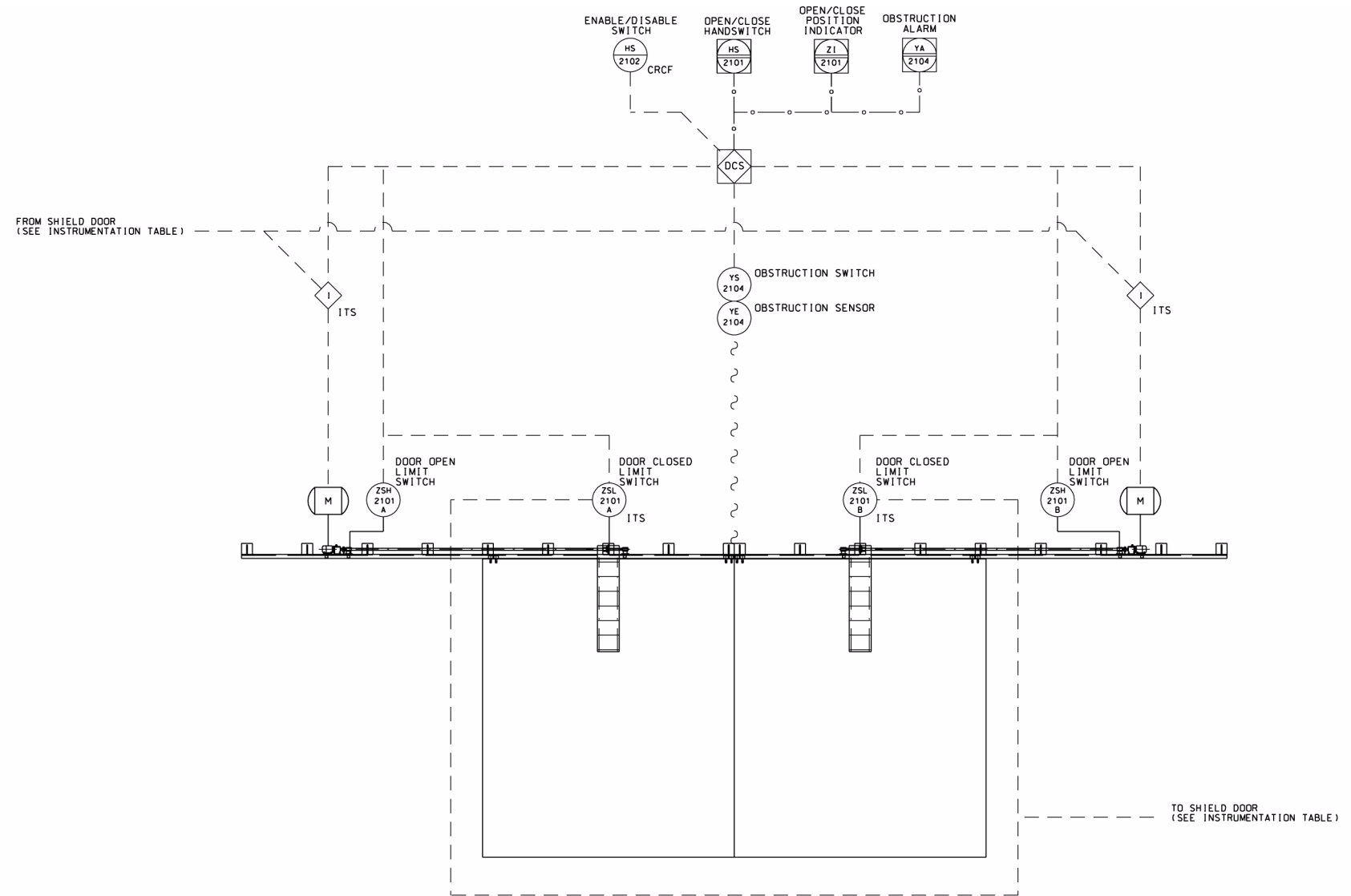

EQUIPMENT CONFINEMENT DOOR INSTRUMENTATION

EXAMPLE DIAGRAM - SEE INSTRUMENTATION TABLE FOR APPLICABLE INSTRUMENTS AND INTERFACES
 DOUBLE DOOR SYSTEM AS SHOWN
 SINGLE DOOR SYSTEM SIMILAR

INSTRUMENTATION TABLE

FACILITY NAME	FACILITY AREA NO.	CONFINEMENT DOOR EQUIPMENT NUMBER	INSTRUMENT SYSTEM CODE	OPEN/CLOSE HANDSWITCH	OPEN/CLOSE POSITION INDICATOR	ENABLE/DISABLE SWITCH	OBSTRUCTION			DOOR LIMIT SWITCHES (SINGLE OR DOUBLE DOOR SYSTEM)				INTERFACING SHIELD DOOR EQUIPMENT NUMBER	
							SENSOR	SWITCH	ALARM	DOOR OPEN LIMIT SWITCH	DOOR CLOSED LIMIT SWITCH	DOOR OPEN LIMIT SWITCH	DOOR CLOSED LIMIT SWITCH		
CANISTER RECEIPT AND CLOSURE FACILITY (CRCF)	060	060-CR00-DR-00010	HMHO	HS-2101	ZI-2101	HS-2102	YE-2104	YS-2104	YA-2104	ZSH-2101A	ZSL-2101A (ITS)	ZSH-2101B	ZSL-2101B (ITS)	060-CR00-DR-00001 060-CR00-DR-00002	
		060-CR00-DR-00011	HMHO	HS-2201	ZI-2201	HS-2202	YE-2204	YS-2204	YA-2204	ZSH-2201A	ZSL-2201A (ITS)	ZSH-2201B	ZSL-2201B (ITS)	060-CR00-DR-00001 060-CR00-DR-00002	
		060-CR00-DR-00012	HMHO	HS-2301	ZI-2301	HS-2302	YE-2304	YS-2304	YA-2304	ZSH-2301A	ZSL-2301A (ITS)	ZSH-2301B	ZSL-2301B (ITS)	060-CR00-DR-00001 060-CR00-DR-00002	
RECEIPT FACILITY (RF)	200	200-RF00-DR-00003	NDN-ITS	HMHO	HS-2101	ZI-2101	HS-2102	YE-2104	YS-2104	YA-2104	ZSH-2101A	ZSL-2101A	ZSH-2101B	ZSL-2101B	200-RF00-DR-00001
WET HANDLING FACILITY (WHF)	050	050-WH00-DR-00001	NDN-ITS	HMHO	HS-2101	ZI-2101	HS-2102	YE-2104	YS-2104	YA-2104	ZSH-2101	ZSL-2101	N/A	N/A	N/A

Figure 1.2.4-23. Nuclear Facilities Equipment Confinement Door Process and Instrumentation Diagram

INTENTIONALLY LEFT BLANK

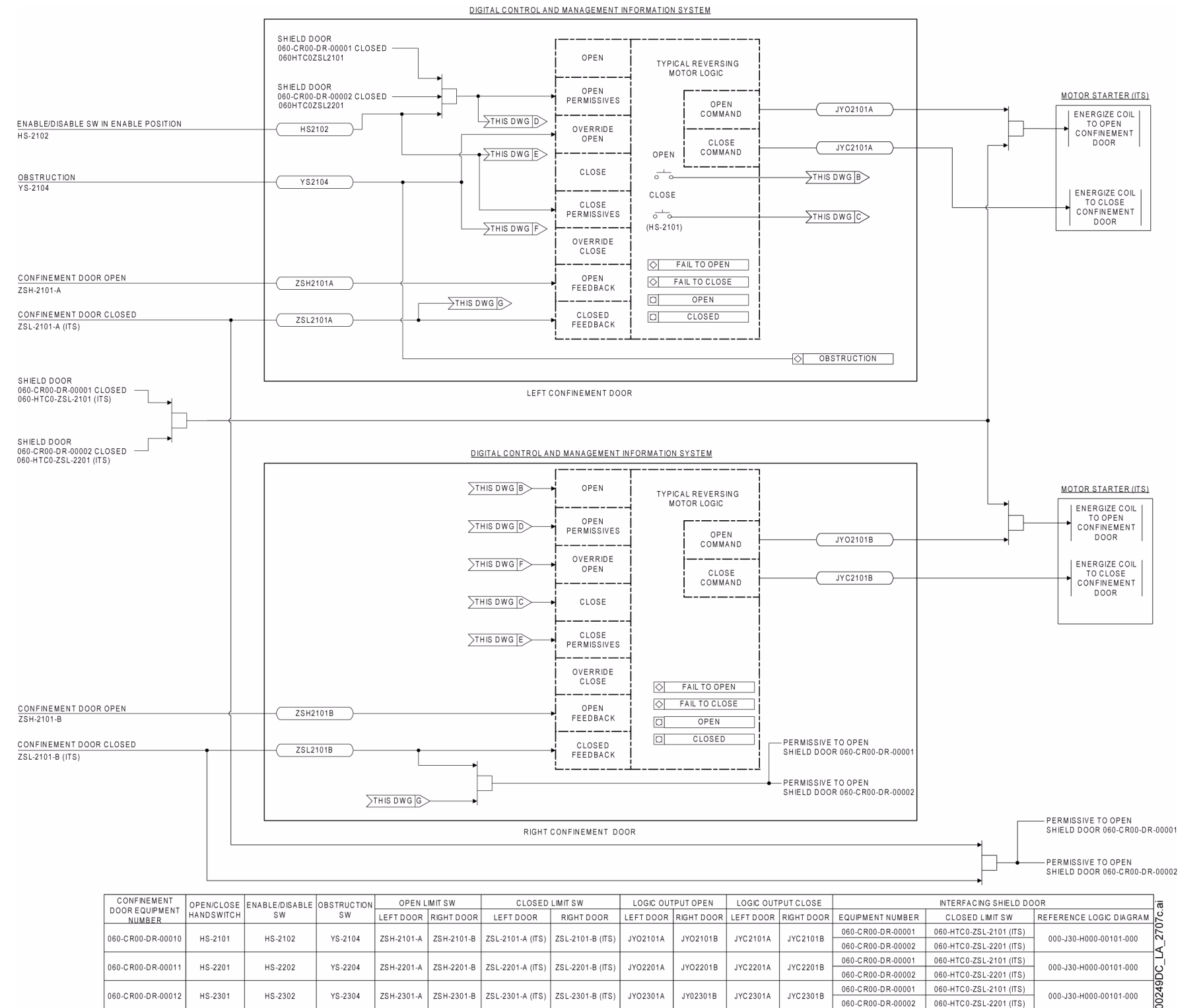

NOTE: ITS controls are identified by the letters "ITS" after the instrumentation tag number or control device identifier. The DCMIS is non-ITS and non-ITWI. Instrumentation tag numbers are prefixed by "XXX-HMH0-" and software tag numbers are prefixed by "XXXHMH0," where XXX is the area code.

Figure 1.2.4-24. Logic Diagram for Equipment Confinement Doors—Double

INTENTIONALLY LEFT BLANK

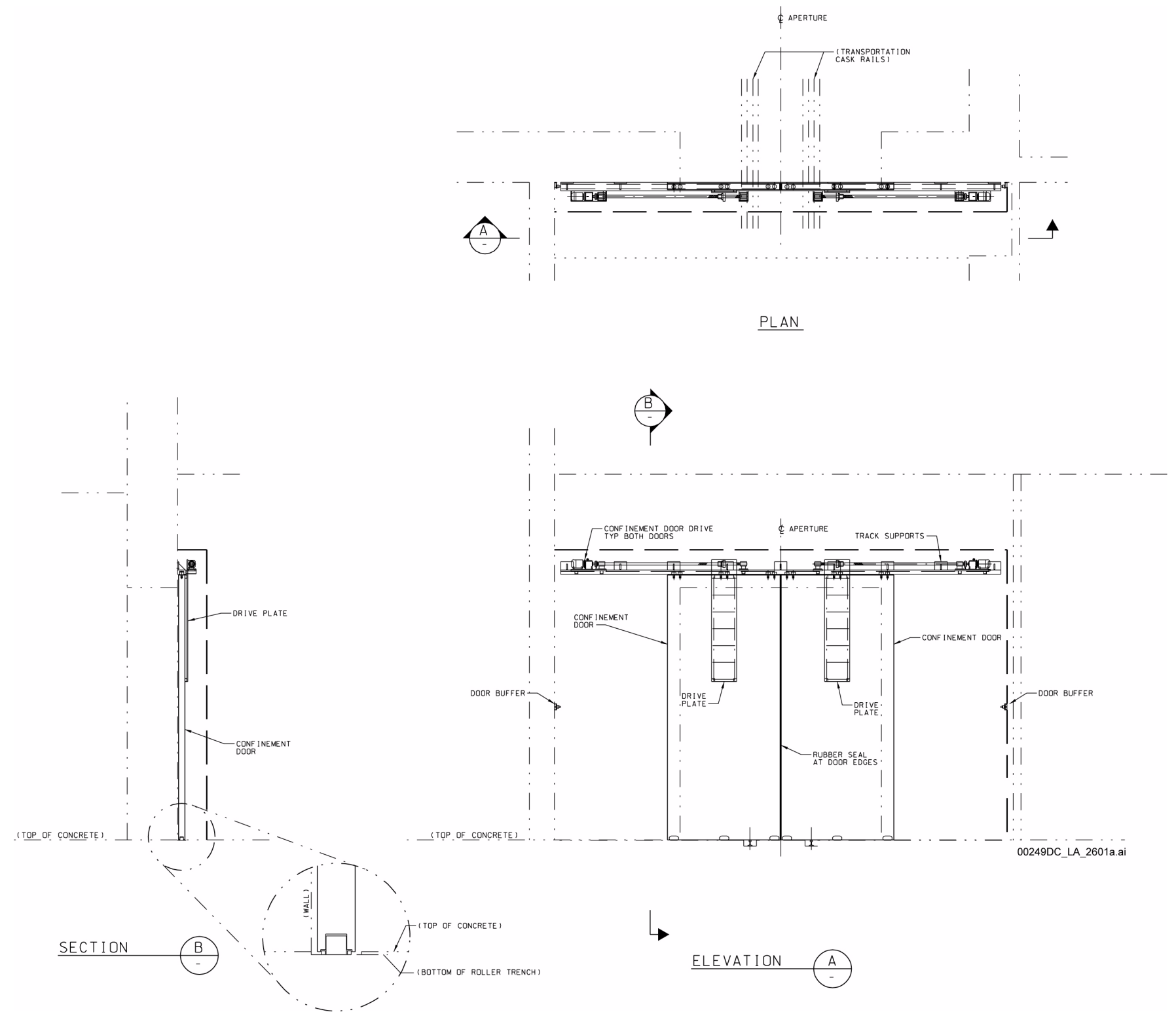
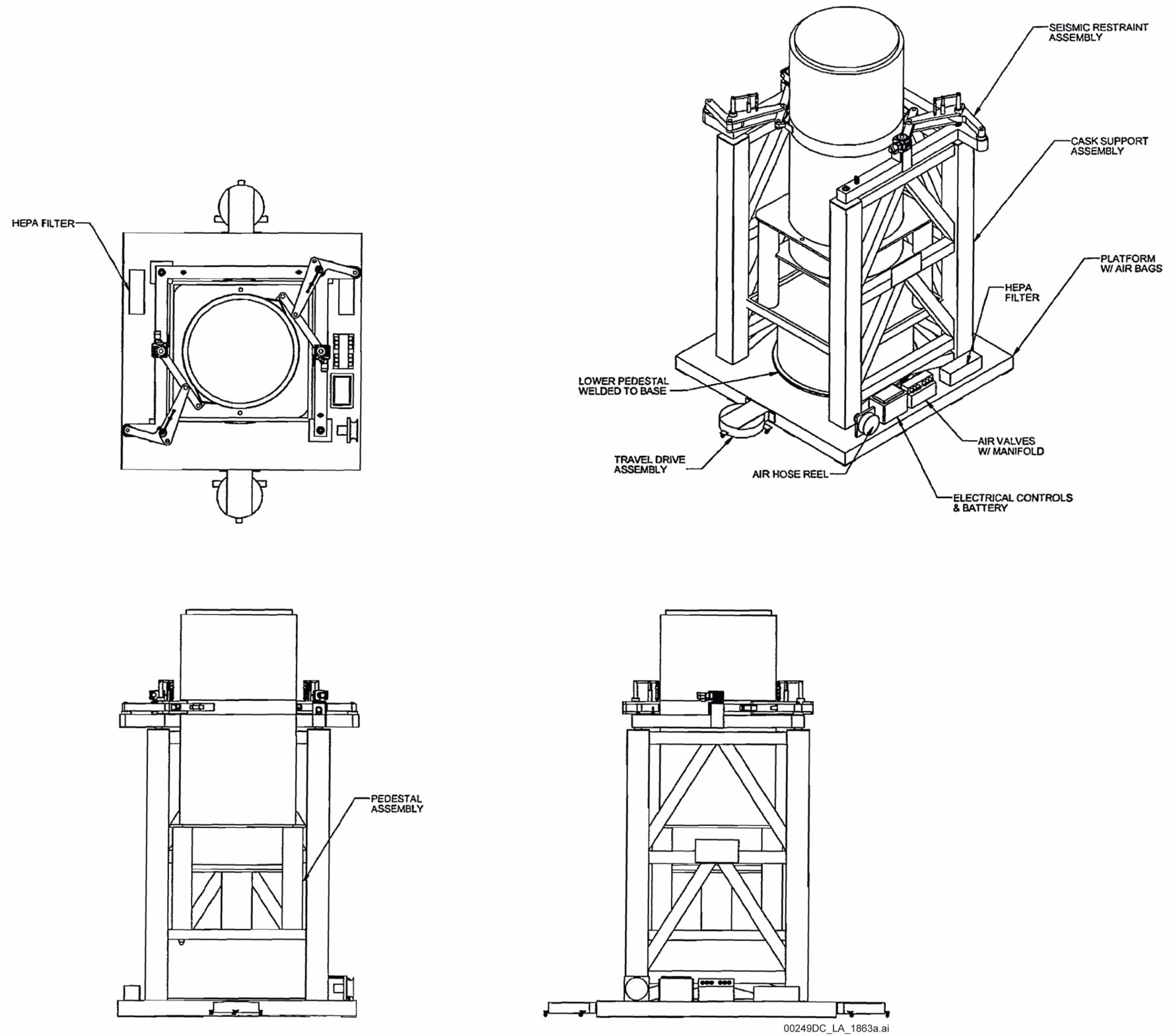

Figure 1.2.4-25. Cask Preparation Room Equipment Confinement Door South Mechanical Equipment Envelope

Equipment Number: 060-CR00-DR-00010, CRCF cask preparation room equipment confinement door south.

INTENTIONALLY LEFT BLANK



NOTE: This equipment is used in the RF, CRCF, and WHF.

Equipment Number: 060-HM00-TRLY-00001/00002, CRCF cask transfer trolley; 200-HM00-TRLY-00001, RF cask transfer trolley; 050-HM00-TRLY-00001, WHF cask transfer trolley.

Figure 1.2.4-26. Cask Transfer Trolley Mechanical Equipment Envelope Plan and Elevations

INTENTIONALLY LEFT BLANK

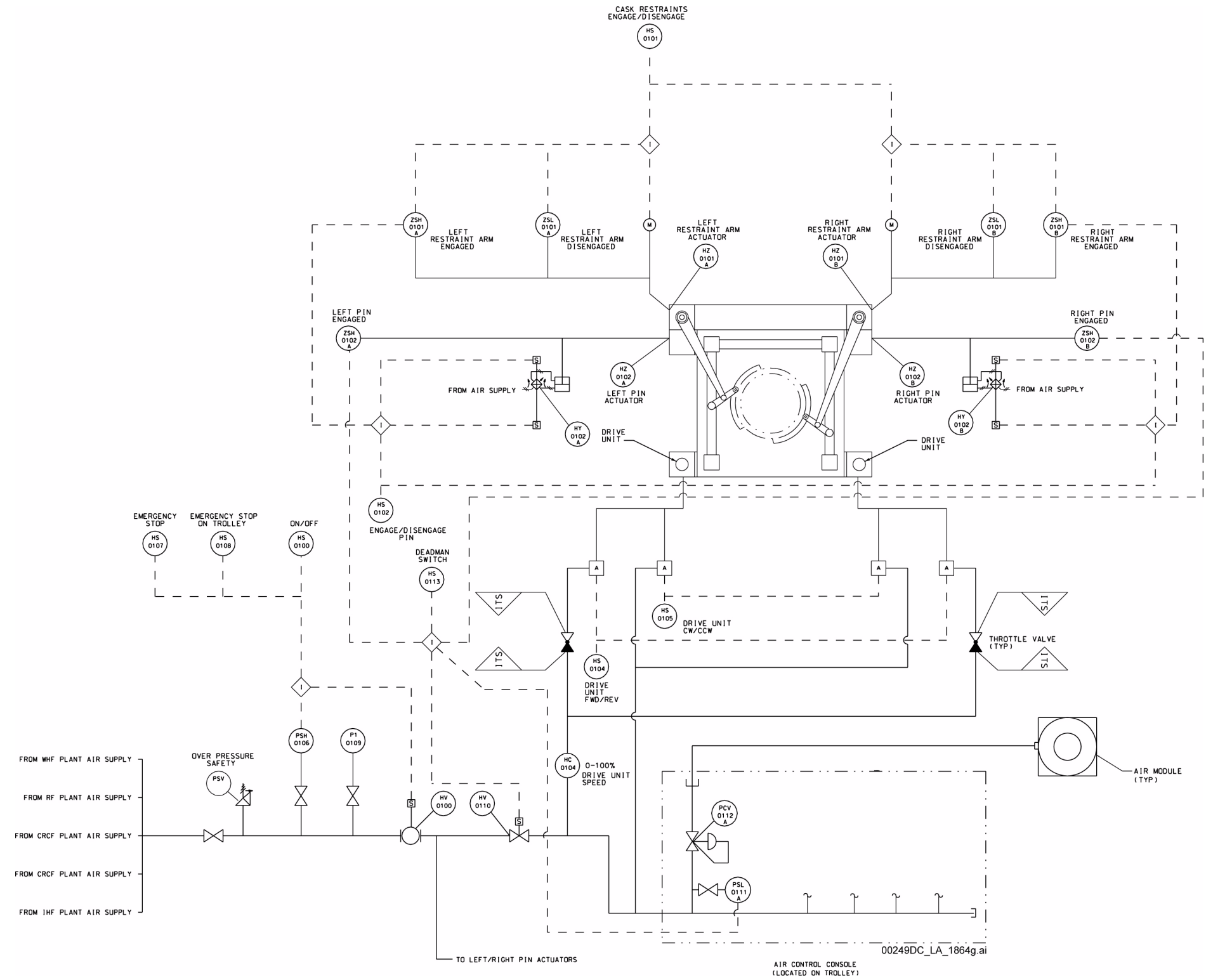

NOTE: This equipment is used in the CRCF, RF, WHF, and IHF.

Equipment Number: 050-HM00-TRLY-00001, WHF cask transfer trolley; 060-HM00-TRLY-00001/00002, CRCF cask transfer trolley; 51A-HM00-TRLY-00001, IHF cask transfer trolley; 200-HM00-TRLY-00001, RF cask transfer trolley.

Figure 1.2.4-27. Cask Transfer Trolley Process and Instrumentation Diagram

INTENTIONALLY LEFT BLANK

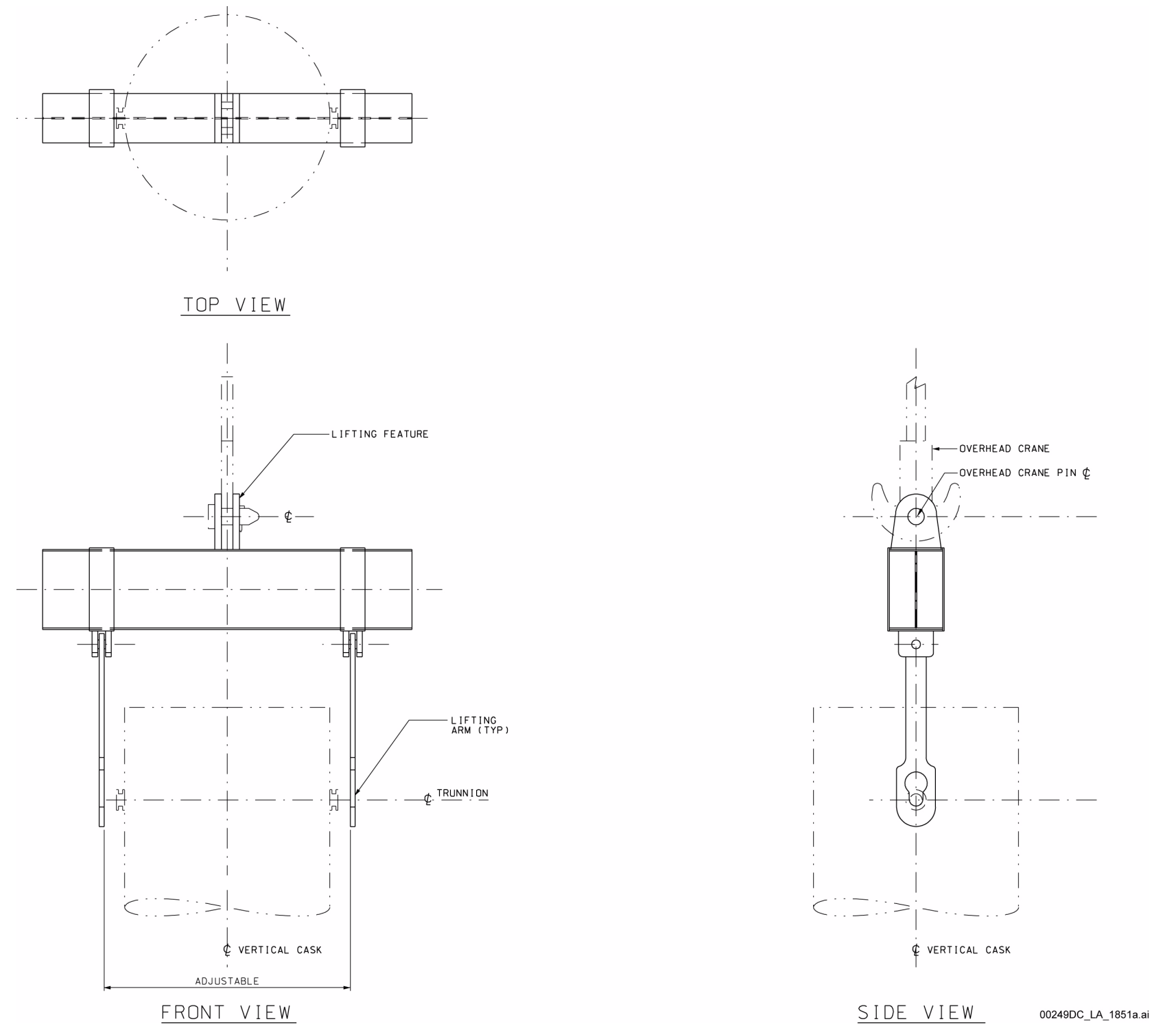

NOTE: This equipment is used in the CRCF, RF, WHF, and IHF.

Equipment Number: 200-HM00-BEAM-00001, RF cask handling yoke; 060-HM00-BEAM-00001, CRCF cask handling yoke; 050-HM00-BEAM-00001, WHF cask handling yoke; 51A-HM00-BEAM-00001, IHF cask handling yoke.

Figure 1.2.4-28. Cask Handling Yoke Mechanical Equipment Envelope

00249DC_LA_1851a.ai

INTENTIONALLY LEFT BLANK

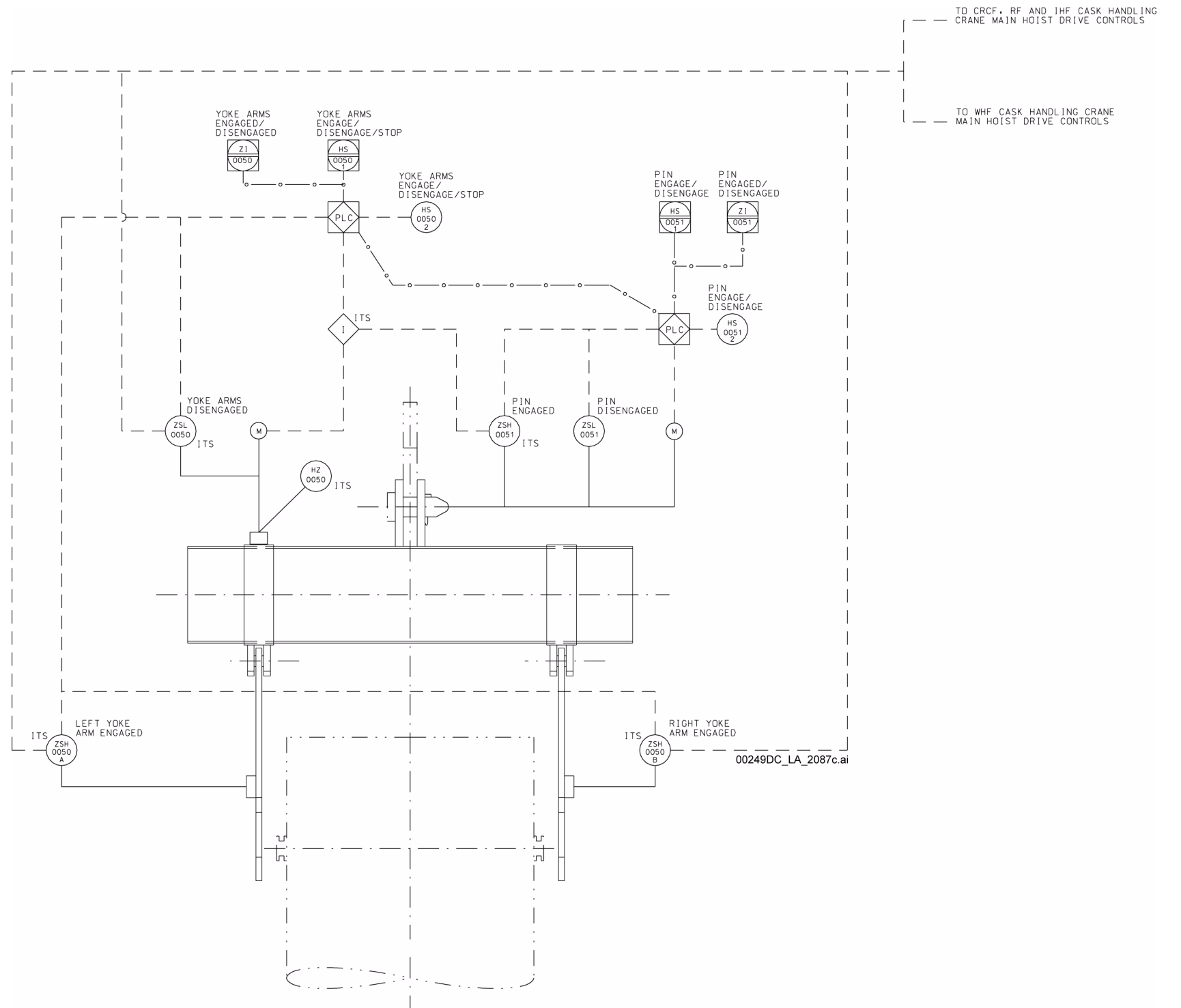

NOTE: This equipment is used in the CRCF, RF, WHF, and IHF.

Equipment Number: 060-HM00-BEAM-00001, CRCF cask handling yoke; 200-HM00-BEAM-00001, RF cask handling yoke; 050-HM00-BEAM-00001, WHF cask handling yoke; 51A-HM00-BEAM-00001, IHF cask handling yoke.

Figure 1.2.4-29. Cask Handling Yoke Process and Instrumentation Diagram

INTENTIONALLY LEFT BLANK

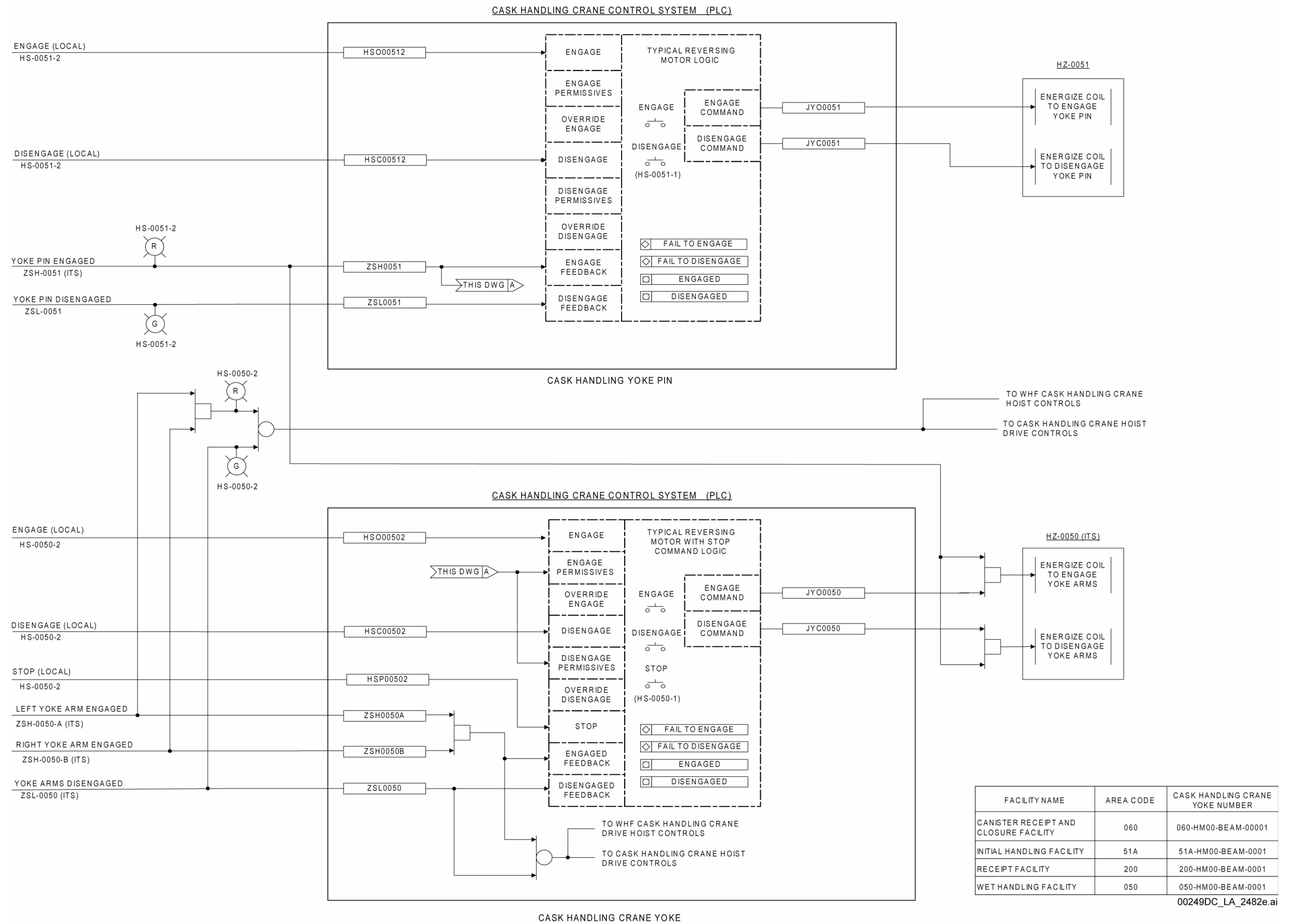

NOTE: ITS controls are identified by the letters "ITS" after the instrumentation tag number or control device identifier. The cask handling crane control system, which controls the cask handling yoke, is non-ITS and non-ITWI. Simultaneous DCMIS and local control is prevented by means of a "local/remote" selector switch associated with the cask handling crane. Instrumentation tag numbers are prefixed by "XXX-HM00-" and software tag numbers are prefixed by "XXXHM00," where XXX is the area code. PLC = programmable logic controller.

Figure 1.2.4-30. Logic Diagram for the Cask Handling Yoke

INTENTIONALLY LEFT BLANK

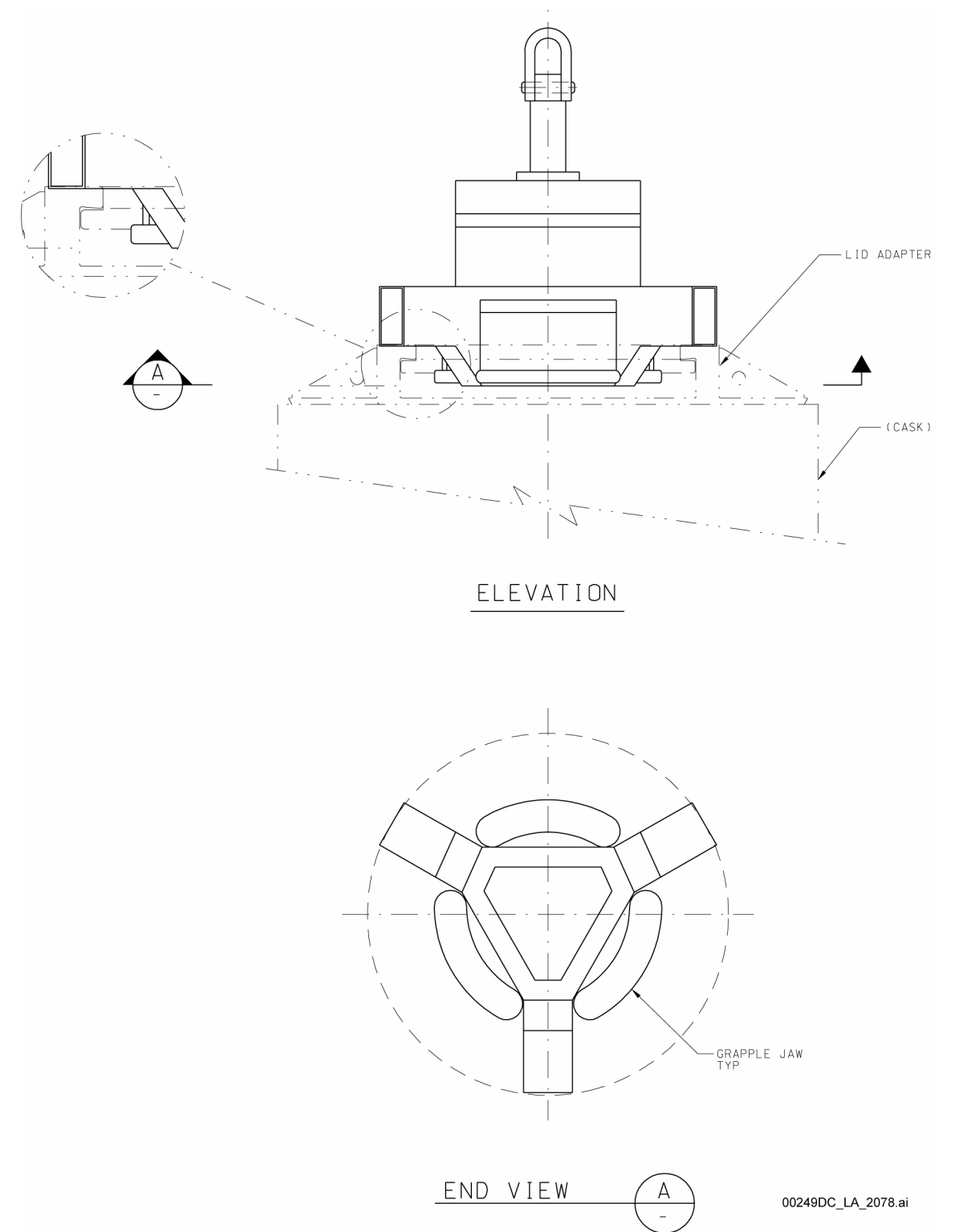

NOTE: This equipment is used in the CRCF and RF.

Equipment Number: 200-HMH0-HEQ-00008, RF cask lid-lifting grapple; 060-HMH0-HEQ-00012, CRCF cask lid-lifting grapple.

Figure 1.2.4-31. Cask Lid-Lifting Grapple Mechanical Equipment Envelope

INTENTIONALLY LEFT BLANK

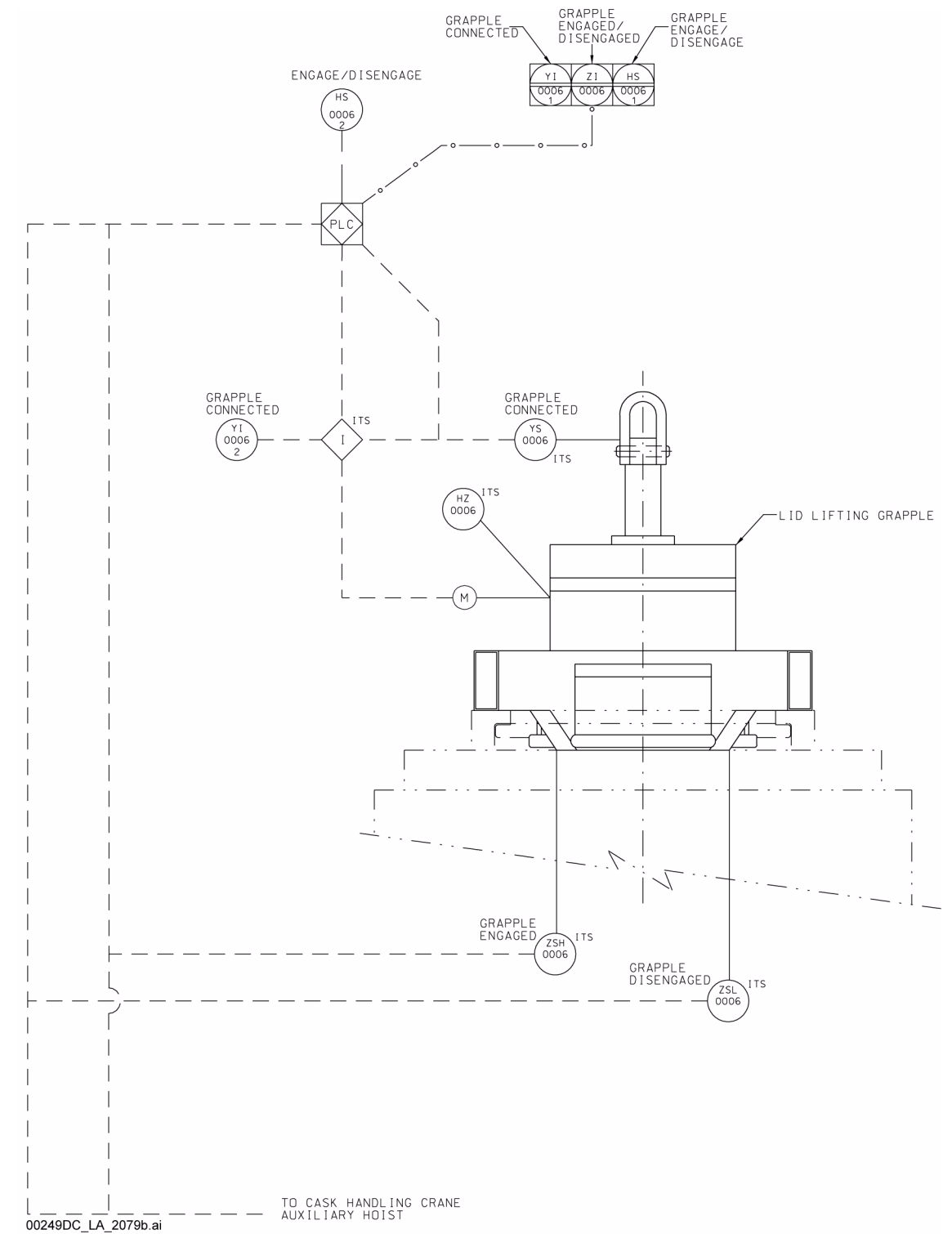

Equipment Number: 060-HMH0-HEQ-00012, CRCF cask lid-lifting grapple; 200-HMH0-HEQ-00008, RF cask lid-lifting grapple.

Figure 1.2.4-32. Cask Lid-Lifting Grapple Process and Instrumentation Diagram

INTENTIONALLY LEFT BLANK

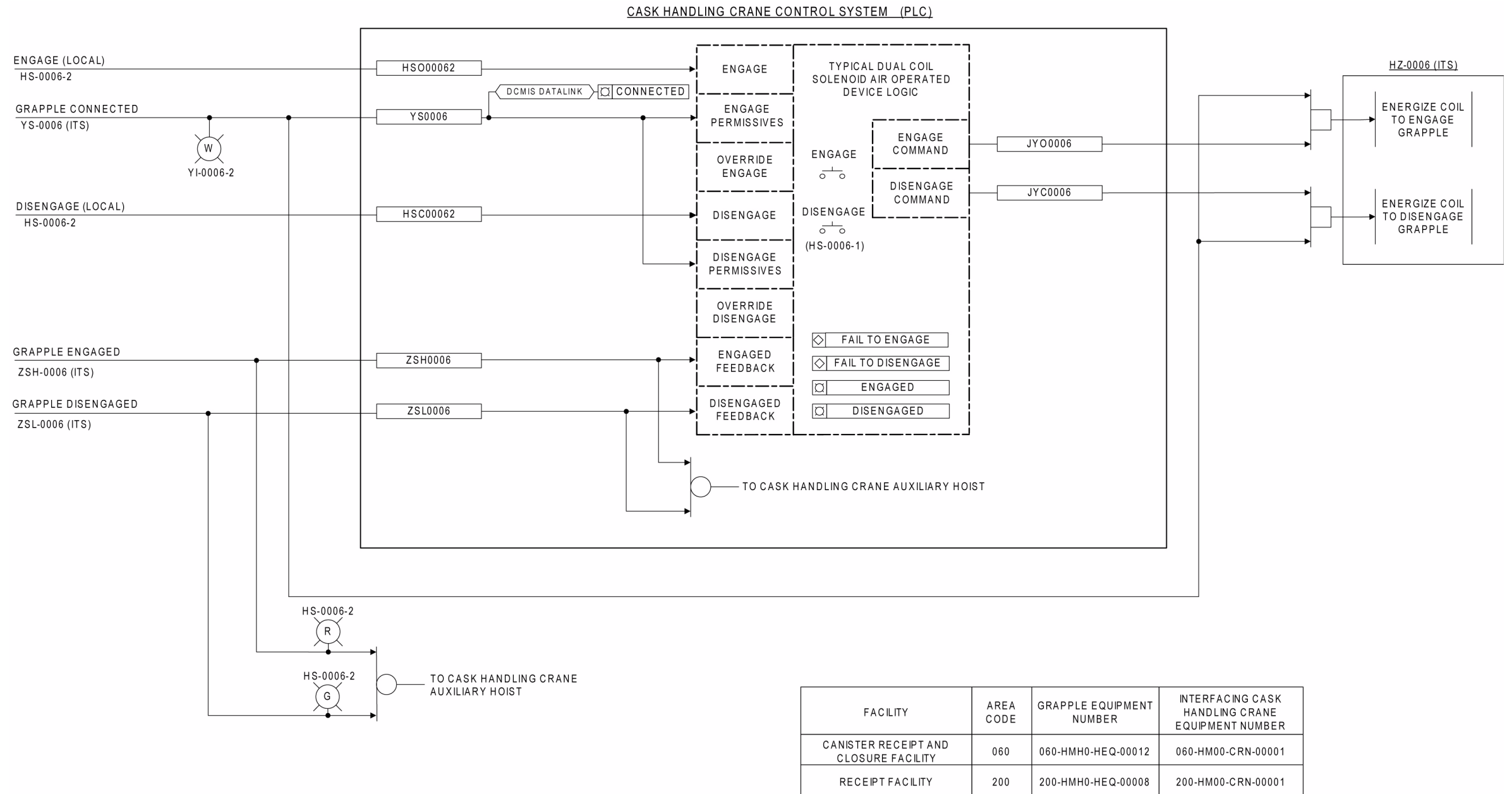

NOTE: ITS controls are identified by the letters "ITS" after the instrumentation tag number or control device identifier. The cask handling crane control system, which controls the grapple, is non-ITS and non-ITWI. Simultaneous DCMIS and local control is prevented by means of a "local/remote" selector switch associated with the cask handling crane controls. Instrumentation tag numbers are prefixed by "XXX-HMH0-" and software tag numbers are prefixed by "XXXHMH0," where XXX is the area code. PLC = programmable logic controller.

Figure 1.2.4-33. Logic Diagram for the Cask Handling Crane Cask Lid-Lifting Grapple

INTENTIONALLY LEFT BLANK

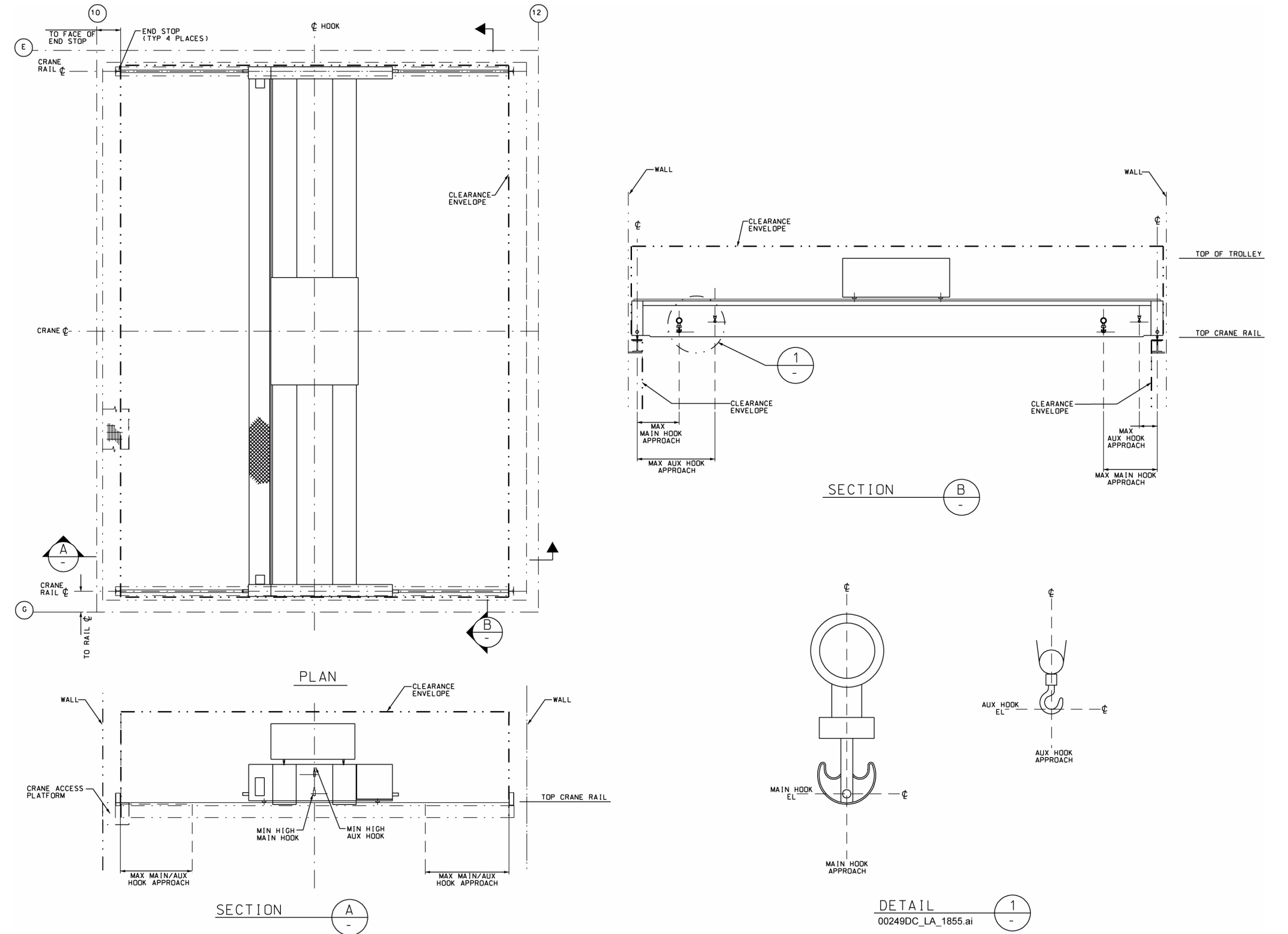
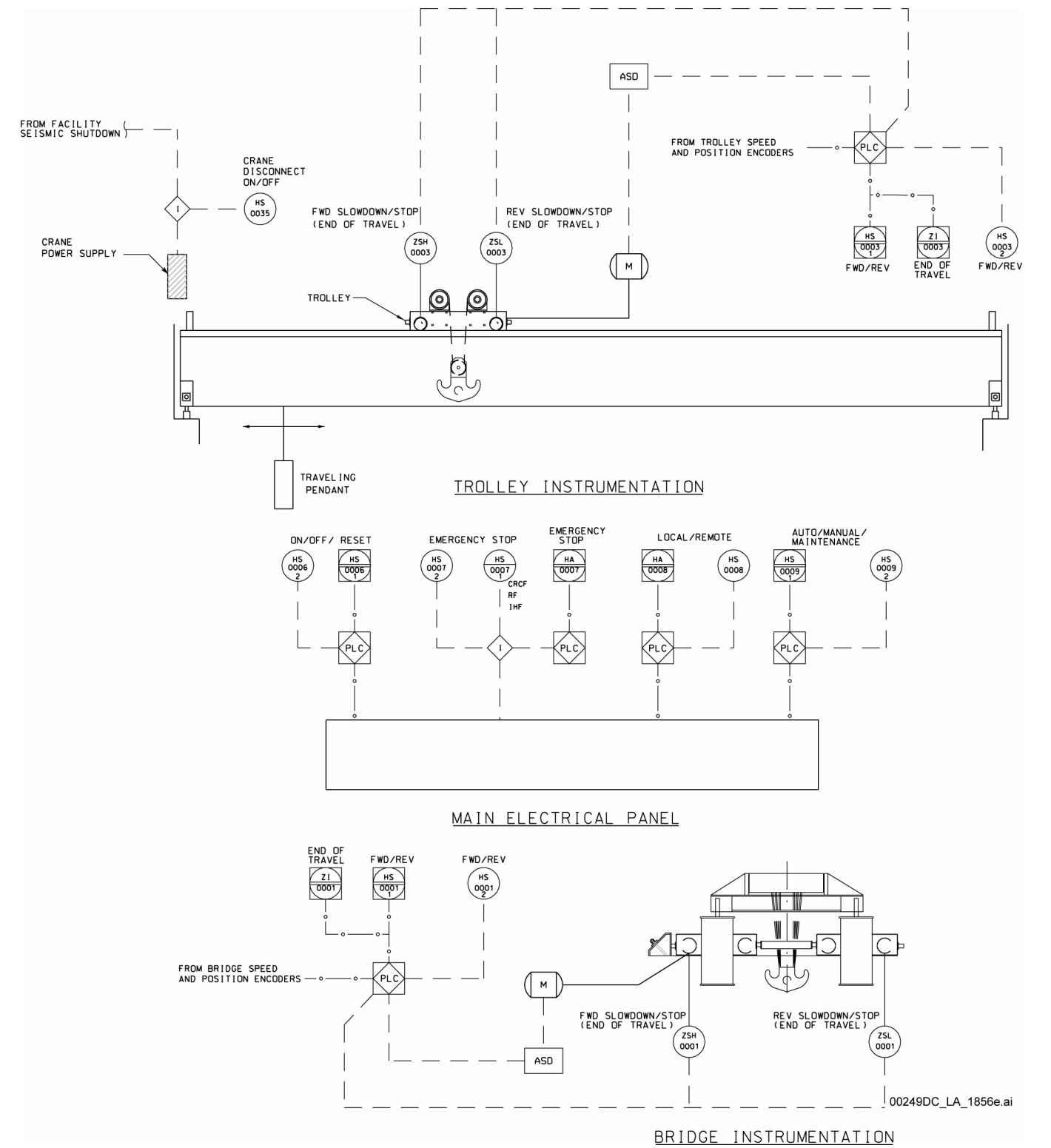

Figure 1.2.4-34. CRCF Cask Handling Crane Mechanical Equipment Envelope

Equipment Number: 060-HM00-CRN-00001, CRCF cask handling crane.

INTENTIONALLY LEFT BLANK



NOTE: This equipment is used in the CRCF, IHF, and RF. ASD = adjustable speed drive.

Equipment Number: 060-HM00-CRN-00001, CRCF cask handling crane; 51A-HM00-CRN-00001, IHF cask handling crane; 200-HM00-CRN-00001, RF cask handling crane.

Figure 1.2.4-35. Cask Handling Crane Process and Instrumentation Diagram (Sheet 1 of 4)

INTENTIONALLY LEFT BLANK

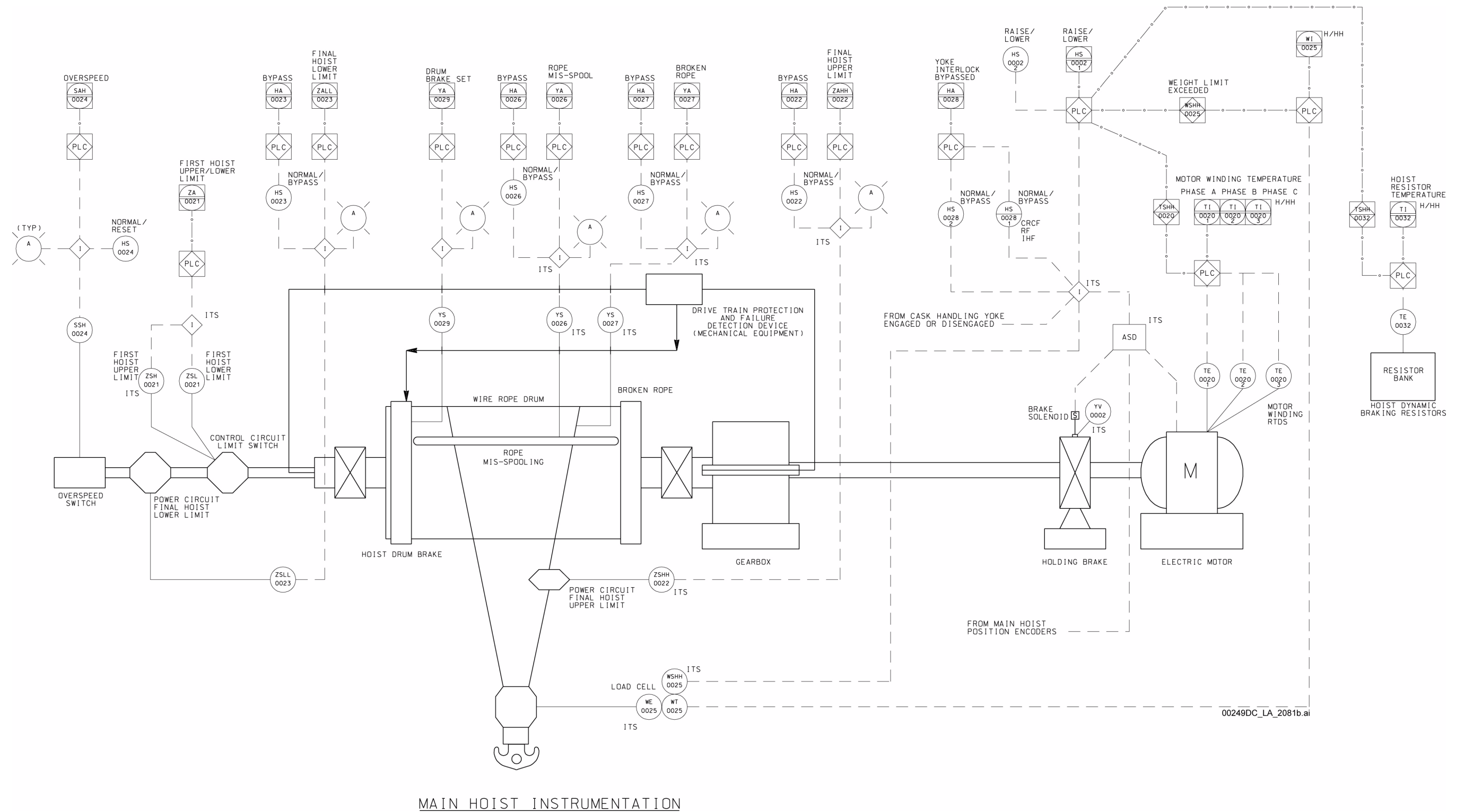

NOTE: This equipment is used in the CRCF, RF, and IHF.
RTDS = resistance temperature detectors.

Figure 1.2.4-35. Cask Handling Crane Process and Instrumentation Diagram (Sheet 2 of 4)

INTENTIONALLY LEFT BLANK

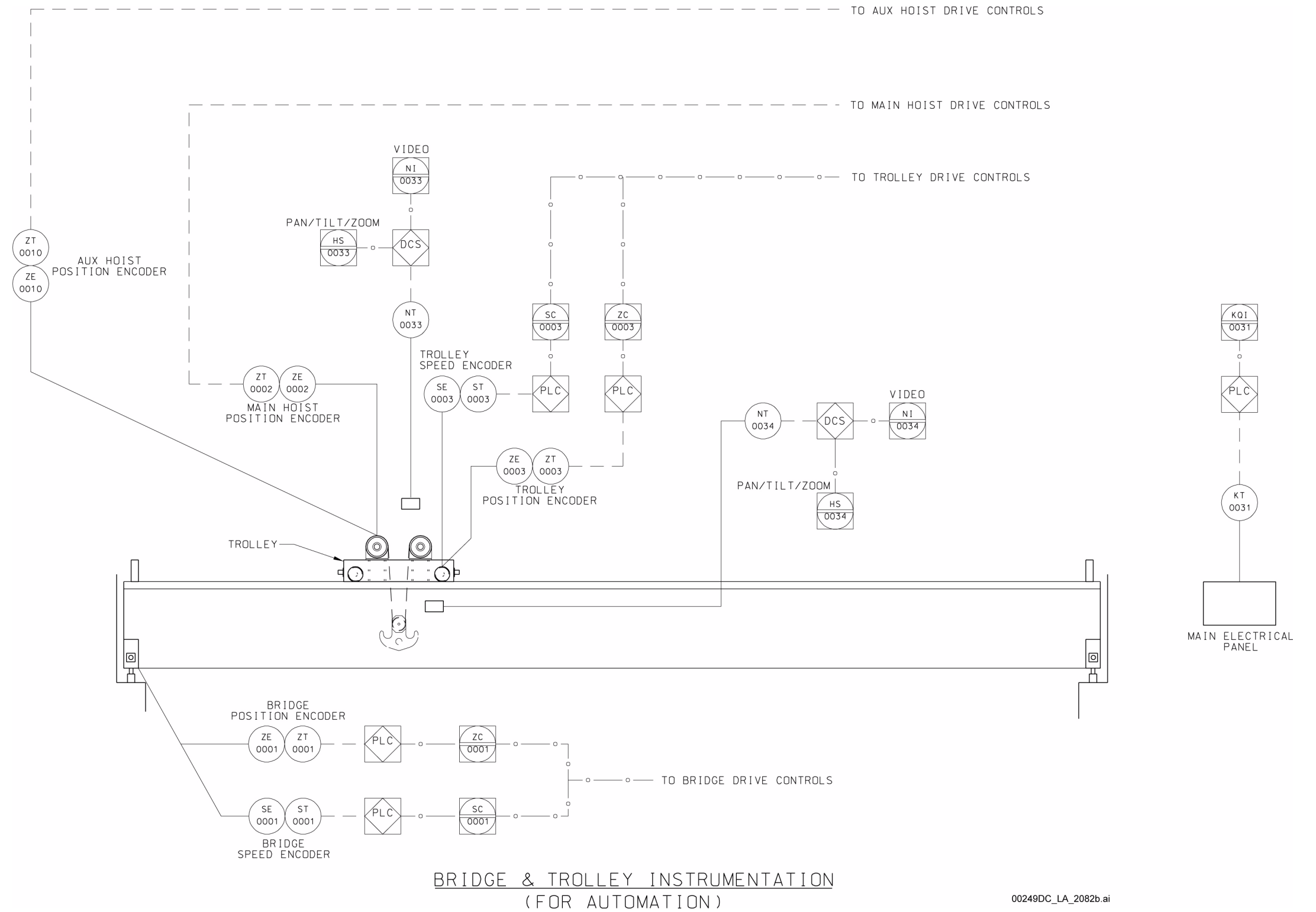

NOTE: This equipment is used in the CRCF, RF, and IHF.

Figure 1.2.4-35. Cask Handling Crane Process and Instrumentation Diagram (Sheet 3 of 4)

00249DC_LA_2082b.ai

INTENTIONALLY LEFT BLANK

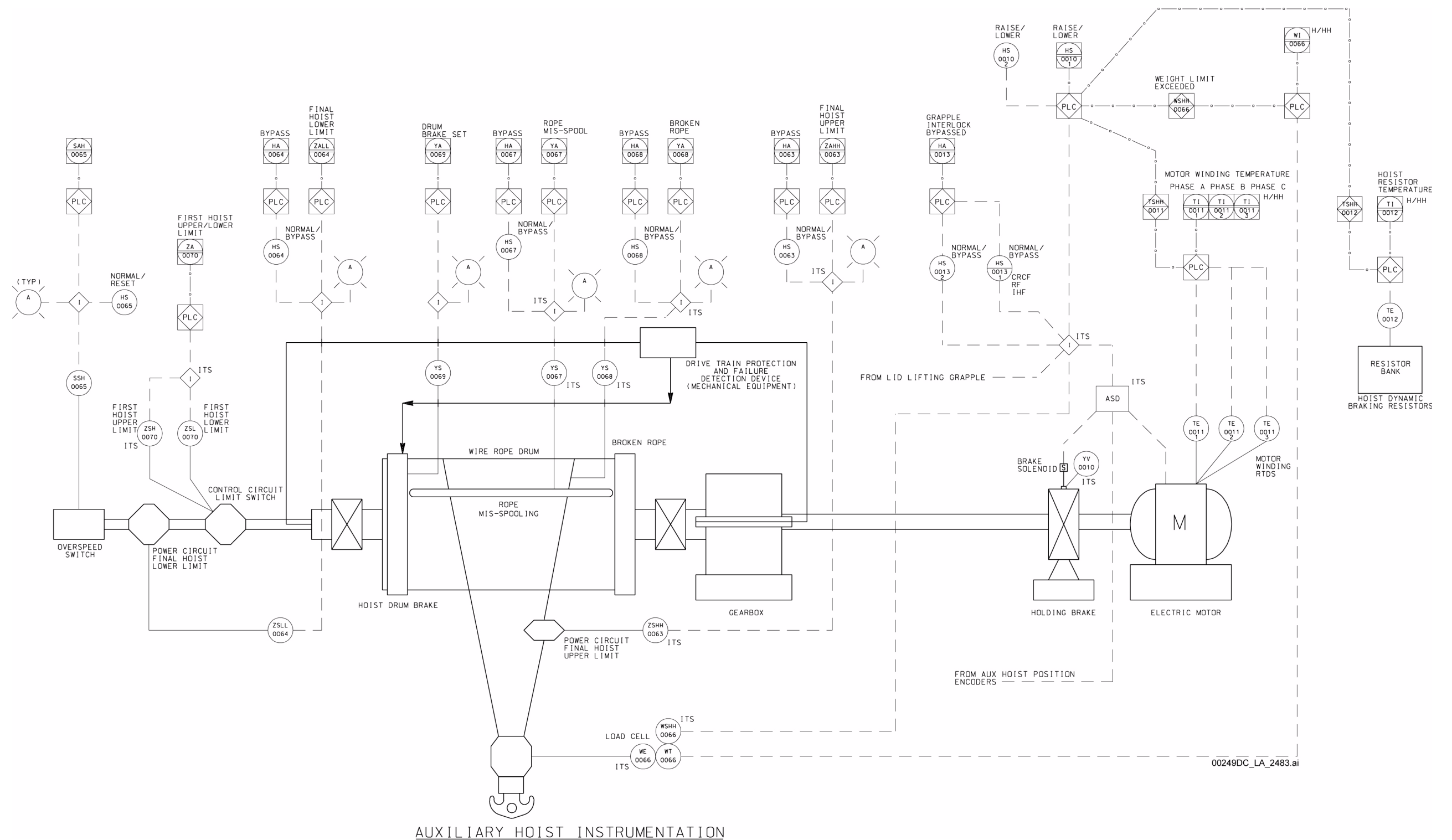

NOTE: This equipment is used in the CRCF and RF.
RTDS = resistance temperature detectors.

Figure 1.2.4-35. Cask Handling Crane Process and Instrumentation Diagram (Sheet 4 of 4)

INTENTIONALLY LEFT BLANK

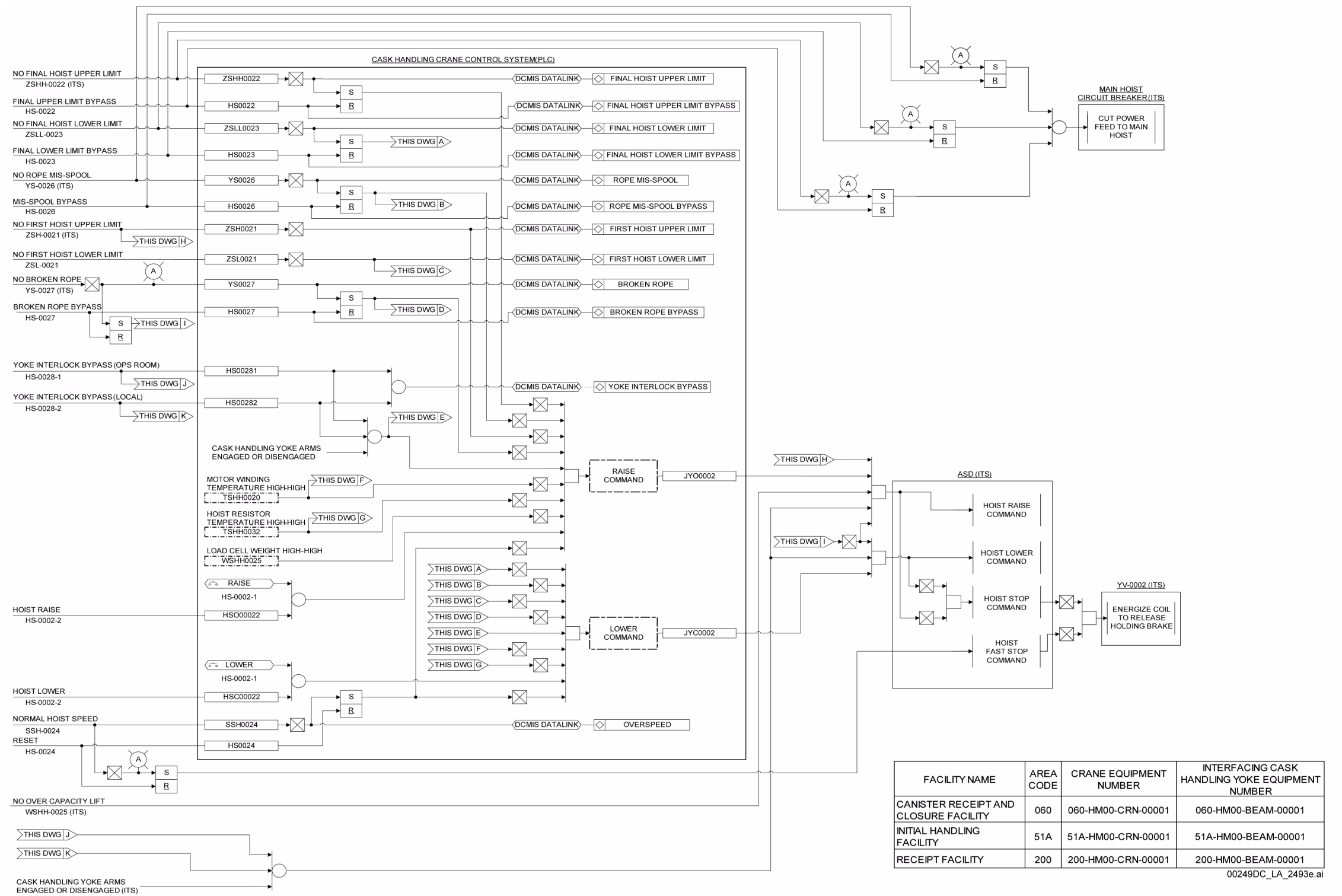

NOTE: ITS controls are identified by the letters "ITS" after the instrumentation tag number or control device identifier. The cask handling crane control system, which controls the main hoist, is non-ITS and non-ITWI. Simultaneous remote and local control is prevented by means of a "local/remote" selector switch associated with the cask handling crane controls. First upper limit shall be set 1 ft above the adjustable speed drive operational upper limit setpoint. Instrumentation tag numbers are prefixed by "060-HM00-", "51A-HM00-", or "200-HM00-", as appropriate. Software tag numbers are prefixed by "51AHM00" or "200HM00," as appropriate. ASD = adjustable speed drive; PLC = programmable logic controller.

Figure 1.2.4-36. Logic Diagram for the Cask Handling Crane Main Hoist

INTENTIONALLY LEFT BLANK

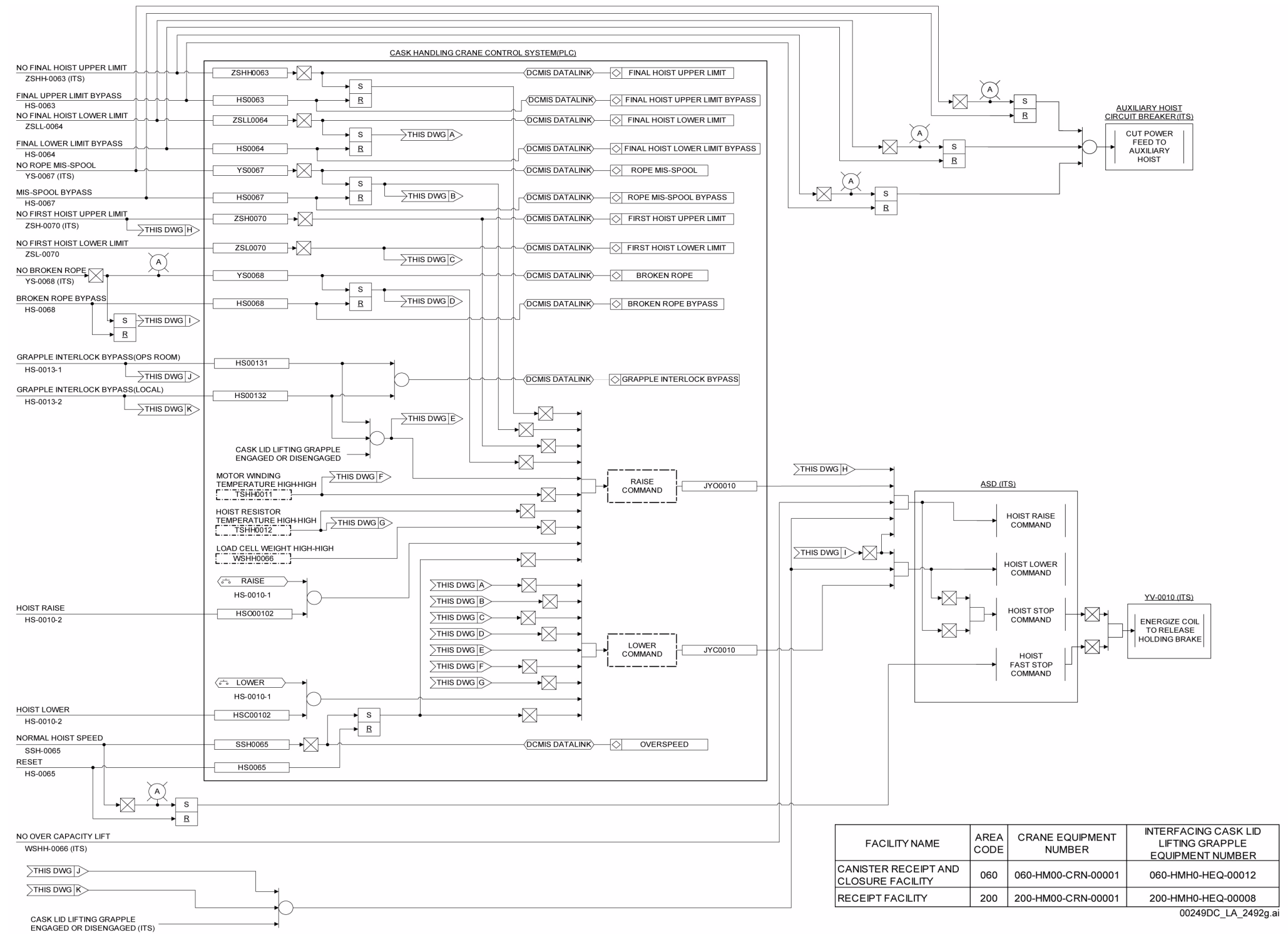

NOTE: ITS controls are identified by the letters "ITS" after the instrumentation tag number or control device identifier. The cask handling crane control system, which controls the auxiliary hoist, is non-ITS and non-ITWI. Simultaneous remote and local control is prevented by means of a "local/remote" selector switch associated with the cask handling crane auxiliary hoist controls. First upper limit shall be set 1 ft above the adjustable speed drive operational upper limit setpoint. Instrumentation tag numbers are prefixed by "060-HM00-" or "200-HM00-" as appropriate, and software tag numbers are prefixed by "060HM00" or "200HM00," as appropriate. ASD = adjustable speed drive; PLC = programmable logic controller.

Figure 1.2.4-37. Logic Diagram for the Cask Handling Crane Auxiliary Hoist

INTENTIONALLY LEFT BLANK

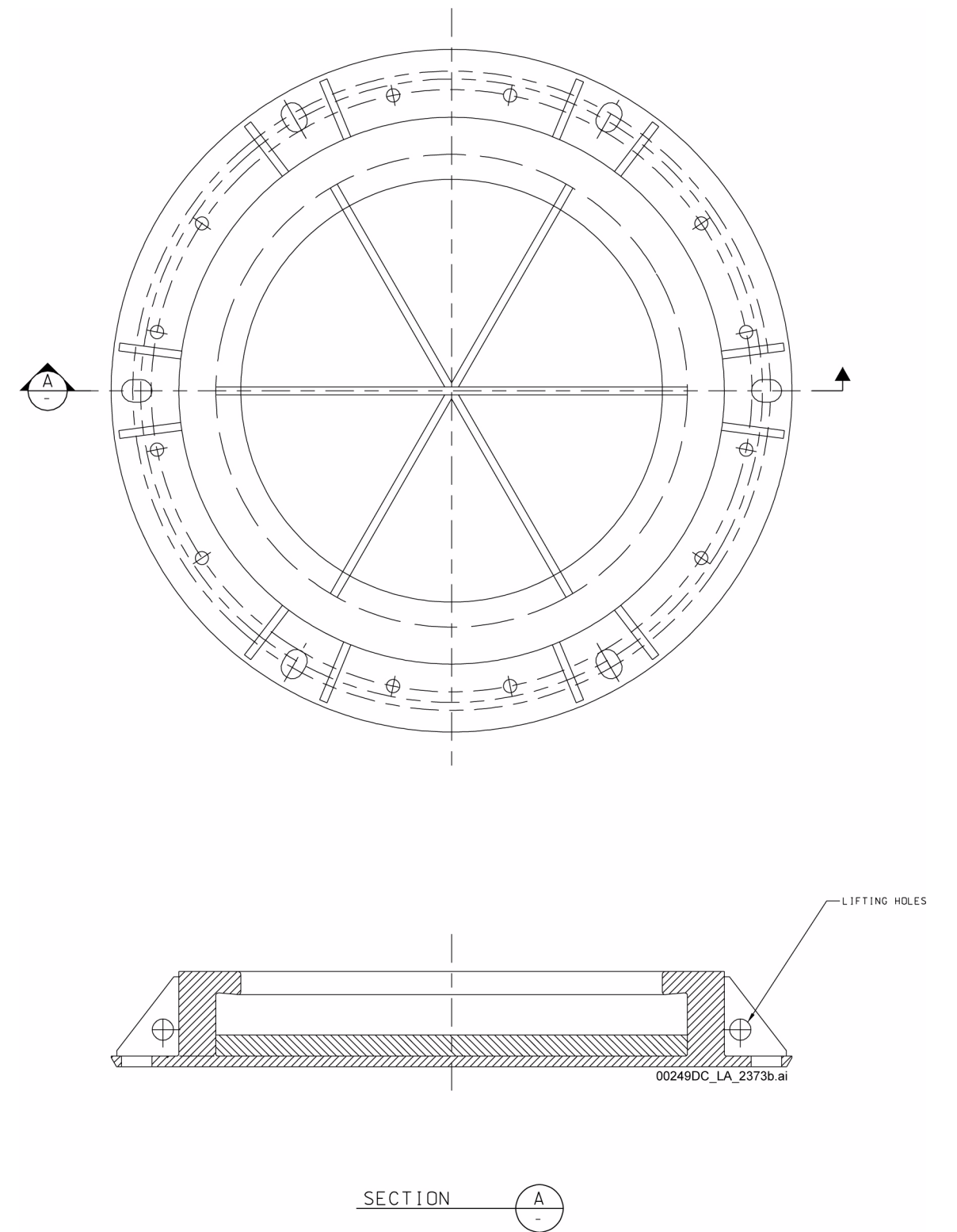

NOTE: This equipment is used in the CRCF, WHF, and RF.

Equipment Number: 050-HMH0-HEQ-00014; 060-HMH0-HEQ-00005; 050-HMH0-HEQ-00006; 200-HMH0-HEQ-00001.

Figure 1.2.4-38. Dual-Purpose Canister Lid Adapter

INTENTIONALLY LEFT BLANK

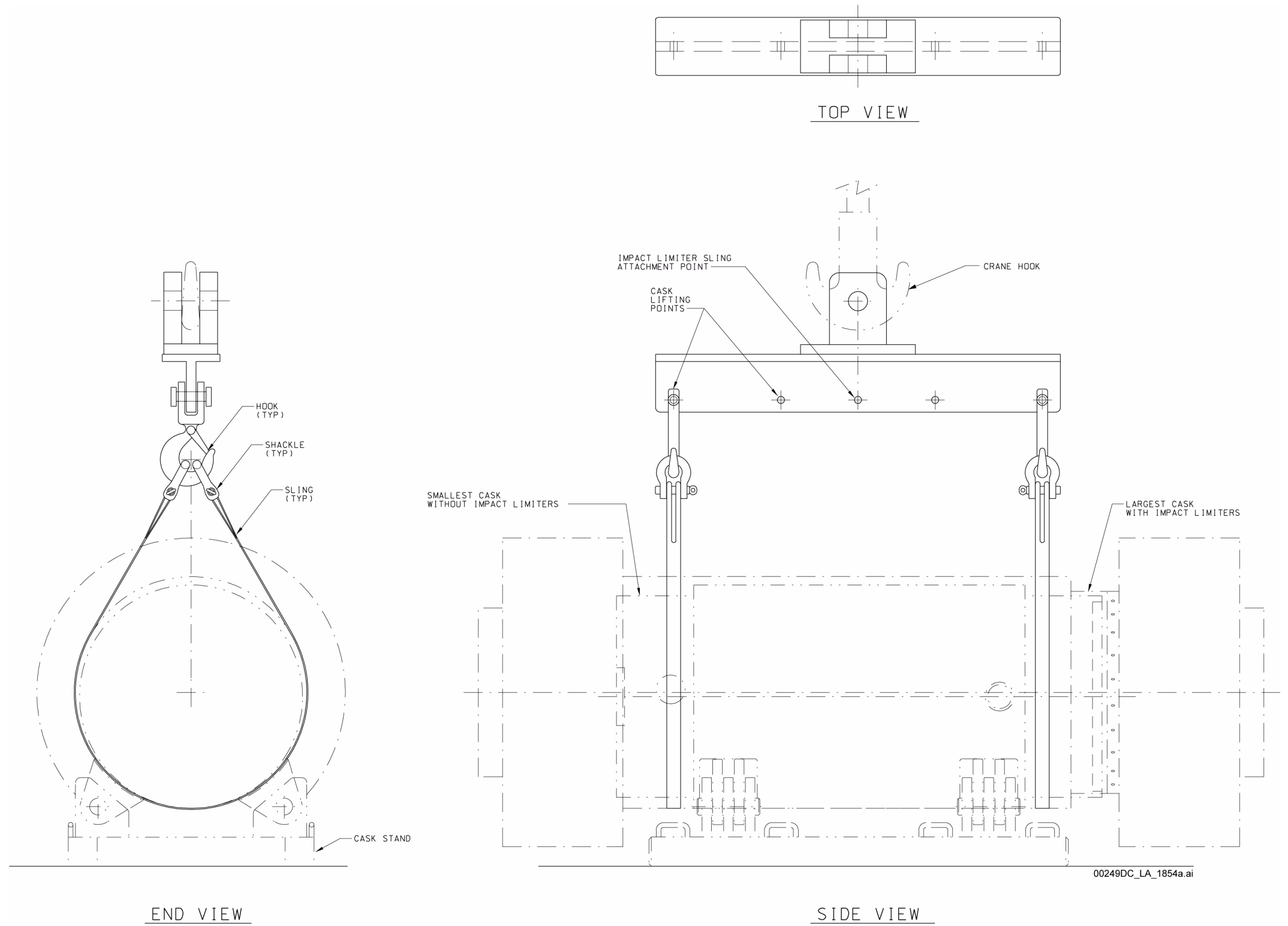

NOTE: This figure includes no SSCs that are ITS or ITWI. This equipment is used in the CRCF and RF.
 Equipment Number: 200-HMC0-BEAM-00001, RF horizontal lifting beam.

Figure 1.2.4-39. Horizontal Lifting Beam Mechanical Equipment Envelope

INTENTIONALLY LEFT BLANK

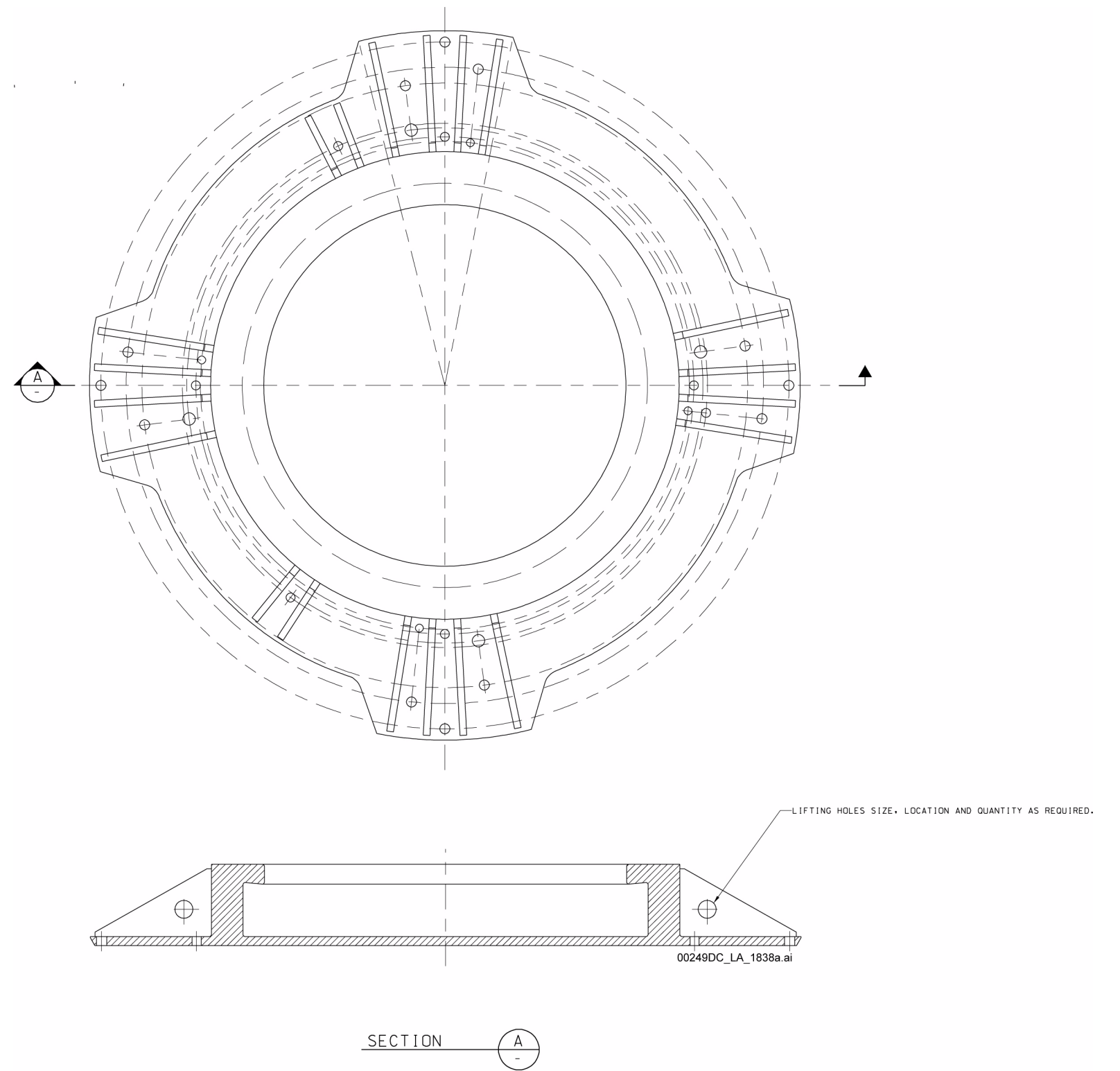

Equipment Number: 050-HMH0-HEQ-00012/00013, WHF rail cask lid adapter; 060-HMH0-HEQ-00003/00004, CRCF rail cask lid adapters; 200-HMH0-HEQ-00002, RF rail cask lid adapter; 51A-HMH0-HEQ-00002, IHF rail cask lid adapter.

Figure 1.2.4-40. Nuclear Facilities Rail Cask Lid Adapter Mechanical Equipment Envelope

INTENTIONALLY LEFT BLANK

This figure has been designated Official Use Only under the Freedom of Information Act (5 U.S.C. 552), Exemption 2, Circumvention of Statute.

This figure is included in Appendix A: Information Designated as Official Use Only, as [Figure A-34](#).

Equipment Number: 060-HMH0-PLAT-00001.

NOTE: The platform, in conjunction with the adjustable energy absorbing features, is designed such that the transportation cask is prevented from impacting the underside of the platform in a seismic event.

Figure 1.2.4-41. Cask Preparation Platform Mechanical Equipment Envelope (Sheet 1 of 2)

INTENTIONALLY LEFT BLANK

This figure has been designated Official Use Only under the Freedom of Information Act (5 U.S.C. 552), Exemption 2, Circumvention of Statute.

This figure is included in Appendix A: Information Designated as Official Use Only, as [Figure A-34](#).

Figure 1.2.4-41. Cask Preparation Platform Mechanical Equipment Envelope (Sheet 2 of 2)

INTENTIONALLY LEFT BLANK

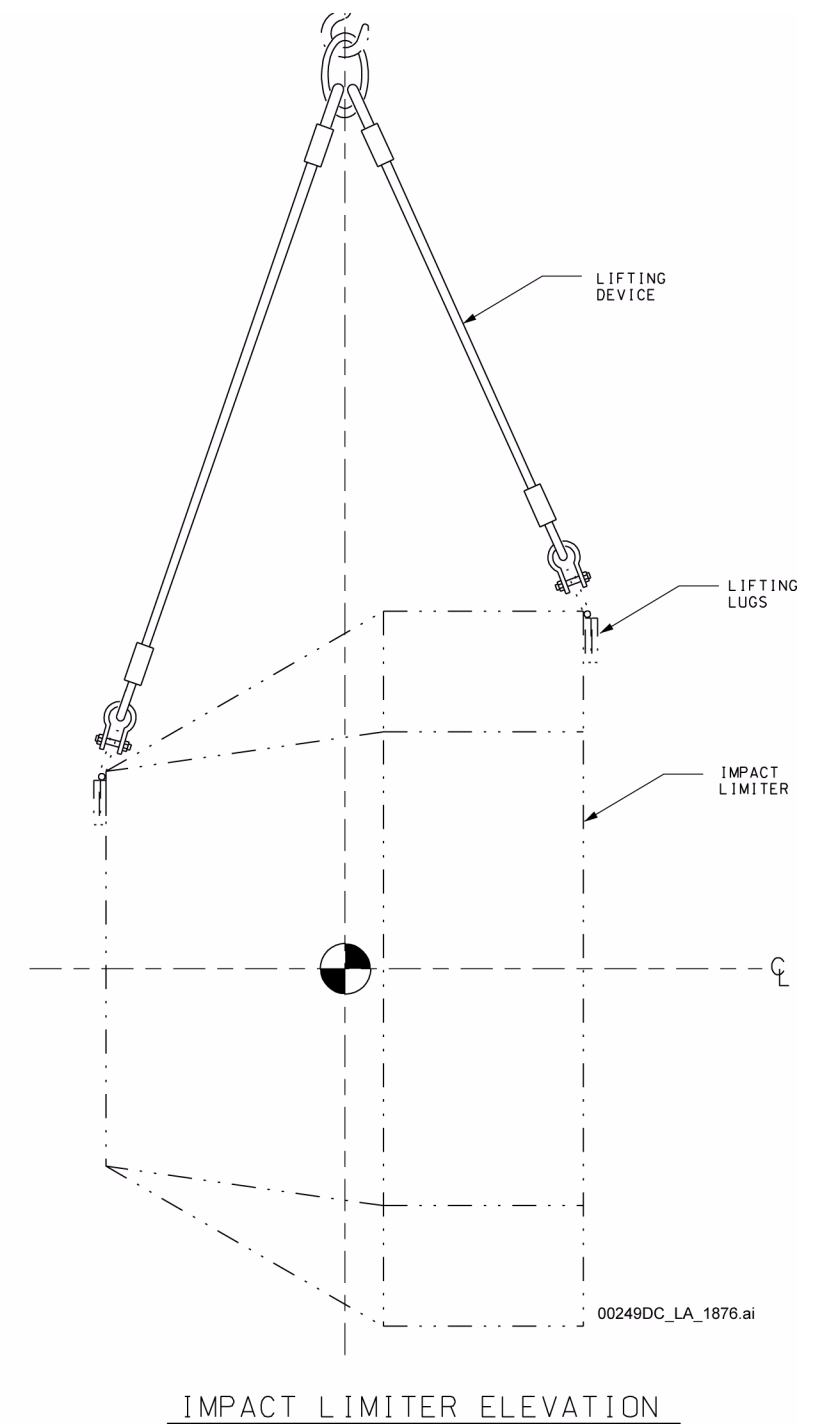
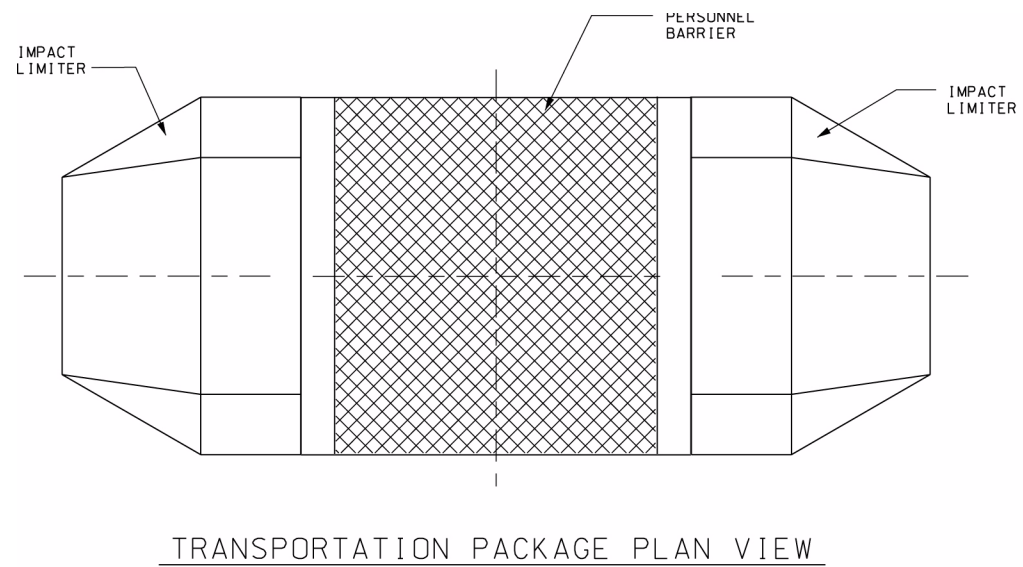

NOTE: This figure includes no SSCs that are either ITS or ITWI. This equipment is used in the CRCF, IHF, WHF, and RF.

Equipment Number: 060-HMC0-HEQ-00001/00002/00003/00004/00005/00006/00007/00008, CRCF impact limiter lifting devices; 060-HMC0-HEQ-00001; 060-HMC0-HEQ-00002; 060-HMC0-HEQ-00003; 060-HMC0-HEQ-00004; 060-HMC0-HEQ-00005; 060-HMC0-HEQ-00006; 060-HMC0-HEQ-00007; 060-HMC0-HEQ-00008; 060-HMC0-HEQ-00019; 060-HMC0-HEQ-00020; 51A-HMC0-HEQ-00001; 51A-HMC0-HEQ-00002; 200-HMC0-HEQ-00007; 200-HMC0-HEQ-00009; 200-HMC0-HEQ-00005; 200-HMC0-HEQ-00003; 200-HMC0-HEQ-00001; 200-HMC0-HEQ-00011; 200-HMC0-HEQ-00014; 050-HMC0-HEQ-00001; 050-HMC0-HEQ-00002; 050-HMC0-HEQ-00003; 050-HMC0-HEQ-00004; 050-HMC0-HEQ-00005; 050-HMC0-HEQ-00006; 050-HMC0-HEQ-00007; 050-HMC0-HEQ-00008; 050-HMC0-HEQ-00009.

Figure 1.2.4-42. Impact Limiter Lifting Device Mechanical Equipment Envelope

INTENTIONALLY LEFT BLANK

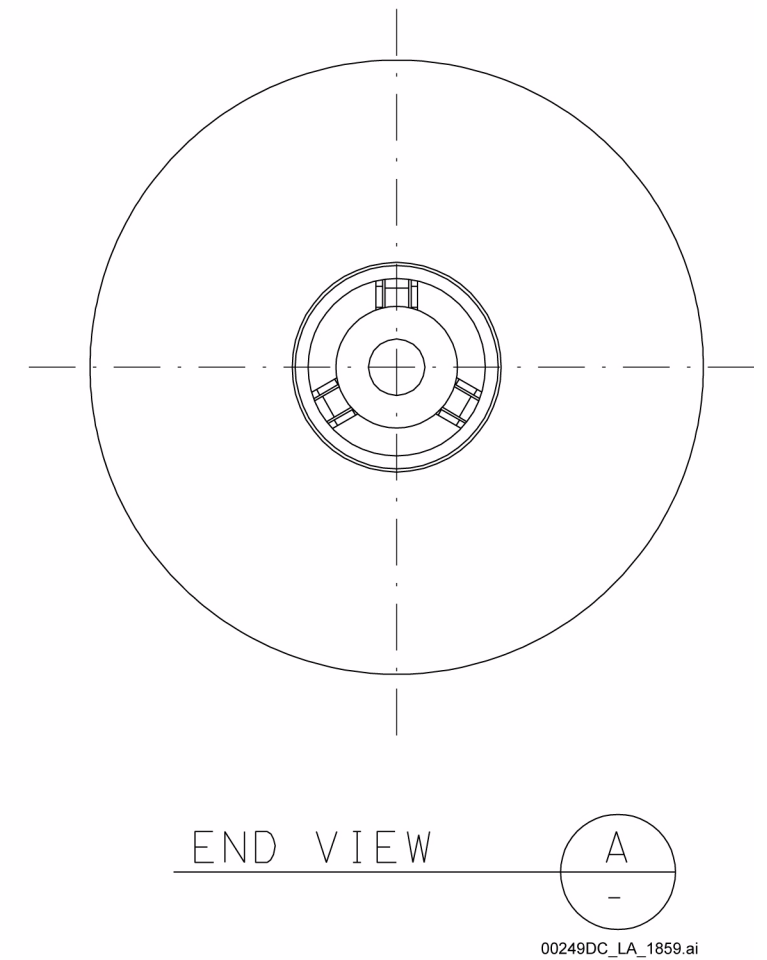
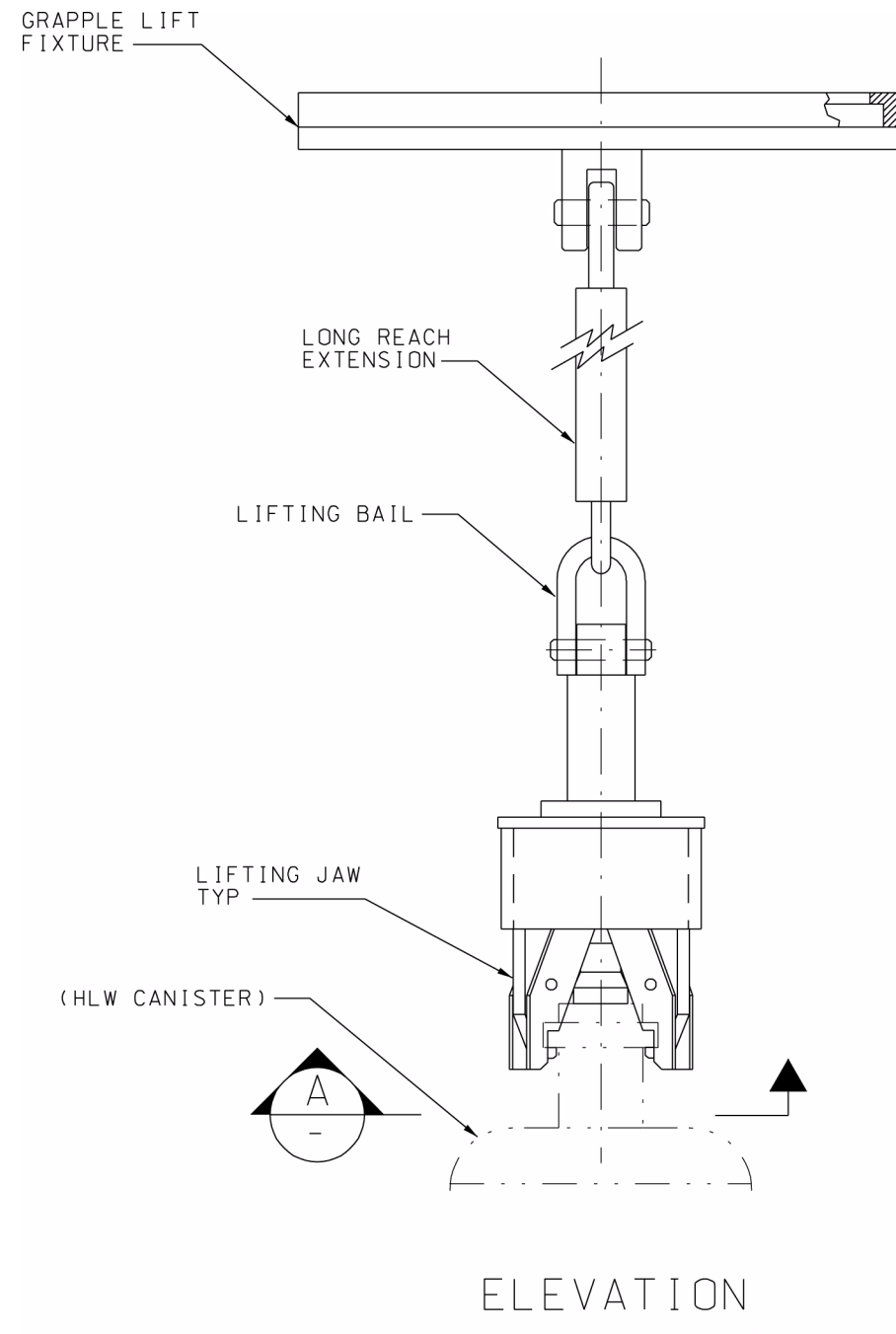

NOTE: This equipment is used in the CRCF and IHF.
Equipment Number: 51A-HTC0-HEQ-00004; 060-HTC0-HEQ-00005.

Figure 1.2.4-43. Defense Waste Processing Facility/Idaho National Laboratory HLW Canister Grapple Mechanical Equipment Envelope

INTENTIONALLY LEFT BLANK

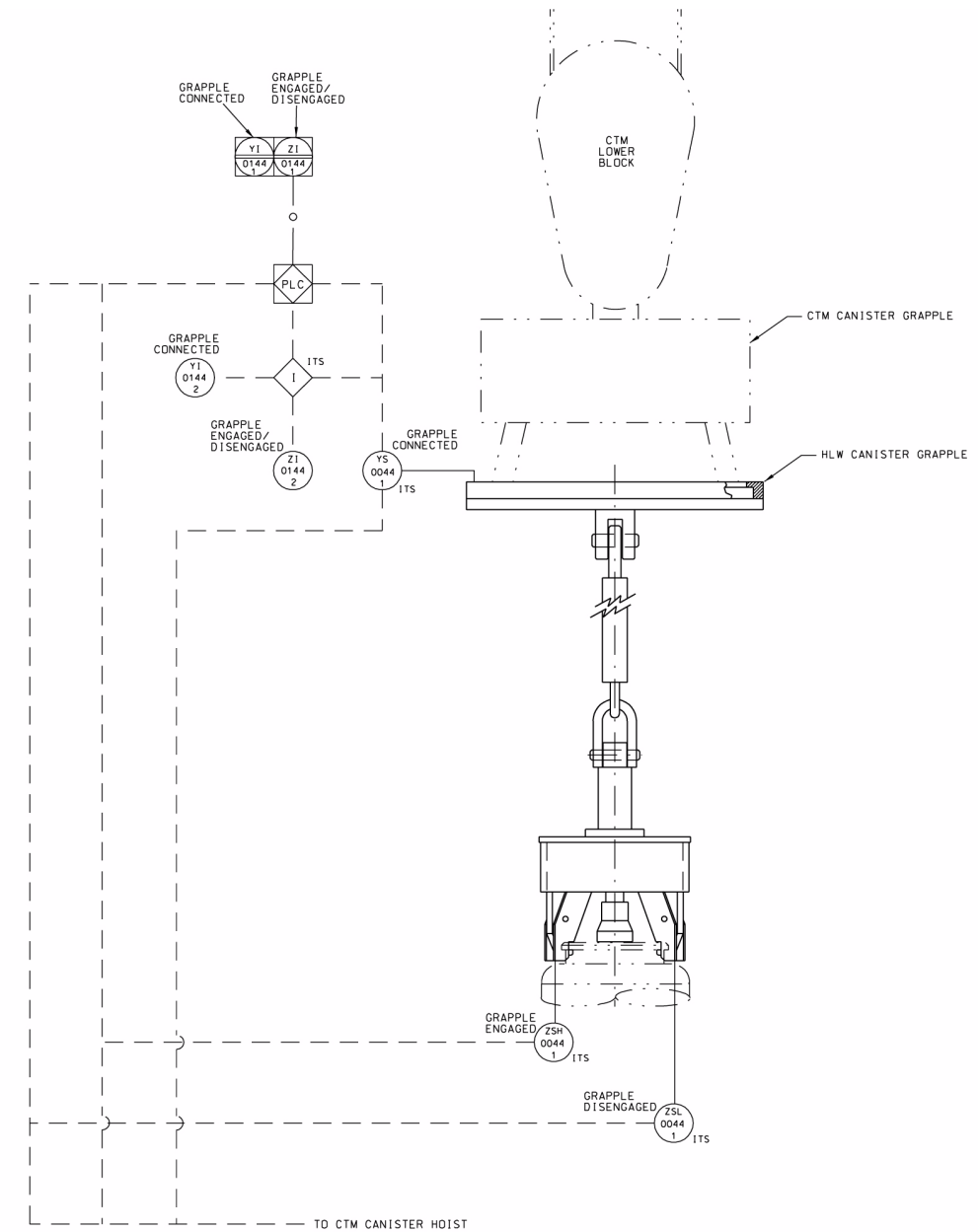

EQUIPMENT AND INSTRUMENTATION TABLE														
FACILITY NAME	FACILITY AREA NO.	EQUIPMENT NUMBER	EQUIPMENT DESCRIPTION	STATUS SWITCHES			CTM #1				CTM #2			
				CONNECTED	ENGAGED	DISENGAGED	DCMIS INDICATORS GRAPPLE CONNECTED	ENGAGED/ DISENGAGED	LOCAL INDICATORS GRAPPLE CONNECTED	ENGAGED/ DISENGAGED	DCMIS INDICATORS GRAPPLE CONNECTED	ENGAGED/ DISENGAGED	LOCAL INDICATORS GRAPPLE CONNECTED	ENGAGED/ DISENGAGED
CRCF	060	060-HTCO-HEO-00003	WVDP/HANFORD HLW CANISTER GRAPPLE	YS-0044-1 (ITS)	ZSH-0044-1 (ITS)	ZSL-0044-1 (ITS)	Y1-0144-1	Z1-0144-1	Y1-0144-2	Z1-0144-2	Y1-0244-1	Z1-0244-1	Y1-0244-2	Z1-0244-2
		060-HTCO-HEO-00005	DWPF/INL HLW CANISTER GRAPPLE	YS-0044-2 (ITS)	ZSH-0044-2 (ITS)	ZSL-0044-2 (ITS)								
IHF	51A	51A-HTCO-HEO-00003	WVDP/HANFORD HLW CANISTER GRAPPLE	YS-0044-1 (ITS)	ZSH-0044-1 (ITS)	ZSL-0044-1 (ITS)	Y1-0144-1	Z1-0144-1	Y1-0144-2	Z1-0144-2	N/A	N/A	N/A	N/A
		51A-HTCO-HEO-00004	DWPF/INL HLW CANISTER GRAPPLE	YS-0044-2 (ITS)	ZSH-0044-2 (ITS)	ZSL-0044-2 (ITS)								

Figure 1.2.4-44. Defense Waste Processing Facility/Idaho National Laboratory and West Valley Demonstration Project/Hanford HLW Canister Grapples Process and Instrumentation Diagram

NOTE: All grapple jaws shall be fully engaged or fully disengaged for "ZSH" or "ZSL," respectively, to activate. The grapple with a suspended canister is prevented mechanically from inadvertent canister disengagement. This equipment is used in the CRCF and IHF.

INTENTIONALLY LEFT BLANK

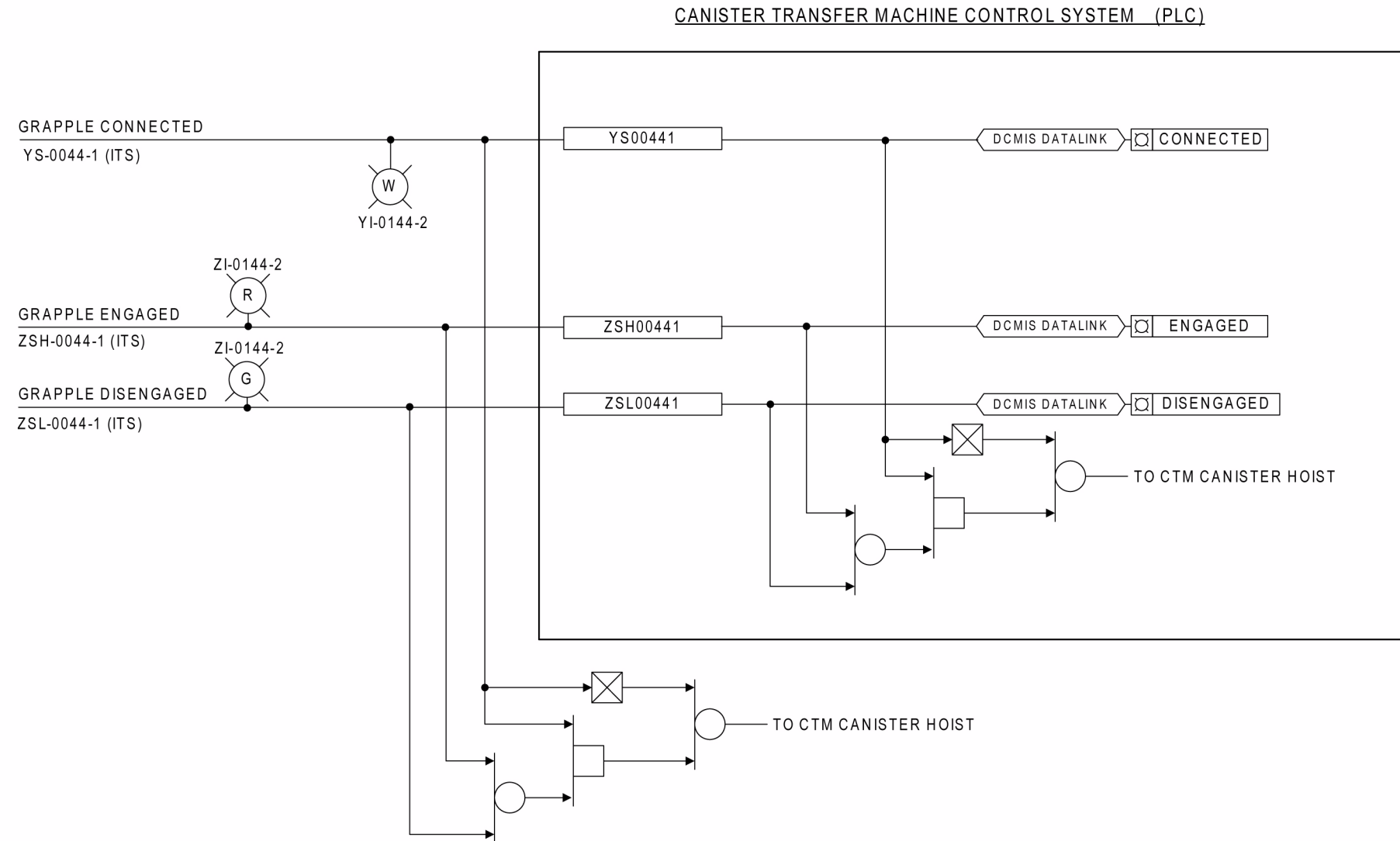

FACILITY	AREA CODE	GRAPPLE EQUIPMENT NUMBER	GRAPPLE DESCRIPTION	STATUS SWITCHES			CTM #1		CTM #2	
				CONNECTED	ENGAGED	DISENGAGED	GRAPPLE CONNECTED LOCAL INDICATOR	ENGAGED/DISENGAGED LOCAL INDICATOR	GRAPPLE CONNECTED LOCAL INDICATOR	ENGAGED/DISENGAGED LOCAL INDICATOR
CANISTER RECEIPT AND CLOSURE FACILITY	060	060-HTC0-HEQ-00003	WVDP/HANFORD HLW CANISTER GRAPPLE	YS-0044-1 (ITS)	ZSH-0044-1 (ITS)	ZSL-0044-1 (ITS)	YI-0144-2	ZI-0144-2	YI-0244-2	ZI-0244-2
		060-HTC0-HEQ-00005	DWPF/INL HLW CANISTER GRAPPLE	YS-0044-2 (ITS)	ZSH-0044-2 (ITS)	ZSL-0044-2 (ITS)				
INITIAL HANDLING FACILITY	51A	51A-HTC0-HEQ-00003	WVDP/HANFORD HLW CANISTER GRAPPLE	YS-0044-1 (ITS)	ZSH-0044-1 (ITS)	ZSL-0044-1 (ITS)	YI-0144-2	ZI-0144-2	N/A	N/A
		51A-HTC0-HEQ-00004	DWPF/INL HLW CANISTER GRAPPLE	YS-0044-2 (ITS)	ZSH-0044-2 (ITS)	ZSL-0044-2 (ITS)				

00249DC_LA_2861.ai

NOTE: All grapple jaws shall be fully engaged or fully disengaged for "ZSH" or "ZSL," respectively, to activate. The grapple with a suspended canister is prevented mechanically from inadvertent canister disengagement. This equipment is used in the CRCF and IHF.

Figure 1.2.4-45. Defense Waste Processing Facility/Idaho National Laboratory and West Valley Demonstration Project/Hanford HLW Canister Grapples Logic Diagram

INTENTIONALLY LEFT BLANK

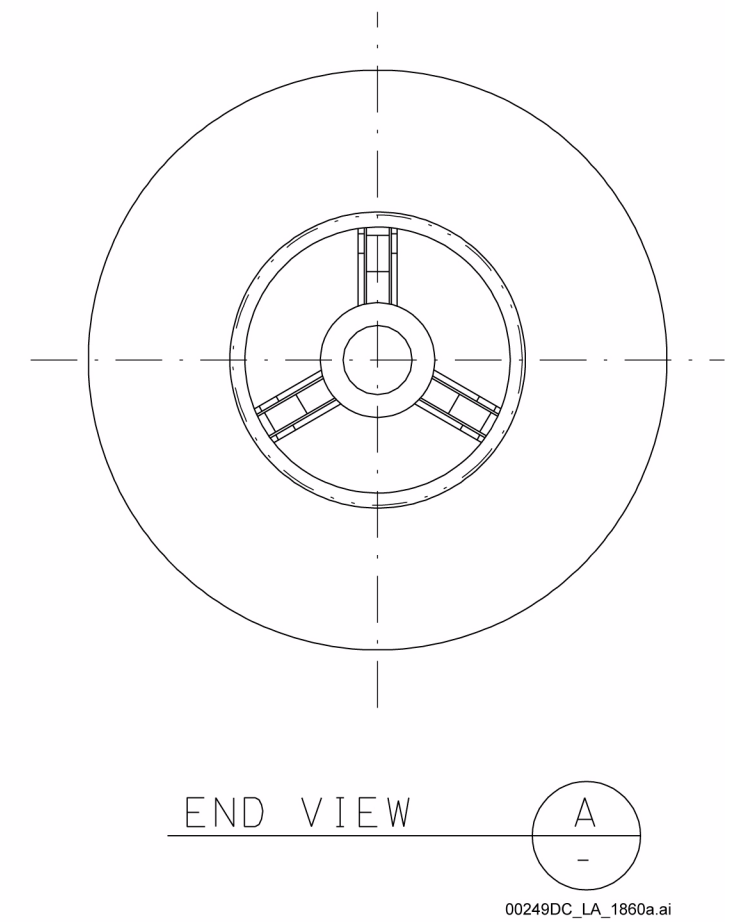
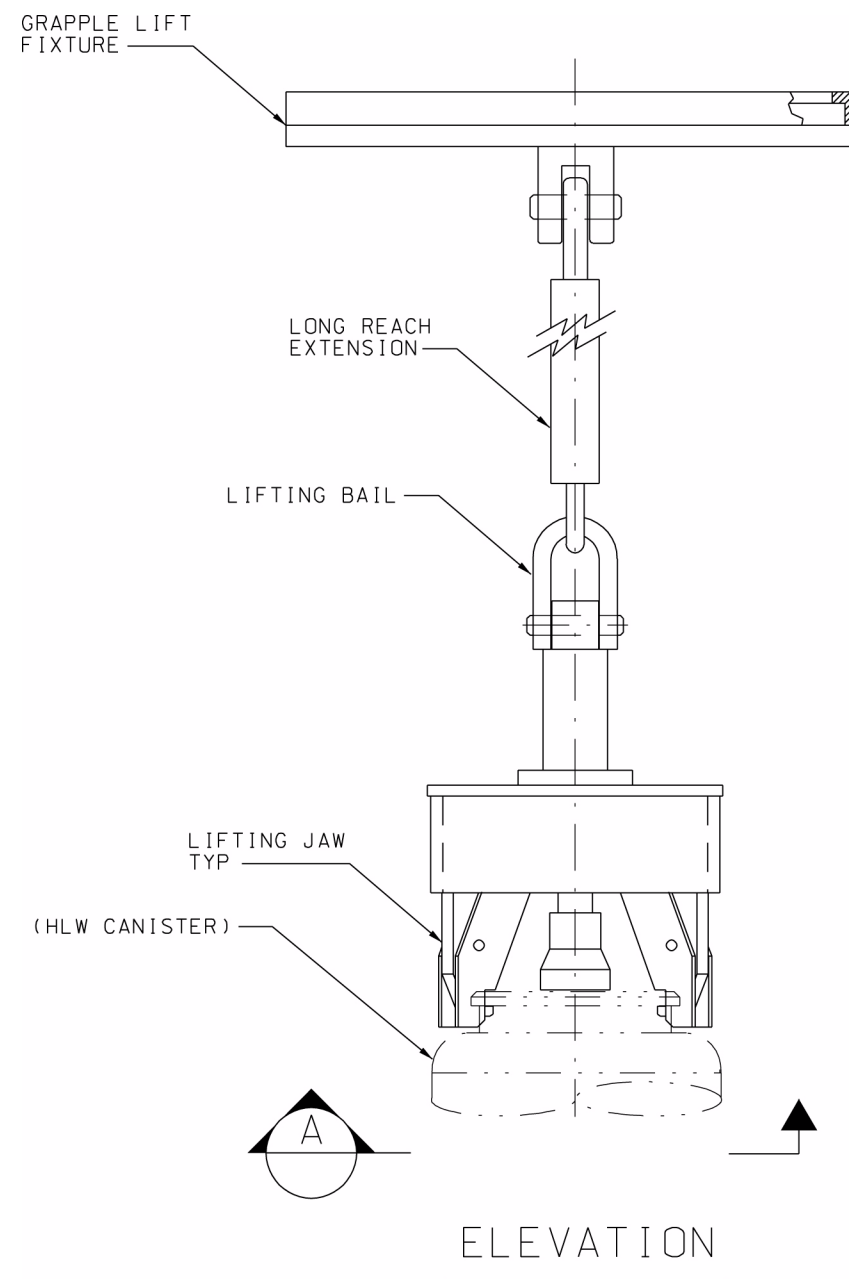

NOTE: This equipment is used in the CRCF and IHF.
Equipment Number:51A-HTC0-HEQ-00003; 060-HTC0-HEQ-00003.

Figure 1.2.4-46. West Valley Demonstration
Project/Hanford HLW Canister Grapple
Mechanical Equipment Envelope

INTENTIONALLY LEFT BLANK

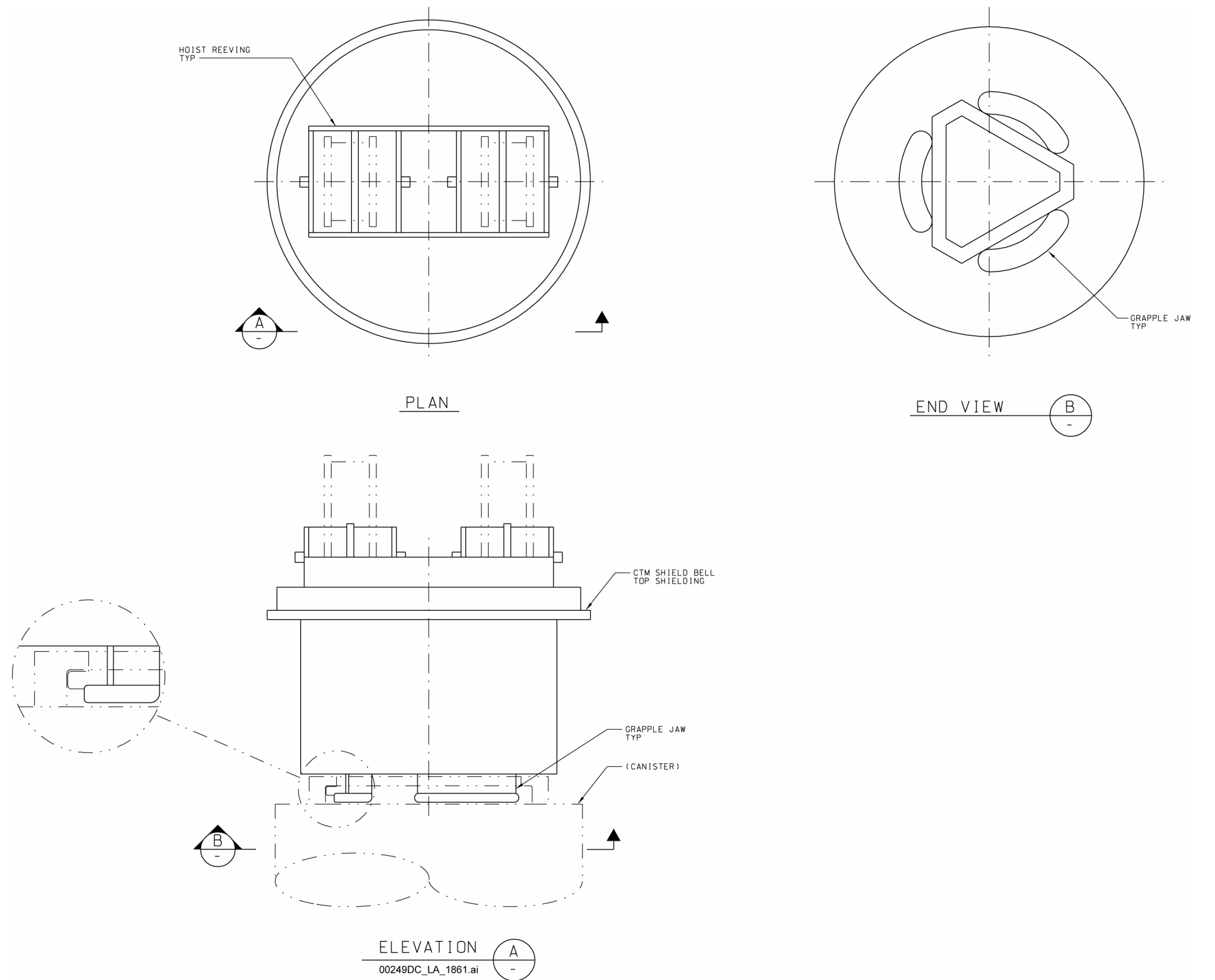

NOTE: This equipment is used in the CRCF, RF, WHF, and IHF. CTM = canister transfer machine.
 Equipment Number: 51A-HTC0-HEQ-00001; 060-HTC0-HEQ-00001/00002; 200-HTC0-HEQ-00001; 050-HTC0-HEQ-00001.

Figure 1.2.4-47. Canister Transfer Machine Canister Grapple

INTENTIONALLY LEFT BLANK

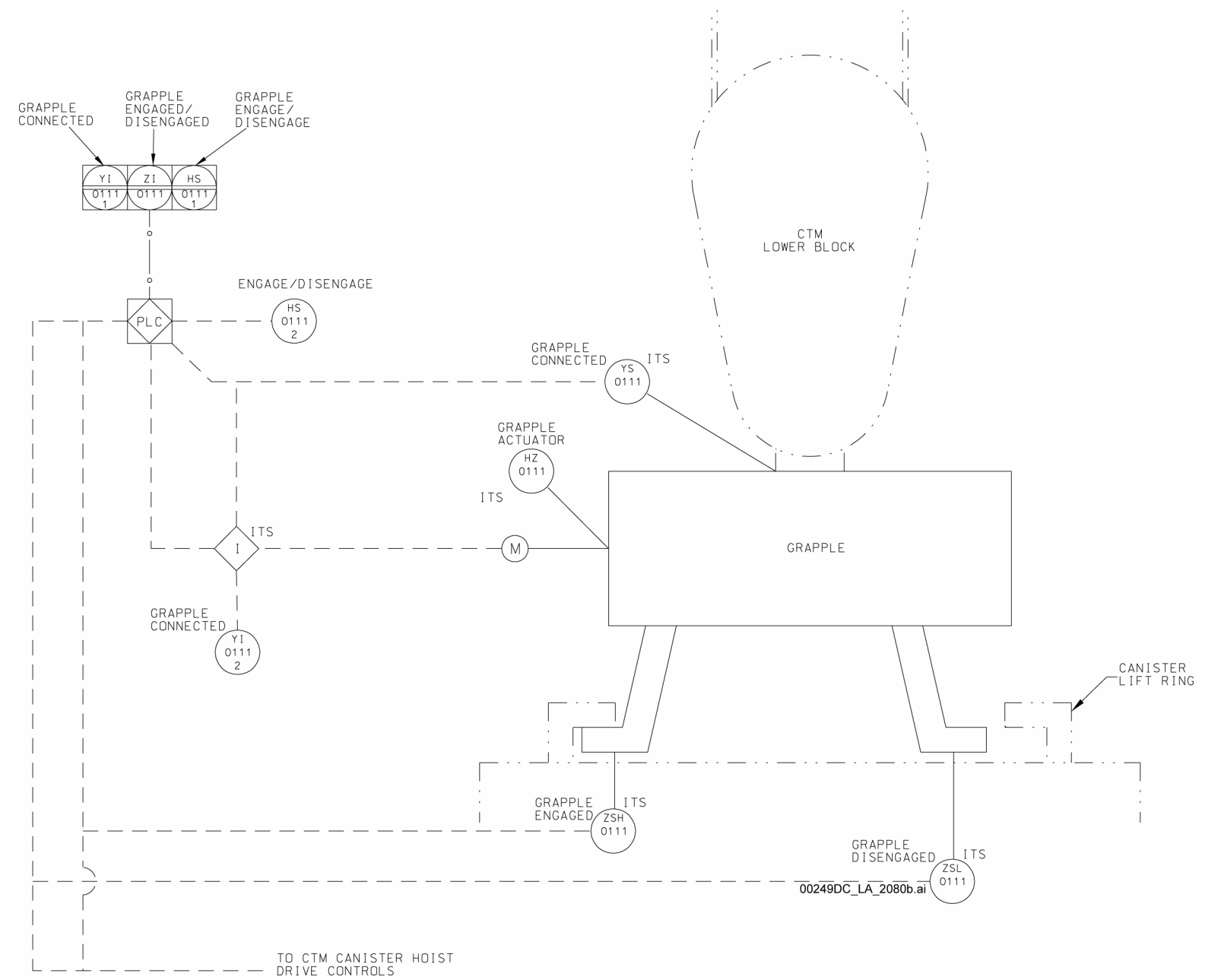

NOTE: The grapple with a suspended canister is prevented mechanically from inadvertent canister disengagement. This equipment is used in the CRCF, RF, WHF, and IHF. CTM = canister transfer machine.

Figure 1.2.4-48. Canister Transfer Machine Canister Grapple Process and Instrumentation Diagram

INTENTIONALLY LEFT BLANK

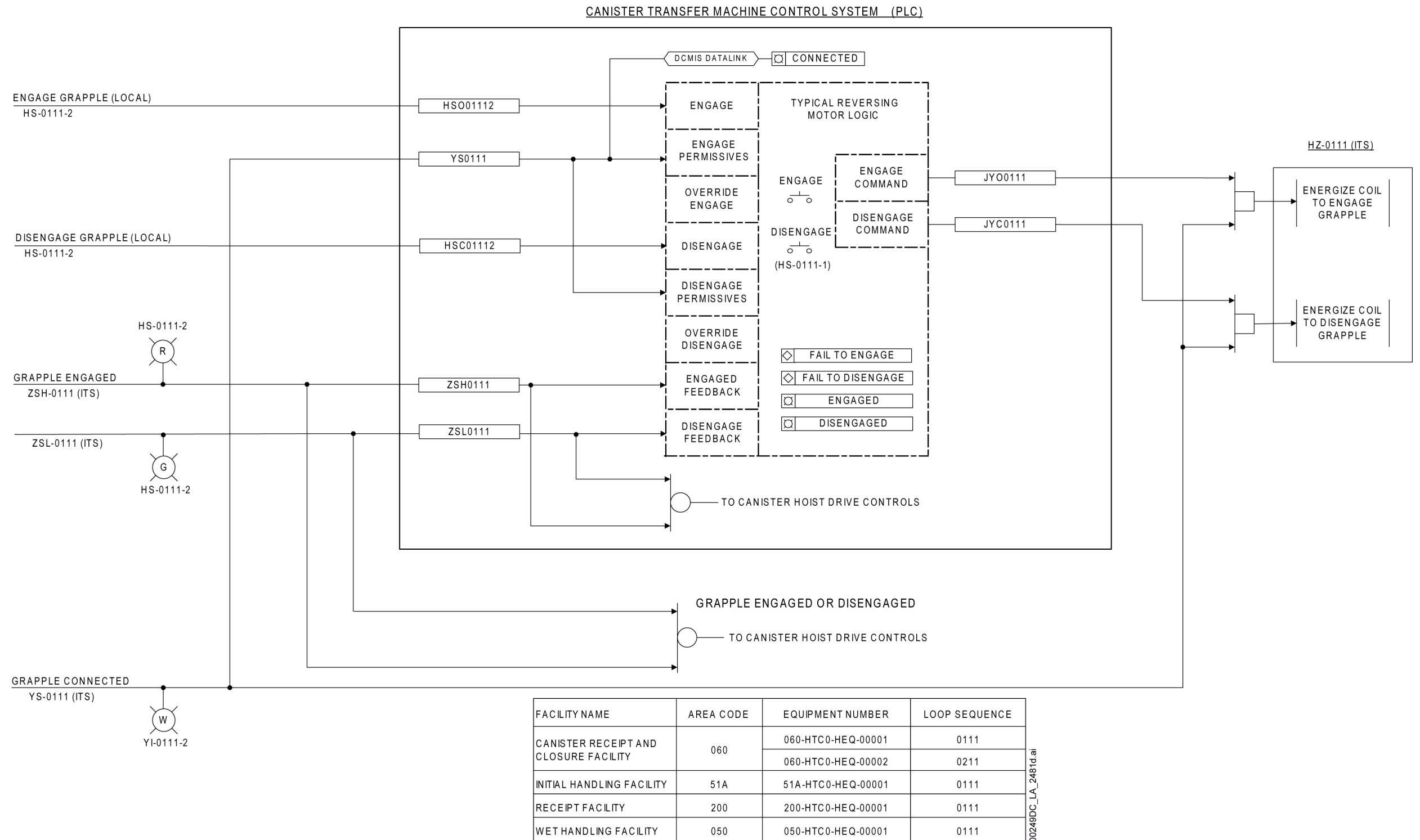

NOTE: Simultaneous DCMIS and local control is prevented by means of a "local/remote" selector switch associated with the canister transfer machine controls. The canister transfer machine control system, which controls the canister grapples, is non-ITS and non-ITWI. ITS controls are identified by the letters "ITS" after the instrumentation tag number or control device identifier. Instrumentation tag numbers are prefixed by "XXX-HTC0-" and software tag numbers are prefixed by "XXXHTC0," where XXX is the area code. PLC = programmable logic controller.

Figure 1.2.4-49. Logic Diagram for the Canister Transfer Machine Canister Grapple

INTENTIONALLY LEFT BLANK

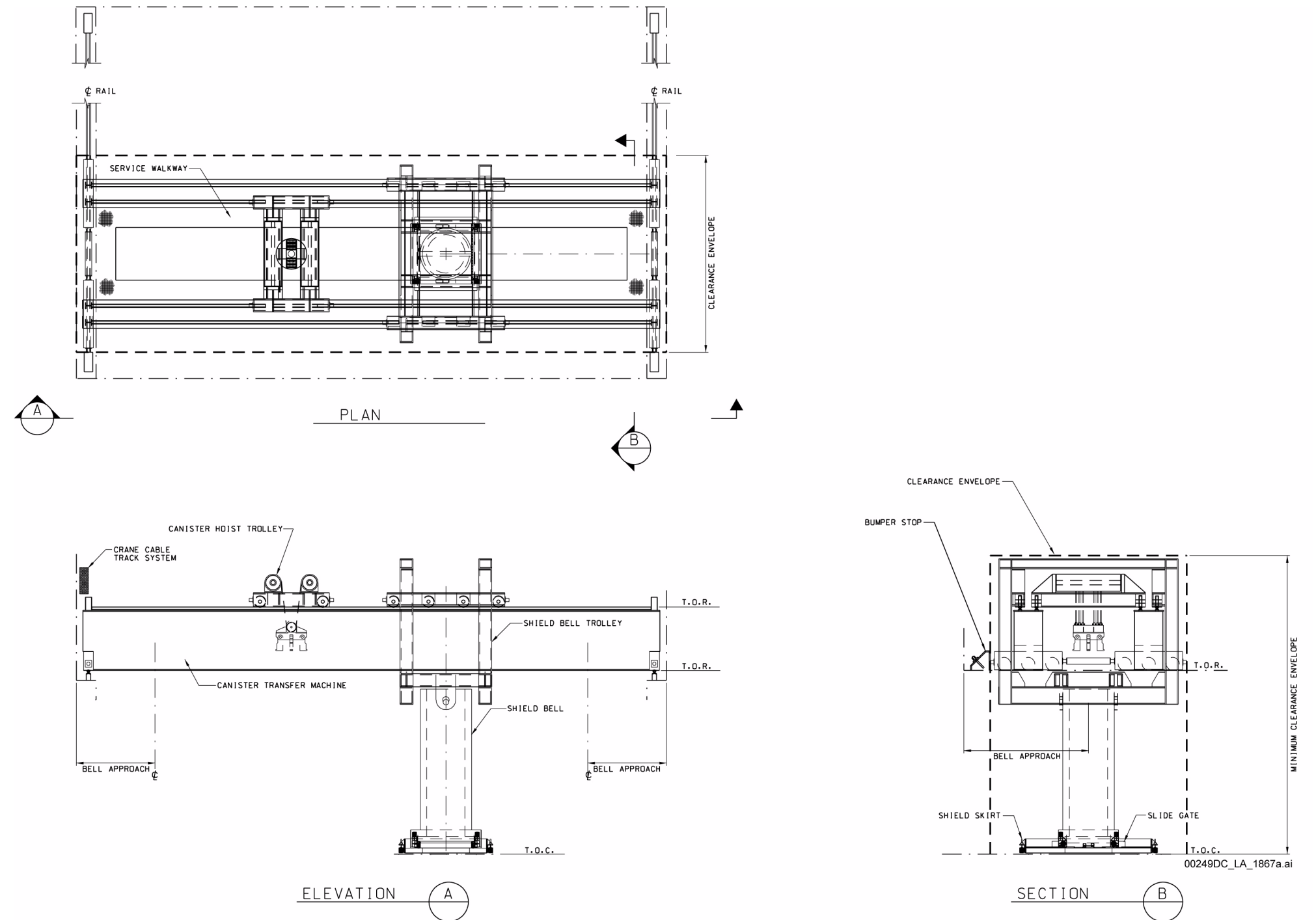

NOTE: The canister transfer machine design incorporates a guide sleeve inside the shield bell that is lowered below the transfer room floor during raising or lowering of a TAD canister, DPC, or naval canister from or into cask, aging overpack, waste package, or shielded transfer cask. In the event of a canister drop, the guide sleeve guides the canister into the cask, aging overpack, waste package, or shielded transfer cask to ensure a flat bottom drop. Torque is limited to prevent shearing of the canister, guide sleeve, or hoist rope if the slide gate were to inadvertently close on a canister, guide sleeve, or hoist rope. This equipment is used in the CRCF, RF, WHF, and IHF.

Equipment Number: 060-HTC0-FHM-00001/00002, CRCF canister transfer machine; 51A-HTC0-FHM-00001, IHF canister transfer machine; 200-HTC0-FHM-00001, RF canister transfer machine; 050-HTC0-FHM-00001, WHF canister transfer machine.

Figure 1.2.4-50. Canister Transfer Machine Mechanical Equipment Envelope

INTENTIONALLY LEFT BLANK

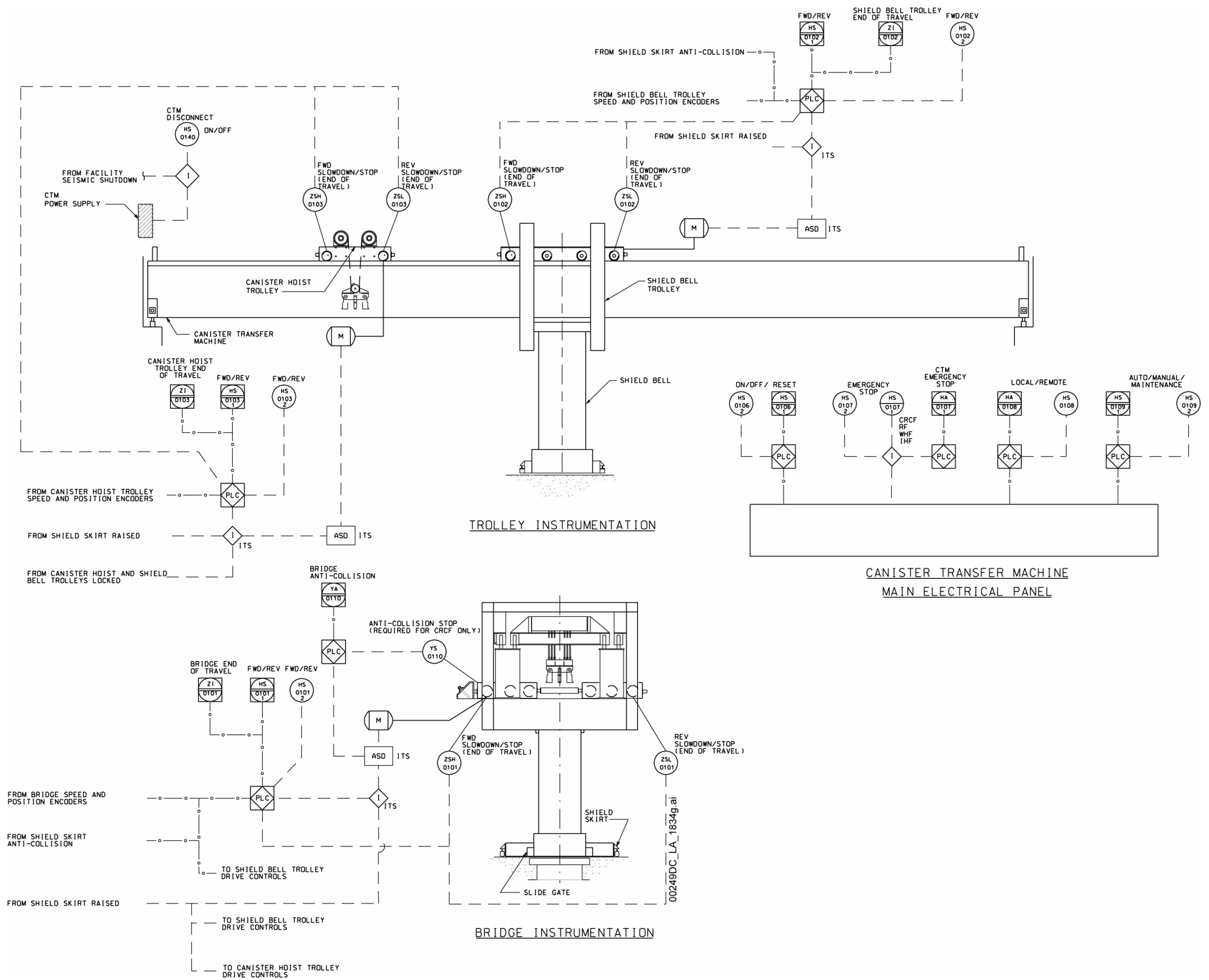

NOTE: The circuit breakers which provide power to the adjustable speed drives include instantaneous over-current protection. This feature is ITS. This equipment is used in the CRCF, RF, WHF, and IHF.
 CTM = canister transfer machine.

Figure 1.2.4-51. Canister Transfer Machine Process and Instrumentation Diagram (Sheet 1 of 3)

INTENTIONALLY LEFT BLANK

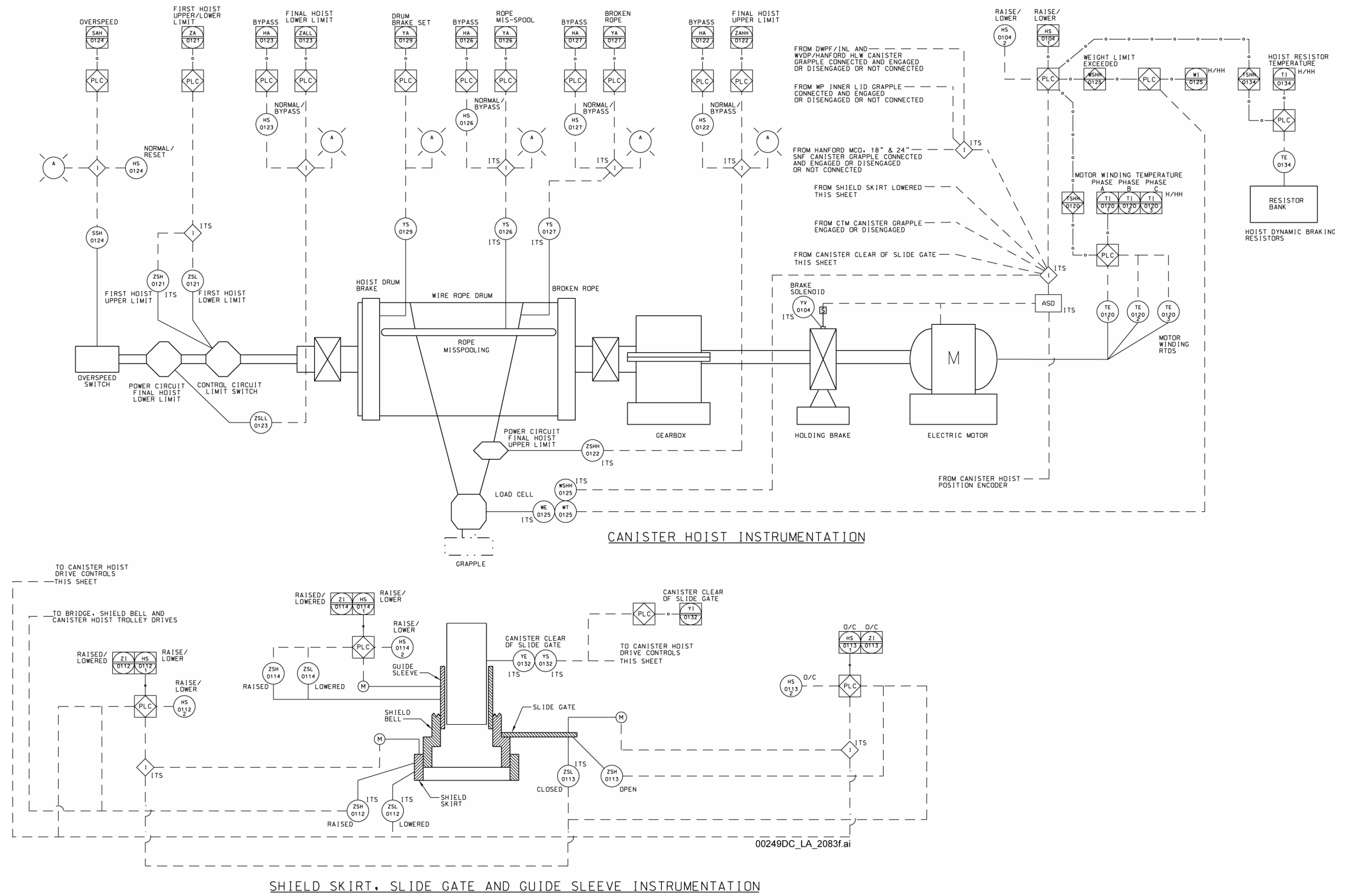

Figure 1.2.4-51. Canister Transfer Machine Process and Instrumentation Diagram (Sheet 2 of 3)

NOTE: This equipment is used in the CRCF, RF, WHF, and IHF. CTM = canister transfer machine; WP = waste package.

INTENTIONALLY LEFT BLANK

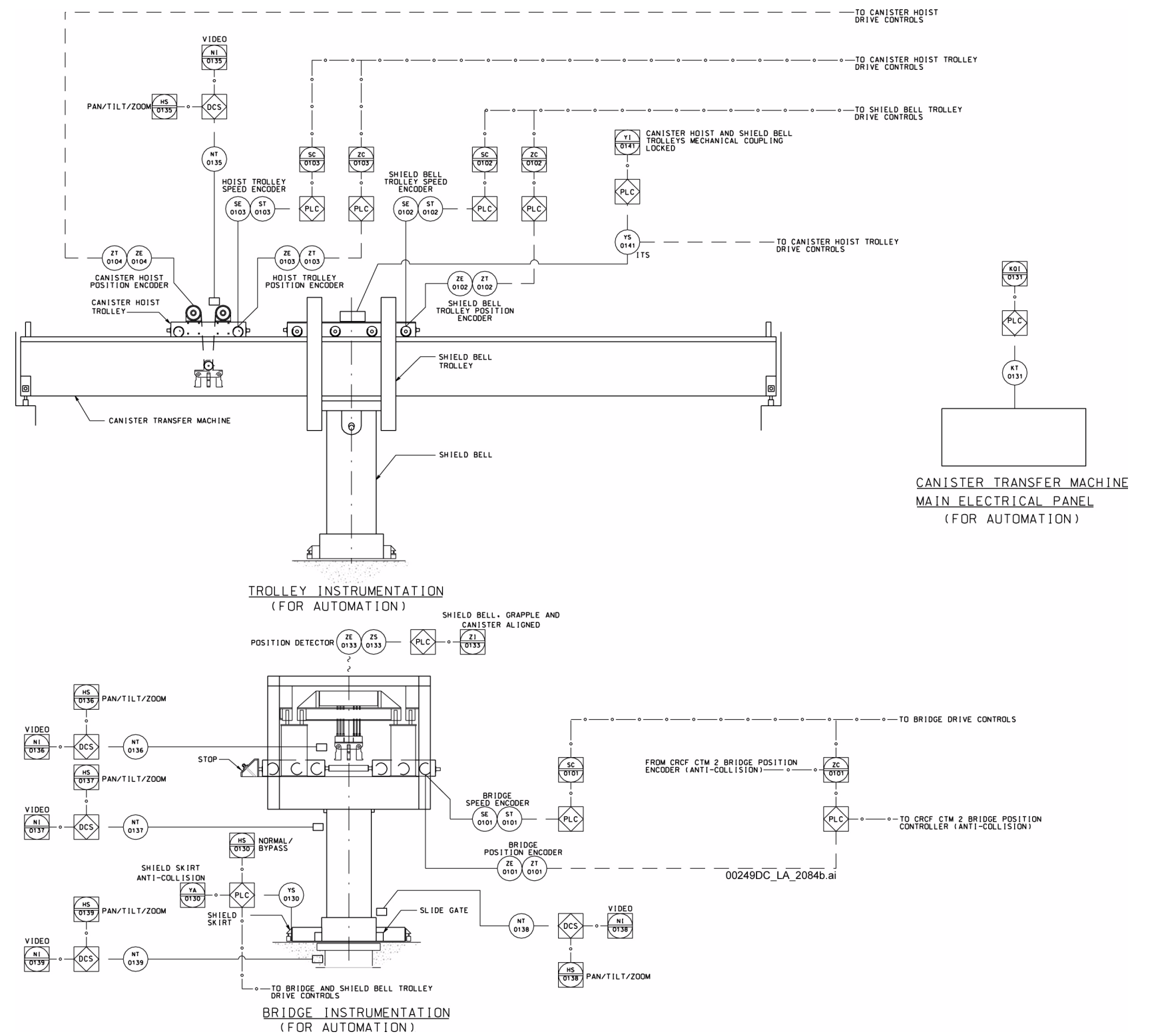
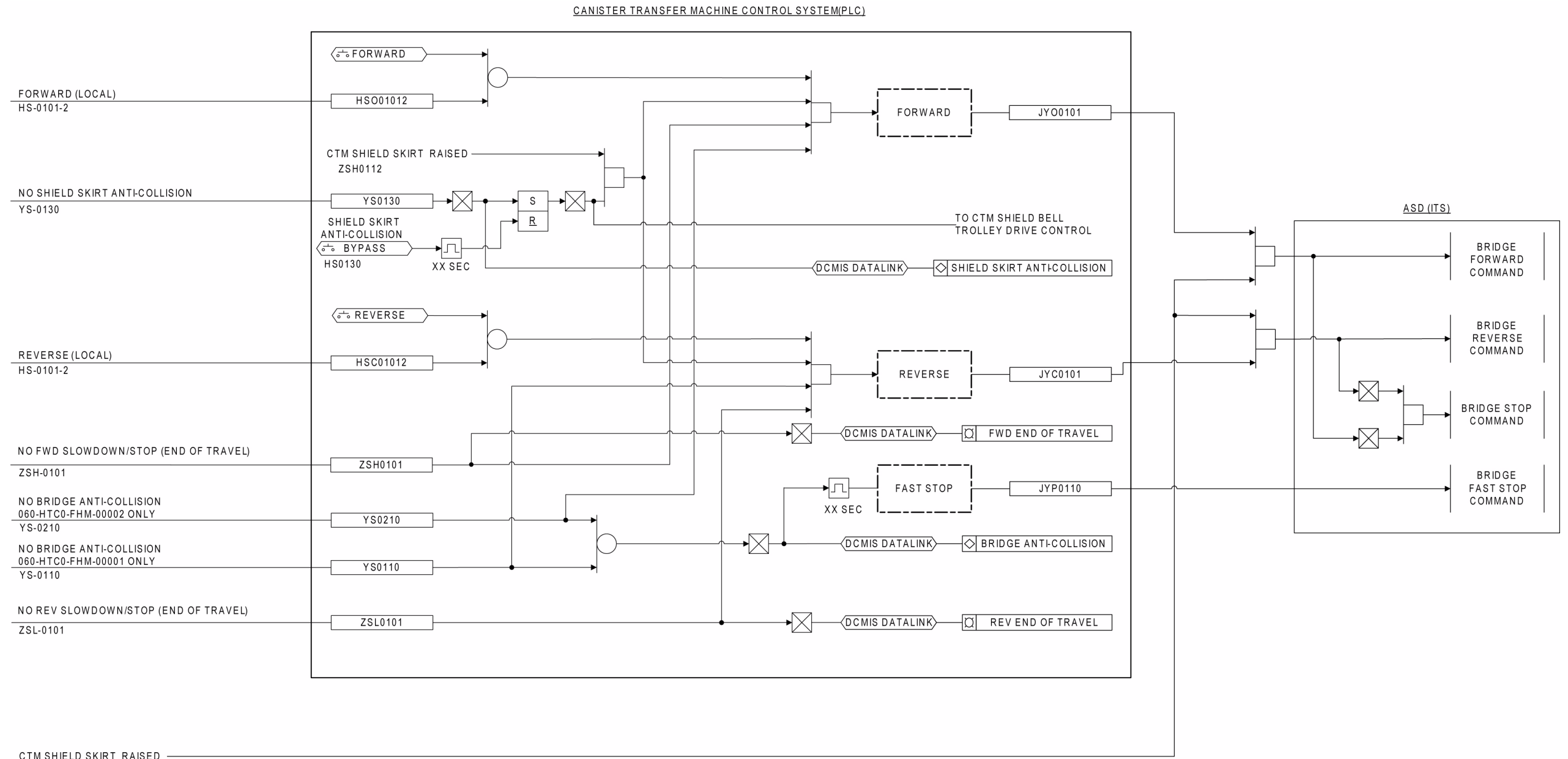

Figure 1.2.4-51. Canister Transfer Machine Process and Instrumentation Diagram (Sheet 3 of 3)

NOTE: This equipment is used in the CRCF, RF, WHF, and IHF. CTM = canister transfer machine.

INTENTIONALLY LEFT BLANK



CTM SHIELD SKIRT RAISED
ZSH-0112 (ITS)

FACILITY NAME	AREA CODE	CTM EQUIPMENT NUMBER	LOCAL HANDSWITCH	FWD SLOWDOWN / STOP SW	BRIDGE ANTI-COLLISION SWITCH	REV SLOWDOWN / STOP SW	SHIELD SKIRT RAISED SWITCH	SHIELD SKIRT ANTI-COLLISION SW	SHIELD SKIRT ANTI-COLLISION BYPASS	HS INPUT FWD	HS INPUT REV	LOGIC OUTPUT FORWARD	LOGIC OUTPUT REVERSE	LOGIC OUTPUT FAST STOP
CANISTER RECEIPT AND CLOSURE FACILITY	060	060-HTC0-FHM-00001	HS-0101-2	ZSH-0101	YS-0110	N/A	ZSH-0112 (ITS)	YS-0130	HS0130	HS001012	HSC01012	JYO0101	JYC0101	JYP0110
		060-HTC0-FHM-00002	HS-0201-2	N/A	YS-0210	ZSL-0201	ZSH-0212 (ITS)	YS-0230	HS0230	HS002012	HSC02012	JYO0201	JYC0201	JYP0210
RECEIPT FACILITY	200	200-HTC0-FHM-00001	HS-0101-2	ZSH-0101	N/A	ZSL-0101	ZSH-0112 (ITS)	YS-0130	HS0130	HS001012	HSC01012	JYO0101	JYC0101	N/A
INITIAL HANDLING FACILITY	51A	51A-HTC0-FHM-00001	HS-0101-2	ZSH-0101	N/A	ZSL-0101	ZSH-0112 (ITS)	YS-0130	HS0130	HS001012	HSC01012	JYO0101	JYC0101	N/A
WET HANDLING FACILITY	050	050-HTC0-FHM-00001	HS-0101-2	ZSH-0101	N/A	ZSL-0101	ZSH-0112 (ITS)	YS-0130	HS0130	HS001012	HSC01012	JYO0101	JYC0101	N/A

NOTE: ITS controls are identified by the letters "ITS" after the instrumentation tag number or control device identifier. The canister transfer machine control system, which controls the bridge, is non-ITS and non-ITWI. Simultaneous DCMIS and local control is prevented by means of a "local/remote" selector switch associated with the canister transfer machine controls. Instrumentation tag numbers are prefixed by "XXX-HTC0-" and software tag numbers are prefixed by "XXXHTC0," where XXX is the area code. ASD = adjustable speed drive; CTM = canister transfer machine; PLC = programmable logic controller.

Figure 1.2.4-52. Logic Diagram for the Canister Transfer Machine Bridge

INTENTIONALLY LEFT BLANK

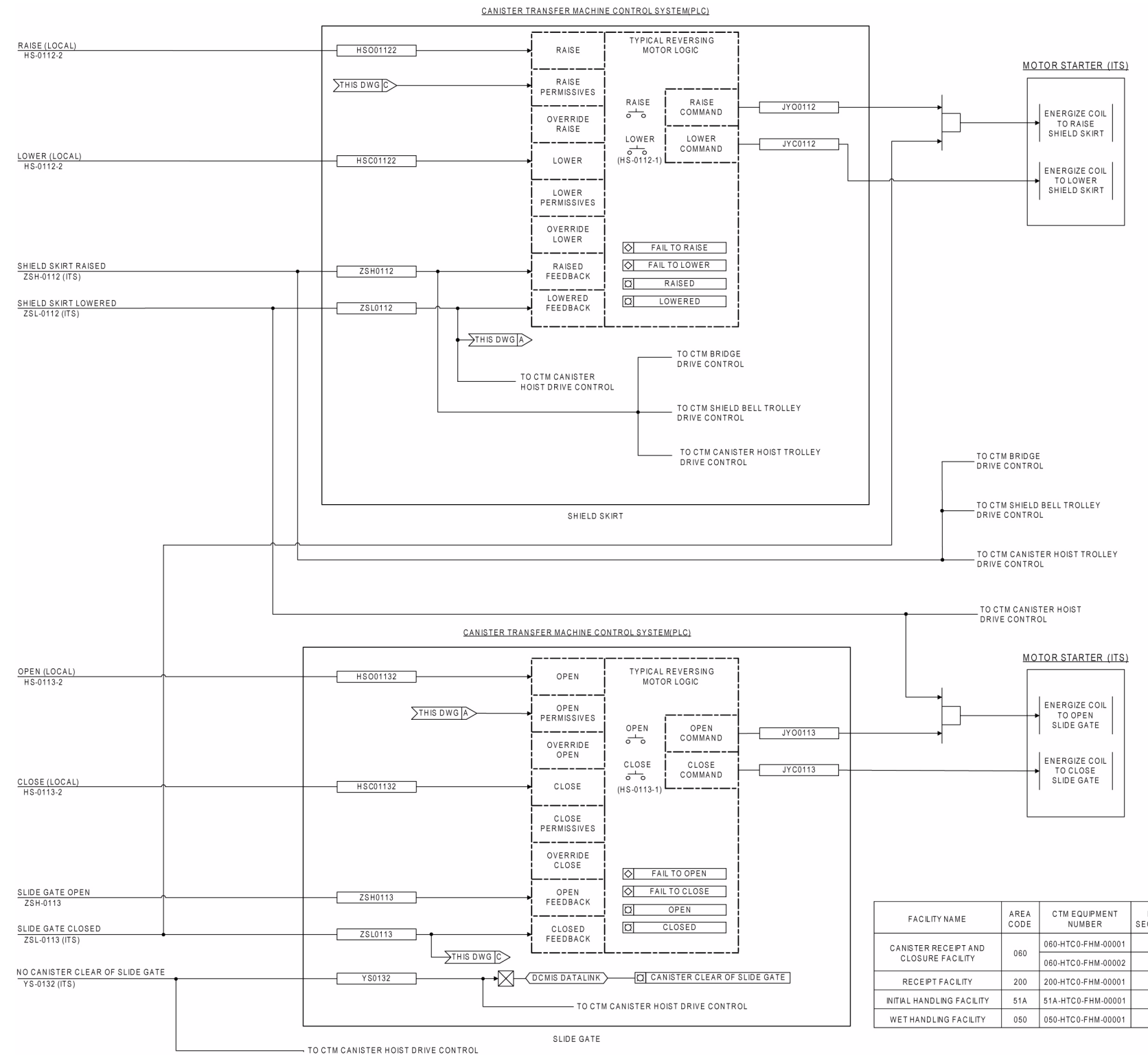

NOTE: ITS controls are identified by the letters "ITS" after the instrumentation tag number or control device identifier. The canister transfer machine control system, which controls the shield skirt and slide gate, is non-ITS and non-ITWI. Simultaneous DCMIS and local control is prevented by means of a "local/remote" selector switch associated with the canister transfer machine controls. Instrumentation tag numbers are prefixed by "XXX-HTC0-" and software tag numbers are prefixed by "XXXHTC0," where XXX is the area code. CTM = canister transfer machine; PLC = programmable logic controller.

Figure 1.2.4-53. Logic Diagram for the Canister Transfer Machine Shield Skirt and Slide Gate

INTENTIONALLY LEFT BLANK

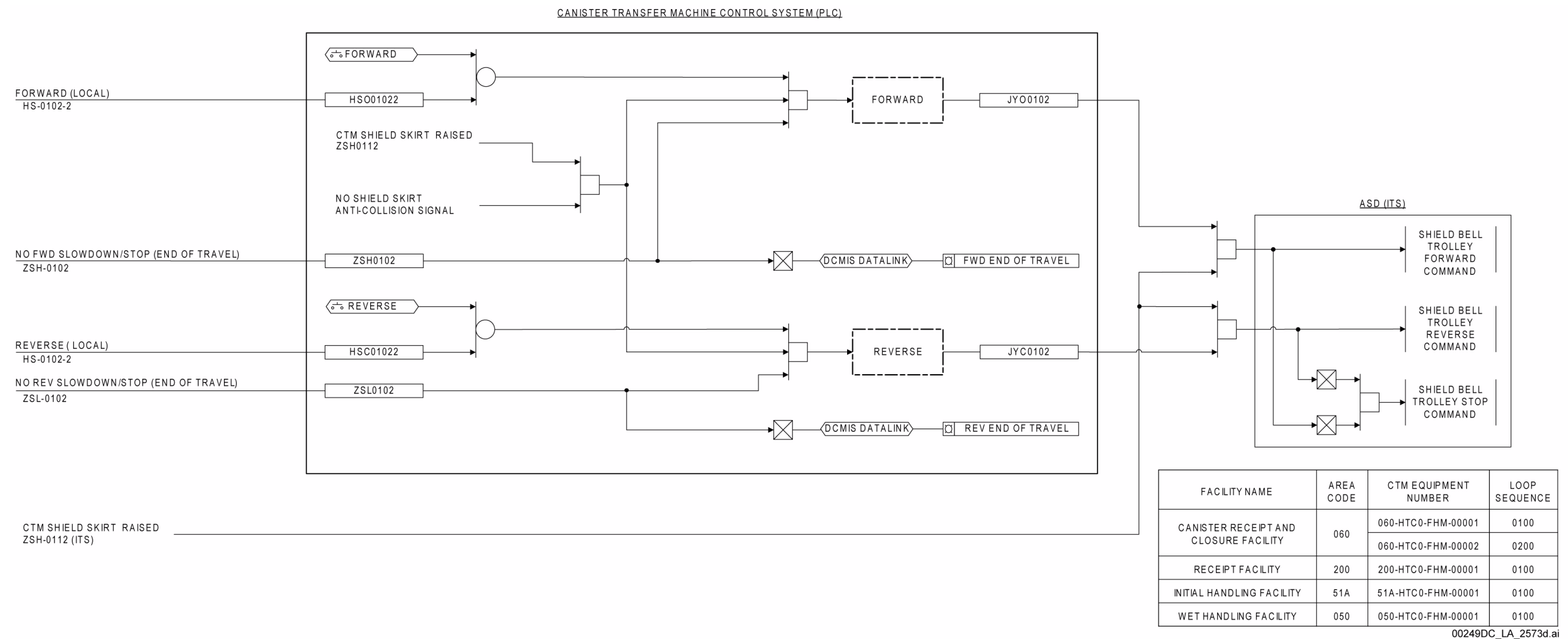

NOTE: ITS controls are identified by the letters "ITS" after the instrumentation tag number or control device identifier. The canister transfer machine control system, which controls the shield bell trolley, is non-ITS and non-ITWI. Simultaneous DCMIS and local control is prevented by means of a "local/remote" selector switch associated with the canister transfer machine controls. Instrumentation tag numbers are prefixed by "XXX-HTC0-" and software tag numbers are prefixed by "XXXHTC0," where XXX is the area code. ASD = adjustable speed drive; CTM = canister transfer machine; PLC = programmable logic controller.

Figure 1.2.4-54. Logic Diagram for the Canister Transfer Machine Shield Bell Trolley

INTENTIONALLY LEFT BLANK

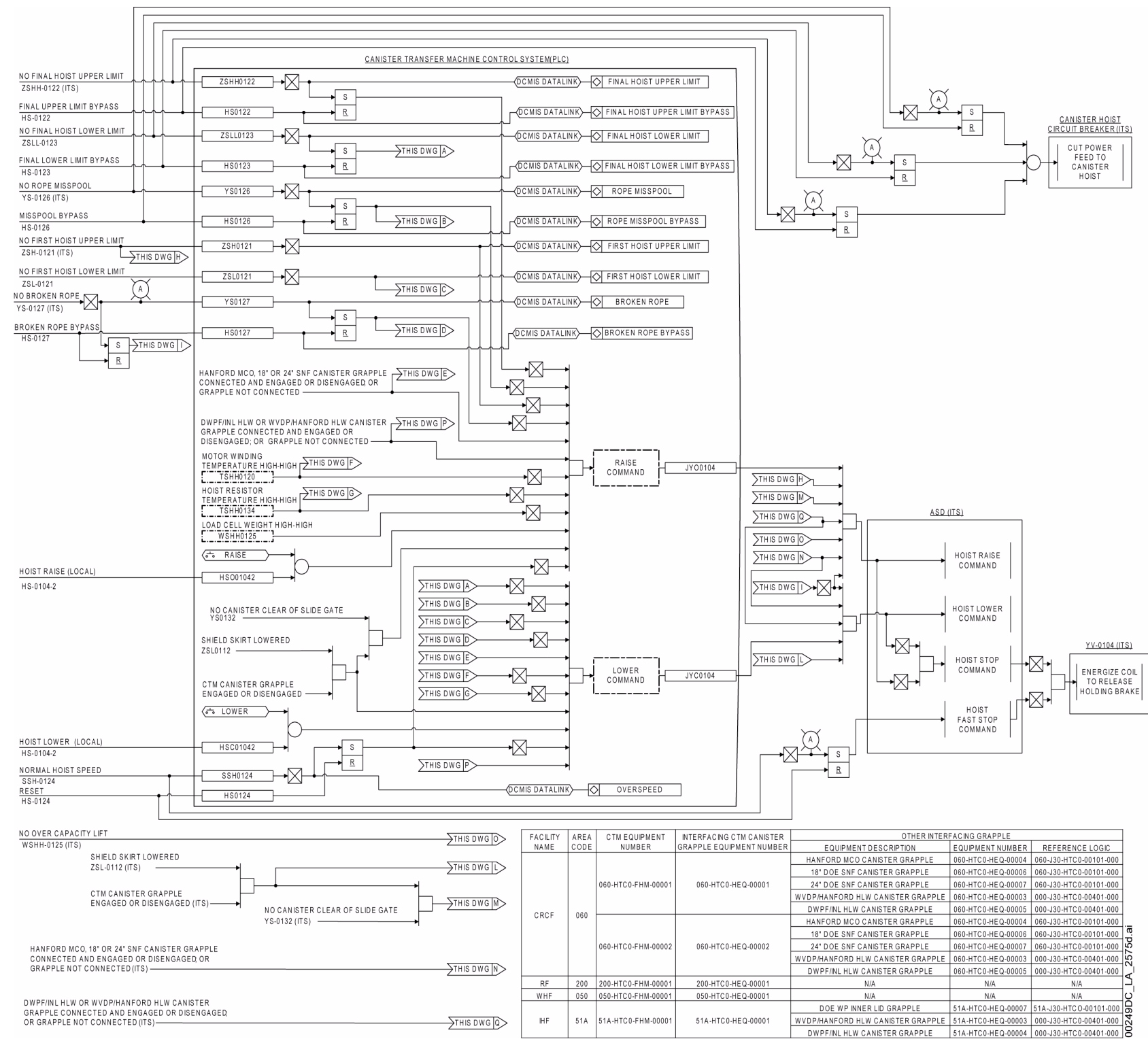

NOTE: ITS controls are identified by the letters "ITS" after the instrumentation tag number or control device identifier. The canister transfer machine control system, which controls the canister hoist, is non-ITS and non-ITWI. Simultaneous DCMIS and local control is prevented by means of a "local/remote" selector switch associated with the canister transfer machine controls. The DCMIS is non-ITS and non-ITWI. Instrumentation tag numbers are prefixed by "XXX-HTC0-" and software tag numbers are prefixed by "XXXHTC0," where XXX is the area code. CRCF canister transfer machine 2 loop sequences are "200" series.
 ASD = adjustable speed drive; CTM = canister transfer machine; PLC = programmable logic controller.

Figure 1.2.4-55. Logic Diagram for the Canister Transfer Machine Canister Hoist

INTENTIONALLY LEFT BLANK

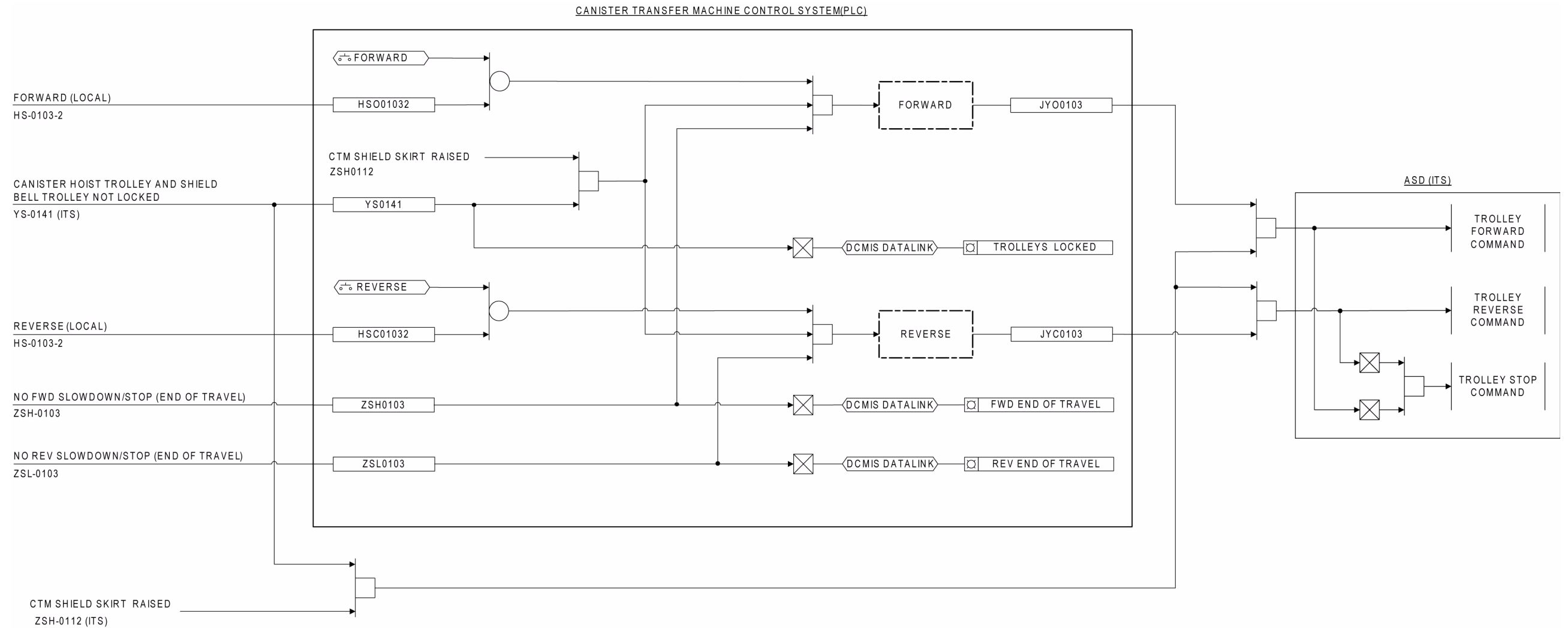

FACILITY NAME	AREA CODE	CTM EQUIPMENT NUMBER	LOOP SEQUENCE
CANISTER RECEIPT AND CLOSURE FACILITY	060	060-HTC0-FHM-00001	0100
		060-HTC0-FHM-00002	0200
RECEIPT FACILITY	200	200-HTC0-FHM-00001	0100
INITIAL HANDLING FACILITY	51A	51A-HTC0-FHM-00001	0100
WET HANDLING FACILITY	050	050-HTC0-FHM-00001	0100

00249DC_LA_2574d.ai

NOTE: ITS controls are identified by the letters "ITS" after the instrumentation tag number or control device identifier. The canister transfer machine control system, which controls the canister hoist trolley, is non-ITS and non-ITWI. Simultaneous DCMIS and local control is prevented by means of a "local/remote" selector switch associated with the canister transfer machine controls. Instrumentation tag numbers are prefixed by "XXX-HTC0-," and software tag numbers are prefixed by "XXXHTC0," where XXX is the area code. ASD = adjustable speed drive; CTM = canister transfer machine; PLC = programmable logic controller.

Figure 1.2.4-56. Logic Diagram for the Canister Transfer Machine Canister Hoist Trolley

INTENTIONALLY LEFT BLANK

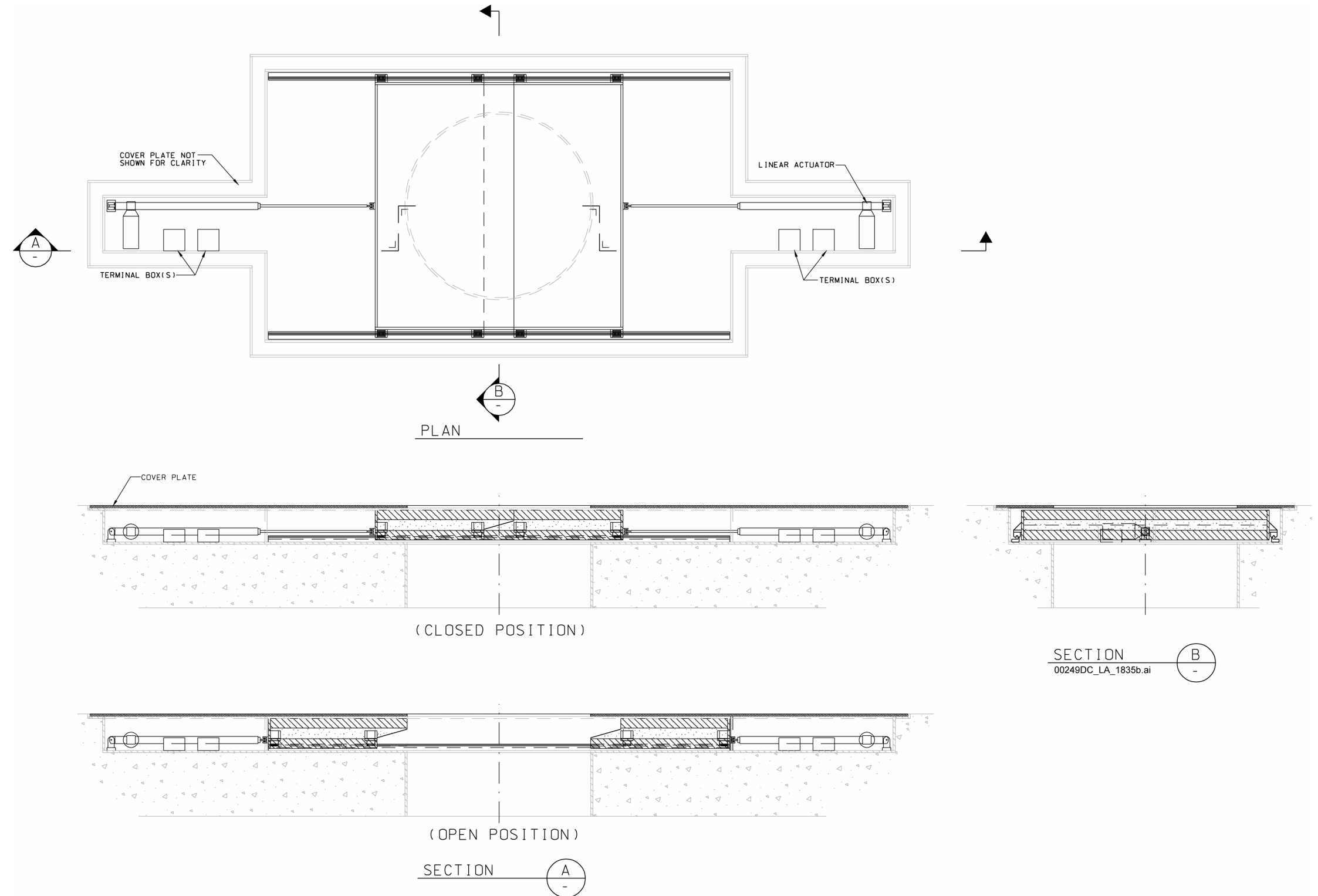

NOTE: This equipment is used in the CRCF, RF, WHF, and IHF.

Equipment Number: 060-HTC0-HTCH-00001/00002, cask port slide gates; 060-HTC0-HTCH-00003/00004, waste package slide gates; 51A-HTC0-HTCH-00001, cask port slide gate; 51A-HTC0-HTCH-00002, waste package port slide gate; 200-HTC0-HTCH-00001, cask port slide gate; 200-HTC0-HTCH-00002, aging overpack port slide gate; 050-HTC0-HTCH-00001, overpack port slide gate; 050-HTC0-HTCH-00002, cask port slide gate.

Figure 1.2.4-57. Port Slide Gate Mechanical Equipment Envelope

INTENTIONALLY LEFT BLANK

INSTRUMENTATION TABLE

FACILITY NAME	FACILITY AREA NO.	SLIDE GATE EQUIPMENT NUMBER	SYSTEM CODE	OPEN/CLOSE HANDSWITCH	OPEN/CLOSE POSITION INDICATOR	ENABLE/DISABLE SWITCH	CTM SKIRT IN PLACE INDICATOR	CTM SKIRT IN PLACE BYPASS SWITCH	BYPASS ALARM	WASTE PACKAGE TRANSFER TROLLEY WITH SHIELD RING PRESENT INDICATOR	TAD WASTE PACKAGE PRESENT INDICATOR	AGING OVERPACK PRESENT INDICATOR	CTM CENTERED INDICATOR	SLIDE GATE SWITCHES (SINGLE OR DOUBLE SLIDE GATE SYSTEM)						INTERFACING SHIELD DOOR EQUIPMENT NUMBER	WASTE PACKAGE TRANSFER TROLLEY EQUIPMENT NUMBER INTERFACE					
														GATE OPEN LIMIT SWITCH	GATE CLOSED LIMIT SWITCH	GATE OPEN LIMIT SWITCH	GATE CLOSED LIMIT SWITCH	CTM SKIRT IN PLACE SWITCH	WASTE PACKAGE TRANSFER TROLLEY WITH SHIELD RING PRESENT SWITCH			TAD WASTE PACKAGE PRESENT SWITCH	AGING OVERPACK PRESENT SWITCH	CTM CENTERED SWITCH		
CANISTER RECEIPT AND CLOSURE FACILITY (CRCF)	060	060-HTCO-HTCH-00001	HTCO	HS-3101	ZI-3101	HS-3102	ZI-3103	N/A	N/A	N/A	N/A	YI-3105	YI-3104	ZSH-3101A	ZSL-3101A (ITS)	ZSH-3101B	ZSL-3101B (ITS)	ZS-3103 (ITS)	N/A	N/A	YS-3105 (ITS)	YS-3104 (ITS)	060-CR00-DR-00001	N/A		
		060-HTCO-HTCH-00002	HTCO	HS-3201	ZI-3201	HS-3202	ZI-3203	N/A	N/A	N/A	N/A	YI-3205	YI-3204	ZSH-3201A	ZSL-3201A (ITS)	ZSH-3201B	ZSL-3201B (ITS)	ZS-3203 (ITS)	N/A	N/A	YS-3205 (ITS)	YS-3204 (ITS)	060-CR00-DR-00002	N/A		
		060-HTCO-HTCH-00003	HTCO	HS-3301	ZI-3301	HS-3302	ZI-3303	N/A	N/A	N/A	YI-3304	YI-3305	N/A	YI-3306	ZSH-3301A	ZSL-3301A (ITS)	ZSH-3301B	ZSL-3301B (ITS)	ZS-3303 (ITS)	YS-3304 (ITS)	YS-3305 (ITS)	N/A	YS-3306 (ITS)	060-CR00-DR-00003	060-HL00-TRLY-00001	
		060-HTCO-HTCH-00004	HTCO	HS-3401	ZI-3401	HS-3402	ZI-3403	N/A	N/A	N/A	YI-3404	YI-3405	N/A	YI-3406	ZSH-3401A	ZSL-3401A (ITS)	ZSH-3401B	ZSL-3401B (ITS)	ZS-3403 (ITS)	YS-3404 (ITS)	YS-3405 (ITS)	N/A	YS-3406 (ITS)	060-CR00-DR-00004	060-HL00-TRLY-00002	
		060-HTCO-HTCH-00005	HTCO	HS-3501	ZI-3501	HS-3502	ZI-3503	N/A	N/A	N/A	N/A	N/A	N/A	N/A	ZSH-3501	ZSL-3501	N/A	N/A	ZS-3503 (ITS)	N/A	N/A	N/A	N/A	N/A	N/A	
		060-HTCO-HTCH-00006	HTCO	HS-3601	ZI-3601	HS-3602	ZI-3603	N/A	N/A	N/A	N/A	N/A	N/A	N/A	ZSH-3601	ZSL-3601	N/A	N/A	ZS-3603 (ITS)	N/A	N/A	N/A	N/A	N/A	N/A	N/A
		060-HTCO-HTCH-00007	HTCO	HS-3701	ZI-3701	HS-3702	ZI-3703	N/A	N/A	N/A	N/A	N/A	N/A	N/A	ZSH-3701	ZSL-3701	N/A	N/A	ZS-3703 (ITS)	N/A	N/A	N/A	N/A	N/A	N/A	N/A
		060-HTCO-HTCH-00008	HTCO	HS-3801	ZI-3801	HS-3802	ZI-3803	N/A	N/A	N/A	N/A	N/A	N/A	N/A	ZSH-3801	ZSL-3801	N/A	N/A	ZS-3803 (ITS)	N/A	N/A	N/A	N/A	N/A	N/A	N/A
		060-HTCO-HTCH-00009	HTCO	HS-3901	ZI-3901	HS-3902	ZI-3903	N/A	N/A	N/A	N/A	N/A	N/A	N/A	ZSH-3901	ZSL-3901	N/A	N/A	ZS-3903 (ITS)	N/A	N/A	N/A	N/A	N/A	N/A	N/A
		060-HTCO-HTCH-00010	HTCO	HS-4001	ZI-4001	HS-4002	ZI-4003	N/A	N/A	N/A	N/A	N/A	N/A	YI-4004	ZSH-4001	ZSL-4001	N/A	N/A	ZS-4003 (ITS)	N/A	N/A	N/A	YS-4004 (ITS)	N/A	N/A	N/A
		060-HTCO-HTCH-00011	HTCO	HS-4101	ZI-4101	HS-4102	ZI-4103	N/A	N/A	N/A	N/A	N/A	N/A	YI-4104	ZSH-4101	ZSL-4101	N/A	N/A	ZS-4103 (ITS)	N/A	N/A	N/A	YS-4104 (ITS)	N/A	N/A	N/A
INITIAL HANDLING FACILITY (IHF)	51A	51A-HTCO-HTCH-00001	HTCO	HS-3101	ZI-3101	HS-3102	ZI-3103	N/A	N/A	N/A	N/A	N/A	N/A	ZSH-3101A	ZSL-3101A (ITS)	ZSH-3101B	ZSL-3101B (ITS)	ZS-3103 (ITS)	N/A	N/A	N/A	N/A	51A-IH00-DR-00001	N/A		
		51A-HTCO-HTCH-00002	HTCO	HS-3201	ZI-3201	HS-3202	ZI-3203	HA-3203	YI-3204	N/A	N/A	N/A	N/A	ZSH-3201A	ZSL-3201A (ITS)	ZSH-3201B	ZSL-3201B (ITS)	ZS-3203 (ITS)	YS-3204 (ITS)	N/A	N/A	N/A	51A-IH00-DR-00002	51A-HL00-TRLY-00001		
RECEIPT FACILITY (RF)	200	200-HTCO-HTCH-00001	HTCO	HS-3101	ZI-3101	HS-3102	ZI-3103	N/A	N/A	N/A	N/A	N/A	N/A	ZSH-3101A	ZSL-3101A (ITS)	ZSH-3101B	ZSL-3101B (ITS)	ZS-3103 (ITS)	N/A	N/A	N/A	N/A	200-RF00-DR-00001	N/A		
		200-HTCO-HTCH-00002	HTCO	HS-3201	ZI-3201	HS-3202	ZI-3203	N/A	N/A	N/A	N/A	N/A	N/A	ZSH-3201A	ZSL-3201A (ITS)	ZSH-3201B	ZSL-3201B (ITS)	ZS-3203 (ITS)	N/A	N/A	N/A	N/A	200-RF00-DR-00002	N/A		
WET HANDLING FACILITY (WHF)	050	050-HTCO-HTCH-00001	HTCO	HS-3101	ZI-3101	HS-3102	ZI-3103	N/A	N/A	N/A	N/A	N/A	N/A	ZSH-3101A	ZSL-3101A (ITS)	ZSH-3101B	ZSL-3101B (ITS)	ZS-3103 (ITS)	N/A	N/A	N/A	N/A	050-WH00-DR-00004	N/A		
		050-HTCO-HTCH-00002	HTCO	HS-3201	ZI-3201	HS-3202	ZI-3203	N/A	N/A	N/A	N/A	N/A	N/A	ZSH-3201A	ZSL-3201A (ITS)	ZSH-3201B	ZSL-3201B (ITS)	ZS-3203 (ITS)	N/A	N/A	N/A	N/A	050-WH00-DR-00003	N/A		

00249DC_LA_1932f.ai

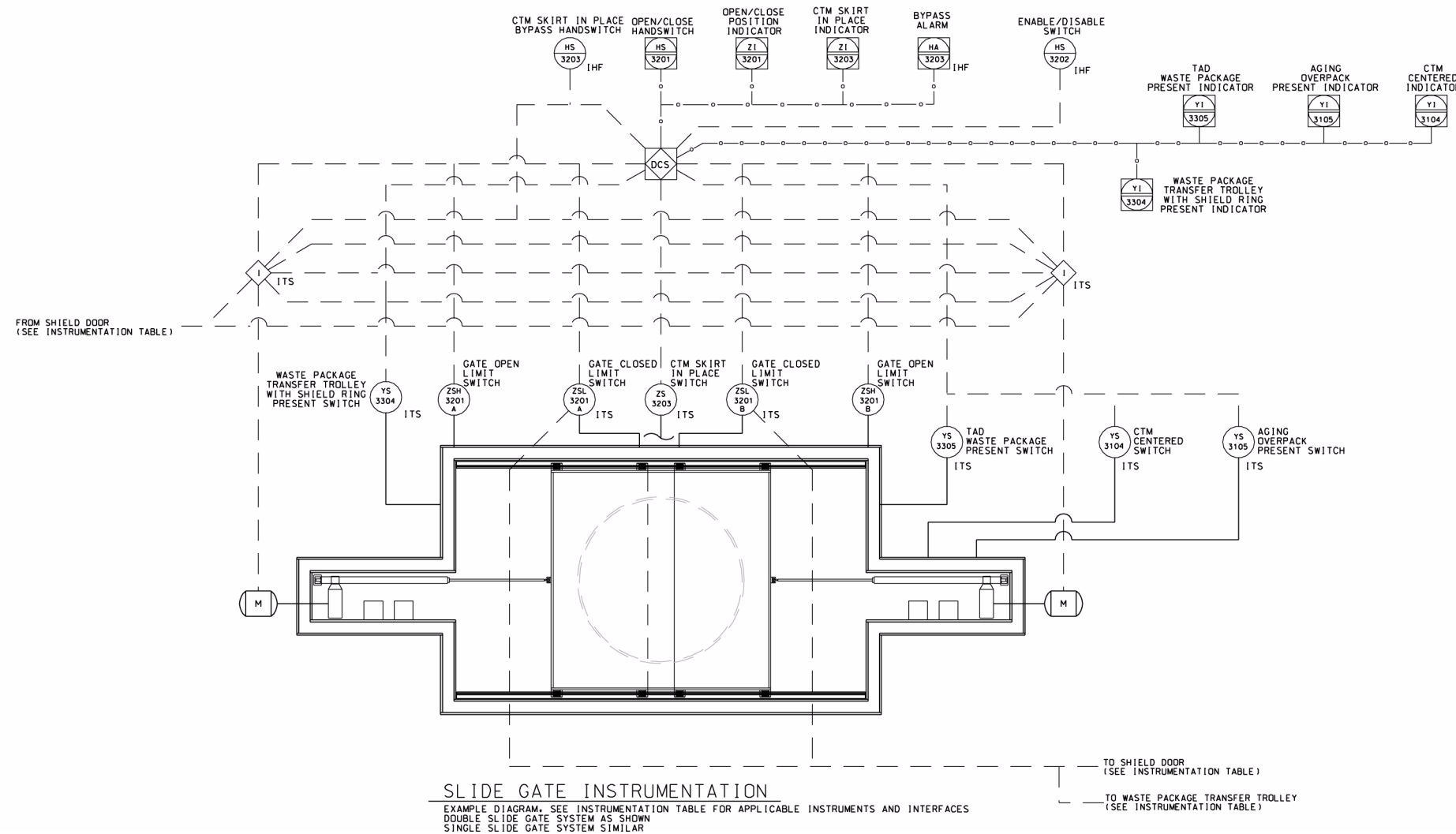

NOTE: The waste package transfer trolley with shield ring in place switch applies to the waste package port slide gates in the CRCF and IHF only. The canister transfer machine skirt in place bypass switch and alarm applies to the IHF waste package port slide gate only. This process and instrumentation diagram applies to the IHF, CRCF, WHF, and RF. CTM = canister transfer machine; WP = waste package.

Figure 1.2.4-58. Slide Gate Process and Instrumentation Diagram

INTENTIONALLY LEFT BLANK

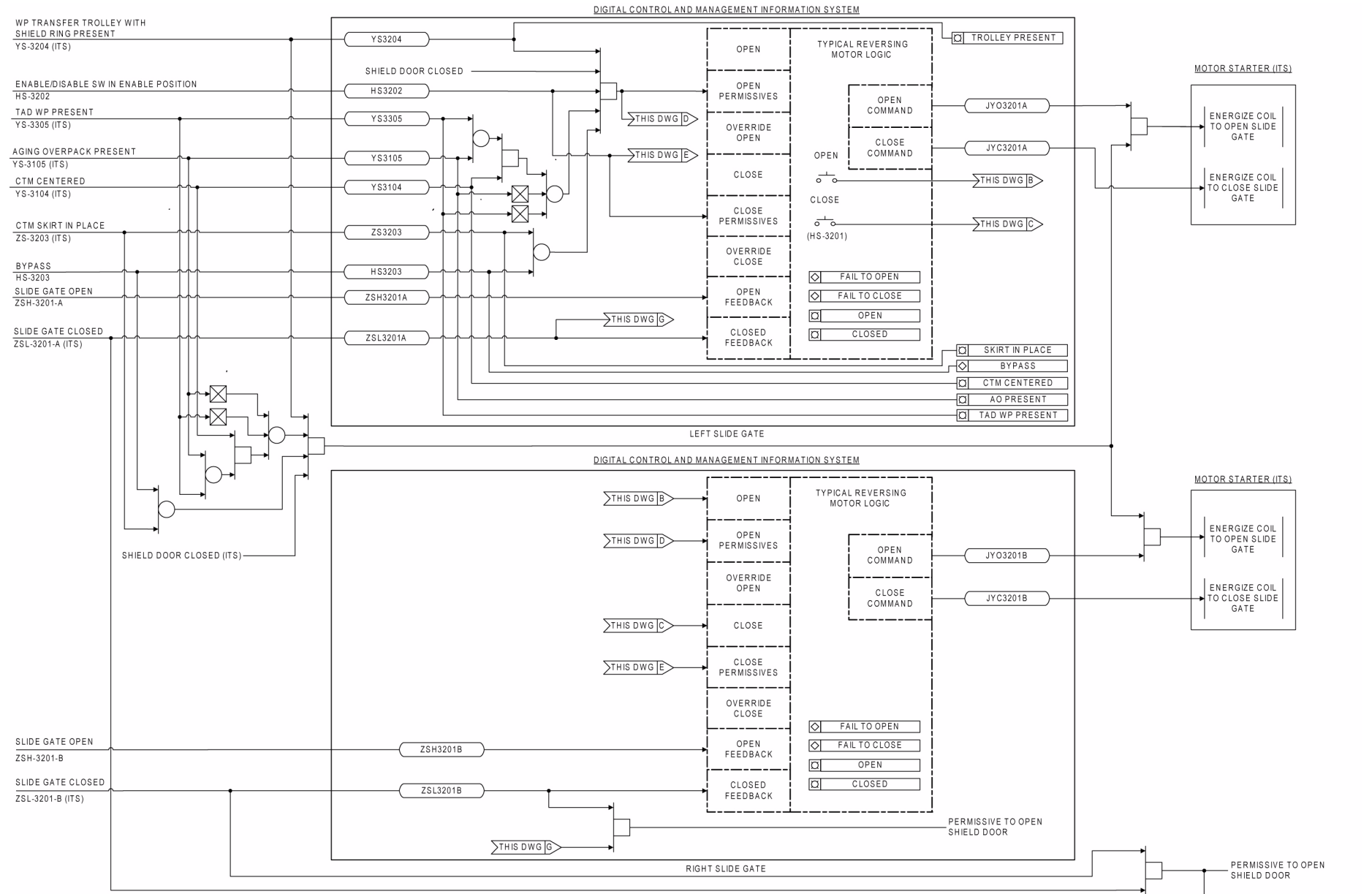

FACILITY NAME	AREA CODE	SLIDE GATE EQUIPMENT NUMBER	OPEN/CLOSE HS	ENABLE/DISABLE SWITCH	BYPASS SW	CTM SKIRT IN PLACE SW	WP TRANSFER TROLLEY WITH SHIELD RING PRESENT SW	OPEN LIMIT SWITCH		CLOSED LIMIT SWITCH		TAD WP PRESENT SW	CTM CENTERED SW	AGING OVERPACK PRESENT SW	LOGIC OUTPUT OPEN		LOGIC OUTPUT CLOSE		INTERFACING SHIELD DOOR EQUIPMENT NUMBER	INTERFACING WP TRANSFER TROLLEY EQUIPMENT NUMBER
								LEFT SLIDE GATE	RIGHT SLIDE GATE	LEFT SLIDE GATE	RIGHT SLIDE GATE				LEFT SLIDE	RIGHT SLIDE	LEFT SLIDE	RIGHT SLIDE		
HF	51A	51A-HTC0-HTCH-00002	HS-3201	HS-3202	HS-3203	ZS-3203 (ITS)	YS-3204 (ITS)	ZSH-3201-A	ZSH-3201-B	ZSL-3201-A (ITS)	ZSL-3201-B (ITS)	N/A	N/A	N/A	JYO3201A	JYO3201B	JYC3201A	JYC3201B	51A-H00-DR-00002	51A-H00-TRLY-00001
		51A-HTC0-HTCH-00001	HS-3101	HS-3102	N/A	ZS-3103 (ITS)	N/A	ZSH-3101-A	ZSH-3101-B	ZSL-3101-A (ITS)	ZSL-3101-B (ITS)	N/A	N/A	N/A	JYO3101A	JYO3101B	JYC3101A	JYC3101B	51A-H00-DR-00001	N/A
CRCF	060	060-HTC0-HTCH-00001	HS-3101	HS-3102	N/A	ZS-3103 (ITS)	N/A	ZSH-3101-A	ZSH-3101-B	ZSL-3101-A (ITS)	ZSL-3101-B (ITS)	N/A	YS-3104 (ITS)	YS-3105 (ITS)	JYO3101A	JYO3101B	JYC3101A	JYC3101B	060-CR00-DR-00001	N/A
		060-HTC0-HTCH-00002	HS-3201	HS-3202	N/A	ZS-3203 (ITS)	N/A	ZSH-3201-A	ZSH-3201-B	ZSL-3201-A (ITS)	ZSL-3201-B (ITS)	N/A	YS-3204 (ITS)	YS-3205 (ITS)	JYO3201A	JYO3201B	JYC3201A	JYC3201B	060-CR00-DR-00002	N/A
		060-HTC0-HTCH-00003	HS-3301	HS-3302	N/A	ZS-3303 (ITS)	YS-3304 (ITS)	ZSH-3301-A	ZSH-3301-B	ZSL-3301-A (ITS)	ZSL-3301-B (ITS)	YS-3305 (ITS)	YS-3306 (ITS)	N/A	JYO3301A	JYO3301B	JYC3301A	JYC3301B	060-CR00-DR-00003	060-HL00-TRLY-00001
RF	200	060-HTC0-HTCH-00004	HS-3401	HS-3402	N/A	ZS-3403 (ITS)	YS-3404 (ITS)	ZSH-3401-A	ZSH-3401-B	ZSL-3401-A (ITS)	ZSL-3401-B (ITS)	YS-3405 (ITS)	YS-3406 (ITS)	N/A	JYO3401A	JYO3401B	JYC3401A	JYC3401B	060-CR00-DR-00004	060-HL00-TRLY-00002
		200-HTC0-HTCH-00001	HS-3101	HS-3102	N/A	ZS-3103 (ITS)	N/A	ZSH-3101-A	ZSH-3101-B	ZSL-3101-A (ITS)	ZSL-3101-B (ITS)	N/A	N/A	N/A	JYO3101A	JYO3101B	JYC3101A	JYC3101B	200-RF00-DR-00001	N/A
WHF	050	200-HTC0-HTCH-00002	HS-3201	HS-3202	N/A	ZS-3203 (ITS)	N/A	ZSH-3201-A	ZSH-3201-B	ZSL-3201-A (ITS)	ZSL-3201-B (ITS)	N/A	N/A	N/A	JYO3201A	JYO3201B	JYC3201A	JYC3201B	200-RF00-DR-00002	N/A
		050-HTC0-HTCH-00001	HS-3101	HS-3102	N/A	ZS-3103 (ITS)	N/A	ZSH-3101-A	ZSH-3101-B	ZSL-3101-A (ITS)	ZSL-3101-B (ITS)	N/A	N/A	N/A	JYO3101A	JYO3101B	JYC3101A	JYC3101B	050-WH00-DR-00004	N/A
WHF	050	050-HTC0-HTCH-00002	HS-3201	HS-3202	N/A	ZS-3203 (ITS)	N/A	ZSH-3201-A	ZSH-3201-B	ZSL-3201-A (ITS)	ZSL-3201-B (ITS)	N/A	N/A	N/A	JYO3201A	JYO3201B	JYC3201A	JYC3201B	050-WH00-DR-00003	N/A

00249DC_LA_2488e.a1

NOTE: ITS controls are identified by the letters "ITS" after the instrumentation tag number or control device identifier. The DCMIS is non-ITS and non-ITWI. Instrumentation tag numbers are prefixed by "XXX-HTC0-" and software tag numbers are prefixed by "XXXHTC0," where XXX is the area code. AO = aging overpack; CTM = canister transfer machine; WP = waste package.

Figure 1.2.4-59. Logic Diagram for the Cask Port and Waste Package Slide Gate (Double)

INTENTIONALLY LEFT BLANK

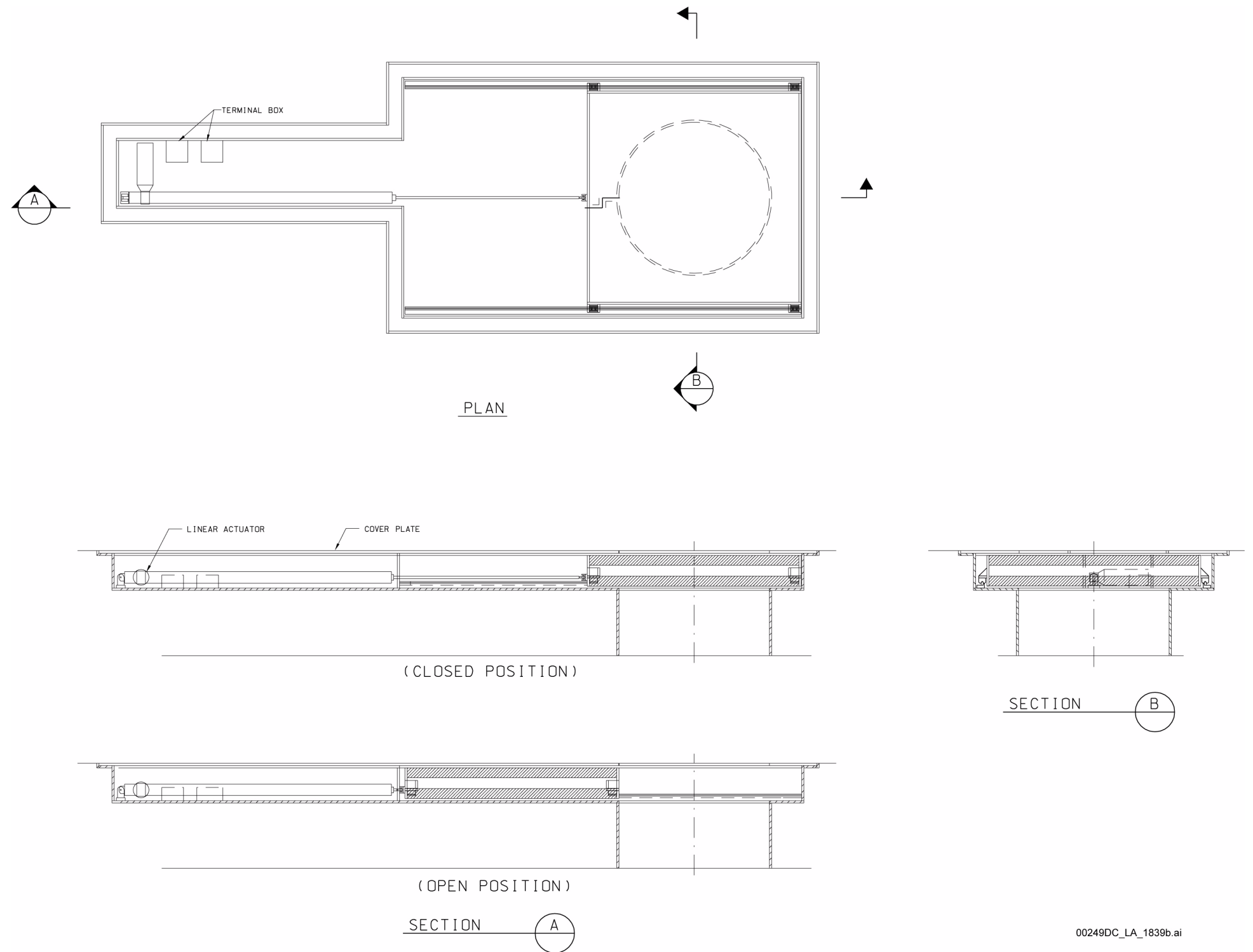

Equipment Number: 060-HTC0-HTCH-00010/00011, CRCF TAD canister slide gate.

Figure 1.2.4-60. TAD Canister Slide Gate Mechanical Equipment Envelope

INTENTIONALLY LEFT BLANK

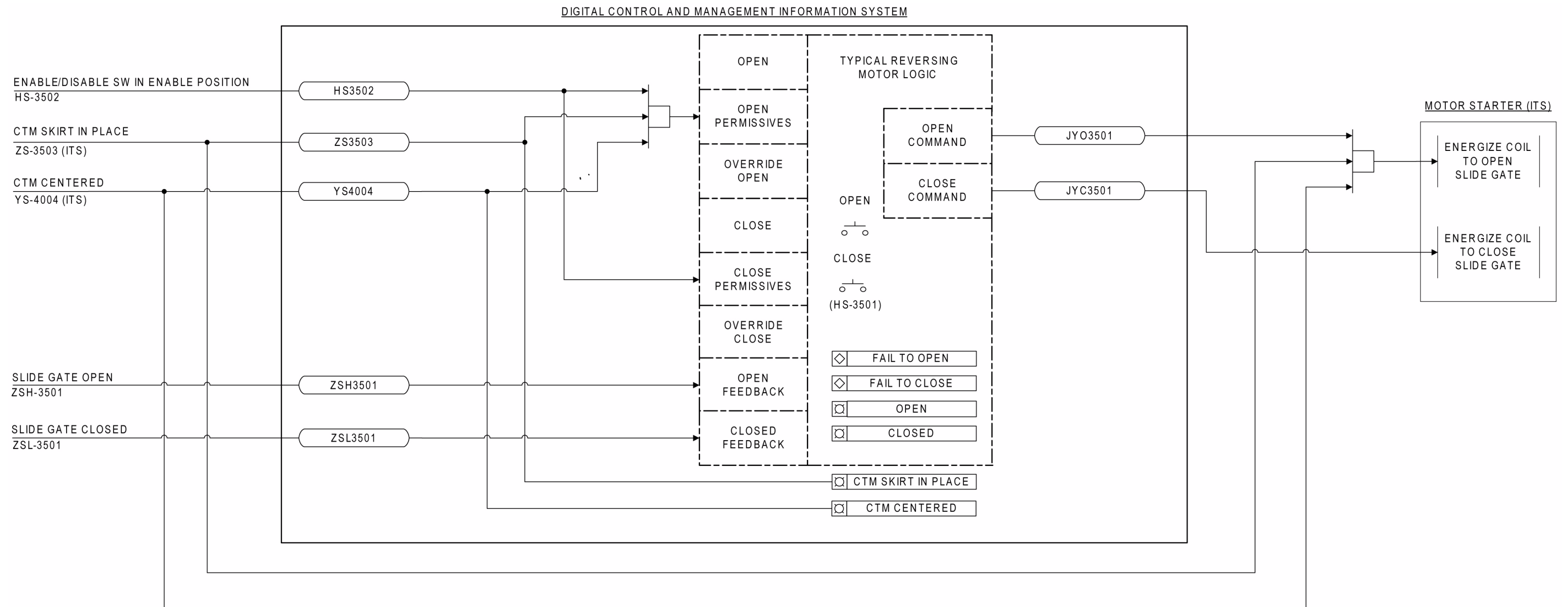

FACILITY NAME	SLIDE GATE EQUIPMENT NUMBER	DESCRIPTION	OPEN/CLOSE HANDSWITCH	ENABLE/DISABLE SW	CTM SKIRT IN PLACE SW	CTM CENTERED SW	SLIDE GATE OPEN LIMIT SW	SLIDE GATE CLOSED LIMIT SW	LOGIC OUTPUT OPEN	LOGIC OUTPUT CLOSE
CANISTER RECEIPT AND CLOSURE FACILITY	060-HTC0-HTCH-00005	DOE CANISTER SLIDE GATE	HS-3501	HS-3502	ZS-3503 (ITS)	N/A	ZSH-3501	ZSL-3501	JYO3501	JYC3501
	060-HTC0-HTCH-00006	DOE CANISTER SLIDE GATE	HS-3601	HS-3602	ZS-3603 (ITS)	N/A	ZSH-3601	ZSL-3601	JYO3601	JYC3601
	060-HTC0-HTCH-00007	DOE CANISTER SLIDE GATE	HS-3701	HS-3702	ZS-3703 (ITS)	N/A	ZSH-3701	ZSL-3701	JYO3701	JYC3701
	060-HTC0-HTCH-00008	DOE CANISTER SLIDE GATE	HS-3801	HS-3802	ZS-3803 (ITS)	N/A	ZSH-3801	ZSL-3801	JYO3801	JYC3801
	060-HTC0-HTCH-00009	DOE CANISTER SLIDE GATE	HS-3901	HS-3902	ZS-3903 (ITS)	N/A	ZSH-3901	ZSL-3901	JYO3901	JYC3901
	060-HTC0-HTCH-00010	TAD SLIDE GATE	HS-4001	HS-4002	ZS-4003 (ITS)	YS-4004 (ITS)	ZSH-4001	ZSL-4001	JYO4001	JYC4001
	060-HTC0-HTCH-00011	TAD SLIDE GATE	HS-4101	HS-4102	ZS-4103 (ITS)	YS-4104 (ITS)	ZSH-4101	ZSL-4101	JYO4101	JYC4101

00249DC_LA_2487d.ai

NOTE: ITS controls are identified by the letters "ITS" after the instrumentation tag number or control device identifier. The DCMIS is non-ITS and non-ITWI. Instrumentation tag numbers are prefixed by "060-HTC0-" and software tag numbers are prefixed by "060HTC0." CTM = canister transfer machine.

Figure 1.2.4-61. Logic Diagram for the Cask Port Slide Gate (Single)

INTENTIONALLY LEFT BLANK

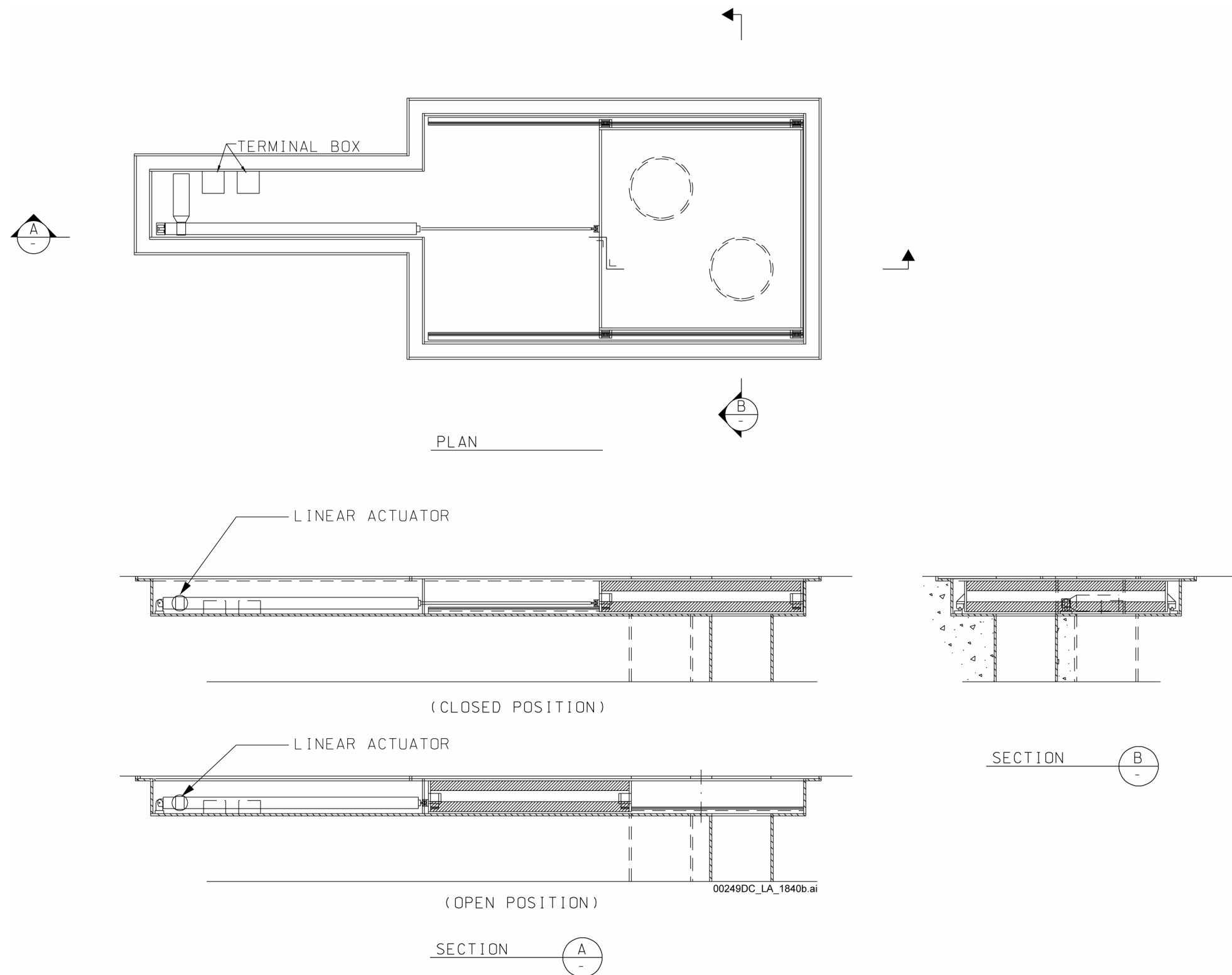

Equipment Number: 060-HTC0-HTCH-00005/00006/00007/00008/00009, CRCF DOE canister slide gates.

Figure 1.2.4-62. DOE Canister Slide Gate Mechanical Equipment Envelope

INTENTIONALLY LEFT BLANK

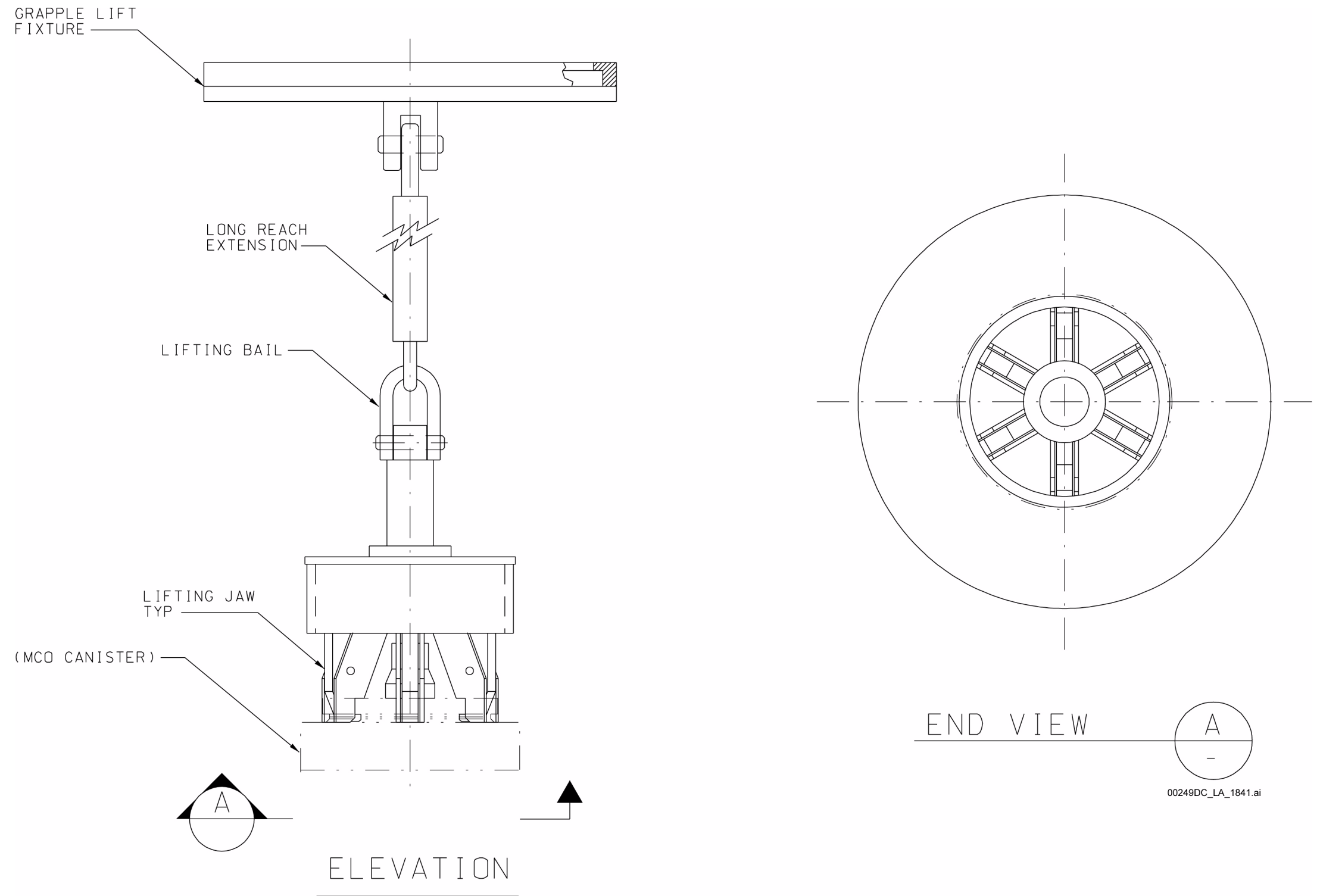

Equipment Number: 060-HTC0-HEQ-00004, Hanford MCO canister grapple.

Figure 1.2.4-63. Hanford Multicanister Overpack Canister Grapple Mechanical Equipment Envelope

INTENTIONALLY LEFT BLANK

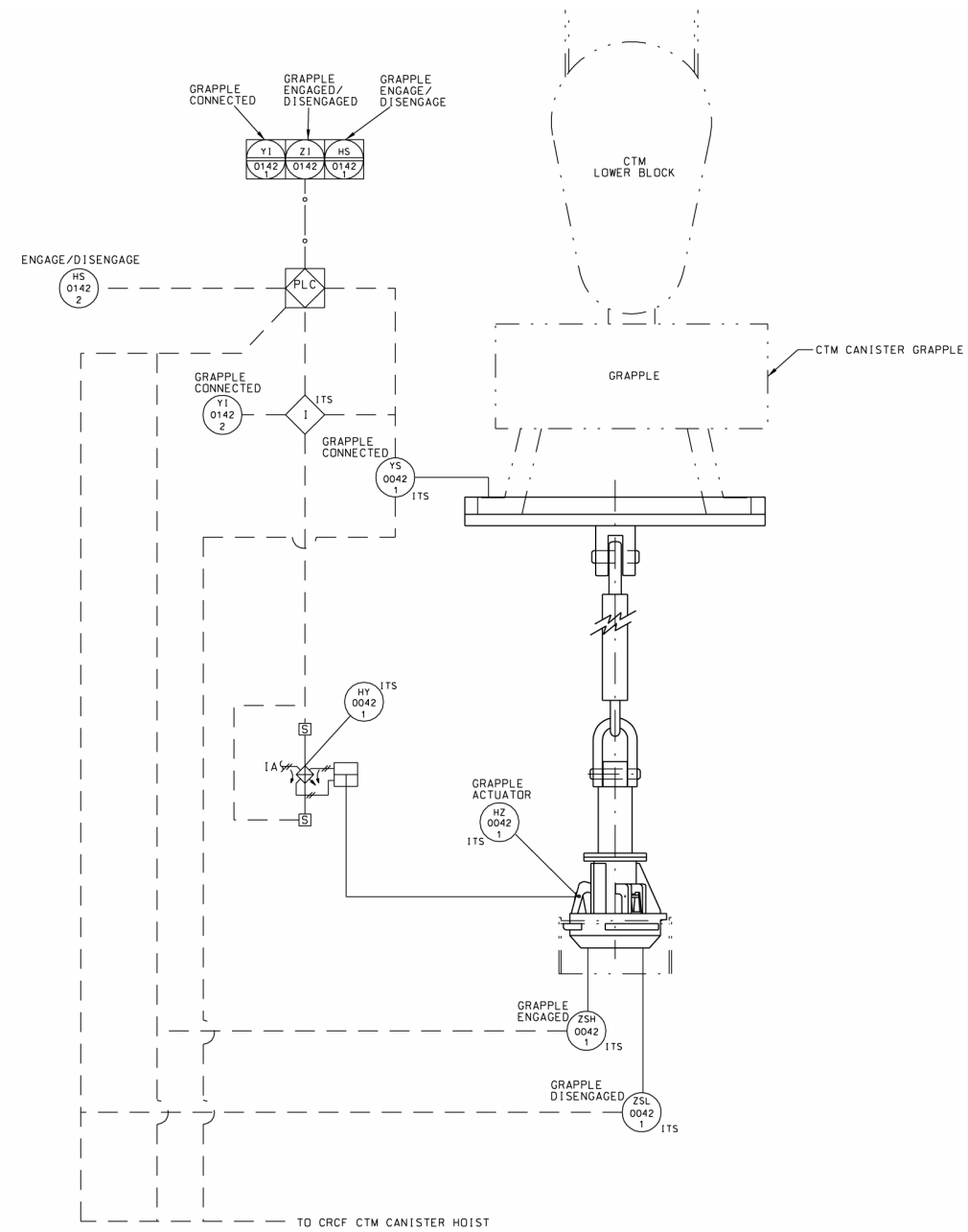

EQUIPMENT AND INSTRUMENTATION TABLE																
EQUIPMENT NUMBER	EQUIPMENT DESCRIPTION	GRAPPLE ACTUATOR	ACTUATOR SOLENOID	STATUS SWITCHES			CTM #1			CTM #2						
				CONNECTED	ENGAGED	DISENGAGED	DCMIS HANDSWITCH	DCMIS INDICATORS GRAPPLE CONNECTED	DCMIS INDICATORS ENGAGED/DISENGAGED	LOCAL HANDSWITCH	LOCAL CONNECTED INDICATOR	DCMIS HANDSWITCH	DCMIS INDICATORS GRAPPLE CONNECTED	DCMIS INDICATORS ENGAGED/DISENGAGED	LOCAL HANDSWITCH	LOCAL CONNECTED INDICATOR
060-HTCO-HEO-00006	18" DOE SNF CANISTER GRAPPLE	HZ-0042-1 (ITS)	HY-0042-1 (ITS)	YS-0042-1 (ITS)	ZSH-0042-1 (ITS)	ZSL-0042-1 (ITS)										
060-HTCO-HEO-00007	24" DOE SNF CANISTER GRAPPLE	HZ-0042-2 (ITS)	HY-0042-2 (ITS)	YS-0042-2 (ITS)	ZSH-0042-2 (ITS)	ZSL-0042-2 (ITS)										
060-HTCO-HEO-00004	HMCO CANISTER GRAPPLE	HZ-0042-3 (ITS)	HY-0042-3 (ITS)	YS-0042-3 (ITS)	ZSH-0042-3 (ITS)	ZSL-0042-3 (ITS)	HS-0142-1	Y1-0142-1	Z1-0142	HS-0142-2	Y1-0142-2	HS-0242-1	Y1-0242-1	Z1-0242	HS-0242-2	Y1-0242-2

00249DC_LA_2077e.ai

Figure 1.2.4-64. Hanford Multicanister Overpack, 18-in., and 24-in. SNF Canister Grapples Process and Instrumentation Diagram

NOTE: CTM = canister transfer machine; HMCO = Hanford MCO; WP = waste package.

INTENTIONALLY LEFT BLANK

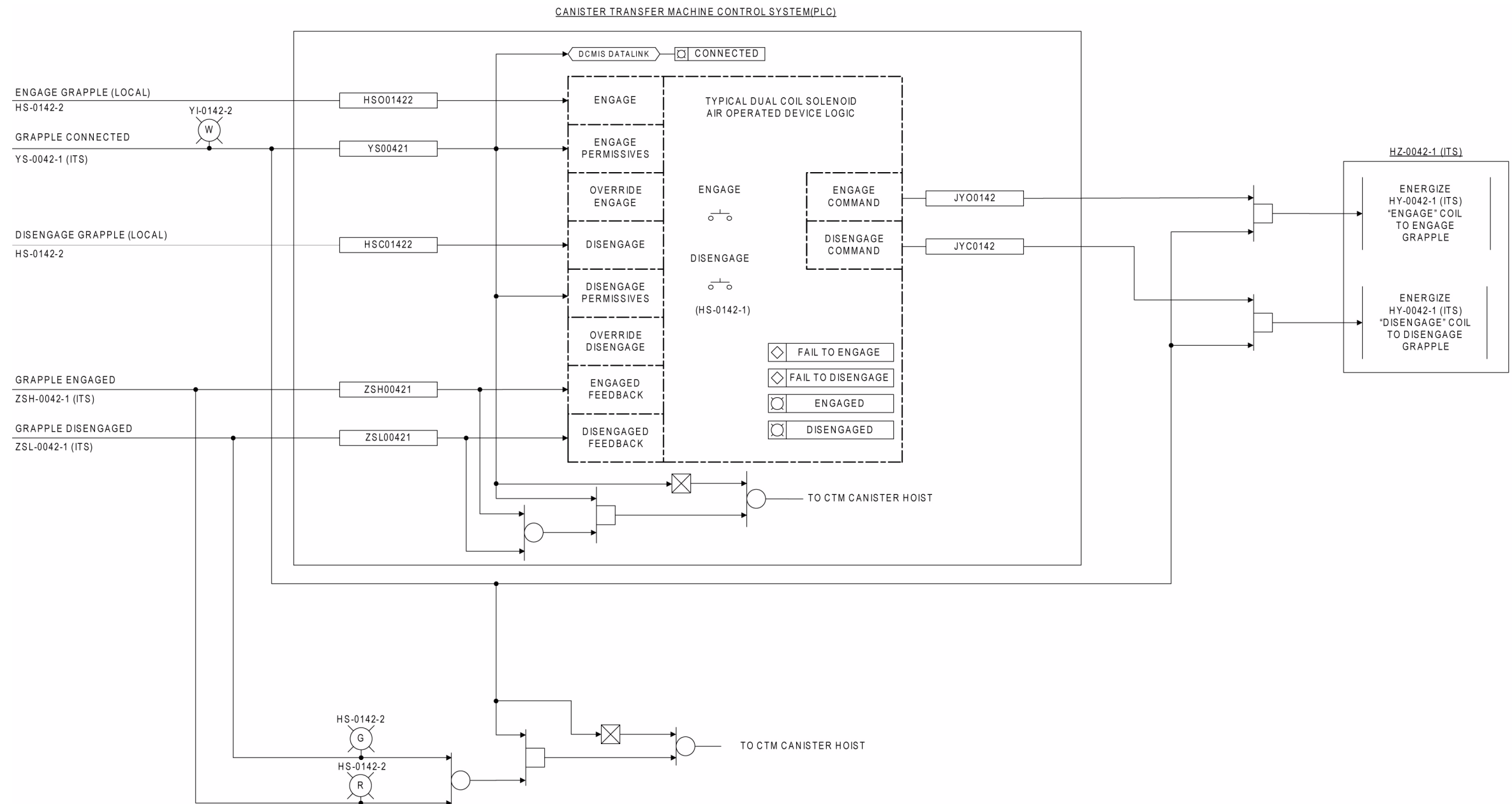

EQUIPMENT	EQUIPMENT NUMBER	CANISTER TRANSFER MACHINE #1						CANISTER TRANSFER MACHINE #2											
		CONNECTED LIMIT SW	DISENGAGED LIMIT SW	ENGAGED LIMIT SW	GRAPPLE ACTUATOR	ACTUATOR SOLENOID	DCMIS HANDSWITCH	LOCAL HANDSWITCH	LOGIC INPUT ENGAGE	LOGIC INPUT DISENGAGE	LOGIC OUTPUT ENGAGE	LOGIC OUTPUT DISENGAGE	DCMIS HANDSWITCH	LOCAL HANDSWITCH	LOGIC INPUT ENGAGE	LOGIC INPUT DISENGAGE	LOGIC OUTPUT ENGAGE	LOGIC OUTPUT DISENGAGE	
18" SNF CANISTER GRAPPLE	060-HTC0-HEQ-00006	YS-0042-1 (ITS)	ZSL-0042-1 (ITS)	ZSH-0042-1 (ITS)	HZ-0042-1 (ITS)	HY-0042-1 (ITS)													
24" SNF CANISTER GRAPPLE	060-HTC0-HEQ-00007	YS-0042-2 (ITS)	ZSL-0042-2 (ITS)	ZSH-0042-2 (ITS)	HZ-0042-2 (ITS)	HY-0042-2 (ITS)	HS-0142-1	HS-0142-2	HSO01422	HSC01422	JY00142	JYC0142	HS-0242-1	HS-0242-2	HSO02422	HSC02422	JY00242	JYC0242	
HANFORD MCO GRAPPLE	060-HTC0-HEQ-00004	YS-0042-3 (ITS)	ZSL-0042-3 (ITS)	ZSH-0042-3 (ITS)	HZ-0042-3 (ITS)	HY-0042-3 (ITS)													

00249DC_LA_2490c.ai

NOTE: ITS controls are identified by the letters "ITS" after the instrumentation tag number or control device identifier. The canister transfer machine control system, which controls the canister grapples, is non-ITS and non-ITWI. Simultaneous DCMIS and local control is prevented by means of a local/remote selector switch associated with the canister transfer machine. Instrumentation tag numbers are prefixed by "060-HTC0-" and software tag numbers are prefixed by "060HTC0." CTM = canister transfer machine.

Figure 1.2.4-65. Hanford Multicanister Overpack, 18-in., and 24-in. SNF Canister Grapples Logic Diagram

INTENTIONALLY LEFT BLANK

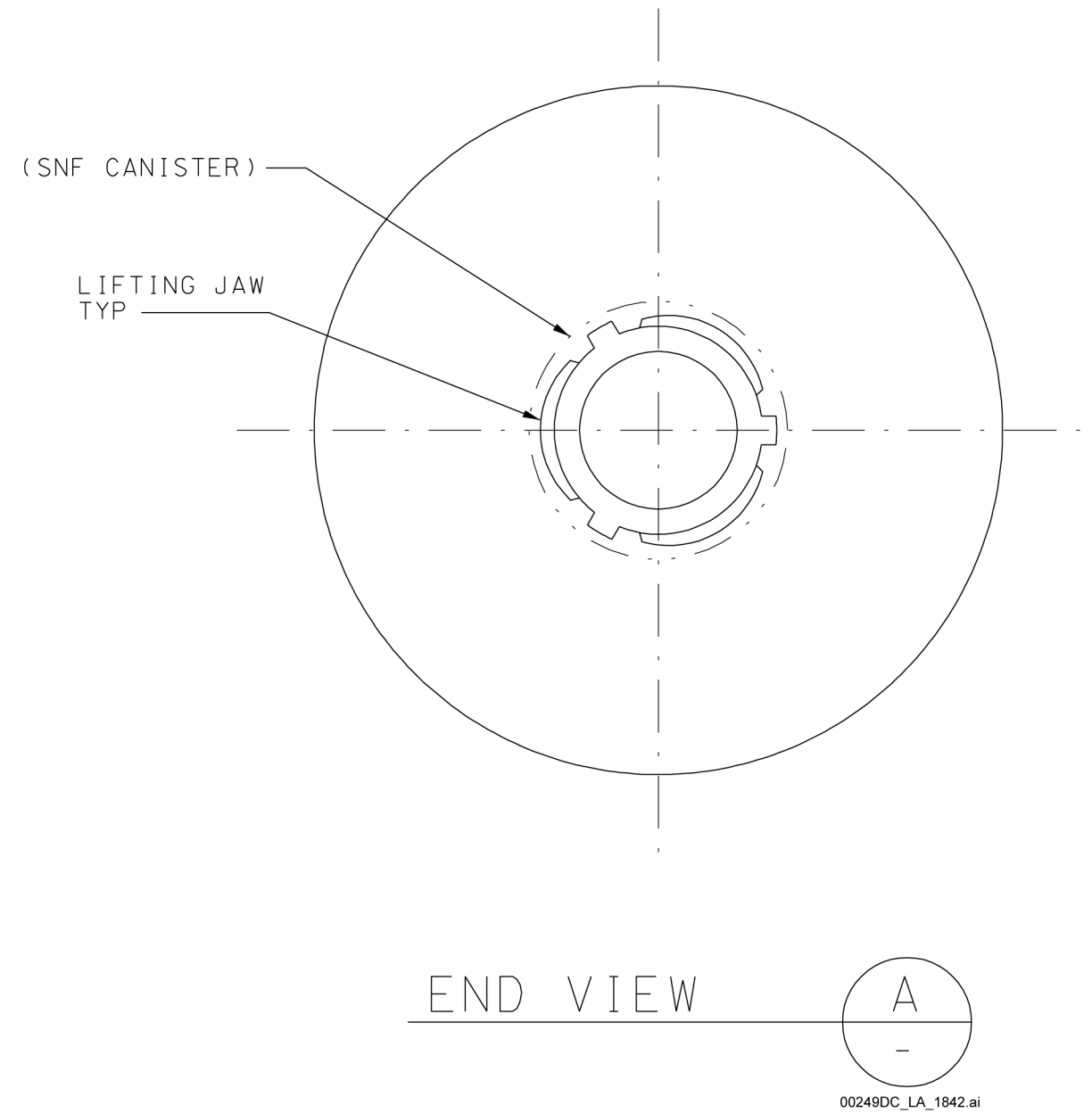
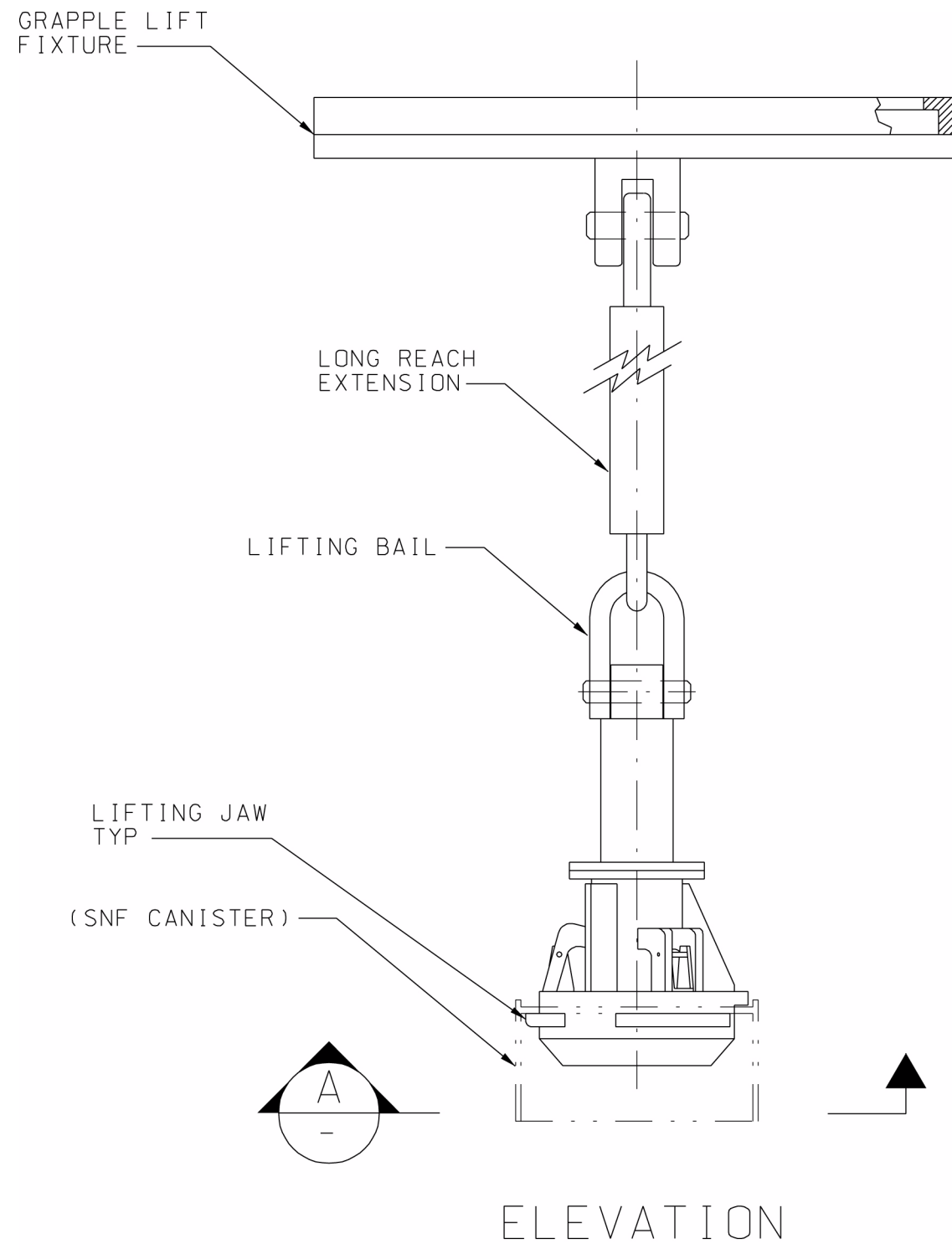

Equipment Number: 060-HTC0-HEQ-00006, CRCF SNF canister grapple, 18-in.

Figure 1.2.4-66. SNF Canister Grapple, 18-in., Mechanical Equipment Envelope

INTENTIONALLY LEFT BLANK

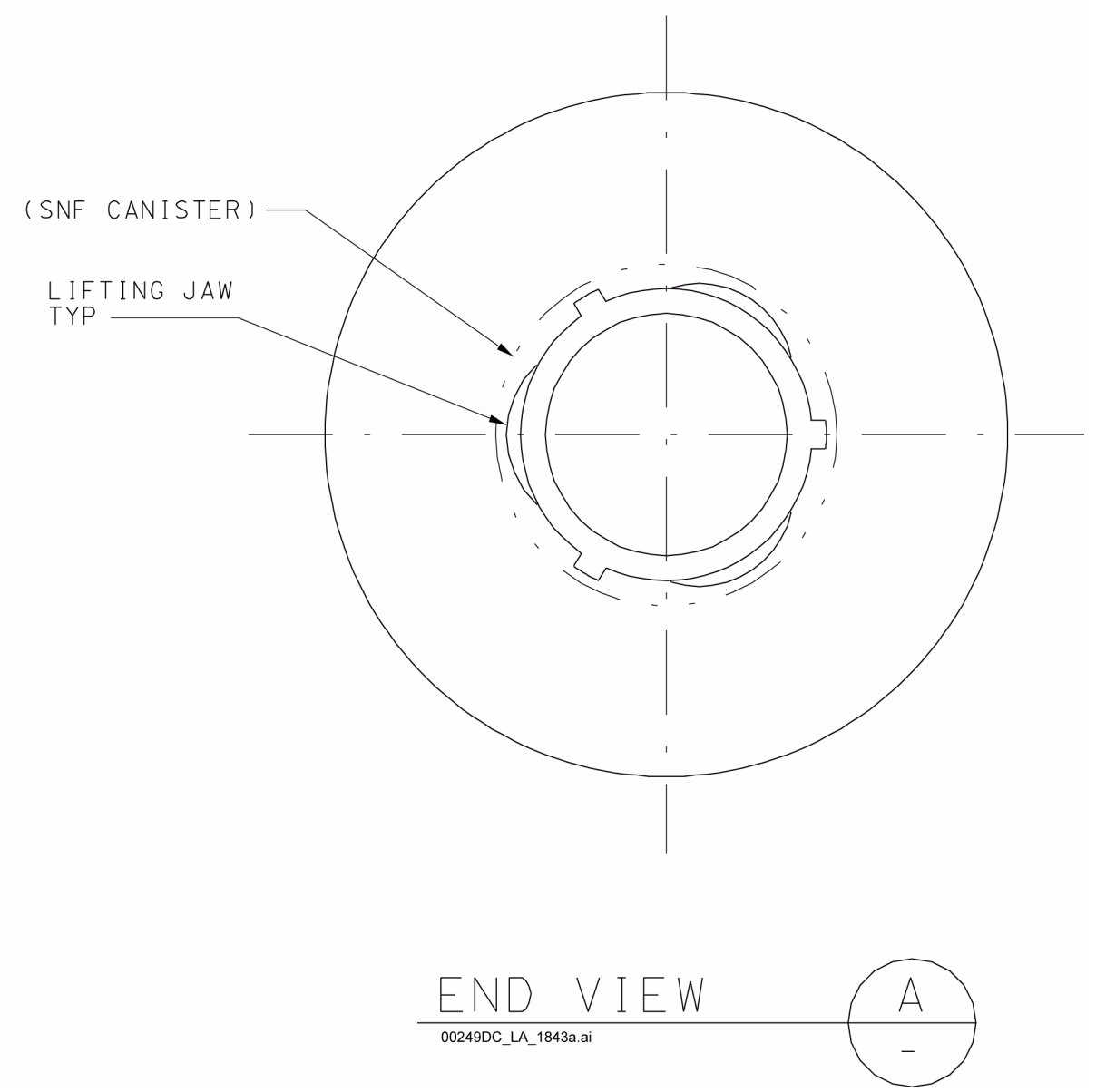
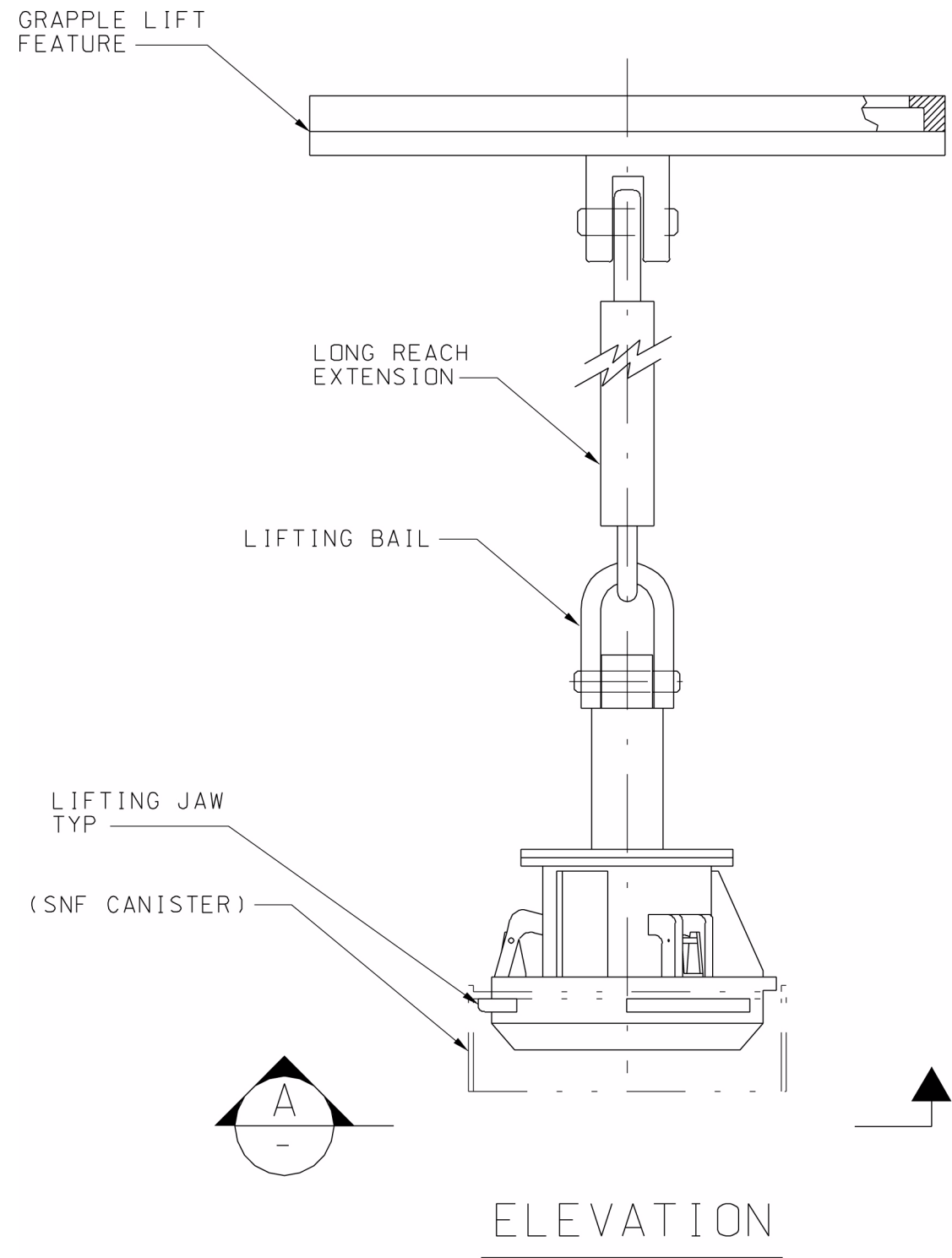

Equipment Number: 060-HTC0-HEQ-00007, CRCF SNF canister grapple, 24-in.

Figure 1.2.4-67. SNF Canister Grapple, 24-in., Mechanical Equipment Envelope

INTENTIONALLY LEFT BLANK

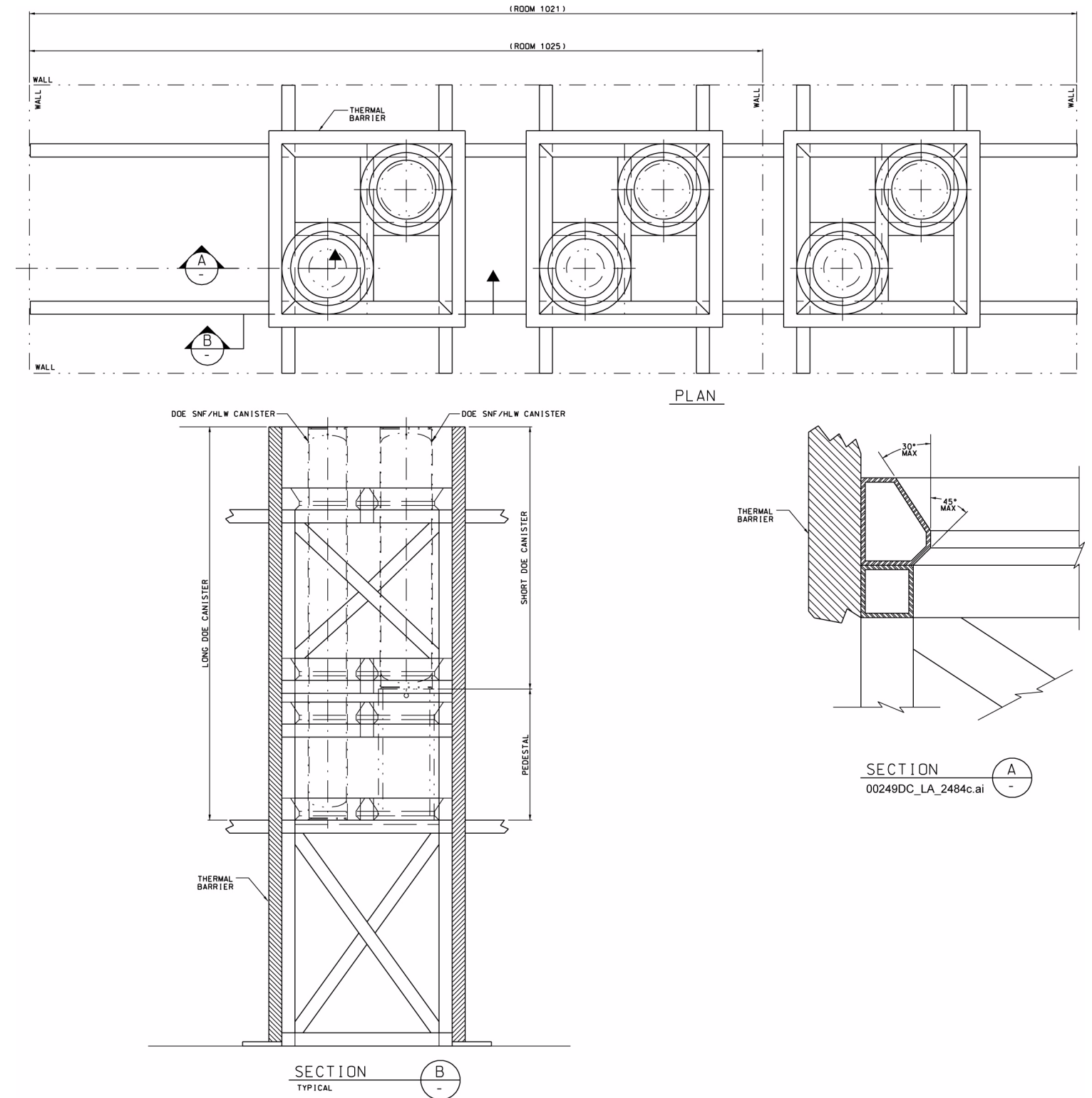

NOTE: The DOE canister staging rack assembly is configured to handle six canisters in Room 1021 and four canisters in Room 1025.

Equipment Number: In Room 1021, 060-HTC0-RK-00006/00007/00008, DOE canister staging rack; in Room 1025, 060-HTC0-RK-00009/00010, DOE canister staging rack.

Figure 1.2.4-68. DOE Canister Staging Rack Mechanical Equipment Envelope

INTENTIONALLY LEFT BLANK

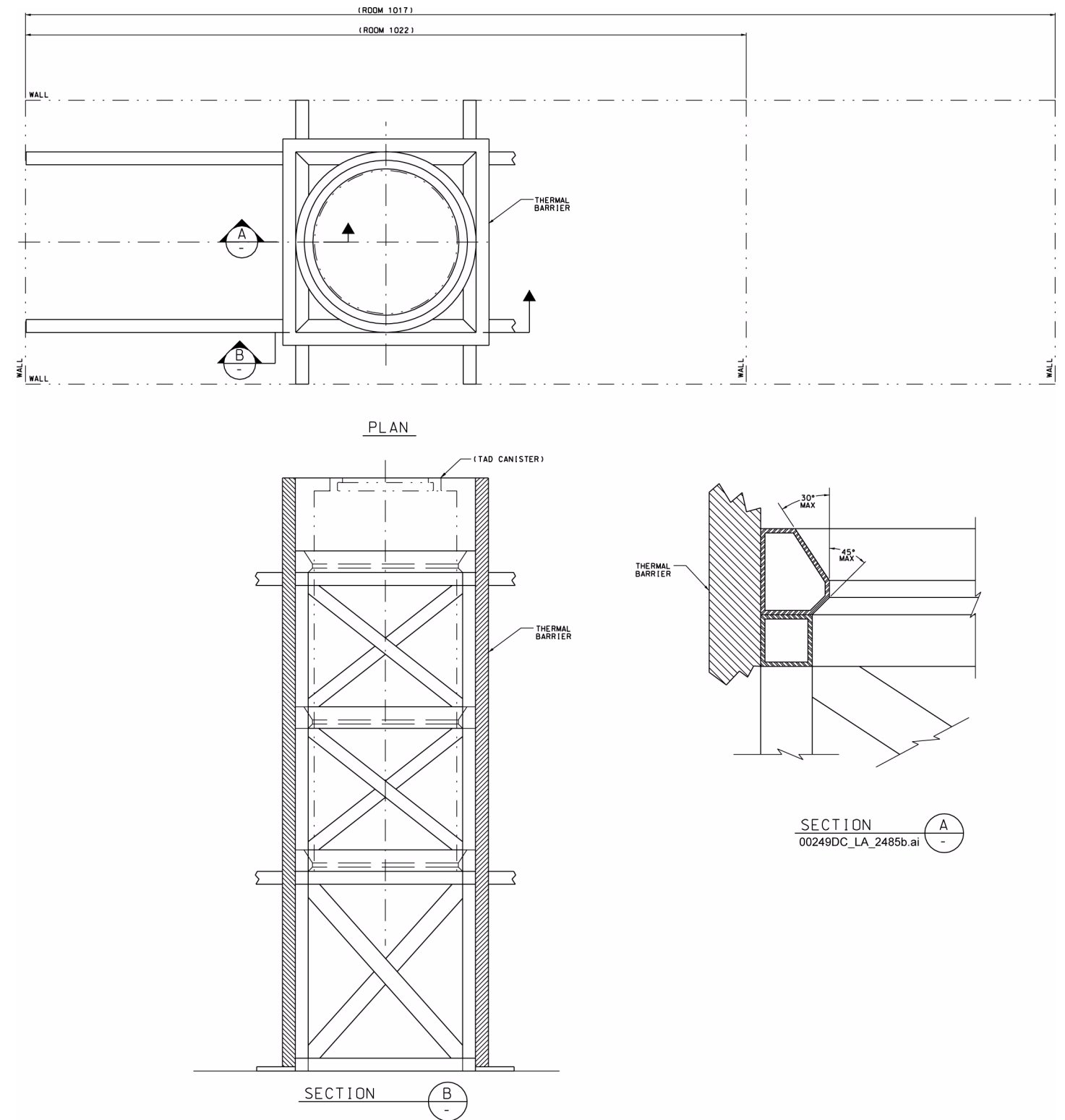

NOTE: The TAD canister staging rack is configured to handle one canister each in Rooms 1017 and 1022.

Equipment Number: In Room 1017, 060-HTC0-RK-00011, TAD canister staging rack; in Room 1022, 060-HTC0-RK-00012.
TAD canister staging rack.

Figure 1.2.4-69. TAD Canister Staging Rack Mechanical Equipment Envelope

INTENTIONALLY LEFT BLANK

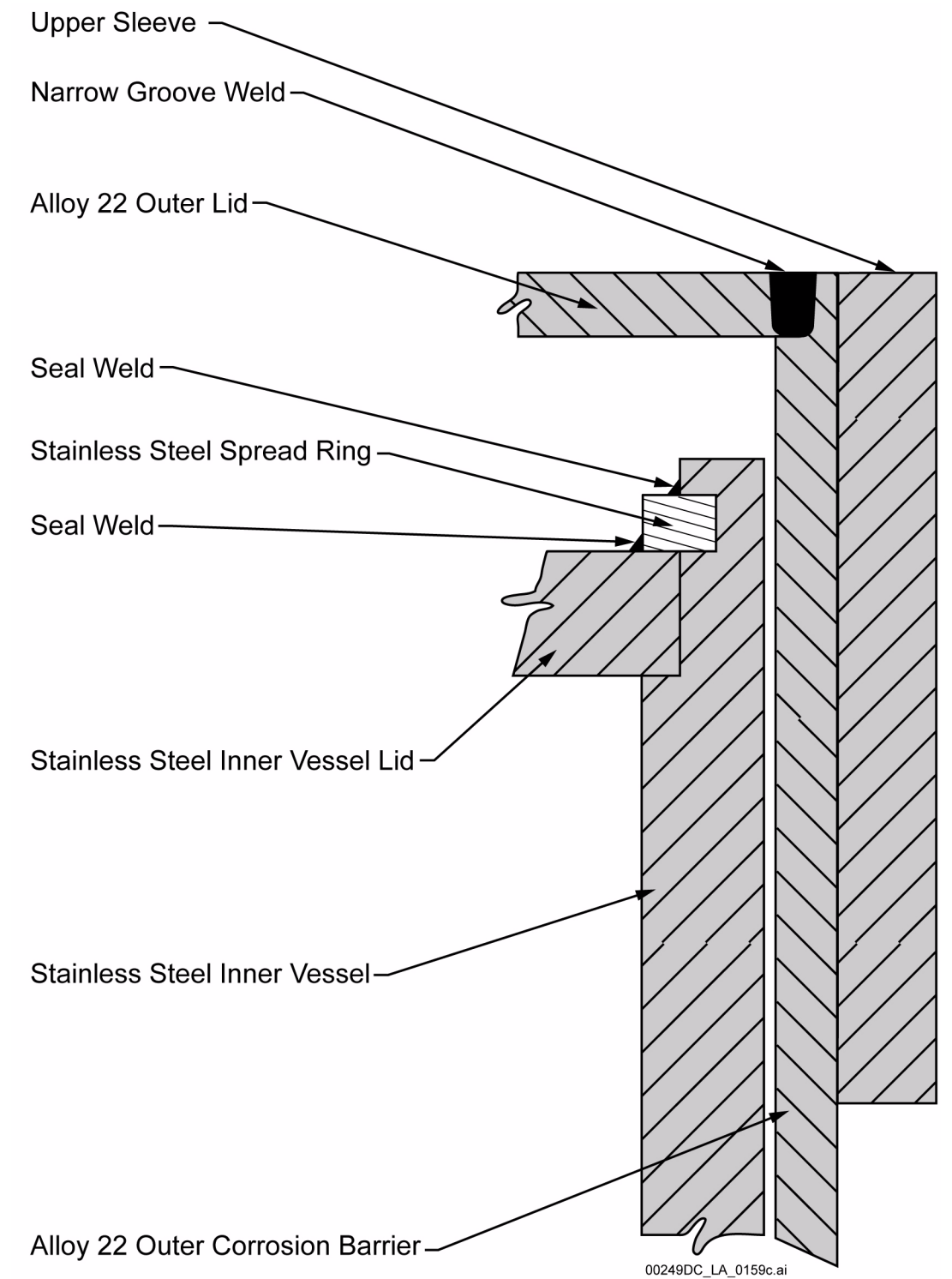

Figure 1.2.4-70. Waste Package Closure Welds (Typical)

INTENTIONALLY LEFT BLANK

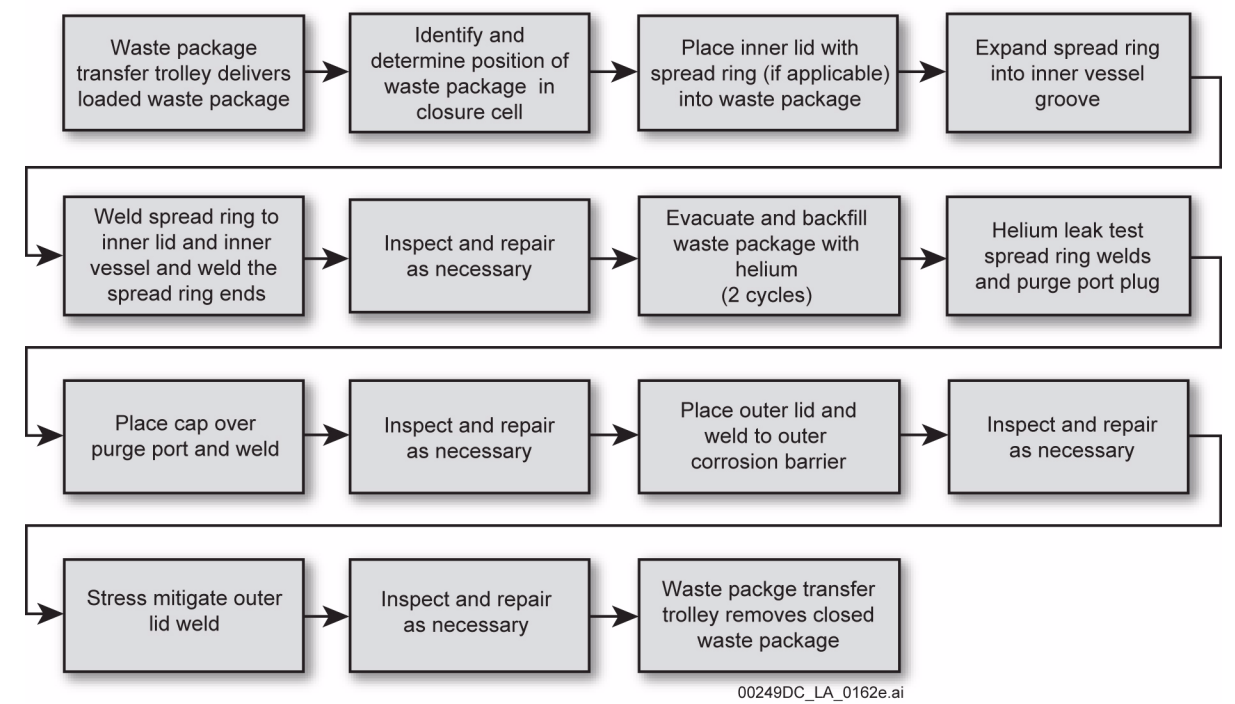

Figure 1.2.4-71. Waste Package Closure System Flow Diagram

INTENTIONALLY LEFT BLANK

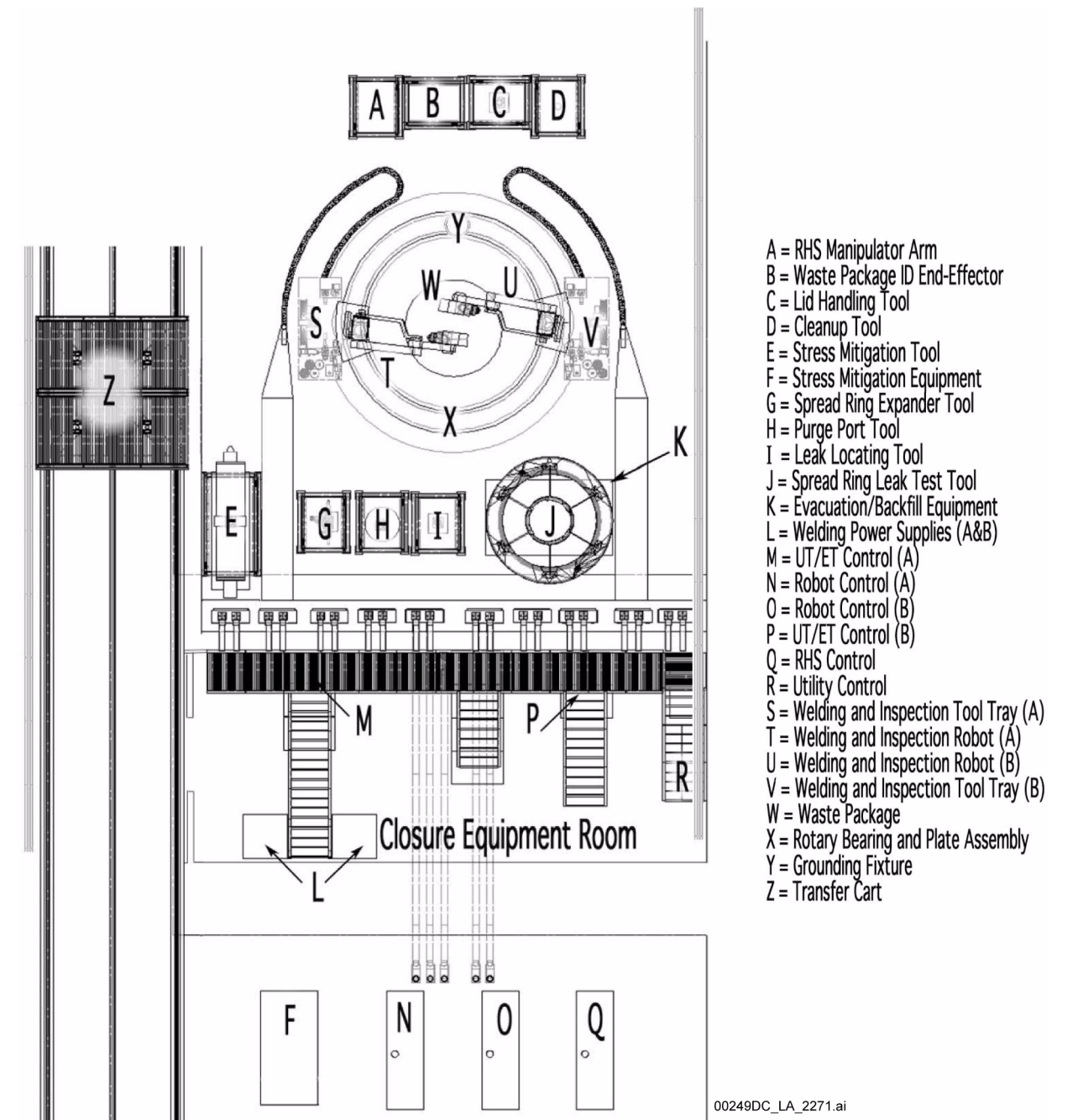
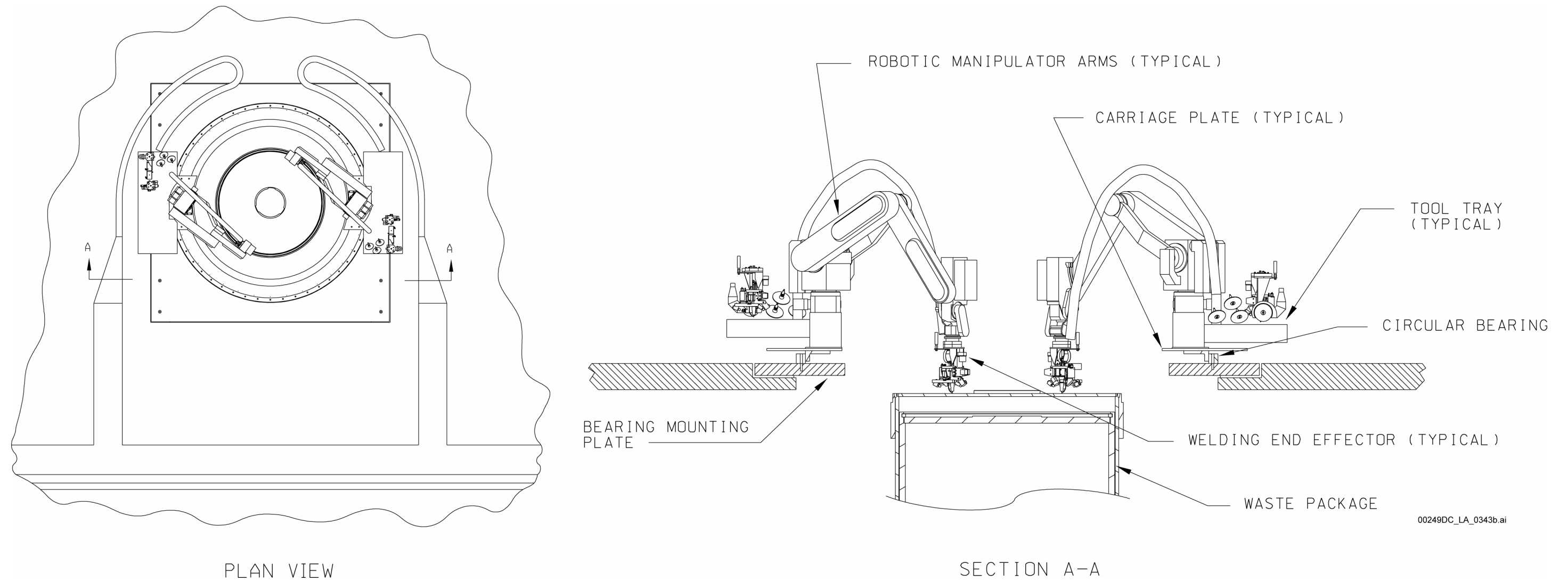

Figure 1.2.4-72. Illustration of Waste Package Closure Area Operating Floor (Partial View)

NOTE: ID = identification; RHS = remote handling system; UT/ET = ultrasonic testing/eddy current testing.

INTENTIONALLY LEFT BLANK



00249DC_LA_0343b.ai

NOTE: This figure includes no SSCs that are either ITS or ITWI.
Equipment Number: 060-HWH0-HEQ-00001/00002, waste package closure room robotic arms.

Figure 1.2.4-73. Waste Package Closure Room Robotic Arms

INTENTIONALLY LEFT BLANK

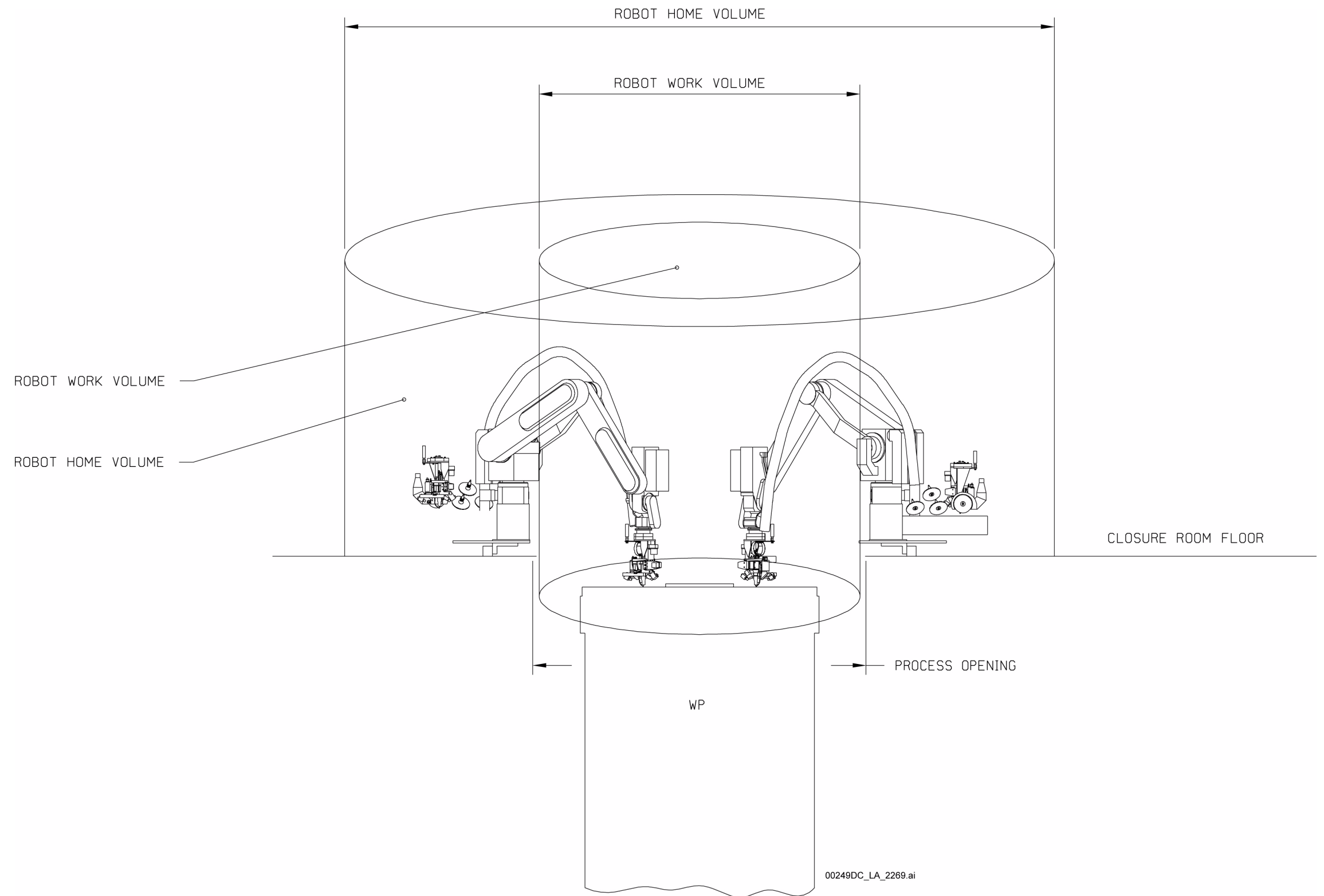

NOTE: This figure includes no SSCs that are either ITS or ITWI. WP = waste package.

Figure 1.2.4-74. Robotic Arms Mechanical Equipment Envelope

INTENTIONALLY LEFT BLANK

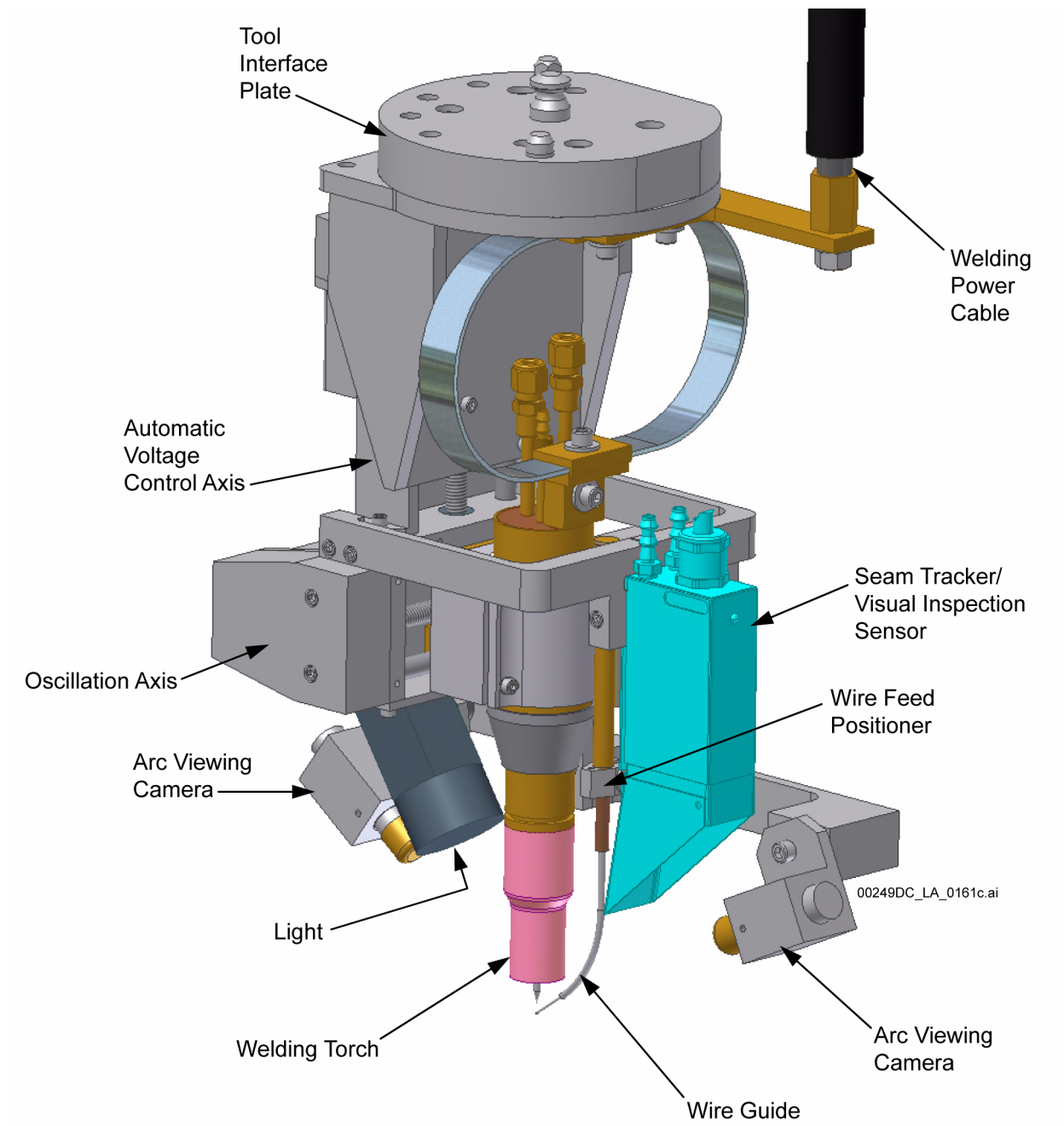

NOTE: This figure includes no SSCs that are either ITS or ITWI.
Equipment Number: 060-HWW0-TOOL-00001/00002, weld end effector.

Figure 1.2.4-75. Welding End Effector

INTENTIONALLY LEFT BLANK

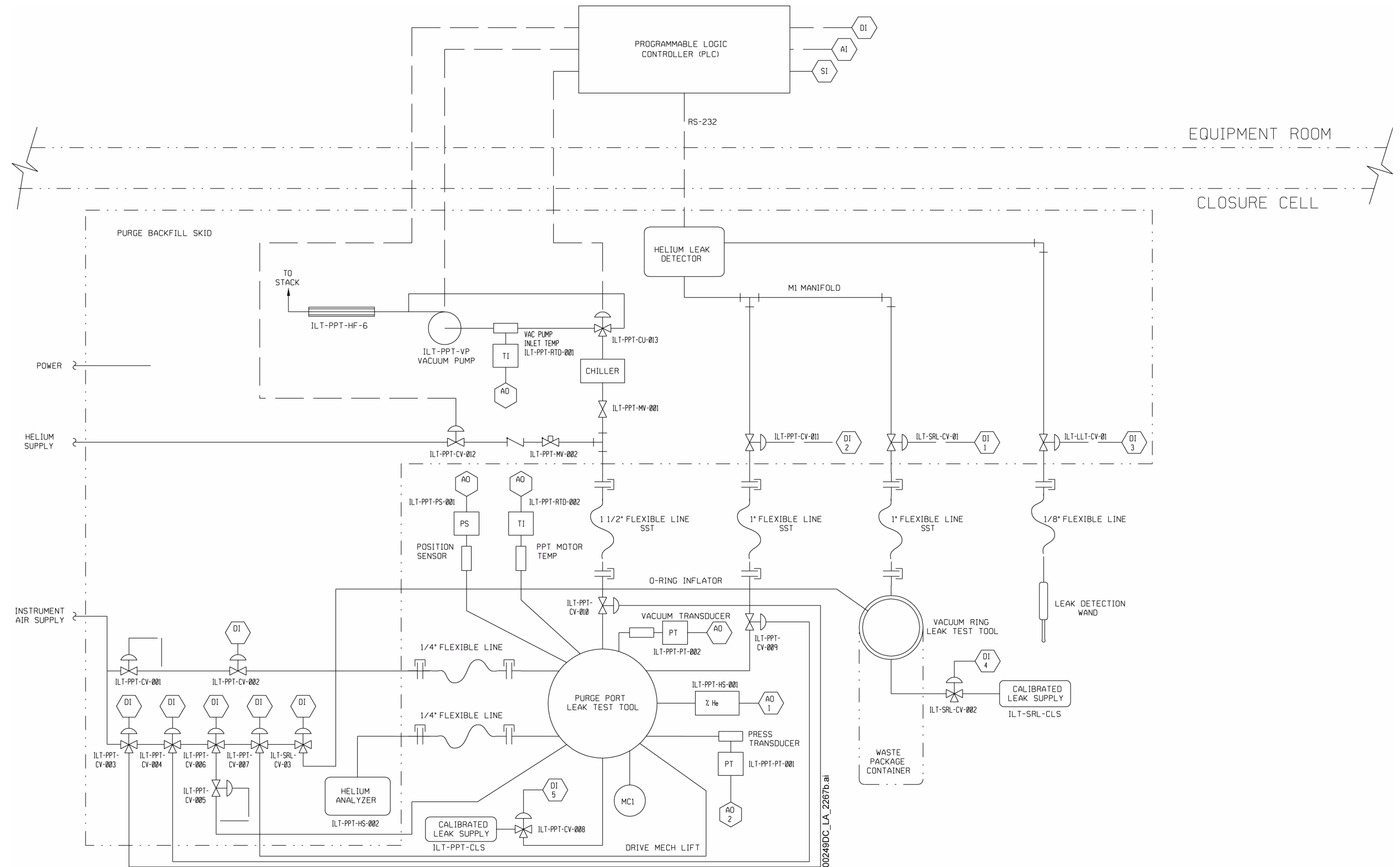

NOTE: This figure includes no SSCs that are either ITS or ITWI.

Figure 1.2.4-76. Waste Package Inerting System Piping and Instrumentation Diagram

INTENTIONALLY LEFT BLANK

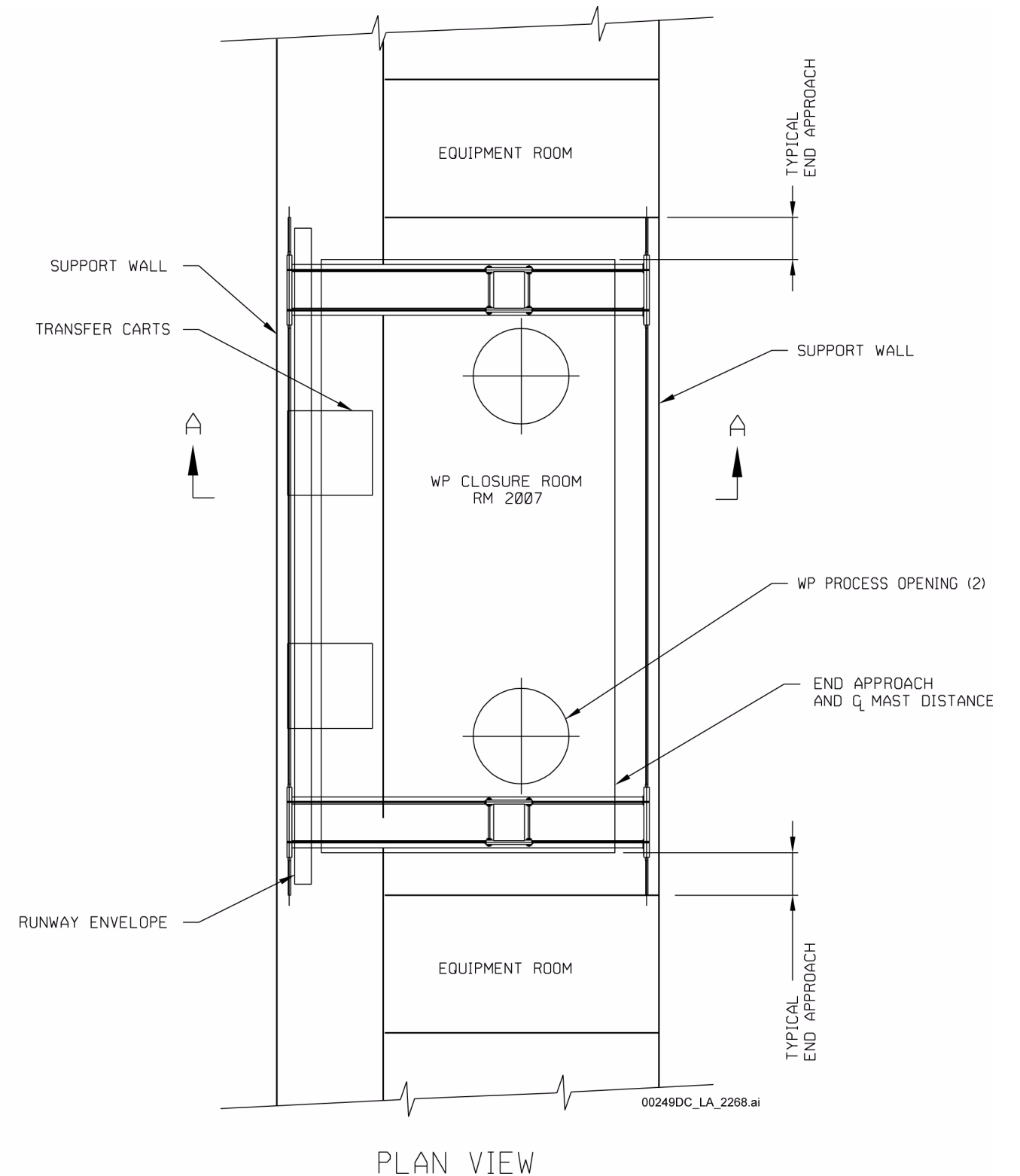
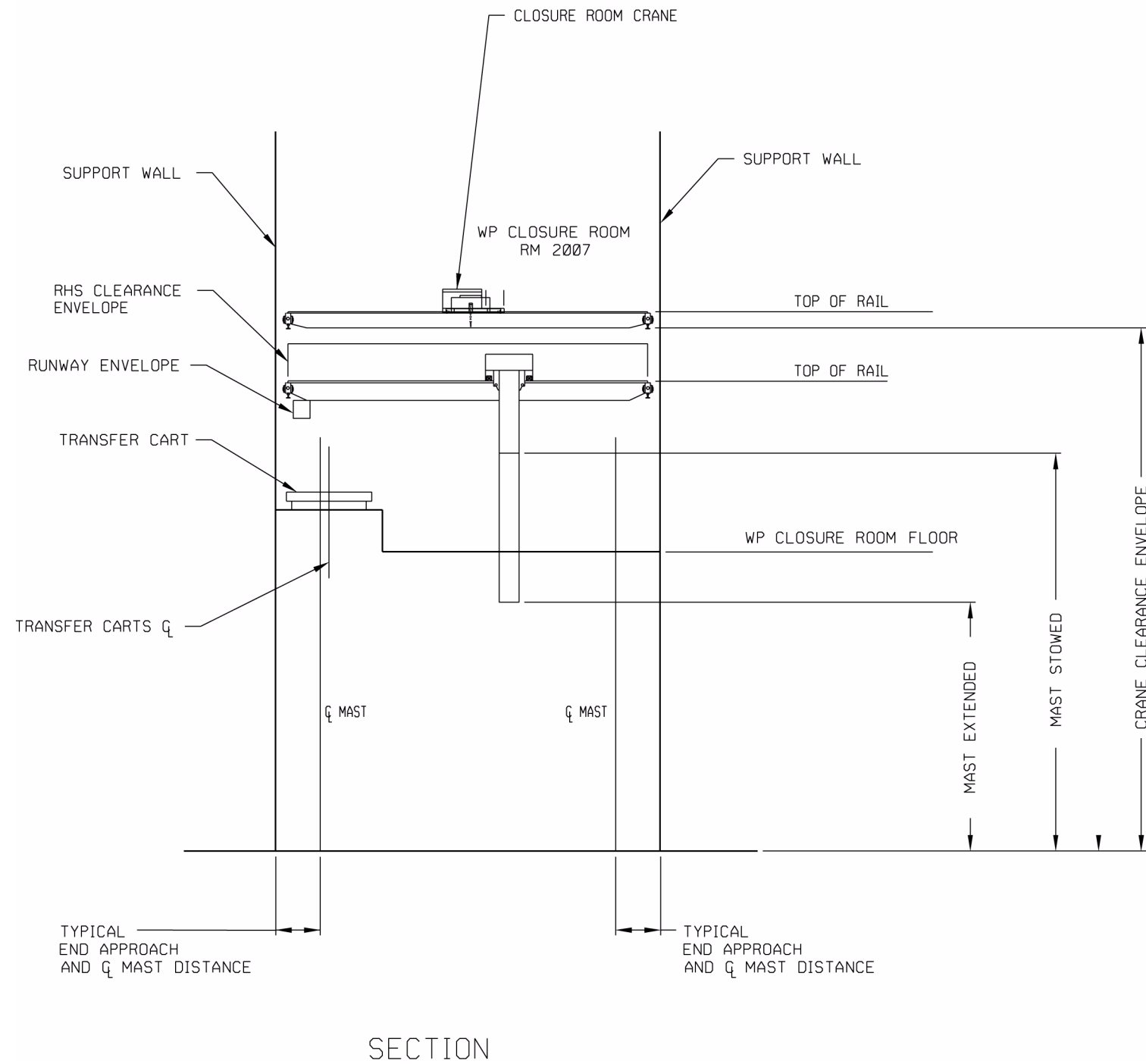

NOTE: RHS = remote handling system; WP = waste package.

Equipment Number: 060-HWH0-HEQ-00003/00005, CRCF waste package closure room remote handling system.

Figure 1.2.4-77. CRCF Waste Package Closure Room Remote Handling System Mechanical Equipment Envelope

INTENTIONALLY LEFT BLANK

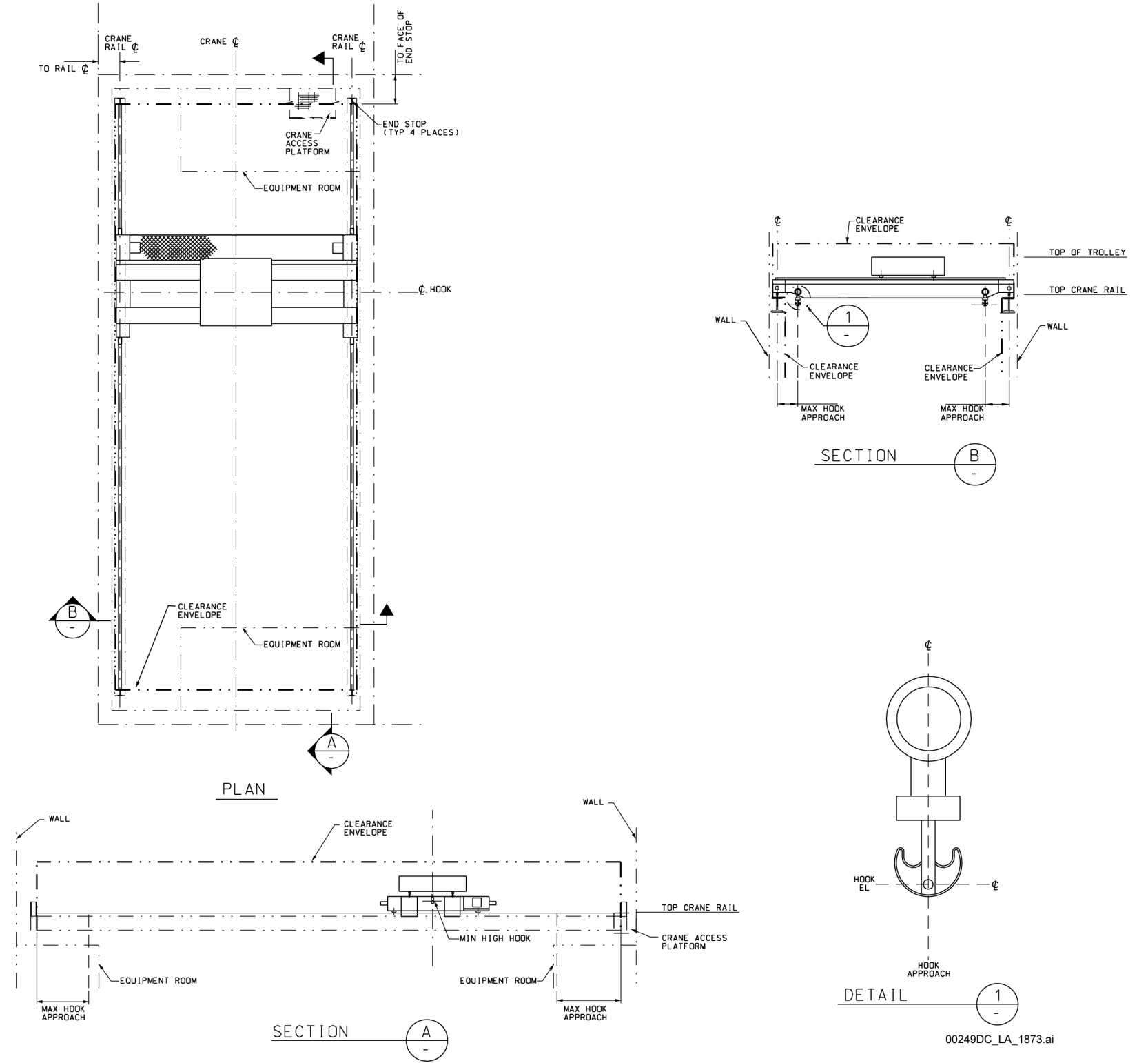

NOTE: This figure includes no SSCs that are either ITS or ITWI.
 Equipment Number: 060-HW00-CRN-00001, waste package closure room crane.

Figure 1.2.4-78. Waste Package Closure Room Crane Mechanical Equipment Envelope

INTENTIONALLY LEFT BLANK

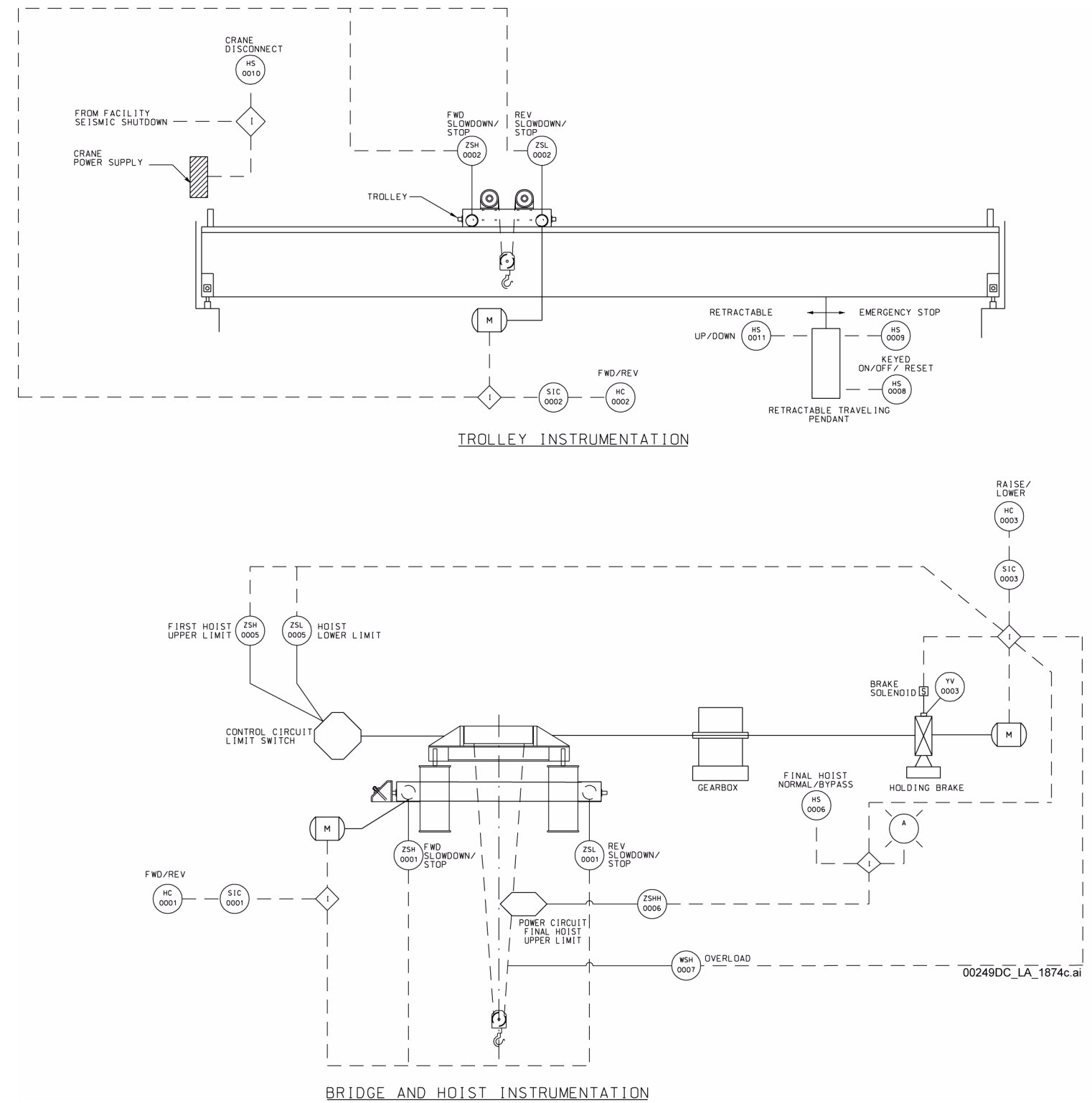

NOTE: This figure includes no SSCs that are either ITS or ITWI. This equipment is used in the CRCF and IHF.

Equipment Number: 060-HW00-CRN-00001, CRCF waste package closure room crane;
51A-HW00-CRN-00001, IHF waste package closure room crane.

Figure 1.2.4-79. Waste Package Closure Room Crane Mechanical Handling Process and Instrumentation Diagram

INTENTIONALLY LEFT BLANK

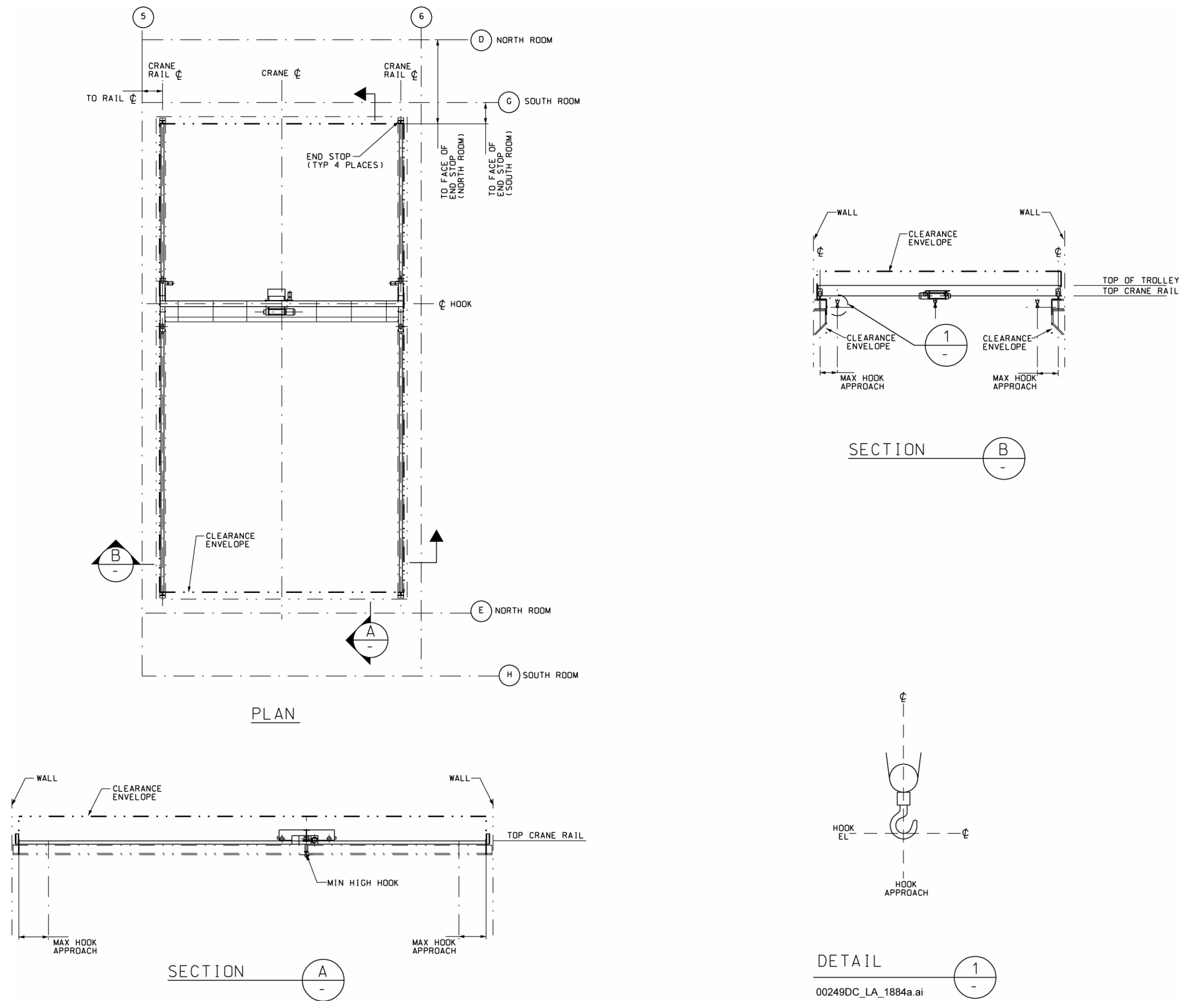

NOTE: This figure includes no SSCs that are either ITS or ITWI.
 Equipment Number: 060-HW00-CRN-00002/00003, CRCF closure support room crane.

Figure 1.2.4-80. Closure Support Room Crane Mechanical Equipment Envelope

INTENTIONALLY LEFT BLANK

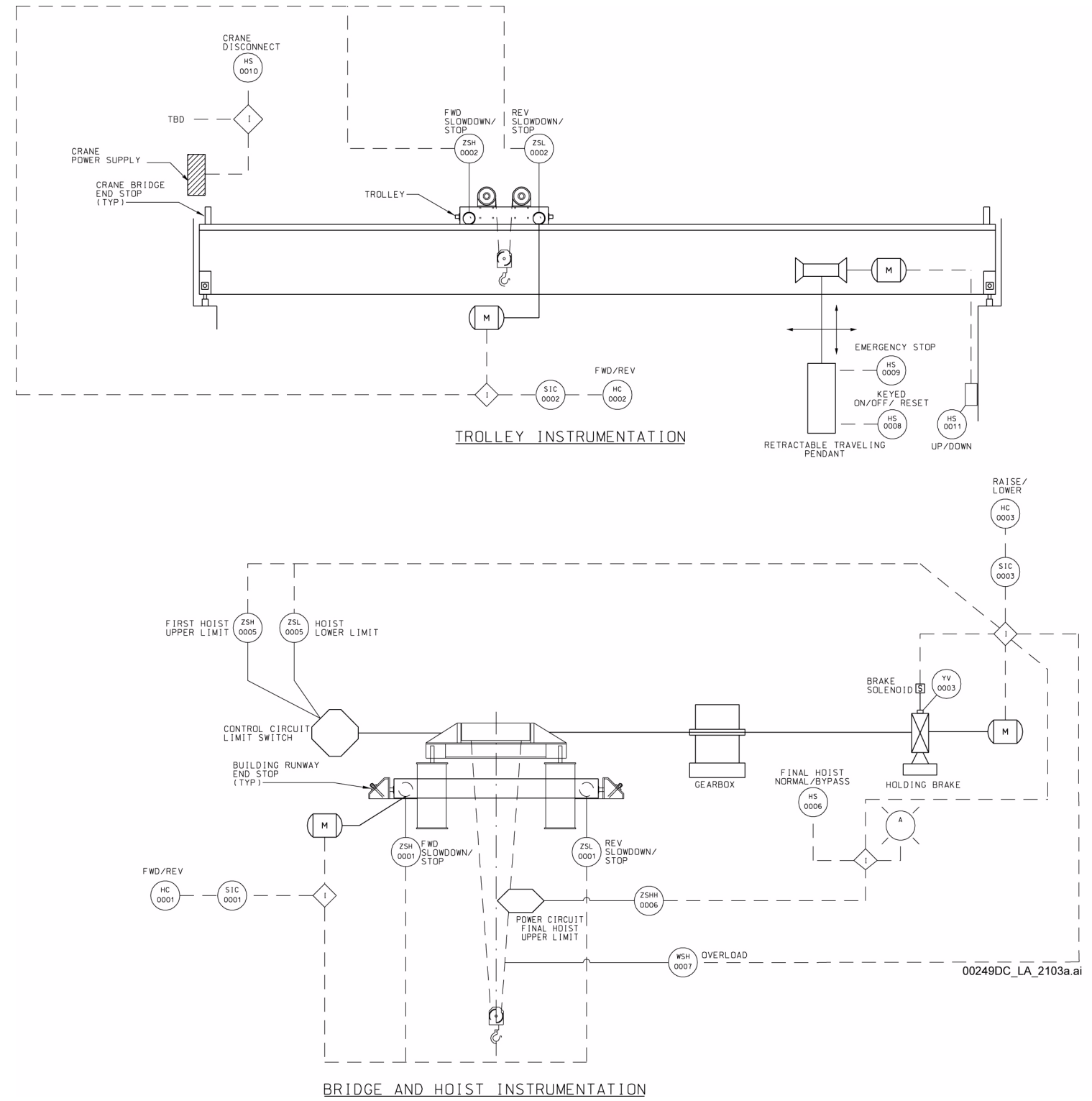

NOTE: This figure includes no SSCs that are either ITS or ITWI.
 Equipment Number: 060-HW00-CRN-00002/00003, waste package closure support room cranes.

Figure 1.2.4-81. Waste Package Closure Support Room Crane Process and Instrumentation Diagram

INTENTIONALLY LEFT BLANK

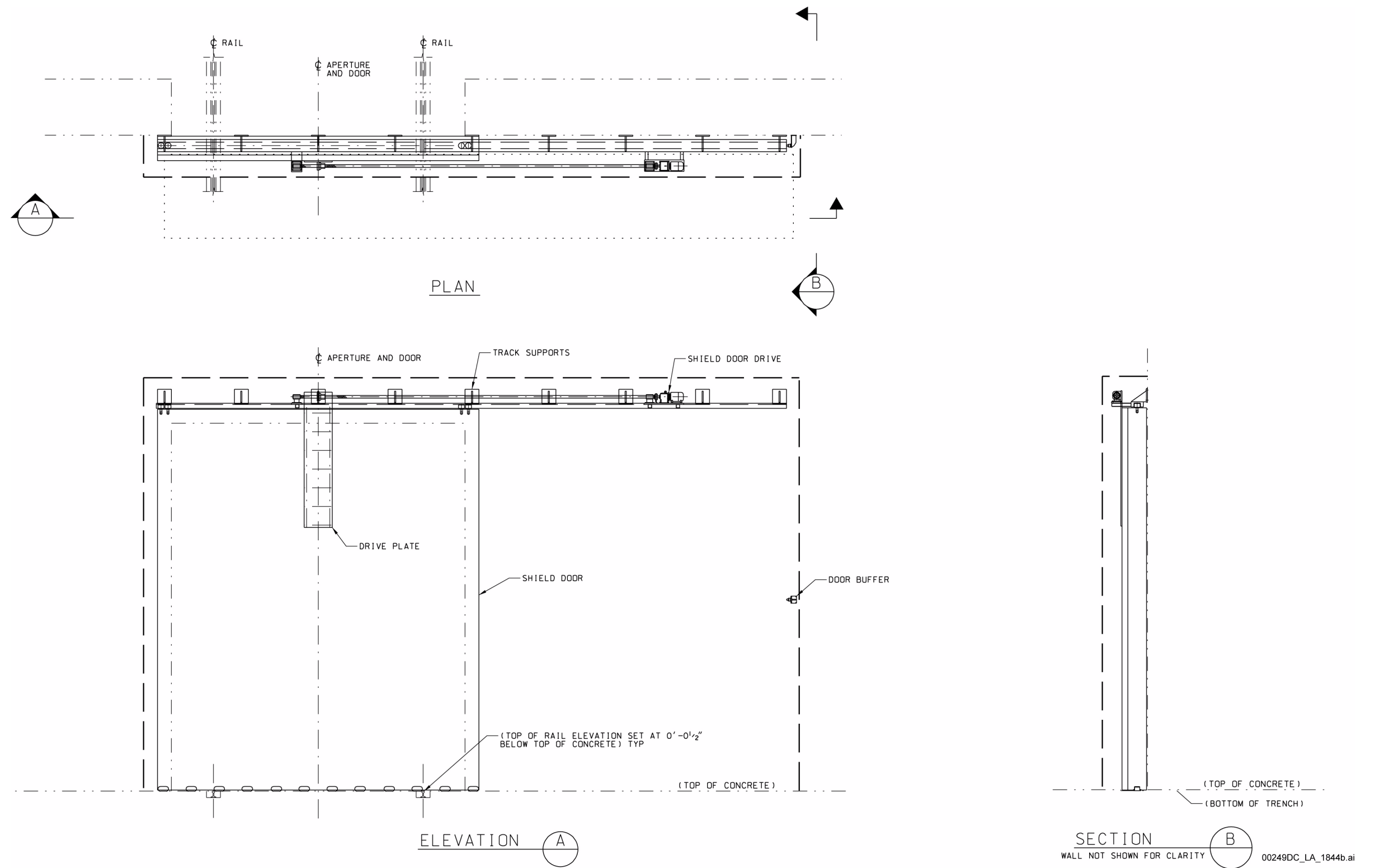

Equipment Number: 060-CR00-DR-00003/00004, CRCF waste package positioning room equipment shield door, north 1/south 2; 060-CR00-DR-00005/00006, CRCF waste package loadout room equipment shield door, door 1/door 2; 050-WH00-DR-00004, WHF site transporter vestibule equipment shield door.

Figure 1.2.4-82. Nuclear Facilities Equipment Shield Door (Type 4) Mechanical Equipment Envelope

INTENTIONALLY LEFT BLANK

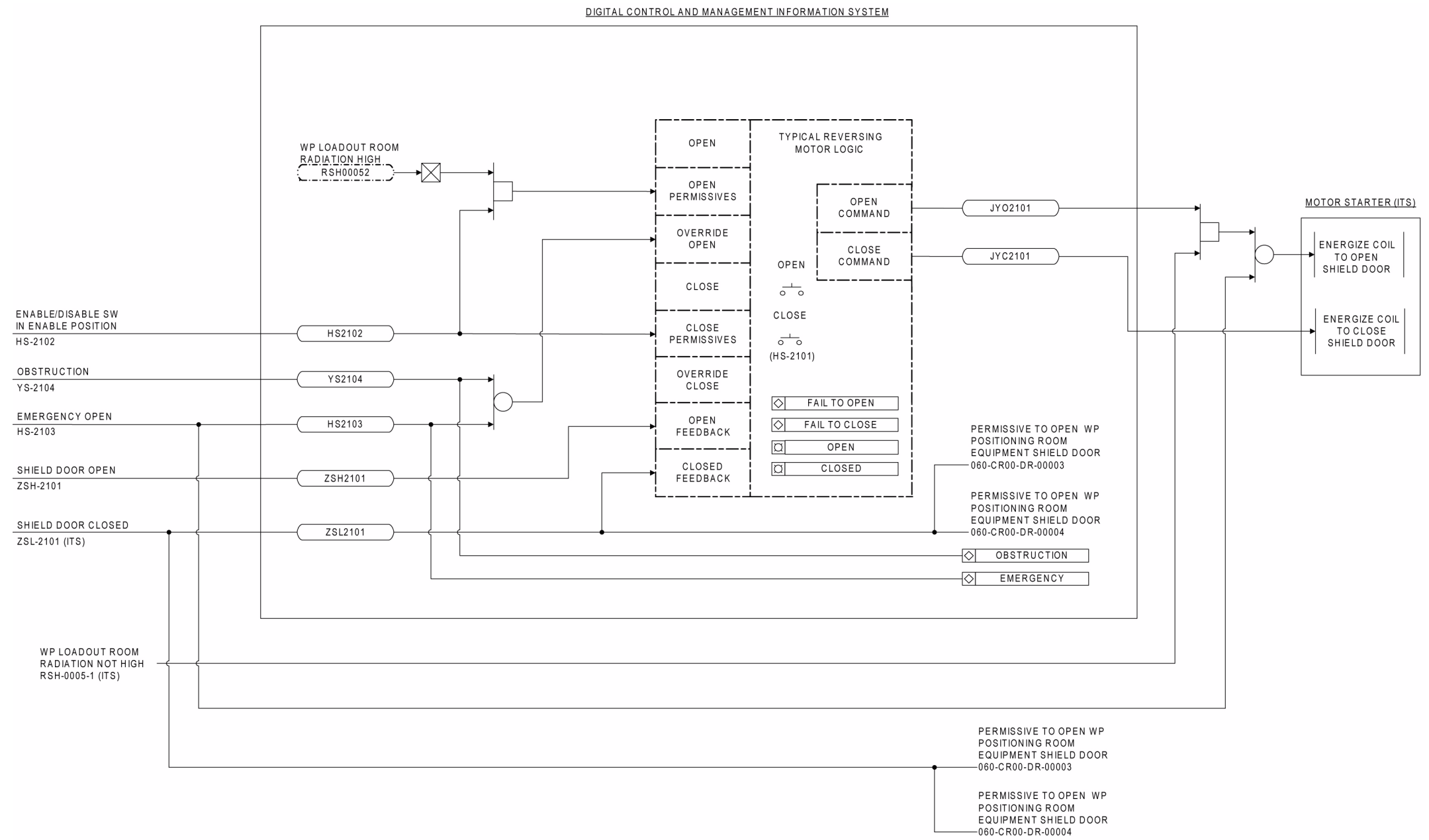

WP LOADOUT ROOM EQUIPMENT SHIELD DOOR EQUIPMENT NUMBER	OPEN/CLOSE HANDSWITCH	ENABLE/DISABLE SW	EMERGENCY OPEN SW	OBSTRUCTION SW	DOOR OPEN LIMIT SW	DOOR CLOSED LIMIT SW	RADIATION HIGH SW	RADIATION HIGH SOFTWARE SW	LOGIC OUTPUT OPEN	LOGIC OUTPUT CLOSE	INTERFACING WP POSITIONING ROOM EQUIPMENT SHIELD DOOR EQUIPMENT NUMBER
060-CR00-DR-00005	HS-2101	HS-2102	HS-2103	YS-2104	ZSH-2101	ZSL-2101 (ITS)	RSH-0005-1 (ITS)	RSH00052	JYO2101	JYC2101	060-CR00-DR-00003 060-CR00-DR-00004
060-CR00-DR-00006	HS-2201	HS-2202	HS-2203	YS-2204	ZSH-2201	ZSL-2201 (ITS)	RSH-0005-1 (ITS)	RSH00052	JYO2201	JYC2201	060-CR00-DR-00003 060-CR00-DR-00004

00249DC_LA_2751a.ai

NOTE: ITS controls are identified by the letters "ITS" after the instrumentation tag number or control device identifier. The DCMIS is non-ITS and non-ITWI. Instrumentation tag numbers are prefixed by "060-HL00-" and software tag numbers are prefixed by "060HL00." WP = waste package.

Figure 1.2.4-83. CRCF Waste Package Loadout Room Equipment Shield Door Logic Diagram

INTENTIONALLY LEFT BLANK

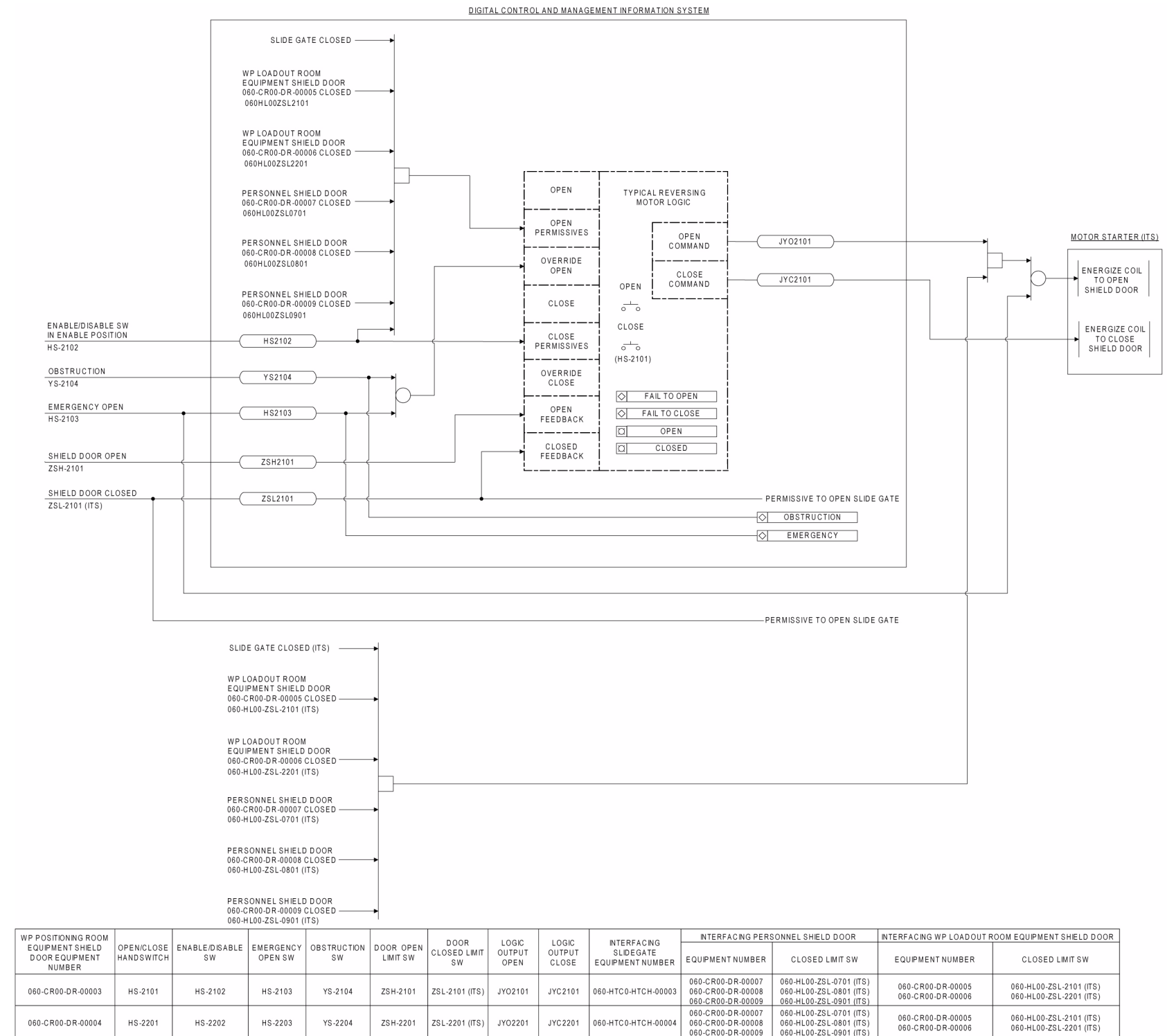

00249DC_LA_2752a.ai

NOTE: ITS controls are identified by the letters "ITS" after the instrumentation tag number or control device identifier. The DCMIS is non-ITS and non-ITWI. Instrumentation tag numbers are prefixed by "060-HW00-" and software tag numbers are prefixed by "060HW00." WP = waste package.

Figure 1.2.4-84. CRCF Waste Package Positioning Room Equipment Shield Door Logic Diagram

INTENTIONALLY LEFT BLANK

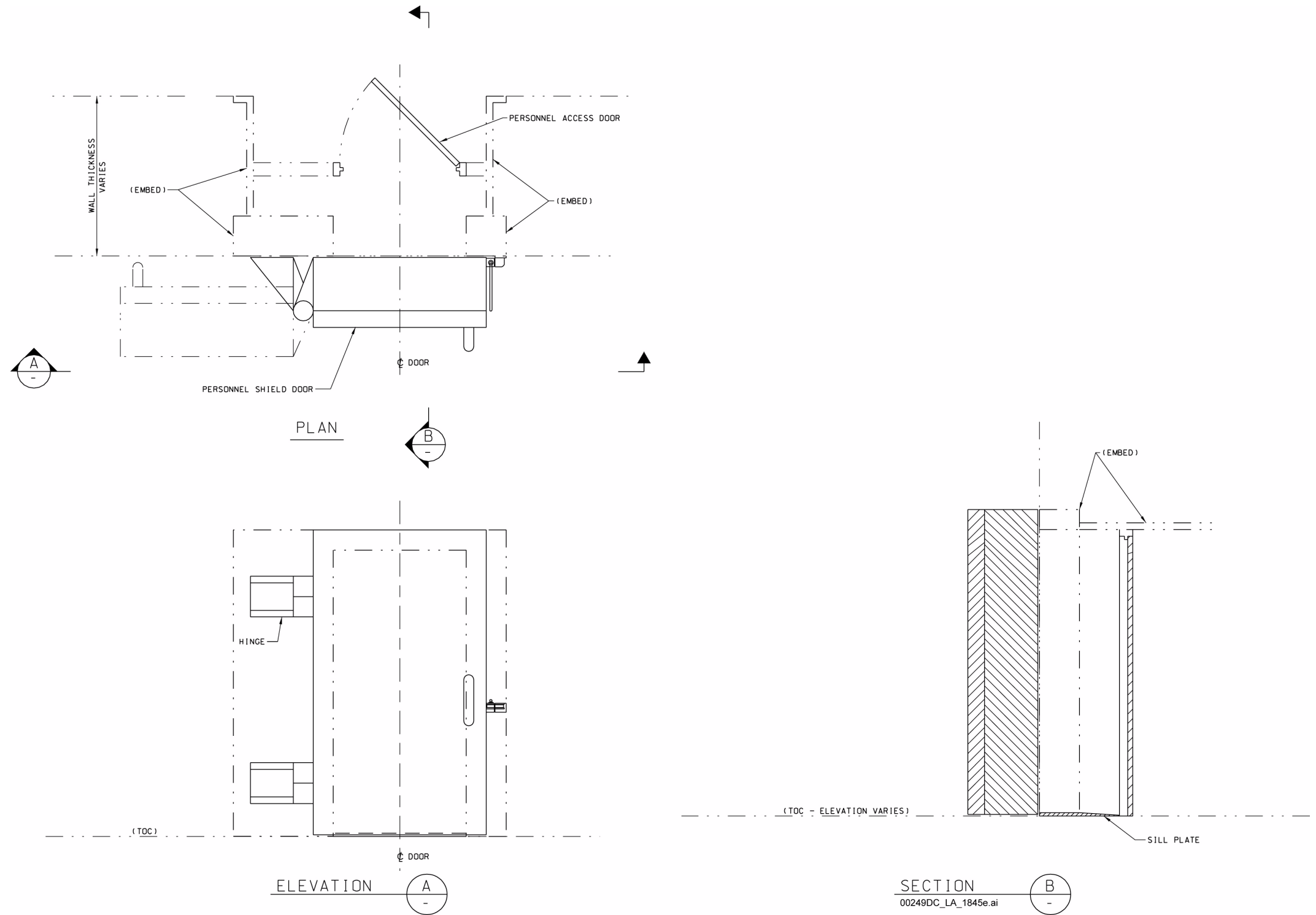

Equipment Number: 060-CR00-DR-00007/00008/00009, CRCF, waste package loadout room personnel access and shield doors; 51A-IH00-DR-00005/00006, IHF, waste package loadout room personnel access and shield door.

Figure 1.2.4-85. Waste Package Loadout Room Personnel Access and Shield Doors Mechanical Equipment Envelope

INTENTIONALLY LEFT BLANK

INSTRUMENTATION TABLE

FACILITY NAME	FACILITY AREA NUMBER	PERSONNEL ACCESS AND SHIELD DOORS EQUIPMENT NUMBER	INSTRUMENT SYSTEM CODE	PERSONNEL ACCESS DOOR								RADIATION MONITOR						
				OPERATIONS ROOM DOOR LOCK/UNLOCK HAND SWITCH	LOCAL DOOR LOCK/UNLOCK HAND SWITCH	DOOR LATCH SOLENOID	DOOR LOCKED INDICATOR	DOOR OPEN LIMIT SWITCH	DOOR CLOSED LIMIT SWITCH	DCMIS DOOR OPEN/CLOSED POSITION INDICATOR	OPERATIONS ROOM DOOR CLOSED POSITION INDICATOR	RADIATION ELEMENT	RADIATION HIGH SWITCH	DCMIS RADIATION HIGH SWITCH	RADIATION TRANSMITTER	RADIATION HIGH INDICATOR	RADIATION ALARM	INTERFACING WP LOAD OUT ROOM EQUIPMENT SHIELD DOOR EQUIPMENT NUMBER
CANISTER RECEIPT AND CLOSURE FACILITY (CRCF)	060	060-CR00-DR-00007	HL00	HS-0702-1 (ITS)	HS-0702-2	HZ-0702 (ITS)	Y1-0702	ZSH-0702	ZSL-0702 (ITS)	Z1-0702-1	Z1-0702-2 (ITS)	RE-0005 (ITS)	RSH-0005-1 (ITS)	RSH-0005-2	RT-0005	RI-0005	RAH-0005	060-CR00-DR-00005
		060-CR00-DR-00008		HS-0802-1 (ITS)	HS-0802-2	HZ-0802 (ITS)	Y1-0802	ZSH-0802	ZSL-0802 (ITS)	Z1-0802-1	Z1-0802-2 (ITS)							060-CR00-DR-00006
		060-CR00-DR-00009		HS-0902-1 (ITS)	HS-0902-2	HZ-0902 (ITS)	Y1-0902	ZSH-0902	ZSL-0902 (ITS)	Z1-0902-1	Z1-0902-2 (ITS)							
INITIAL HANDLING FACILITY (IHF)	51A	51A-IH00-DR-00005	HL00	HS-0502-1 (ITS)	HS-0502-2	HZ-0502 (ITS)	Y1-0502	ZSH-0502	ZSL-0502 (ITS)	Z1-0502-1	Z1-0502-2 (ITS)	RE-0005 (ITS)	RSH-0005-1 (ITS)	RSH-0005-2	RT-0005	RI-0005	RAH-0005	51A-IH00-DR-00004
		51A-IH00-DR-00006		HS-0602-1 (ITS)	HS-0602-2	HZ-0602 (ITS)	Y1-0602	ZSH-0602	ZSL-0602 (ITS)	Z1-0602-1	Z1-0602-2 (ITS)							

INSTRUMENTATION TABLE (CONTINUED)

FACILITY NAME	FACILITY AREA NUMBER	PERSONNEL ACCESS AND SHIELD DOORS EQUIPMENT NUMBER	INSTRUMENT SYSTEM CODE	PERSONNEL SHIELD DOOR				
				DOOR LATCHED OPEN LIMIT SWITCH	DOOR LATCHED CLOSED LIMIT SWITCH	DCMIS DOOR LATCHED OPEN/CLOSED POSITION INDICATOR	LOCAL DOOR OPEN/CLOSED POSITION INDICATOR	INTERFACING WP POSITIONING ROOM EQUIPMENT SHIELD DOOR EQUIPMENT NUMBER
CANISTER RECEIPT AND CLOSURE FACILITY (CRCF)	060	060-CR00-DR-00007	HL00	ZSH-0701	ZSL-0701 (ITS)	Z1-0701-1	Z1-0701-2	060-CR00-DR-00003
		060-CR00-DR-00008		ZSH-0801	ZSL-0801 (ITS)	Z1-0801-1	Z1-0801-2	060-CR00-DR-00004
		060-CR00-DR-00009		ZSH-0901	ZSL-0901 (ITS)	Z1-0901-1	Z1-0901-2	
INITIAL HANDLING FACILITY (IHF)	51A	51A-IH00-DR-00005	HL00	ZSH-0501	ZSL-0501 (ITS)	Z1-0501-1	Z1-0501-2	51A-IH00-DR-00003
		51A-IH00-DR-00006		ZSH-0601	ZSL-0601 (ITS)	Z1-0601-1	Z1-0601-2	

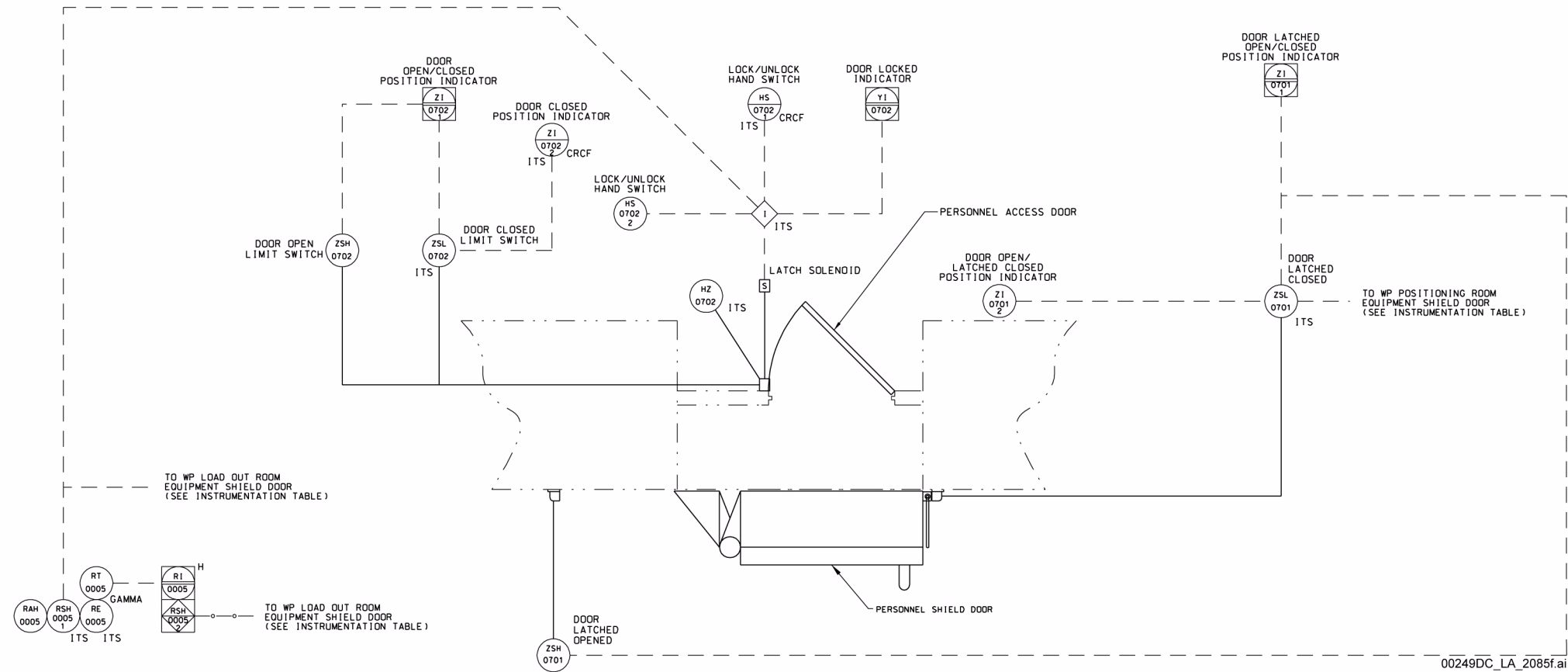

PERSONNEL ACCESS AND SHIELD DOORS INSTRUMENTATION

EXAMPLE DIAGRAM SHOWN REPRESENTS PERSONNEL ACCESS AND SHIELD DOORS 060-CR00-DR-00007

NOTE: Only the personnel access door locked indicator associated with the facility operations room hand switch provides an ITS function.
WP = waste package.

Equipment Number: 060-CR00-DR-00007, personnel access and shield doors.

Figure 1.2.4-86. Waste Package Loadout Room Personnel Access and Shield Doors Process and Instrumentation Diagram

INTENTIONALLY LEFT BLANK

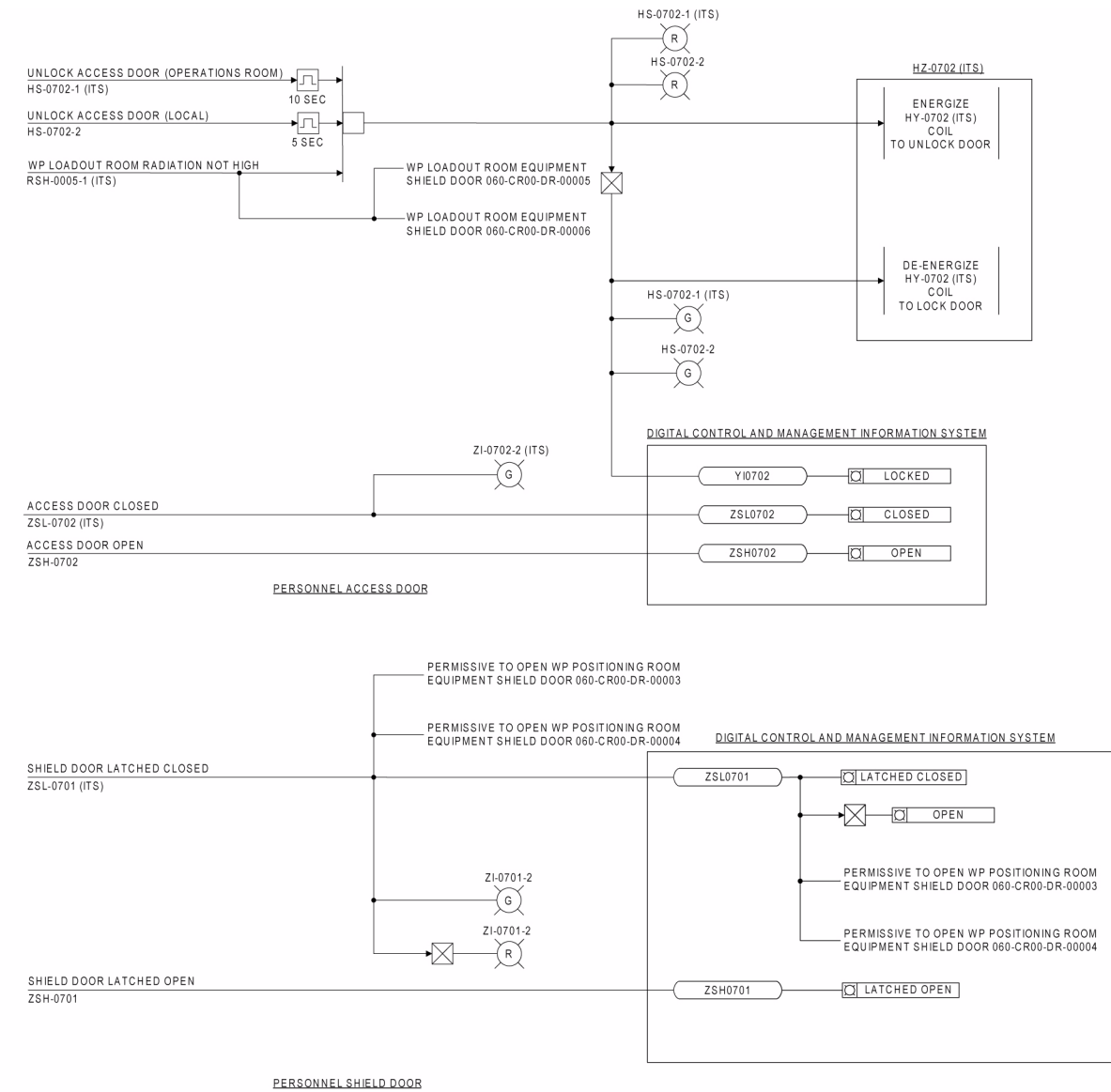

FACILITY NAME	AREA CODE	PERSONNEL ACCESS AND SHIELD DOORS EQUIPMENT NUMBER	PERSONNEL SHIELD DOOR						PERSONNEL ACCESS DOOR						RADIATION HIGH SW	INTERFACING WP LOADOUT ROOM EQUIPMENT SHIELD DOOR EQUIPMENT NUMBER	WP LOADOUT ROOM EQUIPMENT SHIELD DOOR LOGIC DIAGRAM
			DOOR LATCHED OPEN LIMIT SW	DOOR LATCHED CLOSED LIMIT SWITCH	DOOR OPEN/LATCHED CLOSED INDICATION (LOCAL)	INTERFACING WP POSITIONING ROOM EQUIPMENT SHIELD DOOR EQUIPMENT NUMBER	WP POSITIONING ROOM EQUIPMENT SHIELD DOOR LOGIC DIAGRAM	HANDSWITCH (OPERATIONS ROOM)	HANDSWITCH (LOCAL)	LATCH SOLENOID	DOOR OPEN LIMIT SW	DOOR CLOSED LIMIT SW	DOOR CLOSED INDICATION (OPERATIONS ROOM)	LOGIC INPUT LOCKED			
CANISTER RECEIPT AND CLOSURE FACILITY	060	060-CR00-DR-00007	ZSH-0701	ZSL-0701 (ITS)	ZI-0701-2	060-CR00-DR-00003 060-CR00-DR-00004	060-J30-HW00-00101-000	HS-0702-1 (ITS)	HS-0702-2	HZ-0702 (ITS)	ZSH-0702	ZSL-0702 (ITS)	ZI-0702-2 (ITS)	Y0702	RSH-0005-1 (ITS)	060-CR00-DR-00005 060-CR00-DR-00006	060-J30-HL00-00101-000
		060-CR00-DR-00008	ZSH-0801	ZSL-0801 (ITS)	ZI-0801-2	060-CR00-DR-00003 060-CR00-DR-00004	060-J30-HW00-00101-000	HS-0802-1 (ITS)	HS-0802-2	HZ-0802 (ITS)	ZSH-0802	ZSL-0802 (ITS)	ZI-0802-2 (ITS)	Y0802	RSH-0005-1 (ITS)	060-CR00-DR-00005 060-CR00-DR-00006	060-J30-HL00-00101-000
		060-CR00-DR-00009	ZSH-0901	ZSL-0901 (ITS)	ZI-0901-2	060-CR00-DR-00003 060-CR00-DR-00004	060-J30-HW00-00101-000	HS-0902-1 (ITS)	HS-0902-2	HZ-0902 (ITS)	ZSH-0902	ZSL-0902 (ITS)	ZI-0902-2 (ITS)	Y0902	RSH-0005-1 (ITS)	060-CR00-DR-00005 060-CR00-DR-00006	060-J30-HL00-00101-000
INITIAL HANDLING FACILITY	51A	51A-H00-DR-00005	ZSH-0501	ZSL-0501 (ITS)	ZI-0501-2	51A-H00-DR-00003	51A-J30-HW00-00101-000	HS-0502-1 (ITS)	HS-0502-2	HZ-0502 (ITS)	ZSH-0502	ZSL-0502 (ITS)	ZI-0502-2 (ITS)	Y0502	RSH-0005-1 (ITS)	51A-H00-DR-00004	51A-J30-HL00-00101-000
		51A-H00-DR-00006	ZSH-0601	ZSL-0601 (ITS)	ZI-0601-2	51A-H00-DR-00003	51A-J30-HW00-00101-000	HS-0602-1 (ITS)	HS-0602-2	HZ-0602 (ITS)	ZSH-0602	ZSL-0602 (ITS)	ZI-0602-2 (ITS)	Y0602	RSH-0005-1 (ITS)	51A-H00-DR-00004	51A-J30-HL00-00101-000

NOTE: ITS controls are identified by the letters "ITS" after the instrumentation tag number or control device identifier. The DCMIS is non-ITS and non-ITWI. Instrumentation tag numbers are prefixed by "XXX-HL00-" and software tag numbers are prefixed by "XXXHL00," unless noted otherwise, where XXX is the area code. Only the locked indication associated with the personnel access door operations room hand switch provides an ITS function. WP = waste package.

Figure 1.2.4-87. Personnel Access and Shield Door Logic Diagram

INTENTIONALLY LEFT BLANK

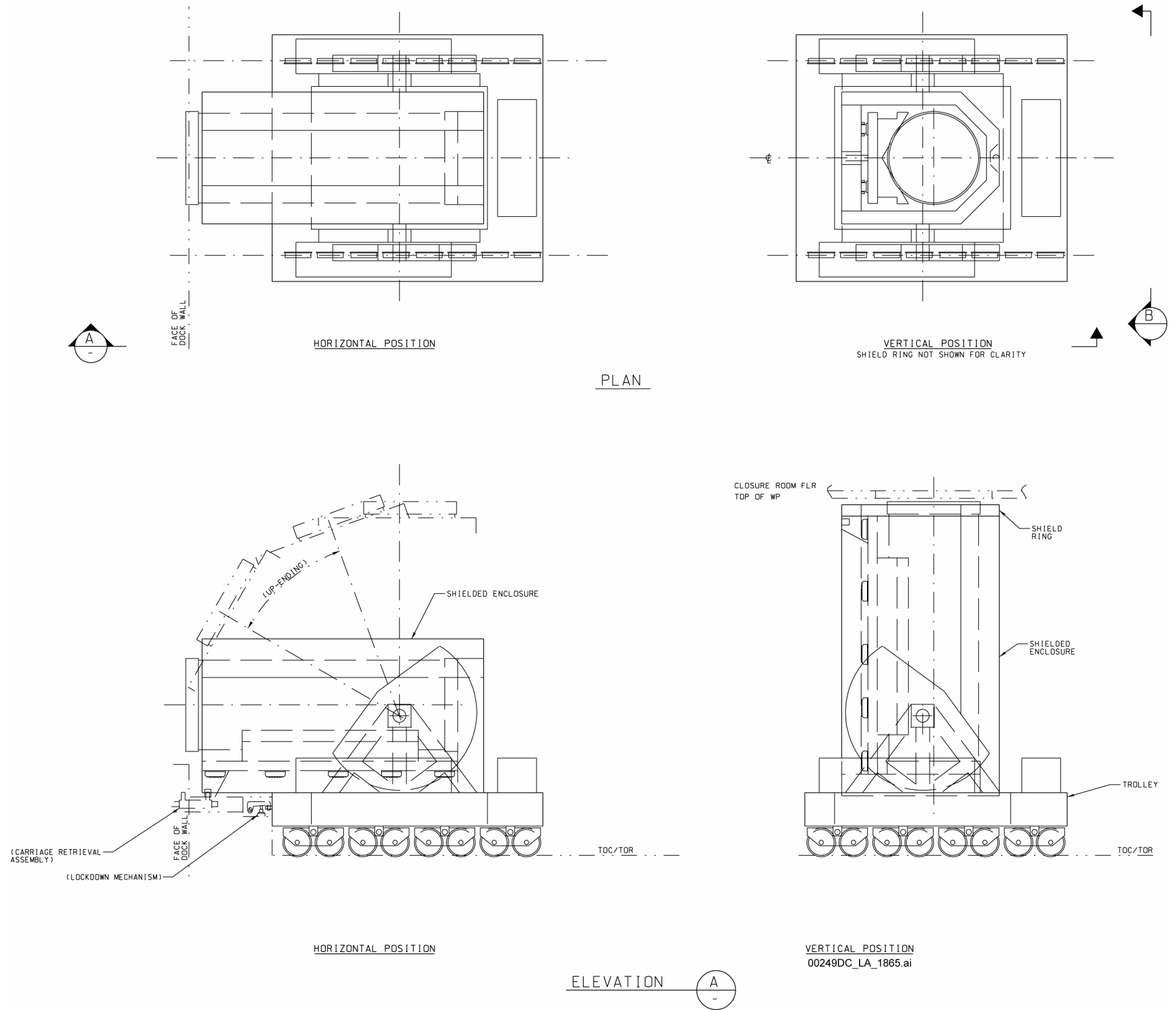

NOTE: This equipment is used in the CRCF and IHF. Section B appears on Sheet 2. WP = waste package.

Equipment Number: 060-HL00-HEQ-00001/00002/00003/00004/00005/00006, CRCF waste package shield ring 1/2/3/4/5/6;
 060-HL00-PED-00001/00002/00003/00004/00005/00006/00007/00008, CRCF waste package pedestal 1/2/3/4/5/6/7/8;
 060-HL00-TRLY-00001/00002, CRCF waste package transfer trolleys;
 51A-HL00-HEQ-00001/00002, IHF waste package shield ring 1/2;
 51A-HL00-PED-00001/00002/00003/00004, IHF waste package pedestal 1/2/3/4;
 51A-HL00-TRLY-00001, IHF transfer trolley.

Figure 1.2.4-88. Waste Package Transfer Trolley Mechanical Equipment Envelope Plan and Elevations (Sheet 1 of 2)

INTENTIONALLY LEFT BLANK

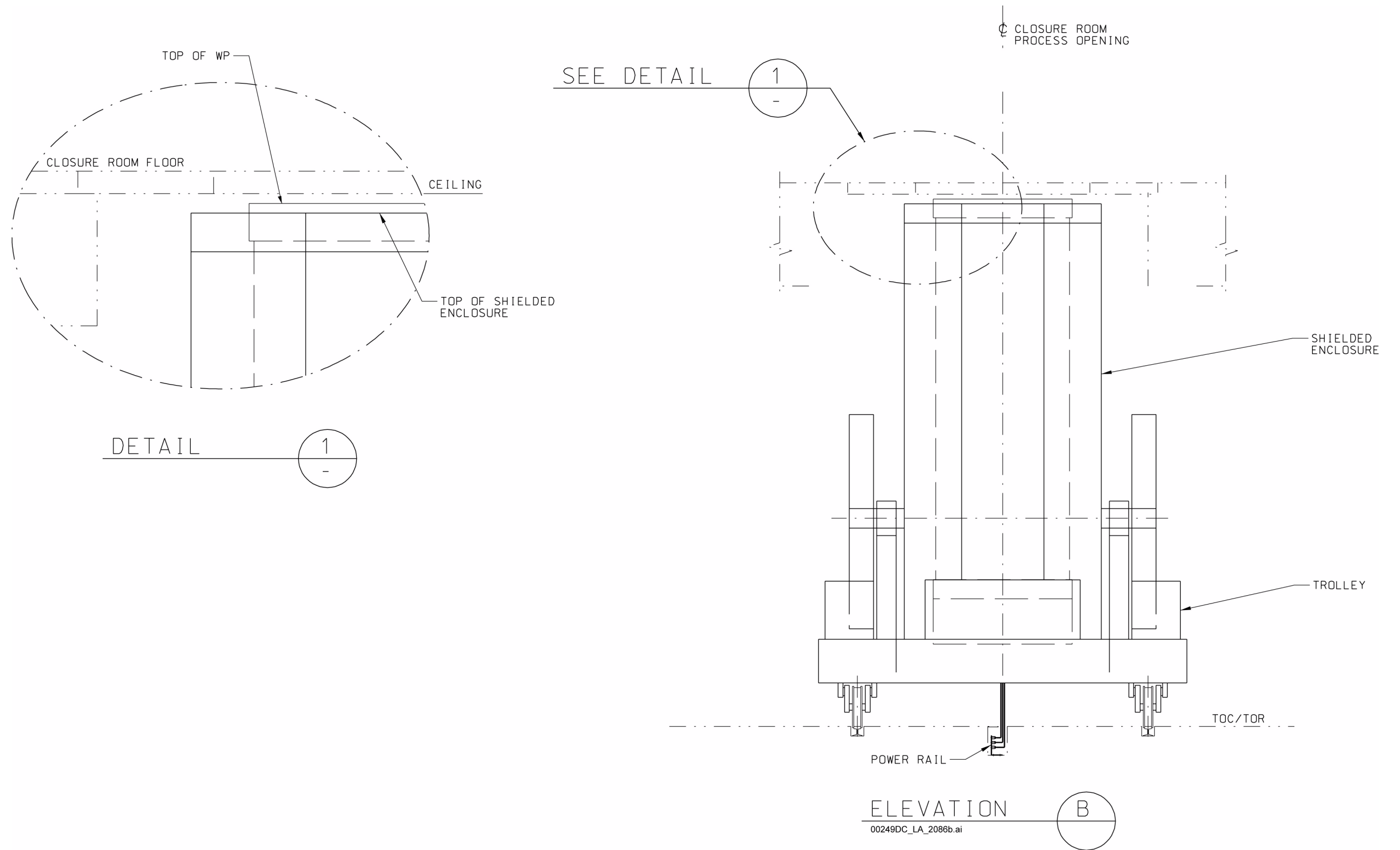

NOTE: This equipment is used in the CRCF and IHF. WP = waste package.

Figure 1.2.4-88. Waste Package Transfer Trolley Mechanical Equipment Envelope Elevation and Detail (Sheet 2 of 2)

INTENTIONALLY LEFT BLANK

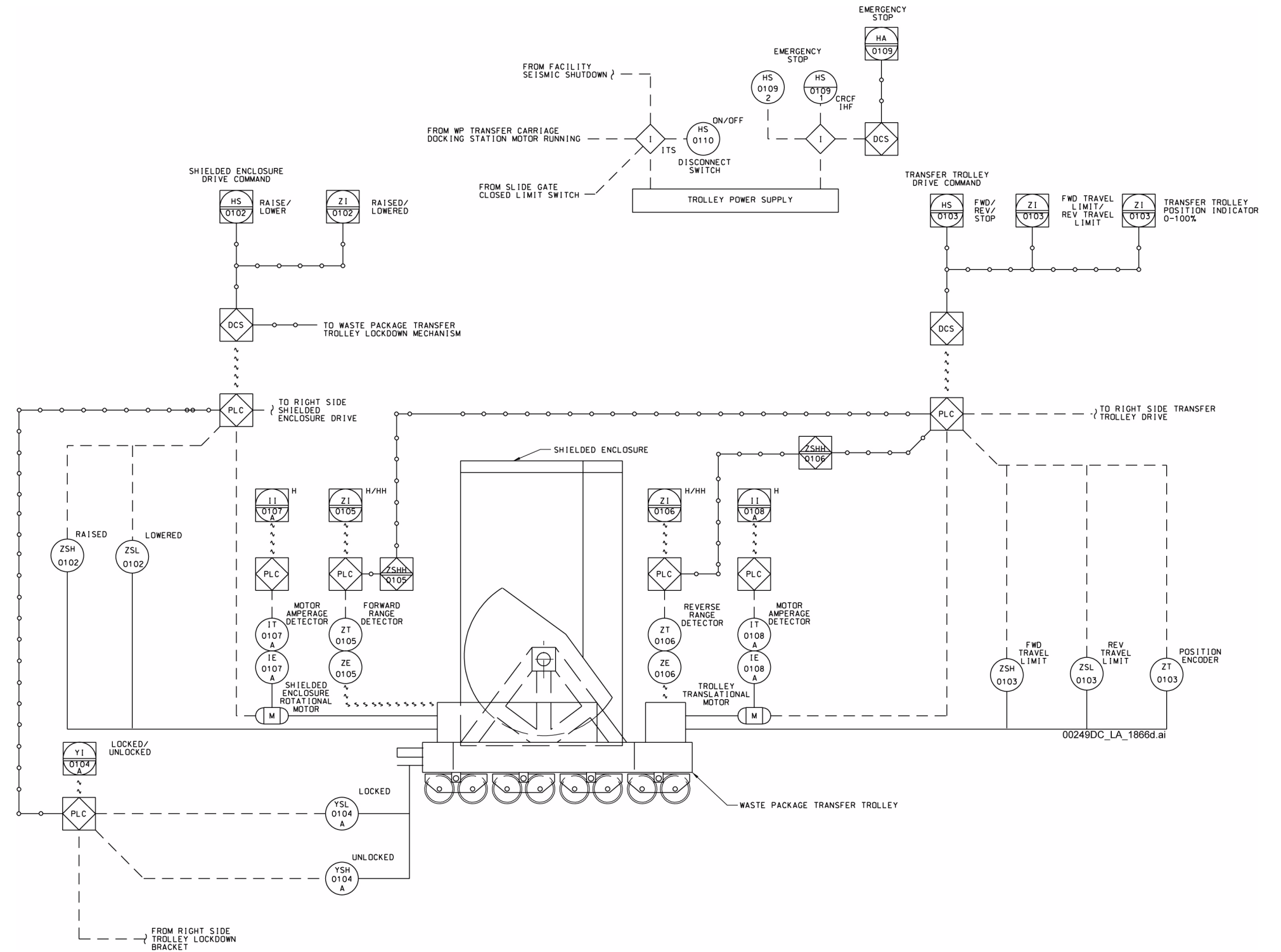

NOTE: This equipment is used in the CRCF and IHF. "A" drive motor is shown; figure is typical for "B" drive motors.
 PLC = programmable logic controller; WP = waste package.

Equipment Number: 060-HL00-HEQ-00001/00002/00003/00004/00005/00006, CRCF waste package shield rings;
 060-HL00-PED-00001/00002/00003/00004/00005/00006/00007/00008, CRCF waste package pedestals;
 060-HL00-TRLY-00001/00002, CRCF waste transfer trolley; 51A-HL00-HEQ-00001/00002, IHF waste
 package shield rings; 51A-HL00-PED-00001/00002/00003/00004, IHF waste package pedestals;
 51A-HL00-TRLY-00001, IHF waste package transfer trolley.

Figure 1.2.4-89. Waste Package Transfer Trolley Process and Instrumentation Diagram

INTENTIONALLY LEFT BLANK

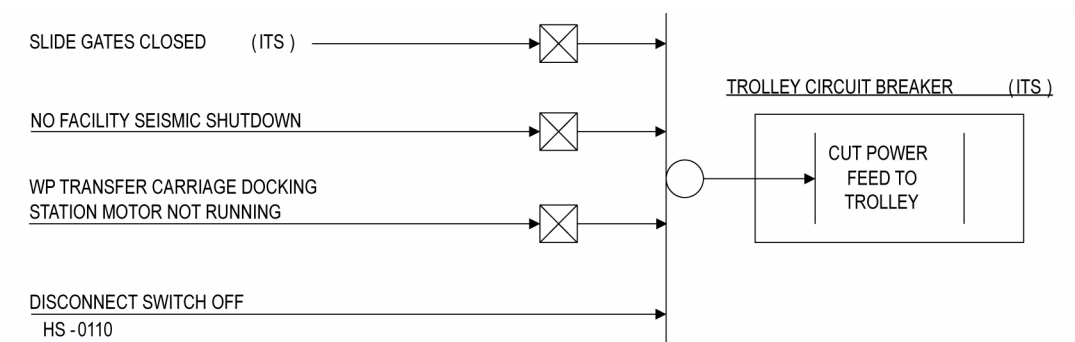

FACILITY	AREA CODE	WASTE PACKAGE TRANSFER TROLLEY	LOOP SEQUENCE	INTERFACING SLIDE GATE EQUIPMENT NUMBER	INTERFACING WP XFER CARRIAGE DOCKING STATION EQUIPMENT NUMBER
IHF	51A	51A-HL00-TRLY-00001	0110	51A-HTC0-HTCH-00002	51A-HL00-75-00001
CRCF	060	060-HL00-TRLY-00001	0110	060-HTC0-HTCH-00003	060-HL00-75-00001
		060-HL00-TRLY-00002	0210	060-HTC0-HTCH-00004	060-HL00-75-00002

00249DC_LA_2495e.ai

NOTE: ITS controls are identified by the letters "ITS" after control device identifier. Instrumentation tag numbers are prefixed by "XXX-HL00-," where XXX is the area code. WP = waste package.

Figure 1.2.4-90. Logic Diagram for the Waste Package Transfer Trolley

INTENTIONALLY LEFT BLANK

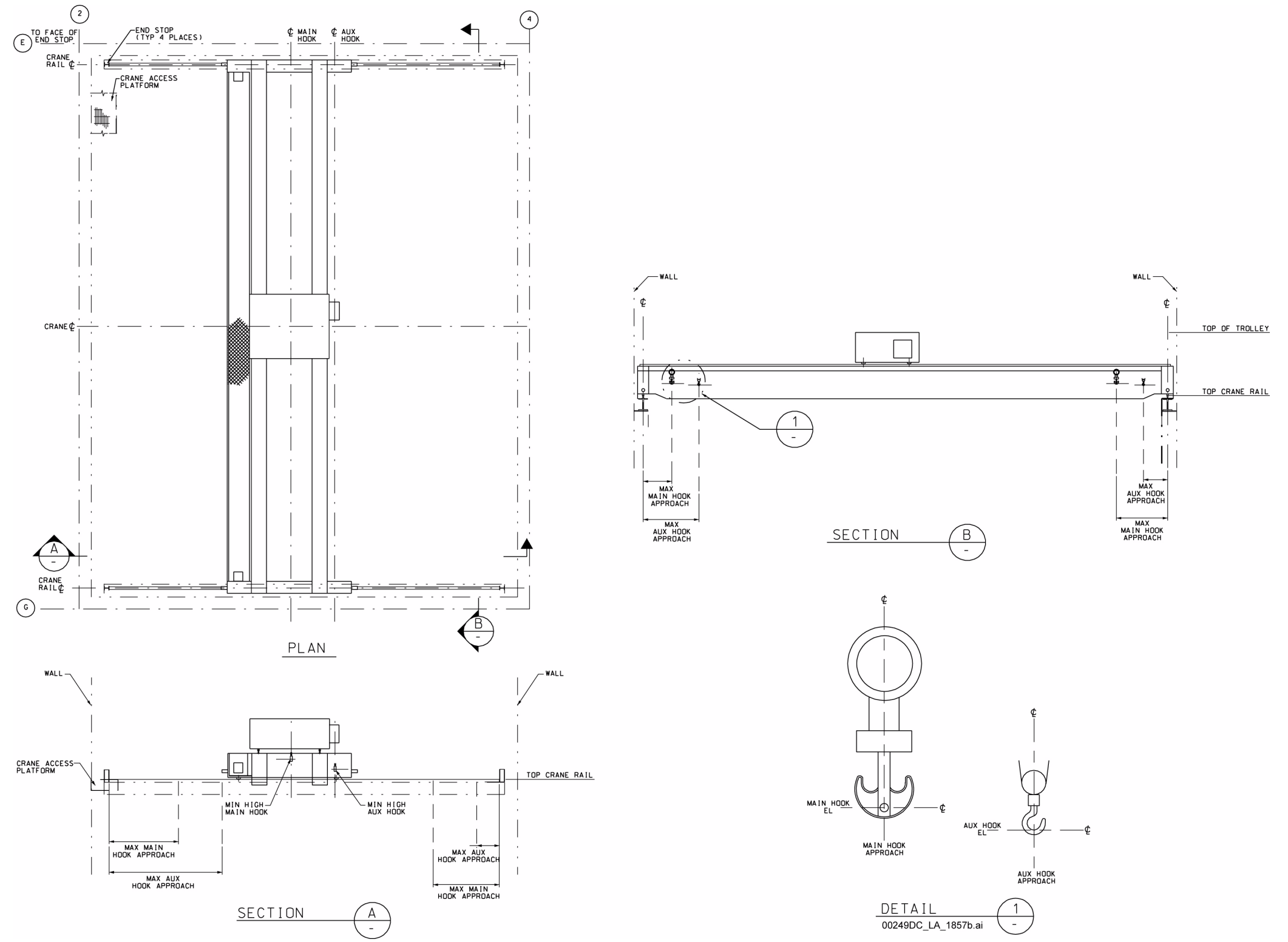

Equipment Number: 060-HMP0-CRN-00001, CRCF waste package handling crane.

Figure 1.2.4-91. Waste Package Handling Crane Mechanical Equipment Envelope

INTENTIONALLY LEFT BLANK

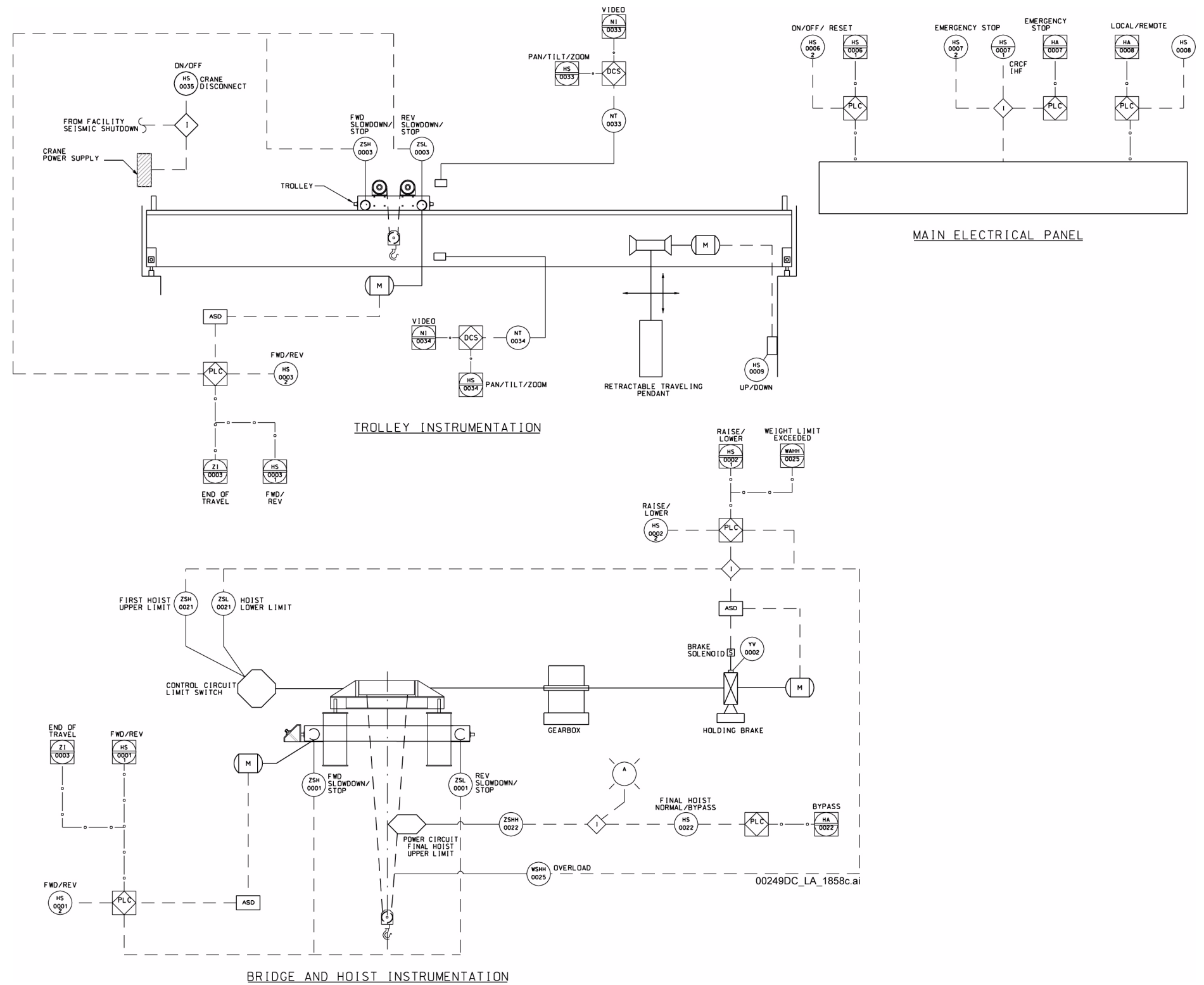

NOTE: This drawing includes the waste package handling crane that has been classified as ITS. While the waste package handling crane is ITS, the instrumentation, electrical, and control devices shown herein are non-ITS and non-ITWI. This equipment is used in the CRCF and IHF.

Equipment Number: 060-HMP0-CRN-00001, CRCF waste package handling crane; 51A-HMP0-CRN-00001, IHF waste package handling crane.

Figure 1.2.4-92. Waste Package Handling Crane Process and Instrumentation Diagram

INTENTIONALLY LEFT BLANK

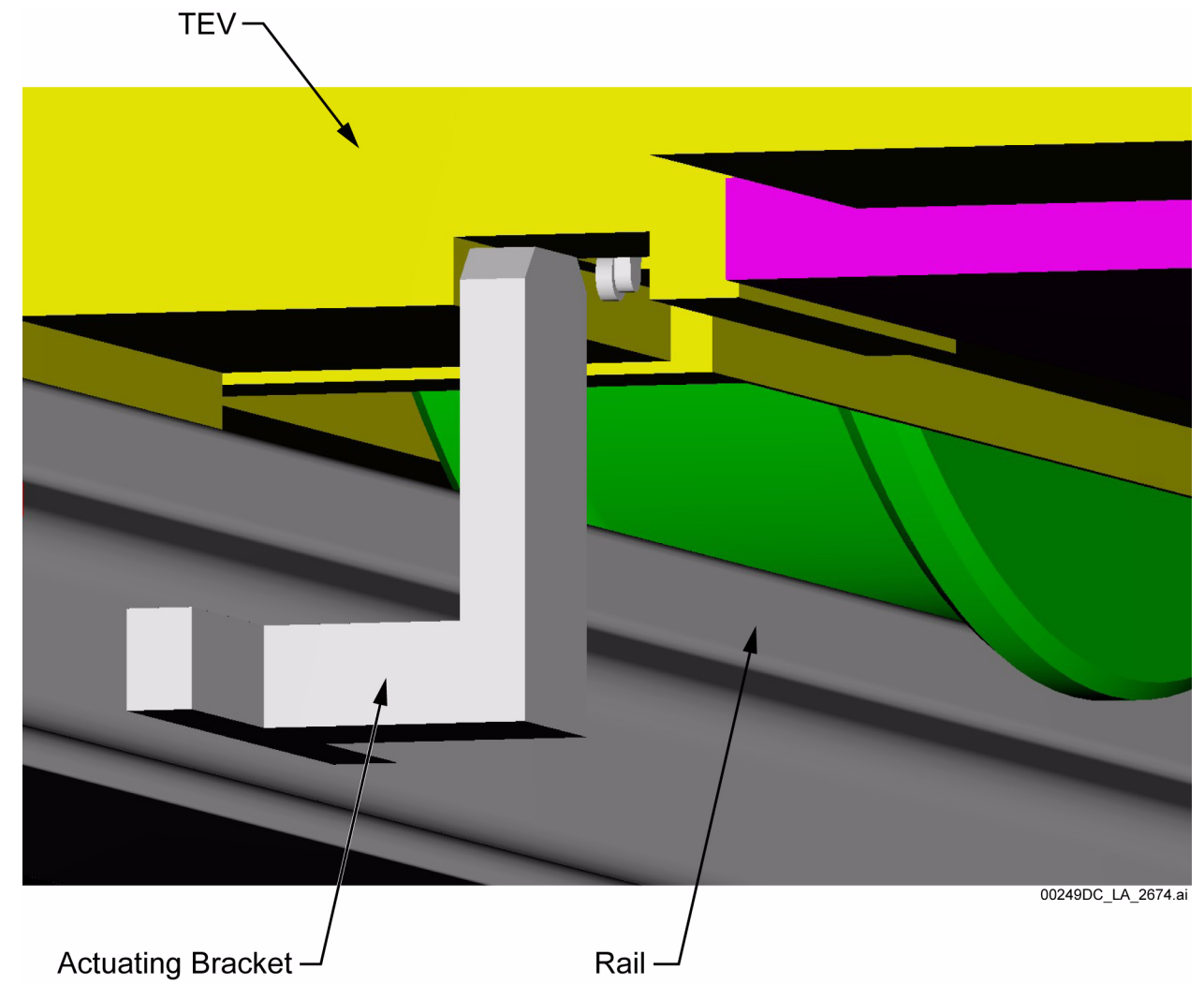
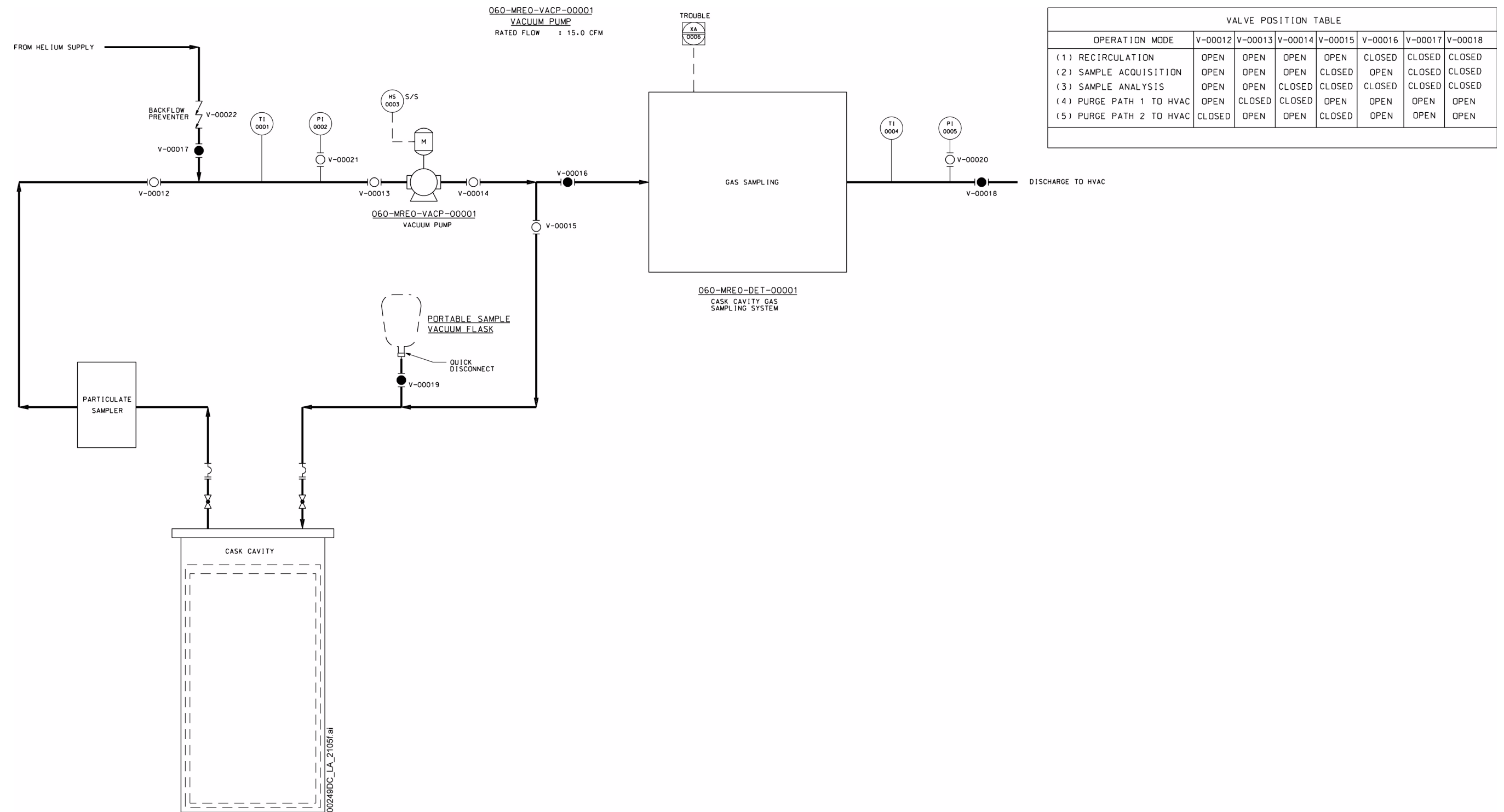

Figure 1.2.4-93. TEV Mechanical Onboard Position Switch and Stationary Actuating Bracket

INTENTIONALLY LEFT BLANK



NOTE: This figure includes no SSCs that are ITS or ITWI. Valves that are not included in the valve position table maintain the position as indicated in the figure.

Figure 1.2.4-94. Cask Cavity Gas Sampling System Piping and Instrumentation Diagram

INTENTIONALLY LEFT BLANK

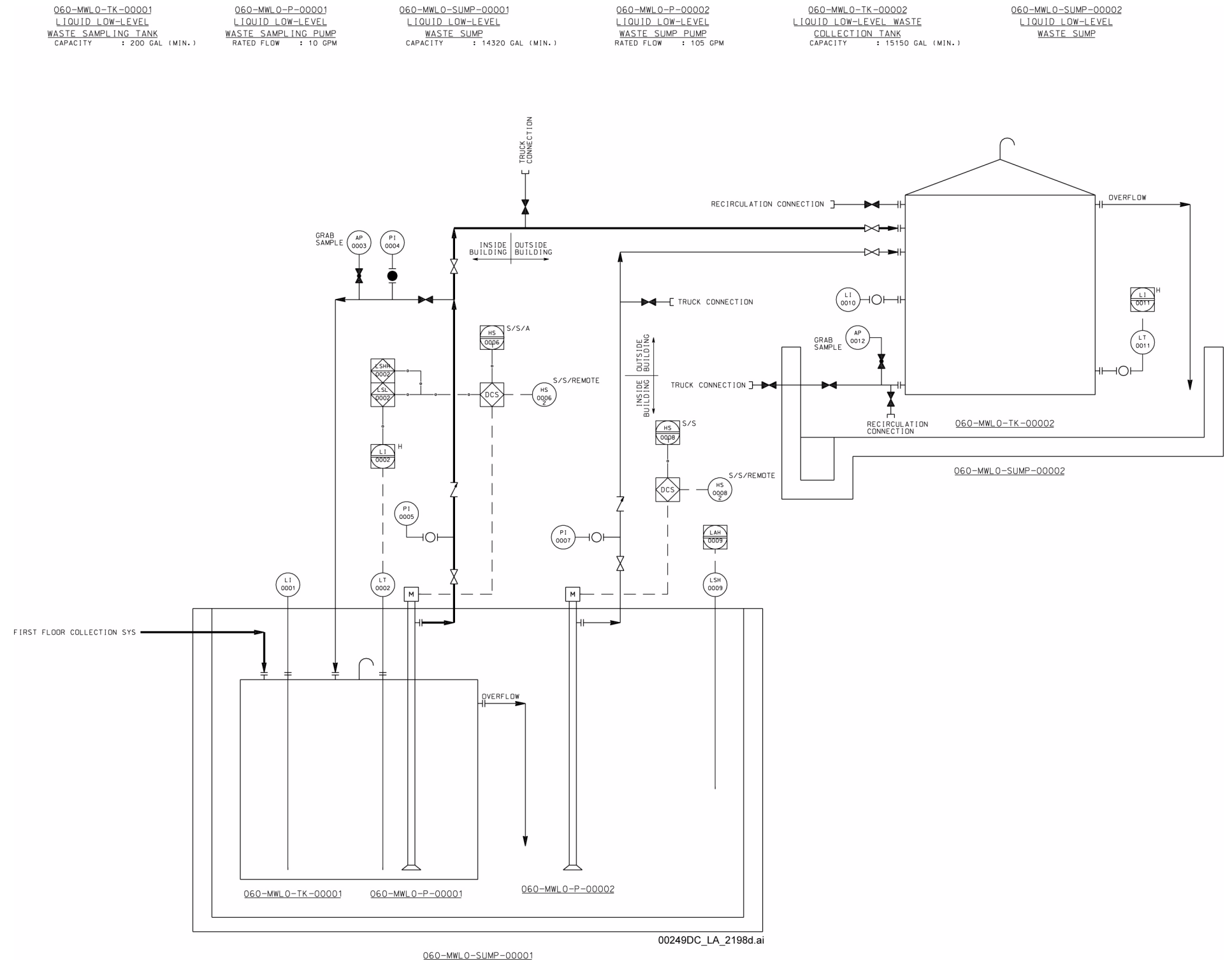

Figure 1.2.4-95. CRCF Liquid Low-Level Waste Sampling and Sump Piping and Instrumentation Diagram

NOTE: This figure includes no SSCs that are either ITS or ITWI.

INTENTIONALLY LEFT BLANK

This figure has been designated Official Use Only under the Freedom of Information Act (5 U.S.C. 552), Exemption 2, Circumvention of Statute.

This figure is included in Appendix A: Information Designated as Official Use Only, as [Figure A-35](#).

Figure 1.2.4-96. CRCF Confinement Zoning, Ground Floor

INTENTIONALLY LEFT BLANK

This figure has been designated Official Use Only under the Freedom of Information Act (5 U.S.C. 552), Exemption 2, Circumvention of Statute.

This figure is included in Appendix A: Information Designated as Official Use Only, as [Figure A-36](#).

Figure 1.2.4-97. CRCF Confinement Zoning, Second Floor

INTENTIONALLY LEFT BLANK

This figure has been designated Official Use Only under the Freedom of Information Act (5 U.S.C. 552), Exemption 2, Circumvention of Statute.

This figure is included in Appendix A: Information Designated as Official Use Only, as [Figure A-37](#).

Figure 1.2.4-98. CRCF Confinement Zoning, Third Floor

INTENTIONALLY LEFT BLANK

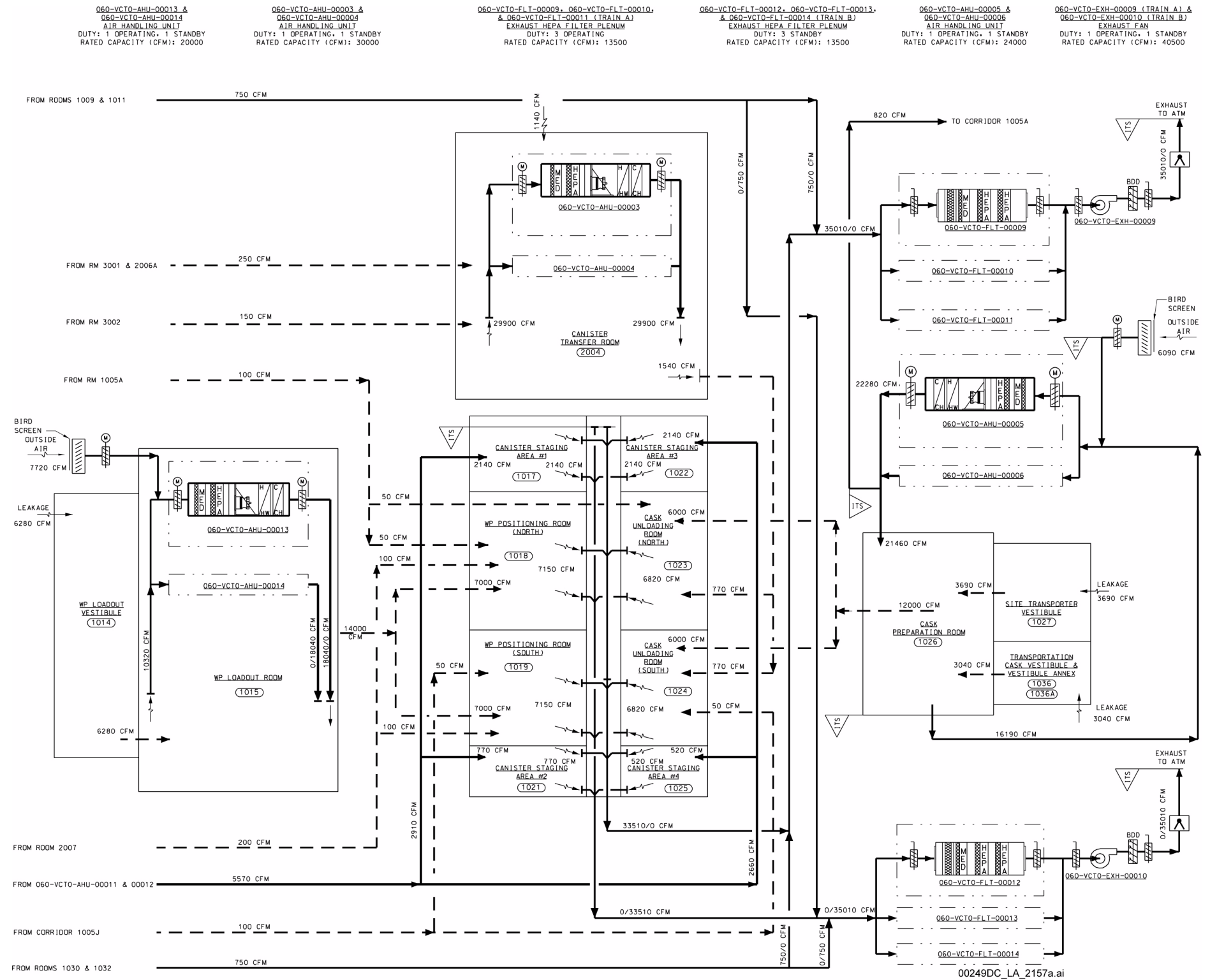
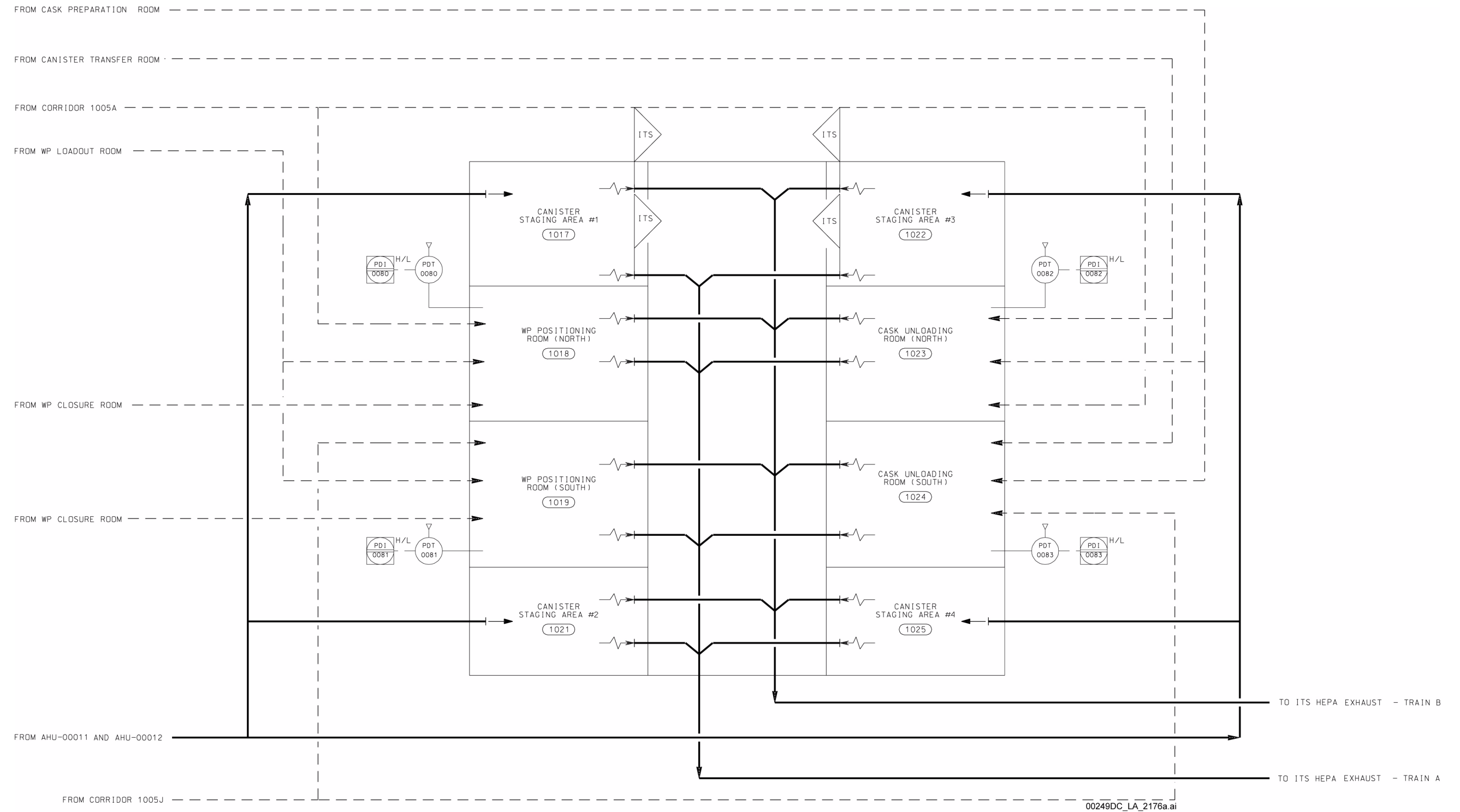

Figure 1.2.4-99. CRCF 1 Composite Ventilation Flow Diagram, Tertiary Confinement ITS Exhaust and Non-ITS HVAC Supply Subsystems

NOTE: The instrument and control devices shown on this drawing are non-ITS. The exhaust distribution ductwork is ITS, and the supply duct to the staging areas is non-ITS. WP = waste package.

INTENTIONALLY LEFT BLANK



NOTE: The instrument and control devices shown on this figure are non-ITS. The exhaust distribution ductwork is ITS and the supply duct to the staging areas is non-ITS. WP = waste package.

Figure 1.2.4-100. CRCF 1 ITS Confinement Areas Air Distribution System Ventilation and Instrumentation Diagram

INTENTIONALLY LEFT BLANK

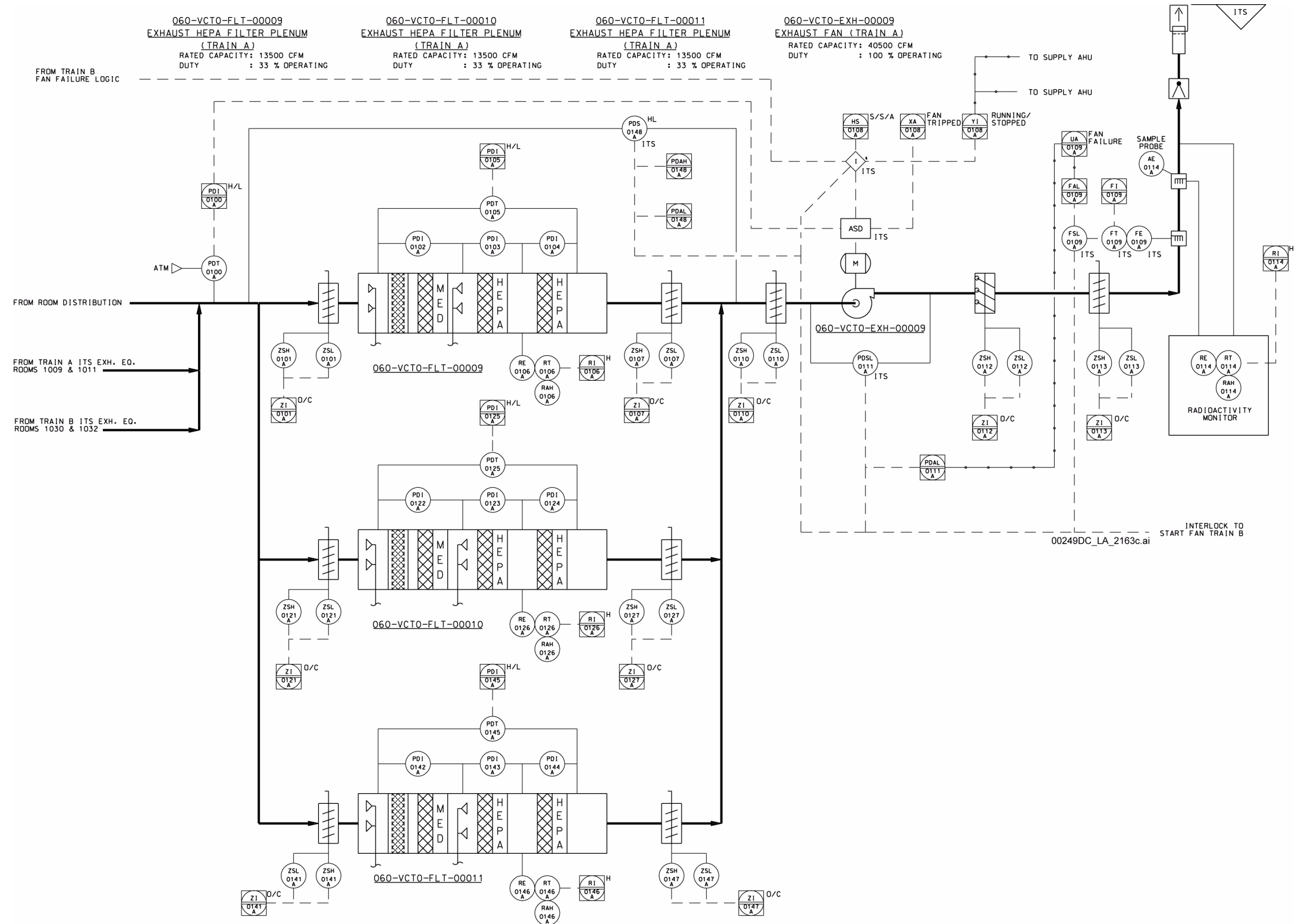

NOTE: Interlocks are provided to shut down the operating fan and automatically start the standby fan if any of the following occur: (1) low differential pressure across the operating fan coincidental with low air flow; (2) high differential pressure across the HEPA filter train; (3) low differential pressure across the HEPA filter train; (4) fan trip. The HVAC equipment, ductwork, and dampers shown on this figure are ITS. ASD = adjustable speed drive.

Figure 1.2.4-101. CRCF 1 ITS Confinement Areas HEPA Exhaust System—Train A Ventilation and Instrumentation Diagram

INTENTIONALLY LEFT BLANK

ASD=ASD

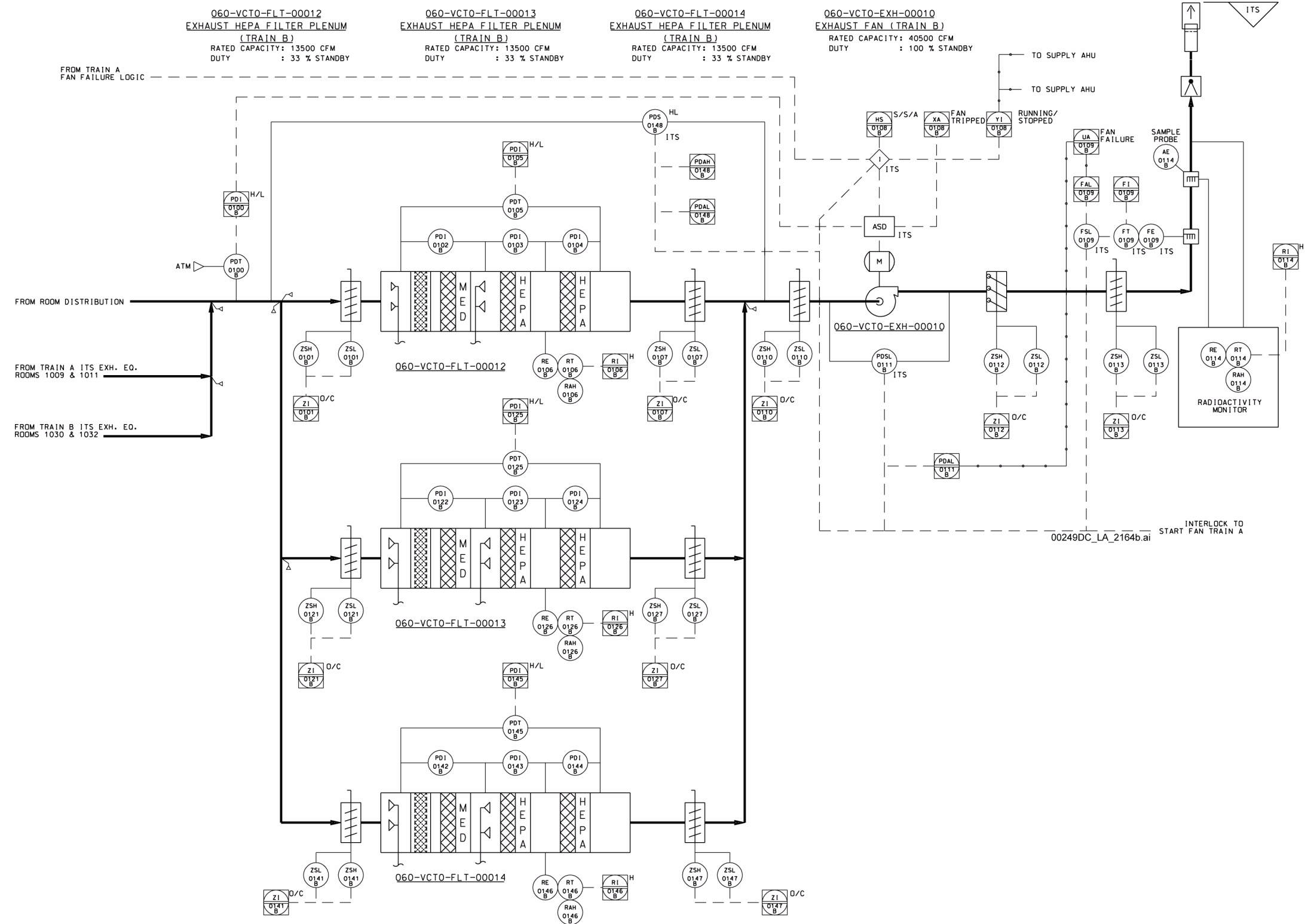

NOTE: Interlocks are provided to shut down the operating fan and automatically start the standby fan if any of the following occur: (1) low differential pressure across the operating fan coincident with low air flow; (2) high differential pressure across the HEPA filter train; (3) low differential pressure across the HEPA filter train; (4) fan trip. The HVAC equipment, ductwork, and dampers shown on this figure are ITS. ASD = adjustable speed drive.

Figure 1.2.4-102. CRCF 1 ITS Confinement Areas HEPA Exhaust System—Train B Ventilation and Instrumentation Diagram

INTENTIONALLY LEFT BLANK

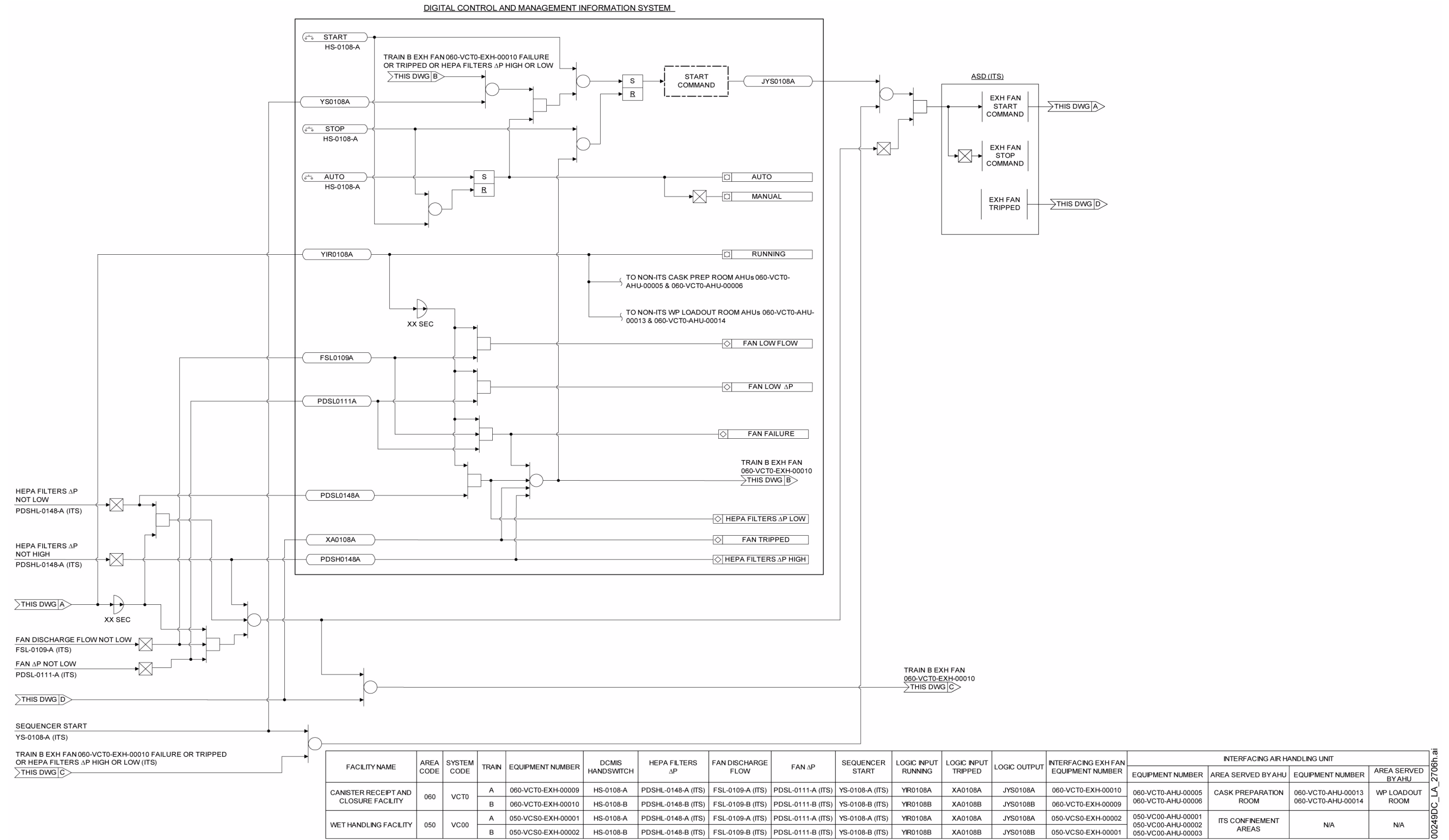

NOTE: ITS controls are identified by the letters "ITS" after the instrumentation tag number or control device identifier. The DCMIS is non-ITS and non-ITWI. Instrumentation tag numbers are prefixed by "XXX-YYYY-" and software tag numbers are prefixed by "XXXYYYY," where XXX is the area code and YYYY is the system code. AHU = air handling unit; ASD = adjustable speed drive; ΔP = differential pressure; WP = waste package.

Figure 1.2.4-103. CRCF and WHF ITS Confinement Areas HEPA Exhaust Fan (Trains A and B) Digital Logic Diagram

INTENTIONALLY LEFT BLANK

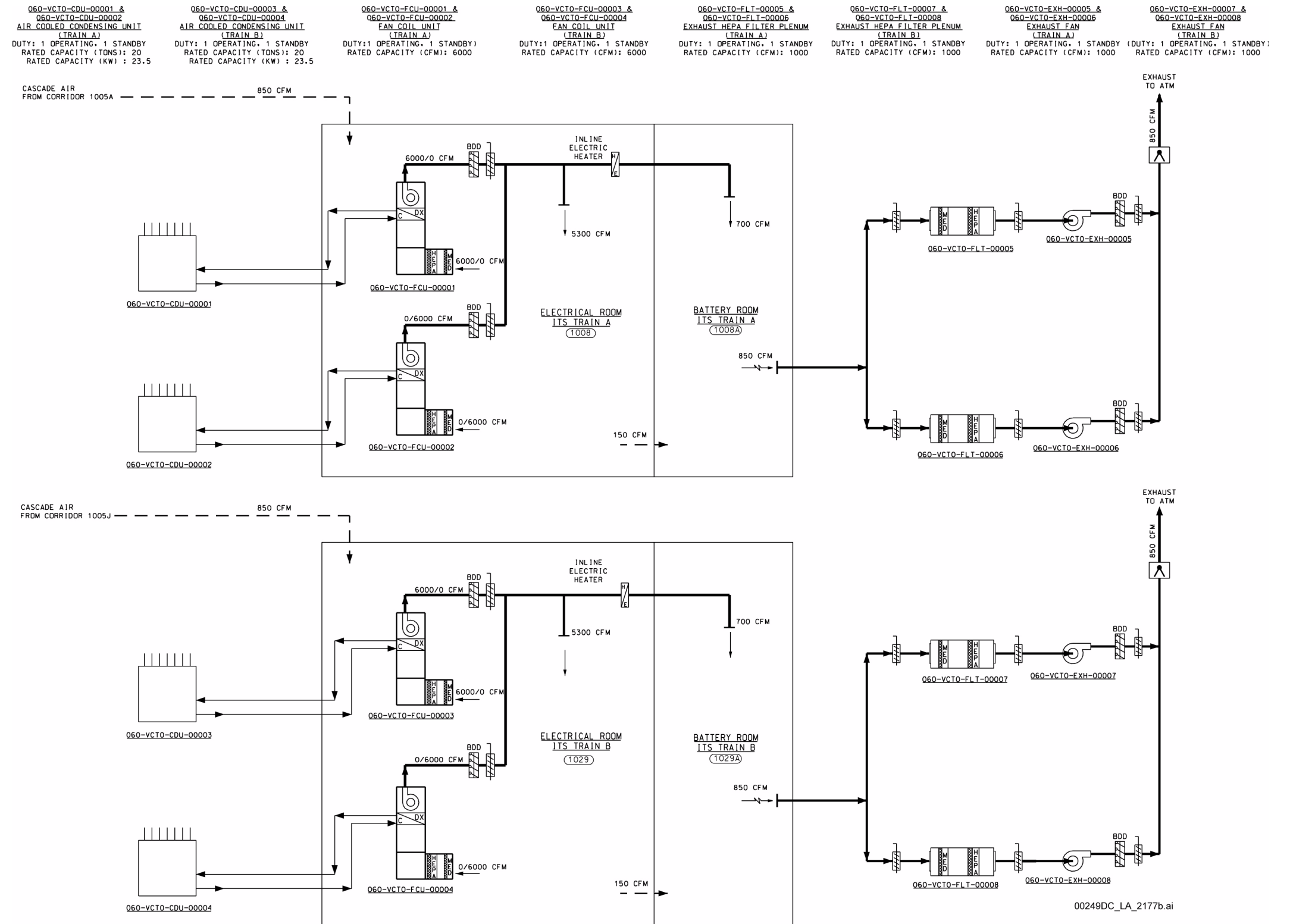

Figure 1.2.4-104. CRCF 1 Composite Ventilation Flow Diagram, Tertiary Confinement ITS HVAC Systems, Electrical and Battery Rooms

NOTE: Backup units are provided in case the operating units are down for maintenance or servicing. However, both units may be operated simultaneously as needed to maintain required room conditions during off-normal mode.

INTENTIONALLY LEFT BLANK

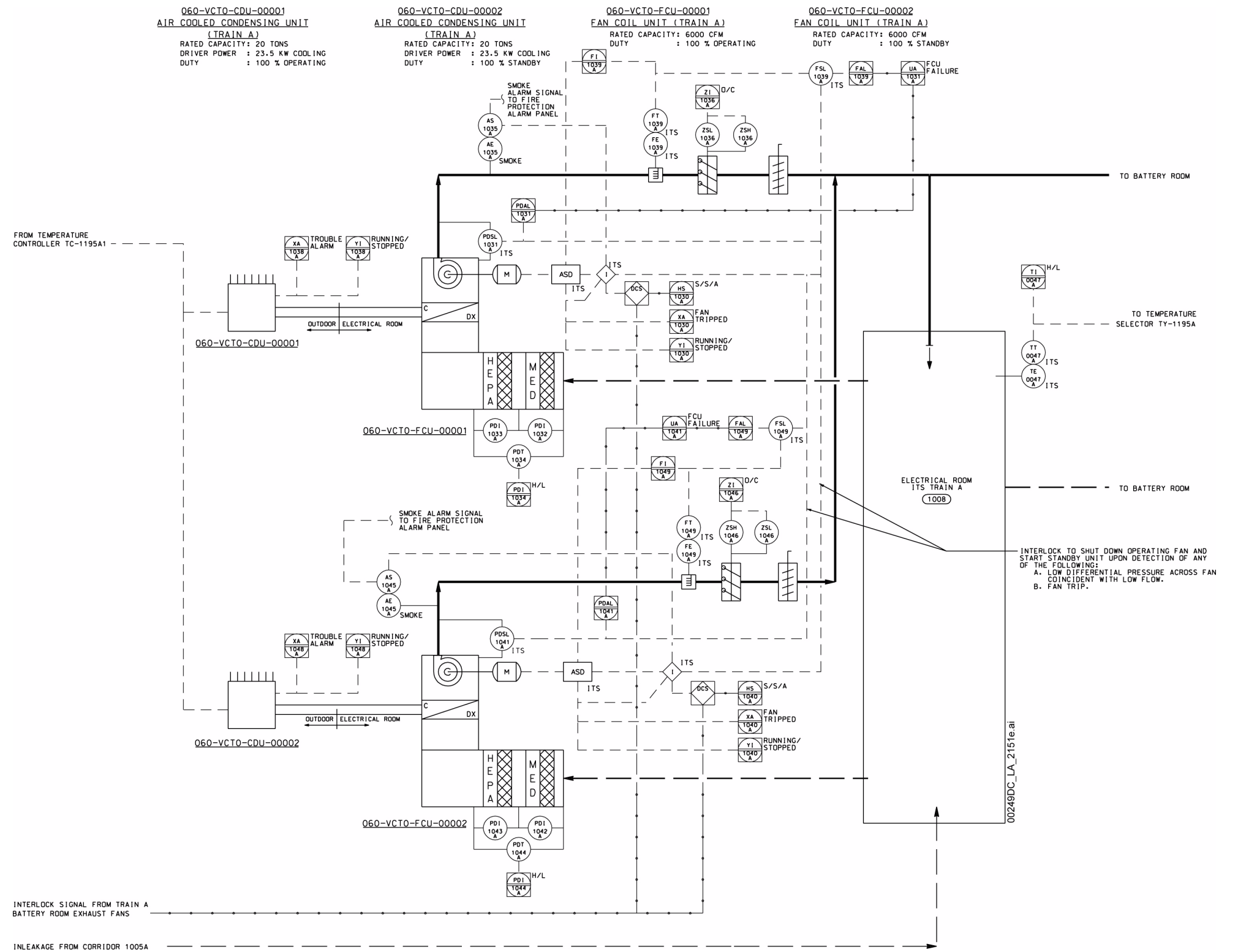
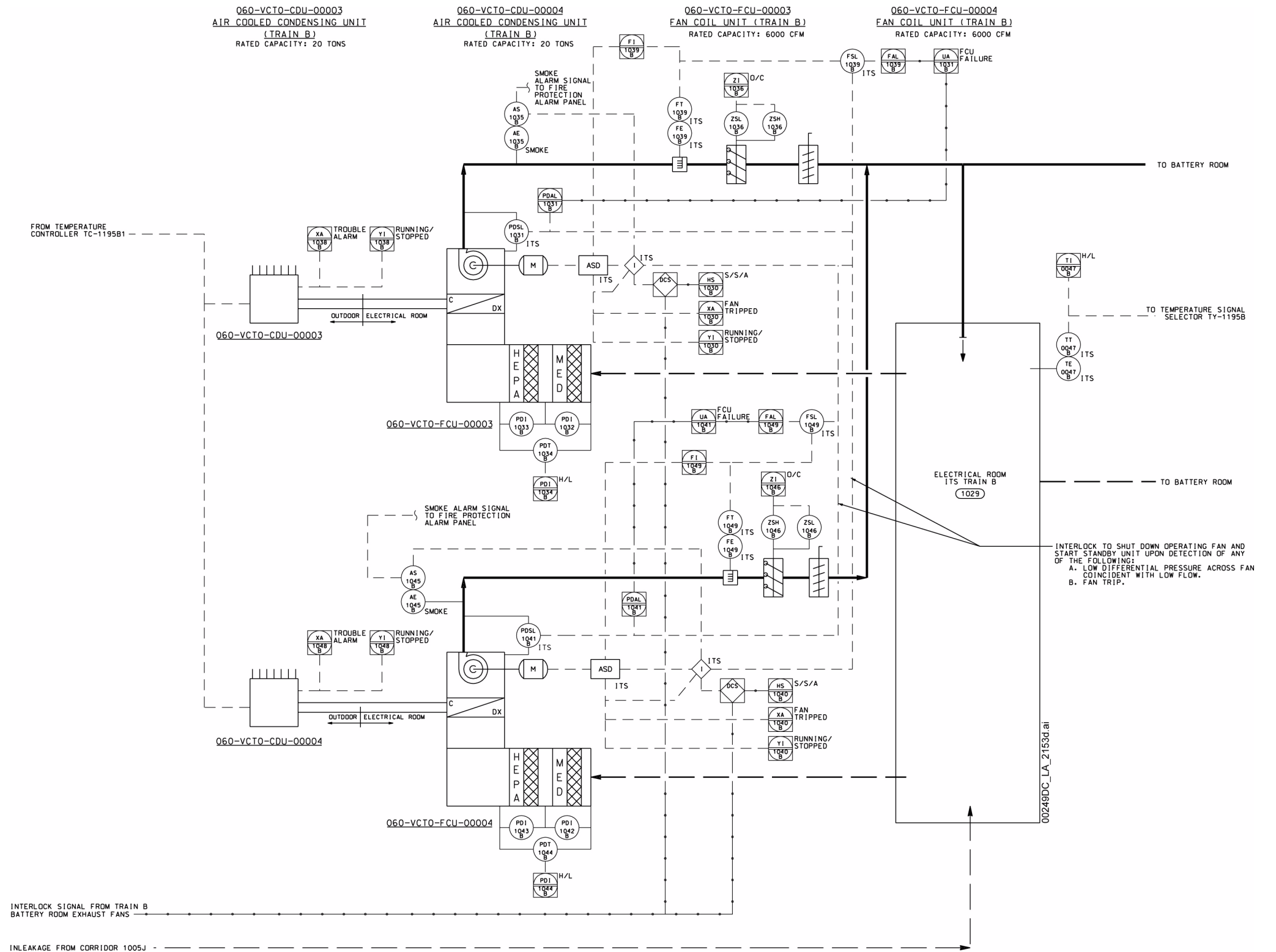

Figure 1.2.4-105. CRCF 1 Confinement ITS Electrical Room HVAC System—Train A Ventilation and Instrumentation Diagram

NOTE: All HVAC equipment, ductwork, and dampers are ITS. The compressor operation for the condensing units is controlled by either the battery room or electrical room temperature. ASD = adjustable speed drive.

INTENTIONALLY LEFT BLANK



NOTE: All HVAC equipment, ductwork, and dampers are ITS. The compressor operation for the condensing units is controlled by either the battery room or electrical room temperature. ASD = adjustable speed drive; FCU = fan coil unit.

Figure 1.2.4-106. CRCF 1 Confinement ITS Electrical Room HVAC System—Train B Ventilation and Instrumentation Diagram

INTENTIONALLY LEFT BLANK

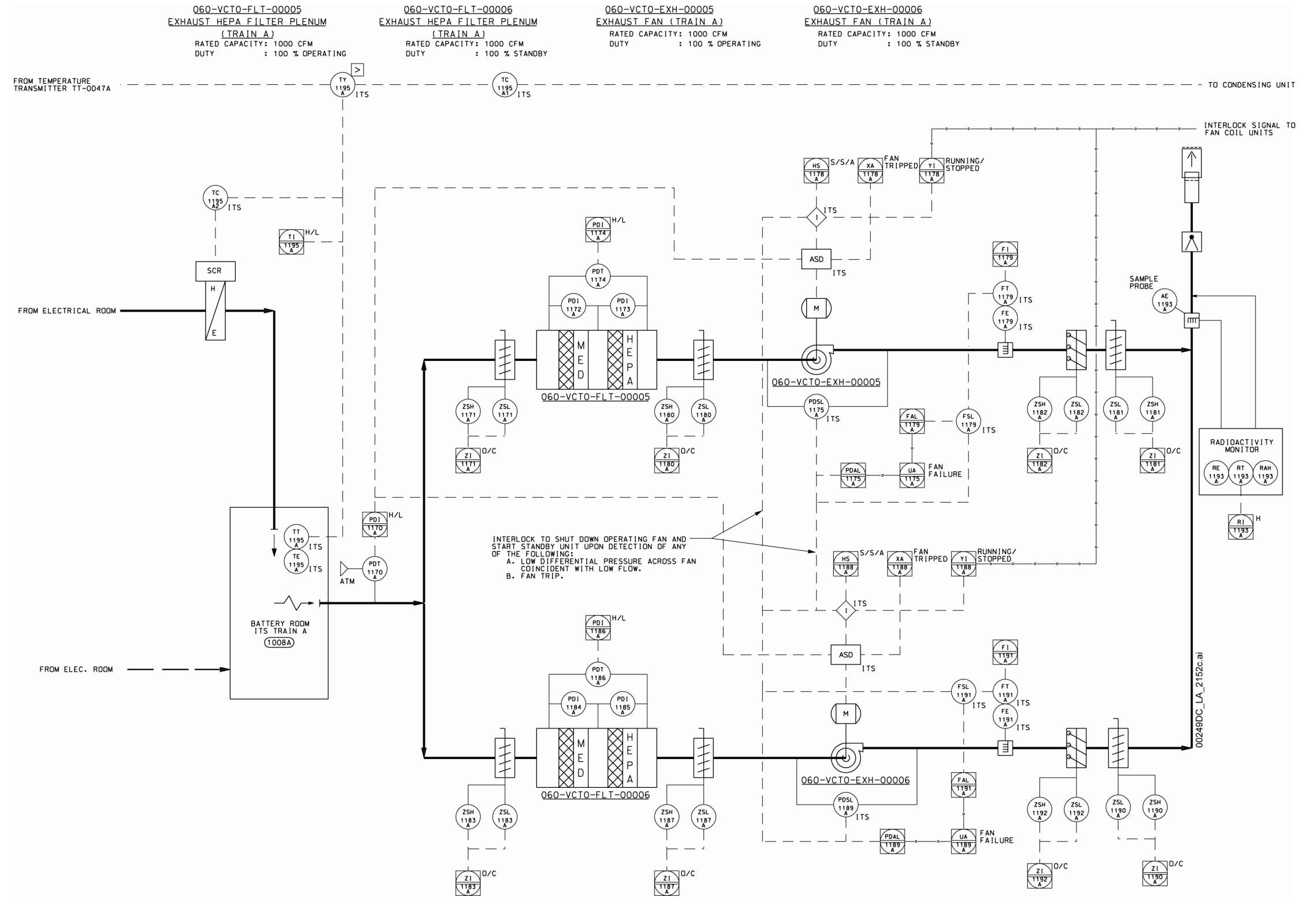

NOTE: HVAC equipment, ductwork, and all duct-mounted HVAC devices are ITS. The silicon controlled rectifier is integral to the electric heating coil and modulates heating in response to the temperature controller signal.
ASD = adjustable speed drive.

Figure 1.2.4-107. CRCF 1 Confinement ITS Battery Room Exhaust System—Train A Ventilation and Instrumentation Diagram

INTENTIONALLY LEFT BLANK

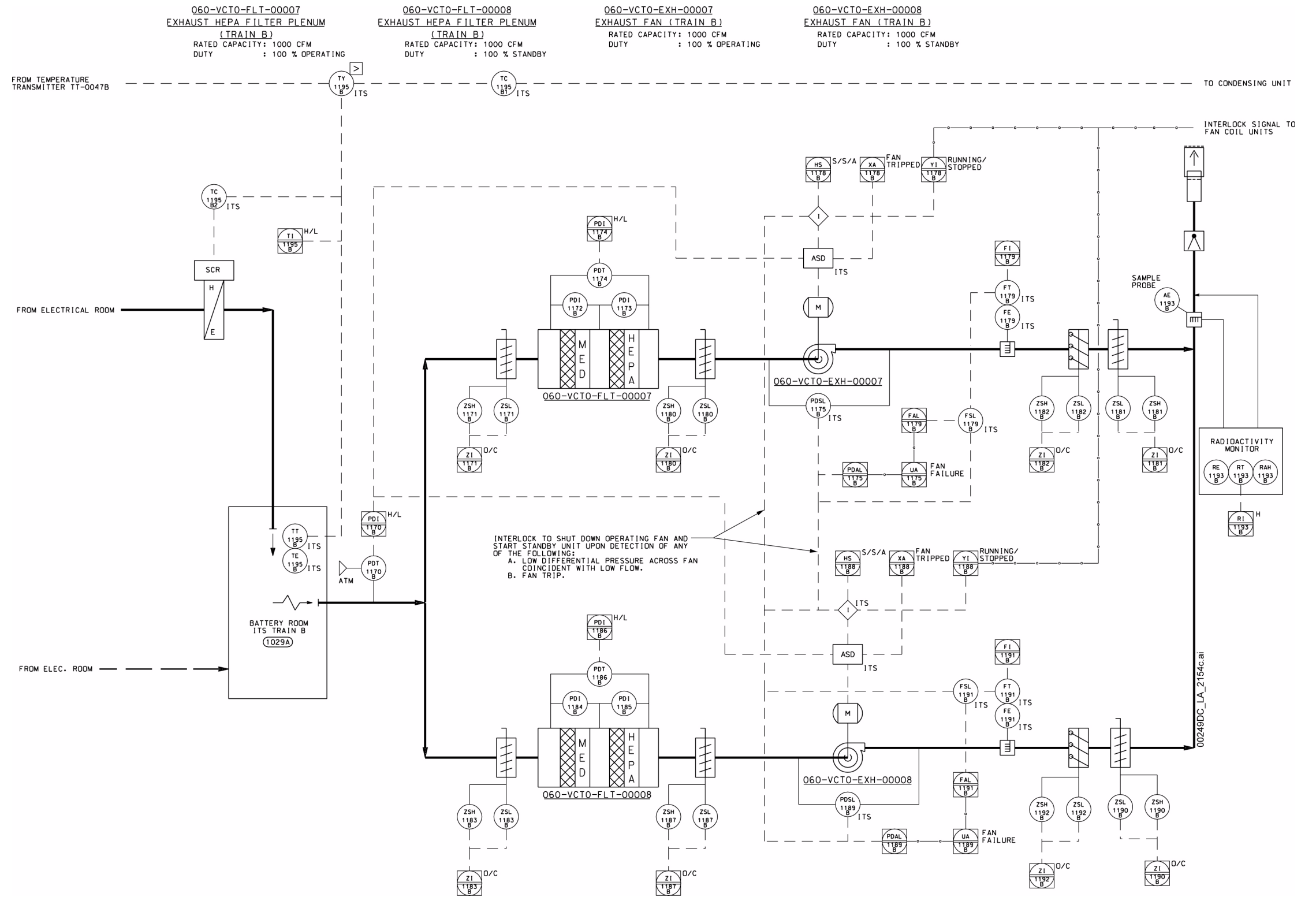

NOTE: HVAC equipment, ductwork, and all duct-mounted HVAC devices are ITS. The silicon controlled rectifier is integral to the electric heating coil and modulates heating in response to the temperature controller signal.
ASD = adjustable speed drive.

Figure 1.2.4-108. CRCF 1 Confinement ITS Battery Room Exhaust System—Train B Ventilation and Instrumentation Diagram

INTENTIONALLY LEFT BLANK

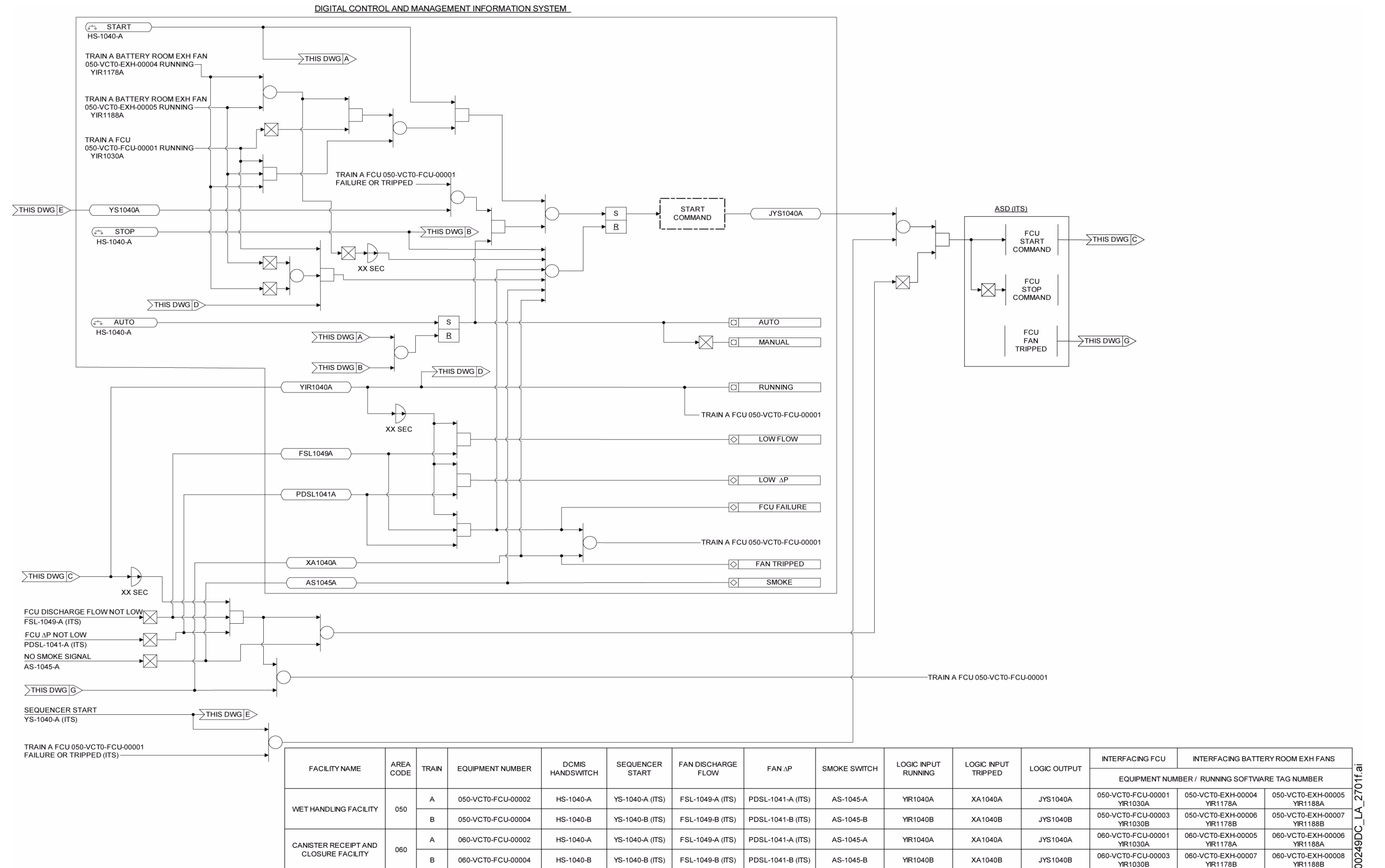

NOTE: This figure shows the logic diagram for the standby fan coil units in either Train A or Train B. ITS controls are identified by the letters "ITS" after the instrumentation tag number or control device identifier. The DCMIS is non-ITS and non-ITWI. Instrumentation tag numbers are prefixed by "XXX-VCT0-" and software tag numbers are prefixed by "XXXVCT0," where XXX is the area code. ASD = adjustable speed drive; ΔP = differential pressure; FCU = fan coil unit.

Figure 1.2.4-109. CRCF and WHF Confinement ITS Electrical Room Fan Coil Unit (Trains A and B) Digital Logic Diagram

INTENTIONALLY LEFT BLANK

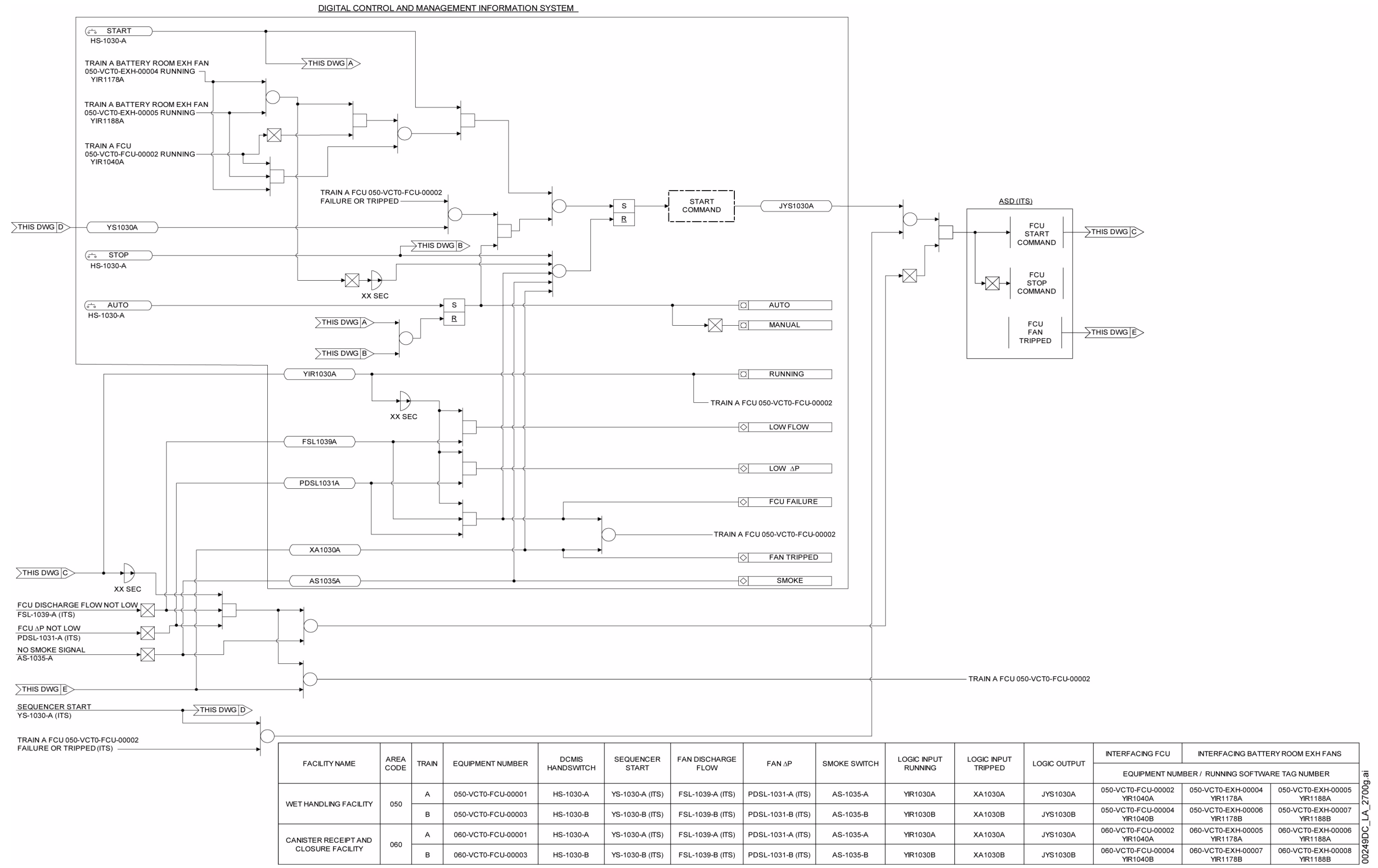

NOTE: This figure shows the logic diagram for the operating fan coil units in either Train A or Train B. ITS controls are identified by the letters "ITS" after the instrumentation tag number or control device identifier. The DCMIS is non-ITS and non-ITWI. Instrumentation tag numbers are prefixed by "XXX-VCT0," where XXX is the area code. ASD = adjustable speed drive; ΔP = differential pressure; FCU = fan coil unit.

Figure 1.2.4-110. CRCF and WHF Confinement ITS Electrical Room Fan Coil Unit (Trains A and B) Digital Logic Diagram

INTENTIONALLY LEFT BLANK

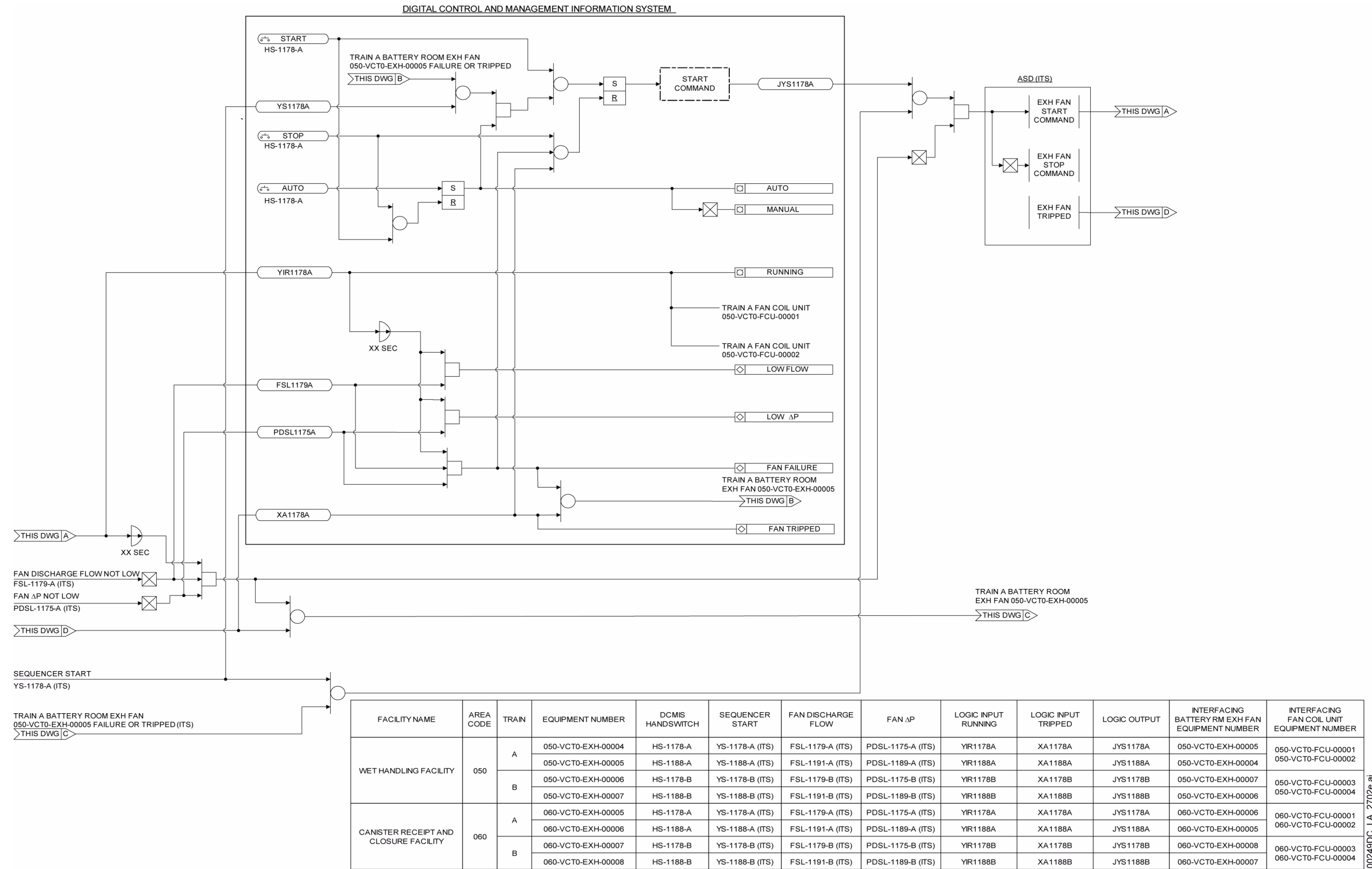

NOTE: ITS controls are identified by the letters "ITS" after the instrumentation tag number or control device identifier. The DCMIS is non-ITS and non-ITWI. Instrumentation tag numbers are prefixed by "XXX-VCT0-" and software tag numbers are prefixed by "XXXVCT0," where XXX is the area code. ASD = adjustable speed drive; ΔP = differential pressure.

Figure 1.2.4-111. CRCF and WHF Confinement ITS Battery Room Exhaust Fan (Trains A and B) Digital Logic Diagram

INTENTIONALLY LEFT BLANK

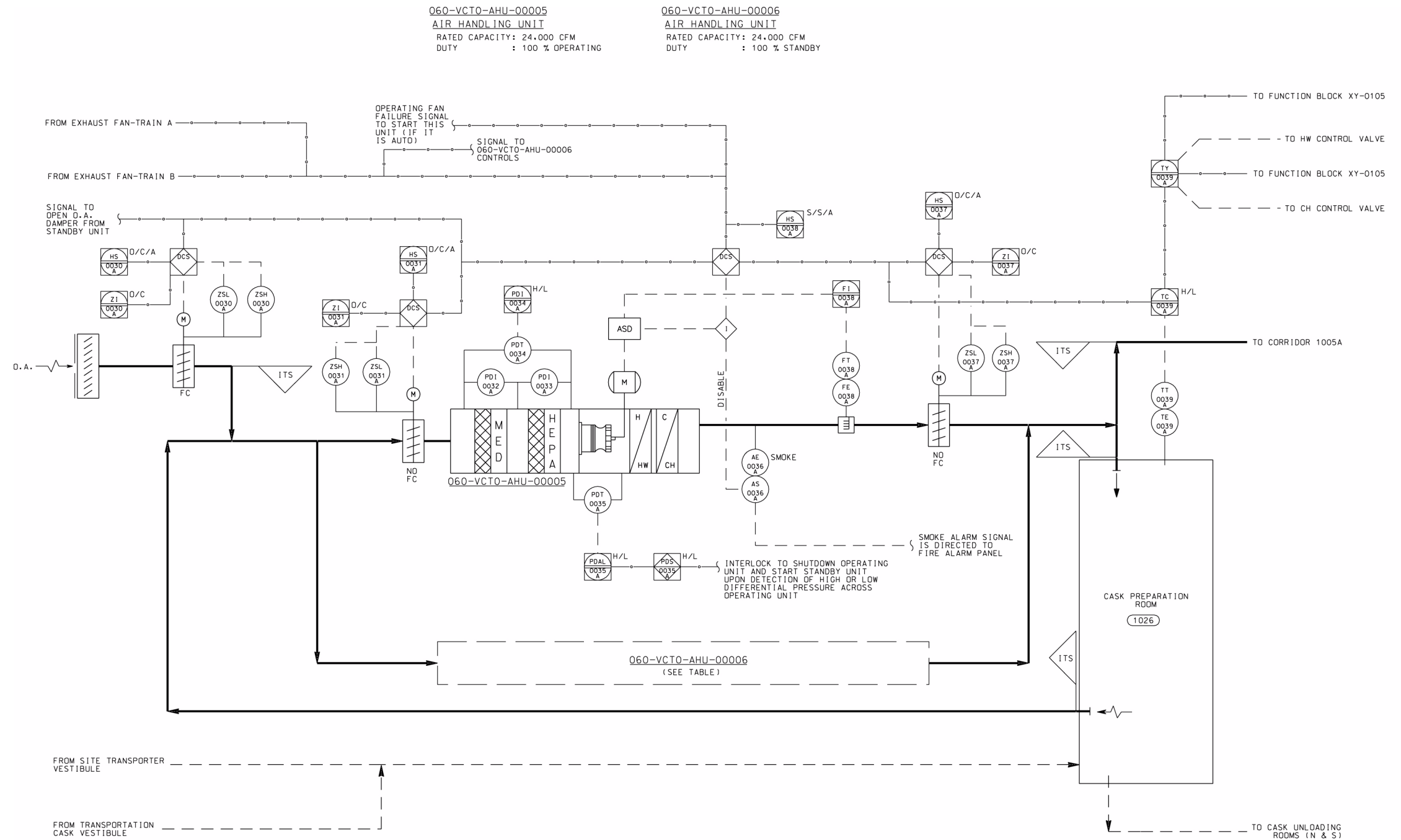

TABLE 1:

MECHANICAL COMPONENT	AIR HANDLING UNIT					INLET DAMPER				OUTLET DAMPER				SMOKE		FLOW			FAN DP				TEMPERATURE			
	HS	PD1	PD1	PDT	PD1	HS	Z1	ZSL	ZSH	HS	Z1	ZSL	ZSH	AE	AS	FE	FT	FI	PDT	PD1	PDS	TE	TT	TC	TY	
060-VCTO-AHU-00005	0038A	0032A	0033A	0034A	0034A	0031A	0031A	0031A	0031A	0037A	0037A	0037A	0037A	0036A	0036A	0038A	0038A	0038A	0035A	0035A	0035A	0039A	0039A	0039A	0039A	
060-VCTO-AHU-00006	0038B	0032B	0033B	0034B	0034B	0031B	0031B	0031B	0031B	0037B	0037B	0037B	0037B	0036B	0036B	0038B	0038B	0038B	0035B	0035B	0035B	0039B	0039B	0039B	0039B	

00249DC_LA_2165b.ai

NOTE: Supply and return ductwork within the flags, including the air handling unit housing, is ITS for pressure boundary only; the air handling unit and isolation dampers do not have any ITS functions. Instrument and control devices are non-ITS.
CH = chilled water; HW = hot water.

Figure 1.2.4-112. CRCF 1 Cask Preparation Room HVAC Supply System Ventilation and Instrumentation Diagram

INTENTIONALLY LEFT BLANK

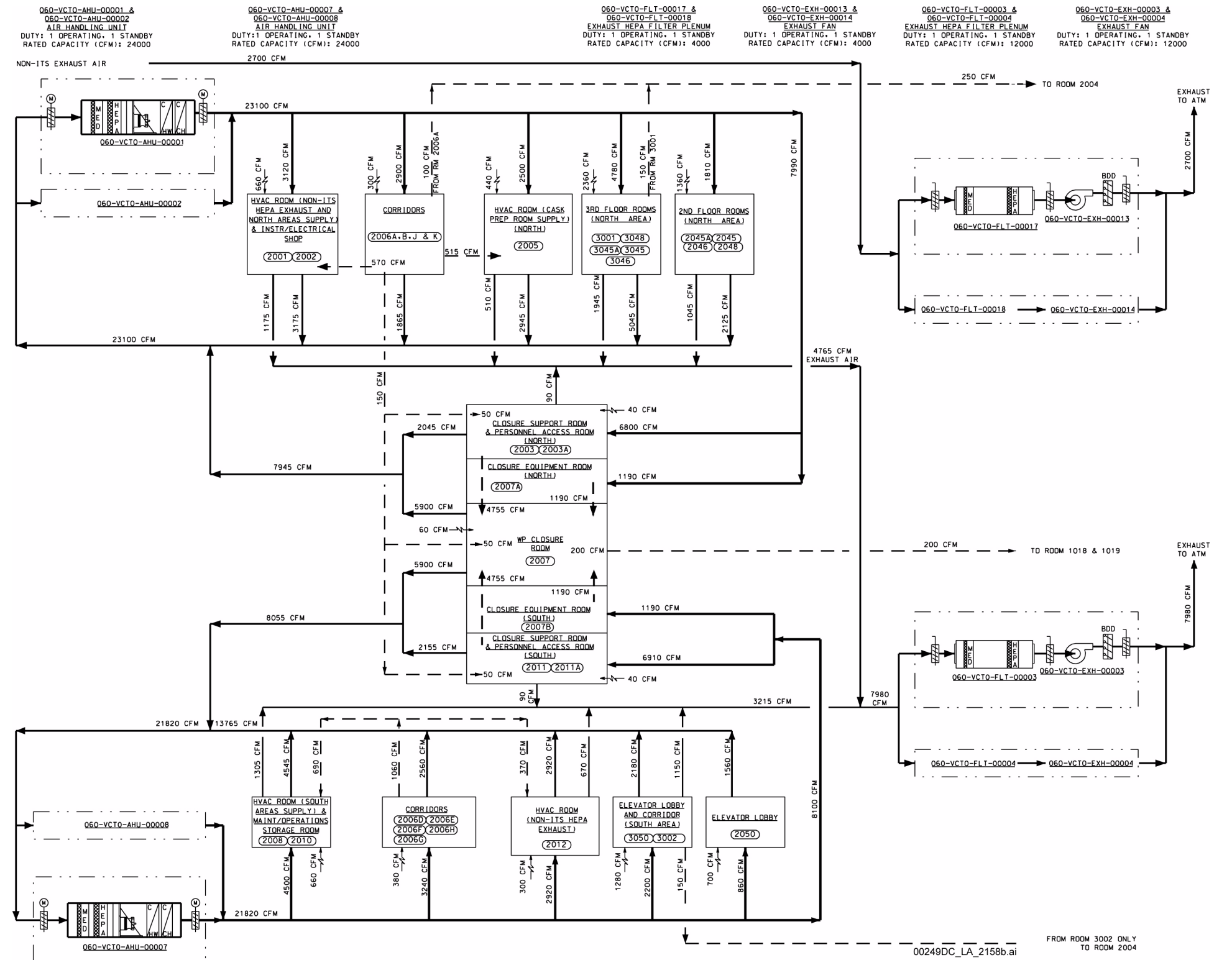
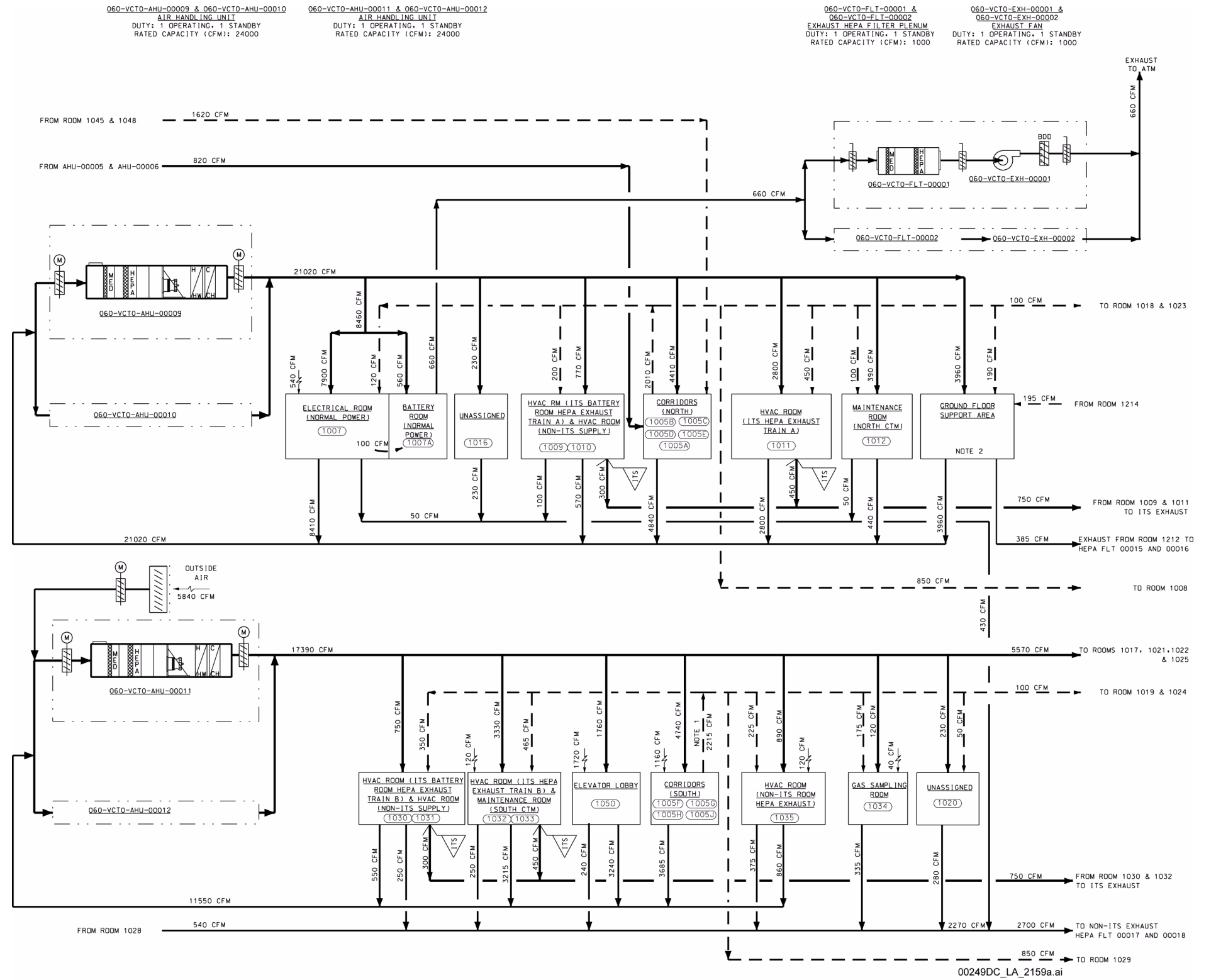

Figure 1.2.4-113. CRCF 1 Composite Ventilation Flow Diagram, Tertiary Confinement Non-ITS Exhaust and HVAC Supply Systems

NOTE: This figure includes no SSCs that are ITS or ITWI. WP = waste package.

INTENTIONALLY LEFT BLANK



NOTE: Exhaust air is coming from the HEPA filter service gallery to the ITS exhaust system. The service gallery enclosure and the exhaust ductwork is ITS. Infiltration air to the corridor will be cascaded to adjacent rooms through doors and openings. It will be exhausted through the non-ITS HEPA filter.
 CTM = canister transfer machine.

Figure 1.2.4-114. CRCF 1 Composite Ventilation Flow Diagram, Tertiary Confinement Ground Floor HVAC Systems

INTENTIONALLY LEFT BLANK

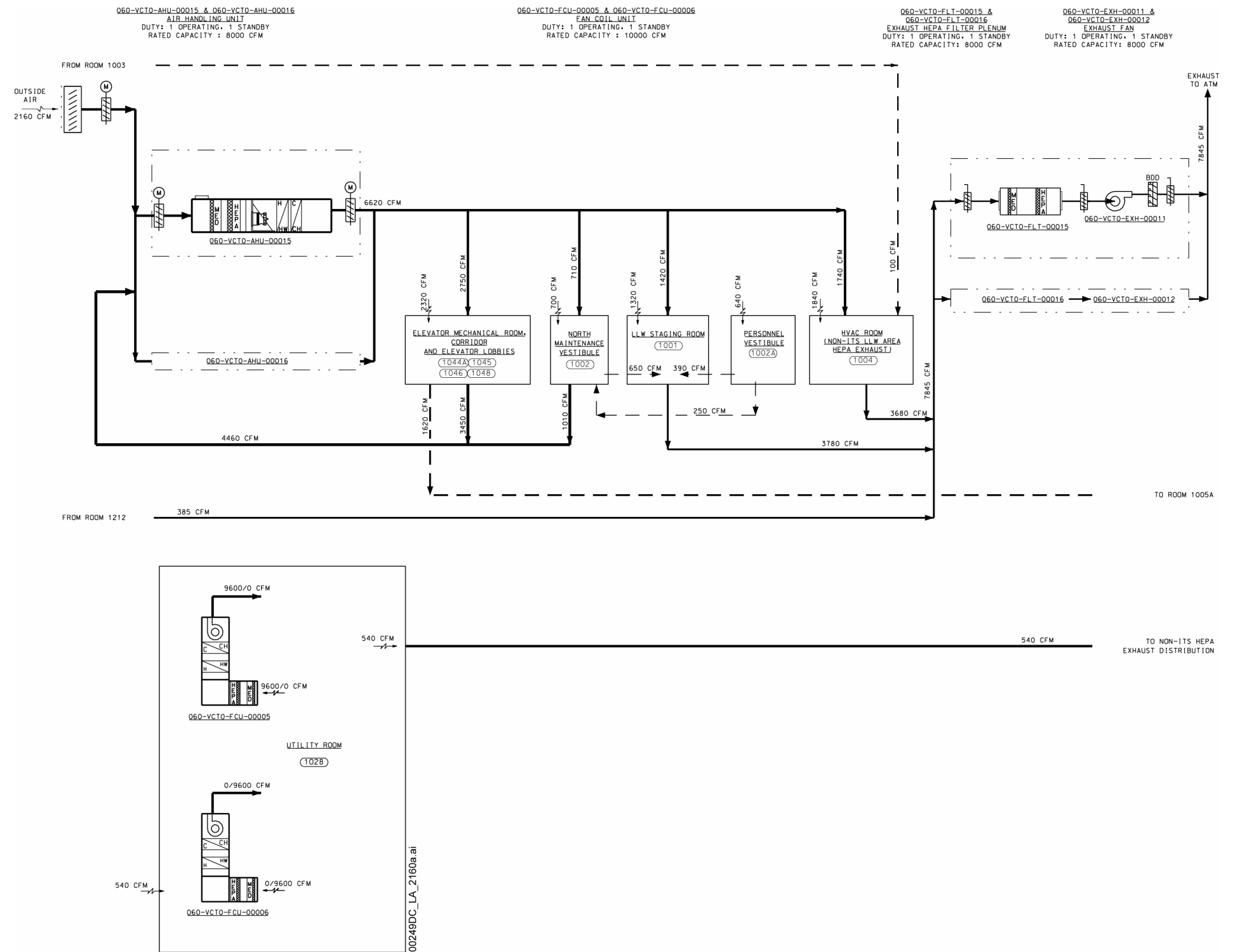

Figure 1.2.4-115. CRCF 1 Composite Ventilation Flow Diagram, Tertiary Confinement Non-ITS HVAC System Supply and Exhaust

NOTE: This figure includes no SSCs that are ITS or ITWI. LLW = low-level radioactive waste.

INTENTIONALLY LEFT BLANK

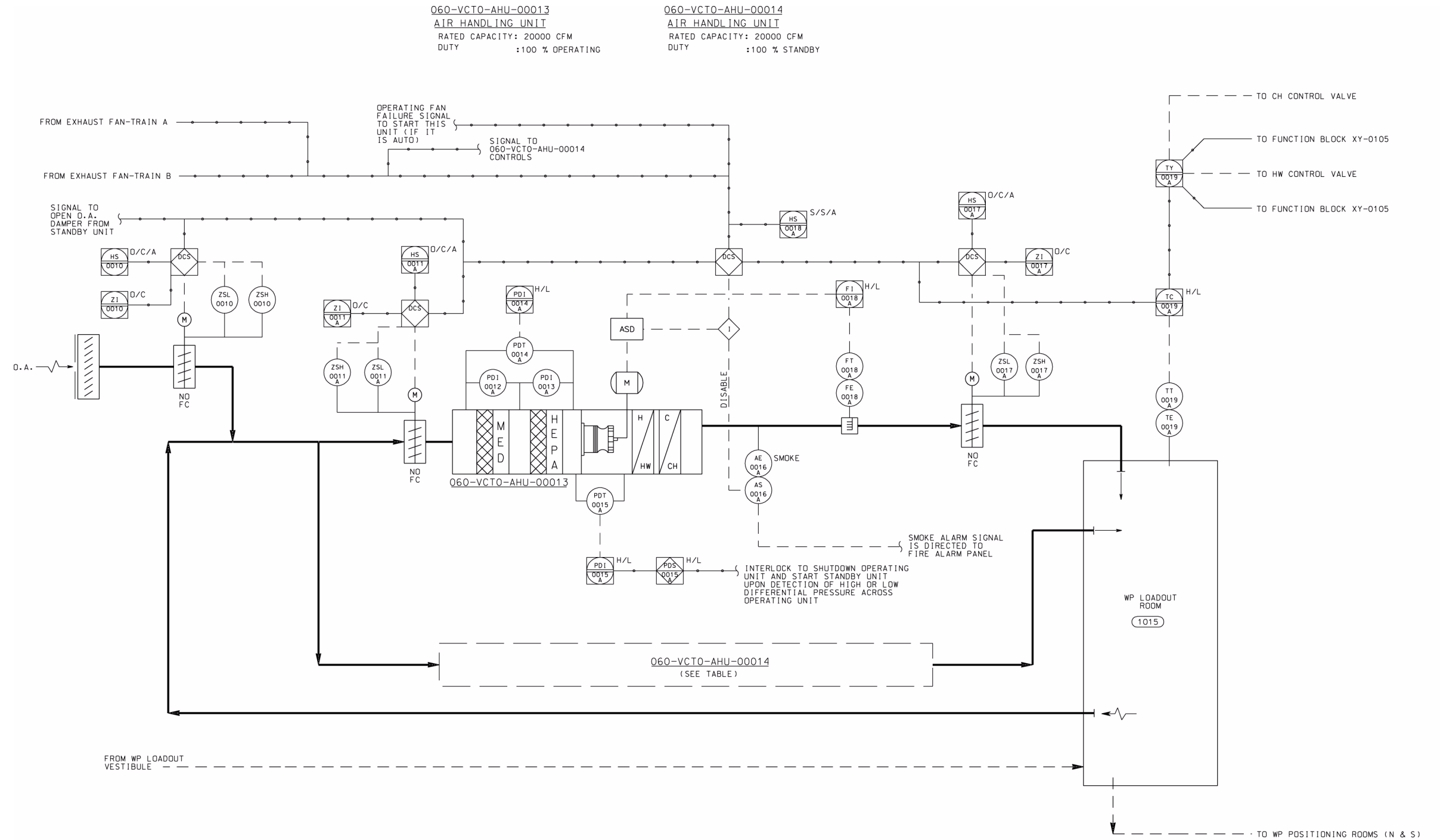

TABLE 1:

MECHANICAL COMPONENT	AIR HANDLING UNIT					INLET DAMPER					OUTLET DAMPER					SMOKE		FLOW					FAN DP					TEMPERATURE				
	HS	PDI	PDI	PDT	PDI	HS	ZI	ZSL	ZSH	HS	ZI	ZSL	ZSH	AE	AS	FE	FT	F I	PDT	PDI	PDS	TE	TT	TC	TY							
060-VCTO-AHU-00013	0018A	0012A	0013A	0014A	0014A	0011A	0011A	0011A	0011A	0017A	0017A	0017A	0017A	0016A	0016A	0018A	0018A	0018A	0015A	0015A	0015A	0019A	0019A	0019A	0019A							
060-VCTO-AHU-00014	0018B	0012B	0013B	0014B	0014B	0011B	0011B	0011B	0011B	0017B	0017B	0017B	0017B	0016B	0016B	0018B	0018B	0018B	0015B	0015B	0015B	0019B	0019B	0019B	0019B							

00249DC_LA_2162c.ai

Figure 1.2.4-116. CRCF 1 Confinement Waste Package Loadout Room HVAC Supply System Ventilation and Instrumentation Diagram

NOTE: This figure includes no SSCs that are ITS or ITWI. CH = chilled water; HW = hot water; WP = waste package.

INTENTIONALLY LEFT BLANK

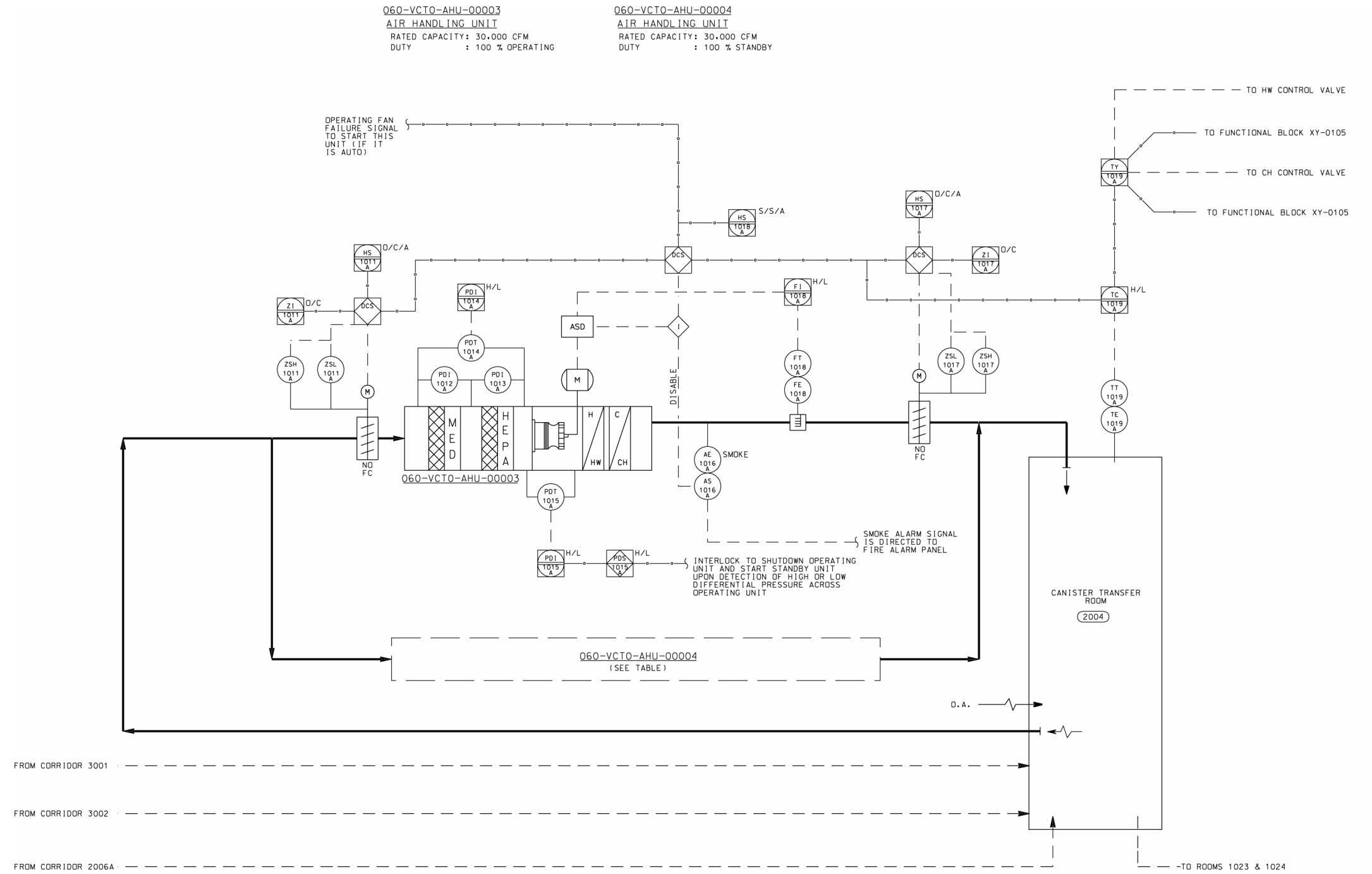

TABLE 1:

MECHANICAL COMPONENT	AIR HANDLING UNIT					INLET DAMPER				OUTLET DAMPER				SMOKE		FLOW					FAN DP				TEMPERATURE			
	HS	PDI	PDI	PDT	PDI	HS	ZI	ZSL	ZSH	HS	ZI	ZSL	ZSH	AE	AS	FE	FT	FJ	PDT	PDI	PDS	TE	TT	TC	TY			
060-VCTO-AHU-00003	1018A	1012A	1013A	1014A	1014A	1011A	1011A	1011A	1011A	1017A	1017A	1017A	1017A	1016A	1016A	1018A	1018A	1018A	1015A	1015A	1015A	1019A	1019A	1019A	1019A			
060-VCTO-AHU-00004	1018B	1012B	1013B	1014B	1014B	1011B	1011B	1011B	1011B	1017B	1017B	1017B	1017B	1016B	1016B	1018B	1018B	1018B	1015B	1015B	1015B	1019B	1019B	1019B	1019B			

00249DC_LA_2166c.ai

Figure 1.2.4-117. CRCF 1 Confinement Canister Transfer Room HVAC System Ventilation and Instrumentation Diagram

NOTE: This figure includes no SSCs that are ITS or ITWI. CH = chilled water; HW = hot water.

INTENTIONALLY LEFT BLANK

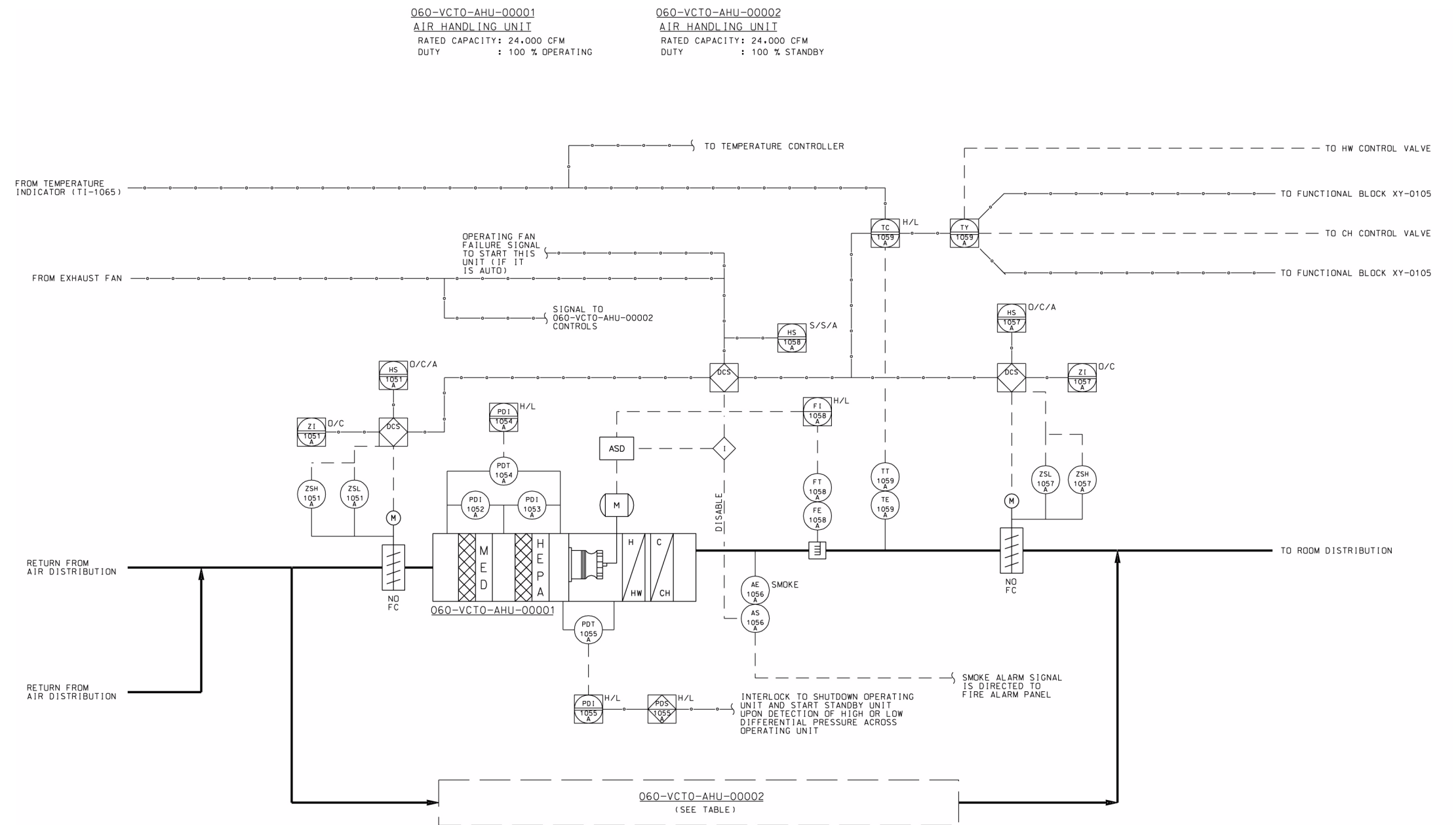

TABLE 1:

MECHANICAL COMPONENT	AIR HANDLING UNIT					INLET DAMPER				OUTLET DAMPER				SMOKE		FLOW					TEMPERATURE				FAN DP		
	HS	PD1	PD1	PDT	PD1	HS	ZI	ZSL	ZSH	HS	ZI	ZSL	ZSH	AE	AS	FE	FT	F I	TE	TT	TC	TY	PDT	PD1	PDS		
060-VCTO-AHU-00001	1058A	1052A	1053A	1054A	1054A	1051A	1051A	1051A	1051A	1057A	1057A	1057A	1057A	1056A	1056A	1058A	1058A	1058A	1059A	1059A	1059A	1059A	1055A	1055A	1055A		
060-VCTO-AHU-00002	1058B	1052B	1053B	1054B	1054B	1051B	1051B	1051B	1051B	1057B	1057B	1057B	1057B	1056B	1056B	1058B	1058B	1058B	1059B	1059B	1059B	1059B	1055B	1055B	1055B		

00249DC_LA_2167b.ai

Figure 1.2.4-118. CRCF 1 Confinement Second Floor North HVAC Supply System Ventilation and Instrumentation Diagram

NOTE: This figure includes no SSCs that are ITS or ITWI. CH = chilled water; HW = hot water.

INTENTIONALLY LEFT BLANK

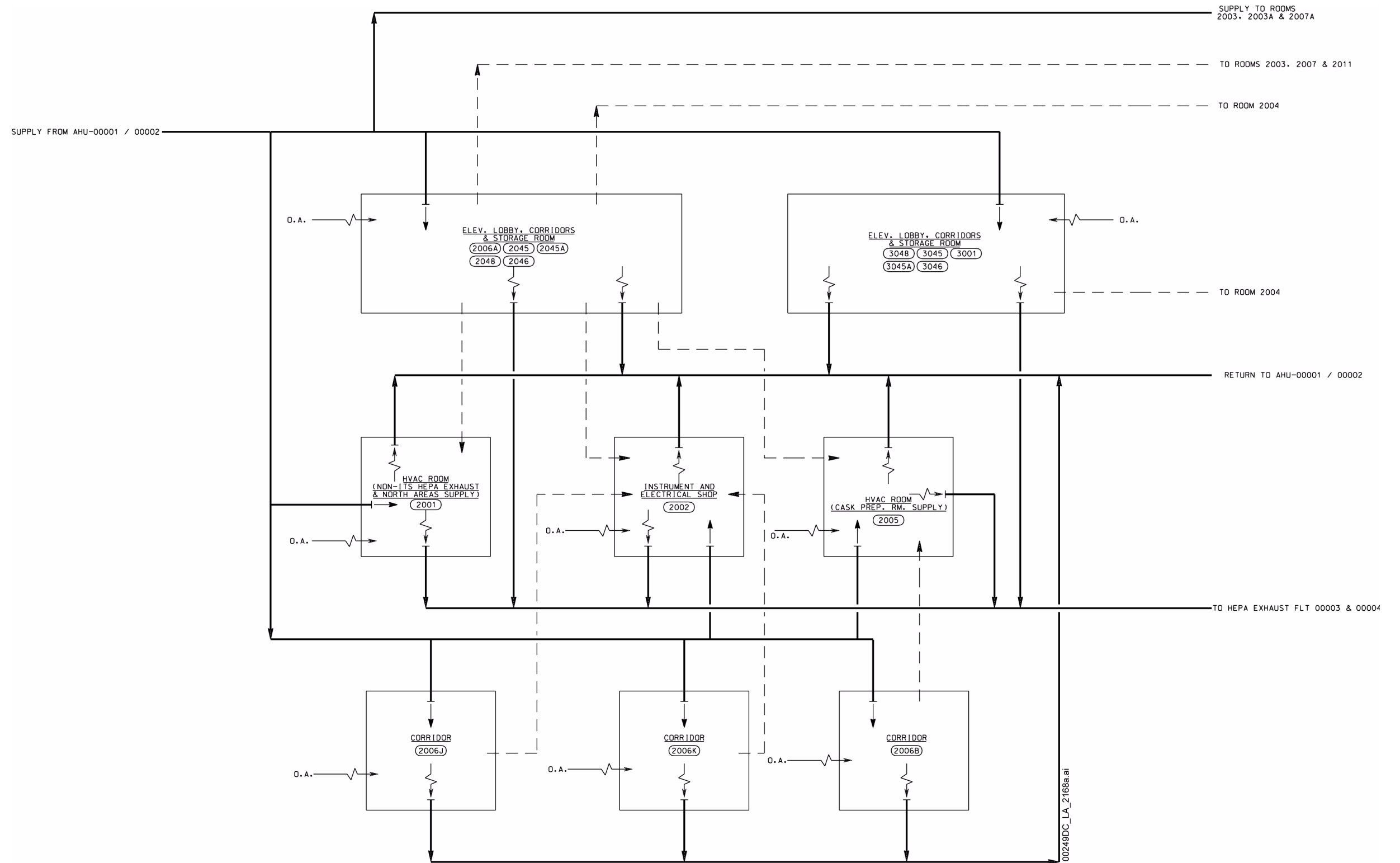

Figure 1.2.4-119. CRCF 1 Confinement Second Floor North Areas Air Distribution System Ventilation and Instrumentation Diagram

NOTE: This figure includes no SSCs that are ITS or ITWI.

INTENTIONALLY LEFT BLANK

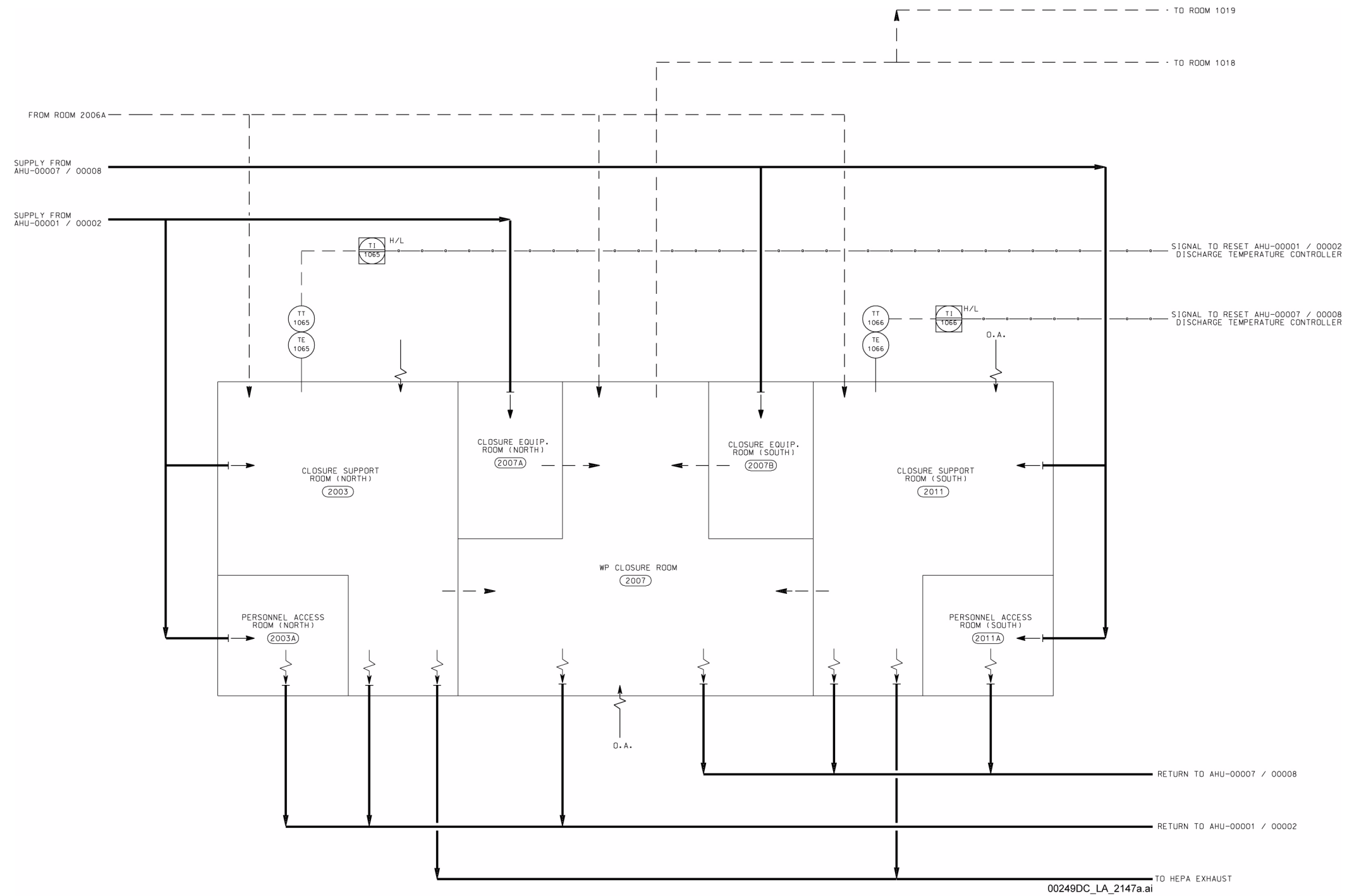

Figure 1.2.4-120. CRCF 1 Confinement Waste Package Closure Areas Air Distribution System Ventilation and Instrumentation Diagram

NOTE: This figure includes no SSCs that are ITS or ITWI. WP = waste package.

INTENTIONALLY LEFT BLANK

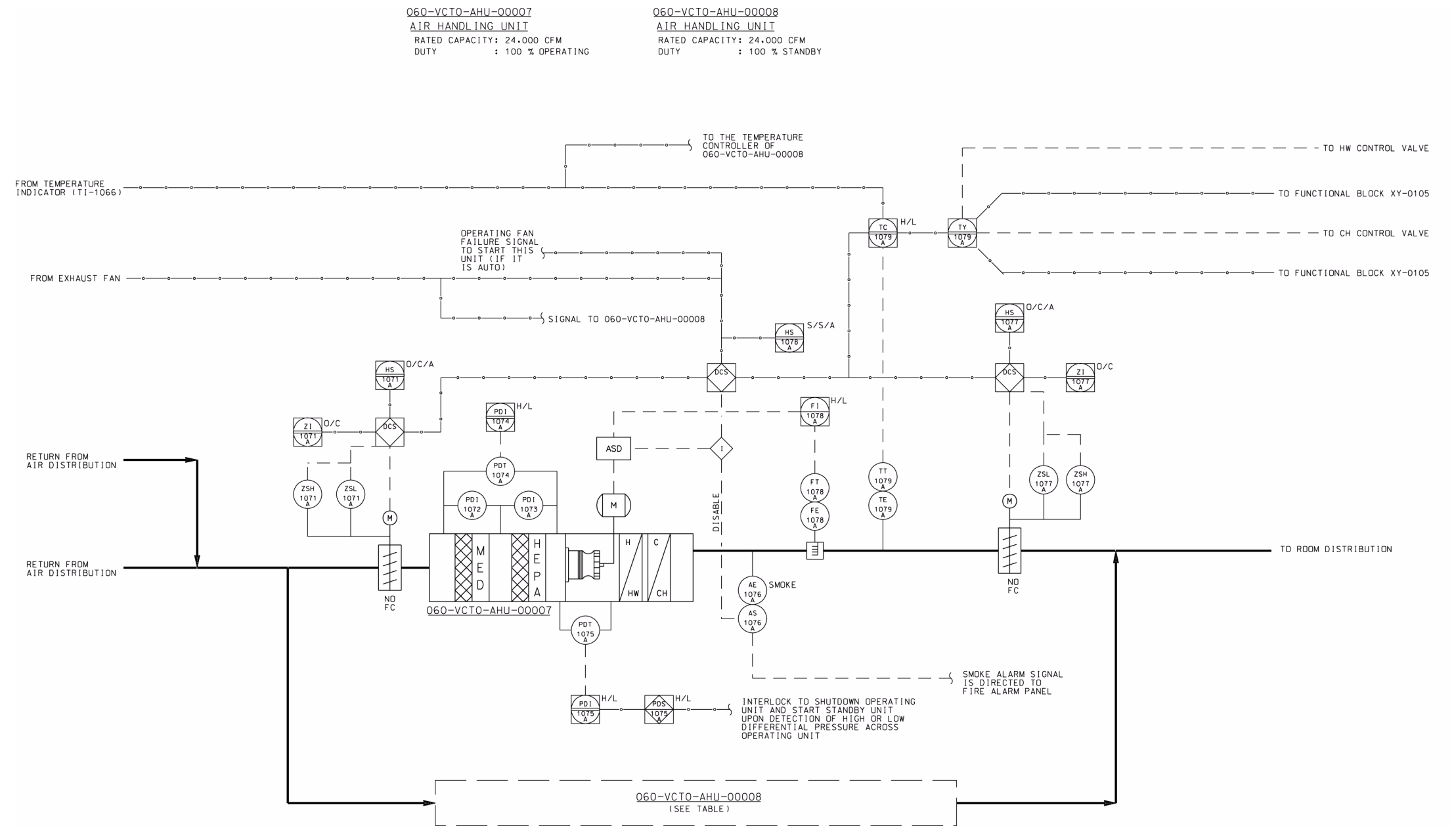

TABLE 1:

MECHANICAL COMPONENT	AIR HANDLING UNIT					INLET DAMPER				OUTLET DAMPER				SMOKE		FLOW					TEMPERATURE			FAN DP		
	HS	PDI	PDI	PDT	PDI	HS	ZI	ZSL	ZSH	HS	ZI	ZSL	ZSH	AE	AS	FE	FT	F I	TE	TT	TC	TY	PDT	PDI	PDS	
060-VCTO-AHU-00007	1078A	1072A	1073A	1074A	1074A	1071A	1071A	1071A	1071A	1077A	1077A	1077A	1077A	1076A	1076A	1078A	1078A	1078A	1079A	1079A	1079A	1079A	1075A	1075A	1075A	
060-VCTO-AHU-00008	1078B	1072B	1073B	1074B	1074B	1071B	1071B	1071B	1071B	1077B	1077B	1077B	1077B	1076B	1076B	1078B	1078B	1078B	1079B	1079B	1079B	1079B	1075B	1075B	1075B	

00249DC_LA_2148b.ai

Figure 1.2.4-121. CRCF 1 Second Floor South HVAC Supply System Ventilation and Instrumentation Diagram

NOTE: This figure includes no SSCs that are ITS or ITWI. CH = chilled water; DP = differential pressure; HW = hot water.

INTENTIONALLY LEFT BLANK

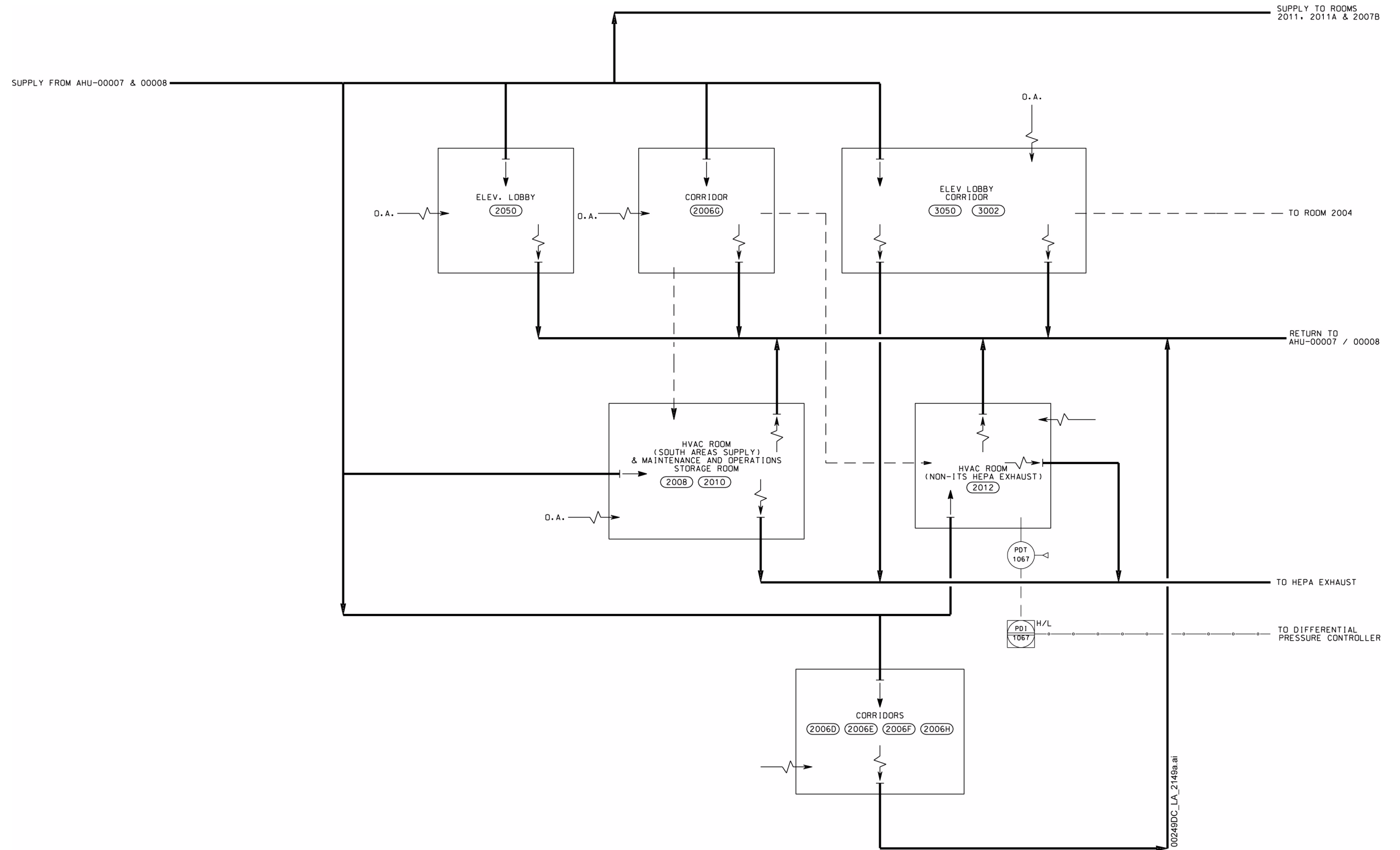

Figure 1.2.4-122. CRCF 1 Confinement Second Floor South Areas Air Distribution System Ventilation and Instrumentation Diagram

NOTE: This figure includes no SSCs that are ITS or ITWI.

INTENTIONALLY LEFT BLANK

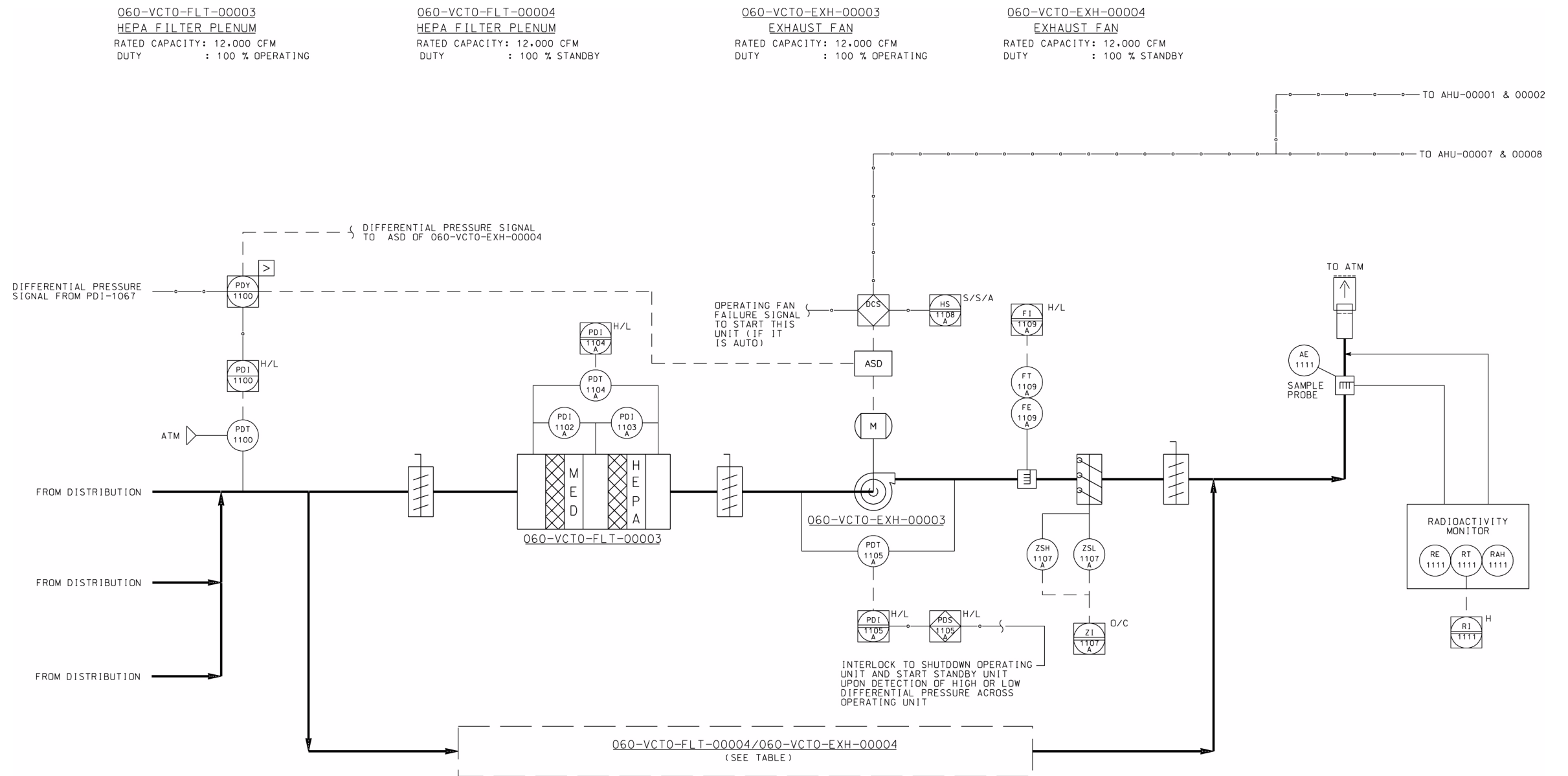

TABLE 1:

MECHANICAL COMPONENT	HEPA PLENUM				MECHANICAL COMPONENT	FAN DP				FLOW			BACKDRAFT DAMPER		
	PD1	PD1	PDT	PD1		FAN	PDT	PD1	PDS	HS	FE	FT	F1	ZSL	ZSH
060-VCTO-FLT-00003	1102A	1103A	1104A	1104A	060-VCTO-EXH-00003	1105A	1105A	1105A	1108A	1109A	1109A	1109A	1107A	1107A	1107A
060-VCTO-FLT-00004	1102B	1103B	1104B	1104B	060-VCTO-EXH-00004	1105B	1105B	1105B	1108B	1109B	1109B	1109B	1107B	1107B	1107B

00249DC_LA_2150e.ai

Figure 1.2.4-123. CRCF 1 Confinement Non-ITS HEPA Exhaust System—Second Floor Ventilation and Instrumentation Diagram

NOTE: This figure includes no SSCs that are ITS or ITWI. ASD = adjustable speed drive.

INTENTIONALLY LEFT BLANK

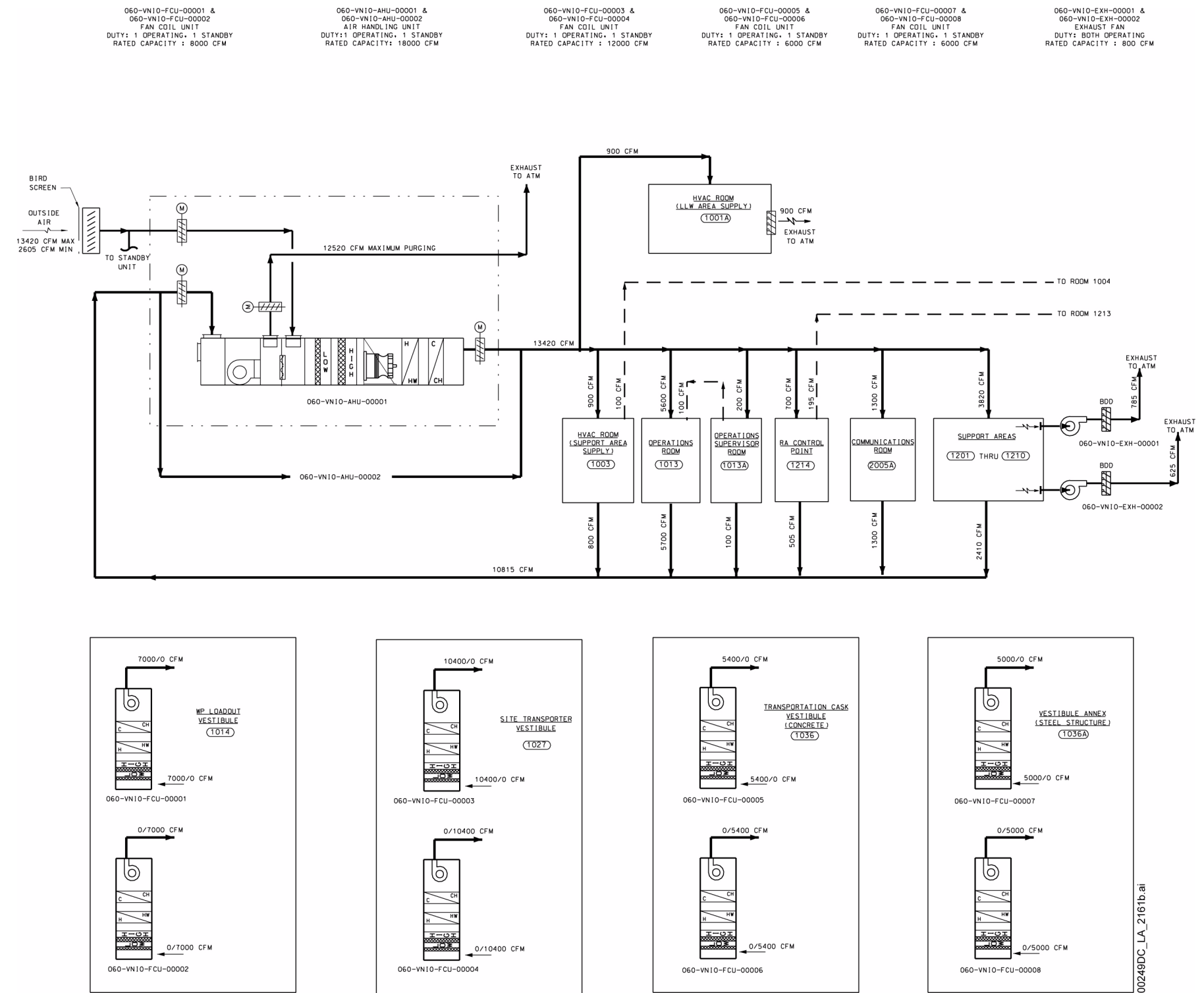
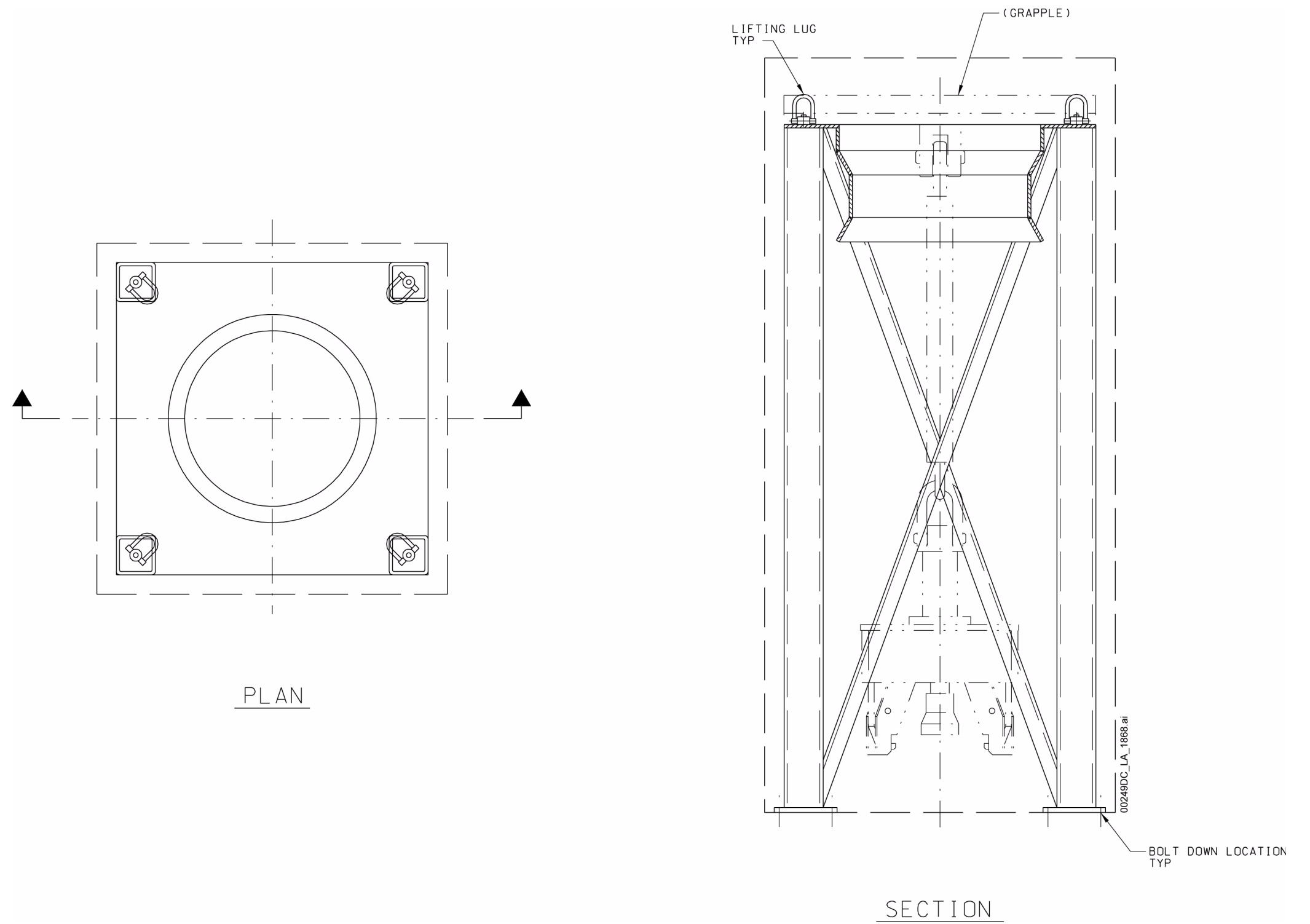

Figure 1.2.4-124. CRCF Composite Ventilation Flow Diagram, Nonconfinement Non-ITS HVAC System, Support and Operations

NOTE: This figure includes no SSCs that are ITS or ITWI. LLW = low-level radioactive waste; RA = radiological access; WP = waste package.

INTENTIONALLY LEFT BLANK



NOTE: This figure includes no SSCs that are ITS or ITWI. This equipment is used in CRCF, IHF, and WHF.

Equipment Number: 060-HTC0-RK-00001/00002//00003/00004/00005, CRCF grapple stands;
 51A-HTC0-RK-00002/00003/00004/00006, IHF grapple stands;
 050-HMH0-RK-00001/00002/00003/00004/00005/00006/00007, WHF grapple stands.

Figure 1.2.4-125. Nuclear Facilities Grapple Stand Mechanical Equipment Envelope

INTENTIONALLY LEFT BLANK

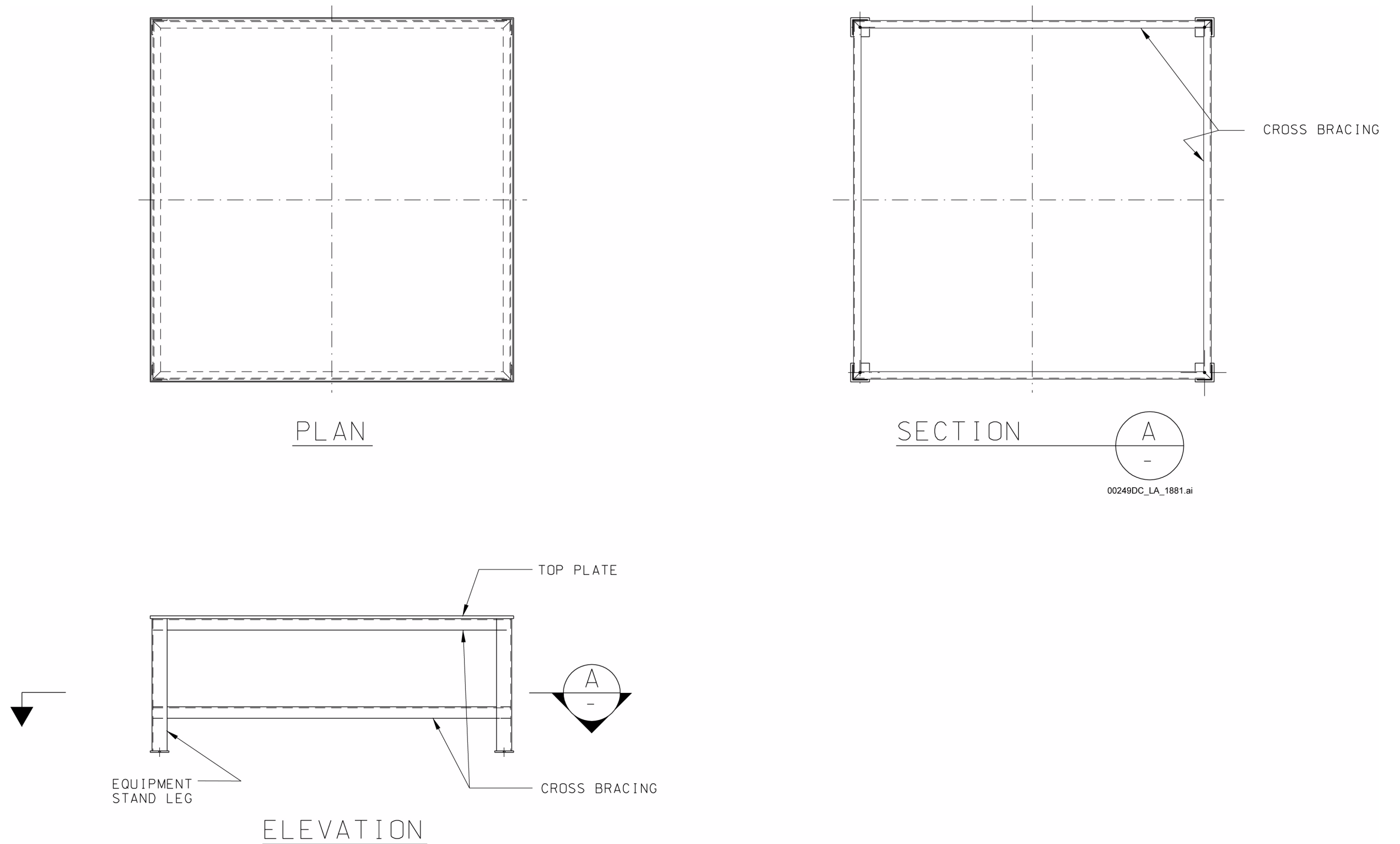

NOTE: This figure includes no SSCs that are ITS or ITWI. This equipment is used in the CRCF, RF, WHF, and IHF. Equipment numbers for the equipment stands are provided in [Table 1.2.4-5](#).

Figure 1.2.4-126. Equipment Stands Mechanical Equipment Envelope

INTENTIONALLY LEFT BLANK

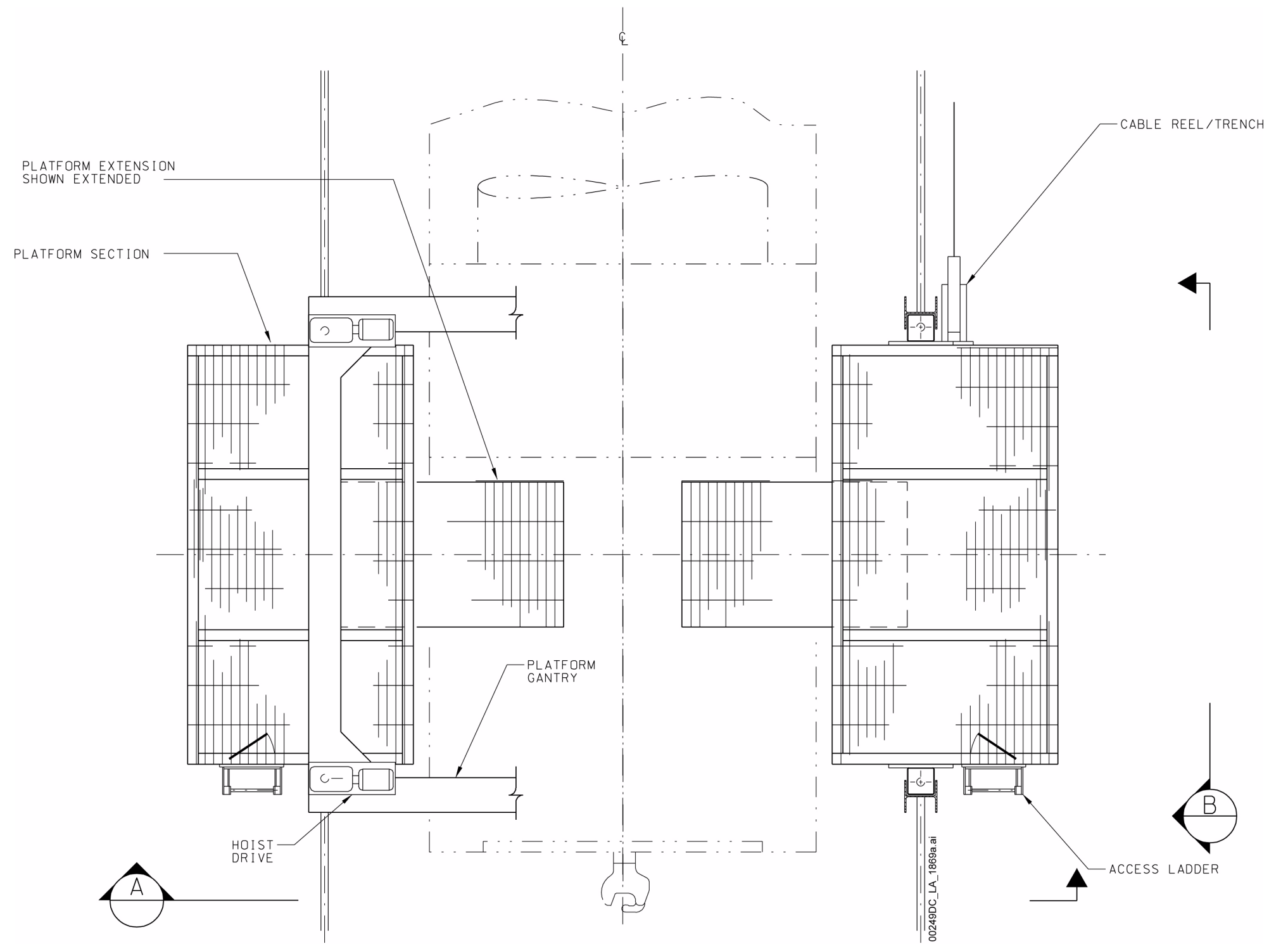

NOTE: This figure includes no SSCs that are ITS or ITWI. This equipment is used in the CRCF, RF, and WHF.
Equipment Number: 050-HMC0-PLAT-00001; 060-HMC0-PLAT-00001; 200-HMC0-PLAT-00001.

Figure 1.2.4-127. Mobile Access Platform Mechanical Equipment Envelope (Sheet 1 of 2)

INTENTIONALLY LEFT BLANK

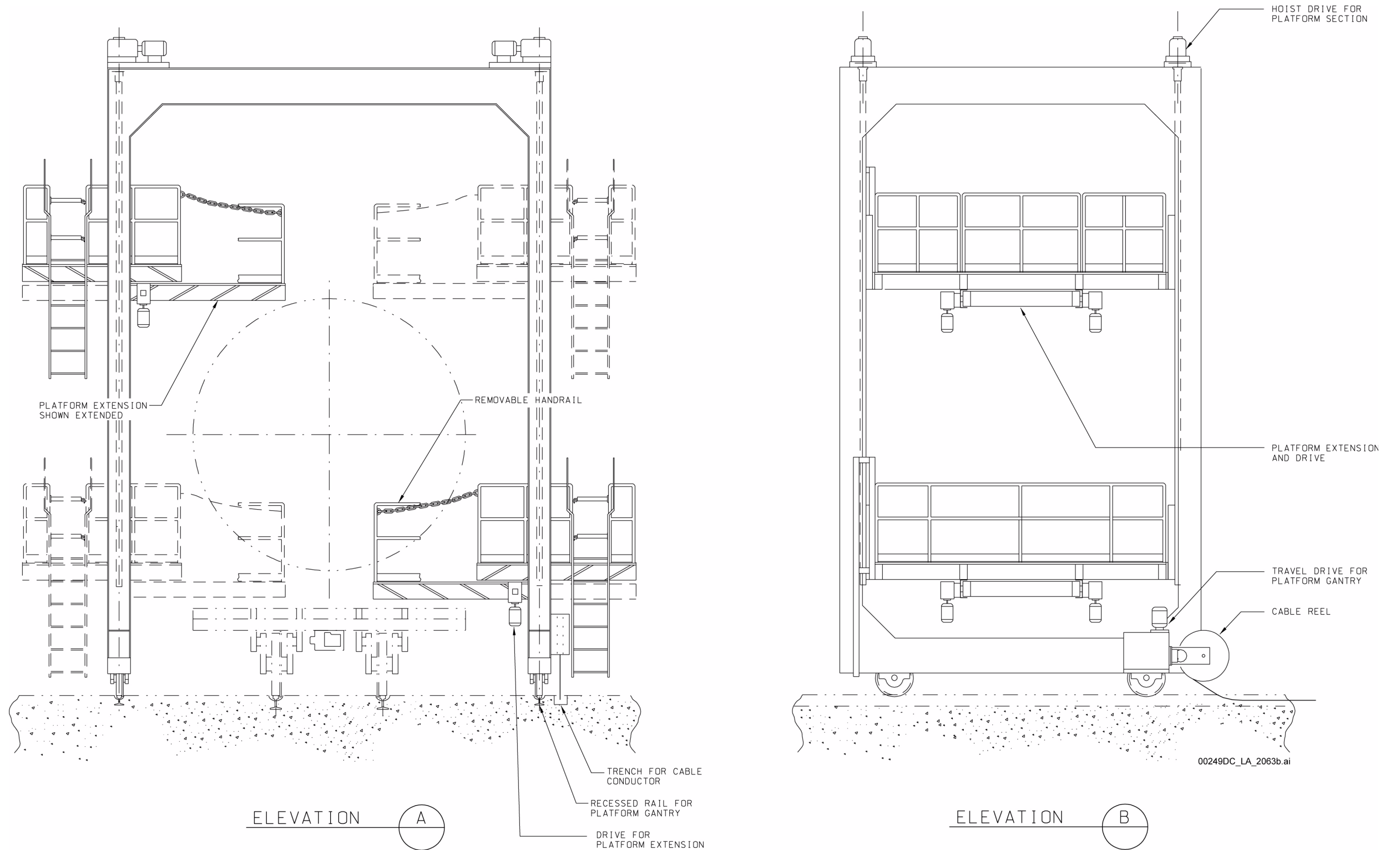

NOTE: This figure includes no SSCs that are ITS or ITWI. This equipment is used in the CRCF, RF, and WHF.

Figure 1.2.4-127. Mobile Access Platform Mechanical Equipment Envelope (Sheet 2 of 2)

INTENTIONALLY LEFT BLANK

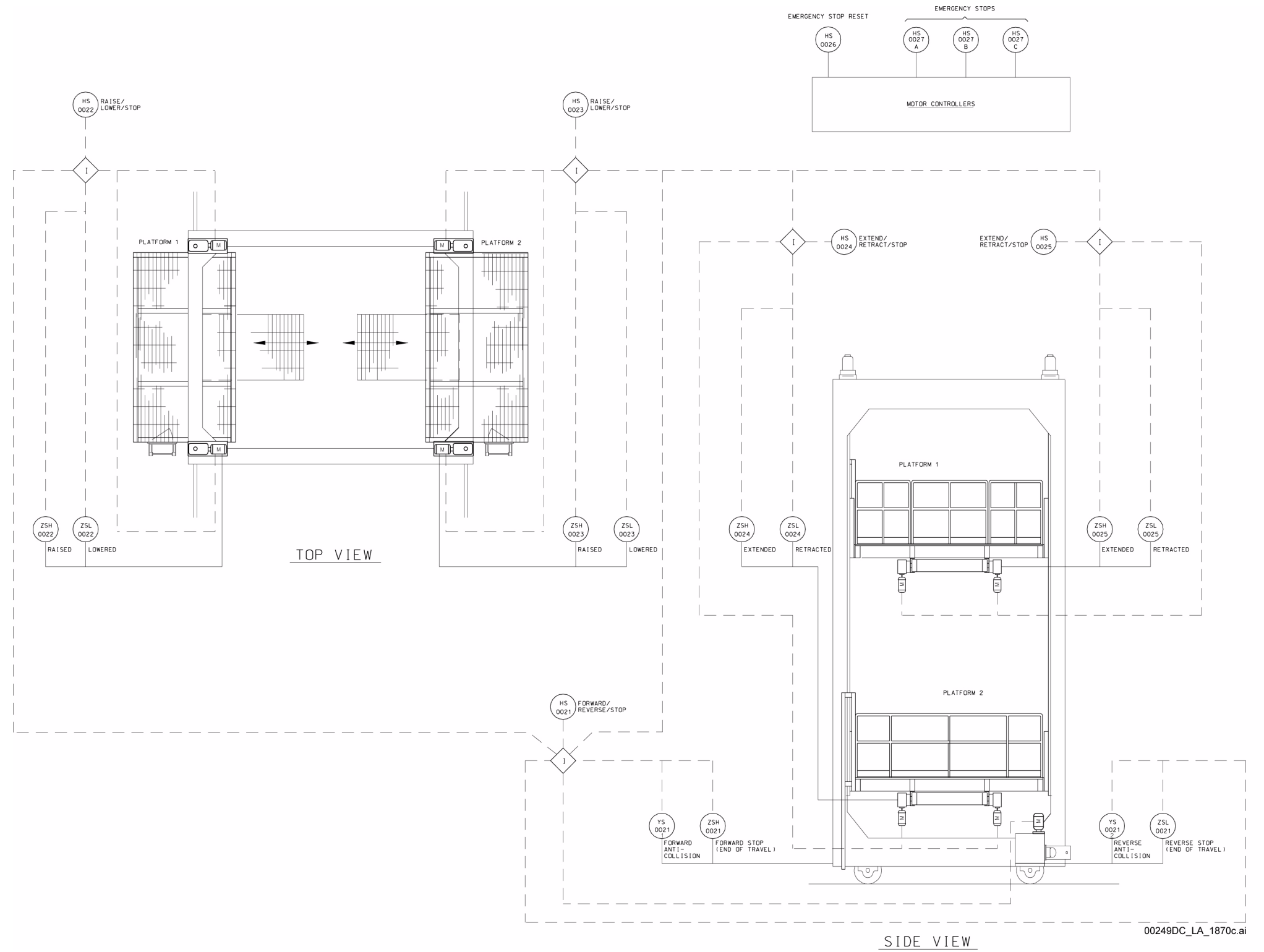

NOTE: This figure includes no SSCs that are ITS or ITWI. This equipment is used in the CRCF, RF, and WHF.

Equipment Number: 050-HMC0-PLAT-00001; 060-HMC0-PLAT-00001; 200-HMC0-PLAT-00001.

Figure 1.2.4-128. Mobile Access Platform Process and Instrumentation Diagram

INTENTIONALLY LEFT BLANK

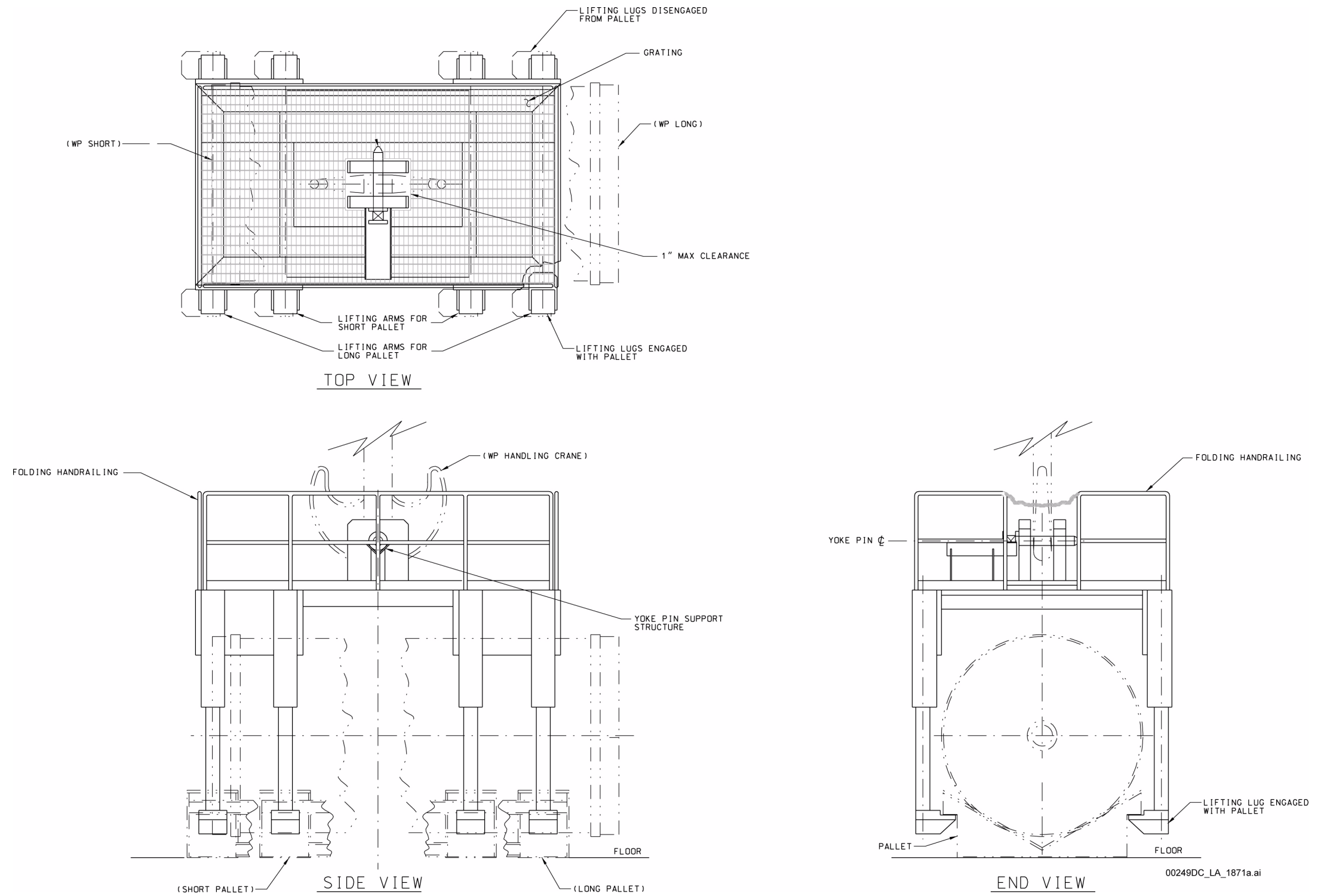

00249DC_LA_1871a.ai

NOTE: This figure includes no SSCs that are ITS or ITWI. This equipment is used in the CRCF and IHF. WP = waste package.

Equipment Number: 060-HMP0-BEAM-00001, CRCF waste package pallet yoke; 51A-HMP0-BEAM-00001, IHF waste package pallet yoke.

Figure 1.2.4-129. Waste Package Pallet Yoke Mechanical Equipment Envelope

INTENTIONALLY LEFT BLANK

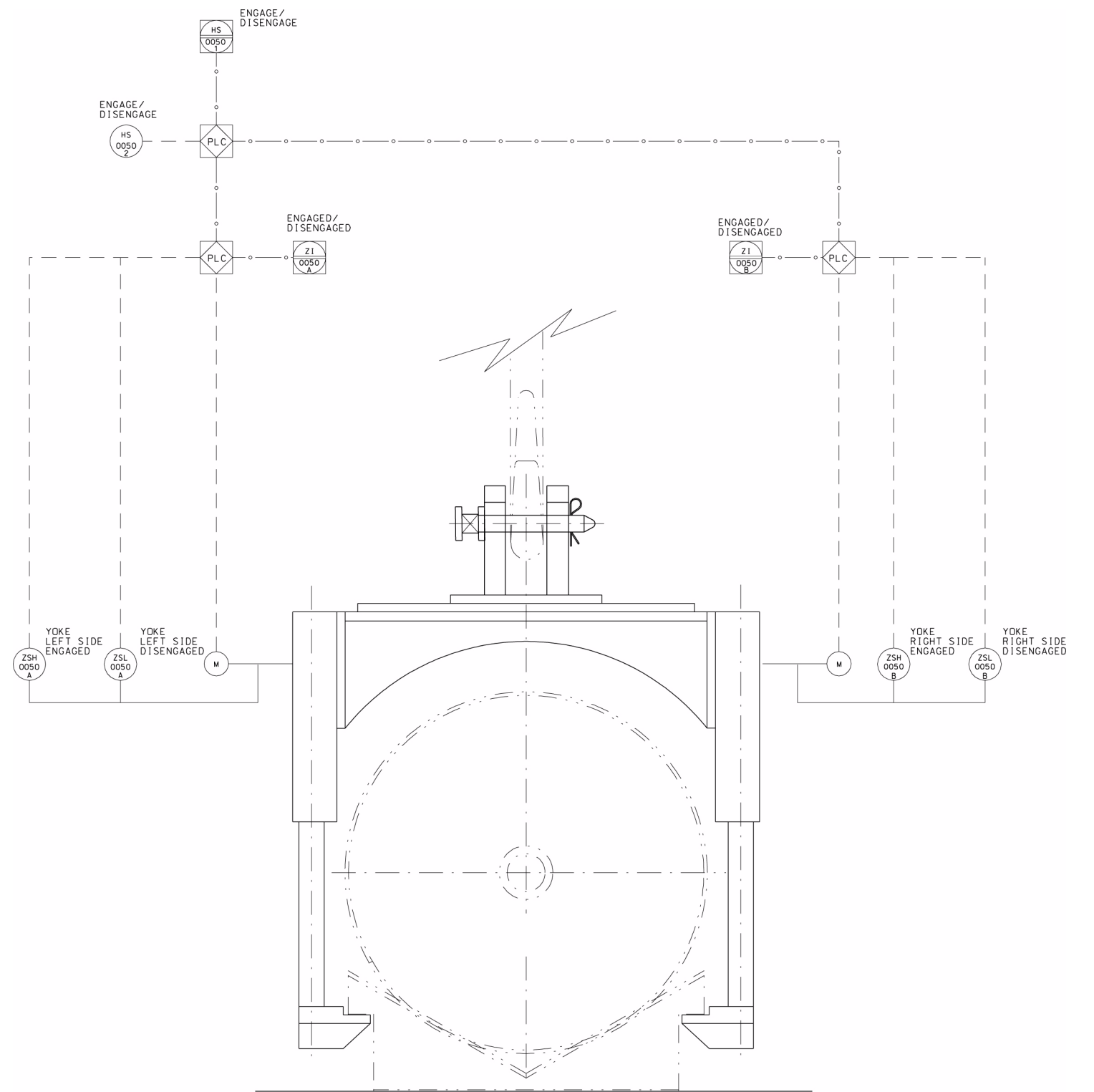

00249DC_LA_1872b.ai

NOTE: This figure includes no SSCs that are ITS or ITWI. This equipment is used in the CRCF and IHF.

Equipment Number: 060-HMP0-BEAM-00001, CRCF waste package pallet yoke; 51A-HMP0-BEAM-00001, IHF waste package pallet yoke.

Figure 1.2.4-130. Waste Package Pallet Yoke Process and Instrumentation Diagram

INTENTIONALLY LEFT BLANK

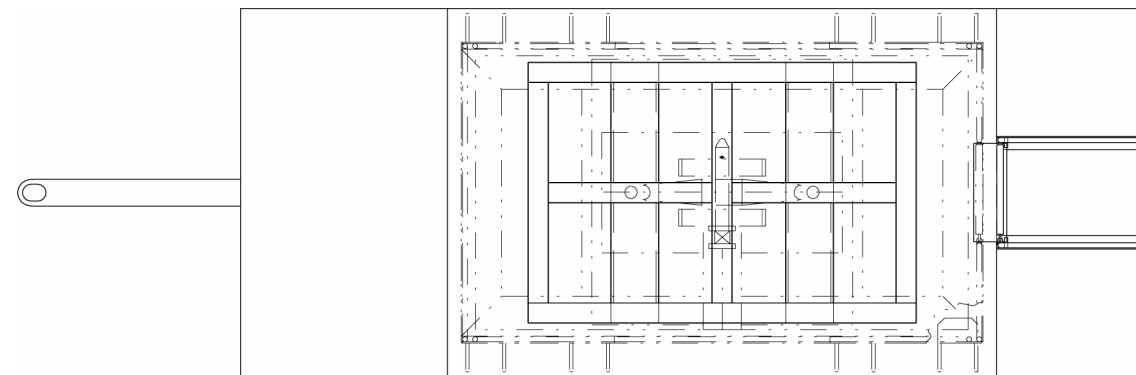

TOP VIEW

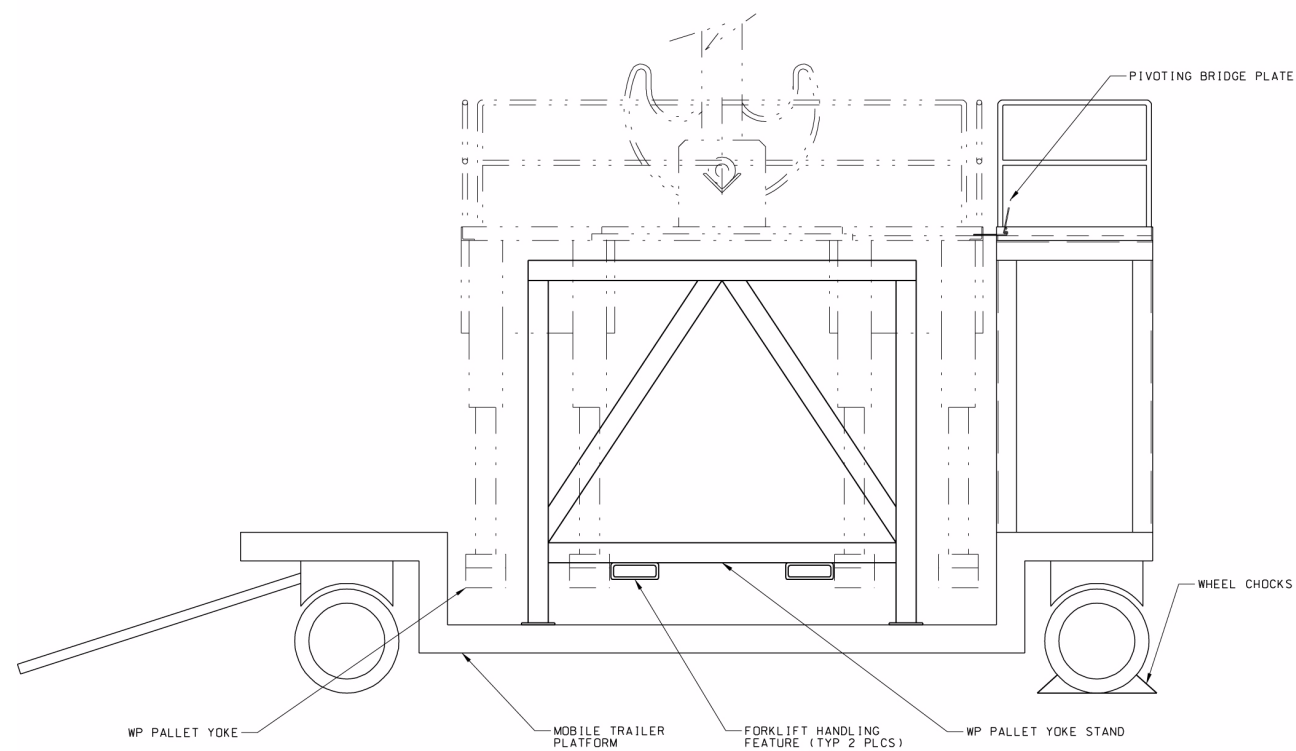

SIDE VIEW

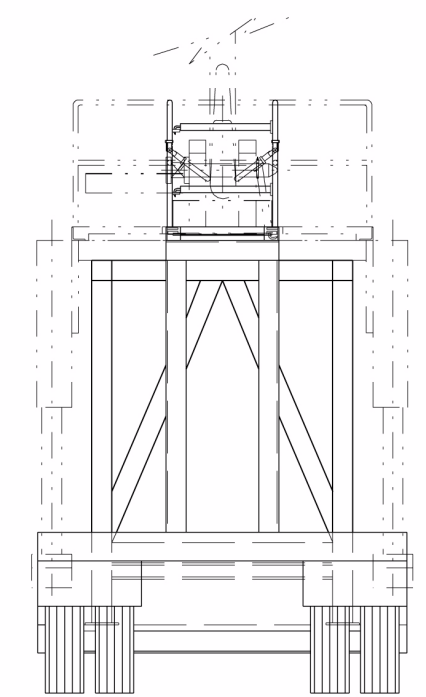

END VIEW

00249DC_LA_2277.ai

NOTE: This figure includes no SSCs that are ITS or ITWI. This equipment is used in the CRCF and IHF. WP = waste package.

Equipment Number: 060-HMP0-RK-00001, CRCF waste package pallet yoke stand; 51A-HMP0-RK-00001, IHF waste package pallet yoke stand.

Figure 1.2.4-131. Waste Package Pallet Yoke Stand Mechanical Equipment Envelope

INTENTIONALLY LEFT BLANK

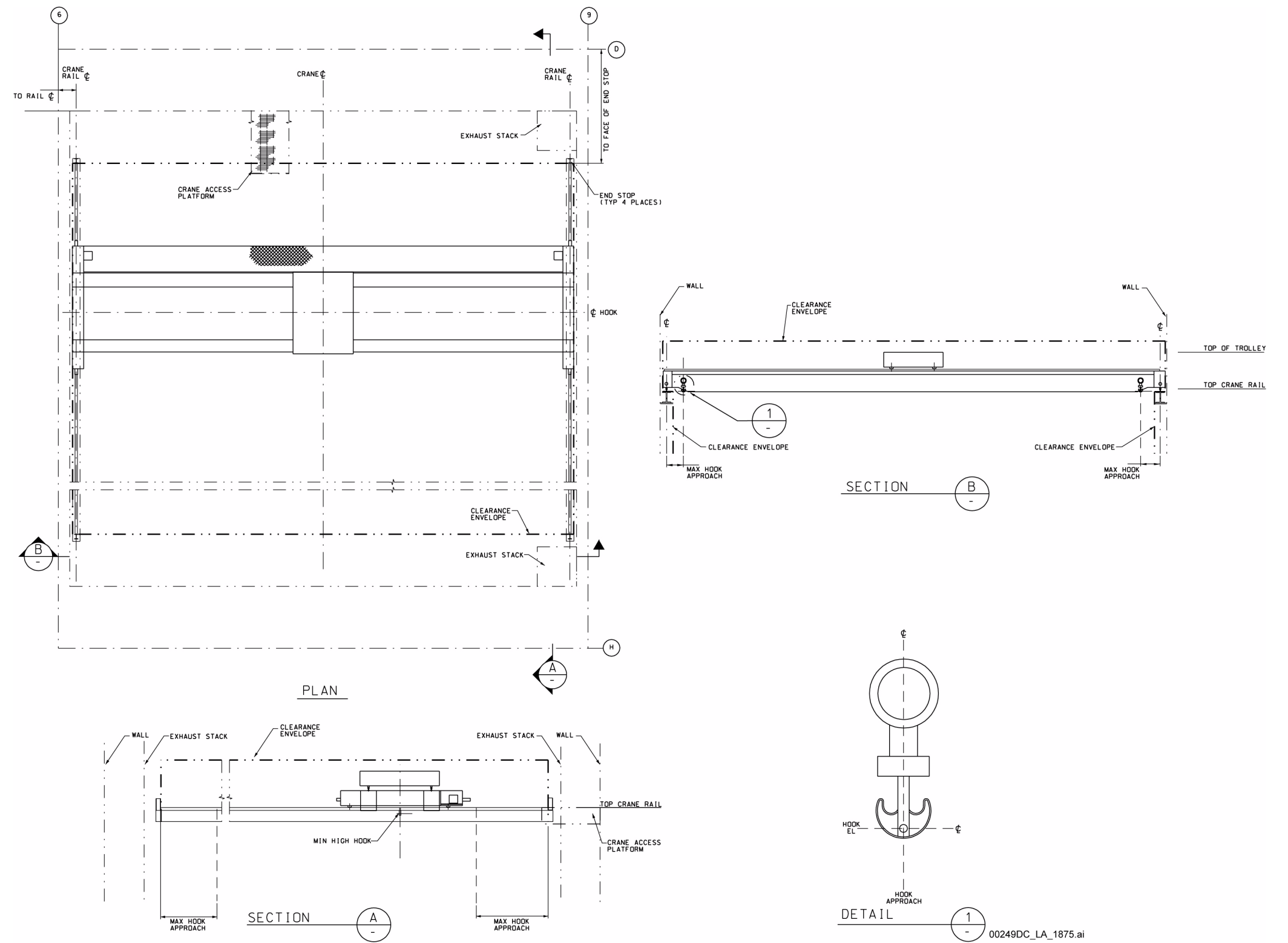

00249DC_LA_1875.ai

NOTE: This figure includes no SSCs that are ITS or ITWI.

Equipment Number: 060-HTC0-CRN-00001, CRCF canister transfer machine maintenance crane.

Figure 1.2.4-132. Canister Transfer Machine Maintenance Crane Mechanical Equipment Envelope

INTENTIONALLY LEFT BLANK

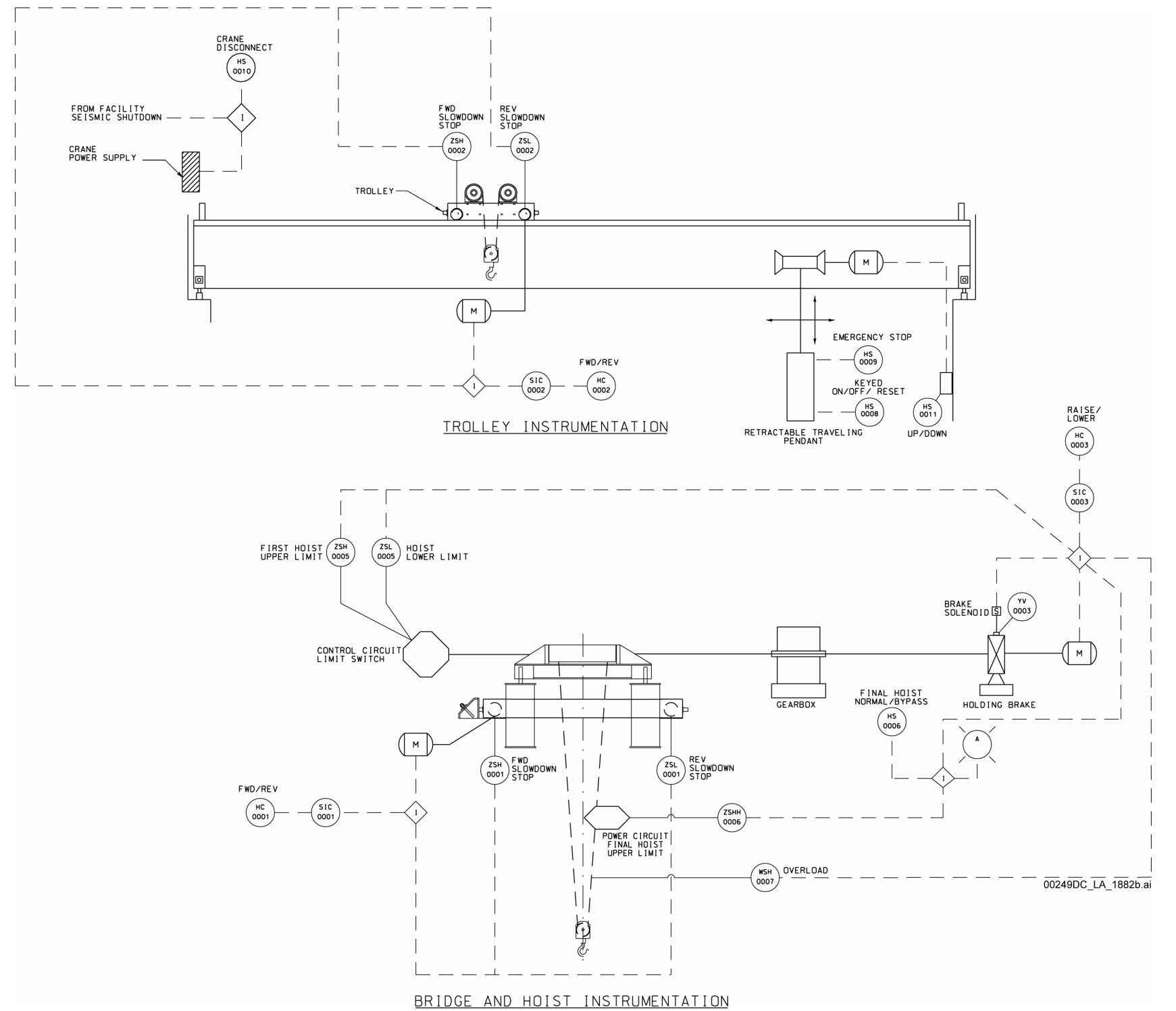

NOTE: This drawing includes the RF canister transfer machine maintenance crane that has been classified as ITS. While the RF canister transfer machine maintenance crane is ITS, the instrumentation, electrical and control devices shown herein are non-ITS and non-ITWI. The CRCF, WHF, and IHF canister transfer machine maintenance cranes and associated instrumentation, electrical, and control devices shown herein are non-ITS and non-ITWI. This equipment is used in the CRCF, IHF, WHF, and RF.

Equipment Number: Canister transfer machine maintenance cranes: 060-HTC0-CRN-00001, CRCF; 51A-HTC0-CRN-00001, IHF; 200-HTC0-CRN-00001, RF; 050-HTC0-CRN-00001, WHF.

Figure 1.2.4-133. Canister Transfer Machine Maintenance Crane Process and Instrumentation Diagram

INTENTIONALLY LEFT BLANK

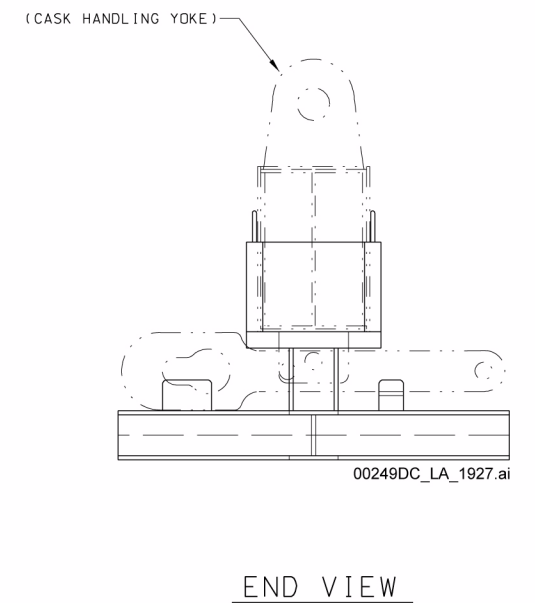
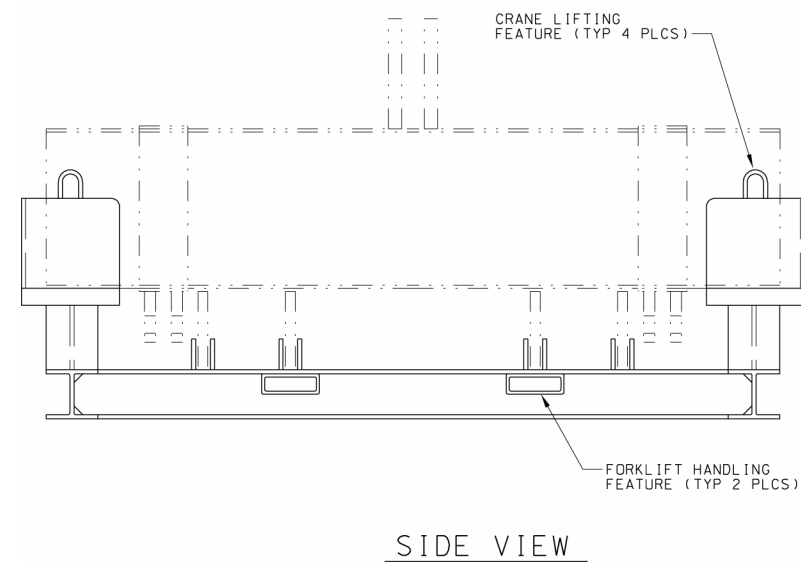
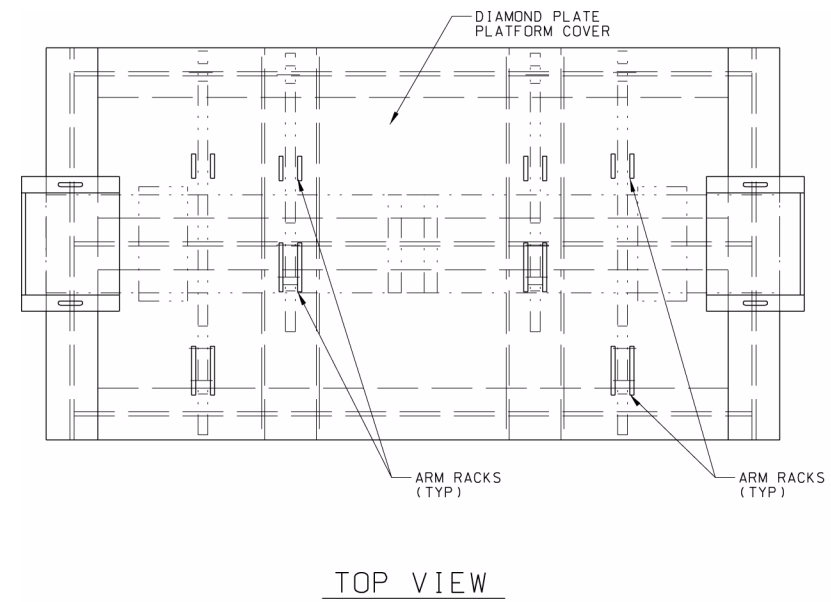

NOTE: This figure includes no SSCs that are ITS or ITWI. This equipment is used in the CRCF and RF.

Equipment Number: 060-HM00-RK-00002, CRCF cask handling yoke stand; 200-HM00-RK-00002, RF cask handling yoke stand.

Figure 1.2.4-134. Cask Handling Yoke Stand Mechanical Equipment Envelope

INTENTIONALLY LEFT BLANK

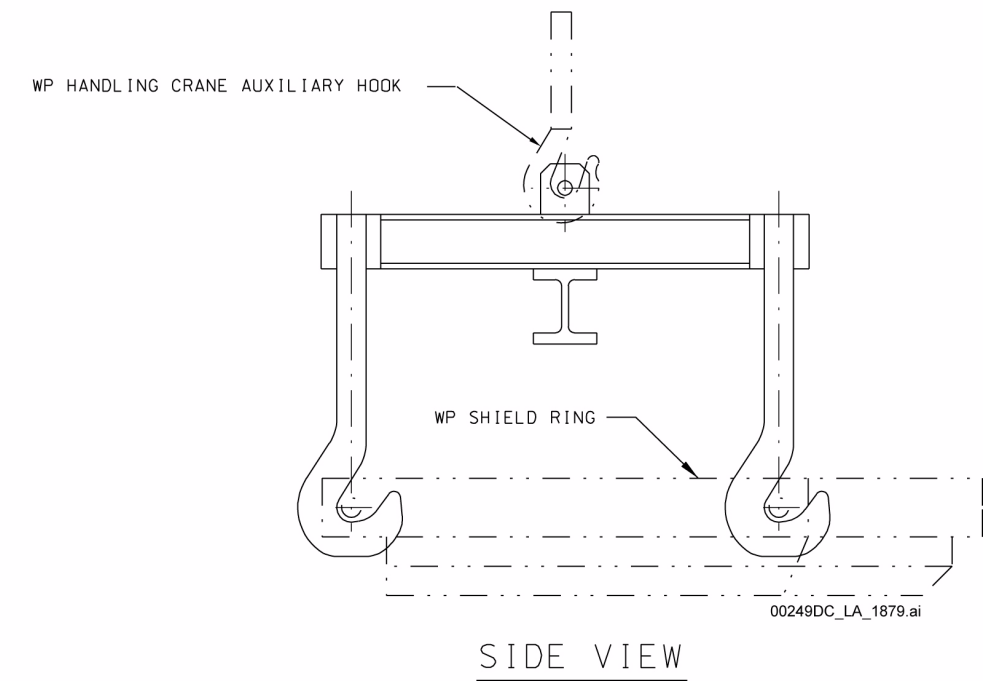
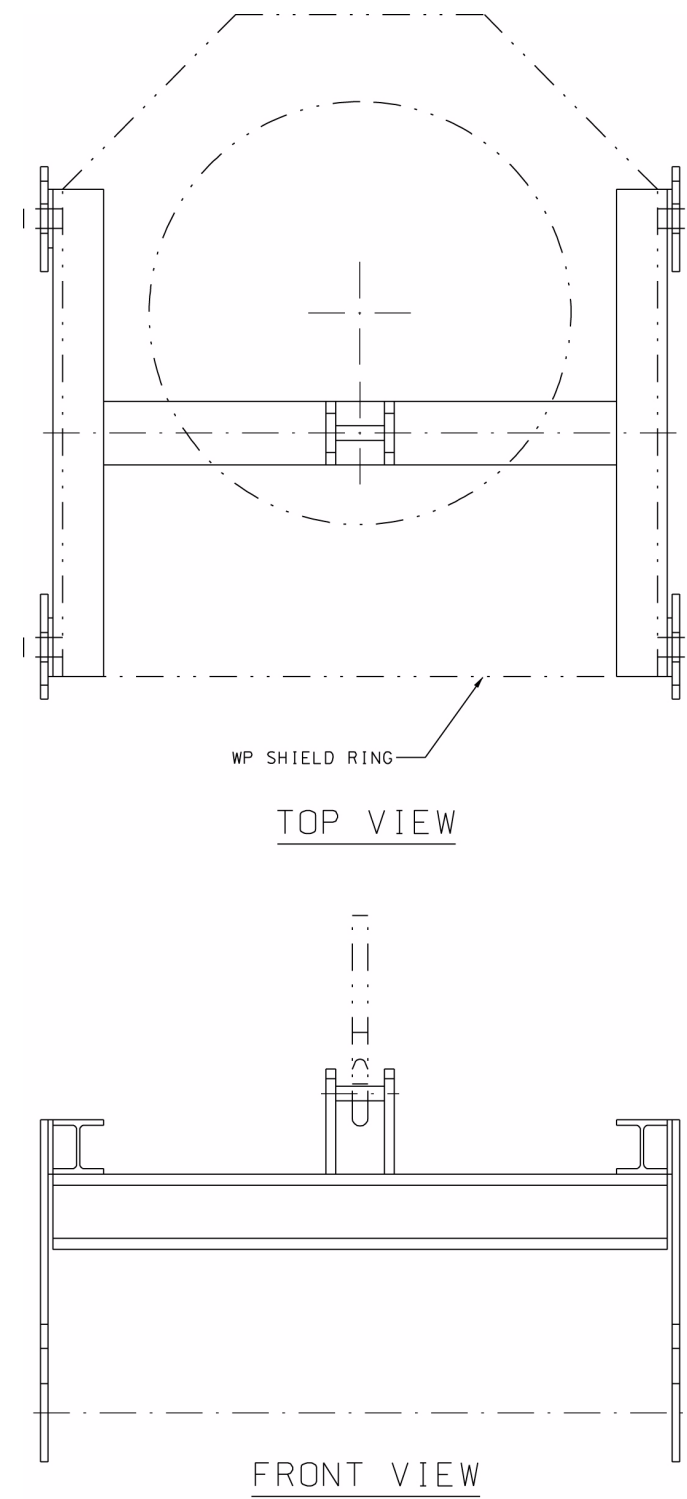

NOTE: This figure includes no SSCs that are ITS or ITWI. This equipment is used in the CRCF and IHF. WP = waste package.

Equipment Number: 060-HL00-BEAM-00001, CRCF waste package shield ring lift beam; 51A-HL00-BEAM-00001, IHF waste package shield ring lift beam.

Figure 1.2.4-135. Waste Package Shield Ring Lift Beam Mechanical Equipment Envelope

INTENTIONALLY LEFT BLANK

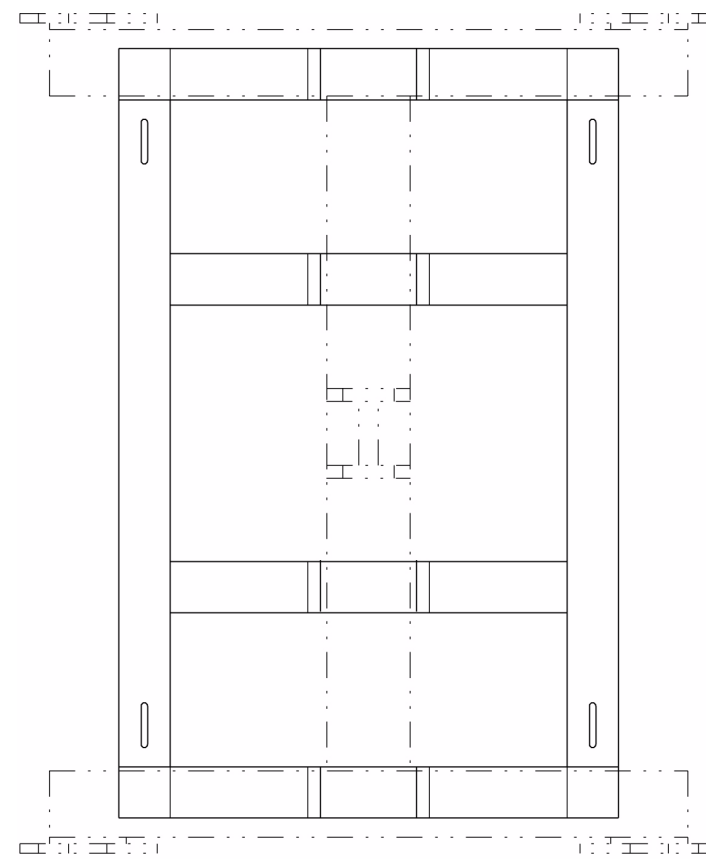

TOP VIEW

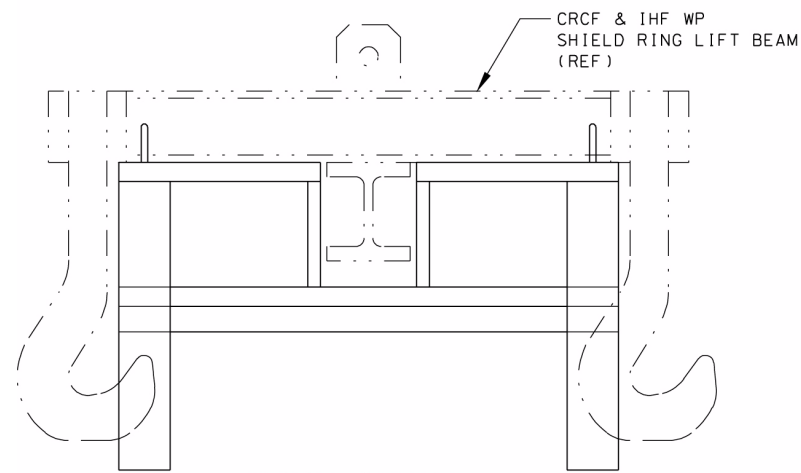

SIDE VIEW

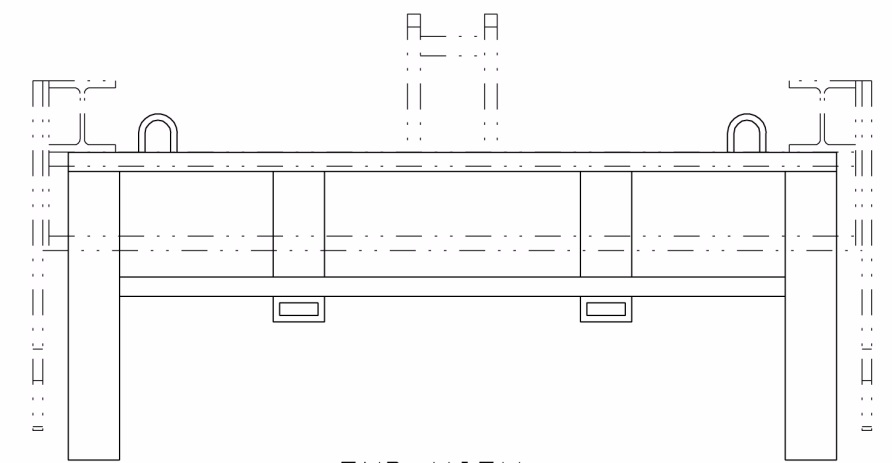

END VIEW

00249DC_LA_1880.ai

NOTE: This figure includes no SSCs that are ITS or ITWI. This equipment is used in the CRCF and IHF. WP = waste package.

Equipment Number: 060-HL00-RK-00002, CRCF waste package shield ring lift beam stand; 51A-HL00-RK-00001, IHF waste package shield ring lift beam stand.

Figure 1.2.4-136. Waste Package Shield Ring Lift Beam Stand Mechanical Equipment Envelope

INTENTIONALLY LEFT BLANK

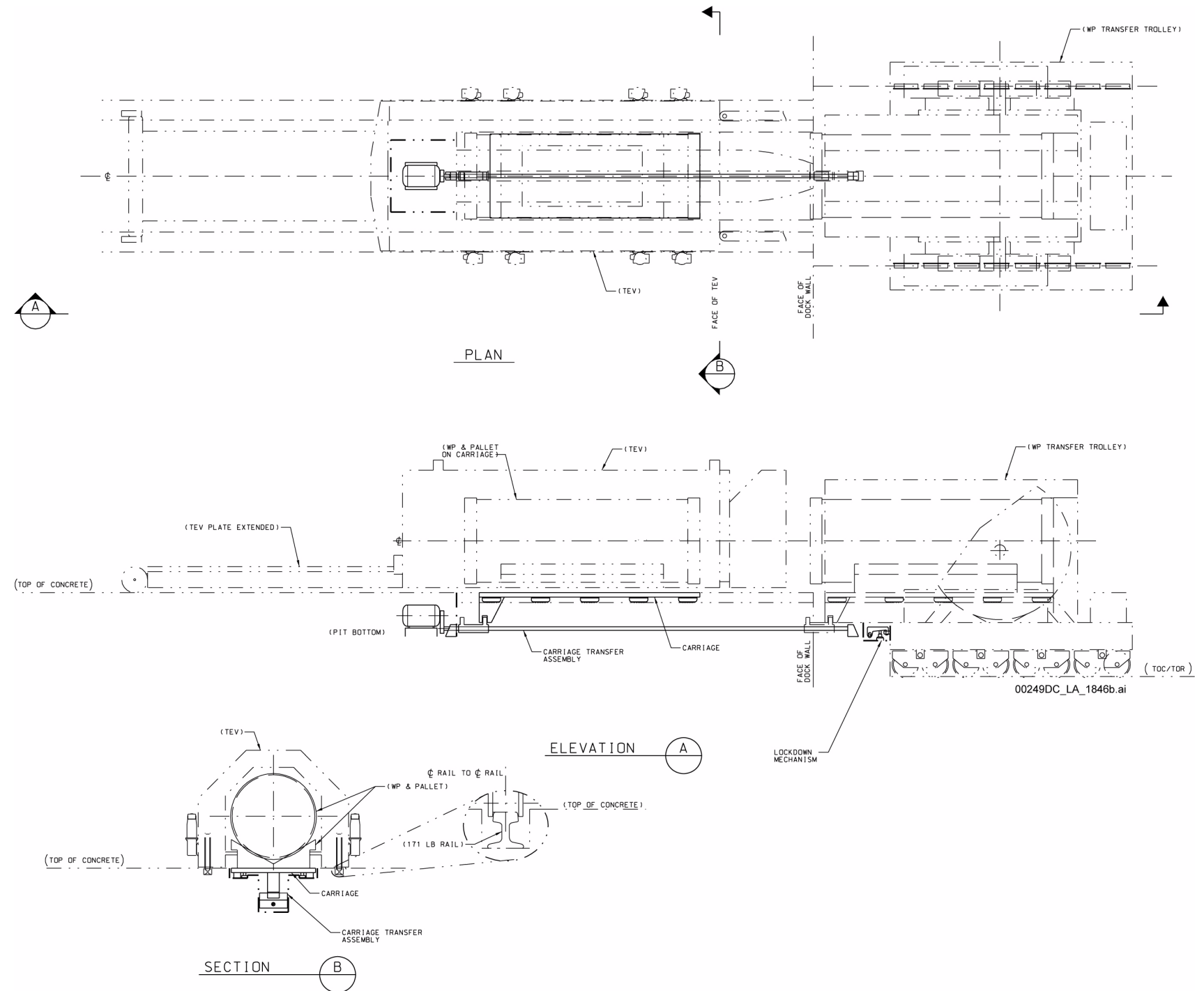

NOTE: This figure includes no SSCs that are ITS or ITWI. This equipment is used in the CRCF and IHF. WP = waste package.

Equipment Number: 060-HL00-75-00001/00002, CRCF waste package transfer carriage docking stations; 060-HL00-TRLY-00004/00005, CRCF waste package transfer carriage 1/2; 51A-HL00-75-00001, IHF waste package transfer carriage docking station; 51A-HL00-TRLY-00002, IHF waste package transfer carriage.

Figure 1.2.4-137. Waste Package Transfer Carriage Docking Station Mechanical Equipment Envelope Plan, Elevation, and Section

INTENTIONALLY LEFT BLANK

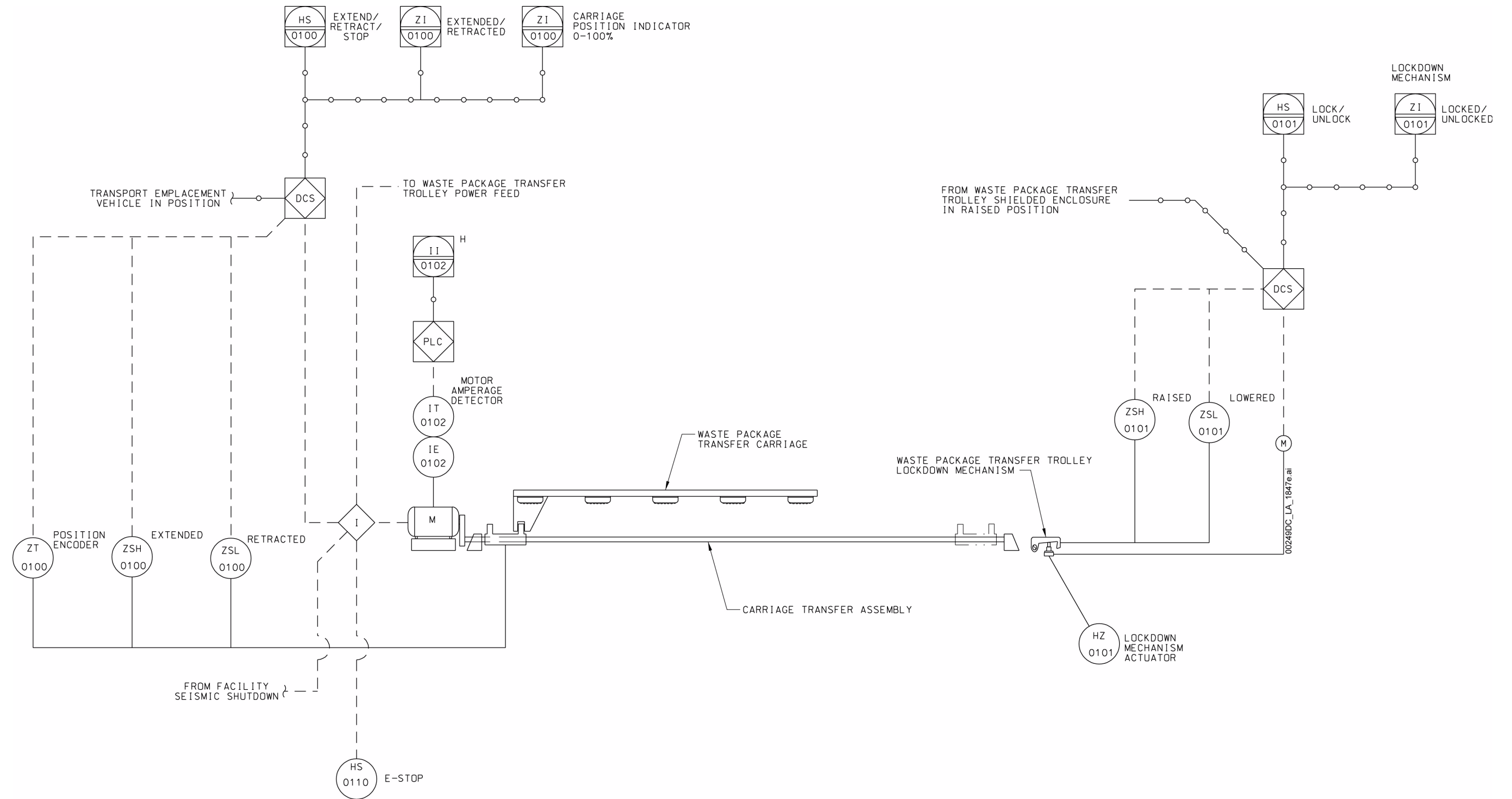

NOTE: This figure includes no SSCs that are ITS or ITWI. This equipment is used in the CRCF and IHF. A carriage transfer drive motor running signal is interlocked with the waste package transfer trolley power feed to prevent it from moving while a waste package is being transferred.

Equipment Number: 060-HL00-75-00001/00002, CRCF waste package transfer carriage docking stations; 060-HL00-TRLY-00004/00005, CRCF waste package transfer carriage 1/2; 51A-HL00-75-00001, IHF waste package transfer carriage docking station; 51A-HL00-TRLY-00002, IHF waste package transfer carriage.

Figure 1.2.4-138. Waste Package Transfer Carriage Docking Station Process and Instrumentation Diagram

INTENTIONALLY LEFT BLANK

This figure has been designated Official Use Only under the Freedom of Information Act (5 U.S.C. 552), Exemption 2, Circumvention of Statute.

This figure is included in Appendix A: Information Designated as Official Use Only, as [Figure A-38](#).

NOTE: This figure includes no SSCs that are ITS or ITWI. This equipment is used in the CRCF. Section views are shown on Sheet 2 of [Figure 1.2.4-139](#).

Equipment Number: 060-HL00-PLAT-00001/00002/00003, CRCF loadout platform 1/2/3.

Figure 1.2.4-139. Loadout Platforms Mechanical Equipment Envelope (Sheet 1 of 2)

INTENTIONALLY LEFT BLANK

This figure has been designated Official Use Only under the Freedom of Information Act (5 U.S.C. 552), Exemption 2, Circumvention of Statute.

This figure is included in Appendix A: Information Designated as Official Use Only, as [Figure A-38](#).

NOTE: This figure includes no SSCs that are ITS or ITWI. This equipment is used in the CRCF. Section locations are shown on Sheet 1 of [Figure 1.2.4-139](#). WP = waste package.

Figure 1.2.4-139. Loadout Platforms Mechanical Equipment Envelope (Sheet 2 of 2)

INTENTIONALLY LEFT BLANK

FACILITY NAME	FACILITY AREA NO.	LOADOUT PLATFORM EQUIPMENT NUMBER	SYSTEM CODE	CONTROL SWITCH	PLATFORM LIMIT SWITCHES	
					RAISED LIMIT SWITCH	LOWERED LIMIT SWITCH
CANISTER RECEIPT AND CLOSURE FACILITY (CRCF)	060	060-HL00-PLAT-00001	HL00	HS-0001	ZSH-0001	ZSL-0001
		060-HL00-PLAT-00002	HL00	HS-0002	ZSH-0002	ZSL-0002
			HL00	HS-0003	ZSH-0003	ZSL-0003
		060-HL00-PLAT-00003	HL00	HS-0004	ZSH-0004	ZSL-0004
INITIAL HANDLING FACILITY (IHF)	51A	51A-HL00-PLAT-00001	HL00	HS-0001	ZSH-0001	ZSL-0001
		51A-HL00-PLAT-00002	HL00	HS-0002	ZSH-0002	ZSL-0002

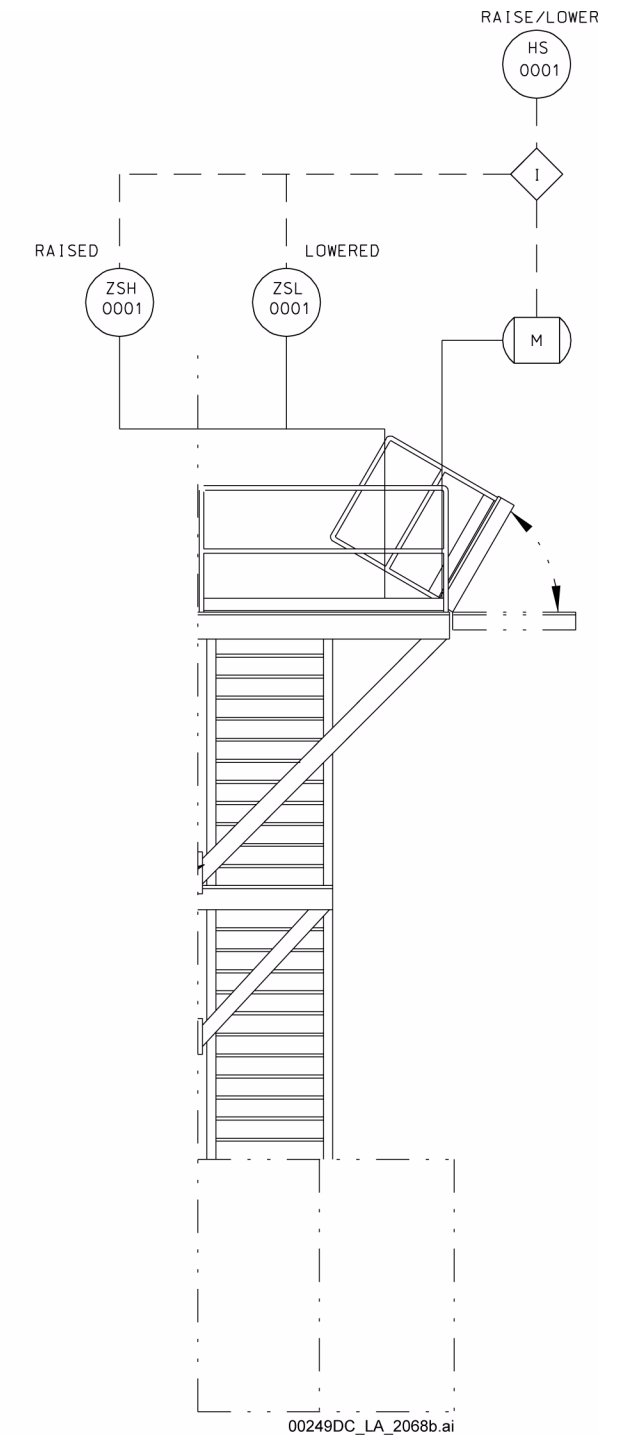
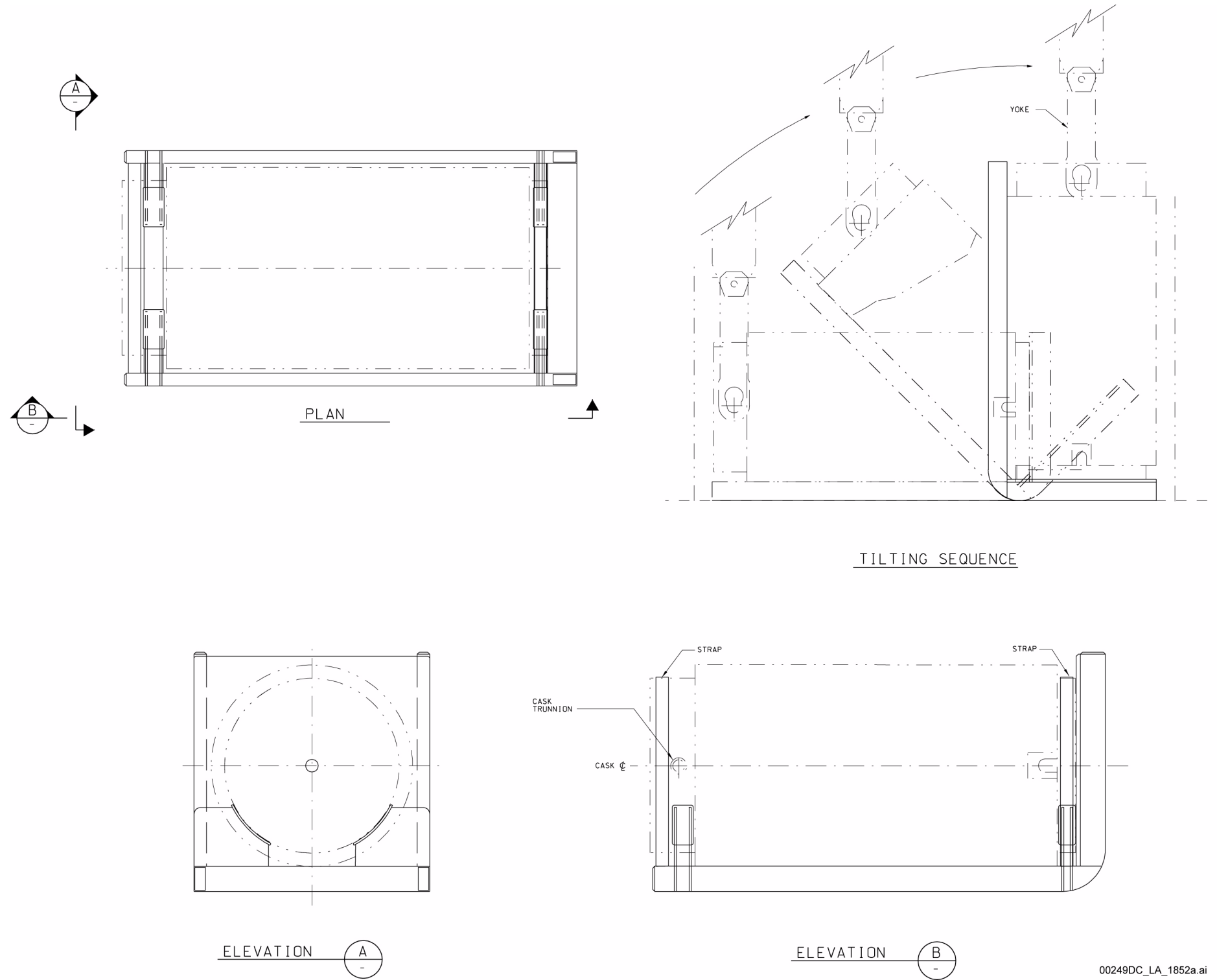

Figure 1.2.4-140. Loadout Platform Process and Instrumentation Diagram

NOTE: This figure includes no SSCs that are ITS or ITWI. This equipment is used in the CRCF and IHF.

INTENTIONALLY LEFT BLANK



00249DC_LA_1852a.ai

NOTE: This figure includes no SSCs that are ITS or ITWI. This equipment is used in the CRCF, RF, and WHF.

Equipment Number: 050-HMC0-FRM-00001, WHF cask tilting frame; 060-HMC0-FRM-00001, CRCF cask tilting frame; 200-HMC0-FRM-00001, RF cask tilting frame.

Figure 1.2.4-141. Cask Tilting Frame Mechanical Equipment Envelope

INTENTIONALLY LEFT BLANK

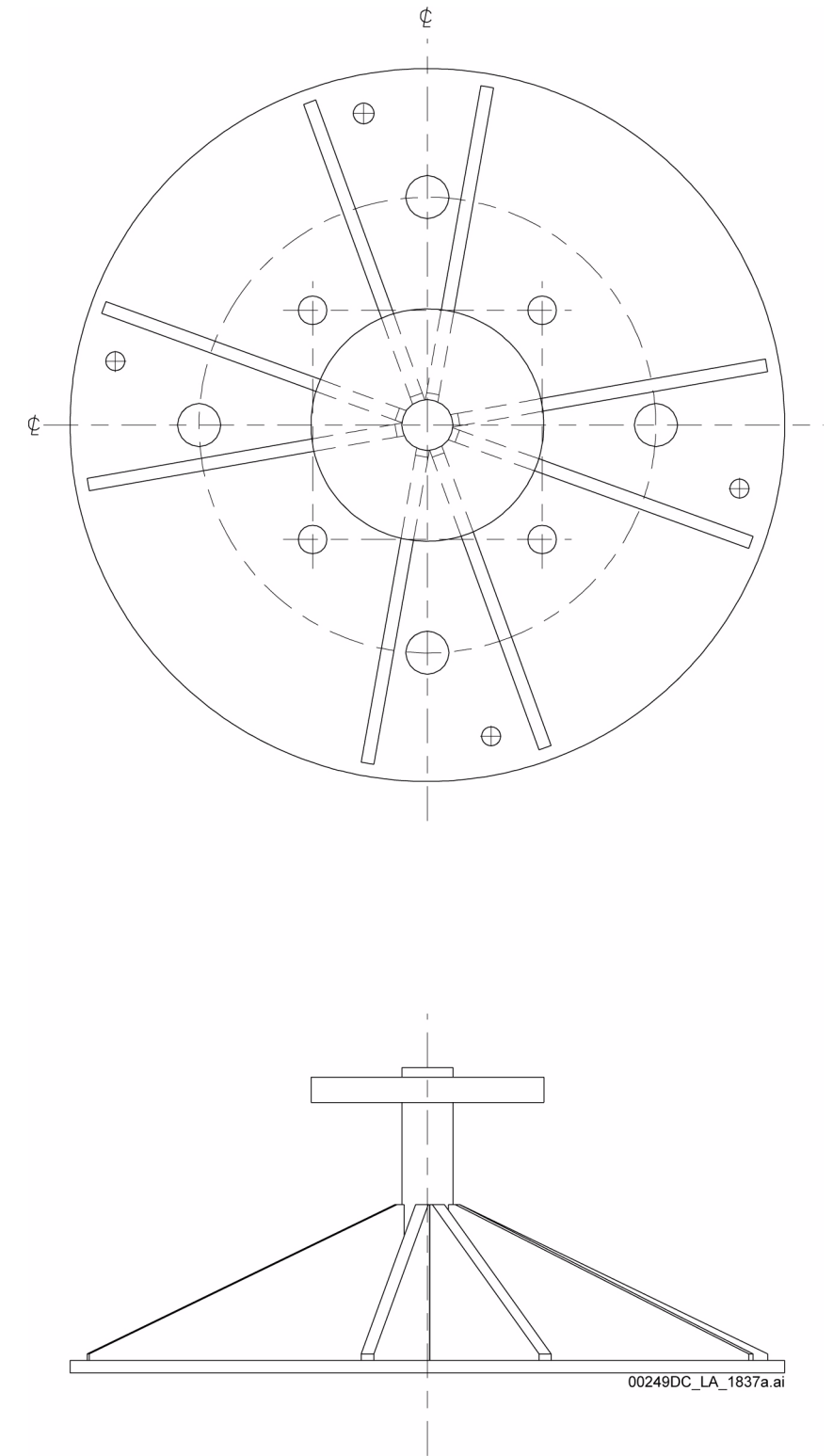

NOTE: This figure includes no SSCs that are ITS or ITWI. This equipment in the WHF is ITS, but it is non-ITS in the IHF and CRCF.

Equipment Number: 050-HMH0-HEQ-00010/00011, WHF truck cask lid adapter; 060-HMH0-HEQ-00001/00002, CRCF truck cask lid adapter; 51A-HMH0-HEQ-00001, IHF truck cask lid adapter.

Figure 1.2.4-142. Nuclear Facilities Truck Cask Lid Adapter Mechanical Equipment Envelope

INTENTIONALLY LEFT BLANK

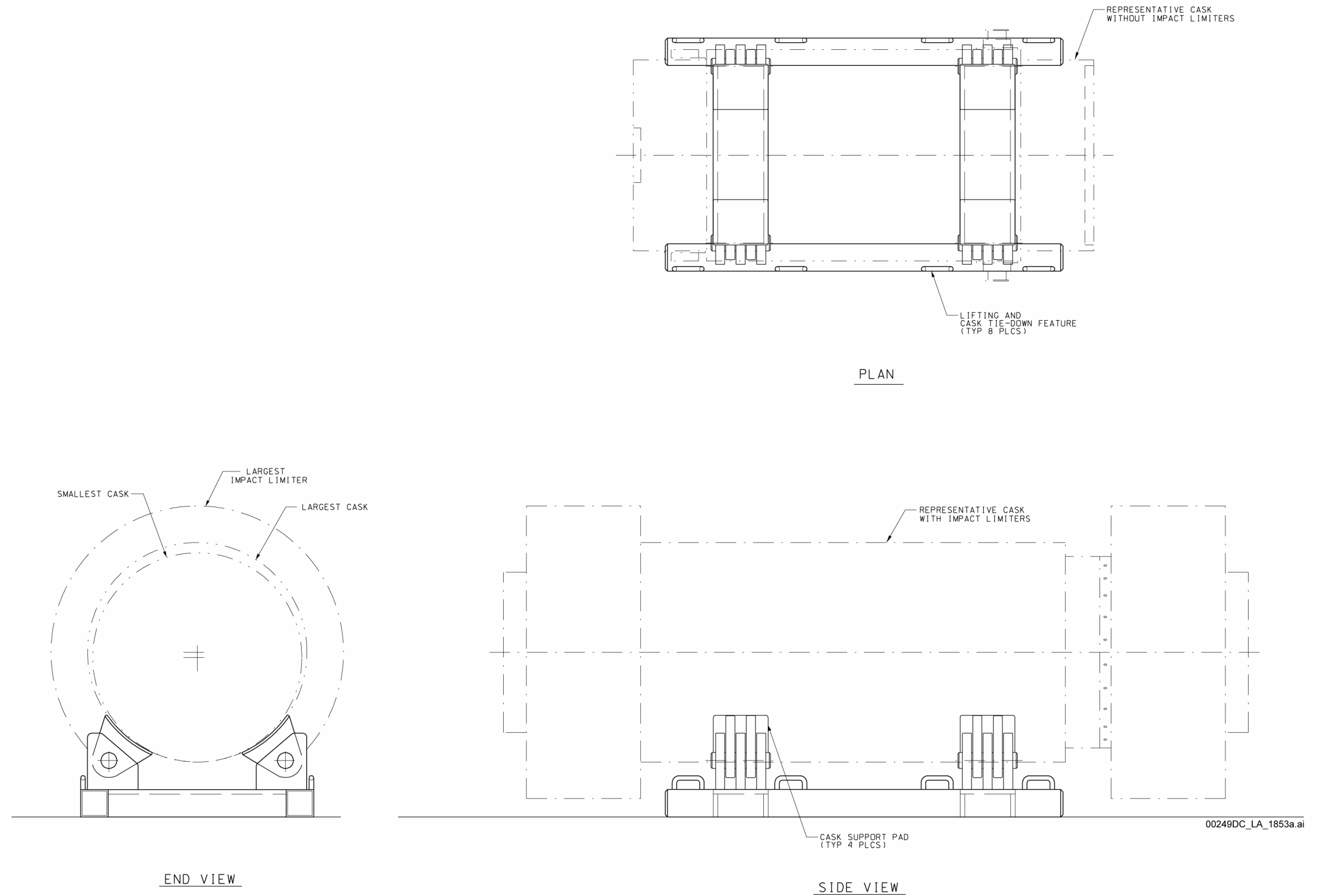

NOTE: This figure includes no SSCs that are ITS or ITWI. This equipment is used in the CRCF and RF.
Equipment Number: 200-HM00-RK-00001, RF horizontal cask stand.

Figure 1.2.4-143. Horizontal Cask Stand Mechanical Equipment Envelope

INTENTIONALLY LEFT BLANK

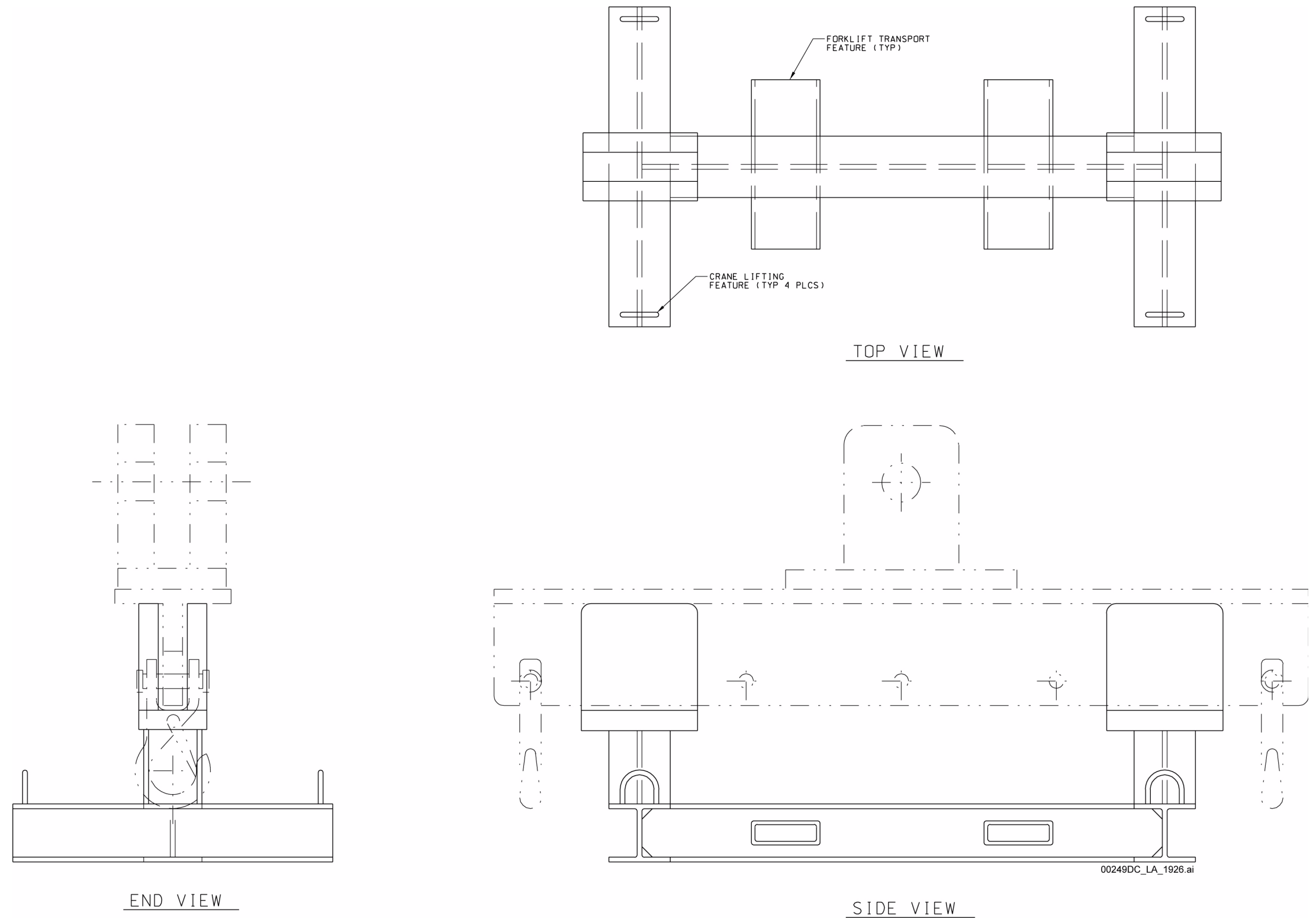

NOTE: This figure includes no SSCs that are ITS or ITWI. This equipment is used in the CRCF, RF, and WHF.

Equipment Number: 200-HMC0-RK-00001, RF horizontal lifting beam stand.

Figure 1.2.4-144. Horizontal Lifting Beam Stand
Mechanical Equipment Envelope

INTENTIONALLY LEFT BLANK

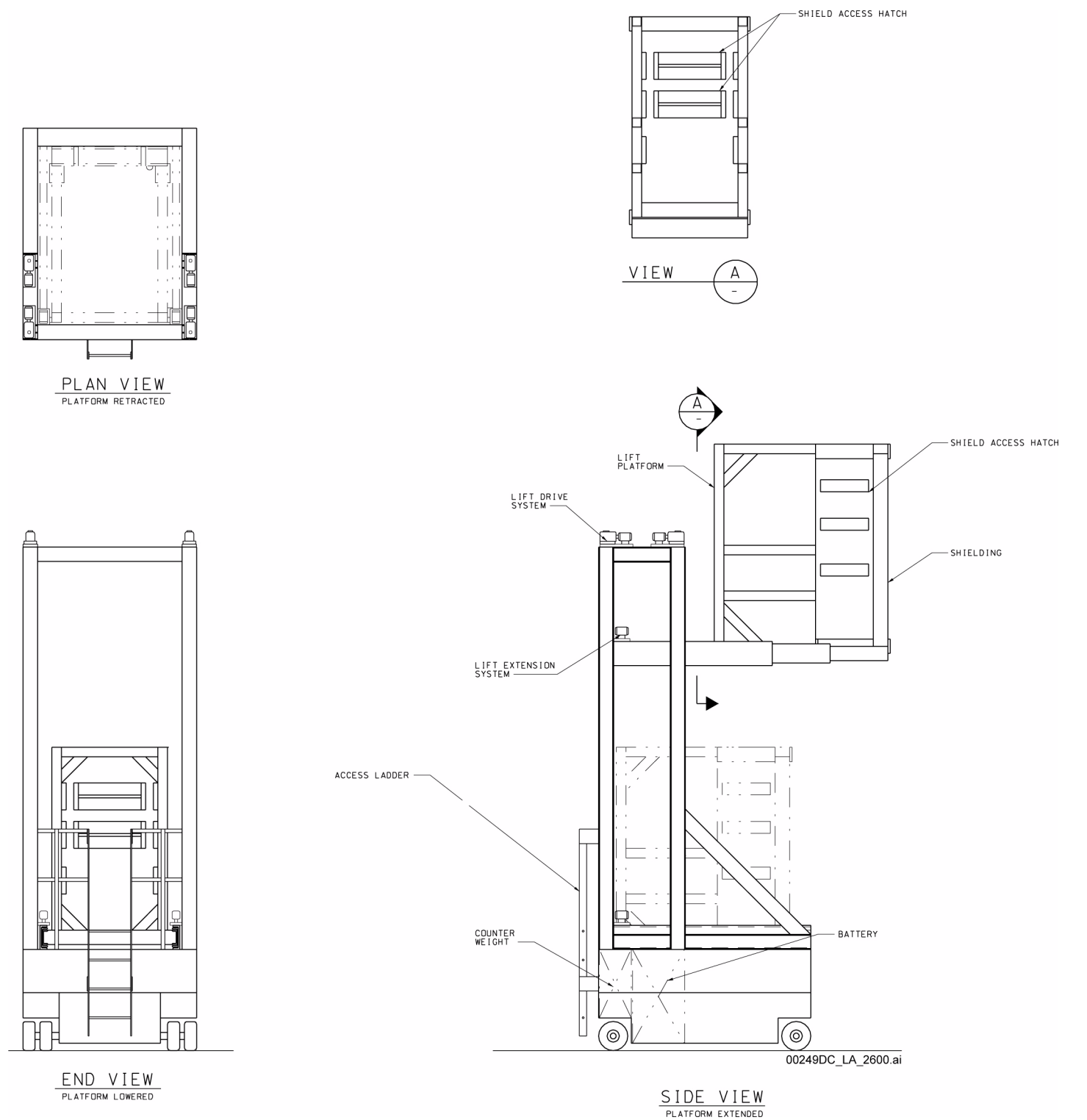

NOTE: This figure includes no SSCs that are ITS or ITWI. This equipment is used in the CRCF, RF, and WHF.

Equipment Number: 060-HM00-ELEV-00001, CRCF mobile lift; 200-HM00-ELEV-00001, RF mobile lift;
050-HM00-ELEV-00001, WHF mobile lift.

Figure 1.2.4-145. CRCF, RF, and WHF Mobile Lift Mechanical Equipment Envelope

INTENTIONALLY LEFT BLANK

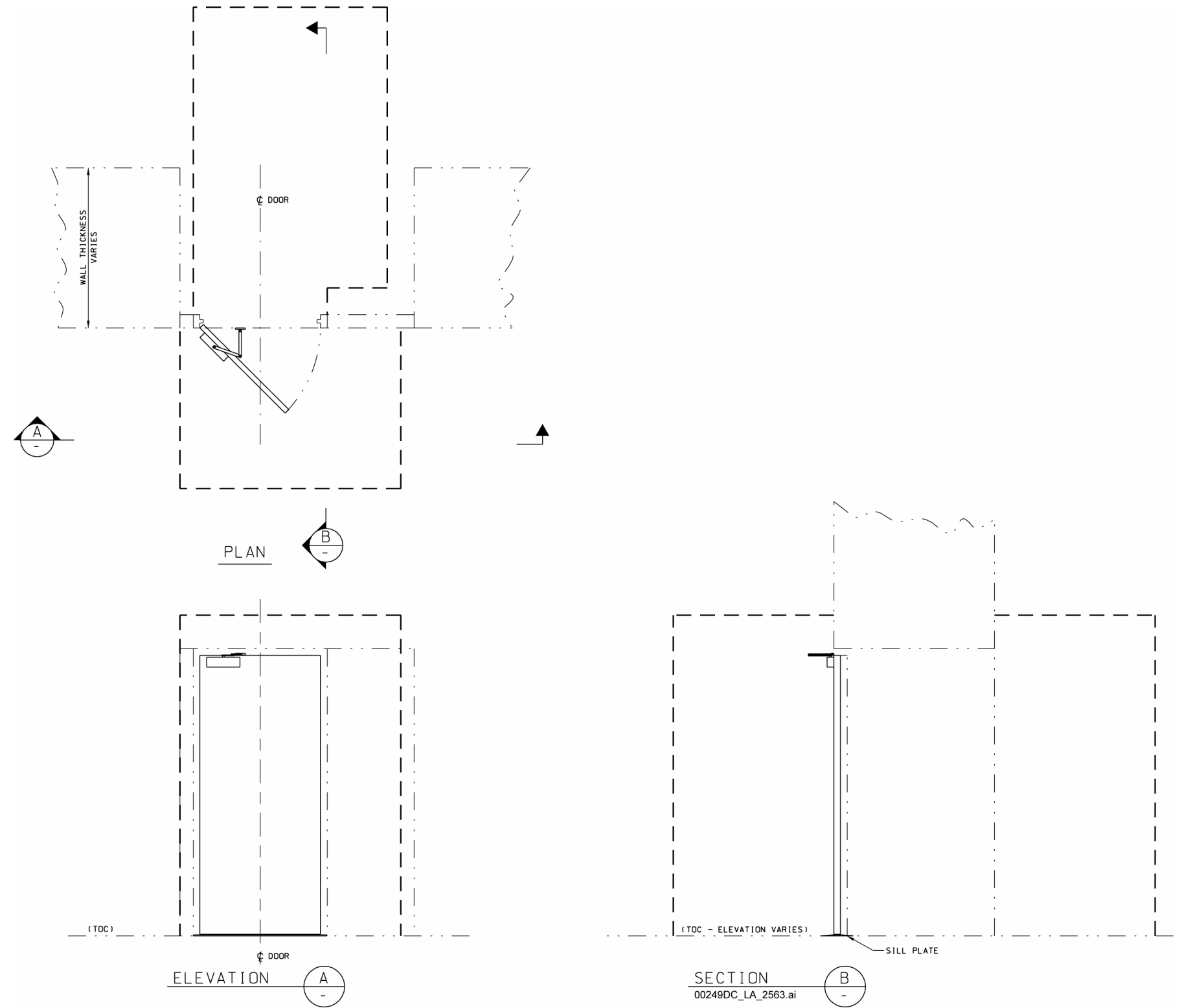

NOTE: This figure includes no SSCs that are either ITS or ITWI.

Equipment Number: 060-CR00-DR-00013/00014/00015, CRCF personnel confinement doors;
 200-RF00-DR-00004/00005/00006/00007, RF personnel confinement doors;
 050-WH00-DR-00005/00006/00007/00013/00014, WHF personnel confinement doors.

Figure 1.2.4-146. Nuclear Facilities Personnel Confinement Single Door Mechanical Equipment Envelope

INTENTIONALLY LEFT BLANK

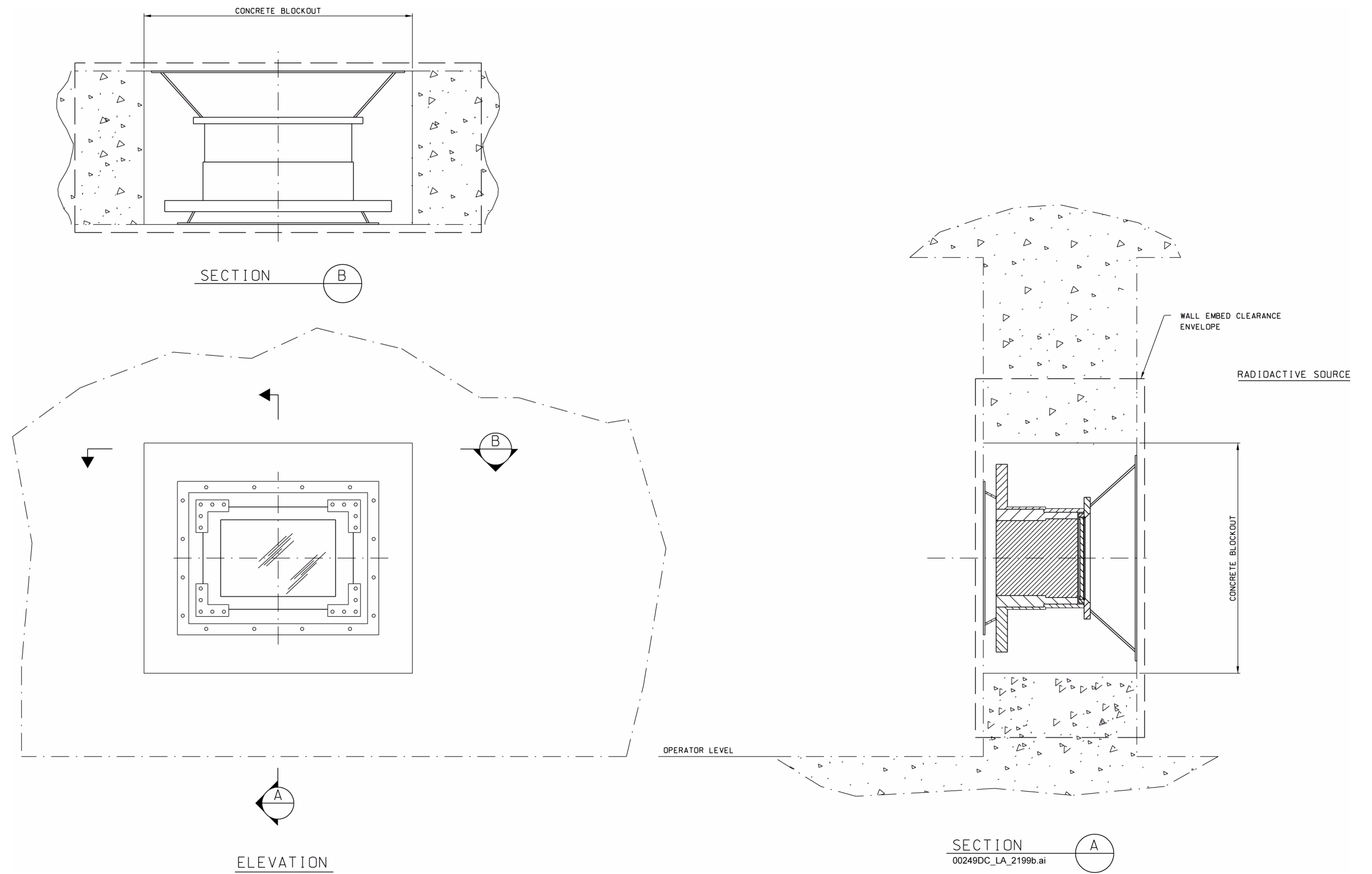

Equipment Number: 060-HTC0-OWND-00001/00002/00003/00004; 060-HW00-OWND-00001/00002;
060-HL00-OWND-00001/00002.

Figure 1.2.4-147. CRCF Shield Window Mechanical Equipment Envelope Elevation and Sections

INTENTIONALLY LEFT BLANK