

NUREG/CR-4840
SAND88-3102

Procedures for the External Event Core Damage Frequency Analyses for NUREG-1150

Prepared by
M. P. Bohn, J. A. Lambright

Sandia National Laboratories
Operated by
Sandia Corporation

Prepared for
U.S. Nuclear Regulatory Commission

AVAILABILITY NOTICE

Availability of Reference Materials Cited in NRC Publications

Most documents cited in NRC publications will be available from one of the following sources:

1. The NRC Public Document Room, 2120 L Street, NW, Lower Level, Washington, DC 20555
2. The Superintendent of Documents, U.S. Government Printing Office, P.O. Box 37082, Washington, DC 20013-7082
3. The National Technical Information Service, Springfield, VA 22161

Although the listing that follows represents the majority of documents cited in NRC publications, it is not intended to be exhaustive.

Referenced documents available for inspection and copying for a fee from the NRC Public Document Room include NRC correspondence and internal NRC memoranda; NRC Office of Inspection and Enforcement bulletins, circulars, information notices, inspection and investigation notices; Licensee Event Reports; vendor reports and correspondence; Commission papers; and applicant and licensee documents and correspondence.

The following documents in the NUREG series are available for purchase from the GPO Sales Program: formal NRC staff and contractor reports, NRC-sponsored conference proceedings, and NRC booklets and brochures. Also available are Regulatory Guides, NRC regulations in the *Code of Federal Regulations*, and *Nuclear Regulatory Commission Issuances*.

Documents available from the National Technical Information Service include NUREG series reports and technical reports prepared by other federal agencies and reports prepared by the Atomic Energy Commission, forerunner agency to the Nuclear Regulatory Commission.

Documents available from public and special technical libraries include all open literature items, such as books, journal and periodical articles, and transactions. *Federal Register* notices, federal and state legislation, and congressional reports can usually be obtained from these libraries.

Documents such as theses, dissertations, foreign reports and translations, and non-NRC conference proceedings are available for purchase from the organization sponsoring the publication cited.

Single copies of NRC draft reports are available free, to the extent of supply, upon written request to the Office of Information Resources Management, Distribution Section, U.S. Nuclear Regulatory Commission, Washington, DC 20555.

Copies of industry codes and standards used in a substantive manner in the NRC regulatory process are maintained at the NRC Library, 7920 Norfolk Avenue, Bethesda, Maryland, and are available there for reference use by the public. Codes and standards are usually copyrighted and may be purchased from the originating organization or, if they are American National Standards, from the American National Standards Institute, 1430 Broadway, New York, NY 10018.

DISCLAIMER NOTICE

This report was prepared as an account of work sponsored by an agency of the United States Government. Neither the United States Government nor any agency thereof, or any of their employees, makes any warranty, expressed or implied, or assumes any legal liability of responsibility for any third party's use, or the results of such use, of any information, apparatus, product or process disclosed in this report, or represents that its use by such third party would not infringe privately owned rights.

NUREG/CR-4840
SAND88-3102

Procedures for the External Event Core Damage Frequency Analyses for NUREG-1150

Manuscript Completed: October 1990
Date Published: November 1990

Prepared by
M. P. Bohn, J. A. Lambright

Sandia National Laboratories
Albuquerque, NM 87185

Prepared for
Division of Systems Research
Office of Nuclear Regulatory Research
U.S. Nuclear Regulatory Commission
Washington, DC 20555
NRC FIN A1384

ABSTRACT

This report presents methods which can be used to perform the assessment of risk due to external events at nuclear power plants. These methods were used to perform the external events risk assessments for the Surry and Peach Bottom nuclear power plants as part of the NRC-sponsored NUREG-1150 risk assessments.

These methods apply to the full range of hazards such as earthquakes, fires, floods, etc. which are collectively known as external events. The methods described in this report have been developed under NRC sponsorship and represent, in many cases, both advancements and simplifications over techniques that have been used in past years. They also include the most up-to-date data bases on equipment seismic fragilities, fire occurrence frequencies and fire damageability thresholds.

The methods described here are based on making full utilization of the power plant systems logic models developed in the internal events analyses. By making full use of the internal events models one obtains an external event analysis that is consistent both in nomenclature and in level of detail with the internal events analyses, and in addition, automatically includes all the appropriate random and tests/maintenance unavailabilities as appropriate.

Hallmarks of the methods described here include, first, the use of extensive computer-aided screening prior to the detailed analysis of each external event hazard to which the plant might conceivably be exposed. These screening procedures identify those external events which could contribute to the risk at the plant and thus, significantly reduce the number of events for which subsequent detailed analysis is required. Both qualitative and quantitative screening steps are applied sequentially. Secondly, for the detailed analysis of fires, floods and other location-dependent scenarios, critical area analysis techniques (heavily dependent on computer analyses) are utilized to identify those areas within the plant for which such events could have a risk significant impact on the plant. Experience has shown that the use of such critical area analysis techniques drastically reduces the number of areas which must be considered.

Taken together, these techniques provide a relatively straightforward and, in some cases, simplified set of techniques for the analysis of the full range of external events and provides for both scrutability and reproducibility of the final results. Furthermore, these techniques have been applied to a number of power plants in a considerably reduced timeframe as compared with external event analyses performed in the past.

TABLE OF CONTENTS

<u>Section</u>	<u>Page</u>
ABSTRACT	iii/iv
EXECUTIVE SUMMARY	xiv
1.0 INTRODUCTION	1-1
1.1 Scope	1-1
1.2 Overview of Procedures and Bases for Simplifications	1-1
1.3 References	1-5
2.0 PLANT VISITS AND EXTERNAL EVENT SCREENING ANALYSES	2-1
2.1 The Plant Visits	2-1
2.2 Screening of Other External Events	2-9
2.3 References	2-10
3.0 SEISMIC ASSESSMENT PROCEDURES	3-1
3.1 Overview of Seismic PRA Procedures	3-2
3.2 Determine the Earthquake Hazard	3-5
3.2.1 General Considerations	3-8
3.2.2 Procedures for Developing Hazard Curves and Spectra	3-8
3.3 Identify Accident Scenarios	3-12
3.3.1 Procedures for Initiating Events	3-12
3.3.2 Seismic Accident Sequences (Event Trees)	3-17
3.4 Seismic Failure Modes of Safety Systems (Fault Trees)	3-20
3.4.1 General Considerations	3-20
3.4.2 Procedures for Seismic Fault Trees	3-20
3.5 Seismic Response of Structures and Components	3-22
3.5.1 Response Calculation Methods Used in Past PRAs	3-22
3.5.2 Procedures for Determining Responses	3-23
3.6 Fragility Analysis	3-27
3.6.1 Procedures for Fragilities	3-27
3.6.2 Special Fragility Issues	3-32
3.7 Seismic Core Damage Frequency Computations	3-34

TABLE OF CONTENTS (Continued)

<u>Section</u>	<u>Page</u>
3.7.1 Quantitative Screening for Dominant Accident Sequences	3-34
3.7.2 Accident Sequence Quantification	3-35
3.7.3 Presentation of Results	3-42
3.8 Summary	3-43
3.9 References	3-44
4.0 FIRE ASSESSMENT PROCEDURES	4-1
4.1 Identification of Relevant Fire Zones	4-2
4.2 Initiating Event Frequencies	4-3
4.3 Determination of Fire-Induced "Off-Normal" Plant States	4-6
4.4 Detailed Description of the Screening Analysis	4-6
4.5 Fire Propagation Modeling	4-8
4.6 Barrier Failure Analysis	4-14
4.7 Recovery Analysis	4-14
4.8 Uncertainty Analysis	4-16
4.9 Conclusion	4-19
4.10 References	4-21
Appendix A Fire Event Data Tables	A-1

LIST OF FIGURES

<u>Figure</u>		<u>Page</u>
3.1	Example Seismic Hazard Curve	3-6
3.2	Example of Site Ground Motion Spectra	3-7
3.3	LLNL Surry Hazard Curve	3-10
3.4	EPRI Surry Hazard Curve	3-11
3.5	Surry Primary Coolant System Layout	3-14
3.6	Distributions of Pipe Failures Causing MLOCA and SLOCA Developed From SSRMP Piping Calculations	3-16
3.7	Initiating Event Hierarchy Tree	3-18
3.8	The Powers n_2 , n_3 , and n_4 as a Function of the Correlation Coefficient	3-39
4.1	Fire Zone Geometry Considered in the COMPBRN Code	4-9

LIST OF TABLES

<u>Table</u>		<u>Page</u>
1.1	List of External Events	1-4
2.1	Items to Examine During Plant Visit	2-2
2.2	Data Required for External Event Core Damage Frequency Assessments	2-8
3.1	Rules for Assigning Response Correlation ρ_{R1R2}	3-28
3.2	Generic Component Categories	3-30
3.3	Generic Component Fragilities	3-31
4.1	Statistical Evidence of Fires in LWRs	4-4
4.2	Modified COMPBRN III Input Parameters	4-12
4.3	Approximate Number of Barriers at a Plant	4-15
4.4	Estimates of Single Barrier Failure Rate	4-15
4.5	Automatic Suppression System Failure Rates (On Demand)	4-17

FOREWORD

This is one of numerous documents that support the preparation of the NUREG-1150 document by the NRC Office of Nuclear Regulatory Research. Figure 1 illustrates the front-end documentation. There are three interfacing programs performing this work: the Accident Sequence Evaluation Program (ASEP), the Severe Accident Risk Reduction Program (SARRP), and the Phenomenology and Risk Uncertainty Evaluation Program (PRUEP). The Zion PRA was performed at the Idaho National Engineering Laboratory and at Brookhaven National Laboratory.

Table 1 is a list of the original primary documentation and the corresponding revised documentation. There are several items that should be noted. First, in the original NUREG/CR-4550 report, Volume 2 was to be a summary of the internal analyses. This report was deleted. In Revision 1, Volume 2 now is the expert judgment elicitation covering all plants. Volumes 3 and 4 include external events analyses for Surry and Peach Bottom, respectively.

The revised NUREG/CR-4551 covers the analysis included in the original NUREG/CR-4551 and NUREG/CR-4700. However, it is different from NUREG/CR-4550 in that the results from the expert judgment elicitation are given in four parts to Volume 2 with each part covering one category of issues. The accident progression event trees are given in the appendices for each of the plant analyses.

Originally, NUREG/CR-4550 was published without the designation "Draft for Comment." Thus, the final revision of NUREG/CR-4550 is designated Revision 1. The label Revision 1 is used consistently on all volumes except Volume 2, which was not part of the original documentation. NUREG/CR-4551 was originally published as a "Draft for Comment" so, in its final form, no Revision 1 designator is required to distinguish it from the previous documentation.

There are several other reports published in association with NUREG-1150. These are:

NUREG/CR-5032, SAND87-2428, Modeling Time to Recovery and Initiating Event Frequency for Loss of Off-site Power Incidents at Nuclear Power Plants, R. L. Iman and S. C. Hora, Sandia National Laboratories, Albuquerque, NM, January 1988.

NUREG/CR-4840, SAND88-3102, Procedures for External Event Core Damage Frequency Analyses for NUREG-1150, M. P. Bohn and J. A. Lambright, Sandia National Laboratories, Albuquerque, NM, November 1990.

SUPPORT DOCUMENTS TO NUREG - 1150

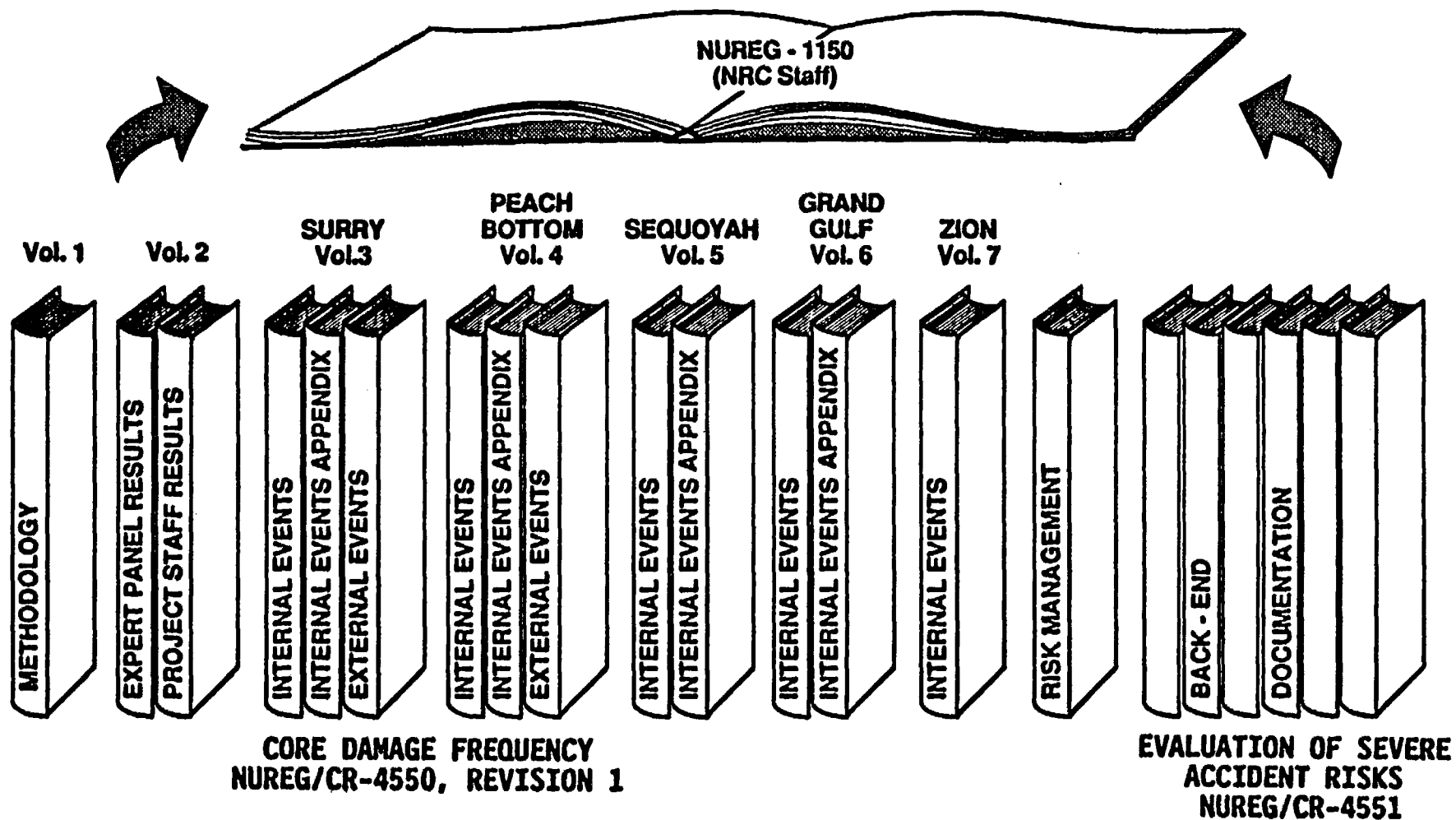

FIGURE 1. DOCUMENTATION FOR NUREG-1150.

Table 1.
NUREG-1150 Analysis Documentation

Original Documentation

NUREG/CR-4550
Analysis of Core Damage Frequency
From Internal Events

- Volume 1 Methodology
- 2 Summary (Not Published)
- 3 Surry Unit 1
- 4 Peach Bottom Unit 2
- 5 Sequoyah Unit 1
- 6 Grand Gulf Unit 1
- 7 Zion Unit 1

NUREG/CR-4551
Evaluation of Severe Accident
Risks and the Potential for
Risk Reduction

- Volume 1 Surry Unit 1
- 2 Sequoyah Unit 1
- 3 Peach Bottom Unit 2
- 4 Grand Gulf Unit 1
- 5 Zion Unit 1

NUREG/CR-4700
Containment Event Analysis
for Potential Severe Accidents

- Volume 1 Surry Unit 1
- 2 Sequoyah Unit 1
- 3 Peach Bottom Unit 2
- 4 Grand Gulf Unit 1

Revised Documentation

NUREG/CR-4550, Revision 1
Analysis of Core Damage Frequency

- Volume 1 Methodology
- 2 Part 1 Expert Judgment Elicit. Expert Panel
- Part 2 Expert Judgment Elicit.--Project Staff
- 3 Part 1 Surry Unit 1 Internal Events
- Part 2 Surry Unit 1 Internal Events App.
- Part 3 Surry Unit 1 External Events
- 4 Part 1 Peach Bottom Unit 2 Internal Events
- Part 2 Peach Bottom Unit 2 Internal Events App.
- Part 3 Peach Bottom Unit 2 External Events
- 5 Part 1 Sequoyah Unit 1 Internal Events
- Part 2 Sequoyah Unit 1 Internal Events App.
- 6 Part 1 Grand Gulf Unit 1 Internal Events
- Part 2 Grand Gulf Unit 1 Internal Events App.
- 7 Zion Unit 1 Internal Events

NUREG/CR-4551, Evaluation
of Severe Accident Risks

- Volume 1 Methodology
- 2 Part 1 Expert Judgment Elicit.--In-vessel
- Part 2 Expert Judgment Elicit.--Containment
- Part 3 Expert Judgment Elicit.--Structural
- Part 4 Expert Judgment Elicit.--Source-Term
- Part 5 Expert Judgment Elicit.--Supp. Calc.
- Part 6 Expert Judgment Elicit.--Proj. Staff
- Part 7 Expert Judgment Elicit.--Supp. Calc.
- Part 8 Expert Judgment Elicit.--MACCS Input
- 3 Part 1 Surry Unit 1 Anal. and Results
- Part 2 Surry Unit 1 Appendices
- 4 Part 1 Peach Bottom Unit 2 Anal. and Results
- Part 2 Peach Bottom Unit 2 Appendices
- 5 Part 1 Sequoyah Unit 2 Anal. and Results
- Part 2 Sequoyah Unit 2 Appendices
- 6 Part 1 Grand Gulf Unit 1 Anal. and Results
- Part 2 Grand Gulf Unit 1 Appendices
- 7 Part 1 Zion Unit 1 Anal. and Results
- Part 2 Zion Unit 1 Appendices

NUREG/CR-4772, SAND86-1996, Accident Sequence Evaluation Program Human Reliability Analysis Procedure. A. D. Swain III, Sandia National Laboratories, Albuquerque, NM, February 1987.

NUREG/CR-5263, SAND88-3100, The Risk Management Implications of NUREG-1150 Methods and Results. A. C. Camp et al., Sandia National Laboratories, Albuquerque, NM, December 1988.

A Human Reliability Analysis for the ATWS Accident Sequence with MSIV Closure at the Peach Bottom Atomic Power Station. A-3272, W. J. Luckas, Jr. et al., Brookhaven National Laboratory, Upton, NY, 1986.

Any related supporting documents to the back-end NUREG/CR-4551 analyses are delineated in NUREG/CR-4551. A complete list of the revised NUREG/CR-4550, volumes and parts is given below.

General

NUREG/CR-4550, Volume 1, Revision 1, SAND86-2084, Analysis of Core Damage Frequency: Methodology Guidelines for Internal Events.

NUREG/CR-4550, Volume 2, SAND86-2084, Analysis of Core Damage Frequency from Internal Events: Expert Judgment Elicitation on Internal Events Issues - Part 1: Expert Panel Results, Part 2: Project Staff Results.

Part 1 and 2 of Volume 2, NUREG/CR-4550 are bound together. This volume was not part of the original documentation and was first published in April 1989 and distributed in May 1989 with the title: Analysis of Core Damage Frequency from Internal Events: Expert Judgment Elicitation. In retrospect, a more descriptive title would be: Analysis of Core Damage Frequency: Expert Judgment Elicitation on Internal Events Issues.

SURRY

NUREG/CR-4550, Volume 3, Revision 1, Part 1, SAND86-2084, Analysis of Core Damage Frequency: Surry Unit 1 Internal Events.

NUREG/CR-4550, Volume 3, Revision 1, Part 2, SAND86-2084, Analysis of Core Damage Frequency: Surry Unit 1 Internal Events Appendices.

NUREG/CR-4550, Volume 3, Revision 1, Part 3, SAND86-2084, Analysis of Core Damage Frequency: Surry Unit 1 External Events.

Peach Bottom

NUREG/CR-4697, EGG-2464, Containment Venting Analysis for the Peach Bottom Atomic Power Station, D. J. Hansen et al., Idaho National Engineering Laboratory (EG&G Idaho, Inc.) February 1987.

NUREG/CR-4550, Volume 4, Revision 1, Part 1, SAND86-2084, Analysis of Core Damage Frequency: Peach Bottom Unit 2 Internal Events.

NUREG/CR-4550, Volume 4, Revision 1, Part 2, SAND86-2084, Analysis of Core Damage Frequency: Peach Bottom Unit 2 Internal Events Appendices.

NUREG/CR-4550, Volume 4, Revision 1, Part 3, SAND86-2084, Analysis of Core Damage Frequency: Peach Bottom Unit 2 External Events.

Sequoyah

NUREG/CR-4550, Volume 5, Revision 1, Part 1, SAND86-2084, Analysis of Core Damage Frequency: Sequoyah Unit 1 Internal Events.

NUREG/CR-4550, Volume 5, Revision 1, Part 2, SAND86-2084, Analysis of Core Damage Frequency: Sequoyah Unit 1 Internal Events Appendices.

Grand Gulf

NUREG/CR-4550, Volume 6, Revision 1, Part 1, SAND86-2084, Analysis of Core Damage Frequency: Grand Gulf Unit 1 Internal Events.

NUREG/CR-4550, Volume 6, Revision 1, Part 2, SAND86-2084, Analysis of Core Damage Frequency: Grand Gulf Unit 1 Internal Events Appendices.

Zion

NUREG/CR-4550, Volume 7, Revision 1, EGG-2554, Analysis of Core Damage Frequency: Zion Unit 1 Internal Events.

EXECUTIVE SUMMARY

The U.S. Nuclear Regulatory Commission (NRC) is sponsoring probabilistic risk assessments (PRAs) of five operating commercial nuclear power plants as part of a major update of the understanding of risk as provided by the original WASH-1400 risk assessments (Ref. 1). Collectively, the five risk assessments are known as the NUREG-1150 risk assessments (Ref. 2). In contrast to the WASH-1400 studies, at least two of the NUREG-1150 risk assessments have included a detailed analysis of risks due to earthquakes, fires, floods etc. which are collectively known as "external events." This report summarizes the methods used in the external event analyses for NUREG-1150, and presents these methods in terms of recommendations for future applications.

The two NUREG-1150 plants for which external events have been considered (to date) are Surry and Peach Bottom, a pressurized water reactor (PWR) and boiling water reactor (BWR), respectively. The external event analyses (through core damage frequency calculations) for these two plants were performed using the methods in this report.

In keeping with the philosophy of the internal events analyses for NUREG-1150, which are intended to be "smart" PRAs making full use of all insights gained during the past ten years developments in risk assessment methodologies, the corresponding external event analyses were also performed by newly developed methods. These methods have been developed at Sandia National Laboratories (SNL) under the sponsorship of the NRC's Office of Nuclear Regulatory Research as part of their Dependent Failure Methodology Development Program. The first application of these new methods was in the seismic analyses of six power plants as part of the NRC's program for the resolution of Unresolved Safety Issue A-45, Adequacy of Decay Heat Removal Systems (Ref. 3). Extension of these methods to fire, flood, etc. has been continuing during the past two years.

In contrast to most past external event analyses, wherein rudimentary systems models were developed reflecting each external event under consideration, the NUREG-1150 analyses are based on the availability of the full internal event PRA systems models (event trees and fault trees) and make use of extensive computer-aided screening to reduce them to the accident sequence cut sets important to each external event. This provides two major advantages in that consistency and scrutability with respect to the internal events analysis is achieved, and the full gamut of random and test/maintenance unavailabilities are automatically included, while only those probabilistically important survive the screening process. Thus, full benefit of the internal event analysis is obtained by performing the internal and external event analyses sequentially.

Each external event analysis begins with a review of the Final Safety Analysis Report (FSAR), related design documents and the plant safety systems descriptions in the internal events PRA documentation. Physical locations of important components are determined from the general arrangement drawings. The plant fire protection Appendix R submittals

form the basis for the initial identification of fire and flood zone boundaries and barriers. Shortly thereafter, a plant visit of 2 to 3 days duration is made involving an integrated team of six to eight specialists in the various external events and at least one systems analyst from the internal events PRA team.

The initial step in the external events analysis consists of a screening analysis of essentially all external events to which the plant could conceivably be exposed. Many hazards can be excluded from further analysis by virtue of their inapplicability to the site in question. Others can be excluded from consideration based on the fact that these events are a subset of more general events already considered (and excluded) in the plant design safety analysis events as documented in the plant FSAR. Finally, a number of the remaining events can usually be excluded based on simple quantitative screening arguments (often based on the frequency of the hazard itself) which demonstrate that the event in question could contribute an increment to core damage frequency substantially less than that already computed for the internal events analysis for the plant. The use of these screening techniques reduces the number of events which must be considered subsequently. In general, both fire and seismic events would always be considered for any plant. Other events are included only if they cannot be screened from further consideration.

The seismic assessment is the critical path item due to the time required to assemble the structural drawings and models. To determine the important buildings' responses to an earthquake, a best estimate structural dynamic response calculation is made by coupling design beam-element models with a realistic model of the underlying soil column and using a soil-structure interaction code. The result is statistical distributions for floor slab accelerations, and estimates of variability and correlations. Component fragilities are obtained either from a generic data base or derived on a plant-specific basis as determined on the initial plant walkdown. A generalized probabilistic screening method is used to determine important cut sets while allowing for explicit incorporation of correlation. The seismic hazard is obtained from the results of two extensive seismic hazard characterization studies, one sponsored by the NRC and the other by the Electric Power Research Institute (EPRI). The hazard curve family, the seismic responses and the seismic fragilities are then combined and utilized with a Monte Carlo analysis to obtain mean frequencies of the accident sequences and core damage as well as uncertainties associated with these mean frequencies.

The fire and internal flooding analysis tasks proceed in a parallel fashion. Fire initiator frequencies are obtained from a historical fire occurrence data base developed at Sandia National Laboratories. Partitioning of building fire frequencies down to sub-area frequencies is based on cable loading, electrical cabinet distributions and transient combustible estimates based on walkdown observations and a transient

combustible data base developed at SNL. Component damage temperatures (rather than auto-ignition temperatures) are based on SNL fire tests. A compartment fire growth code is used to predict component temperatures in fire areas where fire growth and equipment separation are important considerations. Critical area analyses using the SETS code provides accident sequence cut sets for quantification, including barrier failure and random failures as appropriate. A fire detection/ suppression histogram developed at SNL is used to incorporate fire fighting timing into the analysis.

Similar approaches are used for internal and external floods, tornadoes, winds, etc. A major economy is achieved by analyzing fire and flood events together and seismic, wind and tornado events together due to the commonality of the analysis processes. For example, it is a minor task to extend the seismic fragility derivations to be applicable to wind fragilities. Similar economies arise in the screening steps for fire and flood.

Taken together, the methods presented in this report present a straightforward and often simplified approach to the analysis of external events. The methods described enhance both the scrutability and reproducibility of each individual analysis. Further, the manner of displaying the results lends itself to enabling the reader to reproduce point estimate calculations and hence, understand both the input to the analysis as well as important aspects which lead to the final result. Finally, since these techniques are based on the internal events system analysis models, the results are consistent both in form and nomenclature with the internal events analysis and hence, the accident scenario results can be compared with those from the internal events analysis in a relatively simple fashion. Finally experience has shown that these techniques can be applied at a considerable savings in time and cost over similar analyses performed in the past.

References

1. U.S. Nuclear Regulatory Commission, Reactor Safety Study: An Assessment of Accident Risks in U.S. Nuclear Power Plants, WASH-1400, NUREG-75/014, 1975.
2. U.S. Nuclear Regulatory Commission, Severe Accident Risks: An Assessment for Five U.S. Nuclear Power Plants, NUREG-1150, June 1989.
3. Ericson, D. M., et al, Shutdown Decay Heat Removal Analysis: Plant Case Studies and Special Issues, NUREG/CR-5230, April 1989.

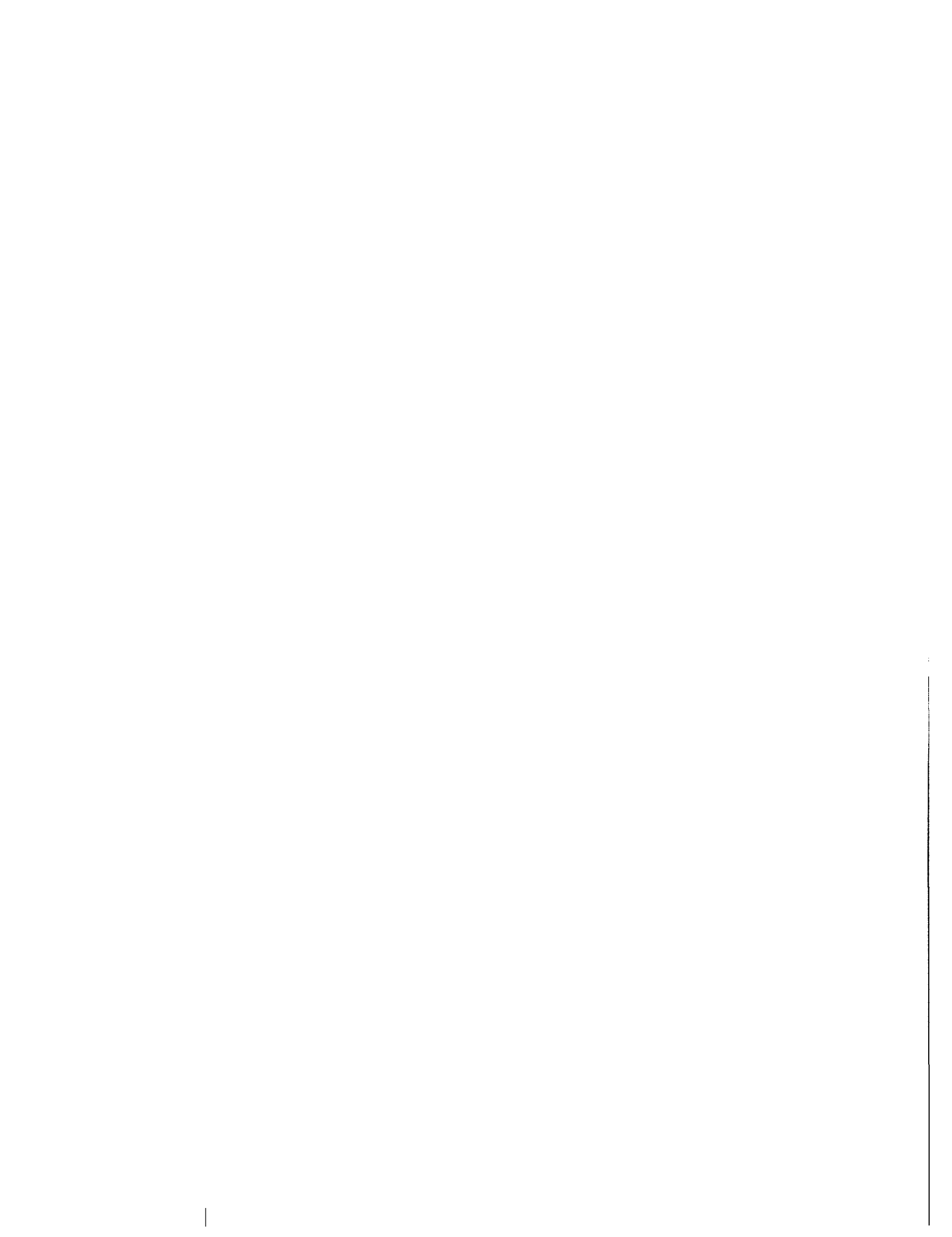

1.0 INTRODUCTION

1.1 Scope

This report summarizes the procedures used in performing external event core damage frequency (CDF) analyses for two commercial nuclear power plants (Surry and Peach Bottom) as part of the NRC-sponsored Accident Sequence Evaluation Program power plant risk reevaluations, often referred to as the NUREG-1150 program (after the principal document summarizing the results of the program). In this program, both internal and external events risk analyses are being performed. Although these risk assessments are intended to be complete and to capture the large majority of plant risk, the NUREG-1150 PRAs are intended to be "smart" PRAs making full use of past experience, generic data bases and other defensible simplifications to the maximum extent possible. However, a number of the analysis procedures described herein represent improvements in the state-of-the-art and result in enhanced defendability of the results even though the actual computational procedures have been simplified. This report describes the procedures and data bases used for performing such external event core damage frequency analyses.

Besides simplification in terms of cost reduction and minimization of execution time, the procedures presented here also meet the following additional objectives, i.e., the simplified external event CDF assessments are:

- a. Consistent with internal event failure analyses: The same event trees/fault trees and random failure data will be used.
- b. Transparent: A standard report format should enable the reader to reproduce most of the results.
- c. Realistic: Best estimate data and models will be used as much as possible. All important plant specific failure modes will be analyzed.

Experience has shown that, given the availability of appropriate risk assessment personnel and cooperation of the plant owner/utility, these analyses can be completed in eight to twelve calendar months per plant. The methodology presented here is suitable for a wide range of nuclear safety applications, and is currently being applied to the resolution of several generic unresolved safety issues as part of on-going NRC programs.

1.2 Overview of Procedures and Bases for Simplifications

The procedures described in this report are based on the following general concepts:

- a. The external event analyses are based on the internal event CDF assessment plant system models and fault trees, and (other than preliminary data gathering) should not be started until the internal events systems analysis (event trees and fault trees) has been finalized.
- b. A systematic screening of the full range of external events to which the plant could conceivably be exposed (e.g., aircraft crash, external flooding, tornado, extreme wind, etc.) is performed early in the process to eliminate all unimportant hazards.
- c. A simultaneous and coordinated evaluation of all (non-negligible) external events is performed to minimize data gathering efforts and prevent duplication of effort. Also, simultaneous evaluation produces insights into hazard interactions (for example, seismic-fire interactions) not otherwise readily available.
- d. Computer-aided screening techniques and conservative failure probabilities based on generic failure data are utilized prior to any detailed component failure analysis calculations to minimize overall effort without sacrificing accuracy.

After the screening analysis of all applicable site hazards has been performed, the general steps in the CDF analysis of each remaining external event are:

- a. Determine the hazard non-exceedance frequency.
- b. Model plant and systems.
- c. Solve fault trees with screening techniques to determine non-negligible accident sequences and cut sets.
- d. Determine responses, fragilities, and correlation for each basic event in the (non-negligible) cut sets.
- e. Evaluate mean values and uncertainty distributions for all accident sequence and core damage frequencies.
- f. Perform sensitivity studies on contributors to CDF and to uncertainty.

It is only the details of the individual steps that are different for the different types of external events. They all have, in common, the internal events plant safety system logic models. These logic models are then specialized to each applicable hazard using computer-aided techniques. However, the general analysis procedure is the same for any individual event.

Table 1.1 presents a list of the external hazards which are considered for each site. Past PRA experience shows that only a very few of these are significant contributors to risk at any particular plant. In fact, all past PRAs show that the seismic and fire events are far and away the most important external event risk contributors. In addition, internal or external flooding, tornado or aircraft crashes are infrequent (and less significant) contributors. Detailed descriptions of the initial screening procedures have already been presented in an earlier report (Ref. 1). Application of these procedures to the Surry and Peach Bottom plants are given in References 2 and 3.

This report focuses on the fire and seismic procedures, for it is these events for which significant advances and simplifications have been made. If one of the "other" external events is found to be non-negligible, its effect is typically not pervasive and its impact easily modeled. In fact, the main difficulty for these "other" events is estimating the associated hazard, which is primarily a site-specific data gathering task. Detailed descriptions of procedures for such "other" events as flooding, tornadoes, etc., have been previously presented in the PRA Procedures Guide (Ref. 4). No significant simplifications were identified for the analysis of these events. Thus, it is fire and seismic methods which are the primary focus of this report. Furthermore, since good descriptions of the basic methodologies used in past seismic and fire PRAs are already available in existing documents (Refs. 4 and 5), this report focusses on the improvements and simplifications which have been developed for the seismic and fire methods, and does not attempt a tutorial presentation.

Table 1.1

List of External Events

Major PRA Consideration

Seismic
Fire
Internal Flood

Minor PRA Consideration

Lightning
Low Lake/River Level
Ice Cover
Avalanche
Forest Fire
Industrial Facility Accident
Landslide
Meteorite
Volcanic Activity
Hail

Occasional PRA Consideration

External flood
Transportation accidents
Pipe line accidents
Aircraft Impact
Extreme Winds
Tornado

1.3 References

1. Ravindra, M. K. and Banon, H., Methods for External Event Screening Quantification, NUREG/CR-4839, August 1990.
2. Bohn, M. P., et al., Analysis of Core Damage Frequency: Surry Power Station External Events, NUREG/CR-4550, Volume 3, Revision 1, Part 3, December 1990.
3. Lambright, J. A., et al., Analysis of Core Damage Frequency: Peach Bottom Unit 2 External Events, NUREG/CR-4550, Volume 4, Revision 1, Part 3, December 1990.
4. U.S. Nuclear Regulatory Commission, PRA Procedures Guide, NUREG/CR-2330, January, 1983.
5. Bohn, M. P., et al., Application of the SSMRP Methodology to the Seismic Risk at the Zion Nuclear Power Plant, Lawrence Livermore National Laboratory, Livermore, CA., NUREG/CR-3428, 1983.

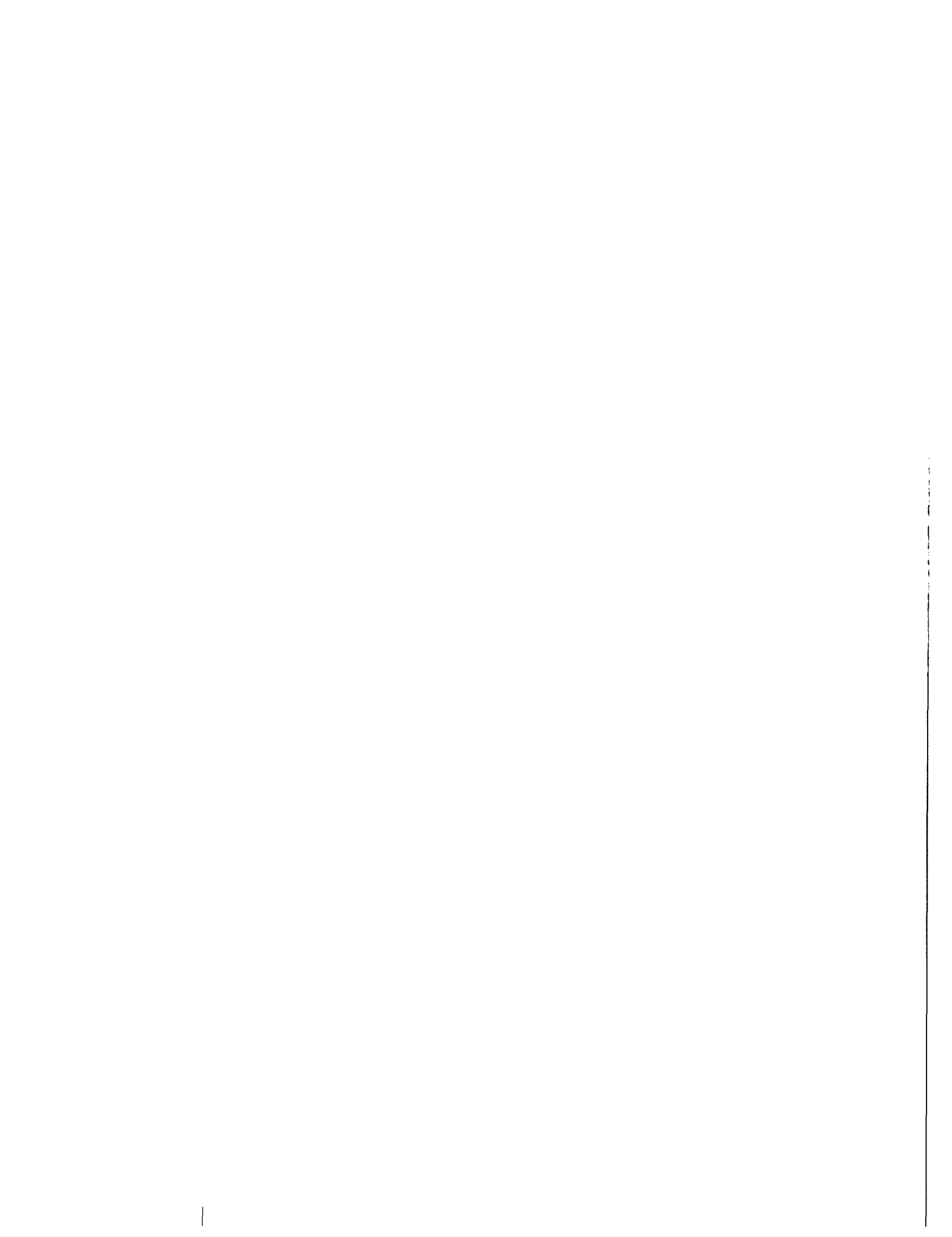

2.0 PLANT VISITS AND EXTERNAL EVENT SCREENING ANALYSES

As described in Chapter 1, a significant amount of effort is saved by performing a systematic and vigorous screening analysis for all external events which could potentially affect the plant. This screening is based on data from the Final Safety Analysis Report and related documents, historical data gathered for the site under consideration (aircraft flight frequencies, flood occurrences, etc.) and on a detailed walk-down of the plant and its surroundings. These aspects are described below.

2.1 The Plant Visits

In general, a minimum of four plant visits are required. The initial visit, involving the full team of analysts, should take place as early as possible, for it serves as the basis for the initial plant information request submittal and the initial hazard screening process. Prior to the first plant visit, the external events team should be briefed by the internal events systems analysts as to the general character of safety systems, support systems, system success criteria and critical interdependencies identified to date. In addition, applicable FSAR sections should be reviewed, and a basic set of plant general arrangement drawings should be available to each team member.

Ideally, the team would consist of the following personnel:

- Team Leader - PRA Project Manager
- Seismic Component Fragility Analyst
- Seismic Structural Fragility Analyst
- Fire PRA Analyst
- Flood PRA Analyst
- External Event Screening Analyst
- Internal Events Systems Analyst

Experience has shown that fewer team members cannot effectively assimilate the information which must be obtained on the initial visit. In addition, data questionnaires, standard data sheets and a flash camera (requiring advance plant notification) are essential. For example, a list of seismic aspects which have often been found to be risk contributors in past seismic PRAs is shown in Table 2.1. Examples of fire and flood data recording sheets are given in Figure 2.1. Tape measures, flash-lights, small rule (for scale in photographs) and a thin, flexible metal rule for checking cabinet anchorage are all necessary and should be available.

The initial walkdown would visit all areas containing safety or essential support equipment. (For these simplified analyses, an in-containment walkdown is usually not possible.) In our experience, two full days are adequate for this initial visit. At the completion of this initial visit, the following should have been obtained:

- a. A list of components suspected of being vulnerable to seismic damage and requiring site-specific fragility analysis.
- b. A list of potential secondary seismic structural failures (masonry walls, etc.) and components with the potential to be damaged by these secondary failures.

Table 2.1

Items to Examine During Plant Visit Based On
Common Vulnerabilities Found in Past Seismic PRAs

-
1. Look for masonry block walls near critical equipment, e.g., battery room enclosures, in diesel generator rooms, near AFWS pumps, etc.
 2. Examine switchgear and motor control centers (especially 4160 V emergency switchgear). Are anchorages to floor (welds or bolts) adequate? Are adjacent cabinets tied together so they would not "hammer" each other during an earthquake. Is there sufficient slack in cables exiting the cabinet?
 3. Look for suspended ceilings or hanging light fixtures in the control room or other critical areas which might fall in an earthquake.
 4. Examine pipe runs between buildings (especially between auxiliary and reactor buildings in PWRs). Estimate span length between nearest anchors in each building. Could relative motion between buildings cause large strains in pipes?
 5. Examine battery racks and batteries. Check for proper bolting to floor and walls, adequacy of rack configuration and presence of spacers between batteries.
 6. Examine important AOV's to see that sufficient slack exists in air lines and that air tanks are properly bolted down. Could valves or operators impact against adjacent pipes, walls, etc?
 7. Examine important MOV's for support of motor operators. Are electrical cables sufficiently slack? Could valves or operators impact against adjacent pipes, walls, etc.
 8. Examine cable trays. At penetrations through walls, could cables shear if trays shift? Are floor supports adequate? Are hangers and bolts or embedded anchors adequate?
 9. Examine motor-driven safety-related pumps. Are floor anchorages adequate? Is there slack in feed lines and electrical cables. Are ancillary lube oil pumps and oil tanks tied down?
 10. Examine condensate storage tank(s) and refuelling water storage tank. Are they adequately bolted to concrete pad. Are other (secondary) storage tanks (e.g., demineralized water tank, pre-treated water tank, etc.) bolted down? Is outlet pipe from CST or RWST anchored so relative motion of tank could cause large strain? Could outlet pipes fail at the building penetration due to relative motion?
-

Equipment Summary

Area _____

Bldg. _____

El. _____

Equipment	Description	Location and Evaluation Off Floor
Switchgear (4.16 KV/480 VAC)	Spray Protected? Likely to be sprayed? Penetrations sealed?	
Motor Control Center		
Motor-operated valve		
125/250 VDC Bus		
Battery		
Pump		
Fan		
Cables/ Junction/Boxes		
Fire Detectors		
Flood Alarms		
Sump Pumps		
Fire Suppression Systems	Automatic, manual?	

2-3

Figure 2.1. Sample Fire/Flood Data Recording Sheets (1 of 4)

Flood Water Sources

Area _____ Bldg _____ El. _____

Flood Sources	System	Size	Hi/Low Pressure	Orifices or Isolation Valves (#)	Description
<u>Pipes</u>					
<u>Tanks</u>					

2-4

Figure 2.1. Sample Fire/Flood Data Recording Sheets (2 of 4)

Fire Combustibles

Area _____ Bldg _____ El. _____

Fire Sources	Fixed or Transient	Location	Combustible Loading	Description

2-5

Figure 2.1. Sample Fire/Flood Data Recording Sheets (3 of 4)

Area Penetrations

Area _____ Bldg. _____ El. _____

2-6

Adjacent Areas	Floor		North		East		South		West	
	Pipe/Cable/Dampers El.	Drains/ Openings	Pipe/Cable/Dampers El.	Door Nos.	Pipe/Cable/Dampers El.	Door Nos.	Pipe/Cable/Dampers El.	Door Nos.	Pipe/Cable/Dampers El.	Door Nos.

Doors

- (a) watertight?
- (b) alarmed?
- (c) raised sill?
- (d) non-watertight-gap?

Penetrations

- (a) sealed?
- (b) unsealed

Drains

- (a) check valve or anti-siphon device?
- (b) number, size, location?

Figure 2.1. Sample Fire Flood Data Recording Sheets (4 of 4)

- c. A copy of the civil/structural drawing index for the plant (usually a 10 to 20 page list) from which needed drawings may be identified.
- d. Sketches of typical anchorage details for important tanks, heat exchanges, electrical cabinets, etc.
- e. A visual evaluation of structural connectivity of floor slabs, wall-to-ceiling connections, location of diaphragm cut-outs etc., which define load carrying paths. (These are to be compared with structural drawings later.)
- f. For each room or compartment containing essential safety equipment, an identification of fire sources (power cables, pumps, solvents etc.), locations of fire barriers, fire/smoke detectors, separation of cable trains etc. and a list of equipment in the room.
- g. For each room or compartment, an identification of flooding sources (tanks, high or low pressure piping), floor drains, sumps, flood walls, flood detectors etc.
- h. A brief list of key plant personnel or utility engineering/licensing personnel to be contacted later if specific questions arise.

As soon as possible following the initial plant visit, a list of needed drawings and documentation should be prepared and sent to the designated NRC or plant contact. A list of the information typically required is shown in Table 2.2. (Note that no emergency procedures guidelines, technical specifications, maintenance procedures, or maintenance request data are shown on this table, as this information is used primarily by the internal events analysts, and should already be available.)

At the end of the first month, a second visit by the external events screening analyst is usually required. During this visit the analyst resolves screening issues that have arisen during the preliminary screening of all external event hazards. In addition, he gathers further data required to aid in eliminating as many external events as possible and also reviews the current configuration of the plant to determine if any of the assumptions made in the FSAR have changed since the plant began operation.

A visit to the plant by fire analysis personnel is later needed to allow for cable path tracing or verification. This is usually not undertaken until the preliminary fire screening analysis has been performed based on a review of the plant fire protection Appendix R submittal.

Sometime around the fifth month, a final plant visit is made. During this final visit, initial conclusions as to plant vulnerabilities

Table 2.2

Data Required for External Event Assessments

Systems

FSAR and amendments
Fire Protection Appendix R Submittal
General arrangement drawings
Licensee event reports
PRAs performed on plant or plant systems, including
 random event fault trees
System descriptions (of type found in plant/operator
 training manuals)
Equipment lists
Fire Brigade Procedures

Site Soil Conditions

Geologic data on site
Soil configurations
Boring information
Ground water data
Static and dynamic soil properties
• Laboratory tests
• In-situ field test results

Structures

Results of dynamic seismic analysis
Dynamic design models
Structural drawings
Slab and wall geometries & reinforcement schedules
Masonry wall specifications
Steel detailing drawings
Beam/column schedules
Containment wall geometry
Concrete cylinder test results
Re-bar test results
Field-erected tank (vendor) drawings civil drawings
 showing foundation, ring girder and anchor bolt details

Equipment

Safety-Related Components List (Location and Qualification Basis)
Power and Control Cable Routing Diagrams
Ventilation Layout Drawings
Fire Protection System Component Descriptions

are reviewed with plant personnel, assumptions verified and any final data required should be obtained. Again, a two-day visit is usually adequate.

2.2 Screening of Other External Events

As mentioned in Section 1.2, the full range of possible external events is considered, but based on the FSAR and the initial plant visit, the vast majority can usually be shown to make negligible contributions to risk. General criteria for screening the various hazards have been given in the PRA Procedures Guide (Ref. 1):

An external event is excluded if:

- a. The event is of equal or lesser damage potential than the events for which the plant has been designed. This requires an evaluation of plant design bases in order to estimate the resistance of plant structures and systems to a particular external event. For example, it is shown by Kennedy, Blejwas and Bennett (Ref. 2) that safety-related structures designed for earthquake and tornado loadings in Zone 1 can safely withstand a 3.0 psi static pressure from explosions. Hence, if the PRA analyst demonstrates that the overpressure resulting from explosions at a source (e.g., railroad, highway or industrial facility) cannot exceed 3 psi, these postulated explosions need not be considered.
- b. The event has a significantly lower mean frequency of occurrence than other events with similar uncertainties and could not result in worse consequences than those events. For example, the PRA analyst may exclude an event whose mean frequency of occurrence is less than some small fraction of those for other events. In this case, the uncertainty in the frequency estimate for the excluded event is judged by the PRA analyst as not significantly influencing the total risk.
- c. The event cannot occur close enough to the plant to affect it. This is also a function of the magnitude of the event. Examples of such events are landslides, volcanic eruptions and earthquake fault ruptures.
- d. The event is included in the definition of another event. For example, storm surges and seiches are included in external flooding; the release of toxic gases from sources external to the plant is included in the effects of either pipeline accidents, industrial or military facility accidents, or transportation accidents.

These criteria are usually sufficient to exclude all but a few external hazards. For those remaining, a simple bounding analysis will often provide sufficient justification for exclusion. Procedures for these screening analyses have been documented previously in this program as given in Reference 3 and will not be repeated here. Detailed examples of applications of these methods are given in References 4-6.

2.3 References

1. U.S. Nuclear Regulatory Commission, PRA Procedures Guide, NUREG/CR-2300, January, 1983.
2. Kennedy, R. P. et al., Capacity of Nuclear Power Plant Structures to Resist Blast Loading, NUREG/CR-2462, September 1983.
3. Ravindra, M. K. and Banon, H., Methods for External Event Screening Quantification, NUREG/CR-4839, to be published.
4. Ravindra, M. K. and Banon, H., Analysis of the LaSalle Unit 2 Nuclear Power Plant: Risk Methods Integration and Evaluation Program (RMIEP) Volume 7: External Event Scoping Quantification, NUREG/CR-4832, August 1990.
5. Bohn, M. P., et al., Analysis of Core Damage Frequency: Surry Power Station External Events, NUREG/CR-4550, Revision 1/Volume 3, December 1990.
6. Lambright, J. A., et al., Analysis of Core Damage Frequency: Peach Bottom Unit 2 External Events, NUREG/CR-4550, Revision 1/Volume 3, December 1990.

3.0 SEISMIC CORE DAMAGE FREQUENCY ASSESSMENT PROCEDURES

A seismic analysis must simultaneously consider all the interrelated factors that determine the probability of radioactive release and exposure to the public. These closely-coupled factors are:

- a. The likelihood and magnitude of potential earthquakes.
- b. The transfer of earthquake energy from the fault source to the power plant site, a phenomenon that varies with the magnitude of an earthquake.
- c. The interaction between the soil underlying the power plant and the structural response, a phenomenon that depends on the soil composition under the plant and the location of the fault source relative to the plant.
- d. The coupling of responses between the power plant's buildings and the massive reactor vessels, piping systems, and emergency safety systems within.
- e. The numerous accident scenarios which vary according to the types of failures assumed and the success or failure of the engineered safety features intended to mitigate the consequences of an accident.

At some level of detail, all these aspects must be addressed in any seismic PRA.

In general, a nuclear power plant is designed to ensure the survival of all buildings and emergency safety systems in a design basis or a safe shutdown earthquake. The assumptions underlying this design process are deterministic and subject to considerable uncertainty. It is not possible, for example, to accurately predict the worst earthquake that will occur at a given site. Soil properties, mechanical properties of buildings, and damping in buildings and internal structures also vary significantly. To model and analyze the coupled phenomena that contribute to the frequency of radioactive release, it is therefore necessary to consider all significant sources of uncertainty as well as all significant interactions. Total risk is then obtained by considering the entire spectrum of possible earthquakes and integrating their calculated consequences. This point underscores an important requirement for a seismic PRA; the nuclear power plant must be examined in its entirety, as a system.

A second important aspect which must be addressed is that, during an earthquake, all parts of the plant are excited simultaneously. This means that there may be significant correlation between component failures, and hence, the redundancy of safety systems could be compromised. For example, in order to force emergency core cooling water into the reactor core following a pipe leak or break, certain valves must

open. To ensure reliability, two valves are located in parallel so that should one fail to open, the second valve would provide the necessary flow path. Since valve failure due to random causes (corrosion, electrical defect, etc.) is an unlikely event, the provision of two valves provides a high degree of reliability. However, during an earthquake both valves would be shaken simultaneously, and there is a high likelihood that both valves would be damaged if one is damaged. Hence, the planned-for redundancy would be compromised. This "common-cause" failure possibility represents a potentially significant risk to nuclear power plants during an earthquake.

Under NRC sponsorship, a detailed seismic risk assessment methodology was developed in the Seismic Safety Margins Research program (SSMRP) as described in Reference 1. That program culminated in a detailed evaluation of the seismic risk at the Zion nuclear power station (Ref. 2). In this evaluation, the attempt was made to accurately compute the responses of all walls and floor slabs in the Zion structures, all moments in the important piping systems, accelerations of all important valves, and the spectral accelerations at each safety system component (pump, electrical bus, motor control center, etc.). Correlation between the responses of all components was computed from the detailed dynamic response calculations. All important safety and auxiliary systems functions were analyzed, and fault trees were developed which traced failure down to the individual component level. Event trees related the system failures to accident sequences and radioactive release modes. Using these detailed models and calculations, it was possible to evaluate the seismic CDF at Zion in a level of detail not previously available, and determine quantitatively the CDF importance of the components, initiating events, and accident sequences. The methods used for and the results obtained from the SSMRP seismic assessment for the Zion plant form the basis for many of the simplifications used in the NUREG-1150 seismic PRA procedures described in this report.

3.1 Overview of Seismic PRA Procedures

There are seven steps required for calculating the seismic risk of core damage at a nuclear power plant:

- a. Determine the local earthquake hazard (hazard curve and site spectra or suite of time histories).
- b. Identify accident scenarios for the plant which lead to radioactive release (initiating events and event trees).
- c. Determine failure modes for the plant safety and support systems (fault trees).
- d. Determine fragilities (probabilistic failure criteria) for the important structures and components.
- e. Determine the responses (accelerations or forces) of all structures and components (for each earthquake level).

- f. Compute the mean values and probability distributions of the accident sequence and the core damage frequencies using the information from Steps 1 through 5.
- g. Perform sensitivity studies to identify the dominant contributors to seismic risk and the relative contributions of the hazard curve, fragility and response uncertainties to the overall uncertainty in core damage frequency.

Procedures for performing the seven steps of the seismic risk analysis procedure are summarized below. More detailed descriptions and references for each step are presented in following sections.

Step 1 - Seismic Hazard Characterization

- a. For sites in the eastern and central United States, hazard curves developed in the NRC sponsored Eastern United States Hazard Characterization Program (Ref. 3) and the EPRI Sponsored Seismic Hazard Methodology Program (Ref. 4) should be used.
- b. For plants west of the Rocky Mountains, site-specific hazard curves must be developed due to the high levels of seismic activity and the influence of identifiable active faults. However, for existing western U. S. commercial power plant sites, such hazard curves are already available.
- c. Site-specific ground motion spectra and time histories must be developed for each site. These can be obtained by selecting an ensemble of recorded earthquake time histories at similar sites and computing a median spectra from these time histories.

Step 2 - Initiating Events and Event Trees

The seismic event trees should be taken directly from those developed for the internal events analysis, with modifications to include any seismically-induced systems level structural failures. Both loss of coolant accidents (vessel rupture, large, medium and small LOCAs) and transient events should be included. In general, two types of transients should be considered; those in which the power conversion system (PCS) is initially available (denoted T_3 transients) and those in which the PCS is failed as a direct consequence of the initiating event (denoted T_1 transients).

The frequencies of vessel rupture (RPV) and large LOCA events can be determined from the probability of failure of the major reactor coolant system component supports. The medium and small LOCA initiating event frequencies can be computed based on a statistical distribution of pipe failures computed as part of the SSMRP program.

The probability of T_1 transients is based on the probability of loss of offsite power (LOSP). This will always be the dominant cause of these transients (for the majority of plants for which LOSP causes loss of main

feedwater). The probability of the T_3 initiating event is computed from the condition that the sum of all the initiating event probabilities considered must be unity. The hypothesis is that, given an earthquake of reasonable size, at least one of the initiating events will occur.

Step 3 - Fault Trees

The fault trees developed for the internal events analysis are used directly although they require modification to include basic events with seismic failure modes and re-solving the trees for pertinent cut sets to be included in the seismic PRA calculations. In solving the fault trees for the seismic cut sets, conservative basic event probabilities (based on the seismic failure probabilities evaluated at a high earthquake peak ground acceleration level combined with the random failure probabilities) are used. Probabilistic culling is used in solving these trees in such a way as to assure that important correlated cut sets (involving dependent seismic failure modes) are not lost.

Step 4 - Component and Structure Failure Descriptions

Component seismic fragilities are obtained either from a generic fragility data base or developed on a plant-specific basis for components not fitting the generic component descriptions. Two sources of fragility data are available.

The first is a data base of generic fragility functions for seismically-induced failures originally developed as part of the SSMRP (Ref. 5). Fragility functions for the generic categories were developed based on a combination of experimental data, design analysis reports, and an extensive expert opinion survey. The experimental data utilized in developing fragility curves were obtained from the results of component manufacturer's qualification tests, independent testing lab failure data and data obtained from an extensive U.S. Corps of Engineers testing program. These data were statistically combined with the expert opinion survey data to produce fragility curves for the generic component categories.

A second useful source of fragility information is a compilation of site-specific fragilities (Ref. 6) derived from past seismic PRAs prepared by Lawrence Livermore National Laboratory (LLNL). By selecting a suite of site-specific fragilities for any particular component, one can obtain an estimate of a generic fragility for that component.

Finally, following the probabilistic screening of the seismic accident sequences, plant specific fragilities are developed for components not fitting in the generic data base categories as determined during the plant visit. These are developed based either on analysis or an extrapolation of the seismic equipment qualification tests.

Step 5 - Seismic Response of Structures and Components

Building and component seismic responses (floor slab spectral accelerations as a function of acceleration) are computed at several peak ground acceleration values on the hazard curve. Three basic aspects of

seismic response (best estimates, variability, and correlation) must be estimated. SSMRP Zion analysis results and simplified methods studies form the basis for assigning variability and correlation of responses.

For soil sites, SHAKE code calculations (Ref. 7) are performed to assess the effect of the local soil column (in any) on the surface peak ground acceleration and to develop strain-dependent soil properties as a function of acceleration level. This permits an appropriate evaluation of the effects of nonhomogeneous underlying soil conditions which can strongly affect the building responses.

Building loads, accelerations and in-structure response spectra are obtained from multiple time history analyses using the plant design fixed-base beam element models for the structures combined with a best-estimate model of the soil column underlying the plant. Variability in responses (floor slab spectral accelerations) can be assigned based on the SSMRP results. Although any structural dynamic analysis code can be used, the CLASSI code (Ref. 8) has been shown to be particularly convenient for these calculations.

Step 6 - Accident Sequence and Core Damage Frequency Uncertainty Analysis

A simple and direct evaluation of accident sequence and core damage frequencies using Monte Carlo sampling is recommended. This has proven to be efficient and much more direct than other competing methods.

Step 7 - Sensitivity Studies

Sensitivity studies should be performed to determine the dominant contributors to risk as well as dominant contributors to the uncertainty in the final risk estimate. One-at-a-time calculations of risk reduction potential for each component provides a measure of relative contribution to the mean frequencies. Recalculation of the core damage frequency with component modelling uncertainties set to zero provides a measure of the relative contribution of each basic event to the total uncertainty in the final result.

In the following, recommendations and their basis for each step above are provided in more detail.

3.2 Determine the Earthquake Hazard

The earthquake hazard at a given power plant site is characterized by a hazard curve and either a suite of earthquake time histories or a site ground motion spectra. The hazard curve is a frequency plot which gives the probability of exceedance (per year) of different peak ground accelerations. Figure 3.1 shows a sample hazard curve. The ordinant of this plot (for a given peak ground acceleration) gives the frequency (per year) of the occurrence of one or more earthquakes having peak ground acceleration greater than the abscissa. Figure 3.2 shows a typical site ground motion response spectra which describes the relative frequency content of the earthquake motions expected at the site, and also reflects the influence of the local soil column and layering in modifying the earthquake frequencies transmitted to the plant foundations.

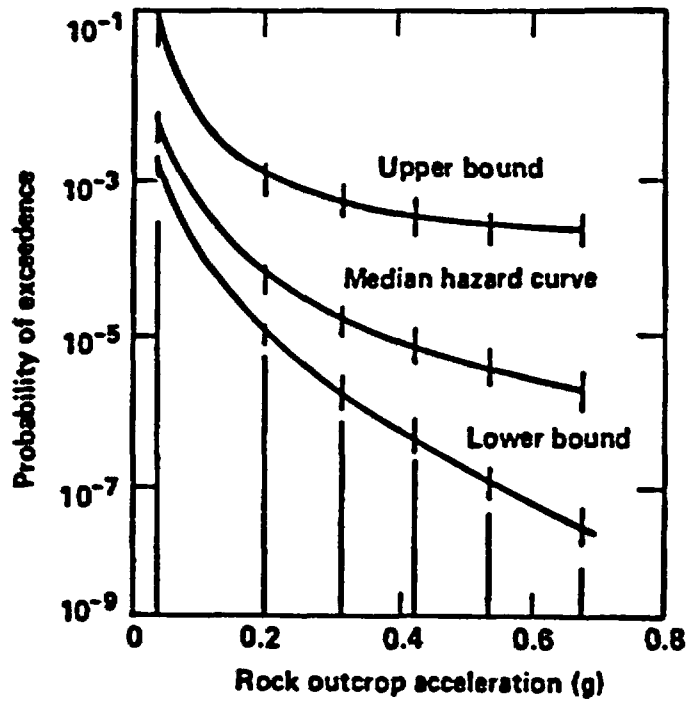

Figure 3.1. Example Seismic Hazard Curve

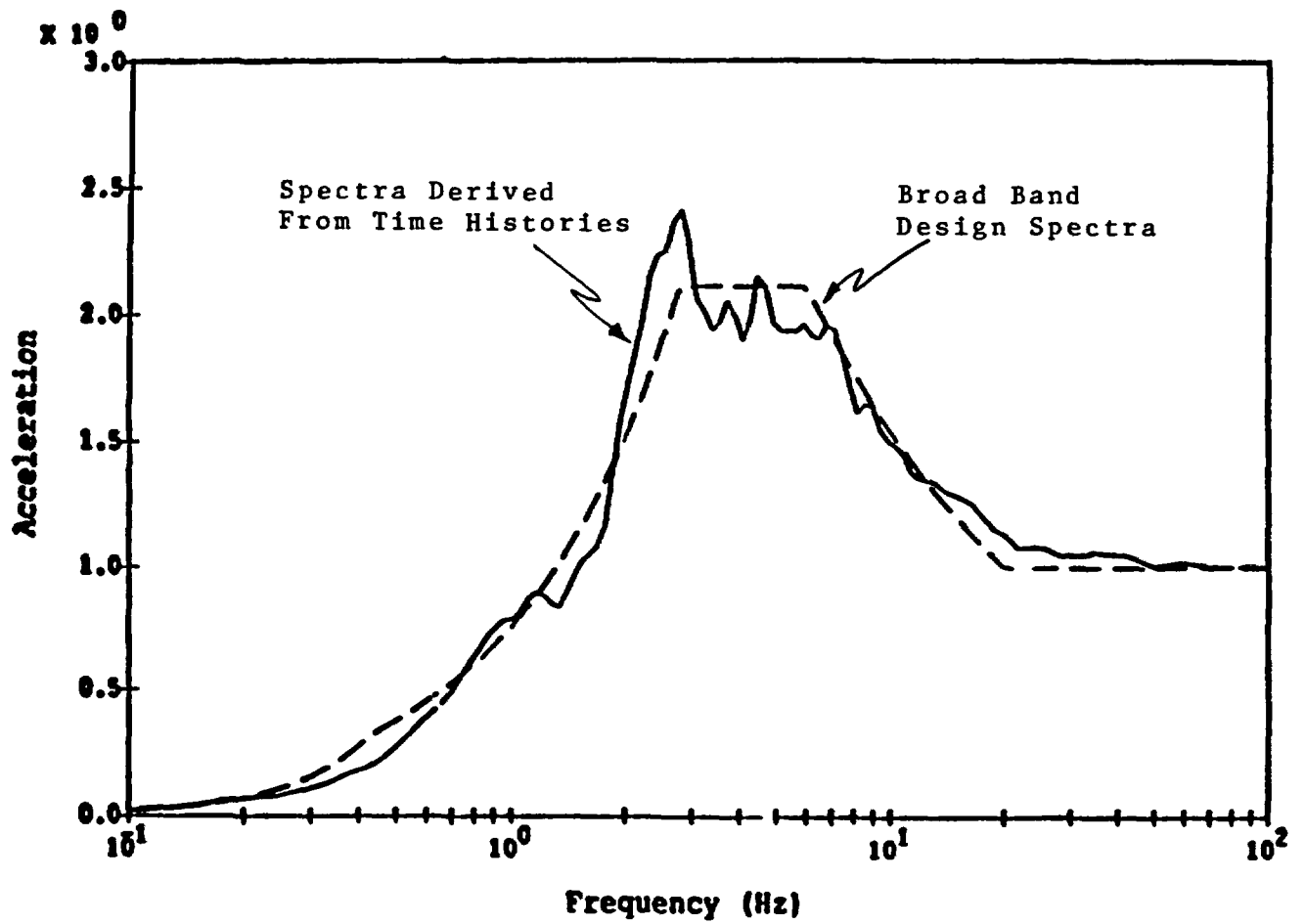

Figure 3.2 Example of Site Ground Motion Spectra

3.2.1 General Considerations

For a given site, the hazard curve is derived from a combination of recorded earthquake data, estimated earthquake magnitudes of known events for which no data are available, review of local geological investigations, and use of expert judgment from seismologists and geologists familiar with the region in question. The region around the site (say within 100 km) is divided into zones, each zone having an (assumed) uniform mean rate of earthquake occurrence. This mean occurrence rate is determined from the historical record, as is the distribution of earthquake magnitudes. Then, for the region under consideration, an attenuation law is determined which relates the ground acceleration at the site to the ground acceleration at the earthquake source, as a function of the earthquake magnitude. The uncertainty in the attenuation law is specified by the standard deviation of the data (from which the law was derived) about the mean attenuation curve. These four pieces of information (zonation, mean occurrence rate and magnitude distribution for each zone, and attenuation law) are then combined statistically to compute the hazard curve.

The low level of seismic activity and the lack of instrumental records make it difficult to carry out seismic hazard analyses for the central and eastern United States using historic data alone. To augment the data base, current methodologies make use of the judgement of experts familiar with the area under consideration.

Expert opinion is solicited on input parameters for both the earthquake occurrence model and the ground motion (attenuation) model. Questions directed to experts cover the following areas: (a) the configuration of seismic source zones, (b) the maximum magnitude or intensity earthquake expected in each zone, (c) the earthquake activity rate and occurrence statistics associated with each zone, and (d) methods for predicting ground motion attenuation in the zones from an earthquake of a given size at a given distance.

Using the information provided by the experts, seismic hazard evaluations for the site are performed. The hazard results thus obtained using each expert's input are combined into a single hazard estimate using a weighting method. Approaches used to generate the subjective input, to assure reliability by feedback loops and cross-checking, and to account for biases and modes of judgment are described in detail in Reference 9.

3.2.2 Procedures for Developing Hazard Curves and Spectra

To perform the seismic PRA, a family of hazard curves and either ensembles of time histories or a site ground motion spectra must be available. To obtain these for a site with no previous investigation usually involves 6 to 12 months effort to develop and process a data base on earthquake occurrences and attenuation relations as described above. For plant sites in the western United States, where the hazard curves are closely tied to local tectonic features which can be identified and for which a significant data base of recorded earthquake time histories

exists, it is usually necessary to go through this process for each individual plant site. However, for sites in the eastern and central United States, there are existing data bases and seismic hazard characterization programs which can be utilized to obtain hazard curves in a very time and resource efficient manner.

Two recently-completed programs provide extensive data bases on earthquake occurrences, magnitude distributions, and appropriate attenuation laws from which hazard curves can be developed for any location in the east or central United States, based on the procedures described above. These two programs are the NRC-sponsored Eastern United States Seismic Hazard Characterization Program (Ref. 3) performed by Lawrence Livermore National Laboratory (LLNL) and the corresponding industry-sponsored EPRI Seismic Hazard Methodology Development Program (Ref. 4). These two programs have developed hazard curves and site spectra for every commercial reactor site in the central and eastern United States. Further, using the data bases developed and the computer programs utilized, it is possible to obtain a hazard curve for any other geographical site in the central or eastern United States which has not already been published. Thus, these two programs provide a convenient and well-documented source from which hazard curves can be obtained. Figure 3.3 shows the hazard curve family for the Surry site obtained from the NRC-sponsored Eastern Seismic Hazard Characterization Study. Figure 3.4 shows the corresponding curves obtained from the EPRI study. On these curves, the mean hazard as well as the 15th percentile, 50th percentile, and the 85th percentile hazard curves are shown. Thus, the uncertainty in the hazard contribution can be estimated from these four curves. The mean hazard curve is particularly significant as it has been demonstrated that the mean curve is the predominant factor in the calculation of the mean core damage frequency.

The two sets of hazard curves shown in Figures 3.3 and 3.4 are significantly different, both in regard to location of the mean hazard curve as well as to the range of uncertainty about the median curve. This is not too surprising inasmuch as the emphasis of the two programs was somewhat different. The EPRI Program focused on very detailed geological studies of the sites in question, and resulted in a somewhat finer zonation of each site. However, only three attenuation (ground motion) models were used. Further, while a number of teams of seismological and geological experts were assembled, each team was proscribed to reach a consensus on the final hazard curve families developed by that team.

By contrast, in the LLNL program considerable emphasis was placed on the full range of attenuation models, and rather than a number of teams, a total of eleven seismicity experts and 5 ground motion experts were individually polled, and a set of 2750 hazard curves were developed for each site by considering each expert's input equally likely. The curves developed in this process encompass somewhat more uncertainty than those produced by the EPRI process, and the increased uncertainty leads to higher probabilities of nonexceedance for points on the LLNL mean hazard curves than are obtained at corresponding peak ground accelerations on the EPRI mean hazard curves.

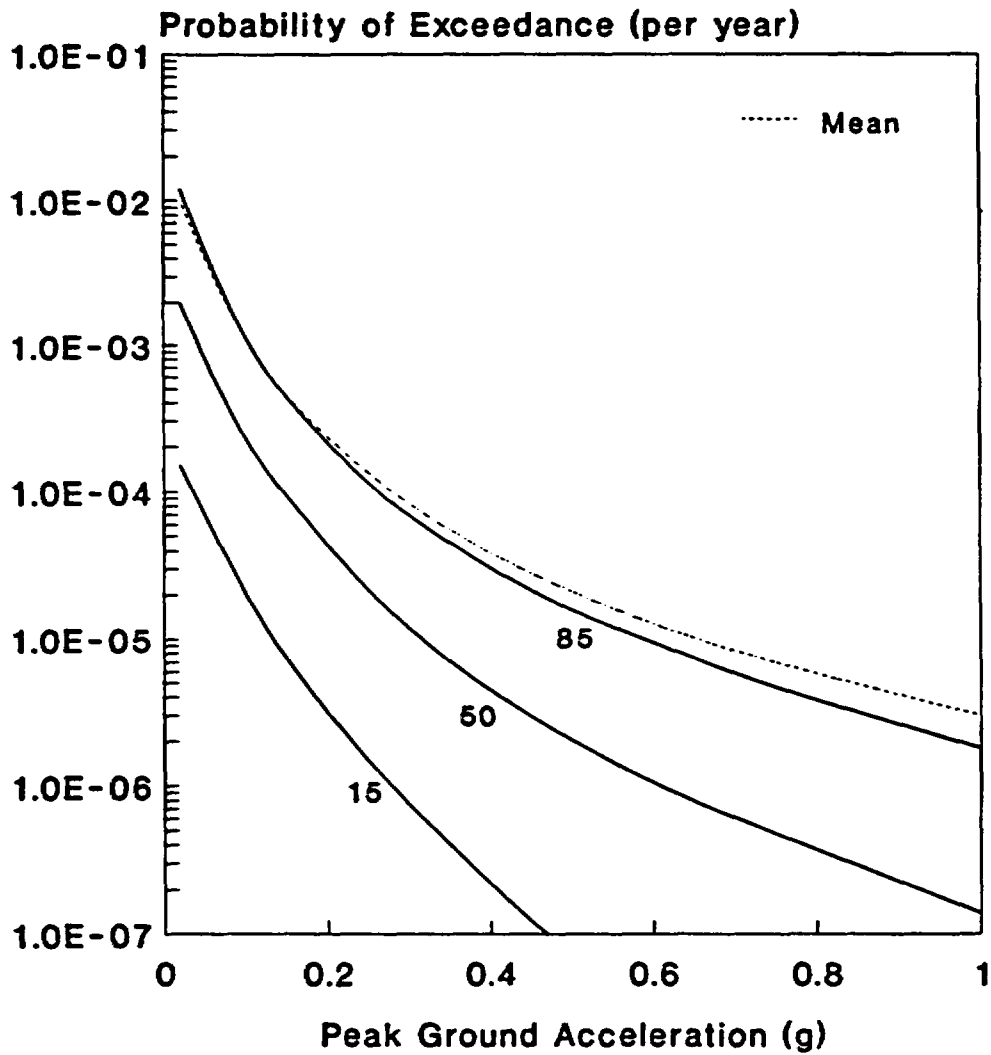

Figure 3.3 LLNL Surry Hazard Curve, Mean, Median, 15 Percent and 85 Percent Curves

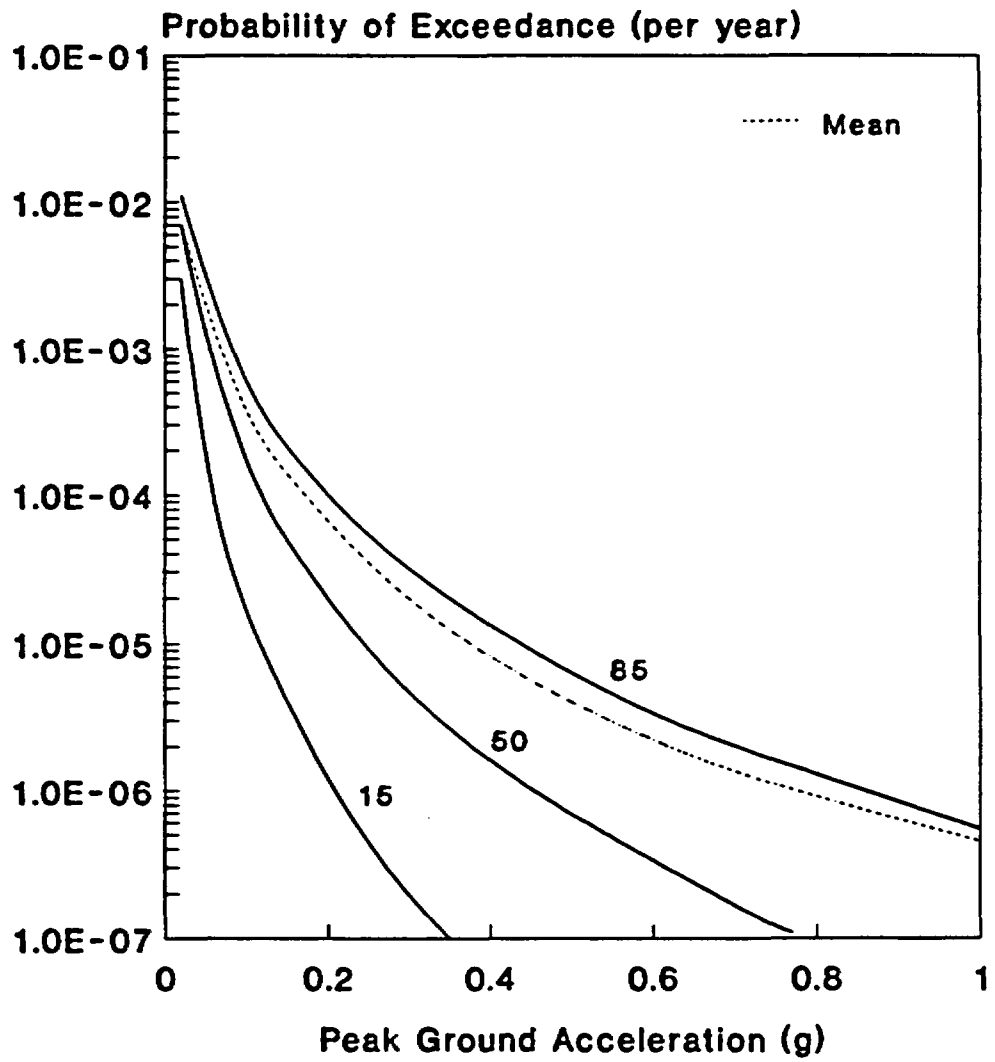

Figure 3.4 EPRI Surry Hazard Curve, Mean, Median, 15 Percent and 85 Percent Curves

At this time, both sets of hazard curves are viewed by the USNRC as being equally credible. As such, calculations of the seismic core damage and plant damage state frequencies can be made for both sets of hazard curves and the results viewed as a measure of methodological uncertainty in the hazard curve developmental process.

As will be described later, it is recommended that the calculation of building responses (floor slab spectral acceleration) be based on structural dynamic response calculations using time histories as input. In order to develop this input, it is recommended that recorded earthquake catalogs be examined and that a suite of time histories (usually 5 to 10) be selected which are judged to be suitable for the site in question. That is, these time histories should be recorded at similar sites to that being considered. As a check on the appropriateness of the suite of time histories selected, the spectra for each time history should be generated and then the suite of spectra combined to generate a median spectra. This median spectra can then be compared with published spectra for various specific site types (eg., rock sites, deep soil sites, etc.) as given, for example, in References 10 and 11.

3.3 Identify Accident Scenarios

In the event of an earthquake or any other abnormal condition in a nuclear power plant, the plant safety systems act to bring the plant to a safe shutdown condition. In this step of the risk analysis process, the possible paths that a nuclear plant would follow are identified, given that an earthquake-related event has occurred which causes shutdown. These paths involve an initiating event and a success or failure designation for systems affecting the course of events, and are referred to as accident sequences.

3.3.1 Procedures for Initiating Events

The seismic analysis performed should be based on a subset of the initiating events and accident sequences developed for the internal event analyses of the plant. Typically, the minimum set of initiating events which should be considered is:

<u>Initiator</u>	<u>Identifier</u>
Vessel Rupture (ECCS Ineffective)	RVR
Large LOCA	ALOCA
Medium LOCA	MLOCA
Small LOCA	SLOCA
Transient with PCS initially inoperative	T ₁
Transient with PCS initially available	T ₃

In addition, there may be site-specific failure events (usually structural failures) which also act as initiating events that must be added to this list. For example, failure of a structure housing the emergency switchgear rooms (which would thus cause LOSEP) or failure of the turbine building (which would cause loss of the PCS) would be treated directly as initiating events.

It is recommended that the reactor vessel rupture (RVR) and large LOCA (ALOCA) events be calculated based on the failure of the supports of the reactor vessel and other major components in the loops of the primary coolant system, that is, the steam generators, pressurizers and reactor coolant pumps for PWRs and the recirculation pumps for BWRs. (Note that direct failure of the primary coolant system main piping due to the earthquake ground motion has been shown to have negligible probability and can be neglected). Specific values for support fragility can be estimated from References 5 and 6. As an illustrative example, consider the Surry 3-loop plant as shown in Figure 3.5. The definition of the RVR event for this plant is the simultaneous failure of at least one steam generator or reactor coolant pump in at least two of the loops. Similarly, the definition of the large LOCA for Surry is a failure of at least one steam generator or one reactor coolant pump in any one of the three loops. Thus, the Boolean expressions which must be evaluated to compute the probability of the RVR and the ALOCA initiating events are:

$$P(\text{RVR}) = P[\text{SG1*SG2 or SG1*SG3 or SG2*SG3 or SG1*RCP2 or SG1*RCP3 or SG2*RCP1 or SG2*RCP3 or SG3*RCP1 or SG3*RCP2 or RCP1*RCP2 or RCP1*RCP3 or RCP2*RCP3}]$$

$$P(\text{ALOCA}) = P[\text{SG1 or SG2 or SG3 or RCP1 or RCP2 or RCP3}]$$

Similar expressions can, of course, be written for any number of loops depending on the layout of the plant. Since these failures are due to the same floor response and the component fragilities are expected to be highly correlated, it is necessary to perform an evaluation of these failure events explicitly including all correlation. In particular, it is necessary to include correlation between cutsets (combinations of component failures) as well as correlation between the failure events in each cut set. This can be accomplished by performing a Monte Carlo evaluation of the Boolean equations for these events at several values of peak ground acceleration (pga) to obtain the RVR and ALOCA event probabilities as a function of pga. Interpolation can then be used to obtain the event probabilities at other pga values as required.

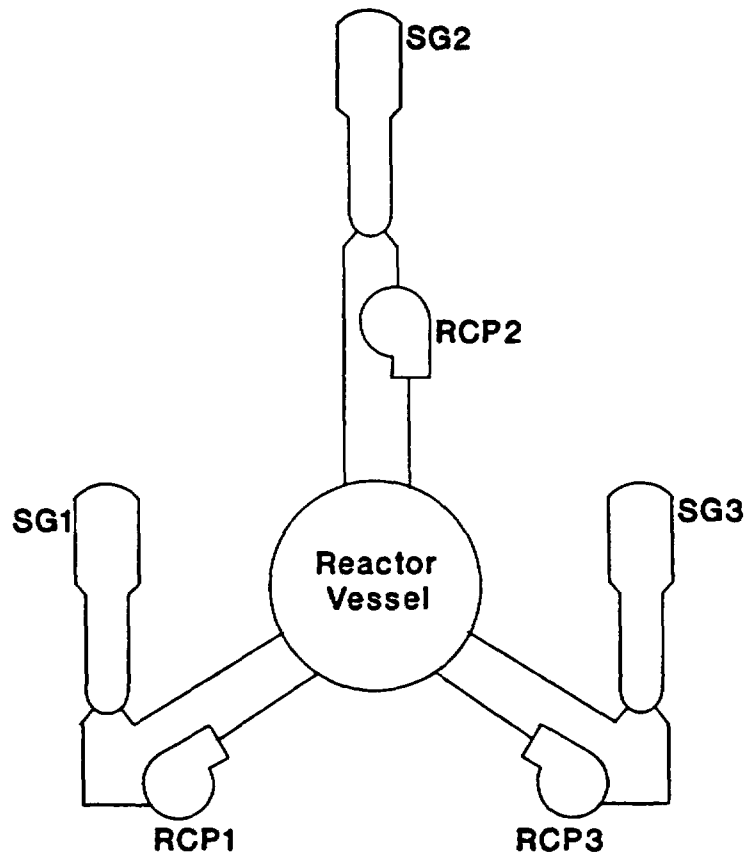

Figure 3.5 Surry Primary Coolant System Layout

The medium LOCA (MLOCA) and small LOCA (SLOCA) initiating events are based on failure of the reactor coolant pump seals and failure of the smaller reactor coolant loop pipes. Since calculation of piping motion and stresses caused by an earthquake is very tedious, and since there are many small pipes in the primary coolant system (whose failure would lead to either a medium or small LOCA) which would have to be analyzed, it is necessary to have some alternative approach to calculating the MLOCA and SLOCA initiating event probabilities in a simplified seismic PRA. To this end, use was made of the extensive primary coolant system piping response calculations performed in the SSMRP. Based on the computed piping moments for all pipes (and pipe combinations) leading to MLOCA breaks (3" < Pipe ID < 6") and SLOCA breaks (1.5" < Pipe ID < 3") in the SSMRP, statistical distributions were generated for these initiating events as shown in Figure 3.6. These distributions can be used to compute the medium and small LOCA initiating events due to pipe breaks in a simplified seismic PRA without the need for extensive (and expensive) piping calculations. In using these as generic estimates, one is making the assumption that there are so many small pipes and combinations of smaller pipes in the primary coolant system at any given plant that all sizes and geometries are likely to be found at all plants. Given the large number of such pipes in the SSMRP calculations, such an assumption seems reasonable.

It is recommended that the T₁ transient initiating event (wherein the power conversion system is lost as a direct consequence of the earthquake) be based on the probability of LOSEP as determined by failure of the ceramic insulators in the switchyard. This has been found to be the dominant cause of such transients in all seismic PRA's to date (for the vast majority of plants for which LOSEP results in loss of the main feedwater system).

Finally, the T₃ initiating event probability is computed from the condition that the sum of the initiating event probabilities considered must be unity. The hypothesis is that, given an earthquake of reasonable size, at least one of the initiating events will occur. At the very least, it is assumed that the operator will shut down the plant following a significant earthquake for inspection purposes (as is currently required in the United States for any earthquake over the operating basis earthquake level). Hence the probability of the T₃ transient initiating event is computed from:

$$P(T_3 \text{ Transient}) = 1.0 - \sum_{j=1}^{n-1} P(IE_j)$$

where n is the total number of initiating events being considered.

In computing the frequency of the initiating events, a hierarchy between them must be established. The order of this hierarchy is defined such that, if one initiating event occurs, the occurrence of other initiating events further down the hierarchy is of no significance in terms of the plant's response. Thus, for example, if a large LOCA occurs, we are not

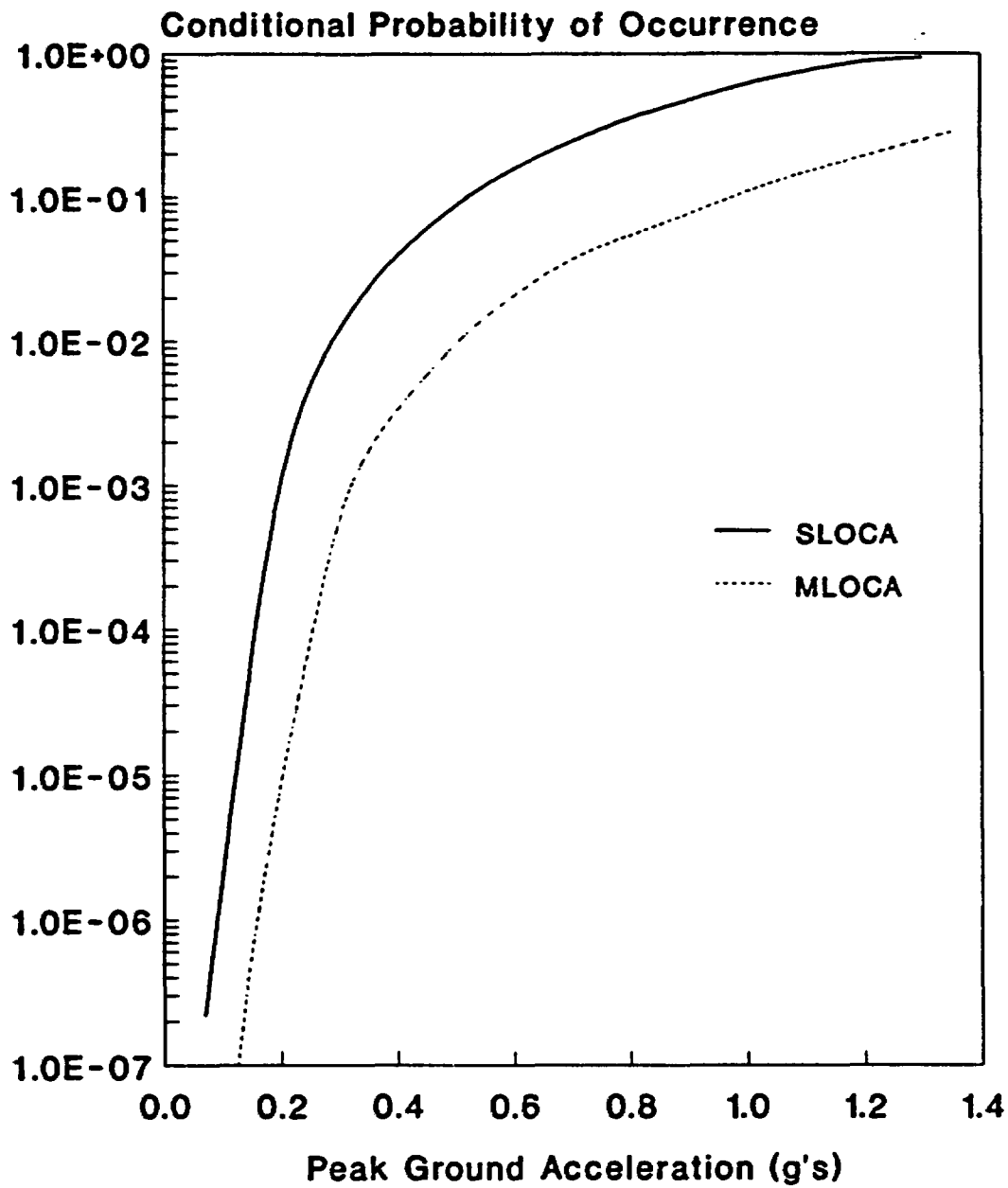

Figure 3.6 Distributions of Pipe Failures Causing MLOCA and SLOCA Initiating Events Developed From SSMRP Piping Calculations

concerned if a small LOCA or a transient also occurs, as the plant's response requirements will be dictated by the need to mitigate the large LOCA. Figure 3.7 shows this hierarchy (for the minimum set of initiating events discussed above) in event tree format. The most serious initiating event is the RVR event. The probability of the ALOCA initiating event is then computed as the probability of the anchorage failure ALOCA event times the complement of the RVR event, and similarly, for the MLOCA, SLOCA and T_1 events. Specific Boolean equations for this set of initiating events are also shown on this figure. Of course, when other structural failures are identified as initiating events, they must be added to the hierarchy as appropriate. An example of this is found in the Peach Bottom NUREG-1150 seismic PRA (Ref. 12).

Implicit in the defined hierarchy of a set of initiating events is the requirement that basic events which define one initiating event in the hierarchy cannot occur in the accident sequences corresponding to initiating events lower in the hierarchy. For example, LOSP can occur as a basic event in any of the LOCA sequences in Figure 3.7, but cannot occur as a basic event in the T_3 accident sequence. This limitation is, of course, directly implied by the tree structure.

3.3.2 Seismic Accident Sequences (Event Trees)

In general, the event trees developed for the internal event analyses should be used, so as to be able to compare the final core damage frequencies due to seismic and random events on a common basis. Again, there may be global failure events (usually structural failures) which directly fail one or more safety systems which can be added directly to the event tree structure.

3.3.2.1 Feed and Bleed Considerations for PWRs

One important consideration which must be made for the seismic analysis of PWRs is the capability of performing feed and bleed cooling for transients in which the auxiliary feedwater system is normally called upon to provide heat removal. If the AFWS is not available, the operator can often perform a heat removal operation called "feed and bleed" in which either the safety injection pumps or the charging pumps are used to inject cooling water directly into the primary coolant system. The resulting steam is then released through the pressurizer relief valves. If the capability to perform feed and bleed is considered credible, then a high degree of backup redundancy for the auxiliary feedwater system is provided.

The ability to perform feed and bleed must be demonstrated on an individual plant basis and, depending upon the normal alignment of valves prior to an earthquake, it is possible that a certain amount of timely operator recognition and intervention is required in order to perform this feed and bleed operation. In addition, depending upon the flow rate capabilities of the high pressure pumps and the possibility of two phase flow through the pressurizer, it may be that feed and bleed may not be possible.

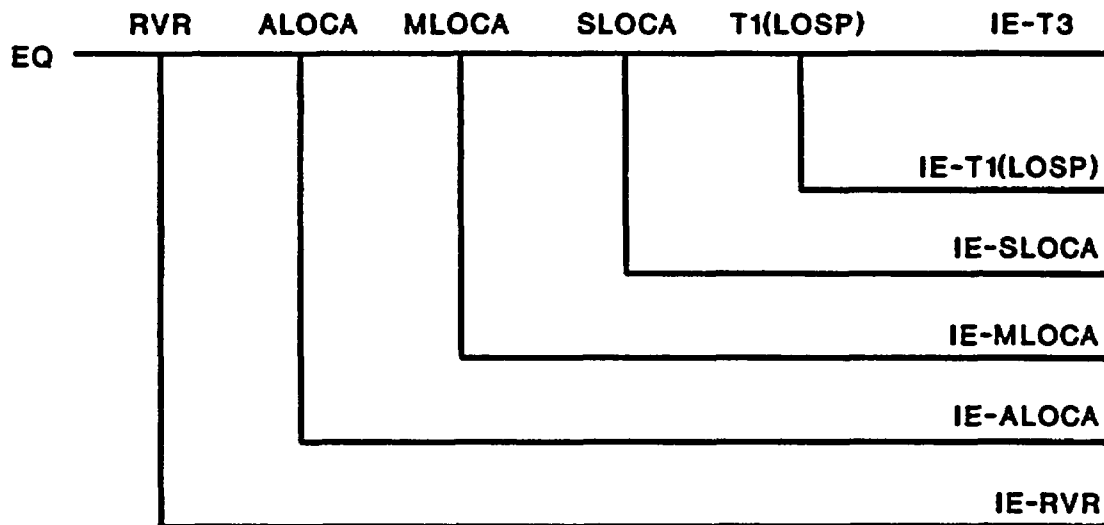

$$P[\text{IE}(\text{RVR})] = \text{RVR}$$

$$P[\text{IE}(\text{ALOCA})] = \overline{\text{RVR}} * \text{ALOCA}$$

$$P[\text{IE}(\text{MLOCA})] = \overline{\text{RVR}} * \overline{\text{ALOCA}} * \text{MLOCA}$$

$$P[\text{IE}(\text{SLOCA})] = \overline{\text{RVR}} * \overline{\text{ALOCA}} * \overline{\text{MLOCA}} * \text{SLOCA}$$

$$P[\text{IE}(\text{T}_1)] = \overline{\text{RVR}} * \overline{\text{ALOCA}} * \overline{\text{MLOCA}} * \overline{\text{SLOCA}} * \text{LOSP}$$

$$P[\text{IE}(\text{T}_3)] = 1 - P[\text{IE}(\text{RVR})] - P[\text{IE}(\text{ALOCA})] - P[\text{IE}(\text{MLOCA})] \\ - P[\text{IE}(\text{SLOCA})] - P[\text{IE}(\text{T}_1)]$$

Figure 3.7 Initiating Event Hierarchy Tree

The event trees for a plant will be different, depending on whether or not feed and bleed is considered a viable option. From a risk viewpoint, the capability to perform feed and bleed cooling greatly lessens the importance of the auxiliary feedwater system, and thus can play a significant role.

3.3.2.2 Seal LOCAs For PWRs

It is usually found, in the case of PWRs, that seal LOCAs contribute significantly to the overall risk. Thus, in developing the accident sequences, transfers from the transient event trees to the small LOCA trees which correspond to the seal LOCA event should be identified and preserved. Failure events leading to the seal LOCA (usually loss of high pressure injection and sometimes loss of the component cooling water system) would be identified in the internal events analysis. Boolean logic is used to combine the transient accident sequences leading to a seal LOCA with the appropriate sequences on the SLOCA tree.

3.3.2.3 Stuck-Open Safety Relief Valves For BWRs

One source of loss of coolant accidents (not related to pipe failures) which should be included in the analysis of BWRs is the situation where one or more safety relief valves have randomly failed to reclose on demand. Depending on the number of valves which fail to close, a small, medium, or large LOCA can result. The exact definition of the resulting LOCA size is determined in the internal events analysis. However, in developing the event trees, transfers from the transient event trees to the LOCA event trees should be identified and preserved so that such sequences are not lost. (Of course, this same situation can also occur in a PWR - usually leading to a small LOCA - but such PWR sequences are usually probabilistically insignificant.)

3.3.2.4 Inclusion of System Successes

When developing the accident sequences from the event trees, it is necessary to explicitly retain the system successes in the logical expressions. This is essential since, as the earthquake peak ground acceleration increases, the probability of system successes decreases substantially. If these are neglected (as is done in internal events analyses) a substantial overestimate of the accident sequence frequencies results. Note that an exact solution of the accident sequences with the successes directly included is currently beyond the state of the art. However, it is necessary to numerically include the system success probabilities in the final accident sequence quantification, since such system success probabilities are significantly less than unity for the higher pga levels, and failure to do so would result in a significant over-estimation of the accident sequence frequencies. In doing this, one should manually examine the accident failure cut sets so as to assure that no logical inconsistencies arise with the equations used to compute the system success probabilities. This consideration applies both to PWRs and BWRs.

3.4 Seismic Failure Modes of Safety Systems (Fault Trees)

To determine failure modes for the plant safety systems, fault tree methodology as described in Reference 13 is used. This methodology systematically identifies all groups of components in a system which, if they failed simultaneously, would result in failure of that system. The fault trees developed for the internal events analysis are used directly, with certain modifications.

3.4.1 General Considerations

Construction of a fault tree begins by identifying the immediate causes of system failure. Each of these causes is then examined for more fundamental causes, until one has constructed a downward branching tree, at the bottom of which are failures not further reducible, i.e., failures of mechanical or electrical components due to all causes such as structural failure, human error, maintenance outage, etc. These lowest order failures on the fault tree are called basic events. Failures of basic events due to seismic ground motions, random failures, human error, and test and maintenance outages should all be included on the seismic fault trees.

The main difference between a fault tree for an internal events analysis and the corresponding fault tree for an external events analysis is that consideration must be given to the physical location of the components, because the physical location determines to what extent both correlation between responses and secondary failures become important. Examples of the latter would be equipment failures due to local masonry wall collapse or due to a high temperature/steam environment from a broken steam line. Hence, in performing the seismic analyses, the locations of all important pieces of equipment must be determined from the general arrangement drawings for the plant, and then a systematic examination for potential response correlations (to be described later) and for secondary failure possibilities must be made during the plant walkdown.

3.4.2 Procedures for Seismic Fault Trees

As stated earlier, the internal event fault trees should form the basis for the fault trees used in the seismic analysis. This allows for a common level of detail between internal and external event analyses, and assures the consistent inclusion of random and test/maintenance outage unavailabilities in the seismic analysis.

Since the internal event fault trees are assumed to have been previously developed and finalized in the internal events analysis, the seismic failure modes must be added by modifying the internal event fault trees to include:

- a. Local structural failures (block walls, cranes, etc.)
- b. Failure of critical passive components (tanks, cable tray failures, and pipes.) if not identified in the internal events analysis.

This is accomplished in several ways. First, secondary or passive failure events can be added directly to the fault trees and the "gate" definition data file modified. Alternatively, the fragility definition of a relatively strong component on the tree may be redefined in terms of the (relatively weaker) associated secondary failure. Finally, events globally affecting a safety system or an accident sequence (such as building failure or liquefaction) can be added directly to the Boolean expression for the accident sequence.

Perhaps the most important aspect of developing fault trees for a seismic risk analysis is the consideration of dependencies. An evaluation of such dependencies should already be available if fault trees already exist for internal events. However, these dependencies must be reexamined in the light of seismic considerations. In particular, one must examine dependencies between safety systems and between safety systems and nonsafety systems. Special consideration should be given to the electric power system, the service water system, and the instrument air system, which in previous seismic PRA's have been found to be a source of pervasive common-mode failures. The dependencies must be examined so as to assure that important failure dependencies were not left off the internal events fault trees because they involved only passive components (tanks, pipes, etc.,) for which the random failure rates were considered negligible.

A second aspect of system dependencies, which while less formal, is no less important, is the consideration of physical interaction between components, especially those not designed for seismic effects. Consideration should be given to the polar crane falling, to weak nonstructural ceilings, to masonry and other nonstructural walls, to small poured concrete panels used for enclosures (such as the pressurizer enclosure slab), and the supports of all major vessels and components. Any such secondary-failure induced component failures should be added directly to the fault trees. (If such a physical interaction were found to be crucial to the final core damage frequencies, follow-up interaction with plant personnel or a plant visit might be required to determine the exact configuration of the components involved.)

Failure of safety systems due to building structural failures is, of course, an important aspect of any seismic PRA. Typically, in past PRA's, gross failure (collapse) of structures has not been found to be a significant cause of core damage. Rather, it is localized failures which have been found to be significant contributors. (However, a complete structural fragility analysis for all important structures must be performed to verify this.) A structural failure may lead directly to core damage, affect an entire system, or fail only isolated equipment. Hence such structural failures are added either as seismic initiators, as top events in the seismic event trees, or as basic events in the system fault trees depending on the extent of their impact.

3.5 Seismic Response of Structures and Components

To compute the failure probability of critical components and safety systems, it is necessary to have a measure of both the maximum load or acceleration that the component experiences during an earthquake, as well as a measure of the load or acceleration level at which it fails. Uncertainties in physical and dynamic characteristics of the soil, structures, and subsystems as well as inherent variability in the free field earthquake motion influence the response of safety systems to an earthquake. All of these uncertainties give rise to uncertainties in estimates of the response and onset of failure of each building and component in the power plant. These uncertainties must be explicitly recognized and propagated through the calculational scheme.

In this section, the response calculations used in past PRAs and the new methods used for the NUREG-1150 seismic PRAs are discussed. (Strength and failure calculations are discussed in Section 3.6.)

3.5.1 Response Calculation Methods Used In Past PRAs

Determining estimates of the responses of the walls and floor slabs of the buildings, and responses of the subsystems themselves, has proven to be one of the more time-consuming and difficult-to-defend aspects of seismic risk assessments. Two approaches have been taken in past seismic PRAs.

(i) Numerical Computer Modeling

This was the approach taken in the very detailed SSMRP analysis of Zion (Ref. 2). In this analysis the buildings, foundations, major components, and piping systems were modeled by the finite element method. Soil-structure interaction and structure response were calculated by the substructure approach. Piping analysis was performed by multisupport time history analysis. Responses at over 400 points in the buildings and over 1000 points in the piping systems were computed for each earthquake time history.

To incorporate variation in input parameters, multiple time history dynamic response analyses of the entire power plant were made. In each of these repeated calculations, the magnitudes of the input parameters describing the physical and dynamic characteristics of the structures and subsystems were varied in a random fashion, and each calculation was performed for a different earthquake defined by a set of three acceleration time histories in the free-field (two horizontal and one vertical). Thirty calculations were made (at each earthquake level) with the result that 30 values of response (ie., zero period acceleration, spectral acceleration or moment) were computed for each building wall, slab, pipe segment, valve and component. From these 30 values, a statistical distribution of the response of each wall, component, etc., was constructed.

This analysis was the most detailed consideration of structural response performed to date and the results have been utilized in identifying generic variabilities and correlation rules as recommended in this report. However, this overall process is too expensive and time-consuming to be used routinely in seismic risk analyses.

(ii) Scaling of Design Calculations

This approach - often called the Factor of Safety method - is the approach typically taken (Ref. 14) in commercial PRA's when (a) the structure and foundation are reasonably typical of current building practices, (b) a reasonably adequate soil structure interaction was performed, and (c) details of the design calculations are readily available. Here, the design loads and accelerations computed at the safe shutdown earthquake (SSE) level are scaled down (or up) to reflect factors of conservatism (or lack thereof) in the method used in the design process to compute the responses. Typically, these factors are derived from structural design reports and component stress reports, and reflect:

- a. Model response to the specified seismic event
- b. Combination of modes
- c. Combination of earthquake components
- d. Soil structure interaction effects
- e. Design vs. best estimate damping levels.

In this approach, all structural responses are expressed in terms of peak ground acceleration. Hence, it is difficult to explicitly include correlation (other than zero or unity) in the seismic failures. In addition, this approach is heavily dependent on the skill and experience of the analyst, and the basis for the results are difficult to document.

As will be described below, a combination of these approaches - making full use of insights and results having generic applicability - can be used to provide a fully defensible and cost-effective means of determining structural responses.

3.5.2 Procedures for Determining Responses

For the seismic analyses, realistic and best estimate values of floor slab spectral accelerations must be generated for input to the equipment failure computations. We cannot, in general, use the existing design floor spectra as they usually have a high degree of conservatism built into them (and the degree of conservatism varies widely plant-to-plant).

In general, three aspects of seismic response must be determined for each floor slab and component of interest:

- a. Median acceleration
- b. Variability in acceleration
- c. Correlation with other responses.

Procedures for developing each of these aspects are described below.

Median Accelerations

As a first step, it is necessary to obtain (from the FSAR and amendments) the underlying soil properties and embedment depths. Secondly, it is necessary to obtain the structural design reports which summarize the structure's fixed-base natural frequencies and characterize the lateral load resisting members. These structural reports should contain the masses, stiffness description, (geometries, material properties, reinforcing schedule, etc.) and soil model used in the design structural analyses. From these data, it is straightforward to construct relatively simple lumped mass/beam element models of the critical structures using standard civil engineering methods as described, for example, in Reference 15. Typical models will contain less than 30 lumped masses, yet such models have been found to adequately model the important global dynamic response of such structures (Ref. 1). Note that detailed finite element models of the structures are not necessary for these computations.

If the structures are founded on rock or very stiff soil (say having a soil shear wave velocity greater than 1800 feet per second) then a fixed-base dynamic structural response analysis can be performed. Input time histories are taken from existing recorded earthquake catalogues, and are selected so as to be appropriate for the site location and local soil conditions. Any benchmarked dynamic structural analysis code can be used for these analyses, and such analyses can usually be performed on a personal computer.

To incorporate inherent uncertainties in the earthquake ground motions, soil material properties and structure dynamic properties, a set of 10 (independent) time history response calculations should be made. The randomness associated with the ground motion is included through the use of multiple time histories. The randomness in soil and structure properties is included by sampling the distributions for these quantities. From Reference 2, these distributions, characterized by their coefficients of variation (COV), can be taken as:

<u>Parameter</u>	<u>COV</u>
Building Natural Frequencies	0.25
Building Damping	0.35
Piping Natural Frequencies	0.25
Piping Damping	0.35
Soil Shear Modulus	0.40
Soil Material Damping	0.50

The coefficient of variation - defined as the ratio between the standard deviation and the mean - applies to any form of statistical distribution. Since the above quantities are always positive, it is appropriate to use the log normal distribution to model their variations, as was done in Reference 1. For each of the 10 time history analyses, random independent samples are chosen for each of the above parameters from their specified distributions. A systematic scheme for choosing these samples is the use of Latin Hypercube Sampling (Ref. 16), although any form of experimental design may be used. (It has been found in Reference 1 that 10 such analyses are adequate to determine the medians of the responses, while considerably more analyses are required to accurately estimate the variability. However, response variability can be estimated separately as described later.)

The result of these multiple time history calculations is a set of 10 values for each response (floor slab spectral or peak acceleration) from which median responses can be inferred. It has been found (Ref. 1) that such responses are adequately modeled as log normally distributed random variables, so this model (see, for example, Reference 14) should be used in estimating the median responses. Note that one must compute the spectral acceleration for each component at the equipment damping corresponding to that used in specifying the equipment fragility so that consistency is maintained.

If the structures are founded on soil (and cannot be reasonably approximated as responding in fixed-base modes), a soil-structure interaction dynamic response analysis must be performed. The effects of shallow or inhomogeneous soil conditions require analyses using the SHAKE code (Ref. 7) in conjunction with previously generated results and approximate rules such as those of Roesset (Ref. 17) to determine the foundation input motion. Analyses are usually performed for several earthquake levels (usually 1 SSE, 2 SSE and 3 SSE), and consistent soil properties are determined in the process.

Finally, for the soil structure analysis, the floor slab accelerations are computed using the lumped mass/beam element model of the structure and foundation using a soil structure interaction code such as the CLASSI

code (Reference 8). This code (available from the Argonne Code Center) takes the fixed-base eigensystem model of the structure and input-specified frequency dependent (or independent) soil impedances and computes the structural response (as well as variation in structural response if desired). The cost of running CLASSI is not great, but it is effectively run only on a main-frame computer.

In order to obtain a model of each median acceleration response as a function of peak ground acceleration (for use in the component failure calculations to be described later), analyses for each set of ten time histories should be performed at three peak ground acceleration levels (say, 1 SSE, 2 SSE and 3 SSE) as a minimum. The same set of time histories - scaled to the different pga values - can be used. From the resulting median response values at these three peak ground accelerations, the median response at any other ground acceleration can be determined by interpolation. It is generally found that the median responses are linear up to 3 SSE or greater, and that a linear curve fit is quite adequate for the interpolation, or is, at most, slightly conservative for higher ground accelerations.

Variability in Responses

As described above, the "exact" variability in the responses could be determined directly by performing a large number (typically 30 to 60) of multiple time history analyses while systematically varying the input parameters. (This would have to be done at multiple peak ground acceleration levels). However, based on examination of the very large number of responses calculated in the SSMRP (Ref. 2), a distinct relationship between magnitude of variability and type of acceleration was found, and it was further found that the magnitudes of the variabilities did not vary significantly with acceleration level.

Hence, variability in responses (floor and spectral accelerations) can be assigned directly based on the SSMRP results, and the number of response calculations required reduced substantially. In order to compute confidence bounds for the final core damage frequencies, both random (irreducible) and systematic (modeling) uncertainties must be considered. The recommended generic uncertainties derived from the extensive response calculations performed in the SSMRP, expressed as standard deviations of the logarithms of the responses (β), are shown below:

<u>Quantity</u>	<u>β random</u>	<u>β systematic</u>
Peak Ground Acceleration	0.25	0.25
Floor Zero Period Acceleration	0.35	0.25
Floor Spectral Acceleration	0.45	0.25

Correlation Between Responses

In calculating the probability of failure of cut sets involving components whose seismic failures may be correlated (i.e., not

independent), it is necessary to consider correlation both in the responses and in the fragilities of each pair of components. Again, the correlations between the responses could be determined by extensive multiple time history analyses as was done in the SSMRP. However, in similar fashion as above, examination of a large number of pairs of responses calculated in the SSMRP showed a distinct pattern to the values of correlation that existed between the various types of responses. From these insights, a set of rules were formulated which predicted the "exact" correlations with adequate accuracy.

Thus, the correlation between pairs of responses can be assigned according to the rules on Table 3.1 and these rules depend only on the nature and location of the responses being considered. These rules to be used for all acceleration levels, and for both BWR and PWR plant configurations. (Correlations between pairs of fragilities are discussed later).

3.6 Fragility Analysis

Component failure is taken as either loss of pressure boundary integrity or loss of operability. Failure (fragility) is characterized by a cumulative distribution function which describes the probability that failure has occurred given a value of loading. Loading may be described by local spectral acceleration or moment, depending on the component and failure mode. The fragilities should be related to the appropriate local response to permit an accurate assessment of the effects of common-cause seismic failures in the evaluation of the accident sequences.

3.6.1 Procedures for Fragilities

Developing fragilities is usually the critical path item in a seismic risk assessment. The work involved can be substantially reduced through:

- a. Screening of the accident sequences using conservative point estimate values for the seismic failure probabilities to determine those accident sequences and components which dominate the risk,
- b. Using generic sources of fragility data for most components (not dominating the final risk value).
- c. Developing site-specific fragilities only for those components critical to the final result which do not fit in the generic categories.

Taken together, these approaches provide significant reduction in the amount of time and effort required to develop the necessary fragilities, and yet provide an easily documentable result.

Two important sources of fragility data exist. The first is the generic data base developed in the SSMRP, and the second is a compendium of site-specific component fragility results assembled at Lawrence Livermore National Laboratory. These are described below.

Table 3.1

Rules for Assigning Response Correlation ρ_{R1R2}

-
1. Components on the same floor slab, and sensitive to the same spectral frequency range (i.e, ZPA, 5-10 Hz, or 10-15 Hz) will be assigned response correlation = 1.0.
 2. Components on the same floor slab, sensitive to different ranges of spectral acceleration will be assigned response correlation = 0.5.
 3. Components on different floor slabs (but in the same building) and sensitive to the same spectral frequency range (ZPA, 5-10 Hz or 10-15 Hz) will be assigned response correlation = 0.75.
 4. Components on the ground surface (outside tanks, etc.) shall be treated as if they were on the grade floor of an adjacent building.
 5. "Ganged" valve configurations (either parallel or series) will have response correlation = 1.0.
 6. All other configurations will have response correlation equal to zero.
-

SSMRP Generic Fragility Data Base

A generic data base of fragility functions for seismically induced failures was developed in the SSMRP (Ref. 5). As a first step, all components were grouped into generic categories. For example, all motor operated valves located on piping with diameters between 2-1/2 and 8 inches were placed into a single generic category, and similarly, all motor control centers were placed into another generic category.

Fragility functions for the generic categories were developed based on a combination of experimental data, design analysis reports, and an extensive expert opinion survey. The experimental data utilized in developing fragility curves were obtained from the results of component manufacturer's qualification tests, independent testing lab failure data and data obtained from the extensive U.S. Corps of Engineers SAFEGUARD Subsystem Hardness Assurance Program. These data were critically examined for applicability and then statistically combined with the expert opinion survey data to produce the fragility curves for the generic component categories given in Reference 5.

LLNL Site-Specific Fragility Compendium

This report (Reference 6) lists fragility medians, random uncertainties and modelling uncertainties for a wide variety of components analyzed in past seismic PRAs. The components are identified as to type but not as to the source plant. It is usually a simple matter to identify whether the component is from a BWR or PWR. All fragility medians are expressed in terms of peak ground acceleration. One can use this to obtain a generic estimate for a certain component by assembling and averaging the data for all components of that type listed in the report. This data was used for the support failures of the Surry steam generator and reactor coolant pump anchorages and for the support failures of the Peach Bottom recirculation pumps in the NUREG-1150 analyses.

Recommended Generic Component Fragilities

A review and comparison of the site-specific component fragilities contained in the Lawrence Livermore data base against the generic component fragilities was made. Based on this review, the SSMRP generic fragilities were, in general, found to be appropriate. However, several of the SSMRP fragilities were updated based on a consensus of more recent data.

The final recommended generic categories and the corresponding fragility medians and uncertainties are shown in Tables 3.2 and 3.3. On Table 3.2 are shown estimates of typical fundamental natural frequencies of these generic components. These frequency estimates should be used to determine the appropriate response quantity to be computed (in the building response analyses) for each component whose seismic failure probability is needed in evaluating the seismic accident sequences. It is recommended that these fragilities be used as the starting point in a

Table 3.2

Generic Component Categories

<u>Fragility Category</u>	<u>Component Class</u>	<u>Typical Components</u>	<u>Frequency (Hz)</u>
1	LOSP	Ceramic Insulators	ZPA
2	Relays		5-10
3	Circuit Breakers		5-10
4	Batteries		ZPA
5	Battery Racks		ZPA
6	Inverters		5-10
7	Transformers	4KV to 480V and 480 to 120V	10
8	Motor Control Centers	Control for ESF Pumps and Valves	5-10
9	Aux. Relay Cabinets		5-10
10	Switchgear (Inc. Transformers, Buses and Breakers)	416V and 480V	5-10
11	Cable Trays		ZPA
12	Control Panels and Racks	RPS Process Control	5-10
13	Local Instruments	Misc. Pressure and Temperature Sensors	5-35
14	Diesel Generators	4160 AC Emergency Power Units	22
15	Horizontal Motors	Motor-Generator Sets	ZPA
16	Motor-Driven Pumps and Compressors	AFWS, RHR, SIS, Charging Pumps, Lube Oil Pumps, Diesel Starting Compressors	7
17	Large Vertical, Centrifugal Pumps (Motor-Drive)	Service Water Pumps	5
18	Large Motor-Operated Valves (> 10")		ZPA
19	Small Motor-Operated Valves (< 10")		ZPA
20	Large Pneumatic/Hydraulic Valves	Includes MSIV, ADP, and PORV	ZPA
21	Large Check and Relief Valves		ZPA
22	Miscellaneous Small Valves (< 8")		ZPA

Table 3.3

Generic Component Fragilities

<u>Comp</u>	<u>Median</u>	<u>Beta-r</u>	<u>Beta-u</u>	<u>Name</u>
1	0.25	0.25	.25	CERAMIC INSULATORS
2	4.00	0.48	.75	RELAY CHATTER
3	7.63	0.48	.74	CIRCUIT BREAKER TRIP
4	2.50	0.40	.39	BATTERIES
5	2.29	0.31	.39	BATTERY RACKS
6	2.00	0.26	.35	INVERTERS
7	8.80	0.28	.30	TRANSFORMERS
8	7.63	0.48	.74	MOTOR CONTROL CENTER
9	7.63	0.48	.66	AUX RELAY CABINET
10	6.43	0.29	.66	SWITCHGEAR
11	2.23	0.34	.19	CABLE TRAYS
12	11.50	0.46	.74	CONTROL PANELS AND RACKS
13	7.68	0.20	.35	LOCAL INSTRUMENTS
14	1.00	0.25	.31	DIESEL GENERATOR
15	12.10	0.27	.31	MOTORS-HORIZONTAL
16	2.80	0.25	.27	MOTOR-DRIVEN PUMPS & COMPRESSORS
17	2.21	0.22	.32	LG. VERT. M-D. CENTRIF PUMP
18	6.50	0.26	.60	LMOV
19	4.83	0.26	.60	SMALL MOV & AOVs
20	6.50	0.26	.34	LG. PNEUM/HYD VALVE
21	8.90	0.20	.35	LG. MANUAL, CHECK, RELIEF VALVE
22	12.50	0.33	.43	MISC. SMALL VALVES
23	3.00	0.30	.53	LG. HORIZ. VESSELS
24	1.84	0.25	.45	SM-MED HEAT EXCHANGERS & VESSELS
25	1.46	0.20	.35	LG. VERT VESSELS w/ FORMED HEADS
26	0.45	0.35	.29	LG. VERT. FLAT BOTTOMED TANKS
27	6.90	0.27	.31	AIR HANDLING UNITS

simplified seismic PRA. As in the use of any generic data base, one must be cognizant of the source of the data and the equipment to which it applies. An important aspect of using this data is to examine the equipment in the plant being analyzed and compare it with the data base for which the generic fragilities were developed. Any deviation should be noted and examined carefully, and site-specific fragilities developed as necessary.

3.6.2 Special Fragility Issues

There are a number of special issues which arise in the course of performing a seismic PRA. The resolution of these issues depends on the ultimate use of the seismic PRA. These issues are described below.

Relay Chatter and Circuit Breaker Trip

Fragilities for electrical components represent a special problem in that there is a wide variety of electrical gear found within a plant.

Typically, all this gear is enclosed in switchgear cabinets or motor control centers. The two lowest failure modes that were identified in the SSMRP fragility data base were relay chatter and inadvertent trip of circuit breakers. Virtually all the electrical switchgear and motor control centers in a nuclear power plant include these two types of components. Relay chatter is the weakest failure mode and, if indiscriminately included in a seismic analysis, would be the dominant failure. Because, in most cases, circuits are protected by time delay circuits and because, in most cases, chatter of relays would not cause a change in the state of a system being controlled, the SSMRP chose not to include relay chatter as a failure mode for electrical gear but rather included only circuit breaker trip. (Similarly, the NUREG-1150 seismic analyses of Surry and Peach Bottom did not include consideration of relay chatter, as the preliminary data on relay chatter - to be described below - did not exist at the time the analyses were performed.)

More recently, the commercial power industry, in recognition of the potential importance of relay chatter in vital control circuits, has sponsored a detailed investigation of relay types and susceptibilities as part of the activities of the Seismic Qualification Utilities Group (SQUG). These investigations, performed by the Electrical Power Research Institute, reviewed the types of relays currently found in nuclear power plants and attempted to classify the common types of relays as to their susceptibility to relay chatter. Certain relays (e.g., mercury switches) were found to be unacceptably vulnerable and it is the current SQUG recommendation that these relays be replaced when found. In general, it was found that control and switching relays were not susceptible to seismically-induced relay chatter. Rather, it is the over-voltage and over-current protective relays (as well as certain types of timing relays) which are susceptible. A preliminary listing of the relay types and their susceptibilities is contained in Reference 18. (Note that test data on all types of relays that were identified was not available, so this data source is not currently complete.)

This data provides a means of systematically including relay chatter in a seismic PRA, if desired. This is accomplished by having plant personnel review all important control circuits in critical safety systems so as to identify types of relays in the circuits. For those circuits involving relays known to be susceptible to chatter, the potential for "locking" behavior in the circuit given that the relay(s) could chatter is evaluated. If such locking behavior is identified in a circuit involving a vulnerable relay, then the generic relay chatter fragility should be applied to the system function controlled by that circuit. (Or, more likely, the utility may choose to replace the relay with one less vulnerable to seismic effects.) For the remaining circuits, the circuit breaker trip generic fragility could be used to model electrical failures in the affected system function. This would be combined with the applicable mechanical failure fragility for the components in the system. In this way, relay chatter effects can be systematically included in a seismic PRA if desired.

Piping Failure Considerations

Because of the extent and complexity of the many piping systems in a nuclear power plant, consideration of piping failure presents special problems in a simplified risk analysis. In general, piping is found to have a high margin of safety if only seismically-induced inertia loads are considered. High stresses tend to arise only where piping runs through walls, or is attached to a large vessel resulting in large relative displacements. However, in piping design, seismic stresses are usually held to a small percentage (say 15 percent) of the overall allowable stress. Hence, our recommendation is not to perform any dynamic piping analysis and neglect piping failures in general. This recommendation is supported by an extensive series of tests jointly sponsored by the NRC and the Electric Power Research Institute (Ref. 19) which showed that typical piping runs designed to nuclear power plant standards have margins of safety of 10-25 over the SSE design level.

Of course, during a walk-through of the plant, personnel familiar with piping design should examine critical pipes in the auxiliary feedwater, ECCS and the RHR systems to determine whether or not there are points where piping from one anchor point attaches to a large component or to an anchor point on a different foundation for which one might anticipate large relative motions. If such locations are found, it is possible, in an approximate sense, to analyze these piping segments for displacement induced stresses and hence develop an appropriate piping fragility for these locations without the need for a complete dynamic piping analysis.

Interbuilding Piping Failure due to Soil Failure or Liquefaction

One generic aspect of piping failure which should be considered is the possibility of interbuilding pipe failure due to relative motion - enhanced by soil failure or soil liquefaction. This applies primarily to PWR's because of their typically tall containment building

configurations and the fact that all safety and shutdown system piping must run between the auxiliary building (or equivalent) and the containment. If soil failure occurs under the containment during rocking motions, large relative displacements between the two buildings could occur, with the resulting possibility of failure of the interbuilding piping. Again, an analysis of the piping stresses for the piping running between the buildings can be performed using quasi-static methods after the relative building motions have been determined.

3.7 Seismic Risk Computations

Accident sequence frequencies are used in determining the frequencies of core damage and of radioactive release for a given release category. Total core damage frequency is defined as the sum of the frequencies of all accident sequences leading to core damage. In the quantification process, conditional accident sequence probabilities are determined at a number of pga values, and then these are de-conditioned by integration over the seismic hazard curve.

3.7.1 Quantitative Screening For Dominant Accident Sequences

Determination and quantification of the accident sequences is a multi-step procedure involving several levels of screening. In the first step, the SETS code (Ref. 20) is used to solve all the system fault trees using mean point estimate input screening values for all the seismic failure events (including the internal events point estimate failure values for all random events). The same fault trees used by the internal events analysis are solved with additions as noted in Section 3.4.2. The mean point estimate seismic screening values are taken as some conservative estimate, usually the component seismic failure probabilities evaluated at three times the SSE. (Since this step is usually performed early in the analysis - prior to the completion of the fragility analysis - generic fragilities are used for the majority of the components. However, for the critical buildings and those components identified during the initial plant walkdown as requiring plant-specific fragility development, the failure probabilities are set to unity.) These values are added to the random failure probabilities, and the total is used in the numerical screening process.

A dual probabilistic culling criterion is used in the culling process in this first step. In this process, a cut set is not deleted unless both its numerical value as well as the minimum value of any component failure probability in the cut set is less than the prescribed cutoff criterion. This dual criterion is used in recognition of the fact that potentially large correlations can exist between basic events in the same cut set due to the pervasive nature of the seismic input motion. The result of this screening step is a set of Boolean equations describing the failure modes of each of the safety and support systems.

In the second step, again utilizing the SETS code, these system Boolean equations are merged together to form the accident sequences as defined by the internal events analysis event trees. At this stage, truncation is

performed based both on the order of the cut sets as well as the probability of the cut sets. The result of this step is a set of Boolean equations describing each accident sequence in terms of cut sets which now contain all the important seismic and random failure events.

Each accident sequence so derived consists of the union of groups of events (successes or failures of safety systems) which must occur simultaneously for the accident sequence to occur. The failure of each safety system can be represented in terms of minimal cut sets, which are groups of component failure which will cause the safety system to fail. These cut sets and the accident sequences are combined together so that every accident sequence can be expressed in a Boolean expression of the form

$$ACC_j = IE_j [C_1C_2C_3 \text{ or } C_4C_5 \text{ or } \dots \text{ or } C_iC_jC_k]$$

in which IE_j is the initiating event and the C_i are basic events (i.e., failure of individual components) identified on the system fault trees. If at least one of the component failure groups $C_iC_jC_k$ occurs, then the accident sequence occurs.

3.7.2 Accident Sequence Quantification

The final step involves the actual quantification of the accident sequences (using best-estimate seismic failure probabilities from the final fragility evaluations) for each earthquake level being evaluated. The same accident sequence expressions are utilized both to compute the mean point estimates of the accident sequence frequencies and to perform the uncertainty analysis calculations. To facilitate computations as well as documentation, a cross reference table should be set up which relates each component to a component identification number, its random point estimate failure rate and error factor, and to its associated seismic fragility category and seismic response category. This cross reference table thus provides all the information required to compute the probability of failure of any basic event (random or seismic or combined) at any peak ground acceleration level.

Computation of each accident sequence probability consists of determining the probability of each cut set, and then combining them to get the accident sequence probability. Finally, the accident sequence probability is computed using the expression

$$P(ACC) = 1 - \prod [1 - P(\text{cutset } j)] .$$

This expression represents an upper limit to the accident sequence probability (assuming nonnegative correlations), and has been found to be a close approximation to the accident sequence probability (Ref. 1). This is true since the exact correlation can be considered in evaluating each cut set, while only the correlation between cut sets is neglected. However,

correlation between "or-ed" events (such as between cut sets) has only a minor effect while correlation between "and-ed" events (such as joint component failures within a cut set) has a major impact on the resulting probability.

These accident sequences are a function of (conditional upon) the peak ground acceleration (pga) used to evaluate the basic event failure probabilities. These must be de-conditioned by integrating each accident sequence (and the expression for core damage frequency) over the hazard curve using:

$$ACC_j = \int P(ACC_j, pga) f_{eq}(pga) d(pga)$$

where

$P(ACC_j, pga)$ is the conditional accident sequence frequency as a function of pga, and $f_{eq}(pga)$ is the probability distribution function for the hazard curve,

Any reasonably accurate numerical integration scheme may be used. In evaluating this integral, a lower limit of 0.05g is appropriate, and the upper limit should be chosen so that the computed estimate of risk can be shown to have converged. This depends very much on the slope of the hazard curve for higher accelerations and must be identified in an iterative fashion. The calculation of basic event failure probabilities, inclusion of correlation and uncertainty analysis are described below.

3.7.2.1 Basic Event Seismic Failure Probability Calculation

The probability of seismic failure of each component is computed using the so-called "interference theory" equation (Ref. 21) given by:

$$P_{fail}(pga) = \int F_{frag}(r) f_{resp}(r; pga) dr \quad (1)$$

where F_{frag} is the cumulative probability function for the fragility in terms of local response r and f_{resp} is the response probability density function on r conditional on pga.

However, it is recommended that each basic event seismic failure probability be computed assuming that the response and fragility distributions are lognormal in form. Calculations in the SSMRP showed that responses were reasonably fit by lognormal distributions. The limited data on fragilities can be fit with lognormal distributions as well as any other type. Hence, for convenience the lognormal distribution is used for both. The above general equation used to calculate seismic failure frequencies then simplifies to:

$$P_{fail} = \Phi \left[\frac{\ln \left(\frac{M_r(pga)}{M_f} \right)}{\sqrt{\beta_{rr}^2 + \beta_{fr}^2}} \right] \quad (2)$$

where

Φ is the standard normal cumulative distribution function and

$M_r(pga)$ is the median of the component response

M_f is the median of the component fragility

β_{rr} , β_{fr} are the random logarithmic standard deviations of the response and fragility, respectively.

Note that the use of lognormal distributions is not essential to the calculational process, and, in fact, any arbitrary pair of distributions could be used for the responses and fragilities provided they are physically meaningful.

3.7.2.2 Calculation of Correlated Basic Event Probabilities

When the individual basic failure events in a cutset $C_1 C_j C_k$ are not independent, correlation between the basic events must be explicitly included. Correlation can be due both to correlation in the responses (which arises due to the common ground shaking which is exciting the plant) and may also be due to correlation in the fragility estimates of the components. If the correlations between the responses and the correlations between the fragilities are known for two correlated components, then the correlation coefficient between the failure of these two components can be computed (Ref. 2) from:

$$\rho = \frac{\beta_{R1}\beta_{R2}}{\sqrt{\beta_{R1}^2 + \beta_{F1}^2}\sqrt{\beta_{R2}^2 + \beta_{F2}^2}} \rho_{R1R2} + \frac{\beta_{F1}\beta_{F2}}{\sqrt{\beta_{R1}^2 + \beta_{F1}^2}\sqrt{\beta_{R2}^2 + \beta_{F2}^2}} \rho_{F1F2} \quad (3)$$

in which

ρ = correlation coefficient between the failures of components 1 and 2

β_{R1}, β_{R2} = standard deviation of the logarithms of the responses of components 1 and 2

β_{F1}, β_{F2} = standard deviations of the logarithms of the fragilities of components 1 and 2

ρ_{R1R2} = correlation coefficient between responses of components 1 and 2

ρ_{F1F2} = correlation coefficient between the fragilities of components 1 and 2.

This relation shows that the correlation between the failures of components 1 and 2 depends not only on the correlations between the respective responses and the respective fragilities, but also on the variances in these responses and fragilities. Inasmuch as there are no data as yet which show correlation between fragilities, it is recommended that the fragility correlations between like components be taken as zero and 1, and the possible effect quantified. The correlation between the responses is computed according to the rules of Table 3.1.

In general, the probability of a cutset involving correlated seismic failures must be computed by evaluating the multi-variate probability distribution for the dependent failure events (Ref. 2). When the responses and the fragilities are log normal variables, the multivariate normal probability distribution can be used to compute the joint failure probabilities. The computer code SEISIM (Ref. 1) developed in the SSMRP was written expressly to calculate the probability of such correlated cutsets. Given the individual component responses and fragilities (in terms of the medians and variances of their distributions) and given the correlations between the responses and the fragilities, the code constructs a multivariate lognormal distribution for each minimal cutset, and then uses n-dimensional numerical integration to compute the probability of the minimal cutset.

For many common situations in seismic analysis, simplified methods for computing such correlated seismic joint failure probabilities exist. For example, when identical components are affected by the same response (e.g., are located on the same floor slab), the calculation of their correlated joint failure probability can be performed in simple fashion using Figure 3.8 as obtained from Reference 22. This allows consideration of up to four identical components having arbitrary failure correlation coefficient. The ordinant on this figure gives the exponent n_k to which the failure probability of a single component P_1 must be raised to obtain the correlated failure probability for joint failure of all k components. The abscissa ρ is the correlation coefficient as computed from equation 3. For example, if three components have an individual failure probability of 0.05, and if the correlation coefficient ρ between the failures is 0.5, then the coefficient n_3 is seen to be about 1.85 and thus the joint failure probability of the three components is

$$P(C_1C_2P_3) = (0.05)^{1.85} = 0.00392$$

(which is quite a bit higher than the failure probability for the cut set assuming the three events are independent, which is 0.000125).

For the case where two unlike basic events in a cutset are assumed to be correlated, the joint probability for the pair may be computed directly by the use of tables and formulae for the bi-variate normal probability

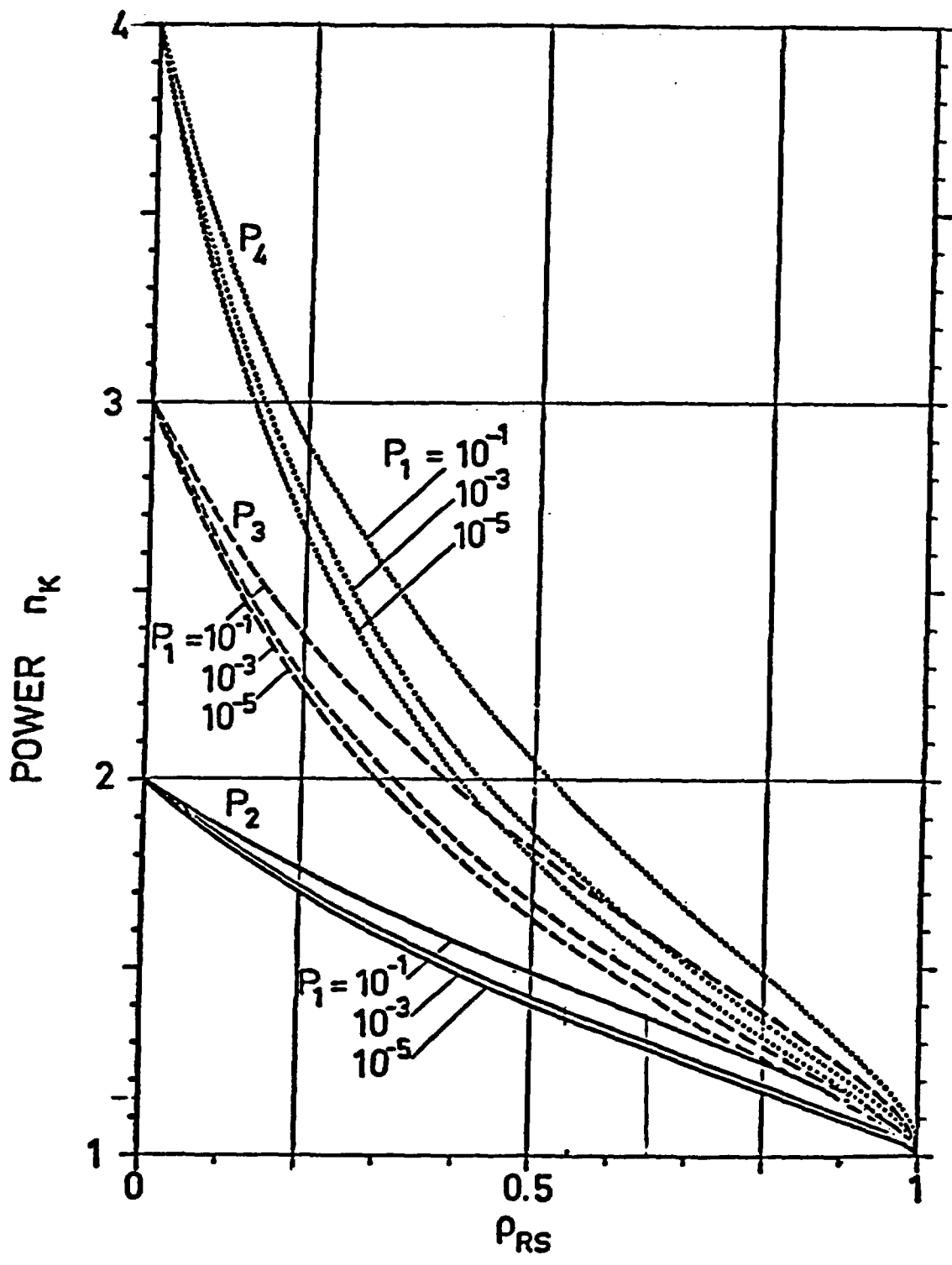

Figure 3.8 The Powers n_2 , n_3 and n_4 as a Function of the Correlation Coefficient and the Single Component Failure Probability P_1

distribution $B(h,k,\rho)$ as given in Reference 23. Again, ρ is computed from equation 3. (The remaining failure probabilities in the cut set, being independent, are multiplied in at the end).

A further savings in effort can be achieved by considering the magnitude of the correlation coefficient itself. In general, when the correlation coefficient between two components is less than 0.25, little error is made in assuming that they are independent. Similarly, when the correlation coefficient is greater than 0.75, it is reasonable to assume that they are fully dependent. These assumptions significantly reduce the labor in computing correlated joint failure probabilities with little loss in accuracy.

3.7.2.3 Uncertainty Analysis

Finally, a complete uncertainty analysis is performed on the dominant accident sequences (and on the dominant cutsets in each accident sequence). A true Monte Carlo analysis is recommended for the NUREG-1150 studies. Thus, the expression for the unconditional accident sequence frequencies (and for core damage frequency), shown below:

$$P(\text{ACC}_j) = \int P(\text{ACC}_j, \text{pga}) f_{\text{eq}}(\text{pga}) d(\text{pga})$$

where

$P(\text{ACC}_j, \text{pga})$ is the conditional accident sequence frequency as a function of pga, and

$f_{\text{eq}}(\text{pga})$ is the probability distribution function for the hazard curve,

is randomly sampled varying the hazard curve parameters, the random failure frequencies, and the seismic response and fragility parameters. From the accumulated values of accident sequence frequency and core damage frequency, exact statistics on their distributions are directly obtainable.

The sampling should be performed as follows. For each sample, a random hazard curve should be selected from the family of hazard curves and random values of the response median and the fragility median should be computed. For each of these three quantities, a random variable from a uniform distribution on [0, 1] is chosen and this is used to determine a new median using the known modelling uncertainties and the inverse of the standard normal probability distribution function. Note that new medians are computed for each response quantity and for each fragility category. The same "new" median must be used for every basic event assigned to either that response or that fragility.

Thus, in performing the uncertainty analyses, full correlation between random samples taken from each response category and from each fragility category is enforced. This is both theoretically correct and consistent with the philosophy utilized in the internal event NUREG-1150 uncertainty calculations.

3.7.2.4 Mean Point Estimate Calculations

In addition to the full uncertainty analysis (which produces exact mean values and exact percentiles of the distributions of the accident sequences and total core damage frequency) a "mean point estimate" should be computed. The mean point estimate is useful for illustrating various intermediate results (conditional accident sequences frequencies, initiating event frequencies, etc.) which explain the flow of the calculations, for demonstrating convergence of the numerical integration, and for performing sensitivity studies in a cost effective manner. Specifically, the mean point estimate is used to understand the contributions of the various basic events to the total frequencies and to understand the contributions to the total uncertainty bands.

The mean point estimate is computed by using the mean random failure frequencies, the mean seismic hazard curve, and the mean values for the seismic failure event frequencies in evaluating the accident sequences. The mean seismic failure probabilities are computed using both random and systematic uncertainties for the responses using:

$$E\{P_{fail}\} = \Phi \left[\frac{\ln (M_r(pga)/M_f)}{\sqrt{\beta_{rr}^2 + \beta_{ru}^2 + \beta_{fr}^2 + \beta_{fu}^2}} \right]$$

where

Φ is the standard normal cumulative distribution function,

$M_r(pga)$ is the median of the component response,

M_f is the median of the component fragility,

β_{rr} , β_{fr} are the random logarithmic standard deviations of the response and fragility, respectively, and

β_{ru} , β_{fu} are the systematic logarithmic standard deviations of the response and fragility, respectively.

Only one evaluation of the accident sequences is required to compute the mean point estimate. This mean point estimate will be seen to be nearly equal to the exact mean values of the accident sequence and core damage frequencies as obtained from the uncertainty analysis. This is to be expected because mean values probabilistically add to yield the mean value of each accident sequence (conditional on the hazard), and the only

difference between the true mean and the mean point estimate has to do with sampling error in the Monte Carlo uncertainty analysis. Experience has shown, however, that the difference between these is small.

3.7.2.5 Sensitivity Studies

In particular, the mean point estimate calculation is particularly useful in performing sensitivity studies. As a minimum, a sensitivity study on basic event importance to the overall mean core damage frequency and a sensitivity study on the relative importance of the hazard curve uncertainty as compared to the response/fragility uncertainties should be made.

The basic event importance can be ascertained by evaluating the "risk reduction potential" for each component. This is accomplished by setting the failure probability of each component (one at a time) to zero and reevaluating the mean (point estimate) core damage frequency. The percentage reduction in core damage frequency is thus a measure of its importance and a direct indication of the decrease in risk which would result if the component were strengthened so that it would never fail in a seismic event. It is clearly a means of ranking components as to the cost-effectiveness of any retrofit to strengthen a component.

The uncertainty importance study can be accomplished by setting the modelling uncertainties for each of the hazard, response and fragilities to zero (one at a time) and reevaluating the Monte Carlo uncertainty analysis to determine changes in the distributions of the accident sequence frequencies and the total core damage frequency. A convenient measure often used as an indication of the degree of uncertainty in any probability distribution is the Error Factor (EF) defined as the ratio between the 95th percentile and the 50th percentile of the distribution. Changes in the computed error factor as the hazard, response and fragility uncertainties are set to zero directly indicate their importance to the overall uncertainty. Examples of both types of sensitivity studies are included in the Surry and Peach Bottom NUREG-1150 seismic PRAs.

3.7.3 Presentation of Results

In order that the assumptions and input be traceable and that the output be relatively transparent, the following set of figures and tables should be provided for each seismic analysis:

- a. Figures showing the mean and median hazard curves at the site, the upper and lower bounds assumed, and a figure showing the site ground motion spectra.
- b. Tabulation of mean and median annual probabilities of exceedance of each discretization point of the hazard curve used in the numerical integration of the accident sequences.
- c. Listing of all earthquake time histories used in the analysis.

- d. Figures showing the event trees as modified for the seismic analysis.
- e. Tables listing the dominant cutsets for all important accident sequences.
- f. Table listing the basic events, their definition, random and test/maintenance probabilities, and corresponding seismic response and fragility categories.
- g. Table listing response points, description of location and elevation of each point, and the response pga multiple.
- h. Table showing the mean initiating event probabilities at each earthquake level.
- i. Table listing the mean conditional accident sequence frequencies/year for each earthquake level.
- j. Table listing the total (unconditional) mean accident sequence contributions for each interval on the hazard curve.
- k. Table listing the mean, variance, 5, 15, 35, 50, 65, 85 and 95 percentiles of the accident sequence and total core damage frequency distributions.

This data will provide the necessary input to allow the reader to reproduce any of the point estimate results.

3.8 Summary

The procedures described in this chapter describe a straightforward approach to the evaluation of seismic CDF which is minimally dependent on analyst judgement. The simplified building response calculation approach provides detailed and accurate results at a level of effort significantly less than that performed in the SSMRP and yet the results are totally defensible. The approach using conservative component failure probabilities in the initial screening minimizes the effort required to develop component fragilities. The use of a Monte Carlo analysis of the accident sequences and total core damage frequency allows for rigorous incorporation of arbitrary response functions and any degree of correlation. Taken together, this approach represents a reasonable and efficient, yet fully documentable and defensible, means of calculating seismic core damage frequency.

3.9 References

1. Smith, P. D., Chuang, T. Y., Bernreuter, D. L., Sheih, L. C., Bohn, M. P., Wells, J. E., Johnson, J. J., Seismic Safety Margins Research Program - Phase I Final Report, NUREG/CR-2015, 10 Volumes, September 1981.
2. Bohn, M. P., et al., Application of the SSMRP Methodology to the Seismic Risk at the Zion Nuclear Power Plant, Lawrence Livermore National Laboratory, Livermore, CA, NUREG/CR-3428 (1983).
3. Bernreuter, D. L., et al., Seismic Hazard Characterization of 69 Nuclear Plant Sites East of the Rocky Mountains, NUREG/CR-5250, October 1988.
4. Electric Power Research Institute, Seismic Hazard Methodology for the Central and Eastern United States, EPRI NP-4726, Vol. 1-10, July 1986.
5. Cover, L. E., et al., Handbook of Nuclear Power Plant Seismic Fragilities, NUREG/CR-3558, December 1983.
6. Campbell, R. D., et al., Compilation of Fragility Information From Available Probabilistic Risk Assessments, Lawrence Livermore National Laboratory Report UCID-20571 Rev. 1, September 1988.
7. Schnabel, P. B., Lysmer, J. and Seed, H. B., SHAKE -- A Computer Program for Earthquake Response Analysis of Horizontally Layered Sites, Earthquake Engineering Research Center, University of California, Berkeley, CA, EERC 72-12, 1972.
8. Wong H. L. and Luco, J. E., Soil-Structure Interaction: A Linear Continuum Mechanics Approach (CLASSI), Dept. of Civil Engineering, University of Southern California, Los Angeles, CA, CE79-03, 1980.
9. Bernreuter, D. L., Seismic Hazard Analysis: Application of Methodology, Results and Sensitivity Studies, Lawrence Livermore National Laboratory, NUREG/CR-1582, October 1981.
10. Seed, H. B., Ugas, C. and Lysmer, J., Site Dependent Spectra for Earthquake Resistant Design, Earthquake Engineering Research Center, University of California, Berkeley, CA, EERC 74-12m, 1974.
11. Newmark, N. M., A Study of Vertical and Horizontal Earthquake Spectra, WASH-1255, 1973.
12. Lambright, J. A., et al., Analysis of Core Damage Frequency: Peach Bottom Unit 2 External Events, NUREG/CR-4550, Vol. 4, Rev. 1, Part 3, December 1990.
13. Vesely, W. E., et al., Fault Tree Handbook, NUREG-0492, January 1981.

14. Kennedy, R. P., et al., "Probabilistic Seismic Safety Study of an Existing Nuclear Power Plant, in Proceedings of 5th International Conference on Structural Mechanics In Reactor Technology, August 1979.
15. Cook, R. D., Concepts and Applications of Finite Element Analysis, John Wiley and Sons, New York, 1974.
16. Iman, R. L. and Shortencarier, M. J., A Fortran 77 Program and User's Guide for the Generation of Latin Hypercube and Random Samples for Use with Computer Models, NUREG/CR-3624, SAND83-2365, March 1984.
17. Roesset, J. M., "The Use of Simple Models in Soil-Structure Interaction," Proceedings of the Second ASCE Conference on Civil Engineering and Nuclear Power, Vol. II, Knoxville, TN, September 15-17, pp. 10-3-1 to 10-3-25.
18. Betlack, J. and Kassawara, R., "Evaluating Seismic Functionality of Relays in Operating Nuclear Power Plants" in Proc. of Tenth Structural Mechanics in Reactor Technology Conference, Anaheim, Ca., August 14-18, 1989.
19. Guzy, D. J., et al., "Piping and Fitting Dynamic Reliability Program" in Proc. Sixteenth Water Reactor Safety Information Meeting, NUREG/CP-0097, October 1988.
20. Worrell, R. B., SETS Reference Manual, NUREG/CR-4213, May 1985.
21. Kapur, K. C. and Lamberson, L. R., Reliability In Engineering Design, John Wiley and Sons, New York, 1977.
22. Mankamo, T., Common Load Model: A Tool for Common Cause Failure Analysis, Electrical Engineering Laboratory Report 31, Technical Research Center of Finland, December 1977.
23. National Bureau of Standards, Tables of the Bivariate Normal Distribution Function and Related Functions, NBS Applied Mathematics Series 50, U.S. Government Printing Office, 1959.

4.0 FIRE ASSESSMENT PROCEDURES

Based on plant operating experience over the last 20 years, it has been observed that typical nuclear power plants will have three to four significant fires over their operating lifetime. Previous probabilistic risk assessments (PRAs) have shown that fires are a significant contributor to the overall core damage frequency, contributing anywhere from 7 percent to 50 percent of the total (considering contributions from internal, seismic, flood, fire, and other events). Because of the relatively high core damage contribution, fires need to be examined in more detail.

An overview of the simplified fire PRA methodology is as follows:

A. Plant Visit

Based on the internal events and seismic analyses, the general location of cables and components of systems of interest is known. The initial plant visit will provide the analyst with a means of seeing the physical arrangements in each of these areas. The analyst will have a fire zone checklist which will aid in the screening analysis.

The second purpose of the initial plant visit is to confirm with plant personnel that the documentation being used is in fact the best available information and to get clarification about any questions that might have arisen in a review of the documentation.

Also, a thorough review of fire-fighting procedures will be conducted.

B. Screening

It is necessary to select important fire locations within the power plant under investigation having the greatest potential for producing risk-dominant accident sequences. The objectives of location selection are somewhat competing and should be balanced in a meaningful risk assessment study. The first objective is to maximize the possibility that all important locations are analyzed, and this leads to the consideration of a potentially large number of candidate locations. The second objective is to minimize the effort spent in the quantification of event trees and fault trees for fire locations that turn out to be unimportant. A proper balance of these objectives is one that results in an ideal allocation of resources and efficiency of assessment.

The screening analysis is comprised of:

1. Identification of relevant fire zones. Fire zones which have either safety-related equipment or power and control cables for that equipment will be identified as requiring further analysis.
2. Screen fire zones on probable fire-induced initiating events. Determination of the fire frequency for all remaining plant

locations and determination of the resulting fire-induced initiating events and "off-normal" plant states is then accomplished.

3. Screen fire zones on both order and frequency of cut sets.
4. Each fire zone remaining is numerically evaluated and culled on frequency.

C. Quantification

After the screening analysis has eliminated all but the probabilistically-significant fire zones, quantification of dominant cut sets will be completed as follows:

1. Determine temperature response in each fire zone.
2. Compute component fire fragilities. The latest version of the fire growth code COMPBRN with some modifications will be used to calculate fire propagation and equipment damage. These fire calculations are only performed for the fire areas that survive the screening analysis.
3. Assess the probability of barrier failure for all remaining combinations of fire zones. A barrier failure analysis is conducted for those combinations of two adjacent fire zones which, with or without additional random failures, remain after the screening analysis.
4. Perform a recovery analysis. In a similar fashion, as in the internal event analysis, recovery of non-fire-related random failures will be addressed. Also, credit for either automatic or manual extinguishment of a fire before the COMPBRN predicted time to damage will be given.
5. An uncertainty analysis is then performed to estimate error bounds on the computed fire-induced core damage frequencies. The TEMAC code will be utilized in the uncertainty analysis.

4.1 Identification of Relevant Fire Zones

Determination of fire areas and the boundaries or barriers between respective areas will be made based on a review of the Appendix R submittal, a comprehensive analysis of the plant layout drawings, and supplemented with a plant walkdown to verify the selections made. Fire area determinations will then be made along major plant functional area boundaries (typically 3-hr rated fire barriers) based on the existing divisions from the general arrangement drawings.

4.2 Initiating Event Frequencies

Data on fires in light water reactors have been analyzed in several studies (Ref. 1, 2, 3). Although they have been done independently, they have some common aspects. For example, almost all studies have used License Event Report (LER) data from the Nuclear Regulatory Commission (NRC). All have reported the overall frequency of fires of approximately 0.16 per reactor year on a plant-wide basis.

To determine fire-initiating event frequencies, there are two kinds of information needed: (1) the number of fire incidents that have occurred in specific compartments during commercial operation, and (2) the number of compartment years that the nuclear industry has accumulated. Most of the data for the first part comes from reports of insurance inspectors to American Nuclear Insurers (ANI), although other sources are also used, e.g., the U.S. Nuclear Regulatory Commission. While the NRC requires the reporting of fires that, in some way, affect the safety of the plant, the ANI has more stringent requirements in the sense that all fire events must be reported. Compartment years are computed by adding the age of all compartments (within a certain category of compartments) of units that were in commercial operation by the end of June 1985. The age is defined as the time between first commercial operation and the end of June 1985 (or date of decommissioning). The combination of specific fire locations and compartment age is given in Table 4.1. Even though fire events that occurred when the plant was shutdown are used, an event is only included if it could be postulated that it also might occur when the plant was at power. Eight areas are typically found in nuclear power plants. These are: (1) the control room, (2) cable spreading room, (3) diesel generator room, (4) reactor building, (5) turbine building, (6) auxiliary building, (7) electrical switchgear room, and (8) battery room. In most plants, the first three areas, the electrical switchgear room, and battery room are single compartments while the other three are typically large buildings. Appendix A provides a listing of all fire events for each of these eight plant areas.

To obtain fire zone-specific initiating frequencies, a partitioning method is required. Partitioning allows the analyst to subdivide the frequency of fire occurrence from a large building (e.g., auxiliary building) to a specific room or area within that building. Also, further partitioning can occur within a specific room or area. One method of partitioning is comprised of ratioing the areas of fire zones within a building. The assumption here is that the probability of fire occurrence is dependent only upon the amount of area a fire zone contains. Another method of partitioning would look at each fire zone and analyze factors important to probability of fire initiation. These factors are the amount of electrical components and cabling, the fire loading, whether the fire zone is controlled, and how often the fire zone is occupied. Partitioning by the first method will only be used when there is no distinguishing characteristics of a fire zone or an area within that zone.

Table 4.1

Statistical Evidence of Fires in LWRs
(As of the end of June 1985)

Area	Number of Fires r	Number of Compartment Years T
Control Room	3	681.0
Cable Spreading Room	2	747.3
Diesel Generator Room	37	1600.0
Reactor Building	15	847.5
Turbine Building	21	654.2
Auxiliary Building	43	673.2
Electrical Switchgear Room	4	1346.4
Battery Room	4	1346.4

COMPBRN code calculations will also be used to partition fire frequency within a particular fire zone. For example, if it is known that a particular cable tray which runs through a fire zone must sustain damage to make a fire scenario valid then the length of this tray can be readily determined. COMPBRN calculations can then assess how far away from this tray a fire can be located and still cause damage. In this way an area of fire influence within a fire zone can be determined.

The fire events and operating years for the eight plant areas were obtained using the fire data base developed by Wheelis (Ref. 4). To determine operating years for electrical switchgear rooms and battery rooms, auxiliary building operating years are doubled. A survey of all U.S. light water reactors indicates that there is an average of 2.25 trains of emergency switchgear and their associated batteries per plant. However, it is known that some plants, such as Surry, locate both trains of their emergency switchgear in one fire zone. So, it was assumed that an average number will be close to two per plant for both types of rooms.

To aid partitioning within a large building or within a specific fire zone in that building, a checklist was used on the initial plant visit to determine the most probable fire-initiating sources. Also, data on past fire occurrences was thoroughly reviewed. For instance, control room data indicate that fires have only occurred in electrical cabinets. Therefore, area ratios will be developed based on cabinet area within this respective area. Since transient combustible-initiated fires have never occurred, they will be eliminated from further consideration for control room areas.

The generic fire occurrence data will be updated using a method developed by Iman (Ref. 5) to determine plant-specific fire occurrence frequencies.

This Bayesian approach models the incidence rate for each plant relative to the incidence rates of all other plants, and the posterior distribution is found for the incidence rate for each plant.

For this analysis the gamma distribution is used as a model, although many other distributions could be used. The probability density function for the two-parameter gamma distribution is:

$$h(\lambda) = f_{\gamma}(\lambda|\alpha, \beta) = \beta^{\alpha} [\Gamma(\alpha)]^{-1} \lambda^{\alpha-1} e^{-\beta\lambda} \quad \lambda \geq 0, \alpha, \beta > 0$$

These parameters α and β are unknown, and the noninformative prior is:

$$p(\alpha, \beta) \propto 1/(\alpha\beta) \quad \alpha, \beta > 0$$

The likelihood function of the datum (s_i, t_i) is Poisson

$$L(s_i, t_i | \lambda_i) = (\lambda_i t_i)^{s_i} e^{-\lambda_i t_i / s_i} / s_i!$$

The posterior density can, therefore, be expressed as:

$$p^*(\alpha, \beta, \lambda_0, \dots, \lambda_n) =$$

$$\frac{p(\alpha, \beta) \prod_{i=0}^n [h(\lambda_i) L(s_i, t_i | \lambda_i)]}{\int_0^\infty \int_0^\infty \int_0^\infty \dots \int_0^\infty p(\alpha, \beta) \prod_{i=0}^n [h(\lambda_i) L(s_i, t_i | \lambda_i)] d\alpha d\beta d\lambda_0 \dots d\lambda_n}$$

In this way plant-specific fire-initiating event frequencies and distributions will be developed.

4.3 Determination of Fire-Induced "Off-Normal" Plant States

One of the most critical steps in a fire analysis is to determine on a plant-specific basis which of a wide range of possible initiating events has the potential to be induced as a result of a fire occurrence.

As in the NUREG-1150 internal events analysis, a comprehensive list of initiators has been identified for further study. It is known from a review of previous fire PRAs that only a limited set of initiating events has the potential to be a significant contributor to fire-induced core damage frequency. Typically, initiating events such as large or medium LOCAs caused directly by the fire have not been analyzed because the vulnerabilities of piping systems or tanks to fire events are considered insignificant.

A comprehensive look at system drawings will be conducted to determine the potential for large or small LOCAs caused by spurious valve actuation. If no probabilistically significant mechanism can be found during this review, then fire-induced spurious actuation will be removed from further consideration. Even if spurious actuations would occur, it is known from past fires (such as at Brown's Ferry) that within approximately one-half hour spurious actuations terminate in open circuits.

The same fault trees and event trees that are used in the internal events analysis will be utilized in the fire analysis. Thus, the level of analytical detail will be consistent with the level in the internal event analysis.

4.4 Detailed Description of the Screening Analysis

A comprehensive screening analysis will be required to reduce the number of potential fire-induced scenarios to only those which have the potential to be probabilistically significant to core damage frequency.

The screening analysis is composed of the following four steps:

Step 1. Identification of Relevant Fire Zones

Fire zones containing equipment or cables associated with safety-related systems which mitigate the effects of the unscreened fire-induced "off-normal" plant states are identified. All other fire zones will then be eliminated from further analysis.

Step 2. Screen Fire Zones Based on a Critical Area Analysis

The remaining fire zones undergo a critical area analysis (location mapping) of components including control and power cables for a limited set of "crucial" components located within these areas. This information is used in conjunction with the SETS computer code (Ref. 6) to solve all front line systems and all of the identified fire-induced sequences of Section 4.3 in terms of fire-related and random failures.

Fire occurrence frequency for each zone will be set to 1.0 and, given a fire, all components within that zone will be assumed to fail. The output of this process is accident cut sets which include both fire zone combinations as well as random failures (i.e., not fire-related).

Truncation of cut sets at a random failure probability of 10^{-4} to 10^{-5} will be accomplished which is equivalent to truncation of internal event cut sets at approximately 10^{-8} since the fire frequency is arbitrarily set for screening purposes to 1.0.

Cut sets which require three or more fire zones will be eliminated. This is deemed appropriate since these cut sets imply the failure of two or more three-hour rated fire barriers. Cut sets which contain two fire zones will be screened on the following three criteria: (1) no adjacency between zones, (2) no penetrations in the adjacency between zones, and (3) if there are penetrations by numerical culling with barrier penetration failure set to a screening value of 0.1. It is known from the analysis of many fire barriers that typical failure rates are on the order of 10^{-2} to 10^{-3} . Therefore, this screening value will be set high enough to ensure potentially important fire zone combinations are not truncated in this screening step.

One additional important piece of information gained from these cut sets is the identification of the remaining plant locations where zone-to-zone barriers need to be analyzed. Dominant cut sets which contain adjacent fire zones are analyzed for barrier failure in the quantification process.

Step 3. Cull Fire Zones on Frequency

Cut sets not eliminated in the first three screening steps will be resolved by utilizing fire-zone-specific initiating event frequencies that are calculated using the method described in Section 4.2.

Also, operator recovery of non-fire-related random failures will be included. For screening purposes only all short-term (less than 24 hr) recovery action failure probabilities (of non-fire failures) will be increased from their respective internal events probabilities by a factor of five to allow for the additional confusion of the fire situation occurring in conjunction with other random failures. If recovery actions are long term (greater than 24 hr) no modification to internal event probabilities is deemed appropriate. It is felt that by this time the fire will be extinguished and any spurious signals will have terminated in open circuits.

Step 4. Confirmatory Plant Visit

For those remaining fire zones all fire-related failure scenarios are identified. A scenario can be thought of as a combination of one or more fire-related equipment failures within a fire zone with or without additional non-fire-related (random) failures outside of the fire area. These failure combinations must minimally lead to core damage. Each fire zone can have one or more scenarios depending on the equipment combinations which must fail due to the fire in that particular area. A second plant visit will then be conducted to determine which of these scenarios are valid based upon cable or equipment locations within a particular fire zone. For instance, if a given scenario requires the fire-related failure of cabling for components A and B, and it can be shown that these cables are always separated by greater than 40 ft and the area is sufficient size to preclude buildup of the hot gas layer or one of the component's cabling is in a 3-hr rated fire wrap, then these types of scenarios can be eliminated from further consideration. Past experience with fire code calculations (discussed in the following section) and fire testing provides much of the basis for assessing the validity of the scenarios.

4.5 Fire Propagation Modeling

The COMPBRN fire growth code (Ref. 7) will be used to calculate fire propagation and equipment damage. COMPBRN was developed specifically for use in nuclear power plant fire PRAs. The code calculates the time to damage critical equipment given that a fire has started. This failure time is then used in conjunction with information on fire suppression to obtain the probability that a given fire will cause equipment failure which leads to core damage before the fire can be suppressed. The latest version of the code, COMPBRN III (Ref. 8), with some additional modifications, is used for the calculations.

COMPBRN follows a quasistatic approach to simulate the process of fire during the preflashover period in an enclosure. COMPBRN uses a zone model breaking the fire environment into three zones: flame/plume, hot gas layer, and ambient (see Figure 4.1). Simple fire and heat transfer models and correlations are employed to predict the thermal environment as a function of time. The thermal response of various targets in the fire scenario is modeled to predict the amount of time required for a

COMPBRN Modeling

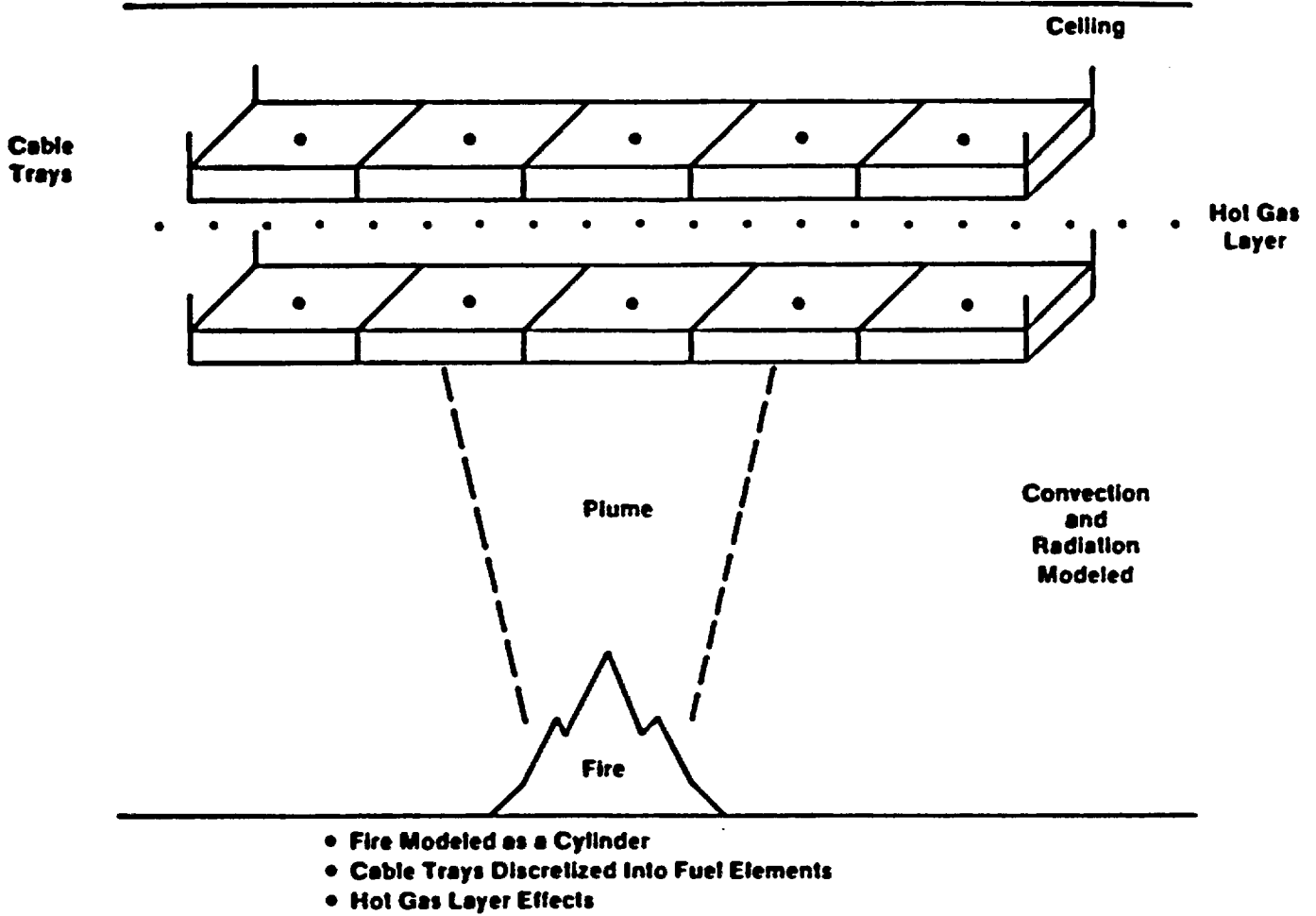

Figure 4.1 Fire Zone Geometry Considered in the COMPBRN Code

fire to damage or ignite critical equipment. The critical equipment is generally taken to be a cable tray carrying cables necessary for safe shutdown of the plant, although other critical components such as pumps may be modeled.

The original version of COMPBRN, now referred to as COMPBRN I, has been used to calculate damage time in the majority of fire PRAs to date. However, the code calculations are thought to be ultra-conservative due to the neglect of heat losses from the targets. A critical assessment of the code containing this and other problems has been performed (Ref. 3). In response to these problems with COMPBRN I, two later versions of the code were developed, COMPBRN II and COMPBRN III (Ref. 8). Neither of the later versions of the code has been extensively validated or compared to data, but presumably represent various degrees of improvement.

As a part of a recent study (Ref. 3) on nuclear power plant fire risk assessment, the latest version of the code (COMPBRN III) was selected to requantify fire damage times from several fire PRAs. Initial attempts to use COMPBRN III in the requantification resulted in the observation of problems with and nonphysical behavior of the code. Many of the code calculations could not be explained on a physical basis. As a result of the observed nonphysical behavior of the code, an effort was undertaken to identify problem areas and to suggest and implement modifications to the code which make the code predictions more reasonable on a physical basis. It was this modified version of the COMPBRN code which is used to provide the fire propagation analysis for this methodology. References 3 and 9 provide detailed discussions of the problems which were identified and addressed in the modified version of the code:

- a. An error, and nonconservative assumption, exists in the forced ventilation hot gas layer model, predicting low hot gas layer temperatures.
- b. Radiative heat transfer directly above the flame is not modeled, yielding cooler temperatures directly above the flame than off to the side of the flame.
- c. Two errors in the calculation of view factors overpredict the heat radiated to targets to the side as compared to objects directly above the flame.
- d. Only convective heat transfer, and not the dominant radiative heat transfer for objects directly engulfed in the flame, is modeled. Time to ignition is highly nonphysical.
- e. The conduction algorithm is unstable, often resulting in premature termination of the code, especially for cases involving objects in the flame or thermal response of barriers.
- f. The mass burning rate of burning objects is underpredicted due to lack of thermal feedback modeling.

- g. Cable insulation ignition and damage failure threshold criteria are not currently well understood and the results are quite sensitive to the input parameters chosen.

Both small and large fires will be postulated in the fire growth calculations. If neither of these fire sizes is shown to be capable of causing damage, fire size will be increased to determine how large a fire would actually have to be to cause damage. A small fire will be assumed to be 2 feet (0.61 m) in diameter and consist of 1 gallon (3.8 l) of oil. A large fire will be assumed to be 3 feet (0.91 m) in diameter and consist of 10 gallons (38 l) of oil. Analysis of a data base of transient combustible fuel sources found at nuclear power plants (Ref. 10) indicates that oil sources less than or equal to 1 gallon (3.8 l) were found approximately 70 percent of the time. Oil sources larger than this were found approximately 30 percent of the time. A similar partitioning between small and large quantities in terms of heat content (BTU or KJ) can be made for other credible transient combustible sources such as solvents or trash paper. Again, analysis indicates that a 70/30 partitioning between small and large fuel sources is appropriate (within ± 10 percent). It can also be shown that 10 gallons (38 l) of oil bounds any large solvent or trash paper combustible source in terms of heat content and is, therefore, an appropriate upper bound on transient combustible fuel source size.

A plant walkdown will be performed to obtain vital information for the COMPBRN calculations. This information includes the location of critical equipment and cable trays, separation between redundant trains, types of cable present, and any shielding of fire barriers that may be present.

Cable insulation and damage thresholds are currently not well known (Ref. 11). For this study, a cable insulation ignition temperature of 773°K (932°F) is assumed along with a damage temperature of 623°K (662°F). For the large fire simulations these thresholds are not as critical to the fire damage time calculations because of the intensity of the flames.

A list of typical parameters for the COMPBRN calculations is shown in Table 4.2. These parameters were selected based on past fire analyses at commercial nuclear facilities to represent typical qualified cable insulation.

A number of fire scenarios are typically considered for many fire areas. In most cases, a "zone of influence" will be determined for the equipment and fire sizes modeled. In other words, the fire location will be varied in the COMPBRN models to determine the maximum distance the fire could be away from the critical equipment and still cause damage. This, in effect, defines a radius on the floor anywhere in which a fire of a given size could occur and cause damage (although the time to damage, of course, varies with the distance from the target). This sensitivity study (zone of influence determination) is done for the two fire sizes described above and, of course, a different radius on the floor is determined for each of the fire sizes. In general, two situations can result:

Table 4.2

Modified COMPBRN III Input Parameters

<u>Cable Insulation Parameters</u>	
Density	1715 kg/m ³
Specific Heat	1045 J/kg-K
Thermal Conductivity	0.092 W/m-K
Heat of Combustion	1.85-2.31E-7 J/kg
Combustion Efficiency	0.6-0.8
Critical Temperature	
Pilot Ignition	773°K
Spontaneous Ignition	773°K
Damage	623°K
Surface Controlled Burning Rate	0.0001-0.0075 kg/m ³ -S
Burning Rate Radiation Augmentation	1.86E-7 kg/J-m ²
Radiative Fraction	0.3-0.5
Smoke Attenuation Factor	1.4
Reflectivity	0.1-0.3
<u>Oil Parameters</u>	
Density	900 kg/m ³
Specific Heat	2100 J/kg-K
Heat of Combustion	4.67E7 J/kg
Combustion Efficiency	0.9
Surface Controlled Burning Rate	0.06
Radiative Fraction	0.3-0.5
Mass of Oil	3.4-34.0 kg

- a. If both fire sizes can cause damage to the target a fire cut set is evaluated for each fire size. The fire occurrence frequency for each cut set is ratioed down by the conditional probability of the fire size occurring as well as the size of the floor area over which damage can result.
- b. If the small size fire cannot cause damage (even directly under the target) but the large fire can, then only a single cut set need be evaluated and the total fire frequency is reduced by the ratio of the floor area over which the large fire can cause damage to the total fire zone floor area and also by a severity factor to account for the fact that most fires that will occur will be of insufficient magnitude to cause damage.

If it is found, however, that even the large pool fire (directly under the target) cannot cause damage, then the fire pool size is increased (up to six feet) and COMPBRN is rerun again to see if any damage can occur. This is done so that no cut set is lost due to the fact that only two discrete pool sizes are used. If, for example, a large pool fire of diameter of four feet is found to cause damage (whereas the initial large fire of three foot diameter did not cause damage) then the cut set is retained and the fire frequency is partitioned even further. This assures that cut sets are not lost due to the discrete nature of the calculations being performed by COMPBRN and the discrete fire sizes recommended.

The times to damage increase exponentially as the fire distance increases. Using these results, the floor area in which a fire would have to occur to damage critical cables can be estimated. An area ratio can then be calculated by dividing this area by the total floor area of the room, fire area, or building (as appropriate). This reduction factor can then be multiplied by the initiating frequency to estimate the frequency of fires which occur in a critical portion of a given room.

It should be noted that a small fire, except for zone of influence cases, does not yield damage in most fire areas. Prior experience with COMPBRN shows that a small fire must be very close to its target to yield damage. Large fires, however, can and do yield damage in most cases. The major exception is in small closed rooms (like a battery room) in which a hot gas layer rapidly develops. In such cases, the hot gas layer effects become quite significant. Thus, for some of the COMPBRN runs, room parameters are used in order to simulate a model of the hot gas layer. For these cases, damage occurs sooner due to the increased thermal input from the hot gases.

It has been found in past experience with COMPBRN and in some of the simulations for Peach Bottom that the COMPBRN results can be quite sensitive to fires located adjacent to walls which are in close proximity to the target cable trays. Using the typical model of the wall as one section results in unrealistic radiative heat fluxes from the wall to the

cable trays of interest. For these cases, the wall is divided into several sections to more realistically calculate the wall thermal response. It is recommended that the wall area be divided into three vertical sections with the section closest to the fire having the same horizontal dimension as the fire diameter. The other two sections equally divide the remaining wall area. Without this division, COMPBRN will predict a constant temperature along the entire wall surface in the horizontal direction. The predicted temperature is thus overestimated for all points except that with the closest distance to the fire. The effect is that re-radiation from the wall at a higher temperature predicts damage in shorter time frames than a more realistic temperature profile would.

4.6 Barrier Failure Analysis

In the unscreened cut sets where a potential for barrier failure has been identified, barrier failure probability will be estimated using barrier failure rates developed as described below.

Barriers are grouped into three types: (1) fire doors, security doors, water-tight doors, and fire curtains, (2) fire dampers and ventilation dampers; and (3) penetration seals and fire walls. The data base contains 628 records from when construction began on any given plant to the end of June 1985. The number of barriers of each type at a plant is required to estimate the rate at which a specific component fails. The number is not known precisely for each plant, but a nominal figure that has been estimated for each barrier type is given in Table 4.3.

The generic barrier failure rates are determined based on estimates of barrier failure rates for each individual type of barrier, i.e., fire damper, door, etc. For a given fire zone, the total barrier failure rate is determined as the union of the probabilities of the individual barrier failure rates. Thus, this is entirely plant specific, as the number and type of barriers in any given zone is plant specific.

The statistical uncertainty of each estimate, reflecting sampling variation and plant-to-plant variation, is represented by 90 percent confidence bounds. These estimates and confidence bounds are given in Table 4.4 where units of both estimates and bounds are failures/year.

During the confirmatory plant visit scenarios require barrier failure will have those barriers inspected. If no plant-specific vulnerabilities (i.e., barriers missing or not intact in its normal configuration) are noted as a result of this inspection, no modification of generic barrier failure rates will be performed.

4.7 Recovery Analysis

For those remaining cut sets which survive the screening process and where the COMPBRN code predicts fire damage will occur, recovery of random failures and credit for extinguishment of the fire before the COMPBRN predicted time to fire damage will be applied.

Table 4.3

Approximate Number of Barriers at a Plant

<u>Type</u>	<u>Nominal</u>
1	150
2	200
3	3000

Table 4.4

Estimates of Single Barrier Failure Rate

<u>Barrier Type</u>	<u>Barrier/ Unit</u>	<u>Estimate</u>	<u>5% Confidence Bound</u>	<u>90% Confidence Bound</u>
1	150	7.4E-3	0.0	2.4E-1
2	200	2.7E-3	0.0	2.2E-1
3	3000	1.2E-3	0.0	3.7E-2

An important component in determination of the frequency of fire-induced core damage scenarios is the ability of the plant fire brigade to respond to and extinguish fires in a timely fashion before damage can occur to plant systems and components important to safety. The COMPBRN fire propagation code predicts the time to ignition or damage of critical cables and components. The COMPBRN predicted fire-induced equipment or cable damage times are used in conjunction with a distribution on time to suppression of fires to obtain the probability that a given fire will damage critical safety equipment before it can be suppressed.

The probability of nonsuppression of a given fire has been determined from a data base on fire suppression times (Ref. 4) and developed in the Fire Risk Scoping Study (Ref. 3). The result is a cumulative probability distribution function which gives the probability that a fire has not been suppressed as a function of time. This distribution function is used in conjunction with the results of the COMPBRN code calculations,

which predict the time to failure for a given piece of equipment in a given fire zone. The time to failure is input into the nonsuppression probability distribution and the result is the probability that the fire has not been extinguished prior to the time that the component will fail due to the fire. This term is in every fire cut set. Given the COMPBRN results which typically predict fire damage in 2 to 15 minutes an adequate bound on the uncertainty is assumed to be ± 15 minutes. This uncertainty estimate was determined based on consultation with fire code and testing experts.

Recovery of random failures (non-fire related) is treated in a similar fashion as in the internal events analysis (Ref. 10). All operator recovery actions that are used in the internal events analysis will be inspected for use where appropriate in the remaining cut sets. If a sequence is long term (greater than 24 hrs), two recovery actions will be allowed. In short-term (less than 24 hrs) sequences only one recovery action will be allowed. A particular recovery action will be chosen if the possibility of multiple recovery actions is present on a hierarchy (based on the highest likelihood of successful recovery) established by the internal events analysts.

In the areas where fire-fighting activity takes place, no credit will be given for local recovery actions until after the fire is extinguished. In non-affected areas, local recovery is allowed for valve manipulation or pump operation when damage to power cabling of an applicable component has not occurred.

The recovery analysis will also give credit for automatic extinguishment of a fire before damage occurs. As part of the plant walkdown, plant-specific aspects such as (1) type of detection and actuation, (2) detector spacing, (3) actuation delay times, (4) required fire location, (5) predicted fire damage times, and (6) type of suppression will be utilized to determine if generic system reliability data will be applied.

Failure rates (on demand) for the three types of fire systems (water deluge, CO₂ and Halon) were developed based on a literature review (Refs. 11 through 14). Table 4.5 lists the failure probabilities given a system demand for each of the three system types.

Based on this literature search best estimate values for system reliability for water, Halon, and CO₂ were taken to be 96%, 94%, and 96% respectively.

4.8 Uncertainty Analysis

Distributions on fire frequency, fire suppression probability, fire code calculations, random failure probability, barrier failure probability, and operator recovery actions generate uncertainties on fire-induced core damage frequencies.

Table 4.5

Automatic Suppression System
Failure Rates (On Demand)

<u>System</u>	<u>Failure Rate</u>
Water Deluge	0.049 ¹¹
	0.038 ¹⁴
	0.0063 ¹²
Halon	0.20 ¹¹
	0.059*
	0.0536 ¹⁴
CO ₂	0.116 ¹¹
	0.04 ¹³
	0.002 ¹²

The uncertainty of these values is propagated through the accident sequence models using two computer codes. A Latin Hypercube Sampling (LHS) algorithm is used to generate the samples for all of the parameter values (Ref. 15) while the Top Event Matrix Analysis Code (TEMAC) is used to quantify the uncertainty of the accident sequence equation using the parameter value samples generated by the LHS code (Ref. 16).

LHS is a constrained Monte Carlo technique which forces all parts of the distribution to be sampled. The LHS code is also flexible in that it can sample a variety of random variable distributions. Furthermore, parameter distributions for similar events can be correlated. For example, if two similar components (e.g., MOV XX-FTO and MOV YY-FTO) are modeled from the same probability distribution, then the sampling of these two distributions is perfectly correlated, meaning the same value is used for both events in a given sample member. For basic events which are modeled with very similar but slightly different distributions (e.g., MOV XX fails to remain closed for 100 hrs and MOV YY fails to remain closed for 200 hrs), the LHS code permits an induced correlation between the samples. However, LHS does not allow the correlation coefficient for this case to be equal to 1.0. LHS does permit sampling with a coefficient of 0.99 in these cases.

* Letter from SAIC Senior Staff Scientist Bill Parkinson to John Lambright, Dated May 3, 1988.

TEMAC uses the LHS parameter samples and the accident sequence equations (cut sets) as input to quantify the core damage estimates. TEMAC generates a sample of the accident sequence frequency, a point estimate of the frequency, and various importance measures and ranking for the base events.

Uncertainty on fire-initiating event frequency will be developed when the generic fire frequencies are updated using plant data. This process which is briefly discussed in Section 4.2 is covered in more detail in Reference 5.

Uncertainty on fire nonsuppression probabilities ($Q(t_g)$) will be addressed by modification of COMPBRN predicted time to damage. The COMPBRN predicted time to damage and its associated non-suppression curve probability are taken to be a best estimate of a maximum entropy distributed variable. Fifteen minutes will be added and subtracted from the COMPBRN predicted time to allow for uncertainty in its result and the uncertainty in the probability of nonsuppression distribution. These probabilities are then taken as a minimum and maximum of a maximum entropy distribution, respectively. The maximum entropy distribution is the simplest distribution one can envision for a random variable for which a lower bound, an upper bound and a mean value are known or estimated and its use is appropriate when nothing else is known about the distribution.

Uncertainty associated with the fire size estimate factor (f_s) can be developed utilizing information associated with plant inspection reports which survey different types of combustibles and their amounts found in nuclear power plants. Two fire sizes, a large and small fire, are modeled as described in Section 4.5. These fire sizes (BTU content) are compared to the distributions on possible fire sizes developed for the different combustibles from the I&E data. The best estimate percentage of fires that were either large or small is taken from an average of the different types of combustibles for an equivalent BTU level fire modeled by COMPBRN. This probability is assumed to be the best estimate value of a maximum entropy distribution. Maximum and minimum probabilities for this distribution are assumed to be based on one individual type of combustible with either the maximum or minimum percentage corresponding to applicable fire size (BTU rating).

Uncertainties in random failure events and operator recovery actions will be treated identically as in the NUREG-1150 internal events analysis. No modification needs to be made for the fire analysis.

Uncertainty in probability of automatic suppression system reliability were developed using the data referenced in Table 4.5. For each type of suppression system the upper and lower bounds were assigned based on the additional data values not assigned as best estimate probabilities. These data values were then represented by a maximum entropy distribution.

The fire zone partitioning factor (f_a) reduces the building fire frequency down to that portion applicable to the fire zone in question. Uncertainty in this factor is obtained by computing the partitioning factor three ways; based on floor area, based on number of electrical components in the zone versus total in the building, and by amount of cable in the zone versus the total. Typical bands are multiplicative factors of 5.0.

The local area partitioning factor reduces the fire zone fire initiating frequency by the ratio of the floor area within the room over which the fire must occur to the total zone floor area, and as described previously is based on COMPBRN sensitivity runs. The uncertainty in this parameter is due to uncertainties in COMPBRN input parameters, uncertainties in the COMPBRN models themselves, and uncertainties in the physical location of the target components. This latter uncertainty often turns out to be the most important source of uncertainty. Our experience leads us to recommend a multiplicative factor of 5, but this could be reduced by greater knowledge of component and cable locations.

Some additional potential areas of risk which could be analyzed by use of this critical area methodology are identified as follows:

- a. Effects due to suppression activities (both automatic and manual) on safety equipment. This includes suppression effects in the zone where the fire is as well as the effects in other areas.
- b. Effects due to smoke, corrosive gases and humidity changes caused by a fire on safety-related equipment.
- c. Electrical independence between control room circuits and remote shutdown type panels (either one central panel or several small panels located in different zones) that allow for control of safety equipment if the control room is evacuated.

Sensitivity analyses will be performed as identified on a plant-specific basis. Plant-specific sensitivity studies should be conducted on those assumptions in the fire analysis that are the most dominant contributors to the overall results. Such factors can be readily identified during the cut set quantification process.

4.9 Conclusion

By use of this methodology, the frequency of significant fire threats to a nuclear power plant can readily be quantified. Significant reductions in time and cost of analysis are accomplished with the aid of a previously completed internal events analysis.

This methodology results in a similar level of detail to that of the internal events and seismic studies. By use of the same fault trees and event trees, these results can be compared directly to core damage estimates from either internal events or seismic initiators. This allows any given nuclear power plant to have a consistent basis on which to make any decisions as to the relative effect of any potential plant modifications. Studies based on engineering judgment alone (without the aid of a computer-based critical area analyses) have been shown to miss many significant fire area contributors to fire-induced core damage frequency. Fire threat analysis supports the NUREG-1150 document as part of a comprehensive external events risk profile.

4.10 References

1. Seabrook Station Probabilistic Safety Assessment, Section 9.4, Public Service Company of New Hampshire and Yankee Atomic Electric Company, December 1983.
2. Severe Accident Risk Assessment Limerick Generating Station, Chapter 4, Main Report, Philadelphia Electric Company, Report #4161, April 1983.
3. Lambright, J. A., et al., Fire Risk Scoping Study: Current Perception of Unaddressed Fire Risk Issues, Sandia National Laboratories, Albuquerque, NM, SAND88-0177, NUREG/CR-5088, December 1988.
4. Wheelis, T., Users Guide for a Personal-Computer-Based Nuclear Power Plant Fire Data Base, Sandia National Laboratories, Albuquerque, NM, SAND86-0300, NUREG/CR-4586, August 1986.
5. Iman, R. L., and Hora, S. C., Modeling Time to Recovery and Initiating Event Frequency for Loss of Off-Site Power Incidents at Nuclear Power Plants, Sandia National Laboratories, Albuquerque, NM, SAND87-2428, NUREG/CR-5032, January 1988.
6. Worrell, R. B., SETS Reference Manual, Sandia National Laboratories, Albuquerque, NM, SAND83-2675, NUREG/CR-4213, May 1985.
7. Siu, N.O., COMPBRN - A Computer Code for Modeling Compartment Fires, University of California, UCLA-ENG-8257, NUREG/CR-3239, May 1983.
8. Ho, V., Siu, N. O., and Apostolakis, G., COMPBRN III - A Computer Code for Modeling Compartment Fires, University of California, UCLA-ENG-8524, November 1985.
9. Ruger, C., Boccio, J. L. and Azarm, M. A., Evaluation of Current Methodology Employed in Probabilistic Risk Assessment (PRA) of Fire Events at Nuclear Power Plants, Brookhaven National Laboratory, NUREG/CR-4229, May 1985.
10. Swain, A. D. and Guttman, H.E., Handbook of Human Reliability Analysis with Emphasis on Nuclear Power Plant Applications, Sandia National Laboratories, Albuquerque, NM, SAND80-0200, NUREG/CR-1278, August 1983.
11. Northeast Utilities, Millstone 3 PRA, Appendix 2-K, 1983.
12. Galluci, R. A Methodology for Evaluating the Probability for Fire Loss of Nuclear Power Plant Safety Functions, PhD. Thesis, Rensselaer Polytechnic Institute, Troy, NY, May 1980.

13. Taiwan Power Company, Maanshan Fire PRA, Appendix D, 1987.
14. Levinson, S. and Yeater, M., Methodology to Evaluate the Effectiveness of Fire Protection Systems at Nuclear Power Plants, Nuclear Engineering and Design, 1983.
15. Iman, R. L. and Shortencarrier, M. J., A FORTRAN 77 Program and User's Guide for the Generation of Latin Hypercube and Radom Samples for Use with Computer Models, Sandia National Laboratories, Albuquerque, NM, SAND83-2365, NUREG/CR-3024, March 1984.
16. Iman, R. L. and Shortencarrier, M. J., A User's Guide for the Top Event Matrix Analyses Code (TEMAC), Sandia National Laboratories, Albuquerque, NM, SAND86-0960, NUREG/CR-4598, August 1986.

APPENDIX A
FIRE EVENT DATA TABLE

Table A.1
Auxiliary Building Fires

<u>Plant Name</u>	<u>Date of Occurrence</u>	<u>Plant Status</u>	<u>Fire Type</u>	<u>Remarks</u>
San Onofre 1	2/7/68	Power Operation	Cable	Thermally overloaded 480 V cables caught fire--55 cables damaged.
San Onofre 1	3/9/68	Power Operation	Cable	Thermally overloaded cables in switchgear room.
Palisades	6/25/71	Cold Shutdown	Air Dryer Filter	Low flow of air through air dryer resulted in temperature buildup and ignition of filter.
LaGrosse	7/15/72	Power Operation	Circulation Pump	Oil on pump lagging ignited by hot pump casing.
Turkey Point 3	12/16/72	Power Operation	Battery Charger	Battery charger overheated and a small fire occurred in the transformer winding insulation.
Robinson 2	4/19/74	Power Operation	Expansion Joint	Cigarette or welding slag from construction workers ignited combustible expansion joint material.
Robinson 2	4/19/74	Power Operation	Expansion Joint	Same type of event as previous event--occurred one week apart.

Table A.1

Auxiliary Building Fires (Continued)

<u>Plant Name</u>	<u>Date of Occurrence</u>	<u>Plant Status</u>	<u>Fire Type</u>	<u>Remarks</u>
Turkey Point 3	5/75	Power Operation (100%)	Battery Charger	Transformer overheated igniting insulation. Similar to previous event on 12/14/72.
Millstone 2	3/24/76	Hot Shutdown	Motor Control Center	Fire resulted from arcing of a supply lead. Extinguished by de-energizing MCC.
Dresden 2	4/76	Cold Shutdown	Circuit Breaker	ECCS Jockey Pump control feed breaker caught fire from a burned-out contactor coil.
Fitzpatrick	6/11/76	Power Operation (93%)	Circuit Breaker	Overload in HPCI valve circuit breaker. Extinguished by de-energizing breaker.
Millstone 2	11/15/76	Hot Shutdown	Relay--MCC	Relay fire in motor control center.
Pilgrim 1	3/77	Hot Shutdown	Circuit Breaker	Circuit breaker under-voltage coil burnt due to high floating charge on station battery.
Fitzpatrick	4/4/77	Power Operation (88%)	Circuit Breaker	Coil failed by fire in HPCI test valve breaker and extinguished by de-energizing. Similar to 7/28/75 event.

Table A.1

Auxiliary Building Fires (Continued)

<u>Plant Name</u>	<u>Date of Occurrence</u>	<u>Plant Status</u>	<u>Fire Type</u>	<u>Remarks</u>
Arnold	5/7/77	Refueling Outage	Circuit Breaker	Breaker relay failed, burning open and starting phase burner material above it on fire.
Salem 1	6/30/77	Power Operation	Relay-- Cabinet	Fire detection instrumentation panel fire due to relay failure.
Unknown	4/13/78	Power Operation	Circuit Breaker-- MCC	Failure breaker contact due to improper maintenance--occurred in motor control center.
Robinson 2	7/16/78	Power Operation	Battery	Resistance heating of terminal connection ignited plastic tops of two cells of a battery.
Unknown	7/27/78	Power Operation	Battery Terminal	Defective terminal or connections not secured.
Arkansas Nuclear One 1	8/16/78	Cold Shutdown	Pump Motor	LPSI pump motor on fire (being used for shutdown cooling) due to incorrect installation of motor bearings resulting in shorting of rotor with the stator.
Salem 1	1/79	Power Operation (95%)	Transformer	Moisture in the windings resulted in a short and subsequent fire.

Table A.1

Auxiliary Building Fires (Continued)

<u>Plant Name</u>	<u>Date of Occurrence</u>	<u>Plant Status</u>	<u>Fire Type</u>	<u>Remarks</u>
Palisades	4/4/79	Power Operation (100%)	Battery	Battery burst due to internal explosion of hydrogen ignited by a test lead being used to measure voltage.
San Onofre 1	11/27/79	Power Operation (100%)	Switchgear	Rodents shorted two phases of a 480-V bus in the switchgear room.
Hatch 2	4/80	Cold Shutdown	Cable	A loose connection resulted in a wire of an RPS motor generator set breaker burning.
Unknown BWR	4/15/80	Power Operation	Bus	Fire involving supply bus occurred in switchgear room.
Peach Bottom 1	6/3/80	Power Operation (100%)	Transformer	A filtering capacitor in a vital bus transformer caught fire damaging the transformer.
Unknown PWR	7/6/80	Power Operation	Circuit Breaker	Circuit breaker caught fire when it failed to close properly because contacts were out of adjustment.
Unknown PWR	10/2/80	Power Operation	Valve Motor	Air sample inlet valve motor issued smoke. Power was removed from motor.

Table A.1

Auxiliary Building Fires (Continued)

<u>Plant Name</u>	<u>Date of Occurrence</u>	<u>Plant Status</u>	<u>Fire Type</u>	<u>Remarks</u>
Trojan	12/31/80	Power Operation (100%)	Circuit Breaker	Breaker stab misaligned causing ignition of plastic dust collector by arcing.
Palisades	1/24/81	Power Operation (98%)	Pump Motor	Component cooling water pump motor caught fire due to bearing failure from loss of lubricating oil.
San Onofre 1	7/17/81	Cold Shutdown	Gas Decay Tank	Explosion of H ₂ in recombiner.
Indian Point 2	8/10/81	Power Operation (100%)	Pump Motor	Short circuit within SI pump caused fire and an overload trip of its supply breaker.
North Anna 1	11/11/81	Power Operation	Pump	Main feedwater pump fire.
Hatch 1	11/23/81	Cold Shutdown	Relay	Insulation breakdown caused fire in a reactor low-low RPS relay.
Point Beach 1	10/15/82	Power Operation (78%)	Circuit	Supply breaker for MG set caught fire.

Table A.1

Auxiliary Building Fires (Continued)

<u>Plant Name</u>	<u>Date of Occurrence</u>	<u>Plant Status</u>	<u>Fire Type</u>	<u>Remarks</u>
Salem 1	11/9/82	Cold Shutdown	Relay	Relay failure resulted in a fire in a fire detection instrumentation panel. Fire detectors for switchgear rooms, battery room, and DG area were rendered inoperable.
Brunswick 1	11/27/82	Power Operation (68%)	Battery Charger	Resistor on charger amplifier board opened causing a voltage increase and capacitor failure.
Oconee 2	2/3/83	Power Operation (100%)	Pump Motor	Loss of lubrication oil resulted in high bearing temperature and smoke.
Brunswick 1	4/26/83	Refueling	Transformer	Following a loss of offsite power, a fire occurred in a transformer between emergency buses.
Oconee 3	5/25/83	Power Operation (100%)	Cable and Conduit	Welding operation started a fire in conduit surrounding a cable (letdown valve).

Table A.1

Auxiliary Building Fires (Concluded)

<u>Plant Name</u>	<u>Date of Occurrence</u>	<u>Plant Status</u>	<u>Fire Type</u>	<u>Remarks</u>
Salem 2	6/20/83	Cold Shutdown	Transformer	Transformer breaker tripped on overcurrent and was reclosed. Fire occurred immediately thereafter.
Peach Bottom 1	9/9/83	Power Operation (100%)	Control Panel	Water entered a control room ventilation chiller control panel shorting motor starter contacters.
Yankee Rowe	8/2/84	Power Operation (100%)	Circuit Breaker	High resistance in the main disconnecting contacts of the center phase of the breaker caused an arc to propagate to outside phases.

Table A.2
Reactor Building Fires

<u>Plant Name</u>	<u>Date of Occurrence</u>	<u>Plant Status</u>	<u>Fire Type</u>	<u>Remarks</u>
Quad Cities 1	12/10/72	Power Operation	Oil, Insulation	A small open flame was observed within a RHR service-water pump housing. Fire was set by welding sparks on oil-soaked insulation.
Peach Bottom 1	12/22/72	Power Operation		The motor on a residual heat removal pump burst into flames due to insufficient lubrication to the lower bearing.
Monticello	5/15/74	Hot Shutdown	Hydrogen	An off-gas ignition occurred resulting in the rupture of both air ejector discharge line rupture discs.
Dresden 3	11/15/74	Power Operation	Hydrogen	An off-gas explosion occurred when the 3A recombiner outlet valve was opened.
Oconee 2	1/31/75	Hot Shutdown	Oil	A small oil fire occurred underneath a reactor coolant pump motor stand.
Brunswick 2	4/14/77	Power Operation	Hydrogen	A hydrogen flame was in the off-gas system burning at the flow orifice or in the jet air ejector.

Table A.2

Reactor Building Fires (Continued)

<u>Plant Name</u>	<u>Date of Occurrence</u>	<u>Plant Status</u>	<u>Fire Type</u>	<u>Remarks</u>
Brunswick 2	6/15/77	Power Operation	Hydrogen	Following an off-gas over-pressurization, a hydrogen fire was detected downstream of the steam jet air ejectors.
Unknown BWR	2/10/78	Power Operation	Electrical	Smoke was noticed coming from a supply breaker.
Indian Point 2	9/4/79	Power Operation	Oil, Insulation	A fire occurred in the reactor coolant pump tube. Insulation was saturated with oil and ignited.
Robinson 2	9/30/79	Power Operation	Oil	Lagging fire on cold leg piping. Fire caused by lubricating oil leak.
San Onofre 1	?/16/80	Hot Shutdown	Oil, Insulation	Oil from leaking reactor coolant pump oil filter came in contact with the hot pump casing and ignited.
Nine Mile Point 1	4/22/80	Power Operation	Oil	Fire resulted from lube oil that leaked from a main turbine shaft-driven feed water pump.

Table A.2

Reactor Building Fires (Concluded)

<u>Plant Name</u>	<u>Date of Occurrence</u>	<u>Plant Status</u>	<u>Fire Type</u>	<u>Remarks</u>
Pilgrim	2/24/81	Power Operation	Insulation	A fire was ignited by welded sparks falling on temporary foam rubber insulation.
Unknown PWR	11/7/81	Power Operation	Electrical	Wiring harness was pinched off inside a cabinet and electrically shorted out.
Unknown BWR	2/12/82	Cold Shutdown	Oil	Pipe vibrating loose leaked onto a hot turbine casing.

II-V

Table A.3

Control Room Fires

<u>Plant Name</u>	<u>Date of Occurrence</u>	<u>Plant Status</u>	<u>Fire Type</u>	<u>Remarks</u>
Unknown	7/4/78	Power Operation	Diode	Zener diode failed in an RPS circuit.
Three Mile Island 2	7/12/79	Cold Shutdown	Circuit Board	Overheated resistor caused fire in a radiation-monitoring readout panel. Extinguished immediately.
Hatch 1*	3/12/83	Power Operation (94%)	Relay	Low reactor water level RPS relay burned causing a 1/2 scram (failed safe). Extinguished by operators.
Hatch 1*	3/30/83	Power Operation (34%)	Relay	Scram discharge volume high-level RPS relay burned a 1/2 scram (failed causing safe). Extinguished by operators. Same type of relay as in previous event.

*Counted as one event for quantification of fire frequency.

Table A.4

Cable Spreading Room Fires

<u>Plant Name</u>	<u>Date of Occurrence</u>	<u>Plant Status</u>	<u>Fire Type</u>	<u>Remarks</u>
Browns Ferry 1 and 2	3/22/75	Power Operation (100%)	Cable Fire	Spread from cable spreading room to reactor building in Unit 1 and affected Unit 2.
Peach Bottom 3	4/18/77	Power Operation (25%)	Relay Fire	Fire in PCIS logic and RHR valve relay.

A-13

Table A.5

Switchgear Room Fires

<u>Plant Name</u>	<u>Date of Occurrence</u>	<u>Plant Status</u>	<u>Fire Type</u>	<u>Remarks</u>
Unknown PWR	11/7/79	Power Operation	480-V Bus	Fire involved 480-V bus; short circuit caused by rodent bridging two energized phases.
Unknown BWR	4/15/80	Power Operation	Bus	Fire involved supply bus in switchgear room.
Unknown PWR	7/6/80	Power Operation	Circuit Breaker	Fire involving switchgear room breaker. Out of adjustment control circuit completed.
Yankee Rowe	8/2/84	Power Operation (100%)	Circuit Breaker	A fault occurred in the 480-V supply ACB to bus 4-1; high resistance in the main disconnecting contacts caused an arc to propagate from the center phase to the outside phases.

A-14

Table A.6
Battery Room Fires

<u>Plant Name</u>	<u>Date of Occurrence</u>	<u>Plant Status</u>	<u>Fire Type</u>	<u>Remarks</u>
Robinson 2	7/16/78	Power	Battery	Plastic tops of two operation cells of a station battery caught fire; caused by resistance heating of a terminal connection during the heavy dc load of the emergency oil pump.
Unknown	7/27/78	Power Operation	Battery	Fire caused by defective terminal or unsecured connections.
Palisades	4/4/79	Power Operation (100%)	Battery	A test lead being used to take battery voltage readings fell and struck a battery connector, causing a spark which ignited hydrogen gas.
Brunswick 1	11/27/82	Power Operation (68%)	Capacitor	Battery charger capacitor caught fire for unknown reason.

A-15

Table A.7

Turbine Building Fires

<u>Plant Name</u>	<u>Date of Occurrence</u>	<u>Plant Status</u>	<u>Fire Type</u>	<u>Remarks</u>
Nine Mile Point	9/13/72	Power Operation	Oil, Insulation	Leak in oil supply line soaked insulation and ignited when it came in contact with hot pipe.
Yankee Rowe	6/15/73	Power Operation	Oil, Insulation	A fire started in oil-soaked insulation around the high-pressure turbine bearing casing.
Unknown PWR	8/15/73	Power Operation	Unknown	Fire around turbine area--unknown cause.
Unknown PWR	9/20/74	Power Operation	Ping Pong Balls	Cigarette ignited box of ping pong balls--automatic deluge system initiated.
Kewaunee	4/15/75	Power Operation	Bus	Bus fault resulted in cable insulation damage.
Unknown PWR	6/27/75	Power Operation	Oil	Leaking oil from a turbine oil purifier ignited when it contacted purifier heaters. Cables above the fire charred.
Haddam Neck	9/75	Power	Oil, Operation	Oil-soaked insulation. Insulation fire on gland steam lines under high-pressure turbine.

A-16

Table A.7

Turbine Building Fires (Continued)

<u>Plant Name</u>	<u>Date of Occurrence</u>	<u>Plant Status</u>	<u>Fire Type</u>	<u>Remarks</u>
Unknown PWR	4/3/77	Power Operation	Hydrogen	Leaking hydrogen at the generator ignited. Purged with CO ₂ by shift personnel.
Saint Lucie 1	4/3/77	Power Operation	Hydrogen	Hydrogen leaked from turbine and ignited. Generator inerted with CO ₂ .
Oyster Creek 1	5/77	Refueling	Cable Insulation	Aluminum-to-copper bus terminal connectors resulted in high resistance and burned cable insulation.
Peach Bottom 3	9/77	Power Operation	Relays	Three relays in feedwater pump relay cabinet ignited. Since flame retardant cables were used in cabinet, fire did not propagate.
Unknown PWR	7/5/78	Power Operation	Auxiliary Boiler	Class B fire including the auxiliary boiler.
Cook 2	11/13/78	Power Operation	Hydrogen	Hydrogen fire under generator. Purged with CO ₂ .
Browns Ferry 1	1/21/80	Power Operation	Cable Insulation	Fire in cable tray beneath the turbine building operating floor.

Table A.7

Turbine Building Fires (Concluded)

<u>Plant Name</u>	<u>Date of Occurrence</u>	<u>Plant Status</u>	<u>Fire Type</u>	<u>Remarks</u>
Cook 2	12/15/80	Power Operation	Electrical	Fire in generator pilot exciter.
Unknown BWR	7/24/81	Power Operation	Pump	Condensate booster pump binding overheated and caught fire.
Sequoyah 1	1/19/82	Cold Shutdown	Transformer	Neutral ground transformer exploded activating deluge system.
Unknown PWR	2/4/82	Power Operation	Hydrogen	Hydrogen leaked from a bad seal into the generator.
Rancho Seco	3/19/84	Power Operation	Hydrogen	Hydrogen explosion occurred following loss of H ₂ side seal oil pump.
Indian Point 2	10/22/84	Power Operation	Insulation	Fire in insulation at the governor end of the high-pressure turbine.
Arnold	11/4/84	Power Operation	Transformer	Transformer fire in yard propagated to the turbine building.

Table A.8

Diesel Generator Room Fires

<u>Plant Name</u>	<u>Date of Occurrence</u>	<u>Plant Status</u>	<u>Fire Type</u>	<u>Remarks</u>
Duane Arnold	3/17/76	Refueling Outage	Oil	The diesel flange gasket leaked exhaust gases with traces of oil onto the exterior of the flange. The oil was ignited by exhaust heat.
Duane Arnold	4/17/76	Power Operation	Oil	Oil leaked onto the diesel exhaust manifold and caught fire.
Millstone 2	9/15/76	Power Operation	Oil, Insulation	A small fire occurred on the exhaust manifold at the control end of the engine.
Zion 2	9/15/76	Power Operation		An operator disconnected a dc tie breaker, tripping the reactor and initiating safe injection. The ma__ generator was overloaded resulting in a fire.
Fitzpatrick	10/15/76	Power Operation	Oil	During testing a fire was discovered in the exhaust the emergency diesel generator.
Duane Arnold	11/4/76	Power Operation	Oil	A hairline fracture in a fuel line fitting caused fuel to spray out and be ignited by heat from the exhaust header.

Table A.8

Diesel Generator Room Fires (Continued)

<u>Plant Name</u>	<u>Date of Occurrence</u>	<u>Plant Status</u>	<u>Fire Type</u>	<u>Remarks</u>
Unknown PWR	12/4/76	Power Operation	Oil	During maintenance on the emergency diesel, a filter was ignited due to overheated oil.
Calvert Cliffs 1	7/11/77	Power Operation	Oil	A small fire developed when lube oil sprayed from the lube oil strainer and ignited on contact with the exhaust manifold.
Kewaunee	9/20/77	Power Operation	Carbon Buildup	A fire was caused by carbon residue buildup in the exhaust path through the turbocharger.
Unknown	12/28/77	Power Operation		Probable cause of fire was combustible materials left in close proximity to the diesel exhaust stack.
Arkansas Nuclear One 1	3/20/78	Refueling Outage	Oil	Failure of bearing oil seal allowed lubricating oil in the turbocharger of the diesel generator.
Arkansas Nuclear One 1	11/15/78	Refueling Outage	Oil	Fire in a diesel exhaust manifold during a test.

A-20

Table A.8

Diesel Generator Room Fires (Continued)

<u>Plant Name</u>	<u>Date of Occurrence</u>	<u>Plant Status</u>	<u>Fire Type</u>	<u>Remarks</u>
Crystal River 3	7/24/79	Hot Shutdown	Oil, Carbon	A fire was caused in the exhaust manifold of an emergency diesel generator an excessive fuel-rich mixture aided by oil and carbon accumulation.
Unknown PWR	7/24/79	Power Operation	Electrical	A fire involved the excite control cabinet of a diesel generator.
Crystal River 3	10/15/79	Hot Shutdown	Oil	Fire in the exhaust manifold fuel-oil mix rich on start-(test).
Maine Yankee	10/15/79	Power Operation	Oil	A diesel turbocharger failed which resulted in a fire within the exhaust system.
Calvert Cliffs 2	3/7/80	Power Operation		A small fire occurred in a diesel generator room.
Davis-Besse 1	7/15/80	Power Operation		Fire in a turbocharger.
Davis-Besse 1	9/23/80	Cold Shutdown	Oil	A diesel turbocharger failure which resulted in a fire in the exhaust pipe.

Table A.8

Diesel Generator Room Fires (Continued)

<u>Plant Name</u>	<u>Date of Occurrence</u>	<u>Plant Status</u>	<u>Fire Type</u>	<u>Remarks</u>
Unknown PWR	3/9/81	Power Operation	Oil, Insulation	Fire involved exhaust manifold insulation.
North Anna 1	4/15/81	Power Operation	Oil	An oil leak in the area of the exhaust manifold started a small fire.
Unknown BWR	5/15/81	Power Operation	Electrical	Smoke filled diesel generator building.
Arkansas Nuclear One 2	6/30/81	Hot Shutdown	Oil, Insulation	Oil leaked through a diesel gasket onto insulation, igniting a fire.
San Onofre 1	7/14/81	Power Operation	Oil	Lube oil spraying from a cracked instrument line was ignited by hot exhaust pipe above the diesel engine.
North Anna 1	7/16/81	Power Operation	Oil	An oil leak in the diesel exhaust manifold caused the fire.
Arkansas Nuclear One 1	7/27/81	Power Operation	Oil, Insulation	Fire on oil-soaked insulation on a diesel engine.

Table A.8

Diesel Generator Room Fires (Concluded)

<u>Plant Name</u>	<u>Date of Occurrence</u>	<u>Plant Status</u>	<u>Fire Type</u>	<u>Remarks</u>
Zion 1	8/15/81	Power Operation	Oil	Lube oil sprayed passed a operation o-ring seal onto hot exhaust manifold caused fire.
Praire Island 1	8/15/82	Power Operation	Oil	Turbocharger oil gasket filter failure sprayed lube oil onto hot exhaust manifold and ignited.
Peach Bottom 2	9/7/83	Maintenance Outage	Oil	A diesel governor increased fuel flow as a result of a turbo-charger failure. Excess fuel ignited in the exhaust.
Peach Bottom 1	12/18/84	Cold Shutdown	Oil	A diesel fire was caused by a leaking fitting on a fuel injector line.

A-23

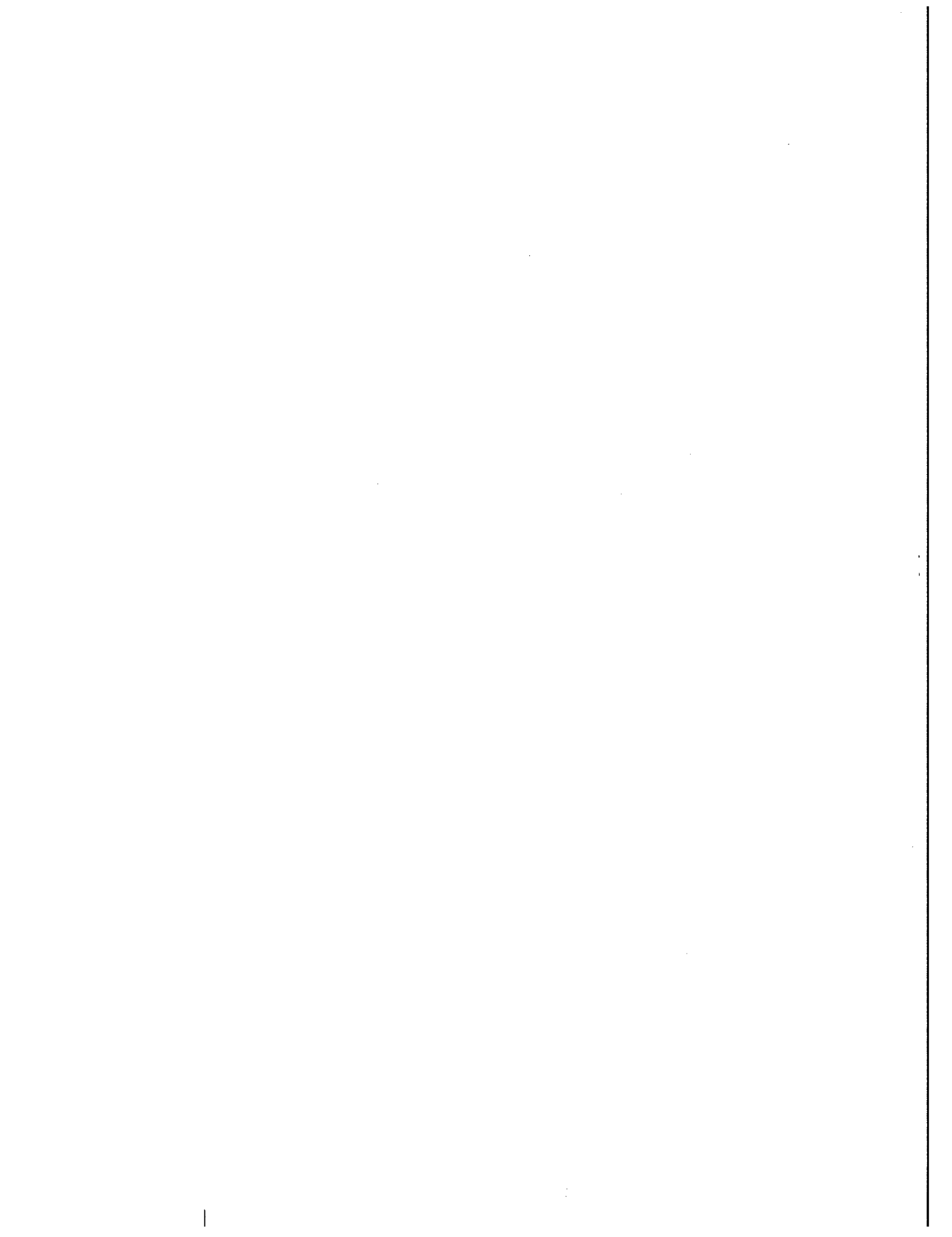

DISTRIBUTION:

Frank Abbey
U. K. Atomic Energy Authority
Wigshaw Lane, Culcheth
Warrington, Cheshire, WA3 4NE
ENGLAND

Kiyoharu Abe
Department of Reactor Safety
Research
Nuclear Safety Research Center
ToKai Research Establishment
JAERI
Tokai-mura, Naga-gun
Ibaraki-ken,
JAPAN

Ulvi Adalioglu
Nuclear Engineering Division
Cekmece Nuclear Research and
Training Centre
P.K.1, Havaalani
Istanbul
TURKEY

Bharat Agrawal
USNRC-RES/AEB
MS: NL/N-344

Kiyoto Aizawa
Safety Research Group
Reactor Research and Development
Project
PNC
9-13m 1-Chome Akasaka
Minatu-Ku
Tokyo
JAPAN

Oguz Akalin
Ontario Hydro
700 University Avenue
Toronto, Ontario
CANADA M5G 1X6

David Aldrich
Science Applications International
Corporation
1710 Goodridge Drive
McLean, VA 22102

Agustin Alonso
University Politecnica De Madrid
J Gutierrez Abascal, 2
28006 Madrid
SPAIN

Christopher Amos
Science Applications International
Corporation
2109 Air Park Road SE
Albuquerque, NM 87106

Richard C. Anoba
SAIC
4900 Motors Edge Drive, Suite 255
Raleigh, NC 27606

George Apostolakis
UCLA
Boelter Hall, Room 5532
Los Angeles, CA 90024

James W. Ashkar
Boston Edison Company
800 Boylston Street
Boston, MA 02199

Donald H. Ashton
Bechtel Power Corporation
P.O. Box 2166
Houston, TX 77252-2166

J. de Assuncao
Cabinete de Proteccao e Seguranca
Nuclear
Secretario de Estado de Energia
Ministerio da Industria
av. da Republica, 45-6°
1000 Lisbon
PORTUGAL

Mark Averett
Florida Power Corporation
P.O. Box 14042
St. Petersburg, FL 33733

Raymond O. Bagley
Northeast Utilities
P.O. Box 270
Hartford, CT 06141-0270

Juan Bagues
Consejo de Seguridad Nucleare
Sarangela de la Cruz 3
28020 Madrid
SPAIN

George F. Bailey
Washington Public Power Supply
System
P. O. Box 968
Richland, WA 99352

H. Bairiot
Belgonucleaire S A
Rue de Champ de Mars 25
B-1050 Brussels
BELGIUM

Louis Baker
Reactor Analysis and Safety
Division
Building 207
Argonne National Laboratory
9700 South Cass Avenue
Argonne, IL 60439

H-P. Balfanz
TUV-Norddeutschland
Grosse Bahnstrasse 31,
2000 Hamburg 54
FEDERAL REPUBLIC OF GERMANY

Patrick Baranowsky
USNRC-NRR/OEAB
MS: 11E-22

H. Bargmann
Dept. de Mecanique
Inst. de Machines Hydrauliques
et de Mecaniques des Fluides
Ecole Polytechnique de Lausanne
CH-1003 Lausanne
M.E. (ECUBLENS)
CH. 1015 Lausanne
SWITZERLAND

Robert A. Bari
Brookhaven National Laboratory
Building 130
Upton, NY 11973

Richard Barrett
USNRC-NRR/PRAB
MS: 10A-2

Kenneth S. Baskin
S. California Edison Company
P.O. Box 800
Rosemead, CA 91770

J. Basselier
Belgonucleaire S A
Rue du Champ de Mars 25, B-1050
Brussels
BELGIUM

Werner Bastl
Gesellschaft Fur Reaktorsicherheit
Forschungsgelände
D-8046 Garching
FEDERAL REPUBLIC OF GERMANY

Anton Bayer
BGA/ISH/ZDB
Postfach 1108
D-8042 Neuherberg
FEDERAL REPUBLIC OF GERMANY

Ronald Bayer
Virginia Electric Power Co.
P. O. Box 26666
Richmond, VA 23261

Eric S. Beckjord
Director
USNRC-RES
MS: NL/S-007

Bruce B. Beckley
Public Service Company
P.O. Box 330
Manchester, NH 03105

William Beckner
USNRC-RES/SAIB
MS: NL/S-324

Robert M. Bernero
Director
USNRC-NMSS
MS: 6A-4

Ronald Berryman [2]
Virginia Electric Power Co.
P. O. Box 26666
Richmond, VA 23261

Robert C. Bertucio
NUS Corporation
1301 S. Central Ave, Suite 202
Kent, WA 98032

John H. Bickel
EG&G Idaho
P.O. Box 1625
Idaho Falls, ID 83415

Peter Bieniarz
Risk Management Association
2309 Dietz Farm Road, NW
Albuquerque, NM 87107

Adolf Birkhofer
Gesellschaft Fur Reaktorsicherheit
Forschungsgelände
D-8046 Garching
FEDERAL REPUBLIC OF GERMANY

James Blackburn
Illinois Dept. of Nuclear Safety
1035 Outer Park Drive
Springfield, IL 62704

Dennis C. Bley
Pickard, Lowe & Garrick, Inc.
2260 University Drive
Newport Beach, CA 92660

Roger M. Blond
Science Applications Int. Corp.
20030 Century Blvd., Suite 201
Germantown, MD 20874

Simon Board
Central Electricity Generating
Board
Technology and Planning Research
Division
Berkeley Nuclear Laboratory
Berkeley Gloucestershire, GL139PB
UNITED KINGDOM

Mario V. Bonace
Northeast Utilities Service Company
P.O. Box 270
Hartford, CT 06101

Gary J. Boyd
Safety and Reliability Optimization
Services
9724 Kingston Pike, Suite 102
Knoxville, TN 37922

Robert J. Breen
Electric Power Research Institute
3412 Hillview Avenue
Palo Alto, CA 94303

Charles Brinkman
Combustion Engineering
7910 Woodmont Avenue
Bethesda, MD 20814

K. J. Brinkmann
Netherlands Energy Res. Fdn.
P.O. Box 1
17552G Petten NH
NETHERLANDS

Allan R. Brown
Manager, Nuclear Systems and
Safety Department
Ontario Hydro
700 University Ave.
Toronto, Ontario M5G1X6
CANADA

Robert G. Brown
TENERA L.P.
1340 Saratoga-Sunnyvale Rd.
Suite 206
San Jose, CA 95129

Sharon Brown
EI Services
1851 So. Central Place, Suite 201
Kent, WA 98031

Ben Buchbinder
NASA, Code QS
600 Maryland Ave. SW
Washington, DC 20546

R. H. Buchholz
Nutech
6835 Via Del Oro
San Jose, CA 95119

Robert J. Budnitz
Future Resources Associates
734 Alameda
Berkeley, CA 94707

Gary R. Burdick
USNRC-RES/DSR
MS: NL/S-007

Arthur J. Buslik
USNRC-RES/PRAB
MS: NL/S-372

M. Bustraan
Netherlands Energy Res. Fdn.
P.O. Box 1
1755ZG Petten NH
NETHERLANDS

Nigel E. BATTERY
Central Electricity Generating
Board
Booths Hall
Chelford Road, Knutsford
Cheshire, WA168QG
UNITED KINGDOM

Jose I. Calvo Molins
Probabilistic Safety Analysis
Group
Consejo de Seguridad Nuclear
Sor Angela de la Cruz 3, Pl. 6
28020 Madrid
SPAIN

J. F. Campbell
Nuclear Installations Inspectorate
St. Peters House
Balliol Road, Bootle
Merseyside, L20 3LZ
UNITED KINGDOM

Kenneth S. Canady
Duke Power Company
422 S. Church Street
Charlotte, NC 28217

Lennart Carlsson
IAEA A-1400
Wagramerstrasse 5
P.O. Box 100
Vienna, 22
AUSTRIA

Annick Carnino
Electricite de France
32 Rue de Monceau SEME
Paris, F5008
FRANCE

G. Caropreso
Dept. for Envir. Protect. & Hlth.
ENEA Cre Casaccia
Via Anguillarese, 301
00100 Roma
ITALY

James C. Carter, III
TENERA L.P.
Advantage Place
308 North Peters Road
Suite 280
Knoxville, TN 37922

Eric Cazzoli
Brookhaven National Laboratory
Building 130
Upton, NY 11973

John G. Cesare
SERI
Director Nuclear Licensing
5360 I-55 North
Jackson, MS 39211

S. Chakraborty
Radiation Protection Section
Div. De La Securite Des Inst. Nuc.
5303 Wurenlingen
SWITZERLAND

Sen-I Chang
Institute of Nuclear Energy
Research
P.O. Box 3
Lungtan, 325
TAIWAN

J. R. Chapman
Yankee Atomic Electric Company
1671 Worcester Road
Framingham, MA 01701

Robert F. Christie
Tennessee Valley Authority
400 W. Summit Hill Avenue, W10D190
Knoxville, TN 37902

T. Cianciolo
BWR Assistant Director
ENEA DISP TX612167 ENEUR
Rome
ITALY

Thomas Cochran
Natural Resources Defense Council
1350 New York Ave. NW, Suite 300
Washington, D.C. 20005

Frank Coffman
USNRC-RES/HFB
MS: NL/N-316

Larry Conradi
NUS Corporation
16835 W. Bernardo Drive
Suite 202
San Diego, CA 92127

Peter Cooper
U.K. Atomic Energy Authority
Wigshaw Lane, Culcheth
Warrington, Cheshire, WA3 4NE
UNITED KINGDOM

C. Allin Cornell
110 Coquito Way
Portola Valley, CA 94025

Michael Corradini
University of Wisconsin
1500 Johnson Drive
Madison, WI 53706

E. R. Corran
Nuclear Technology Division
ANSTO Research Establishment
Lucas Heights Research Laboratories
Private Mail Bag 7
Menai, NSW 2234
AUSTRALIA

James Costello
USNRC-RES/SSEB
MS: NL/S-217A

George R. Crane
1570 E. Hobble Creek Dr.
Springville, UT 84663

Mat Crawford
SERI
5360 I-55 North
Jackson, MS 39211

Michael C. Cullingford
Nuclear Safety Division
IAEA
Wagramerstrasse, 5
P.O. Box 100
A-1400 Vienna
AUSTRIA

Garth Cummings
Lawrence Livermore Laboratory
L-91, Box 808
Livermore, CA 94526

Mark A. Cunningham
USNRC-RES/PRAB
MS: NL/S-372

James J. Curry
7135 Salem Park Circle
Mechanicsburg, PA 17055

Peter Cybulskis
Battelle Columbus Division
505 King Avenue
Columbus, OH 43201

Peter R. Davis
PRD Consulting
1935 Sabin Drive
Idaho Falls, ID 83401

Jose E. DeCarlos
Consejo de Seguridad Nuclear
Sor Angela de la Cruz 3, Pl. 8
28016 Madrid
SPAIN

M. Marc Decreton
Department Technologie
CEN/SCK
Boeretang 200
B-2400 Mol
BELGIUM

Richard S. Denning
Battelle Columbus Division
505 King Avenue
Columbus, OH 43201

Vernon Denny
Science Applications Int. Corp.
5150 El Camino Real, Suite 3
Los Altos, CA 94303

J. Devooget
Faculte des Sciences Appliques
Universite Libre de Bruxelles
av. Franklin Roosevelt
B-1050 Bruxelles
BELGIUM

R. A. Diederich
Supervising Engineer
Environmental Branch
Philadelphia Electric Co.
2301 Market St.
Philadelphia, PA 19101

Raymond DiSalvo
Battelle Columbus Division
505 King Avenue
Columbus, OH 43201

Mary T. Drouin
Science Applications International
Corporation
2109 Air Park Road S.E.
Albuquerque, NM 87106

Andrzej Drozd
Stone and Webster
Engineering Corp.
243 Summer Street
Boston, MA 02107

N. W. Edwards
NUTECH
145 Martinville Lane
San Jose, CA 95119

Ward Edwards
Social Sciences Research Institute
University of Southern California
Los Angeles, CA 90089-1111

Joachim Ehrhardt
Kernforschungszentrum Karlsruhe/INR
Postfach 3640
D-7500 Karlsruhe 1
FEDERAL REPUBLIC OF GERMANY

Adel A. El-Bassioni
USNRC-NRR/PRAB
MS: 10A-2

J. Mark Elliott
International Energy Associates,
Ltd., Suite 600
600 New Hampshire Ave., NW
Washington, DC 20037

Farouk Eltawila
USNRC-RES/AEB
MS: NL/N-344

Mike Epstein
Fauske and Associates
P. O. Box 1625
16W070 West 83rd Street
Burr Ridge, IL 60521

Malcolm L. Ernst
USNRC-RGN II

F. R. Farmer
The Long Wood, Lyons Lane
Appleton, Warrington
WA4 5ND
UNITED KINGDOM

P. Fehrenback
Atomic Energy of Canada, Ltd.
Chalk River Nuclear Laboratories
Chalk River Ontario, KOJ1P0
CANADA

P. Ficara
ENEA Cre Casaccia
Department for Thermal Reactors
Via Anguillarese, 301
00100 ROMA
ITALY

A. Fiege
Kernforschungszentrum
Postfach 3640
D-7500 Karlsruhe
FEDERAL REPUBLIC OF GERMANY

John Flack
USNRC-RES/SAIB
MS: NLS-324

George F. Flanagan
Oak Ridge National Laboratory
P.O. Box Y
Oak Ridge, TN 37831

Karl N. Fleming
Pickard, Lowe & Garrick, Inc.
2260 University Drive
Newport Beach, CA 92660

Terry Foppe
Rocky Flats Plant
P. O. Box 464, Building T886A
Golden, CO 80402-0464

Joseph R. Fragola
Science Applications International
Corporation
274 Madison Avenue
New York, NY 10016

Wiktor Frid
Swedish Nuclear Power Inspectorate
Division of Reactor Technology
P. O. Box 27106
S-102 52 Stockholm
SWEDEN

James Fulford
NUS Corporation
910 Clopper Road
Gaithersburg, MD 20878

Urho Fulkkinen
Technical Research Centre of
Finland
Electrical Engineering Laboratory
Otakaari 7 B
SF-02150 Espoo 15
FINLAND

J. B. Fussell
JBF Associates, Inc.
1630 Downtown West Boulevard
Knoxville, TN 37919

John Garrick
Pickard, Lowe & Garrick, Inc.
2260 University Drive
Newport Beach, CA 92660

John Gaunt
British Embassy
3100 Massachusetts Avenue, NW
Washington, DC 20008

Jim Gieseke
Battelle Columbus Division
505 King Avenue
Columbus, OH 43201

Frank P. Gillespie
USNRC-NRR/PMAS
MS: 12G-18

Ted Ginsburg
Department of Nuclear Energy
Building 820
Brookhaven National Laboratory
Upton, NY 11973

James C. Glynn
USNRC-RES/PRAB
MS: NL/S-372

P. Govaerts
Departement de la Surete Nucleaire
Association Vincotte
avenue du Roi 157
B-1060 Bruxelles
BELGIUM

George Greene
Building 820M
Brookhaven National Laboratory
Upton, NY 11973

Carrie Grimshaw
Brookhaven National Laboratory
Building 130
Upton, NY 11973

H. J. Van Grol
Energy Technology Division
Energieonderzoek Centrum Nederland
Westerduinweg 3
Postbus 1
NL-1755 Petten ZG
NETHERLANDS

Sergio Guarro
Lawrence Livermore Laboratories
P. O. Box 808
Livermore, CA 94550

Sigfried Hagen
Kernforschungszentrum Karlsruhe
P. O. Box 3640
D-7500 Karlsruhe 1
FEDERAL REPUBLIC OF GERMANY

L. Hammar
Statens Karnkraftinspektion
P.O. Box 27106
S-10252 Stockholm
SWEDEN

Stephen Hanauer
Technical Analysis Corp.
6723 Whittier Avenue
Suite 202
McLean, VA 22101

Brad Hardin
USNRC-RES/TRAB
MS: NL/S-169

R. J. Hardwich, Jr.
Virginia Electric Power Co.
P.O. Box 26666
Richmond, Va 23261

Michael R. Haynes
UKAEA Harwell Laboratory
Oxfordshire
Didcot, Oxon., OX11 0RA
ENGLAND

Michael J. Hazzan
Stone & Webster
3 Executive Campus
Cherry Hill, NJ 08034

A. Hedgran
Royal Institute of Technology
Nuclear Safety Department
Bunellvagen 60
10044 Stockholm
SWEDEN

Sharif Heger
UNM Chemical and Nuclear
Engineering Department
Farris Engineering
Room 209
Albuquerque, NM 87131

Jon C. Helton
Dept. of Mathematics
Arizona State University
Tempe, AZ 85287

Robert E. Henry
Fauske and Associates, Inc.
16W070 West 83rd Street
Burr Ridge, IL 60521

P. M. Herttrich
Federal Ministry for the
Environment, Preservation of
Nature and Reactor Safety
Husarenstrasse 30
Postfach 120629
D-5300 Bonn 1
FEDERAL REPUBLIC OF GERMANY

F. Heuser
Gesellschaft Fur Reaktorsicherheit
Forschungsgelände
D-8046 Garching
FEDERAL REPUBLIC OF GERMANY

E. F. Hicken
Gesellschaft Fur Reaktorsicherheit
Forschungsgelände
D-8046 Garching
FEDERAL REPUBLIC OF GERMANY

D. J. Higson
Radiological Support Group
Nuclear Safety Bureau
Australian Nuclear Science and
Technology Organisation
P.O. Box 153
Rosebery, NSW 2018
AUSTRALIA

Daniel Hirsch
University of California
A. Stevenson Program on
Nuclear Policy
Santa Cruz, CA 95064

H. Hirschmann
Hauptabteilung Sicherheit und
Umwelt
Swiss Federal Institute for
Reactor Research (EIR)
CH-5303 Wurenlingen
SWITZERLAND

Mike Hitchler
Westinghouse Electric Corp.
Savanna River Site
Aiken, SC 29808

Richard Hobbins
EG&G Idaho
P. O. Box 1625
Idaho Falls, ID 83415

Steven Hodge
Oak Ridge National Laboratory
P.O. Box Y
Oak Ridge, TN 37831

Lars Hoegberg
Office of Regulation and Research
Swedish Nuclear Power Inspectorate
P. O. Box 27106
S-102 52 Stockholm
SWEDEN

Lars Hoeghort
IAEA A-1400
Wagranerstrasse 5
P.O. Box 100
Vienna, 22
AUSTRIA

Edward Hofer
Gesellschaft Fur Reaktorsicherheit
Forschungsgelände
D-8046 Garching
FEDERAL REPUBLIC OF GERMANY

Peter Hoffmann
Kernforschungszentrum Karlsruhe
Institute for Material
Und Festkorperforschung I
Postfach 3640
D-7500 Karlsruhe 1
FEDERAL REPUBLIC OF GERMANY

N. J. Holloway
UKAEA Safety and Reliability
Directorate
Wigshaw Lane, Culcheth
Warrington, Cheshire, WA34NE
UNITED KINGDOM

Stephen C. Hora
University of Hawaii at Hilo
Division of Business Administration
and Economics
College of Arts and Sciences
Hilo, HI 96720-4091

J. Peter Hoseman
Swiss Federal Institute for
Reactor Research
CH-5303, Wurenlingen
SWITZERLAND

Thomas C. Houghton
KMC, Inc.
1747 Pennsylvania Avenue, NW
Washington, DC 20006

Dean Houston
USNRC-ACRS
MS: P-315

Der Yu Hsia
Taiwan Atomic Energy Council
67, Lane 144, Keelung Rd.
Sec. 4
Taipei
TAIWAN

Alejandro Huerta-Bahena
National Commission on Nuclear
Safety and Safeguards (CNSNS)
Insurgentes Sur N. 1776
Col. Florida
C. P. 04230 Mexico, D.F.
MEXICO

Kenneth Hughey [2]
SERI
5360 I-55 North
Jackson, MS 39211

Won-Guk Hwang
Kzunghee University
Yongin-Kun
Kyunggi-Do 170-23
KOREA

Michio Ichikawa
Japan Atomic Energy Research
Institute
Dept. of Fuel Safety Research
Tokai-Mura, Naka-Gun
Ibaraki-Ken, 319-1
JAPAN

Sanford Israel
USNRC-AEOD/ROAB
MS: MNBB-9715

Krishna R. Iyengar
Louisiana Power and Light
200 A Huey P. Long Avenue
Gretna, LA 70053

Jerry E. Jackson
USNRC-RES
MS: NL/S-302

R. E. Jaquith
Combustion Engineering, Inc.
1000 Prospect Hill Road
M/C 9490-2405
Windsor, CT 06095

S. E. Jensen
Exxon Nuclear Company
2101 Horn Rapids Road
Richland, WA 99352

Kjell Johannson
Studsvik Energiteknik AB
S-611 82, Nykoping
SWEDEN

Richard John
SSM, Room 102
927 W. 35th Place
USC, University Park
Los Angeles, CA 90089-0021

D. H. Johnson
Pickard, Lowe & Garrick, Inc.
2260 University Drive
Newport Beach, CA 92660

W. Reed Johnson
Department of Nuclear Engineering
University of Virginia
Reactor Facility
Charlottesville, VA 22901

Jeffery Julius
NUS Corporation
1301 S. Central Ave, Suite 202
Kent, WA 98032

H. R. Jun
Korea Adv. Energy Research Inst.
P.O. Box 7, Daeduk Danju
Chungnam 300-31
KOREA

Peter Kafka
Gesellschaft Fur Reaktorsicherheit
Forschungsgelände
D-8046 Garching
FEDERAL REPUBLIC OF GERMANY

Geoffrey D. Kaiser
Science Application Int. Corp.
1710 Goodridge Drive
McLean, VA 22102

William Kastenberg
UCLA
Boelter Hall, Room 5532
Los Angeles, CA 90024

Walter Kato
Brookhaven National Laboratory
Associated Universities, Inc.
Upton, NY 11973

M. S. Kazimi
MIT, 24-219
Cambridge, MA 02139

Ralph L. Keeney
101 Lombard Street
Suite 704W
San Francisco, CA 94111

Henry Kendall
Executive Director
Union of Concerned Scientists
Cambridge, MA

Frank King
Ontario Hydro
700 University Avenue
Bldg. H11 G5
Toronto
CANADA M5G1X6

Oliver D. Kingsley, Jr.
Tennessee Valley Authority
1101 Market Street
GN-38A Lookout Place
Chattanooga, TN 37402

Stephen R. Kinnersly
Winfrith Atomic Energy
Establishment
Reactor Systems Analysis Division
Winfrith, Dorchester
Dorset DT2 8DH
ENGLAND

Ryohel Kiyose
University of Tokyo
Dept. of Nuclear Engineering
7-3-1 Hongo Bunkyo
Tokyo 113
JAPAN

George Klopp
Commonwealth Edison Company
P.O. Box 767, Room 35W
Chicago, IL 60690

Klaus Koberlein
Gesellschaft Fur Reaktorsicherheit
Forschungsgelände
D-8046 Garching
FEDERAL REPUBLIC OF GERMANY

E. Kohn
Atomic Energy Canada Ltd.
Candu Operations
Mississauga
Ontario, L5K 1B2
CANADA

Alan M. Kolaczowski
Science Applications International
Corporation
2109 Air Park Road, S.E.
Albuquerque, NM 87106

S. Kondo
Department of Nuclear Engineering
Facility of Engineering
University of Tokyo
3-1, Hongo 7, Bunkyo-ku
Tokyo
JAPAN

Herbert J. C. Kouts
Brookhaven National Laboratory
Building 179C
Upton, NY 11973

Thomas Kress
Oak Ridge National Laboratory
P.O. Box Y
Oak Ridge, TN 37831

W. Kroger
Institut fur Nukleare
Sicherheitsforschung
Kernforschungsanlage Julich GmbH
Postfach 1913
D-5170 Julich 1
FEDERAL REPUBLIC OF GERMANY

Greg Krueger [3]
Philadelphia Electric Co.
2301 Market St.
Philadelphia, PA 19101

Bernhard Kuczera
Kernforschungszentrum Karlsruhe
LWR Safety Project Group (PRS)
P. O. Box 3640
D-7500 Karlsruhe 1
FEDERAL REPUBLIC OF GERMANY

Jeffrey L. LaChance
Science Applications International
Corporation
2109 Air Park Road S.E.
Albuquerque, NM 87106

H. Larsen
Riso National Laboratory
Postbox 49
DK-4000 Roskilde
DENMARK

Wang L. Lau
Tennessee Valley Authority
400 West Summit Hill Avenue
Knoxville, TN 37902

Timothy J. Leahy
EI Services
1851 South Central Place, Suite 201
Kent, WA 98031

John C. Lee
University of Michigan
North Campus
Dept. of Nuclear Engineering
Ann Arbor, MI 48109

Tim Lee
USNRC-RES/RPSB
MS: NL/N-353

Mark T. Leonard
Science Applications International
Corporation
2109 Air Park Road, SE
Albuquerque, NM 87106

Leo LeSage
Director, Applied Physics Div.
Argonne National Laboratory
Building 208, 9700 South Cass Ave.
Argonne, IL 60439

Milton Levenson
Bechtel Western Power Company
50 Beale St.
San Francisco, CA 94119

Librarian
NUMARC/USCEA
1776 I Street NW, Suite 400
Washington, DC 80006

Eng Lin
Taiwan Power Company
242, Roosevelt Rd., Sec. 3
Taipei
TAIWAN

N. J. Liparulo
Westinghouse Electric Corp.
P. O. Box 355
Pittsburgh, PA 15230

Y. H. (Ben) Liu
Department of Mechanical
Engineering
University of Minnesota
Minneapolis, MN 55455

Bo Liwnang
IAEA A-1400
Swedish Nuclear Power Inspectorate
P.O. Box 27106
S-102 52 Stockholm
SWEDEN

J. P. Longworth
Central Electric Generating Board
Berkeley Gloucester
GL13 9PB
UNITED KINGDOM

Walter Lowenstein
Electric Power Research Institute
3412 Hillview Avenue
P. O. Box 10412
Palo Alto, CA 94303

William J. Luckas
Brookhaven National Laboratory
Building 130
Upton, NY 11973

Hans Ludewig
Brookhaven National Laboratory
Building 130
Upton, NY 11973

Robert J. Lutz, Jr.
Westinghouse Electric Corporation
Monroeville Energy Center
EC-E-371, P. O. Box 355
Pittsburgh, PA 15230-0355

Phillip E. MacDonald
EG&G Idaho, Inc.
P.O. Box 1625
Idaho Falls, ID 83415

Jim Mackenzie
World Resources Institute
1735 New York Ave. NW
Washington, DC 20006

Richard D. Fowler
Idaho Nat. Engineering Laboratory
P.O. Box 1625
Idaho Falls, ID 83415

A. P. Malinauskas
Oak Ridge National Laboratory
P.O. Box Y
Oak Ridge, TN 37831

Giuseppe Mancini
Commission European Comm.
CEC-JRC Eraton
Ispra Varese
ITALY

Lasse Mattila
Technical Research Centre of
Finland
Lonnrotinkatu 37, P. O. Box 169
SF-00181 Helsinki 18
FINLAND

Roger J. Mattson
SCIENTECH Inc.
11821 Parklawn Dr.
Rockville, MD 20852

Donald McPherson
USNRC-NRR/DONRR
MS: 12G-18

Jim Metcalf
Stone and Webster Engineering
Corporation
245 Summer St.
Boston, MA 02107

Mary Meyer
A-1, MS F600
Los Alamos National Laboratory
Los Alamos, NM 87545

Ralph Meyer
USNRC-RES/AEB
MS: NL/N-344

Charles Miller
8 Hastings Rd.
Momsey, NY 10952

Joseph Miller
Gulf States Utilities
P. O. Box 220
St. Francisville, LA 70775

William Mims
Tennessee Valley Authority
400 West Summit Hill Drive.
W10D199C-K
Knoxville, TN 37902

Jocelyn Mitchell
USNRC-RES/SAIB
MS: NL/S-324

Kam Mohktarian
CBI Na-Con Inc.
800 Jorie Blvd.
Oak Brook, IL 60521

James Moody
P.O. Box 641
Rye, NH 03870

S. Mori
Nuclear Safety Division
OECD Nuclear Energy Agency
38 Blvd. Suchet
75016 Paris
FRANCE

Walter B. Murfin
P.O. Box 550
Mesquite, NM 88048

Joseph A. Murphy
USNRC-RES/DSR
MS: NL/S-007

V. I. Nath
Safety Branch
Safety Engineering Group
Sheridan Park Research Community
Mississauga, Ontario L5K 1B2
CANADA

Susan J. Niemczyk
1545 18th St. NW, #112
Washington, DC 20036

Pradyot K. Niyogi
USDOE-Office of Nuclear Safety
Washington, DC 20545

Paul North
EG&G Idaho, Inc.
P. O. Box 1625
Idaho Falls, ID 83415

Edward P. O'Donnell
Ebasco Services, Inc.
2 World Trade Center, 89th Floor
New York, NY 10048

David Okrent
UCLA
Boelter Hall, Room 5532
Los Angeles, CA 90024

Robert L. Olson
Tennessee Valley Authority
400 West Summit Hill Rd.
Knoxville, TN 37902

Simon Ostrach
Case Western Reserve University
418 Glenman Bldg.
Cleveland, OH 44106

D. Paddleford
Westinghouse Electric Corporation
Savanna River Site
Aiken, SC 29808

Robert L. Palla, Jr.
USNRC-NRR/PRAB
MS: 10A-2

Chang K. Park
Brookhaven National Laboratory
Building 130
Upton, NY 11973

Michael C. Parker
Illinois Department of Nuclear
Safety
1035 Outer Park Dr.
Springfield, IL 62704

Gareth Parry
NUS Corporation
910 Clopper Road
Gaithersburg, MD 20878

J. Pelce
Departement de Surete Nucleaire
IPSN
Centre d'Estudes Nucleaires du CEA
B.P. no. 6, Cedex
F-92260 Fontenay-aux-Roses
FRANCE

G. Petrangeli
ENEA Nuclear Energy ALT Disp
Via V. Brancati, 48
00144 Rome
ITALY

Marty Plys
Fauske and Associates
16W070 West 83rd St.
Burr Ridge, IL 60521

Mike Podowski
Department of Nuclear Engineering
and Engineering Physics
RPI
Troy, NY 12180-3590

Robert D. Pollard
Union of Concerned Scientists
1616 P Street, NW, Suite 310
Washington, DC 20036

R. Potter
UK Atomic Energy Authority
Winfrith, Dorchester
Dorset, DT2 8DH
UNITED KINGDOM

William T. Pratt
Brookhaven National Laboratory
Building 130
Upton, NY 11973

M. Preat
Chef du Service Surete Nucleaire et
Assurance Qualite
TRACTEBEL
Bd. du Regent 8
B-100 Bruxells
BELGIUM

David Pyatt
USDOE
MS: EH-332
Washington, DC 20545

William Raisin
NUMAEC
1726 M St. NW
Suite 904
Washington, DC 20036

Joe Rashid
ANATECH Research Corp.
3344 N. Torrey Pines Ct.
Suite 1320
La Jolla, CA 90237

Dale M. Rasmuson
USNRC-RES/PRAB
MS: NL/S-372

Ingvard Rasmussen
Riso National Laboratory
Postbox 49
DK-4000, Roskilde
DENMARK

Norman C. Rasmussen
Massachusetts Institute of
Technology
77 Massachusetts Avenue
Cambridge, MA 02139

John W. Reed
Jack R. Benjamin & Associates, Inc.
444 Castro St., Suite 501
Mountain View, CA 94041

David B. Rhodes
Atomic Energy of Canada, Ltd.
Chalk River Nuclear Laboratories
Chalk River, Ontario K0J1P0
CANADA

Dennis Richardson
Westinghouse Electric Corporation
P.O. Box 355
Pittsburgh, PA 15230

Doug Richeard
Virginia Electric Power Co.
P.O.Box 26666
Richmond, VA 23261

Robert Ritzman
Electric Power Research Institute
3412 Hillview Avenue
Palo Alto, CA 94304

Richard Robinson
USNRC-RES/PRAB
MS: NL/S-372

Jack E. Rosenthal
USNRC-AEOD/ROAB
MS: MNBB-9715

Derwood F. Ross
USNRC-RES
MS: NL/S-007

Frank Rowsome
9532 Fern Hollow Way
Gaithersburg, MD 20879

Wayne Russell
SERI
5360 I-55 North
Jackson, MS 39211

Jorma V. Sandberg
Finnish Ctr. Rad. Nucl. and Safety
Department of Nuclear Safety
P.O. Box 268
SF-00101 Helsinki
FINLAND

G. Saponaro
ENEA Nuclear Engineering Alt.
Zia V Brancati 4B
00144 ROME
ITALY

M. Sarran
United Engineers
P. O. Box 8223
30 S 17th Street
Philadelphia, PA 19101

Marty Sattison
EG&G Idaho
P. O. Box 1625
Idaho Falls, ID 83415

George D. Sauter
Electric Power Research Institute
3412 Hillview Avenue
Palo Alto, CA 94303

Jorge Schulz
Bechtel Western Power Corporation
50 Beale Street
San Francisco, CA 94119

B. R. Sehgal
Electric Power Research Institute
3412 Hillview Avenue
Palo Alto, CA 94303

Subir Sen
Bechtel Power Corp.
15740 Shady Grove Road
Location 1A-7
Gaithersburg, MD 20877

S. Serra
Ente Nazionale per l'Energia
Elettrica (ENEL)
via G. B. Martini 3
Rome
ITALY

Bonnie J. Shapiro
Science Applications International
Corporation
360 Bay Street
Suite 200
Augusta, GA 30901

H. Shapiro
Licensing and Risk Branch
Atomic Energy of Canada Ltd.
Sheridan Park Research Community
Mississauga, Ontario L5K 1B2
CANADA

Dave Sharp
Westinghouse Savannah River Co.
Building 773-41A, P. O. Box 616
Aiken, SC 29802

John Sherman
Tennessee Environmental Council
1719 West End Avenue, Suite 227
Nashville, TN 37203

Brian Sheron
USNRC-RES/DSR
MS: NL/N-007

Rick Sherry
JAYCOR
P. O. Box 85154
San Diego, CA 92138

Steven C. Sholly
MHB Technical Associates
1723 Hamilton Avenue, Suite K
San Jose, CA 95125

Louis M. Shotkin
USNRC-RES/RPSB
MS: NL/N-353

M. Siebertz
Chef de la Section Surete' des
Reacteurs
CEN/SCK
Boeretang, 200
B-2400 Mol
BELGIUM

Melvin Silberberg
USNRC-RES/DE/WNB
MS: NL/S-260

Gary Smith
SERI
5360 I-55 North
Jackson, MS 39211

Gary L. Smith
Westinghouse Electric Corporation
Hanford Site
Box 1970
Richland, WA 99352

Lanny N. Smith
Science Applications International
Corporation
2109 Air Park Road SE
Albuquerque, NM 87106

K. Soda
Japan Atomic Energy Res. Inst.
Tokai-Mura Naka-Gun
Ibaraki-Ken 319-11
JAPAN

David Sommers
Virginia Electric Power Company
P. O. Box 26666
Richmond, VA 23261

Herschel Spector
New York Power Authority
123 Main Street
White Plains, NY 10601

Themis P. Speis
USNRC-RES
MS: NL/S-007

Klaus B. Stadie
OECD-NEA, 38 Bld. Suchet
75016 Paris
FRANCE

John Stetkar
Pickard, Lowe & Garrick, Inc.
2216 University Drive
Newport Beach, CA 92660

Wayne L. Stiede
Commonwealth Edison Company
P.O. Box 767
Chicago, IL 60690

William Stratton
Stratton & Associates
2 Acoma Lane
Los Alamos, NM 87544

Soo-Pong Suk
Korea Advanced Energy Research
Institute
P. O. Box 7
Daeduk Danji, Chungnam 300-31
KOREA

W. P. Sullivan
GE Nuclear Energy
175 Curtner Ave., M/C 789
San Jose, CA 95125

Tony Taig
U.K. Atomic Energy Authority
Wigshaw Lane, Culcheth
Warrington, Cheshire, WA3 4NE
UNITED KINGDOM

John Taylor
Electric Power Research Institute
3412 Hillview Avenue
Palo Alto, CA 94303

Harry Teague
U.K. Atomic Energy Authority
Wigshaw Lane, Culcheth
Warrington, Cheshire, WA3 4NE
UNITED KINGDOM

Technical Library
Electric Power Research Institute
P.O. Box 10412
Palo Alto, CA 94304

Mark I. Temme
General Electric, Inc.
P.O. Box 3508
Sunnyvale, CA 94088

T. G. Theofanous
University of California, S.B.
Department of Chemical and Nuclear
Engineering
Santa Barbara, CA 93106

David Teolis
Westinghouse-Bettis Atomic Power
Laboratory
P. O. Box 79, ZAP 34N
West Mifflin, PA 15122-0079

Ashok C. Thadani
USNRC-NRR/SAD
MS: 7E-4

Garry Thomas
L-499 (Bldg. 490)
Lawrence Livermore National
Laboratory
7000 East Ave.
P.O. Box 808
Livermore, CA 94550

Gordon Thompson
Institute for Research and
Security Studies
27 Ellworth Avenue
Cambridge, MA 02139

Grant Thompson
League of Women Voters
1730 M. Street, NW
Washington, DC 20036

Arthur Tingle
Brookhaven National Laboratory
Building 130
Upton, NY 11973

Rich Toland
United Engineers and Construction
30 S. 17th St., MS 4V7
Philadelphia, PA 19101

Brian J. R. Tolley
DG/XII/D/1
Commission of the European
Communities
Rue de la Loi, 200
B-1049 Brussels
BELGIUM

David R. Torgerson
Atomic Energy of Canada Ltd.
Whiteshell Nuclear
Research Establishment
Pinawa, Manitoba, ROE 110
CANADA

Dr. Alfred F. Torri
1421 Hymettus Avenue
Leucadia, CA 92024

Klau Trambauer
Gesellschaft Fur Reaktorsicherheit
Forschungsgelände
D-8046 Garching
FERERAL REPUBLIC OF GERMANY

Nicholas Tsoulfanidis
Nuclear Engineering Dept.
University of Missouri-Rolla
Rolla, MO 65401-0249

Chao-Chin Tung
c/o H.B. Bengelsdorf
ERC Environmental Services Co.
P. O. Box 10130
Fairfax, VA 22030

Brian D. Turland
UKAEA Culham Laboratory
Abingdon, Oxon OX14 3DB
ENGLAND

Takeo Uga
Japan Institute of Nuclear Safety
Nuclear Power Engineering Test
Center
3-6-2, Toranomom
Minato-ku, Tokyo 108
JAPAN

Stephen D. Unwin
Battelle Columbus Division
505 King Avenue
Columbus, OH 43201

A. Valeri
DISP
ENEA
Via Vitaliano Brancati, 48
I-00144 Rome
ITALY

Harold VanderMolen
USNRC-RES/PRAB
MS: NL/S-372

G. Bruce Varnado
ERC International
1717 Louisiana Blvd. NE, Suite 202
Albuquerque, NM 87110

Jussi K. Vaurio
Imatran Voima Oy
Loviisa NPS
SF-07900 Loviisa
FINLAND

William E. Vesely
Science Applications International
Corporation
655 Metro Place South, Suite 745
Dubbin, OH 43017

J. I. Villadoniga Tallon
Div. of Analysis and Assessment
Consejo de Seguridad Nuclear
c/ Sor Angela de la Cruz, 3
28020 Madrid
SPAIN

Willem F. Vinck
Kappellestrat 25
1980
Tervuren
BELGIUM

R. Virolainen
Office of Systems Integration
Finnish Centre for Radiation and
Nuclear Safety
Department of Nuclear Safety
P.O. Box 268
Kumpulantie 7
SF-00520 Helsinki
FINLAND

Raymond Viskanta
School of Mechanical Engineering
Purdue University
West Lafayette, IN 47907

S. Visweswaran
General Electric Company
175 Curtner Avenue
San Jose, CA 95125

Truong Vo
Pacific Northwest Laboratory
Battelle Blvd.
Richland, WA 99352

Richard Vogel
Electric Power Research Institute
P. O. Box 10412
Palo Alto, CA 94303

G. Volta
Engineering Division
CEC Joint Research Centre
CP No. 1
I-21020 Ispra (Varese)
ITALY

Ian B. Wall
Electric Power Research Institute
3412 Hillview Avenue
Palo Alto, CA 94303

Adolf Walser
Sargent and Lundy Engineers
55 E. Monroe Street
Chicago, IL 60603

Edward Warman
Stone & Webster Engineering Corp.
P.O. Box 2325
Boston, MA 02107

Norman Weber
Sargent & Lundy Co.
55 E. Monroe Street
Chicago, IL 60603

Lois Webster
American Nuclear Society
555 N. Kensington Avenue
La Grange Park, IL 60525

Wolfgang Werner
Gesellschaft Fur Reaktorsicherheit
Forschungsgelände
D-8046 Garching
FEDERAL REPUBLIC OF GERMANY

Don Wesley
IMPELL
1651 East 4th Street
Suite 210
Santa Ana, CA 92701

Detlof von Winterfeldt
Institute of Safety and Systems
Management
University of Southern California
Los Angeles, CA 90089-0021

Pat Worthington
USNRC-RES/AEB
MS: NL/N-344

John Wreathall
Science Applications International
Corporation
655 Metro Place South, Suite 745
Dubbin, OH 43017

D. J. Wren
Atomic Energy of Canada Ltd.
Whiteshell Nuclear Research
Establishment
Pinawa, Manitoba, ROE 1L0
CANADA

Roger Wyrick
Inst. for Nuclear Power Operations
1100 Circle 75 Parkway, Suite 1500
Atlanta, GA 30339

Kun-Joong Yoo
Korea Advanced Energy Research
Institute
P. O. Box 7
Daeduk Danji, Chungnam 300-31
KOREA

Faith Young
Energy People, Inc.
Dixou Springs, TN 37057

Jonathan Young
R. Lynette and Associates
15042 Northeast 40th St.
Suite 206
Redmond, WA 98052

C. Zaffiro
Division of Safety Studies
Directorate for Nuclear Safety and
Health Protection
Ente Nazionale Energie Alternative
Via Vitaliano Brancati, 48
I-00144 Rome
ITALY

Mike Zentner
Westinghouse Hanford Co.
P. O. Box 1970
Richland, WA 99352

Kun-Joong Yoo
Korea Advanced Energy Research
Institute
P. O. Box 7
Daeduk Danji, Chungnam 300-31
KOREA

Faith Young
Energy People, Inc.
Dixou Springs, TN 37057

Jonathan Young
R. Lynette and Associates
15042 Northeast 40th St.
Suite 206
Redmond, WA 98052

C. Zaffiro
Division of Safety Studies
Directorate for Nuclear Safety and
Health Protection
Ente Nazionale Energie Alternative
Via Vitaliano Brancati, 48
I-00144 Rome
ITALY

Mike Zentner
Westinghouse Hanford Co.
P. O. Box 1970
Richland, WA 99352

X. Zikidis
Greek Atomic Energy Commission
Agia Paraskevi, Attiki
Athens
GREECE

Bernhard Zuczera
Kernforschungszentrum
Postfach 3640
D-7500 Karlsruhe
FEDERAL REPUBLIC OF GERMANY

1521 J. R. Weatherby
3141 S. A. Landenberger [5]
3151 W. I. Klein
5214 D. B. Clauss
6344 E. D. Gorham
6001 D. D. Carlson
6001 R. J. Breeding
6001 D. M. Kunsman
6400 D. J. McCloskey
6401 D. R. Bradley
6410 D. A. Dahlgren
6412 A. L. Camp
6412 S. L. Daniel
6412 T. M. Hake

6412 L. A. Miller
6412 D. B. Mitchell
6412 A. C. Payne, Jr.
6412 T. T. Sype
6412 T. A. Wheeler
6412 D. W. Whitehead
6413 T. D. Brown
6413 F. T. Harper [2]
6415 R. M. Cranwell
6415 W. R. Cramond [3]
6415 R. L. Iman
6418 J. E. Kelly
6418 K. J. Maloney
6419 M. P. Bohn
6419 J. A. Lambright
6422 D. A. Powers
6424 K. D. Bergeron
6424 J. J. Gregory
6424 D. C. Williams
6425 S. S. Dosanjh
6453 J. S. Philbin
6460 J. V. Walker
6463 M. Berman
6463 M. P. Sherman
6471 L. D. Bustard
6473 W. A. von Rieseemann
6900 A. W. Snyder
8524 J. A. Wackerly

BIBLIOGRAPHIC DATA SHEET

(See instructions on the reverse)

1. REPORT NUMBER
(Assigned by NRC. Add Vol., Supp., Rev.,
and Addendum Numbers, if any.)

NUREG/CR-4840
SAND88-3102

2. TITLE AND SUBTITLE

PROCEDURES FOR THE EXTERNAL EVENT CORE
DAMAGE FREQUENCY ANALYSES FOR NUREG-1150

3. DATE REPORT PUBLISHED

MONTH | YEAR

November | 1990

4. FIN OR GRANT NUMBER

A1384

5. AUTHOR(S)

M. P. Bohn and J. A. Lambright

6. TYPE OF REPORT

Technical

7. PERIOD COVERED (Inclusive Dates)

8. PERFORMING ORGANIZATION - NAME AND ADDRESS (If NRC, provide Division, Office or Region, U.S. Nuclear Regulatory Commission, and mailing address; if contractor, provide name and mailing address.)

Sandia National Laboratories
Albuquerque, New Mexico 87185-5800

9. SPONSORING ORGANIZATION - NAME AND ADDRESS (If NRC, type "Same as above"; if contractor, provide NRC Division, Office or Region, U.S. Nuclear Regulatory Commission, and mailing address.)

Division of Systems Research
Office of Nuclear Regulatory Research
US Nuclear Regulatory Commission
Washington, DC 20555

10. SUPPLEMENTARY NOTES

11. ABSTRACT (200 words or less)

This report presents procedures which can be used to assess external hazards at nuclear power plants. These methods were used to perform the external events risk assessments for the Surry and Peach Bottom nuclear power plants as part of the NRC-sponsored NUREG-1150 program. These methods apply to the full range of hazards such as earthquakes, fires, floods, etc. which are collectively known as external events and are based on making full utilization of the power plant systems logic models developed in the internal events analyses.

Hallmarks of the methods described include the use of extensive computer-aided screening prior to the detailed analysis of each external event hazard to which the plant might conceivably be exposed. These screening procedures identify those external events which could contribute to the risk at the plant and significantly reduce the number of events for which subsequent detailed analysis is required. Taken together, these techniques provide a relatively straightforward and, in some cases, simplified set of techniques for the analysis of the full range of external events and provides for both scrutability and reproducibility of the final results.

12. KEY WORDS/DESCRIPTORS (List words or phrases that will assist researchers in locating the report.)

Probabilistic Risk Assessment (PRA)
External Hazards
safety analysis
uncertainty analysis
accident sequence analysis

13. AVAILABILITY STATEMENT

Unlimited

14. SECURITY CLASSIFICATION

(This Page)

Unclassified

(This Report)

Unclassified

15. NUMBER OF PAGES

16. PRICE

THIS DOCUMENT WAS PRINTED USING RECYCLED PAPER.

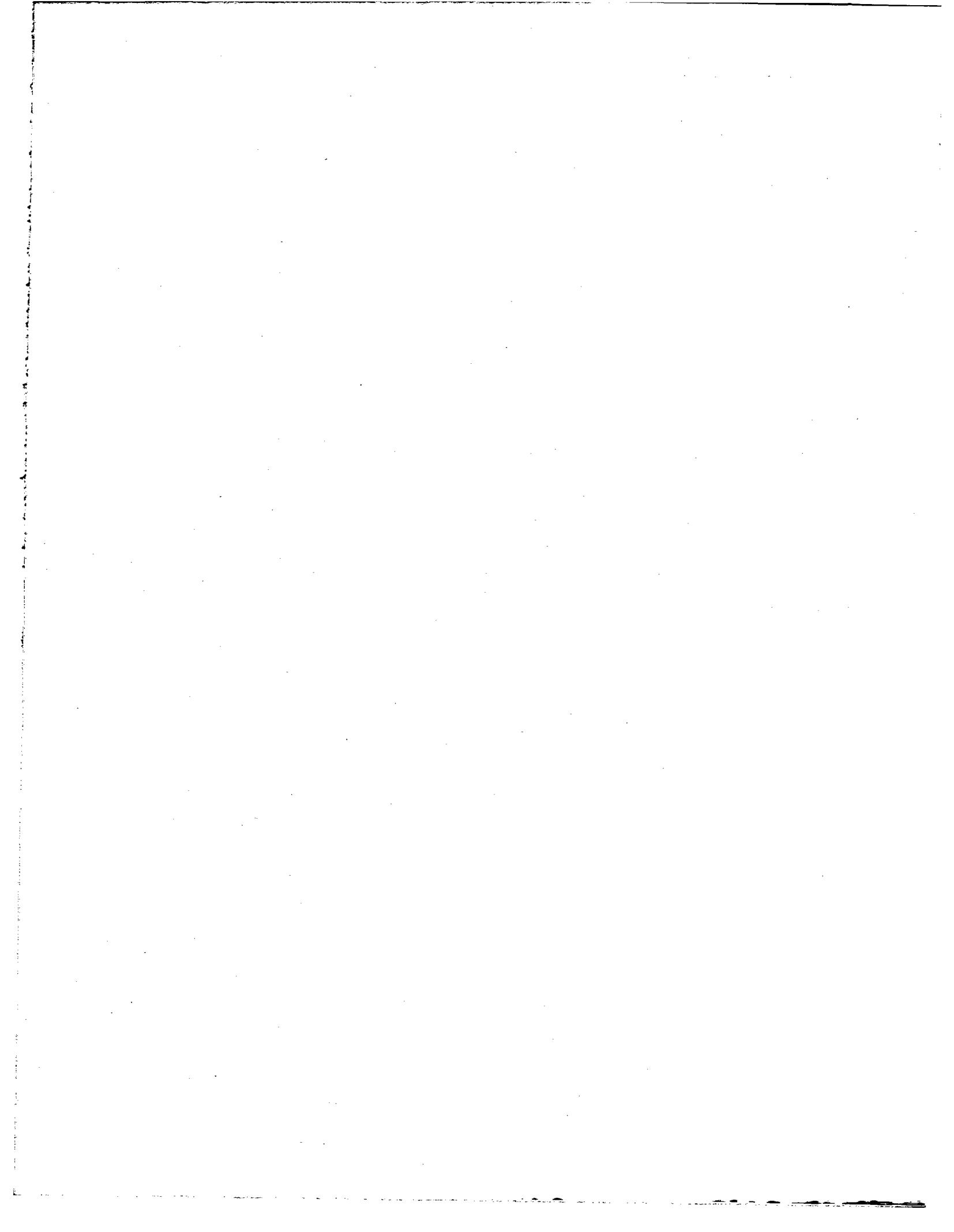

UNITED STATES
NUCLEAR REGULATORY COMMISSION
WASHINGTON, D.C. 20555

OFFICIAL BUSINESS
PENALTY FOR PRIVATE USE, \$300

SPECIAL FOURTH-CLASS RATE
POSTAGE & FEES PAID
USNRC.
PERMIT No. G-67

William Beckner
USNRC-RES/SAIB
MS: NL/S-324