

PWR and BWR Pressure Vessel Fluence Calculation Benchmark Problems and Solutions

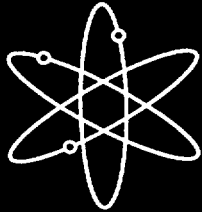

Brookhaven National Laboratory

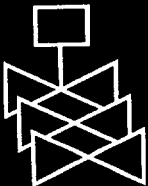
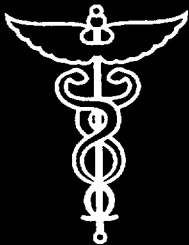

**U.S. Nuclear Regulatory Commission
Office of Nuclear Regulatory Research
Washington, DC 20555-0001**



AVAILABILITY OF REFERENCE MATERIALS IN NRC PUBLICATIONS

NRC Reference Material

As of November 1999, you may electronically access NUREG-series publications and other NRC records at NRC's Public Electronic Reading Room at www.nrc.gov/NRC/ADAMS/index.html.

Publicly released records include, to name a few, NUREG-series publications; *Federal Register* notices; applicant, licensee, and vendor documents and correspondence; NRC correspondence and internal memoranda; bulletins and information notices; inspection and investigative reports; licensee event reports; and Commission papers and their attachments.

NRC publications in the NUREG series, NRC regulations, and *Title 10, Energy*, in the Code of *Federal Regulations* may also be purchased from one of these two sources.

1. The Superintendent of Documents
U.S. Government Printing Office
Mail Stop SSOP
Washington, DC 20402-0001
Internet: bookstore.gpo.gov
Telephone: 202-512-1800
Fax: 202-512-2250
2. The National Technical Information Service
Springfield, VA 22161-0002
www.ntis.gov
1-800-553-6847 or, locally, 703-605-6000

A single copy of each NRC draft report for comment is available free, to the extent of supply, upon written request as follows:

Address: Office of the Chief Information Officer,
Reproduction and Distribution
Services Section
U.S. Nuclear Regulatory Commission
Washington, DC 20555-0001
E-mail: DISTRIBUTION@nrc.gov
Facsimile: 301-415-2289

Some publications in the NUREG series that are posted at NRC's Web site address www.nrc.gov/NRC/NUREGS/indexnum.html are updated periodically and may differ from the last printed version. Although references to material found on a Web site bear the date the material was accessed, the material available on the date cited may subsequently be removed from the site.

Non-NRC Reference Material

Documents available from public and special technical libraries include all open literature items, such as books, journal articles, and transactions, *Federal Register* notices, Federal and State legislation, and congressional reports. Such documents as theses, dissertations, foreign reports and translations, and non-NRC conference proceedings may be purchased from their sponsoring organization.

Copies of industry codes and standards used in a substantive manner in the NRC regulatory process are maintained at—

The NRC Technical Library
Two White Flint North
11545 Rockville Pike
Rockville, MD 20852-2738

These standards are available in the library for reference use by the public. Codes and standards are usually copyrighted and may be purchased from the originating organization or, if they are American National Standards, from—

American National Standards Institute
11 West 42nd Street
New York, NY 10036-8002
www.ansi.org
212-642-4900

Legally binding regulatory requirements are stated only in laws; NRC regulations; licenses, including technical specifications; or orders, not in NUREG-series publications. The views expressed in contractor-prepared publications in this series are not necessarily those of the NRC.

The NUREG series comprises (1) technical and administrative reports and books prepared by the staff (NUREG-XXXX) or agency contractors (NUREG/CR-XXXX), (2) proceedings of conferences (NUREG/CP-XXXX), (3) reports resulting from international agreements (NUREG/IA-XXXX), (4) brochures (NUREG/BR-XXXX), and (5) compilations of legal decisions and orders of the Commission and Atomic and Safety Licensing Boards and of Directors' decisions under Section 2.206 of NRC's regulations (NUREG-0750).

DISCLAIMER: This report was prepared as an account of work sponsored by an agency of the U.S. Government. Neither the U.S. Government nor any agency thereof, nor any employee, makes any warranty, expressed or implied, or assumes any legal liability or responsibility for any third party's use, or the results of such use, of any information, apparatus, product, or process disclosed in this publication, or represents that its use by such third party would not infringe privately owned rights.

PWR and BWR Pressure Vessel Fluence Calculation Benchmark Problems and Solutions

Manuscript Completed: September 2001
Date Published: September 2001

Prepared by
J.F. Carew, K. Hu, A. Aronson, A. Prince, G. Zamonsky

Brookhaven National Laboratory
Upton, NY 11973-5000

W.R. Jones, NRC Project Manager

Prepared for
Division of Engineering Technology
Office of Nuclear Regulatory Research
U.S. Nuclear Regulatory Commission
Washington, DC 20555-0001
NRC Job Code W6968



ABSTRACT

In order to provide the high confidence required in the determination of pressure vessel embrittlement and the evaluation of the Pressurized Thermal Shock (PTS) screening criteria, Regulatory Guide 1.190, "Calculational and Dosimetry Methods for Determining Pressure Vessel Neutron Fluence," recommends detailed benchmarking of pressure vessel fluence calculations. In response to this recommendation, this report provides the detailed specification and corresponding numerical solutions for a set of PWR and BWR pressure vessel fluence benchmark problems. PWR benchmark problems have been specified for (1) a standard core loading pattern, (2) a low-leakage core loading pattern and (3) a partial length shield assembly core design. Since BWR fuel loading patterns are presently not being designed for vessel fluence reduction, only a single BWR problem is specified. These benchmark problems allow a detailed assessment of the numerical procedures, code implementation, and the various modeling approximations against state-of-the-art solutions for representative operating configurations.

The problems have been solved using the DORT discrete ordinates transport code, the MESH source processing code, and the BUGLE-93 ENDF/B-VI nuclear data. Detailed neutron flux solutions are provided at selected pressure vessel azimuthal, radial, and axial locations. A pin-wise core neutron source is provided which includes the fuel burnup dependence of both the magnitude and energy dependence of the neutron source. Dosimeter responses are calculated for a typical set of LWR fast neutron dosimeter materials. In addition, MCNP Monte Carlo calculations have been performed for the PWR standard core and partial length shield assembly core loadings and the BWR problem. Comparisons of the MCNP and DORT vessel fluence calculations are presented.

CONTENTS

	Page
Abstract	iii
List of Figures	vii
List of Tables	ix
Acknowledgments	xiii
1 Introduction	1-1
1.1 Background	1-1
1.2 Regulatory Guide 1.190	1-1
1.3 Pressure Vessel Fluence Benchmark Problems	1-2
1.3.1 DORT Discrete Ordinates Calculations	1-2
1.3.2 MCNP Monte Carlo Calculations	1-2
1.4 Application of the Benchmark Problems	1-3
2 Benchmark Problem Specification	2-1
2.1 PWR Problem Specification	2-1
2.1.1 Introduction	2-1
2.1.2 Specification of the Standard Core Loading Problem	2-1
2.1.3 Specification of the Low-Leakage Core Loading Problem	2-2
2.1.4 Specification of the Partial Length Shield Assembly Core Loading Problem	2-3
2.2 BWR Problem Specification	2-3
2.2.1 Introduction	2-3
2.2.2 Specification of the BWR Problem	2-4
3 DORT Computational Methodology	3-1
3.1 Introduction	3-1
3.2 Neutron Cross Sections and Fission Spectra	3-1
3.3 Core Neutron Source	3-1
3.4 Neutron Transport Calculations	3-1
3.5 Flux Synthesis	3-2
3.6 Dosimetry Cross Sections	3-2
4 DORT Benchmark Problem Calculation Results	4-1
4.1 PWR Benchmark Problem Calculation Results	4-1
4.1.1 Calculated Flux, Reaction Rates and Spectra	4-1
4.1.2 Standard Core Loading Benchmark Problem	4-1
4.1.3 Low-Leakage Core Loading Benchmark Problem	4-2
4.1.4 Partial Length Shield Assembly Core Loading Benchmark Problem	4-2
4.2 BWR Benchmark Problem Calculation Results	4-3
4.2.1 Calculated Flux, Reaction Rates and Spectra	4-3
4.2.2 BWR Benchmark Problem Results	4-3

CONTENTS (Cont'd.)

5	PWR and BWR MCNP Benchmark Problem Calculations	5-1
5.1	Introduction	5-1
5.2	Calculation Methodology	5-1
5.3	PWR MCNP Calculations and Comparison with DORT	5-1
5.4	BWR MCNP Calculations and Comparison with DORT	5-2
6	References	6-1

For each benchmark problem, the pin-wise data (geometry, power and burnup) for all the peripheral assemblies are provided on a separate CD ROM.

FIGURES

	Page
2.1.2.1 Standard Core Loading	2-57
2.1.2.2 Standard Core Loading Axial Geometry at $\theta = 0^\circ$	2-58
2.1.2.3 Location of Surveillance Capsules	2-59
2.1.2.4 Surveillance Capsule	2-60
2.1.3.1 Low-Leakage Core Loading	2-61
2.1.3.2 Low-Leakage Core Loading Axial Geometry at $\theta = 0^\circ$	2-62
2.1.3.3 Location of Surveillance Capsules	2-63
2.1.3.4 Surveillance Capsule	2-64
2.1.4.1 Partial Length Shield Assembly Core Loading	2-65
2.1.4.2 Partial Length Shield Assembly Core Design	2-66
2.1.4.3 Partial Length Shield Assembly Core Loading Axial Geometry at $\theta = 0^\circ$	2-67
2.2.2.1 BWR Planar Geometry	2-104
2.2.2.2 BWR Axial Geometry at $\theta = 0^\circ$	2-105
2.2.2.3 Surveillance Capsule	2-106
4.1.2.1 Standard Core Loading Pressure Vessel Flux Spectrum at the 0-T Location	4-62
4.1.2.2 Standard Core Loading Pressure Vessel Flux Spectrum at the T/4 Location	4-63
4.1.2.3 Standard Core Loading Pressure Vessel Flux Spectrum at the T/2 Location	4-64
4.1.2.4 Standard Core Loading Pressure Vessel Flux Spectrum at the 3T/4 Location	4-65
4.1.2.5 Standard Core Loading Pressure Vessel Flux Spectrum at the 1-T Location	4-66
4.1.2.6 Standard Core Loading Thermal Shield Capsule Flux Spectrum	4-67
4.1.2.7 Standard Core Loading Pressure Vessel Capsule Flux Spectrum	4-68
4.1.2.8 Standard Core Loading Cavity Capsule Flux Spectrum	4-69
4.1.3.1 Low-Leakage Core Loading Pressure Vessel Flux Spectrum at the 0-T Location	4-70
4.1.3.2 Low-Leakage Core Loading Pressure Vessel Flux Spectrum at the T/4 Location	4-71
4.1.3.3 Low-Leakage Core Loading Pressure Vessel Flux Spectrum at the T/2 Location	4-72
4.1.3.4 Low-Leakage Core Loading Pressure Vessel Flux Spectrum at the 3T/4 Location	4-73
4.1.3.5 Low-Leakage Core Loading Pressure Vessel Flux Spectrum at the 1-T Location	4-74
4.1.3.6 Low-Leakage Core Loading Thermal Shield Capsule Flux Spectrum	4-75
4.1.3.7 Low-Leakage Core Loading Pressure Vessel Capsule Flux Spectrum	4-76
4.1.3.8 Low-Leakage Core Loading Cavity Capsule Flux Spectrum	4-77
4.1.4.1 Flux >1.0 MeV at the Pressure Vessel Weld Surface	4-78
4.1.4.2 Flux >0.1 MeV at the Pressure Vessel Weld Surface	4-79
4.1.4.3 Displacements Per Atom at the Pressure Vessel Weld Surface	4-80
4.1.4.4 Pressure Vessel Weld Flux Spectrum at $\theta = 0^\circ$	4-81
4.2.2.1 Pressure Vessel 0-T Flux Spectrum	4-112
4.2.2.2 Pressure Vessel 1/4 T Flux Spectrum	4-113
4.2.2.3 Pressure Vessel 1/2 T Flux Spectrum	4-114
4.2.2.4 Pressure Vessel 3/4 T Flux Spectrum	4-115
4.2.2.5 Pressure Vessel 1.0 T Flux Spectrum	4-116
4.2.2.6 Pressure Vessel Capsule Flux Spectrum	4-117
4.2.2.7 Cavity Peak Location Flux Spectrum	4-118

FIGURES (Cont'd.)

		Page
5.3.1	Region-Wise Importance I for the Standard Core Problem	5-8
5.3.2	MCNP Radial Geometry Standard Core Loading	5-9
5.3.3	MCNP Axial Geometry Standard Core Loading	5-10
5.3.4	MCNP Radial Geometry PLSA Core Loading	5-11
5.3.5	MCNP Axial Geometry PLSA Core Loading	5-12
5.3.6	E>1.0 MeV Flux at Pressure Vessel Inner Wall Standard Core Loading Peak Axial Location	5-13
5.3.7	E>1.0 MeV Flux at Pressure Vessel T/4 Location Standard Core Loading Peak Axial Location	5-14
5.3.8	E>1.0 MeV Flux at Pressure Vessel Lower Weld Standard Core Loading	5-15
5.3.9	E>1.0 MeV Flux at Pressure Vessel Lower Weld Partial Length Shield Assembly Core Loading	5-16
5.4.1	MCNP Radial Geometry	5-21
5.4.2	MCNP Axial Geometry	5-22
5.4.3	Radial Region-Wise Importance I	5-23
5.4.4	Axial Region-Wise Importance I	5-24
5.4.5	Comparison of MCNP and DORT E>1.0 MeV Flux in Downcomer	5-25
5.4.6	Comparison of MCNP and DORT E>1.0 MeV Flux at Pressure Vessel Wall	5-26
5.4.7	E>1.0 MeV Flux in Downcomer at Core Axial Midplane	5-27
5.4.8	E>1.0 MeV Flux at Pressure Vessel Wall at Core Axial Midplane	5-28

TABLES

	Page
2.1.1.1 Fraction of Fissions by Isotope as a Function of Exposure	2-5
2.1.2.1 Standard Core Loading Basic Design Data	2-6
2.1.2.2 Standard Core Loading Core and Fuel Assemblies	2-7
2.1.2.3 Standard Core Loading Design Specification Material Compositions	2-8
2.1.2.3.1 Isotopic Fractions in Cr, Fe and Ni	2-10
2.1.2.4 Standard Core Loading Axial Zone Assignments	2-11
2.1.2.5 Standard Core Loading Fuel Assembly Geometry, Power, and Burnup Distributions	2-12
2.1.2.6 Standard Core Loading Pin Geometry, Power, and Burnup Distributions	2-13
2.1.2.7 Standard Core Loading Axial Power Distributions	2-18
2.1.2.8 Standard Core Loading Edit Locations	2-20
2.1.3.1 Low-Leakage Core Loading Basic Design Data	2-21
2.1.3.2 Low-Leakage Core Loading Core and Fuel Assemblies	2-22
2.1.3.3 Low-Leakage Core Loading Design Specification Material Compositions	2-23
2.1.3.4 Low-Leakage Core Loading Axial Zone Assignments	2-25
2.1.3.5 Low-Leakage Core Loading Fuel Assembly Geometry, Power, and Burnup Distributions	2-26
2.1.3.6 Low-Leakage Core Loading Pin Geometry, Power, and Burnup Distributions	2-27
2.1.3.7 Low-Leakage Core Loading Axial Power Distributions	2-32
2.1.3.8 Low-Leakage Core Loading Edit Locations	2-34
2.1.4.1 Partial Length Shield Assembly Core Loading Basic Design Data	2-35
2.1.4.2 Partial Length Shield Assembly Core Loading Core and Fuel Assemblies	2-36
2.1.4.3 Partial Length Shield Assembly Core Loading Design Specification Material Compositions	2-37
2.1.4.4 Partial Length Shield Assembly Core Loading Axial Zone Assignments	2-39
2.1.4.5 Upper Partial Length Assembly Core Loading Fuel Assembly Geometry, Power, and Burnup Distributions	2-40
2.1.4.6 Lower Partial Length Assembly Core Loading Fuel Assembly Geometry, Power, and Burnup Distributions	2-41
2.1.4.7 Upper Partial Length Assembly Core Loading Pin Geometry, Power, and Burnup Distributions	2-42
2.1.4.8 Lower Partial Length Assembly Core Loading Pin Geometry, Power, and Burnup Distributions	2-47
2.1.4.9 Upper Partial Length Assembly Core Loading Axial Power Distributions	2-52
2.1.4.10 Lower Partial Length Assembly Core Loading Axial Power Distributions	2-54
2.1.4.11 Partial Length Shield Assembly Core Loading Edit Locations	2-56
2.2.1.1 Fraction of Fissions by Isotope as a Function of Exposure	2-68
2.2.2.1 Basic Design Data	2-69
2.2.2.2 Core and Fuel Assemblies	2-70
2.2.2.3 Design Specification Material Compositions	2-71
2.2.2.3.1 Isotopic Fractions in Cr, Fe and Ni	2-75
2.2.2.4 Fuel Assembly Geometry and Power	2-76
2.2.2.5 Pin Geometry and Power	2-79
2.2.2.6 Axial Power Distributions	2-100
2.2.2.7 Edit Locations	2-102

TABLES (Cont'd.)

	Page
3.2.1 Benchmark Problem Fission Spectrum by Isotope	3-3
3.4.1 Sensitivity of the DORT Calculated Flux to Numerical Input Parameters	3-4
3.4.2 Sensitivity of the DORT Calculated Flux to S_n Quadrature	3-6
4.1.1.1 Mesh Used in DORT Calculation (Inner Model)	4-4
4.1.1.2 Mesh Used in DORT Calculation (Outer Model)	4-7
4.1.1.3 47-Group Energy Structure of Cross-Section Library	4-10
4.1.1.4 Nuclear Parameters for Neutron Flux Monitors	4-11
4.1.1.5 Dosimeter Activation Cross Sections (BUGLE 93)	4-12
4.1.2.1 Standard Core Loading Flux ($E>1.0$ MEV) at Pressure Vessel	4-15
4.1.2.2 Standard Core Loading Flux ($E>0.1$ MEV) at Pressure Vessel	4-17
4.1.2.3 Standard Core Loading DPA Rate at Pressure Vessel	4-19
4.1.2.4 Standard Core Loading Flux ($E>1.0$ MEV) at Pressure Vessel Lower Weld	4-21
4.1.2.5 Standard Core Loading Flux ($E>0.1$ MEV) at Pressure Vessel Lower Weld	4-23
4.1.2.6 Standard Core Loading DPA Rates at Pressure Vessel Lower Weld	4-25
4.1.2.7 Standard Core Loading Downcomer Fluxes and DPA Rates	4-27
4.1.2.8 Standard Core Loading Cavity Fluxes and DPA Rates	4-29
4.1.2.9 Standard Core Loading Flux Spectrum at Pressure Vessel (Pressure Vessel Capsule Included)	4-31
4.1.2.10 Standard Core Loading Flux Spectrum at Capsule Location	4-32
4.1.2.11 Standard Core Loading - Effect of Selected Cross Sections on the Calculated Reaction Rates - Axial Peak Reaction Rate Thermal Shield Capsule	4-33
4.1.2.12 Standard Core Loading - Effect of Selected Cross Sections on the Calculated Reaction Rates - Axial Peak Reaction Rate Pressure Vessel Capsule	4-34
4.1.2.13 Standard Core Loading - Effect of Selected Cross Sections on the Calculated Reaction Rates - Axial Peak Reaction Rate - Cavity Capsule	4-35
4.1.3.1 Low-Leakage Core Loading Flux ($E>1.0$ MEV) at Pressure Vessel	4-36
4.1.3.2 Low-Leakage Core Loading Flux ($E>0.1$ MEV) at Pressure Vessel	4-38
4.1.3.3 Low-Leakage Core Loading DPA Rates at Pressure Vessel	4-40
4.1.3.4 Low-Leakage Core Loading Flux ($E>1.0$ MEV) at Pressure Vessel Lower Weld	4-42
4.1.3.5 Low-Leakage Core Loading Flux ($E>0.1$ MEV) at Pressure Vessel Lower Weld	4-44
4.1.3.6 Low-Leakage Core Loading DPA Rates at Pressure Vessel Lower Weld	4-46
4.1.3.7 Low-Leakage Core Loading Downcomer Fluxes and DPA Rates	4-48
4.1.3.8 Low-Leakage Core Loading Cavity Fluxes and DPA Rates	4-50
4.1.3.9 Low-Leakage Core Loading Flux Spectrum at Pressure Vessel (Pressure Vessel Capsule Included)	4-52
4.1.3.10 Low-Leakage Core Loading Flux Spectrum at Capsule Location	4-53
4.1.3.11 Low-Leakage Core Loading - Effect of Selected Cross Sections on the Calculated Reaction Rates - Axial Peak Reaction Rate Thermal Shield Capsule	4-54
4.1.3.12 Low-Leakage Core Loading - Effect of Selected Cross Sections on the Calculated Reaction Rates - Axial Peak Reaction Rate Pressure Vessel Capsule	4-55
4.1.3.13 Low-Leakage Core Loading - Effect of Selected Cross Sections on the Calculated Reaction Rates - Axial Peak Reaction Rate - Cavity Capsule	4-56
4.1.4.1 Partial Length Shield Assembly Core Loading Fluxes and DPA Rates- Pressure Vessel Inner Wall at Lower Weld ($z = 67.1048$ cm)	4-57

TABLES (Cont'd.)

	Page
4.1.4.2 Partial Length Shield Assembly Core Loading Flux Spectrum-Pressure Vessel Inner Wall at Lower Weld ($z = 67.1048$ cm)	4-59
4.1.4.3 Partial Length Shield Assembly Core Loading-Reduction Factors for Fluxes and DPA Rates-Pressure Vessel Inner Wall at Lower Weld ($z = 67.1048$ cm)	4-60
4.2.1.1 Mesh Used in DORT Calculation	4-82
4.2.1.2 47-Group Energy Structure of Cross-Section Library	4-87
4.2.1.3 Nuclear Parameters for Neutron Flux Monitors	4-88
4.2.1.4 Dosimeter Activation Cross Sections (BUGLE 93)	4-89
4.2.2.1 Flux ($E > 1.0$ MEV) at Pressure Vessel	4-91
4.2.2.2 Flux ($E > 0.1$ MEV) at Pressure Vessel	4-93
4.2.2.3 DPA Rate at Pressure Vessel	4-95
4.2.2.4 Flux ($E > 1.0$ MEV) at Pressure Vessel (Axial Midplane)	4-97
4.2.2.5 Flux ($E > 0.1$ MEV) at Pressure Vessel (Axial Midplane)	4-99
4.2.2.6 DPA Rates at Pressure Vessel (Axial Midplane)	4-101
4.2.2.7 Downcomer Fluxes and DPA Rates	4-103
4.2.2.8 Downcomer Fluxes and DPA Rates (Axial Midplane)	4-105
4.2.2.9 Cavity Fluxes and DPA Rates	4-107
4.2.2.10 Flux Spectrum at Pressure Vessel	4-109
4.2.2.11 Flux Spectrum at the Downcomer, Capsule and Cavity Locations	4-110
4.2.2.12 Calculated Reaction Rates at the Capsule	4-111
5.3.1 MCNP Standard Core Loading Flux ($E > 1.0$ MeV) at Pressure Vessel Inner-Wall Peak Axial Location	5-4
5.3.2 MCNP Standard Core Loading Flux ($E > 1.0$ MeV) at Pressure Vessel 1/4 T Peak Axial Location	5-5
5.3.3 MCNP Standard Core Loading Flux ($E > 1.0$ MeV) at Pressure Vessel Inner-Wall Lower Weld Location	5-6
5.3.4 MCNP Flux ($E > 1.0$ MeV) Partial Length Shield Assembly Core Loading at Pressure Vessel Inner-Wall Lower Weld Location	5-7
5.4.1 MCNP Flux at Downcomer - Explicit Water Gap - Flux ($E > 1.0$ MeV)	5-17
5.4.2 MCNP Flux at Pressure Vessel Wall - Explicit Water Gap - Flux ($E > 1.0$ MeV)	5-18
5.4.3 MCNP Flux at Downcomer - Homogenized Water Gap - Flux ($E > 1.0$ MeV)	5-19
5.4.4 MCNP Flux at Pressure Vessel Wall - Homogenized Water Gap - Flux ($E > 1.0$ MeV)	5-20

ACKNOWLEDGMENTS

The work documented in this report was performed under the auspices of the United States Nuclear Regulatory Commission (USNRC). It was funded by the Materials Engineering Branch of the Division of Engineering Technology in the Office of Nuclear Regulatory Research, under Job Code W-6968. The program was monitored at the USNRC by William R. Jones, Carolyn Fairbanks, and Al Taboada, whose support of this work is greatly appreciated.

The authors are also grateful to Mike Mayfield of the Office of Nuclear Regulatory Research and Chuck Serpan, Jr. of the Office of International Programs for many valuable discussions and contributions to this work.

Special thanks are also due to Mrs. N. Siemon and Mrs. N. Santiago who accomplished the difficult task of editing and bringing this final report to compliance with NRC documentation requirements.

1 INTRODUCTION

1.1 Background

The U.S. Nuclear Regulatory Commission (NRC) has promulgated regulations that ensure the structural integrity of the reactor pressure vessel for light water power reactors. Specific fracture toughness requirements for normal operation and for anticipated operational occurrences for power reactors are set forth in Appendix G, "Fracture Toughness Requirements," of 10 CFR Part 50, "Domestic Licensing of Production and Utilization Facilities." These requirements are imposed through 10 CFR Part 50.60. Additionally, in response to concerns over potential pressurized thermal shock (PTS) events in pressurized water reactors (PWRs), the NRC issued 10 CFR 50.61, "Fracture Toughness Requirements for Protection Against Pressurized Thermal Shock Events."

In order to satisfy the requirements of both Appendix G (General Design Criteria 14, 30 and 31) and 10 CFR 50.61, methods for determining the fast neutron fluence ($E > 1$ MeV) are necessary to estimate the fracture toughness of the pressure vessel materials. Appendix H, "Reactor Vessel Material Surveillance Program Requirements," of 10 CFR Part 50 requires the installation of surveillance capsules, including material test specimens and flux dosimeters, to provide data on material damage correlations as a function of fluence.

The fracture toughness of pressure vessel materials is related to the material's "reference nil-ductility temperature," or simply reference temperature, which is denoted as RT_{NDT} . The RT_{NDT} is defined in Revision 2 of Regulatory Guide 1.99, "Radiation Embrittlement of Reactor Vessel Materials," by a correlation of the fast neutron fluence ($E > 1$ MeV), material chemistry (concentrations of Cu and Ni), initial reference temperature, and margin to account for uncertainties in the correlation and input values. Section 10 CFR 50.61 requires evaluation of the reference temperature based on the best estimate of the fast neutron fluence at the end of the license period, and the corresponding reference temperature is termed RT_{PTS} .

1.2 Regulatory Guide 1.190

As the pressure vessels of operating plants continue to accumulate neutron fluence reducing the margin to the vessel RT_{NDT} , certain PWR plants are approaching the RT_{PTS} screening criteria with the potential, in some cases, for reaching this limit prior to end-of-license. The approach to this limit, together with the difficulty in making an accurate determination of the vessel neutron fluence using calculations and/or measurements, requires that the most accurate methods and procedures be used to determine the pressure vessel fluence.

The difficulty in calculating the vessel fluence is due to (1) the strong attenuation of the flux between the core and the vessel and (2) the complexity of the neutron source calculation. The neutron fluence is attenuated by several decades (typically ~ 4 in the case of both PWRs and BWRs) between the core and the vessel which results in a very strong sensitivity of the calculated fluence to the representation of the core and internals geometry and material compositions, nuclear cross sections and numerical procedures for performing the transport calculation. The rapid spatial variation of the neutron source near the core boundary requires that the detailed fuel pin-wise source variation be explicitly represented. In addition, in order to account for the fuel burnup dependence of this source data, the source must be calculated for each plant operating cycle. The source determination is further complicated by the coordinate transformation required to convert the data from the rectangular (x, y) core geometry to the cylindrical (r, θ) geometry typically used for the core-to-vessel neutron transport calculations.

In practice, the pressure vessel fluence estimates required for the Appendix G and RT_{PTS} analyses have been determined using various modeling approximations, computer codes and nuclear cross section sets. Over the past decade, substantial improvements have been made in both the calculation and measurement of the pressure vessel fluence. These improvements have stemmed from both NRC and industry programs. These improvements include the development and improvement of computer codes and calculational models, revision of basic cross-section data, improved measurement techniques, and the

systematic qualification of the fluence methods by comparison to NRC-sponsored benchmark experiments.

The NRC has issued Regulatory Guide 1.190, "Calculational and Dosimetry Methods for Determining Pressure Vessel Neutron Fluence," to provide guidance on the methods and assumptions acceptable to the NRC staff for determining vessel fluence. This Guide provides a detailed description of the methods for constructing the neutron transport model, determination of the core neutron source, and recommendations for the geometric and nuclear input data. Because of the importance and difficulty of these calculations, the Guide recommends that the calculational methodology used for the determination of vessel fluence be validated against power reactor and vessel simulator measurements and calculational benchmarks.

In support of the development of the Regulatory Guide, the Materials Engineering Branch of the NRC Division of Engineering Technology has requested that BNL develop a typical set of PWR and BWR power-reactor calculational benchmark problems together with solutions determined with the methods described in the Regulatory Guide. This report documents the PWR and BWR power-reactor benchmark problems and the associated vessel fluence calculations and results.

1.3 Pressure Vessel Fluence Benchmark Problems

The PWR vessel fluence benchmark problems are for a typical 204 fuel assembly PWR core including the core baffle and barrel, thermal shield, and a vessel having an inner radius of ~219.1 cm. The rated power is 2527.73 MW_t with an average coolant temperature of 293.3 °C. The core power and fuel burnup distributions are for a typical equilibrium cycle. Benchmark problems are defined for three types of fuel loadings: 1) a Standard out-in-Core Loading (SCL), 2) a Low-Leakage Core Loading (LLCL) and 3) a core including Partial Length Shield Assemblies (PLSAs).

The BWR vessel fluence benchmark problem is for a typical 800 fuel assembly core including the shroud, jet pumps and risers and a vessel having an inner radius of ~321.8 cm. The rated power is 3833 MW_t with a core inlet temperature of 278.9 °C. As in the case of the PWR benchmarks, the core power and fuel burnup distributions are for a typical equilibrium cycle.

The benchmark problem calculation requires the calculation of typical in-vessel and/or ex-vessel dosimeter reaction rates.

1.3.1 DORT Discrete Ordinates Calculations

The benchmark problems were calculated using the Oak Ridge National Laboratory (ORNL) DORT Discrete Ordinates Transport code (Reference-1) and the BUGLE-93 (Reference-2) cross section library. The BUGLE-93 cross section library includes the most recent version of the ENDF/B-VI iron, hydrogen and oxygen cross sections, which are known to have a significant effect on the vessel fluences. In performing the calculations, a substantial effort was made to insure an accurate representation of the spatial and energy dependence of the neutron source. In order to determine the annealing or flattening of the axial flux shape between the core and the vessel, calculations were performed in DORT (r, θ), (r, z) and (r) geometries. The methodology used in the benchmark calculations was that described in Regulatory Guide 1.190.

The neutron flux (fluence per unit time) solution is presented in terms of the flux above 1-MeV (>1-MeV), above 0.1 MeV (>0.1 MeV), and the displacements-per-atom per second (dpa/s). These edits are provided at the axial locations of the peak flux and the lower circumferential weld, and at selected radial and azimuthal locations. In the case of the PWR PLSA core loading pattern, the flux reduction at the vessel inner wall at the lower circumferential weld (relative to the standard core loading) is also calculated. The multigroup neutron energy spectrum is calculated at several radial locations.

1.3.2 MCNP Monte Carlo Calculations

MCNP Monte Carlo (Reference-3) calculations of the PWR Standard Core and Partial Length Shield Assembly Core Loadings and the BWR benchmark problem were also performed to provide an independent benchmark solution and to allow comparison with the DORT discrete ordinates methodology. The calculations were performed in three-dimensions using an ENDF/B-VI multigroup nuclear cross section library. A substantial effort was made in the modeling to provide an exact spatial representation of the benchmark problem geometry. The

methodology used in the benchmark calculations was essentially that described in Regulatory Guide 1.190. The neutron flux above 1-MeV is calculated at the inner wall of the vessel as a function of azimuth and compared to the corresponding DORT predictions.

1.4 Application of the Benchmark Problems

The benchmark problems provide a well-documented specification and format which will allow detailed inter comparisons of pressure vessel fluence computational methodologies. The benchmark problems include all the features which have a significant effect on the calculation of pressure vessel fluence and include sufficient space-energy detail to allow (1) comparison of the multigroup fluences through the vessel and cavity and (2) evaluation of the extrapolation of the dosimetry measurements from the surveillance capsules to the vessel.

The fluence solutions provided are based on state-of-the-art transport methodology. These solutions have the advantage that they do not include the as-built and experimental variability that typically limits the benchmarking process when comparisons are made directly with fluence dosimeter measurements.

The calculation-to-calculation benchmark comparisons allow an assessment of the numerical procedures, code implementation, and the various modeling approximations against detailed validated solutions for representative operating configurations. The differences resulting from the uncertainty in the numerical procedures and the modeling of the source and geometry should be small and with present methodologies can be reduced to $\leq(5-10)\%$. The effects of using pre-ENDF/B-VI multigroup cross section sets can be larger; up to a $\sim 20\%$ (30%) underprediction of the $>1\text{-MeV}$ and $>0.1\text{-MeV}$ fluences at the vessel inner (outer) wall.

The observed calculation-to-calculation differences provide the quantitative effect of the procedures and approximations used in the proposed methodology and a basis for model adjustments and improvements. The reference solutions provided in this report are based on present methods and available data. It is intended that as the calculational methods and nuclear data are improved, the benchmark solutions will be updated as necessary.

The benchmark problem specifications are given in Chapter-2 for the PWR standard core, low-leakage core, and the partial length shield assembly core loadings and for the BWR benchmark problem. The DORT calculation and modeling methodology used to determine the solutions is presented in Chapter-3, and the detailed benchmark solutions are given in Chapter-4. The MCNP Monte Carlo calculations together with comparisons with the DORT results are presented in Chapter-5.

2 BENCHMARK PROBLEM SPECIFICATION

2.1 PWR Problem Specification

2.1.1 Introduction

The PWR pressure vessel fluence benchmark problems are for a 204 fuel assembly PWR core having an axial height of 335.28 cm. and including a core barrel, thermal shield, vessel and an outer concrete biological shield. The pressure vessel has an inner radius of 219.075 cm and is 21.59 cm thick including a 0.635 cm stainless steel liner on the inner surface. Separate benchmark problems are provided for a standard core loading, a low-leakage core loading and a partial length shield assembly core. The SCL is for a typical equilibrium cycle core and the LLCL is based on recent core designs in which high burnup fuel assemblies are loaded on the core periphery to reduce the core leakage, and which ultimately reduce the vessel inner-wall fluence. The PLSA core benchmark problem is representative of core designs that have been used to reduce the vessel fluence at the off beltline axial locations of circumferential welds. In the PLSA core design, partial length shield assemblies in which the fuel rods in the lower sections of the fuel assembly have been replaced with stainless steel rods for shielding, are located on the periphery of the core. The LLCL and PLSA problem geometry and materials are identical to the standard core benchmark problem specifications, except for the fuel assembly core loadings.

The problem specification consists of the definition of the problem geometry, material compositions by region, core neutron source, and specification of the solution edits. The problem geometry is specified for a horizontal plane and is assumed to be uniform over the height of the core or, as in the case of the PLSA core, over the specified (upper or lower) section of the core. The regions above and below the core are assumed to be uniform homogeneous compositions out to the core baffle. All regions in the horizontal geometry, except for the core (and including the dosimetry capsules) are assumed to be uniform in the axial dimension and to extend over the full height of the core. The material compositions are specified for each geometrical region.

The source description includes the core power and exposure distributions in rectangular geometry. The power distribution is based on a detailed 15×15 fuel

assembly pin-wise power distribution for a typical core loading. The fuel nuclide fission fraction is provided in Table 2.1.1.1 to allow the determination of the exposure dependence of the neutron source strength (neutrons/MeV) and the source spectrum.

The required edits include the flux above 1-MeV and 0.10 MeV, the displacements-per-atom/sec., and the group-wise flux at specified locations.

In order to evaluate the method of predicting vessel fluence as the product of the surveillance capsule lead factor and a dosimetry measurement, dosimetry reaction rates are calculated for a surveillance capsule at the following locations: (1) on the outer wall of the thermal shield, (2) on the inner wall of the vessel, and (3) in the cavity. The inner capsule is located at an azimuth of 20° on the outer surface of the thermal shield at a radius of 202.25 cm. The vessel capsule is located at an azimuth of 20° near the inner surface of the pressure vessel at a radius of 215.43 cm. The cavity capsule geometry and materials are not represented in the benchmark problem, however, the capsule edit is taken at the azimuth of 9.5° near the concrete shield at a radius of 320.06 cm.[†] In performing the calculations, both the vessel and thermal shield capsules are never in the problem simultaneously. The vessel capsule is always included in the model except when the thermal shield capsule response or downcomer flux and spectrum are being calculated.

The detailed specifications of the benchmark problems for the standard core, low-leakage core and PLSA core are provided in the tables and figures of the following Sections - 2.2, 2.3 and 2.4, respectively.

2.1.2 Specification of the Standard Core Loading Problem

The basic design data for the standard core loading is presented in Table 2.1.2.1 including the radii of the various material regions. The pressure and temperature

[†]The cavity capsule was not included in the problem in order to avoid unnecessarily complicating the azimuthal mesh and to minimize running times. In practice, however, the cavity capsule should be modeled explicitly.

of the coolant regions are included to allow the determination of the coolant density. The material map is given in Figure 2.1.2.1 along with the component locations and dimensions. The x and y orientations are also given in order to orient the source data given in Tables 2.1.2.5 and 2.1.2.6. The core and fuel assemblies are described in Table 2.1.2.2 including the reflector materials and temperatures for the upper and lower reflector regions to be used in the axial calculations. The specification material compositions are provided in Table 2.1.2.3 for each mixture used in the radial and axial geometry of the benchmark problem. The fraction of the individual isotopes (taken from Reference-4) is given in Table 2.1.2.3.1.

The axial map of the SCL benchmark problem is given in Figure 2.1.2.2. This map represents a vertical plane through the core at the core flats at $\theta = 0^\circ$. The material regions outside the core (Regions 4 through 16) are considered to be axially uniform. The axial regions of Figure 2.1.2.2 are assigned in Table 2.1.2.4.

The SCL fuel assembly source data is provided in Table 2.1.2.5 including the location, relative assembly power, and the beginning and end-of-cycle (BOC and EOC) fuel burnup for each fuel assembly in the octant representation. The locations of the peripheral fuel assemblies are included with the assembly pin power data of Table 2.1.2.6. The fuel pin-wise geometry, power and burnup data for a selected peripheral assembly are also given in Table 2.1.2.6. The orientation of this data is defined by the pin-cell boundaries and the directions given in Figure 2.1.2.1. The pin-wise data (geometry, power and burnup) for all the peripheral assemblies are provided on a separate CD ROM. The axial power distributions to be used in determining the axial source are provided in Table 2.1.2.7 for each of the four radial zones defined at the bottom of Table 2.1.2.7.

The specific locations of the in-vessel surveillance capsules and the location where the cavity capsule edit is to be taken are presented in Figure 2.1.2.3. Unlike the in-vessel surveillance locations, no physical capsule is present at the cavity location. The in-vessel capsule geometry, material laydown and orientation are given in Figure 2.1.2.4.

The specific edit quantities and corresponding locations for the standard core loading are given in Table 2.1.2.8. The axial location of the peak flux edits varies since the axial peak location depends on the radial location.

2.1.3 Specification of the Low-Leakage Core Loading Problem

The basic design data for the low-leakage core loading is presented in Table 2.1.3.1 including the radii of the various material regions. The pressure and temperature of the coolant regions are included to allow the determination of the coolant density. The material map is given in Figure 2.1.3.1 along with the component locations and dimensions. The x and y orientations are also given in order to orient the source data given in Tables 2.1.3.5 and 2.1.3.6. The core and fuel assemblies are described in Table 2.1.3.2 including the reflector materials and temperatures for the upper and lower reflector regions to be used in the axial calculations. The specification material compositions are provided in Table 2.1.3.3 for each mixture used in the radial and axial geometry of the benchmark problem.

The axial map of the LLCL benchmark problem is given in Figure 2.1.3.2. This map represents a vertical plane through the core at the core flats at $\theta = 0^\circ$. The material regions outside the core (Regions 4 through 16) are considered to be axially uniform. The axial regions of Figure 2.1.3.2 are assigned in Table 2.1.3.4.

The LLCL fuel assembly source data is provided in Table 2.1.3.5 including the location, relative assembly power, and the beginning and end-of-cycle fuel burnup for each fuel assembly in the octant representation. The locations of the peripheral fuel assembly are included with the assembly pin power data of Table 2.1.3.6. The fuel pin-wise geometry, power and burnup data for a selected peripheral assembly are also given in Table 2.1.3.6. The orientation of this data is defined by the pin-cell boundaries and the directions given in Figure 2.1.3.1. The pin-wise data (geometry, power and burnup) for all the peripheral assemblies are provided on a separate CD ROM. The axial power distributions to be used in determining the axial source are provided in Table 2.1.3.7 for each of the four radial zones defined at the bottom of Table 2.1.3.7.

The specific locations of the in-vessel surveillance capsules and the location where the cavity capsule edit is to be taken are presented in Figure 2.1.3.3. Unlike the in-vessel surveillance locations, no physical capsule is present at the cavity location. The in-vessel capsule geometry, material laydown and orientation are given in Figure 2.1.3.4.

The specific edit quantities and corresponding locations

for the low-leakage core loading are given in Table 2.1.3.8. The axial location of the peak flux edits varies since the axial peak location depends on the radial location.

2.1.4 Specification of the Partial Length Shield Assembly Core Loading Problem

The basic design data for the partial length shield assembly core loading is presented in Table 2.1.4.1 including the radii of the various material regions. The pressure and temperature of the coolant regions are included to allow the determination of the coolant density. The material map is given in Figure 2.1.4.1 along with the component locations and dimensions. The x and y orientations are also given in order to orient the source data given in Tables 2.1.4.5 through 2.1.4.8. The core and fuel assemblies are described in Table 2.1.4.2 including the reflector materials and temperatures for the upper and lower reflector regions to be used in the axial calculations. The specification material compositions are provided in Table 2.1.4.3 for each mixture used in the radial and axial geometry of the benchmark problem.

The PLSA configuration is presented in Figure 2.1.4.2, and the axial map of the PLSA problem is given in Figure 2.1.4.3. This map represents a vertical plane through the core at the core flats at $\theta = 0^\circ$. The material regions outside the core (Regions 6 through 18) are considered to be axially uniform. The axial regions of Figure 2.1.4.3 are assigned in Table 2.1.4.4.

The PLSA fuel assembly source data is provided in Tables 2.1.4.5 and 2.1.4.6 for the upper and lower core regions, respectively, including the location, relative assembly power, and the beginning and end-of-cycle fuel burnup for each fuel assembly in the octant representation. The locations of the peripheral fuel assemblies are included with the assembly pin power data of Tables 2.1.4.7 and 2.1.4.8. The fuel pin-wise geometry, power and burnup data for a selected peripheral assembly for the upper and lower cores are given in Tables 2.1.4.7 and 2.1.4.8, respectively. The orientation of this data is defined by the pin-cell boundaries and the directions given in Figure 2.1.4.1. The pin-wise data (geometry, power and burnup) for all the peripheral assemblies are provided on a separate CD ROM. The axial power distributions to be used in

determining the axial source are provided in Tables 2.1.4.9 and 2.1.4.10 for the upper and lower cores, respectively, for each of the four radial zones defined at the bottom of Tables.

The specific edit quantities and corresponding locations for the partial length shield assembly core loading are given in Table 2.1.4.11.

2.2 BWR Problem Specification

2.2.1 Introduction

The BWR pressure vessel fluence benchmark problem is for an 800 fuel assembly core having an axial height of 381.0 cm and including the shroud, jet pumps and riser, vessel and an outer concrete biological shield. The pressure vessel has an inner radius of ~ 321.786 cm and is 16.129 cm thick with a 0.476 cm stainless steel liner on the inner surface. The core power and fuel assembly burnup distributions are for a typical equilibrium core.

The problem specification consists of the definition of the problem geometry, material compositions by region, core neutron source, and specification of the solution edits. The dimensions are specified for each of the geometrical regions used to define the problem. The inner and peripheral core are each divided into seven axial material regions. The regions above and below the core are assumed to be uniform homogeneous compositions out to the edge of the core. All regions in the horizontal geometry, except for the core (and including the dosimetry capsules) are assumed to be uniform in the axial dimension and to extend over the full height of the core. The material compositions are specified for each geometrical region.

The source description includes the core power and exposure distributions in rectangular geometry. The power distribution is based on a detailed 8×8 fuel assembly pin-wise power distribution for a typical core loading. The fuel nuclide fission fraction is provided in Table 2.2.1.1 to allow the determination of the exposure dependence of the neutron source strength (neutrons/MeV) and the source spectrum.

The required edits include the flux above 1-MeV and 0.10 MeV, the displacements-per-atom/sec., and the group-wise flux at specified locations.

In order to evaluate the method of predicting vessel fluence as the product of the surveillance capsule lead factor and a dosimetry measurement, dosimetry reaction rates are calculated for a surveillance capsule on the inner wall of the vessel. The vessel capsule is located at an azimuth of 3° at the inner surface of the pressure vessel at a radius of 321.310 cm.

The detailed specification of the benchmark problem is provided in the tables and figures of the following Section.

2.2.2 Specification of the BWR Benchmark Problem

The basic design data for the BWR benchmark problem is presented in Table 2.2.2.1 including the radii of the various material regions. The material map is given in Figure 2.2.2.1 along with the component locations and dimensions. The x and y orientations are also given in order to orient the source data given in Tables 2.2.2.5 and 2.2.2.6. The core and fuel assemblies are described in Table 2.2.2.2 including the reflector materials for the upper and lower reflector regions to be used in the axial calculations. The specification material compositions are provided in Table 2.2.2.3 for each mixture used in the radial and axial geometry of the benchmark problem. The fraction of the individual isotopes (taken from Reference-4) is given in Table 2.2.2.3.1.

The axial map of the benchmark problem is given in Figure 2.2.2.2. This map represents a vertical plane through the core at the core flats at $\theta = 0^\circ$. The material regions outside the core are considered to be axially uniform. The axial extent of the jet pumps and risers is taken to be the same as the height of the core. The axial regions of Figure 2.2.2.2 are assigned the compositions in Table 2.2.2.3.

The fuel assembly source data is provided in Table 2.2.2.4 including the location, relative assembly power, and the fuel burnup for each fuel assembly in the octant representation. The locations of the peripheral fuel assemblies are included with the assembly pin power data of Table 2.2.2.5. The fuel pin-wise geometry, power and burnup data for the peripheral assemblies are also given in Table 2.2.2.5. The orientation of this data is defined by the pin-cell boundaries and the directions given in Figure 2.2.2.1. The pin power distribution for assemblies on the edge of the core is represented with an 8x8 array, assemblies one-row from the edge are

represented with a 4x4 array, and assemblies two rows from the edge are represented with a 2x2 array. The pin-wise data (geometry, power and burnup) for all the peripheral assemblies are provided on a separate CD ROM. The axial power distributions to be used in determining the axial source are provided in Table 2.2.2.6 for each of the three radial zones defined at the bottom of Table 2.2.2.6. The pressure vessel capsule geometry, material laydown and orientation are given in Figure 2.2.2.3.

The specific edit quantities and corresponding locations for the BWR core loading are given in Table 2.2.2.7. The axial location of the peak flux edits varies since the axial peak location depends on the radial location.

Table 2.1.1.1

Fraction Of Fissions by Isotope as Function of Exposure

Exposure (MWD)	U-235	U-238	Pu-239	Pu-240	Pu-241	Pu-242
1.500E+02	9.28100E-01	6.17165E-02	1.01828E-02	1.65450E-07	4.25775E-07	0.00000E+00
5.000E+02	9.05149E-01	6.21387E-02	3.26955E-02	1.77633E-06	1.49927E-05	1.88872E-10
1.000E+04	5.57019E-01	7.07435E-02	3.39497E-01	3.10546E-04	3.24187E-02	1.08465E-05
2.000E+04	3.56399E-01	7.81926E-02	4.64707E-01	7.40748E-04	9.98821E-02	7.83614E-05
4.000E+04	1.23133E-01	9.01198E-02	5.82823E-01	1.43769E-14	2.03544E-01	3.80635E-04

Table 2.1.2.1

Standard Core Loading

Basic Design Data

Reactor		Material
Thermal Power	2527.73 MW (TH)	--
Core Inlet Temp.	536 °F (280 °C)	--
Core Operating Pressure	2010 psia (13.859 MPa)	--
Baffle Thickness	1.5875 cm	SS-304
By-Pass	--	H ₂ O (560 °F 293.3 °C) 2010 psia (13.859 MPa)
Inner Radius of Core Barrel	190.185 cm	--
Barrel Thickness	3.81 cm	SS-304
Inner Inlet Thickness	2.54 cm	H ₂ O (536 °F 280 °C) 2010 psia (13.859 MPa)
Inner Radius of Thermal Shield	196.535 cm	--
Thermal Shield Thickness	3.81 cm	SS-304
Outer Inlet Thickness	18.095 cm	H ₂ O (536 °F 280 °C) 2010 psia (13.859 MPa)
Inner Radius of Liner Clad	218.440 cm	--
Vessel Liner Clad Thickness	0.635 cm	SS-304
Vessel Thickness	21.59 cm	SA-302B
PV Insulation Air Thickness	1.835 cm	Air
PV Insulation Thickness	10.16 cm	PV Insulation
Cavity Thickness	82.62 cm	Air
Inner Radius of Biological Shield	335.280 cm	--
Bio-Shield Liner Thickness	0.635 cm	SA-302B
Bio-Shield Thickness	213.36 cm	Concrete

Table 2.1.2.2

Standard Core Loading

Core and Fuel Assemblies

Total Number of Fuel Assemblies	204
Number of Rods per assembly (15x15)	216 fuel rods 8 guide tubes 1 instrument tube
Assembly Pitch	21.485 cm
Pin Pitch	1.43233 cm
Fuel Material	Sintered UO ₂ pellets
Cladding Material	Zr-4
Fuel Active Length	335.28 cm

Standard Core Loading Basic Design Data

Upper and Lower Reflectors

Lower Reflector Thickness	13.97 cm	SS-304 + Water (536 °F) (280 °C)
Upper Reflector Thickness	32.865 cm	SS-304 + Water (584 °F) (306.7 °C)

Table 2.1.2.3

Standard Core Loading

Design Specification Material Compositions

Mixture	Component	Atom Densities (atom/b*cm)
Core	H	2.82500E-02
	B	2.69200E-05
	O	1.41200E-02
	C	2.58100E-05
	O (fuel)	1.28500E-02
	Al	3.56000E-04
	Cr	1.60800E-05
	Fe	2.20500E-05
	Ni	3.87700E-05
	Zr	5.44800E-03
	U-235	1.12000E-04
U-238	6.03000E-03	
Pu-239	2.20000E-05	
Pu-240	7.12000E-06	
Baffle (SS-304)	Cr	1.85300E-02
	Mn	1.75200E-03
	Fe	5.80700E-02
	Ni	8.57400E-03
Bypass ⁺ (560 F) (293.3 °C)	H	4.92900E-02
	O	2.46400E-02
	B	4.90000E-06
Core Barrel (SS-304)	Cr	1.85300E-02
	Mn	1.75200E-03
	Fe	5.80700E-02
	Ni	8.57400E-03
Inlet Water Gap (536 F) (280 °C)	H	5.09600E-02
	O	2.54800E-02
	B	5.10000E-06
Thermal Shield (SS-304)	Cr	1.85300E-02
	Mn	1.75200E-03
	Fe	5.80700E-02
	Ni	8.57400E-03
RPV Liner (SS-304)	Cr	1.85300E-02
	Mn	1.75200E-03
	Fe	5.80700E-02
	Ni	8.57400E-03
Cavity (Air)	N	3.20000E-05
	O	8.00000E-06

+ This composition is also to be used in the water region between the fuel assembly and the core baffle (see Figure 2.2.1).

Table 2.1.2.3

Standard Core Loading

Design Specification Material Compositions (cont'd)

Mixture	Component	Atom Densities (atom/b*cm)
RPV Wall (SA-302B)	C	9.84000E-04
	Si	7.58900E-04
	Mn	1.39100E-03
	Fe	8.18300E-02
	Mo	3.14800E-04
RPV Insulation	Cr	3.43000E-04
	Mn	3.24000E-05
	Fe	1.07400E-03
	Ni	1.59000E-04
	Al	1.30000E-04
	N	3.77000E-05
Bio-Shield Liner (SA-302B)	O	9.96000E-06
	C	9.84000E-04
	Si	7.58900E-04
	Mn	1.39100E-03
	Fe	8.18300E-02
Bio-Shield (Concrete)	Mo	3.14800E-04
	H	7.77000E-03
	C	1.15000E-04
	O	4.38000E-02
	Na	1.05000E-03
	Mg	1.48000E-04
	Al	2.39000E-03
	Si	1.58000E-02
	K	6.93000E-04
	Ca	2.29000E-03
Fe	3.13000E-04	
Lower Reflector (Water-Steel) (536 F) (280 °C)	Cr	4.63250E-03
	Mn	4.38000E-04
	Fe	1.45175E-02
	Ni	2.14350E-03
	H	3.82200E-02
	O	1.91100E-02
	B	3.82500E-06
Upper Reflector (Water-Steel) (584 F) (306.7 °C)	Cr	4.63250E-03
	Mn	4.38000E-04
	Fe	1.45175E-02
	Ni	2.14350E-03
	H	3.55383E-02
	O	1.77656E-02
	B	3.53293E-06

Table 2.1.2.3.1

Isotopic Fractions in Cr, Fe and Ni*

ISOTOPE	WT %	ISOTOPE	WT %	ISOTOPE	WT %
Cr-50	4.345	Fe-54	5.9	Ni-58	68.27
Cr-52	83.79	Fe-56	91.72	Ni-60	26.10
Cr-53	9.5	Fe-57	2.1	Ni-61	1.13
Cr-54	2.365	Fe-58	0.28	Ni-62	3.59
				Ni-64	0.91

*Taken from Reference-4.

Table 2.1.2.4

Standard Core Loading Axial Zone Assignments

Zone	Description
1	Lower Reflector
2	Active Core Fuel Assemblies
3	Upper Reflector
4	Core Baffle
5	By-Pass
6	Core Barrel
7	Inner Inlet Water Gap
8	Thermal Shield
9	Outer Inlet Water Gap
10	Reactor Pressure Vessel Liner
11	Reactor Pressure Vessel
12	Air Gap
13	Pressure Vessel Insulation
14	Cavity
15	Biological Shield Liner
16	Biological Shield

Table 2.1.2.5

Standard Core Loading
Fuel Assembly Geometry, Power, and Burnup Distributions

Assembly Number	X-Left	X-Right	Y-Bot	Y-Top	Relative Assembly Power	BOC Burnup (MWD)	EOC Burnup (MWD)	Axial Peaking Factor	Pin Power Set
1	0.00000E+00	2.14850E+01	0.00000E+00	2.14850E+01	1.01300E+00	0.00000E+00	2.28360E+04	1.0000	0
2	2.14850E+01	4.29700E+01	0.00000E+00	2.14850E+01	1.13100E+00	0.00000E+00	2.28360E+04	1.0000	0
3	4.29700E+01	6.44550E+01	0.00000E+00	2.14850E+01	1.10800E+00	0.00000E+00	2.28360E+04	1.0000	0
4	6.44550E+01	8.59400E+01	0.00000E+00	2.14850E+01	1.03600E+00	0.00000E+00	1.22870E+04	1.0000	0
5	8.59400E+01	1.07425E+02	0.00000E+00	2.14850E+01	1.09700E+00	0.00000E+00	1.27610E+04	1.0000	0
6	1.07425E+02	0.00000E+00	0.00000E+00	0.00000E+00	1.04600E+00	6.62100E+03	1.89180E+04	1.0000	13
7	1.28910E+02	0.00000E+00	0.00000E+00	0.00000E+00	9.53000E-01	1.00270E+04	2.13700E+04	1.0000	14
8	1.50399E+02	0.00000E+00	0.00000E+00	0.00000E+00	8.70000E-01	0.00000E+00	1.02930E+04	1.0000	15
9	2.14850E+01	4.29700E+01	2.14850E+01	4.29700E+01	9.60000E-01	0.00000E+00	2.28360E+04	1.0000	0
10	4.29700E+01	6.44550E+01	2.14850E+01	4.29700E+01	1.08700E+00	0.00000E+00	2.28360E+04	1.0000	0
11	6.44550E+01	8.59400E+01	2.14850E+01	4.29700E+01	1.09800E+00	0.00000E+00	1.29860E+04	1.0000	0
12	8.59400E+01	1.07425E+02	2.14850E+01	4.29700E+01	1.03000E+00	0.00000E+00	1.21130E+04	1.0000	0
13	1.07425E+02	0.00000E+00	2.14850E+01	0.00000E+00	1.00500E+00	1.05600E+04	2.22680E+04	1.0000	10
14	1.28910E+02	0.00000E+00	2.14850E+01	0.00000E+00	1.07000E+00	3.29400E+03	1.60840E+04	1.0000	11
15	1.50399E+02	0.00000E+00	2.14850E+01	0.00000E+00	8.56000E-01	1.30000E+01	1.01550E+04	1.0000	12
16	4.29700E+01	6.44550E+01	4.29700E+01	6.44550E+01	1.08900E+00	0.00000E+00	2.28360E+04	1.0000	0
17	6.44550E+01	8.59400E+01	4.29700E+01	6.44550E+01	1.11000E+00	0.00000E+00	1.28360E+04	1.0000	0
18	8.59400E+01	1.07425E+02	4.29700E+01	6.44550E+01	1.18100E+00	0.00000E+00	1.35620E+04	1.0000	0
19	1.07425E+02	0.00000E+00	4.29700E+01	0.00000E+00	9.20000E-01	1.18730E+04	2.28360E+04	1.0000	7
20	1.28910E+02	0.00000E+00	4.29700E+01	0.00000E+00	1.10800E+00	2.30000E+01	1.30620E+04	1.0000	8
21	1.50399E+02	0.00000E+00	4.29700E+01	0.00000E+00	6.82000E-01	1.20000E+01	8.09600E+03	1.0000	9
22	6.44550E+01	8.59400E+01	6.44550E+01	8.59400E+01	1.02900E+00	0.00000E+00	1.19120E+04	1.0000	0
23	8.59400E+01	0.00000E+00	6.44550E+01	0.00000E+00	9.46000E-01	1.06620E+04	2.16400E+04	1.0000	4
24	1.07425E+02	0.00000E+00	6.44550E+01	0.00000E+00	1.05200E+00	7.03800E+03	1.96890E+04	1.0000	5
25	1.28910E+02	0.00000E+00	6.44550E+01	0.00000E+00	9.33000E-01	1.60000E+01	1.10590E+04	1.0000	6
26	8.59400E+01	0.00000E+00	8.59400E+01	0.00000E+00	1.15900E+00	3.30000E+01	1.36550E+04	1.0000	1
27	1.07425E+02	0.00000E+00	8.59400E+01	0.00000E+00	9.57000E-01	2.30000E+01	1.13490E+04	1.0000	2
28	1.28910E+02	0.00000E+00	8.59400E+01	0.00000E+00	6.00000E-01	1.80000E+01	7.12900E+03	1.0000	3

Note: Assemblies including pin power sets do not have right or top boundaries specified here. These data are included with the pin geometry data.

Table 2.1.2.6

Standard Core Loading

Pin Geometry, Power, and Burnup Distributions

Assembly 6				Pin Power Set 13		
X-Left	X-Right	Y-Bot	Y-Top	Relative Pin Power	BOC Burnup (MWD)	EOC Burnup (MWD)
1.07425E+02	1.08857E+02	0.00000E+00	1.43223E+00	1.09342E+00	6.621E+03	1.892E+04
1.07425E+02	1.08857E+02	1.43223E+00	2.86446E+00	1.03256E+00	6.621E+03	1.892E+04
1.07425E+02	1.08857E+02	2.86446E+00	4.29669E+00	1.00315E+00	6.621E+03	1.892E+04
1.07425E+02	1.08857E+02	4.29669E+00	5.72892E+00	1.00619E+00	6.621E+03	1.892E+04
1.07425E+02	1.08857E+02	5.72892E+00	7.16115E+00	0.00000E+00	6.621E+03	1.892E+04
1.07425E+02	1.08857E+02	7.16115E+00	8.59338E+00	9.98075E-01	6.621E+03	1.892E+04
1.07425E+02	1.08857E+02	8.59338E+00	1.00256E+01	9.75760E-01	6.621E+03	1.892E+04
1.07425E+02	1.08857E+02	1.00256E+01	1.14578E+01	9.69674E-01	6.621E+03	1.892E+04
1.07425E+02	1.08857E+02	1.14578E+01	1.28901E+01	9.77789E-01	6.621E+03	1.892E+04
1.07425E+02	1.08857E+02	1.28901E+01	1.43223E+01	1.00213E+00	6.621E+03	1.892E+04
1.07425E+02	1.08857E+02	1.43223E+01	1.57545E+01	0.00000E+00	6.621E+03	1.892E+04
1.07425E+02	1.08857E+02	1.57545E+01	1.71868E+01	1.00517E+00	6.621E+03	1.892E+04
1.07425E+02	1.08857E+02	1.71868E+01	1.86190E+01	9.90975E-01	6.621E+03	1.892E+04
1.07425E+02	1.08857E+02	1.86190E+01	2.00512E+01	9.96046E-01	6.621E+03	1.892E+04
1.07425E+02	1.08857E+02	2.00512E+01	2.14835E+01	1.01633E+00	6.621E+03	1.892E+04
1.08857E+02	1.10289E+02	0.00000E+00	1.43223E+00	1.09038E+00	6.621E+03	1.892E+04
1.08857E+02	1.10289E+02	1.43223E+00	2.86446E+00	1.03358E+00	6.621E+03	1.892E+04
1.08857E+02	1.10289E+02	2.86446E+00	4.29669E+00	1.00112E+00	6.621E+03	1.892E+04
1.08857E+02	1.10289E+02	4.29669E+00	5.72892E+00	1.02850E+00	6.621E+03	1.892E+04
1.08857E+02	1.10289E+02	5.72892E+00	7.16115E+00	1.03256E+00	6.621E+03	1.892E+04
1.08857E+02	1.10289E+02	7.16115E+00	8.59338E+00	1.02546E+00	6.621E+03	1.892E+04
1.08857E+02	1.10289E+02	8.59338E+00	1.00256E+01	1.00923E+00	6.621E+03	1.892E+04
1.08857E+02	1.10289E+02	1.00256E+01	1.14578E+01	1.00213E+00	6.621E+03	1.892E+04
1.08857E+02	1.10289E+02	1.14578E+01	1.28901E+01	1.01126E+00	6.621E+03	1.892E+04
1.08857E+02	1.10289E+02	1.28901E+01	1.43223E+01	1.02952E+00	6.621E+03	1.892E+04
1.08857E+02	1.10289E+02	1.43223E+01	1.57545E+01	1.03560E+00	6.621E+03	1.892E+04
1.08857E+02	1.10289E+02	1.57545E+01	1.71868E+01	1.02648E+00	6.621E+03	1.892E+04
1.08857E+02	1.10289E+02	1.71868E+01	1.86190E+01	9.84889E-01	6.621E+03	1.892E+04
1.08857E+02	1.10289E+02	1.86190E+01	2.00512E+01	9.91989E-01	6.621E+03	1.892E+04
1.08857E+02	1.10289E+02	2.00512E+01	2.14835E+01	1.00112E+00	6.621E+03	1.892E+04
1.10289E+02	1.11722E+02	0.00000E+00	1.43223E+00	1.09240E+00	6.621E+03	1.892E+04
1.10289E+02	1.11722E+02	1.43223E+00	2.86446E+00	1.03256E+00	6.621E+03	1.892E+04
1.10289E+02	1.11722E+02	2.86446E+00	4.29669E+00	1.00619E+00	6.621E+03	1.892E+04
1.10289E+02	1.11722E+02	4.29669E+00	5.72892E+00	1.01126E+00	6.621E+03	1.892E+04
1.10289E+02	1.11722E+02	5.72892E+00	7.16115E+00	1.01126E+00	6.621E+03	1.892E+04
1.10289E+02	1.11722E+02	7.16115E+00	8.59338E+00	6.09596E-01	6.621E+03	1.892E+04
1.10289E+02	1.11722E+02	8.59338E+00	1.00256E+01	9.99089E-01	6.621E+03	1.892E+04
1.10289E+02	1.11722E+02	1.00256E+01	1.14578E+01	9.90975E-01	6.621E+03	1.892E+04
1.10289E+02	1.11722E+02	1.14578E+01	1.28901E+01	1.00112E+00	6.621E+03	1.892E+04
1.10289E+02	1.11722E+02	1.28901E+01	1.43223E+01	6.16697E-01	6.621E+03	1.892E+04
1.10289E+02	1.11722E+02	1.43223E+01	1.57545E+01	1.01329E+00	6.621E+03	1.892E+04
1.10289E+02	1.11722E+02	1.57545E+01	1.71868E+01	1.00720E+00	6.621E+03	1.892E+04
1.10289E+02	1.11722E+02	1.71868E+01	1.86190E+01	9.86917E-01	6.621E+03	1.892E+04
1.10289E+02	1.11722E+02	1.86190E+01	2.00512E+01	9.86917E-01	6.621E+03	1.892E+04
1.10289E+02	1.11722E+02	2.00512E+01	2.14835E+01	9.99089E-01	6.621E+03	1.892E+04

Table 2.1.2.6

Standard Core Loading

Pin Geometry, Power, and Burnup Distributions (cont'd)

Assembly 6

Pin Power Set 13

X-Left	X-Right	Y-Bot	Y-Top	Relative Pin Power	BOC Burnup (MWD)	EOC Burnup (MWD)
1.11722E+02	1.13154E+02	0.00000E+00	1.43223E+00	1.10762E+00	6.621E+03	1.892E+04
1.11722E+02	1.13154E+02	1.43223E+00	2.86446E+00	1.07719E+00	6.621E+03	1.892E+04
1.11722E+02	1.13154E+02	2.86446E+00	4.29669E+00	1.02648E+00	6.621E+03	1.892E+04
1.11722E+02	1.13154E+02	4.29669E+00	5.72892E+00	1.00112E+00	6.621E+03	1.892E+04
1.11722E+02	1.13154E+02	5.72892E+00	7.16115E+00	9.93003E-01	6.621E+03	1.892E+04
1.11722E+02	1.13154E+02	7.16115E+00	8.59338E+00	9.90975E-01	6.621E+03	1.892E+04
1.11722E+02	1.13154E+02	8.59338E+00	1.00256E+01	9.83874E-01	6.621E+03	1.892E+04
1.11722E+02	1.13154E+02	1.00256E+01	1.14578E+01	9.78803E-01	6.621E+03	1.892E+04
1.11722E+02	1.13154E+02	1.14578E+01	1.28901E+01	9.85903E-01	6.621E+03	1.892E+04
1.11722E+02	1.13154E+02	1.28901E+01	1.43223E+01	9.94017E-01	6.621E+03	1.892E+04
1.11722E+02	1.13154E+02	1.43223E+01	1.57545E+01	9.95032E-01	6.621E+03	1.892E+04
1.11722E+02	1.13154E+02	1.57545E+01	1.71868E+01	9.97060E-01	6.621E+03	1.892E+04
1.11722E+02	1.13154E+02	1.71868E+01	1.86190E+01	1.00822E+00	6.621E+03	1.892E+04
1.11722E+02	1.13154E+02	1.86190E+01	2.00512E+01	1.03053E+00	6.621E+03	1.892E+04
1.11722E+02	1.13154E+02	2.00512E+01	2.14835E+01	1.01532E+00	6.621E+03	1.892E+04
1.13154E+02	1.14586E+02	0.00000E+00	1.43223E+00	0.00000E+00	6.621E+03	1.892E+04
1.13154E+02	1.14586E+02	1.43223E+00	2.86446E+00	1.08733E+00	6.621E+03	1.892E+04
1.13154E+02	1.14586E+02	2.86446E+00	4.29669E+00	1.03256E+00	6.621E+03	1.892E+04
1.13154E+02	1.14586E+02	4.29669E+00	5.72892E+00	9.99089E-01	6.621E+03	1.892E+04
1.13154E+02	1.14586E+02	5.72892E+00	7.16115E+00	9.79817E-01	6.621E+03	1.892E+04
1.13154E+02	1.14586E+02	7.16115E+00	8.59338E+00	9.72717E-01	6.621E+03	1.892E+04
1.13154E+02	1.14586E+02	8.59338E+00	1.00256E+01	9.69674E-01	6.621E+03	1.892E+04
1.13154E+02	1.14586E+02	1.00256E+01	1.14578E+01	9.69674E-01	6.621E+03	1.892E+04
1.13154E+02	1.14586E+02	1.14578E+01	1.28901E+01	9.71703E-01	6.621E+03	1.892E+04
1.13154E+02	1.14586E+02	1.28901E+01	1.43223E+01	9.76774E-01	6.621E+03	1.892E+04
1.13154E+02	1.14586E+02	1.43223E+01	1.57545E+01	9.82860E-01	6.621E+03	1.892E+04
1.13154E+02	1.14586E+02	1.57545E+01	1.71868E+01	9.96046E-01	6.621E+03	1.892E+04
1.13154E+02	1.14586E+02	1.71868E+01	1.86190E+01	1.01532E+00	6.621E+03	1.892E+04
1.13154E+02	1.14586E+02	1.86190E+01	2.00512E+01	1.04169E+00	6.621E+03	1.892E+04
1.13154E+02	1.14586E+02	2.00512E+01	2.14835E+01	0.00000E+00	6.621E+03	1.892E+04
1.14586E+02	1.16018E+02	0.00000E+00	1.43223E+00	1.10458E+00	6.621E+03	1.892E+04
1.14586E+02	1.16018E+02	1.43223E+00	2.86446E+00	1.08023E+00	6.621E+03	1.892E+04
1.14586E+02	1.16018E+02	2.86446E+00	4.29669E+00	6.19739E-01	6.621E+03	1.892E+04
1.14586E+02	1.16018E+02	4.29669E+00	5.72892E+00	9.97060E-01	6.621E+03	1.892E+04
1.14586E+02	1.16018E+02	5.72892E+00	7.16115E+00	9.73731E-01	6.621E+03	1.892E+04
1.14586E+02	1.16018E+02	7.16115E+00	8.59338E+00	9.65617E-01	6.621E+03	1.892E+04
1.14586E+02	1.16018E+02	8.59338E+00	1.00256E+01	9.65617E-01	6.621E+03	1.892E+04
1.14586E+02	1.16018E+02	1.00256E+01	1.14578E+01	9.68660E-01	6.621E+03	1.892E+04
1.14586E+02	1.16018E+02	1.14578E+01	1.28901E+01	9.68660E-01	6.621E+03	1.892E+04
1.14586E+02	1.16018E+02	1.28901E+01	1.43223E+01	9.69674E-01	6.621E+03	1.892E+04
1.14586E+02	1.16018E+02	1.43223E+01	1.57545E+01	9.76774E-01	6.621E+03	1.892E+04
1.14586E+02	1.16018E+02	1.57545E+01	1.71868E+01	9.95032E-01	6.621E+03	1.892E+04
1.14586E+02	1.16018E+02	1.71868E+01	1.86190E+01	6.25825E-01	6.621E+03	1.892E+04
1.14586E+02	1.16018E+02	1.86190E+01	2.00512E+01	1.03662E+00	6.621E+03	1.892E+04
1.14586E+02	1.16018E+02	2.00512E+01	2.14835E+01	1.01227E+00	6.621E+03	1.892E+04

Table 2.1.2.6

Standard Core Loading

Pin Geometry, Power, and Burnup Distributions (cont'd)

Assembly 6

Pin Power Set 13

X-Left	X-Right	Y-Bot	Y-Top	Relative Pin Power	BOC Burnup (MWD)	EOC Burnup (MWD)
1.16018E+02	1.17451E+02	0.00000E+00	1.43223E+00	1.08226E+00	6.621E+03	1.892E+04
1.16018E+02	1.17451E+02	1.43223E+00	2.86446E+00	1.06096E+00	6.621E+03	1.892E+04
1.16018E+02	1.17451E+02	2.86446E+00	4.29669E+00	1.01938E+00	6.621E+03	1.892E+04
1.16018E+02	1.17451E+02	4.29669E+00	5.72892E+00	9.87932E-01	6.621E+03	1.892E+04
1.16018E+02	1.17451E+02	5.72892E+00	7.16115E+00	9.68660E-01	6.621E+03	1.892E+04
1.16018E+02	1.17451E+02	7.16115E+00	8.59338E+00	9.64603E-01	6.621E+03	1.892E+04
1.16018E+02	1.17451E+02	8.59338E+00	1.00256E+01	9.72717E-01	6.621E+03	1.892E+04
1.16018E+02	1.17451E+02	1.00256E+01	1.14578E+01	9.82860E-01	6.621E+03	1.892E+04
1.16018E+02	1.17451E+02	1.14578E+01	1.28901E+01	9.75760E-01	6.621E+03	1.892E+04
1.16018E+02	1.17451E+02	1.28901E+01	1.43223E+01	9.68660E-01	6.621E+03	1.892E+04
1.16018E+02	1.17451E+02	1.43223E+01	1.57545E+01	9.72717E-01	6.621E+03	1.892E+04
1.16018E+02	1.17451E+02	1.57545E+01	1.71868E+01	9.86917E-01	6.621E+03	1.892E+04
1.16018E+02	1.17451E+02	1.71868E+01	1.86190E+01	1.00416E+00	6.621E+03	1.892E+04
1.16018E+02	1.17451E+02	1.86190E+01	2.00512E+01	1.01836E+00	6.621E+03	1.892E+04
1.16018E+02	1.17451E+02	2.00512E+01	2.14835E+01	9.88946E-01	6.621E+03	1.892E+04
1.17451E+02	1.18883E+02	0.00000E+00	1.43223E+00	1.07415E+00	6.621E+03	1.892E+04
1.17451E+02	1.18883E+02	1.43223E+00	2.86446E+00	1.05082E+00	6.621E+03	1.892E+04
1.17451E+02	1.18883E+02	2.86446E+00	4.29669E+00	1.00822E+00	6.621E+03	1.892E+04
1.17451E+02	1.18883E+02	4.29669E+00	5.72892E+00	9.80832E-01	6.621E+03	1.892E+04
1.17451E+02	1.18883E+02	5.72892E+00	7.16115E+00	9.65617E-01	6.621E+03	1.892E+04
1.17451E+02	1.18883E+02	7.16115E+00	8.59338E+00	9.63588E-01	6.621E+03	1.892E+04
1.17451E+02	1.18883E+02	8.59338E+00	1.00256E+01	9.79817E-01	6.621E+03	1.892E+04
1.17451E+02	1.18883E+02	1.00256E+01	1.14578E+01	0.00000E+00	6.621E+03	1.892E+04
1.17451E+02	1.18883E+02	1.14578E+01	1.28901E+01	9.82860E-01	6.621E+03	1.892E+04
1.17451E+02	1.18883E+02	1.28901E+01	1.43223E+01	9.68660E-01	6.621E+03	1.892E+04
1.17451E+02	1.18883E+02	1.43223E+01	1.57545E+01	9.69674E-01	6.621E+03	1.892E+04
1.17451E+02	1.18883E+02	1.57545E+01	1.71868E+01	9.79817E-01	6.621E+03	1.892E+04
1.17451E+02	1.18883E+02	1.71868E+01	1.86190E+01	9.94017E-01	6.621E+03	1.892E+04
1.17451E+02	1.18883E+02	1.86190E+01	2.00512E+01	1.00822E+00	6.621E+03	1.892E+04
1.17451E+02	1.18883E+02	2.00512E+01	2.14835E+01	9.80832E-01	6.621E+03	1.892E+04
1.18883E+02	1.20315E+02	0.00000E+00	1.43223E+00	1.07922E+00	6.621E+03	1.892E+04
1.18883E+02	1.20315E+02	1.43223E+00	2.86446E+00	1.05792E+00	6.621E+03	1.892E+04
1.18883E+02	1.20315E+02	2.86446E+00	4.29669E+00	1.01532E+00	6.621E+03	1.892E+04
1.18883E+02	1.20315E+02	4.29669E+00	5.72892E+00	9.84889E-01	6.621E+03	1.892E+04
1.18883E+02	1.20315E+02	5.72892E+00	7.16115E+00	9.64603E-01	6.621E+03	1.892E+04
1.18883E+02	1.20315E+02	7.16115E+00	8.59338E+00	9.60545E-01	6.621E+03	1.892E+04
1.18883E+02	1.20315E+02	8.59338E+00	1.00256E+01	9.69674E-01	6.621E+03	1.892E+04
1.18883E+02	1.20315E+02	1.00256E+01	1.14578E+01	9.79817E-01	6.621E+03	1.892E+04
1.18883E+02	1.20315E+02	1.14578E+01	1.28901E+01	9.72717E-01	6.621E+03	1.892E+04
1.18883E+02	1.20315E+02	1.28901E+01	1.43223E+01	9.65617E-01	6.621E+03	1.892E+04
1.18883E+02	1.20315E+02	1.43223E+01	1.57545E+01	9.69674E-01	6.621E+03	1.892E+04
1.18883E+02	1.20315E+02	1.57545E+01	1.71868E+01	9.84889E-01	6.621E+03	1.892E+04
1.18883E+02	1.20315E+02	1.71868E+01	1.86190E+01	1.00315E+00	6.621E+03	1.892E+04
1.18883E+02	1.20315E+02	1.86190E+01	2.00512E+01	1.01735E+00	6.621E+03	1.892E+04
1.18883E+02	1.20315E+02	2.00512E+01	2.14835E+01	9.87932E-01	6.621E+03	1.892E+04

Table 2.1.2.6

Standard Core Loading

Pin Geometry, Power, and Burnup Distributions (cont'd)

Assembly 5 Pin Power Set 13

X-Left	X-Right	Y-Bot	Y-Top	Relative Pin Power	BOC Burnup (MWD)	EOC Burnup (MWD)
1.20315E+02	1.21747E+02	0.00000E+00	1.43223E+00	1.09748E+00	6.621E+03	1.892E+04
1.20315E+02	1.21747E+02	1.43223E+00	2.86446E+00	1.07415E+00	6.621E+03	1.892E+04
1.20315E+02	1.21747E+02	2.86446E+00	4.29669E+00	6.15682E-01	6.621E+03	1.892E+04
1.20315E+02	1.21747E+02	4.29669E+00	5.72892E+00	9.90975E-01	6.621E+03	1.892E+04
1.20315E+02	1.21747E+02	5.72892E+00	7.16115E+00	9.67646E-01	6.621E+03	1.892E+04
1.20315E+02	1.21747E+02	7.16115E+00	8.59338E+00	9.59531E-01	6.621E+03	1.892E+04
1.20315E+02	1.21747E+02	8.59338E+00	1.00256E+01	9.59531E-01	6.621E+03	1.892E+04
1.20315E+02	1.21747E+02	1.00256E+01	1.14578E+01	9.62574E-01	6.621E+03	1.892E+04
1.20315E+02	1.21747E+02	1.14578E+01	1.28901E+01	9.63588E-01	6.621E+03	1.892E+04
1.20315E+02	1.21747E+02	1.28901E+01	1.43223E+01	9.64603E-01	6.621E+03	1.892E+04
1.20315E+02	1.21747E+02	1.43223E+01	1.57545E+01	9.72717E-01	6.621E+03	1.892E+04
1.20315E+02	1.21747E+02	1.57545E+01	1.71868E+01	9.93003E-01	6.621E+03	1.892E+04
1.20315E+02	1.21747E+02	1.71868E+01	1.86190E+01	6.21768E-01	6.621E+03	1.892E+04
1.20315E+02	1.21747E+02	1.86190E+01	2.00512E+01	1.03662E+00	6.621E+03	1.892E+04
1.20315E+02	1.21747E+02	2.00512E+01	2.14835E+01	1.01227E+00	6.621E+03	1.892E+04
1.21747E+02	1.23180E+02	0.00000E+00	1.43223E+00	0.00000E+00	6.621E+03	1.892E+04
1.21747E+02	1.23180E+02	1.43223E+00	2.86446E+00	1.08125E+00	6.621E+03	1.892E+04
1.21747E+02	1.23180E+02	2.86446E+00	4.29669E+00	1.02546E+00	6.621E+03	1.892E+04
1.21747E+02	1.23180E+02	4.29669E+00	5.72892E+00	9.91989E-01	6.621E+03	1.892E+04
1.21747E+02	1.23180E+02	5.72892E+00	7.16115E+00	9.72717E-01	6.621E+03	1.892E+04
1.21747E+02	1.23180E+02	7.16115E+00	8.59338E+00	9.65617E-01	6.621E+03	1.892E+04
1.21747E+02	1.23180E+02	8.59338E+00	1.00256E+01	9.63588E-01	6.621E+03	1.892E+04
1.21747E+02	1.23180E+02	1.00256E+01	1.14578E+01	9.63588E-01	6.621E+03	1.892E+04
1.21747E+02	1.23180E+02	1.14578E+01	1.28901E+01	9.66631E-01	6.621E+03	1.892E+04
1.21747E+02	1.23180E+02	1.28901E+01	1.43223E+01	9.71703E-01	6.621E+03	1.892E+04
1.21747E+02	1.23180E+02	1.43223E+01	1.57545E+01	9.78803E-01	6.621E+03	1.892E+04
1.21747E+02	1.23180E+02	1.57545E+01	1.71868E+01	9.94017E-01	6.621E+03	1.892E+04
1.21747E+02	1.23180E+02	1.71868E+01	1.86190E+01	1.01532E+00	6.621E+03	1.892E+04
1.21747E+02	1.23180E+02	1.86190E+01	2.00512E+01	1.04068E+00	6.621E+03	1.892E+04
1.21747E+02	1.23180E+02	2.00512E+01	2.14835E+01	0.00000E+00	6.621E+03	1.892E+04
1.23180E+02	1.24612E+02	0.00000E+00	1.43223E+00	1.10255E+00	6.621E+03	1.892E+04
1.23180E+02	1.24612E+02	1.43223E+00	2.86446E+00	1.07415E+00	6.621E+03	1.892E+04
1.23180E+02	1.24612E+02	2.86446E+00	4.29669E+00	1.02343E+00	6.621E+03	1.892E+04
1.23180E+02	1.24612E+02	4.29669E+00	5.72892E+00	9.97060E-01	6.621E+03	1.892E+04
1.23180E+02	1.24612E+02	5.72892E+00	7.16115E+00	9.89960E-01	6.621E+03	1.892E+04
1.23180E+02	1.24612E+02	7.16115E+00	8.59338E+00	9.87932E-01	6.621E+03	1.892E+04
1.23180E+02	1.24612E+02	8.59338E+00	1.00256E+01	9.81846E-01	6.621E+03	1.892E+04
1.23180E+02	1.24612E+02	1.00256E+01	1.14578E+01	9.76774E-01	6.621E+03	1.892E+04
1.23180E+02	1.24612E+02	1.14578E+01	1.28901E+01	9.84889E-01	6.621E+03	1.892E+04
1.23180E+02	1.24612E+02	1.28901E+01	1.43223E+01	9.95032E-01	6.621E+03	1.892E+04
1.23180E+02	1.24612E+02	1.43223E+01	1.57545E+01	9.98075E-01	6.621E+03	1.892E+04
1.23180E+02	1.24612E+02	1.57545E+01	1.71868E+01	1.00112E+00	6.621E+03	1.892E+04
1.23180E+02	1.24612E+02	1.71868E+01	1.86190E+01	1.01430E+00	6.621E+03	1.892E+04
1.23180E+02	1.24612E+02	1.86190E+01	2.00512E+01	1.03966E+00	6.621E+03	1.892E+04
1.23180E+02	1.24612E+02	2.00512E+01	2.14835E+01	1.02242E+00	6.621E+03	1.892E+04

Table 2.1.2.6

Standard Core Loading

Pin Geometry, Power, and Burnup Distributions (cont'd)

Assembly 6

Pin Power Set 13

X-Left	X-Right	Y-Bot	Y-Top	Relative Pin Power	BOC Burnup (MWD)	EOC Burnup (MWD)
1.24612E+02	1.26044E+02	0.00000E+00	1.43223E+00	1.09748E+00	6.621E+03	1.892E+04
1.24612E+02	1.26044E+02	1.43223E+00	2.86446E+00	1.03763E+00	6.621E+03	1.892E+04
1.24612E+02	1.26044E+02	2.86446E+00	4.29669E+00	1.01329E+00	6.621E+03	1.892E+04
1.24612E+02	1.26044E+02	4.29669E+00	5.72892E+00	1.02039E+00	6.621E+03	1.892E+04
1.24612E+02	1.26044E+02	5.72892E+00	7.16115E+00	1.02242E+00	6.621E+03	1.892E+04
1.24612E+02	1.26044E+02	7.16115E+00	8.59338E+00	6.15682E-01	6.621E+03	1.892E+04
1.24612E+02	1.26044E+02	8.59338E+00	1.00256E+01	1.01025E+00	6.621E+03	1.892E+04
1.24612E+02	1.26044E+02	1.00256E+01	1.14578E+01	1.00315E+00	6.621E+03	1.892E+04
1.24612E+02	1.26044E+02	1.14578E+01	1.28901E+01	1.01532E+00	6.621E+03	1.892E+04
1.24612E+02	1.26044E+02	1.28901E+01	1.43223E+01	6.23797E-01	6.621E+03	1.892E+04
1.24612E+02	1.26044E+02	1.43223E+01	1.57545E+01	1.03155E+00	6.621E+03	1.892E+04
1.24612E+02	1.26044E+02	1.57545E+01	1.71868E+01	1.02648E+00	6.621E+03	1.892E+04
1.24612E+02	1.26044E+02	1.71868E+01	1.86190E+01	1.00619E+00	6.621E+03	1.892E+04
1.24612E+02	1.26044E+02	1.86190E+01	2.00512E+01	1.00619E+00	6.621E+03	1.892E+04
1.24612E+02	1.26044E+02	2.00512E+01	2.14835E+01	1.01938E+00	6.621E+03	1.892E+04
1.26044E+02	1.27476E+02	0.00000E+00	1.43223E+00	1.11776E+00	6.621E+03	1.892E+04
1.26044E+02	1.27476E+02	1.43223E+00	2.86446E+00	1.06400E+00	6.621E+03	1.892E+04
1.26044E+02	1.27476E+02	2.86446E+00	4.29669E+00	1.03256E+00	6.621E+03	1.892E+04
1.26044E+02	1.27476E+02	4.29669E+00	5.72892E+00	1.06908E+00	6.621E+03	1.892E+04
1.26044E+02	1.27476E+02	5.72892E+00	7.16115E+00	1.07516E+00	6.621E+03	1.892E+04
1.26044E+02	1.27476E+02	7.16115E+00	8.59338E+00	1.06806E+00	6.621E+03	1.892E+04
1.26044E+02	1.27476E+02	8.59338E+00	1.00256E+01	1.04980E+00	6.621E+03	1.892E+04
1.26044E+02	1.27476E+02	1.00256E+01	1.14578E+01	1.04372E+00	6.621E+03	1.892E+04
1.26044E+02	1.27476E+02	1.14578E+01	1.28901E+01	1.05488E+00	6.621E+03	1.892E+04
1.26044E+02	1.27476E+02	1.28901E+01	1.43223E+01	1.07820E+00	6.621E+03	1.892E+04
1.26044E+02	1.27476E+02	1.43223E+01	1.57545E+01	1.08733E+00	6.621E+03	1.892E+04
1.26044E+02	1.27476E+02	1.57545E+01	1.71868E+01	1.07820E+00	6.621E+03	1.892E+04
1.26044E+02	1.27476E+02	1.71868E+01	1.86190E+01	1.03053E+00	6.621E+03	1.892E+04
1.26044E+02	1.27476E+02	1.86190E+01	2.00512E+01	1.03966E+00	6.621E+03	1.892E+04
1.26044E+02	1.27476E+02	2.00512E+01	2.14835E+01	1.05082E+00	6.621E+03	1.892E+04
1.27476E+02	1.28908E+02	0.00000E+00	1.43223E+00	1.16848E+00	6.621E+03	1.892E+04
1.27476E+02	1.28908E+02	1.43223E+00	2.86446E+00	1.11269E+00	6.621E+03	1.892E+04
1.27476E+02	1.28908E+02	2.86446E+00	4.29669E+00	1.08733E+00	6.621E+03	1.892E+04
1.27476E+02	1.28908E+02	4.29669E+00	5.72892E+00	1.09139E+00	6.621E+03	1.892E+04
1.27476E+02	1.28908E+02	5.72892E+00	7.16115E+00	0.00000E+00	6.621E+03	1.892E+04
1.27476E+02	1.28908E+02	7.16115E+00	8.59338E+00	1.08429E+00	6.621E+03	1.892E+04
1.27476E+02	1.28908E+02	8.59338E+00	1.00256E+01	1.06400E+00	6.621E+03	1.892E+04
1.27476E+02	1.28908E+02	1.00256E+01	1.14578E+01	1.05893E+00	6.621E+03	1.892E+04
1.27476E+02	1.28908E+02	1.14578E+01	1.28901E+01	1.06908E+00	6.621E+03	1.892E+04
1.27476E+02	1.28908E+02	1.28901E+01	1.43223E+01	1.09545E+00	6.621E+03	1.892E+04
1.27476E+02	1.28908E+02	1.43223E+01	1.57545E+01	0.00000E+00	6.621E+03	1.892E+04
1.27476E+02	1.28908E+02	1.57545E+01	1.71868E+01	1.10458E+00	6.621E+03	1.892E+04
1.27476E+02	1.28908E+02	1.71868E+01	1.86190E+01	1.09240E+00	6.621E+03	1.892E+04
1.27476E+02	1.28908E+02	1.86190E+01	2.00512E+01	1.09951E+00	6.621E+03	1.892E+04
1.27476E+02	1.28908E+02	2.00512E+01	2.14835E+01	1.11878E+00	6.621E+03	1.892E+04

Table 2.1.2.7

Standard Core Loading

Axial Power Distributions

Zone Axial Boundary	Radial Zone			
	1	2	3	4
0.0000E+00	0.0000E+00	0.0000E+00	0.0000E+00	0.0000E+00
1 1.3970E+01	1.9360E-02	2.0747E-02	1.9581E-02	1.7615E-02
2 2.7381E+01	2.8241E-02	2.9300E-02	2.8411E-02	2.7002E-02
3 4.0792E+01	3.5325E-02	3.6001E-02	3.5445E-02	3.4601E-02
4 5.4204E+01	4.0447E-02	4.0745E-02	4.0522E-02	4.0195E-02
5 6.7615E+01	4.3715E-02	4.3682E-02	4.3754E-02	4.3844E-02
6 8.1026E+01	4.5463E-02	4.5160E-02	4.5466E-02	4.5848E-02
7 9.4437E+01	4.6111E-02	4.5620E-02	4.6087E-02	4.6649E-02
8 1.0785E+02	4.6087E-02	4.5499E-02	4.6053E-02	4.6700E-02
9 1.2126E+02	4.5767E-02	4.5147E-02	4.5726E-02	4.6412E-02
10 1.3467E+02	4.5387E-02	4.4778E-02	4.5332E-02	4.6035E-02
11 1.4808E+02	4.5075E-02	4.4495E-02	4.5011E-02	4.5710E-02
12 1.6149E+02	4.4835E-02	4.4319E-02	4.4773E-02	4.5476E-02
13 1.7490E+02	4.4715E-02	4.4218E-02	4.4632E-02	4.5361E-02
14 1.8832E+02	4.4683E-02	4.4192E-02	4.4576E-02	4.5362E-02
15 2.0173E+02	4.4663E-02	4.4189E-02	4.4542E-02	4.5288E-02
16 2.1514E+02	4.4707E-02	4.4258E-02	4.4565E-02	4.5260E-02
17 2.2855E+02	4.4771E-02	4.4378E-02	4.4630E-02	4.5246E-02
18 2.4196E+02	4.4759E-02	4.4446E-02	4.4626E-02	4.5146E-02
19 2.5537E+02	4.4459E-02	4.4264E-02	4.4340E-02	4.4728E-02
20 2.6878E+02	4.3543E-02	4.3515E-02	4.3459E-02	4.3642E-02
21 2.8219E+02	4.1611E-02	4.1800E-02	4.1583E-02	4.1492E-02
22 2.9561E+02				

Table 2.1.2.7

Standard Core Loading

Axial Power Distributions (cont'd)

Zone Axial Boundary	Radial Zone			
	1	2	3	4
22 2.9561E+02	3.8301E-02	3.8718E-02	3.8329E-02	3.7878E-02
23 3.0902E+02	3.3308E-02	3.3962E-02	3.3348E-02	3.2529E-02
24 3.2243E+02	2.6532E-02	2.7405E-02	2.6793E-02	2.5372E-02
25 3.3584E+02	1.8132E-02	1.9163E-02	1.8417E-02	1.6608E-02
26 3.4925E+02	0.0000E+00	0.0000E+00	0.0000E+00	0.0000E+00
27 3.8211E+02				

Radial Zone	Zone Radial Boundary
1	107.175
2	128.610
3	150.040
4	184.461

Table 2.1.2.8

Standard Core Loading Edit Locations

	R (cm)	Z (cm)	θ (degrees)
Thermal Shield Capsule:			
Flux Spectrum and Peak Reaction Rates	202.25	121.79	20
Pressure Vessel Capsule:			
Flux Spectrum	215.43	121.79	20
Peak Reaction Rates	215.43	125.49	20
Cavity Capsule:			
Flux Spectrum and Peak Reaction Rates	320.06	177.27	9.5
Fluxes and DPA Rates	320.06	177.27	0-45
Pressure Vessel 0-T: †			
(A) Axial Peak Location			
(a) E > 1.0 MEV	219.393	125.488	0-45
(b) E > 0.1 MEV	219.393	125.488	0-45
(c) DPA Rates	219.393	125.488	0-45
(d) Flux Spectrum	219.393	125.488	15.5
(B) Lower Weld Location	219.393	67.1048	0-45
Pressure Vessel 1/4 T:			
(A) Axial Peak Location			
(a) E > 1.0 MEV	224.473	125.488	0-45
(b) E > 0.1 MEV	224.473	129.186	0-45
(c) DPA Rates	224.473	129.186	0-45
(d) Flux Spectrum	224.473	125.488	15.5
(B) Lower Weld Location	224.473	67.1048	0-45
Pressure Vessel 1/2 T:			
(A) Axial Peak Location			
(a) E > 1.0 MEV	229.870	129.186	0-45
(b) E > 0.1 MEV	229.870	132.885	0-45
(c) DPA Rates	229.870	132.885	0-45
(d) Flux Spectrum	229.870	125.488	15.5
(B) Lower Weld Location	229.870	67.1048	0-45
Pressure Vessel 3/4 T:			
(A) Axial Peak Location			
(a) E > 1.0 MEV	235.268	129.186	0-45
(b) E > 0.1 MEV	235.268	140.282	0-45
(c) DPA Rates	235.268	136.583	0-45
(d) Flux Spectrum	235.268	125.488	15.5
(B) Lower Weld Location	235.268	67.1048	0-45
Pressure Vessel Outer T:			
(A) Axial Peak Location			
(a) E > 1.0 MEV	240.342	140.282	0-45
(b) E > 0.1 MEV	240.342	152.473	0-45
(c) DPA Rates	240.342	156.775	0-45
(d) Flux Spectrum	240.342	125.488	15.5
(B) Lower Weld Location	240.342	67.1048	0-45
Downcomer			
	210.50	121.79	0-45

† The inner-wall (O-T) and vessel outer-wall (T) edits were taken at the center of the mesh blocks immediately inside the vessel. The vessel internal edits were taken at mesh blocks centered about the required edit location.

Table 2.1.3.1

Low Leakage Core Loading

Basic Design Data

Reactor		Material
Thermal Power	2527.73 MW (TH)	--
Core Inlet Temp.	536° F (280 °C)	--
Core Operating Pressure	2010 psia (13.859 MPa)	--
Baffle Thickness	1.5875 cm	SS-304
By-Pass	--	H ₂ O (560° F 293.3 °C) 2010 psia (13.859 MPa)
Inner Radius of Core Barrel	190.185 cm	--
Barrel Thickness	3.81 cm	SS-304
Inner Inlet Thickness	2.54 cm	H ₂ O (536° F 280 °C) 2010 psia (13.859 MPa)
Inner Radius of Thermal Shield	196.535 cm	--
Thermal Shield Thickness	3.81 cm	SS-304
Outer Inlet Thickness	18.095 cm	H ₂ O (536° F 280 °C) 2010 psia (13.859 MPa)
Inner Radius of Liner Clad	218.440 cm	--
Vessel Liner Clad Thickness	0.635 cm	SS-304
Vessel Thickness	21.59 cm	SA-302B
PV Insulation Air Thickness	1.835 cm	Air
PV Insulation Thickness	10.16 cm	PV Insulation
Cavity Thickness	82.62 cm	Air
Inner Radius of Biological Shield	335.280 cm	--
Bio-Shield Liner Thickness	0.635 cm	SA-302B
Bio-Shield Thickness	213.36 cm	Concrete

Table 2.1.3.2

Low Leakage Core Loading

Core and Fuel Assemblies

. Total Number of Fuel Assemblies	204	.
. Number of Rods per assembly (15x15)	216 fuel rods	.
.	8 guide tubes	.
.	1 instrument tube	.
. Assembly Pitch	21.485 cm	.
. Pin Pitch	1.43233 cm	.
. Fuel Material	Sintered UO ₂ pellets	.
. Cladding Material	Zr-4	.
. Fuel Active Length	335.28 cm	.
.		.

Low Leakage Core Loading Basic Design Data

Upper and Lower Reflectors

. Lower Reflector Thickness	13.97 cm	SS-304 + Water (536° F) (280 °C)
. Upper Reflector Thickness	32.865 cm	SS-304 + Water (584° F) (306.7 °C)

Table 2.1.3.3

Low Leakage Core Loading

Design Specification Material Compositions

Mixture	Component	Atom Densities (atom/b*cm)
Core	H	2.82500E-02
	B	2.69200E-05
	O	1.41200E-02
	C	2.58100E-05
	O (fuel)	1.28500E-02
	Al	3.56000E-04
	Cr	1.60800E-05
	Fe	2.20500E-05
	Ni	3.87700E-05
	Zr	5.44800E-03
	U-235	1.12000E-04
	U-238	6.03000E-03
Pu-239	2.20000E-05	
Pu-240	7.12000E-06	
Baffle (SS-304)	Cr	1.85300E-02
	Mn	1.75200E-03
	Fe	5.80700E-02
	Ni	8.57400E-03
Bypass ⁺ (560°F) (293.3 °C)	H	4.92900E-02
	O	2.46400E-02
	B	4.90000E-06
Core Barrel (SS-304)	Cr	1.85300E-02
	Mn	1.75200E-03
	Fe	5.80700E-02
	Ni	8.57400E-03
Inlet Water Gap (536°F) (280 °C)	H	5.09600E-02
	O	2.54800E-02
	B	5.10000E-06
Thermal Shield (SS-304)	Cr	1.85300E-02
	Mn	1.75200E-03
	Fe	5.80700E-02
	Ni	8.57400E-03
RPV Liner (SS-304)	Cr	1.85300E-02
	Mn	1.75200E-03
	Fe	5.80700E-02
	Ni	8.57400E-03
Cavity (Air)	N	3.20000E-05
	O	8.00000E-06

+ This composition is also to be used in the water region between the fuel assembly and the core baffle (see Figure 2.3.1).

Table 2.1.3.3

Low Leakage Core Loading

Design Specification Material Compositions (cont'd)

Mixture	Component	Atom Densities (atom/b*cm)
RPV Wall (SA-302B)	C	9.84000E-04
	Si	7.58900E-04
	Mn	1.39100E-03
	Fe	8.18300E-02
	Mo	3.14800E-04
RPV Insulation	Cr	3.43000E-04
	Mn	3.24000E-05
	Fe	1.07400E-03
	Ni	1.59000E-04
	Al	1.30000E-04
	N	3.77000E-05
Bio-Shield Liner (SA-302B)	O	9.96000E-06
	C	9.84000E-04
	Si	7.58900E-04
	Mn	1.39100E-03
	Fe	8.18300E-02
Bio-Shield (Concrete)	Mo	3.14800E-04
	H	7.77000E-03
	C	1.15000E-04
	O	4.38000E-02
	Na	1.05000E-03
	Mg	1.48000E-04
	Al	2.39000E-03
	Si	1.58000E-02
	K	6.93000E-04
	Ca	2.29000E-03
Fe	3.13000E-04	
Lower Reflector (Water-Steel) (536°F) (280 °C)	Cr	4.63250E-03
	Mn	4.38000E-04
	Fe	1.45175E-02
	Ni	2.14350E-03
	H	3.82200E-02
	O	1.91100E-02
Upper Reflector (Water-Steel) (584°F) (306.7 °C)	B	3.82500E-06
	Cr	4.63250E-03
	Mn	4.38000E-04
	Fe	1.45175E-02
	Ni	2.14350E-03
	H	3.55383E-02
O	1.77656E-02	
B	3.53293E-06	

Table 2.1.3.4

Low Leakage Core Loading Axial Zone Assignments

Zone	Description
1	Lower Reflector
2	Active Core Fuel Assemblies
3	Upper Reflector
4	Core Baffle
5	By-Pass
6	Core Barrel
7	Inner Inlet Water Gap
8	Thermal Shield
9	Outer Inlet Water Gap
10	Reactor Pressure Vessel Liner
11	Reactor Pressure Vessel
12	Air Gap
13	Pressure Vessel Insulation
14	Cavity
15	Biological Shield Liner
16	Biological Shield

Table 2.1.3.5

Low Leakage Core Loading
Fuel Assembly Geometry, Power, and Burnup Distributions

Assembly Number	X-Left	X-Right	Y-Bot	Y-Top	Relative Assembly Power	BOC Burnup (MWD)	EOC Burnup (MWD)	Axial Peaking Factor	Pin Power Set
1	0.00000E+00	2.14850E+01	0.00000E+00	2.14850E+01	1.08800E+00	1.63043E+04	2.44443E+04	1.0000	0
2	2.14850E+01	4.29700E+01	0.00000E+00	2.14850E+01	1.19500E+00	1.63043E+04	2.44443E+04	1.0000	0
3	4.29700E+01	6.44550E+01	0.00000E+00	2.14850E+01	1.23700E+00	1.63043E+04	2.44443E+04	1.0000	0
4	6.44550E+01	8.59400E+01	0.00000E+00	2.14850E+01	1.13200E+00	1.63043E+04	2.44443E+04	1.0000	0
5	8.59400E+01	1.07425E+02	0.00000E+00	2.14850E+01	1.25100E+00	1.63043E+04	2.44443E+04	1.0000	0
6	1.07425E+02	0.00000E+00	0.00000E+00	0.00000E+00	1.28000E+00	1.50810E+04	2.71080E+04	1.0000	13
7	1.28910E+02	0.00000E+00	0.00000E+00	0.00000E+00	1.22700E+00	0.00000E+00	1.14300E+04	1.0000	14
8	1.50399E+02	0.00000E+00	0.00000E+00	0.00000E+00	3.51000E-01	3.44510E+04	3.78570E+04	1.0000	15
9	2.14850E+01	4.29700E+01	2.14850E+01	4.29700E+01	1.20900E+00	1.63043E+04	2.44443E+04	1.0000	0
10	4.29700E+01	6.44550E+01	2.14850E+01	4.29700E+01	1.04000E+00	1.63043E+04	2.44443E+04	1.0000	0
11	6.44550E+01	8.59400E+01	2.14850E+01	4.29700E+01	1.29100E+00	1.63043E+04	2.44443E+04	1.0000	0
12	8.59400E+01	1.07425E+02	2.14850E+01	4.29700E+01	1.06600E+00	1.63043E+04	2.44443E+04	1.0000	0
13	1.07425E+02	0.00000E+00	2.14850E+01	0.00000E+00	1.31300E+00	0.00000E+00	1.22710E+04	1.0000	10
14	1.28910E+02	0.00000E+00	2.14850E+01	0.00000E+00	1.22200E+00	7.56600E+03	1.90260E+04	1.0000	11
15	1.50399E+02	0.00000E+00	2.14850E+01	0.00000E+00	4.47000E-01	2.67040E+04	3.10300E+04	1.0000	12
16	4.29700E+01	6.44550E+01	4.29700E+01	6.44550E+01	1.04900E+00	1.63043E+04	2.44443E+04	1.0000	0
17	6.44550E+01	8.59400E+01	4.29700E+01	6.44550E+01	1.10200E+00	1.63043E+04	2.44443E+04	1.0000	0
18	8.59400E+01	1.07425E+02	4.29700E+01	6.44550E+01	1.29200E+00	1.63043E+04	2.44443E+04	1.0000	0
19	1.07425E+02	0.00000E+00	4.29700E+01	0.00000E+00	1.38500E+00	9.28750E+03	2.22845E+04	1.0000	7
20	1.28910E+02	0.00000E+00	4.29700E+01	0.00000E+00	1.06300E+00	0.00000E+00	9.90600E+03	1.0000	8
21	1.50399E+02	0.00000E+00	4.29700E+01	0.00000E+00	3.55000E-01	2.58990E+04	2.93340E+04	1.0000	9
22	6.44550E+01	8.59400E+01	6.44550E+01	8.59400E+01	1.24000E+00	1.63043E+04	2.44443E+04	1.0000	0
23	8.59400E+01	0.00000E+00	6.44550E+01	0.00000E+00	1.27100E+00	1.10260E+04	2.29480E+04	1.0000	4
24	1.07425E+02	0.00000E+00	6.44550E+01	0.00000E+00	1.13200E+00	0.00000E+00	1.05460E+04	1.0000	5
25	1.28910E+02	0.00000E+00	6.44550E+01	0.00000E+00	5.25000E-01	2.64120E+04	3.13230E+04	1.0000	6
26	8.59400E+01	0.00000E+00	8.59400E+01	0.00000E+00	7.72000E-01	2.68580E+04	3.40760E+04	1.0000	1
27	1.07425E+02	0.00000E+00	8.59400E+01	0.00000E+00	4.76000E-01	2.60160E+04	3.06280E+04	1.0000	2
28	1.28910E+02	0.00000E+00	8.59400E+01	0.00000E+00	1.69000E-01	3.52640E+04	3.68980E+04	1.0000	3

Note: Assemblies including pin power sets do not have right or top boundaries specified here. These data are included with the pin geometry data.

Table 2.1.3.6

Low Leakage Core Loading

Pin Geometry, Power, and Burnup Distributions

Assembly 6

Pin Power Set 13

X-Left	X-Right	Y-Bot	Y-Top	Relative Pin Power	BOC Burnup (MWD)	EOC Burnup (MWD)
1.07425E+02	1.08857E+02	0.00000E+00	1.43223E+00	1.02683E+00	1.508E+04	2.711E+04
1.07425E+02	1.08857E+02	1.43223E+00	2.86446E+00	1.00624E+00	1.508E+04	2.711E+04
1.07425E+02	1.08857E+02	2.86446E+00	4.29669E+00	9.73782E-01	1.508E+04	2.711E+04
1.07425E+02	1.08857E+02	4.29669E+00	5.72892E+00	9.63490E-01	1.508E+04	2.711E+04
1.07425E+02	1.08857E+02	5.72892E+00	7.16115E+00	0.00000E+00	1.508E+04	2.711E+04
1.07425E+02	1.08857E+02	7.16115E+00	8.59338E+00	9.41323E-01	1.508E+04	2.711E+04
1.07425E+02	1.08857E+02	8.59338E+00	1.00256E+01	9.23906E-01	1.508E+04	2.711E+04
1.07425E+02	1.08857E+02	1.00256E+01	1.14578E+01	9.18364E-01	1.508E+04	2.711E+04
1.07425E+02	1.08857E+02	1.14578E+01	1.28901E+01	9.18364E-01	1.508E+04	2.711E+04
1.07425E+02	1.08857E+02	1.28901E+01	1.43223E+01	9.29448E-01	1.508E+04	2.711E+04
1.07425E+02	1.08857E+02	1.43223E+01	1.57545E+01	0.00000E+00	1.508E+04	2.711E+04
1.07425E+02	1.08857E+02	1.57545E+01	1.71868E+01	9.31031E-01	1.508E+04	2.711E+04
1.07425E+02	1.08857E+02	1.71868E+01	1.86190E+01	9.19947E-01	1.508E+04	2.711E+04
1.07425E+02	1.08857E+02	1.86190E+01	2.00512E+01	9.14406E-01	1.508E+04	2.711E+04
1.07425E+02	1.08857E+02	2.00512E+01	2.14835E+01	8.76404E-01	1.508E+04	2.711E+04
1.08857E+02	1.10289E+02	0.00000E+00	1.43223E+00	1.08779E+00	1.508E+04	2.711E+04
1.08857E+02	1.10289E+02	1.43223E+00	2.86446E+00	1.02603E+00	1.508E+04	2.711E+04
1.08857E+02	1.10289E+02	2.86446E+00	4.29669E+00	9.91200E-01	1.508E+04	2.711E+04
1.08857E+02	1.10289E+02	4.29669E+00	5.72892E+00	1.02524E+00	1.508E+04	2.711E+04
1.08857E+02	1.10289E+02	5.72892E+00	7.16115E+00	1.00862E+00	1.508E+04	2.711E+04
1.08857E+02	1.10289E+02	7.16115E+00	8.59338E+00	9.94367E-01	1.508E+04	2.711E+04
1.08857E+02	1.10289E+02	8.59338E+00	1.00256E+01	9.88033E-01	1.508E+04	2.711E+04
1.08857E+02	1.10289E+02	1.00256E+01	1.14578E+01	9.87241E-01	1.508E+04	2.711E+04
1.08857E+02	1.10289E+02	1.14578E+01	1.28901E+01	9.82491E-01	1.508E+04	2.711E+04
1.08857E+02	1.10289E+02	1.28901E+01	1.43223E+01	9.84075E-01	1.508E+04	2.711E+04
1.08857E+02	1.10289E+02	1.43223E+01	1.57545E+01	9.90408E-01	1.508E+04	2.711E+04
1.08857E+02	1.10289E+02	1.57545E+01	1.71868E+01	9.94367E-01	1.508E+04	2.711E+04
1.08857E+02	1.10289E+02	1.71868E+01	1.86190E+01	9.41323E-01	1.508E+04	2.711E+04
1.08857E+02	1.10289E+02	1.86190E+01	2.00512E+01	9.36573E-01	1.508E+04	2.711E+04
1.08857E+02	1.10289E+02	2.00512E+01	2.14835E+01	9.26281E-01	1.508E+04	2.711E+04
1.10289E+02	1.11722E+02	0.00000E+00	1.43223E+00	1.09966E+00	1.508E+04	2.711E+04
1.10289E+02	1.11722E+02	1.43223E+00	2.86446E+00	1.03553E+00	1.508E+04	2.711E+04
1.10289E+02	1.11722E+02	2.86446E+00	4.29669E+00	6.68189E-01	1.508E+04	2.711E+04
1.10289E+02	1.11722E+02	4.29669E+00	5.72892E+00	1.01891E+00	1.508E+04	2.711E+04
1.10289E+02	1.11722E+02	5.72892E+00	7.16115E+00	9.92783E-01	1.508E+04	2.711E+04
1.10289E+02	1.11722E+02	7.16115E+00	8.59338E+00	9.81699E-01	1.508E+04	2.711E+04
1.10289E+02	1.11722E+02	8.59338E+00	1.00256E+01	9.85658E-01	1.508E+04	2.711E+04
1.10289E+02	1.11722E+02	1.00256E+01	1.14578E+01	6.27813E-01	1.508E+04	2.711E+04
1.10289E+02	1.11722E+02	1.14578E+01	1.28901E+01	9.81699E-01	1.508E+04	2.711E+04
1.10289E+02	1.11722E+02	1.28901E+01	1.43223E+01	9.72991E-01	1.508E+04	2.711E+04
1.10289E+02	1.11722E+02	1.43223E+01	1.57545E+01	9.76949E-01	1.508E+04	2.711E+04
1.10289E+02	1.11722E+02	1.57545E+01	1.71868E+01	9.91200E-01	1.508E+04	2.711E+04
1.10289E+02	1.11722E+02	1.71868E+01	1.86190E+01	6.40480E-01	1.508E+04	2.711E+04
1.10289E+02	1.11722E+02	1.86190E+01	2.00512E+01	9.49240E-01	1.508E+04	2.711E+04
1.10289E+02	1.11722E+02	2.00512E+01	2.14835E+01	9.38948E-01	1.508E+04	2.711E+04

Table 2.1.3.6

Low Leakage Core Loading

Pin Geometry, Power, and Burnup Distributions (cont'd)

Assembly 6				Pin Power Set 13		
X-Left	X-Right	Y-Bot	Y-Top	Relative Pin Power	BOC Burnup (MWD)	EOC Burnup (MWD)
1.16018E+02	1.17451E+02	0.00000E+00	1.43223E+00	1.09729E+00	1.508E+04	2.711E+04
1.16018E+02	1.17451E+02	1.43223E+00	2.86446E+00	1.08304E+00	1.508E+04	2.711E+04
1.16018E+02	1.17451E+02	2.86446E+00	4.29669E+00	1.03158E+00	1.508E+04	2.711E+04
1.16018E+02	1.17451E+02	4.29669E+00	5.72892E+00	9.95158E-01	1.508E+04	2.711E+04
1.16018E+02	1.17451E+02	5.72892E+00	7.16115E+00	9.72991E-01	1.508E+04	2.711E+04
1.16018E+02	1.17451E+02	7.16115E+00	8.59338E+00	9.69032E-01	1.508E+04	2.711E+04
1.16018E+02	1.17451E+02	8.59338E+00	1.00256E+01	9.79324E-01	1.508E+04	2.711E+04
1.16018E+02	1.17451E+02	1.00256E+01	1.14578E+01	9.87241E-01	1.508E+04	2.711E+04
1.16018E+02	1.17451E+02	1.14578E+01	1.28901E+01	9.76949E-01	1.508E+04	2.711E+04
1.16018E+02	1.17451E+02	1.28901E+01	1.43223E+01	9.64282E-01	1.508E+04	2.711E+04
1.16018E+02	1.17451E+02	1.43223E+01	1.57545E+01	9.63490E-01	1.508E+04	2.711E+04
1.16018E+02	1.17451E+02	1.57545E+01	1.71868E+01	9.76949E-01	1.508E+04	2.711E+04
1.16018E+02	1.17451E+02	1.71868E+01	1.86190E+01	9.94367E-01	1.508E+04	2.711E+04
1.16018E+02	1.17451E+02	1.86190E+01	2.00512E+01	1.00545E+00	1.508E+04	2.711E+04
1.16018E+02	1.17451E+02	2.00512E+01	2.14835E+01	9.54782E-01	1.508E+04	2.711E+04
1.17451E+02	1.18883E+02	0.00000E+00	1.43223E+00	1.09570E+00	1.508E+04	2.711E+04
1.17451E+02	1.18883E+02	1.43223E+00	2.86446E+00	1.08620E+00	1.508E+04	2.711E+04
1.17451E+02	1.18883E+02	2.86446E+00	4.29669E+00	6.56314E-01	1.508E+04	2.711E+04
1.17451E+02	1.18883E+02	4.29669E+00	5.72892E+00	1.00149E+00	1.508E+04	2.711E+04
1.17451E+02	1.18883E+02	5.72892E+00	7.16115E+00	9.76158E-01	1.508E+04	2.711E+04
1.17451E+02	1.18883E+02	7.16115E+00	8.59338E+00	9.72991E-01	1.508E+04	2.711E+04
1.17451E+02	1.18883E+02	8.59338E+00	1.00256E+01	9.89616E-01	1.508E+04	2.711E+04
1.17451E+02	1.18883E+02	1.00256E+01	1.14578E+01	0.00000E+00	1.508E+04	2.711E+04
1.17451E+02	1.18883E+02	1.14578E+01	1.28901E+01	9.88033E-01	1.508E+04	2.711E+04
1.17451E+02	1.18883E+02	1.28901E+01	1.43223E+01	9.69032E-01	1.508E+04	2.711E+04
1.17451E+02	1.18883E+02	1.43223E+01	1.57545E+01	9.67449E-01	1.508E+04	2.711E+04
1.17451E+02	1.18883E+02	1.57545E+01	1.71868E+01	9.84075E-01	1.508E+04	2.711E+04
1.17451E+02	1.18883E+02	1.71868E+01	1.86190E+01	6.36521E-01	1.508E+04	2.711E+04
1.17451E+02	1.18883E+02	1.86190E+01	2.00512E+01	1.01099E+00	1.508E+04	2.711E+04
1.17451E+02	1.18883E+02	2.00512E+01	2.14835E+01	9.55574E-01	1.508E+04	2.711E+04
1.18883E+02	1.20315E+02	0.00000E+00	1.43223E+00	1.09966E+00	1.508E+04	2.711E+04
1.18883E+02	1.20315E+02	1.43223E+00	2.86446E+00	1.08541E+00	1.508E+04	2.711E+04
1.18883E+02	1.20315E+02	2.86446E+00	4.29669E+00	1.03474E+00	1.508E+04	2.711E+04
1.18883E+02	1.20315E+02	4.29669E+00	5.72892E+00	9.97533E-01	1.508E+04	2.711E+04
1.18883E+02	1.20315E+02	5.72892E+00	7.16115E+00	9.75366E-01	1.508E+04	2.711E+04
1.18883E+02	1.20315E+02	7.16115E+00	8.59338E+00	9.72199E-01	1.508E+04	2.711E+04
1.18883E+02	1.20315E+02	8.59338E+00	1.00256E+01	9.82491E-01	1.508E+04	2.711E+04
1.18883E+02	1.20315E+02	1.00256E+01	1.14578E+01	9.90408E-01	1.508E+04	2.711E+04
1.18883E+02	1.20315E+02	1.14578E+01	1.28901E+01	9.80908E-01	1.508E+04	2.711E+04
1.18883E+02	1.20315E+02	1.28901E+01	1.43223E+01	9.68241E-01	1.508E+04	2.711E+04
1.18883E+02	1.20315E+02	1.43223E+01	1.57545E+01	9.68241E-01	1.508E+04	2.711E+04
1.18883E+02	1.20315E+02	1.57545E+01	1.71868E+01	9.80908E-01	1.508E+04	2.711E+04
1.18883E+02	1.20315E+02	1.71868E+01	1.86190E+01	9.99908E-01	1.508E+04	2.711E+04
1.18883E+02	1.20315E+02	1.86190E+01	2.00512E+01	1.01099E+00	1.508E+04	2.711E+04
1.18883E+02	1.20315E+02	2.00512E+01	2.14835E+01	9.60324E-01	1.508E+04	2.711E+04

Table 2.1.3.6

Low Leakage Core Loading

Pin Geometry, Power, and Burnup Distributions (cont'd)

Assembly 6 Pin Power Set 13

X-Left	X-Right	Y-Bot	Y-Top	Relative Pin Power	BOC Burnup (MWD)	EOC Burnup (MWD)
1.11722E+02	1.13154E+02	0.00000E+00	1.43223E+00	1.11075E+00	1.508E+04	2.711E+04
1.11722E+02	1.13154E+02	1.43223E+00	2.86446E+00	1.09887E+00	1.508E+04	2.711E+04
1.11722E+02	1.13154E+02	2.86446E+00	4.29669E+00	1.04345E+00	1.508E+04	2.711E+04
1.11722E+02	1.13154E+02	4.29669E+00	5.72892E+00	1.00387E+00	1.508E+04	2.711E+04
1.11722E+02	1.13154E+02	5.72892E+00	7.16115E+00	9.80116E-01	1.508E+04	2.711E+04
1.11722E+02	1.13154E+02	7.16115E+00	8.59338E+00	9.70616E-01	1.508E+04	2.711E+04
1.11722E+02	1.13154E+02	8.59338E+00	1.00256E+01	9.72991E-01	1.508E+04	2.711E+04
1.11722E+02	1.13154E+02	1.00256E+01	1.14578E+01	9.76158E-01	1.508E+04	2.711E+04
1.11722E+02	1.13154E+02	1.14578E+01	1.28901E+01	9.69824E-01	1.508E+04	2.711E+04
1.11722E+02	1.13154E+02	1.28901E+01	1.43223E+01	9.63490E-01	1.508E+04	2.711E+04
1.11722E+02	1.13154E+02	1.43223E+01	1.57545E+01	9.66657E-01	1.508E+04	2.711E+04
1.11722E+02	1.13154E+02	1.57545E+01	1.71868E+01	9.79324E-01	1.508E+04	2.711E+04
1.11722E+02	1.13154E+02	1.71868E+01	1.86190E+01	9.96742E-01	1.508E+04	2.711E+04
1.11722E+02	1.13154E+02	1.86190E+01	2.00512E+01	1.00783E+00	1.508E+04	2.711E+04
1.11722E+02	1.13154E+02	2.00512E+01	2.14835E+01	9.54782E-01	1.508E+04	2.711E+04
1.13154E+02	1.14586E+02	0.00000E+00	1.43223E+00	0.00000E+00	1.508E+04	2.711E+04
1.13154E+02	1.14586E+02	1.43223E+00	2.86446E+00	1.09491E+00	1.508E+04	2.711E+04
1.13154E+02	1.14586E+02	2.86446E+00	4.29669E+00	1.02920E+00	1.508E+04	2.711E+04
1.13154E+02	1.14586E+02	4.29669E+00	5.72892E+00	9.91991E-01	1.508E+04	2.711E+04
1.13154E+02	1.14586E+02	5.72892E+00	7.16115E+00	9.72199E-01	1.508E+04	2.711E+04
1.13154E+02	1.14586E+02	7.16115E+00	8.59338E+00	9.64282E-01	1.508E+04	2.711E+04
1.13154E+02	1.14586E+02	8.59338E+00	1.00256E+01	9.62699E-01	1.508E+04	2.711E+04
1.13154E+02	1.14586E+02	1.00256E+01	1.14578E+01	9.62699E-01	1.508E+04	2.711E+04
1.13154E+02	1.14586E+02	1.14578E+01	1.28901E+01	9.60324E-01	1.508E+04	2.711E+04
1.13154E+02	1.14586E+02	1.28901E+01	1.43223E+01	9.57949E-01	1.508E+04	2.711E+04
1.13154E+02	1.14586E+02	1.43223E+01	1.57545E+01	9.60324E-01	1.508E+04	2.711E+04
1.13154E+02	1.14586E+02	1.57545E+01	1.71868E+01	9.69824E-01	1.508E+04	2.711E+04
1.13154E+02	1.14586E+02	1.71868E+01	1.86190E+01	9.85658E-01	1.508E+04	2.711E+04
1.13154E+02	1.14586E+02	1.86190E+01	2.00512E+01	1.00783E+00	1.508E+04	2.711E+04
1.13154E+02	1.14586E+02	2.00512E+01	2.14835E+01	0.00000E+00	1.508E+04	2.711E+04
1.14586E+02	1.16018E+02	0.00000E+00	1.43223E+00	1.10758E+00	1.508E+04	2.711E+04
1.14586E+02	1.16018E+02	1.43223E+00	2.86446E+00	1.08620E+00	1.508E+04	2.711E+04
1.14586E+02	1.16018E+02	2.86446E+00	4.29669E+00	1.02445E+00	1.508E+04	2.711E+04
1.14586E+02	1.16018E+02	4.29669E+00	5.72892E+00	9.88825E-01	1.508E+04	2.711E+04
1.14586E+02	1.16018E+02	5.72892E+00	7.16115E+00	9.70616E-01	1.508E+04	2.711E+04
1.14586E+02	1.16018E+02	7.16115E+00	8.59338E+00	9.64282E-01	1.508E+04	2.711E+04
1.14586E+02	1.16018E+02	8.59338E+00	1.00256E+01	9.65074E-01	1.508E+04	2.711E+04
1.14586E+02	1.16018E+02	1.00256E+01	1.14578E+01	9.66657E-01	1.508E+04	2.711E+04
1.14586E+02	1.16018E+02	1.14578E+01	1.28901E+01	9.62699E-01	1.508E+04	2.711E+04
1.14586E+02	1.16018E+02	1.28901E+01	1.43223E+01	9.58740E-01	1.508E+04	2.711E+04
1.14586E+02	1.16018E+02	1.43223E+01	1.57545E+01	9.60324E-01	1.508E+04	2.711E+04
1.14586E+02	1.16018E+02	1.57545E+01	1.71868E+01	9.69032E-01	1.508E+04	2.711E+04
1.14586E+02	1.16018E+02	1.71868E+01	1.86190E+01	9.84866E-01	1.508E+04	2.711E+04
1.14586E+02	1.16018E+02	1.86190E+01	2.00512E+01	1.00466E+00	1.508E+04	2.711E+04
1.14586E+02	1.16018E+02	2.00512E+01	2.14835E+01	9.61907E-01	1.508E+04	2.711E+04

Table 2.1.3.6

Low Leakage Core Loading

Pin Geometry, Power, and Burnup Distributions (cont'd)

Assembly 6				Pin Power Set 13		
X-Left	X-Right	Y-Bot	Y-Top	Relative Pin Power	BOC Burnup (MWD)	EOC Burnup (MWD)
1.20315E+02	1.21747E+02	0.00000E+00	1.43223E+00	1.11312E+00	1.508E+04	2.711E+04
1.20315E+02	1.21747E+02	1.43223E+00	2.86446E+00	1.09254E+00	1.508E+04	2.711E+04
1.20315E+02	1.21747E+02	2.86446E+00	4.29669E+00	1.03078E+00	1.508E+04	2.711E+04
1.20315E+02	1.21747E+02	4.29669E+00	5.72892E+00	9.95158E-01	1.508E+04	2.711E+04
1.20315E+02	1.21747E+02	5.72892E+00	7.16115E+00	9.76949E-01	1.508E+04	2.711E+04
1.20315E+02	1.21747E+02	7.16115E+00	8.59338E+00	9.70616E-01	1.508E+04	2.711E+04
1.20315E+02	1.21747E+02	8.59338E+00	1.00256E+01	9.72199E-01	1.508E+04	2.711E+04
1.20315E+02	1.21747E+02	1.00256E+01	1.14578E+01	9.74574E-01	1.508E+04	2.711E+04
1.20315E+02	1.21747E+02	1.14578E+01	1.28901E+01	9.71407E-01	1.508E+04	2.711E+04
1.20315E+02	1.21747E+02	1.28901E+01	1.43223E+01	9.67449E-01	1.508E+04	2.711E+04
1.20315E+02	1.21747E+02	1.43223E+01	1.57545E+01	9.69824E-01	1.508E+04	2.711E+04
1.20315E+02	1.21747E+02	1.57545E+01	1.71868E+01	9.79324E-01	1.508E+04	2.711E+04
1.20315E+02	1.21747E+02	1.71868E+01	1.86190E+01	9.95950E-01	1.508E+04	2.711E+04
1.20315E+02	1.21747E+02	1.86190E+01	2.00512E+01	1.01733E+00	1.508E+04	2.711E+04
1.20315E+02	1.21747E+02	2.00512E+01	2.14835E+01	9.74574E-01	1.508E+04	2.711E+04
1.21747E+02	1.23180E+02	0.00000E+00	1.43223E+00	0.00000E+00	1.508E+04	2.711E+04
1.21747E+02	1.23180E+02	1.43223E+00	2.86446E+00	1.10679E+00	1.508E+04	2.711E+04
1.21747E+02	1.23180E+02	2.86446E+00	4.29669E+00	1.04108E+00	1.508E+04	2.711E+04
1.21747E+02	1.23180E+02	4.29669E+00	5.72892E+00	1.00387E+00	1.508E+04	2.711E+04
1.21747E+02	1.23180E+02	5.72892E+00	7.16115E+00	9.84866E-01	1.508E+04	2.711E+04
1.21747E+02	1.23180E+02	7.16115E+00	8.59338E+00	9.77741E-01	1.508E+04	2.711E+04
1.21747E+02	1.23180E+02	8.59338E+00	1.00256E+01	9.76949E-01	1.508E+04	2.711E+04
1.21747E+02	1.23180E+02	1.00256E+01	1.14578E+01	9.77741E-01	1.508E+04	2.711E+04
1.21747E+02	1.23180E+02	1.14578E+01	1.28901E+01	9.75366E-01	1.508E+04	2.711E+04
1.21747E+02	1.23180E+02	1.28901E+01	1.43223E+01	9.74574E-01	1.508E+04	2.711E+04
1.21747E+02	1.23180E+02	1.43223E+01	1.57545E+01	9.77741E-01	1.508E+04	2.711E+04
1.21747E+02	1.23180E+02	1.57545E+01	1.71868E+01	9.88825E-01	1.508E+04	2.711E+04
1.21747E+02	1.23180E+02	1.71868E+01	1.86190E+01	1.00624E+00	1.508E+04	2.711E+04
1.21747E+02	1.23180E+02	1.86190E+01	2.00512E+01	1.02999E+00	1.508E+04	2.711E+04
1.21747E+02	1.23180E+02	2.00512E+01	2.14835E+01	0.00000E+00	1.508E+04	2.711E+04
1.23180E+02	1.24612E+02	0.00000E+00	1.43223E+00	1.13133E+00	1.508E+04	2.711E+04
1.23180E+02	1.24612E+02	1.43223E+00	2.86446E+00	1.12183E+00	1.508E+04	2.711E+04
1.23180E+02	1.24612E+02	2.86446E+00	4.29669E+00	1.06799E+00	1.508E+04	2.711E+04
1.23180E+02	1.24612E+02	4.29669E+00	5.72892E+00	1.02920E+00	1.508E+04	2.711E+04
1.23180E+02	1.24612E+02	5.72892E+00	7.16115E+00	1.00545E+00	1.508E+04	2.711E+04
1.23180E+02	1.24612E+02	7.16115E+00	8.59338E+00	9.96742E-01	1.508E+04	2.711E+04
1.23180E+02	1.24612E+02	8.59338E+00	1.00256E+01	9.99908E-01	1.508E+04	2.711E+04
1.23180E+02	1.24612E+02	1.00256E+01	1.14578E+01	1.00387E+00	1.508E+04	2.711E+04
1.23180E+02	1.24612E+02	1.14578E+01	1.28901E+01	9.98325E-01	1.508E+04	2.711E+04
1.23180E+02	1.24612E+02	1.28901E+01	1.43223E+01	9.93575E-01	1.508E+04	2.711E+04
1.23180E+02	1.24612E+02	1.43223E+01	1.57545E+01	9.98325E-01	1.508E+04	2.711E+04
1.23180E+02	1.24612E+02	1.57545E+01	1.71868E+01	1.01337E+00	1.508E+04	2.711E+04
1.23180E+02	1.24612E+02	1.71868E+01	1.86190E+01	1.03237E+00	1.508E+04	2.711E+04
1.23180E+02	1.24612E+02	1.86190E+01	2.00512E+01	1.04424E+00	1.508E+04	2.711E+04
1.23180E+02	1.24612E+02	2.00512E+01	2.14835E+01	9.89616E-01	1.508E+04	2.711E+04

Table 2.1.3.6

Low Leakage Core Loading

Pin Geometry, Power, and Burnup Distributions (cont'd)

Assembly 6				Pin Power Set 13		
X-Left	X-Right	Y-Bot	Y-Top	Relative Pin Power	BOC Burnup (MWD)	EOC Burnup (MWD)
1.24612E+02	1.26044E+02	0.00000E+00	1.43223E+00	1.14083E+00	1.508E+04	2.711E+04
1.24612E+02	1.26044E+02	1.43223E+00	2.86446E+00	1.07908E+00	1.508E+04	2.711E+04
1.24612E+02	1.26044E+02	2.86446E+00	4.29669E+00	6.96690E-01	1.508E+04	2.711E+04
1.24612E+02	1.26044E+02	4.29669E+00	5.72892E+00	1.06958E+00	1.508E+04	2.711E+04
1.24612E+02	1.26044E+02	5.72892E+00	7.16115E+00	1.04424E+00	1.508E+04	2.711E+04
1.24612E+02	1.26044E+02	7.16115E+00	8.59338E+00	1.03474E+00	1.508E+04	2.711E+04
1.24612E+02	1.26044E+02	8.59338E+00	1.00256E+01	1.03949E+00	1.508E+04	2.711E+04
1.24612E+02	1.26044E+02	1.00256E+01	1.14578E+01	6.59480E-01	1.508E+04	2.711E+04
1.24612E+02	1.26044E+02	1.14578E+01	1.28901E+01	1.03791E+00	1.508E+04	2.711E+04
1.24612E+02	1.26044E+02	1.28901E+01	1.43223E+01	1.03158E+00	1.508E+04	2.711E+04
1.24612E+02	1.26044E+02	1.43223E+01	1.57545E+01	1.03712E+00	1.508E+04	2.711E+04
1.24612E+02	1.26044E+02	1.57545E+01	1.71868E+01	1.05374E+00	1.508E+04	2.711E+04
1.24612E+02	1.26044E+02	1.71868E+01	1.86190E+01	6.76898E-01	1.508E+04	2.711E+04
1.24612E+02	1.26044E+02	1.86190E+01	2.00512E+01	1.00862E+00	1.508E+04	2.711E+04
1.24612E+02	1.26044E+02	2.00512E+01	2.14835E+01	9.97533E-01	1.508E+04	2.711E+04
1.26044E+02	1.27476E+02	0.00000E+00	1.43223E+00	1.17012E+00	1.508E+04	2.711E+04
1.26044E+02	1.27476E+02	1.43223E+00	2.86446E+00	1.11312E+00	1.508E+04	2.711E+04
1.26044E+02	1.27476E+02	2.86446E+00	4.29669E+00	1.08304E+00	1.508E+04	2.711E+04
1.26044E+02	1.27476E+02	4.29669E+00	5.72892E+00	1.12737E+00	1.508E+04	2.711E+04
1.26044E+02	1.27476E+02	5.72892E+00	7.16115E+00	1.11391E+00	1.508E+04	2.711E+04
1.26044E+02	1.27476E+02	7.16115E+00	8.59338E+00	1.10645E+00	1.508E+04	2.711E+04
1.26044E+02	1.27476E+02	8.59338E+00	1.00256E+01	1.09412E+00	1.508E+04	2.711E+04
1.26044E+02	1.27476E+02	1.00256E+01	1.14578E+01	1.09570E+00	1.508E+04	2.711E+04
1.26044E+02	1.27476E+02	1.14578E+01	1.28901E+01	1.09254E+00	1.508E+04	2.711E+04
1.26044E+02	1.27476E+02	1.28901E+01	1.43223E+01	1.09649E+00	1.508E+04	2.711E+04
1.26044E+02	1.27476E+02	1.43223E+01	1.57545E+01	1.10600E+00	1.508E+04	2.711E+04
1.26044E+02	1.27476E+02	1.57545E+01	1.71868E+01	1.11075E+00	1.508E+04	2.711E+04
1.26044E+02	1.27476E+02	1.71868E+01	1.86190E+01	1.04820E+00	1.508E+04	2.711E+04
1.26044E+02	1.27476E+02	1.86190E+01	2.00512E+01	1.04187E+00	1.508E+04	2.711E+04
1.26044E+02	1.27476E+02	2.00512E+01	2.14835E+01	1.02762E+00	1.508E+04	2.711E+04
1.27476E+02	1.28908E+02	0.00000E+00	1.43223E+00	1.17646E+00	1.508E+04	2.711E+04
1.27476E+02	1.28908E+02	1.43223E+00	2.86446E+00	1.17646E+00	1.508E+04	2.711E+04
1.27476E+02	1.28908E+02	2.86446E+00	4.29669E+00	1.15033E+00	1.508E+04	2.711E+04
1.27476E+02	1.28908E+02	4.29669E+00	5.72892E+00	1.14162E+00	1.508E+04	2.711E+04
1.27476E+02	1.28908E+02	5.72892E+00	7.16115E+00	0.00000E+00	1.508E+04	2.711E+04
1.27476E+02	1.28908E+02	7.16115E+00	8.59338E+00	1.12500E+00	1.508E+04	2.711E+04
1.27476E+02	1.28908E+02	8.59338E+00	1.00256E+01	1.11312E+00	1.508E+04	2.711E+04
1.27476E+02	1.28908E+02	1.00256E+01	1.14578E+01	1.11075E+00	1.508E+04	2.711E+04
1.27476E+02	1.28908E+02	1.14578E+01	1.28901E+01	1.11233E+00	1.508E+04	2.711E+04
1.27476E+02	1.28908E+02	1.28901E+01	1.43223E+01	1.12104E+00	1.508E+04	2.711E+04
1.27476E+02	1.28908E+02	1.43223E+01	1.57545E+01	0.00000E+00	1.508E+04	2.711E+04
1.27476E+02	1.28908E+02	1.57545E+01	1.71868E+01	1.12420E+00	1.508E+04	2.711E+04
1.27476E+02	1.28908E+02	1.71868E+01	1.86190E+01	1.11391E+00	1.508E+04	2.711E+04
1.27476E+02	1.28908E+02	1.86190E+01	2.00512E+01	1.10283E+00	1.508E+04	2.711E+04
1.27476E+02	1.28908E+02	2.00512E+01	2.14835E+01	1.04345E+00	1.508E+04	2.711E+04

Table 2.1.3.7

Low Leakage Core Loading
Axial Power Distributions

Zone Axial Boundary	Radial Zone			
	1	2	3	4
0.0000E+00	0.0000E+00	0.0000E+00	0.0000E+00	0.0000E+00
1 1.3970E+01	2.0078E-02	2.0504E-02	1.9647E-02	2.3472E-02
2 2.7381E+01	2.6358E-02	2.6696E-02	2.6087E-02	2.9048E-02
3 4.0792E+01	3.2677E-02	3.2856E-02	3.2519E-02	3.4631E-02
4 5.4204E+01	3.7477E-02	3.7568E-02	3.7447E-02	3.8815E-02
5 6.7615E+01	3.9837E-02	3.9824E-02	3.9879E-02	4.0735E-02
6 8.1026E+01	4.1797E-02	4.1704E-02	4.1879E-02	4.2295E-02
7 9.4437E+01	4.2797E-02	4.2648E-02	4.2871E-02	4.3079E-02
8 1.0785E+02	4.3677E-02	4.3512E-02	4.3767E-02	4.3743E-02
9 1.2126E+02	4.4156E-02	4.3976E-02	4.4262E-02	4.4079E-02
10 1.3467E+02	4.4596E-02	4.4416E-02	4.4718E-02	4.4383E-02
11 1.4808E+02	4.4876E-02	4.4688E-02	4.4990E-02	4.4519E-02
12 1.6149E+02	4.5156E-02	4.4960E-02	4.5270E-02	4.4647E-02
13 1.7490E+02	4.5316E-02	4.5136E-02	4.5454E-02	4.4671E-02
14 1.8832E+02	4.5516E-02	4.5320E-02	4.5630E-02	4.4687E-02
15 2.0173E+02	4.5596E-02	4.5416E-02	4.5742E-02	4.4639E-02
16 2.1514E+02	4.5716E-02	4.5512E-02	4.5854E-02	4.4567E-02
17 2.2855E+02	4.5676E-02	4.5480E-02	4.5806E-02	4.4367E-02
18 2.4196E+02	4.5596E-02	4.5432E-02	4.5758E-02	4.4159E-02
19 2.5537E+02	4.5156E-02	4.5048E-02	4.5318E-02	4.3639E-02
20 2.6878E+02	4.4636E-02	4.4560E-02	4.4766E-02	4.3031E-02
21 2.8219E+02	4.3117E-02	4.3120E-02	4.3167E-02	4.1671E-02
22 2.9561E+02				

Table 2.1.3.7

Low Leakage Core Loading

Axial Power Distributions (cont'd)

Zone Axial Boundary	Radial Zone			
	1	2	3	4
22 2.9561E+02	4.1157E-02	4.1272E-02	4.1127E-02	3.9967E-02
23 3.0902E+02	3.6277E-02	3.6560E-02	3.6127E-02	3.5896E-02
24 3.2243E+02	2.9678E-02	3.0120E-02	2.9343E-02	3.0384E-02
25 3.3584E+02	2.3078E-02	2.3672E-02	2.2567E-02	2.4872E-02
26 3.4925E+02	0.0000E+00	0.0000E+00	0.0000E+00	0.0000E+00
27 3.8211E+02				

Radial Zone	Zone Radial Boundary
1	107.175
2	128.610
3	150.040
4	184.461

Table 2.1.3.8

Low Leakage Core Loading Edit Locations

	R (cm)	Z (cm)	θ (degrees)
Thermal Shield Capsule:			
Flux Spectrum and Peak Reaction Rates	202.25	195.76	20
Pressure Vessel Capsule:			
Flux Spectrum and Peak Reaction Rates	215.43	195.76	20
Cavity Capsule:			
Flux Spectrum and Peak Reaction Rates	320.06	184.665	9.5
Fluxes and DPA Rates	320.06	184.665	0-45
Pressure Vessel O-T: ⁺			
(A) Axial Peak Location			
(a) E > 1.0 MEV	219.393	195.760	0-45
(b) E > 0.1 MEV	219.393	195.760	0-45
(c) DPA Rates	219.393	195.760	0-45
(d) Flux Spectrum	219.393	195.760	15.5
(B) Lower Weld Location	219.393	67.1048	0-45
Pressure Vessel 1/4 T:			
(A) Axial Peak Location			
(a) E > 1.0 MEV	224.473	195.760	0-45
(b) E > 0.1 MEV	224.473	192.062	0-45
(c) DPA Rates	224.473	195.760	0-45
(d) Flux Spectrum	224.473	195.760	15.5
(B) Lower Weld Location	224.473	67.1048	0-45
Pressure Vessel 1/2 T:			
(A) Axial Peak Location			
(a) E > 1.0 MEV	229.870	195.760	0-45
(b) E > 0.1 MEV	229.870	192.062	0-45
(c) DPA Rates	229.870	192.062	0-45
(d) Flux Spectrum	229.870	195.760	15.5
(B) Lower Weld Location	229.870	67.1048	0-45
Pressure Vessel 3/4 T:			
(A) Axial Peak Location			
(a) E > 1.0 MEV	235.268	192.062	0-45
(b) E > 0.1 MEV	235.268	192.062	0-45
(c) DPA Rates	235.268	192.062	0-45
(d) Flux Spectrum	229.870	192.062	15.5
(B) Lower Weld Location	235.268	67.1048	0-45
Pressure Vessel Outer T:			
(A) Axial Peak Location			
(a) E > 1.0 MEV	240.342	192.062	0-45
(b) E > 0.1 MEV	240.342	188.363	0-45
(c) DPA Rates	240.342	188.363	0-45
(d) Flux Spectrum	240.342	195.760	15.5
(B) Lower Weld Location	240.342	67.1048	0-45
Downcomer	210.50	195.76	0-45

+The inner-wall (O-T) and vessel outer-wall (T) edits were taken at the center of the mesh blocks immediately inside the vessel. The vessel internal edits were taken at mesh blocks centered about the required edit location.

Table 2.1.4.1

Partial Length Shield Assembly Core Loading

Basic Design Data

Reactor		Material
Thermal Power	2527.73 MW (TH)	--
Core Inlet Temp.	536°F (280 °C)	--
Core Operating Pressure	2010 psia (13.859 MPa)	--
Baffle Thickness	1.5875 cm	SS-304
By-Pass	--	H ₂ O (560 °F 293.3 °C) 2010 psia (13.859 MPa)
Inner Radius of Core Barrel	190.185 cm	--
Barrel Thickness	3.81 cm	SS-304
Inner Inlet Thickness	2.54 cm	H ₂ O (536 °F 280 °C) 2010 psia (13.859 MPa)
Inner Radius of Thermal Shield	196.535 cm	--
Thermal Shield Thickness	3.81 cm	SS-304
Outer Inlet Thickness	18.095 cm	H ₂ O (536 °F 280 °C) 2010 psia (13.859 MPa)
Inner Radius of Liner Clad	218.440 cm	--
Vessel Liner Clad Thickness	0.635 cm	SS-304
Vessel Thickness	21.59 cm	SA-302B
PV Insulation Air Thickness	1.835 cm	Air
PV Insulation Thickness	10.16 cm	PV Insulation
Cavity Thickness	82.62 cm	Air
Inner Radius of Biological Shield	335.280 cm	--
Bio-Shield Liner Thickness	0.635 cm	SA-302B
Bio-Shield Thickness	213.36 cm	Concrete

Table 2.1.4.2

Partial Length Shield Assembly Core Loading

Core and Fuel Assemblies

Total Number of Fuel Assemblies	204
Number of Partial Length Fuel Assemblies	24
Number of Rods per assembly (15x15)	216 fuel rods 8 guide tubes 1 instrument tube
Assembly Pitch	21.485 cm
Pin Pitch	1.43233 cm
Fuel Material	Sintered UO ₂ pellets
Cladding Material	Zr-4
Fuel Active Length	335.28 cm
Fuel Active Length of Partial Length Assembly	240.148 cm

Partial Length Shield Assembly Core Loading Basic Design Data

Upper and Lower Reflectors

Lower Reflector Thickness	13.97 cm	SS-304 + Water (536°F) (280°C)
Upper Reflector Thickness	32.865 cm	SS-304 + Water (584°F) (306.7°C)

Table 2.1.4.3

Partial Length Shield Assembly Core Loading

Design Specification Material Compositions

Mixture	Component	Atom Densities (atom/b ³ cm)
Core	H	2.82500E-02
	B	2.69200E-05
	O	1.41200E-02
	C	2.58100E-05
	O (fuel)	1.28500E-02
	Al	3.56000E-04
	Cr	1.60800E-05
	Fe	2.20500E-05
	Ni	3.87700E-05
	Zr	5.44800E-03
	U-235	1.12000E-04
U-238	6.03000E-03	
Pu-239	2.20000E-05	
Pu-240	7.12000E-06	
Baffle (SS-304)	Cr	1.85300E-02
	Mn	1.75200E-03
	Fe	5.80700E-02
	Ni	8.57400E-03
Bypass ⁺ (560°F) (293.3 °C)	H	4.92900E-02
	O	2.46400E-02
	B	4.90000E-06
Core Barrel (SS-304)	Cr	1.85300E-02
	Mn	1.75200E-03
	Fe	5.80700E-02
	Ni	8.57400E-03
Inlet Water Gap (536°F) (280 °C)	H	5.09600E-02
	O	2.54800E-02
	B	5.10000E-06
Thermal Shield (SS-304)	Cr	1.85300E-02
	Mn	1.75200E-03
	Fe	5.80700E-02
	Ni	8.57400E-03
RPV Liner (SS-304)	Cr	1.85300E-02
	Mn	1.75200E-03
	Fe	5.80700E-02
	Ni	8.57400E-03
RPV Wall (SA-302B)	C	9.84000E-04
	Si	7.58900E-04
	Mn	1.39100E-03
	Fe	8.18300E-02
	Mo	3.14800E-04

+ This composition is also to be used in the water region between the fuel assembly and the core baffle (see Figure 2.4.1).

Table 2.1.4.3

Partial Length Shield Assembly Core Loading
Design Specification Material Compositions (cont'd)

Mixture	Component	Atom Densities (atom/b*cm)
RPV Insulation	Cr	3.43000E-04
	Mn	3.24000E-05
	Fe	1.07400E-03
	Ni	1.59000E-04
	Al	1.30000E-04
	N	3.77000E-05
	O	9.96000E-06
Cavity (Air)	N	3.20000E-05
	O	8.00000E-06
Bio-Shield Liner (SA-302B)	C	9.84000E-04
	Si	7.58900E-04
	Mn	1.39100E-03
	Fe	8.18300E-02
	Mo	3.14800E-04
Bio-Shield (Concrete)	H	7.77000E-03
	C	1.15000E-04
	O	4.38000E-02
	Na	1.05000E-03
	Mg	1.48000E-04
	Al	2.39000E-03
	Si	1.58000E-02
	K	6.93000E-04
	Ca	2.29000E-03
Fe	3.13000E-04	
Shield Assembly	Cr	8.78300E-03
	Mn	8.30400E-04
	Fe	2.75300E-02
	Ni	4.06400E-03
	H	2.68400E-02
	O	1.34200E-02
B-10	2.67200E-06	
Lower Reflector (Water-Steel) (536 °F) (280 °C)	Cr	4.63250E-03
	Mn	4.38000E-04
	Fe	1.45175E-02
	Ni	2.14350E-03
	H	3.82200E-02
	O	1.91100E-02
B	3.82500E-06	
Upper Reflector (Water-Steel) (584 °F) (306.7 °C)	Cr	4.63250E-03
	Mn	4.38000E-04
	Fe	1.45175E-02
	Ni	2.14350E-03
	H	3.55383E-02
	O	1.77656E-02
B	3.53293E-06	

Table 2.1.4.4

Partial Length Shield Assembly Core Loading
Axial Zone Assignments

Zone	Description
1	Lower Reflector
2,3	Active Core Fuel Assemblies
4	Upper Reflector
5	Shield Assembly
6	Core Baffle
7	By-Pass
8	Core Barrel
9	Inner Inlet Water Gap
10	Thermal Shield
11	Outer Inlet Water Gap
12	Reactor Pressure Vessel Liner
13	Reactor Pressure Vessel
14	Air Gap
15	Pressure Vessel Insulation
16	Cavity
17	Biological Shield Liner
18	Biological Shield

Table 2.1.4.5

Upper Partial Assembly Core Loading
Fuel Assembly Geometry, Power, and Burnup Distributions

Assembly Number	X-Left	X-Right	Y-Bot	Y-Top	Relative Assembly Power	BOC Burnup (MWD)	EOC Burnup (MWD)	Axial Peaking Factor	Pin Power Set
1	0.00000E+00	2.14850E+01	0.00000E+00	2.14850E+01	7.72900E-01	4.02000E+03	1.54280E+04	1.0000	0
2	2.14850E+01	4.29700E+01	0.00000E+00	2.14850E+01	8.77600E-01	4.02000E+03	1.54280E+04	1.0000	0
3	4.29700E+01	6.44550E+01	0.00000E+00	2.14850E+01	8.91400E-01	4.02000E+03	1.54280E+04	1.0000	0
4	6.44550E+01	8.59400E+01	0.00000E+00	2.14850E+01	7.63500E-01	0.00000E+00	1.21140E+04	1.0000	0
5	8.59400E+01	1.07425E+02	0.00000E+00	2.14850E+01	8.77600E-01	0.00000E+00	1.43140E+04	1.0000	0
6	1.07425E+02	0.00000E+00	0.00000E+00	0.00000E+00	8.20900E-01	1.46200E+04	2.81650E+04	1.0000	13
7	1.28910E+02	0.00000E+00	0.00000E+00	0.00000E+00	8.22400E-01	7.50500E+03	2.09740E+04	1.0000	14
8	1.50399E+02	0.00000E+00	0.00000E+00	0.00000E+00	3.60000E-01	0.00000E+00	3.43500E+03	1.0000	15
9	2.14850E+01	4.29700E+01	2.14850E+01	4.29700E+01	8.20900E-01	4.02000E+03	1.54280E+04	1.0000	0
10	4.29700E+01	6.44550E+01	2.14850E+01	4.29700E+01	7.52500E-01	4.02000E+03	1.54280E+04	1.0000	0
11	6.44550E+01	8.59400E+01	2.14850E+01	4.29700E+01	9.43000E-01	0.00000E+00	1.49700E+04	1.0000	0
12	8.59400E+01	1.07425E+02	2.14850E+01	4.29700E+01	7.80200E-01	0.00000E+00	1.18320E+04	1.0000	0
13	1.07425E+02	0.00000E+00	2.14850E+01	0.00000E+00	8.48400E-01	8.52800E+03	2.24750E+04	1.0000	10
14	1.28910E+02	0.00000E+00	2.14850E+01	0.00000E+00	8.49300E-01	1.21170E+04	2.60290E+04	1.0000	11
15	1.50399E+02	0.00000E+00	2.14850E+01	0.00000E+00	4.58000E-01	0.00000E+00	4.32600E+03	1.0000	12
16	4.29700E+01	6.44550E+01	4.29700E+01	6.44550E+01	8.13600E-01	4.02000E+03	1.54280E+04	1.0000	0
17	6.44550E+01	8.59400E+01	4.29700E+01	6.44550E+01	7.67100E-01	0.00000E+00	1.20663E+04	1.0000	0
18	8.59400E+01	1.07425E+02	4.29700E+01	6.44550E+01	9.42300E-01	0.00000E+00	1.49243E+04	1.0000	0
19	1.07425E+02	0.00000E+00	4.29700E+01	0.00000E+00	6.86000E-01	2.47790E+04	3.61655E+04	1.0000	7
20	1.28910E+02	0.00000E+00	4.29700E+01	0.00000E+00	7.63400E-01	0.00000E+00	1.26090E+04	1.0000	8
21	1.50399E+02	0.00000E+00	4.29700E+01	0.00000E+00	3.60000E-01	0.00000E+00	3.43500E+03	1.0000	9
22	6.44550E+01	8.59400E+01	6.44550E+01	8.59400E+01	8.20900E-01	0.00000E+00	1.28990E+04	1.0000	0
23	8.59400E+01	0.00000E+00	6.44550E+01	0.00000E+00	7.31700E-01	2.08950E+04	3.30110E+04	1.0000	4
24	1.07425E+02	0.00000E+00	6.44550E+01	0.00000E+00	8.60900E-01	0.00000E+00	1.41970E+04	1.0000	5
25	1.28910E+02	0.00000E+00	6.44550E+01	0.00000E+00	5.46200E-01	0.00000E+00	8.91500E+03	1.0000	6
26	8.59400E+01	0.00000E+00	8.59400E+01	0.00000E+00	8.45500E-01	0.00000E+00	1.40180E+04	1.0000	1
27	1.07425E+02	0.00000E+00	8.59400E+01	0.00000E+00	6.60800E-01	0.00000E+00	1.08970E+04	1.0000	2
28	1.28910E+02	0.00000E+00	8.59400E+01	0.00000E+00	4.67600E-01	0.00000E+00	7.63500E+03	1.0000	3

Note: Assemblies including pin power sets do not have right or top boundaries specified here. These data are included with the pin geometry data.

Table 2.1.4.6

Lower Partial Assembly Core Loading
Fuel Assembly Geometry, Power, and Burnup Distributions

Assembly Number	X-Left	X-Right	Y-Bot	Y-Top	Relative Assembly Power	BOC Burnup (MWD)	EOC Burnup (MWD)	Axial Peaking Factor	Pin Power Set
1	0.00000E+00	2.14850E+01	0.00000E+00	2.14850E+01	2.90100E-01	4.02000E+03	1.54280E+04	1.0000	0
2	2.14850E+01	4.29700E+01	0.00000E+00	2.14850E+01	3.29400E-01	4.02000E+03	1.54280E+04	1.0000	0
3	4.29700E+01	6.44550E+01	0.00000E+00	2.14850E+01	3.34600E-01	4.02000E+03	1.54280E+04	1.0000	0
4	6.44550E+01	8.59400E+01	0.00000E+00	2.14850E+01	2.86500E-01	0.00000E+00	1.21140E+04	1.0000	0
5	8.59400E+01	1.07425E+02	0.00000E+00	2.14850E+01	3.29400E-01	0.00000E+00	1.43140E+04	1.0000	0
6	1.07425E+02	0.00000E+00	0.00000E+00	0.00000E+00	3.11100E-01	1.46200E+04	2.81650E+04	1.0000	11
7	1.28910E+02	0.00000E+00	0.00000E+00	0.00000E+00	3.07600E-01	7.50500E+03	2.09740E+04	1.0000	12
9	2.14850E+01	4.29700E+01	2.14850E+01	4.29700E+01	3.08100E-01	4.02000E+03	1.54280E+04	1.0000	0
10	4.29700E+01	6.44550E+01	2.14850E+01	4.29700E+01	2.82500E-01	4.02000E+03	1.54280E+04	1.0000	0
11	6.44550E+01	8.59400E+01	2.14850E+01	4.29700E+01	3.54000E-01	0.00000E+00	1.49700E+04	1.0000	0
12	8.59400E+01	1.07425E+02	2.14850E+01	4.29700E+01	2.92800E-01	0.00000E+00	1.18320E+04	1.0000	0
13	1.07425E+02	0.00000E+00	2.14850E+01	0.00000E+00	3.21500E-01	8.52800E+03	2.24750E+04	1.0000	9
14	1.28910E+02	0.00000E+00	2.14850E+01	0.00000E+00	3.17700E-01	1.21170E+04	2.60290E+04	1.0000	10
16	4.29700E+01	6.44550E+01	4.29700E+01	6.44550E+01	3.05400E-01	4.02000E+03	1.54280E+04	1.0000	0
17	6.44550E+01	8.59400E+01	4.29700E+01	6.44550E+01	2.87900E-01	0.00000E+00	1.20663E+04	1.0000	0
18	8.59400E+01	1.07425E+02	4.29700E+01	6.44550E+01	3.53700E-01	0.00000E+00	1.49243E+04	1.0000	0
19	1.07425E+02	0.00000E+00	4.29700E+01	0.00000E+00	2.60000E-01	2.47790E+04	3.61655E+04	1.0000	7
20	1.28910E+02	0.00000E+00	4.29700E+01	0.00000E+00	2.85600E-01	0.00000E+00	1.26090E+04	1.0000	8
22	6.44550E+01	8.59400E+01	6.44550E+01	8.59400E+01	3.08100E-01	0.00000E+00	1.28990E+04	1.0000	0
23	8.59400E+01	0.00000E+00	6.44550E+01	0.00000E+00	2.77300E-01	2.08950E+04	3.30110E+04	1.0000	4
24	1.07425E+02	0.00000E+00	6.44550E+01	0.00000E+00	3.22100E-01	0.00000E+00	1.41970E+04	1.0000	5
25	1.28910E+02	0.00000E+00	6.44550E+01	0.00000E+00	1.96800E-01	0.00000E+00	8.91500E+03	1.0000	6
26	8.59400E+01	0.00000E+00	8.59400E+01	0.00000E+00	3.20500E-01	0.00000E+00	1.40180E+04	1.0000	1
27	1.07425E+02	0.00000E+00	8.59400E+01	0.00000E+00	2.47100E-01	0.00000E+00	1.08970E+04	1.0000	2
28	1.28910E+02	0.00000E+00	8.59400E+01	0.00000E+00	1.68400E-01	0.00000E+00	7.63500E+03	1.0000	3

Note: Assemblies including pin power sets do not have right or top boundaries specified here. These data are included with the pin geometry data.

Table 2.1.4.7

Upper Partial Assembly Core Loading

Pin Geometry, Power, and Burnup Distributions

Assembly 6

Pin Power Set 13

X-Left	X-Right	Y-Bot	Y-Top	Relative Pin Power	BOC Burnup (MWD)	EOC Burnup (MWD)
1.07425E+02	1.08857E+02	0.00000E+00	1.43223E+00	1.09862E+00	1.462E+04	2.816E+04
1.07425E+02	1.08857E+02	1.43223E+00	2.86446E+00	1.07792E+00	1.462E+04	2.816E+04
1.07425E+02	1.08857E+02	2.86446E+00	4.29669E+00	1.03894E+00	1.462E+04	2.816E+04
1.07425E+02	1.08857E+02	4.29669E+00	5.72892E+00	1.03163E+00	1.462E+04	2.816E+04
1.07425E+02	1.08857E+02	5.72892E+00	7.16115E+00	0.00000E+00	1.462E+04	2.816E+04
1.07425E+02	1.08857E+02	7.16115E+00	8.59338E+00	1.01093E+00	1.462E+04	2.816E+04
1.07425E+02	1.08857E+02	8.59338E+00	1.00256E+01	9.89004E-01	1.462E+04	2.816E+04
1.07425E+02	1.08857E+02	1.00256E+01	1.14578E+01	9.81696E-01	1.462E+04	2.816E+04
1.07425E+02	1.08857E+02	1.14578E+01	1.28901E+01	9.84132E-01	1.462E+04	2.816E+04
1.07425E+02	1.08857E+02	1.28901E+01	1.43223E+01	9.98748E-01	1.462E+04	2.816E+04
1.07425E+02	1.08857E+02	1.43223E+01	1.57545E+01	0.00000E+00	1.462E+04	2.816E+04
1.07425E+02	1.08857E+02	1.57545E+01	1.71868E+01	9.97530E-01	1.462E+04	2.816E+04
1.07425E+02	1.08857E+02	1.71868E+01	1.86190E+01	9.78042E-01	1.462E+04	2.816E+04
1.07425E+02	1.08857E+02	1.86190E+01	2.00512E+01	9.70735E-01	1.462E+04	2.816E+04
1.07425E+02	1.08857E+02	2.00512E+01	2.14835E+01	9.19579E-01	1.462E+04	2.816E+04
1.08857E+02	1.10289E+02	0.00000E+00	1.43223E+00	1.13638E+00	1.462E+04	2.816E+04
1.08857E+02	1.10289E+02	1.43223E+00	2.86446E+00	1.05843E+00	1.462E+04	2.816E+04
1.08857E+02	1.10289E+02	2.86446E+00	4.29669E+00	1.01336E+00	1.462E+04	2.816E+04
1.08857E+02	1.10289E+02	4.29669E+00	5.72892E+00	1.06208E+00	1.462E+04	2.816E+04
1.08857E+02	1.10289E+02	5.72892E+00	7.16115E+00	1.04990E+00	1.462E+04	2.816E+04
1.08857E+02	1.10289E+02	7.16115E+00	8.59338E+00	1.03285E+00	1.462E+04	2.816E+04
1.08857E+02	1.10289E+02	8.59338E+00	1.00256E+01	1.02067E+00	1.462E+04	2.816E+04
1.08857E+02	1.10289E+02	1.00256E+01	1.14578E+01	1.01702E+00	1.462E+04	2.816E+04
1.08857E+02	1.10289E+02	1.14578E+01	1.28901E+01	1.01580E+00	1.462E+04	2.816E+04
1.08857E+02	1.10289E+02	1.28901E+01	1.43223E+01	1.02189E+00	1.462E+04	2.816E+04
1.08857E+02	1.10289E+02	1.43223E+01	1.57545E+01	1.03042E+00	1.462E+04	2.816E+04
1.08857E+02	1.10289E+02	1.57545E+01	1.71868E+01	1.02798E+00	1.462E+04	2.816E+04
1.08857E+02	1.10289E+02	1.71868E+01	1.86190E+01	9.56119E-01	1.462E+04	2.816E+04
1.08857E+02	1.10289E+02	1.86190E+01	2.00512E+01	9.52465E-01	1.462E+04	2.816E+04
1.08857E+02	1.10289E+02	2.00512E+01	2.14835E+01	9.46375E-01	1.462E+04	2.816E+04
1.10289E+02	1.11722E+02	0.00000E+00	1.43223E+00	1.13029E+00	1.462E+04	2.816E+04
1.10289E+02	1.11722E+02	1.43223E+00	2.86446E+00	1.04747E+00	1.462E+04	2.816E+04
1.10289E+02	1.11722E+02	2.86446E+00	4.29669E+00	1.00727E+00	1.462E+04	2.816E+04
1.10289E+02	1.11722E+02	4.29669E+00	5.72892E+00	1.03042E+00	1.462E+04	2.816E+04
1.10289E+02	1.11722E+02	5.72892E+00	7.16115E+00	1.00727E+00	1.462E+04	2.816E+04
1.10289E+02	1.11722E+02	7.16115E+00	8.59338E+00	9.96312E-01	1.462E+04	2.816E+04
1.10289E+02	1.11722E+02	8.59338E+00	1.00256E+01	9.93876E-01	1.462E+04	2.816E+04
1.10289E+02	1.11722E+02	1.00256E+01	1.14578E+01	9.09835E-01	1.462E+04	2.816E+04
1.10289E+02	1.11722E+02	1.14578E+01	1.28901E+01	9.89004E-01	1.462E+04	2.816E+04
1.10289E+02	1.11722E+02	1.28901E+01	1.43223E+01	9.86568E-01	1.462E+04	2.816E+04
1.10289E+02	1.11722E+02	1.43223E+01	1.57545E+01	9.90222E-01	1.462E+04	2.816E+04
1.10289E+02	1.11722E+02	1.57545E+01	1.71868E+01	9.98748E-01	1.462E+04	2.816E+04
1.10289E+02	1.11722E+02	1.71868E+01	1.86190E+01	9.52465E-01	1.462E+04	2.816E+04
1.10289E+02	1.11722E+02	1.86190E+01	2.00512E+01	9.45157E-01	1.462E+04	2.816E+04
1.10289E+02	1.11722E+02	2.00512E+01	2.14835E+01	9.42721E-01	1.462E+04	2.816E+04

Table 2.1.4.7

Upper Partial Assembly Core Loading

Pin Geometry, Power, and Burnup Distributions (cont'd)

Assembly 6

Pin Power Set 13

X-Left	X-Right	Y-Bot	Y-Top	Relative Pin Power	BOC Burnup (MWD)	EOC Burnup (MWD)
1.11722E+02	1.13154E+02	0.00000E+00	1.43223E+00	1.13638E+00	1.462E+04	2.816E+04
1.11722E+02	1.13154E+02	1.43223E+00	2.86446E+00	1.11689E+00	1.462E+04	2.816E+04
1.11722E+02	1.13154E+02	2.86446E+00	4.29669E+00	1.04869E+00	1.462E+04	2.816E+04
1.11722E+02	1.13154E+02	4.29669E+00	5.72892E+00	1.00727E+00	1.462E+04	2.816E+04
1.11722E+02	1.13154E+02	5.72892E+00	7.16115E+00	9.84132E-01	1.462E+04	2.816E+04
1.11722E+02	1.13154E+02	7.16115E+00	8.59338E+00	9.74388E-01	1.462E+04	2.816E+04
1.11722E+02	1.13154E+02	8.59338E+00	1.00256E+01	9.71952E-01	1.462E+04	2.816E+04
1.11722E+02	1.13154E+02	1.00256E+01	1.14578E+01	9.71952E-01	1.462E+04	2.816E+04
1.11722E+02	1.13154E+02	1.14578E+01	1.28901E+01	9.68299E-01	1.462E+04	2.816E+04
1.11722E+02	1.13154E+02	1.28901E+01	1.43223E+01	9.65863E-01	1.462E+04	2.816E+04
1.11722E+02	1.13154E+02	1.43223E+01	1.57545E+01	9.68299E-01	1.462E+04	2.816E+04
1.11722E+02	1.13154E+02	1.57545E+01	1.71868E+01	9.78042E-01	1.462E+04	2.816E+04
1.11722E+02	1.13154E+02	1.71868E+01	1.86190E+01	9.92658E-01	1.462E+04	2.816E+04
1.11722E+02	1.13154E+02	1.86190E+01	2.00512E+01	1.00727E+00	1.462E+04	2.816E+04
1.11722E+02	1.13154E+02	2.00512E+01	2.14835E+01	9.52465E-01	1.462E+04	2.816E+04
1.13154E+02	1.14586E+02	0.00000E+00	1.43223E+00	0.00000E+00	1.462E+04	2.816E+04
1.13154E+02	1.14586E+02	1.43223E+00	2.86446E+00	1.11202E+00	1.462E+04	2.816E+04
1.13154E+02	1.14586E+02	2.86446E+00	4.29669E+00	1.03407E+00	1.462E+04	2.816E+04
1.13154E+02	1.14586E+02	4.29669E+00	5.72892E+00	9.92658E-01	1.462E+04	2.816E+04
1.13154E+02	1.14586E+02	5.72892E+00	7.16115E+00	9.70735E-01	1.462E+04	2.816E+04
1.13154E+02	1.14586E+02	7.16115E+00	8.59338E+00	9.62209E-01	1.462E+04	2.816E+04
1.13154E+02	1.14586E+02	8.59338E+00	1.00256E+01	9.58555E-01	1.462E+04	2.816E+04
1.13154E+02	1.14586E+02	1.00256E+01	1.14578E+01	9.58555E-01	1.462E+04	2.816E+04
1.13154E+02	1.14586E+02	1.14578E+01	1.28901E+01	9.56119E-01	1.462E+04	2.816E+04
1.13154E+02	1.14586E+02	1.28901E+01	1.43223E+01	9.53683E-01	1.462E+04	2.816E+04
1.13154E+02	1.14586E+02	1.43223E+01	1.57545E+01	9.56119E-01	1.462E+04	2.816E+04
1.13154E+02	1.14586E+02	1.57545E+01	1.71868E+01	9.65863E-01	1.462E+04	2.816E+04
1.13154E+02	1.14586E+02	1.71868E+01	1.86190E+01	9.80478E-01	1.462E+04	2.816E+04
1.13154E+02	1.14586E+02	1.86190E+01	2.00512E+01	1.00484E+00	1.462E+04	2.816E+04
1.13154E+02	1.14586E+02	2.00512E+01	2.14835E+01	0.00000E+00	1.462E+04	2.816E+04
1.14586E+02	1.16018E+02	0.00000E+00	1.43223E+00	1.12420E+00	1.462E+04	2.816E+04
1.14586E+02	1.16018E+02	1.43223E+00	2.86446E+00	1.09741E+00	1.462E+04	2.816E+04
1.14586E+02	1.16018E+02	2.86446E+00	4.29669E+00	1.02433E+00	1.462E+04	2.816E+04
1.14586E+02	1.16018E+02	4.29669E+00	5.72892E+00	9.85350E-01	1.462E+04	2.816E+04
1.14586E+02	1.16018E+02	5.72892E+00	7.16115E+00	9.64645E-01	1.462E+04	2.816E+04
1.14586E+02	1.16018E+02	7.16115E+00	8.59338E+00	9.56119E-01	1.462E+04	2.816E+04
1.14586E+02	1.16018E+02	8.59338E+00	1.00256E+01	9.57337E-01	1.462E+04	2.816E+04
1.14586E+02	1.16018E+02	1.00256E+01	1.14578E+01	9.58555E-01	1.462E+04	2.816E+04
1.14586E+02	1.16018E+02	1.14578E+01	1.28901E+01	9.54901E-01	1.462E+04	2.816E+04
1.14586E+02	1.16018E+02	1.28901E+01	1.43223E+01	9.50029E-01	1.462E+04	2.816E+04
1.14586E+02	1.16018E+02	1.43223E+01	1.57545E+01	9.52465E-01	1.462E+04	2.816E+04
1.14586E+02	1.16018E+02	1.57545E+01	1.71868E+01	9.59773E-01	1.462E+04	2.816E+04
1.14586E+02	1.16018E+02	1.71868E+01	1.86190E+01	9.74388E-01	1.462E+04	2.816E+04
1.14586E+02	1.16018E+02	1.86190E+01	2.00512E+01	9.95094E-01	1.462E+04	2.816E+04
1.14586E+02	1.16018E+02	2.00512E+01	2.14835E+01	9.48811E-01	1.462E+04	2.816E+04

Table 2.1.4.7

Upper Partial Assembly Core Loading

Pin Geometry, Power, and Burnup Distributions (cont'd)

Assembly 6 Pin Power Set 13

X-Left	X-Right	Y-Bot	Y-Top	Relative Pin Power	BOC Burnup (MWD)	EOC Burnup (MWD)
1.16018E+02	1.17451E+02	0.00000E+00	1.43223E+00	1.10349E+00	1.462E+04	2.816E+04
1.16018E+02	1.17451E+02	1.43223E+00	2.86446E+00	1.08401E+00	1.462E+04	2.816E+04
1.16018E+02	1.17451E+02	2.86446E+00	4.29669E+00	1.02311E+00	1.462E+04	2.816E+04
1.16018E+02	1.17451E+02	4.29669E+00	5.72892E+00	9.82914E-01	1.462E+04	2.816E+04
1.16018E+02	1.17451E+02	5.72892E+00	7.16115E+00	9.62209E-01	1.462E+04	2.816E+04
1.16018E+02	1.17451E+02	7.16115E+00	8.59338E+00	9.57337E-01	1.462E+04	2.816E+04
1.16018E+02	1.17451E+02	8.59338E+00	1.00256E+01	9.67081E-01	1.462E+04	2.816E+04
1.16018E+02	1.17451E+02	1.00256E+01	1.14578E+01	9.75605E-01	1.462E+04	2.816E+04
1.16018E+02	1.17451E+02	1.14578E+01	1.28901E+01	9.64645E-01	1.462E+04	2.816E+04
1.16018E+02	1.17451E+02	1.28901E+01	1.43223E+01	9.52465E-01	1.462E+04	2.816E+04
1.16018E+02	1.17451E+02	1.43223E+01	1.57545E+01	9.51247E-01	1.462E+04	2.816E+04
1.16018E+02	1.17451E+02	1.57545E+01	1.71868E+01	9.59773E-01	1.462E+04	2.816E+04
1.16018E+02	1.17451E+02	1.71868E+01	1.86190E+01	9.75606E-01	1.462E+04	2.816E+04
1.16018E+02	1.17451E+02	1.86190E+01	2.00512E+01	9.87786E-01	1.462E+04	2.816E+04
1.16018E+02	1.17451E+02	2.00512E+01	2.14835E+01	9.32977E-01	1.462E+04	2.816E+04
1.17451E+02	1.18883E+02	0.00000E+00	1.43223E+00	1.09619E+00	1.462E+04	2.816E+04
1.17451E+02	1.18883E+02	1.43223E+00	2.86446E+00	1.08035E+00	1.462E+04	2.816E+04
1.17451E+02	1.18883E+02	2.86446E+00	4.29669E+00	9.41503E-01	1.462E+04	2.816E+04
1.17451E+02	1.18883E+02	4.29669E+00	5.72892E+00	9.81636E-01	1.462E+04	2.816E+04
1.17451E+02	1.18883E+02	5.72892E+00	7.16115E+00	9.59773E-01	1.462E+04	2.816E+04
1.17451E+02	1.18883E+02	7.16115E+00	8.59338E+00	9.57337E-01	1.462E+04	2.816E+04
1.17451E+02	1.18883E+02	8.59338E+00	1.00256E+01	9.74328E-01	1.462E+04	2.816E+04
1.17451E+02	1.18883E+02	1.00256E+01	1.14578E+01	0.00000E+00	1.462E+04	2.816E+04
1.17451E+02	1.18883E+02	1.14578E+01	1.28901E+01	9.71952E-01	1.462E+04	2.816E+04
1.17451E+02	1.18883E+02	1.28901E+01	1.43223E+01	9.52465E-01	1.462E+04	2.816E+04
1.17451E+02	1.18883E+02	1.43223E+01	1.57545E+01	9.51247E-01	1.462E+04	2.816E+04
1.17451E+02	1.18883E+02	1.57545E+01	1.71868E+01	9.62209E-01	1.462E+04	2.816E+04
1.17451E+02	1.18883E+02	1.71868E+01	1.86190E+01	9.04963E-01	1.462E+04	2.816E+04
1.17451E+02	1.18883E+02	1.86190E+01	2.00512E+01	9.87786E-01	1.462E+04	2.816E+04
1.17451E+02	1.18883E+02	2.00512E+01	2.14835E+01	9.28105E-01	1.462E+04	2.816E+04
1.18883E+02	1.20315E+02	0.00000E+00	1.43223E+00	1.09741E+00	1.462E+04	2.816E+04
1.18883E+02	1.20315E+02	1.43223E+00	2.86446E+00	1.07792E+00	1.462E+04	2.816E+04
1.18883E+02	1.20315E+02	2.86446E+00	4.29669E+00	1.01702E+00	1.462E+04	2.816E+04
1.18883E+02	1.20315E+02	4.29669E+00	5.72892E+00	9.78042E-01	1.462E+04	2.816E+04
1.18883E+02	1.20315E+02	5.72892E+00	7.16115E+00	9.57337E-01	1.462E+04	2.816E+04
1.18883E+02	1.20315E+02	7.16115E+00	8.59338E+00	9.52465E-01	1.462E+04	2.816E+04
1.18883E+02	1.20315E+02	8.59338E+00	1.00256E+01	9.62209E-01	1.462E+04	2.816E+04
1.18883E+02	1.20315E+02	1.00256E+01	1.14578E+01	9.71952E-01	1.462E+04	2.816E+04
1.18883E+02	1.20315E+02	1.14578E+01	1.28901E+01	9.62209E-01	1.462E+04	2.816E+04
1.18883E+02	1.20315E+02	1.28901E+01	1.43223E+01	9.50029E-01	1.462E+04	2.816E+04
1.18883E+02	1.20315E+02	1.43223E+01	1.57545E+01	9.50029E-01	1.462E+04	2.816E+04
1.18883E+02	1.20315E+02	1.57545E+01	1.71868E+01	9.58555E-01	1.462E+04	2.816E+04
1.18883E+02	1.20315E+02	1.71868E+01	1.86190E+01	9.75606E-01	1.462E+04	2.816E+04
1.18883E+02	1.20315E+02	1.86190E+01	2.00512E+01	9.87786E-01	1.462E+04	2.816E+04
1.18883E+02	1.20315E+02	2.00512E+01	2.14835E+01	9.32977E-01	1.462E+04	2.816E+04

Table 2.1.4.7

Upper Partial Assembly Core Loading

Pin Geometry, Power, and Burnup Distributions (cont'd)

Assembly 6

Pin Power Set 13

X-Left	X-Right	Y-Bot	Y-Top	Relative Pin Power	BOC Burnup (MWD)	EOC Burnup (MWD)
1.20315E+02	1.21747E+02	0.00000E+00	1.43223E+00	1.11080E+00	1.462E+04	2.816E+04
1.20315E+02	1.21747E+02	1.43223E+00	2.86446E+00	1.08523E+00	1.462E+04	2.816E+04
1.20315E+02	1.21747E+02	2.86446E+00	4.29669E+00	1.01458E+00	1.462E+04	2.816E+04
1.20315E+02	1.21747E+02	4.29669E+00	5.72892E+00	9.75606E-01	1.462E+04	2.816E+04
1.20315E+02	1.21747E+02	5.72892E+00	7.16115E+00	9.56119E-01	1.462E+04	2.816E+04
1.20315E+02	1.21747E+02	7.16115E+00	8.59338E+00	9.50029E-01	1.462E+04	2.816E+04
1.20315E+02	1.21747E+02	8.59338E+00	1.00256E+01	9.50029E-01	1.462E+04	2.816E+04
1.20315E+02	1.21747E+02	1.00256E+01	1.14578E+01	9.52465E-01	1.462E+04	2.816E+04
1.20315E+02	1.21747E+02	1.14578E+01	1.28901E+01	9.50029E-01	1.462E+04	2.816E+04
1.20315E+02	1.21747E+02	1.28901E+01	1.43223E+01	9.46375E-01	1.462E+04	2.816E+04
1.20315E+02	1.21747E+02	1.43223E+01	1.57545E+01	9.48811E-01	1.462E+04	2.816E+04
1.20315E+02	1.21747E+02	1.57545E+01	1.71868E+01	9.58555E-01	1.462E+04	2.816E+04
1.20315E+02	1.21747E+02	1.71868E+01	1.86190E+01	9.74398E-01	1.462E+04	2.816E+04
1.20315E+02	1.21747E+02	1.86190E+01	2.00512E+01	9.96312E-01	1.462E+04	2.816E+04
1.20315E+02	1.21747E+02	2.00512E+01	2.14835E+01	9.50029E-01	1.462E+04	2.816E+04
1.21747E+02	1.23180E+02	0.00000E+00	1.43223E+00	0.00000E+00	1.462E+04	2.816E+04
1.21747E+02	1.23180E+02	1.43223E+00	2.86446E+00	1.09741E+00	1.462E+04	2.816E+04
1.21747E+02	1.23180E+02	2.86446E+00	4.29669E+00	1.02067E+00	1.462E+04	2.816E+04
1.21747E+02	1.23180E+02	4.29669E+00	5.72892E+00	9.80478E-01	1.462E+04	2.816E+04
1.21747E+02	1.23180E+02	5.72892E+00	7.16115E+00	9.59773E-01	1.462E+04	2.816E+04
1.21747E+02	1.23180E+02	7.16115E+00	8.59338E+00	9.52465E-01	1.462E+04	2.816E+04
1.21747E+02	1.23180E+02	8.59338E+00	1.00256E+01	9.50029E-01	1.462E+04	2.816E+04
1.21747E+02	1.23180E+02	1.00256E+01	1.14578E+01	9.51247E-01	1.462E+04	2.816E+04
1.21747E+02	1.23180E+02	1.14578E+01	1.28901E+01	9.50029E-01	1.462E+04	2.816E+04
1.21747E+02	1.23180E+02	1.28901E+01	1.43223E+01	9.50029E-01	1.462E+04	2.816E+04
1.21747E+02	1.23180E+02	1.43223E+01	1.57545E+01	9.54901E-01	1.462E+04	2.816E+04
1.21747E+02	1.23180E+02	1.57545E+01	1.71868E+01	9.65863E-01	1.462E+04	2.816E+04
1.21747E+02	1.23180E+02	1.71868E+01	1.86190E+01	9.81696E-01	1.462E+04	2.816E+04
1.21747E+02	1.23180E+02	1.86190E+01	2.00512E+01	1.00727E+00	1.462E+04	2.816E+04
1.21747E+02	1.23180E+02	2.00512E+01	2.14835E+01	0.00000E+00	1.462E+04	2.816E+04
1.23180E+02	1.24612E+02	0.00000E+00	1.43223E+00	1.11811E+00	1.462E+04	2.816E+04
1.23180E+02	1.24612E+02	1.43223E+00	2.86446E+00	1.10106E+00	1.462E+04	2.816E+04
1.23180E+02	1.24612E+02	2.86446E+00	4.29669E+00	1.03651E+00	1.462E+04	2.816E+04
1.23180E+02	1.24612E+02	4.29669E+00	5.72892E+00	9.97530E-01	1.462E+04	2.816E+04
1.23180E+02	1.24612E+02	5.72892E+00	7.16115E+00	9.75606E-01	1.462E+04	2.816E+04
1.23180E+02	1.24612E+02	7.16115E+00	8.59338E+00	9.65863E-01	1.462E+04	2.816E+04
1.23180E+02	1.24612E+02	8.59338E+00	1.00256E+01	9.65863E-01	1.462E+04	2.816E+04
1.23180E+02	1.24612E+02	1.00256E+01	1.14578E+01	9.68299E-01	1.462E+04	2.816E+04
1.23180E+02	1.24612E+02	1.14578E+01	1.28901E+01	9.65863E-01	1.462E+04	2.816E+04
1.23180E+02	1.24612E+02	1.28901E+01	1.43223E+01	9.65863E-01	1.462E+04	2.816E+04
1.23180E+02	1.24612E+02	1.43223E+01	1.57545E+01	9.71952E-01	1.462E+04	2.816E+04
1.23180E+02	1.24612E+02	1.57545E+01	1.71868E+01	9.82914E-01	1.462E+04	2.816E+04
1.23180E+02	1.24612E+02	1.71868E+01	1.86190E+01	9.99965E-01	1.462E+04	2.816E+04
1.23180E+02	1.24612E+02	1.86190E+01	2.00512E+01	1.01458E+00	1.462E+04	2.816E+04
1.23180E+02	1.24612E+02	2.00512E+01	2.14835E+01	9.59773E-01	1.462E+04	2.816E+04

Table 2.1.4.7

Upper Partial Assembly Core Loading

Pin Geometry, Power, and Burnup Distributions (cont'd)

Assembly 6 Pin Power Set 13

X-Left	X-Right	Y-Bot	Y-Top	Relative Pin Power	BOC Burnup (MWD)	EOC Burnup (MWD)
1.24612E+02	1.26044E+02	0.00000E+00	1.43223E+00	1.11446E+00	1.462E+04	2.816E+04
1.24612E+02	1.26044E+02	1.43223E+00	2.86446E+00	1.03772E+00	1.462E+04	2.816E+04
1.24612E+02	1.26044E+02	2.86446E+00	4.29669E+00	1.02189E+00	1.462E+04	2.816E+04
1.24612E+02	1.26044E+02	4.29669E+00	5.72892E+00	1.02798E+00	1.462E+04	2.816E+04
1.24612E+02	1.26044E+02	5.72892E+00	7.16115E+00	1.00727E+00	1.462E+04	2.816E+04
1.24612E+02	1.26044E+02	7.16115E+00	8.59338E+00	9.97530E-01	1.462E+04	2.816E+04
1.24612E+02	1.26044E+02	8.59338E+00	1.00256E+01	9.97530E-01	1.462E+04	2.816E+04
1.24612E+02	1.26044E+02	1.00256E+01	1.14578E+01	9.32977E-01	1.462E+04	2.816E+04
1.24612E+02	1.26044E+02	1.14578E+01	1.28901E+01	9.97530E-01	1.462E+04	2.816E+04
1.24612E+02	1.26044E+02	1.28901E+01	1.43223E+01	9.97530E-01	1.462E+04	2.816E+04
1.24612E+02	1.26044E+02	1.43223E+01	1.57545E+01	1.00484E+00	1.462E+04	2.816E+04
1.24612E+02	1.26044E+02	1.57545E+01	1.71868E+01	1.01702E+00	1.462E+04	2.816E+04
1.24612E+02	1.26044E+02	1.71868E+01	1.86190E+01	9.91440E-01	1.462E+04	2.816E+04
1.24612E+02	1.26044E+02	1.86190E+01	2.00512E+01	9.64645E-01	1.462E+04	2.816E+04
1.24612E+02	1.26044E+02	2.00512E+01	2.14835E+01	9.60991E-01	1.462E+04	2.816E+04
1.26044E+02	1.27476E+02	0.00000E+00	1.43223E+00	1.12907E+00	1.462E+04	2.816E+04
1.26044E+02	1.27476E+02	1.43223E+00	2.86446E+00	1.06087E+00	1.462E+04	2.816E+04
1.26044E+02	1.27476E+02	2.86446E+00	4.29669E+00	1.02311E+00	1.462E+04	2.816E+04
1.26044E+02	1.27476E+02	4.29669E+00	5.72892E+00	1.07426E+00	1.462E+04	2.816E+04
1.26044E+02	1.27476E+02	5.72892E+00	7.16115E+00	1.06452E+00	1.462E+04	2.816E+04
1.26044E+02	1.27476E+02	7.16115E+00	8.59338E+00	1.05112E+00	1.462E+04	2.816E+04
1.26044E+02	1.27476E+02	8.59338E+00	1.00256E+01	1.04260E+00	1.462E+04	2.816E+04
1.26044E+02	1.27476E+02	1.00256E+01	1.14578E+01	1.04260E+00	1.462E+04	2.816E+04
1.26044E+02	1.27476E+02	1.14578E+01	1.28901E+01	1.04260E+00	1.462E+04	2.816E+04
1.26044E+02	1.27476E+02	1.28901E+01	1.43223E+01	1.05234E+00	1.462E+04	2.816E+04
1.26044E+02	1.27476E+02	1.43223E+01	1.57545E+01	1.06330E+00	1.462E+04	2.816E+04
1.26044E+02	1.27476E+02	1.57545E+01	1.71868E+01	1.06452E+00	1.462E+04	2.816E+04
1.26044E+02	1.27476E+02	1.71868E+01	1.86190E+01	9.95094E-01	1.462E+04	2.816E+04
1.26044E+02	1.27476E+02	1.86190E+01	2.00512E+01	9.91440E-01	1.462E+04	2.816E+04
1.26044E+02	1.27476E+02	2.00512E+01	2.14835E+01	9.82914E-01	1.462E+04	2.816E+04
1.27476E+02	1.28908E+02	0.00000E+00	1.43223E+00	1.10715E+00	1.462E+04	2.816E+04
1.27476E+02	1.28908E+02	1.43223E+00	2.86446E+00	1.10106E+00	1.462E+04	2.816E+04
1.27476E+02	1.28908E+02	2.86446E+00	4.29669E+00	1.06939E+00	1.462E+04	2.816E+04
1.27476E+02	1.28908E+02	4.29669E+00	5.72892E+00	1.06208E+00	1.462E+04	2.816E+04
1.27476E+02	1.28908E+02	5.72892E+00	7.16115E+00	0.00000E+00	1.462E+04	2.816E+04
1.27476E+02	1.28908E+02	7.16115E+00	8.59338E+00	1.04869E+00	1.462E+04	2.816E+04
1.27476E+02	1.28908E+02	8.59338E+00	1.00256E+01	1.03285E+00	1.462E+04	2.816E+04
1.27476E+02	1.28908E+02	1.00256E+01	1.14578E+01	1.03042E+00	1.462E+04	2.816E+04
1.27476E+02	1.28908E+02	1.14578E+01	1.28901E+01	1.03529E+00	1.462E+04	2.816E+04
1.27476E+02	1.28908E+02	1.28901E+01	1.43223E+01	1.04990E+00	1.462E+04	2.816E+04
1.27476E+02	1.28908E+02	1.43223E+01	1.57545E+01	0.00000E+00	1.462E+04	2.816E+04
1.27476E+02	1.28908E+02	1.57545E+01	1.71868E+01	1.05599E+00	1.462E+04	2.816E+04
1.27476E+02	1.28908E+02	1.71868E+01	1.86190E+01	1.04381E+00	1.462E+04	2.816E+04
1.27476E+02	1.28908E+02	1.86190E+01	2.00512E+01	1.03651E+00	1.462E+04	2.816E+04
1.27476E+02	1.28908E+02	2.00512E+01	2.14835E+01	9.81696E-01	1.462E+04	2.816E+04

Table 2.1.4.8

Lower Partial Assembly Core Loading

Pin Geometry, Power, and Burnup Distributions

Assembly 6

Pin Power Set 11

X-Left	X-Right	Y-Bot	Y-Top	Relative Pin Power	BOC Burnup (MWD)	EOC Burnup (MWD)
1.07425E+02	1.08857E+02	0.00000E+00	1.43223E+00	1.09889E+00	1.462E+04	2.816E+04
1.07425E+02	1.08857E+02	1.43223E+00	2.86446E+00	1.07640E+00	1.462E+04	2.816E+04
1.07425E+02	1.08857E+02	2.86446E+00	4.29669E+00	1.04106E+00	1.462E+04	2.816E+04
1.07425E+02	1.08857E+02	4.29669E+00	5.72892E+00	1.03142E+00	1.462E+04	2.816E+04
1.07425E+02	1.08857E+02	5.72892E+00	7.16115E+00	0.00000E+00	1.452E+04	2.816E+04
1.07425E+02	1.08857E+02	7.16115E+00	8.59338E+00	1.01214E+00	1.462E+04	2.816E+04
1.07425E+02	1.08857E+02	8.59338E+00	1.00256E+01	9.89647E-01	1.462E+04	2.815E+04
1.07425E+02	1.08857E+02	1.00256E+01	1.14578E+01	9.80007E-01	1.462E+04	2.816E+04
1.07425E+02	1.08857E+02	1.14578E+01	1.28901E+01	9.83220E-01	1.462E+04	2.816E+04
1.07425E+02	1.08857E+02	1.28901E+01	1.43223E+01	9.99286E-01	1.462E+04	2.816E+04
1.07425E+02	1.08857E+02	1.43223E+01	1.57545E+01	0.00000E+00	1.462E+04	2.816E+04
1.07425E+02	1.08857E+02	1.57545E+01	1.71868E+01	9.96073E-01	1.462E+04	2.816E+04
1.07425E+02	1.08857E+02	1.71868E+01	1.86190E+01	9.80007E-01	1.462E+04	2.816E+04
1.07425E+02	1.08857E+02	1.86190E+01	2.00512E+01	9.70368E-01	1.462E+04	2.816E+04
1.07425E+02	1.08857E+02	2.00512E+01	2.14835E+01	9.18958E-01	1.462E+04	2.816E+04
1.08857E+02	1.10289E+02	0.00000E+00	1.43223E+00	1.13745E+00	1.462E+04	2.816E+04
1.08857E+02	1.10289E+02	1.43223E+00	2.86446E+00	1.05712E+00	1.462E+04	2.816E+04
1.08857E+02	1.10289E+02	2.86446E+00	4.29669E+00	1.01535E+00	1.462E+04	2.816E+04
1.08857E+02	1.10289E+02	4.29669E+00	5.72892E+00	1.06355E+00	1.462E+04	2.816E+04
1.08857E+02	1.10289E+02	5.72892E+00	7.16115E+00	1.05070E+00	1.462E+04	2.816E+04
1.08857E+02	1.10289E+02	7.16115E+00	8.59338E+00	1.03463E+00	1.462E+04	2.816E+04
1.08857E+02	1.10289E+02	8.59338E+00	1.00256E+01	1.02178E+00	1.462E+04	2.816E+04
1.08857E+02	1.10289E+02	1.00256E+01	1.14578E+01	1.01856E+00	1.462E+04	2.816E+04
1.08857E+02	1.10289E+02	1.14578E+01	1.28901E+01	1.01535E+00	1.462E+04	2.816E+04
1.08857E+02	1.10289E+02	1.28901E+01	1.43223E+01	1.02178E+00	1.462E+04	2.816E+04
1.08857E+02	1.10289E+02	1.43223E+01	1.57545E+01	1.02820E+00	1.462E+04	2.816E+04
1.08857E+02	1.10289E+02	1.57545E+01	1.71868E+01	1.02820E+00	1.462E+04	2.816E+04
1.08857E+02	1.10289E+02	1.71868E+01	1.86190E+01	9.57515E-01	1.462E+04	2.816E+04
1.08857E+02	1.10289E+02	1.86190E+01	2.00512E+01	9.54302E-01	1.462E+04	2.816E+04
1.08857E+02	1.10289E+02	2.00512E+01	2.14835E+01	9.47876E-01	1.462E+04	2.816E+04
1.10289E+02	1.11722E+02	0.00000E+00	1.43223E+00	1.13102E+00	1.462E+04	2.816E+04
1.10289E+02	1.11722E+02	1.43223E+00	2.86446E+00	1.04748E+00	1.462E+04	2.816E+04
1.10289E+02	1.11722E+02	2.86446E+00	4.29669E+00	1.00571E+00	1.462E+04	2.816E+04
1.10289E+02	1.11722E+02	4.29669E+00	5.72892E+00	1.03142E+00	1.462E+04	2.816E+04
1.10289E+02	1.11722E+02	5.72892E+00	7.16115E+00	1.00893E+00	1.462E+04	2.816E+04
1.10289E+02	1.11722E+02	7.16115E+00	8.59338E+00	9.96073E-01	1.462E+04	2.816E+04
1.10289E+02	1.11722E+02	8.59338E+00	1.00256E+01	9.92860E-01	1.462E+04	2.816E+04
1.10289E+02	1.11722E+02	1.00256E+01	1.14578E+01	9.09318E-01	1.462E+04	2.816E+04
1.10289E+02	1.11722E+02	1.14578E+01	1.28901E+01	9.89647E-01	1.462E+04	2.816E+04
1.10289E+02	1.11722E+02	1.28901E+01	1.43223E+01	9.86433E-01	1.462E+04	2.816E+04
1.10289E+02	1.11722E+02	1.43223E+01	1.57545E+01	9.89647E-01	1.462E+04	2.816E+04
1.10289E+02	1.11722E+02	1.57545E+01	1.71868E+01	9.99286E-01	1.462E+04	2.816E+04
1.10289E+02	1.11722E+02	1.71868E+01	1.86190E+01	9.54302E-01	1.462E+04	2.816E+04
1.10289E+02	1.11722E+02	1.86190E+01	2.00512E+01	9.44663E-01	1.462E+04	2.816E+04
1.10289E+02	1.11722E+02	2.00512E+01	2.14835E+01	9.41449E-01	1.462E+04	2.816E+04

Table 2.1.4.8

Lower Partial Assembly Core Loading

Pin Geometry, Power, and Burnup Distributions (cont'd)

Assembly 6				Pin Power Set 11		
X-Left	X-Right	Y-Bot	Y-Top	Relative Pin Power	BOC Burnup (MWD)	EOC Burnup (MWD)
1.11722E+02	1.13154E+02	0.00000E+00	1.43223E+00	1.13745E+00	1.462E+04	2.816E+04
1.11722E+02	1.13154E+02	1.43223E+00	2.86446E+00	1.11496E+00	1.462E+04	2.816E+04
1.11722E+02	1.13154E+02	2.86446E+00	4.29669E+00	1.05070E+00	1.462E+04	2.816E+04
1.11722E+02	1.13154E+02	4.29669E+00	5.72892E+00	1.00893E+00	1.462E+04	2.816E+04
1.11722E+02	1.13154E+02	5.72892E+00	7.16115E+00	9.83220E-01	1.462E+04	2.816E+04
1.11722E+02	1.13154E+02	7.16115E+00	8.59338E+00	9.73581E-01	1.462E+04	2.816E+04
1.11722E+02	1.13154E+02	8.59338E+00	1.00256E+01	9.73581E-01	1.462E+04	2.816E+04
1.11722E+02	1.13154E+02	1.00256E+01	1.14578E+01	9.73581E-01	1.462E+04	2.816E+04
1.11722E+02	1.13154E+02	1.14578E+01	1.28901E+01	9.67155E-01	1.462E+04	2.816E+04
1.11722E+02	1.13154E+02	1.28901E+01	1.43223E+01	9.63941E-01	1.462E+04	2.816E+04
1.11722E+02	1.13154E+02	1.43223E+01	1.57545E+01	9.67155E-01	1.462E+04	2.816E+04
1.11722E+02	1.13154E+02	1.57545E+01	1.71868E+01	9.76794E-01	1.462E+04	2.816E+04
1.11722E+02	1.13154E+02	1.71868E+01	1.86190E+01	9.92860E-01	1.462E+04	2.816E+04
1.11722E+02	1.13154E+02	1.86190E+01	2.00512E+01	1.00571E+00	1.462E+04	2.816E+04
1.11722E+02	1.13154E+02	2.00512E+01	2.14835E+01	9.51089E-01	1.462E+04	2.816E+04
1.13154E+02	1.14586E+02	0.00000E+00	1.43223E+00	0.00000E+00	1.462E+04	2.816E+04
1.13154E+02	1.14586E+02	1.43223E+00	2.86446E+00	1.11175E+00	1.462E+04	2.816E+04
1.13154E+02	1.14586E+02	2.86446E+00	4.29669E+00	1.03463E+00	1.462E+04	2.816E+04
1.13154E+02	1.14586E+02	4.29669E+00	5.72892E+00	9.92860E-01	1.462E+04	2.816E+04
1.13154E+02	1.14586E+02	5.72892E+00	7.16115E+00	9.70368E-01	1.462E+04	2.816E+04
1.13154E+02	1.14586E+02	7.16115E+00	8.59338E+00	9.60728E-01	1.462E+04	2.816E+04
1.13154E+02	1.14586E+02	8.59338E+00	1.00256E+01	9.57515E-01	1.462E+04	2.816E+04
1.13154E+02	1.14586E+02	1.00256E+01	1.14578E+01	9.57515E-01	1.462E+04	2.816E+04
1.13154E+02	1.14586E+02	1.14578E+01	1.28901E+01	9.54302E-01	1.462E+04	2.816E+04
1.13154E+02	1.14586E+02	1.28901E+01	1.43223E+01	9.54302E-01	1.462E+04	2.816E+04
1.13154E+02	1.14586E+02	1.43223E+01	1.57545E+01	9.57515E-01	1.462E+04	2.816E+04
1.13154E+02	1.14586E+02	1.57545E+01	1.71868E+01	9.63941E-01	1.462E+04	2.816E+04
1.13154E+02	1.14586E+02	1.71868E+01	1.86190E+01	9.80007E-01	1.462E+04	2.816E+04
1.13154E+02	1.14586E+02	1.86190E+01	2.00512E+01	1.00571E+00	1.462E+04	2.816E+04
1.13154E+02	1.14586E+02	2.00512E+01	2.14835E+01	0.00000E+00	1.462E+04	2.816E+04
1.14586E+02	1.16018E+02	0.00000E+00	1.43223E+00	1.12460E+00	1.462E+04	2.816E+04
1.14586E+02	1.16018E+02	1.43223E+00	2.86446E+00	1.09568E+00	1.462E+04	2.816E+04
1.14586E+02	1.16018E+02	2.86446E+00	4.29669E+00	1.02499E+00	1.462E+04	2.816E+04
1.14586E+02	1.16018E+02	4.29669E+00	5.72892E+00	9.83220E-01	1.462E+04	2.816E+04
1.14586E+02	1.16018E+02	5.72892E+00	7.16115E+00	9.63941E-01	1.462E+04	2.816E+04
1.14586E+02	1.16018E+02	7.16115E+00	8.59338E+00	9.57515E-01	1.462E+04	2.816E+04
1.14586E+02	1.16018E+02	8.59338E+00	1.00256E+01	9.57515E-01	1.462E+04	2.816E+04
1.14586E+02	1.16018E+02	1.00256E+01	1.14578E+01	9.57515E-01	1.462E+04	2.816E+04
1.14586E+02	1.16018E+02	1.14578E+01	1.28901E+01	9.54302E-01	1.462E+04	2.816E+04
1.14586E+02	1.16018E+02	1.28901E+01	1.43223E+01	9.51089E-01	1.462E+04	2.816E+04
1.14586E+02	1.16018E+02	1.43223E+01	1.57545E+01	9.51089E-01	1.462E+04	2.816E+04
1.14586E+02	1.16018E+02	1.57545E+01	1.71868E+01	9.60728E-01	1.462E+04	2.816E+04
1.14586E+02	1.16018E+02	1.71868E+01	1.86190E+01	9.73581E-01	1.462E+04	2.816E+04
1.14586E+02	1.16018E+02	1.86190E+01	2.00512E+01	9.96073E-01	1.462E+04	2.816E+04
1.14586E+02	1.16018E+02	2.00512E+01	2.14835E+01	9.47876E-01	1.462E+04	2.816E+04

Table 2.1.4.8

Lower Partial Assembly Core Loading

Pin Geometry, Power, and Burnup Distributions (cont'd)

Assembly 6				Pin Power Set 11		
X-Left	X-Right	Y-Bot	Y-Top	Relative Pin Power	BOC Burnup (MWD)	EOC Burnup (MWD)
1.16018E+02	1.17451E+02	0.00000E+00	1.43223E+00	1.10211E+00	1.462E+04	2.816E+04
1.16018E+02	1.17451E+02	1.43223E+00	2.86446E+00	1.08283E+00	1.462E+04	2.816E+04
1.16018E+02	1.17451E+02	2.86446E+00	4.29669E+00	1.02178E+00	1.462E+04	2.816E+04
1.16018E+02	1.17451E+02	4.29669E+00	5.72892E+00	9.83220E-01	1.462E+04	2.816E+04
1.16018E+02	1.17451E+02	5.72892E+00	7.16115E+00	9.60728E-01	1.462E+04	2.816E+04
1.16018E+02	1.17451E+02	7.16115E+00	8.59338E+00	9.57515E-01	1.462E+04	2.816E+04
1.16018E+02	1.17451E+02	8.59338E+00	1.00256E+01	9.67155E-01	1.462E+04	2.816E+04
1.16018E+02	1.17451E+02	1.00256E+01	1.14578E+01	9.73581E-01	1.462E+04	2.816E+04
1.16018E+02	1.17451E+02	1.14578E+01	1.28901E+01	9.63941E-01	1.462E+04	2.816E+04
1.16018E+02	1.17451E+02	1.28901E+01	1.43223E+01	9.51089E-01	1.462E+04	2.816E+04
1.16018E+02	1.17451E+02	1.43223E+01	1.57545E+01	9.51089E-01	1.462E+04	2.816E+04
1.16018E+02	1.17451E+02	1.57545E+01	1.71868E+01	9.60728E-01	1.462E+04	2.816E+04
1.16018E+02	1.17451E+02	1.71868E+01	1.86190E+01	9.76794E-01	1.462E+04	2.816E+04
1.16018E+02	1.17451E+02	1.86190E+01	2.00512E+01	9.89647E-01	1.462E+04	2.816E+04
1.16018E+02	1.17451E+02	2.00512E+01	2.14835E+01	9.31810E-01	1.462E+04	2.816E+04
1.17451E+02	1.18883E+02	0.00000E+00	1.43223E+00	1.09568E+00	1.462E+04	2.816E+04
1.17451E+02	1.18883E+02	1.43223E+00	2.86446E+00	1.07961E+00	1.462E+04	2.816E+04
1.17451E+02	1.18883E+02	2.86446E+00	4.29669E+00	9.41449E-01	1.462E+04	2.816E+04
1.17451E+02	1.18883E+02	4.29669E+00	5.72892E+00	9.83220E-01	1.462E+04	2.816E+04
1.17451E+02	1.18883E+02	5.72892E+00	7.16115E+00	9.60728E-01	1.462E+04	2.816E+04
1.17451E+02	1.18883E+02	7.16115E+00	8.59338E+00	9.57515E-01	1.462E+04	2.816E+04
1.17451E+02	1.18883E+02	8.59338E+00	1.00256E+01	9.73581E-01	1.462E+04	2.816E+04
1.17451E+02	1.18883E+02	1.00256E+01	1.14578E+01	0.00000E+00	1.462E+04	2.816E+04
1.17451E+02	1.18883E+02	1.14578E+01	1.28901E+01	9.73581E-01	1.462E+04	2.816E+04
1.17451E+02	1.18883E+02	1.28901E+01	1.43223E+01	9.54302E-01	1.462E+04	2.816E+04
1.17451E+02	1.18883E+02	1.43223E+01	1.57545E+01	9.51089E-01	1.462E+04	2.816E+04
1.17451E+02	1.18883E+02	1.57545E+01	1.71868E+01	9.63941E-01	1.462E+04	2.816E+04
1.17451E+02	1.18883E+02	1.71868E+01	1.86190E+01	9.06105E-01	1.462E+04	2.816E+04
1.17451E+02	1.18883E+02	1.86190E+01	2.00512E+01	9.86433E-01	1.462E+04	2.816E+04
1.17451E+02	1.18883E+02	2.00512E+01	2.14835E+01	9.28597E-01	1.462E+04	2.816E+04
1.18883E+02	1.20315E+02	0.00000E+00	1.43223E+00	1.09568E+00	1.462E+04	2.816E+04
1.18883E+02	1.20315E+02	1.43223E+00	2.86446E+00	1.07640E+00	1.462E+04	2.816E+04
1.18883E+02	1.20315E+02	2.86446E+00	4.29669E+00	1.01535E+00	1.462E+04	2.816E+04
1.18883E+02	1.20315E+02	4.29669E+00	5.72892E+00	9.76794E-01	1.462E+04	2.816E+04
1.18883E+02	1.20315E+02	5.72892E+00	7.16115E+00	9.57515E-01	1.462E+04	2.816E+04
1.18883E+02	1.20315E+02	7.16115E+00	8.59338E+00	9.54302E-01	1.462E+04	2.816E+04
1.18883E+02	1.20315E+02	8.59338E+00	1.00256E+01	9.63941E-01	1.462E+04	2.816E+04
1.18883E+02	1.20315E+02	1.00256E+01	1.14578E+01	9.70368E-01	1.462E+04	2.816E+04
1.18883E+02	1.20315E+02	1.14578E+01	1.28901E+01	9.60728E-01	1.462E+04	2.816E+04
1.18883E+02	1.20315E+02	1.28901E+01	1.43223E+01	9.47876E-01	1.462E+04	2.816E+04
1.18883E+02	1.20315E+02	1.43223E+01	1.57545E+01	9.47876E-01	1.462E+04	2.816E+04
1.18883E+02	1.20315E+02	1.57545E+01	1.71868E+01	9.57515E-01	1.462E+04	2.816E+04
1.18883E+02	1.20315E+02	1.71868E+01	1.86190E+01	9.73581E-01	1.462E+04	2.816E+04
1.18883E+02	1.20315E+02	1.86190E+01	2.00512E+01	9.89647E-01	1.462E+04	2.816E+04
1.18883E+02	1.20315E+02	2.00512E+01	2.14835E+01	9.35023E-01	1.462E+04	2.816E+04

Table 2.1.4.8

Lower Partial Assembly Core Loading

Pin Geometry, Power, and Burnup Distributions (cont'd)

Assembly 6 Pin Power Set 11

X-Left	X-Right	Y-Bot	Y-Top	Relative Pin Power	BOC Burnup (MWD)	EOC Burnup (MWD)
1.20315E+02	1.21747E+02	0.00000E+00	1.43223E+00	1.11175E+00	1.462E+04	2.816E+04
1.20315E+02	1.21747E+02	1.43223E+00	2.86446E+00	1.08604E+00	1.462E+04	2.816E+04
1.20315E+02	1.21747E+02	2.86446E+00	4.29669E+00	1.01535E+00	1.462E+04	2.816E+04
1.20315E+02	1.21747E+02	4.29669E+00	5.72892E+00	9.73581E-01	1.462E+04	2.816E+04
1.20315E+02	1.21747E+02	5.72892E+00	7.16115E+00	9.54302E-01	1.462E+04	2.816E+04
1.20315E+02	1.21747E+02	7.16115E+00	8.59338E+00	9.47876E-01	1.462E+04	2.816E+04
1.20315E+02	1.21747E+02	8.59338E+00	1.00256E+01	9.51089E-01	1.462E+04	2.816E+04
1.20315E+02	1.21747E+02	1.00256E+01	1.14578E+01	9.51089E-01	1.462E+04	2.816E+04
1.20315E+02	1.21747E+02	1.14578E+01	1.28901E+01	9.47876E-01	1.462E+04	2.816E+04
1.20315E+02	1.21747E+02	1.28901E+01	1.43223E+01	9.47876E-01	1.462E+04	2.816E+04
1.20315E+02	1.21747E+02	1.43223E+01	1.57545E+01	9.47876E-01	1.462E+04	2.816E+04
1.20315E+02	1.21747E+02	1.57545E+01	1.71868E+01	9.57515E-01	1.462E+04	2.816E+04
1.20315E+02	1.21747E+02	1.71868E+01	1.86190E+01	9.73581E-01	1.462E+04	2.816E+04
1.20315E+02	1.21747E+02	1.86190E+01	2.00512E+01	9.96073E-01	1.462E+04	2.816E+04
1.20315E+02	1.21747E+02	2.00512E+01	2.14835E+01	9.51089E-01	1.462E+04	2.816E+04
1.21747E+02	1.23180E+02	0.00000E+00	1.43223E+00	0.00000E+00	1.462E+04	2.816E+04
1.21747E+02	1.23180E+02	1.43223E+00	2.86446E+00	1.09568E+00	1.462E+04	2.816E+04
1.21747E+02	1.23180E+02	2.86446E+00	4.29669E+00	1.02178E+00	1.462E+04	2.816E+04
1.21747E+02	1.23180E+02	4.29669E+00	5.72892E+00	9.80007E-01	1.462E+04	2.816E+04
1.21747E+02	1.23180E+02	5.72892E+00	7.16115E+00	9.60728E-01	1.462E+04	2.816E+04
1.21747E+02	1.23180E+02	7.16115E+00	8.59338E+00	9.51089E-01	1.462E+04	2.816E+04
1.21747E+02	1.23180E+02	8.59338E+00	1.00256E+01	9.51089E-01	1.462E+04	2.816E+04
1.21747E+02	1.23180E+02	1.00256E+01	1.14578E+01	9.51089E-01	1.462E+04	2.816E+04
1.21747E+02	1.23180E+02	1.14578E+01	1.28901E+01	9.51089E-01	1.462E+04	2.816E+04
1.21747E+02	1.23180E+02	1.28901E+01	1.43223E+01	9.51089E-01	1.462E+04	2.816E+04
1.21747E+02	1.23180E+02	1.43223E+01	1.57545E+01	9.54302E-01	1.462E+04	2.816E+04
1.21747E+02	1.23180E+02	1.57545E+01	1.71868E+01	9.63941E-01	1.462E+04	2.816E+04
1.21747E+02	1.23180E+02	1.71868E+01	1.86190E+01	9.83220E-01	1.462E+04	2.816E+04
1.21747E+02	1.23180E+02	1.86190E+01	2.00512E+01	1.00893E+00	1.462E+04	2.816E+04
1.21747E+02	1.23180E+02	2.00512E+01	2.14835E+01	0.00000E+00	1.462E+04	2.816E+04
1.23180E+02	1.24612E+02	0.00000E+00	1.43223E+00	1.11817E+00	1.462E+04	2.816E+04
1.23180E+02	1.24612E+02	1.43223E+00	2.86446E+00	1.10211E+00	1.462E+04	2.816E+04
1.23180E+02	1.24612E+02	2.86446E+00	4.29669E+00	1.03784E+00	1.462E+04	2.816E+04
1.23180E+02	1.24612E+02	4.29669E+00	5.72892E+00	9.95073E-01	1.462E+04	2.816E+04
1.23180E+02	1.24612E+02	5.72892E+00	7.16115E+00	9.76794E-01	1.462E+04	2.816E+04
1.23180E+02	1.24612E+02	7.16115E+00	8.59338E+00	9.67155E-01	1.462E+04	2.816E+04
1.23180E+02	1.24612E+02	8.59338E+00	1.00256E+01	9.67155E-01	1.462E+04	2.816E+04
1.23180E+02	1.24612E+02	1.00256E+01	1.14578E+01	9.67155E-01	1.462E+04	2.816E+04
1.23180E+02	1.24612E+02	1.14578E+01	1.28901E+01	9.67155E-01	1.462E+04	2.816E+04
1.23180E+02	1.24612E+02	1.28901E+01	1.43223E+01	9.67155E-01	1.462E+04	2.816E+04
1.23180E+02	1.24612E+02	1.43223E+01	1.57545E+01	9.70368E-01	1.462E+04	2.816E+04
1.23180E+02	1.24612E+02	1.57545E+01	1.71868E+01	9.83220E-01	1.462E+04	2.816E+04
1.23180E+02	1.24612E+02	1.71868E+01	1.86190E+01	9.99286E-01	1.462E+04	2.816E+04
1.23180E+02	1.24612E+02	1.86190E+01	2.00512E+01	1.01535E+00	1.462E+04	2.816E+04
1.23180E+02	1.24612E+02	2.00512E+01	2.14835E+01	9.60728E-01	1.462E+04	2.816E+04

Table 2.1.4.8

Lower Partial Assembly Core Loading

Pin Geometry, Power, and Burnup Distributions (cont'd)

Assembly 6				Pin Power Set 11		
X-Left	X-Right	Y-Bot	Y-Top	Relative Pin Power	BOC Burnup (MWD)	EOC Burnup (MWD)
1.24612E+02	1.26044E+02	0.00000E+00	1.43223E+00	1.11496E+00	1.462E+04	2.816E+04
1.24612E+02	1.26044E+02	1.43223E+00	2.86446E+00	1.03784E+00	1.462E+04	2.816E+04
1.24612E+02	1.26044E+02	2.86446E+00	4.29669E+00	1.02178E+00	1.462E+04	2.816E+04
1.24612E+02	1.26044E+02	4.29669E+00	5.72892E+00	1.02820E+00	1.462E+04	2.816E+04
1.24612E+02	1.26044E+02	5.72892E+00	7.16115E+00	1.00893E+00	1.462E+04	2.816E+04
1.24612E+02	1.26044E+02	7.16115E+00	8.59338E+00	9.99286E-01	1.462E+04	2.816E+04
1.24612E+02	1.26044E+02	8.59338E+00	1.00256E+01	9.96073E-01	1.462E+04	2.816E+04
1.24612E+02	1.26044E+02	1.00256E+01	1.14578E+01	9.35023E-01	1.462E+04	2.816E+04
1.24612E+02	1.26044E+02	1.14578E+01	1.28901E+01	9.99286E-01	1.462E+04	2.816E+04
1.24612E+02	1.26044E+02	1.28901E+01	1.43223E+01	9.99286E-01	1.462E+04	2.816E+04
1.24612E+02	1.26044E+02	1.43223E+01	1.57545E+01	1.00571E+00	1.462E+04	2.816E+04
1.24612E+02	1.26044E+02	1.57545E+01	1.71868E+01	1.01535E+00	1.462E+04	2.816E+04
1.24612E+02	1.26044E+02	1.71868E+01	1.86190E+01	9.92860E-01	1.462E+04	2.816E+04
1.24612E+02	1.26044E+02	1.86190E+01	2.00512E+01	9.63941E-01	1.462E+04	2.816E+04
1.24612E+02	1.26044E+02	2.00512E+01	2.14835E+01	9.60728E-01	1.462E+04	2.816E+04
1.26044E+02	1.27476E+02	0.00000E+00	1.43223E+00	1.13102E+00	1.462E+04	2.816E+04
1.26044E+02	1.27476E+02	1.43223E+00	2.86446E+00	1.06034E+00	1.462E+04	2.816E+04
1.26044E+02	1.27476E+02	2.86446E+00	4.29669E+00	1.02499E+00	1.462E+04	2.816E+04
1.26044E+02	1.27476E+02	4.29669E+00	5.72892E+00	1.07640E+00	1.462E+04	2.816E+04
1.26044E+02	1.27476E+02	5.72892E+00	7.16115E+00	1.06355E+00	1.462E+04	2.816E+04
1.26044E+02	1.27476E+02	7.16115E+00	8.59338E+00	1.05070E+00	1.462E+04	2.816E+04
1.26044E+02	1.27476E+02	8.59338E+00	1.00256E+01	1.04106E+00	1.462E+04	2.816E+04
1.26044E+02	1.27476E+02	1.00256E+01	1.14578E+01	1.04106E+00	1.462E+04	2.816E+04
1.26044E+02	1.27476E+02	1.14578E+01	1.28901E+01	1.04427E+00	1.462E+04	2.816E+04
1.26044E+02	1.27476E+02	1.28901E+01	1.43223E+01	1.05070E+00	1.462E+04	2.816E+04
1.26044E+02	1.27476E+02	1.43223E+01	1.57545E+01	1.06355E+00	1.462E+04	2.816E+04
1.26044E+02	1.27476E+02	1.57545E+01	1.71868E+01	1.06355E+00	1.462E+04	2.816E+04
1.26044E+02	1.27476E+02	1.71868E+01	1.86190E+01	9.96073E-01	1.462E+04	2.816E+04
1.26044E+02	1.27476E+02	1.86190E+01	2.00512E+01	9.92860E-01	1.462E+04	2.816E+04
1.26044E+02	1.27476E+02	2.00512E+01	2.14835E+01	9.85220E-01	1.462E+04	2.816E+04
1.27476E+02	1.28908E+02	0.00000E+00	1.43223E+00	1.10532E+00	1.462E+04	2.816E+04
1.27476E+02	1.28908E+02	1.43223E+00	2.86446E+00	1.09889E+00	1.462E+04	2.816E+04
1.27476E+02	1.28908E+02	2.86446E+00	4.29669E+00	1.06998E+00	1.462E+04	2.816E+04
1.27476E+02	1.28908E+02	4.29669E+00	5.72892E+00	1.06355E+00	1.462E+04	2.816E+04
1.27476E+02	1.28908E+02	5.72892E+00	7.16115E+00	0.00000E+00	1.462E+04	2.816E+04
1.27476E+02	1.28908E+02	7.16115E+00	8.59338E+00	1.04748E+00	1.462E+04	2.816E+04
1.27476E+02	1.28908E+02	8.59338E+00	1.00256E+01	1.03463E+00	1.462E+04	2.816E+04
1.27476E+02	1.28908E+02	1.00256E+01	1.14578E+01	1.02820E+00	1.462E+04	2.816E+04
1.27476E+02	1.28908E+02	1.14578E+01	1.28901E+01	1.03463E+00	1.462E+04	2.816E+04
1.27476E+02	1.28908E+02	1.28901E+01	1.43223E+01	1.05070E+00	1.462E+04	2.816E+04
1.27476E+02	1.28908E+02	1.43223E+01	1.57545E+01	0.00000E+00	1.462E+04	2.816E+04
1.27476E+02	1.28908E+02	1.57545E+01	1.71868E+01	1.05391E+00	1.462E+04	2.816E+04
1.27476E+02	1.28908E+02	1.71868E+01	1.86190E+01	1.04427E+00	1.462E+04	2.816E+04
1.27476E+02	1.28908E+02	1.86190E+01	2.00512E+01	1.03784E+00	1.462E+04	2.816E+04
1.27476E+02	1.28908E+02	2.00512E+01	2.14835E+01	9.83220E-01	1.462E+04	2.816E+04

Table 2.1.4.9

Upper Partial Assembly Core Loading

Axial Power Distributions

Zone Axial Boundary	Radial Zone			
	1	2	3	4
0.0000E+00	0.0000E+00	0.0000E+00	0.0000E+00	0.0000E+00
1 1.3970E+01	0.0000E+00	0.0000E+00	0.0000E+00	0.0000E+00
2 2.7381E+01	0.0000E+00	0.0000E+00	0.0000E+00	0.0000E+00
3 4.0792E+01	0.0000E+00	0.0000E+00	0.0000E+00	0.0000E+00
4 5.4204E+01	0.0000E+00	0.0000E+00	0.0000E+00	0.0000E+00
5 6.7615E+01	0.0000E+00	0.0000E+00	0.0000E+00	0.0000E+00
6 8.1026E+01	0.0000E+00	0.0000E+00	0.0000E+00	0.0000E+00
7 9.4437E+01	0.0000E+00	0.0000E+00	0.0000E+00	0.0000E+00
8 1.0785E+02	0.0000E+00	0.0000E+00	0.0000E+00	0.0000E+00
9 1.0910E+02	5.4211E-02	5.3658E-02	5.4819E-02	4.2657E-02
10 1.2126E+02	5.9469E-02	5.8826E-02	6.0141E-02	6.0467E-02
11 1.3467E+02	5.9304E-02	5.8727E-02	5.9965E-02	6.0590E-02
12 1.4808E+02	5.9304E-02	5.8837E-02	5.9954E-02	6.0566E-02
13 1.6149E+02	5.9414E-02	5.9014E-02	6.0020E-02	6.0575E-02
14 1.7490E+02	5.9469E-02	5.9157E-02	6.0031E-02	6.0558E-02
15 1.8832E+02	5.9414E-02	5.9124E-02	5.9910E-02	6.0504E-02
16 2.0173E+02	5.9249E-02	5.8970E-02	5.9679E-02	6.0423E-02
17 2.1514E+02	5.9029E-02	5.8782E-02	5.9415E-02	6.0362E-02
18 2.2855E+02	5.8864E-02	5.8650E-02	5.9184E-02	6.0272E-02
19 2.4196E+02	5.8809E-02	5.8595E-02	5.8998E-02	6.0158E-02
20 2.5537E+02	5.8699E-02	5.8540E-02	5.8723E-02	5.9670E-02
21 2.6878E+02	5.8204E-02	5.8186E-02	5.8008E-02	5.6885E-02
22 2.8219E+02				

Table 2.1.4.9

Upper Partial Assembly Core Loading

Axial Power Distributions (cont'd)

	Zone Axial Boundary	Radial Zone			
		1	2	3	4
22	2.8219E+02				
		5.6829E-02	5.7083E-02	5.6458E-02	5.7019E-02
23	2.9561E+02				
		5.4133E-02	5.4667E-02	5.3413E-02	5.4180E-02
24	3.0902E+02				
		4.9512E-02	5.0375E-02	4.8445E-02	4.8655E-02
25	3.2243E+02				
		4.2635E-02	4.3855E-02	4.1200E-02	4.1559E-02
26	3.3584E+02				
		3.3448E-02	3.4952E-02	3.1637E-02	3.2901E-02
27	3.4925E+02				
		0.0000E+00	0.0000E+00	0.0000E+00	0.0000E+00
28	3.8211E+02				

Radial Zone	Zone Radial Boundary
1	107.175
2	128.610
3	150.040
4	184.461

Table 2.1.4.10

Lower Partial Assembly Core Loading

Axial Power Distributions

Zone Axial Boundary	Radial Zone			
	1	2	3	4
0.0000E+00	0.0000E+00	0.0000E+00	0.0000E+00	0.0000E+00
1 1.3970E+01	9.5272E-02	9.8730E-02	9.1657E-02	8.3696E-02
2 2.7381E+01	1.2078E-01	1.2309E-01	1.1872E-01	1.1306E-01
3 4.0792E+01	1.3939E-01	1.4050E-01	1.3873E-01	1.3594E-01
4 5.4204E+01	1.5141E-01	1.5124E-01	1.5196E-01	1.5218E-01
5 6.7615E+01	1.5786E-01	1.5648E-01	1.5922E-01	1.6230E-01
6 8.1026E+01	1.6020E-01	1.5799E-01	1.6216E-01	1.6759E-01
7 9.4437E+01	1.6020E-01	1.5738E-01	1.6245E-01	1.6949E-01
8 1.0785E+02	1.4890E-02	1.4594E-02	1.5108E-02	1.5839E-02
9 1.0910E+02	0.0000E+00	0.0000E+00	0.0000E+00	0.0000E+00
10 1.2126E+02	0.0000E+00	0.0000E+00	0.0000E+00	0.0000E+00
11 1.3467E+02	0.0000E+00	0.0000E+00	0.0000E+00	0.0000E+00
12 1.4808E+02	0.0000E+00	0.0000E+00	0.0000E+00	0.0000E+00
13 1.6149E+02	0.0000E+00	0.0000E+00	0.0000E+00	0.0000E+00
14 1.7490E+02	0.0000E+00	0.0000E+00	0.0000E+00	0.0000E+00
15 1.8832E+02	0.0000E+00	0.0000E+00	0.0000E+00	0.0000E+00
16 2.0173E+02	0.0000E+00	0.0000E+00	0.0000E+00	0.0000E+00
17 2.1514E+02	0.0000E+00	0.0000E+00	0.0000E+00	0.0000E+00
18 2.2855E+02	0.0000E+00	0.0000E+00	0.0000E+00	0.0000E+00
19 2.4196E+02	0.0000E+00	0.0000E+00	0.0000E+00	0.0000E+00
20 2.5537E+02	0.0000E+00	0.0000E+00	0.0000E+00	0.0000E+00
21 2.6878E+02	0.0000E+00	0.0000E+00	0.0000E+00	0.0000E+00
22 2.8219E+02	0.0000E+00	0.0000E+00	0.0000E+00	0.0000E+00

Table 2.1.4.10

Lower Partial Assembly Core Loading

Axial Power Distributions (cont'd)

	Zone Axial Boundary	Radial Zone			
		1	2	3	4
22	2.8219E+02	0.0000E+00	0.0000E+00	0.0000E+00	0.0000E+00
23	2.9561E+02	0.0000E+00	0.0000E+00	0.0000E+00	0.0000E+00
24	3.0902E+02	0.0000E+00	0.0000E+00	0.0000E+00	0.0000E+00
25	3.2243E+02	0.0000E+00	0.0000E+00	0.0000E+00	0.0000E+00
26	3.3584E+02	0.0000E+00	0.0000E+00	0.0000E+00	0.0000E+00
27	3.4925E+02	0.0000E+00	0.0000E+00	0.0000E+00	0.0000E+00
28	3.8211E+02	0.0000E+00	0.0000E+00	0.0000E+00	0.0000E+00

Radial Zone	Zone Radial Boundary
1	107.175
2	128.610
3	150.040
4	184.461

Table 2.1.4.11

Partial Length Shield Assembly Core Loading Edit Locations

Edit	R (cm)	Z (cm)	θ (degrees)
Pressure Vessel Inner 0-T ⁺			
Low Weld Location:			
(a) Fluxes and DPA Rates	219.393	67.1048	0-45
(b) Reduction Factors	219.393	67.1048	0-45

+The inner-wall (0-T) edit was taken at the center of the mesh block immediately inside the vessel.

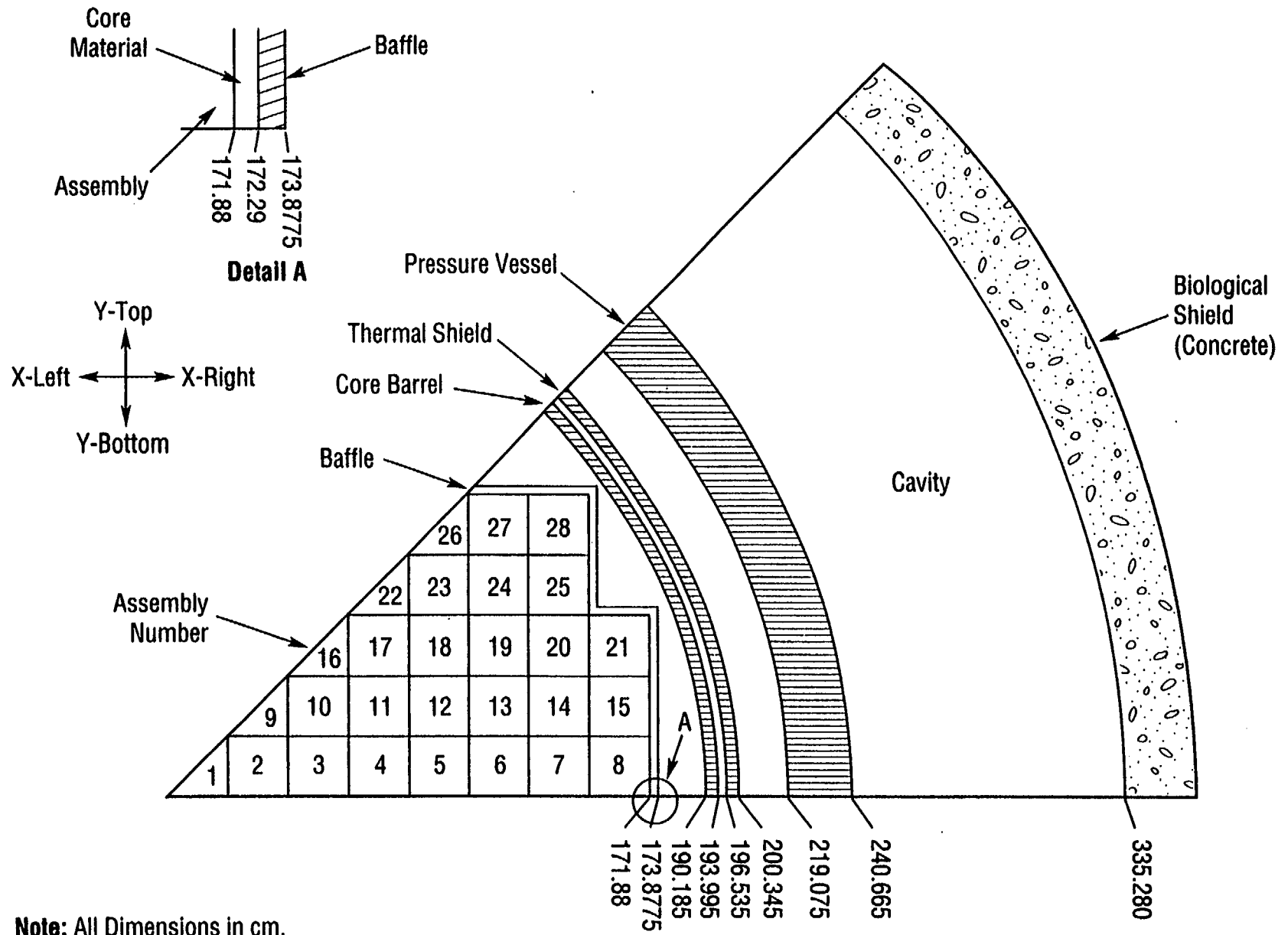

Standard Core Loading

Figure 2.1.2.1

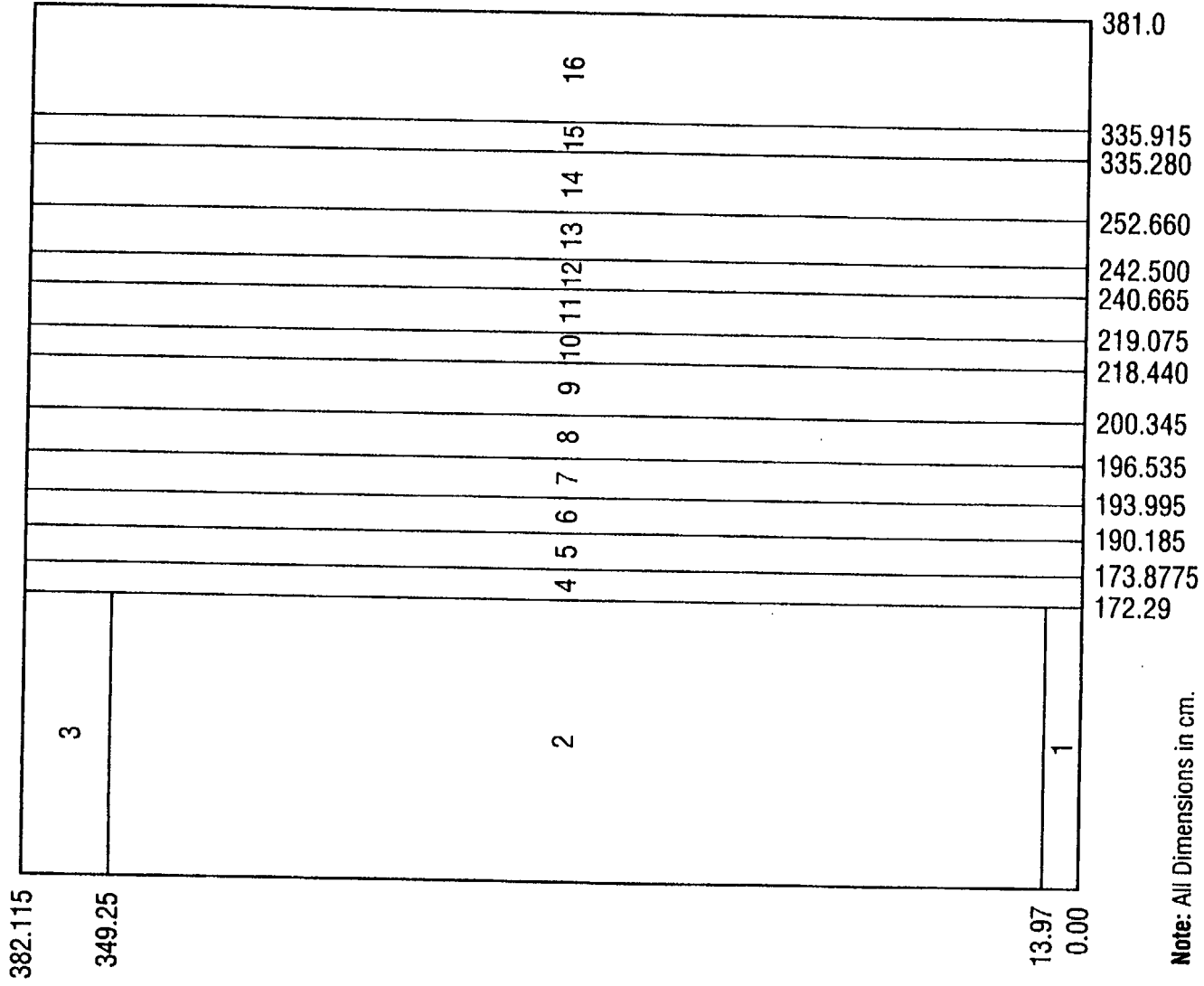

Note: All Dimensions in cm.

Standard Core Loading Axial Geometry at $\theta = 0^\circ$

Figure 2.1.2.2

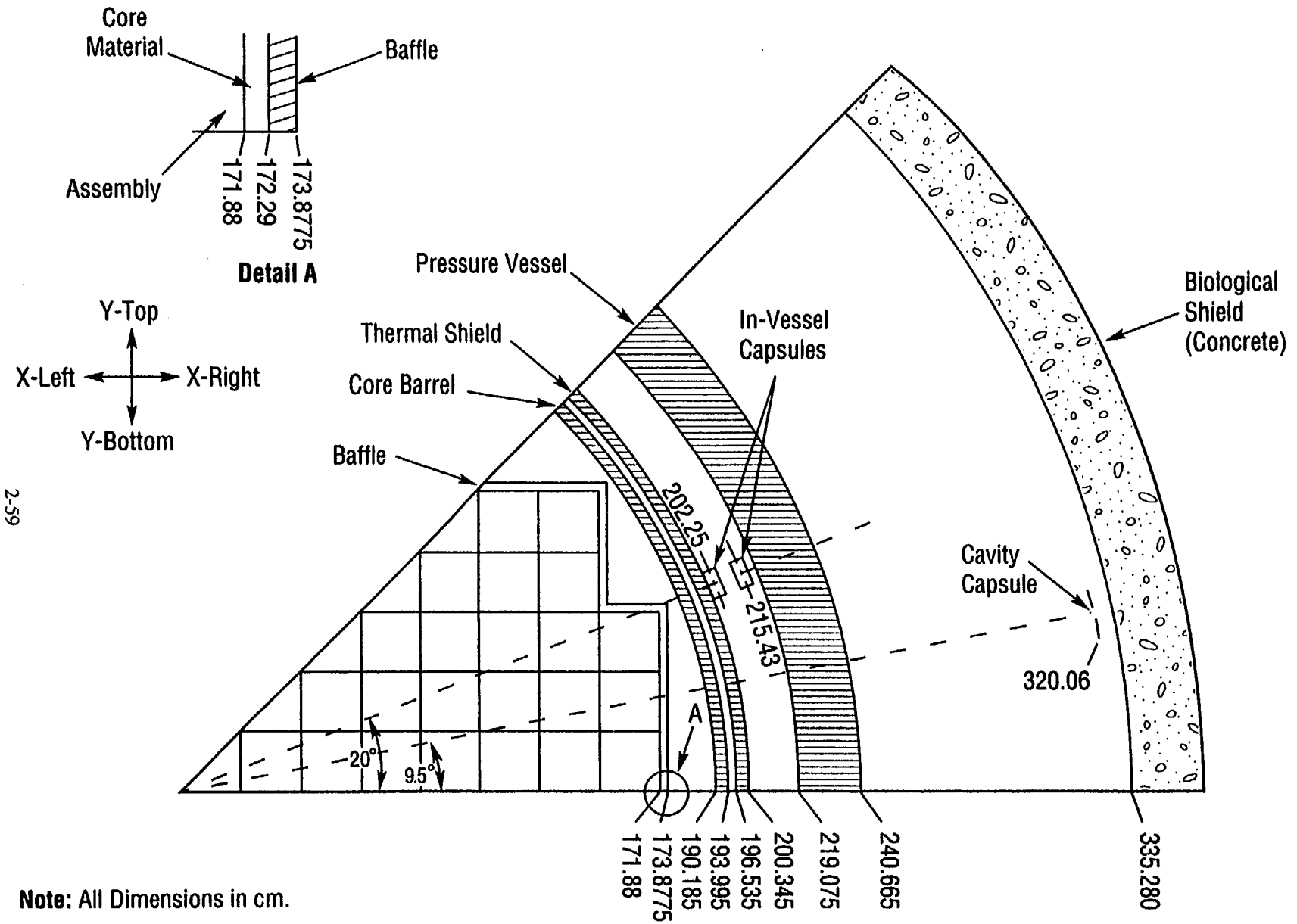

Location of Surveillance Capsules

Figure 2.1.2.3

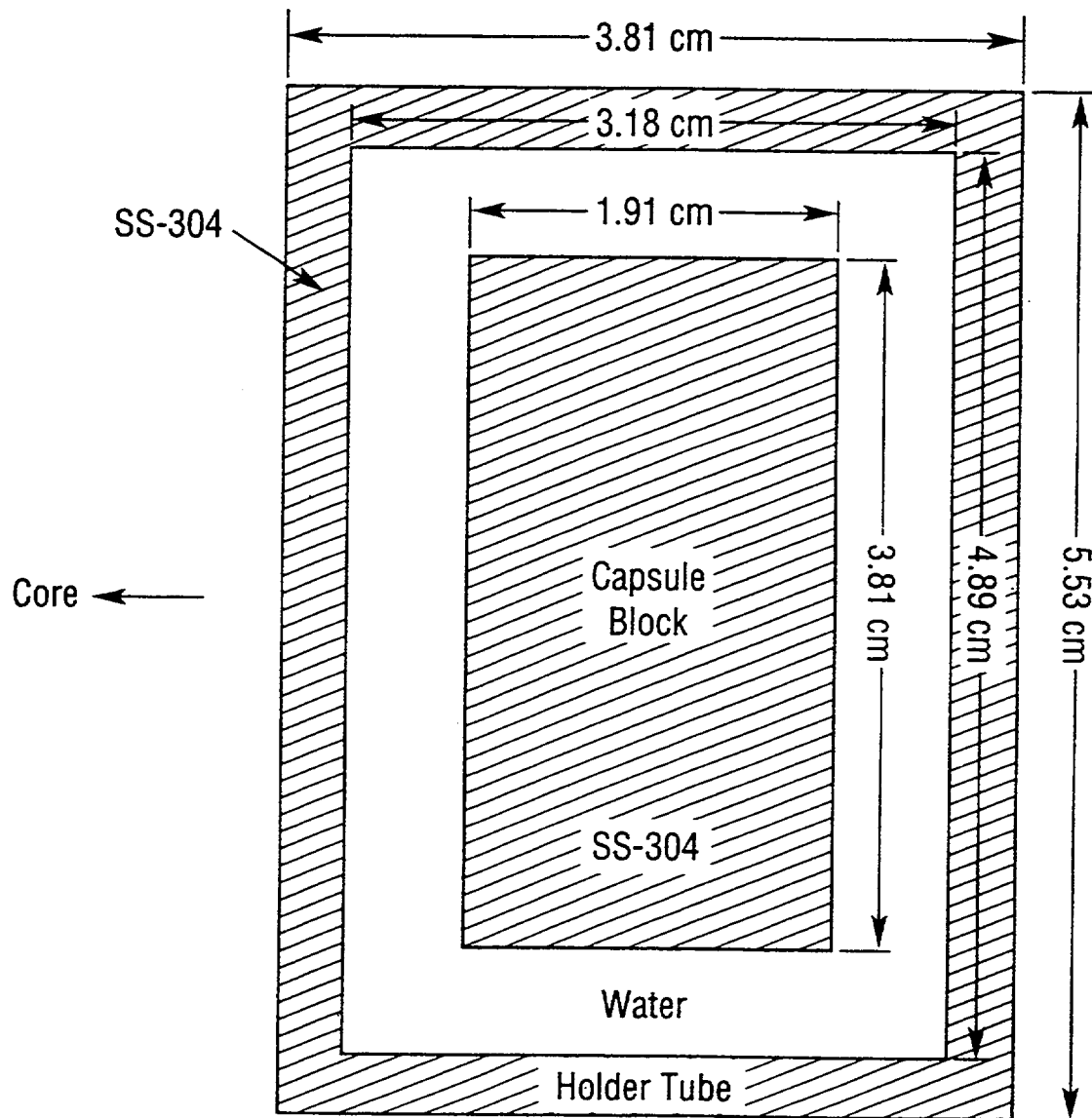

Surveillance Capsule

Figure 2.1.2.4

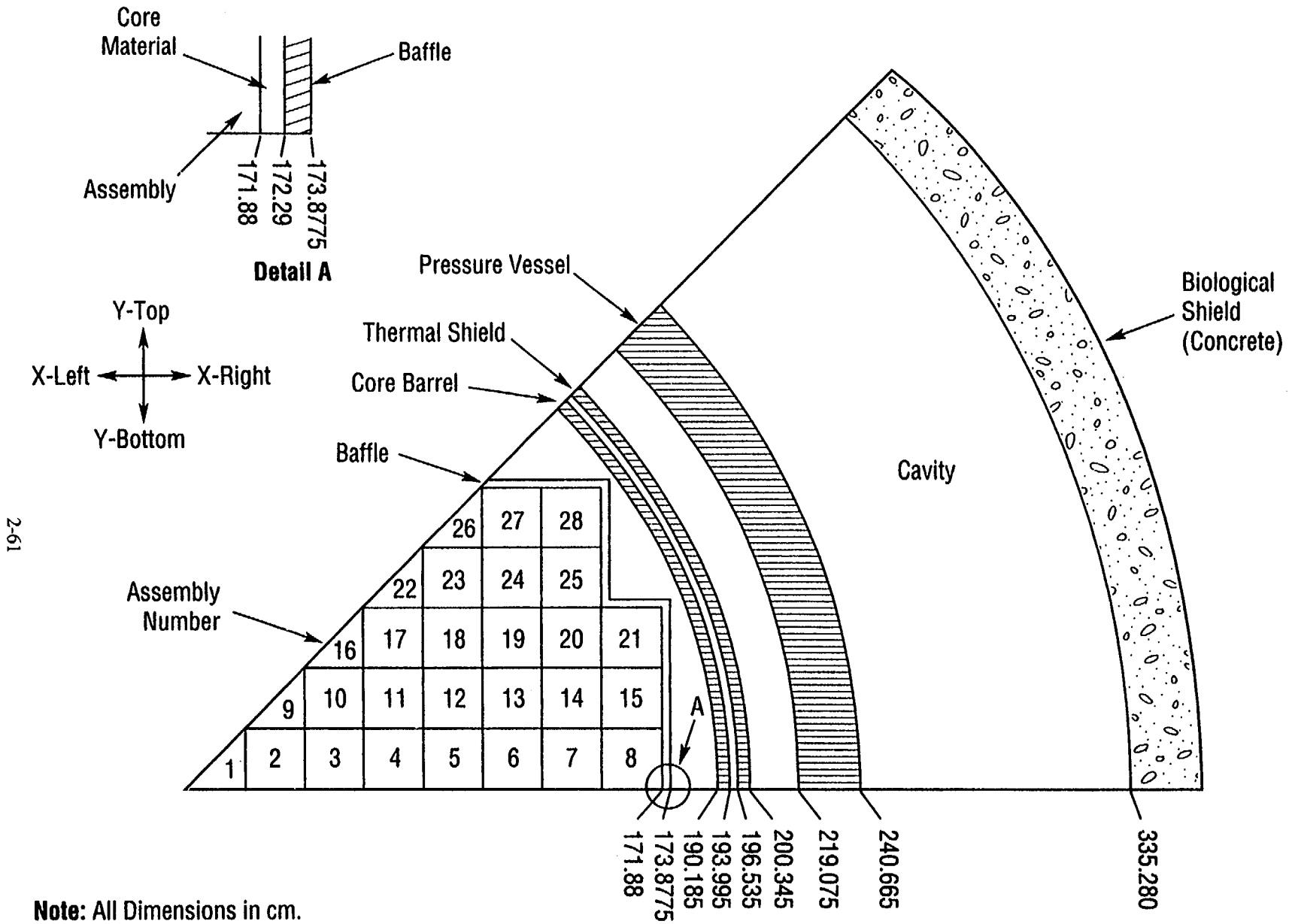

Low Leakage Core Loading

Figure 2.1.3.1

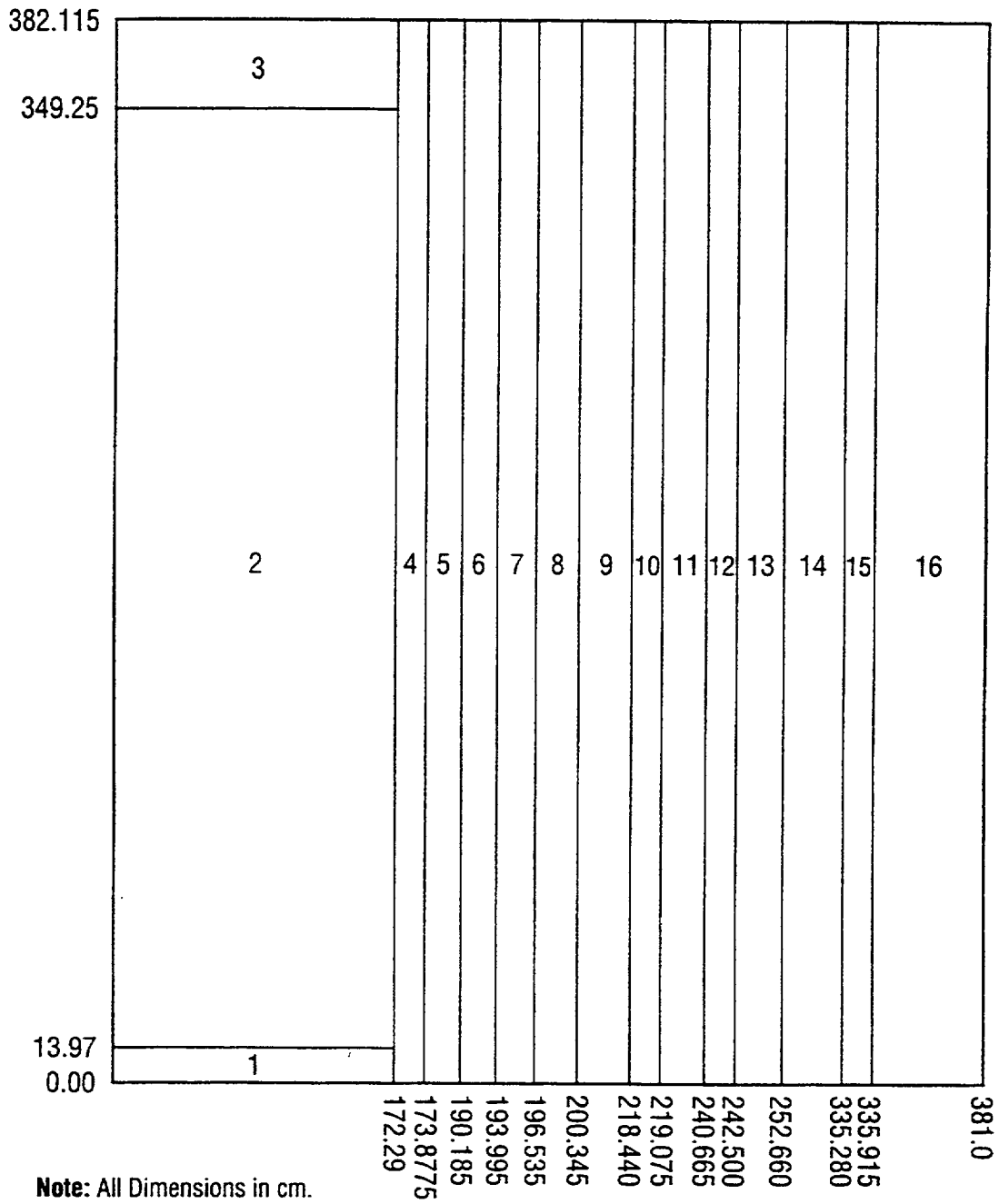

**Low Leakage Core Loading
Axial Geometry at $\theta=0^\circ$**

Figure 2.1.3.2

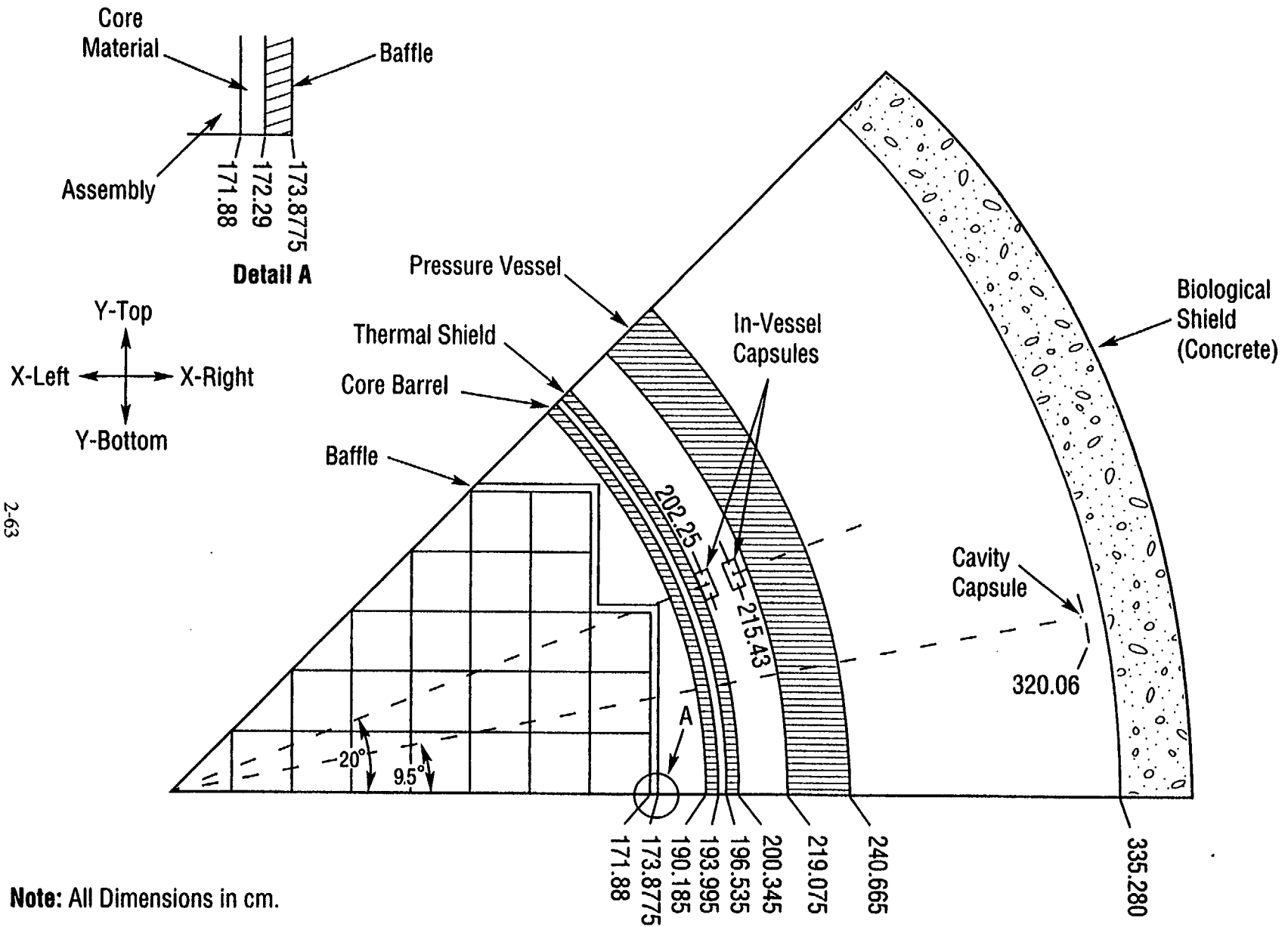

Location of Surveillance Capsules

Figure 2.1.3.3

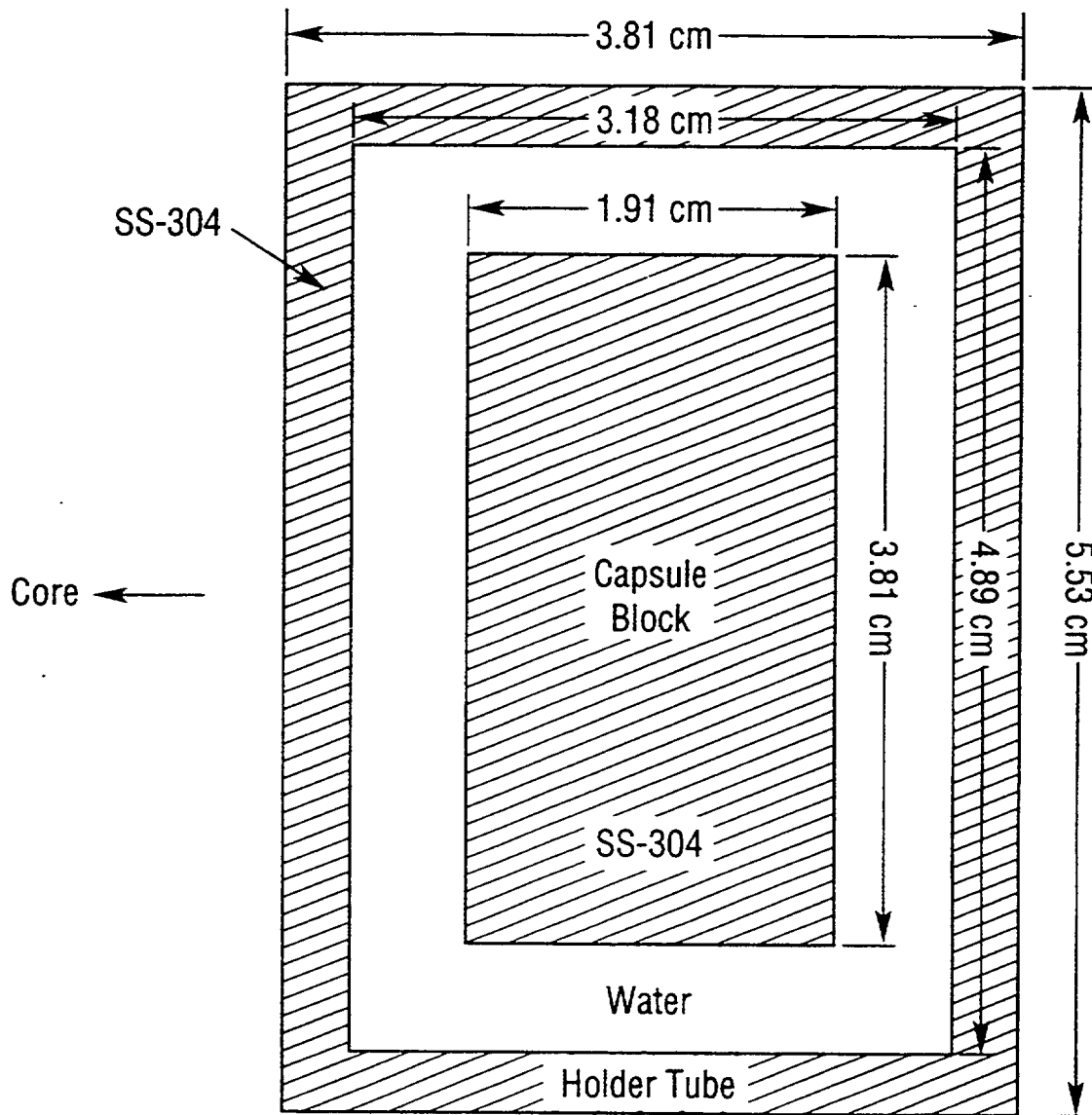

Surveillance Capsule

Figure 2.1.3.4

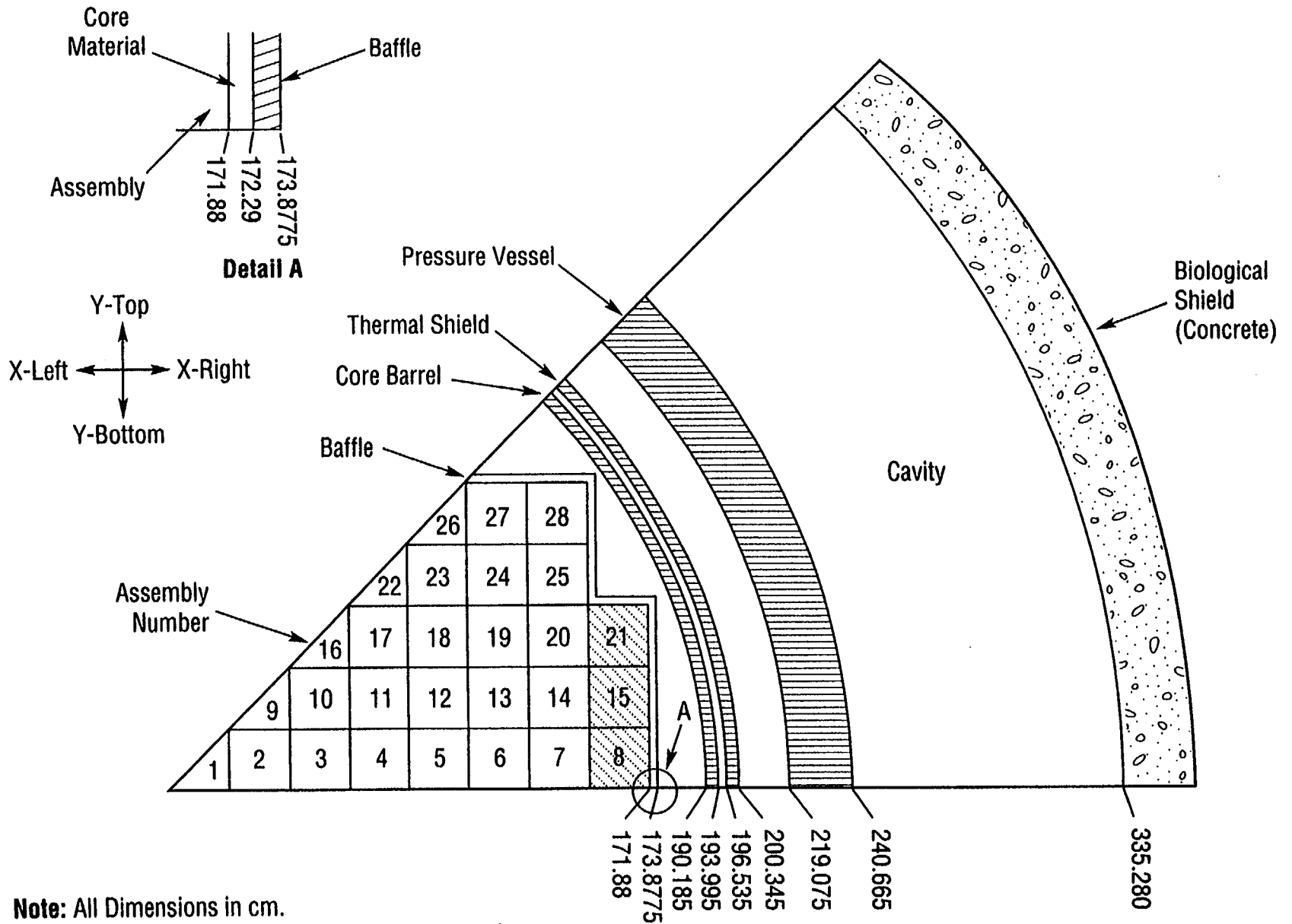

Partial Length Shield Assembly Core Loading

Figure 2.1.4.1

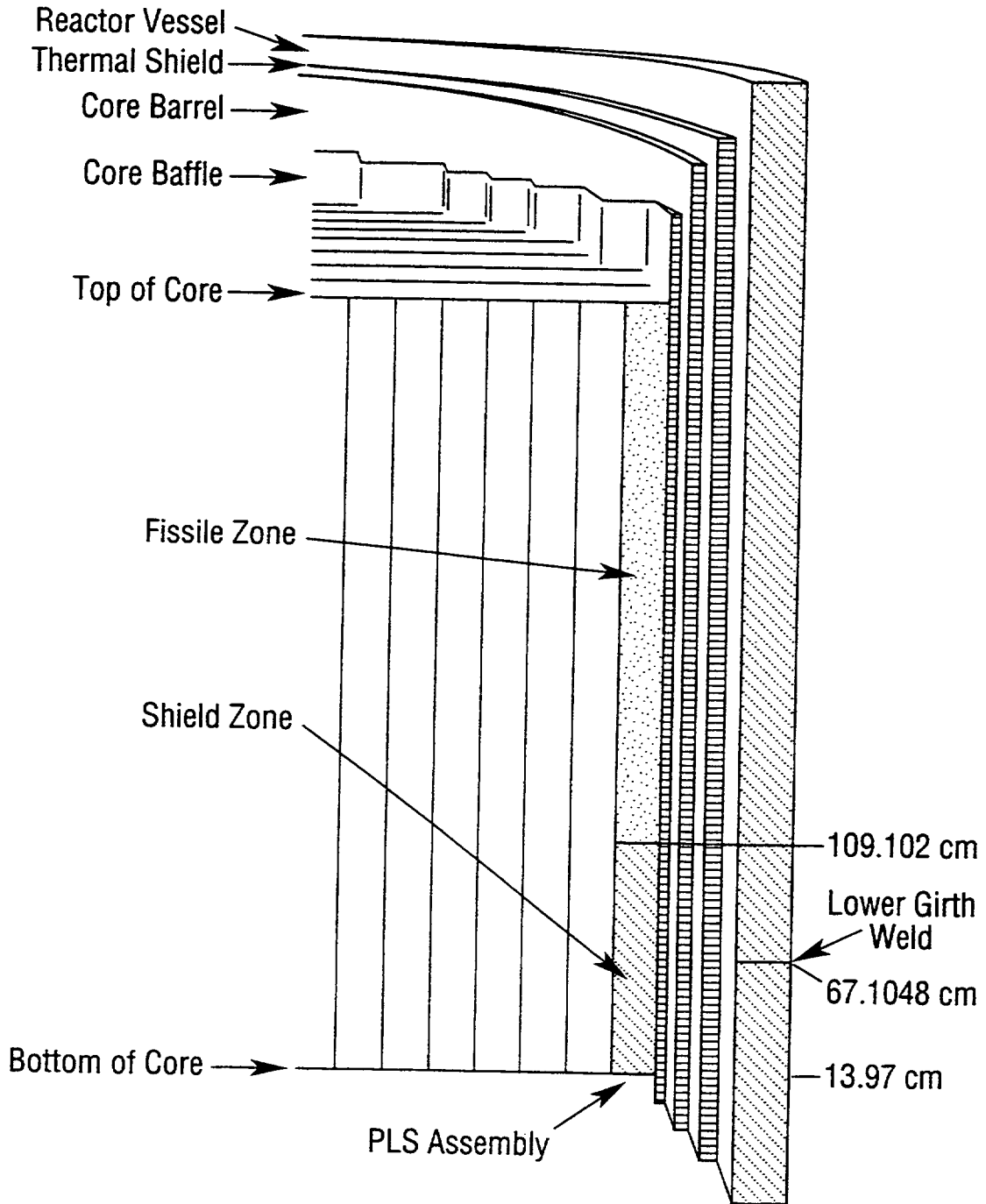

Partial Length Shield Assembly Core Design

Figure 2.1.4.2

Table 2.2.1.1

Fraction of Fissions by Isotope as a Function of Exposure

Exposure (Mwd/T)	U-235	U-238	Pu-239	Pu241
4.33	0.7651	0.0733	0.1566	0.
5.92	0.7190	0.0733	0.1936	0.0059
6.62	0.7085	0.0733	0.2096	0.0074
11.13	0.6153	0.0766	0.2814	0.0220
14.12	0.5630	0.0766	0.3220	0.0373
15.66	0.5370	0.0766	0.3400	0.0440
17.88	0.5070	0.0766	0.3580	0.0533

Table 2.2.2.1

Basic Design Data

Reactor Parameter		Material
Thermal Power	3833 MW (TH)	--
Core Inlet Temp.	278.9 C	--
Core Operating Pressure	7.20 MPa	--
Core Saturated Temp.	287.7 C	--
Inner Radius of Shroud	268.2875 cm	--
Shroud Thickness	5.08 cm	SS-304
Inner Radius of Liner RPV	321.31 cm	--
Thickness of Liner	0.476 cm	SS-304
Inner Radius of RPV	321.786 cm	--
RPV Wall Thickness	16.129 cm	Steel
Inner Radius of Insulation Liner	351.79 cm	--
Thickness of Insulation Liner	0.159 cm	SS-304
Thickness of Insulation	8.571 cm	Al
Inner Radius of Concrete Shield	436.88 cm	--
Thickness of Concrete Shield*	40.62 cm	--
Radius of Center of Jet Pump & Riser to Core Center	293 cm	--
Number of Jet Pumps	24	--
Location of Jet Pump	Every 15 deg. of Circumference	
Location of Risers	Every 30 deg. of Circumference	
Jet Pump ID	18.212 cm	--
Jet Pump OD	20.752 cm	--
Riser ID	25.40 cm	--
Riser OD	28.245 cm	--
Capsule Total Width	8.38 cm	
Radial Thickness	3.385 cm	Steel

* The thickness used in calculation

Table 2.2.2.2

Core and Fuel Assemblies

Total Number of Fuel Assemblies	800
Number of Fuel Rods per assembly (8X8)	62
Number of Water Rods	2
Channel Box Outer Width	13.8557 cm
Thickness of Channel Box	0.3048 cm
Assembly Pitch	15.24 cm
Pin Pitch	1.61544 cm
Cladding Material	Zr
Fuel Active Length	381.0 cm

Basic Design Data

Upper and Lower Reflectors

Region	Height	Material
Lower Reflector:		
Inlet Region	12.39 cm	SS-304, Sat. water, Zr
Core Plate	37.04 cm	SS-304, Sat. water
Upper Reflector:		
Top Guide	37.04 cm	70% void water, Zr
Upper Reflector	18.52 cm	SS-304, 70% void water, Zr
Steam Separation & Dryer Region	327.24 cm	70% void water

Table 2.2.2.3

Material Compositions

Mixture	Component	Atom Densities (atom/b*cm)
Inner Core 1	H	2.88090E-02
	O	1.44040E-02
	O (fuel)	1.04150E-02
	U-235	9.45460E-05
	U-238	5.11200E-03
	Zr	6.48000E-03
Inner Core 2	H	2.67990E-02
	O	1.34000E-02
	O (fuel)	1.04150E-02
	U-235	9.45460E-05
	U-238	5.11200E-03
	Zr	6.48000E-03
Inner Core 3	H	2.17470E-02
	O	1.08730E-02
	O (fuel)	1.04150E-02
	U-235	9.45460E-05
	U-238	5.11200E-03
	Zr	6.48000E-03
Inner Core 4	H	1.85510E-02
	O	9.27550E-03
	O (fuel)	1.04150E-02
	U-235	9.45460E-05
	U-238	5.11200E-03
	Zr	6.48000E-03
Inner Core 5	H	1.64650E-02
	O	8.23250E-03
	O (fuel)	1.04150E-02
	U-235	9.45460E-05
	U-238	5.11200E-03
	Zr	6.48000E-03
Inner Core 6	H	1.51250E-02
	O	7.56270E-03
	O (fuel)	1.04150E-02
	U-235	9.45460E-05
	U-238	5.11200E-03
	Zr	6.48000E-03
Inner Core 7	H	1.42640E-02
	O	7.13210E-03
	O (fuel)	1.04150E-02
	U-235	9.45460E-05
	U-238	5.11200E-03
	Zr	6.48000E-03

Table 2.2.2.3

Material Compositions (Cont'd)

Mixture	Component	Atom Densities (atom/b*cm)
Outer Core 1	H	2.88090E-02
	O	1.44040E-02
	O (fuel)	1.04150E-02
	U-235	9.45460E-05
	U-238	5.11200E-03
	Zr	6.48000E-03
Outer Core 2	H	2.87770E-02
	O	1.43880E-02
	O (fuel)	1.04150E-02
	U-235	9.45460E-05
	U-238	5.11200E-03
	Zr	6.48000E-03
Outer Core 3	H	2.71340E-02
	O	1.35670E-02
	O (fuel)	1.04150E-02
	U-235	9.45460E-05
	U-238	5.11200E-03
	Zr	6.48000E-03
Outer Core 4	H	2.41770E-02
	O	1.20890E-02
	O (fuel)	1.04150E-02
	U-235	9.45460E-05
	U-238	5.11200E-03
	Zr	6.48000E-03
Outer Core 5	H	2.11540E-02
	O	1.05770E-02
	O (fuel)	1.04150E-02
	U-235	9.45460E-05
	U-238	5.11200E-03
	Zr	6.48000E-03
Outer Core 6	H	1.90290E-02
	O	9.51470E-03
	O (fuel)	1.04150E-02
	U-235	9.45460E-05
	U-238	5.11200E-03
	Zr	6.48000E-03
Outer Core 7	H	1.81300E-02
	O	9.06500E-03
	O (fuel)	1.04150E-02
	U-235	9.45460E-05
	U-238	5.11200E-03
	Zr	6.48000E-03

Table 2.2.2.3

Material Compositions (Cont'd)

Mixture	Component	Atom Densities (atom/b*cm)
Inlet Region	H	3.54150E-02
	O	1.77080E-02
	Zr	7.97470E-03
	Cr	1.97490E-03
	Mn	1.72520E-04
	Fe	6.61705E-03
	Ni	9.70425E-04
	Si	1.01356E-04
	C	2.68995E-05
Core Plate	H	4.66420E-02
	O	2.33210E-02
	Cr	1.31544E-03
	Mn	1.14912E-04
	Fe	4.40748E-03
	Ni	6.46380E-04
	Si	6.75108E-05
C	1.79172E-05	
Top Guide	H	1.21530E-02
	O	6.07670E-03
	Zr	7.68960E-03
Upper Reflector	H	9.82230E-03
	O	4.91120E-03
	Zr	7.51250E-03
	Cr	2.81532E-03
	Mn	2.45936E-04
	Fe	9.43294E-03
	Ni	1.38339E-03
	Si	1.44487E-04
	C	3.83466E-05
Steam Separator & Dryer Region	H	1.47850E-02
	O	7.39260E-03
Jet Pump Water	H	5.04550E-02
	O	2.52280E-02
Jet Pump Metal	Cr	1.55174E-02
	Fe	6.37909E-02
	Ni	6.89647E-03
Riser Water	H	5.04550E-02
	O	2.52280E-02
Riser Metal	Cr	1.55126E-02
	Fe	6.37767E-02
	Ni	6.89487E-03

Table 2.2.2.3

Material Compositions (Cont'd)

Mixture	Component	Atom Densities (atom/b*cm)
Reflector	H	4.92840E-02
	O	2.46420E-02
Shroud (SS-304)	Cr	1.74000E-02
	Mn	1.52000E-03
	Ni	8.55000E-03
	Fe	5.83000E-02
	C	2.37000E-04
Downcomer	Si	8.93000E-04
	H	5.04550E-02
Downcomer	O	2.52280E-02
	Cr	1.74000E-02
RPV Liner (SS-304)	Mn	1.52000E-03
	Ni	8.55000E-03
	Fe	5.83000E-02
	C	2.37000E-04
	Si	8.93000E-04
RPV Wall (Steel)	Cr	1.27000E-04
	Mn	1.12000E-03
	Ni	4.44000E-04
	Fe	8.19000E-02
	C	9.81000E-04
Cavity	Si	3.71000E-04
	O	9.62000E-06
Insulation Liner (SS-304)	Cr	1.74000E-02
	Mn	1.52000E-03
	Ni	8.55000E-03
	Fe	5.83000E-02
	C	2.37000E-04
Insulation	Si	8.93000E-04
	Al	6.06030E-03
Concrete Wall	H	1.51367E-02
	C	2.24032E-04
	O	8.53268E-02
	Na	2.04551E-03
	Mg	2.88319E-04
	Al	4.65596E-03
	Si	3.07780E-02
	K	1.35003E-03
	Ca	4.46115E-03
Fe	6.09755E-04	

Table 2.2.2.3.1

Isotopic Fractions in Cr, Fe and Ni*

ISOTOPE	WT %	ISOTOPE	WT %	ISOTOPE	WT %
Cr-50	4.345	Fe-54	5.9	Ni-58	68.27
Cr-52	83.79	Fe-56	91.72	Ni-60	26.10
Cr-53	9.5	Fe-57	2.1	Ni-61	1.13
Cr-54	2.365	Fe-58	0.28	Ni-62	3.59
-----	-----	-----	-----	Ni-64	0.91

*Taken from Reference-4.

Table 2.2.2.4

Fuel Assembly Geometry and Power

Assmb. Number	X-Left	X-Right	Y-Bot	Y-Top	Relative Assembly Power+	Burnup Group*	Axial Peaking Factor	Pin Power Set
1	1.15824	14.08176	1.15824	14.08176	5.0353e-03#	1	1.000	0
2	16.39824	29.32176	1.15824	14.08176	1.0735e-02	1	1.000	0
3	31.63824	44.56176	1.15824	14.08176	1.0578e-02	1	1.000	0
4	46.87824	59.80176	1.15824	14.08176	1.1137e-02	1	1.000	0
5	62.11824	75.04176	1.15824	14.08176	1.1007e-02	1	1.000	0
6	77.35824	90.28176	1.15824	14.08176	1.1072e-02	1	1.000	0
7	92.59824	105.52176	1.15824	14.08176	1.3563e-02	1	1.000	0
8	107.83824	120.76176	1.15824	14.08176	1.0817e-02	1	1.000	0
9	123.07824	136.00176	1.15824	14.08176	1.0795e-02	1	1.000	0
10	138.31824	151.24176	1.15824	14.08176	1.0763e-02	1	1.000	0
11	153.55824	166.48176	1.15824	14.08176	1.3165e-02	1	1.000	0
12	168.79824	181.72176	1.15824	14.08176	1.0626e-02	1	1.000	0
13	184.03824	196.96176	1.15824	14.08176	1.1916e-02	1	1.000	0
14	199.27824	212.20176	1.15824	14.08176	8.2017e-03	1	1.000	1
15	214.51824	227.44176	1.15824	14.08176	6.0158e-03	2	1.000	12
16	229.75824	242.68176	1.15824	14.08176	3.2642e-03	3	1.000	23
17	16.39824	29.32176	16.39824	29.32176	6.4619e-03#	1	1.000	0
18	31.63824	44.56176	16.39824	29.32176	1.1217e-02	1	1.000	0
19	46.87824	59.80176	16.39824	29.32176	1.3327e-02	1	1.000	0
20	62.11824	75.04176	16.39824	29.32176	1.1084e-02	1	1.000	0
21	77.35824	90.28176	16.39824	29.32176	1.3584e-02	1	1.000	0
22	92.59824	105.52176	16.39824	29.32176	1.1164e-02	1	1.000	0
23	107.83824	120.76176	16.39824	29.32176	1.3234e-02	1	1.000	0
24	123.07824	136.00176	16.39824	29.32176	1.0781e-02	1	1.000	0
25	138.31824	151.24176	16.39824	29.32176	1.3192e-02	1	1.000	0
26	153.55824	166.48176	16.39824	29.32176	1.0958e-02	1	1.000	0
27	168.79824	181.72176	16.39824	29.32176	1.2877e-02	1	1.000	0
28	184.03824	196.96176	16.39824	29.32176	9.9125e-03	1	1.000	0
29	199.27824	212.20176	16.39824	29.32176	9.9915e-03	1	1.000	2
30	214.51824	227.44176	16.39824	29.32176	5.8691e-03	2	1.000	13
31	229.75824	242.68176	16.39824	29.32176	3.2011e-03	3	1.000	24
32	31.63824	44.56176	31.63824	44.56176	5.6259e-03#	1	1.000	0
33	46.87824	59.80176	31.63824	44.56176	1.1137e-02	1	1.000	0
34	62.11824	75.04176	31.63824	44.56176	1.3600e-02	1	1.000	0
35	77.35824	90.28176	31.63824	44.56176	1.1276e-02	1	1.000	0
36	92.59824	105.52176	31.63824	44.56176	1.3444e-02	1	1.000	0
37	107.83824	120.76176	31.63824	44.56176	1.0870e-02	1	1.000	0
38	123.07824	136.00176	31.63824	44.56176	1.1092e-02	1	1.000	0

+ The relative assembly power has been normalized so that the one-eighth of the total core power equals 1.0.

* The three burnup groups 1,2 and 3 correspond to assembly burnups of 13.831, 13.788,12.755 GWD/T.

Note that the assembly power for assemblies on the core diagonal at 45 is actually one-half of the assembly power, since only half of the assembly is included in the octant.

Table 2.2.2.4

Fuel Assembly Geometry and Power (cont'd)

Assmb. Number	X-Left	X-Right	Y-Bot	Y-Top	Relative Assembly Power	Burnup Group	Axial Peaking Factor	Pin Power Set
39	138.31824	151.24176	31.63824	44.56176	1.1050e-02	1	1.000	0
40	153.55824	166.48176	31.63824	44.56176	1.3296e-02	1	1.000	0
41	168.79824	181.72176	31.63824	44.56176	1.0577e-02	1	1.000	0
42	184.03824	196.96176	31.63824	44.56176	1.1734e-02	1	1.000	3
43	199.27824	212.20176	31.63824	44.56176	7.9120e-03	2	1.000	14
44	214.51824	227.44176	31.63824	44.56176	5.4178e-03	3	1.000	25
45	46.87824	59.80176	46.87824	59.80176	6.7304e-03#	1	1.000	0
46	62.11824	75.04176	46.87824	59.80176	1.1008e-02	1	1.000	0
47	77.35824	90.28176	46.87824	59.80176	1.3305e-02	1	1.000	0
48	92.59824	105.52176	46.87824	59.80176	1.0890e-02	1	1.000	0
49	107.83824	120.76176	46.87824	59.80176	1.1169e-02	1	1.000	0
50	123.07824	136.00176	46.87824	59.80176	1.0976e-02	1	1.000	0
51	138.31824	151.24176	46.87824	59.80176	1.3404e-02	1	1.000	0
52	153.55824	166.48176	46.87824	59.80176	1.0980e-02	1	1.000	0
53	168.79824	181.72176	46.87824	59.80176	1.2697e-02	1	1.000	0
54	184.03824	196.96176	46.87824	59.80176	9.6807e-03	1	1.000	4
55	199.27824	212.20176	46.87824	59.80176	9.4040e-03	2	1.000	15
56	214.51824	227.44176	46.87824	59.80176	4.7132e-03	3	1.000	26
57	62.11824	75.04176	62.11824	75.04176	5.4676e-03#	1	1.000	0
58	77.35824	90.28176	62.11824	75.04176	1.0832e-02	1	1.000	0
59	92.59824	105.52176	62.11824	75.04176	1.1061e-02	1	1.000	0
60	107.83824	120.76176	62.11824	75.04176	1.0958e-02	1	1.000	0
61	123.07824	136.00176	62.11824	75.04176	1.3438e-02	1	1.000	0
62	138.31824	151.24176	62.11824	75.04176	1.1088e-02	1	1.000	0
63	153.55824	166.48176	62.11824	75.04176	1.3175e-02	1	1.000	0
64	168.79824	181.72176	62.11824	75.04176	1.0412e-02	1	1.000	0
65	184.03824	196.96176	62.11824	75.04176	1.1221e-02	1	1.000	5
66	199.27824	212.20176	62.11824	75.04176	7.3459e-03	2	1.000	16
67	214.51824	227.44176	62.11824	75.04176	4.3773e-03	3	1.000	27
68	77.35824	90.28176	77.35824	90.28176	6.6264e-03#	1	1.000	0
69	92.59824	105.52176	77.35824	90.28176	1.1015e-02	1	1.000	0
70	107.83824	120.76176	77.35824	90.28176	1.3409e-02	1	1.000	0
71	123.07824	136.00176	77.35824	90.28176	1.1139e-02	1	1.000	0
72	138.31824	151.24176	77.35824	90.28176	1.3279e-02	1	1.000	0
73	153.55824	166.48176	77.35824	90.28176	1.0653e-02	1	1.000	0
74	168.79824	181.72176	77.35824	90.28176	1.2053e-02	1	1.000	0
75	184.03824	196.96176	77.35824	90.28176	8.9775e-03	1	1.000	6
76	199.27824	212.20176	77.35824	90.28176	8.3615e-03	2	1.000	17
77	214.51824	227.44176	77.35824	90.28176	3.9167e-03	3	1.000	28

Table 2.2.2.4

Fuel Assembly Geometry and Power (cont'd)

Assmb. Number	X-Left	X-Right	Y-Bot	Y-Top	Relative Assembly Power	Burnup Group	Axial Peaking Factor	Pin Power Set
78	92.59824	105.52176	92.59824	105.52176	6.7159e-03#	1	1.000	0
79	107.83824	120.76176	92.59824	105.52176	1.1005e-02	1	1.000	0
80	123.07824	136.00176	92.59824	105.52176	1.3245e-02	1	1.000	0
81	138.31824	151.24176	92.59824	105.52176	1.0791e-02	1	1.000	0
82	153.55824	166.48176	92.59824	105.52176	1.2404e-02	1	1.000	0
83	168.79824	181.72176	92.59824	105.52176	9.4730e-03	1	1.000	0
84	184.03824	196.96176	92.59824	105.52176	9.7112e-03	1	1.000	7
85	199.27824	212.20176	92.59824	105.52176	5.8641e-03	2	1.000	18
86	214.51824	227.44176	92.59824	105.52176	3.2748e-03	3	1.000	29
87	107.83824	120.76176	107.83824	120.76176	5.4160e-03#	1	1.000	0
88	123.07824	136.00176	107.83824	120.76176	1.0679e-02	1	1.000	0
89	138.31824	151.24176	107.83824	120.76176	1.2509e-02	1	1.000	0
90	153.55824	166.48176	107.83824	120.76176	9.7937e-03	1	1.000	0
91	168.79824	181.72176	107.83824	120.76176	1.0372e-02	1	1.000	8
92	184.03824	196.96176	107.83824	120.76176	6.6826e-03	2	1.000	19
93	199.27824	212.20176	107.83824	120.76176	4.2816e-03	3	1.000	30
94	123.07824	136.00175	123.07824	136.00176	6.2480e-03#	1	1.000	0
95	138.31824	151.24176	123.07824	136.00176	9.9663e-03	1	1.000	0
96	153.55824	166.48176	123.07824	136.00176	1.0792e-02	1	1.000	9
97	168.79824	181.72176	123.07824	136.00176	7.3882e-03	2	1.000	20
98	184.03824	196.96176	123.07824	136.00176	4.8407e-03	3	1.000	31
99	138.31824	151.24176	138.31824	151.24176	2.7223e-03#	1	1.000	0
100	153.55824	166.48176	138.31824	151.24176	7.8106e-03	1	1.000	10
101	168.79824	181.72176	138.31824	151.24176	6.0455e-03	2	1.000	21
102	184.03824	196.96176	138.31824	151.24176	3.6073e-03	3	1.000	32
103	153.55824	166.48176	153.55824	166.48176	3.1472e-03#	1	1.000	11
104	168.79824	181.72176	153.55824	166.48176	4.6201e-03	2	1.000	22
105	184.03824	196.96176	153.55824	166.48176	2.6529e-03	3	1.000	33
106	168.79824	181.72176	168.79824	181.72176	1.6018e-03#	3	1.000	34

Table 2.2.2.5

Pin Geometry and Power Distributions

Pin Pitch Set 1#

X-Left	X-Right	Y-Bot	Y-Top	Pin* Power Fraction	Pin Power Set	Assemb. Number
1.99278E+02	2.05740E+02	1.15824E+00	7.62000E+00	2.58373E-01	1	14
2.05740E+02	2.12202E+02	1.15824E+00	7.62000E+00	2.70264E-01	1	14
1.99278E+02	2.05740E+02	7.62000E+00	1.40818E+01	2.41618E-01	1	14
2.05740E+02	2.12202E+02	7.62000E+00	1.40818E+01	2.29746E-01	1	14
1.99278E+02	2.05740E+02	1.63982E+01	2.28600E+01	2.58807E-01	2	29
2.05740E+02	2.12202E+02	1.63982E+01	2.28600E+01	2.72605E-01	2	29
1.99278E+02	2.05740E+02	2.28600E+01	2.93218E+01	2.43342E-01	2	29
2.05740E+02	2.12202E+02	2.28600E+01	2.93218E+01	2.25246E-01	2	29
1.84038E+02	1.90500E+02	3.16382E+01	3.81000E+01	2.51616E-01	3	42
1.90500E+02	1.96962E+02	3.16382E+01	3.81000E+01	2.64870E-01	3	42
1.84038E+02	1.90500E+02	3.81000E+01	4.45618E+01	2.50658E-01	3	42
1.90500E+02	1.96962E+02	3.81000E+01	4.45618E+01	2.32856E-01	3	42
1.84038E+02	1.90500E+02	4.68782E+01	5.33400E+01	2.51964E-01	4	54
1.90500E+02	1.96962E+02	4.68782E+01	5.33400E+01	2.64982E-01	4	54
1.84038E+02	1.90500E+02	5.33400E+01	5.98018E+01	2.47466E-01	4	54
1.90500E+02	1.96962E+02	5.33400E+01	5.98018E+01	2.35588E-01	4	54
1.84038E+02	1.90500E+02	6.21182E+01	6.85800E+01	2.53546E-01	5	65
1.90500E+02	1.96962E+02	6.21182E+01	6.85800E+01	2.64866E-01	5	65
1.84038E+02	1.90500E+02	6.85800E+01	7.50418E+01	2.50773E-01	5	65
1.90500E+02	1.96962E+02	6.85800E+01	7.50418E+01	2.30815E-01	5	65
1.84038E+02	1.90500E+02	7.73582E+01	8.38200E+01	2.59070E-01	6	75
1.90500E+02	1.96962E+02	7.73582E+01	8.38200E+01	2.64613E-01	6	75
1.84038E+02	1.90500E+02	8.38200E+01	9.02818E+01	2.47647E-01	6	75
1.90500E+02	1.96962E+02	8.38200E+01	9.02818E+01	2.28670E-01	6	75
1.84038E+02	1.90500E+02	9.25982E+01	9.90600E+01	2.63613E-01	7	84
1.90500E+02	1.96962E+02	9.25982E+01	9.90600E+01	2.64005E-01	7	84
1.84038E+02	1.90500E+02	9.90600E+01	1.05522E+02	2.53136E-01	7	84
1.90500E+02	1.96962E+02	9.90600E+01	1.05522E+02	2.19247E-01	7	84
1.68798E+02	1.75260E+02	1.07838E+02	1.14300E+02	2.60743E-01	8	91
1.75260E+02	1.81722E+02	1.07838E+02	1.14300E+02	2.61962E-01	8	91
1.68798E+02	1.75260E+02	1.14300E+02	1.20762E+02	2.54997E-01	8	91
1.75260E+02	1.81722E+02	1.14300E+02	1.20762E+02	2.22297E-01	8	91
1.53558E+02	1.60020E+02	1.23078E+02	1.29540E+02	2.57155E-01	9	96
1.60020E+02	1.66482E+02	1.23078E+02	1.29540E+02	2.59758E-01	9	96
1.53558E+02	1.60020E+02	1.29540E+02	1.36002E+02	2.56820E-01	9	96
1.60020E+02	1.66482E+02	1.29540E+02	1.36002E+02	2.26268E-01	9	96
1.53558E+02	1.60020E+02	1.38318E+02	1.44780E+02	2.65023E-01	10	100
1.60020E+02	1.66482E+02	1.38318E+02	1.44780E+02	2.57084E-01	10	100
1.53558E+02	1.60020E+02	1.44780E+02	1.51242E+02	2.55241E-01	10	100
1.60020E+02	1.66482E+02	1.44780E+02	1.51242E+02	2.22652E-01	10	100
1.53558E+02	1.60020E+02	1.53558E+02	1.60020E+02	2.87226E-01	11	103
1.60020E+02	1.66482E+02	1.53558E+02	1.60020E+02	2.43955E-01	11	103
1.53558E+02	1.60020E+02	1.60020E+02	1.66482E+02	2.43955E-01	11	103
1.60020E+02	1.66482E+02	1.60020E+02	1.66482E+02	2.24865E-01	11	103

Pin Pitch Set 1 is a 2x2 array.

* Pin Power Fraction of Assembly power.

Table 2.2.2.5

Pin Geometry and Power Distributions (cont'd)

§

Pin Pitch Set 2

X-Left	X-Right	Y-Bot	Y-Top	Pin* Power Fraction	Pin Power Set	Assemb. Number
2.14518E+02	2.17749E+02	1.15824E+00	4.38912E+00	7.38249E-02	12	15
2.17749E+02	2.20980E+02	1.15824E+00	4.38912E+00	7.28075E-02	12	15
2.20980E+02	2.24211E+02	1.15824E+00	4.38912E+00	7.61966E-02	12	15
2.24211E+02	2.27442E+02	1.15824E+00	4.38912E+00	7.45121E-02	12	15
2.14518E+02	2.17749E+02	4.38912E+00	7.62000E+00	6.68030E-02	12	15
2.17749E+02	2.20980E+02	4.38912E+00	7.62000E+00	6.74201E-02	12	15
2.20980E+02	2.24211E+02	4.38912E+00	7.62000E+00	4.95235E-02	12	15
2.24211E+02	2.27442E+02	4.38912E+00	7.62000E+00	6.98152E-02	12	15
2.14518E+02	2.17749E+02	7.62000E+00	1.08509E+01	6.31469E-02	12	15
2.17749E+02	2.20980E+02	7.62000E+00	1.08509E+01	4.41128E-02	12	15
2.20980E+02	2.24211E+02	7.62000E+00	1.08509E+01	6.15057E-02	12	15
2.24211E+02	2.27442E+02	7.62000E+00	1.08509E+01	6.03148E-02	12	15
2.14518E+02	2.17749E+02	1.08509E+01	1.40818E+01	5.50509E-02	12	15
2.17749E+02	2.20980E+02	1.08509E+01	1.40818E+01	5.64820E-02	12	15
2.20980E+02	2.24211E+02	1.08509E+01	1.40818E+01	5.40202E-02	12	15
2.24211E+02	2.27442E+02	1.08509E+01	1.40818E+01	5.44638E-02	12	15
2.14518E+02	2.17749E+02	1.63982E+01	1.96291E+01	7.59897E-02	13	30
2.17749E+02	2.20980E+02	1.63982E+01	1.96291E+01	7.77915E-02	13	30
2.20980E+02	2.24211E+02	1.63982E+01	1.96291E+01	7.38117E-02	13	30
2.24211E+02	2.27442E+02	1.63982E+01	1.96291E+01	7.31928E-02	13	30
2.14518E+02	2.17749E+02	1.96291E+01	2.28600E+01	7.14149E-02	13	30
2.17749E+02	2.20980E+02	1.96291E+01	2.28600E+01	5.05720E-02	13	30
2.20980E+02	2.24211E+02	1.96291E+01	2.28600E+01	6.79001E-02	13	30
2.24211E+02	2.27442E+02	1.96291E+01	2.28600E+01	6.54075E-02	13	30
2.14518E+02	2.17749E+02	2.28600E+01	2.60909E+01	6.14037E-02	13	30
2.17749E+02	2.20980E+02	2.28600E+01	2.60909E+01	6.19440E-02	13	30
2.20980E+02	2.24211E+02	2.28600E+01	2.60909E+01	4.35594E-02	13	30
2.24211E+02	2.27442E+02	2.28600E+01	2.60909E+01	6.09388E-02	13	30
2.14518E+02	2.17749E+02	2.60909E+01	2.93218E+01	5.46818E-02	13	30
2.17749E+02	2.20980E+02	2.60909E+01	2.93218E+01	5.31705E-02	13	30
2.20980E+02	2.24211E+02	2.60909E+01	2.93218E+01	5.47570E-02	13	30
2.24211E+02	2.27442E+02	2.60909E+01	2.93218E+01	5.34646E-02	13	30
1.99278E+02	2.02509E+02	3.16382E+01	3.48691E+01	7.16472E-02	14	43
2.02509E+02	2.05740E+02	3.16382E+01	3.48691E+01	7.26314E-02	14	43
2.05740E+02	2.08971E+02	3.16382E+01	3.48691E+01	6.93772E-02	14	43
2.08971E+02	2.12202E+02	3.16382E+01	3.48691E+01	7.01406E-02	14	43
1.99278E+02	2.02509E+02	3.48691E+01	3.81000E+01	6.94787E-02	14	43
2.02509E+02	2.05740E+02	3.48691E+01	3.81000E+01	4.89417E-02	14	43
2.05740E+02	2.08971E+02	3.48691E+01	3.81000E+01	6.67952E-02	14	43
2.08971E+02	2.12202E+02	3.48691E+01	3.81000E+01	6.52023E-02	14	43
1.99278E+02	2.02509E+02	3.81000E+01	4.13309E+01	6.25975E-02	14	43
2.02509E+02	2.05740E+02	3.81000E+01	4.13309E+01	6.24834E-02	14	43
2.05740E+02	2.08971E+02	3.81000E+01	4.13309E+01	4.48911E-02	14	43
2.08971E+02	2.12202E+02	3.81000E+01	4.13309E+01	6.33330E-02	14	43

 § Pin Pitch Set 2 is a 4x4 array.

* Pin Power Fraction of Assembly Power.

Table 2.2.2.5

Pin Geometry and Power Distributions (cont'd)

Pin Pitch Set 2

X-Left	X-Right	Y-Bot	Y-Top	Pin* Power Fraction	Pin Power Set	Assemb. Number
1.99278E+02	2.02509E+02	4.13309E+01	4.45618E+01	5.90314E-02	14	43
2.02509E+02	2.05740E+02	4.13309E+01	4.45618E+01	5.72940E-02	14	43
2.05740E+02	2.08971E+02	4.13309E+01	4.45618E+01	5.90009E-02	14	43
2.08971E+02	2.12202E+02	4.13309E+01	4.45618E+01	5.71545E-02	14	43
1.99278E+02	2.02509E+02	4.68782E+01	5.01091E+01	7.26179E-02	15	55
2.02509E+02	2.05740E+02	4.68782E+01	5.01091E+01	7.18881E-02	15	55
2.05740E+02	2.08971E+02	4.68782E+01	5.01091E+01	7.32261E-02	15	55
2.08971E+02	2.12202E+02	4.68782E+01	5.01091E+01	6.95664E-02	15	55
1.99278E+02	2.02509E+02	5.01091E+01	5.33400E+01	6.80513E-02	15	55
2.02509E+02	2.05740E+02	5.01091E+01	5.33400E+01	5.14407E-02	15	55
2.05740E+02	2.08971E+02	5.01091E+01	5.33400E+01	6.47437E-02	15	55
2.08971E+02	2.12202E+02	5.01091E+01	5.33400E+01	6.83586E-02	15	55
1.99278E+02	2.02509E+02	5.33400E+01	5.65709E+01	6.47394E-02	15	55
2.02509E+02	2.05740E+02	5.33400E+01	5.65709E+01	6.03222E-02	15	55
2.05740E+02	2.08971E+02	5.33400E+01	5.65709E+01	4.68186E-02	15	55
2.08971E+02	2.12202E+02	5.33400E+01	5.65709E+01	6.24668E-02	15	55
1.99278E+02	2.02509E+02	5.65709E+01	5.98018E+01	5.64213E-02	15	55
2.02509E+02	2.05740E+02	5.65709E+01	5.98018E+01	5.86278E-02	15	55
2.05740E+02	2.08971E+02	5.65709E+01	5.98018E+01	5.73603E-02	15	55
2.08971E+02	2.12202E+02	5.65709E+01	5.98018E+01	5.33506E-02	15	55
1.99278E+02	2.02509E+02	6.21182E+01	6.53491E+01	7.36288E-02	16	66
2.02509E+02	2.05740E+02	6.21182E+01	6.53491E+01	7.42735E-02	16	66
2.05740E+02	2.08971E+02	6.21182E+01	6.53491E+01	7.02250E-02	16	66
2.08971E+02	2.12202E+02	6.21182E+01	6.53491E+01	7.02387E-02	16	66
1.99278E+02	2.02509E+02	6.53491E+01	6.85800E+01	7.07413E-02	16	66
2.02509E+02	2.05740E+02	6.53491E+01	6.85800E+01	4.95758E-02	16	66
2.05740E+02	2.08971E+02	6.53491E+01	6.85800E+01	6.69879E-02	16	66
2.08971E+02	2.12202E+02	6.53491E+01	6.85800E+01	6.47069E-02	16	66
1.99278E+02	2.02509E+02	6.85800E+01	7.18109E+01	6.28275E-02	16	66
2.02509E+02	2.05740E+02	6.85800E+01	7.18109E+01	6.24396E-02	16	66
2.05740E+02	2.08971E+02	6.85800E+01	7.18109E+01	4.43827E-02	16	66
2.08971E+02	2.12202E+02	6.85800E+01	7.18109E+01	6.21910E-02	16	66
1.99278E+02	2.02509E+02	7.18109E+01	7.50418E+01	5.82272E-02	16	66
2.02509E+02	2.05740E+02	7.18109E+01	7.50418E+01	5.64215E-02	16	66
2.05740E+02	2.08971E+02	7.18109E+01	7.50418E+01	5.77464E-02	16	66
2.08971E+02	2.12202E+02	7.18109E+01	7.50418E+01	5.53862E-02	16	66
1.99278E+02	2.02509E+02	7.73582E+01	8.05891E+01	7.54454E-02	17	76
2.02509E+02	2.05740E+02	7.73582E+01	8.05891E+01	7.33047E-02	17	76
2.05740E+02	2.08971E+02	7.73582E+01	8.05891E+01	7.41111E-02	17	76
2.08971E+02	2.12202E+02	7.73582E+01	8.05891E+01	6.88551E-02	17	76
1.99278E+02	2.02509E+02	8.05891E+01	8.38200E+01	6.95871E-02	17	76
2.02509E+02	2.05740E+02	8.05891E+01	8.38200E+01	5.22809E-02	17	76
2.05740E+02	2.08971E+02	8.05891E+01	8.38200E+01	6.48424E-02	17	76
2.08971E+02	2.12202E+02	8.05891E+01	8.38200E+01	6.71823E-02	17	76

Table 2.2.2.5

Pin Geometry and Power Distributions (cont'd)

Pin Pitch Set 2

X-Left	X-Right	Y-Bot	Y-Top	Pin* Power Fraction	Pin Power Set	Assemb. Number
1.99278E+02	2.02509E+02	8.38200E+01	8.70509E+01	6.59272E-02	17	76
2.02509E+02	2.05740E+02	8.38200E+01	8.70509E+01	6.06664E-02	17	76
2.05740E+02	2.08971E+02	8.38200E+01	8.70509E+01	4.62258E-02	17	76
2.08971E+02	2.12202E+02	8.38200E+01	8.70509E+01	6.05320E-02	17	76
1.99278E+02	2.02509E+02	8.70509E+01	9.02818E+01	5.63801E-02	17	76
2.02509E+02	2.05740E+02	8.70509E+01	9.02818E+01	5.81633E-02	17	76
2.05740E+02	2.08971E+02	8.70509E+01	9.02818E+01	5.59313E-02	17	76
2.08971E+02	2.12202E+02	8.70509E+01	9.02818E+01	5.05650E-02	17	76
1.99278E+02	2.02509E+02	9.25982E+01	9.58291E+01	7.92382E-02	18	85
2.02509E+02	2.05740E+02	9.25982E+01	9.58291E+01	7.82869E-02	18	85
2.05740E+02	2.08971E+02	9.25982E+01	9.58291E+01	7.11724E-02	18	85
2.08971E+02	2.12202E+02	9.25982E+01	9.58291E+01	6.73636E-02	18	85
1.99278E+02	2.02509E+02	9.58291E+01	9.90600E+01	7.56348E-02	18	85
2.02509E+02	2.05740E+02	9.58291E+01	9.90600E+01	5.17247E-02	18	85
2.05740E+02	2.08971E+02	9.58291E+01	9.90600E+01	6.68024E-02	18	85
2.08971E+02	2.12202E+02	9.58291E+01	9.90600E+01	6.06529E-02	18	85
1.99278E+02	2.02509E+02	9.90600E+01	1.02291E+02	6.58134E-02	18	85
2.02509E+02	2.05740E+02	9.90600E+01	1.02291E+02	6.35309E-02	18	85
2.05740E+02	2.08971E+02	9.90600E+01	1.02291E+02	4.28615E-02	18	85
2.08971E+02	2.12202E+02	9.90600E+01	1.02291E+02	5.71213E-02	18	85
1.99278E+02	2.02509E+02	1.02291E+02	1.05522E+02	5.90890E-02	18	85
2.02509E+02	2.05740E+02	1.02291E+02	1.05522E+02	5.53590E-02	18	85
2.05740E+02	2.08971E+02	1.02291E+02	1.05522E+02	5.45343E-02	18	85
2.08971E+02	2.12202E+02	1.02291E+02	1.05522E+02	5.08145E-02	18	85
1.84038E+02	1.87269E+02	1.07838E+02	1.11069E+02	7.74534E-02	19	92
1.87269E+02	1.90500E+02	1.07838E+02	1.11069E+02	7.68078E-02	19	92
1.90500E+02	1.93731E+02	1.07838E+02	1.11069E+02	7.02795E-02	19	92
1.93731E+02	1.96962E+02	1.07838E+02	1.11069E+02	6.74748E-02	19	92
1.84038E+02	1.87269E+02	1.11069E+02	1.14300E+02	7.42464E-02	19	92
1.87269E+02	1.90500E+02	1.11069E+02	1.14300E+02	5.09560E-02	19	92
1.90500E+02	1.93731E+02	1.11069E+02	1.14300E+02	6.55080E-02	19	92
1.93731E+02	1.96962E+02	1.11069E+02	1.14300E+02	6.09946E-02	19	92
1.84038E+02	1.87269E+02	1.14300E+02	1.17531E+02	6.58713E-02	19	92
1.87269E+02	1.90500E+02	1.14300E+02	1.17531E+02	6.39645E-02	19	92
1.90500E+02	1.93731E+02	1.14300E+02	1.17531E+02	4.30284E-02	19	92
1.93731E+02	1.96962E+02	1.14300E+02	1.17531E+02	5.80998E-02	19	92
1.84038E+02	1.87269E+02	1.17531E+02	1.20762E+02	6.07664E-02	19	92
1.87269E+02	1.90500E+02	1.17531E+02	1.20762E+02	5.65263E-02	19	92
1.90500E+02	1.93731E+02	1.17531E+02	1.20762E+02	5.55264E-02	19	92
1.93731E+02	1.96962E+02	1.17531E+02	1.20762E+02	5.24964E-02	19	92
1.68798E+02	1.72029E+02	1.23078E+02	1.26309E+02	7.50462E-02	20	97
1.72029E+02	1.75260E+02	1.23078E+02	1.26309E+02	7.39381E-02	20	97
1.75260E+02	1.78491E+02	1.23078E+02	1.26309E+02	6.77671E-02	20	97
1.78491E+02	1.81722E+02	1.23078E+02	1.26309E+02	6.59961E-02	20	97

Table 2.2.2.5

Pin Geometry and Power Distributions (cont'd)

Pin Pitch Set 2

X-Left	X-Right	Y-Bot	Y-Top	Pin* Power Fraction	Pin Power Set	Assemb. Number
1.68798E+02	1.72029E+02	1.26309E+02	1.29540E+02	7.33948E-02	20	97
1.72029E+02	1.75260E+02	1.26309E+02	1.29540E+02	4.98977E-02	20	97
1.75260E+02	1.78491E+02	1.26309E+02	1.29540E+02	6.52329E-02	20	97
1.78491E+02	1.81722E+02	1.26309E+02	1.29540E+02	6.12728E-02	20	97
1.68798E+02	1.72029E+02	1.29540E+02	1.32771E+02	6.64117E-02	20	97
1.72029E+02	1.75260E+02	1.29540E+02	1.32771E+02	6.38749E-02	20	97
1.75260E+02	1.78491E+02	1.29540E+02	1.32771E+02	4.36941E-02	20	97
1.78491E+02	1.81722E+02	1.29540E+02	1.32771E+02	5.96622E-02	20	97
1.68798E+02	1.72029E+02	1.32771E+02	1.36002E+02	6.30655E-02	20	97
1.72029E+02	1.75260E+02	1.32771E+02	1.36002E+02	5.89017E-02	20	97
1.75260E+02	1.78491E+02	1.32771E+02	1.36002E+02	5.80814E-02	20	97
1.78491E+02	1.81722E+02	1.32771E+02	1.36002E+02	5.37628E-02	20	97
1.68798E+02	1.72029E+02	1.38318E+02	1.41549E+02	7.70431E-02	21	101
1.72029E+02	1.75260E+02	1.38318E+02	1.41549E+02	7.24457E-02	21	101
1.75260E+02	1.78491E+02	1.38318E+02	1.41549E+02	7.17453E-02	21	101
1.78491E+02	1.81722E+02	1.38318E+02	1.41549E+02	6.66866E-02	21	101
1.68798E+02	1.72029E+02	1.41549E+02	1.44780E+02	7.10549E-02	21	101
1.72029E+02	1.75260E+02	1.41549E+02	1.44780E+02	6.89371E-02	21	101
1.75260E+02	1.78491E+02	1.41549E+02	1.44780E+02	4.73810E-02	21	101
1.78491E+02	1.81722E+02	1.41549E+02	1.44780E+02	6.42501E-02	21	101
1.68798E+02	1.72029E+02	1.44780E+02	1.48011E+02	6.85786E-02	21	101
1.72029E+02	1.75260E+02	1.44780E+02	1.48011E+02	4.59769E-02	21	101
1.75260E+02	1.78491E+02	1.44780E+02	1.48011E+02	6.00146E-02	21	101
1.78491E+02	1.81722E+02	1.44780E+02	1.48011E+02	5.68247E-02	21	101
1.68798E+02	1.72029E+02	1.48011E+02	1.51242E+02	6.14419E-02	21	101
1.72029E+02	1.75260E+02	1.48011E+02	1.51242E+02	6.02735E-02	21	101
1.75260E+02	1.78491E+02	1.48011E+02	1.51242E+02	5.46604E-02	21	101
1.78491E+02	1.81722E+02	1.48011E+02	1.51242E+02	5.26854E-02	21	101
1.68798E+02	1.72029E+02	1.53558E+02	1.56789E+02	8.18676E-02	22	104
1.72029E+02	1.75260E+02	1.53558E+02	1.56789E+02	7.89096E-02	22	104
1.75260E+02	1.78491E+02	1.53558E+02	1.56789E+02	6.99618E-02	22	104
1.78491E+02	1.81722E+02	1.53558E+02	1.56789E+02	6.44585E-02	22	104
1.68798E+02	1.72029E+02	1.56789E+02	1.60020E+02	7.82103E-02	22	104
1.72029E+02	1.75260E+02	1.56789E+02	1.60020E+02	5.19621E-02	22	104
1.75260E+02	1.78491E+02	1.56789E+02	1.60020E+02	6.55618E-02	22	104
1.78491E+02	1.81722E+02	1.56789E+02	1.60020E+02	5.81213E-02	22	104
1.68798E+02	1.72029E+02	1.60020E+02	1.63251E+02	6.82592E-02	22	104
1.72029E+02	1.75260E+02	1.60020E+02	1.63251E+02	6.41111E-02	22	104
1.75260E+02	1.78491E+02	1.60020E+02	1.63251E+02	4.21956E-02	22	104
1.78491E+02	1.81722E+02	1.60020E+02	1.63251E+02	5.50026E-02	22	104
1.68798E+02	1.72029E+02	1.63251E+02	1.66482E+02	6.17959E-02	22	104
1.72029E+02	1.75260E+02	1.63251E+02	1.66482E+02	5.64056E-02	22	104
1.75260E+02	1.78491E+02	1.63251E+02	1.66482E+02	5.42642E-02	22	104
1.78491E+02	1.81722E+02	1.63251E+02	1.66482E+02	4.89129E-02	22	104

Table 2.2.2.5

Pin Geometry and Power Distributions (cont'd)

+
Pin Pitch Set 3

X-Left	X-Right	Y-Bot	Y-Top	Pin* Power Fraction	Pin Power Set	Assemb. Number
2.29758E+02	2.31374E+02	1.15824E+00	2.77368E+00	2.20726E-02	23	16
2.31374E+02	2.32989E+02	1.15824E+00	2.77368E+00	2.15033E-02	23	16
2.32989E+02	2.34605E+02	1.15824E+00	2.77368E+00	2.11050E-02	23	16
2.34605E+02	2.36220E+02	1.15824E+00	2.77368E+00	2.06648E-02	23	16
2.36220E+02	2.37835E+02	1.15824E+00	2.77368E+00	2.05695E-02	23	16
2.37835E+02	2.39451E+02	1.15824E+00	2.77368E+00	2.08215E-02	23	16
2.39451E+02	2.41066E+02	1.15824E+00	2.77368E+00	2.10195E-02	23	16
2.41066E+02	2.42682E+02	1.15824E+00	2.77368E+00	2.13527E-02	23	16
2.29758E+02	2.31374E+02	2.77368E+00	4.38912E+00	2.04287E-02	23	16
2.31374E+02	2.32989E+02	2.77368E+00	4.38912E+00	1.87171E-02	23	16
2.32989E+02	2.34605E+02	2.77368E+00	4.38912E+00	1.82948E-02	23	16
2.34605E+02	2.36220E+02	2.77368E+00	4.38912E+00	1.79038E-02	23	16
2.36220E+02	2.37835E+02	2.77368E+00	4.38912E+00	1.77691E-02	23	16
2.37835E+02	2.39451E+02	2.77368E+00	4.38912E+00	1.79714E-02	23	16
2.39451E+02	2.41066E+02	2.77368E+00	4.38912E+00	1.81896E-02	23	16
2.41066E+02	2.42682E+02	2.77368E+00	4.38912E+00	1.95975E-02	23	16
2.29758E+02	2.31374E+02	4.38912E+00	6.00456E+00	1.87909E-02	23	16
2.31374E+02	2.32989E+02	4.38912E+00	6.00456E+00	1.71445E-02	23	16
2.32989E+02	2.34605E+02	4.38912E+00	6.00456E+00	1.65420E-02	23	16
2.34605E+02	2.36220E+02	4.38912E+00	6.00456E+00	1.65021E-02	23	16
2.36220E+02	2.37835E+02	4.38912E+00	6.00456E+00	1.61547E-02	23	16
2.37835E+02	2.39451E+02	4.38912E+00	6.00456E+00	1.60281E-02	23	16
2.39451E+02	2.41066E+02	4.38912E+00	6.00456E+00	1.65912E-02	23	16
2.41066E+02	2.42682E+02	4.38912E+00	6.00456E+00	1.79118E-02	23	16
2.29758E+02	2.31374E+02	6.00456E+00	7.62000E+00	1.71304E-02	23	16
2.31374E+02	2.32989E+02	6.00456E+00	7.62000E+00	1.56315E-02	23	16
2.32989E+02	2.34605E+02	6.00456E+00	7.62000E+00	1.53893E-02	23	16
2.34605E+02	2.36220E+02	6.00456E+00	7.62000E+00	0.00000E+00	23	16
2.36220E+02	2.37835E+02	6.00456E+00	7.62000E+00	1.55264E-02	23	16
2.37835E+02	2.39451E+02	6.00456E+00	7.62000E+00	1.48557E-02	23	16
2.39451E+02	2.41066E+02	6.00456E+00	7.62000E+00	1.50837E-02	23	16
2.41066E+02	2.42682E+02	6.00456E+00	7.62000E+00	1.62641E-02	23	16
2.29758E+02	2.31374E+02	7.62000E+00	9.23544E+00	1.58553E-02	23	16
2.31374E+02	2.32989E+02	7.62000E+00	9.23544E+00	1.44929E-02	23	16
2.32989E+02	2.34605E+02	7.62000E+00	9.23544E+00	1.40706E-02	23	16
2.34605E+02	2.36220E+02	7.62000E+00	9.23544E+00	1.45028E-02	23	16
2.36220E+02	2.37835E+02	7.62000E+00	9.23544E+00	0.00000E+00	23	16
2.37835E+02	2.39451E+02	7.62000E+00	9.23544E+00	1.39956E-02	23	16
2.39451E+02	2.41066E+02	7.62000E+00	9.23544E+00	1.39956E-02	23	16
2.41066E+02	2.42682E+02	7.62000E+00	9.23544E+00	1.50167E-02	23	16
2.29758E+02	2.31374E+02	9.23544E+00	1.08509E+01	1.50585E-02	23	16
2.31374E+02	2.32989E+02	9.23544E+00	1.08509E+01	1.38327E-02	23	16
2.32989E+02	2.34605E+02	9.23544E+00	1.08509E+01	1.32400E-02	23	16
2.34605E+02	2.36220E+02	9.23544E+00	1.08509E+01	1.31625E-02	23	16
2.36220E+02	2.37835E+02	9.23544E+00	1.08509E+01	1.32714E-02	23	16
2.37835E+02	2.39451E+02	9.23544E+00	1.08509E+01	1.31091E-02	23	16

+ Pin Pitch Set 3 is an 8x8 array.

* Pin Power Fraction of Assembly Power.

Table.2.2.2.5

Pin Geometry and Power Distributions (cont'd)

Pin Pitch Set 3

X-Left	X-Right	Y-Bot	Y-Top	Pin* Power Fraction	Pin Power Set	Assemb. Number
2.39451E+02	2.41066E+02	9.23544E+00	1.08509E+01	1.33408E-02	23	16
2.41066E+02	2.42682E+02	9.23544E+00	1.08509E+01	1.42513E-02	23	16
2.29758E+02	2.31374E+02	1.08509E+01	1.24663E+01	1.46042E-02	23	16
2.31374E+02	2.32989E+02	1.08509E+01	1.24663E+01	1.35745E-02	23	16
2.32989E+02	2.34605E+02	1.08509E+01	1.24663E+01	1.33507E-02	23	16
2.34605E+02	2.36220E+02	1.08509E+01	1.24663E+01	1.30869E-02	23	16
2.36220E+02	2.37835E+02	1.08509E+01	1.24663E+01	1.30156E-02	23	16
2.37835E+02	2.39451E+02	1.08509E+01	1.24663E+01	1.30888E-02	23	16
2.39451E+02	2.41066E+02	1.08509E+01	1.24663E+01	1.31127E-02	23	16
2.41066E+02	2.42682E+02	1.08509E+01	1.24663E+01	1.38468E-02	23	16
2.29758E+02	2.31374E+02	1.24663E+01	1.40818E+01	1.48956E-02	23	16
2.31374E+02	2.32989E+02	1.24663E+01	1.40818E+01	1.49891E-02	23	16
2.32989E+02	2.34605E+02	1.24663E+01	1.40818E+01	1.49135E-02	23	16
2.34605E+02	2.36220E+02	1.24663E+01	1.40818E+01	1.46915E-02	23	16
2.36220E+02	2.37835E+02	1.24663E+01	1.40818E+01	1.46177E-02	23	16
2.37835E+02	2.39451E+02	1.24663E+01	1.40818E+01	1.46755E-02	23	16
2.39451E+02	2.41066E+02	1.24663E+01	1.40818E+01	1.45569E-02	23	16
2.41066E+02	2.42682E+02	1.24663E+01	1.40818E+01	1.42569E-02	23	16
2.29758E+02	2.31374E+02	1.63982E+01	1.80137E+01	2.16985E-02	24	31
2.31374E+02	2.32989E+02	1.63982E+01	1.80137E+01	2.08917E-02	24	31
2.32989E+02	2.34605E+02	1.63982E+01	1.80137E+01	2.03213E-02	24	31
2.34605E+02	2.36220E+02	1.63982E+01	1.80137E+01	1.98806E-02	24	31
2.36220E+02	2.37835E+02	1.63982E+01	1.80137E+01	1.99677E-02	24	31
2.37835E+02	2.39451E+02	1.63982E+01	1.80137E+01	2.07482E-02	24	31
2.39451E+02	2.41066E+02	1.63982E+01	1.80137E+01	2.20546E-02	24	31
2.41066E+02	2.42682E+02	1.63982E+01	1.80137E+01	2.44995E-02	24	31
2.29758E+02	2.31374E+02	1.80137E+01	1.96291E+01	2.00542E-02	24	31
2.31374E+02	2.32989E+02	1.80137E+01	1.96291E+01	1.82018E-02	24	31
2.32989E+02	2.34605E+02	1.80137E+01	1.96291E+01	1.76539E-02	24	31
2.34605E+02	2.36220E+02	1.80137E+01	1.96291E+01	1.72495E-02	24	31
2.36220E+02	2.37835E+02	1.80137E+01	1.96291E+01	1.73548E-02	24	31
2.37835E+02	2.39451E+02	1.80137E+01	1.96291E+01	1.80325E-02	24	31
2.39451E+02	2.41066E+02	1.80137E+01	1.96291E+01	1.93327E-02	24	31
2.41066E+02	2.42682E+02	1.80137E+01	1.96291E+01	2.31567E-02	24	31
2.29758E+02	2.31374E+02	1.96291E+01	2.12446E+01	1.83234E-02	24	31
2.31374E+02	2.32989E+02	1.96291E+01	2.12446E+01	1.66007E-02	24	31
2.32989E+02	2.34605E+02	1.96291E+01	2.12446E+01	1.57211E-02	24	31
2.34605E+02	2.36220E+02	1.96291E+01	2.12446E+01	1.56259E-02	24	31
2.36220E+02	2.37835E+02	1.96291E+01	2.12446E+01	1.59086E-02	24	31
2.37835E+02	2.39451E+02	1.96291E+01	2.12446E+01	1.62101E-02	24	31
2.39451E+02	2.41066E+02	1.96291E+01	2.12446E+01	1.76457E-02	24	31
2.41066E+02	2.42682E+02	1.96291E+01	2.12446E+01	2.14378E-02	24	31
2.29758E+02	2.31374E+02	2.12446E+01	2.28600E+01	1.65681E-02	24	31
2.31374E+02	2.32989E+02	2.12446E+01	2.28600E+01	1.50153E-02	24	31
2.32989E+02	2.34605E+02	2.12446E+01	2.28600E+01	1.44812E-02	24	31
2.34605E+02	2.36220E+02	2.12446E+01	2.28600E+01	1.49062E-02	24	31
2.36220E+02	2.37835E+02	2.12446E+01	2.28600E+01	0.00000E+00	24	31
2.37835E+02	2.39451E+02	2.12446E+01	2.28600E+01	1.49200E-02	24	31
2.39451E+02	2.41066E+02	2.12446E+01	2.28600E+01	1.59612E-02	24	31

Table 2.2.2.5

Pin Geometry and Power Distributions (cont'd)

Pin Pitch Set 3

X-Left	X-Right	Y-Bot	Y-Top	Pin* Power Fraction	Pin Power Set	Assemb. Number
2.41066E+02	2.42682E+02	2.12446E+01	2.28600E+01	1.95107E-02	24	31
2.29758E+02	2.31374E+02	2.28600E+01	2.44754E+01	1.51870E-02	24	31
2.31374E+02	2.32989E+02	2.28600E+01	2.44754E+01	1.38242E-02	24	31
2.32989E+02	2.34605E+02	2.28600E+01	2.44754E+01	1.35245E-02	24	31
2.34605E+02	2.36220E+02	2.28600E+01	2.44754E+01	0.00000E+00	24	31
2.36220E+02	2.37835E+02	2.28600E+01	2.44754E+01	1.36863E-02	24	31
2.37835E+02	2.39451E+02	2.28600E+01	2.44754E+01	1.34681E-02	24	31
2.39451E+02	2.41066E+02	2.28600E+01	2.44754E+01	1.46184E-02	24	31
2.41066E+02	2.42682E+02	2.28600E+01	2.44754E+01	1.79309E-02	24	31
2.29758E+02	2.31374E+02	2.44754E+01	2.60909E+01	1.43094E-02	24	31
2.31374E+02	2.32989E+02	2.44754E+01	2.60909E+01	1.30876E-02	24	31
2.32989E+02	2.34605E+02	2.44754E+01	2.60909E+01	1.25861E-02	24	31
2.34605E+02	2.36220E+02	2.44754E+01	2.60909E+01	1.25240E-02	24	31
2.36220E+02	2.37835E+02	2.44754E+01	2.60909E+01	1.23171E-02	24	31
2.37835E+02	2.39451E+02	2.44754E+01	2.60909E+01	1.25334E-02	24	31
2.39451E+02	2.41066E+02	2.44754E+01	2.60909E+01	1.37490E-02	24	31
2.41066E+02	2.42682E+02	2.44754E+01	2.60909E+01	1.67261E-02	24	31
2.29758E+02	2.31374E+02	2.60909E+01	2.77063E+01	1.38762E-02	24	31
2.31374E+02	2.32989E+02	2.60909E+01	2.77063E+01	1.28838E-02	24	31
2.32989E+02	2.34605E+02	2.60909E+01	2.77063E+01	1.26068E-02	24	31
2.34605E+02	2.36220E+02	2.60909E+01	2.77063E+01	1.23052E-02	24	31
2.36220E+02	2.37835E+02	2.60909E+01	2.77063E+01	1.22444E-02	24	31
2.37835E+02	2.39451E+02	2.60909E+01	2.77063E+01	1.25660E-02	24	31
2.39451E+02	2.41066E+02	2.60909E+01	2.77063E+01	1.32418E-02	24	31
2.41066E+02	2.42682E+02	2.60909E+01	2.77063E+01	1.56014E-02	24	31
2.29758E+02	2.31374E+02	2.77063E+01	2.93218E+01	1.44649E-02	24	31
2.31374E+02	2.32989E+02	2.77063E+01	2.93218E+01	1.45721E-02	24	31
2.32989E+02	2.34605E+02	2.77063E+01	2.93218E+01	1.44611E-02	24	31
2.34605E+02	2.36220E+02	2.77063E+01	2.93218E+01	1.41514E-02	24	31
2.36220E+02	2.37835E+02	2.77063E+01	2.93218E+01	1.40079E-02	24	31
2.37835E+02	2.39451E+02	2.77063E+01	2.93218E+01	1.40969E-02	24	31
2.39451E+02	2.41066E+02	2.77063E+01	2.93218E+01	1.42467E-02	24	31
2.41066E+02	2.42682E+02	2.77063E+01	2.93218E+01	1.46673E-02	24	31
2.14518E+02	2.16134E+02	3.16382E+01	3.32537E+01	1.99385E-02	25	44
2.16134E+02	2.17749E+02	3.16382E+01	3.32537E+01	1.94177E-02	25	44
2.17749E+02	2.19365E+02	3.16382E+01	3.32537E+01	1.85347E-02	25	44
2.19365E+02	2.20980E+02	3.16382E+01	3.32537E+01	1.89932E-02	25	44
2.20980E+02	2.22595E+02	3.16382E+01	3.32537E+01	1.88777E-02	25	44
2.22595E+02	2.24211E+02	3.16382E+01	3.32537E+01	1.91332E-02	25	44
2.24211E+02	2.25826E+02	3.16382E+01	3.32537E+01	1.88036E-02	25	44
2.25826E+02	2.27442E+02	3.16382E+01	3.32537E+01	1.91306E-02	25	44
2.14518E+02	2.16134E+02	3.32537E+01	3.48691E+01	1.87173E-02	25	44
2.16134E+02	2.17749E+02	3.32537E+01	3.48691E+01	1.75690E-02	25	44
2.17749E+02	2.19365E+02	3.32537E+01	3.48691E+01	1.66704E-02	25	44
2.19365E+02	2.20980E+02	3.32537E+01	3.48691E+01	1.79454E-02	25	44
2.20980E+02	2.22595E+02	3.32537E+01	3.48691E+01	1.78965E-02	25	44
2.22595E+02	2.24211E+02	3.32537E+01	3.48691E+01	1.82406E-02	25	44
2.24211E+02	2.25826E+02	3.32537E+01	3.48691E+01	1.71079E-02	25	44
2.25826E+02	2.27442E+02	3.32537E+01	3.48691E+01	1.80554E-02	25	44

Table 2.2.2.5

Pin Geometry and Power Distributions (cont'd)

Pin Pitch Set 3

X-Left	X-Right	Y-Bot	Y-Top	Pin* Power Fraction	Pin Power Set	Assemb. Number
2.14518E+02	2.16134E+02	3.48691E+01	3.64846E+01	1.70923E-02	25	44
2.16134E+02	2.17749E+02	3.48691E+01	3.64846E+01	1.59370E-02	25	44
2.17749E+02	2.19365E+02	3.48691E+01	3.64846E+01	1.66923E-02	25	44
2.19365E+02	2.20980E+02	3.48691E+01	3.64846E+01	1.65200E-02	25	44
2.20980E+02	2.22595E+02	3.48691E+01	3.64846E+01	1.67615E-02	25	44
2.22595E+02	2.24211E+02	3.48691E+01	3.64846E+01	1.41854E-02	25	44
2.24211E+02	2.25826E+02	3.48691E+01	3.64846E+01	1.72357E-02	25	44
2.25826E+02	2.27442E+02	3.48691E+01	3.64846E+01	1.73479E-02	25	44
2.14518E+02	2.16134E+02	3.64846E+01	3.81000E+01	1.67075E-02	25	44
2.16134E+02	2.17749E+02	3.64846E+01	3.81000E+01	1.63730E-02	25	44
2.17749E+02	2.19365E+02	3.64846E+01	3.81000E+01	1.57577E-02	25	44
2.19365E+02	2.20980E+02	3.64846E+01	3.81000E+01	1.55474E-02	25	44
2.20980E+02	2.22595E+02	3.64846E+01	3.81000E+01	0.00000E+00	25	44
2.22595E+02	2.24211E+02	3.64846E+01	3.81000E+01	1.57137E-02	25	44
2.24211E+02	2.25826E+02	3.64846E+01	3.81000E+01	1.58426E-02	25	44
2.25826E+02	2.27442E+02	3.64846E+01	3.81000E+01	1.60241E-02	25	44
2.14518E+02	2.16134E+02	3.81000E+01	3.97154E+01	1.59033E-02	25	44
2.16134E+02	2.17749E+02	3.81000E+01	3.97154E+01	1.56466E-02	25	44
2.17749E+02	2.19365E+02	3.81000E+01	3.97154E+01	1.53251E-02	25	44
2.19365E+02	2.20980E+02	3.81000E+01	3.97154E+01	0.00000E+00	25	44
2.20980E+02	2.22595E+02	3.81000E+01	3.97154E+01	1.51888E-02	25	44
2.22595E+02	2.24211E+02	3.81000E+01	3.97154E+01	1.45402E-02	25	44
2.24211E+02	2.25826E+02	3.81000E+01	3.97154E+01	1.49080E-02	25	44
2.25826E+02	2.27442E+02	3.81000E+01	3.97154E+01	1.50743E-02	25	44
2.14518E+02	2.16134E+02	3.97154E+01	4.13309E+01	1.56300E-02	25	44
2.16134E+02	2.17749E+02	3.97154E+01	4.13309E+01	1.55114E-02	25	44
2.17749E+02	2.19365E+02	3.97154E+01	4.13309E+01	1.26260E-02	25	44
2.19365E+02	2.20980E+02	3.97154E+01	4.13309E+01	1.46680E-02	25	44
2.20980E+02	2.22595E+02	3.97154E+01	4.13309E+01	1.41565E-02	25	44
2.22595E+02	2.24211E+02	3.97154E+01	4.13309E+01	1.40431E-02	25	44
2.24211E+02	2.25826E+02	3.97154E+01	4.13309E+01	1.31623E-02	25	44
2.25826E+02	2.27442E+02	3.97154E+01	4.13309E+01	1.38757E-02	25	44
2.14518E+02	2.16134E+02	4.13309E+01	4.29463E+01	1.52784E-02	25	44
2.16134E+02	2.17749E+02	4.13309E+01	4.29463E+01	1.45832E-02	25	44
2.17749E+02	2.19365E+02	4.13309E+01	4.29463E+01	1.54340E-02	25	44
2.19365E+02	2.20980E+02	4.13309E+01	4.29463E+01	1.48914E-02	25	44
2.20980E+02	2.22595E+02	4.13309E+01	4.29463E+01	1.46273E-02	25	44
2.22595E+02	2.24211E+02	4.13309E+01	4.29463E+01	1.32675E-02	25	44
2.24211E+02	2.25826E+02	4.13309E+01	4.29463E+01	1.36057E-02	25	44
2.25826E+02	2.27442E+02	4.13309E+01	4.29463E+01	1.40383E-02	25	44
2.14518E+02	2.16134E+02	4.29463E+01	4.45618E+01	1.61556E-02	25	44
2.16134E+02	2.17749E+02	4.29463E+01	4.45618E+01	1.62211E-02	25	44
2.17749E+02	2.19365E+02	4.29463E+01	4.45618E+01	1.64760E-02	25	44
2.19365E+02	2.20980E+02	4.29463E+01	4.45618E+01	1.60278E-02	25	44
2.20980E+02	2.22595E+02	4.29463E+01	4.45618E+01	1.57766E-02	25	44
2.22595E+02	2.24211E+02	4.29463E+01	4.45618E+01	1.49440E-02	25	44
2.24211E+02	2.25826E+02	4.29463E+01	4.45618E+01	1.50395E-02	25	44
2.25826E+02	2.27442E+02	4.29463E+01	4.45618E+01	1.46047E-02	25	44
2.14518E+02	2.16134E+02	4.68782E+01	4.84937E+01	2.14131E-02	26	56

Table 2.2.2.5

Pin Geometry and Power Distributions (cont'd)

Pin Pitch Set 3

X-Left	X-Right	Y-Bot	Y-Top	Pin* Power Fraction	Pin Power Set	Assemb. Number
2.16134E+02	2.17749E+02	4.68782E+01	4.84937E+01	2.07553E-02	26	56
2.17749E+02	2.19365E+02	4.68782E+01	4.84937E+01	2.03202E-02	26	56
2.19365E+02	2.20980E+02	4.68782E+01	4.84937E+01	1.98340E-02	26	56
2.20980E+02	2.22595E+02	4.68782E+01	4.84937E+01	1.96884E-02	26	56
2.22595E+02	2.24211E+02	4.68782E+01	4.84937E+01	1.99191E-02	26	56
2.24211E+02	2.25826E+02	4.68782E+01	4.84937E+01	2.02142E-02	26	56
2.25826E+02	2.27442E+02	4.68782E+01	4.84937E+01	2.07928E-02	26	56
2.14518E+02	2.16134E+02	4.84937E+01	5.01091E+01	1.99315E-02	26	56
2.16134E+02	2.17749E+02	4.84937E+01	5.01091E+01	1.82024E-02	26	56
2.17749E+02	2.19365E+02	4.84937E+01	5.01091E+01	1.77064E-02	26	56
2.19365E+02	2.20980E+02	4.84937E+01	5.01091E+01	1.72615E-02	26	56
2.20980E+02	2.22595E+02	4.84937E+01	5.01091E+01	1.71146E-02	26	56
2.22595E+02	2.24211E+02	4.84937E+01	5.01091E+01	1.73219E-02	26	56
2.24211E+02	2.25826E+02	4.84937E+01	5.01091E+01	1.76115E-02	26	56
2.25826E+02	2.27442E+02	4.84937E+01	5.01091E+01	1.92336E-02	26	56
2.14518E+02	2.16134E+02	5.01091E+01	5.17246E+01	1.85154E-02	26	56
2.16134E+02	2.17749E+02	5.01091E+01	5.17246E+01	1.68357E-02	26	56
2.17749E+02	2.19365E+02	5.01091E+01	5.17246E+01	1.61860E-02	26	56
2.19365E+02	2.20980E+02	5.01091E+01	5.17246E+01	1.60612E-02	26	56
2.20980E+02	2.22595E+02	5.01091E+01	5.17246E+01	1.56972E-02	26	56
2.22595E+02	2.24211E+02	5.01091E+01	5.17246E+01	1.56121E-02	26	56
2.24211E+02	2.25826E+02	5.01091E+01	5.17246E+01	1.62260E-02	26	56
2.25826E+02	2.27442E+02	5.01091E+01	5.17246E+01	1.77545E-02	26	56
2.14518E+02	2.16134E+02	5.17246E+01	5.33400E+01	1.70746E-02	26	56
2.16134E+02	2.17749E+02	5.17246E+01	5.33400E+01	1.55184E-02	26	56
2.17749E+02	2.19365E+02	5.17246E+01	5.33400E+01	1.51999E-02	26	56
2.19365E+02	2.20980E+02	5.17246E+01	5.33400E+01	0.00000E+00	26	56
2.20980E+02	2.22595E+02	5.17246E+01	5.33400E+01	1.52097E-02	26	56
2.22595E+02	2.24211E+02	5.17246E+01	5.33400E+01	1.46064E-02	26	56
2.24211E+02	2.25826E+02	5.17246E+01	5.33400E+01	1.49129E-02	26	56
2.25826E+02	2.27442E+02	5.17246E+01	5.33400E+01	1.63248E-02	26	56
2.14518E+02	2.16134E+02	5.33400E+01	5.49554E+01	1.60378E-02	26	56
2.16134E+02	2.17749E+02	5.33400E+01	5.49554E+01	1.45711E-02	26	56
2.17749E+02	2.19365E+02	5.33400E+01	5.49554E+01	1.40874E-02	26	56
2.19365E+02	2.20980E+02	5.33400E+01	5.49554E+01	1.44459E-02	26	56
2.20980E+02	2.22595E+02	5.33400E+01	5.49554E+01	0.00000E+00	26	56
2.22595E+02	2.24211E+02	5.33400E+01	5.49554E+01	1.39486E-02	26	56
2.24211E+02	2.25826E+02	5.33400E+01	5.49554E+01	1.40269E-02	26	56
2.25826E+02	2.27442E+02	5.33400E+01	5.49554E+01	1.53072E-02	26	56
2.14518E+02	2.16134E+02	5.49554E+01	5.65709E+01	1.54554E-02	26	56
2.16134E+02	2.17749E+02	5.49554E+01	5.65709E+01	1.41312E-02	26	56
2.17749E+02	2.19365E+02	5.49554E+01	5.65709E+01	1.34666E-02	26	56
2.19365E+02	2.20980E+02	5.49554E+01	5.65709E+01	1.33623E-02	26	56
2.20980E+02	2.22595E+02	5.49554E+01	5.65709E+01	1.34572E-02	26	56
2.22595E+02	2.24211E+02	5.49554E+01	5.65709E+01	1.33210E-02	26	56
2.24211E+02	2.25826E+02	5.49554E+01	5.65709E+01	1.36109E-02	26	56
2.25826E+02	2.27442E+02	5.49554E+01	5.65709E+01	1.47563E-02	26	56
2.14518E+02	2.16134E+02	5.65709E+01	5.81863E+01	1.52536E-02	26	56
2.16134E+02	2.17749E+02	5.65709E+01	5.81863E+01	1.41466E-02	26	56

Table 2.2.2.5

Pin Geometry and Power Distributions (cont'd)

Pin Pitch Set 3

X-Left	X-Right	Y-Bot	Y-Top	Pin* Power Fraction	Pin Power Set	Assemb. Number
2.17749E+02	2.19365E+02	5.65709E+01	5.81863E+01	1.38758E-02	26	56
2.19365E+02	2.20980E+02	5.65709E+01	5.81863E+01	1.35709E-02	26	56
2.20980E+02	2.22595E+02	5.65709E+01	5.81863E+01	1.34870E-02	26	56
2.22595E+02	2.24211E+02	5.65709E+01	5.81863E+01	1.35875E-02	26	56
2.24211E+02	2.25826E+02	5.65709E+01	5.81863E+01	1.36535E-02	26	56
2.25826E+02	2.27442E+02	5.65709E+01	5.81863E+01	1.45502E-02	26	56
2.14518E+02	2.16134E+02	5.81863E+01	5.98018E+01	1.59101E-02	26	56
2.16134E+02	2.17749E+02	5.81863E+01	5.98018E+01	1.59195E-02	26	56
2.17749E+02	2.19365E+02	5.81863E+01	5.98018E+01	1.58262E-02	26	56
2.19365E+02	2.20980E+02	5.81863E+01	5.98018E+01	1.55763E-02	26	56
2.20980E+02	2.22595E+02	5.81863E+01	5.98018E+01	1.54720E-02	26	56
2.22595E+02	2.24211E+02	5.81863E+01	5.98018E+01	1.55363E-02	26	56
2.24211E+02	2.25826E+02	5.81863E+01	5.98018E+01	1.54115E-02	26	56
2.25826E+02	2.27442E+02	5.81863E+01	5.98018E+01	1.51820E-02	26	56
2.14518E+02	2.16134E+02	6.21182E+01	6.37337E+01	2.24830E-02	27	67
2.16134E+02	2.17749E+02	6.21182E+01	6.37337E+01	2.15363E-02	27	67
2.17749E+02	2.19365E+02	6.21182E+01	6.37337E+01	2.08399E-02	27	67
2.19365E+02	2.20980E+02	6.21182E+01	6.37337E+01	2.02174E-02	27	67
2.20980E+02	2.22595E+02	6.21182E+01	6.37337E+01	2.00014E-02	27	67
2.22595E+02	2.24211E+02	6.21182E+01	6.37337E+01	2.01536E-02	27	67
2.24211E+02	2.25826E+02	6.21182E+01	6.37337E+01	2.02825E-02	27	67
2.25826E+02	2.27442E+02	6.21182E+01	6.37337E+01	2.06286E-02	27	67
2.14518E+02	2.16134E+02	6.37337E+01	6.53491E+01	2.07363E-02	27	67
2.16134E+02	2.17749E+02	6.37337E+01	6.53491E+01	1.86692E-02	27	67
2.17749E+02	2.19365E+02	6.37337E+01	6.53491E+01	1.80141E-02	27	67
2.19365E+02	2.20980E+02	6.37337E+01	6.53491E+01	1.74474E-02	27	67
2.20980E+02	2.22595E+02	6.37337E+01	6.53491E+01	1.72673E-02	27	67
2.22595E+02	2.24211E+02	6.37337E+01	6.53491E+01	1.74002E-02	27	67
2.24211E+02	2.25826E+02	6.37337E+01	6.53491E+01	1.75996E-02	27	67
2.25826E+02	2.27442E+02	6.37337E+01	6.53491E+01	1.89942E-02	27	67
2.14518E+02	2.16134E+02	6.53491E+01	6.69646E+01	1.90832E-02	27	67
2.16134E+02	2.17749E+02	6.53491E+01	6.69646E+01	1.71311E-02	27	67
2.17749E+02	2.19365E+02	6.53491E+01	6.69646E+01	1.61684E-02	27	67
2.19365E+02	2.20980E+02	6.53491E+01	6.69646E+01	1.59227E-02	27	67
2.20980E+02	2.22595E+02	6.53491E+01	6.69646E+01	1.59836E-02	27	67
2.22595E+02	2.24211E+02	6.53491E+01	6.69646E+01	1.57925E-02	27	67
2.24211E+02	2.25826E+02	6.53491E+01	6.69646E+01	1.61418E-02	27	67
2.25826E+02	2.27442E+02	6.53491E+01	6.69646E+01	1.74786E-02	27	67
2.14518E+02	2.16134E+02	6.69646E+01	6.85800E+01	1.74786E-02	27	67
2.16134E+02	2.17749E+02	6.69646E+01	6.85800E+01	1.56861E-02	27	67
2.17749E+02	2.19365E+02	6.69646E+01	6.85800E+01	1.50635E-02	27	67
2.19365E+02	2.20980E+02	6.69646E+01	6.85800E+01	1.53739E-02	27	67
2.20980E+02	2.22595E+02	6.69646E+01	6.85800E+01	0.00000E+00	27	67
2.22595E+02	2.24211E+02	6.69646E+01	6.85800E+01	1.47500E-02	27	67
2.24211E+02	2.25826E+02	6.69646E+01	6.85800E+01	1.47706E-02	27	67
2.25826E+02	2.27442E+02	6.69646E+01	6.85800E+01	1.59777E-02	27	67
2.14518E+02	2.16134E+02	6.85800E+01	7.01954E+01	1.63133E-02	27	67
2.16134E+02	2.17749E+02	6.85800E+01	7.01954E+01	1.46775E-02	27	67

Table 2.2.2.5

Pin Geometry and Power Distributions (cont'd)

Pin Pitch Set 3

X-Left	X-Right	Y-Bot	Y-Top	Pin* Power Fraction	Pin Power Set	Assemb. Number
2.17749E+02	2.19365E+02	6.85800E+01	7.01954E+01	1.43154E-02	27	67
2.19365E+02	2.20980E+02	6.85800E+01	7.01954E+01	0.00000E+00	27	67
2.20980E+02	2.22595E+02	6.85800E+01	7.01954E+01	1.42429E-02	27	67
2.22595E+02	2.24211E+02	6.85800E+01	7.01954E+01	1.35965E-02	27	67
2.24211E+02	2.25826E+02	6.85800E+01	7.01954E+01	1.37845E-02	27	67
2.25826E+02	2.27442E+02	6.85800E+01	7.01954E+01	1.48935E-02	27	67
2.14518E+02	2.16134E+02	7.01954E+01	7.18109E+01	1.56256E-02	27	67
2.16134E+02	2.17749E+02	7.01954E+01	7.18109E+01	1.41494E-02	27	67
2.17749E+02	2.19365E+02	7.01954E+01	7.18109E+01	1.35805E-02	27	67
2.19365E+02	2.20980E+02	7.01954E+01	7.18109E+01	1.34530E-02	27	67
2.20980E+02	2.22595E+02	7.01954E+01	7.18109E+01	1.30876E-02	27	67
2.22595E+02	2.24211E+02	7.01954E+01	7.18109E+01	1.29254E-02	27	67
2.24211E+02	2.25826E+02	7.01954E+01	7.18109E+01	1.32949E-02	27	67
2.25826E+02	2.27442E+02	7.01954E+01	7.18109E+01	1.42755E-02	27	67
2.14518E+02	2.16134E+02	7.18109E+01	7.34263E+01	1.53001E-02	27	67
2.16134E+02	2.17749E+02	7.18109E+01	7.34263E+01	1.40742E-02	27	67
2.17749E+02	2.19365E+02	7.18109E+01	7.34263E+01	1.37473E-02	27	67
2.19365E+02	2.20980E+02	7.18109E+01	7.34263E+01	1.33925E-02	27	67
2.20980E+02	2.22595E+02	7.18109E+01	7.34263E+01	1.32224E-02	27	67
2.22595E+02	2.24211E+02	7.18109E+01	7.34263E+01	1.32696E-02	27	67
2.24211E+02	2.25826E+02	7.18109E+01	7.34263E+01	1.32742E-02	27	67
2.25826E+02	2.27442E+02	7.18109E+01	7.34263E+01	1.40504E-02	27	67
2.14518E+02	2.16134E+02	7.34263E+01	7.50418E+01	1.58415E-02	27	67
2.16134E+02	2.17749E+02	7.34263E+01	7.50418E+01	1.57498E-02	27	67
2.17749E+02	2.19365E+02	7.34263E+01	7.50418E+01	1.55958E-02	27	67
2.19365E+02	2.20980E+02	7.34263E+01	7.50418E+01	1.52749E-02	27	67
2.20980E+02	2.22595E+02	7.34263E+01	7.50418E+01	1.51332E-02	27	67
2.22595E+02	2.24211E+02	7.34263E+01	7.50418E+01	1.51286E-02	27	67
2.24211E+02	2.25826E+02	7.34263E+01	7.50418E+01	1.49673E-02	27	67
2.25826E+02	2.27442E+02	7.34263E+01	7.50418E+01	1.46894E-02	27	67
2.14518E+02	2.16134E+02	7.73582E+01	7.89737E+01	2.26491E-02	28	77
2.16134E+02	2.17749E+02	7.73582E+01	7.89737E+01	2.19041E-02	28	77
2.17749E+02	2.19365E+02	7.73582E+01	7.89737E+01	2.12990E-02	28	77
2.19365E+02	2.20980E+02	7.73582E+01	7.89737E+01	2.06299E-02	28	77
2.20980E+02	2.22595E+02	7.73582E+01	7.89737E+01	2.02825E-02	28	77
2.22595E+02	2.24211E+02	7.73582E+01	7.89737E+01	2.02861E-02	28	77
2.24211E+02	2.25826E+02	7.73582E+01	7.89737E+01	2.03107E-02	28	77
2.25826E+02	2.27442E+02	7.73582E+01	7.89737E+01	2.05602E-02	28	77
2.14518E+02	2.16134E+02	7.89737E+01	8.05891E+01	2.09158E-02	28	77
2.16134E+02	2.17749E+02	7.89737E+01	8.05891E+01	1.90329E-02	28	77
2.17749E+02	2.19365E+02	7.89737E+01	8.05891E+01	1.84201E-02	28	77
2.19365E+02	2.20980E+02	7.89737E+01	8.05891E+01	1.78284E-02	28	77
2.20980E+02	2.22595E+02	7.89737E+01	8.05891E+01	1.75107E-02	28	77
2.22595E+02	2.24211E+02	7.89737E+01	8.05891E+01	1.75225E-02	28	77
2.24211E+02	2.25826E+02	7.89737E+01	8.05891E+01	1.75655E-02	28	77
2.25826E+02	2.27442E+02	7.89737E+01	8.05891E+01	1.88710E-02	28	77
2.14518E+02	2.16134E+02	8.05891E+01	8.22046E+01	1.92512E-02	28	77
2.16134E+02	2.17749E+02	8.05891E+01	8.22046E+01	1.74513E-02	28	77
2.17749E+02	2.19365E+02	8.05891E+01	8.22046E+01	1.66812E-02	28	77

Table 2.2.2.5

Pin Geometry and Power Distributions (cont'd)

Pin Pitch Set 3

X-Left	X-Right	Y-Bot	Y-Top	Pin* Power Fraction	Pin Power Set	Assemb. Number
2.19365E+02	2.20980E+02	8.05891E+01	8.22046E+01	1.64532E-02	28	77
2.20980E+02	2.22595E+02	8.05891E+01	8.22046E+01	1.59326E-02	28	77
2.22595E+02	2.24211E+02	8.05891E+01	8.22046E+01	1.56729E-02	28	77
2.24211E+02	2.25826E+02	8.05891E+01	8.22046E+01	1.60500E-02	28	77
2.25826E+02	2.27442E+02	8.05891E+01	8.22046E+01	1.72612E-02	28	77
2.14518E+02	2.16134E+02	8.22046E+01	8.38200E+01	1.75788E-02	28	77
2.16134E+02	2.17749E+02	8.22046E+01	8.38200E+01	1.59357E-02	28	77
2.17749E+02	2.19365E+02	8.22046E+01	8.38200E+01	1.55310E-02	28	77
2.19365E+02	2.20980E+02	8.22046E+01	8.38200E+01	0.00000E+00	28	77
2.20980E+02	2.22595E+02	8.22046E+01	8.38200E+01	1.53163E-02	28	77
2.22595E+02	2.24211E+02	8.22046E+01	8.38200E+01	1.45278E-02	28	77
2.24211E+02	2.25826E+02	8.22046E+01	8.38200E+01	1.46302E-02	28	77
2.25826E+02	2.27442E+02	8.22046E+01	8.38200E+01	1.57277E-02	28	77
2.14518E+02	2.16134E+02	8.38200E+01	8.54354E+01	1.63389E-02	28	77
2.16134E+02	2.17749E+02	8.38200E+01	8.54354E+01	1.47988E-02	28	77
2.17749E+02	2.19365E+02	8.38200E+01	8.54354E+01	1.42316E-02	28	77
2.19365E+02	2.20980E+02	8.38200E+01	8.54354E+01	1.45262E-02	28	77
2.20980E+02	2.22595E+02	8.38200E+01	8.54354E+01	0.00000E+00	28	77
2.22595E+02	2.24211E+02	8.38200E+01	8.54354E+01	1.37362E-02	28	77
2.24211E+02	2.25826E+02	8.38200E+01	8.54354E+01	1.36286E-02	28	77
2.25826E+02	2.27442E+02	8.38200E+01	8.54354E+01	1.46103E-02	28	77
2.14518E+02	2.16134E+02	8.54354E+01	8.70509E+01	1.55837E-02	28	77
2.16134E+02	2.17749E+02	8.54354E+01	8.70509E+01	1.41824E-02	28	77
2.17749E+02	2.19365E+02	8.54354E+01	8.70509E+01	1.34370E-02	28	77
2.19365E+02	2.20980E+02	8.54354E+01	8.70509E+01	1.32515E-02	28	77
2.20980E+02	2.22595E+02	8.54354E+01	8.70509E+01	1.32387E-02	28	77
2.22595E+02	2.24211E+02	8.54354E+01	8.70509E+01	1.29610E-02	28	77
2.24211E+02	2.25826E+02	8.54354E+01	8.70509E+01	1.30799E-02	28	77
2.25826E+02	2.27442E+02	8.54354E+01	8.70509E+01	1.39529E-02	28	77
2.14518E+02	2.16134E+02	8.70509E+01	8.86663E+01	1.52102E-02	28	77
2.16134E+02	2.17749E+02	8.70509E+01	8.86663E+01	1.40103E-02	28	77
2.17749E+02	2.19365E+02	8.70509E+01	8.86663E+01	1.36552E-02	28	77
2.19365E+02	2.20980E+02	8.70509E+01	8.86663E+01	1.32633E-02	28	77
2.20980E+02	2.22595E+02	8.70509E+01	8.86663E+01	1.30901E-02	28	77
2.22595E+02	2.24211E+02	8.70509E+01	8.86663E+01	1.30635E-02	28	77
2.24211E+02	2.25826E+02	8.70509E+01	8.86663E+01	1.29805E-02	28	77
2.25826E+02	2.27442E+02	8.70509E+01	8.86663E+01	1.36486E-02	28	77
2.14518E+02	2.16134E+02	8.86663E+01	9.02818E+01	1.56929E-02	28	77
2.16134E+02	2.17749E+02	8.86663E+01	9.02818E+01	1.55704E-02	28	77
2.17749E+02	2.19365E+02	8.86663E+01	9.02818E+01	1.53655E-02	28	77
2.19365E+02	2.20980E+02	8.86663E+01	9.02818E+01	1.50237E-02	28	77
2.20980E+02	2.22595E+02	8.86663E+01	9.02818E+01	1.48249E-02	28	77
2.22595E+02	2.24211E+02	8.86663E+01	9.02818E+01	1.47722E-02	28	77
2.24211E+02	2.25826E+02	8.86663E+01	9.02818E+01	1.45308E-02	28	77
2.25826E+02	2.27442E+02	8.86663E+01	9.02818E+01	1.41507E-02	28	77
2.14518E+02	2.16134E+02	9.25982E+01	9.42137E+01	2.37878E-02	29	86
2.16134E+02	2.17749E+02	9.25982E+01	9.42137E+01	2.24182E-02	29	86

Table 2.2.2.5

Pin Geometry and Power Distributions (cont'd)

Pin Pitch Set 3

X-Left	X-Right	Y-Bot	Y-Top	Pin* Power Fraction	Pin Power Set	Assemb. Number
2.17749E+02	2.19365E+02	9.25982E+01	9.42137E+01	2.12006E-02	29	86
2.19365E+02	2.20980E+02	9.25982E+01	9.42137E+01	2.00755E-02	29	86
2.20980E+02	2.22595E+02	9.25982E+01	9.42137E+01	1.94928E-02	29	86
2.22595E+02	2.24211E+02	9.25982E+01	9.42137E+01	1.95559E-02	29	86
2.24211E+02	2.25826E+02	9.25982E+01	9.42137E+01	2.01803E-02	29	86
2.25826E+02	2.27442E+02	9.25982E+01	9.42137E+01	2.19832E-02	29	86
2.14518E+02	2.16134E+02	9.42137E+01	9.58291E+01	2.20408E-02	29	86
2.16134E+02	2.17749E+02	9.42137E+01	9.58291E+01	1.95933E-02	29	86
2.17749E+02	2.19365E+02	9.42137E+01	9.58291E+01	1.85080E-02	29	86
2.19365E+02	2.20980E+02	9.42137E+01	9.58291E+01	1.75098E-02	29	86
2.20980E+02	2.22595E+02	9.42137E+01	9.58291E+01	1.70018E-02	29	86
2.22595E+02	2.24211E+02	9.42137E+01	9.58291E+01	1.70355E-02	29	86
2.24211E+02	2.25826E+02	9.42137E+01	9.58291E+01	1.76446E-02	29	86
2.25826E+02	2.27442E+02	9.42137E+01	9.58291E+01	2.05063E-02	29	86
2.14518E+02	2.16134E+02	9.58291E+01	9.74446E+01	2.01650E-02	29	86
2.16134E+02	2.17749E+02	9.58291E+01	9.74446E+01	1.79191E-02	29	86
2.17749E+02	2.19365E+02	9.58291E+01	9.74446E+01	1.65747E-02	29	86
2.19365E+02	2.20980E+02	9.58291E+01	9.74446E+01	1.59484E-02	29	86
2.20980E+02	2.22595E+02	9.58291E+01	9.74446E+01	1.56917E-02	29	86
2.22595E+02	2.24211E+02	9.58291E+01	9.74446E+01	1.54104E-02	29	86
2.24211E+02	2.25826E+02	9.58291E+01	9.74446E+01	1.61635E-02	29	86
2.25826E+02	2.27442E+02	9.58291E+01	9.74446E+01	1.89309E-02	29	86
2.14518E+02	2.16134E+02	9.74446E+01	9.90600E+01	1.82470E-02	29	86
2.16134E+02	2.17749E+02	9.74446E+01	9.90600E+01	1.62389E-02	29	86
2.17749E+02	2.19365E+02	9.74446E+01	9.90600E+01	1.52842E-02	29	86
2.19365E+02	2.20980E+02	9.74446E+01	9.90600E+01	1.52664E-02	29	86
2.20980E+02	2.22595E+02	9.74446E+01	9.90600E+01	0.00000E+00	29	86
2.22595E+02	2.24211E+02	9.74446E+01	9.90600E+01	1.42718E-02	29	86
2.24211E+02	2.25826E+02	9.74446E+01	9.90600E+01	1.46971E-02	29	86
2.25826E+02	2.27442E+02	9.74446E+01	9.90600E+01	1.72769E-02	29	86
2.14518E+02	2.16134E+02	9.90600E+01	1.00675E+02	1.67506E-02	29	86
2.16134E+02	2.17749E+02	9.90600E+01	1.00675E+02	1.49655E-02	29	86
2.17749E+02	2.19365E+02	9.90600E+01	1.00675E+02	1.43172E-02	29	86
2.19365E+02	2.20980E+02	9.90600E+01	1.00675E+02	0.00000E+00	29	86
2.20980E+02	2.22595E+02	9.90600E+01	1.00675E+02	1.36688E-02	29	86
2.22595E+02	2.24211E+02	9.90600E+01	1.00675E+02	1.29733E-02	29	86
2.24211E+02	2.25826E+02	9.90600E+01	1.00675E+02	1.35585E-02	29	86
2.25826E+02	2.27442E+02	9.90600E+01	1.00675E+02	1.59797E-02	29	86
2.14518E+02	2.16134E+02	1.00675E+02	1.02291E+02	1.57683E-02	29	86
2.16134E+02	2.17749E+02	1.00675E+02	1.02291E+02	1.41670E-02	29	86
2.17749E+02	2.19365E+02	1.00675E+02	1.02291E+02	1.33367E-02	29	86
2.19365E+02	2.20980E+02	1.00675E+02	1.02291E+02	1.29261E-02	29	86
2.20980E+02	2.22595E+02	1.00675E+02	1.02291E+02	1.23446E-02	29	86
2.22595E+02	2.24211E+02	1.00675E+02	1.02291E+02	1.21332E-02	29	86
2.24211E+02	2.25826E+02	1.00675E+02	1.02291E+02	1.28606E-02	29	86
2.25826E+02	2.27442E+02	1.00675E+02	1.02291E+02	1.50409E-02	29	86
2.14518E+02	2.16134E+02	1.02291E+02	1.03906E+02	1.52701E-02	29	86
2.16134E+02	2.17749E+02	1.02291E+02	1.03906E+02	1.38882E-02	29	86

Table 2.2.2.5

Pin Geometry and Power Distributions (cont'd)

Pin Pitch Set 3

X-Left	X-Right	Y-Bot	Y-Top	Pin* Power Fraction	Pin Power Set	Assemb. Number
2.17749E+02	2.19365E+02	1.02291E+02	1.03906E+02	1.33134E-02	29	86
2.19365E+02	2.20980E+02	1.02291E+02	1.03906E+02	1.27043E-02	29	86
2.20980E+02	2.22595E+02	1.02291E+02	1.03906E+02	1.23134E-02	29	86
2.22595E+02	2.24211E+02	1.02291E+02	1.03906E+02	1.22717E-02	29	86
2.24211E+02	2.25826E+02	1.02291E+02	1.03906E+02	1.25168E-02	29	86
2.25826E+02	2.27442E+02	1.02291E+02	1.03906E+02	1.42087E-02	29	86
2.14518E+02	2.16134E+02	1.03906E+02	1.05522E+02	1.58161E-02	29	86
2.16134E+02	2.17749E+02	1.03906E+02	1.05522E+02	1.55354E-02	29	86
2.17749E+02	2.19365E+02	1.03906E+02	1.05522E+02	1.50825E-02	29	86
2.19365E+02	2.20980E+02	1.03906E+02	1.05522E+02	1.44679E-02	29	86
2.20980E+02	2.22595E+02	1.03906E+02	1.05522E+02	1.40525E-02	29	86
2.22595E+02	2.24211E+02	1.03906E+02	1.05522E+02	1.38331E-02	29	86
2.24211E+02	2.25826E+02	1.03906E+02	1.05522E+02	1.36394E-02	29	86
2.25826E+02	2.27442E+02	1.03906E+02	1.05522E+02	1.36750E-02	29	86
1.99278E+02	2.00894E+02	1.07838E+02	1.09454E+02	2.20405E-02	30	93
2.00894E+02	2.02509E+02	1.07838E+02	1.09454E+02	2.07371E-02	30	93
2.02509E+02	2.04125E+02	1.07838E+02	1.09454E+02	1.96380E-02	30	93
2.04125E+02	2.05740E+02	1.07838E+02	1.09454E+02	1.86266E-02	30	93
2.05740E+02	2.07355E+02	1.07838E+02	1.09454E+02	1.81185E-02	30	93
2.07355E+02	2.08971E+02	1.07838E+02	1.09454E+02	1.82620E-02	30	93
2.08971E+02	2.10586E+02	1.07838E+02	1.09454E+02	1.89589E-02	30	93
2.10586E+02	2.12202E+02	1.07838E+02	1.09454E+02	2.08613E-02	30	93
1.99278E+02	2.00894E+02	1.09454E+02	1.11069E+02	2.04906E-02	30	93
2.00894E+02	2.02509E+02	1.09454E+02	1.11069E+02	1.83168E-02	30	93
2.02509E+02	2.04125E+02	1.09454E+02	1.11069E+02	1.73508E-02	30	93
2.04125E+02	2.05740E+02	1.09454E+02	1.11069E+02	1.64599E-02	30	93
2.05740E+02	2.07355E+02	1.09454E+02	1.11069E+02	1.60577E-02	30	93
2.07355E+02	2.08971E+02	1.09454E+02	1.11069E+02	1.62119E-02	30	93
2.08971E+02	2.10586E+02	1.09454E+02	1.11069E+02	1.69679E-02	30	93
2.10586E+02	2.12202E+02	1.09454E+02	1.11069E+02	2.00069E-02	30	93
1.99278E+02	2.00894E+02	1.11069E+02	1.12685E+02	1.90681E-02	30	93
2.00894E+02	2.02509E+02	1.11069E+02	1.12685E+02	1.70513E-02	30	93
2.02509E+02	2.04125E+02	1.11069E+02	1.12685E+02	1.58112E-02	30	93
2.04125E+02	2.05740E+02	1.11069E+02	1.12685E+02	1.52867E-02	30	93
2.05740E+02	2.07355E+02	1.11069E+02	1.12685E+02	1.51082E-02	30	93
2.07355E+02	2.08971E+02	1.11069E+02	1.12685E+02	1.49540E-02	30	93
2.08971E+02	2.10586E+02	1.11069E+02	1.12685E+02	1.58506E-02	30	93
2.10586E+02	2.12202E+02	1.11069E+02	1.12685E+02	1.89092E-02	30	93
1.99278E+02	2.00894E+02	1.12685E+02	1.14300E+02	1.76967E-02	30	93
2.00894E+02	2.02509E+02	1.12685E+02	1.14300E+02	1.58506E-02	30	93
2.02509E+02	2.04125E+02	1.12685E+02	1.14300E+02	1.49661E-02	30	93
2.04125E+02	2.05740E+02	1.12685E+02	1.14300E+02	1.49797E-02	30	93
2.05740E+02	2.07355E+02	1.12685E+02	1.14300E+02	0.00000E+00	30	93
2.07355E+02	2.08971E+02	1.12685E+02	1.14300E+02	1.41361E-02	30	93
2.08971E+02	2.10586E+02	1.12685E+02	1.14300E+02	1.46985E-02	30	93
2.10586E+02	2.12202E+02	1.12685E+02	1.14300E+02	1.75922E-02	30	93
1.99278E+02	2.00894E+02	1.14300E+02	1.15915E+02	1.67804E-02	30	93
2.00894E+02	2.02509E+02	1.14300E+02	1.15915E+02	1.50904E-02	30	93

Table 2.2.2.5

Pin Geometry and Power Distributions (cont'd)

Pin Pitch Set 3

X-Left	X-Right	Y-Bot	Y-Top	Pin* Power Fraction	Pin Power Set	Assembl. Number
2.02509E+02	2.04125E+02	1.14300E+02	1.15915E+02	1.44464E-02	30	93
2.04125E+02	2.05740E+02	1.14300E+02	1.15915E+02	0.00000E+00	30	93
2.05740E+02	2.07355E+02	1.14300E+02	1.15915E+02	1.37766E-02	30	93
2.07355E+02	2.08971E+02	1.14300E+02	1.15915E+02	1.31476E-02	30	93
2.08971E+02	2.10586E+02	1.14300E+02	1.15915E+02	1.38324E-02	30	93
2.10586E+02	2.12202E+02	1.14300E+02	1.15915E+02	1.65264E-02	30	93
1.99278E+02	2.00894E+02	1.15915E+02	1.17531E+02	1.64734E-02	30	93
2.00894E+02	2.02509E+02	1.15915E+02	1.17531E+02	1.48424E-02	30	93
2.02509E+02	2.04125E+02	1.15915E+02	1.17531E+02	1.39336E-02	30	93
2.04125E+02	2.05740E+02	1.15915E+02	1.17531E+02	1.34453E-02	30	93
2.05740E+02	2.07355E+02	1.15915E+02	1.17531E+02	1.28121E-02	30	93
2.07355E+02	2.08971E+02	1.15915E+02	1.17531E+02	1.26002E-02	30	93
2.08971E+02	2.10586E+02	1.15915E+02	1.17531E+02	1.33698E-02	30	93
2.10586E+02	2.12202E+02	1.15915E+02	1.17531E+02	1.57629E-02	30	93
1.99278E+02	2.00894E+02	1.17531E+02	1.19146E+02	1.66928E-02	30	93
2.00894E+02	2.02509E+02	1.17531E+02	1.19146E+02	1.51522E-02	30	93
2.02509E+02	2.04125E+02	1.17531E+02	1.19146E+02	1.44126E-02	30	93
2.04125E+02	2.05740E+02	1.17531E+02	1.19146E+02	1.36280E-02	30	93
2.05740E+02	2.07355E+02	1.17531E+02	1.19146E+02	1.31111E-02	30	93
2.07355E+02	2.08971E+02	1.17531E+02	1.19146E+02	1.29963E-02	30	93
2.08971E+02	2.10586E+02	1.17531E+02	1.19146E+02	1.32217E-02	30	93
2.10586E+02	2.12202E+02	1.17531E+02	1.19146E+02	1.50482E-02	30	93
1.99278E+02	2.00894E+02	1.19146E+02	1.20762E+02	1.80881E-02	30	93
2.00894E+02	2.02509E+02	1.19146E+02	1.20762E+02	1.75758E-02	30	93
2.02509E+02	2.04125E+02	1.19146E+02	1.20762E+02	1.68728E-02	30	93
2.04125E+02	2.05740E+02	1.19146E+02	1.20762E+02	1.59795E-02	30	93
2.05740E+02	2.07355E+02	1.19146E+02	1.20762E+02	1.52942E-02	30	93
2.07355E+02	2.08971E+02	1.19146E+02	1.20762E+02	1.48968E-02	30	93
2.08971E+02	2.10586E+02	1.19146E+02	1.20762E+02	1.45748E-02	30	93
2.10586E+02	2.12202E+02	1.19146E+02	1.20762E+02	1.45504E-02	30	93
1.84038E+02	1.85654E+02	1.23078E+02	1.24694E+02	2.23674E-02	31	98
1.85654E+02	1.87269E+02	1.23078E+02	1.24694E+02	2.12025E-02	31	98
1.87269E+02	1.88885E+02	1.23078E+02	1.24694E+02	2.02093E-02	31	98
1.88885E+02	1.90500E+02	1.23078E+02	1.24694E+02	1.92222E-02	31	98
1.90500E+02	1.92115E+02	1.23078E+02	1.24694E+02	1.86070E-02	31	98
1.92115E+02	1.93731E+02	1.23078E+02	1.24694E+02	1.83060E-02	31	98
1.93731E+02	1.95346E+02	1.23078E+02	1.24694E+02	1.80279E-02	31	98
1.95346E+02	1.96962E+02	1.23078E+02	1.24694E+02	1.80531E-02	31	98
1.84038E+02	1.85654E+02	1.24694E+02	1.26309E+02	2.07813E-02	31	98
1.85654E+02	1.87269E+02	1.24694E+02	1.26309E+02	1.86136E-02	31	98
1.87269E+02	1.88885E+02	1.24694E+02	1.26309E+02	1.77269E-02	31	98
1.88885E+02	1.90500E+02	1.24694E+02	1.26309E+02	1.68605E-02	31	98
1.90500E+02	1.92115E+02	1.24694E+02	1.26309E+02	1.63323E-02	31	98
1.92115E+02	1.93731E+02	1.24694E+02	1.26309E+02	1.60873E-02	31	98
1.93731E+02	1.95346E+02	1.24694E+02	1.26309E+02	1.59244E-02	31	98
1.95346E+02	1.96962E+02	1.24694E+02	1.26309E+02	1.69061E-02	31	98
1.84038E+02	1.85654E+02	1.26309E+02	1.27925E+02	1.94332E-02	31	98
1.85654E+02	1.87269E+02	1.26309E+02	1.27925E+02	1.73832E-02	31	98

Table 2.2.2.5

Pin Geometry and Power Distributions (cont'd)

Pin Pitch Set 3

X-Left	X-Right	Y-Bot	Y-Top	Pin* Power Fraction	Pin Power Set	Assemb. Number
1.87269E+02	1.88885E+02	1.26309E+02	1.27925E+02	1.61997E-02	31	98
1.88885E+02	1.90500E+02	1.26309E+02	1.27925E+02	1.56823E-02	31	98
1.90500E+02	1.92115E+02	1.26309E+02	1.27925E+02	1.54000E-02	31	98
1.92115E+02	1.93731E+02	1.26309E+02	1.27925E+02	1.48814E-02	31	98
1.93731E+02	1.95346E+02	1.26309E+02	1.27925E+02	1.48855E-02	31	98
1.95346E+02	1.96962E+02	1.26309E+02	1.27925E+02	1.58576E-02	31	98
1.84038E+02	1.85654E+02	1.27925E+02	1.29540E+02	1.82003E-02	31	98
1.85654E+02	1.87269E+02	1.27925E+02	1.29540E+02	1.62681E-02	31	98
1.87269E+02	1.88885E+02	1.27925E+02	1.29540E+02	1.54228E-02	31	98
1.88885E+02	1.90500E+02	1.27925E+02	1.29540E+02	1.54510E-02	31	98
1.90500E+02	1.92115E+02	1.27925E+02	1.29540E+02	0.00000E+00	31	98
1.92115E+02	1.93731E+02	1.27925E+02	1.29540E+02	1.41700E-02	31	98
1.93731E+02	1.95346E+02	1.27925E+02	1.29540E+02	1.38835E-02	31	98
1.95346E+02	1.96962E+02	1.27925E+02	1.29540E+02	1.47781E-02	31	98
1.84038E+02	1.85654E+02	1.29540E+02	1.31155E+02	1.74703E-02	31	98
1.85654E+02	1.87269E+02	1.29540E+02	1.31155E+02	1.56222E-02	31	98
1.87269E+02	1.88885E+02	1.29540E+02	1.31155E+02	1.50136E-02	31	98
1.88885E+02	1.90500E+02	1.29540E+02	1.31155E+02	0.00000E+00	31	98
1.90500E+02	1.92115E+02	1.29540E+02	1.31155E+02	1.42943E-02	31	98
1.92115E+02	1.93731E+02	1.29540E+02	1.31155E+02	1.33206E-02	31	98
1.93731E+02	1.95346E+02	1.29540E+02	1.31155E+02	1.32057E-02	31	98
1.95346E+02	1.96962E+02	1.29540E+02	1.31155E+02	1.40373E-02	31	98
1.84038E+02	1.85654E+02	1.31155E+02	1.32771E+02	1.72966E-02	31	98
1.85654E+02	1.87269E+02	1.31155E+02	1.32771E+02	1.55003E-02	31	98
1.87269E+02	1.88885E+02	1.31155E+02	1.32771E+02	1.46123E-02	31	98
1.88885E+02	1.90500E+02	1.31155E+02	1.32771E+02	1.41389E-02	31	98
1.90500E+02	1.92115E+02	1.31155E+02	1.32771E+02	1.34155E-02	31	98
1.92115E+02	1.93731E+02	1.31155E+02	1.32771E+02	1.29155E-02	31	98
1.93731E+02	1.95346E+02	1.31155E+02	1.32771E+02	1.29810E-02	31	98
1.95346E+02	1.96962E+02	1.31155E+02	1.32771E+02	1.36829E-02	31	98
1.84038E+02	1.85654E+02	1.32771E+02	1.34386E+02	1.75640E-02	31	98
1.85654E+02	1.87269E+02	1.32771E+02	1.34386E+02	1.58763E-02	31	98
1.87269E+02	1.88885E+02	1.32771E+02	1.34386E+02	1.51434E-02	31	98
1.88885E+02	1.90500E+02	1.32771E+02	1.34386E+02	1.43744E-02	31	98
1.90500E+02	1.92115E+02	1.32771E+02	1.34386E+02	1.38114E-02	31	98
1.92115E+02	1.93731E+02	1.32771E+02	1.34386E+02	1.34959E-02	31	98
1.93731E+02	1.95346E+02	1.32771E+02	1.34386E+02	1.31763E-02	31	98
1.95346E+02	1.96962E+02	1.32771E+02	1.34386E+02	1.36630E-02	31	98
1.84038E+02	1.85654E+02	1.34386E+02	1.36002E+02	1.88238E-02	31	98
1.85654E+02	1.87269E+02	1.34386E+02	1.36002E+02	1.81817E-02	31	98
1.87269E+02	1.88885E+02	1.34386E+02	1.36002E+02	1.74943E-02	31	98
1.88885E+02	1.90500E+02	1.34386E+02	1.36002E+02	1.66532E-02	31	98
1.90500E+02	1.92115E+02	1.34386E+02	1.36002E+02	1.60392E-02	31	98
1.92115E+02	1.93731E+02	1.34386E+02	1.36002E+02	1.56048E-02	31	98
1.93731E+02	1.95346E+02	1.34386E+02	1.36002E+02	1.50472E-02	31	98
1.95346E+02	1.96962E+02	1.34386E+02	1.36002E+02	1.44200E-02	31	98
1.84038E+02	1.85654E+02	1.38318E+02	1.39934E+02	2.35079E-02	32	102
1.85654E+02	1.87269E+02	1.38318E+02	1.39934E+02	2.23686E-02	32	102

Table 2.2.2.5

Pin Geometry and Power Distributions (cont'd)

Pin Pitch Set 3

X-Left	X-Right	Y-Bot	Y-Top	Pin* Power Fraction	Pin Power Set	Assemb. Number
1.87269E+02	1.88885E+02	1.38318E+02	1.39934E+02	2.13511E-02	32	102
1.88885E+02	1.90500E+02	1.38318E+02	1.39934E+02	2.02742E-02	32	102
1.90500E+02	1.92115E+02	1.38318E+02	1.39934E+02	1.95332E-02	32	102
1.92115E+02	1.93731E+02	1.38318E+02	1.39934E+02	1.91721E-02	32	102
1.93731E+02	1.95346E+02	1.38318E+02	1.39934E+02	1.88762E-02	32	102
1.95346E+02	1.96962E+02	1.38318E+02	1.39934E+02	1.88189E-02	32	102
1.84038E+02	1.85654E+02	1.39934E+02	1.41549E+02	2.19898E-02	32	102
1.85654E+02	1.87269E+02	1.39934E+02	1.41549E+02	1.95799E-02	32	102
1.87269E+02	1.88885E+02	1.39934E+02	1.41549E+02	1.85302E-02	32	102
1.88885E+02	1.90500E+02	1.39934E+02	1.41549E+02	1.75483E-02	32	102
1.90500E+02	1.92115E+02	1.39934E+02	1.41549E+02	1.68791E-02	32	102
1.92115E+02	1.93731E+02	1.39934E+02	1.41549E+02	1.65653E-02	32	102
1.93731E+02	1.95346E+02	1.39934E+02	1.41549E+02	1.63389E-02	32	102
1.95346E+02	1.96962E+02	1.39934E+02	1.41549E+02	1.73330E-02	32	102
1.84038E+02	1.85654E+02	1.41549E+02	1.43165E+02	2.04911E-02	32	102
1.85654E+02	1.87269E+02	1.41549E+02	1.43165E+02	1.81224E-02	32	102
1.87269E+02	1.88885E+02	1.41549E+02	1.43165E+02	1.69219E-02	32	102
1.88885E+02	1.90500E+02	1.41549E+02	1.43165E+02	1.63139E-02	32	102
1.90500E+02	1.92115E+02	1.41549E+02	1.43165E+02	1.54505E-02	32	102
1.92115E+02	1.93731E+02	1.41549E+02	1.43165E+02	1.48959E-02	32	102
1.93731E+02	1.95346E+02	1.41549E+02	1.43165E+02	1.50055E-02	32	102
1.95346E+02	1.96962E+02	1.41549E+02	1.43165E+02	1.59584E-02	32	102
1.84038E+02	1.85654E+02	1.43165E+02	1.44780E+02	1.89268E-02	32	102
1.85654E+02	1.87269E+02	1.43165E+02	1.44780E+02	1.67250E-02	32	102
1.87269E+02	1.88885E+02	1.43165E+02	1.44780E+02	1.59028E-02	32	102
1.88885E+02	1.90500E+02	1.43165E+02	1.44780E+02	0.00000E+00	32	102
1.90500E+02	1.92115E+02	1.43165E+02	1.44780E+02	1.49932E-02	32	102
1.92115E+02	1.93731E+02	1.43165E+02	1.44780E+02	1.39202E-02	32	102
1.93731E+02	1.95346E+02	1.43165E+02	1.44780E+02	1.37783E-02	32	102
1.95346E+02	1.96962E+02	1.43165E+02	1.44780E+02	1.46378E-02	32	102
1.84038E+02	1.85654E+02	1.44780E+02	1.46395E+02	1.77619E-02	32	102
1.85654E+02	1.87269E+02	1.44780E+02	1.46395E+02	1.56786E-02	32	102
1.87269E+02	1.88885E+02	1.44780E+02	1.46395E+02	1.47151E-02	32	102
1.88885E+02	1.90500E+02	1.44780E+02	1.46395E+02	1.46661E-02	32	102
1.90500E+02	1.92115E+02	1.44780E+02	1.46395E+02	0.00000E+00	32	102
1.92115E+02	1.93731E+02	1.44780E+02	1.46395E+02	1.32921E-02	32	102
1.93731E+02	1.95346E+02	1.44780E+02	1.46395E+02	1.29511E-02	32	102
1.95346E+02	1.96962E+02	1.44780E+02	1.46395E+02	1.37099E-02	32	102
1.84038E+02	1.85654E+02	1.46395E+02	1.48011E+02	1.70532E-02	32	102
1.85654E+02	1.87269E+02	1.46395E+02	1.48011E+02	1.51312E-02	32	102
1.87269E+02	1.88885E+02	1.46395E+02	1.48011E+02	1.39969E-02	32	102
1.88885E+02	1.90500E+02	1.46395E+02	1.48011E+02	1.35018E-02	32	102
1.90500E+02	1.92115E+02	1.46395E+02	1.48011E+02	1.32042E-02	32	102
1.92115E+02	1.93731E+02	1.46395E+02	1.48011E+02	1.26713E-02	32	102
1.93731E+02	1.95346E+02	1.46395E+02	1.48011E+02	1.25545E-02	32	102
1.95346E+02	1.96962E+02	1.46395E+02	1.48011E+02	1.32109E-02	32	102
1.84038E+02	1.85654E+02	1.48011E+02	1.49626E+02	1.66855E-02	32	102
1.85654E+02	1.87269E+02	1.48011E+02	1.49626E+02	1.50166E-02	32	102

Table 2.2.2.5

Pin Geometry and Power Distributions (cont'd)

Pin Pitch Set 3

X-Left	X-Right	Y-Bot	Y-Top	Pin* Power Fraction	Pin Power Set	Assemb. Number
1.87269E+02	1.88885E+02	1.48011E+02	1.49626E+02	1.43290E-02	32	102
1.88885E+02	1.90500E+02	1.48011E+02	1.49626E+02	1.36398E-02	32	102
1.90500E+02	1.92115E+02	1.48011E+02	1.49626E+02	1.32003E-02	32	102
1.92115E+02	1.93731E+02	1.48011E+02	1.49626E+02	1.29261E-02	32	102
1.93731E+02	1.95346E+02	1.48011E+02	1.49626E+02	1.26207E-02	32	102
1.95346E+02	1.96962E+02	1.48011E+02	1.49626E+02	1.30585E-02	32	102
1.84038E+02	1.85654E+02	1.49626E+02	1.51242E+02	1.71678E-02	32	102
1.85654E+02	1.87269E+02	1.49626E+02	1.51242E+02	1.67194E-02	32	102
1.87269E+02	1.88885E+02	1.49626E+02	1.51242E+02	1.62149E-02	32	102
1.88885E+02	1.90500E+02	1.49626E+02	1.51242E+02	1.55868E-02	32	102
1.90500E+02	1.92115E+02	1.49626E+02	1.51242E+02	1.51384E-02	32	102
1.92115E+02	1.93731E+02	1.49626E+02	1.51242E+02	1.48425E-02	32	102
1.93731E+02	1.95346E+02	1.49626E+02	1.51242E+02	1.43452E-02	32	102
1.95346E+02	1.96962E+02	1.49626E+02	1.51242E+02	1.36993E-02	32	102
1.84038E+02	1.85654E+02	1.53558E+02	1.55174E+02	2.47813E-02	33	105
1.85654E+02	1.87269E+02	1.53558E+02	1.55174E+02	2.31368E-02	33	105
1.87269E+02	1.88885E+02	1.53558E+02	1.55174E+02	2.16437E-02	33	105
1.88885E+02	1.90500E+02	1.53558E+02	1.55174E+02	2.02768E-02	33	105
1.90500E+02	1.92115E+02	1.53558E+02	1.55174E+02	1.94720E-02	33	105
1.92115E+02	1.93731E+02	1.53558E+02	1.55174E+02	1.92866E-02	33	105
1.93731E+02	1.95346E+02	1.53558E+02	1.55174E+02	1.95892E-02	33	105
1.95346E+02	1.96962E+02	1.53558E+02	1.55174E+02	2.09924E-02	33	105
1.84038E+02	1.85654E+02	1.55174E+02	1.56789E+02	2.29780E-02	33	105
1.85654E+02	1.87269E+02	1.55174E+02	1.56789E+02	2.00695E-02	33	105
1.87269E+02	1.88885E+02	1.55174E+02	1.56789E+02	1.87231E-02	33	105
1.88885E+02	1.90500E+02	1.55174E+02	1.56789E+02	1.75151E-02	33	105
1.90500E+02	1.92115E+02	1.55174E+02	1.56789E+02	1.68025E-02	33	105
1.92115E+02	1.93731E+02	1.55174E+02	1.56789E+02	1.66316E-02	33	105
1.93731E+02	1.95346E+02	1.55174E+02	1.56789E+02	1.69977E-02	33	105
1.95346E+02	1.96962E+02	1.55174E+02	1.56789E+02	1.95839E-02	33	105
1.84038E+02	1.85654E+02	1.56789E+02	1.58405E+02	2.10900E-02	33	105
1.85654E+02	1.87269E+02	1.56789E+02	1.58405E+02	1.83714E-02	33	105
1.87269E+02	1.88885E+02	1.56789E+02	1.58405E+02	1.67488E-02	33	105
1.88885E+02	1.90500E+02	1.56789E+02	1.58405E+02	1.59190E-02	33	105
1.90500E+02	1.92115E+02	1.56789E+02	1.58405E+02	1.54773E-02	33	105
1.92115E+02	1.93731E+02	1.56789E+02	1.58405E+02	1.49992E-02	33	105
1.93731E+02	1.95346E+02	1.56789E+02	1.58405E+02	1.55484E-02	33	105
1.95346E+02	1.96962E+02	1.56789E+02	1.58405E+02	1.80741E-02	33	105
1.84038E+02	1.85654E+02	1.58405E+02	1.60020E+02	1.91694E-02	33	105
1.85654E+02	1.87269E+02	1.58405E+02	1.60020E+02	1.66974E-02	33	105
1.87269E+02	1.88885E+02	1.58405E+02	1.60020E+02	1.54871E-02	33	105
1.88885E+02	1.90500E+02	1.58405E+02	1.60020E+02	1.52821E-02	33	105
1.90500E+02	1.92115E+02	1.58405E+02	1.60020E+02	0.00000E+00	33	105
1.92115E+02	1.93731E+02	1.58405E+02	1.60020E+02	1.39062E-02	33	105
1.93731E+02	1.95346E+02	1.58405E+02	1.60020E+02	1.41376E-02	33	105
1.95346E+02	1.96962E+02	1.58405E+02	1.60020E+02	1.65121E-02	33	105
1.84038E+02	1.85654E+02	1.60020E+02	1.61635E+02	1.76807E-02	33	105
1.85654E+02	1.87269E+02	1.60020E+02	1.61635E+02	1.54553E-02	33	105

Table 2.2.2.5

Pin Geometry and Power Distributions (cont'd)

Pin Pitch Set 3

X-Left	X-Right	Y-Bot	Y-Top	Pin* Power Fraction	Pin Power Set	Assemb. Number
1.87269E+02	1.88885E+02	1.60020E+02	1.61635E+02	1.45476E-02	33	105
1.88885E+02	1.90500E+02	1.60020E+02	1.61635E+02	0.00000E+00	33	105
1.90500E+02	1.92115E+02	1.60020E+02	1.61635E+02	1.35302E-02	33	105
1.92115E+02	1.93731E+02	1.60020E+02	1.61635E+02	1.26497E-02	33	105
1.93731E+02	1.95346E+02	1.60020E+02	1.61635E+02	1.30567E-02	33	105
1.95346E+02	1.96962E+02	1.60020E+02	1.61635E+02	1.52995E-02	33	105
1.84038E+02	1.85654E+02	1.61635E+02	1.63251E+02	1.66951E-02	33	105
1.85654E+02	1.87269E+02	1.61635E+02	1.63251E+02	1.46528E-02	33	105
1.87269E+02	1.88885E+02	1.61635E+02	1.63251E+02	1.35522E-02	33	105
1.88885E+02	1.90500E+02	1.61635E+02	1.63251E+02	1.29689E-02	33	105
1.90500E+02	1.92115E+02	1.61635E+02	1.63251E+02	1.22080E-02	33	105
1.92115E+02	1.93731E+02	1.61635E+02	1.63251E+02	1.18494E-02	33	105
1.93731E+02	1.95346E+02	1.61635E+02	1.63251E+02	1.24077E-02	33	105
1.95346E+02	1.96962E+02	1.61635E+02	1.63251E+02	1.44326E-02	33	105
1.84038E+02	1.85654E+02	1.63251E+02	1.64866E+02	1.61240E-02	33	105
1.85654E+02	1.87269E+02	1.63251E+02	1.64866E+02	1.43381E-02	33	105
1.87269E+02	1.88885E+02	1.63251E+02	1.64866E+02	1.35227E-02	33	105
1.88885E+02	1.90500E+02	1.63251E+02	1.64866E+02	1.27254E-02	33	105
1.90500E+02	1.92115E+02	1.63251E+02	1.64866E+02	1.21807E-02	33	105
1.92115E+02	1.93731E+02	1.63251E+02	1.64866E+02	1.20000E-02	33	105
1.93731E+02	1.95346E+02	1.63251E+02	1.64866E+02	1.21225E-02	33	105
1.95346E+02	1.96962E+02	1.63251E+02	1.64866E+02	1.36815E-02	33	105
1.84038E+02	1.85654E+02	1.64866E+02	1.66482E+02	1.65559E-02	33	105
1.85654E+02	1.87269E+02	1.64866E+02	1.66482E+02	1.59652E-02	33	105
1.87269E+02	1.88885E+02	1.64866E+02	1.66482E+02	1.52874E-02	33	105
1.88885E+02	1.90500E+02	1.64866E+02	1.66482E+02	1.44916E-02	33	105
1.90500E+02	1.92115E+02	1.64866E+02	1.66482E+02	1.39304E-02	33	105
1.92115E+02	1.93731E+02	1.64866E+02	1.66482E+02	1.36134E-02	33	105
1.93731E+02	1.95346E+02	1.64866E+02	1.66482E+02	1.33131E-02	33	105
1.95346E+02	1.96962E+02	1.64866E+02	1.66482E+02	1.32617E-02	33	105
1.68798E+02	1.70414E+02	1.68798E+02	1.70414E+02	2.18757E-02	34	106
1.70414E+02	1.72029E+02	1.68798E+02	1.70414E+02	2.07686E-02	34	106
1.72029E+02	1.73645E+02	1.68798E+02	1.70414E+02	1.90348E-02	34	106
1.73645E+02	1.75260E+02	1.68798E+02	1.70414E+02	1.87378E-02	34	106
1.75260E+02	1.76875E+02	1.68798E+02	1.70414E+02	1.78587E-02	34	106
1.76875E+02	1.78491E+02	1.68798E+02	1.70414E+02	1.75592E-02	34	106
1.78491E+02	1.80106E+02	1.68798E+02	1.70414E+02	1.71507E-02	34	106
1.80106E+02	1.81722E+02	1.68798E+02	1.70414E+02	1.81488E-02	34	106
1.68798E+02	1.70414E+02	1.70414E+02	1.72029E+02	2.07686E-02	34	106
1.70414E+02	1.72029E+02	1.70414E+02	1.72029E+02	1.89095E-02	34	106
1.72029E+02	1.73645E+02	1.70414E+02	1.72029E+02	1.72083E-02	34	106
1.73645E+02	1.75260E+02	1.70414E+02	1.72029E+02	1.78287E-02	34	106
1.75260E+02	1.76875E+02	1.70414E+02	1.72029E+02	1.70523E-02	34	106
1.76875E+02	1.78491E+02	1.70414E+02	1.72029E+02	1.68806E-02	34	106
1.78491E+02	1.80106E+02	1.70414E+02	1.72029E+02	1.57484E-02	34	106
1.80106E+02	1.81722E+02	1.70414E+02	1.72029E+02	1.75467E-02	34	106
1.68798E+02	1.70414E+02	1.72029E+02	1.73645E+02	1.90348E-02	34	106
1.70414E+02	1.72029E+02	1.72029E+02	1.73645E+02	1.72083E-02	34	106

Table 2.2.2.5

Pin Geometry and Power Distributions (cont'd)

Pin Pitch Set 3

X-Left	X-Right	Y-Bot	Y-Top	Pin* Power Fraction	Pin Power Set	Assemb. Number
1.72029E+02	1.73645E+02	1.72029E+02	1.73645E+02	1.73374E-02	34	106
1.73645E+02	1.75260E+02	1.72029E+02	1.73645E+02	1.63938E-02	34	106
1.75260E+02	1.76875E+02	1.72029E+02	1.73645E+02	1.60041E-02	34	106
1.76875E+02	1.78491E+02	1.72029E+02	1.73645E+02	1.30172E-02	34	106
1.78491E+02	1.80106E+02	1.72029E+02	1.73645E+02	1.60097E-02	34	106
1.80106E+02	1.81722E+02	1.72029E+02	1.73645E+02	1.70981E-02	34	106
1.68798E+02	1.70414E+02	1.73645E+02	1.75260E+02	1.87378E-02	34	106
1.70414E+02	1.72029E+02	1.73645E+02	1.75260E+02	1.78287E-02	34	106
1.72029E+02	1.73645E+02	1.73645E+02	1.75260E+02	1.63938E-02	34	106
1.73645E+02	1.75260E+02	1.73645E+02	1.75260E+02	1.61131E-02	34	106
1.75260E+02	1.76875E+02	1.73645E+02	1.75260E+02	0.00000E+00	34	106
1.76875E+02	1.78491E+02	1.73645E+02	1.75260E+02	1.45730E-02	34	106
1.78491E+02	1.80106E+02	1.73645E+02	1.75260E+02	1.47484E-02	34	106
1.80106E+02	1.81722E+02	1.73645E+02	1.75260E+02	1.59019E-02	34	106
1.68798E+02	1.70414E+02	1.75260E+02	1.76875E+02	1.78587E-02	34	106
1.70414E+02	1.72029E+02	1.75260E+02	1.76875E+02	1.70523E-02	34	106
1.72029E+02	1.73645E+02	1.75260E+02	1.76875E+02	1.60041E-02	34	106
1.73645E+02	1.75260E+02	1.75260E+02	1.76875E+02	0.00000E+00	34	106
1.75260E+02	1.76875E+02	1.75260E+02	1.76875E+02	1.40191E-02	34	106
1.76875E+02	1.78491E+02	1.75260E+02	1.76875E+02	1.34332E-02	34	106
1.78491E+02	1.80106E+02	1.75260E+02	1.76875E+02	1.38555E-02	34	106
1.80106E+02	1.81722E+02	1.75260E+02	1.76875E+02	1.49984E-02	34	106
1.68798E+02	1.70414E+02	1.76875E+02	1.78491E+02	1.75592E-02	34	106
1.70414E+02	1.72029E+02	1.76875E+02	1.78491E+02	1.68806E-02	34	106
1.72029E+02	1.73645E+02	1.76875E+02	1.78491E+02	1.30172E-02	34	106
1.73645E+02	1.75260E+02	1.76875E+02	1.78491E+02	1.45730E-02	34	106
1.75260E+02	1.76875E+02	1.76875E+02	1.78491E+02	1.34332E-02	34	106
1.76875E+02	1.78491E+02	1.76875E+02	1.78491E+02	1.28912E-02	34	106
1.78491E+02	1.80106E+02	1.76875E+02	1.78491E+02	1.20911E-02	34	106
1.80106E+02	1.81722E+02	1.76875E+02	1.78491E+02	1.36343E-02	34	106
1.68798E+02	1.70414E+02	1.78491E+02	1.80106E+02	1.71507E-02	34	106
1.70414E+02	1.72029E+02	1.78491E+02	1.80106E+02	1.57484E-02	34	106
1.72029E+02	1.73645E+02	1.78491E+02	1.80106E+02	1.60097E-02	34	106
1.73645E+02	1.75260E+02	1.78491E+02	1.80106E+02	1.47484E-02	34	106
1.75260E+02	1.76875E+02	1.78491E+02	1.80106E+02	1.38555E-02	34	106
1.76875E+02	1.78491E+02	1.78491E+02	1.80106E+02	1.20911E-02	34	106
1.78491E+02	1.80106E+02	1.78491E+02	1.80106E+02	1.23680E-02	34	106
1.80106E+02	1.81722E+02	1.78491E+02	1.80106E+02	1.34382E-02	34	106
1.68798E+02	1.70414E+02	1.80106E+02	1.81722E+02	1.81488E-02	34	106
1.70414E+02	1.72029E+02	1.80106E+02	1.81722E+02	1.75467E-02	34	106
1.72029E+02	1.73645E+02	1.80106E+02	1.81722E+02	1.70981E-02	34	106
1.73645E+02	1.75260E+02	1.80106E+02	1.81722E+02	1.59019E-02	34	106
1.75260E+02	1.76875E+02	1.80106E+02	1.81722E+02	1.49984E-02	34	106
1.76875E+02	1.78491E+02	1.80106E+02	1.81722E+02	1.36343E-02	34	106
1.78491E+02	1.80106E+02	1.80106E+02	1.81722E+02	1.34382E-02	34	106
1.80106E+02	1.81722E+02	1.80106E+02	1.81722E+02	1.30447E-02	34	106

Table 2.2.2.6

Axial Power Distributions

Zone Axial Boundary (cm)	Radial Zone		
	1	2	3
0.000E+00	0.0000	0.0000	0.0000
1 4.9430E+01	0.0127	0.0100	0.0099
2 6.4670E+01	0.0401	0.0308	0.0266
3 7.9910E+01	0.0497	0.0395	0.0340
4 9.5150E+01	0.0519	0.0430	0.0372
5 1.1039E+02	0.0506	0.0439	0.0383
6 1.2563E+02	0.0483	0.0440	0.0392
7 1.4087E+02	0.0463	0.0439	0.0399
8 1.5611E+02	0.0449	0.0440	0.0408
9 1.7135E+02	0.0440	0.0443	0.0418
10 1.8659E+02	0.0435	0.0447	0.0430
11 2.0183E+02	0.0432	0.0453	0.0443
12 2.1707E+02	0.0437	0.0460	0.0457
13 2.3231E+02	0.0441	0.0469	0.0472
14 2.4755E+02	0.0439	0.0476	0.0488
15 2.6279E+02	0.0445	0.0482	0.0500
16 2.7803E+02	0.0448	0.0486	0.0509
17 2.9327E+02	0.0441	0.0484	0.0516
18 3.0851E+02	0.0433	0.0478	0.0516
19 3.2375E+02	0.0430	0.0470	0.0507
20 3.3899E+02	0.0412	0.0450	0.0491
21 3.5423E+02	0.0374	0.0414	0.0462
22 3.6947E+02			

Table 2.2.2.6

Axial Power Distributions (cont'd)

	Zone Axial Boundary (cm)	Radial Zone		
		1	2	3
22	3.6947E+02	0.0348	0.0373	0.0415
23	3.8471E+02	0.0293	0.0309	0.0347
24	3.9995E+02	0.0214	0.0226	0.0258
25	4.1519E+02	0.0091	0.0090	0.0112
26	4.3043E+02	0.0000E+00	0.0000E+00	0.0000E+00
27	8.1323E+02			

Radial Zone	Zone Radial Boundary (cm)
1	220.282
2	234.874
3	259.530

Table 2.2.2.7

Edit Locations

	R (cm)	Z (cm)	θ (degrees)

Pressure Vessel Capsule:			
Flux Spectrum and			
Peak Reaction Rates	319.195	306.605	3

Pressure Vessel 0-T:			
(A) Axial Peak Location			
(a) E > 1.0 MEV	321.786	306.605	0-45
(b) E > 0.1 MEV	321.786	306.605	0-45
(c) DPA Rates	321.786	306.605	0-45
(d) Flux Spectrum	322.286	306.605	42.51
(B) At the Axial Core Midplane			
(a) E > 1.0 MEV	321.786	239.93	0-45
(b) E > 0.1 MEV	321.786	239.93	0-45
(c) DPA Rates	321.786	239.93	0-45

Pressure Vessel 1/4 T:			
(A) Axial Peak Location			
(a) E > 1.0 MEV	325.818	306.605	0-45
(b) E > 0.1 MEV	325.818	302.795	0-45
(c) DPA Rates	325.818	298.985	0-45
(d) Flux Spectrum	325.818	306.605	42.51
(B) At the Axial Core Midplane			
(a) E > 1.0 MEV	325.818	239.93	0-45
(b) E > 0.1 MEV	325.818	239.93	0-45
(c) DPA Rates	325.818	239.93	0-45

Pressure Vessel 1/2 T:			
(A) Axial Peak Location			
(a) E > 1.0 MEV	329.851	306.605	0-45
(b) E > 0.1 MEV	329.851	306.605	0-45
(c) DPA Rates	329.851	306.605	0-45
(d) Flux Spectrum	329.851	306.605	42.51
(B) At the Axial Core Midplane			
(a) E > 1.0 MEV	329.851	239.93	0-45
(b) E > 0.1 MEV	329.851	239.93	0-45
(c) DPA Rates	329.851	239.93	0-45

Pressure Vessel 3/4 T:			
(A) Axial Peak Location			
(a) E > 1.0 MEV	333.883	302.795	0-45
(b) E > 0.1 MEV	333.883	302.795	0-45
(c) DPA Rates	333.883	298.985	0-45
(d) Flux Spectrum	333.883	302.795	42.51
(B) At the Axial Core Midplane			
(a) E > 1.0 MEV	333.883	239.93	0-45
(b) E > 0.1 MEV	333.883	239.93	0-45
(c) DPA Rates	333.883	239.93	0-45

Table 2.2.2.7

Edit Locations (cont'd)

	R (cm)	Z (cm)	θ (degrees)
Pressure Vessel T:			
(A) Axial Peak Location			
(a) E > 1.0 MEV	337.915	302.795	0-45
(b) E > 0.1 MEV	337.915	302.795	0-45
(c) DPA Rates	337.915	298.985	0-45
(d) Flux Spectrum	337.032	302.795	42.51
(B) At the Axial Core Midplane			
(a) E > 1.0 MEV	337.915	239.93	0-45
(b) E > 0.1 MEV	337.915	239.93	0-45
(c) DPA Rates	337.915	239.93	0-45
DownComer			
(A) Axial Peak Location			
(a) E > 1.0 MEV	278.100	306.605	0-45
(b) E > 0.1 MEV	278.100	306.605	0-45
(c) DPA Rates	278.100	306.605	0-45
(d) Flux Spectrum	278.100	306.605	23.5
(B) At the Axial Core Midplane			
(a) E > 1.0 MEV	278.100	239.93	0-45
(b) E > 0.1 MEV	278.100	239.93	0-45
(c) DPA Rates	278.100	239.93	0-45
Cavity			
(A) Axial Peak Location			
(a) E > 1.0 MEV	398.700	282.602	0-45
(b) E > 0.1 MEV	398.700	279.554	0-45
(c) DPA Rates	398.700	279.554	0-45
(d) Flux Spectrum	398.700	282.602	44.975

BWR Planar Geometry

Figure 2.2.2.1

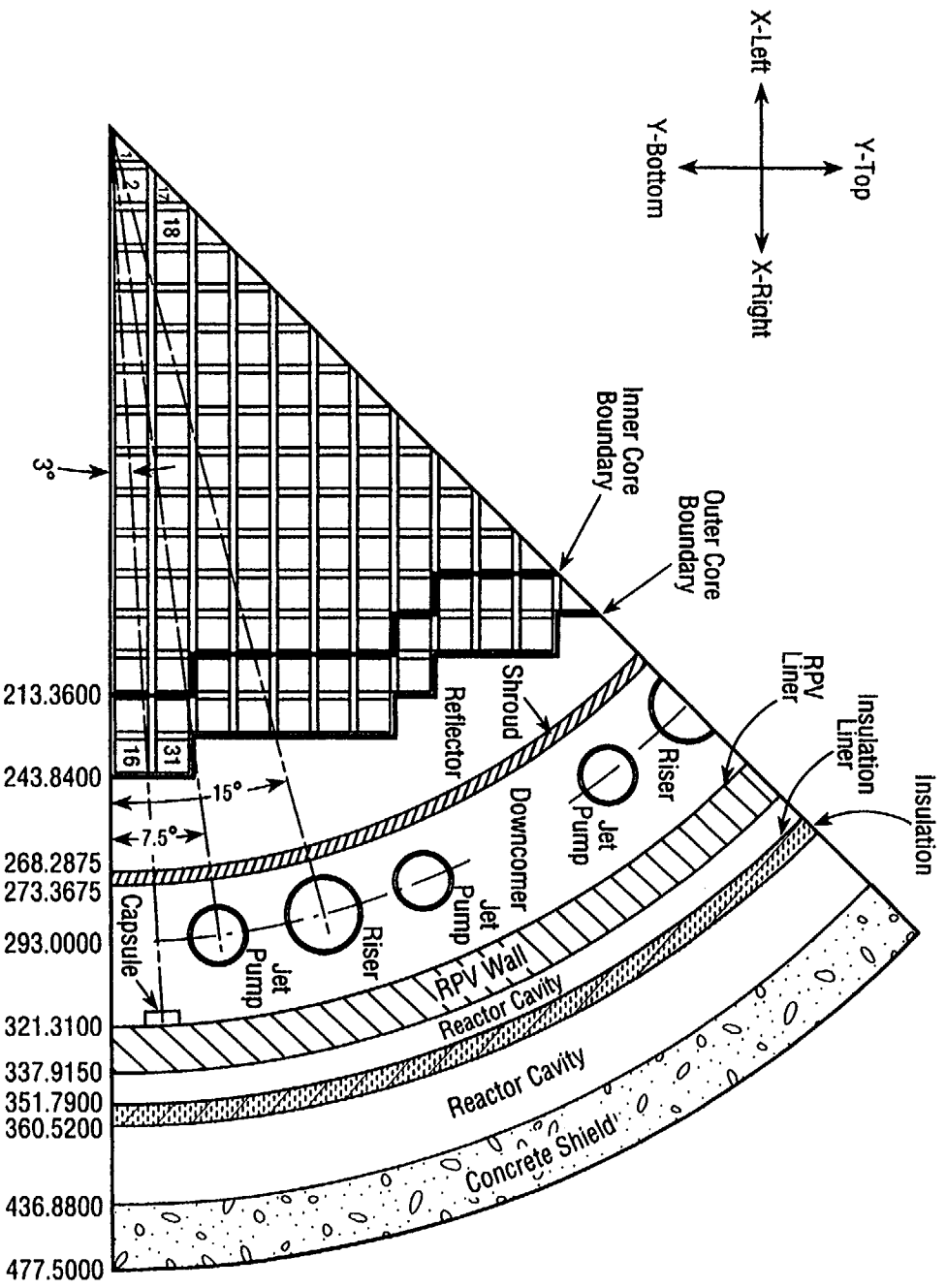
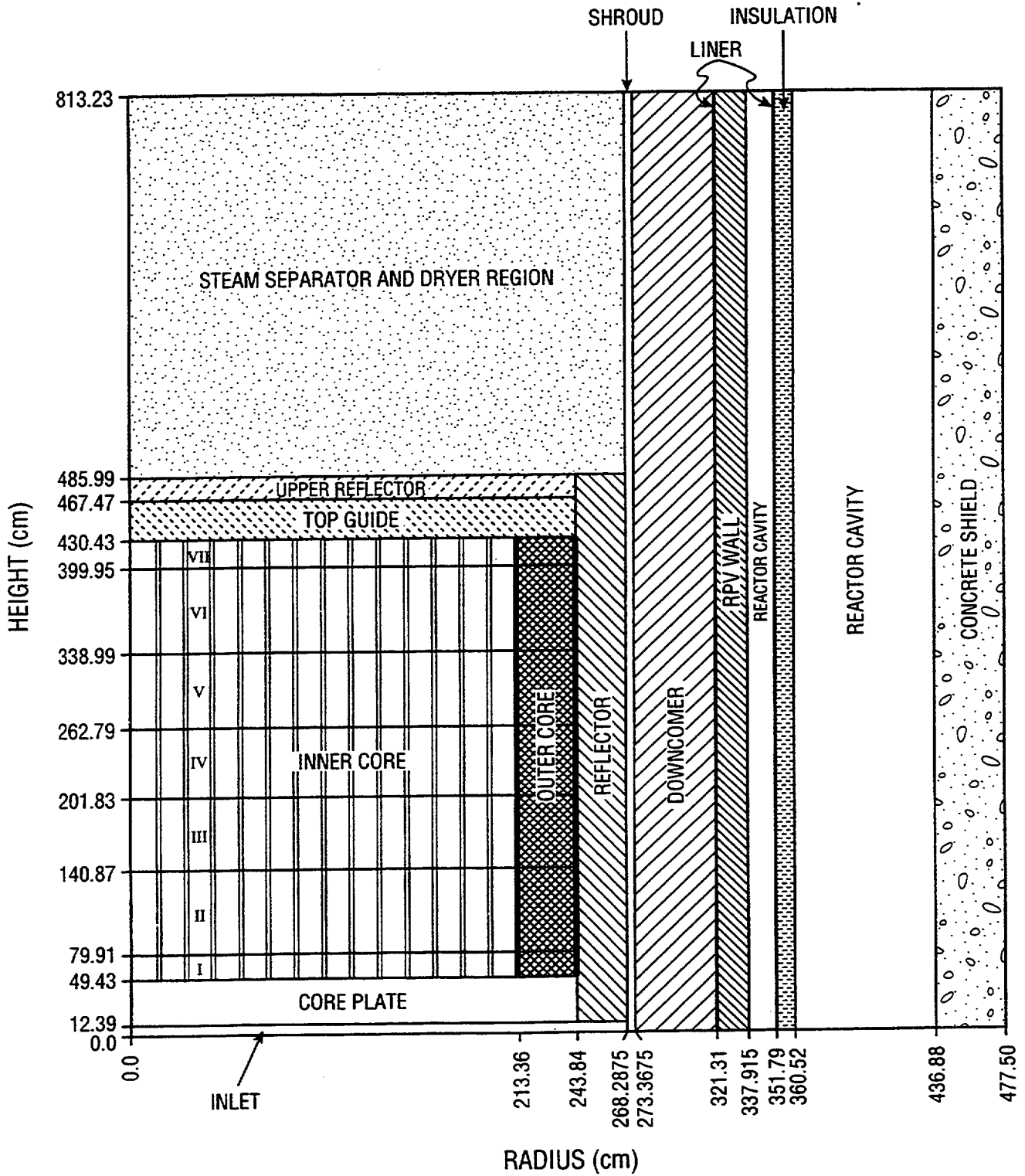

Figure 2.2.2.2

BWR Axial Geometry



NOTE: All Dimensions in cm

Figure 2.2.2.3

Surveillance Capsule

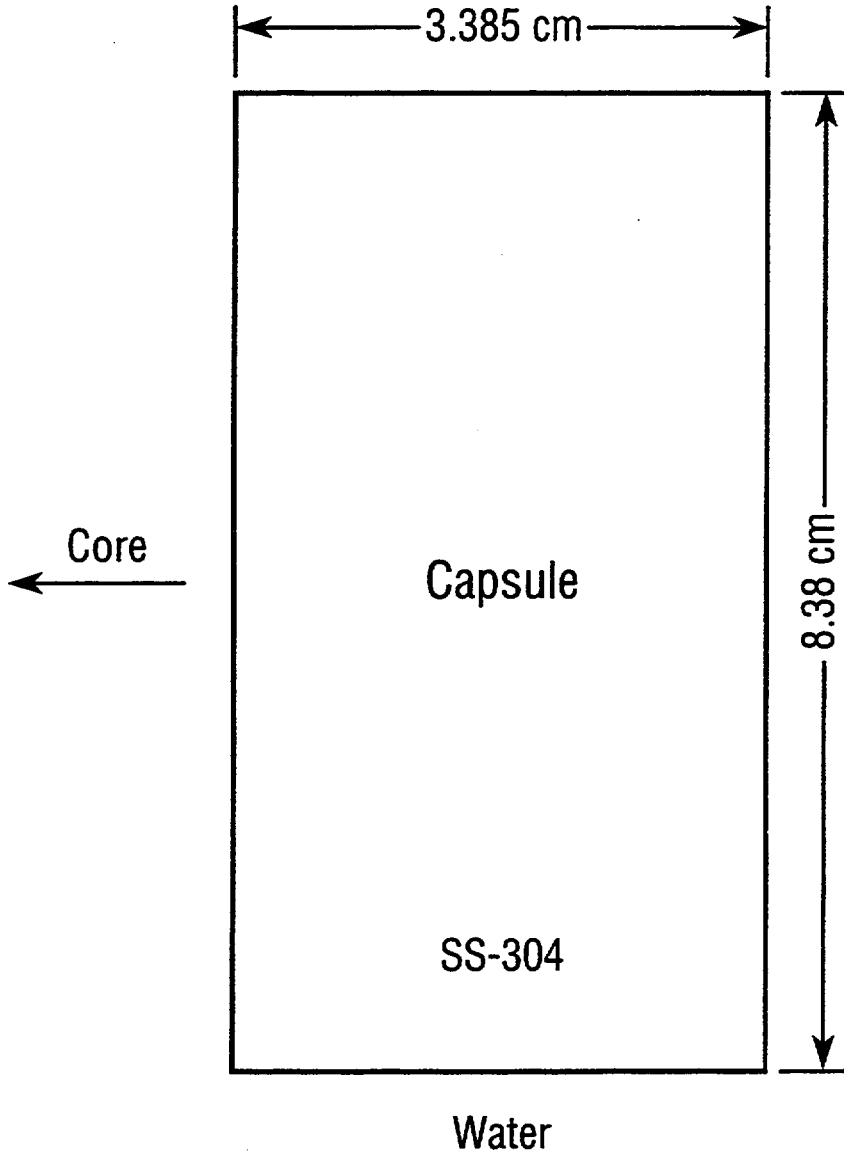

3 DORT CALCULATIONAL METHODOLOGY

3.1 Introduction

The methodology used to perform the pressure vessel fluence benchmark problems follows the methods and approach described in the pressure vessel fluence calculation and measurement methods Regulatory Guide 1.190. The modeling and numerical procedures used in these calculations are based on well established state-of-the-art techniques and, except for nuclear data uncertainties, are believed to provide a flux solution accuracy of a few percent. It is intended that the flux solutions to these benchmark problems will be updated as significant improvements are made in the basic methods and in the nuclear data sets.

The nuclear cross sections, determination of the core neutron source, transport calculations, synthesis approach, and the dosimetry cross sections are described in the following sections.

3.2 Neutron Cross Sections and Fission Spectra

The BUGLE-93 47-group cross section library was used in the benchmark calculations. The BUGLE-93 library was determined by collapsing the ENDF/B-VI VITAMIN-B6 fine-group cross section set using spatially dependent spectra calculated for a typical PWR configuration. The BUGLE-93 library includes the ENDF/B-VI versions of the iron, hydrogen and oxygen cross sections, which are known to have a significant effect on pressure vessel fluence predictions.

The fission spectra for U-235, U-238 and Pu-239 were taken from BUGLE-93 and are provided in Table-3.2.1. The fission spectra for Pu-240, Pu-241 and Pu-242 of Table 3.2.1 were determined with NJOY using the ENDF/B-VI data. These spectra were used in the MESH (Reference-5) calculations of the core neutron source.

3.3 Core Neutron Source

The benchmark calculation of the core neutron source includes the effect of the strong pin-wise variations of the power distribution in the fuel assemblies located near the

core boundary. The MESH code was used to allocate the pin-wise power to the individual (r, θ) mesh blocks. This allocation was performed by a numerical integration of the power distribution, defined on the (x, y) pin-wise mesh, over the (r, θ) mesh block. This numerical integration typically employed ≥ 100 integration mesh per fuel pin and was shown to be accurate to within $\leq 1\%$ for each (r, θ) mesh block.

The magnitude of the core neutron source increases with fuel burnup due to the higher number of neutrons released per MeV of energy produced by Pu fission. This was taken into account by calculating the number of neutrons per MeV, ν/κ [neutrons/MeV], using the fuel burnup dependent isotopic fission fractions. In addition, the fission spectrum was also considered to be dependent on the fuel burnup in order to account for the harder more penetrating neutron spectrum characteristic of the Pu fissions in the high burnup fuel. This exposure dependence was included in both the radial (r, θ) and axial (r, z) source distributions.

3.4 Neutron Transport Calculations

The neutron transport calculations for the benchmark problems were performed with the ORNL DORT discrete ordinates transport code using the 47-group BUGLE-93 library. The calculations were performed in a fixed source mode for a radial (r, θ) plane, an axial (r, z) plane, and in a one-dimensional (r) geometry.

The PWR radial (r, θ) calculations were performed in a two-step "boot strap" fashion in which an inner one-eighth 45° azimuthal sector was first calculated. A second outer one-eighth core 45° annular sector was then calculated using the flux on the inner surface of the annulus, calculated in the first inner calculation, as an input boundary condition. A ~ 15 cm radial overlap-region between the inner and outer calculations was maintained to insure that the neglect of the outer geometry in the inner problem had a negligible effect ($\leq 0.5\%$) on the vessel fluence calculations. In the BWR calculations, the bootstrap method was not used and the solution on the full radial (r, θ) geometry was determined in one step.

The calculations were performed using an S_8 quadrature

and a P-3 angular decomposition of the scattering cross-sections.** In the PWR calculation, the (r, θ) mesh included 61 angular mesh intervals, and 108 and 102 radial mesh intervals in the inner and outer bootstrap calculations, respectively. In the BWR calculation, the (r, θ) mesh included 61 angular mesh intervals and 222 radial mesh intervals. The angular (θ) and radial (r) mesh densities were increased at material interfaces where the geometry was changing rapidly and at the capsule locations. The radial mesh used in the axial (r, z) calculations was essentially identical to that used in the (r, θ) calculations. The spatial mesh used in the calculations is given in Chapter-4 with the calculated results.

Vacuum boundary conditions were used on the outer radial and axial boundaries of the problems and reflecting boundary conditions were used on the internal $\theta = 0^\circ$ and $\theta = 45^\circ$ azimuthal boundaries. A pointwise flux convergence of 10^{-3} was used together with an integrated flux convergence criteria of 10^{-3} .

In order to validate the numerical methods used in these calculations, DORT sensitivity calculations were performed for selected numerical input parameters. The sensitivity calculations included an increase in the angular quadrature from S_8 to S_{16} , an increase in the angular representation of the scattering cross sections from P_3 to P_5 , and a factor of 10 increase in the flux pointwise convergence. The results of these calculations are presented in Table 3.4.1, and indicate that the >1 MeV and >0.1 MeV fluxes vary by less than 2% at all (r, θ) locations when the numerical input parameters are varied.

3.5 Flux Synthesis

The vessel fluxes were determined by combining the DORT (r, θ) and DORT (r, z) calculated fluxes. The flux at the (r, θ, z) location was determined by the relation

$$\phi_g(r, \theta, z) = \phi_g(r, \theta) [\phi_g(r, z) / \phi_g(r)], \quad (1)$$

where $\phi_g(r, \theta)$, $\phi_g(r, z)$ and $\phi_g(r)$ are the group-g fluxes calculated in the indicated geometry. The effective

core radius R_{eff} used in the cylindrical geometry (r, z) and (r) calculations was determined so that the flux above 1-MeV, $\phi_{>1}$, at the vessel inner-wall satisfies the condition

$$\phi_{>1}(r; R_{eff}) = \frac{1}{2\pi} \int_0^{2\pi} \phi_{>1}(r, \theta) d\theta. \quad (2)$$

The radial source distribution in these cylindrical calculations was determined as an azimuthal average of the (r, θ) source distribution.

In the case of the PWR partial length shield assembly core design, equation (2) was applied separately to the axial core regions above and below the partial length shield material interface at $z = 109.102$ cm.

3.6 Dosimetry Cross Sections

The capsule dosimeter reaction rates were calculated using ENDF/B-VI cross sections. The cross section data were collapsed to the 47-group structure using NJOY. The calculated reaction rates are for dosimeter materials having a 90% response range above 0.1 MeV, and include those reactions that are typically used to determine the pressure vessel fluence above 0.1 MeV. The specific dosimeter reactions, response ranges and corresponding half-lives are given in Chapter 4 with the benchmark calculation results.

**While the BWR (r, θ) and (r) calculations were performed using an S_8 quadrature, the BWR (r, z) calculations were performed using an S_{16} quadrature.

Table 3.2.1

Benchmark Problem

Fission Spectrum by Isotope

Group	U-235	U-238	Pu-239	Pu-240	Pu-241	Pu-242
1	5.01790E-05	2.55680E-05	5.62080E-05	1.59837E-04	1.11229E-04	9.41379E-05
2	2.01670E-04	1.38950E-04	2.26770E-04	4.24436E-04	3.33440E-04	2.91573E-04
3	1.14600E-03	9.23970E-04	1.29210E-03	1.90310E-03	1.62701E-03	1.46138E-03
4	2.52230E-03	2.30120E-03	2.93940E-03	3.67560E-03	3.33102E-03	3.05379E-03
5	5.65690E-03	5.39710E-03	6.47000E-03	7.23358E-03	6.82821E-03	6.35974E-03
6	1.61470E-02	1.59700E-02	1.81090E-02	1.83265E-02	1.79642E-02	1.70033E-02
7	3.07130E-02	3.13400E-02	3.40160E-02	3.19116E-02	3.22692E-02	3.09993E-02
8	8.05130E-02	8.35720E-02	8.77920E-02	7.78502E-02	8.08065E-02	7.88116E-02
9	7.67580E-02	7.87770E-02	8.12310E-02	7.04721E-02	7.41343E-02	7.31336E-02
10	4.40110E-02	4.45130E-02	4.55610E-02	3.95926E-02	4.17697E-02	4.14407E-02
11	4.66870E-02	4.67790E-02	4.76560E-02	4.15580E-02	4.38197E-02	4.36216E-02
12	2.00290E-02	1.99590E-02	2.02720E-02	1.78618E-02	1.88091E-02	1.87651E-02
13	4.02620E-03	4.00560E-03	4.04740E-03	3.46967E-03	3.65159E-03	3.64570E-03
14	2.43450E-02	2.41820E-02	2.45230E-02	2.17653E-02	2.28879E-02	2.28701E-02
15	7.35500E-02	7.28080E-02	7.34400E-02	6.58307E-02	6.89789E-02	6.91083E-02
16	7.19480E-02	7.11800E-02	7.12330E-02	6.52904E-02	6.79461E-02	6.83101E-02
17	8.94980E-02	8.88220E-02	8.80130E-02	8.36931E-02	8.62904E-02	8.70281E-02
18	1.15030E-01	1.14380E-01	1.11580E-01	1.14986E-01	1.13412E-01	1.14737E-01
19	6.26870E-02	6.21080E-02	5.98610E-02	6.61640E-02	6.31523E-02	6.40114E-02
20	2.72400E-02	2.68800E-02	2.57760E-02	2.93997E-02	2.77316E-02	2.81294E-02
21	4.68520E-02	4.60320E-02	4.39290E-02	5.13975E-02	4.80479E-02	4.87647E-02
22	3.76160E-02	3.68060E-02	3.49500E-02	4.21326E-02	3.91602E-02	3.96986E-02
23	4.17720E-02	4.10120E-02	3.88410E-02	4.79967E-02	4.44988E-02	4.50850E-02
24	2.13900E-02	2.12210E-02	2.02000E-02	2.51519E-02	2.33548E-02	2.36678E-02
25	3.00470E-02	3.02460E-02	2.86650E-02	3.60326E-02	3.38058E-02	3.42529E-02
26	1.54080E-02	1.58020E-02	1.50480E-02	1.87262E-02	1.80121E-02	1.82283E-02
27	7.42510E-03	7.72090E-03	7.49710E-03	8.99821E-03	8.92036E-03	9.01824E-03
28	3.54620E-03	3.72200E-03	3.55110E-03	4.24394E-03	4.31820E-03	4.36831E-03
29	9.98080E-04	1.05290E-03	9.96940E-04	1.18278E-03	1.23205E-03	1.24343E-03
30	5.69770E-04	6.02400E-04	5.63780E-04	6.71909E-04	7.10592E-04	7.14680E-04
31	1.73370E-04	1.83510E-04	1.74090E-04	2.03574E-04	2.17281E-04	2.18043E-04
32	2.03050E-04	2.15060E-04	2.12840E-04	2.38119E-04	2.55417E-04	2.56065E-04
33	5.40380E-04	5.73110E-04	5.30120E-04	6.32934E-04	6.90362E-04	6.88273E-04
34	4.84200E-04	5.14660E-04	5.19380E-04	5.59137E-04	6.22162E-04	6.19155E-04
35	1.57460E-04	1.67660E-04	1.57790E-04	1.78267E-04	2.00672E-04	2.00929E-04
36	5.11560E-05	5.45120E-05	5.33090E-05	5.76396E-05	6.68779E-05	6.62128E-05
37	2.08270E-05	2.21990E-05	2.19810E-05	2.35810E-05	2.84631E-05	2.76345E-05
38	2.54840E-06	2.71460E-06	2.65010E-06	2.95265E-06	3.78926E-06	3.55021E-06
39	8.27310E-07	8.80310E-07	8.62760E-07	9.93296E-07	1.34411E-06	1.21832E-06
40	3.09000E-07	3.28840E-07	3.14170E-07	3.97077E-07	5.75995E-07	4.99476E-07
41	6.00000E-08	7.96970E-08	6.14480E-08	1.14164E-07	1.82060E-07	1.48558E-07
42	5.40660E-12	9.55630E-09	2.17655E-11	1.93115E-08	3.30303E-08	2.57267E-08
43	0.00000E+00	2.67170E-09	8.29070E-12	4.59724E-09	9.11550E-09	4.77114E-09
44	0.00000E+00	2.16310E-11	6.85750E-13	1.54375E-09	2.79927E-09	1.46516E-09
45	0.00000E+00	0.00000E+00	0.00000E+00	8.08059E-10	1.32100E-09	6.91426E-10
46	0.00000E+00	0.00000E+00	0.00000E+00	7.18356E-10	8.97826E-10	4.69930E-10
47	0.00000E+00	0.00000E+00	0.00000E+00	5.22107E-10	2.85903E-10	1.49644E-10

Table 3.4.1

Sensitivity of the DORT Calculated Flux to Numerical Input Parameters⁺
Standard Problem (r,θ) Calculation

Location	r=202.25 cm θ=20°	r=215.43 cm θ=20°	r=219.393 cm θ=15.5°	r=224.473 cm θ=15.5°	r=229.870 cm θ=15.5°	r=235.268 cm θ=15.5°	r=240.342 cm θ=15.5°	r=320.06 cm θ=9.5°
E > 1.0 MeV								
BASE CASE*	2.74340(+11)**	4.82786(+10)	3.70878(+10)	2.07115(+10)	9.87759(+09)	4.49649(+09)	1.87858(+09)	1.18914(+09)
NEGFIX = 1	2.74341(+11)	4.82769(+10)	3.70878(+10)	2.07116(+10)	9.87756(+09)	4.49645(+09)	1.87854(+09)	1.18908(+09)
% diff.	0.0	0.0	0.0	0.0	0.0	0.0	0.0	0.0
MODE θ = 0.3	2.74782(+11)	4.88035(+10)	3.75722(+10)	2.10279(+10)	1.00388(+10)	4.57132(+09)	1.90718(+09)	1.19941(+09)
% diff.	+0.16	+1.09	+1.31	+1.53	+1.63	+1.60	+1.52	+0.86
NO.DIR.s = 16	2.77494(+11)	4.90304(+10)	3.77070(+10)	2.09948(+10)	1.00378(+10)	4.57470(+09)	1.91243(+09)	1.19121(+09)
% diff.	+1.15	+1.56	+1.67	+1.37	+1.62	+1.74	+1.80	+0.17
EPSPTWISE = 0.0001	2.74340(+11)	4.82786(+10)	3.70878(+10)	2.07115(+10)	9.87760(+09)	4.49649(+09)	1.87858(+09)	1.18914(+09)
% diff.	0.0	0.0	0.0	0.0	0.0	0.0	0.0	0.0
P5 CASE	2.74121(+11)	4.82110(+10)	3.71238(+10)	2.07133(+10)	9.87417(+09)	4.49647(+09)	1.87945(+09)	1.18945(+09)
% diff.	-0.1	-0.1	+0.1	0.0	0.0	0.0	+0.1	0.0

Table 3.4.1 (Cont'd.)
Sensitivity of the DORT Calculated Flux to Numerical Input Parameters*
Standard Problem (r,θ) Calculation

Location	r=202.25 cm θ=20°	r=215.43 cm θ=20°	r=219.393 cm θ=15.5°	r=224.473 cm θ=15.5°	r=229.870 cm θ=15.5°	r=235.268 cm θ=15.5°	r=240.342 cm θ=15.5°	r=320.06 cm θ=9.5°
E > 0.1 MeV								
BASE CASE*	6.33036(+11)	9.60304(+10)	8.54595(+10)	7.10408(+10)	5.07562(+10)	3.26705(+10)	1.68486(+10)	1.18751(+10)
NEGFIX = 1	6.33037(+11)	9.60282(+10)	8.54591(+10)	7.10403(+10)	5.07555(+10)	3.26699(+10)	1.68482(+10)	1.18746(+10)
% diff.	0.0	0.0	0.0	0.0	0.0	0.0	0.0	0.0
MODE θ = 0.3	6.34654(+11)	9.71702(+10)	8.65981(+10)	7.20723(+10)	5.15099(+10)	3.31450(+10)	1.70503(+10)	1.19674(+10)
% diff.	+0.26	+1.19	+1.33	+1.45	+1.48	+1.45	+1.20	+0.78
NO.DIR.s = 16	6.39342(+11)	9.75237(+10)	8.69504(+10)	7.19877(+10)	5.14835(+10)	3.31332(+10)	1.70851(+10)	1.19170(+10)
% diff.	+1.00	+1.56	+1.74	+1.33	+1.43	+1.42	1.40	+0.35
EPSPTWISE = 0.0001	6.33036(+11)	9.60304(+10)	8.54595(+10)	7.10408(+10)	5.07562(+10)	3.26702(+10)	1.68480(+10)	1.18744(+10)
% diff.	0.0	0.0	0.0	0.0	0.0	0.0	0.0	0.0
P5 CASE	6.32864(+11)	9.59391(+10)	8.55101(+10)	7.10480(+10)	5.07512(+10)	3.26692(+10)	1.68492(+10)	1.18752(+10)
% diff.	0.0	-0.1	+0.1	0.0	0.0	0.0	0.0	0.0

* The DORT Numerical options are as follows: NEGFIX is the negative source fix, MODE is the θ-weighted flux extrapolation, NO.DIR.s is the number of angular quadratures, and EPSPTWISE is the flux point wise convergence.

* BASE CASE: NEGFIX = 0, MODE θ = 0.0, NO.DIR.s = 8, EPSPTWISE = 0.001

** Read as $2.74340 \times 10^{+11}$ neutrons/(cm²-sec).

Table 3.4.2
Sensitivity of the DORT Calculated Flux to S_n Quadrature
Partial Length Shield Assembly (r, z) Calculation (at $\theta=0^\circ$)

Axial Peak Location	r=202.25 cm z=188.363 cm	r=215.43 cm z=192.062 cm	r=219.393 cm z=195.761 cm	r=224.473 cm z=199.459 cm	r=229.870 cm z=199.459 cm	r=235.268 cm z=203.158 cm	r=240.342 cm z=206.856 cm	r=320.06 cm z=221.65 cm
E > 1.0 MeV								
S8 CASE	1.93804E+11	5.62798E+10	2.55168E+10	1.44130E+10	6.94778E+09	3.17615E+09	1.26196E+09	6.84196E+08
S16 CASE	1.94670E+11	5.68005E+10	2.59528E+10	1.45980E+10	7.05053E+09	3.22510E+09	1.28726E+09	6.86218E+09
% diff.*	+0.4	+0.9	+1.7	+1.3	+1.5	+1.5	+2.0	0.3
Axial Peak Location	r=202.25 cm z=188.363 cm	r=215.43 cm z=192.062 cm	r=219.393 cm z=199.459 cm	r=224.473 cm z=203.158 cm	r=229.870 cm z=203.158 cm	r=235.268 cm z=206.856 cm	r=240.342 cm z=210.555 cm	r=320.06 cm z=221.65 cm
E > 0.1 MeV								
S8 CASE	4.31404E+11	1.01910E+11	5.87544E+10	4.93831E+10	3.53358E+10	2.23169E+10	1.02282E+10	5.76909E+09
S16 CASE	4.34119E+11	1.02865E+11	5.97682E+10	4.99973E+10	3.58176E+10	2.26348E+10	1.04519E+10	5.79595E+09
% diff.*	+0.6	+0.9	+1.7	+1.2	+1.4	+1.4	+2.2	+0.5

Table 3.4.2 (Cont'd.)
Sensitivity of the DORT Calculated Flux to S_n Quadrature
Partial Length Shield Assembly (r, z) Calculation (at θ=0°)

Lower Weld Location	r=202.25 cm z=67.1048 cm	r=215.43 cm z=67.1048 cm	r=219.393 cm z=67.1048 cm	r=224.473 cm z=67.1048 cm	r=229.870 cm z=67.1048 cm	r=235.268 cm z=67.1048 cm	r=240.342 cm z=67.1048 cm	r=320.06 cm z=67.1048 cm
E > 1.0 MeV								
S8 CASE	2.93827E+09	1.34748E+09	8.77387E+08	5.44246E+08	2.97191E+08	1.67741E+08	1.22672E+08	2.43208E+08
S16 CASE	2.93118E+09	1.35314E+09	8.89447E+08	5.50882E+08	3.02727E+08	1.71633E+08	1.27715E+08	2.48526E+08
% diff.*	-0.2	+0.4	+1.4	+1.2	+1.9	+2.3	+4.1	+2.2
E > 0.1 MeV								
S8 CASE	6.05030E+09	2.27455E+09	2.34299E+09	2.50280E+09	2.30346E+09	2.00939E+09	1.71868E+09	2.43826E+09
S16 CASE	6.07039E+09	2.28721E+09	2.38497E+09	2.54234E+09	2.34933E+09	2.06107E+09	1.79908E+09	2.50080E+09
% diff.*	+0.3	+0.6	+1.8	+1.6	+2.0	+2.6	+4.7	+2.6

* %diff = (S16 CASE - S8 CASE) x 100/S8 CASE

** Cross sections used in calculation are from BUGLE-93

4 DORT BENCHMARK PROBLEM CALCULATION RESULTS

4.1 PWR Benchmark Problem Calculation Results

4.1.1 Calculated Flux, Reaction Rates and Spectra

The scalar neutron flux or fluence rate $\phi(\underline{r}, E)$ [n/cm^2 - sec-MeV] is the fundamental quantity of interest in the pressure vessel benchmark calculations. The neutron flux has been calculated throughout the problem geometry on a discrete spatial and energy dependent mesh. The calculated flux is an average over the three dimensional ($\Delta r, \Delta \theta, \Delta z$) spatial mesh block and is labeled by the coordinates of the center of the mesh block. The calculated group-wise solution is an integral over each energy group. The (r, θ, z) solution spatial mesh is given in Tables 4.1.1.1 and 4.1.1.2. The energy mesh is given in Table 4.1.1.3. Both the group-wise and energy integrated >1 -MeV and >0.1 MeV flux solutions are provided with the benchmark results. The calculated reaction rates for surveillance capsule dosimeter materials typically used for measuring the fast neutron fluence are included, together with the iron displacement-per-atom reaction rates. The nuclear parameters for the neutron flux monitors are given in Table 4.1.1.4. For comparison the dosimeter reaction rates have been calculated using both the SAILOR (Reference-7) and ORNL-TM-11476 (Reference-8) dosimetry cross sections, as well as the ENDF/B-VI dosimetry cross sections given in Table 4.1.1.5. In addition to the group-wise flux, the neutron spectrum at the surveillance capsule locations and several vessel locations is also provided.

The benchmark problem calculated results include:

- the azimuthal distribution of the $E > 1$ -MeV flux, $E > 0.10$ MeV flux and dpa rate at the pressure vessel axial peak location at the inner-wall, T/4, T/2, 3T/4 and outer surface locations,
- the axial peak reaction rates of the neutron dosimeters at the capsule locations,
- the PLSA core-to-standard core flux and dpa reduction factors (e.g., PLSA flux/SCL flux) at the

lower circumferential weld at 0° for the partial length shield assembly core loading,

- the downcomer and cavity fluxes and dpa rates at the radii of 210.50 cm and 320.06 cm, respectively, and
- the flux spectrum at the pressure vessel peak flux location and at the capsule locations.

The benchmark solution for the Standard Core Loading, the Low-Leakage Core Loading and the Partial Length Shield Assembly core are given in Sections 4.1.2 - 4.1.4, respectively.

4.1.2 Standard Core Loading Benchmark Problem

The calculated >1 -MeV and >0.10 MeV fluxes [n/cm^2 -s] and dpa rates [dpa/s] for the standard core loading benchmark problem are given in Tables 4.1.2.1 - 4.1.2.3, respectively. The fluxes and dpa rates are given for the vessel inner-wall and four vessel internal locations, as a function of the azimuthal (θ) location. The flux edit is taken at the axial (z) location where the flux or dpa rate peak occurs, which is seen to increase as the vessel radial location increases. The same data is presented in Tables 4.1.2.4 - 4.1.2.6 for the vessel axial location of the circumferential weld. The vessel inner-wall data at the circumferential weld location will be used to determine the relative reduction factors of Table 4.1.4.3 resulting from the PLSA core loading.

The fluxes and dpa rates are presented in Table 4.1.2.7 for a location near the center of the downcomer and in Table 4.1.2.8 for a cavity location close to the biological shield. These edits are taken at the axial location corresponding to the peak of the >1 -MeV flux. The downcomer fluxes are calculated with the thermal shield capsule included in the model and the vessel capsule removed.

The neutron flux spectrum at the >1 -MeV peak azimuthal/axial location is provided in Table 4.1.2.9 for the vessel inner-wall and four vessel internal locations. The five spectra are also given in Figures 4.1.2.1 - 4.1.2.5.

The neutron flux spectrum for the thermal shield, pressure vessel and cavity capsules at the axial location of the maximum >1-MeV flux is provided in Table 4.1.2.10. These spectra are also given in Figures 4.1.2.6 -4.1.2.8.

The calculated reaction rates for the dosimeter materials of Table 4.1.1.4 are given in Tables 4.1.2.11 - 4.1.2.13 for the thermal shield, pressure vessel and cavity capsules, respectively.^{†††} The axial locations correspond to the peak >1-MeV flux locations for each capsule. For user convenience, the reaction rates have been determined using each of the dosimeter cross section sets given in Table 4.1.1.5 and are provided in the Tables.

4.1.3 Low-Leakage Core Loading Benchmark Problem

The calculated >1-MeV and >0.10 MeV fluxes [$n/cm^2\cdot s$] and dpa rates [dpa/s] for the low-leakage core loading benchmark problem are given in Tables 4.1.3.1-4.1.3.3, respectively. The fluxes and dpa rates are given for the vessel inner-wall and four vessel internal locations, as a function of the azimuthal (θ) location. The flux edit is taken at the axial (z) location where the flux or dpa rate peak occurs, which is seen to increase as the vessel radial location increases. The same data is presented in Tables 4.1.3.4 - 4.1.3.6 for the vessel axial location of the circumferential weld.

The fluxes and dpa rates are presented in Table 4.1.3.7 for a location near the center of the downcomer and in Table 4.1.3.8 for a cavity location close to the biological shield. These edits are taken at the axial location corresponding to the peak of the >1-MeV flux. The downcomer fluxes are calculated with the thermal shield capsule included in the model and the vessel capsule removed.

The neutron flux spectrum at the >1-MeV peak azimuthal/axial location is provided in Table 4.1.3.9 for the vessel inner-wall and four vessel internal locations.

^{†††}It is noteworthy that the dosimeters with thresholds ≥ 7 -MeV were found to be sensitive to the material cross section representation of the peripheral assemblies in the radial calculation. Increasing the core effective radius R_{eff} by ~ 12 cm for the SCL(LLCL) resulted in a $\sim 30\%$ (5%) reduction in these dosimeter responses.

The five spectra are also given in Figures 4.1.3.1 - 4.1.3.5.

The neutron flux spectrum for the thermal shield, pressure vessel and cavity capsules at the axial location of the maximum >1-MeV flux is provided in Table 4.1.3.10. These spectra are also given in Figures 4.1.3.6 - 4.1.3.8.

The calculated reaction rates for the dosimeter materials of Table 4.1.1.4 are given in Tables 4.1.3.11 - 4.1.3.13, for the thermal shield, pressure vessel and cavity capsules, respectively. The axial locations correspond to the peak >1-MeV flux locations for each capsule. For user convenience, the reaction rates have been determined using each of the dosimeter cross section sets given in Table 4.1.1.5 and are provided in the Tables.

4.1.4 Partial Length Shield Assembly Core Loading Benchmark Problem

The calculated >1-MeV and >0.10 MeV fluxes [$n/cm^2\cdot s$] and dpa rates for the partial length shield assembly core loading benchmark problem are given in Table 4.1.4.1. The fluxes and dpa rates are given for the vessel inner-wall at the lower circumferential weld as a function of the azimuthal (θ) location. The same data is also given in Figures 4.1.4.1 - 4.1.4.3.

The vessel inner-wall neutron flux spectrum at the lower circumferential weld is given in Table 4.1.4.2, for the $\theta = 0^\circ$ azimuthal location. This spectrum is also given in Figure 4.1.4.4.

The reduction factors for the vessel inner-wall flux and the dpa defined, for the flux, as

$$RF = \text{PLSA flux/SCL flux}, \quad (3)$$

are presented in Table 4.1.4.3. These RFs are calculated for the circumferential weld as a function of the azimuthal location and are based on the SCL results of Section - 4.1.2.

4.2 BWR Benchmark Problem Calculation Results

4.2.1 Calculated Flux, Reaction Rates and Spectra

The scalar neutron flux or fluence rate $\phi(\vec{r}, E)$ [$n/cm^2 \cdot sec \cdot MeV$] is the fundamental quantity of interest in the pressure vessel benchmark calculations. The neutron flux has been calculated throughout the problem geometry on a discrete spatial and energy dependent mesh. The calculated flux is an average over the three dimensional (Δr , $\Delta \theta$, Δz) spatial mesh block and is labeled by the coordinates of the center of the mesh block. The calculated group-wise solution is an integral over each energy group. The (r , θ , z) solution spatial mesh is given in Table 4.2.1.1, and the energy mesh is given in Table - 4.2.1.2. Both the group-wise and energy integrated $>1\text{-MeV}$ and $>0.1\text{-MeV}$ flux solutions are provided with the benchmark results. The calculated reaction rates for surveillance capsule dosimeter materials typically used for measuring the fast neutron fluence are included, together with the iron displacement-per-atom reaction rates. The nuclear parameters for the neutron flux monitors are given in Table 4.2.1.3. The dosimeter reaction rates were calculated using the BUGLE-93 ENDF/B-VI dosimetry cross sections given in Table 4.2.1.4. In addition to the group-wise flux, the neutron spectrum at the surveillance capsule, cavity and several vessel locations is also provided.

The benchmark problem calculated results include:

- a) the azimuthal distribution of the $E > 1\text{-MeV}$ flux, $E > 0.10\text{ MeV}$ flux and dpa rate at the pressure vessel axial peak and core Midplane locations at the inner-wall, T/4, T/2, 3T/4 and outer surface locations,
- b) the axial peak reaction rates of the neutron dosimeters at the capsule location,
- c) the downcomer and cavity fluxes and dpa rates at the radii of 278.1 cm and 398.7 cm, respectively, and
- d) the flux spectrum at the pressure vessel peak flux location, cavity peak flux location and at the capsule location.

The benchmark solution for the BWR benchmark problem is given in the following section.

4.2.2 BWR Benchmark Problem Results

The calculated $>1\text{-MeV}$ and $>0.10\text{ MeV}$ fluxes [$n/cm^2 \cdot s$] and dpa rates [dpa/s] for the BWR benchmark problem are given in Tables 4.2.2.1 - 4.2.2.3, respectively. The fluxes and dpa rates are given for the vessel inner-wall and four vessel internal locations, as a function of the azimuthal (θ) location. The flux edit is taken at the axial (z) location where the flux or dpa rate peak occurs, which is seen to generally decrease as the vessel radial location increases. The same data is presented in Tables 4.2.2.4 - 4.2.2.6 for the core axial midplane location.

The fluxes and dpa rates are presented in Tables 4.2.2.7 and 4.2.2.8 for a location near the center of the downcomer at the peak axial location and at the core axial midplane location, respectively. In Table 4.2.2.9, the corresponding data is presented for the cavity at the peak axial location close to the biological shield. These edits are taken at the axial location corresponding to the peak of the $>1\text{-MeV}$ flux.

The neutron flux spectrum at the $>1\text{-MeV}$ peak azimuthal/axial location is provided in Table 4.2.2.10 for the vessel inner-wall and four vessel internal locations. The five spectra are also given in Figures 4.2.2.1 - 4.2.2.5.

The neutron flux spectrum for the downcomer, pressure vessel capsule and the cavity at the location of the maximum $>1\text{-MeV}$ flux is provided in Table 4.2.2.11. The spectra for the capsule and cavity locations are also given in Figures 4.2.2.6 and 4.2.2.7, respectively.

The calculated reaction rates for the dosimeter materials of Table 4.2.1.3 are given in Table 4.2.2.12 for the pressure vessel capsule. The axial locations correspond to the peak $>1\text{-MeV}$ flux locations for the capsule.

Table 4.1.1.1

Mesh Used in DORT Calculation (Inner Model)

	R (cm)	Z (cm)	θ (revolution)
1	0.00000	0.00000	0.00000E+00
2	5.00000	4.44500	6.94400E-04
3	10.0000	6.50125	2.08300E-03
4	15.0000	8.55750	4.86100E-03
5	20.0000	10.6138	7.63900E-03
6	25.0000	12.6700	1.04170E-02
7	30.0000	13.9700	1.31940E-02
8	35.0000	16.2200	1.66670E-02
9	40.0000	18.4700	2.01390E-02
10	45.0000	20.7200	2.22220E-02
11	50.0000	22.9700	2.50000E-02
12	55.0000	25.2200	2.77780E-02
13	60.0000	27.4700	3.05560E-02
14	65.0000	29.7200	3.33330E-02
15	70.0000	31.9700	3.61110E-02
16	75.0000	34.2200	3.88890E-02
17	80.0000	36.4700	4.16670E-02
18	85.0000	38.7200	4.44440E-02
19	90.0000	40.9700	4.68750E-02
20	95.0000	43.2200	4.75690E-02
21	100.000	45.4700	5.00000E-02
22	107.106	47.7200	5.13890E-02
23	114.320	49.9700	5.35410E-02
24	120.040	52.2200	5.37770E-02
25	124.320	54.4700	5.41760E-02
26	128.610	56.7200	5.51140E-02
27	132.900	58.9700	5.60520E-02
28	137.180	61.2200	5.69900E-02
29	141.470	63.4700	5.73890E-02
30	144.330	65.7500	5.76250E-02
31	147.190	68.4595	5.94720E-02
32	150.040	71.1690	6.11110E-02
33	151.470	73.8785	6.25000E-02
34	152.628	76.5880	6.38890E-02
35	153.687	79.2975	6.52780E-02
36	154.745	82.0070	6.66670E-02
37	155.886	84.7165	6.94440E-02
38	156.944	87.4260	7.22220E-02
39	158.002	90.1355	7.50000E-02
40	159.061	92.8450	7.77780E-02
41	160.119	95.5545	8.05560E-02
42	161.177	98.2640	8.29860E-02

Table 4.1.1.1

	Mesh Used in DORT Calculation (cont'd)		
	(Inner Model)		
	R (cm)	Z (cm)	θ (revolution)
43	162.236	100.973	8.36810E-02
44	163.294	103.683	8.61110E-02
45	164.352	106.393	8.88890E-02
46	165.411	109.102	9.13190E-02
47	166.469	111.812	9.20140E-02
48	166.998	114.521	9.44440E-02
49	167.527	117.230	9.72220E-02
50	168.057	119.940	1.00000E-01
51	168.586	123.639	1.01389E-01
52	169.115	127.337	1.02778E-01
53	169.644	131.036	1.04861E-01
54	170.173	134.734	1.06944E-01
55	170.702	138.433	1.09028E-01
56	171.232	142.131	1.11111E-01
57	171.761	145.830	1.13889E-01
58	172.290	149.528	1.15972E-01
59	172.819	153.227	1.18750E-01
60	173.348	156.925	1.20833E-01
61	173.878	160.624	1.22917E-01
62	174.407	164.323	1.25000E-01
63	174.936	168.021	
64	175.465	171.720	
65	175.994	175.418	
66	176.523	179.117	
67	177.053	182.815	
68	177.582	186.514	
69	178.111	190.212	
70	178.640	193.911	
71	179.169	197.610	
72	179.698	201.308	
73	180.228	205.007	
74	180.757	208.705	
75	181.286	212.404	
76	181.815	216.102	
77	182.344	219.801	
78	182.873	223.499	
79	183.403	227.198	
80	183.932	230.896	
81	184.461	234.595	
82	184.990	238.294	
83	185.519	241.992	
84	186.578	245.691	

Table 4.1.1.1

	Mesh Used in DORT Calculation (cont'd)	
	(Inner Model)	
	R (cm)	Z (cm)
85	187.636	249.389
86	188.694	253.088
87	189.753	256.786
88	190.185	260.485
89	190.820	264.183
90	191.455	267.882
91	192.090	271.581
92	192.725	275.279
93	193.360	278.978
94	193.995	282.676
95	194.630	286.375
96	195.268	290.073
97	196.535	293.772
98	197.870	297.470
99	199.000	301.169
100	200.345	304.867
101	200.660	308.566
102	201.295	312.265
103	201.932	315.963
104	202.568	319.662
105	203.205	323.360
106	203.840	327.059
107	204.155	330.757
108	205.000	334.456
109	206.000	338.154
110		341.853
111		345.551
112		349.250
113		350.528
114		352.528
115		355.895
116		359.261
117		362.628
118		365.994
119		367.994
120		369.415
121		370.715
122		372.715
123		375.848
124		378.982
125		382.115

Table 4.1.1.2

Mesh Used in DORT Calculation (Outer Model)

	R (cm)	Z (cm)	θ (revolution)
1	190.185	0.00000	0.00000E+00
2	190.820	4.44500	6.94400E-04
3	191.455	6.50125	2.08300E-03
4	192.090	8.55750	4.86100E-03
5	192.725	10.6138	7.63900E-03
6	193.360	12.6700	1.04170E-02
7	193.995	13.9700	1.31940E-02
8	194.630	16.2200	1.66670E-02
9	195.268	18.4700	2.01390E-02
10	196.535	20.7200	2.22220E-02
11	197.870	22.9700	2.50000E-02
12	199.000	25.2200	2.77780E-02
13	200.345	27.4700	3.05560E-02
14	200.660	29.7200	3.33330E-02
15	201.295	31.9700	3.61110E-02
16	201.932	34.2200	3.88890E-02
17	202.568	36.4700	4.16670E-02
18	203.205	38.7200	4.44440E-02
19	203.840	40.9700	4.68750E-02
20	204.155	43.2200	4.75690E-02
21	205.000	45.4700	5.00000E-02
22	206.000	47.7200	5.13890E-02
23	207.000	49.9700	5.35410E-02
24	208.000	52.2200	5.37770E-02
25	209.000	54.4700	5.41760E-02
26	210.000	56.7200	5.51140E-02
27	211.000	58.9700	5.60520E-02
28	212.000	61.2200	5.69900E-02
29	212.750	63.4700	5.73890E-02
30	213.210	65.7500	5.76250E-02
31	213.525	68.4595	5.94720E-02
32	213.845	71.1690	6.11110E-02
33	214.478	73.8785	6.25000E-02
34	215.112	76.5880	6.38890E-02
35	215.748	79.2975	6.52780E-02
36	216.382	82.0070	6.66670E-02
37	217.015	84.7165	6.94440E-02
38	217.335	87.4260	7.22220E-02
39	217.890	90.1355	7.50000E-02
40	218.440	92.8450	7.77780E-02
41	219.075	95.5545	8.05560E-02
42	219.710	98.2640	8.29860E-02

Table 4.1.1.2

Mesh Used in DORT Calculation (cont'd)			
(Outer Model)			
	R (cm)	Z (cm)	θ (revolution)
43	220.694	100.973	8.36810E-02
44	221.774	103.683	8.61110E-02
45	222.853	106.393	8.88890E-02
46	223.933	109.102	9.13190E-02
47	225.012	111.812	9.20140E-02
48	226.092	114.521	9.44440E-02
49	227.171	117.230	9.72220E-02
50	228.251	119.940	1.00000E-01
51	229.330	123.639	1.01389E-01
52	230.410	127.337	1.02778E-01
53	231.489	131.036	1.04861E-01
54	232.569	134.734	1.06944E-01
55	233.648	138.433	1.09028E-01
56	234.728	142.131	1.11111E-01
57	235.807	145.830	1.13889E-01
58	236.887	149.528	1.15972E-01
59	237.966	153.227	1.18750E-01
60	239.046	156.925	1.20833E-01
61	240.020	160.624	1.22917E-01
62	240.665	164.323	1.25000E-01
63	242.500	168.021	
64	245.000	171.720	
65	248.000	175.418	
66	252.660	179.117	
67	257.000	182.815	
68	262.500	186.514	
69	269.240	190.212	
70	279.400	193.911	
71	288.000	197.610	
72	300.000	201.308	
73	315.000	205.007	
74	325.120	208.705	
75	330.200	212.404	
76	334.010	216.102	
77	335.280	219.801	
78	335.915	223.499	
79	336.750	227.198	
80	338.000	230.896	
81	339.750	234.595	
82	341.500	238.294	
83	343.250	241.992	
84	345.000	245.691	

Table 4.1.1.2

Mesh Used in DORT Calculation (cont'd)
(Outer Model)

	R (cm)	Z (cm)
85	346.750	249.389
86	348.500	253.088
87	350.250	256.786
88	352.000	260.485
89	353.750	264.183
90	355.500	267.882
91	357.250	271.581
92	359.000	275.279
93	361.000	278.978
94	363.000	282.676
95	365.000	286.375
96	367.000	290.073
97	369.000	293.772
98	371.000	297.470
99	373.000	301.169
100	375.000	304.867
101	377.000	308.566
102	379.000	312.265
103	381.000	315.963
104		319.662
105		323.360
106		327.059
107		330.757
108		334.456
109		338.154
110		341.853
111		345.551
112		349.250
113		350.528
114		352.528
115		355.895
116		359.261
117		362.628
118		365.994
119		367.994
120		369.415
121		370.715
122		372.715
123		375.848
124		378.982
125		382.115

Table 4.1.1.3

47-Group Energy Structure of Cross-Section Library

Group	Midpoint Energy (MeV)	Energy Width (MeV)	Group	Midpoint Energy (MeV)	Energy Width (MeV)
1	1.5762E+01	3.1410E+00	25	2.4018E-01	1.1405E-01
2	1.3203E+01	1.9770E+00	26	1.4713E-01	7.2070E-02
3	1.1107E+01	2.2140E+00	27	8.9235E-02	4.3711E-02
4	9.3035E+00	1.3929E+00	28	5.4123E-02	2.6511E-02
5	8.0077E+00	1.1989E+00	29	3.6348E-02	9.0400E-03
6	6.7368E+00	1.3429E+00	30	2.8943E-02	5.7700E-03
7	5.5156E+00	1.0994E+00	31	2.5117E-02	1.8820E-03
8	4.3224E+00	1.2871E+00	32	2.3025E-02	2.3010E-03
9	3.3454E+00	6.6690E-01	33	1.8454E-02	6.8410E-03
10	2.8686E+00	2.8660E-01	34	1.1068E-02	7.9323E-03
11	2.5956E+00	2.5930E-01	35	5.2282E-03	3.7471E-03
12	2.4156E+00	1.0070E-01	36	2.4696E-03	1.7700E-03
13	2.3555E+00	1.9600E-02	37	1.0193E-03	1.1306E-03
14	2.2885E+00	1.1440E-01	38	3.3423E-04	2.3955E-04
15	2.0759E+00	3.1080E-01	39	1.5787E-04	1.1315E-04
16	1.7867E+00	2.6750E-01	40	6.9283E-05	6.4034E-05
17	1.5032E+00	2.9960E-01	41	2.3971E-05	2.6589E-05
18	1.1780E+00	3.5080E-01	42	7.8602E-06	5.6335E-06
19	9.1172E-01	1.8175E-01	43	3.4495E-06	3.1881E-06
20	7.8180E-01	7.8110E-02	44	1.3659E-06	9.7897E-07
21	6.7542E-01	1.3464E-01	45	6.4521E-07	4.6244E-07
22	5.5299E-01	1.1023E-01	46	2.5700E-07	3.1399E-07
23	4.3335E-01	1.2904E-01	47	5.0005E-08	9.9990E-08
24	3.3302E-01	7.1620E-02			

Table 4.1.1.4

Nuclear Parameters For Neutron Flux Monitors

Monitor	Reaction of Interest	Product	Response Range	Half-life
Copper	⁶³ Cu(n,α) ⁶⁰ Co	Co	6.13Mev < E < 11Mev	5.27 y
Iron	⁵⁴ Fe(n,p) ⁵⁴ Mn	Mn	2.47Mev < E < 7.8Mev	312.2 d
Nickel	⁵⁸ Ni(n,p) ⁵⁸ Co	Co	2.09Mev < E < 7.6Mev	70.88 d
U-238	²³⁸ U(n,f) ¹³⁷ Cs	Cs	1.51Mev < E < 6.7Mev	30.17 y
Np-237	²³⁷ Np(n,f) ¹³⁷ Cs	Cs	0.67Mev < E < 5.7Mev	30.17 y
Aluminium	²⁷ Al(n,α) ²⁴ Na	Na	6.5Mev < E < 12Mev	14.96 h
Sulfur	³² S(n,p) ³² P	P	2.29Mev < E < 7.4Mev	14.28 d
Iron	⁵⁶ Fe(n,p) ⁵⁶ Mn	Mn	5.44Mev < E < 11Mev	2.578 h
Copper	⁶⁵ Cu(n,2n) ⁶⁴ Cu	Cu	E > 10.5 Mev *	12.70 h
Titanium	⁴⁶ Ti(n,p) ⁴⁶ Sc	Sc	3.86Mev < E < 9.4Mev	83.81 d
Indium	¹¹⁵ In(n,n') ¹¹⁵ In	In	1.16Mev < E < 5.9Mev	4.486 h

+ The upper and lower limits of the energy range are defined such that 95% of the detector response occurs above the lower energy and 5% detector response occurs above the upper energy .

* Effective threshold used for group averaged cross sections .

Table 4.1.1.5

Dosimeter Activation Cross Sections (BUGLE93)

Group	* dpa	27 Al (n, α)	32 S (n,p)	46 Ti (n,p)
1	2.92800E+03	1.07960E-01	1.99690E-01	2.39950E-01
2	2.68300E+03	1.26620E-01	3.21560E-01	2.66490E-01
3	2.45500E+03	1.04600E-01	3.81900E-01	2.60920E-01
4	2.24500E+03	7.47180E-02	3.40150E-01	2.35990E-01
5	2.09200E+03	3.98360E-02	3.17920E-01	2.04580E-01
6	1.97100E+03	9.67520E-03	3.06550E-01	1.54930E-01
7	1.79200E+03	3.57430E-04	2.48610E-01	9.75560E-02
8	1.60000E+03	3.16550E-07	2.76670E-01	4.00220E-02
9	1.36900E+03	0.00000E+00	1.86250E-01	5.25420E-03
10	1.26500E+03	0.00000E+00	9.96220E-02	4.64190E-04
11	1.19800E+03	0.00000E+00	6.87660E-02	6.85870E-06
12	1.24600E+03	0.00000E+00	7.23790E-02	1.06920E-06
13	1.16600E+03	0.00000E+00	6.64680E-02	3.77160E-07
14	1.09600E+03	0.00000E+00	6.10960E-02	3.42230E-07
15	1.03600E+03	0.00000E+00	2.12780E-02	2.33440E-07
16	8.19000E+02	0.00000E+00	3.79620E-03	7.94750E-08
17	9.15000E+02	0.00000E+00	5.72810E-04	8.39500E-10
18	6.32000E+02	0.00000E+00	5.48290E-05	0.00000E+00
19	2.67000E+02	0.00000E+00	1.43450E-07	0.00000E+00
20	5.16000E+02	0.00000E+00	0.00000E+00	0.00000E+00
21	4.00000E+02	0.00000E+00	0.00000E+00	0.00000E+00
22	2.69000E+02	0.00000E+00	0.00000E+00	0.00000E+00
23	3.08000E+02	0.00000E+00	0.00000E+00	0.00000E+00
24	2.24000E+02	0.00000E+00	0.00000E+00	0.00000E+00
25	1.78000E+02	0.00000E+00	0.00000E+00	0.00000E+00
26	1.92000E+02	0.00000E+00	0.00000E+00	0.00000E+00
27	1.34000E+02	0.00000E+00	0.00000E+00	0.00000E+00
28	7.54000E+01	0.00000E+00	0.00000E+00	0.00000E+00
29	7.14000E+01	0.00000E+00	0.00000E+00	0.00000E+00
30	2.94000E+02	0.00000E+00	0.00000E+00	0.00000E+00
31	6.08000E+01	0.00000E+00	0.00000E+00	0.00000E+00
32	3.61000E+00	0.00000E+00	0.00000E+00	0.00000E+00
33	7.73000E+00	0.00000E+00	0.00000E+00	0.00000E+00
34	1.19000E+01	0.00000E+00	0.00000E+00	0.00000E+00
35	7.36000E+00	0.00000E+00	0.00000E+00	0.00000E+00
36	3.82000E+00	0.00000E+00	0.00000E+00	0.00000E+00
37	1.17000E+00	0.00000E+00	0.00000E+00	0.00000E+00
38	9.30000E-02	0.00000E+00	0.00000E+00	0.00000E+00
39	1.36000E-01	0.00000E+00	0.00000E+00	0.00000E+00
40	2.06000E-01	0.00000E+00	0.00000E+00	0.00000E+00
41	1.10000E-01	0.00000E+00	0.00000E+00	0.00000E+00
42	6.09000E-01	0.00000E+00	0.00000E+00	0.00000E+00
43	9.25000E-01	0.00000E+00	0.00000E+00	0.00000E+00
44	1.47000E+00	0.00000E+00	0.00000E+00	0.00000E+00
45	2.12000E+00	0.00000E+00	0.00000E+00	0.00000E+00
46	3.38000E+00	0.00000E+00	0.00000E+00	0.00000E+00
47	7.65000E+00	0.00000E+00	0.00000E+00	0.00000E+00

* dpa is from Reference-8 and not from
BUGLE-93.

Table 4.1.5

Posimeter Activation Cross Sections (BUGLE93) (cont'd)

Group	54	55	56	58	63
	Fe (n,p)	Fe (n,p)	Fe (n,p)	Ni (n,p)	Cu (n,α)
1	2.61610E-01	9.87950E-02	2.60050E-01	3.54140E-02	3.54140E-02
2	4.04120E-01	1.13440E-01	4.70450E-01	4.33760E-02	4.33760E-02
3	4.69690E-01	8.09850E-02	5.92300E-01	3.63770E-02	3.63770E-02
4	4.82250E-01	5.68070E-02	6.23120E-01	2.67930E-02	2.67930E-02
5	4.82340E-01	4.08510E-02	6.25410E-01	1.80500E-02	1.80500E-02
6	4.78150E-01	2.30500E-02	6.04840E-01	9.86820E-03	9.86820E-03
7	4.33950E-01	5.34250E-03	5.08850E-01	3.25320E-03	3.25320E-03
8	3.12820E-01	1.74960E-04	3.81490E-01	5.75050E-04	5.75050E-04
9	1.93220E-01	1.25600E-07	2.44540E-01	4.45250E-05	4.45250E-05
10	1.32630E-01	6.55290E-10	1.71000E-01	8.13620E-06	8.13620E-06
11	7.87050E-02	0.00000E+00	1.24950E-02	2.99060E-06	2.99060E-06
12	5.65520E-02	0.00000E+00	9.65570E-02	9.39370E-07	9.39370E-07
13	5.12010E-02	0.00000E+00	8.85450E-02	8.17650E-07	8.17650E-07
14	4.49420E-02	0.00000E+00	7.91190E-02	6.74430E-07	6.74430E-07
15	2.93480E-02	0.00000E+00	5.06570E-02	2.47260E-07	2.47260E-07
16	8.87320E-03	0.00000E+00	2.78260E-02	1.37490E-08	1.37490E-08
17	2.90280E-03	0.00000E+00	1.46240E-02	0.00000E+00	0.00000E+00
18	7.32000E-04	0.00000E+00	5.61440E-03	0.00000E+00	0.00000E+00
19	8.69480E-05	0.00000E+00	1.29440E-03	0.00000E+00	0.00000E+00
20	6.56090E-06	0.00000E+00	8.92680E-04	0.00000E+00	0.00000E+00
21	2.63610E-07	0.00000E+00	5.21060E-04	0.00000E+00	0.00000E+00
22	0.00000E+00	0.00000E+00	1.76550E-04	0.00000E+00	0.00000E+00
23	0.00000E+00	0.00000E+00	0.00000E+00	0.00000E+00	0.00000E+00
24	0.00000E+00	0.00000E+00	0.00000E+00	0.00000E+00	0.00000E+00
25	0.00000E+00	0.00000E+00	0.00000E+00	0.00000E+00	0.00000E+00
26	0.00000E+00	0.00000E+00	0.00000E+00	0.00000E+00	0.00000E+00
27	0.00000E+00	0.00000E+00	0.00000E+00	0.00000E+00	0.00000E+00
28	0.00000E+00	0.00000E+00	0.00000E+00	0.00000E+00	0.00000E+00
29	0.00000E+00	0.00000E+00	0.00000E+00	0.00000E+00	0.00000E+00
30	0.00000E+00	0.00000E+00	0.00000E+00	0.00000E+00	0.00000E+00
31	0.00000E+00	0.00000E+00	0.00000E+00	0.00000E+00	0.00000E+00
32	0.00000E+00	0.00000E+00	0.00000E+00	0.00000E+00	0.00000E+00
33	0.00000E+00	0.00000E+00	0.00000E+00	0.00000E+00	0.00000E+00
34	0.00000E+00	0.00000E+00	0.00000E+00	0.00000E+00	0.00000E+00
35	0.00000E+00	0.00000E+00	0.00000E+00	0.00000E+00	0.00000E+00
36	0.00000E+00	0.00000E+00	0.00000E+00	0.00000E+00	0.00000E+00
37	0.00000E+00	0.00000E+00	0.00000E+00	0.00000E+00	0.00000E+00
38	0.00000E+00	0.00000E+00	0.00000E+00	0.00000E+00	0.00000E+00
39	0.00000E+00	0.00000E+00	0.00000E+00	0.00000E+00	0.00000E+00
40	0.00000E+00	0.00000E+00	0.00000E+00	0.00000E+00	0.00000E+00
41	0.00000E+00	0.00000E+00	0.00000E+00	0.00000E+00	0.00000E+00
42	0.00000E+00	0.00000E+00	0.00000E+00	0.00000E+00	0.00000E+00
43	0.00000E+00	0.00000E+00	0.00000E+00	0.00000E+00	0.00000E+00
44	0.00000E+00	0.00000E+00	0.00000E+00	0.00000E+00	0.00000E+00
45	0.00000E+00	0.00000E+00	0.00000E+00	0.00000E+00	0.00000E+00
46	0.00000E+00	0.00000E+00	0.00000E+00	0.00000E+00	0.00000E+00
47	0.00000E+00	0.00000E+00	0.00000E+00	0.00000E+00	0.00000E+00

Table 4.1.1.5

Dosimeter Activation Cross Sections (BUGLE93) (cont'd)				
Group	65 Cu (n,2n)	115 In (n,n')	238 U (n,f)	237 Np (n,f)
1	9.90880E-01	6.07760E-02	1.20300E+00	2.20080E+00
2	7.19280E-01	9.42420E-02	1.03450E+00	2.08210E+00
3	1.38520E-01	2.03630E-01	9.84680E-01	2.10550E+00
4	0.00000E+00	2.70850E-01	9.95010E-01	2.17530E+00
5	0.00000E+00	2.95180E-01	9.91140E-01	2.23870E+00
6	0.00000E+00	3.23850E-01	8.30640E-01	1.95680E+00
7	0.00000E+00	3.31200E-01	5.59790E-01	1.49180E+00
8	0.00000E+00	3.15650E-01	5.46370E-01	1.53110E+00
9	0.00000E+00	3.31330E-01	5.25280E-01	1.60980E+00
10	0.00000E+00	3.35530E-01	5.23280E-01	1.65070E+00
11	0.00000E+00	3.32990E-01	5.32720E-01	1.66340E+00
12	0.00000E+00	3.23410E-01	5.36910E-01	1.66060E+00
13	0.00000E+00	3.19360E-01	5.37700E-01	1.66980E+00
14	0.00000E+00	3.12010E-01	5.38310E-01	1.68260E+00
15	0.00000E+00	2.73260E-01	5.30140E-01	1.68220E+00
16	0.00000E+00	2.09410E-01	4.74430E-01	1.64620E+00
17	0.00000E+00	1.66980E-01	3.16460E-01	1.58540E+00
18	0.00000E+00	9.10700E-02	4.08720E-02	1.47170E+00
19	0.00000E+00	4.84140E-02	1.23080E-02	1.33850E+00
20	0.00000E+00	2.50700E-02	3.76100E-03	1.19340E+00
21	0.00000E+00	1.24750E-02	1.40440E-03	9.21250E-01
22	0.00000E+00	3.86310E-03	6.25180E-04	6.14430E-01
23	0.00000E+00	1.74660E-03	2.78530E-04	2.63980E-01
24	0.00000E+00	9.51840E-05	1.52050E-04	9.18480E-02
25	0.00000E+00	0.00000E+00	7.91640E-05	4.62870E-02
26	0.00000E+00	0.00000E+00	1.07100E-04	2.33250E-02
27	0.00000E+00	0.00000E+00	3.69970E-05	1.46710E-02
28	0.00000E+00	0.00000E+00	9.15930E-05	1.18920E-02
29	0.00000E+00	0.00000E+00	2.90420E-05	1.06860E-02
30	0.00000E+00	0.00000E+00	5.28370E-05	1.01340E-02
31	0.00000E+00	0.00000E+00	2.33180E-05	9.90910E-03
32	0.00000E+00	0.00000E+00	2.53650E-05	9.77070E-03
33	0.00000E+00	0.00000E+00	1.44660E-04	9.54510E-03
34	0.00000E+00	0.00000E+00	5.26090E-04	9.14010E-03
35	0.00000E+00	0.00000E+00	1.27240E-05	8.80730E-03
36	0.00000E+00	0.00000E+00	5.90660E-09	9.33510E-03
37	0.00000E+00	0.00000E+00	1.03310E-03	1.36970E-02
38	0.00000E+00	0.00000E+00	1.15010E-05	2.60970E-02
39	0.00000E+00	0.00000E+00	1.70540E-05	3.08330E-02
40	0.00000E+00	0.00000E+00	2.88680E-05	6.26140E-02
41	0.00000E+00	0.00000E+00	1.42830E-04	2.46870E-02
42	0.00000E+00	0.00000E+00	7.56670E-05	8.15180E-03
43	0.00000E+00	0.00000E+00	1.74680E-06	3.95390E-03
44	0.00000E+00	0.00000E+00	1.84880E-06	1.10250E-02
45	0.00000E+00	0.00000E+00	2.47760E-06	7.11220E-03
46	0.00000E+00	0.00000E+00	3.77770E-06	4.98640E-03
47	0.00000E+00	0.00000E+00	7.84540E-06	1.13480E-02

Table 4.1.2.1

Standard Core Loading

Flux ($E > 1.0$ MEV) At Pressure Vessel

z	125.488cm	125.488cm	129.186cm	129.186cm	140.282cm
θ	0-T	1/4 T	1/2 T	3/4 T	T
1	3.14799E+10	1.78931E+10	8.69114E+09	4.00968E+09	1.63867E+09
2	3.14939E+10	1.78948E+10	8.69181E+09	4.01204E+09	1.63590E+09
3	3.15515E+10	1.79309E+10	8.71023E+09	4.01916E+09	1.63546E+09
4	3.18090E+10	1.80707E+10	8.77347E+09	4.04608E+09	1.64438E+09
5	3.22184E+10	1.82947E+10	8.87711E+09	4.09152E+09	1.65943E+09
6	3.27523E+10	1.85911E+10	9.01599E+09	4.15139E+09	1.67925E+09
7	3.34669E+10	1.89955E+10	9.20569E+09	4.23439E+09	1.70608E+09
8	3.44603E+10	1.95427E+10	9.45942E+09	4.34323E+09	1.74117E+09
9	3.54574E+10	2.00747E+10	9.70318E+09	4.44796E+09	1.77511E+09
10	3.63728E+10	2.05806E+10	9.93677E+09	4.54712E+09	1.80693E+09
11	3.74744E+10	2.11727E+10	1.02041E+10	4.66105E+09	1.84307E+09
12	3.85964E+10	2.17730E+10	1.04749E+10	4.77398E+09	1.87884E+09
13	3.96873E+10	2.23491E+10	1.07308E+10	4.88026E+09	1.91205E+09
14	4.06848E+10	2.28693E+10	1.09581E+10	4.97269E+09	1.94069E+09
15	4.15408E+10	2.33066E+10	1.11436E+10	5.04551E+09	1.96229E+09
16	4.22000E+10	2.36185E+10	1.12659E+10	5.08990E+09	1.97516E+09
17	4.25965E+10	2.37640E+10	1.13064E+10	5.09949E+09	1.97593E+09
18	4.25805E+10	2.36866E+10	1.12453E+10	5.06928E+09	1.96689E+09
19	4.21634E+10	2.34630E+10	1.11362E+10	5.02312E+09	1.95418E+09
20	4.20061E+10	2.32440E+10	1.10309E+10	4.98065E+09	1.93913E+09
21	4.11917E+10	2.27246E+10	1.08174E+10	4.90050E+09	1.91354E+09
22	4.02185E+10	2.21933E+10	1.06133E+10	4.82491E+09	1.89446E+09
23	3.88038E+10	2.17186E+10	1.04642E+10	4.77406E+09	1.88876E+09
24	3.82263E+10	2.15915E+10	1.04226E+10	4.75869E+09	1.88401E+09
25	3.73962E+10	2.12952E+10	1.03327E+10	4.72600E+09	1.86809E+09
26	3.67420E+10	2.09653E+10	1.02152E+10	4.68137E+09	1.85169E+09
27	3.63552E+10	2.07451E+10	1.01082E+10	4.63723E+09	1.83997E+09
28	3.64033E+10	2.06613E+10	1.00430E+10	4.60702E+09	1.83573E+09
29	3.65714E+10	2.06166E+10	1.00083E+10	4.59093E+09	1.83048E+09
30	3.70498E+10	2.05760E+10	9.92482E+09	4.54562E+09	1.80541E+09
31	3.68078E+10	2.04258E+10	9.81075E+09	4.48443E+09	1.78065E+09
32	3.62594E+10	2.02359E+10	9.70994E+09	4.43473E+09	1.76407E+09

Table 4.1.2.1

Standard Core Loading

Flux ($E > 1.0$ MEV) At Pressure Vessel (cont'd)

z	125.488cm	125.488cm	129.186cm	129.186cm	140.282cm
θ	0-T	1/4 T	1/2 T	3/4 T	T
33	3.56841E+10	2.00119E+10	9.60770E+09	4.38845E+09	1.74834E+09
34	3.50515E+10	1.97443E+10	9.49650E+09	4.34081E+09	1.73226E+09
35	3.44059E+10	1.94493E+10	9.37791E+09	4.29200E+09	1.71536E+09
36	3.34183E+10	1.89984E+10	9.20303E+09	4.22263E+09	1.69156E+09
37	3.25664E+10	1.85583E+10	9.01527E+09	4.14578E+09	1.66600E+09
38	3.20601E+10	1.82674E+10	8.87729E+09	4.08568E+09	1.64576E+09
39	3.18527E+10	1.81151E+10	8.79206E+09	4.04422E+09	1.63026E+09
40	3.18881E+10	1.80834E+10	8.75314E+09	4.01860E+09	1.61888E+09
41	3.20596E+10	1.81229E+10	8.74310E+09	4.00349E+09	1.61190E+09
42	3.21762E+10	1.81522E+10	8.73745E+09	3.99398E+09	1.60844E+09
43	3.22997E+10	1.81744E+10	8.72901E+09	3.98305E+09	1.60099E+09
44	3.24275E+10	1.81670E+10	8.69442E+09	3.95756E+09	1.58850E+09
45	3.22800E+10	1.80383E+10	8.61449E+09	3.91564E+09	1.57376E+09
46	3.18627E+10	1.78479E+10	8.52620E+09	3.87575E+09	1.56143E+09
47	3.17519E+10	1.77103E+10	8.44757E+09	3.83815E+09	1.54649E+09
48	3.11006E+10	1.73353E+10	8.26856E+09	3.75861E+09	1.51796E+09
49	3.00742E+10	1.68012E+10	8.02813E+09	3.65574E+09	1.48481E+09
50	2.90423E+10	1.62947E+10	7.80654E+09	3.56252E+09	1.45554E+09
51	2.83755E+10	1.59367E+10	7.64313E+09	3.49306E+09	1.43270E+09
52	2.75587E+10	1.54926E+10	7.44148E+09	3.40697E+09	1.40336E+09
53	2.64817E+10	1.49294E+10	7.19011E+09	3.30096E+09	1.36866E+09
54	2.53619E+10	1.43443E+10	6.93103E+09	3.19288E+09	1.33392E+09
55	2.42393E+10	1.37581E+10	6.67180E+09	3.08487E+09	1.29944E+09
56	2.29862E+10	1.31122E+10	6.38859E+09	2.96794E+09	1.26188E+09
57	2.19661E+10	1.25603E+10	6.14181E+09	2.86499E+09	1.22943E+09
58	2.10252E+10	1.20735E+10	5.92692E+09	2.77596E+09	1.20064E+09
59	2.04426E+10	1.17442E+10	5.77594E+09	2.71222E+09	1.18071E+09
60	2.00683E+10	1.15420E+10	5.68379E+09	2.67354E+09	1.16813E+09
61	1.98790E+10	1.14396E+10	5.63730E+09	2.65388E+09	1.16185E+09

Table 4.1.2.2

Standard Core Loading

Flux ($E > 0.1$ MEV) At Pressure Vessel

z	125.488cm	129.186cm	132.885cm	140.282cm	162.474cm
θ	0-T	1/4 T	1/2 T	3/4 T	T
1	7.28418E+10	6.21982E+10	4.52833E+10	2.91806E+10	1.40176E+10
2	7.28885E+10	6.22313E+10	4.53048E+10	2.91970E+10	1.39967E+10
3	7.30665E+10	6.24103E+10	4.54281E+10	2.92636E+10	1.39959E+10
4	7.36611E+10	6.28935E+10	4.57487E+10	2.94435E+10	1.40537E+10
5	7.46130E+10	6.36518E+10	4.62541E+10	2.97305E+10	1.41500E+10
6	7.58764E+10	6.46632E+10	4.69303E+10	3.01121E+10	1.42744E+10
7	7.75947E+10	6.60499E+10	4.78559E+10	3.06333E+10	1.44397E+10
8	7.99122E+10	6.78797E+10	4.90610E+10	3.13046E+10	1.46527E+10
9	8.21982E+10	6.96247E+10	5.01974E+10	3.19367E+10	1.48555E+10
10	8.43711E+10	7.13121E+10	5.12946E+10	3.25410E+10	1.50467E+10
11	8.69307E+10	7.32583E+10	5.25412E+10	3.32270E+10	1.52606E+10
12	8.95420E+10	7.52202E+10	5.37877E+10	3.39031E+10	1.54725E+10
13	9.20828E+10	7.70984E+10	5.49640E+10	3.45375E+10	1.56693E+10
14	9.44203E+10	7.87976E+10	5.60127E+10	3.50960E+10	1.58406E+10
15	9.64313E+10	8.02277E+10	5.68746E+10	3.55449E+10	1.59753E+10
16	9.79835E+10	8.12714E+10	5.74801E+10	3.58499E+10	1.60646E+10
17	9.89511E+10	8.18442E+10	5.77752E+10	3.59865E+10	1.60947E+10
18	9.91436E+10	8.18592E+10	5.77209E+10	3.59385E+10	1.60824E+10
19	9.86822E+10	8.15371E+10	5.74971E+10	3.58115E+10	1.60518E+10
20	9.84408E+10	8.10906E+10	5.71875E+10	3.56443E+10	1.59856E+10
21	9.74895E+10	8.01586E+10	5.66184E+10	3.53451E+10	1.58726E+10
22	9.63065E+10	7.90716E+10	5.59722E+10	3.50055E+10	1.57931E+10
23	9.47901E+10	7.81654E+10	5.54807E+10	3.47522E+10	1.57811E+10
24	9.42138E+10	7.78701E+10	5.53148E+10	3.46670E+10	1.57511E+10
25	9.33791E+10	7.72587E+10	5.49788E+10	3.44913E+10	1.56547E+10
26	9.23160E+10	7.64440E+10	5.45087E+10	3.42406E+10	1.55553E+10
27	9.11457E+10	7.56813E+10	5.40363E+10	3.39867E+10	1.54899E+10
28	9.03482E+10	7.51708E+10	5.36943E+10	3.37974E+10	1.54654E+10
29	9.00590E+10	7.49149E+10	5.35168E+10	3.36973E+10	1.54319E+10
30	8.94794E+10	7.42427E+10	5.30312E+10	3.34214E+10	1.52719E+10
31	8.75827E+10	7.30066E+10	5.22068E+10	3.29555E+10	1.50935E+10

Table 4.1.2.2

Standard Core Loading

Flux ($E > 0.1$ Mev) At Pressure Vessel (cont'd)

z	125.488cm	129.186cm	132.885cm	140.282cm	162.474cm
θ	0-T	1/4 T	1/2 T	3/4 T	T
32	8.56464E+10	7.18420E+10	5.14634E+10	3.25402E+10	1.49675E+10
33	8.39387E+10	7.07282E+10	5.07681E+10	3.21531E+10	1.48426E+10
34	8.22567E+10	6.95934E+10	5.00777E+10	3.17723E+10	1.47160E+10
35	8.06326E+10	6.84715E+10	4.93966E+10	3.14011E+10	1.45857E+10
36	7.84725E+10	6.69894E+10	4.85019E+10	3.09112E+10	1.44115E+10
37	7.64705E+10	6.54650E+10	4.75206E+10	3.03604E+10	1.42241E+10
38	7.52147E+10	6.43821E+10	4.67546E+10	2.99072E+10	1.40690E+10
39	7.46141E+10	6.37040E+10	4.62042E+10	2.95553E+10	1.39384E+10
40	7.45576E+10	6.33731E+10	4.58352E+10	2.92872E+10	1.38290E+10
41	7.48192E+10	6.32593E+10	4.55938E+10	2.90835E+10	1.37526E+10
42	7.50367E+10	6.32186E+10	4.54564E+10	2.89624E+10	1.37153E+10
43	7.52560E+10	6.31725E+10	4.53142E+10	2.88360E+10	1.36448E+10
44	7.54531E+10	6.29892E+10	4.50231E+10	2.86065E+10	1.35394E+10
45	7.51745E+10	6.25228E+10	4.45907E+10	2.83105E+10	1.34383E+10
46	7.45256E+10	6.20101E+10	4.42128E+10	2.80735E+10	1.33661E+10
47	7.40997E+10	6.14746E+10	4.37911E+10	2.78130E+10	1.32583E+10
48	7.26620E+10	6.02641E+10	4.29457E+10	2.73148E+10	1.30735E+10
49	7.04374E+10	5.85724E+10	4.18381E+10	2.66851E+10	1.28675E+10
50	6.82461E+10	5.70037E+10	4.08387E+10	2.61276E+10	1.26931E+10
51	6.66377E+10	5.57971E+10	4.00597E+10	2.56953E+10	1.25494E+10
52	6.46396E+10	5.42843E+10	3.90913E+10	2.51586E+10	1.23630E+10
53	6.21119E+10	5.24208E+10	3.79124E+10	2.45094E+10	1.21485E+10
54	5.94916E+10	5.05040E+10	3.67100E+10	2.38535E+10	1.19377E+10
55	5.68729E+10	4.86011E+10	3.55218E+10	2.32071E+10	1.17295E+10
56	5.40304E+10	4.65561E+10	3.42530E+10	2.25211E+10	1.15076E+10
57	5.16124E+10	4.47535E+10	3.31257E+10	2.19097E+10	1.13142E+10
58	4.94943E+10	4.32268E+10	3.21767E+10	2.13966E+10	1.11471E+10
59	4.80550E+10	4.21135E+10	3.14698E+10	2.10120E+10	1.10271E+10
60	4.71664E+10	4.14481E+10	3.10476E+10	2.07826E+10	1.09526E+10
61	4.67194E+10	4.11122E+10	3.08350E+10	2.06665E+10	1.09151E+10

Table 4.1.2.3

Standard Core Loading

DPA Rate At Pressure Vessel

z	125.488cm	129.186cm	132.885cm	136.584cm	158.775cm
θ	0-T	1/4 T	1/2 T	3/4 T	T
1	4.87642E-11	3.17777E-11	1.90527E-11	1.08896E-11	5.02117E-12
2	4.87791E-11	3.17857E-11	1.90584E-11	1.08955E-11	5.01373E-12
3	4.88673E-11	3.18587E-11	1.91042E-11	1.09183E-11	5.01329E-12
4	4.92580E-11	3.21022E-11	1.92389E-11	1.09864E-11	5.03524E-12
5	4.98761E-11	3.24873E-11	1.94538E-11	1.10967E-11	5.07192E-12
6	5.06854E-11	3.29972E-11	1.97412E-11	1.12430E-11	5.11961E-12
7	5.17683E-11	3.36921E-11	2.01331E-11	1.14433E-11	5.18329E-12
8	5.32618E-11	3.46223E-11	2.06496E-11	1.17031E-11	5.26576E-12
9	5.47531E-11	3.55201E-11	2.11406E-11	1.19495E-11	5.34471E-12
10	5.61318E-11	3.63763E-11	2.16120E-11	1.21840E-11	5.41889E-12
11	5.77802E-11	3.73731E-11	2.21497E-11	1.24512E-11	5.50229E-12
12	5.94572E-11	3.83787E-11	2.26892E-11	1.27149E-11	5.58481E-12
13	6.10822E-11	3.93408E-11	2.31979E-11	1.29623E-11	5.66127E-12
14	6.25667E-11	4.02077E-11	2.36501E-11	1.31788E-11	5.72751E-12
15	6.38360E-11	4.09347E-11	2.40194E-11	1.33513E-11	5.77857E-12
16	6.48097E-11	4.14573E-11	2.42713E-11	1.34637E-11	5.81104E-12
17	6.53942E-11	4.17175E-11	2.43754E-11	1.35047E-11	5.81842E-12
18	6.53972E-11	4.16382E-11	2.43039E-11	1.34653E-11	5.80686E-12
19	6.48353E-11	4.13342E-11	2.41465E-11	1.33921E-11	5.78759E-12
20	6.46337E-11	4.10307E-11	2.39777E-11	1.33140E-11	5.75803E-12
21	6.35187E-11	4.03013E-11	2.36408E-11	1.31685E-11	5.70744E-12
22	6.22097E-11	3.95361E-11	2.32979E-11	1.30182E-11	5.67123E-12
23	6.02722E-11	3.88462E-11	2.30428E-11	1.29120E-11	5.66366E-12
24	5.94514E-11	3.86577E-11	2.29666E-11	1.28782E-11	5.65206E-12
25	5.82509E-11	3.82094E-11	2.28038E-11	1.28070E-11	5.61476E-12
26	5.73072E-11	3.76927E-11	2.25843E-11	1.27069E-11	5.57632E-12
27	5.67185E-11	3.73157E-11	2.23735E-11	1.26057E-11	5.55011E-12
28	5.67577E-11	3.71429E-11	2.22342E-11	1.25331E-11	5.54026E-12
29	5.69619E-11	3.70474E-11	2.21596E-11	1.24946E-11	5.52728E-12
30	5.75501E-11	3.69026E-11	2.19732E-11	1.23862E-11	5.46635E-12
31	5.70412E-11	3.65277E-11	2.16862E-11	1.22209E-11	5.40167E-12

Table 4.1.2.3

Standard Core Loading

DPA Rate At Pressure Vessel (cont'd)

z	125.488cm	129.186cm	132.885cm	136.584cm	158.775cm
θ	0-T	1/4 T	1/2 T	3/4 T	T
32	5.61350E-11	3.61079E-11	2.14259E-11	1.20780E-11	5.35689E-12
33	5.52032E-11	3.56547E-11	2.11724E-11	1.19439E-11	5.31329E-12
34	5.42153E-11	3.51507E-11	2.09090E-11	1.18096E-11	5.26859E-12
35	5.32264E-11	3.46200E-11	2.06401E-11	1.16759E-11	5.22221E-12
36	5.17570E-11	3.38516E-11	2.02667E-11	1.14944E-11	5.15881E-12
37	5.04684E-11	3.30845E-11	1.98597E-11	1.12904E-11	5.09023E-12
38	4.96781E-11	3.25547E-11	1.95473E-11	1.11244E-11	5.03380E-12
39	4.93221E-11	3.22450E-11	1.93325E-11	1.09987E-11	4.98731E-12
40	4.93173E-11	3.21242E-11	1.92015E-11	1.09071E-11	4.94935E-12
41	4.95139E-11	3.21181E-11	1.91261E-11	1.08400E-11	4.92317E-12
42	4.96542E-11	3.21229E-11	1.90818E-11	1.07992E-11	4.90995E-12
43	4.98002E-11	3.21211E-11	1.90345E-11	1.07562E-11	4.88543E-12
44	4.99290E-11	3.20508E-11	1.89239E-11	1.06736E-11	4.84728E-12
45	4.96748E-11	3.17978E-11	1.87376E-11	1.05601E-11	4.80820E-12
46	4.90599E-11	3.14766E-11	1.85598E-11	1.04643E-11	4.77875E-12
47	4.88516E-11	3.12207E-11	1.83846E-11	1.03659E-11	4.73888E-12
48	4.78500E-11	3.05771E-11	1.80152E-11	1.01720E-11	4.66801E-12
49	4.63161E-11	2.96787E-11	1.75301E-11	9.92603E-12	4.58824E-12
50	4.47937E-11	2.88388E-11	1.70896E-11	9.70734E-12	4.51975E-12
51	4.37826E-11	2.82291E-11	1.67569E-11	9.54047E-12	4.46483E-12
52	4.25348E-11	2.74712E-11	1.63449E-11	9.33402E-12	4.39383E-12
53	4.09189E-11	2.65219E-11	1.58391E-11	9.08277E-12	4.31144E-12
54	3.92480E-11	2.55436E-11	1.53211E-11	8.82850E-12	4.23002E-12
55	3.75797E-11	2.45682E-11	1.48073E-11	8.57667E-12	4.14943E-12
56	3.57263E-11	2.35027E-11	1.42519E-11	8.30746E-12	4.06296E-12
57	3.42084E-11	2.25840E-11	1.37642E-11	8.06883E-12	3.98781E-12
58	3.28168E-11	2.17824E-11	1.33455E-11	7.86603E-12	3.92227E-12
59	3.19432E-11	2.12273E-11	1.30433E-11	7.71689E-12	3.87587E-12
60	3.13832E-11	2.08889E-11	1.28605E-11	7.62730E-12	3.84691E-12
61	3.11002E-11	2.07175E-11	1.27684E-11	7.58181E-12	3.83234E-12

Table 4.1.2.4

Standard Core Loading

Flux ($E > 1.0$ MEV) At Pressure Vessel Lower Weld

(z=67.1048cm)

θ	0-T	1/4 T	1/2 T	3/4 T	T
1	2.70106E+10	1.53047E+10	7.40890E+09	3.40212E+09	1.37703E+09
2	2.70227E+10	1.53062E+10	7.40946E+09	3.40413E+09	1.37470E+09
3	2.70722E+10	1.53371E+10	7.42517E+09	3.41016E+09	1.37433E+09
4	2.72932E+10	1.54567E+10	7.47908E+09	3.43301E+09	1.38183E+09
5	2.76446E+10	1.56483E+10	7.56744E+09	3.47156E+09	1.39447E+09
6	2.81029E+10	1.59019E+10	7.68584E+09	3.52236E+09	1.41113E+09
7	2.87163E+10	1.62478E+10	7.84757E+09	3.59279E+09	1.43368E+09
8	2.95690E+10	1.67160E+10	8.06388E+09	3.68514E+09	1.46317E+09
9	3.04249E+10	1.71711E+10	8.27170E+09	3.77401E+09	1.49169E+09
10	3.12107E+10	1.76039E+10	8.47085E+09	3.85815E+09	1.51842E+09
11	3.21563E+10	1.81104E+10	8.69878E+09	3.95482E+09	1.54880E+09
12	3.31195E+10	1.86240E+10	8.92960E+09	4.05064E+09	1.57886E+09
13	3.40559E+10	1.91169E+10	9.14781E+09	4.14083E+09	1.60677E+09
14	3.49123E+10	1.95620E+10	9.34163E+09	4.21925E+09	1.63083E+09
15	3.56472E+10	1.99362E+10	9.49978E+09	4.28104E+09	1.64898E+09
16	3.62132E+10	2.02030E+10	9.60402E+09	4.31870E+09	1.65979E+09
17	3.65537E+10	2.03275E+10	9.63859E+09	4.32684E+09	1.66043E+09
18	3.65402E+10	2.02614E+10	9.58645E+09	4.30120E+09	1.65282E+09
19	3.61825E+10	2.00701E+10	9.49345E+09	4.26202E+09	1.64213E+09
20	3.60475E+10	1.98828E+10	9.40366E+09	4.22597E+09	1.62947E+09
21	3.53490E+10	1.94385E+10	9.22160E+09	4.15794E+09	1.60796E+09
22	3.45140E+10	1.89840E+10	9.04761E+09	4.09379E+09	1.59191E+09
23	3.33007E+10	1.85779E+10	8.92049E+09	4.05063E+09	1.58712E+09
24	3.28057E+10	1.84692E+10	8.88501E+09	4.03759E+09	1.58313E+09
25	3.20941E+10	1.82158E+10	8.80838E+09	4.00985E+09	1.56975E+09
26	3.15329E+10	1.79336E+10	8.70816E+09	3.97198E+09	1.55597E+09
27	3.12006E+10	1.77452E+10	8.61701E+09	3.93453E+09	1.54612E+09
28	3.12411E+10	1.76735E+10	8.56138E+09	3.90889E+09	1.54256E+09
29	3.13849E+10	1.76353E+10	8.53178E+09	3.89524E+09	1.53815E+09
30	3.17941E+10	1.76004E+10	8.46064E+09	3.85679E+09	1.51707E+09
31	3.15857E+10	1.74718E+10	8.36340E+09	3.80488E+09	1.49628E+09

Table 4.1.2.4

Standard Core Loading

Flux ($E > 1.0$ MEV) At Pressure Vessel Lower Weld (cont'd)

(z=67.1048cm)

θ	0-T	1/4 T	1/2 T	3/4 T	T
32	3.11147E+10	1.73093E+10	8.27746E+09	3.76273E+09	1.48235E+09
33	3.06207E+10	1.71176E+10	8.19031E+09	3.72347E+09	1.46914E+09
34	3.00777E+10	1.68887E+10	8.09551E+09	3.68306E+09	1.45563E+09
35	2.95235E+10	1.66363E+10	7.99442E+09	3.64164E+09	1.44144E+09
36	2.86758E+10	1.62506E+10	7.84532E+09	3.58279E+09	1.42144E+09
37	2.79447E+10	1.58741E+10	7.68525E+09	3.51758E+09	1.39997E+09
38	2.75101E+10	1.56253E+10	7.56763E+09	3.46659E+09	1.38296E+09
39	2.73322E+10	1.54950E+10	7.49499E+09	3.43142E+09	1.36994E+09
40	2.73627E+10	1.54679E+10	7.46182E+09	3.40969E+09	1.36037E+09
41	2.75101E+10	1.55018E+10	7.45329E+09	3.39687E+09	1.35451E+09
42	2.76104E+10	1.55269E+10	7.44848E+09	3.38880E+09	1.35160E+09
43	2.77165E+10	1.55459E+10	7.44130E+09	3.37954E+09	1.34534E+09
44	2.78265E+10	1.55397E+10	7.41183E+09	3.35791E+09	1.33484E+09
45	2.77002E+10	1.54297E+10	7.34371E+09	3.32234E+09	1.32244E+09
46	2.73425E+10	1.52669E+10	7.26845E+09	3.28849E+09	1.31208E+09
47	2.72474E+10	1.51492E+10	7.20142E+09	3.25659E+09	1.29952E+09
48	2.66886E+10	1.48284E+10	7.04881E+09	3.18910E+09	1.27555E+09
49	2.58078E+10	1.43715E+10	6.84384E+09	3.10181E+09	1.24769E+09
50	2.49222E+10	1.39382E+10	6.65492E+09	3.02271E+09	1.22309E+09
51	2.43498E+10	1.36320E+10	6.51561E+09	2.96377E+09	1.20389E+09
52	2.36487E+10	1.32520E+10	6.34370E+09	2.89073E+09	1.17924E+09
53	2.27241E+10	1.27702E+10	6.12940E+09	2.80078E+09	1.15009E+09
54	2.17628E+10	1.22697E+10	5.90851E+09	2.70907E+09	1.12090E+09
55	2.07991E+10	1.17681E+10	5.68750E+09	2.61742E+09	1.09192E+09
56	1.97233E+10	1.12155E+10	5.44603E+09	2.51820E+09	1.06035E+09
57	1.88476E+10	1.07433E+10	5.23563E+09	2.43084E+09	1.03309E+09
58	1.80399E+10	1.03268E+10	5.05243E+09	2.35530E+09	1.00889E+09
59	1.75397E+10	1.00451E+10	4.92370E+09	2.30122E+09	9.92144E+08
60	1.72183E+10	9.87210E+09	4.84514E+09	2.26839E+09	9.81573E+08
61	1.70558E+10	9.78452E+09	4.80550E+09	2.25171E+09	9.76293E+08

Table 4.1.2.5

Standard Core Loading

Flux ($E > 0.1\text{MEV}$) At Pressure Vessel Lower Weld

(z=67.1048cm)

θ	0-T	1/4 T	1/2 T	3/4 T	T
1	6.22826E+10	5.27904E+10	3.81521E+10	2.43557E+10	1.14706E+10
2	6.23225E+10	5.28185E+10	3.81703E+10	2.43694E+10	1.14535E+10
3	6.24748E+10	5.29703E+10	3.82741E+10	2.44250E+10	1.14528E+10
4	6.29832E+10	5.33805E+10	3.85442E+10	2.45752E+10	1.15002E+10
5	6.37973E+10	5.40242E+10	3.89703E+10	2.48150E+10	1.15794E+10
6	6.48777E+10	5.48829E+10	3.95403E+10	2.51338E+10	1.16816E+10
7	6.63471E+10	5.60602E+10	4.03205E+10	2.55694E+10	1.18175E+10
8	6.83291E+10	5.76137E+10	4.13365E+10	2.61304E+10	1.19925E+10
9	7.02842E+10	5.90954E+10	4.22947E+10	2.66587E+10	1.21593E+10
10	7.21425E+10	6.05282E+10	4.32197E+10	2.71637E+10	1.23164E+10
11	7.43316E+10	6.21807E+10	4.42708E+10	2.77370E+10	1.24923E+10
12	7.65649E+10	6.38467E+10	4.53218E+10	2.83021E+10	1.26665E+10
13	7.87381E+10	6.54416E+10	4.63136E+10	2.88324E+10	1.28283E+10
14	8.07373E+10	6.68845E+10	4.71979E+10	2.92992E+10	1.29692E+10
15	8.24573E+10	6.80989E+10	4.79246E+10	2.96743E+10	1.30798E+10
16	8.37850E+10	6.89851E+10	4.84350E+10	2.99291E+10	1.31532E+10
17	8.46125E+10	6.94711E+10	4.86834E+10	3.00430E+10	1.31778E+10
18	8.47767E+10	6.94830E+10	4.86369E+10	3.00023E+10	1.31675E+10
19	8.43811E+10	6.92082E+10	4.84472E+10	2.98956E+10	1.31420E+10
20	8.41741E+10	6.88280E+10	4.81855E+10	2.97556E+10	1.30875E+10
21	8.33586E+10	6.80341E+10	4.77043E+10	2.95049E+10	1.29945E+10
22	8.23442E+10	6.71089E+10	4.71585E+10	2.92206E+10	1.29290E+10
23	8.10439E+10	6.63375E+10	4.67434E+10	2.90086E+10	1.29189E+10
24	8.05498E+10	6.60864E+10	4.66035E+10	2.89374E+10	1.28942E+10
25	7.98343E+10	6.55661E+10	4.63199E+10	2.87905E+10	1.28150E+10
26	7.89243E+10	6.48736E+10	4.59232E+10	2.85809E+10	1.27333E+10
27	7.79238E+10	6.42261E+10	4.55249E+10	2.83687E+10	1.26796E+10
28	7.72430E+10	6.37933E+10	4.52366E+10	2.82105E+10	1.26594E+10
29	7.69969E+10	6.35764E+10	4.50870E+10	2.81268E+10	1.26319E+10
30	7.65040E+10	6.30071E+10	4.46779E+10	2.78963E+10	1.25006E+10
31	7.48847E+10	6.19597E+10	4.39837E+10	2.75072E+10	1.23542E+10

Table 4.1.2.5

Standard Core Loading

Flux ($E > 0.1\text{MEV}$) At Pressure Vessel Lower Weld (cont'd)

(z=67.1048cm)

θ	0-T	1/4 T	1/2 T	3/4 T	T
32	7.32302E+10	6.09725E+10	4.33577E+10	2.71605E+10	1.22507E+10
33	7.17707E+10	6.00280E+10	4.27723E+10	2.68374E+10	1.21483E+10
34	7.03326E+10	5.90653E+10	4.21907E+10	2.65195E+10	1.20444E+10
35	6.89440E+10	5.81132E+10	4.16170E+10	2.62096E+10	1.19375E+10
36	6.70963E+10	5.68548E+10	4.08630E+10	2.58005E+10	1.17945E+10
37	6.53843E+10	5.55609E+10	4.00361E+10	2.53406E+10	1.16408E+10
38	6.43107E+10	5.46420E+10	3.93908E+10	2.49623E+10	1.15136E+10
39	6.37975E+10	5.40670E+10	3.89274E+10	2.46686E+10	1.14065E+10
40	6.37499E+10	5.37871E+10	3.86172E+10	2.44451E+10	1.13170E+10
41	6.39743E+10	5.36914E+10	3.84144E+10	2.42754E+10	1.12544E+10
42	6.41607E+10	5.36575E+10	3.82991E+10	2.41745E+10	1.12239E+10
43	6.43487E+10	5.36190E+10	3.81797E+10	2.40693E+10	1.11662E+10
44	6.45179E+10	5.34641E+10	3.79349E+10	2.38778E+10	1.10799E+10
45	6.42800E+10	5.30686E+10	3.75707E+10	2.36307E+10	1.09969E+10
46	6.37247E+10	5.26330E+10	3.72521E+10	2.34328E+10	1.09376E+10
47	6.33609E+10	5.21787E+10	3.68968E+10	2.32152E+10	1.08491E+10
48	6.21315E+10	5.11510E+10	3.61842E+10	2.27990E+10	1.06974E+10
49	6.02288E+10	4.97144E+10	3.52503E+10	2.22728E+10	1.05282E+10
50	5.83543E+10	4.83821E+10	3.44076E+10	2.18069E+10	1.03848E+10
51	5.69788E+10	4.73576E+10	3.37509E+10	2.14456E+10	1.02668E+10
52	5.52703E+10	4.60732E+10	3.29345E+10	2.09971E+10	1.01136E+10
53	5.31085E+10	4.44910E+10	3.19406E+10	2.04546E+10	9.93734E+09
54	5.08674E+10	4.28632E+10	3.09267E+10	1.99064E+10	9.76416E+09
55	4.86276E+10	4.12474E+10	2.99248E+10	1.93662E+10	9.59302E+09
56	4.61963E+10	3.95106E+10	2.88549E+10	1.87927E+10	9.41060E+09
57	4.41282E+10	3.79798E+10	2.79043E+10	1.82817E+10	9.25162E+09
58	4.23165E+10	3.66832E+10	2.71039E+10	1.78527E+10	9.11422E+09
59	4.10856E+10	3.57379E+10	2.65078E+10	1.75313E+10	9.01566E+09
60	4.03256E+10	3.51729E+10	2.61519E+10	1.73396E+10	8.95435E+09
61	3.99433E+10	3.48877E+10	2.59726E+10	1.72425E+10	8.92357E+09

Table 4.1.2.6

Standard Core Loading

DPA Rates At Pressure Vessel Lower Weld

(z=67.1048cm)

θ	0-T	1/4 T	1/2 T	3/4 T	T
1	4.17566E-11	2.70640E-11	1.61195E-11	9.13123E-12	4.13311E-12
2	4.17693E-11	2.70709E-11	1.61243E-11	9.13615E-12	4.12695E-12
3	4.18449E-11	2.71329E-11	1.61630E-11	9.15522E-12	4.12658E-12
4	4.21796E-11	2.73403E-11	1.62770E-11	9.21237E-12	4.14475E-12
5	4.27091E-11	2.76684E-11	1.64589E-11	9.30504E-12	4.17511E-12
6	4.34023E-11	2.81028E-11	1.67022E-11	9.42784E-12	4.21459E-12
7	4.43301E-11	2.86947E-11	1.70339E-11	9.59604E-12	4.26732E-12
8	4.56095E-11	2.94873E-11	1.74712E-11	9.81418E-12	4.33563E-12
9	4.68871E-11	3.02523E-11	1.78869E-11	1.00211E-11	4.40103E-12
10	4.80683E-11	3.09818E-11	1.82861E-11	1.02180E-11	4.46247E-12
11	4.94805E-11	3.18311E-11	1.87413E-11	1.04425E-11	4.53157E-12
12	5.09173E-11	3.26879E-11	1.91982E-11	1.06640E-11	4.59992E-12
13	5.23095E-11	3.35077E-11	1.96290E-11	1.08718E-11	4.66326E-12
14	5.35816E-11	3.42465E-11	2.00118E-11	1.10536E-11	4.71813E-12
15	5.46691E-11	3.48659E-11	2.03245E-11	1.11984E-11	4.76040E-12
16	5.55035E-11	3.53112E-11	2.05377E-11	1.12928E-11	4.78724E-12
17	5.60045E-11	3.55328E-11	2.06257E-11	1.13270E-11	4.79325E-12
18	5.60071E-11	3.54647E-11	2.05646E-11	1.12936E-11	4.78350E-12
19	5.55258E-11	3.52050E-11	2.04307E-11	1.12316E-11	4.76734E-12
20	5.53528E-11	3.49459E-11	2.02874E-11	1.11659E-11	4.74278E-12
21	5.43973E-11	3.43231E-11	2.00012E-11	1.10432E-11	4.70072E-12
22	5.32750E-11	3.36700E-11	1.97102E-11	1.09167E-11	4.67059E-12
23	5.16147E-11	3.30810E-11	1.94938E-11	1.08274E-11	4.66423E-12
24	5.09117E-11	3.29202E-11	1.94291E-11	1.07990E-11	4.65464E-12
25	4.98836E-11	3.25376E-11	1.92912E-11	1.07391E-11	4.62376E-12
26	4.90751E-11	3.20970E-11	1.91051E-11	1.06550E-11	4.59193E-12
27	4.85707E-11	3.17758E-11	1.89265E-11	1.05699E-11	4.57020E-12
28	4.86040E-11	3.16290E-11	1.88087E-11	1.05090E-11	4.56206E-12
29	4.87789E-11	3.15477E-11	1.87456E-11	1.04767E-11	4.55134E-12
30	4.92826E-11	3.14252E-11	1.85879E-11	1.03856E-11	4.50090E-12
31	4.88472E-11	3.11070E-11	1.83456E-11	1.02470E-11	4.44746E-12

Table 4.1.2.6

Standard Core Loading

DPA Rates At Pressure Vessel Lower Weld (cont'd)

(z=67.1048cm)

θ	0-T	1/4 T	1/2 T	3/4 T	T
32	4.80714E-11	3.07502E-11	1.81258E-11	1.01273E-11	4.41050E-12
33	4.72734E-11	3.03647E-11	1.79116E-11	1.00150E-11	4.37452E-12
34	4.64272E-11	2.99358E-11	1.76889E-11	9.90246E-12	4.33764E-12
35	4.55801E-11	2.94840E-11	1.74616E-11	9.79030E-12	4.29935E-12
36	4.43213E-11	2.88292E-11	1.71456E-11	9.63805E-12	4.24697E-12
37	4.32175E-11	2.81758E-11	1.68013E-11	9.46696E-12	4.19033E-12
38	4.25407E-11	2.77248E-11	1.65370E-11	9.32775E-12	4.14373E-12
39	4.22360E-11	2.74613E-11	1.63556E-11	9.22249E-12	4.10538E-12
40	4.22324E-11	2.73588E-11	1.62450E-11	9.14576E-12	4.07411E-12
41	4.24013E-11	2.73542E-11	1.61816E-11	9.08972E-12	4.05255E-12
42	4.25219E-11	2.73587E-11	1.61444E-11	9.05559E-12	4.04167E-12
43	4.26473E-11	2.73574E-11	1.61045E-11	9.01967E-12	4.02146E-12
44	4.27582E-11	2.72979E-11	1.60112E-11	8.95042E-12	3.98998E-12
45	4.25410E-11	2.70826E-11	1.58536E-11	8.85519E-12	3.95766E-12
46	4.20146E-11	2.68088E-11	1.57029E-11	8.77472E-12	3.93325E-12
47	4.18364E-11	2.65910E-11	1.55547E-11	8.69218E-12	3.90030E-12
48	4.09788E-11	2.60427E-11	1.52420E-11	8.52934E-12	3.84166E-12
49	3.96648E-11	2.52771E-11	1.48313E-11	8.32279E-12	3.77562E-12
50	3.83607E-11	2.45613E-11	1.44582E-11	8.13911E-12	3.71891E-12
51	3.74945E-11	2.40419E-11	1.41765E-11	7.99899E-12	3.67345E-12
52	3.64257E-11	2.33962E-11	1.38278E-11	7.82565E-12	3.61469E-12
53	3.50412E-11	2.25874E-11	1.33995E-11	7.61466E-12	3.54648E-12
54	3.36096E-11	2.17538E-11	1.29609E-11	7.40112E-12	3.47907E-12
55	3.21802E-11	2.09226E-11	1.25258E-11	7.18960E-12	3.41234E-12
56	3.05922E-11	2.00146E-11	1.20554E-11	6.96346E-12	3.34072E-12
57	2.92915E-11	1.92317E-11	1.16424E-11	6.76302E-12	3.27849E-12
58	2.80992E-11	1.85486E-11	1.12878E-11	6.59264E-12	3.22418E-12
59	2.73506E-11	1.80757E-11	1.10320E-11	6.46739E-12	3.18576E-12
60	2.68708E-11	1.77873E-11	1.08772E-11	6.39213E-12	3.16178E-12
61	2.66284E-11	1.76412E-11	1.07991E-11	6.35392E-12	3.14971E-12

Table 4.1.2.7

Standard Core Loading

Downcomer Fluxes and DPA Rates

(r=210.50cm, z=121.79cm)

	FLUX	FLUX	DPA/s
0	(E>1.0 MEV)	(E>0.1 MEV)	
1	6.69557E+10	1.19710E+11	1.01187E-10
2	6.69299E+10	1.19688E+11	1.01150E-10
3	6.70314E+10	1.19961E+11	1.01324E-10
4	6.76476E+10	1.21097E+11	1.02248E-10
5	6.85990E+10	1.22908E+11	1.03679E-10
6	6.98858E+10	1.25388E+11	1.05616E-10
7	7.16070E+10	1.28773E+11	1.08224E-10
8	7.40597E+10	1.33554E+11	1.11935E-10
9	7.65923E+10	1.38414E+11	1.15733E-10
10	7.89127E+10	1.43033E+11	1.19257E-10
11	8.18024E+10	1.48743E+11	1.23634E-10
12	8.48495E+10	1.54802E+11	1.28253E-10
13	8.78962E+10	1.60935E+11	1.32885E-10
14	9.08014E+10	1.66898E+11	1.37322E-10
15	9.33791E+10	1.72303E+11	1.41274E-10
16	9.54602E+10	1.76843E+11	1.44507E-10
17	9.68927E+10	1.80188E+11	1.46770E-10
18	9.72561E+10	1.81678E+11	1.47462E-10
19	9.62388E+10	1.80988E+11	1.46166E-10
20	9.61728E+10	1.80991E+11	1.46048E-10
21	9.36431E+10	1.78056E+11	1.42538E-10
22	9.12471E+10	1.74852E+11	1.39068E-10
23	8.78276E+10	1.70559E+11	1.34282E-10
24	8.73276E+10	1.69624E+11	1.33561E-10
25	8.56507E+10	1.67236E+11	1.31066E-10
26	8.36407E+10	1.64018E+11	1.28088E-10
27	8.22150E+10	1.61057E+11	1.25909E-10
28	8.16417E+10	1.59223E+11	1.24984E-10
29	8.12521E+10	1.58249E+11	1.24333E-10
30	8.10532E+10	1.56061E+11	1.23826E-10
31	7.99106E+10	1.51556E+11	1.21809E-10
32	7.85587E+10	1.47340E+11	1.19525E-10

Table 4.1.2.7

Standard Core Loading

Downcomer Fluxes and DPA Rates (Cont'd)

(r=210.50cm, z=121.79cm)

θ	FLUX	FLUX	DPA/s
	(E>1.0 MEV)	(E>0.1 MEV)	
33	7.70282E+10	1.43255E+11	1.17027E-10
34	7.53840E+10	1.39254E+11	1.14400E-10
35	7.37100E+10	1.35372E+11	1.11761E-10
36	7.10300E+10	1.30034E+11	1.07718E-10
37	6.91086E+10	1.25912E+11	1.04697E-10
38	6.81846E+10	1.23951E+11	1.03242E-10
39	6.81982E+10	1.23996E+11	1.03236E-10
40	6.89345E+10	1.25613E+11	1.04354E-10
41	7.01030E+10	1.28214E+11	1.06143E-10
42	7.09580E+10	1.30158E+11	1.07439E-10
43	7.17176E+10	1.31995E+11	1.08654E-10
44	7.29319E+10	1.34839E+11	1.10542E-10
45	7.35366E+10	1.36659E+11	1.11531E-10
46	7.28144E+10	1.36276E+11	1.10618E-10
47	7.31298E+10	1.36780E+11	1.11021E-10
48	7.18644E+10	1.34837E+11	1.09144E-10
49	6.91968E+10	1.30108E+11	1.05151E-10
50	6.61544E+10	1.24561E+11	1.00666E-10
51	6.43077E+10	1.20746E+11	9.78108E-11
52	6.19648E+10	1.15797E+11	9.41684E-11
53	5.87934E+10	1.09279E+11	8.93163E-11
54	5.55210E+10	1.02537E+11	8.43148E-11
55	5.22970E+10	9.59097E+10	7.93982E-11
56	4.87318E+10	8.87261E+10	7.39848E-11
57	4.59419E+10	8.28802E+10	6.96960E-11
58	4.33028E+10	7.76801E+10	6.57280E-11
59	4.17339E+10	7.43051E+10	6.33090E-11
60	4.06858E+10	7.21870E+10	6.17144E-11
61	4.01580E+10	7.11196E+10	6.08971E-11

Table 4.1.2.8

Standard Core Loading
Cavity Fluxes and DPA Rates
($r=320.06\text{cm}$, $z=177.27\text{cm}$)

θ	FLUX ($E>1.0$ MEV)	FLUX ($E>0.1$ MEV)	DPA/s
1	1.02943E+09	9.01502E+09	3.23295E-12
2	1.02944E+09	9.01542E+09	3.23302E-12
3	1.02804E+09	9.00899E+09	3.23017E-12
4	1.02813E+09	9.00762E+09	3.22989E-12
5	1.02837E+09	9.00607E+09	3.22971E-12
6	1.02878E+09	9.00456E+09	3.22968E-12
7	1.02897E+09	9.00078E+09	3.22889E-12
8	1.03016E+09	9.00052E+09	3.22981E-12
9	1.03135E+09	9.00128E+09	3.23097E-12
10	1.03097E+09	8.99529E+09	3.22910E-12
11	1.03047E+09	8.98847E+09	3.22685E-12
12	1.02956E+09	8.98104E+09	3.22405E-12
13	1.02798E+09	8.97178E+09	3.22013E-12
14	1.02565E+09	8.96029E+09	3.21495E-12
15	1.02265E+09	8.94605E+09	3.20846E-12
16	1.01929E+09	8.92877E+09	3.20095E-12
17	1.01584E+09	8.90796E+09	3.19262E-12
18	1.01287E+09	8.88662E+09	3.18475E-12
19	1.01059E+09	8.86927E+09	3.17858E-12
20	1.01040E+09	8.86274E+09	3.17678E-12
21	1.00840E+09	8.84432E+09	3.17058E-12
22	1.00706E+09	8.83167E+09	3.16624E-12
23	1.00604E+09	8.82245E+09	3.16308E-12
24	1.00605E+09	8.82129E+09	3.16279E-12
25	1.00582E+09	8.81787E+09	3.16173E-12
26	1.00505E+09	8.81120E+09	3.15936E-12
27	1.00355E+09	8.80142E+09	3.15555E-12
28	1.00211E+09	8.79281E+09	3.15210E-12
29	1.00127E+09	8.78804E+09	3.15015E-12
30	9.99412E+08	8.77755E+09	3.14580E-12
31	9.96954E+08	8.76228E+09	3.13969E-12
32	9.94791E+08	8.74939E+09	3.13444E-12
33	9.92102E+08	8.73482E+09	3.12830E-12

Table 4.1.2.8

Standard Core Loading

Cavity Fluxes and DPA Rates (cont'd)

(r=320.06cm, z=177.27cm)

	FLUX	FLUX	DPA/s
θ	(E>1.0 MEV)	(E>0.1 MEV)	
34	9.89077E+08	8.71871E+09	3.12148E-12
35	9.85241E+08	8.69836E+09	3.11287E-12
36	9.78658E+08	8.66429E+09	3.09840E-12
37	9.71692E+08	8.62215E+09	3.08174E-12
38	9.64724E+08	8.57789E+09	3.06466E-12
39	9.57418E+08	8.53207E+09	3.04689E-12
40	9.49384E+08	8.48433E+09	3.02793E-12
41	9.41926E+08	8.44180E+09	3.01070E-12
42	9.37228E+08	8.41580E+09	3.00005E-12
43	9.31896E+08	8.38662E+09	2.98805E-12
44	9.23716E+08	8.34163E+09	2.96959E-12
45	9.16185E+08	8.29952E+09	2.95244E-12
46	9.11425E+08	8.27302E+09	2.94169E-12
47	9.07294E+08	8.24855E+09	2.93193E-12
48	9.00514E+08	8.20879E+09	2.91606E-12
49	8.93981E+08	8.16985E+09	2.90062E-12
50	8.90181E+08	8.14608E+09	2.89140E-12
51	8.87471E+08	8.12907E+09	2.88477E-12
52	8.84169E+08	8.10989E+09	2.87705E-12
53	8.80975E+08	8.08973E+09	2.86920E-12
54	8.78105E+08	8.07109E+09	2.86202E-12
55	8.75496E+08	8.05448E+09	2.85558E-12
56	8.71876E+08	8.03293E+09	2.84705E-12
57	8.70113E+08	8.02070E+09	2.84247E-12
58	8.67167E+08	8.00366E+09	2.83569E-12
59	8.66773E+08	7.99914E+09	2.83424E-12
60	8.66015E+08	7.99392E+09	2.83230E-12
61	8.65740E+08	7.99194E+09	2.83157E-12

Table 4.1.2.9

Standard Core Loading

Flux Spectrum At Pressure Vessel (Pressure Vessel Capsule In)

 $\theta=15.5^\circ$ $z=125.488\text{cm}$

Group	0 T	1/4 T	1/2 T	3/4 T	T
1	1.34004E+07	6.03020E+06	2.54426E+06	1.06968E+06	4.65023E+05
2	4.20813E+07	1.86479E+07	7.70275E+06	3.15887E+06	1.33379E+06
3	1.75195E+08	7.77592E+07	3.17580E+07	1.27914E+07	5.30266E+06
4	3.39395E+08	1.51262E+08	6.10609E+07	2.41801E+07	9.83754E+06
5	5.90665E+08	2.58392E+08	1.00967E+08	3.86032E+07	1.51169E+07
6	1.54113E+09	6.46641E+08	2.39974E+08	8.72151E+07	3.23568E+07
7	2.27942E+09	9.40904E+08	3.43468E+08	1.23041E+08	4.44146E+07
8	4.17926E+09	1.72441E+09	6.31242E+08	2.27138E+08	8.02326E+07
9	2.94717E+09	1.26987E+09	4.84919E+08	1.80883E+08	6.38869E+07
10	2.16745E+09	9.81458E+08	3.83223E+08	1.44961E+08	5.12002E+07
11	2.46760E+09	1.16140E+09	4.64842E+08	1.79066E+08	6.28895E+07
12	1.22373E+09	5.84109E+08	2.36458E+08	9.18980E+07	3.23944E+07
13	3.15611E+08	1.59021E+08	6.70858E+07	2.69577E+07	1.00840E+07
14	1.55286E+09	7.96555E+08	3.41008E+08	1.38897E+08	5.15699E+07
15	3.98671E+09	2.15949E+09	9.58512E+08	4.00040E+08	1.45036E+08
16	4.15372E+09	2.49334E+09	1.20167E+09	5.35826E+08	2.03143E+08
17	5.75889E+09	3.68149E+09	1.86892E+09	8.69067E+08	3.38535E+08
18	8.73523E+09	6.61604E+09	3.86360E+09	2.00538E+09	8.18435E+08
19	5.56635E+09	4.68957E+09	3.05523E+09	1.75235E+09	7.89423E+08
20	2.86008E+09	2.20627E+09	1.38858E+09	7.74542E+08	3.28518E+08
21	7.95371E+09	8.09916E+09	6.03883E+09	3.78933E+09	1.70351E+09
22	6.39531E+09	6.54231E+09	5.09178E+09	3.32359E+09	1.53636E+09
23	7.09089E+09	7.37463E+09	5.83849E+09	3.76972E+09	1.54915E+09
24	7.22374E+09	8.79679E+09	7.70684E+09	5.34731E+09	2.38270E+09
25	8.92968E+09	9.14224E+09	7.58075E+09	5.19241E+09	2.44049E+09
26	8.65439E+09	9.59941E+09	8.38386E+09	5.92608E+09	2.78120E+09
27	6.02155E+09	6.12114E+09	5.25983E+09	3.70188E+09	1.72611E+09
28	4.73095E+09	4.45339E+09	3.70920E+09	2.56747E+09	1.16605E+09
29	1.65571E+09	1.19812E+09	9.57109E+08	6.57726E+08	3.15729E+08
30	8.18351E+08	4.08395E+08	3.23962E+08	2.22161E+08	1.28353E+08
31	2.07212E+09	2.27206E+09	1.99328E+09	1.48555E+09	8.43522E+08
32	1.21342E+09	1.29224E+09	1.16184E+09	8.84812E+08	5.06656E+08
33	2.39033E+09	2.08344E+09	1.71712E+09	1.27142E+09	7.41995E+08
34	4.19607E+09	2.41114E+09	1.66284E+09	1.15857E+09	7.21073E+08
35	5.23504E+09	3.65217E+09	2.47138E+09	1.60971E+09	8.35726E+08
36	4.69929E+09	2.85953E+09	1.83504E+09	1.15592E+09	6.19866E+08
37	7.68285E+09	4.43931E+09	2.65387E+09	1.60042E+09	8.84664E+08
38	4.24908E+09	1.96382E+09	1.10425E+09	6.55982E+08	4.04734E+08
39	4.66985E+09	2.37076E+09	1.26143E+09	7.22978E+08	4.25704E+08
40	6.05506E+09	2.92646E+09	1.47883E+09	8.14790E+08	4.94604E+08
41	7.63070E+09	3.66787E+09	1.77643E+09	9.34762E+08	5.62218E+08
42	4.41493E+09	1.97298E+09	9.18737E+08	4.71662E+08	2.96609E+08
43	5.92169E+09	2.39279E+09	1.03252E+09	5.12118E+08	3.53170E+08
44	4.47157E+09	1.60795E+09	6.31627E+08	3.02245E+08	2.38733E+08
45	3.82771E+09	7.61855E+08	2.19882E+08	1.04247E+08	1.66904E+08
46	8.29237E+09	9.88803E+08	1.50504E+08	7.33782E+07	3.16178E+08
47	3.88610E+10	1.19486E+09	3.61846E+07	2.63903E+07	7.03751E+08

Table 4.1.2.10

Standard Core Loading

Flux Spectrum At Capsule Location

Group	Thermal Shield	Pressure Vessel	Cavity
1	4.26711E+07	1.60000E+07	2.86728E+05
2	1.45534E+08	5.10916E+07	8.06094E+05
3	6.88301E+08	2.18393E+08	3.12212E+06
4	1.43540E+09	4.28801E+08	5.66333E+06
5	2.75610E+09	7.58847E+08	8.51957E+06
6	7.41577E+09	1.97883E+09	1.79233E+07
7	1.23333E+10	2.98321E+09	2.45560E+07
8	2.69783E+10	5.61416E+09	4.42734E+07
9	2.26943E+10	4.04138E+09	3.49529E+07
10	1.73637E+10	2.96182E+09	2.78706E+07
11	2.02292E+10	3.33380E+09	3.45107E+07
12	9.91556E+09	1.64268E+09	1.77617E+07
13	2.62757E+09	4.27656E+08	5.53974E+06
14	1.32935E+10	2.09754E+09	2.73420E+07
15	3.57681E+10	5.26555E+09	7.43913E+07
16	3.99955E+10	5.35579E+09	1.04204E+08
17	5.95111E+10	7.37786E+09	1.78811E+08
18	1.00036E+11	1.03559E+10	4.19930E+08
19	6.47656E+10	6.26882E+09	4.08216E+08
20	3.48231E+10	3.49851E+09	2.03052E+08
21	8.40700E+10	7.48525E+09	8.59878E+08
22	6.90718E+10	6.26286E+09	8.37963E+08
23	7.59862E+10	7.03286E+09	8.61022E+08
24	6.45291E+10	5.72732E+09	1.24396E+09
25	9.69050E+10	9.31121E+09	1.60116E+09
26	8.80710E+10	8.28525E+09	1.70632E+09
27	6.92903E+10	6.65551E+09	1.12321E+09
28	5.71735E+10	5.59812E+09	8.11518E+08
29	2.27717E+10	2.35407E+09	2.54254E+08
30	1.49069E+10	1.62842E+09	1.18106E+08
31	1.44251E+10	1.31002E+09	4.10315E+08
32	1.15322E+10	1.05862E+09	2.75023E+08
33	2.78089E+10	2.96885E+09	5.69065E+08
34	5.88810E+10	6.47066E+09	6.34438E+08
35	6.91935E+10	7.30820E+09	6.49980E+08
36	6.67670E+10	6.96069E+09	5.20495E+08
37	1.03894E+11	1.09998E+10	7.76458E+08
38	6.06505E+10	6.62742E+09	3.70476E+08
39	6.24260E+10	6.78022E+09	3.82704E+08
40	8.32327E+10	9.08457E+09	4.53879E+08
41	1.02317E+11	1.13741E+10	5.16374E+08
42	5.96955E+10	6.77776E+09	2.79154E+08
43	7.81268E+10	9.22740E+09	3.44807E+08
44	5.77013E+10	7.10652E+09	2.43411E+08
45	5.41499E+10	7.09199E+09	2.01739E+08
46	1.14442E+11	1.67072E+10	4.18805E+08
47	2.92557E+11	8.37771E+10	1.09568E+09

 Thermal Shield Capsule flux spectrum is at r=202.25cm, z=121.79cm, $\theta=20^\circ$
 Pressure Vessel Capsule flux spectrum is at r=215.43cm, z=121.79cm, $\theta=20^\circ$
 Cavity Capsule flux spectrum is at r=320.06cm, z=177.27cm, $\theta=9.5^\circ$

Table 4.1.2.11

Standard Core Loading

Effect of Selected Cross Sections on the Calculated Reaction Rates

Axial Peak Reaction Rate (reactions/sec*atom)

o

Thermal Shield Capsule (r=202.25cm, z=121.79cm, θ=20)

Detector	SAILOR		
Material	BUGLE93	ENDF/B-IV	ORNL/TM-11476
27	-16	-16	
.Al (n,α)	3.88239x10	4.03620x10	
32	-14	-14	
.S (n,p)	2.44909x10	2.52759x10	
46	-15	-15	
.Ti (n,p)	4.68939x10	4.54495x10	
54	-14	-14	-14
.Fe (n,p)	3.09814x10	3.12051x10	3.07175x10
56	-16	-16	
.Fe (n,p)	5.12145x10	5.54759x10	
58	-14	-14	-14
.Ni (n,p)	4.19745x10	4.17753x10	4.10360x10
63	-16	-16	
.Cu (n,α)	2.51128x10	1.96732x10	
65	-16	-16	
.Cu (n,2n)	2.42305x10	2.99767x10	
115	-14	-14	
.In (n,n')	8.72960x10	8.50503x10	
237	-13	-13	-13
.Np (n,f)	9.98422x10	9.46386x10	9.36238x10
238	-13	-13	-13
.U (n,f)	1.40695x10	1.40763x10	1.41495x10

SAILOR used a flat weighting spectrum to collapse the cross sections.
 BUGLE93 used a pressure vessel 1/4T weighting spectrum to collapse the cross sections.

Table 4.1.2.12

Standard Core Loading

Effect of Selected Cross Sections on the Calculated Reaction Rates

Axial Peak Reaction Rate (reactions/sec*atom)

Pressure Vessel Capsule (r=215.43cm, z=125.49cm, $\theta=20^\circ$)

Detector	SAILOR		
Material	BUGLE93	ENDF/B-IV	ORNL/TM-11476
27	-16	-16	
.Al (n, α)	1.13574x10	1.17931x10	
32	-15	-15	
.S (n,p)	5.08199x10	5.20481x10	
46	-15	-15	
.Ti (n,p)	1.17613x10	1.14241x10	
54	-15	-15	-15
.Fe (n,p)	6.57302x10	6.78698x10	6.50612x10
56	-16	-16	
.Fe (n,p)	1.43009x10	1.54390x10	
58	-15	-15	-15
.Ni (n,p)	8.62894x10	8.68697x10	8.45897x10
63	-17	-17	
.Cu (n, α)	6.86179x10	5.63829x10	
65	-16	-16	
.Cu (n,2n)	8.29140x10	1.01544x10	
115	-14	-14	
.In (n,n')	1.38141x10	1.33868x10	
237	-13	-13	-13
.Np (n,f)	1.18077x10	1.27145x10	1.22359x10
238	-14	-14	-14
.U (n,f)	2.37573x10	2.39417x10	2.38418x10

BUGLE93 used pressure vessel 1/4T weighting spectrum to collapse cross sections.

SAILOR used flat weighting spectrum to collapse cross sections.

Table 4.1.2.13

Standard Core Loading

Effect of Selected Cross Sections on the Calculated Reaction Rates

Axial Peak Reaction Rate (reactions/sec*atom)

o

Cavity Capsule (r=320.06cm, z=177.27cm, $\theta=9.5^\circ$)

Detector		SAILOR	
Material	BUGLE93	ENDF/B-IV	ORNL/TM-11476
27	-18	-18	
.Al (n, α)	1.40434x10	1.45241x10	
32	-17	-17	
.S (n,p)	4.70800x10	4.88722x10	
46	-17	-17	
.Ti (n,p)	1.13189x10	1.10318x10	
54	-17	-17	-17
.Fe (n,p)	6.14379x10	6.25252x10	6.08292x10
56	-18	-18	
.Fe (n,p)	1.59444x10	1.71283x10	
58	-17	-17	-17
.Ni (n,p)	8.63266x10	8.52622x10	8.60783x10
63	-19	-19	
.Cu (n, α)	7.48370x10	6.63479x10	
65	-18	-18	
.Cu (n,2n)	1.29640x10	1.56898x10	
115	-16	-16	
.In (n,n')	2.31850x10	2.28786x10	
237	-15	-15	-15
.Np (n,f)	4.32775x10	4.55761x10	4.62438x10
238	-16	-16	-16
.U (n,f)	3.22105x10	3.18192x10	3.24756x10

BUGLE93 used pressure vessel 1/4T weighting spectrum to collapse cross sections.

SAILOR used flat weighting spectrum to collapse cross sections.

Table 4.1.3.1

Low Leakage Core Loading

Flux ($E > 1.0$ MEV) At Pressure Vessel

z	195.760cm	195.760cm	195.760cm	192.062cm	192.062cm
θ	0-T	1/4 T	1/2 T	3/4 T	T
1	1.53440E+10	8.77316E+09	4.28603E+09	1.99076E+09	8.23397E+08
2	1.53465E+10	8.77444E+09	4.28683E+09	1.99228E+09	8.22090E+08
3	1.53808E+10	8.80021E+09	4.30069E+09	1.99800E+09	8.22556E+08
4	1.55703E+10	8.90427E+09	4.34861E+09	2.01860E+09	8.29407E+08
5	1.58767E+10	9.07218E+09	4.42652E+09	2.05268E+09	8.40659E+08
6	1.62824E+10	9.29594E+09	4.53086E+09	2.09764E+09	8.55525E+08
7	1.68219E+10	9.59862E+09	4.67203E+09	2.15909E+09	8.75460E+08
8	1.75564E+10	1.00013E+10	4.85784E+09	2.23875E+09	9.01185E+08
9	1.82704E+10	1.03835E+10	5.03303E+09	2.31405E+09	9.25666E+08
10	1.89160E+10	1.07406E+10	5.19834E+09	2.38465E+09	9.48505E+08
11	1.96779E+10	1.11528E+10	5.38592E+09	2.46500E+09	9.74243E+08
12	2.04448E+10	1.15664E+10	5.57393E+09	2.54425E+09	9.99594E+08
13	2.11853E+10	1.19619E+10	5.75164E+09	2.61885E+09	1.02321E+09
14	2.18621E+10	1.23200E+10	5.91054E+09	2.68456E+09	1.04386E+09
15	2.24440E+10	1.26233E+10	6.04233E+09	2.73773E+09	1.06007E+09
16	2.28961E+10	1.28465E+10	6.13457E+09	2.77331E+09	1.07080E+09
17	2.31802E+10	1.29663E+10	6.17690E+09	2.78773E+09	1.07424E+09
18	2.32153E+10	1.29529E+10	6.15850E+09	2.77813E+09	1.07143E+09
19	2.30083E+10	1.28464E+10	6.10690E+09	2.75654E+09	1.06545E+09
20	2.29534E+10	1.27433E+10	6.05719E+09	2.73661E+09	1.05837E+09
21	2.25502E+10	1.24785E+10	5.94840E+09	2.69583E+09	1.04510E+09
22	2.20532E+10	1.22022E+10	5.84253E+09	2.65651E+09	1.03514E+09
23	2.12926E+10	1.19476E+10	5.76314E+09	2.62921E+09	1.03195E+09
24	2.09762E+10	1.18797E+10	5.74106E+09	2.62093E+09	1.02934E+09
25	2.05238E+10	1.17203E+10	5.69289E+09	2.60318E+09	1.02052E+09
26	2.01735E+10	1.15437E+10	5.62920E+09	-2.57844E+09	1.01120E+09
27	1.99720E+10	1.14270E+10	5.57020E+09	2.55336E+09	1.00427E+09
28	2.00115E+10	1.13828E+10	5.53295E+09	2.53564E+09	1.00139E+09
29	2.01135E+10	1.13576E+10	5.51286E+09	2.52611E+09	9.98167E+08
30	2.03881E+10	1.13347E+10	5.46461E+09	2.49951E+09	9.83678E+08
31	2.02263E+10	1.12338E+10	5.39127E+09	2.46027E+09	9.67816E+08
32	1.98781E+10	1.11019E+10	5.32148E+09	2.42591E+09	9.56042E+08
33	1.95098E+10	1.09463E+10	5.24838E+09	2.39232E+09	9.44384E+08
34	1.91004E+10	1.07601E+10	5.16669E+09	2.35630E+09	9.31959E+08

Table 4.1.3.1

Low Leakage Core Loading

Flux ($E > 1.0$ MEV) At Pressure Vessel (cont'd)

z	195.760cm	195.760cm	195.760cm	192.062cm	192.062cm
θ	0-T	1/4 T	1/2 T	3/4 T	T
35	1.86739E+10	1.05516E+10	5.07709E+09	2.31783E+09	9.18423E+08
36	1.80366E+10	1.02334E+10	4.94250E+09	2.26129E+09	8.98905E+08
37	1.73041E+10	9.84269E+09	4.76751E+09	2.18682E+09	8.73824E+08
38	1.66555E+10	9.48091E+09	4.59813E+09	2.11312E+09	8.49110E+08
39	1.60820E+10	9.15020E+09	4.43900E+09	2.04247E+09	8.24875E+08
40	1.55741E+10	8.85210E+09	4.29191E+09	1.97554E+09	8.01495E+08
41	1.51352E+10	8.59263E+09	4.16180E+09	1.91534E+09	7.80872E+08
42	1.48690E+10	8.43455E+09	4.08174E+09	1.87822E+09	7.68619E+08
43	1.46073E+10	8.27503E+09	4.00094E+09	1.84044E+09	7.54258E+08
44	1.41865E+10	8.02084E+09	3.87306E+09	1.78133E+09	7.32955E+08
45	1.37151E+10	7.74946E+09	3.74090E+09	1.72135E+09	7.12752E+08
46	1.33673E+10	7.56416E+09	3.65350E+09	1.68243E+09	7.00233E+08
47	1.30799E+10	7.38977E+09	3.56792E+09	1.64378E+09	6.85980E+08
48	1.25494E+10	7.09495E+09	3.42879E+09	1.58211E+09	6.64330E+08
49	1.19600E+10	6.77711E+09	3.28135E+09	1.51753E+09	6.42842E+08
50	1.15097E+10	6.53434E+09	3.16884E+09	1.46838E+09	6.26879E+08
51	1.12010E+10	6.36387E+09	3.08883E+09	1.43340E+09	6.15041E+08
52	1.08357E+10	6.16252E+09	2.99506E+09	1.39239E+09	6.00677E+08
53	1.04211E+10	5.93579E+09	2.88987E+09	1.34649E+09	5.85150E+08
54	1.00285E+10	5.72101E+09	2.79046E+09	1.30341E+09	5.70782E+08
55	9.66131E+09	5.52110E+09	2.69816E+09	1.26330E+09	5.57406E+08
56	9.27224E+09	5.31364E+09	2.60333E+09	1.22253E+09	5.43730E+08
57	8.96927E+09	5.14457E+09	2.52498E+09	1.18853E+09	5.32574E+08
58	8.69695E+09	5.00024E+09	2.45921E+09	1.16033E+09	5.23063E+08
59	8.53277E+09	4.90510E+09	2.41428E+09	1.14066E+09	5.16687E+08
60	8.42832E+09	4.84754E+09	2.38730E+09	1.12900E+09	5.12768E+08
61	8.37590E+09	4.81874E+09	2.37389E+09	1.12311E+09	5.10808E+08

Table 4.1.3.2

Low Leakage Core Loading

Flux ($E > 0.1$ MEV) At Pressure Vessel					
z	195.760cm	192.062cm	192.062cm	192.062cm	188.363cm
θ	0-T	1/4 T	1/2 T	3/4 T	T
1	3.51282E+10	3.02704E+10	2.22113E+10	1.44301E+10	6.99788E+09
2	3.51508E+10	3.02935E+10	2.22270E+10	1.44413E+10	6.98836E+09
3	3.52711E+10	3.04196E+10	2.23157E+10	1.44902E+10	6.99298E+09
4	3.57027E+10	3.07688E+10	2.25483E+10	1.46211E+10	7.03531E+09
5	3.63970E+10	3.13189E+10	2.29139E+10	1.48283E+10	7.10412E+09
6	3.73249E+10	3.20535E+10	2.34021E+10	1.51032E+10	7.19375E+09
7	3.85758E+10	3.30529E+10	2.40649E+10	1.54758E+10	7.31254E+09
8	4.02351E+10	3.43548E+10	2.49191E+10	1.59518E+10	7.46377E+09
9	4.18353E+10	3.55781E+10	2.57160E+10	1.63958E+10	7.60631E+09
10	4.33325E+10	3.67440E+10	2.64770E+10	1.68172E+10	7.74061E+09
11	4.50687E+10	3.80754E+10	2.73363E+10	1.72928E+10	7.89009E+09
12	4.68184E+10	3.94053E+10	2.81898E+10	1.77602E+10	8.03751E+09
13	4.85070E+10	4.06732E+10	2.89946E+10	1.81990E+10	8.17467E+09
14	5.00550E+10	4.18215E+10	2.97159E+10	1.85887E+10	8.29526E+09
15	5.13883E+10	4.27957E+10	3.03180E+10	1.89088E+10	8.39252E+09
16	5.24290E+10	4.35283E+10	3.07608E+10	1.91393E+10	8.46120E+09
17	5.31071E+10	4.39722E+10	3.10136E+10	1.92662E+10	8.49342E+09
18	5.33204E+10	4.40791E+10	3.10528E+10	1.92783E+10	8.49718E+09
19	5.31259E+10	4.39562E+10	3.09660E+10	1.92279E+10	8.48454E+09
20	5.30582E+10	4.37594E+10	3.08260E+10	1.91510E+10	8.45294E+09
21	5.26165E+10	4.32996E+10	3.05414E+10	1.89986E+10	8.39262E+09
22	5.20326E+10	4.27383E+10	3.02019E+10	1.88162E+10	8.34843E+09
23	5.12279E+10	4.22550E+10	2.99359E+10	1.86754E+10	8.33878E+09
24	5.09146E+10	4.20965E+10	2.98451E+10	1.86275E+10	8.32144E+09
25	5.04631E+10	4.17554E+10	2.96591E+10	1.85278E+10	8.26662E+09
26	4.98965E+10	4.13215E+10	2.93951E+10	1.83828E+10	8.20816E+09
27	4.92754E+10	4.09019E+10	2.91246E+10	1.82328E+10	8.16732E+09
28	4.88595E+10	4.06166E+10	2.89248E+10	1.81185E+10	8.14907E+09
29	4.87143E+10	4.04704E+10	2.88199E+10	1.80575E+10	8.12772E+09
30	4.84128E+10	4.00830E+10	2.85286E+10	1.78878E+10	8.03335E+09
31	4.73246E+10	3.93377E+10	2.80150E+10	1.75897E+10	7.91877E+09
32	4.61745E+10	3.86068E+10	2.75316E+10	1.73121E+10	7.83062E+09
33	4.51261E+10	3.78836E+10	2.70617E+10	1.70433E+10	7.74107E+09
34	4.40606E+10	3.71215E+10	2.65755E+10	1.67672E+10	7.64717E+09

Table 4.1.3.2

Low Leakage Core Loading

Flux (E>0.1 MEV) At Pressure Vessel (cont'd)

z	195.760cm	192.062cm	192.062cm	192.062cm	188.363cm
θ	0-T	1/4 T	1/2 T	3/4 T	T
35	4.29928E+10	3.63359E+10	2.60734E+10	1.64844E+10	7.54705E+09
36	4.15235E+10	3.52380E+10	2.53707E+10	1.60876E+10	7.40745E+09
37	3.98175E+10	3.38989E+10	2.44850E+10	1.55824E+10	7.23521E+09
38	3.83011E+10	3.26567E+10	2.36356E+10	1.50896E+10	7.06796E+09
39	3.69579E+10	3.15146E+10	2.28361E+10	1.46187E+10	6.90420E+09
40	3.57727E+10	3.04739E+10	2.20894E+10	1.41716E+10	6.74600E+09
41	3.47560E+10	2.95591E+10	2.14233E+10	1.37682E+10	6.60829E+09
42	3.41401E+10	2.90021E+10	2.10144E+10	1.35201E+10	6.52740E+09
43	3.35318E+10	2.84515E+10	2.06084E+10	1.32718E+10	6.43057E+09
44	3.25757E+10	2.75887E+10	1.99771E+10	1.28889E+10	6.28995E+09
45	3.15486E+10	2.66975E+10	1.93417E+10	1.25076E+10	6.16164E+09
46	3.08280E+10	2.61107E+10	1.89330E+10	1.22649E+10	6.08359E+09
47	3.01550E+10	2.55299E+10	1.85216E+10	1.20206E+10	5.99025E+09
48	2.89910E+10	2.45803E+10	1.78677E+10	1.16368E+10	5.85211E+09
49	2.76998E+10	2.35556E+10	1.71760E+10	1.12353E+10	5.71654E+09
50	2.66928E+10	2.27626E+10	1.66431E+10	1.09280E+10	5.61674E+09
51	2.59685E+10	2.21913E+10	1.62585E+10	1.07070E+10	5.54076E+09
52	2.51160E+10	2.15200E+10	1.58102E+10	1.04496E+10	5.44866E+09
53	2.41484E+10	2.07621E+10	1.53063E+10	1.01608E+10	5.34973E+09
54	2.32216E+10	2.00390E+10	1.48272E+10	9.88800E+09	5.25839E+09
55	2.23494E+10	1.93633E+10	1.43812E+10	9.63410E+09	5.17291E+09
56	2.14467E+10	1.86736E+10	1.39284E+10	9.37780E+09	5.08597E+09
57	2.07062E+10	1.80885E+10	1.35425E+10	9.15878E+09	5.01388E+09
58	2.00750E+10	1.76088E+10	1.32283E+10	8.98124E+09	4.95316E+09
59	1.96533E+10	1.72653E+10	1.29992E+10	8.85108E+09	4.91117E+09
60	1.93961E+10	1.70632E+10	1.28644E+10	8.77485E+09	4.88541E+09
61	1.92676E+10	1.69621E+10	1.27974E+10	8.73658E+09	4.87254E+09

Table 4.1.3.3

Low Leakage Core Loading

DPA Rates At Pressure Vessel

z	195.760cm	195.760cm	192.062cm	192.062cm	188.363cm
θ	0-T	1/4 T	1/2 T	3/4 T	T
1	2.38408E-11	1.55955E-11	9.39363E-12	5.40361E-12	2.51654E-12
2	2.38422E-11	1.56009E-11	9.39798E-12	5.40757E-12	2.51310E-12
3	2.38959E-11	1.56521E-11	9.43129E-12	5.42461E-12	2.51469E-12
4	2.41832E-11	1.58313E-11	9.53091E-12	5.47507E-12	2.53107E-12
5	2.46448E-11	1.61170E-11	9.68945E-12	5.55601E-12	2.55777E-12
6	2.52577E-11	1.64973E-11	9.90120E-12	5.66317E-12	2.59272E-12
7	2.60725E-11	1.70115E-11	1.01876E-11	5.80853E-12	2.63917E-12
8	2.71750E-11	1.76899E-11	1.05604E-11	5.99534E-12	2.69861E-12
9	2.82433E-11	1.83312E-11	1.09096E-11	6.17030E-12	2.75478E-12
10	2.92148E-11	1.89326E-11	1.12406E-11	6.33545E-12	2.80746E-12
11	3.03556E-11	1.96244E-11	1.16153E-11	6.52236E-12	2.86633E-12
12	3.15028E-11	2.03159E-11	1.19884E-11	6.70611E-12	2.92430E-12
13	3.26076E-11	2.09756E-11	1.23403E-11	6.87870E-12	2.97820E-12
14	3.36165E-11	2.15719E-11	1.26551E-11	7.03136E-12	3.02544E-12
15	3.44817E-11	2.20764E-11	1.29166E-11	7.15596E-12	3.06305E-12
16	3.51525E-11	2.24506E-11	1.31046E-11	7.24316E-12	3.08889E-12
17	3.55740E-11	2.26613E-11	1.32017E-11	7.28642E-12	3.09939E-12
18	3.56417E-11	2.26669E-11	1.31923E-11	7.28019E-12	3.09740E-12
19	3.53632E-11	2.25261E-11	1.31215E-11	7.24780E-12	3.08863E-12
20	3.52999E-11	2.23867E-11	1.30431E-11	7.21147E-12	3.07454E-12
21	3.47474E-11	2.20155E-11	1.28717E-11	7.13698E-12	3.04771E-12
22	3.40785E-11	2.16161E-11	1.26920E-11	7.05717E-12	3.02807E-12
23	3.30276E-11	2.12429E-11	1.25544E-11	6.99884E-12	3.02309E-12
24	3.25732E-11	2.11416E-11	1.25133E-11	6.98013E-12	3.01648E-12
25	3.19118E-11	2.08982E-11	1.24244E-11	6.94029E-12	2.99542E-12
26	3.14028E-11	2.06187E-11	1.23030E-11	6.88322E-12	2.97302E-12
27	3.10954E-11	2.04160E-11	1.21841E-11	6.82410E-12	2.95691E-12
28	3.11401E-11	2.03227E-11	1.21033E-11	6.78055E-12	2.94980E-12
29	3.12701E-11	2.02682E-11	1.20595E-11	6.75719E-12	2.94164E-12
30	3.16166E-11	2.01857E-11	1.19489E-11	6.69154E-12	2.90582E-12
31	3.12960E-11	1.99466E-11	1.17665E-11	6.58513E-12	2.86408E-12
32	3.07275E-11	1.96674E-11	1.15918E-11	6.48794E-12	2.83241E-12
33	3.01353E-11	1.93605E-11	1.14154E-11	6.39306E-12	2.80057E-12
34	2.94963E-11	1.90133E-11	1.12258E-11	6.29390E-12	2.76681E-12

Table 4.1.3.3

Low Leakage Core Loading

DPA Rates At Pressure Vessel (cont'd)

z	195.760cm	195.760cm	192.062cm	192.062cm	188.363cm
θ	0-T	1/4 T	1/2 T	3/4 T	T
35	2.88398E-11	1.86380E-11	1.10248E-11	6.19058E-12	2.73052E-12
36	2.78796E-11	1.80855E-11	1.07342E-11	6.04316E-12	2.67923E-12
37	2.67692E-11	1.74071E-11	1.03619E-11	5.85272E-12	2.61479E-12
38	2.57775E-11	1.67755E-11	1.00023E-11	5.66564E-12	2.55170E-12
39	2.48937E-11	1.61941E-11	9.66302E-12	5.48621E-12	2.48977E-12
40	2.41041E-11	1.56642E-11	9.34644E-12	5.31566E-12	2.42983E-12
41	2.34184E-11	1.51989E-11	9.06421E-12	5.16162E-12	2.37729E-12
42	2.30022E-11	1.49147E-11	8.89053E-12	5.06666E-12	2.34620E-12
43	2.25905E-11	1.46309E-11	8.71701E-12	4.97125E-12	2.30949E-12
44	2.19312E-11	1.41807E-11	8.44480E-12	4.82319E-12	2.25563E-12
45	2.12060E-11	1.37072E-11	8.16765E-12	4.67478E-12	2.20575E-12
46	2.06797E-11	1.33889E-11	7.98755E-12	4.57978E-12	2.17518E-12
47	2.02303E-11	1.30858E-11	7.80901E-12	4.48482E-12	2.13953E-12
48	1.94187E-11	1.25806E-11	7.52280E-12	4.33502E-12	2.08621E-12
49	1.85272E-11	1.20384E-11	7.22083E-12	4.17851E-12	2.03375E-12
50	1.78502E-11	1.16250E-11	6.99004E-12	4.05933E-12	1.99505E-12
51	1.73789E-11	1.13316E-11	6.82481E-12	3.97391E-12	1.96598E-12
52	1.68195E-11	1.09859E-11	6.63156E-12	3.87432E-12	1.93071E-12
53	1.61920E-11	1.05979E-11	6.41541E-12	3.76283E-12	1.89281E-12
54	1.55998E-11	1.02315E-11	6.21092E-12	3.65801E-12	1.85783E-12
55	1.50479E-11	9.89088E-12	6.02144E-12	3.56054E-12	1.82520E-12
56	1.44661E-11	9.54003E-12	5.82796E-12	3.46205E-12	1.79201E-12
57	1.40107E-11	9.25079E-12	5.66607E-12	3.37875E-12	1.76468E-12
58	1.36042E-11	9.00690E-12	5.53201E-12	3.31068E-12	1.74160E-12
59	1.33559E-11	8.84186E-12	5.43758E-12	3.26174E-12	1.72582E-12
60	1.31982E-11	8.74286E-12	5.38139E-12	3.23297E-12	1.71617E-12
61	1.31192E-11	8.69328E-12	5.35346E-12	3.21847E-12	1.71132E-12

Table 4.1.3.4

Low Leakage Core Loading

Flux ($E > 1.0$ MEV) At Pressure Vessel Lower Weld

(z=67.1048cm)

θ	0-T	1/4 T	1/2 T	3/4 T	T
1	1.28711E+10	7.33657E+09	3.57204E+09	1.65025E+09	6.74094E+08
2	1.28733E+10	7.33765E+09	3.57271E+09	1.65152E+09	6.73025E+08
3	1.29021E+10	7.35922E+09	3.58427E+09	1.65625E+09	6.73405E+08
4	1.30611E+10	7.44626E+09	3.62421E+09	1.67333E+09	6.79015E+08
5	1.33183E+10	7.58671E+09	3.68915E+09	1.70158E+09	6.88227E+08
6	1.36588E+10	7.77389E+09	3.77612E+09	1.73886E+09	7.00398E+08
7	1.41116E+10	8.02708E+09	3.89380E+09	1.78981E+09	7.16719E+08
8	1.47280E+10	8.36394E+09	4.04869E+09	1.85585E+09	7.37781E+08
9	1.53273E+10	8.68363E+09	4.19472E+09	1.91827E+09	7.57825E+08
10	1.58692E+10	8.98236E+09	4.33252E+09	1.97681E+09	7.76523E+08
11	1.65088E+10	9.32720E+09	4.48889E+09	2.04342E+09	7.97595E+08
12	1.71525E+10	9.67316E+09	4.64562E+09	2.10913E+09	8.18351E+08
13	1.77741E+10	1.00040E+10	4.79375E+09	2.17098E+09	8.37586E+08
14	1.83422E+10	1.03036E+10	4.92622E+09	2.22545E+09	8.54590E+08
15	1.88307E+10	1.05574E+10	5.03609E+09	2.26953E+09	8.67861E+08
16	1.92103E+10	1.07441E+10	5.11298E+09	2.29903E+09	8.76649E+08
17	1.94489E+10	1.08444E+10	5.14828E+09	2.31099E+09	8.79459E+08
18	1.94785E+10	1.08332E+10	5.13296E+09	2.30303E+09	8.77152E+08
19	1.93051E+10	1.07442E+10	5.08997E+09	2.28513E+09	8.72255E+08
20	1.92590E+10	1.06580E+10	5.04853E+09	2.26861E+09	8.66458E+08
21	1.89210E+10	1.04366E+10	4.95786E+09	2.23479E+09	8.55582E+08
22	1.85042E+10	1.02055E+10	4.86962E+09	2.20219E+09	8.47429E+08
23	1.78667E+10	9.99265E+09	4.80344E+09	2.17955E+09	8.44817E+08
24	1.76017E+10	9.93589E+09	4.78504E+09	-2.17269E+09	8.42677E+08
25	1.72228E+10	9.80265E+09	4.74489E+09	2.15797E+09	8.35460E+08
26	1.69291E+10	9.65495E+09	4.69180E+09	2.13746E+09	8.27829E+08
27	1.67598E+10	9.55736E+09	4.64261E+09	2.11667E+09	8.22157E+08
28	1.67921E+10	9.52031E+09	4.61156E+09	2.10197E+09	8.19795E+08
29	1.68773E+10	9.49922E+09	4.59482E+09	2.09408E+09	8.17157E+08
30	1.71066E+10	9.47987E+09	4.55459E+09	2.07202E+09	8.05294E+08
31	1.69701E+10	9.39528E+09	4.49343E+09	2.03950E+09	7.92311E+08
32	1.66776E+10	9.28489E+09	4.43524E+09	2.01101E+09	7.82675E+08
33	1.63684E+10	9.15470E+09	4.37430E+09	1.98317E+09	7.73134E+08

Table 4.1.3.4

Low Leakage Core Loading

Flux ($E > 1.0$ MEV) At Pressure Vessel Lower Weld (cont'd)

(z=67.1048cm)

θ	0-T	1/4 T	1/2 T	3/4 T	T
34	1.60247E+10	8.99886E+09	4.30619E+09	1.95330E+09	7.62965E+08
35	1.56667E+10	8.82449E+09	4.23151E+09	1.92141E+09	7.51886E+08
36	1.51317E+10	8.55825E+09	4.11931E+09	1.87454E+09	7.35910E+08
37	1.45170E+10	8.23144E+09	3.97345E+09	1.81281E+09	7.15377E+08
38	1.39726E+10	7.92884E+09	3.83226E+09	1.75171E+09	6.95144E+08
39	1.34914E+10	7.65224E+09	3.69963E+09	1.69314E+09	6.75303E+08
40	1.30653E+10	7.40293E+09	3.57704E+09	1.63766E+09	6.56161E+08
41	1.26972E+10	7.18595E+09	3.46860E+09	1.58776E+09	6.39276E+08
42	1.24739E+10	7.05376E+09	3.40188E+09	1.55698E+09	6.29244E+08
43	1.22544E+10	6.92036E+09	3.33454E+09	1.52566E+09	6.17486E+08
44	1.19015E+10	6.70781E+09	3.22797E+09	1.47666E+09	6.00044E+08
45	1.15061E+10	6.48088E+09	3.11782E+09	1.42694E+09	5.83502E+08
46	1.12144E+10	6.32593E+09	3.04498E+09	1.39468E+09	5.73252E+08
47	1.09733E+10	6.18010E+09	2.97365E+09	1.36264E+09	5.61582E+08
48	1.05283E+10	5.93354E+09	2.85770E+09	1.31152E+09	5.43856E+08
49	1.00338E+10	5.66771E+09	2.73480E+09	1.25798E+09	5.26263E+08
50	9.65588E+09	5.46464E+09	2.64103E+09	1.21723E+09	5.13194E+08
51	9.39684E+09	5.32206E+09	2.57433E+09	1.18823E+09	5.03501E+08
52	9.09028E+09	5.15364E+09	2.49618E+09	1.15423E+09	4.91741E+08
53	8.74234E+09	4.96398E+09	2.40849E+09	1.11618E+09	4.79030E+08
54	8.41276E+09	4.78431E+09	2.32563E+09	1.08047E+09	4.67267E+08
55	8.10445E+09	4.61705E+09	2.24869E+09	1.04721E+09	4.56317E+08
56	7.77782E+09	4.44349E+09	2.16963E+09	1.01341E+09	4.45120E+08
57	7.52341E+09	4.30203E+09	2.10431E+09	9.85220E+08	4.35988E+08
58	7.29479E+09	4.18128E+09	2.04948E+09	9.61838E+08	4.28201E+08
59	7.15689E+09	4.10166E+09	2.01203E+09	9.45530E+08	4.22982E+08
60	7.06918E+09	4.05350E+09	1.98953E+09	9.35864E+08	4.19773E+08
61	7.02516E+09	4.02940E+09	1.97835E+09	9.30987E+08	4.18169E+08

Table 4.1.3.5

Low Leakage Core Loading

Flux (E > 0.1MEV) At Pressure Vessel Lower Weld

(z=67.1048cm)

θ	0-T	1/4 T	1/2 T	3/4 T	T
1	2.93710E+10	2.51181E+10	1.82841E+10	1.17509E+10	5.58424E+09
2	2.93899E+10	2.51373E+10	1.82970E+10	1.17600E+10	5.57663E+09
3	2.94905E+10	2.52419E+10	1.83700E+10	1.17998E+10	5.58032E+09
4	2.98514E+10	2.55317E+10	1.85616E+10	1.19066E+10	5.61423E+09
5	3.04322E+10	2.59884E+10	1.88628E+10	1.20755E+10	5.66936E+09
6	3.12082E+10	2.65982E+10	1.92649E+10	1.22997E+10	5.74118E+09
7	3.22544E+10	2.74279E+10	1.98110E+10	1.26035E+10	5.83637E+09
8	3.36423E+10	2.85088E+10	2.05147E+10	1.29917E+10	5.95759E+09
9	3.49807E+10	2.95244E+10	2.11713E+10	1.33538E+10	6.07184E+09
10	3.62329E+10	3.04924E+10	2.17983E+10	1.36975E+10	6.17947E+09
11	3.76851E+10	3.15978E+10	2.25063E+10	1.40854E+10	6.29929E+09
12	3.91487E+10	3.27020E+10	2.32095E+10	1.44666E+10	6.41746E+09
13	4.05611E+10	3.37548E+10	2.38727E+10	1.48245E+10	6.52740E+09
14	4.18560E+10	3.47082E+10	2.44670E+10	1.51424E+10	6.62407E+09
15	4.29712E+10	3.55171E+10	2.49631E+10	1.54034E+10	6.70202E+09
16	4.38418E+10	3.61253E+10	2.53278E+10	1.55913E+10	6.75704E+09
17	4.44090E+10	3.64937E+10	2.55359E+10	1.56947E+10	6.78283E+09
18	4.45872E+10	3.65819E+10	2.55678E+10	1.57043E+10	6.78575E+09
19	4.44242E+10	3.64792E+10	2.54958E+10	1.56629E+10	6.77550E+09
20	4.43673E+10	3.63153E+10	2.53801E+10	1.56000E+10	6.75017E+09
21	4.39971E+10	3.59323E+10	2.51449E+10	1.54755E+10	6.70178E+09
22	4.35074E+10	3.54652E+10	2.48648E+10	1.53265E+10	6.66630E+09
23	4.28330E+10	3.50631E+10	2.46453E+10	1.52116E+10	6.65848E+09
24	4.25705E+10	3.49313E+10	2.45704E+10	1.51725E+10	6.64461E+09
25	4.21924E+10	3.46559E+10	2.44171E+10	1.50912E+10	6.60072E+09
26	4.17182E+10	3.42871E+10	2.41995E+10	1.49729E+10	6.55390E+09
27	4.11989E+10	3.39388E+10	2.39766E+10	1.48506E+10	6.52118E+09
28	4.08515E+10	3.37023E+10	2.38121E+10	1.47575E+10	6.50656E+09
29	4.07304E+10	3.35811E+10	2.37257E+10	1.47077E+10	6.48947E+09
30	4.04793E+10	3.32602E+10	2.34859E+10	1.45694E+10	6.41396E+09
31	3.95703E+10	3.26427E+10	2.30633E+10	1.43265E+10	6.32228E+09
32	3.86091E+10	3.20368E+10	2.26656E+10	1.41004E+10	6.25174E+09
33	3.77327E+10	3.14371E+10	2.22789E+10	1.38814E+10	6.18010E+09
34	3.68419E+10	3.08050E+10	2.18788E+10	1.36565E+10	6.10498E+09

Table 4.1.3.5

Low Leakage Core Loading

Flux ($E > 0.1\text{MEV}$) At Pressure Vessel Lower Weld (cont'd)

(z=67.1048cm)

θ	0-T	1/4 T	1/2 T	3/4 T	T
35	3.59489E+10	3.01531E+10	2.14655E+10	1.34261E+10	6.02487E+09
36	3.47201E+10	2.92419E+10	2.08869E+10	1.31028E+10	5.91316E+09
37	3.32933E+10	2.81305E+10	2.01575E+10	1.26911E+10	5.77532E+09
38	3.20252E+10	2.70996E+10	1.94580E+10	1.22894E+10	5.64145E+09
39	3.09021E+10	2.61517E+10	1.87997E+10	1.19057E+10	5.51038E+09
40	2.99111E+10	2.52881E+10	1.81849E+10	1.15413E+10	5.38378E+09
41	2.90611E+10	2.45290E+10	1.76364E+10	1.12126E+10	5.27356E+09
42	2.85462E+10	2.40669E+10	1.72997E+10	1.10104E+10	5.20881E+09
43	2.80376E+10	2.36099E+10	1.69655E+10	1.08081E+10	5.13132E+09
44	2.72383E+10	2.28939E+10	1.64456E+10	1.04960E+10	5.01877E+09
45	2.63794E+10	2.21542E+10	1.59223E+10	1.01852E+10	4.91604E+09
46	2.57768E+10	2.16671E+10	1.55856E+10	9.98731E+09	4.85354E+09
47	2.52141E+10	2.11851E+10	1.52468E+10	9.78816E+09	4.77883E+09
48	2.42407E+10	2.03968E+10	1.47082E+10	9.47526E+09	4.66822E+09
49	2.31608E+10	1.95461E+10	1.41384E+10	9.14794E+09	4.55968E+09
50	2.23185E+10	1.88878E+10	1.36995E+10	8.89740E+09	4.47975E+09
51	2.17128E+10	1.84136E+10	1.33828E+10	8.71725E+09	4.41892E+09
52	2.09999E+10	1.78564E+10	1.30134E+10	8.50741E+09	4.34517E+09
53	2.01906E+10	1.72273E+10	1.25984E+10	8.27198E+09	4.26595E+09
54	1.94156E+10	1.66270E+10	1.22037E+10	8.04958E+09	4.19281E+09
55	1.86861E+10	1.60662E+10	1.18364E+10	7.84258E+09	4.12436E+09
56	1.79310E+10	1.54936E+10	1.14634E+10	7.63362E+09	4.05474E+09
57	1.73116E+10	1.50079E+10	1.11455E+10	7.45507E+09	3.99701E+09
58	1.67836E+10	1.46097E+10	1.08868E+10	7.31032E+09	3.94838E+09
59	1.64309E+10	1.43246E+10	1.06980E+10	7.20422E+09	3.91477E+09
60	1.62159E+10	1.41568E+10	1.05871E+10	7.14208E+09	3.89414E+09
61	1.61084E+10	1.40729E+10	1.05318E+10	7.11088E+09	3.88383E+09

Table 4.1.3.6

Low Leakage Core Loading

DPA Rates At Pressure Vessel Lower Weld

(z=67.1048cm)

θ	0-T	1/4 T	1/2 T	3/4 T	T
1	1.99532E-11	1.29823E-11	7.76481E-12	4.42089E-12	2.01856E-12
2	1.99544E-11	1.29867E-11	7.76839E-12	4.42412E-12	2.01579E-12
3	1.99995E-11	1.30293E-11	7.79590E-12	4.43806E-12	2.01706E-12
4	2.02400E-11	1.31786E-11	7.87829E-12	4.47940E-12	2.03028E-12
5	2.06267E-11	1.34165E-11	8.00945E-12	4.54573E-12	2.05181E-12
6	2.11399E-11	1.37332E-11	8.18464E-12	4.63356E-12	2.08002E-12
7	2.18223E-11	1.41615E-11	8.42159E-12	4.75270E-12	2.11750E-12
8	2.27456E-11	1.47266E-11	8.73003E-12	4.90582E-12	2.16547E-12
9	2.36404E-11	1.52608E-11	9.01903E-12	5.04925E-12	2.21081E-12
10	2.44541E-11	1.57617E-11	9.29286E-12	5.18462E-12	2.25332E-12
11	2.54095E-11	1.63380E-11	9.60288E-12	5.33784E-12	2.30084E-12
12	2.63704E-11	1.69140E-11	9.91163E-12	5.48848E-12	2.34764E-12
13	2.72959E-11	1.74635E-11	1.02028E-11	5.62997E-12	2.39114E-12
14	2.81410E-11	1.79603E-11	1.04633E-11	5.75511E-12	2.42927E-12
15	2.88659E-11	1.83806E-11	1.06797E-11	5.85723E-12	2.45961E-12
16	2.94278E-11	1.86923E-11	1.08352E-11	5.92866E-12	2.48045E-12
17	2.97810E-11	1.88678E-11	1.09155E-11	5.96402E-12	2.48889E-12
18	2.98379E-11	1.88722E-11	1.09075E-11	5.95873E-12	2.48722E-12
19	2.96049E-11	1.87547E-11	1.08485E-11	5.93199E-12	2.48005E-12
20	2.95517E-11	1.86383E-11	1.07835E-11	5.90210E-12	2.46866E-12
21	2.90892E-11	1.83286E-11	1.06412E-11	5.84082E-12	2.44696E-12
22	2.85286E-11	1.79954E-11	1.04922E-11	5.77528E-12	2.43106E-12
23	2.76489E-11	1.76841E-11	1.03782E-11	5.72741E-12	2.42701E-12
24	2.72688E-11	1.75997E-11	1.03441E-11	5.71207E-12	2.42169E-12
25	2.67157E-11	1.73967E-11	1.02706E-11	5.67940E-12	2.40471E-12
26	2.62895E-11	1.71638E-11	1.01701E-11	5.63261E-12	2.38665E-12
27	2.60319E-11	1.69950E-11	1.00717E-11	5.58416E-12	2.37366E-12
28	2.60687E-11	1.69174E-11	1.00049E-11	5.54848E-12	2.36793E-12
29	2.61771E-11	1.68722E-11	9.96867E-12	5.52934E-12	2.36137E-12
30	2.64664E-11	1.68037E-11	9.87730E-12	5.47557E-12	2.33249E-12
31	2.61978E-11	1.66050E-11	9.72667E-12	5.38851E-12	2.29889E-12
32	2.57217E-11	1.63729E-11	9.58245E-12	5.30903E-12	2.27341E-12
33	2.52259E-11	1.61176E-11	9.43677E-12	5.23144E-12	2.24780E-12

Table 4.1.3.6

Low Leakage Core Loading

DPA Rates At Pressure Vessel Lower Weld (cont'd)

(z=67.1048cm)

θ	0-T	1/4 T	1/2 T	3/4 T	T
34	2.46908E-11	1.58286E-11	9.28015E-12	5.15031E-12	2.22065E-12
35	2.41409E-11	1.55163E-11	9.11402E-12	5.06576E-12	2.19144E-12
36	2.33367E-11	1.50562E-11	8.87380E-12	4.94508E-12	2.15014E-12
37	2.24068E-11	1.44913E-11	8.56597E-12	4.78915E-12	2.09824E-12
38	2.15764E-11	1.39654E-11	8.26858E-12	4.63594E-12	2.04741E-12
39	2.08365E-11	1.34813E-11	7.98804E-12	4.48900E-12	1.99753E-12
40	2.01756E-11	1.30402E-11	7.72628E-12	4.34933E-12	1.94924E-12
41	1.96017E-11	1.26528E-11	7.49295E-12	4.22319E-12	1.90690E-12
42	1.92534E-11	1.24163E-11	7.34935E-12	4.14542E-12	1.88185E-12
43	1.89088E-11	1.21800E-11	7.20588E-12	4.06728E-12	1.85227E-12
44	1.83572E-11	1.18053E-11	6.98077E-12	3.94600E-12	1.80867E-12
45	1.77502E-11	1.14110E-11	6.75156E-12	3.82442E-12	1.76866E-12
46	1.73098E-11	1.11460E-11	6.60257E-12	3.74658E-12	1.74401E-12
47	1.69336E-11	1.08936E-11	6.45491E-12	3.66878E-12	1.71527E-12
48	1.62543E-11	1.04729E-11	6.21815E-12	3.54604E-12	1.67229E-12
49	1.55079E-11	1.00213E-11	5.96835E-12	3.41780E-12	1.63000E-12
50	1.49410E-11	9.67703E-12	5.77744E-12	3.32015E-12	1.59879E-12
51	1.45464E-11	9.43270E-12	5.64077E-12	3.25017E-12	1.57536E-12
52	1.40780E-11	9.14481E-12	5.48092E-12	3.16857E-12	1.54694E-12
53	1.35525E-11	8.82172E-12	5.30212E-12	3.07722E-12	1.51638E-12
54	1.30564E-11	8.51653E-12	5.13298E-12	2.99135E-12	1.48818E-12
55	1.25941E-11	8.23284E-12	4.97624E-12	2.91150E-12	1.46188E-12
56	1.21068E-11	7.94060E-12	4.81620E-12	2.83080E-12	1.43513E-12
57	1.17252E-11	7.69970E-12	4.68229E-12	2.76256E-12	1.41310E-12
58	1.13846E-11	7.49655E-12	4.57139E-12	2.70678E-12	1.39450E-12
59	1.11765E-11	7.35909E-12	4.49330E-12	2.66670E-12	1.38178E-12
60	1.10445E-11	7.27665E-12	4.44683E-12	2.64313E-12	1.37400E-12
61	1.09782E-11	7.23535E-12	4.42372E-12	2.63126E-12	1.37010E-12

Table 4.1.3.7

Low Leakage Core Loading

Downcomer Fluxes and DPA Rates

(r=210.50cm, z=195.76cm)

θ	FLUX	FLUX	DPA/s
	(E>1.0 MEV)	(E>0.1 MEV)	
1	3.18651E+10	5.60212E+10	4.83286E-11
2	3.18411E+10	5.60045E+10	4.82945E-11
3	3.18950E+10	5.61790E+10	4.83900E-11
4	3.23444E+10	5.70009E+10	4.90644E-11
5	3.30588E+10	5.83302E+10	5.01388E-11
6	3.40324E+10	6.01477E+10	5.16032E-11
7	3.53272E+10	6.26086E+10	5.35612E-11
8	3.71271E+10	6.60018E+10	5.62794E-11
9	3.89175E+10	6.93465E+10	5.89651E-11
10	4.05292E+10	7.24619E+10	6.14050E-11
11	4.24824E+10	7.62165E+10	6.43572E-11
12	4.44983E+10	8.01112E+10	6.74051E-11
13	4.64801E+10	8.39766E+10	7.04078E-11
14	4.83429E+10	8.76671E+10	7.32390E-11
15	4.99792E+10	9.09645E+10	7.57330E-11
16	5.12922E+10	9.37011E+10	7.77541E-11
17	5.21975E+10	9.57035E+10	7.91657E-11
18	5.24664E+10	9.66256E+10	7.96417E-11
19	5.19313E+10	9.62961E+10	7.89526E-11
20	5.19369E+10	9.63712E+10	7.89538E-11
21	5.06161E+10	9.48906E+10	7.71096E-11
22	4.93955E+10	9.33077E+10	7.53354E-11
23	4.76592E+10	9.11678E+10	7.28851E-11
24	4.74112E+10	9.07098E+10	7.25287E-11
25	4.65370E+10	8.94933E+10	7.12210E-11
26	4.55225E+10	8.78887E+10	6.97135E-11
27	4.48305E+10	8.64338E+10	6.86578E-11
28	4.45762E+10	8.55482E+10	6.82517E-11
29	4.43745E+10	8.50526E+10	6.79163E-11
30	4.43231E+10	8.39937E+10	6.77442E-11

Figure 4.1.3.7

Low Leakage Core Loading

Downcomer Fluxes and DPA Rates (cont'd)

(r=210.50cm, z=195.76cm)

	FLUX (E>1.0 MEV)	FLUX (E>0.1 MEV)	DPA/s
0			
31	4.37137E+10	8.16508E+10	6.66917E-11
32	4.29418E+10	7.93698E+10	6.54131E-11
33	4.20618E+10	7.71129E+10	6.39939E-11
34	4.10899E+10	7.48318E+10	6.24558E-11
35	4.00589E+10	7.25322E+10	6.08455E-11
36	3.84513E+10	6.92870E+10	5.84054E-11
37	3.67752E+10	6.59132E+10	5.58178E-11
38	3.53559E+10	6.31654E+10	5.36466E-11
39	3.41932E+10	6.10148E+10	5.18752E-11
40	3.32277E+10	5.93237E+10	5.04129E-11
41	3.24444E+10	5.80441E+10	4.92320E-11
42	3.20013E+10	5.73483E+10	4.85610E-11
43	3.15354E+10	5.66412E+10	4.78768E-11
44	3.08166E+10	5.55360E+10	4.68020E-11
45	2.99768E+10	5.42423E+10	4.55506E-11
46	2.92380E+10	5.31363E+10	4.44744E-11
47	2.87002E+10	5.22066E+10	4.36479E-11
48	2.75257E+10	5.02271E+10	4.18811E-11
49	2.61091E+10	4.77301E+10	3.97461E-11
50	2.49621E+10	4.56059E+10	3.80329E-11
51	2.42073E+10	4.41343E+10	3.68774E-11
52	2.32986E+10	4.23330E+10	3.54820E-11
53	2.22364E+10	4.02029E+10	3.38616E-11
54	2.12117E+10	3.81266E+10	3.22988E-11
55	2.02471E+10	3.61638E+10	3.08309E-11
56	1.92168E+10	3.40970E+10	2.92691E-11
57	1.84344E+10	3.24515E+10	2.80702E-11
58	1.77035E+10	3.10056E+10	2.69749E-11
59	1.72778E+10	3.00773E+10	2.63223E-11
60	1.69920E+10	2.94950E+10	2.58882E-11
61	1.68483E+10	2.92019E+10	2.56643E-11

Table 4.1.3.8

Low Leakage Core Loading
Cavity Fluxes and DPA Rates
($r=320.06\text{cm}$, $z=184.665\text{cm}$)

	FLUX ($E>1.0$ MEV)	FLUX ($E>0.1$ MEV)	DPA/s
0			
1	5.37593E+08	4.61026E+09	1.66455E-12
2	5.37704E+08	4.61094E+09	1.66479E-12
3	5.36881E+08	4.60706E+09	1.66307E-12
4	5.36931E+08	4.60596E+09	1.66284E-12
5	5.37056E+08	4.60449E+09	1.66258E-12
6	5.37306E+08	4.60298E+09	1.66242E-12
7	5.37364E+08	4.59961E+09	1.66163E-12
8	5.38072E+08	4.59822E+09	1.66189E-12
9	5.38778E+08	4.59748E+09	1.66230E-12
10	5.38455E+08	4.59236E+09	1.66072E-12
11	5.38037E+08	4.58633E+09	1.65881E-12
12	5.37377E+08	4.57974E+09	1.65651E-12
13	5.36326E+08	4.57193E+09	1.65352E-12
14	5.34858E+08	4.56272E+09	1.64979E-12
15	5.33004E+08	4.55177E+09	1.64526E-12
16	5.30911E+08	4.53875E+09	1.64005E-12
17	5.28670E+08	4.52323E+09	1.63415E-12
18	5.26545E+08	4.50684E+09	1.62824E-12
19	5.24726E+08	4.49327E+09	1.62335E-12
20	5.24433E+08	4.48750E+09	1.62166E-12
21	5.22500E+08	4.47190E+09	1.61614E-12
22	5.21189E+08	4.46088E+09	1.61223E-12
23	5.20084E+08	4.45244E+09	1.60917E-12
24	5.19989E+08	4.45110E+09	1.60875E-12
25	5.19622E+08	4.44759E+09	1.60755E-12
26	5.18784E+08	4.44132E+09	1.60522E-12
27	5.17376E+08	4.43261E+09	1.60178E-12
28	5.16059E+08	4.42505E+09	1.59870E-12
29	5.15304E+08	4.42091E+09	1.59699E-12
30	5.13781E+08	4.41222E+09	1.59342E-12

Figure 4.1.3.8

Low Leakage Core Loading

Cavity Fluxes and DPA Rates (cont'd)

(r=320.06cm, z=184.665cm)

	FLUX	FLUX	DPA/s
θ	(E>1.0 MEV)	(E>0.1 MEV)	
31	5.11393E+08	4.39820E+09	1.58772E-12
32	5.09310E+08	4.38629E+09	1.58282E-12
33	5.06999E+08	4.37380E+09	1.57756E-12
34	5.04530E+08	4.36056E+09	1.57199E-12
35	5.01353E+08	4.34372E+09	1.56488E-12
36	4.96574E+08	4.31838E+09	1.55422E-12
37	4.90774E+08	4.28456E+09	1.54063E-12
38	4.85004E+08	4.24941E+09	1.52681E-12
39	4.79168E+08	4.21363E+09	1.51279E-12
40	4.73081E+08	4.17713E+09	1.49833E-12
41	4.67586E+08	4.14480E+09	1.48540E-12
42	4.64309E+08	4.12568E+09	1.47772E-12
43	4.60506E+08	4.10416E+09	1.46899E-12
44	4.54669E+08	4.07103E+09	1.45554E-12
45	4.49120E+08	4.03917E+09	1.44266E-12
46	4.45907E+08	4.02038E+09	1.43515E-12
47	4.42390E+08	4.00035E+09	1.42702E-12
48	4.37117E+08	3.96979E+09	1.41473E-12
49	4.31829E+08	3.93870E+09	1.40230E-12
50	4.28690E+08	3.91921E+09	1.39469E-12
51	4.26250E+08	3.90458E+09	1.38889E-12
52	4.23627E+08	3.88937E+09	1.38276E-12
53	4.20722E+08	3.87197E+09	1.37584E-12
54	4.17937E+08	3.85523E+09	1.36920E-12
55	4.15488E+08	3.84067E+09	1.36339E-12
56	4.12520E+08	3.82357E+09	1.35648E-12
57	4.10654E+08	3.81214E+09	1.35198E-12
58	4.08426E+08	3.79948E+09	1.34585E-12
59	4.07563E+08	3.79392E+09	1.34469E-12
60	4.06810E+08	3.78941E+09	1.34290E-12
61	4.06494E+08	3.78753E+09	1.34215E-12

Table 4.1.3.9

Low Leakage Core Loading

Flux Spectrum At Pressure Vessel (Pressure Vessel Capsule In)

Group	$\theta=15.5^\circ$ $z=195.760\text{cm}$				
	0-T	1/4 T	1/2 T	3/4 T	T
1	8.95971E+06	4.04639E+06	1.71127E+06	7.20446E+05	3.13552E+05
2	2.66728E+07	1.18582E+07	4.91037E+06	2.01695E+06	8.52613E+05
3	1.06687E+08	4.74877E+07	1.94349E+07	7.83696E+06	3.25155E+06
4	2.04944E+08	9.15840E+07	3.70330E+07	1.46790E+07	5.97526E+06
5	3.49216E+08	1.53135E+08	5.99373E+07	2.29414E+07	8.98942E+06
6	8.99565E+08	3.78206E+08	1.40533E+08	5.11175E+07	1.89706E+07
7	1.30087E+09	5.37998E+08	1.96720E+08	7.05824E+07	2.54868E+07
8	2.31851E+09	9.58891E+08	3.52008E+08	1.27042E+08	4.49000E+07
9	1.61447E+09	6.98629E+08	2.67952E+08	1.00362E+08	3.54585E+07
10	1.17790E+09	5.35940E+08	2.10237E+08	7.98665E+07	2.82120E+07
11	1.33508E+09	6.31525E+08	2.54021E+08	9.82945E+07	3.45238E+07
12	6.60471E+08	3.16891E+08	1.28904E+08	5.03147E+07	1.77265E+07
13	1.70224E+08	8.61218E+07	3.64668E+07	1.47036E+07	5.49417E+06
14	8.37224E+08	4.31467E+08	1.85441E+08	7.57869E+07	2.81014E+07
15	2.14839E+09	1.17028E+09	5.21746E+08	2.18524E+08	7.91228E+07
16	2.23472E+09	1.34924E+09	6.52857E+08	2.91964E+08	1.10470E+08
17	3.09285E+09	1.98878E+09	1.01350E+09	4.72548E+08	1.83599E+08
18	4.69342E+09	3.57421E+09	2.09348E+09	1.08842E+09	4.42641E+08
19	2.99026E+09	2.53073E+09	1.65250E+09	9.48778E+08	4.25846E+08
20	1.53302E+09	1.18983E+09	7.51146E+08	4.19502E+08	1.77012E+08
21	4.26216E+09	4.35878E+09	3.25634E+09	2.04435E+09	9.14851E+08
22	3.42242E+09	3.51560E+09	2.74099E+09	1.78949E+09	8.22432E+08
23	3.79426E+09	3.96428E+09	3.14348E+09	2.02927E+09	8.28609E+08
24	3.86580E+09	4.72220E+09	4.14134E+09	2.87263E+09	1.27340E+09
25	4.76833E+09	4.90140E+09	4.06939E+09	2.78572E+09	1.30129E+09
26	4.61586E+09	5.13492E+09	4.48869E+09	3.17051E+09	1.47962E+09
27	3.20577E+09	3.26790E+09	2.81039E+09	1.97630E+09	9.16890E+08
28	2.51505E+09	2.37374E+09	1.97864E+09	1.36828E+09	6.18772E+08
29	8.79362E+08	6.38401E+08	5.10448E+08	3.50385E+08	1.67833E+08
30	4.34403E+08	2.17634E+08	1.72810E+08	1.18348E+08	6.84491E+07
31	1.10068E+09	1.20820E+09	1.06011E+09	7.89183E+08	4.46329E+08
32	6.44102E+08	6.86094E+08	6.16769E+08	4.69131E+08	2.67381E+08
33	1.26761E+09	1.10466E+09	9.10021E+08	6.73229E+08	3.92060E+08
34	2.22481E+09	1.27925E+09	8.82025E+08	6.13543E+08	3.82835E+08
35	2.77412E+09	1.93564E+09	1.30894E+09	8.51121E+08	4.43179E+08
36	2.48875E+09	1.51446E+09	9.71059E+08	6.10536E+08	3.29150E+08
37	4.06557E+09	2.34878E+09	1.40238E+09	8.44043E+08	4.70063E+08
38	2.24728E+09	1.03870E+09	5.83287E+08	3.45706E+08	2.15568E+08
39	2.46858E+09	1.25322E+09	6.65827E+08	3.80715E+08	2.26521E+08
40	3.19862E+09	1.54584E+09	7.79807E+08	4.28626E+08	2.63301E+08
41	4.02753E+09	1.93545E+09	9.35486E+08	4.90924E+08	2.99183E+08
42	2.32885E+09	1.04054E+09	4.83561E+08	2.47461E+08	1.57893E+08
43	3.12152E+09	1.26120E+09	5.42939E+08	2.68401E+08	1.88177E+08
44	2.35583E+09	8.46985E+08	3.31896E+08	1.58293E+08	1.27369E+08
45	2.01571E+09	4.01121E+08	1.15435E+08	5.46227E+07	8.94442E+07
46	4.36504E+09	5.20484E+08	7.91824E+07	3.86840E+07	1.69931E+08
47	2.04036E+10	6.29138E+08	1.87944E+07	1.41357E+07	3.79498E+08

Table 4.1.3.10

Low Leakage Core Loading

Flux Spectrum At Capsule Location

Group	Thermal Shield	Pressure Vessel	Cavity
1	2.86233E+07	1.08290E+07	1.88102E+05
2	9.25192E+07	3.28134E+07	5.00176E+05
3	4.21285E+08	1.34860E+08	1.85392E+06
4	8.72879E+08	2.62567E+08	3.32626E+06
5	1.63932E+09	4.54683E+08	4.88952E+06
6	4.35756E+09	1.16997E+09	1.01258E+07
7	7.05957E+09	1.72212E+09	1.35494E+07
8	1.48779E+10	3.14231E+09	2.37664E+07
9	1.22241E+10	2.22688E+09	1.85833E+07
10	9.33050E+09	1.61970E+09	1.47019E+07
11	1.08180E+10	1.81467E+09	1.81245E+07
12	5.30890E+09	8.92312E+08	9.29861E+06
13	1.41178E+09	2.32396E+08	2.88943E+06
14	7.12017E+09	1.13812E+09	1.42535E+07
15	1.90028E+10	2.84974E+09	3.87701E+07
16	2.11101E+10	2.88950E+09	5.41140E+07
17	3.12948E+10	3.96978E+09	9.25220E+07
18	5.22985E+10	5.56405E+09	2.16581E+08
19	3.37349E+10	3.36514E+09	2.09905E+08
20	1.81129E+10	1.87476E+09	1.04103E+08
21	4.35261E+10	4.00287E+09	4.40184E+08
22	3.56877E+10	3.34595E+09	4.27577E+08
23	3.93046E+10	3.75960E+09	4.38445E+08
24	3.33019E+10	3.05957E+09	6.33305E+08
25	4.99846E+10	4.97060E+09	8.11848E+08
26	4.53695E+10	4.41779E+09	8.63564E+08
27	3.56713E+10	3.54696E+09	5.67060E+08
28	2.94159E+10	2.98244E+09	4.08944E+08
29	1.17175E+10	1.25426E+09	1.27929E+08
30	7.67403E+09	8.67824E+08	5.93436E+07
31	7.41426E+09	6.95390E+08	2.06875E+08
32	5.92500E+09	5.63288E+08	1.38458E+08
33	1.43009E+10	1.58100E+09	2.85779E+08
34	3.02836E+10	3.44303E+09	3.18189E+08
35	3.55670E+10	3.88496E+09	3.25683E+08
36	3.42967E+10	3.69890E+09	2.60552E+08
37	5.33232E+10	5.84162E+09	3.88560E+08
38	3.11189E+10	3.51722E+09	1.85291E+08
39	3.20081E+10	3.59640E+09	1.91398E+08
40	4.26472E+10	4.81535E+09	2.26942E+08
41	5.23847E+10	6.02390E+09	2.58066E+08
42	3.05480E+10	3.58744E+09	1.39480E+08
43	3.99628E+10	4.88106E+09	1.72279E+08
44	2.95076E+10	3.75736E+09	1.21621E+08
45	2.76915E+10	3.74894E+09	1.00872E+08
46	5.85309E+10	8.83175E+09	2.09488E+08
47	1.50116E+11	4.41768E+10	5.48801E+08

 Thermal Shield Capsule flux spectrum is at r=202.25cm, z=195.76cm, $\theta=20^\circ$
 Pressure Vessel Capsule flux spectrum is at r=215.43cm, z=195.76cm, $\theta=20^\circ$
 Cavity Capsule flux spectrum is at r=320.06cm, z=184.665cm, $\theta=9.5^\circ$

Table 4.1.3.11

Low Leakage Core Loading

Effect of Selected Cross Sections on the Calculated Reaction Rates

Axial Peak Reaction Rate (reactions/sec*atom)

o

Thermal Shield Capsule (r=202.25cm, z=195.76cm, θ=20)

Detector	SAILOR		
Material	BUGLE93	ENDF/B-IV	ORNL/TM-11476
27	-16	-16	
.Al (n,α)	2.34084x10	2.43356x10	
32	-14	-14	
.S (n,p)	1.35902x10	1.40130x10	
46	-15	-15	
.Ti (n,p)	2.71072x10	2.62811x10	
54	-14	-14	-14
.Fe (n,p)	1.72762x10	1.74803x10	1.71228x10
56	-16	-16	
.Fe (n,p)	3.04757x10	3.29786x10	
58	-14	-14	-14
.Ni (n,p)	2.33009x10	2.32339x10	2.27883x10
63	-16	-16	
.Cu (n,α)	1.48520x10	1.17917x10	
65	-16	-16	
.Cu (n,2n)	1.53266x10	1.88725x10	
115	-14	-14	
.In (n,n')	4.68765x10	4.56521x10	
237	-13	-13	-13
.Np (n,f)	4.75353x10	5.00191x10	4.94987x10
238	-14	-14	-14
.U (n,f)	7.60617x10	7.61544x10	7.64751x10

BUGLE93 used pressure vessel 1/4T weighting spectrum to collapse cross sections.

SAILOR used flat weighting spectrum to collapse cross sections.

Table 4.1.3.12

Low Leakage Core Loading

Effect of Selected Cross Sections on the Calculated Reaction Rates

Axial Peak Reaction Rate (reactions/sec*atom)

o

Pressure Vessel Capsule (r=215.43cm, z=195.76cm, θ=20)

Detector		SAILOR		
Material		ENDF/B-IV		ORNL/TM-11476
27	-17	-17		
.Al (n,α)	6.90977x10	7.17096x10		
32	-15	-15		
.S (n,p)	2.87891x10	2.94648x10		
46	-16	-16		
.Ti (n,p)	6.89007x10	6.69567x10		
54	-15	-15		-15
.Fe (n,p)	3.74169x10	3.87673x10	3.70166x10	
56	-17	-17		
.Fe (n,p)	8.59219x10	9.26725x10		
58	-15	-15		-15
.Ni (n,p)	4.89663x10	4.93634x10	4.80096x10	
63	-17	-17		
.Cu (n,)	4.10297x10	3.40917x10		
65	-17	-17		
.Cu (n,2n)	5.30130x10	6.46168x10		
115	-15	-15		
.In (n,n')	7.61418x10	7.37723x10		
237	-13	-13		-13
.Np (n,f)	6.44534x10	6.92798x10	6.67566x10	
238	-14	-14		-14
.U (n,f)	1.31794x10	1.32889x10	1.32237x10	

BUGLE93 used pressure vessel 1/4T weighting spectrum to collapse cross sections.

SAILOR used flat weighting spectrum to collapse cross sections.

Table 4.1.3.13

Low Leakage Core Loading

Effect of Selected Cross Sections on the Calculated Reaction Rates

Axial Peak Reaction Rate (reactions/sec*atom)

o

Cavity Capsule (r=320.06cm, z=184.665cm, θ=9.5)

Detector		SAILOR		
Material		BUGLE93	ENDF/B-IV	ORNL/TM-11476
27		-19	-19	
.Al	(n,α)	8.23690x10	8.51363x10	
32		-17	-17	
.S	(n,p)	2.56430x10	2.65870x10	
46		-18	-18	
.Ti	(n,p)	6.39383x10	6.23519x10	
54		-17	-17	-17
.Fe	(n,p)	3.35862x10	3.43927x10	3.32502x10
56		-19	-19	
.Fe	(n,p)	9.24108x10	9.91762x10	
58		-17	-17	-17
.Ni	(n,p)	4.69114x10	4.64371x10	4.67184x10
63		-19	-19	
.Cu	(n,α)	4.31875x10	3.86573x10	
65		-19	-19	
.Cu	(n,2n)	8.02959x10	9.66674x10	
115		-16	-16	
.In	(n,n')	1.21393x10	1.19735x10	
237		-15	-15	-15
.Np	(n,f)	2.23060x10	2.34751x10	2.38177x10
238		-16	-16	-16
.U	(n,f)	1.70382x10	1.68464x10	1.71748x10

BUGLE93 used pressure vessel 1/4T weighting spectrum to collapse cross sections.

SAILOR used flat weighting spectrum to collapse cross sections.

Table 4.1.4.1

Partial Length Shield Assembly Core Loading

Fluxes and DPA Rates

Pressure Vessel Inner Wall at Lower Weld (z=67.1048 cm)

	FLUX	FLUX	DPA/s
0	(E>1.0 MEV)	(E>0.1 MEV)	
1	2.23379E+09	5.38276E+09	3.62020E-12
2	2.23418E+09	5.38584E+09	3.62030E-12
3	2.23845E+09	5.40259E+09	3.62731E-12
4	2.26291E+09	5.46318E+09	3.66648E-12
5	2.30312E+09	5.56249E+09	3.73053E-12
6	2.35724E+09	5.69822E+09	3.81720E-12
7	2.43213E+09	5.88913E+09	3.93721E-12
8	2.54093E+09	6.15797E+09	4.11042E-12
9	2.65700E+09	6.43975E+09	4.29478E-12
10	2.76892E+09	6.72406E+09	4.47400E-12
11	2.91754E+09	7.09340E+09	4.71104E-12
12	3.09111E+09	7.52352E+09	4.98762E-12
13	3.29411E+09	8.02449E+09	5.31052E-12
14	3.53195E+09	8.60801E+09	5.68827E-12
15	3.81302E+09	9.29202E+09	6.13329E-12
16	4.14606E+09	1.00976E+10	6.65903E-12
17	4.54195E+09	1.10492E+10	7.28119E-12
18	4.98766E+09	1.21176E+10	7.98068E-12
19	5.33654E+09	1.29364E+10	8.52741E-12
20	5.62173E+09	1.37063E+10	8.98314E-12
21	6.07852E+09	1.48724E+10	9.70165E-12
22	6.46491E+09	1.59917E+10	1.03184E-11
23	6.72432E+09	1.67994E+10	1.07272E-11
24	6.81068E+09	1.70941E+10	1.08657E-11
25	7.01473E+09	1.76814E+10	1.11807E-11
26	7.41520E+09	1.85605E+10	1.17893E-11
27	7.87787E+09	1.94505E+10	1.24861E-11
28	8.30629E+09	2.01528E+10	1.31337E-11
29	8.54121E+09	2.05372E+10	1.34880E-11
30	8.98766E+09	2.13749E+10	1.41441E-11
31	9.74142E+09	2.28830E+10	1.52631E-11

Table 4.1.4.1

Partial Length Shield Assembly Core Loading

Fluxes and DPA Rates (cont'd)

Pressure Vessel Inner Wall at Lower Weld (z=67.1048 cm)

θ	FLUX	FLUX	DPA/s
	(E>1.0 MEV)	(E>0.1 MEV)	
32	1.04062E+10	2.42896E+10	1.62611E-11
33	1.10525E+10	2.56928E+10	1.72311E-11
34	1.17238E+10	2.71705E+10	1.82430E-11
35	1.24306E+10	2.87461E+10	1.93101E-11
36	1.34318E+10	3.09832E+10	2.08249E-11
37	1.48678E+10	3.41484E+10	2.29840E-11
38	1.63700E+10	3.74935E+10	2.52387E-11
39	1.78870E+10	4.08966E+10	2.75112E-11
40	1.93876E+10	4.42734E+10	2.97507E-11
41	2.07336E+10	4.73207E+10	3.17566E-11
42	2.14759E+10	4.90930E+10	3.28684E-11
43	2.22616E+10	5.08257E+10	3.40339E-11
44	2.33053E+10	5.31482E+10	3.55752E-11
45	2.39822E+10	5.47806E+10	3.65907E-11
46	2.40271E+10	5.52326E+10	3.66894E-11
47	2.43835E+10	5.58794E+10	3.72053E-11
48	2.44085E+10	5.59965E+10	3.72478E-11
49	2.40220E+10	5.52536E+10	3.66997E-11
50	2.34054E+10	5.40702E+10	3.58211E-11
51	2.30299E+10	5.31671E+10	3.52632E-11
52	2.25583E+10	5.19755E+10	3.45514E-11
53	2.18412E+10	5.02998E+10	3.34921E-11
54	2.10390E+10	4.84424E+10	3.23133E-11
55	2.01911E+10	4.64943E+10	3.10704E-11
56	1.92011E+10	4.42950E+10	2.96250E-11
57	1.83672E+10	4.23688E+10	2.83993E-11
58	1.75780E+10	4.06419E+10	2.72450E-11
59	1.70842E+10	3.94581E+10	2.65135E-11
60	1.67637E+10	3.87197E+10	2.60389E-11
61	1.66007E+10	3.83468E+10	2.57980E-11

Table 4.1.4.2

Partial Length Shield Assembly Core Loading

Flux Spectrum

Pressure Vessel Inner Wall at Lower Weld

(z=67.1048cm $\theta=0^\circ$)

Group	Total
1	1.94136E+06
2	5.41025E+06
3	1.94800E+07
4	3.44448E+07
5	5.21147E+07
6	1.17683E+08
7	1.50194E+08
8	2.37159E+08
9	1.54074E+08
10	1.07761E+08
11	1.19241E+08
12	5.79618E+07
13	1.49749E+07
14	7.36268E+07
15	1.90632E+08
16	1.98391E+08
17	2.73455E+08
18	4.25248E+08
19	2.79068E+08
20	1.39489E+08
21	4.16880E+08
22	3.42922E+08
23	3.79122E+08
24	4.36742E+08
25	5.17911E+08
26	5.55939E+08
27	3.84285E+08
28	2.91996E+08
29	9.45355E+07
30	4.41874E+07
31	1.65994E+08
32	1.05850E+08
33	1.77714E+08
34	2.49331E+08
35	3.13009E+08
36	2.68347E+08
37	4.25142E+08
38	2.26666E+08
39	2.47554E+08
40	3.14975E+08
41	3.89356E+08
42	2.21554E+08
43	2.91047E+08
44	2.15918E+08
45	1.80784E+08
46	3.85360E+08
47	1.61766E+09

Table 4.1.4.3

Partial Length Shield Assembly Core Loading

Reduction Factors of Fluxes and DPA Rates

Pressure Vessel Inner Wall at Lower Weld (z=67.1048 cm)

θ	FLUX	FLUX	DPA/s
	(E>1.0 MEV)	(E>0.1 MEV)	
1	1.209E+01	1.157E+01	1.153E+01
2	1.210E+01	1.157E+01	1.154E+01
3	1.209E+01	1.156E+01	1.154E+01
4	1.206E+01	1.153E+01	1.150E+01
5	1.200E+01	1.147E+01	1.145E+01
6	1.192E+01	1.139E+01	1.137E+01
7	1.181E+01	1.127E+01	1.126E+01
8	1.164E+01	1.110E+01	1.110E+01
9	1.145E+01	1.091E+01	1.092E+01
10	1.127E+01	1.073E+01	1.074E+01
11	1.102E+01	1.048E+01	1.050E+01
12	1.071E+01	1.018E+01	1.021E+01
13	1.034E+01	9.812E+00	9.850E+00
14	9.885E+00	9.379E+00	9.420E+00
15	9.349E+00	8.874E+00	8.914E+00
16	8.734E+00	8.298E+00	8.335E+00
17	8.048E+00	7.658E+00	7.692E+00
18	7.326E+00	6.996E+00	7.018E+00
19	6.780E+00	6.523E+00	6.511E+00
20	6.412E+00	6.141E+00	6.162E+00
21	5.815E+00	5.605E+00	5.607E+00
22	5.339E+00	5.149E+00	5.163E+00
23	4.952E+00	4.824E+00	4.812E+00
24	4.817E+00	4.712E+00	4.686E+00
25	4.575E+00	4.515E+00	4.462E+00
26	4.252E+00	4.252E+00	4.163E+00
27	3.961E+00	4.006E+00	3.890E+00
28	3.761E+00	3.833E+00	3.701E+00
29	3.675E+00	3.749E+00	3.616E+00
30	3.538E+00	3.579E+00	3.484E+00

Table 4.1.4.3

Partial Length Shield Assembly Core Loading

Reduction Factors of Fluxes and DPA Rates (cont'd)

Pressure Vessel Inner Wall at Lower Weld (z=67.1048 cm)

	FLUX	FLUX	DPA/s
θ	(E>1.0 MEV)	(E>0.1 MEV)	
31	3.242E+00	3.273E+00	3.200E+00
32	2.990E+00	3.015E+00	2.956E+00
33	2.770E+00	2.793E+00	2.743E+00
34	2.566E+00	2.589E+00	2.545E+00
35	2.375E+00	2.398E+00	2.360E+00
36	2.135E+00	2.166E+00	2.128E+00
37	1.880E+00	1.915E+00	1.880E+00
38	1.681E+00	1.715E+00	1.686E+00
39	1.528E+00	1.560E+00	1.535E+00
40	1.411E+00	1.440E+00	1.420E+00
41	1.327E+00	1.352E+00	1.335E+00
42	1.286E+00	1.307E+00	1.294E+00
43	1.245E+00	1.266E+00	1.253E+00
44	1.194E+00	1.214E+00	1.202E+00
45	1.155E+00	1.173E+00	1.163E+00
46	1.138E+00	1.154E+00	1.145E+00
47	1.117E+00	1.134E+00	1.124E+00
48	1.093E+00	1.110E+00	1.100E+00
49	1.074E+00	1.090E+00	1.081E+00
50	1.065E+00	1.079E+00	1.071E+00
51	1.057E+00	1.072E+00	1.063E+00
52	1.048E+00	1.063E+00	1.054E+00
53	1.040E+00	1.056E+00	1.046E+00
54	1.034E+00	1.050E+00	1.040E+00
55	1.030E+00	1.046E+00	1.036E+00
56	1.027E+00	1.043E+00	1.033E+00
57	1.026E+00	1.042E+00	1.031E+00
58	1.026E+00	1.041E+00	1.031E+00
59	1.027E+00	1.041E+00	1.032E+00
60	1.027E+00	1.041E+00	1.032E+00
61	1.027E+00	1.042E+00	1.032E+00

Standard Core Loading Pressure Vessel Flux Spectrum At The O-T Location

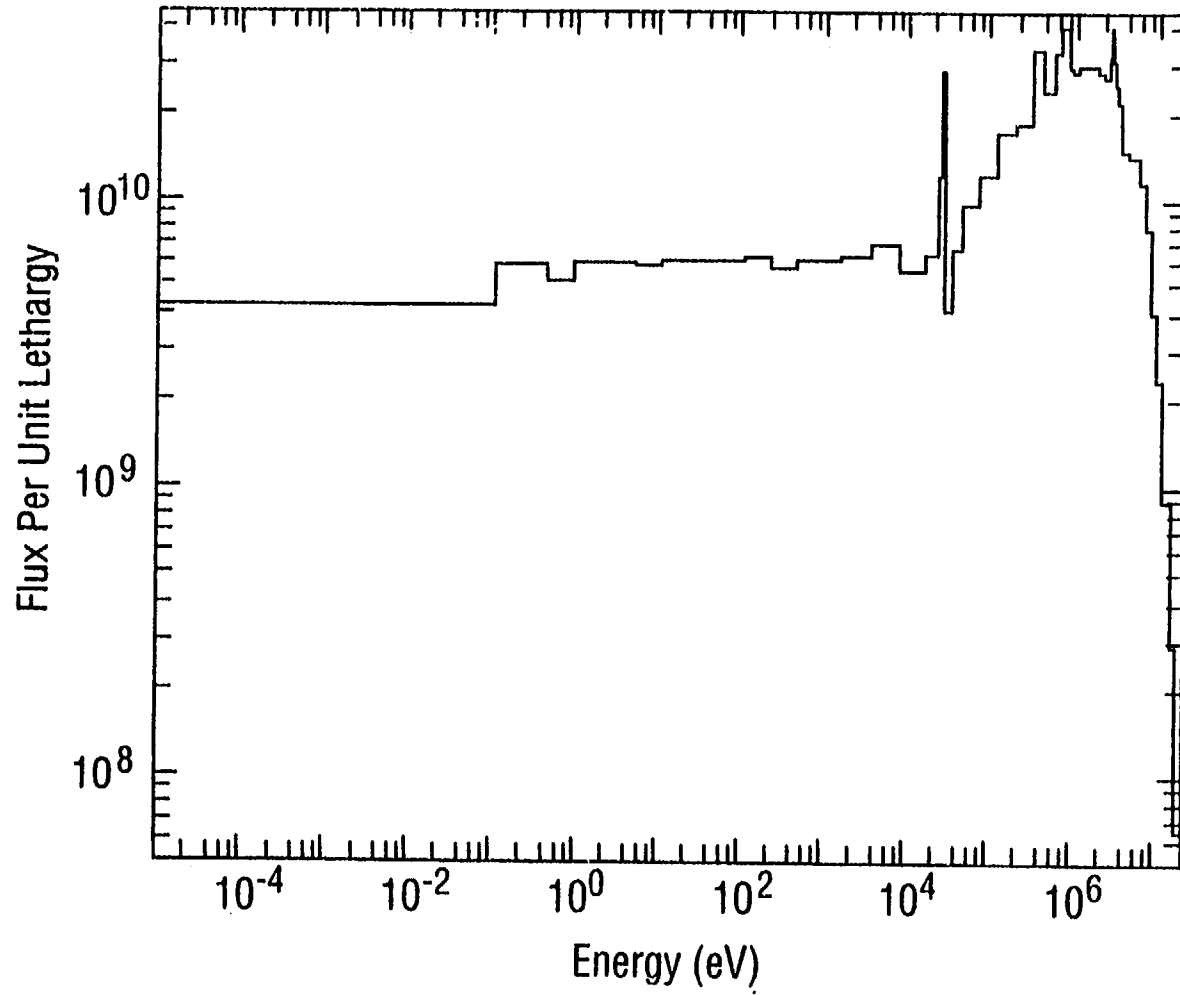

Figure 4.1.2.1

Standard Core Loading Pressure Vessel Flux Spectrum At The T/4 Location

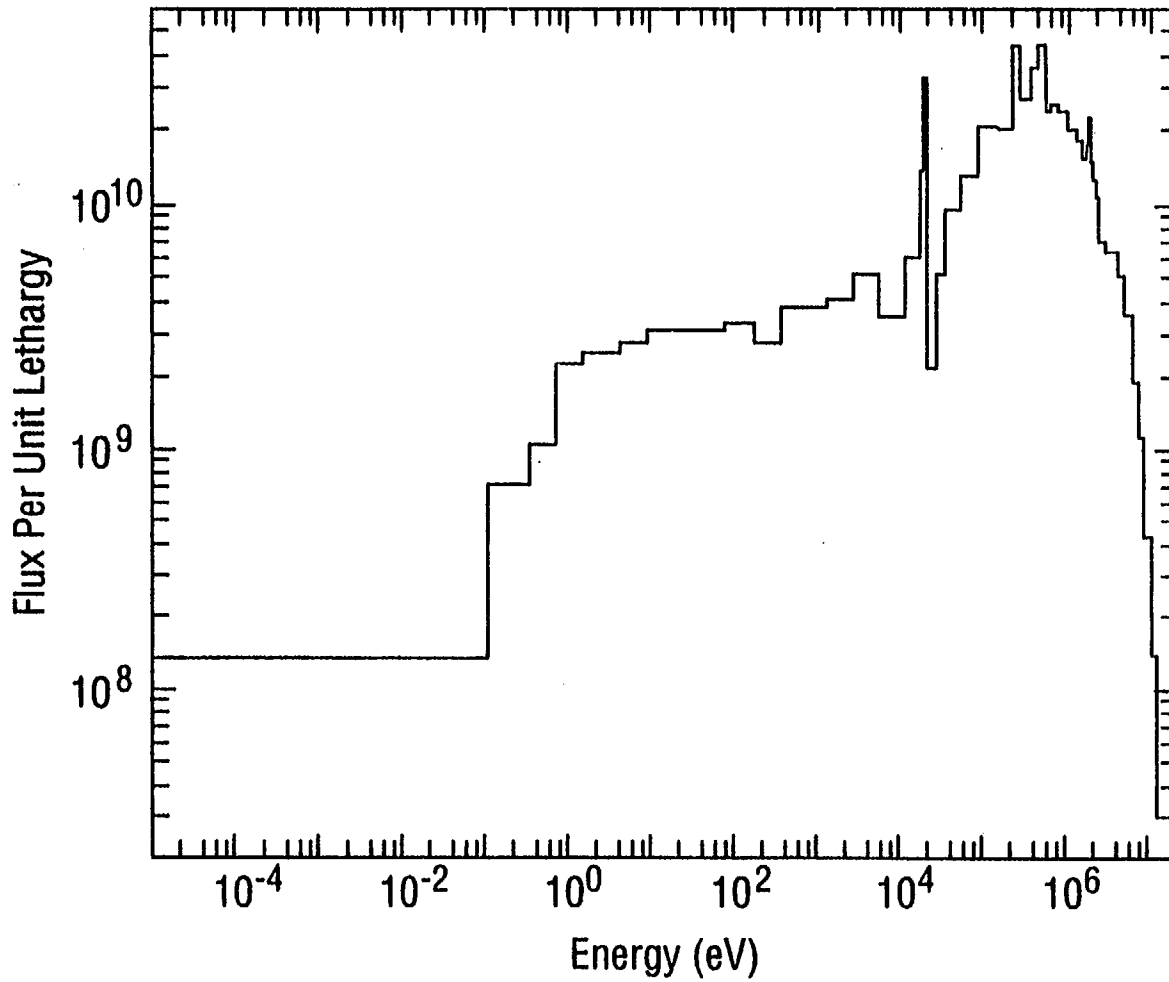

Figure 4.1.2.2

Standard Core Loading Pressure Vessel Flux Spectrum At The T/2 Location

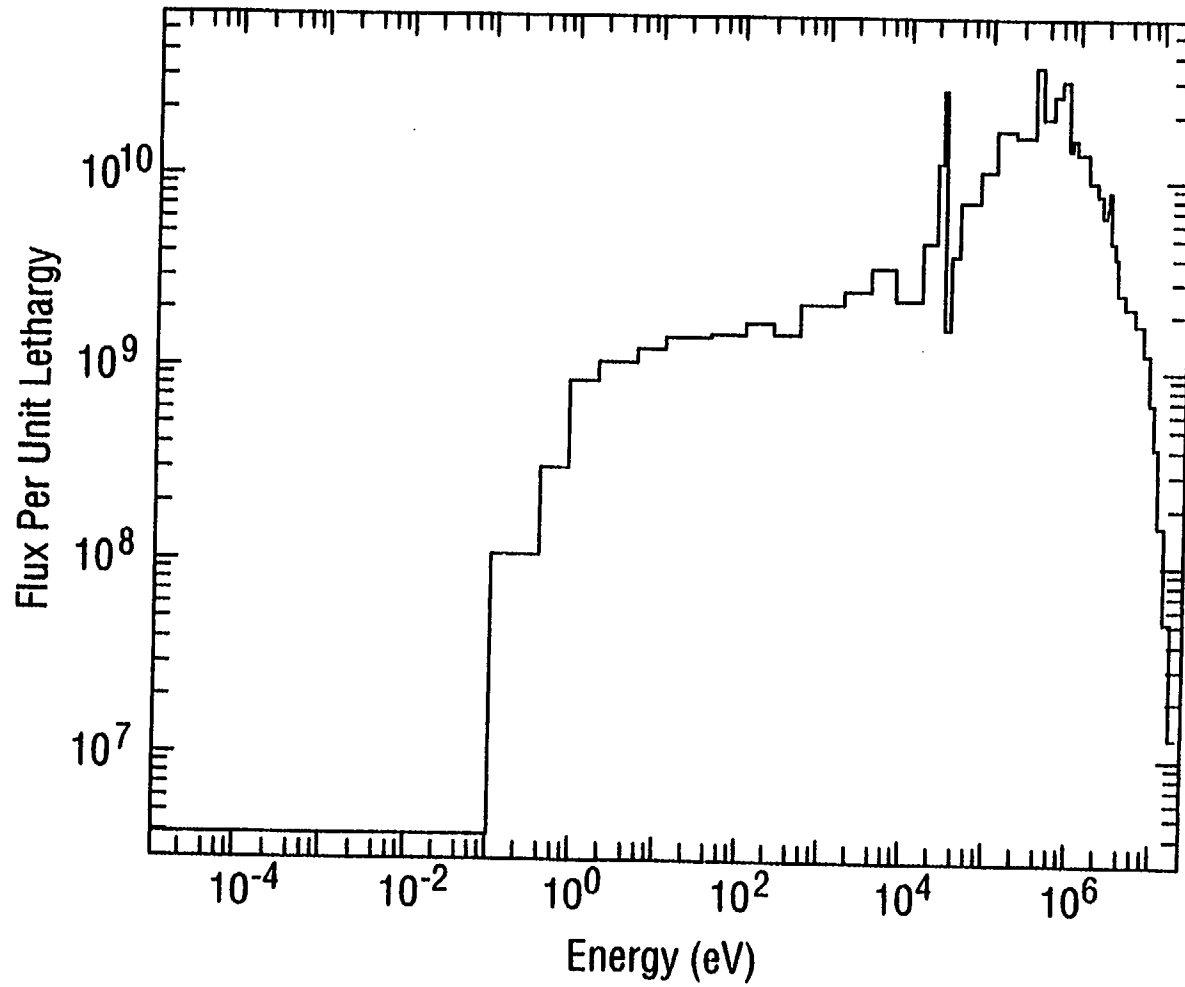

Figure 4.1.2.3

Standard Core Loading Pressure Vessel Flux Spectrum At The 3T/4 Location

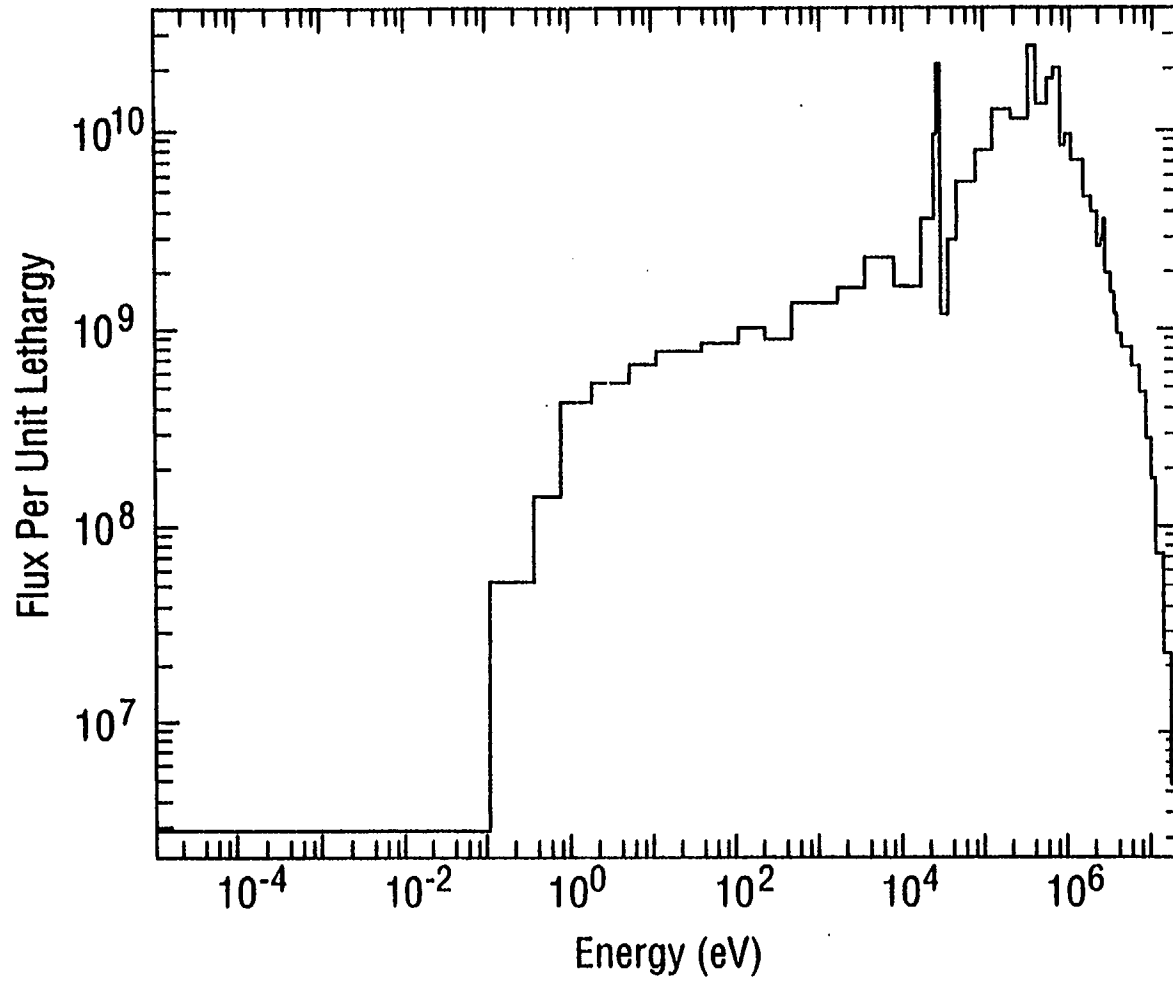

Figure 4.1.2.4

Standard Core Loading Pressure Vessel Flux Spectrum At The 1-T Location

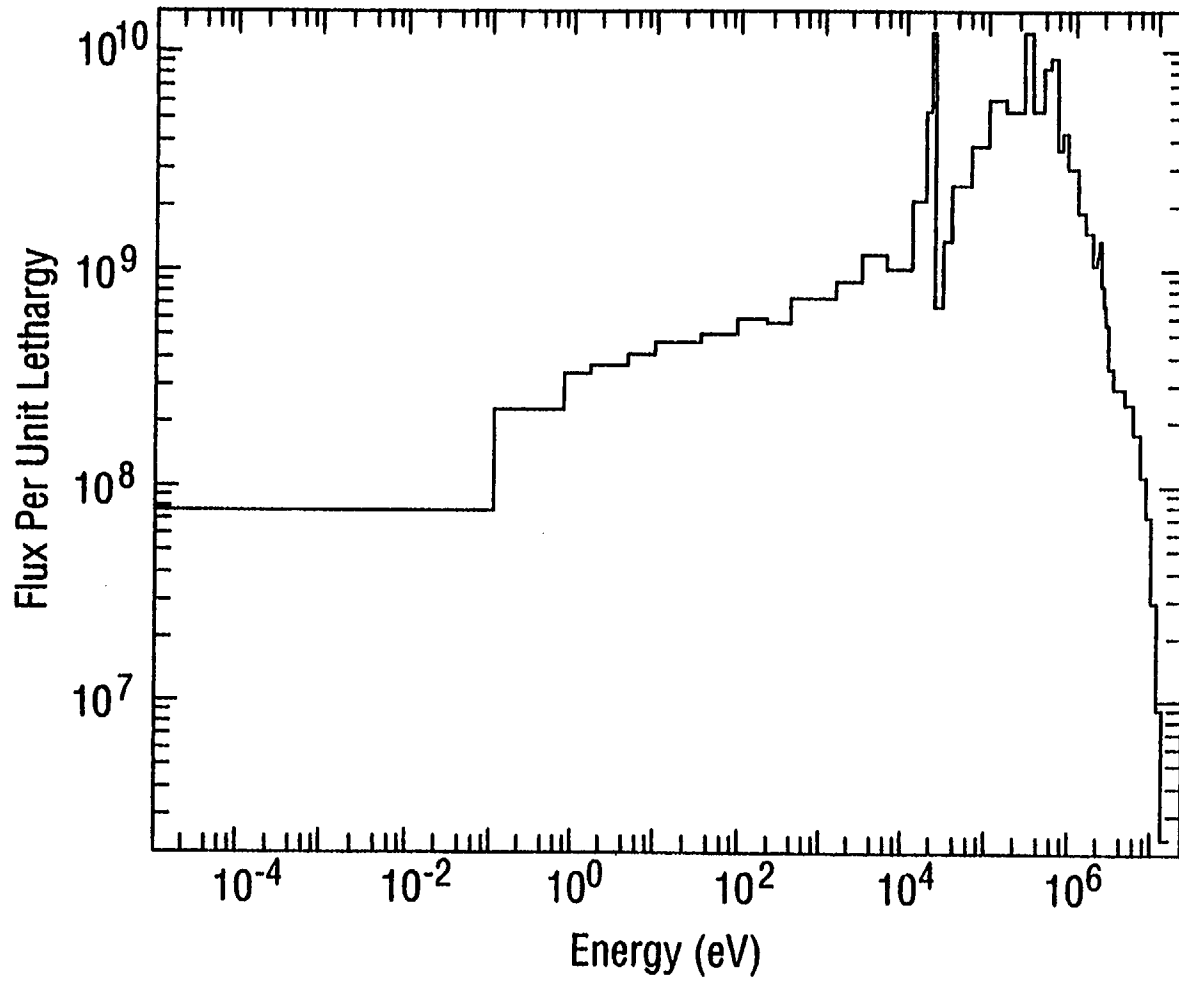

Figure 4.1.2.5

Standard Core Loading Thermal Shield Capsule Flux Spectrum

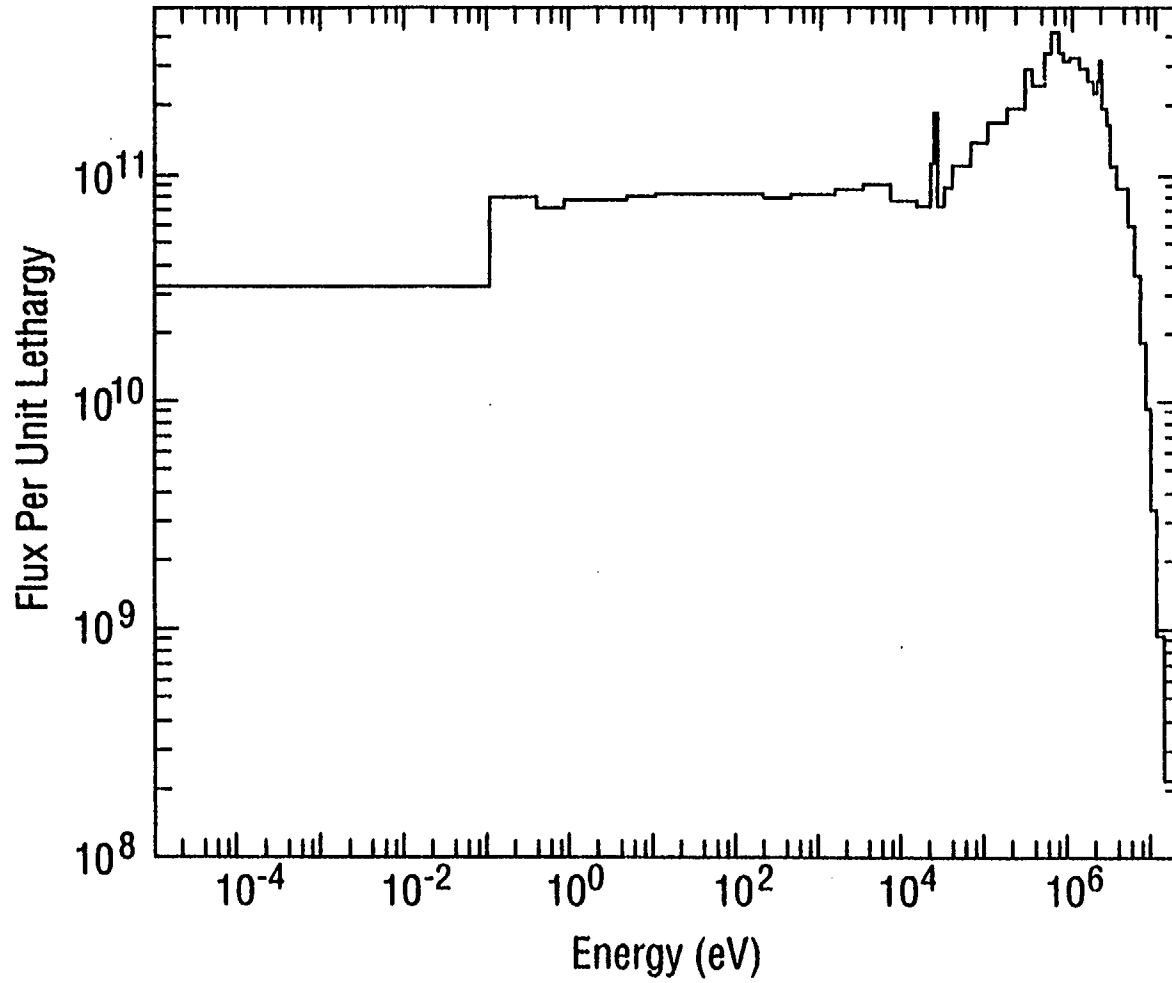

Figure 4.1.2.6

Standard Core Loading Pressure Vessel Capsule Flux Spectrum

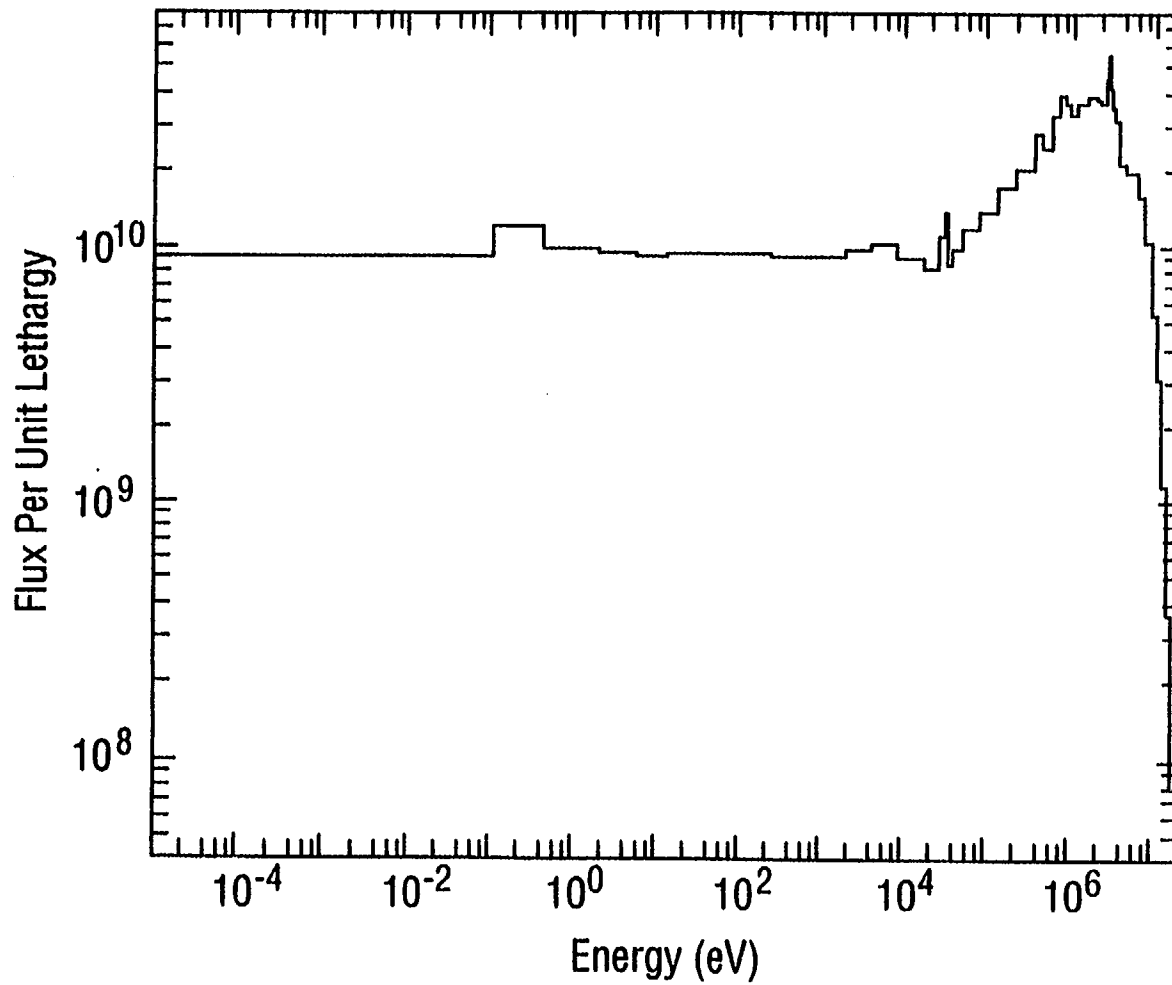

Figure 4.1.2.7

Standard Core Loading Cavity Capsule Flux Spectrum

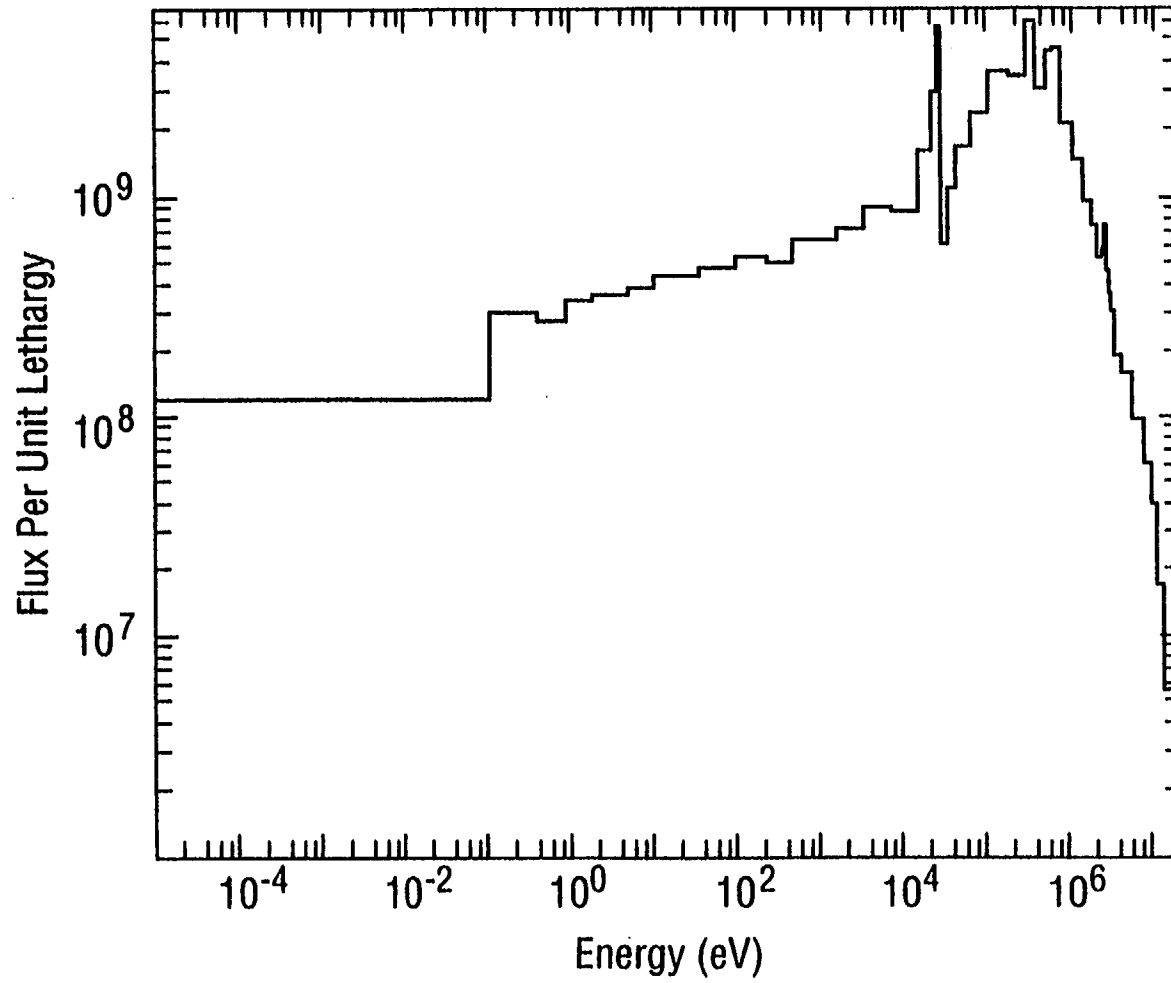

Figure 4.1.2.8

Low-Leakage Core Loading Pressure Vessel Flux Spectrum At The 0-T Location

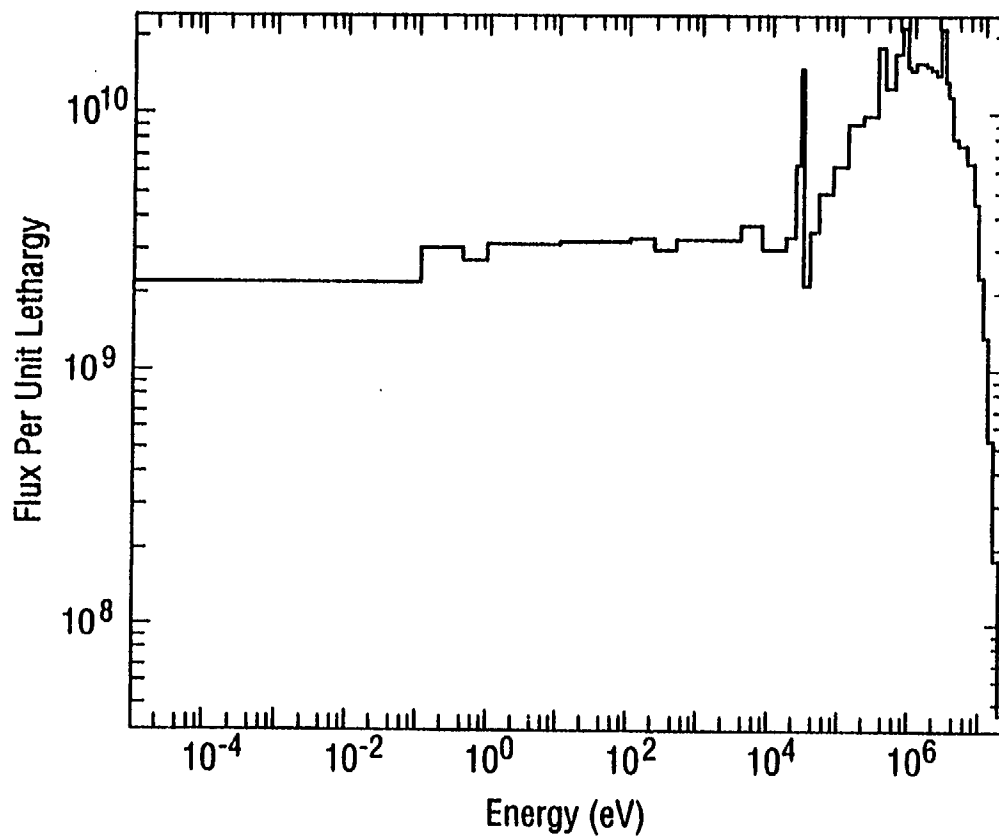

Figure 4.1.3.1

Low-Leakage Core Loading Pressure Vessel Flux Spectrum At The T/4 Location

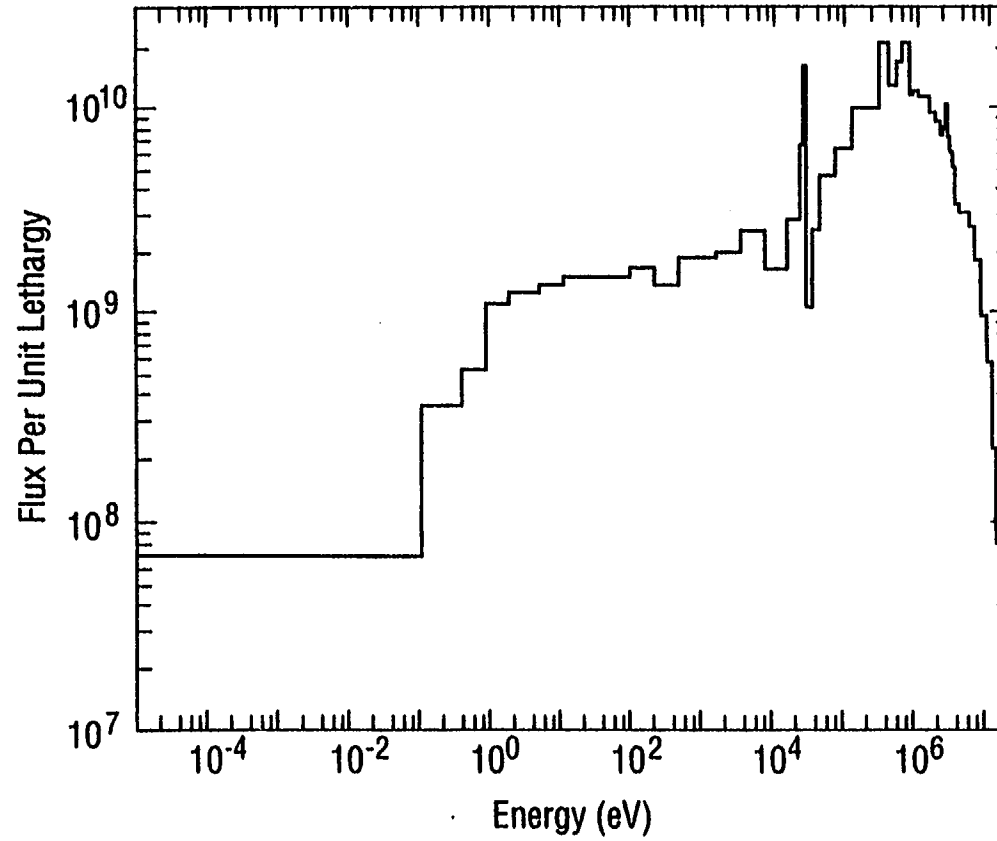

Figure 4.1.3.2

Low-Leakage Core Loading Pressure Vessel Flux Spectrum At The T/2 Location

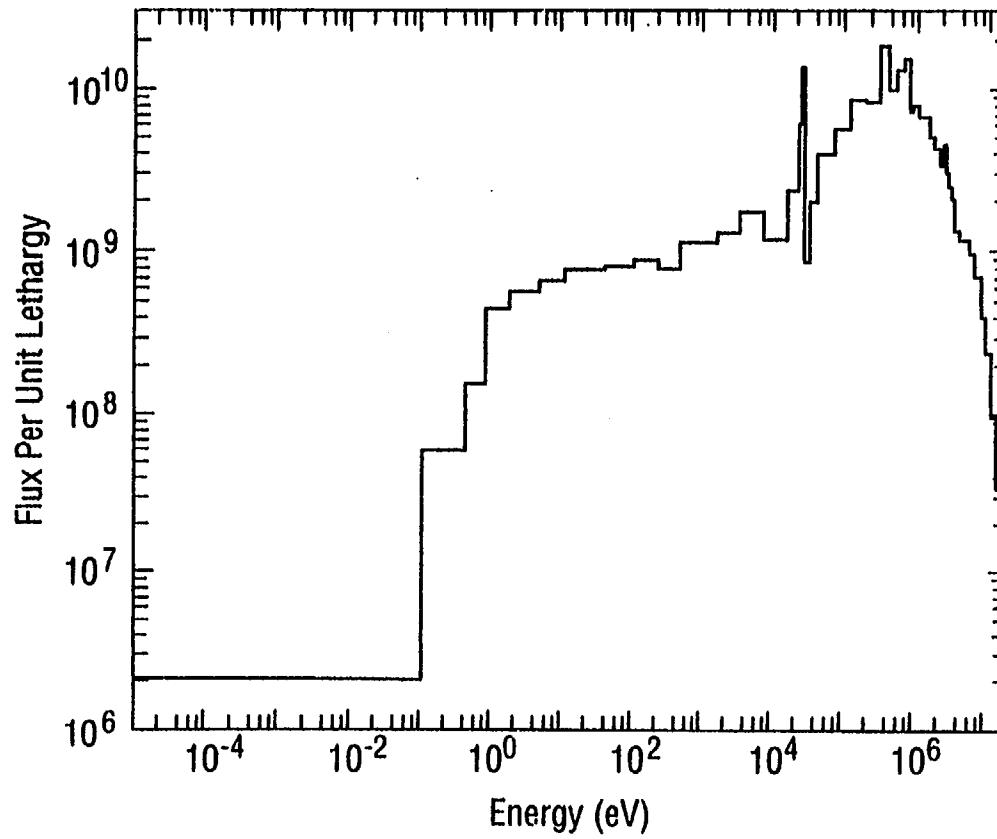

Figure 4.1.3.3

Low-Leakage Core Loading Pressure Vessel Flux Spectrum At The 3T/4 Location

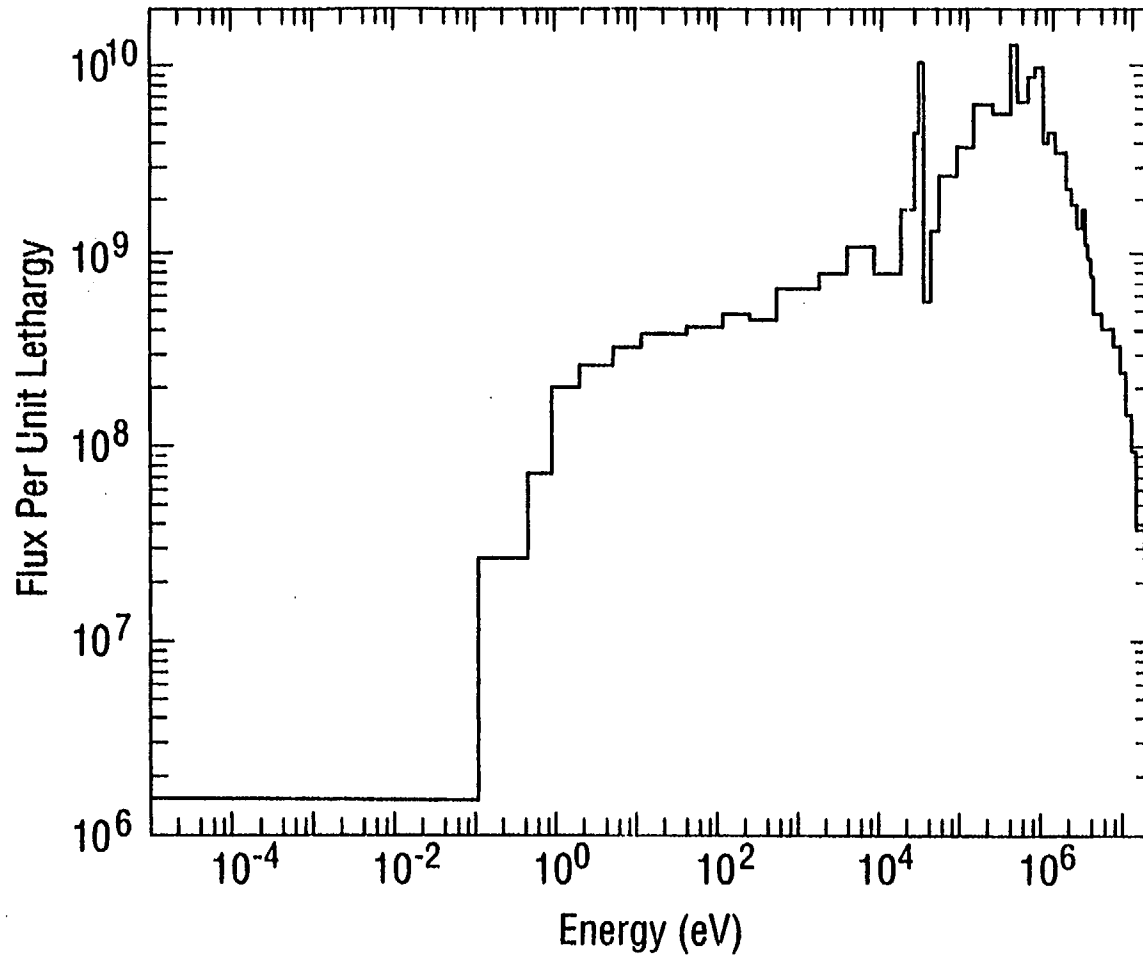

Figure 4.1.3.4

**Low-Leakage Core Loading Pressure Vessel Flux Spectrum
At The 1-T Location**

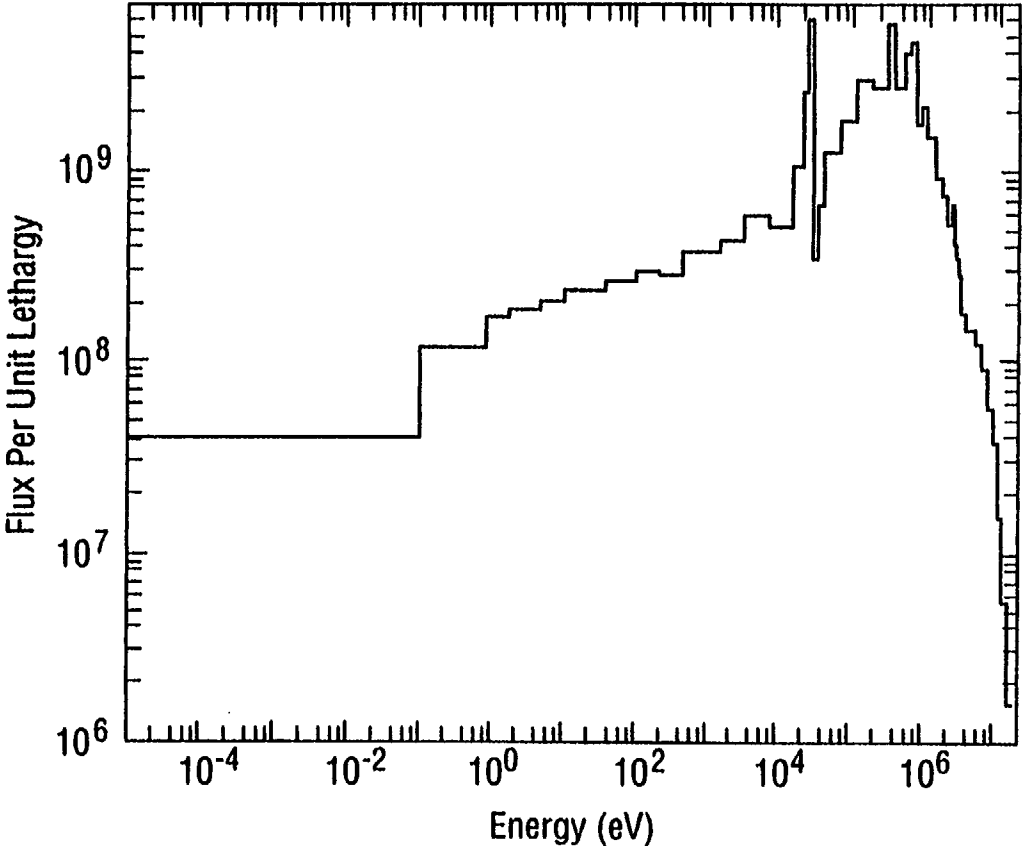

Figure 4.1.3.5

Low-Leakage Core Loading Thermal Shield Capsule Flux Spectrum

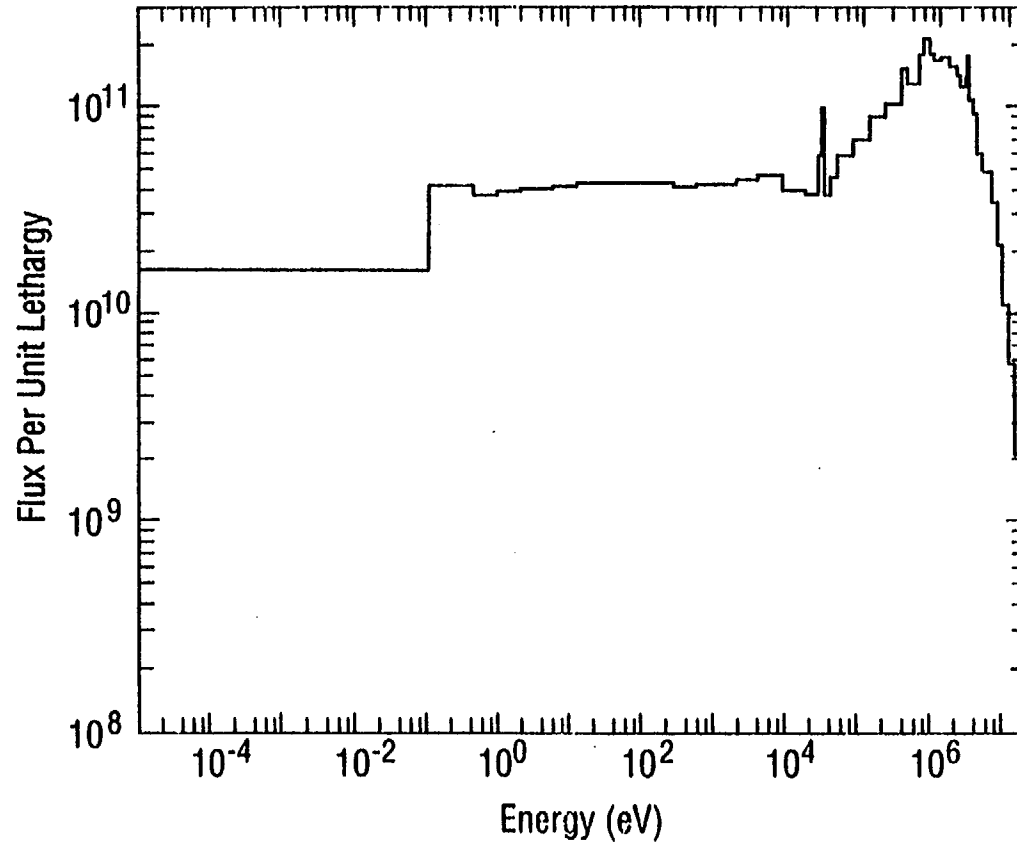

Figure 4.1.3.6

Low-Leakage Core Loading Pressure Vessel Capsule Flux Spectrum

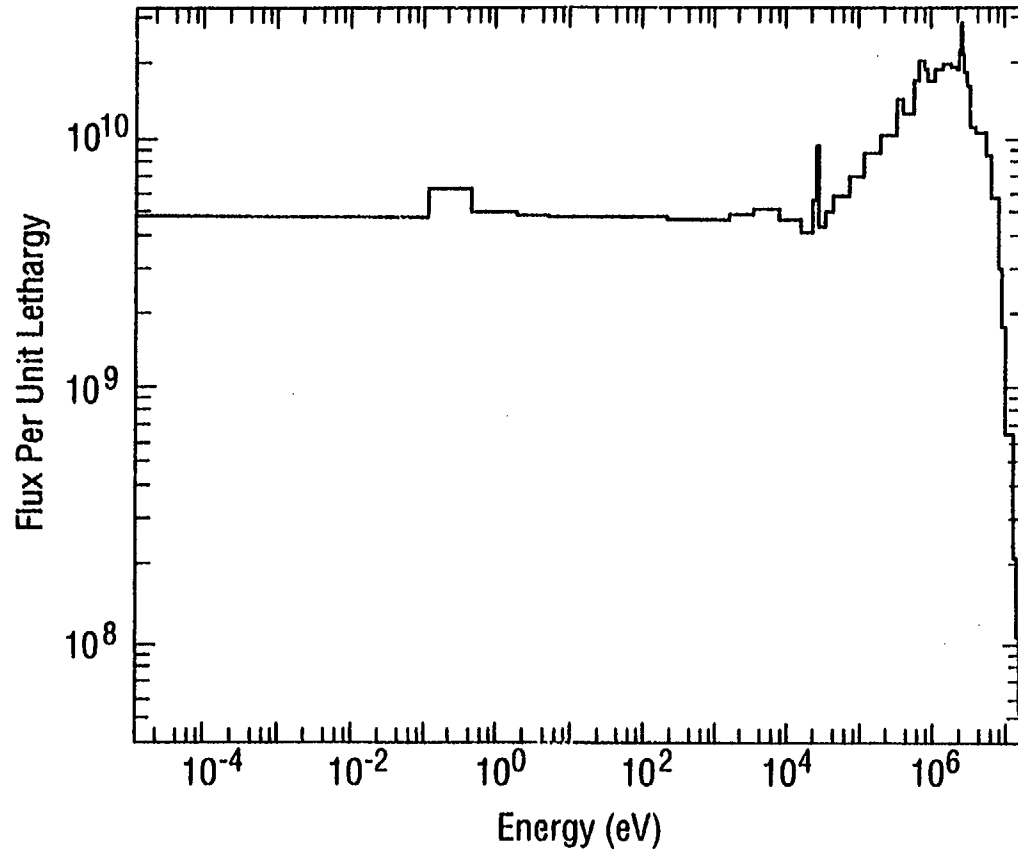

Figure 4.1.3.7

Low-Leakage Core Loading Cavity Capsule Flux Spectrum

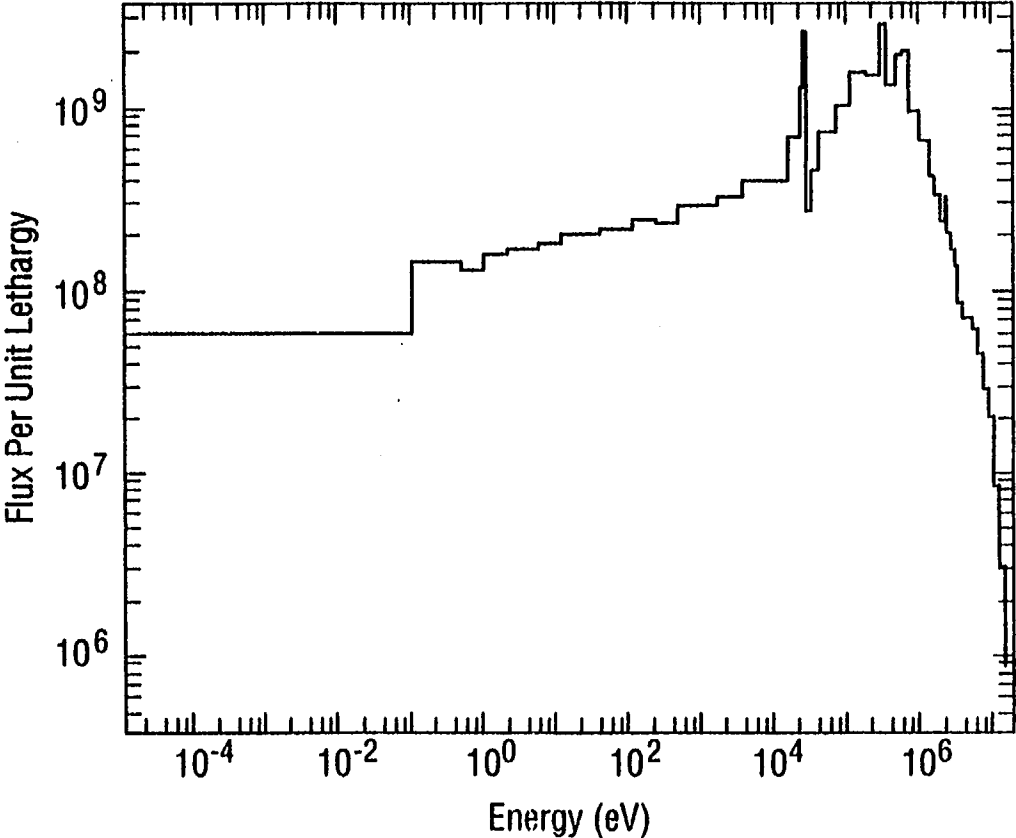

Figure 4.1.3.8

Flux >1.0 MeV At The Pressure Vessel Weld Surface

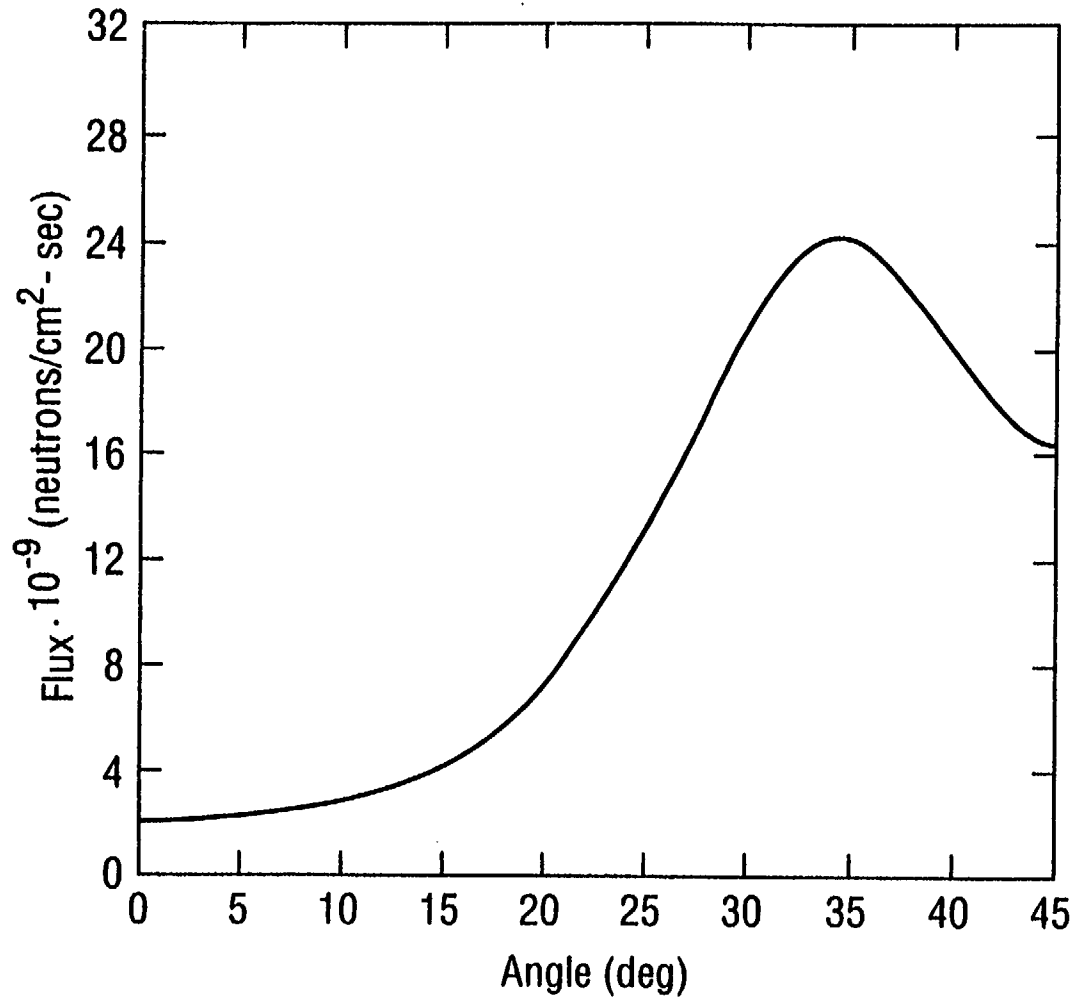

Figure 4.1.4.1

Flux >0.1 MeV At The Pressure Vessel Weld Surface

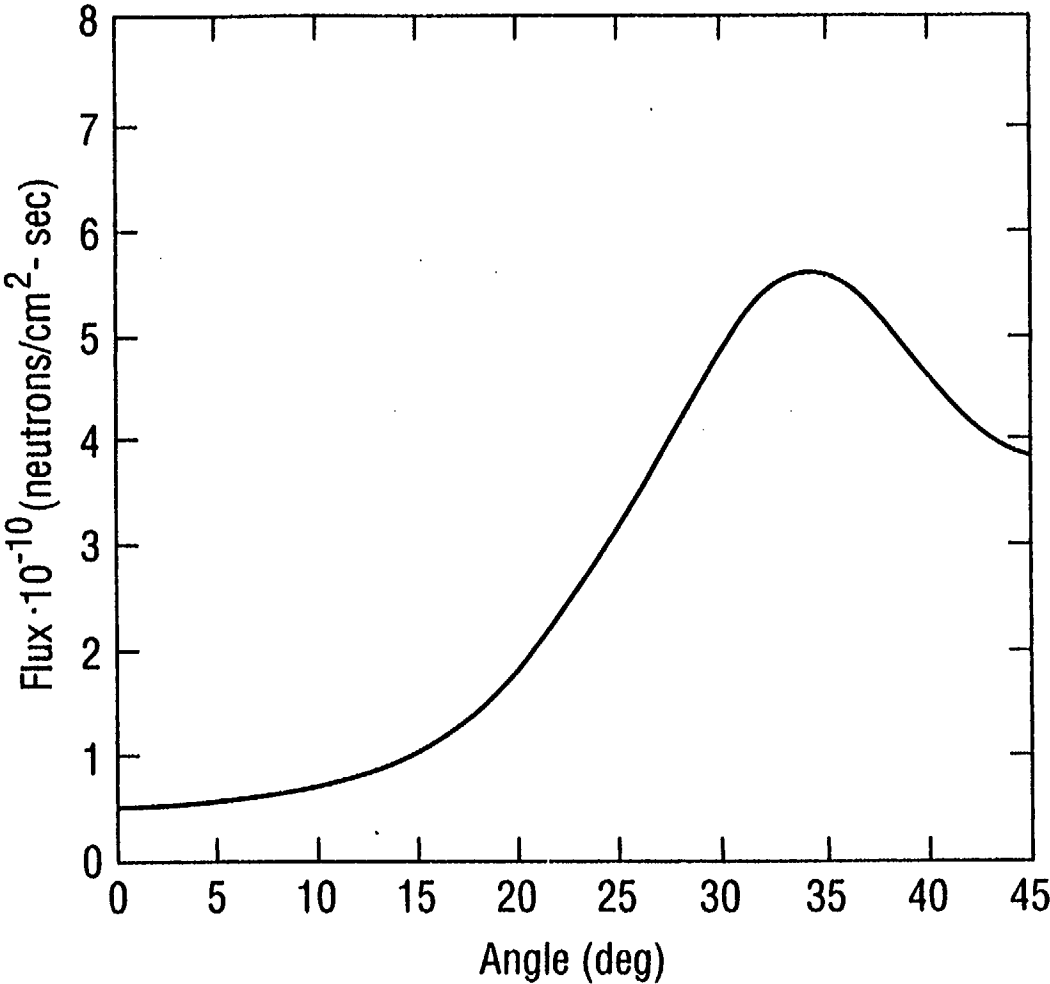

Figure 4.1.4.2

Displacements Per Atom At The Pressure Vessel Weld Surface

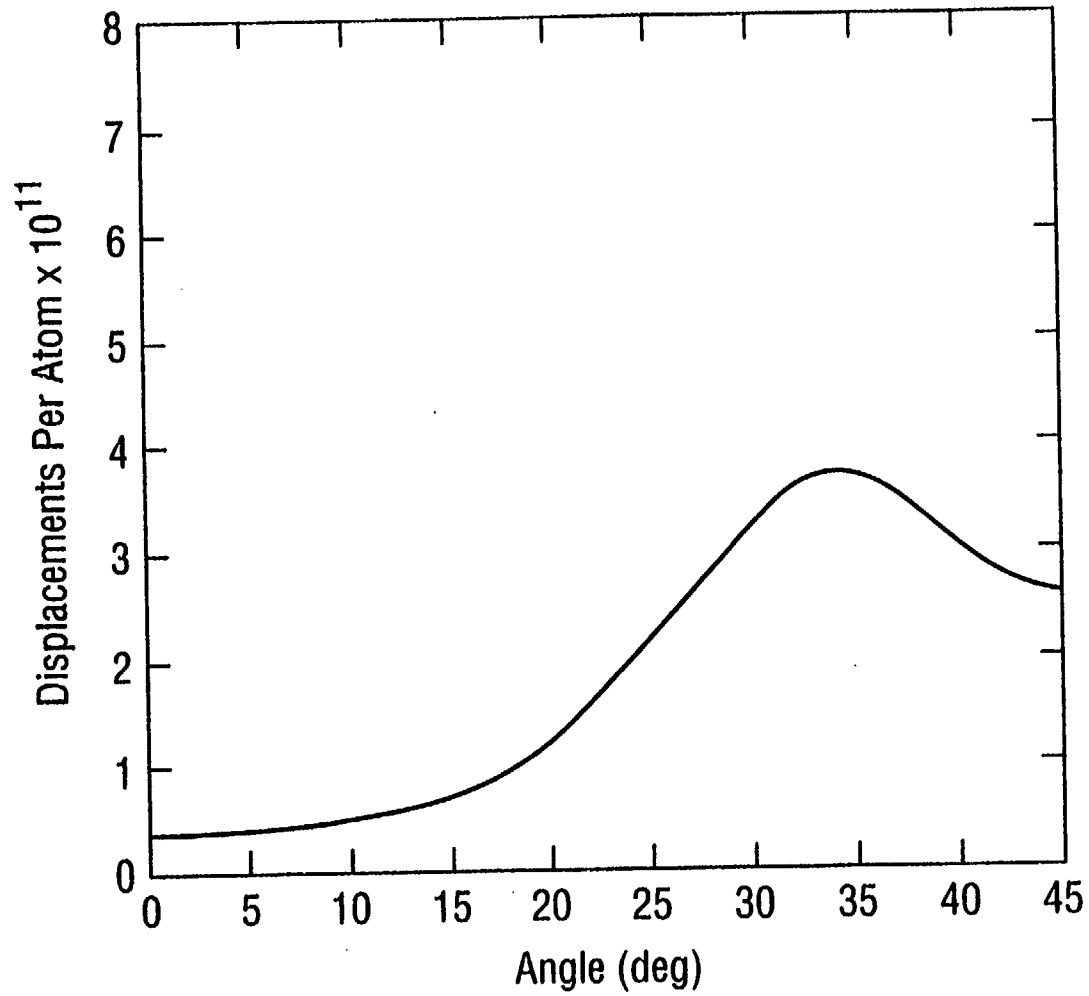

Figure 4.1.4.3

Pressure Vessel Weld Flux Spectrum at $\theta = 0$ deg

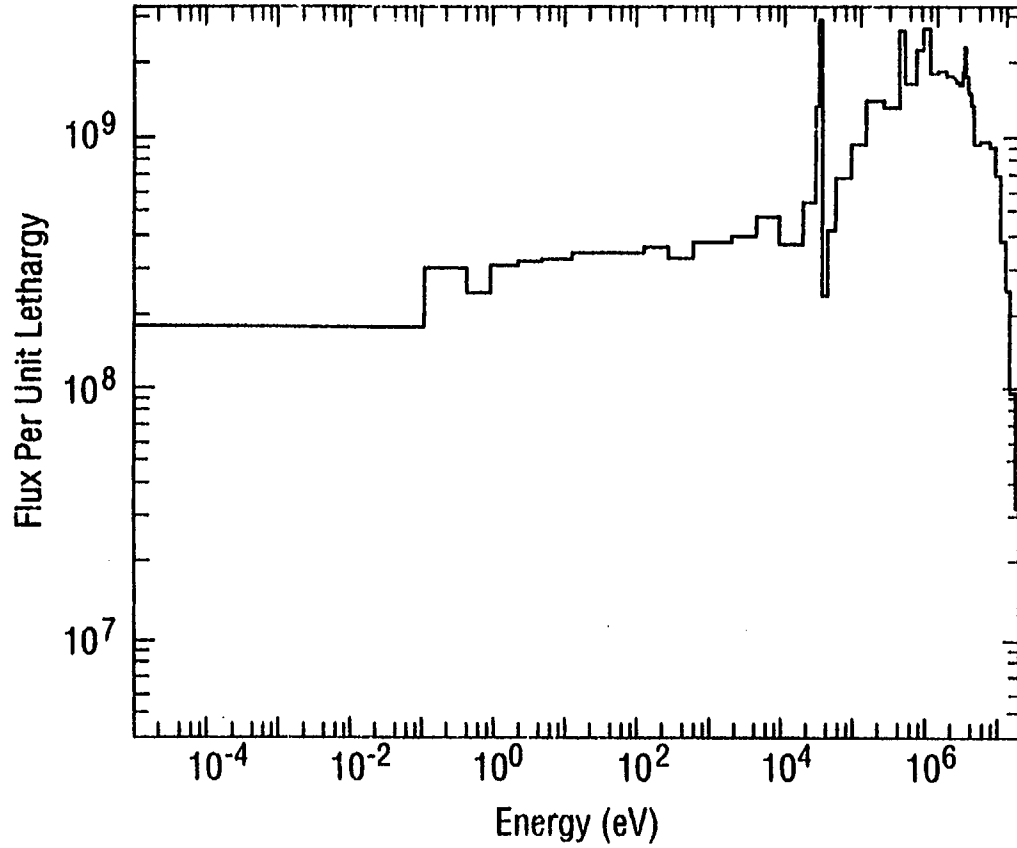

Figure 4.1.4.4

Table 4.2.1.1

Mesh Used in DORT Calculation

	R (cm)	Z (cm)	θ (revolution)
1	0.00000	0.00000	0.00000E+00
2	7.50000	3.09750	6.24722E-03
3	15.0000	6.19500	7.63889E-03
4	22.5000	9.29250	9.02778E-03
5	30.0000	12.3900	1.04194E-02
6	37.5000	15.4767	1.37889E-02
7	45.0000	18.5633	1.53167E-02
8	52.5000	21.6500	1.79556E-02
9	60.0000	24.7367	1.95444E-02
10	67.5000	27.8233	2.00389E-02
11	75.0000	30.9100	2.06556E-02
12	82.5000	33.9967	2.15389E-02
13	90.0000	37.0833	2.36278E-02
14	97.5000	40.1700	2.37944E-02
15	105.000	43.2567	2.47944E-02
16	112.500	46.3433	2.63556E-02
17	120.000	49.4300	3.06500E-02
18	127.500	52.4780	3.39278E-02
19	135.000	55.5260	3.89833E-02
20	142.500	58.5740	4.15722E-02
21	150.000	61.6220	4.45389E-02
22	157.500	64.6700	4.71278E-02
23	165.000	67.7180	4.94056E-02
24	172.500	70.7660	5.26833E-02
25	180.000	73.8140	5.56500E-02
26	182.602	76.8620	5.67889E-02
27	185.560	79.9100	6.12056E-02
28	186.709	82.9580	6.37944E-02
29	187.785	86.0060	6.67611E-02
30	188.897	89.0540	6.80222E-02
31	189.782	92.1020	6.88444E-02
32	190.616	95.1500	7.01389E-02
33	191.625	98.1980	7.16222E-02
34	192.706	101.246	7.21278E-02
35	193.369	104.294	7.54611E-02
36	194.008	107.342	7.76833E-02
37	194.782	110.390	7.95444E-02
38	195.444	113.438	8.04611E-02
39	196.207	116.486	8.20389E-02
40	198.098	119.534	8.32111E-02
41	198.825	122.582	8.48778E-02
42	199.580	125.630	8.60167E-02
43	200.562	128.678	8.75944E-02

Table 4.2.1.1

Mesh Used in DORT Calculation (cont'd)

	R (cm)	Z (cm)	θ (revolution)
44	201.416	131.726	8.80056E-02
45	202.458	134.774	9.03722E-02
46	203.446	137.822	9.29611E-02
47	204.500	140.870	9.42056E-02
48	205.506	143.918	9.71278E-02
49	206.520	146.966	9.86445E-02
50	207.440	150.014	1.01506E-01
51	208.610	153.062	1.05650E-01
52	209.491	156.110	1.09689E-01
53	210.474	159.158	1.11206E-01
54	211.606	162.206	1.12328E-01
55	212.585	165.254	1.15372E-01
56	213.795	168.302	1.17356E-01
57	214.611	171.350	1.18811E-01
58	215.643	174.398	1.22222E-01
59	216.308	177.446	1.23611E-01
60	217.732	180.494	1.24861E-01
61	218.318	183.542	1.25000E-01
62	219.483	186.590	
63	220.282	189.638	
64	221.543	192.686	
65	222.394	195.734	
66	223.735	198.782	
67	225.048	201.830	
68	226.423	204.878	
69	227.237	207.926	
70	228.431	210.974	
71	229.450	214.022	
72	230.719	217.070	
73	231.344	220.118	
74	232.630	223.116	
75	233.895	226.214	
76	234.874	229.262	
77	235.625	232.310	
78	236.176	235.430	
79	237.228	238.430	
80	238.470	241.430	
81	239.300	244.430	
82	240.227	247.550	
83	240.783	250.598	
84	241.970	253.646	
85	242.570	256.694	
86	243.672	259.742	

Table 4.2.1.1

Mesh Used in DORT Calculation (cont'd)

	R (cm)	Z (cm)
87	244.461	262.790
88	244.974	265.838
89	245.616	268.886
90	247.540	271.934
91	248.091	274.982
92	249.019	278.030
93	250.597	281.078
94	251.148	284.126
95	251.568	287.174
96	252.267	290.222
97	254.077	293.270
98	255.598	297.080
99	257.727	300.890
100	258.519	304.700
101	259.530	308.510
102	260.326	310.430
103	261.122	313.430
104	261.918	316.430
105	262.715	319.430
106	263.511	323.750
107	264.307	326.798
108	265.103	329.846
109	265.899	332.894
110	266.695	335.942
111	267.491	338.990
112	268.288	344.070
113	269.557	349.150
114	270.828	354.230
115	272.098	359.310
116	273.367	364.390
117	274.073	369.470
118	274.778	374.550
119	275.484	379.630
120	276.189	384.710
121	276.895	389.790
122	277.600	394.870
123	278.600	399.950
124	278.878	405.030
125	279.627	410.110
126	280.376	415.190
127	281.125	420.270
128	281.875	425.350

Table 4.2.1.1

Mesh Used in DORT Calculation (cont'd)

	R (cm)	Z (cm)
129	282.624	430.430
130	283.454	436.603
131	284.284	442.777
132	285.114	448.950
133	285.944	455.123
134	286.774	461.297
135	287.604	467.470
136	288.435	473.643
137	289.265	479.817
138	290.095	485.990
139	290.925	495.637
140	291.755	505.284
141	292.585	514.931
142	293.415	524.578
143	294.245	534.225
144	295.075	543.872
145	295.905	553.519
146	296.735	563.166
147	297.565	572.814
148	298.396	582.461
149	299.226	592.108
150	300.056	601.755
151	300.886	611.402
152	301.716	621.049
153	302.546	630.696
154	303.376	640.343
155	304.125	649.990
156	304.875	659.637
157	305.624	669.284
158	306.373	678.931
159	307.122	688.578
160	307.919	698.225
161	308.716	707.872
162	309.513	717.519
163	310.310	727.166
164	311.156	736.813
165	312.002	746.461
166	312.848	756.108
167	313.695	765.755
168	314.541	775.402
169	315.387	785.049
170	316.233	794.696

Table 4.2.1.1

Mesh Used in DORT Calculation (cont'd)

	R (cm)	Z (cm)
171	317.079	804.343
172	317.925	813.990
173	318.772	
174	319.618	
175	320.464	
176	321.310	
177	321.786	
178	322.786	
179	324.500	
180	325.318	
181	326.318	
182	327.834	
183	329.351	
184	330.351	
185	331.867	
186	333.383	
187	334.383	
188	336.149	
189	337.915	
190	340.790	
191	346.290	
192	351.790	
193	351.949	
194	354.806	
195	357.663	
196	360.520	
197	365.611	
198	370.701	
199	375.792	
200	380.883	
201	385.973	
202	391.064	
203	396.155	
204	401.245	
205	406.336	
206	411.427	
207	416.517	
208	421.608	
209	426.699	
210	431.789	
211	436.880	
212	437.500	
213	441.500	
214	445.500	
215	449.500	
216	453.500	
217	457.500	
218	461.500	
219	465.500	
220	469.500	
221	473.500	
222	477.500	

Table 4.2.1.2

47-Group Energy Structure of Cross-Section Library

Group	Lower Energy (Mev)	Group	Lower Energy (Mev)
1	14.19*	25	1.83×10^{-1}
2	12.21	26	1.11×10^{-1}
3	10.00	27	6.76×10^{-2}
4	8.61	28	4.09×10^{-2}
5	7.41	29	3.18×10^{-2}
6	6.07	30	2.61×10^{-2}
7	4.97	31	2.42×10^{-2}
8	3.68	32	2.19×10^{-2}
9	3.01	33	1.50×10^{-2}
10	2.73	34	7.10×10^{-3}
11	2.47	35	3.36×10^{-3}
12	2.37	36	1.59×10^{-3}
13	2.35	37	4.54×10^{-4}
14	2.23	38	2.14×10^{-4}
15	1.92	39	1.01×10^{-4}
16	1.65	40	3.73×10^{-5}
17	1.35	41	1.07×10^{-5}
18	1.00	42	5.04×10^{-6}
19	8.21×10^{-1}	43	1.86×10^{-6}
20	7.43×10^{-1}	44	8.76×10^{-7}
21	6.08×10^{-1}	45	4.14×10^{-7}
22	4.98×10^{-1}	46	1.00×10^{-7}
23	3.69×10^{-1}	47	0.00
24	2.98×10^{-1}		

* The upper energy of group 1 is 17.33 Mev.

Table 4.2.1.3

Nuclear Parameters For Neutron Flux Monitors

Monitor	Reaction of Interest	Product	Response Range	Half-life
Copper	⁶³ Cu(n,α) ⁶⁰ Co	Co	6.13Mev < E < 11Mev	5.27 y
Iron	⁵⁴ Fe(n,p) ⁵⁴ Mn	Mn	2.47Mev < E < 7.8Mev	312.2 d
Nickel	⁵⁸ Ni(n,p) ⁵⁸ Co	Co	2.09Mev < E < 7.6Mev	70.88 d
U-238	²³⁸ U(n,f) ¹³⁷ Cs	Cs	1.51Mev < E < 6.7Mev	30.17 y
Np-237	²³⁷ Np(n,f) ¹³⁷ Cs	Cs	0.67Mev < E < 5.7Mev	30.17 y
Titanium	⁴⁶ Ti(n,p) ⁴⁶ Sc	Sc	3.86Mev < E < 9.4Mev	83.81 d

+ The upper and lower limits of the energy range are defined such that 95% of the detector response occurs above the lower energy and 5% detector response occurs above the upper energy .

* Effective threshold used for group averaged cross sections .

Table 4.2.1.4

Dosimeter Activation Cross Sections (BUGLE93)

Group	* dpa	54 Fe (n,p)	58 Ni (n,p)	46 Ti (n,p)
1	2.92800E+03	2.61610E-01	2.60050E-01	2.39950E-01
2	2.68300E+03	4.04120E-01	4.70450E-01	2.66490E-01
3	2.45500E+03	4.69690E-01	5.92300E-01	2.60920E-01
4	2.24500E+03	4.82250E-01	6.23120E-01	2.35990E-01
5	2.09200E+03	4.82340E-01	6.25410E-01	2.04580E-01
6	1.97100E+03	4.78150E-01	6.04840E-01	1.54930E-01
7	1.79200E+03	4.33950E-01	5.08850E-01	9.75560E-02
8	1.60000E+03	3.12820E-01	3.81490E-01	4.00220E-02
9	1.36900E+03	1.93220E-01	2.44540E-01	5.25420E-03
10	1.26500E+03	1.32630E-01	1.71000E-01	4.64190E-04
11	1.19800E+03	7.87050E-02	1.24950E-01	6.85870E-06
12	1.24600E+03	5.65520E-02	9.65570E-02	1.06920E-06
13	1.16600E+03	5.12010E-02	8.85450E-02	3.77160E-07
14	1.09600E+03	4.49420E-02	7.91190E-02	3.42230E-07
15	1.03600E+03	2.93480E-02	5.06570E-02	2.33440E-07
16	8.19000E+02	8.87320E-03	2.78260E-02	7.94750E-08
17	9.15000E+02	2.90280E-03	1.46240E-02	8.39500E-10
18	6.32000E+02	7.32000E-04	5.61440E-03	0.00000E+00
19	2.67000E+02	8.69480E-05	1.29440E-03	0.00000E+00
20	5.16000E+02	6.56090E-06	8.92680E-04	0.00000E+00
21	4.00000E+02	2.63610E-07	5.21060E-04	0.00000E+00
22	2.69000E+02	0.00000E+00	1.76550E-04	0.00000E+00
23	3.08000E+02	0.00000E+00	0.00000E+00	0.00000E+00
24	2.24000E+02	0.00000E+00	0.00000E+00	0.00000E+00
25	1.78000E+02	0.00000E+00	0.00000E+00	0.00000E+00
26	1.92000E+02	0.00000E+00	0.00000E+00	0.00000E+00
27	1.34000E+02	0.00000E+00	0.00000E+00	0.00000E+00
28	7.54000E+01	0.00000E+00	0.00000E+00	0.00000E+00
29	7.14000E+01	0.00000E+00	0.00000E+00	0.00000E+00
30	2.94000E+02	0.00000E+00	0.00000E+00	0.00000E+00
31	6.08000E+01	0.00000E+00	0.00000E+00	0.00000E+00
32	3.61000E+00	0.00000E+00	0.00000E+00	0.00000E+00
33	7.73000E+00	0.00000E+00	0.00000E+00	0.00000E+00
34	1.19000E+01	0.00000E+00	0.00000E+00	0.00000E+00
35	7.36000E+00	0.00000E+00	0.00000E+00	0.00000E+00
36	3.82000E+00	0.00000E+00	0.00000E+00	0.00000E+00
37	1.17000E+00	0.00000E+00	0.00000E+00	0.00000E+00
38	9.30000E-02	0.00000E+00	0.00000E+00	0.00000E+00
39	1.36000E-01	0.00000E+00	0.00000E+00	0.00000E+00
40	2.06000E-01	0.00000E+00	0.00000E+00	0.00000E+00
41	1.10000E-01	0.00000E+00	0.00000E+00	0.00000E+00
42	6.09000E-01	0.00000E+00	0.00000E+00	0.00000E+00
43	9.25000E-01	0.00000E+00	0.00000E+00	0.00000E+00
44	1.47000E+00	0.00000E+00	0.00000E+00	0.00000E+00
45	2.12000E+00	0.00000E+00	0.00000E+00	0.00000E+00
46	3.38000E+00	0.00000E+00	0.00000E+00	0.00000E+00
47	7.65000E+00	0.00000E+00	0.00000E+00	0.00000E+00

* dpa is from Reference-8 and not from
BUGLE-93.

Table 4.2.1.4

Dosimeter Activation Cross Sections (BUGLE93) (cont'd)

Group	63	238	237
	Cu (n, α)	U (n,f)	Np (n,f)
1	3.54140E-02	1.20300E+00	2.20080E+00
2	4.33760E-02	1.03450E+00	2.08210E+00
3	3.63770E-02	9.84680E-01	2.10550E+00
4	2.67930E-02	9.95010E-01	2.17530E+00
5	1.80500E-02	9.91140E-01	2.23870E+00
6	9.86820E-03	8.30640E-01	1.95680E+00
7	3.25320E-03	5.59790E-01	1.49180E+00
8	5.75050E-04	5.46370E-01	1.53110E+00
9	4.45250E-05	5.25280E-01	1.60980E+00
10	8.13620E-06	5.23280E-01	1.65070E+00
11	2.99060E-06	5.32720E-01	1.66340E+00
12	9.39370E-07	5.36910E-01	1.66060E+00
13	8.17650E-07	5.37700E-01	1.66980E+00
14	6.74430E-07	5.38310E-01	1.68260E+00
15	2.47260E-07	5.30140E-01	1.68220E+00
16	1.37490E-08	4.74430E-01	1.64620E+00
17	0.00000E+00	3.16460E-01	1.58540E+00
18	0.00000E+00	4.08720E-02	1.47170E+00
19	0.00000E+00	1.23080E-02	1.33850E+00
20	0.00000E+00	3.76100E-03	1.19340E+00
21	0.00000E+00	1.40440E-03	9.21250E-01
22	0.00000E+00	6.25180E-04	6.14430E-01
23	0.00000E+00	2.78530E-04	2.63980E-01
24	0.00000E+00	1.52050E-04	9.18480E-02
25	0.00000E+00	7.91640E-05	4.62870E-02
26	0.00000E+00	1.07100E-04	2.33250E-02
27	0.00000E+00	3.69970E-05	1.46710E-02
28	0.00000E+00	9.15930E-05	1.18920E-02
29	0.00000E+00	2.90420E-05	1.06860E-02
30	0.00000E+00	5.28370E-05	1.01340E-02
31	0.00000E+00	2.33180E-05	9.90910E-03
32	0.00000E+00	2.53650E-05	9.77070E-03
33	0.00000E+00	1.44660E-04	9.54510E-03
34	0.00000E+00	5.26090E-04	9.14010E-03
35	0.00000E+00	1.27240E-05	8.80730E-03
36	0.00000E+00	5.90660E-09	9.33510E-03
37	0.00000E+00	1.03310E-03	1.36970E-02
38	0.00000E+00	1.15010E-05	2.60970E-02
39	0.00000E+00	1.70540E-05	3.08330E-02
40	0.00000E+00	2.88680E-05	6.26140E-02
41	0.00000E+00	1.42830E-04	2.46870E-02
42	0.00000E+00	7.56670E-05	8.15180E-03
43	0.00000E+00	1.74680E-06	3.95390E-03
44	0.00000E+00	1.84880E-06	1.10250E-02
45	0.00000E+00	2.47760E-06	7.11220E-03
46	0.00000E+00	3.77770E-06	4.98640E-03
47	0.00000E+00	7.84540E-06	1.13480E-02

Table 4.2.2.1

Flux ($E > 1.0$ MEV) At Pressure Vessel					
z	306.605cm	306.605cm	306.605cm	302.795cm	302.795cm
θ	0-T	1/4 T	1/2 T	3/4 T	T
1	8.04704E+08	5.38242E+08	3.20670E+08	1.80936E+08	8.53931E+07
2	7.51923E+08	4.86441E+08	2.94913E+08	1.69523E+08	8.24166E+07
3	7.30486E+08	4.62759E+08	2.82809E+08	1.64414E+08	8.06129E+07
4	7.14457E+08	4.59483E+08	2.77362E+08	1.59558E+08	7.92864E+07
5	7.04935E+08	4.61510E+08	2.75164E+08	1.57319E+08	7.77229E+07
6	6.75798E+08	4.57436E+08	2.73660E+08	1.55429E+08	7.66896E+07
7	6.35154E+08	4.36763E+08	2.64619E+08	1.51886E+08	7.57088E+07
8	6.03784E+08	4.14114E+08	2.53652E+08	1.46982E+08	7.41660E+07
9	5.84788E+08	4.06232E+08	2.45636E+08	1.44847E+08	7.33537E+07
10	5.72970E+08	3.97521E+08	2.45363E+08	1.42808E+08	7.28916E+07
11	5.64775E+08	3.92897E+08	2.41872E+08	1.42073E+08	7.26591E+07
12	5.64012E+08	3.89864E+08	2.39961E+08	1.39633E+08	7.21474E+07
13	5.69041E+08	3.89601E+08	2.39832E+08	1.36479E+08	7.17359E+07
14	5.71479E+08	3.91101E+08	2.36730E+08	1.39215E+08	7.11394E+07
15	5.75982E+08	3.90400E+08	2.37748E+08	1.36899E+08	7.09126E+07
16	5.64153E+08	3.83472E+08	2.32058E+08	1.34802E+08	7.01720E+07
17	5.53714E+08	3.75614E+08	2.28697E+08	1.32995E+08	6.95822E+07
18	5.40836E+08	3.71960E+08	2.26994E+08	1.32548E+08	7.00568E+07
19	5.39869E+08	3.72041E+08	2.29485E+08	1.34961E+08	7.12561E+07
20	5.62998E+08	3.89891E+08	2.39874E+08	1.40508E+08	7.38026E+07
21	6.20419E+08	4.26224E+08	2.60021E+08	1.51224E+08	7.70577E+07
22	6.80138E+08	4.62021E+08	2.78695E+08	1.59409E+08	8.02247E+07
23	7.18103E+08	4.84872E+08	2.91483E+08	1.67431E+08	8.29682E+07
24	7.46659E+08	5.02767E+08	3.02462E+08	1.72620E+08	8.54608E+07
25	7.59540E+08	5.13283E+08	3.06972E+08	1.77024E+08	8.68721E+07
26	7.60286E+08	5.18336E+08	3.14537E+08	1.80638E+08	8.92499E+07
27	7.67001E+08	5.30253E+08	3.23542E+08	1.87423E+08	9.25041E+07
28	8.08205E+08	5.55070E+08	3.38661E+08	1.94837E+08	9.52940E+07
29	8.53479E+08	5.82831E+08	3.51052E+08	2.01298E+08	9.78804E+07
30	8.77507E+08	5.94074E+08	3.58735E+08	2.05336E+08	9.89335E+07
31	8.95443E+08	6.06078E+08	3.65439E+08	2.08148E+08	1.00427E+08
32	9.15604E+08	6.20048E+08	3.73060E+08	2.13136E+08	1.02240E+08
33	9.32874E+08	6.29801E+08	3.80233E+08	2.16443E+08	1.03631E+08

Table 4.2.2.1

Flux (E>1.0 MEV) At Pressure Vessel (cont'd)					
z	306.605cm	306.605cm	306.605cm	302.795cm	302.795cm
θ	0-T	1/4 T	1/2 T	3/4 T	T
34	9.68023E+08	6.53259E+08	3.92472E+08	2.23152E+08	1.06081E+08
35	9.98636E+08	6.79698E+08	4.08384E+08	2.32147E+08	1.09543E+08
36	1.01103E+09	6.87299E+08	4.15113E+08	2.36182E+08	1.11559E+08
37	1.01494E+09	6.90897E+08	4.17490E+08	2.38269E+08	1.12341E+08
38	1.02032E+09	6.95353E+08	4.18937E+08	2.38827E+08	1.13152E+08
39	1.01705E+09	6.93485E+08	4.20985E+08	2.40336E+08	1.13613E+08
40	1.01342E+09	6.94697E+08	4.20275E+08	2.40649E+08	1.14403E+08
41	1.01598E+09	6.93365E+08	4.21776E+08	2.41186E+08	1.14809E+08
42	1.02131E+09	6.99027E+08	4.23864E+08	2.43304E+08	1.15531E+08
43	1.02973E+09	7.05702E+08	4.26405E+08	2.45224E+08	1.16096E+08
44	1.04678E+09	7.13300E+08	4.31426E+08	2.46550E+08	1.16697E+08
45	1.06991E+09	7.25584E+08	4.36796E+08	2.48372E+08	1.17736E+08
46	1.07300E+09	7.27117E+08	4.37853E+08	2.49995E+08	1.18294E+08
47	1.06388E+09	7.24919E+08	4.38525E+08	2.50546E+08	1.19283E+08
48	1.06000E+09	7.25573E+08	4.40045E+08	2.52216E+08	1.20492E+08
49	1.07420E+09	7.36789E+08	4.48227E+08	2.57372E+08	1.22585E+08
50	1.13609E+09	7.80327E+08	4.73936E+08	2.71027E+08	1.27828E+08
51	1.25809E+09	8.56192E+08	5.15659E+08	2.92448E+08	1.34781E+08
52	1.36002E+09	9.14869E+08	5.44577E+08	3.05598E+08	1.39500E+08
53	1.39142E+09	9.30684E+08	5.53277E+08	3.11440E+08	1.40812E+08
54	1.41713E+09	9.47785E+08	5.63783E+08	3.16262E+08	1.43178E+08
55	1.43720E+09	9.63974E+08	5.73208E+08	3.22041E+08	1.45093E+08
56	1.44114E+09	9.67931E+08	5.77174E+08	3.23511E+08	1.45892E+08
57	1.39076E+09	9.47376E+08	5.69035E+08	3.21387E+08	1.45722E+08
58	1.34542E+09	9.20414E+08	5.58133E+08	3.17121E+08	1.45039E+08
59	1.32628E+09	9.10632E+08	5.52710E+08	3.15108E+08	1.44557E+08
60	1.32311E+09	9.08093E+08	5.49483E+08	3.18484E+08	1.43199E+08

Table 4.2.2.2

Flux (E>0.1 MEV) At Pressure Vessel					
z	306.605cm	302.795cm	306.605cm	302.795cm	302.795cm
θ	0-T	1/4 T	1/2 T	3/4 T	T
1	1.56025E+09	1.41189E+09	1.09493E+09	7.64354E+08	4.06886E+08
2	1.63429E+09	1.37310E+09	1.06105E+09	7.43910E+08	4.00694E+08
3	1.63585E+09	1.34334E+09	1.03822E+09	7.31504E+08	3.96432E+08
4	1.56057E+09	1.31611E+09	1.01929E+09	7.17086E+08	3.92436E+08
5	1.41384E+09	1.26338E+09	9.84322E+08	6.96896E+08	3.85385E+08
6	1.29754E+09	1.20310E+09	9.48537E+08	6.74410E+08	3.78459E+08
7	1.22810E+09	1.14630E+09	9.11404E+08	6.54818E+08	3.72593E+08
8	1.17013E+09	1.09349E+09	8.76533E+08	6.34540E+08	3.66529E+08
9	1.13906E+09	1.07362E+09	8.56435E+08	6.25840E+08	3.64008E+08
10	1.12219E+09	1.05768E+09	8.52746E+08	6.20391E+08	3.62239E+08
11	1.10833E+09	1.04751E+09	8.43418E+08	6.16015E+08	3.60978E+08
12	1.10015E+09	1.03367E+09	8.33000E+08	6.07778E+08	3.58611E+08
13	1.09694E+09	1.02686E+09	8.27923E+08	5.99594E+08	3.56510E+08
14	1.10110E+09	1.02647E+09	8.21707E+08	6.00989E+08	3.55974E+08
15	1.10400E+09	1.02094E+09	8.17776E+08	5.96337E+08	3.54532E+08
16	1.08399E+09	1.00568E+09	8.04681E+08	5.88726E+08	3.52772E+08
17	1.06665E+09	9.89202E+08	7.94615E+08	5.83396E+08	3.51686E+08
18	1.05111E+09	9.87251E+08	7.96262E+08	5.86127E+08	3.54855E+08
19	1.06066E+09	9.99982E+08	8.11102E+08	5.98443E+08	3.60605E+08
20	1.10585E+09	1.04396E+09	8.43533E+08	6.18693E+08	3.69237E+08
21	1.20049E+09	1.11768E+09	8.93451E+08	6.49633E+08	3.79699E+08
22	1.29536E+09	1.18996E+09	9.41277E+08	6.76471E+08	3.90113E+08
23	1.36942E+09	1.24964E+09	9.83863E+08	7.05213E+08	4.00655E+08
24	1.42700E+09	1.30043E+09	1.02327E+09	7.29924E+08	4.11571E+08
25	1.45591E+09	1.32887E+09	1.04323E+09	7.46486E+08	4.18120E+08
26	1.46965E+09	1.35410E+09	1.07114E+09	7.64695E+08	4.27632E+08
27	1.49910E+09	1.39556E+09	1.10738E+09	7.92174E+08	4.40165E+08
28	1.56891E+09	1.45286E+09	1.15078E+09	8.18816E+08	4.51139E+08
29	1.64285E+09	1.51061E+09	1.18641E+09	8.41918E+08	4.60458E+08
30	1.68121E+09	1.53635E+09	1.20777E+09	8.54108E+08	4.64780E+08
31	1.71449E+09	1.56477E+09	1.22659E+09	8.65961E+08	4.69852E+08
32	1.75231E+09	1.59810E+09	1.25098E+09	8.82115E+08	4.76242E+08
33	1.78205E+09	1.62172E+09	1.26951E+09	8.93700E+08	4.80978E+08

Table 4.2.2.2

Flux ($E > 0.1$ Mev) At Pressure Vessel (cont'd)

z	306.605cm	302.795cm	306.605cm	302.795cm	302.795cm
θ	0-T	1/4 T	1/2 T	3/4 T	T
34	1.83717E+09	1.66830E+09	1.30169E+09	9.14092E+08	4.89150E+08
35	1.89057E+09	1.72336E+09	1.34306E+09	9.41422E+08	5.00489E+08
36	1.91487E+09	1.74621E+09	1.36401E+09	9.55991E+08	5.07620E+08
37	1.92263E+09	1.75706E+09	1.37415E+09	9.64183E+08	5.11446E+08
38	1.93322E+09	1.76788E+09	1.38119E+09	9.69470E+08	5.14780E+08
39	1.93224E+09	1.77081E+09	1.38930E+09	9.75447E+08	5.18003E+08
40	1.93296E+09	1.77829E+09	1.39397E+09	9.80786E+08	5.21467E+08
41	1.94006E+09	1.78245E+09	1.40176E+09	9.85511E+08	5.24542E+08
42	1.95199E+09	1.79604E+09	1.40985E+09	9.92960E+08	5.27723E+08
43	1.96736E+09	1.80835E+09	1.41847E+09	9.97886E+08	5.30363E+08
44	1.99227E+09	1.82534E+09	1.43002E+09	1.00514E+09	5.33493E+08
45	2.03125E+09	1.85358E+09	1.44907E+09	1.01618E+09	5.39414E+08
46	2.04414E+09	1.86627E+09	1.45960E+09	1.02575E+09	5.43715E+08
47	2.04555E+09	1.87766E+09	1.47355E+09	1.03565E+09	5.49602E+08
48	2.05525E+09	1.89537E+09	1.49080E+09	1.04960E+09	5.56284E+08
49	2.09347E+09	1.93421E+09	1.52332E+09	1.07146E+09	5.65411E+08
50	2.21614E+09	2.04281E+09	1.60256E+09	1.12133E+09	5.83898E+08
51	2.43274E+09	2.21413E+09	1.71968E+09	1.19166E+09	6.07884E+08
52	2.60458E+09	2.34074E+09	1.80079E+09	1.23864E+09	6.23827E+08
53	2.66457E+09	2.38385E+09	1.83107E+09	1.25770E+09	6.29953E+08
54	2.71879E+09	2.43087E+09	1.86545E+09	1.27903E+09	6.37947E+08
55	2.76047E+09	2.47111E+09	1.89570E+09	1.29857E+09	6.45252E+08
56	2.76594E+09	2.48029E+09	1.90513E+09	1.30520E+09	6.48093E+08
57	2.70341E+09	2.45294E+09	1.89554E+09	1.30312E+09	6.49094E+08
58	2.64411E+09	2.41673E+09	1.87993E+09	1.29795E+09	6.48772E+08
59	2.62005E+09	2.40287E+09	1.87280E+09	1.29446E+09	6.48475E+08
60	2.61399E+09	2.39932E+09	1.86895E+09	1.29896E+09	6.46926E+08

Table 4.2.2.3

DPA Rate At Pressure Vessel					
z	306.605cm	298.985cm	306.605cm	298.985cm	298.985cm
θ	0-T	1/4 T	1/2 T	3/4 T	T
1	1.26616E-12	8.94866E-13	5.85760E-13	3.63642E-13	1.85131E-13
2	1.18024E-12	8.19774E-13	5.47685E-13	3.46251E-13	1.80386E-13
3	1.14819E-12	7.84016E-13	5.28927E-13	3.37831E-13	1.77393E-13
4	1.12469E-12	7.77918E-13	5.19075E-13	3.29444E-13	1.74999E-13
5	1.11281E-12	7.75517E-13	5.11263E-13	3.23148E-13	1.71887E-13
6	1.06609E-12	7.63526E-13	5.04010E-13	3.17148E-13	1.69595E-13
7	1.00064E-12	7.27669E-13	4.86343E-13	3.09166E-13	1.67421E-13
8	9.52544E-13	6.90047E-13	4.66314E-13	2.99328E-13	1.64447E-13
9	9.20754E-13	6.77194E-13	4.53233E-13	2.94955E-13	1.63011E-13
10	9.02673E-13	6.63253E-13	4.51974E-13	2.91791E-13	1.62151E-13
11	8.89908E-13	6.55229E-13	4.46295E-13	2.89876E-13	1.61675E-13
12	8.88707E-13	6.50300E-13	4.41800E-13	2.85654E-13	1.60536E-13
13	8.98539E-13	6.50149E-13	4.40647E-13	2.80778E-13	1.59559E-13
14	9.02923E-13	6.52192E-13	4.36890E-13	2.83611E-13	1.58893E-13
15	9.09732E-13	6.50951E-13	4.36853E-13	2.80331E-13	1.58301E-13
16	8.90527E-13	6.38872E-13	4.27697E-13	2.76255E-13	1.57090E-13
17	8.74508E-13	6.26816E-13	4.21885E-13	2.73301E-13	1.56256E-13
18	8.54713E-13	6.22202E-13	4.20609E-13	2.73477E-13	1.57473E-13
19	8.52701E-13	6.23290E-13	4.25694E-13	2.78531E-13	1.59980E-13
20	8.87620E-13	6.51260E-13	4.43580E-13	2.88707E-13	1.64582E-13
21	9.77105E-13	7.08846E-13	4.76844E-13	3.07104E-13	1.70440E-13
22	1.06975E-12	7.65022E-13	5.07653E-13	3.21669E-13	1.76064E-13
23	1.12715E-12	8.00407E-13	5.29340E-13	3.35878E-13	1.81150E-13
24	1.16943E-12	8.28803E-13	5.48541E-13	3.46332E-13	1.85991E-13
25	1.19120E-12	8.46565E-13	5.57765E-13	4.28333E-13	2.20392E-13
26	1.19042E-12	8.56283E-13	5.71692E-13	4.40014E-13	2.25051E-13
27	1.20060E-12	8.76495E-13	5.88991E-13	4.56173E-13	2.31485E-13
28	1.26441E-12	9.16629E-13	6.14641E-13	4.63874E-13	2.35322E-13
29	1.33648E-12	9.60695E-13	6.36098E-13	4.67748E-13	2.37045E-13
30	1.37377E-12	9.78922E-13	6.48467E-13	4.69628E-13	2.38593E-13
31	1.40087E-12	9.97188E-13	6.59676E-13	4.72519E-13	2.39897E-13
32	1.43135E-12	1.01901E-12	6.72729E-13	4.73944E-13	2.41407E-13
33	1.45804E-12	1.03427E-12	6.84169E-13	4.28333E-13	1.88906E-13

Table 4.2.2.3

DPA Rate At Pressure Vessel (cont'd)					
z	306.605cm	298.985cm	306.605cm	298.985cm	298.985cm
θ	0-T	1/4 T	1/2 T	3/4 T	T
34	1.51410E-12	1.07226E-12	7.05342E-13	4.40014E-13	1.93551E-13
35	1.56300E-12	1.11550E-12	7.32687E-13	4.56173E-13	1.99886E-13
36	1.58230E-12	1.12826E-12	7.44668E-13	4.63874E-13	2.05217E-13
37	1.59011E-12	1.13497E-12	7.49248E-13	4.67748E-13	2.09954E-13
38	1.59850E-12	1.14243E-12	7.52537E-13	4.69628E-13	2.11963E-13
39	1.59319E-12	1.14078E-12	7.56498E-13	4.72519E-13	2.14633E-13
40	1.58715E-12	1.14223E-12	7.56210E-13	4.73944E-13	2.17967E-13
41	1.59057E-12	1.14084E-12	7.59049E-13	4.75326E-13	2.42528E-13
42	1.59925E-12	1.14985E-12	7.63188E-13	4.79320E-13	2.43978E-13
43	1.61152E-12	1.16038E-12	7.67949E-13	4.82562E-13	2.45215E-13
44	1.63945E-12	1.17343E-12	7.76344E-13	4.85599E-13	2.46488E-13
45	1.67645E-12	1.19318E-12	7.86051E-13	4.89858E-13	2.48776E-13
46	1.68007E-12	1.19624E-12	7.88904E-13	4.93348E-13	2.50246E-13
47	1.66382E-12	1.19310E-12	7.91396E-13	4.95738E-13	2.52380E-13
48	1.65563E-12	1.19469E-12	7.95551E-13	5.00042E-13	2.54998E-13
49	1.67625E-12	1.21336E-12	8.10496E-13	5.09949E-13	2.59050E-13
50	1.76882E-12	1.28157E-12	8.54123E-13	5.34821E-13	2.68535E-13
51	1.95400E-12	1.39958E-12	9.23120E-13	5.72184E-13	2.80885E-13
52	2.10860E-12	1.48980E-12	9.70449E-13	5.95508E-13	2.89037E-13
53	2.15576E-12	1.51397E-12	9.84946E-13	6.05234E-13	2.91590E-13
54	2.19308E-12	1.54031E-12	1.00267E-12	6.14616E-13	2.95711E-13
55	2.22526E-12	1.56716E-12	1.01967E-12	6.25147E-13	2.99388E-13
56	2.23280E-12	1.57572E-12	1.02709E-12	6.28645E-13	3.00993E-13
57	2.15436E-12	1.54497E-12	1.01598E-12	6.26031E-13	3.01098E-13
58	2.08265E-12	1.50421E-12	9.99383E-13	6.19985E-13	3.00254E-13
59	2.05333E-12	1.48852E-12	9.91360E-13	6.16801E-13	2.99529E-13
60	2.04584E-12	1.48526E-12	9.86301E-13	6.21254E-13	2.97762E-13

Table 4.2.2.4

Flux ($E > 1.0$ MEV) At Pressure VesselAt the Axial Core Midplane $z = 239.93$ cm

θ	0-T	1/4 T	1/2 T	3/4 T	T
1	7.26704E+08	4.86038E+08	2.90146E+08	1.64137E+08	7.91649E+07
2	6.78830E+08	4.39211E+08	2.66826E+08	1.53785E+08	7.64112E+07
3	6.59431E+08	4.17809E+08	2.55870E+08	1.49150E+08	7.47423E+07
4	6.45008E+08	4.14865E+08	2.50942E+08	1.44745E+08	7.35144E+07
5	6.36571E+08	4.16730E+08	2.48963E+08	1.42714E+08	7.20637E+07
6	6.10317E+08	4.13080E+08	2.47613E+08	1.41000E+08	7.11014E+07
7	5.73601E+08	3.94408E+08	2.39434E+08	1.37786E+08	7.01897E+07
8	5.45277E+08	3.73949E+08	2.29509E+08	1.33337E+08	6.87598E+07
9	5.28103E+08	3.66832E+08	2.22256E+08	1.31400E+08	6.80072E+07
10	5.17419E+08	3.58961E+08	2.22008E+08	1.29550E+08	6.75791E+07
11	5.10015E+08	3.54780E+08	2.18849E+08	1.28884E+08	6.73628E+07
12	5.09342E+08	3.52051E+08	2.17120E+08	1.26671E+08	6.68891E+07
13	5.13915E+08	3.51822E+08	2.17007E+08	1.23809E+08	6.65083E+07
14	5.16125E+08	3.53182E+08	2.14202E+08	1.26290E+08	6.59555E+07
15	5.20206E+08	3.52554E+08	2.15121E+08	1.24192E+08	6.57453E+07
16	5.09513E+08	3.46291E+08	2.09973E+08	1.22289E+08	6.50598E+07
17	5.00084E+08	3.39195E+08	2.06931E+08	1.20649E+08	6.45136E+07
18	4.88438E+08	3.35893E+08	2.05390E+08	1.20245E+08	6.49543E+07
19	4.87540E+08	3.35954E+08	2.07640E+08	1.22433E+08	6.60669E+07
20	5.08415E+08	3.52067E+08	2.17038E+08	1.27465E+08	6.84265E+07
21	5.60294E+08	3.84889E+08	2.35273E+08	1.37185E+08	7.14415E+07
22	6.14253E+08	4.17224E+08	2.52171E+08	1.44610E+08	7.43763E+07
23	6.48517E+08	4.37843E+08	2.63736E+08	1.51885E+08	7.69204E+07
24	6.74283E+08	4.53988E+08	2.73663E+08	1.56591E+08	7.92334E+07
25	6.85914E+08	4.63483E+08	2.77745E+08	1.60585E+08	8.05424E+07
26	6.86551E+08	4.68038E+08	2.84587E+08	1.63864E+08	8.27465E+07
27	6.92577E+08	4.78785E+08	2.92733E+08	1.70019E+08	8.57617E+07
28	7.29799E+08	5.01200E+08	3.06412E+08	1.76745E+08	8.83482E+07
29	7.70715E+08	5.26277E+08	3.17626E+08	1.82605E+08	9.07457E+07
30	7.92426E+08	5.36431E+08	3.24576E+08	1.86267E+08	9.17224E+07
31	8.08620E+08	5.47266E+08	3.30639E+08	1.88818E+08	9.31068E+07
32	8.26817E+08	5.59875E+08	3.37534E+08	1.93342E+08	9.47864E+07
33	8.42415E+08	5.68681E+08	3.44022E+08	1.96341E+08	9.60769E+07

Table 4.2.2.4

Flux ($E > 1.0$ MEV) At Pressure Vessel (cont'd)At the Axial Core Midplane $z=239.93$ cm

θ	0-T	1/4 T	1/2 T	3/4 T	T
34	8.74186E+08	5.89877E+08	3.55101E+08	2.02428E+08	9.83445E+07
35	9.01848E+08	6.13768E+08	3.69506E+08	2.10589E+08	1.01550E+08
36	9.13042E+08	6.20631E+08	3.75596E+08	2.14250E+08	1.03417E+08
37	9.16585E+08	6.23880E+08	3.77746E+08	2.16143E+08	1.04142E+08
38	9.21437E+08	6.27906E+08	3.79056E+08	2.16649E+08	1.04894E+08
39	9.18479E+08	6.26217E+08	3.80907E+08	2.18019E+08	1.05321E+08
40	9.15174E+08	6.27300E+08	3.80262E+08	2.18302E+08	1.06055E+08
41	9.17480E+08	6.26092E+08	3.81617E+08	2.18789E+08	1.06432E+08
42	9.22295E+08	6.31204E+08	3.83508E+08	2.20709E+08	1.07101E+08
43	9.29895E+08	6.37234E+08	3.85809E+08	2.22450E+08	1.07625E+08
44	9.45307E+08	6.44104E+08	3.90353E+08	2.23655E+08	1.08183E+08
45	9.66213E+08	6.55198E+08	3.95210E+08	2.25308E+08	1.09148E+08
46	9.68985E+08	6.56573E+08	3.96164E+08	2.26779E+08	1.09667E+08
47	9.60701E+08	6.54567E+08	3.96764E+08	2.27278E+08	1.10587E+08
48	9.57141E+08	6.55136E+08	3.98133E+08	2.28792E+08	1.11710E+08
49	9.69930E+08	6.65251E+08	4.05530E+08	2.33467E+08	1.13652E+08
50	1.02577E+09	7.04546E+08	4.28786E+08	2.45853E+08	1.18512E+08
51	1.13593E+09	7.73041E+08	4.66530E+08	2.65280E+08	1.24957E+08
52	1.22798E+09	8.26015E+08	4.92690E+08	2.77207E+08	1.29333E+08
53	1.25631E+09	8.40283E+08	5.00555E+08	2.82503E+08	1.30551E+08
54	1.27951E+09	8.55711E+08	5.10056E+08	2.86878E+08	1.32746E+08
55	1.29763E+09	8.70334E+08	5.18586E+08	2.92120E+08	1.34520E+08
56	1.30121E+09	8.73920E+08	5.22180E+08	2.93455E+08	1.35259E+08
57	1.25565E+09	8.55344E+08	5.14814E+08	2.91530E+08	1.35102E+08
58	1.21466E+09	8.30975E+08	5.04942E+08	2.87660E+08	1.34471E+08
59	1.19735E+09	8.22129E+08	5.00030E+08	2.85833E+08	1.34027E+08
60	1.19447E+09	8.19835E+08	4.97111E+08	2.88890E+08	1.32770E+08

Table 4.2.2.5

Flux ($E > 0.1$ MEV) At Pressure VesselAt the Axial Core Midplane $z=239.93\text{cm}$

θ	0-T	1/4 T	1/2 T	3/4 T	T
1	1.41066E+09	1.28037E+09	9.97952E+08	7.02148E+08	3.84296E+08
2	1.47760E+09	1.24540E+09	9.67224E+08	6.83487E+08	3.78504E+08
3	1.47902E+09	1.21848E+09	9.46472E+08	6.72133E+08	3.74511E+08
4	1.41096E+09	1.19376E+09	9.29223E+08	6.58921E+08	3.70757E+08
5	1.27832E+09	1.14583E+09	8.97289E+08	6.40341E+08	3.64115E+08
6	1.17315E+09	1.09107E+09	8.64597E+08	6.19642E+08	3.57577E+08
7	1.11037E+09	1.03954E+09	8.30740E+08	6.01633E+08	3.52043E+08
8	1.05796E+09	9.91669E+08	7.98965E+08	5.83014E+08	3.46335E+08
9	1.02986E+09	9.73654E+08	7.80676E+08	5.75023E+08	3.43967E+08
10	1.01460E+09	9.59206E+08	7.77301E+08	5.70039E+08	3.42302E+08
11	1.00208E+09	9.49988E+08	7.68808E+08	5.66012E+08	3.41114E+08
12	9.94682E+08	9.37430E+08	7.59303E+08	5.58459E+08	3.38883E+08
13	9.91797E+08	9.31250E+08	7.54660E+08	5.50969E+08	3.36903E+08
14	9.95572E+08	9.30886E+08	7.49016E+08	5.52207E+08	3.36411E+08
15	9.98194E+08	9.25873E+08	7.45411E+08	5.47955E+08	3.35053E+08
16	9.80096E+08	9.12032E+08	7.33497E+08	5.40973E+08	3.33406E+08
17	9.64423E+08	8.97103E+08	7.24329E+08	5.36091E+08	3.32397E+08
18	9.50374E+08	8.95354E+08	7.25857E+08	5.38622E+08	3.35394E+08
19	9.58994E+08	9.06920E+08	7.39396E+08	5.49939E+08	3.40820E+08
20	9.99839E+08	9.46782E+08	7.68936E+08	5.68519E+08	3.48943E+08
21	1.08541E+09	1.01358E+09	8.14370E+08	5.96871E+08	3.58782E+08
22	1.17118E+09	1.07908E+09	8.57903E+08	6.21481E+08	3.68578E+08
23	1.23811E+09	1.13317E+09	8.96696E+08	6.47848E+08	3.78508E+08
24	1.29015E+09	1.17922E+09	9.32608E+08	6.70548E+08	3.88800E+08
25	1.31630E+09	1.20502E+09	9.50806E+08	6.85747E+08	3.94977E+08
26	1.32870E+09	1.22793E+09	9.76246E+08	7.02482E+08	4.03941E+08
27	1.35531E+09	1.26553E+09	1.00930E+09	7.27712E+08	4.15748E+08
28	1.41842E+09	1.31747E+09	1.04881E+09	7.52157E+08	4.26087E+08
29	1.48529E+09	1.36981E+09	1.08127E+09	7.73351E+08	4.34861E+08
30	1.51996E+09	1.39314E+09	1.10070E+09	7.84526E+08	4.38933E+08
31	1.55005E+09	1.41889E+09	1.11784E+09	7.95406E+08	4.43707E+08
32	1.58423E+09	1.44910E+09	1.14006E+09	8.10218E+08	4.49722E+08
33	1.61111E+09	1.47051E+09	1.15693E+09	8.20846E+08	4.54179E+08

Table 4.2.2.5

Flux ($E > 0.1$ Mev) At Pressure Vessel (cont'd)At the Axial Core Midplane $z=239.93\text{cm}$

θ	0-T	1/4 T	1/2 T	3/4 T	T
34	1.66096E+09	1.51272E+09	1.18623E+09	8.39538E+08	4.61867E+08
35	1.70925E+09	1.56263E+09	1.22389E+09	8.64595E+08	4.72535E+08
36	1.73122E+09	1.58335E+09	1.24298E+09	8.77964E+08	4.79249E+08
37	1.73825E+09	1.59320E+09	1.25222E+09	8.85487E+08	4.82859E+08
38	1.74783E+09	1.60301E+09	1.25865E+09	8.90353E+08	4.86004E+08
39	1.74693E+09	1.60569E+09	1.26604E+09	8.95843E+08	4.89052E+08
40	1.74758E+09	1.61247E+09	1.27032E+09	9.00761E+08	4.92320E+08
41	1.75399E+09	1.61626E+09	1.27743E+09	9.05111E+08	4.95229E+08
42	1.76478E+09	1.62858E+09	1.28480E+09	9.11947E+08	4.98230E+08
43	1.77867E+09	1.63974E+09	1.29266E+09	9.16458E+08	5.00722E+08
44	1.80119E+09	1.65514E+09	1.30317E+09	9.23132E+08	5.03677E+08
45	1.83645E+09	1.68074E+09	1.32053E+09	9.33282E+08	5.09272E+08
46	1.84809E+09	1.69226E+09	1.33015E+09	9.42083E+08	5.13340E+08
47	1.84934E+09	1.70261E+09	1.34289E+09	9.51208E+08	5.18902E+08
48	1.85808E+09	1.71870E+09	1.35864E+09	9.64043E+08	5.25212E+08
49	1.89261E+09	1.75394E+09	1.38829E+09	9.84108E+08	5.33816E+08
50	2.00348E+09	1.85237E+09	1.46046E+09	1.02987E+09	5.51214E+08
51	2.19925E+09	2.00762E+09	1.56710E+09	1.09435E+09	5.73782E+08
52	2.35459E+09	2.12235E+09	1.64094E+09	1.13745E+09	5.88780E+08
53	2.40880E+09	2.16142E+09	1.66853E+09	1.15492E+09	5.94556E+08
54	2.45779E+09	2.20405E+09	1.69984E+09	1.17451E+09	6.02076E+08
55	2.49548E+09	2.24054E+09	1.72740E+09	1.19243E+09	6.08954E+08
56	2.50045E+09	2.24887E+09	1.73599E+09	1.19852E+09	6.11627E+08
57	2.44390E+09	2.22414E+09	1.72731E+09	1.19664E+09	6.12581E+08
58	2.39027E+09	2.19137E+09	1.71315E+09	1.19196E+09	6.12293E+08
59	2.36851E+09	2.17882E+09	1.70668E+09	1.18876E+09	6.12025E+08
60	2.36302E+09	2.17561E+09	1.70319E+09	1.19286E+09	6.10587E+08

Table 4.2.2.6

DPA Rate At Pressure Vessel

At the Axial Core Midplane z=239.93cm

θ	0-T	1/4 T	1/2 T	3/4 T	T
1	1.14500E-12	8.10792E-13	5.32240E-13	3.32735E-13	1.73412E-13
2	1.06705E-12	7.42808E-13	4.97725E-13	3.16902E-13	1.69013E-13
3	1.03804E-12	7.10428E-13	4.80709E-13	3.09224E-13	1.66236E-13
4	1.01684E-12	7.04900E-13	4.71759E-13	3.01569E-13	1.64010E-13
5	1.00629E-12	7.02701E-13	4.64627E-13	2.95781E-13	1.61101E-13
6	9.64114E-13	6.91817E-13	4.58000E-13	2.90253E-13	1.58943E-13
7	9.04913E-13	6.59322E-13	4.41940E-13	2.82940E-13	1.56902E-13
8	8.61430E-13	6.25236E-13	4.23745E-13	2.73942E-13	1.54128E-13
9	8.32650E-13	6.13592E-13	4.11874E-13	2.69943E-13	1.52791E-13
10	8.16284E-13	6.00963E-13	4.10724E-13	2.67056E-13	1.51989E-13
11	8.04735E-13	5.93688E-13	4.05567E-13	2.65304E-13	1.51543E-13
12	8.03674E-13	5.89229E-13	4.01478E-13	2.61446E-13	1.50479E-13
13	8.12615E-13	5.89098E-13	4.00427E-13	2.56997E-13	1.49567E-13
14	8.16597E-13	5.90951E-13	3.97025E-13	2.59563E-13	1.48953E-13
15	8.22775E-13	5.89830E-13	3.96975E-13	2.56578E-13	1.48400E-13
16	8.05394E-13	5.78879E-13	3.88668E-13	2.52853E-13	1.47277E-13
17	7.90902E-13	5.67961E-13	3.83389E-13	2.50157E-13	1.46506E-13
18	7.72981E-13	5.63787E-13	3.82245E-13	2.50331E-13	1.47650E-13
19	7.71121E-13	5.64771E-13	3.86869E-13	2.54960E-13	1.49998E-13
20	8.02680E-13	5.90100E-13	4.03112E-13	2.64261E-13	1.54288E-13
21	8.83632E-13	6.42265E-13	4.33306E-13	2.81052E-13	1.59745E-13
22	9.67449E-13	6.93147E-13	4.61271E-13	2.94355E-13	1.64987E-13
23	1.01932E-12	7.25182E-13	4.80963E-13	3.07341E-13	1.69738E-13
24	1.05752E-12	7.50894E-13	4.98401E-13	3.16912E-13	1.74268E-13
25	1.07720E-12	7.66986E-13	5.06791E-13	3.24256E-13	1.76996E-13
26	1.07643E-12	7.75795E-13	5.19443E-13	3.31677E-13	1.81335E-13
27	1.08558E-12	7.94100E-13	5.35168E-13	3.43693E-13	1.87247E-13
28	1.14330E-12	8.30458E-13	5.58456E-13	3.56314E-13	1.92226E-13
29	1.20852E-12	8.70375E-13	5.77942E-13	3.66959E-13	1.96647E-13
30	1.24225E-12	8.86889E-13	5.89168E-13	3.73409E-13	1.98525E-13
31	1.26675E-12	9.03426E-13	5.99342E-13	3.78326E-13	2.01015E-13
32	1.29430E-12	9.23181E-13	6.11195E-13	3.86150E-13	2.04124E-13
33	1.31843E-12	9.37003E-13	6.21574E-13	3.91867E-13	2.06387E-13

Table 4.2.2.6

DPA Rate At Pressure Vessel (cont'd)

At the Axial Core Midplane z=239.93cm

θ	0-T	1/4 T	1/2 T	3/4 T	T
34	1.36917E-12	9.71420E-13	6.40801E-13	4.02533E-13	2.10726E-13
35	1.41343E-12	1.01060E-12	6.65633E-13	4.17286E-13	2.16718E-13
36	1.43087E-12	1.02217E-12	6.76515E-13	4.24324E-13	2.20296E-13
37	1.43795E-12	1.02825E-12	6.80678E-13	4.27867E-13	2.21907E-13
38	1.44554E-12	1.03501E-12	6.83672E-13	4.29594E-13	2.23356E-13
39	1.44072E-12	1.03352E-12	6.87271E-13	4.32239E-13	2.24579E-13
40	1.43523E-12	1.03482E-12	6.87019E-13	4.33552E-13	2.25994E-13
41	1.43831E-12	1.03357E-12	6.89597E-13	4.34824E-13	2.27048E-13
42	1.44615E-12	1.04172E-12	6.93362E-13	4.38473E-13	2.28405E-13
43	1.45724E-12	1.05127E-12	6.97691E-13	4.41430E-13	2.29560E-13
44	1.48253E-12	1.06309E-12	7.05310E-13	4.44214E-13	2.30756E-13
45	1.51602E-12	1.08099E-12	7.14130E-13	4.48120E-13	2.32904E-13
46	1.51925E-12	1.08376E-12	7.16731E-13	4.51322E-13	2.34290E-13
47	1.50448E-12	1.08091E-12	7.19006E-13	4.53529E-13	2.36298E-13
48	1.49699E-12	1.08234E-12	7.22793E-13	4.57486E-13	2.38755E-13
49	1.51558E-12	1.09925E-12	7.36371E-13	4.66549E-13	2.42546E-13
50	1.59921E-12	1.16100E-12	7.75982E-13	4.89281E-13	2.51394E-13
51	1.76661E-12	1.26787E-12	8.38611E-13	5.23405E-13	2.62913E-13
52	1.90640E-12	1.34955E-12	8.81569E-13	5.44720E-13	2.70518E-13
53	1.94901E-12	1.37144E-12	8.94732E-13	5.53603E-13	2.72909E-13
54	1.98272E-12	1.39528E-12	9.10820E-13	5.62189E-13	2.76754E-13
55	2.01182E-12	1.41961E-12	9.26272E-13	5.71810E-13	2.80184E-13
56	2.01867E-12	1.42739E-12	9.33010E-13	5.75011E-13	2.81678E-13
57	1.94766E-12	1.39954E-12	9.22954E-13	5.72639E-13	2.81783E-13
58	1.88272E-12	1.36263E-12	9.07900E-13	5.67144E-13	2.81007E-13
59	1.85619E-12	1.34841E-12	9.00626E-13	5.64245E-13	2.80341E-13
60	1.84939E-12	1.34545E-12	8.96044E-13	5.68288E-13	2.78707E-13

Table 4.2.2.7

Downcomer Fluxes and DPA Rates

(r=278.10cm, z=306.605cm)

	FLUX (E>1.0 MEV)	FLUX (E>0.1 MEV)	DPA/s
0			
1	7.25624E+10	1.32820E+11	1.10502E-10
2	7.29598E+10	1.32613E+11	1.11082E-10
3	7.26484E+10	1.31726E+11	1.10644E-10
4	7.16205E+10	1.29708E+11	1.08979E-10
5	6.77477E+10	1.23602E+11	1.03184E-10
6	6.39683E+10	1.17110E+11	9.74438E-11
7	6.16799E+10	1.12612E+11	9.39032E-11
8	5.90013E+10	1.07374E+11	8.98694E-11
9	5.84768E+10	1.05921E+11	8.89752E-11
10	5.81329E+10	1.04797E+11	8.84450E-11
11	5.71350E+10	1.02867E+11	8.69997E-11
12	5.56754E+10	9.96783E+10	8.47665E-11
13	5.41228E+10	9.70504E+10	8.25602E-11
14	5.30998E+10	9.48583E+10	8.09817E-11
15	5.14766E+10	9.19491E+10	7.86062E-11
16	4.81467E+10	8.60722E+10	7.36487E-11
17	4.68881E+10	8.38222E+10	7.15378E-11
18	4.95816E+10	8.85162E+10	7.51518E-11
19	5.31465E+10	9.54570E+10	8.02959E-11
20	5.65551E+10	1.02120E+11	8.54056E-11
21	6.19186E+10	1.11952E+11	9.34593E-11
22	6.70586E+10	1.21153E+11	1.01452E-10
23	7.20848E+10	1.30825E+11	1.09561E-10
24	7.82011E+10	1.43204E+11	1.19084E-10
25	8.32541E+10	1.53070E+11	1.26566E-10
26	9.04047E+10	1.66423E+11	1.37366E-10
27	9.86623E+10	1.81314E+11	1.49569E-10
28	9.91442E+10	1.84136E+11	1.50534E-10
29	9.79038E+10	1.82787E+11	1.48854E-10
30	9.76924E+10	1.82694E+11	1.48618E-10
31	9.70467E+10	1.81053E+11	1.47838E-10
32	9.76712E+10	1.80787E+11	1.48638E-10
33	9.74799E+10	1.79699E+11	1.48537E-10

Table 4.2.2.7

Downcomer Fluxes and DPA Rates (Cont'd)

(r=278.10cm, z=306.605cm)

	FLUX	FLUX	DPA/s
θ	(E>1.0 MEV)	(E>0.1 MEV)	
34	9.61024E+10	1.75665E+11	1.46186E-10
35	9.06185E+10	1.65623E+11	1.37976E-10
36	8.48232E+10	1.55773E+11	1.29350E-10
37	8.16531E+10	1.50329E+11	1.24532E-10
38	7.95092E+10	1.46334E+11	1.21408E-10
39	7.90791E+10	1.44564E+11	1.20598E-10
40	7.87170E+10	1.43282E+11	1.20151E-10
41	7.98183E+10	1.44043E+11	1.21747E-10
42	8.02073E+10	1.44508E+11	1.22321E-10
43	8.00899E+10	1.44332E+11	1.22175E-10
44	8.15130E+10	1.47087E+11	1.24256E-10
45	8.43237E+10	1.53396E+11	1.28692E-10
46	8.81747E+10	1.61410E+11	1.34585E-10
47	9.58350E+10	1.76402E+11	1.46028E-10
48	1.05302E+11	1.95758E+11	1.60424E-10
49	1.17721E+11	2.20651E+11	1.79092E-10
50	1.40142E+11	2.66256E+11	2.13342E-10
51	1.68364E+11	3.22637E+11	2.56196E-10
52	1.83158E+11	3.54577E+11	2.79363E-10
53	1.87330E+11	3.64740E+11	2.86302E-10
54	1.95986E+11	3.81241E+11	2.99061E-10
55	2.05900E+11	3.99845E+11	3.12691E-10
56	2.11886E+11	4.11390E+11	3.19917E-10
57	2.14478E+11	4.16842E+11	3.22964E-10
58	2.13838E+11	4.17023E+11	3.22038E-10
59	2.11683E+11	4.14384E+11	3.19146E-10
60	2.12178E+11	4.15588E+11	3.19652E-10

Table 4.2.2.8

Downcomer Fluxes and DPA Rates
(At the Axial Core Midplane r=278.10cm, z=239.93cm)

	FLUX (E>1.0 MEV)	FLUX (E>0.1 MEV)	DPA/s
0			
1	6.37689E+10	1.16516E+11	9.71895E-11
2	6.41228E+10	1.16341E+11	9.77082E-11
3	6.38515E+10	1.15566E+11	9.73277E-11
4	6.29473E+10	1.13795E+11	9.58624E-11
5	5.95411E+10	1.08433E+11	9.07593E-11
6	5.62185E+10	1.02737E+11	8.57088E-11
7	5.42094E+10	9.87932E+10	8.25989E-11
8	5.18584E+10	9.42019E+10	7.90568E-11
9	5.13990E+10	9.29299E+10	7.82738E-11
10	5.10988E+10	9.19465E+10	7.78113E-11
11	5.02236E+10	9.02558E+10	7.65435E-11
12	4.89432E+10	8.74614E+10	7.45839E-11
13	4.75803E+10	8.51574E+10	7.26460E-11
14	4.66817E+10	8.32354E+10	7.12585E-11
15	4.52557E+10	8.06837E+10	6.91700E-11
16	4.23288E+10	7.55272E+10	6.48082E-11
17	4.12225E+10	7.35531E+10	6.29520E-11
18	4.35905E+10	7.76722E+10	6.61346E-11
19	4.67210E+10	8.37578E+10	7.06555E-11
20	4.97133E+10	8.95987E+10	7.51434E-11
21	5.44260E+10	9.82231E+10	8.22257E-11
22	5.89434E+10	1.06295E+11	8.92547E-11
23	6.33574E+10	1.14776E+11	9.63790E-11
24	6.87252E+10	1.25626E+11	1.04739E-10
25	7.31611E+10	1.34275E+11	1.11311E-10
26	7.94440E+10	1.45987E+11	1.20808E-10
27	8.66980E+10	1.59048E+11	1.31537E-10
28	8.71147E+10	1.61513E+11	1.32371E-10
29	8.60210E+10	1.60324E+11	1.30886E-10
30	8.58352E+10	1.60242E+11	1.30678E-10
31	8.52711E+10	1.58807E+11	1.29997E-10
32	8.58240E+10	1.58580E+11	1.30710E-10
33	8.56617E+10	1.57633E+11	1.30632E-10

Table 4.2.2.8

Downcomer Fluxes and DPA Rates

(At the Axial Core Midplane $r=278.10\text{cm}$, $z=239.93\text{cm}$)

	FLUX	FLUX	DPA/s
θ	($E>1.0$ MEV)	($E>0.1$ MEV)	
34	8.44549E+10	1.54101E+11	1.28572E-10
35	7.96374E+10	1.45294E+11	1.21354E-10
36	7.45431E+10	1.36650E+11	1.13764E-10
37	7.17556E+10	1.31872E+11	1.09524E-10
38	6.98736E+10	1.28369E+11	1.06779E-10
39	6.94984E+10	1.26821E+11	1.06073E-10
40	6.91849E+10	1.25703E+11	1.05689E-10
41	7.01579E+10	1.26377E+11	1.07103E-10
42	7.05008E+10	1.26787E+11	1.07610E-10
43	7.03974E+10	1.26632E+11	1.07481E-10
44	7.16462E+10	1.29047E+11	1.09308E-10
45	7.41121E+10	1.34575E+11	1.13201E-10
46	7.74922E+10	1.41600E+11	1.18376E-10
47	8.42162E+10	1.54741E+11	1.28425E-10
48	9.25277E+10	1.71709E+11	1.41070E-10
49	1.03429E+11	1.93529E+11	1.57465E-10
50	1.23113E+11	2.33508E+11	1.87548E-10
51	1.47887E+11	2.82931E+11	2.25186E-10
52	1.60869E+11	3.10922E+11	2.45522E-10
53	1.64528E+11	3.19827E+11	2.51609E-10
54	1.72128E+11	3.34293E+11	2.62819E-10
55	1.80833E+11	3.50605E+11	2.74798E-10
56	1.86086E+11	3.60724E+11	2.81146E-10
57	1.88362E+11	3.65503E+11	2.83826E-10
58	1.87798E+11	3.65658E+11	2.83009E-10
59	1.85903E+11	3.63339E+11	2.80460E-10
60	1.86334E+11	3.64391E+11	2.80901E-10

Table 4.2.2.9

Cavity Fluxes and DPA Rates

r=398.70cm

θ	FLUX	FLUX	DPA/s
	(E>1.0 MEV)	(E>0.1 MEV)	
	z=282.602cm	z=279.554cm	z=279.554cm
1	5.19479E+07	2.54473E+08	1.15963E-13
2	5.23948E+07	2.54803E+08	1.16678E-13
3	5.25180E+07	2.54716E+08	1.16829E-13
4	5.25311E+07	2.54611E+08	1.16871E-13
5	5.22965E+07	2.54347E+08	1.16508E-13
6	5.19117E+07	2.54138E+08	1.15932E-13
7	5.16546E+07	2.54200E+08	1.15561E-13
8	5.15872E+07	2.54302E+08	1.15476E-13
9	5.16924E+07	2.54459E+08	1.15666E-13
10	5.17694E+07	2.54532E+08	1.15798E-13
11	5.19453E+07	2.54706E+08	1.16085E-13
12	5.21545E+07	2.54948E+08	1.16451E-13
13	5.21079E+07	2.55045E+08	1.16495E-13
14	5.22074E+07	2.55037E+08	1.16583E-13
15	5.21325E+07	2.55065E+08	1.16428E-13
16	5.19375E+07	2.55417E+08	1.16169E-13
17	5.20797E+07	2.56622E+08	1.16542E-13
18	5.30672E+07	2.59465E+08	1.18321E-13
19	5.41511E+07	2.62516E+08	1.20301E-13
20	5.46691E+07	2.64710E+08	1.21318E-13
21	5.53507E+07	2.67316E+08	1.22525E-13
22	5.57146E+07	2.69311E+08	1.23285E-13
23	5.63417E+07	2.72255E+08	1.24544E-13
24	5.76811E+07	2.76394E+08	1.26972E-13
25	5.86674E+07	2.79530E+08	1.28817E-13
26	5.99887E+07	2.83705E+08	1.31185E-13
27	6.14913E+07	2.88908E+08	1.33943E-13
28	6.26567E+07	2.93103E+08	1.36141E-13
29	6.35637E+07	2.96182E+08	1.37841E-13
30	6.39799E+07	2.97893E+08	1.38675E-13
31	6.43432E+07	2.99347E+08	1.39383E-13
32	6.48287E+07	3.01374E+08	1.40330E-13
33	6.52671E+07	3.02902E+08	1.41128E-13

Table 4.2.2.9

Cavity Fluxes and DPA Rates (cont'd)

	r=398.70cm		
	FLUX	FLUX	DPA/s
	z=282.602cm (E>1.0 MEV)	z=279.554cm (E>0.1 MEV)	z=279.554cm
0			
34	6.60600E+07	3.05956E+08	1.42639E-13
35	6.73731E+07	3.10582E+08	1.45063E-13
36	6.85105E+07	3.14241E+08	1.47140E-13
37	6.92978E+07	3.16764E+08	1.48588E-13
38	7.00342E+07	3.19020E+08	1.49946E-13
39	7.08230E+07	3.21431E+08	1.51384E-13
40	7.14632E+07	3.23735E+08	1.52599E-13
41	7.20260E+07	3.25909E+08	1.53666E-13
42	7.24539E+07	3.27801E+08	1.54484E-13
43	7.28179E+07	3.29240E+08	1.55127E-13
44	7.30954E+07	3.30948E+08	1.55744E-13
45	7.38825E+07	3.34326E+08	1.57261E-13
46	7.45634E+07	3.37075E+08	1.58548E-13
47	7.56717E+07	3.40485E+08	1.60521E-13
48	7.69237E+07	3.44192E+08	1.62772E-13
49	7.80299E+07	3.47575E+08	1.64721E-13
50	7.91807E+07	3.51918E+08	1.66792E-13
51	8.00746E+07	3.55983E+08	1.68482E-13
52	8.05541E+07	3.58188E+08	1.69392E-13
53	8.06036E+07	3.58805E+08	1.69537E-13
54	8.08069E+07	3.60049E+08	1.69954E-13
55	8.12391E+07	3.61605E+08	1.70733E-13
56	8.17068E+07	3.62700E+08	1.71549E-13
57	8.25914E+07	3.64401E+08	1.73009E-13
58	8.32210E+07	3.65700E+08	1.74101E-13
59	8.33420E+07	3.65999E+08	1.74314E-13
60	8.36596E+07	3.66444E+08	1.74711E-13

Table 4.2.2.10

Flux Spectrum At Pressure Vessel

$\theta=42.51^\circ$

Group	z=306.605cm	z=306.605cm	z=306.605cm	z=302.795cm	z=302.795cm
	0 T	1/4 T	1/2 T	3/4 T	T
1	1.45144E+06	8.51148E+05	4.55280E+05	2.40675E+05	1.45519E+05
2	3.98221E+06	2.31806E+06	1.22421E+06	6.36146E+05	3.78338E+05
3	1.38250E+07	8.07480E+06	4.24131E+06	2.18018E+06	1.28286E+06
4	2.42949E+07	1.43174E+07	7.48060E+06	3.80477E+06	2.21551E+06
5	3.66752E+07	2.14025E+07	1.09403E+07	5.43558E+06	3.10342E+06
6	8.85306E+07	5.02178E+07	2.46778E+07	1.17776E+07	6.51678E+06
7	1.10113E+08	6.15821E+07	2.99427E+07	1.41802E+07	7.75899E+06
8	1.62710E+08	9.10256E+07	4.47425E+07	2.14402E+07	1.16773E+07
9	1.01256E+08	5.89232E+07	3.02845E+07	1.49937E+07	8.21885E+06
10	6.86134E+07	4.22007E+07	2.23501E+07	1.13156E+07	6.17816E+06
11	7.33791E+07	4.62005E+07	2.49657E+07	1.28534E+07	7.03824E+06
12	3.50676E+07	2.24949E+07	1.23057E+07	6.38137E+06	3.51085E+06
13	8.65360E+06	5.77535E+06	3.26255E+06	1.73874E+06	9.83372E+05
14	4.33860E+07	2.93996E+07	1.67870E+07	9.01552E+06	5.06771E+06
15	1.12498E+08	7.99966E+07	4.72184E+07	2.58196E+07	1.43668E+07
16	1.15858E+08	8.92594E+07	5.62290E+07	3.22770E+07	1.83716E+07
17	1.54977E+08	1.24302E+08	8.12742E+07	4.80871E+07	2.79281E+07
18	2.39865E+08	2.18249E+08	1.58086E+08	1.00680E+08	5.98535E+07
19	1.45214E+08	1.36801E+08	1.04883E+08	7.10078E+07	4.46924E+07
20	7.61680E+07	7.03784E+07	5.35826E+07	3.57649E+07	2.20858E+07
21	2.23453E+08	2.53669E+08	2.20689E+08	1.59703E+08	9.84222E+07
22	1.47690E+08	1.54698E+08	1.33078E+08	9.82825E+07	6.50064E+07
23	1.89661E+08	2.16406E+08	1.92411E+08	1.39829E+08	8.37832E+07
24	1.81696E+08	2.21221E+08	2.09219E+08	1.59934E+08	9.98713E+07
25	1.91614E+08	1.91157E+08	1.65710E+08	1.24799E+08	8.53724E+07
26	2.04774E+08	2.31926E+08	2.14825E+08	1.65236E+08	1.07721E+08
27	1.51798E+08	1.70517E+08	1.59793E+08	1.22859E+08	7.91146E+07
28	9.13819E+07	7.80000E+07	6.47475E+07	4.84103E+07	3.30616E+07
29	3.36533E+07	2.28332E+07	1.75979E+07	1.28947E+07	8.89195E+06
30	2.21608E+07	1.23038E+07	9.40842E+06	6.89944E+06	6.27014E+06
31	4.31436E+07	4.53749E+07	3.99941E+07	3.14806E+07	2.24942E+07
32	2.33147E+07	2.36310E+07	2.12853E+07	1.70028E+07	1.21623E+07
33	4.82868E+07	3.97948E+07	3.19665E+07	2.47100E+07	1.86002E+07
34	7.98184E+07	3.97861E+07	2.53249E+07	1.89619E+07	1.81539E+07
35	1.21562E+08	9.64862E+07	6.81251E+07	4.67343E+07	3.13456E+07
36	1.05427E+08	7.91381E+07	5.57745E+07	3.72227E+07	2.47032E+07
37	1.57190E+08	1.04127E+08	6.80836E+07	4.46165E+07	3.22886E+07
38	9.41541E+07	5.92886E+07	3.72325E+07	2.40360E+07	1.75710E+07
39	9.61211E+07	6.22186E+07	3.84280E+07	2.42199E+07	1.72371E+07
40	1.27251E+08	8.25196E+07	5.04327E+07	3.11393E+07	2.17334E+07
41	1.53565E+08	9.53296E+07	5.65150E+07	3.41860E+07	2.41848E+07
42	8.80941E+07	5.14179E+07	2.94949E+07	1.75775E+07	1.28650E+07
43	1.12239E+08	5.66321E+07	2.93236E+07	1.72131E+07	1.40101E+07
44	8.17431E+07	3.54918E+07	1.63386E+07	9.37243E+06	8.66707E+06
45	7.43535E+07	2.38461E+07	8.91602E+06	5.00614E+06	6.29555E+06
46	1.57507E+08	3.28214E+07	7.80908E+06	4.51151E+06	1.14895E+07
47	1.08282E+09	7.03264E+07	4.63913E+06	2.21562E+06	2.71357E+07

Table 4.2.2.11

Flux Spectrum at the Downcomer, Capsule and Cavity

Group	Downcomer	Pressure Vessel Capsule	Cavity
1	3.06440E+07	1.20397E+06	8.82735E+04
2	9.94113E+07	3.21690E+06	2.22049E+05
3	4.34619E+08	1.06770E+07	7.27237E+05
4	8.69995E+08	1.84146E+07	1.22673E+06
5	1.57902E+09	2.71738E+07	1.67074E+06
6	4.24337E+09	6.54588E+07	3.42529E+06
7	6.44469E+09	8.01483E+07	4.00089E+06
8	1.18478E+10	1.15285E+08	5.85934E+06
9	8.28758E+09	7.12901E+07	4.01597E+06
10	5.72389E+09	4.74982E+07	2.94413E+06
11	6.28604E+09	5.03231E+07	3.36623E+06
12	3.01237E+09	2.38313E+07	1.71368E+06
13	7.81276E+08	5.80002E+06	4.71627E+05
14	3.72442E+09	2.93640E+07	2.34469E+06
15	8.89592E+09	7.66362E+07	6.17582E+06
16	8.93241E+09	7.85537E+07	7.88597E+06
17	1.19526E+10	1.03870E+08	1.22991E+07
18	1.59615E+10	1.57156E+08	2.50803E+07
19	1.00176E+10	9.33834E+07	1.96089E+07
20	5.75172E+09	4.87374E+07	1.08405E+07
21	1.06772E+10	1.36337E+08	3.84548E+07
22	9.47762E+09	8.96021E+07	3.03620E+07
23	1.05198E+10	1.14643E+08	3.41054E+07
24	8.27485E+09	1.05726E+08	4.09960E+07
25	1.52337E+10	1.14367E+08	4.93562E+07
26	1.28278E+10	1.20772E+08	5.05848E+07
27	1.08677E+10	8.91329E+07	3.76139E+07
28	9.59758E+09	5.37322E+07	2.22784E+07
29	4.47478E+09	1.89532E+07	7.16805E+06
30	3.46514E+09	1.08276E+07	7.45577E+06
31	1.28394E+09	2.57457E+07	1.00461E+07
32	1.69532E+09	1.37871E+07	6.53739E+06
33	6.21169E+09	3.12861E+07	1.40931E+07
34	1.19938E+10	4.56788E+07	1.82946E+07
35	1.17352E+10	7.63772E+07	2.03678E+07
36	1.17072E+10	6.39967E+07	1.76332E+07
37	1.95127E+10	9.43503E+07	2.58626E+07
38	1.18174E+10	5.64554E+07	1.41391E+07
39	1.18917E+10	5.81865E+07	1.35024E+07
40	1.59635E+10	7.70609E+07	1.68843E+07
41	2.01242E+10	9.25460E+07	1.92489E+07
42	1.21640E+10	5.27821E+07	1.06510E+07
43	1.70609E+10	6.63114E+07	1.27264E+07
44	1.36351E+10	4.76412E+07	8.62314E+06
45	1.49940E+10	4.14897E+07	7.54572E+06
46	4.18799E+10	8.56534E+07	1.71394E+07
47	7.26381E+11	5.95337E+08	5.50658E+07

Downcomer flux spectrum is at r=278.10cm, z=306.605cm, θ =23.5.

Pressure Vessel Capsule flux spectrum is at r=319.195cm, z=306.605cm, θ =3.

Cavity flux spectrum is at r=398.70cm, z=282.602cm, θ =44.975.

Table 4.2.2.12

Calculated Reaction Rates (reactions/sec*atom) at the Capsule

Detector	r=318.348cm	r=319.195cm	r=320.041cm	r=320.887cm
46	-17	-17	-17	-17
.Ti (n,p)	4.19811x10	3.70240x10	3.22615x10	2.78949x10
54	-16	-16	-16	-16
.Fe (n,p)	1.81953x10	1.61912x10	1.41706x10	1.22869x10
58	-16	-16	-16	-16
.Ni (n,p)	2.32589x10	2.07686x10	1.82286x10	1.58472x10
63	-18	-18	-18	-18
.Cu (n, α)	2.89411x10	2.54905x10	2.22507x10	1.92927x10
237	-15	-15	-15	-15
.Np (n,f)	2.10361x10	2.03505x10	1.90963x10	1.76904x10
238	-16	-16	-16	-16
.U (n,f)	5.04572x10	4.65176x10	4.17612x10	3.71114x10

BUGLE93 used pressure vessel 1/4T weighting spectrum to collapse cross sections.

46
Te (n,p) axial peak reaction rate at z=302.795cm
54
Fe (n,p) axial peak reaction rate at z=302.795cm
58
Ni (n,p) axial peak reaction rate at z=302.795cm
63
Cu (n, α) axial peak reaction rate at z=302.795cm
237
Np (n,f) axial peak reaction rate at z=306.605cm
238
U (n,f) axial peak reaction rate at z=306.605cm

PRESSURE VESSEL O-T FLUX SPECTRUM

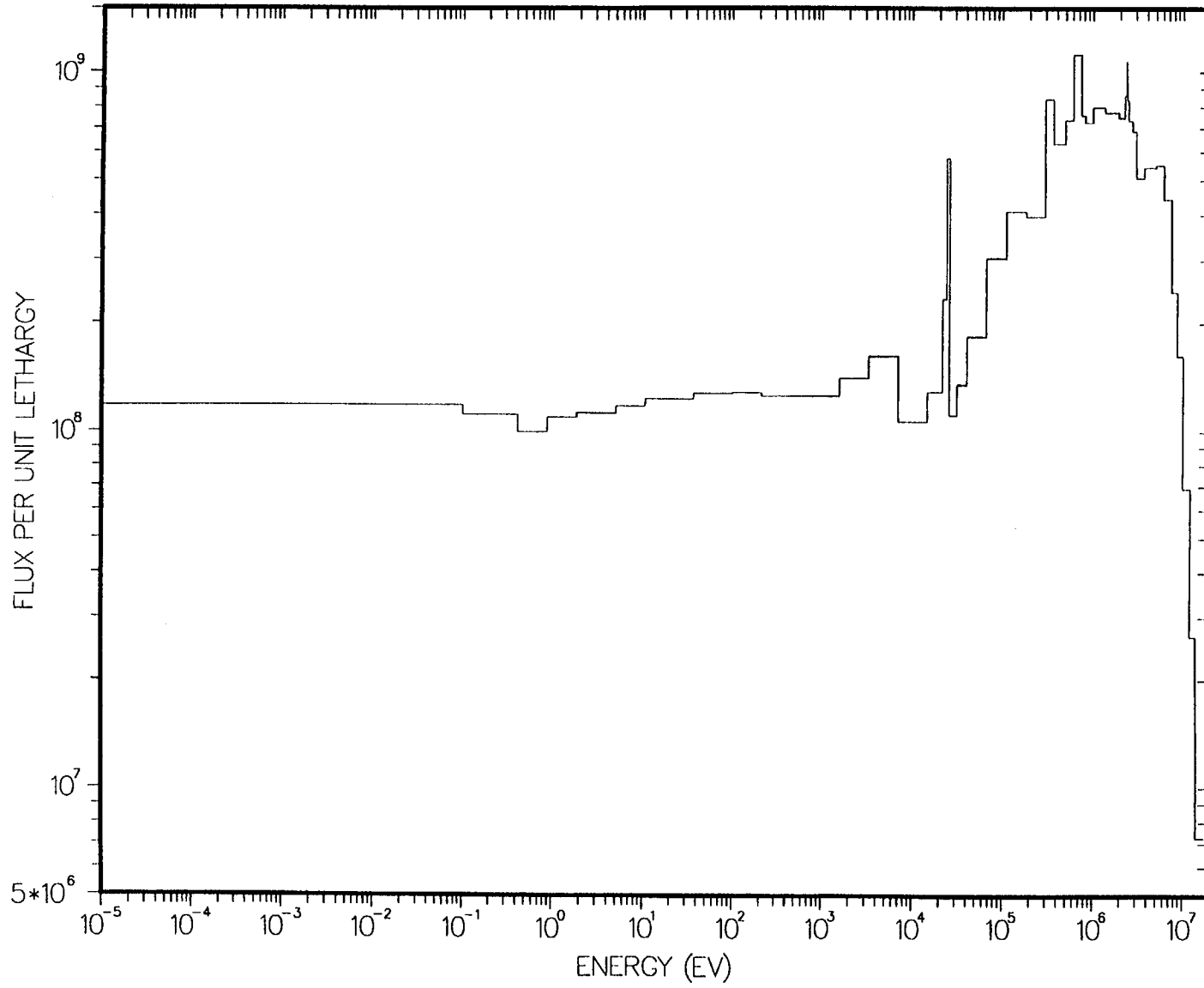
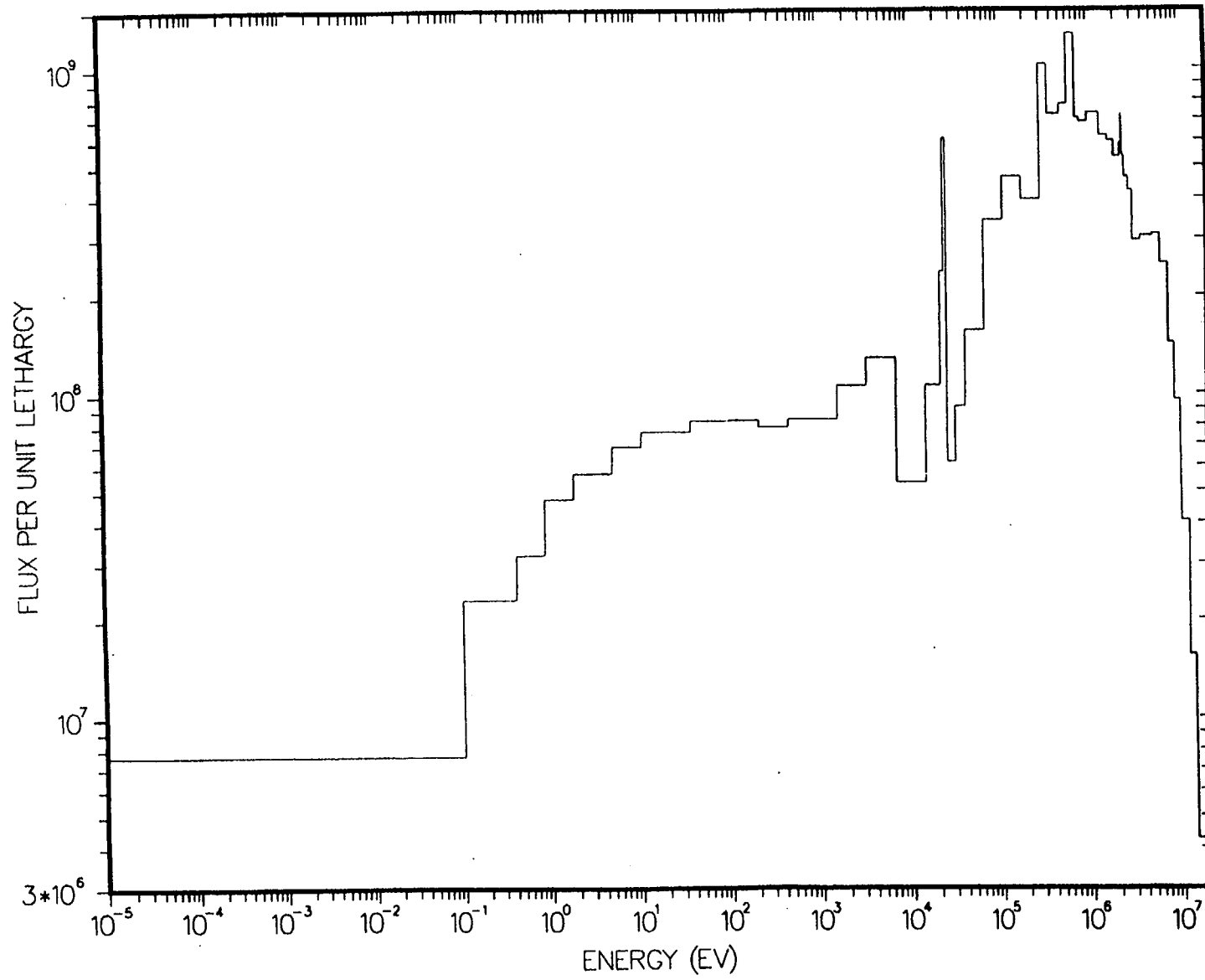

Figure 4.2.2.1

Figure 4.2.2.2

PRESSURE VESSEL 1/4 T FLUX SPECTRUM



4-113

PRESSURE VESSEL 1/2 T FLUX SPECTRUM

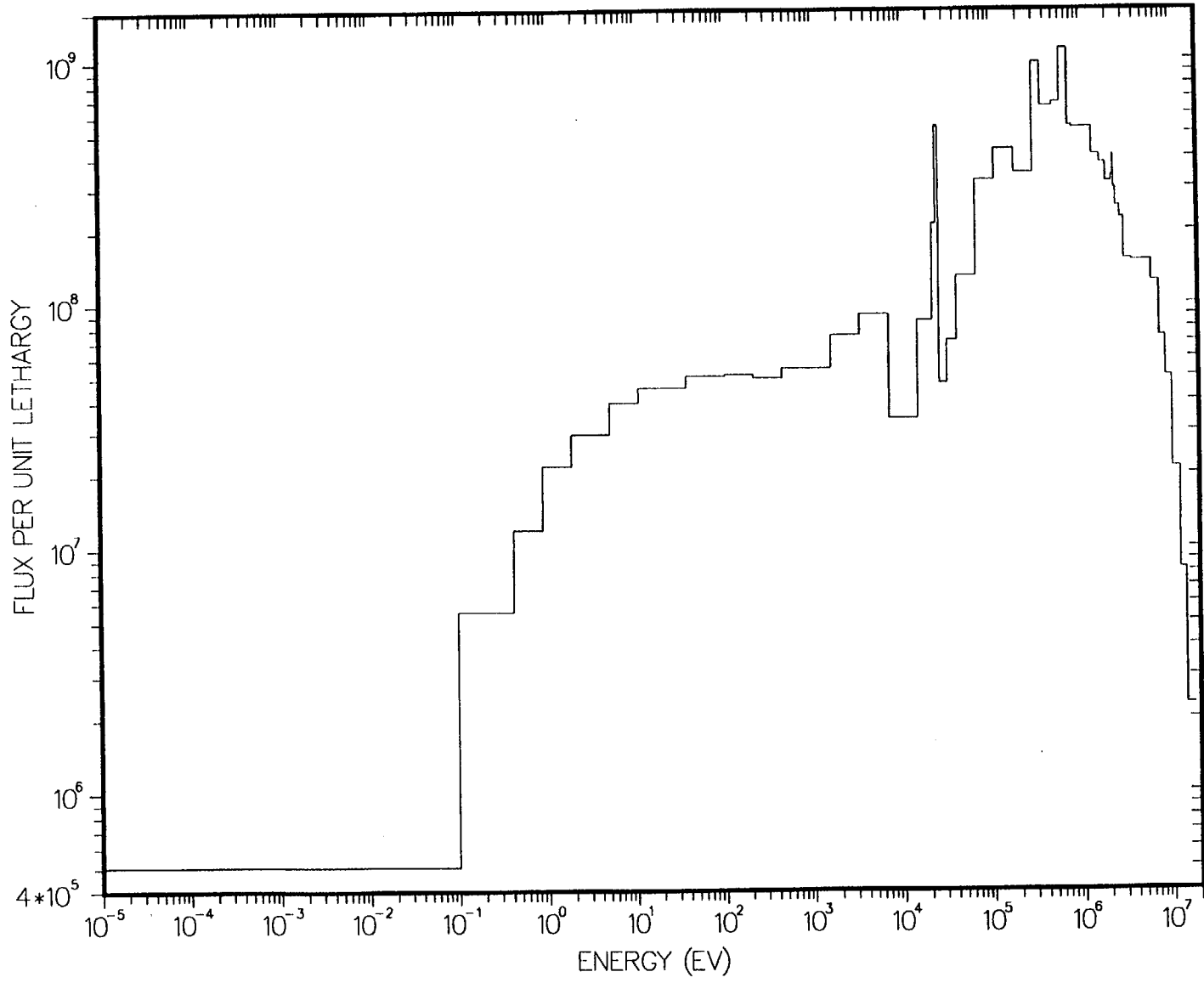
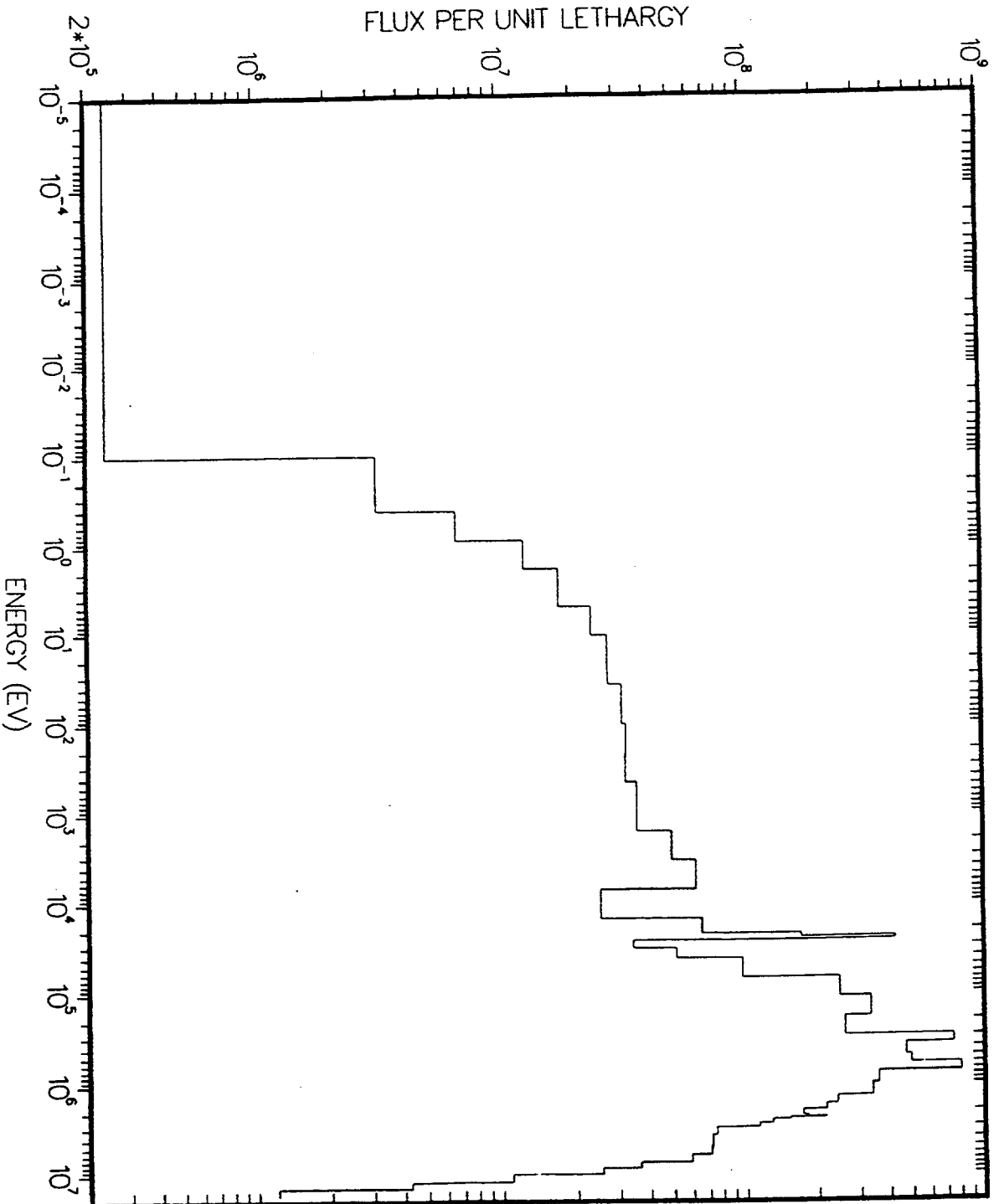

Figure 4.2.2.3

Figure 4.2.2.4

PRESSURE VESSEL 3/4 T FLUX SPECTRUM



PRESSURE VESSEL 1.0 T FLUX SPECTRUM

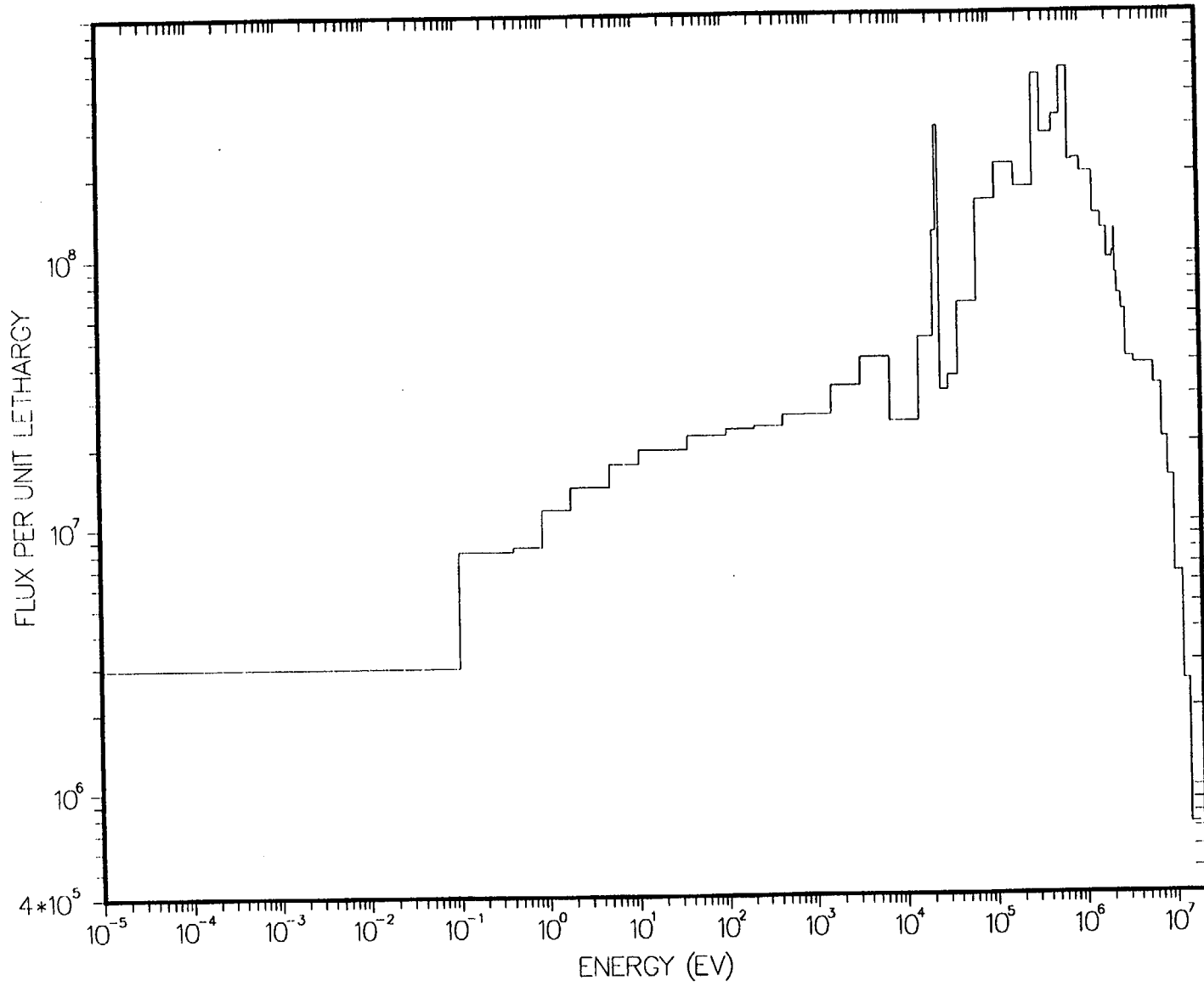

Figure 4.2.2.5

PRESSURE VESSEL CAPSULE FLUX SPECTRUM

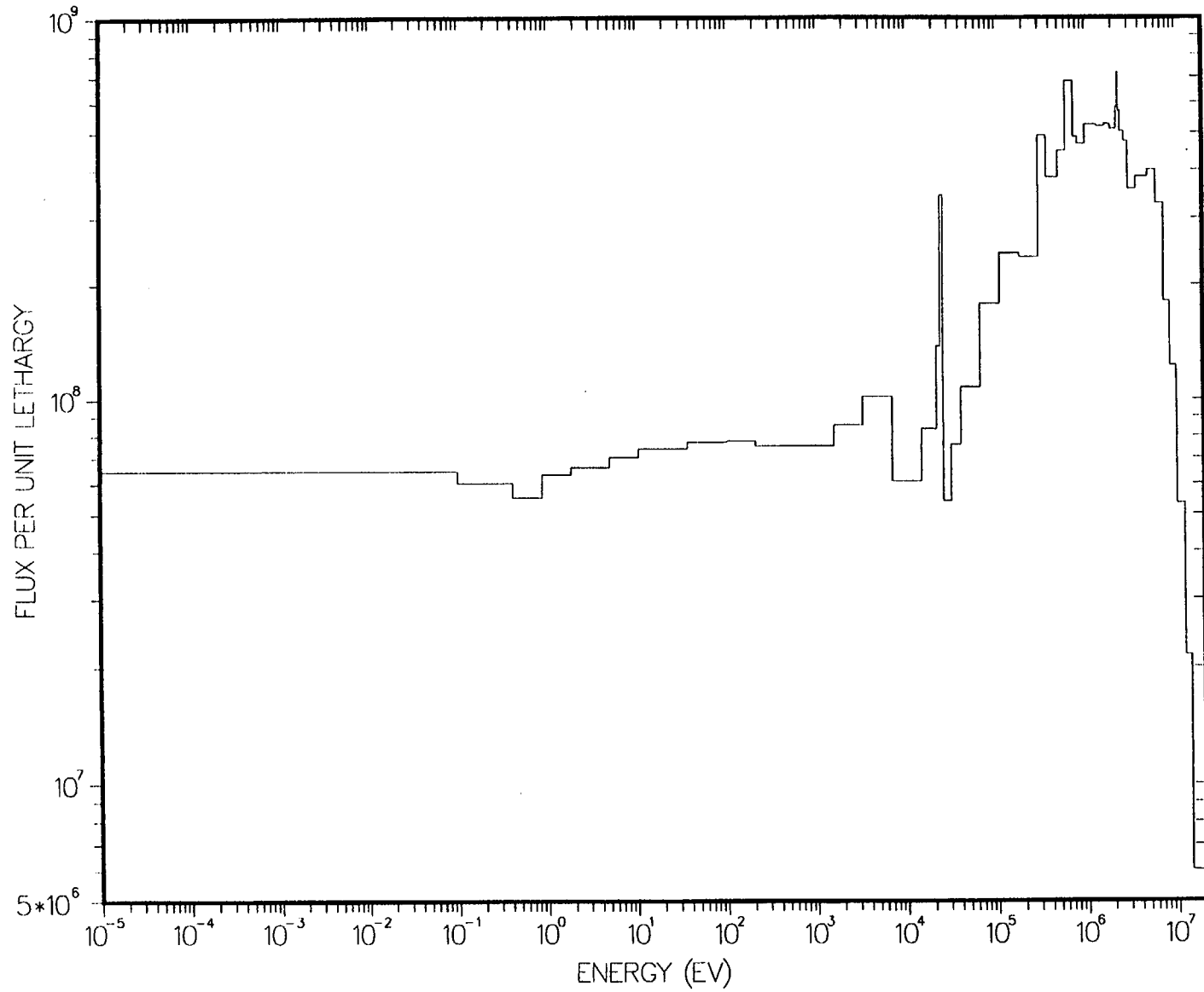
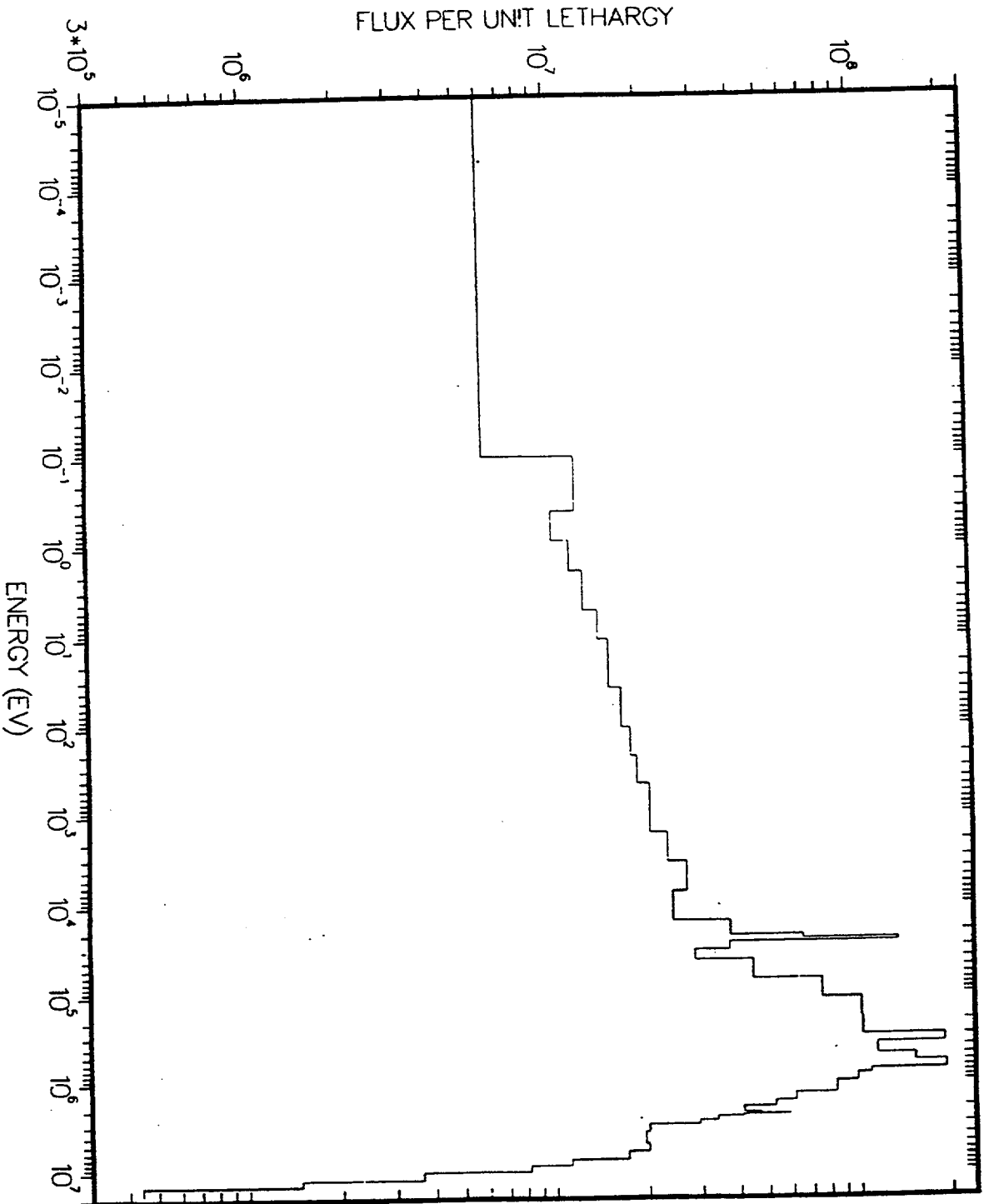

Figure 4.2.2.6

Figure 4.2.2.7

CAVITY PEAK LOCATION FLUX SPECTRUM



5 PWR and BWR MCNP BENCHMARK PROBLEM CALCULATIONS

5.1 Introduction

MCNP calculations were performed for (1) the PWR Standard Core and Partial Length Shield Assembly Core Problems and (2) the BWR Benchmark Problem. The purpose of these calculations is to allow an independent assessment of the DORT discrete ordinates methodology and to provide an additional solution to the benchmark problems. The calculations are based on the configuration geometry, material assignments and core neutron source provided with the problem definitions of Chapter 2. The methods used in the MCNP calculations follow the guidance of Regulatory Guide 1.190 and, except for the methods associated with the solution of the transport equation, are consistent with the DORT methods of Chapter 3. In addition to the numerical transport techniques, the major differences between the DORT and MCNP calculations are: (1) the DORT (r, θ) representation of the core (x, y) cartesian geometry and (2) the axial synthesis of the (r, θ) and (r, z) fluxes required to determine the three-dimensional solution in the DORT methodology. The details of the MCNP calculations and the calculated fluxes are presented in the following sections.

5.2 Calculation Methodology

The Monte Carlo calculations were performed in the fixed source mode with the MCNP 4A Version of MCNP. Essentially, no approximations were made in representing the problem geometry. Reflecting boundary conditions were imposed on the azimuthal boundaries at 0 and 45 degrees and a void boundary condition was employed in the cavity outside of the pressure vessel. Axial void boundary conditions were imposed at the outside of the top and bottom reflector regions. The detailed fuel pin geometry including fuel pellet, clad and surrounding moderator region was represented as a homogenized fuel composition.

The material compositions of each region were essentially those given in the Chapter 2 problem definition. However, because all material compositions were not available in the cross section library, the Pu-239 and Pu-240 were not included in the core composition and

Molybdenum was not included in the vessel composition. These nuclides are relatively small components of the material compositions and have been determined, using DORT, to have a negligible effect ($<0.1\%$) on the vessel inner-wall fluence.

The BUGLE-93 ENDF/B-VI 47-group cross section library used in the DORT calculations (Section 3.2) was reformatted for use in MCNP using the CRSRD (Version-2) cross section processing program described in Reference-9.

5.3 PWR MCNP Calculations and Comparison with DORT

The MCNP PWR core neutron source was constructed using the pin-wise source given in the Chapter-2 problem definition. The pin-wise spatial detail of the source in the outer two rows of fuel assemblies in the core was represented explicitly in the MCNP model. The source in the inner fuel assemblies was homogenized over the volume of the fuel assembly. The fission spectrum used in the MCNP calculation was identical to that used in the DORT calculations and included the effects of fuel assembly burnup and Pu buildup (Section-3.3).

The MCNP calculated fluxes were edited in tally regions located radially on the vessel inner-wall and at the T/4 location, and distributed uniformly over 20 azimuthal locations. Axially, the tally regions were located at the location having the peak (DORT) flux in the Standard Core Problem and at the axial location of the circumferential weld in the PLSA Problem. An energy cutoff of 1-MeV was used.

In order to improve the neutron tracking efficiency and reduce the variance in the flux edits, geometrical splitting with Russian Roulette was applied using the region-wise importances of Figure-5.3.1. Each calculation was run for 40×10^6 neutron histories which provided a relative (one-sigma) probable error of $\leq 3.0\%$. The edited fluxes satisfied all of the statistical acceptance criteria on the mean value, probable error, variance of the variance and the figure of merit.

In order to allow consistent comparisons between the MCNP and DORT calculations several adjustments were made to the DORT results. The DORT >1-MeV vessel inner-wall fluxes were increased by: (1) 1.31 % to account for the difference between the $\theta = 0.0$ and $\theta = 0.3$ flux extrapolation (Table 3.4.1), recommended in Regulatory Guide 1.190, and (2) 3.0% to account for the difference between S_8 and higher order discrete ordinate calculations. While the DORT and MCNP flux edits were taken at identical radial locations and over identical volumes in the standard core loading calculations, in the PLSA calculation the MCNP and DORT edit locations and volumes are slightly different. To account for this difference, the PLSA DORT calculation was edited at a vessel internal mesh location centered at $r=220.202$ cm, and this edit was used for the comparison to MCNP. (This resulted in an angular dependent reduction of the Table 4.1.4.1 ($r=219.393$ cm) fluxes, which ranged from 0.937 at $\theta=0^\circ$ to 0.931 at $\theta=45^\circ$.) In order to provide an MCNP calculation for comparison with DORT, the MCNP (Table 5.3.4) fluxes were increased by 1.6% to account for the extrapolation from $r=220.345$ cm to $r=220.202$ cm and for the difference in the edit volumes.

The MCNP radial and axial geometry models for the Standard and PLSA benchmark problems are provided in Figures 5.3.2 - 5.3.5. The MCNP calculated vessel > 1-MeV fluxes for the Standard Core Loading at the inner-wall, T/4 and lower weld locations are presented in Tables 5.3.1, 5.3.2 and 5.3.3, respectively. The results are presented for each azimuthal location including the relative probable error. The MCNP calculated fluxes at the lower axial weld location are presented in Table 5.3.4 for the Partial Length Shield Assembly core. The MCNP and corresponding DORT calculated fluxes for the Standard and PLSA core loadings are presented in Figures 5.3.6 - 5.3.9 and indicate generally good agreement between the two methods.

5.4 BWR MCNP Calculations and Comparison with DORT

The BWR MCNP core neutron source was constructed using the pin-wise source given in the Chapter-2 problem definition. In the BWR problem, the outer most assemblies included an explicit source for each of the fuel rods in the 8x8 fuel rod lattice. The second row of assemblies from the core edge were modeled using a 4 x 4 power distribution to represent the 8x8 fuel rod array, and the fuel assemblies in the third row from the core edge were represented using a 2x2 power distribution.

The source in the inner fuel assemblies was homogenized over the volume of the fuel assembly. The fission spectrum used in the MCNP calculation was identical to that used in the DORT calculations and included the effects of fuel assembly burnup and Pu buildup (Section-3.3).

As shown in Figure 5.4.1, the MCNP calculated fluxes were edited in tally regions located radially in the downcomer, just inside the riser, and on the vessel inner-wall, and distributed uniformly over 20 azimuthal locations. Axially the tally regions were located at the core axial midplane (Figure 5.4.2). An energy cutoff of 1-MeV was used.

In order to improve the neutron tracking efficiency and reduce the variance in the flux edits, geometrical splitting with Russian Roulette was applied using the region-wise importances of Figures 5.4.3 and 5.4.4. Each calculation was run for 40×10^7 neutron histories which provided a relative (one-sigma) probable error of $\leq 5.0\%$. The edited fluxes satisfied all of the statistical acceptance criteria on the mean value, probable error, variance of the variance and the figure of merit.

In order to allow consistent comparisons between the MCNP and DORT calculations an adjustment was made to the DORT results. An azimuthally dependent adjustment was applied to the DORT > 1-MeV downcomer and vessel inner-wall fluxes to account for the difference between the $\theta=0.9$ and $\theta=0.3$ flux extrapolation, recommended in Regulatory Guide 1.190. The average adjustment applied at the downcomer (vessel) was -0.05% (-0.7%). Since the MCNP and DORT edit volumes were identical, no geometrical adjustment was required. Also, since the BWR (r,z) calculations were performed using an S_{16} quadrature, no adjustment was made for the effect of using an S_8 quadrature.

The MCNP radial and axial geometry models for the BWR benchmark problem are provided in Figures 5.4.1 and 5.4.2. The MCNP calculated > 1-MeV fluxes in the downcomer and at the vessel inner-wall are presented in Tables 5.4.1 and 5.4.2, respectively. The results are presented for each azimuthal location including the relative probable error. The MCNP and corresponding DORT calculated fluxes for the BWR benchmark problem are presented in Figures-5.4.5 and 5.4.6 and indicate generally good agreement between the two methods.

In the MCNP calculations of Tables 5.4.1 and 5.4.2, the inter-assembly water gap was modeled explicitly. In order to evaluate the effect of homogenizing the water gap, a second set of calculations was performed in which the water gap was homogenized with the channel box, fuel rods and intra-assembly water. The results of these calculations are presented in Tables 5.4.3 and 5.4.4 and are compared with the corresponding explicit water gap calculations in Figures 5.4.7 and 5.4.8. The comparisons indicate that the approximate homogenized water gap calculations are in good agreement with the explicit water gap results.

**Table 5.3.1 MCNP Standard Core Loading Flux ($E > 1.0$ MeV) at the Pressure Vessel Inner-Wall
Peak Axial Location
($R=219.393$ cm, $Z=125.488$ cm)**

θ degrees	FLUX [*]	ERROR ⁺	θ degree	FLUX [*]	ERROR ⁺
1.125	3.30326e+10	0.0243	23.625	3.72762e+10	0.0214
3.375	3.36730e+10	0.0230	25.875	3.57059e+10	0.0204
5.625	3.51559e+10	0.0208	28.125	3.49483e+10	0.0213
7.875	3.59988e+10	0.0209	30.375	3.59072e+10	0.0224
10.125	3.86426e+10	0.0201	32.625	3.41357e+10	0.0221
12.375	4.26095e+10	0.0202	34.875	3.27583e+10	0.0233
14.625	4.34216e+10	0.0206	37.125	3.01682e+10	0.0245
16.875	4.40699e+10	0.0197	39.375	2.54211e+10	0.0240
19.125	4.36045e+10	0.0210	41.625	2.35423e+10	0.0270
21.375	4.19659e+10	0.0220	43.875	2.09435e+10	0.0299

*FLUX in $[n/cm^2-s]$.

+ERROR is the 1-sigma relative probable error.

**Table 5.3.2 MCNP Standard Core Loading Flux ($E > 1.0$ MeV) at the Pressure Vessel 1/4 T Location
Peak Axial Location
($R=224.473$ cm, $Z=125.488$ cm)**

θ degrees	[*] FLUX	⁺ ERROR	θ degrees	FLUX	ERROR
1.125	1.91850e+10	0.0260	23.625	2.11687e+10	0.0213
3.375	1.89468e+10	0.0231	25.875	1.94504e+10	0.0212
5.625	1.97919e+10	0.0225	28.125	1.98708e+10	0.0220
7.875	2.14177e+10	0.0214	30.375	1.99643e+10	0.0233
10.125	2.14849e+10	0.0210	32.625	1.91480e+10	0.0229
12.375	2.37752e+10	0.0206	34.875	1.85446e+10	0.0236
14.625	2.46090e+10	0.0201	37.125	1.63334e+10	0.0248
16.875	2.37518e+10	0.0203	39.375	1.42662e+10	0.0261
19.125	2.38443e+10	0.0219	41.625	1.26837e+10	0.0286
21.375	2.22642e+10	0.0214	43.875	1.20046e+10	0.0298

*FLUX in $[n/cm^2-s]$.

⁺ERROR is the 1-sigma relative probable error.

**Table 5.3.3 MCNP Standard Core Loading Flux ($E > 1.0$ MeV) at the Pressure Vessel Inner-Wall
Lower Weld Location
($R=219.393$ cm, $Z=67.1048$ cm)**

θ degrees	FLUX [*]	ERROR ⁺	θ degrees	FLUX [*]	ERROR ⁺
1.125	2.79499e+10	0.0307	23.625	3.08956e+10	0.0247
3.375	2.82001e+10	0.0249	25.875	3.05221e+10	0.0256
5.625	3.04488e+10	0.0235	28.125	2.94234e+10	0.0246
7.875	3.17712e+10	0.0238	30.375	2.99037e+10	0.0247
10.125	3.45589e+10	0.0243	32.625	3.03531e+10	0.0259
12.375	3.89546e+10	0.0250	34.875	3.06920e+10	0.0369
14.625	3.89420e+10	0.0230	37.125	2.62849e+10	0.0286
16.875	3.99371e+10	0.0250	39.375	2.24878e+10	0.0285
19.125	3.61876e+10	0.0226	41.625	1.96412e+10	0.0311
21.375	3.27623e+10	0.0240	43.875	1.79155e+10	0.0336

*FLUX in $[n/cm^2-s]$.

+ERROR is the 1-sigma relative probable error.

**Table 5.3.4 MCNP Flux (E>1.0 MeV) Partial Length Shield Assembly Core Loading
at the Pressure Vessel Inner-Wall
Lower Weld Location
(R=220.345 cm,** Z=67.1048 cm)**

θ degree	[*] FLUX	⁺ ERROR	θ degree	FLUX	ERROR
1.125	2.05086e+09	0.0416	23.625	1.23452e+10	0.0164
3.375	2.19044e+09	0.0379	25.875	1.61689e+10	0.0154
5.625	2.29836e+09	0.0354	28.125	1.97642e+10	0.0145
7.875	2.41004e+09	0.0319	30.375	2.27788e+10	0.0145
10.125	2.61979e+09	0.0317	32.625	2.50328e+10	0.0149
12.375	3.00202e+09	0.0335	34.875	2.46216e+10	0.0144
14.625	3.55716e+09	0.0285	37.125	2.26603e+10	0.0146
16.875	4.57061e+09	0.0238	39.375	2.04922e+10	0.0145
19.125	6.41668e+09	0.0208	41.625	1.80545e+10	0.0153
21.375	9.17252e+09	0.0186	43.875	1.65248e+10	0.0168

*FLUX in [n/cm²-s].

⁺ERROR is the 1-sigma relative probable error.

**This radius is the center of the MCNP Tally cell and does not correspond exactly to the inner-wall location.

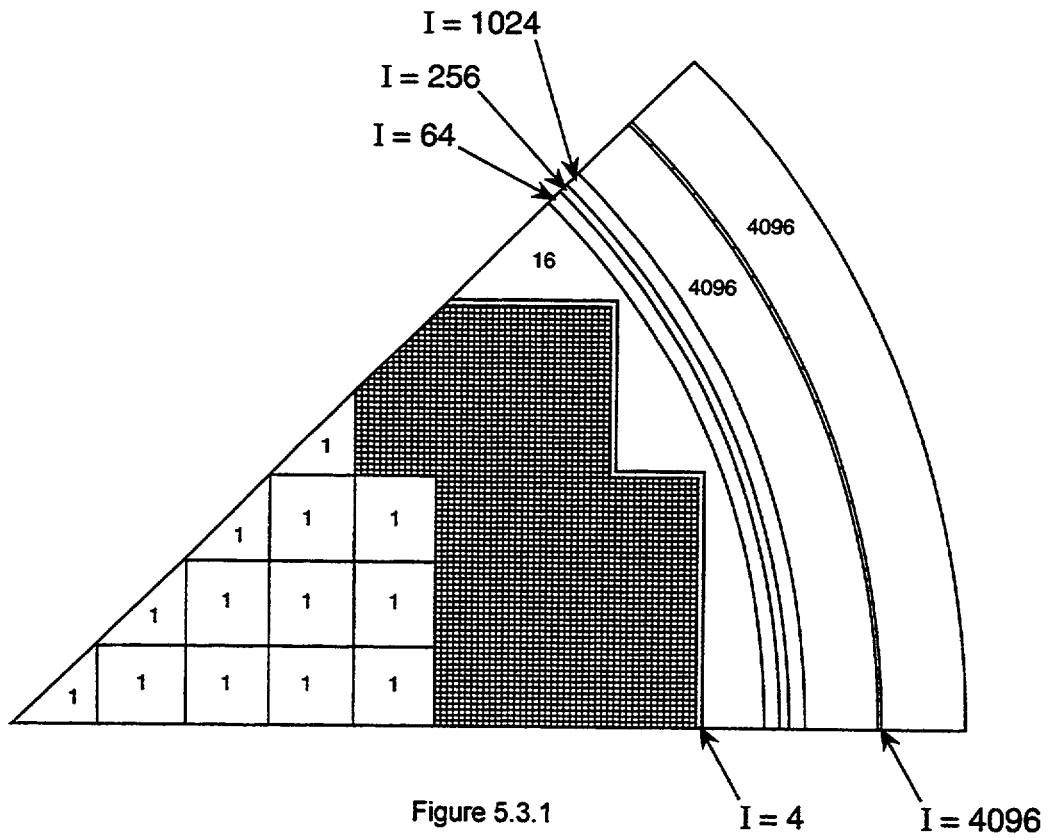

**Region-wise Importance I For The
Standard Core Problem**

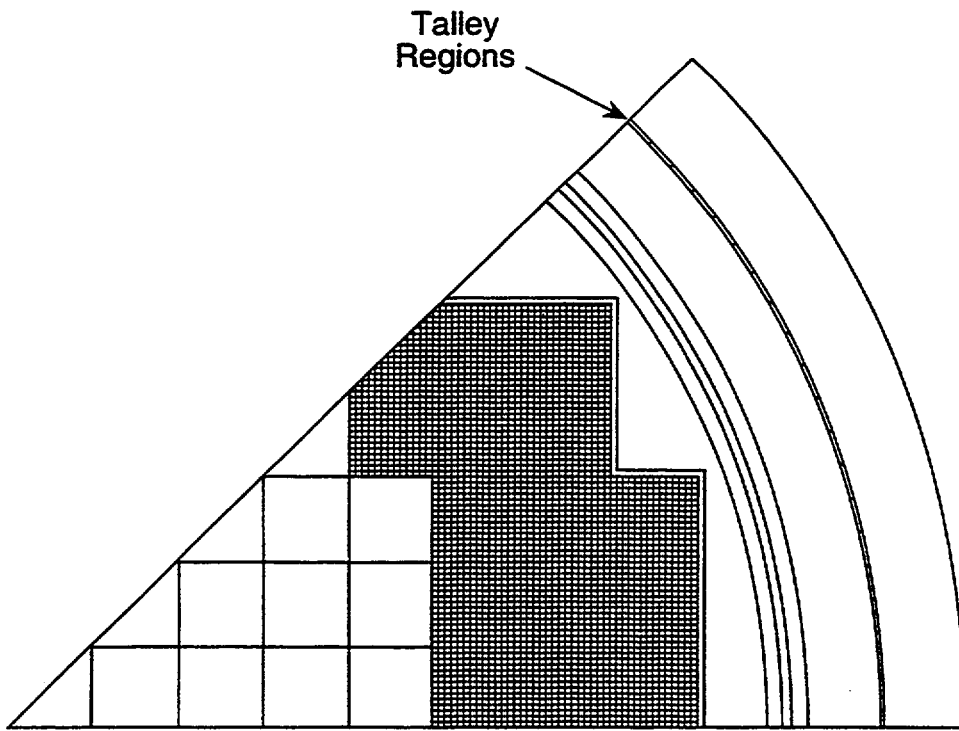

Figure 5.3.2

MCNP Radial Geometry Standard Core Loading

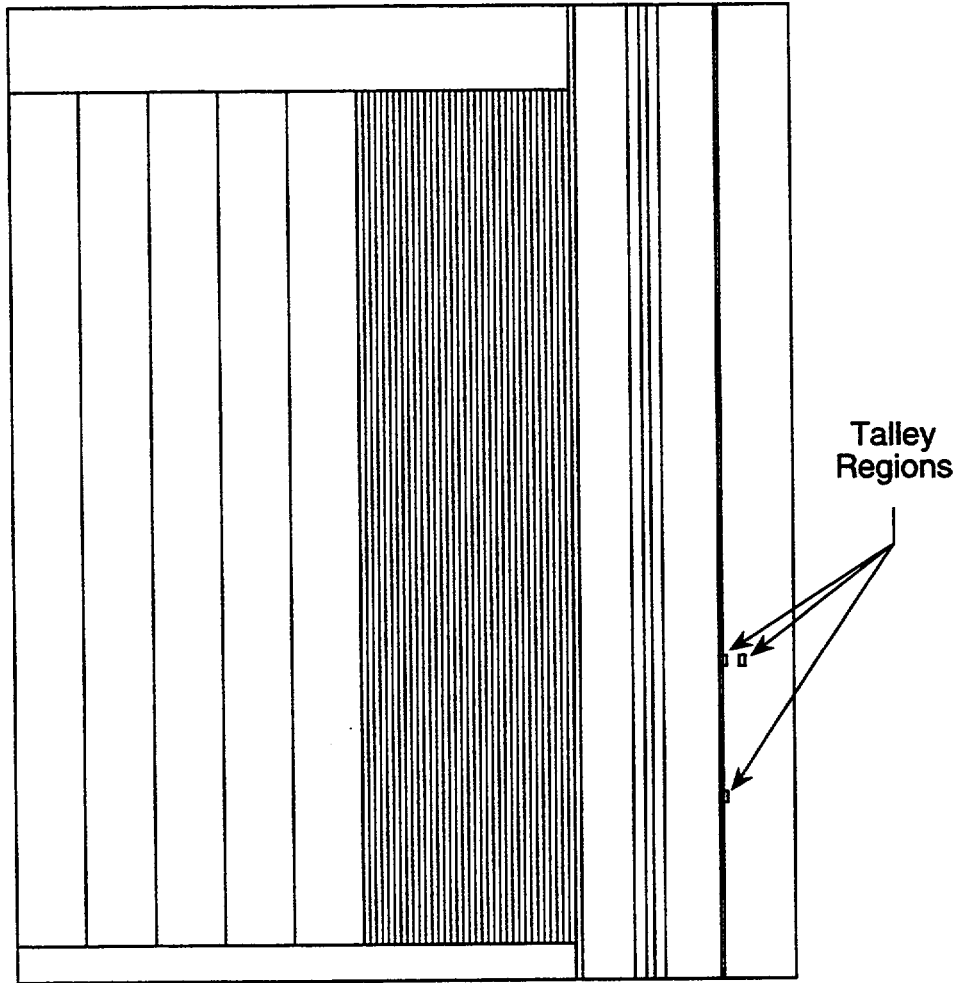

Figure 5.3.3

**MCNP Axial Geometry
Standard Core Loading**

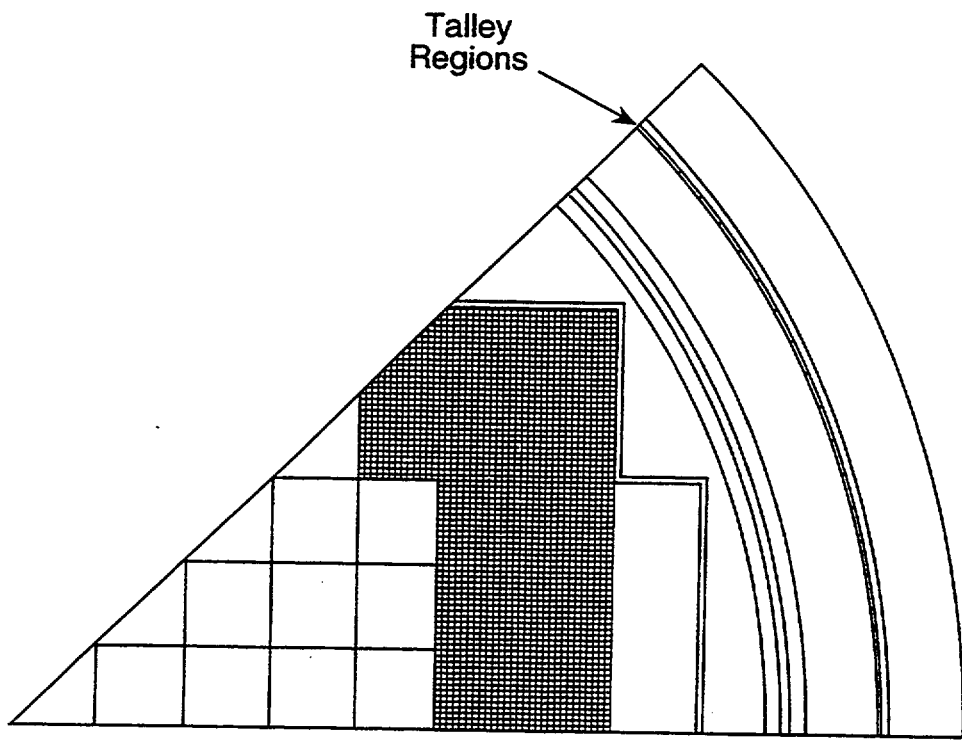

Figure 5.3.4

**MCNP Radial Geometry
PLSA Core Loading**

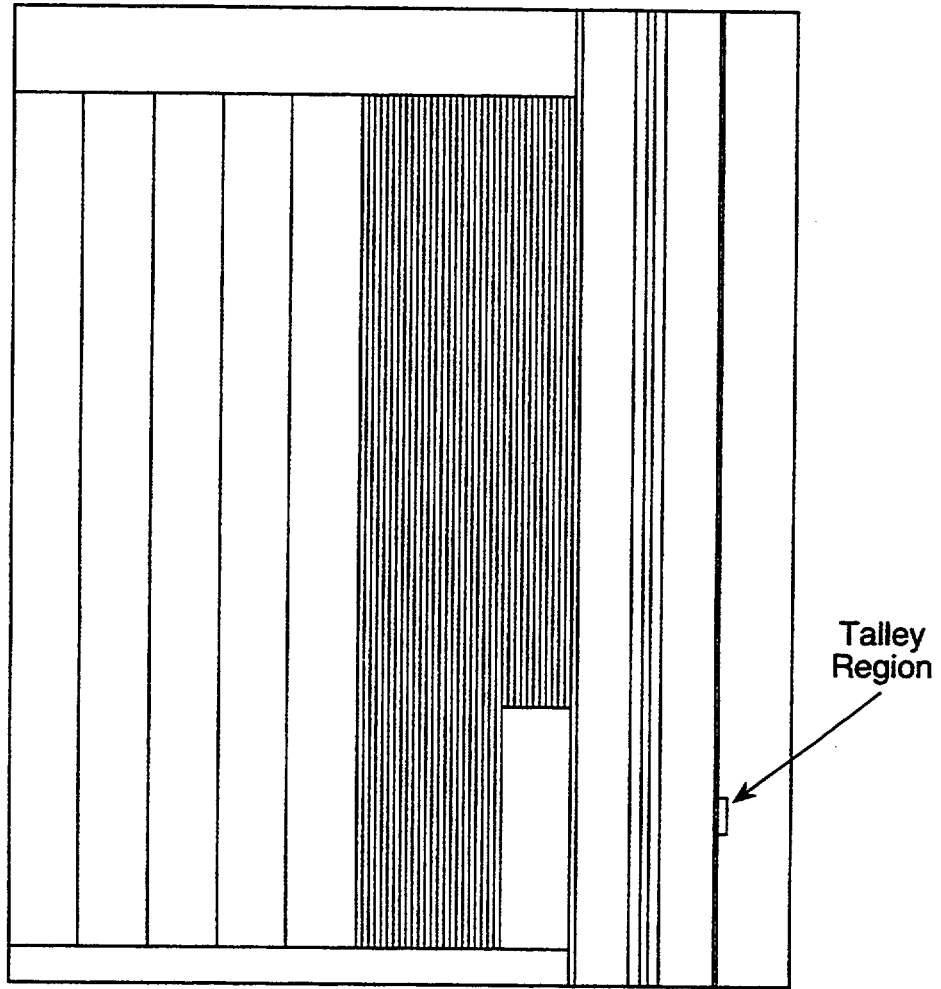

Figure 5.3.5

**MCNP Axial Geometry
PLSA Core Loading**

Figure 5.3.6

**E > 1-MeV Flux At Pressure Vessel Inner Wall
Standard Core Loading
Peak Axial Location**

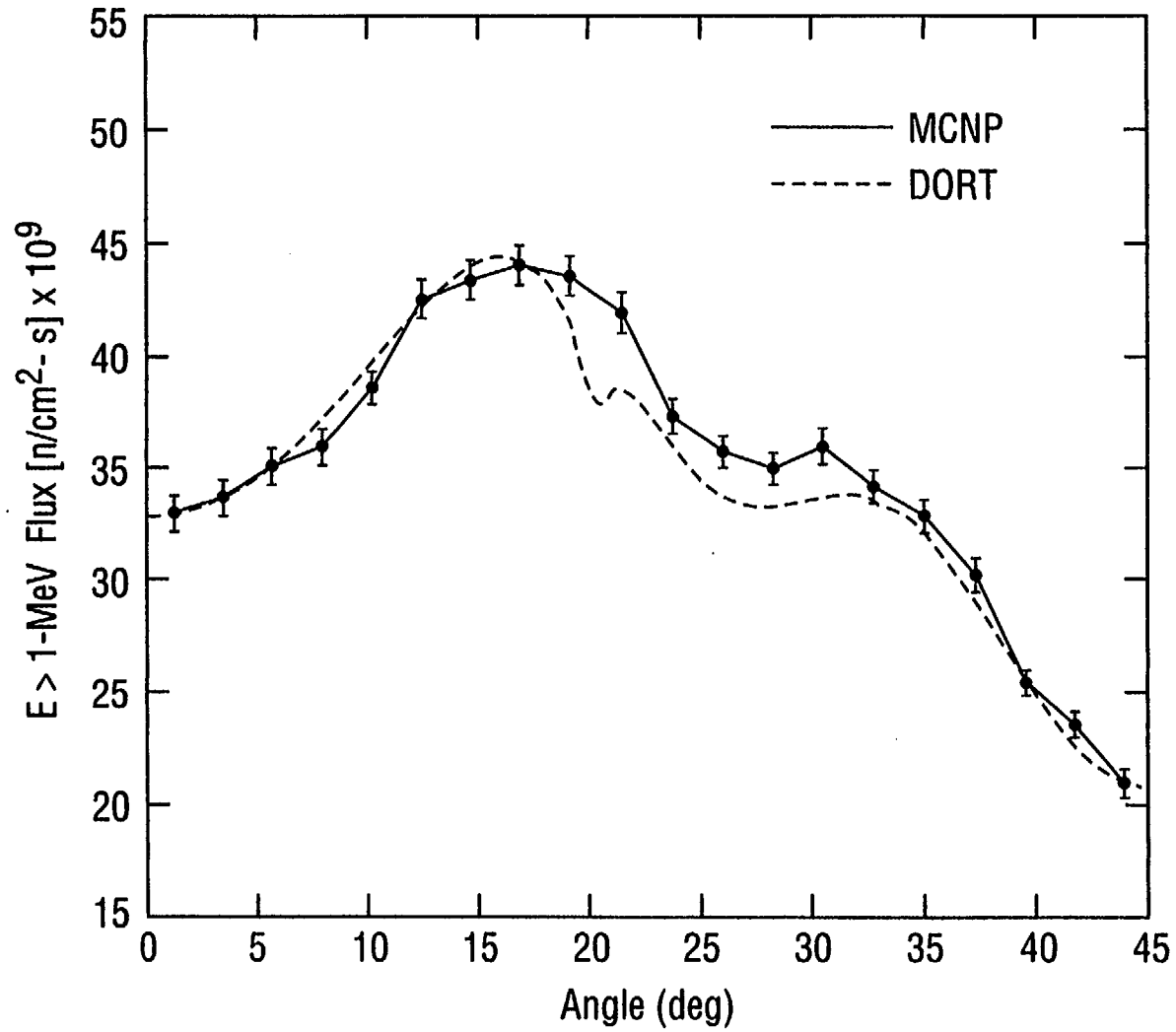

Figure 5.3.7

**E > 1-MeV Flux At Pressure Vessel T/4 Location
Standard Core Loading
Peak Axial Location**

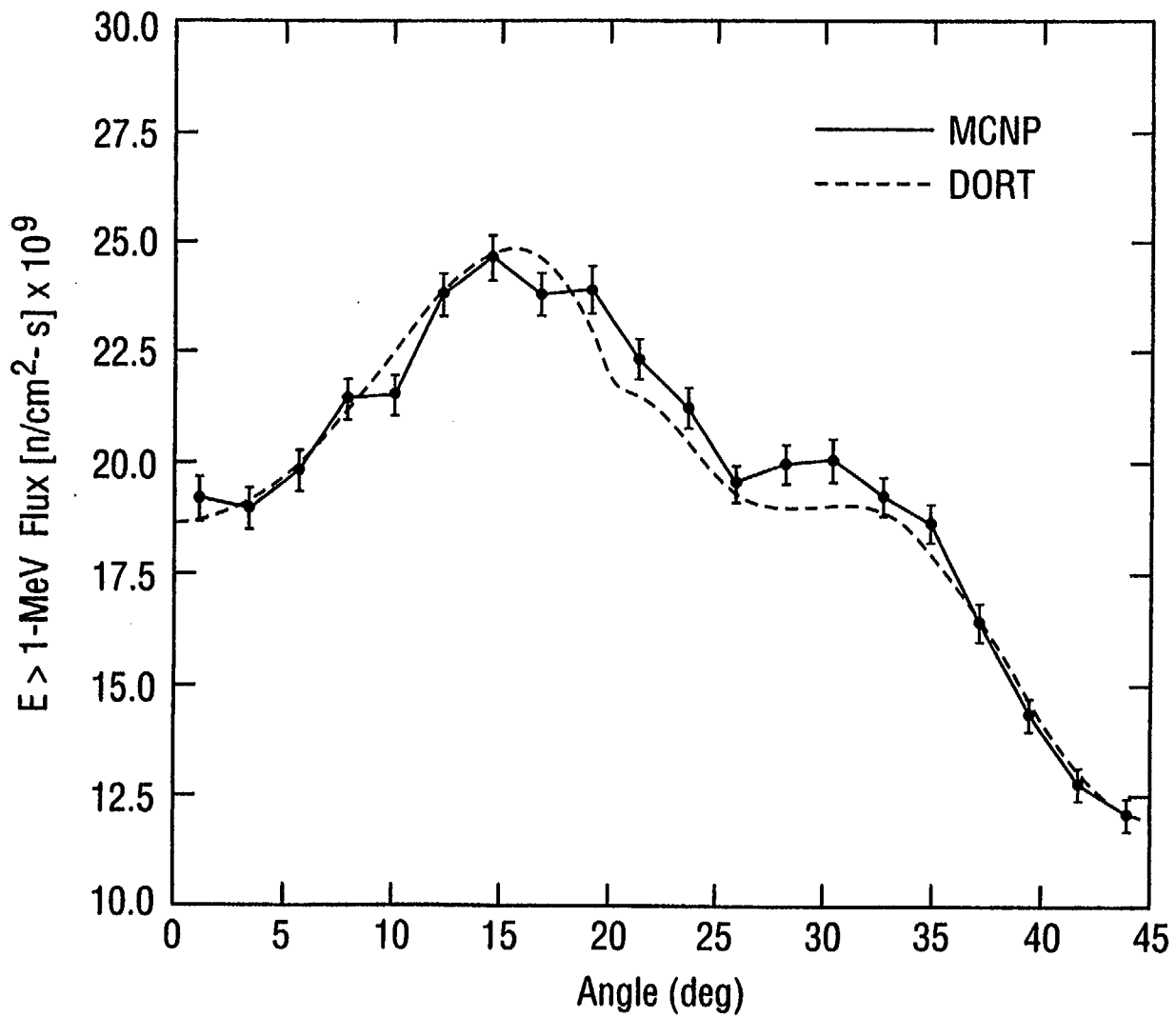

Figure 5.3.8

E > 1-MeV Flux At Pressure Vessel Lower Weld Standard Core Loading

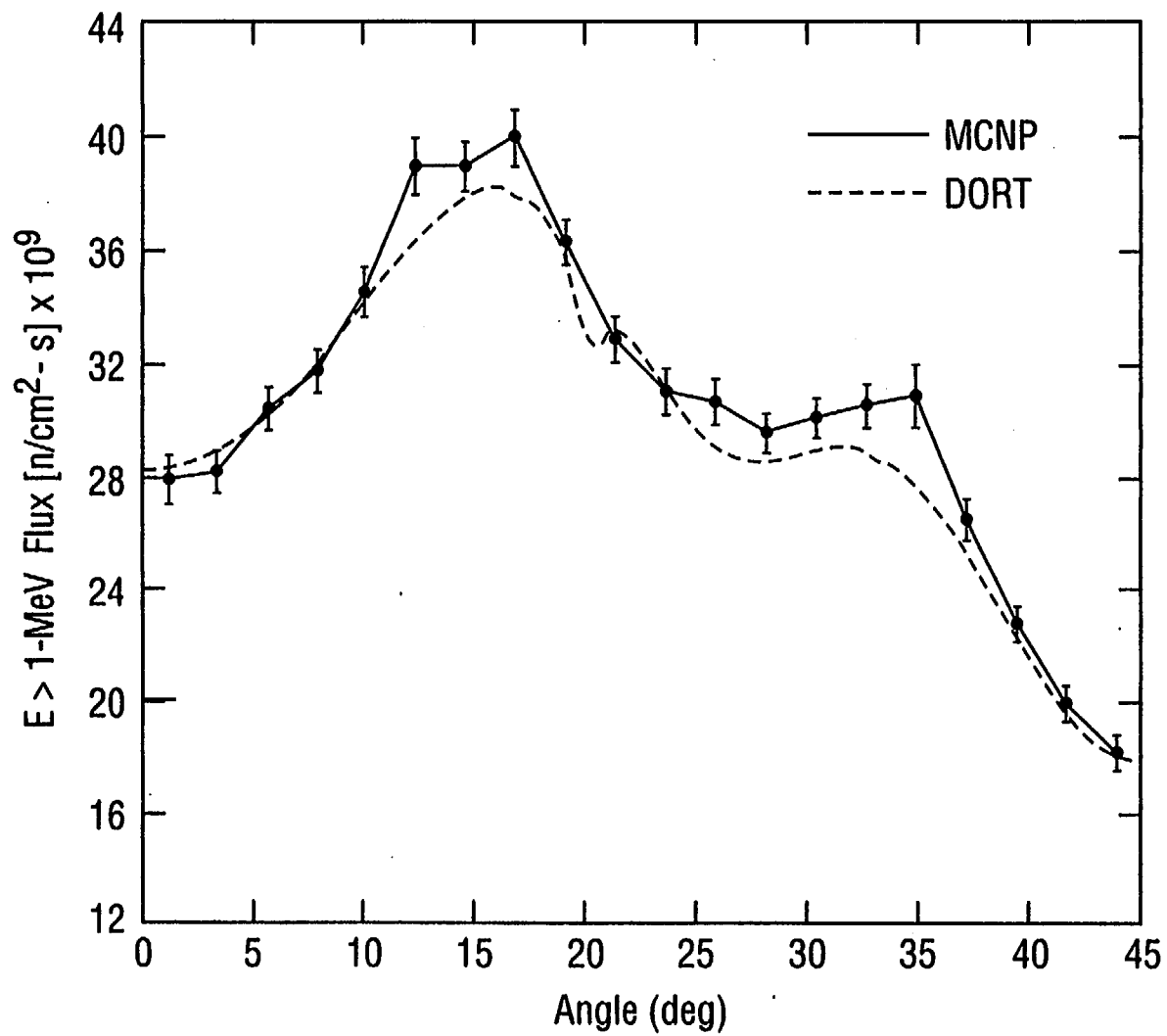

Figure 5.3.9

E > 1-MeV Flux At Pressure Vessel Lower Weld Partial Length Shield Assembly Core Loading

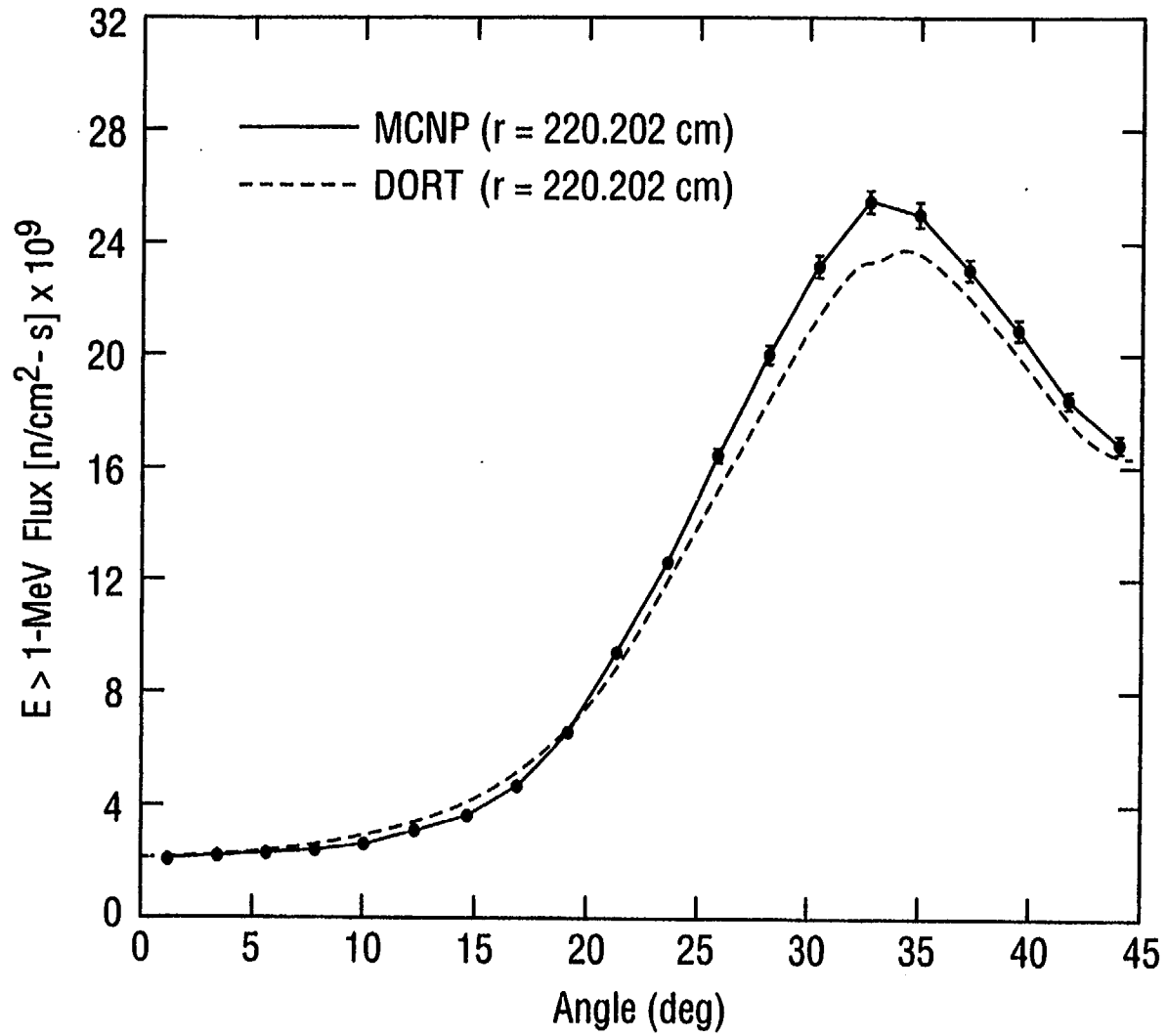

Table 5.4.1

MCNP Flux at Downcomer

Explicit Water Gap

(R=278.10cm, Z=239.93cm)

θ degree	FLUX (E >1.0 Mev)		θ degree	FLUX (E >1.0 Mev)	
	* FLUX	+ ERROR		FLUX	ERROR
1.125	5.83903e+10	0.0442	23.625	8.78056e+10	0.0348
3.375	5.33293e+10	0.0424	25.875	8.20344e+10	0.0363
5.625	5.89746e+10	0.0439	28.125	7.46868e+10	0.0378
7.875	4.45477e+10	0.0472	30.375	7.61948e+10	0.0383
10.125	3.97564e+10	0.0486	32.625	7.40129e+10	0.0382
12.375	3.85787e+10	0.0509	34.875	8.95386e+10	0.0345
14.625	4.67540e+10	0.0497	37.125	1.25014e+11	0.0303
16.875	5.89143e+10	0.0426	39.375	1.55212e+11	0.0273
19.125	6.86036e+10	0.0399	41.625	1.83638e+11	0.0251
21.375	8.16774e+10	0.0360	43.875	1.92218e+11	0.0264

 * FLUX in $[n/cm^2-s]$.

+ ERROR is the 1-sigma relative probable error.

Table 5.4.2

MCNP Flux at Pressure Vessel Wall

Explicit Water Gap

**

(R=323.143cm, Z=239.93cm)

		FLUX (E >1.0 Mev)			
θ degree	*	+	θ degree	FLUX	ERROR
	FLUX	ERROR			
1.125	6.03113e+08	0.0511	23.625	7.01064e+08	0.0433
3.375	6.01035e+08	0.0458	25.875	7.25801e+08	0.0417
5.625	5.14640e+08	0.0503	28.125	8.08798e+08	0.0390
7.875	4.12581e+08	0.0505	30.375	8.78108e+08	0.0398
10.125	4.25150e+08	0.0510	32.625	8.43930e+08	0.0375
12.375	4.08336e+08	0.0534	34.875	8.07605e+08	0.0365
14.625	4.73165e+08	0.0499	37.125	9.30806e+08	0.0352
16.875	5.05795e+08	0.0472	39.375	1.12012e+09	0.0339
19.125	5.70097e+08	0.0447	41.625	1.20922e+09	0.0335
21.375	6.42908e+08	0.0420	43.875	1.11808e+09	0.0354

 ** This radius is the center of the MCNP Tally cell, and does not correspond exactly to the inner-wall location.

* FLUX in [n/cm²-s].

+ ERROR is the 1-sigma relative probable error.

Table 5.4.3

MCNP Flux at Downcomer (HOM)

Homogenized Water Gap

(R=278.10cm , Z=239.93cm)

FLUX (E >1.0 Mev)					
θ	*	+	θ	*	+
degrees	FLUX	ERROR	degrees	FLUX	ERROR
1.125	6.10441e+10	0.0432	23.625	8.52113e+10	0.0349
3.375	5.42945e+10	0.0428	25.875	8.31111e+10	0.0355
5.625	5.51802e+10	0.0440	28.125	7.45137e+10	0.0377
7.875	4.49564e+10	0.0471	30.375	7.52133e+10	0.0384
10.125	4.11493e+10	0.0490	32.625	7.41093e+10	0.0381
12.375	4.20877e+10	0.0491	34.875	9.01422e+10	0.0342
14.625	4.88037e+10	0.0478	37.125	1.28040e+11	0.0303
16.875	5.83458e+10	0.0423	39.375	1.55341e+11	0.0268
19.125	6.91055e+10	0.0410	41.625	1.81845e+11	0.0252
21.375	7.81624e+10	0.0368	43.875	1.90983e+11	0.0260

In the homogenized case HOM, each assembly including the fuel rods, in-channel water, channel box and water gap is homogenized, rather than being included explicitly.

* FLUX in [n/cm²-s].

+ ERROR is the 1-sigma relative probable error.

Table 5.4.4

MCNP Flux at Pressure Vessel Wall (HOM)

Homogenized Water Gap

(R=323.143cm , Z=239.93cm)

FLUX (E >1.0 Mev)					
θ	*	+	θ	*	+
degrees	FLUX	ERROR	degrees	FLUX	ERROR
1.125	5.69317e+08	0.0525	23.625	6.87684e+08	0.0433
3.375	5.88823e+08	0.0465	25.875	7.32140e+08	0.0418
5.625	5.30936e+08	0.0500	28.125	8.20822e+08	0.0380
7.875	4.28586e+08	0.0515	30.375	8.58914e+08	0.0393
10.125	4.09933e+08	0.0497	32.625	8.57230e+08	0.0374
12.375	4.31201e+08	0.0523	34.875	8.20901e+08	0.0363
14.625	4.69051e+08	0.0505	37.125	9.10506e+08	0.0363
16.875	5.35999e+08	0.0466	39.375	1.08834e+09	0.0344
19.125	5.70021e+08	0.0447	41.625	1.18576e+09	0.0326
21.375	6.28348e+08	0.0432	43.875	1.13768e+09	0.0353

In the homogenized case HOM, each assembly including the fuel rods, in-channel water, channel box and water gap is homogenized, rather than being included explicitly.

* FLUX in [n/cm²-s].

+ ERROR is the 1-sigma relative probable error.

Figure 5.4.1

MCNP Radial Geometry

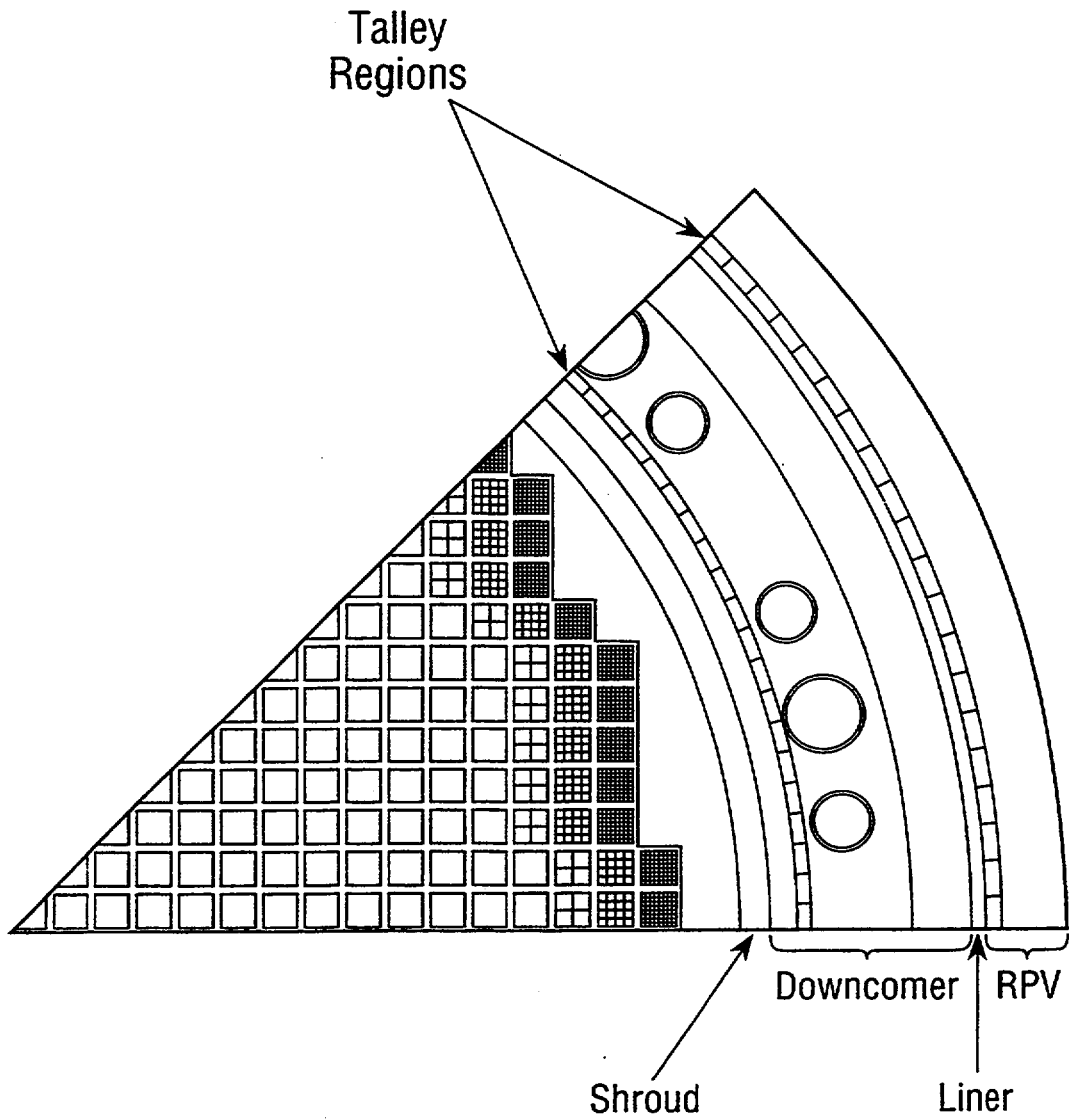

Figure 5.4.2
MCNP Axial Geometry

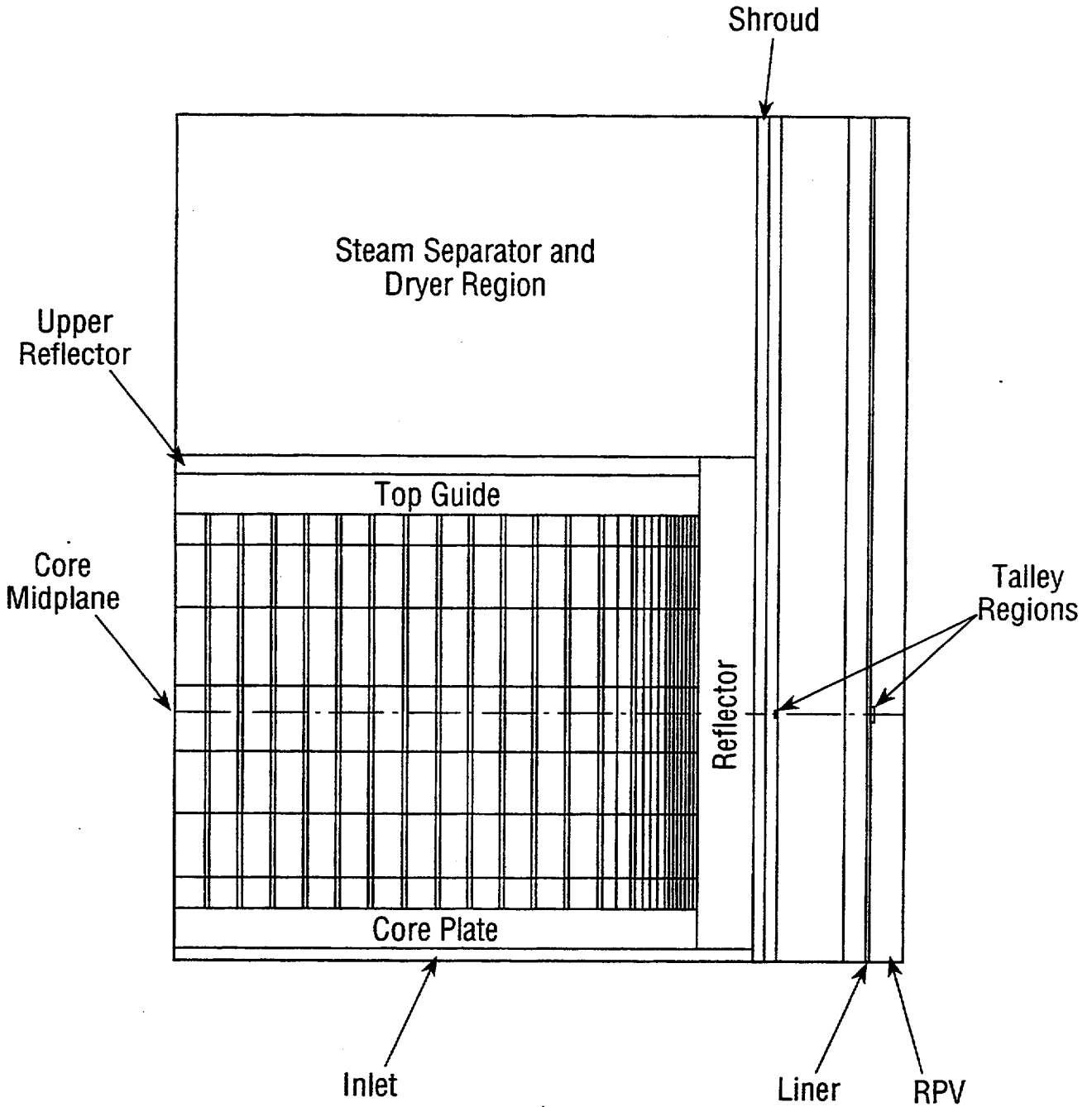

Figure 5.4.3

Radial Region-Wise Importance I.

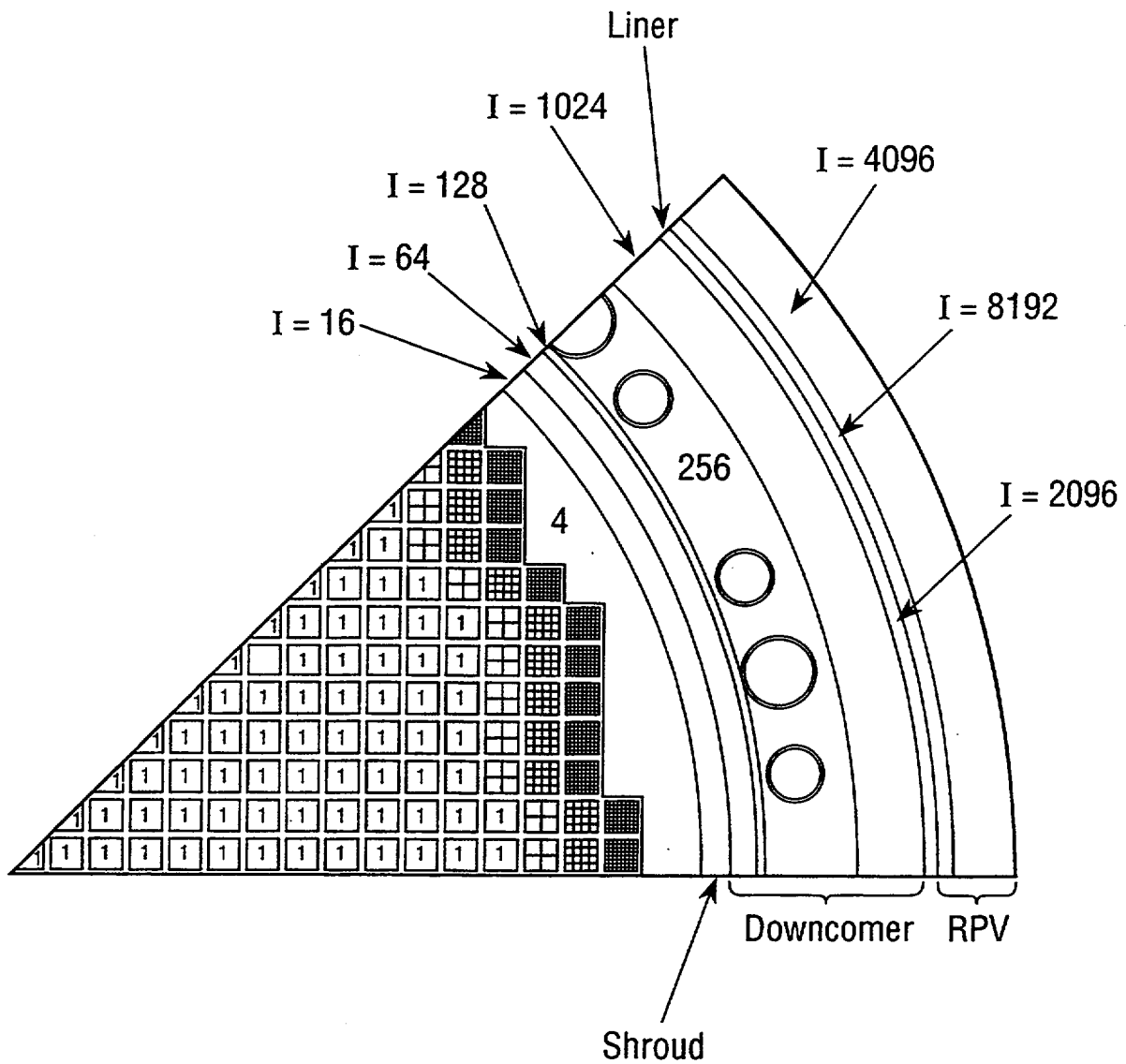

Figure 5.4.4

Axial Region-Wise Importance I

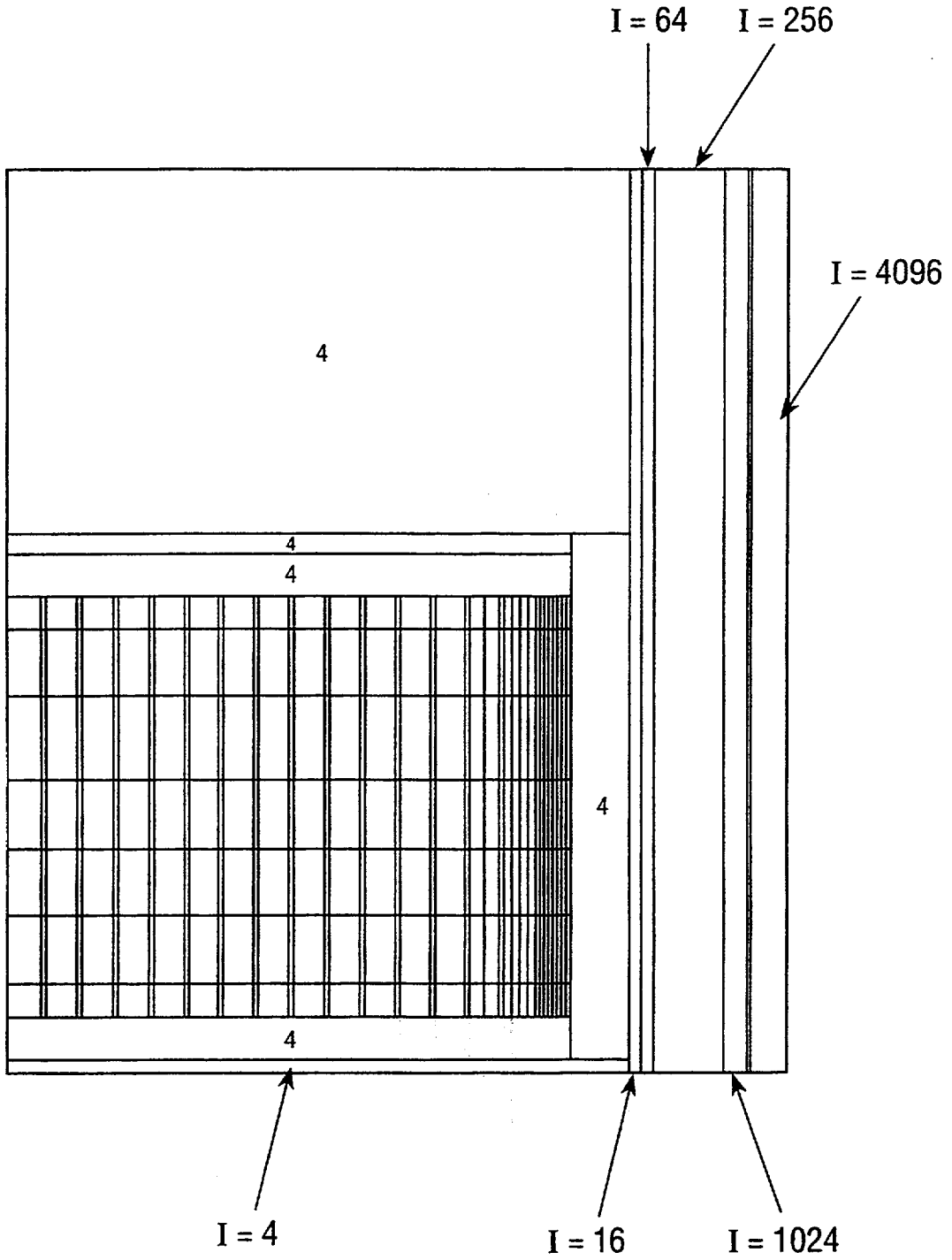

Figure 5.4.5

**Comparison of MCNP and DORT E > 1-MeV Flux In Downcomer
(r= 278.10 cm) at The Core Axial Midplane**

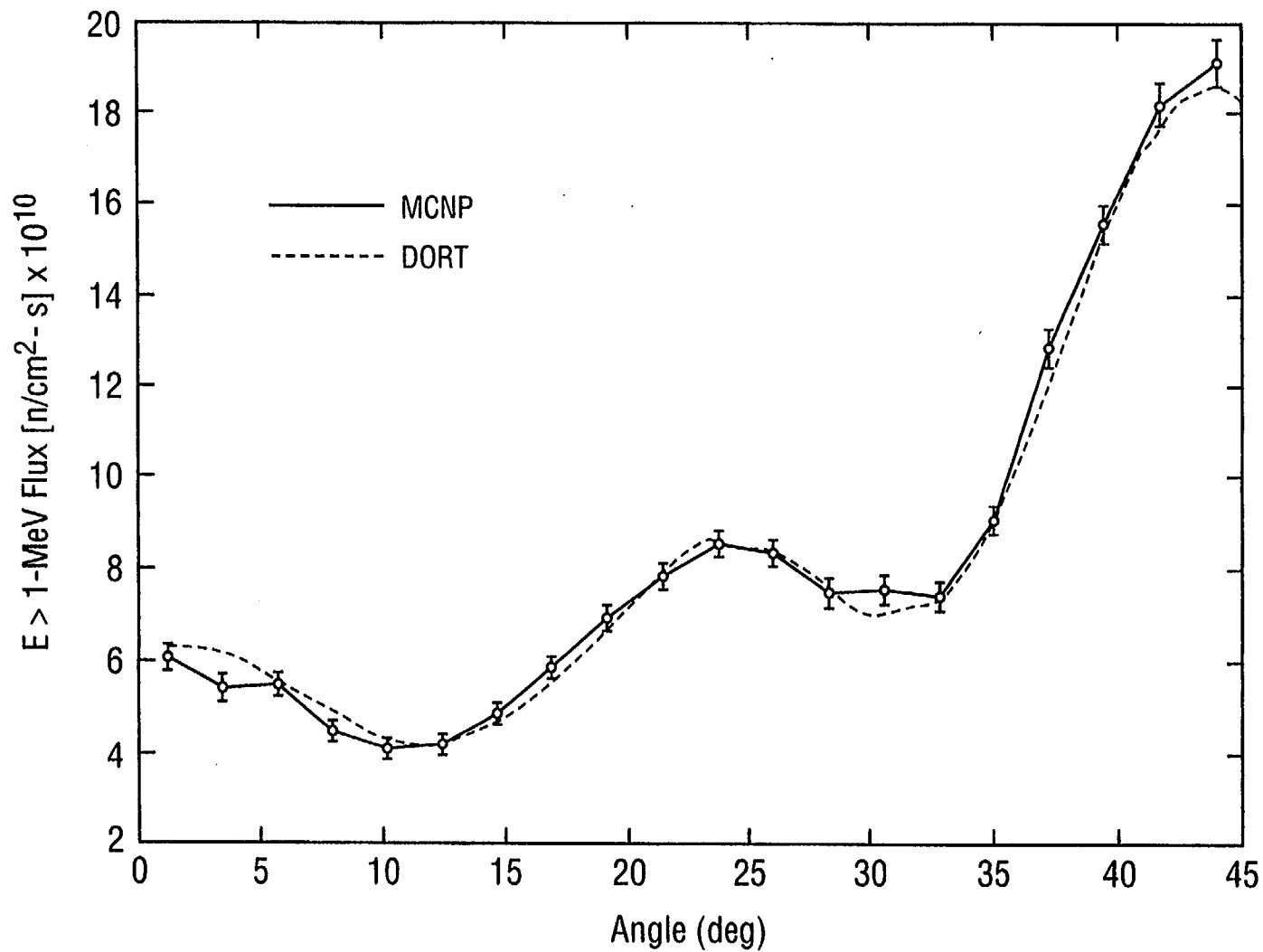

Figure 5.4.6

Comparison of MCNP and DORT E > 1-MeV Flux at Pressure Vessel Inner Wall (r = 323.143 cm) at The Core Axial Midplane

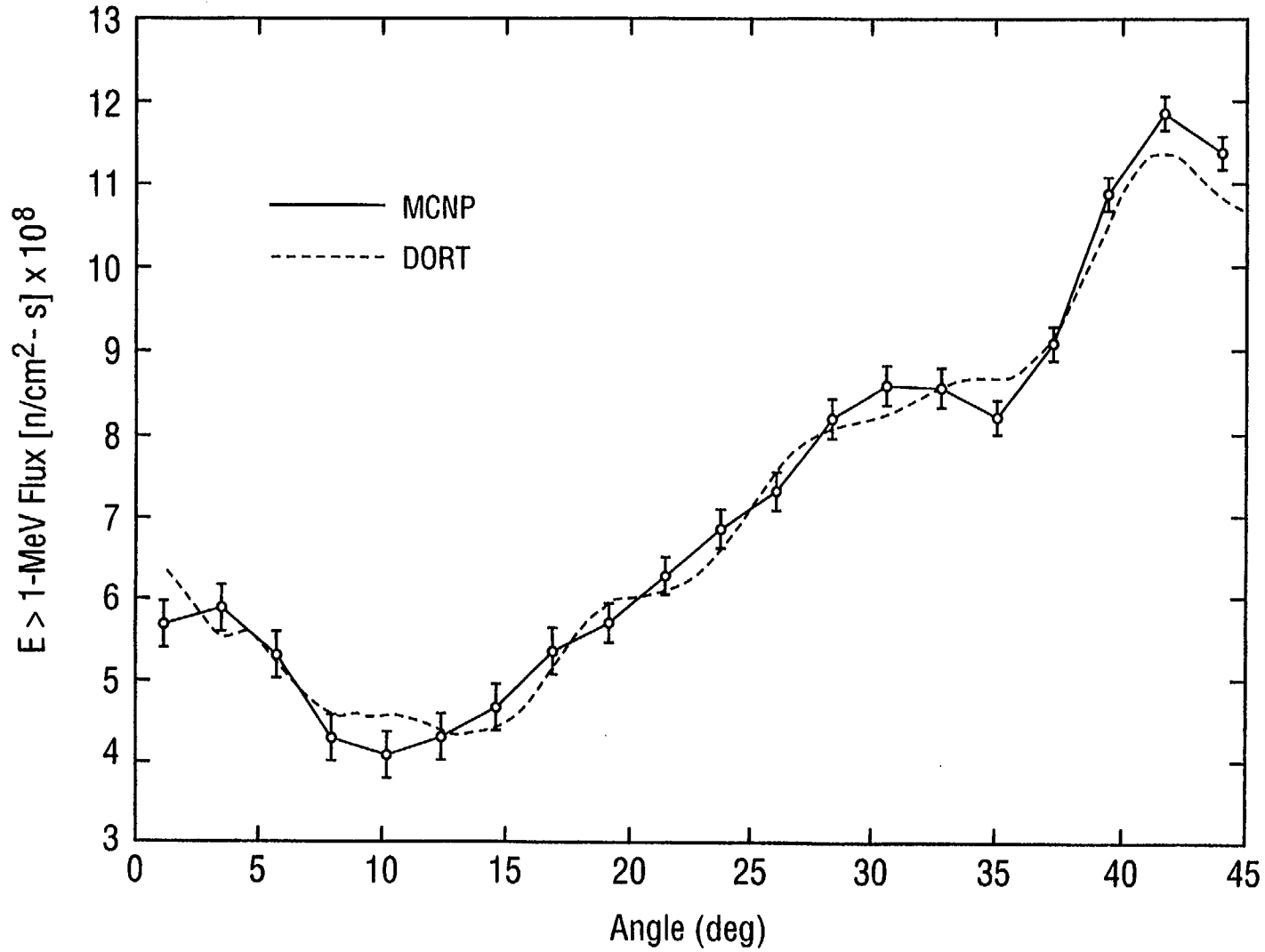

Figure 5.4.7

E > 1-MeV Flux In Downcomer (r = 278.10 cm) at The Core Axial Midplane With Probable Error

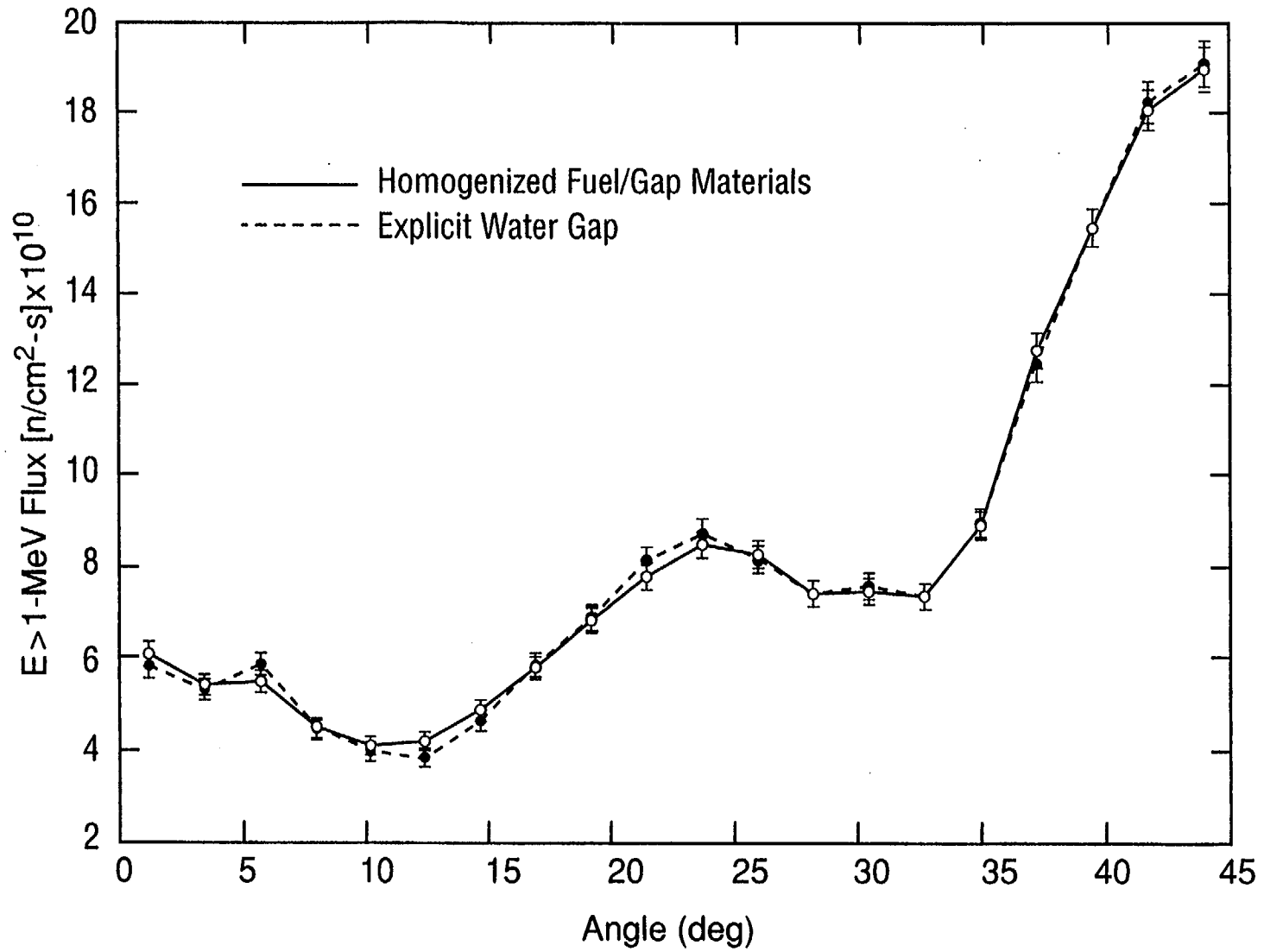
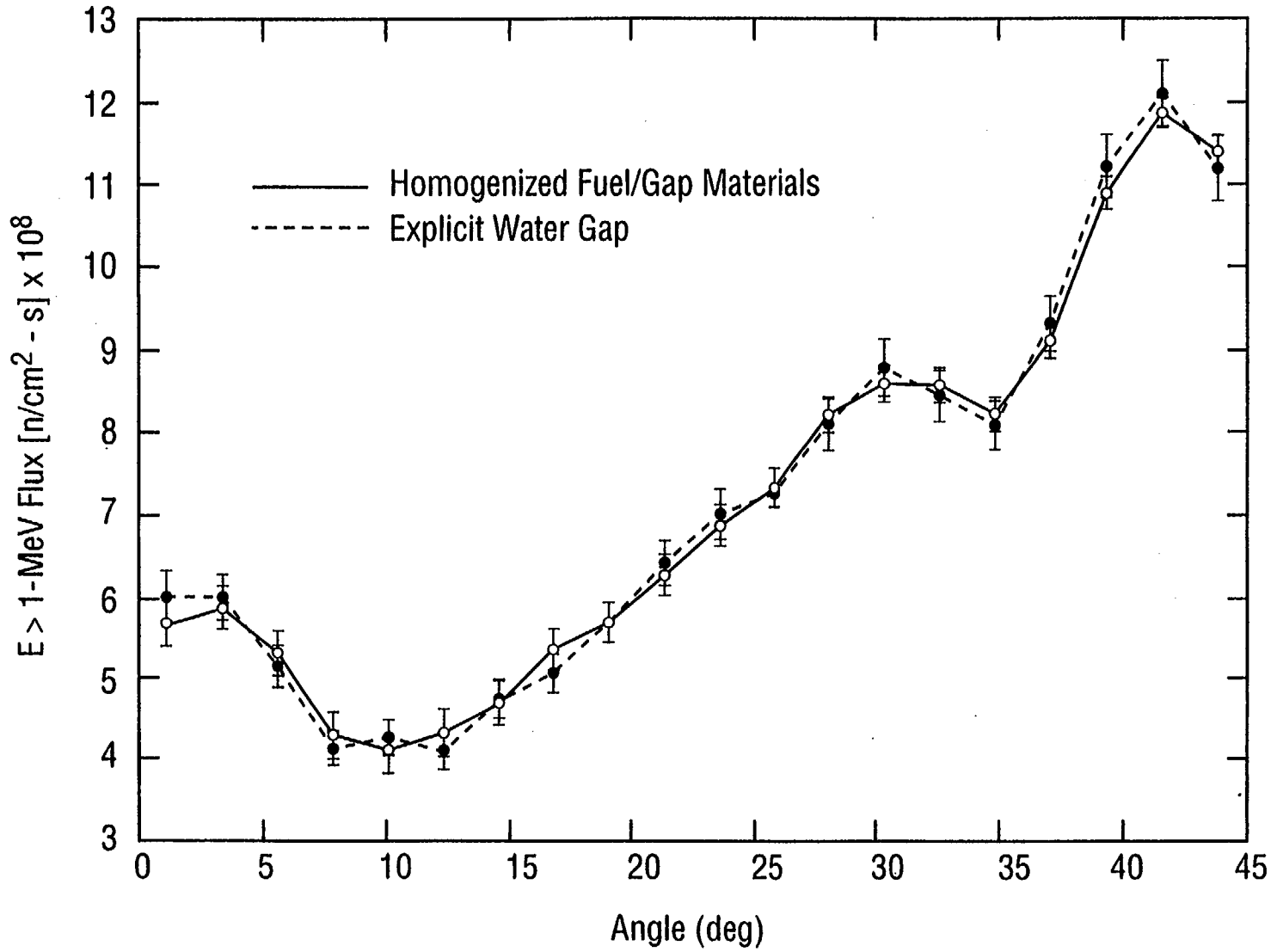

Figure 5.4.8

**$E > 1\text{-MeV}$ Flux at Pressure Vessel Inner-Wall ($r = 323.143\text{ cm}$)
at The Core Axial Midplane With Probable Error**



6 REFERENCES

1. W. A. Rhoades et. al., "TORT-DORT Two- and Three-Dimensional Discrete Ordinates Transport, Version 2.8.14," CCC-543, Radiation Safety Information Computational Center, Oak Ridge National Laboratory, 1994.¹
2. D. T. Ingersoll, J. E. White, R. Q. Wright, H. T. Hunter, C. O. Slater, N. M. Greene, R. E. MacFarlane, R. W. Roussin, "Production and Testing of the VITAMIN-B6 Fine-Group and the BUGLE-93 Broad-Group Neutron/Photon Cross-section Libraries Derived from ENDF/B-VI Nuclear Data," ORNL-6795, NUREG/CR-6214, January 1995.¹
3. J. F. Breismeister (Ed.), "MCNP - A General Monte Carlo N-Particle Transport Code, Version 4b," LA-12625, Los Alamos National Laboratory, March 1997.¹
4. F. W. Walker, J. R. Parrington, F. Feiner, "Nuclides and Isotopes," (Fourteenth Edition), 1989, Nuclear Energy Operations, General Electric Company.
5. "MESH - A Code for Determining the DOT Fixed Neutron Source," BNL-Memorandum, M. D. Zentner to J. F. Carew, August 25, 1981.
6. R. E. MacFarlane and D. W. Muir, "The NJOY Nuclear Data Processing System, Version 91," LA-12740-M, Los Alamos National Laboratory, October 1994.¹
7. G.L. Simmons and R.W. Roussin, "SAILOR-Coupled, Self-Shielded, 47 Neutron, 20 Gamma Ray, P3, Cross-Section Library for Light Water Reactors," RSIC-DLC-76, Oak Ridge National Laboratory, June 1985.¹
8. M. L. Williams, R. L. Childs, M. Asgari, "Analysis of H. B. Robinson PWR Vessel Fluence For Cycle-10 Utilizing Partial Length Shield Assemblies," NUREG/CR-5530, ORNL/TM-11476, September 1990.
9. J. C. Wagner, E. L. Redmond, S. P. Palmtag, and J. S. Hendricks, "MCNP: Multigroup/Adjoint Capabilities," LA-12704, Los Alamos National Laboratory, April 1994.

¹ Available from the Radiation Safety Information Computational Center, Oak Ridge National Laboratory, Post Office Box 2008, Oak Ridge, TN 37831-6362.

BIBLIOGRAPHIC DATA SHEET

(See instructions on the reverse)

1. REPORT NUMBER
(Assigned by NRC, Add Vol., Supp., Rev.,
and Addendum Numbers, if any.)

NUREG/CR-6115
BNL-NUREG-52395

2. TITLE AND SUBTITLE

PWR and BWR Pressure Vessel Fluence Calculation Benchmark Problems and Solutions

3. DATE REPORT PUBLISHED

MONTH YEAR

September 2001

4. FIN OR GRANT NUMBER

W6968

5. AUTHOR(S)

J. F. Carew, K. Hu, A. Aronson, A. Prince, and G. Zamonsky

6. TYPE OF REPORT

Technical

7. PERIOD COVERED (Inclusive Dates)

8. PERFORMING ORGANIZATION - NAME AND ADDRESS (If NRC, provide Division, Office or Region, U.S. Nuclear Regulatory Commission, and mailing address; if contractor, provide name and mailing address.)

Brookhaven National Laboratory
Upton, NY 11973-5000

9. SPONSORING ORGANIZATION - NAME AND ADDRESS (If NRC, type "Same as above"; if contractor, provide NRC Division, Office or Region, U.S. Nuclear Regulatory Commission, and mailing address.)

Division of Engineering Technology
Office of Nuclear Regulatory Research
U.S. Nuclear Regulatory Commission
Washington, DC 20555-0001

10. SUPPLEMENTARY NOTES

W. R. Jones, NRC Project Manager

11. ABSTRACT (200 words or less)

In order to provide the high confidence required in the determination of pressure vessel embrittlement and the evaluation of the RTPTS screening criteria, Regulatory Guide 1.190, "Calculational and Dosimetry Methods for Determining Pressure Vessel Neutron Fluence," recommends detailed benchmarking of pressure vessel fluence calculations. In response to this recommendation, this report provides the detailed specification and corresponding numerical solutions for a set of PWR and BWR pressure vessel fluence benchmark problems. PWR benchmark problems have been specified for (1) a standard core loading pattern, (2) a low-leakage core loading pattern and (3) a partial length shield assembly core design. Since BWR fuel loading patterns are presently not being designed for vessel fluence reduction, only a single BWR problem is specified. These benchmark problems allow a detailed assessment of the numerical procedures, code implementation, and the various modeling approximations against state-of-the-art solutions for representative operating configurations.

The problems have been solved using the DORT discrete ordinates transport code, the MESH source processing code, and the BUGLE-93 ENDF/B-VI nuclear data. Detailed neutron flux solutions are provided at selected pressure vessel azimuthal, radial, and axial locations. A pin-wise core neutron source is provided which includes the fuel burnup dependence of both the magnitude and energy dependence of the neutron source. Dosimeter responses are calculated for a typical set of LWR fast neutron dosimeter materials. In addition, MCNP Monte Carlo calculations have been performed for the PWR standard core and partial length shield assembly core loadings and the BWR problem. Comparisons of the MCNP and DORT vessel fluence calculations are presented.

12. KEY WORDS/DESCRIPTORS (List words or phrases that will assist researchers in locating the report.)

Pressure Vessel Fluence, Pressure Vessel Embrittlement, Regulatory Guide 1.190, Vessel Fluence Benchmark Problems, Core Loadings, Numerical Calculational Procedures, Modeling Approximations, DORT Discrete Ordinates Transport Code, Neutron Source, Dosimeter, MCNP Monte Carlo Code, Fast Neutron Fluence

13. AVAILABILITY STATEMENT

unlimited

14. SECURITY CLASSIFICATION

(This Page)

unclassified

(This Report)

unclassified

15. NUMBER OF PAGES

16. PRICE

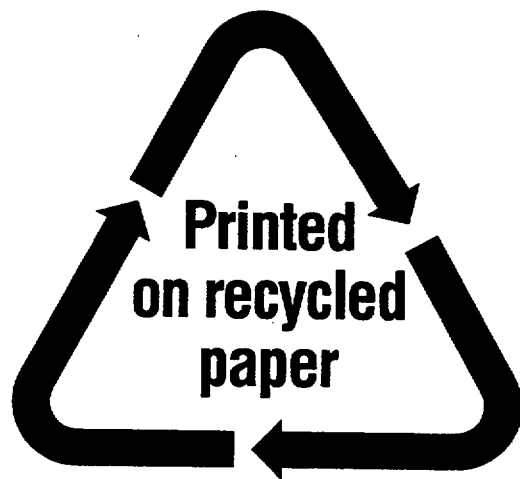

Federal Recycling Program

UNITED STATES
NUCLEAR REGULATORY COMMISSION
WASHINGTON, DC 20555-0001

OFFICIAL BUSINESS
PENALTY FOR PRIVATE USE, \$300